

# SP75

SPEECH  
PROCESSOR

by  **DRAKE**

## TABLE OF CONTENTS

	PAGE
I. General Description .....	1
II. Specifications .....	1
III. Installation .....	2
IV. Operation .....	6
V. Theory of Operation .....	7
VI. Alignment and Troubleshooting .....	8
VII. Service Data .....	9

## ILLUSTRATIONS

Fig. 1	Connecting SP75 to TR7 and PS7 .....	4
Fig. 2	Connecting SP75 to Systems Other Than TR7 and PS7 .....	4
Fig. 3	Phone Patch Connection to SP75 .....	5
Fig. 4	Tape Player Connection to SP75. ....	5
Fig. 5	P. C. Board Pictorial, SP75 .....	11
Fig. 6	Schematic, SP75 .....	12

ILLUSTRATIONS

Fig. 1 Connecting SP75 to TRT and FST ..... 4  
Fig. 2 Connecting SP75 to System Other Than TRT and FST ..... 4  
Fig. 3 Phone Patch Connection to SP75 ..... 5  
Fig. 4 Tape Player Connection to SP75 ..... 5  
Fig. 5 P. O. Board Internal FST ..... 11  
Fig. 6 ..... 12



**SP75**

## I. GENERAL DESCRIPTION

The SP75 Speech Processor is designed to provide an increase in average power and readability of a single sideband voice signal during weak signal or high interference conditions. The SP75 is connected between the microphone and microphone input of the single sideband transmitter, thus requiring no modification of the existing transmitter or transceiver. A front panel switch allows the processor to be switched in or bypassed as conditions warrant. Two additional inputs, such as a tape player or phone patch, may be front panel selected in place of the normal microphone input.

The amount of RF envelope clipping is adjustable between zero and twenty decibels by a front panel control. A LED indicates proper audio input level. Because of the pre-clipping audio compression, small changes in voice levels do not widely affect the clipping level.

Muting circuitry reduces gain during speech pauses, thus reducing undesirable background noise pickup and allowing VOX operation with the processor on.

The SP75 was designed for optimum performance using the Drake model 7077 microphone and the Drake TR7 transceiver or Drake 4-line transmitters. However, excellent performance can be obtained with most other transmitters which have a microphone input impedance of approximately 50 K ohm or greater. Microphones other than the Drake 7077 may be used successfully. However, microphones with a more sharply rising frequency response may produce a less pleasant response than a microphone with a flatter response.

## II. SPECIFICATIONS

Processing Type:	Preclipping audio compression followed by RF envelope clipping at the processor intermediate frequency.
RF Clipping Range:	Adjustable 0 to 20 dB from front panel control.
Input Level (Microphone Input):	3.5 mV minimum for full processing. Gain adjustable to accommodate up to 300 mV maximum.



Input Level (Tape & Patch Inputs):	15 mV minimum for full processing, 30 mV maximum.
Input Impedance (Microphone):	1 Megohm
Input Impedance (Tape & Patch):	50 K ohm
Output Level w/Processing:	0-50 mV adjustable into 50 K ohm load.
Output Impedance:	50 K ohm
Muting (Microphone Input Only):	10 to 20 dB attenuation during speech pauses.
Frequency Response:	400-6000 Hz @ -6 dB
Distortion:	Less than 5% T.H.D. @ 1 kHz, 20 dB clipping.
Supply Requirements:	11-16 VDC @ 95 mA
Size:	7" L x 6-1/4" W x 2-1/4" H (17.8 cm x 15.9 cm x 5.4 cm)
Weight:	1.4 lb. (.63 kg)

### III. INSTALLATION

Locate the SP75 at a convenient location. If the SP75 is placed on top of the TR7 transceiver, the microphone cable from the rear of the SP75 can be routed along the side and underneath the TR7. DO NOT block the power amplifier cooling slots on the right side of the TR7.

The SP75 may be secured to the top of a RV7, MS7, or equivalent cabinet with the two retaining clips provided. First, remove the screw-in mounting feet on the SP75 and replace with the four number 6 screws provided. Place the four stick-on rubber feet on the bottom of the SP75 next to the cover mounting screws on the cover. Remove the top screws on each front extrusion end cap of the MS7 or RV7 and the bottom screws on each SP75 end cap. Place a retaining clip between the end cap and extrusion. Position so that the hole is properly aligned and replace end cap screws. Repeat retaining clip installation on the other side.

Plug the SP75 output cable into the TR7 microphone input connector. Plug the phono plug on the SP75 supply cable into the 13.6 volt accessory output jack on the PS7 power supply. The microphone may then be connected to the SP75 input.

If another transmitter other than the TR7 is used, the proper mating connector can be installed on the SP75 cable replacing the TR7 microphone plug supplied. Connect the red wire to the PTT connection, the white center conductor of the shielded cable to the microphone audio connection, and the shield and black wires to the ground connection.

When using a transmitter/power supply combination other than the TR7/PS7, connect the positive SP75 supply (11-16 V) lead to the tip of the SP75 supply cable plug. Connect the negative supply lead to the *chassis of the transmitter*. Do not connect the negative supply lead to the shield of the SP75 supply cable as this shield is not internally connected in the SP75. *The SP75 must receive its supply negative connection through the output cable ground by way of the transmitter or transceiver chassis.* This is done to prevent ground currents from being introduced across the SP75 output cable which could result in an RF feedback condition.

### ADDITIONAL GROUNDING NOTES

In addition to the above supply connection the following must be observed to prevent any possibility of creating undesirable ground currents through the SP75 which could result in RF feedback.

- 1) Any microphones or other inputs connected to the SP75 **MUST NOT** be grounded through any other path other than through the SP75 input connector.
- 2) When a phone patch or tape recorder are connected to the SP75, they should **NOT** be grounded elsewhere, such as through a three wire AC supply cord. If the patch or recorder must be grounded, then the audio connection to the SP75 may need to be isolated by a transformer.
- 3) *See* the following diagrams for examples.

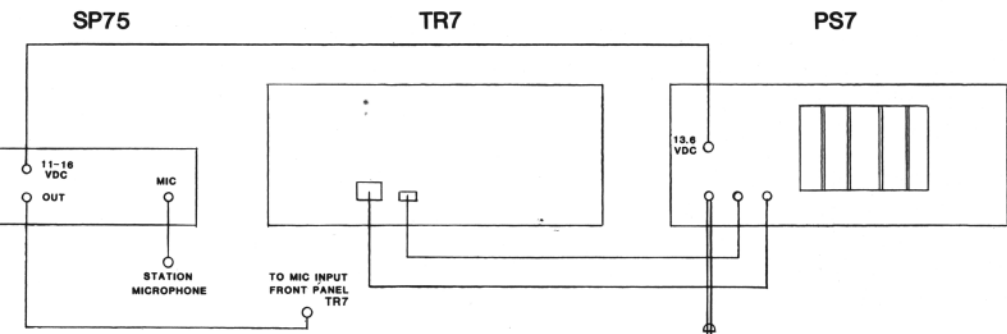

Figure 1 Connecting SP75 to TR7 and PS7

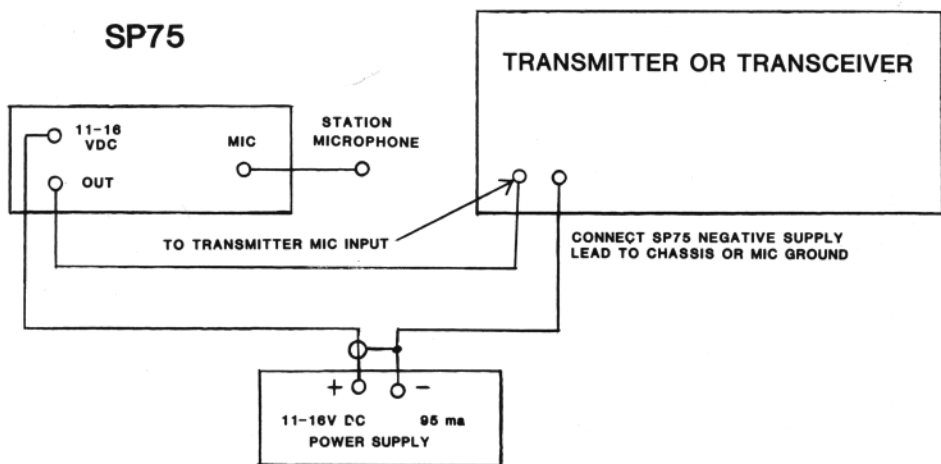

Figure 2 Connecting SP75 to Systems Other Than TR7 and PS7

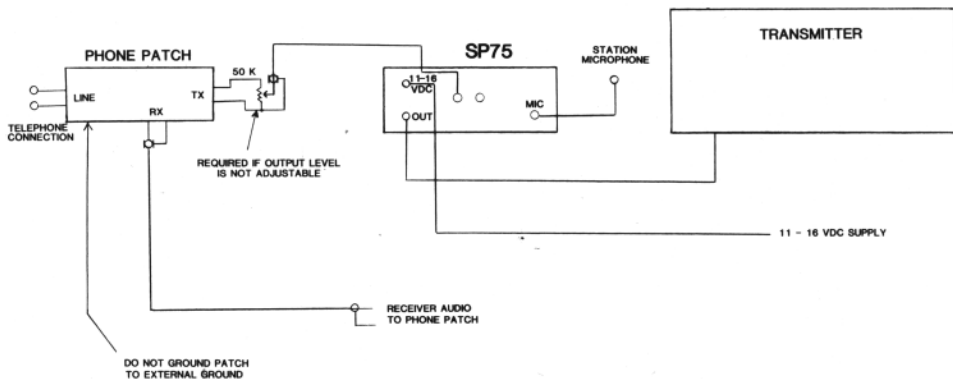

Figure 3 Phone Patch Connection to SP75

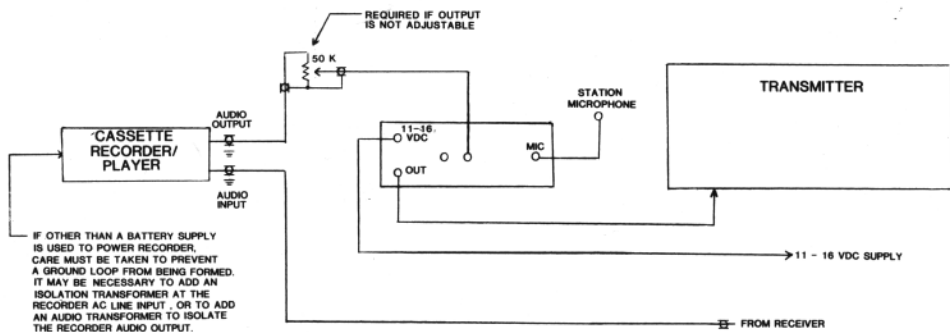

Figure 4 Tape Player Connection to SP75



## POWER SWITCHING OPTION

As supplied from the factory (jumper option A) the SP75 is always connected the DC supply regardless of the position of the ON/OFF pushbutton. This is true even though the green "ON" LED is switched. This is done to allow instant IN/OUT audio switching. If it is desirable to eliminate all power consumption when the ON/OFF pushbutton is OFF, the power jumper can be moved as shown in the schematic, jumper option B. When this change is made, there will be a slight delay before the processor is operational when the unit is turned ON. Unless battery power is used it is usually desirable to leave the jumper in the factory supplied position. See figure 5 for power jumper location.

## IV OPERATION

Before operating with the SP75 it may be necessary to set the SP75 microphone gain and output audio levels. Once these adjustments are made it should not be necessary to readjust them unless a microphone with a different output level is used. The SP75 set up procedure is as follows:

- 1) With the SP75 bypassed, ("ON" button out) adjust transmitter microphone gain for normal transmitter operation. Select the microphone input by depressing the MIC pushbutton.
- 2) Set the SP75 clipping level to 0 dB.
- 3) Turn SP75 on by depressing "ON" pushbutton. While speaking normally, advance the SP75 microphone gain, accessible through SP75 rear panel, with a small screwdriver until the green "AUDIO" LED on the SP75 just stays on while speaking. Do not advance-beyond this point. NOTE: Observing from the rear panel, full CCW setting is minimum gain. Advancing the potentiometer CW increases gain. The LED should not blink while speaking continuously, but should start dropping out if you back away from the microphone a few inches farther than normal and should go out completely when you stop speaking.
- 4) Place transmitter in transmit. -With the SP75 at 0 dB clipping level, talk normally into the microphone and advance the SP75 output level control, accessible through rear panel, starting at minimum level (CCW), for normal

transmitter operation With the TR7 this means advancing the SP75 output level until the green TR7 ALC indicator just lights to full brilliance. Do not advance output level beyond this point. NOTE: Transmitter microphone gain should not be changed from the setting determined in step 1.

- 5) To use the processor with a tape or phone patch input, depress the appropriate pushbutton. Do not change the processor output level or transmitter microphone gain control from the settings determined above. Adjust the output level *on the patch or* tape player for proper audio level using the same general procedure as step 3 above. The SP75 microphone gain control is not operative in the TAPE or PATCH mode and the level *must be set by the control on the tape player or patch.*

Once the SP75 has been adjusted as per the above procedures it is ready for operation. One of the three possible inputs can be selected by depressing the appropriate interlocking pushbutton. Any input can be fed directly to the transmitter, bypassing the processor, by leaving the ON pushbutton in the out position. When the ON pushbutton is depressed, the processor is switched in. The clipping control can be advanced to obtain the desired amount of clipping. The best setting will depend on band conditions and the individual operator, however 9 to 12 dB is usually a good setting.

## V. THEORY OF OPERATI'ON

Refer to the schematic diagram. The audio input is amplified by the microphone preamp when the microphone input is selected. Gain control R5 allows the gain to be set properly for the particular microphone being used. The output from the microphone preamp is then routed to the audio compressor stage. When selected, tape or phone patch inputs are routed directly to the compressor. The audio compressor compresses the dynamic range thus providing a more constant level to the RF clipper. This compression also allows more RF clipping of the softer speech passages.

The audio compressor output is fed through the clipping level potentiometer and muting circuitry to the input of a MC1496 balanced modulator integrated circuit. A double sideband output signal is generated by the balanced modulator at an intermediate carrier frequency of 459 kHz. This signal then passes through two cascaded ceramic filters, leaving only a single sideband signal at

their output. This SSB signal is then RF clipped by the clipper and after buffering, is again filtered by a third ceramic filter to remove undesired harmonics induced by the clipping process. The resulting clipped signal has a much higher average to peak power ratio than the original signal before clipping. This processed SSB signal is converted back to audio by the product detector circuitry. Use of the same local oscillator for the balanced modulator and product detector assures that no audio frequency shift is produced. The processing also reduces some of the lower audio frequencies resulting in a rising response which adds to the processing effectiveness.

During audio pauses when the output from the audio compressor falls below the input threshold of the threshold detector circuitry, additional attenuation is inserted in the audio path by the FET audio attenuator circuitry to reduce background noise pickup.

## **VI. ALIGNMENT AND TROUBLESHOOTING**

The following procedures may be used to align the SP75 if there is good reason to believe alignment is required. There are only two adjustments in addition to the normal microphone gain and output level set-up.

- 1) Turn unit on.
- 2) Attach a counter to test point 13. Refer to the photo in figure 5. Adjust the variable capacitor C44 for a frequency of 459.0 kHz. Remove frequency counter connection.
- 3) Connect an RF voltmeter or scope capable of measuring an RF voltage of approximately 10 to 25 mV to test point 6. Disconnect all audio inputs and select the TAPE or PATCH switch position. While observing the scope or RF voltmeter adjust R26 for a minimum RF indication.

This completes the alignment procedure.

If the SP75 fails to work properly the following signal levels may be checked. Refer to the schematic, figure 6, and pictorial, figure 5.

With an input signal of 10 mV at the microphone input and with the microphone gain, R5, set to maximum, the following audio levels should result. All values are r.m.s, AC volts.

- 1) At test point 2,50 mV.
- 2) At test point 3,200 mV.
- 3) At test point 4,1.0 volt.
- 4) At test point 5,70 mV with clipping control at 20 dB.
- 5) Approximately 25 mV at test point 12.

## VII. SERVICE DATA

The SP75 will be checked and aligned at the factory for a nominal fee if there is no evidence of tampering. Transportation charges are extra. Any necessary repairs will be made on a time and materials basis. Please write or call the factory for authorization before returning your unit for alignment or service. Address your requests for authorization to:

R. L. DRAKE COMPANY  
540 Richard Street  
Miamisburg, OH 45342  
ATTN: Customer Service Department.  
Telephone: (Area Code 513) 866-3211  
Telex: 288-017

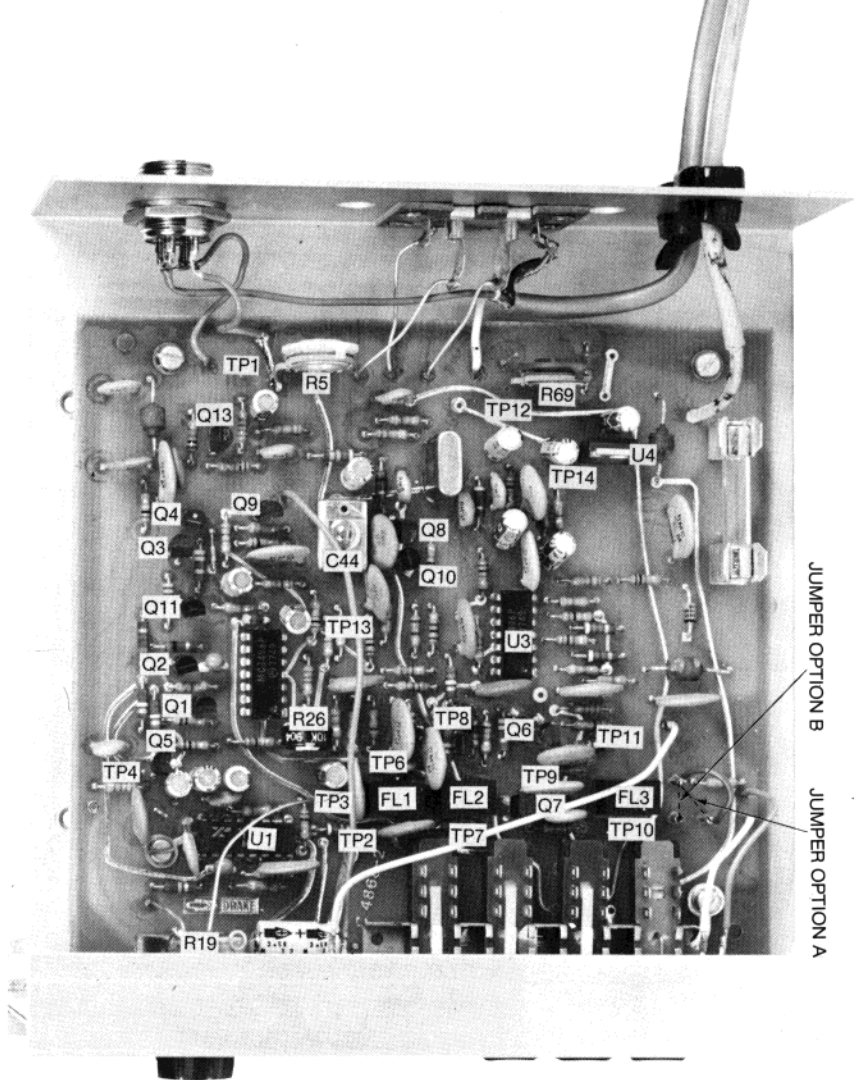
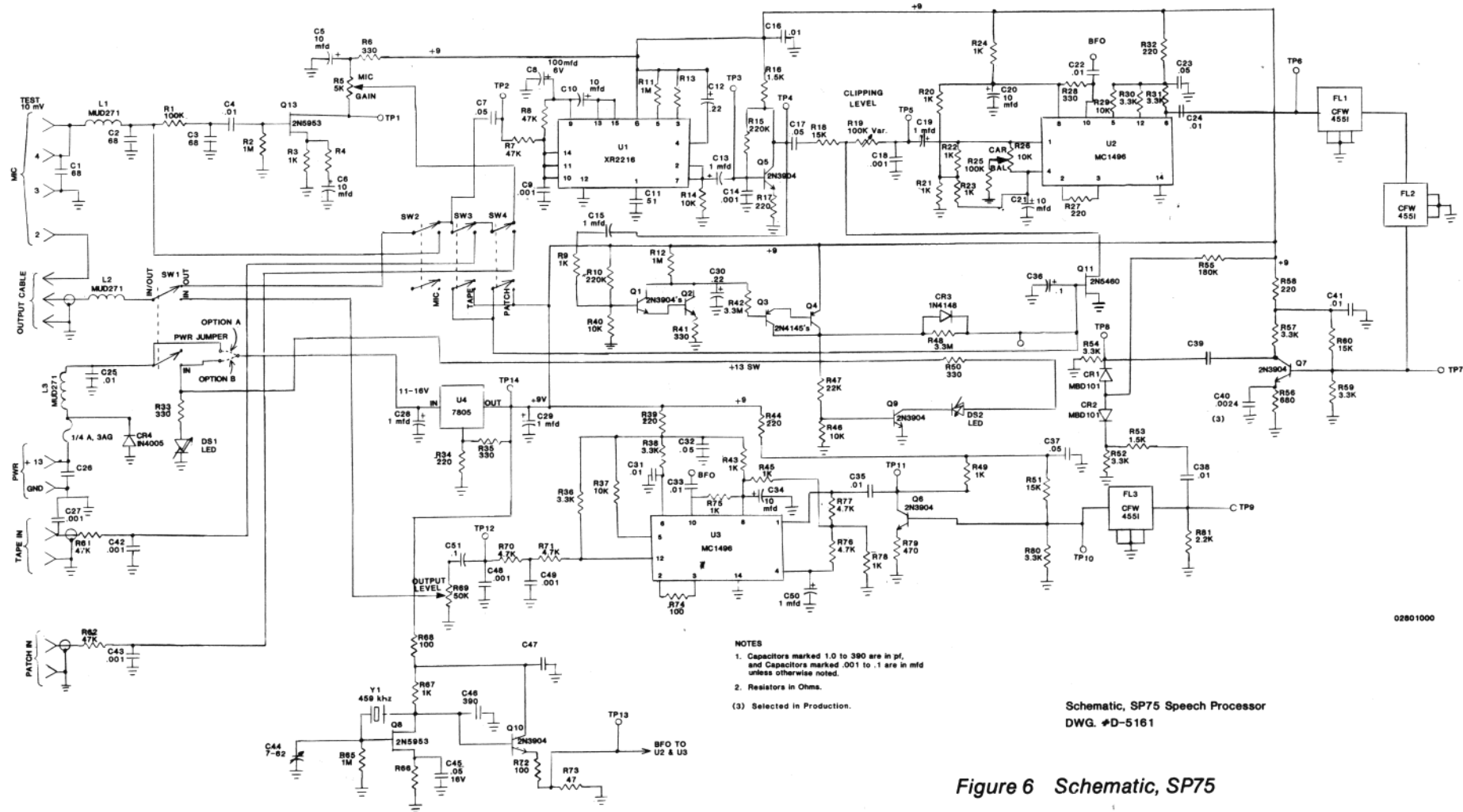

Figure 5 P. C. Board Pictorial, SP75

R	R61 R62	R1 R33	R2	R3 R4	R5 R65	R66 R67 R66	R69 R34 R35	R7 R8 R70 R71 R72	R9 R10	R11 R12 R13 R14	R15 R16 R17	R18 R19 R76 R76	R78	R20 R21 R22 R23 R24 R25 R49 R50	R26 R27 R28	R29 R30 R31 R32 R33	R81	R55	R56 R57 R56	R60 R59		
C	C1 C26 C27	C2 C42 C43	C3	C4	C44	C5 C6	C28 C45	C7 C46 C48	C8 C9	C47 C10 C15	C11 C31	C12 C13 C30	C14	C16 C17	C50	C35	C18 C19	C20 C21	C58 C37 C22	C23 C24 C38	C39 C40	C41
L	L1 L2																					



- NOTES
1. Capacitors marked 1.0 to 390 are in pf, and capacitors marked .001 to .1 are in mfd unless otherwise noted.
  2. Resistors in Ohms.
  - (3) Selected in Production.

Schematic, SP75 Speech Processor  
DWG. #D-5161

Figure 6 Schematic, SP75

02801000