

REGISTERED TRADEMARK OF ALLIED RADIO CORP - 100 NORTH WESTERN AVENUE, CHICAGO 80, ILLINOIS - TELEPHONE HAYMARKET 1-5800

Copyright © 1958, by Allied Radio Corp. / Printed in U.S.A.



MODEL G-30
GRID DIP METER

83 Y 721

ASSEMBLY MANUAL



knight-kit



G-30 GRID DIP METER

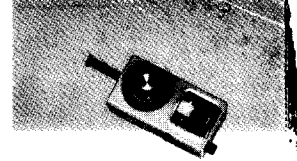

G-30 GRID DIP METER

The G-30 Grid Dip Meter is a tuneable oscillator covering 1.5 to 300 mc in 6 overlapping ranges. Its main use is to determine the resonant frequency of tuned circuits. It can also serve as an absorption wave-meter, oscillating detector, signal generator or relative field strength meter. Plug in a crystal and you have a crystal oscillator—or use it with a known coil or capacitor to determine the value of unknown capacitors or coils.

The unusually convenient color coding and extremely compact size make the G-30 one of the handiest instruments for lab, shop or ham shack.

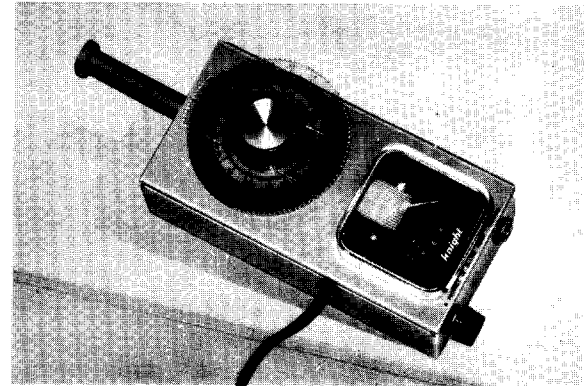

**THIS
KIT
MUST BE
PROPERLY
SOLDERED!**

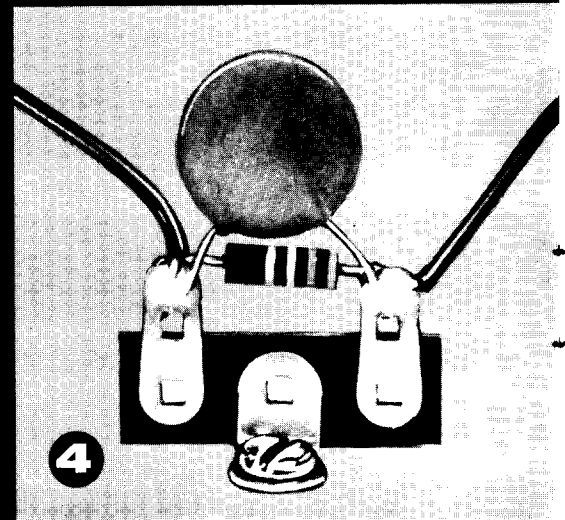
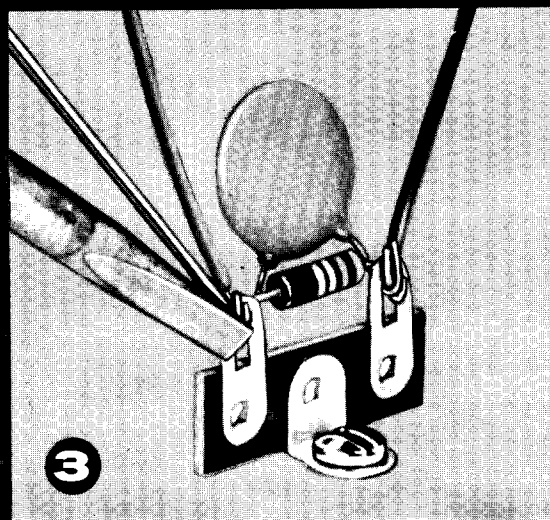
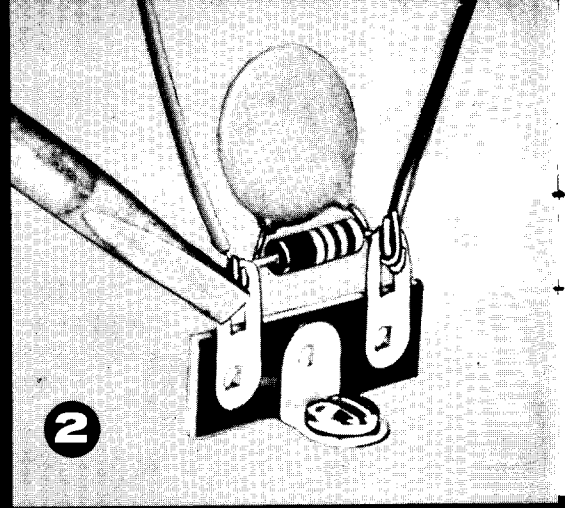
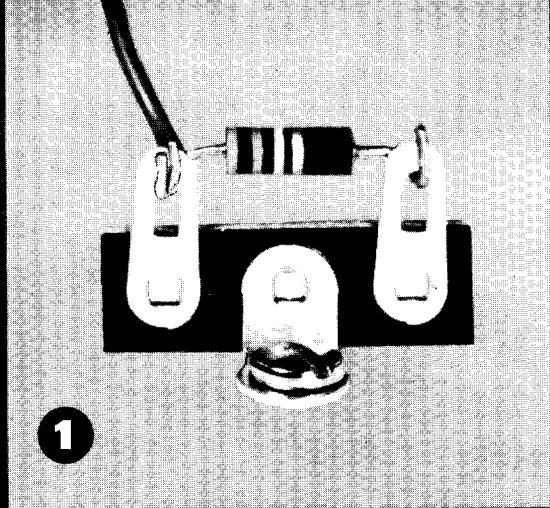

FIGURE 1.

USE ENOUGH HEAT

This is the main idea of good soldering. Apply enough heat to the metal surfaces you are joining to make the solder spread freely, until the contour (shape) of the connection shows under the solder.

AN ELECTRONIC UNIT WILL NOT WORK . . .

unless it is properly soldered. Read these instructions carefully to understand the basic ideas of good soldering.

Enough heat must be used so the solder can actually penetrate the metal surfaces, making an unbroken path over which electricity can travel. You are not using enough heat if the solder barely melts and forms a rounded ball of rough, flaky solder.

Use the Right Soldering Tool

A soldering iron in the 40-100 watt range is recommended. Any

iron in this range with a clean, chisel-shaped tip will supply the correct amount of heat to make a good solder gun but make sure the tip reaches full heat before you solder.

Keep the iron or gun tip brightly coated with solder. When necessary, wipe the hot tip clean with a cloth. If you are using an old tip, clean it before you start soldering. Use a fine file or steel wool to expose the bright metal. Heat the iron and immediately coat the tip with solder.

Use Only Rosin Core Solder

We supply the right kind of solder (*rosin core solder*). Do not use any other kind of solder! **Use of Acid Core Solder, Paste, or Irons Cleaned on a Sal Ammoniac Block will ruin any Electronic Unit and will Void the Guarantee.**

HERE'S HOW TO DO IT...

 Join bare metal to bare metal; insulation must be removed. Make good mechanical connections and keep resistor and capacitor leads as short as possible, unless otherwise specified.

 Coat the tip of a hot iron with solder. Then **Firmly Press the Flat Side of the Tip** against the parts to be soldered together. Keep the iron there while you . . .

 Apply the solder between the metal to be soldered and the iron tip. Use only enough solder to flow over all surfaces of the connection, and all wires in the connection. Remove the iron.

Do Not Move Parts Until the Solder Hardens. If you accidentally move the wires as the solder is hardening, apply your iron and reheat.

 Compare your soldering with the pictures on this page. You have a good connection if your solder has flowed over all surfaces to be connected, following the shape of the surfaces. It should appear smooth and bright and all wires in the connection should be well-soldered.

You Have Not Used Enough Heat: If your connection is rough and flaky-looking, or if the solder has formed a round ball instead of spreading.

The difference between good soldering (enough heat) and poor soldering (not enough heat) is just a few extra seconds with a hot iron **firmly** applied.

Remember, larger metal surfaces take a longer time to heat.



CONSTRUCTION HINTS

Be sure to follow the step-by-step instructions exactly. Do not wire this kit from the pictorials or schematic diagram alone because it must be assembled and wired in a definite sequence. For your convenience, a box is provided to check off each step after you have completed it.

Use only the color of wire specified in the instructions because the colored wire has been stripped and precut to definite lengths. Spaghetti (flexible tubing supplied with the kit) is used wherever it is needed to cover a bare lead to prevent it from touching other metal parts.

First check each part against the parts list. All parts are illustrated in the pictorial diagrams. Symbols used to give the value of parts include Ω for ohm, K for one thousand, Meg for one million, μ for micro or one millionth and fd for farad.

Keep the different sizes and types of screws separate to save time during construction. The self-tapping screws resemble woodscrews. The thickest screws are the 6-32; the thinnest are the 3-48.



CONSTRUCTION

MOUNTING THE OSCILLATOR PARTS

SEE FIGURE 2.

- Close the plates of the C-1 tuning capacitor to protect them from damage.
- Bend terminals 1 and 2 of C-1, as shown. Cut off terminals 3 and 4 of C-1. Be sure to cut **ONLY THE CORRECT TERMINALS**.
- Mount the V-1 tube socket on the tube bracket attached to C-1. Position the keyway (wide space between two pins) as shown. Secure with two 3-48 x 3/16" screws and nuts.

Prepare V-1 as follows:

- Bend pins 4 and 5 down to the metal saddle of V-1.

FIGURE 2

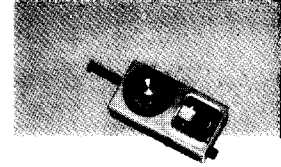

- ☑ Solder the V-1 saddle to the tube bracket. Be sure that as much of the saddle as possible is soldered to the bracket. At the same time, solder pins 4 and 5 to the saddle.

EXTRA HEAT IS NEEDED TO SOLDER THE TUBE SADDLE TO THE BRACKET. APPLY THE SOLDERING IRON AN EXTRA MINUTE TO BE SURE YOU MAKE A GOOD SOLDER CONNECTION.

- ☑ With your cutters, cut off the tops of pins 2 and 6. Bend the shortened pins into the center of the socket as shown.
- ☑ Cut off the top of pin 7.
- ☑ With your pliers, twist pin 1 as shown. Cut off the top of pin 1.
- ☑ Put a right angle bend in pin 3, as shown.
- ☑ Mount the coil socket on the coil bracket with a 3-48 x 1/2" screw and nut.
- ☑ Attach the coil bracket to C-1, as shown. Use two 6-32 screws with rounded heads.

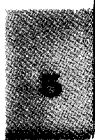
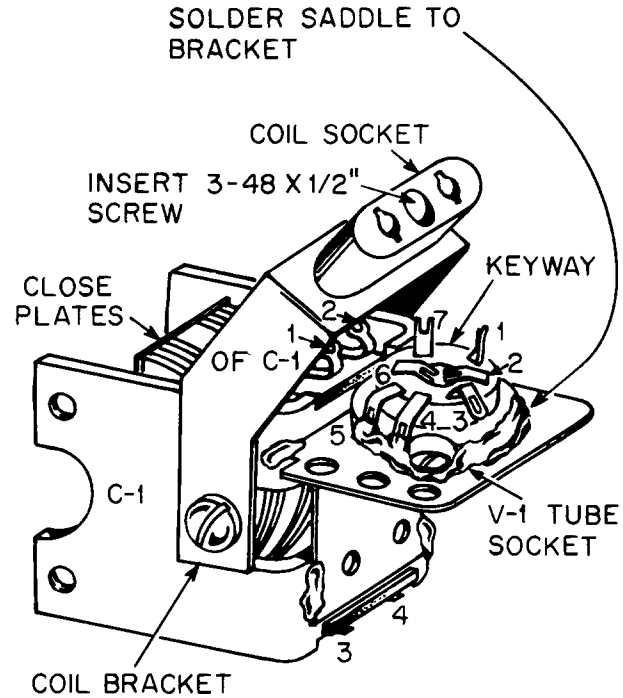

WIRING THE OSCILLATOR SECTION

SEE FIGURE 3.

- ☑ Mount C-4, C-5 and C-6, the 1000 $\mu\mu\text{fd}$ feed-through capacitors.

NOTE: When soldering to the leads of the feed-through capacitors C-4, C-5, C-6, use your pliers as a heat sink to protect the capacitors. Clamp the tip of your long nose pliers around the lead near the body of the capacitor then solder the lead. The pliers will conduct the heat away from the capacitor body. A rubber band can be used to keep the pliers in position during this procedure.

- ☑ Solder the collars of C-4, C-5 and C-6 to the tube bracket. *Do not allow solder to flow to the end leads and short the capacitors.*
- ☑ Carefully bend the top lead of C-5 and solder to pin 3 of V-1. Be careful to avoid cracking the ceramic body of C-5.
- ☑ Shorten the top leads of C-4 and C-6 to $\frac{1}{4}$ ".

IMPORTANT! KEEP ALL LEADS TO TUBE AND COIL SOCKETS AS SHORT AND STRAIGHT AS POSSIBLE.

- ☑ Using your pliers as a heat sink, solder one lead of R-1, a 10K Ω resistor (marked with color bands brown, black, orange) to the top lead of C-4. Connect, but do not solder, the other lead of R-1 to the junction formed by pins 2 and 6 of V-1.
- ☑ Center R-2, a 10K Ω resistor (brown, black, orange) between C-6 and pin 7 of V-1, so the body of the resistor is seated between the tube socket and the frame of C-1. Solder one lead of R-2 to the top lead of C-6, using your pliers as a heat sink. Connect, but do not solder, the other lead of R-2 to pin 7 of V-1.
- ☑ Cut a $\frac{3}{4}$ " length of the bare wire supplied with the kit. Solder one end to the junction of pins 2 and 6 of V-1 (2 wires). Solder the other end to terminal 1 of C-1 and terminal 1 of the coil socket as shown in figure 4.

NOTE: (2 wires) means there are 2 wires or leads in the terminal and both should be soldered at this time.

- ☑ Solder one end of a $\frac{1}{2}$ " bare wire to pin 1 of V-1. Connect, but do not solder, the other end to pin 7 of V-1.
- ☑ Solder one lead of C-2, a 150 $\mu\mu\text{fd}$ disc capacitor, to pin 7 of V-1 (3 wires). Solder the other lead to terminal 2 of C-1 and the coil socket, as shown in Figure 4.

FIGURE 3

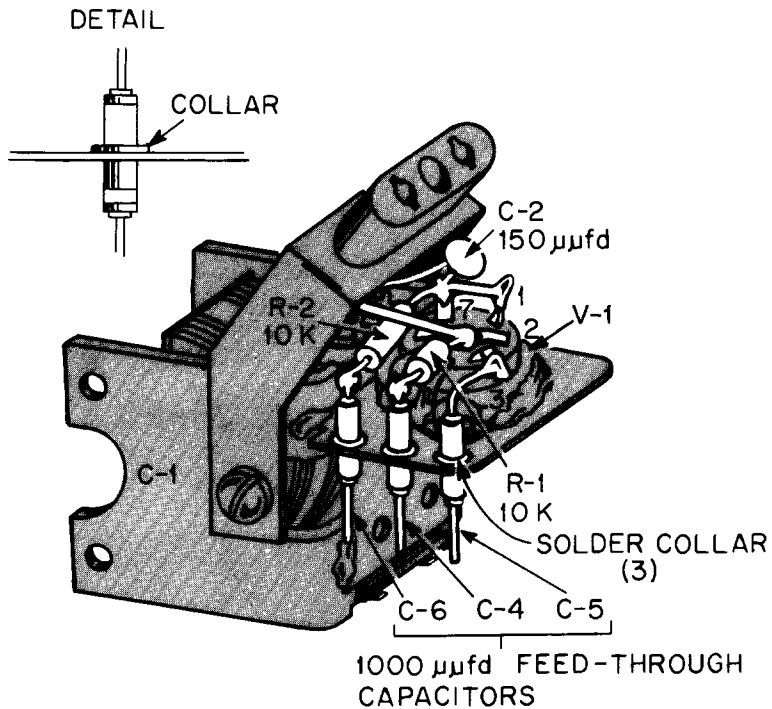
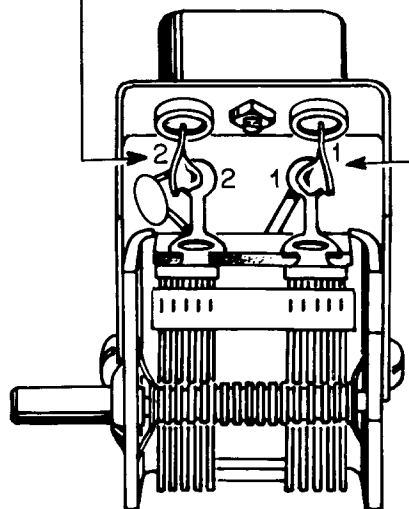

FIGURE 4



SOLDER C-2 LEAD
TO TERMINALS 2
OF C-1 AND COIL
SOCKET.

SOLDER BARE WIRE
TO TERMINALS 1 OF
C-1 AND COIL SOCKET.





MOUNTING PARTS IN THE CASE

SEE FIGURE 5.

- Place the case on a cloth or other soft surface to protect the finish of the case.
- Remove the screw attaching the coil bracket to the shaft side of C-1.
- Position C-1 in the case. Slip two #10 lockwashers under the C-1 mounting holes as shown in Figure 5. Mount C-1 with three flat-head 6-32 screws inserted from the front of the case, as shown in Figure 8. Notice that one screw also secures the coil bracket to the case.
- Slip a $\frac{3}{8}$ " lockwasher on the shaft of J-1, the jack for PHONES. Mount J-1, positioning the terminals as shown. Secure with the flatwasher and nut supplied with the jack.
- Mount R-3, the 100K Ω GAIN control, with the nut supplied. The S-1 switch is attached to R-3.
- slight adjustment*
Slightly bend terminals 1 and 2 of S-1, as shown.
- Mount the two solder lugs on the meter as shown. Use the two nuts supplied.
- Temporarily remove the mounting bracket from M-1, the meter. From the front of the case, insert the meter so the plus (+) terminal is positioned as shown. Replace the bracket on the meter's mounting screws. Do not replace the nuts at this time.
- Bend the mounting foot of TS-1, a 3-terminal strip, to allow positioning on the M-1 mounting screw as shown. Mount TS-1. Replace and tighten the two nuts on the M-1 mounting screws.

FIRST WIRING IN THE CASE

SEE FIGURE 6.

- Slip the rubber grommet on the line cord to about $4\frac{1}{2}$ " from the bare ends. Knot the cord; then separate the 2 line cord wires back to the knot. Push the grommet and line cord into the slot in the case, as shown.
- Solder one of the line cord leads to the bottom hole of terminal 1 of TS-1. Solder the other line cord lead to terminal 2 of S-1.
- Solder one end of a red wire to terminal 1 (marked +) of M-1. Connect, but do not solder, the other end to terminal 2 of TS-1.

Read the next two steps very carefully. The plus and minus ends of C-3 or CR-1 must not be

interchanged or the instrument will not work.

- Slip 2" spaghetti on the lead from the negative (-) end of C-3, the 20 μ fd tubular capacitor. Connect, but do not solder, this lead to terminal 2 of TS-1. ~~Slip 3" spaghetti on the positive (+) lead of C-3. Connect, but do not solder, this lead to terminal 3 of R-3.~~
- Slip 1" spaghetti on each lead of CR-1, the tubular shaped selenium rectifier. ~~Solder the lead from the RED END to terminal 3 of R-3 (2 wires).~~ Connect, but do not solder, the other lead to terminal 3 of TS-1.
- ~~Solder one end of a yellow wire to terminal 1 of R-3.~~ Route as shown. Solder the other end to terminal 3 of J-1.

see supplement

FIGURE 6

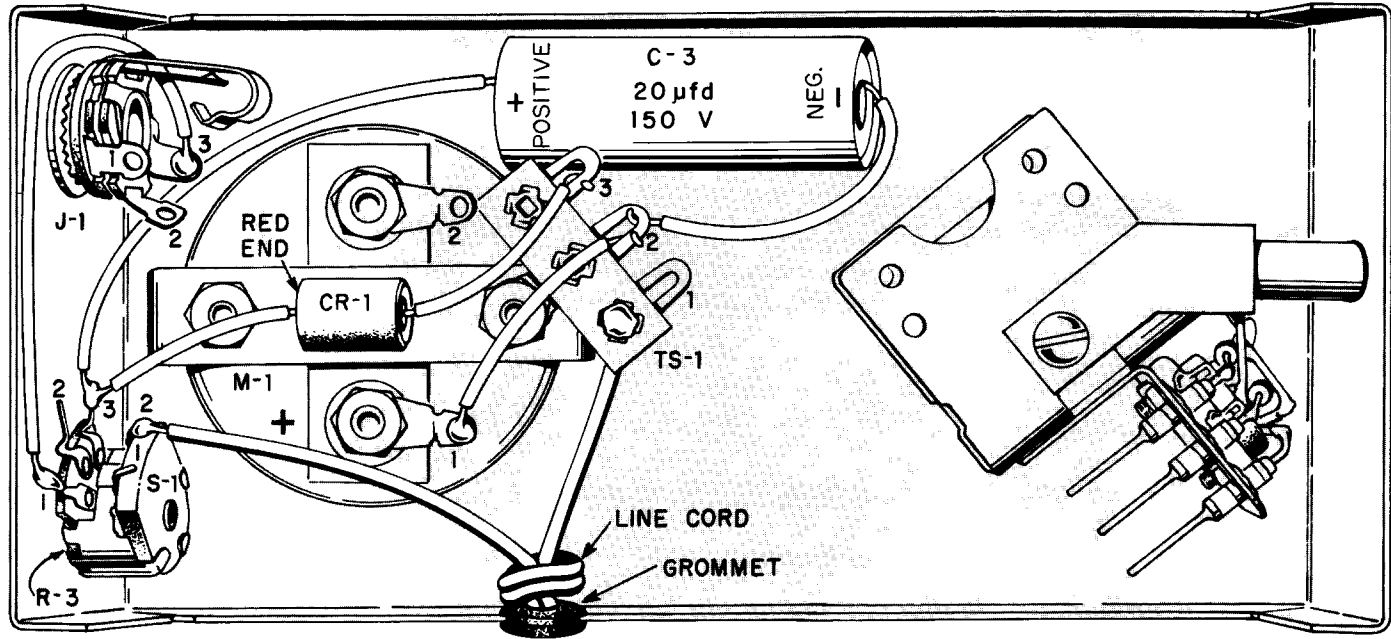
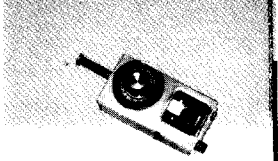

FINAL WIRING

SEE FIGURE 7.

- Solder one end of a red wire to terminal 2 of M-1. Solder the other end to terminal 2 of J-1.
- Solder one end of a blue wire to terminal 1 of J-1. Hook the other end to C-4, and solder.
- Position T-1, the power transformer as shown. Push a mounting clip over each mounting foot of T-1. The smooth side of the clip should be positioned as shown.
- Solder the short red and the short green lead of T-1 to terminal 2 of TS-1 (4 wires). Hook the long green lead of T-1 to the free end lead of C-5, and solder. Use your pliers as a heat sink.
- Solder the short black lead of T-1 to terminal 1 of TS-1.
- Solder the long black lead of T-1 to terminal 1 of S-1.
- Solder the remaining red lead of T-1 to terminal 3 of TS-1 (2 wires).
- Solder one end of a green wire to terminal 2 of R-3. Hook, then solder the other end to C-6, gently bending the C-6 lead as needed. Be careful not to break the ceramic body of C-6.

- Wiring of the grid-dip meter is now completed. Carefully check the wiring to be sure all connections are correct and all terminals are soldered. If in doubt about a solder connection, apply a hot iron to it until solder flows over all wires in the terminal.

PRELIMINARY TEST

CAUTION: NEVER TOUCH ANY OF THE WIRING WHEN THE LINE CORD IS CONNECTED TO AN OUTLET.

- Insert the 6AF4A tube in the tube socket.
- Plug one of the coils into the socket. Plug the line cord into an outlet supplying 105-125 volts, 50-60 cycles AC. Turn the GAIN control to the right until the meter needle rises, indicating that the unit is oscillating.
- Turn the GAIN control OFF; remove the line cord from the outlet; turn the shaft of C-1 fully counter-clockwise. You are now ready to mount the cover. However, if you did not get a meter reading in the last step, stop here and read the Service Hints.

FIGURE 7

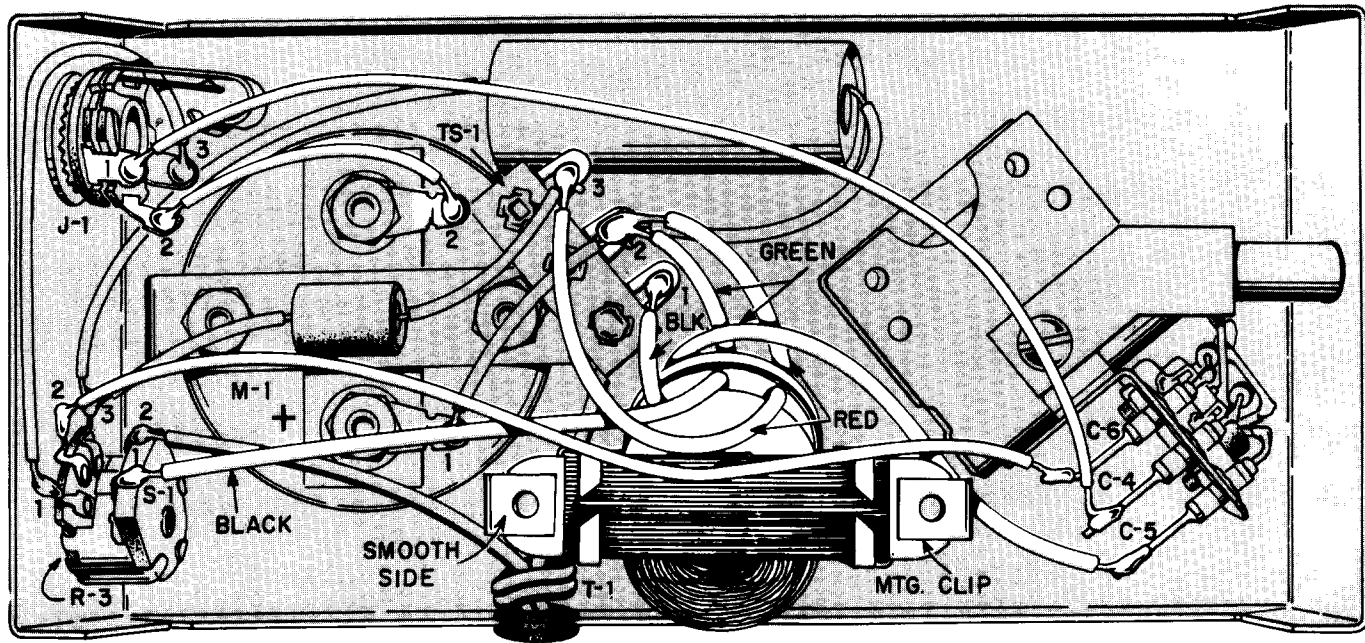

MOUNTING THE COVER AND DIAL

- Route all wires away from the T-1 mounting clips, so the wires will not be squeezed by the cover.
- Fit the cover over the case so the notch in the cover slides into the groove in the grommet.
- Secure the T-1 transformer to the cover by inserting the 2 flat-head self-tapping screws through the countersunk holes in the cover and tightening the screws in the mounting clips on T-1. An open paper clip or piece of heavy bare wire can be used to align the holes in the mounting clips with the holes in the cover.
- Attach the cover to the case with 4 round-head self-tapping screws.
- Place the small knob on the shaft of R-3. Tighten the setscrew.

SEE FIGURE 8.

- Place the hairline adjust on the shaft of C-1 so that the hairline side faces away from the case. Position the serrated edge as shown.
- Push the fiber washer and the countersunk lockwasher all the way down on the shaft until they are seated on the hairline adjust. They must rest firmly on the adjust to prevent it from moving with the tuning dial.

- Place the calibrated dial on the shaft of C-1. Turn the shaft of C-1 fully counterclockwise so the dividing line, next to the 1.5 calibration, points to the center of the coil socket. If your model has reference lines on the case, set the dividing line to the center reference line. Tighten the dial knob setscrew.

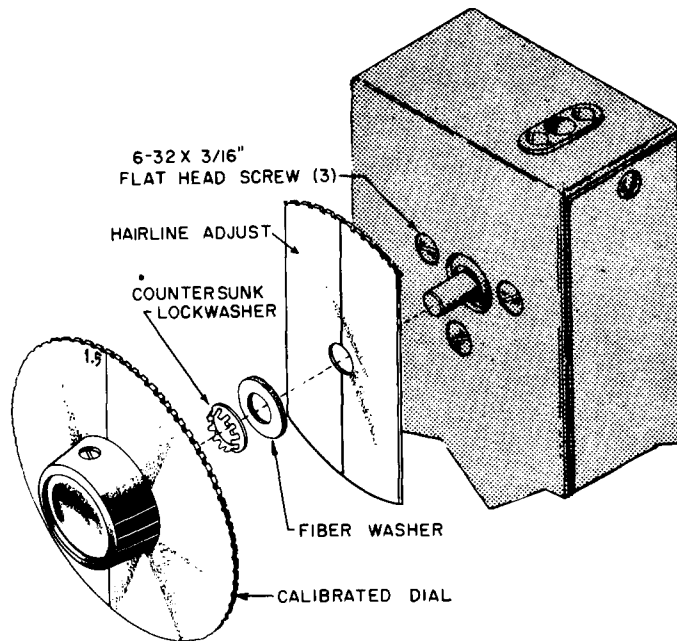
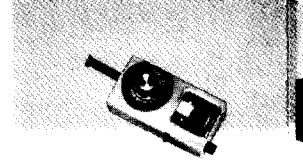

FIGURE 8. MOUNTING THE DIAL

HOW IT WORKS



HOW IT WORKS

This circuit is built around a Colpitts oscillator using an ultra-high frequency tube, the 6AF4A. The high-Q tank circuit between plate and grid can be tuned across a wide range by adjusting C-1 and changing coils (L-1 through L-6).

Part of the voltage developed across the tank circuit is fed back to the grid. Oscillation takes place because the voltage applied to the grid (across C-1B) is 180 degrees out of phase with the voltage applied to the plate (across C-1A). Since the grid is driven positive during part of the cycle, grid current flows and is read at the meter as average DC current. The desired range of grid current is obtained by using R-3 to adjust the plate voltage.

GRID DIP OPERATION

In itself, this instrument is a variable frequency oscillator. If it is coupled to an unactivated circuit which is resonant at the oscillator frequency, the unactivated circuit will absorb energy from the oscillator. The loss of energy shows as a dip in grid current.

Tuning the oscillator for the dip gives the resonant frequency of a circuit without the need to apply power to the circuit under study.

OSCILLATING DETECTOR

Plugging phones into J-1 disconnects the meter and provides an audible means of finding the fundamental or harmonic frequencies of energized RF circuits. As your oscillator is tuned close to the frequency under study, the two frequencies will mix and an audible beat note or click will be heard.

ABSORPTION WAVE METER

When R-3 is turned fully counterclockwise, the plate is grounded and the grid functions as the plate of a diode detector. If the tank circuit is tuned to the frequency of a nearby RF source, it will absorb energy from the source. During positive peaks, the grid will attract electrons from the cathode and current will flow through the meter. By tuning for the greatest rise in grid current, the unknown frequency can be determined.

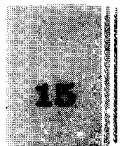



MODES OF OPERATION

This instrument can function as a grid dip oscillator, absorption wavemeter, oscillating detector or signal generator. As a **grid dip oscillator**, it is used to find the resonant frequency of tuned circuits without applying power to the circuit under test. As an **absorption wavemeter**, it is used to find the frequency of strong oscillations. Used with phones, as an **oscillating detector**, it provides a sensitive means of determining the frequency of low-power radiations. As a **signal generator**, it can be used to check receiver operation and to measure the Q of a circuit. With a crystal, it can be used as a crystal oscillator to check receiver calibration or as a visual marker.

HOW TO USE AS A GRID DIP OSCILLATOR

Remove power from the unit under test. Plug a coil into the grid dip oscillator to cover the expected frequency range. Connect the grid dip oscillator line cord to an outlet supplying 105-125 volts, 50-60 cycle AC. Turn the GAIN control as needed to maintain a meter reading of 8 (marked with a triangle on the meter face). The grid dip oscillator dial is calibrated for this value of grid current except for the 110-130 mc range. On this range grid current is normally below 8 and correct calibration is obtained by turning the GAIN control fully clockwise.

Counter

Couple the grid dip oscillator to the circuit under test. See Figures 9, 11, and 12 for suggested methods of coupling. Turn the grid dip oscillator dial until the meter needle makes a pronounced dip. This dial setting gives the resonant frequency of the circuit under test—just read the scale that matches the color of the coil. At either side of this dial setting, the needle should rise.

If the coupling is too tight, the reading may be slightly higher or lower than the resonant frequency. For the most accurate reading, move the grid dip oscillator away until the dip is barely perceptible.

At the high end of the 1.5 - 3.5 mc and 3.4 - 8.5 mc bands very careful reading is needed. On these sections of the range, grid current normally drops as frequency is increased. Be sure you have a real dip, which may appear as a hesitation in the downscale movement of the needle.

To search for a dip when the range of the resonant frequency is unknown, start with the lowest-frequency coil in the grid dip oscillator. Tune through the entire range of the grid dip oscillator, going to the next highest frequency coil, until a dip is found. This method is preferred to starting the search at the high frequency end where a dip may be found for a harmonic before the fundamental is located.

FIGURE 9

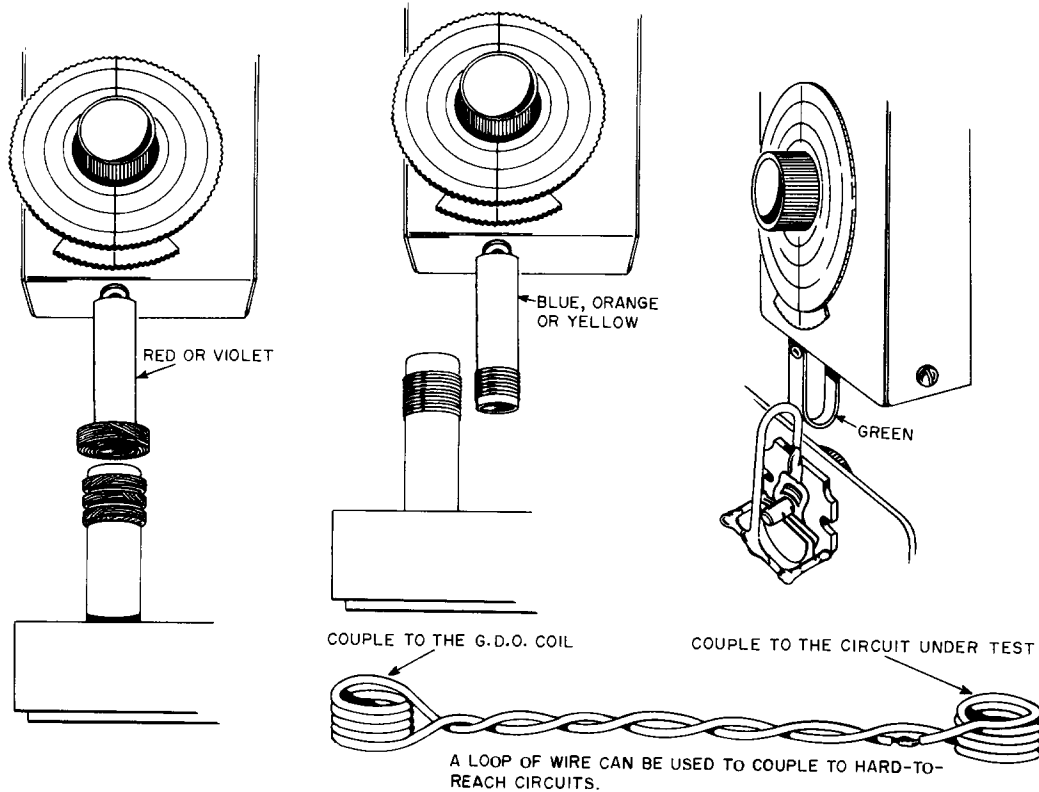
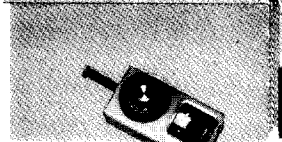



HOW TO USE AS AN ABSORPTION WAVEMETER

CAUTION: NEVER BRING THIS INSTRUMENT CLOSE TO LIVE HIGH VOLTAGE CIRCUITS.

Select a coil for the expected frequency range. Turn the switch on the GAIN control ON, but keep the GAIN all the way down (no meter reading). Place the grid dip oscillator close to the source of the oscillations, but never close to high-potential circuits. Turn the dial until the meter needle begins to RISE. Continue turning until a maximum meter reading is obtained. The dial will then be set for the frequency of the oscillations being absorbed. Coupling must remain fixed during this procedure.

In this application, the instrument can be used as a relative field strength meter. A higher meter reading shows a greater field strength.

HOW TO USE AS A SIGNAL GENERATOR

Plug the desired coil into the grid dip oscillator. Set gain properly and turn the dial to the desired frequency.

HOW TO USE AS AN OSCILLATING DETECTOR

Plug low-impedance phones into the PHONES jack; plug in a coil to cover the expected frequency range. To detect unmodulated signals, turn GAIN fully clockwise and couple closely to the test circuit. **CAUTION: NEVER BRING THIS INSTRUMENT CLOSE TO LIVE HIGH VOLTAGE CIRCUITS.** Turn the grid dip oscillator dial until you hear a beat note or click in the headphones.

For modulated signals, turn GAIN down. Rotate the grid dip oscillator dial until you hear the modulation clearly. For greater sensitivity, the GAIN can be turned up slightly and operated as a regeneration control.

HOW TO USE AS A CRYSTAL OSCILLATOR

Any crystal with pin diameter of .093" and spacing of .486" will fit the coil socket. Use of a crystal in place of the coil converts the grid dip oscillator to a crystal controlled oscillator. The frequency will now be fixed by the crystal and will not be affected by the dial setting. To improve radiation, a few inches of wire can be used as an antenna. Wrap one end of the wire a few turns around the crystal.

SUGGESTED APPLICATIONS



ADJUSTING THE HAIRLINE

For most purposes, the dial can be read with sufficient accuracy when the hairline is positioned as shown in Figure 8. For the greatest accuracy on a particular section of the band, the hairline can be set to match a standard. The standard can be a receiver, signal generator, or transmitter with accurately calibrated dials.

RECEIVER AS STANDARD. Set the receiver dial at the desired frequency. With the correct coil in the grid dip meter, and GAIN properly set, turn the grid dip dial until the signal is heard at the receiver or until the S meter shows a peak. If the hairline is not directly under the desired frequency, reset the hairline. Now this portion of the grid dip oscillator dial will be as accurate as your receiver.

TRANSMITTER AS STANDARD. Similar to using the receiver as standard, except that the grid dip oscillator is used as an absorption wavemeter (GAIN turned down and tuned for peak).

SIGNAL GENERATOR AS STANDARD. Similar to receiver as standard, except grid dip oscillator is used as an oscillating detector and phones are used to hear the beat note or click.

RECEIVERS

TUNING AND TRACKING

1. Use in place of a signal generator with an activated receiver. Peak RF or oscillator coils as recommended by the receiver manufacturer. An "S" meter serves as an excellent indicator for peaking.

2. Use as a grid dip oscillator to check the tracking of RF and oscillator stages. These stages correctly track if for all positions of the tuning dial, the difference between the resonant frequency of the RF and the oscillator stages is the IF frequency. Remove power from the receiver and make this check on each receiver band:

With the receiver tuning dial set near the low end, couple the grid dip oscillator to the receiver's RF or antenna coil and read the resonant frequency. The same reading should be found at the mixer coil. Now read the resonant frequency of the local oscillator by coupling the grid dip oscillator to the oscillator coil. The difference between these two readings should be the IF frequency.

Turn the receiver tuning dial near the high end and repeat the readings made at the low end. Again, the difference between RF-mixer and oscillator readings should be the IF frequency, if tracking is correct. Repeat the procedure for the middle of the dial.



SUGGESTED APPLICATIONS

LOCAL OSCILLATOR

Plug in phones and use the grid dip oscillator as an oscillating detector. With the receiver power on, bring the grid dip oscillator close to the receiver oscillator coil. If the local oscillator is working, you should hear it on your phones.

CALIBRATION

Use the grid dip oscillator as a variable frequency oscillator for an approximate check of the calibration of your receiver. Or plug in a crystal and use the instrument as a crystal-controlled oscillator for a very accurate check of receiver calibration at the frequency of the crystal.

TRANSMITTERS

TUNING

Use as a grid dip oscillator. Remove plate power from the transmitter. Adjust the tuned circuits of the oscillator, buffer, doubler, driver and RF amplifier stages to obtain the desired frequency reading on the grid dip oscillator. The range of the controls used in any of these circuits can be checked by tuning the control and the grid dip oscillator.

OSCILLATOR STAGE

Use as an absorption wave meter. The rise of the meter needle at the correct frequency setting indicates the oscillator is functioning.

NEUTRALIZATION

Use as a grid dip oscillator. Do not apply power to the transmitter. Couple the grid dip oscillator to the input of the stage to be neutralized and read the resonant frequency. Adjust the neutralizing control until there is no change in the grid dip oscillator reading when the output of this stage is tuned throughout its range.

HARMONICS AND PARASITIC OSCILLATIONS

Use as an absorption wavemeter. Be very careful that the instrument does not touch any high-voltage circuits.

Apply power to the transmitter. After reading the fundamental frequency of the transmitter output, use suitable coils in the grid dip oscillator to see if harmonics are present. If the coupling remains constant, the meter reading will indicate the relative strength of fundamental and harmonics.

Parasitic oscillations can be found by tuning the grid dip oscillator through its complete range. If a parasitic is found, its source can be located by removing power from the transmitter and using the instrument as a grid dip oscillator (GAIN at 8) to locate circuits resonant at the parasitic frequency.

FIGURE 10

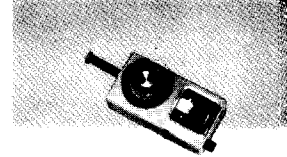

STUBS

Use the instrument as a grid dip oscillator to find the resonant frequency of stubs. The method of coupling varies with the type of line used for the stub. In most cases, inductive coupling can be used.

At this point, it is helpful to have some understanding of transmission line characteristics. Figure 10 shows that the reactance of a line, also input impedance, varies with the electrical line length. All possible values of reactance can be obtained by selecting a suitable length of line up to $\frac{1}{4}$ wave long. A stub of this length will be an inductive reactance if shorted, capacitive if open. Stubs are often used as circuit elements, as capacitors or inductors. Stubs are also widely used for impedance matching or isolating devices.

Figure 10 also shows that a $\frac{1}{2}$ wave open line has the same resonance properties as a $\frac{1}{4}$ wave shorted line because in both cases input impedance (parallel resonance) is at a maximum. This fact should be remembered when grid dip readings are taken.

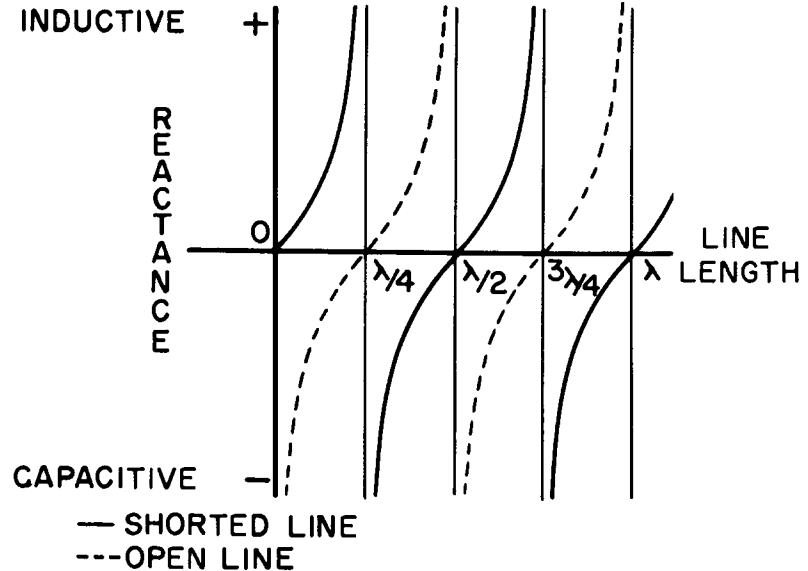

INPUT IMPEDANCE/LINE LENGTH IN WAVELENGTHS FOR A LOSSLESS LINE

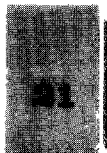

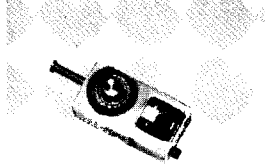

A transmission line terminated in a pure resistance equal to its characteristic impedance will exhibit no resonances. Incidentally, characteristic impedance is not a function of line length and should not be confused with input impedance.

Readings should be made with all fittings in place.

¼ WAVE SHORTED LINES

Select a coil to cover the expected frequency range. Couple the grid dip oscillator as shown in Figure 11. Inductive coupling can be conveniently used because current is at a maximum at the shorted end.

Tune for a dip to find the resonant frequency of the line. For ¼ wave lines, this reading can be used directly.

½ WAVE SHORTED LINES

Same as for ¼ wave shorted lines except the reading must be multiplied by 2 to find the correct resonant frequency. Select a coil for the grid dip oscillator to cover a frequency approximately half the expected resonant frequency.

¼ WAVE OPEN LINES

For open wire, select a coil for the grid dip oscillator to cover twice the expected resonant frequency. Couple inductively to the center of the line and tune for a dip. Divide the reading by 2 to find the correct resonant frequency.

For coax, short one end and proceed as for ¼ wave shorted lines. Remove the short after you have recorded your reading.

½ WAVE OPEN LINES

For open wire, select a coil to cover the expected resonant frequency. Inductively couple the grid dip oscillator to the center of the line and tune for a dip. This reading can be used directly.

For coax, short one end. Select a coil for the grid dip oscillator to cover a frequency approximately half the expected frequency. Couple inductively to the shorted end and tune for a dip. Multiply the reading by 2 to find the correct resonant frequency. Remove the short.

ANTENNAS

AT THE ANTENNA

Use the instrument as a grid dip oscillator to determine the resonant frequency of an antenna. To make the check directly at the antenna, temporarily disconnect the feed line and short across the feedpoint with a short length of wire. Couple inductively to a maximum current point. For example, a maximum current point occurs at the center of a half-wave antenna. Tune for a dip and read the resonant frequency.

Resonance readings made at a multi-band antenna may include undesired resonances and be difficult to interpret. Clear readings can be obtained by using the grid dip oscillator as a signal generator with an SWR bridge and a meter movement of $200 \mu a$ or less. As shown in Figure 12, the antenna is connected as the load for the bridge and a loop of wire is used to loosely couple the grid dip oscillator to the input of the bridge. Set the bridge control to match the rated impedance of the antenna; then tune the grid dip oscillator until the SWR meter shows a pronounced dip. Readjust the bridge control and the grid dip dial until the deepest dip is obtained. Read the resonant frequency of the antenna.

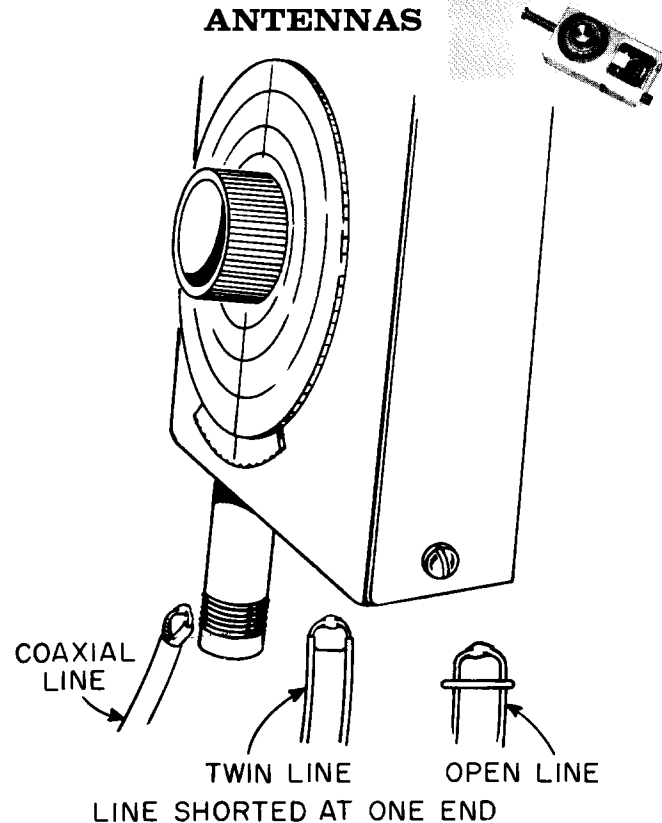

FIGURE 11. COUPLING TO TRANSMISSION LINES.

ANTENNAS

AT FEED END OF LINE

Sometimes it is more convenient to check the resonant frequency of an antenna at the feed end of the transmission line. If a tuned feeder is used, couple the grid dip oscillator to the link of the antenna tuner at the transmitter. If an untuned feeder is used, couple the grid dip oscillator to the feed end of the line, as shown in Figure 11. Tune for a dip to find the resonant frequency of the antenna. This method is useful if line and antenna are closely matched so that there are no resonances in the line to interact with antenna resonance.

Most matched lines have some degree of mismatch—their characteristic impedance does not exactly match the antenna impedance at the resonant frequency. In a mismatched line, the electrical length is an important factor and varies with frequency. In turn, the reactance of the line depends on the electrical length, as shown in Figure 10. At many frequencies, the combination of line and antenna reactances results in resonance. The grid dip oscillator will then show many dips without providing information on antenna performance.

If the mismatch is not too serious, clear readings can be obtained by using the grid dip oscillator as a signal generator to feed an SWR bridge. The feed end of the transmission line is connected as the load for the SWR bridge. A sensitive meter used with the SWR bridge will show a deep dip when the grid dip oscillator is tuned to the resonant frequency of the antenna. Only slight dips will be produced by the irrelevant resonances which result from the mismatch, and these can be disregarded.

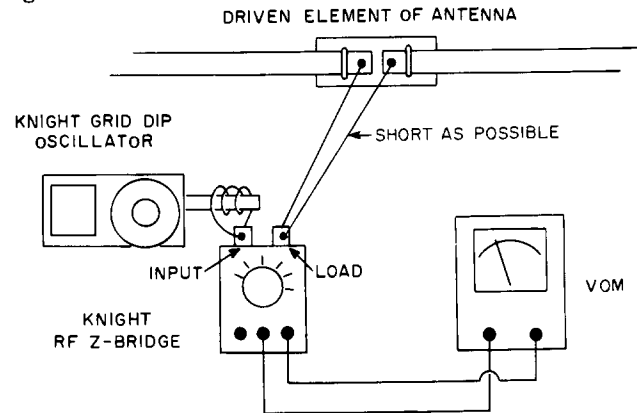
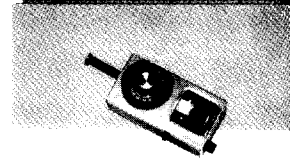

FIGURE 12. COUPLING TO AN ANTENNA THROUGH AN SWR BRIDGE.

CAPACITANCE



Use the instrument as a grid dip oscillator to find the value of an unknown capacitor. With the coils supplied with the kit, it is possible to check values from 50 $\mu\mu\text{fd}$ to more than 7000 $\mu\mu\text{fd}$. Values below 50 $\mu\mu\text{fd}$ can also be checked if another, known capacitor is added.

Make up a tuned circuit by connecting the unknown capacitor across a suitable coil. The inductance of the orange coil (1.3 μh), blue coil (6.7 μh), violet coil (40 μh) and red coil (200 μh) are marked on the chart in Figure 13. **DO NOT SOLDER THE CAPACITOR TO THE COIL.** Alligator clips such as Mueller #30C can be used for convenient connection.

Couple the grid dip oscillator to this tuned circuit and find the resonant frequency. The capacitance can now be calculated from the formula

$$f = \frac{1}{2\pi \sqrt{LC}}$$

Or use the handy chart in Figure 13 as follows:

Draw a straight line between the resonant frequency point and the point for the coil inductance. It will cross

the capacitance line at a point which gives the value of the unknown capacitor. For greater accuracy, subtract the distributed capacitance of the coil. The distributed capacitance of the orange coil is 4 $\mu\mu\text{fd}$, 4.5 $\mu\mu\text{fd}$ for the blue, 5 $\mu\mu\text{fd}$ for the violet and 6.5 $\mu\mu\text{fd}$ for the red.

For example, consider an unknown capacitor connected across the blue coil (6.7 μh). With the red coil plugged into the instrument, a resonant frequency of 2.1 mc is read. A straight line connecting 6.7 μh on the inductance line and 2.1 mc on the frequency line passes through 860 $\mu\mu\text{fd}$ on the capacitance line. Subtract 4.5 $\mu\mu\text{fd}$, the distributed capacitance of the blue coil, to get 855.5 $\mu\mu\text{fd}$, the value of the unknown capacitor.

If the capacitance you are checking is between 10 and 50 $\mu\mu\text{fd}$, it will fall in a range that cannot be directly checked without duplicating one of the oscillator coils. For this range, it is suggested that a known capacitor of 50 to 100 $\mu\mu\text{fd}$ be connected across the unknown capacitor and the selected coil. The added capacitance should be subtracted from the reading obtained from Figure 13 to find the correct capacitance.

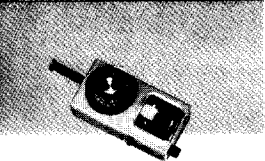

INDUCTANCE

The value of an unknown inductance can be found in a manner similar to finding an unknown capacitance, as described above. In this case, the unknown inductance must be connected across a known capacitor.

RELATIVE FIELD STRENGTH

Use as an absorption wave meter. A higher meter reading indicates a stronger field.

CIRCUIT Q

If a VTVM is available, the grid dip oscillator can be used as a signal generator (GAIN at 8) to measure circuit Q. Connect the RF probe of the VTVM across the circuit under test and couple the grid dip oscillator to the circuit. Tune the grid dip oscillator for a maximum VTVM reading and note this frequency, f_0 . Retune to the right, then to the left, to find frequencies f_1 and f_2 for which the VTVM reading drops to 70.7% of its value for f_0 . The coupling must remain the same.

Calculate Q from this simple formula:

$$Q = \frac{f_0}{f_1 - f_2}$$

SERVICE HINTS

If your grid dip oscillator does not operate, disconnect the line cord and recheck all the wiring to be sure there are no wiring errors. Poor solder connections are the most frequent cause of faulty operation. Resolder any connections that are not well soldered.

Operation of the power supply can be checked by reading the voltage from terminal 2 of R-3 to ground, with R-3 fully clockwise and a coil plugged into the socket. The reading should be + 120 to + 130 DC volts, depending on the choice of coil.

Tube operation can be checked by reading the voltage from pin 1 or pin 7 to ground, with R-3 set for a meter reading of 8. The reading should be + 25 to + 60 DC volts depending on the setting of C-1 and the choice of coil.

If the meter shows grid current is flowing, the instrument is oscillating. If there is no grid current reading, although the tube is operating, check C-2 for an open condition; check C-4 for a short; check correctness of wiring at J-1.

FIGURE 13

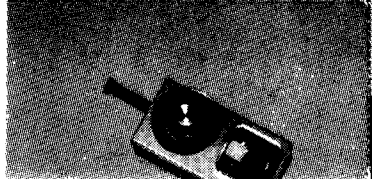

Courtesy, Sylvania Electric Products Inc.

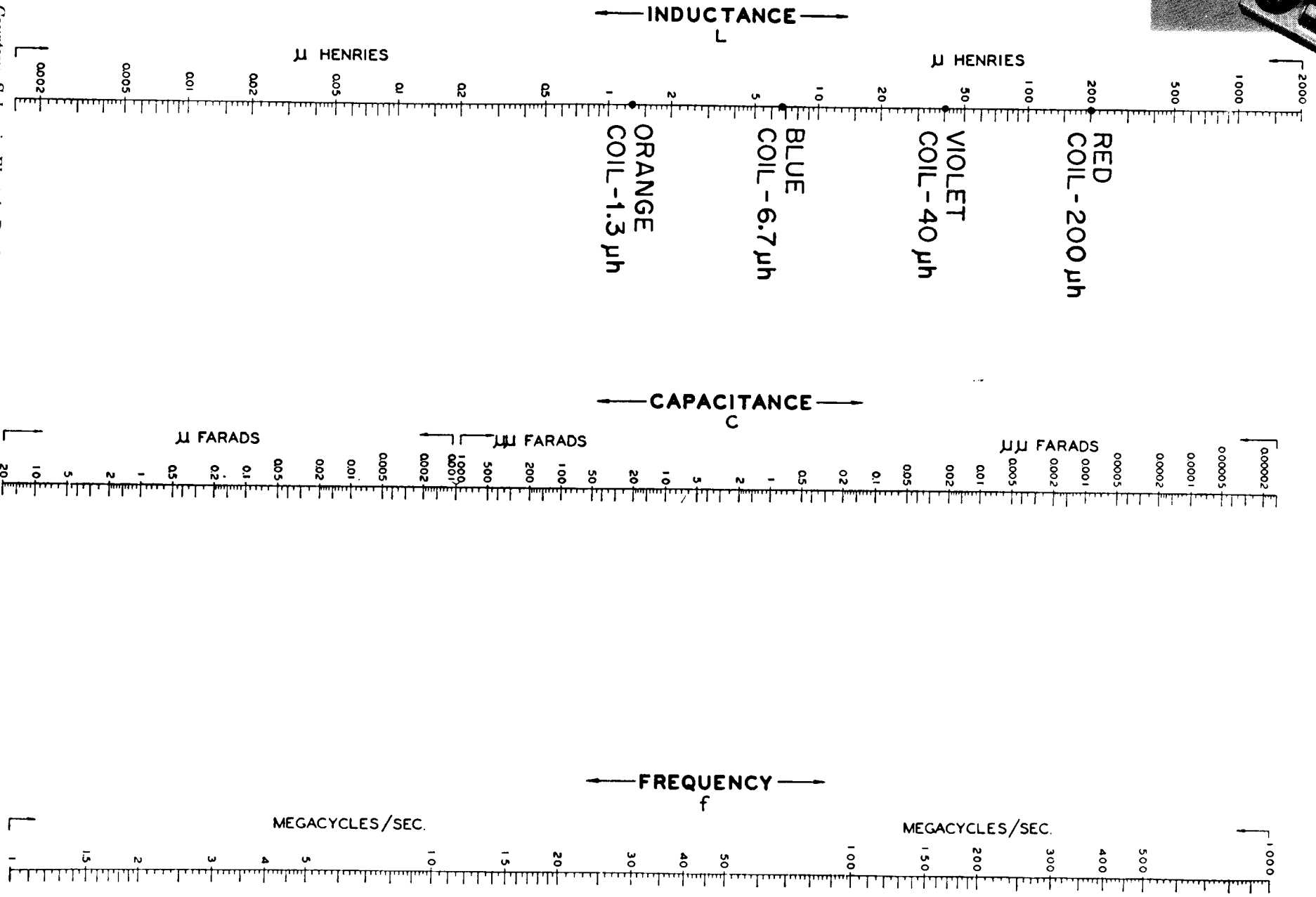



SPECIFICATIONS AND PARTS LIST

SPECIFICATIONS

FREQUENCY COVERAGE:	Red coil	1.5 - 3.5 mc
	Violet coil	3.4 - 8.5 mc
	Blue coil	8.2 - 20 mc
	Orange coil	19 - 45 mc
	Yellow coil	45 - 115 mc
	Green loop	110 - 300 mc

POWER REQUIREMENT: 105-125 volts, 50-60 cycle AC

POWER CONSUMPTION: 3 watts

DIMENSIONS: 6¼ x 3⅛ x 1½"

NET WEIGHT: 1 lb. 10 oz.

COIL SOCKET: .486" spacing, .093" pin diam.

PARTS LIST

CAPACITORS

Symbol	Description	Part No.
✓C-1	2-section variable, copper stators, with tube bracket attached	040059
✓C-2	150 μμfd, 600 v. disc	276158
✓C-3	20 μμfd, 150 v. electrolytic	203201
✓C-4, 5, 6	1000 μμfd feed-through type	294003

COILS

✓L-1	Red (1.5-3.5 mc)	152036
✓L-2	Violet (3.4-8.5 mc)	152037
✓L-3	Blue (8.2-20 mc)	152038
✓L-4	Orange (19-45 mc)	152039
✓L-5	Yellow (45-115 mc)	152040
✓L-6	Green (110-300 mc)	152041

RESISTORS

✓R-1	10KΩ, ½ watt, 10%	301103
✓R-2	10KΩ, ½ watt, 10%	301103
✓R-3	100KΩ Gain control with S-1 on-off switch	390141

PARTS LIST



MISCELLANEOUS

Symbol	Description	Part No.
CR-1	Selenium Rectifier	620005
J-1	Phones jack	502228
M-1	Meter, 0-1 ma DC	652206
T-1	Power transformer	101321
V-1	6AF4A tube	610059

Description	Quan.	Part No.
Bracket for coil socket	1	470164
Case, aluminum	1	462245
Case cover	1	463109
Coil case, plastic	1	880012
Coil socket	1	501220
Dial and knob assembly	1	040078
Grommet, rubber	1	830100
Hairline adjust, plastic	1	870047
Knob, small	1	764529
Instruction manual	1	750230
Pad for coil case	1	890002
Terminal strip (3 terminals)	1	440301
Tube socket	1	501270

WIRE, SOLDER AND SPAGHETTI

Bare wire, #16, 3"	1	806400
Insulated wire 2" red	2	801002

Symbol	Description	Part No.
4" yellow	1	801004
5" green	1	801005
6" blue	1	801006
Line cord	1	802001
Solder, 20"	1	930004
Spaghetti, 10"	1	812011

HARDWARE

Clips, mounting	2	531010
Nuts, 3-48	3	570110
Nut, large	1	579751

Screws	Quantity	Part No.
6-32x1/8", rounded head	2	560340
6-32x3/16", flat head	3	563347
3-48x3/16"	2	560114
3-48x1/2"	1	560113
#4, 1/4" self-tapping, round head	4	562292
#4, 1/2" self-tapping, flat head	2	562293

Washers

Fiber washer	1	590703
Lockwasher, #10	2	581500
Lockwasher, 3/8"	1	582700
Lockwasher, countersunk	1	587900

FIGURE 14

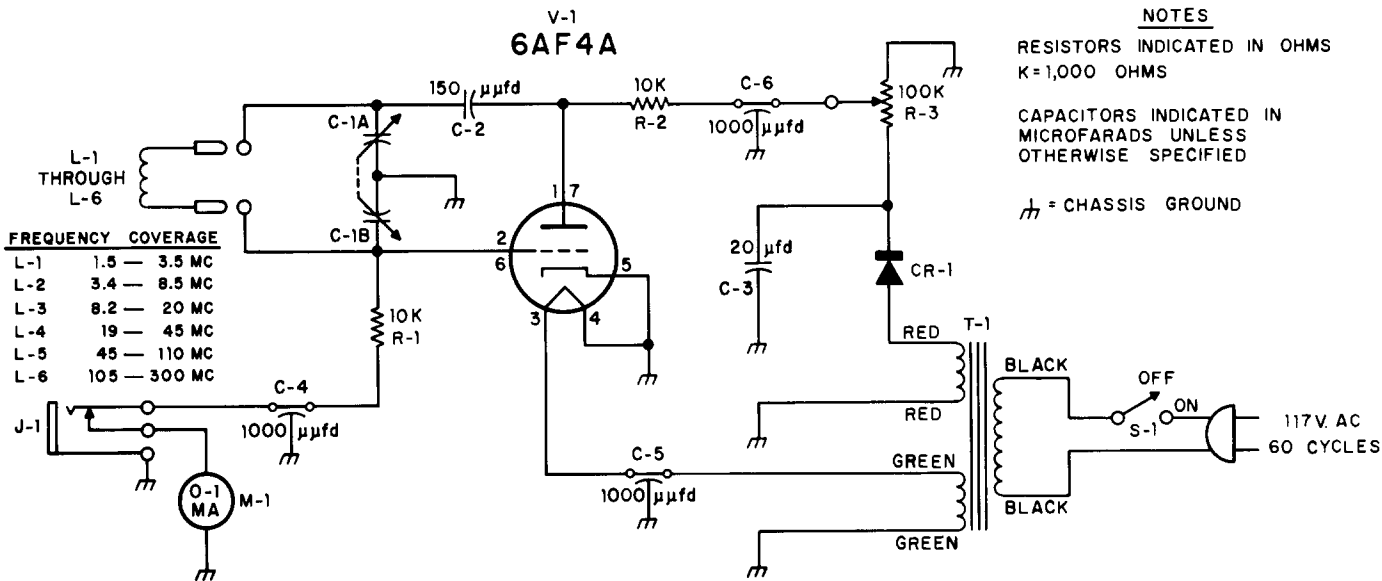

SCHEMATIC DIAGRAM OF GRID DIP METER

GRID DIP METER

83 Y 721

An improved type of GAIN control has been added to your kit. With this control, the connections to terminals 1 and 3 have been interchanged.

Please make the following connections to your manual before starting construction.

Page 8, Column 2, Step 1. Be sure to position R-3 so that the terminals are facing toward PHONES jack J-1, as shown in Figure 5.

Page 10, Column 2, Step 1. Change the last two sentences to read: Slip 2-5/8" spaghetti on the positive (+) lead of C-3. Connect, but do not solder, this lead to terminal 1 of R-3.

Page 10, Column 2, Step 2. Change the second sentence of this step to read: Solder the lead from the RED END to terminal 1 of R-3 (2 wires).

Page 10, Column 2, Step 3. Change the first sentence of this step to read: Solder one end of a yellow wire to terminal 3 of R-3.

Page 28, PARTS LIST.

Change the part number of R-3 to 392190.

NOTE: The new gain control action has been reversed as compared to the action described in the Operating Instructions and Circuit Description. Therefore, if instructions are given to turn the gain control clockwise, it must now be turned counterclockwise, etc.