

SERVICE MANUAL

B&K Model E-200D

RF Signal Generator

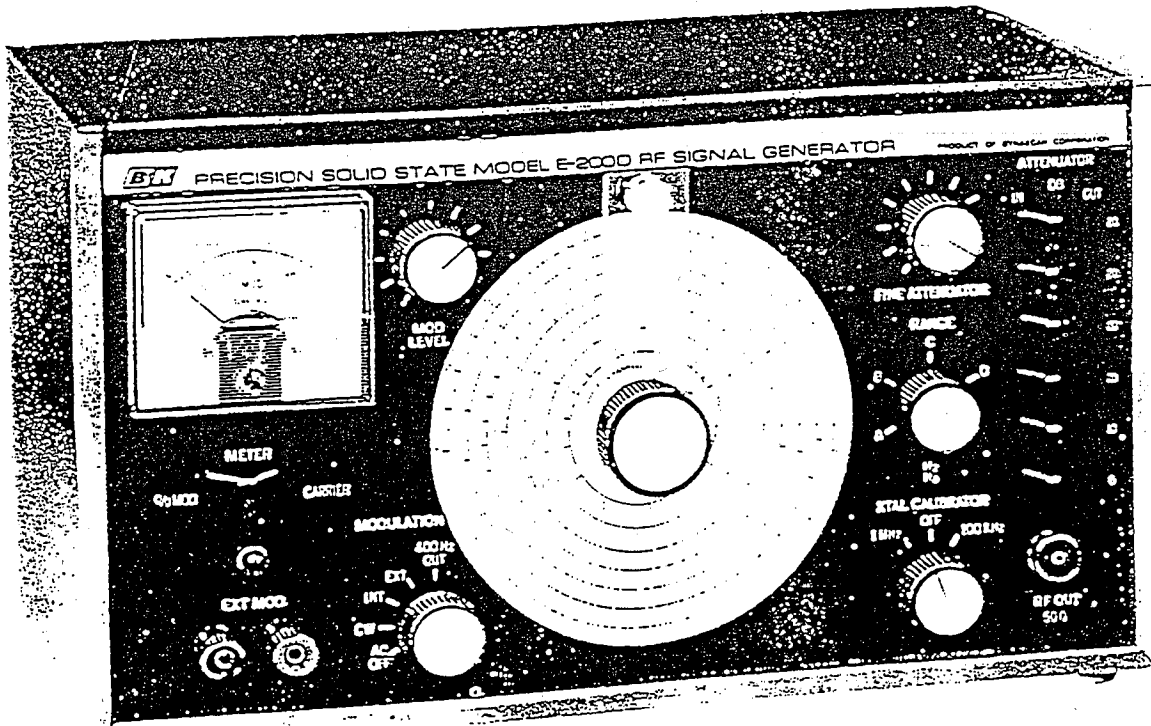

TEST INSTRUMENT SAFETY

WARNING

Normal use of test equipment exposes you to a certain amount of danger from electrical shock because testing must often be performed where exposed voltage is present. An electrical shock causing 10 milliamps of current to pass through the heart will stop most human heartbeats. Higher voltages pose an even greater threat because such voltage can more easily produce a lethal current. However, voltage as low as 35 volts dc or ac rms should be considered dangerous and hazardous since it can produce a lethal current under certain conditions. Your normal work habits should include all accepted practices that will prevent contact with exposed high voltage, and that will steer current away from your heart in case of accidental contact with a high voltage. You will significantly reduce the risk factor if you know and observe the following safety precautions:

1. Don't expose high voltage needlessly. Remove housings and covers only when necessary. Turn off equipment while making test connections in high-voltage circuits. Discharge high-voltage capacitors after removing power.
2. Use an insulated floor material or a large, insulated floor mat to stand on, and an insulated work surface on which to place equipment; and make certain such surfaces are not damp or wet. Where insulated floor surface is not available, wear heavy gloves.
3. Use the time-proven "one hand in the pocket" technique while handling an instrument probe. Be particularly careful to avoid contacting a nearby metal object that could provide a good ground return path.
4. Always use an isolation transformer to power transformerless "hot chassis" equipment, where one side of the ac power line is connected directly to the chassis. This includes most recent television sets and audio equipment. Without an isolation transformer, the chassis of such equipment may be floating at line voltage (120 VAC, 60 Hz in USA), depending upon which way the 2-wire ac power plug is inserted. Not only does this present a dangerous shock hazard if the chassis is touched, but damage to test instruments or the equipment under test may result from connecting the ground lead of some test instruments to a "hot" chassis. The ground lead of this signal generator and most other test instruments with 3-wire power plugs is at earth ground.
5. On test instruments or any equipment with a 3-wire ac power plug, use only a 3-wire outlet. This is a safety feature to keep the housing or other exposed elements at earth ground.
6. If possible, familiarize yourself with the equipment being tested and the location of its high voltage points. However, remember that high voltage may appear at unexpected points in defective equipment.
7. Also remember that ac line voltage is present on some power input current points such as on-off switches, fuses, power transformers, etc., even when the equipment is turned off.
8. Never work alone. Someone should be nearby to render aid if necessary. Training on CPR (cardo-pulmonary resuscitation) first aid is highly recommended.

B & K MODEL E-200D PARTS LIST

488-101-9-002

SCHEMATIC
SYMBOL

DESCRIPTION

B & K
PART No.

CONTROLS

R-28	30K Ω , Trim Pot—Mixer Adjust	008-049-9-002
R-42, 48	1K Ω , Trimpot—Carrier Cal. & Audio Osc.	008-068-9-001
R-50	50K Ω , Trimpot—RF Threshold	008-093-9-001
R-54	10K Ω , Trimpot—Mod. Cal.	008-058-9-001
R-60	100 Ω , Fine Attenuator	008-132-9-001
R-79	10K Ω , Pot. Mod. Level	008-133-9-001

CAPACITORS

C-41A, 41B	Dual, Var. Condenser	029-010-9-001
------------	----------------------------	---------------

DIODES AND TRANSISTORS

D-1, 2, 4, 5, 7	Diode, Silicone, 1 Amp 600 PIV	151-018-9-001
D-3	Diode, Germanium	150-003-9-001
D-6	Diode, Zener, 10V, 1 W, 5%	152-016-9-001
D-8	Diode, Germanium	150-001-9-001
Q-1	NPN, Transistor	176-027-9-001
Q-2, 5, 7, 8, 11	NPN, Transistor	176-021-9-001
Q-3	NPN, Transistor	176-022-9-001
Q-4	NPN, Transistor	176-005-9-001
Q-6, 9, 10	NPN, Transistor	176-020-9-001

SWITCHES

S-1	Range Rotary Switch	083-097-9-001
S-2	Xtal Rotary Switch	083-103-9-001
S-3	Mod. Selector Rotary Switch	083-099-9-001
S-4, 5, 6, 7, 8, 9, 10	Slide Switch-Step Attenuator and Meter	084-014-9-001

COILS AND CHOKES

CH-1, 2	Choke, Line Filter	041-034-9-001
L-1	Choke, 10 mh	041-001-9-023
L-2	Peaking Coil 2.5 mh	041-028-9-001
L-3	Oscillator Coil 100 KHz	044-011-9-001
L-4	Oscillator BAND "A" 100 KHz-370 KHz	044-022-9-001
L-5	Oscillator BAND "B" 370 KHz-1.4 MHz	044-022-9-002
L-6	Oscillator BAND "C" 1.4 MHz-5.1 MHz	044-022-9-003
L-7	Oscillator BAND "D" 5.1 MHz-16 MHz	044-022-9-004
L-8	Oscillator BAND "E" 16 MHz-54 MHz	044-022-9-005

B & K MODEL E-200D PARTS LIST

SCHEMATIC SYMBOL	DESCRIPTION	B & K PART No.
MISCELLANEOUS		
T-1	Output Transformer061-011-9-001
T-2	Power Transformer 117V AC PR065-060-9-001
ME-1	Meter, 2¼", 200 μ A, 600 Ω320-027-9-001
	Fuse, ¼ amp. 3AG191-251-3-104
	Case, Top & Back272-069-9-001
	Case, Sides & Bottom272-070-9-903
	Cursor Marker380-132-9-001
	Glamor Cap (Black)384-008-9-001
PL-1	Neon Lamp w/100K Resistor401-001-9-002
	Line Cord 3-wire420-001-9-001
	RF Cable Assembly522-058-9-001
	Speaker, 8 Ω , 2¼"580-005-9-001
	Clip Tinnerman (Speaker)652-027-9-001
	Red Jewel w/Nut750-003-9-001
	Knob, Small751-005-9-002
	Knob, Large751-005-9-004
	Knob, Cursor Drive751-076-9-001
	Dial Plate756-005-9-903
	Dial Drive, Planetary769-042-9-001
	Extender Shaft769-047-9-001
	Coupling, ¼" Shaft769-056-9-001
	Binding Post, Red773-022-9-805
	Binding Post, Black773-023-9-805
	Instruction Manual480-108-9-001
	Container, Shipping500-170-9-001
	Fillers, Carton503-047-9-001

NOTE: Standard value resistors and capacitors are not listed, values may be obtained from schematic diagram.

Minimum charge \$2.00 per invoice. Orders will be shipped C.O.D. unless previous open account arrangements have been made or remittance accompanies order. Advance remittance must cover postage or express charge.

Specify serial number when ordering replacement parts.

R.F. GENERATOR -- E-200D
CALIBRATION PROCEDURE

Page 2 of 5

A. R.F. Output Calibration

- 1). Set the switches and controls as follows:

	<u>Positions</u>
Meter	Carrier
Mod. Selector	AC OFF
Range	Band "C"
Step Attenuators	OUT (0 db)
Fine Attenuator	Min.

- 2). Attach the RF Cable to the generator with 51 Ω termination.
- 3). Check the meter to be sure the needle is resting on the first line, at the left hand side of the scale. If it is not, adjust the meter set screw.
- 4). Set the Modulation switch to "CW".
- 5). With VTVM Mod. 177--Range 15 VDC--check test points on the R.F. P.C. Board 10.6V and 10.0V. It should be between +10 and +11 V for test point 10.6 V and + 9V and 10V for test point 10.0V.
- 6). Adjust R.F. threshold control (Audio & Power P.C. Board) -R-50 (008-093-9-001) for a 2.5 reading on the % Mod. Meter Scale.
- 7). Set the R.F. dial to 2 MHz. Connect VTVM Mod. 177--Range 1.5 VDC. to the cathode of diode D3 (RF. P.C. Board).
- 8). Set the fine attenuator for a reading of +.74 V. Adjust the carrier cal. control R-48 (008-068-9-001) for a 0 db reading on the carrier scale.

B. Modulation Adjustment

- 1). Connect R.F. output cable with 51 Ω termination to the scope Mod. 1450.
- 2). Set the fine attenuator for -2 db.
- 3). Place the meter switch in pos. % mod.
- 4). Set the Modulation switch in pos. INT.

- 5). Set mod. level control for min.
- 6). Connect VTVM Mod. 177 -- Range 1.5 V. AC to the test point "Z".
- 7). Adjust trim pot R-42 for reading on the VTVM 1.3 VRMS.
- 8). Set the mod. level control to read 50% on the % mod. scale.
- 9). Adjust the scope gain and positions controls for a modulated envelope display. If you note distortion in the envelope, slowly turn trim pot R-42, counter-clockwise until modulation just becomes sinusoidal.
- 10). Adjust trim pot R-54, for a 3:1 P-P valley-to-valley ratio on the scope.

C. 100 KC. Osc. Calibration

- 1). Set modulation switch in pos. "CW". Connect frequency counter mod. 738A to the test point "N" (Audio & Power P.C. Board).
- 2). Set fine attenuator to min.
- 3). Set Xtal cal. switch in pos. 100 KC.
- 4). Adjust coil L-3 for reading on the counter 100.00 KC.
- 5). Turn the Xtal Cal. switch to the 1 MHz position.
- 6). Set range switch in the position "E". Rock the RF. dial between 16.5 MHz and 17.5 MHz. Set trim pot R-28 for the strongest beat.

D. Frequency Calibration

- 1). Pre-set the trimer set screws as follows:
C-44, C-45 and C-47 -- 5/16" from nut to screw end.
C-46 and C-48 -- 3/8" from nut to screw end. Place RF cover.
- 2). Set range switch to Band "E".
- 3). Adjust cursor marker in the middle.
- 4). Adjust RF dial when the tuning gang is fully meshed. The line marked "Cal" on the dial should be directly under the cursor hairline.
- 5). Attach the RF cable with 51 Ω termination to the frequency counter.
- 6). Place the meter switch in pos. carrier.
- 7). Place the modulation switch in pos. CW.
- 8). Place the Xtal cal. switch in pos. OFF.

NOTE: DO NOT USE XTAL CALIBRATOR
DURING THE FREQUENCY CALIBRATION

- 9). Adjust the RF dial to 17 MHz.
- 10). Set fine attenuator for 0 db reading on the carrier scale.
- 11). Set L-8 for reading 17 MHz. on the counter.
- 12). Adjust the RF dial to 54 MHz.
- 13). Set fine attenuator for 0 db reading on the carrier scale.
- 14). Adjust C-48 for reading 54 MHz. on the counter. Repeat adjustments of L-8 for 17 MHz and C-48 for 54 MHz. Check 17 through 54 MHz. for the best tracking.

- 1). Set the range switch to Band "D".
- 2). Set the RF dial to 6 MHz.
- 3). Adjust fine attenuator for 0 db.
- 4). Adjust L-7 for 6 MHz reading on the counter.
- 5). Set RF dial to 14 MHz.
- 6). Adjust fine attenuator for 0 db.
- 7). Adjust C-47 for 14 MHz. reading on the counter.
- 8). Repeat adjustments of L-7 for 6 MHz. and C-47 for 14 MHz. Check 6 MHz. through 14 MHz. for the best tracking.

- 1). Set the range switch to Band "C".
- 2). Set the dial to 1.5 MHz.
- 3). Adjust fine attenuator for 0 db.
- 4). Adjust L-6 for 1.5 MHz reading on the counter.
- 5). Set RF dial to 4.0 MHz.
- 6). Adjust fine attenuator for 0 db.
- 7). Adjust C-46 for 4.0 MHz reading on the counter.
- 8). Repeat adjustments of L-6 for 1.5 MHz and C-46 for 4.0 MHz. Check 1.5 MHz through 4.0 MHz for the best tracking.

- 1). Set the range switch to Band "B".
- 2). Set the dial to 370 KHz.
- 3). Adjust fine attenuator for 0 db.
- 4). Adjust L-5 for 370 KHz reading on the counter.
- 5). Set RF dial to 1.350 KHz.
- 6). Adjust fine attenuator for 0 db.
- 7). Adjust C-45 for 1.350 KHz reading on the counter.
- 8). Repeat adjustments of L-5 for 370 KHz and C-45 for 1.350 KHz. Check 370 KHz through 1.350 KHz for the best tracking.

- 1). Set the range switch to Band "A".
- 2). Set the dial to 100 KHz.
- 3). Adjust fine attenuator for 0 db.
- 4). Adjust L-4 for 100 KHz reading on the counter.
- 5). Set RF dial to 360 KHz.
- 6). Adjust fine attenuator for 0 db.
- 7). Adjust C-44 for 360 KHz reading on the counter.
- 8). Repeat adjustments of L-4 for 100 KHz and C-44 for 360 KHz. Check 100 KHz through 360 KHz. for the best tracking.

Install the hole plug in the RF Oscillator cover.

SHEET 1 OF 3

487 157 9 001

ISSUE INDEX CHANGES BY / CHAD

RECEIVED
JUL 2 1970

MODEL E-200 D
TROUBLESHOOTING CHART

- DISTRIBUTION: QUANTITY
- Production Incl. 2
 - Quality Control 1
 - Service 2
 - Incoming Inspection 1
 - Project Engineer 1
 - Engineering Records 1
 - Cal. Dept. 1

DYNASCAN CORPORATION
1801 W. BELLE PLAINE
CHICAGO, ILLINOIS 60613

TITLE
Troubleshooting Chart, Model E-200 D

UNLESS OTHERWISE INDICATED 1. ALL DIMENSIONS ARE IN INCHES 2. ALL BENDS ARE 90° 3. TOLERANCES: FRACTIONS ± 1/64 DECIMAL ± .005 HOLES ± .003 ANGLES ± 0° - 30'	DRAWN BY CN	7-9-70	NS
	APPROVED	APPROVED	1ST MODEL
SHEET 1 OF 3			
487		157	9 001

DO NOT SCALE DRAWING

MODEL E-2000
TROUBLESHOOTING CHART

Symptom	Possible Cause
No output, Pilot light lit, meter reads high.	Open circuit in attenuator read resistance to ground from J1 with only S-5 in the -20 db position. Should be 50-52 Ω .
No output, Pilot light lit, meter does not indicate R.F.	<p>Check each band to see if only one is inoperative. If all are out, check for output at the emitter of Q2, then base and collector of modulator Q3.</p> <p>Base of Q3- Mod. Sw. in "CW" position .05 V P-P fine attenuator max. position. Collector of Q3-Mod. Sw. in "CW" position .40 - .56V P-P, Fine attenuator for 0 db.</p>
Highly distorted R.F. output at -2 db or lower.	Q3 forward bias too low. Check Q3, all bias resistors and coupling condensers.
Highly distorted modulation envelope at -2 db and 2 MHz. Audio clean. Poor modulation depth.	Q3 forward bias too high. Check Q3, all bias resistors and C-10.
Meter reads neither carrier nor modulation.	Check diode D7, ME1, Q11, and S4.
Meter reads modulation only.	Check R14, C15, R19, D3, R21, and C1.
Meter reads Carrier only.	Check C39, R53, diode D8, R51, and R52.
No modulation.	Trim pot. R-42 too far CCW, oscillator won't start. Check Q9 and Q10 and all associated components. Is Mod. Cal pot R54 set?

Page 3 of 3

Symptom

Possible Cause

No crystal Cal. output in either position.

Check Q7, Q8 and speaker. Q8 can be checked by injecting audio from the emitter of Q10 into Q8 base with a .01 μ f capacitor.

Check setting of trim pot R28.

No output in 1 MHz Cal.

Check Q5 and associated components.

No output in 100 KHz Cal.

Check Q6 and associated components.

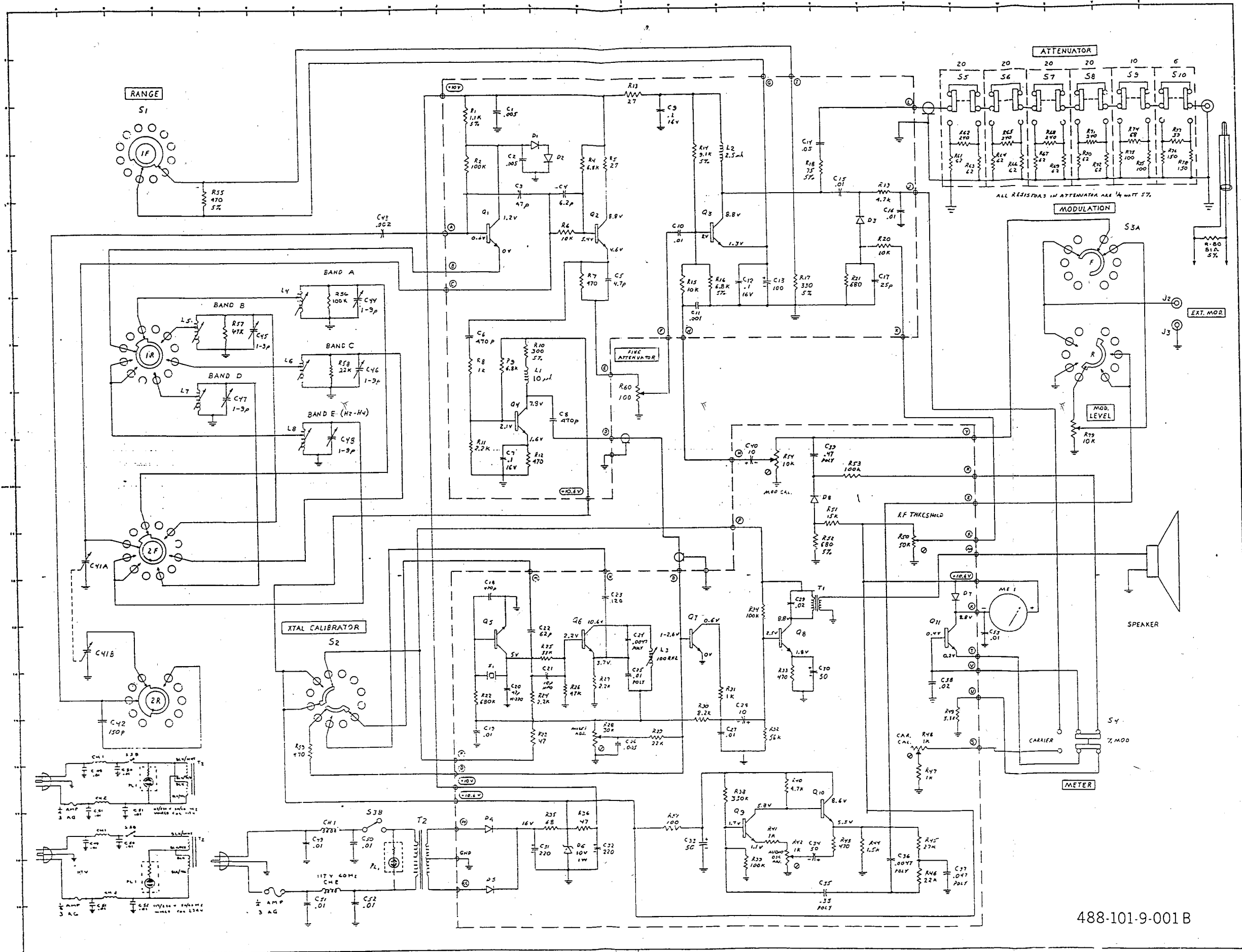

488-101-9-001B