

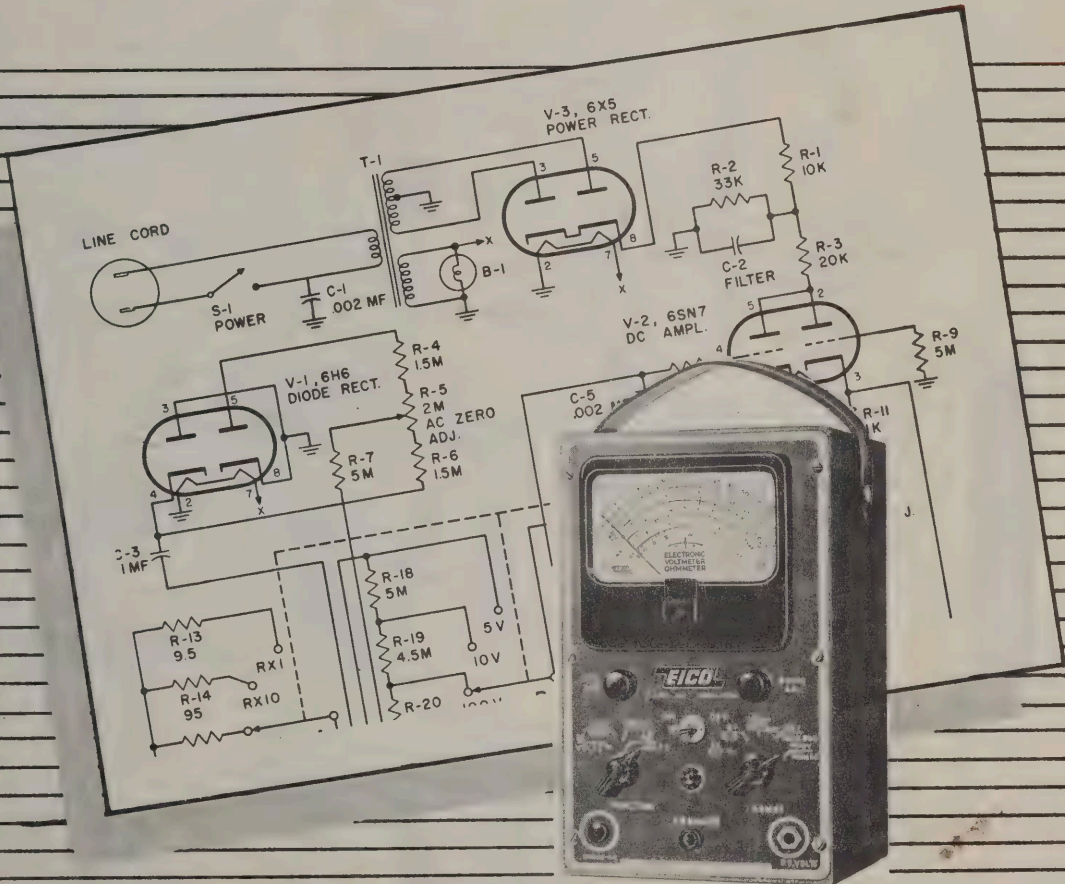

CONSTRUCTION MANUAL

Model 221 ELECTRONIC VOLT-OHM METER



ELECTRONIC INSTRUMENT CO., Inc. 84 WITHERS STREET, BROOKLYN 11, N. Y.

Reg. U. S. Pat. Off.

©1952

CAPACITOR COLOR CODES

RMA 3-DOT COLOR CODE FOR MICA-DIELECTRIC CAPACITORS

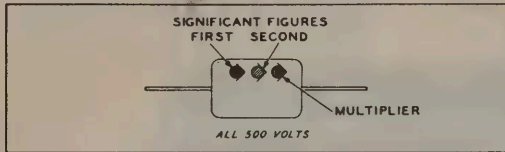

JAN 6-DOT COLOR CODE FOR PAPER-DIELECTRIC CAPACITORS

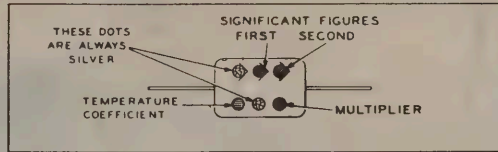

RMA 6-DOT COLOR CODE FOR MICA-DIELECTRIC CAPACITORS

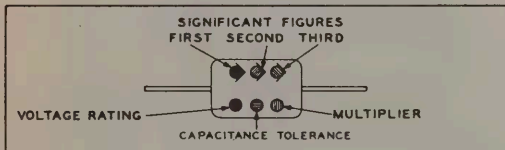

JAN 6-DOT COLOR CODE FOR MICA-DIELECTRIC CAPACITORS

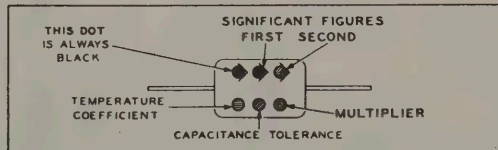

RMA COLOR CODE FOR TUBULAR CERAMIC-DIELECTRIC CAPACITORS

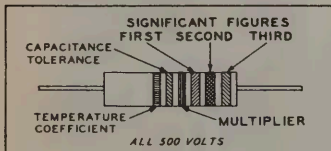

JAN COLOR CODE FOR FIXED CERAMIC-DIELECTRIC CAPACITORS

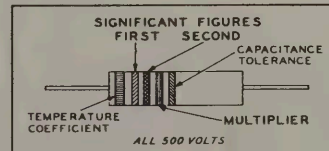
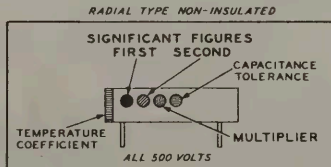

RMA: RADIO MANUFACTURERS ASSOCIATION
JAN: JOINT ARMY-NAVY

RESISTORS

TOLERANCE	MULTIPLIER	SIGNIFICANT FIGURE	COLOR	CAPACITORS			VOLTAGE RATING	TEMPERATURE COEFFICIENT
				RMA MICA AND CERAMIC-DIELECTRIC	MULTIPLIER	JAN MICA AND PAPER-DIELECTRIC		
	1	0	BLACK	1	1	1		A
	10	1	BROWN	10	10	10	100	B
	100	2	RED	100	100	100	200	C
	1000	3	ORANGE	1000	1000	1000	300	D
	10000	4	YELLOW	10000			400	E
	100000	5	GREEN	100000			500	F
	1000000	6	BLUE	1000000			600	G
	10000000	7	VIOLET	10000000			700	
	100000000	8	GRAY	100000000		0.01	800	
	1000000000	9	WHITE	1000000000		0.1	900	
5	0.1		GOLD	0.1	0.1		1000	
10	0.01		SILVER	0.01	0.01		2000	
20			NO COLOR				500	

RESISTOR COLOR CODES

RMA COLOR CODE FOR FIXED COMPOSITION RESISTORS

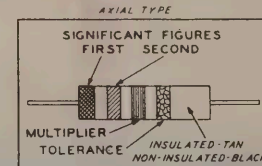

RADIAL TYPE

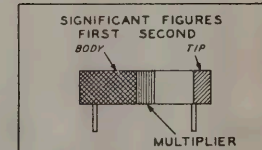

JAN COLOR CODE FOR FIXED COMPOSITION RESISTORS

AXIAL TYPE INSULATED

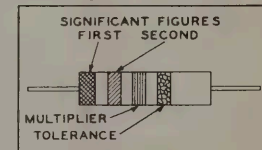

RADIAL TYPE NON-INSULATED

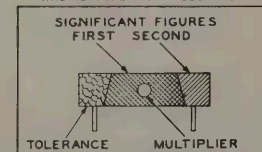

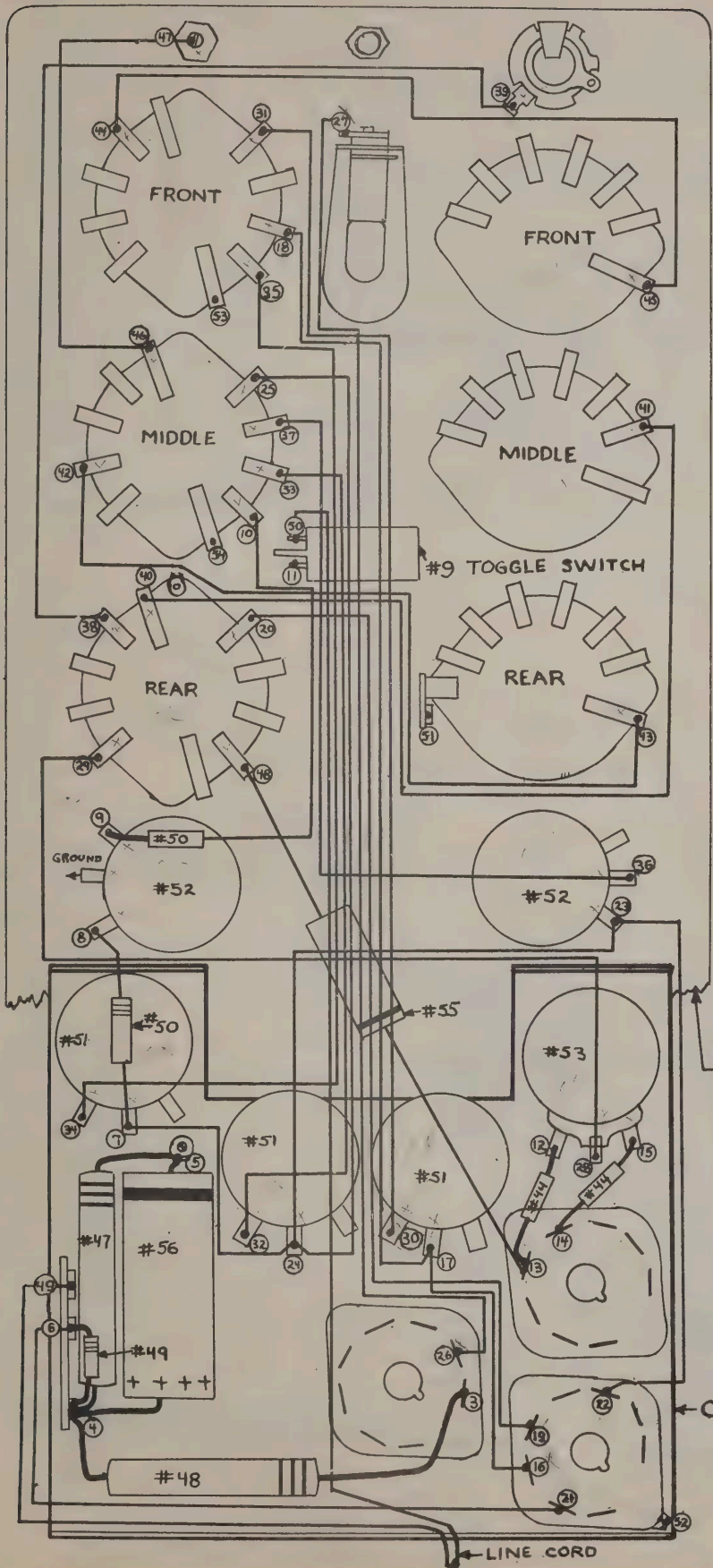

WIRING			
PART	DESCRIPTION	FROM	TO
48	10K (2W)	3	4
47	33K (2W)	4	5
56	2 MFD COND	4	5
49	20K Ω	4	6
50	1K Ω	7	8
50	1K Ω	9	10
	BLACK WIRE	TRANS.	11
44	1.5 MEG	12	13
44	1.5MEG	14	15
	WIRE	16	17
	WIRE	17	18
	WIRE	19	20
	WIRE	6	21
	WIRE	22	23
	WIRE	23	24
	WIRE	7	24
	WIRE	24	25
	WIRE	26	27
	WIRE	28	29
	WIRE	30	31
	WIRE	32	33
	WIRE	34	35
	WIRE	36	37
	WIRE	38	39
	WIRE	40	41
	WIRE	42	43
	WIRE	44	45
	BARE WIRE	46	47
55	.01 COND	13	48
	LINE CORD		49
	LINE CORD		50
	WIRE	BATTERY	51
	WIRE	BAT. -	52
	WIRE	53	METER LUG "A"
	WIRE	54	METER LUG "B"

PANEL

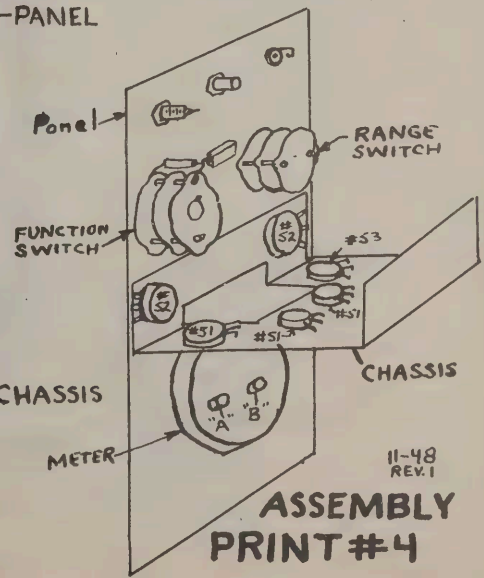

EICO

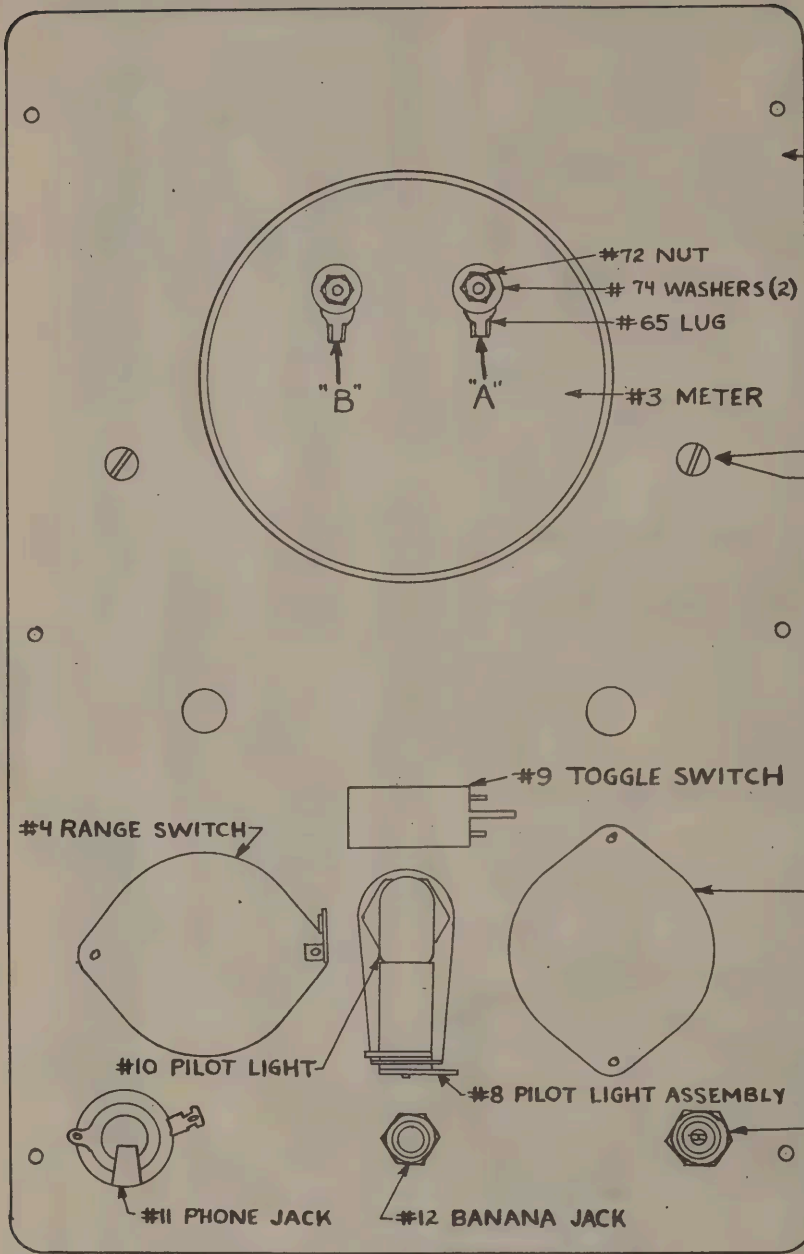

← PANEL

#72 NUT
 #74 WASHERS (2)
 #65 LUG
 #3 METER

#60 SCREW
 #67 LOCKWASHERS (2)

#9 TOGGLE SWITCH

#4 RANGE SWITCH

#5 FUNCTION SWITCH

#10 PILOT LIGHT

#8 PILOT LIGHT ASSEMBLY

#13 PIN JACK

#11 PHONE JACK

#12 BANANA JACK

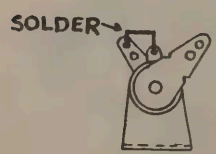

PILOT LIGHT ASSEMBLY

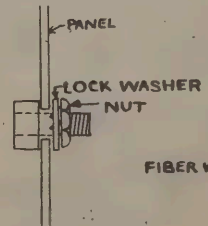

BANANA JACK

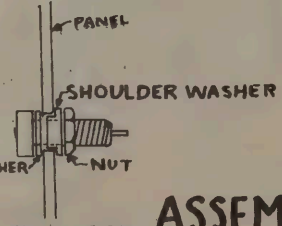

PIN JACK

ASSEMBLY PRINT #3

The drawing at the left is an exploded view of the chassis mounting. To keep the drawing uncrowded, unnecessary repetition is avoided. For example, the method of mounting is shown only for potentiometer R5, as potentiometers R12, R27, R28, R29, and R30 are mounted in exactly the same way.

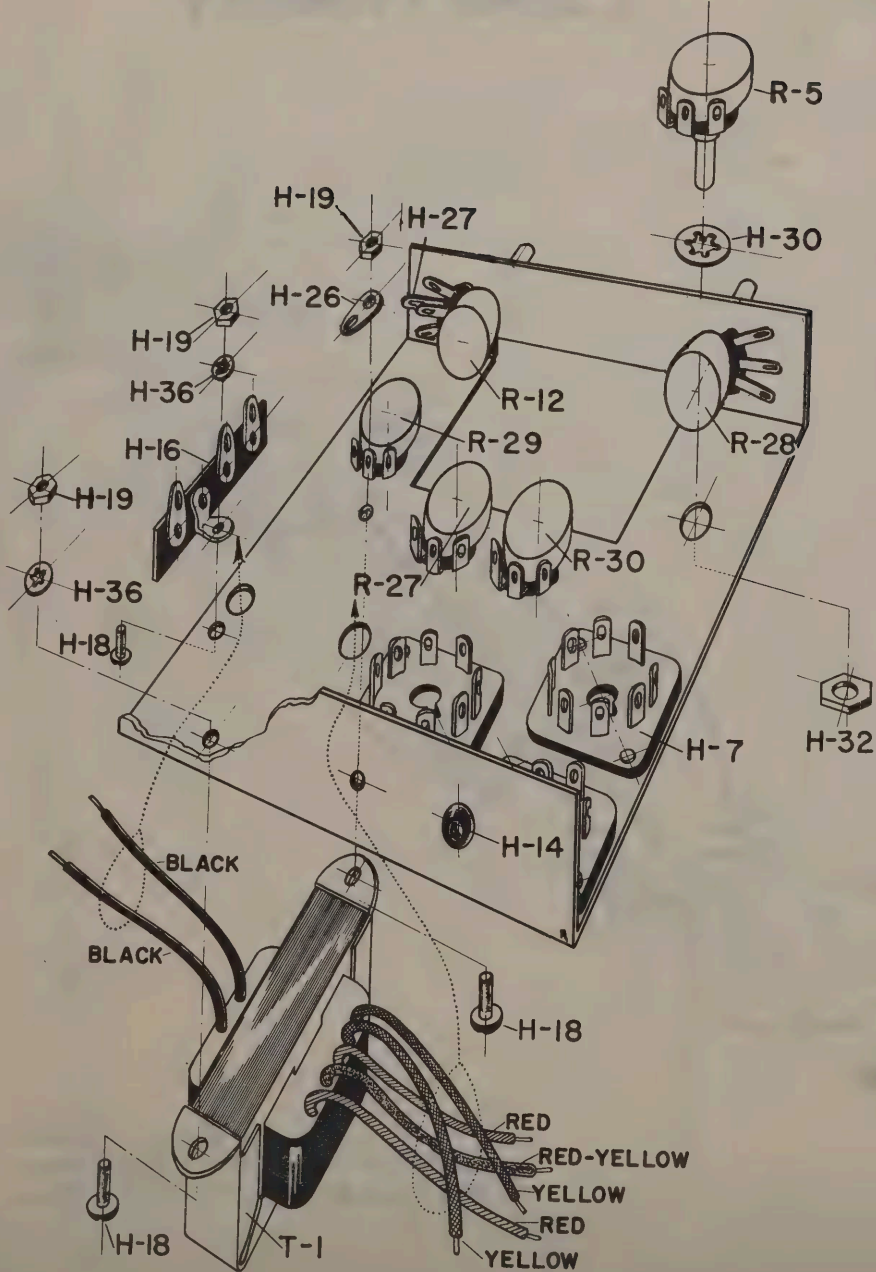

MOUNTING TO THE CHASSIS

✓ Step #	Sym.	Description	Mounted With
3-1	R5	2M ohm pot	1#H30, 1#H32
3-2	R30	1K ohm pot	1#H30, 1#H32
3-3	R27	1K ohm pot	1#H30, 1#H32
3-4	R29	1K ohm pot	1#H30, 1#H32
3-5	*R12	2K ohm pot	1#H30, 1#H27 1#H32
3-6	*R28	1K ohm pot	1#H30, 1#H32
3-7	H16	3 lug term. str.	1#H18, 1#H36 1#H19
3-8	T1	power xfmr.	2#H18, 2#H19 1#H36, 1#H26
3-9	H14	3/8 grogmet	

*The 3/8 hex nuts (H32) on the 1K ohm pots (R12 & R28) must be temporarily removed later on to attach the chassis to the panel.

EICO

ASSEMBLY PRINT 3

Model 221

NOTE: SOLDER GROUNDING LUG

#75 TO CENTER LUG OF POT #52

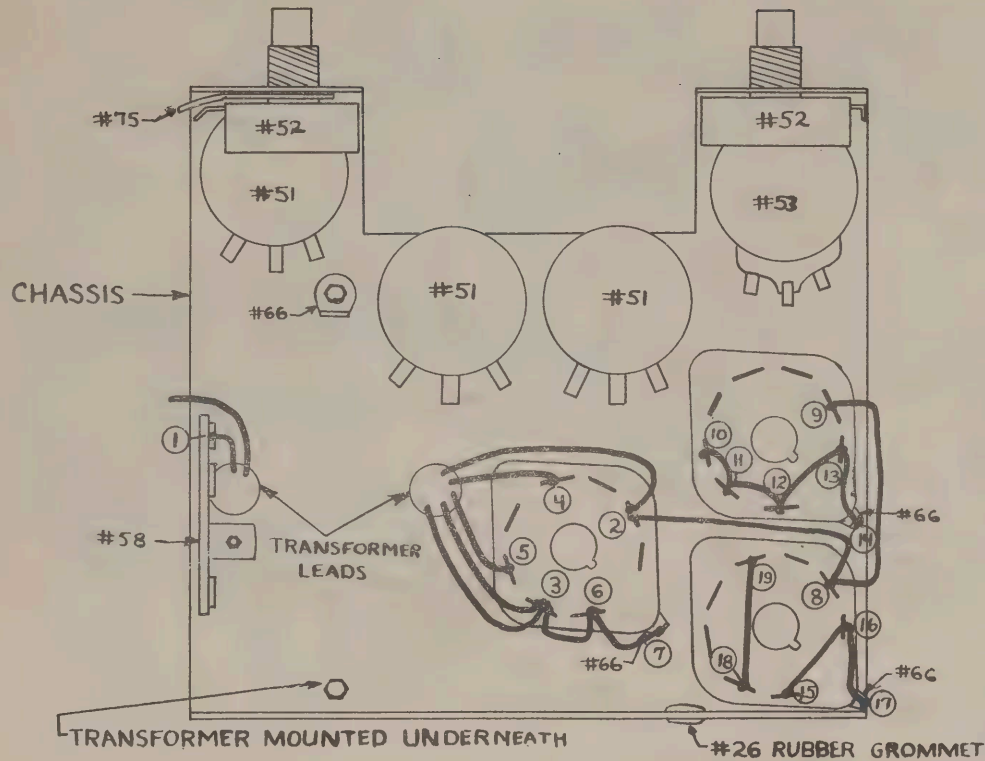

MOUNTING			
PART NO.	DESCRIPTION	HARDWARE	
52	1,000 Ω pot	1#70 LOCKWASHER	
52	1,000 Ω pot	1#70, 1#75 LUG	
51	1,000 Ω pot	SCREW SHAPT 1#70, 1#73 NUT	
51	1,000 Ω pot	" " 1#70, 1#73	
51	1,000 Ω pot	" " 1#70, 1#73	
53	2 MEG POT	1#70, 1#73	
22	TRANSFORMER	2#60 SCREWS 2#61 NUTS 2#67 LOCKWASHERS 1#66 GROUND LUG	
58	TERMINAL STRIP	1#60, 1#61, 1#67	
26	RUBBER GROMMET		
WIRING			
WIRE	FROM	TO	REMARKS
TRANS. BLACK	TRANS	1	
TRANS. YELLOW	"	2	
TRANS. YELLOW	"	3	
TRANS. RED	"	4	
TRANS. RED	"	5	
TRANS. RED-YEL.	"	3	
BARE	3	6	
BARE	6	7	
BARE	2	8	SPAGETTI
BARE	8	9	SPAGETTI
BARE	10	11	
BARE	11	12	
BARE	12	13	
BARE	13	14	
BARE	15	16	
BARE	16	17	
BARE	18	19	

ASSEMBLY PRINT #1

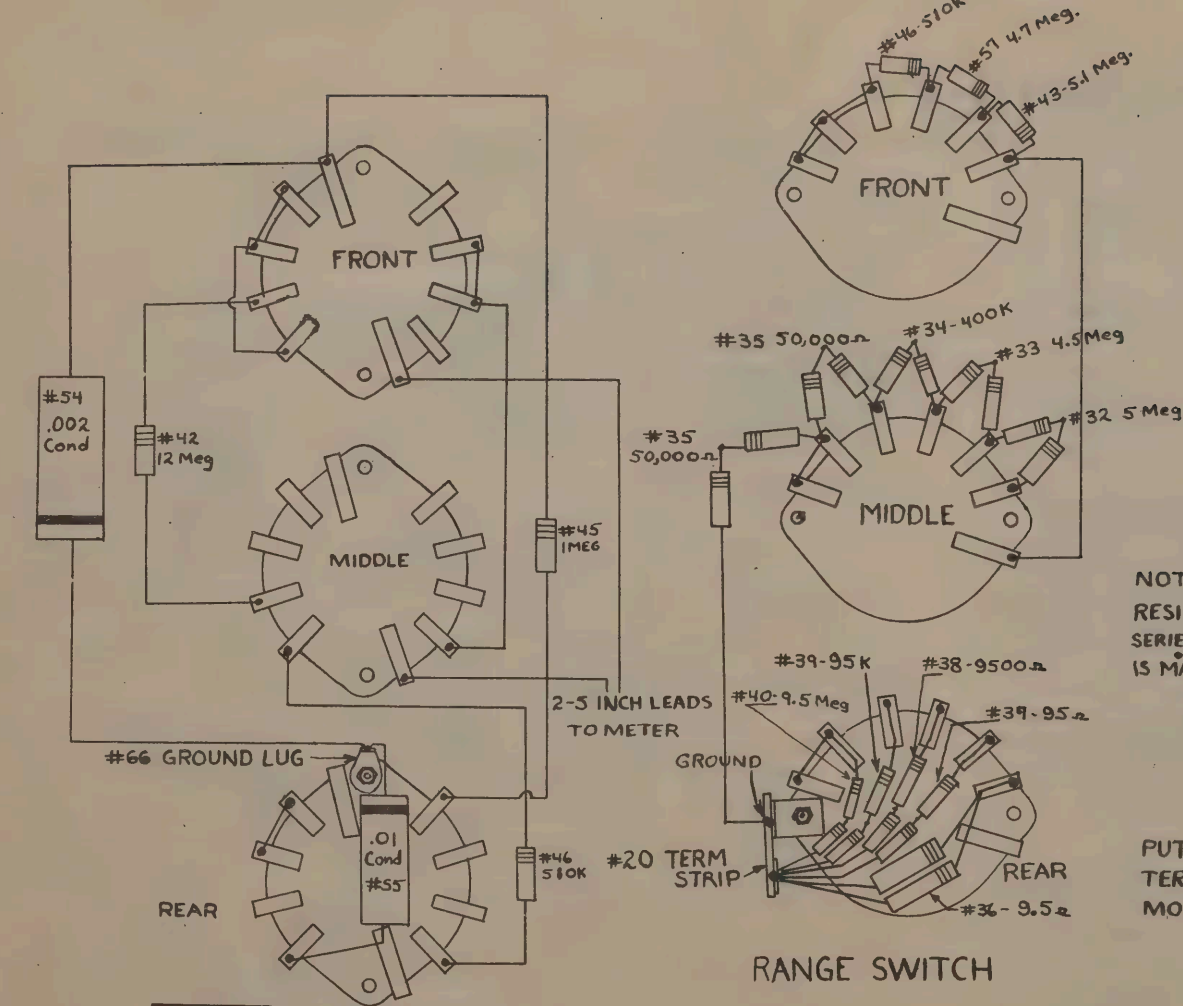

NOTE: ALL MATCHED PAIR RESISTORS ARE MATCHED IN SERIES EXCEPT 9.5 OHMS WHICH IS MATCHED IN PARALLEL.

K=1,000 OHMS
MEG=1,000,000 OHMS

PUT FIBRE WASHER UNDER TERMINAL STRIP WHEN MOUNTING ON RANGE SWITCH

ASSEMBLY PRINT #2

WHEN ORDERING A PART FOR REPLACEMENT,
please include the stock number of the part
and the serial number of your instrument.

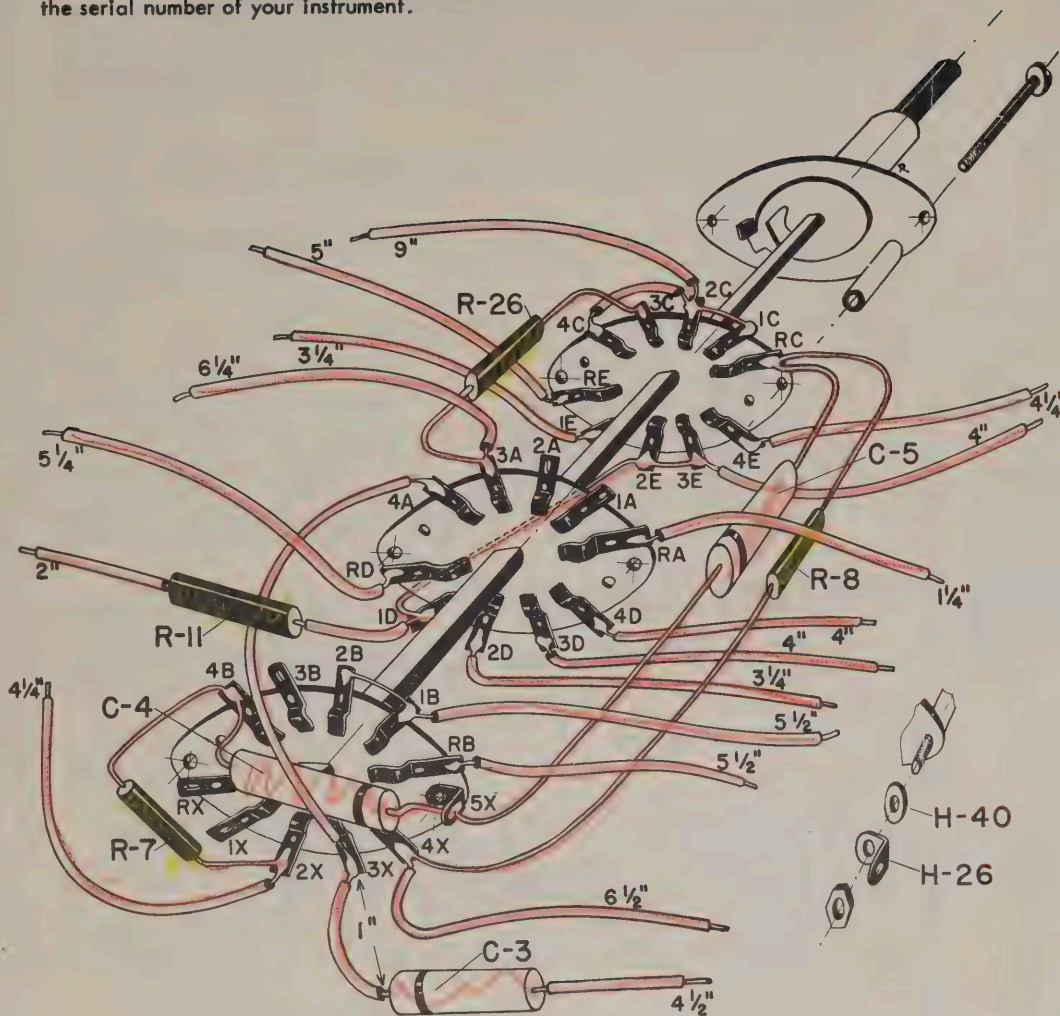

Step #1-1 Assembly: Remove the nut and lockwasher from the switch ass'y. screw (at 5X). Replace the lockwasher with the #6 fibre washer (H40) and the ground lug (H26). Fasten with the nut previously removed. See detail sketch.

PREWIRING OF FUNCTION SWITCH S3

(S) means solder, (C) means connect but do not solder.

Step#	Sym.	Description	From	To (Length)
X 1-2	C5	.002 mfd cond.	(C) RC	(C) 5X
X 1-3	R8	1M ohm res.	(S) RC	(C) 4X
X 1-4	H37	bare wire	(S) 1C	(C) 2C
X 1-5	H33	wire	(C) 2C	9"
X 1-6	H33	wire	(S) 2C	(S) 4C
X 1-7	R26	5.6M ohm res.	(S) 3C	(C) 3A
X 1-8	H33	wire	(S) RE	5"
X 1-9	H33	wire	(S) 1E	3 1/4"
X 1-10	H37	bare wire	(C) 2E	(C) 1D
X 1-11	H37	bare wire	(S) 2E	(C) 3E
X 1-12	H33	wire	(S) 3E	4"
X 1-13	H33	wire	(S) 4E	4 1/4"
X 1-14	H33	wire	(S) RA	1 1/4"
X 1-15	H33	wire	(S) 3A	6 1/4"
X 1-16	H33	wire	(S) 4A	(C) 3X
X 1-17	H33	wire	(S) RD	5 1/4"
X 1-18	R11	*1K ohm res.	(S) 1D	2"
X 1-19	H33	wire	(S) 2D	3 1/4"
X 1-20	H33	wire	(S) 3D	4"
X 1-21	H33	wire	(S) 4D	4"
X 1-22	H33	wire	(S) RB	5 1/2"
X 1-23	H33	wire	(C) 1B	5 1/2"
X 1-24	H37	bare wire	(S) 1B	(S) 2B
X 1-25	C4	.01 mfd cond.	(C) 4B	(S) 5X
X 1-26	R7	5M ohm res.	(S) 4B	(C) 2X
X 1-27	H33	wire	(S) 2X	4 1/4"
X 1-28	C3	*.1 mfd cond.	(S) 3X	4 1/2"
X 1-29	H33	wire	(S) 4X	6 1/2"

*With spaghetti

GENERAL INSTRUCTIONS

1) The Model 221 Electronic Volt-Ohm Meter is constructed very easily with the aid of fully detailed perspective drawings and step-by-step instructions. Before starting the actual construction, it is advisable to study the schematic and pictorial wiring diagrams until all of the steps are clear in your mind. Do not rush the construction, as careful work will result in a properly constructed instrument in the shortest time. In addition, it is suggested that you run all leads exactly as shown on the pictorial wiring diagrams, as this will make the wiring an easier job and insure proper operation of the instrument.

2) USE A GOOD GRADE OF ROSIN CORE SOLDER ONLY. UNDER NO CIRCUMSTANCES USE ACID CORE SOLDER OR ACID FLUX inasmuch as the acid flux can cause serious corrosion. Before soldering, make certain there is a good mechanical connection. The solder must flow before you remove the soldering iron as this will prevent rosin joints which are poor electrical conductors. If you are soldering close to a part, hold the ends of a pair of longnose pliers between the part and the solder joint. The pliers will conduct the heat away and prevent the component from being unduly overheated.

3) Carefully unwrap all the parts and check them in the space provided on the parts list. Note: In order to maintain the supply of kits and insure prompt delivery, we are forced to buy the same component from several sources (standard manufacturers' parts are interchangeable). You may find that the value of a component will vary within the allowable circuit tolerance. This means a resistance of 470,000 ohms may be substituted for, or may measure 510,000 ohms, etc. Any part supplied will work as well as the part for which it was substituted. No substitutions will be made on precision components.

CONSTRUCTION PROCEDURE

For your convenience, the construction of the instrument has been broken down into a logical series of Assembly Prints. Each Assembly Print consists of a detailed drawing and a table of step-by-step instruction so that no step can be overlooked. Space has been provided on the tables to check off each step as it is completed. Follow the order of the Assembly Prints to finish the mechanical assembly and the wiring quickly and easily.

PARTS LIST FOR MODEL 221

St. #	Sym.	Description	Amt.	St. #	Sym.	Description	Amt.	St. #	Sym.	Description	Amt.
100	B1	pilot light.....	1 ✓	130	H25	meter washer.....	4	158	R9	5M ohm res.....	1
101	BT1	1.5 v battery.....	1 ✓	131	H26	ground lug.....	5	159	R10	1K ohm res.....	1
102	C1	.002 mfd cond.....	1 ✓	132	H27	pot ground lug....	1	159	R11	1K ohm res.....	1
103	C2	filter cond.....	1 ✓	133	H28	1/4" standoff.....	2	160	R12	2K ohm pot adj....	1 ✓
104	C3	.1 mfd cond.....	1 ✓	134	H29	#10-24 nut.....	2	161	R13	9.5 ohm 1% res....	1
105	C4	.01 mfd cond.....	1 ✓	135	H30	3/8" lock washer..	10	162	R14	95 ohm 1% res....	1
102	C5	.002 mfd cond.....	1 ✓	136	H31	3/8" flat washer...	4	163	R15	9.5K ohm 1% res...	1
106	H1	panel.....	1 ✓	137	H32	3/8" hex nut.....	9	164	R16	95K ohm 1% res...	1
107	H2	chassis.....	1 ✓	138	H33	wire.....	roll	165	R17	9.5M ohm 1% res...	1
108	H3	cabinet.....	1 ✓	139	H34	test lead wire.....	2	166	R18	5M ohm 1% res....	1
109	H4	handle.....	1 ✓	140	H35	shielded wire....	pc.	167	R19	4.5M ohm 1% res...	1
110	H5	pilot light ass'y...	1 ✓	141	H36	#6 lock washer....	7	168	R20	400K ohm 1% res...	1
111	H6	line cord.....	1 ✓	142	H37	bare wire.....	pc. ✓	169	R21	50K ohm 1% res...	1
112	H7	wafer socket.....	3 ✓	143	H38	nut, shldr. washer...	1	169	R22	50K ohm 1% res...	1
113	H8	battery bracket....	1 ✓	144	H39	nut, washer.....	1	170	R23	2M ohm res.....	1
114	H9	red test prod.....	1 ✓	145	H40	#6 fibre washer...	2	171	R24	3.3M ohm res.....	1
115	H10	black test prod....	1 ✓	146	J1	phone jack.....	1 ✓	172	R25	500K ohm res.....	1
116	H11	alligator clip....	1 ✓	147	J2	pin jack.....	1 ✓	173	R26	5.6M ohm res.....	1
117	H12	bar knob.....	2 ✓	148	J3	banana jack.....	1 ✓	174	R27	1K ohm pot cal....	1 ✓
118	H13	round knob.....	2 ✓	149	M1	meter.....	1 ✓	175	R28	1K ohm pot adj....	1 ✓
119	H14	3/8" grommet....	1 ✓	150	P1	phone plug.....	1 ✓	174	R29	1K ohm pot cal....	1 ✓
120	H15	1 lug term. strip...	1 ✓	151	P2	pin plug.....	1 ✓	174	R30	1K ohm pot cal....	1 ✓
121	H16	3 lug term. strip...	1 ✓	152	P3	banana plug.....	1 ✓	176	R31	15M ohm res.....	1
122	H17	7/16" nut (S1)....	2	153	R1	10K ohm res. 2W...	1	177	S1	SPST switch.....	1 ✓
123	H18	#6-32 screw.....	4	154	R2	33K ohm res. 2W...	1	178	S2	3 pole, 5 pos. sw...	1 ✓
124	H19	#6-32 nut.....	8	155	R3	20K ohm res.....	1	179	S3	6 pole, 4 pos. sw...	1 ✓
125	H20	#10-24 screw.....	2	156	R4	1.5M ohm res.....	1	180	T1	transformer.....	1 ✓
126	H21	spaghetti.....	pc.	157	R5	2M ohm pot.....	1	181	V1	6H6 tube.....	1 ✓
127	H22	#6 P. K. screw....	7	156	R6	1.5M ohm res....	1	182	V2	6SN7 tube.....	1 ✓
128	H23	meter lug.....	2	158	R7	5M ohm res.....	1	183	V3	6X5 tube.....	1 ✓
129	H24	meter nut.....	2	159	R8	1M ohm res.....	1	184		instruction book...	1 ✓

Notes: 1) All resistors 1/2 watt unless noted differently. 2) WHEN ORDERING A PART FOR REPLACEMENT, please include the stock number of the part and the serial number of your instrument.

The needle should move very little, usually no movement at all. Connect the common and AC test leads to the 115 volt AC line and adjust the AC calibration potentiometer until the scale reads 115 volts. This is usually within 5% and sufficient for service work. If greater accuracy is desired, the instrument should be calibrated against a known AC standard voltage.

To check the ohms scale, set the function switch on ohms and adjust the zero adjust potentiometer with the leads shorted. Unshort the leads and set the needle on the last line past the 1000 mark on the ohms scale with the ohms adjust potentiometer. The ohmmeter is ready for use. If the ohms adjust potentiometer will not bring the needle past the last mark on the scale, try a higher gain 6SN7 or a new battery. If neither of the above will do, put two batteries in series.

To use meter scales: Because of the linearity of AC diode rectification, the same scale is used for both AC and DC reading. The top half of the AC-DC scale is used for 5 volt readings and the lower half for 10 volt readings. To use the 500 volt scale, use the top scale and add two zero's to the reading. Thus read 5 and add two zero's to make it 500. To use the 100 volt scale, use the 10 volt scale and add one zero. To use the 1000 volt scale use the 10 volt scale and add two zero's to the reading.

To use the ohmmeter, read the top scale directly and multiply by the number of zero's (e.g. Rx1, Rx100, etc.) shown on the range switch.

The db meter is calibrated for a 600 ohm load with a reference level of 1.0 multiwatt. To use, set the function switch to AC and the range switch to 5 volts. Read decibels directly on DB scale. To measure higher levels, turn the range switch to a higher setting, read decibels on scale and add to this reading the factor listed below.

10 V Range add -7 6db, 100 V Range add -7 26 db, 500 V add -7 40 db, 1000V add -7 46 db
If you have trouble

1. Check wiring carefully. Most cases of trouble result from wrong or reversed wiring.
2. Check tubes and battery. (See that DC isolation resistor (R1) is in DC Probe).
3. If pointer swings to right on ∇ DC and cannot be brought back, the grid circuit including the range switch may be open.
4. Check voltages on tubes. The 6SN7 plate voltage should be about 85 volts and the cathode voltage about 3.5 volts.
5. Check DC probe carefully to make sure shielding is not shorting the wire. Check jacks for shorting to ground
6. If you are unable to obtain satisfactory results, write the engineering department, giving all information possible, voltages obtained, any indications on meter, etc., which will help diagnosing the trouble.
7. If desired, your instrument may be returned to the factory. It will be put in operating condition for a charge of \$4.00 plus any parts or alterations required due to damaged or improper construction. Pack well and mark fragile. Ship prepaid. Instrument will be returned as soon as possible.

The assembly of the vacuum tube voltmeter is not difficult, and if care is used, no trouble should be encountered. First unpack all the parts, checking them against the parts list, identifying each one to make sure no parts are thrown away with the packing. Standard manufacturers values may be interchangeable etc. We are forced to order from several sources in order to assure the supply of these kits. You may therefore find that a value may vary within the permissible circuit tolerance, e.g., a resistance of 470,000 may be substituted or may measure 510,000 etc. All parts supplied will work just as well as the part for which it is substituted. Most parts have a tolerance rating of 20% and the circuit is designed to take these variations into account.

The tools needed for the work are a cleaned and tinned soldering iron, screwdrivers, pliers, and side cutters. Use a good grade of rosin cored solder. Do not use acid core solder or flux. When making connections, wrap the wire securely around the joint and then solder, making sure solder flows into the joint.

Before starting the actual construction, study the schematic and pictorial wiring diagrams thoroughly, getting all the steps clear in your mind. Do not rush the assembly. Care will pay dividends. When this kit is completed, it will represent a fine piece of laboratory test equipment. Most troubles in building kits can be traced to wrong connections or reversed parts and poor soldering.

Mount the parts of the chassis first, using lock washers under all potentiometers. The calibration potentiometers have screwdriver slots in the shafts, while the adjust potentiometers going on the panel do not. Mount the transformer on the top of the chassis after mounting terminal strip 58. Wire as shown. Be sure to solder grounding lug #75 to center arm of potentiometer 52.

Now assemble the function and range switches. Many troubles encountered in the assembly have occurred in wiring these switches. Some difficulties are the result of poor soldering connections. Use care to prevent rosin from running on to the contacts as this will result in erratic operation. Trace out the wiring with a colored pencil to make sure you have left out no connections. When mounting the ground lug on the function switch, make sure it does not touch the wafer terminals. Matched (or single) 1% Precision resistors are supplied in the VTVM for all multipliers. These will be found in a paper sleeve with the value indicated on the sleeve. Do not separate these resistors. They are to be soldered together either in series (parts #32 to 35 and 37 to 40) or parallel (part #36) as per assembly print #2. All paired resistors are matched to within 1% accuracy and care should be taken not to over heat them. Carbofilm single 1% resistors may be used instead of the matched pairs and are equally good. Use each carbofilm resistor instead of a pair. After building the switches, they should be carefully cleaned with generous amounts of carbon tetrachloride.

Mount the panel as shown on assembly print 3. Tighten the banana jack well, as it is a ground connection. Mount the panel flush to the chassis by fastening it with the nuts. Put flat washers under the nuts to keep from marring the panel. Wire the unit as shown in assembly print 4. Watch the polarity of the electrolytic condenser. When the instrument is completed, the wiring should be carefully checked. In this way, any connections overlooked or incorrect, will be disclosed.

Plug the line cord into 110 volt 60 cycle AC current. Set selector switch to \pm DC volts, and turn instrument on. To insure maximum accuracy, the tubes should be aged. Preliminary calibration can be made after a warm up period of approximately 30 minutes. However, final calibration should be made after aging the tubes. This can be done by leaving the instrument on for 48 hours or by using it for several weeks. After final calibration is made against known accurate voltages (described below), apply glue to the base of the calibration potentiometer to prevent jarring them out of place. The instrument should then not vary from calibration unless tubes are changed.

In switching ranges, a change in the zero setting of the meter pointer will be observed. A small amount of this (not more than two fractional divisions on the voltage scales) is normal and will decrease as the tubes are aged. Some 6SN7 and 6H6 tubes however, are sufficiently unbalanced to cause a great deal more change. If possible, these should be exchanged for other tubes locally, as they are entirely satisfactory for radio use, but not for VTVM use. These tubes should not be returned, as they are guaranteed only as good for radio use.

Before turning the instrument on to calibrate, set meter needle to zero with the set screw on bakelite meter case. In this way, the needle will stay on zero when switching from plus to minus DC. Be sure (R1) isolation resistor is in DC (red) probe.

To calibrate DC, use two flashlight cells in series. This adds up to a total of 3.10 volts when fresh. Put the function switch on \pm DC and the range switch on 5v. Short the DC lead to ground and adjust zero control until meter reads exactly zero (ignore any change after test leads are disconnected). Put batteries between the ground clip and DC test lead with the ground clip touching the positive side of the battery. Adjust the \pm DC calibration potentiometer to read 3.10 volts on the 5 volt scale. To calibrate the \pm DC, repeat the above steps with the function on \pm DC and the battery positive touching the DC lead. Adjust the \pm DC potentiometer. The electrostatic pick up which appears when the AC or DC lead is held or touched is normal in sensitive VTVM, and is due to the extreme sensitivity of the instrument. When the lead is grounded, and zero adjusted, the actual zero will remain correct for meter readings. No error is introduced because of this pick up.

To calibrate AC, set function switch to AC and range switch to 1000 volts. Short AC test lead to ground or to common test lead. Set meter needle on zero with zero adjust knob. Turn range switch to 5 volt position. Turn the AC zero shift balance potentiometer until the needle returns to zero. Turn the range switch to 500 volts.

PARTS LIST

- | | |
|--|---|
| 1. Panel.....1 | 40. 9.5 meg ohm 1% matched pair.....1 |
| *2. Chassis assembly.....1 | 41. 15 meg ohm BTS resistor..1 |
| 3. Meter.....1 | 42. 11 meg or 12 megohm resistor.....1 |
| 4. Range switch.....1 | 43. 5 megohm resistor.....1 |
| 5. Function switch.....1 | 44. 1.5 megohm resistor.....2 |
| 6. Cabinet.....1 | 45. 1 megohm resistor.....1 |
| 7. Handle.....1 | 46. 510,000 ohm resistor.....2 |
| 8. Pilot light assembly.....1 | 47. 33,000 ohm 2w resistor...1 |
| 9. SPST toggle switch.....1 | 48. 10,000 ohm 2w resistor...1 |
| 10. Pilot light.....1 | 49. 20,000 ohm resistor.....1 |
| 11. Phone jack.....1 | 50. 1,000 ohm resistor.....2 |
| 12. Banana jack.....1 | 51. 1,000 ohm pot screwdriver shaft (calibrate).....3 |
| 13. Pin jack.....1 | 52. 1,000 ohm pot (adjust)...2 |
| 14. Banana plug.....1 | 53. 2 meg pot.....1 |
| 15. Phone plug.....1 | 54. .002 condenser.....1 |
| 16. Phone tip.....1 | 55. .01 condensers.....2 |
| 17. Test prod (black).....1 | 56. 2mfd. 250v condenser.....1 |
| 18. Test prod (red).....1 | 57. 4.7 megohm resistor.....1 |
| 19. Alligator clip.....1 | 58. 3 lug terminal strip....1 |
| 20. 1 lug terminal strip....1 | 59. standoff 1/4" for handle...2 |
| *21. Wafer sockets.....3 | 60. 6/32-1/4 screws.....6 |
| 22. Transformer.....1 | 61. 6/32 nuts.....4 |
| 23. 6X5 tube.....1 | 62. 10/24-3/8 button head screw.....2 |
| 24. 6SN7 tube.....1 | 63. 10/24 nuts.....2 |
| 25. 6H6 tube.....1 | 64. #6-1/4" "A" PK screws....7 |
| 26. Rubber grommet.....1 | 65. Meter lugs.....2 |
| 27. Battery bracket.....1 | *66. Ground lugs.....5 |
| 28. 1.5v battery.....1 | 67. Lock washers, small #6...5 |
| 29. Bar knobs.....2 | 68. Fibre washers.....2 |
| 30. Round knobs.....2 | 69. Roll wire.....1 |
| 31. Line cord.....1 | 70. 3/8" lock washer, lge....8 |
| 32. 5 meg 1% resistor matched pair.....1 | 71. 3/8" flat washer , panel.....4 |
| 33. 4.5 meg ohm 1% matched pair.....1 | 72. 10/32 nut brass (meter)..2 |
| 34. 400,000 ohm 1% matched pair.....1 | 73. 3/8 nuts.....10 |
| 35. 50,000 ohm 1% matched pair.....2 | 74. Brass washers (meter)....4 |
| 36. 9.5 ohm 1% matched pr....1 | 75. Control grounding lug....1 |
| 37. 95 ohm 1% matched pr....1 | 76. AC & common test lead wire 48" strip.....2 |
| 38. 9,500 ohm 1% matched pr..1 | 77. Shielded wire 48" (DC test lead).....1 |
| 39. 95,000 ohm 1% matched pair.....1 | 78. Instruction book.....1 |

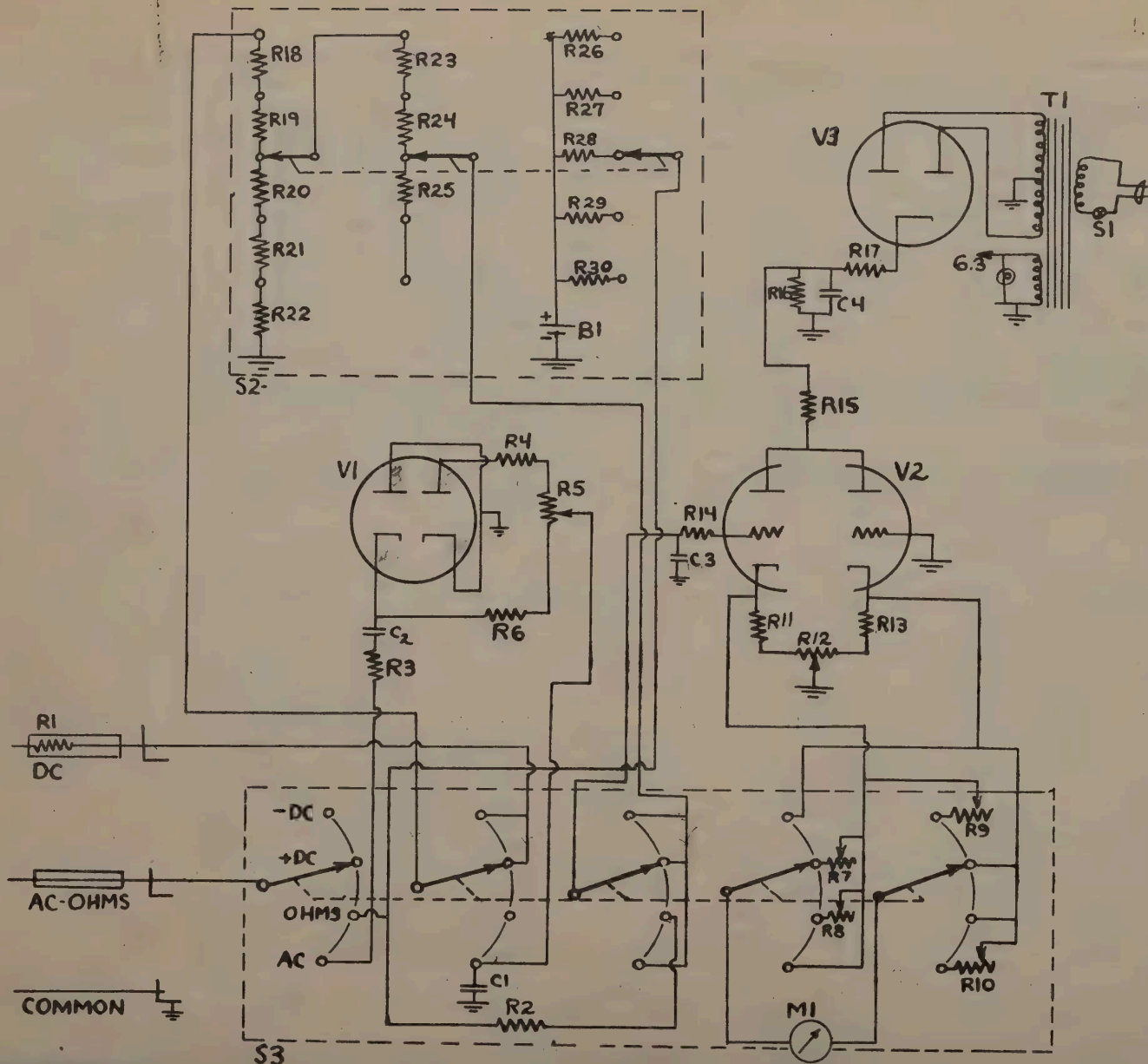

ITEM	PART	SPECIFICATION
R1	41	15 MEG. RES.
R2	42	12 MEG. RES.
R3	46	500,000 Ω
R4	44	1.5 MEGOHM
R5	53	2 MEG AC ZERO POT
R6	44	1.5 MEGOHM
R7	51	1K +DC. CAL. POT
R8	52	1K OHMS ADJ. POT
R9	51	1K -DC CAL. POT
R10	51	1K AC CAL. POT
R11	50	1,000 Ω BTS
R12	52	1K ZEROADJ. POT
R13	50	1,000 Ω BTS
R14	45	1 MEG Ω BTS
R15	49	20,000 Ω
R16	47	33,000 Ω 2W
R17	48	10,000 Ω 2W
R18	32	5MEG Ω 1%
R19	33	4.5 MEG Ω 1%
R20	34	400,000 Ω 1%
R21	35	50,000 Ω 1%
R22	35	50,000 Ω 1%
R23	43	5MEG Ω BTS
R24	57	4.7 MEG Ω BTS
R25	46	500,000 Ω BTS
R26	36	5.5 Ω 1%
R27	37	95 Ω 1%
R28	38	9500 Ω 1%
R29	39	95,000 Ω 1%
R30	40	9.5 MEG Ω 1%
C1	55	.01 CONDENSER
C2	55	.01 COND.
C3	54	.002 COND.
C4	56	2MFD COND.
V1	25	6H6 TUBE
V2	24	6SN7 TUBE
V3	23	6X5 TUBE
T1	22	TRANSFORMER
M1	3	0-1 MA. METER
B1	28	1.5 VOLT BATTERY
S1	9	ON-OFF SWITCH
S2	4	RANGE SWITCH
S3	5	FUNCTION SWITCH

MODEL 221-CIRCUIT DIAGRAM

11-48
REV.1



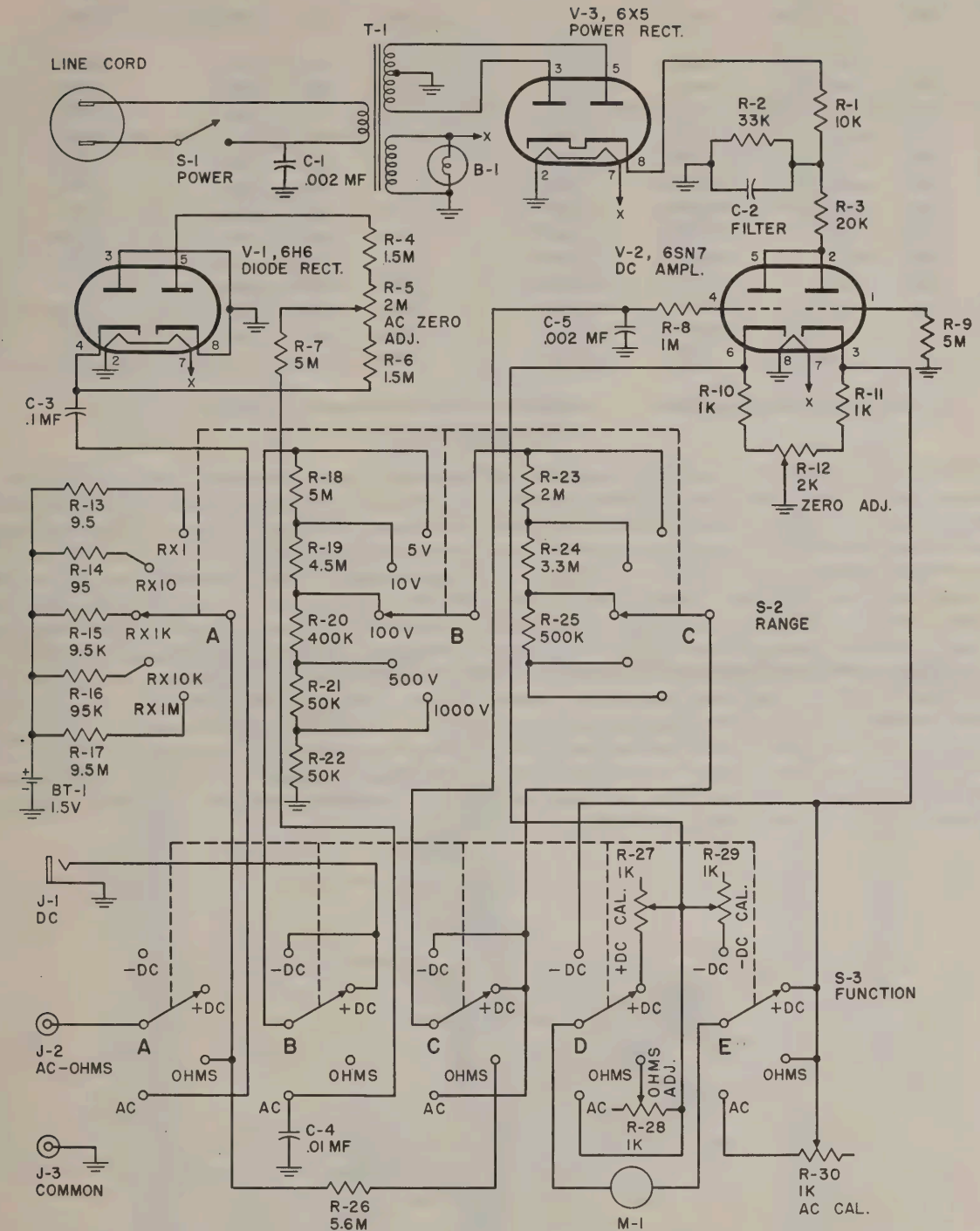

DC TEST LEAD

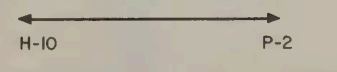

AC TEST LEAD



COMMON TEST LEAD

FINAL MOUNTING AND WIRING

✓ Step#	Sym.	Description	From	To	✓ Step#	Sym.	Description	From	To
7-1	T1	power xfmr.	black	(S) S1#1	7-14	H33	wire	*S3#1B	(S) J1
7-2	H6	line cord	lead	(S) S1#2	7-15	H33	wire	*S3#RA	(S) J2
7-3	**Mount	switch S3 with 1#H30, 1#H31, 1#H32			7-16	H33	wire	*S3#RE	(S) M1#1
7-4	H33	wire	*S3#3E	(S) R30#2	7-17	**Mount	switch S2 with 1#H30, 1#H31, 1#H32		
7-5	H33	wire	*S3#4E	(S) R30#1	7-18	H33	wire	*S3#2C	(S) S2#RC
7-6	H33	wire	*S3#4X	(S) V2#4	7-19	H33	wire	*S3#RD	(S) M1#2
7-7	H33	wire	*S3#4D	(S) R27#2	7-20	H33	wire	*S3#3A	(S) S2#RA
7-8	H33	wire	*S3#2D	(S) R27#1	7-21	H33	wire	*S3#RB	(S) S2#1B
7-9	H33	wire	*S3#3D	(S) R28#2	7-22	H33	wire	*H15#1	(S) BT1#1
7-10	H33	wire	*S3#1E	(S) R29#1	7-23	H33	wire	*H15#2	(S) BT1#2
7-11	H33	wire	*S3#2X	(S) R5#2	7-24	H37	bare wire	(S) H5#2	(S) H5#3
7-12	C3	.1 mfd cond.	*S3#3X	(S) V1#4	7-25	H33	wire	*V3#7	(S) H5#1
7-13	R11	1K ohm res.	*S3#1D	(S) R12#1	7-26	Knob Placement - Instructions on Ass'y. Print 5			

*Connection soldered previously. **Mount to panel as shown on Ass'y. Print 5.

FINAL STEPS

You have now completed the mechanical assembly and the wiring of your instrument. Insert the tubes and the pilot light as shown in the figure below. Check the wiring carefully for errors or omissions. If you have an ohmmeter, measure the resistance from V3, pin 8 to ground (before connecting the instrument to the power line). If it is less than 40,000 ohms, check the rectifier circuit. Insert the plug on the line cord into the 115 VAC power supply and turn the instrument on. If you have a voltmeter, check to see if you have the following voltages to ground (within 20%): V2, pins 2 & 5 — 90v; V2, pin 3 — 3 to 4v; V2, pin 6 — 3 to 4v. If these voltages are not present, check the wiring and components in the circuits involved. Whether you have made the voltage and resistance checks or not, proceed with these remaining steps. Check to see that rotation of the "ZERO ADJ." potentiometer results in movement of the meter pointer. Set the FUNCTION switch at "OHMS" and observe whether the meter pointer swings to the right as it should. Check to see whether the "OHMS ADJ." potentiometer can adjust the meter pointer to full-scale deflection.

After you have made these checks, proceed with the calibration. The calibration procedure is described completely in the MAINTENANCE section of the Instruction Book. After calibration, mount the battery bracket, H8, on the cabinet with 2#H18, 2#H19, and 2#H36 as shown in the figure below. Then mount the handle, H4, on the cabinet with 2#H20, 2#H28, and 2#H29 as shown in the detail sketch. Insert the battery in bracket H4, and slide the chassis into the cabinet, securing it with 7#H22 as shown in the figure below.

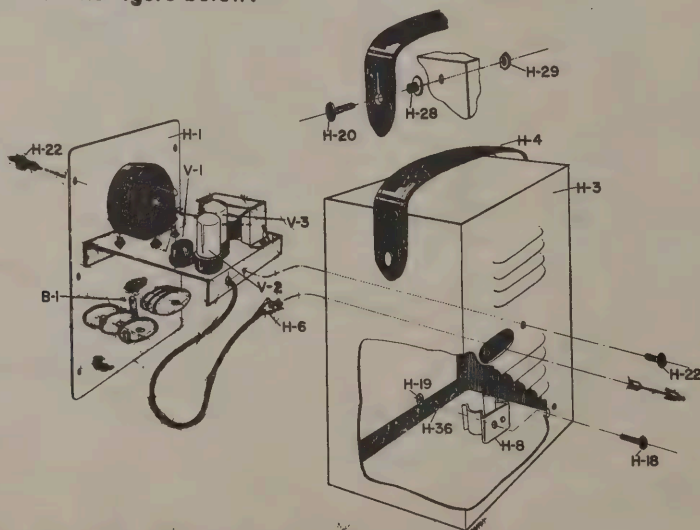

If the instrument fails to operate properly, make certain that the wiring and the components in the circuit are correct. Almost all troubles reported to us in the past, have had improper wiring as their cause. If the wiring is correct, test for continuity and check individual components for breakdown. If you are still having difficulty, write to our engineering department (Electronic Instrument Co., Inc., 84 Withers Street, Brooklyn 11, New York) listing all indications which might be helpful. The serial number of your instrument should be included in any correspondence. If desired, you may return the instrument to our factory, where it will be placed in operating condition and calibrated for \$4.00 plus the cost of parts replaced due to their being damaged in the construction of the instrument. Pack the unit very carefully; in the original shipping carton, if possible. Send it to the above address, prepaid Railway Express. The instrument will be returned as soon as possible. express collect.

DC TEST LEAD



Strip ends of shielded wire, H35, as shown. Solder one end of inner conductor to 15M ohm resistor, R31. Be sure that shielding is well separated from exposed inner conductor. Unscrew ring nut from tip of test prod, H9. Slide cable through prod, resistor first, until resistor lead protrudes from small hole in prod tip. Wind protruding lead once around tip and secure with ring nut. Unscrew cover from phone plug, P1, and slide other end of the shielded wire through it. Solder inner conductor to short terminal lug of P1. Insert exposed shielding in clamp at the end of the long terminal. Crimp it so that the cable is held securely. Solder shielding to clamp. Make sure that shielding is well separated from exposed end of inner conductor. Slide cover to end of plug and screw tight.

AC TEST LEAD



Strip ends of test lead wire, H34. Remove ring nut from black test prod, H10. Slide wire through prod until one stripped end protrudes from small hole in prod tip. Wind exposed wire around prod tip and secure with ring nut. Unscrew cover from pin plug, P2, and slide other end of wire through it. Solder end of wire to terminal on pin plug. Slide cover to end of plug and screw tight.

COMMON TEST LEAD

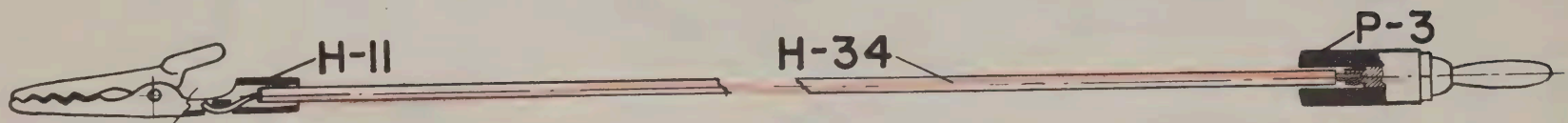

Strip ends of test lead wire, H34. Solder one end to alligator clip, H11. Unscrew cover from banana plug, P3, and slide other end of wire through it. Solder end of wire to terminal on banana plug. Slide cover to end of plug and screw tight.

OK Steve

ASSEMBLY PRINT 7

Model 221

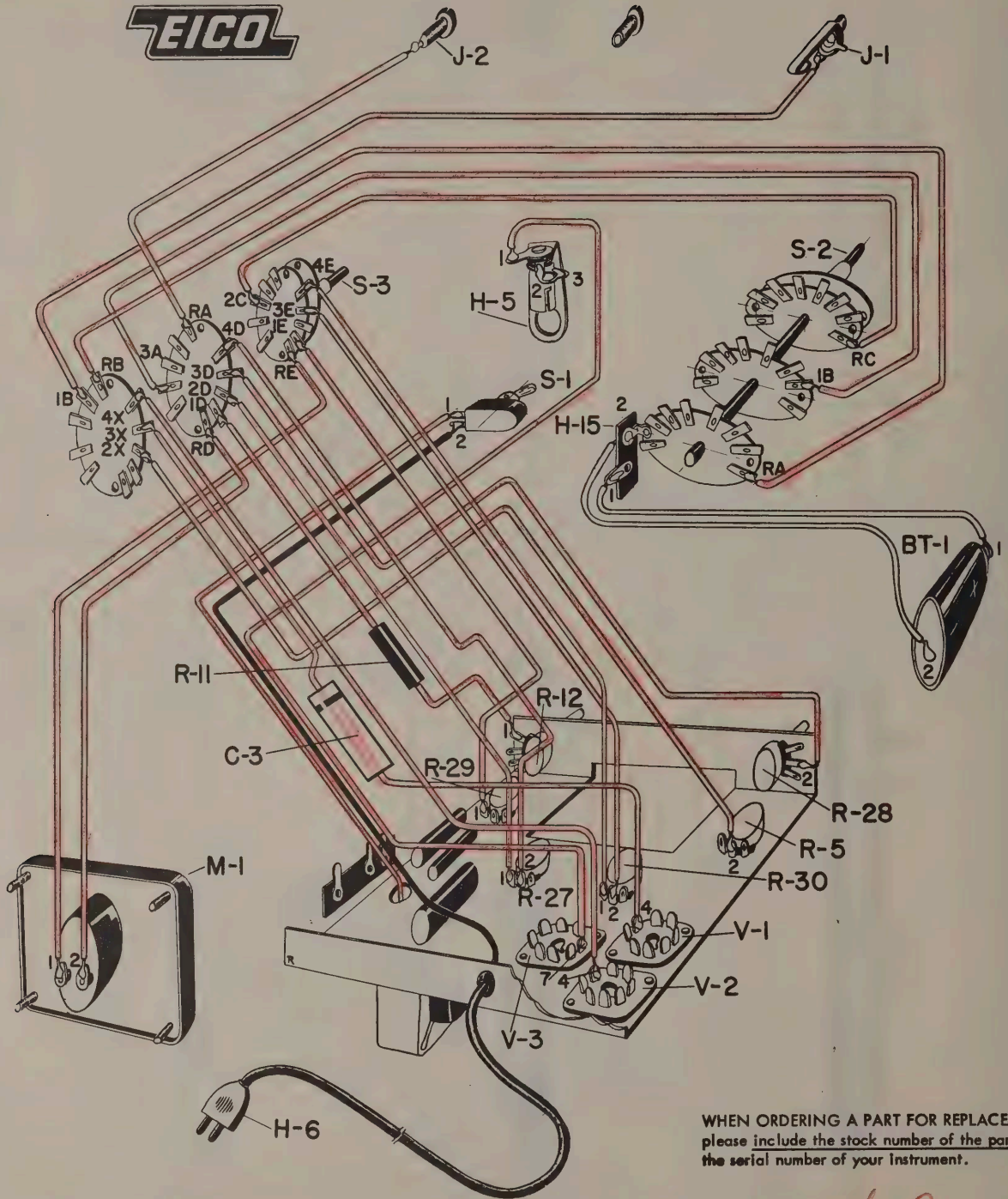

WHEN ORDERING A PART FOR REPLACEMENT,
please include the stock number of the part and
the serial number of your instrument.

OK Steve

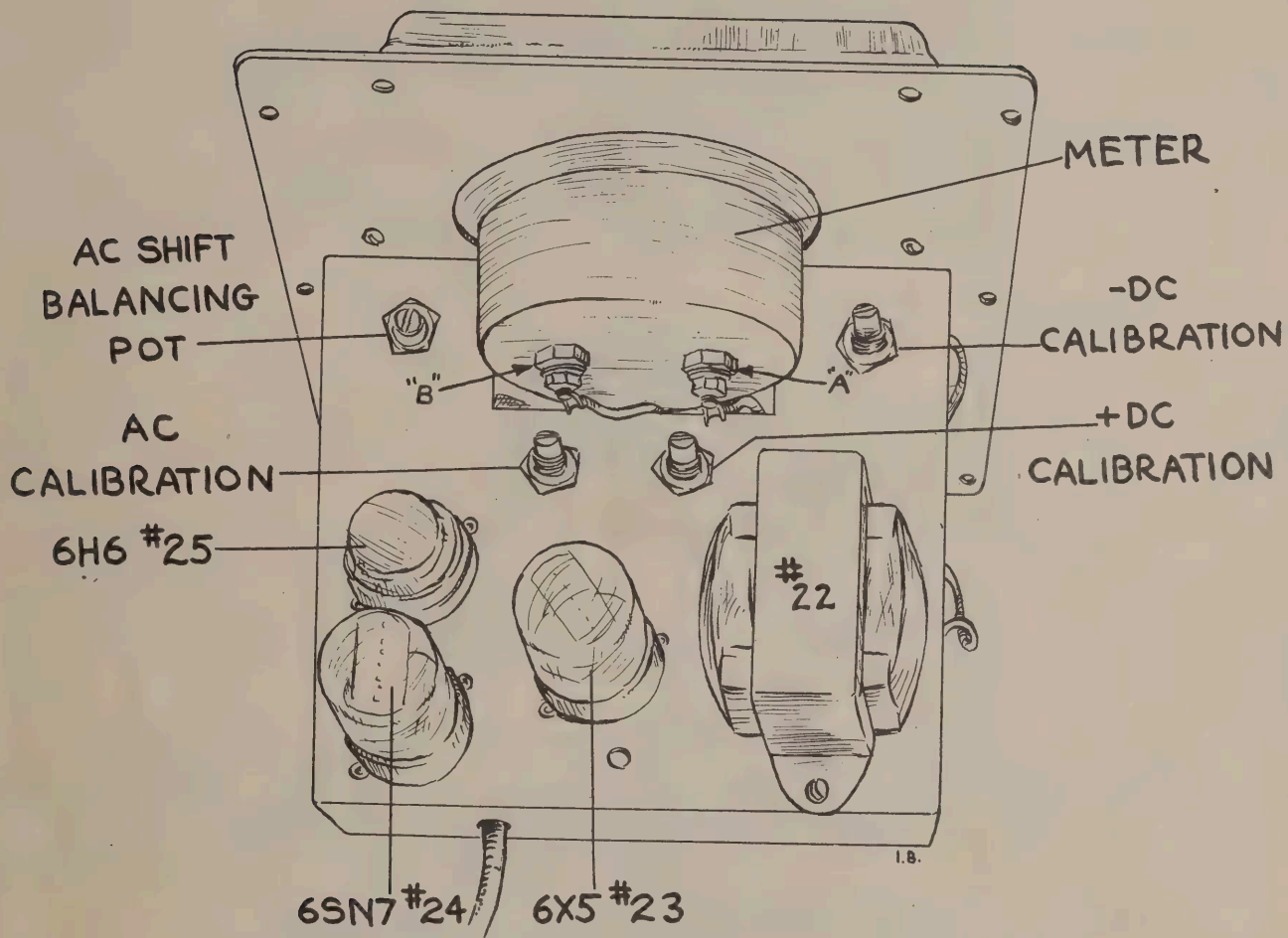

TOP VIEW
ASSEMBLY PRINT #6

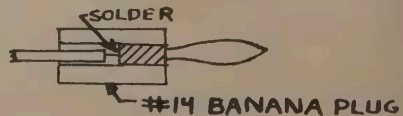
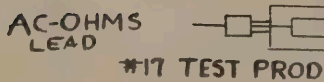
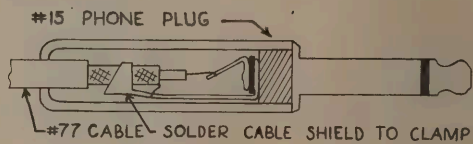
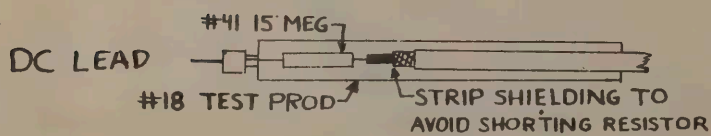
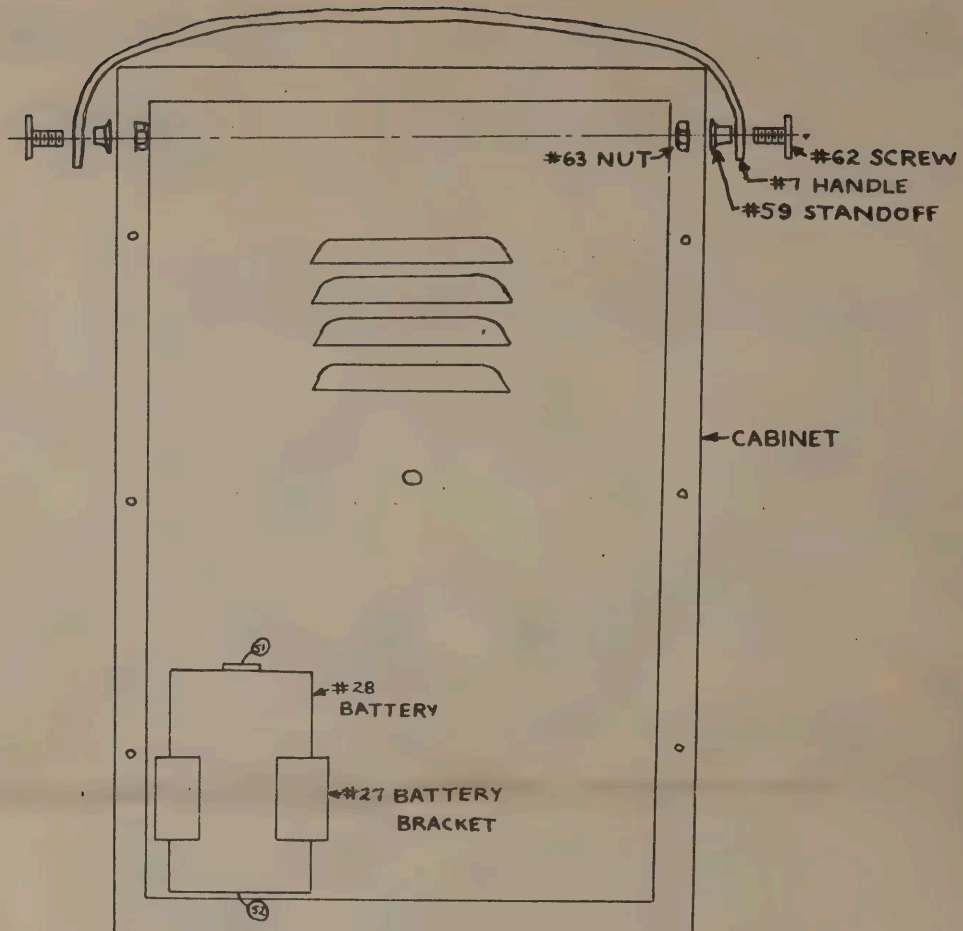

ASSEMBLY PRINT #5

WHEN ORDERING A PART FOR REPLACEMENT,
please include the stock number of the part and
the serial number of your instrument.

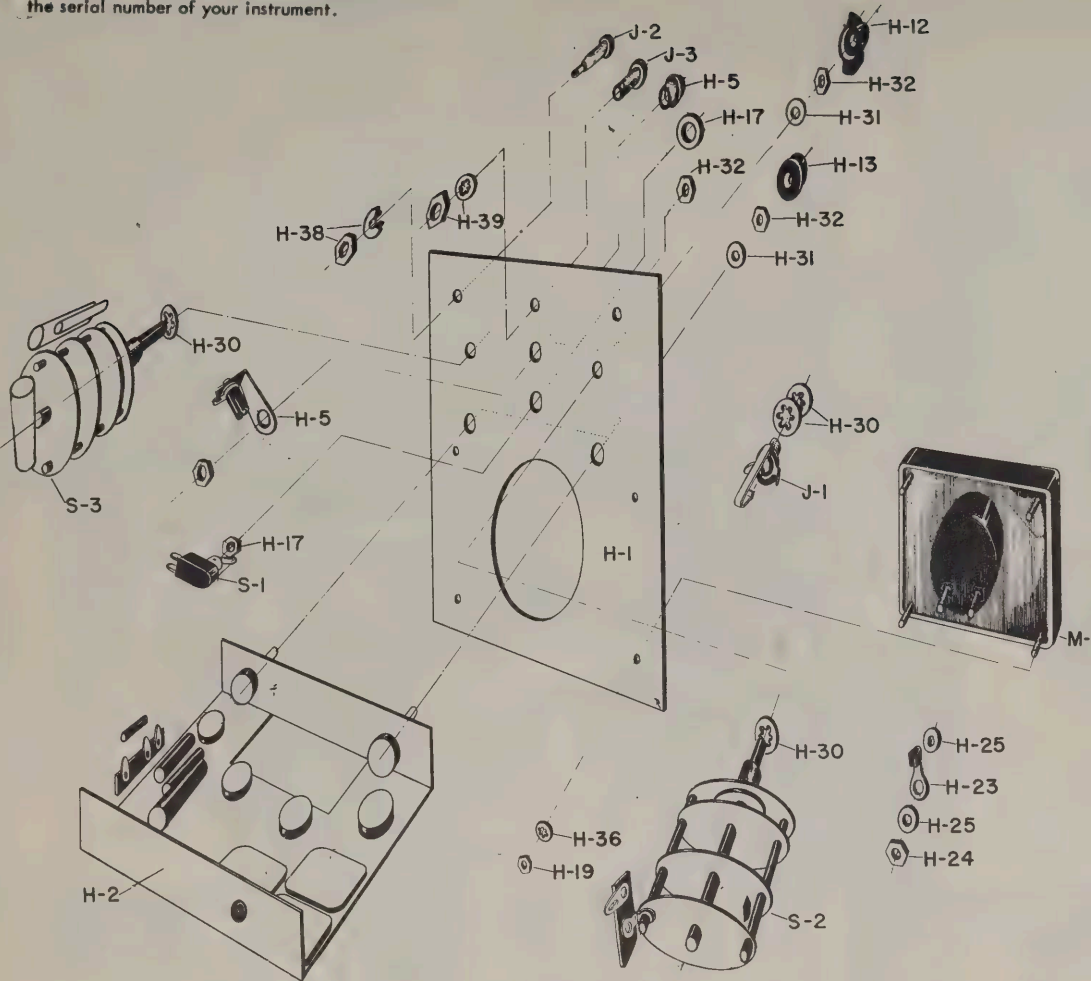

MOUNTING ON PANEL*

✓ Step#	Sym.	Description	Mounted With
5-1	H5	pilot light	associated hdwre.
5-2	J2	pin jack	1#H38 nut & shldr. washer
5-3	J3	banana jack	1#H39 nut & lock washer
5-4	S1	SPST toggle switch	2#H17
5-5	J1	phone jack	2#H30, 1#H32
5-6	M1	meter movement	4#H36, 4#H19
5-7	H23	meter lugs	4#H25, 2#H24
5-8	H2	chassis	2#H31, 2#H32**

*For convenience in wiring, switches S2 and S3 are mounted later.

**3/8 hex nuts previously mounted - remove temporarily and replace after the pot shafts are through the panel.

KNOB PLACEMENT - STEP #7-26

(To be done after switches S2 and S3 have been mounted as part of "FINAL MOUNTING AND WIRING", the table accompanying Assembly Print 7).

Place the small round knobs (H13) on the shafts of the OHMS ADJ. and ZERO ADJ. potentiometers respectively, and tighten the set screws.

Place the bar knobs (H12) on the shafts of the FUNCTION switch, S3, and the RANGE switch, S2, and tighten the set screws. Rotate the switches counter-clockwise as far as they will go. Loosen the set screws, and line up the FUNCTION switch and RANGE switch knobs with the markers for the "-DC VOLTS" and "5V, RX1" positions respectively. Tighten the set screws. The knobs now indicate properly.

OK checked



CHASSIS WIRING

(S) means solder, (C) means connect but do not solder.

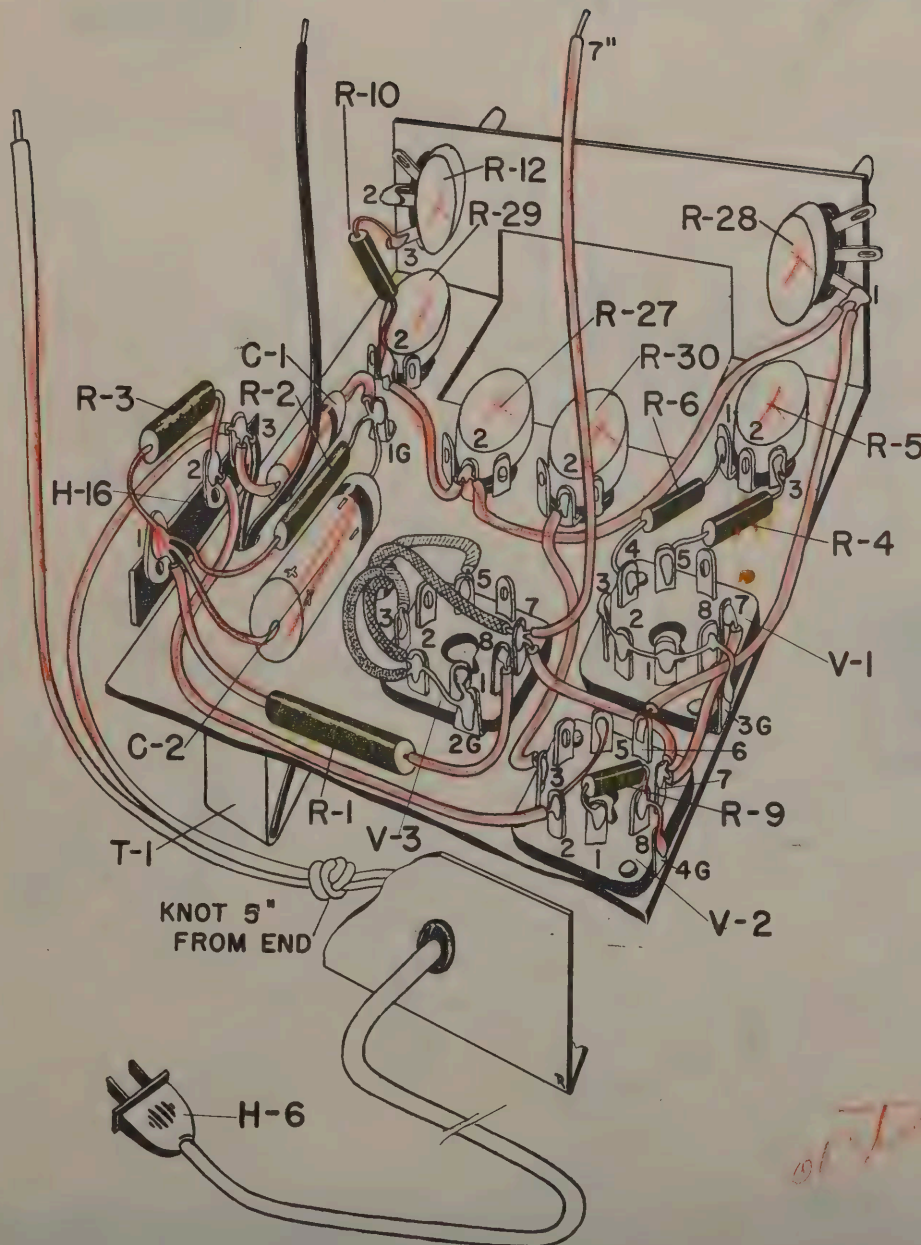

✓ Step#	Sym.	Description	From	To (Length)
✓ 4-1	H33	wire	(C) H16#2	(C) V2#2
✓ 4-2	H37	*bare wire	(S) V2#2	(S) V2#5
✓ 4-3	T1	red wire	T1	(S) V3#3
✓ 4-4	T1	red wire	T1	(S) V3#5
✓ 4-5	T1	red-yellow wire	T1	(C) V3#2
✓ 4-6	T1	yellow wire	T1	(C) V3#2
✓ 4-7	H37	bare wire	(S) V3#2	(C) 2G
✓ 4-8	H37	bare wire	(S) V3#1	(S) 2G
✓ 4-9	T1	yellow wire	T1	(C) V3#7
✓ 4-10	H33	wire	(C) V3#7	(C) V2#7
✓ 4-11	H33	wire	(S) V3#7	7"
✓ 4-12	H33	wire	(S) V2#7	(S) V1#7
✓ 4-13	H37	bare wire	(S) V1#3	(C) V1#2
✓ 4-14	H37	bare wire	(S) V1#2	(C) V1#1
✓ 4-15	H37	bare wire	(S) V1#1	(C) V1#8
✓ 4-16	H37	bare wire	(S) V1#8	(S) 3G
✓ 4-17	R4	1.5M ohm res.	(S) V1#5	(S) R5#3
✓ 4-18	R6	1.5M ohm res.	(S) R5#1	(C) V1#4
✓ 4-19	H33	wire	(S) V2#6	(C) R28#1
✓ 4-20	H33	wire	(S) R28#1	(C) R27#2
✓ 4-21	H33	wire	(S) V2#3	(C) R30#2
✓ 4-22	R10	*1K ohm res.	(S) R12#3	(C) R29#2
✓ 4-23	H33	wire	(S) R29#2	(C) R27#2
✓ 4-24	R9	5M ohm res.	(S) V2#1	(C) V2#8
✓ 4-25	H37	bare wire	(S) V2#8	(S) 4G
✓ 4-26	R3	20K ohm res.	(S) H16#2	(C) H16#1
✓ 4-27	R1	*10K ohm res.	(S) V3#8	(C) H16#1
✓ 4-28	T1	black wire	T1	(C) H16#3
✓ 4-29	C1	.002 mfd cond.	(C) H16#3	(C) 1G
✓ 4-30	R2	*33K ohm res.	(C) H16#1	(C) 1G
✓ 4-31	C2	*filter cond.	(S) H16#1	(S) 1G
✓ 4-32	H6	line cord (1 lead)		(S) H16#3
✓ 4-33	H27	pot grounding lug		(S) R12#2

*With spaghetti

EICO

ASSEMBLY PRINT 4 Model 221

New! 7 INCH PUSH-PULL OSCILLOSCOPE

Only **EICO** Has All These Features:

- VERTICAL FREQ. RESPONSE: flat ± 2 db 10 cps - 1 mc
- VERTICAL SENS.: .01 volts rms/inch
- HOR. FREQ. RESP.: flat ± 0 db 10 cps - 200 kc, -4 db at 500 kc
- HOR. SENS.: .3 volts rms/inch
- SWEEP RANGE: 15 cps-100 kc
- 3-STEP FREQ.-COMPENSATED ATTENUATOR eliminates freq. distortion, overloading.
- CATHODE FOLLOWER inputs to both amplifiers
- PUSH-PULL outputs in both amplifiers
- RETURN TRACE BLANKING
- INT. VOLTAGE CALIBRATOR
- V & H TRACE EXPANSION & CENTERING: 1.5X full screen without distortion.
- DIRECT CONNECTION to vert. CRT plates.
- PHASING CONTROL of internal 60 cps sine wave sweep.
- AT FRONT PANEL: intensity mod. input; 60 cps, sawtooth outputs.

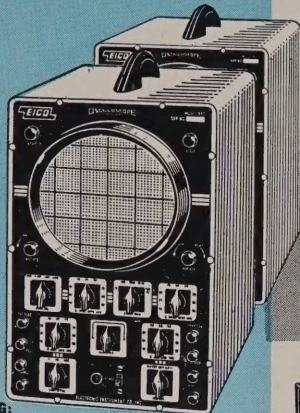

MODEL 470K
KIT \$79.95. WIRED \$129.50.

Also Available:
425K 5" PUSH-PULL SCOPE KIT \$44.95. WIRED \$79.95.

- AC & DC volts: 0-5, 10, 100, 500, 1000 V (30 KV with HVP-1 probe).
- 5 ohm ranges from .2 ohm to 1000 megohms.
- DC input Z 26 megohms.
- 4 1/2" meter movement in can't-burn-out circuit.
- 1% mult. resistors.

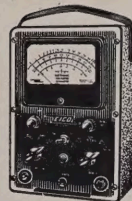

221K VTVM KIT \$25.95. WIRED \$49.95.

- HIGH VOLTAGE PROBE \$6.95
- Extends range of VTVMs & voltmeters to 30 KV.



- PIX TUBE ADAPTER for Tube Testers \$4.50.
- Checks TV picture tubes while in set.



625K TUBE TESTER KIT \$34.95. WIRED \$49.95.

- Illum. gear-driven "Speed Rollchart."
- New lever-action switches for individual testing of every element.
- Tests all conventional & TV tubes.

- Covers all TV & FM freqs. between 500 kc & 228 mc in continuous sweep.
- Sweep width variable 0-30 mc.
- Crystal marker oscillator, variable amplitude.

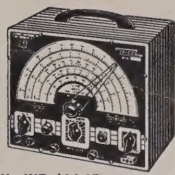

360K SWEEP GEN. KIT \$34.95. WIRED \$49.95.



214K VTVM KIT \$34.95. WIRED \$54.95.

- Large 7 1/2" meter, can't-burn-out circuit.
- AC/DC volts: 0-5, 10, 200, 500, 1000 (30 KV with HV Probe).
- 5 ohm ranges from .2 ohm to 1000 megohms.
- DC input Z 26 megohms.
- 1% mult. resistors.

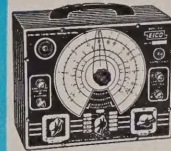

950A-K R-C BRIDGE & R-C-L COMP. KIT \$19.95. WIRED \$29.95.

- Measures & tests all resistors; 5 ohm to 500 megohms.
- Every type condenser, 10 mmf to 5000 mfd.
- 0-500 DC voltage source for capacitor leakage testing.

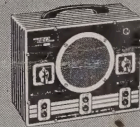

145K SIG. TRACER KIT \$19.95. WIRED \$28.95.

- Audibly signal traces all IF, RF, Video & Audio circuits from ANT to SPKR or CRT in all TV, FM, AM, etc. without switching.
- Germanium crystal diode probe responsive to over 200 mc.
- Integral test speaker.



320K SIG. GEN. KIT \$19.95. WIRED \$29.95.

- Fundamentals 150 kc to 34 mc, harmonics to 102 mc.
- 5-step band switching.
- Colpitts audio oscillator generates 400 cps pure sine wave voltage.
- Permits pure RF, modulated RF, or pure AF.



536K MULTIMETER KIT \$12.90. WIRED \$14.90.

- 1000 Ω /V; 31 ranges
- DC/AC volts: Zero to 1, 5, 10, 50, 100, 500, 5000.
- DC/AC Current: 0-1, 10 ma; 0.1, 1 A.
- Ohms: 0-500, 100 K, 1 meg.

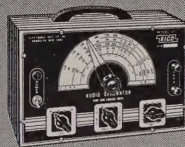

377K SINE & SQUARE WAVE AUDIO GEN. KIT \$31.95. WIRED \$49.95.

- Complete sine wave coverage, 20-200,000 cps in 4 direct-reading ranges.
- Complete square wave coverage, 60-50,000 cps.
- Cathode follower output circuit.



1717K RES. DECADE BOX KIT \$19.95. WIRED \$24.95.

- Resistance values from 0 to 99,999 ohms with 0.5% precision.
- All resistors have 0.5% accuracy.



565K MULTIMETER KIT \$24.95. WIRED \$29.95.

- 20,000 Ω /V; 31 ranges.
- DC/AC/Output volts: 0-2.5, 10, 50, 250, 1000, 5000.
- DC Current: 0-100 ua; 10, 100, 500 ma; 10 A.
- Ohms: 0-2K, 200K, 20 meg.



- Covers range of 75 kc to 150 mc.
 - 7 calibrated scales; accuracy better than 1%.
 - Bandsread vernier tuning.
 - 4-step RF shielded output multiplier; constant output Z.
- 315K DELUXE SIG. GEN. KIT \$39.95. WIRED \$59.95.

NOW! ONLY EICO

the largest manufacturer of its kind in the world - gives you LIFETIME SERVICE & CALIBRATION GUARANTEE*

...the Industry's greatest protection for your test equipment investment!

- * at less than our cost of handling (see the EICO Guarantee Card enclosed with each Kit and Instrument).

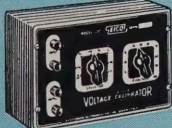

NEW!
SCOPE VOLTAGE CALIBRATOR KIT 495K KIT \$12.95. WIRED \$17.95.

- Sq. wave output at power-line freq. with full-scale readings of 1, 1, 10 or 100 V. peak-to-peak.
- Accuracy $\pm 5\%$ of full-scale on each range.

NEW!
6V & 12V BATTERY ELIMINATOR KIT 1050K KIT \$29.95. WIRED \$38.95.

- DC output: 0-8 V or 0-16 V.
- Continuous current rating: 10 A at 6 V, 6 A at 12 V.
- Intermittent current rating: 20 A at 6 V, 12 A at 12 V.
- Separate Voltmeter & Ammeter.



NEW!
DECADE CONDENSER BOX KIT 1180K KIT \$14.95. WIRED \$19.95.

- All capacitors precision silver mica, accuracy $\pm 1\%$.
- Range from 100 mmf - 0.111 mfd in steps of 100 mmf.
- Smooth-action positive detent ceramic switches.

Prices 5% higher on West Coast. Specifications and prices subject to change without notice.

EICO

Write NOW for FREE latest Catalog

You build EICO Kits in one evening, but . . . they last a lifetime!
And you **SAVE OVER 50%**! See the famous EICO line TODAY, in stock at your local jobber.

ELECTRONIC INSTRUMENT CO., Inc., 84 Withers Street, Brooklyn 11, N. Y.