



**MODEL 460  
DC-WIDE BAND  
OSCILLOSCOPE**

**CATHODE-RAY TUBE**

Type .....	5UP1
Accelerating Potential .....	1200 volts (2nd anode with respect to cathode)
Illuminated Scale .....	Engraved, illuminated plexiglass scale over face of tube; dimmer control provided on front panel.
Filter .....	Special green acetate matches screen phosphor.
Bezel .....	Standard 5" CRT bezel fits standard photographic equipment.

**VERTICAL CHANNEL**

Sensitivity (at full gain) .....	25 millivolts rms/inch
Undistorted Deflection .....	greater than 4 inches
Frequency Response (sinusoidal)	
Direct Coupling .....	Flat (+1, -3 db) from DC to 4.5 mc
Capacitive Coupling .....	Flat (+1, -3 db) from 1 cps to 4.5 mc
Transient Response	
Rise Time .....	0.06 microseconds or max.
Overshoot .....	8% or max.
Input voltage (Maximum)	
Unbalanced (either coupling) .....	600 volts (dc plus peak ac)
Balanced .....	1 volt p-p
Input Coupling .....	Capacitive or direct
Attenuation (switch-type) .....	By factors of 1, 10, 100, and 1000 ± 5% as selected by VERT. ATTENUATOR selector; frequency compensated so that there is no visible change in waveshape at any attenuator position.
Input Impedance	
Single-ended (unbalanced) .....	3 megs shunted by 35 mmf
Balanced .....	6 megs shunted by 20 mmf
Positioning .....	± 2 inches; permits centering on screen of any portion of trace expanded vertically to 4" peak-to-peak.

**HORIZONTAL CHANNEL**

Sensitivity .....	0.6 rms volts/inch
Frequency Response .....	Flat (+1, -3 db) 1 cps to 400 kc
Input Impedance .....	Approximately 5 megs shunted by 35 mmf (at 1 kc).
Expansion .....	To 2 times full screen diameter without distortion.
Positioning .....	So any portion of expanded trace may be examined on screen.
Horizontal Inputs .....	Linear time base with choice of synchronization described below, phase-controlled 60 cps input, or external input.

## LINEAR TIME-BASE GENERATOR (RECURRENT)

Frequency Range .....	10 to 100,000 cps sawtooth in 4 ranges plus EXTERNAL CAPACITOR position. Sweep range down to 1 cps may be obtained by connecting appropriate capacitor between EXT. CAP. terminal and ground. Special TV-V and TV-H positions provide 30 cps and 7875 cps sweeps respectively for convenience in tv servicing.
Synchronization .....	"+" internal, "-" internal, 60 cps (phase controlled), or external.

## INTENSITY MODULATION CIRCUIT (Z AXIS)

Input Impedance .....	Approximately 0.1 meg at medium intensity setting.
Sensitivity .....	Approximately 3 volts rms for blanking the beam.
Polarity .....	Beam intensity increased on positive excursion of signal.

## CALIBRATION VOLTAGE

Availability .....	Switched to input of vertical amplifier by setting VERT. ATTENUATOR selector to CAL.
Waveshape .....	Sinusoidal
Frequency .....	60 cps
Amplitude .....	400 millivolts peak-to-peak.
Accuracy .....	±5% factory-adjusted; add accuracy of meter used for initial adjustment in kit instruments.
Useful range .....	With calibrated graph screen and calibrated vertical attenuator provided, permits voltage measurement over range of 100,000 to 1.

## SAWTOOTH OUTPUT

Availability .....	Front-panel terminal
Amplitude .....	15 volts peak-to-peak max. (varies with Hor. Gain control).
Polarity .....	Positive
Frequency .....	Same as linear time-base generator.
Impedance .....	Approximately 300 ohms.

## 60 CPS OUTPUT

Availability .....	Front-panel terminal
Amplitude .....	3 volts rms

## GENERAL

Sync Voltage .....	Amplifier limiter circuit provides automatic control; no sync voltage adjustment required.
Phasing Control .....	Provides fully controlled phase shift for 60 cps sweep application.
Power Supplies .....	One high voltage, one low voltage; both transformer rectifier type with RC filter systems.

TUBE COMPLEMENT ..... 2-6AU8, 2-6CB6, 2-6J6, 1-12AU7, 1-6AX5, 1-1V2,

## PHYSICAL SPECIFICATIONS

Shipping Weight .....	30 lbs.
Overall Dimensions .....	14 3/4" high, 8 1/2" wide, 16 1/2" deep
Cabinet .....	Steel; grey wrinkle finish.
Panel .....	Heavy gauge aluminum; brushed satin finish; deep-etched rub-proof legends.

## FUNCTIONS OF CONTROLS AND TERMINALS

(Numbers — (1), (2), etc. refer to notes on the following page.)

The oscilloscope controls and terminals are easy to use once their functions are understood.

If the controls are divided into specific groups, for purposes of explanation, it will be easier to understand and keep in mind just what these functions are.

The INTENSITY and FOCUS knobs together control the appearance of the trace. The INTENSITY knob controls the brightness of the trace and the FOCUS knob controls the sharpness or definition of the trace on the scope screen. Proper adjustment of these controls should give a trace formed from a thin bright line or an undeflected spot of light that is tiny, round, and bright.<sup>(1)</sup> These controls interact to an extent; that is, adjustment of the FOCUS knob is usually necessary when the setting of the INTENSITY knob is changed.<sup>(2)</sup>

The V-POS (Vertical-Position) and H-POS (Horizontal-Position) knobs control the location of the trace on the screen. Turning the H-POS knob shifts the trace left or right<sup>(3)</sup> and turning the V-POS knob moves the trace up or down.<sup>(4) (5)</sup>

The VERTICAL-ATTENUATOR provides a choice of no attenuation or three decade steps of frequency-compensated attenuation<sup>(6)</sup> of the input voltage fed to the vertical amplifier. Each attenuation is obtainable with either direct coupling provided to the vertical amplifier (positions under the DC arc on the dial) or capacitive coupling to the vertical amplifier (positions under the AC arc on the dial). At either "1" position, the amplitude of the signal voltage is unchanged (no attenuation). At either "10", "100", "1000" position, the amplitude is attenuated by a ratio of 10 : 1, 100 : 1, and 1000 : 1 respectively. At the CALIBRATOR position, a 0.4 volt peak-to-peak sine wave at power line frequency is fed to the vertical amplifier.<sup>(7) (8)</sup>

The VERTICAL GAIN control allows continuous adjustment of the vertical amplifier gain.<sup>(9)</sup> It is used with the VERTICAL ATTENUATOR selector to adjust trace height to the desired value.

The HOR. SELECTOR combines the functions of sync selector for the internal sweep and input selector for the horizontal amplifier. At any of the four most counterclockwise positions (under SYNC-SWEEP arc on dial) the internal linear sweep is fed to the horizontal amplifier. These four positions permit selection of sync voltages for the sweep oscillator. At the "+" and "-" positions, the synchronizing voltage is taken internally from the vertical amplifier. (At "-", sweep trace flyback starts during the negative-going excursion of the voltage applied to the vertical amplifier. At "+", the sweep trace flyback starts during the positive-going excursion of the voltage applied to the vertical amplifier).<sup>(10)</sup> At the "EXT." position, an external synchronizing voltage applied between the H-INPUT/EXT. SYNC. terminal and ground is fed to the

sweep oscillator.<sup>(11)</sup> At the 60CPS position, an ac signal of power line frequency is taken from the power supply and applied to the sweep oscillator to sync it at line frequency. The PHASING control is effective in the "60CPS" SYNC position and permits phase adjustment of the 60 cps sync voltage to shift the starting point of the waveform display to any desired point on the waveform.<sup>(12)</sup>

At either of the two most clockwise positions of the HOR. SELECTOR (under HOR arc on dial), the sweep oscillator is disabled. At the 60CPS HOR. position, an ac signal of power line frequency is taken from the power supply and applied to the input of the horizontal amplifier. The PHASE knob controls the phase shift of the line frequency voltage used for sinusoidal sweep.<sup>(13)</sup> At the EXT. HOR. position, an external signal voltage fed between the H-INPUT/EXT. SYNC. terminal and ground is applied to the input of the horizontal amplifier. The HOR-GAIN control is effective in both the 60CPS HOR. and EXT. HOR. positions.

The SWEEP FREQUENCY band selector selects the frequency band over which the SWEEP VERNIER (fine sweep frequency control) can be varied for frequency adjustment of the internal linear sweep. The numbers on either side of the markers are the upper and lower limits of the band (approximately). The four positions, reading from left to right are 10-100 cps, 100 cps - 1 kc, 1-10 kc, 10-100 kc. The EXT. CAP position is used when it is desired to obtain a linear sweep below 10 cps down to approximately 1 cps. A 0.5 mf external capacitor (rated at least 200 WVDC) must be connected between the EXT. CAP and SAWTOOTH terminals for sweeps down to 1 cps.<sup>(14)</sup>

The V & H positions (under the TV arc on the dial) are designed to eliminate the need for repeated readjustment of the SWEEP VERNIER in tv work. If, with the SWEEP SELECTOR set at the TV-V position, the SWEEP VERNIER is set to display two full cycles of a 60 cps signal to obtain a sweep frequency of 30 cps, turning the SWEEP SELECTOR to TV-H will result in a sweep frequency of 7875 cps without readjustment of the SWEEP VERNIER.<sup>(15)</sup>

The V-INPUT terminals provide for connection of external signals to the vertical amplifier. An external jumper must always be used to short the lower of the two terminals to ground for conventional single-ended input. Remove jumper for balanced input. (No attenuation may be derived from the vertical step attenuator on balanced input because this attenuator affects only input signals fed to the upper of the two V-INPUT terminals.) See NOTES ON CONTROLS & TERMINALS for use of balanced input.<sup>(16)</sup>

An external voltage for purpose of intensity (Z-AXIS) modulation may be applied between the Z-AXIS Binding post and ground. Never apply an intensity modulating signal that is large enough to swing the grid of the cathode ray tube positive, or the life of the tube may be greatly shortened. Positive grid swing is indicated by noticeable defocusing of the trace during the positive phase of the intensity modulating signal.

A test voltage of power line frequency is available between the 60 cps terminal and ground. The amplitude of this voltage varies with load.

A sawtooth voltage from the output of the sweep circuit oscillator is available between the SAWTOOTH terminal and ground. The frequency of the sawtooth is, of course, variable by the SWEEP SELECTOR and SWEEP VERNIER controls. The amplitude is variable by the HOR.-GAIN control.

The AC POWER switch is ganged with a dimmer control for the lamp which edge-lights the plexiglass scale.

## NOTES ON CONTROLS AND TERMINALS

1. Proper trace definition will be obtained only if the astigmatism control is correctly adjusted (See Maintenance) and the scope is not operated in strong fields such as are found near transformers, transmitters, and power generating equipment, etc., which may distort the electron beam that produces the trace.
2. A sharply focused short line or a small spot of high intensity should not be permitted to remain stationary on the screen for any considerable length of time (more than 1/2 minute) or the screen will be burned. A trace of excessively high intensity will burn the screen in 3 to 5 minutes. These burned portions of the screen will no longer fluoresce and are useless for observation. If it is required to have a fixed trace on the screen for a long period, reduce the intensity of the trace to a minimum.
3. A trace can be expanded horizontally to several times full screen width without distortion. This is particularly important in dealing with sweep waveforms. The range of horizontal positioning is several times full screen to permit examination of any part of the expanded trace.
4. A trace can not be expanded vertically beyond full screen width without distortion. Vertical positioning beyond the  $\pm 2$  inches obtainable is therefore not useful, since this range of positioning will permit bringing the top or bottom of any trace expanded vertically to full screen width into the central region of the screen where screen curvature will not cause blurring of these portions of the trace.
5. When the VERT.-ATTENUATOR control is set at one of the positions under the DC (direct-coupled) arc on the dial, the dc component of any signal fed to the vertical amplifier will be amplified along with the ac component of the signal and be reflected on the screen by a proportional vertical movement of the trace. The direction of trace movement depends on the polarity of the dc component. Therefore, when going from observation of a pure ac wave to one containing dc or vice versa, it may be necessary to use the V-POS control to bring the trace back to center screen. The dc component of a signal has no effect at the AC (capacitive-coupled) positions of the VERT.-ATTENUATOR.
6. Trimmer capacitors C2, C3, and C4 are used for compensating the vertical step attenuator at the 1000, 100, and 10 positions respectively. See MAINTENANCE section for procedure.
7. See OPERATION section for use of CALIBRATION position.
8. Potentiometer R6 is used to set the peak-to-peak value of the calibrating voltage to the prescribed value. See MAINTENANCE section for procedure.
9. Potentiometer R16 is the dc balance adjustment. When R16 is adjusted properly, there will be no shifting up or down of the trace on turning the VERT. GAIN control from minimum to maximum with no input signal to the vertical amplifier. See MAINTENANCE section for adjustment procedure.
10. The +(INT.) and -(INT.) positions allow the synchronization of any type of non-sinusoidal waveform.
11. The EXT. sync position is for use with generators or other devices which have sync outputs.
12. The PHASING control action in the "60CPS" SYNC position is useful when observing discriminator "S" curves.
13. The PHASING control action in the "60CPS" HOR. position permits use of sweep generators that do not have phase-controlled 60 cps sinusoidal sweep outputs or dispensing with connections to such outputs when they are available.
14. Large valued capacitors will give lower sweep frequencies (approximately 1 mf for a sweep as low as 0.5 cps). However, good results below a few cps can not be assured.
15. Trimmer C22 must be adjusted initially in kit instruments to display two full cycles of a 15750 cps signal at the TV-H position after the SWEEP VERNIER has been set to display two full cycles of a 60 cps signal at the TV-V positions. See MAINTENANCE section.
16. Use of the balanced input to the vertical amplifier makes it possible to reject considerably any common-mode signal (in-phase signal applied to both inputs) while at the same time passing and amplifying the balanced input signal. In this way, noise pickup in the test leads or in the equipment under test can be greatly reduced. Balanced input is obtained by removing the jumper between the lower of the two V-INPUT terminals and ground, setting the VERT. ATTENUATOR at the "1" position under the DC arc, and feeding the signal to be observed between the two upper V-INPUT terminals. Use of the balanced input is limited by the fact that no step attenuation is possible because there is only one step attenuator in the instrument and therefore only one of the inputs could be attenuated. Therefore, with balanced input, full scope sensitivity is obtained and the maximum amplitude of signal that can be observed without distortion due to overloading is 1 volt p-p.

17. The maximum undistorted output voltage of the vertical amplifier generally does not produce vertical deflection in excess of 5". Maximum deflection of 4" will provide adequate utilization of screen area.

18. A slight overshoot or ringing may be evident with high frequency square-wave inputs. This effect should not exceed 8%. Keep in mind, however, that sometimes the square wave generator may be at fault and this should be checked before attributing the effect to the scope.

19. At maximum gain settings, the sensitivity of the amplifiers is very high. Under these conditions stray pickup may produce patterns on the screen when no signal source is connected to the vertical input terminals. This is normal and does not interfere with the scope operation.

## OPERATION

**NOTE:** To obtain proper results with your 'scope, it is advisable to become acquainted with the functions and correct use of the panel controls and terminals by making some simple tests. These tests will also serve to assure you that the instrument is in proper working condition. Do not attempt this procedure with kits before all final checks have been completed and all initial adjustments have been made as described in the MAINTENANCE section.

1. Set the INTENSITY, VERT. GAIN, and HOR. GAIN controls at their furthest counter-clockwise positions.

2. Set the FOCUS, V-POS., and H-POS. controls at the center of their ranges. All other controls may be set at any position.

3. Insert the power cord into a 105-125 volt, 50-60 cycle ac outlet.

**WARNING:** This instrument will not operate, or operate improperly, and even be seriously damaged if connected to any other type of power line (such as dc, 25 cycle ac, or an ac line above 125 volts).

4. Turn the POWER control clockwise (on), at which the pilot lamp should light. (Note scale illumination control by potentiometer attached to POWER switch.) Allow the unit to warm up for about a minute. Then gradually turn the INTENSITY control clockwise until a spot appears somewhere on the screen of the cathode-ray tube. If the spot does not appear, adjust the V-POS. and H-POS. controls slightly, as it may be off screen.

5. Adjust the V-POS. and H-POS. controls until the spot is in the exact center of the screen, and then adjust the FOCUS control for the sharpest image. Notice that for every setting of the INTENSITY control, there is a best setting for the FOCUS control. The finest focus is usually obtained at low intensity.

6. Set the HOR. SELECTOR at +(INTERNAL) SYNC. Now advance the setting of the HOR. GAIN control gradually, and note that the spot extends to a horizontal line. This is the linear horizontal sweep.

7. Set the HOR. SELECTOR at EXT.-HOR. Notice that the horizontal line returns to a spot, as the horizontal amplifier is now connected to the H-INPUT binding posts. Any signal applied to the H-INPUT terminals will cause the line to lengthen horizontally in proportion to the peak value of the applied signal.

8. Set the HOR. SELECTOR at 60CPS-HOR. The horizontal line on the screen is the 60 cycle sine sweep. The phase of this sweep is adjusted by the PHASING control. To check this, connect a wire between the 60 cps, and the V-INPUT binding posts. Adjust the VERT. GAIN and HOR. GAIN controls until the pattern is a few inches high and a few inches across. The pattern on the screen is a stationary ellipse because the vertical and horizontal inputs are identical in frequency. Rotate the PHASING control and notice that because of the changing phase difference between the vertical and horizontal inputs, the ellipse either flattens or broadens out.

9. Set the HOR. SELECTOR back at +(INTERNAL) SYNC, the VERT. ATTENUATOR at 100, the SWEEP FREQ. selector between 10 and 100, the SWEEP VERN. control at 10. The jumper between the 60CPS and V-INPUT binding posts remains. Now adjust the VERT-GAIN and HOR-GAIN controls until the pattern extends about two-thirds the width and the height of the cathode-ray tube. The pattern will not be clear because of its rapid horizontal drift. Advance the setting of the SWEEP VERNIER gradually until a single sine wave of power line frequency appears and remains stationary on the screen.

**NOTE 1:** In rotating the SWEEP VERNIER, it will be noticed that the drift of the pattern slows down as certain critical frequencies are approached, and then reverses direction when the critical frequency is passed. At these critical frequencies, a clear pattern can be discerned. These critical sweep frequencies are submultiples of the signal frequency, or the signal frequency itself (when only one cycle of the signal is displayed). The pattern may be locked in at submultiples of the signal frequency when it is desired to view more than one cycle of the signal. The sweep frequency is equal to the signal frequency divided by the number of complete cycles displayed on the screen. For example, if two complete cycles of the 60 cps signal are displayed, the sweep frequency is 30 cps.

**NOTE 2:** At low sweep frequencies, flickering of the pattern is normal due to the slow writing speed of the spot and the persistence of the screen, which together are insufficient to cause the motion to blend into a fixed image.

10. With the single sine wave pattern locked in, switch the HOR. SELECTOR from +(INT.) to -(INT.). The same waveform should appear, but displaced by 180°.

11. With the single sine wave pattern locked in, switch the HOR. SELECTOR to the 60CPS SYNC position. Turn the PHASING control and note the shift in starting point of the displayed waveform.

12. Set up the 'scope controls as in paragraph 8, adjusting the PHASING control for a broad ellipse. Then set the INTENSITY control at minimum. From an audio oscillator, apply about 3 volts at 300 cps between the INT. MOD. binding post and ground, and then gradually advance the INTENSITY control until a broken line ellipse is seen on the screen. Adjust the frequency of the audio oscillator carefully, until the broken lines stand still, and note that there are 5 such lines. This indicates that the ratio between the frequency applied to the INT. MOD. binding post and the frequency applied to the V. INPUT binding post (60 cps) is 5. The INT. MOD. binding post may be used for inserting timing markers on a trace or determining the frequency of an unknown signal.

**CAUTION:** In any application where a signal is applied to the INT. MOD. binding post, the INTENSITY control should just be set at minimum and then advanced until the desired intensity is obtained.

13. To operate the internal calibrator for measuring peak-to-peak voltage, use the following procedure: (p-p) is an abbreviation for peak-to-peak).

**MEASUREMENT OF P-P VOLTAGES** (a) Set the VERT. ATTEN. at CAL. This operation injects a 0.4 volt p-p sine wave of power line frequency into the vertical input circuit at a point following the vertical step attenuator but preceding the vertical gain control. (b) Set the HOR. SELECTOR at "+" and the HOR. GAIN control at zero (so that the pattern on the screen is simply a vertical line). (c) Adjust the VERT. GAIN and VERT. POS. controls until the vertical line extends exactly 4 major divisions (a division is 1 inch) on the calibrated screen.

You have now standardized the sensitivity of the vertical amplifier to permit direct p-p voltage measurements. Do not touch the VERT. GAIN controls while voltage measurements are being made, as any disturbance of the setting makes it necessary to recalibrate the vertical amplifier.

The p-p amplitude of a signal voltage applied to the V. INPUT terminals may be read as follows. Set the VERT. ATTEN. selector at a position that gives a pattern under 4 in. in height, without touching the VERT. GAIN control. Use the VERT. POS. control to place the bottom of the pattern on the lowest graduation of the calibrated scale. If the VERT. ATTEN. selector is at the 1 position, full scale (4 in.) is 0.4 volt p-p. At the 10 position, full scale is 4 volts p-p. At the 100 position, full scale is 40 volts p-p. At the 1000 position full scale is 400 volts p-p.

**MEASUREMENT OF P-P VOLTAGES ABOVE 400 VOLTS:** Steps a and b are the same as when measuring voltages under 400 volts p-p. In step c, however, the VERT. GAIN control is adjusted for a deflection that is a convenient fraction of full scale. At most, this deflection should be as many times smaller than full scale as the expected value of the unknown voltage is larger than 400 volts p-p. The VERT. ATTEN. is then set at 1000 and the p-p deflection of the unknown signal is read off the calibrated screen.

The ratio of this deflection to the deflection set at calibration is then multiplied by 400 to obtain the amplitude of the unknown signal in volts p-p. **EXAMPLE:** The deflection set at calibration is 10 divisions or 2 inches. With the VERT. ATTEN. set at 1000, the p-p deflection of the unknown signal is 20 divisions or 4 inches. The amplitude of the signal is equal to  $(20/10) \times 400 = 800$  volts p-p.

**NOTE:** If the signal under observation is a sine wave (only), the rms value of the amplitude may be obtained by dividing the p-p value by 2.8.

## APPLICATIONS

**GENERAL:** The oscilloscope is an instrument designed for viewing electrical oscillations and transients. Phenomena having a repetition rate from a few cycles per second to several megacycles per second may be displayed on a scope

**WAVEFORM INVESTIGATION:** When the output of the internal sweep generator is fed to the horizontal channel, the pattern on the screen is actually a graph showing the variation with time of the instantaneous amplitude of the signal applied to the vertical channel. The sweep frequency is usually a sub-harmonic of the signal frequency, so that several complete cycles of the signal are displayed on the screen.

**DISPLAY OF WAVEFORMS:** Displaying a waveform means obtaining a picture that shows how the amplitude of the signal under observation varies with time. It is generally most convenient to use a time-base signal that varies linearly with time, so that equal intervals of time are represented on the screen by equal intervals of distance along the same axis. The sawtooth output of the sweep generator gives such a time-base on the horizontal axis, the time (in seconds) represented by the overall horizontal deflection being equal to the reciprocal of the sweep frequency (in cycles per second).

Apparently if the frequency of the observed signal is equal to the sweep frequency, one complete cycle will be observed on the screen. If the frequency of the applied signal is twice the sweep frequency, two complete cycles will be obtained on the screen and so on. Fig. 1 is a projection drawing of a sinewave applied to the vertical plates and a sawtooth wave of the same frequency applied to the horizontal plates. Fig. 2 is a projection drawing showing the resultant pattern when the frequency of the sawtooth is one-half that employed in Fig. 1.

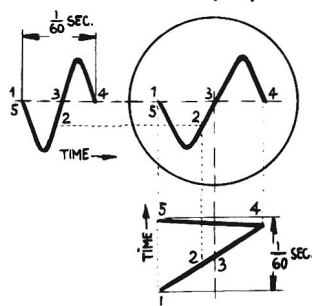

Fig. 1

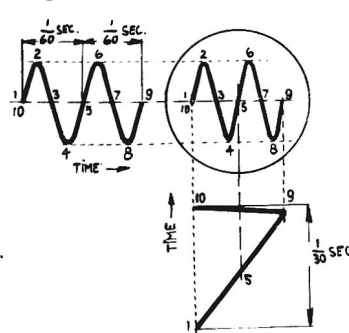

Fig. 2

In these figures, points that occur simultaneously are numbered the same. The circle represents the tube screen. If simultaneous projections were drawn from every point on each wave, the intersections would trace out the sine-waves shown in the circles. The sections of the sawtooth between 1 and 4 in Fig. 1 and between 1 and 9 in Fig. 2 are the sweep sections during which the displays are produced. The sections of the sawtooth between 4 and 5 in Fig. 1 and between 9 and 10 in Fig. 2 are the sections during which the beam is returned very rapidly to the starting point at the left-hand side of the screen. The return trace appears on the screen as a fine horizontal line.

**LISSAJOUS PATTERNS:** Another type of fundamental pattern is obtained when both the vertical and horizontal deflection voltages are sinewaves that are related in frequency as follows: one frequency is a whole number of times larger than the other; one frequency is a simple fraction of the other. When one or the other of these conditions is fulfilled, stationary closed-loop patterns are obtained. These patterns are called Lissajous figures after the 19th century French Scientist. They are particularly useful in determining the frequency ratio between two sinewave signals. If the frequency of one signal is known, the frequency of the other signal can be easily determined from the frequency ratio. Usually the known signal is applied to the horizontal channel and the unknown signal to the vertical channel. The shape of the pattern changes with the phase relationship between the known and unknown signals. For example, all the patterns shown in Fig. 3 (and those intermediate) are possible with a frequency ratio of 1:1 if the phase differences indicated exist.

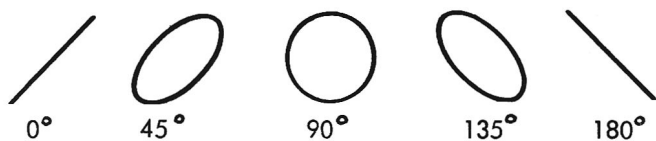

Fig. 3

In general to determine frequency ratio from the Lissajous figure, count the number of points of tangency to horizontal and vertical lines, drawn or imagined (See Fig. 4). Points of tangency at the top of the figures result from the unknown frequency applied to the vertical channel. Those at the side of the figure result from the known frequency applied to the horizontal axis. As a matter of fact, the following relationship holds true in all cases:

$$\frac{V \text{ axis freq.}}{H \text{ axis freq.}} = \frac{V \text{ pts of tangency}}{H \text{ pts of tangency}}$$

As an example, take Fig. 4c, which shows four points of tangency at the top and one point at the side. This indicates that the unknown frequency applied to the vertical axis is four times the known frequency. In Fig. 4f, one point of tangency at the top and four at the side indicate that the unknown frequency is one-fourth the known frequency.

**SQUAREWAVE TESTING OF AMPLIFIERS:** In conjunction with the scope, square wave signals provided by the

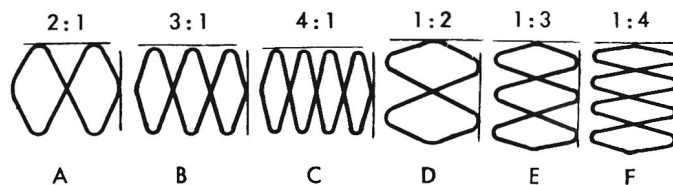

Fig. 4

Model 377 Audio Generator or Model 488 Electronic Switch can be used to check amplifiers as to frequency response, phase shift, transient response, deficient design, or faulty components. The equipment is set up as shown in Fig. 5.

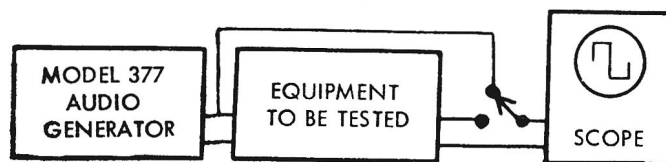

Fig. 5

First, as a means of comparison, the square wave output from the Audio Generator is viewed on the 'scope. The horizontal sweep of the 'scope should be adjusted so that at least two full cycles can be seen on the screen. (Fig. 6a shows one full cycle of a perfect square wave). The 'scope is then connected to the output of the amplifier under test so that the modified square wave can be viewed on the screen. Possible output wave shapes are shown in Fig. 6b to 6i, and the significance of each waveshape is explained below.

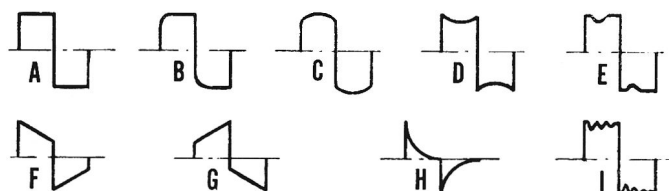

Fig. 6

Fig. 6b shows "rounding" of the leading edge of the square wave. This indicates a drop off in gain at high frequencies. "Rounding" will generally be observable when there is a substantial drop in the gain by the tenth harmonic (or less). Therefore, if a 2 Kc square wave fed to the amplifier is reproduced on the 'scope without "rounding", the amplifier is flat to  $10 \times 2 \text{ Kc} = 20 \text{ Kc}$ .

Fig. 6c shows the effect of increased gain and Fig. 6d shows the effect of decreased gain at the square wave frequency. Fig. 6e indicates lowered gain at a narrow frequency band. If the square wave frequency is brought into this narrow frequency band, Fig. 6d will result.

The effect of phase shift in the amplifier is shown in Figs. 6f and 6g. If, at low frequencies, there is phase shift in the leading direction, the square wave will be tilted as in Fig. 6f. If there is phase shift in the lagging direction, the top of the square wave will be tilted as in Fig. 6g. The steepness of the tilt is proportional to the amount of phase shift. Phase shift is not important in audio amplifiers, although the ear is not entirely insensitive to it. In television and 'scope amplifiers, however, phase shift should not be tolerated.

Fig. 6h shows the pulse output from the amplifier that results when the square wave has undergone differentiation. This will happen when the grid resistor or the coupling condenser is too low in value or if the coupling condenser is partially open. Lastly, Fig. 6i, shows a square wave with damped oscillations following the leading edge. This results when a high frequency square wave is fed to an amplifier in which distributed capacities and lead inductances resonate at low frequencies. In television and 'scope amplifiers it may result from an undamped peaking coil.

High fidelity audio amplifiers may be given a rapid check by testing first with a square wave of fundamental frequency not less than 3 to 4 times the low frequency limit of the amplifier (3 db point) and then with a square wave of fundamental frequency which may be anywhere between 1/100 to 1/10 of the high frequency limit of the amplifier depending upon how many harmonics are considered necessary to produce an acceptable version of a square waveform. Usually square waves of fundamental frequency from 40 to 60 cps and 1000 to 2000 cps are employed to cover the range up to 20,000 cps.

To insure correct results, the following is suggested: Connect the proper value of load across the amplifier output terminals; use low capacitance cable for connecting the generator to the amplifier input; if the amplifier has a high impedance input, use a 1 meg isolating resistor between the generator and the amplifier, shunted by a .001 mf capacitor if there is capacitance present in the amplifier input; set the generator output to an ample value but be sure not to overload the amplifier. The square wave signal is fed to the amplifier input and the scope is connected across the amplifier load. Use the internal linear sweep to observe the waveform. Note that tone controls have a very marked effect on square wave response and should be set to the "flat" positions unless it is desired to observe their effect. Note, also, that low fidelity and p.a. amplifiers will not reproduce the square waveform.

Video amplifiers may be square wave tested in the same manner as described for testing audio amplifiers. The test frequencies might be 60 cps for the low and 25,000 cps for high frequency end.

**SERVICING TV RECEIVERS:** One major use of the scope in tv servicing is alignment in conjunction with a TV/FM Sweep Generator. First the IF stages are aligned, and then the RF and local oscillator stages, following the same general procedure used in AM receivers. The general method and theory of alignment is described in the sweep generator instructions manuals. The specific methods of alignment depend on the receiver, and the manufacturer's service instruction should always be followed.

Another major use of the scope is to check the waveform of the complex tv signal as it passes through the receiver. The exceptional fidelity of the Model 460 scope is very important in this application, since you must be able to observe small variations in waveform in order to localize

and correct the cause of poor picture quality. Here again the set manufacturer provides representative waveforms to be expected at specific points in a specific model of receiver. These waveform pictures are furnished for the entire receiver, with the exception of the tuner portion. EICO manufactures a complete line of high quality oscilloscope probes meeting all the requirements for waveform observation in any part of a tv receiver.

Keep in mind that two basic frequencies are involved in checking waveform of signals in tv receivers. The vertical or field frequency is 60 cps. Any waveform check, except within the horizontal oscillator, its differentiator network, and the horizontal amplifier stages, can generally be made using an internal linear sweep frequency of 30 cycles to show two complete fields of the signal. To examine the horizontal pulse shape, or the operation of the horizontal deflection system, it is generally suitable to use an internal linear sweep frequency of 7875 cps, again to show two complete lines of the signal. The TV-V position (30 cps) and the TV-H position (7875 cps) on the SWEEP SELECTOR were provided to permit rapid changeover from one basic tv sweep frequency to the other without need for other control readjustments.

## MAINTENANCE

**GENERAL:** Included in this section are instructions for internal adjustments, trouble-shooting, and part replacement. All internal adjustments must be performed in the order given on completed kit instruments before they can be placed in use. The same procedures will serve for periodic readjustments in both kit and factory-wired instruments when required by component ageing or replacement.

**REMOVAL FROM CABINET:** To remove the instrument from the cabinet, first disconnect it from the power line and remove the two screws at the cabinet rear. Then slide the chassis out the front of the cabinet.

**WARNING:** The voltages in this instrument are dangerous. Take caution to avoid personal contact with these voltages when the instrument is being operated outside of its cabinet. Remember that capacitors may remain charged to dangerously high voltages for a considerable time after power has been removed.

**INTERNAL ADJUSTMENTS:** The need for repetition of any of the following adjustments after the instrument has been in use can be determined by referring to the trouble-shooting chart. Therefore no reference will be made here to the symptoms which indicate readjustment is necessary.

a) Insert the AC plug in the 115 volt AC line outlet and turn the power on by rotating the SCALE LIGHT control clockwise from AC-OFF. While the scope is warming up, install the shorting link supplied between ground and the lower V-INPUT terminal (remains in place throughout adjustments and in normal use of 'scope, except when balanced input is desired) and then set the panel controls as

follows: INTENSITY, FOCUS, V-POS, H-POS, PHASING, SWEEP VERNIER, VERT. GAIN to approximate middle of rotation; SWEEP SELECTOR at "10-100"; VERT. ATTENUATOR to CAL.; HOR. SELECTOR to "+"; HOR. GAIN to 40.

b) Adjust panel controls for a stationary pattern of several 60 cps sine waves (approximate overall pattern dimensions: 2" high, 3" wide). Make a preliminary adjustment for sharpness of the trace with the FOCUS control. Then set the INTENSITY control to produce a trace of normal brightness (excessive intensity will be evidenced by "blooming" of the trace). At this point any astigmatism in the trace will be evidenced by some portions of the trace being thicker than others. Now jointly adjust the astigmatism control R81 (see Fig. 7) and the FOCUS control until a sharp trace with the greatest possible uniformity of thickness is obtained.

c) Short the V-INPUT terminals. Set the VERT. ATTENUATOR to "1000" under the AC arc on the dial and the VERT. GAIN control for minimum gain. Adjust the V. POS. control for a trace vertically at dead center. Now set the VERT. GAIN control for maximum gain and adjust the DC balance control R16 (see Fig. 7) until the trace is returned vertically to dead center. Repeat until no vertical shift in the trace can be detected when the VERT. GAIN control is rotated from minimum to maximum.

d) Adjust linearity controls R26 and R27 (see Fig. 7) exactly as follows. Set the VERT. GAIN control for minimum gain. Set your VTVM or VOM (at least 1000  $\Omega$ /volt) to a low DC volts range on which 2 volts dc can be read with reasonable accuracy. Connect the negative voltmeter lead to grid pin 1 of the 6CB6 tube V3 and the positive lead to cathode pin 2. Adjust the linearity control R26 for a voltmeter reading of 2 volts; or as near 2 volts as the control permits. Disconnect both voltmeter leads from the grid and cathode pins of V3. Now connect the negative voltmeter lead to grid pin 1 of the other 6CB6 tube V4 and the positive lead to the cathode pin 2. Adjust the other linearity control R27 for a voltmeter reading of 2 volts also, or if 2 volts was not obtainable in the previous adjustment, to whatever voltage was obtained in this adjustment. Do not attempt voltage measurements to ground as there is a voltage of approximately 100 volts between each 6CB6 cathode and ground which might seriously damage a voltmeter set to a low range. Change in H positioning is normal during these adjustments.

e) After completing the linearity adjustments described above, leave the scope in operation for at least a 1/2 hour interval. Then repeat the DC balance adjustment described in paragraph c.

f) Check for a screen (pin 6) to cathode (pin 2) voltage of approximately 150 volts dc on each of the 6CB6 tubes, V3 and V4.

g) Check for a dc voltage of 45 volts  $\pm$  10% across 500  $\Omega$  resistor R77 coming directly off the V9 (6AX5) tube cathode pin 8. This is a check of the B+ drain after vertical amplifier adjustments are completed.

h) Stray capacities shunting the resistive components in each of the vertical input attenuator networks would result in frequency discrimination were not each of these attenuator networks frequency-compensated by an individual trimmer. These trimmers are accessible through holes in the left front bracket; uppermost trimmer C2 for the 10:1 attenuator, middle trimmer C3 for the 100:1 attenuator, and lowest trimmer C4 for the 1000:1 attenuator.

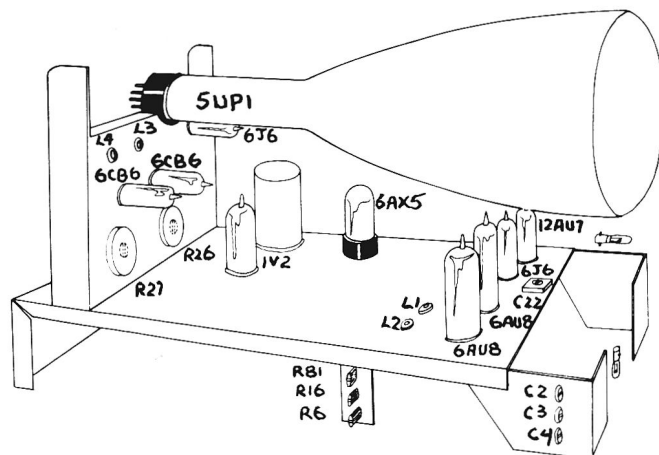

Fig. 7

Method of adjusting trimmers: Connect a jumper between the SAWTOOTH and V-INPUT terminals. Set the HOR. SELECTOR at "+", the SWEEP SELECTOR at the 100-1K position, the SWEEP VERNIER at 100, the VERT. GAIN control at 50, and the HOR. GAIN at 40. Now set the VERT. ATTENUATOR selector at 10 (either DC or AC) and then use the panel controls to obtain a centered, focused trace (readjust VERT. & HOR. GAIN controls if required to obtain a trace entirely on the screen). With the upper trimmer C2 adjusted improperly, the trace will appear either as in Fig. 8a or Fig. 8b. If this is the case, adjust the uppermost trimmer C2 until the hook disappears and the trace is a straight line as in Fig. 8c.

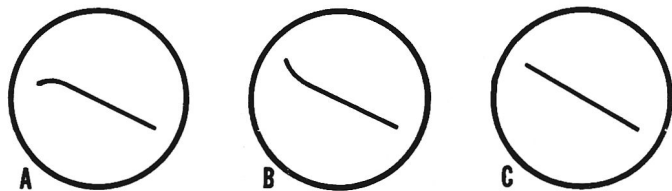

Fig. 8

Now set the VERT. ATTENUATOR selector at 100 (either AC or DC) and turn the VERT. GAIN control to maximum. With the middle trimmer C3 adjusted improperly, the trace will again appear as in Fig. 8a or Fig. 8b. If this is the case, adjust the middle trimmer C3 until the hook disappears and the trace appears as in Fig. 8c.

Now set the VERT. ATTENUATOR selector at 1000 (either AC or DC) and carefully replace the SAWTOOTH to V.-INPUT terminals jumper by a jumper between pin 9 of the cathode-ray tube and the V. INPUT terminal. With the lowest trimmer C4 adjusted improperly, the trace will again appear as in Fig. 8a or Fig. 8b. If this is the case,

adjust lowest trimmer C4 until the hook disappears and the trace appears as in Fig. 8c.

A much to be preferred method of adjustment, when the equipment is available, is to apply a square wave of approximately 1 kc fundamental frequency to the V-INPUT terminals and adjusting each trimmer in turn, with the VERT. ATTENUATOR selector set at the corresponding position, for best possible square wave reproduction. Internal sweep is employed and the panel controls set for several stationary square waves on the screen before adjusting the trimmers for proper frequency compensation.

Under-compensation and over-compensation are indicated square waves appearing as in Figs. 9a and 9b respectively. Proper compensation is indicated by square waves appearing as in Fig. 9c.

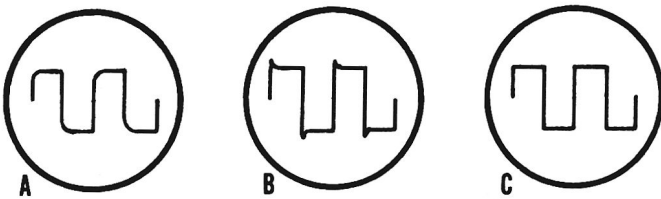

Fig. 9

i) Adjustment of calibration voltage: Set your VTVM or VOM to the ac voltage range on which 1.42 volts rms (or 4 volts peak-to-peak) can be read as accurately as possible. Connect one voltmeter lead to the junction of rheostat R6 and resistor R5 and the other lead to chassis ground. Adjust rheostat R6 (see Fig. 7) for a reading of 1.42 volts rms or 4 volts peak-to-peak. Note that this voltage is applied to a 10:1 divider composed of R4 and R5, so that the voltage actually injected into the vertical amplifier is 400 millivolts peak-to-peak.

j) Adjustment of TV-H sweep trimmer: Set the SWEEP SELECTOR at TV-V. Then set the VERT. ATTENUATOR to CAL., the HOR. SELECTOR at "+", and adjust the SWEEP VERNIER to obtain a stationary pattern of two complete cycles on the screen indicating a 30 cps sweep frequency. Now turn the SWEEP SELECTOR to the TV-H position and apply a 15,750 cps signal taken from the horizontal section of any tv set to the V. INPUT terminals. Adjust the VERT. ATTENUATOR & VERT. GAIN controls to obtain a drifting pattern entirely on screen but do not touch the SWEEP VERNIER. Now adjust trimmer C22 (see Fig. 7) until a stationary pattern of two complete cycles is obtained on the screen, indicating a 7875 cps sweep frequency. This completes the adjustment. Now, whenever the SWEEP VERNIER is set to produce a 30 cps sweep (indicated by two cycle display of 60 cps signal) with the SWEEP SELECTOR set at TV-V, turning the SWEEP SELECTOR to TV-H without touching the SWEEP VERNIER will automatically give a 7875 cps sweep.

k) High frequency-response adjustment: In factory-wired instruments adjustable peaking coils L1, L2, L3, and L4 have been adjusted to provide optimum reproduction of a 500 kc square wave. In kit instruments, these peaking coils are supplied with the slugs pre-set. The design of the vertical amplifier is such that the high frequency re-

sponse will be within a few db of specified response without further adjustment of the peaking coils.

Unless a generator capable of producing at least 100 kc square wave or a generator having a metered sine-wave output up to 5 mc is available, it is recommended that no further adjustment of the peaking coils be attempted. In the case where a metered sine-wave generator of range up to 5 mc is used, the procedure is to adjust the peaking coils for uniform response of the vertical amplifier (constant peak-to-peak deflection of any arbitrary value up to 4" with generator output maintained at any arbitrary value up to 4 volts p-p and the VERT. ATTENUATOR set at "1" AC as the frequency is varied) with an expected 3 db drop at 4.5 mc (approximately 30% down).

If high frequency response adjustment is thought necessary for any reason, and neither a square wave generator nor a metered sine-wave generator as described above is available, satisfactory adjustment for most purposes may be made using an unmetred signal generator as follows. Connect the generator to the V. INPUT terminals and set it at 5 mc. Use maximum generator output. Set the VERT. ATTENUATOR Selector at "1" AC. Use internal sweep but do not attempt to "lock in" the signal, since only the p-p amplitude of the signal is of interest and a drifting display will form a "band", the p-p height of which is easy to observe. Set the VERT. GAIN control for a small p-p vertical deflection of say 1". Now use an insulated screwdriver to adjust the slugs in the four peak-coils L1, L2, L3, and L4) for maximum vertical p-p deflection. First adjust the L3 and L4 pair and then the L1 and L2 pair. Repeat until no further increase in response is obtained. For best results, the depth of the slugs in each of the two coils that form a pair should be about the same. For this reason, it is best to adjust the two coils in a pair alternately, making a small adjustment in one coil and duplicating this adjustment on the other coil of pair before proceeding to further adjustment of the first coil.

TROUBLE-SHOOTING THE 460 OSCILLOSCOPE: The block diagram of the 460 (Fig. 12) should aid in isolating the circuit in which the trouble is located. Once this is done, reference should be made to the appropriate section of the complete schematic (Fig. 13). The next step is to localize the trouble in the particular section to the tube circuit involved and then to try a replacement tube. If the trouble is not eliminated, voltage and resistance checks should be made and compared with the data provided in the voltage and resistance chart provided (Fig. 11).

As an aid in localizing trouble, common symptoms together with their possible causes and remedies have been listed in groups corresponding to the major sections of the instrument (Fig. 10). Of course, all possible troubles could not be included in the chart and the make-up of the chart has been based on the assumption that the instrument has worked properly at some previous time. Keep in mind that in trouble-shooting, the main endeavor is to find and eliminate the source of the trouble. Recurrence of a trouble usually indicates that the effect, not the cause has been remedied.

**Fig. 10 TROUBLE SHOOTING CHART**  
**POWER SUPPLY**

Pilot light fails to light	SCALE LIGHT switch in AC-OFF position No AC line voltage Pilot lamp open Fuse defective Power Transformer defective Broken lead/or leads in the filament path	Turn SCALE LIGHT switch clockwise. Trace line failure Replace I2 Replace F1 Replace T1 Repair defective connections
Fuse, F1, blows when AC power is turned on.	Shorted AC line cable on the primary side of the power transformer. Defective rectifier tubes Defective filter capacitors  Short in filament connections	Repair the short  Check V8, V9. Replace if bad Check C27, C28, C26, C25 for low resistance or short. Replace if necessary Check filament connections for shorts. Repair if necessary.
Some or all filaments fail to light.	Defective tube or tubes Broken lead from power transformer  Power transformer defective	Replace tube or tubes* Check with an ohmmeter for continuity. Repair if necessary. Replace.
Scale does not light	Broken lead or leads to I1 Bulb I1 defective Potentiometer R80 defective	Check and repair if necessary. Replace Replace

**CRT CIRCUIT**

No spot on CRT screen.	High voltage rectifier tube, V8, defective. Filament leads broken No voltage on second anode Note: Spot may be deflected off screen. Adjust V-POS. control for equal voltages from CRT pins 6 & 7 to ground (V. defl. plates) and H. POS. control for equal voltages from CRT pins 9 & 10 to ground (H. defl. plates). The spot should then be centered. If either adjustment is impossible, refer to the vertical or horizontal amplifier sections.	Replace Repair Check circuit. Repair if necessary.
No spot on CRT screen. (All CRT voltages correct)	Defective CRT (V10)	Replace V10
Retrace blanking inoperative	C23 open Broken lead from the sweep frequency generator to the grid of V10.	Replace Check and repair if necessary.
No focusing	R75 defective R81 defective Note: R75 is the focusing potentiometer. Its action is dependent on the setting of the astigmatism potentiometer R81. For best focus, both pots must be adjusted simultaneously as an initial adjustment.	Replace Replace
No horizontal positioning	Refer to horizontal amplifier	
No vertical positioning	Refer to vertical amplifier	
Astigmatism control inoperative.	R81 defective	Replace

## SWEEP CIRCUIT

No sweep (hor. ampl. checks O.K.)	Hor. Selector switch is not set to Sweep Sync positions. Lead or leads broken V6 defective S3 defective S2 defective R24 defective Check R47-54 for open	Set HOR. SELECTOR to position under SYNC-SWEEP arc on dial. Check and repair if necessary Replace Check. Replace if necessary Check. Replace if necessary Check. Replace if necessary Replace if necessary
Sweep inoperative on some ranges	One of C17-C22 defective S3 defective	Replace the defective capacitor * Replace
Incorrect sweep frequency obtained at TV-H position	C22 out of adjustment	Adjust C22
Loss of synchronization	V5-A defective S2 defective C29 open R47 open Sync. twin-lead defective	Replace V5 Check. Replace if necessary Replace Replace Replace

## VERTICAL AMPLIFIER

With appropriate signal applied to INPUT, no vertical displacement of the trace results.	Defective S1 One or more tubes defective  One or more components in the vertical amplifier defective.	Check. Replace if necessary. Check V1, V2, V3, V4 *. Replace if defective. Check resistors and potentiometers with ohmmeter. Replace if defective.
Signal distorted; unable to balance.	Peaking coil or coils open. R16 defective R26, R27 defective	Check for continuity. Replace if defective. Replace Replace
No vertical positioning	R42 defective	Replace
VERT. GAIN control affects position of trace	DC unbalance	Balance with R16.
No vertical signal in AC attenuator pos.; O.K. in DC pos.	C1 open	Replace C1
Size of pattern changes with positions on CRT screen.	Vertical linearity out of adjustment.	Adjust R26, R27
Square wave (10KC) distorted on 10, 100, 1000V pos. of the attenuator.	C2, C3, C4 out of adjustment.	Adjust C2, C3, C4
DC balance impossible; all components O.K.	One of the tubes in vertical amplifier out of tolerance.	Switch V1 and V2; switch V3 and V4 Note: If this does not improve the balance, try one or more replacement tubes.
No gain adjust	R24 defective	Replace R24
Trace "jumps" on CRT screen in vertical direction	Loose connection in vertical amplifier section. One of the tubes "microphonic"	Repair  Tap tubes lightly. Replace the one which is "microphonic".

## VERTICAL AMPLIFIER CONTINUED

No trace when VERT. ATTENUATOR at CAL. pos.	R5 or R6 open	Check and replace if necessary.
No adjust possible with peaking coil or coils.	Peaking coil or coils short circuited.	Replace the defective coil.
P-p voltage reading made with scope by use of the reference voltage supplied at the CAL. position of the VERT. ATTEN. selector are inaccurate (or no reference voltage obtained at CAL. position).	R6 out of adjustment or R4, R5, R6, S1 defective.	Adjust R6, or replace R4, R5, R6, or S1.

## HORIZONTAL AMPLIFIER

No horizontal deflection; sweep checks O. K. and HOR. SELECTOR in one of SYNC-SWEEP positions.	C13 open V5 or V7 defective C15 shorted C14 open R60 defective S3 defective	Replace Check and replace if bad. Replace Replace Replace Replace
No horizontal positioning.	R63, R64, or R68 defective C16 shorted R62 defective	Check and replace if necessary. Replace Replace
Horizontal deflection present but distorted.	C15 open C16 open V7 defective R67, R66 defective	Replace Replace Replace Replace

\* Indicates replacement of component in this group makes it necessary to repeat some part of the initial adjustment procedure.

**TUBE REPLACEMENT:** Tube location is shown in Fig. 7. Readjustment will be required when replacing V1, V2, V3, or V4. When the CRT is replaced, it must be rotated until the horizontal trace is level.

**FUSE REPLACEMENT:** A 1 amp fuse is located in the fuse holder on the rear chassis apron. If the fuse should blow, the component that has failed and caused the excessive current drain must be found and replaced before a new fuse is inserted.

### SERVICE

If trouble develops in your instrument which you cannot remedy yourself, write to our service department listing all possible indications that might be helpful. If desired, you may return the instrument to our factory where it will

be placed in operating condition for \$12.50 plus the cost of parts replaced due to their being damaged in the course of construction. **NOTE:** Before returning this unit, be sure all parts are securely mounted. Attach a tag to the instrument, giving your home address and the trouble with the unit. Pack very carefully in a rugged container, using sufficient packing material (cotton, shredded newspaper, or excelsior), to make the unit completely immovable within the container. The original shipping carton is satisfactory, providing the original inserts are used or sufficient packing material is inserted to keep the instrument immovable. Ship by prepaid Railway Express, if possible, to Electronic Instrument Co., Inc., 33-00 Northern Blvd., Long Island City 1, N.Y. Return shipment will be made by express collect. Note that a carrier cannot be held liable for damages in transit if packing IN HIS OPINION, is insufficient.

**Fig. 11**  
**VOLTAGE CHART**

TUBE	V1 6AU8	V2 6AU8	V3 6CB6	V4 6CB6	V5 12AU7	V6 6J6	V7 6J6	V8 IV2	V9 6AX5	V10 5UP1
PIN#										
1	105	105	105 Note 6	105 Note 6	123	150	260 Note 1	-950 Note 8	NC	-870 Note 9
2	101	101	107 Note 6	107 Note 6	28	85	260 Note 1	NC	3.15 ac	-740 to -870 Note 4
3	230	230	3.15 ac	3.15 ac	41	3.15 ac	3.15 ac	NC	400 ac	-820 Note 4
4	3.15 ac	3.15 ac	3.15 ac	3.15 ac	3.15 ac	3.15 ac	3.15 ac	750 ac Note 7	NC	-400 to -750 Note 3
5	3.15 ac	3.15 ac	270	270	3.15 ac	46	0	750 ac Note 7	400 ac	NC
6	2	2	257	257	40 to 60	48	0 Note 1	NC	NC	230 Note 2
7	0	0	107	107	-0.3 to -0.9	54	6 Note 1	NC	3.15 ac	230 Note 2
8	120	120	-	-	0	-	-	NC	380	270 Note 5
9	101	101	-	-	3.15 ac	-	-	-950	-	260 Note 1
									PIN 10	260 Note 1
									PIN 11	NC
									PIN 12	-870 Note 9

REFERENCES FOR VOLTAGE & RESISTANCE CHARTS

NC No Connection  
 Note 1 Varies with H. POS. control setting—Values given for centered trace.  
 Note 2 Varies with V. POS. control setting—Values given for centered trace.  
 Note 3 Varies with FOCUS control setting.  
 Note 4 Varies with INTENSITY control setting.  
 Note 5 Varies with astigmatism control setting  
 Note 6 The difference between the voltages on pins 1 and 2 of each tube is the grid bias. The bias voltages for V3 and V4 should be closely equal and near 2 volts when linearity controls R26 and R27 are adjusted properly as described in the Initial Adjustment section of MAINTENANCE.  
 Note 7 Check with tube out, each pin to gnd. Don't check fil. volt. between.  
 Note 8 Pin 1 internally connected to pin 9  
 Note 9 6.3 volts AC between pins. CAUTION: These pins 870 volts off chassis.  
 Note 10 Varies with SWEEP VERNIER setting.  
 Note 11 Varies with HOR. GAIN setting.  
 Note 12 Varies with settings of VERT. GAIN control and linearity controls R26 and R27.  
 UNLESS OTHERWISE INDICATED, ALL VOLTAGES ARE DC, POSITIVE AND MEASURED TO CHASSIS  
 Line Voltage: 115 volts, 60 cps  
 All measurements made with VTVM of approximately 11 megs input impedance.

CONTROL SETTINGS

SWEEP FREQ. selector at 100-1K position  
 SWEEP VERNIER control at center of range (55)  
 VERT. ATTENUATOR set at 1000 AC  
 VERT. GAIN at 10 (minimum)  
 HOR. INPUT selector at "EXT" under the SYNC-SWEEP arc on the dial  
 HOR. GAIN at 30  
 PHASING at center of range  
 Shorting Link in place between lower V. INPUT terminal and ground terminal.  
 Upper V. INPUT terminal also shorted to ground terminal.  
 Set FOCUS control for focused trace  
 Set INTENSITY control for normal trace brightness.  
 Set V. POS. & H. POS. controls for centered trace.  
 Note: All prescribed internal adjustments are presumed to have been made.  
 —Required for voltage checks only.

Unless otherwise noted, all voltage and resistance values may normally vary by ± 15%.

RESISTANCE CHART

TUBE	V1 6AU8	V2 6AU8	V3 6CB6	V4 6CB6	V5 12AU7	V6 6J6	V7 6J6	V8 IV2	V9 6AX5	V10 5UP1
PIN#										
1	47K	47K	47K	47K	130K *	80K *	80K *	NC	NC	4.8 meg
2	80K *	80K *	1.5-4K Note 12	1.5-4K Note 12	2.5 meg	30K *	80K *	NC	0	5 meg
3'	80K *	80K *	0	0	24K	0	0	NC*	600	4.7 meg
4	0	0	0	0	0	0	0	875	NC	2-4 meg Note 3
5	0	0	80K *	80K *	0	2-10 meg Note 10	0-7K Note 11	875	600	NC
6	1.2K	1.2K	80K *	80K *	100K *	30K	15-35K Note 1	NC	NC	0.8-1.1 meg Note 2
7	3.5 meg	3.5 meg	4.3K	4.3K	200K	4.7K	7K	NC	0	0.8-1.1 meg Note 2
8	80K *	80K *	-	-	0	-	-	NC	80K	0-2 meg Note 5
9	80K *	80K *	-	-	0	-	-	5 meg	-	80K *
									PIN 10	80K *
									PIN 11	NC
									PIN 12	4.8 meg

\* Measurement reaches final value slowly due to long RC time constants. Values given are approximately 2/3 of final value.

## PARTS LIST MODEL 460

Stock#	Symbol	Description	Am't.	Stock#	Symbol	Description	Am't.
20028	C1,17	cap., molded, .1 mfd	2	16014	R42,54	pot., 10Meg $\Omega$ (vert. posn; sweep)	2
29505	C2,3,4	cap., trimmer, 3-13 mfd	3	10015	R44	res., 1K $\Omega$ , 1/2 W, 20%	1
22001	C5	cap., ceramic, 100 mmf	1	16005	R45	pot., 100K $\Omega$ (phasing)	1
21000	C6	cap., mica, 1000 mmf	1	10851	R47	res., 22K $\Omega$ , 1W, 10%	1
22505	C7,8,9	cap., disc, .01 mfd - 500 V	3	10956	R48	res., 10K $\Omega$ , 2W, 10%	1
23003	C10	cap., elec., 16 mfd - 350 V	1	10847	R51,57	res., 100K $\Omega$ , 1W, 10%	2
22517	C11,12	cap., disc, .025 mfd	2	10029	R53	res., 680K $\Omega$ , 1/2 W, 20%	1
20004	C13,16	cap., paper, .25 mfd - 400 V	3	10423	R58	res., 2.2K $\Omega$ , 1/2 W, 10%	1
	30			16010	R60	pot., 10K $\Omega$ , (hor. gain)	1
23011	C14,28	cap., elec., 50 mf - 50 V	2	10854	R62	res., 6.8K $\Omega$ , 1W, 10%	1
23010	C15	cap., elec., 10 mf - 150 V	1	16004	R64	pot., 50K $\Omega$ (hor. posn.)	1
20022	C18	cap., molded, .01 mfd	1	10431	R68	res., 470K $\Omega$ , 1/2 W, 10%	1
20016	C19	cap., molded, .001 mfd	1	10416	R69	res., 15K $\Omega$ , 1/2 W, 10%	1
22009	C20	cap., ceramic, 68 mmf	1	16002	R72	pot., 250K $\Omega$ , (intensity)	1
21001	C21	cap., mica, 270 mmf	1	18045	R73	res., 220K $\Omega$ , 1W, 10%	1
29507	C22	cap., trimmer, 5-80 mmf	1	10843	R74	res., 470K $\Omega$ , 1W, 10%	1
20003	C23,25,	cap., paper, .1 mfd - 1000 V	3	16011	R75	pot., 2Meg $\Omega$ (focus)	1
	26			10839	R76	res., 2.2Meg $\Omega$ , 1W, 10%	1
22503	C24	cap., disc, .01 mfd - 1KV or 1500 V	1	14500	R77,78,	res., 500 $\Omega$ , 5W, 10%	3
24004	C27	cap., elec., 3 X 20 mfd - 450 V	1	79			
20006	C29	cap., paper, .1 mfd	1	19007	R80	pot., 75 $\Omega$ , W.W. w/switch	1
91002	F1	fuse, 1 Amp.	1			(scale light)	
92000	I1,2	bulb, #47	2	18017	R81	pot., 2Meg $\Omega$ , (astigm.)	1
52001	J1-9	binding post, 5 way	9	60036	S1	switch, 9 Posn (vert. att.)	1
36010	L1,2,3,	coil, var., 100 uH	4	60031	S2	switch, 6 Posn (hor. sel.)	1
	4			60037	S3	switch, 1P - 7 Posn (sweep sel.)	1
10533	R1,2,3	res., 3.3Meg $\Omega$ , 1/2 W, 5%	3	30015	T1	power transformer	1
10535	R4	res., 91 $\Omega$ , 1/2 W, 5%	1	54000	TB14	terminal strip, 1P. left	1
10536	R5	res., 820 $\Omega$ , 1/2 W, 5%	1	54001	TB12	terminal strip, 1P. right	1
18014	R6,16	pot., 2K $\Omega$ (cal; DC bal.)	2	54002	TB10,19	terminal strip, 1P. right w/ground	2
10500	R7	res., 360K $\Omega$ , 1/2 W, 5%	1	54003	TB1,11,	terminal strip, 2P.	3
10503	R8,49	res., 33K $\Omega$ , 1/2 W, 5%	2	17			
10502	R9	res., 3.3K $\Omega$ , 1/2 W, 5%	1	54004	TB4,6,7,	terminal strip, 2P. w/ground	5
10417	R10,12	res., 220K $\Omega$ , 1/2 W, 10%	3	16,18			
	71			54006	TB2,8,9,	terminal strip, 3P. 2 right	4
10954	R11	res., 820 $\Omega$ , 2W, 10%	1	15			
10951	R13	res., 3.9K $\Omega$ , 2W, 10%	1	54007	TB3	terminal strip 3P. 2rt. w/ground	1
10400	R14,18	res., 10K $\Omega$ , 1/2 W, 10%	2	54008	TB5,13	terminal strip, 4P	2
10950	R15,17,	res., 2.2K $\Omega$ , 2W, 10%	4	90027	V1,2	tube, 6AU8	2
	30,38			90028	V3,4	tube, 6CB6	2
14503	R19,29	res., 2.5K $\Omega$ , 5W, 10%	2	90013	V5	tube, 12AU7	1
10003	R20,21,	res., 100 $\Omega$ , 1/2 W, 20%	5	90029	V6,7	tube, 6J6	2
	55,61,65			90030	V8	tube, 1V2	1
10849	R22,23,	res., 47K $\Omega$ , 1W, 10%	4	90035	V9	tube, 6AX5	1
	66,67			90026	V10	tube, 5UP1, CRT	1
16007	R24	pot., 2.5K $\Omega$ (vert. gain)	1	97800	XF1	fuse holder	1
10952	R25,28,	res., 4.7K $\Omega$ , 2W, 10%	3	97707	XI1	pilot lite assembly (snap bracket)	1
	52			97700	XI2	pilot lite assembly	1
19008	R26,27	pot., 5K $\Omega$ , W.W. (lin. adj.)	2	97025	XV1,2,	socket, 9 pin miniature	4
10424	R31,32,	res., 22K $\Omega$ , 1/2 W, 10%	7	5,8			
	36,37,50,			97024	XV3,4,	socket, 7 pin miniature	4
	59,63			6,7			
10771	R33,34	res., 820 $\Omega$ , 1W, 5%	2	97003	XV9	socket, octal	1
10953	R35	res., 8.2K $\Omega$ , 2W, 10%	1	97026	XV10	socket, CRT, 12 pin	1
10407	R39,40	res., 1Meg $\Omega$ , 1/2 W, 10%	2	40000		nut, hex, 6-32	48
10032	R41,43,	res., 2.2Meg $\Omega$ , 1/2 W, 20%	5	40001		nut, hex, 3/8-32	18
	46,56,70			40007		nut, hex, 4-40	16
				40008		nut, hex, 8-32	21

Stock#	Symbol	Description	Am't.	Stock#	Symbol	Description	Am't.
40016		nut, hex, for fuseholder	1	58300		spaghetti	length
41000		screw, 6-32 X 1/4	36	58402		300Ω twin lead	length
41002		screw, self tap	2	58501		bare wire	length
41003		screw, 8-32 X 3/8	4	59002		graph screen	1
89527		holder for handle	2	59003		screen filter	1
41007		screw, 6-32 X 3/4	2	59303		felt (front tube)	1
41014		screw, 6-32 X 3/8	8	59304		felt (neck tube)	1
41016		screw, 4-40 X 1/4	16	59504		3-trimmer bracket	1
42000		washer, lock, 3/8	14	80042		panel	1
42001		washer, flat, 3/8	12	81053		pot., bracket	1
42002		washer, lock, #6	46	81064		chassis, main	1
42007		washer, lock, #4	16	81065		chassis, rear	1
42008		washer, lock, #8	13	81066		bracket, front, left	1
42017		washer, fibre, flat, #8	7	81067		bracket, front, right	1
42018		washer, fibre, shoulder, #8	9	81068		bracket, rear, left	1
42029		washer, rubber for fuseholder	1	81069		bracket, rear, right	1
43000		lug, ground, #6	2	81070		strut, left	1
43001		lug, pot., ground	3	81071		strut, right	1
43004		lug, solder, #8	7	81072		chassis shield	1
46000		grommet, rubber, 3/8	1	81073		bulb bracket	1
46001		grommet, rubber, 1/4	10	81074		bezel, front	1
46003		grommet, rubber 1/2	1	81075		bezel, rear	1
46004		grommet, rubber, 5/8	1	81076		clamp, CRT	2
46005		foot, rubber	4	81902		binding post link	1
48000		plug button	3	87004		handle, leather	1
53002		knob, small round pointer	5	88027		cabinet	1
53006		knob., round bar	7	66265		manual of instructions (kit only)	1
57000		line cord	1	66015		manual of instructions (wired only)	1
58000		hook-up wire	length				

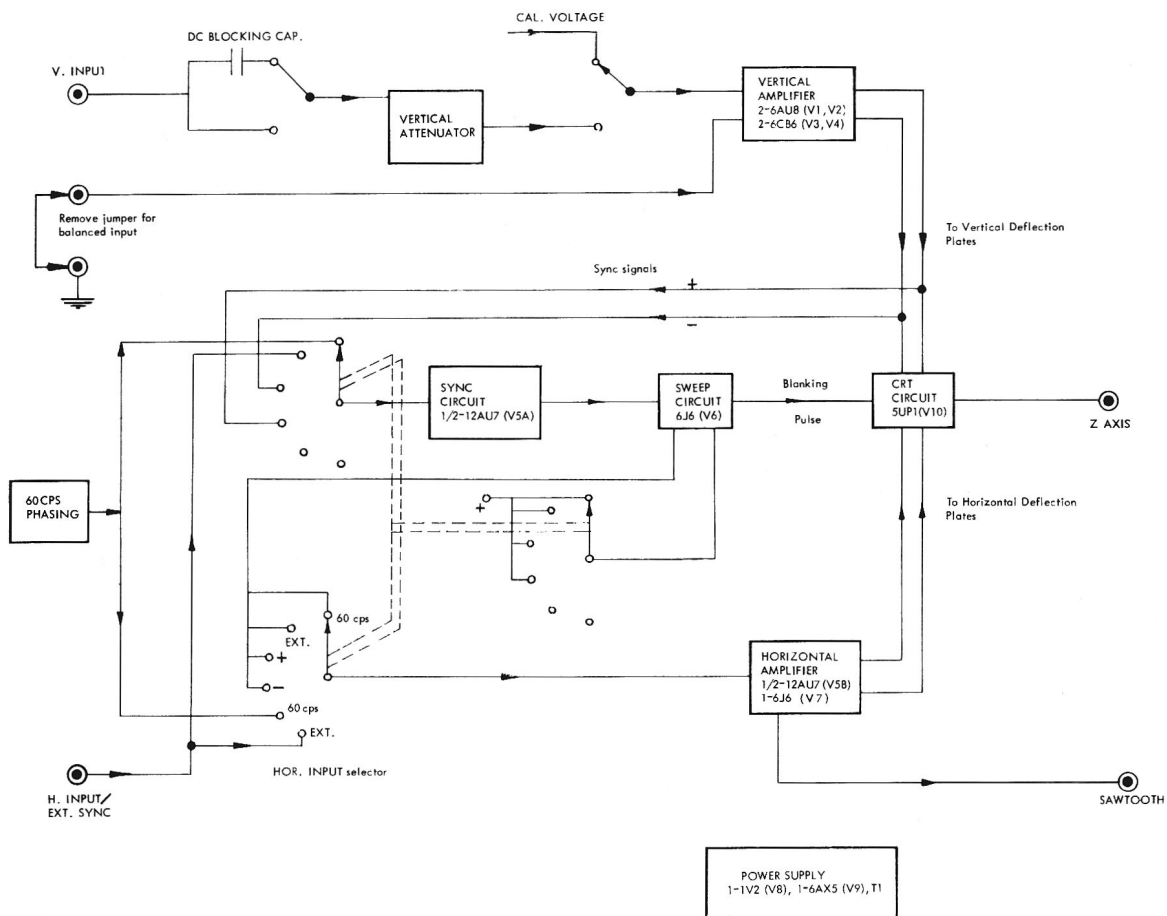

BLOCK DIAGRAM  
Fig. 12

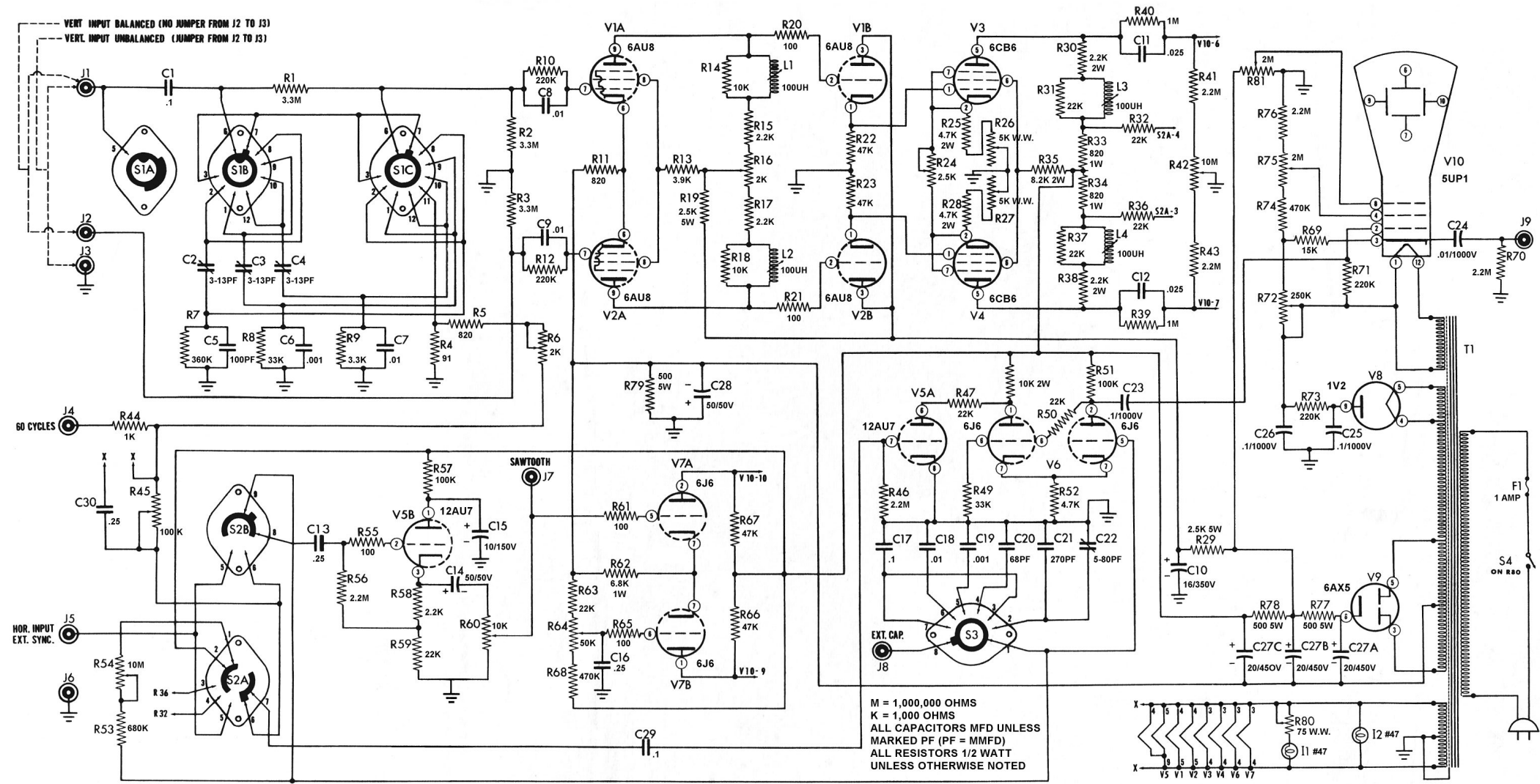

VERT. ATTEN. S1 SWITCH POSITION

	AC				CAL	DC			
	1	10	100	1000		1000	100	10	1
S1A	NC					5 to common rotor of A & B *			
S1B	6-7	6-8	6-9	6-10	NC	6-12	6-1	6-2	6-3
S1C	6-7	6-8	6-9	6-10	6-11	6-12	6-1	6-2	6-3

\* The construction of Switch S1 is such that rotors A and B are electrically connected.



HOR. SELECTOR S2 SWITCH POSITION

	SYNC-SWEEP				HOR.	
	60CPS	EXT	+	-	60CPS	EXT
S2A	1-2 7-6	1-2 7-5	1-2 7-4	1-2 7-3	NC	NC
S2B	8-9	8-9	8-9	8-9	8-6	8-5

SWEEP SELECTOR S3 SWITCH POSITION

EXT. CAP	10-100	100-1K	1K-10K	10K-100K	TV-V	TV-H
1-8	1-7	1-6	1-5	1-4	1-3	1-2

# MODEL 460 DC-WIDE BAND OSCILLOSCOPE