

TECHNICAL MANUAL
MODEL 1615
FREQUENCY COUNTER

*technical
manual*

ELDORADO

ELDORADO ELECTRODATA CORPORATION

935 DETROIT AVENUE - CONCORD, CALIF. 94518 U.S.A. - TEL. (415) 686-4200 - TWX 910-481-9476

TECHNICAL MANUAL
MODEL 1615
FREQUENCY COUNTER

ELDORADO ELECTRODATA CORP.
601 Chalomar Road
Concord, California 94518
Telephone: 415-686-4200
TWX: 910-481-9476

ERRATA
MODEL 1615

Only option P as described on the attached Digital Output Errata is available. Option P1 and P2 have been deleted. The P1 and P2 schematics have been replaced by the P option schematic C-11-09036.

Input A Schematic C-11-05491:

Delete L102 and L106 and replace each with a jumper.

Delete CR109 and R114.

CR113 is an X component and can be either a 1N695 diode, a 10 ohm resistor or a short circuit.

Change C106 from 15 pF to 27 pF.

Change R102 from 102 Ω to 82 Ω .

Change R103 from 430 Ω to 330 Ω .

Change R109 from 270 Ω to 220 Ω .

Change R113 from 62 Ω to 82 Ω .

Change R123 from 820 Ω to 560 Ω .

Count Chain Schematic D-11-05493:

Return R223 (emitter circuit of Q216/Q217) to +12 volts net to -12 volts as shown.

Control and Time Base Logic D-11-05495;

Change R10 from 3.9k to 3.3k.

Change CR7 from 1N695 to 1N3605.

ADDENDUM
OPTION K

Option K provides increased sensitivity and is further broken down into five categories. Option K, K1, K2, K3 and K4. The following table defines the characteristics of each option.

OPTION K

MODEL 1605, 1607

Sensitivity: 5 mV rms
Range: DC - 100 kHz
Channel: A
Overload: 1V rms
Maximum Input: +2V rms
Input Impedance: 50k Ω
Controls: Switch selectable, rear panel.

OPTION K1

MODEL 1615, 1650

Sensitivity: 35-50 mV rms
Range: 20 Hz - 136 MHz
(136 MHz - 200 MHz 100 mV rms)
Channel: A
Overload: 10V rms 20 Hz - 500 Hz
5V rms 500 Hz - 200 MHz
Maximum Input: 20 Hz - 500 Hz, 100V rms
500 Hz - 200 MHz, 10V rms
Input Impedance: 1 M Ω
Controls: Sensitivity control, front panel.
Visual Display: May cause a 1 to appear
in the least significant digit
with no input signal applied.

*OPTION K2

MODEL 1615, 1650

Sensitivity: 50 mV rms
Range: 1 kHz - 200 MHz
Channel: A
Overload: 300 mV rms
Maximum Input: 2.2V rms (+20 dBm)
Input Impedance: 50 Ω
Controls: Automatic

*OPTION K3

MODEL 1615, 1650

Sensitivity: 10 mV rms
Range: 1 kHz - 200 MHz
Channel: A
Overload: 300 mV rms
Maximum Input: 2.2V rms (+20 dBm)
Input Impedance: 50 Ω
Controls: Automatic

*OPTION K4

MODEL 1650

Sensitivity: 10 mV rms
Range: 25 MHz - 500 MHz
Channel: C
Overload: 250 mV rms
Maximum Input: 2.2V rms (+20 dBm)
Input Impedance: 50 Ω
Controls: Automatic

* Options K2, K3 and K4 are exclusive, however both Option K1 and K4 may be installed in one instrument.

K = Standard Eldorado amplifier, see schematic in manual.

K1 = Standard Eldorado amplifier, modified to specified frequency, see schematic in manual.

K2 = Contains 1 each Eldorado High Gain Amplifier, see schematic in manual.

K3 = Contains 1 each Eldorado High Gain Amplifier, see schematic in manual.

K4 = Contains 1 each Eldorado High Gain Amplifier, see schematic in manual.

When K2, K3 or K4 are installed, input levels to ≤ 300 mV for K2 and K3 or 250 mV for K4, are accepted. Inputs > 400 mV for K2 and K3 and 300 mV for K4, applied to the amplifier may cause frequency doubling resulting in erroneous readings. If the input signal exceeds 250 and/or 300 mV some method of attenuation should be used.

When Option K1 is supplied, a 1 in the first digit (LSD) may be present when no frequency is applied.

Return Material Authorization (RMA)

Complete the RMA card and enclose with the returned instrument. To obtain RMA number call or write to:

ELDORADO ELECTRODATA
 601 Chalomar Road
 Concord, California 94520
 c/o Customer Service
 Tel: (415) 686-4200
 TWX: 910-481-9476

RETURN MATERIAL AUTHORIZATION			RMA NO.
NAME			DATE
COMPANY			PHONE
SHIPPING ADDRESS			MODEL
CITY	STATE	ZIP	SERIAL NUMBER
REASON FOR RETURN			
PURCHASING AGENT			
BILLING ADDRESS			
Eldorado Electrodata Corp., 601 Chalomar Road, Concord, California 94520			

In Eldorado's efforts to produce the best in support literature, we would like to know how useful you, our customer, find the Technical Manual. Please complete this questionnaire and drop it in the mail box.

Thank you,
 Publications Department

- Instrument Model _____ Serial Number _____
- Do you operate or maintain this instrument ?
- After reading the Specifications and Introduction Section did you feel that you had an adequate idea of the instrument's capabilities? Yes No
- After reading the Operating Instructions were you able to operate the instrument to your satisfaction? Yes No
- Were you able to calibrate the instrument with the calibration procedure? Yes No
- Are you able to find the information you need on replacement parts in the parts list? Yes No
- What would you like to see in future Eldorado Technical Manuals?

Comments please _____

Name _____ Date _____
 Title _____ MS _____
 Company _____ Tel: () _____
 Address _____ City _____
 State _____ Zip _____

Please:

Contact me regarding _____

Do not contact me, but send literature on _____

- | | |
|---|---|
| <input type="checkbox"/> Time Interval Counters | <input type="checkbox"/> Continuous Reversing Ratiometers |
| <input type="checkbox"/> Time Code Instrumentation | <input type="checkbox"/> Digital Delay Generators |
| <input type="checkbox"/> Computer and Data Terminals | <input type="checkbox"/> Digital Volt/Ohm Meters |
| <input type="checkbox"/> Frequency Counters | <input type="checkbox"/> Power Pack |
| <input type="checkbox"/> Microwave Frequency Counters | <input type="checkbox"/> Universal Counter/Timers |

My application requirements are _____

Product Line Inquiry Card

Use this convenient postage paid card for instrumentation information request.

FIRST CLASS
PERMIT NO. 205
CONCORD
CALIFORNIA

BUSINESS REPLY MAIL

No postage stamp necessary if mailed in the United States

POSTAGE WILL BE PAID BY

**Eldorado Electrodata Corp.
601 Chalomar Road
Concord, California 94520**

FIRST CLASS
PERMIT NO. 205
CONCORD
CALIFORNIA

BUSINESS REPLY MAIL

No postage stamp necessary if mailed in the United States

POSTAGE WILL BE PAID BY

**Eldorado Electrodata Corp.
601 Chalomar Road
Concord, California 94520**

INITIAL TESTING OF UNHEATED
CRYSTAL OSCILLATORS
(Non-Ovenized)

Extensive testing of the aging rates of the unheated type crystal oscillators has recently been completed. Based on this research, verification of the published aging rate can be accurately determined within a reduced time interval. The following procedure will validate the initial aging specifications.

1. Attach a thermometer or temperature sensing device to the crystal case.
2. Apply instrument power for a twenty four hour period.
3. Measure the crystal's external temperature to within 1° C.
4. Measure the crystal oscillator's frequency to within 1 part in 10^7 (0.1 Hz).
5. After one week's continuous operation again measure the crystal temperature and output frequency.
6. The two frequencies will be within 2 parts in 10^6 (2 Hz), taking into consideration a temperature coefficient of $\pm 0.5 \times 10^{-6}/^{\circ} \text{C}$.
7. The above test confirms the published oscillator specifications.

PRELIMINARY

FEDERAL COMMUNICATIONS COMMISSION SUPPLEMENT

SCOPE:

Measurement techniques for Eldorado FCC-type approved frequency monitoring devices in commercial AM and FM broadcast stations.

GENERAL:

The use of instrumentation approved by the FCC as frequency monitors for commercial AM and FM broadcast equipment in itself is not sufficient. Required in addition to type approval is the implementing of the proper measurement techniques to ensure accuracy of measurements as required by the FCC. Because of the wide variations in transmitting and receiving equipment as presently being used in the broadcast industry this supplement cannot discuss all of the possible variations in the application of this equipment as a frequency monitoring instrument. The following outline suggests generally accepted proper measurement techniques. It is assumed that technically competent users will be in operation of this equipment, therefore a detailed discussion of how and why a frequency counter works is not incorporated in this addendum. Technical information on this level is incorporated in the basic text of the associated technical manual.

SAMPLING POINTS AND CAUTIONS:

Frequency and test points are provided by the manufacturer of the transmitting or receiving equipment (refer to the equipment manual). A caution to be offered at this point is to ensure that (1) the input signal to the counter is of sufficient level as defined in the specifications section of this manual to allow accurate measurements and (2) a completely opposite consideration to observe is that this input level does not exceed the capabilities of the input circuitry of the frequency monitoring device. Harm to both personnel and equipment could result if a high level voltage or RF is applied. If high level voltage or RF radiation is present, an inductive pick up with a DC blocking capacitor is an accepted method of sampling the frequency. It is generally not advisable to DC couple the RF source to the frequency counter. Working in a low power oscillator section of a transmitter, a direct connection could load the circuit and inadvertently cause a frequency shift. The output from the frequency doubling or buffer stage is the recommended point to monitor the frequency. Normally sufficient signal is available at this stage to make accurate measurements and a buffer situation exists between the doubler and the primary oscillator. Under no circumstances should a frequency

monitoring device of this type be directly connected to the power amplifier output stage or at the base of the radiating antenna, unless proper safeguards are observed to block the high level voltages and RF energy. Frequency monitors should be connected to the sampler output from the appropriate stage of the transmitter. This monitoring point should be operating on the nominal channel frequency, rather than a submultiple of that frequency.

To prevent erroneous readings the input signals applied to the frequency counter must be of the carrier frequency only at a stage prior to injection of the modulating frequency. Since digital frequency counters count input events they cannot discriminate between CW inputs and MCW inputs. During the period the counter is gated on (gate time) all input signals are counted by the count circuits and ultimately displayed as the input frequency. If the input contains both the carrier frequency and the modulation frequency the counter will count the resultant signal (MCW) rather than the desired CW signal. Therefore, all carrier frequencies should be monitored with zero modulation or at a point prior to modulation injection.

WARM-UP REQUIREMENTS:

Before accurate measurements can be made both the RF source to be measured and the frequency monitor have to warm up and stabilize.

The warm up to stabilize time required by the RF source to be monitored will be detailed in that equipment manual. The Eldorado type-approved instruments require a warm up time of one hour from a cold start. If the Eldorado Frequency Counter has been allowed to remain plugged into active AC mains, even when the instrument has been turned off, the proportional crystal oven has maintained a stabilized temperature, thus allowing accurate measurements to be made within 20 minutes after initial turn on. Because of all solid state construction, it is acceptable to allow the frequency counter to remain on at all times.

CALIBRATION:

It is recommended that a 6 month scheduled calibration cycle be established to ensure stability and accuracy of readings as required by the FCC. The governing accuracy factor being the 1 MHz crystal controlled time base. This 1 MHz crystal oscillator should be checked against a frequency standard with a stability rating better than the oscillator stability supplied in this instrument (normally five to ten times more accurate).

COLD START TESTS

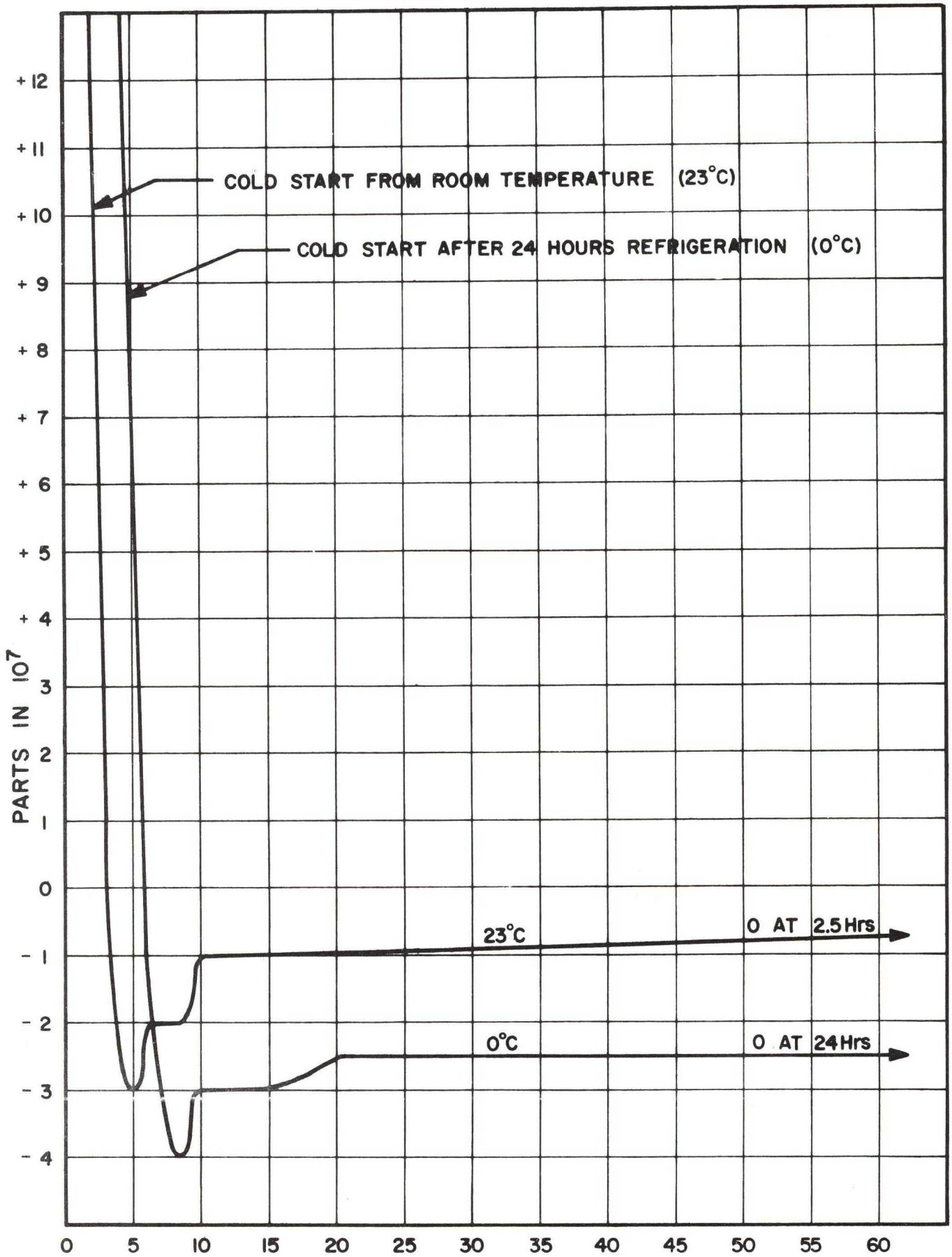

C & C1 OPTION OSCILLATOR

WARRANTY

Eldorado instruments are warranted during a period of one year from date of shipment to original purchaser to be free from defects in material and workmanship. The liability of Eldorado under this warranty is limited to replacing or repairing any instrument of component thereof which is returned by Buyer and has not been subjected to misuse, neglect, improper installation, repair, alteration, or accident. Eldorado shall have the right of final determination as to the existence and cause of a defect. In no event shall Eldorado be liable for collateral or consequential damages. This warranty is in lieu of any other warranty, express, implied, or statutory, and no agreement extending or modifying it will be binding upon Eldorado unless in writing and signed by a duly authorized officer.

RECEIVING INSPECTION

Every Eldorado instrument is carefully inspected and is in perfect working order at the time of shipment. Each instrument should be checked as soon as received. If the instrument or packing case is damaged in any way or fails to operate, a claim should immediately be filed with the transportation company. In any case where damage occurs in transit, Eldorado's obligations under warranty are dependent on the customer's immediately notifying the carrier, so that inspection can be made and a claim filed.

REPAIRS

Experienced service personnel and special test equipment are available at the factory to perform any necessary repairs. Every effort will be made to expedite the repair of instruments returned for servicing. Repair work will be performed only upon receipt of a written purchase order or authorization. Instruments to be repaired should be addressed to SERVICE AND REPAIR DEPARTMENT with transportation charges prepaid. Repaired instruments will be returned to the purchaser with transportation charges collect.

Please specify both model and serial number in all correspondence concerning Eldorado instruments. Address all inquires regarding Eldorado instruments to your nearest sales representative or Marketing Manager, Eldorado Electronics Company, 601 Chalomar Road, Concord, California 94520.

The information necessary to complete this page appears on the serialized name plate located on the rear panel of the instrument.

This manual is packaged with Model 1615 Serial Number _____.

The following options are incorporated into this instrument.

- Option C
- Option D
- Option E
- Option P1
- Option R6
- Option Y2

Special Modification Number _____.

Model Number and Option Legend

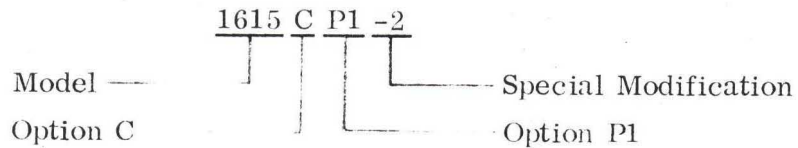

TABLE OF CONTENTS

		PAGE
SECTION 1	INTRODUCTION AND SPECIFICATIONS	
1.1	General	1-1
1.2	Specifications	1-2
SECTION 2	INSTALLATION AND OPERATION	
2.1	General	2-1
2.2	Incoming Inspection	2-1
2.3	Installation	2-2
2.4	Operation	2-3
SECTION 3	THEORY OF OPERATION	
3.1	General	3-1
3.2	Block Diagram	3-1
SECTION 4	MAINTENANCE AND CALIBRATION	
4.1	General	4-1
4.2	Preventive Maintenance	4-1
4.3	Test Procedure/Calibration	4-2
4.4	Parts Removal and Replacement Techniques	4-5
SECTION 5	PARTS LIST	
5.1	General	5-1
5.2	Ordering Information	5-1
SECTION 6	SCHEMATICS	

LIST OF ILLUSTRATIONS

- Model 1615 Simplified Block Diagram
- Model 1615 PCB Component Layout
- Integrated Circuits Schematic Equivalents MC715P - MC725P
- Integrated Circuits Schematic Equivalents MC726P - MC787P
- Integrated Circuits Schematic Equivalents MC788P - MC799P
- Integrated Circuit Schematic Equivalent MC1013
- Integrated Circuit Schematic Equivalent $C\mu L9958$
- Integrated Circuit Schematic Equivalent $C\mu L9959$
- Integrated Circuit Schematic Equivalent $C\mu L9960$
- Schematic, Input A C-11-05491
- Schematic, Count Chain and Display D-11-05493
- Schematic, Time Base and Control D-11-05495
- Schematic, Option P D-11-09036
- Schematic, Power Supply C-11-05384

LIST OF TABLES

TABLE	TITLE	PAGE
1-1	Options	1-5
2-1	Operating Controls	2-2
2-2	Option P1, Connector Wiring	2-5

OPTION D and E
HIGH STABILITY OSCILLATOR

D.1 INTRODUCTION

Options D and E incorporate an oven-heated high stability oscillator in place of the standard 1 MHz crystal oscillator. The output frequency of the oscillator is 5 MHz requiring the addition of a divider to produce the required 1 MHz clock signal to the time base circuits.

D.2 SPECIFICATIONS OPTION D

Internal temperature controlled crystal oscillator.

Short Term Stability: 5 parts in 10^{10} (peak-to-peak) over a 7 minute period.

Long Term: 2 parts in 10^9 per day after 48 hours continuous operation.

Temperature: 2 parts in 10^{10} per ° C (average) over a temperature range of 0° C to +50° C.

Retrace: 5 parts in 10^9 of previous frequency after 60 minutes operation following a 24 hour off time.

D.3 SPECIFICATIONS OPTION E

Internal temperature controlled crystal oscillator.

Short Term Stability: 5 parts in 10^{10} (peak-to-peak) over a 7 minute period.

Long Term: 1 part in 10^9 per day after 48 hours continuous operation.

Temperature: 2 parts in 10^{10} per ° C (average) over a temperature range of 0° C to +50° C.

Retrace: ± 5 parts in 10^9 of previous frequency after 60 minutes operation following a 24 hour off time.

D.4 OPERATION

When Option D or E oscillators are installed additional circuitry is required. See schematic C-11-06115. The oscillator, a 5 MHz crystal, is mounted in an oven and

D.4 OPERATION (Continued)

wired to its own power supply and frequency divider PCB assembly. Oven power is provided by the zener regulated 26V supply. The transformer T1 is mounted on the Power Transformer and connected across one of the primary windings. The 5 MHz output (pin 5) from the oscillator is routed to the frequency divider via pad 2 of the PCB and the driver amplifier Q4. The frequency divider consist of a J-K Flip-flop (an MC826P integrated circuit) and a Dual J-K Flip-flop (an MC891P integrated circuit) wired in a divide-by-five configuration. The 1 MHz output (pad 8) is coupled to the shaper amplifier circuit Q1/Q2 of the time base and control logic circuits (D-11-05495).

D.5 CALIBRATION

Calibration of the D Option oscillator is similar to the standard oscillator calibration procedure as outlined in Section 4 (para. 4.3.2). The 1 MHz frequency standard should, however, be at least five times the accuracy of the D Option oscillator.

D.6 PARTS LIST

Reference	Description	Mfr.	Mfr. No.	EE No.	Qty.
	Divider PCB Assy.	EE	C-33-06108	046108	1
C1	Capacitor, Electrolytic 50 μ F, 50 wvdc	Sprague	TE1307	000298	1
C2, 3	Capacitor, Ceramic .02 μ F, 100 wvdc	Sprague	TGS20	000176	2
C4	Capacitor, Film .01 μ F, 50 wvdc	GE	65F-10A-103C	000163	1
CR1	Diode	Motorola	1N5254A	003475	1
MC1	Integrated Circuit J-K Flip-flop	Motorola	MC826P	000872	1
MC2	Integrated Circuit Dual J-K Flip-flop	Motorola	MC891P	003430	1
Q3	Transistor NPN	Motorola	MJE520	003274	1
Q4	Transistor NPN	Fairchild	2N3646	001731	1
R1, 5, 7	Resistor, Fixed Carbon 680 Ω , 1/4W, 5%	AB	CB6815	001096	3
R2	Resistor, Fixed Carbon 1K, 1/4W, 5%	AB	CB1025	001098	1
R6	Resistor, Fixed Carbon 470 Ω , 1/4W, 5%	AB	CB4715	001092	1
T1	Transformer	Stancor	P-8395	003679	1
Z1	Rectifier	Motorola	MDA920A-2	003053	1
*	Oscillator, 5 MHz Option D	Austron	1100-2	003119	1
*	Oscillator, 5 MHz Option E	Austron	1100-1	003509	1

* Not located on the Divider PCB

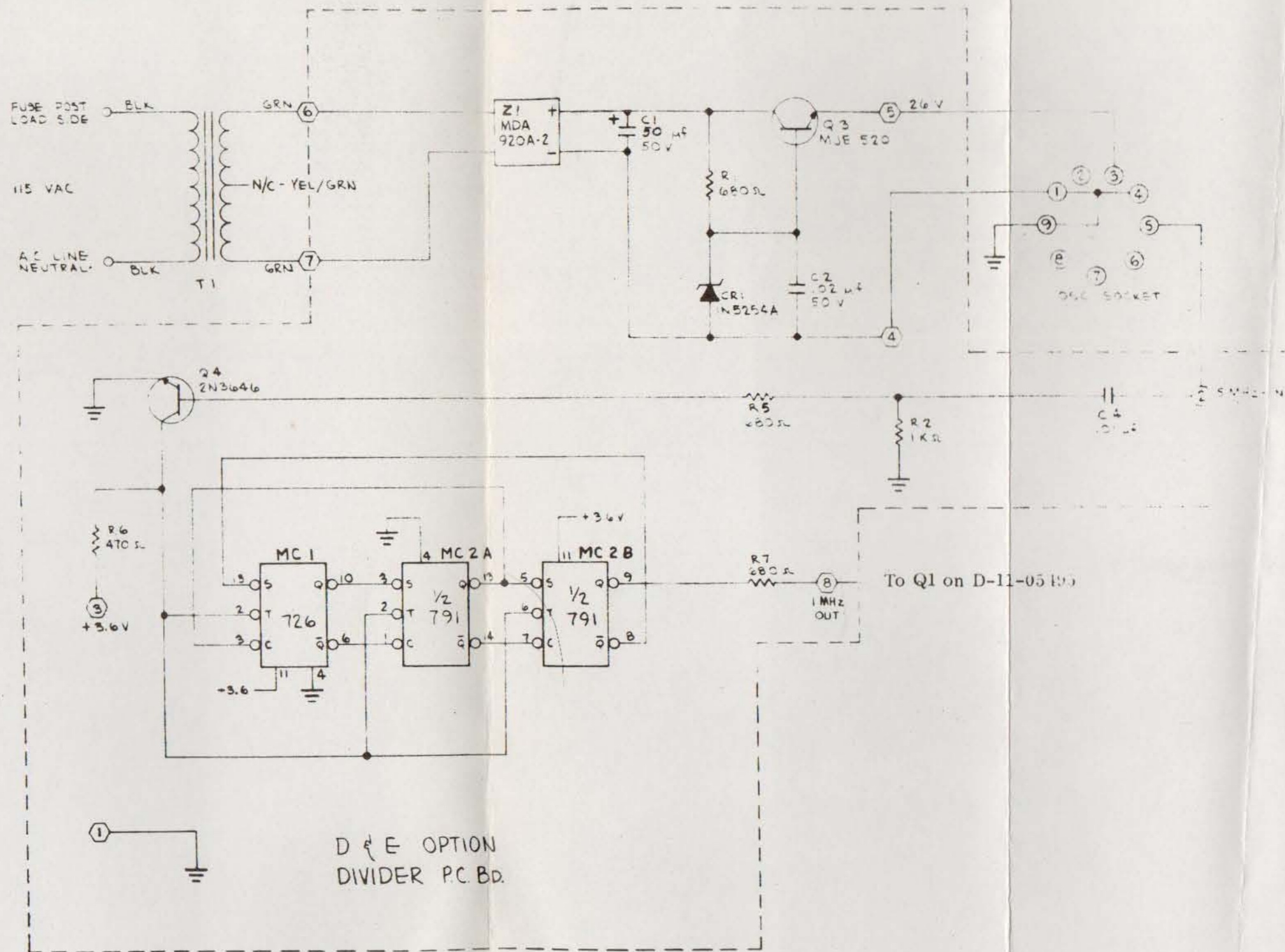

MODEL 1615
 D and E OPTION
 MILLER ELECTRONICS

SECTION 1
INTRODUCTION AND SPECIFICATIONS

SECTION 1

INTRODUCTION AND SPECIFICATIONS

CRYSTAL OSCILLATOR	STORED DISPLAY
INTEGRATED CIRCUITS	0.01 Hz
HIGH INPUT IMPEDANCE	VARIABLE GAIN
LOW POWER	LIGHT WEIGHT

SELF TEST FUNCTION

1.1 GENERAL

This new general purpose counter uses integrated circuits extensively providing a light, compact, and rugged instrument package with low power consumption and high reliability. The Model 1615 will measure Frequency, Ratio and Totalize.

The 1615 has a maximum counting rate of 200 MHz. Gate times of 1 ms through 100 s provide resolution to 0.01 Hz. A bench mounted instrument, with well defined front panel mounted operating controls, can also be equipped for rack mount installation. The six decade digital display features stored display during the measurement cycle with the readout in kHz and an automatically positioned decimal point.

Optional features include a choice of three high stability oven controlled crystal oscillators for greater stability requirements. Two digital printout options compatible to virtually all recording devices. Expansion of the visual display to eight decades and the previously mentioned rack mounting kit.

1.2 SPECIFICATIONS

FUNCTIONS

Totalize - Frequency - Ratio

TOTALIZE MEASUREMENT

Input: A channel.
 Maximum Count Displayed: 999,999.
 Maximum Counting Rate: 200 MHz.
 Count A: Count on function continuously counts inputs until count off.
 Count Off: Inhibits input.
 Accuracy: Absolute.
 Self Test: Counts internal 1 MHz clock pulses.

FREQUENCY

Input: A channel.
 Frequency Range: 20 Hz to 200 MHz.
 Gate Times: 1 ms, 10 ms, 0.1 s, 1.0 s, 10 s, and 100 s.
 Visual Display: Reads in kHz with automatically positioned decimal point.
 Accuracy: ± 1 count \pm oscillator stability.
 Self Test: Measures 1 MHz internal oscillator frequencies.

RATIO A/B

Inputs: A and B channels.
 Frequency Range:
 A input: 20 Hz to 200 MHz.
 B input: 10 Hz to 2 MHz.
 Visual Display: Indicates $\frac{A}{B}$ x the mode switch setting. 10^3 through 10^8 (1 ms - 100 s mode switch settings).
 Accuracy: ± 1 count of input A \pm trigger error of input B/multiplier.

INPUT CHARACTERISTICS

Channel A

Frequency and Ratio Numerator input.
 Frequency Range: 20 Hz to 200 MHz.
 Sensitivity: 100 mV rms for sinewave input. 0.3V peak for positive or negative inputs ($\frac{1}{2}$ ns minimum width).

INPUT CHARACTERISTICS

Channel A (continued)

Dynamic Range:	Typically > 40 dB.
Maximum Operating Input:	10V rms < 500 Hz, 5V rms > 500 Hz.
Maximum Input Without Damage:	100V rms < 500 Hz, 10V rms > 500 Hz.
Coupling:	ac.
Impedance:	~ 1 Megohm shunted by 20 pF.
Gain Control:	Variable control permits changing input sensitivity from 100 mV rms to 10V rms.
Connector:	Front panel mounted BNC.

Channel B:

Frequency Range:	External Time Base input and Ratio denominator. dc to 2 MHz.
Sensitivity:	1.0V rms for sinewave inputs, 1.5V peak for positive pulses (250 ns minimum width).
Maximum Operating Input:	5V rms.
Maximum Input Without Damage:	50V rms.
Coupling:	dc.
Impedance:	~ 5k Ω .
Switch Selection:	Front panel slide switch must be in the Input B position.
Connector:	Front panel mounted BNC.

1 MHz OSCILLATOR STABILITY

Aging rate after 30 days operation:	$\pm 1 \times 10^{-6}$ /month.
Temperature:	$\pm 2 \times 10^{-5}$ over 0° C to +50° C range. (Total 4×10^{-5} over 0° C to +50° C.)
Line Voltage:	$\pm 1 \times 10^{-6}$ for 10% change.
Signal Output:	1 MHz, ≈ 1 V rms, < 1k Ω source. Available at B input connector when switched to Int. Osc. position. When option C, D or E oscillators are installed output signal amplitude is ≈ 2 V peak-to-peak.

EXTERNAL OSCILLATOR

Connector:	Switch selectable. Front panel switch selects either use of the internal oscillator or use of an external oscillator. Signal applied to B Channel Input. See Channel B input characteristics. Front panel mounted BNC.
------------	---

RESET

Automatic: After display time.
Manual: Front panel pushbutton.

VISUAL DISPLAY

Numerical: Six decades of in-line long life digital display indicators with automatically positioned decimal point. Readings are in kHz.
Gate: Gate lamp indicates count gate open.
Display Time: Continuously variable from less than 0.1 second to approximately 10 seconds independent of gate time. Display time control includes an infinite display time position.
Storage: Display storage holds readings between samples.

POWER REQUIREMENTS

115Vac $\pm 10\%$, 50-60 Hz or 230Vac $\pm 10\%$, 50-60 Hz; selection of 230Vac provided by internal wiring change. Power, 42 watts.

ENVIRONMENTAL

Operating: 0° C to +50° C.
Storage: -55° C to +80° C.

MECHANICAL

Dimensions: 3.5" x 8.4" x 11" (HxWxD) without bail.
6" x 8.4" x 11" (HxWxD) with bail extended.
Weight: Net 6 lbs. Shipping 12 lbs.

ACCESSORIES SUPPLIED

1 each 3 to 2 prong cord adapter.
1 each Technical Manual.

TABLE 1-1
OPTIONS

- OPTION C: Internal 1 MHz crystal oscillator. Available only with 115 Vac operation. Provides oscillator stability of:
 Short Term: $\pm 7 \times 10^{-9}$ average per 10 second period.
 Long Term: $\pm 3 \times 10^{-8}$ /week after 45 days operation.
 Temperature: $\pm 5 \times 10^{-9}/^{\circ}\text{C}$ over temperature range of 0°C to $+50^{\circ}\text{C}$.
 Adds 14 watts to power consumption.
- OPTION C1: Same as C above except available only with 230 Vac operation.
- OPTION D: Internal 1 MHz crystal oscillator provides osc. stability of 2×10^{-9} /day.
- OPTION D1: Same as D above except available only with 230 Vac operation.
- OPTION E: Internal 1 MHz crystal oscillator provides osc. stability of 1×10^{-9} /day.
- OPTION E1: Same as E above except available only with 230 Vac operation.
- OPTION K: Provides improved sensitivity to 200 MHz without rolloff capacitor; separate channel input, switch selectable. See K option Addendum.
- OPTION N: Provides Channel C overload protection; input line fused (120 mA).
- OPTION P1: Provides BCD output at rear panel connector. Positive true, positive zone logic. Binary "0" = 0V nominal, binary "1" = +5V nominal. Source is DTL with Vcc at +5V with $2\text{k}\Omega$ pullup.
 Reset Inhibit: Negative inhibit is 0V or more negative. Release is +1 to +5V or open circuit. Sink current is 3mA @ 0V; a diode clamps negative levels to ground through 100Ω .
 Positive inhibit is +2.5V to 15V into $2\text{k}\Omega$. Release is 0V or open circuit.
 Print Command: Positive going step at the end of the count cycle from 0V to +5V nominal with rise time less than 1 microsecond. Source is either saturated transistor to ground ("0") or saturated transistor to +5V ("1"). Series resistance 100Ω .
 Connector: Amphenol 50 pin #57-40500.
- OPTION R6: Provides rack mounting hardware for mounting in a 19" rack width.
- OPTION R8: Provides rack mounting hardware for 2 instruments side by side in a 19" rack width.
- OPTION Y1: Expands visual display to seven decades.
- OPTION Y2: Expands visual display to eight decades.

SECTION 2
INSTALLATION AND OPERATION

SECTION 2

INSTALLATION AND OPERATION

2.1 GENERAL

This section describes Incoming Inspection, Installation, and Operation of the Model 1615 Frequency Counter.

2.2 INCOMING INSPECTION

Prior to packaging for shipment, this instrument received extensive operational, alignment and calibration tests, and was in perfect working order.

Upon receipt a visual inspection for damage incurred in shipment, and an inventory of the package contents as listed on the packing slip should be made. If the instrument has been damaged, notify carrier immediately (see warranty).

2.2.1 Incoming Operational Check

The following procedure outlines an overall operational check of the instrument. No special test equipment or tools are needed.

- a. Connect the instrument to the proper ac power source.
- b. Place the Power ON/OFF Switch to the ON position.
- c. Position the Display potentiometer at a minimum setting.
- d. Place the oscillator selector switch to the internal oscillator position.
- e. Place the "Test/Normal" Switch to the Test position.
- f. Place the Mode Switch to the Count Off position.
- g. Place the Mode Switch to the Count A position and observe the display. Count will accumulate.
- h. Place the Mode Switch to the Frequency 1 ms position. Observe the display reads 001000.* or 00001000.* for eight digit instruments.
- i. Place the Mode Switch to the Frequency 10 ms position. Observe the display reads 01000.0* or 0001000.0* for eight digit instruments.
- j. Place the Mode Switch to the Frequency 0.1 s position. Observe the display reads 1000.00 or 001000.00 for eight digit instruments.
- k. Place the Mode Switch to the Frequency 1.0 s position. Observe the display reads 01000.000*.
- l. Place the Mode Switch to the Frequency 10 s position. Observe the display reads 1000.0000*.

- m. Place the Mode Switch to the Frequency 100 s position. Observe the display reads 000.00000*.
- n. This completes the operational check.

* ± 1 count

2.3 INSTALLATION

The Model 1615 is shipped for bench mounting with a self locking elevating bail installed. Only connection to the ac power source and signal input cables are required for installation.

2.4 OPERATION

Operation after initial installation is by front panel controls and switches. A complete description of each control is supplied in Table 2-1.

TABLE 2-1
MODEL 1615 FREQUENCY COUNTER
OPERATING CONTROLS

<u>CONTROLS</u>	<u>FUNCTION</u>
POWER	Power ON/OFF slide switch.
DISPLAY Two Controls	
Time	Display time potentiometer and switch. Varies display time from 0.1 second to 10 seconds, instrument is automatically reset at the end of display time. Also, in the full clockwise position, switch is activated providing an infinite display time and inhibiting the automatic reset function.
Reset	Manual reset pushbutton. Overrides all controls and resets the instrument.

EXT OSC · RATIO

Input B/1 MHz Out

BNC connector allows monitoring of the internal oscillator or injection of: an external reference 1 MHz oscillator or Ratio B channel inputs.

Input B/Int. Osc. Switch

Slide switch selects either use of the internal oscillator (BNC output = 1 MHz) or use of: an external oscillator or Ratio B inputs.

COUNT A · FREQ A · RATIO

A channel input controls

Gain

Channel A input sensitivity control, provides variable trigger level from 100 mV rms to 10V rms.

NORM · TEST

Normal/Test function switch. Provides coupling to the input circuits. In the TEST position connects the internal 1 MHz oscillator to the input circuits removing any signal input on the BNC. In the NORMAL position routes Input BNC to Input Circuits.

Input A

A channel input BNC connector. 1 M Ω impedance.

FREQUENCY A (kHz)

Mode Switch

Eight position rotary switch programs instrument to a mode of operation.

Provides for:

Count A/Count Off. Places instrument in Totalizer Mode. Count A provides continuous accumulation of input A signals. Count Off inhibits the input.

1 ms. Time base setting for frequency measurements. Provides for 1 kHz resolution of input A signals, also positions decimal point.

10 ms. Time base setting for frequency measurements. Provides for 100 Hz resolution of input A signals and positions the decimal point.

0.1 s. Time base setting for frequency measurements. Provides for 10 Hz resolution of input A signals and positions the decimal point.

1 s. Time base setting for frequency measurements. Provides for 1 Hz resolution of input A signals and positions the decimal point.

10 s. Time base setting for frequency measurements. Provides for 0.1 Hz resolution of input A signals and positions the decimal point.

100 s. Time base setting for frequency measurements. Provides for 0.01 Hz resolution of input A signals and positions the decimal point.

GATE

Gate indicator lamp. Provides front panel display of gate open time.

VISUAL DISPLAY

Provides six decades of in-line digital display indicators (eight with option Y2) with decimal point. Display reads in kHz in all positions of the mode switch.

TABLE 2-2
OPTION P, CONNECTOR WIRING

PIN NO.	FUNCTION	PIN NO.	FUNCTION
1	10^0 1 bit	26	10^0 4 bit
2	10^0 2 bit	27	10^0 8 bit
3	10^1 1 bit	28	10^1 4 bit
4	10^1 2 bit	29	10^1 8 bit
5	10^2 1 bit	30	10^2 4 bit
6	10^2 2 bit	31	10^2 8 bit
7	10^3 1 bit	32	10^3 4 bit
8	10^3 2 bit	33	10^3 8 bit
9	10^4 1 bit	34	10^4 4 bit
10	10^4 2 bit	35	10^4 8 bit
11	10^5 1 bit	36	10^5 4 bit
12	10^5 2 bit	37	10^5 8 bit
13	10^6 1 bit	38	10^6 4 bit
14	10^6 2 bit	39	10^6 8 bit
15	10^7 1 bit	40	10^7 4 bit
16	10^7 2 bit	41	10^7 8 bit
17	Decimal 1 bit	42	Decimal 4 bit
18	Decimal 2 bit	43	Decimal 8 bit
19	Legend 1 bit	44	Legend 4 bit
20	Legend 2 bit	45	Legend 8 bit
21	NC	46	NC
22	+ Inhibit	47	- Inhibit
23	+ Print Command	48	NC
24	0 Volts (low reference)	49	NC
25	+5 Volts (high reference)	50	Ground

NOTES:

- 10^0 is the least significant digit and appears as the digit farthest to the right.
- When the number of digits in the instrument exceeds eight the decimal point location data is not available and the binary data word substituted.
- Binary Data Word. 1-2-4-8 BCD, positive true positive zone. Binary "0" = 0V nominal, binary "1" = +5V nominal. Source is DTL with Vcc at +5V with 2K Ω pull-up.
- Decimal Point and Legend - One digit each, 1-2-4-8 BCD, binary "0" = 0V nominal, binary "1" = +5V nominal. Output resistance is 2K Ω
- Print Command - Positive going step at the end of the count cycle from 0V to +5V nominal with rise time less than 1 microsecond. Source is either saturated transistor to ground ("0") or saturated transistor to +5V ("1"). Series resistance 100 Ω .
- Reset Inhibit - Negative inhibit is 0V or more negative. Release is +1 to +5V or open circuit. Sink current is ≈ 3 mA @ 0V; a diode clamps negative levels to ground through 100 Ω .
Positive inhibit is +2.5V to 15V into 2K Ω . Release is 0V or open circuit.
- Output connector is Amphenol 57-40500; mating connector is Amphenol 57-30500.
- Printer Format - Standard LDXXXXXXXXX:
L = Legend
1 = μ s, 2 = ms, 3 = s, 4 = MHz, 5 = kHz.
D = Decimal Point, position from right.

SECTION 3
THEORY OF OPERATION

SECTION 3

THEORY OF OPERATION

3.1 GENERAL

This section of the manual describes the Model 1615 Frequency Counter theory of operation from a block diagram analysis.

The Model 1615 Frequency Counter is designed to perform frequency measurements to 200 MHz, with time base selections of 1 ms through 100 seconds in decade steps, and to perform totalizing of random events at rates to 200 MHz. Operation in either the Count Mode or frequency mode is controlled by the front panel Mode switch which programs respective circuits throughout the instrument. Ratio measurements are also possible in the frequency modes when an external signal is applied to the external oscillator input (B input) connector.

The visual display is presented on six in-line digital display indicators with automatic decimal points for a reading in kHz. Stored display is featured with updating, once per measurement, accomplished by a store command pulse. Display Time, independent of gate time, is variable from 0.1 second to 10 seconds with a switched infinite position. Reset is automatic and produced by the trailing edge of the display time pulse. In the infinite display setting automatic reset is not produced and the instrument requires a manually generated reset trigger.

3.2 BLOCK DIAGRAM

A simplified block diagram is shown on figure 3-1, for more detailed circuit description and identification of circuit components and locations refer to the respective schematics. As shown on figure 3-1 the Model 1615 consist of: The Input Circuits; the Time Base and Control Circuits and the Count Chain Circuits.

The input circuits consists of a high gain, wide band frequency amplifier. Inputs from 20 Hz to 200 MHz over a dynamic sensitivity range of 100 mV rms to 10V rms are readily accepted. A unique combination of input attenuators, variable gain control, and frequency compensation provide for wide band amplification with high noise rejection capability.

The time base and control circuits develop: the time base gates, 1 ms through 100 seconds, for frequency measurements; gate control, for count measurements; the store command; print command and automatic reset signals.

The count chain circuits perform: counting of the input signal, storage, and converting it to decimal data for display on the visual digital display indicators.

3.2.1 Circuit Operation

Operation is in two basic modes, i. e. Count or Frequency. A third mode of operation is the Ratio Mode which is similar to operating in the Frequency Mode. In either mode of operation count signal flow through the Input Circuits is controlled (gated) by the Start Stop Flip-flop in the Control Logic: In the "count" mode this gate is manually produced by manipulation of the Mode switch. In the "Count A" position the Start Stop Flip-flop is set (gate on) and in the Count Off position the flip-flop is reset (gate off). In the Frequency Modes the gate is automatically controlled by the time base counter circuits. The input circuits are gated on at Start time and off at Stop time. At Stop time the BCD data is transferred to the storage circuits, decoded and coupled to the visual display indicators. Unless placed in the infinite display setting a new measurement cycle is automatically initiated with the reset signal.

3.2.2 Input Circuits Operation (see Input A Schematic C-11-05491)

The input trigger amplifier consist of: The input attenuators, and limiter network; the wide band input amplifier stage; the shaper amplifiers and count chain driver and the gate circuits.

Input signals are coupled to Q101 the input FET amplifier via the input attenuator and gain control network. The gain control potentiometer R127 functions as a voltage divider for the attenuator network bias control. The input signal is developed across the variable impedance produced by the relative conduction state of the attenuator diodes CR103 and CR104. Increasing the conduction of the attenuator diodes reduces the load impedance and thus increases the attenuation. Dual attenuation with both high and low frequency compensation provides a more uniform flat response over and entire band. The attenuator network performs the dual function of gain control and limiting, thus preventing overdriving of the input amplifier. Less than unity gain is realized with limiting (due to CR103 and CR104) occurring at 0.7 volts.

The input FET Q101 and amplifier stages Q102, Q103 and Q104 function as a wide band amplifier with an overall gain of ten. DC feedback coupled through Q111 compensates for any temperature drift experienced in the amplifier. Q111 is a comparator stage and monitors the output of Q104. Q111's output is filtered by the frequency bypassing

action of C112, 113 and 114. Both high and low frequency compensation is employed to provide a flat response over the entire band.

Q104's output is coupled to the dual schmitt trigger shaper stages Q105-Q108. Operation of Q105, 106 is controlled by the gate signal applied to the gate switch Q110. During gate on time Q110 is turned off which allows the schmitt trigger to operate. At gate off time Q110 is turned on thereby gating off the schmitt trigger stage.

The output from the shaper circuits is coupled to the emitter follower ring driver amplifier Q109. Q109 performs the dual function of producing the count signal to the count chain and setting the quinary ring bias level. R105 the ring counter level adjust is set to provide optimum triggering of the ring counter for all count ranges.

R105 should not require adjustment and normally should not be adjusted in the field. A rough alignment of R105 can be obtained by making note of the position of R105 at 20 Hz and 200 MHz that allows the counter to operate correctly at both frequencies for the same adjustment setting.

3.2.3 Time Base and Control Logic Operation. (see Time Base schematic D-11-05495)

The Time Base and Control Logic contains: The 1 MHz reference oscillator circuits; the time base dividers; the store command generator; the display timer, manual and automatic reset generator; and the control logic.

The time base circuits are continuous running frequency dividers. The time base gate selected is determined by the mode switch setting. Opening the gate permits accumulation of input counts whereas closing the gate stops the counting action and produces the store command signal and display timer enabling. The end of the display cycle generates the automatic reset signal which initiates a new measurement cycle. In the "Count" mode the control circuit is continuously enabled producing a gate on condition and the storage command signal line is held in an enable state allowing the count chain to follow the accumulating count procession in the count chain.

1 MHz Reference Oscillator Circuitry. The reference oscillator is a modified 1 MHz crystal controlled colpitts oscillator. The 1 MHz crystal and Q1 through Q4 make up the oscillator circuits. Q1 an FET source follower provides the amplification and feedback to sustain oscillations with Q2 an emitter follower providing, isolation for the

frequency determining circuits and drive to the load. The 1 MHz Test signal is also taken from this output. The clock output is ac coupled to the shaper Q3 and 4 through the Int/Ext oscillator selector switch. J3 the internal monitor/external input (B input) connector is also wired to this junction. The shaped clock output from the collector of Q4 is used to drive the divide-by-1000 counting unit.

Time Base Counter. The time base counter contains a divide-by-1000 counting unit and five DCU's interconnected in cascade to provide gate times of 1 millisecond to 100 seconds. In frequency operation these are selected by the mode switch. Clock outputs of 1 millisecond, 10 milliseconds, 0.1 seconds, 1 second, 10 seconds or 100 seconds are coupled as start and stop signals to the start stop control flip-flop here-in-after referred to as the control flip-flop. The divide-by-1000 CU contains 10 cascaded binaries, MC1 - MC5 with feed back to stages 4 and 5, which produce an output for every 1000 clock inputs. This 1 millisecond clock is coupled to the 10 millisecond DCU (MC10 and MC11) and the mode switch. The output of the 10 millisecond DCU is coupled to the 0.1 second DCU (MC8 and MC9) and the mode switch. The output of the 0.1 second DCU is coupled to the 1 second DCU (MC6 and MC&) and the mode switch. The output of the 1 second DCU is coupled to the 10 second DCU (MC14 and MC15) and the mode switch. The output of the 10 second DCU is coupled to the 100 second DCU (MC12 and MC13) and the mode switch. The mode switch is an eight position rotary switch. In the frequency mode positions the clock output from the time base counters is routed via the mode switch, to the control flip-flop.

3.2.3.1 Control and Display Flip-flop Operation. The control and display flip-flops are derived from an MC790P Dual J-K Flip-flop integrated circuit. After reset both flip-flops are enabled and will toggle on negative going inputs. The first clock output after reset from the time base counter (1 ms through 100 s whatever) sets the control flip-flop. This complements the output levels, (pin 8 goes low and pin 9 goes high) and gates on Q5, the gate lamp driver, and the input circuits gate shaper Q6 and Q7. The gate lamp provides visual indication, at the front panel, of gating action. The input gate shaper couples an inhibit gate to Q111 of the input circuits thereby allowing input signals through to the count chain by gating Q111 off. The next clock input (negative transition) to the control flip-flop toggles it back to the reset state. Complementing the control flip-flop from the set state to the reset state couples a negative going trigger to the display flip-flop which sets it, and enables the store command circuits. Setting the display flip-flop inhibits the control flip-flop and enables the display timer.

The display flip-flop inhibits the control flip-flop until the reset signal resets the display flip-flop. At the end of the display time a reset pulse is generated. This returns all circuits to a normal state and allows a new measurement cycle by removing the inhibit level applied to the control flip-flop.

3.2.3.2 Store Command. The store command circuits consist of: The input gate MC17D, the one shot trigger circuit C8, R22-24 and CR7 and the 8 microsecond one shot MC16A and C7. The closing of the gate (resetting the control flip-flop) enables MC17D. MC17D's output is differentiated by R24 and C8 and coupled as the negative trigger pulse via CR7 to the store command one-shot MC16A. MC16A is an MC788P wired in a one-shot configuration with regenerative feedback through C8 holding it on for approximately 8 microseconds. The 6 to 8 microsecond pulse output from MC16A is routed to the count chain buffer storage elements as the store command signal. This transfers the stored data to the visual display circuits.

3.2.3.3 Display Timer and Reset Generator Operation. Setting the display flip-flop complements its output with pin 14 going low and pin 13 going high. This performs the dual function of inhibiting the start flip-flop, thus preventing the continuous clock outputs from the time base from generating a new measurement; and turns Q9 on which enables the display timer circuits. The display timer is basically a relaxation oscillator comprised of: The display time control potentiometer R34, the timing capacitor C13 and the switching element Q11 a uni-junction transistor (UJT). The switch S3 is concentric with the display potentiometer and is opened in the full clockwise position of the control. This inhibits display timer action and requires a manual reset to initiate a measurement cycle.

In the quiescent state: Q10 is off, Q11 is off and the capacitor C13 is in a neutral state (no charge). Setting the display flip-flop turns on Q10 and allows the timing capacitor to charge through the high resistive path of the display potentiometer and R32. When the charge on C13 reaches the emitter peak point voltage Q11 turns on. This discharges the timing capacitor through the relatively low resistance of the UJT and develops the trigger pulse for the reset generator. MC16B (the other half of the store command chip) is also wired in a one-shot configuration and provides a reset pulse approximately 28 microseconds wide. This signal is coupled through the emitter follower reset line driver Q12 and distributed throughout the instrument.

3.2.3.4 Gate Shaper Circuits Q6 and Q7. The gate shaper compensates for gating ambiguity caused by the fall time characteristics of the gate off signal. The gate on gate off rise and fall time constants are very different with a much longer fall time for the gate off signal as compared to the gate on rise time. This non-linearity, when used to gate increments at 5 nanosecond (200 MHz) rates, can cause counting errors as great as ± 4 counts. Q6, Q7 and C6 function as an integrating network and is used to delay the rise time characteristics of the gate on signal. Integrating the leading edge of the gate allows for balancing the inequities between the two edges; and permits adjustment of the gate to within ± 1 count errors. Q6 is normally a factory adjust (requiring a phased locked signal) and should not require field calibration.

3.2.4 Count Chain and Display Circuits (see schematics D-11-05493).

The count chain circuits consist of the decade counters, decoding matrices and storage elements for counting the input signals and providing the necessary binary to decimal conversion for stored display of the decoded information.

3.2.4.1 The decade counters consist of six cascaded DCU's (decade counting units). In the first DCU's, due to the high speed requirement, a combination of discrete and micrologic circuitry is employed.

The 10^0 DCU is a Qui-binary discrete circuit with Q220 through Q228 and CR221 through CR225 making up the quinary ring. The N/5 count is coupled via the binary divider Q216 and Q217 to the binary element MC21. The binary weighted information is coupled by the encoding gates, comprised of: the resistive network R225 through R234, the gate transistors Q203 through Q213 and encoding diodes CR201 through CR216; as four line 1-2-4-8 BCD to the storage register MC32.

The 10^1 DCU is a bi-quinary hybrid DCU comprised of MC20 an MC1013P micrologic, and the quinary stage MC18 and MC19. The 1-2-4-8 BCD output is coupled to the Storage register MC33.

The 10^2 through 10^5 DCU's are $C\mu L$ 9958 micrologic decade counters MC39 through MC43.

The 10^0 through 10^5 storage registers are $C\mu L$ 9959 Buffer Storage elements MC32 through MC37. Here the 1-2-4-8 BCD data is stored and coupled to the decoding matrix for visual readout. The store command signal enables the storage elements once each measurement.

cycle (at gate closure time) thus updating the register with the new measurement information.

The 10^0 through 10^5 decoding matrices are C μ L 9960 decimal decoding drivers MC24 through MC29. Here the four line 1-2-4-8 BCD is decoded into a decimal number and drives the appropriate cathode of the gas filled readout tube displaying the number.

3.2.4.2 Decimal Display. The visual display consist of six decades of digital display tubes with built-in decimal point. Which decimal point in which tube lights is controlled by the Mode Switch. See the Time Base and Control Logic Schematic D-11-05495. Section B of S1 is returned to ground and as the mode switch is positioned the appropriate decimal light is turned on in the display tube. See paragraph 2.2.1 for the decimal point location and the visual display for each switch position. This section of S1 also controls the decimal point for printers when printer option P1 or P2 is installed.

3.2.4.3 Count Chain reset. Because of the hybrid nature in circuit construction of the count chain logic, four different reset signals are developed. These are coincident with "Reset" and are shaped and references to particular dc levels for proper reset toggling of the various flip-flops and discrete circuits employed. MC17C, Q218, and Q219 and their respective differentiating circuits provide three separate reset signals for the discrete count chain and the MECL micrologics MC20 and MC21. Q218's output is shaped, to a positive 6 volt reset trigger, by CR205 and C201 and clamped to a -6 volt reference level by CR226. Q218's output is also routed to alternate stages of the quinary ring (Q221 and Q225) via C203. However, R240 and R241 reference this pulse to a -6 volts. The negative going output from Q219 is coupled to the remaining stages (Q223, Q227 and Q229) of the quinary ring via C205. This pulse is reference to +6 volts by R244 and R245. The remaining 10^1 through 10^5 decade counters are reset directly by the reset generator output.

3.2.5 Power Supply Operation (see schematic C-11-05384)

The Model 1615 power supply develops the regulated -12Vdc, +12Vdc, +3.6Vdc and the unregulated 210Vdc voltages. A fourth regulated voltage, a -5.2Vdc is developed by CR226.

The power transformer T1 has a dual primary and can be wired for 230Vac or 115Vac operation. Three secondary windings provide the voltage distribution for the appropriate

outputs. The +12, -12 and +3.6 volt supplies are series regulators and are calibrated by R5 and R7. The -12V supply is the reference source and should be calibrated first.

-12 Volt operation

The -12 volt regulated supply consist of: The fullwave rectifier circuit CR6 and 8 and filter capacitor C4; the series pass element Q4 and the error sense amplifier circuit Q3. CR5 and R5 set the reference bias for Q3. Q3 in turn controls the bias on the series pass element Q4. The conduction of Q4 provides a constant -12 volt output. Any change in the output level is detected by the sense amplifier and applied as a change in bias on Q4. This increases or decreases the conduction (increasing or decreasing the IR drop) of Q4 to compensate for the change and correct it.

+12 Volt operation

The +12 volt supply is similar to the -12 volt supply with R7 providing the calibration control. Q5 is the series pass element and Q6, 7 and 9 the error sense amplifier circuitry.

+3.6 Volt operation

The +3.6 volt supply is regulated but not adjustable. CR4 and R4 provide the reference bias to the error sensing amplifier Q2, thereby, controlling the conduction of the series pass element Q1.

-5.2 Volt operation

The -5.2 volt regulated supply is a zener regulated (CR226) output taken from the -12 volt supply and is used by the MECL logic in 10^0 and 10^1 DCU's in the count chain circuits.

+210 Volt operation

The +210 volt supply is developed by the halfwave rectifier circuit CR1 and R2. The output is applied as the excitation voltage for the digital display indicators.

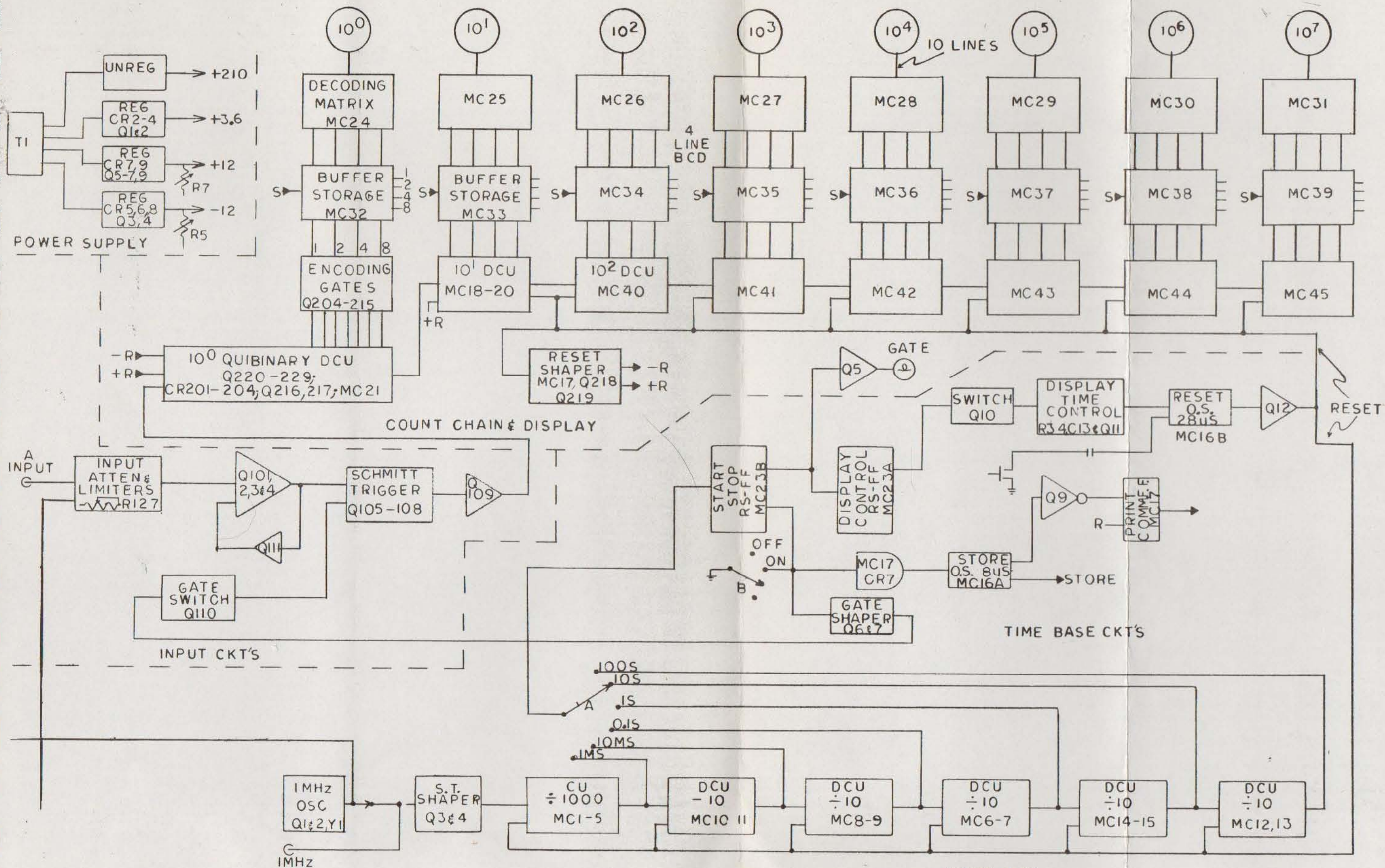

MODEL 1615
 FIGURE 3-1 SIMPLIFIED BLOCK DIAGRAM

SECTION 4

MAINTENANCE AND CALIBRATION

SECTION 4

MAINTENANCE AND CALIBRATION

4.1 GENERAL

This section outlines maintenance test and calibration procedures, component location drawings and parts removal/replacement techniques.

4.2 PREVENTIVE MAINTENANCE

Preventive maintenance is the systematic care, servicing, and inspection of the equipment to prevent the occurrence of trouble, to reduce down time and to assure that the equipment is servicable. When implemented into a meaningful schedule these checks and services provide significant operational data on the instrument to help prevent instrument failure and improve reliability. The severity of the environment will determine the frequency of the maintenance.

4.2.1 Cleaning. Clean the equipment by brushing, wiping with a lint free cloth, vacuuming or by blowing with compressed air. Solvents (non-corrosive) may be used for additional cleaning action if necessary. The following materials, or their equivalents, are used for maintenance.

Lint free cloth

Stiff (non-metallic) bristle brush

Solvent (alcohol and water 50/50)

RP Filter coat

Compressed air (filtered, moisture-and-oil-free, 30 psi maximum)

WARNING: When using solvents provide adequate ventilation and skin protection.

4.2.2 Preventive Maintenance Checks

Monthly (as deemed appropriate) maintenance schedule.

1. Check the tightness and general condition of all external connectors.
2. Operate in the Self Test mode and observe that the mechanical action of each switch is smooth and free of external or internal binding and no excessive looseness is apparent.
3. Check the 1 MHz output with a frequency standard.
4. Check for unobstructed airflow and blower operation.

Quarterly maintenance schedule.

1. Power transformer and power supply. Inspect wiring on the power transformer, inspect filter capacitors, no dirt, corrosion or oil should be evident, check for signs of overheating.
2. Inspect all internal and external connectors for mechanical condition.
3. Inspect the air filter and blower, no dirt, etc.
4. Inspect cords, cables and wires for chafed, cracked or frayed insulation.
5. Perform incoming operational check as outlined in Section 2.

4.3 TEST PROCEDURE/CALIBRATION

Test and calibration of electronic equipment should be performed to maintain optimum overall operational efficiency. Testing, to seek out circuit abnormalities; and calibration, to return the system to within published specifications. Indiscriminate tweaking, probing, etc., is ill advised and rather than improving operation the opposite can result.

A list of test equipment includes: any voltmeter or DVM (3% accuracy), almost any oscilloscope (to 10 MHz) an audio and RF signal generator, a 1 MHz frequency standard and a 200 MHz Multiplier Test Jig (coherent to the 1 MHz time base reference oscillator).

CAUTIONS:

1. This instrument contains transistorized circuits. If any equipment item does not have an isolation transformer in its power supply circuit, connect one in the power input circuit.
2. Never connect test equipment (other than oscilloscopes, multimeters and VTM's) outputs directly to a transistor circuit, use a coupling capacitor.
3. Make test equipment connections with care so that shorts will not be caused by test equipment connectors. When making contact to the circuit under test, tape or sleeve (spaghetti) test prods or clips to leave as little area exposed as possible to minimize inadvertant shorts.
4. The equipment must be turned off before removing any plug-in component PCB, micrologic, transistor, etc.

4.3.1 Power Supply

This unit has five operating voltage from regulated and non-regulated supplies. Test points are identified and screened on the PCB see schematic and PCB component location diagrams.

Apply power (115Vac, 60 Hz) and measure the power supply outputs as listed below:

$$+210\text{Vdc} = +210\text{Vdc} \pm 20\text{Vdc}$$

$$+12\text{Vdc} = +12\text{Vdc} \pm 0.15\text{Vdc}$$

$$+3.6\text{Vdc} = +3.6\text{Vdc} \pm 0.36\text{Vdc}$$

$$-5.2\text{Vdc} = -5.2\text{Vdc} \pm 0.15\text{Vdc}$$

$$-12\text{Vdc} = -12\text{Vdc} \pm .15\text{Vdc}$$

With an oscilloscope check for ripple on the supplies. Ripple should be less than 100 mV/P-P on the +12, -12 and +3.6 volt regulated supplies. The +210 volt supply is used for readout illumination and ripple in excess of 40V P-P is normal.

Power Supply Calibration

The -12Vdc supply is the reference source for both the +12 and +3.6 volt supplies and must be calibrated first.

-12Vdc: Adjust R5 for $-12\text{Vdc} \pm 0.15\text{Vdc}$

+12Vdc: Adjust R7 for $+12\text{Vdc} \pm 0.15\text{Vdc}$

This should bring the +3.6 volts to within ± 0.36 volts of 3.6Vdc.

The -5.2Vdc supply is developed by CR226 a 5.2V zener diode, no adjustment is required. Replace diode if level is out of tolerance.

4.3.2 Time Base Test and Reference Oscillator Calibration

Test the time base circuits for proper counting of the reference oscillator to produce the appropriate time base gates.

- a. Connect an oscilloscope to the Oscillator Monitor BNC (slide switch set to Int. Osc.) and monitor the frequency and amplitude of the output for 1 MHz at $\approx 6\text{V}$ peak-to-peak.
- b. Apply a 100 kHz test signal input to the Input A BNC and observe the visual display for the proper readout on each setting (1 ms through 100 s) of the frequency selector switch. For six digit instruments use 10 kHz and for the 100 s setting use 1 kHz.
- c. Monitor the gate light operation on time base settings above 0.1s.

Reference Oscillator Calibration

- a. Connect the 1 MHz frequency standard to the oscilloscope external trigger input.
- b. Connect a cable between the 1 MHz output connector and the oscilloscope vertical input. Place the oscillator switch to the Int. Position.
- c. Monitor the scope and adjust C1 so that as nearly as possible the trace stops moving. Scope sweep should stabilize for ≈ 8 to 10 seconds.

4.3.3 Storage Transfer, Display Time and Reset Test

Store commands and reset signals are automatic in the frequency modes.

- a. Store Command - With an oscilloscope monitor the output, pin 12, of MC16A for a +2 volt, 2 - 8 microsecond width store command signal.
- b. Reset - With an oscilloscope monitor the reset output, Test point R, for a +1.5V ($\pm 0.3V$) 27 microsecond ($\pm 5 \mu s$) pulse.
- c. Display Time - In the Self Test frequency mode setting >0.1 s observe the gate lamp for gate off time of <0.1 second to >10 seconds while varying the Display Time Control.

4.3.4 Gating Error

Rated accuracy of ± 1 count \pm oscillator stability is checked by monitoring the visual display while measuring a 200 MHz input signal. To nullify the effect of oscillator stability the 200 MHz test signal must be coherent to the 1 MHz reference oscillator. This is accomplished by using the internal oscillator output, multiplying it by 200 and feeding it back as the input to the A input connector. An alternate method would be to use an external 1 MHz for the reference time base source (fed into input B) and multiply this up to 200 MHz for the A input signal. What ever the method, the visual display should read 200000 kHz ± 1 count.

Gating Error Adjust. This adjustment (C6) is normally considered a factory adjust and should not require adjusting. If component replacement necessitates calibration, trim C6 for an optimum reading ± 1 count at 200 MHz. This adjustment should only be made under conditions as outlined above and only if replacement of circuit components makes it mandatory.

4.3.5 Count Chain Ring Counter Bias Adjust

This is normally a one time factory adjust. The 10^0 DCU of the count chain provides the divide-by-ten function from a Qui-binary counter. The quinary ring contains precision

components and matched transistors. If however, repairs or aging necessitate adjusting R105 proceed as follows:

- a. With a dc coupled oscilloscope observe the ring drive (signal line) and the ring output signals. The ring output, at any of the 150Ω ring bias resistors R246-R250 should be:

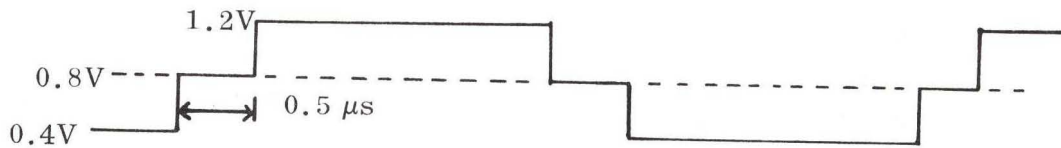

The ring drive input signal should be:

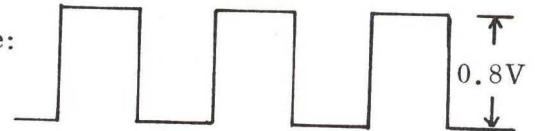

- b. While observing these signals adjust R105 to optimize this condition:

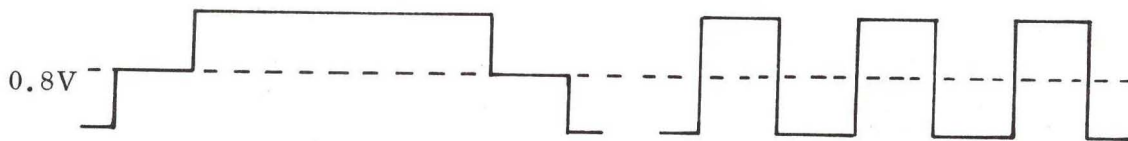

4.4 PARTS REMOVAL AND REPLACEMENT TECHNIQUES

Removal and/or replacement of component parts within the instrument are removable with tools normally found on any work bench.

The following precautionary procedures should be observed.

- a. Use a pencil-type solder iron with 40 watts maximum capacity. Do not use a soldering gun; damaging voltages can be induced in components and heat generated will damage the PCB.
- b. When soldering transistors leads, micromodules, etc., solder quickly. Whenever wiring permits, use a heat sink (long nose pliers, etc.) between the solder joint and the component. Use approximately the same length and dress of transistor leads as used originally.
- c. When desoldering work quickly and do not overheat PCB wiring.
- d. When installing a shielded wire, reconnect shield to the same tie point that it was removed from. Dress all wires in the same manner as removed. Route all wires in the same route as removed.

4.4.1 Micromodule Removal and Replacement - Removal and replacement of the micromodule is simplified by the use of proper tools. Although a soldering iron, small long nose pliers, small diagonals and a round tooth pick will do the job, the use of a rectangular soldering tip and a vacuum solder pick-up bulb (vacuum bulb) can greatly simplify the task.

To remove a micromodule:

- a. Working from the top of the PCB, cut all leads on the micromodule at the plastic case.
- b. Remove each lead from the PCB by heating with a soldering iron and withdrawing leads from the PCB (from the top) with small long nose pliers.
- c. Remove all excess solder with a vacuum bulb or by heating holes and reaming clean with a round tooth pick.

To replace a micromodule:

- a. Remove all excess solder from the PCB holes with soldering iron and vacuum bulb.
- b. Insert replacement micromodule. Refer to component layout drawing for proper pin (pin 1) orientation.
- c. Using small tip individually solder all connections from the bottom of the board.

Alternate procedure to remove a micromodule:

- a. Using a solder iron with a special rectangular tip, apply heat simultaneously to all the micromodule connections.
- b. Lift or pry micromodule out.
- c. Remove excess solder with vacuum bulb.
- d. Apply heat with caution, do not overheat PCB.

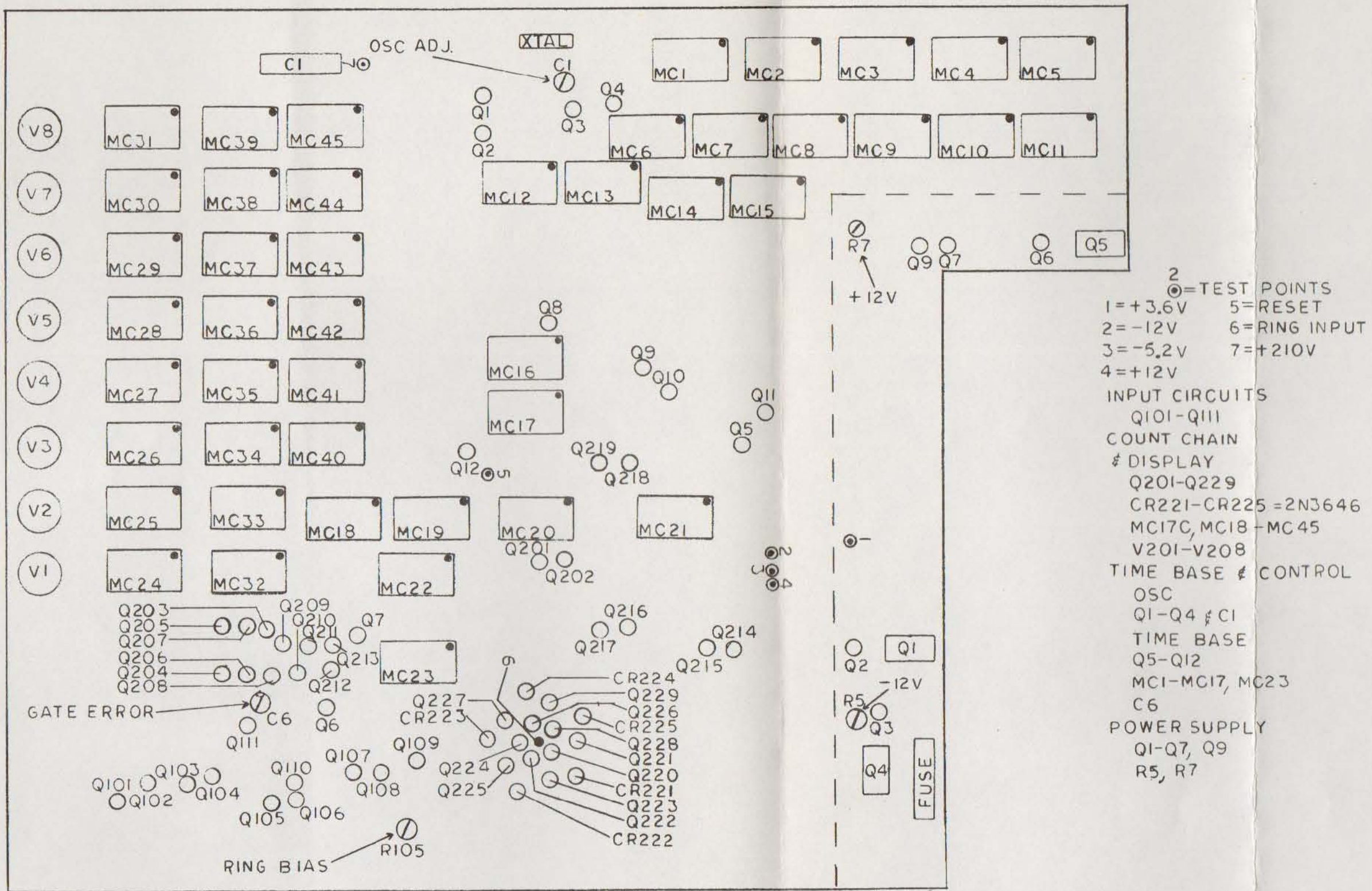

MODEL 1615/1650
PCB COMPONENT LAYOUT

SECTION 5
PARTS LIST

SECTION 5
PARTS LIST

5.1 GENERAL

This section contains the necessary information for the procurement or replacement parts from either Eldorado Electrodata or directly from commercial sources.

5.2 ORDERING INFORMATION

To order replacement parts directly from Eldorado Electrodata, address all orders or inquiries directly to:

CUSTOMER SERVICE PARTS DEPARTMENT
ELDORADO ELECTRODATA CORP.
601 Chalomar Road
Concord, California 94520
Telephone: (415) 686-4200
TWX: (910) 481-9476

When ordering replacement parts be certain to specify complete instrument model and serial number and complete part description including reference, description, manufacturer, manufacturer's part number and the Eldorado part number.

5.3 COMPONENT IDENTIFICATION

The following parts list describes the Model 1615 as called out on the enclosed schematics.

The Power Supply components, schematic C-11-05384, use unit numbers from 1-99 and are preceded by an asterisk (*) to differentiate those unit numbers 1-99 called out for the Time Base and Control Logic components, schematic D-11-05495. The A Input Schematic C-11-05491, components are numbered 101-199 and the Count Chain, Schematic D-11-05493, components are numbered 201-299.

PARTS LIST

Reference	Description	Mfr.	Mfr. No.	EE No.	Qty.
	P. C. Board Ass'y.	EE	045478	045478	1
B1	Fan	Pamotor	8500	003068	1
C1	Capacitor, Variable 2-8 pF	Erie	538-011A-2-8	000339	1
*C1	Capacitor, Electrolytic 2 μ F, 350 wvdc	Mallory	TC595	003022	1
C2, X	Capacitor, Dipped Mica 39 pF, 500 wvdc	Sangamo	D155F390JO	000060	2
*C2	Capacitor, Electrolytic 8000 μ F, 12 wvdc	STM	91C12SH83	003036	1
C3, 4, 10, 107-109, 207, 208	Capacitor, Ceramic Disc. .01 μ F, 100 wvdc	Sprague	TGS10	000158	8
*C3	Capacitor, Electrolytic 100 μ F, 15 wvdc	Sprague	TE1162	003028	1
*C4, *5	Capacitor, Electrolytic 1000 μ F, 25 wvdc	STM	23C25TS13	003032	2
C5, 7, 12, 205	Capacitor, Ceramic Disc. .001 μ F, 1000 wvdc	Centralab	DD102	000117	4
C6	Capacitor, Variable 15-60 pF	Erie	538-011F-15-60	003288	1
C8	Capacitor, Dipped Mica 180 pF, 500 wvdc	Sangamo	D155F181JO	000087	1
C9	Capacitor, Dipped Mica 120 pF, 500 wvdc	Sangamo	D155F121JO	000081	1
C11	Capacitor, Mylar .033 μ F, 50 wvdc	GE	65F-11A-333C	000185	1
C13	Capacitor, Tant 6.8 μ F, 35 wvdc	Sprague	150D685X9035B2	000264	1
C102	Capacitor, Dipped Mica 18 pF, 500 wvdc	Sangamo	D155F180JO	000042	1
C103	Capacitor, Dipped Mica 220 pF, 500 wvdc	Sangamo	D155F221JO	000089	1
C104	Capacitor, Dipped Mica 15 pF, 500 wvdc	Sangamo	D155F150JO	000038	1
C105, 116	Capacitor, Plastic Film 0.1 μ F, 250 wvdc	Amperex	C280AE/P1005	000211	2
C106	Capacitor, Dipped Mica 27 pF, 500 wvdc	Sangamo	D155F270JO	000056	1
C110, 112	Capacitor, Dipped Mica 100 pF, 500 wvdc	Sangamo	D155F101JO	000079	2

Reference	Description	Mfr.	Mfr. No.	EE No.	Qty.
C111	Capacitor, Dipped Mica 2 pF, 500 wvdc	Sangamo	D155F020JO	000026	1
C113	Capacitor, Film 2.2 μ F, 25 wvdc	Sprague	5C15	000258	1
C114	Capacitor, Electrolytic 2500 μ F, 2.5 wvdc	Amperex	C437AR/A2500	003034	1
C115	Capacitor, Dipped Mica 10 pF, 500 wvdc	Sangamo	D155F100JO	000034	1
C117	Capacitor, Dipped Mica 22 pF, 500 wvdc	Sangamo	D155F220JO	000050	1
C201	Capacitor, Dipped Mica 330 pF, 500 wvdc	Sangamo	D155F331JO	000095	1
C202	Capacitor, Dipped Mica 47 pF, 500 wvdc	Sangamo	D155F470JO	000065	1
C203	Capacitor, Ceramic Disc. .002 μ F, 100 wvdc	Erie	835-Z5U-202P	000127	1
C204, 206	Capacitor, Electrolytic 5 μ F, 15 wvdc	Sprague	TE1152	003026	2
CR1-6, 113	Diode	GE	1N695	000523	7
*CR1, 110-112	Diode	Texas Inst.	1N2071	000542	4
*CR2, *3, *6-9	Diode	ITT	1N4001	003062	6
*CR4, 229, 230	Diode, Zener	Motorola	1N749A	000527	3
*CR5, *10	Diode, Zener	Motorola	1N752A	000530	2
CR7, 102-105 205-218	Diode	Sylvania	1N3605	000550	19
CR8, 9	Diode, Zener	Motorola	1N746A	000524	2
*CR11, 107, 108	Diode, Zener	Motorola	1N753A	000531	3
*CR12	Diode, Zener	Motorola	1N754A	000532	1
CR106	Diode, Zener	Motorola	1N755A	000533	1
CR201-204	Diode, Zener	Motorola	1N758A	000536	4
CR219, 220, 226-228	Diode	Fairchild	FD777	000488	5
CR221-225,	Transistor	Fairchild	2N3646	001731	5
CR226	Diode, Zener	Motorola	1N751A	000529	1
DS1	Lamp, 28V (Gate)	Dialco	507-3917-145- 600	003089	1
F1	Fuse, 1A SB	Littelfuse	313001	000605	1
FL1	Filter, Line	Potter	5004-6075	003070	1
J1, 3	Connector, BNC	Amphenol	UG1094/U	000383	2

Reference	Description	Mfr.	Mfr. No.	EE No.	Qty.
L103	Inductor, .15 μ H	Delevan	1025-00	000647	1
L104, 105	Inductor, .22 μ H	Delevan	1025-04	000649	2
L107, 201, 202	Inductor, 1.8 μ H	Delevan	1025-26	000660	3
MC1-4, 7, 9-13, 15, 18, 19, 23	Integrated Circuit Dual J-K Flip-flop	Motorola	MC890P	000875	14
MC5, 6, 8, 14	Integrated Circuit Dual J-K Flip-flop	Motorola	MC891P	003430	4
MC16	Integrated Circuit Dual 3-Input Buffer	Motorola	MC888P	000873	1
MC17, 22	Integrated Circuit Quad 2-Input Gate	Motorola	MC824P	000871	2
MC20, 21	Integrated Circuit J-K Flip-flop	Motorola	MC1013P	003105	2
MC24-31	Integrated Circuit Decoder Driver	Fairchild	C μ L 9960	003103	6
MC32-39	Integrated Circuit Buffer Storage	Fairchild	C μ L 9959	003102	6
MC40-45	Integrated Circuit Decade Counter	Fairchild	C μ L 9958	003101	4
Q1	Transistor	Motorola	MPF103	001747	1
*Q1, *4	Transistor	Motorola	MJE520	003274	2
Q2, *7, 204-215	Transistor	GE	2N2924	001716	14
*Q2	Transistor	Fairchild	2N3638	001726	1
Q3, 4, 6-9, 13, 201, 202, 219	Transistor	Fairchild	2N3646	001731	10
*Q3, *6, 10, 111, 203	Transistor	Texas Inst.	2N3702	001733	5
Q5, 12	Transistor	Fairchild	2N3569	001724	2
*Q5	Transistor	Motorola	MJE370	003273	1
Q11	Transistor	Texas Inst.	T1S43	001751	1
Q101	Transistor	Motorola	MPF106	003277	1
Q102, 104-110, 220-229	Transistor	Motorola	MPS3563	003276	18
Q103, 216-218	Transistor	Fairchild	2N3640	001728	4
R1	Resistor, Fixed 4.7M Ω , 1/4W, 5%	AB	CB4755	001151	1
*R1	Resistor, Fixed 120 Ω , 1/4W, 5%	AB	CB1215	001082	1

Reference	Description	Mfr.	Mfr. No.	EE No.	Qty.
C111	Capacitor, Dipped Mica 2 pF, 500 wvdc	Sangamo	D155F020JO	000026	1
C113	Capacitor, Film 2.2 μ F, 25 wvdc	Sprague	5C15	000258	1
C114	Capacitor, Electrolytic 2500 μ F, 2.5 wvdc	Amperex	C437AR/A2500	003034	1
C115	Capacitor, Dipped Mica 10 pF, 500 wvdc	Sangamo	D155F100JO	000034	1
C117	Capacitor, Dipped Mica 22 pF, 500 wvdc	Sangamo	D155F220JO	000050	1
C201	Capacitor, Dipped Mica 330 pF, 500 wvdc	Sangamo	D155F331JO	000095	1
C202	Capacitor, Dipped Mica 47 pF, 500 wvdc	Sangamo	D155F470JO	000065	1
C203	Capacitor, Ceramic Disc. .002 μ F, 100 wvdc	Erie	835-Z5U-202P	000127	1
C204, 206	Capacitor, Electrolytic 5 μ F, 15 wvdc	Sprague	TE1152	003026	2
CR1-6, 113	Diode	GE	1N695	000523	7
*CR1, 110-112	Diode	Texas Inst.	1N2071	000542	4
*CR2, *3, *6-9	Diode	ITT	1N4001	003062	6
*CR4, 229, 230	Diode, Zener	Motorola	1N749A	000527	3
*CR5, *10	Diode, Zener	Motorola	1N752A	000530	2
CR7, 102-105 205-218	Diode	Sylvania	1N3605	000550	19
CR8, 9	Diode, Zener	Motorola	1N746A	000524	2
*CR11, 107, 108	Diode, Zener	Motorola	1N753A	000531	3
*CR12	Diode, Zener	Motorola	1N754A	000532	1
CR106	Diode, Zener	Motorola	1N755A	000533	1
CR201-204	Diode, Zener	Motorola	1N758A	000536	4
CR219, 220, 226-228	Diode	Fairchild	FD777	000488	5
CR221-225,	Transistor	Fairchild	2N3646	001731	5
CR226	Diode, Zener	Motorola	1N751A	000529	1
DS1	Lamp, 28V (Gate)	Dialco	507-3917-145- 600	003089	1
F1	Fuse, 1A SB	Littelfuse	313001	000605	1
FL1	Filter, Line	Potter	5004-6075	003070	1
J1, 3	Connector, BNC	Amphenol	UG1094/U	000383	2

Reference	Description	Mfr.	Mfr. No.	EE No.	Qty.
R2, 4, 6, 12, 20, 36, 38, 41, 42, 111, 130, 212	Resistor, Fixed 1k, 1/4W, 5%	AB	CB1025	001098	12
*R2, 106	Resistor, Fixed 1M Ω , 1/4W, 5%	AB	CB1055	001145	2
R3, *11, 240-245	Resistor, Fixed 10k, 1/4W, 5%	AB	CB1035	001116	8
*R4, 27, 123, 124, 133	Resistor, Fixed 820 Ω , 1/4W, 5%	AB	CB8215	001097	5
R5	Resistor, Fixed 4.7k, 1/4W, 5%	AB	CB4725	001109	1
*R5	Resistor, Variable 1k	Beckman	62PR1K	000959	1
*R6, *8, 201-204, 258-265	Resistor, Fixed 22k, 1/4W, 5%	AB	CB2235	001120	14
R7, 19, 129, 134	Resistor, Fixed 680 Ω , 1/4W, 5%	AB	CB6815	001096	4
*R7	Resistor, Variable 5k	Beckman	62PR5K	000988	1
R8	Resistor, Fixed 3.9k, 1/4W, 5%	AB	CB3925	001108	1
R9, 15, 213	Resistor, Fixed 1.2k, 1/4W, 5%	AB	CB1225	001099	3
R10, 16, 23, 28, 223	Resistor, Fixed 3.3k, 1/4W, 5%	AB	CB3325	001107	5
R10, 125, 218, 219	Resistor, Fixed 220 Ω , 1/4W, 5%	AB	CB2215	001086	4
R11	Resistor, Fixed 27k, 1/4W, 5%	AB	CB2735	001121	1
*R12, 131, 221	Resistor, Fixed 12k, 1/4W, 5%	AB	CB1235	001117	3
R14	Resistor, Fixed 15 Ω , 1/4W, 5%	AB	CB1505	001069	1
R17, 30, 47	Resistor, Fixed 1.5k, 1/4W, 5%	AB	CB1525	001100	3
R18, 24, 37	Resistor, Fixed 2.2k, 1/4W, 5%	AB	CB2225	001103	3
R21, 26, 222	Resistor, Fixed 470 Ω , 1/4W, 5%	AB	CB4715	001092	3
R22, 31, 32	Resistor, Fixed 15k, 1/4W, 5%	AB	CB1535	001118	3
R29, 205-209	Resistor, Fixed 5.6k, 1/4W, 5%	AB	CB5625	001111	6

Reference	Description	Mfr.	Mfr. No.	EE No.	Qty.
R33	Resistor, Fixed 47k, 1/4W, 5%	AB	CB4735	001124	1
R34/S3	Resistor, Variable with Switch 1M Ω	CTS	3796	000963	1
R35, 122	Resistor, Fixed 47 Ω , 1/4W, 5%	AB	CB4705	001075	2
R39	Resistor, Fixed 3.3M Ω , 1/4W, 5%	AB	CB3355	001150	1
R40, 116, 117	Resistor, Fixed 100 Ω , 1/4W, 5%	AB	CB1015	001081	3
R101	Resistor, Fixed 510 Ω , 1/4W, 5%	AB	CB5115	001093	1
R102	Resistor, Fixed 82 Ω , 1/4W, 5%	AB	CB8205	001080	1
R103, 110, 132	Resistor, Fixed 430 Ω , 1/4W, 5%	AB	CB4315	003178	3
R105	Resistor, Variable 100 Ω	Beckman	62PR100	000926	1
R107	Resistor, Fixed 200 Ω , 1/4W, 5%	AB	CB2015	001085	1
R108	Resistor, Fixed 300 Ω , 1/4W, 5%	AB	CB3015	001089	1
R109, 120	Resistor, Fixed 270 Ω , 1/4W, 5%	AB	CB2715	001088	2
R112	Resistor, Fixed 51 Ω , 1/4W, 5%	AB	CB5105	001076	1
R113	Resistor, Fixed 62 Ω , 1/4W, 5%	AB	CB6205	001078	1
R115	Resistor, Fixed 390 Ω , 1/4W, 5%	AB	CB3915	001091	1
R118	Resistor, Fixed 3k, 1/4W, 5%	AB	CB3025	001106	1
R119	Resistor, Fixed 39 Ω , 1/4W, 5%	AB	CB3905	001074	1
R121	Resistor, Fixed 150 Ω , 1/4W, 5%	AB	CB1515	001083	1
R126	Resistor, Fixed 68 Ω , 1/4W, 5%	AB	CB6805	001079	1
R127	Resistor, Variable 500 Ω	Clarstat	RV6NAYS501A	000950	1
R128	Resistor, Fixed 620 Ω , 1/4W, 5%	AB	CB6215	001095	1

Reference	Description	Mfr.	Mfr. No.	EE No.	Qty.
R210, 211	Resistor, Fixed 20k, 1/4W, 5%	AB	CB2035	003183	2
R214	Resistor, Fixed 2.7k, 1/4W, 5%	AB	CB2725	001105	1
R215, 216, 220	Resistor, Fixed 2k, 1/4W, 5%	AB	CB2025	001102	3
R224, 256	Resistor, Fixed 1k, 1/8W, 5%	AB	BB1025	001054	2
R225-234	Resistor, Fixed 10k, 1/8W, 5%	AB	BB1035	001060	10
R235-239	Resistor, Fixed 1.5k, 1/4W, 2%	Corning	C4 Series	003210	5
R246-250	Resistor, Fixed 150 Ω , 1/4W, 2%	Corning	C4 Series	003205	5
R251-255	Resistor, Fixed 360 Ω , 1/4W, 2%	Corning	C4 Series	003209	5
R257	Resistor, Fixed 75 Ω , 1/2W, 5%	AB	EB7505	001170	1
S1	Switch, Rotary	CTS	59085/3 215-X-PC	003236	1
*S1, 2, 101	Switch, Slide DPDT	Cont. Wirt	G-126	001554	3
S4	Switch, Momentary Pushbutton	Grayhill	30-1	001583	1
*T1	Transformer, Power	Tranex	4-1946	003255	1
V201-208	Tube, Numerical Display	Burrough	B5750	003279	8
XF1	Holder, Fuse	Littelfuse	372001	000619	1
XV201-208	Socket	Burrough	SK-207	003220	8
Y1	Crystal 1 MHz	Filtaire	CR18/U	003049	1

SECTION 6
SCHEMATICS

Integrated Circuits Schematic Equivalents MC715P - MC725P.

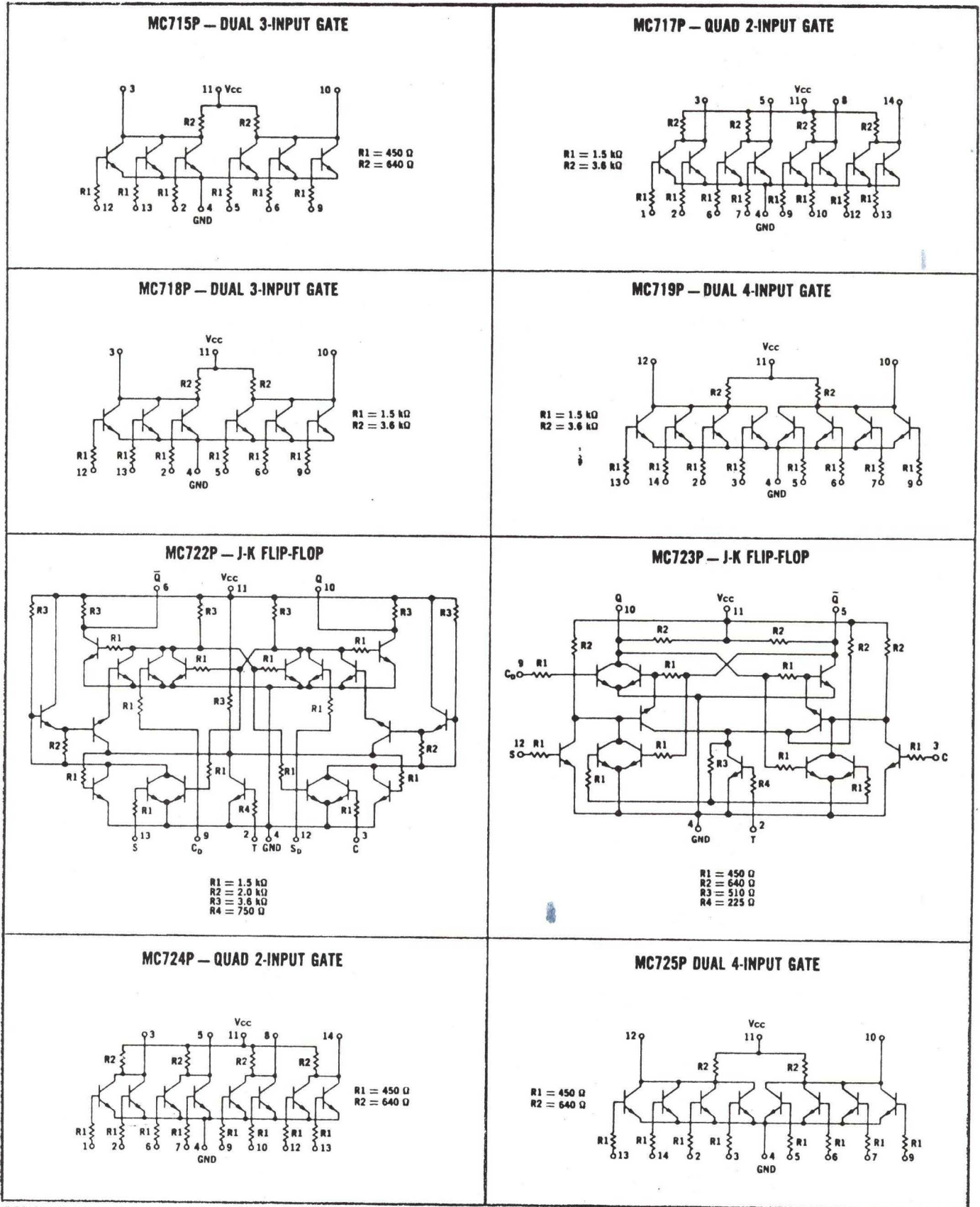

RESISTOR VALUES ARE TYPICAL.

Integrated Circuits Schematic Equivalents MC726P - MC787P.

MC726P - J-K FLIP-FLOP

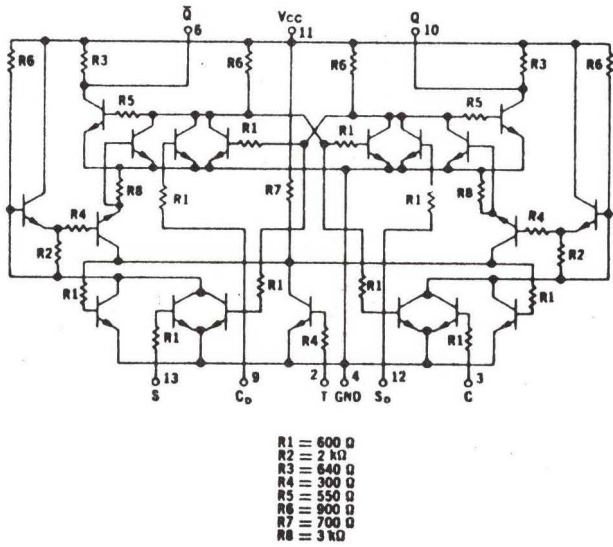

MC778P - DUAL TYPE "D" FLIP-FLOP

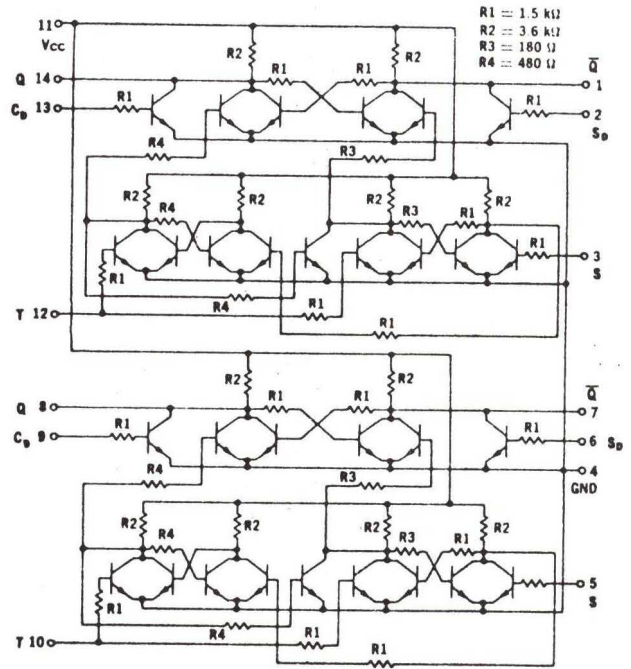

MC779P - MULTIFUNCTION (1 J-K FLIP-FLOP, 1 EXPANDER, 2 BUFFERS)

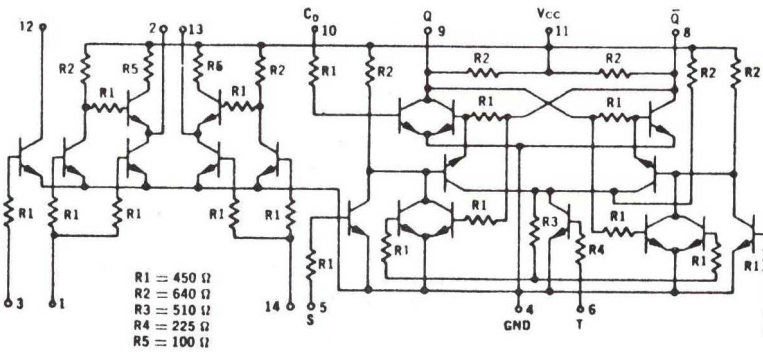

MC785P - QUAD 2-INPUT EXPANDER

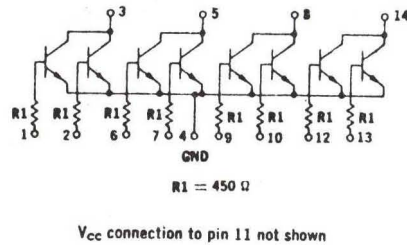

MC786P - DUAL 4-INPUT EXPANDER

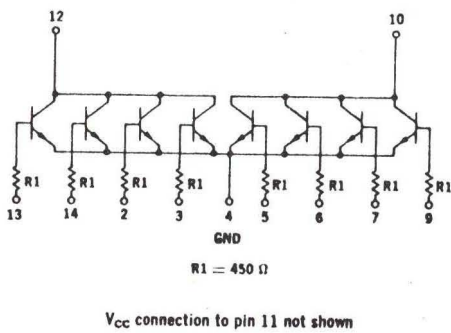

MC787P - MULTIFUNCTION (1 J-K FLIP-FLOP, 1 INVERTER, 2 BUFFERS)

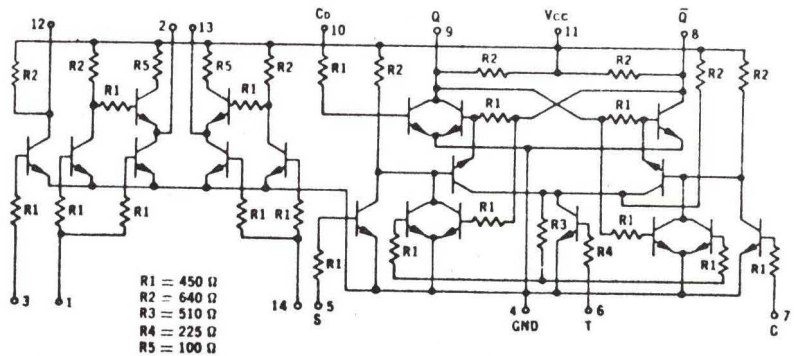

RESISTOR VALUES ARE TYPICAL.

Integrated Circuits Schematic Equivalents MC788P - MC799P.

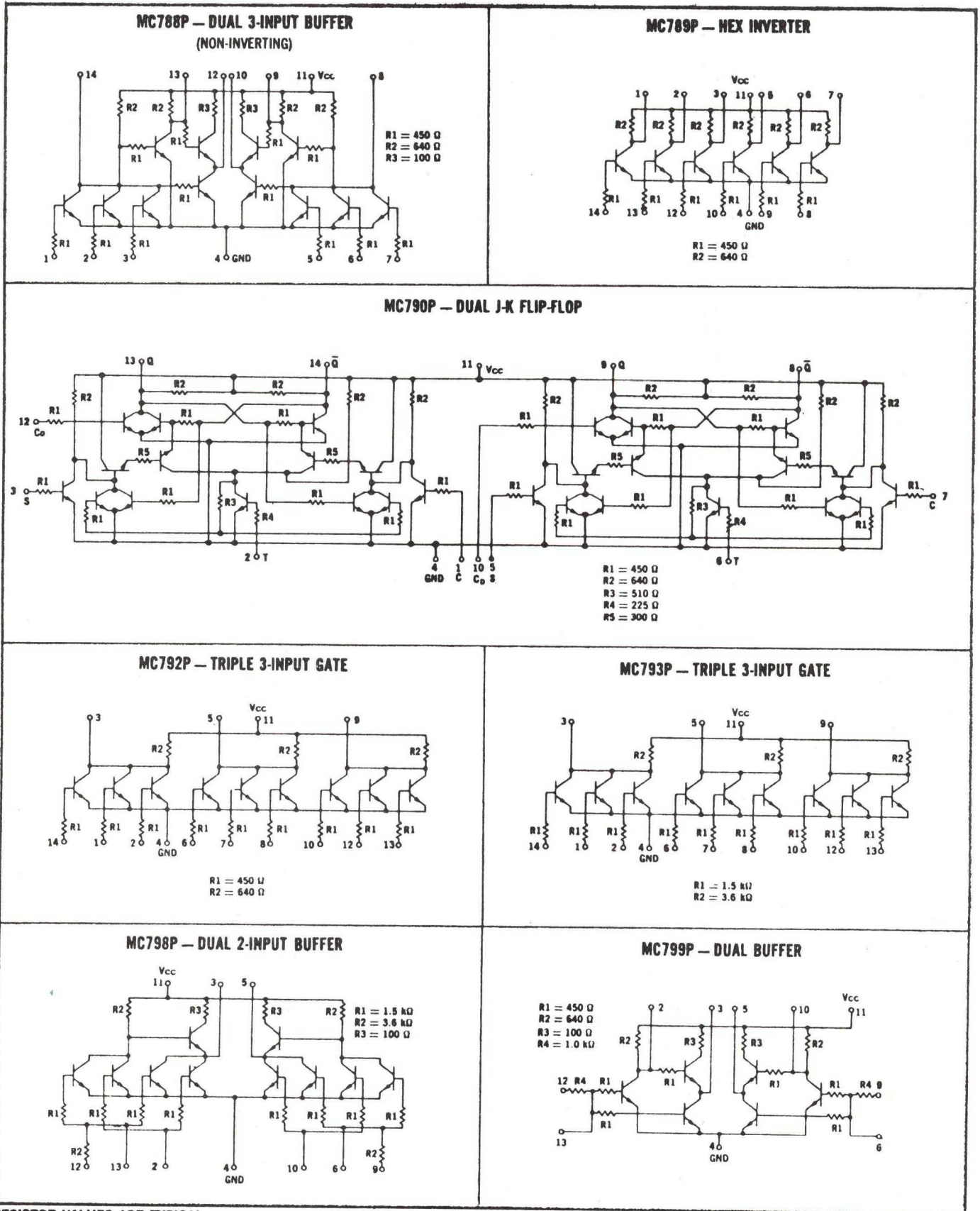

RESISTOR VALUES ARE TYPICAL.

MC1013
MC1213

Designed for use at clock frequencies to 70 MHz minimum (85 MHz typical). Logic performing inputs (\bar{J} and \bar{K}) are available, as well as dc SET and RESET inputs.

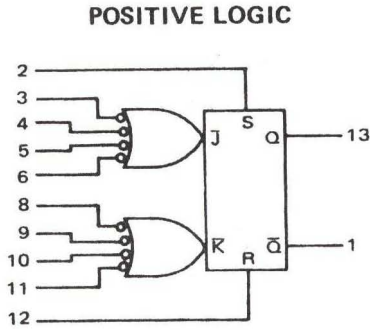

DC Input Loading Factor = 1
 DC Output Loading Factor = 25
 Power Dissipation = 125 mW typical

- * Any \bar{J} or \bar{K} Input, not used for \bar{C}_D .
- ** \bar{C}_D obtained by connecting one \bar{J} and one \bar{K} input together.

The \bar{J} and \bar{K} inputs refer to logic levels while the \bar{C}_D input refers to dynamic logic swings. The \bar{J} and \bar{K} inputs should be changed to a logical "1" only while the \bar{C}_D input is in a logic "1" state. (\bar{C}_D maximum "1" level = $V_{CC} - 0.6$ V). Clock \bar{C}_D is obtained by tying one \bar{J} and one \bar{K} input together.

R-S TRUTH TABLE

Pin No.	R	S	Q^{n+1}
12	2	13	
0	0	Q^n	
0	1	1	
1	0	0	
1	1	N.D.	

All \bar{J} - \bar{K} Inputs Are Static

\bar{J}_D - \bar{K}_D TRUTH TABLE

Pin No.	\bar{J}_D	\bar{K}_D	Q^{n+1}
*	*	13	
0	0	Q^n	
0	1	0	
1	0	1	
1	1	\bar{Q}^n	

All Other \bar{J} - \bar{K} Inputs And The R-S Inputs Are At a "0" Level

CLOCKED \bar{J} - \bar{K} TRUTH TABLE

Pin No.	\bar{J}	\bar{K}	\bar{C}_D	Q^n
*	*	**	13	
ϕ	ϕ	0	Q^n	
0	0	1	\bar{Q}^n	
0	1	1	1	
1	0	1	0	
1	1	1	Q^n	

All Other \bar{J} - \bar{K} Inputs And The R-S Inputs Are At a "0" Level

CIRCUIT SCHEMATIC

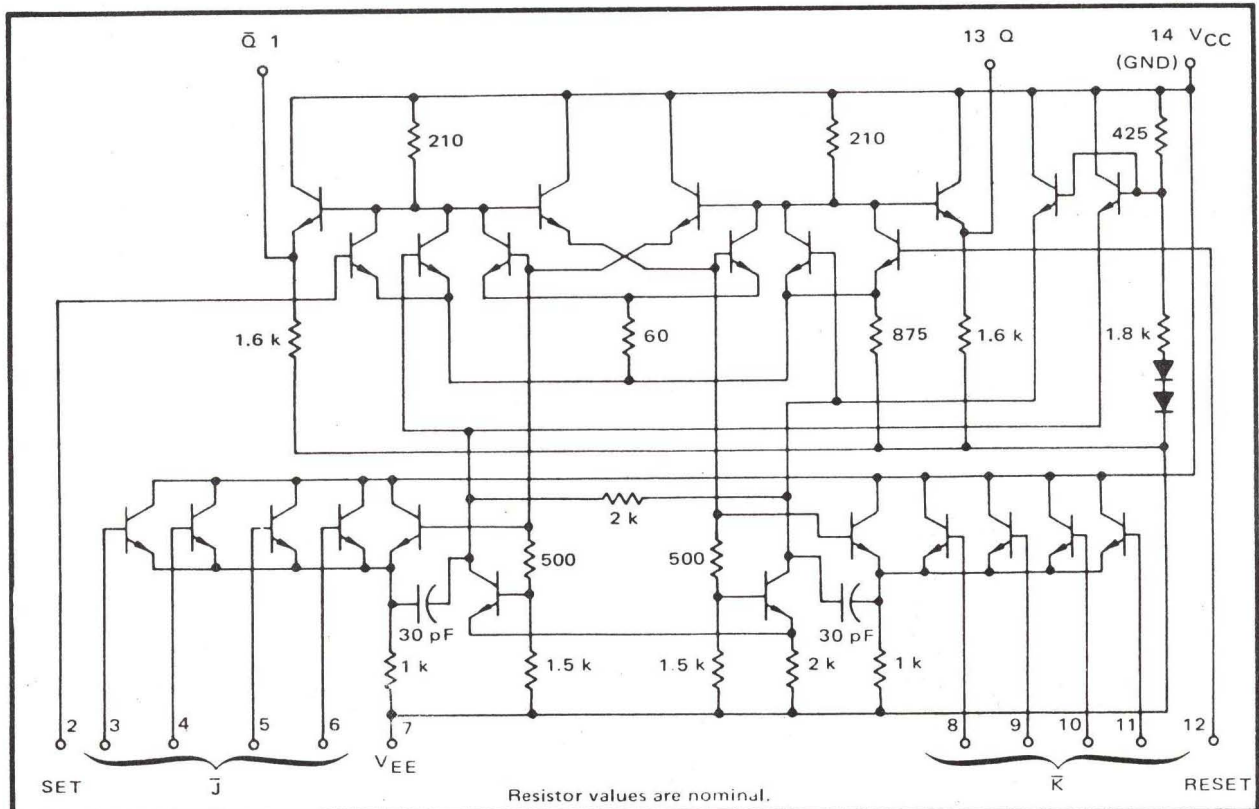

Resistor values are nominal.

Integrated Circuits Schematic Equivalent C μ L 9958

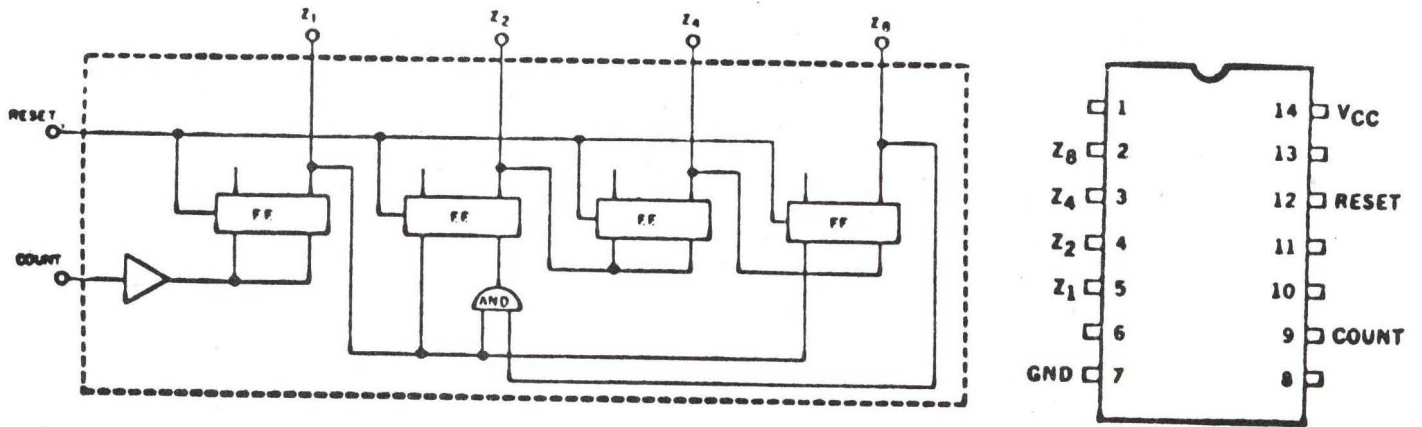

BLOCK DIAGRAM

	0	1	2	3	4	5	6	7	8	9
Z ₁	H	L	H	L	H	L	H	L	H	L
Z ₂	H	H	L	L	H	H	L	L	H	H
Z ₄	H	H	H	H	L	L	L	L	H	H
Z ₈	H	H	H	H	H	H	H	H	L	L

TRUTH TABLE

(H=HIGH L=LOW)

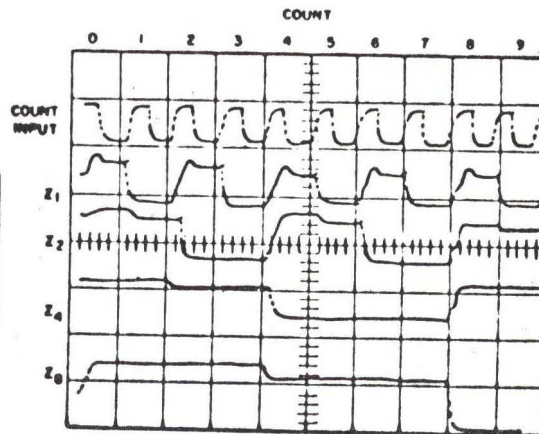

Circuit Block Diagram and Pin Number Functions C μ L 9958

Integrated Circuits Schematic Equivalent $C\mu L$ 9959

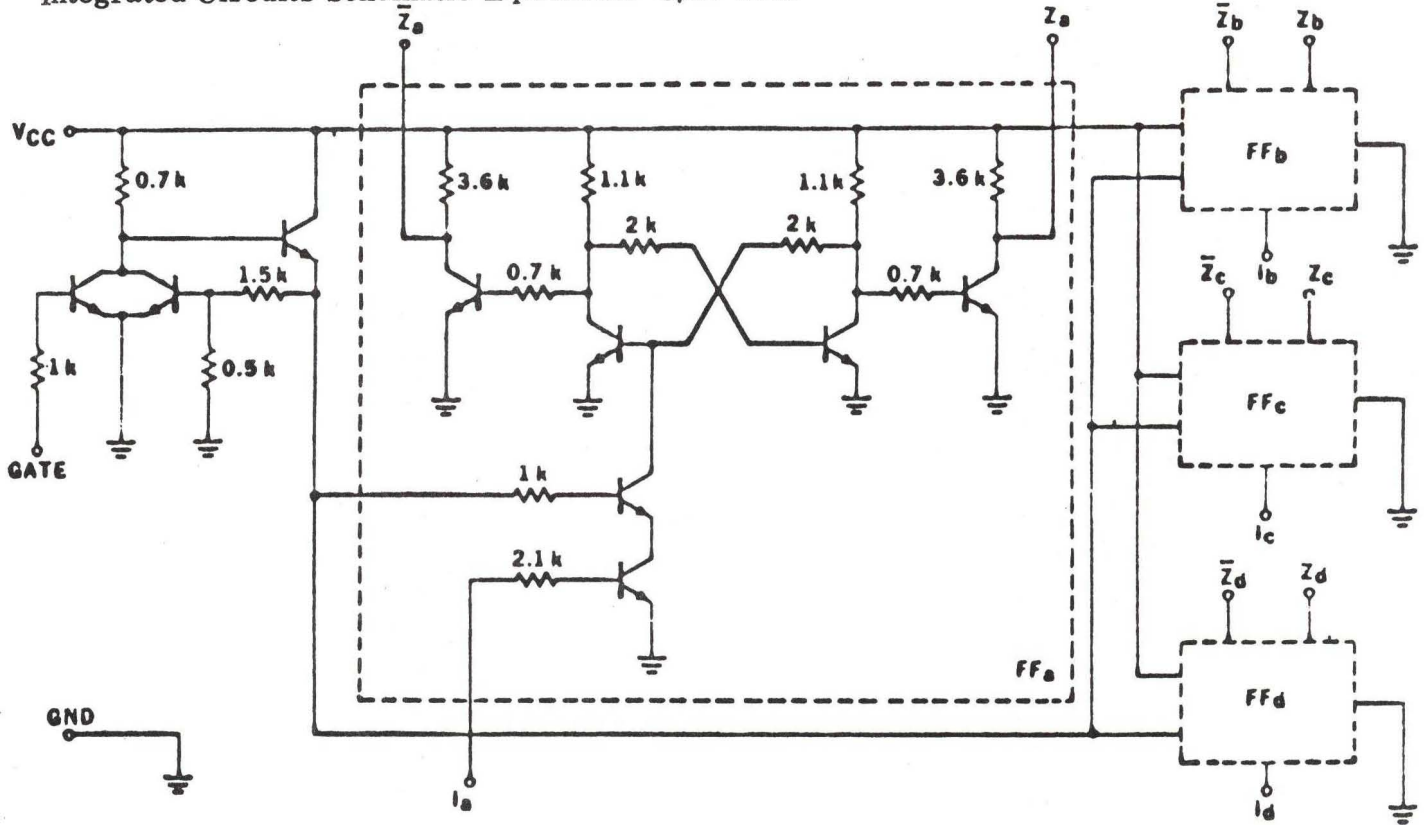

Schematic Diagram Buffer Storage Unit $C\mu L$ 9959

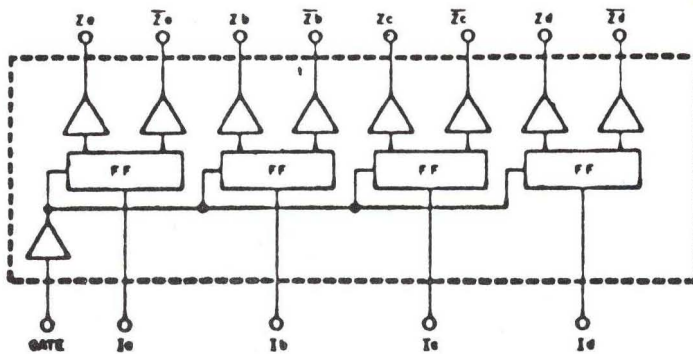

BLOCK DIAGRAM

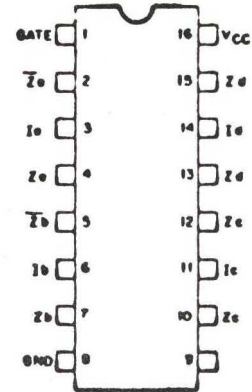

BASE CONNECTIONS

GATE	I	Z	Z̄
L	L	L	H
L	H	H	L
H	ANY	Q	Q̄

TRUTH TABLE

H = HIGH
 L = LOW
 Q = THE STATE ASSUMED
 PRIOR TO "GATE HIGH"
 IS MAINTAINED

Block Diagram and Pin Number Functions $C\mu L$ 9959

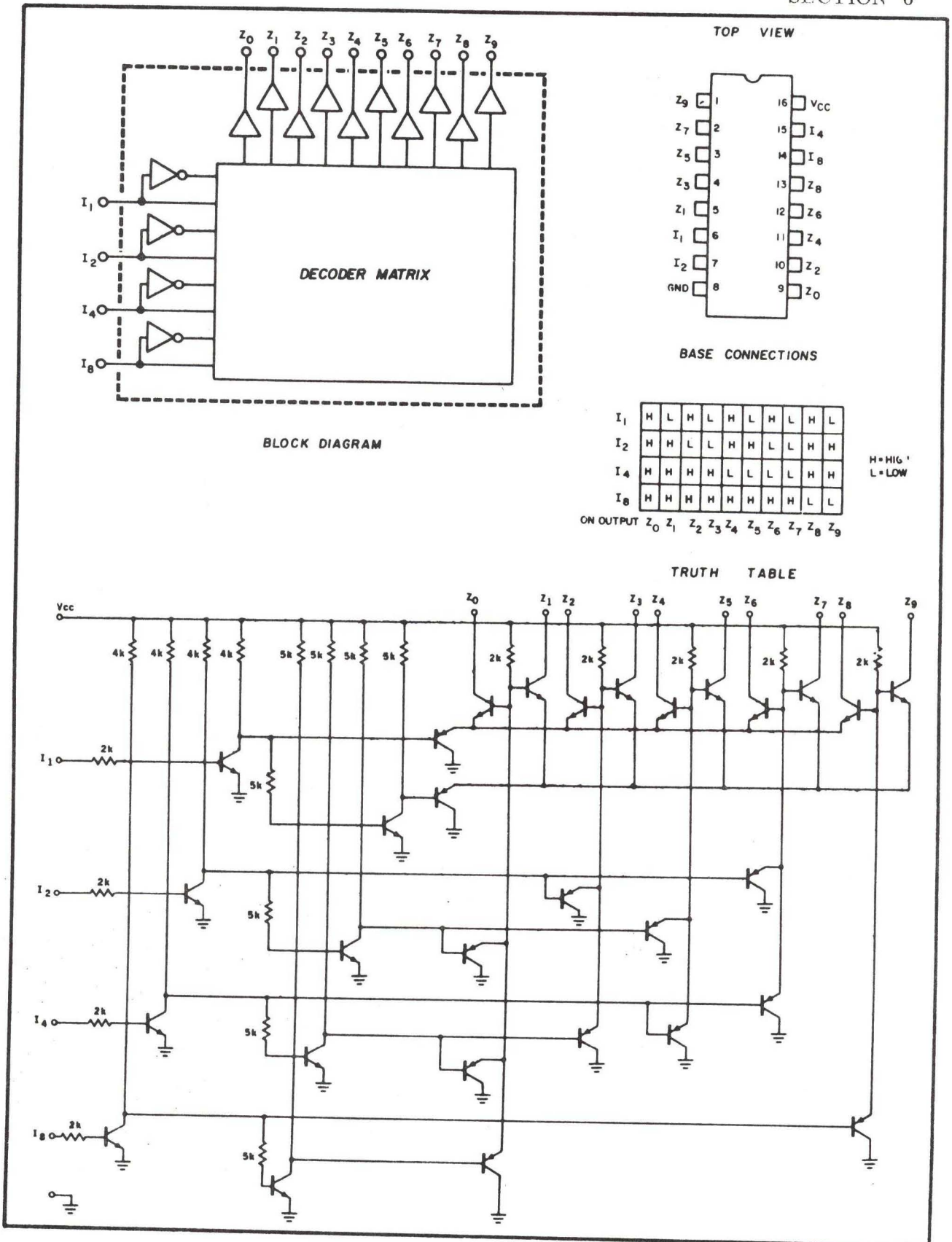

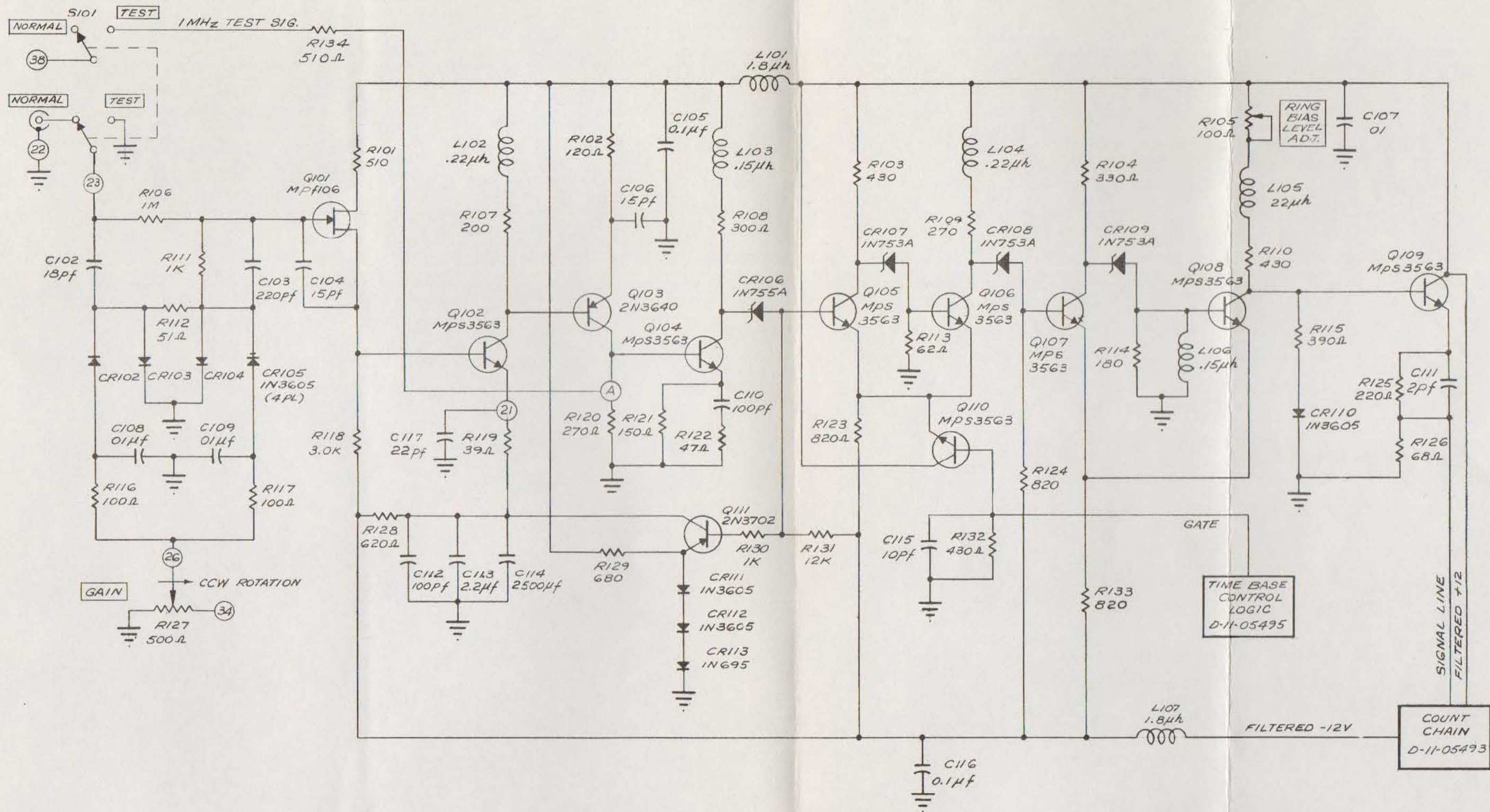

INPUT A SCHEMATIC
 C-11-05491

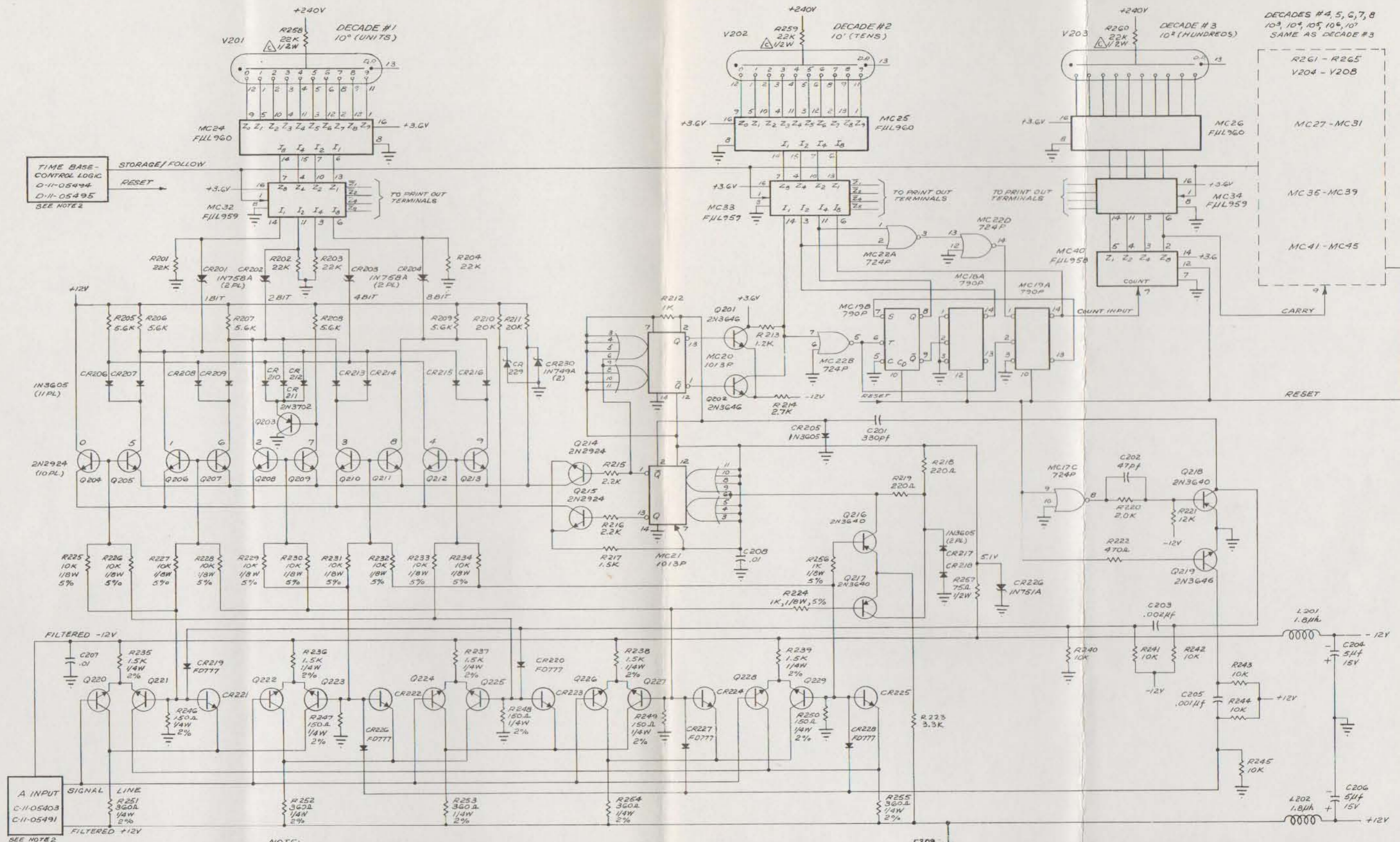

NOTE:
 1- Q220 THRU Q229 SELECTED 2N3563
 CR221 THRU CR225 SELECTED 2N3646
 2-C-11-05403 - MODEL 1650, C-11-05491 - MODEL 1615
 D-11-05494 - MODEL 1650, D-11-05495 - MODEL 1615

MODEL 1615/1650
 COUNT CHAIN and DISPLAY SCHEMATIC
 D-11-05493

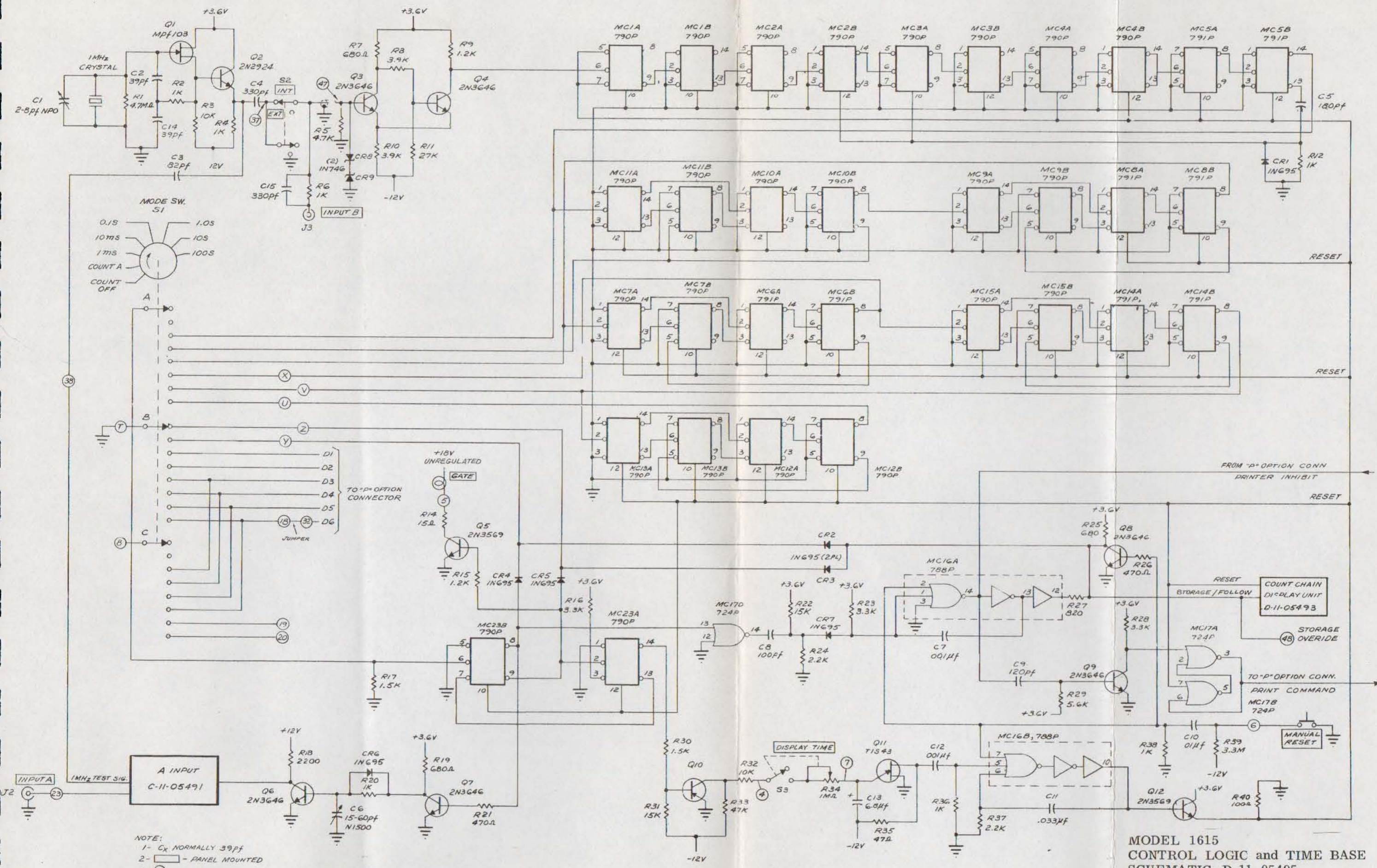

NOTE:
 1- C_x NORMALLY 39pf
 2- - PANEL MOUNTED
 3- ○ - PCB PAD NUMBERS

MODEL 1615
 CONTROL LOGIC and TIME BASE
 SCHEMATIC D-11-05495

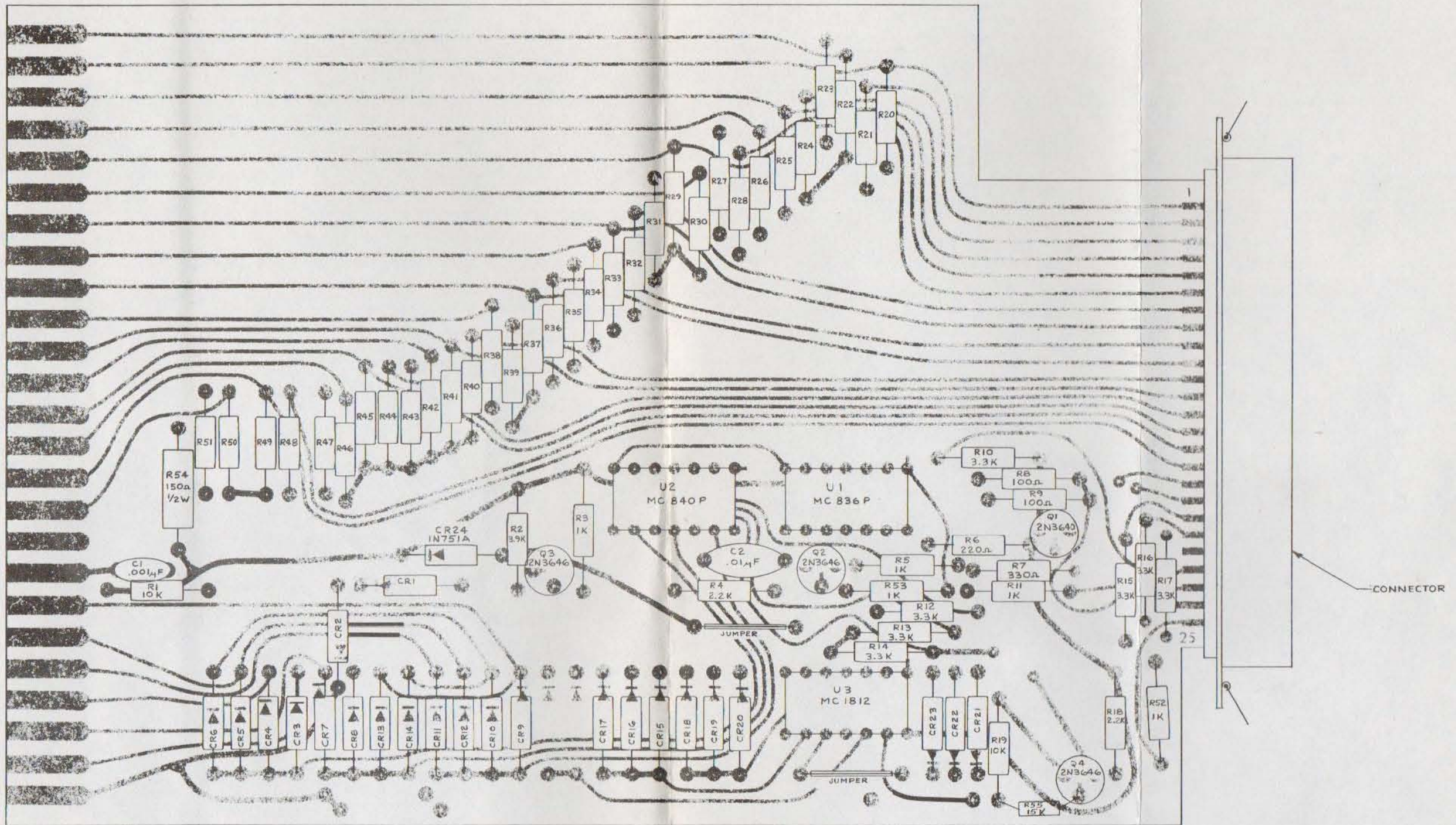

NOTE:
 1. R20-R51 ARE 22K, 1/4W, 5%
 2. CR3-CR14 ARE 3-1001
 3. CR1-CR2 & CR15-CR23 ARE 1N3605

COMPONENT LOCATION
 P OPTION

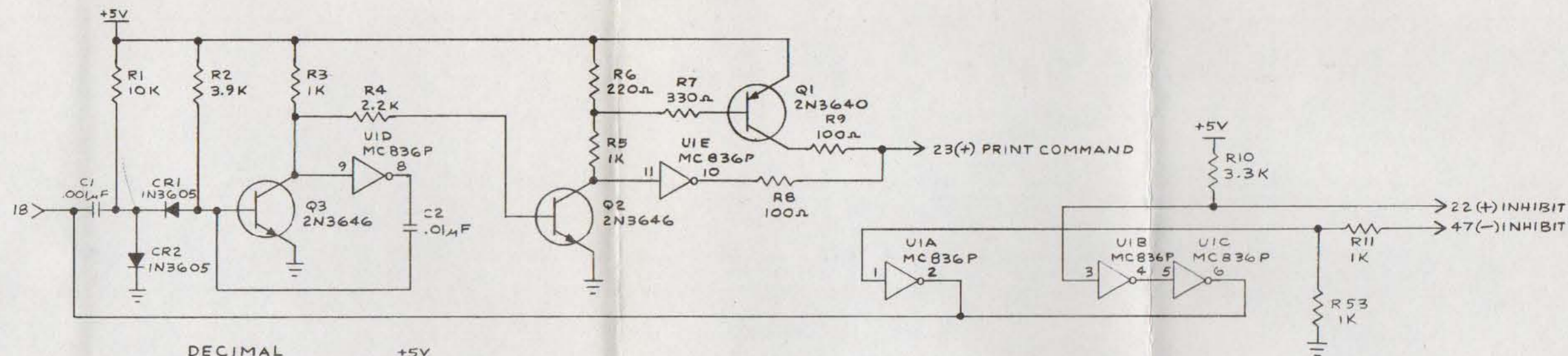

DECIMAL

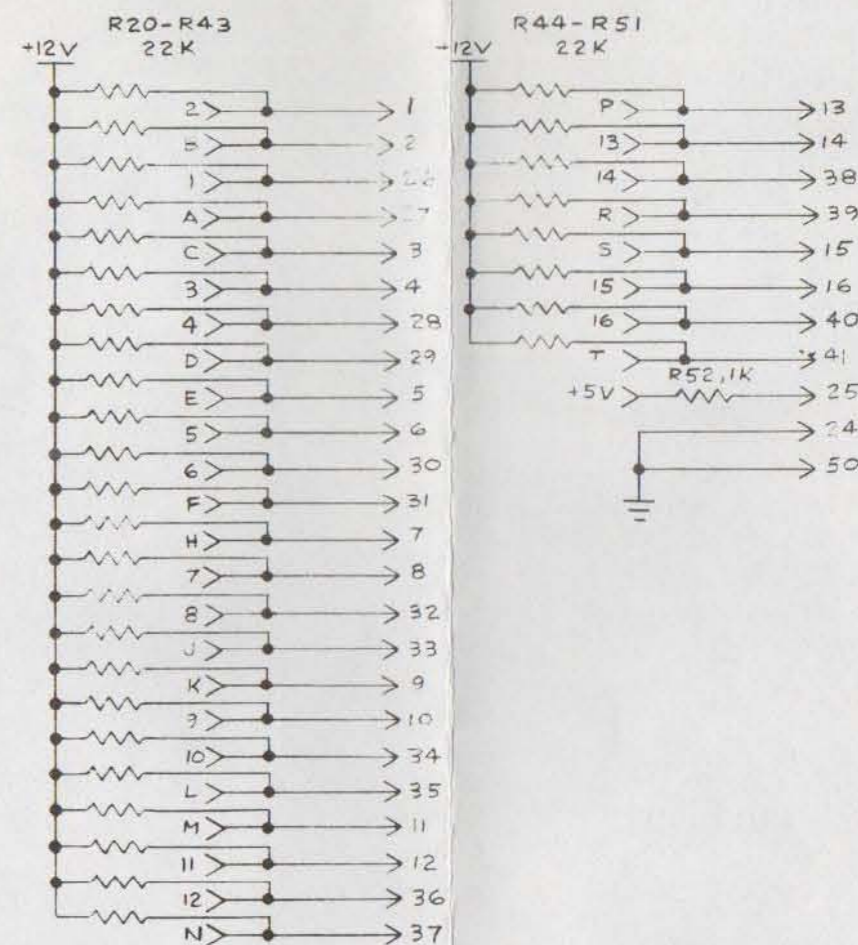
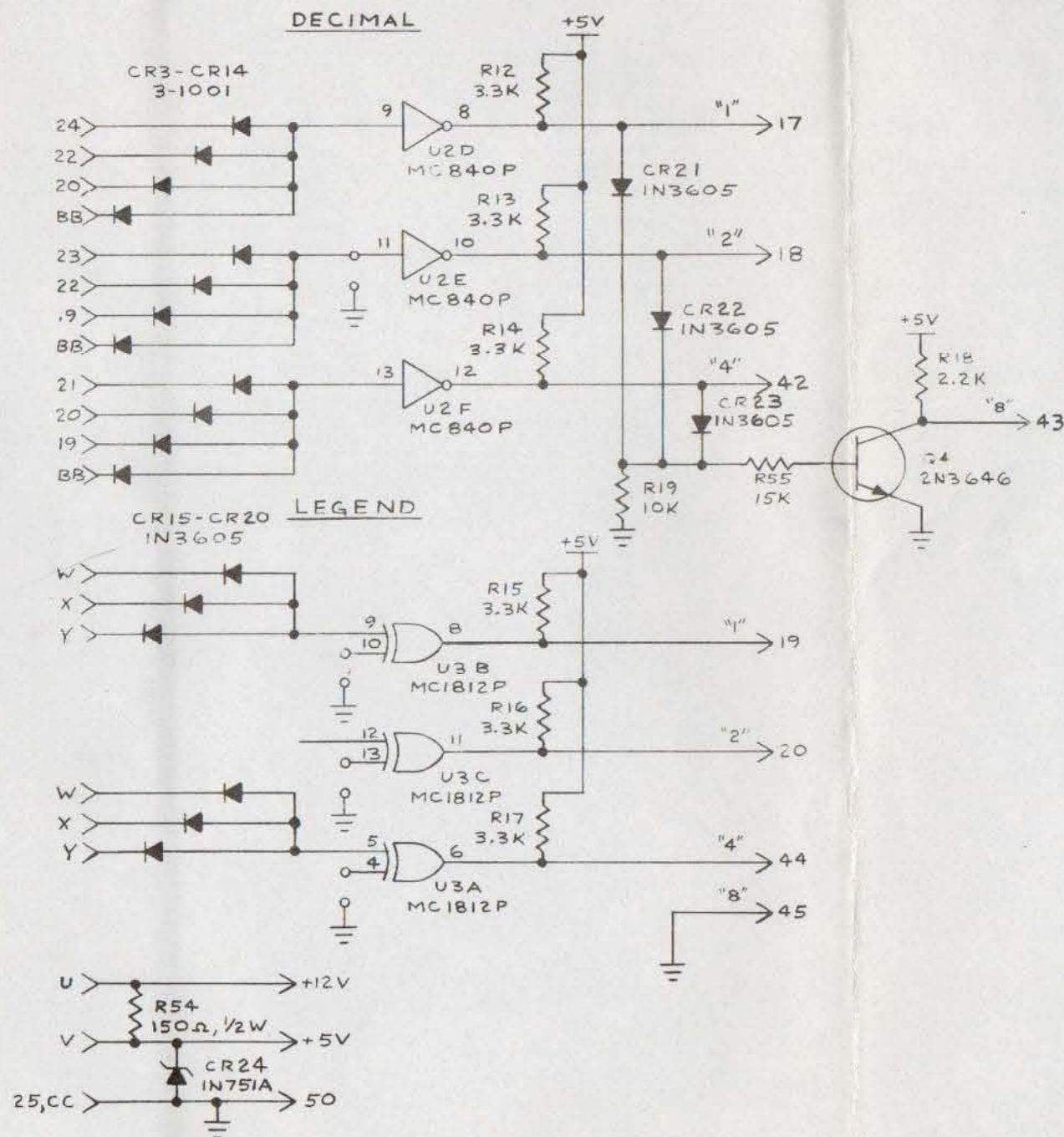

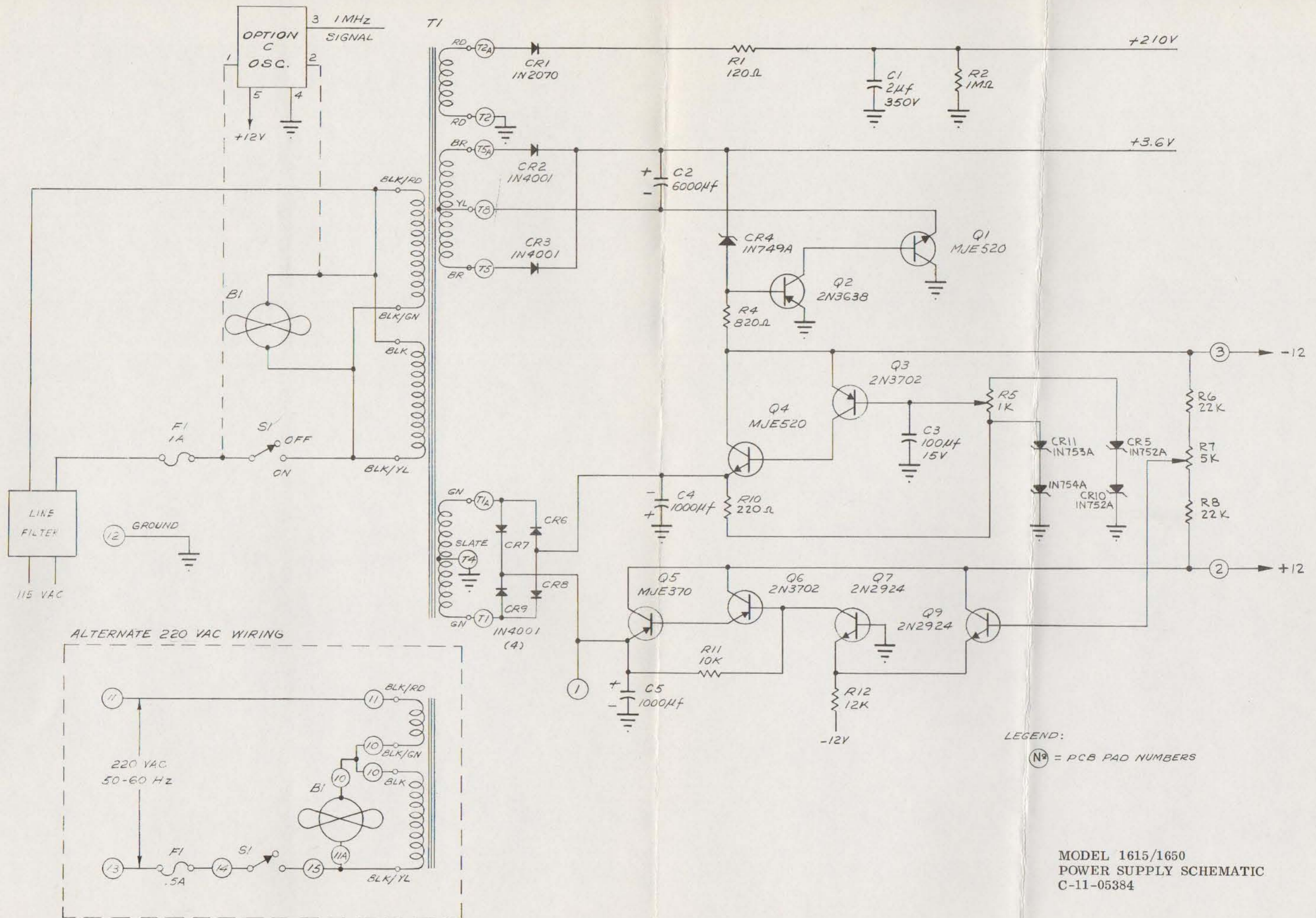

LEGEND:
 (N^o) = PCB PAD NUMBERS

MODEL 1615/1650
 POWER SUPPLY SCHEMATIC
 C-11-05384

