

# HEATHKIT<sup>®</sup> MANUAL

*for the*

**AC VOLTMETER**

Model IM-5238

595-1868-03

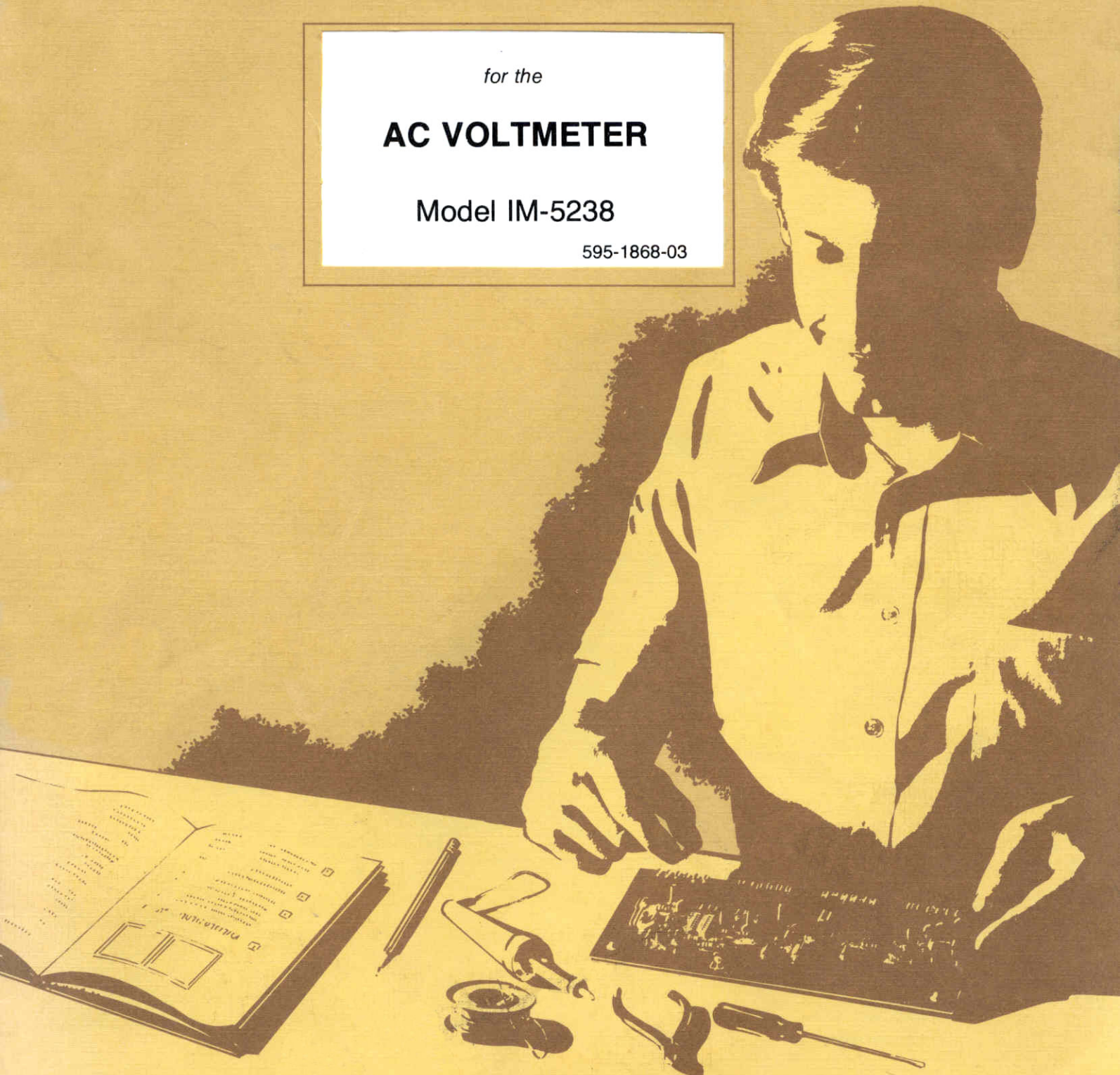

HEATH COMPANY • BENTON HARBOR, MICHIGAN

# HEATH COMPANY PHONE DIRECTORY

The following telephone numbers are direct lines to the departments listed:

Kit orders and delivery information ..... (616) 982-3411  
Credit ..... (616) 982-3561  
Replacement Parts ..... (616) 982-3571

## Technical Assistance Phone Numbers

8:00 A.M. to 12 P.M. and 1:00 P.M. to 4:30 P.M., EST, Weekdays Only  
R/C, Audio, and Electronic Organs ..... (616) 982-3310  
Amateur Radio ..... (616) 982-3296  
Test Equipment, Weather Instruments and  
Home Clocks ..... (616) 982-3315  
Television ..... (616) 982-3307  
Aircraft, Marine, Security, Scanners, Automotive,  
Appliances and General Products ..... (616) 982-3496  
Computers — Hardware ..... (616) 982-3309  
Computers — Software:  
Operating Systems, Languages, Utilities ..... (616) 982-3860  
Application Programs ..... (616) 982-3884  
Heath Craft Wood Works ..... (616) 982-3423



## YOUR HEATHKIT 90-DAY LIMITED WARRANTY

### Consumer Protection Plan for Heathkit Consumer Products

Welcome to the Heath family. We believe you will enjoy assembling your kit and will be pleased with its performance. Please read this Consumer Protection Plan carefully. It is a "LIMITED WARRANTY" as defined in the U.S. Consumer Product Warranty and Federal Trade Commission Improvement Act. This warranty gives you specific legal rights, and you may also have other rights which vary from state to state.

#### Heath's Responsibility

**PARTS** — Replacements for factory defective parts will be supplied free for 90 days from date of purchase. Replacement parts are warranted for the remaining portion of the original warranty period. You can obtain warranty parts direct from Heath Company by writing or telephoning us at (616) 982-3571. And we will pay shipping charges to get those parts to you . . . anywhere in the world.

**SERVICE LABOR** — For a period of 90 days from the date of purchase, any malfunction caused by defective parts or error in design will be corrected at no charge to you. You must deliver the unit at your expense to the Heath factory, any Heathkit Electronic Center (units of Veritechnology Electronics Corporation), or any of our authorized overseas distributors.

**TECHNICAL CONSULTATION** — You will receive free consultation on any problem you might encounter in the assembly or use of your Heathkit product. Just drop us a line or give us a call. Sorry, we cannot accept collect calls.

**NOT COVERED** — The correction of assembly errors, adjustments, calibration, and damage due to misuse, abuse, or negligence are not covered by the warranty. Use of corrosive solder and/or the unauthorized modification of the product or of any furnished component, will void this warranty in its entirety. This warranty does not include reimbursement for inconvenience, loss of use, customer assembly, set-up time, or unauthorized service.

This warranty covers only Heath products and is not extended to other equipment or components that a customer uses in conjunction with our products.

SUCH REPAIR AND REPLACEMENT SHALL BE THE SOLE REMEDY OF THE CUSTOMER AND THERE SHALL BE NO LIABILITY ON THE PART OF HEATH FOR ANY SPECIAL, INDIRECT, INCIDENTAL OR CONSEQUENTIAL DAMAGES, INCLUDING BUT NOT LIMITED TO ANY LOSS OF BUSINESS OR PROFITS, WHETHER OR NOT FORSEEABLE.

Some states do not allow the exclusion or limitation of incidental or consequential damages, so the above limitation or exclusion may not apply to you.

#### Owner's Responsibility

**EFFECTIVE WARRANTY DATE** — Warranty begins on the date of first consumer purchase. You must supply a copy of your proof of purchase when you request warranty service or parts.

**ASSEMBLY** — Before seeking warranty service, you should complete the assembly by carefully following the manual instructions. Heathkit service agencies cannot complete assembly and adjustments that are customer's responsibility.

**ACCESSORY EQUIPMENT** — Performance malfunctions involving other non-Heath accessory equipment, (antennas, audio components, computer peripherals and software, etc.) are not covered by this warranty and are the owner's responsibility.

**SHIPPING UNITS** — Follow the packing instructions published in the assembly manuals. Damage due to inadequate packing cannot be repaired under warranty.

If you are not satisfied with our service (warranty or otherwise) or our products, write directly to our Director of Customer Service, Heath Company, Benton Harbor MI 49022. He will make certain your problems receive immediate, personal attention.

# Heathkit® Manual

for the

## AC VOLTMETER

Model IM-5238

595-1868-03



HEATH COMPANY  
BENTON HARBOR, MICHIGAN 49022

Copyright © 1976  
Heath Company  
All Rights Reserved  
Printed in the United States of America



## TABLE OF CONTENTS

PARTS LIST .....	3	IN CASE OF DIFFICULTY	
STEP-BY-STEP ASSEMBLY		General .....	45
Assembly Notes .....	7	Problem Isolation .....	47
Circuit Board Assembly .....	9	SPECIFICATIONS .....	50
Chassis Assembly .....	21	CIRCUIT DESCRIPTION	
TESTS AND CALIBRATION .....	32	Preamplifier Circuit .....	51
Initial Tests .....	33	Main Amplifier .....	51
Calibration .....	34	AC-DC Converter Circuit .....	52
Calibration Without Instruments .....	34	Log Converter .....	52
Calibration With Instruments .....	36	Power Supply .....	54
FINAL ASSEMBLY .....	38	SEMICONDUCTOR IDENTIFICATION CHARTS	55
OPERATION .....	40	CIRCUIT BOARD X-RAY	
Voltage Measurements .....	41	VIEW .....	In the Illustration Booklet.
dB Measurements .....	42	SCHMATIC .....	(fold-in)
dB Offset .....	42	WARRANTY .....	Inside front cover
Voltmeter Outputs .....	43	CUSTOMER SERVICE .....	Inside rear cover
APPLICATIONS .....	44		

# PARTS LIST

Check each part against the following list. Any part that is packed in an individual envelope with the part number on it should be placed back in the envelope after you identify it until it is called for in a step. Do not discard any packing materials until all parts are accounted for.

The key numbers correspond to the numbers on the "Parts Pictorial" in the separate "Illustration Booklet" on Page 1.

Each circuit part in this kit has its own "Circuit Component Number" (R1, C11, D101, etc.). This is a specific number for only that one part. The purpose of these numbers is to help you easily identify the same part in each section of the Manual.

These numbers will appear:

- In the Parts List.
- At the beginning of each step where a component is installed.
- In some illustrations.
- In the sections at the rear of the Manual.

To order a replacement part: Always include the PART NUMBER. Use the Parts Order Form furnished with the kit. If one is not available, see "Replacement Parts" inside the rear cover of the Manual. Your Warranty is located inside the front cover. For price information, refer to the separate "Heath Parts Price List."

KEY No.	HEATH Part No.	QTY.	DESCRIPTION	CIRCUIT Comp. No.
---------	----------------	------	-------------	-------------------

**RESISTORS, 1/2-WATT**

## NOTES:

1. A fourth color band of silver indicates a 10% tolerance; a fourth band of gold indicates 5% tolerance.
2. The resistors may be packed in more than one envelope. Open all the resistor envelopes in this pack before you check them against the Parts List.

**10% Tolerance Resistors**

A1	1-3	7	100 Ω (brown-black-brown)	R102, R106, R133, R144, R151, R157, R163
A1	1-66	1	150 Ω (brown-green-brown)	R107
A1	1-4	3	330 Ω (orange-orange-brown)	R108, R193, R194
A1	1-8	1	820 Ω (gray-red-brown)	R109
A1	1-9	4	1000 Ω (brown-black-red)	R171, R182, R188, Test
A1	1-93	2	1800 Ω (brown-gray-red)	R152, R168
A1	1-46	2	3900 Ω (orange-white-red)	R149, R162
A1	1-16	5	4700 Ω (yellow-violet-red)	R147, R164, R179, R183, R190
A1	1-73	1	8200 Ω (gray-red-red)	R126
A1	1-20	3	10 kΩ (brown-black-orange)	R101, R150, R181
A1	1-22	2	22 kΩ (red-red-orange)	R127, R134
A1	1-25	1	47 kΩ (yellow-violet-orange)	R3
A1	1-121	1	120 kΩ (brown-red-yellow)	R117
A1	1-30	1	270 kΩ (red-violet-yellow)	R186
A1	1-71	1	4.7 MΩ (yellow-violet-green)	R140

**5% Tolerance Resistors**

A1	1-155	1	24 Ω (red-yellow-black)	R125
A1	1-56	1	240 Ω (red-yellow-brown)	R118
A1	1-63	1	510 Ω (green-brown-brown)	R136
A1	1-131	2	620 Ω (blue-red-brown)	R148, R161
A1	1-90	3	2000 Ω (red-black-red)	R173, R184, R187
A1	1-57	1	2200 Ω (red-red-red)	R138
A1	1-89	2	2400 Ω (red-yellow-red)	R104, R132
A1	1-122	1	3300 Ω (orange-orange-red)	R105
A1	1-82	2	3600 Ω (orange-blue-red)	R119, R123
A1	1-64	5	5100 Ω (green-brown-red)	R121, R131, R145, R158, R176
A1	1-164	1	7500 Ω (violet-green-red)	R192

KEY No.	HEATH Part No.	QTY.	DESCRIPTION	CIRCUIT Comp. No.
---------	----------------	------	-------------	-------------------

**5% Tolerance Resistors (cont'd.)**

A1	1-133	3	15 kΩ (brown-green-orange)	R122, R165, R189
A1	1-162	3	18 kΩ (brown-gray-orange)	R124, R135, R191
A1	1-65	1	51 kΩ (green-brown-orange)	Test
A1	1-190	2	470 kΩ (yellow-violet-yellow)	R142, R156

**Precision Resistors, 1% Tolerance**

A2	2-131	1	10 Ω, 1/2-watt	R116
A2	2-219	1	21.62 Ω, 1/2-watt	R115
A2	2-23	1	68.38 Ω, 1/2-watt	R114
A2	2-64	1	110 Ω, 1/2-watt	R129
A2	2-25	1	216.2 Ω, 1/2-watt	R113
A2	2-192	1	426 Ω, 1/2-watt	R139
A2	2-28	1	683.8 Ω, 1/2-watt	R112
A2	2-293	2	1500 Ω (1.5 k), 1/2-watt	R137, R167
A2	2-228	2	2000 Ω (2 k), 1/2-watt	R178, R185
A2	2-31	1	2162 Ω (2.162 k), 1/2-watt	R111
A2	2-68	1	3000 Ω (3 k), 1/2-watt	R166
A2	2-88-12	1	5000 Ω (5 k), 1/4-watt	R154
A2	2-50	4	10 kΩ, 1/2-watt	R141, R146, R153, R159
A2	2-40-11	1	10.1 kΩ, 1/8-watt	R2
A2	2-20-11	1	14.3 kΩ, 1/8-watt	R4
A2	2-68-12	1	20 kΩ, 1/4-watt	R177
A2	2-680-12	1	32 kΩ, 1/4-watt	R174
A2	2-672-12	1	400 kΩ, 1/4-watt	R172
A2	2-17	1	10 MΩ, 1/2-watt	R1

**Other Resistor**

A2	9-72	1	1000 Ω (1K), precision, compensating	R175
----	------	---	--------------------------------------	------

**CAPACITORS****Disc Capacitors**

B1	21-149	2	2.7 pF	C130, C115
B1	21-73	1	10 pF	C117
B1	21-7	2	33 pF	C110, C116
B1	21-147	1	47 pF	C118
B1	21-11	1	150 pF	C122
B1	21-21	3	200 pF	C123, C125, C131
B1	21-17	1	270 pF	C124
B1	21-140	1	.001 μF	C121
B1	21-72	1	.005 μF	C4



KEY No.	HEATH Part No.	QTY.	DESCRIPTION	CIRCUIT Comp. No.
---------	----------------	------	-------------	-------------------

### Capacitors (cont'd.)

#### Electrolytic Capacitors

B2	25-165	1	6 $\mu$ F, non-polarized	C109
B3	25-262	1	250 $\mu$ F tubular	C111
B4	25-149	1	5 $\mu$ F	C119
B4	25-257	4	10 $\mu$ F, 50 volt	C113, C114 C128, C129
B4	25-116	2	50 $\mu$ F	C106, C112
B4	25-160	2	250 $\mu$ F	C103, C105
B4	25-234	2	500 $\mu$ F	C126, C127
B4	25-148	1	1000 $\mu$ F	C104
B5	25-220	2	10 $\mu$ F tantalum	C120, C140

#### Other Capacitors

B6	20-110	1	75 pF mica	C108
B6	20-108	1	200 pF mica	C107
B7	27-104	2	4700 pF (.0047) Mylar*	C3, C102
B7	27-110	1	.047 $\mu$ F Mylar	C1
B8	31-56	1	1.5-20 pF trimmer	C2

#### CONTROLS-SWITCHES

C1	10-294	1	2000 (2K) $\Omega$ CONTROL	R169
C1	10-390	2	20 k $\Omega$ control	R103, R128
C1	10-941	1	100 k $\Omega$ control	R194
C1	10-989	2	5 M $\Omega$ control	R143, R155
C2	60-54	1	Slide switch	SW2
C3	63-1278	1	Rotary switch with 50 k $\Omega$ control	RS1, RS2, R5
C4	64-852	1	3-section pushbutton switch assembly	SW1, SW3, SW4

#### DIODES-TRANSISTORS-INTEGRATED CIRCUITS (IC's)

D1	56-56	9	1N4149 diode	D101, D102, D103, D104, D105, D106, D107, D108, D109
D1	56-57	2	1N716A zener diode (12-volt)	ZD115, ZD116
D1	56-629	1	BZX83C3V zener diode (4.7 volt)	ZD110
D1	57-65	4	1N4002 diode	D111, D112, D113, D114

KEY No.	HEATH Part No.	QTY.	DESCRIPTION	CIRCUIT Comp. No.
---------	----------------	------	-------------	-------------------

### Diodes-Transistors-Integrated Circuits (cont'd.)

NOTE: Transistors and integrated circuits may be marked for identification in any of the following four ways:

1. Part number.
2. Type number. (On integrated circuits, this refers only to the numbers; the letters may be different or missing.)
3. Part number and type number.
4. Part number with a type number other than the one listed.

D2	417-260	2	2N4258A transistor	Q108, Q109
D3	417-134	3	MPS6520 transistor	Q103, Q104, Q106
D3	417-235	5	2N4121 transistor	Q102, Q105, Q107, Q110, Q111
D4	417-802	1	E304 JFET	Q101
D5	417-876	2	CA3046 IC	IC101, IC104
D6	442-22	1	LM741CN IC	IC103
D6	442-66	1	LM308N IC	IC102
D7	442-617	1	UA78MGT2C IC	IC105
D7	442-618	1	UA79MGT2C IC	IC106

#### METAL PARTS

E1	90-1186-1	1	Cabinet top
E2	200-1288-1	1	Chassis
E3	205-1669-1	2	Side panel
E4	204-2188	2	Meter bracket
E5	204-2189	1	Switch bracket
E6	204-2211	1	Circuit board bracket
E7	206-1237	1	Input shield
E8	216-69	1	Trim bar

#### BINDING POST PARTS

F1	75-17	1	Black base
F1	75-197	2	Red base
F2	100-16-2	1	Black cap
F2	100-16-18	1	Red cap
F3	427-3	2	Binding post



KEY No.	HEATH Part No.	QTY.	DESCRIPTION	CIRCUIT Comp. No.
---------	----------------	------	-------------	-------------------

### CONNECTOR-SOCKETS- JACKS-BUSHINGS-KNOBS

G1	432-134	7	Wire connector (1 extra)	
G2	434-230	2	8-pin IC socket	
G3	434-298	2	14-pin IC socket	
G4	436-11	3	Red banana jack	
G4	436-22	2	Black banana jack	
G5	455-71	1	Inner knob bushing	
G6	455-613	1	Outer knob bushing	
G7	462-363	1	Red knob	
G8	462-951	1	Black knob	

### LINE CORD-WIRE-SLEEVING

89-54	1	Line cord	
344-2	48"	Black stranded wire	
344-50	36"	Black wire	
344-52	66"	Red wire	
346-1	7"	Black sleeving	

### HARDWARE

NOTE: Hardware packets are marked to show the size of the hardware they contain (HDW #4, or HDW #6 and #8, etc.). You may have to open more than one packet to locate all the hardware of any one size (#4 for example).

#### #4 Hardware

H1	250-1124	4	4-40 × 1/4" black screw	
H2	250-1194	2	4-40 × 1/2" T-bolt	
H3	252-2	2	Large 4-40 nut	
H4	252-15	4	Small 4-40 nut	
H5	254-9	2	#4 lockwasher	
H6	254-41	4	#4 split lockwasher	

#### #6 Hardware

J1	250-274	4	6-32 × 5/16" flat head screw	
J2	250-155	13	#6 × 5/16" black sheet metal screw	
J3	250-381	7	6-32 × 3/8" black screw	
J4	250-1150	2	6-32 × 1/2" phillips screw	
J5	252-3	9	6-32 nut	
J6	253-27	1	#6 flat washer	
J7	254-1	6	#6 lockwasher	
J8	254-6	1	#6 external lockwasher	
J9	259-1	3	#6 solder lug	

KEY No.	HEATH Part No.	QTY.	DESCRIPTION	CIRCUIT Comp. No.
---------	----------------	------	-------------	-------------------

### Other Hardware

K1	250-49	2	3-48 × 1/4" screw	
K2	250-137	2	8-32 × 3/8" screw	
K3	252-4	2	8-32 nut	
K4	252-7	1	Control nut	
K5	252-32	1	Push-on nut	
K6	252-127	4	Spring nut	
K7	253-10	1	Control flat washer	
K8	254-7	2	#3 lockwasher	
K9	254-2	2	#8 lockwasher	
K10	254-4	1	Control lockwasher	

### MISCELLANEOUS

L1	54-926	1	Power transformer	T1
	73-77	3"	Foam tape	
L2	75-736	1	Strain relief	
	75-738	1	1" × 2" paper insulator	
	85-2035-1	1	Circuit board	
L3	211-74	1	Handle	
L4	261-34	4	Foot	
L5	407-738	1	Meter	M1
L6	412-15	1	Neon lamp	PL1
L7	413-10	1	Red lens	
L8	421-26	1	1/8-ampere, slow-blow fuse	F1
L9	422-1	1	Fuseholder	
L10	490-5	1	Nut starter	

Solder

### PRINTED MATERIAL

M1	391-34	1	Blue and white label	
----	--------	---	----------------------	--

NOTE: Be sure you refer to the numbers on the blue and white label in any communications you may have about this kit with Heath Company. You may want to write the model and series numbers in the sample for future convenience.

M2	390-1255	1	Fuse label	
M3	390-1274	1	"Heathkit" label	
	597-260	1	Parts Order Form	
		1	Assembly Manual (See Page 1 for part number.)	

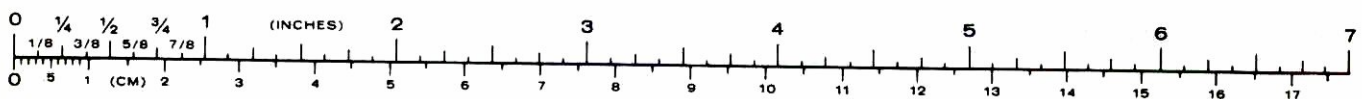



# STEP-BY-STEP ASSEMBLY

## ASSEMBLY NOTES

### TOOLS

You will need these tools to assemble your kit.

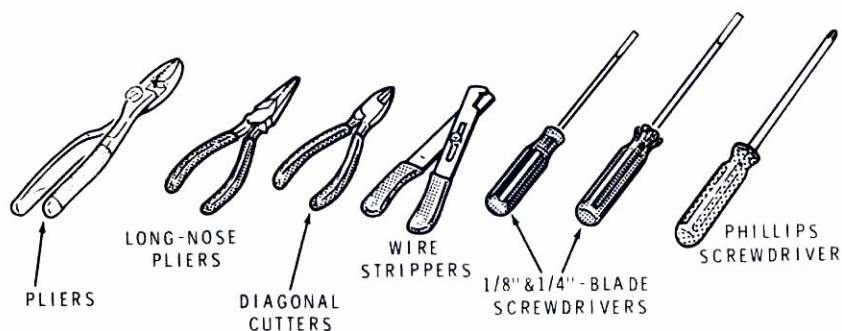

HEATHKIT  
SOLDERING  
IRON

OR

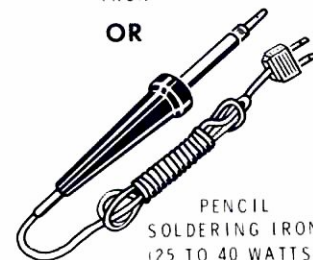

PENCIL  
SOLDERING IRON  
(25 TO 40 WATTS)

### OTHER HELPFUL TOOLS



NUT STARTER  
(MAY BE SUPPLIED  
WITH KIT)



DESOLDERING  
BULB\*



SOLDER  
BRAID\*

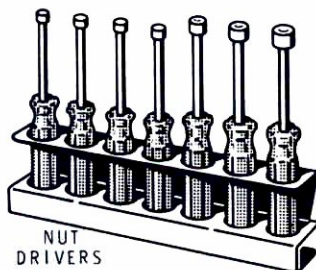

NUT  
DRIVERS

\*TO REMOVE SOLDER FROM CIRCUIT CONNECTIONS.

### ASSEMBLY

- Follow the instructions carefully, and read the entire step before you perform the operation.
- Position all parts as shown in the Pictorials.
- The illustrations in the Manual are called Pictorials and Details. Pictorials show the overall operation for a group of assembly steps; Details generally illustrate a single step. When you are directed to refer to a certain Pictorial "for the following steps," continue using that Pictorial until you are referred to another Pictorial for another group of steps.
- A separate "Illustration Booklet" contains illustrations (Pictorials, Details, etc.) that are too large for the Assembly Manual. When the Manual says to refer to a certain Pictorial or Detail and that illustration is not on the same page, or on the page across from it, refer to the "Illustration Booklet."

Keep the "Illustration Booklet" with the Assembly Manual. The illustrations in it are arranged in Pictorial number sequence.

- Solder a part or a group of parts only when you are instructed to do so.

6. Resistors will be called out by their resistance value in  $\Omega$  (ohms),  $k\Omega$  (kilohms), or  $M\Omega$  (megohms), and color code. Use 1/2-watt resistors unless directed otherwise.
7. Capacitors will be called out by their capacitance value (in pF or  $\mu F$ ) and type (disc ceramic, Mylar, or electrolytic).
8. When you are instructed to cut something to a particular length, use the scales (rulers) provided at the bottom of the Manual pages.

**SAFETY WARNING: Avoid eye injury when you cut off excess lead lengths. Hold the leads so they cannot fly toward your eyes.**

## SOLDERING

Soldering is one of the most important operations you will perform while assembling your kit. A good solder connection will form an electrical connection between two parts, such as a component lead and a circuit board foil. A bad solder connection could prevent an otherwise well-assembled kit from operating properly.

It is easy to make a good solder connection if you follow a few simple rules:

1. Use the right type of soldering iron. A good quality, 25 to 40-watt, pencil soldering iron with a 1/8" or 3/16" chisel or pyramid tip works best.
2. Keep the soldering iron tip clean. Wipe it often on a wet sponge or cloth; then apply solder to the tip to give the entire tip a wet look. This process is called tinning, and it will protect the tip and enable you to make good connections. When solder tends to "ball" or does not stick to the tip, the tip needs to be cleaned and retinned.
3. Due to the small foil area around the circuit board holes and the small areas between foils, you must use the utmost care to prevent solder bridges between adjacent foil areas.

A solder bridge between two adjacent foils is shown in photograph A below. Photograph B shows how the connection should appear. A solder bridge may occur if you accidentally touch an adjacent previously soldered connection, if you use too much solder, or if you "drag" the soldering iron across other foils as you remove it from the connection. A good rule to follow is: Always take a good look at the foil area around each lead before you solder it. Then, when you solder the connection, make sure the solder remains in this area, and does not bridge to another foil. This is especially important when the foils are small and close together. NOTE: It is alright for solder to bridge two connections on the same foil.

Use only enough solder to make a good connection, and lift the soldering iron straight up from the circuit board. If a solder bridge should develop, turn the circuit board foil-side-down and heat the solder between connections. The excess solder will run onto the tip of the soldering iron, and this will remove the solder bridge. NOTE: The foil side of each circuit board has a coating on it called "solder resist." This is a protective insulation to help prevent solder bridges.

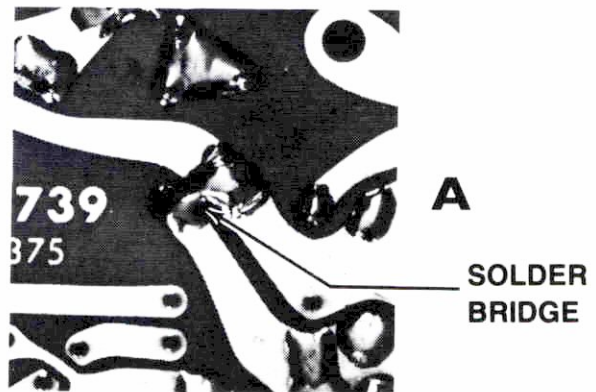

# CIRCUIT BOARD ASSEMBLY

IDENTIFICATION  
DRAWING

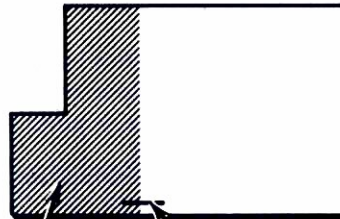

The steps performed in this Pictorial are in this area of the circuit board.

PART  
NUMBER

**CONTINUE** ↩

( ) Solder the resistor leads to the circuit board as follows:

1. Push the soldering iron tip against both the lead and the circuit board foil. Heat both for 2 or 3 seconds.

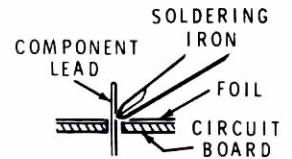

2. Then apply solder to the other side of the connection. **IMPORTANT:** Let the heated lead and the circuit board foil melt the solder.

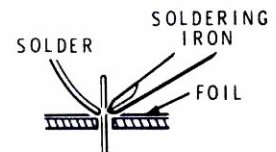

3. As the solder begins to melt, allow it to flow around the connection. Then remove the solder and the iron and let the connection cool.

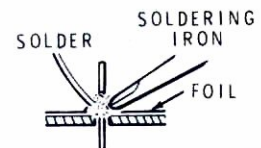

( ) Hold the lead with one hand while you cut off the excess lead length close to the connection. This will keep you from being hit in the eye by the flying lead.

( ) Check the connection. Compare it to the illustrations on the next page. After you have checked the solder connections, proceed with the assembly on Page 11. Use the same soldering procedure for each connection.

**START** ↘

In the following steps you will be given detailed instructions on how to install and solder the first part on the circuit board. Read and perform each step carefully. Then use the same procedure whenever you install parts on a circuit board.

( ) Position the circuit board as shown in the identification drawing with the printed side (not the foil side) up.

( ) Hold a 100 Ω (brown-black-brown) resistor by the body as shown and bend the leads straight down.

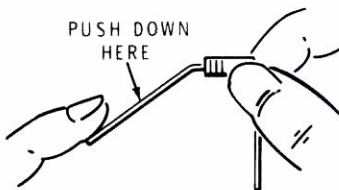

( ) R102: Push the leads through the holes at the proper location on the circuit board. The end with color bands may be positioned either way.

( ) Press the resistor against the circuit board. Then bend the leads outward slightly to hold the resistor in place.

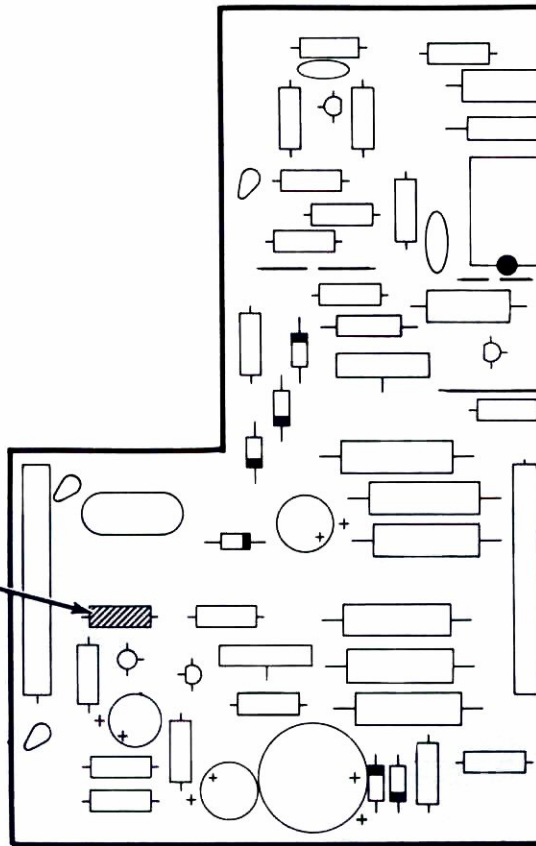

PICTORIAL 1-1

## A GOOD SOLDER CONNECTION

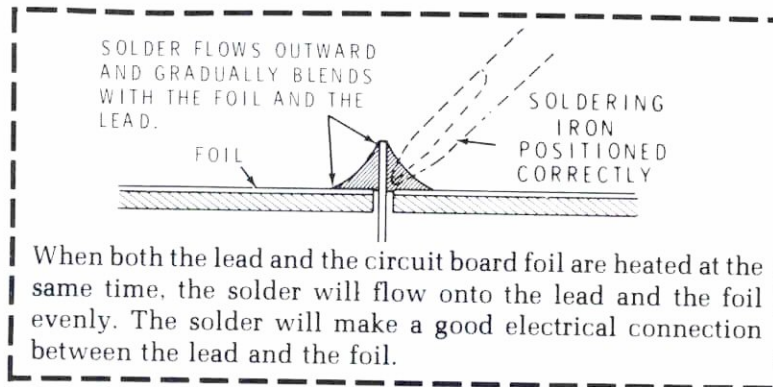

## POOR SOLDER CONNECTIONS

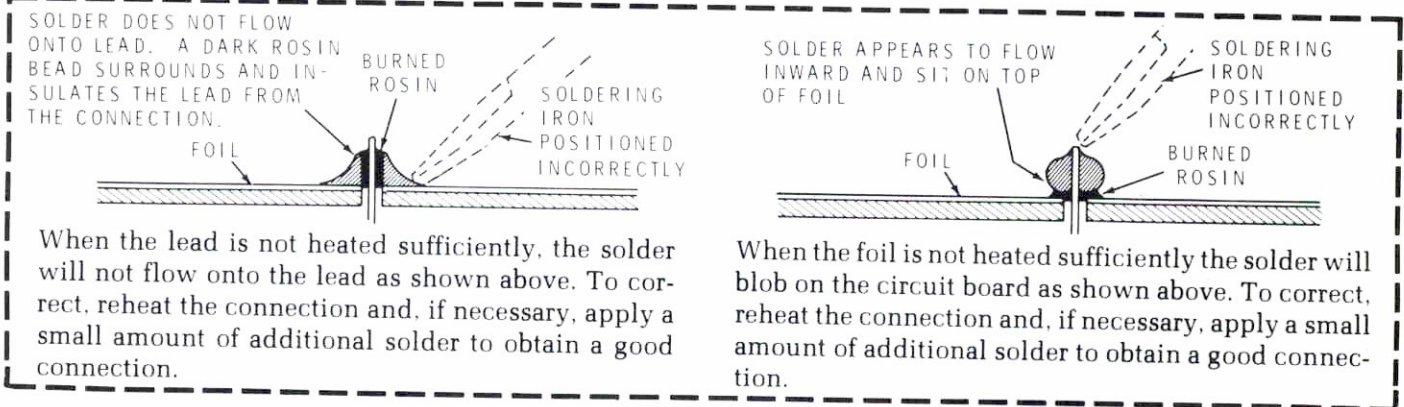

## SOLDER CONNECTIONS TO WATCH OUT FOR

The following photographs show examples of the types of bad solder connections that are the most common cause of trouble. If you locate any of these bad solder connections in your kit, correct them as instructed.

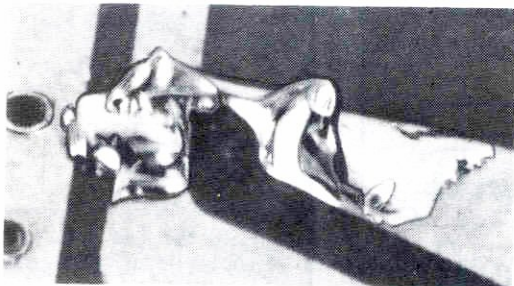

Here, hot solder has been dropped onto the foil and the solder connected or bridged (or crossed) three foils. To correct, hold the circuit board above the soldering iron and reheat the solder. As the solder melts, it will flow down the iron.

NOTE: Solder that bridges two connections on the SAME FOIL is alright and should not be corrected.

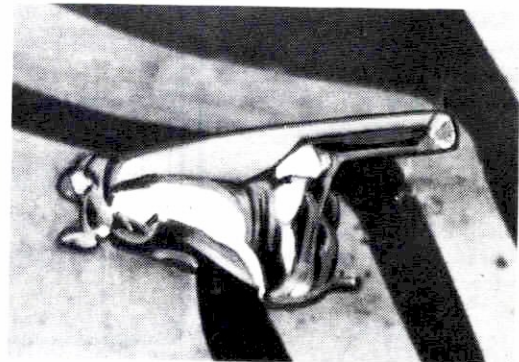

Here, solder has flowed along a lead and bridged to another foil. To correct, hold the circuit board above the soldering iron and reheat the solder. As the solder melts, it will flow down the iron. Then cut off the excess lead lengths. PROTECT YOUR EYES.

The steps performed in this Pictorial are in this area of the circuit board.

**START** ▾

( ) **IMPORTANT:** No specific soldering instructions will be given as you install parts in the circuit board Pictorials. You will usually find it convenient to solder five or six components to the foil at one time. After the components have been soldered, cut off the excess lead lengths.

( ) R187: 2000 Ω (red-black-red).

( ) R188: 1000 Ω (brown-black-red).

( ) R186: 270 kΩ (red-violet-yellow).

( ) R182: 1000 Ω (brown-black-red).

( ) R181: 10 kΩ (brown-black-orange).

( ) R179: 4700 Ω (yellow-violet-red).

( ) R184: 2000 Ω (red-black-red).

( ) R168: 1800 Ω (brown-gray-red).

**SAFETY WARNING:** Avoid eye injury when you cut off excess leads. Hold the leads so they cannot fly toward your eyes.

**NOTE:** When you install precision resistors, bend the resistor leads so you can see the value of each resistor after it is installed.

( ) R116: 10 Ω precision.

( ) R115: 21.62 Ω precision.

( ) R114: 68.38 Ω precision.

( ) R113: 216.2 Ω precision.

( ) R107: 150 Ω (brown-green-brown).

( ) R112: 683.8 Ω precision.

( ) R111: 2162 (2.162k) precision.

( ) R117: 120 kΩ (brown-red-yellow).

( ) R118: 240 Ω (red-yellow-brown).

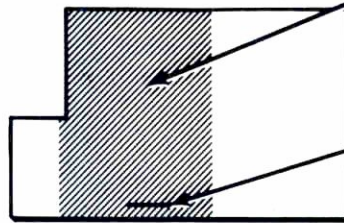

IDENTIFICATION DRAWING

PART NUMBER

**CONTINUE** ▾

( ) R178: 2000 (2k) Ω precision.

( ) R185: 2000 (2k) Ω precision.

( ) R190: 4700 Ω (yellow-violet-red).

( ) R183: 4700 Ω (yellow-violet-red).

( ) R171: 1000 Ω (brown-black-red).

( ) R176: 5100 Ω (green-brown-red).

( ) R177: 20 kΩ precision.

( ) R175: 1000 (1k) Ω precision compensating (#9-72).

( ) R173: 2000 Ω (red-black-red).

( ) R174: 32 kΩ precision.

( ) R172: 400 kΩ precision.

( ) R109: 820 Ω (gray-red-brown).

( ) R137: 1500 (1.5k) Ω precision.

( ) R139: 426 Ω precision.

( ) R119: 3600 Ω (orange-blue-red).

( ) R132: 2400 Ω (red-yellow-red).

( ) R123: 3600 Ω (orange-blue-red).

( ) R133: 100 Ω (brown-black-brown).

( ) R121: 5100 Ω (green-brown-red).

( ) R122: 15 kΩ (brown-green-orange).

( ) R126: 8200 Ω (gray-red-red).

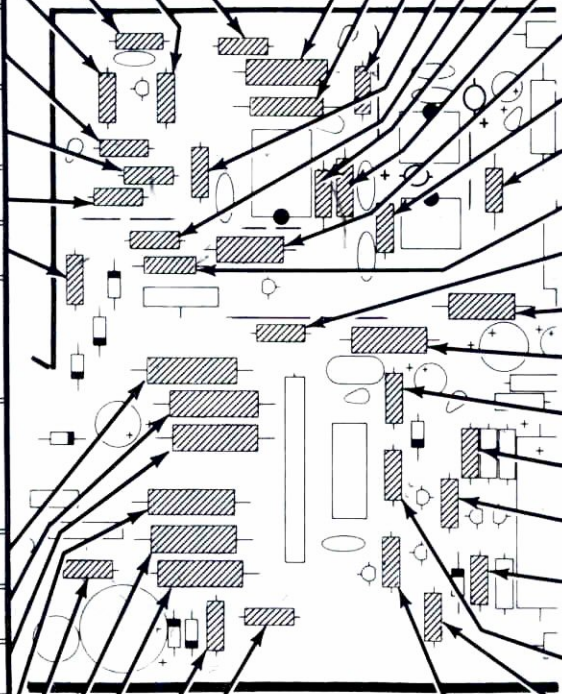

PICTORIAL 1-2

The steps performed in this Pictorial are in this area of the circuit board.

PART NUMBER

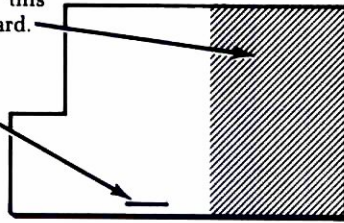

IDENTIFICATION DRAWING

CONTINUE

START

- ( ✓ ) R162: 3900 Ω (orange-white-red).
- ( ✓ ) R161: 620 Ω (blue-red-brown).
- ( ✓ ) R165: 15 kΩ (brown-green-orange).
- ( ✓ ) R167: 1500 (1.5k) Ω precision.
- ( ✓ ) R166: 3000 (3k) Ω precision.
- ( ✓ ) R159: 10 kΩ precision.
- ( ) R156: 470 kΩ (yellow-violet-yellow).
- ( ✓ ) R144: 100 Ω (brown-black-brown).
- ( ) R146: 10 kΩ precision.
- ( ✓ ) R141: 10 kΩ precision.
- ( ) R135: 18 kΩ (brown-gray-orange).
- ( ✓ ) R127: 22 kΩ (red-red-orange).
- ( ✓ ) R134: 22 kΩ (red-red-orange).
- ( ✓ ) R131: 5100 Ω (green-brown-red).
- ( ✓ ) R136: 510 Ω (green-brown-brown).
- ( ) R138: 2200 Ω (red-red-red).
- ( ✓ ) R124: 18 kΩ (brown-gray-orange).
- ( ✓ ) R125: 24 Ω (red-yellow-black).
- ( ✓ ) R129: 110 Ω precision.

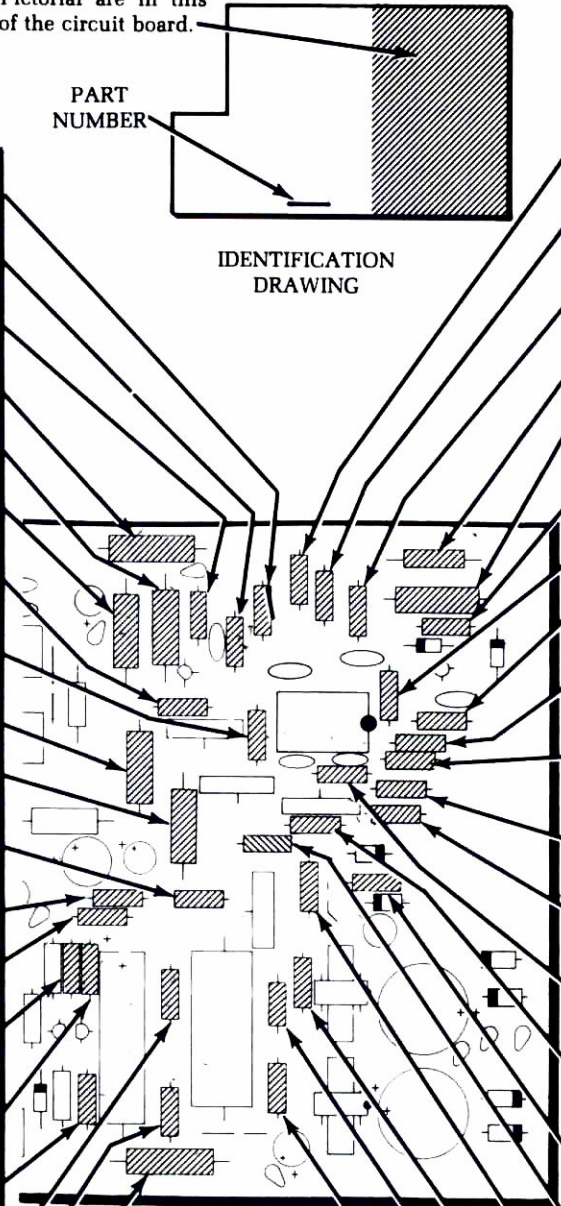

- ( ) R163: 100 Ω (brown-black-brown).
- ( ) R164: 4700 Ω (yellow-violet-red).
- ( ✓ ) R157: 100 Ω (brown-black-brown).
- ( ✓ ) R154: 5000 (5k) Ω precision.
- ( ) R153: 10 kΩ precision.
- ( ) R150: 10 kΩ (brown-black-orange).
- ( ✓ ) R158: 5100 Ω (green-brown-red).
- ( ✓ ) R152: 1800 Ω (brown-gray-red).
- ( ✓ ) R148: 620 Ω (blue-red-brown).
- ( ✓ ) R149: 3900 Ω (orange-white-red).
- ( ✓ ) R147: 4700 Ω (yellow-violet-red).
- ( ✓ ) R151: 100 Ω (brown-black-brown).
- ( ✓ ) R145: 5100 Ω (green-brown-red).
- ( ✓ ) R142: 470 kΩ (yellow-violet-yellow).
- ( ✓ ) R193: 330 Ω (orange-orange-brown).
- ( ✓ ) R140: 4.7 MΩ (yellow-violet-green).
- ( ✓ ) R194: 330 Ω (orange-orange-brown).
- ( ✓ ) R189: 15 kΩ (brown-green-orange).
- ( ✓ ) R192: 7500 Ω (violet-green-red).
- ( ✓ ) R191: 18 kΩ (brown-gray-orange).

PICTORIAL 1-3

**START**

**NOTE:** To prepare a jumper wire, as in the following step, cut a red wire to the indicated length. Then remove 1/4" of insulation from each wire end.

( ) Prepare the following red wires:

- 1-1/2"            1-3/4"
- 1"                1-1/8"
- 1-1/4"

- ( ) 1-1/2" jumper wire.
- ( ) 1" jumper wire.
- ( ) 1-1/4" jumper wire.
- ( ) 1-3/4" jumper wire.

**IMPORTANT:** THE BANDED END OF DIODES CAN BE MARKED IN A NUMBER OF WAYS.



**BANDED END**  
CAUTION: ALWAYS POSITION THE BANDED END AS SHOWN ON THE CIRCUIT BOARD.

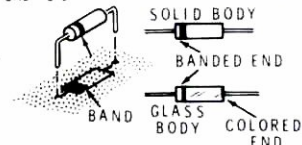

If your diode has a solid body, the band is clearly defined. If your diode has a glass body, do not mistake the colored end inside the diode for the banded end. Look for a band painted on the outside of the glass.

**NOTE:** When you install diodes, as in the following steps, be sure you position the banded end of each diode as it is shown on the circuit board.

- ( ) D101: 1N4149 diode (#56-56).
- ( ) D102: 1N4149 diode (#56-56).
- ( ) D109: 1N4149 diode (#56-56).
- ( ) ZD110: 4.7-volt zener diode (#56-629).
- ( ) D104: 1N4149 diode (#56-56).
- ( ) D103: 1N4149 diode (#56-56).

The steps performed in this Pictorial are in this area of the circuit board.

PART NUMBER

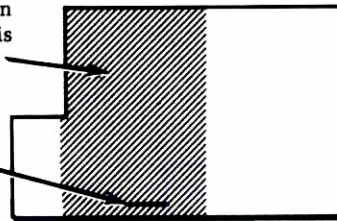

IDENTIFICATION DRAWING

**CONTINUE**

**NOTE:** In the following steps, before you mount the IC sockets, make sure all the socket pins are straight. Then, as you mount the socket, make sure all its pins are through the foil before you solder them.

- ( ) 14-pin IC socket at IC104. Solder its pins to the foil.
- ( ) 8-pin IC socket at IC102. Solder its pins to the foil.
- ( ) 1-1/8" red jumper wire.
- ( ) 8-pin IC socket at IC103. Solder the IC pins to the foil.

IC's will be installed in the following steps. Install IC's as follows: Identify the pin 1 of the IC, then match the pin 1 end of the IC with the marked end of the IC outline on the circuit board and in the Pictorial. Then, carefully push the IC down into its socket.

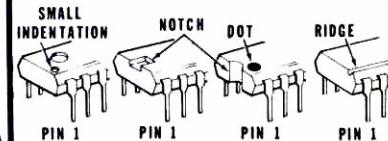

- ( ) IC103: LM741CN IC (#442-22).
- ( ) IC102: LM308N IC (#442-66).
- ( ) IC104: CA3046 IC (#417-876).
- ( ) D106: 1N4149 diode (#56-56).
- ( ) D105: 1N4149 diode (#56-56).

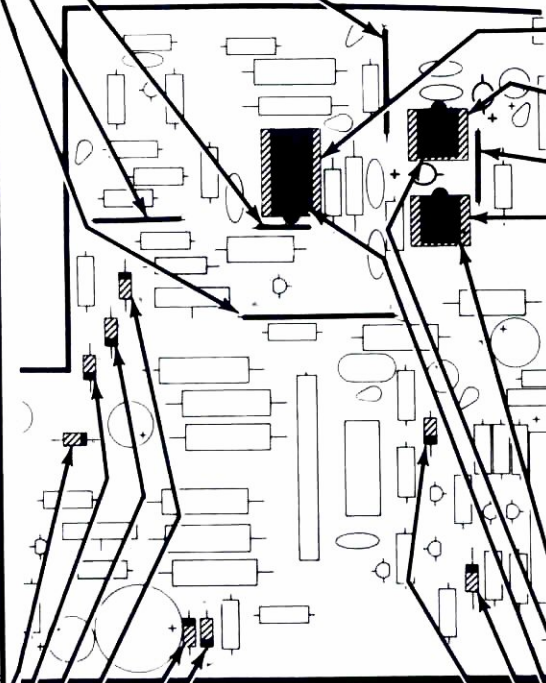

PICTORIAL 1-4



The steps performed in this Pictorial are in this area of the circuit board.

**START** ▾

NOTE: Before you mount the IC socket in the following step, make sure all the socket pins are straight. Then, as you mount the socket, make sure all its pins are through the foil before you solder them.

( 1 ) 14-pin IC socket at IC101. Solder its pins to the foil.

Install IC's as follows: Identify the pin 1 of the IC. Then match the pin 1 end of the IC with the marked end of the IC outline on the circuit board and in the Pictorial. Then, carefully push the IC down into its socket.

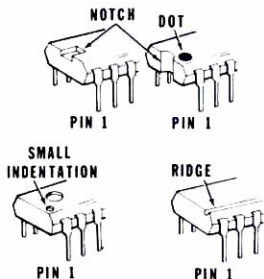

( 1 ) IC101: CA3046 integrated circuit. (#417-876).

NOTE: When you install electrolytic capacitors, position the positive (+) end as shown.

POSITIVE (+) MARKING

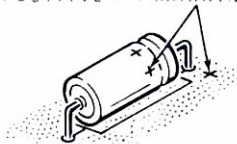

( 2 ) C111: 250  $\mu$ F tubular electrolytic.

NOTE: The following electrolytic capacitor is nonpolarized and may be positioned either way. It may be marked as shown, or have no marking.

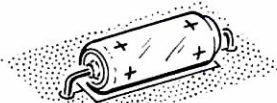

( ) C109: 6  $\mu$ F non-polarized electrolytic.

PART NUMBER

IDENTIFICATION DRAWING

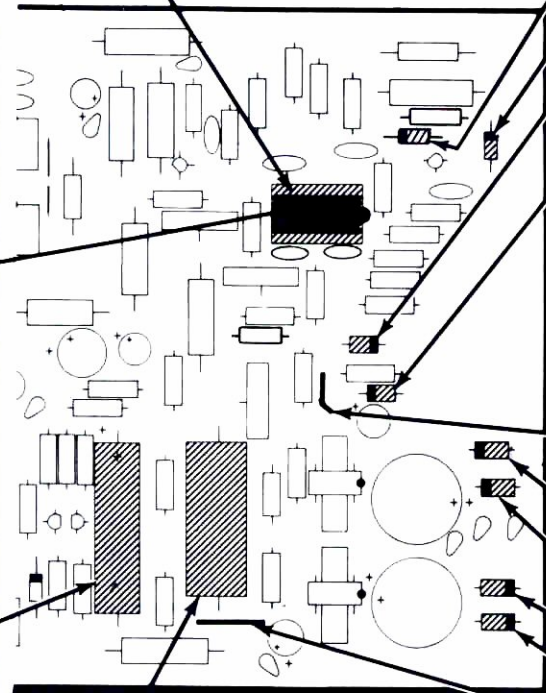

**CONTINUE** ▾

NOTE: When you install diodes, as in the following step, be sure you position the banded end of the diodes as shown on the circuit board.



( ) D107: 1N4149 diode (#56-56).

( ) D108: 1N4149 diode (#56-56).

( ) ZD116: 1N716A 12-volt zener diode (#56-57).

( ) ZD115: 1N716A 12-volt zener diode (#56-57).

NOTE: To prepare jumper wires, cut the red wire to the length indicated; then remove all the insulation from the wire.

( 1 ) Prepare two 1" jumper wires.

( ) 1" jumper wire. Form the wire to the outline on the board.

( 2 ) D114: 1N4002 diode (#57-65).

( ) D113: 1N4002 diode (#57-65).

( 2 ) D111: 1N4002 diode (#57-65).

( ) D112: 1N4002 diode (#57-65).

( ) 1" jumper wire.

PICTORIAL 1-5

The steps performed in this Pictorial are in this area of the circuit board.

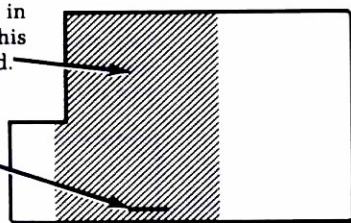

IDENTIFICATION DRAWING

PART NUMBER

**START**

The transistors installed in the Pictorial are shown below. Identify their E, B, and C leads and insert them in the corresponding E, B, and C holes in the circuit board. As each transistor is installed, solder its leads to the foil and cut off the excess lead lengths.

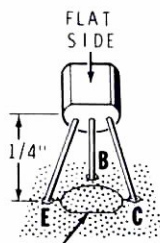

FLAT SIDE

( ) Q111: 2N4121 transistor (#417-235).

( ) Q110: 2N4121 transistor (#417-235).

NOTE: To install a control, insert the lugs into their holes and press the control against the circuit board. Solder the lugs to the foil as you install each control:



( ) R169: 2000 (2K)  $\Omega$  control (#10-294).

NOTE: When you install vertical electrolytic capacitors, be sure you match the positive (+) mark on the capacitor with the positive (+) mark on the circuit board.

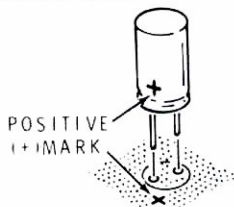

( ) C105: 250  $\mu$ F electrolytic.

**CONTINUE**

NOTE: Before you install the following disc and Mylar capacitors, use long-nose pliers to remove any excess insulation from the capacitor leads.



REMOVE COATING EVEN WITH BOTTOM OF CAPACITOR BODY

( ) C131: 200 pF disc.

( ) C125: 200 pF disc.

( ) C124: 270 pF disc.

( ) C121: .001  $\mu$ F disc.

NOTE: When you install a tantalum capacitor, always match the positive (+) or dot mark of the capacitor with the positive (+) mark on the circuit board.

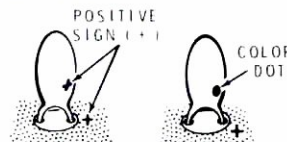

( ) C120: 10  $\mu$ F tantalum.

( ) C140: 10  $\mu$ F tantalum.

( ) C122: 150 pF disc.

( ) C123: 200 pF disc.

( ) C107: 200 pF mica.

( ) C114: 10  $\mu$ F electrolytic. Position the plus (+) mark as shown.

( ) C108: 75 pF mica.

NOTE: To install transistors in the following steps, refer to the instructions at the top of the left column on this page.

( ) Q106: MPS6520 transistor (#417-134).

( ) Q105: 2N4121 transistor (#417-235).

( ) Q104: MSP6520 transistor (#417-134).

( ) Q103: MSP6520 transistor (#417-134).

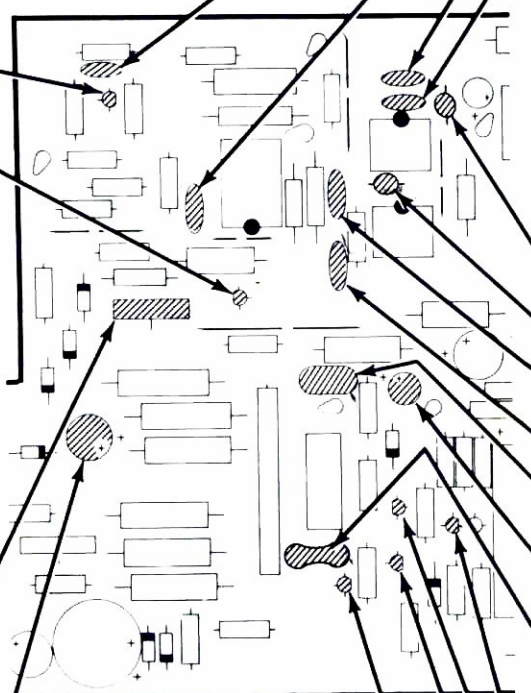

PICTORIAL 1-6



The steps performed in this Pictorial are in this area of the circuit board.

PART NUMBER

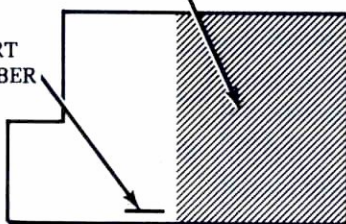

IDENTIFICATION DRAWING

**START** ↘

- ( ✓ ) C115: 2.7 pF disc.
- ( ) C116: 33 pF disc.
- ( ) C117: 10 pF disc.
- ( ) C118: 47 pF disc.

NOTE: As you install electrolytic capacitors in the following steps, be sure to match the positive (+) mark on the capacitor with the (+) mark on the board.

- ( ) C119: 5  $\mu$ F electrolytic.
- ( ✓ ) R155: 5 M $\Omega$  control.
- ( ) R143: 5 M $\Omega$  control.
- ( ) R103: 20 k $\Omega$  control.

- ( ✓ ) C112: 50  $\mu$ F electrolytic. Position the positive (+) mark as shown.
- ( ✓ ) C113: 10  $\mu$ F electrolytic. Position the positive (+) mark as shown.

On the following transistor, identify the E, B, and C leads and insert them in the corresponding holes in the circuit board. After the transistor is installed, solder its leads to the foil and cut off the excess lead lengths.

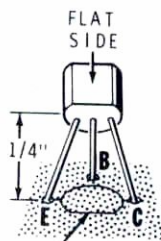

FLAT SIDE

- ( ) Q107: 2N4121 transistor (#417-235).
- ( ) C110: 33 pF disc.
- ( ) C130: 2.7 pF disc.

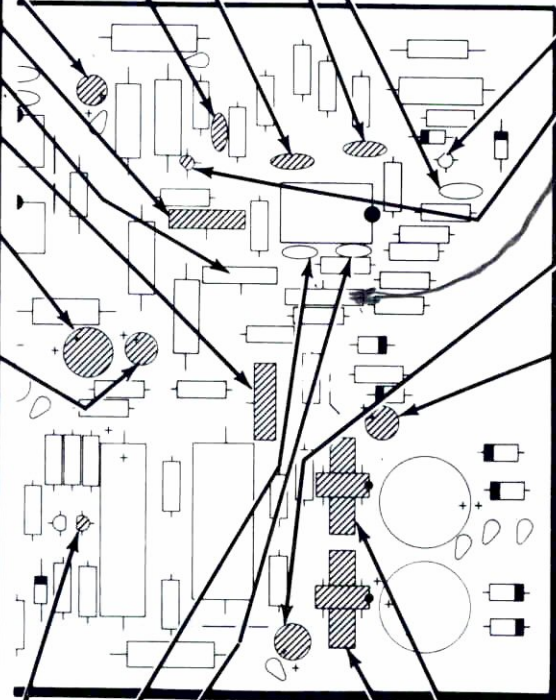

**CONTINUE** ↘

NOTE: Install transistors in the manner shown. Line up the flat, tab, or wide space of the transistor with the outline on the circuit board. Identify the transistor leads from the drawings and insert each lead into its proper hole. Push the transistor down to within 1/4" of the circuit board. Then solder each lead to the foil and cut off the excess lead lengths.

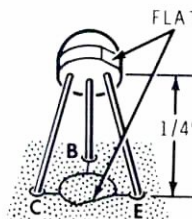

- ( ) Q108: 2N4258A transistor (#417-260).
- ( ) Q109: 2N4258A transistor (#417-260).
- ( ) R194: 100 k $\Omega$  control.
- ( ) C129: 10  $\mu$ F electrolytic. Position the positive (+) mark as shown.
- ( ) C128: 10  $\mu$ F electrolytic. Position the positive (+) mark as shown.

When you install the following IC's, match the index mark on the IC with the mark on the board. Push the IC leads through the holes in the board. Then secure the IC's with 4-40 hardware as shown. Be careful not to twist the IC tabs. Then solder the IC leads to the foil.

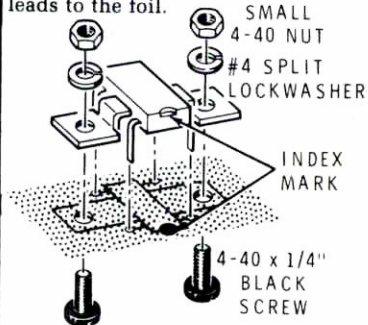

- ( ) IC105: UA78MGT2C IC (#442-617).
- ( ) IC106: UA79MGT2C IC (#442-618).

PICTORIAL 1-7

The steps performed in this Pictorial are in this area of the circuit board.

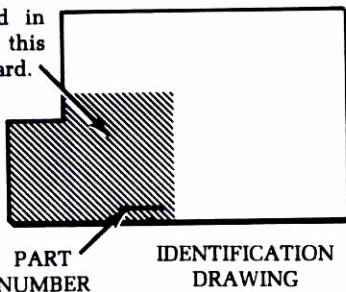

**START**

Refer to Detail 1-8A at the bottom of this page. Then install three wire connectors at Q101 and three wire connectors at Q102 as shown. NOTE: It may help to lightly push the connectors into the board with a pencil eraser. Also, see the transistor illustrations in the right column.

- ( ) R101: 10 kΩ (brown-black-orange).
- ( ) C103: 250 μF electrolytic. Be sure to position the positive (+) mark as shown.
- ( ) R105: 3300 Ω (orange-orange-red).
- ( ) R106: 100 Ω (brown-black-brown).
- ( ) R108: 330 Ω (orange-orange-brown).

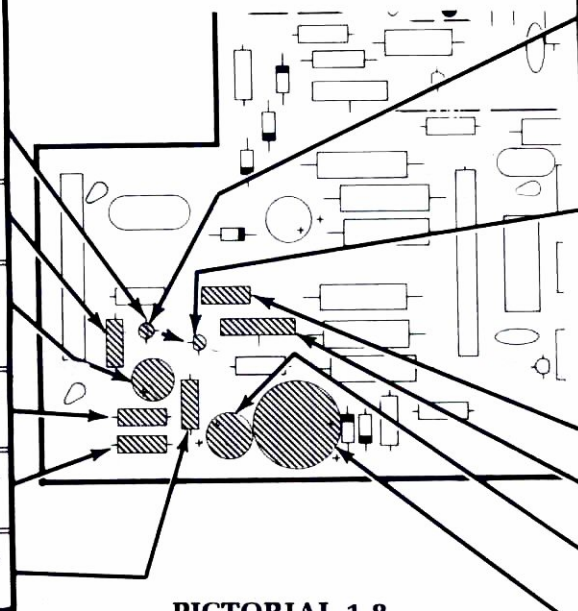

**PICTORIAL 1-8**

**CONTINUE**

Cut 1/4" from each lead of the transistors to be mounted in the next two steps. Do not solder the leads as you install these transistors.

- ( ) Q101: E304 JFET (#417-802). See Detail 1-8B at the bottom of the Page.

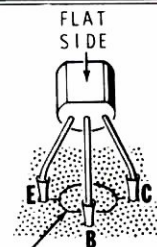

FLAT SIDE

- ( ) Q102: 2N4121 transistor (#417-235).
- ( ) R104: 2400 Ω (red-yellow-red).
- ( ) R103: 20 kΩ control.
- ( ) C106: 50 μF electrolytic. Position the positive (+) mark as shown.
- ( ) C104: 1000 μF electrolytic. Position the positive (+) mark as shown.

( ) Install wire connectors (#432-134) three at a time at the indicated locations as shown. Use a minimum of heat and solder, but be sure you have a good connection. Do not pinch the connectors with pliers.

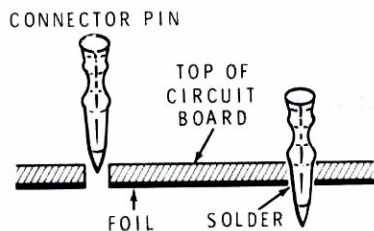

**Detail 1-8A**

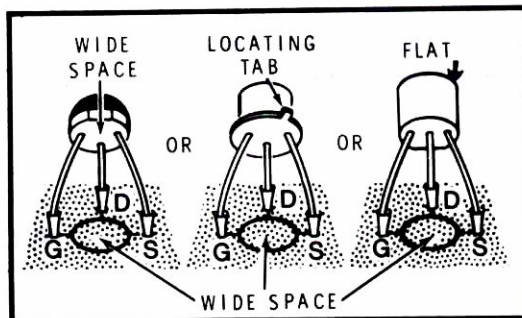

**Detail 1-8B**

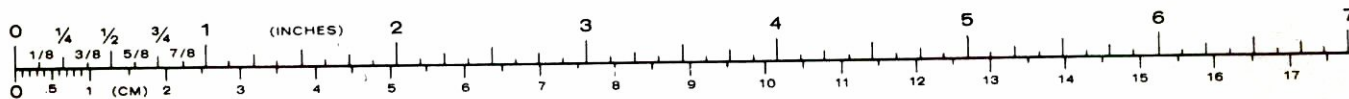

The steps performed in this Pictorial are in this area of the circuit board.

PART NUMBER

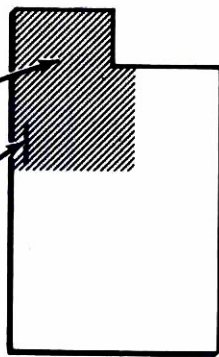

IDENTIFICATION DRAWING

CONTINUE

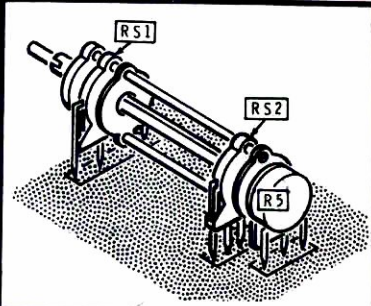

( ) RS1, RS2, R5: Rotary switch with control (#63-1278).

START

( ) C102: 4700 pF (.0047) Mylar.  
NOTE: Disregard any band on the capacitor.

NOTE: As you mount the rotary switch with control in the following step, make sure sections RS1, RS2, and control R5 lugs are firmly pressed onto the top of the circuit board as shown. Then solder one lug on each switch wafer to the foil. Check to see that the lugs on each wafer are all the way down onto the circuit board. If not, reheat the one solder connection as you push down on the switch. Then solder the remaining wafer lugs. Do this with both switch wafers and control R5.

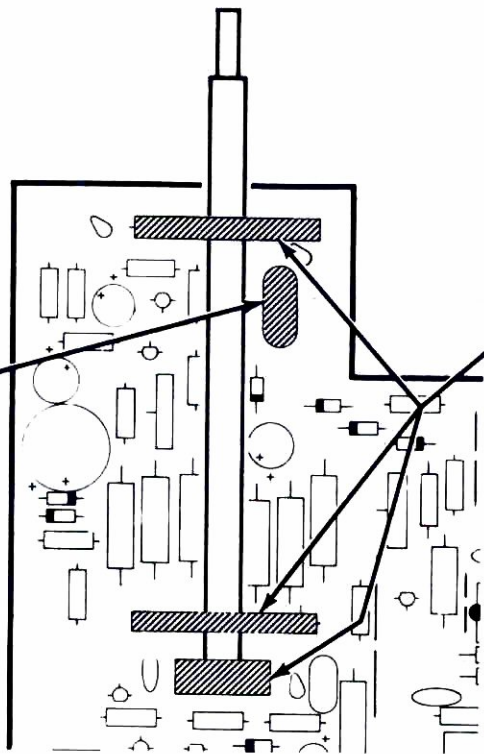

CIRCUIT BOARD CHECKOUT

Carefully inspect the circuit board for the following conditions.

- ( ) Unsoldered connections.
- ( ) Poor solder connections.
- ( ) Solder bridges between foil patterns.
- ( ) Protruding leads which could touch together.
- ( ) Transistors for the proper type and installation.
- ( ) Electrolytic capacitors for the correct position of the positive (+) end.
- ( ) Diodes for the correct position of the banded end.

NOTE: Two 500  $\mu$ F electrolytic capacitors will be installed later.

PICTORIAL 1-9



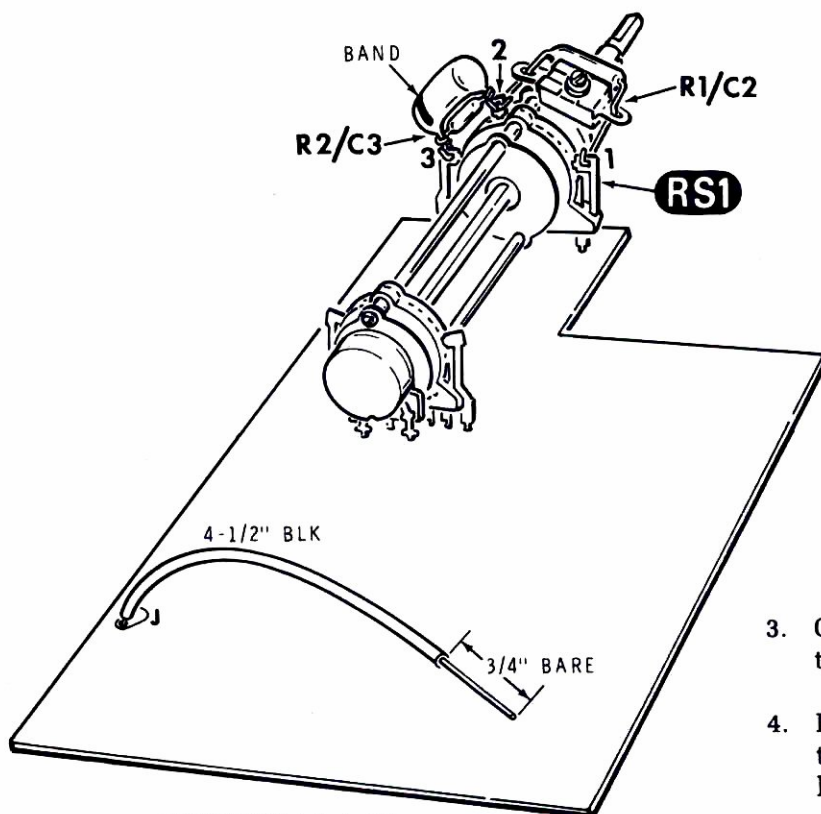

PICTORIAL 1-10

Refer to Pictorial 1-10 for the following steps.

- ( ) Prepare a 4-1/2" black **solid** wire. Remove an additional 1/2" (total 3/4") of insulation from one end of this wire.
- ( ) Push the 1/4" prepared end of this 4-1/2" black wire through hole J. Solder the wire to the foil and cut off the excess wire length.
- ( ) Refer to Detail 1-10A and prepare a 10 M $\Omega$  precision resistor and the 1.5-20 pF trimmer as follows:
  1. Turn the trimmer screw until it is just snug.
  2. Bend the trimmer tabs straight out horizontally.

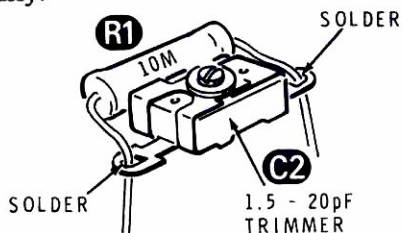

Detail 1-10A

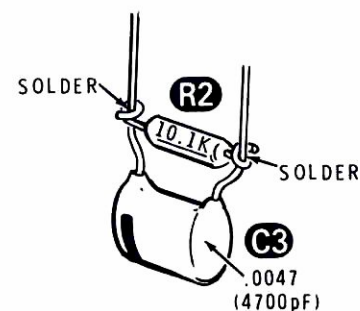

Detail 1-10B

3. Cut the leads of the 10 M $\Omega$  precision resistor to 1".
4. Position the resistor along the side of the trimmer body as shown; form the resistor leads through each of the trimmer tabs.
5. Solder each resistor lead to one of the trimmer tabs.

NOTE: After a wire or component lead is connected in a step, an abbreviated solder instruction will also be given. (NS) means not to solder, because other wires will be added later. "S-" with a number, such as (S-3), means to solder the connection. The number following the "S-" tells how many wires are at the connection.

- ( ) R1/C2: Mount the resistor-trimmer assembly between switch RS1 lugs 1 (S-1) and 2 (NS). Position the assembly so the bottom tip of the trimmer screw is approximately 1/8" above the switch wafer. Cut off the excess lead lengths.
- ( ) Refer to Detail 1-10B and form the leads of a 10.1 k $\Omega$  precision resistor around the leads of a 4700 pF (.0047) Mylar capacitor as shown. Solder the leads of the two components together.
- ( ) R2/C3: Mount the resistor-capacitor assembly between switch RS1 lugs 2 (S-2) and 3 (S-1) as shown in the Pictorial. Cut off the excess lead lengths. NOTE: If there is a band on one end of this capacitor, connect the lead coming from this end to RS1 lug 3.

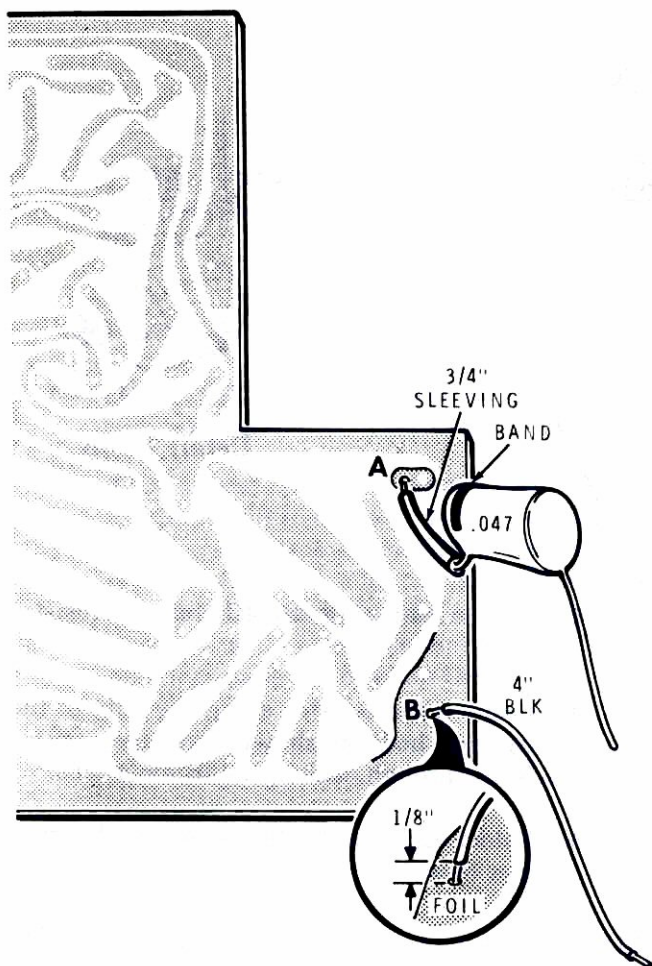

PICTORIAL 1-11

Refer to Pictorial 1-11 for the following steps.

- ( ✓ ) Prepare a 4" length of solid black wire.
- ( ) Turn the circuit board foil-side-up. Then, after you check the location of hole B on the component side of the board, push one end of the prepared black wire into the hole. Leave 1/8" of the bare wire exposed above the circuit board foil. Solder the wire to the foil.
- ( ✓ ) Cut both leads of a .047  $\mu$ F Mylar capacitor to 1". Cut a 3/4" length of sleeving, and place the sleeving on the lead at the banded-end of the capacitor.
- ( ) C1: Push the end of the sleeved capacitor lead into hole A on the foil side of the circuit board. Leave 1/8" of the bare capacitor lead exposed above the foil; then solder the lead to foil A.

Set the circuit board aside temporarily.

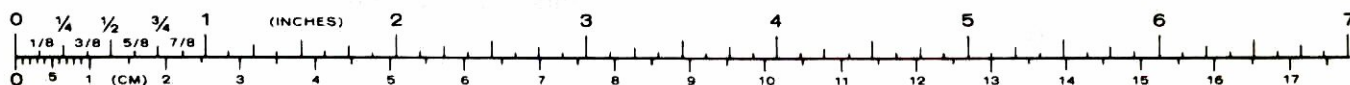

## CHASSIS ASSEMBLY

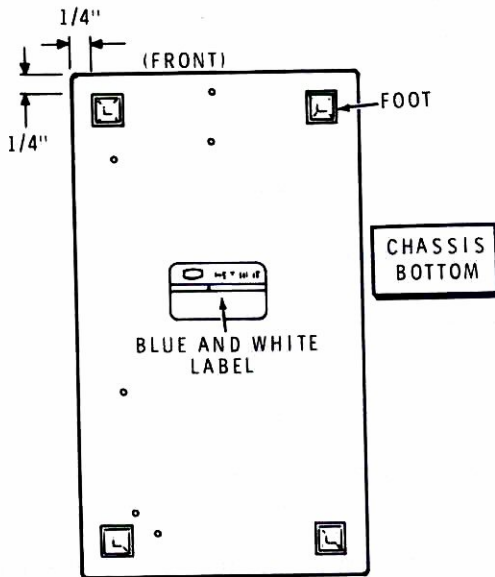

**Detail 2-1A**

Refer to Pictorial 2-1 (on Page 2 in the "Illustration Booklet") for the following steps.

- ( ) Turn the chassis bottom-side-up.
- ( ) Refer to Detail 2-1A and mount four feet on the bottom of the chassis as follows: Remove the paper backing from each of the feet and press them in place on the corner of the chassis as shown in the Detail.
- ( ) Remove the paper backing from the blue and white label and press the label in place on the underside of the chassis as shown in the Pictorial. NOTE: Be sure to refer to the Model and Series numbers on the blue and white label in any correspondence you have with the Heath Company about your kit.
- ( ) Turn the chassis upright.

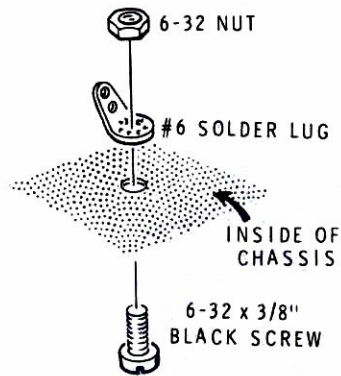

**Detail 2-1B**

NOTE: When hardware is called for in a step, only the screw size will be given. For instance, if 6-32 x 3/8" hardware is called for, it means that you should use a 6-32 x 3/8" screw, one or more #6 lockwashers, and a 6-32 nut. The Pictorial or a Detail will show the proper number of lockwashers that are used. The plastic nut starter can be used to pick up and start 6-32 and 4-40 nuts on screws.

- ( ) Refer to Detail 2-1B and mount a #6 solder lug in the chassis at A. Use 6-32 x 3/8" black hardware.
- ( ) J3: Refer to Detail 2-1C and mount a red banana jack on the chassis rear panel at J3. Use the nut supplied with the jack.

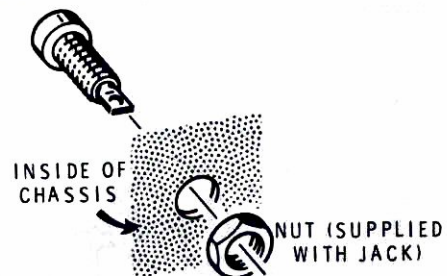

**Detail 2-1C**

*Series 204B*

- ( ) J5, J7: In the same manner, mount red banana jacks in the rear panel at J5 and J7.
- ( ) J4, J6: Similarly, mount black banana jacks in rear panel holes J4 and J6.

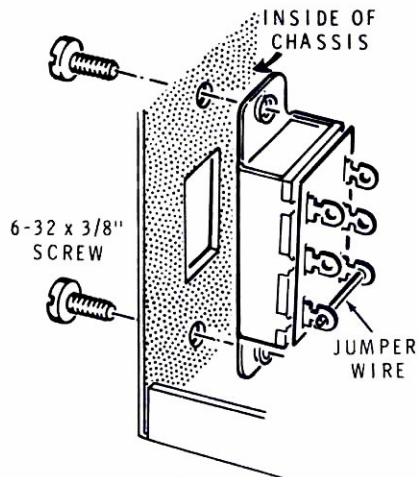

Detail 2-1D

- ( ) SW2: Refer to Detail 2-1D and mount the line switch in the rear panel at SW2 with two 6-32 × 3/8" black screws as shown. Be sure to position the jumped switch lugs downward as shown in the Pictorial.
- ( ) Refer to Detail 2-1E and mount the fuseholder on the rear panel at F1. Position the fuseholder as shown in the Pictorial. Use 6-32 × 3/8" black hardware.

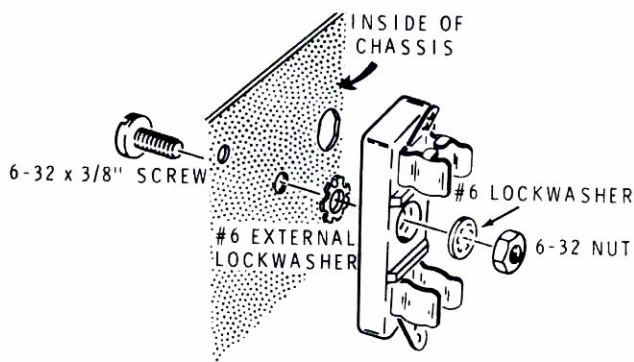

Detail 2-1E

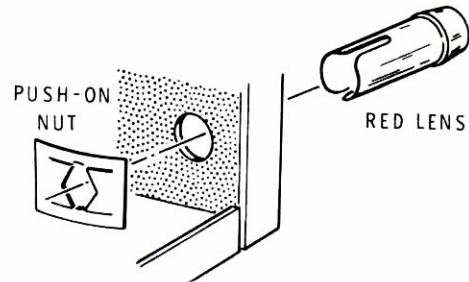

Detail 2-1F

- ( ) Refer to Detail 2-1F and mount the red lens on the front panel at PL1 with a push-on nut as shown. Push firmly on the inner corners of the nut shown in Pictorial 2-1.

Set the chassis aside temporarily.

Refer to Pictorial 2-2 (on Page 2 in the "Illustration Booklet") for the following steps.

- ( ) SW1/SW3/SW4: Mount the 3-pushbutton switch assembly onto the switch bracket in the manner shown. Use 3-48 × 1/4" hardware.
- ( ) With diagonal cutters, cut the six lugs **without holes** from the underside of switch SW1.

**NOTE:** To prepare stranded wire, as in the following step, cut the wire to the indicated length and remove 1/4" of insulation from each end. Then tightly twist each wire end and add a small amount of solder to hold the strands together.

- ( ) Prepare the following wires:

8" black stranded	6" red
10-1/2" black stranded	7-1/2" red
8-1/2" black stranded	4-1/2" black solid
1" red	4" red
8-1/2" red	

**NOTE:** As you install the black stranded wires in the following three steps, wrap each wire end securely around its switch lug to assure a good mechanical connection. See inset drawing #1 on the Pictorial. Inset drawing #2 shows a direct view of the numbered switch lugs.

- ( ) Connect an 8" black stranded wire to SW1 lug 5 (NS).



- ( ) Connect a 10-1/2" black stranded wire to SW1 lug 4 (S-1).
  - ( ) Connect an 8-1/2" black stranded wire to SW1 lug 1 (S-1).
  - ( ) R3: Cut the leads of a 47 kΩ resistor (yellow-violet-orange) to 1/2". Connect the resistor between switch SW1 lugs 2 (S-1) and 3 (NS) as shown in the Pictorial.
  - ( ) Cut the leads of the neon lamp to 1-1/2".
  - ( ) Cut two 1-1/4" lengths of sleeving. Place a length of this sleeving on each of the lamp leads.
  - ( ) PL1: Connect the neon lamp leads to SW1 lugs 5 (S-2) and 3 (S-2) as shown in the Pictorial.
  - ( ) Connect a 1" red wire from switch SW3 lug 3 (S-1) to SW4 lug 4 (S-1).
  - ( ) Connect one end of an 8-1/2" red wire to switch SW3 lug 2 (S-1).
  - ( ) Connect one end of a 6" red wire to switch SW3 lug 1 (S-1).
  - ( ) Connect one end of a 7-1/2" red wire to switch SW4 lug 3 (S-1).
  - ( ) Remove an additional 1/4" of insulation from one end of a 4-1/2" black solid wire.
- NOTE: When a wire passes through a connection and goes to another point, as in the following step, it will count as two wires in the solder instructions (S-2); one entering and one leaving the connection.
- ( ) Pass the 1/2" bare wire end of the 4-1/2" black wire through switch SW4 lug 1 (S-2) and connect the end to SW4 lug 6 (S-1) as shown. Position the wire between the other switch lugs so it will not touch any of these connections.
  - ( ) Cut one lead of a 14.3 kΩ precision resistor to 1/2". Cut a 1-1/4" length of sleeving; then push the sleeving onto the long resistor lead.
  - ( ) R4: Connect the long lead of the 14.3 Ω precision resistor to switch SW4 lug 2 (S-1). The free resistor lead will be connected later.
  - ( ) Connect one end of a 4" red wire to switch SW4 lug 5 (S-1). The free ends of the wires connected to switches SW1, SW3, and SW4 will be connected later.

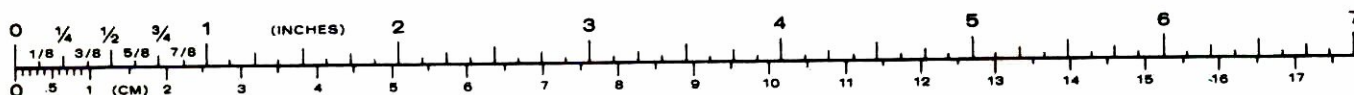

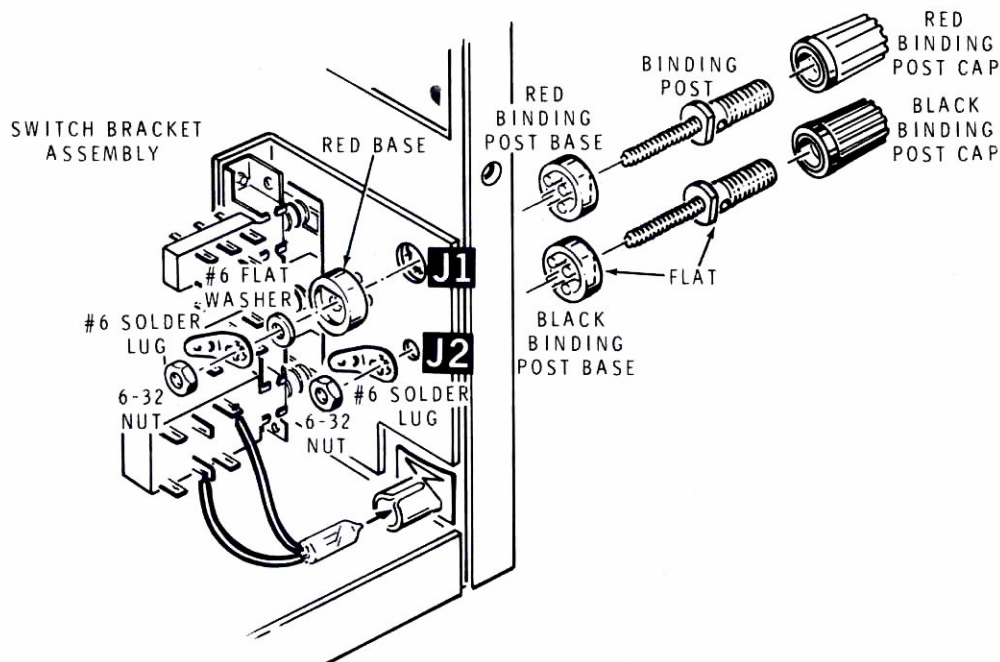

PICTORIAL 2-3

Refer to Pictorial 2-3 for the following steps.

- ( ) Place a red binding post base onto a binding post as shown. Be sure to match the flat on the post with the flat on the base.
- ( ) Position the switch bracket assembly into the front panel from the inside of the chassis. Then secure the bracket at J1 with the binding post and base on the outside of the front panel, another red binding post base, and 6-32 hardware on the inside of the panel and switch bracket. Position the solder lug as shown in the Pictorial.
- ( ) Place a black binding post base on the other binding post. Secure the switch bracket and binding post on the inside of the front panel at J2 with 6-32 hardware.
- ( ) Place a black binding post cap on binding post J2 and a red binding post cap on binding post J1.
- ( ) PL1: Push the neon lamp (connected to switch SW1) into the front panel red lens as shown. NOTE: Check to be sure the lamp leads are not crossed as this will short out the lamp.

NOTE: Be sure the switch pushbuttons do not bind against the front panel opening. If necessary, loosen the binding post nuts slightly and reposition the switch assembly.

Refer to Pictorial 2-4 (on Page 3 in the "Illustration Booklet") for the following steps.

- ( ) Connect the black stranded wire coming from switch SW1 lug 4 to fuseholder lug 1 (S-1). Be sure to wrap the wire end around the lug to assure a good mechanical connection.
- ( ) F1: Push the 1/8-ampere slow-blow fuse into fuseholder F1.
- ( ) Write the following in the blank space on the fuse label:  

"1/8 AMP, SLOW-BLOW."
- ( ) Remove the paper backing from the fuse label and press the label in place in the bottom of the chassis approximately 2-1/2" to the rear of the front panel as shown in the Pictorial.

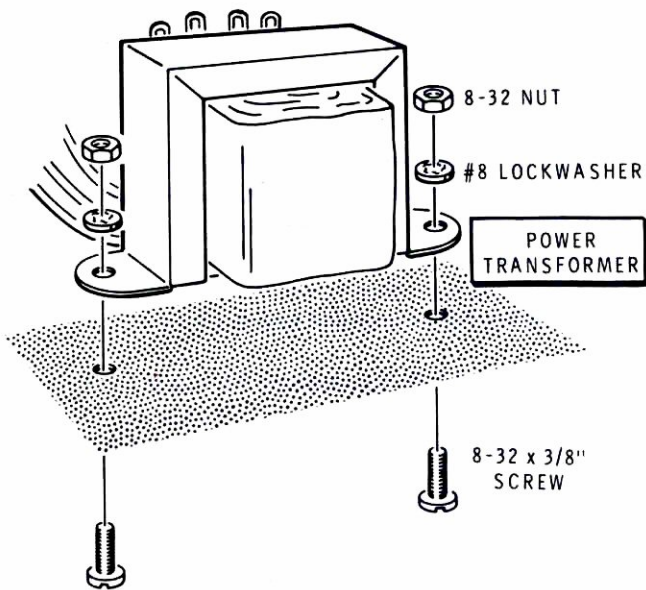

Detail 2-4A

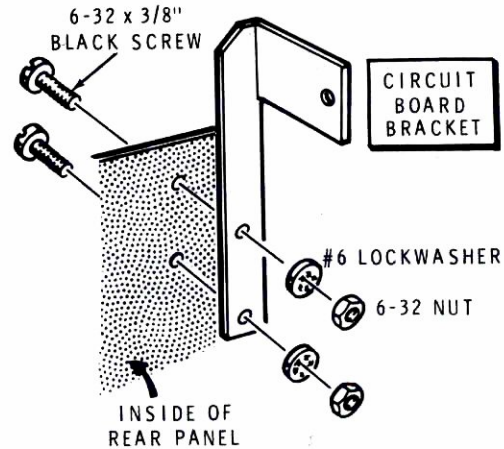

Detail 2-4B

- ( ) Refer to Detail 2-4A and mount the power transformer at T1 with 8-32  $\times$  3/8" hardware. Be sure to position the transformer leads and lugs as shown in Pictorial 2-4. Tighten the mounting hardware securely.
- ( ) Refer to Detail 2-4B and mount the circuit board bracket at C on the rear panel with 6-32  $\times$  3/8" black hardware as shown.
- ( ) Prepare the following hookup (solid) wires:
- |            |             |
|------------|-------------|
| 7-1/2" red | 11-1/2" red |
| 9" red     |             |
- ( ) Connect one end of a 7-1/2" red wire to banana jack J3 (S-1). The free end will be connected later.
- ( ) Connect one end of a 9" red wire to banana jack J5 (S-1). The free end will be connected later.
- ( ) Connect one end of a 11-1/2" red wire to banana jack J7 (S-1). The free end will be connected later.
- ( ) Prepare the following black stranded wires:
- |        |        |
|--------|--------|
| 4-1/2" | 3-1/2" |
| 4-1/2" | 5-1/2" |
- NOTE:** When you connect the black stranded wires in the following steps, securely wrap each wire end around its connecting lug to assure a good mechanical connection. Position the wires straight out from the transformer lugs and **keep as much space as possible between the wire connections.**
- ( ) Connect a 4-1/2" black stranded wire from switch SW2 lug 2 (S-1) to transformer T1 lug 2 (NS).

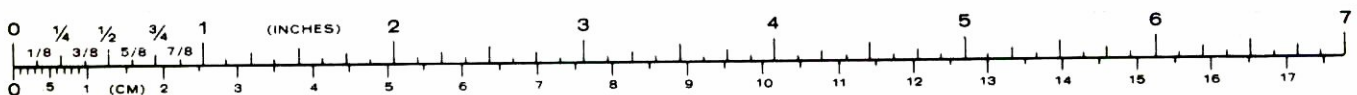

- ( ) Connect a 4-1/2" black stranded wire from SW2 lug 5 (S-1) to T1 lug 3 (S-1).
- ( ) Connect a 3-1/2" black stranded wire from SW2 lug 1 (S-1) to T1 lug 4 (NS).
- ( ) Connect a 5-1/2" black stranded wire from SW2 lug 4 (S-1) to T1 lug 1 (NS).
- ( ) Connect the free end of the black stranded wire coming from front panel switch SW1 lug 5 to transformer T1 lug 1 (S-2).
- ( ) Connect the free end of the black stranded wire coming from front panel switch SW1 lug 1 to transformer T1 lug 2 (S-2).

- ( ) Refer to Detail 2-4C and prepare the end of the line cord as shown. Then push the end of the line cord through rear panel hole D as shown in the Pictorial.

Refer to Pictorial 2-4 and connect the line cord wires in the following three steps. NOTE: Be sure to wrap each wire end securely to assure a good mechanical connection.

- ( ) Green wire to solder lug A (S-1).
- ( ) Black wire to fuseholder F1 lug 2 (NS).
- ( ) White wire to transformer T1 lug 4 (NS).
- ( ) Cut two 3/4" lengths of sleeving.
- ( ) Cut the leads of a .005  $\mu$ F, 1.4 kV disc capacitor to 1". Place a 3/4" piece of sleeving on each of the capacitor leads.
- ( ) C4: Connect the leads of the prepared .005  $\mu$ F disc capacitor from fuseholder F1 lug 2 (S-2) to transformer T1 lug 4 (S-3). Wrap both capacitor leads around the lugs to assure a good mechanical connection.
- ( ) Refer to Detail 2-4D. Pull outward on the line cord to remove any slack. Then, grip the line cord strain relief tightly with pliers, close to the rear panel as shown in the Detail. Push the line cord strain relief into the rear panel opening.

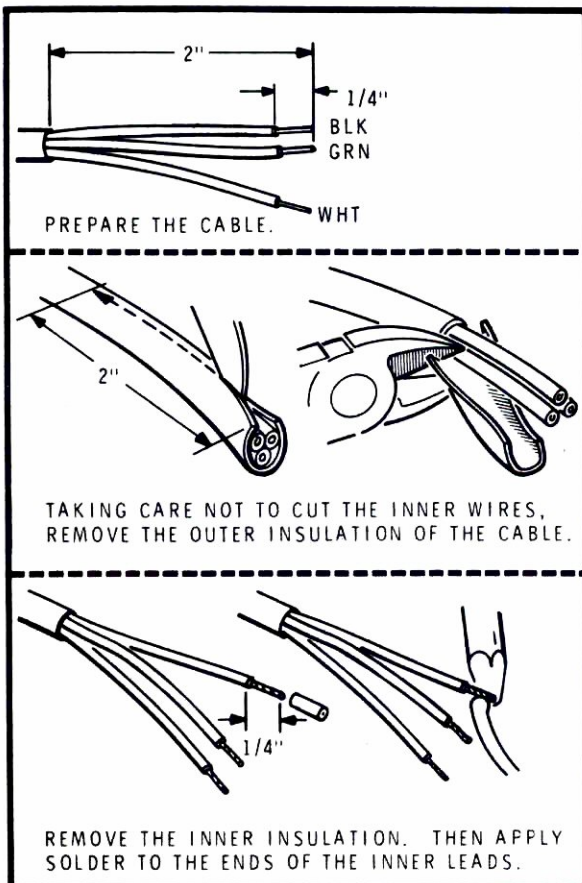

**Detail 2-4C**

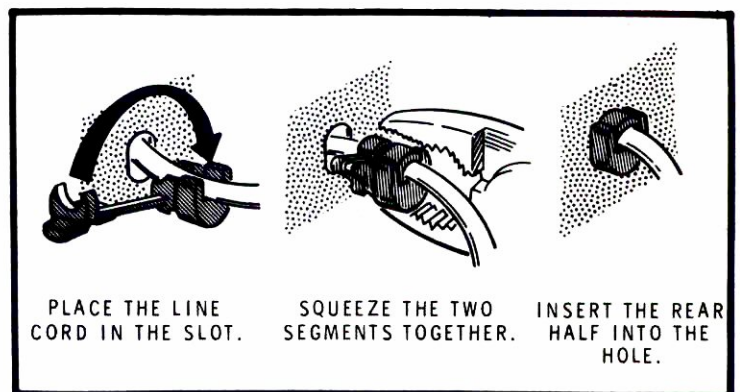

**Detail 2-4D**



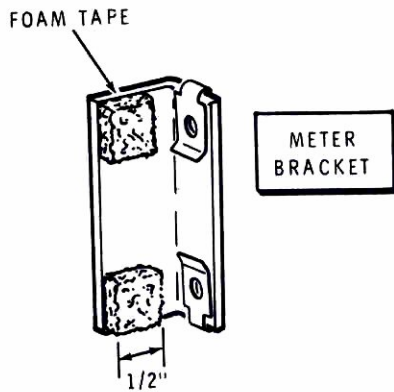

**Detail 2-5A**

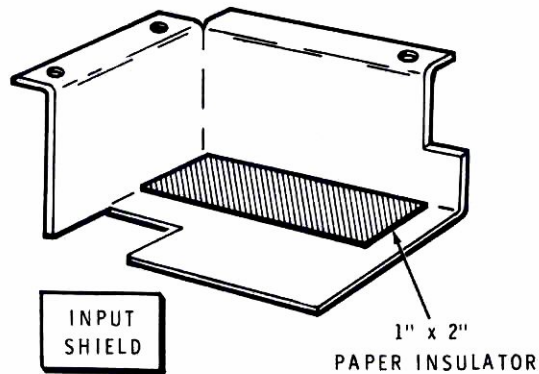

**Detail 2-5B**

Refer to Pictorial 2-5 (on Page 4 in the "Illustration Booklet") for the following steps.

- ( ) Slide two T-bolts into the slots at each end of the trim bar as shown. Position each of them 1/4" in from the end of the bar.
- ( ) Mount the trim bar onto the top of the front panel as shown in the Pictorial. Use 4-40 nuts and #4 lockwashers. NOTE: Be sure to center the trim bar from side-to-side as shown.
- ( ) Mount two spring nuts on a meter bracket as shown. Be sure the flat side of each nut is on the outside of the bracket, and that the hole in the nut is centered over the bracket hole.
- ( ) In the same manner, mount two spring nuts on the remaining meter bracket.
- ( ) Cut four 1/2" lengths of foam tape.
- ( ) Refer to Detail 2-5A. Remove the paper backing from a 1/2" piece of foam tape and press it in place on the inside top of a meter bracket as shown. Press another 1/2" piece of foam tape on the inside bottom of the meter bracket.
- ( ) In the same manner, press two pieces of foam tape on the inside of the other meter bracket.

- ( ) If there is a shorting wire between the meter terminals, remove and discard the wire.
- ( ) Check to be sure the meter lugs are positioned as shown in the Pictorial. Be sure the lug-mounting hardware is snug.
- ( ) Position the meter assembly into the front panel as shown in the Pictorial. Center the meter into the front panel opening; then secure the two meter brackets to the front panel side flanges with 6-32 x 5/16" flat head screws.
- ( ) Refer to Detail 2-5B. Remove the paper backing from the 1" x 2" paper insulator and press the insulator in place on the inside of the input shield as shown.
- ( ) Position the heavy black wires coming from power switch SW1 into the lower left corner of the chassis bottom as shown in the Pictorial. Position all the remaining front panel wires upward, away from the power switch. Then place the input shield into the lower front corner of the chassis, and in between power switch SW1 and dB switch SW3. Secure the shield to the bottom of the front panel with three #6 x 3/8" sheet metal screws.

Refer to Pictorial 2-6 for the following steps.

- ( ) Position the rear panel banana jack wires toward the outside of the chassis, and the red and red-yellow power transformer leads over the top of the transformer, out of the center area of the chassis.
- ( ) Place a control lockwasher on the shaft of switch RS1.

- ( ) Tilt the rear of the circuit board upward, and position the shaft of switch RS1 through the hole in the front panel as shown. Tilt the component side of the circuit board outward and downward slightly until the circuit board fits down and inside the rear panel as shown in the Pictorial.
- ( ) Straighten the circuit board in the center of the chassis so it is vertical, and so switch RS1 shaft extends fully through the front panel. Loosely secure the switch shaft with a control flat washer and a control nut.
- ( ) At the rear of the circuit board, loosely secure the circuit board bracket to the foil side of the board with 6-32  $\times$  3/8" black hardware.
- ( ) On the front panel, tighten the Range switch mounting hardware.
- ( ) Tighten the circuit board bracket mounting screw on the rear edge of the board.

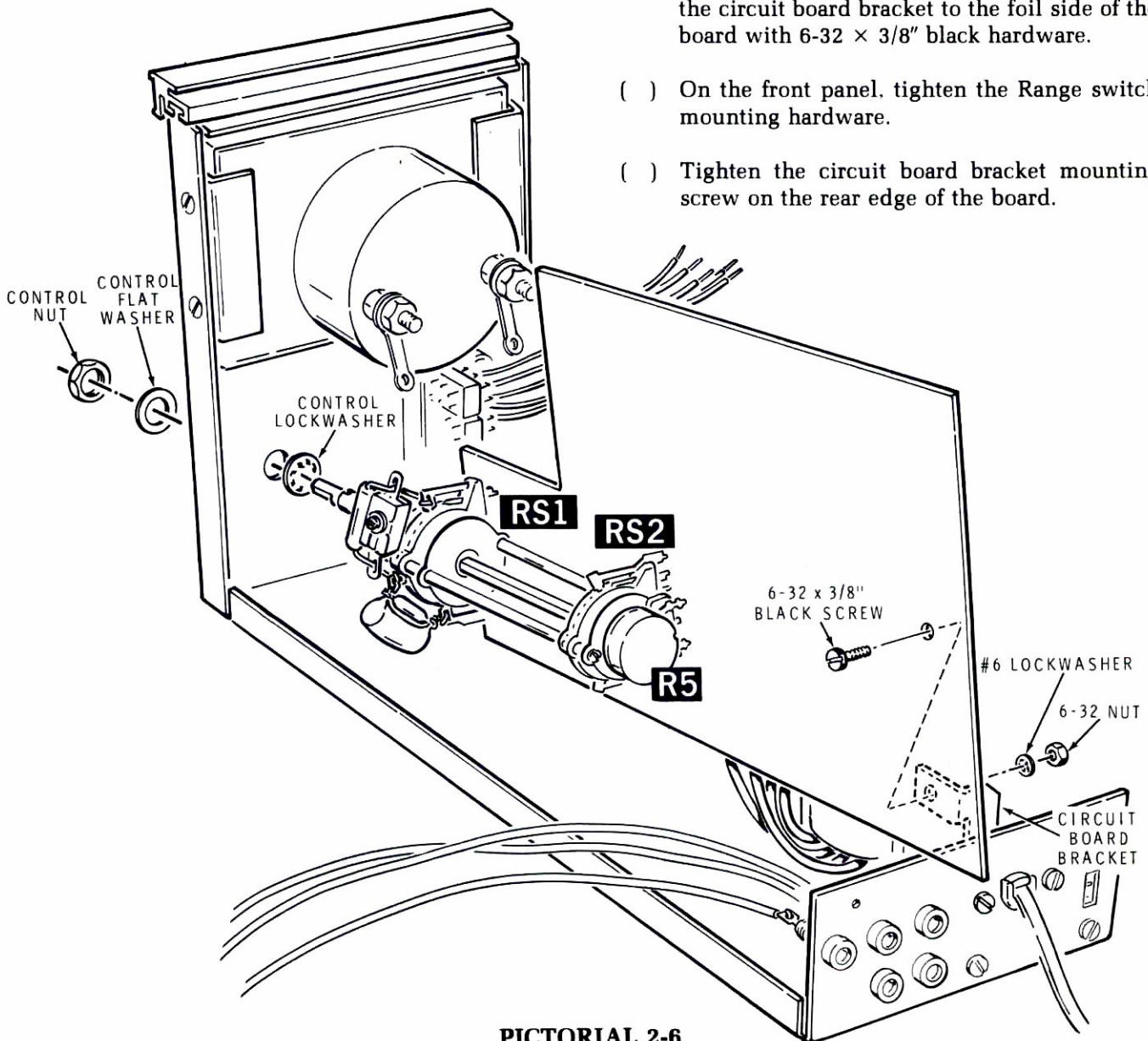

PICTORIAL 2-6

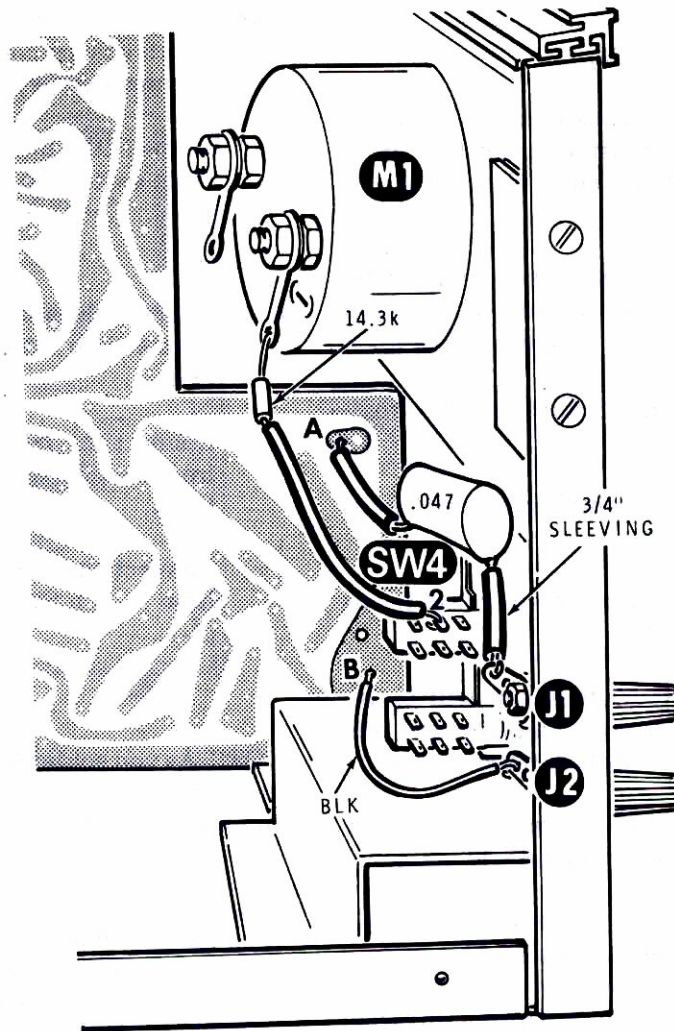

PICTORIAL 2-7

Refer to Pictorial 2-7 for the following steps.

- ( ) Locate the black wire coming from the lower front area of the circuit board foil (hole B). Connect the free end of this wire to front panel jack J2 (S-1).
- ( ) Cut a 3/4" length of sleeving. Place the sleeving on the free lead of the .047  $\mu\text{F}$  capacitor coming from foil pad A on the circuit board. Connect the end of the capacitor lead to front panel jack J1 (S-1) as shown in the Pictorial.
- ( ) Locate 14.3 k $\Omega$  precision resistor R4 coming from switch SW4 lug 2. Connect, but do not crimp, the free lead of the resistor to the negative (-) or unmarked lug of meter M1 (S-1). NOTE: You may be instructed to temporarily disconnect this resistor lead for test purposes.

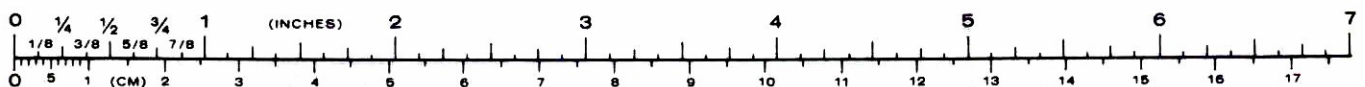

Refer to Pictorial 2-8 (on Page 5 in the "Illustration Booklet") for the following steps.

- ( ) At the rear of the circuit board, route the two red and the red-yellow transformer leads between the rear panel and the edge of the board as shown.

**NOTE:** In the following steps, as you connect the wires and leads to the circuit board, solder each one to the foil and cut off the excess lengths.

- ( ) Connect either red transformer lead to circuit board hole C (S-1).
- ( ) Connect the other red transformer lead to circuit board hole E (S-1).
- ( ) Connect the red-yellow transformer lead to circuit board hole D (S-1).

**NOTE:** In the following four steps you will be instructed to connect the wires coming from the rear panel banana jacks. Route each of the wires as shown.

- ( ) Connect the free end of the red wire coming from J3 to circuit board hole F (S-1).
- ( ) Connect the free end of the red wire coming from J5 to circuit board hole H (S-1).
- ( ) Pass the free end of the black wire coming from circuit board hole J up through banana jack J4 (S-2) to banana jack J6 (S-1) on the rear panel.
- ( ) Connect the free end of the red wire coming from J7 to circuit board hole R (S-1).
- ( ) Route the free ends of the one black and four red wires coming from the front panel switch assembly through the opening between the lower side of the meter and the upper front edge of the circuit board as shown in the Pictorial.

- ( ) Connect but do not crimp the free end of the short red wire coming from switch SW4 lug 5 to the positive (+) meter lug (S-1).

- ( ) Connect the free end of the black wire coming from switch SW4 lug 1 to circuit board hole P (S-1).

- ( ) Connect the free end of the red wire coming from switch SW4 lug 3 to circuit board hole N (S-1).

- ( ) Connect the free end of the red wire coming from switch SW3 lug 2 to circuit board hole K (S-1).

- ( ) Connect the free end of the red wire coming from switch SW3 lug 1 to circuit board hole L (S-1).

**NOTE:** As you solder the capacitor leads to the foil in the next two steps, use extreme care to avoid touching any wires with the soldering iron.

- ( ) C127: Mount a 500  $\mu$ F electrolytic capacitor on the circuit board in the location shown. Be sure to match the positive mark (+) on the capacitor with the positive marking on the circuit board. Solder both leads to the foil and cut off the excess lead lengths.

- ( ) C126: In the same manner, mount the remaining 500  $\mu$ F electrolytic capacitor on the circuit board in the location shown. Be sure to match the positive mark (+) on the capacitor with the positive marking on the circuit board. Solder both leads to the foil and cut off the excess lead lengths.

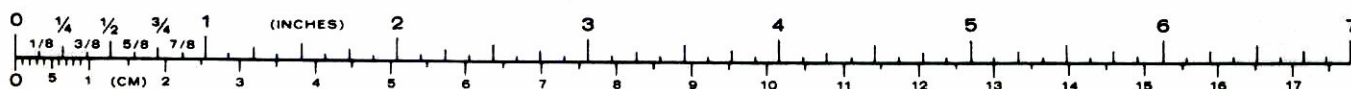

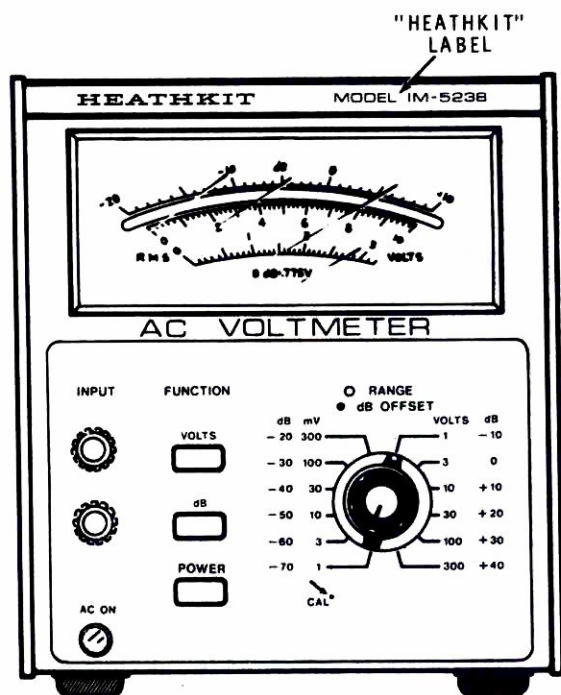

**PICTORIAL 2-9**

Refer to Pictorial 2-9 for the following steps.

- ( ) Remove the paper backing from the "Heathkit" label and press the label in place in the space provided on the trim bar as shown in the Pictorial.

Refer to Detail 2-9A for the following steps.

- ( ) Place the inner knob bushing onto the Range switch shaft. **NOTE:** Be sure the round-hole side of the bushing is toward the surface of the front panel as shown.
- ( ) Grasp the bushing firmly and rotate the switch fully counterclockwise. Turn the switch **six** clicks clockwise.
- ( ) Position the black knob onto the bushing and align the white knob pointer with the "1" line (at the 1 o'clock position). When you are sure the knob is correctly positioned on the bushing as shown in the Pictorial, firmly push the knob onto the bushing.
- ( ) Remove the knob and the bushing from the Range switch shaft.
- ( ) With a nut driver, or other suitable tool, tap the bushing into the center of the black knob.

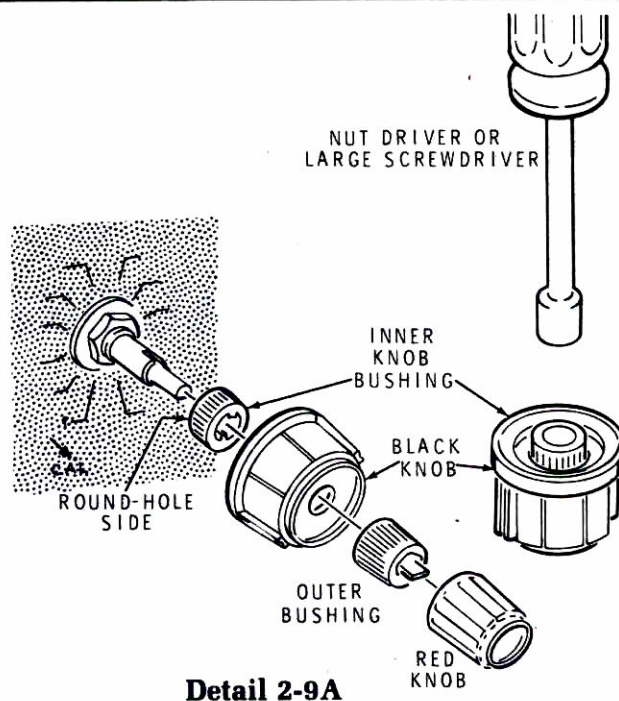

**Detail 2-9A**

- ( ) Replace the black knob and bushing onto the Range switch shaft.
- ( ) Press the outer knob bushing onto the end of the inner Range switch shaft. Turn the bushing fully counterclockwise.
- ( ) Place the red knob onto the bushing as you align the knob pointer with the CAL dot on the front panel.
- ( ) When you are sure the knob is properly positioned, push the red knob firmly onto the bushing. Then remove the knob and bushing, and as in the previous steps, tap the bushing into the knob until it is fully seated.
- ( ) Replace the red knob and bushing onto the inner Range switch shaft.

Except for the Final Assembly, this completes the Step-by-Step Assembly of your AC Voltmeter. Carefully inspect the Voltmeter to be sure all connections have been well soldered, that there are no leads shorting together or touching any part of the chassis, and that there are no bits of solder or wire ends lodged in the wiring or circuitry. Proceed to "Tests and Calibration."

**NOTE:** You should have one 1000  $\Omega$  (brown-black-red) resistor and one 51 k $\Omega$  (green-brown-orange) resistor left for use later.

# TESTS AND CALIBRATION

NOTE: Do not plug your AC Voltmeter line cord into an AC outlet until you are told to do so.

Refer to Pictorials 3-1 and 3-2 (on Pages 6 and 7 in the "Illustration Booklet") to become familiar with the locations of the controls, switches, and the input and output jacks.

( ) Carefully check the pointer of your meter to be sure it is exactly on zero (RMS).

A. If it is not, perform steps 1, 2, and 3 below.

B. Disregard steps 1, 2, and 3 if the pointer is already properly zeroed.

( ) 1. Be sure the line cord is not plugged into an AC outlet.

( ) 2. Refer to Pictorial 3-3 (on Page 8 in the "Illustration Booklet") and place a small screwdriver tip into the small hole directly under the center of the meter. This hole is labeled "Mechanical zero adjust." Turn the screwdriver as you align the pointer and its mirrored reflection with the "0" at the left side of the RMS scales.

( ) 3. Remove the screwdriver and recheck the pointer to be sure it is exactly over the "0."

**WARNING:** In the following steps, you will make adjustments inside the chassis of your Voltmeter. Refer to Pictorial 3-4 (on Page 8 in the "Illustration Booklet") and become familiar with the high voltage areas in your kit. Carefully avoid these areas as you perform the adjustments. Otherwise, you may receive a serious injury from electrical shock.

( ) On the rear panel of your Voltmeter, be sure the LINE switch is set to agree with the source voltage in your area. For instance, if the AC voltage in your area is between 100 and 135 volts AC, set the switch to expose "120" as shown in Part B of Pictorial 3-1, and if the supply voltage is between 200 and 270 volts, set the switch to expose "240."

NOTE: The VOLTS, dB and POWER switches on the front panel are pushbutton On-Off switches. When you depress the POWER button to the "in position," the circuit is **on**. When you depress the POWER pushbutton a second time, the switch is released to its "out-position" and the circuit is off. The dB and VOLTS pushbuttons interact; one will always be OFF when the other is ON.

( ) Set the front panel controls as follows:

VOLTS switch: On.

POWER switch: Off. NOTE: Depress this switch once or twice to make sure the switch is **out**.

RANGE switch (black knob): 10-volt position ("10").

dB OFFSET control (red knob): Fully counterclockwise.



## INITIAL TESTS

NOTE: You will need a volt-ohmmeter or a multimeter to perform the following tests. If one is not available, proceed directly to "Calibration" on Page 34.

- ( ) Connect the common lead of your ohmmeter to any convenient bare-metal point on the chassis, or directly to ground post J2 on the front panel.
- ( ) Set the ohmmeter range switch to a high setting.
- ( ) With the positive ohmmeter lead, check the following points and be sure you obtain the indicated readings on the ohmmeter.

NOTE: Perform the following line cord checkout steps with the POWER switch Off. Then repeat the steps with the POWER switch On.

Positive Ohmmeter Lead Connected To:	Meter Reading
( ) Either line cord flat prong.	Greater than 1 megohm.
( ) The other line cord flat prong.	Greater than 1 megohm.
( ) Line cord round prong.	(Set the ohmmeter switch to its lowest range.) Less than 0.1 ohm.

mediately push the POWER switch to Off and unplug the line cord from the AC outlet. Then refer to "In Case of Difficulty" on Page 45.

- ( ) Push the red POWER switch to On. The pilot lamp should light and you should observe some movement of the meter needle. NOTE: If you do not observe these indications, or if you notice any indication of other problems, immediately push the POWER switch to Off, remove the line cord from the AC outlet, and refer to "In Case of Difficulty."
- ( ) Set your test voltmeter to read 20 volts DC.
- ( ) Refer to Pictorial 3-2 and check for the following DC voltages at the indicated circuit board test points.

	Test Point	Voltage +20%
( )	Jumper "A"	+20 volts
( )	<b>Banded</b> end of zener diode ZD115	+12 volts
( )	Jumper "B"	-20 volts
( )	<b>Unbanded</b> end of zener diode ZD116	-12 volts

- ( ) Push the POWER switch to Off.
- ( ) Plug the line cord into an AC outlet.

NOTE: If at any time during the following tests and adjustments, including the calibration of your instrument, you fail to obtain the desired results, im-

- ( ) Push the POWER switch to Off.
- ( ) Remove the line cord from the AC outlet.

This completes the "Initial Tests" of your AC Voltmeter.

## CALIBRATION

You may prefer to calibrate your AC Voltmeter with laboratory-standard instruments. If you have the following instruments, proceed directly to "Calibration With Instruments" on Page 36.

You will need:

- A high-input impedance DC voltmeter.
- A signal generator capable of producing a sine-wave output of 1000 Hz and 700 kHz at 1 volt.

### CALIBRATION WITHOUT INSTRUMENTS

- ( ) Prepare a 12", a 6", and a 3" length of black (solid) wire. These wires will be used as jumpers in the following steps.

#### Bias Adjust

Refer to Pictorial 4-1 (on Page 9 in the "Illustration Booklet") and perform the following steps.

- ( ) Connect a 3" jumper wire between front panel binding posts J1 and J2.
- ( ) Refer to Part A of Pictorial 4-1 (on Page 9 in the "Illustration Booklet") and on the rear of the meter, temporarily disconnect the 14.3 k $\Omega$  precision resistor (R4) from the negative (-) meter lug. Also, temporarily disconnect the end of the red wire from the positive (+) meter lug.
- ( ) Temporarily tack solder one lead of a 51 k $\Omega$  (green-brown-orange) resistor to the negative meter lug. Tack solder the other lead of this resistor to the ground foil on the circuit board as shown.
- ( ) Refer to Part B of Pictorial 4-1 and tack solder one end of the 12" black jumper wire to the positive (+) meter lug. Connect, but **do not** solder, the other end of this wire to the wire connector at the collector (C) of circuit board transistor Q102.

- ( ) Preset the front panel controls as follows:

VOLTS switch: On.

POWER switch: Off.

dB OFFSET control: Fully counterclockwise.

RANGE SWITCH (black knob): 10 VOLTS.

- ( ) Plug the line cord into an AC outlet and push the POWER switch to On.
- ( ) Refer to Pictorial 4-1 and adjust BIAS SET control R103 to produce a reading of "4" on the 10-volt meter scale.
- ( ) Push the POWER switch to Off.

#### AC-DC Converter Adjust

- ( ) Tack solder one end of the 6" black jumper wire to banana jack J6 on the rear panel as shown in Part B of Pictorial 4-1.
- ( ) Refer to Part B of the Pictorial and tack solder the other end of the 6" jumper wire to the indicated end of 10 k $\Omega$  precision resistor R141 as shown.
- ( ) Disconnect the long jumper wire from the collector (C) of Q102. Hold this end of the long jumper to the collector of Q108.
- ( ) Push the POWER switch to On.
- ( ) Observe the pointer on the meter; it should read slightly above or slightly below zero. NOTE: If the meter reads below zero, turn off the power to the Voltmeter and reverse the 12" black wire and the 51 k $\Omega$  lead to the meter lugs. Turn the power on; the pointer should now read above zero.
- ( ) Turn the circuit board DC LEVEL (A1) control R143 slightly in either direction until the meter reads zero within two small divisions (0.4 volt) on the 0-10 volt scale.

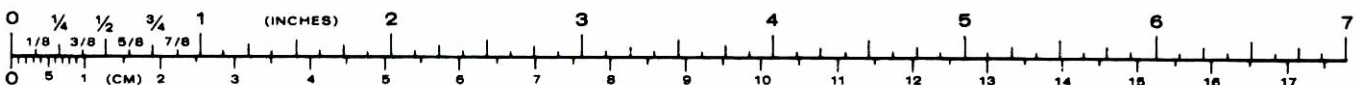



- ( ) Turn DC LEVEL control (A2) slightly in either direction until the meter reads zero ( $\pm 0.1$  volt).
- ( ) Push the POWER switch to Off.
- ( ) Disconnect the wire and resistor lead from the meter lugs and from the circuit board foil.
- ( ) Refer to Part A of Pictorial 4-1. Tack solder a 1000  $\Omega$  (brown-black-red) resistor from the negative (-) meter lug to the circuit board foil as shown.
- ( ) Disconnect the 12" jumper wire from the collector (C) of Q108.
- ( ) Connect, but do not solder, the end of the jumper to the collector of transistor Q109. Then connect the other end of the jumper wire to the positive (+) meter lug.
- ( ) Push the Voltmeter POWER switch to On.
- ( ) Observe the meter pointer. If it reads below zero, reverse the resistor and wire connections on the meter lugs.
- ( ) Adjust circuit board DC LEVEL (B) control R155 for a zero reading on the 0-10 volt meter scale.
- ( ) Push the POWER switch to Off.
- ( ) Disconnect the 6" and the 12" jumper wires from the circuit and set them aside. Remove the jumper from the front panel binding posts. Remove the 1000  $\Omega$  resistor.
- ( ) Reconnect and solder the 14.3 k $\Omega$  precision resistor coming from switch SW4 lug 2 to the negative (-) meter lug.
- ( ) Connect and solder the short red wire coming from switch SW4 lug 5 to the positive (+) meter lug.
- ( ) Refer to Pictorial 4-2 (on Page 10 in the "Illustration Booklet") and connect a 12" jumper wire from INPUT binding post J1 to the anode (un-banded) lead of diode D114. NOTE: This diode is just above and to the rear of large capacitor C126.
- ( ) Turn the front panel RANGE switch to 30 VOLTS.
- ( ) Plug in the line cord and push the POWER switch to On.
- ( ) Refer to Part B of Pictorial 4-1 and carefully turn GAIN ADJ control R128 until the meter pointer indicates 2.9 (29 volts) on the bottom scale.
- ( ) Refer to Part B of Pictorial 4-1 and turn the adjusting screw on trimmer C2 clockwise until it is just snug. Then turn the screw 3/8 turn counterclockwise. This trimmer calibrates the high-frequency end of the Voltmeter.

### dB Converter Calibration

- ( ) Turn the red dB OFFSET control knob fully counterclockwise to its CAL (calibrate) position.
- ( ) Set the RANGE switch to the +30 dB position.
- ( ) Disconnect the line cord from the AC outlet. Then connect a jumper wire from front panel input (red) binding post J1 to the anode of diode D114 as shown in Pictorial 4-2. Reconnect the line cord and push the POWER switch to On.
- ( ) Push dB switch SW3 to On.
- ( ) Refer to Part B of Pictorial 4-1 and adjust dB REF ADJ control R169 on the circuit board until the meter pointer indicates 2 small divisions (+2 dB) above zero on the upper meter scale.
- ( ) Push the POWER switch to Off.
- ( ) Remove the jumper wire.

This completes the "Calibration" of your Voltmeter. Proceed to "Final Assembly."

### Mid-Frequency Calibration

- ( ) Disconnect the line cord from the AC outlet.

## CALIBRATION WITH INSTRUMENTS

- ( ) Preset the AC Voltmeter front panel controls as follows:

VOLTS switch: On.

POWER switch: Off.

dB OFFSET control (red knob): Fully counterclockwise.

RANGE switch (black knob): 10 VOLTS.

### Bias Adjust

Refer to Pictorial 5-1 (on Page 10 in the "Illustration Booklet") for the following steps.

- ( ) Connect a 3" wire between input binding posts J1 and J2.

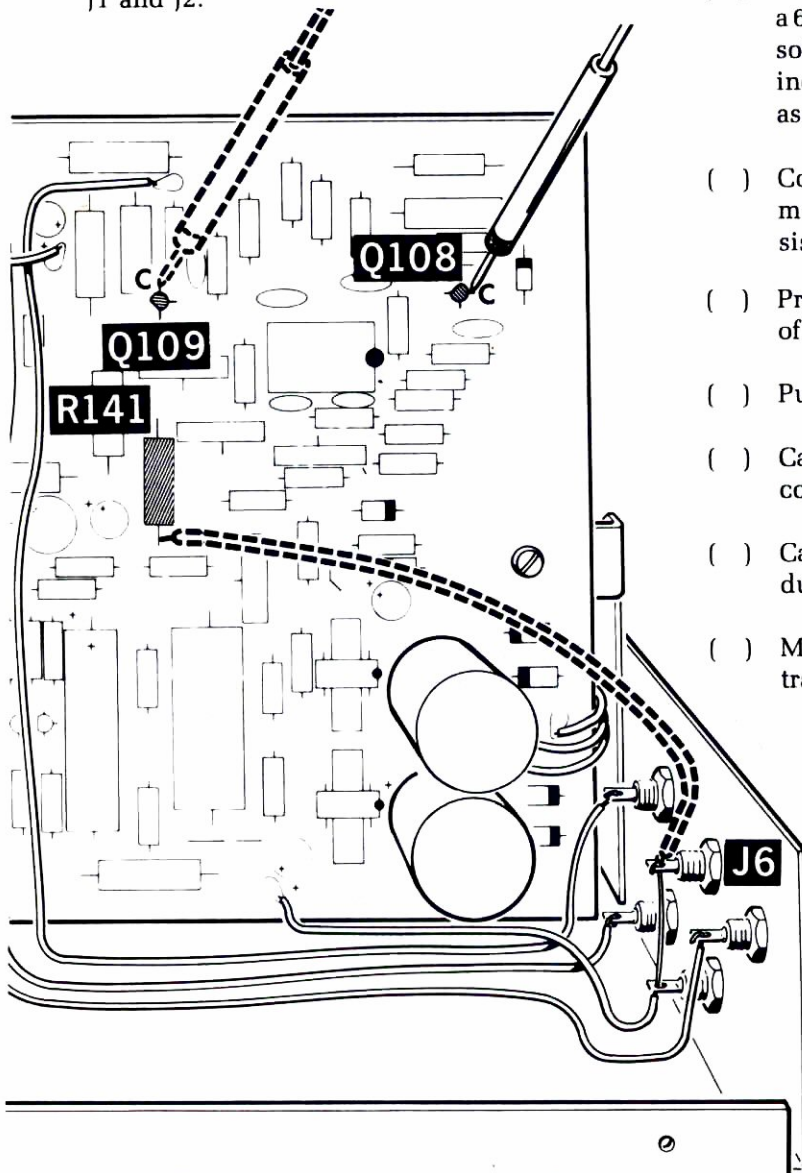

- ( ) Connect the common lead of a high-input impedance voltmeter to black ground post J2. Connect the other voltmeter lead to the collector (C) lead of transistor Q102 on the circuit board.
- ( ) Plug in the line cord and push the Voltmeter POWER switch to On.
- ( ) Refer to Part B of Pictorial 4-1 and carefully adjust BIAS SET control R103 on the circuit board for an output of 4 volts ( $\pm 0.5$  volts) on the test meter.
- ( ) Push the POWER switch to Off.

### AC-DC Converter Adjust

- ( ) Refer to Pictorial 5-2 and tack solder one end of a 6" black jumper wire to rear panel jack J6. Tack solder the other end of the jumper wire to the indicated end of 10 k $\Omega$  precision resistor R141 as shown.
- ( ) Connect the positive input lead of the test voltmeter to the collector (C) of circuit board transistor Q108.
- ( ) Preset DC LEVEL control (A2) to the mid point of its rotation.
- ( ) Push the POWER switch to On.
- ( ) Carefully adjust circuit board DC LEVEL (A1) control to produce a reading of zero volts.
- ( ) Carefully adjust DC LEVEL control (A2) to produce a reading of zero volts ( $\pm 0.1V$ ).
- ( ) Move the test lead to the collector (C) lead transistor Q109.

PICTORIAL 5-2

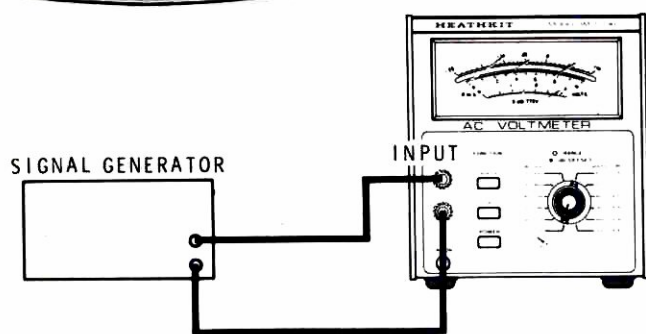

PICTORIAL 5-3

- ( ) Adjust circuit board DC LEVEL (B) control for a reading of zero volts ( $\pm 2$  mV).
- ( ) Push the POWER switch to Off.
- ( ) Remove the 6" jumper wire from jack J6 and resistor R141, disconnect the test meter leads, and remove the shorting wire from the front panel input jacks.

### High-Frequency Calibration

Refer to Pictorials 4-1 and 5-3 as you perform the following steps.

1. Turn the RANGE switch to 300 mV.
2. Connect the signal generator to the Voltmeter input jacks.
3. Set the signal generator to produce 1000 Hz (1 kHz) sine wave.
4. Push the Voltmeter POWER switch to On.
5. Adjust the amplitude of the signal to produce exactly a full scale indication on the Voltmeter.
6. Turn the RANGE switch to 1 VOLT. Note the meter indication.
7. Turn the RANGE switch to 300 mV.
8. Set the signal generator to produce a 700 kHz sine wave.
9. Adjust the signal generator amplitude to produce exactly full scale on the Voltmeter scale.
10. Turn the RANGE switch to 1 VOLT.
11. Adjust trimmer capacitor C2 (see Pictorial 4-1) to produce the same meter reading you noted in step 6.
12. Push the POWER switch to Off.

### Mid-Frequency Calibration

- ( ) Turn the RANGE switch to 1 VOLT.
- ( ) Refer to Pictorial 5-3 and connect the output of the signal generator to the input jacks on the AC Voltmeter as shown.
- ( ) Set the signal generator to produce a 1000 Hz (1 kHz) sine-wave signal at 1 volt amplitude.
- ( ) Push the Voltmeter POWER switch to On.
- ( ) Refer to Part B of Pictorial 4-1. On the circuit board, adjust GAIN ADJ control R128 until the AC Voltmeter 0-10 RMS (center) scale indicates exactly "10."

### dB Converter Adjust

- ( ) Set the front panel controls as follows:
  - dB switch: On.
  - dB OFFSET control (red knob): CAL (fully counterclockwise).
  - RANGE switch (black knob): -10 dB.
- ( ) Apply an external, 0.775 volt, 1000 Hz (1 kHz) signal to the AC Voltmeter input jacks.
- ( ) Push the POWER switch to On.
- ( ) Refer to Part B of Pictorial 4-1. On the circuit board, adjust dB REF ADJUST control R169 until the meter pointer indicates exactly "+10" on the upper (dB) meter scale.
- ( ) Reset the input voltage level to 0.0245 volts.
- ( ) On the circuit board, readjust DC LEVEL (B) control R155 until the Meter pointer indicates exactly "-20" on the upper meter scale.
- ( ) Remove the signal input from the AC Voltmeter.
- ( ) Push the Voltmeter POWER switch to Off and remove the line cord from the AC outlet.

This completes the "Calibration" of your AC Voltmeter. Proceed to "Final Assembly."

# FINAL ASSEMBLY

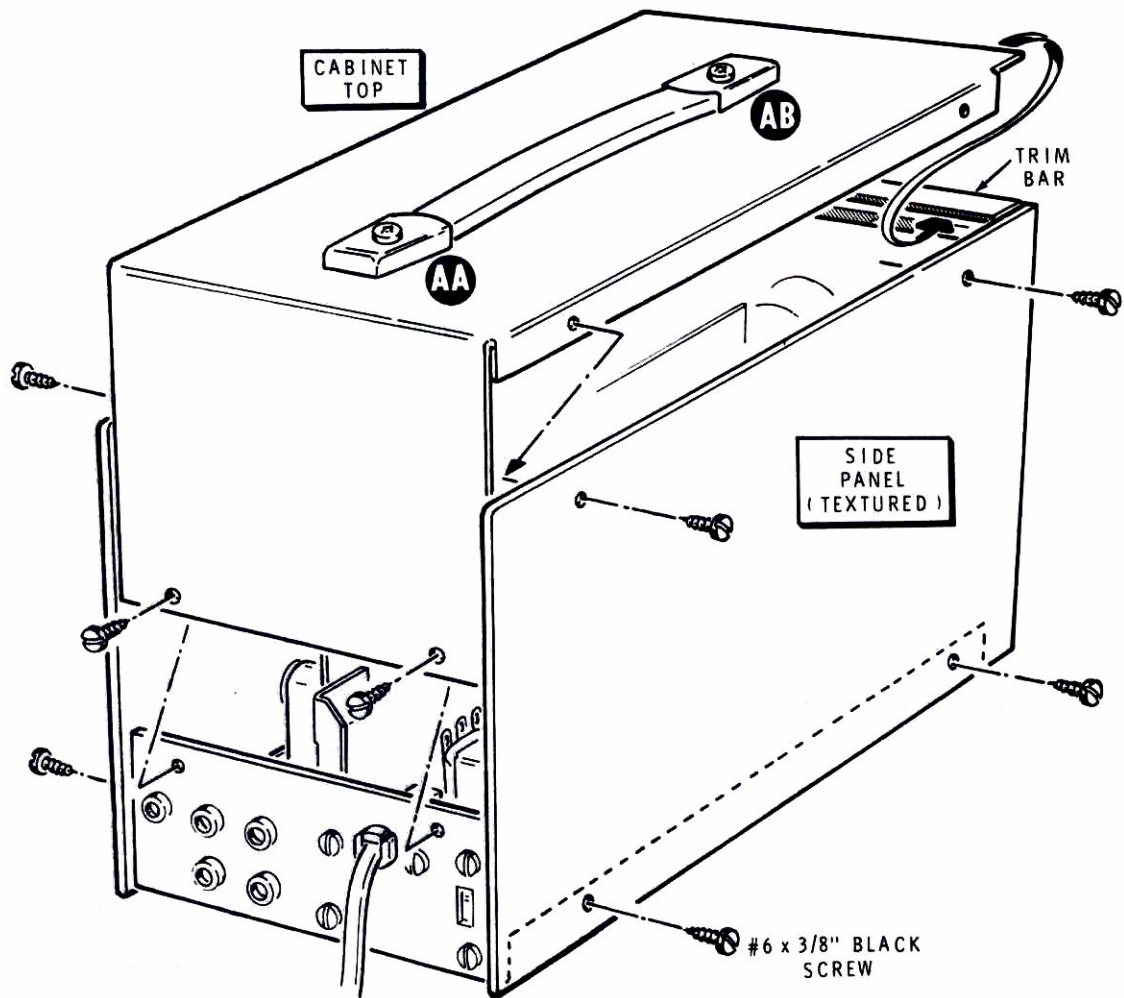

PICTORIAL 6-1

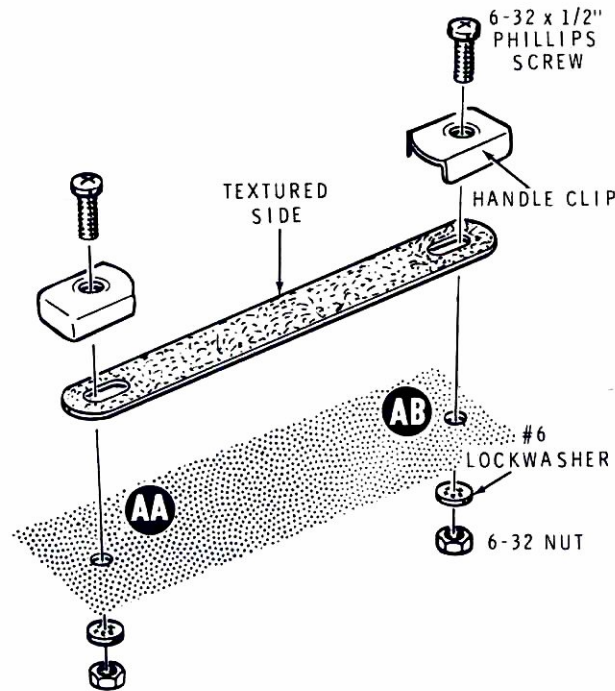

Detail 6-1A

Refer to Pictorial 6-1 for the following steps.

- ( ) Place the cabinet top on your work area. Then proceed with the following steps.
- ( ) Refer to Detail 6-1A and assemble and install one handle clip as follows:
  1. Push a 6-32 × 1/2" phillips screw through the handle clip.
  2. Position the end of the screw through one end of the handle strap (textured side up) as shown.
  3. Push the screw through the cabinet top mounting hole at AA.
  4. Loosely secure the screw with a #6 lockwasher and a 6-32 nut.
- ( ) Position each of the handle clips so they are squarely aligned with one another, from front to rear, and from side to side. Then tighten the handle mounting hardware.
- ( ) Position the front edge of the cabinet top into the slot in the rear of the front panel trim bar as shown in the Pictorial. Then secure the lower rear edge of the cabinet top to the rear panel with two #6 × 3/8" black sheet metal screws.
- ( ) Position a side panel (textured side out) onto one side of the cabinet assembly as shown. Secure the side panel to the chassis and cabinet top with four #6 × 3/8" sheet metal screws.
- ( ) In the same manner, secure the remaining side panel to the other side of the cabinet assembly with four #6 × 3/8" sheet metal screws.

This completes the assembly of your AC Voltmeter.

# OPERATION

**NOTE:** Due to the high sensitivity of your AC Voltmeter, you may notice some meter readings when there is no input to the Voltmeter. This is normal when the RANGE switch is set for lower voltage ranges; it will not interfere with the correct operation of the Voltmeter when in use.

**CAUTION:** The circuit ground and the case of this instrument are both connected to the power line ground through the green line cord lead. Always connect the ground test lead of this Voltmeter to the chassis, or circuit ground, of the device being tested or measured.

## TURN-ON PROCEDURE

To turn on your AC Voltmeter, first make sure Line switch SW2 on the rear panel is set to agree with the line voltage in your area, either "120" volts AC or "240" volts AC. Plug the line cord into an AC outlet. Then depress the POWER switch pushbutton on the front panel. The indicator lamp will light to indicate that the Voltmeter is ready for use.

## READING THE METER

The RANGE switch positions cover a range from 1 millivolt to 300 volts in 12 steps, and from  $-70$  to  $+40$  decibels.

The meter has two voltage scales; one is marked 0 to 3 and the other 0 to 10. When you take a meter reading, it is important that you place the decimal in the proper position in order to derive the correct voltage for each range.

**Example 1:** The RANGE switch is on 30 mV and the meter pointer is at "2" (bottom scale). To convert this reading (2) to its actual value on this range, move the decimal point two places to the left. Thus, 2 becomes .02 (20 mV).

**Example 2:** The RANGE switch is on 100 VOLTS and the meter pointer is at 6.4 (top scale). To convert this reading to its actual value on this range, move the decimal point one place to the right. Thus, 6.4 becomes 64 (64 volts).

## CAUTION

- DO NOT** — apply more than 600 volts to the input of the Voltmeter.
- DO NOT** — overload the 1 mV through 300 mV ranges with more than 100 volts at frequencies less than 2000 Hz (2 kHz), or more than 50 volts at frequencies greater than 2000 Hz. If these limits are exceeded, the Voltmeter may be damaged.
- DO NOT** — connect the high side of any utility power line to the black front panel input jack. This jack is directly connected to the low side of the AC line and to the common (ground) lead of the line cord. To determine the “high” side of a utility power line, first connect one side of the line to the red input jack on the front panel (be sure to set the RANGE switch to 300 V); then disconnect the first side and connect the other side of the line to the red input jack. The side of the line that gives an appreciable reading will be the high side of the power line.

## VOLTAGE MEASUREMENTS

Refer to Pictorial 3-1 (on Page 6 in the “Illustration Booklet”) for the following front and rear panel component callouts and functions.

Set the front panel controls as follows:

- VOLTS switch: On.
- RANGE switch (black knob): For the maximum voltage to be indicated in the circuit under test. If this voltage is unknown, start at the highest (300-volt) range and, after the test voltage has been
- applied to the input jacks, reduce the RANGE, switch setting until you obtain a usable reading on the meter.
- dB OFFSET control (red knob): No setting is required for voltage tests.
- POWER switch: On.
- Input Red and Black front panel jacks: Connect the circuit to be tested to these input terminals.

## dB MEASUREMENTS

To make decibel measurements, first set the front panel controls as follows:

- dB switch: On.
- POWER switch: On.
- dB OFFSET control (red knob): Fully counterclockwise to CAL (calibrate).
- RANGE switch (black knob): Set to the maximum dB to be indicated in the circuit under test. If this is unknown, start at the highest range and, after the circuit has been connected to the Voltmeter input jacks, reduce the RANGE switch setting until you obtain a usable reading on the meter.
- Input Red and Black front panel jacks: Connect the circuit to be tested to these input terminals.

To measure decibels, the reading of the meter is algebraically added to the setting of the RANGE switch. For example, if the RANGE switch is set at +10 dB and if the meter indicates a -3 dB, the sum of the two is +7 dB.

NOTE: The decibel (dB) is defined as a ratio of two power levels. However, it can be used to determine the ratio between two voltage levels if the load impedance is the same for both. Since dBm (decibels relative to 1 milliwatt) is in common use, this meter is calibrated to read zero dBm when it is connected across a 600-ohm load consuming 1 milliwatt of power. One milliwatt of power into 600  $\Omega$  is 0.775 volt rms. If the circuit under test is not 600  $\Omega$ , the dB reading must be adjusted mathematically to compensate for the difference.

## dB OFFSET

In most cases, a reference other than 1 milliwatt into 600  $\Omega$  or 0.775 volt is required. The dB OFFSET control (red knob) changes the reference voltage over a 10 dB range, so you may set any reference you wish.

For example, if you wish to use 1 volt as a reference, set the RANGE switch to 1 VOLT, depress the VOLTS switch, and connect one-volt rms to the input terminals. Then press the dB switch, turn the RANGE switch to +10 dB, and adjust the red dB OFFSET control to obtain a zero dB indication on the meter...disconnect the one-volt signal from the input; the meter is now set to measure dB with 1 volt as reference.

EXAMPLE: Assume that the meter indicates a reading of -12 dB. The voltage measured is, therefore 12 dB down, or -12 dB referenced to 1 volt.

If it becomes necessary to adjust the Voltmeter controls to get a better indication on the meter, change only the RANGE switch setting. If, in another example, you found it necessary to turn the RANGE switch to -20 dB and you get a +2 dB meter indication, the input level in dB, referenced to 1 volt will be: -30 dB (from +10 to -20 dB) +2 dB (reading) = -28 dB.

## VOLTMETER OUTPUTS

### AMPLIFIED AC VOLTS

**CAUTION:** Use extreme care to avoid common ground paths between the input and output circuits. Because of the high gain in low voltage ranges, common paths can cause oscillations at higher frequencies.

The meter may be used as a signal amplifier by feeding a signal to the input front panel jacks and then taking an output signal from the AC OUT rear panel banana jacks.

The following chart lists the AC amplifier gain factors for each switch range. **NOTE:** The output reference is a 1-volt peak. When using the input to the Voltmeter as a reference, 3 dB must be subtracted from each range because the input voltage is rms.

VOLTS Range	Gain (dB)
300	-50
100	-40
30	-30
10	-20
3	-10
1	0
300 mV	+10
100 mV	+20
30 mV	+30
10 mV	+40
3 mV	+50
1 mV	+60

### VOLTS OUTPUT

A DC output voltage, proportional to the voltage indicated on the meter, is present at the VOLTS OUT banana jacks on the rear panel whenever the front panel VOLTS switch is depressed. This output is one volt DC when the meter pointer is at full scale. The output will be present during both the VOLTS and dB functions. It is a direct linear output whose output impedance is 1000 ohms.

### dB OUTPUT

Only when the front panel dB switch is depressed will there be a usable output at the dB OUT banana jacks on the rear panel. This output is 0.1 volt DC per dB, or 3 volts DC for a full-scale reading at +10 dB. Some negative voltage may appear at these jacks if the front panel VOLTS switch is depressed. The dB output impedance is less than 100 ohms and is current-limited at approximately 10 mA.

## APPLICATIONS

Almost any type of AC voltage can be accurately measured with your AC Voltmeter. However, although the Voltmeter is an average-responding, rms-calibrated instrument, any distortion in a waveform will affect the accuracy of its measurement. Such waveforms include: square waves, pulse variations, and sawtooth or trapezoidal waveshapes.

Your AC Voltmeter also features a linear dB scale, and its outputs allow you to make automatic frequency response plots of audio and higher frequency circuits and equipment. If, for example, you wish to test a given circuit for frequency response, you may use the AC Voltmeter, with a sweep-function generator and an X-Y plotter, to produce a graph of the response. The setup for this procedure is shown in Pictorial 7-1 (on Page 11 in the "Illustration Booklet").

With this arrangement, one sweep through the selected frequency spectrum will yield a curve on the X-Y plotter of the frequency versus the circuit output amplitude in decibels. Since the input to the test circuit is constant, the plot will be the response of that circuit. If the response of the circuit changes with level, such as the amplifier in an audio circuit, various levels can be injected into the test circuit, and repeated plots taken for each of them. This will result in a family of response plots for the circuit.

**NOTE:** Avoid ground loops which may cause oscillations or supply-line frequency interference.

# IN CASE OF DIFFICULTY

This section of the Manual will help you locate and correct any difficulty which might occur in your Voltmeter. The information is divided into two sections. The first section, "General," contains suggestions in the following areas:

- A. Visual checks and inspection.
- B. Bench testing and precautions.
- C. Repair techniques.

The second section consists of a "Problem Isolation" chart. It calls out specific problems that may occur and lists one or more conditions or components that could cause each difficulty. A "Circuit Board X-Ray View" is provided (on Page 12 in the "Illustration Booklet") to help you locate the components.

**NOTE:** In an extreme case where you are unable to resolve a difficulty, refer to "Customer Service" information inside the rear cover of the Manual. Your Warranty is located inside the front cover.

## GENERAL

### VISUAL CHECKS

1. About 90% of the kits that are returned for repair do not function properly due to poor connections and soldering. Therefore, you can eliminate many difficulties by a careful inspection of connections to make sure they are soldered as described in the "Soldering" section of the "Assembly Notes." Reheat any doubtful connections and be sure all the wires are connected.
2. Check the circuit board to be sure there are no solder bridges between adjacent connections. Remove any solder bridges that may exist. Compare the circuit board foil pattern with the "Circuit Board X-Ray View."
3. Be sure each transistor and integrated circuit is in the proper location (correct part number and type number). Be sure that each transistor lead is positioned properly and has a good solder connection to the foil. Check the integrated circuits for proper positioning and good connections.
4. Check capacitor values carefully. Be sure the proper part is wired into the circuit at each capacitor location. For example, it would be easy to mistake a .001  $\mu$ F capacitor for a 100 pF capacitor. Always check the polarity of electrolytic capacitors to be sure the "+" lead is installed at the correct location.

5. Check each resistor carefully. It would be easy, for example, to install a 150  $\Omega$  (brown-green-brown) resistor where a 510  $\Omega$  (green-brown-brown) resistor is called for. A resistor that is discolored, cracked, or shows any sign of bulging would indicate that it is faulty and should be replaced.
  6. Be sure the correct diode is installed at each diode location, and that the banded end is positioned correctly.
  7. Recheck the wiring. Trace each lead in colored pencil on the Pictorial as it is checked. It is frequently helpful to have a friend check your work; someone who is not familiar with the unit may notice something you have consistently overlooked.
  8. Check all component leads connected to the circuit board. Make sure the leads do not extend through the circuit board and make contact with other connections or parts.
  9. Read the "Circuit Description." If you understand the manner in which the circuits interact, you may localize a problem more easily.
- When you make repairs to the Voltmeter, make sure you eliminate the cause as well as the effect of the trouble. If you should find a damaged resistor, be sure you find out what caused the resistor to become damaged. If the cause is not eliminated, the replacement resistor may also become damaged when the Voltmeter is put back into operation.
  - Refer to the "Circuit Board X-Ray View" (in the "Illustration Booklet") and to the fold-in Schematic diagram to locate the various components.
  - Use a high-input impedance voltmeter to make any voltage measurements. Be sure the AC Voltmeter and all test instruments are properly grounded to each other.

## BENCH TESTING

**WARNING:** The full AC line voltage is present at several points in the Voltmeter. Be careful to avoid personal shock when you work on the Voltmeter. Refer to Pictorial 3-4 (on Page 8 in the "Illustration Booklet").

- Be cautious when you test the transistors and integrated circuits. Although they have almost unlimited life when used properly, they are much more vulnerable to damage from excessive voltage and current than are other circuit components.
- Be careful that you do not short any terminals to ground when you make voltage measurements. If the probe should slip, for example, and short out a bias or voltage supply point, it may damage one or more components.
- Do not remove any components while the Voltmeter line cord is connected to the AC outlet.

## REPAIR TECHNIQUES

### Components

To remove faulty resistors or capacitors from the circuit board, first clip the component body from its leads on the top of the board; then heat the solder on the foil and allow the lead to fall out of the hole. Preshape the leads of the replacement part and insert them into the holes in the circuit board. Solder the leads to the foil and cut off the excess lead lengths.

Transistors can be removed in the same manner. The replacement transistor must be installed with its leads in the proper holes. Then quickly solder the leads to avoid heat damage. Cut off the excess lead lengths.

**CAUTION:** On several areas of the circuit board, the foil patterns are quite narrow. When you unsolder a part for checking or replacement, avoid excessive heat when you remove the part. A suction-type desoldering tool will make part removal easier.

### Foil Repair

A break in a circuit board foil can be bridged by soldering across the break. Large gaps in the foil should be bridged with a length of bare wire. Lay the wire across the gap and solder each end to the foil.

## PROBLEM ISOLATION

Before a problem can be isolated to a particular component or a definite circuit area, it must be localized to a certain area, such as the power supply, the preamplifier circuit, the AC-DC converter, and so on. A high-input impedance voltmeter is necessary to properly perform the following isolation checks.

### INITIAL TESTS

Refer again to Pictorial 3-2 for the following tests.

1. Check the power supply voltages:
  - ✓ A. +20 volts at jumper "A."
  - ✓ B. -20 volts at jumper "B."
  - ✓ C. +12 volts at the banded end of zener diode ZD115.
  - ✓ D. -12 volts at the unbanded end of zener diode ZD116.
    - If all voltages are within  $\pm 20\%$  tolerance, the power supply is working properly.
    - If any of the voltages are too high, there is a problem in the power supply. Refer to "Power Supply" on Page 49.
    - If any of the voltages are too low, unsolder and lift either the top end of jumper "A" or the left end of jumper "B." Recheck for +20 volts and -20 volts on the lifted jumpers. If the readings are now normal, the problem is in a circuit other than the power supply. If the readings are still incorrect, refer to "Power Supply" on Page 49.
2. If the meter operates correctly on the "Volts" functions, the Voltmeter preamplifier, main amplifier, and AC-DC converter are functioning properly.

If the meter does not operate correctly on the "Volts" functions, refer to "Volts Functions" in the following paragraphs.

If the "Volts" functions operate correctly, and there is a problem in the "dB" function, refer to Page 48 and perform the checks in the "dB Functions."

### VOLTS FUNCTIONS

If there is a problem in the "Volts" functions, and the meter is not indicating the proper levels for known inputs, or if the meter is not functioning at all, the problem could be in the preamplifier, the main amplifier, or in the AC-DC converter. At this time, it is assumed that you have checked the power supply and it is operating correctly.

NOTE: Refer to the fold-in Schematic diagram and to the "Circuit Board X-Ray View" for locating components and checking voltages in the following circuit sections.

#### Preamplifier Checks

1. Check all DC voltages in the preamplifier circuit as indicated on the Schematic diagram.
2. Set the meter range switch to 300 mV. Connect an AC signal to the input of the Voltmeter, 300 mV or less. Check the amplitude of the signal on the collector (C) of transistor Q102. The gain of the preamplifier should be 4.
3. If the checks performed in steps 1 and 2 produce the proper indications, the preamplifier is okay. Proceed to the following "Main Amplifier Checks."
4. If the checks made in steps 1 and 2 are not correct, a problem exists in the preamplifier stages. Check for the following:
  - a. All diodes — correct positioning of the banded ends.
  - b. All transistors — correct positioning of the flat side of the transistor; proper component type as shown in the "Step-by-Step Assembly."

- c. Check electrolytic capacitors for correct positioning of positive (+) marking.
  - d. Refer to the "Step-by-Step Assembly" pages and check each of the remaining components for the correct type and value.
  - e. Check the DC voltages.
5. A DC voltage across a transistor that is low may indicate that component is shorted, or is improperly turned on by a preceding stage. If the DC voltage across a transistor is high, the transistor is either open, or it is not being correctly driven by the preceding stage.

### Main Amplifier Checks

1. If the preamplifier has been checked and is operating correctly, connect a 300 mV (or less) AC signal to the input of the Voltmeter. Measure the output of the main amplifier at the collector (C) of transistor Q107. The overall gain of the first two stages should be approximately 10 (Range switch on 300 mV).
  2. If the preceding test produced the desired results, the main amplifier stage is operating correctly; proceed to the "AC-DC Converter Checks" in the following paragraphs.
  3. If the test in step 1 did not produce the desired results, check for the following:
    - a. Diodes — correct positioning of the banded ends.
    - b. Transistors — correct positioning of the flat side of the transistor and proper type as shown in the "Step-by-Step Assembly."
    - c. Refer to the "Step-by-Step Assembly" pages and check each of the remaining components for the correct type and value.
    - d. Check all DC voltages in the main amplifier stage; be sure they are as shown on the Schematic.
    - e. If the voltages appear to be correct, but the gain of this stage is still incorrect, check each of the electrolytic capacitors to be sure it is the correct value and its positive (+) marking is positioned correctly.
4. Check the voltages across each of the transistors. A very low voltage may indicate that the transistor is shorted, or is incorrectly turned on by a preceding stage. A very high voltage may indicate that the transistor is open, or that it is not being correctly driven by the preceding stage.

### AC-DC Converter Checks

1. If the preamplifier and the main amplifier stages are operating correctly, and there is no indication on the meter, check all the DC voltages in the AC-DC converter stage; these voltages are shown on the Schematic.
2. If the DC voltage measurements do not produce the desired results, check the following:
  - a. Diodes — correct positioning of the banded ends.
  - b. Transistors — correct type and proper positioning of the flat sides.
  - c. Check the "Step-by-Step Assembly" pages to be sure each of the remaining components is the correct type and value.
3. To verify the operation of integrated circuit IC101, interchange IC101 with IC104.
4. If the AC-DC converter stage produced all the proper results, and there is still no meter indication, check switch SW3, all its wiring, and the meter.

### dB FUNCTIONS

If the "VOLTS" function is operating properly, but the indication for the "dB" function is not correct, first set the Voltmeter controls as follows:

- dB switch: On.
- dB OFFSET control (red knob): Fully counterclockwise.
- RANGE switch (black knob): -10 dB.

Apply a 300 mV rms signal to the Voltmeter input jacks.

**NOTE:** The DC voltages noted on the Schematic diagram, in the dB circuit, are the result of converted AC-to-DC signal voltages. The correct 300 mV rms signal must be applied to the input jacks to obtain the DC voltages shown.

1. Check the DC voltages in the dB circuits.
2. If the DC voltages are correct as shown on the Schematic diagram, check the wiring to switch SW3.
3. If the DC voltages are not correct, check the following:
  - a. Diodes for the correct positioning of the banded end.
  - b. Integrated circuits for the correct positioning of the marked end.
  - c. Transistors for correct type and proper installation.
  - d. All remaining components for correct type or value and proper installation.

## **POWER SUPPLY**

1. Check the line switch on the Voltmeter rear panel. Be sure it is set to agree with the line voltage in your area.

2. Measure the DC voltages at the positive lead of capacitor C126 and at the negative (unmarked) lead of capacitor C127. If either of these voltages is incorrect, check both capacitors and make sure the positive leads are correctly matched with the marking on the circuit board.

3. Check the output voltages of integrated circuits IC105 and IC106. If either output is incorrect, lift the corresponding jumper wire at "A" or "B" and recheck the IC outputs. If the voltage(s) is still incorrect, the corresponding IC is bad or it is incorrectly mounted on the circuit board. If the IC output is now correct, there is an overload in the meter circuit that corresponds to that IC. If the IC output was high, check resistors R189, R191, and R192; if the values measure correctly, the integrated circuit is faulty.

4. Check the voltages at the banded end of zener diode ZD115 and at the unbanded end of zener diode ZD116. If these voltages are too high, the diodes are faulty. If the voltages are too low, the diodes (one or both) are incorrectly installed, or there is an overload in the circuits supplied by these regulators.

# SPECIFICATIONS

Voltage Range (full scale) .....	1 millivolt to 300 volts AC, 12 ranges.
Decibel Range .....	-70 dB to +40 dB; 12 ranges in 10 dB steps, variable offset.
Input .....	10 megohms, 30 picofarads, negative input grounded to chassis.
Frequency Response	
Voltage Ranges .....	10 Hz to 1 MHz $\pm$ 2dB. 10 Hz to 500 kHz $\pm$ 1dB.
Linear dB Ranges .....	10 Hz to 250 kHz $\pm$ 1dB.
Outputs:	
DC, proportional to input volts .....	1 volt full scale.
DC, proportional to log of input volts .....	3 volts full scale.
AC amplified signal .....	1 volt peak, full scale.
All Output Impedances .....	1 kilohm or less.
Scale (mirrored) .....	0-10 volts. 0-3.16 volts. -20 to +10 dB.
Accuracy	
All Voltage Ranges .....	$\pm$ 4% of full scale at 1 kHz plus accuracy of calibration standard.
All dB Ranges .....	$\pm$ 0.5 dB at 1 kHz plus accuracy of calibration standard.
Operating Temperature Range .....	+10° C. to +40° C.
Power Requirements .....	100-135 VAC, 200-270 VAC, 50/60 Hz, 20 watts.
Dimensions (overall) .....	10-7/8" deep $\times$ 5-5/8" wide $\times$ 6-3/4" high (27.6 $\times$ 14.3 $\times$ 17.2 cm).
Net weight .....	5.5 lbs (2.5 kg.)

---

The Heath Company reserves the right to discontinue products and to change specifications at any time without incurring any obligation to incorporate new features in products previously sold.

# CIRCUIT DESCRIPTION

Refer to the fold-in Schematic diagram as you read the following circuit description. The AC Voltmeter is comprised of the following basic circuits:

Preamplifier  
Main Amplifier  
AC-DC Converter  
Log Converter  
Power Supply

## PREAMPLIFIER CIRCUIT

The preamplifier circuit consists of an input attenuator, an amplifier, and a step attenuator.

The input signal, applied to front panel jacks J1 and J2, is coupled through capacitor C1 to the input attenuator. This attenuator is a 1000-to-1 divider comprised of resistors R1 and R2, and is frequency-compensated at high frequencies by capacitors C2 and C3.

Diodes D101 and D102 limit excessive input voltages to  $\pm 12$  volts to protect transistor Q101. Transistors Q101 and Q102 form a high-impedance input amplifier with a gain of approximately 4. Control R103 allows adjustment of the operating point of Q102's collector. The output of this amplifier is coupled into the step attenuator on Range switch RS2.

## MAIN AMPLIFIER

Transistors Q103 through Q107 and their associated components form a high gain amplifier. The DC gain, approximately 3 to provide good stability, is fixed by a network composed of resistors R124, R125, R127, and R134. The AC gain of the circuit is approximately 800, as set by a network of resistors (R125, R128, R135) and capacitors (C109 and C112). High frequency stabilization is provided by capacitors C107

and C108. Diodes D103 and D104 provide input transient protection for this circuit.

The full-scale output voltage from this circuit is 3.5 volts AC. This signal is also coupled to the input of the AC-DC converter. Resistors R137 and R139 form a voltage divider network which provides the amplified AC output.

## AC-DC CONVERTER CIRCUIT

The AC-DC converter is composed of IC101 transistor array, sections A, B, C, and D, and discrete transistors Q108 and Q109, with their associated components. The converter contains two, nearly-identical high-gain inverting DC amplifiers. One amplifier is made-up of IC101 transistors A and B which form a differential pair to drive transistor Q108.

The converter functions as follows: If there is a +1-volt DC signal at the input of the circuit at transistor A (C113-R141), the collector of transistor Q108 will go negative, diode D107 will be biased off, and diode D108 will be biased on. Resistor R153 forms a feedback path to force IC101(A) base close to zero, or the same voltage as on the base of IC101(B).

Since the voltage at the input end of resistor R141 is +1 volt, and resistors R141 and R153 are of equal value, a voltage of -1 volt at the junction of resistors R153 and R154 is required to produce a zero voltage at the junction of R141 and R153.

The amplifier comprised of IC101(C), IC101(D), transistor Q109, and their associated components, has a feedback path through resistor R159 which will provide an output at Q109 collector such that the junction of R159 and R154 is very close to zero.

Since the voltage at R153-R154 is -1 volt, and the voltage at R154-R159 is zero, there is 1/5000 or 0.2 mA current flowing through R154. The voltage at R141-R146 is +1 volt, and the voltage at R146-R154 is zero, so there is 0.1 mA of current flowing through R146.

As there is 0.2 mA through R154, and only 0.1 mA through R146, the remaining 0.1 mA of current must come through R159. The output of the converter at the collector of Q109 must be at +1 volt to provide the current and voltage to balance the junction at resistors R154-R159.

In this example it is seen that a positive input voltage will have a unity gain in the circuit, and that the circuit has not inverted the polarity of the input voltage.

In another example, assume that the input to the AC-DC Converter at the junction of capacitor C113 and resistor R141 is -1 volt.

Diode D107 is forward biased and D108 is reverse biased. The cathode of D107 is connected to the input of IC101(A), and this point is near zero.

The amplifier comprised of IC101(C), IC101(D), and transistor Q109 acts to hold the junction of resistors R146-R159 at zero. Since the cathode of diode D107 is zero and the junction of R154-R146 is zero, no current flows through resistors R153 and R154. Therefore, to maintain a voltage of zero at R146-R159, with a voltage of -1 volt at C113-R146, the voltage at the collector of transistor Q109 must be +1 volt.

In this example the converter circuits have produced a unity-gain, inverted signal. Since the converter inverts a negative signal and follows a positive input, the circuit acts as a full-wave rectifier with no forward drop to cause inaccuracies in the following circuits.

## LOG CONVERTER

The log converter consists of a reference current source, a log conversion circuit, and an inverter-buffer. The reference current source supplies the log conversion circuit with a constant current. The log conversion circuit converts the output from the AC-DC converter to dB for the dB scale on the meter. The inverter-buffer inverts the output from the log conversion circuit (from negative to positive) and provides buffering for the dB output at J7.

### LOG CONVERSION

The log converter converts the output voltage from the AC-DC converter to dB by taking the logarithm of the ratio between this output voltage and a reference. The log converter must provide a meter indication corresponding to the following equation:

$$\text{dB} = 20 \log_{10} \frac{V_2}{V_1}$$

The graph in Pictorial 7-2 shows the relationship between the log of the collector current ( $I_c$ ) and the base-emitter voltage ( $V_{be}$ ) for a typical silicon transistor. Since the transistors operate in the straight-line portion of the curve, the output voltage ( $V_{be}$ ) is proportional to input dB ( $\log I_c$ ).

It is customary to give dB readings with respect to a reference, such as 1 milliwatt into 600 ohms (or .775 volts). This voltmeter is calibrated at 0 dB (with dB Reference Adjust, R169) using a .775-volt reference. So, V1 becomes .775 volts.

Transistor Q110 and its associated circuitry provide a constant current output, which is the reference for the log converter. Since the voltage across D109 and ZD110 are fixed, the voltage at the base of Q110 will also be fixed for any given setting of dB REF ADJ control R169. The base-emitter voltage of Q110 is also constant, which forces the voltage across R172 to be constant. With a constant voltage across the resistor, the current through it is constant and, since the collector current of Q110 is very nearly equal to the emitter current, the output current of this circuit is constant.

The DC input to the log converter is developed across resistors R176 and R177 and dB Offset control R5. The current through this resistor network is fed into the collector of transistor IC104(D). The base-emitter voltage of this transistor is the output voltage, and is the log of its collector current.

The reference current from the collector of Q110 is fed into the collector of IC104(C). The base-emitter voltage of this transistor is the output voltage, and is the log of its collector current.

The emitters of IC104(D) and IC104(C) are connected together. Therefore, the voltage at the base of IC104(C) will be the difference between the base-emitter voltages of the two transistors. In this manner, the circuit subtracts the log of the reference current ( $V_{be}$  of IC104C) from the log of the input current ( $V_{be}$  of IC104D). The result is the log of the ratio of the two collector currents.

IC103 provides a floating drive for transistor IC104(C). IC102 provides a floating drive for IC104(D) and, with R174 and R175, amplifies the 60 millivolt-per-decade output of the transistors to a more convenient 1 volt per decade.

Since all silicon junction devices have a nearly constant negative temperature coefficient, R175 (which has a positive coefficient) reduces the effect that temperature has on the output of the converter.

Capacitors C121, C122, C123, and C124 are stabilizing components to prevent oscillations.

As dB Offset control R5 is turned clockwise from the calibrate (fully counterclockwise) position, it increases the current gain of the voltage-to-current converter comprised of R173, R5, and R172. This causes more current to flow through R173 and R5, and into IC104(D), which causes the output of the inverter to increase up to 1 volt (10 dB).

### INVERTER-BUFFER

IC104 transistors A, B, and E, and transistor Q111, form a unity-gain inverter which inverts the log converter output from negative to positive and provides buffering for the dB output.

PICTORIAL 7-2

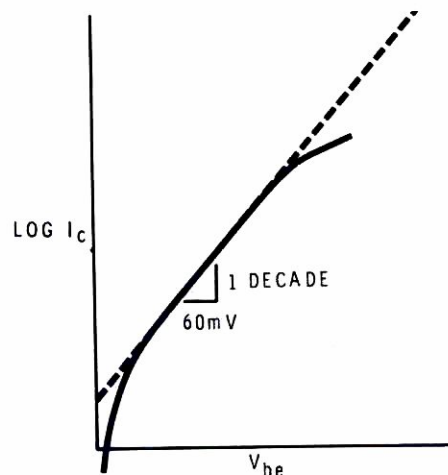

## POWER SUPPLY

The AC line voltage is transformed and rectified by dual-voltage transformer T1 and diode bridge D111 through D114. Switch SW2 selects the nominal operating voltage (either 120 or 240 volts AC). The diode bridge rectifier is center-tapped at a ground potential and provides outputs of approximately  $\pm 30$  volts DC. These outputs are filtered by capacitors C126 and C127.

The filtered DC is routed into integrated circuit regulators IC105 and IC106. The IC regulators have

internal short-circuit and thermal-overload protection. The outputs of the regulators are routed across capacitors C128 and C129 which provide low output impedance and circuit stability to the  $\pm 20$ -volt circuits.

The outputs of the  $\pm 20$ -volt DC circuits are also routed across dropping resistors R193 and R194 and across zener diode regulators ZD115 and ZD116 to produce a  $\pm 12$ -volt source for the remaining circuits.

# SEMICONDUCTOR IDENTIFICATION CHARTS

## DIODES

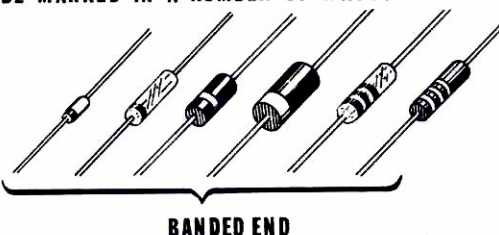
COMPONENT	HEATH PART NO.	MANUFACTURER'S NUMBER	IDENTIFICATION
D101 THROUGH D109	56-56	1N4149	<p><b>IMPORTANT: THE BANDED END OF DIODES CAN BE MARKED IN A NUMBER OF WAYS.</b></p>  <p><b>BANDED END</b></p>
ZD110	56-629	BZX83C3V	
D111 THROUGH D114	57-65	1N4002	
ZD115, ZD116	56-57	1N716A	

## TRANSISTORS

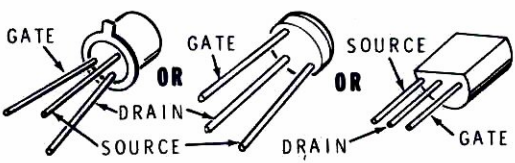
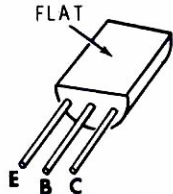
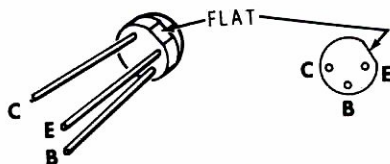
COMPONENT	HEATH PART NO.	MANUFACTURER'S NUMBER	IDENTIFICATION
Q101	417-802	E304	
Q102, Q105, Q107, Q110, Q111	417-235	2N4121	
Q103, Q104, Q106	417-134	MPS6520	
Q108, Q109	417-260	2N4258A	

**INTEGRATED CIRCUITS**

COMPONENT	HEATH PART NO.	MANUFACTURER'S NUMBER	BASE DIAGRAM (TOP VIEW)
IC101, IC104	417-876	CA3046	
IC103	442-22	741	
IC102	442-66	308	
IC105	442-617	78MGC	<p style="text-align: center;"><b>IDENTIFICATION</b></p>
IC106	442-618	79MGC	



**FOR PARTS REQUESTS ONLY**

- Be sure to follow instructions carefully.
- Use a separate letter for all correspondence.
- Please allow 10 - 14 days for mail delivery time.

DO NOT WRITE IN THIS SPACE

**INSTRUCTIONS**

- Please print all information requested.
- Be sure you list the correct **HEATH** part number exactly as it appears in the parts list.
- If you wish to prepay your order, mail this card and your payment in an envelope. Be sure to include 10% (25¢ minimum, \$3.50 maximum) for insurance, shipping and handling. Michigan residents add 4% tax.  
Total enclosed \$\_\_\_\_\_
- If you prefer COD shipment, check the COD box and mail this form. COD

NAME \_\_\_\_\_  
 ADDRESS \_\_\_\_\_  
 CITY \_\_\_\_\_  
 STATE \_\_\_\_\_ ZIP \_\_\_\_\_

The information requested in the next two lines is not required when purchasing nonwarranty replacement parts, but it can help us provide you with better products in the future.

Model # \_\_\_\_\_ Invoice # \_\_\_\_\_  
 Date Purchased \_\_\_\_\_ Location Purchased \_\_\_\_\_

LIST <b>HEATH</b> PART NUMBER	QTY.	PRICE EACH	TOTAL PRICE

TOTAL FOR PARTS	
HANDLING AND SHIPPING	
MICHIGAN RESIDENTS ADD 4% TAX	
<b>TOTAL AMOUNT OF ORDER</b>	

SEND TO: **HEATH COMPANY**  
 BENTON HARBOR  
 MICHIGAN 49022  
**ATTN: PARTS REPLACEMENT**

Phone (Replacement parts only): 616 982-3571

**FOR PARTS REQUESTS ONLY**

- Be sure to follow instructions carefully.
- Use a separate letter for all correspondence.
- Please allow 10 - 14 days for mail delivery time.

DO NOT WRITE IN THIS SPACE

**INSTRUCTIONS**

- Please print all information requested.
- Be sure you list the correct **HEATH** part number exactly as it appears in the parts list.
- If you wish to prepay your order, mail this card and your payment in an envelope. Be sure to include 10% (25¢ minimum, \$3.50 maximum) for insurance, shipping and handling. Michigan residents add 4% tax.  
Total enclosed \$\_\_\_\_\_
- If you prefer COD shipment, check the COD box and mail this form. COD

NAME \_\_\_\_\_  
 ADDRESS \_\_\_\_\_  
 CITY \_\_\_\_\_  
 STATE \_\_\_\_\_ ZIP \_\_\_\_\_

The information requested in the next two lines is not required when purchasing nonwarranty replacement parts, but it can help us provide you with better products in the future.

Model # \_\_\_\_\_ Invoice # \_\_\_\_\_  
 Date Purchased \_\_\_\_\_ Location Purchased \_\_\_\_\_

LIST <b>HEATH</b> PART NUMBER	QTY.	PRICE EACH	TOTAL PRICE

TOTAL FOR PARTS	
HANDLING AND SHIPPING	
MICHIGAN RESIDENTS ADD 4% TAX	
<b>TOTAL AMOUNT OF ORDER</b>	

SEND TO: **HEATH COMPANY**  
 BENTON HARBOR  
 MICHIGAN 49022  
**ATTN: PARTS REPLACEMENT**

Phone (Replacement parts only): 616 982-3571

CUT ALONG DOTTED LINE

# CUSTOMER SERVICE

## REPLACEMENT PARTS

Please provide complete information when you request replacements from either the factory or Heath Electronic Centers. Be certain to include the **HEATH** part number exactly as it appears in the parts list.

## ORDERING FROM THE FACTORY

Print all of the information requested on the parts order form furnished with this product and mail it to Heath. For telephone orders (parts only) dial 616 982-3571. If you are unable to locate an order form, write us a letter or card including:

- Heath part number.
- Model number.
- Date of purchase.
- Location purchased or invoice number.
- Nature of the defect.
- Your payment or authorization for COD shipment of parts not covered by warranty.

Mail letters to: Heath Company  
Benton Harbor  
MI 49022  
Attn: Parts Replacement

**Retain original parts until you receive replacements. Parts that should be returned to the factory will be listed on your packing slip.**

## OBTAINING REPLACEMENTS FROM HEATH ELECTRONIC CENTERS

For your convenience, "over the counter" replacement parts are available from the Heath Electronic Centers listed in your catalog. Be sure to bring in the original part and purchase invoice when you request a warranty replacement from a Heath Electronic Center.

## TECHNICAL CONSULTATION

Need help with your kit? — Self-Service? — Construction? — Operation? — Call or write for assistance. you'll find our Technical Consultants eager to help with just about any technical problem except "customizing" for unique applications.

The effectiveness of our consultation service depends on the information you furnish. Be sure to tell us:

- The Model number and Series number from the blue and white label.
- The date of purchase.
- An exact description of the difficulty.
- Everything you have done in attempting to correct the problem.

Also include switch positions, connections to other units, operating procedures, voltage readings, and any other information you think might be helpful.

**Please do not send parts for testing**, unless this is specifically requested by our Consultants.

Hints: Telephone traffic is lightest at midweek — please be sure your Manual and notes are on hand when you call.

Heathkit Electronic Center facilities are also available for telephone or "walk-in" personal assistance.

## REPAIR SERVICE

Service facilities are available, if they are needed, to repair your completed kit. (Kits that have been modified, soldered with paste flux or acid core solder, cannot be accepted for repair.)

**If it is convenient, personally deliver your kit to a Heathkit Electronic Center. For warranty parts replacement, supply a copy of the invoice or sales slip.**

If you prefer to ship your kit to the factory, attach a letter containing the following information directly to the unit:

- Your name and address.
- Date of purchase and invoice number.
- Copies of all correspondence relevant to the service of the kit.
- A brief description of the difficulty.
- Authorization to return your kit COD for the service and shipping charges. (This will reduce the possibility of delay.)

Check the equipment to see that all screws and parts are secured. (Do not include any wooden cabinets or color television picture tubes, as these are easily damaged in shipment. Do not include the kit Manual.) Place the equipment in a strong carton with at least **THREE INCHES** of *resilient* packing material (shredded paper, excelsior, etc.) on all sides. Use additional packing material where there are protrusions (control sticks, large knobs, etc.). If the unit weighs over 15 lbs., place this carton in another one with 3/4" of packing material between the two.

Seal the carton with reinforced gummed tape, tie it with a strong cord, and mark it "Fragile" on at least two sides. Remember, the carrier will not accept liability for shipping damage if the unit is insufficiently packed. Ship by prepaid express, United Parcel Service, or insured Parcel Post to:

Heath Company  
Service Department  
Benton Harbor, Michigan 49022



HEATH COMPANY • BENTON HARBOR, MICHIGAN  
**THE WORLD'S FINEST ELECTRONIC EQUIPMENT IN KIT FORM**

LITHO IN U.S.A.