

DIAGNOSTIC LIMITED BRISTOL ROAD, GLOUCESTER GL2 0EF

HEATHKIT ASSEMBLY MANUAL



SERVICE OSCILLOSCOPE

MODEL OS-2

COLOUR CODE FOR FIXED RESISTORS - (B.S.1852-1952) COLOUR BAND MARKING

FIG1. (COLOURED BAND MARKING PREFERRED)

THIS EXAMPLE SHOWS A GRADE I. RESISTANCE OF $6,800 \Omega \pm 5\%$

A BLUE (6)
B GREY (8)
C RED ($\times 10^2$)
D GOLD ($\pm 5\%$)
E SALMON PINK (GRADE I.)
 (THIS MAY BE GENERAL BODY COLOUR)

FIG2. BODY, TIP & SPOT MARKING

FIG3. BODY TIP & CENTRAL BAND MARKING

AMERICAN "RMA", "JAN" & COMMERCIAL CODING FOR MOULDED MICA CAPACITORS

CURRENT STANDARD CODE

MOULDED FLAT CAPACITOR COMMERCIAL CODE

JAN. CODE CAPACITOR

COLOUR CODE FOR RESISTORS AND CAPACITORS

Colour	Value in Ohms or pF for Cols. A, B & C.				COL. D. (TOLERANCE RATING)			CAPACITORS COL. E. TEMP. COEFFICIENT per 10° per °C.
	COL. A. 1st Figure	COL. B. 2nd Figure	COL. C. (MULTIPLIER)		Resistors	Ceramic Capacitors		
			Resistors ohms	Capacitors pF		Up to 10 pF	Over 10 pF	
BLACK	-	0	1	1	-	2 pF	± 20%	0
BROWN	1	1	10	10	± 1%	0.1 pF	± 1%	-30
RED	2	2	100	100	± 2%	-	± 2%	-80
ORANGE	3	3	1,000	1,000	-	-	± 2.5%	-150
YELLOW	4	4	10,000	10,000	-	-	-	-220
GREEN	5	5	100,000	-	-	0.5 pF	± 5%	-330
BLUE	6	6	1,000,000	-	-	-	-	-470
VIOLET	7	7	10,000,000	-	-	-	-	-750
GREY	8	8	100,000,000	.01	-	0.25 pF	-	+30
WHITE	9	9	1,000,000,000	.1	-	1 pF	± 10%	+100
SILVER	-	-	.01	-	± 10%	-	-	-
GOLD	-	-	.1	-	± 5%	-	-	-
SALMON	-	-	-	-	-	-	-	-
PINK	-	-	-	-	-	-	-	-
NO "D"	-	-	-	-	-	-	-	-

COLOUR

The Colour coding should be read from left to right, in order, starting from the end and finishing near the middle.

Standard \pm tolerances for resistors are:- Wire-wound: 1%, 2%, 5%, 10%. Composition, Grade 1: 1%, 2%, 5%. Grade 2: 5%, 10%, 20%. (20% is indicated by 4th (or 'D') colour). Grade 1: ("high-stability") composition resistors are distinguished by a salmon-pink fifth ring or body colour. (Reference: B.S.1852: 1952 B.S.I.).
 N. B. High-Stability Resistors supplied with this kit are not as a rule colour coded but enamelled in one colour on which the value in Ohms is printed in figures. Capacitors supplied in this kit usually have their capacity clearly marked in figures. Some Capacitors coded as above also have additional "voltage rating" coding.

Assembly and Operation of the Heathkit Service Oscilloscope Model OS-2

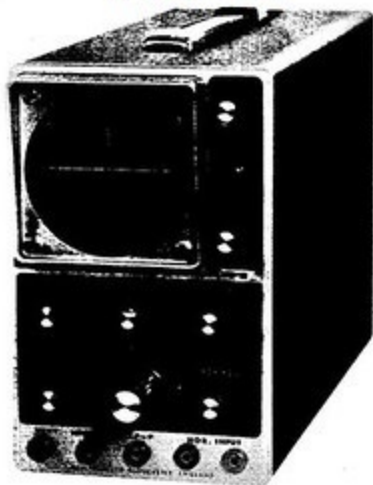

SPECIFICATION

Vertical Amplifier:

Sensitivity	100 mV r.m.s. per cm
Frequency Response	2 c/s - 3 Mc/s, ± 3 dB
Input Impedance	3.3 M Ω shunted by 20 pF

Horizontal Amplifier:

Sensitivity	100 mV r.m.s. per cm
Frequency Response	2 c/s - 300 kc/s, ± 3 dB
Input Impedance	10 M Ω shunted by 20 pF

Time Base Generator:

Recurrent Type	Linear sawtooth produced by multivibrator
Range	20 c/s to 200 kc/s in four steps. Approximate ranges, 1. 20-200 c/s, 2. 200-2000 c/s, 3. 2-20 kc/s, 4. 20-200 kc/s
Synchronisation	Automatic lock-in circuit, using self-limiting synchronising cathode follower
Retrace Blanking	Blanking amplifier provided, operates on all ranges

General:

Valve Complement:	1 - ECF80, 4 - 12AU7, 1 - 12AX7, 1 - EZ80 ¹ , 1 - 3RP1
Front Panel Controls:	CRT, medium persistence, green trace BRILLIANCE - AC ON/OFF FOCUS

	HOR/FREQ. SELECTOR (horizontal input and time base generator frequency selector)
	FINE FREQUENCY
	VERTICAL POSITION
	VERTICAL GAIN
	HORIZONTAL POSITION
	HORIZONTAL GAIN
Rear Panel Controls:	Vertical input switch Astigmatism (spot shape)

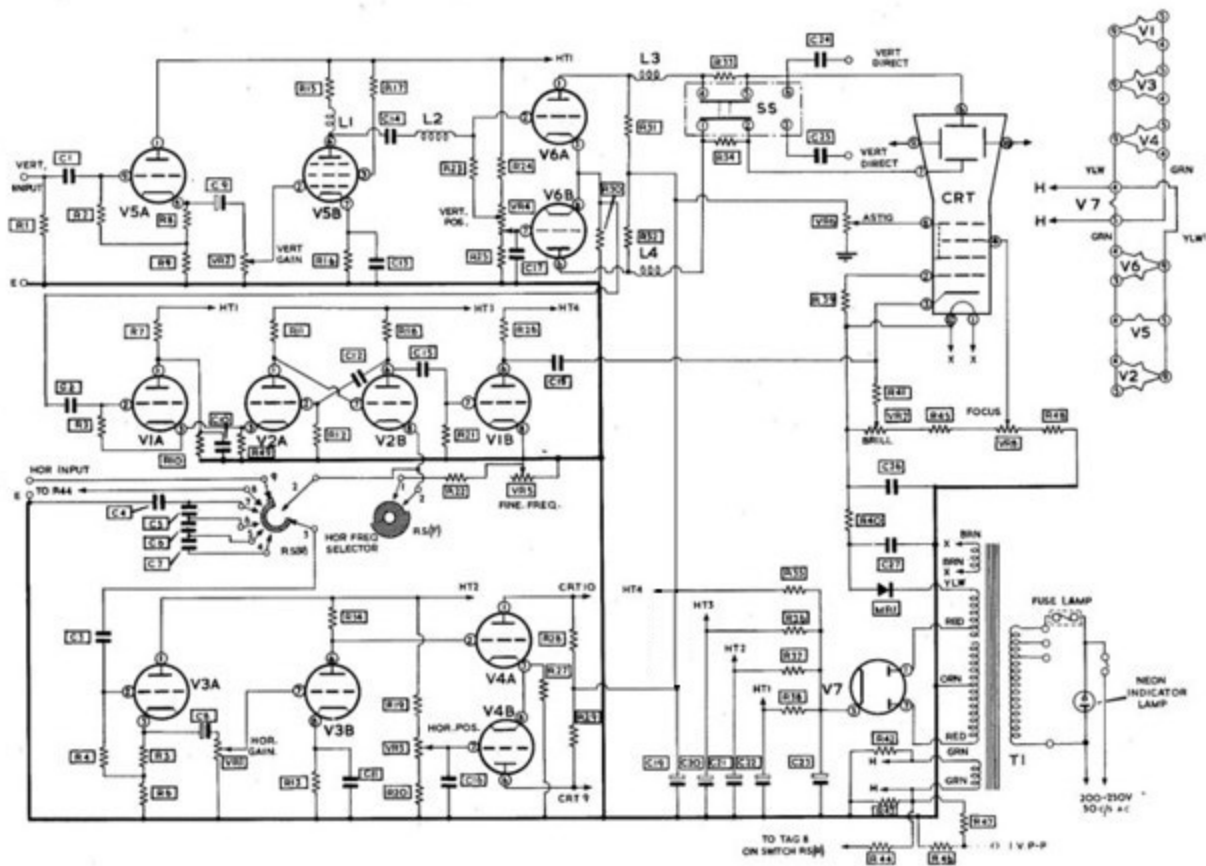

CIRCUIT DIAGRAM
 HEADHILL SERVICE CORPORATION
 Model 95-2

Inputs:	VERTICAL INPUT HORIZONTAL INPUT
Voltage Calibrator:	Input to vertical plates of CRT, via .002 μ F 1 kV capacitors, at rear of oscilloscope
Power Requirements:	1 volt peak-to-peak
Dimensions:	200-250V, 40-60 c/s a.c., 40 watts
Net Weight:	5" wide x 7.3/8" high x 12" deep
Shipping Weight:	9 1/2 lb.
	12 lb.

RESISTOR AND CAPACITOR CHART

R1	4.7 M Ω	R26	100 K Ω	C1	.1 μ F 400V	C26	.1 μ F 1000V
R2	1 M Ω	R27	6.8 K Ω 2W	C2	.1 μ F 250V	C27	.1 μ F 1000V
R3	470 K Ω	R28	22 K Ω 1W	C3	.1 μ F 400V		
R4	2.2 M Ω	R29	22 K Ω 1W	C4	.2 μ F		
R5	1.2 K Ω	R30	3.3 K Ω 2W	C5	.02 μ F		
R6	56 K Ω	R31	6.8 K Ω 2W	C6	.002 μ F	V1	12AU7
R7	150 K Ω	R32	6.8 K Ω 2W	C7	200 pF	V2	12AX7
R8	470 Ω 5%	R33	1 M Ω	C8	16 μ F 150V	V3	12AU7
R9	10 K Ω	R34	1 M Ω	C9	16 μ F 150V	V4	12AU7
R10	33 K Ω	R35	470 Ω 1W	C10	.1 μ F 250V	V5	ECF80
R11	6.8 K Ω	R36	39 K Ω 1W	C11	.002 μ F	V6	12AU7
R12	2.2 M Ω	R37	27 K Ω 1W	C12	.02 μ F	V7	EZ-51
R13	1.2 K Ω	R38	18 K Ω 5W	C13	1000 pF		
R14	100 K Ω	R39	100 K Ω	C14	.1 μ F 250V		
R15	6.8 K Ω	R40	470 K Ω	C15	1000 pF		
R16	220 Ω	R41	1 M Ω	C16	.02 μ F	VR1	20 K Ω HOR. GAIN
R17	270 Ω	R42	47 Ω	C17	.25 μ F	VR2	20 K Ω VERT. GAIN
R18	3.3 K Ω	R43	47 Ω	C18	.03 μ F	VR3	100 K Ω HOR. POS.
R19	240 K Ω 5%	R44	56 K Ω	C19	50 μ F	VR4	100 K Ω (C/TAP) VERT. POS.
R20	47 K Ω 5%	R45	470 K Ω	C20	20 μ F	VR5	7.5 M Ω FINE FREQ.
R21	22 M Ω	R46	62 Ω 5%	C21	40 μ F	VR6	250 K Ω (preset) ASTIGMATISM
R22	220 K Ω	R47	470 Ω 5%	C22	40 μ F	VR7	500 K Ω (w. switch) BRILL.
R23	1 M Ω	R48	2.2 M Ω	C23	50 μ F	VR8	1 M Ω FOCUS
R24	100 K Ω	R49	330 Ω	C24	.002 μ F		
R25	100 K Ω			C25	.002 μ F		

All resistors are 10% unless otherwise stated.



INTRODUCTION

The Model OS-2 Oscilloscope was designed as a small, compact instrument for use by the electronic engineer, laboratory technician or by amateur radio enthusiasts and hobbyists.

A number of useful facilities are incorporated including push-pull horizontal and vertical amplifiers, lock-in synchronisation circuit, retrace blanking amplifier, provision for connection to vertical plates

CIRCUIT DESCRIPTION

In order to obtain a better understanding of the circuit, follow the CIRCUIT DIAGRAM while reading the DESCRIPTION.

Vertical Amplifier.

A signal applied to the VERT. INPUT sockets is coupled to the grid of the input cathode follower valve, V4A via C1. The signal from the cathode of V5A is coupled through C9 and VERT. GAIN control VR2 to amplifier V5B. This valve is frequency compensated by L1 and partly by C13. From the anode of V5B, the amplified signal is passed through the series peaking coil L2 and coupled to the push-pull output stage V6A and V6B. Phase reversal in the vertical direction is accomplished by adjusting the VERT. POS. control VR4. This varies the relative d.c. voltages between the two halves of the push-pull amplifier, the fixed tap on control VR4 providing the reference voltage for V6A. The coupling of the cathodes of V6A and V6B accomplishes the necessary phase reversal between the two halves of the push-pull amplifier which drives the CRT vertical plates to provide a balanced deflection of the electron beam. Series compensation is provided by L3 and L4. The signal at the cathodes is coupled to the synchronising cathode follower via C2.

Connecting the vertical input switch to the EXT. position allows the oscilloscope to be used, via sockets at the rear of the oscilloscope, for monitoring the quality of power supplies and similar uses.

Horizontal Amplifier.

The HORIZONTAL/FREQUENCY SELECTOR switch is used to select the desired input signal to the cathode of V3A. This signal may be from the time base generator, 50 c/s sweep, or an external signal from the HORIZ. INPUT socket. The signal is coupled from V3A to the HOR. GAIN control VR1 and thence to the amplifier stage V3B. The amplified signal at V3B is d.c. coupled to the push-pull stage and horizontal positioning of the trace is accomplished by adjusting the HOR. POS. control VR3. Common cathode coupling is used to provide a push-pull output which provides a balanced deflection of the electron beam.

Time Base Generator.

The time base generator consists of V2A and V2B arranged as a multivibrator. The timing capacitor that is connected into the cathode circuit of V2B with the HOR./FREQ. SELECTOR switch determines the time base frequency. The FINE FREQ. control VR5 provides fine frequency adjustment. The time base waveform, a sawtooth signal, is of fixed amplitude which is synchronised by the internal sync. signal.

The synchronisation signal from V6A/B is coupled to the sync. cathode follower V1A which is coupled to the time base generator by means of the common cathode resistor R49. A retrace blanking signal is taken from the time base generator, amplified at the blanking amplifier stage V1B and coupled to the CRT via C18.

Cathode Ray Tube (CRT).

The operating voltages for the cathode ray tube are supplied by a resistor network connected between the EHT and earth. This network contains the BRILLIANCE and FOCUS controls VR7 and VR8 respectively. VR9 is the ASTIGMATISM control and is adjusted in conjunction with the BRILLIANCE and FOCUS controls to produce a well defined trace.

Power Supplies.

The high voltage supply (EHT) for the cathode ray tube is obtained from an overwind on the secondary of the power transformer. It is rectified by the selenium EHT rectifier MR1, smoothed by R40, C27 and C26 and thence coupled to the CRT.

The normal HT voltage is supplied by full wave rectifier V7 and its associated smoothing circuitry, R20, R21, R35, C23, C22, C21, C20 and C19.

The 1 volt peak-to-peak calibrating voltage is derived from the 6.3 volt heater supply by means of a potential divider R47 and R46. The heater supply also supplies an a.c. voltage to the HOR./FREQ. SELECTOR switch for the sine sweep facility.

PRELIMINARY NOTES AND INSTRUCTIONS

The Step-by-Step instructions given in this manual should be followed implicitly to ensure a minimum of difficulty during construction and a completely satisfactory result, including many years of accurate, trouble-free service from the finished instrument.

UNPACK THE KIT CAREFULLY, EXAMINE EACH PART AND CHECK IT AGAINST THE PARTS LIST. In so doing, you will become acquainted with the parts. You will find it helpful to refer to the component identification sheet and also to the general details printed on the inside covers of the manual. If a shortage is found, attach the inspection slip to your claim and notify us promptly.

Lay out all the parts so that they are readily available in convenient categories. Refer to the general information inside the covers of this manual for instructions on how to identify components.

Moulded egg containers make handy trays for holding small parts. Resistors and capacitors may be placed in the edge of a corrugated cardboard box until they are needed.

Unless otherwise stated, use lockwashers under all nuts, and also between controls and the chassis. When shake-proof solder tags are mounted under nuts, the use of lockwashers is unnecessary.

Resistors and capacitors have a tolerance rating of $\pm 10\%$ unless otherwise stated. Therefore a 100 K Ω resistor may test anywhere between 90 and 110 K Ω . Frequently capacitors show an even greater variation such as -50% to +100%. This Heathkit accommodates such variations.

Unless otherwise stated all wire used is insulated. Bare wire is only used where lead lengths are short and there is no possibility of a short circuit. Wherever there is a possibility of the bare wire leads of resistors or capacitors, etc., shorting to other parts or to chassis, such leads must be covered with insulated sleeving.

To facilitate describing the location of parts, all valveholders, controls, tagstrips, etc., have been lettered or numbered. Where necessary all such coding is clearly shown in the illustrations. When instructions say, for example, "wire to socket G3", refer to the proper figure and connect a wire to tag 3 of socket G.

Valveholders illustrated in the manual are always shown with their tags numbered in a clockwise sequence, from the blank tag position or keyway, when viewed from underneath.

All resistors may be wired either way round.

All capacitors, excepting electrolytic capacitors, may be wired either way round unless otherwise stated.

Carefully letter and number tagstrips, valveholders, transformers, etc. A wax pencil is ideal for this purpose.

When mounting resistors and capacitors make sure that the value can be read when in position.

Observe polarity on all electrolytic capacitors, i. e. RED = POSITIVE = +.

A circuit description is included in this manual so that those with some knowledge of electronics will be able to obtain a clearer picture of the actual functioning of this instrument. It is not expected that those with little experience will understand the description completely, but it should be of help in the event that they desire to become more familiar with the circuit operation and thus learn more from building the kit than just the placing of parts and the wiring.

Read this manual right through before starting actual construction. In this way, you will become familiar with the general step-by-step procedure used. Study the pictorials and diagrams to get acquainted with the circuit layout and location of parts. When actually assembling and wiring, READ THROUGH THE WHOLE OF EACH STEP so that no point will be missed.

A tick (✓) should be made in the space provided at the beginning of each instruction immediately it has been completed. This is most important as it will avoid omissions or errors, especially whenever work is interrupted in the course of construction. Some Kit-builders have found it helpful in addition to mark each lead in the pictorial in coloured pencil as it is completed.

Successful instrument construction requires close observance of the step-by-step procedure outlined in this manual. For your convenience, some illustrations may appear in large size folded sheets. It is suggested that these sheets be fastened to the wall over your work area for reference purposes during instrument construction.

The Company reserves the right to make such circuit modification and/or component substitutions as may be desirable, indication being by "Advice of Change" included in the kit.

NOTE: Daystrom Ltd. will not accept any responsibility or liability for any damage or personal injury sustained during the building, testing, or operation of this instrument.

ALL GUARANTEES ARE VOIDED AND WE WILL NOT REPAIR OR SERVICE INSTRUMENTS IN WHICH ACID CORE SOLDER OR PASTE FLUXES HAVE BEEN USED. WHEN IN DOUBT ABOUT SOLDER, IT IS RECOMMENDED THAT ONLY "60/40" RESIN CORE RADIO SOLDER BE PURCHASED.

Only a small percentage of Heathkit purchasers find it necessary to return an instrument for factory service. Of these, by far the largest proportion function improperly due to poor or improper soldering.

Correct soldering technique is extremely important. Good soldered joints are essential if the performance engineered into the kit is to be fully realized. If you are a beginner with no experience in soldering, half an hour's practice with odd lengths of wire and a valveholder, etc., will be invaluable.

Highest quality resin-cored solder is essential for efficiently securing this kit's wiring and components. The resin core acts as a flux or cleaning agent during the soldering operation.

NO SEPARATE FLUX OR PASTE OF ANY KIND SHOULD BE USED. We specifically caution against the use of so-called "non-corrosive" pastes or liquids. Such compounds, although not corrosive at room temperature, will form residues when heated. These residues are deposited on surrounding surfaces and attract moisture. The resulting compounds are not only corrosive but actually destroy the insulation value of non-conductors. Dust and dirt tend to accumulate on these "bridges" and eventually will cause erratic or degraded performance of the instrument.

IMPORTANT

IN THE "STEP-BY-STEP" PROCEDURE the abbreviation "NS" indicates that the connection should not yet be soldered, for other wires will be added. At a later stage the letter "S" indicates that the connection must now be soldered. Note that a number appears after each solder (S) instruction. This number indicates the number of leads connected to the terminal in question. For example, if the instructions read, "Connect one lead of a 47 K Ω resistor to tag 1 (S-2)", it will be understood that there should be two leads connected to the terminal at the time it is soldered. This additional check will help to avoid errors.

SPECIAL NOTE: Where a wire is passed through a tag to other parts of the circuit, this will be regarded as two connections (S-2).

When two or more connections are made to the same solder tag a common mistake is to neglect to solder the connections on the bottom. Make sure all the wires are soldered.

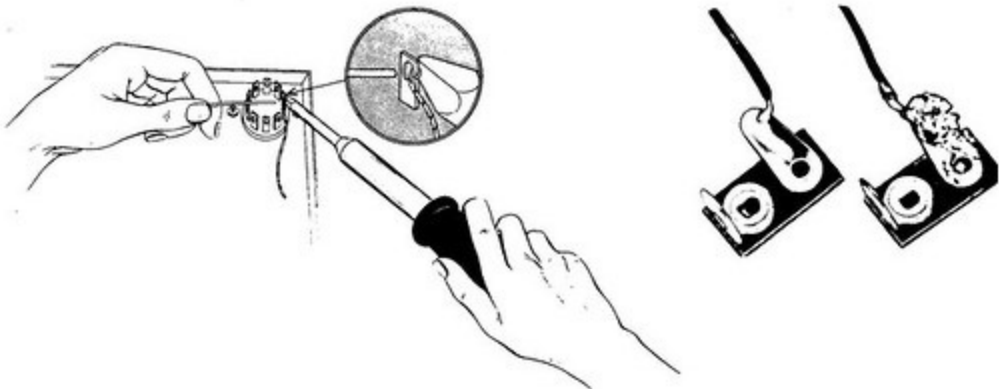

If the tags are bright and clean and wires free of wax, frayed insulation and other foreign substances, no difficulty will be experienced in soldering. Crimp or otherwise secure the wire (or wires) to the terminal, so a good mechanical joint is made without relying on solder for physical strength.

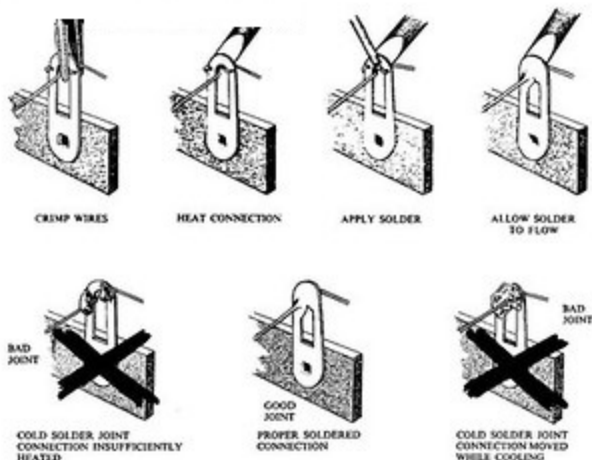

Typical good and bad soldered joints are shown above.

A poor soldered joint will usually be indicated by its appearance. The solder will stand up in a blob on top of the connection, with no evidence of flowing out caused by actual "wetting" of the contact. A crystalline or grainy texture on the solder surface caused by movement of the joint before it solidifies is another evidence of a "cold" connection and possible "dry" joint. In either event, reheat the joint until the solder flows smoothly over the entire junction, cooling to a smooth, bright appearance.

To make a good soldered joint, the clean tip of the hot soldering iron should be placed against the joint to be soldered so that the flat tag is heated sufficiently to melt the solder. Resin-core solder is then placed against both the tag and the tip of the iron and should immediately flow over the joint. See illustrations. Use only enough solder to cover the wires at the junction; it is not necessary to fill the entire hole in the tag with solder. Do not allow excess solder to flow into valveholder contacts, ruining the sockets, or to creep into switch sockets and destroy their spring action. Position the work so that gravity tends to keep the solder where you want it.

A clean, well-tinned soldering iron is also important to obtain consistently perfect connections. For most wiring, a 25 to 50 watt iron, or the equivalent in a soldering gun, is very satisfactory. Keep the iron hot and its tip and the connections to be soldered bright and clean. Always place the solder on the heated "work" and then place the bit on top of the solder until it flows readily and "wets" the joint being made. Do not take the solder on to the bit and then try to bring it to the work directly from the soldering iron. Whenever possible a joint should be secured mechanically by squeezing tight with pliers prior to soldering it. The hot soldering bit should frequently be scraped clean with a knife, steel wool or a file, or wiped clean quickly by means of a rag or steel wool.

Do not apply too much solder to the soldered joint. Do not apply the solder to the iron only, expecting that it will roll down onto the connection. Try to follow the instructions and illustrations as closely as possible.

Do not bend a lead more than once around a connecting point before soldering, so that if it should have to come off due to a mistake or for maintenance it will be much easier to remove.

Follow these instructions and use reasonable care during assembly of the kit. This will ensure the deserved satisfaction of having the instrument operate perfectly the first time it is switched on.



PROPER MOUNTING
Bend wires of each component to keep them from falling out when the board is turned

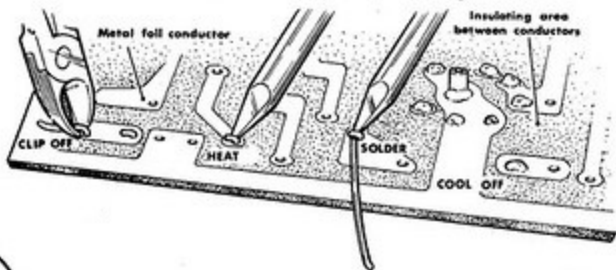

CIRCUIT BOARD WIRING AND SOLDERING

Before attempting any work on the circuit board, read the following instructions carefully and study the figures shown. The observation of a few basic precautions will ensure proper operation of the unit when first switched on.

Proper mounting of components on the board is essential for good performance. A good general rule to follow is that all components on the board should be mounted tightly to the board, unless instructions state otherwise. All wires should be kept as short as possible to minimize the effects of stray capacity in the wiring. Proper and improper methods of mounting are illustrated in the accompanying Figures. Tubular capacitors and resistors will fit properly if their wires are bent as shown. Disc capacitors will generally fit in place with no lead preparation other than determining that the leads are straight. Components with tags normally require no preparation unless the tags are bent, in which case they can be straightened with a pair of pliers. Parts should be inserted as instructed, and the leads bent outward to retain in position. Each lead is then cut about $1/8$ " from the board and dressed flat against the foil, making sure that it does not extend beyond the conductor area.

The technique of soldering leads to a circuit board is quite simple. Position the tip of the soldering iron so that it firmly contacts both the circuit board foil and the wire or tag to be soldered as shown. Then the solder should immediately be placed between the iron and the joint to be soldered. Hold the tip of the iron in place until the solder has "wetted" both the component lead and the foil pattern on the board. Apply more solder if necessary and allow it to flow smoothly over both surfaces and when this is achieved, quickly remove the iron. Sufficient solder must be used to surround and adhere to a component lead on all sides but the possibility of an unwanted bridge between adjacent conductor areas whether by solder or an excessively long component lead must not be overlooked. It is important that no movement should occur during cooling off, otherwise a "cold joint" will occur which will sooner or later give trouble.

A soldering iron of 20 to 30 watts is ideal and in general such irons cannot damage the board due to overheating. If however, a higher wattage iron is used, it is important to remove it as soon as a satisfactory flow of solder is achieved.

After soldering a group of components each and every joint must be carefully examined to ensure that no joint is overlooked and by comparing with the figures above, that no solder bridges, dry, cold or otherwise imperfect joints have been made. This is very important as a higher percentage of failures occur for these reasons than for any others.

If solder is accidentally bridged across insulating areas between conductors, it can be cleaned off by heating the connection carefully and quickly wiping the solder away with a soft cloth. Holes which become plugged can be cleared by heating the area immediately over the hole while gently pushing the lead of a resistor through the hole from the opposite side, and withdrawing the lead before the solder rehardens. Do not force the wire through; too much pressure before the solder has time to soften may separate the foil from the board. In cases where foil becomes damaged a break in the foil can be rejoined with a small piece of bare wire soldered across the gap, or between the foil and the lead of a component.

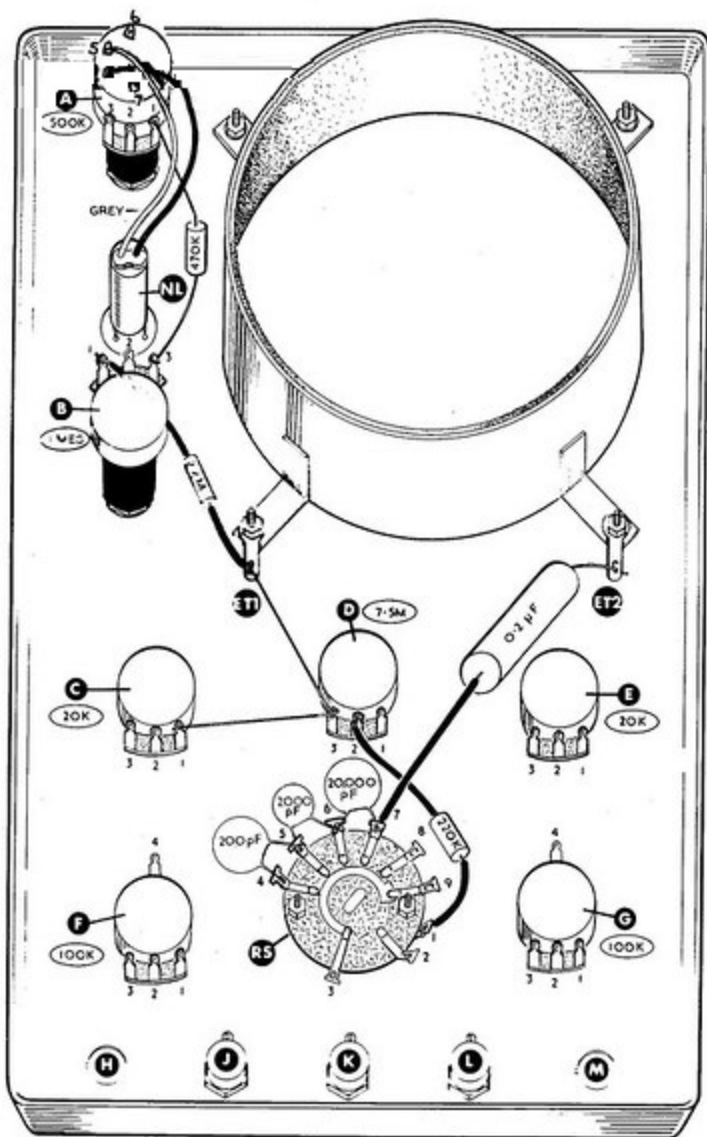

PICTORIAL - 1

STEP-BY-STEP ASSEMBLY INSTRUCTIONS

- () If there is an amendment sheet to this manual, make sure that you have made the alterations at the appropriate places.

FRONT PANEL SUB-ASSEMBLY

Refer to Pictorial 1 and Figure 1 for the following steps:

- (✓) Select the front panel and place face down on a soft cloth to avoid damage.
- (✓) Mount a 500 K Ω HV insulated potentiometer with switch at A with tags positioned as shown.
- (✓) Mount the neon indicator lamp at NL ensuring that the locating pip is correctly seated in the panel hole. Secure using the speednut supplied.
- (✓) Mount a 1 megohm HV insulated potentiometer at B.
- (✓) Mount two 20 K Ω potentiometers at C and E respectively.
- (✓) Mount a 7.5 megohm potentiometer at D.
- (✓) Mount one RED socket at K ensuring that locating pip is correctly seated in the panel hole.
- (✓) Mount two BLACK sockets at J and L respectively.
- (✓) Identify the CRT support ring.
- (✓) Clean the inside of the support ring with 'Thawpitt' or a similar cleaner. Take the foam plastic strip and peel off an inch or so of the protective paper backing from the self-adhesive surface. Insert the strip on the inside surface of the support ring and proceed completely round the ring, peeling off the paper backing as you progress. Cut off the surplus material, length and width, when completed.
- (✓) Identify the square bezel, the GREEN plastic grid screen and the grid screen window.
- () Assemble these parts to the front of the panel in the order shown in Figure 2.
- (✓) Secure using four 4BA x 5/8" chrome screws, nuts and lockwashers with two 4BA solder tags located at ET1 and ET2 respectively.
- (✓) Mount the 1-pole 6-way rotary switch at RS with the tags positioned as shown.

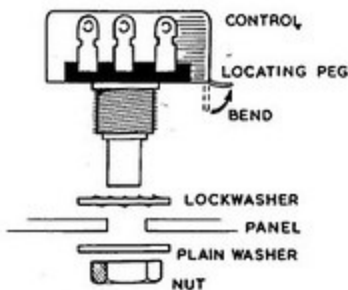

FIGURE 1

PRELIMINARY WIRING OF FRONT PANEL

Refer to Pictorial 1 for the following steps:

NOTE: Use the thick solder for all connections unless otherwise stated.

- (✓) Connect a bare wire from ET1 (NS) through D3 (S-2) to C1 (S-1).
- (✓) Using sleeving, connect a 220 K Ω resistor (RED, RED, YELLOW) from D2 (S-1) to RS1 (S-1).
- (✓) Cut the leads of a 200 pF ceramic disc capacitor to 3/8" long and connect between RS4 (S-1) and RS5 (NS).
- (✓) Cut the leads of a 2000 pF (.002 μ F) ceramic disc capacitor to 1/2" long and connect between RS5 (S-2) and RS6 (NS).
- (✓) Cut the leads of a 20,000 pF (.02 μ F) ceramic disc capacitor to 3/8" long and connect between RS6 (S-2) and RS7 (NS).

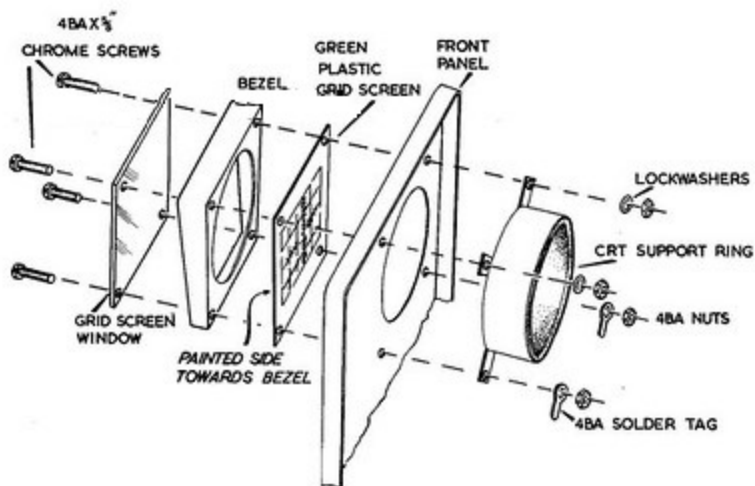
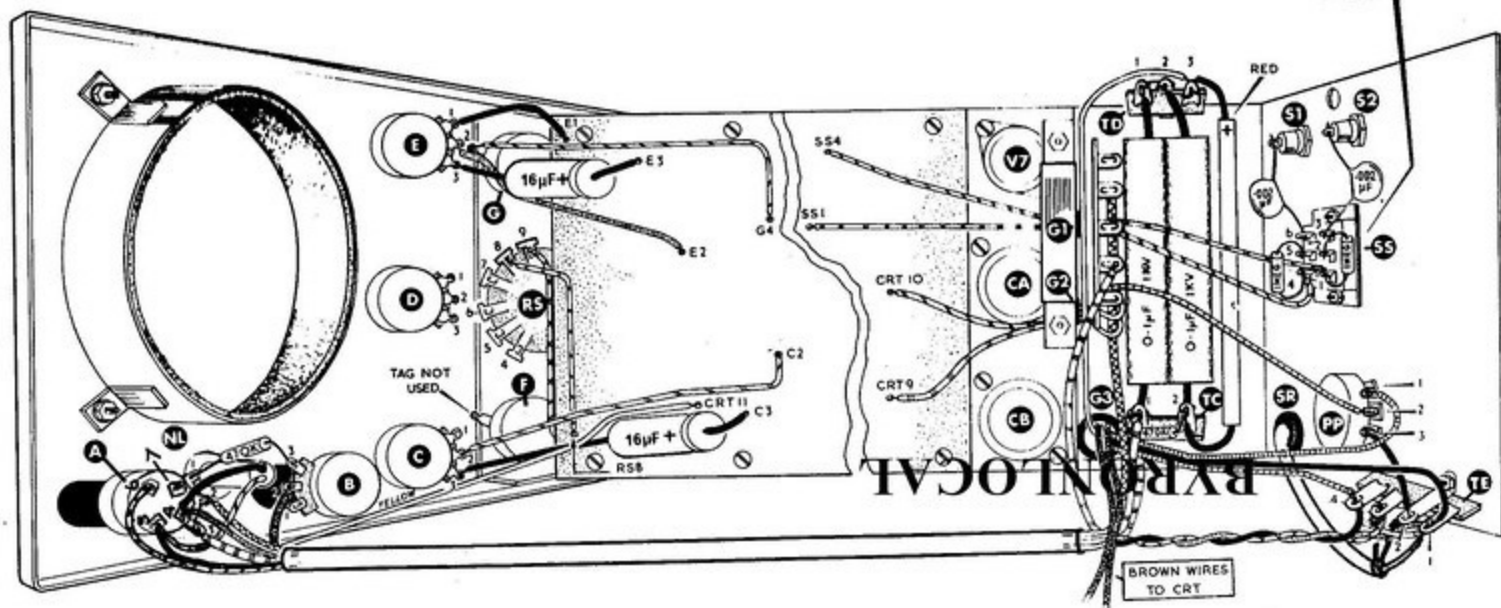
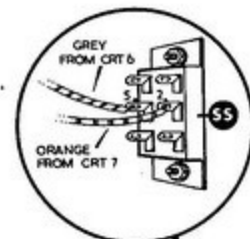
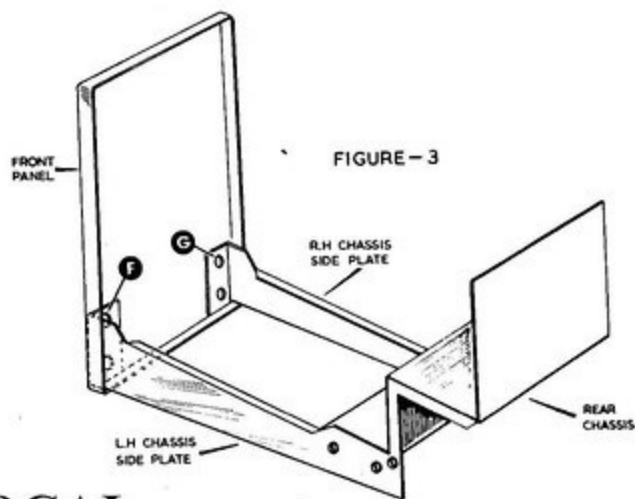
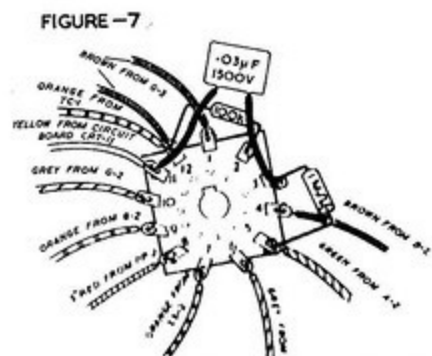

FIGURE - 2

- ✓ Cut both leads of a 0.2 μ F tubular paper capacitor to 1" long. Using $\frac{1}{4}$ " of sleeving, connect one end to RS7 (S-2) and the other end to ET2 (S-1).
- ✓ Cut leads to length and connect a 470 K Ω resistor (YELLOW, VIOLET, YELLOW) between A1 (S-1) and B3 (S-1).
- ✓ Using sleeving, connect a 2.2 megohm resistor (RED, RED, GREEN) between ET1 (S-2) and B1 (S-1).
- ✓ Cut the leads from NL to length, connect the GREY lead to A5 (NS) and the BLACK lead to A4 (NS).

Place this unit to one side.

- (✓) Refer to Figure 3. Identify the left and right-hand side plates and the rear chassis.
- (✓) Assemble the side plates to chassis using six 6BA x $\frac{1}{4}$ " screws, nuts and lockwashers.
- ✓ Identify CRT support bracket and refer to Figure 4. Fit two $\frac{3}{16}$ " grommets at G1 and G2.
- ✓ Locate the two CRT clamps. Cut two 2.1/8" lengths of cushion strip and place over clamps.
- ✓ Assemble one clamp to the support bracket using two 4BA x $\frac{5}{8}$ " screws, nuts and lockwashers.
- ✓ Assemble the bracket to chassis in the manner shown using two 4BA x $\frac{1}{2}$ " screws, nuts and lockwashers.
- ✓ Refer to Figure 5 and fit two capacitor mounting plates to the underside of the chassis at CA and CB with a 1-way tagstrip located at TA. Use 6BA x $\frac{1}{4}$ " screws, nuts and lockwashers.
- ✓ Select a 40-40-20 μ F electrolytic capacitor and mount at CB ensuring coloured tags are positioned as shown. Twist the mounting prongs approximately a 1.6 turn to secure.
- ✓ In a similar manner, fit a 50-50 μ F capacitor at CA.



PICTORIAL - 2

- (✓) Place the front panel at the front of the chassis as shown in Figure 3.
- (✓) Refer to Figure 3 and Pictorial 3 and fit a 100 K Ω potentiometer to each of the holes at F and G respectively and loosely fit nuts and washers.
- (✓) Fit a RED socket to each of the holes at H and M.
- (✓) Now tighten the nuts securing the potentiometers ensuring that tags are positioned as shown in Pictorial 3.
- (✓) Refer to Pictorial 2 and assemble a 9-pin valveholder at V7 with a 2-way and earth tagstrip at TB. Use 6BA x $\frac{1}{4}$ " screws, nuts and lockwashers. See also Figure 5.
- (✓) Mount a 2-way tagstrip at TC using a 4BA x $\frac{1}{4}$ " screw, nut and lockwasher.
- (✓) Mount a 2-way and earth tagstrip at TD using a 4BA x $\frac{1}{4}$ " screw, nut and lockwasher.
- (✓) Fit a 3/8" grommet at G3.
- (✓) Fit a BLACK socket at S1.
- (✓) Fit a RED socket at S2.
- (✓) Using 6BA x $\frac{1}{4}$ " screws and nuts only, assemble the 6-tag slide switch at SS.
- (✓) See Figure 1 and fit a 250 K Ω potentiometer at PP.
- (✓) Fit a 3-way and earth tagstrip at TE using a 4BA x $\frac{1}{4}$ " screw, nut and lockwasher.
- () Identify the mains transformer. It will be seen that the wire terminations are arranged in two groups emerging from each side of the transformer. Fit a 2 $\frac{1}{2}$ " length of 7 mm. sleeving on the wire group comprising 2 - RED's, 2 - GREEN's, 1 - ORANGE.
- (✓) Refer to Pictorial 3 and locate the transformer to the chassis placing the remaining group of wires through the adjacent grommet G3. Secure using 4BA x $\frac{1}{4}$ " screws, nuts and lockwashers. NOTE: The nuts and lockwashers are fitted to the transformer side of the chassis.

PRELIMINARY CHASSIS WIRING

Refer to Pictorial 2 for the following steps:

- (✓) Cut both leads of a 1 megohm resistor (BROWN, BLACK, GREEN) to 5/8". Connect between SS1 (NS) and SS2 (NS).
- (✓) Connect another 1 megohm resistor (BROWN, BLACK, GREEN) in a similar manner between SS4 (NS) and SS5 (NS).
- (✓) Select the two 0.1 μ F tubular high voltage capacitors (1000V d.c.). Cut the leads at both ends to 1" long and cover all leads with $\frac{1}{2}$ " sleeving.
- (✓) Connect one capacitor between TC1 (NS) and TD1 (NS).
- (✓) Connect the other capacitor between TC2 (NS) and TD2 (NS).
- (✓) Connect a short bare wire link between TD1 (S-2) and TD2 (S-2).
- (✓) Cut both leads of the tubular selenium rectifier 1" long, cover with $\frac{1}{2}$ " sleeving and connect the RED positive end to TD3 (NS) and the other end to TC2 (NS).
- (✓) Cut the leads of a 470 K Ω resistor (YELLOW, VIOLET, YELLOW) to 5/8" long and connect between TC1 (NS) and TC2 (S-3).
- (✓) Cut both leads of a .002 μ F (1 kV) ceramic disc capacitor to 5/8" long and connect between slide switch SS6 (S-1) and socket S1 (S-1).

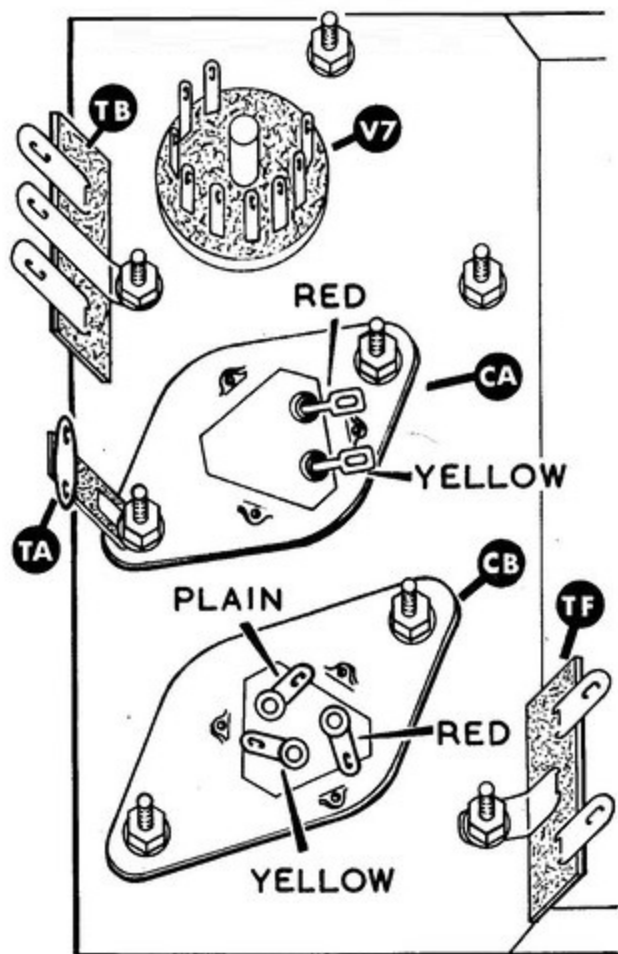

FIGURE 5

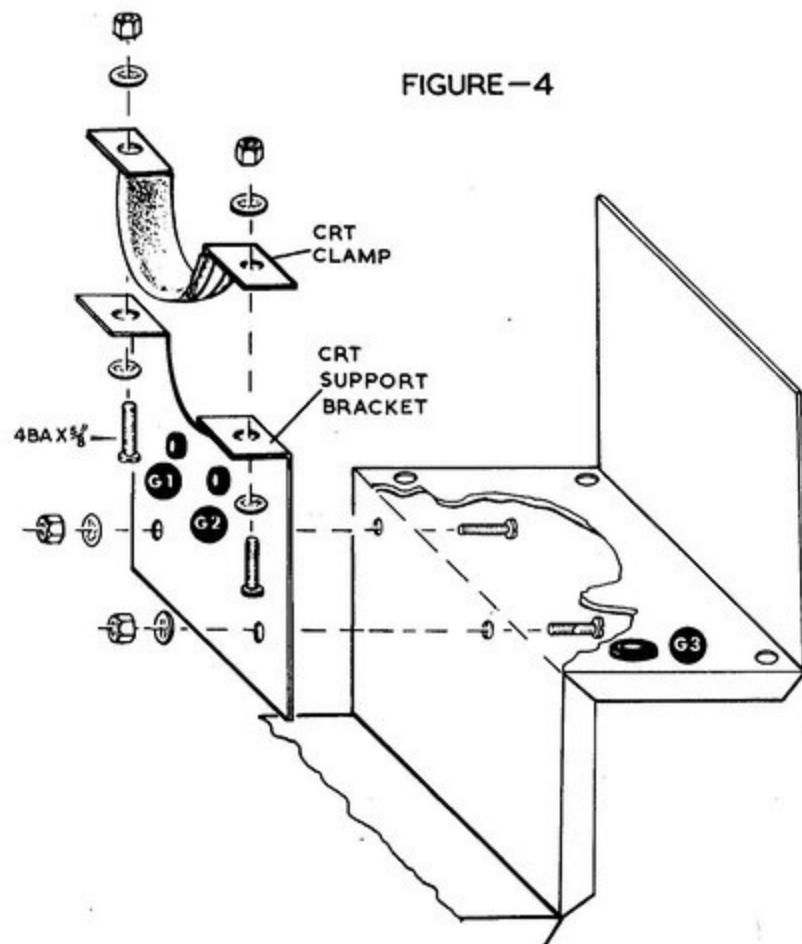

FIGURE-4

- (✓) In a similar manner, connect a second .002 μ F capacitor between SS3 (S-1) and S2 (S-1).
- (✓) Select the YELLOW transformer lead emerging from grommet G3, route as shown, cut to length and connect to TD3 (S-2).

Refer to Pictorial 3 for the following steps:

- (✓) Select the pair of RED transformer leads at LH side of chassis, cut to length, strip ends $\frac{1}{4}$ " and connect either of the leads to V7-1 (S-1) and the other to V7-7 (S-1).
- (✓) Cut the ORANGE lead to length, strip end $\frac{1}{4}$ " and connect to TB2 (NS).
- (✓) Cut the pair of GREEN leads to length, strip ends $\frac{1}{4}$ " and remove varnish from wire. Connect either of the leads to TB1 (NS) and the other lead to TB3 (NS).
- (✓) Using bare wire, make a short connection between TB1 (NS) and V7-5 (S-1).
- (✓) Using bare wire and sleeving, make a short connection between TB3 (NS) and V7-4 (S-1).
- (✓) Using bare wire and sleeving, connect from TB2 (NS) through CA4 (S-2) to CB4 (S-1).
- (✓) Using bare wire and sleeving, connect from V7-3 (S-1) through CA1 (NS) to TA1 (NS).
- (✓) Cut one lead of an 18 K Ω 5 watt resistor (value marked on body) to 1" long, cover with $\frac{3}{4}$ " sleeving and connect to CB3 (NS).
- (✓) Cut the other lead to $\frac{3}{8}$ " long and connect to TA1 (S-2).
- (✓) Cut both leads of a 27 K Ω 1 watt resistor (RED, VIOLET, ORANGE) to $\frac{3}{8}$ ". Connect one end to TA2 (NS) and the other end to CB1 (NS).
- (✓) Cut both leads of a 39 K Ω 1 watt resistor (ORANGE, WHITE, ORANGE) to $\frac{3}{8}$ ". Connect one end to TA2 (S-2) and the other end to CB2 (NS).
- (✓) Ensure that the tagstrip TA is not touching the transformer.
- (✓) Cut both leads of a 47 Ω 1 watt resistor (YELLOW, VIOLET, BROWN) to $\frac{1}{2}$ " long and connect between CA1 (S-3) and CA2 (NS).
- (✓) Cut both leads of a 47 Ω resistor (YELLOW, VIOLET, BLACK) to $\frac{5}{8}$ " long and connect between TB1 (NS) and TB2 (NS).
- (✓) In a similar manner, connect another 47 Ω resistor (YELLOW, VIOLET, BLACK) between TB3 (NS) and TB2 (S-4). Place both resistors vertically above the tag board.

COMPONENT WIRING TO CIRCUIT BOARD

- NOTE: 1. Before proceeding, read the notes on CIRCUIT BOARD WIRING AND SOLDERING on Page 8.
2. Use the thin solder for all circuit board connections.

Refer to Pictorial 4 for the following steps:

- (✓) Select the printed circuit board and the six printed circuit type valveholders.
- (✓) Mount the valveholders at locations V1, V2, V3, V4, V5 and V6 ensuring that each valveholder is firmly seated on the board.
- (✓) Solder each tag and centre spigot to the foil of the circuit board.
- (✓) Using BLACK connecting wire, connect between the points marked J-J and solder both points. NOTE: Run the wire along the top of the board as shown.

() Continue with the steps as shown in Pictorial 4 soldering only when instructed.

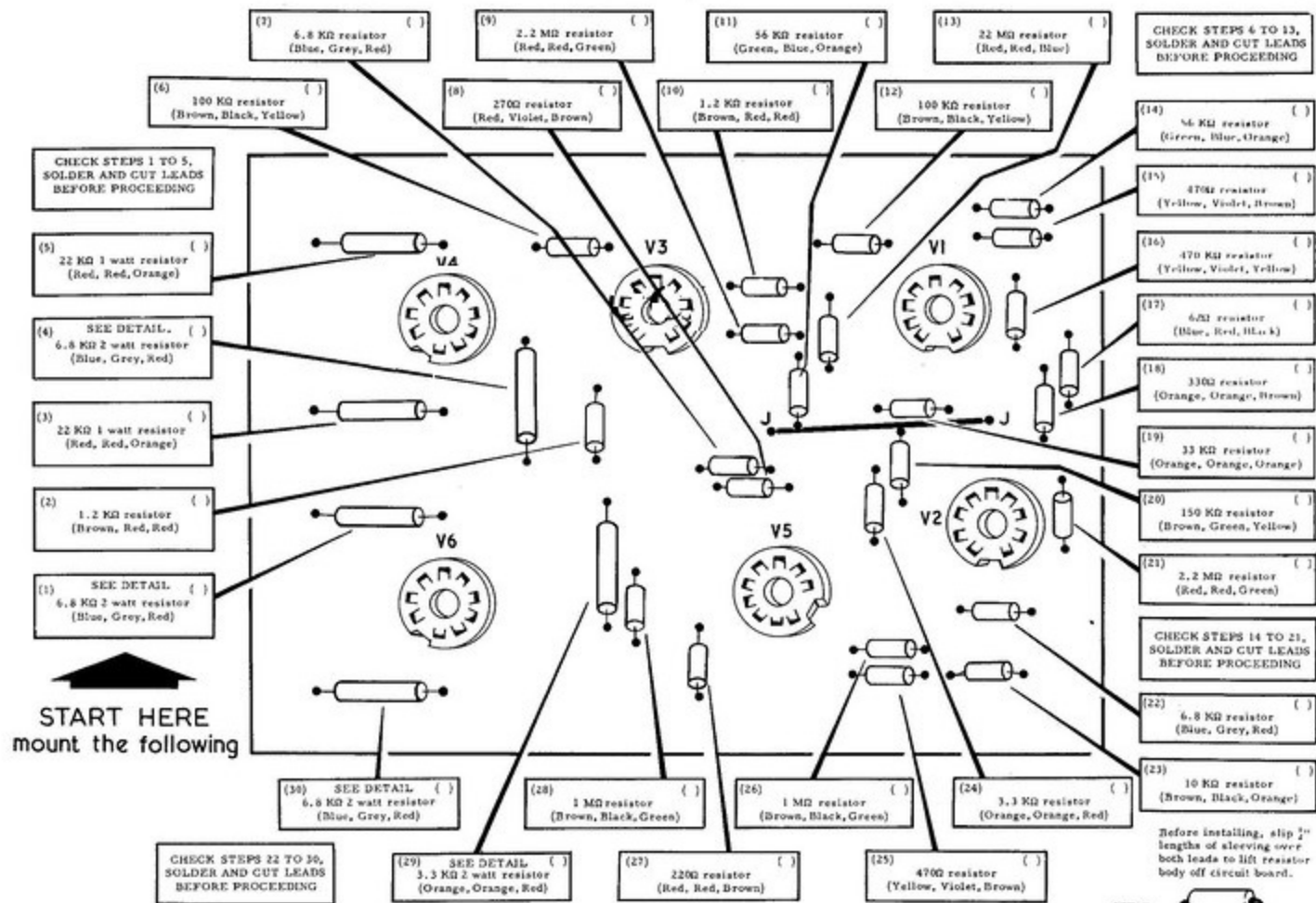

PICTORIAL - 4

() Continue with the steps as shown in Pictorial 5, soldering only when instructed.

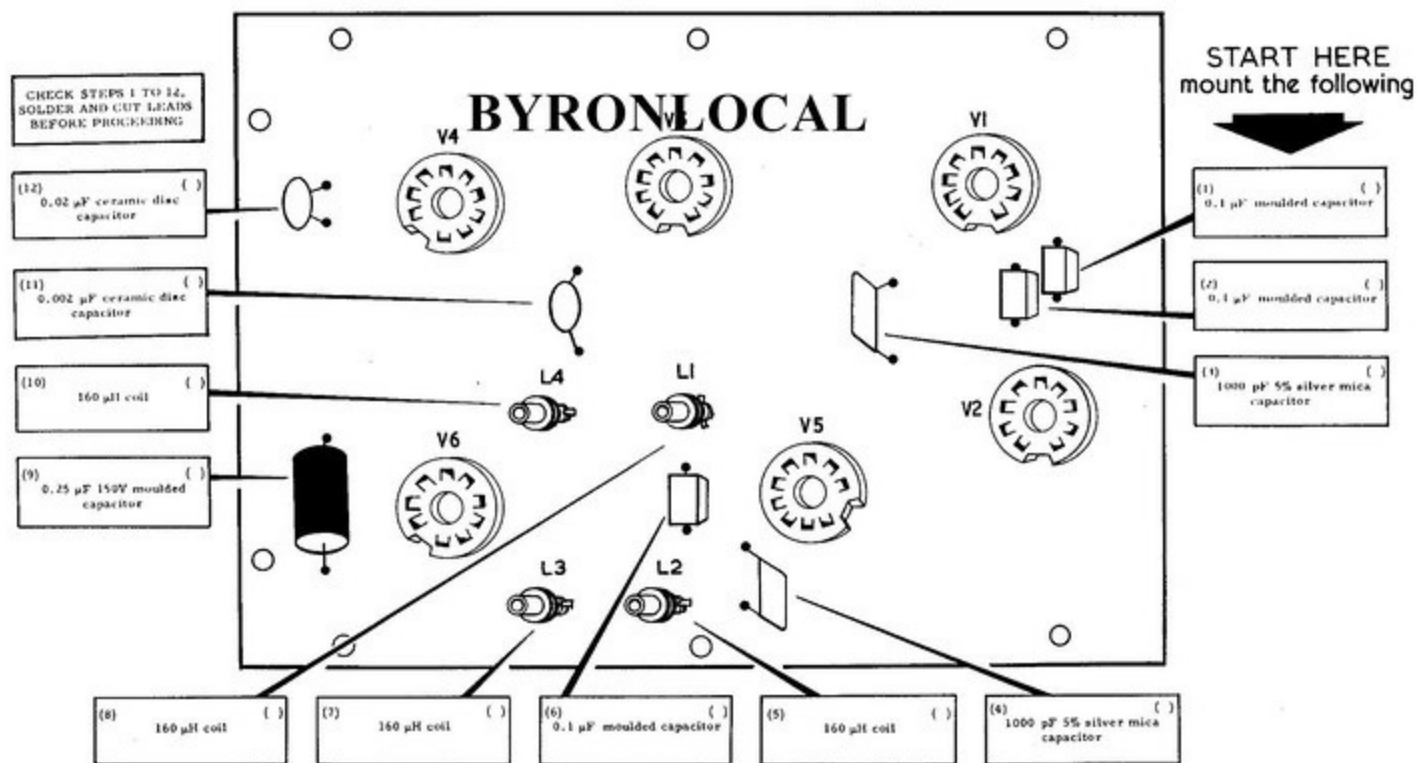

PICTORIAL - 5

- () Refer to Pictorials 2 and 3 and place the circuit board in position on the chassis with V2 nearest the front panel. Secure using eight 6BA x $\frac{1}{4}$ " screws, nuts and lockwashers with a 2-way tagstrip at TF. Ensure that no part of the copper foil is in contact with the chassis.

WIRING BELOW CHASSIS

Refer to Pictorial 3 for the following steps:

NOTE: Route twisted GREEN and YELLOW wires along corners of chassis as shown.

- (✓) Cut a $6\frac{1}{4}$ " length of GREEN and YELLOW wire, twist together except for $\frac{1}{4}$ " each end and strip all ends $\frac{1}{4}$ ".
- (✓) Connect at one end, the GREEN wire to TB1 (NS) and the YELLOW wire to TB3 (NS).
- (✓) At the other end, connect the GREEN wire to HL (NS) on the printed circuit board and the YELLOW wire to HM (NS) by placing the bare end of the wires into the noses.
- (✓) Cut a $5\frac{1}{4}$ " length of GREEN and YELLOW wire, twist together except for $\frac{1}{4}$ " each end and strip all ends $\frac{1}{4}$ ".
- (✓) Connect at one end, the GREEN wire to HL (S-2) and the YELLOW wire to HM (S-2).
- (✓) At the other end, connect the GREEN wire to HJ (NS) and the YELLOW wire to HK (NS).
- (✓) Cut a $6\frac{1}{4}$ " length of GREEN and YELLOW wire, twist together except for $\frac{1}{4}$ " each end and strip all ends $\frac{1}{4}$ ".
- (✓) Connect at one end, the GREEN wire to HJ (S-2) and the YELLOW wire to HK (S-2).
- (✓) At the other end, connect the GREEN wire to HG (S-1) and the YELLOW wire to HH (S-1).
- (✓) Cut an $8\frac{1}{2}$ " length of GREEN and YELLOW wire, twist together except for $\frac{1}{4}$ " each end and strip all ends $\frac{1}{4}$ ".
- () At one end, connect the GREEN wire to TB1 (S-5) and the YELLOW wire to TB3 (S-5).
- (✓) At the other end, connect the GREEN wire to HE (NS) and the YELLOW wire to HF (NS).
- (✓) Cut a $5\frac{1}{4}$ " length of GREEN and YELLOW wire, twist together except for $\frac{1}{4}$ " each end and strip all ends $\frac{1}{4}$ ".
- (✓) Connect at one end, the GREEN wire to HE (S-2) and the YELLOW wire to HF (S-2).
- (✓) At the other end, connect the GREEN wire to HC (NS) and the YELLOW wire to HD (NS).
- (✓) Cut a $5\frac{1}{2}$ " length of GREEN and YELLOW wire, twist together except for $\frac{1}{4}$ " each end and strip all ends $\frac{1}{4}$ ".
- (✓) Connect at one end, the GREEN wire to HC (S-2) and the YELLOW wire to HD (S-2).
- (✓) At the other end, connect the GREEN wire to HA (S-1) and the YELLOW wire to HB (S-1).
- (✓) Using bare wire and sleeving, make a connection between CA3 (S-1) and location N (S-1) on the printed circuit board.
- (✓) Connect a short RED lead between CA2 (NS) and HT4 (S-1) on the printed circuit board.
- (✓) Connect one end of a $9\frac{1}{2}$ " length of RED wire to CA2 (S-3). Route the free end toward and through G3 to be connected later.
- (✓) Connect a 3" RED lead from HT2 (S-1) on printed circuit board to CB1 (NS).
- (✓) Cut leads to length and connect a 100 K Ω resistor (BROWN, BLACK, YELLOW) between TF1 (NS) and CB3 (NS).
- (✓) Cut leads to length and connect a 240 K Ω 5% resistor (RED, YELLOW, YELLOW, GOLD) between TF2 (NS) and CB1 (S-3).
- (✓) Using bare wire and sleeving, connect from L (S-1) on the printed circuit board through socket L (NS) and again using sleeving, to J (NS). Dress clear from socket K.

- (✓) Using bare wire and sleeving, connect from socket J (NS) to J (S-1) on the printed circuit board.
- (✓) Cut leads to length and connect a 100 KΩ resistor (BROWN, BLACK, YELLOW) between potentiometer G1 (S-1) and socket L (NS).
- (✓) Cut leads to length and connect a 4.7 megohm resistor (YELLOW, VIOLET, GREEN) between sockets M (NS) and L (S-4).
- (✓) Cut leads to length and connect a 47 KΩ 5% resistor (YELLOW, VIOLET, ORANGE, GOLD) between F3 (S-1) and socket J (S-3).
- (✓) Using bare wire and sleeving, make a connection from switch RS2 (double tag) (S-1) to RS2 (S-1) on the printed circuit board. Ensure that both tags at RS2 are soldered.
- (✓) Using bare wire and sleeving, make a connection between socket K (S-1) and K (S-1) on the printed circuit board.
- (✓) Cut both leads of a .02 μF disc ceramic capacitor to $\frac{1}{2}$ " long. Solder one lead to V2-2 and the other lead to V2-6. NOTE: These connections are already soldered, simply re-heat the joint and insert the component lead into the solder fillet, remove the iron and allow the joint to cool.
- (✓) Connect a $6\frac{1}{2}$ " length of BLACK wire from potentiometer G2 (S-1) to G2 (S-1) on the printed circuit board.
- (✓) Connect a $6\frac{1}{2}$ " length of BLACK wire from potentiometer F2 (S-1) to F2 (S-1) on the printed circuit board.
- (✓) Cut both leads of a 0.1 μF 400V tubular capacitor to $\frac{7}{8}$ " long, fit $\frac{5}{8}$ " sleeving over each lead and connect between socket M (S-2) and M (S-1) on the printed circuit board.
- (✓) Cut both leads of a 0.1 μF 400V tubular capacitor to $1\frac{1}{4}$ " long, fit 1" sleeving over each lead and connect between switch RS3 (S-1) and RS3 (S-1) on the printed circuit board.
- (✓) Connect a $6\frac{1}{2}$ " length of RED wire from CB2 (S-2) to HT3 (S-1) on the printed circuit board.
- (✓) Connect a $5\frac{1}{2}$ " length of RED wire from CB3 (S-3) to HT1 (S-1) on the printed circuit board.
- (✓) Connect a $6\frac{1}{2}$ " length of ORANGE wire from TF1 (S-2) to potentiometer G3 (S-1).
- (✓) Connect a $6\frac{1}{2}$ " length of ORANGE wire from TF2 (S-2) to potentiometer F1 (S-1).
- (✓) Connect one end of a $3\frac{1}{2}$ " length of BLUE wire to socket H (S_r1) and pass the free end toward switch RS.

WIRING ABOVE CHASSIS

Refer to Pictorial 2 for the following steps:

- (✓) Place chassis upright on workspace.
- (✓) Identify the free end of the BLUE wire (previously connected to H) and connect to RS9 (S-1).
- (✓) Connect a 3" length of BLUE wire between switch RS8 (S-1) and RS8 (S-1) on the printed circuit board.
- (✓) Connect a short BLACK wire from potentiometer E1 (S-1) to E1 (S-1) on the printed circuit board. NOTE: It may be necessary to temporarily move the 0.1 μF capacitor to gain access to the copper foil at E1.
- (✓) Routing wire as shown, connect a 6" length of GREY wire from potentiometer G4 (S-1) to G4 (S-1) on the printed circuit board.
- (✓) Connect a $3\frac{1}{2}$ " length of VIOLET wire between potentiometer E2 (S-1) and E2 (S-1) on the printed circuit board.
- (✓) Cut both leads of a 16 μF, 150V electrolytic capacitor to $\frac{3}{4}$ " long, fit $\frac{1}{2}$ " sleeving over each end. Connect the + (positive) end to E3 (S-1) on the printed circuit board and the - (negative) end to potentiometer E3 (S-1).
- (✓) Connect a 5" length of GREY wire between potentiometer C2 (S-1) and C2 (S-1) on the printed circuit board.

- (✓) Cut both leads of a 16 μ F 150V electrolytic capacitor to $1\frac{1}{2}$ " long, fit 1" sleeving over each end. Connect the + (positive) end to C3 (S-1) on the printed circuit board and the - (negative) end to potentiometer C3 (S-1).
- (✓) Connect one end of a $10\frac{1}{2}$ " length of ORANGE wire to SS1 (S-1) on the printed circuit board, route the wire at right angles to the board passing the other end through grommet G1 and connect to switch SS1 (S-2).
- (✓) Connect one end of a $10\frac{1}{2}$ " length of GREY wire to SS4 (S-1) on the printed circuit board, route the wire at right angles to the board passing the other end through grommet G1 and connect to switch SS4 (S-2). NOTE: Route this wire clear of the previous ORANGE wire otherwise the vertical frequency response will be impaired.
- (✓) Connect one end of a 7" length of ORANGE wire to CRT9 (S-1) on the printed circuit board, pass the other end through grommet G2 and leave free.
- (✓) Connect one end of a 7" length of GREY wire to CRT10 (S-1) on the printed circuit board, pass the other end through grommet G2 and leave free.

CAUTION: Carefully open the carton containing the cathode ray tube. Handle the tube with reasonable care, since it has been highly evacuated. Should the envelope be broken the resulting implosion could spray the area with shattered glass with possible serious consequences. Avoid handling the tube while wearing diamond rings which might scratch the glass. Do not strike the envelope with tools and do not subject it to impact or shock.

- (✓) Carefully remove the cathode ray tube (CRT) from its container and, using a soft cloth, wipe the face to remove any dust particles.
- () Identify the CRT mumetal shield and place in position on the base of the CRT level with the glass envelope as indicated in Figure 6.
- (✓) Identify the 12-pin CRT socket and fit to the base of the CRT.
- (✓) Place the CRT in position within the CRT support ring and CRT clamp. Orientate the CRT with pin 1 in the 12 o'clock position.
- (✓) Place the top clamp over the CRT base and lightly secure using 4BA nuts and lockwashers.

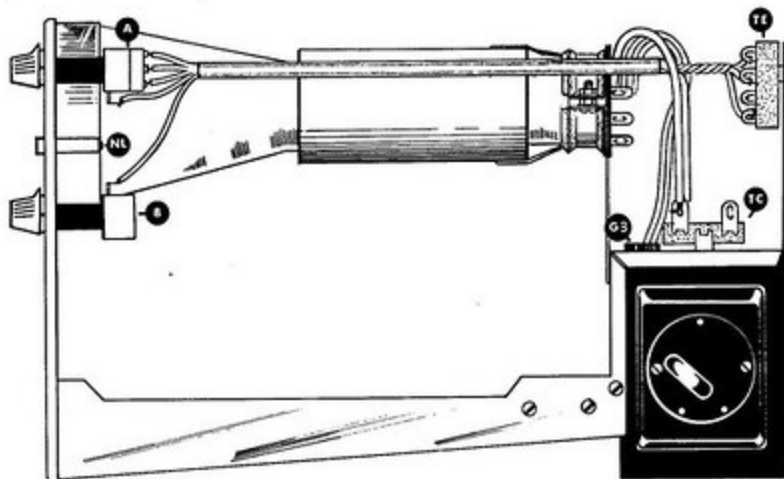

FIGURE - 6

CONNECTION OF WIRES FORMING WIRING HARNESS

Refer to Pictorial 2 and Figure 7:

- () Cut 10½" lengths of connecting wire of the colours BLACK, BLUE and VIOLET, strip all ends ¼" and twist together except for 1" at each end.
- (✓) Insert these wires through a 6½" length of 7 mm. sleeving.

At one end near the front panel, connect as follows:

- () BLACK to A5 (S-2).
- (✓) BLUE to A6 (S-1).
- (✓) VIOLET to A4 (S-2).

At the other end, make the following connections to tagstrip TE:

- (✓) VIOLET to TE1 (NS).
- (✓) BLUE to TE3 (NS).
- (✓) BLACK to TE4 (NS).

- () Cut a 5" length of ORANGE wire, strip ends ¼" and connect between TC1 (NS) and tag 12 (NS) on CRT socket.
- (✓) Cut a 12½" length of BROWN wire, strip ends ¼" and pass through the 7 mm. sleeving.
- (✓) Connect one end to B2 (S-1) and the other end to CRT4 (S-1).
- () Cut a 13" length of GREEN wire, strip ends ¼" and pass through sleeving.
- (✓) Connect one end to A2 (S-1) and the other end to CRT5 (NS).
- (✓) Cut an 11" length of ORANGE wire, strip ends ¼" and pass through sleeving.
- (✓) Connect ends between TC1 (S-4) and A3 (S-1).
- (✓) Cut a 14" length of YELLOW wire, strip ends ¼" and pass through sleeving.
- (✓) Connect one end to CRT11 (S-1) on circuit board and the other end to CRT11 (NS).
- () Dress the wiring for neat appearance.
- (✓) Using bare wire and sleeving, make a short connection between potentiometer PP3 (S-1) and TE2 (NS).
- (✓) Identify the RED wire from grommet G3 (previously connected under chassis to CA2) and connect to PP1 (S-1).
- (✓) Strip both ends of a 3" length of RED wire and connect between PP2 (S-1) and CRT8 (S-1).
- (✓) Strip both ends of a 2½" length of GREY wire and connect between switch SS5 (S-2) and CRT6 (S-1).
- () Strip both ends of a 2½" length of ORANGE wire and connect between SS2 (S-2) and CRT7 (S-1). NOTE: Position this wire clear of the previous GREY wire.
- (✓) Identify the ORANGE wire appearing through grommet G2 and connect to CRT9 (S-1).
- (✓) Identify the GREY wire appearing through grommet G2 and connect to CRT10 (S-1).
- () Remove all surplus wire ends protruding above the printed circuit board.
- (✓) Identify the two BROWN transformer leads appearing through grommet G3.
- () Cut to length and connect either one of the two leads to CRT12 (NS).
- () Cut to length and connect the remaining lead to CRT1 (S-1).

- (✓) Cut both leads of a 100 K Ω resistor (BROWN, BLACK, YELLOW) 5/8" long and connect between CRT12 (S-3) and CRT2 (S-1).
- (✓) Cut both leads of a 1 megohm resistor (BROWN, BLACK, GREEN) 5/8" long and connect between CRT3 (NS) and CRT5 (S-2).
- (✓) Cut both leads of a .03 μ F 1500V ceramic capacitor to 2" long, fit 1/2" sleeving to each lead and connect between CRT11 (S-2) and CRT3 (S-2).
- (✓) Identify the RED and BLACK transformer leads coming through grommet G3.
- (✓) After cutting them to length, connect the BLACK lead to TE1 (NS) and the RED lead to TE4 (S-2).
- (✓) Select the mains cable and carefully remove 1" of the outer insulation.
- (✓) Pass this end through hole SR. Connect the Blu wire to TE1 (S-3), the Gr~~een~~ wire to TE2 (S-2) and the Brn wire to TE3 (S-2).
- (✓) Refer to Figure 8 and fit the strain relief bush over the cable and insert into hole SR in a direction from the outside face of chassis leaving 1/2" slack of mains cable inside the chassis.

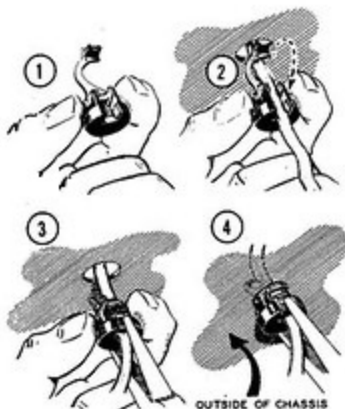

FIGURE-8

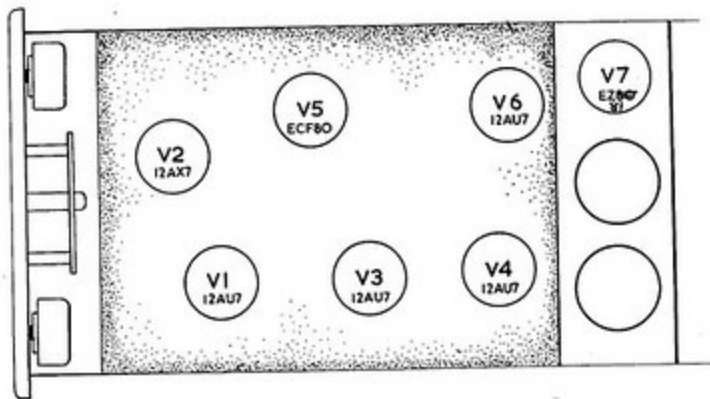

FIGURE-9

FINAL ASSEMBLY

IMPORTANT WARNING: Miniature valves can be easily damaged when plugging them into their valveholders, therefore, use extreme care when installing them. We do not guarantee or replace miniature valves broken during installation. Support the underside of the circuit board when inserting valves located on the board.

Refer to Figure 9 and insert valves in valveholders as follows:

Valveholder V1 - 12AU7 (ECC82),	Valveholder V2 - 12AX7 (ECC83),	Valveholder V3 - 12AU7 (ECC82),
V4 - 12AU7 (ECC82),	V5 - ECF80,	V6 - 12AU7 (ECC82),
V7 - EZ81.		

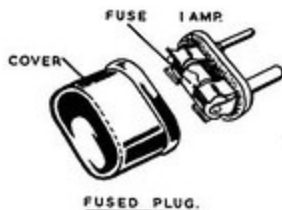

FIGURE-10



FIG-11

- (✓) Insert the 1 amp fused plug in the transformer voltage selector panel at the appropriate voltage tapping to suit your mains supply. Figure 10 shows an ~~example of the correct replacement of fuse.~~
- (✓) Remove the paper protecting the self-adhesive label and install the label on the rear of the chassis as shown in Pictorial 3.
- (.) Turn all front panel controls fully anti-clockwise.
- (✓) Fit the large knob to the HOR./FREQ. SELECTOR switch with the pointer at EXT and tighten the grub screw.
- (✓) Fit seven small knobs to the remaining front panel controls with their pointers in the 7 o'clock position and tighten grub screws.
- (.) Install the handle on top of the cabinet using the special nuts and end plates provided.
- (.) Insert the rubber feet into the holes in the bottom of the cabinet as shown in Figure 11. Moistening the feet will facilitate insertion.
- (.) Assemble the pair of test leads, one RED and one BLACK as shown in Figure 12.



FIGURE-12



TEST AND ADJUSTMENT

CAUTION; VOLTAGES IN THIS INSTRUMENT ARE DANGEROUS. Extreme care should be exercised whenever the instrument is operated or handled without being installed in the cabinet. Some of the highest voltages in the circuit appear on the CRT socket and the Brilliance and Focus control terminals. These voltages could be fatal.

We suggest that you read this section of the manual before performing the following steps.

- () Set the controls as follows before connecting the mains cable to an AC outlet:

BRILLIANCE	- Fully anticlockwise
FINE FREQ.	- Fully anticlockwise
VERT. GAIN	- Fully anticlockwise
HOR. GAIN	- Fully anticlockwise
VERT. POS.	- Centre of rotation
HOR. POS.	- Centre of rotation
HOR/FREQ. SELECTOR	- Fully clockwise
FOCUS	- Centre of rotation
Astigmatism	- Centre of rotation
VERT (INT-EXT)	- INT) of the instrument

- () Connect the mains cable to a 200-250 volt ~~AC~~ ~~power~~ ~~source~~. This instrument may be seriously damaged if connected to a power source other than that stated.

- () Turn the BRILLIANCE control fully clockwise. This will apply power to the oscilloscope. All valves should glow. Allow one minute for the valves to warm up.

- () Watch the screen of the CRT until a spot appears.

- () If no spot appears, rotate both the HOR. POS. and VERT. POS. knobs simultaneously until a spot appears. If the spot cannot be located, refer to the IN CASE OF DIFFICULTY section of the manual.

- () Rotate the HOR. POS. control and notice that the spot moves horizontally across the screen. Now turn the VERT. POS. control and the spot will move up and down. Adjust these two controls so that the spot is centred on the screen.

- () Now adjust both the FOCUS and Astigmatism controls for minimum spot size. CAUTION: Do not permit the spot to remain stationary on the screen for any length of time. This may destroy the fluorescent material on the screen and leave a dark spot. If necessary, reduce spot brilliance by turning the BRILL control in an anticlockwise direction.

- () With the spot centred, slowly turn the HOR. GAIN control clockwise. The spot should now become a horizontal line.

- () If the trace is not perfectly horizontal, correct this condition as follows:

Observe the position of the trace on the CRT and estimate how far the CRT should be turned. Turn off the power and disconnect the mains lead. Loosen the clamp at the base of the CRT and rotate the tube the proper amount. Do not allow the tube to slide forward and come into contact with the grid screen. This process may be repeated if the trace is still slightly tilted. When finished, carefully tighten the CRT clamp to hold the tube in place. Do not overtighten as the tube could be broken.

- () Connect a test lead between the VERT. INPUT RED socket and the socket marked 1V P-P.

- () Adjust the VERT. GAIN control for a trace height of about 2 cm. Move the HOR/FREQ. SELECTOR switch to the \sim (50 c/s LINE SWEEP) position and slowly advance the HOR. GAIN control clockwise. The vertical line should begin to slope to the left (anticlockwise motion) as the HOR. GAIN control is rotated. At maximum horizontal amplitude, the line will be almost horizontal and it will extend well beyond the edges of the CRT.

- () Turn the HOR. GAIN control fully anticlockwise and move the HOR/FREQ. SELECTOR switch to the No. 1 position. Advance the HOR. GAIN control until the pattern reaches a width of about 4 cm. Now adjust the FINE FREQ. control until you obtain a pattern similar to that shown in Figure 13. The pattern will flicker because of the low sweep rate. The next three positions of the HOR/FREQ. SELECTOR switch should produce varied patterns, depending upon the frequency relationships between the 50 cycle voltage applied to the VERT. INPUT socket and the time base generator frequency, which is controlled by the HOR/FREQ. SELECTOR switch in conjunction with the FINE FREQ. control.



FIGURE 13

NOTE: When using the calibrating voltage from the 1V P-P socket it may be noticed that small breaks appear near the peaks in the display. This is of no importance and will not occur with external signals.

- () Turn off the oscilloscope by turning the BRILLIANCE control fully anticlockwise. If proper results were obtained in the preceding steps, the oscilloscope may be assumed to be adjusted correctly and operating properly.
- () Position the chassis in the cabinet so the front panel fits snugly around the front rim of the cabinet. Fasten the chassis in place by installing two 4BA x 3/8" chrome screws through the rear of the cabinet, into the nuts on the rear of the chassis.

OPERATION

The operation of an oscilloscope and its many controls is quite simple once the basic principles are clear.

The controls can be divided into groups with specific functions.

The BRILLIANCE and FOCUS controls and the Astigmatism preset control (the latter mounted at the rear of the instrument) control the quality of the trace.

Two knobs, marked VERT. GAIN and HOR. GAIN, ~~control the brightness of~~ the pattern on the screen.

Two knobs, marked VERT. POS. and HOR. POS., control the location of the trace on the screen. Turning the VERT. POS. knob moves the trace up or down; the HOR. POS. knob is used to move the trace left or right.

Two knobs, marked HOR./FREQ. SELECTOR and FINE FREQ., control the operation of the time base generator. The HOR./FREQ. SELECTOR and FINE FREQ. controls permit selection of the desired sweeping rate to provide a stationary pattern. The HOR./FREQ. SELECTOR switch also performs the following functions.

EXT: In this position, the HOR. INPUT socket is connected directly to the input grid of the horizontal amplifier system. The time base generator is not operating and external signals can be applied to the sockets.

\sim (50 c/s LINE SWEEP): In this position, a 50 c/s voltage is applied to the horizontal amplifier system. The sweep thus applied to the amplifier is sinusoidal in waveform.

VERT. INT-EXT switch: Unless the oscilloscope is required for direct connection to the Y plates, this switch MUST be in the INT position, otherwise the vertical frequency response will be impaired.

GENERAL CONSIDERATIONS

1. OPERATING LOCATION. Although the CRT is shielded to prevent trace distortion due to magnetic fields, it is possible that some trace distortion due to a very high field may still occur. The shield will certainly reduce these effects, but may not entirely eliminate them, and if this appears to be a problem the simplest remedy is usually to find a location for the 'scope further from the offending equipment or source of the field.
2. OVERLOAD. To prevent overloading the input stages in the amplifier, keep the vertical and horizontal input signal voltages less than 20 volts r.m.s. Use an auxiliary attenuator probe for higher voltages to prevent overloading. The Heathkit Model PK-1 is suitable for this purpose.
3. VERT. and HOR. POSITION. In operating the position controls, you will observe a 'dead spot' near the centre of rotation; that is, the position of the trace does not change even though the control is turning through several degrees. This is perfectly normal and is caused by the slider of the control passing over the tap position on the resistance element. At this tap position, no change in resistance takes place, hence the trace does not change position.
4. INTENSITY MODULATION. At reduced brilliance settings and low time base speeds, some intensity modulation of the trace may be noticed. This condition is normal and may be eliminated by a slight increase in trace brilliance.
5. STRAY PICK-UP. At maximum gain settings, the sensitivity of the amplifiers is very high. Therefore, without a signal source connected to the input sockets, stray pick-up may produce patterns on the CRT screen. Such behaviour is normal to this type of instrument.

APPLICATIONS

As mentioned in the INTRODUCTION to this manual, the cathode ray oscilloscope is a most versatile device. It has the ability to measure the basic electrical quantities and more important, to show the relationship between any two of these quantities at any one time. It can also be used to relate any one of the variables against a controlled time reference. Therefore, it can indicate such characteristics as frequency, phase relations and waveform.

Transducers are used to convert sound, heat, light stress or physical movement into electrical impulses. The impulses can be studied by displaying them on the screen of the oscilloscope.

The following portion of this manual is simply to familiarise you with the basic applications of your oscilloscope.

WAVEFORM INVESTIGATION

Probably the major use of most oscilloscopes is in the study of recurrent or transient variations in an electrical quantity. Since the oscilloscope is a voltage operated device, these variations must be first converted into changes in voltage.

It is common practice to apply the signal voltage to the vertical input of the oscilloscope. By the use of amplifiers, this voltage is made to displace vertically the electron beam in the cathode ray tube. At the same time, the beam is being swept horizontally by the time base generator within the instrument. The sweep frequency is normally a sub-harmonic or simple fraction of the signal frequency. Therefore, more than one complete cycle of the signal is shown on the screen.

Described below are the more common applications of the oscilloscope in studying waveforms.

TESTING AUDIO AMPLIFIERS AND CIRCUITS

Figure 14 shows the conventional set-up of equipment for this application. The audio generator should be capable of producing a pure sine wave with a very low harmonic distortion. The load resistor should match the output impedance of the amplifier. The usual practice is to perform all tests at an input voltage sufficient only to develop a reference power output. This prevents overloading any portion of the amplifier and consequent inaccuracies in measurements.

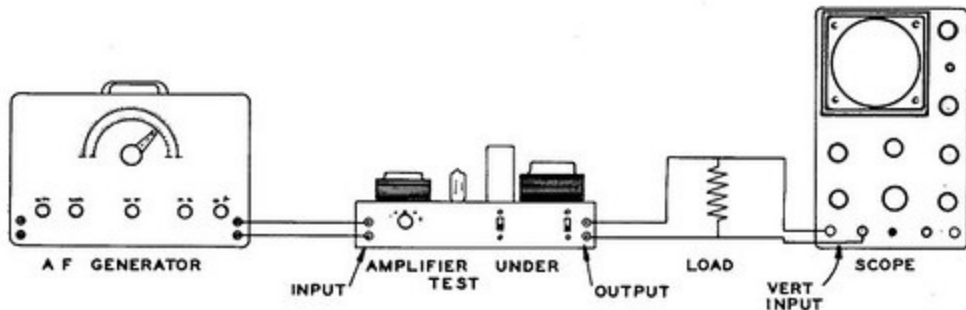

FIGURE - 14



FIGURE-15

Figure 15A shows serious flattening of one peak representing about 10% harmonic distortion. This condition may be caused by incorrect bias on any stage or by an inoperative valve in the push-pull stage. Figure 15B indicates third harmonic distortion, a particularly objectionable distortion. Figure 15C shows a flattening of both peaks, usually an indication of overload somewhere in the circuit.



FIGURE-16

Although the use of sine wave input tells us a lot about an amplifier, the use of a square wave input waveform gives a very accurate and extremely sensitive indication of the performance of the system with respect to both amplitude distortion and phase shift. Assume that we apply a wave of the form shown in Figure 16A with a fundamental frequency of 50 c/s. In a theoretically perfect amplifier, the output waveform would be an exact duplicate except at a greater power level as determined by the gain of the amplifier. Actually, the distortion of this waveform as shown on the 'scope tells a great deal about the amplifier at frequencies considerably separated from the test frequency. If the high frequency performance of the amplifier is excellent, the front of the waveform will be sharp-cornered and clean.

A distortion similar to that shown in Figure 16B indicates a poor high frequency response, which may be amplitude distortion, phase shift or both. We may assume, therefore, that the shape of the rising portion of the waveform indicates the ability of the amplifier to faithfully reproduce high frequencies. Conversely, the slope of the flat-top portion of the wave indicates the performance of the amplifier in the low frequency range. Figure 16C is the characteristic indication of an amplifier with a poor low frequency response.

Again, the square wave generator used must be capable of producing the desired waveform with excellent voltage regulation and low inherent distortion.

SERVICING TELEVISION RECEIVERS

Servicing television receivers is a rapidly expanding application of the cathode ray oscilloscope. Each of the following basic uses require some additional equipment, but none of them can be performed without using the oscilloscope.

Alignment of a television receiver is virtually impossible without the use of an oscilloscope and a television alignment sweep generator. This type of generator supplies an RF signal over all the frequencies involved in modern television receiver operation. This signal can be frequency modulated at 50 c/s with a deviation of several megacycles. The generator also provides a 50 c/s sweep voltage controllable in phase to drive the horizontal deflection

amplifiers in the oscilloscope. It also provides a blanking system which cuts off the RF output of the generator during one-half of its operating cycle. In effect, the generator output starts at a reference frequency and sweeps alternately at a uniform rate from reference frequency to frequencies several megacycles above and below. Vertical input to the 'scope is driven by voltage developed at the input of the video amplifier. Since this voltage varies in exact accordance with the gain of the RF and/or IF amplifier stages over the frequency range being swept, the trace on the screen is actually a graphic representation of the response of the amplifiers being tested.

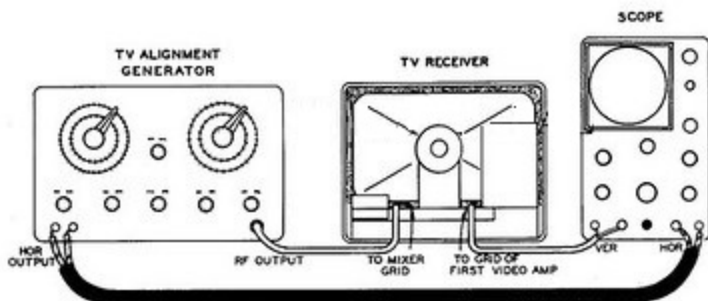

FIGURE - 17

Figure 17 outlines the connections between the alignment generator, receiver and oscilloscope. The exact procedure for alignment varies greatly. This information is generally available in the manufacturers' service information. Usually a drawing of the desired response curve is given together with a sequence of adjustments to roughly approach the desired pattern. Final adjustments are made while watching the trace on the oscilloscope.

The waveform of the complex television picture signal as it is passed through the receiver is undoubtedly the most important characteristic of the signal voltage. In order to properly display the minute variations in waveform which incidentally make up the difference between good and bad picture quality, the oscilloscope is required to amplify and display voltage changes over an extremely wide frequency range without distorting them.

Again you must rely on the manufacturer to furnish representative patterns showing the waveform to be expected at specific points within the receiver. You will find that these diagrams cover the entire receiver with the exception of the front end or tuner portion. However, in order to pick off the modulation envelope in the IF or video amplifier sections, a demodulator probe is used to make connections to the anode, grid or cathode of the stage being investigated. This is necessary since the signal in these stages is still contained in the amplitude modulation envelope of the carrier and must be detected or demodulated before it can be shown on the oscilloscope.

At any point after the video detector, no such probe is necessary and a simple shielded low capacity cable can be used.

In either case, the signal voltage is fed into the vertical amplifier of the oscilloscope. At any point up to the video detector, the voltages picked off will be quite small and considerable vertical gain will be required. Within the sync. circuits and deflection circuits of the TV receiver, however, these voltages reach very respectable proportions and very little amplification is required.

The signal tracing method of analysis is most helpful in going through a receiver in this fashion, since faulty receiver operation is generally caused by the loss of all or a significant portion of the picture information and pulses at some stage within the receiver. With a basic understanding of the function of each part of the signal and with the means available to determine what the signal actually looks like at any part of this receiver, it is a comparatively simple matter to isolate the defective portion and the particular component causing the failure.

Remember in making connections to the test points that grid circuits are generally high impedance points and that the addition of any capacity can disrupt the performance of the stage to some degree. Anode circuits and cathode circuits are usually lower impedance points and more desirable for testing purposes. Also bear in mind that the anode circuit indication with respect to polarity will be exactly opposite to indications obtained on grid or cathode, since a phase difference of 180 degrees takes place within the valve. Therefore, the pattern shown on the 'scope

screen will be inverted when such interchanges are made. The form of the wave should not be changed however. Video amplifier response can be measured in exactly the same manner described for testing audio amplifiers and again a square wave signal is the most efficient method to use. Because a video amplifier must pass signals as low as 20 c/s and as high as 4 or 5 megacycles, a more comprehensive test is required. Usually a 50 c/s check is made to cover low and medium frequency characteristics. A second check at 25 kc/s covers the high frequency portion of the response curve. Again such tests require accuracy on the part of the oscilloscope. The signal tracing technique can be used in these tests also. The square wave generator is fed directly into the first video amplifier grid. Very low signal input will be required. Then the oscilloscope is connected to various anodes starting near the output end and working back until any distortion is isolated. Patterns such as Figure 16B are responsible for poor picture detail or fuzziness, while distortion of the waveform shown in Figure 16C can cause shading of the picture from top to bottom.

OBSERVING MODULATION PATTERNS

Amateur radio operators often use the oscilloscope to check the quality of modulated RF signals obtained from their transmitters. Since the vertical amplifier frequency response of the oscilloscope is not adequate to accurately reproduce the frequencies of the RF carrier, direct connections to the vertical deflection plates of the cathode ray tube are required. These connections are available at the rear of the oscilloscope.

When using the oscilloscope for this purpose, the trapezoidal pattern for test purposes. Such a pattern is formed when a modulated RF signal is applied to the vertical deflection plates of the cathode ray tube and modulating audio signal used for horizontal deflection. This modulating signal can be applied to the horizontal input terminals of the oscilloscope.

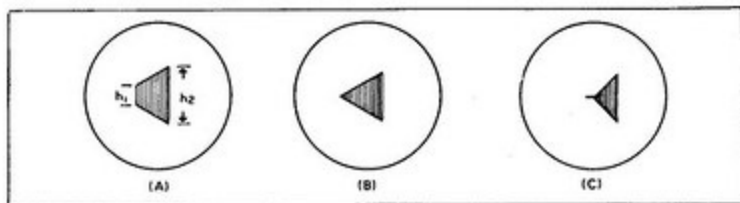

FIGURE - 18

The appearance of a typical trapezoidal pattern is given in Figure 18A. As the modulation percentage increases, the pattern becomes more triangular in shape, approaching a perfect triangle with 100% modulation as shown in Figure 18B. Over modulation gives patterns shown in Figure 18C.

A trapezoidal pattern is useful for determining percentage modulation. The maximum (h_2) and minimum (h_1) heights of the trapezoid are measured using any convenient unit. Percentage of modulation may then be calculated as follows:

$$\frac{(h_2 - h_1)}{(h_2 + h_1)} \times 100 = \text{Percentage modulation}$$

Trapezoidal patterns are also useful for indicating the operational characteristics of RF signals obtained from carrier current transmitters, audio oscillators and similar devices. Typical patterns that may be obtained are shown in Figure 18.

Figure 19A shows the type of pattern obtained with less than 100% modulation, but with phase shift in the audio signal between the point at which the audio signal is taken for the oscilloscope horizontal deflection and the point at which carrier modulation occurs. Such a pattern corresponds essentially to the pattern given in Figure 19B. It does not indicate a defect or improper operation.

Figure 19C gives the type of pattern obtained where an improperly operated Class C RF amplifier is used. Such a pattern may be caused by regeneration, improper neutralisation or excessive bias.

The pattern shown in Figure 19C may be caused by insufficient RF grid drive to a modulated amplifier or a weak amplifier valve. Saturation is reached on the modulated peaks, resulting in the flattened appearance.

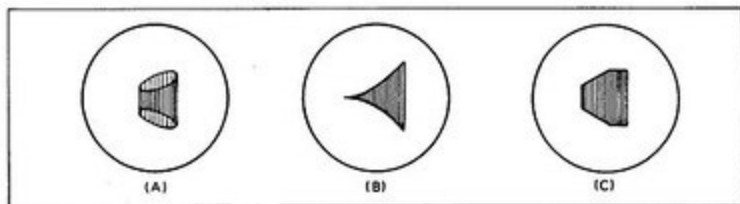

FIGURE—19

MISCELLANEOUS WAVEFORM MEASUREMENTS

In this category, we can place such waveform investigations as studies of noise and vibration, sub-sonic and ultra-sonic applications and hundreds of others. Each of these fields is highly specialised and it is obviously impossible to cover them here.

AC VOLTAGE MEASUREMENTS

Because of its peculiar characteristics, the oscilloscope is particularly suited to the measurement of a.c. voltages. With the advent of television, it has become imperative that such measurements be made accurately without respect to wave shape, so that the conventional r.m.s. reading a.c. voltmeter is no longer adequate. Most television service sheets specify peak-to-peak voltages which appear at various points of the circuit. Other applications for such measurements are becoming more common every day.

The oscilloscope can be used to accurately measure and display these voltages. It can be calibrated by any one of many methods for this purpose.

When using the oscilloscope for a.c. voltage measurement, it is sometimes helpful to use the HOR. IN position of the HOR./FREQ. SELECTOR switch. This produces a vertical line which can be focused and centred exactly for most accurate readings.

The following relationships exist between sine wave a.c. voltage:

r.m.s. x 1.414	= Peak Voltage
r.m.s. x 2.828	= Peak-to-Peak Voltage
Peak Voltage x 0.707	= r.m.s. Voltage
Peak-to-Peak Voltage x 0.3535	= r.m.s. Voltage

AC CURRENT MEASUREMENTS

To measure a.c. currents, the unknown current must be passed through a resistor of known value. The voltage drop across this resistor is measured as described above. From Ohm's Law, $I = \frac{E}{R}$, the current can be calculated.

It is important that the resistor be non-reactive at the frequency involved. It should also be relatively small with respect to the resistance of the load.

FREQUENCY MEASUREMENTS

Frequency measurements can be made with an accuracy limited only by the reference frequency source available. In most cases, this can be the 50 c/s mains frequency which is usually controlled very closely. The unknown frequency is applied to the vertical input and the reference frequency to the horizontal input. The internal time base generator is not used. The resultant pattern may take on any one of a number of shapes. Typical patterns are shown in Figure 20.

The frequency ratio can be calculated from the formula, $f_x = \frac{T_h \times f}{T_v}$ f_x is the unknown frequency:

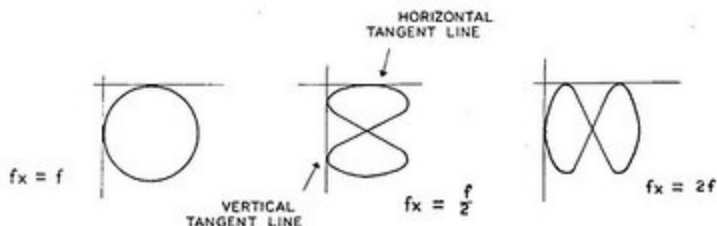

FIGURE - 20

T_h is the number of loops which touch the horizontal tangent line; T_v is the number of loops which touch the vertical tangent line; f is the known frequency.

When using Lissajous figures, as these curves represent, it is good practice to have the figure rotating slowly rather than stationary. This eliminates the possibility of an error in counting the tangent points. If the pattern is stationary, a double image may be formed. In such cases, the end of the trace should be counted as one-half a tangent point rather than a full point. This condition may occur when neither frequency can be varied.

PHASE MEASUREMENTS

It is sometimes necessary to determine the phase relationship between two a.c. voltages of the same frequency. This can be accomplished quite easily by applying one of the voltages to the horizontal input and the other voltage to the vertical input. The phase relationship can be estimated from Figure 21.



FIGURE - 21

To calculate the phase relationship, use the following formula: $\sin \phi = \frac{A}{B}$

The distance A is measured from the X axis to the intercept point of the trace and the Y axis. The distance B represents the heights of the pattern above the X axis. The axis of the ellipse must pass through the point O as shown by Figure 22.

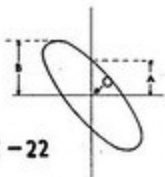

FIGURE - 22



CONTROL SETTINGS FOR VOLTAGE CHECKS

BRILLIANCE	-	Visible trace	HOR. POS.	-	Trace centred
FOCUS	-	Well defined trace	FINE FREQ.	-	Centre of rotation
VERT. GAIN	-	Anticlockwise	HOR./FREQ. SELECTOR	-	1
HOR. GAIN	-	4 cm. trace length approx.	ASTIGMATISM	-	Well defined trace
VERT. POS.	-	Trace centred	VERT. INT - EXT.	-	INT.

VOLTAGE CHART

VALVE TYPE	REF.	Pin 1	Pin 2	Pin 3	Pin 4	Pin 5	Pin 6	Pin 7	Pin 8	Pin 9
12AU7	V1	12	N	1.0	H		48	0.35	0	H
12AX7	V2	200	N	1.0	H		216	200	200	H
12AU7	V3	215	-	140	H		54	N	1.65	H
12AU7	V4	225	54	61	H		222	52 (25-67)	61	H
ECF80	V5	112	-	112	E	H	60	1.5	51	N
12AU7	V6	260	38	63 (56-66)	H		256	53 (25-67)	63 (56-66)	H
EZ80	V7	320 a.c.	NC	332	H	H	NC	320 a.c.	NC	NC
3RP1	CRT	HVH	-710	-665 (600-685)	-440 (360-550)	-680 (620-710)	+260 (200-315)	+256 (195-325)	+270 (0-325)	+222 (135-315)
3RP1	CRT	Pin 10	Pin 11	Pin 12	HT1	HT2	HT3	HT4	RECTIFIER MR1	
		+225 (145-300)	48	HVH	112V	215V	215V	320V	-850V	

All voltages are positive with respect to chassis unless indicated otherwise.

All voltages measured with a 20,000 ohms/volt meter.

Voltages may vary by $\pm 15\%$ due to component tolerances etc.

Voltages in brackets represent approximate variations over the range of the particular control.

H - a.c. voltage this point to chassis: 3.15 volt. Between points: 6.3 volts.

HVH - a.c. voltage between pins: 6.3 volt. CAUTION: These terminals -725 volt with respect to chassis.

NC - No connection.

- - No reading.

N - Not significant.

SERVICE INFORMATION

SERVICE

If, after applying the information contained in this manual, you are still unable to obtain proper performance, it is suggested that you take advantage of the technical facilities which we make available to our customers.

The Technical Consultation Department is maintained for your benefit. This service is available to you at no charge. Its primary purpose is to provide assistance for those who encounter difficulty in the construction, operation or maintenance of HEATHKIT equipment.

Although the Technical Consultants are familiar with all details of this kit, the effectiveness of their advice will depend entirely upon the amount and the accuracy of the information furnished by you. Please use this outline:

1. Before writing, fully investigate each of the hints and suggestions listed in this manual under In Case of Difficulty. Possibly one of these will solve your problem.
2. When writing, clearly describe the nature of the trouble and mention all associated equipment. Specifically report operating procedures, switch positions, connections to other units and anything else that might help to isolate the cause of trouble.
3. Report fully on the results obtained when following the suggestions under In Case of Difficulty. Be as specific as possible and include voltage readings if test equipment is available.
4. Identify the kit model number, invoice number and date of purchase, if available.
5. Print or type your name and address, preferably at the head of the letter.

With the preceding information, the consultant will know exactly what kit you have, what you would like him to do for you and the difficulty you wish to correct. The date of purchase tells him whether or not engineering changes have been made since it was sent to you. He will know what you have done in an effort to locate the cause of trouble and, thereby, avoid repetitious suggestions. In short, he will devote full time to the problem at hand, and through his familiarity with the kit, plus your accurate report, he will be able to give you a complete and helpful answer. If replacement parts are required, they will be sent to you, subject to the terms of the Guarantee.

HEATHKIT equipment purchased locally and returned to Daystrom Limited for service must be accompanied by your copy of the dated sales receipt from your authorised HEATHKIT dealer in order to be eligible for parts replacement under the terms of the Guarantee.

If the completed instrument should fail to function properly and attempts to find and cure the trouble prove ineffective, the facilities of Daystrom's Service Department are at your disposal. Your instrument may be returned carriage paid to Daystrom Limited, Gloucester, and the Company will advise you of the service charge where not covered within the terms of the Guarantee (i.e. a faulty component supplied by us).

For information regarding modification of HEATHKIT equipment for special applications, it is suggested that you refer to any one or more of the many publications that are available on all phases of electronics. They can be obtained at or through your local library, as well as at most electronic equipment stores. Although Daystrom Ltd. sincerely welcomes all comments and suggestions, it would be impossible to design, test, evaluate and assume responsibility for proposed circuit changes for special purposes. Therefore, such modifications must be made at the discretion of the kit builder, using information available from sources other than Daystrom Limited.

REPLACEMENTS

Material supplied with HEATHKIT products has been carefully selected to meet design requirements and ordinarily will fulfill its function without difficulty. Occasionally improper instrument operation can be traced to a faulty component. Should inspection reveal the necessity for replacement, write to Daystrom Limited and supply all of the following information.

- A. Thoroughly identify the part in question by using the part number and description found in the manual Parts List.
- B. Identify the type and model number of kit in which it is used.
- C. Mention date of purchase.
- D. Describe the nature of defect or reason for requesting replacement.



Daystrom Limited will promptly supply the necessary replacement. PLEASE DO NOT RETURN THE ORIGINAL COMPONENT UNTIL SPECIFICALLY REQUESTED TO DO SO. Do not dismantle the component in question as this will void the guarantee. This replacement policy does not cover the free replacement of parts that may have been broken or damaged through carelessness on the part of the kit builder.

SHIPPING INSTRUCTIONS

Before returning a unit for service, be sure that all parts are securely mounted.

ATTACH A LABEL TO THE INSTRUMENT GIVING
NAME, ADDRESS AND TROUBLE EXPERIENCED.

Pack in a rugged container, preferably wood, using at least three inches of shredded newspaper, wood wool or plastic cushioning material on all sides. DO NOT DESPATCH IN THE ORIGINAL KIT CARTON AS THIS CARTON IS NOT CONSIDERED ADEQUATE FOR SAFE SHIPMENT OF THE COMPLETED INSTRUMENT. Note that a carrier cannot be held liable for damage in transit if packing, in HIS OPINION, is insufficient.

PRICES: All prices are subject to change without notice.

MODIFICATIONS TO SPECIFICATIONS: Daystrom Limited reserves the right to discontinue instruments and to change specifications at any time without incurring any obligation to incorporate new features in instruments previously sold.

* * * * *

The Heathkit builder is again strongly urged to follow the instructions given in this Manual to ensure successful results. Daystrom Limited assumes no responsibility for any damages or injuries sustained in the assembly or handling of any of the parts of this kit or the completed instrument.

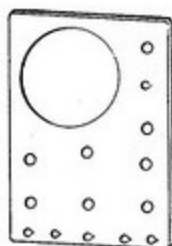

FRONT PANEL

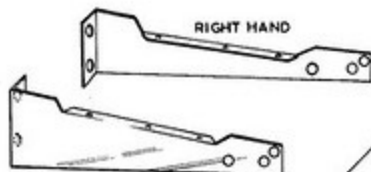

LEFT HAND
CHASSIS SIDE PLATES

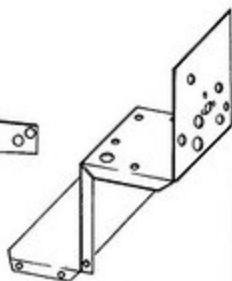

REAR CHASSIS



CRT SUPPORT
BRACKET



CRT CLAMP

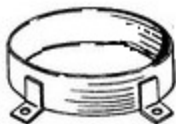

CRT SUPPORT RING



12 PIN CRT SOCKET



STRAIN RELIEF
BUSH



CRT MUMETAL SHIELD



BEZEL



GRID SCREEN
WINDOW

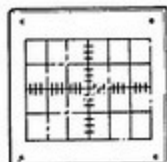

GREEN PLASTIC
GRID SCREEN



160µH PEAKING
COIL



500kΩ POTENTIOMETER
HV INSULATED, WITH SWITCH



1-WAY



2-WAY AND
EARTH



TUBULAR
SELENIUM RECTIFIER



2-WAY

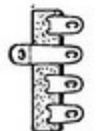

3-WAY AND
EARTH

PARTS LIST

PART No.	PARTS Per Kit	DESCRIPTION	PART No.	PARTS Per Kit	DESCRIPTION
Resistors (10%, ½ watt, carbon)			Potentiometers, Switches (cont'd.)		
H-470C10	2	47Ω (Yellow, Violet, Black)	10-534	1	250 KΩ lin
H-221C10	1	220Ω (Red, Red, Brown)	19-522	1	500 KΩ lin HV insulated, with switch
H-271C10	1	270Ω (Red, Violet, Brown)	10-559	1	1 MΩ lin HV insulated
H-331C10	1	330Ω (Orange, Orange, Brown)	10-560	1	7.5 MΩ lin
H-122C10	2	1.2 KΩ (Brown, Red, Red)	60-513	1	DPDT 6-tag slide switch
H-332C10	1	3.3 KΩ (Orange, Orange, Red)	63-562	1	1-pole 6-way switch
H-682C10	2	6.8 KΩ (Blue, Grey, Red)	Valveholders, Sockets		
H-103C10	1	10 KΩ (Brown, Black, Orange)	434-502	1	9-pin chassis type valveholder
H-333C10	1	33 KΩ (Orange, Orange, Orange)	434-521	6	9-pin printed circuit type valveholder
H-563C10	2	56 KΩ (Green, Blue, Orange)	434-546	1	12-pin CRT socket
H-104C10	5	100 KΩ (Brown, Black, Yellow)	436-503	3	Black socket
H-154C10	1	150 KΩ (Brown, Green, Yellow)	436-504	4	Red socket
H-224C10	1	220 KΩ (Red, Red, Yellow)	Tagstrips, Knobs		
H-474C10	3	470 KΩ (Yellow, Violet, Yellow)	431-1	1	1-way tagstrip
H-105C10	5	1 megohm (Brown, Black, Green)	431-10	2	2-way and earth tagstrip
H-225C10	3	2.2 megohm (Red, Red, Green)	431-32	2	2-way tagstrip
H-475C10	1	4.7 megohm (Yellow, Violet, Green)	431-32	2	3-way and earth tagstrip
H-226C10	1	22 megohm (Red, Red, Blue)	462-G539	1	Large knob
Resistors (5%, ½ watt, carbon)			462-G540	7	Small knob
H-620C5	1	62Ω (Blue, Red, Black, Gold)	Rectifier, Valves, CRT		
H-471C5	2	470Ω (Yellow, Violet, Brown, Gold)	57-505	1	Tubular selenium rectifier
H-473C5	1	47 KΩ (Yellow, Violet, Orange, Gold)	411-25	4	12AU7 (ECC82)
H-244C5	1	240 KΩ (Red, Yellow, Yellow, Gold)	411-502	1	ECF80
Resistors (various)			411-507	1	12AX7 (ECC83)
1-471C10	1	470Ω 1 watt (Yellow, Violet, Brown)	411-512	1	EZ81
2-332C10	1	3.3 KΩ 2 watt (Orange, Orange, Red)	411-537	1	3RP1 cathode ray tube
2-682C10	3	6.8 KΩ 2 watt (Blue, Grey, Red)	Plugs, Grommets, etc.		
1-223C10	2	22 KΩ 1 watt (Red, Red, Orange)	70-501	1	Black wander plug
1-273C10	1	27 KΩ 1 watt (Red, Violet, Orange)	70-502	1	Red wander plug
1-393C10	1	39 KΩ 1 watt (Orange, White, Orange)	73-501	1	3/8" grommet
5-183W5	1	18 KΩ 5 watt wire-wound (value marked)	73-508	2	3/16" grommet
Capacitors (all types)			75-30	1	Cushion strip
21-507	1	200 pF 500V ceramic disc	261-1	4	Strain relief bush
20-504	2	1000 pF 5% silver mica	320-501	1 length	Rubber feet
21-518	4	.002 μF (2,000 pF) 1000V (1 kv) ceramic disc	421-509	1	Foam plastic strip
21-512	3	.02 μF (20,000 pF) ceramic disc	438-513	1	Fuse, 1 amp (spare)
21-525	1	.03 μF 1500V ceramic disc	1 amp fused plug		
21-545	3	.1 μF 250V moulded	Sheet Metal Parts		
23-502	2	.1 μF 400V paper tubular	90-G546	1	Cabinet
23-527	2	.1 μF 1000V paper tubular	200-559	1	Rear chassis
23-58	1	.2 μF 200V paper tubular	203-G594	1	Front panel
23-525	1	.25 μF 150V paper tubular	204-591	1	CRT support bracket
25-5	2	16 μF 150V electrolytic	205-555	1	L.H. chassis side plate
25-507	1	40-40-20 μF 275V electrolytic	205-556	1	R.H. chassis side plate
25-523	1	50-50 μF 350V electrolytic	207-513	2	CRT clamp
Coils			210-505	1	CRT support ring
45-517	4	160 μH peaking coil	Hardware (screws, nuts, washers etc.)		
Potentiometers, Switches			250-501	22	6BA x ½" binderhead screw
10-557	2	20 KΩ lin	250-513	9	4BA x ¼" binderhead screw
10-558	2	100 KΩ lin, centre tapped			

PARTS LIST (cont'd.)

PART No.	PARTS Per Kit	DESCRIPTION	PART No.	PARTS Per Kit	DESCRIPTION
Hardware (screws, nuts, washers etc.) (cont'd.)			Wire, Solder, Sleeving (cont'd.)		
251-514	2	4BA x 3/8" binderhead chrome plated screw	341-1	1 length	Black test lead
250-563	6	4BA x 5/8" binderhead chrome plated screw	341-2	1 length	Red test lead
252-501	22	6BA hex nut	331-501	1 length	Solder, 18 swg. (thick)
252-3	17	4BA hex nut	331-502	1 length	Solder, 22 swg. (thin)
252-531	9	3/8" control nut (black)	340-501	1 length	Tinned copper wire, 22 swg.
254-501	20	6BA lockwasher	346-1	1 length	1 mm. sleeving
254-1	18	4BA lockwasher	346-505	1 length	7 mm. plastic sleeving
254-503	9	3/8" lockwasher	Miscellaneous		
253-522	9	3/8" flat washer (black)	54-536	1	Power transformer
259-504	2	4BA shakeproof solder tag	85-536	1	Printed circuit board
Wire, Solder, Sleeving			206-546	1	CRT mumetal shield
44-504	1 length	Mains cable	210-12-2	1	Bezel
444-500	1 length	Black connecting wire	211-G506	1	Handle with two end plates
444-501	1 length	Brown connecting wire	240-1	2	Crocodile clip
444-502	1 length	Red connecting wire	500-907	1	Self-adhesive label
444-503	1 length	Orange connecting wire	412-511	1	Neon indicator lamp
444-504	1 length	Yellow connecting wire	414-506	1	Grid screen window
444-505	1 length	Green connecting wire	414-507	1	Green plastic grid screen
444-506	1 length	Blue connecting wire	481-504	2	Mounting plate for electrolytic capacitor
444-507	1 length	Violet connecting wire	630-501	1	4BA/6BA nutstarter
444-508	1 length	Grey connecting wire	595-G626	1	Instruction manual

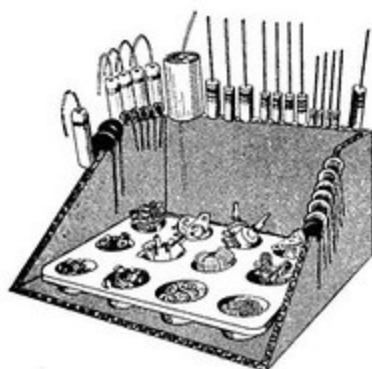

This illustration shows how resistors and capacitors may be placed in the cut edge of a corrugated cardboard carton until they are needed. Their values can be written on the cardboard next to each component.

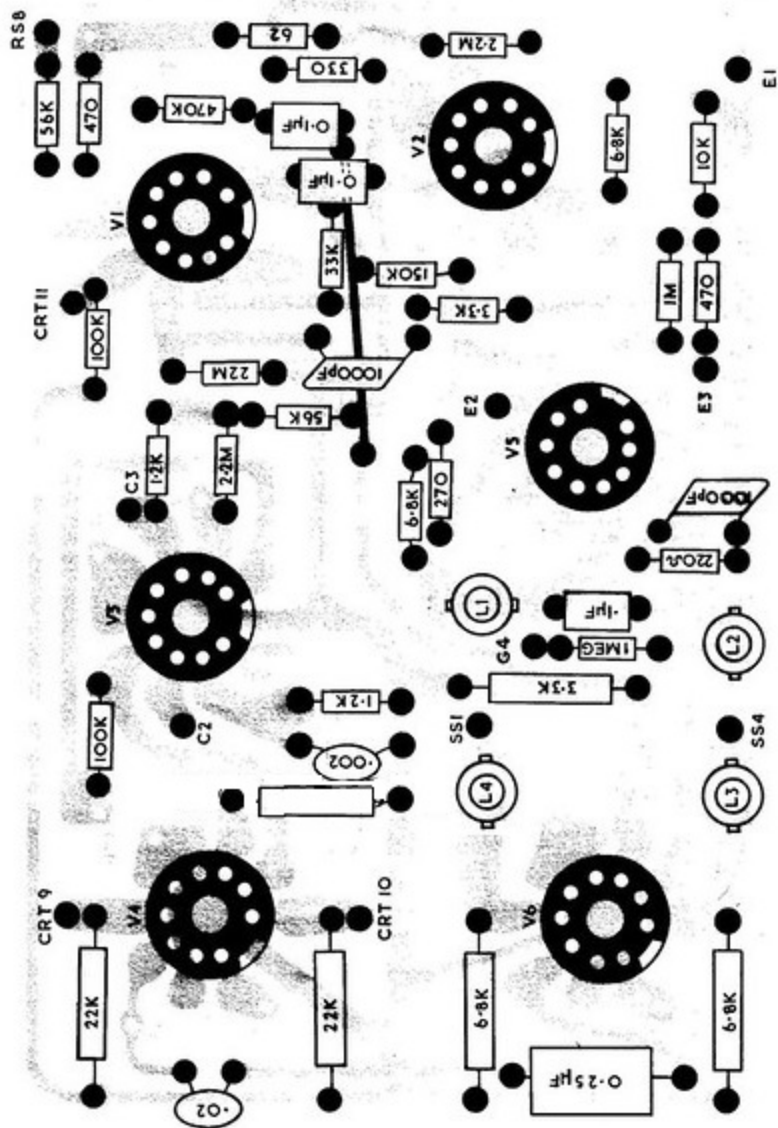









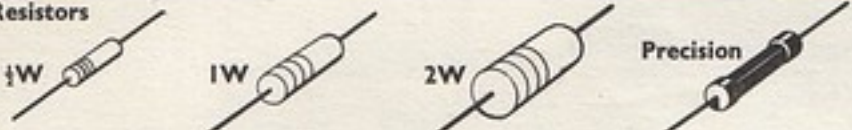

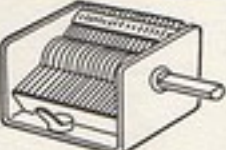
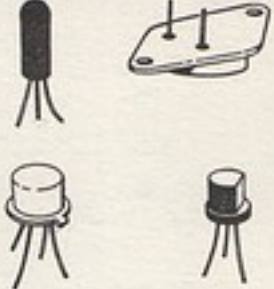





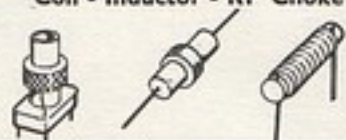

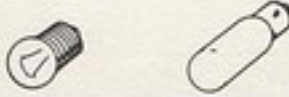





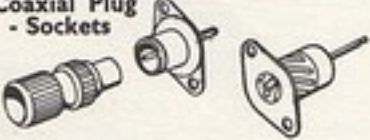

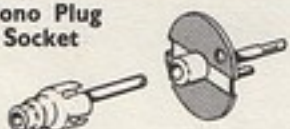
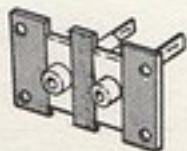















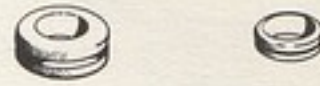



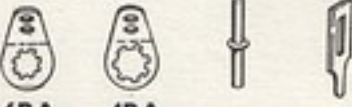







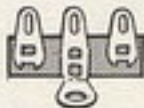



PICTORIAL—6

X-RAY VIEW OF CIRCUIT BOARD VIEWED FROM COMPONENT SIDE

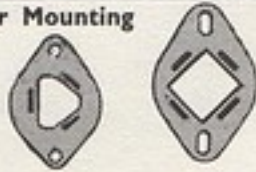
Component Identification Chart

These components are not necessarily identical to the parts in this kit but are sufficiently clear to help you identify components in general use.

Resistors 		Capacitors 
Electrolytic Capacitors 	Variable Capacitor 	Transistors 
Trimmers 		
Potentiometer (Control) 	Diode 	Transformer - Choke 
IF Transformer 	Coil - Inductor - RF Choke 	Mains (Power) Transformer 
Lampholders 	Illuminating - Pilot Lamps 	Neon Indicators 
Toggle Switch 	Rotary Switch 	Slide Switch 
Fuse - Fuseholders 	Coaxial Plug - Sockets 	Wander Plug - Socket 
Phono Plug - Socket 	2-Way Phono Socket 	Crystal Socket 
Phone Jack Sockets 	Phone Jack Plug 	Terminal 

Screws  6BA 4BA 2BA	Binderhead 	Countersunk Head 	Instrument Head 	Feet 
Lockwashers  6BA 4BA 2BA	Round Head 	Cheese Head 	Sheet Metal Screw 	Grommets 
Flatwashers  6BA 4BA 2BA	3/8" Control Hardware  Lockwasher Flatwasher Nut			Strain Relief Bush 
Nuts  6BA 4BA 2BA	Solder Tags - Spill  6BA 4BA			Cable Clamp 
Speednuts 	Pillars - Spacers 			Springs Compression  Tension 
Tagstrip 1-Way 	Tagstrip 2-Way 			Tagstrip 2-Way & Earth 
Tagstrip 4-Way & Earth 	Terminal Strip 3-Way 			Printed Circuit Valveholders 7-pin  9-pin 
Chassis Mounting Valveholder 	Skirted Valveholder 			Octal Valveholder  8-pin
Valve Can - Sleeve - Clip 	Capacitor Mounting Plates 			Couplings Flexible  Solid 
Bush 	Nutstarter 6BA  4BA			Alignment - Trimmer Tools 

RESISTOR CODING

686/18/ALL MODELS

Any insulated wire wound resistors in this kit may be value coded as shown below.

Resistor

Resistor Value	Code
0.1 Ω	R10
0.24 Ω	R24
1 Ω	1R0
10 Ω	10R
1 K Ω	1K0
1.5 K Ω	1K5

Tolerance

Tolerance	Code
+ 0.1 % - 0.1 %	B
+ 0.25 % - 0.25 %	C
+ 0.5 % - 0.5 %	D
+ 1% - 1%	F
+ 2% - 2%	G
+ 5% - 5%	J
+ 10% - 10%	K
+ 20% - 20%	M
+ 30% - 30%	N
+ .05 Ω - .05 Ω	+ .05 Ω - .05 Ω

Examples

Value	Code
0.24 Ω + - .05 Ω	R24 + - .05 Ω
10 Ω + - 5%	10R J
90 Ω + - 10%	90R K

GENERAL ADVICE OF CHANGE

Some of the components supplied with this kit may differ slightly from the descriptions and pictorials given in the manual.

Resistors

These may be colour coded instead of value marked. For identification, use the chart found on the inside cover of the Manual.

Capacitors (Polyester)

These may be colour coded instead of value marked. The value colour code is the first three colour bands, starting with the end furthest from the leads. Where the first two colours are the same, this is denoted by a very wide first colour band. The remaining colours are used to denote tolerance and voltage working. The following values are in common use:-

.01 μ F	=	10,000 pF	=	Brown, Black, Orange
.022 μ F	=	22,000 pF	=	Red, Red, Orange
.1 μ F	=	100,000 pF	=	Brown, Black, Yellow
.22 μ F	=	220,000 pF	=	Red, Red, Yellow
.47 μ F	=	470,000 pF	=	Yellow, Violet, Yellow.

Capacitors, (Electrolytic) Polarity Identification

The positive (+) lead of electrolytic capacitors is the end with a Red, White or Black insulator and on the larger types also with a + sign. The negative lead is always the lead attached to the aluminum case.

The capacity values supplied may be slightly higher or lower than that specified in the parts. For example 2.5 μ F may be supplied in lieu of 2 μ F and 640 μ F may be supplied in lieu of 650 μ F. Also the voltage working may be slightly higher than that specified.

Diodes and Transistors

Transistors and diodes may be supplied with an improved or alternative type to that stated in the manual and will perform satisfactorily.

For example:-

- Part No. 56-510 IN191 / OA79 Diode. Now replaced by AA119 Diode. The positive (+) end is marked with a coloured ring.
- Part No. 417-522 2N408 Transistor. AC128 transistors may be supplied in lieu.

may 70

ERRATA

Please make the following changes in your OS-2 manual before you start to assemble this kit -

Page		
1	Valve Compliment	Delete EZ80 and Insert EZ81
3	Resistor and Capacitor Chart	Ditto
23	Figure 9	Ditto
34	Voltage Chart	Ditto

17.10.69/OS-2

ADVICE OF CHANGE

Colour Coding of Mains Cables.

H.M. Government have decided to make regulations requiring the core colours of three-core flexible cables to comply with the following international coding recently agreed by most of the countries in Europe:

Green and Yellow striped core	EARTH
Brown core	LIVE
Light blue core	NEUTRAL

Under the old system the colour code was Green- EARTH; Red - LIVE; Black - NEUTRAL.

When connecting the mains cable in your kit, please amend the appropriate step/s in your manual as follows:-

Amend Green to read Green and Yellow stripe.
Amend Red to read Brown.
Amend Black to read Light blue.

Additional Notes on Oscilloscope Model OS-2

We occasionally receive requests from customers asking for information on how to obtain alternative facilities on the OS-2. This information is given below for your convenience but it must be appreciated that these facilities can only be provided at the expense of some other facility.

Provision for Time Base Output

This involves the connection of a wire between the junction of C8, VR1 and a socket on the front panel, say, the 1 volt P-P socket.

- () Remove the existing wire between this socket and the circuit board.
- () Refer to Pictorial 2 and connect a new wire between potentiometer C3 and the 1 volt P-P socket.

The time base output will now be available from this socket. You will have lost the 1 volt calibration facility.

Provision for External Synchronisation.

It is suggested for this facility that the two vertical input sockets and slide switch on the chassis rear are used.

- () Refer to Pictorial 2 and remove all wires and components from sockets S1 and S2 and switch SS.
- () Connect the free end of the GREY wire from circuit board location SS4 to CRT6.
- () Connect the free end of the ORANGE wire from circuit board location SS1 to CRT7.
- () Refer to Pictorial 4 and remove the connecting wire between circuit board locations J - J.
- () Twist together a length of BLUE and YELLOW wire. At one end connect the BLUE wire to J near V1 and the YELLOW to J near V5.
- () Route the other end of this twisted pair to the rear of the chassis and connect the BLUE wire to switch SS2 (S-1) and the YELLOW wire to SS1 (S-1).
- () Connect a wire between socket S1 (S-1) and control PP tag 3 (S-2).
- () Connect a wire between socket S2 (S-1) and switch SS3 (S-1).

The slide switch will now operate as an INT/EXT synchronisation switch. In the EXT position, external sync. signals can be connected to the two sockets, the lower one being at chassis potential. You will have lost the input facility to the vertical plates.

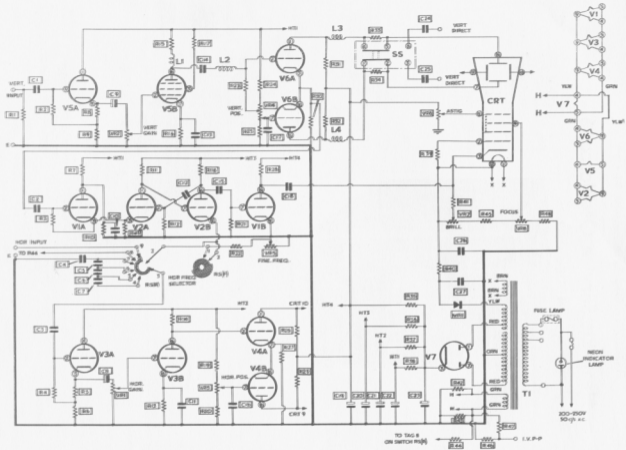

CIRCUIT DIAGRAM
 HEATHKIT SERVICE OSCILLOSCOPE
 Model OS-2

G U A R A N T E E

Daystrom Limited guarantee subject to the following terms to repair or replace free of charge any defective parts (with the exception of cathode ray tubes and valves referred to hereunder) of any Heathkit model which fails owing to faulty workmanship or material provided the defective parts are returned to Daystrom Limited within 12 months from date of purchase:—

1. This guarantee is given to and for the benefit of the original buyer only, and is and shall be in lieu of, and there is hereby expressly excluded, all other guarantees conditions or warranties, whether express or implied, statutory or otherwise, as to quality or fitness for any purpose of the equipment, and in no event shall Daystrom Limited be liable for any loss of anticipated profits, damages, consequential or otherwise, injury loss of time or other losses whatsoever incurred or sustained by the buyer in connection with the purchase, assembly or operation of Heathkit models or components thereof.

2. No replacement will be made of parts damaged by the buyer in the course of handling, assembling, testing or operating Heathkit equipment.

3. The purchaser shall comply with the Replacements Procedure laid down in the relevant Heathkit Manual.

4. Daystrom Limited will not replace, repair or service instruments or parts thereof in which acid core solder or paste fluxes have been used and in such event this guarantee shall be completely void.

Note: Any Cathode Ray Tubes and Valves which form part of the equipment are guaranteed by the respective manufacturers. It should be noted that their guarantee is given only in respect of faulty workmanship and/or material and does not cover misuse or consequential damage.

A selection of typical symbols found in circuit diagrams

AERIAL		CAPACITOR (VARIABLE)		SWITCH — SINGLE POLE (S.P.) SINGLE THROW (S.T.)		BATTERY	
LOOP		RESISTOR		SWITCH — DOUBLE POLE (D.P.) DOUBLE THROW (D.T.)		FUSE	
DIPOLE		RESISTOR (TAPPED)		SWITCH — TRIPLE POLE (T.P.) DOUBLE THROW (D.T.)		CRYSTAL	
EARTH		RESISTOR (VARIABLE)		LOUDSPEAKER		TERMINAL & TERMINAL STRIP	
INDUCTOR (COIL OR R.F. CHOKE)		POTENTIOMETER		RECTIFIER		WIRING BETWEEN LIKE LETTERS IS UNDERSTOOD	
R.F. COIL WITH ADJUSTABLE IRON DUST CORE		JACK (TWO CONDUCTOR)		MICROPHONE		MICRO (x 1/1,000,000) = μ	
L.F. CHOKE (IRON CORE) WITH TAPPINGS		JACK (THREE CONDUCTOR)		TYPICAL TUBE SYMBOL 		MILLI (x 1/1000) = m	
R.F. TRANSFORMER (AIR CORE)		WIRES CONNECTED			KILO (x 1000) = K		
TRANSFORMER (R.F. OR ADJUSTABLE L.F. IRON DUST CORE)		WIRES CROSSING BUT NOT CONNECTED		TRANSISTOR (P.N.P. TYPE)		MEGA (x 1,000,000) = M	
TRANSFORMER (MAINS OR L.F.) IRON CORE		A-AMMETER V-VOLTMETER mA-MILLIAMMETER μA-MICROAMMETER ETC.		TRANSISTOR (N.P.N. TYPE)		OMEGA (OHMS) = Ω	
CAPACITOR		NEON LAMP STABILISER VALVE		SOCKET OUTLET — CO AXIAL		MICROFARAD = μF	
CAPACITOR (ELECTROLYTIC)		LAMP PILOT OR ILLUMINATING		TWO PIN SOCKET AND TWO PIN PLUG		PICOFARAD — pF MICRO, MICRO FARAD — μμF	

DAYSTROM LIMITED

BRISTOL ROAD - GLOUCESTER GL2 5EE

THE WORLD'S FINEST ELECTRONIC EQUIPMENT IN KIT FORM



McM Ltd, Cheltenham, Gloucestershire
GL50 1JH