

Heathkit of the Month #84:
by Bob Eckweiler, AF6C



KIT RESTORATION:

Heathkit V-6 VTVM Restoration Part I
“Siliconizing” the V-6 Selenium Rectifier
(Heathkit part # 57-1, Sarkes Tarzian Model 35)

Introduction:

I didn't think I'd have a Heathkit article this month. However, while awaiting parts to arrive I decided to see if I could convert the #57-1 selenium rectifier to silicon (See figure 1) in the V-6 VTVM under restoration. It presented a bit of a challenge and one I was happy to undertake slowly, whenever I needed a break from the less exciting task of doing taxes. Now, all the parts I believe I need have arrived save one (one vendor sent me the wrong part and is resending a correct one).

Currently the rebuild of the V-6 is coming along slowly, mostly due to the lack of parts and a lot of other obligations. However, the preliminary wiring of the chassis assembly is finished, and the assembly and wiring of the front panel is in progress. Still to do, before mating the two, is the teardown, cleaning and lubrication of the function switch, and the cleaning and lubrication of the the range switch. The precision resistors remain attached to the range switch since they are hard to replace and delicate. One resistor is open, but a replacement is finally on hand. After that, assembly can be completed and testing and calibration can begin.



Figure 1: Heathkit #57-1 Selenium Rectifier.
(Sarkes Tarzian Model 35)

The Selenium Rectifier:

The power supply in the early Heathkit VTVMs uses different forms of rectification as the models progress. The V-1 and V-2 use a 6X5 dual diode vacuum tube. The V-3 is battery powered (though whether any were sold is in question). The V-4(A)* uses a selenium rectifier (part # V97) which is a green commercial multi-plate rectifier similar to the one shown in figure 2. The V-5(A), and V-6 use a small Sarkes Tarzian Model 35 selenium rectifier (Heathkit part # V123, renumbered 57-1 in their revamped parts numbering system). Finally Heathkit settled on a sealed, small and inexpensive selenium rectifier in the V-7(A) (part # 57-13), also manufactured by Sarkes-Tarzian (Model 50); it is rated for 130 vac and 50 ma. In 1963 it sold in single quantities for 48¢; likely, significantly less at Heathkit quantities.

* **Note:** When a Heathkit model number is shown with one or more letters after it in parentheses it refers to multiple kits. Thus:

V-4(A) refers to V-4 and V-4A.

HP-23(A)(B)(C) refers to HP-23, HP-23A
HP-23B and HP-23C

Here is a link to the index of Heathkit of the Month (HotM) articles:

http://www.w6ze.org/Heathkit/Heathkit_Index.html

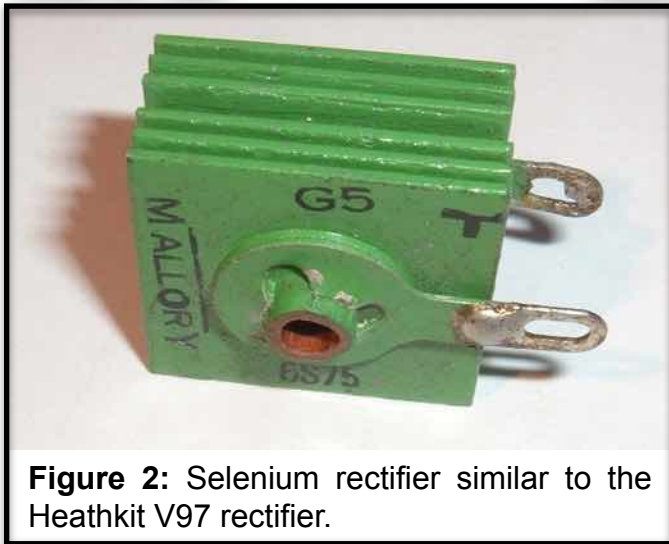

Figure 2: Selenium rectifier similar to the Heathkit V97 rectifier.

Selenium rectifiers tend to deteriorate over time according to many sources. And though I've never had a failure nor felt the need to replace one of the later sealed #57-13 rectifiers, the unsealed #57-1 worried me. The simple solution is to remove the rectifier, mount a Cinch 810 terminal strip in the hole where the rectifier mounted, and solder a 1N4004 diode across the two terminals of the terminal strip. However, this reduces the authenticity of the restoration. It would be better to convert the selenium rectifier to silicon, and keep its form factor.

An examination of the 57-1 rectifier shows it is held together with a spring clip and easily disassembled into a phenolic housing, two phenolic end plates, two terminal end plates and a stack of selenium-coated plates (figure 3).

The selenium plates were wrapped and discarded as toxic waste. Selenium, in excess, is toxic so wash your hands well when you are done. Next, the two metal terminal end pieces were cleaned and a small hole drilled in the center of the large rectangular section of each plate. (a #55 drill - 0.052" dia. was used). The area around the holes were tinned on one side. The leads of a 1N4004 diode we're also tinned. The cathode end of the diode was then soldered through the hole in one terminal end plate (tinned side towards the diode cathode), and the lead trimmed flush to the plate. This cathode terminal should be marked as such with a felt-tip marker.

A 1/2" diameter phenolic spacer, about 0.325" in length, was found in the junk box It just barely wouldn't slip into the phenolic case until four flats were ground 90° apart around the spacer. One phenolic end plate and the terminal end plate with the diode attached



Figure 3: The disassembled 57-1 Rectifier.

- 1. Phenolic case
 - 2. Phenolic end plates
 - 3. Terminal End plates
 - 4. Selenium coated plates
- Not shown - Spring clamp with mounting tab (#5 in figure 4)

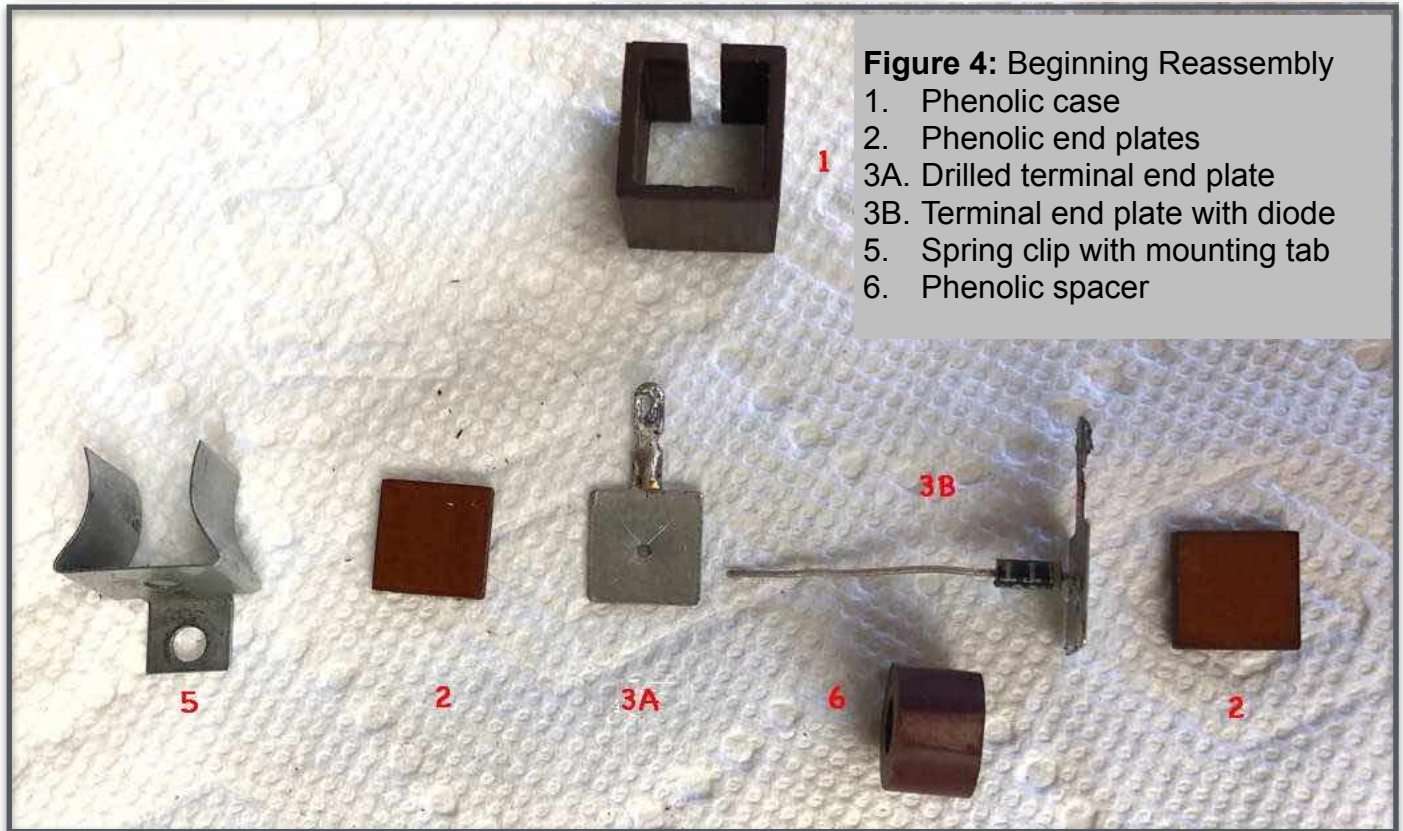

Figure 4: Beginning Reassembly
 1. Phenolic case
 2. Phenolic end plates
 3A. Drilled terminal end plate
 3B. Terminal end plate with diode
 5. Spring clip with mounting tab
 6. Phenolic spacer

were slid into the phenolic case. The spacer was then slid over the diode and the second terminal end plate was pressed flush to the phenolic spacer and soldered. If the diode lead was already tinned along with the side

of the terminal end plate that is towards the diode, the solder should be drawn into the hole with little solder remaining on the outer side. This diode lead is then also cut off flush to the terminal end plate. Finally the second phenolic end plate is placed above the top terminal plate and the whole assembly is

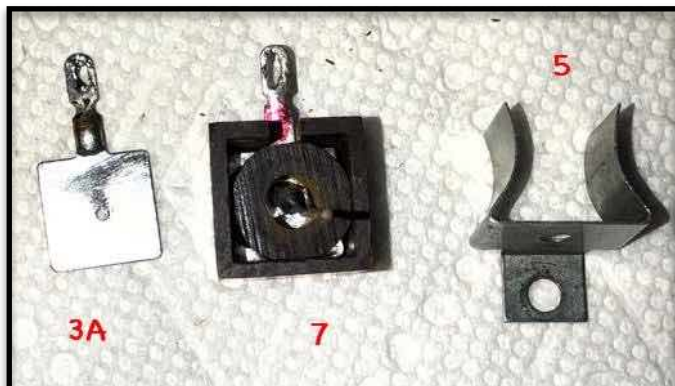

Figure 5: Partial Reassembly.
 3A. Drilled terminal end plate.
 5. Spring clip with mounting tab
 7. Assembly of:
 a. A phenolic end plate
 b. A end terminal plate with diode soldered on
 c. Phenolic case
 d. Phenolic spacer

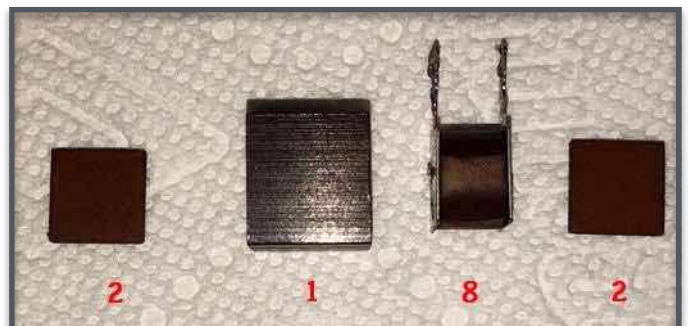

Figure 6: Ready for Final Assembly
 1. Phenolic case (slot up)
 2. Phenolic end plate
 8. Assembly of:
 a. two terminal end plates
 b. phenolic spacer
 c. 1N4004 diode (or equivalent)



Figure 7: Completed Selenium Rectifier Converted to Silicon with Cathode Marked

Prior to installation in the V-6, the 'K' was cleaned off with alcohol, but the red marking on the cathode terminal stem was left on.

placed into the spring clip with mounting tab. This has to be assembled so the cathode terminal end, with its lug pointing up, is towards you when the mounting clip is pointed to the right (See figures 4, 5, 6 and 7).

The result is a silicon 1N4004 rectifier diode mounted inside the case of the #57-1 selenium rectifier case. This diode should outlast the V-6 VTVM.

Comments:

Usually I try to write about an unusual kit for the April issue. There was the Heathkit mahogany candlestick (my favorite), the Heathkit "freebee" flashlight. Once I even published a writeup of an imaginary kit, the Heathkit C-7 Lakota. Needless to say the author was a historian of General Custer. Other unusual Heathkits that were covered in the April issues are a log splitter, a garbage compactor, a \$6,000+ 15 lb. 386 based laptop computer, and a motorbike. I hope this article is esoteric enough to fit in.

Ten Year Anniversary:

Can you believe that it was ten years ago this past February that the first Heathkit of the

Month article appeared in the Orange County Amateur Radio Club newsletter *RF*! In those ten years there have been 84 feature articles including this one, and a few short articles. That amounts to over eight articles each year. No, it's not exactly accurate to call the series *Heathkit of the Month*, but's close enough that I don't have any guilt feelings. That first article covered the GR-121 Clock Radio that followed me through my college days.

The New Heathkit:

It's been some time since the new Heathkit started operations. The current kits they offer are a TRF AM Radio (in soldered and solder-less versions), a Stealth 2m/0.75m antenna, a Digital Clock, and a Precision RF meter (for which Heath is currently accepting preorders). They also have some neat accessories, updates and replacement parts for various legacy Heathkits such as the AJ-1510(A) tuner, the HG10(B) VFO, the IG-18 audio generator, and some replacement parts for the weather stations. You might want to checkout their website at:

www.heathkit.com

Their GC-1006 "Most Reliable Clock" sells for \$99.95 which some feel is expensive for a digital clock. However, in 1990 dollars that is \$52. Hopefully the new Heathkit will release some ham related kits that will draw the new generation of hams back into kit building.

73, from AF6C



This article originally appeared in the April 2018 issue of RF, the newsletter of the Orange County Amateur Radio Club - W6ZE.

Remember, if you are getting rid of any old Heathkit Manuals or Catalogs, please pass them along to me for my research.

Thanks - AF6C

Heathkit of the Month #86:
by Bob Eckweiler, AF6C



KIT RESTORATION

Heathkit V-6 VTVM Restoration Part II.

Introduction:

It seems like this project took forever to complete, though actual time working on it was not many hours over a long period. Part I appeared in the April 2018 issue of *RF* and covered “siliconizing the selenium rectifier” in the V-6. This amounts to removing the selenium plates and replacing them with a silicon diode (a 1N4004 here) while keeping the outside appearance of the original part. The restored Heathkit V-6 VTVM (circa 1952 to 1954) is shown in **Figures 1** and **2** during burn-in. **Figure 15** shows the V-6 schematic.

If this project were to be done over, there are a few things that should have done that weren't. The first is taking photos of the original V-6. When the cover first was removed a disaster was revealed and the plan changed to recover any parts and take the rest to the electronic scrap yard. Like most all VTVMs the Heathkit V-6 uses a battery for its ohmmeter circuit, a 1.5 volt 'C' battery. The battery was no longer in the unit but the damage it had done from leaking was extensive. Two of the three metal chassis parts were corroded significantly and the third less so, but still damaged. The almost “unobtainium” 7.5 Meg Ω potentiometer in the A.C. balance



Figure 1: Completed restoration of the Heathkit V-6 VTVM during burn-in. The slight meter offset is intentional and indicates the circuit continues to function.

circuit was badly corroded. So much so that removing it resulted in the threaded bushing disintegrating. Amazingly the pot element appeared okay. After reading a discussion¹ on cleaning and restoring a chassis, the decision was made to try a restore despite the damage.

The second thing that should have been done was to check and clean the **OFF-ON** slide switch. This was an oversight; a fair amount of time was spent cleaning the two rotary switches, actually disassembling one. The OFF-ON switch however, when removed from the chassis, had its terminals cleaned of excess solder and put in the box of parts with-

¹ Notes are on page **.

Here is a link to the index of Heathkit of the Month (HotM) articles:

http://www.w6ze.org/Heathkit/Heathkit_Index.html



Figure 2: Another photo of the completed restoration of the Heathkit V-6 VTVM during burn-in. This photo shows the repainted case color.

out further consideration. What’s less complicated than an SPST slide switch after all?

Degrees of Restoration:

There are various degrees of restoration when it comes to a Heathkit product. A minimum restoration probably includes a thorough cleaning (some better than others), replacing or repairing any obviously bad parts, and possibly some or all the electrolytic capacitors. A better restoration involves changing all the electrolytic capacitors as well as any tubular paper type capacitors - also replacing any resistors that look overheated or are beyond their marked tolerance. Then there is the “total” restoration. This involves stripping the kit back into a set of parts, checking and cleaning everything, replacing any hardware deemed deteriorated that is still available and replacing the small parts such as resistors, capacitors, terminal strips and anything else

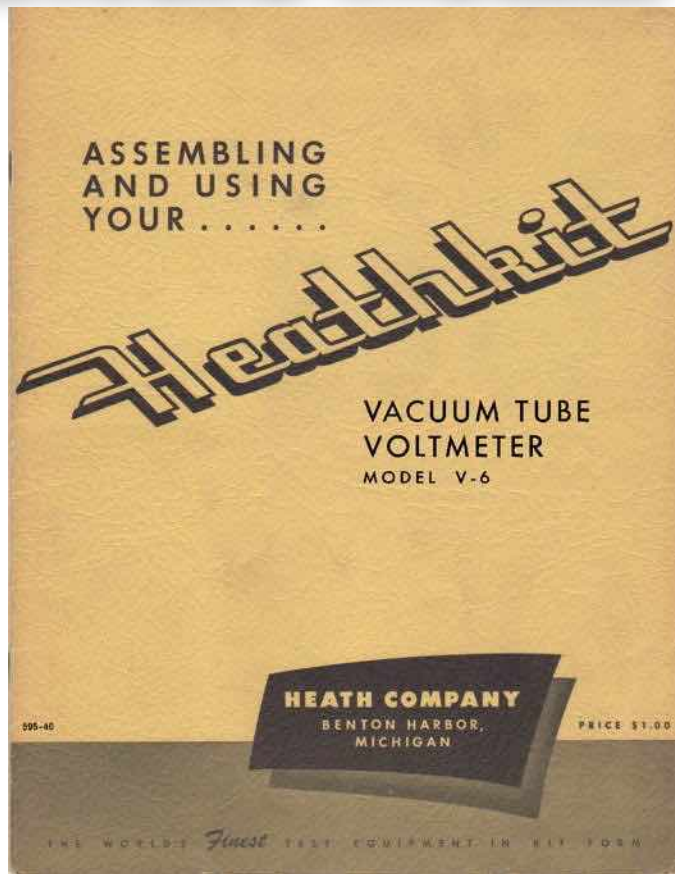

Figure 3: Having a complete manual is important.

that can easily be obtained that could go bad in the future.

Obtain the Manual:

Get a copy of the Heathkit manual for the model you’re restoring; it is a wise investment (**Figure 3**). If you are going to do anything but the most primitive restoration the manual is valuable for teardown as well as for rebuild. Sometimes manuals can be found online, however many of those online are missing the step-by-step assembly instruction section. There are many vendors that sell replacement manuals for vintage Heathkits. One source is the new Heathkit Company². Other vendor sources can also be found online. Prices and quality vary so shop around. Often original manuals can be found on eBay. It is wise to know your kit; some kits change over time. For instance there are two versions of the DX-40, each with its own

manual. Also, in larger kits, circuits often change resulting in a new different circuit board. The IO-4550 oscilloscope used at least two different HV power supply boards due to a change made to the chop blanking circuit.

This V-6 Restoration Degree:

This restoration is close to total. The whole kit was stripped down to individual parts except for the RANGE switch (which will be discussed later), and each part was tested, and cleaned if it was to be reused (except, alas, for the power switch). Other than precision resistors, all resistors were replaced; so were two of the three capacitors. A mica-type capacitor (0.003 μ f) was kept because it checked good and was of the classic square molded style. It is huge compared to today's dipped mica of the same value, and sits over one of the tube sockets. Later, it kept getting in the way during checkout, so there is some minor regret in not changing it.

Modifications(?):

Another part of restoration may be making modifications to the kit. Generally this is not recommended, especially if it includes modifying or drilling holes in the chassis, or worse the front or back panel. Still, there are safety modifications that can be appropriate, like a three-wire power cord, replacing capacitors used across the A.C. line with safety capacitors and adding a fuse in the primary circuit. Of course, modifications sanctioned by the Heathkit factory are acceptable, and even warranted if they meet the user's needs. The only modification made to this V-6 was the addition of a 3-wire line cord³.

Disassembly:

Returning the kit to its basic parts requires some thought and skill. The manual will help govern the order of disassembly. For a kit like the V-6, first remove the tubes and place them in tube boxes or wrap them in

newspaper. Be sure to mark what's inside. Remove the power cord if there is one; you will likely want to replace it⁴. This kit came with about four inches of power cord sticking out of the back where it had been cut off. For a VTVM you want to get the easily damaged meter removed as soon as possible and stored safely, so remove what's necessary to get there quickly. Heavy items are removed next (if they weren't already). The power transformer is the only heavy item in the V-6. Remove the leads first; unsolder, if you're able, to keep the leads as long as possible for reinstalling. Also note where each lead goes to. This transformer has six leads two black (now gray), two red (now a slightly different shade of gray) and two green, (now yet a third shade of gray) - perhaps a slight exaggeration, but still determining the lead color would not have been a snap, like when the transformer was new.

Finally it is time to remove the wiring and components. Hookup wire generally should be cut off at each end and discarded. Resistors can be measured in situ after you free one end. If they are in tolerance try to save them; you'll probably not use them but they are valuable if you can't easily find a replacement. The same is true of capacitors. The general rule is to save as much as you can, unless you know you have or can obtain a replacement.

It is important to organize and store all the parts in one place so they can be found easily for checking and later for reinstallation. A large shoe box was used for this small kit.

The V-6 Range Switch:

The range switch is a two deck, seven position, wafer switch. Each deck not only contains seven switch terminals but also four dummy terminals that are used for tie points for the resistors. The two decks are spaced far

enough apart so large precision resistors can be mounted from one deck to the other. In total, the switch holds fourteen precision resistors. Since they are easy to damage and hard to replace, there was no reason to remove them. The switch itself was cleaned and all resistors checked. One 200 K Ω precision resistor was obviously open as it was bypassed by two tiny 0.1 watt 100K precision resistors in series. These were removed, as was the dead original, and a 200K precision resistor was ordered from a parts warehouse (luckily it was a common value, unlike some of the others). The range switch had suffered some of the corrosion damage caused by the leaking battery. It manifested itself on the nut end of one of the long screws holding the wafers. The nut and an area of the screw around the nut were rusted. Instead of trying to unscrew it a rust converter⁵ was used to neutralize the rust and prevent further damage.

The Function Switch:

The second rotary switch is the function switch. It is a four-position rotary switch with two wafers. The switch was disassembled, the mechanism cleaned and lubricated with white lithium grease. The wafers were carefully cleaned with good a contact cleaner. This is so much easier to do with the switch disassembled, and one is less likely to get cleaner on the phenolic insulation, which can compromise the insulation quality (not good in an ohmmeter that measures up to 1 giga-ohm! After cleaning, the switch was wrapped in newspaper and stored, awaiting assembly.

Checking Parts:

Each component that you plan to reinstall should be checked. Resistors may be checked with a good VOM or VTVM. Tubes will require a tube tester; if you don't have one check with your ham friends. Capacitors can be more of a problem. Handheld capacitance meters are okay for determining the capaci-

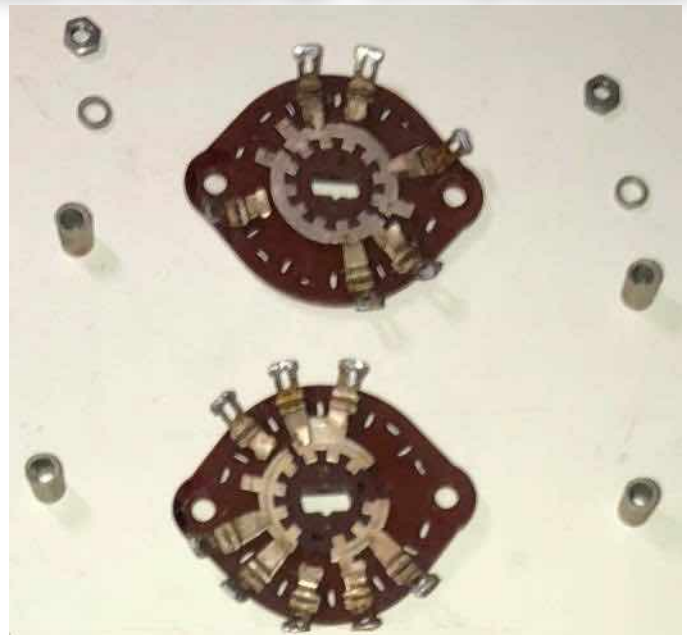

Figure 4: Disassembled function switch wafers awaiting cleaning.

tance but give no indication of leakage, a problem often encountered in older electronics. A Heathkit IT-11 Capacitor Checker⁶ measures leakage up to 600 V as well as capacitance and ESR. Other components should be checked as necessary; check switches for continuity with an ohmmeter, (including the power switch!)

In the case of the V-6, the two tubes tested okay on the Philco 7050 tube tester, another recent restoration product. The V-6 uses only three capacitors the 0.003 μ f mica, discussed earlier, a 16 μ f electrolytic capacitor used in the power supply and a 0.01 axial tubular capacitor. All three original capacitors were tested; the electrolytic showed an above acceptable leakage rate as did the 0.01 2 KV capacitor (even at a low voltage of 200 volts). This capacitor is common enough except for its voltage rating of 2 KV. Mouser carries them, but was out, as were other sources, so it took awhile until they could be obtained. Several were ordered as there are other Heathkits in house that use this same capacitor.

There are only six non-precision fixed resistors and they all were destined to be replaced; though all but two were within tolerance. Both 10K front panel potentiometers were also replaced. One had been replaced by a ten-turn Bourns pot - a nice touch, but overkill. A three turn pots would be ideal, and make a reasonable modification, but none could be found at a reasonable price. The two 10 KΩ calibration pots were also open for replacement, but tested out okay, so the replacements that had been purchased remained on the shelf. the 7.5 MΩ AC balance pot was still a problem.

Obtaining Replacement Parts:

Each year this becomes more of a problem. Through-hole resistors are still readily available, though newer metal oxide and film resistors are replacing the older carbon composition resistors. While radially-leaded capacitors are still easily obtained, axially-leaded capacitors are growing scarce and getting expensive, as are all types of higher voltage capacitors.

There is a problem today buying replacement potentiometers. Many come from Asia and most are metric. You can buy them with 1/4" shafts so the original knobs will fit, but the bushings are usually not the standard 3/8", (0.375"), but instead 8 mm, which is about 0.315" Thus the pot mounts with a lot of slop in the original mounting hole. A single wrap of #22 solid wire around the base of the bushing can remove a lot of the slack. Otherwise it is hard to get the control centered in the 3/8" mounting hole.

The 7.5 MΩ potentiometer was still the biggest problem. After checking the Heathkit "boneyard"⁷ without any luck, a member of the Yahoo Heathkit group passed along an eBay link where a Clarostat NOS (new, old stock) 7.5MΩ pot was being sold. The price

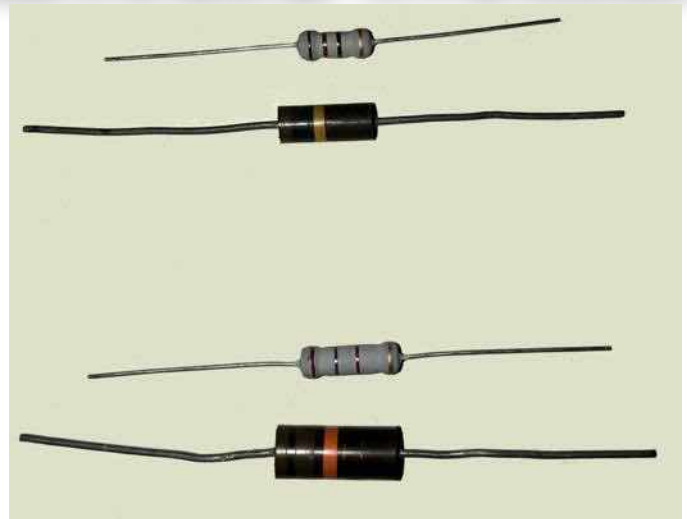

Figure 5: Resistor size comparison (from top to bottom): 1-watt metal oxide, 1-watt carbon composition, 2-watt metal oxide, 2-watt carbon composition.

was high, but not unreasonable, so one was ordered. While the part measured low, slightly out of its 20% tolerance band, it was like new otherwise and worth trying.

Many component parts may be obtained from regular parts houses such as **Allied, Digi-Key, Mouser, Newark** and others. One good source for capacitors and resistors is **Just Radio**⁸. They are in Canada and carry axial 630V capacitors in various capacitances, at good prices, some even in the older capacitances that are hard to find. They also stock a good inventory of axial and radial elec-



Figure 6: The V-6 chassis, cleaned, coated and partially populated with parts.

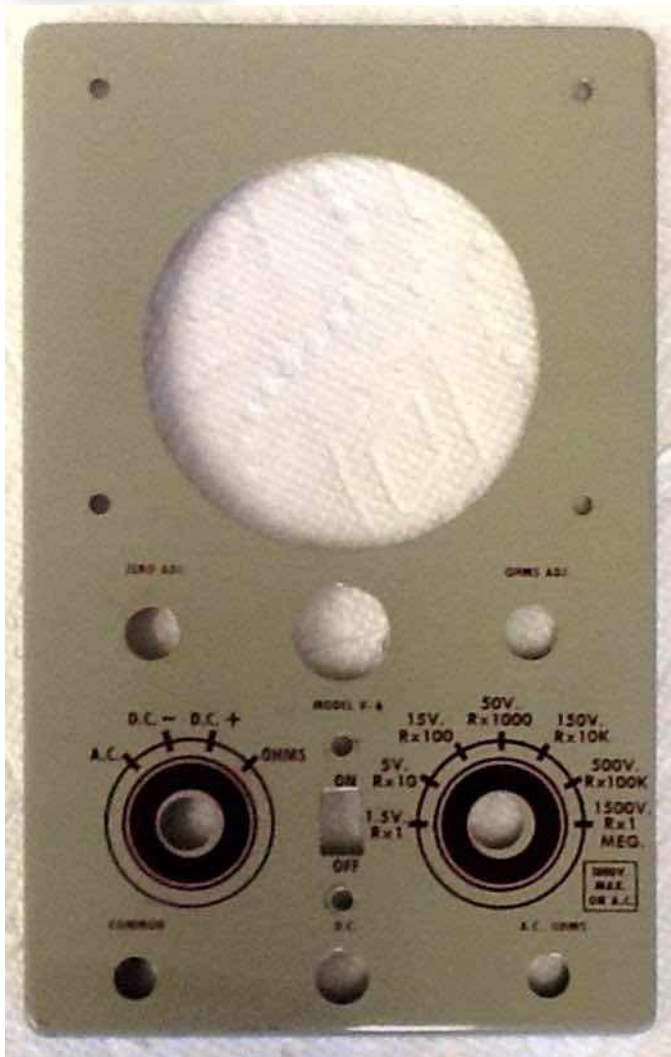

Figure 7: The front panel cleaned up nicely with just some Dawn detergent and warm water.

trollytic capacitors up to 600V. It was here that I actually found an axial 16 μ f 160V electrolytic capacitor to replace the original 16 μ f 150V one. Normally it would have been replaced with a 22 μ f electrolytic capacitor. Just Radio also has a selection of 1/2, 1 and 2 watt metal oxide and carbon composition resistors at reasonable prices. Be aware that they also sell “audiophile quality” capacitors; these are expensive and not worth the cost for general Heathkit restoration. Also be aware that metal oxide resistors are smaller than their carbon composition resistors of the same wattage (see Figure 5). As the prices are reasonable one might be tempted to replace a

1/2-watt carbon composition resistor with 1-watt metal oxide resistor and a 1-watt carbon composition resistor with 2-watt metal oxide resistor. With some exceptions, there is nothing wrong with doing this.

Restoring the Chassis and Front Panel:

Once all components were off, the chassis and the two associated brackets were cleaned with an SOS pad and sanded to remove as much of the pitted corrosion as possible. When it was finally looking reasonably smooth it was coated with Rust-oleum Satin Nickel Metal and allowed to cure. The chassis with one of the brackets attached, along with the major components is shown in Fig-



Figure 8: The front panel rear with ZERO ADJ. and OHMS ADJ. controls, pilot lamp, D.C. jack, A.C. - OHMS jack and OFF - ON switch installed.

HOM rev. new

Figure 6. Be sure all lock washers are present during reassembly and all hardware is tight to assure good grounding. No problems were encountered in area, though all grounds were checked with an ohmmeter.

The front panel can be difficult to restore if scratched excessively, chipped or stained. Luckily the V-6 front panel cleaned up with just Dawn and warm water. The few minor scratches were allowed to remain “to add character”. **Figure 6** shows the front panel drying and **Figure 7** shows the back with some components installed.

Renewing Hardware:

Another consideration of restoration is hardware. the kit may be restored electronically to perfection, but if the screws are rusted, partially stripped or not what they should be, the result will appear shabby. Heathkit used binder head slotted screws in most of their kits. Rarely, if ever, was a Philips-head screw used. Yet if you go to a local hardware store the bulk of the machine screws you will find are Philips. Many of the older kits also used round-head slotted screws, including the V-6. Still the pan head screws were used to replace them as they are



Figure 9: The underside of the chassis prior to wiring. The adjustment pots and tube sockets are original but cleaned and tested. The vacant hole is for the 7.5 MΩ pot.

Heath of the Month #86 - V-6 VTVM Restoration

the most common screws used by Heathkit. these screws can still be found online and in some of the larger commercial hardware stores. When you find them pick up a box of a hundred of the common sizes Heathkit uses. They are #6-32 x 3/8", #6-32 x 1/4" and 4-40 x 1/4". A source is Jameco Electronics⁹.

Often parts are hard to replace. The two 3/8" slide-on speed nuts that hold the A.C. - OHMS and COMMON jacks are an example. These were cleaned up and reused, which required them to be removed carefully during disassembly. Occasionally hard-to-find parts can be located in the little “Hillerman” drawers at local hardware stores. They are often rather expensive for what you get, but if you just need one or two you’re set.



Figure 10: The underside of the chassis prior to wiring. The adjustment pots and tube sockets are original but cleaned and tested. The vacant hole is for the 7.5 MΩ pot.



Figure 11: Chassis right side, showing range switch. Access to the 7.5 MΩ resistor is through the A.C. balance hole.



Figure 12: Chassis rear, showing 6H6 tube, Ohms battery, AC and DC CAL pots and power transformer.

Assembly:

Finally it's time to reassemble the kit. Again here is where the manual is so helpful. In the case of the V-6, the assembly step-by-step instructions were followed, just as if building a new kit.

If you're restoring an older kit you will immediately be aware of the many improvements Heathkit made in their construction manuals over the decades of their existence. Two areas stood while assembling the V-6, The first is that hookup wire lengths were not generally given unless the far end of the wire was to be connected at a later time. The second is the soldering instruction (S) for solder did not yet include a number for how many leads should be connected to the terminal to

be before soldering. For instance this instruction from page 6 of the V-6 manual reads:

"Run a wire from J2 (S) to K2 (S)."

If this were a later manual the instruction might instead read:

"Connect a 2-1/2" wire between J2 (S-2) and K2 (S-1)."

Construction of the V-6 takes place in three parts. First the chassis is wired, then the front panel is wired, and finally the two are wired together. **Figure 9** shows the chassis underside prior to wiring. **Figure 10** shows the wired front panel prior to it being joined to the chassis and **Figures 11, 12 and 13** show the completed V-6 prior to being installed in the cabinet.



Figure 13: Chassis left side, showing "siliconized" selenium rectifier (left), 7.5 M Ω potentiometer (lower center), old style mica capacitor and new 0.01 2,000V capacitor (above octal tube socket), and function switch (in cutout, to right).

The V-6 “Reversed Diode” Situation:

One chronic problem Heathkit VTVMs suffered is poor AC balance. When switching from one of the DC positions to AC the meter zero would change; this is caused by the contact potential generated by each section of the duo-diode tube. The V-1 and V-2 did not have any adjustment to correct this. When the V-4 came out (the V-3 was a different beast) it sported an **A.C. Balance** adjustment pot. This pot used the contact potential in one diode section to cancel out the contact potential in the second section, however this only works if the correct tube section has the higher contact potential. Heath probably preselected the tubes for the V-4, but this meant about half their 6H6 tube inventory could not be used in the V-4. Heath fought the AC balance problem from the V1 up to the V7. Each had a different AC rectification circuit, and at one time Heath even changed the tube to a loctal 7A6. In the V-7 Heath solved the problem by tapping off voltage from the B+ supply using a variable resistor, and coupling it to the duo-diode tube through a string of five 22 MΩ resistors. This circuit worked extremely well and has not been

changed in the numerous newer VTVM models sold since.

Starting with the V-4A, and continuing through the V-6 the 6H6 (or 7A6) tube that came with the kit was either unmarked or marked on the box “REVERSED DIODES” and, depending on marking, the VTVM was wired in one of two ways. The wiring changes effectively reversed the two diode sections of the tube. See **Figure 14** for Heath’s note.

The Moment of Truth:

With the rebuild complete, the wiring carefully checked and resistance measurements taken (there was no resistance table in the manual, but sensible measurements could still be made), it was time to “fire it up”. The tubes lit and so did the very bright pilot lamp. As it was warming up it suddenly went dark. Visions of a bad power transformer formed, but at the slightest touch of the power switch the pilot light lit up again. The ON-OFF switch was intermittent. Press a finger on the switch it came on; take the finger off and it might stay on but any slight jarring and it would open. A simple in situ switch cleaning did nothing; the switch

IMPORTANT NOTICE: WHEN A TUBE IS FIRST OPERATED, ITS CHARACTERISTIC ARE NOT AS STABILIZED AS AFTER A PERIOD OF “AGING.” THEREFORE EACH 6H6 HAS BEEN “AGED” AND ITS ACTUAL OPERATING CHARACTERISTICS DETERMINED AT THE HEATH COMPANY. THIS AGING AND TESTING PROCESS IS PERFORMED SO THAT THE KIT BUILDER WILL BE ABLE TO MAKE A GOOD INITIAL CALIBRATION AND WILL BE ABLE TO CONNECT THE DUO-DIODE (6H6) IN A MANNER WHICH WILL CAUSE HIS INSTRUMENT TO OPERATE WITH OPTIMUM PERFORMANCE. THUS, IN THE INSTRUCTIONS WHICH FOLLOW, IF THE 6H6 CARTON HAS THE WORDS “REVERSED DIODES” STAMPED ON IT IN LARGE LETTERS, SKIP ALL STARRED STEPS (*), AND PERFORM THOSE STEPS WHICH START OUT “REVERSED DIODES.” FOLLOW THOSE PICTORIALS WHICH ARE CLEARLY LABELED “REVERSE DIODES.”

IF THE CARTON DOES NOT HAVE THE WORDS “REVERSED DIODES” STAMPED ON IT IN LARGE LETTERS, PERFORM THE STARRED STEPS (*), AND SKIP THE STEPS WHICH START OUT “REVERSED DIODES.” FOLLOW THOSE PICTORIALS WHICH ARE NOT LABELED “REVERSE DIODES.”

Figure 14: “REVERSED DIODES” explanation from the V-6 manual.

HOM rev. new

would have to be removed, disassembled and cleaned¹⁰. Removal was difficult due to all the parts and wires around it. Heathkit's handy red "nut starter" saved the day. after a complete cleaning the switch works well.

Hookup Wire:

Here's something discovered after the fact: Heathkit almost always used #22 AWG solid hookup wire for general wiring in its kits. Special wire was used when necessary, but otherwise PVC coated #22 solid wire was the norm. The wire used to rewire the kit turned out to be rated at 300V. The common value on most current hookup wire. Original Heathkit hookup wire most certainly had either a 600 or 1000 volt rating. This is something to be investigated and will be considered in future restorations. Wire rated at 300 volts would not do well in a DX-40 transmitter!

On the V-6 insulation for the AC and DC jack wires and spaghetti on the 0.01 μ f capacitor should be capable of handling at least 1500 VDC. So should the wire from terminal P13 of the function switch to terminal R10 of the range switch.

Cabinet Paint:

The cabinet of the V-6 was generally in good shape. there were a few scratches on one side and the paint was faded and stained, even after a good cleaning. The V-6 is in the "Late Pre-Classic" style¹¹. The case is painted a gray wrinkle and seems to have a hint of brown. Finding wrinkled paint, let alone paint to match, is a problem. A base paint of the proper texture has yet to be found. I ended up choosing to leave the original paint, with its wrinkle finish in place as a base coat and cover it with a new coat of satin paint. After much searching I found Rust-oleum 2X London Gray (shouldn't that be London Grey?) paint while perhaps a little on the brown side, once on it looked close to original.

Heath of the Month #86 - V-6 VTVM Restoration

Summary:

Restoring Heathkits can be a fun hobby. It often comes with as much, or more, satisfaction than building a kit originally.

The next project is an IO-4550 scope with serious problems to its HV board. Repair of that board is underway. It's also about time to get the SB-220 back on the air.

73, from AF6C



This article originally appeared in the July issue of RF, the newsletter of the Orange County Amateur Radio Club - W6ZE.

Remember, if you are getting rid of any old Heathkit Manuals or Catalogs, please pass them along to me for my research.

Be sure to update > Thanks - AF6C

Notes:

1. The Heathkit Yahoo group.
2. <https://shop.heathkit.com/page/vintage-replacement-manuals>
3. A three-wire cord results in the chassis being directly connected to an earth ground. This should be taken into consideration when making any differential voltage measurements.
4. This is also for safety, so you don't accidentally plug in the unfinished kit by mistake.
5. Rust-oleum® *Rust Reformer*® available at ACE Hdwr.
6. See Heathkit of the Month article #2. Available at: http://www.w6ze.org/Heathkit/Heathkit_Index.html
7. Heathkit Boneyard - (parts kits) <http://www.d8apro.com>
8. Just Radio: <https://www.justradios.com/>
9. Jameco Electronics: <http://www.jameco.com/>
10. See Heathkit of the Month maintenance article #MO2. Available at: http://www.w6ze.org/Heathkit/Heathkit_Index.html.
11. See *Heathkit Test Equipment Products* by Chuck Penson WA7ZZE starting on page v for style information.

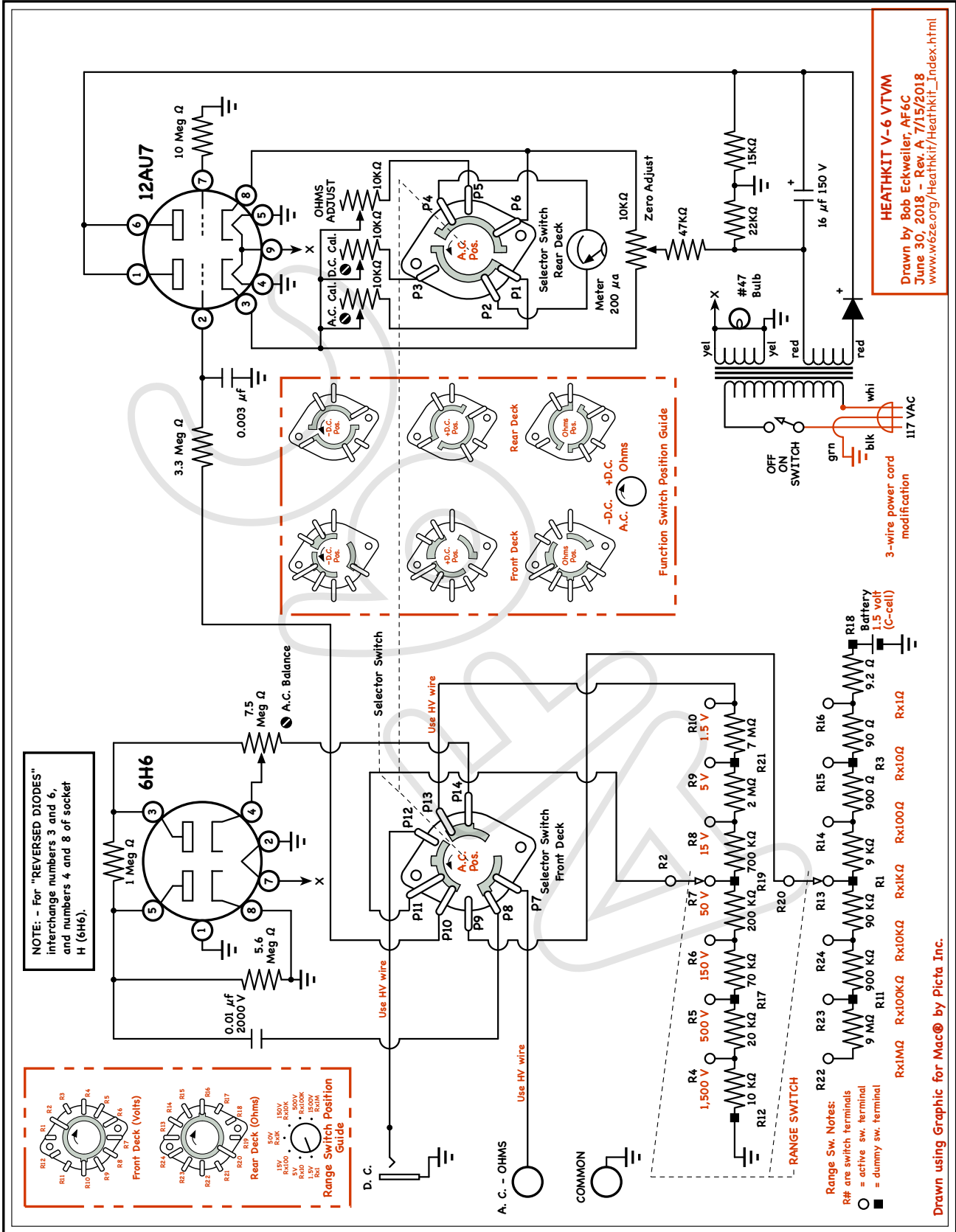

HEATHKIT V-6 VTVM
 Drawn by Bob Eckweiler, AF6C
 June 30, 2018 - Rev. A 7/15/2018
www.w6ze.org/Heathkit/Heathkit_Index.html

Figure 15: V-6 Schematic. A high resolution copy is at: www.w6ze.org/Heathkit/Sch/V-6-Sch.pdf