

TF 2175

TF 2175

R.F. Amplifier

INSTRUCTION MANUAL



MARCONI INSTRUMENTS

Instruction Manual
No. EB 2175
for

R.F. Amplifier
TF 2175

MARCONI INSTRUMENTS LIMITED
ST. ALBANS HERTFORDSHIRE ENGLAND



Contents

Chapter 1 GENERAL INFORMATION

1.1	Introduction	3
1.2	Data Summary	4

Chapter 2 OPERATION

2.1	Introduction	6
2.2	Installation	6
	2.2.1 Mains Voltage Setting	6
	2.2.2 Mains Fuse Rating	6
	2.2.3 Mains Lead Connection	7
2.3	Operation	7
2.4	Determination of Power Output Capability	7
	2.4.1 Output Load Impedance	7
	2.4.2 Distortion Level	8
	2.4.3 Noise Figure	9

Chapter 3 TECHNICAL DESCRIPTION

3.1	General Description	10
-----	---------------------	-----	-----	-----	-----	----

Chapter 4 MAINTENANCE

4.1	Introduction	11
4.2	Access and Layout	11
4.3	Performance Checks	11
	4.3.1 Initial Check	12
4.4	Re-alignment Procedure	13
	4.4.1 Measurement of Gain	13
	4.4.2 Measurement of Harmonics	14
	4.4.3 Measurement of Power Output	15
4.5	Packaging for Reshipment	15

Chapter 5 REPLACEABLE PARTS

5.1	Introduction	16
5.2	Ordering	16
5.3	Parts List	16

CIRCUIT DIAGRAM



1.1. INTRODUCTION

The TF 2175 RF Amplifier, consisting of a hybrid integrated circuit mounted on a micro-strip module, is a broad band power amplifier for use over the frequency range 2 MHz to 500 MHz.

With a gain of 27 dB, the TF 2175 is capable of delivering up to 300 mW into a 50 Ω load with very low harmonic and intermodulation distortion. Full output is obtainable with an input voltage of approximately 170 mV. The unit will withstand a +14 dB overdrive (input signal of 1 volt RMS) for all output load conditions and is unconditionally stable when connected to any load impedance (from open circuit to a short circuit condition) with absolute protection against damage or oscillation.

The TF 2175 with its wide frequency response and absence of any need to tune or readjust, provides a readily available means of extending the output power capability of signal generators, sweep generators and other signal sources.

With its low noise linear Class A design, the amplifier will operate over a wide range and faithfully reproduces pulse waveforms with rise times as short as 1 nanosecond. Thus, the unit is ideally suited for AM, FM and pulse modulation applications.

The low noise figure and high output makes it ideal for the amplification and distribution of signals over long cables or through multi-coupler networks.

As a drive source in Antenna, NMR and many other applications, the unit will provide essentially constant forward power, regardless of transducer load impedance.

1.2. DATA SUMMARY

FREQUENCY RANGE

Bandwidth	2 MHz to 500 MHz
Response characteristics	Flat ± 1 dB when feeding 50Ω load

OUTPUT LEVEL

Maximum Linear Power (Input for 300 mW output)	> 300 mW (24.8 dBm, 3.9 V/ $50\ \Omega$) 0.6 mW (-2.2 dBm, 170 mV/ $50\ \Omega$)
---	---

GAIN

27 dB ± 1 dB

OUTPUT IMPEDANCE

$50\ \Omega$

SIGNAL PURITY

Harmonic Distortion	Total harmonic content is less than -30 dB relative to fundamental (at 200 mW)
---------------------	--

Typical 3rd Order Intermodulation Intercept Point	+35 dBm
---	---------

NOISE FIGURE

Less than 9.5 dB (typically 8 dB)

DYNAMIC RANGE

> 80 dB

STABILITY

Unconditionally stable

INPUT CONDITIONS

Input Impedance
VSWR
Protection

50 Ω
< 2.1
Unit will withstand a +14 dB over-
drive (input signal of 1 volt RMS) for
all output load conditions.

CONNECTORS

BNC

POWER REQUIREMENTS

115, 230 V a. c. $\pm 12\%$
50-400 Hz at 12 watts

SIZE AND WEIGHT

Height	Width	Length	Weight
98 mm	165 mm	112 mm	1.13 kg
(3 $\frac{1}{2}$ inch)	(6 $\frac{1}{2}$ inch)	(4 $\frac{1}{2}$ inch)	(2.5 lbs)

2.1 INTRODUCTION

The TF 2175 RF Amplifier is used to increase the r. f. output level of signal sources in the 2 to 500 MHz range. No tuning or any other form of adjustment is required other than the selection of the correct power supply input voltage.

The Amplifier is unconditionally stable and can be connected into any load impedance with absolute protection against damage or oscillation.

2.2 INSTALLATION

The TF 2175 RF Amplifier is housed in a hooded aluminium instrument case. The front and rear panels forming part of the "U" section chassis. The unit is supported on four rubber feet fitted on the base of the chassis.

2.2.1 Mains Voltage Setting

The supply voltage selection switch is located at the rear of the instrument and is normally set for 230 V a. c. operation.

CAUTION

Before connecting the unit to the mains supply, check that the supply voltage selection switch is correctly set. Extensive damage will result if the Amplifier is connected to the wrong supply voltage. Under no circumstances should this switch be operated whilst the supply is connected.

2.2.2 Mains Fuse Rating

The mains fuse F1 is located on the rear panel. The replacement part number and details are:-

0.5 amp

Slow Blow

M.I. Part No. FPP/23401

The 0.5 amp rating is correct for both 115 and 230 volt a. c. mains working.

2.2.3 Mains Lead Connection

A suitable mains supply plug must be fitted to the mains lead attached to the instrument. The three conductors are colour coded according to the international standards as follows:-

Brown	-	LIVE
Blue	-	NEUTRAL
Green/Yellow	-	EARTH

2.3 OPERATION

Determine and adjust the voltage setting and fuse rating as described in the previous Chapters 2.2.1 and 2.2.2. then proceed as follows:

- (i) Ensure input voltage is not excessive

CAUTION

The 1V indicated maximum input voltage is five times the level of the input signal (170 mV RMS) required to achieve maximum output (300 mW). Input voltages in excess of 1 V may permanently damage the instrument.

- (ii) Connect input signal via a 50 Ω co-axial lead and BNC plug to the input sockets.
- (iii) Connect the output via a 50 Ω co-axial lead and BNC plug to the load. Chapter 2.4 gives advice in determining output power capability.

2.4 DETERMINATION OF POWER OUTPUT CAPABILITY

The power output capability of an amplifier is meaningful only when the output load impedance and distortion level specifications are also considered.

2.4.1 Output Load Impedance

Output Load Impedance is not necessarily similar to output impedance and in the case of the TF 2175 is not related.

The output load impedance refers to the optimum load impedance which when connected to the amplifier output will produce specified output power.

The TF 2175 produces the rated power output at the output connectors, regardless of load impedance. Any power reflected due to output load mismatch is absorbed in the amplifier. Therefore although the output impedance is 50 Ω

(typical VSWR 2:1) the amplifier will work into any load impedance.

2.4.2 Distortion Level

There are two types of distortion which must be considered when using the TF 2175, they are Total Harmonic Distortion and Intermodulation Distortion.

TOTAL HARMONIC DISTORTION is the sum of all the harmonics generated by the amplifier and is defined as

$$\begin{aligned} \% \text{ THD} &= \sqrt{E_2^2 + E_3^2 + E_4^2 + \dots} \times 100 \\ \text{where } E_2 &= \frac{E \text{ 2nd harmonic}}{E \text{ fundamental}} \\ E_3 &= \frac{E \text{ 3rd harmonic}}{E \text{ fundamental}} \text{ etc.} \end{aligned}$$

Therefore if the Total Harmonic Distortion is 6%, the power in all of the harmonics is 0.36% of the power in the fundamental.

The 2nd harmonic is the highest level harmonic present at the output and is typically better than 30 dB down on the fundamental at 200 mW output.

NOTE Distortion level is strictly dependent on power output. The lower the power output, the lower the percentage distortion.

The 2nd harmonic distortion output decreases twice as fast as the fundamental power output, therefore at half power the 2nd harmonic is typically better than -36 dB down from the fundamental.

INTERMODULATION DISTORTION is the mixing products, generated by the non-linear properties of an amplifier of a two tone test signal. The 3rd Order Intermodulation Intercept Point is one method used to specify this type of distortion.

3RD ORDER INTERMODULATION INTERCEPT POINT is the theoretical power level at which the 3rd order products of a two-tone test signal are equal to the test signal output (the amplifier would saturate before this point was reached). The TF 2175 has a 3rd Order Intermodulation Intercept Point of +35 dBm.

This method is easier to use and more accurate than say the compression method.

Example - To calculate the maximum peak envelope power obtainable from a TF 2175 with intermodulation products not greater than 32 dB.

- i) Subtract half the acceptable intermodulation distortion from the intercept point.

$$+35 \text{ dBm} - \frac{32 \text{ dB}}{2} = 19 \text{ dBm}$$

(Remember the distortion power decreases twice as fast as the fundamental power decrease)

- ii) 19 dBm (79 mW) is the power in each signal. To convert to peak envelope power multiply by 4

$$79 \text{ mW} \times 4 = 316 \text{ mW p.e.p.}$$

2.4.3 Noise Figure

NOISE FIGURE is the noise contributed by the amplifier. The Noise Figure for the TF 2175 is less than 9.5 dB (typically <8. dB). This means that the equivalent noise at the input is 9.5 dB higher than that produced by thermal energy.

$$P \text{ equivalent noise} = P \text{ thermal} + 9.5 \text{ dB}$$

$$(\text{assume } P \text{ thermal approximates to } -92 \text{ dBm})$$

$$P \text{ equivalent noise} = -92 \text{ dBm} + 9.5 \text{ dB} = -82.5 \text{ dBm}$$

$$P \text{ equivalent noise} = 0.56 \times 10^{-11} \text{ watts}$$

Since the equivalent input noise is -82.5 dBm and the signal required for maximum output of 300 mW is -2.2 dBm, the dynamic range of the TF 2175 is -80.3 dBm.

Translation of Noise Figure into equivalent noise voltage is as follows:-

$$\begin{aligned} E \text{ equivalent noise} &= \sqrt{P \cdot R} \\ &= \sqrt{0.56 \times 10^{-11} \times 50 \text{ Volts}} \\ &= \sqrt{280 \times 10^{-12} \text{ Volts}} \\ &= 16.7 \mu\text{V} \end{aligned}$$

3.1 GENERAL DESCRIPTION

The TF 2175 is designed to amplify signals by 27 dB in the frequency band 2 to 500 MHz. The signal from the front panel BNC connector is fed via a length of micro-strip transmission line to a π network attenuator R1, R2, and R3. The attenuator is adjusted during alignment to ensure that the gain of the amplifier is 27 dB.

The output from the attenuator is then fed via impedance matching transformer T2 to a thin film amplifier module ENI 802 which has been specially developed for this instrument. The ENI 802 consists of a four transistor circuit mounted on a 0.5 inch x 1.0 inch alumina substrate. The transistor chips are bonded to 'heat spreaders' to reduce their operational temperature and therefore permit higher power output.

Transformer T3 and trimmer capacitor C7 match the power output stage of the module to the 50 Ω output line.

The TF 2175 power requirements are 115 V or 230 V a. c. The power supply unit provides a 24 V d. c. 300 mA source, regulated by the series pass transistor Q2 and integrated circuit regulator Q3 mounted on the mother board, adjacent to the amplifier module. R7 adjusts the d. c. rail to 24 volts.

The light emitting diode D1, connected to the regulated output and mounted on the front panel, will indicate when the power supply is operating.

4.1 INTRODUCTION

The TF 2175 RF Amplifier requires no periodic maintenance. The instrument is unconditionally stable and is therefore 'failsafe' under all load conditions. Damage can only be caused by the incorrect selection of the supply voltage or by an input signal in excess of the specified 1 volt maximum.

This Chapter therefore deals only with certain fundamental procedures for fault location and with the subsequent re-alignment procedures.

Performance limits quoted are for guidance only and should not be taken for guaranteed performance specifications unless they are also quoted in the Data Summary Chapter 1.2.

In case of difficulties which cannot be resolved with the aid of this manual, please contact our Service Division at the address stated on the back cover, or your nearest Marconi Instruments representative quoting the type and serial number of the instrument. If the instrument is being returned for repair, please indicate clearly the nature of the fault or the work you require to be done.

4.2 ACCESS AND LAYOUT

The TF 2175 RF Amplifier is housed in a hooded aluminium case. The front and rear panels forming part of the "U" section chassis. The hooded cover can be detached by releasing the four 4-40 ANC Phillips headed screws located on the sides of the instrument.

The rear panel supports the mains fuse unit and the mains input voltage selector switch (S2) and also acts as a heat sink for integrated circuit Q1.

CAUTION

Do not remove the amplifier and module retaining screws, as the units must be precisely aligned for proper mechanical fit.

4.3 PERFORMANCE CHECKS

To determine the amplifier's efficiency carry out the following procedure.

4.3.1 Initial Check

The follow check can be made following repair and adjustments or whenever the condition of the unit is in question.

- (i) Connect power supply. Switch on power and observe that the supply lamp (D1) illuminates.
- (ii) Connect a sweep generator (TF 2361 or similar) capable of sweeping the frequency range 2 to 500 MHz to the input connector.
- (iii) Adjust the output level of the sweep generator so that a 50 Ω video detector connected at the output of the TF 2175 will not be damaged by excessive power output.
- (iv) Observe the gain versus frequency ripple on an oscilloscope calibrated in decibels. The gain variation must be not more than ± 1 dB over the frequency range.
- (v) Connect a calorimetric power meter through a short length of 50 Ω cable to the output connector. Adjust the input CW signal at any frequency between 2 and 500 MHz for 200 mW output.
- (vi) Observe the harmonic distortion of the output on a spectrum analyser. The harmonic components contributed by the amplifier must be more than 30 dB down from the fundamental.

If the requirements of this check are not met, verify that -

- (a) the mains supply switch and fuse are correctly selected and that D1 is illuminated.
- (b) the voltage at the emitter of Q2 is set at 24.25 volts by R7.

If the above checks are found to be correct, then normal fault location procedures, with reference to the circuit diagram Fig. 7.1 should be followed to determine the correct operation of the attenuator, amplifier module (ENI 802) and matching transformers T2 and T3.

If the ENI 802 module is found to be faulty it will be necessary to obtain a replacement module from our Service Division or return the complete unit for repair.

Replacement of the module or any other part of the signal line will require the instrument to be re-aligned.

4.4 RE-ALIGNMENT PROCEDURE

Before any adjustment is made to the TF 2175, first

- (i) Ensure that the mains switch and fuse are correctly selected and that D1 is illuminated.
- (ii) Measure the voltage at Q2 emitter and adjust for an indicated 24.25 volts.

4.4.1 Measurement of Gain

Equipment required -

TF 2361 Sweep Generator with TM 9693 and TM 9694
TF 2212A X-Y Display
TM 9701 VHF/UHF Detector

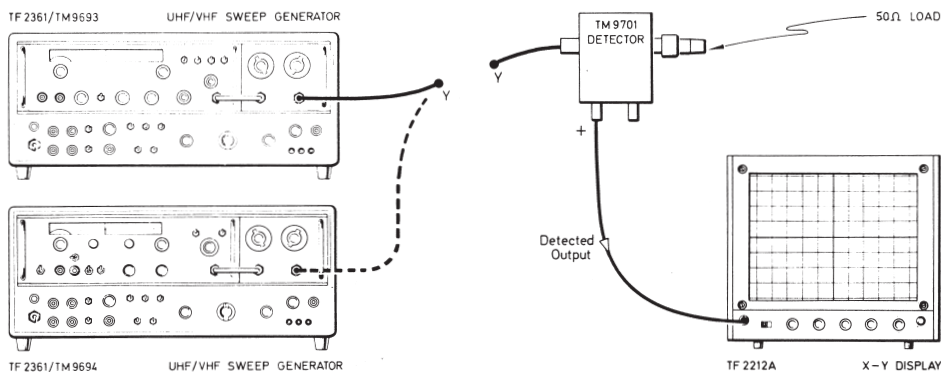

Fig. 4.1 Gain Measurement

Connect the equipment as shown in Fig. 4.1, then proceed as follows:-

- (i) Adjust the VHF Sweep Generator to sweep 2 MHz to 220 MHz, CW mode and with the output set at 0dB.
- (ii) Align the TF 2212 display to one of the centre graticule lines. Check the flatness of the response, noting the low and high extremes, their frequency and level.
- (iii) Reduce the output of the TF 2361 by 27 dB using the calibrated attenuator.
- (iv) Insert the TF 2175 at points Y-Y and observe the TF 2212 display which should be centred on the original line in (ii). This is the amplifier gain and should be within 27 dB \pm 1dB.

- (v) Determine and record the lowest and highest peaks, allowing for the variations observed in (ii) also note the level at 220 MHz.
- (vi) Replace the TM 9693 VHF unit with the TM 9694 UHF unit. Repeat checks (i) to (v) for the frequency band 220 MHz to 500 MHz, ensuring that the level indicated at 220 MHz is the same as that recorded in check (v) using the VHF unit.
- (vii) Check that the lowest and highest peaks over the whole frequency range 2 to 500 MHz does not differ by more than 1 dB from the amplifier gain determined in check (iv).
- (viii) The amplifier response can be varied by (a) inserting or increasing the value of R4 across the line input and earth (shown dotted on the circuit diagram). An increase in the value of R4 will reduce the gain of the amplifier, or by (b) adjusting the value of C7 to vary the high frequency response.
- (ix) Repeat (i) to (v)

4.4.2 Measurement of Harmonics

Equipment required -

- TF 2011 VHF/FM Signal Generator 130-180 MHz
- TF 2603 RF Electronic Millivoltmeter
- VHF/UHF Spectrum Analyser

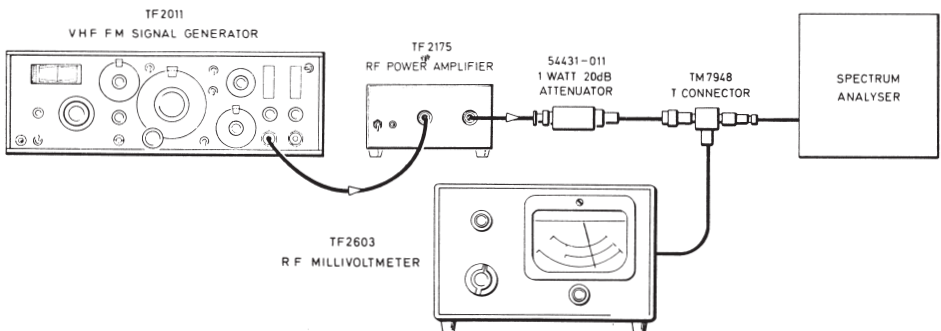

Fig. 4.2 Harmonic Measurement

Connect the equipment as shown in Fig. 4.2. then proceed as follows:-

- (i) Adjust the signal generator at 150 MHz for an indicated output of 316 mV on the TF 2603.
- (ii) Using the spectrum analyser check that the level of the carrier harmonics are less than -30 dB with respect to the carrier.

4.4.3 Measurement of Power Output

Equipment required:-

TF 801D/1 VHF/UHF Signal Generator
TF 2501 RF Power Meter
TF 2603 RF Electronic Millivoltmeter

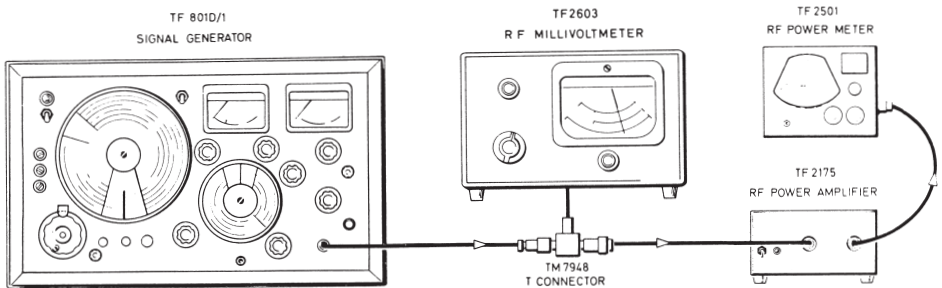

Fig 4.3 Power Output Measurement

Connect the equipment as shown in Fig. 4.3 and proceed as follows:-

- (i) Adjust the output of the TF 801D/1 Signal Generator to 500 mV at 200 MHz and check that the TF 2501 indicates an output from the TF 2175 of greater than 300 mW.
- (ii) Reduce the output of the TF 801D/1 until the TF 2501 just indicates 300 mW. Ensure that the output of the TF 801D/1 as indicated on the Voltmeter is approximately 170 mV.

4.5 PACKAGING FOR RESHIPMENT

In the event of the equipment being returned for servicing it should be packed in the original shipping carton and packing material. If this is not available wrap the instrument in heavy paper or plastic and place in a rigid outer box of wood, fibre-board or very strong corrugated cardboard. Use ample soft packing to prevent movement. Provide additional support for projecting parts to relieve these of unnecessary shock. Close the carton securely and seal with durable tape. Mark the shipping container FRAGILE to ensure careful handling.

5.1 INTRODUCTION

The circuit reference numbers are listed in alpha-numerical order. The following abbreviations are used:-

B	Bridge Rectifier	Q	Transistor/integrated circuit
C	Capacitor	R	Resistor
D	Diode	S	Switch
Elect	Electrolytic	T	Transformer
F	Fuse	W	Watts
J	Connector		

5.2 ORDERING

When ordering replacements of spare parts, address order to -

Marconi Instruments Service Division
The Airport,
Luton, Bedfordshire

or to your nearest representative. Please specify the following information for each part required.

- (i) Type of instrument (TF 2175)
- (ii) Circuit reference number (C1)
- (iii) Description of part (2 pF $\pm 5\%$ Ceramic)
- (iv) M. I. Part Number (FPP/26001)

5.3 PARTS LIST

Circuit Reference	Description	M. I. Part Number (FPP/TF 2175....)
Rectifier		
B1	2A 75 PIV	28102
Capacitors		
C1, 2, 11	2 pF $\pm 5\%$ Ceramic	26001
C3	4.7 pF Ceramic	26002
C4, 6	0.012 μ F Ceramic	26003

Circuit Reference	Description	MI. Part Number (FPP/TF 2175...)
Capacitors		
C5	0.033 μ F Ceramic	26004
C7	1.7 - 10 pF Variable	26005
C8	500 μ F 50 V Elect	26006
C9	0.1 μ F Ceramic	26007
C10	560 pF 500 V d.c Ceramic	26008
Diodes		
D1	Pilot lamp (LED)	28101
Fuse		
F1	0.5 A 3AG Slow Blow for 115 V	23401
Sockets		
J1	BNC socket (INPUT)	23001
J2	BNC socket (OUTPUT)	23001
Transistor and Integrated Circuits		
Q1	ENI 802 (2-500 MHz Amplifier)	28401
Q2	40312	28201
Q3	μ A 723T (Voltage Regulator)	28402
Resistors		
R1, R3	390 Ω $\pm 5\%$ $\frac{1}{4}$ W	24001
R2	12 Ω $\pm 5\%$ $\frac{1}{4}$ W	24002
R5	2.2 k Ω $\pm 5\%$ $\frac{1}{4}$ W	24003
R6	6.8 k Ω $\pm 5\%$ $\frac{1}{2}$ W	24004
R7	200 Ω $\pm 5\%$ $\frac{1}{2}$ W Variable	25001
R8	2.7 k Ω $\pm 5\%$ $\frac{1}{2}$ W	24005
Switches		
S1	SPDT toggle (POWER)	23101
S2	DPDT slide (230/115 V)	23102
Transformers		
T1	AM 6400A (Mains) 117-234 V AC	43101
T2	ENI (matching)	43102
T2	ENI (matching)	43103

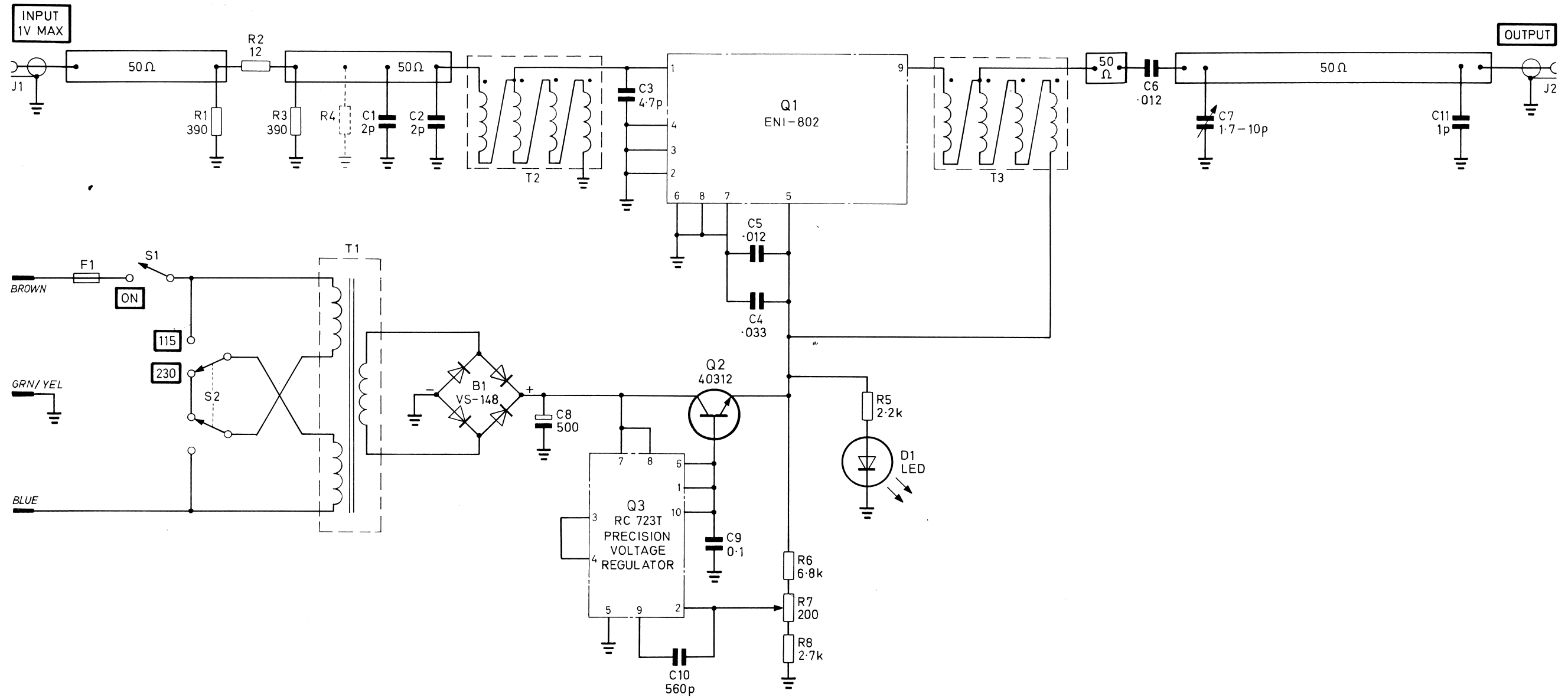

Fig. 7.1 TF 2175 RF Amplifier
Circuit Diagram

MARCONI INSTRUMENTS LIMITED

SERVICE DIVISION

**THE AIRPORT, LUTON,
BEDFORDSHIRE LU2 9NS**

Telephone : Luton 33866

**HOME and EXPORT
SALES OFFICES**

**LONGACRES, ST. ALBANS,
HERTFORDSHIRE AL4 0JN**

*Telephone : St. Albans 59292
Telegrams : Measurtest, St. Albans
Telex : 23350*

U.S.A.

**MARCONI INSTRUMENTS DIVISION,
MARCONI ELECTRONICS INC.,
100 STONEHURST COURT, NORTHVALE,
NEW JERSEY 07647**

*Telephone : (201) 767-7250
Telex : 710-991-9752*

**BUNDESREPUBLIK
DEUTSCHLAND**

**MARCONI MESSTECHNIK G.m.b.H.,
P.O. BOX NO. 210330
JOERGSTRASSE 74
8 MUNICH 21**

*Telephone : 582041
Telex : 05 24642*

FRANCE

**MARCONI INSTRUMENTS,
SUCCURSALE DE FRANCE,
32 AVENUE DES ECOLES,
91600 SAVIGNY SUR ORGE**

*Telephone : 921.93.86
Telex : 60541*

A GEC MARCONI ELECTRONICS COMPANY