

Tektronix[®]
COMMITTED TO EXCELLENCE

**308 DATA
ANALYZER**

OPERATORS

INSTRUCTION MANUAL

TABLE OF CONTENTS

	Page		Page
LIST OF ILLUSTRATIONS	ii	OPERATORS FAMILIARIZATION	
LIST OF TABLES	iv	POWERING UP THE 308	34
OPERATOR'S SAFETY SUMMARY	v	THE CONTROL FUNCTION ACCESS	
GENERAL INFORMATION		CHART	34
INTRODUCTION		THE NEXT STATE TABLE	34
DESCRIPTION	1	BASIC OPERATING INFORMATION	37
MODES OF OPERATION	1	DATA ACQUISITION	51
ACCESSORIES	2	DISPLAYING DATA	71
OPERATING INSTRUCTIONS		APPLICATION EXAMPLE	
INSTALLATION		INTRODUCTION	
POWER REQUIREMENTS	3	SIGNATURE VERIFICATION	76
POWER CORD	3	PARALLEL AND SERIAL DATA	
PROBE CONNECTION	4	ACQUISITION	79
CONTROLS, CONNECTORS AND		SPECIFICATION	83
INDICATORS		ACCESSORIES	107
ACQUISITION CONTROLS	9	APPENDIX A	108
INSTRUMENT AND DISPLAY MODE		NOTES	
CONTROLS	12	CHANGE INFORMATION	
ENTRY CONTROLS	14		
SIGNATURE CONTROLS	16		
INPUT CONTROLS AND CONNECTORS	16		
OPERATORS CHECKOUT PROCEDURE	24		
DIAGNOSTICS	24		

LIST OF ILLUSTRATIONS

Figure No.		Page No.	Figure No.		Page No.
	Frontis The 308 Data Analyzer	vi	12	Serial Inputs and Display	20
1	Location of the Line Voltage Indicator ..	3	13	Parallel Inputs/Outputs and Display	21
2	Connecting the Power Cord	4	14	Signature Inputs and Display	22
3	Optional Power Cords for the 308	5	15	Data Transitions, Filter Adjustment, and Triggering	23
4	Connecting the 308 Using a Data Analyzer Probe	6	16	Typical 308 Error Message	26
5	Connecting the 308 Using a Word Recognizer Probe	7	17	308 Diagnostic Test Setup	27
6	Connecting the 308 Using a 10X Serial Signature Probe	8	18	308 Diagnostic Menu	28
7	Acquisition Controls and Indicators	11	19	308 Diagnostic \emptyset Keyboard Code	29
8	Instrument and Display Mode Controls ..	13	20	Typical 308 Diagnostic Displays	32
9	Entry Controls	15	21	Diagnostic #5 Reference Pattern	33
10	Signature Controls	17	22	Next State Table	36
11	Right Side Panel Controls and Connectors	19	23	Basic 308 Acquisition and Display System	38
			24	Positive Logic with Number Assignments to Voltage Inputs	39

LIST OF ILLUSTRATIONS (cont)

Figure No.		Page No.	Figure No.		Page No.
25	Sampling with the Internal Sample Rate Generator	40	33	Triggering on Events Other Than Data ..	50
26	Using an External Clock to Control Sample Rate	41	34	Parallel Acquisition Menu	55
27	Using the Internal Sample Rate Generator with a Minimum Data Width (in Sample Mode)	42	35	Serial Acquisition Menu	55
28	Setup and Hold Time for an External Clock	43	36	Asynchronous Serial Data	59
29	Finding Glitches When Sampling Synchronously	44	37	Synchronous Serial Data	61
30	Asynchronous Sampling for Infrequent Short Events	45	38	Resynchronization Time Requirements ..	62
31	Data Storage In the POST Trigger Data Mode	47	39	Typical Signature Data Sequences	68
32	Data Storage in the PRE Trigger Data Mode	49	40	Data to Signature Sequence	69
			41	Test Schematic for the 308 Application Example	77
			42	308 Dimensional Drawing	106
			43	Control Function Access Chart	111

LIST OF TABLES

Table No.		Page No.	Table No.		Page No.
1	Power-up Error Codes	25	5	Application Example Signature List	78
2	Equipment Required for User-Initiated Diagnostic Tests	25	6	Electrical Characteristics	83
3	User-Initiated Diagnostics	30	7	Environmental Characteristics	104
4	Parallel And Serial Acquisition Parameters	52	8	Physical Characteristics	105

OPERATORS SAFETY SUMMARY

The general safety information in this part of the summary is for both operating and servicing personnel. Specific warnings and cautions will be found throughout the manual where they apply, but may not appear in this summary.

TERMS

In This Manual

CAUTION statements identify conditions or practices that could result in damage to the equipment or other property.

WARNING statements identify conditions or practices that could result in personal injury or loss of life.

As Marked on Equipment

CAUTION indicates a personal injury hazard not immediately accessible as one reads the marking, or a hazard to property including the equipment itself.

DANGER indicates a personal injury hazard immediately accessible as one reads the marking.

SYMBOLS

As Marked on Equipment

 **DANGER** — High voltage.

 Protective ground (earth) terminal.

Power Source

This product is intended to operate from a power source that will not apply more than 250 volts rms between the supply conductors or between either supply conductor and ground. A protective ground connection by way of the grounding conductor in the power cord is essential for safe operation.

Grounding the Product

This product is grounded through the grounding conductor of the power cord. To avoid electrical shock, plug the power cord into a properly wired receptacle before connecting to the product input or output terminals. A protective ground connection by way of the grounding conductor in the power cord is essential for safe operation.

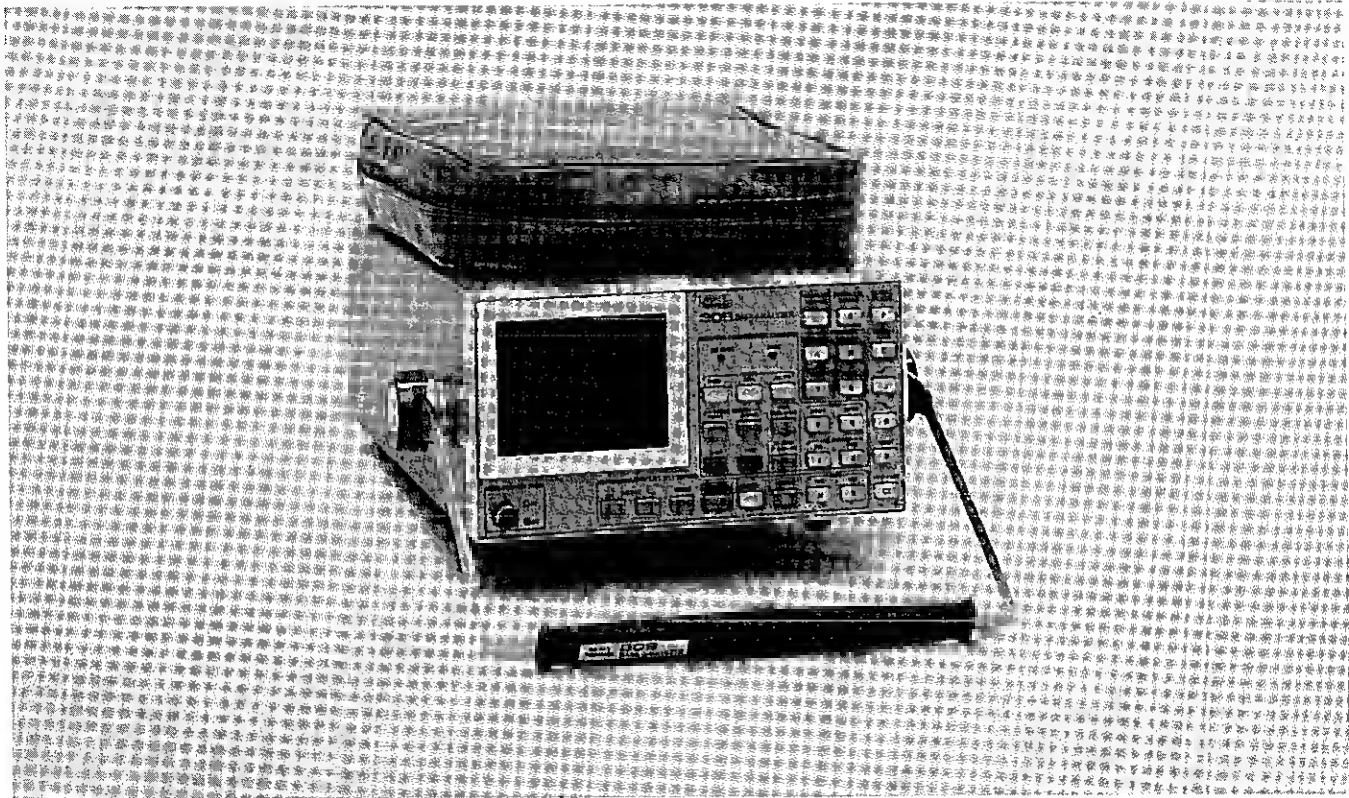

The 308 Data Analyzer.

2663-01

GENERAL INFORMATION

INTRODUCTION

DESCRIPTION

The Sony/Tektronix 308 is a keyboard-controlled, multifunctional, portable data analyzer. Intended to meet the need for a portable and inexpensive service aid. The 308 can also be used as a digital design instrument and as a production-line checkout tool for in-circuit tests. Four modes of operation provide the user with a variety of data-analyzing methods. This instrument can be used for timing analysis of parallel signals, state analysis of parallel signals, state analysis of serial transmissions (including data communications), and signature analysis.

MODES OF OPERATION

Parallel Timing Analyzer Function

When used as a Parallel Timing analyzer, the 308 provides an eight-channel input, a 20 MHz clock speed, and 252 bits/channel memory size. The eight-channel

parallel word recognizer triggers upon recognition of a preset digital word. This word-recognition capability is expandable to 24 channels with an accessory word recognizer probe. If no preset data is specified, the 308 software immediately generates an internal trigger at the start of an acquisition. The digital delay counts up to 65,535 clocks. Data sampled before or after the delayed trigger can be stored either at sample intervals ranging from 50 ns to 200 ms or synchronously with an external clock. The latch input allows the 308 to capture glitches narrower than the sample interval. Stored data is displayed on the CRT in digitized timing format representing the HI and LO levels of the stored data, but not the actual waveform.

Parallel State Analyzer Function

The Parallel State Analyzer function is identical to the Parallel Timing Analyzer function except for the display. Data is displayed in binary, octal, and hexadecimal formats.

Serial State Analyzer Function

When operated as a Serial State analyzer, the 308 receives serial data which conforms to EIA STD RS-232-C. Data of five, six, seven, or eight bits per character may be inputted using either synchronous or asynchronous timing. A two-character word recognizer provides internal triggering upon recognition of a preset digital word. The digital delay counts up to 65,535 words. Data sampled before or after the delayed trigger can be stored, using an internal clock, at baud rates of 50 Hz to 9.6 kHz or using an external clock. Stored data is displayed on the crt readout in binary, hexadecimal, and ASCII formats.

Signature Analyzer Function

The Signature Analyzer function provides data inputs, start-stop gating inputs, and a 20 MHz clock input. A sequence of data between the start and stop gates is converted to a four-digit word and displayed as a four-digit signature.

USING THE 308

The 308 is a versatile service and design aid that features simplicity of operation while being adaptable to a wide variety of applications. Qualified personnel can first establish the proper setup for a particular application (e.g., trigger data, display mode, and entry format). Operators can then use the instrument to make routine in-circuit tests. Illustrations contained in this manual may also be helpful as guides. There are many variables at the operator's control that affect the mode, timing, comparison of previously-acquired data with new data, and other subfunctions. These are easily selected if needed.

Several examples that may be adapted to your particular needs are shown in this manual. These are but a few; many more uses will be found with continued utilization of the 308.

ACCESSORIES

For information on the accessories used with the 308, see the Accessories page at the rear of this manual.

OPERATING INSTRUCTIONS

INSTALLATION

Installation consists of selecting the appropriate operating voltage, connecting the 308 to a power input source, and connecting the probe (or probes) as required to the 308 and the circuit under test.

POWER REQUIREMENTS

The 308 operates from a nominal 115 or 230 V, 48 to 440 Hz, single-phase power input source. Before connecting the instrument to a power source, verify that the line-voltage indicator on the bottom of the instrument is displaying the correct nominal voltage for the power input source to be used (refer to Figure 1).



If the line-voltage indicator shows the wrong voltage for the power input source to be used, refer the instrument to qualified service personnel.

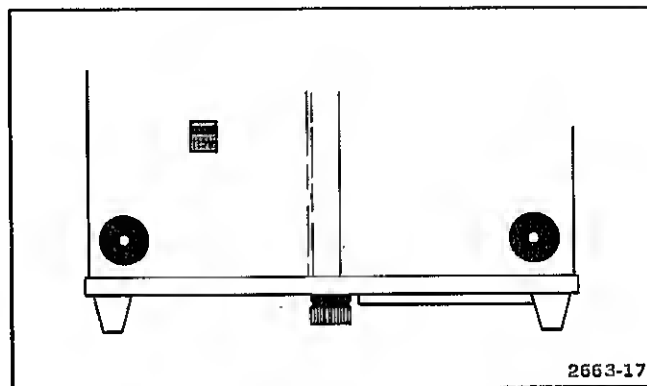

Figure 1. Location of the Line-Voltage Indicator.

POWER CORD

This equipment has a 3-wire power cord with a 3-contact plug for connection to the power source and to protective ground. The plug protective-ground contact

connects (through the power cord protective-grounding conductor) to the accessible metal parts of the equipment. For electrical-shock protection, insert this plug into a power input source socket that has a securely grounded protective-ground contact.

The power cord is detachable (refer to Figure 2). When not in use it should be stored in the accessory pouch.

Instruments are usually factory equipped with a 115 V power cord unless otherwise ordered. Other cords that

can be used with the tester are shown in Figure 3. For more information on power cords, contact your Tektronix representative or your local Tektronix Field Office.

PROBE CONNECTIONS

The basic connections and the proper connectors for the three different types of probes used with the 308 are illustrated in Figures 4, 5, and 6.

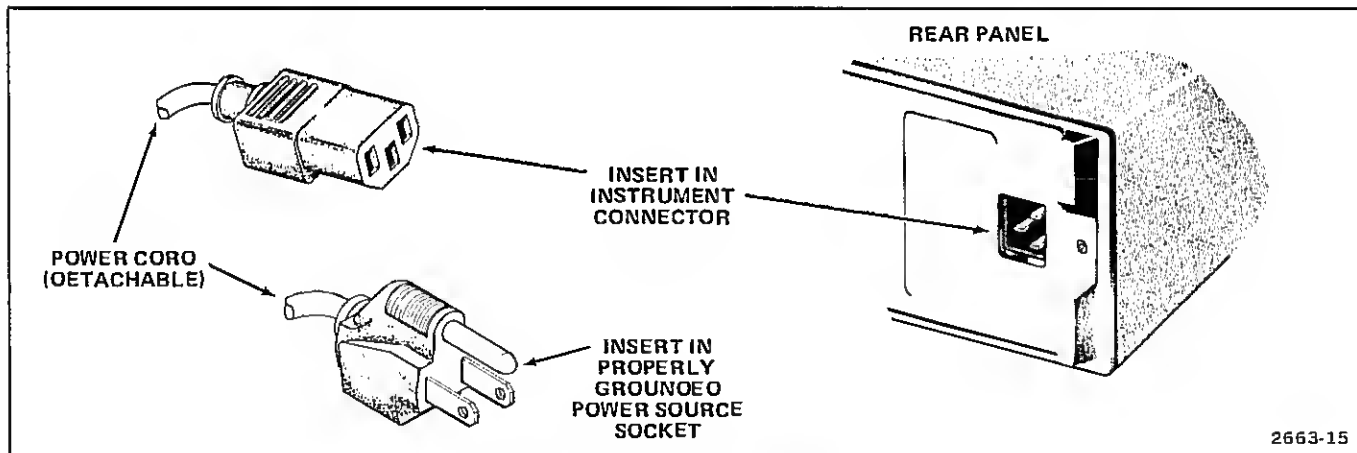
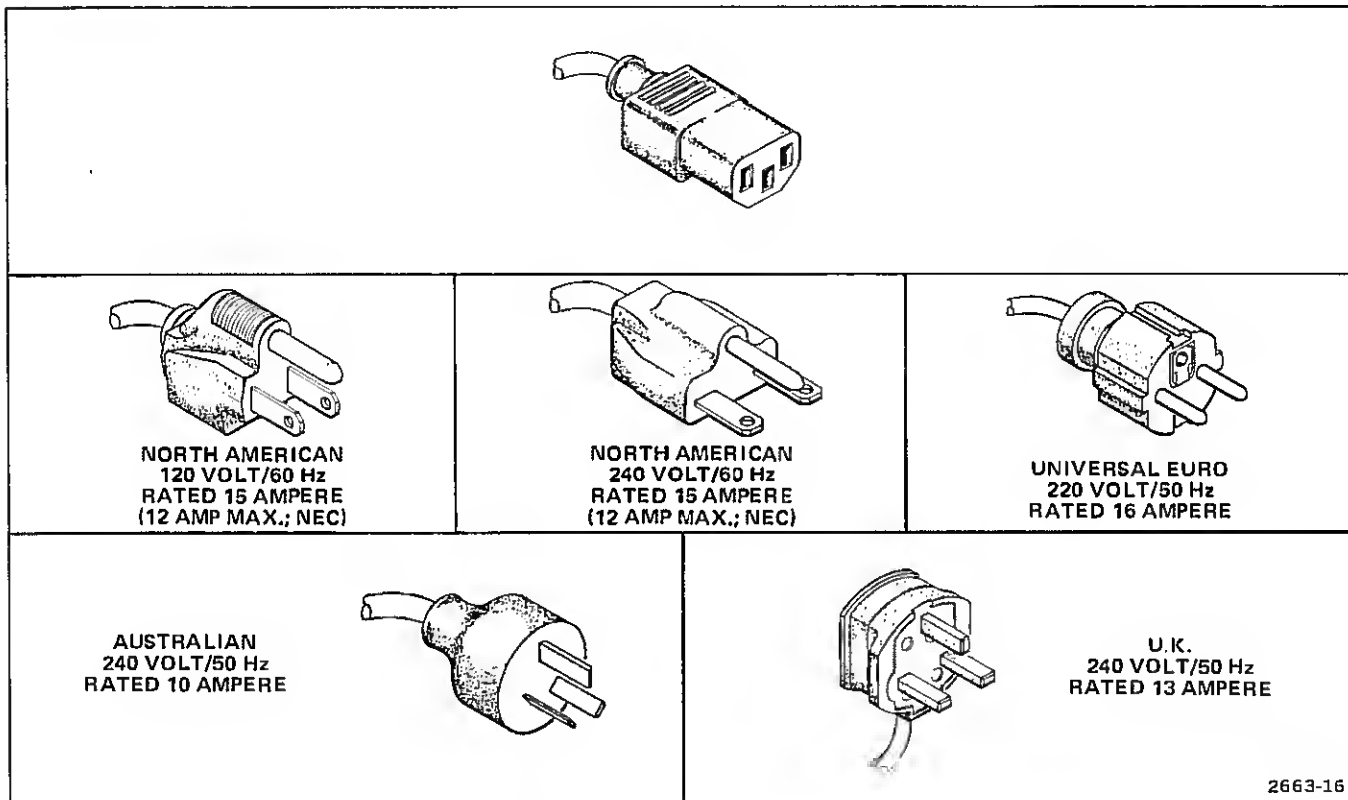

Figure 2. Connecting the Power Cord.



2663-16

Figure 3. Optional Power Cords for the 308.

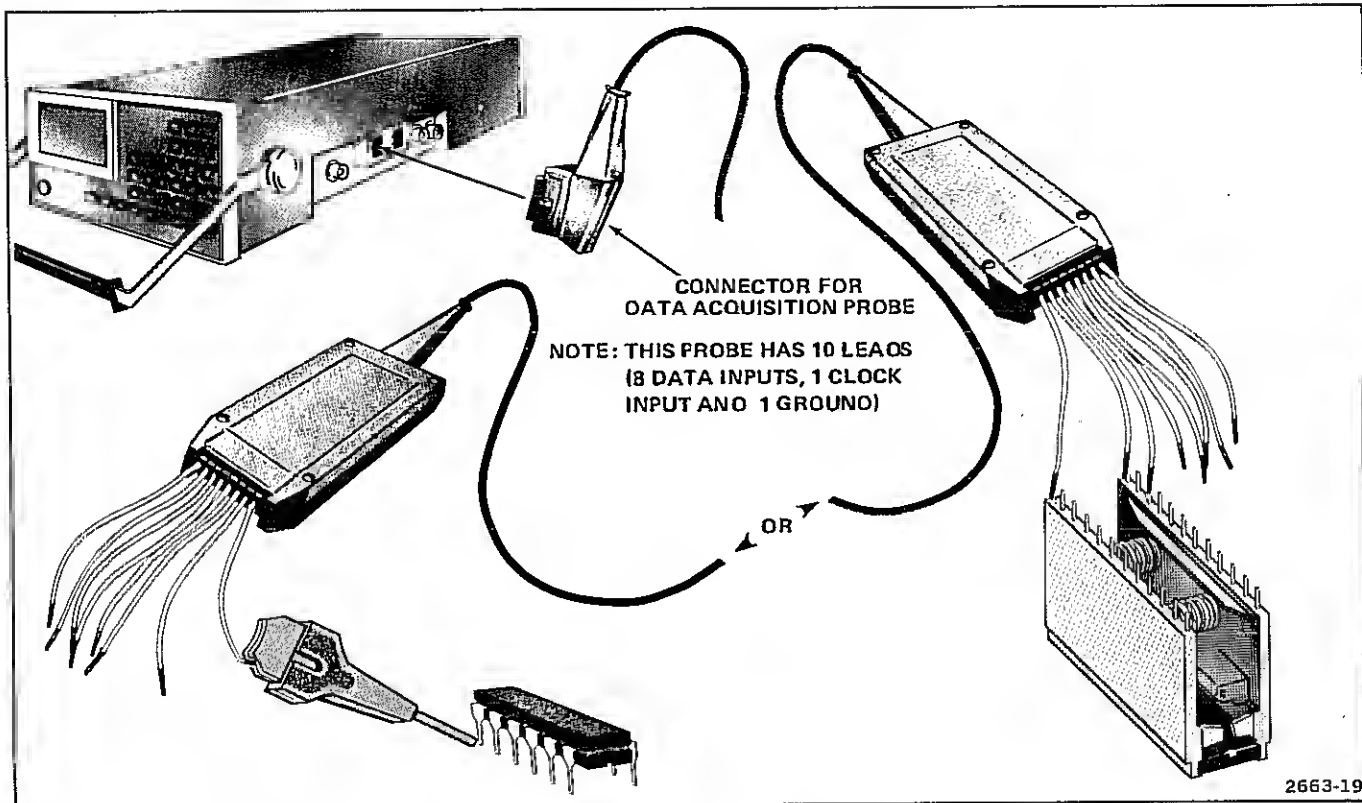

Figure 4. Connecting the 308 Using a Data Analyzer Probe.

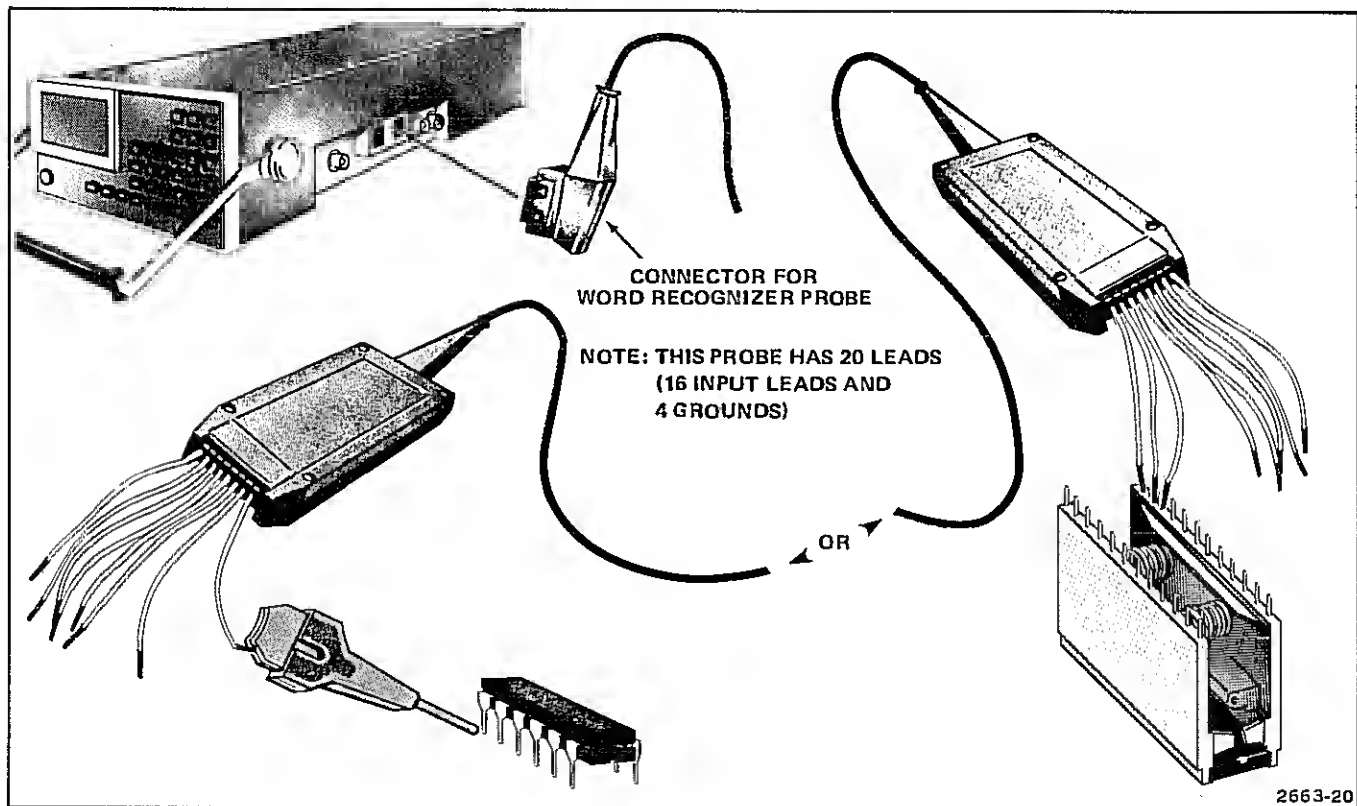

Figure 5. Connecting the 308 Using a Word Recognizer Probe.

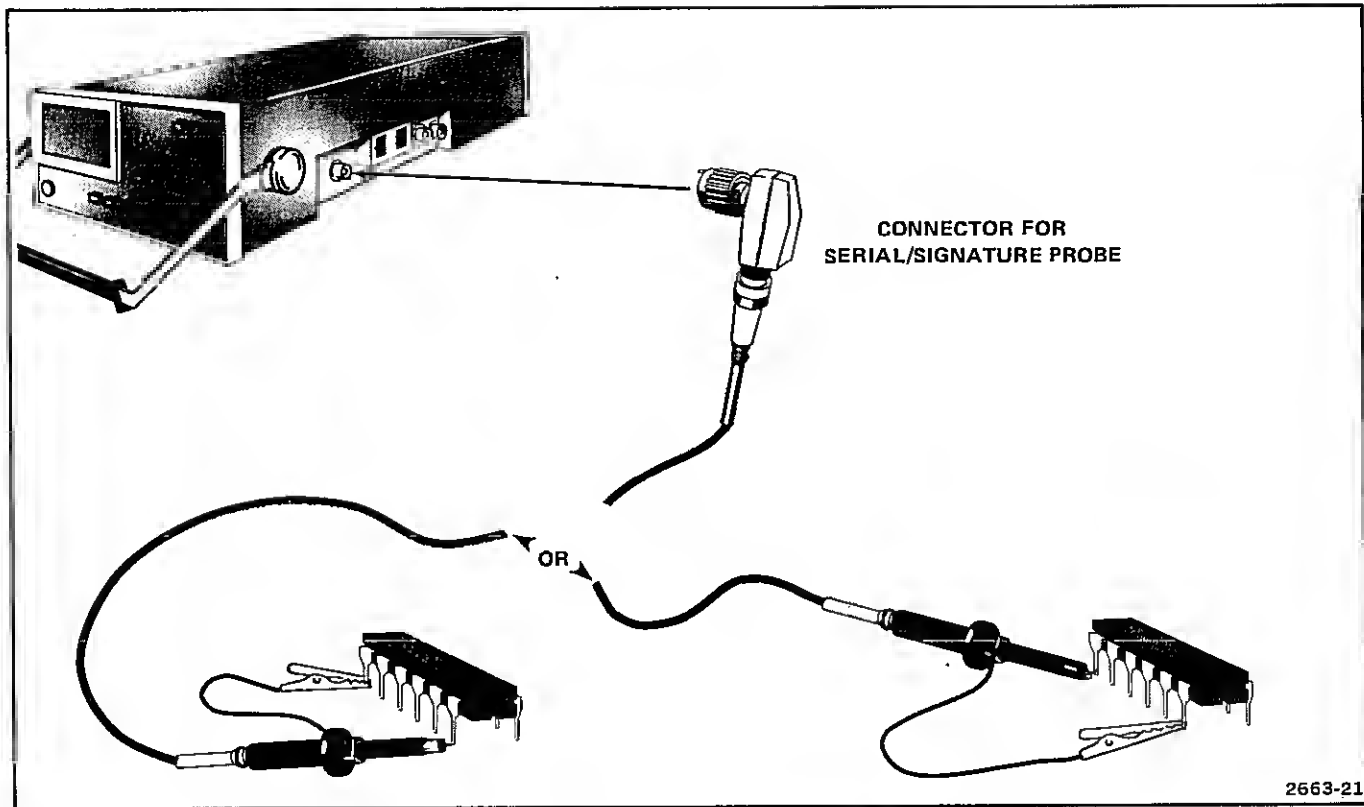

Figure 6. Connecting the 308 Using a 10X Serial Signature Probe.

CONTROLS, CONNECTORS, AND INDICATORS

The following descriptions and illustrations explain the Acquisition Controls, Instrument and Display Mode Controls, Entry Controls, Signature Controls, and Input Controls and Connectors. The four major functions of the 308 and uses of its keyboard controls are also explained. Keyboard controls are grouped in the sequence that they would normally be used by the operator.

The controls are described in the order that they affect acquisition of data, the display of that data, how the operator enters parameters to affect acquisition of that data, and how controls permit using the 308 as a signature analyzer.

The operator must first determine the requirements for a particular data acquisition, the mode of acquiring it, and finally how to enter the correct parameters for the data acquisition. Specific details of control usage and function in particular applications are covered in the Operators Familiarization and Applications portions of this manual.

ACQUISITION CONTROLS

The acquisition controls and indicators illustrated in Figure 7 determine the manner in which the 308 acquires the information for application to the Data Memory.

- ① **EXT CLOCK Light**—Light stays on when clock input remains at high level. Light stays off when clock input remains at low level. Light blinks when signal is present at the clock input.
- ② **TRIG'D Light**—Light is illuminated when trigger word is recognized.
- ③ **TRIGGER DATA=**—Programs instrument to receive Data Trigger.
- ④ **TRIGGER EXT=**—Programs instrument to receive External trigger word.

- ⑤ **TRIGGER DELAY**—Programs Instrument to receive Clock Delay Setting.
- ⑥ **SAMPLE INTERVAL FASTER** and **SAMPLE INTERVAL SLOWER**—These controls select the sample interval of internal clock and clock edge of external clock. Sample interval is sequenced through 23 positions in Parallel mode and 17 positions in Serial State mode.
- ⑦
- ⑧ **STORE DATA—REF**—Causes Data Memory contents to be duplicated in the Reference Memory.
- ⑨ **START**—Starts acquisition process.
- ⑩ **STOP**—Stops acquisition process with manual stop trigger.
- ⑪ **RE-START IF DATA=REF**—Starts and re-starts acquisition process if valid portion of new Data Memory contents are equal to the valid portion of the Reference Memory content.
- ⑫ **DATA POSITION PRE**—Positions the Delayed Trigger at the 240th position in the 252-byte Data Memory.
- ⑬ **DATA POSITION POST**—Positions the Delayed Trigger at the 13th position in the 252-byte Data Memory.
- ⑭ **INPUT SAMPLE**—Input is sampled according to clock edges.
- ⑮ **INPUT LATCH**—Latch mode can only be used for parallel acquisitions. Input data is affected only between clock edges as explained later in Information Gathering.

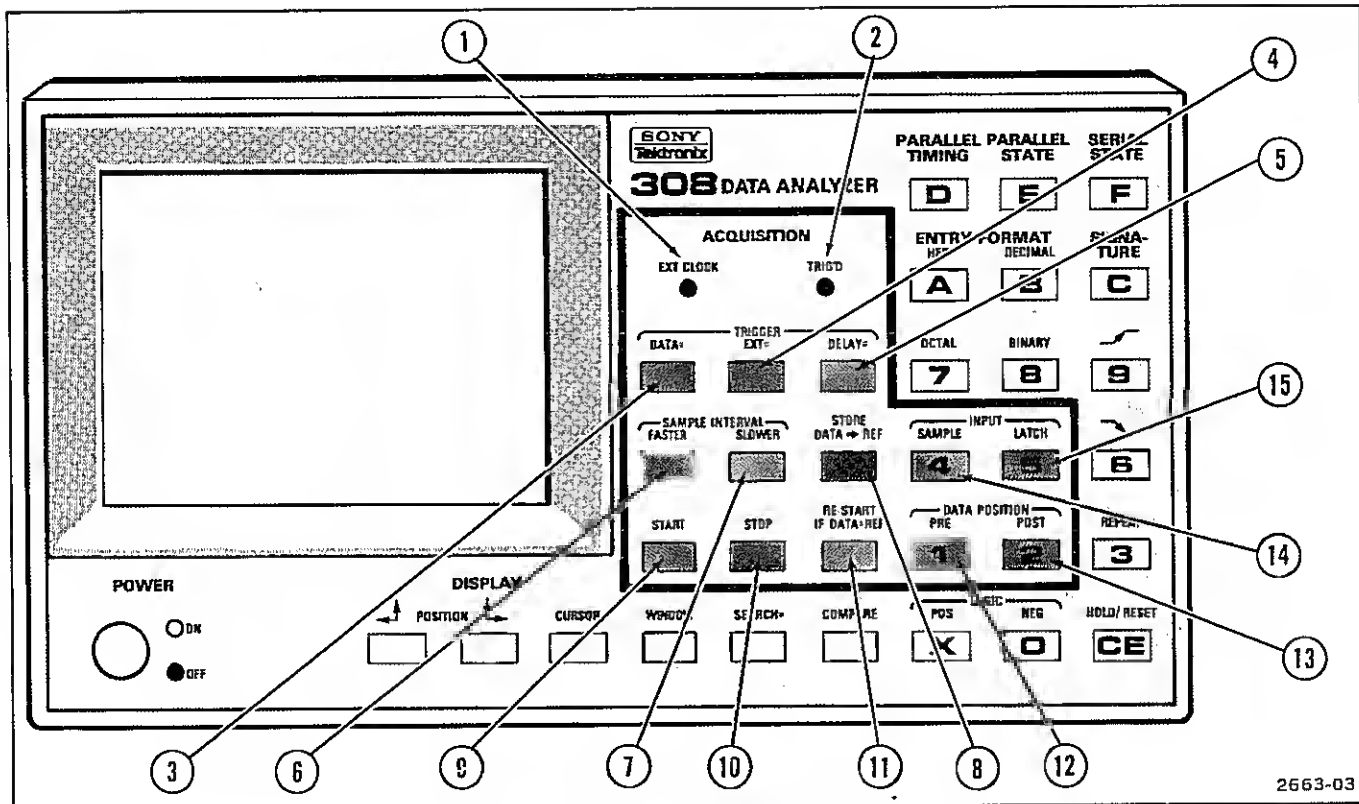

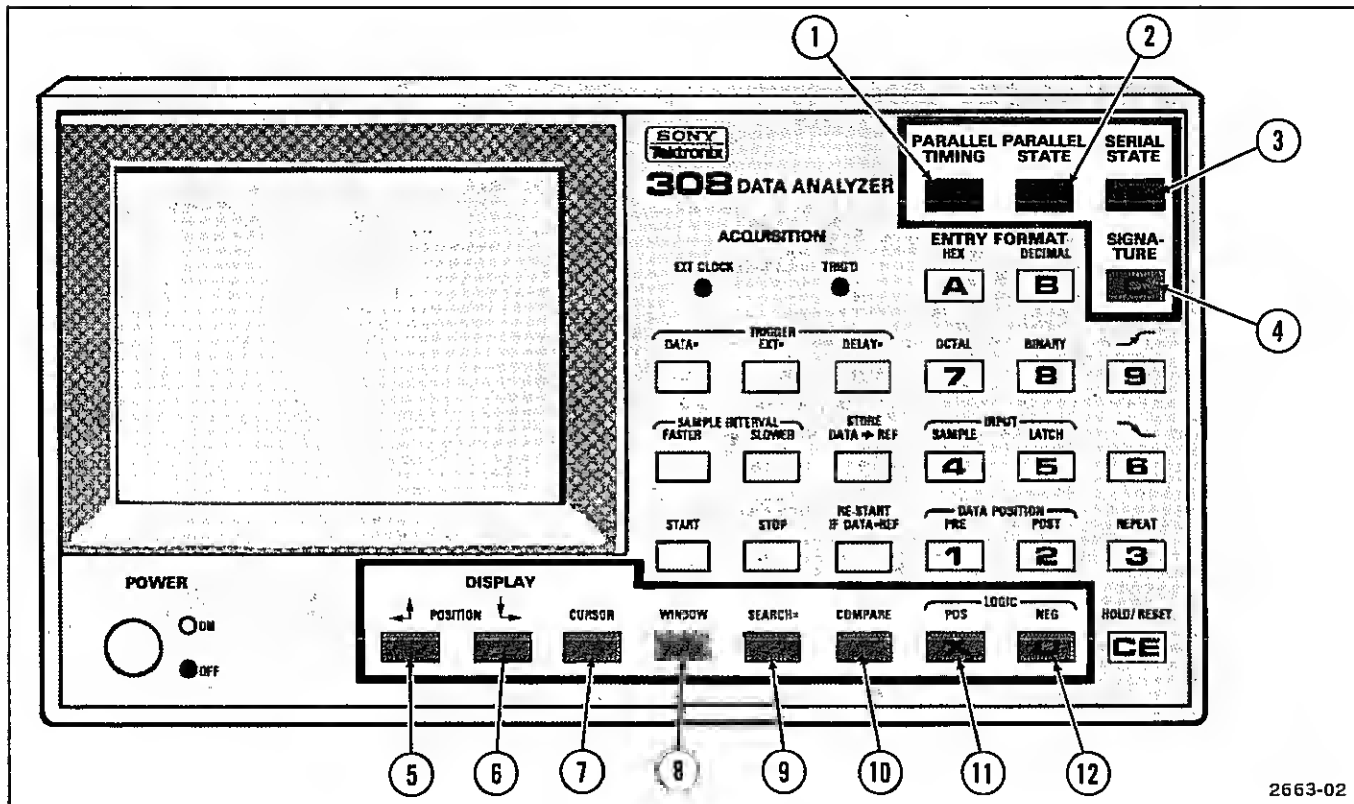

Figure 7. Acquisition Controls and Indicators.

INSTRUMENT AND DISPLAY MODE CONTROLS

All of the Instrument and Display Mode controls shown in Figure 8 affect the 308's display of Information from the Data Memory. The first four controls also affect the choice of instrument acquisition system (Parallel Timing, Parallel State, Serial State, and Signature).

- ① **PARALLEL TIMING**—Selects eight-channel parallel input signal to be stored and displayed in timing format.
- ② **PARALLEL STATE**—Selects eight-channel parallel input signal to be stored and displayed in hexadecimal, binary, and octal formats.
- ③ **SERIAL STATE**—Selects a serial-input signal to be stored and displayed in hexadecimal, binary, and ASCII formats.
- ④ **SIGNATURE**—Selects a serial-input signal to be decoded and displayed in signature format.
- ⑤ **POSITION**  —Moves Window or Cursor to earlier position. If key is pressed and held, position steps automatically.
- ⑥ **POSITION**  —Moves Window or Cursor to later position. If key is pressed and held, position steps automatically.
- ⑦ **CURSOR**—Chooses Cursor display in Parallel Timing, Parallel State, and Serial State modes.
- ⑧ **WINDOW**—Chooses Window display in Parallel Timing mode.
- ⑨ **SEARCH**—Chooses Search display in Parallel and Serial State modes.
- ⑩ **COMPARE**—Chooses Compare display in Parallel and Serial State modes. Highlights the data which differs from data in the Reference Memory in inverse video.
- ⑪ **LOGIC POS**—Selects positive-true data from Data Memory for display.
- ⑫ **LOGIC NEG**—Selects negative-true data from Data Memory for display.



2663-02

Figure 8. Instrument and Display Mode Controls.

ENTRY CONTROLS

Entry controls shown in Figure 9 allow the user to change instrument parameters by creating inverse video blanks and allowing the operator to fill the blanks in hexadecimal, decimal, binary, or octal format.

- ① TRIGGER DATA=
- ② EXT=
- ③ DELAY=
- ④ SEARCH=

These four controls cause inverse video prompting. Inverse video area may be filled by using data entry keys (labeled 0 through F, X, and CE) in data-entry sequence. See Triggering, Delayed Triggering, and the Data Memory paragraphs for more information.

- ⑤ X—In some data-entry sequences, pressing the X (don't care) key causes the 308 to ignore that bit. See Parallel and Serial Acquisition Parameter paragraph for more information.

- ⑥ CE—The CE (Clear Entry) key may be used to cancel a single data entry or sequence of entries. Canceling a sequence of entries restores the previous setting.

- ⑦ HEX
- ⑧ DECIMAL
- ⑨ OCTAL
- ⑩ BINARY

These four controls determine the entry format (hexadecimal, etc.) of data to be entered by the operator, such as DELAY=, DATA=, or SEARCH=. The Entry Format is operator-selected to meet testing requirements.

Keys 0—9 and A—F are used to enter the actual information when required (for entries such as DATA=, DELAY=, and SEARCH=, etc.). The size of the area on the screen where information is entered changes as the selected Entry Format is changed and will blink on and off if an illegal character is used. For example, if the entry format is changed from hexadecimal to binary, the entry area increases in size and blinks if any character other than a zero or one (or in some cases, X) is entered.

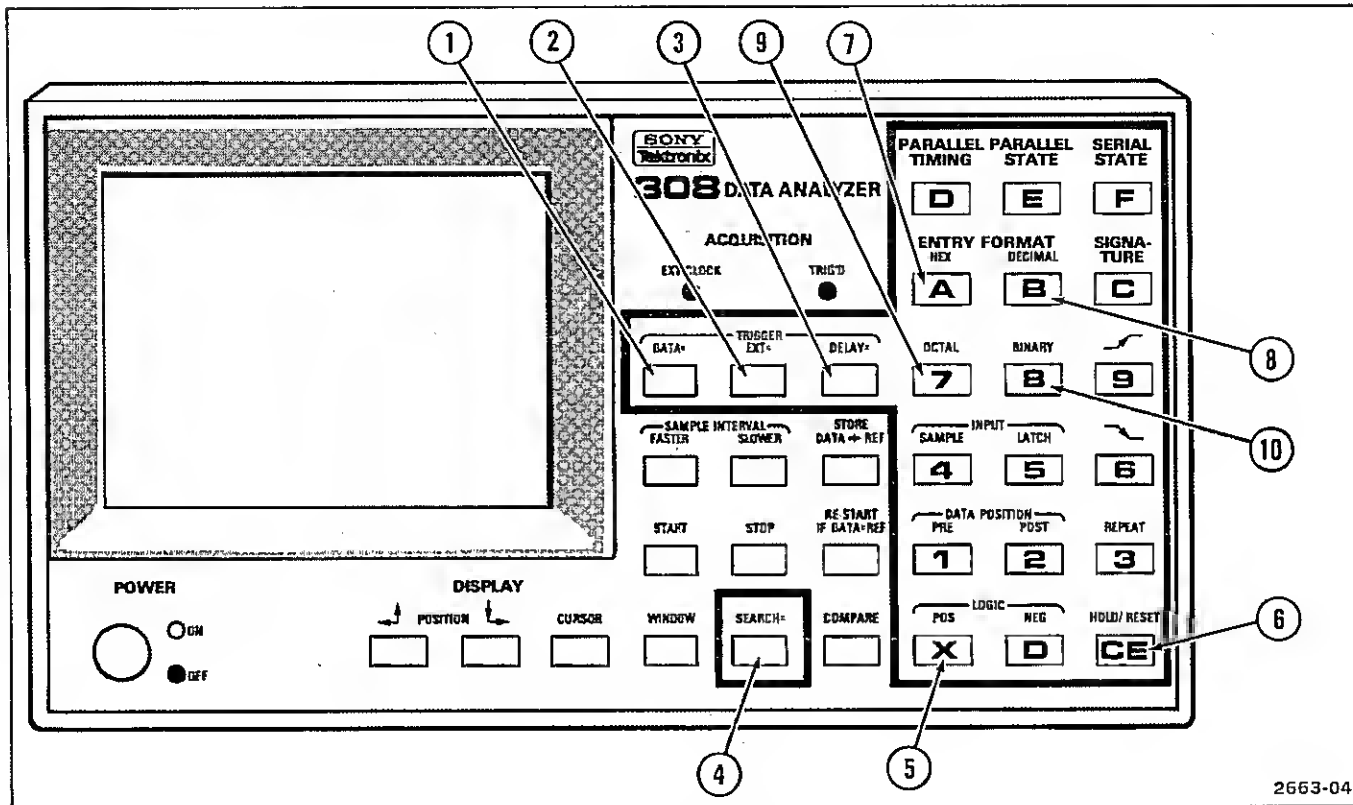



Figure 9. Entry Controls.

SIGNATURE CONTROLS

Controls shown in Figure 10 are for signature acquisition only. The operator may return to and use previously acquired data in the Data Memory.

- ① **SIGNATURE**—Enters Signature mode for new setup.
- ② —Chooses rising transition for Start and Clock, and a zero-one sequence for Stop.
- ③ —Chooses falling transition for Start and Clock, and a one-zero sequence for Stop.
- ④ **REPEAT**—Causes a repeat of any acquisition of input data and displays the most recent data in signature format, losing the old signature. If new signature is different from the old one, FAULT is displayed on the screen for about one second.
- ⑤ **HOLD/RESET**—Causes storage of the signature each time this key is pressed. Up to eight signatures can be displayed on the screen. New

signature is displayed on top of signature table. If new signature is different from old signature, < is displayed on the screen beside the new signature.

INPUT CONTROLS AND CONNECTORS

As shown in Figure 11, all the Input controls and connectors, along with the only output connector (**WORD RECOG TRIGGER OUTPUT**) are located on the right side panel of the 308.

- ① **VAR/TTL**—When placed in the TTL position, the VAR/TTL switch sets the input thresholds for nominal TTL levels of 1.4 ± 0.2 V. When placed in the VAR position, the input thresholds are continuously variable from +12 V to -12 V. The VAR/TTL positions and adjustments affect all the signal inputs to the 308. Word Recognizer probe inputs accept only TTL levels.
- ② **THRESHOLD VOLTAGE**—A screwdriver adjustment for varying the input thresholds when the VAR/TTL switch is in the VAR position.
- ③ **MONITOR**—Actual threshold voltage may be checked with a meter at the MONITOR jack.

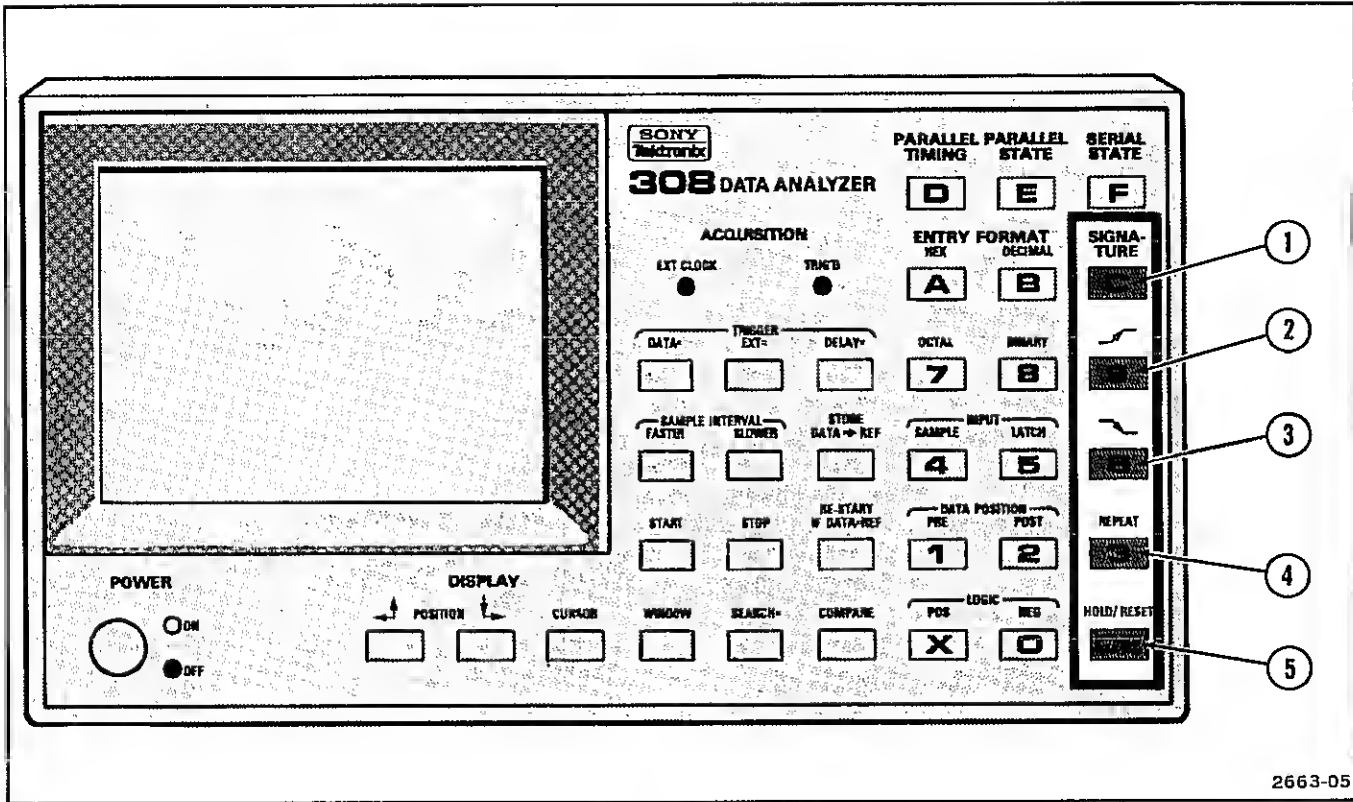

2663-05

Figure 10. Signature Controls.

- ④ **SERIAL/SIGNATURE DATA INPUT**—This input must have the proper data probe connected to it for serial or signature applications. Data applied to the serial data input shown in Figure 12 is processed according to EIA STD RS-232-C protocol prior to being stored in the Data Memory and is displayed in the same manner as the parallel data shown in Figure 13. The same probe and connector are used for signature applications, but the operator-selected input signal requirements and the display are different (see Figure 14).
- ⑤ **P6451 INPUT ONLY**—The Data Acquisition probe can only be connected to this connector. The eight parallel bits of data acquired by the Data Acquisition probe are processed differently than the serial data; however, the data is stored in the Data Memory and displayed in the same manner.
- ⑥ **P6406 INPUT ONLY**—The Word Recognizer probe can only be connected to this connector. Figure 13 shows how the Word Recognizer can be used to expand the 308 trigger capabilities. Keep in mind only the eight data bits acquired by the Data Acquisition probe will be stored and displayed.
- ⑦ **EXTERNAL TRIGGER QUALIFIER INPUT and T/C**—This input can be used in several manners depending on the position of the T/C (Trigger/Clock) switch. With the T/C switch set to T, word recognition capabilities are extended.
- ⑧
- ⑨ **ASYNC FILTER**—This screwdriver adjustment can be set to prevent false triggering on word recognition patterns of shorter duration than provided for by the filter setting, when operating in the asynchronous mode. Figure 15 (Detect Transitions, Filter Adjustment, and Triggering) illustrates how a false trigger can occur, giving the operator erroneous data indications.
- ⑩ **WORD RECOG TRIGGER OUTPUT**—This output goes to a TTL logic HI whenever the input data matches data programmed by the operator.

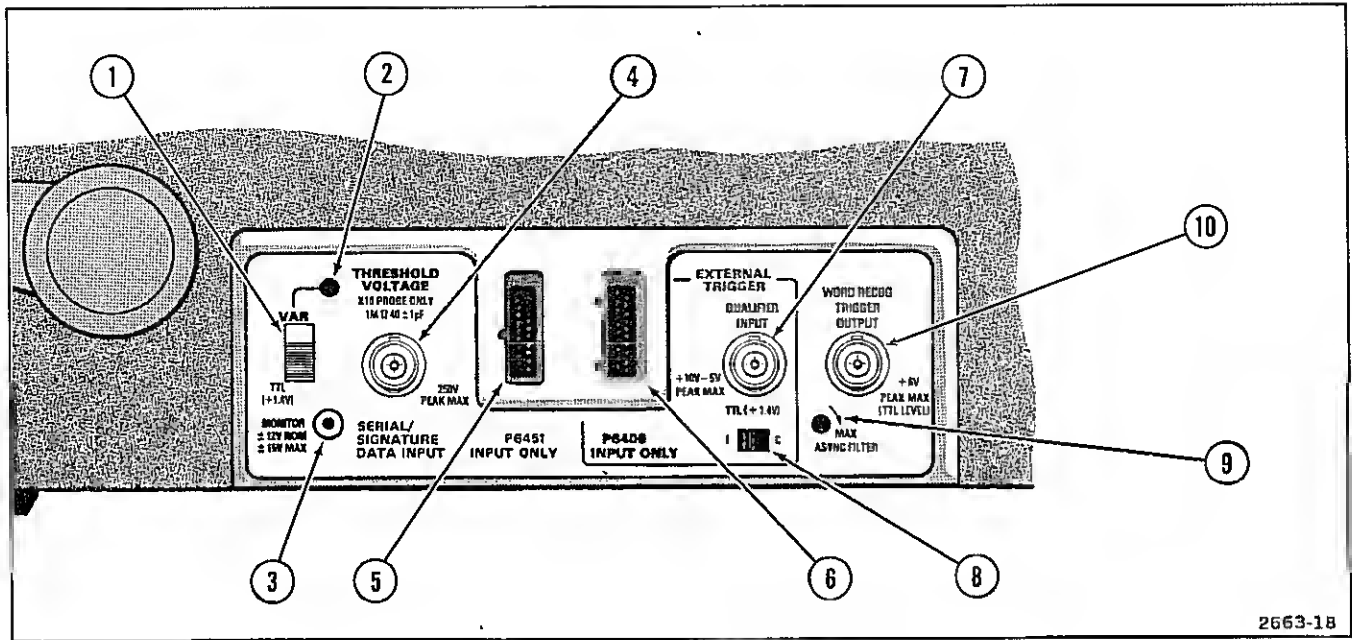

2663-1B

Figure 11. Right Side Panel Controls and Connectors.

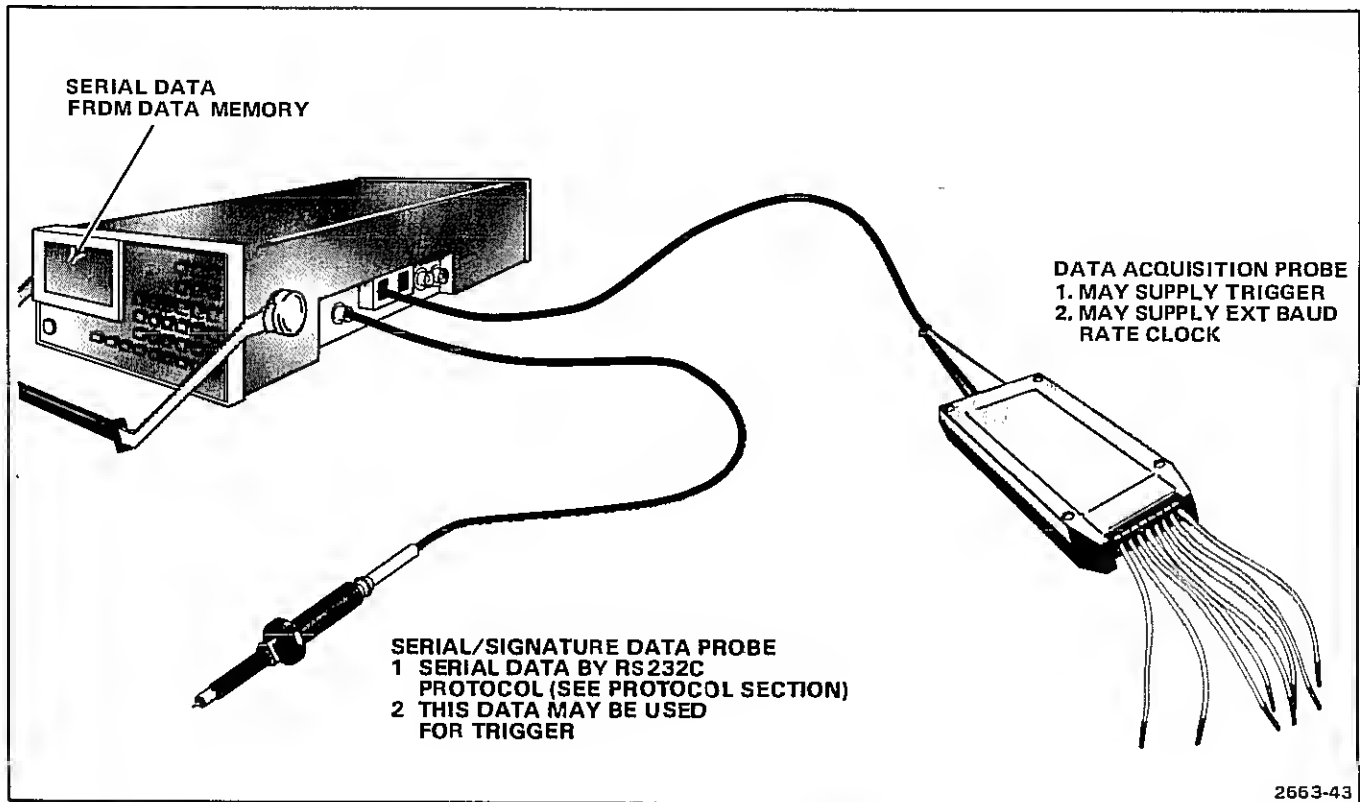

Figure 12. Serial Inputs and Displays.

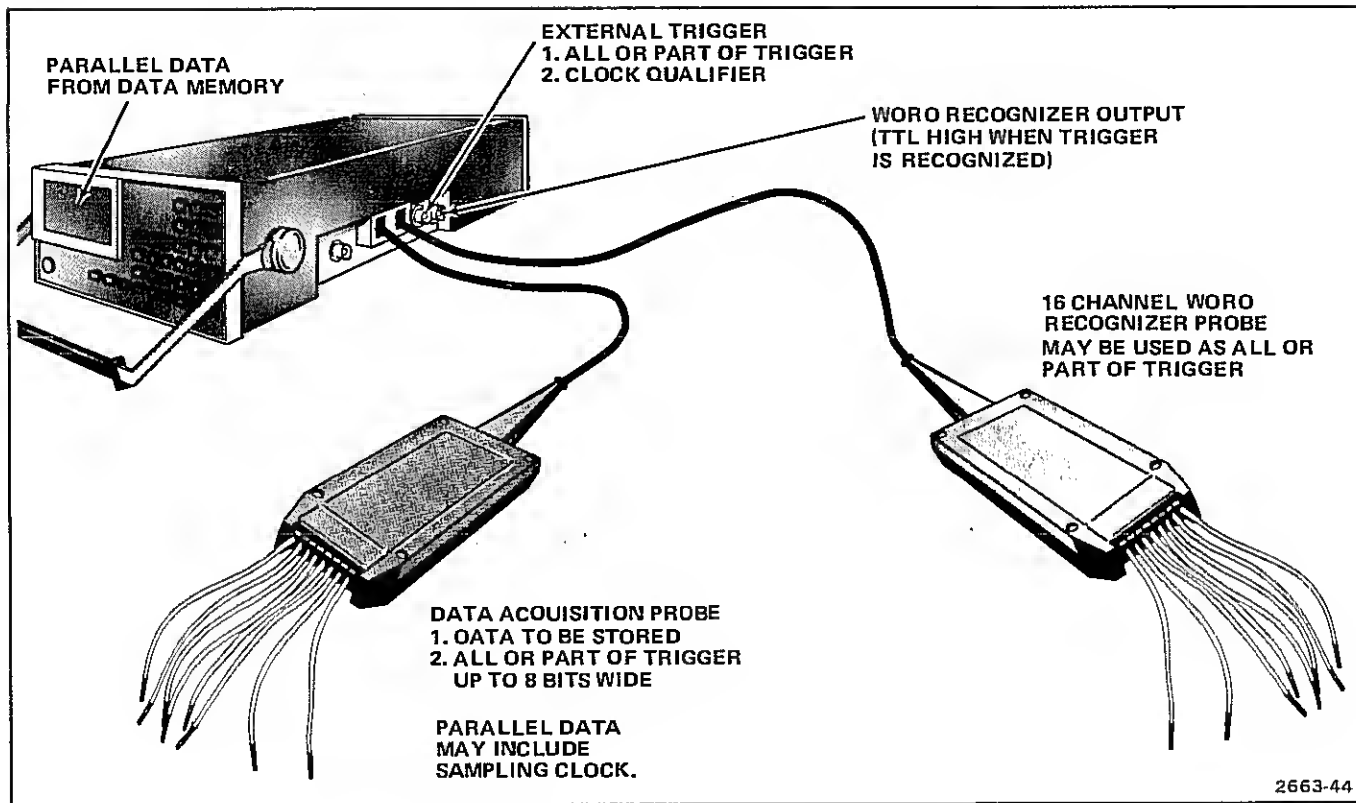

Figure 13. Parallel Inputs/Outputs and Display.

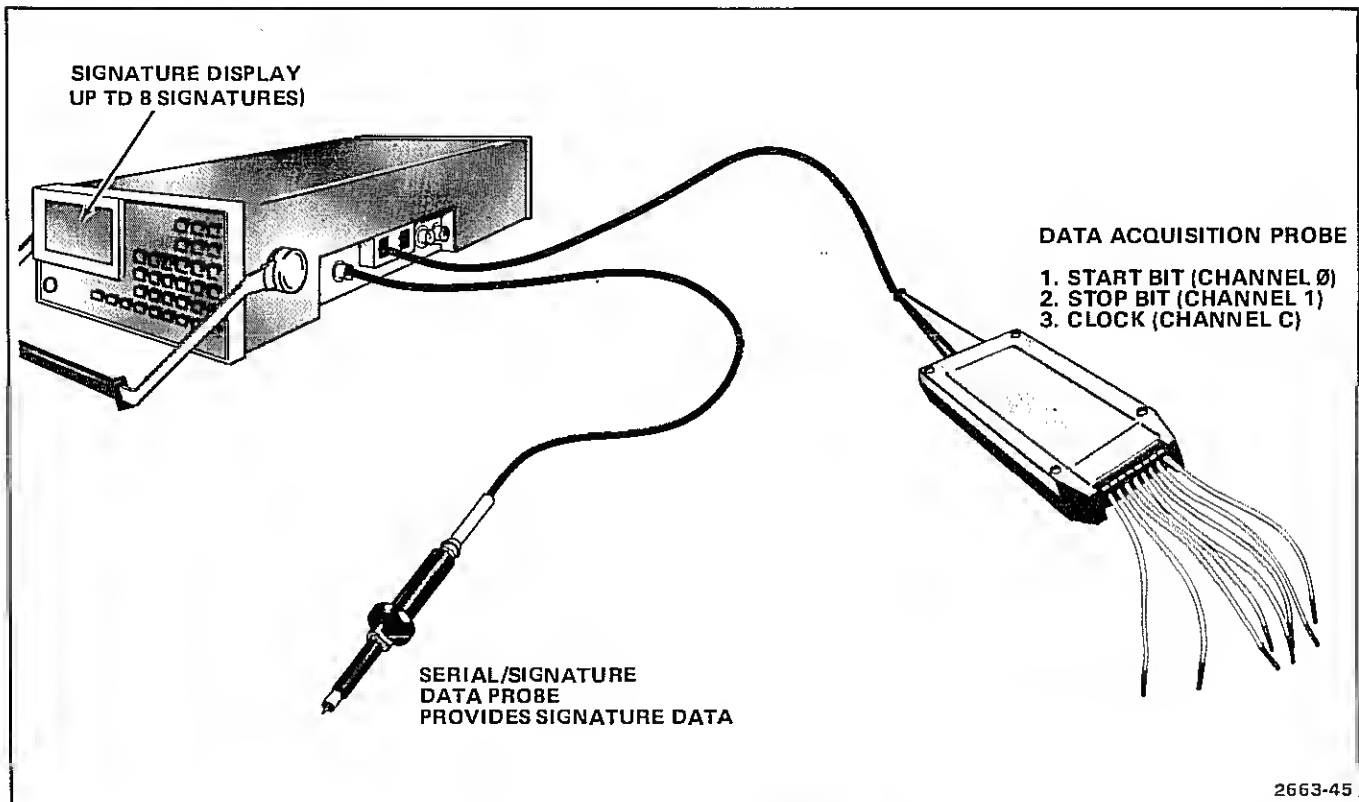
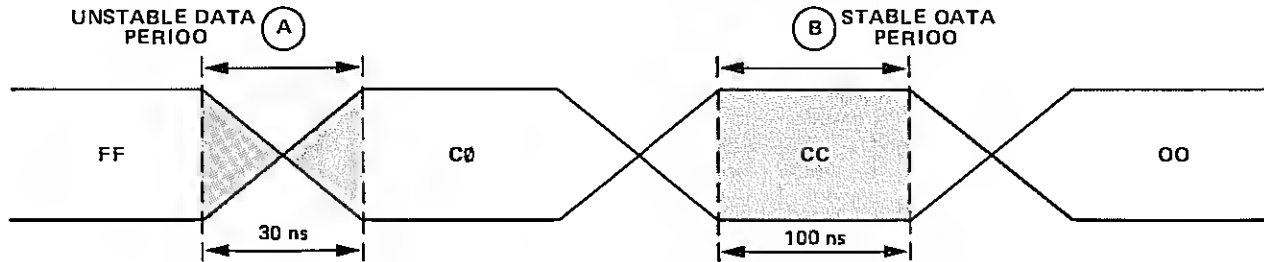

Figure 14. Signature Inputs and Display.

ASYNCHRONOUS PARALLEL OATA STREAM INTO WORO RECOGNIZER



SETUP TRIGGER CONOITIONS: OATA [H] = CC; EXT [H] = XXXX-X (OON'T CARE)

SLOW TRANSITION MAY SEEM TO CONTAIN THE TRIGGER WORO
 FILTER SHOULD BE AOJUSTEO TO PREVENT TRIGGERING AT
 POINT (A) ANO ALLOW TRIGGERING AT POINT (B)

AOJUSTMENT METHOO WITH OELAY = 0000:

- 1) AOJUST THE FILTER TO THE OESIREO POINT
- 2) ACQUIRE THE OATA
- 3) CHECK THE OISPLAY AGAINST THE LISTING BELOW
- 4) REPEAT STEPS 1-3 AS NEEDED

TOO LITTLE FILTER
 OELAY

FF
 OT=***C0***
 CC
 OO

CORRECT OELAY

FF
 C0
 OT=***CC***
 OO

TOO MUCH FILTER
 OELAY

FF
 C0
 CC
 OT=***OO***

NOTE: THIS CONOITION OR NO TRIGGER
 MAY BE RECOGNIZED.

2663-46

Figure 15. Oata Transitions, Filter Adjustment, and Triggering.

OPERATORS CHECKOUT PROCEDURE

The 308 has internal diagnostics to help the operator verify that the instrument is performing properly. Some of the diagnostics occur automatically whenever the 308 is powered on. Other diagnostics require that probes be properly attached to test points or that operator input to the keyboard is needed.

Any error found during correct operation of the diagnostics means that an instrument failure has occurred, has been detected, and that service is required.

By executing the power-on diagnostics and user-initiated diagnostics 0 through 5, the operator can quickly verify that signal paths of the 308 are operating properly. User-initiated diagnostic 6 is provided for the use of qualified service personnel only.

DIAGNOSTICS

Power Up

When the operator presses the **POWER** switch, the 308 automatically performs a self-diagnostic procedure and will display **SELF TEST-IN PROGRESS**. If no errors are found, the **IN PROGRESS** display will change to **OK** in inverse video in about 10 seconds or less. Then the Parallel Timing Menu will be displayed. However, if an error occurs, the operator may determine the nature of the error from the list in Table 1. Some errors may allow the operator to use the instrument if the portion that is defective does not affect the test to be performed. An error message example is shown in Figure 16.

User-Initiated

All user-initiated diagnostics require the same preliminary setup procedure (except for the **VAR/TTL** switch) to ensure valid tests and correct displays. Figure 17, 308 Diagnostic Test Setup, shows you the correct setup for each user-initiated diagnostic test. Configure the 308 for each test as shown in Figure 17 (including the Serial/Signature probe but do not connect ground leads). Equipment required is listed in Table 2.

Table 1
POWER-UP ERROR CODES

Error Codes	Failure
1—6	RAM or ROM—Instrument will not function.
7—23	Parallel acquisition functions improperly.
(16—19)	While parallel acquisition may take place, the delay selected will not be correct.
(20—23)	While parallel acquisition may take place, the sample rate will not select properly.
24	Serial acquisition functions improperly.
25	Shows that a keyboard key was pressed in during power up.
26—28	Signature acquisition functions improperly.

Table 2
EQUIPMENT REQUIRED FOR USER-INITIATED DIAGNOSTICS

Description	Minimum Specification	Usage	Applicable Equipment Example
Adapter	Bnc male-to-dual binding post	Signal interconnection	Tektronix Part No. 103-0035-00
Wire	Bus wire, 5 Inches, at least 18 gauge	Signal interconnection	

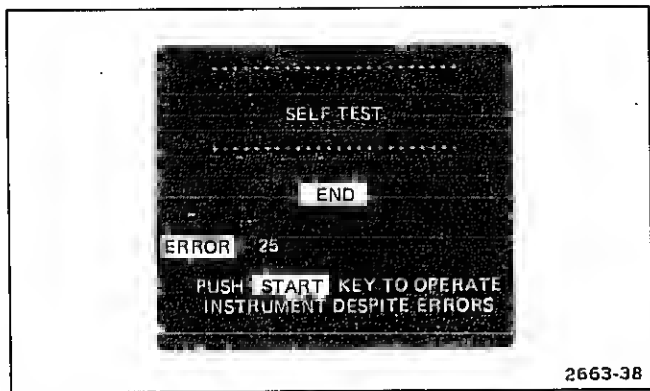

Figure 16. Typical 308 Error Message.

First initiate the Diagnostic Menu by pressing the **STOP** key seven times. The 308 Diagnostic Menu, Figure 18, will be displayed on the screen. Then, referring to Table 3, perform Diagnostics 0 through 5 in sequence. An example of how to perform a diagnostic test follows.

Diagnostic 0, Keyboard Check, is initiated by pressing Entry key 0 then pressing each keyboard key (except **STOP**) in any order while cross-checking the number displayed on the screen against the key number pressed (Figure 19). After all keys have been checked, press **STOP** to end this diagnostic routine and return to the Diagnostic Menu.

The sequences for performing other diagnostic tests are generally run like the one described for Diagnostic 0. Each test may have some particular setup conditions that should be performed (see Table 3 and Figure 17). The operator may exit from any test at any time by pressing the **STOP** key. Pressing the **START** key will return the 308 to its normal operating mode. Figure 20, Typical Diagnostic Displays, shows samples of pass and fail displays that may appear on the screen.

NOTE

If any diagnostic test fails, refer the problem to qualified service personnel.

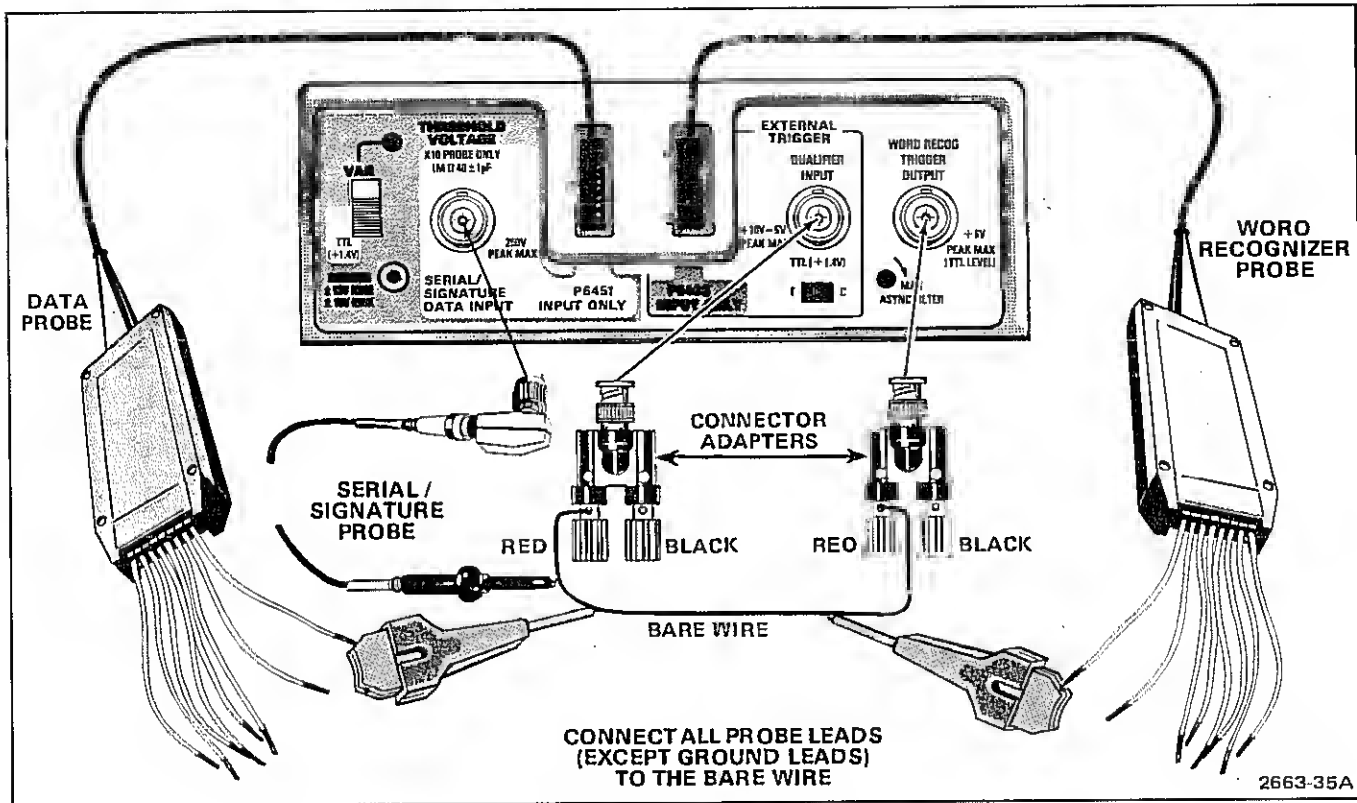

Figure 17. 308 Diagnostic Test Setup.

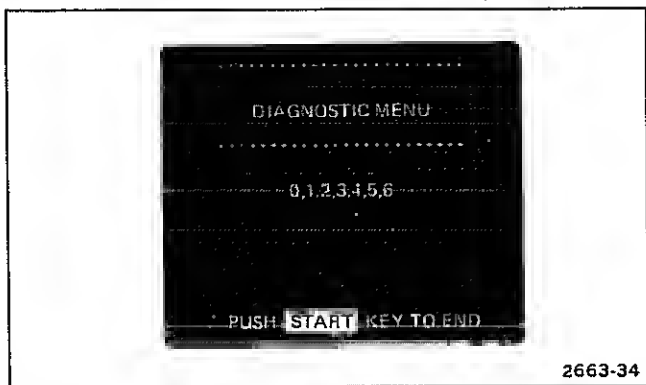

Figure 18. 308 Diagnostic Menu.

Diagnostic 5 Reference Pattern

NOTE

Diagnostic 5 may be performed either with or without a word recognizer probe.

If a failure display is obtained during Diagnostic 5, use Figure 21 to compare displayed patterns with expected patterns. Start at the lower right corner and progress from right to left, verifying each displayed pattern with its

corresponding expected pattern in Figure 21. If no discrepancies are found, proceed to the second row up from the bottom and again verify the patterns from right to left. If no discrepancies are found, proceed to the next row up. Continue verifying in this manner, from bottom to top and from right to left until the first discrepancy is found. The first discrepancy in the pattern causes a halt to the diagnostic routine, thus invalidating the remainder of the pattern.

The bottom row of the pattern indicates the ability of the External Trigger to recognize a LO and then a HI; then each channel of the Data Acquisition probe is checked to recognize first a LO and then a HI. Next are the Don't Care Control Bits for the Word Recognizer probe, followed by the trigger settings for the Word Recognizer probe.

The failure pattern shown in Figure 20 for Diagnostic 5 shows the operator that a failure occurred on the HI check of channel two of the Data Acquisition probe. This could indicate a faulty connection, a probe failure on channel two, or a failure of the 308. After verifying the connection for channel two, the operator should repeat the test. If the failure still occurs, refer the problem to qualified service personnel.

Table 3

USER-INITIATED DIAGNOSTICS

Diagnostic Number	Setup Conditions	Pass Indications	Failure Mode
0	Press Entry Key 0.	All display numbers correspond to keyboard codes shown in Figure 19.	Keyboard circuit board or switch failed.
1	Connect probes per Figure 17. Set VAR/TTL Switch to VAR. Rotate the THRESHOLD VOLTAGE control fully clockwise, then press Entry key 1.	OK displayed in inverse video.	Parallel LO-data acquisition failed.
2	Set VAR/TTL switch to TTL, then press Entry key 2.	OK displayed in inverse video.	Parallel HI-data acquisition failed.
3	Press Entry key 3.	OK displayed in inverse video.	Serial HI-data acquisition failed.

Table 3 (cont)

Diagnostic Number	Setup Conditions	Pass Indications	Failure Mode
4	Set VAR/TTL switch to VAR, THRESHOLD VOLTAGE control fully CW, then press Entry key 4.	OK displayed in inverse video.	Serial LO-data acquisition failed.
5 ^a	Connect probes per Figure 17, set VAR/TTL switch to TTL, then press Entry key 5.	OK displayed in inverse video. EXT CLOCK light flashes.	External trigger data, Data Acquisition probe, Word Recognizer or Word Recognizer probe failed. ^{b c}

^a Run this test twice: first without the Word Recognizer probe, then with the Word Recognizer probe installed. If a failure appears only with the probe installed, the 308 is functioning properly.

^b Figure 21 and the related text gives additional details.

^c After all tests have been run, press the START key to return to normal operation.

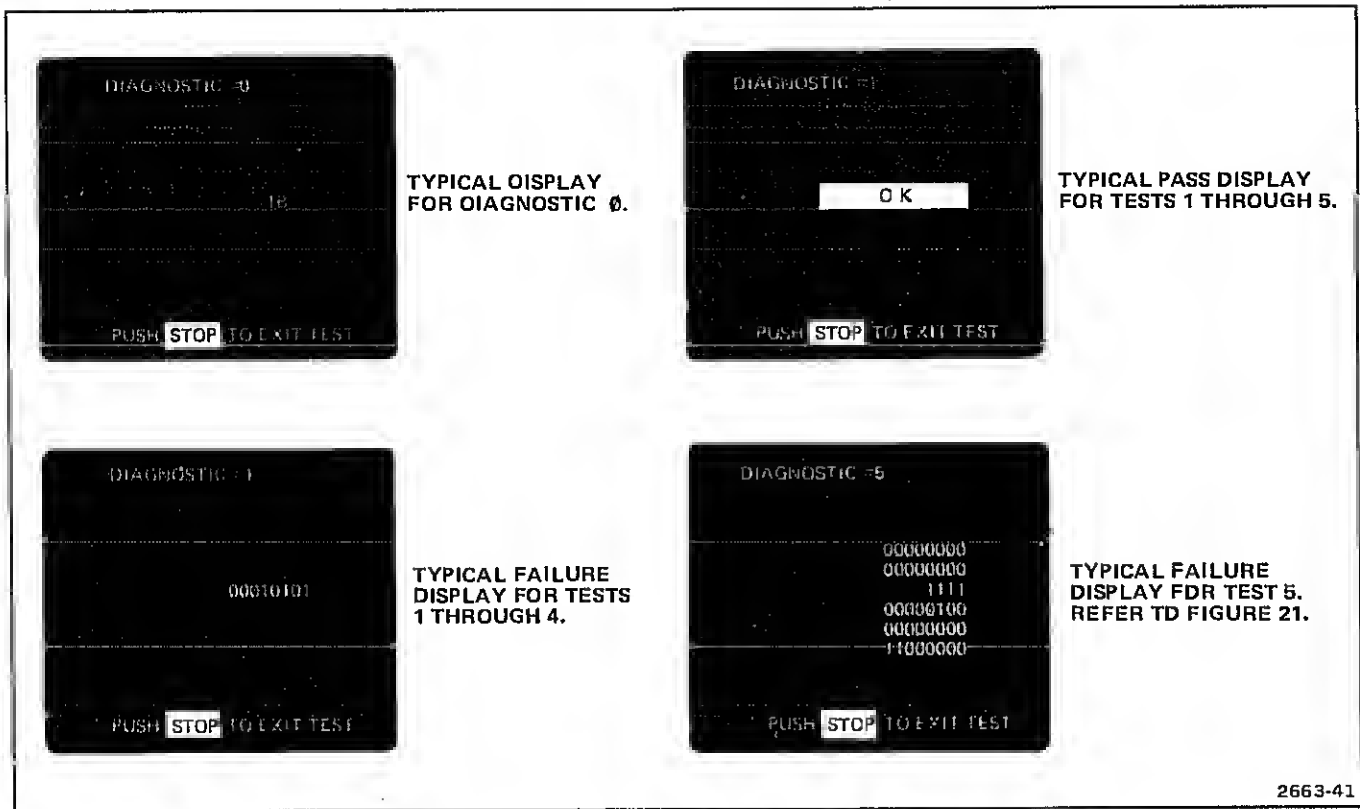

Figure 20. Typical 308 Diagnostic Displays.

MSB	15	14	13	12	11	10	9	8	
0	0	0	0	0	0	0	0	0	
WORD RECOGNIZER PROBE TRIGGER SETTING									
	7	6	5	4	3	2	1	LSB 0	
0	0	0	0	0	0	0	0	0	
WORD RECOGNIZER PROBE TRIGGER SETTING									
NOT USED				BITS 12-15		BITS 8-11		BITS 4-7	BITS 0-3
				WORD RECOGNIZER PROBE		DON'T CARE CONTROL			
				1		1		1	1
MSB	7	6	5	4	3	2	1	LSB 0	
0	0	0	0	0	0	0	0	0	
SET TO RECOGNIZE DATA PROBE HIGHS									
MSB	7	6	5	4	3	2	1	LSB 0	
0	0	0	0	0	0	0	0	0	
SET TO RECOGNIZE DATA PROBE LOWS									
THIS DATA NOT USED							EXTERNAL TRIGGER		
							0 0		



2663-39

Figure 21. Diagnostic #5 Reference Pattern.

OPERATORS FAMILIARIZATION

POWERING-UP THE 308

When the 308 is first turned on, it will automatically perform a self-diagnostic procedure, and the screen will display SELF TEST-IN PROGRESS. If no problems are found, IN PROGRESS will change to OK in inverse video. The 308 will then automatically progress to the Parallel Timing menu display.

If a problem or fault is detected, the screen display will indicate the error number. If an error message appears on the screen, the operator should immediately refer the problem to qualified service personnel.

THE CONTROL FUNCTION ACCESS CHART

The Control Function Access Chart, Figure 43 (foldout at the rear of this manual), will aid the operator in learning how to access (or move) from one function or subfunction to another. The following paragraphs explain the organization and use of the Control Function Access Chart and describe the four major operating modes with the three acquisition systems provided by the 308.

Organization of the Control Function Access Chart

This chart emphasizes the major analyzing modes of the 308. These modes are: Parallel Timing, Parallel State, Serial State, and Signature. Each major mode and its subfunctions are grouped in separate vertical columns for ease of understanding. The fourth column shows the extended Serial State Menu and the user-Initiated Diagnostic Menu. Reading the chart horizontally, you will see four menus in the first row, three cursor displays in the second row, two search word displays in the third row, and two compare displays in the fourth row.

Each display is numbered and titled, and lines connect the various displays. Usually pressing a single key will allow the operator to change from one display to another. The key that must be pressed to change a display is shown next to the line along with an arrow indicating the direction of change.

Using the Control Function Access Chart

Refer to the Control Function Access Chart for the following discussion. When the 308 is first powered up and has finished its diagnostic routines, the Parallel Timing

NOTE

Items 4 and 5 on the extended Serial Menu Addition will only be displayed when the SYNC=EXT baud rate is selected.

Pressing the **SERIAL STATE** key again obtains the Serial State Menu (display 8). Therefore, the only way to get into or out of the extended Serial Menu Addition is to pass through the Serial State Menu display.

THE NEXT STATE TABLE

The information contained in the Next State Table, Figure 22, is similar (with a few differences) to the information contained in the Control Function Access Chart. In the Next State Table the Signature modes are broken down into the Setup, Hold, and Repeat modes. The effect of using keys to enter instrument variables is also included. The following example illustrates how the table works. Assuming the instrument is in the State Cursor state (5) and the **DATA=** key is pressed, the next state the instrument would automatically enter is the State Menu (3). This is indicated in the table by the *3 at the intersection of the lines between State Cursor and Data=. The asterisk shows that in addition to going into the State Menu state, an instrument variable has been set, and a data entry sequence must be completed by using the data entry keys (see Figure 9, Entry Controls).

Menu (display 1) is automatically displayed. If the Serial State Search Word function (display 10) is required, first push the **SERIAL STATE** key (display 8) then the **SEARCH=** key to obtain the Serial State Search Word display (display 10). A search word display always requires entering a data entry sequence. One way to complete this data entry sequence is to press the **CE** (Clear Entry) key.

When the 308 is first powered up, the search word is automatically initialized to 00 hexadecimal and the displayed data will all be 00 hexadecimal and highlighted in inverse video because it is all equal to the search word.

Most of the steps required to change functions are virtually identical in manner to the one just described and require a single key to be pressed.

Extended Serial Menu Addition

Usually one or two keys are pressed to obtain the required display. An exception to this is the extended Serial Menu Addition. If the operator selects another function, such as Signature (display 13), by pressing the **SIGNATURE** key, and then needs to change to the extended Serial Menu Addition, pressing the **SERIAL STATE** key will obtain the Serial State Menu (display 8) again. Next, press the **SERIAL STATE** key a second time to obtain the extended Serial Menu Addition (display 12).

PRESENT STATE →

KEY ENTERED ↓

	TIMING MENU	TIMING CURSOR	TIMING WINDOW	STATE MENU	STATE SEARCH	STATE CURSOR	STATE COMPARE	SERIAL MENU	SERIAL SEARCH	SERIAL CURSOR	SERIAL COMPARE	SIGNATURE SETUP	HOLD	REPEAT	EXTENDED SERIAL MENU
	0	1	2	3	4	5	6	7	8	9	A	B	C	D	E
DATA=	*0	*0	*0	*3	*3	*3	*3	*7	*7	*7	*7				
FAST	0	0	0	3	3	3	3	7	7	7	7				
WINDOW	2	2	2												
EXT=	*0	*0	*0	*3	*3	*3	*3	*7	*7	*7	*7				
SLOW	0	0	0	3	3	3	3	7	7	7	7				
SEARCH=				*4	*4	*4	*4	*B	*B	*B	*B				
CURSOR	1	1	1	5	5	5	5	9	9	9	9				
OELAY=	*0	*0	*0	*3	*3	*3	*3	*7	*7	*7	*7				
STORE DATA	0	1	2	3	4	5	6	7	8	9	A				
RESTART	0	1	2	3	4	5	6	7	8	9	A				
COMPARE				6	6	6	6	A	A	A	A				
PRL TIMING	0	0	0	0	0	1	0	0	0	1	0	0	0	0	
PRL STATE	3	5	3	3	3	3	3	3	4	5	6	3	3	3	
SERIAL	7	9	7	7	8	9	A	E	7	7	7	7	7	7	7
SIGNATURE	*B	*B	*B	*B	*B	*B	*B	*B	*B	*B	*B	*B	*B	*B	
RISING EDGE												B			
FALLING EDGE												B			
REPEAT												D	D	D	
HOLD/RESET												C	C	C	
START	0	1	2	3	4	5	6	7	8	9	A				

* ACCEPTS DATA ENTRY SEQUENCE AFTER GOING TO NEXT STATE

2663-06

Figure 22. Next State Table.

BASIC OPERATING INFORMATION

The 308 gathers information from a device under test, stores it, and displays it in several forms to allow easy interpretation by the user. All information for display is stored in the Data Memory and may also be stored indefinitely in a Reference Memory for later comparison with data in the Data Memory. Figure 23, Basic 308 Acquisition and Display System, illustrates this process.

Using the 308 is a three-step process. The first step is gathering data via the probe(s) and processing it according to the operator-determined parameters. The second step is storing the data in the Data Memory and later in the Reference Memory, if needed. The data gathering and storing processes together are referred to as a data acquisition.

Pressing the **START** key initiates an acquisition. This does not always cause automatic storage of incoming data since various triggering, clocking and/or word recognition requirements programmed by the operator may delay or prevent storage. Once all of the proper conditions have been met, the data is stored in the Data Memory to allow the third step, displaying the data. Data acquisitions are identical for certain classes of instrument modes. All Parallel Timing and Parallel State modes have identical

acquisitions, and all Serial modes have identical acquisitions. Stored data from either a Parallel or a Serial acquisition is placed in the same (and only) Data Memory. Thus, all of the serial and parallel display formats can be used to examine the data acquired, regardless of whether the acquisition took place in a Serial or a Parallel mode. After a data acquisition has been made, the operator can place this same data into the Reference Memory for a later comparison with other data that is acquired.

Information Gathering

The 308 gathers digital information that is recorded as a sequence of numbers, not as voltages. Figure 24, Positive Logic with Number Assignments to Voltage Inputs, illustrates how the number assignments are determined. The digital equivalent of the input voltage is either a one or a zero, depending on whether the voltage level is above or below the preset threshold voltage.

Another factor affecting the recording of numbers to represent input voltages is the time of sampling. There are two methods provided by the 308 for selecting the times to sample and store the resulting number. One method is to employ the internal programmable sample-rate generator in the 308. This causes the inputs to be sampled at regular intervals as shown in Figure 25, Sampling with the Internal Sample-Rate Generator, and the results stored for later

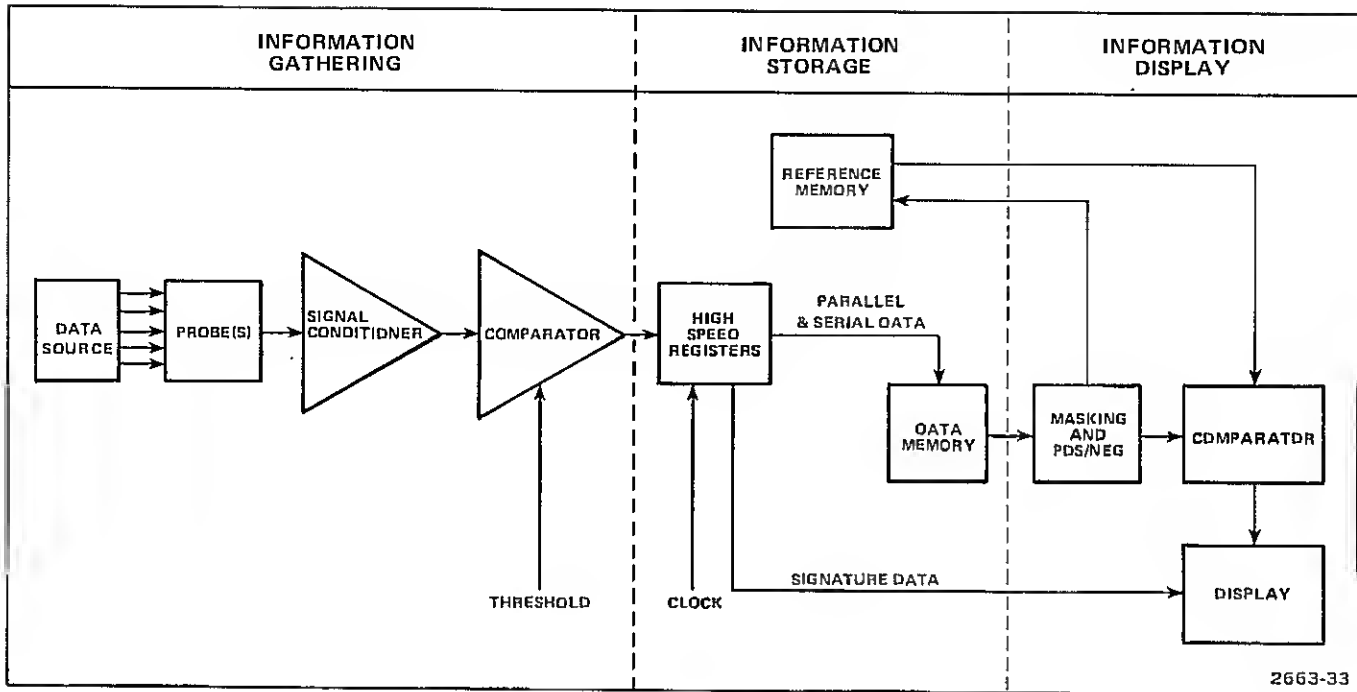

Figure 23. Basic 308 Acquisition and Display System.

display. The other method is to use an external sample-rate generator, usually referred to as a clock. When using an external clock, the time of sampling is controlled by the time that the clock makes a transition from one side of the threshold voltage to the other (see Figure 26, Using an External Clock to Control Sample Rate). Rising or falling clock transitions may be chosen (as required) for this purpose.

If the internal sample-rate generator is used, the input information must be present and valid for a minimum length of time in order to appear in the sample output.

Sample and Latch modes are two ways of gathering data. Signal-timing requirements are different for the two

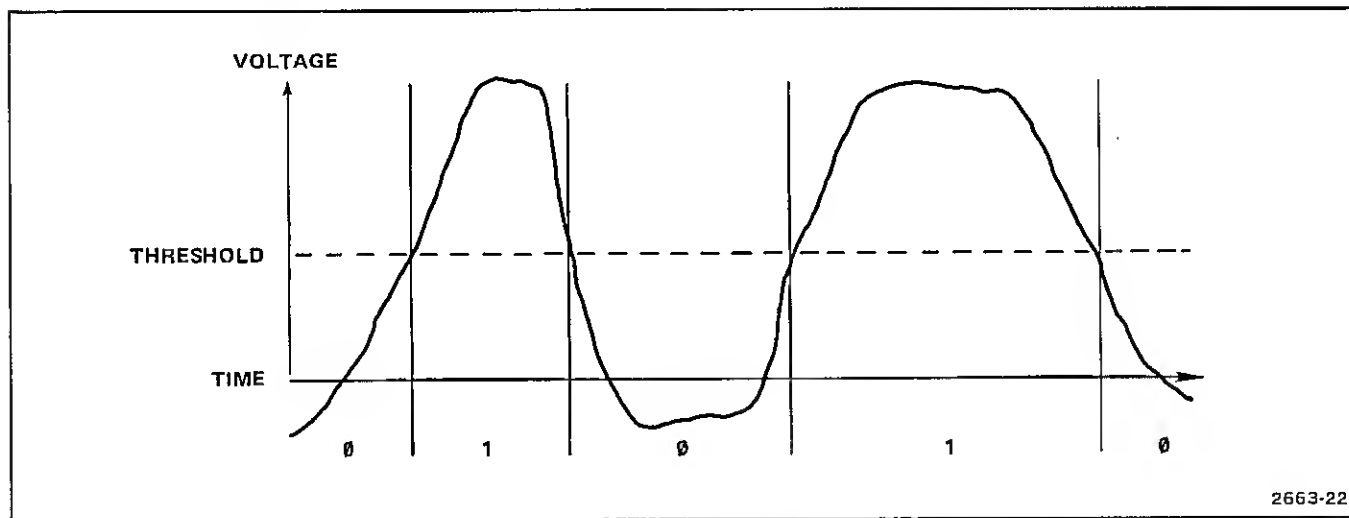

Figure 24. Positive Logic with Number Assignments to Voltage Inputs.

modes. When the Sampling mode is used, data is determined by the input at the sample times.

Figure 27 shows the relationship of sampling intervals and minimum data width. For controlled sampling by an external clock, the data must have a minimum time width,

which is measured as setup and hold times (see Figure 28, Setup and Hold Time for an External Clock). Setup times refer to the time the data must have a constant assigned value before the clock transition. Hold time refers to the time that the assigned value must remain the same after the clock transition.

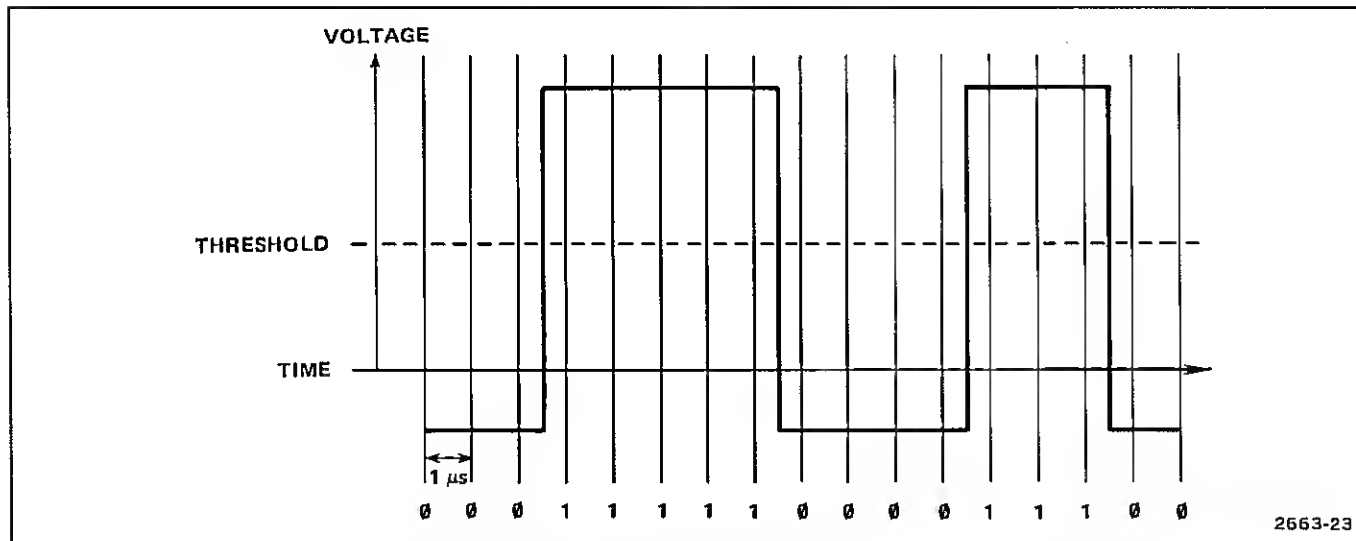

Figure 25. Sampling with the Internal Sample Rate Generator.

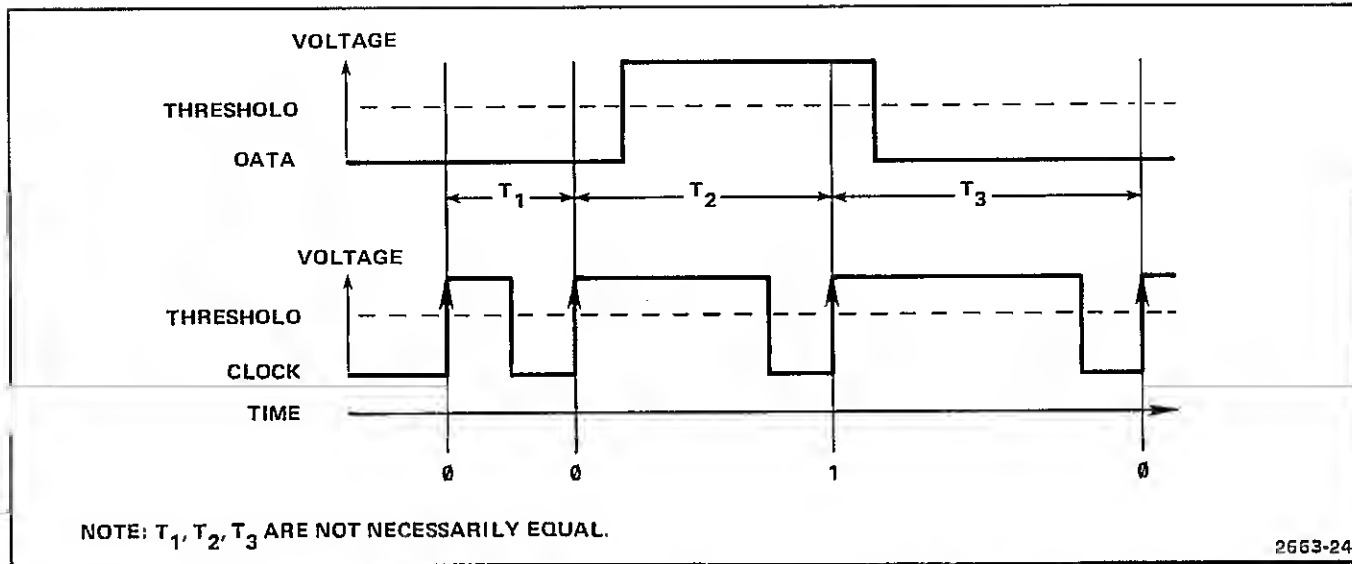

Figure 26. Using an External Clock to Control Sample Rate.

The Latch mode is used to find input changes between sample times. Glitches and infrequent short events may be found and displayed using this mode, but will not be displayed when using the Sample mode. In the Latch mode the output data shows changes in input data. During each sample interval the input is compared to the previous interval value. If the entire present interval is the same as the previous interval, it is recorded as being the same. If any part of the present interval differs from the previous

interval value, the present interval is recorded as being different.

Figure 29, Finding Glitches When Sampling Synchronously, shows how data is latched with an external clock. If data changes only once per sample interval, there is no difference between the Sample mode and the Latch mode. Only one change is accepted in each interval. When

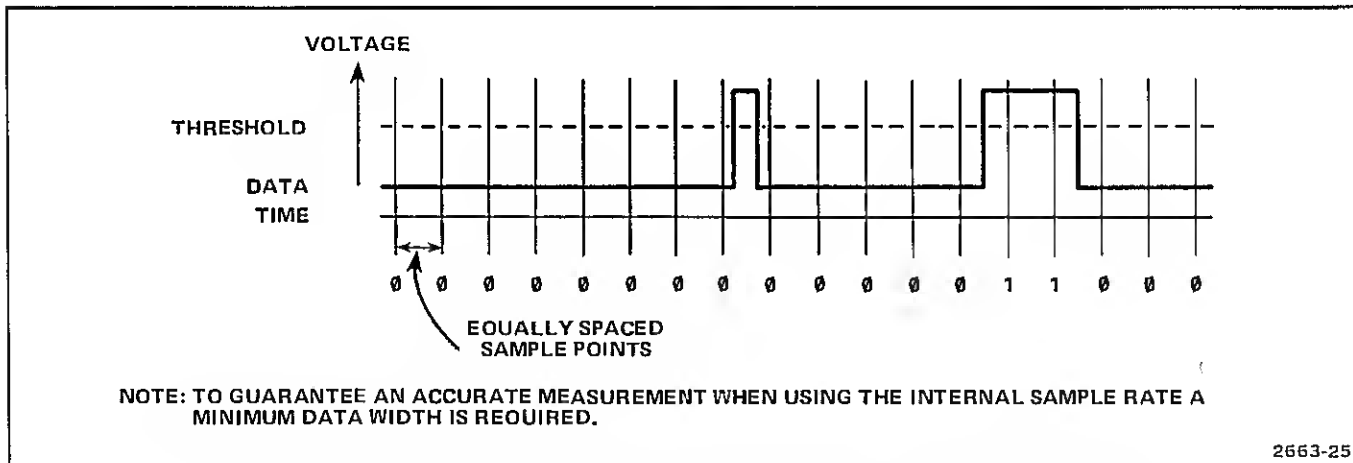

Figure 27. Using the Internal Sample Rate with a Minimum Data Width (In Sample Mode).

two changes occur, only the first one is recorded. Two glitches are shown that will produce different recorded values in the Latch mode.

find a pulse. When using a long sample interval, the pulse can be found using the Latch mode. This allows storing many short events separated by longer intervals.

Figure 30, Asynchronous Sampling for Infrequent Short Events, shows how to latch events too short to be sampled during the required sample period. Figure 27 shows how a decreased sample interval can be used to

Data Storage

There are three ways in which digital data is stored by the 308 for presentation to the user.

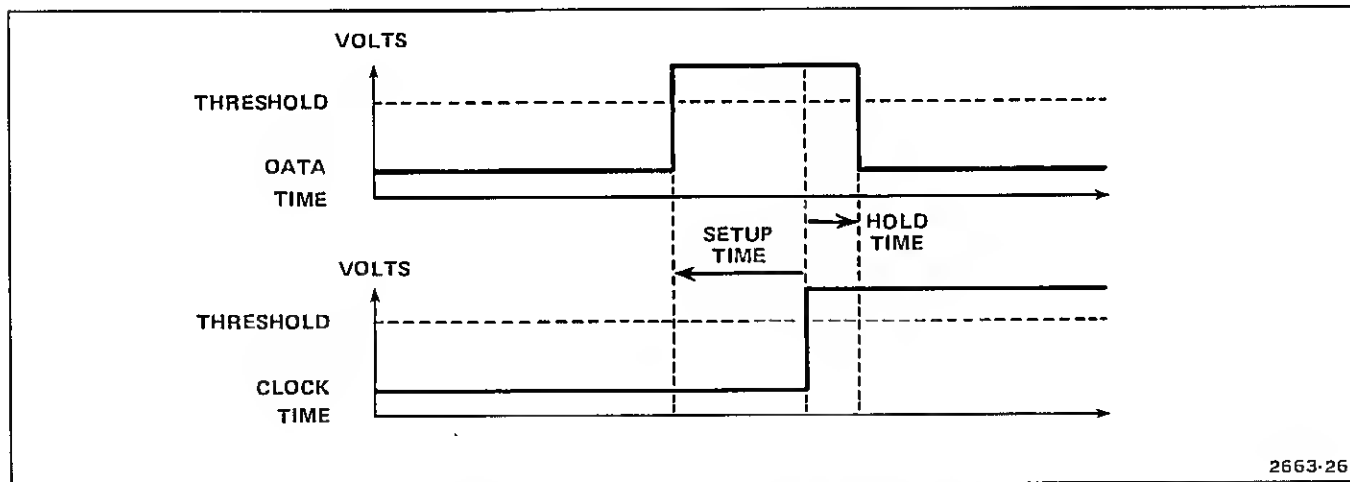
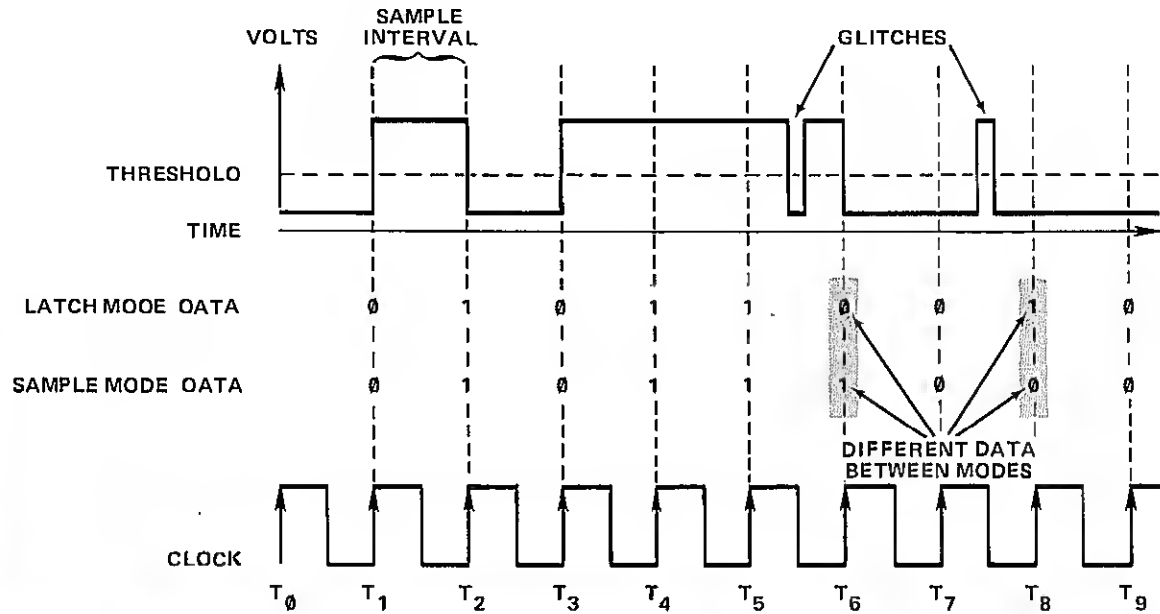

Figure 28. Setup and Hold Time for an External Clock.



NOTE: EACH CLOCK PERIOD IS A SAMPLE PERIOD AND IN THIS EXAMPLE THE (↑) RISING EDGE OF THE CLOCK HAS BEEN SELECTED TO BEGIN THE NEW SAMPLE PERIOD.

2663-36

Figure 29. Finding Glitches When Sampling Synchronously.

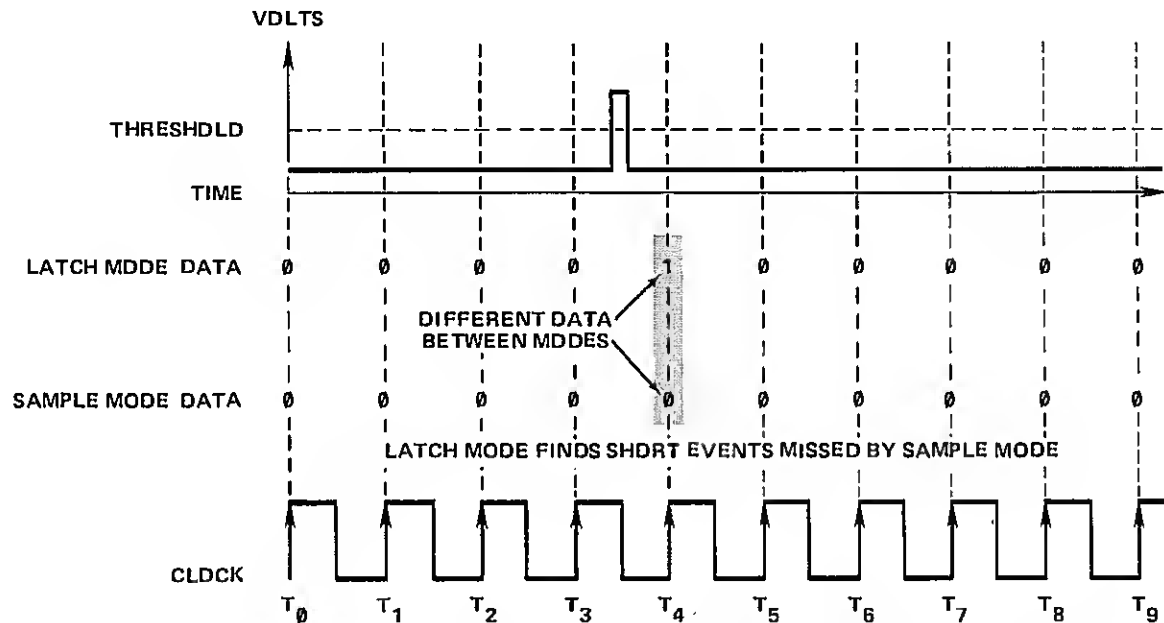

NDTE: EACH CLDCK PERIDD IS A SAMPLE PERIDD AND IN THIS EXAMPLE THE (↑) RISING EDGE OF THE CLDCK HAS BEEN SELECTED TO BEGIN EACH SAMPLE PERIDD.

2663-37

Figure 30. Asynchronous Sampling for Infrequent Short Events.

In the Parallel Timing and Parallel State modes, data is acquired simultaneously on eight separate lines. The eight bits of each sample point are stored in the Data Memory that can hold up to 252 eight-bit samples (bytes).

In the Serial State mode, Incoming data on one line is interpreted according to EIA STD RS-232-C rules into bytes of data that may be from five to eight bits in length. Each resulting byte is stored in the 252-byte Data Memory. This is the same 252-byte Data Memory that is used for storing parallel data. The methods of triggering and storing are so similar for serial and parallel modes that they will be discussed together in later paragraphs.

In the Signature mode, the data is transformed into a 16-bit, 4-digit alphanumeric code. If the trigger conditions always allow the same sequence of samples to be obtained, a valid signature will be generated.

Triggering, Delayed Triggering, and the Data Memory

The number sequence that results from sampling the input voltage is continuously stored until the delayed-trigger condition is met. At that time, there will be from 1 to 252 sample points in the Data Memory from which the display is formed.

Within the Data Memory there are two sample-point positions that can be chosen as a reference point. The one eight-bit point chosen will contain the byte associated with the delayed trigger condition. The two conditions are selectable to allow more data to be retained from before (PRE) or after (POST) the delayed trigger condition.

To understand this acquisition process, refer to Figure 31, Example of Data Storage in POST Trigger Data Mode, and assume a sequence of bytes has been gathered from an 8-bit counter and some storage has taken place. Assume also that the acquisition has been set to trigger on 255_{10} , to delay 18_{10} to the Delayed Trigger location, and to put the delayed trigger in the POST Trigger data position. When the trigger is obtained, the acquisition acquires 18 more bytes to reach the Delayed Trigger point, then acquires 239 more bytes to finish defining the information needed for the Data Memory. Next, the information is transferred to the Data Memory in such a way that the Delayed Trigger byte is in the correct POST Trigger data position. The result is that the first byte into the Data Memory (Position=Delayed Trigger-12) is the number 00000101_2 or 5_{10} . The last byte in the Data Memory is 00000000_2 . Notice that the trigger byte did not get placed into the Data Memory. This is not always true, as the next example will show.

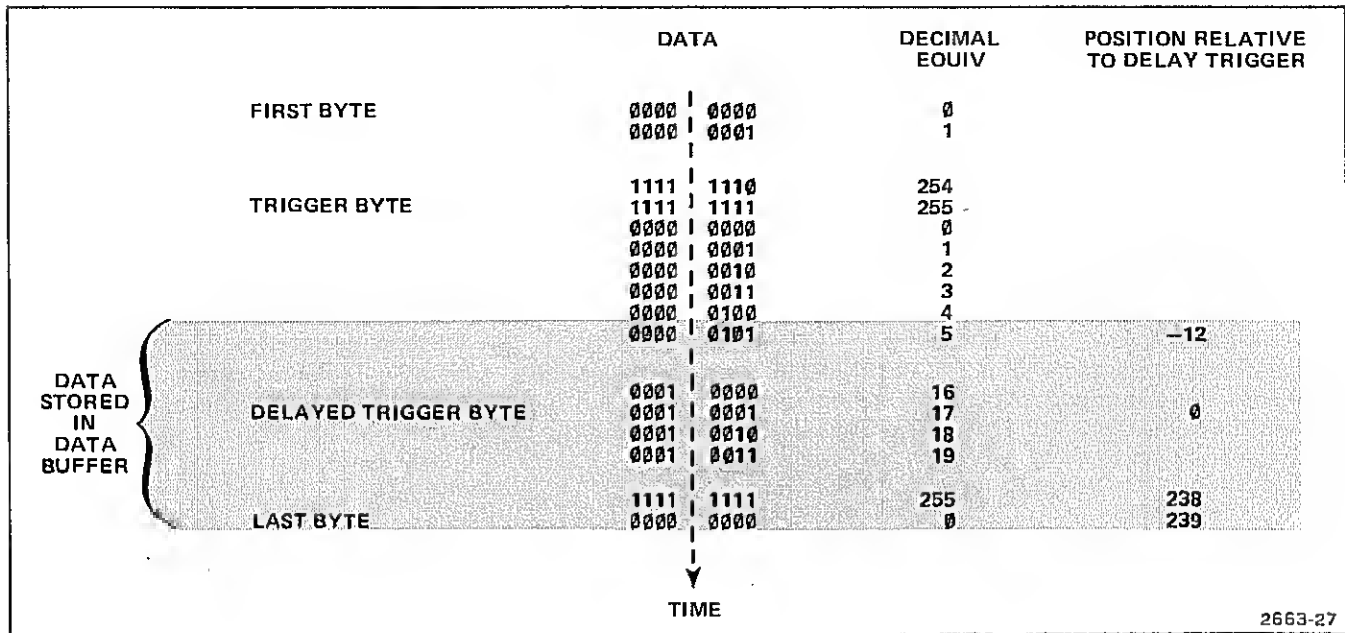

Figure 31. Data Storage in Post Trigger Data Mode.

In Figure 32, Example of Data Storage in the PRE Trigger Mode, an acquisition took place that was identical to the one discussed in the POST Trigger Data Mode, except that the storage was done in the PRE Trigger Data Mode. The result is that 10 of the 252 bytes were placed in the Data Memory, and 239 of them occurred before the Delayed Trigger. This was enough to include the trigger condition which occurred at Position=Delayed Trigger -238.

All displays are based on the Data Memory and use the Delayed Trigger as a reference point. The trigger location also varies, and it is important to remember that it will not be the same as the Delayed Trigger reference point. When the **DELAY=** is set to zero, the Trigger will occur at the same location as the Delayed Trigger. Whenever **DELAY=** is not set to zero, the Delayed Trigger will be separated from the Trigger by the number of sample intervals the **DELAY=** is set to. To observe the effect of specifying different delay values, compare Figure 31 and Figure 33.

Extending the Trigger

In the previous example, the Trigger was based on the data being recorded. It was a single byte of the data being

recorded. There are many other variations. The most important concept to accept is that the Trigger may not be a part of the data stream at all. To find out what is happening to a data stream at the time another event is occurring, that event can be inputted to another trigger-only input (such as in Figure 12). The resultant recorded data may or may not be used as a part of the Trigger, as required. In Figure 33, Triggering on Events Other Than Data, several printers are receiving data from the same bus. The enabling signal to one of the printers (number 2 in this example) can be used as all or part of the trigger condition. This allows inspecting messages to only one of the printers. In addition, the printer data may be used as part of the Trigger so that one particular message to one particular printer may be inspected.

The 308 has several methods of triggering. The methods are different for parallel acquisitions than for serial acquisitions. The specific methods will be discussed in the paragraphs on Data Acquisition and Displaying Data.

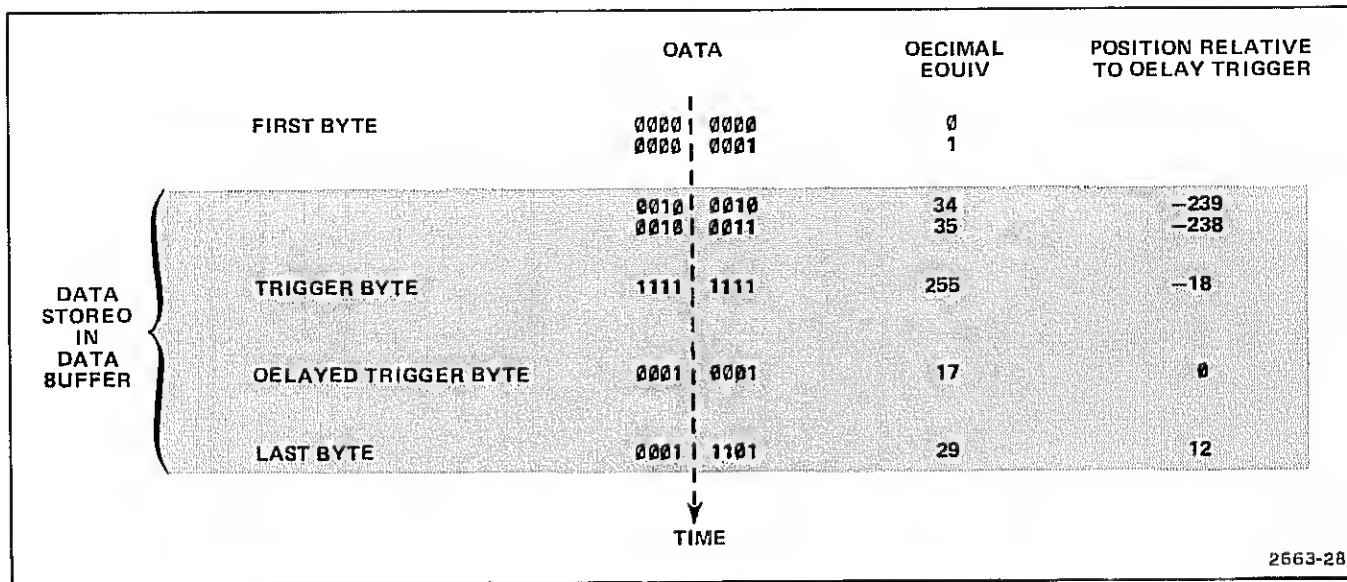
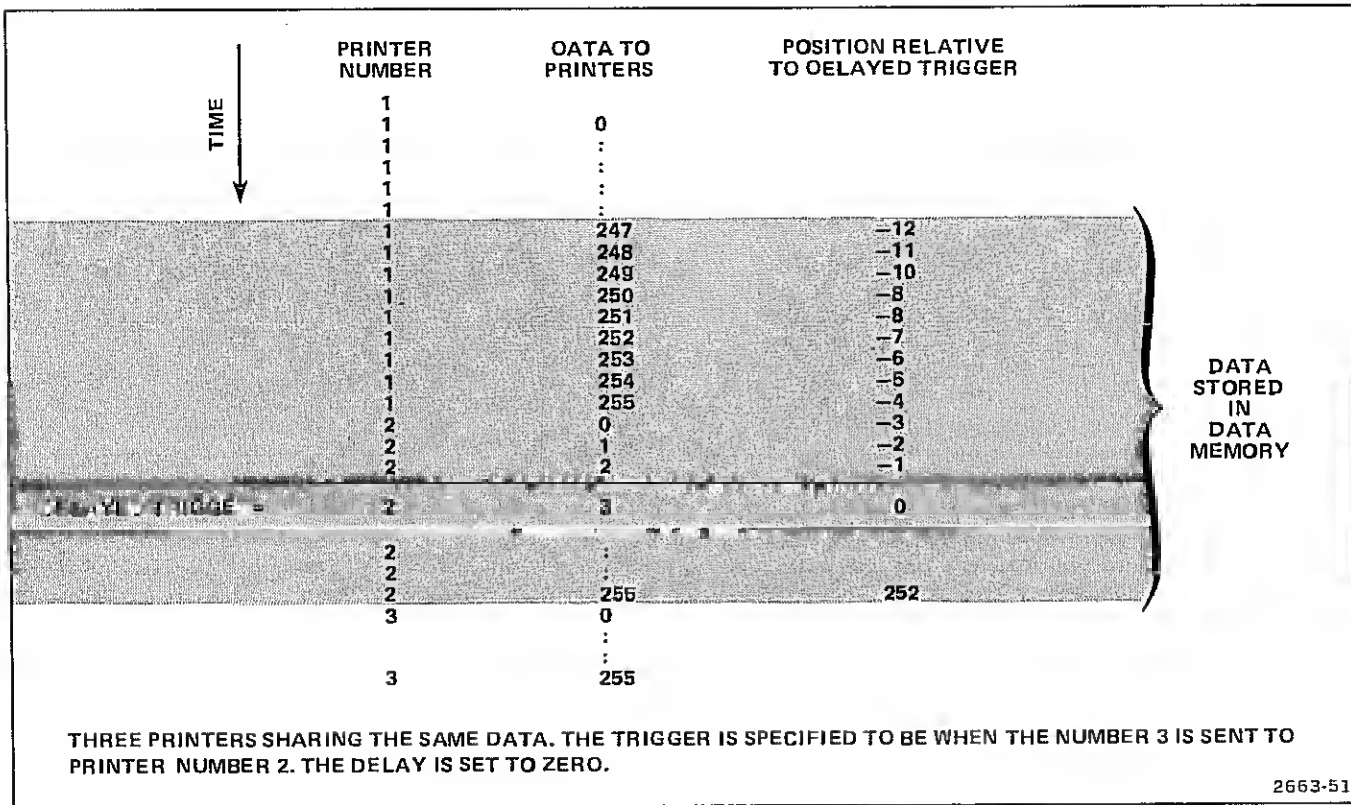

Figure 32. Data Storage in PRE Trigger Data Mode.



2663-51

Figure 33. Triggering on Events Other Than Data.

DATA ACQUISITION

Introduction

The modes of acquiring data with the 308 are Parallel Timing, Parallel State, Serial State, and Signature. Each mode will be discussed, and the similarities and differences pointed out. The similarities are most easily seen by looking at the Control Function Access Chart, displays 1, 4, 8, and 12. The variables for Parallel Timing and Parallel State are identical, while Serial State can have an extended menu and other differences that will be explained. This includes the Word Recognizer probe and Trigger Qualifier.

The Parallel and Serial menu are covered first because of the high degree of commonality. Each mode discussion has an illustration with corresponding numbers for the same information blocks. This gives the operator a rapid cross reference to the variables and the ability to see the similarities and differences of each mode.

How to start and stop an acquisition (which was covered in a different context under Basic Operational Information) is the next logical step in learning to operate

the 308. Additional and more specific details are included later in the manual under the Application Example.

Serial protocol variables that are different from parallel variables are then explained in terms of EIA Standard RS-232-C.

Special features of **RE-START IF DATA=REF** with its use of the Reference Memory are described next.

The final mode explained is the Signature mode, with its unique capabilities and uses.

Parallel and Serial Acquisition Parameters

The Parallel Timing and Parallel State menus have identical menu information; therefore, any selection made in either mode will have the same effect, and only the display will change. The Serial State menu has a great deal of commonality with the Parallel State menu, and they will be discussed together. Table 4 is keyed to Figures 34 and 35 and describes the acquisition parameters for Parallel State and Serial State menus.

Table 4

PARALLEL AND SERIAL ACQUISITION PARAMETERS

Item	Applicable Menu	Description
1	PARALLEL AND SERIAL	Shows main instrument mode: Parallel Timing, Parallel State, Serial State, or Signature. Inverse video shows that data was acquired in another mode.
2	PARALLEL AND SERIAL	Data entry mode: Hexadecimal, Decimal, Octal, or Binary. Controlled by the Entry Format keys described in Figure 9 and affects only the data entered in the acquisition parameter information blocks. Does not affect the data format of the display.
3	PARALLEL PARALLEL AND SERIAL	Sample or Latch: Affects the method of gathering data. See Figures 29 and 30 and associated text. When In Sample mode, the data is clocked-in using specified setup and hold times.
4	PARALLEL AND SERIAL	PRE Trigger Data or POST Trigger Data: Controls location of Delayed Trigger to be In the 13th or 240th byte acquired in the Data Memory. For general concept information refer to the discussion on Data Storage and the Data Memory under Basic Operational Information.
5	PARALLEL AND SERIAL	POSITIVE or NEGATIVE : These are not acquisition variables. They control the sense by which the Data Memory displays information. POS means that voltages above the threshold appear as 1's. NEG means that voltages below the threshold appear as 1's. For more information refer to Masking and Data Inversion.

Table 4 (cont.)

Item	Applicable Menu	Description
6	PARALLEL AND SERIAL	<p>DLY=: Sets the number of sample intervals between the Start Trigger and the Delayed Trigger. The Inverse video character that appears between DLY and = Indicates the number system in use, as follows: H means Hexadecimal and O means Octal. For decimal values no character is inserted. The value cannot be set in binary.</p>
7	<p>PARALLEL</p> <p>SERIAL</p> <p>PARALLEL</p>	<p>SMPL=: Selected by the SAMPLE INTERVAL/FASTER/SLOWER keys. Internally-generated periods have a range of 50 ns to 200 ms in a 1-2-5 sequence. Externally generated sample periods controlled by either the rising or falling edge of the Clock Input may be selected.</p> <p>SYNC= or ASYNC=: Selected by the SAMPLE INTERVAL/FASTER/SLOWER keys. ASYNChronous baud rates from 50 Hz to 9600 Hz may be selected. Externally generated sample periods controlled by either the rising or falling edge of the Clock Input may be selected.</p> <p>DATA=: Displays the data portion of the trigger specification. Selecting the data format (information block 2) will cause an O, H, or B to be inserted in Inverse video between DATA and = if the values are in a non-decimal format. Pressing the DATA= key will cause the display to light up an Inverse video block of the appropriate length for the data format selected; then the data entry keys can be used to fill the block. Errors may be corrected with the CE (Clear Entry) key.</p>

Table 4 (cont.)

Item	Applicable Menu	Description
7	PARALLEL	<p>EXT=: An expansion of the Trigger specification for inputs other than data inputs. Pressing the EXT= key will cause the display to light up an inverse video block of the appropriate length for the data format selected; then the data entry keys can be used to fill the block. Errors may be corrected with the CE (Clear Entry) key.</p> <p>If the Word Recognizer Probe is connected, pressing the EXT= key allows the operator to specify its word. In that case, the external/clock qualifier entry block will be moved to the right of the word recognizer entry block, and separated by a hyphen.</p>
8	SERIAL	<p>DATA 1= and DATA 2=: Pressing the DATA= key will cause both of these blocks to light up in inverse video. These blocks specify a two-byte sequence for triggering serial acquisition. More information is contained in Serial Protocol Variables.</p>

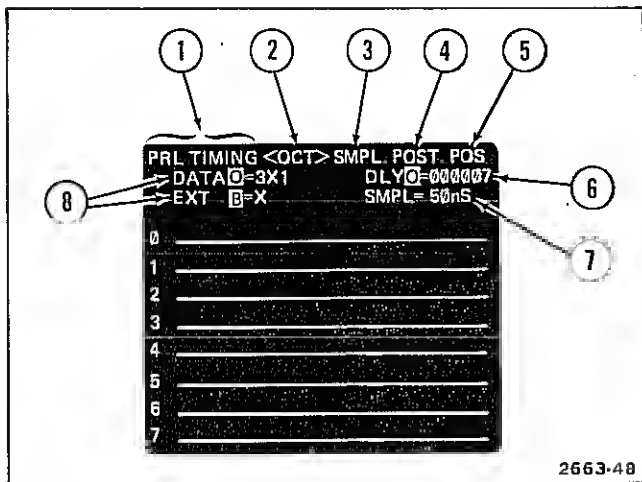

Figure 34. Parallel Acquisition Menu.

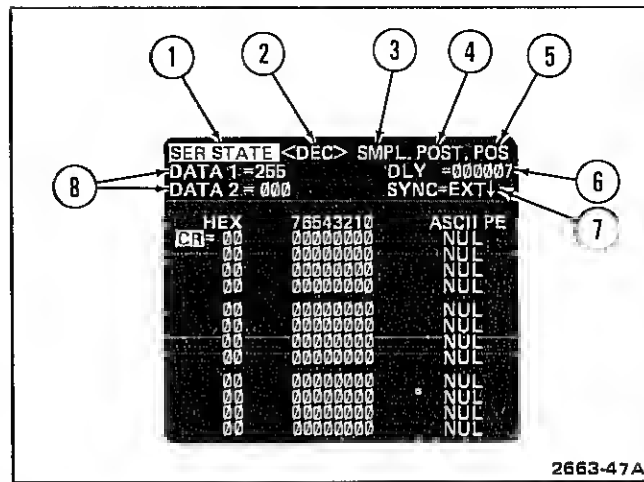

Figure 35. Serial Acquisition Menu.

Starting the Acquisition

An acquisition is started when the following conditions have been met:

1. All of the parameters are correctly set, as discussed in previous paragraphs.

2. The probes have been properly connected.

3. The threshold has been set or adjusted properly.

4. The correct timing information is available for the sampling inputs.

NOTE

PARALLEL: No data is received if the sample rate is set to an external clock which is not crossing the threshold level.

SERIAL: No data is received if the sample rate (baud rate) clock is set for an external clock which is not crossing the threshold, or if protocol timing information is not present to cause synchronization of the receiver. See the portion on Serial Protocol Variables for more information.

5. Either the **START** key or the **RE-START IF DATA = REF** key is pressed. Starting may be done repeatedly by using the Reference Memory to pre-qualify an automatic restart using the **RE-START IF DATA = REF** key.

The data portion of the display will disappear during the acquisition and does not return until the acquisition is completed and new data is available for display in the Data Memory.

Stopping the Acquisition

An acquisition is stopped when any one of the following conditions is met:

1. The preset trigger condition is met (Indicated when the **TRIG'D** Indicator is illuminated); **and**

The programmed delay has been completed; **and**

The Data Memory is filled as needed for the PRE or POST modes.

2. The **STOP** key is pressed, generating a Stop Trigger.

3. The Data Memory is completely filled.

When a Stop Trigger is provided by pressing the **STOP** key, the following actions occur:

The most recently acquired byte becomes the Stop Trigger and up to 239 previously acquired bytes will be available in the Data Memory. The Stop Trigger byte is placed in location 240 in the Data Memory. The last 12 bytes of the Data Memory are unfilled (and shown as

invalid data). Data from the Data Memory immediately appears on the screen.

Trigger Conditions

The flexibility of the 308 is increased by the large variety of trigger conditions that it can be programmed to accept. These conditions differ considerably between Parallel and Serial acquisitions and are described as follows:

PARALLEL

1. The trigger can be based on up to 25 different inputs at the same time.

2. The Data Acquisition probe provides eight inputs (any byte of input data) to the Trigger. Inputs can be specified by the DATA= block of the menu. Any input may be required to be HI, LO, or X (don't care). For example, if the operator set the screen display to DATA **B** = 011XXXXX, then bits zero through four are set to Don't Care (X), bits five and six are set to a HI, and bit seven is set to a LO.

3. With a Word Recognizer probe attached, EXT= can be expanded by an additional sixteen bits, with the **EXTERNAL TRIGGER QUALIFIER INPUT**

always being the 17th bit. These bits can be set like the ones for the data acquisition probe. Don't Care (X) bits are available only in the HEX entry format. The external Word Recognizer probe accepts X's as equivalent to a four-bit group. An example with the Binary format selected would be:

EXT **B** = 11110000
00001111—1

4. With the T/C switch set to the T and with no Word Recognizer probe installed, this bit is always a part of the trigger qualifier. An example of the screen display is EXT = X. If the T/C switch is set to C, that bit must be HI in order for a data byte to be acquired and recorded in the Data Memory. Therefore, not every byte will be accepted (only those with the EXT = 1). Special timing requirements on this clock-qualifying function are described in the Specification portion of this manual.

SERIAL

1. The data stream into the Serial/Signature probe can be used for a trigger source if the DATA = key is pressed. This requires the operator to fill in two information blocks that define exactly what two consecutive data bytes will be used to trigger the

308. An example of the screen display in this case would be:

DATA 1 \boxed{B} = 00001111

DATA 2 \boxed{B} = 11110011

2. The second way of triggering the serial data stream is to press the **EXT** = key; then the trigger will be a single bit coming in through channel zero of the Data Acquisition probe. The screen display will change (e.g., **EXT** \boxed{B} = 1).

Serial Protocol Variables

Serial data presents some problems in determining when one byte (or word) ends and the next begins. This is because the serial data is transmitted on one line, with possibly an associated clock line. Additionally, timing problems may be fairly simple or very complex, depending on the system in use. The 308 meets the needs of a wide variety of systems.

There are two different ways of separating bytes. The first method uses additional bits to frame bytes and is called Asynchronous Protocol. The second method uses whole bytes to indicate the beginning and ending of a block of data bytes and is called Synchronous Protocol. In

both protocols the sense of the line is usually inverted so that a 1 is represented by a LO and a 0 is represented by a HI.

Asynchronous Protocol Variables. The 308 receives in an Asynchronous Protocol mode when the Baud Rate (or bit sample rate) is set to one of the ASYNC= positions, with a screen display such as ASYNC= 300 Hz (300 Hz or bits per second).

In the Asynchronous mode the data input line idles in either the HI or LO state, depending on the selection of Input Polarity in the Serial Menu. The default value (if no selection is made) is negative to conform to EIA Standard RS-232-C. It may be changed to positive for special applications. If the polarity is negative, the line idles in a LO state. A rising edge on this line triggers the beginning of a Start bit. The validity of this Start bit is checked by strobing the bit again at its expected center, if the 308 is supplying the Baud Rate clock. If the HI is detected again (or the 308 is using an external clock), the bit counter starts counting. The form of the data is shown in Figure 36, Asynchronous Serial Data.

Following the Start bit is the Data character. It starts with bit zero and ends with the most significant bit. If there

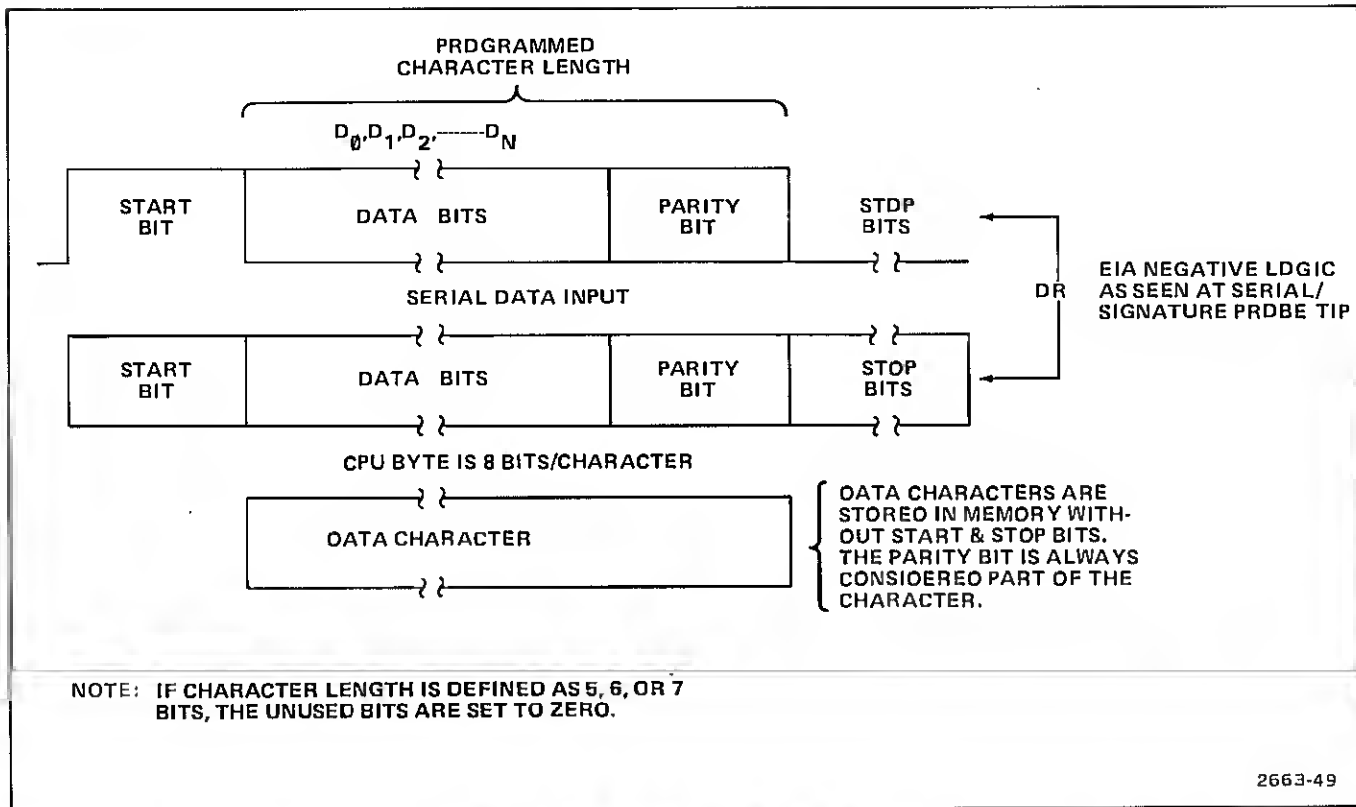

Figure 36. Asynchronous Serial Data.

is a parity bit used, it is usually the last bit of the character. The 308 accepts bytes of 5, 6, 7, or 8 bits, including the parity bit. These are selected through the Serial Menu. Each byte must be followed by at least one byte period of idle time, known as a Stop bit. While some systems require 1-1/2 or 2 Stop bits, the 308 accepts one or more.

Synchronous Protocol Variables. When the 308 is operating in a Synchronous Protocol mode, the screen display SYNC= will be followed by EXT with an arrow to indicate either the rising or falling edge of the externally-supplied clock. The data input is sampled on the chosen edge of the externally-supplied clock. The byte size (N-bits) chosen changes the size of the programmable Sync word and Hunt word that are available in this mode. The most recent group of N-bits is compared to the Sync character until a match is found. When a match is found, the next group of N-bits is also checked to see if it is a Sync word. If there were two *consecutive* matches, the data stream is sampled in N-bit groups, and each group is stored as a byte.

If a Hunt word is specified, it is the last byte accepted in any group of bytes. After it is received, two *consecutive* Sync words must be received before the 308 will resynchronize and store any more bytes from the data

stream. If for any reason there are three bytes received from an Idle line (e.g., FF) these bytes will be stored and the 308 will enter the Hunt mode looking for the two *consecutive* Sync words again.

In the Synchronous Protocol mode (see Figure 37), as in the Asynchronous Protocol mode, the parity bit is a part of the data byte regardless of whether the byte is 5, 6, 7, or 8 bits.

After a Hunt word is recognized, there are time requirements for resynchronizing with the serial data stream as illustrated in Figure 38. This is a typical example of how serial data is handled by the 308. There are three examples shown, with the bold portion of the data representing the part that is recorded in the Data Memory.

The top example in Figure 38 shows a typical 2400 baud data stream that ends with a Hunt word. The 308 must receive and recognize the Hunt word, then seek two *consecutive* Sync words before it will again record. Notice the two Sync words that start the recording process again are not recorded, but the two Sync words occurring in the next block are recorded as data. This is typical of the process. The Sync words divide the data blocks and are

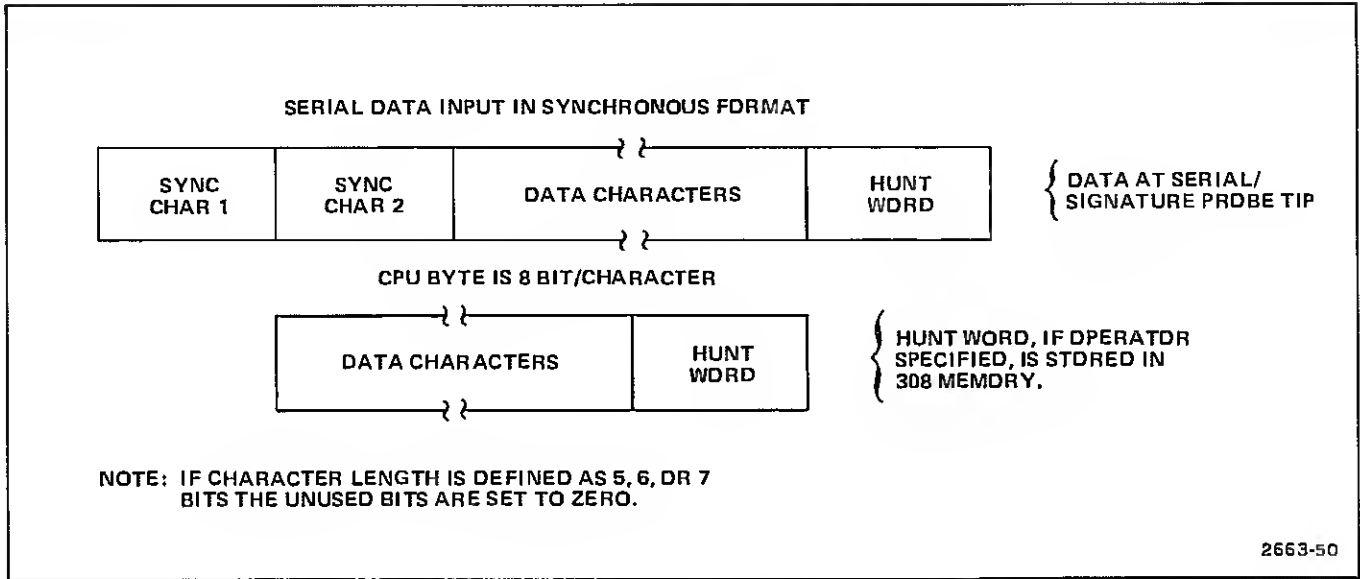

Figure 37. Synchronous Serial Data.

2400
BAUD



- ① IMMEDIATE RESYNCHRONIZATION OF SPEEDS OF 2400 BAUD OR LESS WITHOUT LOSS OF ANY PORTION OF DATA STREAM.

9600
BAUD

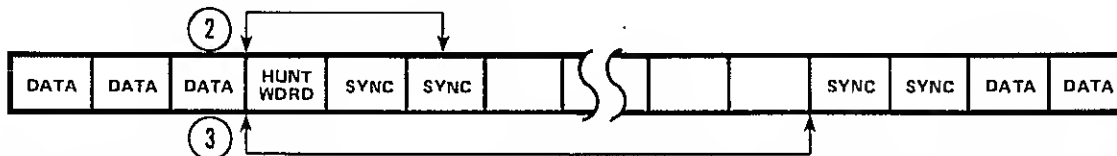

- ② HARDWARE FAILURE TO RECOGNIZE THE NEXT SYNC WORD AFTER A HUNT WORD AT SPEEDS ABOVE 2400 BAUD.
- ③ LOSS OF DATA STREAM UNTIL THE NEXT PAIR OF SYNC WORDS THEN RESYNCHRONIZATION (INCLUDING 9600 BAUD).

9600
BAUD

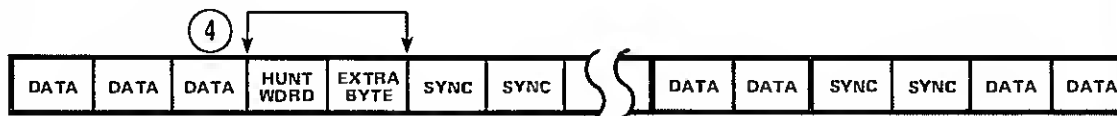

- ④ INSERTION OF ONE BYTE TIME ALLOWS IMMEDIATE RESYNCHRONIZATION AT ANY BAUD RATE.

2663-30

Figure 38. Resynchronization Time Requirements.

recognized immediately if a Hunt word is received to stop the recording process and start the search for Sync words to begin the recording process again.

NOTE

Any three-byte period filled with 1's specifies a Hunt condition regardless of whether the operator has specified a Hunt word.

The second example in Figure 38 shows that at 9600 baud (or possibly less), if the Sync words immediately follow the Hunt word, they may not be found and recognized by the 308. This may happen at baud rates above 2400, with the Sync words starting within the next byte period. The example shows how an entire data block, framed between the Sync words, is lost under these conditions.

The third example shows how this possibility can be prevented by inserting at least one byte period between the Hunt and Sync words. This gives the 308 time to recognize the Sync word and record the following data block.

Extended Serial Menu

Pressing the **SERIAL STATE** key twice displays the extended Serial State menu on the screen. Up to five parameters are operator-controlled through this menu. The first three are the same for both Asynchronous and Synchronous modes of operation. Only the first three will be displayed if the operator has selected the Asynchronous mode. The other two parameters are displayed only if the operator has selected the Synchronous mode.

These parameters are explained in the order and by the numbers that identify them on the screen display. When a parameter is selected for definition, its screen display changes to inverse video.

1. **INPUT LOGIC.** This selects either positive or negative logic. Controlling the sense of the line is important because an idling line must be interpreted properly to allow the 308 to locate timing information. The default condition is negative to agree with EIA Standard RS-232-C. If the operator must change to positive logic for a different application, first press the **1** key to select INPUT LOGIC, then press the **1** key again to select positive.

2. **BITS/CHAR.** This selects the number of bits per character (or byte size). The operator may select 5, 6, 7, or 8 by first pressing the 2 key, then pressing the 5, 6, 7, or 8 key as necessary. If fewer than eight bits per character are selected, only that number of bits will be stored in the Data Memory. The most significant bits not selected will be stored as zeroes for display purposes. There will still be 252 bytes stored in the Data Memory. If the bits per character is increased (from any previous smaller setting), the Sync word and Hunt word must be reprogrammed.

3. **PARITY.** This control does not change the data acquired by the 308 in any way. It controls the display of errors by telling the 308 display system whether the bytes being displayed should be even parity, odd parity, or ignored (no parity). First press the 3 key, then press either the 0, 1, or 2 key to select none, odd, or even.

4. **SYNC WORD.** This word is initialized to the ASCII Sync word 00010110₂. If the application requires changing it, first press the 4 key, then press the 0 or 1 key until the Sync word has been completed. This word is always entered in *binary* and will require 5, 6, 7, or 8 digits depending on the number of bits per character selected. If the bits per character is increased (from any previous smaller setting), the Sync word and Hunt word must be reprogrammed.

5. **HUNT WORD.** This word may be entered by first pressing the 5 key, then pressing the 0 or 1 key. If the application does not require a Hunt word, the operator may press the X key once, and the Hunt word will fill with all X's to indicate that no Hunt word is specified. If the bits per character is increased (from any previous smaller setting), the Sync word and Hunt word must be reprogrammed.

Reference Memory

The 308 contains a Reference Memory which provides the operator with two more means of examining the data acquired. The contents of the Data Memory can be stored indefinitely (as long as the power remains on) in the Reference Memory. After an acquisition is complete, press the **STORE DATA—REF** key to copy the contents of the Data Memory into the Reference Memory. This does not change the data in the Data Memory. With data in both memories, the 308 can do a Compare function and a Restart If Data = Ref function (an automatic restart). These operations can be done with either parallel or serial acquisitions. The contents of the Reference Memory cannot be displayed on the screen.

COMPARE Mode. COMPARE mode operation is performed as follows:

1. Do an acquisition to fill the Data Memory.

2. Press the **STORE DATA—REF** key to copy the data acquired into the Reference Memory.

3. Do another acquisition.

4. Press the **COMPARE** key to compare the newly acquired data with the data from the previous acquisition.

Acquired data that differs from stored data will be displayed in Inverse video. This may be done from either state display and changed to the other state if needed. If the data is acquired in the Parallel State mode, for example, the operator can press the **SERIAL STATE** key to change the displayed data from hexadecimal, binary, and octal to hexadecimal, binary, and ASCII.

RE-START IF DATA = REF Mode. The 308 can automatically re-start its acquisition as many times as necessary to enable finding a Data Memory that differs from the Reference Memory. This allows an automatic search for an intermittent problem. Because this mode is used to find changes in the acquired data, the cursor will automatically move to point to the first mismatch between the memories.

The Re-start If Data = Ref mode operation is performed as follows:

1. Do an acquisition to fill the Data Memory.

2. Press the **STORE DATA—REF** key to copy the data acquired into the Reference Memory.

3. Press the **RE-START IF DATA = REF** key.

The 308 will then do an acquisition and compare the results of that acquisition with the contents of the Reference Memory. If the data in the Data Memory matches the data in the Reference Memory, the 308 will do another acquisition, compare the results, and continue this process until a mismatch is found. If a mismatch is found, the Data Memory data is displayed with the cursor pointing to the first mismatch.

While in the Re-start mode, the screen will display **RST=XXXX** below the data for each acquisition. This is the re-start counter that increments each time an acquisition and comparison is successfully completed. A display of **RST=0019** means that 19 comparisons produced no errors and the 20th produced the error and the stop. If more than 9,999 re-starts occur, the display is **RST=9999 OVER**.

NOTE

If the RE-START IF DATA=REF key is pressed while in the Compare mode, there will be at least one error highlighted in the display.

The Data Memory is not always completely filled during an acquisition. When that occurs, the empty space is referred to as invalid data. During any compare for Compare Display or Re-start If Data = Ref, invalid data is not used. No error can be obtained by comparing an empty space in one memory with a full (or empty) space in another memory.

This can be useful in providing a free-running display for checking data patterns, determining whether a particular process has started, or checking to see whether the probes are connected properly. One method of obtaining this free-running display is as follows.



1. Do an acquisition setup for an external clock without the clock line connected. The **STOP** key must be pressed to provide the stop trigger and end the acquisition.
2. Press the **STORE DATA=REF** key to transfer the empty Data Memory contents into the Reference Memory.

3. Now connect the external clock line or set the sample rate.

4. Press the **RE-START IF DATA = REF** key.

There will now be a continuous series of acquisitions until the **STOP** key is pressed. For example, if the 308 is in Parallel Timing mode, the operator can remove and replace each individual probe to verify whether it is connected to the proper test point.

Signature Analysis

The 308's signature analyzer is accessed by pressing the key labeled **SIGNATURE**. The Signature mode is entered in a way that allows the operator to specify the signal transition of the signature the operator is looking for. This is done by using the  and the  keys to select the required signal transition for Clock, Start, and Stop signals.

There are two ways of acquiring signatures and displaying them. To obtain one signature and display it, press the **HOLD/RESET** key. This will obtain one signature, display it, and stop. Another signature can be obtained and displayed by pressing the **HOLD/RESET** key

again. The new signature will be put on the top of the list, with the old signature under it. If the new signature is different from the old signature, there will be a < sign placed to its right. Up to eight signatures can be displayed at one time using this Hold mode.

When there is no Start signal present, the **TRIG'D** indicator will not be illuminated. When a Start signal is present, but there is no Stop signal, the **TRIG'D** indicator will be illuminated continuously and no signature will be displayed on the screen. In the latter case, press the **STOP** key to terminate the search for a signature. This causes an invalid signature to be generated and displayed. Control settings may then be changed, if necessary.

To repeatedly obtain signatures and update the screen, press the **REPEAT** key. In this mode the signature-acquisition circuit starts seeking for a new signature while an old signature is being displayed. Whenever the new signature differs from the next most recently acquired signature, the new signature will be displayed and the message **FAULT** will be displayed for about one second. If the signature is continually changing (unstable) the **FAULT** message will blink continuously.

Signatures are four-character alphanumeric codes that are characteristic of certain repeating data streams. To

obtain a signature, there must be a Clock signal, a Start signal, and a Stop signal in addition to the Data signal. The Start and Stop signals are used to open and close a gate for the Data signal. During the open gate, the Data signal is fed into a shift register with feedback paths. At the close of the gate, the contents of the 16-bit shift register is turned into a display. The **TRIG'D** light on the front panel is turned on when the gate is opened by the Start signal and is turned off when the gate is closed by the Stop signal.

Figure 39, Typical Signature Data Sequences, shows how Start and Stop signals gate the signature data sequence. Figure 40, Data to Signature Sequence, shows how the gated data is formed into a signature by a shift register circuit. Before the gate is opened, the shift register is reset to all zeroes. As each bit of data is passed by the gate, it is exclusive-ORed with shift register bits 7, 9, 12, and 16. The output is shifted into the register. The contents of the shift register, after the gate is closed by the Stop signal, is the signature in binary form. The display is formed by showing one character for each four bits of the shift register. The display codes are a special set of numbers and letters that correspond to the hexadecimal digits shown in the figure.

To use the Signature Analyzer in the 308, the start, stop, and clock leads on the Parallel Data Acquisition probe must be connected to appropriate test points. Then the

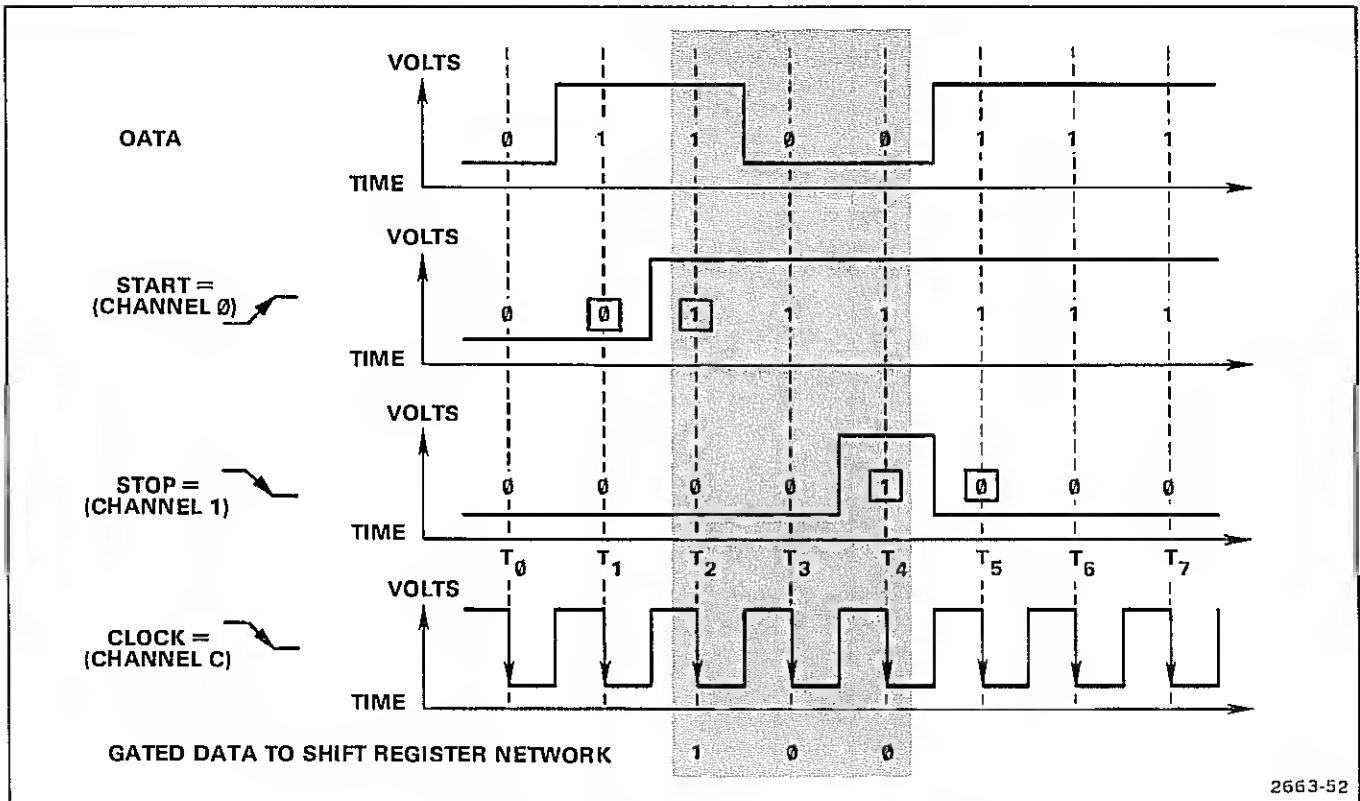

2663-52

Figure 39. Typical Signature Data Sequences.

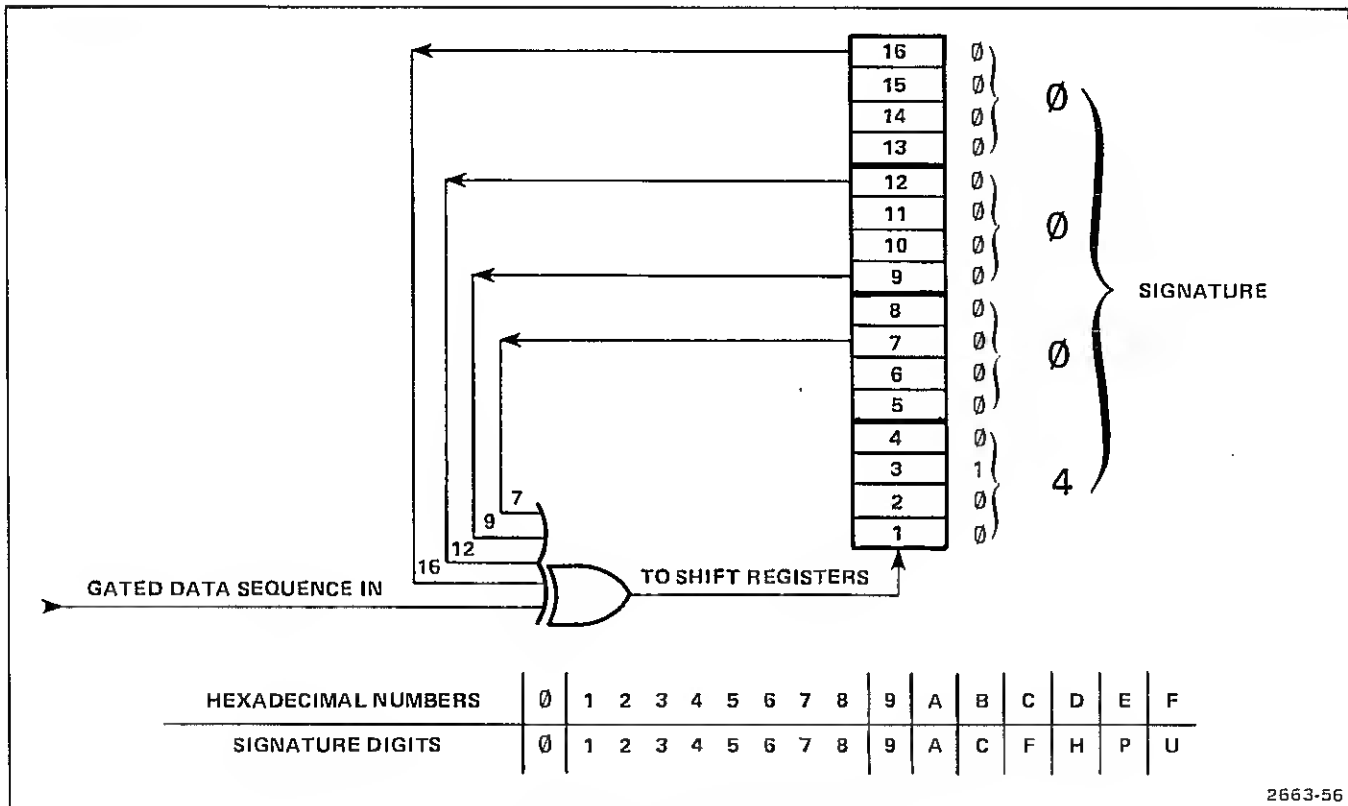

Figure 40. Data to Signature Sequence.

Serial/Signature probe must be attached to the Data test point. The threshold must be adjusted for these probes by selecting either TTL or VAR and setting **THRESHOLD VOLTAGE** to the appropriate value.

The input to the 308 Serial/Signature Data probe is 10 M Ω at approximately 13 pF. This input is voltage-sensing and furnishes no current to the test node (the test point for signature data input). The Start, Stop, and Clock inputs are also high-impedance, voltage-sensing inputs (but at about 1 M Ω). The voltage is converted to ones and zeroes by comparing it to a threshold level in the same manner as with other serial data. The Data, Start, Stop, and Clock Input signals are all compared to the same threshold (TTL or Variable), allowing the 308 to be compatible with many logic families.

Figure 39 shows the relationship between the Data, Start, Stop, and Clock inputs and indicates when there is a gated data output sequence. The sample periods are dependent on the inputs making a level transition and staying at that level until the next Clock edge occurs. Signature analysis forms sequences of ones and zeroes on the three input lines. These three lines are sampled by the clock input on the basis of the operator-selected clock edge. The data sequence is formed into a signature

starting from the clock edge associated with a Start and to (but not through) the edge associated with a Stop. Figure 39 illustrates that a Start sequence includes a zero followed by a one at consecutive clock edges in the example shown. The opposite sequence would be true if the operator had selected the other Start transition direction. Stop works the same way as Start, and either sequence may be selected.

Nodes are tested for their ability to provide the proper data sequence (correct signature). A node that does not assert the proper values for each clock-generated sample during an open gate will produce the wrong signature 99.998% of the time (probably a wrong or unstable signature). Some of the situations that will produce unstable signatures follow:

1. Any of the sequences not repeating in a stable cycle.
2. An open circuit on the data node or the selected driving circuit.
3. A tri-state node in the high-impedance state during a data-sequence-sample time.

Some of the situations that will produce incorrect (but stable) signatures are as follows:

1. A faulty circuit in the previous stage.
2. A shorted line.

DISPLAYING DATA

Parallel and Serial Displays

Data the 308 has acquired and stored in its Data Memory can be displayed in several ways. Data Memory can contain up to 252 bytes. The manner in which data is displayed is determined by pressing the **PRE** or **POST** key, unless the **STOP** key was pressed to end the acquisition. This applies to all modes except Signature. Refer to Figures 31 and 32 for illustrations of **PRE** and **POST** data storage. For normal displays, the Delayed Trigger is put into either the **PRE** or **POST** trigger data position. When the **STOP** key is pressed, a special display is automatically selected. When the operator presses the **STOP** key, the 308 will display up to 239 bytes of data (from the Data Memory) that occurred before the **STOP** key was pressed.

The displays never show the entire Data Memory at once. They may show as few as 12 bytes (in a state mode)

or as many as 168 bytes (in the Timing mode). Each display has a different purpose.

Data can be acquired in either a parallel or serial mode and displayed in either mode. The words on the display screen indicate that the mode of operation will be in inverse video if the data being displayed was acquired in another mode. If the data was acquired in the Parallel mode and the display was changed to the Serial mode, the words **SER STATE** will appear in inverse video in the upper left corner of the screen to indicate that the data being displayed was acquired in another mode.

Cursor Displays

There are three cursor displays that refer to the same cursor. The Parallel Timing Cursor (display 2 in the Control Function Access Chart) is used to inspect the Data Memory in a timing-diagram format. The cursor may be moved onto the screen with the **POSITION** controls. The cursor word will be displayed in hexadecimal, octal, decimal, or binary depending on the operator-selected format. A numeral indicates the relative position of the cursor and the Delayed Trigger. The numeral indicates the number of spaces between the cursor and the Delayed Trigger, and the sign (+ or -) indicates whether the cursor precedes (-) or follows (+) the Delayed Trigger.

The Parallel State Cursor display (display 5 in the Control Function Access Chart) shows twelve bytes from the Data Memory, starting with the Cursor byte. The Cursor position, after Delayed Trigger, is shown at the top of the data listing. The listing shows the data in hexadecimal in the first column, binary in the second column, and octal in the third column. The **POSITION** controls move the cursor to any position in the Data Memory. These controls may be held down for continuous motion of the cursor.

The Serial State Cursor display (display 9 in the Control Function Access Chart) is similar to the Parallel State Cursor display. The difference is that the third data display column has the ASCII equivalent of the data instead of the octal equivalent. A table of the ASCII equivalents for seven-bit numbers is located in Appendix A.

Everything that has been mentioned so far concerns getting data into the 308 Data Memory. The next areas to be discussed evolve around displaying the memory contents, the controls for displaying the data, the methods of displaying the data, and finally, how data acquired in one mode may be intermixed and displayed in another mode. Particular details of the masking and inversion that occur in certain cases will also be explained along with the general usage of the Reference Memory.

The number of bytes displayed on the screen and the position of this segment in the Data Memory are controlled through the Parallel Timing window display which is discussed next.

Parallel Window Display

The Parallel Window display (display 3 in the Control Function Access Chart) is used to control the portion of the display that is shown in the timing displays and the magnification factor. In this display, the window size will change from 168 to 84 to 42 bytes and back around as the **WINDOW** button is pressed repeatedly. The position of the window within the Data Memory is controlled by the **POSITION** keys while in this display. The cursor position will not change, relative to the data, when using the **POSITION** controls in this display. It will continue pointing at the same data byte as that byte is moved to different places in the display. The window size is displayed at the top of the screen.

The bar at the top of the data display is a representation of the Data Memory. The dark area indicates the part of the Data Memory showing in the display. The \emptyset indicates where the Delayed Trigger is positioned in the Data Memory. It will be either in the PRE Trigger data or POST Trigger data position. Usually, the Parallel Timing and Parallel Cursor displays would be used together to

position the window into the memory and then to inspect the memory with the cursor. The next step could be to use the Parallel State display to further increase the detail available from a portion of the memory.

Search Word Displays

The two Search Word displays (displays 6 and 10 in the Control Function Access Chart) work identically, except that the Parallel State Search Word display shows an octal listing and the Serial State Search Word display shows an ASCII listing.

The purpose of this display is to allow the user to quickly locate a byte in the Data Memory or to determine whether it is in the Data Memory. To use the Search Word displays, press the **SEARCH=** key, then press the appropriate data entry keys to fill in the word to be found. Any data entry format can be used to make this entry. The display will return a message showing the location of the first occurrence of the word in the Data Memory, and the word will appear in the cursor location. If the word is not found, the cursor will not move, and the display will read SRCH POS = SW NOT FOUND. The **POSITION** keys can be used to find successive occurrences of the Search Word. Each time a **POSITION** key is pressed, the display will move the next occurrence of the search word to the

top of the display and update the rest of the display. If the only part of the display that changes is the SRCH POS = section, then the whole pattern repeats. This might occur when the data is acquired from a data bus during execution of a program loop.

Compare Displays

The Compare displays are used in conjunction with the Reference Memory. The Reference Memory is filled with a copy of the Data Memory when the **STORE DATA — REF** key is pressed. The Compare displays would then show differences between the Reference Memory contents and any later Data Memory contents. The display is highlighted in inverse video for data which differs between the Data Memory and Reference Memory. This display is often used with the Re-start mode described in the paragraph on the Reference Memory.

Intermixing Parallel and Serial Displays

There are two major areas of special consideration for intermixing serial and parallel display modes. These are of concern when data acquired in Parallel mode acquisitions are displayed in Serial mode displays or vice versa. The important points concern bits-per-character masking and data inversion by using the **POS** and **NEG** keys.

There is one general rule for use of the Reference Memory. The Reference Memory will always store data when the **STORE DATA — REF** key is pressed. That data will have the same form as the data being displayed when the key is pushed. The effects of this will be discussed later.

Parallel Acquisitions and Serial Displays

Any time the serial displays are being used to view parallel-sourced data, the data will be affected by the current bits-per-character setting in the extended Serial Menu. This means that if eight bits of parallel data were acquired but the display is Serial State Cursor, there might be some bits displayed as zero (even though the same bits would not be zero in a Parallel State Cursor display). If the bits-per-character variable is set to 5, then bit 7, bit 6, and bit 5 will always be shown as zero in this situation. This is true for both POSITIVE and NEGATIVE logic selections.

This behavior allows the operator to make direct comparisons of serial and parallel data with the Reference Memory. If a byte of parallel data is 1111111_2 and it is being observed in a serial display with bits-per-character set to 5, then it will appear as 0001111_2 . If the display is one of the serial displays and the **STORE DATA — REF** key is pressed, then that byte will be stored as 0001111_2 . If the display were parallel, then 1111111_2 would be stored.

In this example, if data was obtained from the parallel side of a serial-to-parallel conversion process (or a parallel-to-serial process), the data would be shown and stored in the Reference Memory in the same form as if it had been acquired from the serial side of the converter.

This behavior can be seen by first acquiring all ones, 1111111_2 in parallel (initialize the instrument by turning it on and pressing the **NEG** key). Then select the extended Serial Menu and set bits-per-character to 5. Then select the serial menu display. The data will now appear as 0001111_2 . To further emphasize this effect, press the **STORE DATA — REF** key. Now select the Parallel State Compare display. The first three bits of the state listing will be highlighted as $\boxed{111} 1111_2$. This is because the Reference Memory contains 0001111_2 while the Display Memory is being shown as 1111111_2 .

Serial Acquisition and Parallel Displays

When using the Serial Acquisition system, the bits-per-character variable takes effect with the next acquisitions. To allow the 308 to correctly interpret serial data, the bits-per-character setting must agree with the data being received. See Serial Protocol Variables for more information. When fewer than eight bits are being received, they are stored in the least significant bit locations in the Data Memory. The most significant bits which are not used are

set to zero. For example, if the data 11111₂ was being sent on the serial line under test, the bits-per-character setting should be set to 5. The data will be stored in the Data Memory as 00011111₂.

There is a noticeable difference between the behavior of serial and parallel acquired data. If the data has a serial acquisition source, the display masking will not change when the bits-per-character is changed until a new acquisition is done. For parallel acquired data, the change is immediate.

The contents of the Data Memory filled from serial acquisitions can be compared against parallel acquisition data stored in the Reference Memory. If data acquired from a parallel source is later stored into the Reference Memory while the display is set to SERIAL STATE, the data acquired in a new serial acquisition can match it exactly and the Compare displays can be used to find errors. The Re-start If Data = Ref mode can be used by the

308 to continuously monitor and record (babysitting mode) a serial line with a reference from a parallel acquisition.

Masking and Inversion

Refer to Figure 23, Basic 308 Acquisition and Display System, as Masking and Inversion are discussed. Any data bits that are not filled by a serial acquisition are displayed as zeroes. If parallel data is being shown in a serial display mode, it is treated exactly as serial data with the same number of bits per character. The parallel acquisition is an eight-bit byte and, if displayed serially with a six-bit byte selected, bits 6 and 7 will appear as zeroes.

The masking (setting of data bits to zero) happens after the data sense is determined and after an acquisition has been made, if the data was acquired in a parallel mode. This is true for both the negative and positive logic sense. All unused bits are set to zero to show that they are unused.

APPLICATION EXAMPLE



INTRODUCTION

All four modes of 308 operation are demonstrated in the following example. Then the Intermixing of data, Compare, Search, and Re-start examples will be explained. All of these applications are explained with reference to a partial schematic, Figure 41, which illustrates a typical serial port on a bus-oriented instrument. The port accepts eight-bit parallel data and changes it to asynchronous serial data with Start and Stop bits at 9600 baud.

The testing sequence first takes Signature verification, makes a Parallel Acquisition, then a Serial Acquisition, and then examines the data acquired in one mode in a different mode. Finally, the Re-start, Search, and Compare subfunctions are demonstrated. Refer to your 308 and Figures 8 through 14 for control locations and how to connect the probes. The circuit in Figure 41 is TTL, so place the VAR/TTL switch in the TTL position.

Displays in Figure 43, Control Function Access Chart (at the rear of this manual) are referred to by display number as examples of data entries and screen displays.

SIGNATURE VERIFICATION

Verify that the 308 Line Voltage Indicator is in the 115 Vac position, connect the 308 to a 115 Vac power source, and press the **POWER** key. After the 308 has completed the self-test diagnostic routine and is displaying a Parallel Timing Menu, press the **SIGNATURE** key. Then press the  key twice and the  key once. This sets the 308 to use a positive-going clock edge, begins acquiring signature data on a zero-one start sequence, and stops acquiring data on a one-zero sequence. The screen display now shows this information.

Connect the Data Acquisition probe to the 308, the C lead to TP1, the 0 lead to TP2, and the 1 lead to TP3. Now connect the Serial/Signature probe to the 308, with the ground clip lead to TP4, circuit ground. This probe will be used to acquire the actual signature data. Refer to Table 5 for the application example signature list.

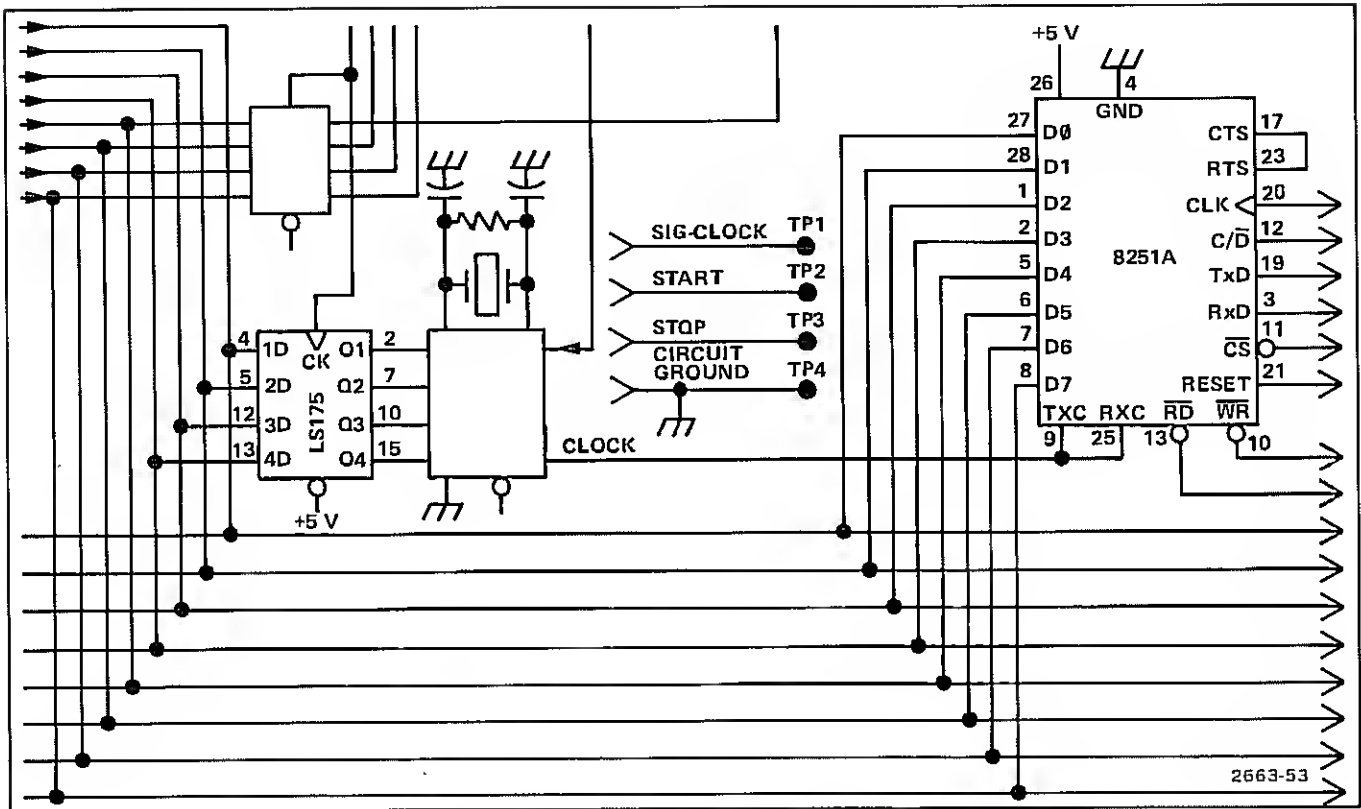

Figure 41. Test Schematic for the 308 Application Example.

Table 5

APPLICATION EXAMPLE SIGNATURE LIST

TEST POINT	SIGNATURE
+5 V	175A ¹
GROUND	0000 ¹
74LS175 Pin 2	6PF9
7	PHFF ¹
10	028A
15	75PF ¹
8251A Pin 8	0771
7	6HCH
6	H233
5	P9CF ¹
2	7322
1	0007 ¹
28	U8H0
27	4698
12	2H92
11	6PF0

¹Used in this test example.

At this point the operator would normally refer to the manual for the particular equipment under test for information on how to place this circuit in a specific loop or mode of operation. This allows the operator to determine exactly what data will be present on the bus or at certain pins of the components. Some examples of how this is accomplished (depending on the particular equipment) would be: user callable routines, grounding or connecting certain pins to a supply voltage, or placing control switches to a certain position.

Place the probe tip on TP4 and press the **HOLD** key three times. The screen display now shows three signatures of 0000. Place the probe tip on +5 V and press the **HOLD** key. Now another signature of 175A has been added to the display. By doing this the operator has proved that the 308 is correctly starting and stopping with the clock start and stop edges.

During any signature test, finding a pin with a 0000 signature instead of the one listed for it suggests that the pin is stuck to ground. The same would be true of a pin reading the signature for +5 V instead of what is listed for it. That pin is probably stuck to +5 V.

Place the probe tip at the following test points and press the **HOLD** key one time while at each test point: 74LS175 pins 7 and 15, 8251A pins 5 and 1. Any of the other test points and signatures listed in the table could have been used as needed. Press **STOP** once to end this signature acquisition process.

PARALLEL AND SERIAL DATA ACQUISITION

Parallel

Connect the Serial/Signature probe to 8251A pin 19. This is the serial data output port of this device. Connect Data Acquisition probe leads 0—7 to 8251A pins 27, 28, 1, 2, 5, 6, 7, and 8 respectively and the ground lead to TP4. Connect the clock lead to pin 10. The 0—7 leads are now connected to the parallel data inputs of 8251A, and the clock lead to the WR pin.

On the 308, press the following keys and enter the data listed or perform the action required.

KEY	DATA OR ACTION
PARALLEL STATE	Press once
HEX	None
POS	None
POST	None
DELAY =	0000
FASTER	Press once (to set up an EXT =1 sample rate)
DATA =	9D
EXT =	X

The 308 is now set to make a parallel acquisition with data entries to be made in hexadecimal, positive logic, data to be displayed after the Delayed Trigger (POST), no delay acquisition times, a positive-going external clock, the trigger word to be 9D, and the External Qualifier set to don't care. The screen display now matches the menu portion of display 4.

Press the **START** key. The 308 does an acquisition, and the screen displays a portion of the Data Memory contents. Press the **CURSOR** key, and the screen display changes to indicate the Cursor position is -12 bytes

relative to the Delay Trigger. Press the  **POSITION** key five times, and the screen now matches display 5. Press the **STORE DATA— REF** key to copy the contents of the Data Memory into the Reference Memory. This will be compared later to data acquired in a Serial Acquisition.

Serial

After next doing a Serial Acquisition, the operator will examine the serial data output of 8251A and compare it to the parallel data input that was stored in the Reference Memory.

Press the **SERIAL STATE** key twice. The 308 is now set to examine the data output port using the same clock that was used for the Parallel Acquisition. The screen display now matches display 8, except that part of the menu for synchronization is displaying **ASYN = 9600 Hz**. The serial output port provides the necessary start and stop bits for asynchronous operation as discussed in Serial Protocol Variables.

Press the **START** key. The 308 does an acquisition and displays a page of data on the screen. Any piece of data that was or should have been acquired can be searched for and displayed. Press the **SEARCH =** key and enter **0B** in the inverse video block. The screen display now matches display 10, showing the desired word in inverse video at the top of the screen display. Also, the data in the screen

display matches displays 5 and 6, except that the right column is the ASCII equivalent instead of the octal equivalent. The desired word position is **-007** (same as the cursor position relative to the Delay Trigger in the previous parallel acquisition). This shows that the serially acquired data is, at least for the first part, the same as the data acquired in parallel. The search function can be used to step through the data, and every occurrence of the desired word will cause it to be displayed at the top of the screen in inverse video.

COMPARE AND RE-START

The operator will next do a Compare function and a Re-start function to prove that the data acquired in both parallel and serial modes is the same in this example, and the device under test is correctly accepting parallel data and outputting that same data in a serial format. Remember that the data acquired in parallel is stored in the Reference Memory.

The data acquired during the last Serial Acquisition is in the Data Memory and can be compared to the data stored in the Reference Memory. Press the **COMPARE** key. Any data that is different will be displayed in inverse video.

Page through the entire memory contents by pressing and holding the **POSITION** keys alternately and you will

find no differences displayed. The Compare function can be proved to be functioning properly by pressing the **NEG** key. This will invert the logic sense of the display and compare the data in the Data Memory with the Reference Memory. The entire data display is now in Inverse video. Again page through the entire memory contents by alternately pressing and holding the **POSITION** keys and you will see that all of the memory contents are displayed in inverse video. Press the **POS** key to return to the positive logic sense in which the data was acquired.

Press the **RE-START IF DATA = REF** key. The 308 now begins to repeat acquisitions in the Serial mode and compare each set of newly acquired data to the Reference Memory. If the new data matches, the 308 increments the re-start counter (whose content is being displayed at the bottom of the screen) and does another acquisition. This process continues until a mismatch is found or the **STOP** key is pressed to provide a manual Stop Trigger. After the 308 has performed a few successful re-starts, press the **STOP** key.

SPECIFICATION

Tables 6, 7, and 8 list the electrical, environmental, and physical characteristics of the 308. The electrical characteristics are valid for the 308 when the 308 has been adjusted as described in the Service Manual (Calibration)

at an ambient temperature between +20° to +30° C (+68° to +86°F), is operating in an ambient temperature between 0° to +50° C (+32° to +122°F) and has warmed up for at least 15 minutes.

Table 6
ELECTRICAL CHARACTERISTICS

Characteristics	Performance Requirements	Supplemental Information
PARALLEL TIMING ANALYZER FUNCTION		
Inputs to P6451 Data Acquisition Probe (Clock and data)		
Input R and C	1 M Ω \pm 5%.	Paralleled by \approx 5 pF.
Threshold Voltage at the MONITOR Jack		
VAR	At least -12 V to +12 V.	
TTL	+1.4 V \pm 0.2 V.	

Table 6 (cont)

Characteristics	Performance Requirements	Supplemental Information
PARALLEL TIMING ANALYZER FUNCTION (cont)		
Logic Swing		
Minimum	500 mV p-p +2% of threshold voltage.	Centered on the threshold voltage.
Maximum	-40 V.	A threshold voltage of at least +10 V.
Nondestructive Input Voltage (Maximum)	At least -40 V to +40 V.	
Latch Mode		Any transition that occurs between two sample clocks is displayed as one clock-period-wide data during the next clock interval.
Width of Data Input (Minimum)		
400 mV Overdrive	10 ns.	
250 mV Overdrive		15 ns.
550 mV Overdrive		5 ns.

Table 6 (cont)

Characteristics	Performance Requirements	Supplemental Information
PARALLEL TIMING ANALYZER FUNCTION (cont)		
External Clock Mode		
Clock Period (Minimum)	50 ns.	
Clock Pulse Width (Minimum)		
High-Logic Level	24.5 ns.	
Low-Logic Level	24.5 ns.	
Data Setup Time (Minimum)	25 ns.	Data must precede clock transition by this amount of time.
Data Hold Time (Minimum)	0 ns.	7ns when Clock Qualifier is active.
Internal Clock Mode		
Sample Interval (Minimum)	50 ns.	
Data Pulse Width to ensure sampling (Minimum)	1 sample interval plus 10 ns.	
Input Delay between Channels Channels 0—7		15 ns or less.

Table 6 (cont)

Characteristics	Performance Requirements	Supplemental Information
PARALLEL TIMING ANALYZER FUNCTION (cont)		
Internal Clock Mode (cont) Frequency of Crystal Oscillator	100 MHz \pm 0.005 MHz.	0.0025% from 0°C to 50°C ambient, 0.0015% at 25°C \pm 3°C ambient. Aging: 5 ppm per year.
Sample Intervals	50 ns to 200 ms/sample in 1,2,5 sequence.	
Clock Qualifier	Function is enabled when Qualifier Input switch (S171) on side panel is set to C.	S171 set to position T (Trigger Qualifier function) at factory.
Input Threshold	+1.4 V \pm 0.2 V (TTL level).	
Input Impedance		10 k Ω or more for TTL signal.
Setup Time		5 ns or less.
Hold Time		30 ns or less.
Safe Peak Input Voltage	+10 V to -5 V.	
Memory Size		
Acquisition	8 x 252 (bits).	
Reference	8 x 252 (bits).	

Table 6 (cont)

Characteristics	Performance Requirements	Supplemental Information
PARALLEL TIMING ANALYZER FUNCTION (cont)		
Trigger Data Word Recognizer	Programmable to set 8 bits of recognition pattern.	
Input	8-channel data input from P6451 Data Acquisition Probe.	
Asynchronous Mode Input Pulse Width (Minimum)	20 ns for any single channel. 35 ns for any combination of channels.	Internal sample interval requires asynchronous word recognition.
Filter	Continuously variable to at least 300 ns.	Matching combinations of narrower width than filter setting are not recognized.
Synchronous Mode Setup Time	35 ns.	External sample interval requires synchronous word recognition.
Hold Time	0 ns.	With reference to selected (rising or falling) clock edge.

Table 6 (cont)

Characteristics	Performance Requirements	Supplemental Information
PARALLEL TIMING ANALYZER FUNCTION (cont)		
Trigger (cont)		
External Qualifier	Programmable to set 1-bit qualifier.	
Input Threshold	+1.4 V \pm 0.2 V (TTL level).	
Input Impedance		10 k Ω or more for TTL signal.
Asynchronous Mode		
Pulse Width (Minimum)	20 ns for qualifier input only.	
Synchronous Mode		
Setup Time	0 ns or less.	With reference to selected (rising or falling) clock edge.
Hold Time	40 ns or less.	
Safe Peak Input Voltage	+10 V to -5 V.	
External Word Recognizer (Optional P6406 Probe)	Programmable to set 16-bit recognition pattern.	
Input Channels	16 channels of input data from P6406.	

Table 6 (cont)

Characteristics	Performance Requirements	Supplemental Information
PARALLEL TIMING ANALYZER FUNCTION (cont)		
External Word Recognizer (cont)		
Input Threshold	+1.4 V \pm 0.2 V (TTL level).	
Input Current		
High-Logic Level	40 μ A maximum at +2.7 V.	
Low-Logic Level	-400 μ A maximum at 0.4 V.	
Safe Peak Input Voltage	+15 V to -1 V peak.	
Asynchronous Mode		
Pulse Width (Minimum)	20 ns for any single channel. 45 ns for any combination of the 24 channel inputs from P6451 and P6406.	
Synchronous Mode		
Setup Time	45 ns.	
Hold Time	0 ns.	With reference to selected (rising or falling) clock edge.

Table 6 (cont)

Characteristics	Performance Requirements	Supplemental Information
PARALLEL TIMING ANALYZER FUNCTION (cont)		
Trigger Output of Word Recognizer Output Level	TTL level.	0.5 V or less for low-level output; 2.4 V or more for high-level output.
Voltage (Maximum)	+6 V peak.	
Current (Maximum) High-Logic Level Low-Logic Level	-1 mA. 2 mA.	
Typical Propagation Delay (Probe tip to word recognizer output with filter set to minimum)		60 ns.
Trigger Delay Delay Count	Programmable to set the delay count. Up to 65,535 count.	Delayed by clock.

Table 6 (cont)

Characteristics	Performance Requirements	Supplemental Information
PARALLEL TIMING ANALYZER FUNCTION (cont)		
Data Position PRE	Positions the Delayed Trigger at the 240th position in the 252-byte Data Memory.	
POST	Positions the Delayed Trigger at the 13th position in the 252-byte Data Memory.	
Full Valid Data Display/First Trigger Mode Selection	Selectable by internal jumper.	Instrument is shipped in Full Valid Data Mode. Under certain circumstances a fraction of display is indicated as invalid data to indicate unused storage location.
Full Valid Data Display	Produces a full valid data display.	
First Trigger Mode	Accepts first trigger after start of a data acquisition.	
START Control	Starts data acquisition when START key is pressed in.	
STOP Control	Stops data acquisition and switches to display mode when STOP key is pressed in.	

Table 6 (cont)

Characteristics	Performance Requirements	Supplemental Information
PARALLEL TIMING ANALYZER FUNCTION (cont)		
RE-START Control	Repeats acquisition if valid new Data Memory matches data in Reference Memory. If not equal, stops data acquisition and switches to display mode.	
Display		
Data Format	Timing Diagram.	
Window Size	42, 84, or 168 bits/channel.	
Display Mode		
MENU	Displays all setting information for acquisition.	
WINDOW	Window position and size are displayed on screen.	
CURSOR	Displays position of cursor line and word at cursor line.	

Table 6 (cont)

Characteristics	Performance Requirements	Supplemental Information
PARALLEL STATE ANALYZER FUNCTION		
Characteristics, Performance Requirements and Supplemental Information for Parallel State Analyzer Function are identical to the Parallel Timing Function except for the Display format.		
Display		
Data Format	Binary, octal, and hexadecimal.	
Data Table Size	12 rows.	
Display Mode		
MENU	Displays all setting information for acquisition.	
CURSOR	Displays the cursor position and 12 bytes of data beginning at the cursor point and the cursor position.	
SEARCH	Displays data which matches search word setting. Data is displayed on top of the table in Inverse video. Programmable to set a search word pattern.	
COMPARE	Highlights data different from data in Reference Memory. Data is displayed in inverse video.	

Table 6 (cont)

Characteristics	Performance Requirements	Supplemental Information
SERIAL STATE ANALYZER FUNCTION		
Data Input (via P6107 Probe) Input R and C	10 M Ω \pm 3%, paralleled by approximately 13 pF at probe tip. 1 M Ω paralleled by 40 pF \pm 1 pF at bnc input connector.	
Threshold Voltage at MONITOR Jack VAR	-12 V to +12 V.	
TTL	+1.4 V \pm 0.2 V.	
Logic Swing Minimum	500 mV p-p +2% of threshold voltage.	Centered on the threshold voltage.
Maximum	\pm 30 V peak.	
Nondestructive Peak Input Voltage	\pm 500 V at probe tip. \pm 250 V at bnc input connector.	

Table 6 (cont)

Characteristics	Performance Requirements	Supplemental Information
SERIAL STATE ANALYZER FUNCTION (cont)		
External Clock and Trigger Input (via P6451 Probe)		
Clock Input	Clock input from P6451.	
Trigger Input	CH 0 input from P6451.	
Input R and C	1 M Ω \pm 5%, paralleled by about 5 pF.	
Threshold Voltage at MONITOR Jack		Sets threshold voltage at 0 V for measurement of RS-232-C Interface signal.
VAR	-12 V to +12 V.	
TTL	+1.4 V \pm 0.2 V.	
Logic Swing		Centered on the threshold voltage.
Minimum	500 mV p-p +2% of threshold voltage.	
Maximum Peak Input Voltage	\pm 30 V.	
Nondestructive Input Voltage (Maximum)	At least -40 V to +40 V.	
Data Sampling Timing	Synchronous and asynchronous.	

Table 6 (cont)

Characteristics	Performance Requirements	Supplemental Information
SERIAL STATE ANALYZER FUNCTION (cont)		
Bits per Character	5, 6, 7, or 8.	Includes parity bit if parity is active.
Data Sampling Rates		
Internal Clock for Asynchronous Mode	50, 75, 110, 134.5, 150, 200, 300, 600, 1200, 1800, 2400, 4800, and 9600 bits per second.	
Accuracy of Internal Clock	±0.02%.	
External Clock for Asynchronous Mode	Up to 9600 bits per second.	
External Clock for Synchronous Mode	Up to 9600 bits per second.	
Input Logic	Negative or positive.	
Parity	Odd, even, or none.	
Synchronizing Word (Synchronous Mode Only)	Programmable to require two equal words. If not programmed, defaults to ASCII SYN word.	The ASCII SYN word is binary 00010110.

Table 6 (cont)

Characteristics	Performance Requirements	Supplemental Information	
SERIAL STATE ANALYZER FUNCTION (cont)			
Hunt Word (Synchronous Mode Only)	Programmable to require one word. If not programmed, defaults to xxxxxxxx.	In this particular case xxxxxxxx means <i>not used</i> , normally x equals <i>don't care</i> .	
Setup and Hold Time for Synchronous Mode Setup Time	3 μ s maximum with respect to external clock edge.		
	Hold Time		3 μ s maximum with respect to external clock edge.
Stop Bits (Asynchronous Mode Only)	Responds to one or more stop bits.	Not adjustable.	
Trigger Data Word Recognizer	Programmable to require a sequence of two words (characters).		
	External Trigger		Programmable to require one bit.
	Trigger Delay Delay Count		Programmable to set delay count. Up to 65,635.

Table 6 (cont)

Characteristics	Performance Requirements	Supplemental Information
SERIAL STATE ANALYZER FUNCTION (cont)		
Trigger (cont) Data Position PRE <hr/> POST	Positions the Delayed Trigger at the 240th position in the 252-byte Data Memory. <hr/> Positions the Delayed Trigger at the 13th position in the 252-byte Data Memory.	
START Control	Switches to acquisition mode and prepares to recognize acquisition start signal when START key is pressed in.	
Acquisition Start Signal Asynchronous Mode <hr/> Synchronous Mode	Recognition of start bit. <hr/> Recognition of two equal SYNC characters.	

Table 6 (cont)

Characteristics	Performance Requirements	Supplemental Information
SERIAL STATE ANALYZER FUNCTION (cont)		
STOP Control	Stops data acquisition and switches to display mode when STOP key is pressed in.	
RE-START Control	Repeats acquisition if valid data in Data Memory matches data in Reference Memory. If there is no match, stops acquisition and display mode is enabled.	
Framing Error Detection	When a valid stop bit is not detected, data acquisition is stopped and switched to display mode, unless fewer than 9 bytes have been received. In that case, acquisition is restarted.	This allows acquiring data from a continuous data stream in asynchronous protocol.

Table 6 (cont)

Characteristics	Performance Requirements	Supplemental Information
SERIAL STATE ANALYZER FUNCTION (cont)		
Display		
Data Format	Binary, hexadecimal, and ASCII.	
Data Table Size	12 rows.	
Parity Error	Parity error is indicated beside ASCII character.	If parity is programmed.
Framing Error (Asynchronous Mode Only)	Framing error point is marked with FEST .	
Mode		
MENU	Identical to Parallel State Function.	
EXTENDED MENU	Identical to Parallel State Function.	Additional programming capabilities are provided through the Extended Menu.
CURSOR	Identical to Parallel State Function.	
SEARCH	Identical to Parallel State Function.	
COMPARE	Identical to Parallel State Function.	

Table 6 (cont)

Characteristics	Performance Requirements	Supplemental Information
SIGNATURE ANALYZER FUNCTION		
Data Input (via P6107 Probe)		
Setup Time	15 ns maximum.	Data to be valid at least 15 ns before selected clock edge.
Hold Time	0 ns.	With reference to selected (rising or falling) clock edge.
Input R and C	10 M Ω \pm 3%, paralleled by approximately 13 pF at probe tip. 1 M Ω paralleled by 40 pF \pm 1 pF at bnc input connector.	
Threshold Voltage at MONITOR Jack		
VAR	-12 V to +12 V.	
TTL	+1.4 V to \pm 0.2 V.	
Logic Swing		
Minimum	500 mV p-p +2% of threshold voltage.	Centered on the threshold voltage.
Maximum	\pm 30 V peak.	

Table 6 (cont)

Characteristics	Performance Requirements	Supplemental Information
SIGNATURE ANALYZER FUNCTION (cont)		
Data Input (cont) Nondestructive Peak Input Voltage	± 500 V at probe tip. ± 250 V at bnc input connector.	
Clock Input (via Clock Input of P6451 Probe) Clock Period (Minimum) Clock Pulse Width (Minimum) High-Logic Level Low-Logic Level	Input performance requirements are same as data input requirements for Parallel Timing Analyzer Function. 50 ns. 24.5 ns. 24.5 ns.	
Start and Stop Gate Start Input (via CH 0 Input of P6451 Probe)	Input performance requirements are same as data input requirements for Parallel Timing Analyzer Function.	

Table 6 (cont)

Characteristics	Performance Requirements	Supplemental Information
SIGNATURE ANALYZER FUNCTION (cont)		
Start and Stop Gate (cont) Stop Input (via CH 1 Input of P6451 Probe)	Input performance requirements are same as data input requirements for Parallel Timing Analyzer Function.	
Setup Time	25 ns.	Start or Stop to be valid at least 25 ns before selected clock edge.
Hold Time	0 ns.	With respect to the selected (rising or falling) clock edge.
Gate Length (Minimum)	One clock cycle.	
Timing between Gates (Maximum)	2.5 ms or 1 clock cycle, whichever is longer.	
Probability of Classifying Correct Data Stream as Correct	100%.	
Probability of Classifying Faulty Data Stream as Faulty	99.998%.	

Table 6 (cont)

Characteristics	Performance Requirements	Supplemental Information
SIGNATURE ANALYZER FUNCTION (cont)		
Display		
Data Format	4-digit signature.	
Characters	0, 1, 2, 3, 4, 5, 6, 7, 8, 9, A, C, F, H, P, U.	
Mode	Hold or Repeat.	
Indication of Faulty Signature	< symbol displayed in Hold Mode. FAULT displayed in Repeat Mode.	
CRT DISPLAY SYSTEM		
CRT		
Display Area		6.8 cm (W) x 5.4 cm (H).
Phosphor		P4.
POWER SUPPLY		
Range of Line Voltages	90 V to 132 V ac or 180 V to 250 V ac, 48 Hz to 440 Hz.	

Table 7
ENVIRONMENTAL CHARACTERISTICS

Characteristics	Description
Temperature	
Operating	0°C to +50°C.
Storage	-55°C to +75°C.
Altitude	
Operating	To 15,000 ft (4,500 m). Maximum allowable ambient temperature decreased by 1°C/1,000 ft (300 m) from 5,000 ft (1,500 m) to 15,000 ft (4,500 m).
Storage	To 50,000 ft (15,000 m).
Humidity (Storage)	Five cycles (120 hr. total) with equipment tested at 90% to 95% Relative Humidity. Tested non-operating at 60°C and operating to meet MIL-STD-810C Method 507.1 Procedure IV, modified as specified in MIL-T-28800B paragraph 4.5.5.1.1.2.
Vibration (Operating)	With instrument operating, vibration frequency swept from 10 to 55 to 10 Hz in 1-minute sweeps in each of three major axes at total displacement of 0.025 inch. Held 3 minutes at 55 Hz. All major resonances must be above 55 Hz.
Shock (Operating and Storage)	30 g, half-sine, 11 ms duration, 2 guillotine-type shocks per axis each direction, for a total of 12 shocks.
Electromagnetic Interference (EMI)	Reference MIL STD 461A-462. Radiated emission as specified. Conducted emission, relax 20 dB below 150 kHz. Omit susceptibility.

Table 8
PHYSICAL CHARACTERISTICS

Characteristics	Description
Weight	
Net, Without Accessories	3.7 kg (8.157 lb).
Shipping, Domestic	8.8 kg (19.4 lb).
Dimensions	
Width, With Handle	23.7 cm (9.3 in).
Depth, Handle Not Extended	35.4 cm (14 in).
Depth, Handle Extended	45.4 cm (17.9 in).
Heights	
Without Accessory Pouch	11.7 cm (4.6 in).
With Accessory Pouch	17.0 cm (6.7 in).

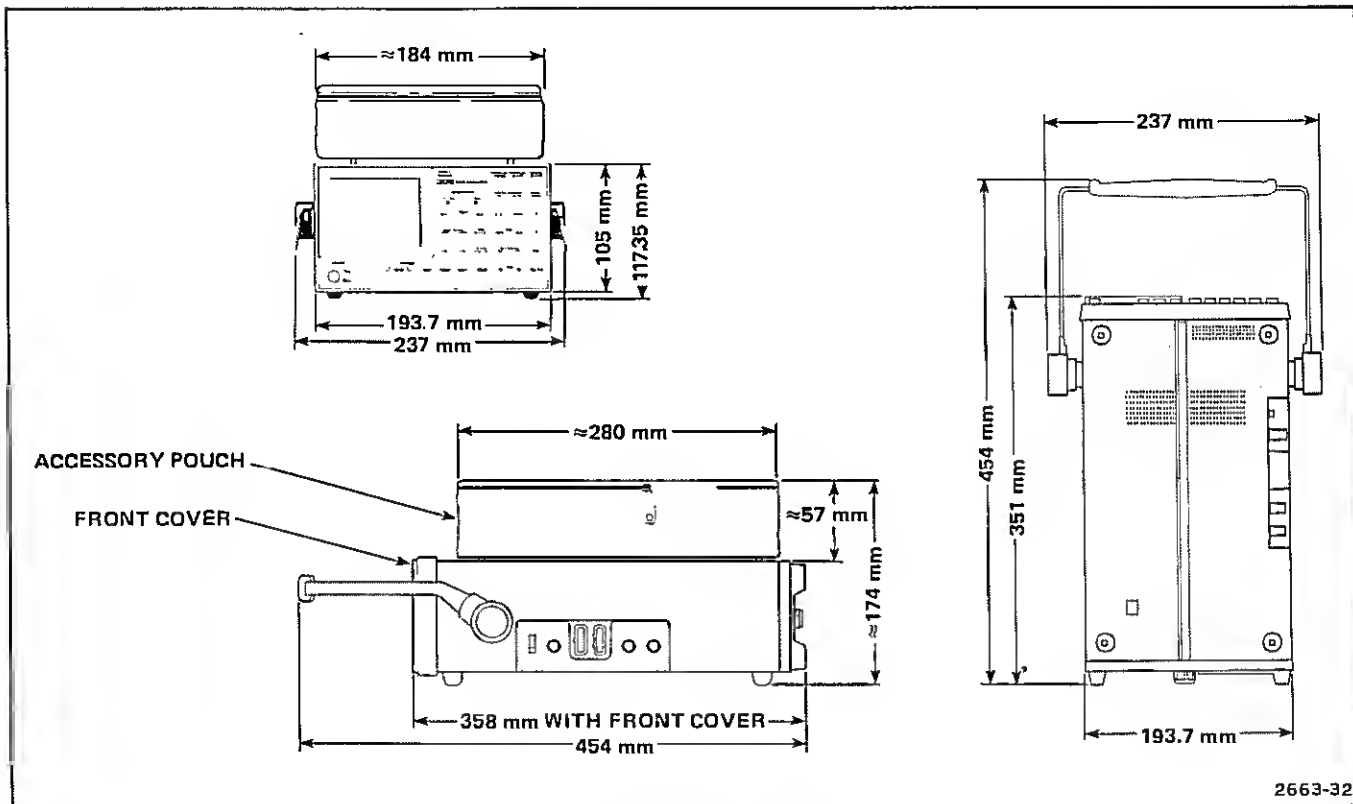

ACCESSORIES

Standard Accessories

1 Data Acquisition Probe, P6451	010-6451-05
1 Passive Probe, P6107	010-6107-03
1 Accessory Pouch	016-0654-00
1 Service Manual	070-2662-00
1 Operators Manual	070-2663-00
1 Power Cord	161-0104-00
1 Marker, Input Identification	334-3468-00

Option Accessories

1 Word Recognizer Probe	010-6406-01
-------------------------	-------------

APPENDIX A (cont.)

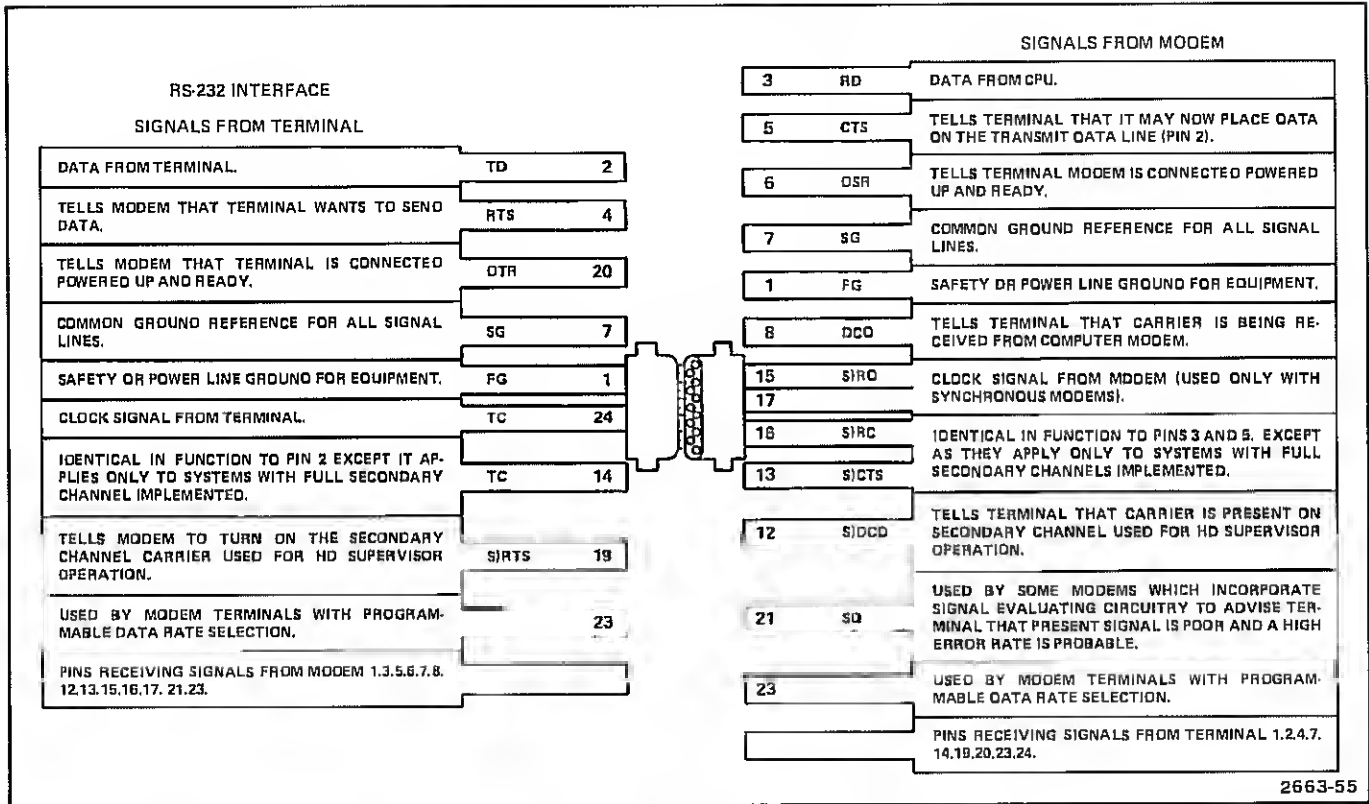

2663-55

NOTES

NOTES

NOTES

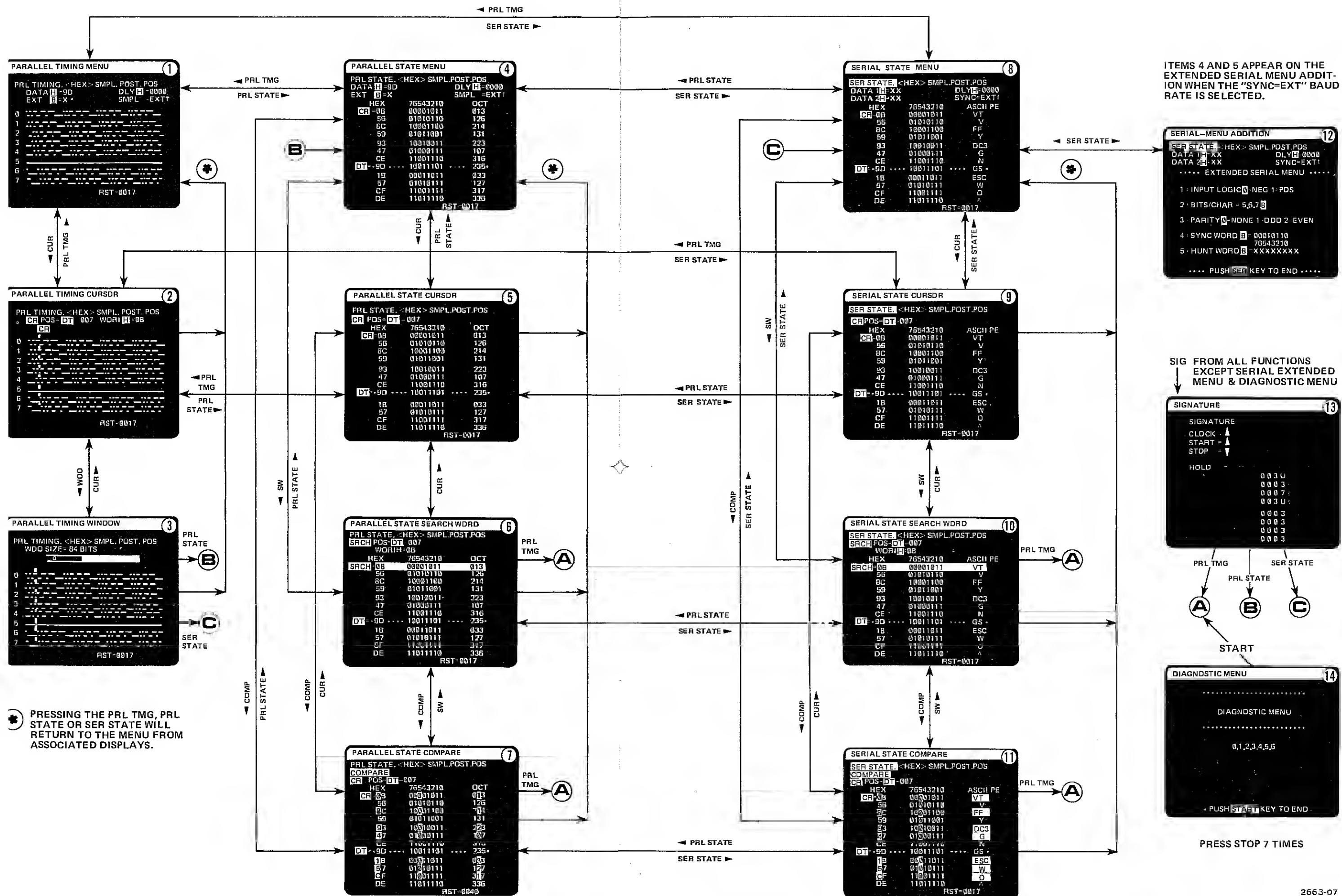

Figure 43. Control Function Access Chart.