



MODEL
60-A

VOLT-OHM-MILLIAMMETER

TRIPLET
INSTRUCTION MANUAL

SAFETY RULES

WARNING

This tester has been designed with your safety in mind. However, no design can completely protect against incorrect use. Electrical circuits can be dangerous and/or lethal when lack of caution or poor safety practices are used.

READ THE MANUAL

Read this Instruction Manual carefully and completely.

Voltages and currents within the capability of this test equipment can be hazardous. Follow the instructions in this manual for every measurement. Read and understand the general instructions before attempting to use this tester. Do not exceed the limits of the tester.

SAFETY CHECK

Double check the switch setting and lead connections before making measurements. Are you following all of the instructions?

Disconnect the tester or turn off the power before changing switch positions.

Do not connect to circuits with voltage present when switch is in any ohms or current position.

When replacing fuses use only specified type fuses and insert in correct fuse holder.

DON'T TOUCH

Don't touch exposed wiring, connections or other "live" parts of an electrical circuit. If in doubt, check the circuit first for voltage before touching it.

Turn off the power to a circuit before connecting test

probes to it. Be sure there is no voltage present before you touch the circuit.

Do not use cracked or broken test leads.

HIGH VOLTAGE IS DANGEROUS

Always start with the power off. Be sure there is no voltage present before making connections to the circuit.

Don't touch the tester, its test leads, or any part of the circuit while it is on.

Before disconnecting the tester, turn the circuit off and wait for the meter to return to "zero."

DISTRIBUTION CIRCUITS PACK A PUNCH

In high energy circuits such as distribution transformers and bus bars, dangerous arcs of explosive nature can occur if the circuit is shorted. If the tester is connected across a high energy circuit when set to a low resistance range, a current range, or any other low impedance range, the circuit is virtually shorted.

Special equipment designed for use with these circuits is available. Contact a qualified person for assistance before attempting to make measurements on any high energy circuit.

SAFETY IS NO ACCIDENT

TABLE OF CONTENTS

	Page No.
Specifications	4
Description	6
General Instructions	8
Measuring Resistance	12
Measuring DC Volts	14
Measuring AC Volts	16
Measuring Output Voltage	16
Measuring DC Current	18
Measuring AC Current With Model 10 Adapter	20
Measuring Decibels (dB)	22
Confidence-Test	23
Calibration	24
Maintenance	26
Accessories	29
Replaceable Parts List	32
Parts Location (Circuit Board)	34
Schematic (Fold Out)	35
Warranty	36

SPECIFICATIONS

RANGES:

DC VOLTAGE

0-0.3 volts at approximately 10,000 ohms/volt
(see page 14 for instructions).

0-1, 3, 10, 30, 100, 300, 1000 volts at approximately 20,000 ohms/volt.

AC VOLTAGE

0-3, 10, 30, 100, 300, 1000 volts at approximately 5,000 ohms/volt.

DC CURRENT

0-0.1, 10, 100, 1000 milliamperes at approximately 320 millivolts.

RESISTANCE

0-1k, 10k, 100k, 1 Meg, 10 Meg
(12, 120, 1.2k, 12k, 120k ohms center scale).

DECIBELS

-20 dB to +62 dB.

AC CURRENT RANGES WITH MODEL 10 ADAPTER

6, 12, 30, 60, 120, 300 AC Amps

OHMMETER SPECIFICATIONS

Range	Maximum Values				
	X1	X10	X100	X1k	X10k
Voltage - Volts	1.7	1.7	1.7	1.7	10.2
Current - mA	142	14.2	1.42	0.14	0.09
Power Transfer To Load - mW (Max)	60.4	6.04	.60	0.06	0.22

SPECIFICATIONS (cont'd.)

ACCURACY (Calibrated at 77° F):

DC Voltage	± 1 1/2% of full scale value
DC Current	± 1 1/2% of full scale value
AC Voltage	± 3% of full scale value
Resistance	± 1 1/2% of arc length

METER:

Suspension type mirrored scale. Separate housing for easy replacement.

TEST LEADS:

One red and one black test lead supplied, each 48 inches long.

CARRYING HANDLE:

Position indent provides inclined tester stand.

OVERLOAD PROTECTION:

Meter movement protected by a diode module.

1/8 Amp/250V Fuse (Littelfuse 362.125 8AG).

1 Amp/250V Fuse (Bussmann ABC-1 or Littelfuse 314001 3AB).

2 Amp/1000V Fuse is located inside tester. Replace with Bussmann HVA-2 or Littelfuse 621002.

BATTERIES:

One 1.5 Volt "D" cell (NEDA 13F).

One 9 Volt "transistor" battery (NEDA 1604).

WEIGHT:

Approximately 2 1/2 pounds.

SIZE:

Approximately 3 1/4" x 5 1/4" x 7 1/4".

DESCRIPTION

The Triplett Model 60-A Volt-Ohm-Milliammeter (VOM) is a multi-range instrument for general electrical and electronic trouble shooting and measurement. It has been especially designed to satisfy the need for a precision instrument which can stand up under rigorous hard usage of the industrial and maintenance environment and at the same time provide a degree of safety in its use heretofore unavailable with an instrument of this kind. Maintenance is simplified by designing an independent meter module for quick replacement or service and easy to follow parts layout.

X'TRA RUGGED: Unique design and selection of materials permits the instrument to withstand the normal accidents of dropping and rough handling which occur in hard day to day use. The Model 60-A is warranted to withstand an accidental drop up to a five foot height with deviation from its stated accuracy not exceeding $\pm 4\%$. The warranty does not include mechanical parts being defaced (scratched, etc.) from a drop or normal usage.

OVERLOAD PROTECTED: The instrument has been engineered for significant reduction in the need for maintenance by virtual elimination of parts burn out (other than fuses), and parts damage from severe mechanical abuse. Three fuses are employed for unusual protection to the instrument and safety for the user. The 1/8 Amp and 1 Amp instrument fuses are used for normal overload conditions. Spares for each are included in the instrument. Protection is provided for high energy fault currents beyond the capabilities of the instrument fuses up to the capacity of the 2 Amp/1000V (20 kW) fuse.

SAFETY DESIGNED: Unusual effort has gone into the instrument's design to provide the greatest possible safety to the user.

DESCRIPTION (cont'd.)

The Model 60-A provides a specially engineered internal electrical system to prevent explosive arcs in high energy circuits up to the 2 Amp/1000V (20 kW) fuse capacity. Complete insulation of the instrument itself plus a new type test lead are additional safety features.

CONFIDENCE-TEST: A feature built into the instrument for periodic reassurance checks of its meter. While not intended as a comprehensive test of the instrument it does permit a high level of confidence in the instrument meter if the pointer indicates within the area of the test symbol.

Ranges have been designed to cover nearly all applications with the added convenience of signal level measurements in decibel decade steps.

The carrying handle can be rotated to provide a stand for placing the instrument at a viewing angle of approximately 30 degrees.



A separately sealed battery compartment permits access to batteries and fuses without removal of the remainder of the instrument. In addition, battery acids are sealed off to prevent damage to components.

GENERAL INSTRUCTIONS

INSTALL BATTERIES:



1. Loosen captive screw.

2. Slide cover off.

3. Install batteries.

4. Replace cover.



ADJUST POINTER TO ZERO:



With unit in operating position use a screwdriver to adjust pointer for a zero indication. While keeping the pointer on zero, reverse the rotation of the screw slightly to disengage it. This will reduce the affect of pointer shift under shock.

GENERAL INSTRUCTIONS (cont'd.)

START WITH HIGHEST RANGE

When the approximate value of the voltage or current being measured is not known, always start with the highest range to avoid overload and blowing a fuse.

RANGE CHOICE

For greatest accuracy choose the range which allows readings to be made in the upper (right hand) portion of the scale. Accuracies are rated as percent of full scale so the closer to full scale the better the accuracy.

DO NOT CHANGE SWITCHES UNDER LOAD

Quality switches are used but any switch will arc if changed while under load. Disconnect the test probes or shut off the circuit under test before the range switch or polarity switch positions are changed. This practice will result in increased life and reliability of the instrument.

MEASUREMENT ERRORS

Readings on the sensitive ranges may sometimes be different than expected due to thermoelectric or electrochemical effects.

Readings on the high resistance ranges can be affected by touching the circuit causing the body to act as a shunting resistor.

Consideration should be given to the loading affect of the instrument when measuring voltages from sources of high impedance.

GENERAL INSTRUCTIONS (cont'd.)

SWITCH CONTACTS

It is good practice when an instrument has not been used for a long period of time, to operate both switches several times to wipe the contacts and assure accurate measurements.

USE OF CONTROLS

Pointer

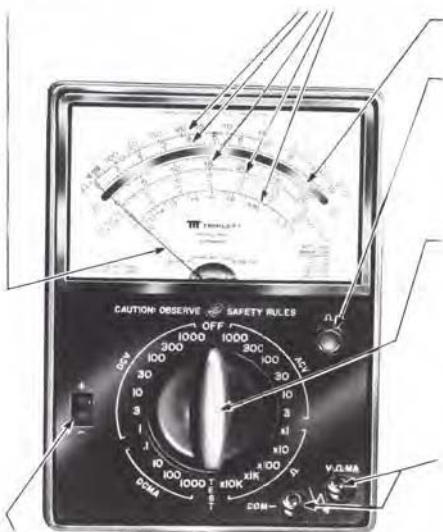

Scales - See page 11.

Mirror

Ohms Adjust Control
- sets full scale (0 ohms) indication on ohms ranges with test leads shorted.

Range Switch - selects measurement range - should be placed in OFF position when unit is not in use for best meter protection.

Panel Jacks - plug black test lead into "COM-" jack and red test lead into "V- Ω -mA" jack.

Polarity Switch - when in the + position a positive voltage applied to the "V- Ω -mA" jack will cause an up-scale pointer deflection and on the ohms ranges the "V- Ω -mA" jack will be positive. When in the " - " position the polarity is reversed.

GENERAL INSTRUCTIONS (cont'd.)

USE OF SCALES

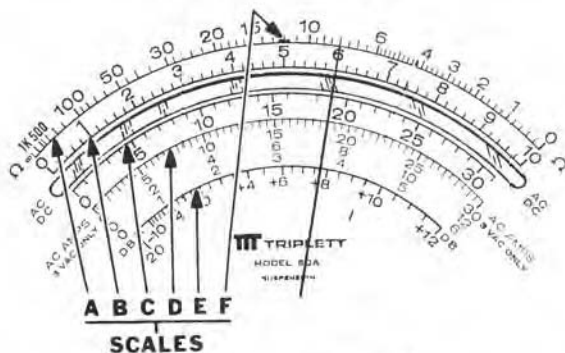

Range Switch Position	Read Scale	Reading For Above Indication	Range Switch Position	Read Scale	Reading For Above Indication
1000DCV	B	600VDC	X10k	A	80k Ω
300DCV	C	190VDC	X1k	A	8k Ω
100DCV	B	60VDC	X100	A	800 Ω
30DCV	C	19VDC	X10	A	80 Ω
10DCV	B	6VDC	X1	A	8 Ω
3DCV	C	1.9VDC	3ACV	D	1.85VAC
1DCV	B	.6VDC	3ACV	E	7.7dB
.1DCmA	C	.19VDC	10ACV	B	6VAC
.1DCmA	B	.06mADC	10ACV	E	17.7dB
10DCmA	B	6mADC	30ACV	C	19VAC
100DCmA	B	60mADC	30ACV	E	27.7dB
1000DCmA	B	600mADC	100ACV	B	60VAC
			100ACV	E	37.7dB
			300ACV	C	190VAC
			300ACV	E	47.7dB
Test	F	Out Of Tolerance	1000ACV	B	600VAC

MEASURING RESISTANCE

0 TO 10 MEGOHMS (X1 THRU X10k):

1. Set range selector switch to desired (Ω) range.
2. Plug the test leads into the jacks. Short test prods and adjust the " Ω " control to set the pointer over the right (0 ohms) end of the red " Ω " scale.
3. Turn off all power to the circuit to be measured and/or disconnect one end of component being checked. Connect test leads across the circuit or part. **OBSERVE ALL SAFETY PRECAUTIONS.**
4. Read resistance on the " Ω " scale. Multiply the indication by the range multiplier (e. g. - multiply by 10 on the X10 range, 10,000 on the 10k range).

CONTINUITY TESTING:

Use the X1k resistance range. The lower battery drain will give longer battery life.

CAUTION:

Some semiconductor devices can be damaged by the voltage and current available in the ohmmeter circuit. Compare ratings of semiconductor devices and ohmmeter specifications (page 4) before making measurements.

POLARITY SWITCH:

The polarity switch reverses the polarity of the jacks. This feature can be used for checking semiconductors. The V- Ω -mA jack is connected to the positive battery terminal with the polarity switch in the "+" position.

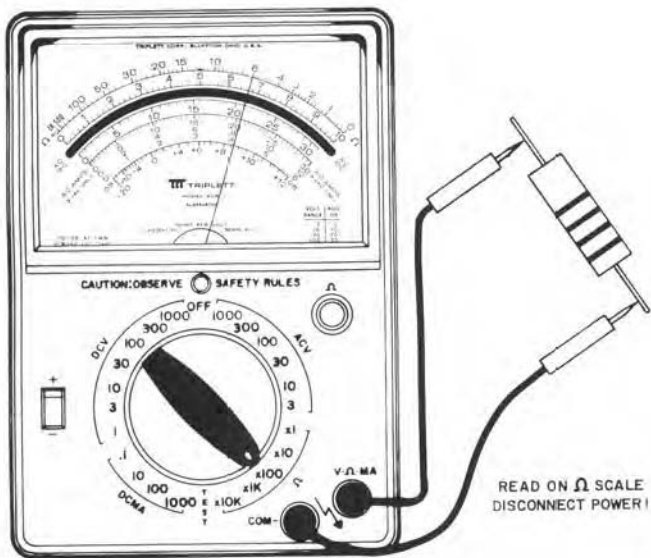

Measuring Resistance

MEASURING DC VOLTS

0-1 THRU 0-1000 DC VOLTS:

1. Select the desired DC voltage (DCV) range with the range selector switch.
2. Check the setting of the polarity switch for proper polarity.
3. Plug the test leads into the jacks.
4. Connect the test leads across the circuit to be measured. OBSERVE ALL SAFETY PRECAUTIONS.
5. Read DC voltage on the appropriate black "AC-DC" scale.

0-0.3 DC VOLTS:

1. Set the range selector switch to 0.1 DCmA. This is also 0-0.3 DC Volts.
2. Check the setting of the polarity switch for proper polarity.
3. Plug the test leads into the jacks.
4. Connect the test leads across the circuit to be measured. OBSERVE ALL SAFETY PRECAUTIONS.
5. Read DC voltage on the black 0-30 "AC-DC" scale. Divide the indication by 100.



READ ON AC-DC SCALE

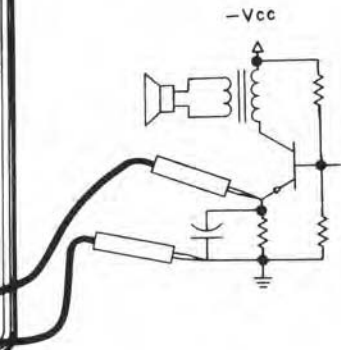

Measuring DC Volts

MEASURING AC VOLTS

0-3 THRU 0-1000 AC VOLTS:

1. Select the desired AC voltage (ACV) range with the range selector switch.
2. Plug the test leads into the jacks.
3. Connect the test leads across the circuit to be measured. **OBSERVE ALL SAFETY PRECAUTIONS.**
4. Read AC voltage on the appropriate scale. For 30 and 300 volts, use the black 0-30 "AC-DC" scale. For 10, 100 and 1000 volts, use the black 0-10 "AC-DC" scale. For 3 volts use the special red 0-30 AC Amp scale and drop a zero.

MEASURING OUTPUT VOLTAGE

If there is a DC component to the voltage to be measured and only the value of the AC component is desired, a capacitor may be placed in series with the test lead to block the DC voltage. The remaining AC voltage is known as "output voltage."

For general audio frequency measurements, use a .22 μ F capacitor. For low frequency measurements or for measurements on the 3 AC volt range, use a 1.0 μ F or larger capacitor. Capacitor working voltage should be higher than the sum of DC voltage and peak value of the AC voltage. In general a 600 volt capacitor is sufficient.

0-3 THRU 0-300 AC VOLTS:

1. Connect a capacitor to the point in the circuit to be measured. See note above for value and volt rating.
2. Same as steps 1 thru 4 for AC VOLTS (above).

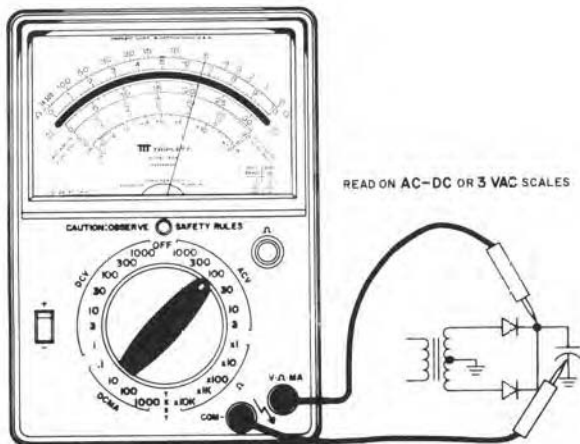

Measuring AC Volts

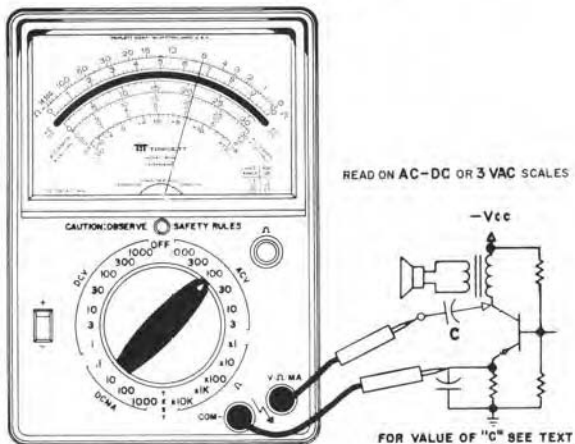

Measuring Output Voltage

MEASURING DC CURRENT

0-0.1 THRU 0-1000 DC MILLIAMPERES:

1. Select the desired DC current (DCmA) range with the range selector switch.
2. Check the setting of the polarity switch for proper polarity.
3. Plug the test leads into the jacks.
4. Connect the test leads in series with the circuit to be measured.
OBSERVE ALL SAFETY PRECAUTIONS.
5. Read DC current on the black 0-10 "AC-DC" scale.

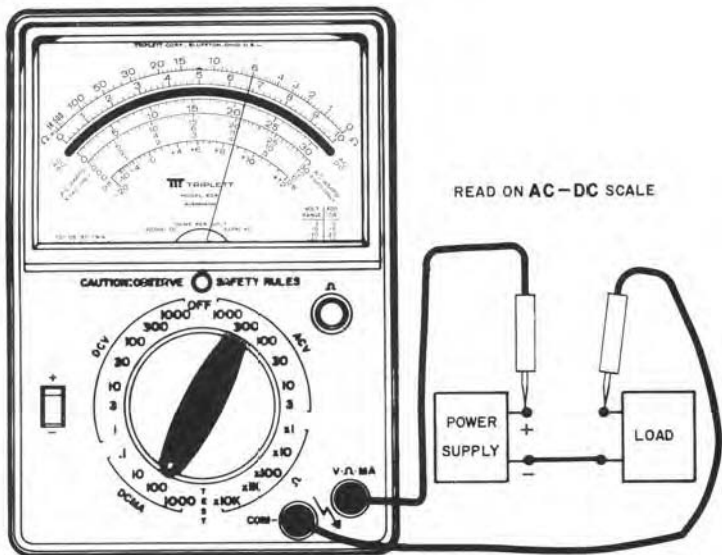

Measuring DC Current

MEASURING AC CURRENT WITH MODEL 10 ADAPTER

When a single conductor is available with up to 300 amperes of current, set up tester as follows:

1. Connect a Triplet Model 10 AC Ammeter Adapter to the Model 60-A panel jacks using 79-354 lead assembly.
2. Set the Model 60-A selector switch to 3 ACV.
3. Set the switch on the Model 10 to the 300 AC Amperes position.
4. Press the plunger on the side of the Model 10 to open the jaws, place the jaws around ONE conductor of the circuit to be measured and release the plunger. Locate conductor in center of jaws for best accuracy. Do not place the jaws of the Model 10 around more than one wire. An incorrect reading will result. Observe all safety precautions.

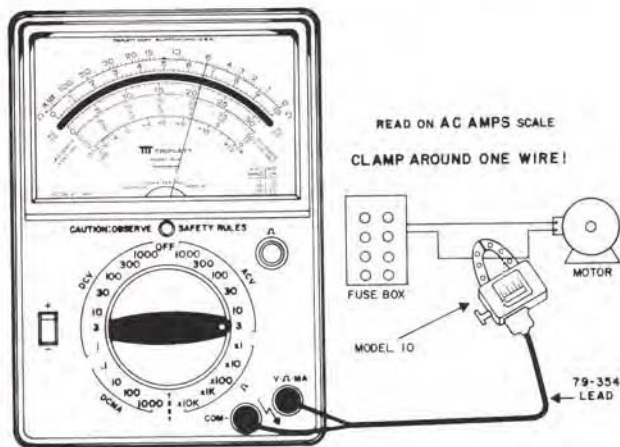

MEASURING AC CURRENT (cont'd.)

When a single conductor is not available a Model 101 line splitter can be used for currents up to 30 AC Amperes.

Steps 1 - 2. Same as for single conductor.

3. Plug the line cord of the apparatus to be tested into the "Direct" outlet of the Model 101 and plug the Model 101 into a wall outlet.

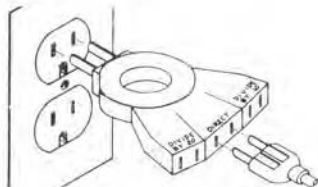

4. Set the Model 10 range switch to the 30 AC Ampere position.

5. Place the jaws of the Model 10 through the hole in the Model 101.

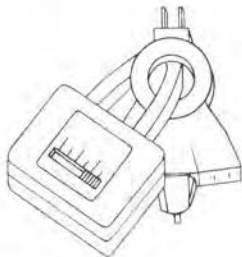

6. Adjust the Model 10 range switch for maximum meter deflection. Do Not Use the 60, 120 or 300 Amp positions.
7. Read AC current on the AC Amps scale.
8. The sensitivity of the measurement can be increased 10 or 20 times by following the above procedure except plugging the line cord into the "Divide by 10" or "Divide by 20" outlet of the Model 101 in Step 3.

MEASURING DECIBELS (dB)

The decibel is a unit that expresses the ratio of power levels. It is mathematically derived to reduce multiplication and division to addition and subtraction, respectively, (e. g. - 10 dB represents multiplication by 10, 20 dB by 100, 30 dB by 1000). The decibel roughly approximates human hearing ratios. For this reason, it is commonly used in audio and telephone measurements.

Because the decibel represents a ratio, there is a reference level. The Model 60-A reference level for 0 dB is 1 milliwatt into a 600 ohm load (.775 ACV across 600 ohms). Measurements made across load other than 600 ohms are relative measurements.

To measure decibels, connect the Model 60-A the same as for measuring AC voltage (or OUTPUT voltage, if there is DC voltage present). But, read the dB scale instead of the voltage scales. A chart on the dial shows the dB values to be added to the reading for the different voltage ranges. (e. g. - when the selector switch is set to the 30 VAC position, add 20 dB to the indicated value). As explained above, addition of dB represents multiplication of power (or voltage).

CONFIDENCE-TEST:

A "Confidence-Test" feature has been built into the instrument to allow the user to make periodic reassurance checks of the meter. To make the test proceed as follows:

1. Make mechanical adjustment by placing the tester in operating position, using a screwdriver to adjust pointer for a zero indication. While keeping the pointer on zero, reverse the rotation of the screw slightly to disengage it. Other information given in General Instructions on page 8.
2. Set range selector to RX10k ohms position.
3. Plug in test leads in appropriate jacks and short test tips together and adjust ohms control to full scale ohms zero.
4. With the test leads shorted together, switch range selector to "Test" position. The pointer should indicate in the area of the test symbol (red block), located at the mid scale of " Ω " scale at top of dial.

CALIBRATION

Should calibration be necessary voltage and current sources of .2% or better accuracy should be used and the sequence listed below should be followed.

1. MECHANICAL ZERO

- A. Adjust pointer to zero (see General Instructions page 8).

2. 50 MICRO-AMPERE CALIBRATION

- A. Set function switch to 1 DCV position.
- B. Set polarity switch to +.
- C. Connect test leads to a 50 μ A source.
- D. Adjust R34 for full scale on the 0-10 scale.

3. DCmV CALIBRATION

- A. Set function switch to .1 DCmA position.
- B. Set polarity switch to +.
- C. Connect test leads to a 316 mV source.
- D. Adjust R35 for full scale 0-10 scale.

4. 3 AC VOLTS CALIBRATION

- A. Set function switch to 3 ACV range.
- B. Set polarity switch to +.
- C. Connect test leads to 3 ACV source.
- D. Adjust R29 to full scale on 3 ACV scale.

CALIBRATION (cont'd.)

5. 300 AC VOLTS CALIBRATION

- A. Set function switch to 300 ACV range.
- B. Set polarity switch to +.
- C. Connect test leads to 300 ACV source.
- D. Adjust R30 to full scale on the 0-30 scale.

6. REPEAT STEPS 4 AND 5

- A. Re-adjust R29 and R30 if necessary to compensate for interaction of the two controls.

7. CHECK ALL RANGES FOR ACCURACY

- A. With appropriate voltage, current and ohms standards check all ranges.

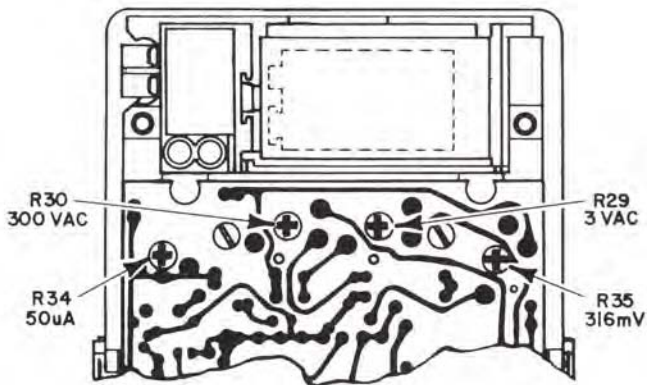

Calibration Controls
Accessible From Top Of PCB

MAINTENANCE

DISCONNECT TEST LEADS FROM EXTERNAL
CIRCUIT BEFORE SERVICING TESTER

BATTERY TEST AND REPLACEMENT

Two batteries are used in the ohmmeter circuit. A 1.5V D cell (NEDA 13F) is used for the X1, X10, X100 and X1k ranges. If the pointer cannot be adjusted to zero on any of these ranges, with the test prods touched together, the 1.5 volt battery should be replaced.

A 9V "transistor" (NEDA 1604) battery is used on the X10k range. If the pointer cannot be adjusted to zero on the X10k range the 9 volt battery should be replaced.

See General Instructions (page 8) for battery replacement procedure.

FUSE REPLACEMENT

Three fuses are included, two of which are accessible by removing the battery compartment cover and the third, which is a 2 Amp, 1000 volt fuse intended to blow only if the primary fuses arc over is accessible by removing the back cover.

**CAUTION: USE ONLY SPECIFIED TYPE FUSES
AND INSERT IN CORRECT FUSE HOLDER**

MAINTENANCE (cont'd.)

To replace 1/8 Amp or 1 Amp fuse:

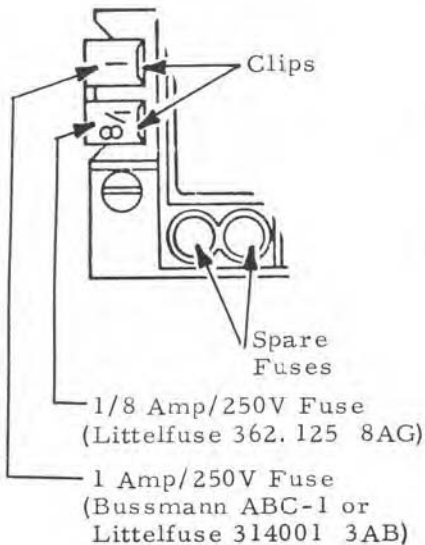

1. Remove battery compartment cover (see General Instructions page 8).
2. Slide clip towards edge of case until the fuse releases. Pull fuse out.
3. Holding clip towards edge, insert replacement fuse.
4. Press fuse down until clip springs back over fuse (use probe to assist, if desired).
5. Replace battery compartment cover.



MAINTENANCE (cont'd.)

To replace 2 Amp (1000V) fuse:

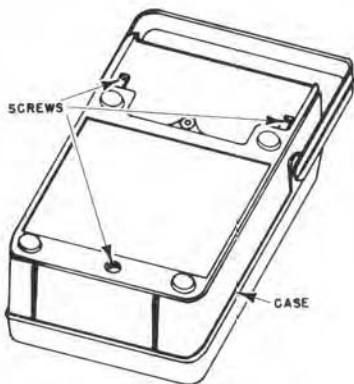

1. Remove battery compartment cover (see General Instructions page 8).

2. Remove three screws containing case. Remove case.

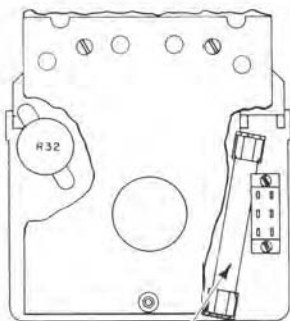

3. Locate fuse, remove and replace.

4. Replace case and battery cover.

2 AMP/1000V FUSE
(BUSSMANN HVA-2 OR
LITTELFUSE 621002)

ACCESSORIES

The usefulness and range of the VOM can be extended by the use of the following accessories:

1. Miniature Clip For High Density Circuits



Part No.
79-373

2. Leather Case



Part No.
10-2739



ACCESSORIES (cont'd.)

3. DC Current Shunts



Part Numbers
0-30 Amp 91-628
0-100 Amp 91-629

4. High Voltage Probes

Part Numbers
0-30kV DC 79-357
0-30kV AC 79-362



ACCESSORIES (cont'd.)

5. AC Current Measuring Accessories

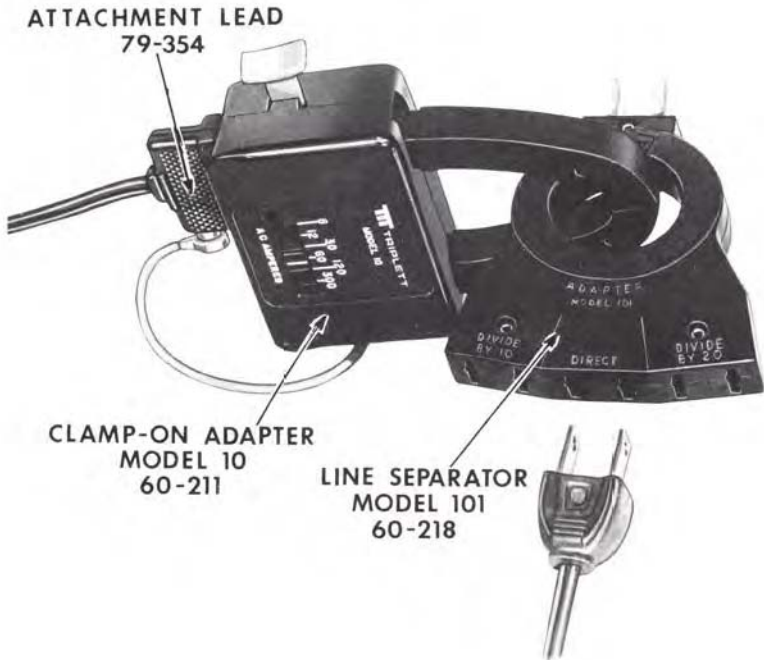

Replaceable Parts Model 60-A

<u>Description</u>	<u>Ref. No.</u>	<u>Part No.</u>
Battery 1.5V (NEDA 13F)	B1	2426-1
Battery 9V (NEDA 1604)	B2	37-36
Fuse, 1 Amp/250V (Bussmann ABC-1), (Littelfuse 314001 3AB)	F1	3207-58
Fuse, 1/8 Amp/250V (Littelfuse 362.125 8AG)	F2	3207-45
Fuse, 2A/1000V (Bussmann HVA-2), (Littelfuse 621002)	F3	3207-60
Meter Assembly		52-6115
Meter Front w/Window		10-2733
PC Board w/Components		87-445
Diode *	CR1	11056
Diode *	CR2	11056
Diode	CR3	11670
Lamp, Neon	DS1	67-98
Resistor, 6.3 Ω W. W.	R18	15-5618
Resistor, 63.2 Ω W. W.	R19	15-5660
Resistor, 655 Ω W. W.	R20	15-5659
Resistor, 10.2k Prec.	R21	15K-1022UC5
Resistor, 27.9k Prec.	R22	15K-2792UC5
Resistor, .316 Ω W. W.	R23	15-5625
Resistor, 3.16 Ω W. W.	R24	15-5624
Resistor, 31.8 Ω W. W.	R25	15-5626
Resistor, 6.32k Prec.	R26	15K-6321UC5
Resistor, Variable 5k	R29	16-193
Resistor, Variable 5k	R30	16-193
Resistor, Variable 7.5k	R32	16-272
Resistor, Variable 50k	R34	16-277
Resistor, Variable 500	R35	16-237

Replaceable Parts Model 60-A (cont'd.)

<u>Description</u>	<u>Ref. No.</u>	<u>Part No.</u>
Switch, Rotary	SW1	22-654
Shaft for Switch, Rotary		61-210
Polarity Reversal Switch	SW2	22-661
Battery Terminal, 1 1/2V		46-156
Battery Terminal 9V		92-8
Fuse Clip		2451-122
Mainframe/Battery		
Compartment Assy.		28-1123
Printed Panel w/Hardware		28-1150
Knob, Rotary Switch		34-167
Knob, Ω Adjust		34-164
Fuse Clip Back-up Spring		42-289
Coil Spring, Fuse		42-278
Case Assembly w/Handle		
Handle w/Hardware		3206-59
Rubber Foot		98-49
Battery Compartment Cover		
		10-2830
Test Leads Package		
		79-374

* If CR1 or CR2 is replaced, recalibration of AC
Volts is required.

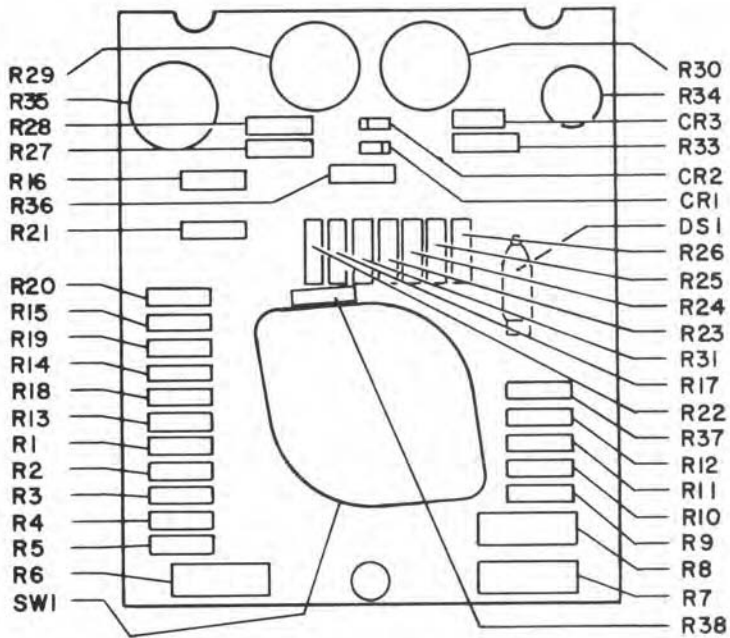

Parts Location (Circuit Board)

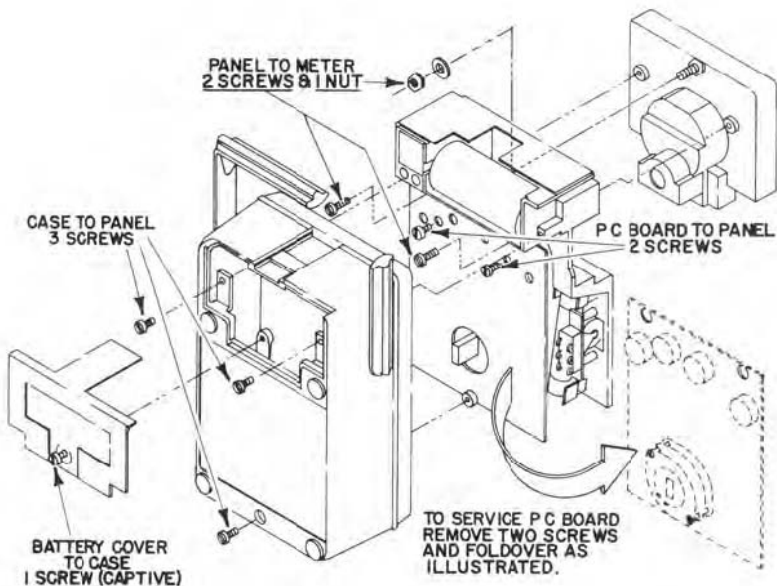

Disassembly Instructions

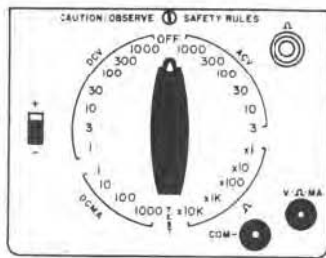

DECKS VIEWED FROM KNOB END OF SWITCH.

● POSITION NO. 1.

⊙ STRUT SCREW.

ROTARY SWITCH SHOWN IN OFF POSITION.

POLARITY SWITCH SHOWN IN + POSITION.

DECK A NEAREST TO KNOB.

DECK B MIDDLE.

DECK C FARTHEST FROM KNOB.

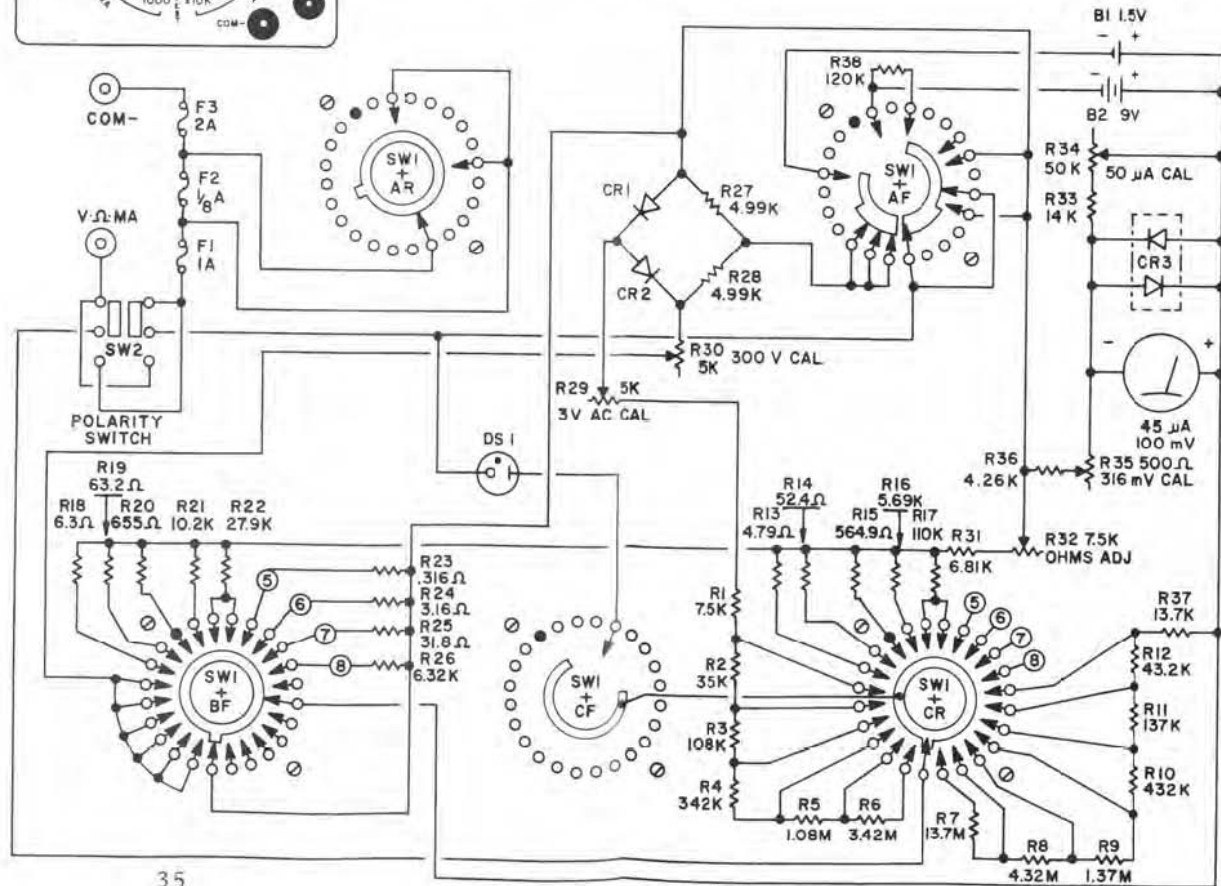

LIMITED WARRANTY

The Triplett Corporation warrants instruments and test equipment manufactured by it to be free from defective material or factory workmanship and agrees to repair or replace such products which, under normal use and service, disclose the defect to be the fault of our manufacturing, with no charge for parts and service. If we are unable to repair or replace the product, we will make a refund of the purchase price. Consult the Instruction Manual for instructions regarding the proper use and servicing of instruments and test equipment. Our obligation under this warranty is limited to repairing, replacing or making refund on any instrument or test equipment which proves to be defective within one year from the date of original purchase.

This warranty does not apply to any of our products which have been repaired or altered by unauthorized persons in any way so as, in our sole judgment, to injure their stability or reliability, or which have been subject to misuse, abuse, misapplication, negligence or accident or which have had the serial numbers altered, defaced, or removed. Accessories, including batteries, not of our manufacture used with this product are not covered by this warranty.

To register a claim under the provisions of this warranty, return the instrument or test equipment to Triplett Corporation, Bluffton, Ohio 45817, transportation prepaid. Upon our inspection of the product, we will advise you as to the disposition of your claim.

ALL WARRANTIES IMPLIED BY LAW ARE HEREBY LIMITED TO A PERIOD OF ONE YEAR, AND THE PROVISIONS OF THE WARRANTY ARE EXPRESSLY IN LIEU OF ANY OTHER WARRANTIES EXPRESSED OR IMPLIED.

The purchaser agrees to assume all liability for any damages and bodily injury which may result from the use or misuse of the product by the purchaser, his employees, or others, and the remedies provided for in this warranty are expressly in lieu of any other liability Triplett Corporation may have, including incidental or consequential damages.

Some states do not allow the exclusion or limitation of incidental or consequential damages, so the above limitation or exclusion may not apply to you. No representative of Triplett Corporation or any other person is authorized to extend the liability of Triplett Corporation in connection with the sale of its products beyond the terms hereof.

Triplett Corporation reserves the right to discontinue models at any time, or change specifications, price or design, without notice and without incurring any obligation.

This warranty gives you specific legal rights, and you may have other rights which vary from state to state.

Triplett Corporation

Bluffton, Ohio 45817