

SWR & POWER METER

SP-300

OPERATING MANUAL

CONTROLS AND THEIR FUNCTIONS

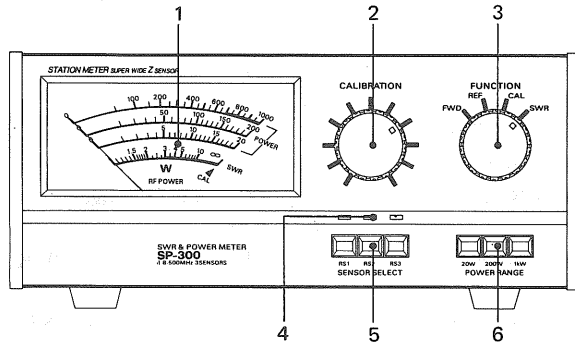

FRONT VIEW

1. METER

Indicates three range power and SWR.

Do not continue to use over 30 seconds at the red-zone on the power range of the meter to avoid destroying the power sensor.

2. CALIBRATION KNOB

If you measure SWR, set the meter at the "CAL" position by turning this knob.

3. FUNCTION SELECTOR

You can select the function of this set, FWD, REF, CAL, V.S.W.R. by this selector.

4. SENSOR INDICATOR

Indicates which sensor is selected from the sensor selector located below this indicator. 10 watts power or more will be needed to light this indicator.

5. SENSOR SELECTOR

You can select the sensor by pushing this feather touch selector before measurement.

6. POWER RANGE SELECTOR

You can select the power range of the meter by pushing this feather touch selector.

REAR VIEW

1. OUTPUT TERMINAL RS3

Set the 50 ohms coaxial cable from the antenna to this terminal.

Frequency range : 130 to 500 MHz

Maximum power : 150 W

Connector : N type

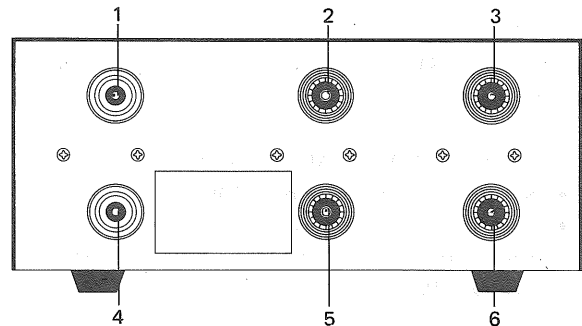

2. OUTPUT TERMINAL RS2

Set the 50 ohms coaxial cable from the antenna to this terminal.

Frequency range : 1.8 to 200 MHz

Maximum power : 200 W

Connector : UHF type

3. OUTPUT TERMINAL RS1

Set the 50 ohms coaxial cable from the antenna to this terminal.

Frequency range : 1.8 to 200 MHz

Maximum power : 1 kW

Connector : UHF type

4. INPUT TERMINAL RS3

Set the 50 ohms coaxial cable from the transmitter to this terminal.

Frequency : 130 ~ 500 MHz

Maximum power : 150 W

Connector : N type

5. INPUT TERMINAL RS2

Set the 50 ohms coaxial cable from the transmitter to this terminal.

Frequency : 1.8 ~ 200 MHz

Maximum power : 200 W

Connector : UHF type

6. INPUT TERMINAL RS1

Set the 50 ohms coaxial cable from the transmitter to this terminal.

Frequency range : 1.8 to 160 MHz

Maximum power : 1 kW

Connector : UHF type

OPERATION

BEFORE OPERATION

1. 50 ohms coaxial cable with connector at both end will be needed to measure the SWR and power.
(Check the impedance of the cable is 50 ohms.)
2. If you want to measure the output power of your transmitter, use 50 ohms reliable coaxial termination.
3. SP-300 was perfectly tuned and adjusted by us, so don't try to remove the cover of this set and touch the inside.

OPERATION

SP-300 can use three transmitters at once. You can measure each SWR and power of them only selecting the RS selector.

1. FORWARD POWER MEASUREMENT

- Set the function selector at FWD.
- Push the power range selector button.
- Select the sensor selector. You can read the Forward Power on the meter.

2. REFLECTED POWER MEASUREMENT

- Set the function selector at REF.
- Push the power range selector button.
- Select the sensor selector. You can read the Reflected Power on the meter.

3. EFFECTIVE POWER MEASUREMENT

You can know the Effective Power by taking away REF power from FWD power.

ex. When the FWD indicates 100 W and REF indicates 4 W, then Effective Power is 96 W.

4. STANDING WAVE RATIO MEASUREMENT

- Set the function selector at CAL.
- Set the calibration knob.
Adjust the meter to indicate the CAL point by turning the Calibration Knob.
- Then set the function selector at SWR, you can read the SWR on the meter.

5. CAUTION

- Don't use over maximum power.
Maximum durable power of each sensor is as follows;

RS1	1.8 to 60 MHz	700 W	continuously
	1.8 to 60 MHz	1 kW	within 30 seconds
	60 to 160 MHz	250 W	continuously
RS2	1.8 to 200 MHz	200 W	continuously
RS3	130 ~ 500 MHz	150 W	continuously

- Avoid shock to protect the meter.
- Set the function selector at SWR and turn the calibration knob to MIN, when the set is carrying the other place.

SPECIFICATIONS

Frequency Range	: 1.8 ~ 500 MHz (RS1: 1.8 ~ 160 MHz, RS2: 1.8 ~ 200 MHz, RS3: 130 ~ 500 MHz)
Power Measurement	: RS1: 0 ~ 1 kW (CW) 1.8 ~ 60 MHz (within 30 seconds) RS1: 0 ~ 700 W (CW) 1.8 ~ 60 MHz (continuously) RS1: 0 ~ 250 W (CW) 60 ~ 160 MHz (continuously) RS2: 0 ~ 200 W (CW) continuously RS3: 0 ~ 150 W (CW) continuously
Accuracy (Power Measurement)	: ±10% F.S.
Power Range	: 20, 200, 1 kW, 3 ranges selectable
Measurement Function	: FWD, REF, CAL & V.S.W.R. (SWR)
Sensor Selection	: 3 sensors (RS1, RS2 & RS3) selectable
Insertion Loss	: RS1: less than 0.2 dB RS2: less than 0.3 dB RS3: less than 0.5 dB
SWR Measurement Range	: 1 ~ 10
Minimum Power (SWR Measurement)	: RS1: 5 W, RS2: 7 W, RS3: 1.5 W
Impedance	: 50 ohms
Residual SWR	: less than 1.1 ... RS1 & RS2 less than 1.2 ... RS3
Connectors	: UHF type (RS1 & RS2), N type (RS3)
Sensor	: 3 Transformer type "SUPER WIDE 'Z' SENSOR" RS 1000 V & RS 200 V (RS1 & RS2) built-in. "SUPER WIDE 'Z' SENSOR" - RS150U (RS3) built-in.
Dimension	: 220(W)×91(L)×113(D) mm 1.8 kgs.

