

*The* **NATIONAL**  
**VFO-62**

**VARIABLE FREQUENCY OSCILLATOR**

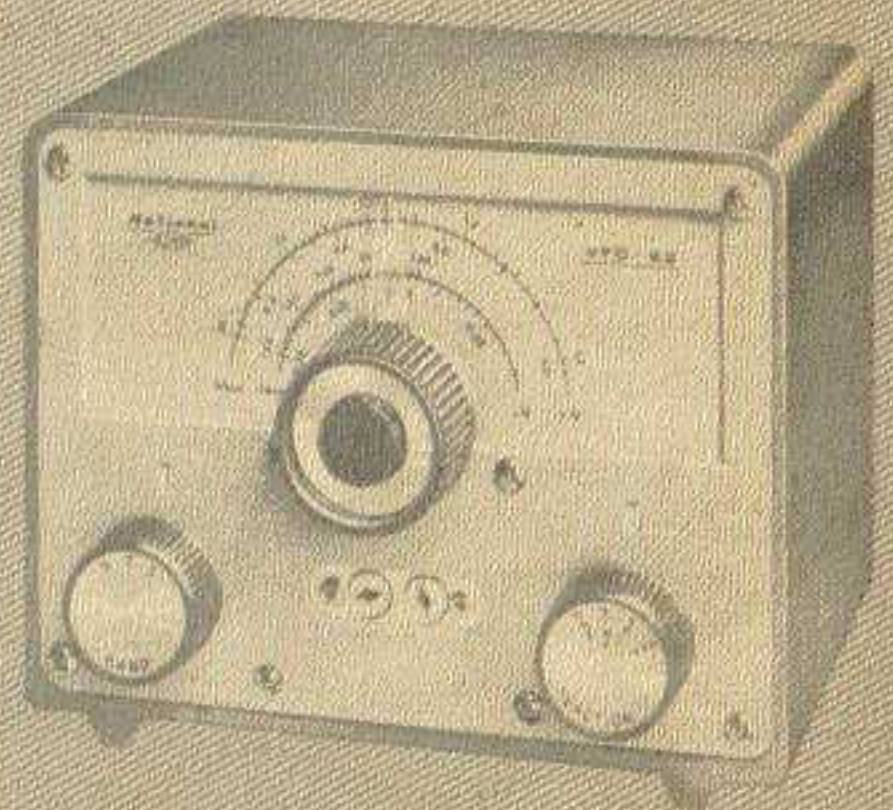

**NATIONAL COMPANY INC., MALDEN, MASSACHUSETTS**

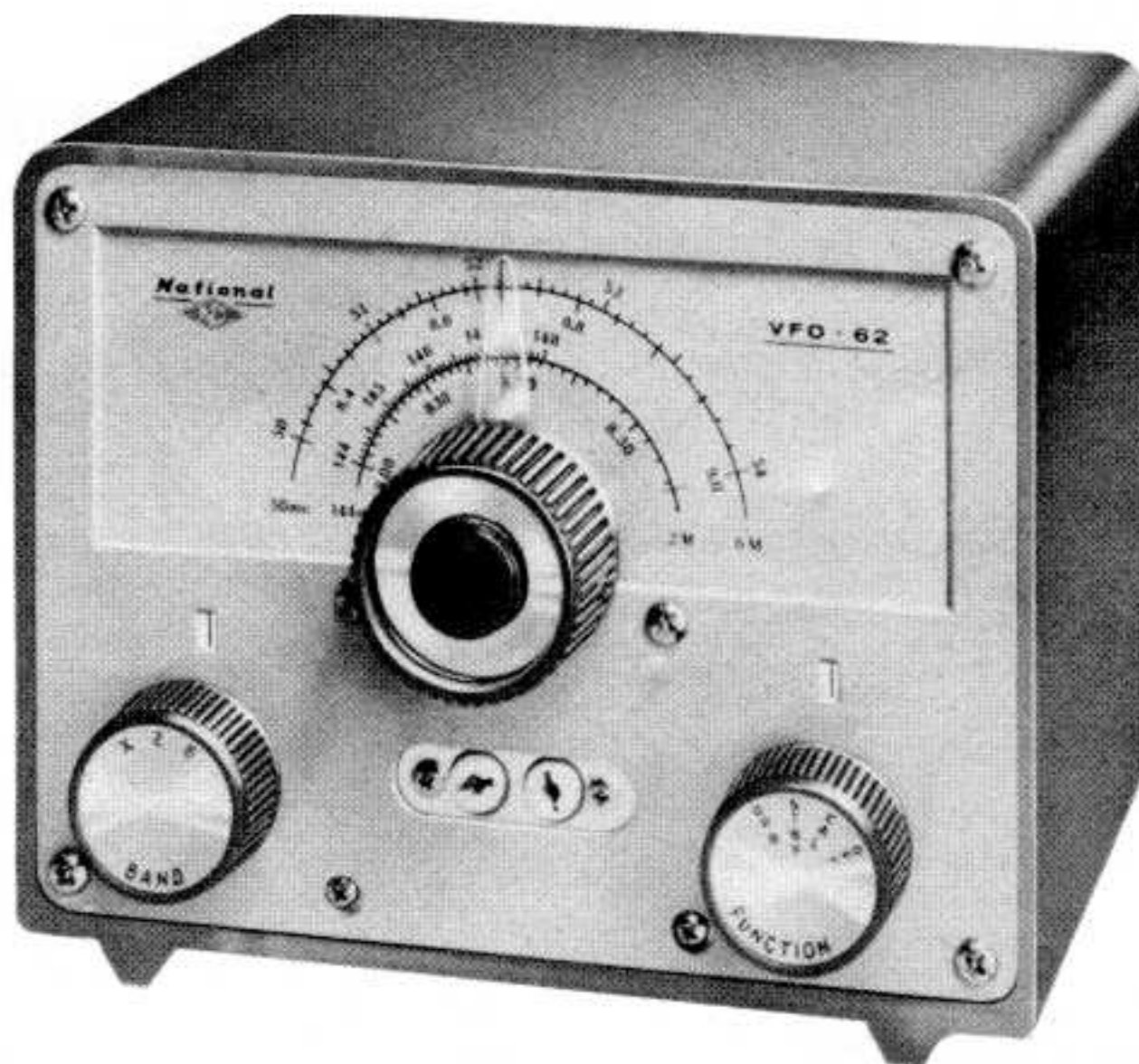

**Figure 1. The National VFO-62 Variable Frequency Oscillator**

## 1. DESCRIPTION

**1.1 General** — Your National VFO-62, shown in figure 1, is a precision variable frequency oscillator for the 2- and 6-meter bands. The VFO-62 is designed to operate with most equipment using crystal oscillators operating in the 8- to 9-mc region or with most equipment using overtone oscillators in the 25- to 27-mc range.

Easy installation is provided, since the low-level RF-output signal developed by the VFO-62 can be connected directly to the crystal socket of existing commercial transmitters. Provisions for crystal operation are provided in the VFO-62 without the necessity of changing interconnecting cables.

**1.2 Circuit Description** — Your VFO-62 is a completely self-contained unit which operates from a 105-125 volts ac power source. The unit uses a full-wave rectifier and two vacuum tubes, including a voltage regulator and a dual-purpose oscillator-output stage to develop the RF signal.

The oscillator section employs the triode half of a 6BH8 tube as a tuned-grid tuned-plate oscillator, with the plate-tank circuit fixed tuned at approximately 9.5 mc. This eliminates the necessity of tracking and peaking the plate circuit while obtaining reliable oscillation over the entire operating band (8 to 9 mc). The oscillator covers the 6-meter band by using the 6th harmonic of its fundamental output frequency range (8.33 to 9.00 mc) and the 2-meter band by using the 18th harmonic of its 8.00- to 8.33-mc range. When the

BAND switch is in the X position the variable tuned circuits are disconnected, and the fundamental oscillator becomes crystal-controlled, provided a crystal is inserted in the front panel socket.

To attenuate the effects of output loading, a very low value coupling capacitor (10 mmfd) is used to provide a high degree of isolation between the oscillator and output stages. During normal operation (FUNCTION switch in OPR or STBY), the output stage is a cathode follower with an output impedance of approximately 100 ohms.

If a 1-mc crystal is inserted in the calibration crystal socket and the FUNCTION switch is in the CAL position, the cathode follower is converted to a crystal-controlled Pierce oscillator, which is used for internal calibration. When the FUNCTION switch is placed in the CAL position, both the fundamental and calibrating oscillators are operating, and beat notes are developed in the audio load in the plate circuit of the output stage. This output is coupled to the headset jack (J1) at the rear of the unit.

Standby provisions are incorporated in the cathode of the fundamental oscillator circuit. The cathode is connected to the FUNCTION switch and rear terminals so that the oscillator may be made operative by the front panel control of the VFO-62 or by a remote shorting contact.

DC voltages for the unit are provided by a full-wave power supply. The output of the power supply is held constant by an OB2 voltage regulator.

## 2. INSTALLATION

### CAUTION

YOUR VFO-62 IS DESIGNED TO OPERATE FROM 105- TO 125-VOLT, 50- TO 60-CYCLE AC SOURCE ONLY. CONNECTION TO A DC POWER SOURCE WILL RESULT IN SERIOUS DAMAGE TO THE UNIT.

**2.1 Initial Setup** — The following information will assist you in preparing the VFO-62 for operation. The output of the unit is capable of properly driving most transmitters through standard coaxial cable not exceeding 5 feet in length. If it is necessary to make this connection longer than 5 feet, the use of low-capacity coaxial cable is recommended. For best results, always make the connection to your transmitter as short as possible. In most cases, one side of the crystal circuit in a transmitter is grounded; therefore, it is important that the coaxial shield be connected to the ground side of the crystal socket and the ground side of the VFO output jack, shown in figure 2.

To retain the crystal mode of operation, plug your crystal in the socket provided on the front panel of the VFO-62.

For internal calibration, it is necessary to plug a standard 1-mc crystal into the calibrating-crystal socket (see figure 4) and connect a headset to the phone jack at the rear of the VFO, shown in figure 2.

With the FUNCTION switch in the OFF position, connect the power line to a normal 105- to 125-volt ac power source. Your VFO-62 is now ready for local operation.

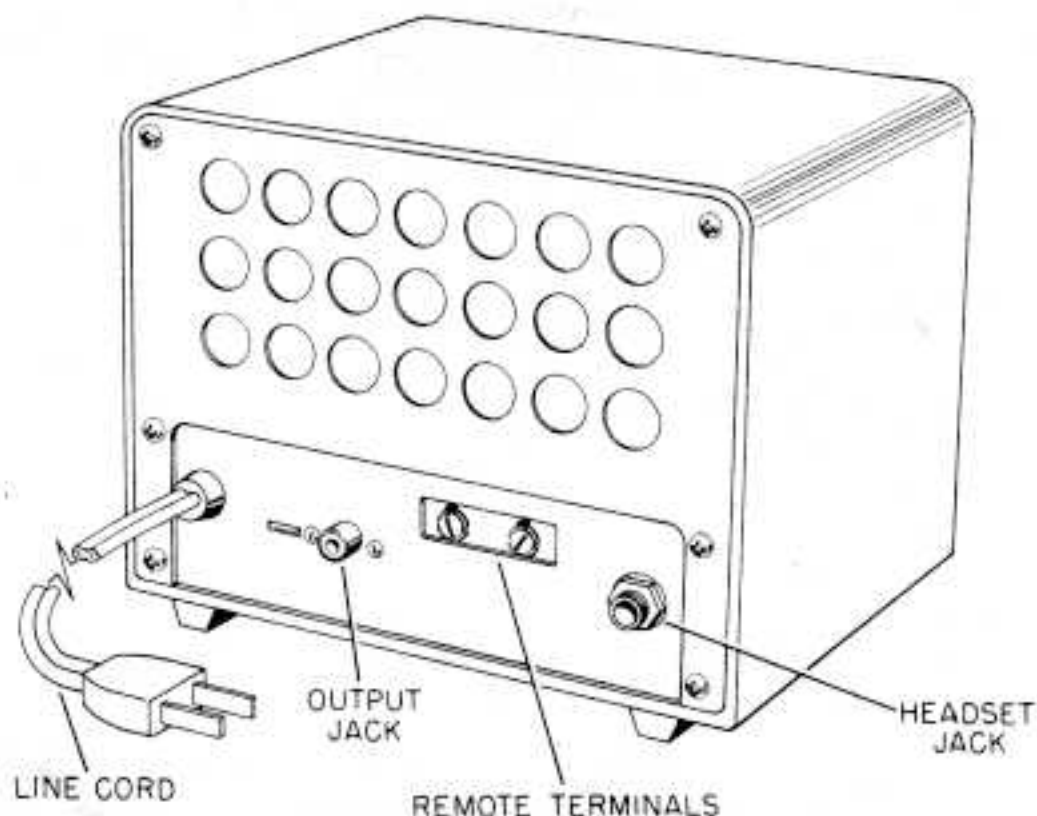

**Figure 2. Rear View of VFO-62**

---



## 3. OPERATION

### WARNING

PARAGRAPH 12.135 OF THE FEDERAL COMMUNICATIONS COMMISSION RULES GOVERNING AMATEUR RADIO SERVICE REQUIRES REGULAR FREQUENCY MEASUREMENT OF THE EMITTED CARRIER FREQUENCY, INDEPENDENT OF THE MEANS USED TO CONTROL THE FREQUENCY OF THE TRANSMITTER.

**3.1 Controls** — The three controls required to operate the VFO-62 are located on the front panel. Figure 3 shows the physical location and gives a short description of each control.

The dial scale of the VFO-62 is calibrated at the output frequency of the unit and also the

fundamental frequency of the oscillator. The latter frequency scale, located under the operating frequency scale on both the 2- and 6-meter bands, is included for the convenience of those persons interested in bands other than the direct amateur band.

**3.2 Crystal Control Operation** — For crystal operation, insert a proper crystal in the front panel socket. Turn the BAND switch to X and the FUNCTION switch to OPR. Since all tuned circuits of the VFO-62 are now disconnected, the position of the dial pointer is not important. Tune the transmitter stages in the normal manner prescribed by the transmitter operating instructions.

The VFO-62 output may not provide as much excitation as is normally obtained with the crystal plugged directly into the transmitter. However, the output level is sufficient to keep the transmitter input stage within its rating, and, after one or two stages of frequency multiplications, normal operating levels will be obtained.

**3.3 Two- and Six- Meter Operation** — Operation in either the 2- or 6-meter band is obtained by turning the BAND switch to the desired band position and placing the FUNCTION switch in the OPR position. The VFO-62 output-signal frequency is then equal to the frequency indicated by the dial pointer. Normal tuning procedure for the transmitter should be followed. To change operating frequency, turn the main tuning dial to the new frequency setting and retune the transmitter.

If the FUNCTION switch is placed in the OPR position, the VFO-62 will continue to operate even when the transmitter mode control has been set to the receive position. To tune the VFO-62 to the exact frequency of a received signal, turn the main tuning dial to obtain a zero beat on the receiver. After the zero beat is obtained, place the FUNCTION switch to the STBY position until you wish to transmit.

**3.4 Remote Operation** — Connections are provided in the rear of the unit for remote standby control. If remote standby operation is desired, it is necessary only to short circuit the remote terminals, shown in figure 2, through the use of remote relay contacts or a remote switch. The FUNCTION switch should be placed in the STBY position for remote operation. Do not connect any external power source to these rear connections of the VFO-62. Primary power and output-signal connections remain the same as those given in paragraph 2.1.

For remote operation, place the FUNCTION switch in the STBY position and the BAND switch to the desired band position. If the remote installation instructions given above were completed, the output of the VFO-62 is now controlled by the remote contacts.

**3.5 Checking Dial Calibration** — If a 1-mc crystal is inserted in the internal calibrating-crystal socket, calibration of the output frequency can be performed by turning the FUNCTION switch to CAL and inserting a headset plug into the rear phone jack.

**NOTE**

Whenever the FUNCTION switch is placed in the CAL position, no RF-output signal is available for the transmitter.

When the main tuning dial is rotated through its range, beat notes which represent a harmonic relationship between the fundamental oscillator and crystal oscillator can be heard in the headset. For example, when operating in the 2-meter band, a beat note will be heard at 144 mc (fundamental oscillator frequency is 8 mc). The beat

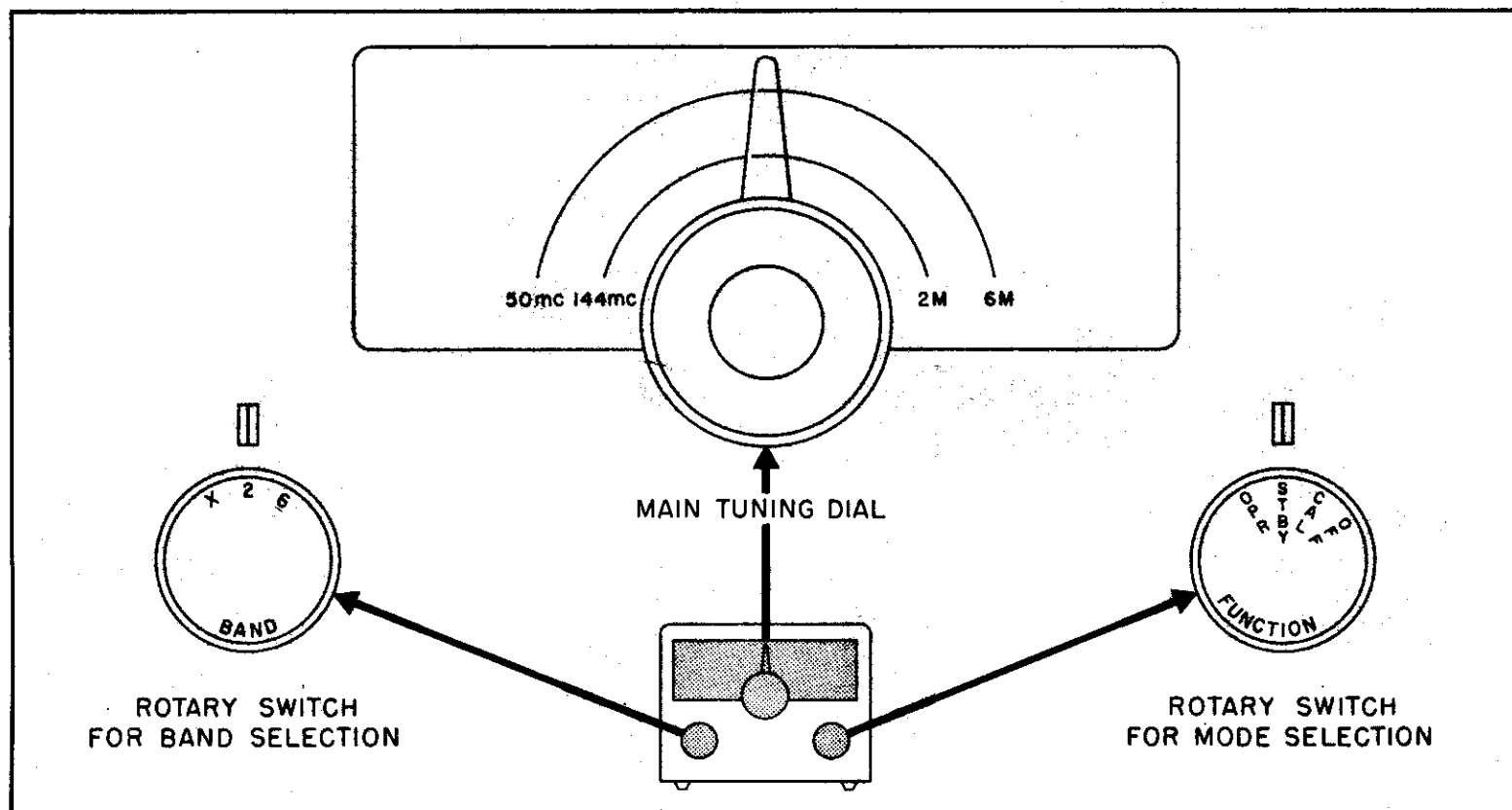

**Figure 3. Location and Function of Controls**

note is produced by heterodyning the 8-mc output frequency from the fundamental oscillator against the 8th harmonic of the 1-mc calibration oscillator. All points on the dial scale where beat notes

should be heard are indicated by a red mark.

If the beat notes do not occur at the red marks, refer to the alignment procedure given in the maintenance section of the manual.

#### 4. MAINTENANCE

**4.1 General** — The information contained in this section will aid qualified radio service personnel in repairing and aligning the VFO-62.

**4.2 Removing The Chassis** — To remove the chassis from the case, perform the following:

- a. Remove the phillips-head screws located in the corners of the front panel.
- b. Remove the two screws which hold the back cover to the chassis.
- c. Slide the chassis from the front of the cabinet.

**4.3 Alignment** — Normal Alignment. The internal crystal oscillator is used for normal alignment.

a. Six-meter Band. To align the 6-meter band, remove the chassis from the case and place the following controls in the indicated positions:

FUNCTION .....	CAL
BAND .....	6
MAIN TUNING DIAL .....	50

With the controls set at these positions, a loud

beat note should be heard in the headset. If the beat note is not heard, the slug of L2 (figure 4) should be turned slightly in either direction until the beat note is heard. Now turn the main tuning dial to 54. Again a beat note should be heard. If it is not heard, adjust trimmer capacitor C6 (figure 4) to obtain the beat note. Return the main tuning dial to 50 and readjust L2 for the beat note. Repeat the adjustments to C6 and L2 until both ends of the dial scale are in agreement.

b. Two-Meter Band. The procedure used to align the 2-meter band is similar to the procedure used above for the 6-meter band except the BAND control is in the 2 position. For the low end of the dial scale, tune L1 (figure 4), and for the high end of the scale, adjust C2 (figure 4).

Major Alignment. If the VFO-62 requires complete alignment, a signal generator is required to determine what beat note is being heard; the procedures outlined above can then be used.

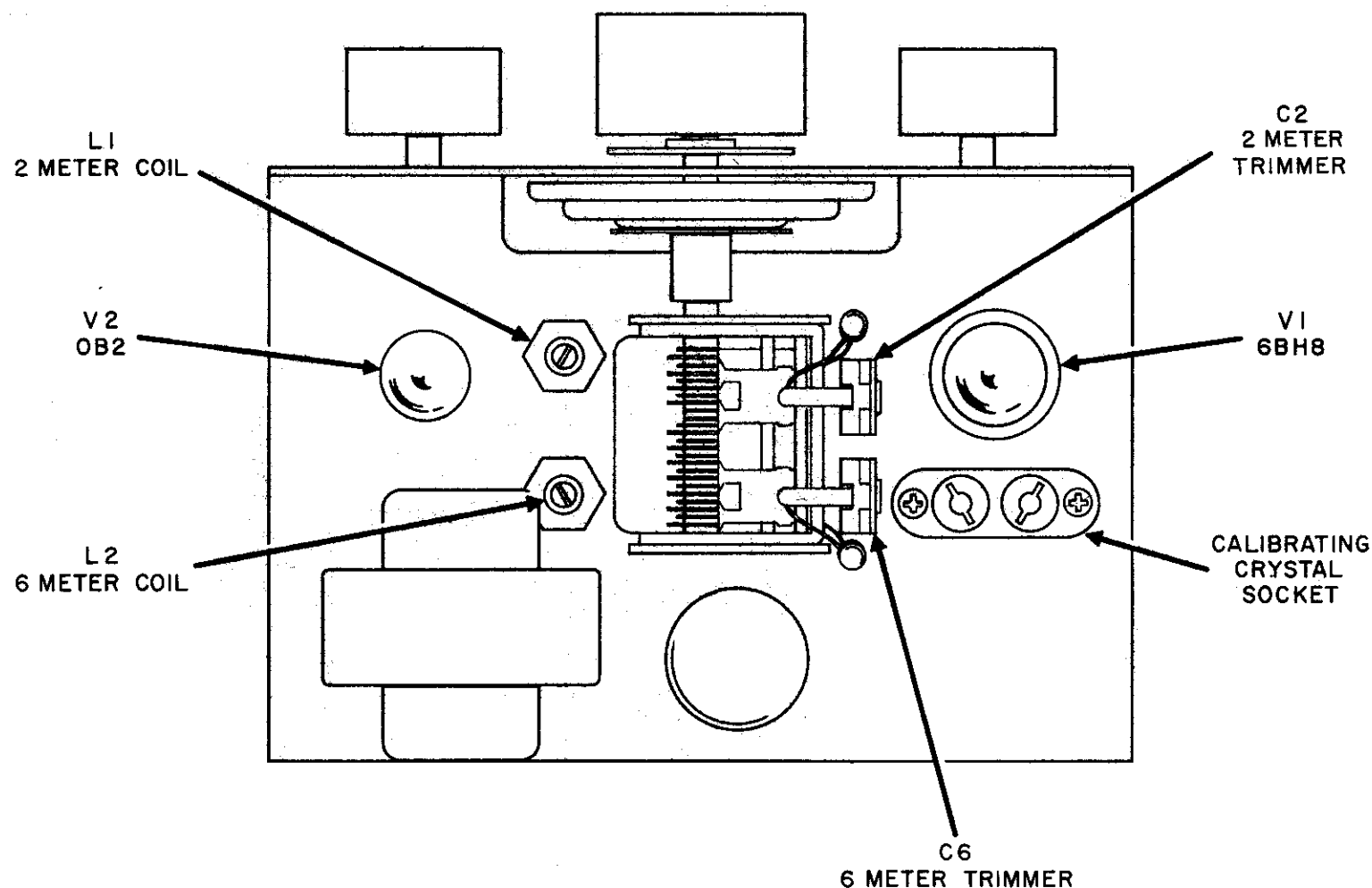
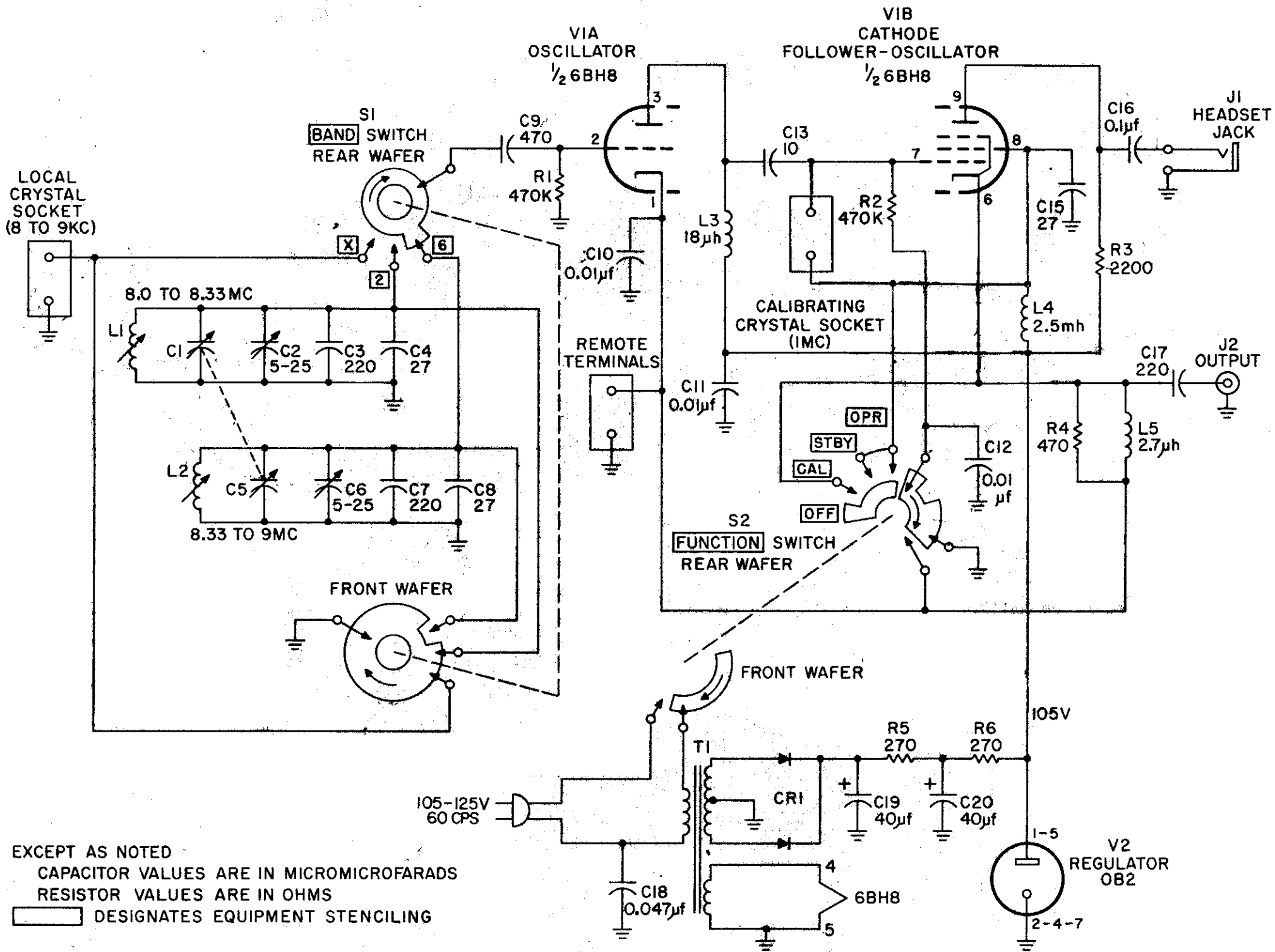
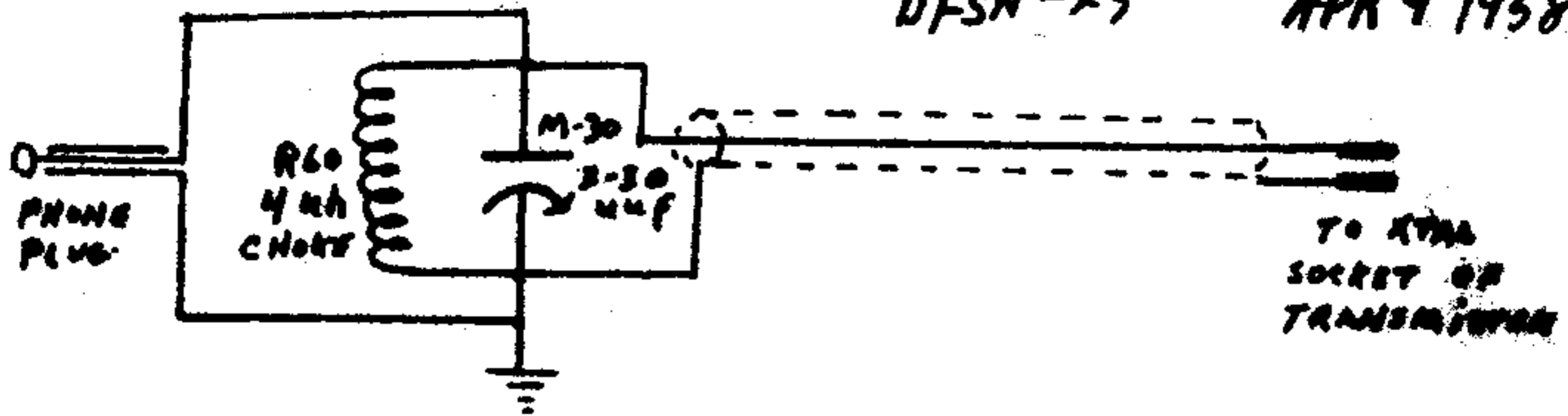

Figure 4. Alignment Controls





HOW TO OBTAIN INCREASED OUTPUT FROM VFO-62  
FOR HARD TO DRIVE TRANSMITTERS.

Connect a 4 mh choke or coil with a 3 to 30 uuf capacitor across it as shown in the diagram. This coil-condenser combination may be either at the phone plug end of the cable or at the transmitter. The length of coaxial cable is critical since it becomes part of the tuned circuit. Usually two feet should be the maximum length recommended. If longer lengths are used, the coil-condenser combination must be reduced or tailored accordingly.

Tune the 3-30 capacitor so that it resonates approximately in the center of the band or 8.666 mc. for 8 meters; 8.111 mc. for two meters.

Under these conditions, the phone plug should be inserted in the phone jack on the back of the VFO-62 and connections should not be taken from the cathode follower output jack.

Very truly yours,

NATIONAL COMPANY, INC.

Robert J. Murray, W1FSN  
Service Manager

RJM/jed

## TECHNICAL TIP

Operators of the National VFO-62 variable-frequency oscillator who need a bit more output to excite hard-to-drive 2- and 6-meter transmitters should be interested in the following modification from Victor E. Penny, W1MTS.

First, add a tuned circuit to the output circuit of the VFO-62, as suggested in the National Company's field service note #23. Connect a 3-30  $\mu\text{f.}$  trimmer across a 4- $\mu\text{h.}$  r.f. choke (such as the National R-60) or equivalent coil. Next, connect the paralleled combination across the solder terminals of a standard phone plug, and connect one end of a 2' length of coax to the phone plug also. Be sure to wire the coax shield braid to the sleeve of the plug, and the coax center conductor to the plug tip connection. Terminate the other end of the coax in a plug that mates with your transmitter's crystal socket.

Insert the phone plug into the phone jack (not the cathode follower jack) on the back of the VFO-62, and insert the other plug into the transmitter crystal socket. Then adjust the 3-30  $\mu\text{f.}$  capacitor for maximum output in the center of the desired band—8.666 mc. for 6 meters, 8.111 mc. for 2 meters.

Adding the tuned circuit will in itself increase the VFO-62's output appreciably. But carrying out the rest of W1MTS's modification will increase the output much more. Immediately behind the phone jack under the VFO-62 chassis, an insulated 2-terminal tie strip is mounted. Replace it with a 3-terminal strip or mount an additional single-terminal strip near it.

Referring to the VFO-62 circuit diagram, disconnect the screen r.f. choke  $L_4$  (which comes from pin #8 of the tube socket) and the plate load resistor  $R_3$  from the original tie point. Replace resistor  $R_3$  with a 3300-ohm,  $\frac{1}{2}$ -watt unit; then connect both the resistor and choke

to the added third terminal. Bypass the terminal to the chassis through a 0.01- $\mu\text{f.}$  ceramic capacitor, and solder a short length of wire between the terminal and the junction of resistors  $R_5$  and  $R_6$  and the filter capacitor. Solder the connections, and the job is done.

This change removes the pentode section of the 6BH8 tube from the OB2 voltage regulator; the critical B+ volt-

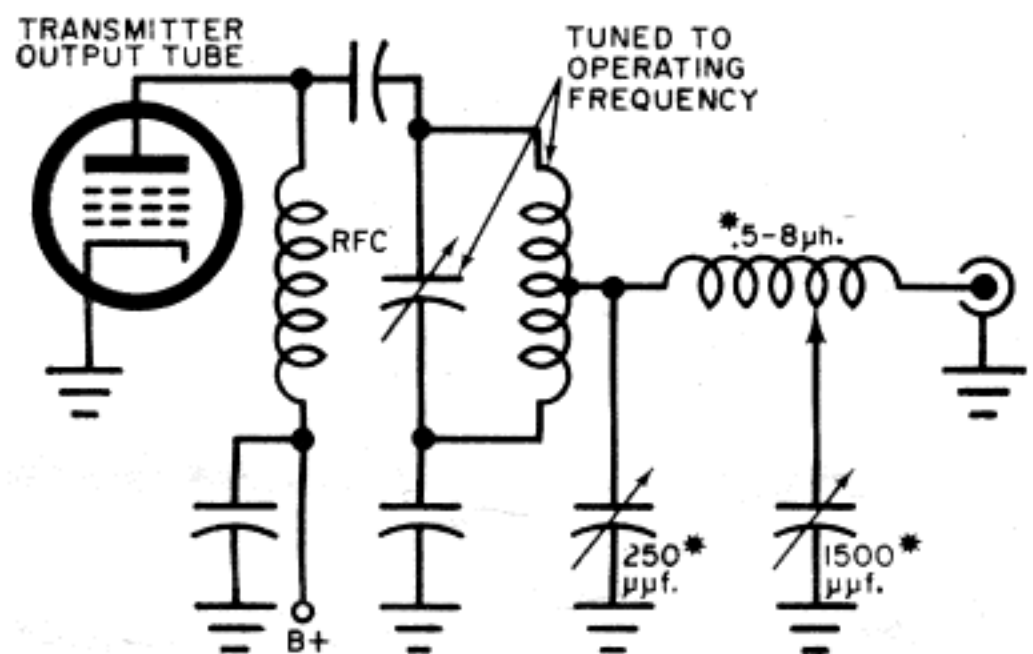

The diagram above shows how the classic pi-network circuit was first used in amateur transmitters in conjunction with a parallel-tuned tank circuit as an antenna-matching network. The modern, simplified arrangement below employs a pi-network combination plate tank circuit and antenna-matching network.

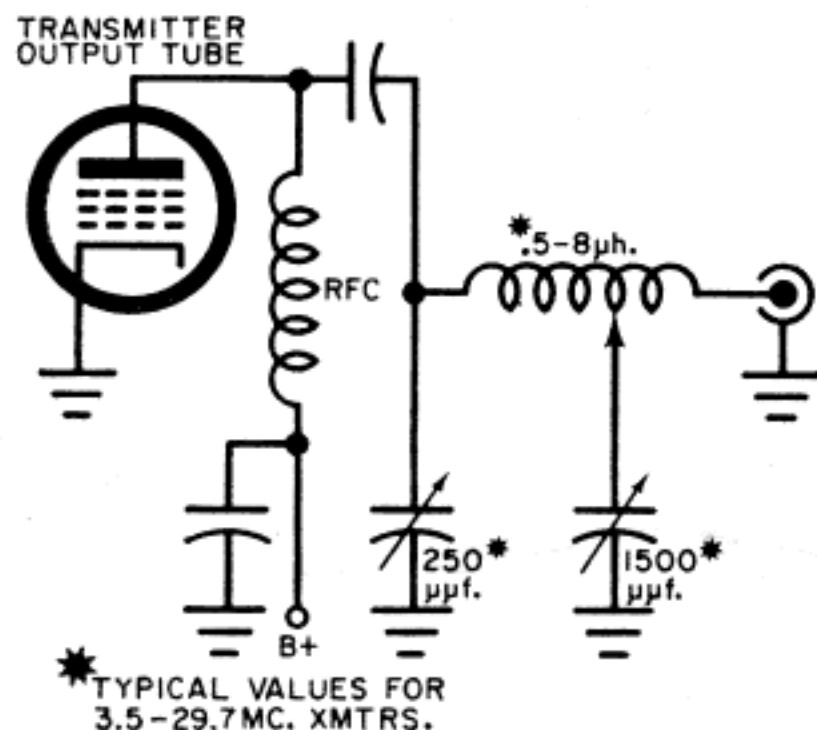

ages on the oscillator section are still regulated, however. Incidentally, while you *can* take the first step in the modification without taking the second, *don't* reverse the procedure.

