

CT 2 1 0 0
C O M M U N I C A T I O N S
T E R M I N A L

INSTRUCTION MANUAL



HAL COMMUNICATIONS CORP.
BOX 365
URBANA, ILLINOIS 61801

QUALITY COMMUNICATIONS EQUIPMENT

CT 2 1 0 0
C O M M U N I C A T I O N S
T E R M I N A L

Copyright © 1981 by HAL Communications Corp., Urbana, Illinois.
Printed in the United States of America. All rights reserved.
Contents of this publication may not be reproduced in any form without
the written permission of the copyright owner.

February, 1984 Printing

CT2100 COMMUNICATIONS TERMINAL

CONTENTS:

INTRODUCTION	1
CHAPTER 1. UNPACKING AND INSPECTION	3
CHAPTER 2. SIMPLE HOOK-UP FOR THE EAGER AND IMPATIENT	5
2.1 Connections to the CT2100	5
2.2 Presetting CT2100 Controls	6
2.3 Presetting the Transceiver Controls	7
2.4 RTTY Operation	7
2.5 Morse Operation	8
CHAPTER 3. RECEIVING WITH THE CT2100	10
3.1 Connecting the CT2100 to Your Receiver	10
3.2 Receiving RTTY Signals	11
3.3 Low Tones or High Tones?	14
3.4 Modem Tones	17
3.5 Receiving Morse Code	18
CHAPTER 4. TRANSMITTING WITH THE CT2100	23
4.1 The KB2100 Keyboard	23
4.2 Transmit Features	25
4.3 Use of the KSR Keyboard Entry Mode	26
4.4 Use of the Split Screen Keyboard Mode	28
4.5 Use of the HERE-IS Messages	30
4.6 Use of the MSG2100 Option	31
4.7 Special Considerations When Transmitting Morse	31
4.8 Special Considerations When Transmitting Baudot	35
4.9 Special Considerations When Transmitting ASCII	39
4.10 HDX / FDX Operation	43
4.11 Synchronous Idle Feature	44
4.12 The NORM/LOOP Transmit Feature	45
4.13 The KOS Feature	45
CHAPTER 5. CONNECTIONS TO THE CT2100	48
5.1 Normal Amateur Station Connections	48
5.2 Use of the RS232 Data Connections	51
5.3 Use of the RTTY LOOP Data Connection	52
5.4 Connection of an ASCII Printer	52
5.5 Connection of an Audio Tape Recorder	53
5.6 RTTY Tuning Oscilloscope Connections	54
5.7 Using a Television Set as a Monitor	55
5.8 RF-Induced Problems	57
5.9 Power Line Voltage and Frequency Changes	63
5.10 User Adjustments	66

CONTENTS:

CHAPTER 6.	IN CASE OF DIFFICULTY	67
6.1	Care and Feeding of Your CT2100	67
6.2	Typical Operational Problems	69
6.3	Repair Procedures	71
CHAPTER 7.	SPECIFICATIONS	73
APPENDIX:	PROGRAMMING AND INSTALLING THE MSG2100	80
1.	Specifying the Messages	80
2.	Installation of the EPROM	82
3.	Programming the 2716 Yourself	82
	LIMITED WARRANTY	85

ILLUSTRATIONS:

Figure 1.	The CT2100 and KB2100	2
Figure 2.	Simplified CT2100 Connections	4
Figure 3.	The KB2100 Keyboard	22
Figure 4.	Morse Weight Timing	33
Figure 5.	Connections to the CT2100	47
Figure 6.	KOS Circuit Connections	49
Figure 7.	Typical Video Detector	56
Figure 8.	Modified Video Dectector	56
Figure 9.	RFI Reduction Techniques	58
Figure 10.	RFI Power Line Filters	60
Figure 11.	Power Transformer Voltage Tap Connections	64
Figure 12.	Power Frequency Change Jumpers	65
Figure 13.	User Adjustable Controls	67

TABLES:

TABLE 1.	CONTINENTAL MORSE CODE	34
TABLE 2.	BAUDOT DATA CODE	37
TABLE 3.	DISPLAY SYMBOLS FOR THE ASCII CODE	41
TABLE 4.	ASCII DATA CODE	42

CT2100 USER MANUAL

INTRODUCTION

This manual describes the installation and operation of the HAL CT2100 Communications Terminal. The technical details with schematic diagrams and user-repair procedures are described in a second publication, the CT2100 Customer Maintenance Manual, available separately from HAL Communications Corp. or its designated dealers and representatives.

The features of the CT2100 have been designed for convenient and straight forward customer use; many features are self-explanatory from a close examination of the CT2100 front panel, rear panel, screen display, or the keytops of the KB2100. However, like many sophisticated electronic devices, there are some features and operator techniques which you may not understand until you have read this manual. You should plan to devote several hours to becoming familiar with your CT2100.

However, there are many hobbyists, including this writer, who are eager to try the new "gadget" and lack the patience to plow through chapters of technical talk without at least turning it on and trying out something. Therefore, for the eager and impatient new owners, we offer Chapter 2 - SIMPLE HOOK-UP AND OPERATION FOR THE EAGER AND IMPATIENT. After you have your CT2100 running as described in Chapter 2, please then sit down and read the rest of this manual; you'll find the CT2100 will do a lot more things than can be outlined in the simplified instructions.

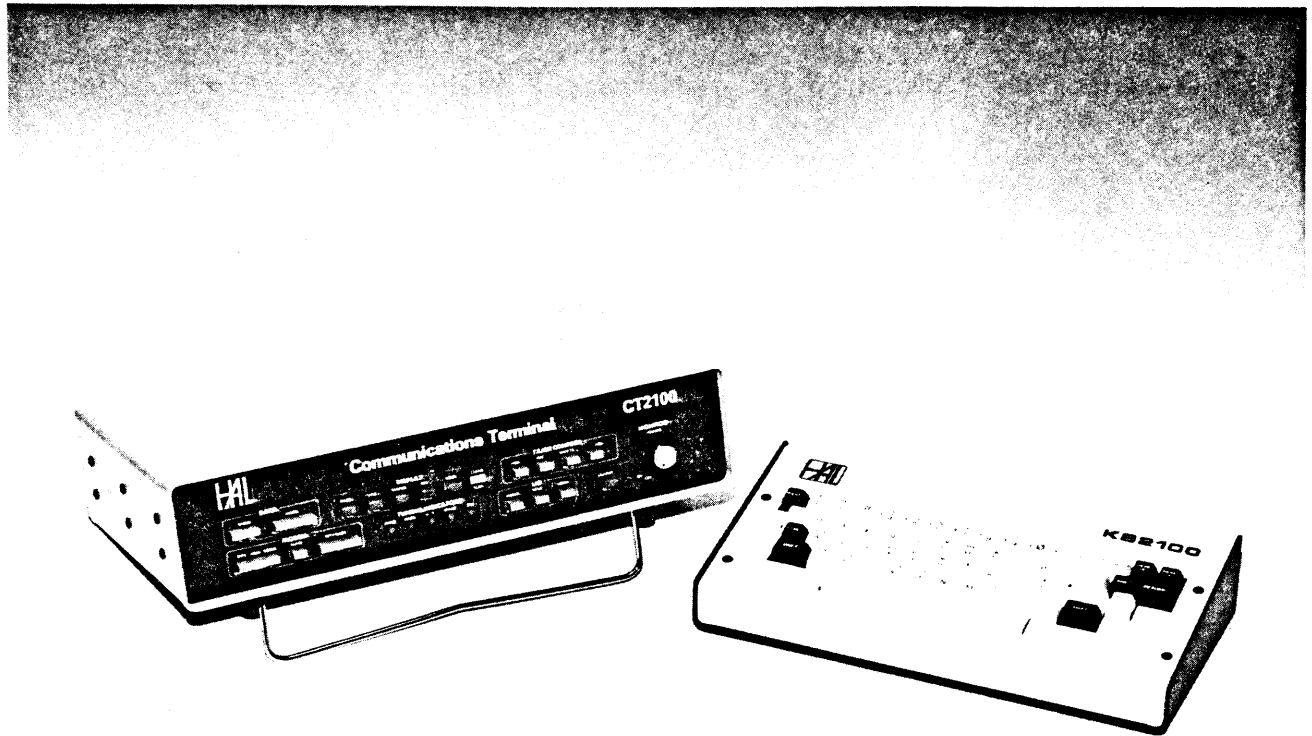

Figure 1 The CT2100 and KB2100

CHAPTER 1

UNPACKING AND INSPECTION

When you unpack your CT2100 and KB2100, carefully inspect the shipping carton and each cabinet for shipping damage. Any evidence of shipping damage should be immediately reported to your supplying dealer or shipping carrier. Be sure to save all packing materials if damage is found - the shipping carrier will want to inspect them for any insurance claim. Before discarding the packing materials check that all parts and accessories are accounted for. Check the accessories against the following list. If any are found missing, double-check the packing for loose parts and then notify either your dealer or HAL Communications Corp. of the shortage. Please specify the HAL part number!

Accessory parts:

Accessories Packed With CT2100:

- 1 - 333-17250 AC Power Cord
- 16 - 310-35012 Phono Pin Plug
- 2 - 770-05001 0.5 Ampere slow-blow fuse
- 1 - 960-02051 Video cable
- 1 - 870-02110 CT2100 USER MANUAL
- 1 - Set MSG2100 Programming Forms

Accessories Packed With KB2100:

- 1 - 355-00755 7 Ft. Coil Keyboard Cable

```

*****
*
*   CAUTION!  A SERIOUS SHOCK HAZARD MAY EXIST WHEN CONNECTING
*               THE CT2100 TO OTHER EQUIPMENT.  BEFORE MAKING ANY
*               CONNECTIONS, BE SURE TO DISCONNECT THE CT2100 AND
*               OTHER EQUIPMENT FROM THE AC POWER LINE.
*
*****

```

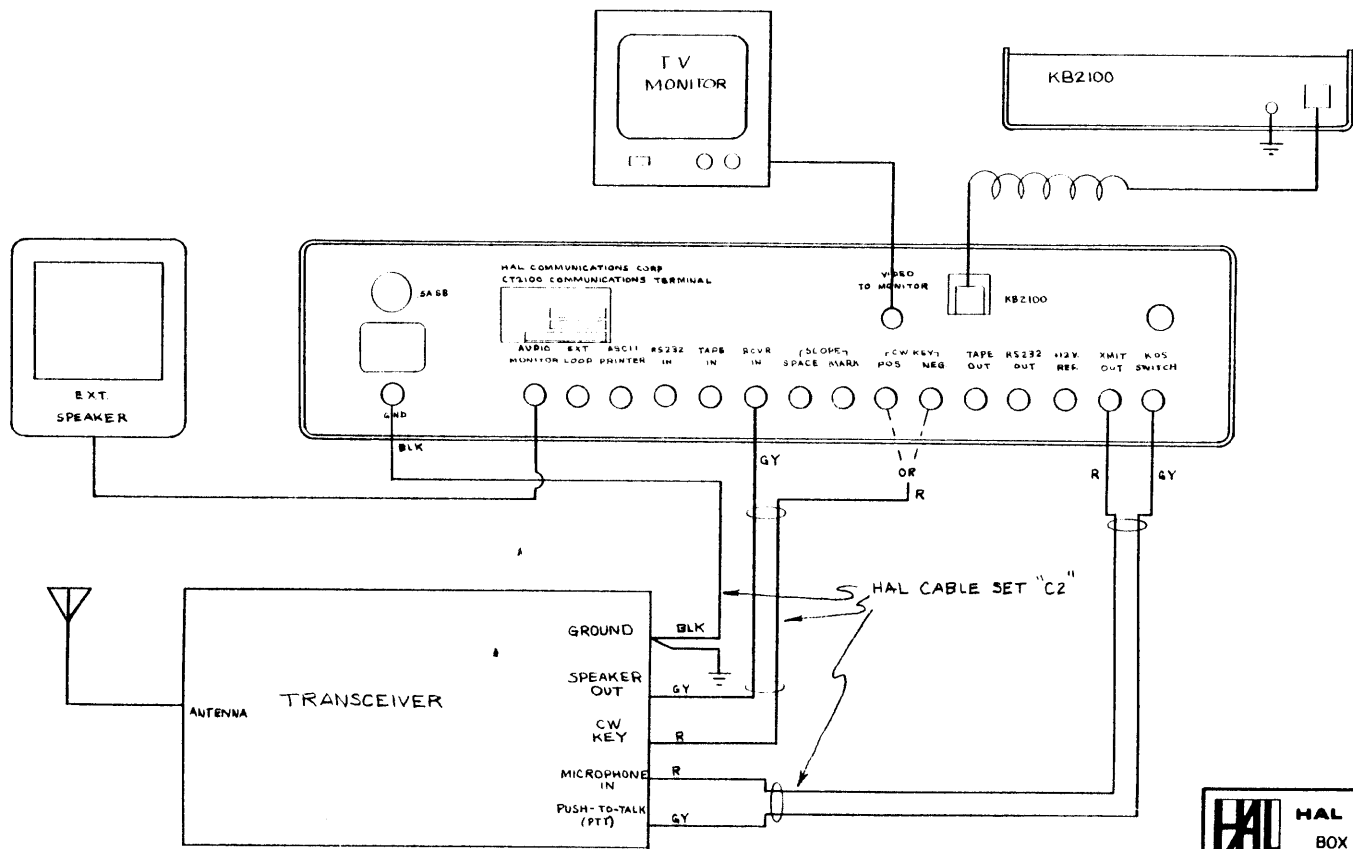

HAL COMMUNICATIONS CORP.
 BOX 365, URBANA, ILLINOIS 61801

FIGURE 2.
 Simplified CT2100 Connections

DATE	8-21-81	SCALE	NONE
DRN BY	GWH	No. C1035	
APP BY			

CHAPTER 2

SIMPLE HOOK-UP AND OPERATION FOR THE EAGER AND IMPATIENT

Although there are many features of the CT2100 explained in this manual, you may wish to first "plug-it-in" and "try-it-out" without reading the whole book. This section of the manual presents enough information to start using the CT2100, but you will eventually need to read Chapters 3, 4, and 5 to take full advantage of the many conveniences included in your CT2100.

2.1 Connections to the CT2100

Refer to Figure 2 and notice the various connections you may make to and from the CT2100. For a start, it is recommended that you make the following connections at the present and leave the other connections until after you have read Chapters 3, 4, and 5. By all means, do not connect the CT2100 or other station equipment to the AC power source until all other connections have been made.

1. Connect a good ground wire (1/4" shield braid preferred) between the CT2100 cabinet, transceiver cabinet, and all other station equipment cabinets.
2. Connect a shielded audio cable between the receiver speaker (audio) output and the CT2100 RCVR IN connector.
3. Connect a shielded audio cable between an external speaker (4 - 16 ohms) and the CT2100 AUDIO MONITOR connector. (Optional, but recommended)
4. Connect a shielded audio cable between the transmitter microphone audio input and the CT2100 XMIT OUT connector. Check your transmitter manual - some transmitters have +12 VDC on the mike input lead to run remote controls; use a 1 uF blocking capacitor at the mike connector to prevent damage to such a transmitter.
5. Connect a shielded audio cable between the transmitter push-to-talk input and the CT2100 KOS SWITCH connector. (Steps 4 and 5 may be combined in a 2 conductor "stereo" cable with the transmitter end connected to a microphone connector; these steps are only necessary if you intend to transmit during these preliminary tests).
6. Connect a coaxial cable between the video input of your monitor and the CT2100 VIDEO TO MONITOR connector.
7. Connect the KB2100 to the CT2100 with the coil cord supplied (KB2100 connector on CT2100).
8. Connect the CT2100, Video Monitor, and transceiver to the AC power source; do not turn-on the equipment yet. Use a grounding type of AC outlet if at all possible.

2.2 Presetting CT2100 Controls

Before applying any power to the transceiver or the CT2100, preset the controls as follows:

DATA:	SPEED	=	as turned on (45 BAUD)
	MODE	=	" " " (BAUDOT)
DISPLAY:	PAGE CYCLE	=	" " " (Page 2)
	LINE CYCLE	=	" " " (72/line)
	STATUS	=	on (button in)
	REV VIDEO	=	either position
	USOS	=	on (button in)
	CLEAR SCRN	=	as turned on
TX/RX	HDX/FDX	=	HDX (button in)
CONTROL:	IDLE	=	off (button out)
	MAN TX/AUTO	=	AUTO (button out)
	KOS	=	off (button out)
MODEM:	RTTY/MODEM	=	RTTY (button in)
	HIGH/LOW	=	LOW (button out)
	NORM/REV	=	NORM (button in)
	AUTO	=	off (button out)
	RTTY SHIFT	=	170 (right button in)
I/O:	AUDIO/RS232	=	AUDIO (button in)
	RCVE/TAPE	=	RCVE (button in)
	NORM/LOOP	=	NORM (button in)
MONITOR	OUTPUT/INPUT	=	INPUT (button out)
	VOLUME	=	turn on CT2100 power; set to "12 o'clock"

Now, turn on the video monitor power and see the following text on the top line of the display:

```
45 BD BAUDOT TX OFF USOS P2 CT2100 V1.x
```

This line is the status line and shows the CT2100 code and data rate selected, condition of the TX/RX data output, and, in this case that the Unshift On Space (USOS) feature has been selected. Also shown is that page 2 (of 2 available) is being viewed. The "V1.x" shows the production version of internal computer program ("software") installed in your unit.

If you use a monitor other than that supplied by HAL, you will probably need to adjust its horizontal and vertical size and position controls. Be sure that you can view all four edges of the TV raster on the screen.

2.3 Presetting the Transceiver Controls

Preset your transceiver controls as follows:

FREQUENCY:	14.075 to 14.100
ANTENNA:	Antenna for above frequency range
MODE:	LSB (lower sideband)
PASSBAND TUNING:	LSB
RECEIVER AGC:	ON - SLOW
RCVR SELECTIVITY:	2 kHz - voice bandwidth
RCVR RF GAIN:	Maximum
XMTR MIC. GAIN:	Minimum
XMTR VOX:	Off
POWER SWITCH:	On
RCVR AUDIO VOL:	Comfortable Level

You should now be able to tune signals on the receiver and hear them either on the receiver speaker or through the external speaker attached to the CT2100. If you are using the external speaker, you can use the MONITOR VOLUME control on the CT2100 to control the volume.

2.4 RTTY Operation

Tune the receiver for a RTTY signal ("deedle-deedle" noise). Correct RTTY tuning is shown with a vertical tuning bar on the upper left section of the screen; tune for maximum bar length on both RTTY tones. If you do NOT see the tuning bar, make sure that the STATUS button is pushed in; if still no tuning bar is seen, readjust the horizontal width and position controls of the monitor. Properly tuned, the bar will have a maximum length and not change appreciably as the signal changes from mark to space. Also, the MARK, +/+, and SPACE tuning LEDs on the CT2100 front panel can be used for tuning; the +/+ LED should stay on and the MARK and SPACE LEDs flash alternately. You should now have "print" of the received signal on the monitor screen. If not, try other speeds, shifts, NORM/REV, etc.

To transmit RTTY, make sure that the XMIT AUDIO GAIN control is set to minimum, turn the transmitter on with either its TX ON control or use the CT2100 MAN TX control (button in). Increase the XMIT AUDIO GAIN until some RF output is obtained, tune the transmitter if necessary, and set the XMIT AUDIO GAIN to the recommended power level for RTTY (see your transceiver manual). After tuning and adjusting, turn off the transmitter (with the transmitter switch or the CT2100 MAN TX switch (to AUTO = button out) and turn on the CT2100 KOS feature (button in). Type the text to be transmitted on the CT2100 keyboard - it will be displayed in reverse video on the bottom portion of the screen. When you are ready to transmit, type CTRL-7 (hold CTRL key down and tap the "7" key). The KOS (Keyboard Operated Switch) circuit of the CT2100 will turn the transmitter on and the text will be transmitted. This text was entered using KSR or bottom line entry

mode; split screen is selected with CTRL-1. KSR and split screen modes are discussed in sections 4.3 and 4.4 of this manual. Programming and use of the HERE IS and IDENT messages is covered in sections 4.5 and 4.6. The transmitter will turn off automatically when all of the text has been transmitted and the transmit cursor is on a blank new display line. ALWAYS END A TRANSMISSION WITH THE NEW LINE KEY. The transmit text may be stopped at any time by typing CTRL-7 again (status line on screen would go back to TX OFF indication). Word mode, word wrap-around, end-of-line sequences, KOS, IDLE, and many other features are discussed in detail in Chapter 4.

2.5 Morse Operation

To use the CT2100 for Morse code reception, press and release the MORSE button in the DATA - MODE field of the CT2100 front panel. Leave the transceiver mode in LSB for the present and tune to a Morse code signal. When the receiver is correctly tuned, the audio beat note will be approximately 800 Hz and the CW LED on the CT2100 front panel will flash in sync with the key-down condition of the signal. You may monitor the code as processed by the CT2100 by switching the MONITOR switch to OUTPUT (button in); the Morse decoding circuit drives the internal sidetone oscillator. Since the sidetone oscillator is frequency synthesized to 800 Hz, you may compare its frequency to that of the received signal by switching between MONITOR INPUT and OUTPUT and adjust the receiver tuning until they match. This technique gives a very accurate way of optimizing the tuning. The Morse receive section of the CT2100 is more amplitude sensitive than the RTTY section; set the receiver audio gain so that the audio output from the CT2100 MONITOR OUTPUT is similar for MONITOR INPUT and OUTPUT switch settings. Occasionally, you may find that the Morse receive section appears to have "locked-up" - no longer displays received characters. This is usually due to reception of a long time-duration CW carrier; the autotrack circuit of the CT2100 is looking for some very very slow Morse code! Eventually, the autotrack circuit will adjust upward in speed and resume copying the received signal. However, the autotrack program can be reset for moderate speeds by pressing and releasing the MORSE DATA MODE switch; each press resets the receive circuitry. You will then see several "T" and "E" characters as the autotrack program adjusts to the received signal's speed. Correct copy should resume within 1 to 10 characters after resetting the MORSE button if the signal is correctly tuned.

To transmit Morse code, first determine if your transmitter has a positive or negative voltage keying circuit. Next, connect a shielded cable between the appropriate CT2100 CW KEY jack (POS or NEG) and the CW KEY connection on the transceiver. Make sure that the KOS switch of the CT2100 is off (button out) and the MAN TX/AUTO is in AUTO position (button out). Now, select CW mode on the transceiver. Tune the transmitter and set the CW level if necessary using the KB2100 BRK key; this key gives key-down condition for as long as you hold it down in Morse mode. Now, transmit Morse code in the same manner as explained above for RTTY, using CTRL-7 to turn the transmitted data on or off.

Now that the basic operations of the CT2100 have been explored, sit back and read the rest of this manual.

CHAPTER 3

RECEIVING WITH THE CT2100

3.1 Connecting the CT2100 to Your Receiver

Connecting the CT2100 to your receiver can be extremely simple - just hook a cable between the receiver audio output (external speaker or phone patch output jacks) and the "RCVR IN" connector on the CT2100 rear panel. Most receivers can be connected with a standard "high-fidelity" phono-to-phono cable, available at all "HI-FI" shops (some receiver external speaker jacks may require an adapter, so check out your receiver before you buy the cable). Or, if you like to make cables, use the phono plugs supplied in the CT2100 accessories. By all means, use shielded cables - this will reduce the chances of RFI from the linear when you start transmitting! The CT2100 has been designed to work well directly from the low-impedance speaker output, but may work even better if a 500-600 ohm audio line output is available. Few modern receivers include this option, but a speaker-to-line transformer can be inserted in the audio line if desired. If you choose to add the line transformer, pick one that will handle at least 1 to 2 Watts of audio - most receivers are capable of producing enough audio output to destroy one of those little 1/4 or 1/2 Watt "transistor specials"! Refer to Figure 2 in the previous chapter for these simple CT2100 connections; full connections are found in Figure 5 in Chapter 5.

If you have an external monitor speaker for your receiver, you may wish to take advantage of the built-in CT2100 audio monitor amplifier system. To use this feature, hook the "RCVR IN" connector of the CT2100 to the receiver external speaker jack and plug the external speaker itself into the "AUDIO MONITOR" jack on the CT2100. A 2 Watt audio amplifier in the CT2100 will now drive your external speaker (as well as a small internal monitor speaker). This internal monitor can be switched with the "MONITOR - INPUT/ OUTPUT" switch on the CT2100 front panel (blue button, lower right corner). With the button pushed out (INPUT), the monitor lets you listen to the audio signal from your receiver, controlled by the front panel "MONITOR VOLUME" control. With the button pushed in (OUTPUT), you can listen to your transmitted RTTY tones or to the Morse sidetone output.

Even though we are just thinking about receiving at the present, this is a good time to put in a good ground between the receiver and CT2100. Use a short, low-inductance wire, preferably a 1/4" or wider piece of shield braid. Make the ground lead as short as convenient, direct from the CT2100 ground terminal to the receiver (or transmitter) ground terminal. Again, this is most important for transmitter RFI protection, but it may also prevent receive RFI problems. By all means, USE GROUNDING TYPE AC OUTLETS - this is a safety measure that does not replace the need for a good RF ground.

Now, connect the CT2100 to the video monitor with the coaxial cable provided. Connect between the CT2100 "VIDEO TO MONITOR" output and the TV monitor "VIDEO INPUT" connector. You may find that your video monitor requires an adapter between the UHF cable connection and the monitor video input. You may also wish to hook an RF ground lead between the monitor and CT2100.

Finally, plug-in the AC power to the receiver, CT2100, and monitor and turn-on the power switches to each. Proper settings for the CT2100 front panel switches will be discussed in the next section.

3.2 Receiving RTTY Signals

As a first step, preset the CT2100 front panel switches as follows:

DATA:	SPEED	= as turned on
	MODE	= BAUDOT (push in and release)
DISPLAY:	PAGE CYCLE	= as turned on - no change for now
	LINE CYCLE	= " " " " " " "
	CLEAR SCRN	= " " " " " " "
	STATUS	= on - button in
	REV VIDEO	= off - button out
	USOS	= on - button in
TX/RX	HDX/FDX	= HDX - button in
CONTROL:	IDLE	= off - button out
	MAN TX/AUTO	= AUTO - button out
	KOS	= off - button out
MODEM:	RTTY/MODEM	= RTTY - button in
	HIGH/LOW	= LOW - button out
	NORM/REV	= NORM - button in
	AUTO	= off - button out
	SHIFT	= 850 - left-hand button in
I/O:	AUDIO/RS232	= AUDIO- button in
	RCVE/TAPE	= RCVE - button in
	NORM/LOOP	= NORM - button in
MONITOR:	OUTPUT/INPUT	= INPUT- button out
	VOLUME	= "12 o'clock" knob position

You should now see the following text on your TV monitor screen:

```
45 BD BAUDOT TX OFF USOS P2 CT2100 V1.x
```

This is the status line that indicates some of the terminal operating conditions. The "45 BD BAUDOT" indicates that Baudot RTTY mode has been selected with a data rate ("speed") of 45 baud (60 wpm). The "TX OFF" shows that the transmitter data output has been turned off and that text will not be transmitted. "USOS" shows that the Baudot Un-Shift-On-Space feature has been selected. "P2" shows that page 2, the normal new text entry page is presently displayed. "CT2100 V1.x" identifies the version of the computer program installed in your CT2100. (The "x" will be another number, such as "1,2,3, etc".)

If all of these indicators are as described, your CT2100 is function-

ing properly; if not, re-check your front panel switch settings. You may now wish to try the LINE CYCLE switch - note how the size of the characters in the status line change when you switch between the 72 character-per-line mode and the 36 character-per-line mode. Select the 72 character mode and momentarily push the PAGE CYCLE button - note how the page number changes from P2 to P1 and back to P2 on the next button press. Switch to 36 character mode and note that now there are four pages that can be selected. It is important to remember that new received text (and keyboard typed text) ALWAYS appears on the HIGH numbered page - page 2 in 72 character line mode and page 4 in 36 character line mode. When you are familiar with these features, try the reverse video button - interesting? There are many display combinations you can select with these three controls. Now, return the display to 72 character lines, page 2, and normal video. (Switching line length and video polarity is a good test of your monitor - a high-quality monitor will not require much if any readjustment when making these changes.)

Now, preset your receiver for the following conditions:

FREQUENCY:	14.075 to 14.100 MHz
ANTENNA:	Adequate to receive signals in above range
MODE:	LSB (lower sideband)
PASSBAND TUNING:	LSB
AGC:	ON - SLOW
SELECTIVITY:	2 KHz - normal SSB voice bandwidth
RF GAIN:	Maximum
AUDIO GAIN:	Comfortable listening level - see following discussion.

If you have used the internal monitor amplifier of the CT2100, you should set the receiver audio gain for a comfortable listening level out of the external speaker.

If your receiver has an internal crystal calibrator, turn it on and tune the receiver to it so that you get a 1 - 3 kHz audio beat note; if you do not have a crystal calibrator, tune the frequency until you get a beat note on a received carrier signal. There are four different types of tuning indicators you may use on the CT2100:

1. The tuning bar in the left vertical margin on the screen
2. The MARK, SPACE, and +/+ LEDs on the front panel
3. Audio tone comparison between the received tone and the internal transmit tones of the CT2100
4. A crossed-ellipse indication on an external X-Y oscilloscope (connected to the SCOPE - MARK and SPACE rear panel connectors)

We will experiment with the first three techniques at this time; the external scope can be tried at a later time (see Chapter 5).

Tune your receiver frequency and notice that, as the beat note frequency changes, so does the length of the tuning bar on the screen; also, the MARK and SPACE LEDs will alternately turn on as you tune through their filters. You will need to tune slowly and carefully since the mark and space filters differ in frequency by only 850 Hz. Note that the lower frequency audio tone (at 1275 Hz) turns on the MARK light and peaks the tuning bar; the higher frequency tone (2125 Hz) turns on the SPACE light and gives another peak on the tuning bar. The +/+ LED should be on for both mark and space conditions. Therefore, a correctly tuned RTTY signal will be indicated by alternate flickering of the MARK and SPACE LEDs, constant light on the +/+ LED, and by a tuning bar whose length changes little between mark and space conditions.

Now, set the receiver tuning as accurately as you can to the MARK condition (MARK light on, tuning bar peak). Use the MONITOR INPUT/OUTPUT switch to select OUTPUT (button in). The tone you hear is the crystal-synthesized AFSK output tone from the CT2100; it should closely match the frequency of your receiver beat note. Switch the INPUT/OUTPUT button back and forth and compare the tone frequencies you hear. It may be necessary to slightly adjust the receiver and monitor volume controls so that so that the INPUT and OUTPUT volume levels match - this adjustment of the receive volume is the correct setting. (The OVLD LED should not be on since it indicates an excessive receiver volume control setting.) You can actually tune the receiver so that its beat note matches that of the CT2100 AFSK tone. This technique will assure you of true transceive operation if used carefully (assuming your transceiver's RF circuits are adjusted for true transceive frequency match). Try the same test with the receiver tuned for the space tone.

Next, turn-off the receiver calibrator (or tune away from the carrier) and select 170 shift (170 SHIFT button in). Tune the receiver while listening through the monitor speaker (MONITOR set for INPUT - button out) until you find a moderately strong amateur RTTY signal (identified by the characteristic "deedle-deedle" tones). With careful tuning you should be able to tune so that the tuning bar is near full length and the MARK and SPACE light flicker alternately. Also, the

+/+ LED should stay on and the received tones should match the CT2100 internal tones (switch INPUT/OUTPUT back and forth). You should now see understandable text on the screen. If you don't, try the NORM/REVERSE switch - if this corrects the reception, double check your receiver settings to be sure you really are receiving LSB and not USB. If this doesn't give you good "print", try increasing the CT2100 speed, trying both NORM and REV polarities for each speed. Speeds are changed with the INC (for increase) and DEC buttons; each press and release will increment to the next speed up or down. If you hold the button in, the CT2100 will continue changing speeds until it is released. The current speed is shown on the status line on the screen. If you still can't make sense out of the display, try the ASCII code at 110 baud, either polarity. If all the combinations of MODE, SPEED, and NORM/REV fail, tune to another station, you have probably tuned-in an encrypted signal! Tune around the 20 meter amateur band and get used to tuning-in RTTY signals. It's difficult at first, but becomes much easier with some practice!

If you have a general coverage receiver, you may now wish to try receiving short-wave press RTTY signals. Commercial press RTTY stations can often be found on frequencies around: 5.2 MHz, 5.4 MHz, 5.8 MHz, 6.8 MHz, 7.5 MHz, 7.8 MHz, 8.0 MHz, 9.0 MHz, 9.4 MHz, 9.8 MHz, 10.2 MHz, 10.5 MHz, 10.8 MHz, 11.1 MHz, 11.5 MHz, 12.2 MHz, 13.5 MHz, 14.5 MHz, 14.9 MHz, 15.5 MHz, 15.9 MHz, 16.2 MHz, 16.4 MHz, 17.3 MHz, 17.5 MHz, 18.2 MHz, 18.4 MHz, 18.7 MHz, and 19.0 to 20.5 MHz (plus others!). Commercial RTTY stations will operate with either 850 or 425 Hz shift and may have speeds of 45 (60 wpm), 50 (67 wpm), 57 (75 wpm), or 74 (100 wpm) baud, Baudot code. The signals may be of either signal polarity, so try both NORM and REV conditions. There may be a few commercial press stations operating at 110 baud ASCII, also. Tuning these commercial stations will require some patience due to the wide variety of shifts, speeds, and polarities used.

The receive non-overprint feature will automatically place characters on the next line of the screen if more than 72 (or 36) characters are received between line feed characters. The word wrap-around feature prevents the splitting in such cases, transferring the entire last word to the next line. To further prevent overprint, the receive section ignores all received carriage return (CR) characters and always executes a carriage return and line feed (LF) whenever a LF character is received.

3.3 Low Tones or High Tones?

So far we have only used one of the four possible CT2100 demodulator combinations. You may wish to switch to the RTTY "high-tone" option - push the HIGH/LOW button in. The "high tones" (for higher-frequency audio tones) are really the traditional standard U.S. RTTY tones, used since the early days of amateur RTTY. The "low tones" are the

IARU international standard are used extensively in most other countries of the world. When receiving (or transmitting) on the HF bands (3-30 MHz), either set of tones will work since you tune the receiver to produce the desired beat note frequency. However, when AFSK modulation is added to an FM or AM signal, you must be prepared to receive the same tone frequencies as those used by the transmitting station (the AM or FM receiver does not use a BFO to produce the audio tone). In the United States, the long-standing VHF AFSK tone standard has been to use the "high tones" (2125 Hz mark and 2295, 2550, or 2975 Hz space); you must use a high-tone demodulator to be compatible! In Europe, in particular, the reverse standard is developing - the IARU "low tone" (1275 Hz mark and 1445, 1700, or 2125 Hz space) is the standard to be observed. The two systems are basically incompatible for VHF AFSK operation! Due to low-pass filter parameters, use of data rates greater than 150 BAUD is not recommended when "high" or "low" tone demodulator combinations are used; the MODEM TONES should be used for higher data rates as explained in Section 3.4.

Each tone set has its advantages and disadvantages - the CT2100 lets you choose the optimum combination for your station. Some of the considerations for each tone set are as follows:

HIGH TONES (Mark = 2125 Hz, Space = 2295, 2550, or 2975 Hz):

Advantages:

1. High tones are the U.S. VHF AFSK standard - their use is required for compatibility when operating VHF AFSK in the U.S. A high tone demodulator may be used for both VHF and HF use in the United States.
2. When high tones are used on HF, using tones into a LSB transmitter audio input (microphone or phone patch input - see Chapter 4), there may be less problems with spurious signals (usually due to overdriving the transmitter audio stages). Since the tone frequencies are high, the harmonics and most distortion products occur at audio frequencies beyond the audio passband of the transmitter and should therefore not be transmitted.

Disadvantages:

1. The relatively high audio frequencies used in the high tone set may not fall within the audio frequency response of the receiver or transmitter. In general, the standard amateur shift, 170 Hz, will pass most current receivers and transmitters (the Collins S-Line is an exception). However, few pieces of equipment will pass the tones for both receiving and transmitting 425 or 850 shift with high tones (the Drake TR-7 is an exception). The use of high tone demodulators for HF RTTY is therefore restricted to transmission of just 170 shift, and only receivers incorporating either a variable BFO or pass-band tuning will receive all three shifts.
2. High tones are not the IARU standard and will not be compatible with VHF AFSK in many countries of the world.

LOW TONES (Mark = 1275 Hz, Space = 1445, 1700, or 2125 Hz):

Advantages:

1. Low tones are the IARU international standard and their use assures compatibility with VHF AFSK operations in many areas of the world.
2. Low tones can be used with virtually all SSB receivers and transmitters for all three standard shifts. Variable BFO or passband tuning features are not required to assure good reception of 425 and 850 Hz shift stations.

Disadvantages:

1. Low tones are not compatible with existing U.S. VHF AFSK operations. Since there is a great deal of high tone AFSK equipment already in use in the United States and neighboring countries, it is unreasonable to expect that the U.S. standard will shift to low tones.
2. When low tones are used with a LSB transmitter to generate F1 RTTY emissions (see Chapter 4), there is a strong probability that over-driving the transmitter audio and modulator stages will result in spurious harmonics and mixer products that will be radiated. Of course, these problems will not occur if the audio drive level is properly set.

Although you may develop your own personal preferences, we recommend that you consider the following operating conditions as a starting point:

In the United States:

Use HIGH tones for all VHF AFSK amateur communications and for normal 170 Hz shift HF operation; use LOW tones when receiving HF commercial RTTY stations unless you have a receiver with a variable pitch BFO or with IF pass-band tuning. The exception applies to use of the older Collins S-Line equipment - use LOW tones for all HF operations, amateur or commercial.

In Europe (and all other areas where IARU standards apply):

Use LOW tones exclusively for both VHF AFSK and HF operations. The only exception would be when you communicate with another VHF AFSK station who is using HIGH tones.

3.4 Modem Tones

In addition to inclusion of both HIGH and LOW RTTY demodulator circuits, the CT2100 also has provisions for reception and transmission of two different sets of data-type modem tones. These tones are the same as the half-duplex tones used in the United States for phone-line communications of computer data. The tones are patterned after the "103 Modem" or the "202 Modem" standards. The "103 Modem" uses tones of 1270 Hz for mark and 1070 Hz for space and may be used at data rates up through 300 baud. These tones are selected when the RTTY/MODEM and HIGH/LOW switch buttons are out. The "202 Modem" uses tones of 1200 Hz mark and 2200 Hz space and may be used for data rates through 1200 baud. These tones are selected when the RTTY/MODEM switch is out and when the HIGH/LOW switch is in. The NORM/REV switch functions as before, reversing the polarity of the input and output signals. The SHIFT switch has no function when MODEM is selected. The AUTO feature functions when the MODEM TONES are selected, operating off the "carrier detect" signal from the modem integrated circuits. Also, the MARK and SPACE lamps still function in MODEM mode, but the +/+ lamp, Screen tuning bar, and external scope outputs have no meaning for this mode. In summary:

MODEM + LOW = 1270 Hz Mark, 1070 Hz Space (up to 300 baud)

MODEM + HIGH = 1200 Hz Mark, 2200 Hz Space (up to 1200 baud)

These demodulator options have been included in the CT2100 to allow transmission of higher data rates with VHF AFSK techniques. It is anticipated that the primary application of these modem tones will be for the exchange of large quantities of text or data at high data rates, probably using the ASCII computer code; Baudot may also be used in areas where the high data rates are allowed. U.S. FCC amateur regulations presently do not permit amateur use of Baudot at data rates exceeding 74 baud (100 wpm).

The "103 Modem" and "202 Modem" circuitry of the CT2100 use phase-lock types of demodulators which work well for VHF AFSK and phone line service, but will not give the interference rejection of the conventional RTTY HIGH or LOW tone demodulators in HF applications. Therefore, it is recommended that the MODEM tones be used primarily for strong signal, low noise VHF AFSK applications.

3.5 Receiving Morse Code

Morse code reception with the CT2100 requires very little change in switch settings from those used for RTTY in section 3.2; just change the DATA MODE to MORSE from BAUDOT or ASCII and retune the receiver to a CW (Morse code) signal. In case you have lost track of the settings or have jumped to this section of the manual, here are the CT2100 and receiver settings again:

CT2100:

DATA:	MODE	= MORSE	(press-in and release button)
	SPEED	= as turned on	(20 wpm transmit speed)
DISPLAY:	PAGE CYCLE	= as turned on	- no change for now (P2)
	LINE CYCLE	= " " " " " " " "	(72)
	CLEAR SCRN	= " " " " " " " "	
	STATUS	= on	- button in
	USOS	= either position	- does not affect CW
TX/RX	HDX/FDX	= HDX	- button in
CONTROL:	IDLE	= off	- button out
	MAN TX/AUTO	= AUTO	- button out
	KOS	= off	- button out
MODEM:	RTTY/MODEM	= either position	- does not affect CW
	HIGH/LOW	= " " " " " " " "	
	NORM/REV	= " " " " " " " "	
	AUTO	= " " " " " " " "	
	SHIFT	= any	" " " " " "
I/O:	AUDIO/RS232	= AUDIO	- button in
	RCVE/TAPE	= RCVE	- button in
	NORM/LOOP	= NORM	- button in
MONITOR:	OUTPUT/INPUT	= INPUT	- button out
	VOLUME	= "12 o'clock"	knob position

You should see the following text on the status line of the monitor:

```
20 WPM MORSE TX OFF WT=4 P2 CT2100 V4.x
```

RECEIVER:

FREQUENCY:	14.000 to 14.080 MHz
ANTENNA:	Adequate to receive signals in above range
MODE:	LSB or USB (do not select CW filter, yet)
PASSBAND TUNING:	Match above sideband
AGC:	ON - SLOW
SELECTIVITY:	2 kHz - normal SSB filter
RF GAIN:	Maximum
VOLUME:	Comfortable listening level

The information in the status line takes on a slightly different meaning when Morse code is selected. The "20 WPM" speed notation refers to transmit speed only - the CT2100 receive system automatically adjusts to match the speed of the received signal. Also, the "WT=4" no-

tation refers to the "weight" of the Morse code transmitted. This feature will be further discussed in Section 4.7.

There are two tuning monitors available to indicate correct receiver tuning for Morse reception - the CW LED on the CT2100 front panel, and audio tone frequency comparison using the internal audio monitor. The CT2100 receive circuit is designed to lock onto an 800 Hz tone, so tune your receiver until the CW LED flashes in sync with the CW signal (key down = tone on = LED on). When the CT2100 is receiving CW signals, the filtered and detected Morse data is connected to both the microprocessor for decoding and to the CW side-tone oscillator. Thus the received CW signal is regenerated in the CT2100 and you may listen to the processed signal simply by selecting MONITOR OUTPUT. Also, since the CW side-tone is frequency synthesized to 800 Hz, the desired receive CW tone, you can do a very accurate frequency comparison between the receiver signal and the regenerated signal by switching back and forth between MONITOR INPUT and MONITOR OUTPUT. Try this on a few signals - you will soon find out that Morse tuning can be very easy! It is highly recommended that you use an external monitor speaker since the low-frequency response of the CT2100 internal speaker is limited.

The CT2100 uses a heterodyne phase-lock loop (PLL) detection circuit, adjusted for a center-frequency of 800 Hz, the common audio tone center frequency for CW filters in modern receivers and transceivers. At normal receiver volume levels, the PLL will track frequency variations over at least a + or - 100 Hz range and is therefore quite tolerant of slight tuning errors and it will track slight frequency drift of the received signal or compensate for receiver drift. At high volume levels, the PLL bandwidth tends to increase - to as much as + or - 250 Hz; at low levels, the bandwidth reduces. Therefore, with interference, try to use a lower rather than higher receiver volume control setting. Since the PLL is aligned to 800 Hz, the same frequency as the CT2100 Morse side-tone, using the MONITOR circuit to match received tone to CT2100 sidetone is a very accurate way to get optimum results from the PLL detector.

Tuning indicators that are used for RTTY are not used in Morse reception, even though you may continue to get indications on the MARK, +/+, or SPACE LED's. Likewise, the external RTTY scope, if connected, may still show patterns, but for frequencies matching the RTTY demodulator filters, not the Morse receive filter. The tuning bar used for RTTY is not active for Morse reception. The OVLD LED will be lit if you have too high an audio level from the receiver. This light should not come on under normal operating volume levels. Try to adjust your receiver's volume control so that the monitor audio output level is the same for INPUT or OUTPUT switch positions.

After you have mastered tuning of the Morse code signal, you may notice that what shows up on the screen doesn't always make the best of sense at first glance! This is usually due to the fact that human operators often send imperfect code! When we copy Morse code with our

ears and decode in our brains, we can be adaptive and translate what the sending operator "meant to send" instead of what actually was sent. The most blatant examples of this are run-together characters and incorrect spacing between letters and words. It is very easy for the transmitting operator to get in a hurry and run some letters together - particularly on something he's transmitted often like "CQ" or his own call. Since we are also good Morse operators who have sent "CQ" and call letters often, we adapt when receiving by ear and interpret what was intended. The microprocessor, on the other hand, is looking for some long CW character (like -.-.-- for CQ) that doesn't exist: it therefore does not display anything! Similarly, it is a very common thing to insert longer than normal pauses between letters, especially when using a straight key to send Morse. The computer interprets these pauses as spaces between words and puts a space on the screen. When receiving by ear, we tend to group the letters received into recognizable words, ignoring irregularities in spacing. In these two cases in particular, the computer is a severe critic and "prints 'em as it hears 'em"! On the other hand, the Morse decoding programs are very tolerant of weight variations and will usually correctly decipher a heavy "swing fist" (sometimes called a "Lake Erie swing"). This type of "interface timing" problem will occur with all computer decoding of hand-sent Morse code, much as it will on RTTY if improper or irregular timing is used.

You may notice that sometimes the Morse reception appears to stop or be "locked-up". This is usually caused by reception of a carrier for some period of time. The automatic speed tracking program of the CT2100 interprets the long carrier as very slow CW and adjusts the speed tracking system for very very slow Morse code. The CT2100 will eventually readjust the speed tracking back up to the correct signal speed. However, the process is accelerated by resetting the tracking circuit. To reset the Morse receive system, press and release the MORSE button. You will now receive a few "T" and "E" characters as the speed readjusts.

Also, Morse code reception is particularly susceptible to interference when the transmitting station's key is up (between dots and dashes or between letters and words). Comparing RTTY and Morse techniques for the moment, recall that the RTTY signal is sent by frequency shifting a signal (the RF signal for HF, and audio tone for VHF AFSK); for either mark or space RTTY data conditions, there is a definite signal transmitted. On Morse code, the transmitter carrier is turned on when the key is down (mark), but when the key is up (space), there is no signal to be received; your receiver and particularly the automatic Morse detection circuits are now "wide-open" to reception of noise, other signals, etc. This is a basic disadvantage of on-off A1 type emission we use for Morse versus the F1 or F3 emissions we use for RTTY. If we used F1, frequency shift keying for Morse transmission (as do many commercial networks), automatic CW reception would be much improved. Here again, when we copy CW by ear, we are adaptive and "tune-out" interference and noise in the pauses between dots and dashes; the computer looks at all signals!

Therefore, it is not realistic to assume that the computer will do all the work of Morse reception for you, especially when receiving less than perfect CW! On the other hand, if you tune to another station using a keyboard or a professional CW operator (such as on the ship-to-shore frequencies), the CT2100 will display received Morse with close to RTTY-like perfection.

If your receiver has a narrow-bandwidth CW filter, you may now wish to try it for CW reception. Tuning the signal will be a lot more critical, but you may improve the "copy" noticeably if interference has been a problem. Conversely, the narrow filter may actually degrade the copy, especially if the narrow filter "rings" on noise! The degree of problem caused by filter ringing varies with the filter, receiver, and noise conditions, so you will want to experiment with your own equipment. Often, the effects of noise, both with or without a narrow filter, can be minimized by reducing the RF gain control until the AGC no longer controls the receiver gain, increasing the receiver volume control as required to maintain copy. This technique, of course, makes the receive system more susceptible to fading ("QSB") and will require more active participation on your part in adjustment of the RF gain control. Good Morse reception will require some patience and practice until you "get the hang of it".



KB2100

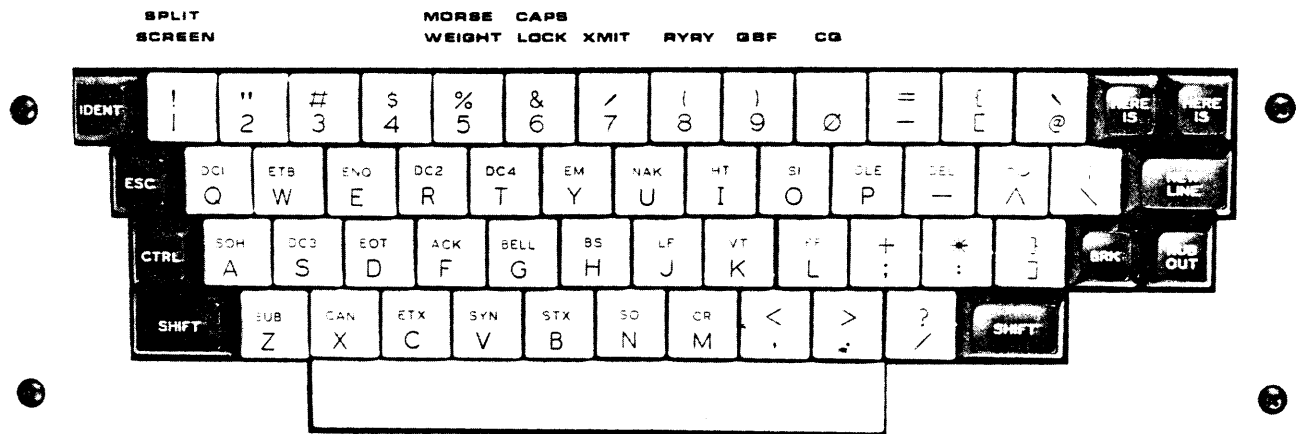

Figure 3. The KB2100 Keyboard

CHAPTER 4

TRANSMITTING WITH THE CT2100

This section of the manual will discuss the transmitting features of the CT2100. Extensive use will be made of transmitting using the Morse mode and the CT2100's internal side-tone monitor to illustrate various transmit actions. Unless otherwise noted, all actions demonstrated while in Morse mode also apply to RTTY modes.

4.1 The KB2100 Keyboard

The KB2100 accessory for the CT2100 is a small separate unit, attached to the CT2100 through a coil, telephone-type cord. This keyboard can be placed on the operating table, or you may prefer to try the "easy chair" approach, holding the keyboard in your lap.

As shown in Figure 3, the KB2100 has 59 keys, arranged similar to those on a standard typewriter with "extra" control keys to the left and right of the alphanumeric group. Two, three, or four different characters may be typed by using the SHIFT, CTRL (control), or SHIFT with CTRL keys in conjunction with the white keys. The actual characters or functions generated with each combination varies to some degree with the code selected (ASCII, BAUDOT, or MORSE); details of these special combinations will be explained more fully in Section 4.7, 4.8, and 4.9.

In general, use the KB2100 as you would a typewriter, making use of the SHIFT key when required. For example, typing on just the "1" key will enter a number 1 for transmitting; SHIFT-"1" would enter an exclamation point, "!". As on a typewriter, hold the SHIFT down while striking the second key. Similarly, when ASCII is used, striking "G" will enter a lower case "g", SHIFT-"G" an upper case "G", and CTRL-"G" will transmit the code for the signal bell. The double combination, SHIFT-CTRL-"G" is not used on this particular key and will therefore not enter any character for transmission. The KB2100 has an automatic repeat feature - any key combination held down for more than 1/2 second will be repeated at the approximate rate of 7 characters per second. Don't let your fingers rest with a key down, or you may have a whole screen-full!

The standard alphabet, numbers, and punctuation symbols are all located on white colored keytops; the black keys are for control or special uses. Starting in the top row, the black IDENT key is used to insert a Morse code call identification for amateur radio use when transmitting a RTTY codes. This key will always produce a Morse code output, regardless of whether ASCII, BAUDOT, or MORSE is selected. As will be discussed in Section 4.5, the message transmitted by the IDENT key is the same as programmed for the left-hand HERE IS key in the top

row. The two HERE IS keys are used to transmit two different user-programmed identification messages. The use and programming of these functions is also discussed in Section 4.5. The ESC key is an ASCII code character and will be discussed in Section 4.9.

The NEW LINE key is a special feature, common to HAL electronic keyboards. When Morse code is being typed, the NEW LINE key simply selects the next line of the display for typing; no extra characters are inserted. The CT2100 does, however assume that the end of a line coincides with the end of a word and inserts a word space pause before the first character of the next line is transmitted. Since the CT2100 has the word wrap-around feature for both receive and transmit, you need never use the NEW LINE key for Morse. When ASCII code is selected (and HDX- half-duplex is also selected), use of the NEW LINE key generates the ASCII characters for both a carriage return (CR) and a line feed (LF), eliminating the need to type both instructions. Special considerations involving the NEW LINE key and HDX or FDX modes are discussed in Section 4.9. When BAUDOT code is used, the NEW LINE key generates three characters in this sequence: carriage return, line feed, letters (CR-LF-LTRS). This sequence assures that the receiving printer has completed its transition to the left column of the next line and is in condition to receive letters (LTRS), rather than figures (FIGS) characters. Further details are given in Section 4.8.

The RUB OUT key (just below the NEW LINE key), allows you to edit any errors you may have made while typing. Each operation of the RUB OUT key will back-up the keyboard cursor one space, removing any characters previously occupying that position. Use of the RUB OUT is discussed in more detail in Section 4.3.

The BRK (break) key allows testing of the radio transmitter system. The BRK key must always be used with either SHIFT or CTRL (or both) keys; this avoids accidental mistyping. In Morse mode, the BRK key gives a continuous transmitter key-down (on the air) condition for as long as you hold the BRK (and SHIFT or CTRL) down. This feature can be used to tune or check the tuning of the transmitter or antenna system, or for spotting when separate receiver and transmitter are used. Actually, each momentary operation of BRK produces an approximate 1 second burst of key down; holding the BRK key down gives multiple, uninterrupted, periods of one second. THE BRK KEY WORKS WHETHER TX OUTPUT IS TURNED ON OR OFF (as indicated on the screen status line). The operation of BRK in ASCII and BAUDOT codes is similar, except that it produces a continuous space signal condition while it is held down, again independent of transmitter output condition. For RTTY, this allows testing of the space signals and is used in some equipment to trigger accessories.

Special use is made of the CTRL and SHIFT-CTRL combinations with the top row of white keys (1234567890-[@]). The labeling on the KB2100 cabinet, above the keytops, applies to use of the CTRL key with the top row keys. The CTRL-1 combination turns the SPLIT SCREEN option on and off, as explained in Section 4.4. CTRL-5 with a third key allows you to set the weight, or dot-to-dash ratio, of the transmitted Morse

code, as explained in Section 4.7. CTRL-6 turns the ASCII CAPS-LK feature on or off; the ASCII code allows either transmission of both upper and lower case letters or of only upper case letters (CAPS LK) as explained in Section 4.9. CTRL-7 turns the CT2100 transmit text control on or off as will be explained in Section 4.3 and 4.4. CTRL-8 inserts a string of 36 RYRYRYRY (or U*U*U*U* for ASCII) characters into the transmit area for testing of equipment. CTRL-8 likewise inserts the standard THE QUICK BROWN FOX JUMPS OVER THE LAZY DOG'S BACK 0123456789 test message. CTRL-0 inserts a string of four CQ characters.

As will be explained in Section 4.5, SHIFT-CTRL-HERE IS is used to program the identification messages. If you have installed the MSG2100 option, SHIFT-CTRL-1 through SHIFT-CTRL-8 are used to transmit the contents of the eight message segments of the "brag tape" ROM. Use of the MSG2100 is discussed in Section 4.6 and program specification in the Appendix.

4.2 Transmit Features

In addition to the features discussed above with regard to the KB2100, the CT2100 with KB2100 offers many transmit features, giving a great deal of operational flexibility. These features will be discussed in detail throughout this chapter, but here is a summary of the most important ones.

Text typed on the KB2100 can be entered into the CT2100 in either "KSR Mode" or "Split Screen Mode". As explained in Section 4.3, typed text is entered on the bottom line of Page 2 (or Page 4 in 36 character line mode) when KSR mode is used. Up to the total 3456 characters may be typed in this manner, but only when you are not also using the screen for receiving. The "Split Screen Mode" sets aside the bottom 12 lines for text composition and allows pre-typing of transmit text, even while receiving, thus giving a type of ASR operation. Use of the Split Screen is explained in section 4.4.

When the CT2100 is used for RTTY with ASCII or BAUDOT codes, you may select either half duplex (HDX) or full duplex (FDX) modes of operation. Half duplex is the normal mode for amateur RTTY operation - the receive and transmit sections of the CT2100 are linked so that text is shown in the receive area ("local echo") as it is transmitted. Thus, your receive display or printer shows the received text plus your transmitted reply. Full duplex is sometimes used with computers - receive and send data circuits are completely separate and no internal connections are made to "echo" transmit text onto the receive display. Often, the computer provides the "remote echo", sending the transmitted characters back to the receive display as it interprets them. This provides a visual check on the quality of the communications circuit between the terminal and the computer. Use of FDX and its special considerations are discussed in Section 4.10.

Radio amateur RTTY stations often intermix electronic video systems with older, loop current operated RTTY machines. The CT2100 provides a RTTY loop output circuit that can be used to drive external printers and tape perforators (external loop power supply required). Special provision is also included so that these external, loop operated devices can be used to generate transmit text and drive the AFSK transmit tone circuitry of the CT2100. Thus the RTTY machine keyboard or tape distributor (TD) can also be used. The NORM/LOOP front panel switch allows reception on loop devices in the NORM position (button in) and will transmit data from loop devices in the LOOP position. Further discussion of this feature will be found in Section 4.12.

Synchronous idle, or "diddle" transmit fill characters can be added for ASCII, Baudot, or Morse with the IDLE front panel switch. This feature is most convenient in RTTY modes (ASCII and Baudot), providing a continuous stream of non-printing characters during pauses in typing when a continuous mark signal would otherwise be transmitted. Under noisy conditions, this helps the RTTY machine at the receiving station maintain synch, reducing the error characters ("hits"). This feature is most useful when talking to stations using mechanical machines and is discussed in more detail in Section 4.11.

An automatic transmit-receive control circuit is provided so that the CT2100 can control the transmit-receive operation of the station, turning the transmitter on when text is to be transmitted and off when transmission is complete. The KOS feature (for Keyboard Operated Switch) is discussed in Section 4.13.

The CT2100 can transmit (and receive) from various I/O (Input/Output) devices using several different I/O interfaces. For example, data can be interfaced from audio sources (receiver, transmitter, tape recorder), RTTY loop devices (KSR, ASR, and paper tape machine), or with RS232 data connections (computer, some machines, and modems). Use of these I/O connections is discussed in Chapter 5.

4.3 Use of the KSR Keyboard Entry Mode

To demonstrate the use of the CT2100 transmit features, you will need to hook-up the KB2100 to the CT2100 and have the video monitor also connected to the CT2100. You may also wish to have an external speaker connected to the AUDIO MONITOR jack on the CT2100. No other connections to a receiver, transmitter, or other piece of equipment is necessary at this time. To demonstrate the MSG2100 "brag-tape" feature, it will be necessary to have installed the ROM as described in the Appendix; all other features will function as described without this ROM, however.

Set-up the CT2100 as follows:

CT2100

DATA:	MODE	= MORSE (press-in and release button)
	SPEED	= as turned on (20 wpm xmt speed)
DISPLAY:	PAGE CYCLE	= " " " " - no change for now (P2)
	LINE CYCLE	= " " " " " " " " (72)
	CLEAR SCRN	= " " " " " " " "
	STATUS	= on - button in
	USOS	= on - button in (does not affect CW)
TX/RX	HDX/FDX	= HDX - button in
CONTROL:	IDLE	= off - button out
	MAN TX/AUTO	= AUTO - button out
	KOS	= off - button out
MODEM:	RTTY/MODEM	= RTTY - button in (does not affect CW)
	HIGH/LOW	= HIGH - button in (" " " ")
	NORM/REV	= NORM - button in (" " " ")
	AUTO	= on - button in (" " " ")
	SHIFT	= 170 - button in (" " " ")
I/O:	AUDIO/RS232	= AUDIO - button in
	RCVE/TAPE	= RCVE - button in
	NORM/LOOP	= NORM - button in (does not affect CW)
MONITOR:	OUTPUT/INPUT	= OUTPUT - button in
	VOLUME	= "12 o'clock" knob position

Press and release the CLEAR SCRN button on the CT2100 to clear-out any text that may remain on the screen. Now, type a line of text on the keyboard - such as "Now is the time for all good men" (do not use the NEW LINE key at this time). Notice how the text you've typed is displayed with reverse video compared to the text in the status line - typed text always shows reverse to that received. Also note that all the letters typed are capitalized - this is because there is no upper/lower case in Morse code; Baudot is the same. ASCII code, however, does have valid codes for both upper and lower case letters and either may be typed. Now, transmit the text by using the CTRL-7 key combination (push and hold CTRL key while pressing and releasing the 7 key). The words should now be transmitted in Morse code at 20 words-per-minute (wpm) and you should hear the CW in the CT2100 side-tone monitor output (re-adjust the MONITOR VOLUME if necessary). You may have noticed that all of the text except the last word "MEN" was transmitted. The CT2100 uses the "WORD MODE" to transmit text - a word is not transmitted until the next word is started. To test this, type the next word "TO" and notice that now "MEN" is transmitted, as indicated by the CW sidetone and by the moving transmit cursor. Within a given line, the CT2100 transmits one word behind the keyboard. To send the last word in a line, simply use the NEW LINE key to end that line and start another.

Now type more words - "COME TO THE AID" - and stop typing. The CT2100 transmits all but the last word, "AID"; you can now use the RUB OUT key to back-up and erase the word "AID" before it is transmitted, and

correct any spelling errors or mistyped characters. This is the advantage of word mode. Next, try typing several lines of text, letting the transmit output continue. At 20 wpm Morse speed, it is fairly easy to get several lines ahead of the transmitted data. Try using the RUB OUT key now and note that you can back-up several words for corrections. In fact, you may back-up clear to the transmit output cursor if you choose. End your current line of typing with a NEW LINE key and let the transmitted Morse catch up to the keyboard.

Turn on the synchronous idle feature by pushing in the IDLE button. At first, there is no visible difference. However, type a couple of words without using the NEW LINE key. Note that all but the last word is transmitted as before, but now, when the output pauses ahead of the last word typed, repeated BT characters are inserted. Type another word and the previously held word is transmitted and it reverts to the BT character. Although this IDLE feature is of dubious value for Morse code, this demonstrates the use of synchronous idle (or "did-dle") for RTTY. Now type a NEW LINE key and stop. Note that the last word on the previous line is transmitted and the transmitted output stops with no more BT character insertions; touch the space bar or another character and the BT IDLE character starts again. Therefore, it is very important to remember to send the NEW LINE key as the very last key operation when ending a transmission; otherwise, your CT2100 may still be in transmit mode, awaiting another key press, rather than receiving signals. This can be extremely confusing in RTTY, especially if you aren't listening to your output tones (normal)! ALWAYS END A TYPED TRANSMISSION WITH "NEW LINE" AS THE LAST KEY PRESSED! Now, turn off the IDLE feature (button out).

This "KSR" or "Bottom Line Entry" mode is very convenient to use and is very much like what you would use on a KSR (Keyboard Send-Receive) RTTY machine. In this mode, you may pretype up to the maximum CT2100 screen capacity of 48 lines of 72 characters each, a total of 3456 characters (this could also be 96 lines of 36 characters if that mode were selected). However, as on the KSR type RTTY machines, you may do only one thing at a time, compose keyboard text or receive text on the screen. Actually, as on the HAL DS2000 and DS2050, you may type keyboard characters while receiving. The screen will show an interleaving of received characters and reversed video transmit characters. When you enable transmit output with CTRL-7, the CT2100 will then pick-out the reversed video characters and transmit them only. However, this can be very confusing and may not be all that useful for normal operation! The CT2100 has another mode that is much more convenient for pretyping of transmit text - the split-screen mode.

4.4 Use of the Split Screen Keyboard Mode

To enable the split-screen keyboard feature, type CTRL-1. Notice on the screen that the previous text is all shifted to the middle of the screen on page 2 (P2) and that there is an arrow at mid-screen. The

arrow indicates the bottom line of the receive area of the screen. The last 12 lines of page 2 are now devoted to pre-typing on the keyboard. Turn off the CT2100 transmit output by typing CTRL-7 again (see TX OFF in the status line). Pretype several lines of transmit text - note how typing is entered at mid-screen and continues on downward. You now have up to 12 lines available for pretyping.

Enable the transmit output with CTRL-7 and notice how transmitted text is written onto the bottom line of the receive screen area as it is output. Also, a line is removed from the transmit area as it is transmitted. (You may wish to increase the CW speed with the INC button to speed-up the process!) Keep typing while text is being transmitted - the new characters are added to the end of the previous text.

Turn off the transmit output again with CTRL-7. Pretype several lines into the transmit section. Notice that the H, J, K, and I keys have additional legends of "BS, LF, VT, and HT", respectively. In split screen mode, these keys with the CTRL key allow you to move the keyboard cursor around on the screen without destroying the text that is already in position. Thus, you can move the cursor back to a word and change or remove a letter. You cannot, however, add spaces or characters within a line without re-typing the balance of that line. The cursor controls are:

CTRL-H (BS) = Back-space, move cursor one position left
 CTRL-J (LF) = Line-feed, move cursor one line down
 CTRL-K (VT) = Vertical-tab, move cursor up one line
 CTRL-I (HT) = Horizontal-tab, move cursor one space right
 CTRL-L (FF) = Form-feed, CLEAR ENTIRE TX SCREEN AREA!

Obviously, be very careful about using CTRL-L: it can be very frustrating! This points up a small difference between split-screen and KSR modes. In KSR mode, the front panel CLEAR SCRNR button will clear the entire screen, transmit and receive text. In split-screen mode, the CLEAR SCRNR button clears ONLY the receive section of the screen; use CTRL-L (FF) to clear the transmit area of the screen.

When using the CTRL-H,J,K,or I keys to move the cursor around, be sure to return the cursor to the end of the text when done. The CT2100 will transmit text only up to the location of the keyboard cursor on the screen.

The split-screen feature allows you up to 12 lines to precompose transmit text (12 display lines in either 72 or 36 character line modes). If you attempt to type more than 12 lines into the split-screen area, the additional characters will not be accepted and the bell-tone of the CT2100 will sound, indicating that you should stop typing. After you have started transmitting the pretyped text, you may then continue typing up to a maximum of 12 lines ahead of the transmit output.

4.5 Use of the HERE IS Messages

The CT2100 has two 32 character message storage areas in which you may store station call letters, name, location, etc. The text is written into the HERE IS message in the following manner:

```
SHIFT-CTRL-HERE IS
(notice programming area on top line)
type text for message - 32 characters maximum
SHIFT-CTRL-HERE IS
```

for example:

```
SHIFT-CTRL-HERE IS (left key)
DE KZ9ZZZ
SHIFT-CTRL-HERE IS (left key)
```

and

```
SHIFT-CTRL-HERE IS (right key)
DE 'JOE' KZ9ZZZ, PODUNK CITY
SHIFT-CTRL-HERE IS (right key)
```

The "short form" of the ID was put into the left-hand HERE IS storage because this message also serves for CW identification of RTTY signals (IDENT key). The IDENT key functions the same in all codes - it always gives a Morse code output of the contents of the left-hand HERE IS.

If your CT2100 does not have the MSG2100 message ROM, the texts stored in the HERE IS message areas are volatile and must be re-written if the AC power is removed from the CT2100. The MSG2100 adds a power-on initial message to the HERE IS features. With the MSG2100, the initial contents of both HERE IS messages are stored in the ROM. When power is first turned on, these messages are automatically loaded into the HERE IS storage areas. You may then use these messages without further programming or you may over-write them using the technique explained above. Now, when AC power is turned off and then back on, the original texts from the MSG2100 are again stored in the HERE IS memories.

4.6 Use of the MSG2100 Option

If you have installed the MSG2100 message storage ROM option (see the Appendix) you may transmit the various segments with the following key operations:

```

SHIFT-CTRL-1: Load the contents of message 1 for transmission
SHIFT-CTRL-2: " " " " " 2 " "
etc
SHIFT-CTRL-8: " " " " " 8 " "
```

Note that all three keys must be down at the same time (SHIFT-CTRL-1, for example); don't hold them down too long or the auto-repeat feature will add in several messages! Also, remember the 12 line maximum restriction of the split-screen transmit screen area. If you try to load more than 12 lines into the split-screen area, only the first 12 lines will be loaded! Use KSR mode for longer messages or compose shorter texts for the MSG2100 segments.

4.7 Special Considerations When Transmitting Morse

Morse code may be transmitted with the CT2100 and KB2100 by selecting MORSE with the MODE DATA switch. This switch is momentary in action and need only be pressed and released. The status line on the screen will now indicate MORSE 20WPM. The speed specification applies only to the transmitted speed; receive speeds are tracked automatically as discussed in Section 3.5. To change the Morse transmit speed, use the INC or DEC (for increase or decrease) momentary push buttons. Each press changes the speed by 1 wpm; hold the button down for continuous increase or decrease increments.

Also shown on the status line is the notation "WT=4", indicating the "weight" or dot-to-dash ratio of the transmitted code. A total of nine different Morse weights are available from a "very light" (very short dots) to a "heavy weight" (very long dots). Morse codes standards are defined so that the transmitted time required for the dot (key-down) is equal to the time spacing between dots and dashes within the character. Normally, you would want to transmit "perfect" Morse code and would send code with the dot and space times equal. However, under some conditions, it is desirable to be able to change the relative "weight" of the transmitted code. This is often the case when high speed Morse code is sent; it is easier for a listener to distinguish between dots and dashes if the dot is shorter than standard at speeds greater than 50 wpm. Also, most transmitter keying circuits include by-pass and shaping circuits that tend to "stretch" the length of both dots and dashes. At high speeds, this causes the dots, in particular, to "smear" into the following bits of data. Using a "lighter weight" (shortened dots) helps this situation (but does nothing for the stretched dash bits).

The weight adjustment feature is set so that the CT2100 always turns on with standard Morse code transmit weight. You may, however easily change it with a three key control combination. The weight may be changed in increments of 1/8 th of the standard dot length, from 1/2 to 1 1/2 times the normal dot time. The CTRL-5 key combination (hold CTRL down while pressing and releasing the 5), labeled MORSE WEIGHT on the KB2100, allows you to specify weight. After the CTRL-5 combination type a number from 0 to 8 to specify weight (the CT2100 will ignore any other number or character accidentally typed after a CTRL-5 and restore the previous weight setting). A "4" weight specification sets standard dot lengths (dot time = space time); weights from "0" to "3" give light weights and "5" to "8" give heavy weights. The relative dot to space ratios and dot-to-dash ratios for each weight are:

WEIGHT NO.	DOT-TO-SPACE TIME		DOT:DASH RATIO
0	1/2		1:6.00
1	5/8		1:4.80
2	3/4	(light)	1:4.00
3	7/8		1:3.40
4	1	(standard)	1:3.00
5	1 1/8		1:2.67
6	1 1/4	(heavy)	1:2.40
7	1 3/8		1:2.18
8	1 1/2		1:2.00

For example, to transmit a light Morse weight with the dot = 3/4 space time (1:4 dot:dash), type:

"CTRL-5" and then "2"

The timing for the variable weight feature is shown for the letter "A" in Figure 4.

The KB2100 also includes the capability of transmitting several common Morse code prosigns. These special characters are transmitted as run-together characters as you would send them by hand. The following key combinations are used to transmit the prosigns:

PROSIGN	KEYBOARD SYMBOL	KEY OPERATION
AR	@	@ key
AS	=	= key (shift "-")
BT	+	+ key (shift ";")
SK	*	* key (shift ":")
AA	<	< key (shift ",")
KN	>	> key (shift ".")
error (8 dots)	none	shift "1", shift "3", shift "4", shift "5", shift "6", "", "", ""

The Continental Morse Code used in the CT2100 is shown in Table 1.

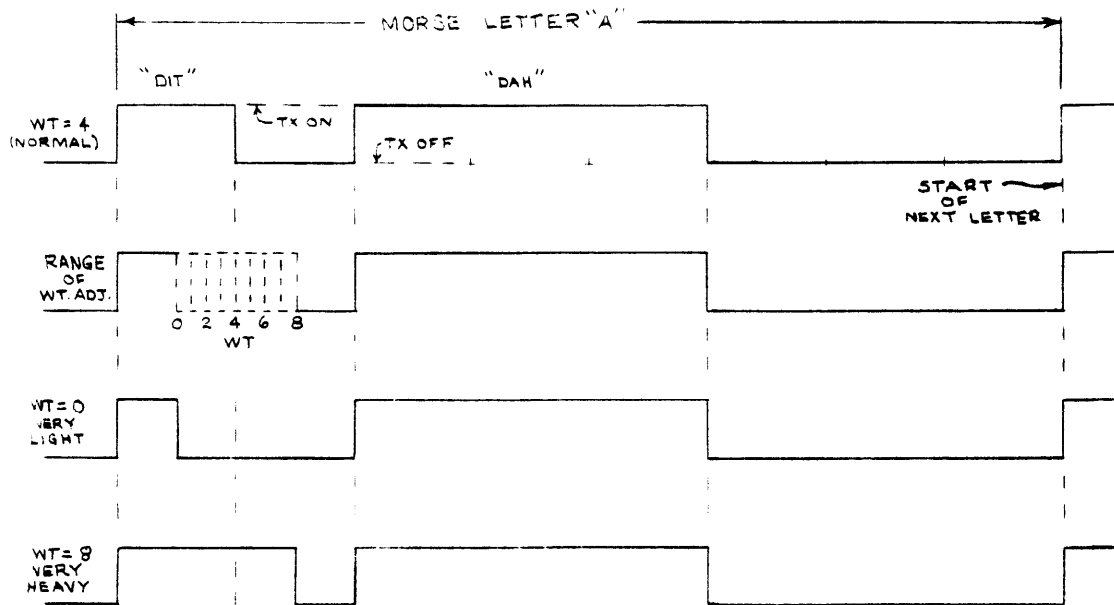

Figure 4. Morse Weight Timing

The CT2100 normally uses word mode to transmit all text as explained in section 4.3. However, there may be occasions in which it might be preferable to give up the editing capability of word mode and transmit each character as it is typed. Called "Continuous Mode", this feature may be selected for only Morse transmit by selecting "FDX" rather than "HDX". Since the CT2100 always operates half-duplex (HDX) with Morse (non-simultaneous transmit and receive), this switch serves a different function for Morse. However, the HDX/FDX switch does provide true half or full duplex operation for the RTTY codes, Baudot or ASCII. Sections 4.8, 4.9, and 4.10 discuss HDX/FDX as it applies to RTTY operations. Of course, when continuous mode is used, the RUB OUT key will not allow editing of typed text that has already been transmitted! As before, ALWAYS END A TRANSMISSION WITH THE NEW LINE KEY!

TABLE 1. CONTINENTAL MORSE CODE

A	.-	1	.----	
B	-...	2	..---	NOTES:
C	-.-.	3	...--	
D	-..	4-	. = one dot unit of key down time
E	.	5	- = one dash unit of key down time
F	..-.	6	-....	(space) = three dot units
G	--.	7	--...	
H	8	---..	Element space = one dot unit
I	..	9	----.	Letter space = three dot units
J	.----	0	-----	Word space = seven dot units
K	-.-	.	.-.-.	Speed in WPM = (dots/min)/25
L	-.-	,	--..--	= 2.4 dots/sec
M	--	:	---...	= no. of 0's repeated in 26 seconds
N	-.	;	-.--.	(1.5% accuracy).
O	---	-	-....-	
P	.---	'	-.----	
Q	---.-	/	-.--.	AA = SHIFT - (comma) (<)
R	.-.	"	-.--.	AR = @
S	...	?	..--..	AS = SHIFT - (dash) (=)
T	-	AA	.-.-.	BT = SHIFT - ; (+)
U	..-	AR	.-.-.	KN = SHIFT - (period) (>)
V	...-	AS	-.--.	SK = SHIFT - : (*)
W	.---	BT	-....-	error = SHIFT - 1, 3, 4, 5, 6
Y	-.--	KN	-.--.	BRK = Key down (for testing)
Z	---..	SK	...-.-	
		error	

Transmitted Morse code may be monitored using the internal side-tone oscillator of the CT2100 by selecting OUTPUT on the monitor switch. On the other hand, if your transmitter includes a side-tone oscillator that you prefer to listen to, select INPUT with the monitor switch. Now, the CT2100 audio monitor system amplifies the audio output of the transceiver.

The CT2100 has Morse key output circuits to drive either a positive or negative voltage keying circuit. Most older tube-type transmitter circuits used grid-block or negative voltage circuits; most solid-state transmitters use a positive voltage key circuit. However, there are a number of exceptions to be found (particularly with transmitters that include built-in keyer circuits), so check your transmitter manual to be sure. Normal connection circuits are discussed in Section 5.1. Both keying outputs may be used simultaneously to drive different transmitters if desired.

Since the transmit-receive control for Morse code is the key circuit itself, the KOS feature is not active for Morse transmitting. The KOS output is always set to transmit condition (transistor switch "on") when Morse is selected. This may be manually set to "off" by setting the MAN TX/AUTO switch to AUTO (button out) and the KOS switch to off (button out).

4.8 Special Considerations When Transmitting Baudot

Baudot RTTY code may be transmitted with the CT2100 and KB2100 by using the BAUDOT MODE DATA switch (press and release the momentary action switch). Baudot data rates are selected with the INC (increase) or DEC (decrease) SPEED switches. These switches are also momentary action and each press increments one data rate; hold a button down for repeated increments. At present, only the following data rates are authorized for U.S. amateur use by the FCC:

- 45 baud (60 wpm)
- 50 baud (66 wpm)
- 57 baud (75 wpm)
- 74 baud (100 wpm)

Other data rates should not be used for on-the-air U.S. amateur Baudot transmissions but may be used for local use, such as writing letters to the printer, etc.

The Baudot RTTY code uses 5 data bits to specify a given character. Since the 32 possible combinations are insufficient to represent all 26 letters, 10 numbers, and punctuation plus control codes, all 5 bit Baudot codes are used twice. Case shift characters are sent to the printer to signal whether a following character will be a letter case (LTRS) or number/punctuation (FIGS). When using a manual Baudot RTTY machine, special keys are provided for these shift codes, LTRS and FIGS; you must type these extra keys as they are required by the text. The CT2100 and KB2100 automatically keep track of the Baudot case code required for a given character and insert the proper code in the transmitted data as required. Thus a standard type-writer keyboard arrangement is used for Baudot and there is no difference in typing required between Morse, Baudot, or ASCII codes. However, the Baudot code itself does not distinguish between upper and lower case letters and the same code is transmitted whether you type a capital or small letter.

The transmit features of the CT2100 include word wrap-around and non-overprint as well as word mode when half-duplex operation is used. The word wrap-around feature prevents the splitting of a word at the end of a typed line; if you over-type the end of a line, all of the current word (back to the last space) is simply transferred to the next line. The non-overprint feature then automatically inserts the printer carriage control codes, carriage return (CR), line feed (LF), and letters (LTRS) at the end of each 72 character line. Thus, you need not be concerned with line lengths and insertion of the proper printer controls - the CT2100 does it for you! Just start typing! The standard U.S. model of the CT2100 will transmit up to 72 characters per line, the U.S. teleprinter standard; some export models are configured for a 69 character transmit line to conform to a European standard printer line. Selection of either 72 or 36 character display lines will not affect the transmit line length - the CT2100 will still use word wrap-around and non-overprint to transmit 72 char-

acter (or 69 character) lines.

If you wish to transmit shorter lines, such as in a table, etc., use the NEW LINE key. Each operation of the NEW LINE key in Baudot HDX condition causes the transmission of the sequence:

CR (carriage return) + LF (line feed) + LTRS (letters)

As mentioned in earlier discussions, ALWAYS END EACH TRANSMISSION WITH A NEW LINE KEY, even if you have used word wrap-around and non-overprint to automatically define the lines. This assures that the CT2100 truly switches back to receive condition.

Even though the NEW LINE key and word wrap-around and non over-print features automatically generate the CR and LF characters when needed, there are some conditions when it is desirable to transmit the individual Baudot codes for these operations. In this case you may use the following key combinations to transmit these codes:

BAUDOT CHARACTER	KEY COMBINATIONS	SCREEN SYMBOL
LTRS	Shift ", "	" < "
FIGS	Shift ". "	" > "
CR	CTRL "M"	" CR "
LF	CTRL "J"	" LF "
BELL	CTRL "G"	" Δ "
blank	ESC	" E _c "

The Baudot Code used in the CT2100 is shown in Table 2.

TABLE 2 BAUDOT DATA CODE

BIT NUMBER 5 4 3 2 1	CASE		NOTES:
	Letters	Figures	
0 0 0 0 0	BLANK	BLANK	Mark = "1" = loop current on = - RS232 voltage
0 0 0 0 1	E	3	Space = "0" = loop current off = + RS232 voltage
0 0 0 1 0	LF	LF	LF = Line Feed = CTRL-J
0 0 0 1 1	A	-	CR = Carriage Return = CTRL-M
0 0 1 0 0	SPACE	SPACE	LTRS = Letters Shift = SHIFT-,
0 0 1 0 1	S	BELL	FIGS = Figure Shift = SHIFT-.
0 0 1 1 0	I	8	NEW LINE = CR + LF + LTRS (HDX) = CR only (FDX)
0 0 1 1 1	U	7	BELL = CTRL-G
0 1 0 0 0	CR	CR	BLANK = ESC
0 1 0 0 1	D	\$	STOP = (FIGS case H)
0 1 0 1 0	R	4	BRK = Space condition (for test)
0 1 0 1 1	J	'	Transmission order = Bit 1 to Bit 5
0 1 1 0 0	N	,	Start Pulse = 1 unit space
0 1 1 0 1	F	!	Stop Pulse = 1.5 unit mark
0 1 1 1 0	C	:	
0 1 1 1 1	K	(
1 0 0 0 0	T	5	BAUD RATE
1 0 0 0 1	Z	"	AVERAGE WPM
1 0 0 1 0	L)	SELECT PULSE
1 0 0 1 1	W	2	45.45 60.61 22.00 ms
1 0 1 0 0	H	#	50.00 66.67 20.00 ms
1 0 1 0 1	Y	6	56.92 75.89 17.57 ms
1 0 1 1 0	P	0	74.20 98.99 13.47 ms
1 0 1 1 1	Q	1	100.0 133.3 10.00 ms
1 1 0 0 0	O	9	110.0 146.7 9.09 ms
1 1 0 0 1	B	?	150.0 200.0 6.67 ms
1 1 0 1 0	G	&	300.0 400.0 3.33 ms
1 1 0 1 1	FIGS	FIGS	600.0 800.0 1.67 ms
1 1 1 0 0	M	.	1200.0 1600.0 0.333 ms
1 1 1 0 1	X	/	
1 1 1 1 0	V	;	
1 1 1 1 1	LTRS	LTRS	

Special Baudot Features:

- * Automatic LTRS/FIGS generation when transmitting
- * USOS (Unshift On Space) selectable for reception of noisy signals.
- * SYNC (Synchronous Idle) selectable to transmit LTRS during pauses in typing.

Notice that the phrase "CW ID FOLLOWS" was not needed - the other station knows it is there and his printer has been protected by the NEW LINE insertions. The string of "RYRYRYRYRYRY" is a courtesy and it often helps the other station tune his receiver to your signal exactly without losing any text. Try to start and end each transmission with a NEW LINE key.

Baudot RTTY may be transmitted and received in several formats with the CT2100. A total of four different demodulator/modulator audio tone sets may be used as explained in Sections 3.3 and 3.4. The transmit tones are computer synthesized and match the receive demodulator filters to assure true transceive frequency matching. These same tones may also be used to record and play back messages with an audio tape recorder as explained in Section 5.4. Simultaneous with the selected transmit tone output, the data is also available to the RS232 OUTPUT connector and to the LOOP connector (external loop power supply required). RTTY data may also be transmitted from a loop connected device (such as a transmitter distributor (TD, or paper tape reader). In this case, the NORM/LOOP switch is set to the LOOP position (button out) and the CT2100 transmit circuitry then senses any data originating from the RTTY loop circuit. When the loop device transmission is completed, return the switch to the NORM position (button in) so that the CT2100 will again respond to typed text. Always leave the NORM/LOOP switch in the NORM position when loop transmit devices are not in active use.

The KOS (Keyboard Operated Switch) feature is very convenient for RTTY operation of an amateur station. The KOS circuits functions much the same as a VOX - voice controlled break-in - circuit of a SSB transmitter, automatically controlling the transmit-receive switching of the station. To use KOS, select AUTO (button out) and KOS (button in). When you have text to be transmitted and the transmit output is enabled (CTRL-7 set for TX ON status), the KOS LED will come on and the KOS switch transistor will turn-on the transmitter. After a short pause (to let the transmitter, amplifier, and antenna relays settle), the first of the typed text will start transmitting. When all of the text has been transmitted and a new line is completed, the KOS turns off the transmitter and you may receive. ALWAYS END A TRANSMISSION WITH THE NEW LINE KEY to assure that the KOS and IDLE features turn off and the CT2100 returns to receive condition.

4.9 Special Considerations When Transmitting ASCII

ASCII RTTY code may be transmitted with the CT2100 and KB2100 by using the momentary action ASCII MODE DATA switch (press and release). Data rates are shown on the status line and may be changed with the INC (increase) or DEC (decrease) momentary switches. Each press of the INC or DEC switch increments the CT2100 one data rate; holding each switch down allows stepping-through the rate increments. ASCII may be transmitted or received at any of the data rates, 45 baud through 1200

baud. Current U.S. amateur FCC regulations do not stipulate specific ASCII data rates that must be used. However, the following are the maximum data rates that may be used for particular frequency ranges:

FREQUENCY RANGE	MAXIMUM DATA RATE	EMISSION
3.5 to 21.25 MHz	300 baud	F1
28.0 to 225 MHz	1200 baud	F1, F2, A2
420 MHz and higher	19,600 baud	F1, F2, A2

Although there are many data rates available for use, 110 baud is used almost exclusively on frequencies below 30 MHz due to popular use, commercially available mechanical machines, and the poor noise performance of the higher data rates. On the VHF bands, 110, 300 baud, and 1200 baud have proven popular. However, there is a big advantage to use of the slower data rates (45 or 50 baud for example) with the ASCII code in the 3 - 30 MHz frequency range. The slower data rates are considerably more effective when faced with the noise, interference, and varying signal conditions common on these frequency bands. Also, the ASCII code offers a considerably larger character set than the Baudot code normally used at these slow rates.

The CT2100 will transmit and receive the full, unabridged 128 character ASCII code set, including upper and lower case letters, all punctuation and symbols, and all control codes when used in the KSR transmit mode. In split screen mode, the five cursor control key combinations are reserved for on-screen editing and are not inserted in the transmit buffer for transmission. Each ASCII character and control code has a unique symbol that is displayed on the CT2100 screen. These symbols are shown in Table 3. The key combinations used to produce each ASCII character are shown in Table 4.

Often, it is desirable to be able to transmit an abridged form of the ASCII code, using only upper case (capital) letters. This feature, called CAPS LK, is turned on with the CTRL-6 key combination. This feature affects only the transmit section of the CT2100 - received ASCII will be displayed in upper or lower case as it was transmitted.

As in the discussion of the Baudot code in Section 4.8, the word wrap-around and non-overprint features of the CT2100 make it unnecessary to type printer control characters when typing text. The transmit lines are automatically set for a maximum of 72 characters (or 69 characters in export models). When the end of a line is over-typed, the entire last word is transferred to the next line and CR (carriage return) and LF (line feed) characters are inserted. Transmit lines are set for 72 (or 69) characters whether the screen is set for 36 or 72 character lines. If you wish to type shorter lines, use of the NEW LINE key causes the insertion of both CR and LF characters. These characters may also be transmitted separately if desired with the CTRL-J and CTRL-M key combinations as shown in Table 4.

TABLE 3 DISPLAY SYMBOLS FOR THE ASCII CODE

CONTROL CHARACTER	SCREEN SYMBOL	KEY COMBINATION
ACKNOWLEDGE	AK	CTRL - F (ACK)
SIGNAL BELL	<u>␣</u>	CTRL - G (BELL)
BACK SPACE	BS	CTRL - H (BS)
CANCEL	CN	CTRL - X (CAN)
CARRIAGE RETURN	CR	CTRL - M (CR)
DELETE (RUB OUT)		SHIFT - DEL
DEVICE CONTROL 1	D1	CTRL - Q (DC1)
DEVICE CONTROL 2	D2	CTRL - R (DC2)
DEVICE CONTROL 3	D3	CTRL - S (DC3)
DEVICE CONTROL 4	D4	CTRL - T (DC4)
END OF MEDIUM	EM	CTRL - Y (EM)
ENQUIRY (WRU)	EQ	CTRL - E (ENQ)
END OF TRANSMISSION	ET	CTRL - D (EOT)
ESCAPE	EC	ESC
END OF BLOCK	EB	CTRL - W (ETB)
END OF TEXT	EX	CTRL - C (ETX)
FORM FEED (HOME)	FF	CTRL - L (FF)
FORM SEPARATOR	FS	SHIFT - CTRL - L
GROUP SEPARATOR	GS	SHIFT - CTRL - M
HORIZONTAL TAB	HT	CTRL - I (HT)
LINE FEED	LF	CTRL - J (LF)
NOT ACKNOWLEDGE	NK	CTRL - U (NAK)
NULL	NL	SHIFT - CTRL - P
RECORD SEPARATOR	RS	SHIFT - CTRL - N
SHIFT IN	SI	CTRL - O (SI)
SHIFT OUT	SO	CTRL - N (SO)
START OF HEADING	SH	CTRL - A (SOH)
START OF TEXT	SX	CTRL - B (STX)
SUBSTITUTE	SB	CTRL - Z (SUB)
SYNCHRONOUS IDLE	SY	CTRL - V (SYN)
UNIT SEPARATOR	US	SHIFT - CTRL - O
VERTICAL TAB	VT	CTRL - K (VT)

TABLE 4 ASCII DATA CODE

BITS	7	0	0	0	0	1	1	1	1	NOTES:
	6	0	0	1	1	0	0	1	1	Mark = "1"
4 3 2 1	5	0	1	0	1	0	1	0	1	= loop on
										= - RS232 V.
0 0 0 0		NUL	DLE	SPC	0	@	P	`	p	Space = "0"
0 0 0 1		SOH	DC1	!	1	A	Q	a	q	= loop off
0 0 1 0		STX	DC2	"	2	B	R	b	r	= + RS232 V.
0 0 1 1		ETX	DC3	#	3	C	S	c	s	BRK = Space Condx.
0 1 0 0		EOT	DC4	\$	4	D	T	d	t	FS = SHIFT-CTRL-L
0 1 0 1		ENQ	NAK	%	5	E	U	e	u	GS = SHIFT-CTRL-M
0 1 1 0		ACK	SYN	&	6	F	V	f	v	NUL = SHIFT-CTRL-P
0 1 1 1		BEL	ETB	'	7	G	W	g	w	RS = SHIFT-CTRL-N
1 0 0 0		BS	CAN	(8	H	X	h	x	US = SHIFT-CTRL-O
1 0 0 1		HT	EM)	9	I	Y	i	y	NEW LINE = RTN+LF
1 0 1 0		LF	SUB	*	:	J	Z	j	z	(HDX)
1 0 1 1		VT	ESC	+	;	K	[k	{	= RTN
1 1 0 0		FF	FS	,	<	L	\	l		(FDX)
1 1 0 1		RTN	GS	-	=	M]	m	}	
1 1 1 0		SO	RS	.	>	N	^	n	~	
1 1 1 1		SI	US	/	?	O	_	o	RBO	

			BAUD	CHAR/	SELECT
			RATE	SEC.	PULSE
					(ms)
ACK = acknowledge	HT = horizontal tab				
BEL = signal bell	LF = line feed				
BS = back space	NAK = not acknowledge				
CAN = cancel	NUL = null		45.45	4.13	22.00
DC1 = device control 1	RS = record separator		50.00	4.55	20.00
DC2 = device control 2	RTN = carriage return		56.92	5.17	17.57
DC3 = device control 3	RBO = RUB OUT = DEL		74.20	6.75	13.47
DC4 = device control 4	SI = shift in		100.0	9.09	10.00
DLE = data link escape	SO = shift out		110.0	10.0	9.09
EM = end of medium	SOH = start of heading		150.0	15.0	6.67
EOT = end of trans.	STX = start of text		300.0	30.0	3.33
ESC = escape	SUB = substitute		600.0	60.0	1.67
ETB = end of block	SYN = synchronous idle		1200.0	120	0.833
ETX = end of text	US = unit separator				
FF = form feed (home)	VT = vertical tab	Transmission bit order:			
FS = form separator	ENQ = enquiry = WRU	bit 1 to bit 7			
GS = group separator	SPC = space bar	bit 8 = space			

Normal amateur RTTY transmissions use a half-duplex connection where the transmitted text is repeated or "echoed" on the receive printer or screen. Selection of HDX (button in) connects the CT2100 for normal half-duplex operation. The ASCII code may also be used in the full duplex (FDX) mode (HDX/FDX button out). When full duplex is used, the receive and transmit audio and RS232 data interfaces may function simultaneously. However, the word wrap-around, non-overprint, word mode, KSR mode, split-screen mode, and KOS features are not available. Typed text is not displayed on the screen and characters are transmitted as they are typed. The full duplex connection is sometimes used between

a computer and a terminal; "echo" of transmit text is usually provided by the computer itself. When FDX is used, the NEW LINE key inserts only a CR (carriage return) code. Use of FDX is discussed in greater detail in Section 4.10.

The synchronous idle ("diddle") character for the ASCII code is the NUL character (000 0000). As was discussed in Section 4.8 in regard to the Baudot code, synchronous idle may assist the reception of your signal and it is advisable to use it when KOS is also used. As before, ALWAYS END A TRANSMISSION WITH A NEW LINE KEY.

The KOS (Keyboard Operated Switch) feature may be used to automatically control the transmit-receive circuitry of the station. The KOS transistor switch will turn-on the transmitter whenever typed text is available for transmission and the transmit output of the CT2100 is enabled (CTRL-7 to get TX ON on the status line). KOS only functions in HDX mode and is always set for transmitter on condition when FDX is chosen. It is suggested that IDLE be used with KOS and that the transmission always be ended with a NEW LINE key. The KOS feature is active when the TX/RX CONTROL switches are set for AUTO (button out) and KOS (button in).

The CT2100 may be interfaced to other ASCII equipment through the audio tones (four demodulators/modulators), RS232, and RTTY current LOOP connections (external loop power supply required). All data outputs are available simultaneously. The NORM/LOOP switch allows use of loop-connected data transmitting devices such as paper tape readers. To transmit from a loop connected device, set the switch to LOOP (button out) while transmitting. Be sure to restore the switch to NORM after the loop transmission to assure that the CT2100 will transmit keyboard text again.

4.10 HDX / FDX Operation

The CT2100 may be operated in either a half-duplex (HDX) or full duplex (FDX) transmit connection, selected with the HDX/FDX switch. Normal amateur RTTY communications are usually conducted with equipment connected for half duplex operation. A full duplex connection is often used between a computer and a terminal.

With a half duplex connection, all transmitted text from the CT2100 may be seen on the screen before and after it has been transmitted. In KSR mode, the transmitted text is indicated by the reversed-video characters; in split-screen mode, the transmit characters are "written onto" the receive section of the screen as they are transmitted. The word wrap-around, non over-line, word mode, NEW LINE sequence, and KOS features of the CT2100 may all be used with half duplex. However, the CT2100 may only receive or transmit one at a time.

When full duplex is chosen, the CT2100 can receive and transmit text simultaneously. However, the automatic transmit features are not ava-

ilable and typed text is NOT shown on the screen as it is typed or as it is transmitted. Typical full duplex connections with a computer usually include a computer-generated "echo" back to the receive display or printer, showing the characters as received and interpreted by the computer; transmission errors are therefore soon noticed. The complete ASCII and Baudot character sets may be transmitted in FDX mode. When FDX is used, the NEW LINE key will cause insertion of only the CR (carriage return) code.

THE HDX/FDX switch has a special function when Morse code is selected. In Morse, the HDX position allows use of the word mode for composing and editing keyboard text. In FDX position, characters are transmitted as they are typed, a continuous mode. Of course the word mode edit capability and word wrap-around on the display are no longer available in continuous mode. The CT2100 always operates as a half-duplex terminal when Morse is selected.

4.11 Synchronous Idle Feature

A synchronous idle feature may be selected with the IDLE switch (button in). IDLE provides a fill character that can be inserted during pauses in the keyboard typing. The idle (or "diddle") character maintains the "rhythmn" of the output signal, helping to keep the receiving station's equipment synchronized to your signal. This may improve copy that is otherwise marred because of weak signals or interference.

The IDLE character is only inserted when the transmitted text has "caught-up" with the keyboard typing and a line has not been completed. The IDLE will turn off if a NEW LINE has been started but no characters have been typed in that line. Thus, if KOS is turned on, it will remain on during lulls in the typing but turn off after the final NEW LINE is sent. Therefore, always end each transmission with a NEW LINE key.

When Baudot code is transmitted, the LTRS (letters = 11111) character is used for IDLE. This character maintains the receiving printer or display in the LTRS case (preferred condition for text) and does not cause spacing of some receive printers (as the blank Baudot character does). When ASCII is used, the IDLE character inserted is the NUL (000 0000) character. This is the standard ASCII synchronous idle character.

The IDLE feature also functions with Morse code, inserting the BT (-...-) prosign. This feature may be of some advantage when testing equipment but can be irritating to the receiving operator. It's use with Morse code should probably be limited!

4.12 The NORM/LOOP Transmit Feature

Full RTTY current-loop compatibility is assured in the CT2100 with the NORM/LOOP switch. In the NORM (button in) position, the CT2100 receives data and keys any loop receive devices (printer, reperf, etc). Also, all keyboard composed text will key the loop as it is transmitted. The loop output ALWAYS operates at the same data rate and code as that of the received signal or that transmitted by the CT2100; it does not provide a code conversion. The ASCII printer output (Section 5.5) provides a Baudot or Morse conversion to ASCII. Note that the LOOP output is NOT controlled by the demodulator AUTO feature; the AUTO feature only suppresses screen printing of non-RTTY signals.

The LOOP switch position (button out) allows data transmit devices (paper tape reader, or TD, for example) to be used with the CT2100, keying the output audio tones, RS232, and KOS feature. However, the CT2100 will not transmit from text typed on the KB2100 unless this switch is restored to NORM after the loop generated text has been completed.

An external loop supply must be used with loop devices that is compatible with the equipment used. Most Baudot current-loop machines use a 100-200 volt, 60 ma dc loop; some ASCII machines use 20 ma high or low voltage loops. The CT2100 will key loop circuits up to 200 volts maximum and up to 120 ma. maximum loop current. Often, the loop power supply is built into the RTTY machine (Model 19 and Model 28 machines for example).

4.13 The KOS Feature

The KOS (Keyboard Operated Switch) feature of the CT2100 allows automatic control of the transmit-receive circuits of the station in much the same manner as the SSB VOX circuit. Select the KOS feature by setting the MAN TX/AUTO switch to AUTO (button out) and the KOS switch on (button in). When keyboard text is ready to be transmitted, start the data output with CTRL-7 to get TX ON on the screen status line. The KOS switch transistor will now "turn-on" (low impedance to ground for a positive voltage), the KOS LED will come on, and, after a short pause, the text will be transmitted. The short pause allows the transmitter, amplifier, and antenna relays to complete their switching before text is released. The KOS switch will now stay in transmit condition for as long as there is typed text to be transmitted or a line has not been completed. Since the KOS (when IDLE is also used) only turns off at the beginning of a line that includes no typed characters, it is therefore quite important to ALWAYS END A TRANSMISSION WITH A NEW LINE KEY! If the IDLE is not used, the KOS will revert to receive anytime that the transmitted output has "caught-up" with the typed text.

The KOS switch transistor is NPN and will therefore key only

transmitters with a positive voltage tx-rx control line (push-to-talk line, usually). If your transmitter has a negative voltage control line (the Drake T4 is an example), it will be necessary to use a relay or additional transistor switch between the CT2100 KOS output and the transmitter. This variation is discussed in Section 5.1.

In Morse code and when FDX (full duplex) is selected, the KOS is always in the transmit condition. It is recommended that you turn the KOS switch off (button out) when Morse or FDX is selected.

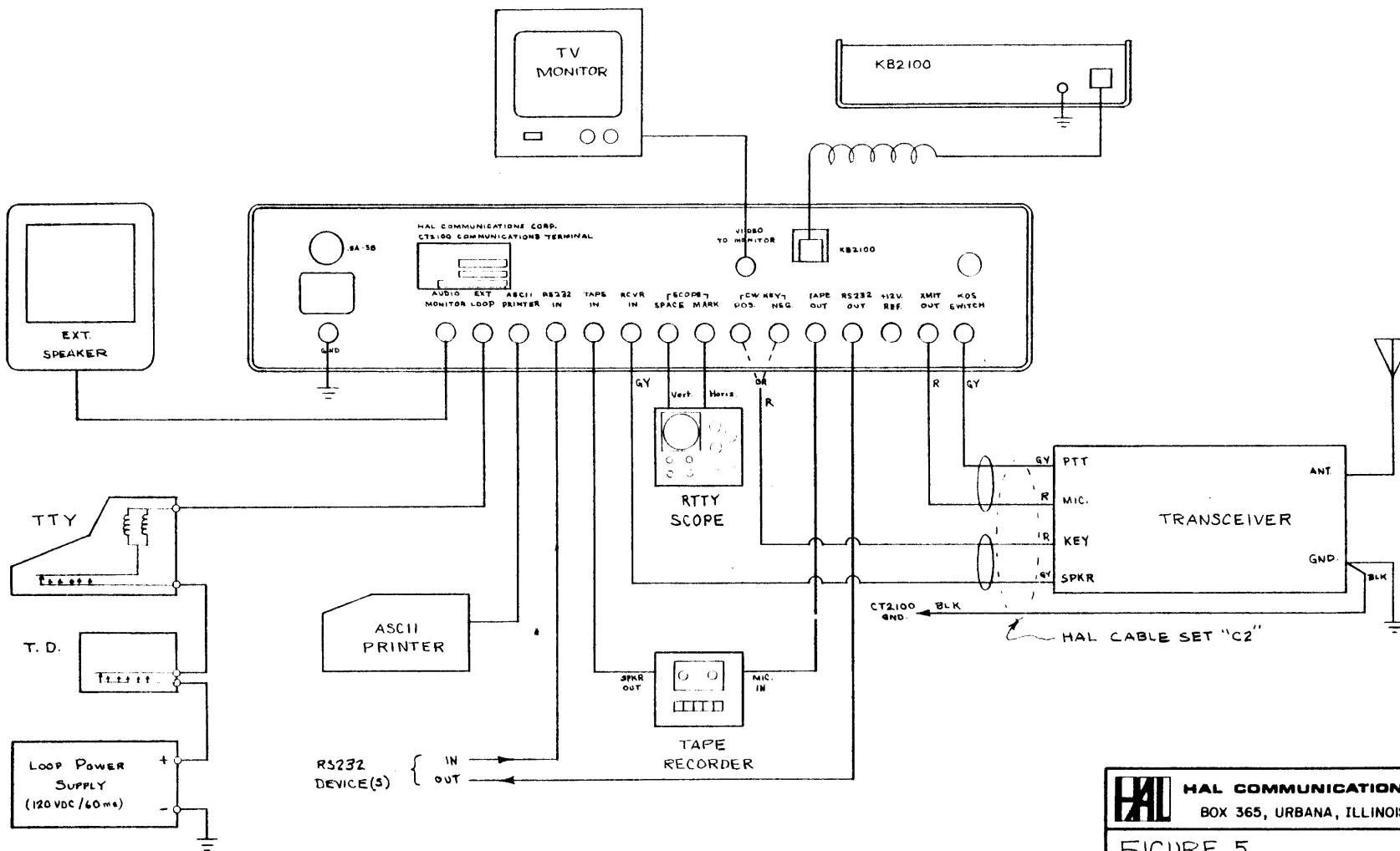

HAL COMMUNICATIONS CORP.
 BOX 365, URBANA, ILLINOIS 61801

FIGURE 5.
 Connections to the CT2100

DATE	8-21-81	SCALE	NONE
DRN BY	GWH	No. C1036	
APP BY			

CHAPTER 5

CONNECTIONS TO THE CT2100

This section of the CT2100 manual discusses how to connect the CT2100 to your equipment. Section 5.1 will discuss basic connections you may wish to make in a typical radio amateur station. Later sections of this chapter discuss specialized connections.

5.1 Normal Amateur Station Connections

The basic minimum connections required for a transmit-receive station connection have been shown in Figure 2 in Chapter 2; more elaborate connections are shown in Figure 5. The HAL cable set "C2" makes the simple connections or you may fashion your own cables. The "basic required connections" of Figure 2 are:

1. A good RF ground between all components of the system. Use heavy wire or 1/4" shield braid.
2. A shielded audio cable between the receiver speaker output and the CT2100 RVCR IN connector. A high fidelity phono cable will do nicely.
3. A shielded audio cable between the transmitter microphone audio input and the CT2100 XMIT OUT connector. A stereo phono cable can be used for this and the KOS connection described next. Note that the phono connector(s) will probably need to be cut-off on the transmitter end of this cable and the correct microphone plug connected. Consult your owner's manual for the correct connector and pin numbers. The output level from the XMIT OUT jack may be adjusted if necessary as explained in Section 5.10. Consult your transmitter manual and insert a series capacitor if required as noted in Section 2.1.
4. A shielded cable between the transmitter microphone push-to-talk (PTT) input and the CT2100 KOS SWITCH connector. The other half of the stereo cable used for transmit audio can be used for this connection. As above, consult the transmitter manual for connector and pin numbers. The NPN transistor KOS switch will only switch positive voltage PTT circuits directly; negative voltage PTT circuits will require an external relay. This relay may be connected as shown in Figure 6. If a 12 VDC relay with a low current coil is used, the +12 VDC required may be obtained on the "+12V REF" CT2100 connector (20 ma maximum output).

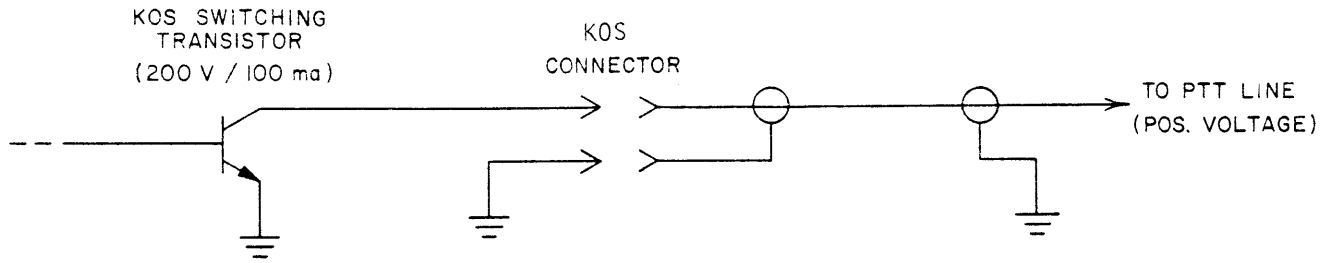

CONNECTION KOS CIRCUIT (POSITIVE VOLTAGE)

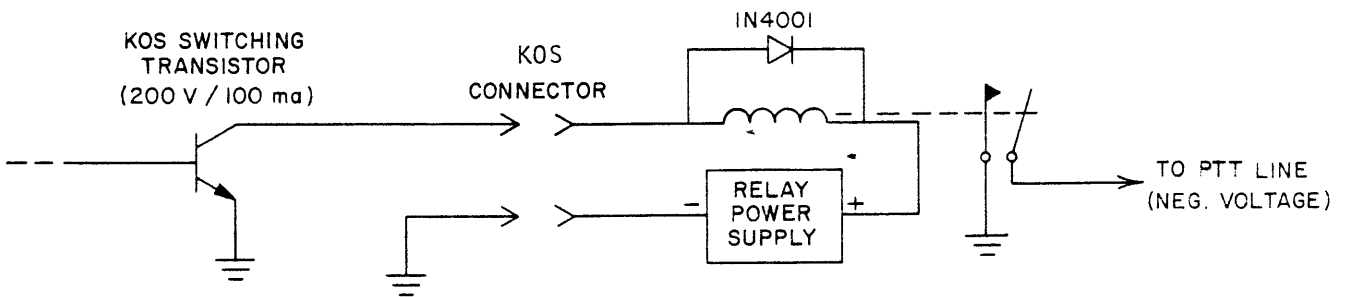

CONNECTION TO KOS CIRCUIT (NEGATIVE VOLTAGE)

Figure 6. KOS Circuit Connections

5. A shielded cable between the transmitter Morse code key input and the CT2100 CW KEY connector. Consult your transmitter manual to determine if your transmitter keying circuit keys a positive or negative voltage and connect to the appropriate output of the CT2100 CW KEY. Again, this cable can be a high fidelity phono cable with the transceiver plug end modified as appropriate. This connection can often be combined in a stereo cable with the receiver audio cable (item 2) when connections are made to a transceiver.
6. A shielded coaxial cable between the video monitor video input and the CT2100 VIDEO TO MONITOR connector. The CT2100 output is direct composite video RS170 standard, 1.0 V p-p, 72 ohms. Models of the CT2100 sold in the U.S. do not generate an RF TV signal and TV sets must be modified for a direct video input. See Section 5.7 for typical TV set modification details. This video cable should preferably use a 72 ohm coaxial cable, but a phono high fidelity cable will suffice for short runs up to 6 feet. The cable furnished with the CT2100 will mate to a monitor using the standard UHF video connector. If your monitor requires a different connector, use an adapter or cut the UHF plug off and install the required connector. You may need to adjust the monitor size and position controls to view the full screen.
7. Connect the KB2100 to the CT2100 with the coil-cord cable furnished. This is a standard 6 conductor telephone cable; longer lengths can be found at local electronics stores. Be careful about using very long lengths as they may act as antennas and produce RFI (Radio Frequency Interference) problems. See Section 5.8 for RFI suppression suggestions. By all means, use a ground wire between the KB2100 and the CT2100 if RFI is observed.
8. Connect an external speaker (4 to 8 ohms) to the CT2100 AUDIO MONITOR connector; a high fidelity phono cable will suffice for this connection.
9. Connect the line cords of the CT2100, video monitor, transmitter and receiver to a suitable AC mains outlet. CT2100's sold in the United States will be connected for 120 VAC/ 60 Hz; export models will usually be connected for 220 VAC / 50 Hz. If the internal connections are for other than 120 VAC / 60 Hz, it will be indicated on a special label tag on the CT2100 rear panel. Be sure that your CT2100 is connected to match you ac mains voltage and frequency. Section 5.9 discusses internal changes to be made in the CT2100 to change AC voltage or frequency. For safety, ALWAYS USE GROUNDING TYPE AC OUTLETS.

5.2 Use of the RS232 Data Connections

The CT2100 includes input and output connectors for use with RS232 data devices ("RS232 IN" and "RS232 OUT"). These I/O connections can be used with any RS232 compatible device. The RS232-C voltage standard is as follows:

MARK = -5 volts maximum, any load
= -15 volts minimum, 3000 ohm load
= -25 volts minimum, open circuit

SPACE = +5 volts minimum, any load
= +15 volts maximum, 3000 ohm load
= +25 volts maximum, open circuit

UNDEFINED: -5 volts to +5 volts

R source - less than 300 ohms
R load - between 3000 and 7000 ohms
C load - less than 2500 pF

Notice that the voltage levels of the RS232-C standard are NOT compatible with those of +5 volt TTL IC logic. Do not be misled by some claims of direct TTL - RS232 compatibility; damage may be caused to one or both units! The RS232 output of the CT2100 is approximately + or - 10 VDC with a 300 ohm internal resistance.

The RS232 I/O connections may be used for connection to printers, computers, or other RS232 data devices. The so-called "handshaking" modem control signals (request to send, clear to send, etc.) are not furnished since the CT2100 has two different modems built-in. Consult Section 3.4 for information concerning these modems. The RS232 I/O connectors will find a major application in full duplex (FDX) data circuits since input and output "ports" may be used simultaneously.

The RS232 output is always available for all ASCII and Baudot signals; the RS232 input is selected with the I/O AUDIO/RS232 switch (button out for RS232 receive). The RS232 output is NOT controlled by the demodulator AUTO feature.

5.3 Use of the RTTY LOOP Data Connection

Loop-connected RTTY machines and devices may be used with the CT2100. A typical loop connection is shown in Figure 5. Note that the loop power supply is NOT built into the CT2100; it should be included with the external loop devices. The specifications for the loop supply are:

Loop Voltage	=	200 volts maximum (no loop current)
Loop Current	=	18 to 120 mA DC (mark condition)
Reference	=	CT2100 switch transistor to ground; plus to center pin of EXT LOOP connector.

The loop voltage and current used depend upon the machine used. Older, Model 15 and 28 TTY machines, for example, usually operate from a 100 to 200 volt, 60 mA loop supply; some newer machines such as the 32 and 33 often use a lower voltage, 20 mA current loop.

The CT2100 output to the EXT LOOP connector is in the same code and data rate as selected with the front panel DATA SPEED and MODE switches. For example, if 45 BAUD, Baudot code is selected for the display, the data at the EXT LOOP connector will also be 45 baud, Baudot code; there is no speed or code conversion associated with the CT2100 EXT LOOP output. Similarly, selection of ASCII code will mean that the EXT LOOP output is also in the ASCII code. There is no output from the EXT LOOP connector when Morse is selected. A code conversion to ASCII, 300 baud is furnished by the ASCII PRINTER output discussed in the next section. The LOOP output is NOT controlled by the demodulator AUTO feature.

A unique feature of the CT2100 is the capability of transmitting data generated on a loop-connected transmit device, such as a tape reader ("T-D" or "TEE-DEE"). To transmit data from loop devices, select "LOOP" on the NORM/LOOP I/O switch (button out). The loop data will now drive the CT2100 transmit tone generator as well as the RS232 output. When the loop device has finished the transmission, be sure to reselect "NORM" (button in) to assure that the CT2100 will again respond to text typed on the CT2100 keyboard.

It is highly recommended that you use shielded cable to connect the loop devices to the CT2100 to avoid RFI problems. Also, be sure to use BOTH safety and RF ground connections to these devices. BE SURE TO TURN-OFF THE LOOP SUPPLY BEFORE WORKING WITH THE EXT LOOP CONNECTION - A SERIOUS SHOCK COULD OTHERWISE BE RECEIVED FROM THE HIGH VOLTAGE LOOP SUPPLY!

5.4 Connection of an ASCII Printer

A serial ASCII data printer may be used with the CT2100 by connection to the ASCII PRINTER connector. This output is serial, RS232-C ASCII

data, normally set at the factory for 300 baud. All received and transmitted data of the CT2100 is output to the ASCII printer, regardless of code or data rate used (up to 300 bd). Thus, the ASCII printer output provides a code and speed conversion, allowing printing of Morse, Baudot, or ASCII data on the same printer. Use a shielded cable to connect the printer to the CT2100; be sure to connect a good RF ground to the printer as well.

As furnished by the factory, The ASCII printer output will provide print-out for signal data rates up to 300 baud; at higher data rates, print may be garbled since it is being received faster than printed. The ASCII printer output may be changed to any data rate between 100 and 1200 baud by adjustment of the PRINTER DATA RATE control discussed in Section 5.10. In general, the printer should reliably print signals whose data rates are equal to or less than that of the printer; eg, a 300 baud printer would print data received at 45, 110, or 300 baud, but not at 600 or 1200 baud. Although it at first seems attractive to set the printer to the highest data rate, 1200 baud, to assure compatibility with all of the CT2100 data rates, most popular printers cannot handle this data "through-put" (120 characters per second), especially for line feed and carriage return operations. Unless your printer has extensive input buffering available, it is recommended that you use the 300 baud output as furnished to avoid overflowing the printer input and losing characters.

5.5 Connection of an Audio Tape Recorder

An audio tape recorder may be connected to the TAPE OUT and TAPE IN connectors of the CT2100 for recording and playing back of messages. The TAPE OUT connector furnishes the CT2100 transmit tones to the tape recorder input (microphone or auxiliary input). On transmit, these tones are keyed by transmit data, such as that typed on the KB2100 or played through the RTTY loop circuit. Thus, you can make-up long "brag-tapes" or messages on the CT2100 screen and record them as you "transmit" them. You may prevent the transmitter from turning on by selecting AUTO and KOS off on the TX/RX CONTROL switches (both buttons out). This feature can be used to supplement the MSG2100 Message Storage ROM. The TAPE OUT level may be adjusted as discussed in Section 5.10.

To transmit tape recorded text, select TAPE on the RCVE/TAPE I/O switch (button out), turn on the transmitter (KOS or MAN TX), and start the tape in the playback mode. The recorded tones are now fed-through the CT2100 receive demodulator, filtered and detected, and then modulate the CT2100 transmit output tones (and RS232 output). Thus, the tape data is reprocessed before transmission, helping to eliminate some of the distortion otherwise caused by tape wear and stretch.

In addition, the TAPE OUT may be used to record incoming data. In this case (RCVE/TAPE in RCVE position), the received signal is pro-

cessed in the CT2100 demodulator and then used to key the CT2100 output tones; again, the tape recorded signal has been reprocessed so that low-distortion data is recorded.

The connection of the tape recorder to the CT2100 is shown in Figure 5. Use shielded cables for these connections; include RF and safety grounds to minimize any RF pickup in the tape recorder.

5.6 RTTY Tuning Oscilloscope Connections

In addition to all of the input/output (I/O) connections discussed above, you may also wish to use an external monitor scope for a RTTY tuning indicator. The SCOPE (SPACE and MARK) connectors are provided for tuning indicator use. These outputs are the filtered signals present at the RTTY demodulator discriminator circuits. The signals are approximately 2 V p-p in amplitude and have an internal impedance of approximately 1000 ohms. As shown in Figure 5, the standard convention is to use an X-Y oscilloscope with the MARK signal connected to the horizontal scope input and the SPACE to the vertical input. Since these signals have a relatively low output level, it is necessary to use an oscilloscope with amplifier stages in both the vertical and horizontal sections. Use shielded cable for these connections; be sure to include safety power as well as RF ground connections.

The display on the oscilloscope screen for correct receiver tuning will be of the crossed-ellipse type. Because of the purposely broad discriminator filters of the CT2100 demodulator, fairly broad ellipses will be seen on the screen rather than sharp lines as might be seen on other equipment. Correct tuning is indicated when the horizontal ellipse (mark signal) and the vertical ellipse (space) have maximum amplitude (length of the ellipse) and are orthogonal. The 170 Hz shift ellipses will be fairly wide and will not necessarily be at 90 degrees to each other - this is normal! The ellipses for the wider shifts (425 and 850) will be noticeably narrower and closer to a full 90 degrees apart. With practice, the tuning scope provides the most accurate tuning indicator available. Properly interpreted, the scope patterns tell which direction to tune the receiver and whether the signal shift matches that of the selected demodulator shift. The tuning oscilloscope outputs are only useful for tuning of RTTY signals when the HIGH or LOW tone demodulators are used; indications when Morse code or RTTY with modem demodulators are used should be ignored.

5.7 Using a Television Set as a Monitor

Some good quality black and white TV sets can be easily modified to serve as video monitors. The change does not affect normal operation of the set except that the video cable from the CT2100 must be removed from the TV when the set is to be used to receive television programs. The 24 line by 72 character-per-line display of the CT2100 may require critical adjustment of the TV set width and linearity controls. However, use of the 36 character-per-line mode of the CT2100 will probably make it easier to achieve a satisfactory display on the TV screen. For either mode, it is important that the selected TV have adjustments available for both horizontal and vertical size. Normal TV alignment results in "over-scan" of the viewing screen, preventing margin lines but also losing parts of the picture at the edges and corners. To avoid losing characters of the CT2100 display along the corners and edges, it will be necessary to "shrink" the size of the TV raster with the width and height controls. These adjustments will be made after the TV set is modified and when you can look at the CT2100 video output.

```
*****
*
* CAUTION: DO NOT attempt to use as a monitor any television *
* receiver in which one side of the AC line is *
* connected to the chassis or circuit ground of the *
* set unless you supply AC power to the set through *
* an isolation transformer. *
*
*****
```

The modification is simply a matter of capacitively coupling the external video signal to the input of the first video amplifier stage in the TV set. Figure 7 shows a typical transistor TV video circuit. Although the component values and the biasing scheme may be slightly different in your set, the circuit should be essentially as shown. The CT2100 video signal is injected at point A.

The modified circuit is shown in Figure 8. Connect the negative end of a 100 uF, 16 V electrolytic capacitor to the base of the first video amplifier transistor. Mount a UHF (or BNC) video connector on the cabinet as close as possible to the capacitor connection. Connect the center pin of the coax connector to the positive end of the electrolytic capacitor. Use hook-up wire if the connection is less than 6 inches; use a small coaxial cable such as RG174 for longer connections.

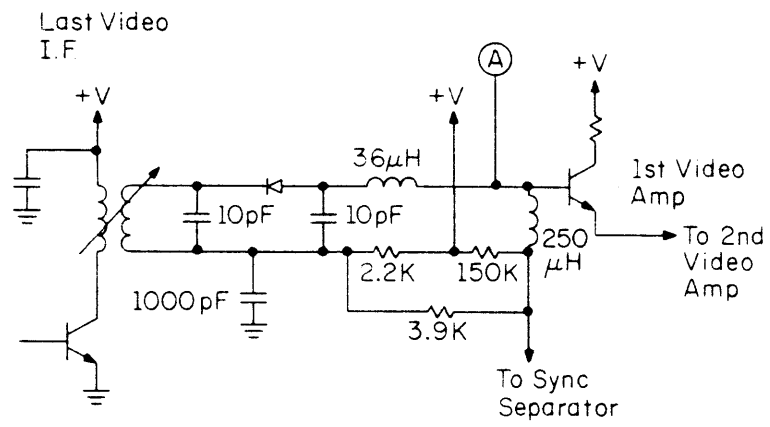

Figure 7. Typical Video Detector

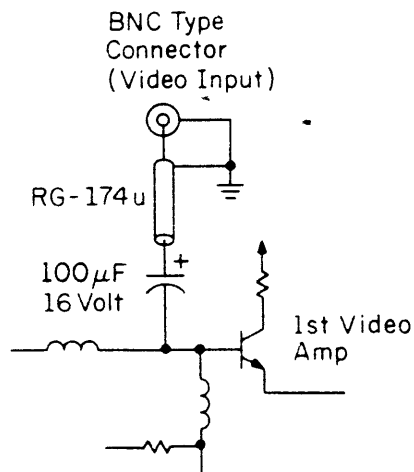

Figure 8. Modified Video Detector

5.8 RF-Induced Problems

The CT2100 is designed to operate in close proximity to radio frequency transmitting and receiving equipment. Particular attention has been paid to the shielding and by-passing of the CT2100 circuitry. However, under certain conditions in an RF-saturated environment, the CT2100 may be susceptible to RF-induced interference. This may manifest itself in any of a number of ways, such as partial or complete lack of response to switches or keyboard operations, or erratic behavior of the video display.

The first thing that should be checked if RF problems are suspected is the GROUND system. The transmitter should be properly grounded for rf (in addition to an electrical safety ground) and all other station equipment grounds should be connected to the transmitter chassis. The rf ground should consist of a short length of heavy copper wire or braid terminated at a good earth ground (ground rod, cold water pipe, etc.). If a water system ground is used, be sure that the pipes are 100 percent metal from the connection point to these water mains - plastic plumbing will break the ground path. If the distance between your transmitter and ground connection is more than a quarter wavelength at the highest operating frequency, make the ground wire an integral number of half-wavelengths long. If you plan to operate 10 and 15 meters, you may need to run separate ground wires for each band.

Stations located on the second floor of wood frame houses can present special problems for RF grounding. One technique that has worked well when none of the usual ground returns work is to spread copper screen material on the floor of the room under the operating position. The equipment ground is then attached to the screen with one or more low inductance leads. The screen creates an "artificial" ground plane in the studio. A carpet is usually placed over the screen to improve the appearance of the room! Consult any of the amateur handbooks or antenna books for a more in-depth discussion of grounding techniques.

The best way to confirm that a problem is caused by RF-induction is to temporarily eliminate the source. This may be done in stages, starting with a partial reduction in exciter drive, and ending with transmitter shut-off. Since RF energy may be induced in the CT2100 through several paths, connecting the transmitter to a dummy load may not eliminate all RF related problems, although this is an excellent first step in verifying RF problems.

POOR

WORSE

CORRECT

BEST

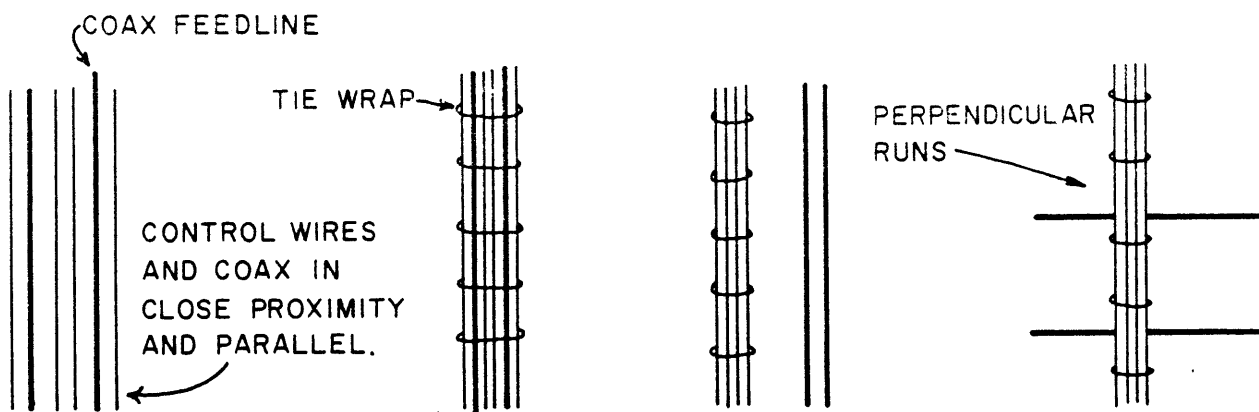

(A)

PLACE RF CHOKE CLOSE TO REAR PANEL OF EQUIPMENT

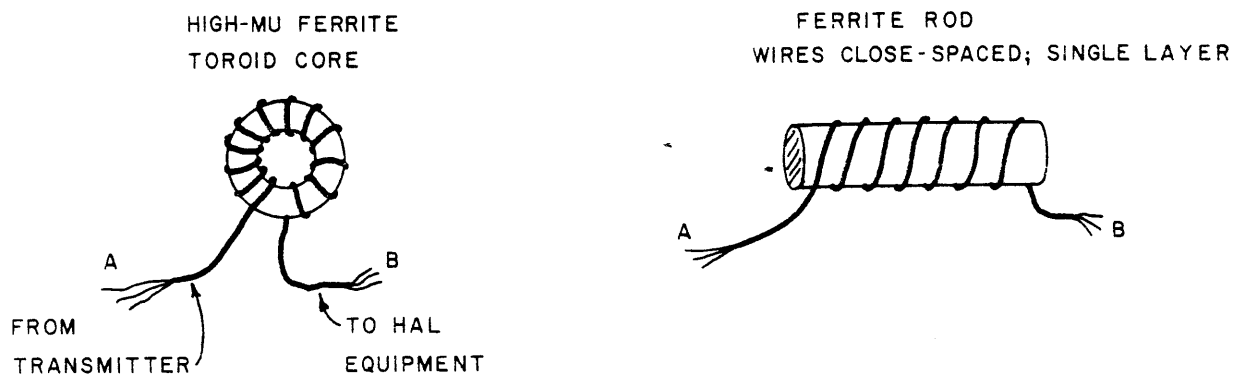

(B)

Figure 9. RFI Reduction Techniques

Radiation of RF energy from linear amplifiers, antenna tuners, coaxial switches, monitor scopes and interconnecting coax-cable jumpers is also possible. In fact, it is this type of radiation that is most likely to be coupled into nearby I/O and power cables of the CT2100. To locate the point or points of radiation, experiment with different cable arrangements to see if the RF-induced problem can be eliminated by reducing coupling between any of the CT2100 cables and nearby coaxial lines carrying RF power. Figure 9A shows several cable arrangements, both good and bad, showing how to keep RF coupling to a minimum. Figure 9B shows how to use high- μ (950 - 2000) ferrite toroids or rods to choke the flow of RF on audio and control lines.

If cable rearrangement doesn't yield positive results, then begin eliminating pieces of equipment and sections of coaxial cable until the transmitter is connected directly to a shielded dummy load. As each piece of equipment is removed from the transmission line, check to see if the RF-related problems have diminished or disappeared. If the RF problem persists with the exciter connected directly to a dummy load, reduce the drive level to see if that eliminates the problem.

If operation into a dummy load does not significantly reduce the rf-related problems, disconnect all I/O cables from the CT2100. Test the operation while it is connected only to ac power. At the same time, enable the transmitter so that it sends a CW signal into a dummy load. If rf problems are still present, then rf energy is probably being introduced to the CT2100 through the power cord by way of the common AC mains power line. This is usually indicative of poor AC-line filtering in the radio transmitter power supply section. Figure 10A shows a common by-pass filter method used in many transmitters. Figure 10B shows a "brute-force" AC line filter that can be added to the transmitter or other equipment to eliminate the flow of rf on the AC power line.

In addition to the liberal use of rf by-passing capacitors on station equipment, the use of certain antennas may offer reduced levels of rf in the radio room in many cases. Whenever possible, use RESONANT dipole, vertical, quad, or Yagi antennas and try to achieve a good impedance match AT THE ANTENNA instead of relying on an antenna tuner. Random-length wire antennas and others that require extensive antenna tuning are more likely to create high levels of rf within the vicinity of the operating position.

The location of the transmitting antenna with respect to the radio room also has an affect on the rf energy that is coupled into interconnecting cables. Apartment dwellers may have the most difficulty achieving a good installation since many times an indoor antenna is the only type allowed. Where outdoor antennas are allowed, they should be placed as high as practical. Not only will this provide for better reception and transmission, but it will also reduce the level of rf in the shack. Also, if possible, avoid bringing an end of a half-wave dipole in close proximity to the operating position; there is a high voltage field at the ends of the dipole that may be hard to shield.

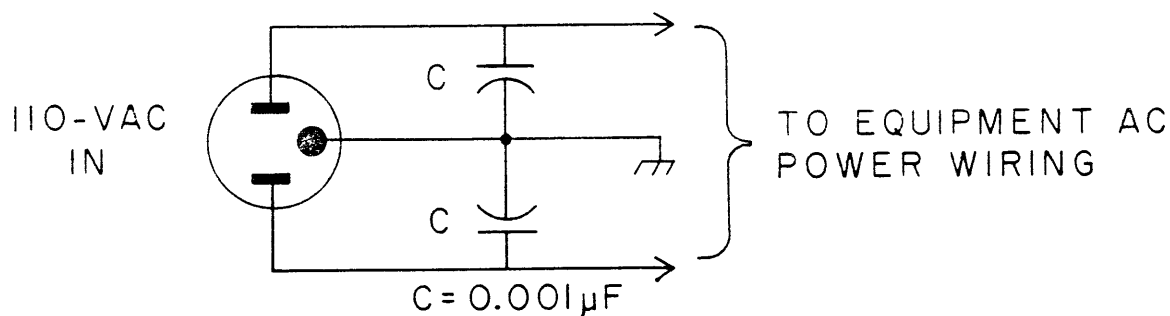

(A)

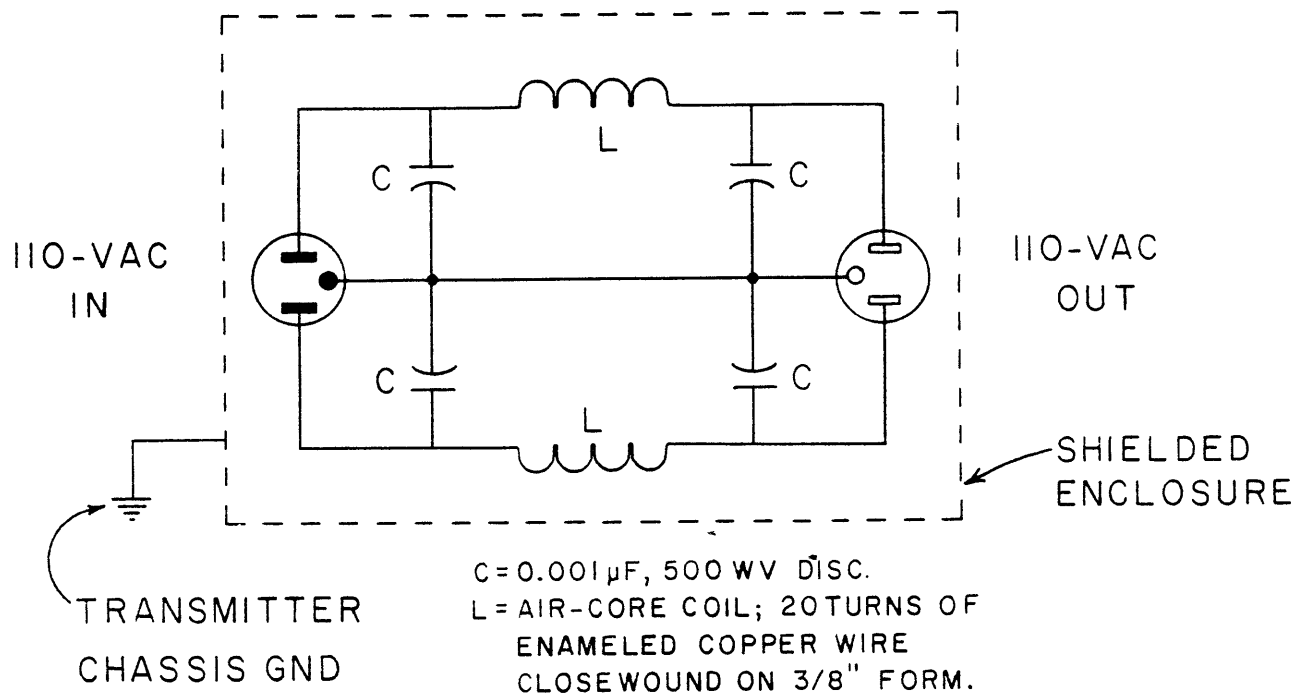

(B)

Figure 10. RFI Power Line Filters

In general, a shielded, coaxial cable feedline with low SWR is much preferred over open wire, twin-lead, or single wire feed systems. The self-shielding property and lower voltages present act to make the coaxial feedline much less susceptible to radiation of rf energy in the shack rather than at the antenna. RF energy may also be conducted back to the station by conduction down the outside of the coaxial cable shield. This may be a particular problem with half-wave dipoles on 40 and 80 meters that are center-fed with only coaxial cable. A balun at the antenna tends to reduce this problem. Also, dress the coaxial cable from the balun so that it drops perpendicular to the dipole, rather than parallel. In stubborn cases, you may find that dropping the coaxial cable clear to the ground and burying it (5 or 6 inches) for the horizontal run to the shack may help reduce rf coupling considerably. This technique has worked particularly well for second-story station installations. As an alternate to the balun, construction of an rf choke out of the coax itself is sometimes effective; wind six or more turns of the coaxial cable in a six inch diameter coil. Place the coil at the antenna and wrap it with electrical tape to hold its shape. If there is a moderate to high SWR on the line (2:1 or more), you may find that varying the length of the line helps, although this is a poor substitute for a properly matched antenna.

Experience has shown that the TV monitor itself may be a source or conductor of RF interference. Various circuits of the TV monitor (particularly the sweep circuits) can and do generate RF interference which may be heard in the receiver. Also, the video output to the monitor is a wide-bandwidth digital signal with rich harmonic content as is required to produce the crisp character display. If the TV set is poorly shielded (not at all in some plastic-cabinet models) or lacks proper power line by-passing, the RF from the monitor's circuits or from the video output may escape to cause receiver interference. Also, RF from the transmitter may enter the monitor and disrupt the monitor or CT2100 operation. This may be quickly tested by simply disconnecting the video cable from the CT2100. There is no substitute for good shielding and by-passing; metal cabinet monitors are highly recommended!

The CT2100 has been tested and is verified by HAL Communications Corp. to be in compliance with Part 15, Subpart J of the FCC Rules And Regulations, Class B computing device. The following text is a requirement of that regulation:

"This equipment generates and uses radio frequency energy and if not installed and used properly, that is, in strict accordance with the manufacturer's instructions, may cause interference to radio and television reception. It has been type tested and found to comply with the limits for a Class B computing device in accordance with the specifications in Subpart J of Part 15 of FCC Rules, which are designed to provide reasonable protection against such interference in a residential installation. However, there is no guarantee that interference will not occur in a particular installation. If this equipment does cause interference to radio or television reception, which can be determined by turning the equipment off and on, the user is encouraged to try to correct the interference by one or more of the following measures:

- reorient the receiving antenna
- relocate the computer with respect to the receiver
- move the computer away from the receiver
- plug the computer into a different outlet so that computer and receiver are on different branch circuits.

If necessary, the user should consult the dealer or an experienced radio/television technician for additional suggestions. The user may find the following booklet prepared by the Federal Communications Commission helpful:

"How to Identify and Resolve Radio-TV Interference Problems."
This booklet is available from the US Government Printing Office, Washington, DC 20402, Stock No. 004-000-00345-4."

In addition, the following rear-panel label is located on the CT2100 rear panel:

"This equipment has been tested and found to comply with the technical specifications in Part 15 of FCC Rules for a Class B computing device."

Also, the following FCC text applies to use of peripherals attached to the CT2100:

"WARNING: This equipment has been verified to comply with the limits for a Class B computing device, pursuant to Subpart J of Part 15 of FCC Rules. Only peripherals (computer input/output devices, terminals, printers, etc.) certified to comply with the Class B limits may be attached to this computer. Operation with non-certified peripherals is likely to result in interference to radio and TV reception."

5.9 Power Line Voltage and Frequency Changes

Voltage Change:

The CT2100 can be connected for operation from either 95-125 VAC, or 190-250 VAC power lines. In addition, provision is included to compensate for lower than normal 120/240 VAC U.S. standard power voltage.

```
*****
*
*   CAUTION: DO NOT MAKE ANY CHANGES IN POWER CONNECTIONS UNLESS
*             THE TERMINAL HAS BEEN DISCONNECTED FROM THE POWER
*             LINE AND OTHER EQUIPMENT.
*
*****
```

Power transformer primary winding taps must be changed to select the various power-line voltage possibilities. Refer to Figure 11 for the following discussion.

110 to 125 VAC

The CT2100 is normally factory-wired for this voltage unless the unit is specifically ordered for another voltage. Any power connection other than 110-125 VAC / 60 Hz will be indicated by a tag on the rear panel of the unit. If you desire to convert a CT2100 previously wired for another voltage range, follow the the diagram in Figure 11A.

90 to 125 VAC

If the power line voltage available is CONSISTENTLY lower than 110 volts, the transformer can be rewired as shown in Figure 11B. If, however, line voltage problems are being caused by poor line regulation that allows greater than a 15 volt change in the line voltage, you should contact your power company and have the problem corrected. Use of the saturable-reactor type regulators (with or without sine-wave filtering) is NOT recommended; the "spikes" generated in such devices will interfere with proper operation of the CT2100! Also, the CT2100 can be damaged if the low-voltage taps are used and the line voltage increases later

220 to 250 VAC

This connection is normally supplied for export use when so requested by the customer. If this connection has been factory installed, it will be indicated on a tag on the rear panel of the cabinet. If you desire to change a unit that has previously been connected for 110-125 VAC, follow the instructions of Figure 11C. The primary jumper wires (jumpers "A" and "B") are left long enough to allow conversion that involves removal of jumper "B" and moving ONE end of jumper "A".

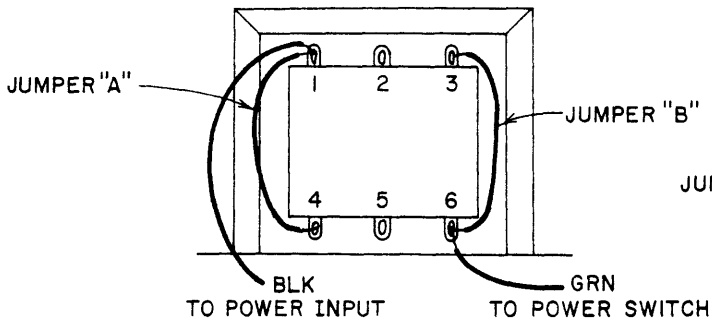

(a) 110 - 125 VAC Connection
(Standard)

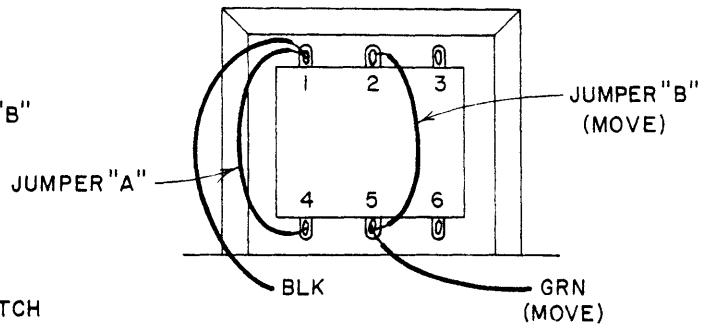

(b) 95 - 110 VAC Connection

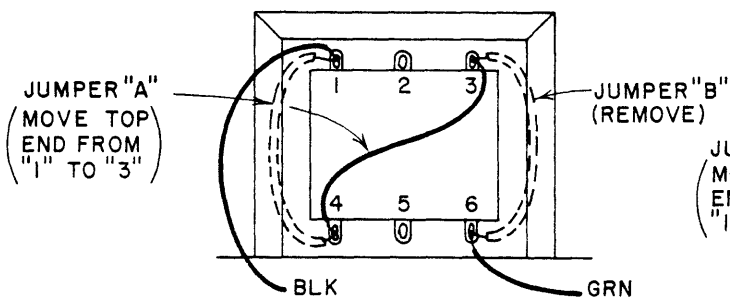

(c) 220 - 250 VAC Connection

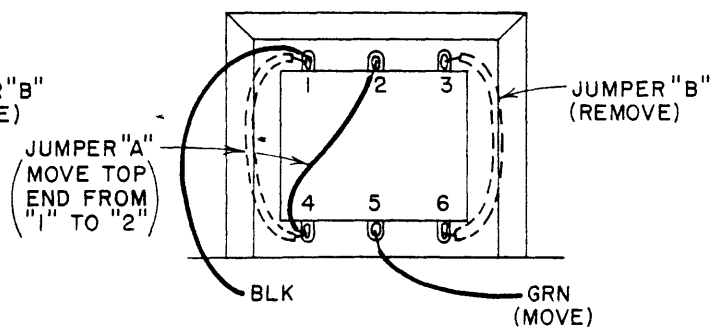

(d) 190 - 220 VAC Connection

Figure 11. Power Transformer Voltage Tap Connections

190 to 220 VAC

If the power line voltage is CONSISTENTLY lower than 220 volts, the connection shown in Figure 11D should be used. The same precautions discussed above (95 to 125 VAC) also apply to this connection. Poor line voltage regulation may result in unsatisfactory terminal operation.

Power Frequency Change:

The power supply section of the CT2100 works equally well for power line frequencies of 50 or 60 Hz. However, four jumper changes are required to operate the timing circuitry from 50 rather than the U.S. standard 60 Hz power mains. If the 50 Hz power requirement is specified when the CT2100 is ordered, these jumper changes will be made at the factory and the change noted on the power line voltage and frequency tag on the CT2100 rear panel.

The four jumper locations are shown in Figure 12. The circuit board is constructed so that the 60 Hz jumper is included as a circuit path on the board itself. Therefore, to convert a 60 Hz unit to 50 Hz, it is first necessary to cut the 60 Hz "jumper path" and then insert a wire jumper in the 50 Hz position. Use a sharp knife or scribe to cut the 60 Hz jumper paths; be sure that you have cut all the way through the path! Note that it is necessary to add two diodes and one resistor for one 50 Hz jumper. If a 50 Hz unit is to be converted to 60 Hz, move the 50 Hz wire jumper to the 60 Hz location - the PC path will already be cut.

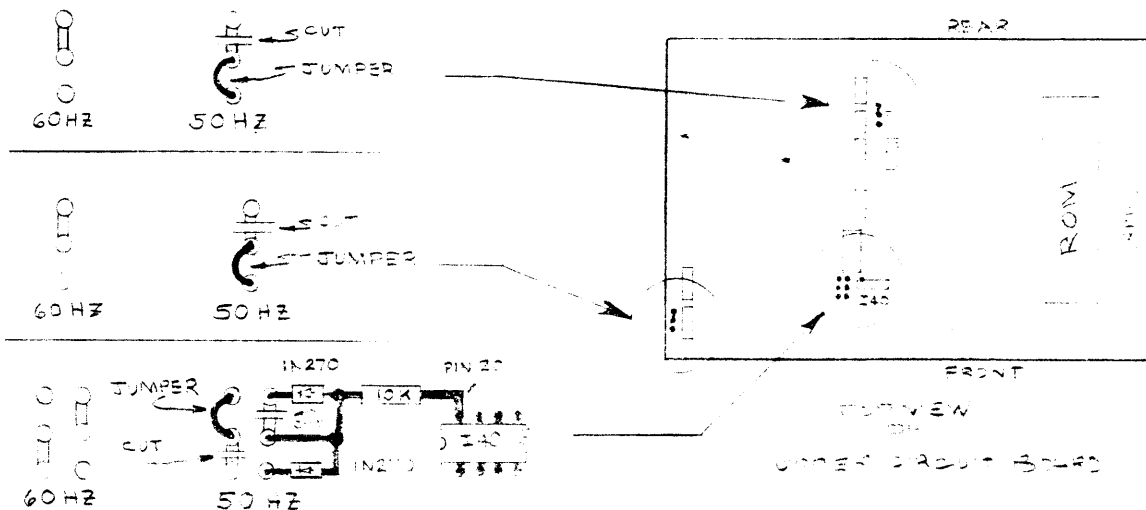

Figure 12. Power Frequency Change Jumpers

5.10 User Adjustments

There are 4 user-adjustable potentiometers located on the bottom of the lower printed circuit board ("analog board"). To access these adjustments, it is first necessary to remove the top and bottom covers of the CT2100. Remove the six Phillips-head screws on each side of the cabinet exterior and remove the top and bottom covers.

BE SURE THAT THE AC POWER LINE IS DISCONNECTED BEFORE REMOVING COVERS!

Place the CT2100 upside down and reconnect the cables as required, being careful not to come into contact with the AC power input circuitry. The four controls are shown in Figure 13.

XMIT OUT Control:

The voltage level of the audio to the transmitter microphone for RTTY transmission is set by this control. The factory setting of 20 mV (-32 dBm) is usually optimum for most transmitters, but you may desire to readjust this for your particular transmitter. To adjust, set the transmitter up to transmit RTTY into a dummy load (LSB, in general), turn on the transmitter, and adjust the XMIT OUT control and the transmitter MIC. GAIN for the desired transmitter rf output. Be careful to avoid overdriving the transmitter - spurious transmission may otherwise occur!

TAPE OUT Control:

The voltage level of the audio to the tape recorder input is set by this control. The factory pre-set level of 20 mV (-32 dBm) should be adequate for most tape recorders, particularly for those using an AGC or ALC level control circuit. Otherwise, set the control for the best quality tape recording.

ASCII PRINTER Data Rate Control:

This control is factory set for use with a serial, 300 baud ASCII printer, the recommended printer for use with the CT2100. However, it may be re-adjusted for any data rate between 100 and 1200 baud. To adjust the baud rate for the ASCII printer output, connect a frequency counter to the test point shown in Figure 13. The counter frequency should indicate two times the desired data rate (in baud). Simply re-adjust the control for the desired baud rate. For example, set the control for a 600 counter indication for a 300 baud printer. Unless your printer's internal clock is way out of adjustment, the printer will print correctly. If it doesn't, try adjusting the data rate control slightly one way or the other from the correct setting.

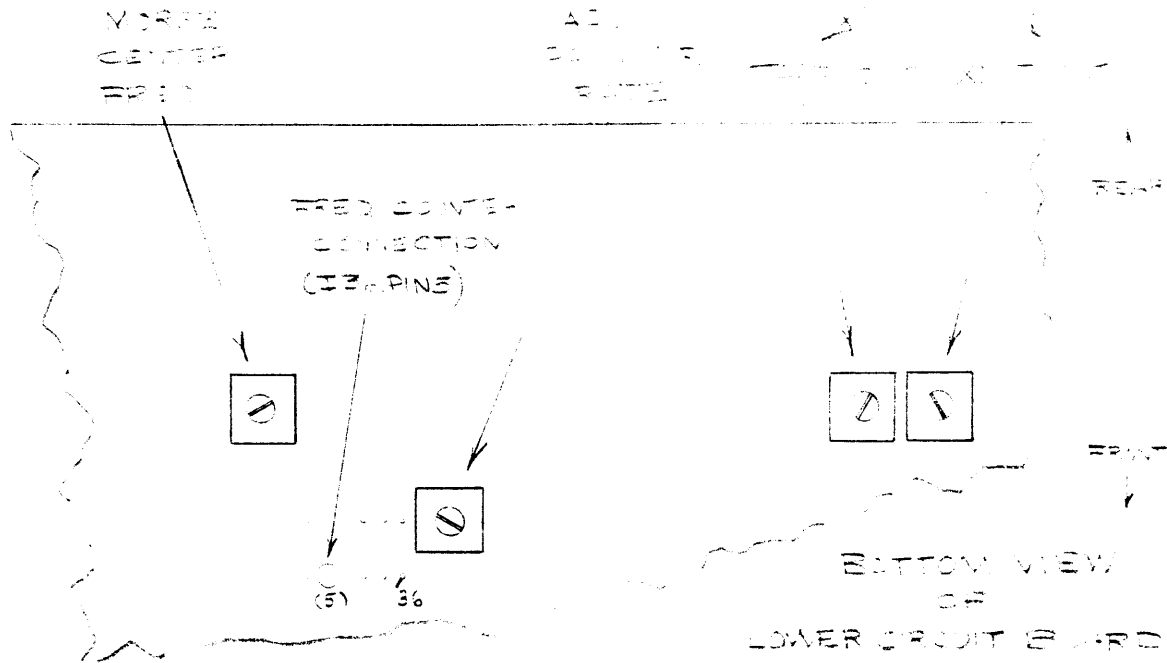

Figure 13. User Adjustable Controls

Morse Receive Tone Center Frequency Control:

The CT2100 is factory aligned to receive an 800 Hz tone for Morse code reception. Since a relatively broad heterodyne phase-lock loop circuit is used, this adjustment will be very tolerant of receiver mistuning. However, this input center frequency of the CT2100 may be adjusted over the range of 600 to 1200 Hz. To adjust the Morse control, connect an audio signal generator to the CT2100 RCVR IN (or TAPE IN) connector. Using a frequency counter, set the generator to 800 Hz frequency. Adjust the generator output voltage until the CW led has just turned-on. Now, reset the generator for the new desired center frequency and adjust the Morse center frequency control until the CW led is again "lit". Notice that there is a range of adjustment between where the LED turns on and then turns off again; set the control for the mid-point of this range.

These are the ONLY controls recommended for user-adjustment. Other controls should be re-adjusted by the factory or an authorized repair facility.

CHAPTER 6

IN CASE OF DIFFICULTY

This section of your user's manual will discuss in general terms how to keep your CT2100 in top operating condition and typical operating problems you might encounter (and some solutions). Circuit description, repair procedures, and schematic diagrams are included in the separate CT2100 CUSTOMER MAINTENANCE MANUAL, available separately from HAL Communications Corp. or its dealers.

6.1 Care and Feeding of Your CT2100

Your CT2100 is the latest of seven generations of terminals manufactured by HAL Communications. In every way, it has been designed, constructed, and tested to assure years of trouble-free operation. However, there are a number of simple procedures that you, the user, can follow to further improve the reliability, performance, and lifetime of the terminal. The following suggestions are offered to help preserve a long operating life for your CT2100.

Environment:

Electric equipment is very susceptible to variations in temperature, relative humidity, and to dust and dirt accumulations. The CT2100 will operate in normal room-temperature environments and should be as tolerant of temperature extremes as you are while operating it. However, inadvertent blockage of the ventilating holes in the cabinet will cause the INTERNAL temperature of the terminal to rise considerably above the ambient room temperature and may in fact cause circuit failure. Also, accumulations of dust or dirt, particularly when accompanied by high humidity conditions, can also cause overheating and may result in long-term corrosion of the internal circuitry. Therefore, try to position the terminal so that its ventilating holes are not obstructed and try to avoid extremely dusty or dirty environments. On the other hand, the solid-state components in the CT2100 are designed to operate at considerably higher temperatures than we humans; do not be overly disturbed if the cabinet of the CT2100 (particularly the right-hand end) operates quite warm to the touch. This internal heat often helps to "dry-out" humidity in the cabinet.

In the normal course of operation, the terminal and its display may attract a build-up of dust or smoke "haze". This may be expected even in the cleanest areas, particularly if tobacco smoking is prevalent. The display screen, because of the air flow around it and the high voltage applied to the CRT, actually attracts particulate matter from the air. This causes over a period of time what may appear to be a gradual fading of the screen intensity as well as de-focusing of the characters. Therefore, the face of the CRT should be cleaned often.

Be careful when cleaning any plastic parts as they scratch easily! Cleaning materials available for phonograph records are usually excellent for cleaning plastic, but may not be strong enough to do the job if too much dirt has accumulated.

The keyswitches in an electronic keyboard seem to be particularly vulnerable to humidity and particulate air contaminants. Experience has shown that keyswitch failures are considerably more likely in equipment used in a high humidity location (in a basement, for example); even more so if the basement operator also smokes! The keyswitches in the KB2100 are commercial quality switches that should last for many years. However, they are essentially mechanical parts, unsealed from the environment and will tend to be much more susceptible to this type of problem than any other CT2100/KB2100 part.

Electrical Connection:

All electrical connection points of the CT2100 have maximum voltage and current ratings as given in this manual. If these ratings are exceeded for even a short period of time, considerable damage to the terminal may result. Therefore, be very careful -- KNOW the ratings of the CT2100 and the characteristics of any other equipment before making connections. Some common causes of electrical failures have been found to be:

- A. Inadequate grounding, causing RF interference problems as well as sensitivity to AC power line transients.
- B. Incorrect connection of the high-voltage loop supply, causing destruction of the circuit to which it was incorrectly connected.
- C. Inadvertent use of more than one loop power supply causing a very high loop voltage or current, destroying the loop keying transistor.
- D. Damage from lightning, or other transients on the power line or station antenna system. A good lightning protection system may help, as will disconnecting the terminal during electrical storms. However, such things are unpredictable and the CT2100 is no more susceptible to such problems than other electronic equipment in the station.

6.2 Typical Operational Problems

Because a large number of features are offered in the CT2100, it is by nature a complicated device. Therefore, there may be times when it first appears that the terminal has either quit completely or gone off to "do its own thing". If some of the circuitry has failed, you may well get such symptoms. However, most often when a new owner finds the terminal "unresponsive", it is actually doing what it has been instructed to do. Familiarity with the CT2100 controls will quickly reduce the chances of "cockpit error" during terminal operation.

The status line and front panel switch position are the best keys to what is happening in the CT2100. Until you are quite familiar with the CT2100 operations, it is highly recommended that you keep the status line turned on (STATUS button in).

Often mistyping one key for another may cause a result entirely different from that intended. Some of the more confusing conditions you may encounter are:

1. Forgetting to terminate the programming of a HERE-IS message. Normally, when you finish typing the desired HERE-IS message text, you terminate the programming with a SHIFT-CTRL-HERE-IS operation. Failure to use either SHIFT or CTRL means that the text continues to be stored in the HERE-IS buffer UNTIL THE 32ND CHARACTER IS TYPED: at this point, the programming is automatically TERMINATED because the HERE-IS buffer is filled. If, after over-flowing the HERE-IS buffer storage, you type another SHIFT-CTRL-HERE-IS sequence (as you would normally do), the HERE-IS storage will be re-opened, erasing the previous text programmed into the buffer. This can be particularly confusing if exactly 32 characters are written into a HERE-IS memory. A clue to the terminal's state is the HERE-IS programming area itself. During HERE-IS programming, the status line is replaced on the screen top line by the programming field. The square block cursor in this field indicates the keyboard position within the HERE-IS program. When the HERE-IS programming is completed, the status line replaces the programming field; if you see the status line, you are no longer programming a HERE-IS message!
2. When separate LF or CR characters are to be transmitted in KSR mode (using SHIFT-comma or SHIFT-period, in Baudot, for example), the presence of these characters will be shown in the transmit reverse video section of the screen by the appropriate symbol. However, when transmitted, the effects of these characters is not shown on the screen. They are, none the less, transmitted. As noted before, these control characters may-only be transmitted in KSR (bottom line entry) mode or when FDX is used. These characters are used for cursor control in split screen mode and are not transmitted separately; use the NEW LINE key!
3. When IDLE is used and KOS controls the transmit/receive circuit of the station, the synchronous idle feature will keep the KOS and the CT2100 in a continuous-transmit condition (outputting sync characters) until a NEW LINE key is typed and no characters are typed on the next line. Therefore, it is a good operating practice to ALWAYS END A TRANSMISSION WITH THE NEW LINE KEY.
4. The CT2100 may be operated in either half duplex (HDX) or full duplex (FDX). However, text typed on the keyboard ONLY appears on the display in HDX mode; there is no on-screen local "echo" of keyboard text in FDX mode. Also, the TX ON condition will be immediately shown on the status line when FDX is selected, indicat-

ing that all typed characters are transmitted IMMEDIATELY when a key is typed; there is no CTRL-7 control of TX ON/OFF status and word mode, etc are not available.

5. The CT2100 will only receive RTTY text if ALL THREE I/O switches (RCVE/RS232, RCVE/TAPE, and NORM/LOOP) are pushed in. Be sure to restore these switches to this position after using a tape recorder or loop transmitting device in particular.
6. Be sure that you have properly selected the desired demodulator and shift combination; trying to tune a high tone RTTY signal when the switches have selected MODEM HIGH can be particularly frustrating!
7. Remember that using the LINE CYCLE switch automatically clears all pages of the display; don't accidentally hit the LINE CYCLE switch when you really want the PAGE CYCLE switch.
8. All tuning LEDs operate at any time that there is audio input to the CT2100. Recall that the RTTY MARK, SPACE, and +/+ LEDs are only useful when RTTY demodulators are in use (not when the Morse mode is selected); the MARK and SPACE LED's work with the MODEM tones, but the +/+ LED indicates no useful information. Similarly, the CW LED is only useful when receiving Morse code. The OVLD LED indicates correctly for all audio input to the CT2100.
9. The MAN TX switch position (button in) over-rides KOS control of the transmit/receive line and the transmitter will be on for as long as this button is pushed in. Be sure sure to turn off the KOS for Morse operation.
10. The "HELP" switches of the CT2100 are:

CTRL-7 (XMIT):	Will stop transmission of text
STATUS:	Display status line
CLR SCRN:	Clears all pages .
MORSE:	Resets CW receive circuitry
ON-OFF:	Start over (last resort!)

6.3 Repair Procedures

In the event that your CT2100 develops a malfunction, the first step is to carefully note all of the symptoms of the problem. Statements such as "BROKEN" or "DOESN'T WORK" are of little help to the service technician, and usually lead to longer repair times than might otherwise be required. Try to provide as much information concerning the failure as you can before you contact your dealer. By all means, consult your dealer before calling the factory; he may be able to fix the unit locally and avoid the shipping and delay times. The follow-

ing are some of the things that will concern the dealer or factory:

1. Model number and version number (V1.x)
2. Serial number
3. How long have you owned it?
4. Where did you purchase it (dealer's name)?
5. If purchased used, who was the previous owner? (Used to refer to any previous repair history on that particular unit.)
6. What terminal modes, rates, codes, and conditions are associated with the failure? Does it happen only in receive, transmit, or both?
7. Are there extenuating circumstances? (Lightning, spilled liquids, dropped unit?)
8. Is the problem confined to a particular unit? (CT2100, KB2100, monitor?)
9. Is there anything else you can add to the description that you think might be useful?

AFTER you have determined answers to the above, contact your dealer and discuss the problem with him. If he indicates that he will be unable to assist you, the unit should be returned to the HAL factory for repair. Before returning the unit to the factory, either you or the dealer should call and receive factory return authorization so that we may expect the unit in shipping and be prepared to work on it when it arrives. Whenever possible, return the unit via UPS to the factory address below, insuring it for the full value. The shipping cost to the factory should be paid by you; the return shipping costs from the factory (48 contiguous states only) are paid by HAL. The factory "ship-to" address is:

HAL COMMUNICATIONS CORP
1201 W. KENYON ROAD
BOX 365
URBANA, ILLINOIS 61801
ATTENTION: REPAIR DEPARTMENT

Because of the complexity of the circuitry used in the CT2100, we do NOT recommend that you personally undertake repairs of the terminal circuit boards themselves. If you have used the CT2100 CUSTOMER MAINTENANCE MANUAL to isolate the problem to a particular circuit board or sub-assembly, an exchange of boards may sometimes be made, subject to the availability of exchange parts.

The one-year limited warranty (listed in full at the end of this manual) provides for repair of the CT2100 for a full year after purchase. The purchase invoice date from your dealer marks the beginning of the warranty period - save your copy of the invoice! Please read the warranty carefully to determine the full extent of the privileges and limitations.

CHAPTER 7
SPECIFICATIONS

INPUT/OUTPUT:

AUDIO INPUT:	0.5 V p-p, 4-600 ohm audio 800 Hz for Morse receive 1000-3000 Hz for RTTY
AUDIO OUTPUT:	XMIT OUT = -32 dBm (20 mV nom), 600 ohms (adj.) TAPE OUT = -32 dBm (20 mV nom), 600 ohms (adj.) MON OUT = adj. to 2 Watts, 4-8 ohms All harmonics below 9th are attenuated > 30 dB
RS232 I/O:	Standard RS232 data interface levels; Mark = -5 to -15 VDC Space = +5 to +15 VDC
LOOP I/O:	Standard current loop; Voltage = 200 VDC maximum Current = 18 to 120 mA Mark = Loop current on Space = Loop current off Loop referenced to chassis ground at the CT2100; External loop power supply required; data may be transmitted from external loop device.
MORSE KEYS:	Separate transistor switches to key + or - circuits Voltage = 150 VDC maximum Current = 150 mA maximum
SCOPE OUTPUTS:	Separate mark and space connections for crossed ellipse indication on X-Y scope display. Voltage = 2.0 V p-p typical, 1000 ohms
ASCII PRINTER:	Serial, RS232-C, 300 baud ASCII printer output; all received and transmitted text may be printed on the ASCII printer, regardless of code, up to the data rate of the printer itself.
KOS SWITCH:	NPN transistor switch to ground to control TX/RX function of station. Voltage = 150 +VDC maximum Current = 150 mA maximum Isolation relay or circuit required to switch neg- ative voltage control lines.
+12 V. REF.:	Reference output voltage for low current devices; may be used with low current relay to switch nega- tive voltage TX/RX control lines.

KB2100: Connection to KB2100 accessory keyboard.

VIDEO TO MONITOR: RS170 standard composite video output;
1.0 V p-p, 72 ohms, 6.1 MHz bandwidth.

DATA CODES AND RATES:

BAUDOT CODE: U.S. Standard 5-level International Telegraphic Alphabet No. 2 Baudot Code with 1 unit start and 1.5 unit stop bit. (Interchange of BELL and ' available on export units for CCITT 2)

ASCII CODE: American National Standard Code for Information Interchange (ASCII) as defined by ANSI Standard X3.4-1968. 8 unit code with 1 unit start pulse; 2 unit stop pulse for 110 baud and lower rates, one unit stop pulse for 150 baud and higher rates. Full 128 character set may be transmitted and received; 8th data bit ("parity bit") set to space condition.

RTTY DATA RATES: Baudot or ASCII codes may be transmitted and received at 45, 50, 57, 74, 100, 110, 150, 300, 600, and 1200 baud.

MORSE CODE: Continental Morse Code including all letters, numbers, period, comma, colon, semi-colon, dash, apostrophe, parenthesis, quote, question mark, and AA, AR, AS, BT, KN, SK, and error prosigns. Receive speed automatically tracks from 1 to 100 wpm speeds - transmit speed may be set for 1 to 100 wpm in 1 wpm increments.

MODEMS:

MORSE: Phase-lock loop; 800 Hz nominal center frequency; adjustable over 400 - 1200 Hz range; tracks drift-signal +/- 250 Hz of center frequency.

RTTY HIGH TONES: Mark = 2125 Hz
Space = 2295 Hz (170 Shift)
= 2550 Hz (425 Shift)
= 2975 Hz (850 Shift)
CW ID = 2025 Hz (all shifts)

RTTY LOW TONES: Mark = 1275 Hz (170 Shift)
Space = 1445 Hz (170 Shift)
= 1700 Hz (425 Shift)
= 2125 Hz (850 Shift)
CW ID = 1175 Hz (all shifts)

103 MODEM: Mark = 1270 Hz
Space = 1070 Hz
CW ID = 1370 Hz

202 MODEM: Mark = 1200 Hz
Space = 2200 Hz
CW ID = 1100 Hz

Transmit audio tone frequencies are automatically set to correspond to selected modem and shift; NORM/REV switch changes polarity of both TX and RX tones.

DISPLAY:

VIDEO: Standard RS170, 1.0 V p-p, 72 ohm composite video; 6.1 MHz (72 character lines) or 3 MHz BW (36 character lines).

SCREEN: 24 lines of 72 or 36 characters per line; top line may be used to display terminal status or for programming of HERE IS messages; vertical tuning bar in upper left margin indicates RTTY tuning.

PAGE MEMORY 48 lines of 72 characters per line (2 pages); or 96 lines of 36 characters per line (4 pages).

POLARITY: Normal = receive white characters on dark screen;
transmit dark characters on white screen
Reverse = receive dark characters on white screen;
transmit white characters on dark screen

SPLIT SCREEN: Bottom 12 lines of page 2 (page 4 in 36 character line mode) devoted to pre-typing of transmit text. Cursor may be repositioned in four directions for full editing. Available only when KB2100 is used; text may be typed while receiving.

KSR MODE: Text typed on KB2100 is entered on bottom line of page 2 (page 4 in 36 character line mode). Up to the full display capacity of 3456 characters may be typed before transmitting; not recommended for text composure while receiving. RUB OUT key used for editing.

CHARACTERS: Full upper and lower case letters, all numbers and punctuation of the ASCII character set, special graphic symbols for ASCII control codes; 5 x 7 dot matrix with half-dot shift; full lower case descenders.

SCROLL: Smooth scroll of line feeds rather than abrupt scrolling of lines; new received text is entered on bottom line of page 2 (page 4 in 36 character line mode); scrolls upward through page 2, continues to bottom line of page 1 (page 3 and then 2 and 1 in 36 mode). Receive text starts at line 13 if split screen is elected.

TX/RX CONTROL:

HDX/FDX: Operate terminal in either half duplex (HDX) or full duplex (FDX) modes; HDX gives screen display of typed text and local "echo" as it is transmitted; typed text is not displayed and there is no local "echo" in FDX mode. The KOS, word mode, word wrap-around, and non over-print features do not function in FDX mode. FDX allows simultaneous transmit and receive operation via RS232 or audio I/O connections.

IDLE: Synchronous idle character may be automatically inserted during lulls in typing. SYNC character is:
NUL (000 0000) in ASCII;
LTRS (11111) in Baudot;
BT (-...-) in Morse.

KOS: Transistor switch automatically controls station TX/RX line. This function may also be controlled manually with the MAN TX switch.

MONITOR: Internal audio monitoring system allows monitoring of either input or output audio signals on the internal monitor speaker or on an external monitor speaker with front panel volume control. Input audio switch position allows listening direct to receiver or tape signal. Output audio switch position allows listening to 800 Hz Morse sidetone or to RTTY tones to be transmitted in Baudot or ASCII.

INDICATORS:

LED: Six LED indicators show MARK, SPACE, RTTY center tuning (+/+), Morse center tuning (CW), audio input overload (OVL), and KOS on-off status.

TX/RX HDX/FDX = Select half of full duplex
 CONTROL: IDLE = Turn on synchronous idle feature
 MAN TX/AUTO = Select manual or automatic TX control

MODEM: RTTY/MODEM = Select RTTY or Modem tones
 HIGH/LOW = Select high or low tones
 NORM/REV = Reverse polarity of tones
 AUTO = Turn on RTTY auto print control
 SHIFT = 850 Hz Shift
 = 425 Hz Shift
 = 170 Hz Shift

I/O: AUDIO/RS232 = Select audio or RS232 input data
 RCVE/TAPE = Select input audio source
 NORM/LOOP = Transmit from RTTY loop device

MONITOR: OUTPUT/INPUT = Monitor input or output audio
 VOLUME = Adjust audio monitor volume
 ON/OFF = AC power switch (on Monitor Volume)

REAR PANEL CONNECTIONS: AUDIO MONITOR; EXT. LOOP; ASCII PRINTER; RS232 IN;
 TAPE IN; RCVR IN; SCOPE SPACE; SCOPE MARK; CW KEY
 POS; CW KEY NEG; TAPE OUT; RS232 OUT; +12 V REF;
 XMIT OUT; KOS SWITCH; VIDEO TO MONITOR; KB2100;
 GND; AC POWER; and 0.5 A-SB FUSE.

MECHANICAL
 SPECIFICATIONS:

CT2100: 16.75"W x 3.625"H x 10.375"D (17" wide with RM2100)
 42.55cm x 9.21cm x 26.35cm (43.18cm W with RM2100)
 16.0 lbs net; 19.0 lbs shipping
 7.3 kg net; 8.6 kg shipping
 Color: Light gray top and bottom; black front panel;
 red and blue switch buttons and front panel trim.

KB2100: 14.00"W x 2.375"H x 7.00"D
 35.56cm x 6.03cm x 17.78cm
 4.5 lbs net; 7.0 lbs shipping
 2.0 kg net; 3.2 kg shipping
 Color: Light gray top; dark gray bottom; black and
 white keytops.

POWER: 95 - 130 VAC, 50 or 60 Hz
 190 - 250 VAC, 50 or 60 Hz
 30 Watts

ACCESSORIES
AVAILABLE:

- KB2100 - Keyboard for transmitting text; special code is used and other keyboards may not be substituted.
- RM2100 - Rack-mount adapter to fasten CT2100 into U.S. standard 19 inch relay rack; uses 3.50 inches of vertical rack space.
- MSG2100 - Message Storage ROM (2716 type part) to store up to 2040 characters of text. May be changed by user.
- ESM914 - 9 inch video TV monitor for display; may be supplied for EITHER 120 or 240 VAC; units are not switchable.

The text in the programming chart above would be transmitted as:

DE WB9XYZ, JIM IN URBANA, IL. CQ CQ CQ CQ CQ CQ CQ CQ CQ CQ CQ CQ CQ
 THIS IS A TEST. THE QUICK BROWN FOX JUMPED OVER THE LAZY DOG'S BACK.
 NOW IS THE TIME FOR ALL GOOD MEN TO COME TO THE AID OF THEIR COUNTRY.
 PACK MY BOX WITH FIVE DOZEN LIQUOR JUGS.
 AR SK

If a message longer than 255 characters is required, you may combine two or more message blocks to obtain the necessary space. To do this, simply program continuously through several messages without putting a termination character at the end of each message block, but filling in a square after the end of the entire message text.

If the message text is shorter than 255 characters, be sure to place the termination character immediately after the end of text to prevent extra spaces from being sent following the message text.

Programming Notes:

1. Be sure to PRINT when programming message text in the programming chart.
2. Print capital letters when upper case is desired. When lower case letters are printed in the programming chart, lower-case characters will be stored in your MSG2100 ROM.
3. If a message containing lower and upper case letters is programmed, it will be sent exactly as programmed when the CT2100 is in ASCII mode, but when either Baudot or Morse codes are used, the CT2100 will "map" the lower case characters to upper case before transmitting them.
4. ASCII control codes or special characters that have no equivalent in Morse or Baudot will be displayed on the screen along with the standard text. However, when the CT2100 transmits the message text from the screen, it will skip over the invalid characters, sending only the valid Baudot or Morse characters.
5. If you program ASCII control codes, or special characters, refer to the listing below for the proper two- or three-letter designation that you should print in the programming squares. Please adhere to these codes to prevent mistakes in the programming of your ROM.
6. Try to use less than 12 lines per message so that the whole message will fit onto the 12 lines of the split screen.

ASCII Codes: (See Table 4 for a complete listing)

ACK	EM	HT	SOH
BEL	ENQ	LF	STX
BS	EOT	NAK	SUB
CAN	ESC	NUL	SYN
DC1	ETB	RS	US
DC2	ETX	RTN	VT
DC3	FF	RBO	
DC4	FS	SI	NEW LINE = LF
DLE	GS	SO	ID (CW ID)

Baudot Codes: (See Table 2 for a complete listing)

LTR	CR	BEL
FIG	LF	BNK (blank)
ID (CW ID)		NEW LINE = LF

Morse Codes: (See Table 1 for a complete listing)

AA	BT	ID (CW ID)
AR	KN	
AS	SK	

2. Installation of the EPROM

To install the MSG2100 ROM in the CT2100, DISCONNECT THE AC POWER LINE and remove only the top cover of the CT2100 (three top screws on each side of cabinet). When viewing the CT2100 from the front, you will notice a row of large IC's and sockets along the right-side of the top circuit board. The first four integrated circuits (close to the front panel) are ROMs containing the controlling programs ("software") of the CT2100. The rear-most socket, next to the power transformer, is reserved for installation of the MSG2100 ROM.

Note the orientation of the "software" ROMs: the pin 1 end of each ROM (the end with the half-round notch in it) is at the left end of socket. ALL ROMS ARE INSTALLED IN THE SAME DIRECTION. The MSG2100 ROM should also be installed with pin one (or the "notch") towards the left end of the socket (away from the power transformer). When inserting the IC into the socket, be very careful to be sure that ALL of the pins of the IC are started correctly and that none of them "hang" outside of the socket or are bent under the IC before pushing the IC into the socket. The socket will be a very tight fit; this is intended so that a good contact is made and so that the parts do not fall out in shipping. A successful insertion technique is to slightly "tilt" the IC so that all the pins in one row are correctly started, then "roll" the IC towards the other side, making sure that these pins line up in the socket holes (use your finger nail or flat-blade screw driver to get the pins started in the right direction). When removing an IC, do it slowly and carefully! Use a small screw driver to gently pry each end of the IC up; don't try to get it out with one operation - make several small prying adjustments. With some practice, you can replace IC's in just a few seconds, but take your time until you have the technique mastered.

3. Programming the 2716 Yourself

Since a standard 2716 EPROM integrated circuit is used, it may be programmed by anyone with EPROM programming equipment and experience. However, this is not recommended unless you have (or a friend has) an EPROM erasing facility, programmer, and experience in their proper use; HAL will be glad to program each MSG2100 for you. If HAL programs the IC, we do insist that we supply the integrated circuit it-

self to assure the quality of the final product.

The first step in programming the ROM is to first be sure that you start with a completely "empty" part. Either erase the part with an ultra-violet erasing machine or verify to your own satisfaction that it is unprogrammed (with a computer, etc). Since all text is stored in the MSG2100 ROM in ASCII format, you need only to specify the start of a message at the beginning of a message segment, each character to be stored (in ASCII code), and the end of each text block (with the FF HEX character). For example, the following is a listing of how a short message would be stored in the MSG2100 ROM:

Text to be stored: DE WQ9XYZ
 Message block used: Message number 3

ROM LOCATION		CONTENTS		COMMENTS
DEC.	HEX	HEX	BIN	
512	02 00	44	0100 0100	"D"
513	02 01	45	0100 0101	"E"
514	02 02	20	0010 0000	"space"
515	02 03	57	0101 0111	"W"
516	02 04	51	0101 0001	"Q"
517	02 05	39	0011 1001	"9"
518	02 06	58	0101 1000	"X"
519	02 07	59	0101 1001	"Y"
520	02 08	5A	0101 1010	"Z"
521	02 09	20	0010 0000	"space"
522	02 0A	FF	1111 1111	End of message 3

Notice that a space was included at the very end of the text. This is highly recommended as it prevents the running-together of messages if you wish to send several in sequence. All message segments are programmed as in the above example. The starting memory locations for each message are:

MESSAGE NUMBER	START LOCATION	
	DEC.	HEX
1	0	00 00
2	256	01 00
3	512	02 00
4	768	03 00
5	1024	04 00
6	1280	05 00
7	1536	06 00
8	1792	07 00
HERE-IS 1	1984	07 C0
HERE-IS 2	2016	07 E0

When programming a special Baudot or Morse character, use the "key-related" ASCII code for that character. For example:

```
Baudot LTRS = "<" = 3C H or 0011 1100 b
Baudot Figs = ">" = 3E H or 0011 1110 b
Morse AR    = "@" = 40 H or 0100 0000 b (The @ key is used)
Morse BT    = "+" = 2B H or 0010 1011 b (The + key is used)
```

Where an ASCII symbol corresponds to a Baudot operation (CR, LF, BELL for example), use that ASCII code. The IDENT operation may be included in a message program; specify hex code "BA" to call the ID from a message. Also, note that a NEW LINE is specified by programming the code for LF.

LIMITED WARRANTY

HAL Communications Corp. of Urbana, Illinois, hereby warrants to the original purchaser only that any new equipment manufactured by HAL Communications Corp. shall be free from defects in materials and workmanship for a period of one year from the date of original purchase. In the case of parts kits, this warranty applies only to materials and not to workmanship in kit assembly.

In the event of a defect in materials or workmanship during the warranty period, HAL Communications Corp. will, at its own expense, repair the defective unit and replace any defective parts. Cost of shipping the unit to HAL Communications Corp. shall be paid by the purchaser, as well as costs of removal and reinstallation of the unit. HAL Communications Corp. will bear the shipping costs incurred in returning the unit to the purchaser (48 contiguous states only).

To obtain service under this warranty, the original purchaser should do the following:

1. Notify, as soon as possible, the Customer Service Department of the original selling dealer or HAL Communications Corp., Urbana, Illinois, either in writing or by telephone, of the existence of a possible defect;
2. At the time of notification, identify the model and serial number, date of purchase, place of purchase, and the possible defect;
3. Hold the unit until a written return authorization is received.
4. Return the unit, freight prepaid, upon the receipt of the written return authorization.

Correct installation, use, maintenance, and repair are essential for proper performance of this product. The purchaser should carefully read the technical manual.

This warranty does not apply to any defect which HAL Communications Corp. determines is due to any of the following:

1. Improper maintenance or repair, including the installation of parts or accessories that do not conform to the quality and specifications of the original parts;
2. Misuse, abuse, neglect, improper installation, or improper operation (including operation without a proper safety ground connection);
3. Accidental or intentional damage.

All implied warranties, if any, are limited in duration to a period of one year from the date of original purchase. Some states do not allow limitations on how long an implied warranty lasts, so the above limitation may not apply to you.

HAL Communications Corp. disclaims any liability for incidental or

consequential damages arising out of the use of, or inability to use, this product. Some states do not allow the exclusion or limitation of incidental or consequential damages, so the above limitation or exclusion may not apply to you.

This warranty gives you specific legal rights, and you may also have other rights which vary from state to state.



HAL COMMUNICATIONS CORP.
Box 365
Urbana, Illinois 61801
217-367-7373

RF INTERFERENCE TO THE KB2100:

In some installations, the coiled-cord used between the CT2100 and the KB2100 may act as an antenna and pick-up RF interference from a radio transmitter. This may be particularly noticed if the antenna is fed from an antenna tuner, is not fed with a coaxial cable, or if the antenna is physically close to the operating position. If interference is noticed, try removing the coiled cord AT THE CT2100 end. If this stops the interference, add the enclosed toroid to the coil cord AT THE CT2100 END as shown below. Only five or six turns of the coil cord need be wrapped onto the toroid. If this does not solve the interference, study the techniques listed in Section 5.8 of the CT2100 manual. This toroid should not be required if good station grounds are used and the antenna radiating sections are not close to the operating position.

