

PCI-4000 CLOVER - II

**HF RADIO
MODEM**

**OPERATOR
and
REFERENCE
MANUALS**



HAL COMMUNICATIONS CORP.
BOX 365
URBANA, ILLINOIS 61801

QUALITY COMMUNICATIONS EQUIPMENT



HAL COMMUNICATIONS CORP.

Post Office Box 365
Urbana, Illinois 61801
217/367-7373
FAX 217/367-1701

To: PCI-4000/M Customers

Re: PCI-4000/M Updates, Information

Congratulations on your purchase of a PCI-4000/M system. Your unit contains the latest release of software available at the time of shipment. As with other software-based products, there may be changes in the future. We maintain a mailing list of all PCI-4000/M users and will notify you of any major changes.

If you are interested in reading about recent developments, third party software, or general correspondence between other users, you may dial into our TECHLINE BBS at 217-367-5547. The TECHLINE BBS is used for everything from scheduling contacts to releasing bulletins concerning CLOVER or new developments at HAL.

Also, always check the "README" files on your PCI-400/M diskette. These contain the latest information about the software release included with your system.

We welcome reports from users via the TECHLINE BBS. If you have a report to relay to us, please use the following format:
"CLREPORT (YOUR ID)"

Please report anything you desire, including new ideas.

We thank you for choosing the HAL PCI-4000/M system and look forward to working with you in the future.

ENJOY YOUR PCI-400/M SYSTEM

Sincerely,
HAL Communications Corp.

PCI-4000 / PC-CLOVER
DOCUMENTATION REVISION
CLDOC001.TXT
30 November 1992

PC-CLOVER	PCC.EXE	V1.0
Up-Load File	PCC.S28	V1.0
Up-Load File	PCC.LOD	V1.0
PCI-4000 ROM	U2/U4	V1.0

"PC-CLOVER OPERATOR'S MANUAL" 15NOV92 Printing
"PCI-4000 REFERENCE MANUAL" 16NOV92 Printing

REVISION 001:

1. [Alt]-S = Manual ARQ Modulation Access

The "Operator's Manual" (p. 5-2) incorrectly indicates that the [Alt]-S key combination is used to adjust Auto-ARQ Bias. Bias, both for Adaptive ARQ (Auto-ARQ) and Manual ARQ modes is set via the Configuration Menu, Page 1, Adaptive ARQ Sub-Menu.

When Manual ARQ mode is used, [Alt]-S is used to access the Waveform menu. The modulation may then be changed by using the [Space Bar]. When a modulation form has been chosen, exit the menu by typing [Enter]. The new modulation to be used by the other station's transmitter will be signaled after the Waveform menu is exited. The modulation form may be changed while a Manual ARQ link is in progress, allowing you to manually test the viability of the propagation path. The other waveform parameters of Manual ARQ mode (Code Efficiency and Block Size, may NOT be change during a link. Code efficiency may be changed while not linked by changing the Bias as noted above (Robust = 60%, Normal = 75%, Fast = 90%). The Block Size is always 255 bytes for both Manual and Auto ARQ modes.

Please change the description of [Alt]-S on page 5-2 of the "Operator's Manual" to:

[Alt]-S Change Manual ARQ Modulation

2. Pages 5-1 and 6-5 of the "Operator's Manual" list three methods to end CLOVER transmissions. Tests have shown that there was very little operational difference between "Quick End" and "Panic Kill". In the interest of minimizing confusion, the CLOVER END options and access keys are now:

[F7] or ZZZZ = Normal END
[Alt]-F7 or [Ctrl]-F7 = PANIC END

Please make the following revisions to the "Operator's Manual":

Page 5-1:

[Alt]-F7 Immediate Disconnect (same as [Ctrl]-F7)

Page 6-5:

- a. Delete paragraph "Pressing [Alt]-F7 (QUICK END) ...".
- b. Modify the start of the following paragraph to:

"Pressing [Alt]-F7 or [Ctrl]-F7 (PANIC END) ...".

3. LISTEN Mode:

At present, LISTEN mode is only partially implemented. If you tune to a CLOVER ARQ link in process, you will see the message "[HISCALL] MONITORED" when the ARQ station's call sign is sent in a CCB (about once every 2 minutes). However, text sent by either ARQ station will not be decoded. Text decoding and display will be added to CLOVER in a future software up-date. Received FEC transmissions will, however, be monitored and text will be displayed once synchronization is achieved. Patience is advised as it may take as long as 30 seconds after tuning is set to synchronize FEC reception.

Descriptions of LISTEN mode will be expanded when the software is updated.

4. Recording Data Link Statistics and Other File Operations:

PC-CLOVER allows many different types of disk file operations. You may load the transmit buffer, send directly from disk, record receive data to disk, or record file statistics to a disk file. At present, PC-CLOVER cannot perform two disk read/write operations at once - for example, send from disk while recording statistics or record text and statistics at the same time. It is planned to at least partially remove this restriction in future versions of PC-CLOVER so that at least two disk operations may be used at the same time. Documentation descriptions will be revised when this change is made to the software.

END

PC-CLOVER

OPERATOR'S MANUAL

Copyright © 1992 by HAL Communications Corp., Urbana, Illinois. Printed in the United States of America. Contents of this publication may not be reproduced in any form without the written permission of the copyright owner.

870-04001

October 1, 1993 Printing

PC-CLOVER OPERATOR'S MANUAL

CONTENTS:

CHAPTER 1: INTRODUCTION TO PC-CLOVER

1.1 Introduction.....	1-1
1.2 This Manual.....	1-2
1.2.1 How This Manual is Organized.....	1-2
1.2.2 Conventions Used In This Manual.....	1-3
1.3 The Software Package.....	1-4
1.3.1 System Requirements.....	1-4
1.3.2 PC Software Compatibility.....	1-4
1.3.3 Software and Documentation Update.....	1-5

CHAPTER 2: GETTING STARTED WITH PC-CLOVER

2.1 Loading PC-CLOVER.....	2-1
2.2 Configuring Your System.....	2-2
2.2.1 Verifying The Receive Audio Connection.....	2-2
2.2.2 Verifying the PTT and Transmit Audio Connections.....	2-3
2.3 Setting Station Parameters.....	2-5
2.4 Entering Programmable Messages.....	2-6

Chapter 3: THE PC-CLOVER SCREEN

3.1 The PC-CLOVER Tuning Indicators.....	3-1
3.1.1 Amplitude Tuning Bars.....	3-2
3.1.2 Frequency Tuning Bar.....	3-2
3.2 The RX/TX Status Table.....	3-2
3.3 The PC-CLOVER Receive (RX) Buffer.....	3-3
3.4 The PC-CLOVER Status Line.....	3-4
3.5 The Command Line.....	3-5
3.6 The PC-CLOVER Transmit (TX) Buffer.....	3-5
3.7 The Information Line.....	3-5

CHAPTER 4: PC-CLOVER MENUS

4.1 The Main Menu.....	4-1
4.2 The Mode Sub-menu.....	4-1
4.2.1 The ARQ Sub-menu.....	4-2
4.2.2 The FEC Sub-Menu.....	4-3
4.2.3 The Listen Sub-menu.....	4-3
4.2.4 The Test Sub-menu.....	4-4
4.3 The Control Sub-menu.....	4-4
4.4 The Messages Sub-menu.....	4-5
4.5 The Files Sub-menu.....	4-5

PC-CLOVER OPERATOR'S MANUAL

CHAPTER 5: PC-CLOVER KEYS AND COMMANDS

5.1 Function Keys.....	5-1
5.2 Alt Keys.....	5-2
5.3 Other Special Keys.....	5-3
5.2 "Expert Key" Commands.....	5-4
5.3 PC-CLOVER And The Expert User.....	5-4

CHAPTER 6: OPERATING PC-CLOVER

6.1 Tuning A CLOVER Signal.....	6-1
6.2 The Adaptive ARQ Mode.....	6-2
6.2.1 The ARQ QSO.....	6-5
6.2.2 The ARQ END Commands.....	6-5
6.2.3 Initiating An ARQ CQ.....	6-5
6.2.4 Answering An ARQ CQ.....	6-6
6.2.5 Performance Hints For Keyboarders.....	6-6
6.3 The FEC Mode.....	6-7
6.4 The Listen Mode.....	6-9
6.5 The Test Mode.....	6-9

CHAPTER 7: IN CASE OF DIFFICULTY

7.1 Software Problems.....	7-1
7.2 User Service.....	7-1
7.3 User Information.....	7-2
7.4 Returning Equipment For Factory Repair.....	7-2

APPENDIX A: The PC-CLOVER Configuration File

CHAPTER 1: Introduction To PC-CLOVER

The PCI-4000 is supplied with two manuals - the PC-CLOVER OPERATOR'S MANUAL and the PCI-4000 REFERENCE MANUAL. Operation instructions for each mode of CLOVER-II are described in detail in this OPERATOR'S MANUAL. The PCI-4000 REFERENCE MANUAL provides detailed directions for installation, special operations, and technical details of the HAL PCI-4000 CLOVER-II HF Modem. PC-CLOVER software is designed to be very "user-friendly" and much of its operation is self explanatory. However, a careful reading of this manual is highly recommended so that you gain full benefit of all of the many features of PC-CLOVER and the PCI- 4000.

This HAL product has two names - "PC-CLOVER" and "PCI-4000". The manuals will use "PC-CLOVER" when referring to the software. "PCI-4000" refers specifically to hardware details. "CLOVER-II" refers to the CLOVER wave form used in the PCI-4000.

Chapter 2 of the PCI-4000 REFERENCE MANUAL provides detailed instructions for installation of the PCI-4000 circuit board in your PC and how to make connections to your transmitter and receiver system.

Chapter 2 of the PCI-4000 REFERENCE MANUAL is very important - BE SURE TO READ IT!

A "minimum reading assignment" for all PCI-4000 / PC-CLOVER owners is Chapters 1 and 2 of the REFERENCE MANUAL and all of this OPERATOR'S MANUAL.

Be sure to read the Limited Warranty. It is the standard HAL Warranty - the same one we have used for years. HAL stands behind its products. If you have a problem - LET US KNOW!

Finally, this manual includes a complete index. The index covers both manuals. Can't recall where you read a detail? --- TRY THE INDEX!

Additional Software

HAL Communications Corp. continues to work closely with a number of software authors and firms to provide additional user software. Please call HAL Communications Corp. for a current list of "3rd Party" authors for CLOVER and the PCI-4000.

1.2 This Manual

The PC-CLOVER Operator's Manual has been designed to get you up and running quickly, yet provide detailed information that is easy to find when needed. When you finish reading this chapter, go to Chapter 2 for all the information you need to get your system ready to run. Other chapters provide answers to more specific questions you may have as you become more familiar with PC-CLOVER.

1.2.1 How this Manual Is Organized

The remainder of the PC-CLOVER OPERATOR'S Manual is divided into the following chapters:

Chapter 2: Getting Started With PC-CLOVER This chapter leads you through all the steps necessary to configure the PCI-4000 board and PC-CLOVER for your station.

Chapter 3: The PC-CLOVER Screen This chapter describes the purpose and function of each part of the PC-CLOVER screen.

Chapter 4: PC-CLOVER Menus This chapter details all of the PC-CLOVER main menu and sub-menu options. The chapter is composed of tables that make it easy to find a description of each menu option.

Chapter 5: PC-CLOVER Keys and Commands This chapter describes the keys and commands used to control PC-CLOVER and the PCI-4000.

Chapter 6: Operating PC-CLOVER Here is the meat of the PC-CLOVER Operator's Manual. This chapter presents step-by-step procedures for operating PC-CLOVER in the ARQ, FEC, LISTEN and TEST modes.

Chapter 7: In Case of Difficulty Here is a collection of helpful hints in case you encounter a problem with PC-CLOVER.

Appendix A: The PC-CLOVER Configuration Files PC-CLOVER allows you to create a configuration file (PCC.CFG) that contains all the parameters necessary to operate. You can customize the configuration to suit your own needs, or create multiple configuration files that are loadable. This appendix explains each parameter in the PC-CLOVER configuration file and the options available for you to customize your system. It also describes the process for creating multiple configuration files.

Additional documentation will be provided at the same time PC-CLOVER and the PCI-4000 software are updated.

1.2.2 Conventions Used In This Manual

When PC-CLOVER software runs in your personal computer, it uses the standard "IBM-Compatible" keyboard. The following, manual conventions will be used to describe which keys should be used:

1. All user-entered keystrokes are in **BOLD** print.
2. If a letter is to be typed as a command, it may be either lower case or UPPER CASE.
3. Multi-letter keytop labels are shown in [BRACKETS]. For example:

[Enter], [F1], [F8], [Ctrl], [Alt], [Shift], [Home], [PgUp], etc.
Each [BRACKETED] set represents one key to be pressed.

4. Some keys must be held down while pressing a second key. These will be shown with a dash (-) between key presses.

For example: [Alt]-C This notation should be interpreted as:
press and hold the [Alt] key
press and release the C key
release the [Alt] key

5. Separate sequential command entries are separated by commas.

For example: [F1], M implies:
press and release the [F1] key
press and release the M key.

All PC-CLOVER commands are entered in one of three ways:

1. Type [F1] to show the command menus. Use [arrow keys], [Enter], and [Space bar] to choose options; type [Esc] to back up one menu step.
2. Type "Hot-keys": [Alt]-Q, [Shift]-[F6], for example.
3. An "expert user" may use single-letter command abbreviations once [F1] is typed to enter command mode. For example, [F1] then M enters command mode and selects the Mode menu window. The appropriate "expert" keys associated with each command are shown in the command windows as highlighted characters. The "expert user" may speed type the entire command sequence without waiting for each command menu to be displayed.

1.3 The Software Package

The PCI-4000 is unique in that the software required to operate CLOVER is loaded from computer disk files. The disk provided with your PCI-4000 includes (1) software for the PCI-4000 DSP processor, (2) software for the PCI-4000 control processor, and (3) the PC-based operating system that controls PC-CLOVER. The current version of each program is furnished with each PCI-4000.

1.3.1 System Requirements

PC-CLOVER and the PCI-4000 circuit board are compatible with IBM-compatible Personal Computers with the following minimum capabilities:

- PC-AT or higher (286, 386, 486) with MS-DOS or PC-DOS (V2.0 or later)
- Fully supported AT-bus accessory slot
- IBM-compatible ROM BIOS
- Minimum of 640K RAM (Random Access Memory)
- One floppy drive and a hard disk
- MDA monochrome, CGA color, EGA color, or VGA color video card and monitor
- The following power from the PC power supply:

+5 VDC	200 ma
+12 VDC	20 ma
-12 VDC	20 ma

1.3.2 PC Software Compatibility

PCC, the PC-CLOVER control program is written for single-user, dedicated PC use. When you are running PCC, you should not expect your computer to do other tasks. However, under some conditions, PCC may also run quite well in a "window" or "multi-tasking" PC operating system. HAL has made no effort to preclude any of these multi-tasking uses. HAL does not support PCC in any but a single-user operating environment.

Some PC users find it convenient to use "DOS SHELL" programs. These are utility programs in which you may list the programs you frequently use, select them from an on-screen menu, and run that program without having to use DOS commands to change directories, load programs, etc. A DOS Shell may in fact make it even

simpler to run PCC. However, a "DOS Shell" may also automatically load other programs which interfere with some features of PC-CLOVER. There are many varieties of "DOS Shell" programs available, some good, and some "not so good". Try running PC-CLOVER without the DOS Shell first and make sure it works properly. If it does, then try using your DOS Shell. If problems develop, change your DOS Shell program or run PCC without using the Shell program.

Some PC users also make use of memory resident utility programs (also called "TSR" programs). Typical uses of such programs may be to scroll the CRT screen, check spelling, or redirect video for an application program. A resident program is typically loaded as part of the AUTOEXEC.BAT program and stays resident in RAM thereafter. It may or may not work properly with PCC. It may use memory space that is required by PCC. PCC will fail to run if it cannot allocate enough memory. It is impossible to predict whether or not a given memory resident program will or will not work with PCC. HAL suggests that you first try PCC with all resident programs removed and then try adding each resident program one-by-one to test for compatibility. HAL cannot guarantee operation with any resident programs.

If you are using a "Third-Party" PC-based program with the PCI-4000 (one not written by HAL - APlink, for example), carefully read the documentation provided with that program and follow its instructions. Note that even "Third Party" programs must down-load the PCC.S28 and PCC.LOD programs to the PCI-4000 before CLOVER-II can be used.

1.3.3 Software and Documentation Up-Date

New versions of each program are available to all PCI-4000 owners as they are released by HAL Communications. Some software changes may also require changes to the documentation (manuals). Current copies of both the PCI-4000 programs and documentation updates may be obtained by calling the HAL TECH-LINE customer-service BBS. The details of TECH-LINE are:

Data Phone:	(217) 367-5547 (24 hours/day)
Data Rates:	9600 V.42; 2400, 1200, or 300 baud ASCII
Data Format:	"N 8 1" (No Parity, 8 Data Bits, 1 Stop Bit)

TECH-LINE may also include general information files and you may leave messages in the BBS for our customer service department. If you have problems or need additional information, please call:

Customer Service Manager

Voice:	(217) 367-7373 (8AM - 5PM CST/CDT; Monday - Friday)
FAX:	(217) 367-1701 (24 hours/day)

Chapter 2: Getting Started With PC-CLOVER

2.1 Loading PC-CLOVER

Before you load PC-CLOVER onto your hard disk, make a backup of the PC-CLOVER disk and place the original in a safe place. Label the workdisk and use it for loading PC-CLOVER.

Use the following procedure to load PC-CLOVER:

STEP	ACTION												
1	Put the back-up diskette in drive A: and type A: [Enter]												
2	Type A:> INSTALL [Enter] and follow the directions. A new directory will be created on your hard disk C: named "PCC" and all PCI-4000 files will be loaded into this directory. When installation is complete, you will be directed to remove the diskette from disk A:.												
3	<p>Run PC-CLOVER as follows: C:\PCC>PCC [Enter]</p> <p>RESULT: You will see a message window indicating that PCC.LOD and PCC.S28 are being installed.</p> <div data-bbox="623 1241 932 1352" style="border: 2px solid black; padding: 5px; margin: 10px auto; width: fit-content;"> <p style="text-align: center;">PC-CLOVER Loading: PCC.S28</p> </div> <p>This is followed by the PC-CLOVER version window:</p> <div data-bbox="545 1478 1027 1829" style="border: 2px solid black; padding: 10px; margin: 10px auto; width: fit-content;"> <p style="text-align: center;">HAL COMMUNICATIONS CORP. PC-CLOVER</p> <table style="width: 100%; border-collapse: collapse;"> <tr> <td style="padding: 2px;">PC-CLOVER</td> <td style="padding: 2px;">Version 1.0</td> </tr> <tr> <td style="padding: 2px;">PCC.LOD</td> <td style="padding: 2px;">Version 1.0</td> </tr> <tr> <td style="padding: 2px;">PCC.S28</td> <td style="padding: 2px;">Version 1.0</td> </tr> <tr> <td style="padding: 2px;">Card Rom</td> <td style="padding: 2px;">Version 1.0</td> </tr> <tr> <td style="padding: 2px;">Card Address</td> <td style="padding: 2px;">360</td> </tr> <tr> <td style="padding: 2px;">Copyright</td> <td style="padding: 2px;">1992</td> </tr> </table> </div>	PC-CLOVER	Version 1.0	PCC.LOD	Version 1.0	PCC.S28	Version 1.0	Card Rom	Version 1.0	Card Address	360	Copyright	1992
PC-CLOVER	Version 1.0												
PCC.LOD	Version 1.0												
PCC.S28	Version 1.0												
Card Rom	Version 1.0												
Card Address	360												
Copyright	1992												

If PC-CLOVER is unable to find the PCI-4000, an error message will display. If this occurs, check to see that you have properly installed the PCI-4000. Also, this error may occur if the address being used by the PCI-4000 conflicts with other I/O addresses used by your PC. See Appendix A of the REFERENCE Manual for additional information about PCI-4000 I/O addressing.

NOTE: Files "PCC.EXE", "PCC.S28", and "PCC.LOD" **must** be in the current directory when running PC-CLOVER.

2.2 Configuring Your System

Before you can begin using the PCI-4000 and PC-CLOVER, you must configure both for your station. The first step in connecting the PCI-4000 to your radio is described in Chapter 2 of the PCI-4000 REFERENCE Manual. It is **strongly** recommended that you hook the receive audio, push-to-talk (PTT) line and transmit audio to either the auxiliary jack or the phone patch jack on the back panel of your radio. Do not use the headphone jack on the front panel to acquire audio.

Note: The ICOM IC-735 transceiver (and possibly other models) has a rear panel transmit audio input connection but its level is not adjustable from the front panel MIC GAIN control. In this case, audio level and transmitter power could be adjusted via the PCI-4000 rear panel screw-driver audio output adjustment. However, it is much more convenient to be able to use the transceiver's front panel MIC GAIN control while watching the ALC and RF output meter. Therefore, we suggest that transmit audio (and PTT) connections to these transceiver models be made through the front panel MIC connector, and NOT via the non-adjustable rear panel input.

2.2.1 Verifying the Receive Audio Connection

Hook an antenna to your transceiver and rotate the MIC gain control fully counter-clockwise. Perform the following steps to verify that receive audio is getting to the PCI-4000.

STEP	ACTION
1	Type PCC [Enter] to Start PCC and be sure the Amplitude Tuning screen shown in step two is displayed at the top left corner of the screen. If they are not there, type [Alt]-A one or more times to toggle them on.

2 Increase the audio until the four amplitude tuning bars are visible and fluctuating in response to random receiver noise .

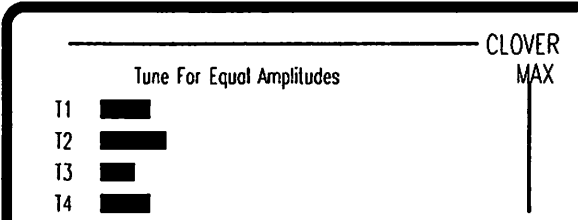

NOTE: If the amplitude bars do not show some small fluctuation, check both the AF and RF gain controls to be sure these are in the correct position. If there is still no apparent response in the amplitude bars, check the hookup to be sure it is wired correctly.

2.2.2 Verifying The PTT and Transmit Audio Connections

When you have verified that receiver audio is getting to the PCI-4000, hook a dummy load to your transceiver and remove all audio inputs (key, MIC etc.) except the CLOVER connections. Perform the following procedure to verify the PTT and transmit audio connections.

STEP	ACTION
1	Check to see that the PTT and transmit audio lines are correctly wired to the transceiver. Turn on the transceiver, set the transmit audio gain fully counter-clockwise and set the meter to indicate <i>ALC</i> .
2	Press [F1] , M , and T to access the Test sub-menu.
3	Press the [space bar] once to activate the transceiver with a "Single Tone Test". You should see a transmit indication from your transceiver, but no output power (because transmit audio is set to zero).
4	Increase the MIC gain slowly until you see a slight <i>ALC</i> indication on the meter.

5	Decrease the MIC gain until there is no <i>ALC</i> indication on the meter. The MIC gain level should be set just below the threshold of the <i>ALC</i> . (Note 1)
6	Change the meter to the power position and note the output indicated. If you do not see some indication of power, repeat steps 1 through 6 of this table.
7	Press [space bar] to activate the Four Tone Test mode. The power meter may show a reading that is reduced somewhat from the power indicated during the Single Tone Test. This is normal. <i>Do not change this MIC setting! (Note 3)</i>

Notes:

1. *ALC* or Automatic Level Control is a feedback system used in transmitters to reduce the gain of previous stages to prevent overdriving the transmitter final stage. Remember, if you have an indication of *ALC* action, you are driving the transmitter with too much audio (MIC gain). This can severely distort a CLOVER transmission.
2. This procedure should be performed each time you start your system, retune your transmitter or change bands, especially if antenna tuning is involved. That will ensure that these settings will be optimum at all times.
3. Single tone versus four-tone power levels: Unlike simple FSK data systems, CLOVER modulation is made up of four tones. Because the time waveforms of the tone pulses overlap, the peak power of the CLOVER signal is greater than the average power. We say that the *crest factor* of CLOVER is 6 dB. This is similar to SSB voice modulation in which the peak power can be much greater than the average power. Wattmeters used to measure transmitter output vary considerably - some read "peak power", some read "average power". The output amplitudes of the single and four-tone test signals are calibrated so that setting transmitter power in the single tone mode will automatically produce the correct peak power setting when four-tone CLOVER modulation is transmitting. Set the transmitter maximum output using the single test tone and then note your wattmeter reading when running four tones. This is the maximum power reading you should see when running CLOVER. If you also use AUTOPOWER, the transmitter power will often be reduced to a level well below the maximum reading.

2.3 Setting Station Parameters

PC-CLOVER comes with a default configuration file that contains all the parameters necessary for normal operation. The only parameter you must set before using PC-CLOVER is MYCALL by following these steps:

STEP	ACTION
1	Type PCC [Enter] to run PC-CLOVER
2	To program MYCALL, Type [Alt]-M. You will see this window: <div style="text-align: center; border: 1px solid black; padding: 5px; margin: 10px auto; width: fit-content;">Mycall (callsign)</div>
3	Type your callsign and press [Enter] to accept it. <div style="text-align: center; border: 1px solid black; padding: 5px; margin: 10px auto; width: fit-content;">Mycall (K5CVD)</div>
4	Type [Esc] to return to the CLOVER screen.

PC-CLOVER is now ready for use. You should save the new configuration file at the time you exit PC-CLOVER by typing Y in answer to this message box:

Save Current Configuration (Y/N) ?

Also, new versions of PC-CLOVER may require a new configuration file. PC-CLOVER assumes the default configuration file (PCC.CFG) is in the current directory. If none is found PC-CLOVER will use the preset default values and you will need to repeat the above procedure to insert your callsign.

2.4 Entering Programmable Messages

PC-CLOVER allows you to program ten messages that you may load into the TX buffer and send during a CLOVER QSO. The length of these messages is limited to 255 characters each, but several can be sent in sequence to make a larger message. To create or edit a programmable message, follow these steps:

STEP	ACTION
<p data-bbox="272 541 293 573">1</p>	<p data-bbox="375 541 1036 573">Press [F1] to access the CLOVER main menu:</p> <div data-bbox="375 611 1263 667" style="border: 1px solid black; padding: 5px; margin: 10px 0;"> <p style="text-align: center;">CLOVER STBY T R DIS CHAR R001 T001 08:19</p> <p style="text-align: center;"> Mode Control Messages Files Exit</p> </div> <p data-bbox="375 709 1414 783">This menu is displayed just below the CLOVER status line at the top of the TX buffer window.</p>
<p data-bbox="272 863 293 894">2</p>	<p data-bbox="375 863 1414 936">Press F to select the Files menu. The Files window will open on your screen:</p> <div data-bbox="448 972 1341 1297" style="border: 1px solid black; padding: 10px; margin: 10px 0;"> <div style="border: 1px solid black; padding: 5px; margin-bottom: 10px;"> <p style="text-align: center;">CLOVER STBY T R DIS CHAR R001 T001 08:19</p> <p style="text-align: center;"> Mode Control Messages</p> </div> <div style="border: 1px solid black; padding: 5px; display: inline-block; vertical-align: top;"> <p>Load TX Buffer</p> <p>Save T Disk</p> <p>Sto S Send / Save</p> <p>Send F From Disk</p> <p>Directory</p> <p>CONFIGURATION</p> </div> <div style="border: 1px solid black; padding: 5px; margin-top: 10px;"> <p>Use CONFIGURATION To View Or Change System Defaults</p> <p>Enter To Select Option ← ↑ ↓ → To Move ESC To Exit Files Options</p> </div> </div>

3

Type **C** to access the Configuration File then look for the Options window in the lower right-hand corner of the screen:

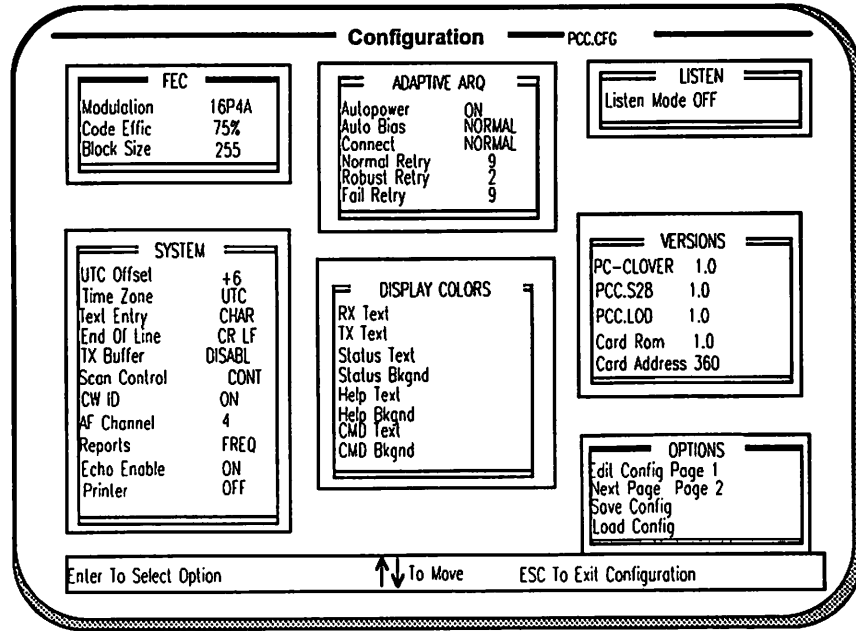

4

Press the **[down arrow]** to highlight "Next Page - - Page 2" in the Options window and then press **[Enter]**. The second page of the Configuration file will appear:

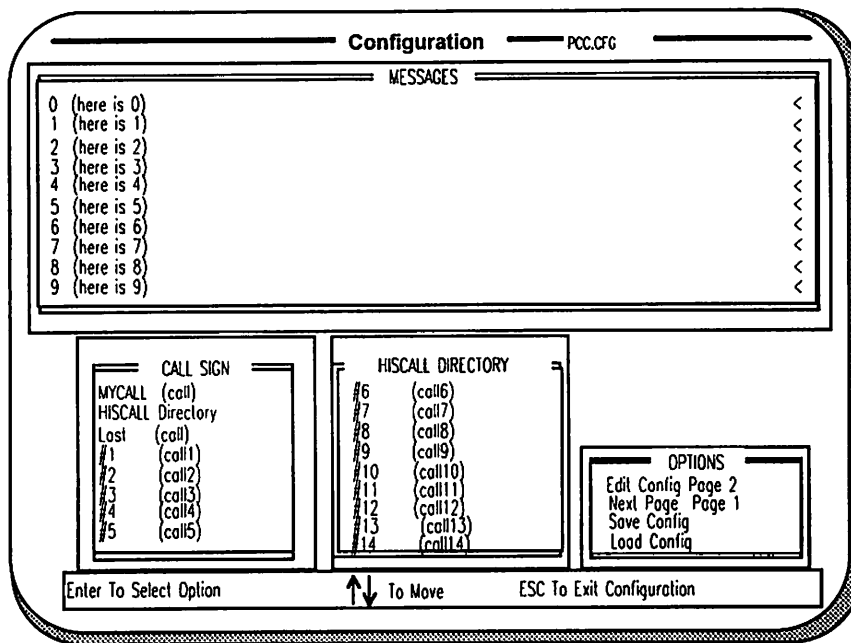

5	Press [Enter] edit the configuration. The first "Here is" will be highlighted.
6	<p>Press [Enter] to edit the first "Here is". The message edit window will appear:</p> <div data-bbox="396 468 1349 993" style="border: 1px solid black; padding: 10px;"> <div style="border: 1px solid black; padding: 5px;"> <div style="display: flex; justify-content: space-between; border-bottom: 1px solid black;"> Here is 0 Here is 0 </div> <div style="border: 1px solid black; height: 150px; margin-top: 5px;"></div> <div style="text-align: center; margin-top: 5px;">Space Available : Characters = 246 Lines = 9</div> </div> <div style="border: 1px solid black; text-align: center; margin-top: 10px; padding: 5px;">Enter New Here Is Message Then Press ALT-C To End</div> </div>
7	Type the text you wish to use. Then type [Alt]-C to close the message edit window and then press [Esc] to return to the Options menu. Several special keys are available to edit these messages (see Chapter 5 section 5.3).
8	<p>Press S to select the "Save Config" option Then press [Enter].</p> <div data-bbox="553 1381 1252 1514" style="border: 3px double black; padding: 10px; margin: 10px auto; width: fit-content;"> <div style="border: 1px solid black; padding: 5px;"> Enter New Configuration Filename Or Press ENTER Key To Save Current Configuration File > </div> </div> <p>Respond to the message box that appears by either entering a name for your configuration file (be sure to end the name with ".CFG") and press [Enter] or press [Enter] without typing a name to make the changes to the current configuration file.</p>
9	Press [Esc] three times to return to the CLOVER screen.

The preceding steps are the recommended way to enter your programmed messaged the first time. Later, you may wish to edit or completely replace one or more of the programmed messages. The following table presents the procedure for creating or editing the programmed messages. Do not forget to save the new configuration file when you exit PC-CLOVER by typing Y during the exit sequence.

STEP	ACTION
<p>1</p>	<p>Press [Ctrl-F5] and the number for the message you wish to create or edit.</p> <p>RESULT:</p> <p>You will see the following window on the screen:</p> <div style="border: 1px solid black; padding: 10px; margin: 10px auto; width: fit-content;"> <div style="border: 1px solid black; padding: 5px; margin-bottom: 5px;"> <p style="text-align: center;">Here Is 1</p> </div> <div style="border: 1px solid black; padding: 5px; margin-bottom: 5px;"> <p>Here Is 1</p> </div> <div style="border: 1px solid black; padding: 5px; margin-bottom: 5px;"> <p style="text-align: center;">Space Available : Characters = 246 Lines = 9</p> </div> <div style="border: 1px solid black; padding: 5px; margin-bottom: 5px;"> <p style="text-align: center;">Enter New Here Is Message Then Press ALT-C To End</p> </div> </div>
<p>3</p>	<p>Type in the text of your message. Use the keys listed in 5.3 to assist in editing your message.</p> <p>Note: There are only 255 characters of text available per message, but several messages can be sent, to compose a much larger "brag" file .</p>
<p>4</p>	<p>When you have entered and edit your message, press [Alt-C] to return to the main screen.</p>

Repeat these steps for any message you wish to program. Remember you can always press **[Esc]** to exit the edit session without saving any changes.



Save Current Configuration (Y/N) ?

You must answer **[Y]** for Yes to the prompt when you exit PC-CLOVER, or the text you entered into the programmable messages will not be saved.

Chapter 3: The PC-CLOVER Screen

The PC-CLOVER screen is composed of seven distinct elements:

- PC-CLOVER Tuning Indicators
- RX/TX Status Table
- Receive (RX) Buffer
- PC-CLOVER Status Line
- Command Line
- Transmit (TX) Buffer
- Information Line

Example:

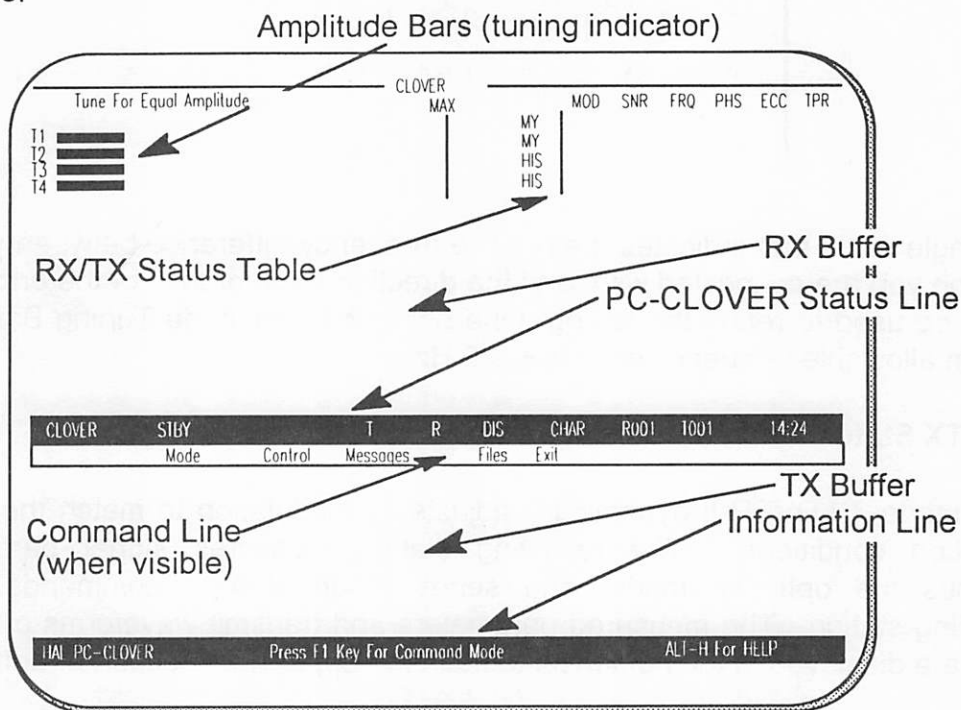

3.1 The PC-CLOVER Tuning Indicators

PC-CLOVER includes tuning displays which assure very accurate and rapid tuning of a CLOVER signal. Simply type **[Alt]-A** to turn the tuning bar display *ON*, tune for maximum and equal bar length for all four tones. Then press **[Alt-A]** again to access the Frequency tuning bar and adjust for minimum frequency error. Then *let go of the knob*. The PC-CLOVER Tuning Bars are easy to read, but may take some practice. Remember, if you tweak the knob, CLOVER must start over with its frequency/phase integration and either data may be lost (FEC mode) or extra repeats may be required (ARQ mode).

3.1.1 Amplitude Tuning Bars

The Amplitude Tuning Bars are shown at start-up or may be accessed by pressing [Alt]-A . The four bars each represent one of the four tones of the CLOVER-II waveform. The object is to *slowly* tune in a CLOVER signal until all four bars are of equal length. It is not necessary for the bars to reach the "MAX" mark (the tuning bars are shown in the example on page 3-1).

3.1.2 Frequency Tuning Bar

The Frequency Tuning Bar is accessed by pressing [Alt]-A from the Amplitude Tuning Bars and is located in the same area of the PC-CLOVER screen.

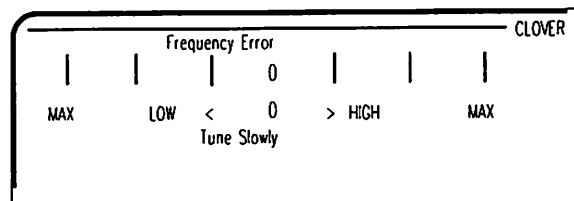

It is a single scale that indicates the relative frequency difference between you and the station you are connected with, and the direction (high or low) of the error. This bar may be used to refine the tuning done using the Amplitude Tuning Bars. The maximum allowable frequency error is +/-30 Hz.

3.2 RX/TX Status Table

In ARQ mode, CLOVER-II dynamically adjusts its modulation to match the current propagation conditions. The receiving station measures signal parameters, determines the optimum mode, and sends mode change commands to the transmitting station. The measured parameters and transmit waveforms of the two stations are displayed in the numerical table in the upper right section of both tuning screens.

	MOD	SNR	FRO	PHS	ECC	TPR
MY	16P4A	31	+01	010	00	50
MY	16P4A	32	+03	015	02	50
HIS	8PSM	13	-02	122	10	100
HIS	8PSM	15	-01	110	14	100

Four rows of numbers are shown, two that show MY station parameters and two rows that show HIS station parameters. In ARQ mode, all four rows are used. The lower MY row of numbers shows data from the last transmission. Similarly, the lower HIS row is the current data; the upper HIS row shows conditions during the previous transmission.

The data columns show:

MOD = Modulation mode (BPSM through 16P4A)
SNR = Detector signal-to-noise ratio (dB)
FRQ = Frequency tuning error (\pm 1Hz increments)
PHS = Phase dispersion in log units (low numbers are good)
ECC = Error correction capacity used (0 to 100%; XX = fail)
TPR = Percent transmitter power (set by AUTOPOWER)

This information can be extremely interesting and useful when analyzing propagation conditions. The data may be saved to disk via the Files menu for later analysis.

3.3 The PC-CLOVER Receive (RX) Buffer

The PC-CLOVER RX Buffer uses the upper half of the screen to display incoming data. The RX area on the PC-CLOVER screen consists of a maximum of 14 lines. Only 9 are visible when the Tuning Bars and RX/TX Status Table are displayed. The buffer is scrollable and will hold up to 250 lines. **[ALT]-R** selects the RX buffer for scrolling. The **[up arrow]** and **[down arrow]** scroll the display. The RX buffer can be cleared with **[Alt]-U**.

3.4 The PC-CLOVER Status Line

The PC-CLOVER Status Line indicates the current status of several of the PC-CLOVER parameters. The status line displays the following information (left to right):

- Mode - STBY (stand-by), AUTO-ARQ, ARQ-RX, ARQ-CQ, FEC, or LISTEN.
- TX/RX data state - TXT (sending text), RPT (repeating a block), IDL (FEC)
- TX data throughput - computed throughput of data transmitted by your station (bytes-per-second)
- RX data throughput- computed throughput of data received by your station (bytes-per-second)
- TX Buffer state - DIS (disabled) or EN (enabled)
- Keyboard mode - CHAR (transmit each character as typed), WORD (send each word when completed), or LINE (send each line when completed).
- RX Buffer line number - Lower displayed line, or the line location of the cursor during RX Buffer scrolling.
- TX Buffer line number - current cursor entry position.
- Printer - LP (if the printer is enabled), or blank.
- Time - current time as set in the computer, 24-hour format: hh:mm (modified by UTC offset)

3.5 The Command Line

This line shows the various options of the PC-CLOVER main menu. The entire menu shows only if you press **[F1]** (see Figure 3.1a and 3.1b, pages 3.6 and 3.7).

The main menu options are as follows:

Mode - ARQ, CQ, FEC, Listen, and Test (the mode in which you wish to operate). These menu selections lead to additional sub-menus where you may select parameters for each of the modes. Those menus and there selections are discussed with each mode description in Chapter 6: Operating PC-CLOVER.

Control - TX EN/DIS (uses the space bar to toggle between enabled and disabled transmit buffer), Line/Word/Char (space bar rolls through each possible keyboard mode), and Reports toggles the Tuning Bars and TX/RX status table on or off)

Messages - Displays a window with a list that includes Mycall, Hiscall, His DE My, and the 10 programmable messages. One of these 13 texts can be selected, loading it into the TX buffer. (Note: this information cannot be edited here.)

Files - Load TX Buffer , Save To Disk , Stop Send/Save, Send From Disk (query box asks for a file name), Directory (query box for the path or directory desired), CONFIGURATION (the PC-CLOVER Configuration file editing menus).

Exit - Closes PC-CLOVER and presents a query box allowing you to save any changes you have made to your system during the current session, Then return you to DOS.

3.6 The PC-CLOVER Transmit (TX) Buffer

The PC-CLOVER TX Buffer uses the lower area of the screen to display data ready for transmission. The TX Buffer screen area consists of 11 lines between the CLOVER status line and the Information line. The buffer is scrollable and will hold up to 250 lines. **[Alt]-X** selects the TX buffer for scrolling. The **[up arrow]** and **[down arrow]** as well as **[PgUp]** and **[PgDn]** scroll the display. The TX buffer can be cleared with **[Alt]-V**.

3.7 The Information Line

The last line of the PC-CLOVER screen is the PCC information line. The information line may be thought of as a "mini-Help" line. Commands and control key functions are listed here for the various menus. When in doubt about what key to hit, look here first!

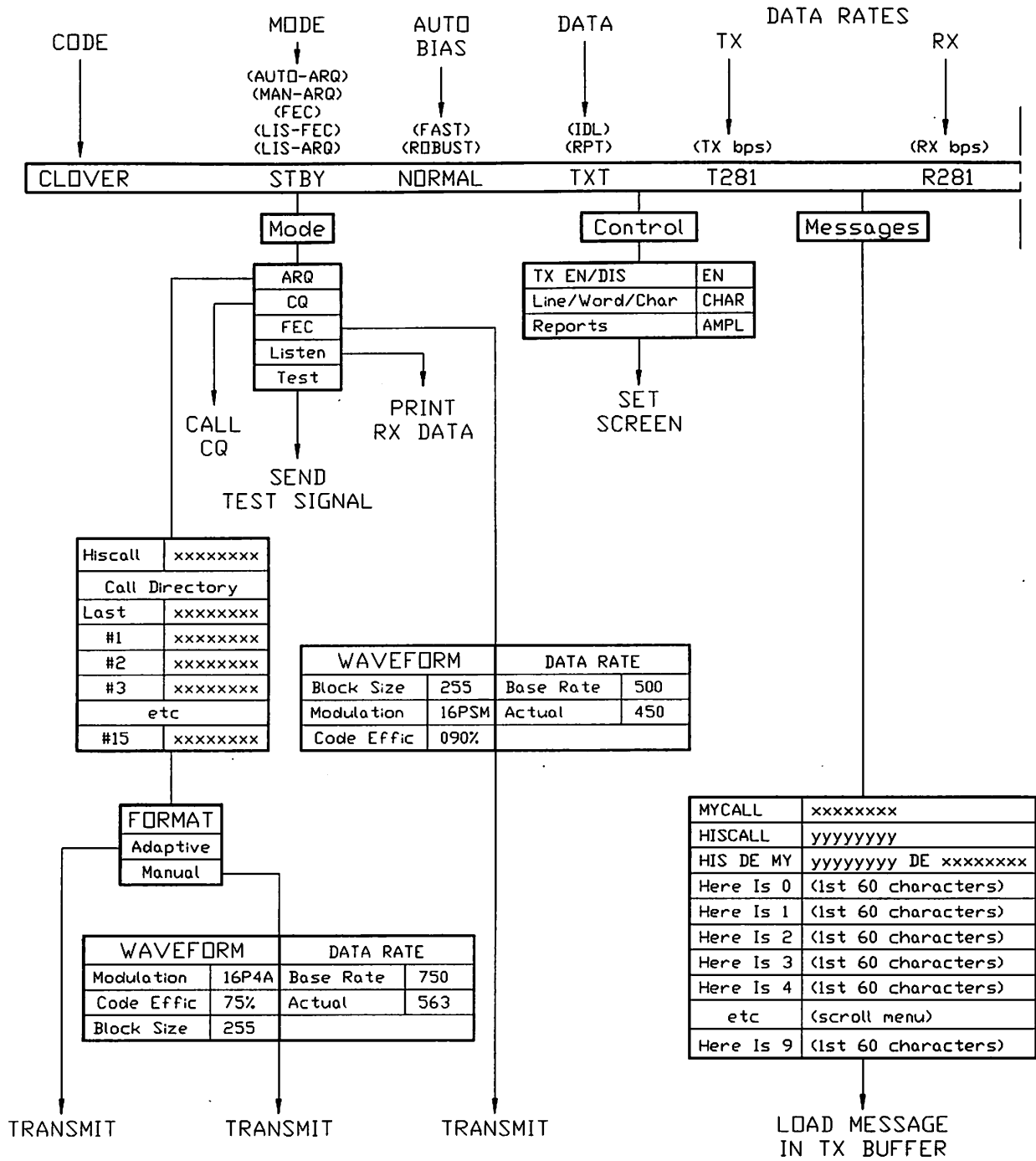

Figure 3.1a PC-CLOVER MENU TREE (left side)

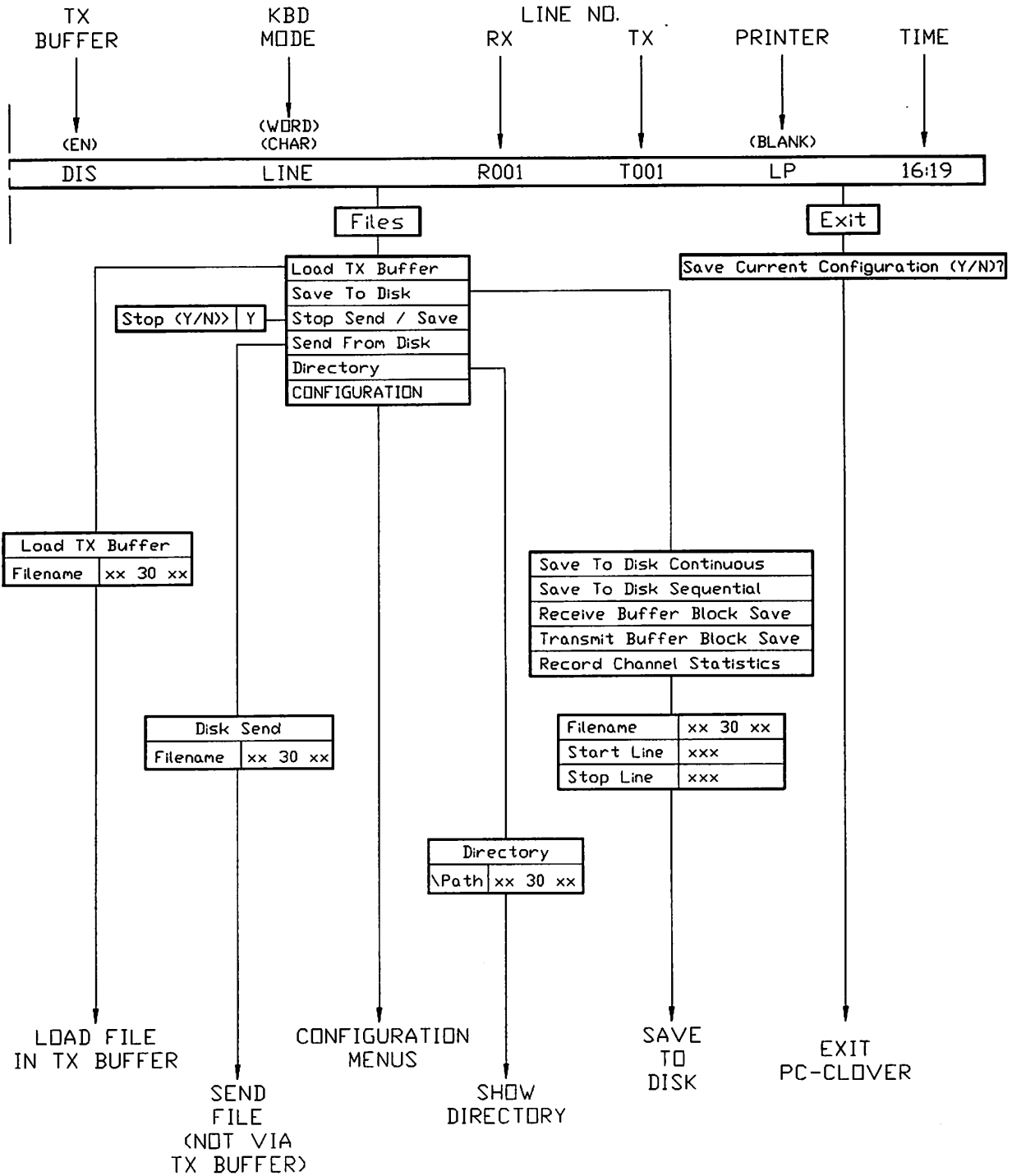

Figure 3.1b PC-CLOVER MENU TREE (right side)

Chapter 4: PC-CLOVER Menus

PC-CLOVER is a menu driven program that makes it easy for the new user to get started quickly without a lot of confusion. This chapter reviews the options available in the various PC-CLOVER menus, as follows:

- The Main Menu
- The Mode Sub-menu
- The Control Sub-menu
- The Message Sub-menu
- The Files Sub-menu
- Exit

4.1 The Main Menu

When you press [F1] from within PC-CLOVER, the main menu of options is displayed just below the Status Line on your screen. The options are as follows:

CLOVER	STBY	T	R	DIS	CHAR	R001	T001	08:19
	Mode	Control		Messages		Files		Exit

These options may be selected by moving the cursor to the option you wish to access, or by pressing the "hot key" for the desired option (shown in reverse video on the actual screen). Selecting an option displays the sub-menu associated with it.

4.2 The Mode Sub-menu

Use the Mode Sub-menu to select your operating mode. Clover offers five possible modes:

4.2.1 The ARQ Sub-menu

ARQ (Automatic Repeat Query) - Two way, station-to-station communication. This mode allows only two stations to communicate at a time. This mode automatically adapts operating parameters to changing propagation conditions.

When you select the ARQ option, you are shown the Call directory containing "Hiscall" and 15 other calls in a scrollable window.

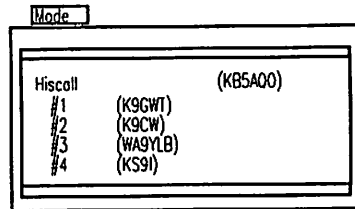

Calls for this list are saved in the configuration file.

Note: You may also change the current call sign in "Hiscall" using **[Ctrl]-[F2]**. That command gives you a window where you type in the new call sign and press **[Enter]** to make it the current "Hiscall". You must press **[Esc]** to return to the PC-CLOVER screen. Or, you can enter a new Hiscall here.

Use **[down arrow]** to highlight the call of the station you wish to contact, then press **[Enter]**. The call sign you selected is placed in the Hiscall option at the top of the list. Press **[Enter]** again to see the final Mode sub-menu. This sub-menu contains two options: Adaptive and Manual.

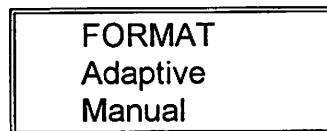

The difference between the Adaptive ARQ and the Manual ARQ is that adaptive mode allows the receiving station to control the waveform, data rate and power (if the Autopower parameter is set to "ON") of the transmitting station. In the manual mode you select the modulation you wish to use. In most cases you will want to select the Adaptive ARQ mode.

Use either **[down arrow]** or **[up arrow]** to toggle between Adaptive and Manual ARQ mode and press **[Enter]** to select the one you have highlighted. If you selected Adaptive mode an ARQ connect attempt will begin immediately. If you select Manual mode another sub-menu will appear and you may select the modulation you wish to use.

WAVEFORM		DATA RATE	
Modulation	16PSM	Base Rate	500
Code Effic	90%	Actual	300
Block Size	255		

Manual ARQ mode may be set for six modulation waveforms: 16P4A, 16PSM, 8P2A, 8PSM, QPSM and BPSM. These waveforms must be set before the link is established. The "bias" and therefore Reed-Solomon coder efficiency (code effic) used in Manual ARQ is the same as set in the Configuration Menu for Adaptive ARQ. The "bias" cannot be changed during an ARQ link. The block size for Manual and (Auto) ARQ mode is always 255 bytes.

[Space bar] displays each of the possible modulation selections . When you have selected the modulation you wish to use press **[Enter]** to begin a manual ARQ connect attempt.

Note: You may change the modulation waveform during transmission but the bias (code efficiency) cannot be changed once a link is established.

4.2.2 The FEC Sub-menu

FEC - One way, one-to-many broadcast mode. The parameters for this mode are manually set and do not adapt to circuit conditions. However, the Reed-Solomon error correction encoder (Hardware Manual section 3.2.3) of the receiving station is used to provide receive error correction of all FEC transmissions.

When you select the FEC mode you see a the same menu that appeared when you selected Manual ARQ mode (section 4.2.1). The sub-menu containing the Modulation selections for your FEC transmission. The **[space bar]** allows you to toggle through the choices. When you have made your selections, press **[Enter]** to begin your FEC transmission. As in the case of the Manual ARQ mode, you may change the modulation waveform during transmission, but code efficiency is fixed at 75% for all FEC rates.

4.2.3 The Listen Sub-menu

The Listen sub-menu has two choices: Listen On and Listen Off. This allows you to place PC-CLOVER in a passive Listen mode similar to AMTOR Listen mode or to leave your system in the standby Mode.

Listen mode is active when you are not linked. Links can still occur even if Listen mode in ON.

4.2.4 The Test Sub-menu

The Test mode provides three choices: Test Mode Off, Single Tone Test and Four Tone Test to use in setting your transmitter audio levels (see Chapter 2, section 2.2.2 for more information).



4.3 The Control Sub-menu

The control sub-menu contains three sets of parameters:



- TX EN/DIS - This parameter enables or disables the TX Buffer (i.e. enable or disable transmission of data in your transmit buffer). You can also use **[Alt]-[F10]**, or **[Ctrl-F10]** to toggle between these two options. This parameter is set to DIS as the default, however, you may change the default to EN in the configuration file.
- Line/Word/Char - Toggles the keyboard mode between line, word, or character. This parameter defaults to CHAR but can be changed in the configuration file. The setting determines the point at which data is sent to the TX buffer. Line sends an entire line to the TX buffer. WORD sends a set of characters when you type a space. CHAR send each character to the TX buffer as you type.

PC-CLOVER includes a text editor that may be used with any text contained in the transmit buffer. This editor has many features and should be satisfactory for all radio text communications.

- Reports - Toggles the Amplitude and Frequency Error tuning bars with the RX/TX Status Table on or off. You may select either of the tuning bars (or none) and set the default of your choice in the configuration file. If the Reports option is set to OFF, five additional lines are displayed at the top of the RX buffer display area on your screen.

4.4 The Messages Sub-menu

The Message Sub-menu allows you to load text you previously programmed into the TX Buffer. The text consists of Mycall, Hiscall, His DE My, and any one of the ten programmable messages. The arrow keys allow you to select the text you wish to load and pressing **[Enter]** sends it to the TX Buffer.

Mycall	K5CVD
Hiscall	KB5A00
His DE My	KB5A00 DE K5CVD
Here is 0	Here is programmed message 0
Here is 0	Here is programmed message 1

4.5 The Files Sub-Menu

The Files Sub-menu provides the means to capture and send files from your system. It also provides access to the PC-CLOVER configuration files.

Load TX Buffer
Save to Disk
Stop Send/Save
Send From Disk
Directory
CONFIGURATION

Note: Specification of the directory and path with a file name is optional. If only a file name is given, the current PCC directory is assumed.

The Files menu options are as follows:

- **Load TX Buffer** - This option allows you to load a file into the TX Buffer for transmission. Files loaded using this option are limited to the size of the TX-buffer (250 lines). If you wish to send a file that is larger than the TX buffer, use the Send From Disk option explained below.

- **Save To Disk** - This option allows you to capture incoming text to a file. You must specify the file name. When you select Save To Disk, a sub-menu will appear so that you may select the data and method of saving to disk:

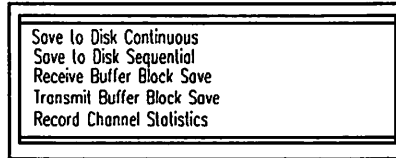

- **Save To Disk Continuous** - This method of saving data captures all data as it is received. It begins capturing the data as soon as you name the file and continues until you stop the capture with the Stop Send/Save option.
- **Save to Disk Sequential** - save received text This is the second way to record received text. It will result in the creation of a sequence of similarly named files. When you select this option you are asked to provide the name *only* for the sequence of files. PC-CLOVER adds an extension to each of the files that is the sequence number. Each time PC-CLOVER detects an NNNN one file is closed and another opened with a new extension. Text is not lost between the closing of one file and the opening of the next one.
- **Receive Buffer Block Save** - This option allows you to save a portion of the receive buffer. You specify a range of text to be saved from the receive buffer, *by line*.
- **Transmit Buffer Block Save** - This option allows you to save a portion of the transmit buffer. You specify a range of text to be saved from the transmit buffer, *by line*.
- **Record Channel Statistics** - This option allows you to save the current channel statistics to a file. This is useful for analyzing the current band conditions for future reference. Saving continues until you select the Stop Send/Save option.
- **Stop Send/Save** - This option permits you to end either a send file or save file action currently in progress.
- **Send From Disk** - This option permits you to send a complete file from a disk. You must specify the file to be sent. The file is transmitted directly, bypassing the TX buffer. This allows you to send a file that is larger than the TX buffer. In addition, end of line characters in the file are not changed.

- **Directory** - This option permits you to look up a file name anywhere in your system. The directory for the path you specify is displayed for your viewing.
- **CONFIGURATION** - This option takes you to the configuration file for PC-CLOVER where you may make changes to your system parameters, programmable messages, call list, and other elements of PC-CLOVER. For complete details of the configuration parameters, see Appendix A.
- **Exit** - This option allows you to close PC-CLOVER after you are finished using it. When you select Exit, you have the chance to save or discard any changes you may have made to PC-CLOVER during the current session.

Chapter 5: PC-CLOVER Keys And Commands

PC-CLOVER is controlled by the following key operations:

- Function keys F1 through F10 and [Alt]-[F#] or [Ctrl]-[F#] combinations
- [Alt]-[A] through [Alt]-[Z] keys
- Special edit-function keys for cursor movement

5.1 FUNCTION KEYS

NOTE: F5 # and Ctrl-F5 # are two key operations (# specifies a number of the HERE IS message to be loaded or programmed/edited). For HELP menus type [Alt]-[H].

KEY	OPERATION
F1	Enter Command Mode
Alt-F1	Enter Command Mode
Ctrl-F1	Enter Command Mode
F2	Load HISCALL DE MYCALL into TX buffer
Alt-F2	(Reserved)
Ctrl-F2	Change HISCALL
F3	Load HISCALL into TX buffer (or HERE IS...)
Alt-F3	(Reserved)
Ctrl-F3	(Reserved)
F4	Load MYCALL into TX buffer (or HERE IS...)
Alt-F4	Insert CW ID into TX buffer (or HERE IS...)
Ctrl-F4	Force CW-ID at 1st opportunity
F5 #	Load HERE IS # into TX buffer (# = 0-9)
Alt-F5	(Reserved)
Ctrl-F5#	Program/edit HERE IS # (# = 0-9)
F6	(Reserved)
Alt-F6	(Reserved)
Ctrl-F6	(Reserved)
F7	Insert END into TX Buffer (Causes Link disconnect or FEC end)
Alt-F7	Quick Disconnect
Ctrl-F7	Immediate Disconnect (all modes)
F8	LISTEN ON/OFF
Alt-F8	(Reserved)
Ctrl-F8	(Reserved)
F9	Initiate ARQ call
Alt-F9	Initiate an ARQ CQ
Ctrl-F9	Answer an ARQ CQ
F10	TX BUFFER EN/DIS
Alt-F10	TX BUFFER EN/DIS
Ctrl-F10	TX BUFFER EN/DIS

5.2 Alt KEYS

KEY	OPERATION
Alt-A	Toggle TUNE INDICATORS & TX/RX STATUS ON/OFF
Alt-B	Insert time and date into TX buffer (& HERE IS...)
Alt-C	Terminate HERE IS message programming
Alt-D	Insert date into TX buffer (& HERE IS...)
Alt-E	Jump to FILES, Save to Disk menu option
Alt-F	Reformat text in TX buffer (edit)
Alt-G	(not used at this time)
Alt-H	HELP Pages
Alt-I	Toggle CW ID ON/OFF
Alt-J	Stop SAVE/SEND disk operation
Alt-K	Delete lines in TX buffer (edit)
Alt-L	Jump to FILES, load TX Buffer menu option
Alt-M	Program Mycall
Alt-N	(Not used at this time)
Alt-O	Go to Test Mode
Alt-P	Toggle PRINTER ON/OFF
Alt-Q	Load QBF message into TX buffer
Alt-R	Select RX buffer (to scroll screen)
Alt-S	Increment Auto-ARQ Bias (FAST/NORMAL/ROBUST)
Alt-T	Insert time into TX buffer (& HERE IS...)
Alt-U	Clear RX buffer
Alt-V	Clear TX buffer
Alt-W	Delete word (edit)
Alt-X	Select TX buffer (scrolling)
Alt-Y	Toggle AUTO POWER ON/OFF
Alt-Z	Insert MARS time group into TX buffer (& HERE IS...)

5.3 Other Special Keys

KEY	OPERATION
Shift-PrtSc	Print Current Display Screen
Esc	Back up one step in command menus
Left-Arrow	Move cursor left one character (edit)
Right-Arrow	Move cursor right one character (edit)
Ctrl-Left	Move cursor left one word (edit)
Ctrl-Right	Move cursor right one word (edit)
Up-Arrow	Move cursor up one line (edit)
Down-Arrow	Move cursor down one line (edit)
PgUp	Move cursor up one page (7 lines TX & RX buffer)
PgDn	Move cursor down one page (7 lines TX & RX buffer)
Home	Move cursor to beginning of line (edit)
Ctrl-Home	Move cursor to start of buffer (edit & RX buffer)
End	Move cursor to end of line (edit)
Ctrl-End	Move cursor to end of buffer (edit & RX buffer)
BS (Ctrl-H)	Delete character to the left of cursor (edit)
Back-Arrow	Delete character to left of cursor (edit)
Del	Delete character at cursor
Ins	Toggle Insert/Overtyping edit mode (edit)

5.4 "Expert Key" Commands

In Chapter 3, you saw the PC-CLOVER menus with certain letters in each menu name highlighted. Those letters function as "hot keys" or keys that cause an immediate response from PC-CLOVER, without any additional action. After accessing the PC-CLOVER main menu, you will see that a single letter in each menu command is highlighted. That letter can be used to choose the submenu of commands.

Once a sub-menu has been opened, **[left-arrow]** and **[right-arrow]** keys move you from sub-menu to sub-menu. You move within the sub-menus by using the **[up-arrow]** and **[down-arrow]**. In the sub-menus, the "expert key" for each menu option is highlighted. Press the highlighted letter to activate the option you wish to change.

EXCEPTION: There are no "expert keys" within the Messages sub-menu. Use **[up-arrow]** and **[down-arrow]** to highlight the message you wish to select, then press **[ENTER]** to place that message in the TX buffer.

5.5 PC-CLOVER And The Expert User

PC-CLOVER was designed to meet the needs of all users. The beginner will find the PC-CLOVER menu and sub-menus simple to understand and easy to access. As you become more familiar with the workings of PC-CLOVER you will be able to take "short-cuts" by using the function keys to accomplish your goals. For example, there are several ways to initiate an ARQ call.

BEGINNER: You can press **[F1]** to access the main menu then press **[ENTER]** in succession to select Mode and ARQ. Then type in the call of the station you wish to contact and press **[ENTER]** again to set that call. Finally, press **[ENTER]** twice to select HISCALL and the Adaptive mode. PC-CLOVER will begin the calling sequence.

EXPERT: You press **[F9]**, select or enter the call of the station you wish to contact, then press **[ENTER]** twice for Adaptive mode and the ARQ call will begin.

Other actions that can be initiated from either menu selection or function keys include loading the prepared messages into the TX buffer (**[F5]** followed by the number of the message), initiating an ARQ CQ (**[ALT-F9]**) and answering an ARQ CQ (**[Ctrl-F9]**).

Chapter 6: Operating PC-CLOVER

This chapter describes the steps in operating PC-CLOVER and the various modes available to you. You will find information on the following topics:

- Tuning A CLOVER Signal
- The Adaptive ARQ Mode
- Calling CQ
- The FEC Mode
- LISTEN Mode
- Test Mode

6.1 Tuning A CLOVER Signal

STEP	ACTION
1	Use [Alt]-A to access the Amplitude Tuning Bars in the top-left corner of the PC-CLOVER screen. You should see four bars of varying lengths below the message "Tune For Equal Amplitudes".
2	Tune the transceiver until all four bars are generally equal in magnitude. When the bars "freeze" and the link message or FEC message appears above them, continue to step 3.
3	Press [Alt]-A to access the Frequency Error Tuning Bar.
4	Check the FRQ column on the top right of the screen and the Frequency Error Tuning Bar to see how far off frequency you may be. The number shown in that column is in Hertz.
5	Make VERY small adjustments to the receiver to reduce the frequency error. It will be a moment before the Frequency Tuning Bar reflects the change you have made. Repeat this step until you are "close" to the frequency of the sending station. STOP TUNING. (Note 1)

NOTES:

1. You may not be able to precisely "zero" the Frequency Tuning Bar on the frequency of the sending station. This is not a problem. Some transceivers tune in 10 hertz steps.
2. If you are the sending station you should avoid tuning at all after a link is made. The receiving station should use this procedure to refine the link frequency.
3. The CW ID is T2.

6.2 The Adaptive ARQ Mode

The PC-CLOVER Adaptive ARQ mode is a two station point-to-point communications mode using fully adaptive waveform control and two separate error detection/correction methods (see Hardware Manual, section 3.3.3).

There are two ways to start an ARQ link. The following steps show you one way to initiate an ARQ contact:

STEP	ACTION
1	Press [F1] to access the PC-CLOVER main Menu.
2	Press M to display the Mode sub-menu. Result: You see five selections: <div style="border: 1px solid black; padding: 5px; margin: 10px auto; width: fit-content;"> ARQ CQ FEC Listen Test </div>

3	<p>Press A for ARQ or Press [Enter] (if ARQ is already highlighted)</p> <p>Result:</p> <p>You see the following window:</p> <div data-bbox="699 558 1053 758" style="border: 1px solid black; padding: 5px; margin: 10px auto; width: fit-content;"> <pre>Hiscall (K5CVD) #1 (WD4PKZ) #2 (W9GWT) #3 (W9CW) #4 (KB5AQO)</pre> </div>
4	<p>Type the desired call in the Hiscall position and press [Enter] or use the [down-arrow] key to select the call of your choice. Press [Enter] to select the call that is highlighted.</p> <p>Result:</p> <div data-bbox="686 1062 935 1192" style="border: 1px solid black; padding: 5px; margin: 10px auto; width: fit-content;"> <pre>FORMAT Adaptive Manual</pre> </div>
5	<p>Use the arrow keys to highlight Adaptive and press [Enter] or Press A for Adaptive.</p> <p>An Adaptive ARQ link attempt will begin. Note the "Calling" Message.</p>

Note: Remember to use **[F10]** to toggle the TX EN/DIS to EN to enable the transmit buffer. Use **[Ctrl]-F7** to stop a call and return to standby before exceeding the retry count.

Here is another method of initiating an ARQ link attempt:

STEP	ACTION
1	<p>Press [F9] to initiate the PC-CLOVER contact.</p> <p>Result:</p> <p>You see the following window:</p> <div data-bbox="662 634 1019 837" style="border: 1px solid black; padding: 5px; margin: 10px auto; width: fit-content;"> <pre>Hiscall (K5CVD) #1 (WD4PKZ) #2 (W9GWT) #3 (W9CW) #4 (KB5AQO)</pre> </div>
2	<p>Type the desired call in the Hiscall position and press [Enter] or use the [down-arrow] key to select the call of your choice. Press [Enter] to select the call that is highlighted.</p> <p>Result:</p> <div data-bbox="652 1142 902 1272" style="border: 1px solid black; padding: 5px; margin: 10px auto; width: fit-content;"> <pre>FORMAT Adaptive Manual</pre> </div>
3	<p>Use the arrow keys to highlight Adaptive and press [Enter] or or Press A for Adaptive.</p> <p>Result:</p> <p>An ARQ link attempt will begin. Note the "Calling" message.</p> <p>Note: Remember to use [F10] to toggle the TX EN/DIS to EN to enable the transmit buffer.</p>

6.2.1 The ARQ QSO

During an ARQ QSO, data is transmitted in two ways. When both stations are "chatting" and the transmitted data from both sides is relatively short, the data is sent as part of each CCB (CLOVER Control Block). When the TX buffer of either station reaches a certain level of fill, Clover begins sending the information in a series of data blocks, followed by a CCB. Once the data in the TX buffer is sent, CLOVER returns to the CCB "chat" mode.

Data can be pre-programmed in the ten programmable messages, or as text files on a disk. You can use Load TX Buffer on the Files menu or press **[Alt]-L** to load a file from disk that does not exceed the 250 line capacity of the buffer. For files larger than the TX buffer, use the Send From Disk option of the Files menu. Files sent that way are transmitted directly, rather than through the TX buffer. A CWID will occur every ten minutes if enabled.

6.2.2 The ARQ END Commands

There are three methods of ending a PC-CLOVER ARQ QSO:

- Pressing **[F7]** (END) breaks the link in the normal manner after all pending text has been sent. The link does not drop until the other station has confirmed receipt of the disconnect request and CW ID's (if enabled) have been sent. You will see "ZZZZ" appear when [F7] is typed while text remains in the TX buffer.
- Pressing **[Alt]-F7** (QUICK END) drops the link as with **[F7]** except that notice is provided to the other station only once: if the other station fails to decode the disconnect request signal, it will report "Signal Lost" and continue to send CCB's until it either retries out or the operator stops action using **[Alt]-F7** or **[Ctrl]-F7** keys.
- Pressing **[Ctrl]-F7** (PANIC END) produces similar action to **[Alt]-F7** except that all pending transmit data is abandoned and a disconnect request is issued immediately. Use this key combination only if you need to get off-the-air very quickly! As with [Alt]-F7, [Ctrl]-F7 may force the other station to "retry out".

6.2.3 Initiating an ARQ CQ

To initiate an ARQ CQ call in PC-CLOVER press **[Alt]-F9**. PC-CLOVER will begin the CQ sequence, with several CCB's inviting contact (the number is set with the "Fail Retries" parameter in the configuration file). Other CLOVER stations on your frequency will see a message at the top left of their screen "ARQ CQ from (your call)". Anyone wishing to answer your CQ may do so.

6.2.4 Answering an ARQ CQ

To answer an ARQ CQ call, press **[Ctrl]-F9**. Your station will respond by linking to the calling station and you will see the other station's call at the top of your screen. If a CQ CCB is received, your transceiver is already tuned close enough in frequency to link. Use the Frequency Error Bar to fine tune after the link is established. From that point all else proceeds as in a regular ARQ QSO.

If a CCB fails to decode during the connect process, it will cause both stations to return to standby mode, regardless of the retry counters. Once a connect is established the link will hold together very tenaciously.

6.2.5 Performance Hints For Keyboarders

If you are making a connect for keyboard-to-keyboard chat and not (for example) to a BBS to read and send messages, select the manual ARQ mode and choose BPSM. This is PC-CLOVER's slowest and most robust data mode. Both stations will be set to this mode by your actions. Both operators may now chat with very infrequent repetitions needed by the modems and the data rate is still faster than most people type

If there are fewer than 256 characters awaiting transmission, they will be sent using the "slow" CCB "Chat Mode". As soon as you exceed 255 pre-buffered transmit characters, the modem will "shift gears" and begin transmitting data in large data blocks using faster modulation forms. Block mode transmission will continue until all pending transmit text has been sent. ARQ mode then returns to "Chat Mode". Both operators may type at the same time and data will be sent in both directions automatically without use of "OVER" commands. If you wish to immediately shift out of "Chat mode" to higher rate modes, preload the transmit buffer with at least 255 characters (about 3 1/2 lines) - a fully-loaded HERE IS message may be used for this purpose.

If echo enable is turned ON (Configuration Menu, page 1), your transmitted text will appear in the receive window as it is being encoded for transmission. Received text will be shown in "bright video" and echoed transmit text as "dim video". In some case, it may be less confusing to turn echo OFF and only display received text in the RX buffer screen area.

6.3 The FEC Mode

While ARQ is the prevailing means of communications, within CLOVER for passing traffic and general conversation, occasionally there is a need for a "one-station-to-many" broadcast. The FEC mode serves to provide just such a service. Any station tuned to the frequency of the FEC transmission will be able to monitor it. Errors are corrected at the receiving station, although it is not possible to request repeats. Also, FEC is not adaptive so you must make some judgement about current band conditions and select the modulation for your FEC transmission. The modulation you select can be changed during transmission.

- Modulation modes: 2DFSM, BPSM, QPSM, 8PSM, 16PSM, 16P4A

In general, more robust modes for poor band conditions are the slower modulation rates (the first few in the above list).

ARQ features not available in FEC mode are:

- Repeat of blocks whose errors exceed the Reed-Solomon capacity
- Adaptive modulation control
- Chat, 1-way block or 2-way block modes

While all six modulation modes may be used for FEC transmissions, it must be remembered that very good propagation conditions are required to support the high data rate modes. It is therefore advisable to be "conservative" in the choice of transmission modes, particularly when FEC is used to send data to multiple stations. QPSM modulation generally works well under typical daytime conditions and provides throughput of 20 bytes per second (three times the AMTOR rate). If conditions are poor or disturbed, use BPSM. 8PSM, 16PSM, and 16P4A modes should be reserved for situations in which the propagation path is known to be stable.

For additional information about these parameters see the PCI-4000 Reference Manual, section 3.3.2.

This table shows how to:

- Enter FEC mode
- Select the modulation and efficiency
- Initiate the FEC transmission
- End the FEC transmission

STEP	ACTION																
1	Press [F1] to access the CLOVER main menu.																
2	Press M to display the Mode sub-menu.																
3	<p>Press F to select FEC</p> <p>Result:</p> <table border="1" data-bbox="500 905 1117 1094"> <thead> <tr> <th colspan="2" data-bbox="508 940 808 968">WAVEFORM</th> <th colspan="2" data-bbox="815 940 1109 968">DATA RATE</th> </tr> </thead> <tbody> <tr> <td data-bbox="508 974 602 1001">Modulation</td> <td data-bbox="667 974 732 1001">16PSM</td> <td data-bbox="815 974 911 1001">Base Rate</td> <td data-bbox="959 974 1003 1001">500</td> </tr> <tr> <td data-bbox="508 1001 602 1029">Code Effic</td> <td data-bbox="667 1001 716 1029">60%</td> <td data-bbox="815 1001 894 1029">Actual</td> <td data-bbox="959 1001 1003 1029">300</td> </tr> <tr> <td data-bbox="508 1029 602 1056">Block Size</td> <td data-bbox="667 1029 716 1056">255</td> <td></td> <td></td> </tr> </tbody> </table>	WAVEFORM		DATA RATE		Modulation	16PSM	Base Rate	500	Code Effic	60%	Actual	300	Block Size	255		
WAVEFORM		DATA RATE															
Modulation	16PSM	Base Rate	500														
Code Effic	60%	Actual	300														
Block Size	255																
4	<p>Use the [space bar] to toggle through the selections, then press [Enter] to initiate the FEC transmission.</p> <p>Note: Remember to use [Alt]-F10 to toggle the TX EN/DIS to enable the transmit buffer.</p>																
5	<p>Press [F7] to end the FEC transmission.</p> <p>Result:</p> <p>CLOVER terminated the FEC transmission with your CW ID, if enabled.</p>																

6.4 Listen Mode

As you read in Chapter 4, Listen mode is a passive monitoring mode, similar to the Listen mode in AMTOR. It allows you to monitor any CLOVER activity that may be occurring. To enter Listen mode, you may press **[F1]** then **M** to access the Mode menu. Then press **L** to select Listen from the mode menu and use **[space bar]** to toggle Listen on. The same series of actions are used to toggle Listen off.

Another method of toggling Listen mode on or off is to press **[F8]**. As you do, **LISTEN** will replace **STBY** on the status line. Press **[F8]** again and you return to **STBY** (stand-by).

Listen mode is active when you are not linked. Links can still occur even if Listen mode is in **ON**.

6.5 The Test Mode

The PC-CLOVER Test mode provides two different selections of test tones: Single Tone Test and Four Tone Test. As you saw in Chapter 2, section 2.2.2, the Test mode is primarily for setting transmit audio levels. You can return to section 2.2.2 any time you alter the set-up of your transceiver to verify that the audio output levels are correctly set.

Chapter 7: In Case of Difficulty

This chapter provides general guidance in case your PCI-4000 hardware and/or PC-CLOVER software no longer function correctly. Please read all sections of Chapter 5 of the PCI-4000 Hardware Manual before attempting maintenance or returning a PCI-4000 to the factory.

7.1 Software Problems

Some programs when run in the PC may create problems that prevent the PCI-4000 and/or PC-CLOVER from operating correctly. Review the comments of section 2.3 regarding software compatibility. "TSR" and "shell" programs may cause intermittent operation of PC options, often appearing as "hardware problems" or causing software "lock-up". If problems have developed since changing software (new programs or different versions of old programs), restore the previous software configuration and re-test the PC-CLOVER.

7.2 User Service

The PCI-4000 does not require periodic alignment. Components should be replaced only if they fail and not as a part of any routine maintenance procedure. As a general rule, component replacement should be done at the factory under controlled ESD (Electro-Static Discharge) conditions. Before returning the PCI-4000 to the factory, consider the following questions:

- Did it work before something changed?
- If so, what has changed (computer, software, radio, etc.)

Then, please check the following:

1. All jumpers and option switches are set correctly.
2. All socketed components are fully seated in their sockets.
3. Cables to the PCI-4000 are installed properly and are not open or shorted.
4. All other features of your PC function correctly.

If the above items are correct, contact the factory to arrange for return and repair.

7.3 User Information

HAL Communications Corp. provides a user support "TECH-LINE BBS" which may be called by HAL customers to obtain current PCI-4000 and PC-CLOVER software releases. TECH-LINE also provides user service bulletins and can be used to communicate with our factory repair personnel. Also, customer service personnel may be contacted directly via telephone or FAX.

Before contacting customer service, have the model number, serial number, software version numbers, and name of the original ordering customer available.

Customer service may be contacted via:

Mail: HAL Communications Corp.
Customer Service Department
1201 W. Kenyon Road
Urbana, Illinois 61801

Phone: (217) 367-7373, 8 AM - 5 PM CST/CDT,
Monday - Friday

FAX: (217) 367-1701, (24 hours/day)

TECH-LINE: Computer BBS
(217) 367-5547 (24 hours/day)
9600, V.42; 2400, 1200, or 300 baud ASCII
"N 8 1" (No Parity, 8 Data Bits, 1 Stop Bit)

7.4 Returning Equipment for Factory Repair

If your equipment must be returned to HAL for repair, please do the following:

1. Call, FAX, or write to HAL and obtain a *Return Material Authorization (RMA)*.
2. *ALWAYS* include the following information *in the package containing the item to be repaired*:
 - a. Your name, and address for return of the repaired equipment. *Give a street address if at all possible.*
 - b. Model, serial number, and approximate purchase date of returned item.

- c. If the warranty period has expired, the payment means you prefer. See the HARDWARE REFERENCE Manual for warranty details.
 - d. A *short but informative* description of the problems. "Broke" is too short; 2 or more pages is usually too much!
 - e. The shipping carrier or means by which the equipment should be returned to you. HAL will use UPS (Brown Label) shipping unless otherwise directed.
3. Carefully pack the PCI-4000 and protect it from shipping damage. Place the PCI-4000 in the original anti-static bag. The original HAL carton is a good choice if it is available and undamaged. A new carton may be purchased from HAL.
 4. Insure the PCI-4000 for its full value.
 5. Clearly mark HAL's name, address, and "ATTN: SERVICE" on the shipping container.

The HAL service department attempts to repair all equipment within 30 days of its arrival at HAL. If the repairs cannot be made within 30 days, you will be notified by mail of the approximate shipping date. You may call the HAL service department to confirm repair dates.

If you require rush service of your PCI-4000, please notify HAL and we will make all attempts possible to expedite your repair. However, our service time is often dependent upon arrival of parts which is not within our control. Also, please understand that testing takes time and that each hardware repair should be "burned-in" for an extended period (24 hours) and re-tested.

APPENDIX A: The PC-CLOVER CONFIGURATION Menu

PC-CLOVER contains a set of default configuration parameters necessary for the system to work. You can alter some of those parameters, and save them all to a configuration file (PCC.CFG). This file does not have to be set up for PC-CLOVER to run.

While some of the PC-CLOVER parameters can be set via main screen menus, full access to all parameters for all modes is provided in the CONFIGURATION menu. When you wish to customize your PC-CLOVER you can alter the default parameters to suit your needs by editing the parameters and saving them as PCC.CFG or by creating several new configuration files (you name them) that you can load from a disk.

The Configuration menus consists of 9 windows on two pages. Page 1 contains the operating and screen parameters for PC-CLOVER as well as an information only window that shows current versions of the PC-CLOVER software and the hardware address. Page 2 contains the Messages directory and the Hiscall directory. The Options window appears on both pages.

A.1 Accessing the PC-CLOVER Configuration File

The PC-CLOVER Configuration Menu is accessed using the following steps:

STEP	ACTION																		
1	<p data-bbox="380 1209 1040 1245">Press [F1] to access the CLOVER main menu:</p> <div data-bbox="380 1278 1268 1339" style="border: 1px solid black; padding: 5px; margin: 10px 0;"> <table style="width: 100%; border-collapse: collapse;"> <tr> <td style="text-align: left; padding: 2px;">CLOVER</td> <td style="text-align: left; padding: 2px;">STBY</td> <td style="text-align: left; padding: 2px;">T</td> <td style="text-align: left; padding: 2px;">R</td> <td style="text-align: left; padding: 2px;">DIS</td> <td style="text-align: left; padding: 2px;">CHAR</td> <td style="text-align: left; padding: 2px;">R001</td> <td style="text-align: left; padding: 2px;">T001</td> <td style="text-align: left; padding: 2px;">08:19</td> </tr> <tr> <td style="text-align: left; padding: 2px;">Mode</td> <td style="text-align: left; padding: 2px;">Control</td> <td colspan="2" style="text-align: left; padding: 2px;">Messages</td> <td colspan="2" style="text-align: left; padding: 2px;">Files</td> <td colspan="3" style="text-align: left; padding: 2px;">Exit</td> </tr> </table> </div> <p data-bbox="380 1379 1386 1451">This menu is displayed just below the CLOVER status line at the top of the TX buffer window.</p>	CLOVER	STBY	T	R	DIS	CHAR	R001	T001	08:19	Mode	Control	Messages		Files		Exit		
CLOVER	STBY	T	R	DIS	CHAR	R001	T001	08:19											
Mode	Control	Messages		Files		Exit													

2

Press F to select the Files menu. The Files window will open on your screen:

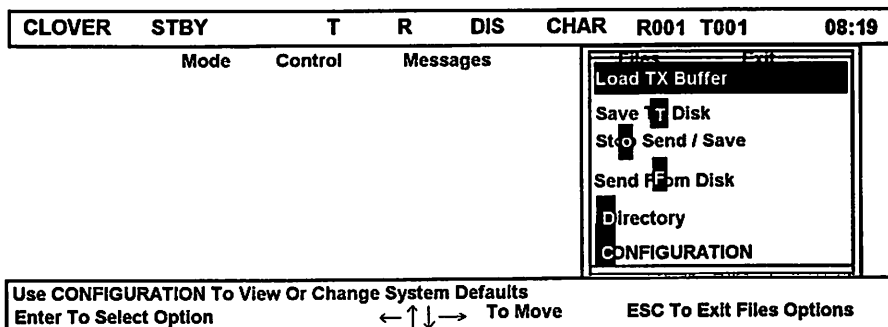

3

Type C to access the Configuration File:

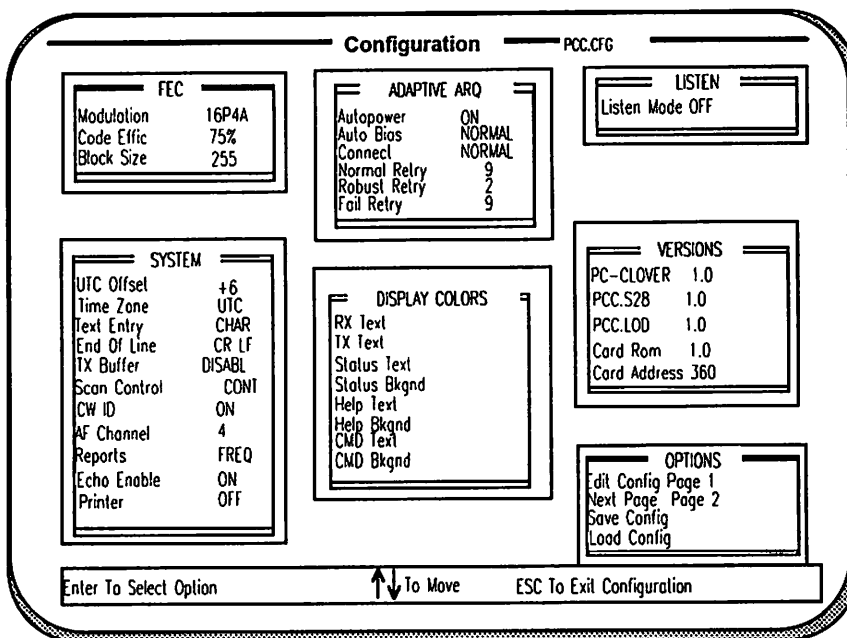

A.2 Configuration File Parameters, Page 1

Page 1 of the Configuration menu displays and allows setting of all the operational parameters for standard CLOVER modes. Access to the parameters is via arrow-key highlighting and [Enter] selection. The displayed configuration parameters may also be saved to a configuration file for later use. As stated earlier, different configuration files may be loaded by menu selection as needed.

A.2.1 The FEC Configuration Menu

This menu allows you to set the waveform parameters for FEC. There are six choices:

- 2DPSM, BPSM, QPSM, 8PSM, 16PSM, AND 16P4A.

Changes to this menu are used the next time an FEC transmission begins. The FEC menu always reflects the current parameters.

A.2.2 The ADAPTIVE ARQ Menu

These parameters are only available from the configuration menu.

- **AUTOPOWER:** The on/off selection of the automatic transmitter power control feature of the ADAPTIVE ARQ mode. When this parameter is set to on, the PCI-4000 evaluates the received signal and sends commands to adjust the power of the sending station by controlling the audio output (amplitude) of the sending stations CLOVER modulator. The calling modem at the beginning of a link sets AUTOPOWER state (ON/OFF) for both stations for the duration of the link.
- **Auto Bias:** This parameter controls how quickly the sending station is instructed to change modes (e.g. change throughput). There are three options: ROBUST, NORMAL, and FAST.

ROBUST biases the decision for slower changes and lower data rates when conditions are very unstable or disturbed.

NORMAL biases the decision more toward medium changes and data rates used during usual conditions where instability in band conditions is minimal.

FAST favors high data rates and complex waveforms, best used when conditions are very stable.

CONNECT: This parameter determines the type of ARQ connect attempt used by your station. It has two options: NORMAL and ROBUST. The default is NORMAL. NORMAL connections will be made within 2 seconds and you should always use NORMAL when accessing a scanning APLink BBS station. A ROBUST connection requires approximately 5 seconds to establish an ARQ link. Once the link is established, ADAPTIVE ARQ mode takes over and adjusts for the current conditions over the full range of PC-CLOVER modes.

- **Normal Retry:** The number of connect retries that will occur when attempting an ARQ link in NORMAL connect mode. The number of retries is from 0-255.
- **Robust Retry:** The number of connect retries that will occur when attempting an ARQ link in ROBUST connect mode. The number of retries is from 0-255.
- **FAIL Retry:** The number of retries before the link fails. The number of retries may be set from 0-255.

A.2.3 The LISTEN Menu

This parameter sets the PC-CLOVER listen mode to on or off. If set to "off" the PCI-4000 is in standby mode. If this parameter is set to "on", PC-CLOVER monitors both ARQ and FEC signals on frequency. Regardless of the state of this parameter (ON or STBY) If an ARQ link attempt using the programmed Mycall is monitored, the PCI-4000 immediately switches to ARQ mode and links. when the link is completed, the PCI-4000 returns to the pre-link state (ON or STBY).

A.2.4 The SYSTEM Menu

The SYSTEM Menu allows you to set those parameters that are common to all PC-CLOVER modes, or those that do not to be changed frequently.

- **UTC Offset:** A two digit \pm hour offset from your PC clock. The offset for EST is +5, CST is +6, MST is +7 and PST is +8. The offset is shown on the right edge of the main screen status line and is used whenever **[ALT]-T** (time) and **[ALT]-B** (date/time) are used.
- **Time Zone:** A three character entry to specify your time zone. Use a single character for military time (e.g. "z" for Zulu time).
- **Text Entry:** This parameter determines the amount of text sent to the transmitter at one time. There are three choices: CHAR, WORD, and LINE. If CHAR is selected, each character typed enters the TX buffer immediately. If the parameter is set to WORD, a string of characters enters the TX buffer after each space is typed. If LINE is selected, text enters the TX buffer only after **[Enter]** is pressed. Editing is possible with WORD and LINE options.
- **END OF LINE:** This parameter sets the end-of-line character to be sent when text is passed through the TX buffer. There are two choices: CR (carriage return) only, or CR LF (carriage return + line feed). The selected

end-of-line sequences has no effect on text transmitted using the Send From File option. Only those characters included in the file being sent are transmitted.

- **TX Buffer:** This parameter enables or disables the Transmit buffer. There are two options: EN (enable) and DIS (disabled). This parameter can be changed from the main screen using **[Alt-F10]**.
- **Scan Control:** This parameter can be used to control the scanning of radio equipment. It may be used to stop scanning when Mycall is received during a NORMAL ARQ link attempt and resume scanning when the link is ended. The two options are: CONT (continuous) and PULSE. Continuous simulates a continuous switch (on/off). The PULSE option sends a pulse at the beginning of the link, then sends another when your station is no longer linked. See sections 2.4.4 and 3.3.3.10 of the REFERENCE MANUAL for additional details.
- **CW ID:** This parameter turns the CW ID ON or OFF. When set ON, a 20 WPM Morse code station ID using MYCALL is sent at the beginning and end of a link, and every 10 minutes during the ARQ QSO. CW ID uses a single tone format (T2) that is used in no other PC-CLOVER mode.
- **AF CHANNEL:** PC-CLOVER and the PCI-4000 supports four different 500 Hz wide audio frequency channels: #1 at Fc=750 Hz, #2 at Fc=1250 Hz, #3 at Fc=1750 Hz, and #4 at Fc=2250 Hz. Channel #4 (Fc=2250) is the best suited for existing radio equipment and is the default setting.
- **ECHO ENABLED:** This parameter sets ECHO to ON or OFF. If ON, transmitted text is displayed with "dim" attribute in the receive buffer.
- **PRINTER:** This parameter turns the printer ON or OFF. When set to ON, all text received and all text transmitted *as it is echoed to the receive buffer* is sent to the system printer PRN at LPT1. When set to OFF, no text is sent to the printer. This parameter may be toggled on or off using **[Alt]-P**.

A.2.5 DISPLAY COLORS Menu

This menu allows you to select the foreground (character) and background colors used for screen display. Each color may be tested by cycling through the options using the **[space bar]** while viewing the highlighted parameter.

A.2.6 The VERSIONS Menu

This table shows the software version numbers for each software module in use. The card address in hexadecimal format is also shown on this menu. Address 360H is the factory default setting.

A.2.7 The OPTIONS Menu

The OPTIONS menu provides editing access to the two pages of the CONFIGURATION menu and allows saving and retrieving of configuration files. The SAVE CONFIG and LOAD CONFIG options show the last used configuration file name (*.CFG) for each option. A configuration file name may be 8 characters long and uses the .CFG extension. This menu is accessible on both pages of the CONFIGURATION menu.

A.3 Configuration File Parameters, Page 2

Page 2 of the CONFIGURATION Menu is used to program the text of the HERE IS messages and enter call signs into the Call Directory.

Configuration		PCC.CFG																																																			
MESSAGES																																																					
0	(here is 0)	<																																																			
1	(here is 1)	<																																																			
2	(here is 2)	<																																																			
3	(here is 3)	<																																																			
4	(here is 4)	<																																																			
5	(here is 5)	<																																																			
6	(here is 6)	<																																																			
7	(here is 7)	<																																																			
8	(here is 8)	<																																																			
9	(here is 9)	<																																																			
<table border="1" style="width: 100%;"> <tr> <td style="width: 33%;"> <table border="1"> <thead> <tr> <th colspan="2">CALL SIGN</th> </tr> </thead> <tbody> <tr> <td>MYCALL</td> <td>(call)</td> </tr> <tr> <td>HISCALL</td> <td>Directory</td> </tr> <tr> <td>Last</td> <td>(call)</td> </tr> <tr> <td>#1</td> <td>(call1)</td> </tr> <tr> <td>#2</td> <td>(call2)</td> </tr> <tr> <td>#3</td> <td>(call3)</td> </tr> <tr> <td>#4</td> <td>(call4)</td> </tr> <tr> <td>#5</td> <td>(call5)</td> </tr> </tbody> </table> </td> <td style="width: 33%;"> <table border="1"> <thead> <tr> <th colspan="2">HISCALL DIRECTORY</th> </tr> </thead> <tbody> <tr> <td>#6</td> <td>(call6)</td> </tr> <tr> <td>#7</td> <td>(call7)</td> </tr> <tr> <td>#8</td> <td>(call8)</td> </tr> <tr> <td>#9</td> <td>(call9)</td> </tr> <tr> <td>#10</td> <td>(call10)</td> </tr> <tr> <td>#11</td> <td>(call11)</td> </tr> <tr> <td>#12</td> <td>(call12)</td> </tr> <tr> <td>#13</td> <td>(call13)</td> </tr> <tr> <td>#14</td> <td>(call14)</td> </tr> </tbody> </table> </td> <td style="width: 33%;"> <table border="1"> <thead> <tr> <th colspan="2">OPTIONS</th> </tr> </thead> <tbody> <tr> <td>Edit Config</td> <td>Page 2</td> </tr> <tr> <td>Next Page</td> <td>Page 1</td> </tr> <tr> <td>Save Config</td> <td></td> </tr> <tr> <td>Load Config</td> <td></td> </tr> </tbody> </table> </td> </tr> </table>			<table border="1"> <thead> <tr> <th colspan="2">CALL SIGN</th> </tr> </thead> <tbody> <tr> <td>MYCALL</td> <td>(call)</td> </tr> <tr> <td>HISCALL</td> <td>Directory</td> </tr> <tr> <td>Last</td> <td>(call)</td> </tr> <tr> <td>#1</td> <td>(call1)</td> </tr> <tr> <td>#2</td> <td>(call2)</td> </tr> <tr> <td>#3</td> <td>(call3)</td> </tr> <tr> <td>#4</td> <td>(call4)</td> </tr> <tr> <td>#5</td> <td>(call5)</td> </tr> </tbody> </table>	CALL SIGN		MYCALL	(call)	HISCALL	Directory	Last	(call)	#1	(call1)	#2	(call2)	#3	(call3)	#4	(call4)	#5	(call5)	<table border="1"> <thead> <tr> <th colspan="2">HISCALL DIRECTORY</th> </tr> </thead> <tbody> <tr> <td>#6</td> <td>(call6)</td> </tr> <tr> <td>#7</td> <td>(call7)</td> </tr> <tr> <td>#8</td> <td>(call8)</td> </tr> <tr> <td>#9</td> <td>(call9)</td> </tr> <tr> <td>#10</td> <td>(call10)</td> </tr> <tr> <td>#11</td> <td>(call11)</td> </tr> <tr> <td>#12</td> <td>(call12)</td> </tr> <tr> <td>#13</td> <td>(call13)</td> </tr> <tr> <td>#14</td> <td>(call14)</td> </tr> </tbody> </table>	HISCALL DIRECTORY		#6	(call6)	#7	(call7)	#8	(call8)	#9	(call9)	#10	(call10)	#11	(call11)	#12	(call12)	#13	(call13)	#14	(call14)	<table border="1"> <thead> <tr> <th colspan="2">OPTIONS</th> </tr> </thead> <tbody> <tr> <td>Edit Config</td> <td>Page 2</td> </tr> <tr> <td>Next Page</td> <td>Page 1</td> </tr> <tr> <td>Save Config</td> <td></td> </tr> <tr> <td>Load Config</td> <td></td> </tr> </tbody> </table>	OPTIONS		Edit Config	Page 2	Next Page	Page 1	Save Config		Load Config	
<table border="1"> <thead> <tr> <th colspan="2">CALL SIGN</th> </tr> </thead> <tbody> <tr> <td>MYCALL</td> <td>(call)</td> </tr> <tr> <td>HISCALL</td> <td>Directory</td> </tr> <tr> <td>Last</td> <td>(call)</td> </tr> <tr> <td>#1</td> <td>(call1)</td> </tr> <tr> <td>#2</td> <td>(call2)</td> </tr> <tr> <td>#3</td> <td>(call3)</td> </tr> <tr> <td>#4</td> <td>(call4)</td> </tr> <tr> <td>#5</td> <td>(call5)</td> </tr> </tbody> </table>	CALL SIGN		MYCALL	(call)	HISCALL	Directory	Last	(call)	#1	(call1)	#2	(call2)	#3	(call3)	#4	(call4)	#5	(call5)	<table border="1"> <thead> <tr> <th colspan="2">HISCALL DIRECTORY</th> </tr> </thead> <tbody> <tr> <td>#6</td> <td>(call6)</td> </tr> <tr> <td>#7</td> <td>(call7)</td> </tr> <tr> <td>#8</td> <td>(call8)</td> </tr> <tr> <td>#9</td> <td>(call9)</td> </tr> <tr> <td>#10</td> <td>(call10)</td> </tr> <tr> <td>#11</td> <td>(call11)</td> </tr> <tr> <td>#12</td> <td>(call12)</td> </tr> <tr> <td>#13</td> <td>(call13)</td> </tr> <tr> <td>#14</td> <td>(call14)</td> </tr> </tbody> </table>	HISCALL DIRECTORY		#6	(call6)	#7	(call7)	#8	(call8)	#9	(call9)	#10	(call10)	#11	(call11)	#12	(call12)	#13	(call13)	#14	(call14)	<table border="1"> <thead> <tr> <th colspan="2">OPTIONS</th> </tr> </thead> <tbody> <tr> <td>Edit Config</td> <td>Page 2</td> </tr> <tr> <td>Next Page</td> <td>Page 1</td> </tr> <tr> <td>Save Config</td> <td></td> </tr> <tr> <td>Load Config</td> <td></td> </tr> </tbody> </table>	OPTIONS		Edit Config	Page 2	Next Page	Page 1	Save Config		Load Config				
CALL SIGN																																																					
MYCALL	(call)																																																				
HISCALL	Directory																																																				
Last	(call)																																																				
#1	(call1)																																																				
#2	(call2)																																																				
#3	(call3)																																																				
#4	(call4)																																																				
#5	(call5)																																																				
HISCALL DIRECTORY																																																					
#6	(call6)																																																				
#7	(call7)																																																				
#8	(call8)																																																				
#9	(call9)																																																				
#10	(call10)																																																				
#11	(call11)																																																				
#12	(call12)																																																				
#13	(call13)																																																				
#14	(call14)																																																				
OPTIONS																																																					
Edit Config	Page 2																																																				
Next Page	Page 1																																																				
Save Config																																																					
Load Config																																																					
Enter To Select Option ↑↓ To Move ESC To Exit Configuration																																																					

A.3.1 The HERE IS Menu

The HERE IS Menu allows you to program a total of 10 messages for repeated use during PC-CLOVER QSO's. Each message may contain up to 255 characters. The first 70 characters of each message are displayed on this menu. If the message shown is complete, the end of that line shows "<". If the

message extends beyond 70 characters a "+" is displayed at the end of that line. (See Chapter 2, section 2.4 for guidance in programming your messages).

A.3.2 The CALL SIGNS Menu

The CALL SIGNS Menu allows you to program MYCALL and up to 15 HISCALL text streams. Also, the last used HISCALL is displayed. Each call sign may be up to 8 characters long and may consist of any combination of letters, numbers, and most printable, non-blank ASCII punctuation symbols.

Since MYCALL is not changed frequently, it can only be accessed through this menu and by the use of **[Alt]-M** from the PC-CLOVER main screen.

The HISCALL Directory allows the storage of up to 15 call signs for frequently called stations.

Call signs may be entered in either upper or lower case, but are stored and sent in upper case only.

MYCALL and all HISCALL entries are stored when a configuration file is saved (PCC.CFG).

NOTE: Although the Configuration File Menu parameters may be accessed and changed while linked in ARQ or sending in FEC modes, the new parameters may not be used until the PCI-4000 returns to STBY or LISTEN mode.

**PCI-4000
CLOVER - II DATA MODEM**

REFERENCE MANUAL

Copyright © 1992 by HAL Communications Corp., Urbana, Illinois. Printed in the United States of America. Contents of this publication may not be reproduced in any form without the written permission of the copyright owner.

870-04000
October 1, 1993 Printing

PCI-4000 REFERENCE MANUAL

CONTENTS:

CHAPTER 1. INTRODUCTION	1-1
1.1 Unpacking and Inspection	1-2
1.2 PCI-4000 Accessories	1-2
1.3 Software and Documentation Up-Date	1-3
CHAPTER 2. INSTALLATION	2-1
2.1 Personal Computer Installation	2-1
2.1.1 Pre-installation Test	2-1
2.1.2 Installing the PCI-4000 Circuit Board	2-1
2.1.3 Loading PCI-4000 and PC-CLOVER Software	2-2
2.1.4 PCI-4000 Software Files	2-3
2.2 PC Hardware Compatibility	2-4
2.3 PC Software Compatibility	2-5
2.4 Radio System Connections	2-6
2.4.1 Audio Input	2-9
2.4.2 Audio Output	2-9
2.4.3 PTT Output	2-10
2.4.4 SEL-CAL Output	2-10
2.5 Initial Transmitter and Receiver Adjustment	2-11
2.6 HF Transmitter/Receiver Compatibility	2-12
2.6.1 Frequency Control	2-12
2.6.2 Transmitter Modulation	2-13
2.6.3 Receiver AGC and Noise Limiter	2-14
2.6.4 Receiver Filters	2-14
2.6.5 Receiver Audio Level	2-15
2.6.6 Adaptive Control and Radios	2-15
2.6.7 FCC Rules & CW ID	2-16
2.7 CLOVER-II Tuning Indicators	2-16
2.7.1 Tuning with PC-CLOVER	2-17
2.7.2 Using the HAL SPECTRA-TUNE Indicators	2-17
CHAPTER 3. CLOVER-II WAVEFORM	3-1
3.1 CLOVER Background	3-1
3.2 CLOVER-II Waveform	3-1
3.2.1 Time/Frequency Domain	3-1
3.2.2 Data Modulation	3-5
3.2.3 Error Detection and Correction	3-8
3.2.4 CLOVER Waveform Modes	3-9
3.2.5 Baud, Data Rate, and Throughput	3-10
3.3 CLOVER-II Protocols	3-11
3.3.1 CLOVER Control Block (CCB)	3-11
3.3.2 FEC Protocol	3-11

PCI-4000 REFERENCE MANUAL

CONTENTS: (Continued)

3.3.3	ARQ Protocol	3-14
3.3.3.1	CCB Protocol Layer	3-14
3.3.3.2	ARQ Data Block Layer	3-16
3.3.3.3	Adaptive ARQ (AUTO-ARQ)	3-16
3.3.3.4	Adaptive ARQ Bias Parameter	3-18
3.3.3.5	ARQ Connection	3-18
3.3.3.6	One-Way and Two-Way ARQ	3-19
3.3.3.7	ARQ AUTOPOWER	3-19
3.3.3.8	ARQ CQ Mode	3-20
3.3.3.9	ARQ Disconnect	3-20
3.3.3.10	SEL-CAL & Scan-Control	3-20
3.3.4	LISTEN Mode	3-20
3.3.5	CW ID	3-20
3.4	CLOVER Bibliography	3-21
CHAPTER 4.	TECHNICAL DESCRIPTION	4-1
4.1	PCI-4000 Controller	4-1
4.1.1	Microprocessor Section	4-1
4.1.2	Memory Decoding, Clocks, and Reset	4-2
4.1.3	AT Bus Interface Circuitry	4-3
4.1.4	AT Bus FIFO Buffers	4-4
4.1.5	Controller Status Registers	4-4
4.1.6	PTT and SELCAL Output Register	4-5
4.2	PCI-4000 DSP and Audio Section	4-6
4.2.1	DSP RAM	4-6
4.2.2	Audio Output	4-6
4.2.3	Audio Input	4-6
4.3	PCI-4000 Power and I/O Connections	4-7
4.4	PCI-4000 Options	4-7
CHAPTER 5.	IN CASE OF DIFFICULTY	5-1
5.1	User Adjustments and Alignment	5-1
5.2	PCI-4000 Hardware Problems	5-1
5.3	Software Problems	5-2
5.4	Operational Problems	5-3
5.5	User Service	5-4
5.6	User Information	5-4
5.7	Returning Equipment for Factory Repair	5-5
CHAPTER 6.	SPECIFICATIONS	6-1
APPENDIX A.	PCI-4000 I/O ADDRESS SELECTION	A-1
	LIMITED WARRANTY	W-1
	INDEX	I-1

PCI-4000 REFERENCE MANUAL

TABLES:

TABLE 2.1	PCI-4000 I/O Connections	2-6
TABLE 2.2	PCI-4000/CLOVER-II HF RADIO REQUIREMENTS	2-13
TABLE 3.1	CLOVER-II MODULATION MODES	3-7
TABLE 3.2	DATA BYTES TRANSMITTED PER BLOCK	3-9
TABLE 3.3	CORRECTABLE BYTE ERRORS PER BLOCK	3-9
TABLE 3.4	FEC MODES	3-13
TABLE 4.1	PCI-4000 ADDRESS MAP	4-2
TABLE 4.2	PC I/O ADDRESS ASSIGNMENTS	4-3
TABLE 4.3	FIFO STATUS	4-4
TABLE 4.4	PCI-4000 CONTROL LATCH	4-5
TABLE 5.1	USER-SET OPTIONS	5-1
TABLE A.1	PCI-4000 I/O BASE ADDRESS SELECTION	A-1
TABLE A.2	PC I/O ADDRESS ASSIGNMENTS	A-2

ILLUSTRATIONS:

Figure 2.1	PCI-4000 I/O Connector	2-7
Figure 2.2	PCI-4000 Radio Connections	2-8
Figure 3.1	CLOVER-II Tone Pulse Sequence	3-2
Figure 3.2	CLOVER-II Time/Frequency Relationship	3-3
Figure 3.3	CLOVER-II Frequency Spectra	3-4
Figure 3.4	FEC Mode Format	3-12
Figure 3.5	ARQ Mode - CCB Layer Timing	3-15
Figure 3.6	ARQ Mode - Data Block Layer Timing	3-17
Figure 4.1	PCI-4000 Block Diagram	4-8
Figure 4.2	Control Processor, RAM, ROM	4-9
Figure 4.3	Clocks & Control	4-10
Figure 4.4	PC Bus Interface, I/O Address	4-11
Figure 4.5	PC Input/Output FIFO, PC Interrupt	4-12
Figure 4.6	68000 Bus Interface	4-13
Figure 4.7	PTT Relay, SEL-CAL Output	4-14
Figure 4.8	Digital Signal Processor, DSP RAM	4-15
Figure 4.9	D/A Converter, Modulator Output	4-16
Figure 4.10	A/D Converter, Demodulator Input	4-17
Figure 4.11	I/O Connections, Voltage Regulators	4-18
Figure 4.12	PCI-4000 Circuit Board	4-19

FCC RADIO FREQUENCY EMISSIONS STATEMENT
(Reference: CFR 47, Part 15)

U.S. Federal Communications Commission (FCC) Rules and Regulations, CFR 47, Part 15, require inclusion of the following text in this manual.

INFORMATION TO THE USER (Section 15.105)

NOTE: This equipment has been tested and found to comply with the limits for a Class B digital device, pursuant to Part 15 of the FCC Rules. These limits are designed to provide reasonable protection against harmful interference in a residential installation. This equipment generates, uses and can radiate radio frequency energy and, if not installed and used in accordance with the instructions, may cause harmful interference to radio communications. However, there is no guarantee that the interference will not occur in a particular installation. If this equipment does cause harmful interference to radio or television reception, which can be determined by turning the equipment off and on, the user is encouraged to try to correct the interference by one or more of the following measures:

- Reorient or relocate the receiving antenna
- Increase the separation between the equipment and the receiver.
- Connect the equipment into an outlet on a circuit different from that to which the receiver is connected.
- Consult the dealer or experienced Radio/TV technician for help.

INFORMATION TO USER (Section 15.21)

The user is cautioned that any changes or modifications not expressly approved by the party responsible for compliance could void the user's authority to operate the equipment.

SPECIAL ACCESSORIES (Section 15.27)

The user is also cautioned that any peripheral device installed with this equipment such as a modem or printer, must be connected with a high-quality shielded cable to insure compliance with FCC limits.

FCC CLASS B LABEL (Section 15.19)

FCC ID NUMBER KEE93404000

This device complies with Part 15 of the FCC rules. Operation is subject to the following two conditions: (1) This device may not cause harmful interference, and (2) this device must accept any interference received, including interference that may cause undesired operation.

CHAPTER 1

INTRODUCTION

The PCI-4000 is supplied with two manuals - the PCI-4000 REFERENCE MANUAL (this book) and the PC-CLOVER OPERATOR'S MANUAL. Operation instructions for each mode of CLOVER-II are described in detail in the OPERATOR'S MANUAL. This REFERENCE MANUAL provides detailed descriptions for installation, special operations, and technical details of the HAL PCI-4000 CLOVER-II HF Modem for IBM-Compatible Personal Computers (PC). PC-CLOVER software is designed to be very "user-friendly" and much of its operation is self explanatory. However, a careful reading of this manual is highly recommended so that you gain full benefit of all of the many features of the PCI-4000 and PC-CLOVER.

This HAL product has two names - "PC-CLOVER" and "PCI-4000". The manuals will use "PC-CLOVER" when referring to the software. "PCI-4000" refers specifically to hardware details. "CLOVER-II" refers to the CLOVER waveform used in the PCI-4000.

Chapter 2 provides detailed instructions for installation of the PCI-4000 circuit board in your PC and how to make connections to your transmitter and receiver system.

Chapter 2 is very important - BE SURE TO READ IT!

A "minimum reading assignment" for all PCI-4000 / PC-CLOVER owners is Chapters 1 and 2 of this REFERENCE MANUAL and all of the OPERATOR'S MANUAL.

Chapter 3 explains CLOVER-II modulation and the protocols used when sending and receiving CLOVER-II emissions. This chapter may be read at your convenience, but the information will help you to understand the different CLOVER modes and how they may be used.

Chapter 4 contains a complete Technical Description of the hardware used on the PCI-4000 circuit board. This Chapter may be read at your option, but the "engineers" among us will find the details interesting.

Chapter 5 discusses problems you may encounter and suggests cures. Information for return of the PCI-4000 for factory repair is included. Please read this chapter carefully before returning any materials to HAL.

Chapter 6 lists all technical specifications of the PCI-4000. It is interesting reading, particularly if you want to compare notes with hams who have not yet purchased their own PC-CLOVER system.

Be sure to read the Limited Warranty. This is the form our lawyers tell us we have to include. What it means is that you get the standard HAL Warranty - the same one we have used for years. HAL stands behind its products. If you have a problem - LET US KNOW!

Finally, this manual includes a complete index. The index covers both manuals. Can't recall where you read a detail? --- TRY THE INDEX!

1.1 Unpacking and Inspection

Your PCI-4000 / PC-CLOVER system includes the following materials:

- 1 - 900-04000 Complete PCI-4000 product

Includes:

- 1 - 934-04000 PCI-4000 Circuit Board
- 1 - 870-04000 PCI-4000 REFERENCE MANUAL
- 1 - 870-04001 PC-CLOVER OPERATOR'S MANUAL
- 1 - 865-040yz PC-CLOVER Software Diskette (Latest Version Vy.z)
- 1 - 960-04000 PCI-4000 Radio Cable
- 1 - 310-03502 DC Power Jack for SPT-1

The PCI-4000 circuit board is contained in a conductive-plastic protector bag. Do not remove the PCI-4000 circuit board from this protective bag until you are ready to install the board in your computer. When you do remove the circuit board from the bag, be sure to follow the instructions in Chapter 2.

When opening the PCI-4000 shipping carton, carefully inspect it for any evidence of shipping damage. Any damage should be immediately reported to your shipping carrier. Be sure to save any damaged packing materials as the carrier will have to inspect them if you have a claim. Note that a damage claim must be filed *by you* with the shipping carrier - NOT HAL Communications. HAL will of course be glad to assist in such cases, but it is only the shipping carrier who can pay damage claims.

Check to be sure that all of the materials listed above are contained in your PCI-4000 package. If you find any materials missing, please contact your dealer or HAL Communications as soon as possible.

1.2 PCI-4000 / PC-CLOVER Accessories

The PCI-4000 is a complete CLOVER-II HF data communications package and will operate with just the materials supplied (plus your personal computer, transceiver, and antenna, of course). However, certain accessories may enhance the operation and use of your PCI-4000. These accessories are:

SPT-1 SPECTRA-TUNE™ Tuning Indicator:

The SPT-1 provides a frequency spectral display of the audio output of your receiver. The SPT-1 is particularly useful when running "3rd-party" user PC software that does not include the tuning bar display of PC-CLOVER. Tuning CLOVER signals becomes very easy when using the SPT-1. Chapter 2 provides installation instructions for using the SPT-1.

DS-3486 Radio Data Terminal:

The HAL DS-3486 Radio Data Terminal makes an excellent "PC base" for use with the PCI-4000. The DS-3486 is completely "IBM-compatible", is "radio-friendly" (very low RFI), and is available in either a two-floppy disk or hard disk version. Keyboard, CRT, and MS-DOS are included. Both 120 VAC, 60 Hz and 220VAC, 50 Hz models are available.

Additional Software:

HAL Communications Corp. has worked closely with a number of software authors and firms to provide additional user software. Please call HAL Communications Corp. for a current list of "3rd Party" authors for CLOVER and the PCI-4000.

1.3 Software and Documentation Up-Date

The PCI-4000 is unique in that all software required to operate CLOVER is provided in IBM-PC down-loadable format. The diskette provided with your PCI-4000 includes files that are (1) down-load software for the PCI-4000 DSP processor, (2) down-load software for the PCI-4000 control processor, and (3) PC-CLOVER, the PC-based interface program that controls the PCI-4000 itself. The current version of each program is furnished with each PCI-4000. New versions of each program are available to all PCI-4000 owners as they are released by HAL Communications. Some software changes may also require changes to the documentation (manuals). Current copies of both the PCI-4000 programs and documentation updates may be obtained by calling the HAL TECH-LINE customer-service BBS. The details of TECH-LINE are:

Data Phone:	(217) 367-5547 (24 hours/day)
Data Rates:	9600 V.42; 2400, 1200, or 300 baud ASCII
Data Format:	"N 8 1" (No Parity, 8 Data Bits, 1 Stop Bit)

TECH-LINE may also include general information files and you may leave messages in the BBS for our customer service department. If you have problems or need additional information, please call:

Customer Service Manager

Voice:	(217) 367-7373 (8AM - 5PM CST/CDT; Monday - Friday)
FAX:	(217) 367-1701 (24 hours/day)

CHAPTER 2

INSTALLATION

This Chapter discusses all of the steps necessary to install the PCI-4000 circuit board and PC-CLOVER software in your personal computer (PC) and then connect it to your radio station equipment.

2.1 Personal Computer Installation

Installing the PCI-4000 and PC-CLOVER in your personal computer is a two-step process: (1) install the board itself, and (2) install the software. Please follow these steps in sequence. If you have any questions concerning hardware compatibility between your PC and the PCI-4000, please consult section 2.2 of this chapter. Software compatibility issues are discussed in section 2.3.

2.1.1 Pre-installation Test

Before installing the PCI-4000, first be sure that your PC works! If it is a new PC, spend some time with it and learn how to use DOS functions - load programs, format and copy disks, and all the other "routine" PC type operations. If you have never used a PC, get a friend who has PC experience to help. Most computer stores also offer low-cost courses in how to run your PC. Good familiarity with your PC is essential to proper operation of PC-CLOVER.

2.1.2 Installing the PCI-4000 Circuit Board.

Next, turn off all power to your PC and remove the top cover. The placement and number of PC cabinet screws vary from model-to-model, but the retaining screws are usually on the rear panel - about 5 of them.

BE SURE TO SAVE THE SCREWS!

STATIC ELECTRICITY NOTE:

The PCI-4000 circuit board is not extremely sensitive to static discharge. With careful handling, static should not be a problem. However, if your environment is very dry (very low relative humidity), it may be wise to attach a clip-lead ground between the PCI-4000 rear panel and the PC cabinet while installing the board. Other precautions such as not wearing wool clothing while installing the board are also advisable.

Once you have the PC cabinet open, install the PCI-4000:

1. Locate an empty accessory "slot" in your PC and remove the blank rear panel for that slot (save the screw!). The PCI-4000 requires a full-length accessory slot that has *two* edge connectors ("PC-AT slot").
2. Remove the PCI-4000 circuit board from the conductive bag and plug it into the empty slot in your PC. It should NOT be necessary to adjust any jumpers or the circuit board DIP switch at this time.
3. Fasten the PCI-4000 rear panel using the PC rear panel screw saved in step 1.
4. Put the cover back on your PC. Be sure to screw the cabinet together to minimize RFI.

2.1.3 Loading PCI-4000 and PC-CLOVER software.

After installing the PCI-4000 circuit board and replacing the PC cover, turn the PC power switch ON. The PC should "boot" just like it did before you installed the PCI-4000. If it does *not*, STOP RIGHT HERE AND CHECK YOUR INSTALLATION.

Assuming that your PC did boot correctly, it's time to try the HAL software. The HAL programs are furnished in compressed form on the installation diskette. These programs are NOT copy protected and you may freely copy them to another diskette or onto your hard disk. The HAL disk does NOT contain system files required to "boot" the computer. We highly recommend that you copy the HAL diskette and then use the copy. Store the original diskette in a safe, dry, and non-magnetic location. Be sure to have a new and blank diskette available.

Your HAL diskette includes a special INSTALL program that decompresses the files and leads you through the disk copy and installation procedure. In the following instructions, type the commands that are **BOLD**. [Enter] means type the key labeled "Enter".

To install PCI-4000 and PC-CLOVER software:

1. Boot your PC (turn the power ON)
2. Put the HAL diskette in drive A: and type **A: [Enter]**
3. At the A:> prompt type: **A:> INSTALL [Enter]**
4. Follow the instructions!

A new directory will be created on your hard disk named "PCC" and all PCI-4000 files will be loaded into this directory.

5. When installation is complete, remove the HAL diskette from drive A.
6. Installation is done! Run PC-CLOVER by typing: **C:\PCC> PCC [Enter]**

You should now see the opening screens of PC-CLOVER. Read the on-screen directions and try a few mode changes.

HINT: The [F1] key is "magic". It allows changing of any of the parameters. [Alt]-H gives you "HELP" information at any time.)

2.1.4 PCI-4000 Software Files

When software installation has been completed, you will find that there are now at least four files in the PCC directory. These files include:

PCC.S28	Down-load software for 68EC000 on PCI-4000
PCC.LOD	Down-load software for DSP56001 on PCI-4000
PCC.EXE	PC-based PC-CLOVER user software
PCC.CFG	Configuration file for PC-CLOVER
READ.ME	Information document file (optional)

The PCI-4000 architecture is unique in that software necessary to make the DSP processor (PCC.LOD) and control processor (PCC.S28) on the PCI-4000 operate is down-loaded from the PC rather than being contained in a Read Only Memory (ROM) IC on the circuit board. This system allows a great deal of flexibility for future software updates since only the download files need to be changed.

IMPORTANT

Files PCC.S28 and PCC.LOD *must* be resident in the same directory as the PC-based user program used with the PCI-4000 (PC-CLOVER or others). These two files must be down-loaded to the PCI-4000 during the start-up of any applications software that uses the PCI-4000.

File PCC.EXE is the PC-CLOVER application program that provides split-screen control, mode selection, etc. PCC.CFG is a configuration file that stores your preferred operating parameters. If a *.CFG file is not found when PC-CLOVER is run, operation will use factory default settings in PC-CLOVER. You may also create multiple special configuration files from PC-CLOVER. All Configuration files must use ".CFG" as the file name extension.

You may also find "READ.ME" or other document files which will provide additional information about the software versions furnished. To make a "hard-copy" printout of a READ.ME file:

1. Connect a printer to the PC and turn the printer and PC on.
2. Change to the PCC directory
3. Type:

Print READ.ME [Enter]

Software for the PCI-4000 and PC-CLOVER will be up-dated by HAL Communications periodically. All new software versions may be obtained by calling the HAL TECH-LINE BBS and downloading the modified files (see Section 1.3). Only modified files need be replaced in the PCC directory and the INSTALL program should not be used for up-dates unless specifically noted. Software updates normally include a document file which details the changes made in the new software. Use the above procedure to print a copy of these files.

2.2 PC Hardware Compatibility

PC-CLOVER and its PCI-4000 circuit board should be compatible with any truly "IBM-compatible" Personal Computer with the following minimum capabilities:

1. The PC must be "IBM-compatible" and use the MS-DOS or PC-DOS software operating system (V2.0 or higher).
2. The PC model must be "PC-AT" or higher (PC-286, PC-386, PC-486), but not a "PC-XT" or any PC that does not support the two-connector "AT-bus".
3. Most versions of "Turbo" models should work. If problems are experienced when a PC is operated in "Turbo" mode, try the "standard" speed mode. PC-CLOVER does NOT need the extra speed of a "Turbo" mode.
4. The PCI-4000 circuit board requires a "full-length" plug-in slot that is approximately 13.25" long. It cannot be used in computers that do not meet size standards for PC accessories. The Tandy 1000 series of PC's and most "lap-top" PC's do not have full-length accessory slots.
5. The PCI-4000 circuit board may be plugged into any fully-supported "AT-bus" (ISA bus compatible) accessory slot. Some PC's do not include all bus signals on all plug-in slots. Do not use these slots for the PCI-4000.
6. The PC should have "IBM-compatible" ROM BIOS routines, bus connector, and interrupt routines. If your PC runs standard PC software and plug-in cards, it probably does have these compatible features.
7. A minimum of 640K of RAM (Random Access Memory) is recommended.
8. The PC should have a minimum of one floppy disk drive and one hard disk. A 5.25" 360K diskette is supplied with each PCI-4000; a 3.5" 1.44MB diskette will be furnished upon request. The hard disk may be any size.
9. The PC video card and CRT monitor may be "Hercules-compatible" monochrome, "CGA" color, "EGA" color, or "VGA" color. PC-CLOVER automatically senses which video option you have and requires no special video set-up program. Colors may be set in the CONFIGURATION menu as explained in the OPERATOR'S MANUAL.
10. The PC may include a "full complement" of serial and parallel I/O cards. Standard "COM1" and "COM2" serial I/O ports will work without interference. In general, non-standard "COM3", "COM4", or more serial I/O expansion cards may also work without interference, but a careful reading of the expansion card manual may be necessary to assure that it and the PCI-4000 are not accidentally set to the same I/O address. The PCI-4000 I/O address may be changed to avoid such a conflict. (See APPENDIX A.)
11. PC-CLOVER assumes use of a standard parallel printer device connected to "LPT1". Printer ON/OFF is controlled by [Alt]-P and through the PC-CLOVER configuration menu. [Prtsc] and/or [Shift]-[Prtsc] may also be used but it may not reproduce all on-screen graphics of PC-CLOVER.

12. The PCI-4000 interface to the PC-bus is "I/O mapped". The PCI-4000 does not require use of "standard" I/O address or interrupt assignments. Further, the I/O address of the PCI-4000 has been intentionally assigned to "un-used" locations. If conflicts do occur, the PCI-4000 includes a five-section DIP switch that may be used to set a range of PC I/O addresses used. This address is set to "360H" on all PCI-4000's shipped from the factory. If you have problems with running the PCI-4000 and suspect an I/O conflict, a close reading of APPENDIX A is recommended. The PCI-4000 I/O address may be changed to avoid conflicts. However, a change will not generally be necessary. PC-CLOVER software automatically searches for the PCI-4000 circuit board and adjusts its address to match the hardware.
13. The PCI-4000 (PC-CLOVER) and PCI-3000 (PC-AMTOR) products may both be operated in the same PC. The two cards should be set to different I/O addresses. The factory default addresses of 360H for the PCI-4000 and 260H for the PCI-3000 are compatible. Please read Appendix A of this manual and Appendix B of the PC-AMTOR REFERENCE MANUAL for guidance in the choice of I/O addresses. Multiple PCI-4000 and/or PCI-3000 boards may also be operated in one PC, but I/O addresses must be compatible and PC-based software must be capable of distinguishing between physical units.
14. Each PCI-4000 circuit board requires the following power from the PC's power supply:

+ 5	VDC	200 ma
+ 12	VDC	20 ma
- 12	VDC	20 ma

2.3 PC Software Compatibility

PC-CLOVER is written for single-user, dedicated PC use. It is assumed that when you are running PC-CLOVER, you are also not at the same time expecting the PC to do other tasks. However, under some conditions, PC-CLOVER may also run quite well in a "window" or "multi-task" PC operating system. HAL has made no effort to preclude any of these multi-task uses. However, it is beyond the scope of this product for HAL to support PC-CLOVER in any but a single-user operating environment.

Some PC users find it convenient to use "DOS SHELL" programs. These are utility programs in which you may list the programs you frequently use, select them from an on-screen menu, and run that program without having to use DOS commands to change directories, load programs, etc. A DOS Shell may in fact make it even simpler to run PC-CLOVER. However, a "DOS Shell" may also automatically load other programs which interfere with some features of PC-CLOVER. There are many varieties of "DOS Shell" programs available, some good, and some "not so good". Try running PC-CLOVER without the DOS Shell first and make sure it works properly. If it does, then try using your DOS Shell. If problems develop, change your DOS Shell program or run PC-CLOVER without using the Shell program.

Some PC users also make use of memory resident utility programs (also called "TSR" programs). Typical uses of such programs may be to scroll the CRT screen, check spelling, or redirect video for an application program. A resident program is typically loaded as part of the AUTOEXEC.BAT program and stays resident in RAM thereafter. It may or may not work properly with PC-CLOVER. It may use memory space that is required by PC-CLOVER, causing loss of features of either PC-CLOVER or the resident program. It is impossible to

predict whether or not a given memory resident program will or will not work with PC-CLOVER. HAL suggests that you first try PC-CLOVER with all resident programs removed and then try adding each resident program one-by-one to test for compatibility. HAL cannot guarantee operation with any resident programs.

If you are using a "Third-Party" PC-based program with the PCI-4000 (one not written by HAL - APlink, for example), carefully read the documentation provided with that program and follow its instructions. Note that even "Third Party" programs must down-load the PCC.S28 and PCC.LOD programs to the PCI-4000 before CLOVER-II can be used.

2.4 Radio System Connections

All PCI-4000 I/O connections are made to the 9-pin connector on the rear panel. This connector is a standard DE-9S (female pins) style; the mating cable connector is a type DE9P (male pins).

Do not confuse the PCI-4000 connector with other DE-9 connectors that may also be used on your PC!

Radio connections to the PCI-4000 are made directly to this DE9 connector. The pin, signal, and limits of each signal are shown in Table 2.1. A careful study of this table is highly recommended before you start soldering wires! Typical connections to the DE-9 connector are shown in Figure 2.1.

The limits should be compatible with practically all modern amateur transmitters and receivers. **DO NOT EXCEED THESE LIMITATIONS.**

The HAL 960-04000 cable furnished with the PCI-4000 allows connection to unbalanced audio input and output terminals of the radio equipment, the most common radio interface used. As shown in Figure 2.1, the PCI-4000 may also be used with balanced audio input and output lines when they are available. Be sure to use shielded wire and make a good RF ground connection between the PC and radio equipment. Cables should be no longer than 10 ft. to minimize RFI.

TABLE 2.1
PCI-4000 I/O CONNECTIONS

PIN	NAME	FUNCTION	I/O	LIMITS
1	AF IN	Audio from receiver	Input	5V p-p
2	AF IN	Audio from receiver	Input	5V p-p
3	GND	Ground (PTT & SEL-CAL)	(Gnd)	
4	AF OUT	Audio to Transmitter	Output	-30dBm (25 mV)
5	AF OUT	Audio to Transmitter	Output	-30dBm (25 mV)
6	GND	Ground (for AF IN)	(Gnd)	
7	SELCAL	SEL-CAL Output	Output	+50V @ 100 ma
8	PTT	Push-to-Talk Output	Output	±50V @ 100 ma
9	GND	Ground (for AF OUT)	(Gnd)	

A typical connection to an amateur radio station is shown in Figure 2.2. Connection requirements are discussed in the following sections.

PCI-4000
RADIO I/O

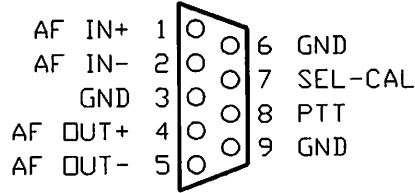

REAR VIEW OF
MATING CONNECTOR
(DE-9P)

HAL CABLE 960-04000
(UNBALANCED AUDIO I/O)

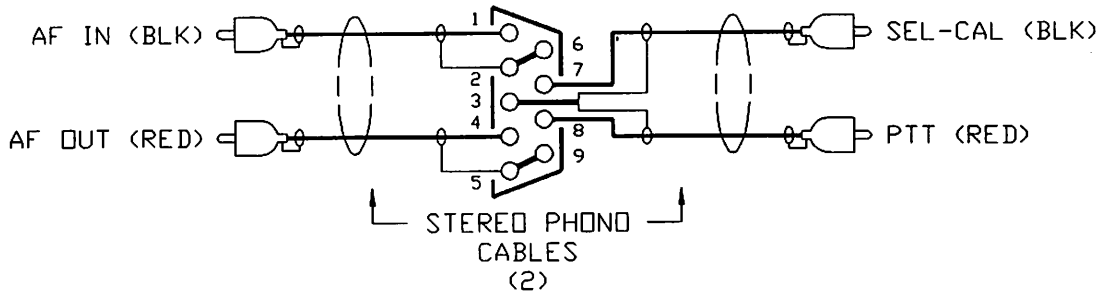

ALTERNATE I/O CONNECTION
(BALANCED AUDIO)

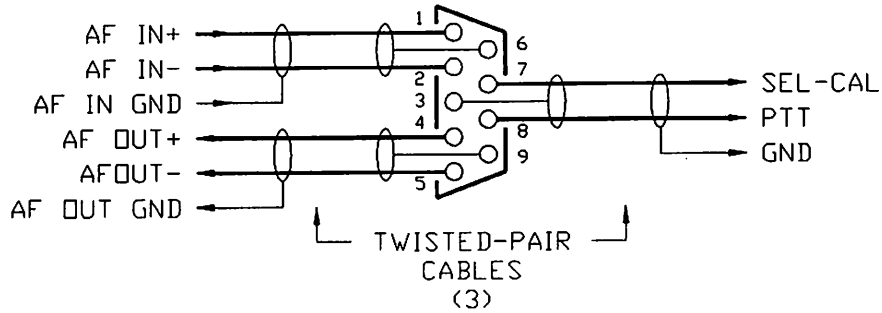

Figure 2.1 PCI-4000 I/O Connector

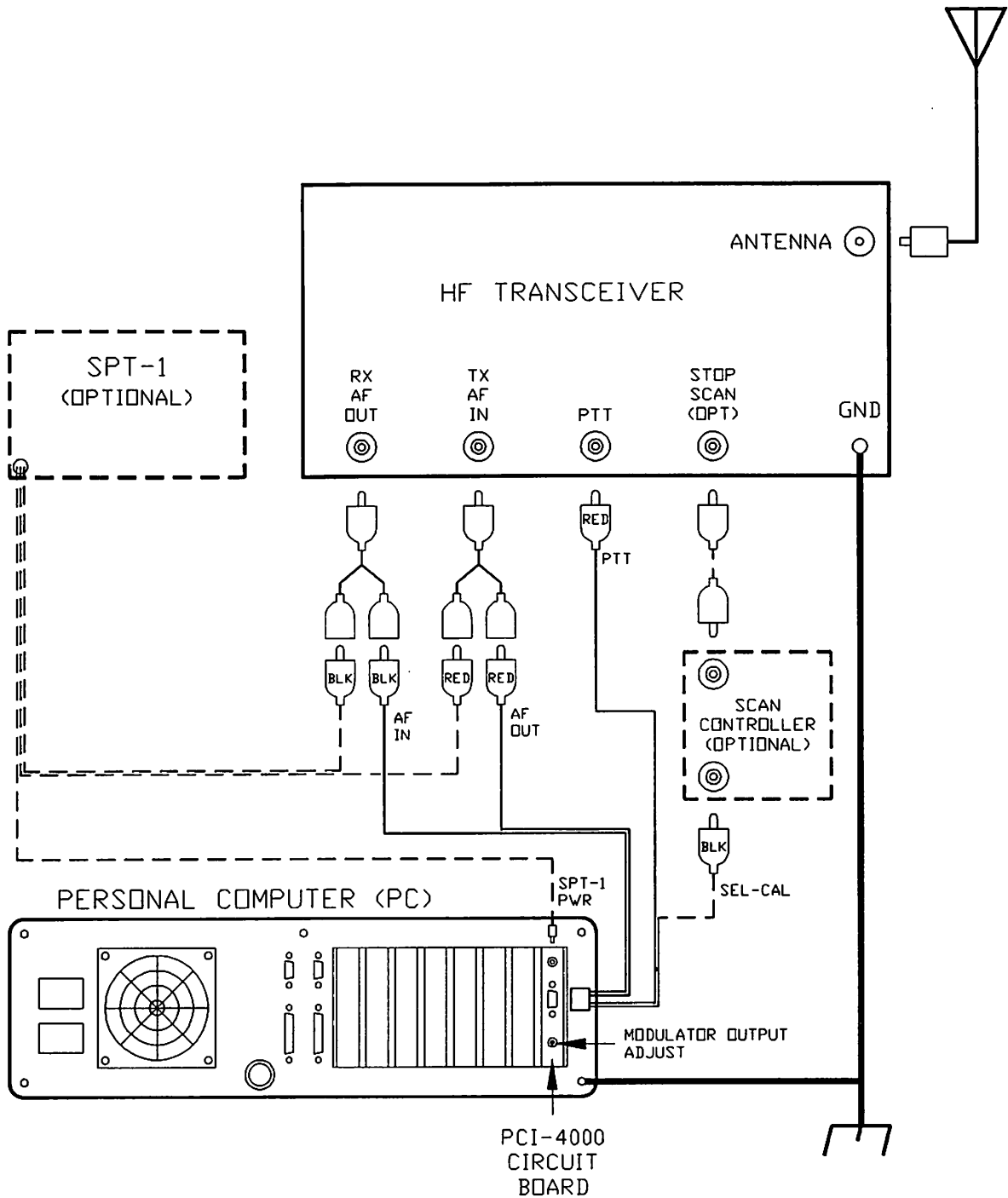

Figure 2.2 PCI-4000 Radio Connections

2.4.1 Audio Input

The PCI-4000 Audio Input (AF IN) is transformer isolated and may be used with balanced or unbalanced connections. The Input impedance is 10,000 ohms, $\pm 10\%$. This input can be directly connected to a wide variety of receiver output terminals including low-impedance speaker (4 - 16 ohms), line (600 ohms), headphone (2K ohms) or "recorder output" (10,000 ohms). A matched terminating resistor is not required. The maximum input level to the PCI-4000 should not exceed 5 volts peak-to-peak (1.7 V rms; +7 dBm). PC-CLOVER software includes tuning indicator bars which are used to adjust the receiver output level ("volume"). If a 600 ohm, 0 dBm continuous receiver audio output jack is available, it should be used.

2.4.2 Audio Output

The PCI-4000 Audio Output (AF OUT) is transformer isolated and may be used with balanced or unbalanced connections. The output impedance is 600 ohms, $\pm 10\%$. The PCI-4000 audio output need not be terminated in a 600 ohm matching resistor. This output may be directly connected to a wide variety of transmitter audio input terminals including microphone (low or high-impedance), "phone patch", or "line (600 ohm)". If a 600 ohm, 0 dBm transmitter audio input is available it should be used. The PCI-4000 AF OUT circuit includes a 10uF series capacitor to prevent DC loading of transmitter microphone inputs which have a DC bias voltage.

Two output level voltage ranges may be set by jumper J1 on the PCI-4000 circuit board (near IC U1, see Figure 4.12). The exact level may be set via the rear panel screw-driver potentiometer. The output level ranges are:

Jumper J1	Nominal	Adjustment Range
Open	-30 dBm (25 mV rms)	-50 to -20 dBm (2.5 to 78 mV rms)
Closed	0 dBm (775 mV rms)	-20 to +6 dBm (78 mV to 1.5 V rms)

All PCI-4000 units are shipped with jumper J1 in the -30 dBm position (J1 = open) and the rear panel output control set for -30 dBm. This output voltage will be correct for use with microphone (or "phone patch") inputs of most HF SSB transmitters. J1 should be changed to the "Closed" position when the PCI-4000 is connected to transmitters which have a separate 600 ohm, 0 dBm line audio input.

IMPORTANT

The PCI-4000 does *not* have an "FSK Output" and the CLOVER-II waveform cannot be generated when transmitters are operated in the "FSK" mode. The PCI-4000 and CLOVER-II *require* that the transmitter be operated in an SSB mode and that the CLOVER-II audio tone signal be connected to the transmitter audio input. Either USB (Upper Side Band) or LSB (Lower Side Band) may be used with CLOVER-II, but amateur radio convention is to use LSB mode.

Proper adjustment of the transmitter audio level and RF output are discussed in section 2.5.

2.4.3 PTT Output

The PCI-4000 provides TX/RX control of the radio equipment via the PTT (Push-To-Talk) relay contact output on pin 8 of the I/O connector. Pin 8 is shorted to ground in transmit state and is open circuit in receive state. The TX/RX PTT circuit may use either positive or negative polarity with a maximum open-circuit voltage (RX state) of 50 volts DC and a maximum closed circuit current (TX state) of 100 ma DC.

2.4.4 SEL-CAL Output

The SEL-CAL output of the PCI-4000 is an open-collector NPN transistor (MPS-A42) that switches to ground during an ARQ link. This signal may be used to signal that the CLOVER station has been called and linked in ARQ mode or to control frequency scanning radio systems. The rating of the switching transistor is +50 VDC maximum (open circuit) and 100 ma DC maximum (closed circuit).

The SEL-CAL output is normally open ("high") until the call sign of the local station (MYCALL) is recognized during an ARQ link request. When MYCALL is recognized, the SEL-CAL output shorts to ground ("low"). Two SEL-CAL modes are provided to match switching requirements of various equipment. These modes are "CONTInuous" and "PULSE".

When PC-CLOVER has selected the CONTInuous SEL-CAL mode, the SEL-CAL signal remains in the "low" state throughout the ARQ link. The signal will revert to "high" when the ARQ link is terminated (at disconnect)

When PC-CLOVER selects the PULSE SEL-CAL mode, the SEL-CAL signal pulses "low" for 2 seconds when MYCALL is recognized, remains "high" during the ARQ link, and then pulses "low" for 2 seconds again when the ARQ link is broken (disconnected).

The actual interface wiring between the SEL-CAL output and radio equipment varies widely with radio manufacturer and model. Detailed connection information should be obtained from either the radio manufacturer or from other radio operators who have made successful scan-control interfaces to their radios. At this writing, *none* of the commercially available amateur radio transceivers provide a rear-panel scan-control input connection - all makes and models require modification. Articles describing frequency scanning controllers are:

KE5HE:	<u>RTTY Journal</u> , October, 1992; p 4
KE5HE:	<u>RTTY Journal</u> , July/August, 1992; pp 3-4
KE5HE:	<u>RTTY Journal</u> , February, 1992; pp 13-14
N7CR:	<u>RTTY Journal</u> , February, 1992; pp 4-5
KC4ES:	<u>QST</u> , September, 1991; pp 24-25
WB7QWG:	<u>RTTY Journal</u> , February, 1990; p 20

While HAL warrants the operation of the SEL-CAL output signal to be as described above, this warranty does not extend to the functionality of use of the SEL-CAL signal with other equipment. Further, HAL must disclaim any damage to the radio equipment or to the PCI-4000 which may result as a consequence of user modification of his radio equipment.

2.5 Initial Transmitter and Receiver Adjustment

The following procedure describes how to test the PCI-4000 and PC-CLOVER with your radio equipment and make initial adjustments.

1. Connect the PCI-4000 AF IN, AF OUT, and PTT to the HF Radio Equipment. Disconnect the microphone and any other transmitter audio inputs.
2. Set the receiver and transmitter controls as follows:
 - a. BAND = convenient "RTTY frequency"
 - b. Mode = LSB
 - c. RX AF OUT = 25% of maximum
 - d. RX FILTER = "Voice"
 - e. RF OUT = dummy load
 - f. TX AF IN (MIC GAIN) = minimum
 - g. TX RF OUT = minimum
 - h. TX ALC and COMPRESSION = OFF
 - i. TX VOX = OFF
 - j. RIT / XIT = OFF
3. Turn PC power ON, let it boot, change to PCC directory.
4. Type PCC [Enter]
5. Type [Alt]-A to turn-on the amplitude bar display.
6. Turn Transceiver AC power ON.
7. Adjust RX AF GAIN control until amplitude bars show movement on noise.
8. Type [Alt]-T to enter TX TEST mode.
9. Type [Space bar] to set single-tone test and turn transmitter ON.
10. Slowly increase the MIC GAIN control (and TX RF OUT control if necessary) until the desired full RF output power is obtained. Watch the ALC meter and/or light; set the RF Output to *just below* the level at which ALC control starts. DO NOT CHANGE THIS MIC GAIN SETTING. See step 14 if the MIC GAIN control must be set at the extreme low end of its range (near counter-clockwise end).
11. Switch the transceiver meter to read RF output and note the reading. This is the *peak* power output of your transmitter when using CLOVER-II.
12. Type the [Space bar] again to enable four-tone test mode. Note the new reading of the RF Output meter. This is the *average* power output of your transmitter.
13. Type [Space bar] once again to turn the transmitter OFF. Type [Alt]-O or [Esc] to exit TX TEST mode.

The difference in RF output measured in steps 11 and 12 varies greatly with the make and model of the transceiver and the design of the Watt meter circuit. Some meters may show no difference; others may show as much as a 4:1 (6 dB) difference. The exact meter readings are not critical. However, it is very important that the adjustment in step 11 set the maximum non-ALC controlled power output level of the transmitter.

IMPORTANT:

Do NOT increase the transmitter microphone gain control setting beyond that set in step 11. While this might cause the RF output meter to read higher output power, it will also assure that your transmitted CLOVER signal is distorted and degrades system performance. Over-driving may also results in wide-bandwidth "splatter".

14. The PCI-4000 transmitter audio output level may be adjusted with the screw-driver set control on the rear panel. This control is set at the factory to its maximum output position. If the setting of the MIC GAIN control determined in step 10 is very low (near the CCW end), try setting the PCI-4000 rear panel control to the middle of its range and then repeat steps 10 through 13. This will reduce the output from the PCI-4000 and increase the setting of the transmitter's MIC GAIN control. Use the highest setting of the PCI-4000 control that produces a usable setting of the transmitter's MIC GAIN control to minimize "hum" and noise on the modulation.
15. We are informed that some transceiver models (IC-735 and possibly others) include a rear panel transmit audio input but that its level is *not* adjustable by the front panel MIC GAIN control. If this input is used, transmitter power level adjustments must be made using the PCI-4000 rear panel control as noted in #14. It may be simpler to connect directly to the front panel microphone jack of these transceivers.

2.6 HF Transmitter and Receiver Compatibility

The PCI-4000 and CLOVER-II waveform may be used with most HF SSB transmitters and receivers. HF equipment used with the PCI-4000 and CLOVER-II should meet or exceed the requirements shown in Table 2.2. The more important radio parameters are discussed in the following sections.

2.6.1 Frequency Control

CLOVER-II waveform uses multiple tones and phase-shift modulation. Performance is best when the transmitter and receiver frequencies match exactly. CLOVER will link and communicate when tuning errors are as great as ± 30 Hz. However, tuning should be within ± 10 Hz to obtain top performance at the highest data rate modulation modes. Therefore, the radio equipment should be *tunable* in at least 10 Hz tuning increments, and in finer increments if possible. Receivers whose frequency may be adjusted in 1.0 Hz increments are ideal for use with CLOVER.

It is also very convenient if the transmitter and receiver frequency dials have 10 Hz or even 1 Hz resolution. This is particularly true for network operation. Tuning aids such as the PC-CLOVER on-screen tuning bars or the SPT-1 SPECTRA-TUNE are essential to obtain full performance from CLOVER. Dial calibration accuracy is not essential for proper CLOVER operation - but is *very* useful for reliable network operation.

The frequency stability of the transmitter and receiver should be as high as possible. Frequency drift within ± 5 Hz per hour is desirable for manually controlled stations. Long-term stability of ± 10 Hz is advised for automated network applications. The "High Stability" option offered for many transmitters, receivers, and transceivers is recommended for automated network stations.

TABLE 2.2
PCI-4000/CLOVER-II HF RADIO REQUIREMENTS

<u>PARAMETER</u>	<u>REQUIREMENTS</u>
Tuning Increments	10 Hz maximum; 5 Hz or less desirable
Frequency Stability	± 5 Hz/hour short-term; ± 30 Hz long-term "High Stability" option is recommended
Frequency Accuracy	± 10 Hz optimum; ± 30 Hz maximum "High Stability" option is recommended
TX/RX Mode	LSB (<i>not "FSK"</i>)
Receiver Filter	"Voice" bandwidth optimum; 500 Hz bandwidth usable Filter must be selectable in LSB or USB modes Center Frequency = 2250 Hz ± 50 Hz
TX/RX ON/OFF Times	32 ms maximum
TX Audio Input	0 dBm (0.7 V rms) or -30 dBm (25 mV rms) Impedance = 600 ohms minimum
RX Audio Output	Constant level, 0 dBm, 600 ohms preferred; speaker output is usable. RX Output Impedance = 10,000 ohms or less
Phase Linearity	Not Critical
TX ALC	OFF
TX Compression	OFF
RX AGC	SLOW (<i>not Fast</i>)
RX Noise Blanker	OFF or minimum level required

2.6.2 Transmitter Modulation

CLOVER-II is a "J2" emission - it is an audio waveform that must be connected to the audio input of an *SSB transmitter*. CLOVER does *not* use the "FSK" transmitter feature of some HF transceivers. Either USB or LSB may be used with CLOVER, but we recommend LSB to be compatible with conventions used by other HF data modes.

As noted in the tune-up procedures of section 2.5, the modulation level into the SSB transmitter audio input should be set for minimum ALC (Automatic Level Control) action. ALC controls transmitter output power and smooths-out amplitude variations in the modulation. This is a desirable feature for voice and prevents voice peak overload distortion. However, CLOVER uses amplitude modulation as well as phase modulation. Heavy ALC operation on CLOVER modulation will cause distortion. ALC can in fact *remove* some or all of the amplitude modulation. Therefore, be sure to adjust transmitter output for low or no ALC activity when transmitting CLOVER. For similar reasons, other

speech enhancing features such as compression, DSP processing, etc. should be turned OFF when operating CLOVER. Of course, the microphone must be disconnected from the SSB transmitter when using CLOVER!

2.6.3 Receiver AGC and Noise Limiter

Receiver AGC (or AVC) may also cause a demodulation and distortion effect like that described above for transmitter ALC. However, receiver AGC also prevents overload of the receiver by strong signals. In most situations, it is recommended that SLOW receiver AGC be used to receive CLOVER signals; under no conditions should "FAST" AGC be used. In some models of receivers, a small amount of AGC "pumping" may be noted when receiving 8P2A and 16P4A modulation. In these cases, use of the receiver's manual RF GAIN control may improve operation. However, non-manned automated stations should always use AGC set to the SLOW mode.

Noise limiters and/or blankers should be used as little as possible as they are also amplitude leveling devices. A good noise blanker may be used in severe conditions, but it should be turned OFF as soon as conditions permit.

2.6.4 Receiver Filters

Figure 3.3 (see next Chapter) shows the frequency spectra of a CLOVER signal. The -50 dB bandwidth of CLOVER-II is 500 Hz. The audio center frequency is normally set to 2250 Hz, producing a -50 dB audio spectrum from 2000 to 2500 Hz. This spectra is similar to that occupied by "high-tone AFSK" RTTY/AMTOR signals - 2210 Hz \pm 500 Hz. However, unlike RTTY/AMTOR modems, the PCI-4000 uses very precise and "sharp-skirted" digital filters that exactly match the transmitted CLOVER spectra. In addition, the PCI-4000 uses a 16-bit A/D (analog-to-digital) converter with a dynamic range of approximately 90 dB. The DSP filters within the PCI-4000 are therefore optimized for CLOVER and will generally be considerably better than those used in the receiver. In most cases it is *not necessary* to use a narrow IF filter in the receiver. The standard 2.1 to 2.7 kHz wide "voice filter" is quite adequate for CLOVER reception.

The high dynamic range of the CLOVER DSP modem filters will handle most conditions, including strong adjacent channel interference. However, a narrow receiver filter may be useful at times to prevent receiver overload from extremely strong adjacent channel interference. A good "rule of thumb" is:

A narrow receiver IF filter protects the receiver against overload. It may not improve CLOVER reception and can, in fact, add distortion which reduces CLOVER performance. Use narrow filters sparingly and only when required to reduce receiver overload.

If a narrow receiver filter is used, it must be carefully positioned to be centered on the received CLOVER signal spectra. A continuously variable "pass-band tuning" (PBT) control is very desirable when narrow filters are used. Filters as narrow as "500 Hz" may be used, but it must be noted that filter bandwidths are "gross" and approximate specifications. If a choice is available, a slightly wider filter is much preferred over one that is "slightly too narrow". A "600" or even "900" Hz filter will give similar performance and be easier to use than a "500 Hz" wide filter. The following adjustment procedure is recommended when narrow receiver filters are used.

1. Establish a CLOVER ARQ link using the "voice bandwidth" receiver filter.
2. Carefully adjust receiver tuning to reduce frequency offset as much as possible. In PC-CLOVER, use the amplitude bar display to "get close" and then change to the frequency display (Alt-A). Slowly adjust receiver frequency to reduce the frequency error to as close to "zero" as possible. Lock the tuning dial to prevent accidental miss-adjustment.
3. Set PC-CLOVER to display the amplitude tuning bars.
4. Change to the narrow receiver filter and adjust the "pass-band tuning" (PBT) control for a "symmetrical" display of the four tone amplitudes. For example, when properly adjusted, a 500 Hz filter will add some attenuation to both tones "T1" and "T4". Adjust PBT so that the T1/T4 attenuation is the same. Note this setting of the PBT control and always use it for CLOVER reception. Over the short term, the amplitudes of the four tones will vary up and down, showing the effect of selective fading. The PBT should be set so that "on-average", the four tone amplitudes are symmetrical.

2.6.5 Receiver Audio Level

The PCI-4000 is designed to work with common audio levels that may be obtained from modern HF communications receivers. The amplitude tuning bar display of PC-CLOVER clearly shows the maximum audio level input. Adjust receiver audio volume so that average received CLOVER signals are below the "MAX" line on the PC-CLOVER screen.

The PCI-4000 has a wide dynamic range input and will work well even if the receiver output is low. The scale of the amplitude tuning bar display is intentionally expanded. Receiver audio level is not critical and good performance will be obtained when the amplitude bars are in the upper half of the display. Increasing the volume control will *not* improve reception! The following procedure will help determine a good receiver volume control setting for your equipment.

1. When receiving noise (no signals), adjust receiver volume until the four amplitude bars of PC-CLOVER vary on noise over the lower 1/4 of the scale.
2. Establish a CLOVER ARQ link. Refine the receiver volume control setting so that the bar lengths are approximately 3/4 of full scale. Note this setting and use it for all future CLOVER operations.

2.6.6 Adaptive Control and Radios

CLOVER ARQ mode automatically adapts to changing ionosphere conditions. This is a unique feature of CLOVER and a major reason why it works so well for HF radio data communications. However, adaptive control may at first appear to cause some confusing operations. Please consider the following:

1. When linked in ARQ mode, my CLOVER modem analyzes your received signal. My modem then signals to you which modulation mode will be most effective under current conditions. Your modem then uses that modulation for the next data transmission to me. In other words, your transmitter modulation mode is under control of the *other* station and is *not* set by you.

2. When the AUTOPOWER feature is turned ON, it is still the receiving station that sets the power output level of the sending station. You may well note that your transmitter appears to be sending "zero power". This is in fact normal and is *not* cause for panic or to increase the MIC GAIN control. If the ARQ link continues, you must still be sending sufficient signal strength to the other station, even if it is only 10 milliwatts. Most HF transmissions have from 10 to 30 dB excess transmitter power; data transmission is generally limited by ionosphere distortion, not by insufficient signal strength!
3. If you decide to turn AUTOPOWER OFF (or use manual ARQ), the condition is imposed on *both* stations of the ARQ link.

The AUTOPOWER feature adds a third efficiency dimension to CLOVER. The very tightly packed frequency spectra makes CLOVER *bandwidth efficient*. The adaptive ARQ mode passes data as quickly as possible making CLOVER *time efficient*. AUTOPOWER uses as little transmitter power as required, thus reducing interference to other stations. It can therefore be said that CLOVER is also *interference energy efficient*. It is recommended that all stations use AUTOPOWER as much as possible, especially unattended automated stations.

2.6.7 FCC Rules & CW ID

The CCIR emission designator for CLOVER is "500H J2 DEN". The FCC has stated that CLOVER-II is a legal U.S. amateur HF data emission. CLOVER may be used on any high frequency that is also legal for RTTY, AMTOR, or packet radio. However, this is a brand new emission with a completely different "sound". CLOVER call signs are exchanged during linking, but we suggest that CW ID also be enabled on all CLOVER stations. CW ID clearly identifies your station and signal as a valid amateur emission - and not that of an "interloper".

2.7 CLOVER-II Tuning Indicators

The CLOVER-II signal of the PCI-4000 is very unique and unlike any HF data signal previously used. The CLOVER-II waveform is made up of four tone pulses that are sent sequentially in time. The phase and amplitude of each tone is changed when transmitting data. When tuned on a receiver, the CLOVER signal sounds something like an electronic telephone ringer ("bell"). We say CLOVER has a "twitter" sound.

Accurate tuning of the received CLOVER signal is *very important*. Receiver tuning must be within ± 30 Hz of the correct frequency and with ± 10 Hz for optimum operation. Receiver adjustment to these tolerances requires an accurate tuning indicator and generally cannot be done "by ear".

In addition, CLOVER continually computes an internal phase and frequency reference from the received signal and uses these references to (1) detect data, (2) measure and compensate for ionospheric variations, and (3) compensate for tuning inaccuracy and frequency drift between the two stations. It requires approximately 2 seconds of integration to obtain the necessary frequency and phase accuracy. Because of this required integration time, it can be *very destructive* to adjust the receiver frequency once correct tuning has been found and CLOVER demodulation has begun.

Therefore the following **GOLDEN RULES** should be followed.

1. Tune slowly and accurately.
2. When correct tuning is achieved, *Get your hand off the knob!*
3. *Keep your hands off the tuning knob* (Lock the dial if necessary)

2.7.1 Tuning With PC-CLOVER

PC-CLOVER includes a tuning screen which assures very accurate and rapid tuning of a CLOVER signal. Simply type [Alt]-A to turn the tuning bar display ON, tune for maximum and equal bar length for all four tones, and then *let go of the knob*. It's easy to read, but may take some practice. Remember, if you adjust the knob, CLOVER must start over with its frequency/phase integration and either data will be lost (FEC mode) or extra repeats will be required (ARQ mode).

2.7.2 Using the HAL SPECTRA-TUNE™ Indicators

Both the HAL SPT-1 and SPT-2 SPECTRA-TUNE indicators may be used to tune a strong CLOVER signal. The preferred and more accurate tuning indicator is the tuning bars included in PC-CLOVER. However, if these tuning bars are not available (as when a 3rd party program uses the PCI-4000), the SPT-1 and SPT-2 can provide sufficiently accurate tuning indication when signals are strong or interference is weak.

If your installation includes a PCI-3000 and SPT-2 as well as the PCI-4000, the SPT-2 is already connected to the receiver audio output and you may center the received CLOVER signal's spectra about the "M" and "S" marks on the SPT-2 scale. Note, however, that the bandwidth of the CLOVER signal is 500 Hz and it is therefore considerably wider than the 170 Hz shift marked by "M" and "S" on the SPT-2. When correctly tuned, the CLOVER signal will consume most of the SPT-2's 600 Hz wide scale with about 2 un-lit segments on each end of the 20-segment display.

The SPT-1 SPECTRA-TUNE is probably more suitable for tuning a CLOVER signal since it has a much wider frequency spectra range (1000 Hz). A special 1/8" diameter jack is provided on the PCI-4000 rear panel to provide +12 VDC power to the SPT-1. Connect the positive power lead of the SPT-1 to the tip of the 1/8" plug and the negative lead to the sleeve or "barrel" of the plug (no connections to the "ring"). Note that the SPT-1 will then obtain +12V @ 90 ma. from the PC's power supply. Connections to the SPT-1 are shown in Figure 2.2.

The SPT-1 has two audio connection cables. Connect the RX input to the receiver audio output in parallel with the PCI-4000 audio input. Connect the "CAL" SPT-1 input in parallel with the PCI-4000 audio output to the transmitter. When transmitting a CLOVER signal (four-tone test mode or sending in FEC mode), select the "CAL" input and adjust the SPT-1 scale control to center the displayed spectra (near the "FAX/SSTV" markings). Return to receive and set the SPT-1 switch to "ON". Tune the receiver to obtain the same spectra pattern viewed on the transmitted signal.

CHAPTER 3

CLOVER-II WAVEFORM & PROTOCOL

The PCI-4000 hardware is designed for use as a HF radio modulator/demodulator (modem). This chapter provides details of the PCI-4000 CLOVER-II waveform.

3.1 CLOVER Background

"CLOVER" is the name of a series or class of modem modulation techniques ("waveforms") specifically designed for use over high frequency (HF) radio systems. The "CLOVER-II" waveform used in the PCI-4000 was developed by Ray Petit and HAL Communications. CLOVER waveforms are characterized by the following general properties:

- a. Very low base data rate.
- b. Time-sequence of amplitude-shaped pulses.
- c. Very narrow frequency spectra.
- d. Differential modulation between pulses.
- e. Multi-level modulation

3.2 CLOVER-II Waveform

3.2.1 Time/Frequency Domain

The CLOVER-II waveform in the PCI-4000 modem uses four tone pulses which are spaced in frequency by 125 Hz. Default parameters of PC-CLOVER set the following center and tone pulse frequencies:

$F_c = 2250.0$ Hz	$F(\text{center})$
$F_1 = 2062.5$ Hz	$F(\text{tone pulse \#1})$
$F_2 = 2187.5$ Hz	$F(\text{tone pulse \#2})$
$F_3 = 2312.5$ Hz	$F(\text{tone pulse \#3})$
$F_4 = 2437.5$ Hz	$F(\text{tone pulse \#4})$

The four tone pulses are sent in time sequence with 8 milliseconds (ms) between the center of each pulse (8 ms between pulse 1 and 2, 8 ms between pulse 2 and 3, etc.). A complete tone pulse sequence is repeated every 32 ms; i.e., 32 ms elapse between the 1st and 2nd occurrence of tone pulse #1. The four tone pulses are then combined to produce the composite tone pulse sequence diagramed in Figure 3.1. Figure 3.2 shows a three dimensional amplitude, time, and frequency representation of the CLOVER-II modulating signal. Figure 3.3 shows the resulting CLOVER-II frequency spectra.

Please note that while Figures 3.1 and 3.2 have been simplified and idealized to clarify this discussion, Figure 3.3 shows the actual measured spectra of CLOVER-II modulation at the PCI-4000 modulator output terminals.

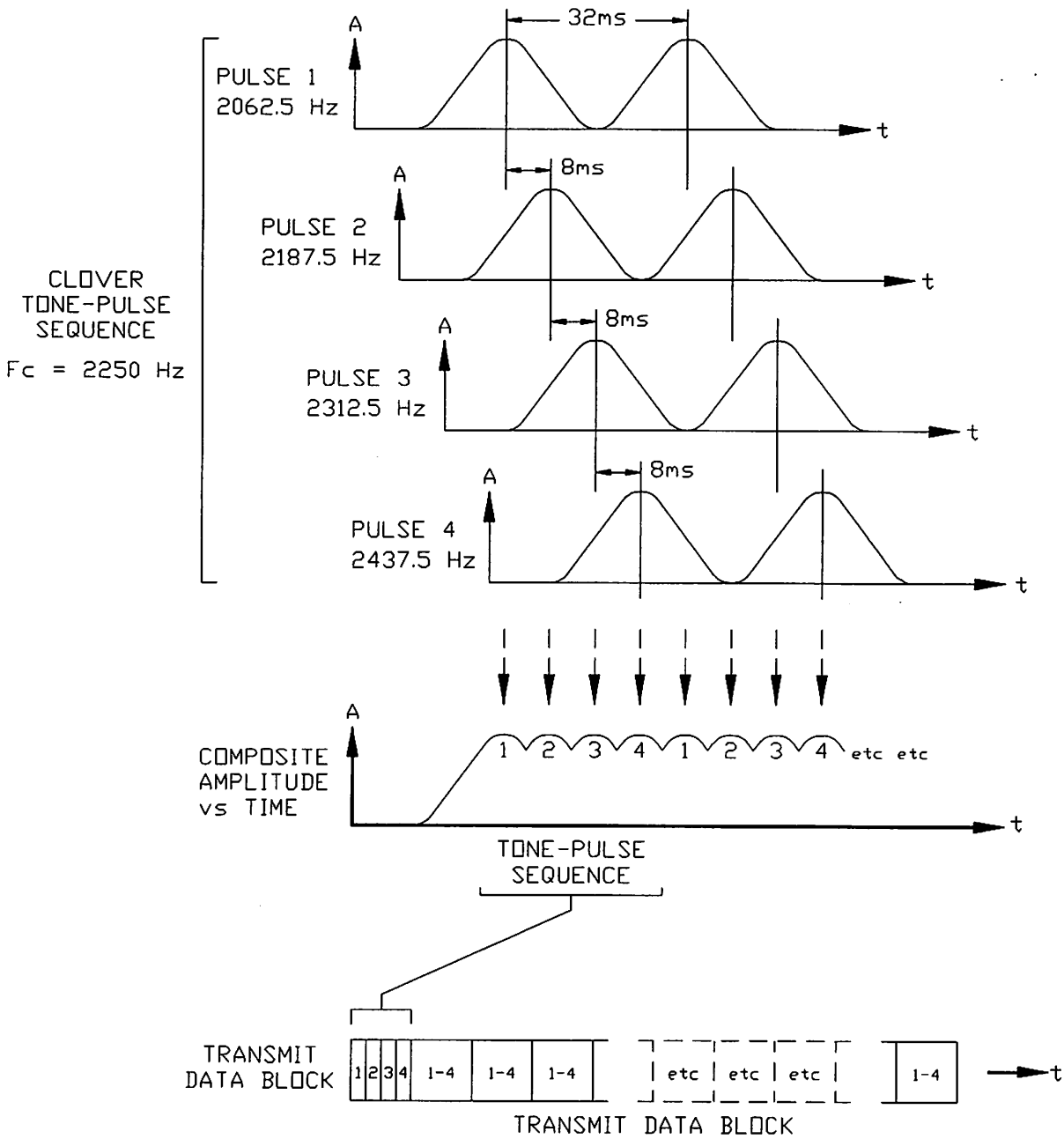

Figure 3.1 CLOVER-II Tone Pulse Sequence

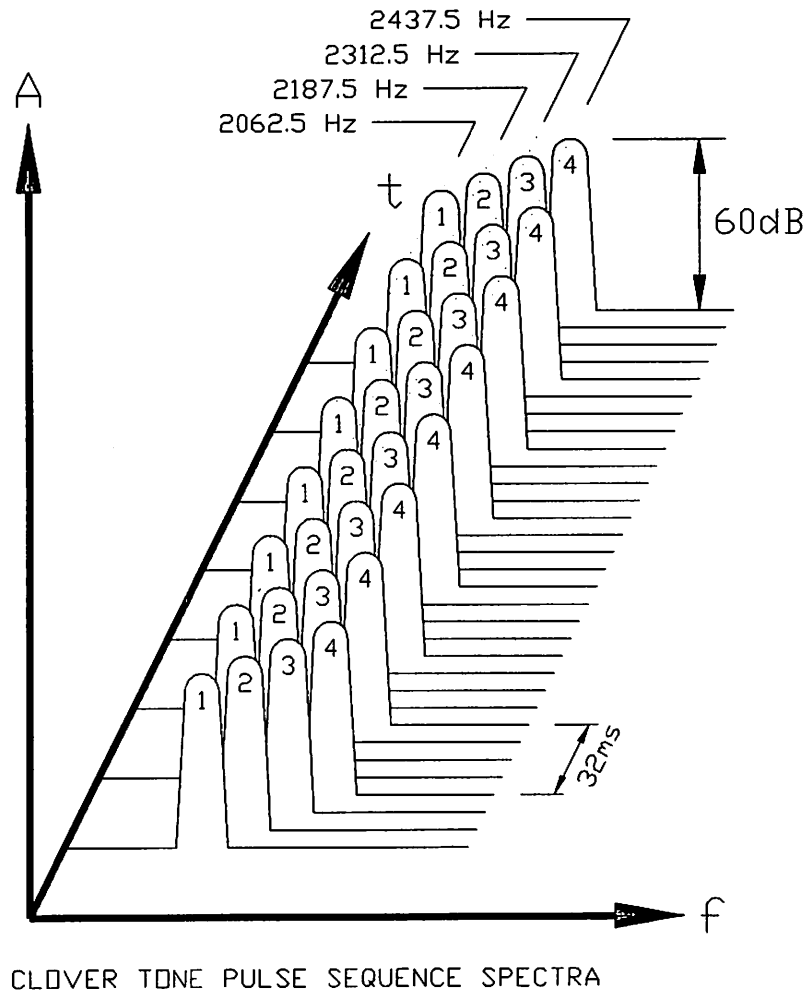

Figure 3.2 CLOVER-II Time/Frequency Relationship

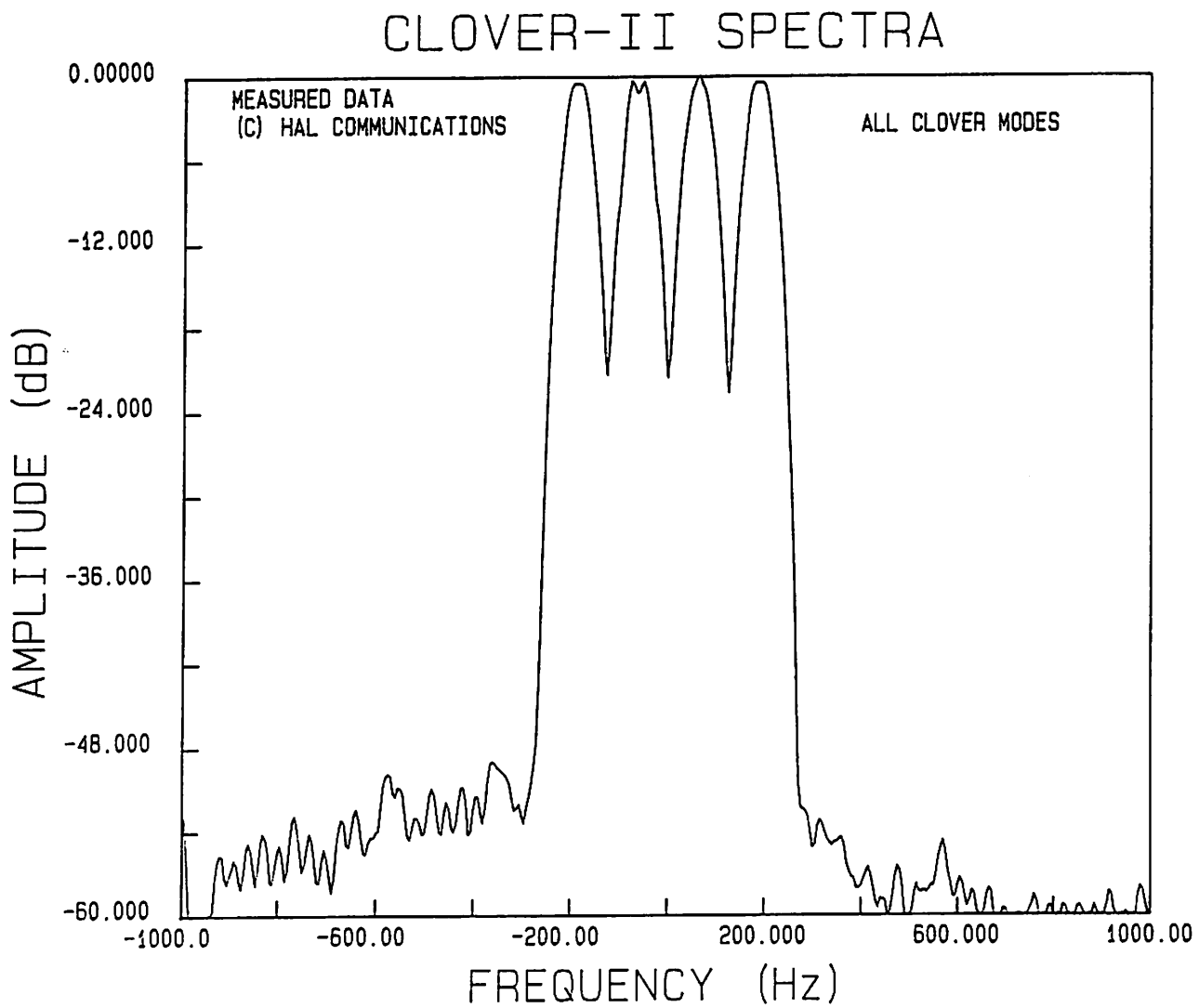

Figure 3.3 CLOVER-II Frequency Spectra

The spectral efficiency of a CLOVER-II signal is quite evident in Figure 3.3. This spectra is obtained by using amplitude shaping of each of the four tone pulses. A Dolph-Chebyshev function with -60 dB side-lobe level is used as the shaping function.

NOTE: CLOVER-II is a J2 emission that is applied to the audio input of an SSB HF transmitter. "FSK" modes provided in some HF transmitters cannot be used with CLOVER-II modulation.

Key parameters of the CLOVER-II emission are:

Occupied Bandwidth = 500 Hz @ -50 dB below peak level

Crest Factor = Peak/Average
 \leq 2:1 (voltage)
 \leq 6 dB (power)

CCIR Emission = 500H J2 DEN or 500H J2 BEN

3.2.2 Data Modulation

Data is impressed or modulated upon the CLOVER-II signal by varying the phase and/or amplitude of the tone pulses. Further, all data modulation is differential on the same tone pulse; data is represented by the phase (or amplitude) *difference* from one pulse to the next. For example, when binary phase modulation is used, a data change from "0" to "1" may be represented by a change in the phase of tone pulse #1 by 180 degrees between the 1st and 2nd occurrence of that pulse. Note that the phase is changed between occurrences of a tone pulse (while the pulse amplitude is zero) and *not* when the tone pulse is turned ON. Therefore, the phase of each tone pulse is constant for the entire time that the pulse is "ON". This is true for all modulation formats of CLOVER-II.

The CLOVER-II spectra is the same for all modulation forms.

CLOVER-II uses four tone pulses. The phase and/or amplitude of each tone pulse is modulated and demodulated as a separate narrow-bandwidth data channel. As noted above, all modulation of a tone pulse is differential - between occurrences of a given tone pulse. Since the time spacing between tone pulse frames is fixed at 32 ms:

The base modulation rate of a CLOVER signal is always 31.25 symbols/sec.

This low symbol rate makes CLOVER-II demodulation extremely resistant to pulse width/delay distortion that is caused by multiple path HF propagation. For example, time dispersion caused by HF "multi-path" distortion may often cause a time uncertainty of 1 to 5 ms in the received signal. Traditional FSK data demodulation systems are very susceptible to this distortion whenever the dispersion approaches 1/4 to 1/2 of the basic pulse width. For this reason, use of FSK is generally restricted to minimum pulse widths of 7 to 13 ms, corresponding to maximum FSK data rates of 75 to 150 baud. Higher FSK data rates may sometimes be used on HF, but only when multi-path distortion is low (usually when the operating radio frequency is close to the Maximum Usable Frequency, or "MUF"). Because of its low symbol rate (31.25 bps):

CLOVER-II is extremely tolerant of HF "multi-path" distortion.

CLOVER-II uses multiple tone channels to increase the effective data throughput rate. The previous example used binary phase shift modulation (BPSM) on tone pulse #1. Actually, the same modulation format is applied to all four tone pulses of CLOVER. Thus, 4 data bits are sent by differential binary phase modulation for each 32 ms tone pulse frame. Even though the base modulation rate is 31.25 bits-per-second (bps), the actual throughput using BPSM on all four tone pulses is four times that, or, 125 bps. This is one way in which CLOVER-II sends data at a relatively high throughput rate but maintains a very low base rate.

CLOVER-II uses multiple tones to increase data throughput.

Note the above usage of "Phase Shift Modulation" (PSM) rather than "Phase Shift Keying" (PSK). Since "PSK" is traditionally used to describe the modulation of a constant carrier which results in a wide signal bandwidth, the phrase "Phase Shift Modulation" (PSM) is used to describe CLOVER which uses differential modulation when tone pulses have zero amplitude and does not produce a wide frequency spectra.

In much the same manner that using four tones increases the data throughput, CLOVER also uses multi-level differential phase modulation of each tone pulse. For example, if each pulse is modulated using QPSM (Quad Phase Shift Modulation), the differential phase of each pulse may be changed in 90 degree increments, 2 bits of data modulated on each tone pulse, and 8 bits of data sent in each 32 ms four tone-pulse frame. This increases the net data throughput by a factor of 8 from the base rate (to 250 bps). Similarly, 8-ary PSM (8-level, 8PSM) provides throughput of 375 bps and 16-ary PSM (16-level, 16PSM) provides throughput of 500 bps. In all cases, the base symbol rate for any one CLOVER-II tone pulse remains at 31.25 bps and the total spectra is as shown in Figure 3.3.

Extending this concept even further, CLOVER includes two amplitude modulation modes: 2-level and 4-level Amplitude Shift Modulation (2ASM, 4ASM). 4-level ASM is used with 16PSM to produce the fastest modulation with a net throughput of 750 bps. Also, 2-level ASM may be used with 8PSM modulation to produce 500 bps throughput.

CLOVER-II uses multi-level and multi-format differential modulation to increase data throughput.

A logical question at this point might be:

"If multi-tone and multi-level modulation produces high throughput, why bother with the slower data modes?"

The answer is, of course, that complex modulation modes also require high detector precision and very stable signals. For example, consider that 16PSM uses phase changes of 22.5 degrees to represent the state of 4 data bits per tone pulse. To accurately detect this change, the phase "jitter" or dispersion caused by propagation must also be less than ± 11.25 degrees. Further, the receiver's detector must be capable of resolving phase changes as small as ± 11.25 degrees which means that the internal phase reference for detection must be very phase stable. In short:

Stable ionosphere conditions are required to use the "faster" modes.

Recognizing that HF propagation conditions are often less than optimum and may deteriorate rapidly from "ideal" conditions, CLOVER-II includes several very robust modulation modes as well as the "fast" modes. These robust modes take advantage of the four tone pulses of CLOVER-II for narrow-bandwidth diversity modulation and demodulation. For example, 2DPSM is dual diversity binary phase shift modulation in which the same data is repeated on alternate CLOVER tone pulses (#1 and #3 and #2 and #4). Upon reception, both copies of each data bit are examined and combined to minimize errors. Of course, the net throughput is also reduced from 125 bps (BPSM) to 62.5 bps (2DPSM), but with a corresponding improvement in detection accuracy. Similarly, 4DPSM mode sends the same data bits on each of the four tone pulses, providing four-channel diversity, gaining even more detection accuracy, but at an even slower throughput rate (31.25 bps).

Since some ionospheric paths may be extremely phase dispersive, CLOVER includes two Frequency Shift Modulation (FSM) modes, FSM and 2DFSM. In FSM mode, tones #1 and #3 form one frequency-shift pair to send one bit of data and tones #2 and #4 another frequency-shift pair, sending a second bit of data. The throughput is therefore 2 times, the base symbol rate (62.5 bps). In a manner similar to that used in PSM modes, 2DFSM provides two-channel diversity in which the same data is sent in paired channels #1/#3 and #2/#4 with a throughput of 31.25 bps.

CLOVER-II supports a total of 10 different modulation formats: 6 using Phase Shift Modulation (PSM), 2 using Amplitude Shift Modulation (ASM, with PSM), and 2 using Frequency Shift Modulation (FSM).

Multiple modulation modes allow CLOVER to operate over a wide range of ionosphere conditions.

The ten CLOVER-II modulation modes are shown in Table 3.1. Adaptive ARQ mode control is discussed in section 3.3.3.3.

**TABLE 3.1
CLOVER-II MODULATION MODES**

<u>NAME</u>	<u>DESCRIPTION</u>	<u>IN-BLOCK DATA RATE</u>
16P4A	16 Phase, 4-Amplitude Modulation	750 bps
16PSM	16-level Phase Shift Modulation	500 bps
8P2A	8 Phase, 2-Amplitude Modulation	500 bps
8PSM	8-level Phase Shift Modulation	375 bps
QPSM	4-level Phase Shift Modulation	250 bps
BPSM	Binary Phase Shift Modulation	125 bps
2DPSM	2-Channel Diversity BPSM	62.5 bps
FSM	Frequency Shift Modulation	62.5 bps
4DPSM	4-Channel Diversity BPSM	31.25 bps
2DFSM	2-Channel Diversity FSM	31.25 bps

3.2.3 Error Detection and Correction

HF radio can be a very cost-effective and convenient means to send digital data over very long distances. This is particularly true in locations which are not served by wire lines (telephone) and satellite relays are either not available or very expensive. HF radio equipment can be quickly placed in remote field locations and is often ideal for use in emergencies and locations which lack any other means of communications.

However, HF radio propagation may add severe distortion to data signals, causing errors and loss of data. The task of the HF modem device is to accept ionosphere distortion as it occurs and adjust, correct, or compensate the recovered signal to minimize data errors or loss.

CLOVER-II uses special *forward error correction (FEC)* data encoding which allows the receiving station to correct errors without requiring a repeat transmission. This is a very powerful error correction technique that is not available in other common HF data modes such as AX.25 packet radio or AMTOR ARQ mode.

Reed-Solomon FEC data coding is used in all CLOVER modes. This is a byte and block oriented code. Errors are detected on bytes of data (8-bits) rather than on the individual bits themselves. This block-oriented code is ideally suited for HF use in which errors due to fades or interference are often "bursty" (short lived) but cause total destruction of a number of sequential data bits. CLOVER-II data is sent in fixed-length blocks of 17 bytes, 51 bytes, 85 bytes, or 255 bytes.

Error correction at the receiver is determined by "check" bytes which are inserted in each block by the transmitter. The receiver uses these check bytes to reconstruct data which has been damaged during transmission. The *capacity* of the error corrector to fix errors is limited and set by how many check bytes are sent per block. Obviously, check bytes are also "overhead" on the signal (non productive data bytes) and their addition effectively reduces the efficiency and therefore the "throughput rate" at which user data is passed between transmitter and receiver.

CLOVER-II has four "coder efficiencies" options: 60%, 75%, 90%, and 100% ("efficiency" being the approximate ratio of real data bytes to total bytes sent). "60% efficiency" corrects the most errors but has the lowest net data throughput. "100% efficiency" turns the Reed-Solomon encoder OFF and has the highest throughput but fixes *no* errors. There is therefore a trade-off between raw data throughput vs the number of errors which can be corrected without resorting to retransmission of the entire data block.

Note that while the "EFFECTIVE DATA RATE" numbers listed in Table 3.1 go as high as 750 bps (bits-per-second), inclusion of other desired features in CLOVER add overhead and thus reduce the *net* throughput or *overall efficiency* of a CLOVER transmission. Reed-Solomon error correction encoding makes CLOVER very robust in the face of severe ionospheric distortion but also reduces the efficiency of the transmission. As will be noted in later sections, protocol requirements of FEC and ARQ modes for synchronization and control also add overhead and reduce the net efficiency.

Tables 3.2 and 3.3 detail the relationships between block size, coder efficiency, data bytes per block, and correctable byte errors per block.

**TABLE 3.2
DATA BYTES TRANSMITTED PER BLOCK**

BLOCK SIZE	Reed-Solomon Encoder Efficiency			
	60%	75%	90%	100%
17	8	10	12	14
51	28	36	42	48
85	48	60	74	82
255	150	188	226	252

**TABLE 3.3
CORRECTABLE BYTE ERRORS PER BLOCK**

BLOCK SIZE	Reed-Solomon Encoder Efficiency			
	60%	75%	90%	100%
17	1	1	0	0
51	9	5	2	0
85	16	10	3	0
255	50	31	12	0

Reed-Solomon data coding is the primary means by which errors are corrected in CLOVER "FEC" mode (also called "broadcast mode"). In ARQ mode, CLOVER-II employs a three-step strategy to combat errors. First, channel parameters are measured and the modulation format is adjusted to minimize errors and maximize data throughput. This is called the "Adaptive ARQ Mode" of CLOVER-II. Second, Reed-Solomon encoding is used to correct a limited number of byte errors per transmitted block. Finally, data blocks in which errors exceeding the capacity of the Reed-Solomon decoder are repeated. Adaptive ARQ mode is discussed in section 3.3.3.2.

3.2.4 CLOVER Waveform Modes

As detailed in Table 3.1, CLOVER-II has a set of ten different modulation formats which may be used to send and receive data. In addition, each of these modulation formats may be sent using four data block lengths (17, 51, 85, or 255 bytes) and four Reed-Solomon coder efficiencies (60%, 75%, 90%, and 100%). There are *160 different waveform modes* which could theoretically be used to send data via CLOVER (10 x 4 x 4). However, the performance characteristics of many of these modes overlap (minimum S/N, data throughput, phase dispersion tolerance, etc). Other system limitations and considerations for optimizing the FEC and ARQ protocols place further limits on the selection of block length and coder efficiency in particular. When these factors are weighed and optimized, the result is that there are 6 to 8 different waveform combinations which may be used in each protocol. The optimum waveform modes for each protocol are discussed in the following sections.

3.2.5 Baud, Data Rate, and Throughput

The terms "Baud", "data rate", "overhead", and "throughput" are all used to describe CLOVER-II emissions. The following conventions are used to describe data "speeds" of CLOVER-II:

The SYMBOL RATE of CLOVER-II is always 31.25 Baud.

This is true for all modulation forms and all error-corrector settings of CLOVER. It is true for either FEC or ARQ modes.

The Data Rate in CLOVER-II varies with the modulation form.

Data rate is a measure of the rate at which data bits may be sent using the various forms of modulation available in CLOVER-II. The data rate is always an integer multiple of the *symbol rate* (31.25) of CLOVER-II. As may be seen in Table 3.1, multi-level modulation provides data rates of 31.25, 62.5, 125, 250, 375, 500, and 750 bps (bits-per-second). As used in this discussion, data rate numbers *do not* include the effects of "overhead".

"Overhead" is used to describe any function or operation in CLOVER-II that diverts transmitted bits or adds time delays which tend to reduce the data flow between transmitter and receiver below that implied by the modulation data rate. The Reed-Solomon error corrector diverts data bits (actually data bytes) for error correction use; block numbering and check sums also require data bytes. These are all necessary overhead parameters that are necessary for proper operation but which also reduce the number of bytes in each block that may be used to send data between stations.

As will be described in following sections, FEC and ARQ modes each add overhead to the CLOVER transmission. FEC and ARQ both require CLOVER Control Blocks (CCB's) for synchronization and link control. ARQ mode adds time delays to switch transmitters and receivers ON and OFF. These are also necessary overhead parameters which further reduce the net rate at which data may be passed.

For the purpose of clarity, CLOVER-II documentation uses *throughput* to describe the overall rate at which data is passed between transmitter and receiver. Further, throughput using CLOVER-II is described in units of *bytes-per-second (byps)*. Unless otherwise specified, each "character" is assumed to be 8 bits (1 byte) long.

Throughput is the net data flow between two stations, including overhead.

Throughput is specified in units of bytes-per-second (byps).

Unless otherwise specified, throughput values are for a one-way transmission path.

Reviewing, *Baud* is used to describe the base symbol rate of CLOVER-II (31.25), *bits-per-second (bps)* describe the data rate within a modulation block, and *bytes-per-second (byps)* describe the rate at which information is passed between two CLOVER-II stations.

Note that at present, all data characters are formatted into 8-bit bytes. Some future applications of CLOVER-II may use data compression which require less than 8 bits to represent each character. Compressed data will therefore have a higher net *characters-per-second* throughput than the bytes-per-second values presented in these discussions.

3.3 CLOVER-II Protocols

CLOVER-II data may be sent using FEC ("broadcast") or ARQ protocols. In addition, each of these protocols have minor variants which are tailored for specific applications. A unique and optimum set of waveform parameters is offered for each protocol.

3.3.1 CLOVER Control Block (CCB)

The CLOVER Control Block (CCB) is the coordinating control signal used in all CLOVER protocols - FEC and ARQ. The CCB contains information which tells the receiving modem details of the data blocks which will follow. The CCB is used to:

- a. Send MYCALL
- b. Send Waveform parameters of data blocks
- c. Synchronize receiver detector
- d. Connect request (ARQ mode)
- e. Disconnect request (ARQ mode)
- f. Repeat request (ARQ mode)
- g. Keyboard entry text (ARQ mode when time permits)
- h. Exchange channel statistics (ARQ mode, when time permits)
- i. Call CQ (ARQ mode)

The CCB is *a/ways* sent using a very robust waveform format. In general, the CCB uses 17 byte blocks with 60% coder efficiency. Also, the CCB usually uses a modulation mode that is one or two levels more robust than that used for the following data frames. Correct reception of the CCB is essential to further reception and decoding of data blocks that follow.

3.3.2 FEC Protocol

CLOVER-II FEC mode allows a sending station to transmit data to one or more receiving stations. This mode is also often called a *broadcast* and sometimes an *unproto* mode. FEC mode is a one-way transmission and does not provide error correction via repeat transmission. However, the Reed-Solomon error correction encoder (section 3.2.3) is used to provide receive error correction of all FEC transmissions.

FEC mode transmission does not use adaptive waveform control. Rather, the sending station must choose a transmitting modulation format in advance and assume that conditions between his station and all other stations are adequate for the chosen mode.

Since FEC transmissions cannot use repeat transmission or adaptive waveform selection, all FEC transmissions are sent using 75% Reed-Solomon error correction efficiency. The block lengths used for each FEC data "speed" are chosen for an optimum balance of throughput and receive synchronization requirements in a changing ionosphere.

The data transmission format used for FEC mode is shown in Figure 3.4.

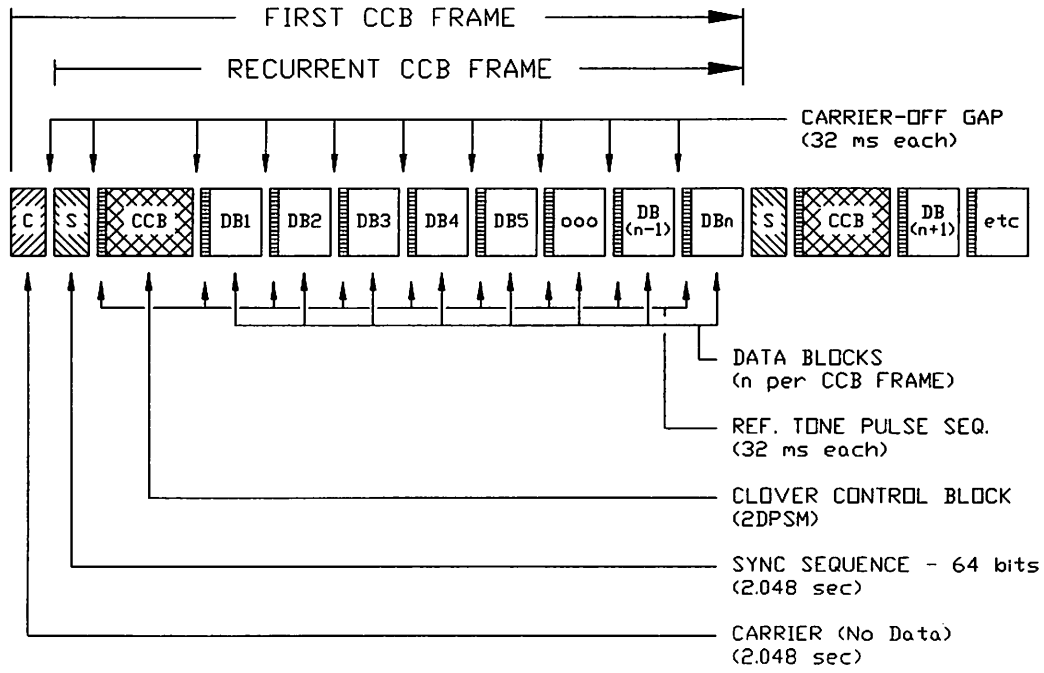

RATE	MOD	BLOCK	EFFIC	CCB	BLOCK TIME	BLKS/ FRAME	FEC FRAME TIME	THRU-PUT BYTES/SEC
58	16P4A	255	75%	2DPSM	2.720 sec	9	29.376 sec	57.6
39	16PSM	255	75%	2DPSM	4.080 sec	6	29.184 sec	38.7
30	8PSM	255	75%	2DPSM	5.440 sec	5	31.840 sec	29.5
20	QPSM	255	75%	2DPSM	8.160 sec	3	28.992 sec	19.5
10	BPSM	85	75%	2DPSM	5.440 sec	5	31.840 sec	9.4
5	2DPSM	51	75%	2DPSM	6.528 sec	4	30.688 sec	4.7

Figure 3.4 FEC Mode Format

Note in Figure 3.4 that each group of data blocks is preceded by the transmission of a CLOVER Control Block (CCB). The CCB announces the sending station's call sign and the modulation format of the data blocks which follow. Also note that the CCB and each data block are separated by "gaps" (no-signal periods) and a reference tone pulse frame.

The 32 ms "gaps" between CCB and data blocks are used to dynamically measure the received Signal-To-Noise ratio (S/N) and adjust signal detection in CLOVER to current operating conditions. This allows the CLOVER demodulator to quickly compensate for rapidly varying signal amplitudes when propagation is poor or when receiver AGC is adversely affected by interfering signals. The 32 ms "REF" period at the start of each CCB and data block provides the frequency and phase reference required to decode the balance of the CCB or data block.

The FEC data waveform modes vary for each FEC rate chosen. These modes are chosen to optimize FEC performance (throughput, error correction, and system synchronization) for each rate. The FEC CCB is always sent using 2DPSM modulation, 17 byte block size, and 60% encoder efficiency. Six data throughput choices are available for FEC transmission. Details of FEC modes are shown below in Figure 3.4 and Table 3.4.

**TABLE 3.4
FEC MODES**

RATE	CCB	BLOCK WAVEFORM	BLKS/ CCB	BLOCK TIME	T-PUT (byps)
58	2DPSM	16P4A/255/75	9	2.720	57.6
39	2DPSM	16PSM/255/75	6	4.080	38.7
30	2DPSM	8PSM/255/75	5	5.440	29.5
20	2DPSM	QPSM/255/75	3	8.160	19.5
10	2DPSM	BPSM/85/75	5	5.440	9.4
5	2DPSM	2DPSM/51/75	4	6.528	4.7

The "Rates" shown in Table 3.4 are approximations of the computed bytes-per-second data throughput rates (last column) for each setting. Throughput calculation is based upon 8-bit bytes and includes time required for "overhead" functions (CCB, reference sequence, gaps). The effect of shorter bit-lengths per character or code compression is not included in these calculations. The BLOCK WAVEFORM is abbreviated in the format [Modulation]/[Block Size]/[Coder Efficiency]. For example:

8PSM/255/75 = 8-ary Phase Shift Modulation
 = 255 byte blocks
 = 75% Reed-Solomon code efficiency

The "BLOCK TIME" column shows the time required to transmit each block of data. Since CLOVER uses a block protocol, all bytes in a block must be received before any data in the block can be passed to the receiving device - i.e., displayed on the receive terminal. Therefore, the "BLOCK TIME" is an indicator of how frequently the receive screen will be updated with new text.

3.3.3 ARQ Protocol

ARQ is the "work-horse" mode of CLOVER-II. While messages may be *broadcast* using FEC mode (one point to multiple point transmission), only ARQ mode provides fully adaptive and error-corrected communications. ARQ is a two-station point-to-point mode; one station "links" to a second station and data flows between the two stations. The full advantages of adaptive waveform control and error correction via repeat transmission are provided to these two stations.

The CLOVER-II ARQ protocol is actually two-layered. The lower, more basic layer involves exchange of only CLOVER Control Blocks between the two ARQ stations. All link maintenance operations are performed at the CCB level. This structure assures that the ARQ link integrity is always preserved. While a limited amount of data may also be exchanged within the CCB's (called "Chat Mode"), bulk data transfers are made at a high, *data block layer* of the ARQ protocol. The data block layer uses longer blocks and high-rate modulation waveforms to expedite data transfer.

3.3.3.1 CCB Protocol Layer

CLOVER Control Blocks (CCB's) are used to coordinate the two ARQ stations. As is the case for FEC mode, CCB's in ARQ mode are always sent using a more robust waveform than that used for data transmission. ARQ CCB's always have a block length of 17 bytes and a coder efficiency of 60%. CCB's perform the link control functions listed in section 3.3.1.

In ARQ mode, CLOVER Control Blocks (CCB's) *a/ways* use the following waveform format:

Modulation	=	BPSM	=	Binary Phase Shift Modulation
Block Size	=	17 bytes		
Efficiency	=	60%		

This is a very robust, but slow waveform format. This CCB structure is used for modulation modes from BPSM (125 bps) up through 16P4A (750 bps).

The timing structure of the CCB-layer of the ARQ protocol is shown in Figure 3.5. The "CCB Frame" includes time delays to compensate for propagation delays, transmitter/receiver delays, and modem processing delays.

CLOVER-II BASIC ARQ CCB FRAME

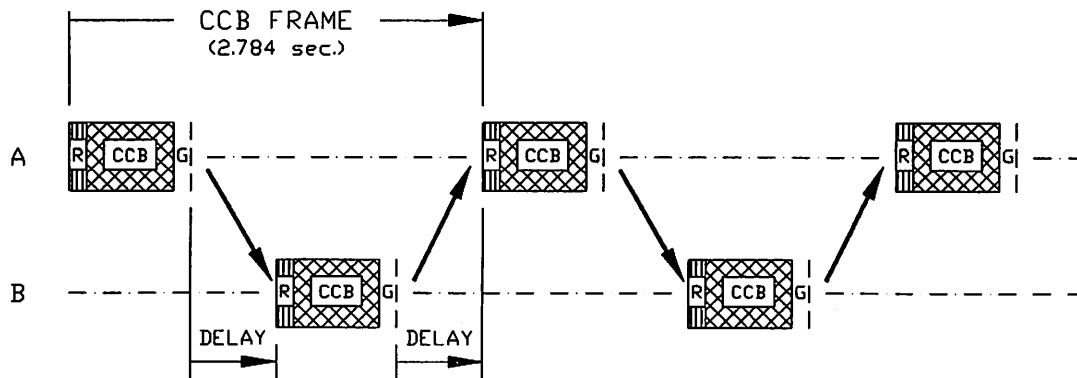

DELAYS:

R = Reference Sequence = 0.032 sec.	t(prop) = Propagation = 0.096 sec. (max)
CCB = CLOVER Control Block = BPSM/17/60 = 1.088 sec.	t(filter) = Filter Delay = 0.032 sec.
G = No-Signal Gap = 0.032 sec.	t(coder) = R-S Coder = 0.080 sec.
	t(PTT) = PTT Delay = 0.032 sec.

CCB FRAME TIMING:

PARAMETER	TIME	TPS FRAMES
REF (A)	0.032	1
CCB (A)	1.088	34
GAP (A)	0.032	1
t(A-B prop)	0.096	3
t(B-fil)	0.032	1
t(B-coder)	0.080	2.5
t(B-PTT)	0.032	1
REF (B)	0.032	1
CCB (B)	1.088	34
GAP (B)	0.032	1
t(B-A prop)	0.096	3
t(A-fil)	0.032	1
t(A-coder)	0.080	2.5
t(A-PTT)	0.032	1
	<u>2.784 sec.</u>	<u>87.0 TPS Frames</u>

NOTE: *TPS* = Tone Pulse Sequence (32 ms)

Figure 3.5 ARQ Mode - CCB Layer Timing

3.3.3.2 ARQ Data Block Layer

Data is communicated between two ARQ stations by adding a series of data blocks to the CCB protocol. This mode is illustrated in Figure 3.6. Although the CCB's waveform parameters remain fixed, the waveform of the data blocks is adaptively adjusted to match current propagation conditions. The throughput rate during data block transmission is generally much higher than that used for the CCB's.

As in the case of FEC, a varying number of data blocks are sent in each ARQ/CCB time frame. The number of data blocks and other timing parameters are adjusted so that the total time for each ARQ frame is exactly 19.488 seconds, regardless of modulation waveform combination used. 255 byte long data blocks are used in all ARQ modes. The Reed-Solomon coder efficiency is set to 60%, 75%, or 90% depending upon the *ARQ Bias* selected (Robust, Normal, and Fast bias, respectively). ARQ bias will be discussed in section 3.3.3.4. ARQ mode parameters are shown in Figure 3.6.

3.3.3.3 Adaptive ARQ (AUTO-ARQ)

The CLOVER-II AUTO-ARQ mode provides a three-fold strategy to attack the problems of HF data signal distortion.

1. Reed-Solomon forward error correction on all data transmitted. Using NORMAL Bias, a total of 31 flawed data bytes may be repaired for every 188 bytes transmitted *without* requiring repeat transmissions. In comparison, AMTOR, PACTOR, or AX.25 packet radio) can detect errors but *cannot* correct these errors without retransmission.
2. Selective Repeat ARQ protocol. When byte errors in ARQ mode exceed the capacity of the Reed-Solomon decoder, *only* the damaged data blocks are repeated. In comparison, AMTOR and PACTOR must repeat all data of a pulse if one character is damaged. One character error in AX.25 requires that the flawed packet and *all following packets* must be repeated.
3. Adaptive modulation waveform control. The CLOVER-II demodulator measures S/N ratio, frequency offset, and phase dispersion on *every* block of data received. The current signal conditions are known and used to adaptively change the other station's transmitter parameters to match these conditions. In comparison, AMTOR and AX.25 packet radio do not have any adaptive capability. PACTOR uses a two-rate algorithm which can be easily confused by multi-path distortion, often causing an increase in the number of repeats required when the rate is increased from 100 to 200 baud.

It is important to note that under adaptive waveform control the *receiving station* measures signal parameters and dictates the modulation mode to be used by the *transmitter*. Thus, in the ARQ link, MY transmitter is controlled by HIS receiver, *not* by parameter I may set at my terminal.

CLOVER-II MULTI-BLOCK ARQ DATA FRAME

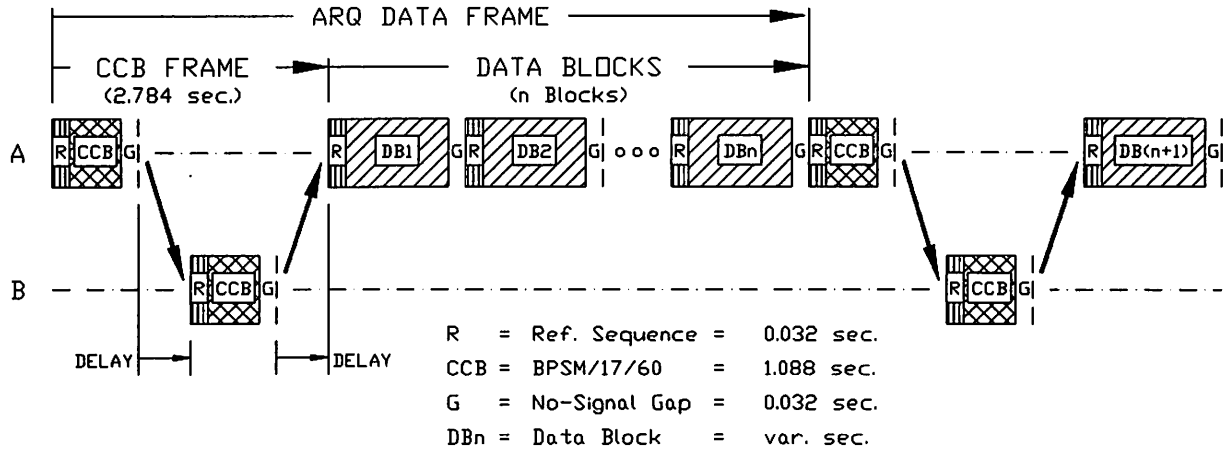

ROBUST BIAS (60%)

RATE	MOD	BLOCK	BYTES/ FRAME	MAX ERRORS	BLOCK TIME	BLKS/ FRAME	ARQ FRAME TIME	THRU-PUT BYTES/SEC
30	16PSM	255	600	200	4.080 sec	4	19.488 sec	30.8
30	8P2A	255	600	200	4.080 sec	4	19.488 sec	30.8
23	8PSM	255	450	150	5.440 sec	3	19.488 sec	23.0
15	QPSM	255	300	100	8.160 sec	2	19.488 sec	15.4
8	BPSM	255	150	50	16.320 sec	1	19.488 sec	7.7

NORMAL BIAS (75%)

RATE	MOD	BLOCK	BYTES/ FRAME	MAX ERRORS	BLOCK TIME	BLKS/ FRAME	ARQ FRAME TIME	THRU-PUT BYTES/SEC
39	16PSM	255	752	124	4.080 sec	4	19.488 sec	38.6
39	8P2A	255	752	124	4.080 sec	4	19.488 sec	38.6
29	8PSM	255	564	93	5.440 sec	3	19.488 sec	28.9
19	QPSM	255	376	62	8.160 sec	2	19.488 sec	19.3
10	BPSM	255	188	31	16.320 sec	1	19.488 sec	9.7

FAST BIAS (90%)

RATE	MOD	BLOCK	BYTES/ FRAME	MAX ERRORS	BLOCK TIME	BLKS/ FRAME	ARQ FRAME TIME	THRU-PUT BYTES/SEC
46	16PSM	255	904	48	4.080 sec	4	19.488 sec	46.4
46	8P2A	255	904	48	4.080 sec	4	19.488 sec	46.4
35	8PSM	255	678	36	5.440 sec	3	19.488 sec	34.8
23	QPSM	255	452	24	8.160 sec	2	19.488 sec	23.2
12	BPSM	255	226	12	16.320 sec	1	19.488 sec	11.6

Figure 3.6 ARQ Mode - Data Block Layer Timing

3.3.3.4 Adaptive ARQ Bias Parameter

The AUTO-ARQ format and modes used are shown in Figure 3.6. The "BIAS" setting of AUTO-ARQ is used to control the mode switching strategy.

ROBUST bias gives the highest error correction but lowest throughput. It also requires a long integration time in good conditions before the effective data rate is increased. ROBUST is useful in situations where conditions must be maintained on an unstable path, regardless of data throughput. This mode is most useful when fixed frequency operation below 7 MHz is the only choice (high multi-path condition). ROBUST bias uses 60% Reed-Solomon encoder efficiency. While a 255 byte block will send only 150 bytes of data, a total of 50 byte errors of that block (1/3 the number sent) may be corrected without repeat transmission.

Conversely, **FAST** bias uses minimum in-block error correction and will quickly shift to high rate modes. This mode maximizes data throughput and will be most useful on stable paths at frequencies that are near the MUF (Maximum Usable Frequency). FAST bias uses 90% coder efficiency, sending 226 data bytes per block and may correct up to 12 byte errors in each block.

NORMAL bias provides a good operational balance between error correction, throughput, and rate change responsiveness. NORMAL mode is recommended for most uses of CLOVER-II, especially when CLOVER is used in a frequency scanning HF BBS station. NORMAL mode uses 75% coder efficiency, sending 188 data bytes per block and may correct 31 byte errors in each block. FEC modes use the equivalent of "NORMAL" bias.

3.3.3.5 ARQ Connection

CLOVER has two connect modes - NORMAL and ROBUST. NORMAL connect mode is specifically designed to link two ARQ stations within 1.5 seconds. This is compatible with BBS stations that use frequency scanning receivers. ROBUST connect mode will link two ARQ stations in approximately 5 seconds and under weaker signal conditions than when NORMAL is used. ROBUST mode is most useful in fixed-frequency communications systems. Once linked, CLOVER shifts to adaptive control which is the same regardless of the connect mode chosen.

A ROBUST connection proceeds as follows:

```

MASTER:   Send Connect Request CCB (contains HISCALL)
SLAVE:    Send "Here Is" CCB (Acknowledges with HISCALL)
MASTER:   Send "I Am" CCB (sends MYCALL)
SLAVE:    Send Signal Reports CCB (of MASTER's signal)
MASTER:   Send Signal Reports CCB (of SLAVE's signal)

```

Note:

```

MASTER =  Station that initiated ARQ link request
SLAVE =   Station that answered ARQ link request

```

A NORMAL connection differs only in that a short "ping" exchange of the SLAVE's call sign is sent:

```

MASTER:   Send HISCALL in short "ping"
SLAVE:    Echo-back 1's complement of call sign
          Continue as for ROBUST link

```

3.3.3.6 One-Way and Two-Way ARQ

AMTOR ARQ mode sends in only one direction at a time and requires use of the OVER command to change the direction of data flow. AX.25 packet radio is flexible and either station may send data to the other station without use of an OVER command. CLOVER ARQ mode does not require an OVER command (like packet), but uses a precisely timed ARQ frame similar to that of AMTOR. When first linked, two CLOVER ARQ stations operate in "chat mode". Both stations may send a limited amount of data to the other (6 bytes per CCB). When the amount of buffered transmit data at one station exceeds 255 bytes, that modem shifts into data block mode, sending in the format shown for station "A" in Figure 3.6. Data from station "A" now flows at a high rate and in large blocks. However, data from station "B" will still be passed to "A" within the CLOVER Control Block (CCB). When station "A" has sent all of its buffered data, it reverts to the initial "CCB-level" of the protocol and both stations may continue in "chat mode". If station "B" now has bulk data to send, its modem shifts into data block mode and "A" remains in "chat mode".

This procedure is a very close match to the way that all current HF BBS stations operate. For example, to read a BBS message, your station makes short command transmissions (using "chat mode") and the BBS makes long transmissions (the requested message in block mode). Conversely, when you store a message in the BBS, your station uses block mode to send the message and the BBS responds with prompts and acknowledgements in "chat mode".

CLOVER-II also supports high rate block mode transmissions in *both* directions. In this case, when both station "A" and station "B" have large amounts of transmit data to send, both transmissions use block mode and data flow in the communications channel alternates direction each ARQ frame (approximately every 20 seconds). This is called the "Two-way ARQ mode" of CLOVER operation. Since transmitters and receivers switch ON and OFF alternatively, the mode is not truly "Full-Duplex" - data does not flow in both directions *simultaneously*.

Selection of "chat", "one-way", or "two-way" ARQ modes of operation is automatic and dynamic. The mode used is determined by the amount of buffered transmit data to be sent. The ARQ mode is always adjusted to make the most efficient use of the available time on the communications channel. CLOVER is therefore both bandwidth efficient *and* time efficient.

3.3.3.7 ARQ AUTOPOWER

CLOVER ARQ mode also includes the capability to dynamically adjust the power output of each transmitter. In most cases, the performance limit for data exchange is set by phase and frequency dispersion, and *not* by insufficient received signal power. When AUTOPOWER is ON, the CLOVER demodulator computes the "excess received S/N ratio" on each data frame, adds a safety margin, and the commands the transmitting station to adjust its power accordingly. Thus CLOVER uses only the minimum transmitter power required to carry-on communications. Often, the transmitter power output is 1 Watt or less. As in the case of adaptive modulation control, MY receiver sets HIS transmitter power. AUTOPOWER may be turned ON or OFF via PC-CLOVER command. AUTOPOWER is not used if either ARQ station has AUTOPOWER turned OFF. It is recommended that all automated stations turn AUTOPOWER ON and that user stations also set AUTOPOWER ON as much as possible. In some cases, the presence of strong ON/OFF local noise may require setting AUTOPOWER to OFF. CLOVER ARQ will adapt to this situation, but time may be gained by forcing both transmitters to full power (AUTO = OFF).

3.3.3.8 ARQ CQ Mode

The CLOVER CCB is also used to make a "general call for communications" - commonly known as "CQ". In this case, the originating station sends a "CQ CCB that includes his call sign. The receiving station's modem recognizes the CQ CCB, and decodes the call sign. *If the receiving station desires*, he may then press a key and initiate ARQ communications with the calling station. The listening station may also choose to ignore the CQ call by not taking any action.

3.3.3.9 ARQ Disconnect

Two types of disconnects are available in ARQ - "NORMAL" and "PANIC". A NORMAL disconnect request is processed in the order it is received. All data loaded into the modem prior to the disconnect is sent and acknowledged before the link is stopped. A PANIC disconnect will immediately cease transmitting at the originating station. The other station will then cease only when its retry counter is exceeded.

3.3.3.10 SEL-CAL & Scan-Control

The PCI-4000 includes a SEL-CAL switch output that may be used to control frequency scanning transmitters and receivers. As in the HAL PCI-3000, SEL-CAL output may be set for either continuous (low at connect, high at disconnect), or pulsed operation (pulse low at connect, pulse low at disconnect). The "NORMAL" (Ping) connect mode should be used to link with stations using frequency scanning equipment.

3.3.4 LISTEN Mode

PCI-4000 equipped stations may monitor ARQ or FEC transmissions of any CLOVER station. Listening stations are able to decode text and call signs of the sending stations.

Reed-Solomon error correction within a data block is provided in both FEC and ARQ listen modes. However, error correction via repeat transmission is only provided to the two linked ARQ stations and not to any stations that may be listening. When the error-correction capacity of the Reed-Solomon decoder is exceeded in Listen mode, all data for that block is lost.

The listening PCI-4000 station *must* correctly receive the CCB before any following data blocks may be decoded. If reception of a CCB is missed or corrupted, all data blocks between this and the next successfully received CCB will be lost. Since the period between CCB's is approximately 30 seconds in FEC mode and 20 seconds in ARQ mode, patience is required by the listening station operator, particularly when tuning a new signal.

3.3.5 CW ID

The PCI-4000 includes Morse code identification (CW ID) which may be set to OFF or for automatic operation in ten minute intervals. The MYCALL character stream may also be sent from the keyboard at any time. When used, CW ID always sends at a rate of 20 wpm (words-per-minute) using standard 1/3 dot/dash weight. CW ID is sent using tone #2 of the four tone set (2187.5 Hz).

3.4 CLOVER Bibliography

For those who desire additional information about CLOVER-II or CLOVER waveforms, the following articles may be of assistance.

Petit, Ray C.: "The CLOVER-II Communication Protocol - Technical Overview", ARRL 11th Computer Networking Conference Proceedings (1992), American Radio Relay League (ARRL), Newington, CT.

Henry, George W., Ray C. Petit: "HF Radio Data Communications: CW to CLOVER", Communications Quarterly, Spring, 1992, pp 11-24; CQ Publishing, Hicksville, NY.

Henry, George W., Ray C. Petit: "CLOVER: Fast Data on HF Radio", CQ, May, 1992, pp. 40-44; CQ Publishing, Hicksville, NY.

Horzepa, Stan (ed); George W. Henry & Ray C. Petit: "CLOVER Development Continues", "Gateway", QEX, March, 1992, pp. 12-14, American Radio Relay League (ARRL), Newington, CT.

Henry, George W., Ray C. Petit: "CLOVER Status Report", RTTY Journal, Fountain Valley, CA; January, 1992, pp. 8-9.

Henry, George W., Ray C. Petit: "Digital Communications for HF Radio - AMTOR & CLOVER"; paper presented at Amateur Radio Digital Communication Seminar, St. Louis, Mo., October 26, 1991.

Petit, Ray C.: "CLOVER-II: A Technical Overview", ARRL 10th Computer Networking Conference Proceedings (1991), pp. 125-129; American Radio Relay League (ARRL), Newington, CT.

Petit, Ray C.: "CLOVER is Here", RTTY Journal, Fountain Valley, CA; January, 1991, pp. 16-18; February, 1991, pp. 12-13; March, 1991, pp. 16-17; April, 1991, p 10.

CHAPTER 4

TECHNICAL DESCRIPTION

The HAL PCI-4000 is a single board microprocessor controlled DSP communication interface card designed to support a variety of HF radio communication protocols. The PCI-4000 operates in all ISA bus compatible PC-AT, PC-286, PC-386, and PC-486 computers. A full length expansion slot is required for the PCI-4000 circuit board, and all power for the PCI-4000 is taken from the PC. All of the I/O connections to radio equipment are made with a single DE-9S connection on the rear panel. The only rear panel adjustment is the modulator output level.

The PCI-4000 uses a dual processor architecture with a powerful 16 bit microprocessor controller and a fast DSP for audio processing. Except for selected utility routines and tables, all of the software executed by the PCI-4000 is downloaded from the host PC. As a result, the PCI-4000 is a powerful platform for implementing many different modems without any hardware changes.

A block diagram of the PCI-4000 is shown in Figure 4.1. There are three major sections: 1) the Microprocessor section, 2) the DSP and audio section, and 3) the Power and I/O section. Each of these sections is described in this chapter.

4.1 PCI-4000 Controller

The PCI-4000 uses a 16 bit 68000 based microprocessor to control the board operations. This processor controls all board outputs, downloads application software into the DSP and its own RAM, and handles all communications with the PC application program.

4.1.1 Microprocessor Section

The PCI-4000 controller is a Motorola MC68EC000 microprocessor operating with an 8 MHz crystal oscillator clock. Figure 4.2 illustrates the microprocessor, U17, and the associated RAM and EPROM memory. Since the MC68EC000 uses a 16 bit external data bus, the PCI-4000 uses two industry standard 64K byte by 8 bit EPROM's, U2 and U4, for 128K bytes of program storage and two 32K byte by 8 bit RAM's, U1 and U3, for 64K bytes of read-write memory.

The two EPROM and two RAM chips connected to the microprocessor may be accessed as 8 bit bytes or 16 bit words. The microprocessor can access all external memory as 8 bit bytes on even and odd addresses or 16 bit words on even addresses only. EPROM U4 and RAM U3, enabled by LCS.L, store the low or even address data bytes, and EPROM U2 and RAM U1, enabled by UCS.L, store the high or odd address data bytes.

As will be described in the next section, the EPROM base address is 00000H and the RAM memory starts at 20000H. All memory and other board registers are mapped in memory address space; there are no I/O addresses used. Since none of the board level memory or registers require wait or idle states, the address strobe signal, AS.L, drives the access acknowledge signal, DTACK.L, through two inverters.

The PCI-4000 is unique in that the board application software is downloaded from the host PC during program initialization. The on-board EPROM stores a boot-strap loading program, commonly used utility subroutines, and data tables for the DSP. The application program itself is loaded into RAM during initialization, then that program is executed from RAM when the PC-CLOVER system is running.

The MC68EC000 has three possible board level interrupt sources: HREQ.L from the DSP, UINT.L from a testing diagnostic port (not used in the PCI-4000), and HCSTAT.L the PC application immediate command interrupt.

The PCI-4000 microprocessor controller is reset in one of two fashions. When power is first applied, a dead-man timer automatically resets the microprocessor and starts running the boot-strap loader program. Another hardware reset signal can be set by a PC application program to force the controller into the boot-strap loader state without cycling the power. The reset signals are described in the next section.

4.1.2 Memory Decoding, Clocks, and Reset

Figure 4.3 illustrates the microprocessor memory decoding circuits, the clock oscillator and divider circuits, and the hardware reset generator circuits.

Since all board memory and registers are mapped in memory address space, one dual two line to four line decoder is used to enable individual EPROM and RAM chips and other board registers. Note that the upper select signal UCS.L enables the upper EPROM and RAM chips while the lower select signal LCS.L independently enables the lower EPROM and RAM chips and other miscellaneous input and output registers. U16 and U18 decode all memory addressed. The PCI-4000 implements the address map shown in Table 4.1.

**TABLE 4.1
PCI-4000 ADDRESS MAP**

Address Range	Signal	Description
00000H - 1FFFFH	ROML.L ROMH.L	EPROM Memory Read (128K)
20000H - 2FFFFH	RAM1L.L RAM1H.L	RAM Memory Read/Write (64K)
60000H	68FWR.L	68000 FIFO Data Write
60004H	68FRD.L	PC FIFO Data Read
60008H	68IN.L	Immediate Command Acknowledge
6000CH	68STAT.L	FIFO Status Read
60010H	CONTROL.L	Control Latch Write
60014H	UART.L	Diagnostic Port (not used)
60018H	HEN.L	DSP Read/Write
6001CH	(not used)	

Note that all memory and peripheral devices operate without any externally added wait states.

The MC68EC000 system clock is provided by the 8 MHz crystal oscillator X2.

The DSP and analog to digital converter clocks are provided by the 20.48 MHz crystal oscillator X1. While the DSP uses this clock, DSPCLK, directly, the A/D converter clock, ADCCLK, is divided by 8 in U25 to generate a 2.56 MHz oscillator signal.

The hardware reset signal is controlled by the dead-man timer U28. During normal operation, this chip is continually re-triggered by 68STAT.L, however should these pulses stop for more than about 250 ms, the hardware reset signal RESET.L is activated. In addition, the host PC application program may force a hardware reset with a certain I/O address that pulses RESETIN. Note that the PC bus reset will also reset the PCI-4000 using signal RESETDRV.

4.1.3 AT Bus Interface Circuitry

The host PC interface circuitry is presented in Figure 4.4. The PCI-4000 requires a 16 bit data bus connection to the PC. Bus transceivers U30 and U33 buffer the upper and lower bytes of the data bus and insure that the PCI-4000 presents only 1 HCT additional load to the PC data bus.

The PCI-4000 is mapped in PC I/O space at a base addresses determined by the setting of SW1. APPENDIX A of this manual shows all possible settings for this switch; the factory default I/O base address is 360H. Two 8 bit comparators, U31 and U32, compare the SW1 switch setting with the PC address bits and signal a valid access address with EN.L on U29-6. IOCS16.L on U14-7 is an acknowledge signal required by the host PC for proper operation.

Note that both the host PC I/O read and write signals are buffered by two sections of U22 to avoid loading the PC bus.

The PCI-4000 requires 5 separate I/O addresses in the PC address space. Assuming the factory default base address, the I/O assignments are listed in the table below:

**TABLE 4.2
PC I/O ADDRESS ASSIGNMENTS**

PC I/O	Signal	Description
360H	PCFWR.L	PC FIFO Write
362H	PCFRD.L	68000 FIFO Read
364H	FSTAT.L	FIFO Status
366H	PCOUT.L	Immediate Command Interrupt
368H	RESETIN	Hardware Reset Read
36AH	(reserved)	
36CH	(reserved)	
36EH	(reserved)	

The PCI-4000 is designed to operate at full PC bus speed; no wait states are added by the PCI-4000. All input and output registers are 16 bits wide.

4.1.4 AT Bus FIFO Buffers

The data communication bus between the PCI-4000 and the host PC bus uses two elastic FIFO buffers, one for each direction, as illustrated in Figure 4.5. All data from the PC is loaded into the PC FIFO, U22, a 512 x 9 dual ported FIFO device. PC data bus bits 0 to 7 are mapped to PC FIFO bits 0 to 7 and PC data bit 15 is connected to PC FIFO bit 9. The PC FIFO, has three status signals read by the MC68EC000 to indicate FIFO empty, FIFO half full, and FIFO full. Unless an error has occurred, data is read from the FIFO by the MC68EC000 whenever PCT68E indicates that the FIFO is not empty. This FIFO should never fill completely since data would be lost. The PC application program reads these status bits to know when more data may be sent to the FIFO.

Data flowing between the MC68EC000 and the PC passes through the 68000 FIFO, U23, also a 512 x 9 dual ported FIFO device. As previous described for the PC interface, the microprocessor data bus bits 0 to 7 and 15 are connected to FIFO input bits 0 to 9, respectively. The 68000 FIFO status indicates FIFO empty, FIFO half full, and FIFO full.

The microprocessor controller and the PC application program read the status of the PC FIFO and the 68000 FIFO through the buffers described in the next section.

Note that the hardware reset signal RESET.L clears both FIFO buffers.

Although it is not presently used, the PCI-4000 hardware can provide an interrupt signal to the PC bus as shown in this figure. Whenever the microprocessor writes data to the 68000 FIFO, U19-9 goes high and remains high until the PC reads this FIFO. This interrupt signal may be connected to any one of several interrupt signals with a suit case jumper on J3. The factory default for this option is "NO INT".

4.1.5 Controller Status Registers

The status of the PC and 68000 FIFO buffers are read by both the MC68EC000, with 68STAT.L, and the PC application program, with FSTAT.L, as shown in Figure 4.5. All six status bits are available to both the microprocessor and the PC application program although typical programs will not use all of these signals.

For each FIFO, there are three status signals: FIFO empty, FIFO half full, and FIFO full. These bit assignments are shown in Table 4.3.

**TABLE 4.3
FIFO STATUS**

<u>Bit</u>	<u>FSTAT (PC READ)</u>	<u>68STAT (MC68EC000 READ)</u>
15	Immediate Command	Immediate Command
14-11	(undefined)	(undefined)
10	68000 FIFO Full	PC FIFO Full
9	68000 FIFO Half Full	PC FIFO Half Full
8	68000 FIFO Empty	PC FIFO Empty
7-3	(undefined)	(undefined)
2	PC FIFO Full	68000 FIFO Full
1	PC FIFO Half Full	68000 FIFO Half Full
0	PC FIFO Empty	68000 FIFO Empty

The Immediate Command signal HCSTAT.L on U19-6 is used by the PC to interrupt the MC68EC000 without passing any data through the PC FIFO buffer. This interrupt signal is enabled by the PC writing the PCOUT.L control address which pulses the set input on U19-4, and forces HCSTAT.L low. This interrupt signal remains active until cleared by the microprocessor through signal 68IN.L on U19-1. All other data communication between the MC68EC000 and the PC application program takes place through the two FIFO buffers.

4.1.6 PTT and SELCAL Output Register

Figure 4.7 shows the control latch register. Included on this latch are the PTT relay, the SELCAL output, and three DSP control signals. Note that the RESET.L signal clears all of the outputs on this latch whenever a hardware reset is performed. The bit assignments for the control latch are shown in Table 4.4.

TABLE 4.4
PCI-4000 CONTROL LATCH

Bit	Description
7-5	(not assigned)
4	DSP Reset Output (active low)
3	DSP Mode control signal B
2	DSP Mode control signal A
1	PTT Output (active high)
0	SELCAL Output (active high)

The PTT output is controlled by relay K1, thus it will switch either positive or negative voltages. Resistor R16 and diode D1 are provided to hold the PTT output at a positive voltage when relay K1 is open, as required by some radios. The ratings of K1 should not be exceeded.

The SELCAL output is an open collector that will only switch a positive voltage to ground. The ratings of the Q1 should not be exceeded.

Note that any MC68EC000 command that writes this latch must insure that all of these bits are in the correct state since all bits are written in parallel. Since the microprocessor cannot read this latch, it must store the current states for all of these bits elsewhere in memory.

4.2 PCI-4000 DSP and Audio Section

The real power of the PCI-4000 is the versatility of the DSP audio input and output sections. Once programmed, the DSP can generate nearly any audio waveform, and can receive and decode very complex audio signals, such as CLOVER-II.

In the PCI-4000, the DSP uses a 16 bit A/D converter to sample the input audio signal, and uses a 16 bit D/A converter to generate the audio output signal.

4.2.1 DSP RAM

The DSP and associated 24 bit wide RAM is shown in Figure 4.8. During board initialization, the DSP program is downloaded from the host PC to the MC68EC000 controller and finally into the DSP program RAM. A special boot-strap loading procedure allows the microprocessor to pass all of the DSP program to the DSP over an 8 bit data bus enabled by the HEN.L and WR.L signals.

For CLOVER-II, the 8K word DSP RAM is configured with 4K words of program memory, and 2K words each of X and Y data memory.

The DSP clock, DSPCLK, runs at a fixed 20.48 MHz rate.

The DSP has one interrupt signal, HREQ.L, that it can use to interrupt the MC68EC000 during operation.

4.2.2 Audio Output

The audio output section, illustrated in Figure 4.9, uses a 16 bit serial input D/A converter, U12, to generate the modulated audio output signal.

Two op amps in U13 implement a low pass filter with a design cutoff frequency of 3 kHz to filter any quantizing noise and clock leakage on the output of the D/A converter. Jumper option J1 is provided to select an audio output level of 0 dBm (jumper installed) or -30 dBm (jumper open). Transformer coupling permits a balanced or unbalance 600 ohm output, depending on which is required.

4.2.3 Audio Input

Figure 4.10 illustrates the simple audio input section with A/D converter. Due to the wide dynamic range of the A/D converter, U10, no input AGC or analog filtering is required. Resistors R1, R2, and R3, combined with zener diode D3 and C22, provide a DC bias on the balanced audio inputs to the A/D converter. Transformer coupling between the audio input and the A/D converter permit either balanced or unbalanced input connections.

The A/D converter operates with an internal clock of 2.56 MHz provided on the ADCCLK input. The connection between the A/D converter and the DSP is a serial data channel.

Also included on this schematic page is the diagnostic port connector (J4). Presently, the PCI-4000 does not use this connection, but it is provided for applications that need an additional port for testing or alternate input and output connections. HAL does not install a connector in this location on the PCI-4000.

4.3 PCI-4000 Power and I/O Connections

Figure 4.11 summarizes all the PCI-4000 input and output connections. Connector J6 is located on the rear mounting panel of the board. The PC bus connections use signals on both edge connectors, which is why this card can only be installed in the PC ISA bus 16 bit mother board locations.

The PCI-4000 uses +8 VDC and -8 VDC on the A/D converter. To reduce the possibility of digital noise from the PC, these two voltages are generated on the board by three terminal regulators VR1 and VR2.

The PCI-4000 provides one accessory jack (J5) for powering an external SPT-1 tuning indicator. +12 VDC is available on this output.

4.4 PCI-4000 Options

The PCI-4000 has few board options. As illustrated in Figure 4.12, the board base address is set with SW1 (factory default 360H) and the modulator audio output is selected with J1 (factory default -30 dBm). One additional option setting, PC Interrupt level, is not used by PC-Clover (factory default NO INT).

There are no user serviceable parts or adjustments on the board except for the options and the modulator output level adjustment. Typical installations should require no changes in the factory settings.

Figure 4.1 PCI-4000 Block Diagram

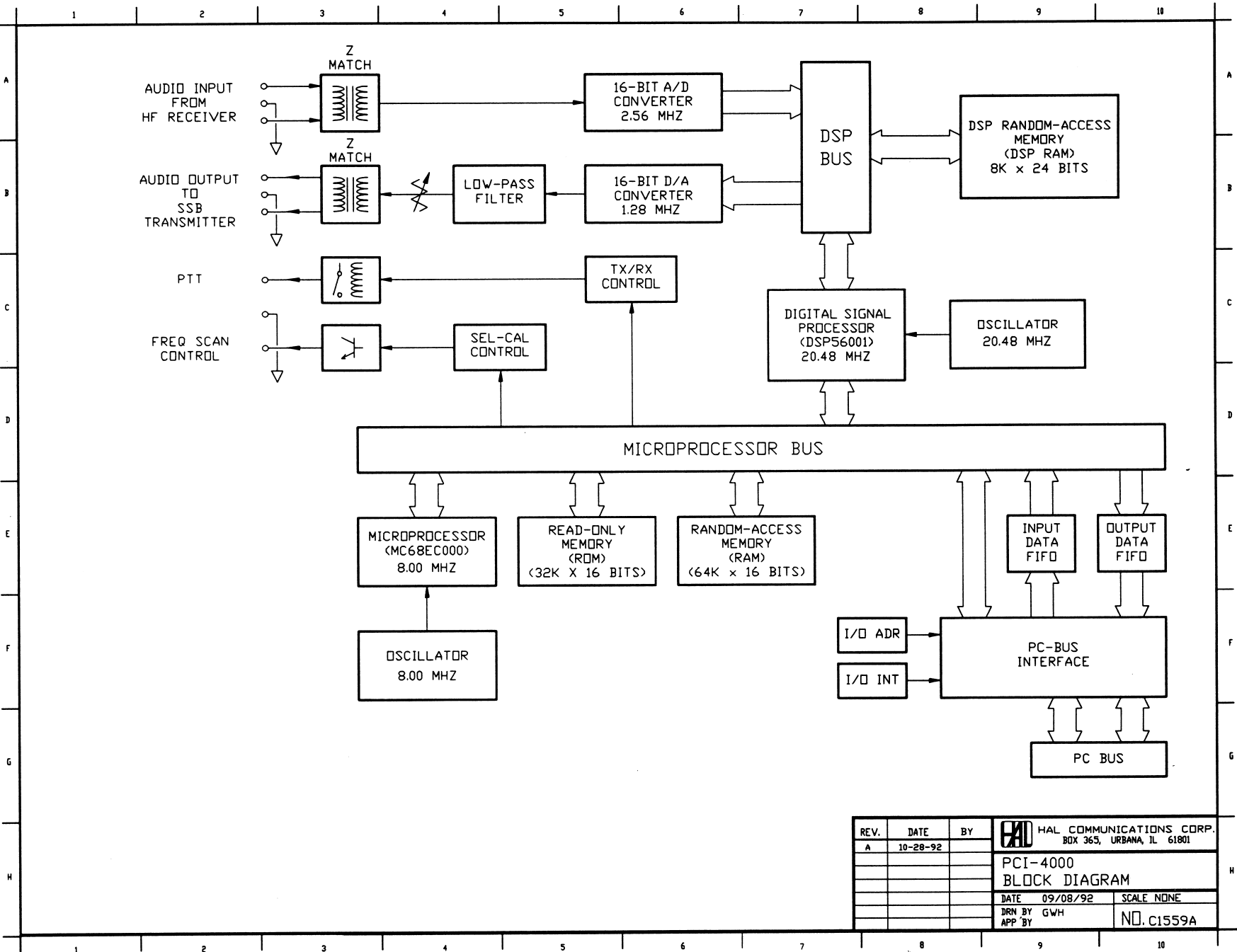

REV.	DATE	BY	HAL COMMUNICATIONS CORP. BOX 365, URBANA, IL 61801	
A	10-28-92		PCI-4000 BLOCK DIAGRAM	
	DATE	09/08/92	SCALE NONE	
	DRN BY	GWH	NO. C1559A	
	APP BY			

Figure 4.2 Control Processor, RAM, ROM

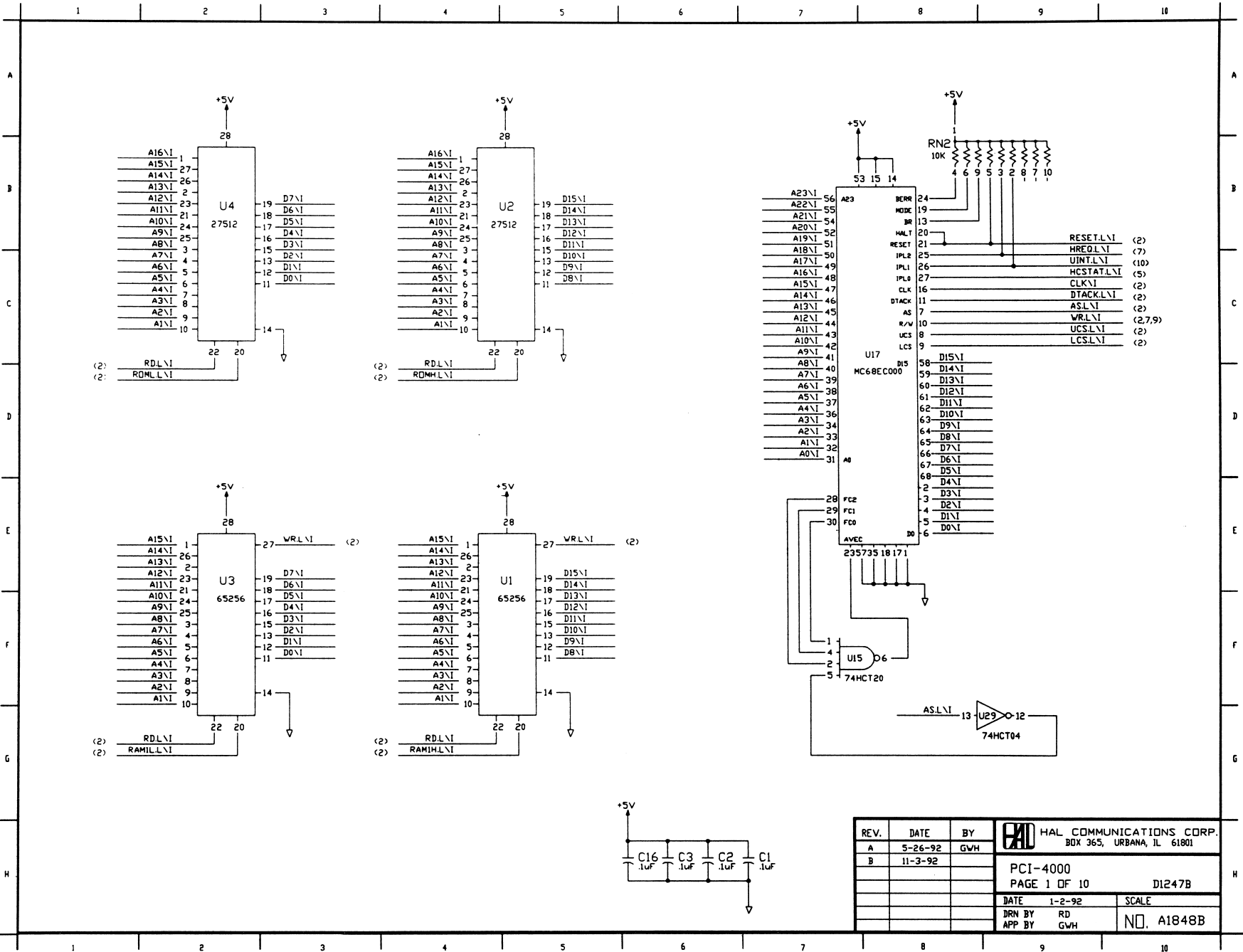

REV.	DATE	BY	HAL COMMUNICATIONS CORP.
A	5-26-92	GWH	BOX 365, URBANA, IL 61801
B	11-3-92		
			PCI-4000
			PAGE 1 OF 10
			D1247B
DATE		1-2-92	SCALE
DRN BY		RD	
APP BY		GWH	NO. A1848B

Figure 4.4 PC Bus Interface, I/O Address

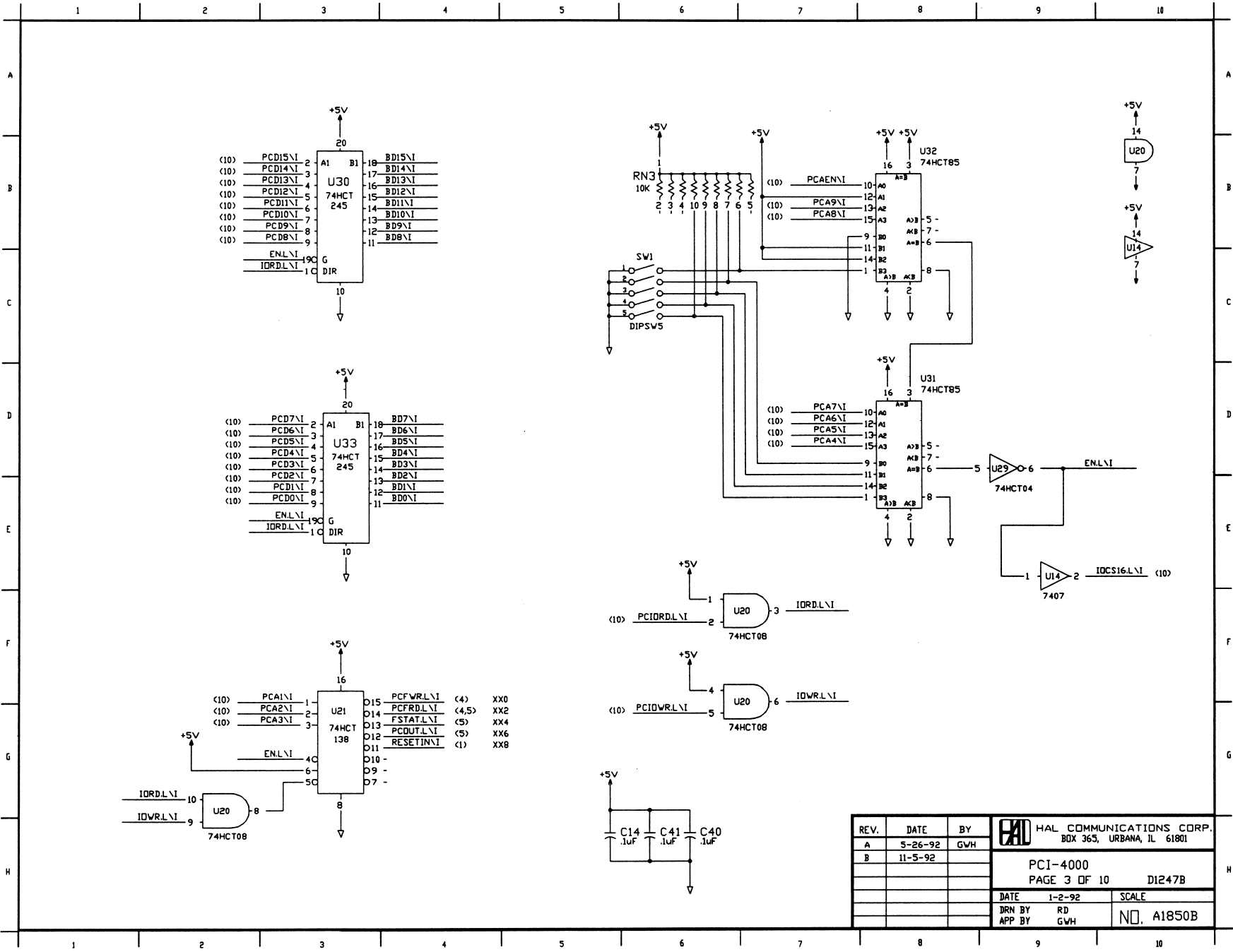

REV.	DATE	BY	HAL COMMUNICATIONS CORP. BOX 363, URBANA, IL 61801	
A	5-26-92	GWJ	PCI-4000	
B	11-5-92		PAGE 3 OF 10 D1247B	
	DATE	1-2-92	SCALE	
	DRN BY	RD		
	APP BY	GWJ	NO. A1850B	

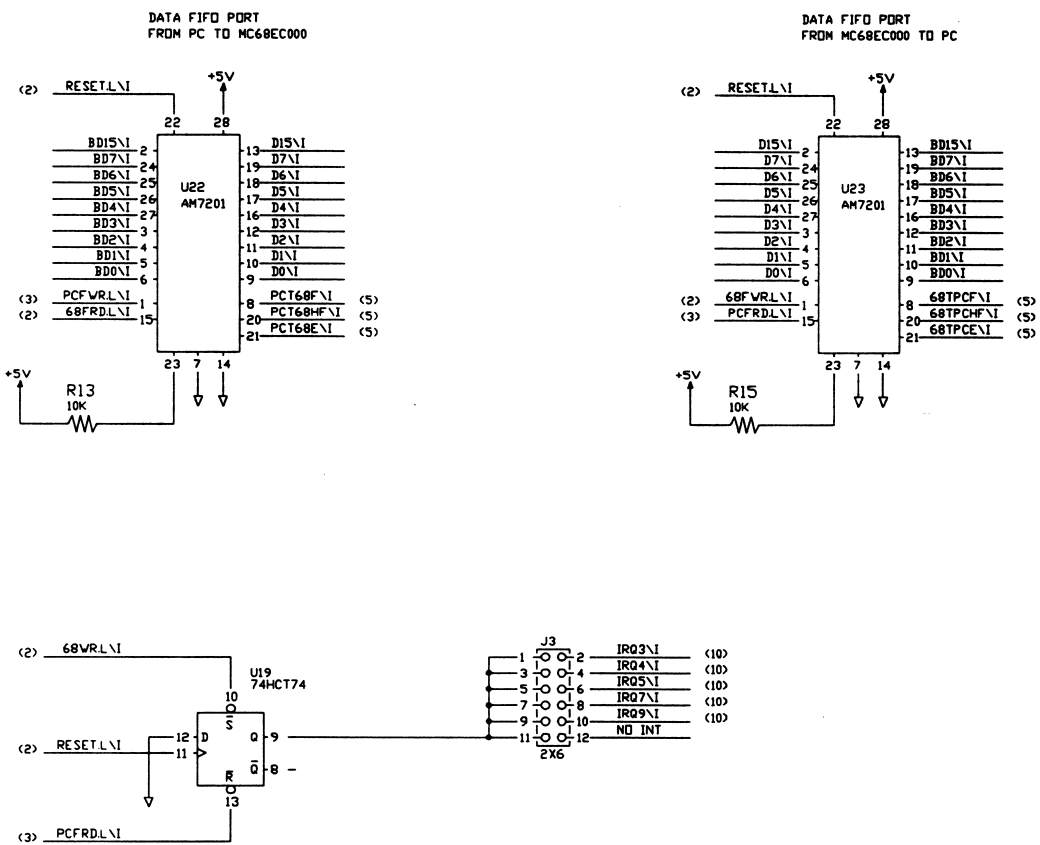

REV.	DATE	BY	SCALE
A	5-26-92	GW	
B	11-5-92		
HAL COMMUNICATIONS CORP. BOX 363, URBANA, IL 61801			
PCI-4000 PAGE 4 OF 10			D1247B
DATE	1-2-92	RD	SCALE
DRN BY		RD	
APP BY		GW	NO. A1851B

Figure 4.5 PC Input/Output FIFO, PC Interrupt

HAL921111

REFERENCE MANUAL

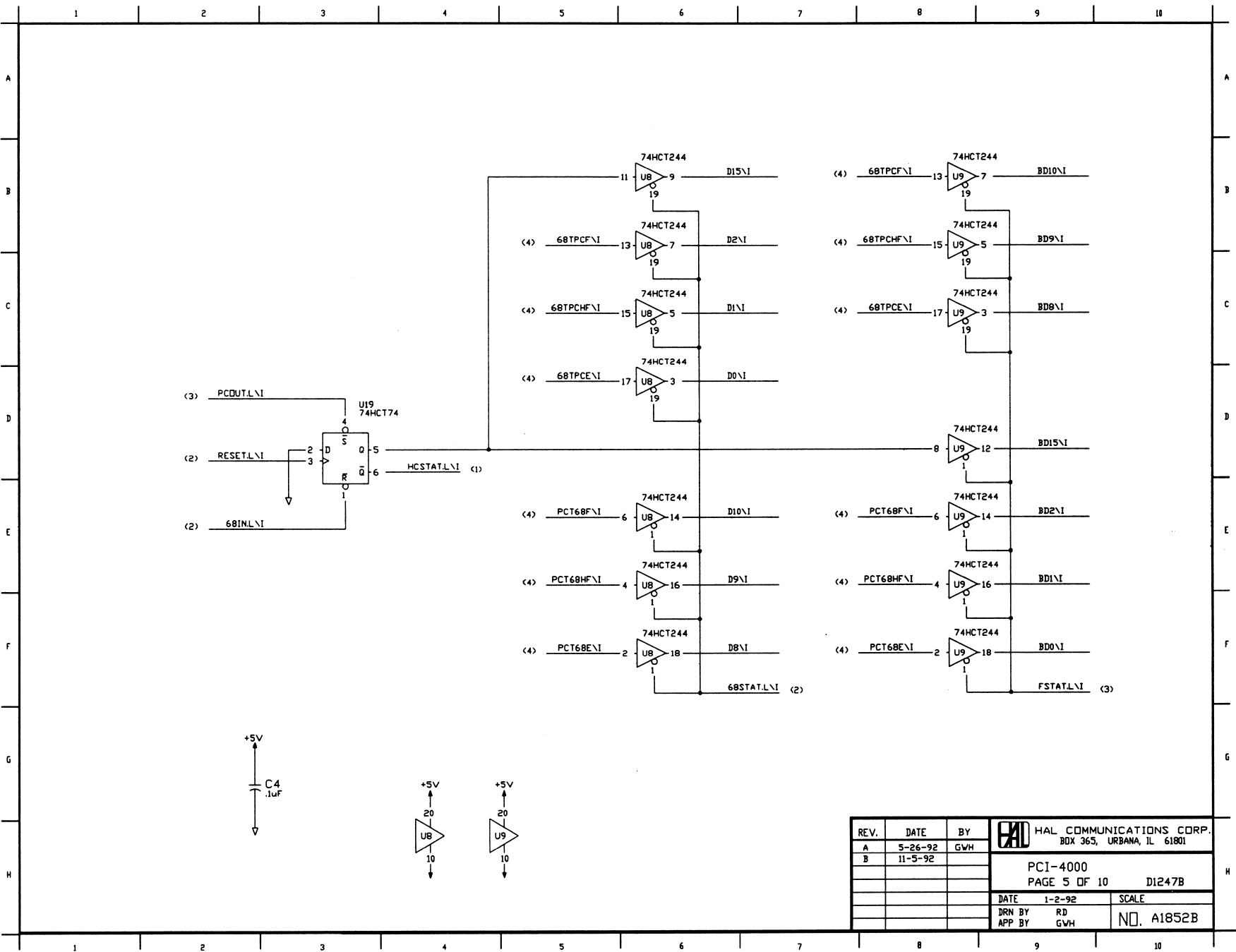
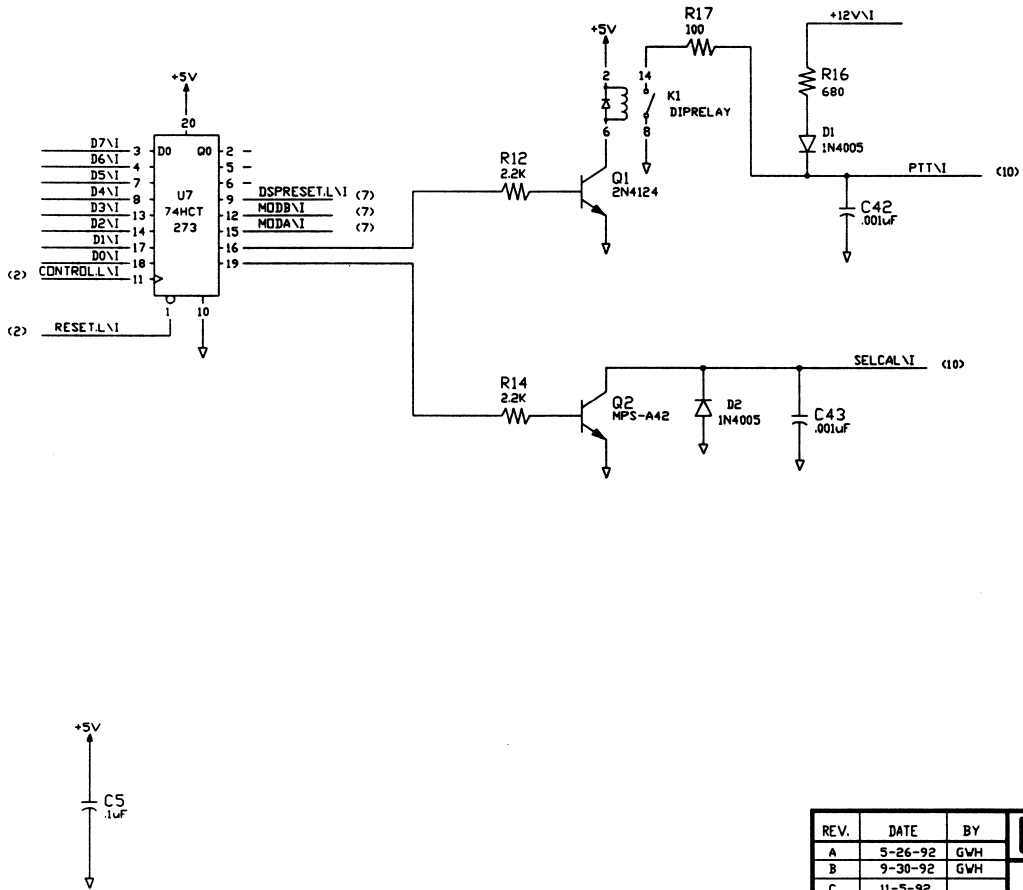

Figure 4.6 68000 Bus Interface

REV.	DATE	BY	HAL COMMUNICATIONS CORP. BDX 365, URBANA, IL 61801
A	5-26-92	GW	PCI-4000 PAGE 5 OF 10 D1247B
B	11-5-92	GW	
			DATE 1-2-92 SCALE
			DRN BY RD
			APP BY GWH NO. A1852B



REV.	DATE	BY	HAL COMMUNICATIONS CORP. BOX 365, URBANA, IL 61801
A	5-26-92	GVH	
B	9-30-92	GVH	
C	11-5-92		
			PCI-4000
			PAGE 6 OF 10
			DI247B
DATE	1-2-92	SCALE	
DRN BY	RD		
APP BY	GVH		NO. A1853C

Figure 4.7 PTT Relay, SEL-CAL Output

Figure 4.8 Digital Signal Processor, DSP RAM

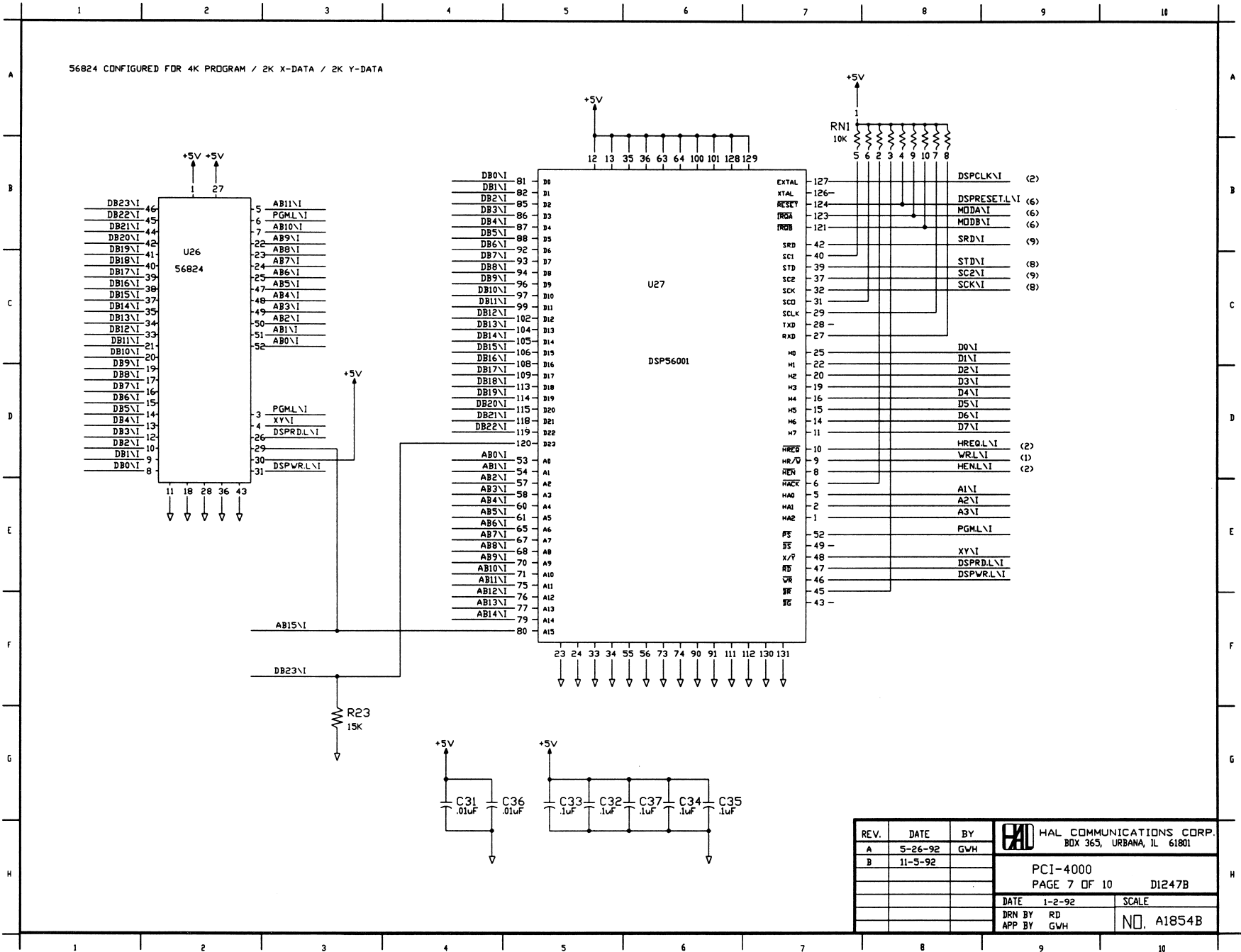

REV.	DATE	BY	HAL COMMUNICATIONS CORP. BOX 363, URBANA, IL 61801
A	5-26-92	GWH	
B	11-5-92		PCI-4000 PAGE 7 OF 10 D1247B
DATE		1-2-92	SCALE
DRN BY	RD		
APP BY	GWH	NO. A1854B	

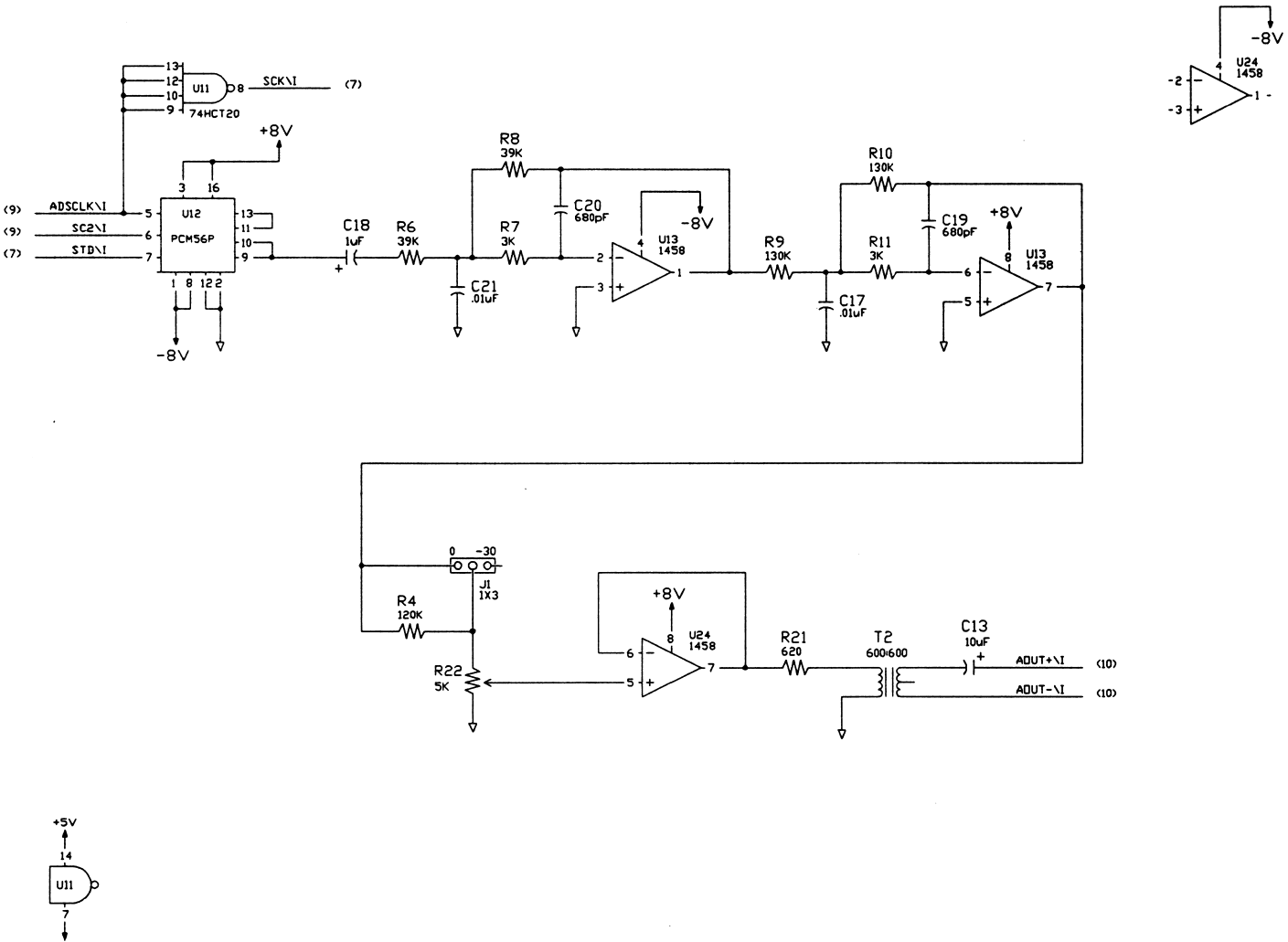

REV.	DATE	BY	 HAL COMMUNICATIONS CORP. BOX 363, URBANA, IL 61801
A	5-26-92	GWH	
B	11-5-92		PCI-4000 PAGE 8 OF 10 DI247B
			DATE 1-2-92 SCALE DRN BY RD NO. A1855B APP BY GWH

Figure 4.9 D/A Converter, Modulator Output

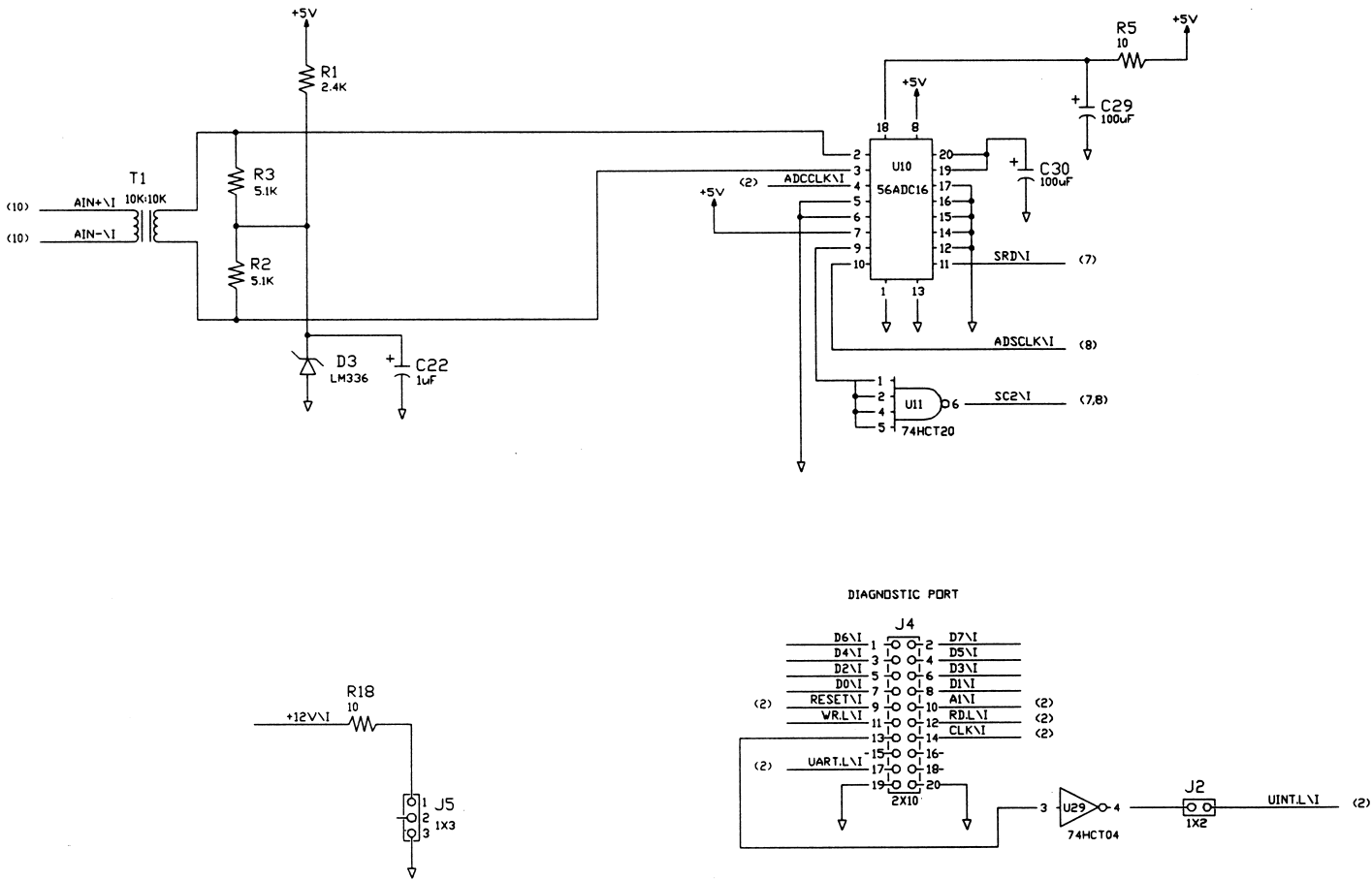
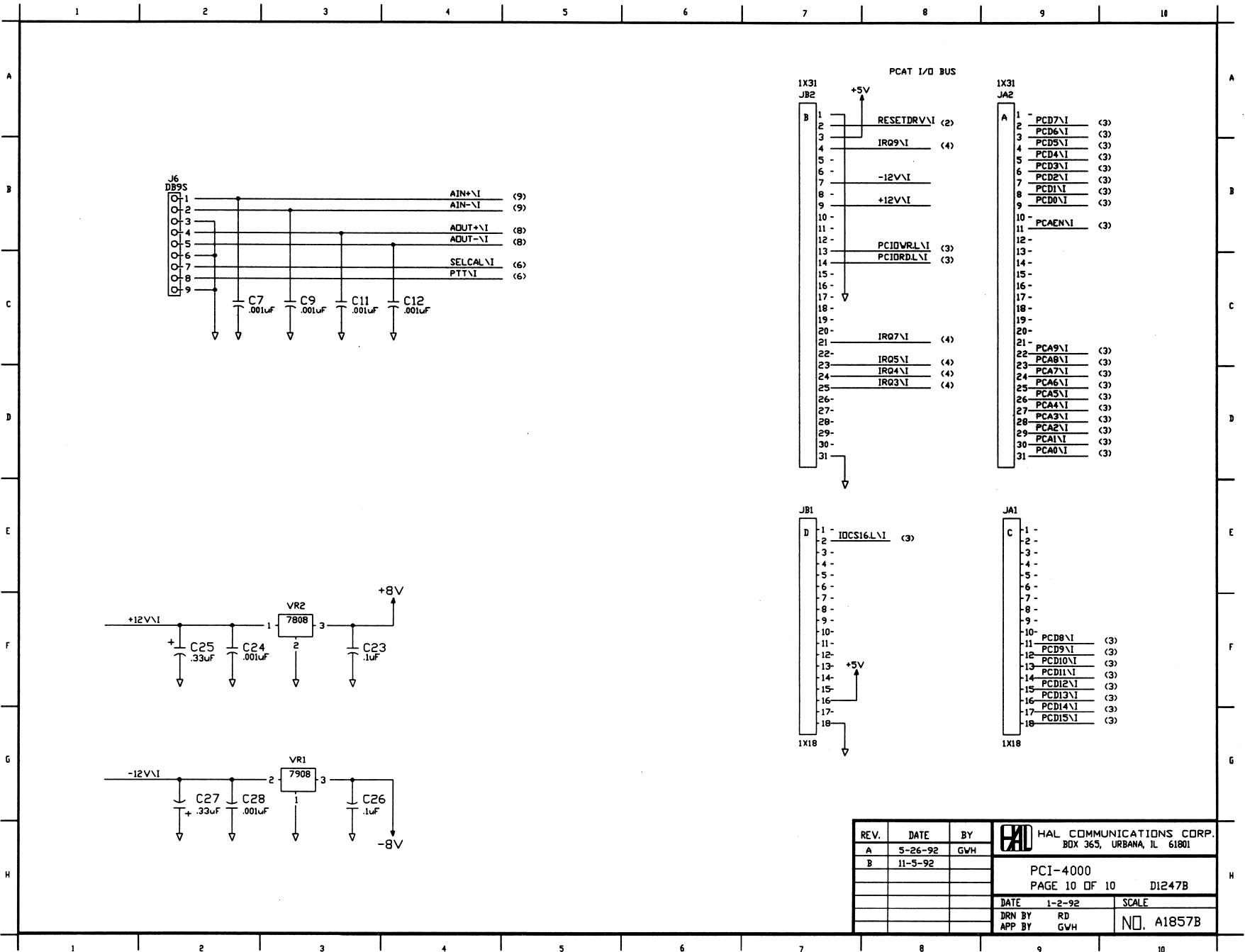

Figure 4.10 A/D Converter, Demodulator Input

REV.	DATE	BY	HAL COMMUNICATIONS CORP. BOX 365, URBANA, IL 61801	
A	5-26-92	GW	PCI-4000 PAGE 9 OF 10 D1247B	
B	9-30-92	GW		
C	11-5-92			
			DATE 1-2-92	SCALE
			DRN BY RD	NO. A1856C
			APP BY GW	

Figure 4.11 I/O Connections, Voltage Regulators



REV.	DATE	BY	HAL COMMUNICATIONS CORP. BOX 365, URBANA, IL 61801
A	5-26-92	GVH	PCI-4000 PAGE 10 OF 10 D1247B
B	11-3-92		
			DATE 1-2-92 SCALE
			DRN BY RD
			APP BY GVH NO. A1857B

Figure 4.12 PCI-4000 Circuit Board

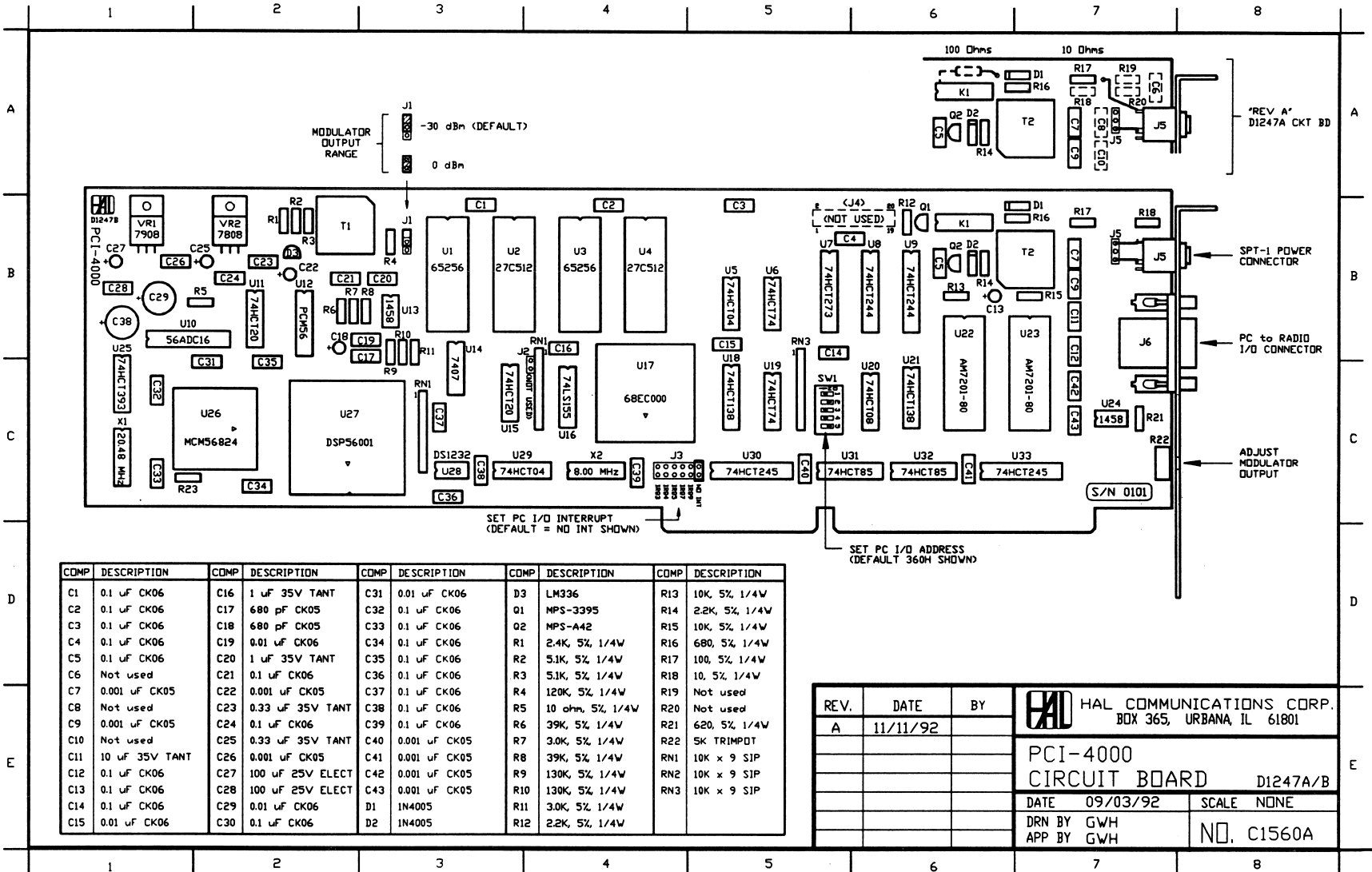

CHAPTER 5 IN CASE OF DIFFICULTY

This chapter provides general guidance in case your PCI-4000 hardware and/or PC-CLOVER software no longer function correctly. Please read all sections before attempting maintenance or returning a PCI-4000 to the factory.

5.1 User Adjustments and Alignment

The PCI-4000 circuitry is completely digital and has *no* alignment controls. However, there are user-settable jumpers, a switch, and an output level control which might be incorrectly set. The correct procedures to set these options are discussed in the manual sections shown in Table 5.1 below. Before considering any other maintenance procedures, re-read the referenced section and confirm that each option is set correctly.

**TABLE 5.1
USER-SET OPTIONS**

<u>SETTING</u>	<u>FUNCTION</u>	<u>MANUAL SECTION</u>
J1	Modulator Output Range	2.4.2
J3	PC I/O Interrupt	APPENDIX A
SW1	PC I/O Address	APPENDIX A
R22	Modulator Output Level	2.4.2

Unless changes have been made in the PC or radio system, none of these options should have changed from when the PCI-4000 was first installed.

5.2 PCI-4000 Hardware Problems

PCI-400 hardware problems will generally be caused by one or more of the following situations:

1. Exceeding the voltage or current rating of any of the radio I/O connections may damage PCI-4000 components. The maximum rating of each connection is shown in Table 2.1; do not exceed these limits. Static electricity or lightning is a common way that one or more of these limits may be exceeded.
2. Making a hardware *or software* change in the host personal computer may produce results that appear to be a PCI-4000 hardware problem. Installing additional or different hardware boards in the PC may create an I/O address conflict; a *software* change may create a conflict that *appears* to be a hardware problem.
3. Inadequate PC power supply capacity or improper ventilation of the host PC may cause the PCI-4000 to not operate correctly.

4. Accidental interchange of the PCI-4000 DE-9 cable connections with those intended for other PC functions may damage both the PCI-4000 and the other like-connector device. Visually confirm that the correct cables and connectors are mated before applying power to the PC.
5. Faults in the transmitter or receiver may at first appear to be PCI- 4000 problems. Confirm that radio controls are set correctly and that the radio equipment operates as it should.
6. Review the PC hardware compatibility list in section 2.2 and radio compatibility list in section 2.6 (Table 2.2).
7. Radio frequency interference (RFI) can be a major problem, particularly if transmitter energy invades the PC itself. A good RF ground connection (1/4" wide shield braid) should always be made between the cabinets of the PC and the radio equipment. All cables should be shielded and as short as possible - no more than ten feet long. Test for transmitter RFI by transmitting at very low power into a well shielded dummy load (1 to 10 Watts). If the PCI-4000 works correctly with low power into a dummy load but not with normal power to the antenna, the RFI problem *must* be cured before the PCI-4000 may be used to its full potential.
8. RFI to the receiver may be heard in the form of "birdie" signals at various frequencies. As in the case of transmitter RFI, good grounding, shielding, and short cables are the best cures. Also, "modern" PC cabinets and CRT monitors (made since 1991) have *considerably* better shielding and RFI suppression than their predecessors. Pre-1991 slow PC's (PC-XT, etc.) tended to generate less RFI than faster models ('286, etc.). Since 1991, this no longer appears to be the case as modern '386 PC's are often quieter than early PC-XT's.

5.3 Software Problems

Some programs when run in the PC may create problems that prevent the PCI-4000 and/or PC-CLOVER from operating correctly. Review the comments of section 2.3 regarding software compatibility. "TSR" and "shell" programs are notorious for causing intermittent operation of PC options, often appearing as "hardware problems" or causing software "lock-up". If problems have developed since changing software (new programs or different versions of old programs), restore the previous software configuration and re-test the PCI-4000.

5.4 Operational Problems

CLOVER uses a new waveform and new protocol. Some operations which are in fact "normal" may at first appear to be a "problem". Typical situations which may produce confusing results are:

1. CLOVER signals must be tuned correctly at the *receiver*. Optimum performance will be obtained only when tuning is correct. However, the CLOVER modem must also obtain frequency, phase, and time synchronization from the received signal. To minimize the effects of noise and short-term ionosphere variations, a running-average integration is computed over a 2 second period (approximate length of a data pulse). Each time the receiver tuning control is adjusted, the integration process is disturbed and that data block will usually be "damaged" - data will not be recovered and a repeat will be necessary in ARQ mode. Further, it may take receipt of several more data blocks to regain synchronization. CLOVER transmissions also use long blocks - 2.7 to 6.5 seconds long (see Figure 3.6). The tuning indicators are updated only *once per data block*. Receiver tuning adjustments at a faster rate will not produce useful results and may in fact confuse the system. The following guidelines are recommended:
 - a. Tune the receiver *slowly*. One increment per data block is sufficient.
 - b. Avoid the temptation to make small frequent receiver adjustments.
2. CLOVER adaptive ARQ mode measure receive signal parameters and then sets the optimum transmit modulation mode *from the other station*. If your station appears to not be able to send data at a fast rate, it is due to receive conditions *at the other station* and usually *not* transmit problems at your station.
3. If it appears that many stations have difficulty transmitting data to you at a high rate, it *could* be due to a problem in your receiving equipment, particularly if these also appear to be strong and stable signals. Typical receiver parameters which can limit CLOVER performance are:
 - a. Receiver AGC set to FAST or SLOW mode distorts 8P2A or 16P4A - use the manual RF gain control.
 - b. Receiver narrow IF filter distorts CLOVER signal - use the SSB filter.
 - c. Noise limiter or blanker distorts CLOVER - turn OFF.
 - d. Receiver drift exceeds CLOVER compensation - retune as required.
4. CLOVER uses long data blocks and multi-level modulation to obtain high data throughput. However, the ARQ transmit/receive protocol operates much slower than other popular ARQ modes - AMTOR, PACTOR, or packet radio. It must be remembered that all aspects of CLOVER ARQ mode occur at a slow rate and that major changes must occur in increments of 20 seconds (ARQ frame time). Have patience and wait for CLOVER to finish its assigned task before rushing into a new mode or assuming that something is not quite right.
5. When CW ID is enabled, each station sends a CW ID at the end of a link. The disconnecting station will send a CW ID as soon as data ends. However, the other station must wait *20 seconds* for the completion of an ARQ frame and then send its CW ID. Let the CW ID's clear before starting new modes!

5.5 User Service

The PCI-4000 does not require periodic alignment or renewal of any component. Components should be replaced only if they fail and not as a part of any routine maintenance procedure. As a general rule, component replacement should be done at the factory under controlled ESD (Electro-Static Discharge) conditions. Before returning the PCI-4000 to the factory, please check the following:

1. All jumpers and option switches are set correctly.
2. All socketed components are fully seated in their sockets.
3. Cables to the PCI-4000 are installed and are not open or shorted.
4. All other features of your PC function correctly.

If the above items are correct, contact the factory to arrange for return and repair.

5.6 User Information

HAL Communications Corp. provides a user support "TECH-LINE BBS" which may be called by HAL customers to obtain current PCI-4000 and PC-CLOVER software releases. TECH-LINE also provides user service bulletins and may be used to communicate with our factory repair personnel. Also, customer repair personnel may be contacted directly via telephone or FAX.

Before contacting customer service, have the model number, serial number, software version numbers, and name or original ordering customer available.

Customer service may be contacted via:

Mail:	HAL Communications Corp. Customer Service Department 1201 W. Kenyon Road Urbana, Illinois 61801
Phone:	(217) 367-7373, 8 AM - 5 PM CST/CDT, Monday - Friday
FAX:	(217) 367-1701, 24 hours/day
TECH-LINE:	Computer BBS (217) 367-5547 (24 hours/day) 9600 V.42; 2400, 1200, or 300 baud ASCII "N 8 1" (No Parity, 8 Data Bits, 1 Stop Bit)

5.7 Returning Equipment for Factory Repair

If your equipment must be returned to HAL for repair, please do the following:

1. Call, FAX, or write to HAL and obtain a *Return Authorization*.
2. *ALWAYS* include the following information *in the package containing the item to be repaired*:
 - a. Your name, and address for return of the repaired equipment. *Give a street address if at all possible.*
 - b. Model, serial number, and approximate purchase date of returned item.
 - c. If the warranty period has expired, the payment means you prefer. See Chapter 6 for warranty details.
 - d. *A short but informative* description of the problems. "Broke" is too short; 2 or more pages is usually too much!
 - e. The shipping carrier or means by which the equipment should be returned to you. HAL will use UPS (Brown Label) shipping unless otherwise directed.
3. Carefully pack the PCI-4000 and protect it from shipping damage. The original HAL carton is a good choice if it is available and undamaged. A new carton may be purchased from HAL.
4. Insure the PCI-4000 for its full value.
5. Clearly mark HAL's name, address, and "ATTN: SERVICE" on the shipping box.

The HAL service department attempts to repair all equipment within 30 days of its arrival at HAL. If the repairs cannot be made within 30 days, you will be notified by mail of the approximate shipping date. You may call the HAL service department to confirm repair dates.

If you require rush service of your PCI-4000, please notify HAL and we will make all attempts possible to expedite your repair. However, our service time is often conditional upon arrival of parts which is not within our control. Also, please understand that testing takes time and that each hardware repair should be "burned-in" for an extended period (24 hours) and re-tested.

Also, be sure that you have thoroughly checked all other equipment connected to the PCI-4000 and that the PCI-4000 is actually at fault. It takes much longer to test a device that is in fact not defective. We must charge for all repair time, including time spent testing a device that is not defective. A thorough examination of the problem by you and a clearly written description of problems noted will save time and money for both of us.

CHAPTER 6

PCI-4000 SPECIFICATIONS

INPUT/OUTPUT:

- AF IN: Audio from receiver;
30 mV to 3 V rms (-30 to +10 dBm);
Z_{in} = 10,000 ohms
- AF OUT: Audio output to transmitter;
2.5 mV to 1.5 V rms (-50 to +6 dBm) in two ranges
Z_{out} = 600 ohms
- PTT: Push-To-Talk TX/RX control output
+50 VDC open-circuit (RX) maximum
±100 ma DC closed-circuit (TX) maximum
- SEL-CAL: Selective Call control output
NPN type MPS-A42 transistor collector
+50 VDC open circuit maximum
+100 ma DC closed circuit maximum

CLOVER WAVEFORM:

Tone Pulses: 4 Tone pulses, spaced 125 Hz and 8 ms apart
Amplitude shaped via Dolph-Chebychev for -60 dB
composite side-lobe suppression.

Channels: 4 tone channels; Channel #4 is default in PC-CLOVER

F	CHAN 1	CHAN 2	CHAN 3	CHAN 4
F _c	750.0 Hz	1250.0 Hz	1750.0 Hz	2250.0 Hz
F1	562.5 Hz	1062.5 Hz	1562.5 Hz	2062.5 Hz
F2	687.5 Hz	1187.5 Hz	1687.5 Hz	2187.5 Hz
F3	812.5 Hz	1312.5 Hz	1812.5 Hz	2312.5 Hz
F4	937.5 Hz	1437.5 Hz	1937.5 Hz	2437.5 Hz

Frequency Spectra: F_c ±250 Hz;
Bandwidth = 500 Hz @ -50 below peak level.

TX Crest Factor: Peak/Average ≤ 2:1 (voltage)
≤ 6 dB (power)

CCIR Emission: 500H J2 DEN or 500H J2 BEN

Modulation: 31.25 baud, all modulation formats

Modulation Format: Ten modulation modes using Phase Shift Modulation (PSM), Amplitude Shift Modulation (ASM), Frequency Shift Modulation, and multiple combinations.

<u>MODE</u>	<u>DESCRIPTION</u>	<u>RATE</u>
16P4A	16PSM + 4 ASM	750 bps
16PSM	16-ary PSM	500 bps
8P4A	8PSM + 2 ASM	500 bps
8PSM	8-ary PSM	375 bps
QPSM	Quadrature PSM	250 bps
BPSM	Binary PSM	125 bps
2DPSM	Dual Diversity BPSM	62.5 bps
FSM	Frequency Shift Mod.	62.5 bps
4DPSM	Quad Diversity BPSM	31.25 bps
2DFSMS	Dual Diversity FSM	31.25 bps

Error Correction: Reed-Solomon (GF(2e8)) data encoding.
 Block Sizes = 17, 51, 85, 255 bytes
 Coding Efficiency = 60%, 75%, 90%, 100% (no coding)

Waveform Combinations: 160 total: 10 modulation, 4 block sizes, 4 coder efficiencies.

CLOVER PROTOCOL:

CLOVER Control Block (CCB) Underlying synchronizing and control signaling layer for all CLOVER transmissions.

CCB Format: Always same or more robust than data blocks.
 2DPSM/17/60 for FEC transmissions
 BPSM/17/60 for ARQ transmissions

FEC Mode: One transmitter to multiple receiver broadcast mode.
 Reed-Solomon forward error correction coding
 Data throughput set in 6 ranges:
 60, 40, 30, 20, 10, or 5 bytes-per-second (byps)

ARQ Mode: One transmitter to one receiver point-to-point mode.
 Reed-Solomon forward error correction coding
 Repeat transmission of uncorrectable data blocks
 Adaptive selection of waveform modulation for 5 ranges:
 60, 40, 30, 20, or 10 bytes-per-second (byps)
 Automatic power control of transmitters

LISTEN Mode: Monitor all FEC or ARQ CLOVER transmissions.
 Identify call signs of all CLOVER signals
 Identify and track waveform of received signals

CW ID: Morse code (20 wpm) identification of station call sign.
 Optional ON/OFF and 10-minute automatic timer.

PC-CLOVER SOFTWARE:

- GENERAL:** PC-CLOVER personal computer software includes split-screen, pull-down menu windows, "hot keys", programmable messages, HISCALL directory, Configuration menus and files, Save to disk, Send from disk, Transmit editor, macro command key programming and storage, on-screen tuning indicators, on-screen real-time ionospheric channel statistics.
- MENUS:** COMMAND Menu, CODE, MODE, CONTROL, MESSAGES, FILES, and CONFIGURATION sub-menus.
- STORAGE:** 250 Line Receive Buffer; 250 Line Transmit Buffer
Save To Disk File
Local ID and call sign (MYCALL)
Call sign of last-worked station (LAST HISCALL)
Call signs of ten frequently worked stations (HISCALLS)
Ten HERE IS messages, each 255 characters long.
CONFIGURATION files to save operating parameters
- PRINTER:** ON/OFF control of LPT1 PC printer device.

COMPATIBILITY:

All IBM^{*}-Compatible PC-AT (80286) and higher personal computers (PC-286, PC-386, PC-486, etc.; *not* PC-XT). Must be IBM BIOS and MS/PC-DOS compatible. One floppy and one hard disk drive; 640K RAM minimum. PCI-4000 and PC-CLOVER programs furnished on diskette. Software up-grades available via HAL TECH-LINE BBS.

HARDWARE:

16-bit sigma-delta A/D converter
16-bit D/A converter
24-bit DSP-56001 Digital Signal Processor
16-bit 68EC000 Control Processor
Dual 512 byte FIFO interface to PC bus
4-layer, low RFI epoxy-glass circuit board
Transformer isolated audio input and output
Relay contacts for PTT control

MECHANICAL:

Full size PC circuit board (13.25" x 4.25")
All I/O connections via rear-panel DE9S connector
All PC connections via PC-AT bus connections
0.75 lbs (0.34 kg) net, 3.0 lbs (1.3 kg) shipping

^{*}IBM is a registered trademark of the IBM Corporation

APPENDIX A I/O ADDRESS SELECTION

PC I/O Address

The PCI-4000 circuit board includes a unique bus interface for communications with the host personal computer. Rather than using a PC address (and interrupt) that may already be assigned to another device, the PCI-4000 uses I/O mapped port addressing. In normal use, the PCI-4000 does not use any of the PC's standard hardware interrupts. Instead, the PC-CLOVER software "polls" the PCI-4000 I/O addresses. As a result, major conflicts are avoided with serial I/O ports, printer ports, and other devices that may also be installed.

Circuit board DIP switch SW1 may be set to a wide range of I/O base addresses. Thus, even if another PC accessory card uses the PCI-4000 factory default I/O address, the PCI-4000 may be moved to another, non-conflicting location.

All PCI-4000 circuit boards are set to I/O base address 360H when shipped from the factory. If you have a conflict, this address may be changed by simply changing the setting of DIP switch SW1. When loading, PC-CLOVER first examines the PCC.CFG or specified *.CFG file and then checks to see if the PCI-4000 is located at the specified I/O address. If the PCI-4000 is not found at the *.CFG address or at 360H, PC-CLOVER then checks all available locations between 200H and 3F0H and adjusts to the new I/O address. The actual I/O address found by PC-CLOVER is listed on Page 1 of the Configuration menu. Available I/O memory addresses and SW1 settings are shown in Table A.1.

**TABLE A.1
PCI-4000 I/O BASE ADDRESS SELECTION**

SWITCH SW1					BASE ADDRESS	SWITCH SW1					BASE ADDRESS
1	2	3	4	5		1	2	3	4	5	
C	C	C	C	C	N/A	O	C	C	C	C	300H
C	C	C	C	O	210H	O	C	C	C	O	310H
C	C	C	O	C	N/A	O	C	C	O	C	N/A
C	C	C	O	O	N/A	O	C	C	O	O	330H
C	C	O	C	C	240H	O	C	O	C	C	340H
C	C	O	C	O	250H	O	C	O	C	O	350H
C	C	O	O	C	260H *	O	C	O	O	C	360H **
C	C	O	O	O	N/A	O	C	O	O	O	N/A
C	O	C	C	C	280H	O	O	C	C	C	380H
C	O	C	C	O	290H	O	O	C	C	O	390H
C	O	C	O	C	2A0H	O	O	C	O	C	3A0H
C	O	C	O	O	2B0H	O	O	C	O	O	N/A
C	O	O	C	C	2C0H	O	O	O	C	C	N/A
C	O	O	C	O	2D0H	O	O	O	C	O	N/A
C	O	O	O	C	2E0H	O	O	O	O	C	N/A
C	O	O	O	O	N/A	O	O	O	O	O	N/A

NOTE: (C) = Switch CLOSED or ON
(O) = Switch OPEN or OFF
N/A = NOT AVAILABLE; do not use.
(*) = PCI-3000 (PC-AMTOR) Factory Default Address (260H)
** = PCI-4000 (PC-CLOVER) Factory Default Address (360H)

Various other devices may use PC I/O addresses within the available range of the PCI-4000. As of this date, Table A.2 lists those PC accessory devices known to HAL and their I/O address requirements. We suggest that you avoid any address where there may be a conflict within your PC system.

**TABLE A.2
PC I/O ADDRESS ASSIGNMENTS**

<u>BASE</u>	<u>DESCRIPTION</u>	<u>BASE</u>	<u>DESCRIPTION</u>
200H	Game Port	300H +	"Prototype Card"
208H	Game Port	308H	"Prototype Card"
210H +	PC Expansion Unit	310H +	"Prototype Card"
218H	(not assigned)	318H	"Prototype Card"
220H	"Reserved"	320H	Fixed Disk
228H	"Reserved"	328H	Fixed Disk
230H	"Reserved"	330H +	(not assigned)
238H	"Reserved"	338H	(not assigned)
240H +	Clock Card (Primary)	340H +	Clock Card (Secondary)
248H	Clock Card (Primary)	348H	Clock Card (Secondary)
250H +	Clock Card (Primary)	350H +	Clock Card (Secondary)
258H	Clock Card (Primary)	358H	Clock Card (Secondary)
260H + *	PCI-3000 Default	360H + **	PCI-4000 Default
268H	(not assigned)	368H	(PCI-4000)
270H +	(not assigned)	370H +	(not assigned)
278H	Printer (LPT2)	378H	Printer (LPT1)
280H +	ARCNET LAN Card	380H +	Sync Port (Secondary)
288H	(not assigned)	388H	Sync Port (Secondary)
290H +	(not assigned)	390H +	PC Cluster (PC-AT)
298H	(not assigned)	398H	(not assigned)
2A0H +	(not assigned)	3A0H +	Sync Port (Primary)
2A8H	(not assigned)	3A8H	Sync Port (Primary)
2B0H +	Alternate EGA	3B0H	Monochrome Display
2B8H	(not assigned)	3B8H	Monochrome Display
2C0H +	Clock Card (AST)	3C0H	"Reserved"
2C8H	Clock Card (AST)	3C8H	"Reserved"
2D0H +	Clock Card (AST)	3D0H	CGA Card
2D8H	Clock Card (AST)	3D8H	CGA Card
2E0H +	ARCNET LAN Card	3E0H	"Reserved"
2E8H	(not assigned)	3E8H	(not assigned)
2F0H	"Reserved"	3F0H	Disk Controller
2F8H	Async I/O (COM2)	3F8H	Async I/O (COM1)

NOTE: (+) = Available PCI-4000 I/O base addresses.
 * = Factory Default PCI-3000 Address (260H)
 ** = Factory Default PCI-4000 Address (360H)

The Above Board "MEGAPAGE" card may use address 0260H. If conflicts are found, try setting the PCI-4000 to address 0330H.

The PCI-4000 (PC-CLOVER) and PCI-3000 (PC-AMTOR) may both be plugged into the same PC. The factory default addresses are intentionally chosen to assure this compatibility. If you have changed one or the other addresses, you must be sure that the chosen PCI-4000 and PCI-3000 addresses do not conflict with each other or with other I/O devices which may be installed in your PC.

PC I/O Interrupt

As noted above, the HAL PC-CLOVER program does *not* require use of any of the personal computer's limited I/O interrupt lines. However, this capability is provided via jumper field J3 on the PCI-4000 to support I/O interrupt operation if "3rd Party" software authors (software not written by HAL) require this capability. Unless you are certain that your software requires I/O interrupt support, leave jumper J3 set to the "NO INT" default setting.

LIMITED WARRANTY

HAL Communications Corp. of Urbana, Illinois, hereby warrants to the purchaser that the product herein described shall be free from defects in materials and workmanship, and from failure of operation from ordinary use, for a period of one year from the date of sale to the purchaser.

In the event of a defect in materials or workmanship during the warranty period, HAL Communications Corp. will, at its own expense, repair the defective unit and replace any defective parts. Cost of shipping the unit to HAL Communications Corp. as well as costs of removal and reinstallation of the unit shall be paid by the purchaser. HAL Communications Corp. will pay the shipping costs incurred in returning the unit to the purchaser.

To obtain warranty service, the customer should:

1. Notify, as soon as possible, the Customer Service Department of HAL Communications Corp., Box 365, Urbana, Illinois, 61801, of the existence of a possible defect.
2. At the time of notification, identify the serial number, and the possible defect.
3. HAL Communications will issue a Return Authorization Number at this time.
4. Return the unit, freight prepaid. Include in the shipping carton a reference to the Return Authorization Number and a brief description of the problem.

Correct installation, use, maintenance, and repair are essential for proper performance of this product. The purchaser should carefully read the equipment manual. The purchaser will be billed for labor and shipping charges on any unit determined by HAL to be in working order when received for repair.

This warranty does not apply to any defect which HAL Communications Corp. determines is due to any of the following:

1. Improper maintenance or repair, including the installation of parts or accessories that do not conform to the quality and specifications of the original parts;
2. Misuse, abuse, neglect, improper installation, or improper operation, including improper AC power and RF grounding techniques.
3. Accidental or intentional damage.

All implied warranties are limited in duration to a period of one year from the date of purchase by the original retail purchaser. HAL Communications Corp. disclaims any liability for incidental or consequential damages arising out of the use of, or inability to use, this product. This warranty gives you specific legal rights, but there may be additional rights.

PCI-4000 / PC-CLOVER COMBINED INDEX

TOPIC	REFERENCE MANUAL	OPERATOR'S MANUAL
A/D Converter	4-6 17	
AF Channel (Configuration)	3-1; 6-1	A-5
AF IN, PCI-4000	2-6 9; 4-6; 6-1	
AF OUT, PCI-4000	2-6 9; 4-6; 6-1	
AGC, receiver	2-13 14	
ALC, transmitter	2-13	2-4
AMTOR error correction	3-8	
APlink program	2-6	
ARQ Block Mode	3-19	6-6
ARQ CCB Frame	3-14 15	
ARQ CCB Frame time	3-15	
ARQ CQ (Alt-F9; Ctrl-F9)		5-1 4; 6-5
ARQ CQ, Answer (Ctrl-F9)		5-1
ARQ CQ, Call (Alt-F9)		5-1
ARQ Chat Mode	3-19	6-6
ARQ Configuration		A-3
ARQ Connect Type (Configuration)		A-3
ARQ Data Block Layer	3-16	
ARQ Data Frame	3-17	
ARQ Data Frame time	3-16 17	
ARQ Data Throughput	3-17	
ARQ End		6-5
ARQ Fail Retry		A-4
ARQ Fast Bias		A-3
ARQ Format Menu		4-2; 6-3
ARQ Manual Waveform Menu		4-2
ARQ Modes	3-9 14 16	
ARQ Normal Bias		A-3
ARQ Normal Retry (Configuration)		A-4
ARQ Protocol Layers	3-14	
ARQ QSO		6-5
ARQ Robust Bias		A-3
ARQ Robust Retry		A-4
ARQ Sub-menu		4-1
ARQ, Adaptive		6-2
ARQ, One-Way	3-19	6-6
ARQ, Start Link (F9)		5-1
ARQ, Starting QSO		6-5
ARQ, Two-Way	3-19	6-6
AT Bus FIFO	4-4 12	
AT Bus Interface	4-3 11	
AUTO BIAS (Configuration P. 1)		A-3
AUTO BIAS, Increment (Alt-S)		5-2

TOPIC	REFERENCE MANUAL	OPERATOR'S MANUAL
AUTOPOWER		2-4
AUTOPOWER (Configuration P. 1)		A-3
AUTOPOWER ON/OFF (Alt-Y)		5-2
AX.25 error correction	3-8	
Accessories	1-2	
Adaptive ARQ Configuration		A-3
Adaptive ARQ mode	3-16	6-2
Adjustment	2-11; 5-1	
Alignment	5-1	
Alt-A (Tune Screens)	2-15 16 17	5-2; 6-1
Alt-B (Load Time and Date)		5-2
Alt-C (End HERE IS Programming)		5-2
Alt-D (Load Date)		5-2
Alt-E (Save To Disk)		5-2
Alt-F (Reformat TX Buffer Text)		5-2
Alt-F1 (Command Mode)		5-1
Alt-F10 (TX Buffer EN/DIS)		5-1
Alt-F2 (not assigned)		5-1
Alt-F3 (not assigned)		5-1
Alt-F4 (Load CW ID)		5-1
Alt-F5 (not assigned)		5-1
Alt-F6 (not assigned)		5-1
Alt-F7 (Quick Disconnect)		5-1
Alt-F8 (not assigned)		5-1
Alt-F9 (Call ARQ-CQ)		5-1
Alt-G (not assigned)		5-2
Alt-H (View HELP Screens)		5-2
Alt-I (CW ID ON/OFF)		5-2
Alt-J (Stop File Send/Save)		5-2
Alt-K (Delete Line)		5-2
Alt-L (Load File Into TX Buffer)		5-2
Alt-M (Program MYCALL)		5-2
Alt-N (not assigned)		5-2
Alt-O (Test Mode)	2-11	5-2
Alt-P (Printer ON/OFF)	2-4	5-2
Alt-Q (Load QBF Message)		5-2
Alt-R (Select RX Buffer)		5-2
Alt-S (Increment AUTO-BIAS)		5-2
Alt-T (Load Time)		5-2
Alt-U (Clear RX Buffer)		5-2
Alt-V (Clear TX Buffer)		5-2
Alt-W (Delete Word)		5-2
Alt-X (Select TX Buffer)		5-2
Alt-Y (AUTOPOWER ON/OFF)		5-2
Alt-Z (Load MARS Time Group)		5-2

TOPIC	REFERENCE MANUAL	OPERATOR'S MANUAL
Amplitude Tuning Bars		2-3; 3-2; 6-1
Amplitude Shift Modulation	3-6	
Audio Input Circuit	4-6 17	
Audio Output Circuit	4-6 16	
Audio input, radio	2-15	
Audio output, radio	2-13	
Average power, transmitter	2-11	
BPS	3-10	
BPSM	3-7	
BS (Ctrl-H)		5-3
Bandwidth, occupied	3-5; 6-1	
Base modulation rate	3-5	
Baud	3-10	
Bias, ARQ		A-3
Bibliography, CLOVER	3-21	
Block Mode, 1-Way & 2-Way	3-19	6-6
Block length	3-8	
Block waveform	3-13	
Broadcast mode	3-9 11	
Bytes	3-10	
CCIR Emission	3-5; 6-1	
CLOVER Bibliography	3-21	
CLOVER Control Block (CCB)	3-11 12 14 15	
CLOVER waveforms	3-1 9	
COM1, COM2	2-4	
CPS (Characters/Second)	3-10	
CQ, Answering (Ctrl-F9)		5-1; 6-6
CQ, Calling (Alt-F9)		5-1; 6-5
CW ID	2-16; 3-20; 6-1	
CW ID (Configuration)		A-5
CW ID ON/OFF (Alt-I)		5-2
CW ID, Force (Ctrl-F4)		5-1
CW ID, Load (Alt-F4)		5-1
Cable, radio	1-2; 2-7 8	
Call Signs Menu (Configuration)		A-6
Channel Statistics Files	See ADDEN-1	4-6
Channel Statistics	3-11	4-6
Channel, CLOVER	3-1; 6-1	A-5
Char/Line/Word Modes		4-4
Chat Mode	3-19	6-6
Check-sum	3-8	
Clear RX Buffer (Alt-U)		5-2
Clear TX Buffer (Alt-V)		5-2
Clocks	4-3 10	
Coder efficiency	3-8 9	

TOPIC	REFERENCE MANUAL	OPERATOR'S MANUAL
Command Line		3-1 5
Command Mode (F1, Alt-F1, Ctrl-F1)		5-1
Compatibility, HF radio	2-13	
Compatibility, MS-DOS	2-4	
Compatibility, PC BIOS	2-4	
Compatibility, PC hardware	2-4	
Compatibility, PC-AT 386 486	2-4	
Compatibility, PC-XT	2-4	
Compatibility, Serial I/O	2-4	
Compatibility, software	2-5	
Compatibility, video	2-4	
Configuration File		2-5; 4-7
Configuration Screens		2-7; A-1
Configuration, Page 1		2-7; A-2
Configuration, Page 2		2-7; A-6
Configuring PC-CLOVER		2-2 5; A-1
Connect request	3-11 18	
Connections, limits	2-6; 5-1	
Connections, radio	2-6 8; 5-2	
Connector, I/O	2-6 7	
Control Processor	4-1 9	
Control Status Registers	4-4 11	
Control Sub-menu		4-4
Correctable errors per block	3-9	
Crest factor	2-11; 3-5; 6-1	2-4
Ctrl-End		5-3
Ctrl-F1 (Command Mode)		5-1
Ctrl-F2 (Change HISCALL)		5-1
Ctrl-F3 (not assigned)		5-1
Ctrl-F4 (Force CW ID)		5-1
Ctrl-F5 (Program HERE IS #)		5-1
Ctrl-F6 (not assigned)		5-1
Ctrl-F7 (Panic Disconnect)		5-1
Ctrl-F8 (not assigned)		5-1
Ctrl-F9 (Answer ARQ-CQ)		5-1
Ctrl-H (BS)		5-3
Ctrl-Home		5-3
Ctrl-Left-Arrow		5-3
Ctrl-Right-Arrow		5-3
Customer Service	1-3; 5-4 5	1-5
D/A Converter	4-6 16	
DS-3486	1-2	
DSP	4-1 6 15	
DSP RAM	4-6 15	
Data Link Statistics	See ADDEN-1	4-6
Data Rate	3-10	

TOPIC	REFERENCE MANUAL	OPERATOR'S MANUAL
Del		5-3
Delete Line (Alt-K)		5-2
Delete Word (Alt-W)		5-2
Differential modulation	3-5	
Directory		4-7
Disconnect request	3-11 20	
Display Colors Menu (Config.)		A-5
Down-Arrow		5-3
EPROM	4-1 2 9	
ESD	2-1; 5-4	
Echo Enable (Configuration)		A-5
Editor Keys		5-2 3
Editor, Delete Line (Alt-K)		5-2
Editor, Delete Word (Alt-W)		5-2
Editor, Reformat TX Buffer (Alt-F)		5-2
Emission, CLOVER CCIR	2-16; 3-5; 6-1	
End		5-3
End Of Line (Configuration)		A-4
End, Normal (ZZZZ, F7)		5-1; 6-5
End, Panic Disconnect (Ctrl-F7)		5-1
End, Quick Disconnect (Alt-F7)		5-1
Error correction	3-8	
Error detection	3-8	
Esc		5-3
Exit PC-CLOVER		4-7
Expert Key Commands		5-4
F1 (Command Mode)		5-1
F10 (TX Buffer EN/DIS)		5-1
F2 (Load HIS de MY)		5-1
F3 (Load HISCALL)		5-1
F4 (Load MYCALL)		5-1
F5 (Load HERE IS #)		5-1
F6 (not assigned)		5-1
F7 (Normal End)		5-1
F8 (Listen ON/OFF)		5-1
F9 (Start ARQ Link)		5-1
FEC Block time	3-12	
FEC CCB Frame	3-12	
FEC Configuration		A-3
FEC Data Frame	3-12	
FEC Data Throughput	3-12 13	
FEC Frame time	3-12	
FEC Mode	3-12 13	6-7
FEC Sub-menu		4-3
FEC Waveforms	3-12	6-7
FEC, Sending		6-8

TOPIC	REFERENCE MANUAL	OPERATOR'S MANUAL
FSK Transmitter Mode	2-9 13	
FSM	3-7	
Factory repair	5-5	
File, READ.ME	2-3	
Files Sub-menu		4-5
Files, Channel Statistics	See ADDEN-1	4-6
Files, Configuration	2-3	2-5; 4-7; A-1
Files, Continuous Save		4-6
Files, Directory		4-7
Files, Load TX Buffer (Menu)		4-5
Files, Load TX Buffer (Alt-L)		5-2
Files, Receive Buffer Block Save		4-6
Files, Save To Disk Menu)		4-6
Files, Save To Disk (Alt-E)		5-2
Files, Send From Disk		4-6
Files, Sequential Save		4-6
Files, Stop Send/Save (Menu)		4-6
Files, Stop Send/Save (Alt-J)		5-2
Files, Transmit Buffer Block Save		4-6
Files, download	2-3	
Floppy disk drives	2-2	
Floppy-disk install	2-2	
Forward Error Correction	3-9 11	
Frequency Shift Modulation	3-7	
Frequency Tuning Bar		3-2; 6-1
Frequency accuracy, radio	2-12 13	
Frequency domian	3-1	
Frequency scan control	2-10	
Frequency stability, radio	2-12 13	
Function Keys		5-1
Grounding	2-6; 5-2	
HELP Screens (Alt-H)		5-2
HERE IS Messages		2-7 9
HERE IS Program, Menu (Config.)		A-6
HERE IS, End Programming (Alt-C)		5-2
HERE IS, Load (F5)		5-1
HERE IS, Program (Ctrl-F5)		5-1
HF Radio compatibility	2-12	
HIS de MY (F2)		5-1
HISCALL		4-2 5; 6-3
HISCALL, Load (F3)		5-1
HISCALL, Program (Ctrl-F2)		5-1
Hard disk drives	2-2	
Hard-disk install	2-2	
Hardware problems	5-1	
Home		5-3

TOPIC	REFERENCE MANUAL	OPERATOR'S MANUAL
I/O connections	2-6	
In Case of Difficulty Information Line	5-1	7-1 3-1 5
Ins		5-3
Inspection		1-2
Install, PC	2-1	
Install, PCI-4000	2-1	
Install, software	2-2	2-1
Keys and Commands		5-1
Keys, Edit		5-2 3
Keys, Expert		5-4
Keys, Function		5-1
Keys, Special		5-3
LPT1	2-4	
LSB radio mode	2-11 13	
Left-Arrow		5-3 4
Line printer, PC	2-4	
Line/Word/Char Modes		4-4
Listen (Configuration P. 1)		A-4
Listen Mode	3-20	6-9
Listen ON/OFF (F8)		5-1
Listen Sub-menu		4-3
Load File Into TX Buffer (Alt-L)		5-2
Load File Into TX Buffer (Menu)		4-5
MARS Date-Time-Group (Alt-Z)		5-2
MYCALL	3-11	2-5; 4-5; A-1
MYCALL, Load (F4)		5-1
MYCALL, Program (Alt-M)		5-2
Main Menu		4-1
Maintenance, preventative	5-4	
Manuals	1-1	1-1
Manuals, Up-date	1-3	1-3
Memory	4-2 9 15	
Memory Address Map	4-2	
Menu		4-1
Menu Tree		3-6 7
Menu, ARQ		4-1
Menu, ARQ Format		4-2; 6-3
Menu, ARQ Manual Waveform		4-2
Menu, Call Signs (Configuration)		A-6
Menu, Configuration		2-7; A-1
Menu, Control		4-4
Menu, Display Colors (Config.)		A-5
Menu, FEC		4-3
Menu, Files		4-5
Menu, HELP (Alt-H)		5-2
Menu, HISCALL		4-2; 6-3

TOPIC	REFERENCE MANUAL	OPERATOR'S MANUAL
Menu, Listen		4-3
Menu, Main		4-1
Menu, Messages		4-5
Menu, Mode		4-1; 6-2
Menu, Program HERE IS (Config.)		A-6
Menu, Program HISCALL (Config.)		A-7
Menu, System (Configuration)		A-4
Menu, Test		4-4
Menu, Versions (Configuration)		A-6
Messages Sub-menu		4-5
Messages, Programmable Microprocessor, 68EC000	4-1 9	2-6; 4-5
Mode Sub-menu		4-1; 6-2
Modulation modes	3-7; 6-1	
Modulation, 16P4A	3-7	
Modulation, 16PSM	3-7	
Modulation, 2ASM	3-6	
Modulation, 2DFSM	3-7	
Modulation, 2DPSM	3-7	
Modulation, 4ASM	3-6	
Modulation, 4DPSM	3-7	
Modulation, 8P2A	3-7	
Modulation, 8PSM	3-7	
Modulation, data	3-5; 6-1	
Modulator output level	2-9 12; 5-1	
Modulator output range	2-9 12; 5-1	
Monitoring CLOVER signals	3-20	
Multi-format modulation	3-6	
Multi-level modulation	3-6	
Multi-path distortion	3-5	
Noise blanker, receiver	2-14	
One-Way Block Mode	3-19	6-6
Operating PC-CLOVER		6-1
Overhead	3-10	
PC Bus FIFO	4-4 12	
PC Bus Interface	4-3 11	
PC I/O Address	2-5; 4-3; 5-1; A-1	
PC I/O Interrupt	5-1; A-1	
PC Installation	2-1	
PC Pre-install test	2-1	
PC compatibility	2-4	1-4
PC slot length	2-4	
PC-CLOVER	1-1	All
PC-CLOVER, loading	2-2	2-1

TOPIC	REFERENCE MANUAL	OPERATOR'S MANUAL
PCI-3000, operation with PCI-4000	2-5; A-1 All	
PCI-4000 Install	2-1	
PCI-4000 Options	1-2; 4-7	
PCI-4000 power requirements	2-6; 4-7	
PTT Output Register	4-5 14	
PTT Verification		2-3
PTT, PCI-4000	2-6 10; 4-5 14; 6-1	
Panic Disconnect (Ctrl-F7)		5-1; 6-5
Peak power, transmitter	2-11	
PgDn		5-3
PgUp		5-3
Phase Shift Modulation (PSM)	3-5	
Phase jitter	3-6	
Phase linearity, radio	2-13	
Power requirements	2-5	
Printer Default (Configuration)		A-5
Printer ON/OFF (Alt-P)		5-2
Program HISCALL Menu (Config.)		A-7
Protocols	3-11	
QBF Message, Load (Alt-Q)		5-2
QPSM	3-7	
Quick Disconnect (Alt-F7)		5-1; 6-5
RAM	4-1 9	
RX Buffer		3-1 3
RX Buffer Clear (Alt-U)		5-2
RX Buffer Select (Alt-R)		5-2
RX/TX Status Table		3-1 2
Radio Frequency Interference	5-2	
Receive Audio Verification		2-2
Receiver Audio Gain	2-15	
Receiver Buffer Block Save		4-6
Receiver adjustments	2-13	
Record Channel Statistics		4-6
Reed-Solomon block length	3-8	
Reed-Solomon code	3-8; 6-1	
Reed-Solomon code efficiency	3-8	
Reformat TX Buffer (Alt-F)		5-2
Repeat request	3-11	
Reports		4-4
Retry, ARQ		A-4
Return authorization	5-5	7-2
Returning equipment	5-5	7-2
Right-Arrow		5-3 4
Robust waveform	3-18	
Run, PC-CLOVER	2-2	
Rush service	5-5	

TOPIC	REFERENCE MANUAL	OPERATOR'S MANUAL
SEL-CAL, PCI-4000	2-6 10; 6-1	
SELCAL Output Register	4-5 14	
SPT-1	1-2; 2-17; 4-7	
Save To Disk (Menu)		4-6
Save To Disk (Alt-E)		5-2
Save To Disk Sequential		4-6
Save to Disk Continuous		4-6
Scan Control (Configuration)		A-5
Scan control	2-10	
Screen, Main		3-1
Screen, RX Buffer (Alt-R)		5-2
Screen, TX Buffer (Alt-X)		5-2
Send From Disk		4-6
Service, user	5-4	
Shell programs	2-5	1-5
Shift-PrtSc	5-3	
Software compatibility	2-5; 5-1	1-4
Software problems	5-2	1-4; 7-1
Software, 3rd Party	1-3; 2-6	1-1
Software, APLink	2-6	1-5
Software, PC-CLOVER	1-1 3	All
Software, TSR	2-5	1-5
Software, Up-date	1-3	1-5
Software, files	2-3	2-1
Software, loading	2-2	2-1
Software, shell	2-5	1-5
Software, window	2-5	1-5
Special Keys		5-3
Specifications	6-1	
Spectra, CLOVER	3-1 4; 6-1	
Spectral efficiency	3-5	
Start ARQ Link (F9)		5-1
Static Electricity	2-1	
Statistics, Data Link	See ADDEN-1	4-6
Status Line		3-1 4
Status Registers	4-4 11	
Stop File Send/Save (Alt-J)		5-2
Stop Send/Save (Menu)		4-6
Symbol rate	3-5 10	
System Menu (Configuration)		A-4
TECH-LINE BBS	1-3; 2-4; 5-4	1-5; 7-2
TSR software	2-5	
TX Buffer		3-1 5
TX Buffer Clear (Alt-V)		5-2
TX Buffer Control (Configuration)		A-5
TX Buffer EN/DIS (F10)		4-4; 5-1

TOPIC	REFERENCE MANUAL	OPERATOR'S MANUAL
Technical Description	4-1	
Technical Problems	5-1	
Test Mode (Alt-O)		5-2; 6-9
Test Sub-menu		4-4
Test, Four Tone		4-4
Test, Single Tone		4-4
Text Entry Mode (Configuration)		A-4
Throughput	3-10 13 17	
Time (Alt-T)		5-2
Time Zone (Configuration)		A-4
Time and Date (Alt-B)		5-2
Time domain	3-1	
Tone pulse	3-1; 6-1	
Tone pulse sequence	3-1 2	
Transceiver adjustments	2-11	2-3
Transmit Audio Verification		2-3
Transmit Buffer Block Save		4-6
Transmitted bytes per block	3-9	
Transmitter Mic. Gain	2-11	2-3
Transmitter adjustments	2-11	2-3 4
Tune Screens (Alt-A)		5-2; 6-1
Tuning A Signal		6-1
Tuning Bar, Frequency		3-2; 6-1
Tuning Bars, Amplitude		2-3; 3-1; 6-1
Tuning increments, radio	2-12	
Tuning indicators	2-16	2-3; 3-1; 6-1
Two-Way Block Mode	3-19	6-6
USB radio mode	2-13	
UTC Offset (Configuration)		A-4
Unpacking	1-2	
Up-Arrow		5-3
User-set Options	5-1	
User Information	5-4	7-2
User adjustment & alignment	5-1	
User service	5-4	1-5; 7-1
Versions Menu (Configuration)		A-6
Video types	2-4	
Warranty	W-1	
Waveform	3-1 13	
Window software	2-5	1-5
Word/Char/Line Modes		4-4
ZZZZ End (F7)		5-1; 6-5

ADDENDA

DATA LINK STATISTICS

PCI-4000 / CLOVER-II
ADDENDUM 1

1 October 1993

Data link statistics may be displayed on the PC-CLOVER screen (TX/RX Status) and saved to disk (Record Channel Statistics). These numbers reflect measured received signal quality statistics, current operating parameters, and measured data transmission performance. The screen display provides information about the current operating status of CLOVER. The statistics files may be used to gain knowledge about CLOVER operation and ionosphere conditions. The choice of how parameters are displayed or recorded is still "experimental". The screen status field and statistics file format have changed several times during development - and will probably change again as we all gain operating experience with CLOVER. Therefore we have elected to discuss these details in this "Addendum" rather than in either of the manuals. New sections will be added to one or both manuals at a later date.

1. Channel Statistics

The CLOVER ARQ protocol is adaptive - it adjusts the transmitted waveform to match existing propagation conditions. Signal parameters are measured on each received data transmission. Receive signal quality is analyzed and used to determine CLOVER transmit waveform parameters that most closely match measured conditions. The receiving station then relays new mode information to the transmitting station which it uses during the next data transmission. Independent measurement, analysis, and control is provided for each direction of the ARQ link - my received parameters set your transmit waveform and your receive conditions set my transmit waveform. Modes for each direction are determined independently and do not have to be the same.

The key channel parameters are:

- A. Measured Receive Signal Parameters:
 - 1. Frequency Offset (FRQ)
 - 2. Signal-To-Noise Ratio (SNR)
 - 3. Phase Dispersion (PHS)

- B. Controlled Transmit Signal Parameters:
 - 1. Transmit Modulation Waveform (MOD)
 - 2. Transmit Power Level (TPR; with Auto-Power ON)

- C. Link Performance Parameters:
 - 1. Actual Data Throughput (TX & RX Rate)
 - 2. Error Corrector Loading (ECC)

1.1 Measured Receive Signal Parameters

Frequency offset, signal-to-noise ratio, and phase dispersion are measured during reception of data blocks and CLOVER Control Blocks (CCB's). These parameters are used to set operating modes of CLOVER.

1.1.1 Frequency Offset (FRQ)

The frequency offset measurement determines the error between the transmitted signal frequency and the current receiver frequency. A positive frequency offset indicates that the receiver is tuned higher in frequency than optimum - the dial reading should be decreased to achieve correct tuning. CLOVER software will track tuning errors and equipment drift up to ± 30 Hz, but optimum performance can be maintained only when the frequency offset is within ± 10 Hz of the correct frequency. The higher modulation level modes (e.g., 16PSM and 16P4A) may not work correctly with frequency offsets that exceed ± 10 Hz. Frequency offset is measured and displayed in increments of 1 Hz.

1.1.2 Signal-To-Noise Ratio (SNR)

The Signal-To-Noise Ratio (SNR; S/N) is measured at the detector within the CLOVER receive demodulator. CLOVER uses matched DSP filters to detect each of the four tone pulses. Since the SNR measurement bandwidth in CLOVER is much less than the receiver output, SNR numbers reported by CLOVER are correspondingly higher than the S/N measured at the receiver audio output. The receive noise amplitude is measured during the no-signal "gaps" between each data block (see Reference Manual, Figure 3.6). Signal amplitudes are measured during data transmissions. The CLOVER SNR measurement is therefore dynamic and relatively unaffected by receiver AGC response. SNR is displayed and recorded to disk in increments of 1 dB. High SNR numbers indicate "good" conditions and low numbers "poor" conditions.

1.1.3 Phase Dispersion (PHS)

Frequency errors are measured, reported, and the offset value is used as a reference to determine phase fluctuations on each of the four tone pulses in the CLOVER Tone Pulse Sequence (see Chapter 3 and Figures 3.1 and 3.2 of the Reference Manual). The cumulative phase variation over the four pulses is then used to compute Phase Dispersion (PHS) using the following formula:

$$\text{PHS (Phase Dispersion)} = 10[\log_2(\text{phase var})] + K$$

Cumulative phase variations are measured in increments of $360/256$ (1.4063) degrees or "hexians" (256ths of a circle). The system constant "K" calibrates the measurement so that "PHS = 00" corresponds to "zero" phase dispersion (wire-line between transmitter and receiver). Reported PHS numbers are therefore low for "good" conditions and high for "poor" conditions.

1.2 Controlled Transmit Signal Parameters

Measurements of FRQ, SNR, and PHS are used to set the transmitting waveform (MOD) and to adjust transmitter power (TPR) when AUTO-POWER is turned ON.

1.2.1 Transmit Modulation Control

The transmit modulation format used in adaptive ARQ mode is set by parameters measured at the receiving station - my received data controls your transmitter mode. Experience has shown that Phase Dispersion (PHS) measurements provide the most sensitive indicator of modulation effectiveness. The high-order modes ("fast modes") require that PHS have low values. Each time PHS numbers increase by 10, Phase Dispersion has double. This approximately corresponds to a requirement to decrease the modulation format one mode (16P4A to 16PSM, for example). This is further conditioned by the ARQ Bias chosen, Signal-To-Noise (SNR) variability, and the performance of the Error Corrector (ECC).

1.2.2 Transmit Power Control

When multiple-path propagation ("multipath") is not dominant, SNR and PHS tend to vary in inverse proportion - an increase in SNR corresponds to a similar decrease in PHS. However, when distortion due to multipath propagation is present, PHS is much more variable than SNR. Multipath is often typified by high SNR and high phase dispersion - increasing the transmitter power to produce higher received SNR will not improve reception. In this case, the data modulation form and therefore data throughput is limited by the large amounts of phase dispersion. Under these conditions, CLOVER uses PHS to determine a suitable transmit modulation waveform *and* computes a value of "excess SNR" in dB. When the transmitter "AUTO-POWER" feature is turned ON, the receiving modem then instructs the transmitter to reduce its power by the amount of "excess SNR" minus a 13 dB "safety margin" factor. The AUTO-POWER algorithm also includes rapid return to full power when received SNR changes radically (such as when the receiver is suddenly inundated by noise or interference).

1.3 Link Performance Parameters

The CLOVER modem computes two important link performance parameters - data throughput and error corrector loading. These are dynamic numbers, recomputed for each ARQ frame received.

1.3.1 Data Throughput

The center status line of PC-CLOVER includes two fields that show data throughput - "Txxx" for transmit data and "Rxxx" for received data. These values are also stored in the disk file as the "RATE" parameter for both "MYCALL" and "HISCALL". Data throughput is computed in bytes-per-second (*byps*) as data is received. The computation is based on output receive data from the modem and includes compensation for ARQ overhead and repeated data blocks. Throughput calculations do *not* make a distinction between "real data" and null characters that may result when the CLOVER modem transmit rate is higher than the rate at which data is supplied by the PC application.

1.3.2 Error Corrector Loading (ECC)

CLOVER uses the Reed-Solomon error correction algorithm for all transmissions. In ARQ mode, the block size is always 255 bytes. The BIAS command may be used to choose three different coder "rates" or "efficiencies" - 60%, 75%, and 90% (Robust, Normal, and Fast bias, respectively). Table 3.3 of the REFERENCE MANUAL shows how many byte errors may be corrected in each data block for the three "efficiencies" - 50 errors @60% (Robust), 31 errors @75% (Normal), or 12 errors @90% (Fast). The "ECC" numbers in the TX/RX status table on the tuning screen and in the disk file show the "percentage" of the total corrector capacity that is used to receive each data block. "ECC" may therefore be thought of a measurement of the "loading" or use of the error corrector. "ECC" may vary over the range of "00" (0%, no errors) to "100" (100%, full capacity of the corrector). In addition, "XX" is displayed whenever the number of byte errors exceeds the corrector's capacity. In this case, the data block must be retransmitted.

The number of flawed bytes per transmission is simply the product of ECC (in percent) times the error corrector capacity for the chosen bias (50 bytes for Robust, 31 bytes for Normal, and 12 bytes for Fast). The measurement increment of ECC therefore varies with the Bias selected (2% per byte error in Robust, 3.2% per byte error in Normal, and 8.33% per byte error in Fast bias).

2. HIS and MY Data Reports

The PC-CLOVER screen display and the statistics disk file provide data reports for both stations, "MY" and "HIS". In addition, the current and previous readings of MY and HIS signals are shown on the screen (current data is on lower line in both cases). The disk file records each data measurement provided by the modem for each station. In FEC mode, only received data from HIS station is displayed or recorded.

As may be noted from the previous discussion, practically all data analysis is done by the receive demodulator. The receiver examines channel statistics, chooses the appropriate transmit parameters for the other station, and then measures link performance. Therefore, data about HIS signal will be reported as it is measured at MY station. However, analysis of MY signal is done by HIS receiver. This data must be relayed back to MY station before it can be displayed or recorded. As may be seen in the CCB task list in section 3.3.1 of the REFERENCE MANUAL, "Exchange Channel Statistics" (item "h") is just one of the tasks assigned to the CCB. There are, in fact a lot of other tasks that must also be done by the CCB and which have a *higher priority*. If you are using "Chat Mode" or one-way ARQ and sending "back-channel" text, relay of MY statistics will be suppressed. Therefore, there is a high probability that "MY" channel statistics may not be updated as frequently as "HIS" statistics. Since only current data is passed when the CCB is available for HIS statistics reports, each new HIS data update will be current, if infrequent.

Under some conditions, activity by the PC-based application software may also produce delays in statistics reporting. All communications to and from the PCI-4000 modem board is made via hardware FIFO (First-In/First-Out) buffers. These buffers allow the PC to use multi-tasking and other time-division software techniques without losing transmit or receive data. However, receive data *and* channel statistics must be passed from the PCI-4000 to the PC via the PCI-4000 Output Data FIFO. If the PC program reads the FIFO slower than the CLOVER mode data rate, data and channel statistics will accumulate in the FIFO. Eventually, all received data will be passed to the PC without loss, but the statistics will be temporarily lost until the PC software catches-up with the PCI-4000. When MY status reports resume on the display or in the disk file, they will reflect current conditions. Screen

intensive operations of PC-CLOVER such as scrolling the transmit or receive screen buffer may cause this to temporarily occur. The delay induced is generally minor. A more serious delay may occur when multi-tasking PC software is used in a "slow" PC (e.g., "Windows in a PC-286). The solution is to either use a faster PC or not use multi-tasking software.

3. PC-CLOVER TX/TX Status Screens

PC-CLOVER includes two tuning and status report screen formats, one which shows Amplitude Tuning bars and the other which shows a Frequency Tuning Bar. Both tuning screens show a TX/RX data table in the upper right corner of the screen. These numbers and the "Txxx" and "Rxxx" numbers on the center status line are the CLOVER Data Link Statistics. Typical Tuning and Status screens are shown in Figure 1.

The table is organized in 4 horizontal rows with six columns for each row. The lower HIS and lower MY rows show data for the most recently received data. The upper HIS and MY rows show data for the previously received data frame. All four rows show active data when in ARQ mode. In FEC mode, only HIS data is shown when receiving an FEC transmission.

The MOD (Modulation) column shows the data block modulation mode used during the reported transmission. In ARQ mode, the modulation may be BPSM, QPSM, 8PSM, 8P2A, 16PSM, or 16P4A when data has been sent in ARQ Multi-block format. When "Chat" mode or the "back-channel" of ARQ is used, the CCB waveform (BPSM) will be reported. CCB parameters are not reported on multi-block ARQ transmissions. When FEC transmissions are received, the transmitter data block waveform will be reported (2DPSM, BPSM, QPSM, 8PSM, 16PSM, or 16P4A).

The SNR column reports the received Signal-To-Noise Ratio at the PCI-4000 demodulator in 1 dB increments. A "perfect" signal (wire-line direct connection) will show a SNR in the range of 50-60 dB. As noted previously, the SNR value is measured after processing by the demodulator's narrow bandwidth matched filters. Since this bandwidth is much less than that of the receiver, noise power ("N") is much less and CLOVER's S/N is much higher than might be measured at the receiver's audio output. A SNR value of "13 dB" corresponds to a receiver S/N that is less than "zero dB" (noise stronger than signal).

The FRQ column reports the frequency offset between the two stations in increments of 1 Hz. FRQ has a maximum value of approximately ± 37 Hz. Tuning must be within ± 30 Hz for CLOVER reception to synchronize and within ± 10 Hz for optimum performance. Mismatching and frequency drift may be determined from this data. The most recently processed FRQ data is also used to up-date the Frequency Tuning Bar when this screen is selected.

The PHS column reports the amount of Phase Dispersion as defined in section 1.1.3. Low PHS numbers indicate good or at least stable propagation conditions. High PHS numbers are typical of unstable conditions - disturbed ionosphere and/or multi-path interference. PHS numbers below 20 usually indicate "good" conditions which permit use of high data rate modes. PHS numbers that exceed 50 indicate disturbed conditions which will usually limit CLOVER to the more robust modes.

The ECC columns shows the Error Corrector performance as explained in section 1.3.2. Low numbers in this column are typical of good and stable propagation conditions. High and widely varying ECC numbers will be noticed during disturbed conditions and when intermittent interference and/or noise is present.

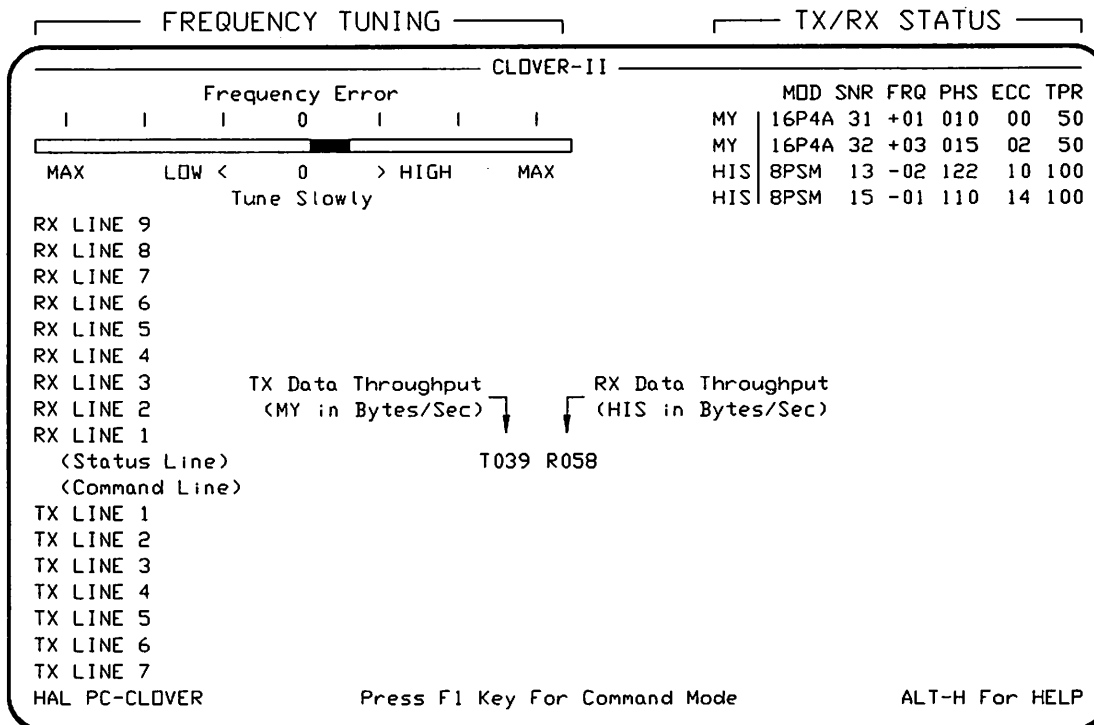
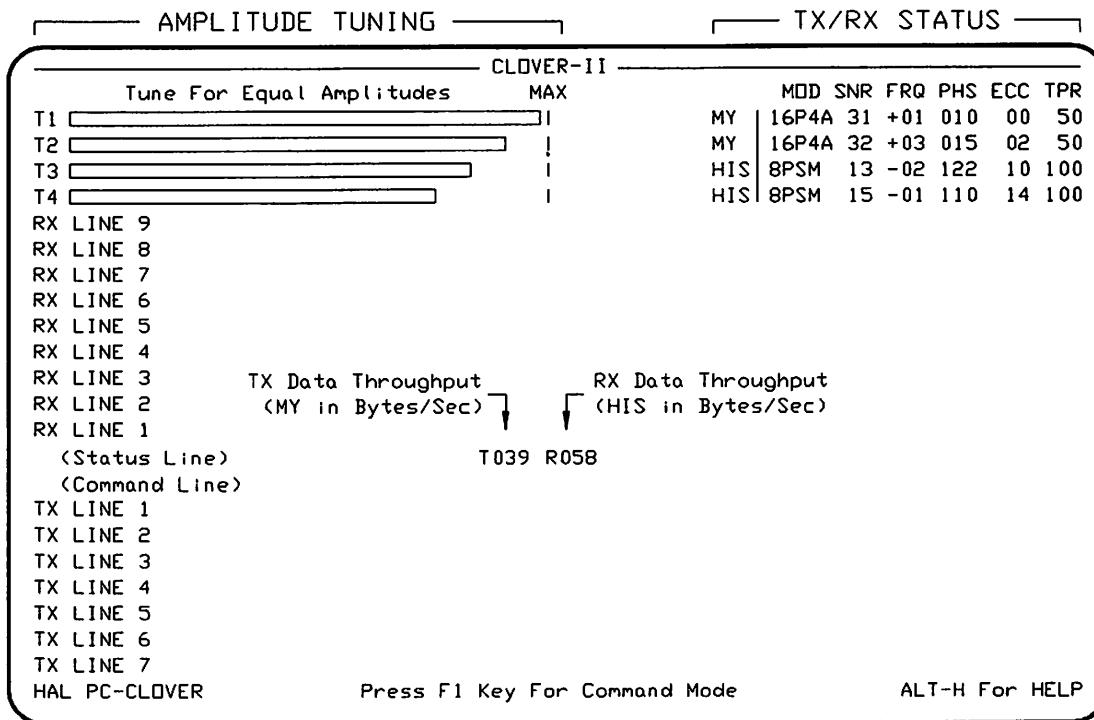

Figure ADD1.1 PC-CLOVER Tuning and Status Screens

The TPR column shows the percentage of maximum transmitter power in use. Unless AUTO-POWER is enabled, this column will always show "100%" for both stations. When AUTO-POWER is turned ON, TPR indicates the percentage of the maximum power that is used. As discussed in section 1.2.2, the CLOVER modem continuously computes the amount of "excess transmitter power" that is received. When AUTO-POWER is enabled, transmitter power is frequently reduced to 10% or less of its maximum value (to 10 Watts or less).

Transmitted and Received data throughput values are shown near the middle of the PC-CLOVER Status Line. These are the actual bytes-per-second data throughput of the system measured for each data frame. The throughput calculations include compensation for protocol overhead and repeated data blocks in ARQ mode. The throughput may vary from as low as 2 bytes-per-second (byps) when "Chat" ARQ mode is used to as high as 70 byps when 16P4A modulation is used with Fast bias. The current implementation of CLOVER and PC-CLOVER sends 8-bit bytes for each ASCII character sent; character-per-second (cps) and bytes-per-second (byps) values are the same. Data compression may be added at a later date, increasing the character-per-second throughput of CLOVER. If the "Huffman algorithm" used in PACTOR is applied to CLOVER, the average compression gain is 1.6:1 and the throughput of CLOVER would vary from 3 to 112 characters-per-second.

In comparison, AMTOR sends data in a 5-bit data format at a maximum rate of 6.67 characters-per-second (no repeats). Recent modifications have extended the AMTOR character set to include lower case letters and all ASCII printed symbols. Modified AMTOR is therefore now equivalent to sending the *printable* set of ASCII characters (but not control characters). PACTOR and packet radio send most characters of the 7-bit ASCII character set, less some control characters. PACTOR sends data at approximately 7 to 16 bytes-per-second (100 or 200 baud). When Huffman compression is used, PACTOR throughput may be in the range of 11 to 25 characters-per-second. HF packet radio using 300 baud FSK modulation may send at a rate as high as 20 bytes-per-second, but typical HF performance is more in the range of 5 to 10 bytes-per-second due to modulation and protocol limitations.

4. Statistics Data Files

PC-CLOVER also includes the capability of recording channel statistics information in a PC data file. The data may then later be used to study link performance and propagation conditions. The file is specifically formatted so that it may be imported into one of the standard Lotus™ spreadsheet programs. The spreadsheet program may then be used to sort and scale the data as desired.

4.1 Data File Format

The following format is used for all data statistics files:

File Name: MMDDHHmm.TST
 where: MM = month (01 = January to 12 = December)
 DD = day (00 - 31)
 HH = start hour (00 - 23)
 mm = start minute (00 - 59)
 TST = all test data files

The PC's internal clock and calendar are used to determine the file name and the time for each data record.

User Entry Field: Each time a data file is opened, the user is prompted to enter text into three data fields:

FREQ = [] (6 character field; ex: 14.098, 07.092)
 NAME = [] (16 character field)
 OTHER = [] (16 character field)

The "OTHER" field may be parameters of your choosing. Suggested data are: time zone, "A" index (Axxx), "K" index (Ky), etc.

Data recording begins when the user entry fields are entered and continues until the Stop "Files Send/Save" PC-CLOVER option is used. Data is always recorded as ASCII characters in the following file format using commas as field delimiters and [cr][lf] (carriage return and line feed) as the record delimiter:

```
[FREQ],[NAME],[OTHER][cr][lf]
[time],[my/his],[mod],[bias],[rate],[snr],[frq],[phs],[ecc],[tpr][cr][lf]
[time],[my/his],[mod],[bias],[rate],[snr],[frq],[phs],[ecc],[tpr][cr][lf]
[time],[my/his],[mod],[bias],[rate],[snr],[frq],[phs],[ecc],[tpr][cr][lf]
[time],[my/his],[mod],[bias],[rate],[snr],[frq],[phs],[ecc],[tpr][cr][lf]
etc.
```

The field dimensions are:

```
[6],[16],[16][cr][lf]
[6],[8],[6],[1],[2],[3],[4],[3],[3],[3][cr][lf]
[6],[8],[6],[1],[2],[3],[4],[3],[3],[3][cr][lf]
[6],[8],[6],[1],[2],[3],[4],[3],[3],[3][cr][lf]
[6],[8],[6],[1],[2],[3],[4],[3],[3],[3][cr][lf]
etc.
```

The data fields have the following meaning and ranges:

time = HHmmss = HH hours, mm minutes, ss seconds
 my = MYCALL [8 characters max]
 his = HISCALL [8 characters max]
 mod = Modulation (2DPSM, BPSM, QPSM, 8PSM, 8P2A, 16PSM, 16P4A)
 bias = 1 (Robust), 2 (Normal), 3 (Fast), or 0 (FEC receive)
 rate = Throughput in bytes-per-second; 00 - 99
 snr = Signal-To-Noise Ratio; 0 - 99 (dB)
 frq = Frequency Offset; \pm 30 (Hz)
 phs = Phase Dispersion; 000 - 256
 ecc = Error Correction Capability; 00 to 100 & XX
 tpr = Transmitter Power; 00 to 100 (%)

4.2 Typical Data File Recordings

A typical ARQ Mode data file might appear as follows:

```
14.090,G. Henry      ,CST A008 K2 T#16[cr][lf]
191132,K9GWT      ,16P4A,2,59,030,-010,010,050,075[cr][lf]
191152,W7GHM      ,8PSM ,2,29,020, 010,035,025,090[cr][lf]
191218,K9GWT      ,16P4A,2,59,030,-010,010,000,075[cr][lf]
191238,W7GHM      ,8PSM ,2,21,020, 010,038,075,090[cr][lf]
191258,K9GWT      ,16P4A,2,59,030,-009,012,000,075[cr][lf]
191317,W7GHM      ,8PSM ,2,26,020, 009,025,000,090[cr][lf]
etc.
```

In FEC, MYCALL reports are deleted, bias is "0" (FEC), and TPR is always "100" (maximum power). A typical FEC recording might be:

```
21.098,G. Henry      ,CST A017 K3 T#33[cr][lf]
090116,WA9YLB/5,QPSM ,0,20,015,-010,030,000,100[cr][lf]
090145,WA9YLB/5,QPSM ,0,20,018,-005,040,025,100[cr][lf]
090214,WA9YLB/5,QPSM ,0,20,016, 000,035,050,100[cr][lf]
090243,WA9YLB/5,QPSM ,0,20,020, 005,020,000,100[cr][lf]
etc.
```

4.3 Use of Data Files

The data file is formatted to be compatible with the "comma" file import mode available in most spreadsheet programs. This will conveniently place each data field in a separate column and each time data record in sequential rows of the spreadsheet. The "comma" format preserves the mixed alphanumeric and numerical format of the various fields - with one possible exception. Some spreadsheets interpret "-020" type numbers in the FRQ column as alphanumeric text rather than as negative numbers. If this occurs, the FRQ column may have to be reformatted after the file is loaded.

Note that data is recorded as it is generated in the ARQ system and that therefore ARQ data for MYCALL and HISCALL stations are interleaved. It may therefore be desirable to sort the data after it is loaded into the spreadsheet. Sort the entire data field of the spreadsheet using the call sign column as the primary sort key and the time as the secondary key (sort both in ascending order). FEC receive data files will not require sorting since they contain only records of the received signal (HISCALL).

Second, it may be desirable to convert the mixed "HHmmss" time format into elapsed time in minutes or seconds. Various spreadsheet formulas are available to make this conversion.

The data may then be left in tabular form or used to make a wide variety of graphs. A particularly interesting graph may be made by plotting throughput (RATE), Signal-To-Noise (SNR), and Phase Dispersion (PHS) vs time for data collected while receiving large blocks of data sent using adaptive ARQ (AUTO-ARQ). As SNR and PHS change with propagation conditions, CLOVER will dynamically adjust the throughput rate. The CLOVER ARQ link therefore serves as both a data transfer protocol and an oblique-incidence path sounder.

4.4 Practical Precautions

Data recording is a fascinating additional feature of the PCI-4000 and much insight may be gained by studying the results. However, it is also relatively easy to overwhelm your PC and especially a spreadsheet program with a large amount of data. For example, data recorded during a 2 hour ARQ link produced a 160,000 byte data file. When this file was loaded into 1-2-3sm, sorted, scaled, and formatted for plotting, the spreadsheet had grown into a 1.6 megabyte file (over 3000 rows!). We suggest that you start by recording a few short 5-10 minute runs and perfect your data processing techniques on relatively short files before exploring long-term phenomena.

It is also useful to recall that the CLOVER *receiver* does all data processing and that data for HIS signal at MY station will be more timely than data for MY signal recorded at HIS station and then relayed via "spare-time" during CCB's. Run of thumb: "HIS" data will always be more timely than "MY" data.

In addition, recall that CLOVER ARQ mode adjusts to the volume of pending transmit text. CLOVER ARQ does not transition into block mode and does use high-rate modulation forms unless a large volume of data is sent (prebuffer contents greater than 80 characters). Therefore, if you wish to record maximum throughput as a function of time, SNR, and PHS, the best arrangement is to have HIS station send large files to MY station and record data at MY station.

Conversely, if only SNR and PHS and not throughput are of interest, A CLOVER ARQ link works very well as a bidirectional oblique incidence sounder. In this case, select Manual ARQ mode, BPSM modulation, and do not send data from either station. Both stations will then exchange only CCB's that contain signal statistics data.

4.5 Typical Data Recordings.

The following graphs present data recorded using an early version of the statistics file save feature. In these recordings, CLOVER computation of throughput had not been installed and throughput was estimated from the modulation mode selected by AUTO-ARQ using values from Figure 3.6 in the REFERENCE MANUAL (eg, 16P4A = 57.9, 8PSM = 28.9, etc.). However, several interesting traits may be observed from this primitive data.

10/27/92 Data Graphs

This is a 15 minute ARQ link at 18.109 MHz, very close to the "MUF" (Maximum Usable Frequency). Signals at the start of the link were moderately strong and reasonably high throughput rates were possible. As time passed, receive conditions at W7GHM ("AKOX to W7GHM") deteriorated and the band "closed" to him 14 minutes into the link. Note that Adaptive ARQ quickly compensated for variations in S/N (dashed curve) and Phase Dispersion (dotted curve). Data for both directions was recorded at W7GHM. Data from AKOX to W7GHM (HIS data) shows considerably more "fine structure" than W7GHM to AKOX data since MY data had to be relayed back to W7GHM via CCB when time permitted.

11/03/92 Data Graphs

These four graphs show a continuous 2 hour Adaptive ARQ link during late morning hours of November 3rd operating on 14.083 MHz. Next to the highest throughput (38.6 byps, 16PSM or 8P2A) was maintained for most of the link in both directions - about 6 times faster than AMTOR's top throughput (6.67 cps). The highest rate (16P4A, 57.9 byps) was used several times on the AKOX to W7GHM path and for extended periods on the W7GHM to AKOX path. S/N and phase dispersion data were not available for this run. This data was recorded at AKOX but the difference in data reporting frequency ("fine structure") is not apparent due to the longer time frame of the graphs and the lack of SNR and PHS data.

11/04/92 Data Graphs

This is nighttime data at 7.083 MHz - a typical "multipath" situation. At the W7GHM receiver, phase dispersion was high, signals weak, and the adaptively selected throughput is lower than in previous graphs. BUT - CLOVER-II consistently passed data over the 900 mile path from AKOX to W7GHM at rates between 10 and 20 bytes-per-second - about 1.5 to 3 times the character rate of AMTOR. Note that the path from W7GHM to AKOX had lower phase dispersion, higher S/N, and higher throughput; propagation conditions were NOT symmetrical. CLOVER adaptive control functions independently for each direction, easily compensating for asymmetrical conditions. This data was recorded at W7GHM and, like the 10/27/92 example, shows the difference in reporting frequency between HIS data (AKOX measured at W7GHM) and MY data (W7GHM measured at AKOX, relayed back to W7GHM).

HAL welcomes all data reports and graphs you may wish to record. Please use the HAL TECHLINE BBS @ (217) 367-5547 for all communications.

Lotus[™] and 1-2-3[™] are trademarks of the Lotus Development Corporation

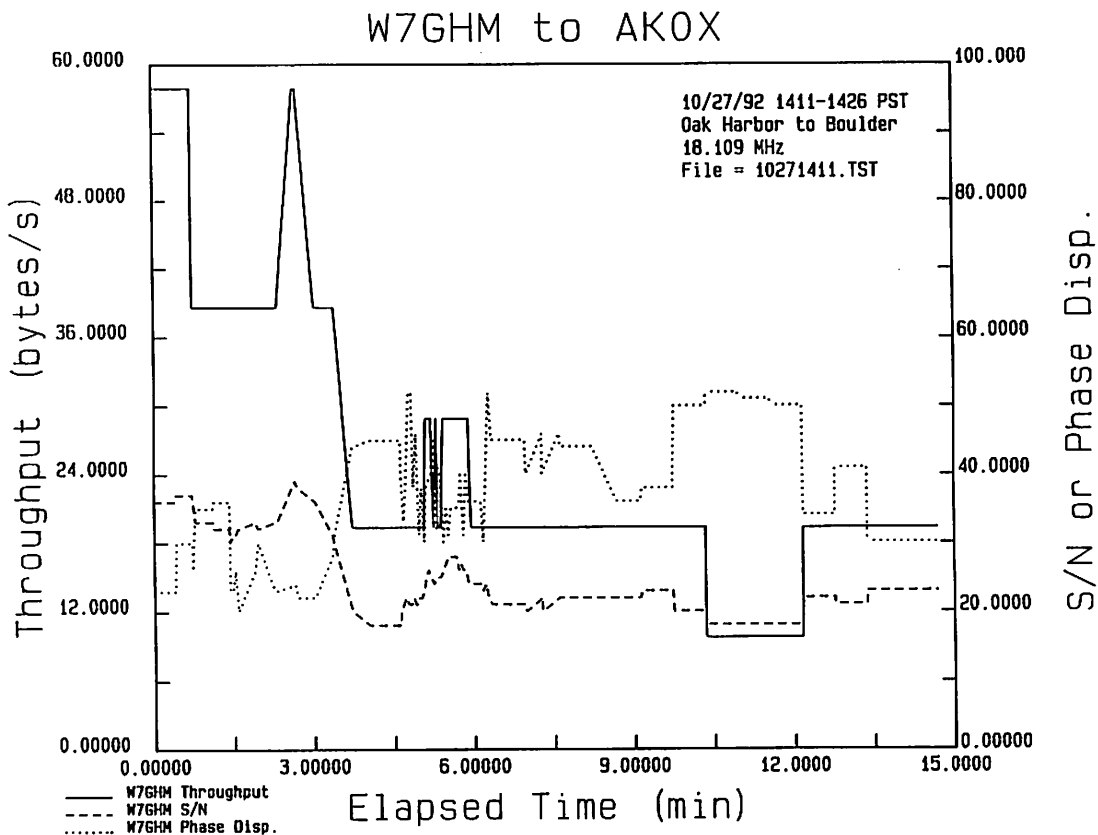
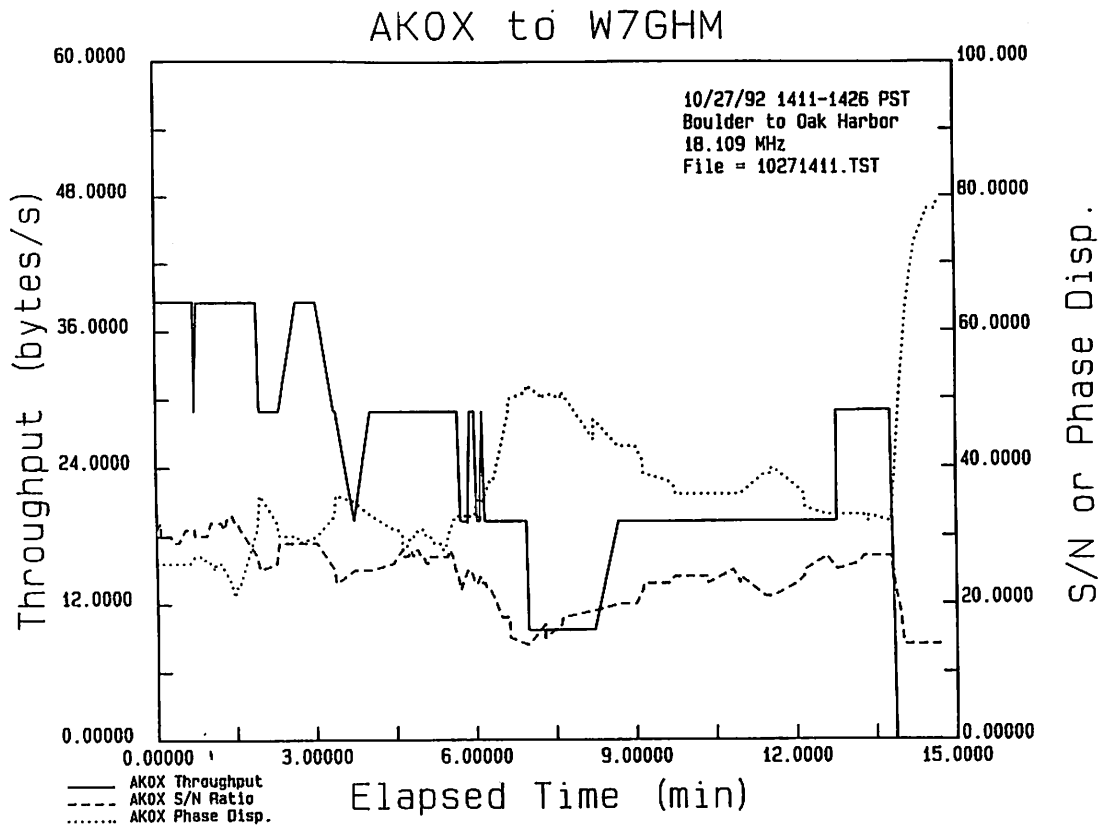
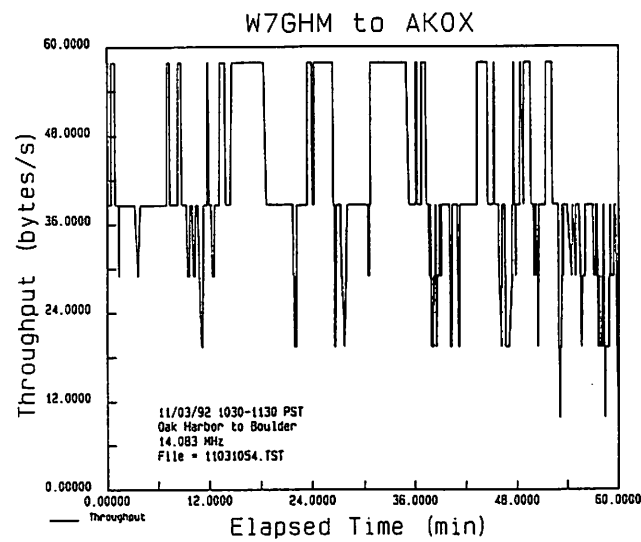
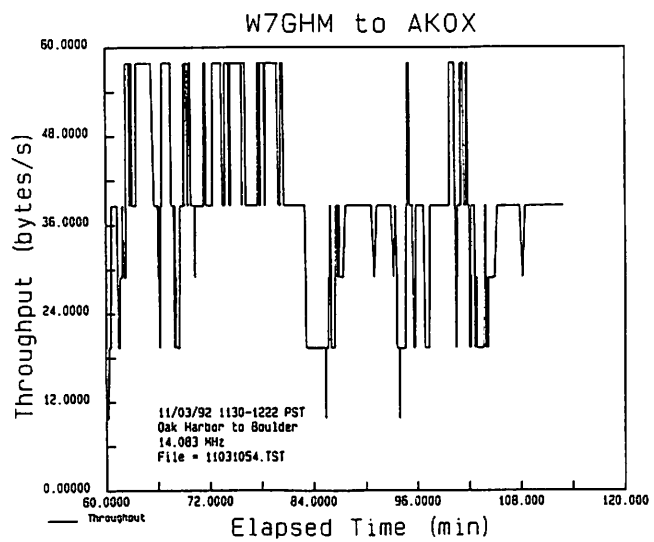
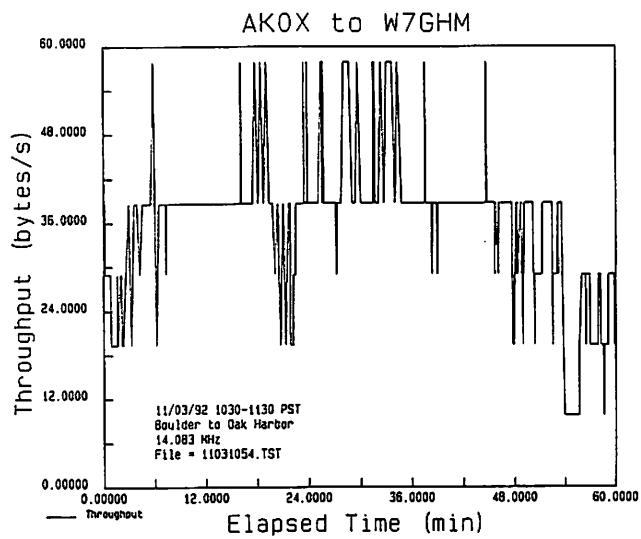
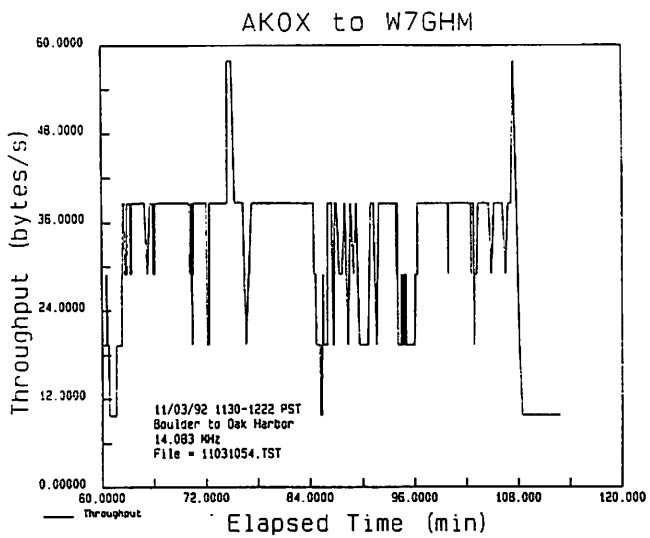

Figure ADD1.2 October 27, 1992 Data (Near MUF)



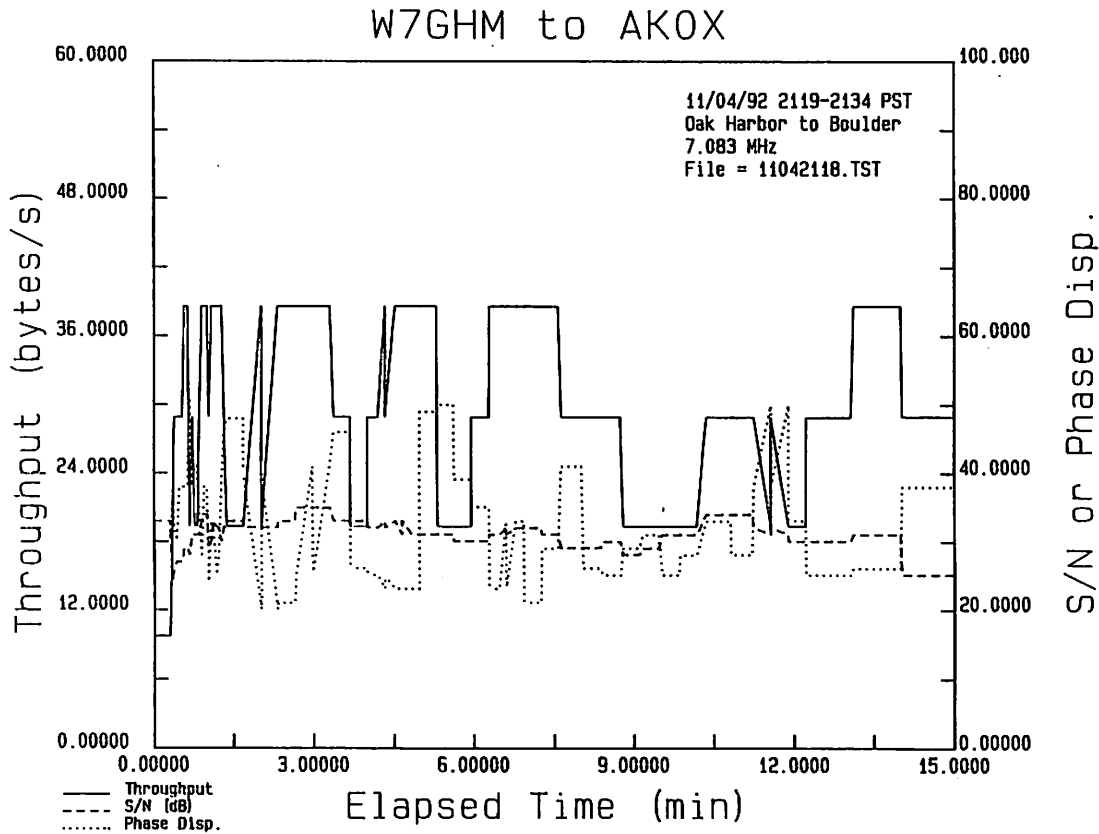
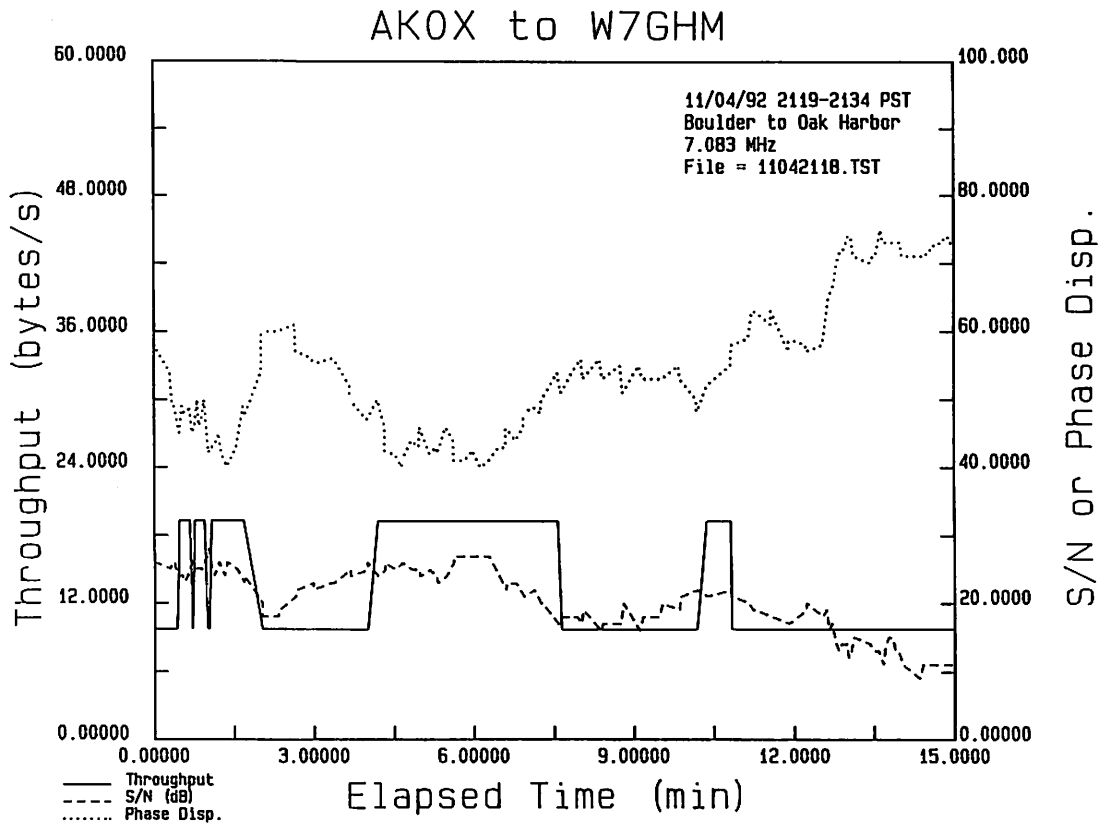

Figure ADD1.4 November 4, 1992 Data (Nigttime Multipath)

**PCI-4000/M
MULTI-MODE
DSP MODEM**

USE OF FSK MODES - AMTOR, PACTOR, RTTY

Addenda to *OPERATOR'S* and *REFERENCE* Manuals
for
PCI-4000 HF RADIO MODEM

Copyright © 1994 by HAL Communications Corp., Urbana, Illinois. Printed in the United States of America. Contents of this publications may not be reproduced in any form without the permission of the copyright owner.

870-04002
April 25, 1994 Printing

PCI-4000/M Multi-Mode DSP Modem

TABLE OF CONTENTS:

1.	INTRODUCTION	1
	1.1 Packing List	1
	1.2 Hardware Installation.	2
	1.3 Software Installation	2
	1.4 Starting PCI-4000/M Software	3
2.	A QUICK LOOK AT THE NEW MODES	3
	2.1 Selecting a Code	4
	2.2 CLOVER-II	4
	2.3 A Quick Look at AMTOR	5
	2.4 A Quick Look at PACTOR	7
	2.5 A Quick Look at RTTY	8
	2.6 More on LISTEN and STBY Modes	9
3.	PC-COMM SCREEN DISPLAYS	10
	3.1 Main Screen Displays	10
	3.2 Configuration Menus	17
4.	PC-COMM "HOT-KEYS"	21
	4.1 Function Hot-Keys	21
	4.2 Alt-letter Hot-Keys	21
5.	OPERATING AMTOR	24
	5.1 ARQ Mode ("Mode A")	24
	5.1.1 Starting ARQ Mode	24
	5.1.2 Entering ARQ SEL-CAL Codes	25
	5.1.3 Establishing the ARQ Link	26
	5.1.4 The ARQ QOS	26
	5.1.5 ARQ OVER Commands	27
	5.1.6 ARQ END Commands	28
	5.1.7 ARQ WRU Feature	28
	5.1.8 AMTOR Parameters	29
	5.2 FEC Mode ("Mode B")	30
	5.2.1 Starting FEC Mode	30
	5.2.2 FEC Send/Receive Control	31
	5.2.3 FEC Return to STBY Mode	31
	5.2.4 Typical FEC CQ Call	31
	5.2.5 Typical FEC Mode QSO	32
	5.3 SEL-FEC Mode ("Mode S")	32
	5.3.1 Starting SEL-FEC Mode	32
	5.3.2 SEL-FEC END Commands	33
	5.4 LISTEN Mode ("Mode L")	33
	5.4.1 Starting LISTEN Mode	33
	5.4.2 LISTEN Mode Performance	33
	5.4.3 LISTEN vs STBY Modes	34

PCI-4000/M Multi-Mode DSP Modem

TABLE OF CONTENTS (Continued):

6.	OPERATING PACTOR	35
6.1	ARQ Mode	35
6.1.1	ARQ Data Rates	35
6.1.2	Starting ARQ Modes	36
6.1.3	PACTOR Call Signs	36
6.1.4	Establishing the ARQ Link	36
6.1.5	The ARQ QSO	37
6.1.6	ARQ OVER Commands	37
6.1.7	PACTOR END Commands	38
6.1.8	PACTOR ARQ Parameters	39
6.2	FEC MODE (UNPROTO)	40
6.2.1	FEC Data Rates	40
6.2.2	Starting FEC Mode	40
6.2.3	FEC Send/Receive	40
6.2.4	FEC Return to STBY Mode	41
6.2.5	Typical FEC CQ Call	41
6.2.6	Typical FEC Mode QSO	41
6.2.7	FEC Configuration Parameters	42
6.3	LISTEN Mode ("Mode L")	42
6.3.1	Starting LISTEN Mode	42
6.3.2	LISTEN Mode Performance	43
6.3.3	LISTEN vs STBY Modes	43
7.	OPERATING RTTY	44
7.1	RTTY Code	44
7.2	Starting RTTY Modes	44
7.3	RTTY Data Rates	45
7.4	RTTY CONTROL Options	45
7.4.1	TX EN/DIS	46
7.4.2	WORD/LINE/CHAR	46
7.4.3	NORM/REV	47
7.4.4	SYNC	47
7.4.5	USOS	48
7.5	Baudot FORCE LTRS Key	48
7.6	CW ID	48
7.7	Other RTTY Options	48
7.7.1	End Of Line Sequence	48
7.7.2	Baudot Character Set	49
7.8	RTTY Print Squelch	49
7.9	Special RTTY Transmit Keys	50
8.	TUNING INDICATORS	51

PCI-4000/M Multi-Mode DSP Modem

ILLUSTRATIONS:

Figure 1	Main Menu Tree for CLOVER (left side)	11
Figure 2	Main Menu Tree for ALL Codes (right side)	12
Figure 3	Main Menu Tree for AMTOR (left side)	13
Figure 4	Main Menu Tree for PACTOR (left side)	14
Figure 5	Main Menu Tree for Baudot RTTY (left side)	15
Figure 6	Main Menu Tree for ASCII RTTY (left side)	16
Figure 7	Configuration Menu - Page 1 (CLOVER & System)	18
Figure 8	Configuration Menu - Page 2 (HERE IS & HISCALL)	19
Figure 9	Configuration Menu - Page 3 (FSK Codes)	20
Figure 10	ARQ SEL-CAL Menu	25
Figure 11	RTTY Control Options	45

TABLES:

Table 1	Function HOT-KEY Assignments	22
Table 2	Alt-Letter HOT-KEY Assignments	23
Table 3	RTTY Data Rates and Speeds	45
Table 4	U.S. vs CCITT No. 2 Baudot	49
Table 5	Special RTTY Transmit Keys	50

PCI-4000/M Multi-Mode DSP Modem

USE OF FSK MODES - AMTOR, PACTOR, RTTY

Addenda to
OPERATOR and *REFERENCE* MANUALS
for
PCI-4000 CLOVER-II HF RADIO MODEM

1. INTRODUCTION:

This document describes use of RTTY, AMTOR, and PACTOR data modes of the HAL PCI-4000/M Multi-mode HF Radio Modem. This material is supplementary to the PCI-4000 CLOVER-II *OPERATOR MANUAL* and *REFERENCE MANUAL*. Refer to these manuals to install the PCI-4000 (Reference Manual, Chapter 2) and to operate the CLOVER-II mode.

The PCI-4000/M is an upgrade of the PCI-4000 DSP HF Radio Modem, adding Baudot and ASCII radio teleprinter modes ("RTTY"), the CCIR-476/625 ARQ Error correction mode ("AMTOR", "SITOR", or "TOR"), and the "PACTOR" ARQ error correction mode. Addition of these "FSK Modes" is accomplished by use of new computer programs (software) that are loaded into the PCI-4000 circuit board (up-loaded) and by a revised version of "PCC", the HAL terminal program that runs in the personal computer itself. The only change required to the PCI-4000 circuit board is to replace the read-only memory IC's (EPROM's).

1.1 Packing List:

Included with the PCI-4000/M update package are:

- 1 - U2 EPROM IC, V2.0 (or V2.0a for S/N < 600)
- 1 - U4 EPROM IC, V2.0 (or V2.0a for S/N < 600)
- 1 - Diskette, Release 7.0
- 1 - PCI-4000/M Addenda (this document)

1.2 Hardware Installation:

Before handling the PCI-4000 circuit board, be sure to read the *Static Electricity Note* on page 2-1 of the *PCI-4000 Reference Manual*. Use caution when removing and replacing U2 and U4 EPROM IC's. Do not bend the pins and make sure ALL IC pins are fully seated in the sockets.

To install the new PCI-4000/M U2 and U4 EPROM IC's:

1. Turn power to your PC off and disconnect the PCI-4000 cable.
2. Remove the cover from the PC cabinet.
3. Remove the PCI-4000 circuit board.
4. Remove IC's U2 and U4 from their sockets with a small screw driver.
5. Install new IC's U2 and U4 (place notch to top of board).
6. Check that all pins are seated in the sockets and not bent.
7. Re-install the PCI-4000 in the PC.
8. Replace the PC cabinet cover.
9. Reconnect the PCI-4000 cable.

1.3 Software Installation:

1. Place new HAL diskette in drive A:
2. Run the HAL install program:
C:\PCC>INSTALL A:[Enter]

Note: The INSTALL program will create a new directory named "PCC" if one did not previously exist or will overwrite old files if directory "PCC" already exists. If you wish to retain files contained in a previous "PCC" directory, copy these files to a diskette or to another directory (e.g., "PCC_OLD"). This upgrade changes *all* PCI-4000 files you may have previously used. Do NOT attempt to use old versions of PCC.S28, PCC.LOD, PCC.EXE, PCC.CFG, or any other *.CFG file you may have used before. None of these old files will be compatible with the PCI-4000/M update ROM IC's (V2.0).

The new Release 7 software includes six new files:

PCC.S28	CLOVER-II software for 68EC000
PCC.LOD	CLOVER-II software for DSP56001
PCCFSK.S28	FSK Mode software for 68EC000
PCCFSK.LOD	FSK Mode software for DSP56001
PCC.EXE	New terminal software for PC
PCC.CFG	New configuration parameters for PCC.EXE

1.4 Starting PCI-4000/M Software:

PCI-4000/M operation is started using the same procedures previously used to run CLOVER-II with the PCI-4000. To operate:

1. Change to the PCC directory
C:> CD PCC[Enter]
2. Run PCC.EXE:
C:\PCC> PCC[Enter]

The HAL "PCC" terminal program will now load the PCC.S28 and PCC.LOD files and display the standard PCC split-screen format shown on page 3-1 of the *OPERATOR'S MANUAL*. Initially, no differences will be noted from the previous CLOVER-only version. However, selection of AMTOR, PACTOR, or RTTY codes will change the screen parameters to those of the desired code. Note that while the *first* use of the new version of PCC.EXE will start with the code set to CLOVER, you may change the start-up code simply by selecting the desired code and then saving a new configuration file (PCC.CFG).

2. A QUICK LOOK AT THE NEW MODES

The PCI-4000/M upgrade adds AMTOR, PACTOR, and RTTY codes to the PCI-4000. The screens, command formats, and command windows for these new codes closely resemble those used for CLOVER in the original PCI-4000. In addition, AMTOR and RTTY screen presentations, control keys, and commands have been made as similar as possible to those used in the HAL PCI-3000 modem and PC-AMTOR software. Prior users of the PCI-4000 and/or the PCI-3000 should have few problems in using the new codes; the following "quick-look" instructions may be all you need. However, the new PACTOR code and details of RTTY and AMTOR modes are discussed in following chapters of this document.

The screen display and parameters of AMTOR and RTTY codes closely follow those used in the HAL PCI-3000 PC-AMTOR screens; PACTOR screens are very similar to those used for AMTOR. As in all HAL terminal software, HELP screens may be accessed by typing Alt-H. Set-up parameters may be viewed and changed via the Configuration menu pages - type F1 followed by E and then C. AMTOR, PACTOR, and RTTY parameters are shown on Configuration Page 3.

2.1 Selecting A Code:

Type **F1** and press **[Enter]** to display the new "CODE" command menu. Using the up/down arrow keys, you may now select:

CLOVER
AMTOR
PACTOR
RTTY-BAUDOT
RTTY-ASCII

Selecting a new CODE results in the following actions:

1. If previously set to CLOVER and an FSK code is selected (AMTOR, PACTOR, or RTTY), there is a time delay to load PCCFSK.S28 and PCCFSK.LOD files. The following messages will be shown in the upper half of the screen:

Resetting PCI-4000

Loading PCCFSK.LOD

Loading PCCFSK.S28

2. If previously set to an FSK code (AMTOR, PACTOR, or RTTY) and CLOVER is selected, there is a time delay to load PCC.S28 and PCC.LOD files. The following messages will be shown in the upper half of the screen:

Resetting PCI-4000

Loading PCC.LOD

Loading PCC.S28

3. The parameters shown on the center status line and the command windows change to match the selected code. The selected code is also shown at the center of the top line of the screen.

The amount of time required to load the "LOD" and "S28" files varies with the speed of your personal computer (PC) and its hard disk. The delay will be 10 seconds or less for most PC-386 and higher configurations.

2.2 CLOVER-II:

Selection of CLOVER provides all of the features discussed in detail in the *PCI-4000 PC-CLOVER OPERATOR'S MANUAL*. Please refer to this manual for further details

2.3 A Quick Look at AMTOR:

When the AMTOR code is selected, a second window appears that lists the operating modes of AMTOR. The available selections are:

Send ARQ (Mode A)	Start an AMTOR call in ARQ mode
Send FEC (Mode B)	Start a transmission using FEC mode
Send SFEC (Mode S)	Start a transmission using Selective FEC mode
LISTEN	Enter LISTEN mode for ARQ, FEC or SFEC signals
STBY	Standby mode for ARQ call (or FEC or SFEC)

AMTOR modem parameters are:

Protocol:	CCIR-476 and/or CCIR-625
Character Set:	All caps or G3PLX/W5SMM upper/lower case "ASCII"
Data Rate:	100 baud
FSK Tones:	Mark & Space independently set, 500 to 3000 Hz Set tones with Ctrl-F11 or via CONFIG Page 3
FSK Shift:	Adjustable, 85 Hz to 2500 Hz
Tone Default:	Mark = 2165 Hz, Space = 2335 Hz, Shift = 170 Hz Center = 2250 Hz (CLOVER CHAN 4 compatible)
Polarity:	Normal (M = low) or Reverse (M = high)
Tuning:	Tuning bars for Mark & Space (enable with Alt-A)

Send ARQ: Selection of the Send ARQ option opens a third command window in which you must specify the selective call (SEL-CAL) letters of the station you wish to call. You may type this directly in response to "HISCALL", select the last HISCALL used, or choose from a list of 15 selective call signs you use frequently (set via the CONFIG Page 2 menu). Enter 4 characters for CCIR476 or 7 characters for CCIR625. After entry or selection of the other station's SEL-CAL, type [Enter] to start the ARQ call.

Send FEC: Upon selection of the Send FEC option *and entry of text to be transmitted*, the PCI-4000 turns your transmitter on and starts an FEC transmission. The FEC transmission ends automatically when all transmitted text has been sent. Be sure to end your typing with an [Enter] key (transmit cursor at left margin of a blank line).

Send SFEC: The SFEC (Selective FEC) mode operates the same as the FEC mode except that a window is provided to enter the *group* call sign. This call sign is then sent at the start of the transmission. This transmission will be printed only by stations who have programmed this *group* call sign for SFEC reception.

LISTEN: Selection of LISTEN mode allows the PCI-4000 to print received AMTOR signals that use ARQ, FEC, or SFEC modes. Note that error correction by repeat transmissions is not available when listening to ARQ transmissions; receive errors are indicated by the underline character (_). Note that, continuing the standard set for CLOVER and *unlike* AMTOR in the PCI-3000, the PCI-4000 *will link* from LISTEN mode if your programmed MYCALL selective call sequence is heard.

STBY: When in the STBY mode, the PCI-4000 actively monitors for ARQ, FEC, and SFEC AMTOR signals. If an ARQ call using your SEL-CAL is heard, the PCI-4000 will automatically switch to ARQ mode and link with the calling station. The PCI-4000 will return to STBY mode when the ARQ link is ended. FEC transmissions will also be received and displayed when in STBY mode. SFEC transmission using a call sign that matches your programmed SFEC SEL-CAL will also be printed from STBY mode. As in the case of ARQ mode, the PCI-4000 will return to STBY at the end of an FEC or SFEC transmission. Unless calling a station, the PCI-4000 should normally be set to STBY mode.

Commonly Used AMTOR Commands: These commands closely follow those used in the PCI-3000 and PCI-4000. Important "Hot-Key" commands for AMTOR are:

F1	Access command menus
Alt-F1	Access command menus
Ctrl-F1	Access command menus
F2	Load HISCALL DE MYCALL into TX buffer
F3	Load HISCALL only into TX buffer
* Alt-F3	Change his SEL-CAL (4 or 7 characters)
Ctrl-F3	Change his call sign
F4	Load MYCALL into TX buffer
Alt-F4	Insert CW ID into TX buffer
* Ctrl-F4	Force a CW ID at the earliest time
F5 #	Load HERE IS # into TX buffer
Ctrl-F5 #	Program/edit HERE IS #
* F6	OVER (insert +? in TX buffer)
* Ctrl-F6	Forced OVER (OVER from IRS)
* F7	END (insert ZZZZ in TX buffer)
* Ctrl-F7	Forced END ("panic kill")
* F8	Turn LISTEN mode ON/OFF
F9	Start ARQ link
* F10	Enable/disable TX screen buffer output
Alt-F10	Enable/disable TX screen buffer output
Ctrl-F10	Enable/disable TX screen buffer output
* Ctrl-F11	Set new FSK tone frequencies ("Mark" & "Space")
* Alt-A	Select on-screen tuning indicator
* Alt-C	End HERE IS programming
* Alt-G	Force LTRS case when receiving
Alt-H	Access HELP screens
* Alt-I	Turn automatic CW ID On/Off
* Alt-M	Change MY SEL-CAL
Alt-N	Change FSK polarity (NORM/REV)
* Alt-P	Turn PC printer On/Off
*	These hot-keys are new or differ from those used in the PCI-3000.

See Section 5 for a complete discussion of AMTOR operation.

2.4 A Quick Look at PACTOR:

PACTOR operation closely parallels that of AMTOR. Like AMTOR, PACTOR ARQ mode requires specification of the other station's call sign before an ARQ call is started. In addition, ARQ mode may be operated using only 100 baud, only 200 baud, or adaptive 100/200 baud operation. Unlike other PACTOR systems, the HAL PACTOR implementation allows you to select 100, 200, or 100/200 baud operation before linking as well as after an ARQ link has been established.

PACTOR modem parameters are:

Protocol:	SCS PACTOR protocol
Data Rate:	100/200 baud
FSK Tones:	"F1" & "F2" independently set, 500 to 3000 Hz Set tones with Ctrl-F11 or via CONFIG Page 3.
FSK Shift:	Adjustable, 85 Hz to 2500 Hz
Tone Default:	"F1" = 2150 Hz, "F2" = 2350 Hz, Shift = 200 Hz Center = 2250 Hz (CLOVER CHAN 4 compatible)
Tuning:	Tuning bars for "F1" & "F2" (enable with Alt-A)

PACTOR Modes are:

ARQ:	Adaptive 100/200 baud, 100 baud, or 200 baud Normal or long-path timing
UNPROTO:	FEC-type transmission; 100 or 200 baud
COMPRESSION:	Huffman data compression (on or off)
LISTEN:	Monitor PACTOR ARQ or UNPROTO transmissions
STBY:	Stand-by mode for ARQ call (or UNPROTO)

Commonly Used PACTOR Commands: These commands closely follow those used in the PCI-3000 and PCI-4000. Important "Hot-Key" commands for AMTOR are:

F1	Access command menus
Alt-F1	Access command menus
Ctrl-F1	Access command menus
F2	Load HISCALL DE MYCALL into TX buffer
F3	Load HISCALL only into TX buffer
Ctrl-F3	Change his call sign
F4	Load MYCALL into TX buffer
Alt-F4	Insert CW ID into TX buffer
Ctrl-F4	Force a CW ID at the earliest time
F5 #	Load HERE IS # into TX buffer
Ctrl-F5 #	Program/edit HERE IS #
F6	OVER (insert +? in TX buffer)
Ctrl-F6	Forced OVER (OVER from IRS)
F7	END (insert ZZZZ in TX buffer)
Ctrl-F7	Forced END ("panic kill")

F8	Turn LISTEN mode ON/OFF
F9	Start ARQ link
F10	Enable/disable TX screen buffer output
Alt-F10	Enable/disable TX screen buffer output
Ctrl-F10	Enable/disable TX screen buffer output
Ctrl-F11	Set new FSK tone frequencies ("F1" & "F2")
Alt-A	Select on-screen tuning indicator
Alt-C	End HERE IS programming
Alt-H	Access HELP screens
Alt-I	Turn automatic CW ID On/Off
Alt-M	Change MY Call sign
Alt-P	Turn PC printer On/Off
Alt-S	Change ARQ data rate (100-200-AUTO-100-etc)
Alt-Y	Turn Huffman coding On/Off

See Section 6 for a complete discussion of PACTOR operation.

2.5 A Quick Look at RTTY:

Both Baudot and ASCII codes may be used for RTTY; see Section 7 for complete details. RTTY parameters are:

Code:	U.S. Baudot, CCIR #2 Baudot, or ANSI X3.4 ASCII
Data Rates:	45, 50, 57, 75, 100, or 110 baud
FSK Tones:	Mark & Space independently set, 500 to 3000 Hz Set tones with Ctrl-F11 or via CONFIG Page 3.
FSK Shift:	Adjustable, 85 Hz to 2500 Hz
Tone Default:	Mark = 2165 Hz, Space = 2335 Hz, Shift = 170 Hz Center = 2250 Hz (CLOVER CHAN 4 compatible)
Polarity:	Normal (Mark = low) or Reverse (Mark = high)
Print Squelch:	Adjustable, set via Alt-O
Tuning:	Tuning bars for Mark & Space (enable with Alt-A)

Commonly Used RTTY Commands: These commands closely follow those used in the PCI-3000 and PCI-4000. Important "Hot-Key" commands for AMTOR are:

F1	Access command menus
Alt-F1	Access command menus
Ctrl-F1	Access command menus
F2	Load HISCALL DE MYCALL into TX buffer
F3	Load HISCALL only into TX buffer
Ctrl-F3	Change his call sign
F4	Load MYCALL into TX buffer
Alt-F4	Insert CW ID into TX buffer
* Ctrl-F4	Force a CW ID at the earliest time

- | | | |
|----------|------------------|--|
| | F5 # | Load HERE IS # into TX buffer |
| | Ctrl-F5 # | Program/edit HERE IS # |
| * | F10 | Enable/disable TX screen buffer output |
| | Alt-F10 | Enable/disable TX screen buffer output |
| | Ctrl-F10 | Enable/disable TX screen buffer output |
| * | Ctrl-F11 | Set new FSK tone frequencies ("Mark" & "Space") |
| * | Alt-A | Select on-screen tuning indicator |
| * | Alt-C | End HERE IS programming |
| * | Alt-G | Force LTRS case when receiving (Baudot only) |
| | Alt-H | Access HELP screens |
| * | Alt-I | Turn automatic CW ID On/Off |
| | Alt-N | Change FSK polarity (NORM/REV) |
| * | Alt-P | Turn PC printer On/Off |
| * | Alt-S | Increment RTTY data rate (45-50-57-75-100-110-45-etc) |
- *** These hot-keys are new or differ from those used in the PCI-3000.

See Section 7 for a complete discussion of RTTY operation.

2.6 More on LISTEN and STBY Modes:

The PCI-4000 includes LISTEN modes that will receive and print AMTOR, PACTOR, and CLOVER. Selection of LISTEN when using any FSK mode will result in the automatic reception of the AMTOR or PACTOR. In a similar manner, the STBY modes of AMTOR and PACTOR are linked so that an ARQ call in either code using your selective call sign will result in linking in that code.

However, due to hardware limitations of the PCI-4000, FSK code software and CLOVER mode software cannot both reside in PCI-4000 memory at the same time. As noted in section 2.1, different files are loaded into the PCI-4000 for FSK or for CLOVER. Therefore, LISTEN and STBY features in the PCI-4000/M upgrade cannot "cross" between FSK codes and CLOVER. This is normally not a problem for individual users who select the code they wish to use at a given time.

However, an enhanced version of the PCI-4000 to support multi-code automatic bulletin board stations (BBS or mailbox) is under development as of this writing. The **PCI-4000/MB** upgrade increases the memory capacity of the PCI-4000 hardware and will provide all-code LISTEN and link-from-STBY capability. The PCI-4000/MB upgrade requires factory modification of each PCI-4000 circuit board and is, of course, more expensive than this PCI-4000/M up-grade. Please contact HAL for further details.

3. PC-COMM SCREEN DISPLAYS:

The new PCC.EXE terminal program, now called "PC-COMM" has been designed to have screens that appear as similar as possible to the screens used in PC-AMTOR for the HAL PCI-3000 and PC-CLOVER for the PCI-4000.

3.1 Main Screen Menus:

CLOVER:

Figures 1 and 2 show the menu "tree" for left-hand and right-hand sides of the main screen when CLOVER code is selected. With the exception of the addition of the CODE menu, this screen display is identical with the most recent versions of PC-CLOVER. Note that these figures have been updated from the menus presented in Figures 3.1a and 3.1b of the *PC-CLOVER OPERATOR'S MANUAL* (pages 3-6 & 3-7).

While the left-hand portion of the main screen changes for each CODE selected, the right-hand section is the *same* for ALL CODES. Therefore, refer to Figure 2 for all CODES used.

AMTOR:

The left-side of the main screen menus as they pertain to AMTOR CODE are shown in Figure 3. The menu structure and STATUS LINE information closely parallel those used in PC-AMTOR for the PCI-3000.

PACTOR:

The left-side of the main screen menus as they pertain to PACTOR CODE are shown in Figure 4. The menu structure and STATUS LINE information closely parallels those used for AMTOR.

RTTY:

The left-side of the main screen menus as they pertain to Baudot and ASCII RTTY codes are shown in Figures 5 and 6. The menu structure and STATUS LINE information closely parallels that used in PC-AMTOR for the PCI-3000.

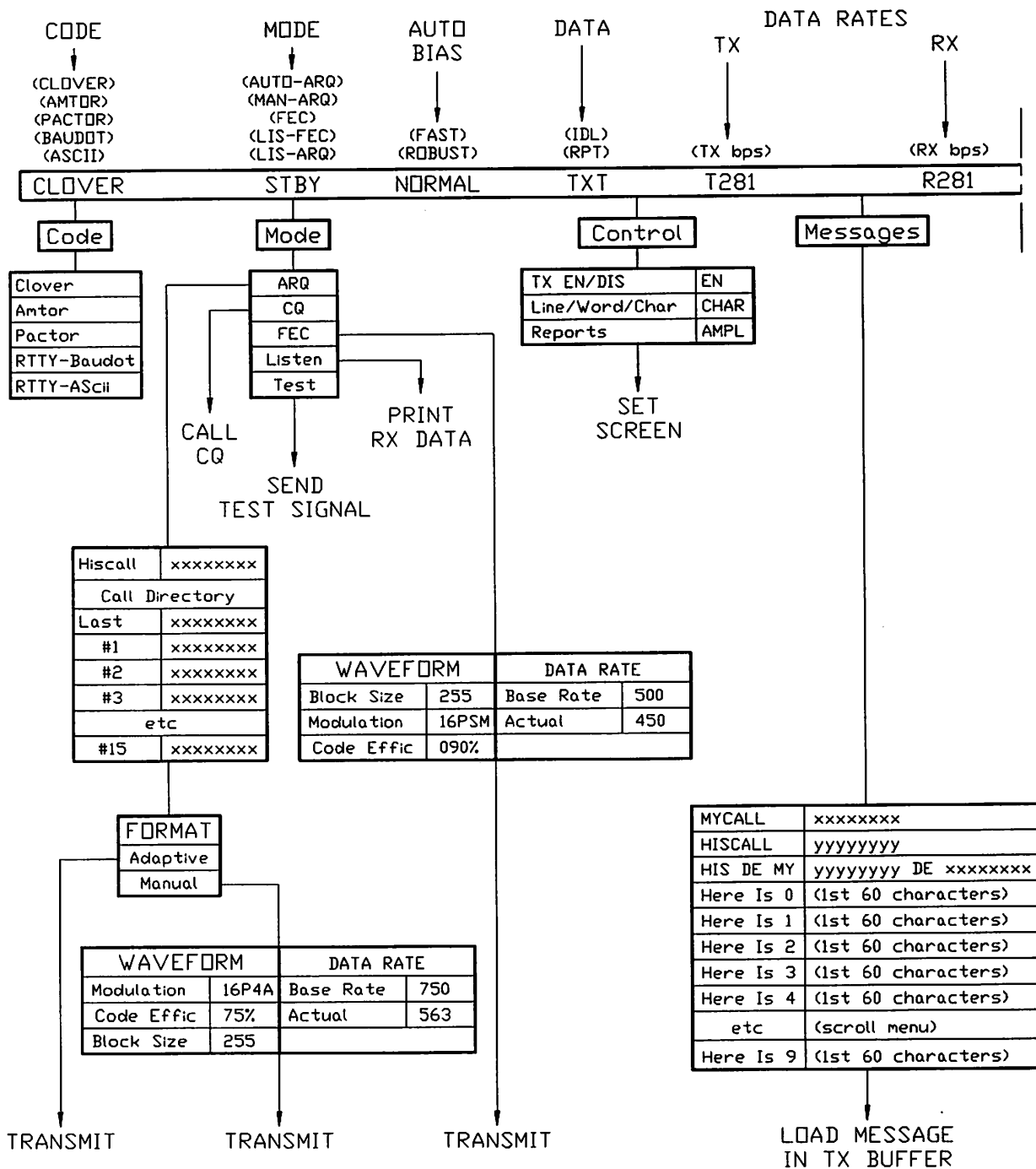

Figure 1 - Main Menu Tree for CLOVER (left side)

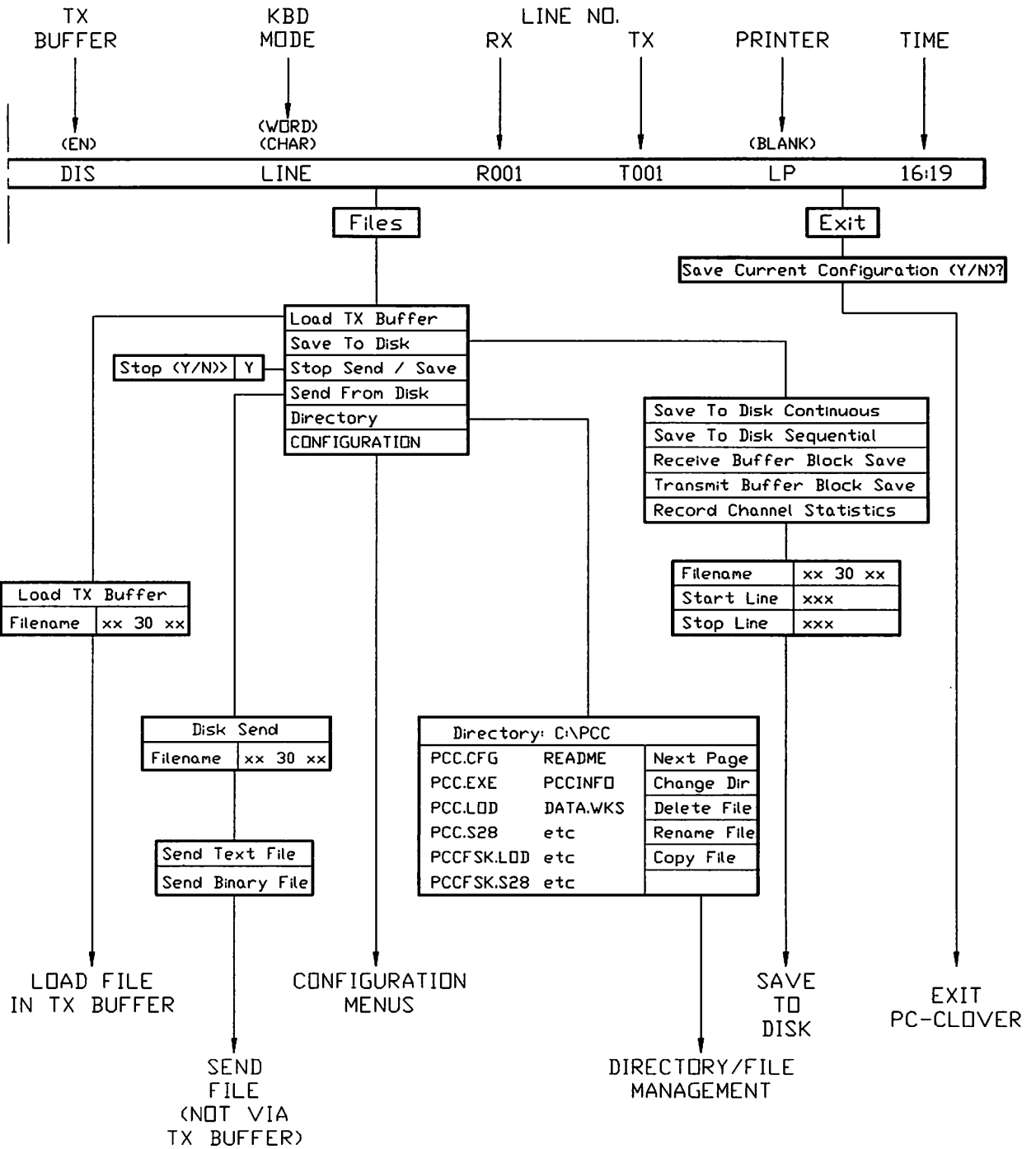

Figure 2 - Main Menu Tree for ALL Codes (right side)

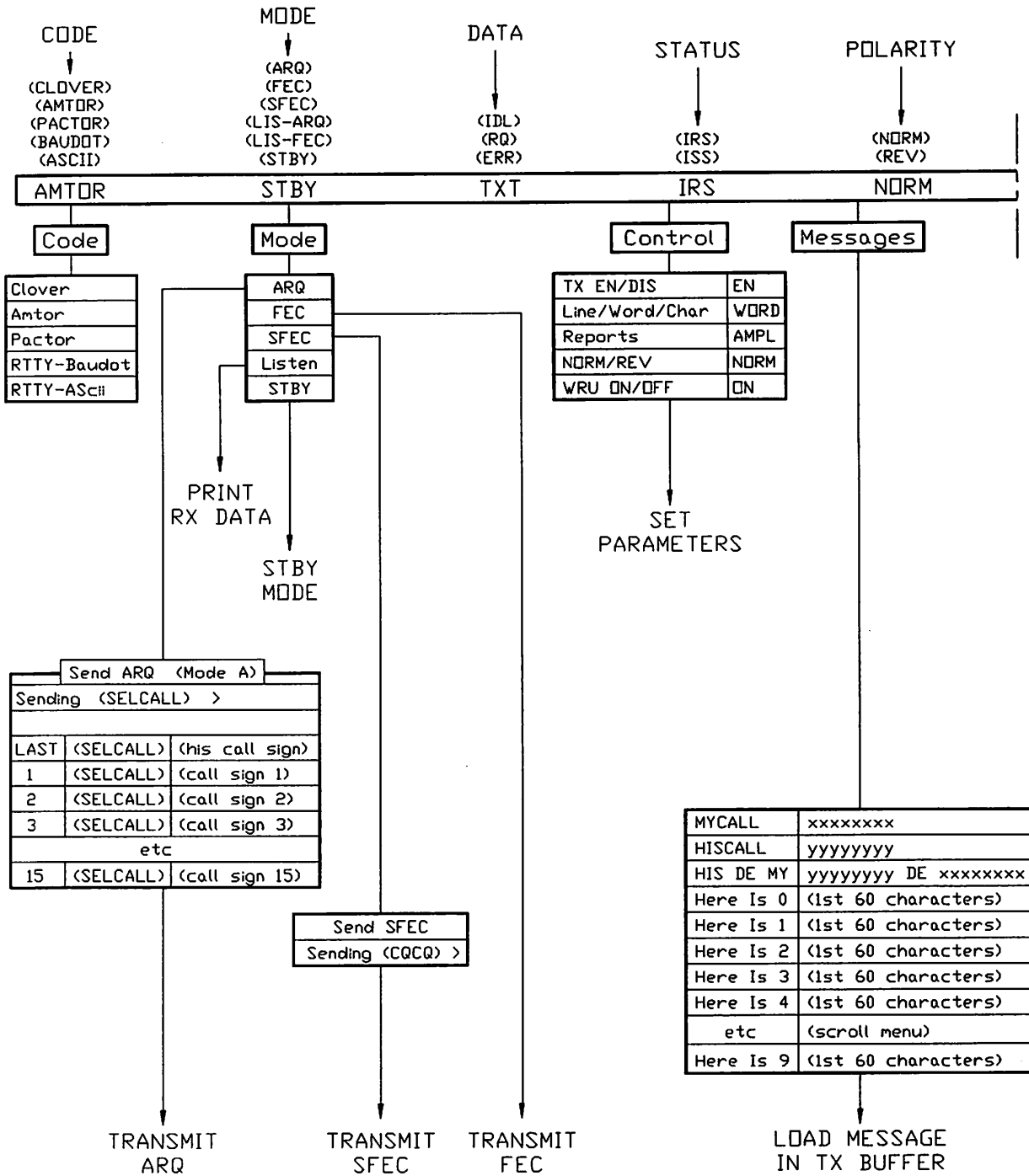

Figure 3 - Main Menu Tree for AMTOR (left side)

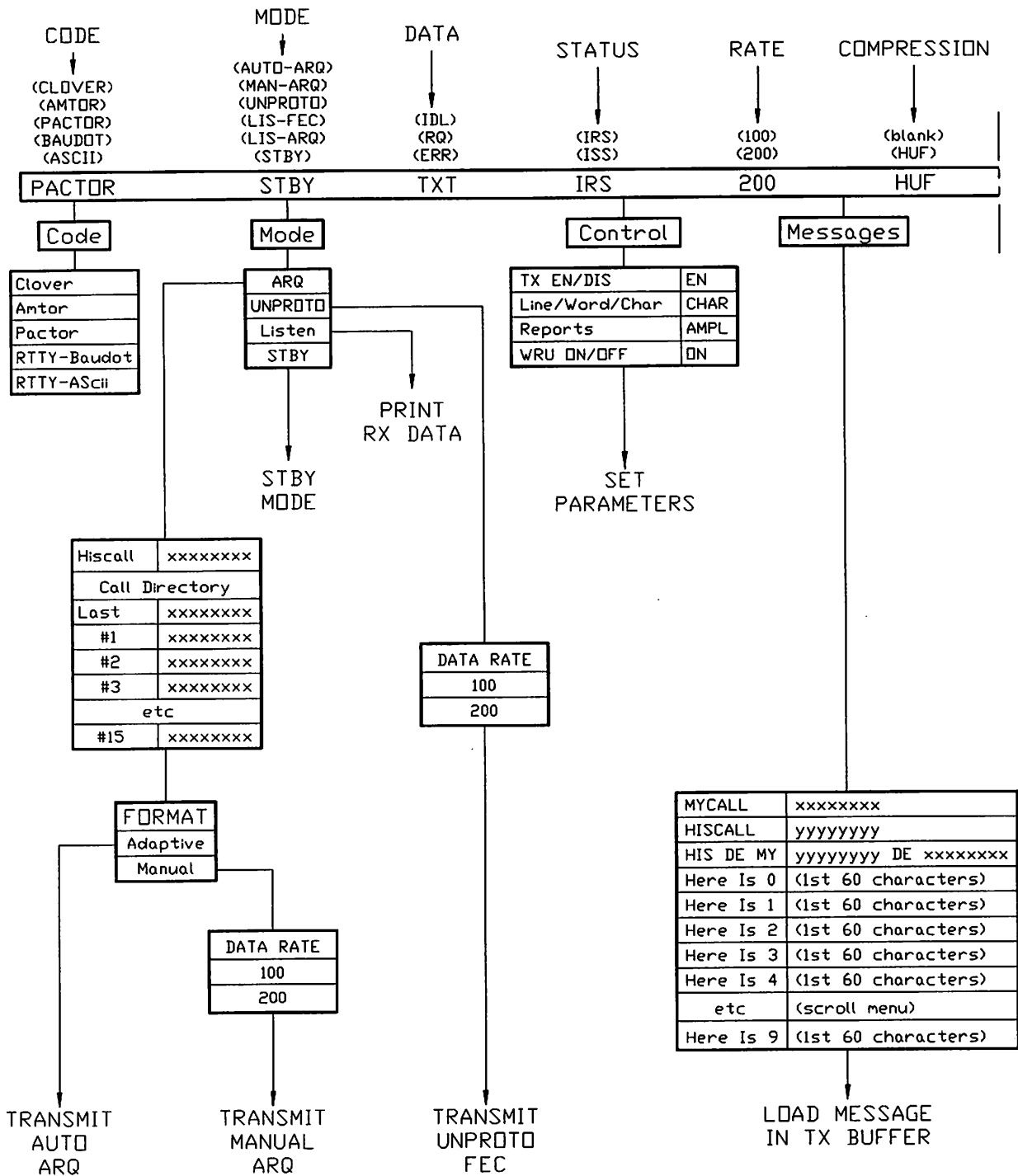

Figure 4 - Main Menu Tree for PACTOR (left side)

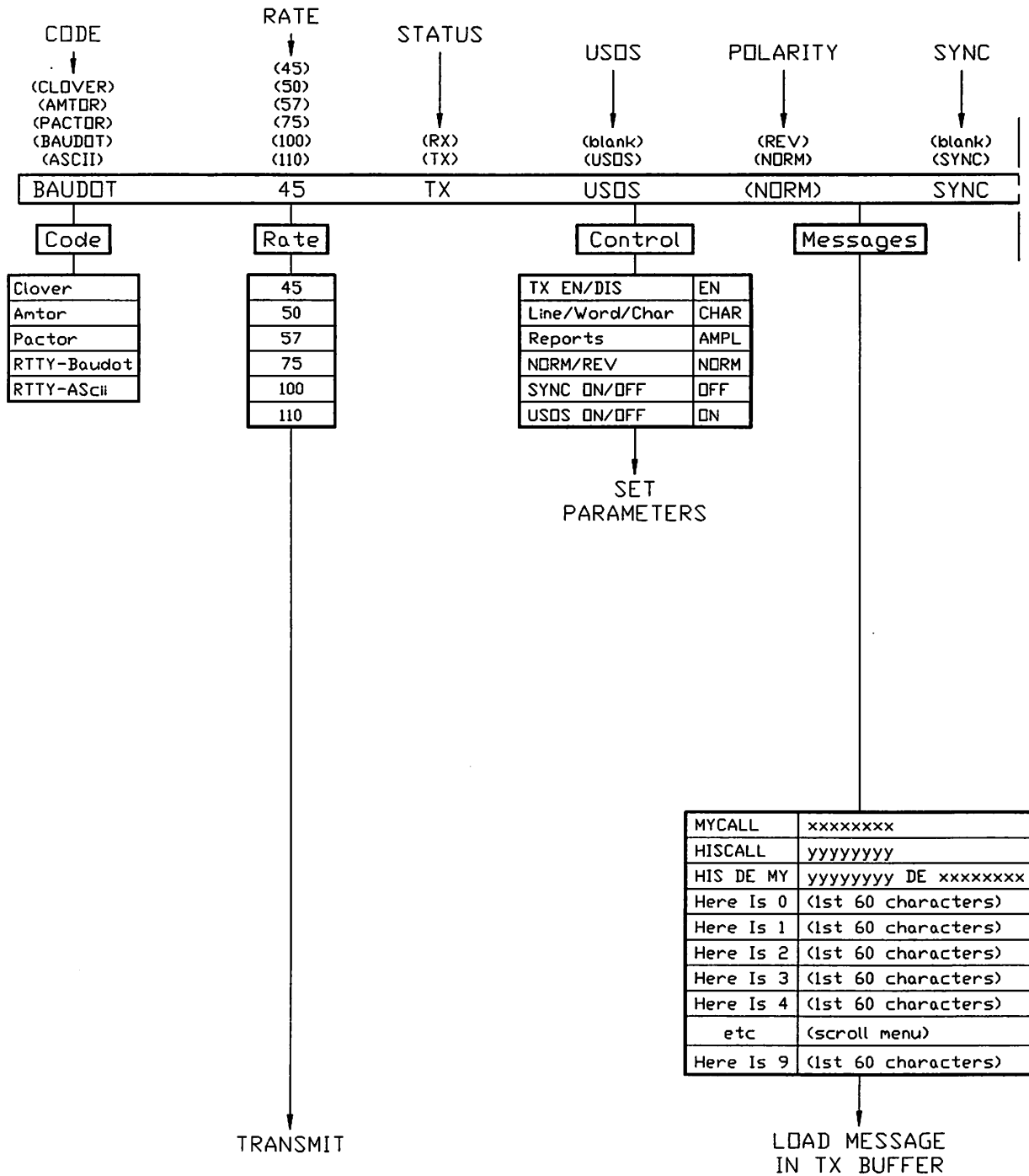

Figure 5 - Main Menu Tree for Baudot RTTY (left side)

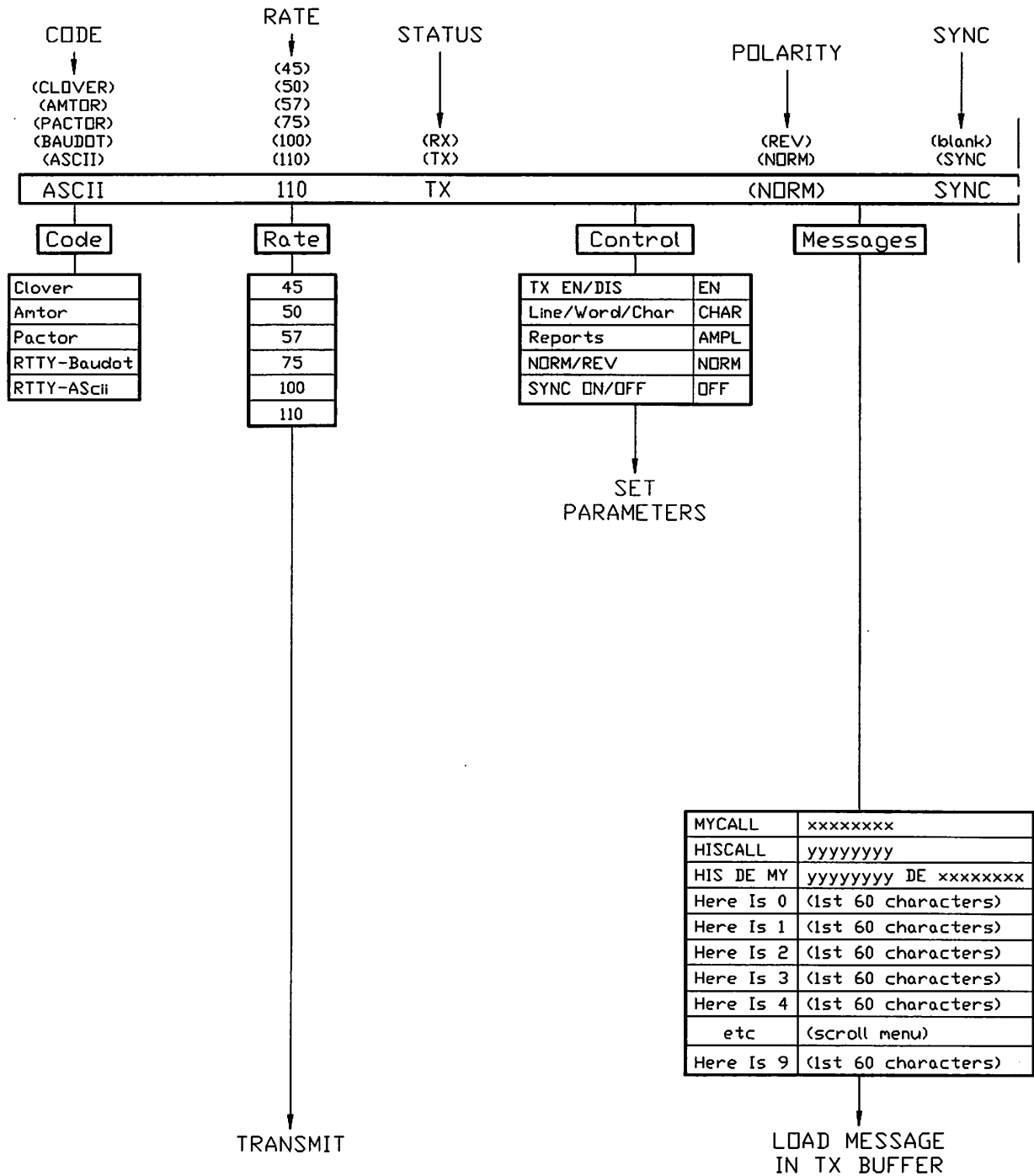

Figure 6 - Main Menu Tree for ASCII RTTY (left side)

3.2 Configuration Menus:

PC-COMM includes 3 Configuration Menu pages. Pages 1 and 2 follow the same format used in PC-CLOVER, updated to include the most recent changes to CLOVER operations. Page 3 provides display and access to FSK-mode (AMTOR, PACTOR & RTTY) parameters, following the format used in PC-AMTOR.

Software Version Numbers: The "VERSIONS" box in Page 1 of the Configuration menu includes fields to show the version number of both CLOVER and FSK code software. However, version numbers are read as each file is loaded and a blank field will be shown until a file has actually been loaded. For example, if the PCI-4000 starts in CLOVER code, version numbers for PCC.LOD and PCC.S28 will be shown; PCCFSK.LOD and PCCFSK.S28 fields will be blank. If an FSK mode is then chosen, the version numbers for PCCFSK.LOD and PCCFSK.LOD will then be updated; version numbers for the previously loaded CLOVER files will be retained until exiting PC-COMM (PCC.EXE). If you require assistance from the factory, it is very important that you be able to state the software version number for each file used.

Configuration Files: A new Configuration file (PCC.CFG) may be saved from each of the three Configuration menus and when exiting PC-COMM. The exact code, mode, and other parameters as of that time are saved in the *.CFG file. You may also set up multiple configuration files for different operations if you wish. All configuration files must use the ".CFG" extension and have a legal DOS file name (8 characters maximum). You may select or save custom configuration files via any configuration menu. You may also start PC-COMM using a custom configuration file in the following manner:

```
C:\PCC> PCC MYCONFIG.CFG [Enter]
```

where "MYCONFIG" is the name of a custom configuration file.

CAUTION: The arrangement of .CFG files may change with each revision of PCC.EXE. Do *not* attempt to use old .CFG files after loading a new version of PCC.EXE.

Figure 7 shows Page 1 of the Configuration Menu. Use this menu to set CLOVER operating parameters, common System parameters, and screen colors and to view the software versions in use.

Figure 8 shows Page 2 of the Configuration Menu. Use this menu to view and/or change the contents of the 10 HERE IS messages, MYCALL, HISCALL, and the HISCALL Directory.

Figure 9 shows Page 3 of the Configuration Menu. Use this menu to view or change the parameters for the FSK modes - AMTOR, Baudot RTTY, ASCII RTTY, or PACTOR. Note that the FSK TX and RX tones may be set on this menu. Since AMTOR and RTTY commonly use 170 Hz FSK shift and PACTOR uses 200 Hz shift, separate entry fields are provided. The tones may be set anywhere within the range of 500 Hz to 2500 Hz, but it is recommended that best performance will be obtained when the lowest frequency is higher than 1000 Hz and the shift (difference between Mark and Space) is 100 Hz or more.

CONFIGURATION MENU
PAGE 1

CLOVER — Configuration — PCC.CFG

FEC	
Modulation	QPSM
Code Effic	60%
Block Size	85

ADAPTIVE ARQ	
Autopower	OFF
Auto Bias	NORMAL
Connect	ROBUST
Normal Retry	30
Robust Retry	10
Fail Retry	20
Chat Count	1

LISTEN	
Listen Mode	DN

SYSTEM	
UTC Offset	+0
Time Zone	UTC
Text Entry	WORD
End Of Line	CR LF
TX Buffer	ENABLE
Scan Control	CONT
CW ID	OFF
AF Channel	4
Reports	AMPL
Echo Enable	DN
Printer	OFF
Print Squelch	DN
Squelch Level	68

VERSIONS	
PCC.EXE	V2.0
PCC.S28	V2.5
PCC.LOD	V1.1
PCCFSK.S28	V1.0
PCCFSK.LOD	V1.0
Card ROM	V2.0
Card Address	360

DISPLAY COLORS	
RX Text	RX
TX Text	TX
Status Text	STAT
Status Bkgnd	
Help Text	HELP
Help Bkgnd	
CMD Text	CMD
CMD Bkgnd	

OPTIONS	
Edit Config	Page 1
Go To	Page 2
Go To	Page 3
Go To	Main
Save Config	
Load Config	

ENTER To Select Option ↑↓ To Move ESC To Exit Configuration

Figure 7 - Configuration Menu - Page 1 (CLOVER & System)

CONFIGURATION MENU
PAGE 2

Configuration — PCC.CFG		
MESSAGES		
0	(here is 0)	<
1	(here is 1)	<
2	(here is 2)	<
3	(here is 3)	<
4	(here is 4)	<
5	(here is 5)	<
6	(here is 6)	<
7	(here is 7)	<
8	(here is 8)	<
9	(here is 9)	<

	CALL SIGN	SEL-CAL		CALL SIGN	SEL-CAL
MYCALL	(mycall)	(myseical)	#7	(call7)	(scal7)
HISCALL Directory			#8	(call8)	(scal8)
Last	(last hiscall)	last scal	#9	(call9)	(scal9)
#1	(call1)	(scal1)	#10	(call10)	(scal10)
#2	(call2)	(scal2)	#11	(call11)	(scal11)
#3	(call3)	(scal3)	#12	(call12)	(scal12)
#4	(call4)	(scal4)	#13	(call13)	(scal13)
#5	(call5)	(scal5)	#14	(call14)	(scal14)
#6	(call6)	(scal6)	#15	(call15)	(scal15)

OPTIONS	
Edit Config	Page 2
Go To	Page 3
Go To	Page 1
Go To	Main
Save Config	
Load Config	

Enter To Select Option ↑↑ To Move ESC To Exit Configuration

Figure 8 - Configuration Menu - Page 2 (HERE IS & HISCALL)

CONFIGURATION MENU
PAGE 3

----- FSK MODES ----- Configuration ----- PCC.CFG -----

AMTOR		FACTOR		BAUDOT		ASCII	
TXEN On/Off	ON	TXEN On/Off	ON	TXEN On/Off	ON	TXEN On/Off	ON
WORD/CHAR	WORD	WORD/CHAR	WORD	WORD/CHAR	WORD	WORD/CHAR	WORD
NORM/REV	NORM	EOL	CR LF	NORM/REV	NORM	NORM/REV	NORM
EOL	CR LF LTRS	CS DELAY	30	EOL	CR LF LTRS	EOL	CR LF
WRU On/Off	OFF	MAX DOWN	6	SYNC On/Off	ON	SYNC On/Off	OFF
Time Out	OFF	MAX UP	3	USQS On/Off	ON	RATE	110
TD	10	MAX TRY	2	RATE	45		
CD	50	MAX ERROR	80	CODE No2/US	US		
LETTER CASE	U/L	MAX ARG SUM	30				
MY 476 SCAL	KGWT	FEC Repeats	2				
MY 625 SCAL	WIWKCXX	HUFFMAN	ON				
GROUP CALL	CQCQ						

FSK TONES			
AMTOR/Baudot/ASCII			
MARK	2165	CENTER	2250
SPACE	2335	SHIFT	170
FACTOR			
FREQ 1	2150	CENTER	2250
FREQ 2	2350	SHIFT	200

OPTIONS	
Edit Config	Page 3
Go To	Page 1
Go To	Page 2
Go To	Main
Save Config	
Load Config	

ENTER To Select Option ↑↑ To Move ESC To Exit Configuration

Figure 9 - Configuration Menu - Page 3 (FSK Codes)

4. PC-COMM "HOT-KEYS":

PC-COMM makes use of the function keys (F1 through F11) and Alt-letter keys (Alt-A through Alt-Z) for rapid control of important operating parameters. As much as possible, the "hot-keys" used for each code parallel those used in PC-CLOVER and PC-AMTOR. Due to the finite limit on the number of "hot-key" combinations available, some keys have different functions as the code is changed.

4.1 Function Hot-Keys:

Table 1 shows the operation of each function key for each code. Three possible levels are possible for each function key: the "F#" itself, Alt-F#, and Ctrl-F#. Not all possible combinations are used for each code and whenever possible similar operations carry-over between codes. Differences between PC-CLOVER and PC-AMTOR function key assignments are noted.

4.2 Alt-letter Hot-Keys:

Table 2 shows the operation of each Alt-letter key for each code. As in the case of the function keys, assignments closely follow those used in PC-CLOVER and PC-AMTOR and similar operations carry-over between codes. Differences from PC-CLOVER and PC-AMTOR are noted.

FN Key	CLOVER	AMTOR	PACTOR	BAUDOT	ASCII
F1	Enter CMD Mode	Enter CMD Mode	Enter CMD Mode	Enter CMD Mode	Enter CMD Mode
Alt-F1	Enter CMD Mode	Enter CMD Mode	Enter CMD Mode	Enter CMD Mode	Enter CMD Mode
Ctrl-F1	Enter CMD Mode	Enter CMD Mode	Enter CMD Mode	Enter CMD Mode	Enter CMD Mode
F2	Load HIS DE MY	Load HIS DE MY	Load HIS DE MY	Load HIS DE MY	Load HIS DE MY
Alt-F2	*	*			
Ctrl-F2					
F3	Load HISCALL	Load HIS callsign	Load HIS callsign	Load HIS callsign	Load HIS callsign
Alt-F3		*Change HIS SELCAL			
Ctrl-F3	*Change HIS callsign	Change HIS callsign	Change HIS callsign	Change HIS callsign	Change HIS callsign
F4	Load MYCALL to TX	Load MYCALL to TX	Load MYCALL to TX	Load MYCALL to TX	Load MYCALL to TX
Alt-F4	Load CWID to TX	Load CWID to TX	Load CWID to TX	Load CWID to TX	Load CWID to TX
Ctrl-F4	Force CWID	*Force CWID	Force CWID	*Force CWID	*Force CWID
F5 #	Load HERE IS#	Load HERE IS#	Load HERE IS#	Load HERE IS#	Load HERE IS#
Alt-F5					
Ctrl-F5 #	Program HERE IS#	Program HERE IS#	Program HERE IS#	Program HERE IS#	Program HERE IS#
F6		*Load OVER	Load OVER		
Alt-F6					
Ctrl-F6		*Force OVER (IRS)	Force OVER (IRS)		
F7	Insert END (ZZZZ)	*Insert END (ZZZZ)	Insert END (ZZZZ)	*Insert END (ZZZZ)	*Insert END (ZZZZ)
Alt-F7	Panic Kill				
Ctrl-F7	Panic Kill	*Panic Kill	Panic Kill		
F8	Listen On/Off	*Listen On/Off	Listen On/Off		
Alt-F8		*			
Ctrl-F8					
F9	Initiate ARQ Link	Initiate ARQ Link	Initiate ARQ Link		
Alt-F9	Initiate ARQ CQ Call				
Ctrl-F9	Answer ARQ CQ Call				
F10	TX Buffer EN/DIS	*TX Buffer EN/DIS	TX Buffer EN/DIS	*TX Buffer EN/DIS	*TX Buffer EN/DIS
Alt-F10	TX Buffer EN/DIS	TX Buffer EN/DIS	TX Buffer EN/DIS	TX Buffer EN/DIS	TX Buffer EN/DIS
Ctrl-F10	TX Buffer EN/DIS	TX Buffer EN/DIS	TX Buffer EN/DIS	TX Buffer EN/DIS	TX Buffer EN/DIS
F11					
Alt-F11					
Ctrl-F11	*Select Freq Chan	*Set Tone Freqs	Set PACTOR Freqs	*Set Tone Freqs	*Set Tone Freqs
F12					
Alt-F12					
Ctrl-F12	* differs from PC-CLOVER	* differs from PC-AMTOR		* differs from PC-AMTOR	* differs from PC-AMTOR

Table 1 - Function HOT-KEY Assignments

Alt Key	CLOVER	AMTOR	FACTOR	BAUDOT	ASCII
Alt-A	Tune/Status Indic	*Tune/Status Indic	Tune/Status Indic	*Tune/Status Indic	*Tune/Status Indic
Alt-B	Load TIME+DATE	Load TIME+DATE	Load TIME+DATE	Load TIME+DATE	Load TIME+DATE
Alt-C	End HERE IS Program	*End HERE IS Program	End HERE IS Program	*End HERE IS Program	*End HERE IS Program
Alt-D	Load DATE	Load DATE	Load DATE	Load DATE	Load DATE
Alt-E	Save Files To Disk	*Save Files To Disk	Save Files To Disk	*Save Files To Disk	*Save Files To Disk
Alt-F	Reformat TX Buffer	Reformat TX Buffer	Reformat TX Buffer	Reformat TX Buffer	Reformat TX Buffer
Alt-G		*Force LTRS		*Force LTRS	
Alt-H	Access HELP Screens	Access HELP Screens	Access HELP Screens	Access HELP Screens	Access HELP Screens
Alt-I	CW ID On/Off	*CW ID On/Off	CW ID On/Off	*CW ID On/Off	*CW ID On/Off
Alt-J	Stop Disk Operation	*Stop Disk Operation	Stop Disk Operation	*Stop Disk Operation	*Stop Disk Operation
Alt-K	Delete line	Delete line	Delete line	Delete line	Delete line
Alt-L	Load File in TX Buf	*Load File in TX Buf	Load File in TX Buf	*Load File in TX Buf	*Load File in TX Buf
Alt-M	Change MYCALL	*Change MYCALL	Change MYCALL	*Change MYCALL	*Change MYCALL
Alt-N		NORM/REV		NORM/REV	NORM/REV
Alt-O	TX Test Mode On/Off			Print Squelch	Print Squelch
Alt-P	Printer On/Off	*Printer On/Off	Printer On/Off	*Printer On/Off	*Printer On/Off
Alt-Q	Load QBF Message	Load QBF Message	Load QBF Message	Load QBF Message	Load QBF Message
Alt-R	Select RX Buffer	Select RX Buffer	Select RX Buffer	Select RX Buffer	Select RX Buffer
Alt-S				*RTTY Data Rate	*RTTY Data Rate
Alt-T	Load TIME	Load TIME	Load TIME	Load TIME	Load TIME
Alt-U	Clear RX Buffer	Clear RX Buffer	Clear RX Buffer	Clear RX Buffer	Clear RX Buffer
Alt-V	Clear TX Buffer	Clear TX Buffer	Clear TX Buffer	Clear TX Buffer	Clear TX Buffer
Alt-W	Delete Word	Delete Word	Delete Word	Delete Word	Delete Word
Alt-X	Select TX Buffer	Select TX Buffer	Select TX Buffer	Select TX Buffer	Select TX Buffer
Alt-Y	Autopower On/Off	*Load 12xLTRS	Huffman On/Off	*Load 12xLTRS	
Alt-Z	Load MARS Time Group	Load MARS Time Group	Load MARS Time Group	Load MARS Time Group	Load MARS Time Group
	* differs from PC-CLOVER	* differs from PC-AMTOR		* differs from PC-AMTOR	* differs from PC-AMTOR

Table 2 - Alt-letter HOT-KEY Assignments

5. OPERATING AMTOR

AMTOR is an error-correcting communications mode. AMTOR actually has five sub-modes that may be chosen: (1) ARQ ("Mode A"), (2) FEC ("Mode B"), (3) Selective FEC ("Mode S"), (4) LISTEN ("Mode L"), and (5) STBY (Standby).

All AMTOR modes use a special error-correcting code. This is a 7-bit synchronous code that always has a data rate of 100 baud. AMTOR ARQ mode is sent in pulses and both stations transmit in a time-sequenced order. Each station automatically requests a repeat if an error is detected. FEC and SEL-FEC modes do not use pulses and sound much like RTTY. In FEC and SEL-FEC, each character is sent twice (with a time separation). AMTOR LISTEN is a receive-only mode that may be used to listen to ARQ, FEC, or SEL-FEC signals. LISTEN mode cannot correct errors in received ARQ mode signals. STBY mode is the normal "rest" condition of an AMTOR station when monitoring a frequency. If your station ARQ SEL-CAL code is received, PC-COMM automatically switches from STBY to ARQ mode and responds. FEC and SEL-FEC reception is also automatic from STBY mode. STBY and LISTEN modes are compared in section 5.4.3.

5.1 ARQ Mode ("Mode A")

AMTOR ARQ mode may also be called "Mode A". The letters "ARQ" stand for Automatic Repeat ReQuest (or Query). ARQ is a full error-correcting mode in which one station sends a group of three characters and then the other station either sends an acknowledge or requests a repeat of a group received in error. Thus, the transmitters of *both* stations are pulsed ON and OFF. AMTOR ARQ mode requires use of transmitters and receivers that can rapidly switch between receive and transmit. Most recent models of amateur equipment have fast switching for AMTOR and Packet Radio. Consult your equipment manual if you have any doubts. ARQ QSO's may be between *two* stations *only* - no "round-tables".

5.1.1 Starting ARQ Mode

There are two ways to start an ARQ mode transmission: (1) the COMMAND menus, and (2) the "hot keys".

The COMMAND menu method is:

1. Press [F1]
The first COMMAND menu will appear with CODE highlighted.
2. Press [Enter]
The CODE menu will be shown
3. Use the [up-arrow] or [down-arrow] keys to highlight AMTOR.
4. Press [Enter]
The MODE menu will now be shown with Send ARQ highlighted
5. Press [Enter]
The ARQ SEL-CAL menu now appears.
6. Type a new SEL-CAL code or choose one of the CALL DIRECTORY choices.
(SEL-CAL codes are discussed in the following section).

The [F9] "hot key" bypasses steps 1 through 5 and immediately shows you the SEL-CAL menu. [F9] is by far the easiest way to get on-the-air in ARQ mode.

5.1.2 Entering ARQ SEL-CAL Codes

In ARQ mode, you *must* know the SEL-CAL of the other station to originate a call. Amateurs call CQ in FEC mode, giving their SEL-CAL code. Answer the CQ in ARQ mode using this SEL-CAL code. FEC CQ calls are discussed in detail in Section 5.2.4 of this manual.

PC-COMM gives you several choices for SEL-CAL codes. A sample SEL-CAL menu is shown in Figure 10.

Sending	(KKCW)	>
LAST	(KKCW)	(K9CW)
1	(WWKC)	(W9WKC)
2	(KKCW)	(K9CW)
3	(WKOB)	(W8KOB)
4	(WIWKCXX)	(W9WKC)
	etc	
15	(KCSI)	(KS9I)

Figure 10 ARQ SEL-CAL Menu

Note that both the SEL-CAL and the full call sign of the other station are listed and that there are 16 options available. This is PC-COMM's unique "call directory". PC-COMM remembers the last ARQ SEL-CAL you used and offers it as the first option when sending. PC-COMM also stores SEL-CAL and call signs for up to 15 frequently worked stations.

The SEL-CAL codes in memory No. 4 has 7-letters rather than 4-letters. This is a CCIR-625 SEL-CAL code. You may use *any* combination of 7 letters you wish. The example shows a letter substitution for the call sign number ("I" = 9), and fill unused positions with "X". You may enter either 4-letter or 7-letter SEL-CAL codes in any memory. *ONLY LETTERS* may be used; numbers or other characters are NOT accepted in the SEL-CAL field.

Your first menu choice is to send the same SEL-CAL that you may have previously used. If this is the station you wish to call, simply type [Enter], and the ARQ calling sequence starts.

If this is not the station you wish to call, you may simply just type the SEL-CAL code for the station you wish to call, type [Enter], and you will be "on-the-air".

You may also select one of the Call Directory Numbers (1-15) to call a frequently worked station.

Changes made in "LAST" or in any of the 15 call directory listings may be temporary or permanent. Once changed, these memories will remain as long as PC-COMM is running. When you exit PC-COMM, you have the choice of saving the current configuration or not. If you choose to save the current configuration, the new entries will be stored in the PCC.CFG file and reloaded the next time you run PC-COMM. If you choose "NO", the new setting will be discarded and PC-COMM will start with the previous entries when next loaded.

5.1.3 Establishing the ARQ Link

The sequence at the beginning of an ARQ QSO is as follows:

1. Press [F9]
2. Set SEL-CAL code and type [Enter]
3. Your station starts sending the other station's SEL-CAL code.
4. The other station recognizes his SEL-CAL and responds.
5. Enable your transmit buffer by typing [F10]
6. Start typing transmit text.

Once these steps have been successfully completed, the ARQ QSO may continue and you may send text to the other station. However, *no* text will be passed until the first five steps have been finished. When a link is in progress (not all five steps complete), the top line of the screen will display the message:

---- Calling - (KKCW) ----- AMTOR -----

The center status line will show:

ARQ ISS EN TXT/RQ NORM

This indicates that an ARQ call is in progress, you are the ISS (Information Sending Station), and that the call-up sequence is in progress. Your transmitter should now be pulsing ON and OFF ("chirping").

Once the link has been established, the "Calling" label will change to "Linked With XXXX". If your receiver speaker is turned ON, you will also hear the other station's short "chirp" response (control signals).

If you do not get a response from the other station, the TIME OUT option controls whether your transmitter continues "chirping forever" (TO = OFF) or the ARQ call automatically "times-out" (TO = 32 or 128). The TIME OUT (TO) option is normally set to "32" but may be changed in the CONFIGURATION menu. *You may do a "quick-kill" or "panic-kill" at any time by typing the [Ctrl]-[F7] keys.* An in-progress AMTOR transmission may also be stopped by re-entering the COMMAND and CODE menus and selecting AMTOR (or any other code). Both procedures will return you to AMTOR "STBY" condition and the transmitter will cease chirping.

5.1.4 The ARQ QSO

By now, the AMTOR link has been established and you may start typing text to the other station. Since you started the QSO, you are now the "ISS" - the Information Sending Station.

PC-COMM includes a transmit text buffer so that you may type as fast as you desire, but characters will always be transmitted at the proper rate. Transmitted characters are "echoed" on the receive screen *as they are sent* ("Echo As Sent"). You can always gauge the progress of the ARQ transmitted output by simply looking at the receive buffer. If your typing pauses or is not as fast as the transmitted rate, PC-COMM automatically inserts AMTOR "idle" characters as indicated by the "IDL" status word instead of "TFC" on the center status line.

If the ARQ link has detected errors, the "TFC"/"IDL" indicator will change to "ERR" to show that you have received an error or "RQ" to show that the other station has requested a repeat. The "ERR" and "RQ" labels will usually flash very quickly and may not be noticeable on good quality links. However, if either "ERR" or "RQ" are frequently observed, it may be a sign that the ARQ link is about to fail.

5.1.5 ARQ OVER Commands

In ARQ mode, information flow is *one-way*, even though both transmitters are alternately "chirping away". Thus, it is very much like all other amateur modes - RTTY, CW, or Voice - you send for a while and then let the other station send for a while. However, in AMTOR, we cannot just turn our transmitters ON and OFF to control who talks and who listens -- both transmitters are already switching ON and OFF.

AMTOR ARQ mode has a very special command to control which station *sends text* (ISS) and which station *receives text* (IRS). This is called the "OVER" command. There are two slightly different versions, "Normal OVER" the "Forced OVER".

If you are the current *ISS* (Information Sending Station), all you need to do is end your typed comments with the plus and question mark characters (+?). These characters are entered into the transmit buffer and a special ARQ control sequence is executed when +? is sent. The control sequence has the effect of *reversing* the roles of the two stations. Your station will now become the *IRS* (Information Receiving Station) and the other station becomes the ISS. He will then send text to you. Likewise, he can return sending control to you by typing +?. The ARQ QSO thus continues in the typical amateur back-and-forth manner with each station ending his comments with a +? sequence. You may enter the OVER command by either typing the [F6] key or by typing +?. *This "OVER" command will work ONLY if you are the ISS.*

The "FORCED OVER" command is like full break-in CW. For example, you might be the receiving (IRS) station, but wish to interject a comment or otherwise interrupt the sending of the other station. Use the [Ctrl]-[F6] keys to inject a FORCED OVER operation. If you are the IRS, the FORCED OVER is the only way you can reverse the channel without waiting for the other station to finish his typing. Keep in mind that a FORCED OVER operates *immediately* and therefore interrupts whatever the other station is sending. Use it with care!

The ISS may also use [Ctrl]-[F6] to give a FORCED OVER. If so, the channel will turn-around as soon as you press [Ctrl]-[F6], without sending any text that may still remain in your transmit buffer. It is better practice to use +? or [F6] for a Normal OVER that is placed at the *end* of your transmit pre-typed text.

Even if a FORCED OVER is used, PC-COMM preserves any unsent text in the transmit buffer. It will be held until it is again your turn to transmit and then sent *before any newly pretyped text*. You may, however, erase the entire transmit buffer at any time by typing [Alt]-V. Be careful - you can lose a lot of pre-typing!

To review the "OVER" options:

1. If ISS, type [F6] or +? at end of your text to be sent
2. If ISS or IRS, type [Ctrl]-[F6] to immediately reverse the channel.

5.1.6 AMTOR END Commands

AMTOR requires another special set of control codes to be sent at the end of the QSO. This is called the "END" command. If you are the ISS, END an AMTOR QSO by typing either the [F7] key or ZZZZ in the transmit buffer. (Actually, [F7] enters "ZZZZ" in the transmit buffer as well but saves 4 key presses). When "ZZZZ" is sent, it automatically triggers the required AMTOR END control sequence.

As in the case of OVER, there is also a "FORCED END" command that you can use to immediately stop the link. You may use [Ctrl]-[F7] to give a FORCED END when operating as either ISS or IRS. *Note that a FORCED END operates immediately and does not wait until any pre-typed text has been sent.* Any unsent text will be cleared from the transmit buffer when [Ctrl]-[F7] is typed. [Ctrl]-[F7] may also be called a "panic-kill" for ARQ mode. If the transmitter is smoking, you want to get off the air as soon as possible!

5.1.7 ARQ WRU Feature

PC-COMM includes a WRU (Who aRe yoU) feature that allows the other station to confirm the identity of your station. APLink and some amateur mailboxes use WRU when you first connect to the system. A special character is sent by the APLink or mailbox station that causes PC-COMM to respond with the *ANSWERBACK* message (a special type of "HERE IS" message).

The PC-COMM WRU feature may be turned ON or OFF, using the CONFIGURATION and AMTOR menus. The ANSWERBACK message is HERE IS 9 (CONFIGURATION, Page 2).

Assuming that you have WRU turned ON and an ANSWERBACK message programmed, the full operation sequence for WRU is as follows:

1. Other station is ARQ ISS and sends "\$" (dollar sign; FIGS-D)
2. PC-COMM forces an OVER so that you are now the ISS
3. Your ANSWERBACK text is sent (no other text is sent)
4. PC-COMM sends a second OVER so that you are now back to IRS state.

You may program any ANSWERBACK text you wish up to a total of 80 characters. The following formats are suggested:

APLINK: QRA [call sign] [SEL-CAL] Ex: QRA K9GWT KGWT
OTHER: DE [call sign] (SEL-CAL) Ex: DE K9GWT (KGWT)

APLink looks for a WRU response and then uses your call sign and SEL-CAL to log-in your station. The latest versions of APLink will accept either of the above formats. Other mailbox stations may have slightly different format requirements.

WRU is a feature that should generally be left in the OFF state unless you are actively using APLink or a mailbox that requires WRU. The reason for this suggestion is that some amateurs may send the dollar sign as part of their AMTOR text. If your WRU is turned ON, he will get a very confusing response when he sends you the dollar sign. Also, even though AMTOR is an error correcting mode, it is not 100% infallible and errors can and do occur. Noise hits could therefore trigger unwanted OVER and ANSWERBACK transmissions. The WRU feature does not operate in FEC, SEL-FEC, RTTY, or PACTOR modes and is NOT a general purpose message response feature.

UNLESS YOU NEED WRU, LEAVE THIS FEATURE TURNED OFF!

The PCI-4000 and PC-COMM include special requirements to prevent accidental false triggering of the WRU ANSWERBACK. These are:

When a FIGS-D (\$) is received, the following conditions must be met before the ANSWERBACK text is sent:

1. WRU must be turned ON.
2. ANSWERBACK text must be programmed.
3. When received, the FIGS-D (\$) must be followed by the AMTOR "IDLE.B" or CR/LF characters. Any following AMTOR "triplets" must not include data or errors (but can be "IDLE.B" control characters).

When the PCI-4000 sends a FIGS-D (\$), it is sent so that the AMTOR "IDLE.B" character "fills" the current and the following data triplet.

5.1.8 AMTOR Parameters

Several operating parameters for AMTOR ARQ mode may be set via the Page 3 CONFIGURATION Menu. To access this menu:

1. Press [F1]
The first COMMAND menu will appear with CODE highlighted.
2. Press [E]
The FILES menu will be shown
3. Press [C]
Page 1 of the CONFIGURATION menu will be shown
4. Press [Down Arrow] twice
5. Press [Enter]
Page 3 of the CONFIGURATION menu will be shown.
6. Press [Enter]
7. Use the up/down arrow keys to highlight and edit AMTOR parameters.

ARQ mode parameters have the following meaning:

WRU	Enable or disable WRU mode (see previous section 5.1.7). Default = OFF
TIME OUT	Turn time out on or off. When ON, ARQ call to another station will cease after 1 minute of unsuccessful calls. Default = ON.
TD	Transmitter turn on delay; the delay from setting the push-to-talk (PTT) line to transmit (TX) state and the start of the AFSK tones. Data modulation of the tones starts 5 ms after PTT is set to TX. Adjustable from 5 to 99 ms; Default = 10 ms.
CD	Control delay between the end of a received block and the start of the first IRS transmission. Adjustable from 10 to 99 ms. Default = 50 ms.
Letter Case	Chose "standard" CCIR upper-case only letters or the G3PLX/W5SMM upper/lower case algorithm (also called "ASCII AMTOR"). Default = U/L (upper/lower case).

- MY 476 SCAL** Selective call (SEL-CAL) characters for my station in CCIR-476 format; 4 letters maximum (no numbers).
- MY 625 SCAL** Selective call (SEL-CAL) characters for my station in CCIR-625 format; 7 letters maximum (no numbers).
- GROUP CALL** Group Call characters for my station in Selective FEC (SFEC) mode in CCIR-476 format; 4 letters maximum (no numbers).

5.2 FEC Mode ("Mode B")

AMTOR FEC mode may also be called "Mode B" or "Collective Broadcast Mode". The letters "FEC" stand for Forward Error Correction. FEC uses the same 7-bit character code as ARQ mode but sends each character twice, separated by the time it takes to send four other characters (called a "4-character interleave"). If the first received character is in error, the FEC receiving equipment examines the second character. FEC is sent much like standard RTTY; one station transmits continuously and then turns OFF its transmitter to receive text from the other station. However, FEC code is *not* the same as RTTY and you must have an AMTOR decoder to receive FEC signals. Rapid switching times are not required for FEC mode. However, like RTTY, transmitting FEC imposes a 100% duty cycle on your transmitter (full power is always ON).

Amateurs use FEC mode for two purposes: (1) calling CQ for an ARQ mode QSO, and (2) a general "rag-chew" QSO using "RTTY-like" operating procedures. FEC is most frequently used to call a CQ which will lead to an ARQ mode QSO. However, FEC is also used in "round-table" situations where more than two stations may wish to participate in the same QSO.

5.2.1 Starting FEC Mode

To start FEC mode, access the COMMAND menu and select FEC. The following steps are recommended:

1. Press [F1]
The first COMMAND menu will appear with CODE highlighted.
2. Press [Enter]
The CODE menu will be shown
3. Use the [up-arrow] or [down-arrow] keys to highlight AMTOR.
4. Press [Enter]
The MODE menu will now be shown with "Send ARQ" highlighted
5. Use the [up-arrow] or [down-arrow] keys to highlight Send FEC
6. Press [Enter]
You are now in FEC mode
7. Type some text to be transmitted
8. Type [F10] to enable the transmit buffer output
You will now be on-the-air in FEC mode.

FEC does not require a SEL-CAL code and may be used much like RTTY.

5.2.2 FEC Send/Receive Control

The FEC code itself includes special character sequences at the start and end of each FEC transmission. PC-COMM automatically inserts these and intermediate idle sequences as required and no special operator or key operations are required.

Transmit/receive control of FEC is done entirely by the [F10] key combination. Once FEC mode has been selected, use [F10] to enable or disable the transmit buffer output.

NOTE: The [F10] keys control transmit-receive state in FEC mode, but PC-COMM does not return to AMTOR-STBY mode in receive. Rather, PC-COMM remains in FEC-only receive mode so that you may conduct an FEC QSO. See the following section if you wish to return to STBY mode after an FEC transmission.

5.2.3 FEC Return to STBY Mode.

In some cases, it is desirable for PC-COMM to return to AMTOR-STBY mode rather than to FEC-only receive mode. Calling CQ for an ARQ mode response is such a situation. In this case, insert ZZZZ at the end of the transmitted text. The [F7] key may be used to insert the ZZZZ sequence.

FEC also includes a "panic kill" hot-key -- [Ctrl]-[F7]. In this case, pressing [Alt]-[F8] will cause an *immediate* end of FEC transmission, clears any unsent text out of the transmit buffer, and returns PC-COMM to STBY mode (not to FEC). Use [Ctrl]-[F7] with restraint!

5.2.4 Typical FEC CQ Call

FEC is often used by amateurs to issue a CQ call for an ARQ Mode QSO. A typical format for this CQ call might be as follows.

1. Select **AMTOR** and **Send FEC** via the **COMMAND** menus.
2. Type:

CQ CQ CQ DE K9GWT K9GWT K9GWT (KGWT KGWT KGWT)
CQ CQ CQ DE K9GWT K9GWT K9GWT (KGWT KGWT KGWT)
ZZZZ

3. Press [F10] to enable the transmit buffer output
4. When the complete message has been sent, PC-COMM will return to STBY, ready for an ARQ call.

The CQ message may be pre-loaded into one of the HERE IS buffers. The "ZZZZ" sequence may be loaded manually or loaded by typing the [F7] key. The above procedure will send your CQ call in FEC mode and return to STBY mode when complete. When the calling station answers in ARQ mode using your SEL-CAL, PC-COMM will automatically switch to ARQ, link, and the ARQ QSO will be in progress. The procedures for both stations to use FEC mode in a QSO are slightly different as will be explained in the following section.

NOTE: In any FEC transmission, do not start with a series of "RYRYRY.." characters. The "RYRYRY.." sequence may confuse the other station's equipment, preventing it from synchronizing to your FEC signal.

5.2.5 Typical FEC Mode QSO

If you want to have a QSO in which both stations send and receive in FEC mode, a slightly different procedure is used. In this case you want PC-COMM to return to FEC-receive rather than STBY mode when you have completed transmitting. You can do this by:

1. **DO NOT** end your transmission with ZZZZ, [F7], or [Ctrl]-[F7].
2. **DO** use the transmit buffer control key [F10] to control transmit and receive - just like RTTY.
3. PC-COMM will *automatically* return to FEC-receive when all text in the transmit buffer has been sent. However, if you also wish to pre-type your next transmission, be sure to DIS-able the buffer output using [F10] before typing. (Otherwise, the transmitter will go back on-the-air and start sending the newly typed text.)

FEC is an error-correcting mode, but each character is sent only twice and there is no "repeat request" feature as in ARQ mode. Therefore, some reception errors will occur if both of the FEC repeat characters are flawed. When PC-COMM detects a reception error in FEC (and SEL-FEC), the error is shown on the screen as an under bar (_) symbol. *This is entirely normal and does not indicate a malfunction of PC-COMM or of the sending station's equipment.*

5.3 SEL-FEC Mode ("Mode S")

AMTOR SEL-FEC mode may also be called "Mode S" or "Selective Broadcast Mode". SEL-FEC mode is a cross between ARQ and FEC AMTOR modes. SEL-FEC, like ARQ, uses a SEL-CAL code (called the "GROUP CALL") but is a continuous send mode like FEC. However, data sent in SEL-FEC mode is *inverted* from that sent in FEC mode.

To date, SEL-FEC has not been a frequently-used AMTOR mode. It is a convenient mode to use if it is desired to send text to a group of stations, all using the *same* "GROUP CALL" SEL-CAL code. When SEL-CAL is used, amateurs typically use "CQCQ" as the GROUP CALL.

NOTE: GROUP CALL and ARQ SEL-CAL are NOT the same.

5.3.1 Starting SEL-FEC Mode

To start SEL-FEC mode, access the COMMAND mode and select SFEC. The following steps are recommended:

1. Press [F1]
The first COMMAND menu will appear with CODE highlighted.
2. Press [Enter]
The CODE menu will be shown
3. Use the [up-arrow] or [down-arrow] keys to highlight AMTOR.
4. Press [Enter]
The MODE menu will now be shown with "Send ARQ" highlighted
5. Use the [up-arrow] or [down-arrow] keys to highlight Send SFEC
6. Press [Enter]
The SEL-FEC SEL-CAL entry blank now appears.
7. Accept the default (CQCQ) by typing [Enter] or enter a new 4-character SEL-CAL code followed by [Enter].
8. Type some text to be transmitted
9. Type [F10] to enable the transmit buffer output
You will now be on-the-air in SEL-FEC mode.

5.3.2 SEL-FEC END Commands

SEL-FEC requires a special set of control codes to be sent at the end of a transmission. This is called the "END" command. You may END the SEL-FEC transmission by typing either the [F7] key or ZZZZ in the transmit buffer. (Actually, [F7] enters ZZZZ in the transmit buffer as well, but saves 3 key presses). When "ZZZZ" is sent, it automatically triggers the required SEL-FEC END control sequence. SEL-FEC *always* returns to STBY mode at the end of a transmission.

There is also a "FORCED END" command that you can use when you want to get off the air quickly. Type [Ctrl]-[F7] to force an *immediate* END, regardless of whether or not all of your pre-typed text has been sent.

5.4 LISTEN Mode ("Mode L")

PC-COMM also includes a receive-only mode so that we may listen to all AMTOR transmissions. The LISTEN mode (also called "MONITOR" or "Mode L") will automatically select the mode and decode characters from ARQ, FEC, or SEL-FEC received signals. It uses the same 7-bit code as the other AMTOR modes.

5.4.1 Starting LISTEN Mode

To start LISTEN mode, access the COMMAND menu and select LISTEN. The following steps are recommended:

1. Press [F1]
The first COMMAND menu will appear with CODE highlighted.
2. Press [Enter]
The CODE menu will be shown
3. Use the [up-arrow] or [down-arrow] keys to highlight AMTOR.
4. Press [Enter]
The MODE menu will now be shown with "Send ARQ" highlighted
5. Use the [up-arrow] or [down-arrow] keys to highlight LISTEN
6. Press [Enter]
You are now in LISTEN mode and received signals using ARQ, FEC, or SEL-FEC modes will be received and displayed.

The status-line indicators will show "ARQ", "FEC", or "SEL-FEC" when an AMTOR signal is detected and decoded. Also, the "PHS"/"TFC"/"ERR" indicator will show data type when a signal is being received.

5.4.2 LISTEN Mode Performance

LISTEN mode does not give full error-correction of received ARQ mode signals since it does not transmit repeat request signals back to the sending station. Rather, LISTEN "makes the best with what it hears" and either prints the decoded character or an under bar symbol for flawed characters. If the ARQ signal is strong, it may print perfectly with no errors. However, weak, fading, or signals with interference will likely show several errors per line, requiring some "interpretive reading" on your part.

LISTEN mode reception of FEC and SEL-FEC modes is essentially the same as when these modes are selected manually. However, as explained in Section 5.2.5, some reception errors are possible in FEC and SEL-FEC modes and these errors are also shown as under bar symbols on the screen.

5.4.3 LISTEN vs STBY Modes

At first glance, it might appear that LISTEN and STBY modes are the same. However there are some major differences:

LISTEN:

1. RECEIVE ONLY - but will link in ARQ if your SEL-CAL is heard
2. NO SEL-CAL A SEL-CAL match in ARQ or SEL-FEC is not required to obtain decoding and print-out characters
3. AUTOMATIC MODE SELECTION - ARQ, FEC, or SEL-FEC modes will all be decoded and displayed. The selected mode is shown on the status indicators.
4. PC-COMM returns to LISTEN after reception of a mode is complete.

Note that PC-COMM's LISTEN mode includes ALL AMTOR modes.

STBY:

1. SEND AND/OR RECEIVE - if an ARQ signal using your SEL-CAL is received, PC-COMM automatically changes to ARQ mode and starts transmitting the correct control signal response.
2. SEL-CAL REQUIRED - in ARQ and SEL-FEC modes, PC-COMM ignores received signals whose SEL-CAL codes do *not* match those programmed for your station.
3. AUTOMATIC MODE SELECTION - a received FEC signal will be displayed immediately; an ARQ mode QSO will be started automatically if the SEL-CAL matches yours; SEL-FEC print will begin if the GROUP CALL matches that stored for your station.
4. PC-COMM returns to STBY at the end of an ARQ, FEC, or SEL-FEC QSO.

6. OPERATING PACTOR

PACTOR is an error-correcting communications mode. PACTOR has four sub-modes that may be chosen: (1) ARQ, (2) UNPROTO (FEC), (3) LISTEN, and (4) STBY (Standby).

PACTOR is similar in many respects to AMTOR. All PACTOR modes use a special error-correcting code sent using either 100 or 200 baud data rate. ARQ mode is sent in pulses and both stations transmit in a time-sequenced order. Each station automatically requests a repeat if an error is detected. UNPROTO (FEC) mode does not use pulses and sounds much like RTTY. In UNPROTO mode, each character is sent 2, 3, 4, or 5 times with a time separation between each repeat. PACTOR LISTEN mode is a pure receive-only mode that may be used to listen to ARQ or UNPROTO (FEC) signals. LISTEN mode cannot correct errors in received ARQ mode signals. STBY mode is the normal "rest" condition of a PACTOR station when monitoring a frequency. If your station ARQ SEL-CAL code is received, PC-COMM automatically switches from STBY to ARQ mode and responds. FEC and SEL-FEC reception is also automatic from STBY mode. Comments of previous section 5.4.3 comparing STBY and LISTEN modes also apply to PACTOR.

PACTOR includes the special "Huffman" data compression code which may improve the apparent "speed" (actually the throughput rate) at which data is sent. However, Huffman coding is context sensitive and the amount of compression or "speed gained" varies with the actual data content. In addition, Huffman coding is limited to standard printed text and does not include "full ASCII" control characters. When Huffman coding is turned off, *most* ASCII characters may be sent. PACTOR will send most of the ASCII symbol set and is much more flexible than AMTOR in this respect. However, unlike CLOVER, PACTOR does not send 8-bit computer data and therefore "executable" computer files cannot be sent via PACTOR.

6.1 ARQ Mode

As in AMTOR, PACTOR "ARQ" stands for Automatic Repeat ReQuest (or Query). ARQ is a full error-correcting mode in which one station sends a group of characters and then the other station either sends an acknowledge or requests a repeat of a group received in error. Thus, the transmitters of *both* stations are pulsed ON and OFF. PACTOR ARQ mode requires use of transmitters and receivers that can rapidly switch between receive and transmit. Most recent models of amateur equipment have fast switching for AMTOR and PACTOR Radio. Consult your equipment manual if you have any doubts. ARQ QSO's may be between *two* stations *only* - no "round-tables".

6.1.1 ARQ Data Rates

PACTOR ARQ may be operated using a data rate of 100 baud, 200 baud, or in "AUTO" mode which automatically switches between the two data rates as channel conditions dictate. Most PACTOR ARQ mode links use the "AUTO" mode. Various parameters controlling ARQ mode are set via Page 3 of the CONFIGURATION menu as will be discussed in section 6.3. For the present, it is assumed that the PC-COMM default values will be used.

6.1.2 Starting ARQ Mode

There are two ways to start an ARQ mode transmission; (1) using the COMMAND menus, and (2) using "hot keys".

The COMMAND menu method is:

1. Press [F1]
The first COMMAND menu will appear with CODE highlighted.
2. Press [Enter]
The CODE menu will be shown
3. Use the [up-arrow] or [down-arrow] keys to highlight PACTOR.
4. Press [Enter]
The MODE menu will now be shown with Send ARQ highlighted
5. Press [Enter]
The ARQ call sign menu now appears.
6. Type a new call sign code or choose one of the CALL DIRECTORY choices.
7. Press [Enter]
8. Select "Adaptive" in the FORMAT menu
9. Press [Enter]

The [F9] "hot key" bypasses steps 1 through 5 and immediately shows you the call sign menu. [F9] is by far the easiest way to get on-the-air in ARQ mode.

6.1.3 PACTOR Call Signs

Unlike AMTOR, but like CLOVER, PACTOR does not require a special selective call sequence of letters. Rather, the call signs of each station are used directly. Therefore, no special steps need be taken to program a "SEL-CALL" sequence for PACTOR.

6.1.4 Establishing the ARQ Link

The sequence at the beginning of an ARQ QSO is as follows:

1. Press [F9]
2. Select the call sign and type [Enter]
3. Your station starts sending the other station's call sign.
4. The other station recognizes his call sign and responds.
5. Enable your transmit buffer by typing [F10]
6. Start typing transmit text.

Once these steps have been successfully completed, the ARQ QSO may continue and you may send text to the other station. However, *no* text will be passed until the first five steps have been finished. When a link is in progress (not all five steps complete), the top line of the screen will display the message:

---- Calling - (K9CW) ----- PACTOR -----

The center status line will show:

ARQ ISS EN TXT/RQ

This indicates that an ARQ call is in progress, you are the ISS (Information Sending Station), and that the call-up sequence is in progress. Your transmitter should now be pulsing ON and OFF ("chirping").

Once the link has been established, the "Calling" label will change to "Linked With XXXX". If your receiver speaker is turned ON, you will also hear the other station's short "chirp" response (control signals).

If you do *not* get a response from the other station, the MAX ERROR option controls whether your transmitter continues "chirping forever" (MAX ERROR = 255) or the ARQ call automatically "times-out" (MAX ERROR = 30, the minimum). The MAX ERROR option is normally set to "80", but may be changed in the CONFIGURATION menu. *You may do a "quick-kill" or "panic-kill" at any time by typing the [Ctrl]-[F7] keys.* An in-progress PACTOR transmission may also be stopped by re-entering the COMMAND and CODE menus and selecting PACTOR (or any other code). Both procedures will return you to PACTOR "STBY" condition and the transmitter will cease its chirping.

6.1.5 The ARQ QSO

By now, the PACTOR link has been established and you may start typing text to the other station. Since you started the QSO, you are now the "ISS" - the Information Sending Station.

PC-COMM includes a transmit text buffer so that you may type as fast as you desire, but characters will always be transmitted at the proper rate. Transmitted characters are "echoed" on the receive screen *as they are sent* ("Echo As Sent"). You can always gauge the progress of the ARQ transmitted output by simply looking at the receive buffer. If your typing pauses or is not as fast as the transmitted rate, PC-COMM automatically inserts PACTOR "idle" characters as indicated by the "IDL" status word instead of "TFC" on the center status line.

If the ARQ link has detected errors, the "TFC"/"IDL" indicator will change to "ERR" to show that you have received an error or "RQ" to show that the other station has requested a repeat. The "ERR" and "RQ" labels will usually flash very quickly and may not be noticeable on good quality links. However, if either "ERR" or "RQ" are frequently observed, it may be a sign that the ARQ link is about to fail.

6.1.6 ARQ OVER Commands

In ARQ mode, information flow is *one-way*, even though both transmitters are alternately "chirping away". Thus, it is very much like all other amateur modes - RTTY, CW, or Voice; you send for a while and then let the other station send for a while. However, in PACTOR, we cannot just turn our transmitters ON and OFF to control who talks and who listens -- both transmitters are already switching ON and OFF.

Like AMTOR, PACTOR ARQ mode has a very special command to control which station *sends text* (ISS) and which station *receives text* (IRS). This is called the "OVER" command. There are two slightly different versions, "Normal OVER" and "Forced OVER".

If you are the current *ISS* (Information Sending Station), all you need to do is end your typed comments with the plus and question mark characters (+?). These characters are entered into the transmit buffer and a special ARQ control sequence is executed when [+?] is sent. The control sequence has the effect of *reversing* the roles of the two stations. Your station will now become the *IRS* (Information Receiving Station) and the other station becomes the ISS. The other operator will then send text to you. Likewise, he can

return sending control to you by typing [+?]. The ARQ QSO thus continues in the typical amateur back-and-forth manner with each station ending its comments with a +? sequence. You may enter the OVER command by either typing the [F6] key or by typing +?. *This "OVER" command will work ONLY if you are the ISS.*

The "FORCED OVER" command is like full break-in CW. For example, you might be the receiving (IRS) station, but wish to interject a comment or otherwise interrupt the sending of the other station. Use the [Ctrl]-[F6] keys to inject a FORCED OVER operation. If you are the IRS, the FORCED OVER is the only way you can reverse the channel without waiting for the other station to finish his typing. Keep in mind that a FORCED OVER operates *immediately* and therefore interrupts whatever the other station is sending. Use it with care!

The ISS may also use [Ctrl]-[F6] to give a FORCED OVER. If so, the channel will turn-around as soon as you press [Ctrl]-[F6], without sending any text that may still remain in your transmit buffer. It is better practice to use +? or [F6] for a Normal OVER that is placed at the *end* of your transmit pre-typed text.

Even if a FORCED OVER is used, PC-COMM preserves any unsent text in the transmit buffer. It will be held until it is again your turn to transmit and then sent - *before any newly pre-typed text*. You may, however, erase the entire transmit buffer at any time by typing [Alt]-V. Be careful - you can lose a lot of pre-typing!

To review the "OVER" options:

1. If ISS, type [F6] or +? at end of your text to be sent
2. If ISS or IRS, type [Ctrl]-[F6] to *immediately* reverse the channel.

6.1.7 PACTOR END Commands

PACTOR requires another special set of control codes to be sent at the end of the QSO. This is called the "END" command. If you are the ISS, END a PACTOR QSO by typing either the [F7] key or ZZZZ in the transmit buffer. Actually, [F7] enters "ZZZZ" in the transmit buffer as well, but saves 3 key presses. When "ZZZZ" is sent, it automatically triggers the required PACTOR END control sequence.

As in the case of OVER, there is also a "FORCED END" command that you can use to immediately stop the link. You may use [Ctrl]-[F7] to give a FORCED END when operating as either ISS or IRS. *Note that a FORCED END operates immediately and does not wait until any pre-typed text has been sent.* Any unsent text will be cleared from the transmit buffer when [Ctrl]-[F7] is typed. [Ctrl]-[F7] may also be called a "panic-kill" for ARQ mode. If the transmitter is smoking, you want to get off the air as soon as possible!

6.1.8 FACTOR ARQ Parameters

Several operating parameters for FACTOR ARQ mode may be set via the Page 3 CONFIGURATION Menu. To access this menu:

1. Press [F1]
The first COMMAND menu will appear with CODE highlighted.
2. Press [F]
The FILES menu will be shown
3. Press [C]
Page 1 of the CONFIGURATION menu will be shown
4. Press [Down Arrow] twice
5. Press [Enter]
Page 3 of the CONFIGURATION menu will be shown.
6. Press [Enter]
8. Press [Right Arrow] once
9. Use the up/down arrow keys to highlight and edit FACTOR parameters.

ARQ mode parameters have the following meaning:

CS DELAY	Delay between the end of a received block and the start of the first IRS control data bit. Adjustable from 10 to 50 ms. Default = 30 ms.
MAX DOWN	In Auto-ARQ mode, the maximum number of flawed data blocks before changing the data rate from 200 baud to 100 baud. Adjustable from 2 to 30; Default = 6.
MAX UP	In Auto-ARQ mode, the number of error-free blocks before changing the data rate from 100 baud to 200 baud. Adjustable from 2 to 30; Default = 3.
MAX TRY	In Auto-ARQ mode, the maximum number of attempts to change the data rate from 100 to 200 baud. Adjustable from 0 to 9; Default = 2.
MAX ERROR	In all ARQ modes, the maximum number of retries when calling to link or the maximum repeats to correct errors when linked. Adjustable from 30 to 255; Default = 80.
MAX ARQ SUM	In all ARQ modes, the maximum number of the memory-ARQ counter. Memory-ARQ summation is cleared when MAX ARQ SUM is exceeded. Adjustable from 5 to 60; Default = 10.
HUFFMAN	In all ARQ and UNPROTO/FEC modes, enable or disable Huffman data compression coding. Default = ON.

6.2 FEC Mode (UNPROTO)

FACTOR UNPROTO (FEC) uses Forward Error Correction. FEC uses the same character code as FACTOR ARQ mode but sends each character 2 to 5 times, separated in time. If the first received character is in error, the FEC receiving equipment examines the 2nd, 3rd, etc. character. FEC is sent much like standard RTTY - one station transmits continuously and then turns OFF his transmitter to receive text from the other station. However, FEC code is *not* the same as RTTY and you must have a FACTOR decoder to receive FEC signals. Rapid switching times are *not* required for FEC mode. However, like RTTY, transmitting FEC imposes a 100% duty cycle on your transmitter (full power is always ON).

Amateurs use FEC mode for two purposes: (1) calling CQ for an ARQ mode QSO, and (2) a general "rag-chew" QSO using "RTTY-like" operating procedures. FEC is most frequently used to call a CQ which will lead to an ARQ mode QSO. However, FEC is also used in "round-table" situations where more than two stations may wish to participate in the same QSO.

6.2.1 FEC Data Rates

FACTOR UNPROTO (FEC) transmissions may use either a 100 or 200 baud data rate. The rate used is selected as transmission is started. Unless the communications path is extremely stable, 100 baud is recommended.

6.2.2 Starting FEC Mode

To start FEC mode, access the COMMAND menu and select FEC. The following steps are recommended:

1. Press [F1]
The first COMMAND menu will appear with **CODE** highlighted.
2. Press [Enter]
The **CODE** menu will be shown
3. Use the [up-arrow] or [down-arrow] keys to highlight **FACTOR**.
4. Press [Enter]
The **MODE** menu will now be shown with "Send ARQ" highlighted
5. Use the [up-arrow] or [down-arrow] keys to highlight **Send FEC**
6. Press [Enter]
7. Use the up/down arrow keys to select 100 or 200 baud (100 recommended)
8. Press [Enter]
You are now in FEC mode
9. Type some text to be transmitted
10. Type [F1Q] to enable the transmit buffer output
You will now be on-the-air in FEC mode.

FEC does not require a call sign code and may be used much like RTTY.

6.2.3 FEC Send/Receive Control

The FEC code itself includes special character sequences at the start and end of each FEC transmission. PC-COMM automatically inserts these and intermediate idle sequences as required and no special operator or key operations are required.

Transmit/receive control of FEC is done entirely by the [F10] key combination. Once FEC mode has been selected, use [F10] to enable or disable the transmit buffer output.

NOTE: The [F10] keys control transmit-receive state in FEC mode, but PC-COMM does not return to PACTOR-STBY mode in receive. Rather, PC-COMM remains in FEC-only receive mode so that you may conduct an FEC QSO. See the following section if you wish to return to STBY mode after an FEC transmission.

6.2.4 FEC Return to STBY Mode.

In some cases, it is desirable for PC-COMM to return to PACTOR-STBY mode rather than to FEC-only receive mode. Calling CQ for an ARQ mode response is such a situation. In this case, insert ZZZZ at the end of the transmitted text. The [F7] key may be used to insert the ZZZZ sequence.

FEC also includes a "panic kill" hot-key -- [Ctrl]-[F7]. In this case, pressing [Alt]-[F8] will cause an immediate end of FEC transmission, clears any unsent text out of the transmit buffer, and returns PC-COMM to STBY mode (not to FEC). *Use [Ctrl]-[F7] with restraint!*

6.2.5 Typical FEC CQ Call

FEC is often used by amateurs to issue a CQ call for an ARQ Mode QSO. A typical format for this CQ call might be as follows.

1. Select PACTOR - Send FEC via the COMMAND menus.
2. Type:

```
CQ CQ CQ DE K9GWT K9GWT K9GWT
CQ CQ CQ DE K9GWT K9GWT K9GWT
ZZZZ
```

3. Press [F10] to enable the transmit buffer output
4. When the complete message has been sent, PC-COMM will return to STBY, ready for an ARQ call.

The CQ message may be pre-loaded into one of the HERE IS buffers. The "ZZZZ" sequence may be loaded manually or loaded by typing the [F7] key. The above procedure will send your CQ call in FEC mode and return to STBY mode when complete. When the calling station answers in ARQ mode using your SEL-CAL, PC-COMM will automatically switch to ARQ, link, and the ARQ QSO will be in progress. The procedures for both stations to use FEC mode in a QSO are slightly different as will be explained in the following section.

NOTE: In any FEC transmission, do not start with a series of "RYRYRY.." characters. The "RYRYRY..." sequence may confuse the other station's equipment, preventing it from synchronizing to your FEC signal.

6.2.6 Typical FEC Mode QSO

If you want to have a QSO in which *both stations* send and receive in FEC mode, a slightly different procedure is used. In this case you want PC-COMM to return to FEC-receive rather than STBY mode when you have completed transmitting. You can do this by:

1. **DO NOT** end your transmission with ZZZZ, [F7], or [Ctrl]-[F7].
2. **DO** use the transmit buffer control key [F10] to control transmit and receive - just like RTTY.
3. PC-COMM will *automatically* return to FEC-receive when all text in the transmit buffer has been sent. However, if you also wish to pre-type your next transmission, be sure to DIS-able the buffer output using [F10] before typing. (Otherwise, the transmitter will go back on-the-air and start sending the newly typed text.)

FEC is an error-correcting mode, but each character is sent only twice and there is no "repeat request" feature as in ARQ mode. Therefore, some reception errors will occur if both of the FEC repeat characters are flawed. When PC-COMM detects a reception error in FEC (and SEL-FEC), the error is shown on the screen as an under bar () symbol. *This is entirely normal and does not indicate a malfunction of PC-COMM or of the sending station's equipment.*

6.2.7 FEC Configuration Parameters

As detailed in section 6.1.8, access the PACTOR menu page 3 of the CONFIGURATION menu. Two parameters apply to FEC mode:

FEC Repeats The number of times each character to be transmitted is repeated. Adjustable from 2 to 5; Default = 2.

HUFFMAN In all ARQ and UNPROTO/FEC modes, enable or disable Huffman data compression coding. Default = ON.

6.3 LISTEN Mode ("Mode L")

PC-COMM also includes a receive-only mode so that we may listen to all AMTOR transmissions. The LISTEN mode (also called "MONITOR" or "Mode L") will automatically select the mode and decode characters from ARQ or UNPROTO (FEC) received signals.

6.3.1 Starting LISTEN Mode

To start LISTEN mode, access the COMMAND menu and select LISTEN. The following steps are recommended:

1. Press [F1]
The first COMMAND menu will appear with CODE highlighted.
2. Press [Enter]
The CODE menu will be shown
3. Use the [up-arrow] or [down-arrow] keys to highlight PACTOR.
4. Press [Enter]
The MODE menu will now be shown with "Send ARQ" highlighted
5. Use the [up-arrow] or [down-arrow] keys to highlight LISTEN
6. Press [Enter]
You are now in LISTEN mode and received signals using ARQ or FEC modes will be received and displayed.

The status-line indicators will show "ARQ" or "FEC" when a PACTOR signal is detected and decoded. Also, the "PHS"/"TFC"/"ERR" indicator will show data type when a signal is being received.

6.3.2 LISTEN Mode Performance

LISTEN mode does not give full error-correction of received ARQ mode signals since it does not transmit repeat request signals back to the sending station. Rather, LISTEN "makes the best with what it hears" and either prints the decoded character or an under bar symbol for flawed characters. If the ARQ signal is strong, it may print perfectly with no errors. However, weak, fading, or signals with interference will likely show several errors per line, requiring some "interpretive reading" on your part.

LISTEN mode reception of FEC mode is essentially the same as FEC is selected manually. However, as explained in Section 6.2.5, some reception errors are possible in FEC mode and these errors are also shown as under bar symbols on the screen.

6.3.3 LISTEN vs STBY Modes

At first glance, it might appear that LISTEN and STBY modes are the same. However there are some major differences:

LISTEN:

1. RECEIVE ONLY - but will link in ARQ if your SEL-CAL is heard
call sign match in ARQ is not required to obtain decoding and print-out characters
2. NO Call Sign A
3. AUTOMATIC MODE SELECTION - ARQ or FEC modes will be decoded and displayed. The selected mode is shown on the status indicators.
4. PC-COMM returns to LISTEN after reception of a mode is complete.

Note that PC-COMM's LISTEN mode includes all PACTOR modes.

STBY:

1. SEND AND/OR RECEIVE - if an ARQ signal using your call sign is received, PC-COMM automatically changes to ARQ mode and starts transmitting the correct control signal response.
2. Call Sign REQUIRED - in ARQ mode, PC-COMM ignores received signals whose call signs do not match the one programmed for your station.
3. AUTOMATIC MODE SELECTION - a received FEC signal will be displayed immediately; an ARQ mode QSO will be started automatically if the call sign matches yours.
4. PC-COMM returns to STBY at the end of an ARQ or FEC QSO.

7. OPERATING RTTY

7.1 RTTY Codes

PC-COMM includes two RTTY modes - Baudot, and ASCII. Either may be sent and received with data rates of 45, 50, 57, 75, 100, or 110 baud.

Baudot is the original 5-bit asynchronous RTTY code amateurs have used for many years. Baudot RTTY is still in active use on the HF bands. Baudot supports *only* upper-case letters, numbers, and some symbols (the same as used in standard CCIR AMTOR). Amateurs typically use 45 baud (60 WPM) or 75 baud (100 WPM) for HF Baudot RTTY. Either the "U.S. Military Baudot" or the "CCITT No. 2" Baudot character set may be selected via Page 3 of the CONFIGURATION menu.

ASCII is an 8-bit code commonly used for asynchronous computer communications. ASCII is sometimes used for HF amateur communications, but not as frequently as is Baudot. ASCII includes upper and lower case letters, numbers, and many symbols and control codes. Amateurs typically use 110 baud (100 WPM) for HF ASCII RTTY.

7.2 Starting RTTY Modes

To start RTTY modes, access the COMMAND menu and select RTTY-BAUDOT or RTTY-ASCII. The following steps are recommended:

1. Press [F1]
The first COMMAND menu will appear with CODE highlighted.
2. Press [Enter]
The CODE menu will be shown
3. Use the [up-arrow] or [down-arrow] keys to highlight RTTY-BAUDOT or RTTY-ASCII.
4. Press [Enter]

The status line will now show the selected CODE (BAUDOT or ASCII), and the selected speed, polarity, and other parameters. If these are the speed and parameters you wish to use, you are ready to start transmitting. If not, use the following steps.

5. Press [F1] to get the COMMAND menu again.
6. Use the [right-arrow] key to select RATE
7. Press [Enter]
8. Press the [up-arrow] or [down-arrow] keys to choose a speed.
9. Press [Enter]
10. Press the [right-arrow] key to select Control.
11. Press [Enter]
12. Use the [down-arrow] key to select any desired Control feature.
Note, this menu uses the [Space Bar] key to toggle each option.
13. After all options have been set, type [Enter]
14. Type [Esc] two times to leave the COMMAND menu.

The extra steps of 5 through 14 are only necessary when you wish to change more than just the code to be used. The speed and control parameters may be set to default values using the CONFIGURATION menu.

7.3 RTTY Data Rates

Steps 5 through 14 in the above procedure allow setting of the Baudot or ASCII data rate. There are five data rates in common use for amateur HF RTTY. These are: 45, 50, 57, 75, 100, and 110 baud. Either Baudot or ASCII may be used at any of these rates, but common usage is Baudot at 45 baud ("60 WPM") or 75 baud ("100 WPM") and ASCII at 110 baud ("100 WPM"). The Baud and WPM equivalents for each code and speed are shown in Table 3.

**TABLE 3
RTTY DATA RATES AND SPEEDS**

<u>CODE</u>	<u>BAUD</u>	<u>WPM</u>	<u>COMMENTS</u>
BAUDOT	45	60	"Standard" Baudot Speed
BAUDOT	50	66	"European" Baudot Speed
BAUDOT	57	75	"Weather" Baudot Speed
BAUDOT	75	100	Most Baudot "Mailboxes"
BAUDOT	100	125	Non-standard Speed
BAUDOT	110	137.5	Non-standard Speed
ASCII	45	41	Non-standard Speed
ASCII	50	45	Non-standard Speed
ASCII	57	52	Non-standard Speed
ASCII	74	67	Non-standard Speed
ASCII	100	91	Non-standard Speed
ASCII	110	100	"Standard" ASCII Speed

A special "Hot Key" is included for rapid RTTY data rate changes. Type **[Alt]-S** to increment through the available RTTY data rates. Each press of **[Alt]-S** increases the rate one "notch".

7.4 RTTY CONTROL Options

The available CONTROL menu options are shown in Figure 11.

Control

TX EN/DIS	DIS
WORD/CHAR	WORD
NORM/REV	NORM
SYNC ON/OFF	ON
USOS ON/OFF	ON

Figure 11 RTTY Control Options

Note: the "USOS" option is available only for Baudot code.

7.4.1 TX EN/DIS

This option controls the state of the transmit buffer and radio transmit/receive control signal (PTT line). In "DIS" (DISabled) state, the transmitter will not be turned ON and text typed into the transmit buffer will be held until this control is set to "EN" (ENabled). "DIS" is the normal receive state. This control changes from "DIS" to "EN" each time this option is selected and [Space Bar] is typed. "Hot-key" [F10] also toggles the state of this control. Key [F10] is normally used in this manner to control the transmit/receive state of your RTTY station.

The "EN" (ENabled) condition actually has two states:

1. If you have pre-typed text into the transmit buffer and the state is changed from "DIS" to "ACT", the transmitter is turned ON (PTT line to TX condition) and text is sent at the chosen code and data rate. There is a short delay of Mark- only condition at the start to assure that your transmit relays are actually in transmit state before data is sent.

The transmitter will remain "on-the-air" and text will be sent for as long as *text remains to be sent*. After the last text character has been sent, the PTT line reverts to receive and you will again be able to receive RTTY. In this case, the state reverts to "EN" and "RX" since there is no text to be sent. The send-to-receive transition is also affected by WORD mode and SYNChronous idle as will be explained shortly.

An *immediate* return to receive may be made at any time by typing [Alt]-[F10] again or by accessing the COMMAND and CONTROL menus and selecting the "TX EN/DIS" option.

2. If there is *no* pre-typed text in the transmit buffer and the state is changed from "DIS" to "EN", PC-COMM and your radio will *remain* in receive condition. However, the state will immediately change to transmit (ACT) as soon as you type the first character into the transmit buffer. This mode is analogous to "full break-in".

In actual use, most amateurs prefer to always set this option to "DIS" except when it is their turn to transmit. This allows pre-typing your response while receiving the other station ("ASR" mode).

HINT: IT IS SIMPLEST TO USE [F10] TO CHANGE FROM TX/RX IN RTTY.

7.4.2 WORD/LINE/CHAR

PC-COMM may be set to WORD, LINE, or CHARacter transmit modes. Assuming that you have *not* pre-typed any transmit text, in "CHAR" mode the transmitter will be turned ON and each character will be sent *as you type it*. There is a one second delay between the last character sent and switching from TX to RX, but if you are a slow typist, the transmitter can "pop" ON and OFF frequently - very disconcerting to you and the receiving station.

In WORD mode, the transmitter is turned ON when you type the first character of a word, but no data is sent until you have completed the word. The transmitter stays in "Mark-hold" until a complete word is ready for transmission (or sends SYNC-idles if SYNC is also ON - see next section). WORD mode thus allows you to correct spelling and other typographical errors before they are sent.

IMPORTANT: For the purposes of WORD mode, a "word" is defined as the characters and following space(s) to the first letter of the next word; OR if a "new line" is started in the transmit buffer. Therefore, a "word" is not released to be transmitted until you either start typing the next word or you end the current line. The transmitter will stay in "Mark-hold" (or SYNC-idle) state until the new word is released for transmission.

HINT: WORD mode is the *preferred* mode for RTTY transmission.

In LINE mode, the transmitter is turned ON when you type the first character of a line, but no data is sent until you have completed the *entire line*. The transmitter stays in "Mark-hold" until a complete line is ready for transmission (or sends SYNC-idles if SYNC is also ON. LINE mode allows you to correct spelling and other typographical errors before they are sent but release text to be transmitted only at the end of each line.

7.4.3 NORM/REV

This option allows selection of the polarity of your RTTY signal. It sets the polarity of *both* the receive and transmit data sections of the PCI-4000. Use "NORM" polarity for most amateur RTTY operations. Be sure that your radio is also set to "LSB" or "FSK" mode. The AFSK RX and TX tones of the PCI-4000 may be set over the range of 500 to 3000 Hz via Page 3 of the CONFIGURATION menu. The default settings of PC-COMM for RTTY and AMTOR are:

Polarity:	<u>NORM</u> (Mark = lower frequency tone)
TONES:	Mark = 2165 Hz; Space = 2335 Hz Shift = 170 Hz; Center = 2250 Hz (CLOVER compatible)
RADIO:	LSB mode

AMTOR, Baudot-RTTY, and ASCII-RTTY all follow these standards.

NOTE: "Hot-Key" [Alt]-N also changes NORM/REV.

7.4.4 SYNC

The SYNC option is often called "SYNC-IDLE" or "RTTY DIDDLE". When ON, it will insert non-printing characters in the transmit data stream if your typing has not produced a word or character to be transmitted.

In Baudot RTTY, the "LTRS" (Letters) character is sent; in ASCII, the "NULL" character is used. Both are "non-printing" characters and may help the other station's demodulator and display ("printer") maintain synchronization with your RTTY signal.

IMPORTANT:

*HAL recommends that both WORD and SYNC options be turned ON when operating RTTY. In this case, you **MUST** end each RTTY text with a blank new line in the transmit buffer. The SYNC feature turns OFF and allows automatic return to reception only when all possible words have been sent. A blank new line condition is the only way to assure that this occurs. This is the same WORD and SYNC mode used in all previous HAL RTTY terminals (DS3000, DS3100, DS2000, DS2050, CT-2100, CT-2200, PCI-2000, PCI-3000).*

2115
120
233

7.4.5 USOS

This is a special option only for Baudot RTTY. Baudot code uses most 5-bit combinations twice - once for letters and again for numbers and symbols. A special pair of Baudot characters set the receiving terminal to the correct "shift" - Letters (LTRS) or Figures (FIGS). Noise can and does often appear to be a LTRS or, worse, FIGS Baudot character. The receiving station may therefore be unintentionally set to FIGS case by noise, corrupting what would otherwise be printable text.

The USOS (UnShift On Space) option works only on Baudot receive and will reset PC-COMM's Baudot receive case to LTRS after reception of *every* Space-Bar character. It is recommended that USOS be turned ON for most amateur Baudot RTTY use. However, some applications such as NAVY MARS and reception of some numerical data may require that USOS be turned OFF. USOS works *only* on Baudot RTTY and has *no effect* on ASCII RTTY.

7.5 Baudot FORCE LTRS Key

In addition to the USOS option, the [Alt]-G key combination may be used to force your Baudot receive terminal to LTRS case at any time. If you actively watch the print as received, you may prefer to use [Alt]-G to manually set LTRS condition rather than use USOS.

7.6 CW ID

RTTY CW ID is *not* required of U.S. amateur stations, but it may still be required in some countries. PC-COMM includes provision for sending your call sign in CW using the [ALT]-[F4] key. When pressed, the same text as programmed for your ID (normal F4 key) will be inserted in the transmit buffer in "bracketed form". For example, if "DE K9GWT" is my normal RTTY ID, the CW ID will be identified as >DE K9GWT<. When this bracketed ID is about to be sent, PC-COMM will automatically change to CW mode and send the bracketed text in FSK-CW at 20 WPM. The RTTY CW ID sends "Mark - 100 Hz" transmit frequency for key-down and "Mark" state for key-up. PC-COMM automatically reverts to the chosen RTTY code and rate after completion of the CW ID. The CW-ID may be automatically inserted every 10 minutes by use of the [Alt]-[I] "hot key".

7.7 Other RTTY Options

Other RTTY options may be set via page 3 of the CONFIGURATION menu (Figure 9.)

7.7.1 End Of Line Sequence

The "EOL", End Of Line sequence may also be set for both ASCII and Baudot. HAL recommends that you use "CR LF LTRS" for Baudot and "CR LF" for ASCII. Some applications such as NAVY MARS and RTTY pictures may require different EOL sequences.

7.7.2 Baudot Character Set

Two Baudot characters sets are in use: the "U.S. Military" Baudot character set or that designated as "CCITT No. 2", the "European standard". The differences between the two codes are minor, but can be significant for some applications. The differences between the two codes are outlined in Table E.2.

TABLE 4
U.S. vs CCITT No. 2 BAUDOT

<u>CODE</u>	<u>U.S. Baudot</u>	<u>CCITT No. 2 in PC-COMM</u>
FIGS-D	§ (dollar sign)	§ (dollar sign)
FIGS-H	# (number sign)	# (number sign)
FIGS-J	' (apostrophe)	BELL
FIGS-S	BELL	' (apostrophe)
FIGS-V	; (semi-colon)	= (equal sign)
FIGS-Z	" (quotation)	+ (plus sign)

AMTOR uses the CCITT No. 2 code and therefore the "=" and "+" keys are operational in AMTOR. U.S. amateurs generally use the U.S. version of the Baudot code. Computerized stations may use either set. If, when receiving Baudot, your signal "BELL" "beeps" frequently, the other station is probably using the opposite Baudot code from what you are. RTTY pictures and NAVY MARS use the U.S. Baudot character set.

7.8 RTTY Print Squelch

RTTY receive includes a "print squelch" control that can be used to suppress screen display of "garbage characters" that may result from reception of noise when a valid RTTY signal is not being received. The "print squelch" control functions much like the squelch control on a VHF-FM receiver, but it is a *digital keyboard* control in PC-COMM. Special status indicators and key combinations are provided to control print squelch.

To set PRINT SQUELCH, you must first be sure that you are NOT in COMMAND mode (no COMMAND menus). Then, type [Alt]-Q. A new menu will then appear in the transmit buffer to set "Print Squelch Level" and "Print Squelch ON/OFF".

Think of "Print Squelch Level" as a control knob position from "00" to "99". At the low end of the scale ("00"), all signals will be printed - squelch is essentially turned OFF. At the upper end of the scale ("99") no signals will be printed - squelch is turned ON. HAL suggests that you start with a level setting between "60" and "70"; "65" is a good starting place.

The PRINT SQUELCH LEVEL may also be changed by typing the [+] and [-] keys. The [+] key increases the level and the [-] key decreases the level.

After setting a print squelch level, enable the squelch by using the [down-arrow] key to highlight the "ON/OFF" option. Type the [Space Bar] key to change the state (toggle between ON and OFF). When both the level and ON/OFF control have been set, return to the operating screen by either typing [Enter] or [Esc].

Some points to consider when using PRINT SQUELCH are:

1. PRINT SQUELCH *only* works with RTTY - Baudot or ASCII.
2. PRINT SQUELCH has *no effect* on AMTOR or PACTOR signals.
3. Setting too high a PRINT SQUELCH LEVEL requires very accurate tuning and you may miss some characters if the signal is weak, fading, poorly tuned, or if the shift of the signal differs from that set (170 Hz default).
4. Setting too low a PRINT SQUELCH LEVEL will allow "hits" on noise between the end of one transmission and the start of another. A low setting will also extend the time after a signal quits that noise "hits" are printed.
5. The optimum PRINT SQUELCH LEVEL may change with receiver filter settings and with background noise levels from band-to-band and from day-to-day. A "narrow" receiver filter will require a higher PRINT SQUELCH LEVEL setting to eliminate noise "hits".
6. You can "fine-tune" the level by tuning the RTTY signal and then adjusting the PRINT SQUELCH LEVEL while watching the status line star. The [+] and [-] increment keys are very useful for this adjustment.

7.9 Special RTTY Transmit Keys

Special key combinations are provided to allow transmitting special RTTY characters. These keys are shown in Table 5:

TABLE 5
SPECIAL RTTY TRANSMIT KEYS

<u>KEY</u>	<u>CHARACTER</u>	<u>NOTES</u>
[Ctrl]-G	Signal Bell	"Diamond" symbol on screen
<	LTRS	Only Baudot and AMTOR
>	FIGS	Only Baudot and AMTOR
[Alt]-Y	12 LTRS	Sequence of 12 LTRS

The [Alt]-Y key (12 letters) is a special requirement for U.S. NAVY MARS message formats.

8. TUNING INDICATORS

PC-COMM is designed to give outstanding recovery of received AMTOR, PACTOR, and RTTY signals. The DSP demodulator hardware and software has been refined many times through 15 generations of HAL modem products. In many cases, the PCI-4000 will print signals you cannot even hear.

However, optimum reception of FSK signals (RTTY, AMTOR, and PACTOR) can only be obtained if the receiver is correctly tuned so that the tones match the filters in the PCI-4000.

PC-COMM makes use of the very accurate tuning bars previously developed for use with CLOVER. Unlike other tuning bar indicators you may have used previously, the PC-COMM bars are derived directly from the very selective filters in the DSP demodulator. The horizontal length of each bar represents a precise measurement of the signal amplitude in the "Mark" and "Space" filters, in increments of 1.0 dB, in fact. Correct tuning is achieved when the length of each tuning bar is maximum and the two bars have approximately the same length. Practice tuning your receiver while watching the tuning bars. As the tones from the receiver increase in frequency, first the upper bar ("T2" position, "Mark" filter) will increase in length. Further rotation of the receiver dial in the same direction will cause a temporary decrease in Mark amplitude and then an increase in the amplitude of the "Space" signal (lower "T3" bar). As correct tuning is achieved, both bars will come to a maximum length, usually 1/2 to 3/4 of full-scale. Tuning FSK signals becomes quite simple after just a few trial runs.

ADDENDUM 3

FSK OPTION SELECTION

The PCI-4000 FSK output circuit may be used with modern transceivers that include an FSK input to transmit the FSK modes (e.g. AMTOR, RTTY, and PACTOR). Please note that CLOVER cannot be transmitted using the transceiver FSK input because CLOVER is a 4-tone signal. At this printing, a "universal" FSK interface standard does not exist between manufacturers or models of transceivers. Based on our previous experience with using FSK inputs, HAL has provided four interface options that will work with current equipment. If you have additional information regarding FSK inputs, we would appreciate your comments.

The PCI-4000 is provided with an RCA-type phono jack for the FSK output. This phono jack is located on the back panel above the DE-9 I/O connector.

The FSK output is a transistor output which can be set for open collector (O.C.) or pulled up to + 5 Volts D.C. (+5V) by setting jumper plug J7. J7 is located near the back top edge of the circuit board. There are two positions for J7. The Open Collector (O.C.) setting uses the two pins toward the rear panel of the PC (this is the factory setting). The +5V pullup setting uses the two pins nearest the front of the PC. Turn off all power to the computer and use caution when moving the jumper plug.

The polarity of the FSK output is selected from the operating program. To reach the polarity setting go to Configuration Page 3 by selecting F1, Files, Configuration, Page 3. The FSK Polarity is in the lower left corner of the screen. FSK Polarity is factory set to Normal. It toggles between Normal and Reverse with the space bar.

The FSK output is a data signal - not an audio signal. The factory settings are O.C. (open collector) and Normal polarity (NORM). Some transceivers require a switch to ground on the FSK input. In this case, you would use the O.C. (Open Collector) setting for J7. Other transceivers require a voltage on the FSK line. In this case, use the +5V setting for J7. Table AD3.1 summarizes the four possible combinations of PCI-4000 FSK output signal.

TABLE AD3.1
PCI-4000 FSK OUTPUT OPTIONS

<u>POLARITY</u>	<u>J7 SETTING</u>	<u>MARK</u>	<u>SPACE</u>
NORM	O.C.	0V	Floating
REV	O.C.	Floating	0V
NORM	+ 5V	0V	+ 5V
REV	+ 5V	+ 5V	0V

A careful reading of your transceiver manual or a call to the manufacturer's "Customer Assistance Department" may be required to determine which interface level is required for your equipment.

Table AD3.2 lists the correct FSK combinations for a few transceivers. This data is based on reports from HAL customers. HAL would like to know of any other information you may have concerning FSK inputs.

**TABLE AD3.2
FSK FOR TYPICAL AMATEUR TRANSCEIVERS**

<u>MFGR</u>	<u>MODEL</u>	<u>POLARITY</u>	<u>J7 SETTING</u>
TEN-TEC	CORSAIR	NORM	+ 5V
TEN-TEC	PARAGON (585)	NORM	+ 5V
TEN-TEC	OMNI V (562)	NORM	+ 5V
KENWOOD	TS-180	NORM	O.C.
KENWOOD	TS-440	NORM	+ 5V
KENWOOD	TS-930s	REV	O.C.
KENWOOD	TS-940s	NORM	O.C.
ICOM	IC-730	REV	O.C.
ICOM	IC-740	REV	O.C.
ICOM	IC-745	REV	O.C.
ICOM	IC-751	REV	O.C.
ICOM	IC-761	REV	O.C.
ICOM	IC-781	REV	O.C.
YAESU	FT-101ZD	NORM	O.C.
YAESU	FT-107	NORM	O.C.
YAESU	FT-910/902	NORM	O.C.
YAESU	FT-980	NORM	O.C.
YAESU	FT-ONE	NORM	O.C.

This table reflects a collection of data given to HAL by our customers and the manufacturers. We at HAL have not personally verified each of the above listings, but they are offered as a guide. If you have additional information regarding these or other transceiver models, HAL would appreciate your input.

If your transceiver is not listed or you have some doubts about the required level or polarity, try the following:

1. Start with NORM and J7 setting of O.C.
2. Try sending simple FSK RTTY to a friend with a working RTTY station.
3. If you cannot send Mark/Space RTTY, the J7 setting may be wrong. Try setting J7 to +5 V.
4. If you can send FSK, but it is upside down, change the polarity to REV.

NOTE:

The above information is offered as a service to our amateur customers only. HAL cannot guarantee performance for FSK mode. HAL cannot be held responsible for any damage that may result from connection of voltages to a transceiver "FSK" input jack. If you have any doubts, please contact the transceiver manufacturer first - before making any connections.

FSK vs "AFSK" in ARQ Modes:

The PCI-4000 may be used in AMTOR, RTTY, or PACTOR using "AFSK" tones into a LSB transmitter or using the FSK input and FSK mode if it is available. You may, however, notice a slight difference in AMTOR ARQ mode transmit/receive switching performance.

When "AFSK" tones are used with a LSB transmitter, HAL has included short additional delays to be sure that "hot switching" of the transmitter cannot occur. When AFSK tones are used, the transmitter PTT line is always switched at times when there is no audio drive and therefore no transmit RF output.

Conversely, the FSK mode and input on transceivers does not allow this additional delay between PTT switching and transmitter RF output. In FSK mode, the transmitter generates RF output for as long as the PTT line is held in the TX ON state. The transceiver manufacturer may have included internal delays to prevent "hot switching" in FSK mode, but it is a feature that HAL cannot provide when FSK mode is used.

"Hot-switching" may result in:

1. ON / OFF "key clicks" on frequencies near your transmitted frequency.
2. Loss of part of the transmit data pulse - frequent loss of link or errors on otherwise strong signals.
3. Reduced life of transmit/receive relays - or destruction of relay contacts.

"Hot-switching" can be particularly destructive if you also use a linear amplifier in a fast-switching mode such as AMTOR-ARQ. It is our suggestion that a linear amplifier is rarely necessary for good AMTOR-ARQ performance and the risks far outweigh the potential gain!