

XTK-100
AFSK
OSCILLATOR

INSTRUCTION
MANUAL

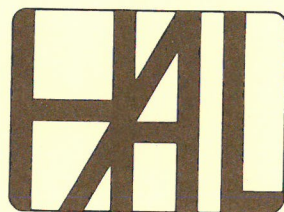

HAL COMMUNICATIONS CORP.
BOX 365
URBANA, ILLINOIS 61801

QUALITY COMMUNICATIONS EQUIPMENT

HAL XTK-100 CRYSTAL TONE KEYS

T E C H N I C A L M A N U A L

XTK-100

AFSK

OSCILLATOR

Copyright © 1975 by HAL Communications Corp., Urbana, Illinois. Printed in the U.S.A. All rights reserved. Contents of this publication may not be reproduced in any form without the written permission of the copyright owner.

November, 1982 Printing

1. INTRODUCTION

The model XTK-100 Crystal Controlled RTTY Oscillator generates tone-encode teleprinter signals for transmission by either HF or VHF radio. The oscillator provides the superior frequency stability of crystal control. The XTK-100 is designed to be a plug-in accessory for the ST-6 demodulator and it can be used in place of the AK-1 AFSK oscillator in existing ST-6's or in new assembled or kit units. The XTK-100 may also be used on a stand alone basis with the addition of a power supply, input interface circuitry, and a cabinet, for any application where it is desired to convert serial digital data to audio FSK data.

Encoding is accomplished by controlled selection of one of four crystal controlled oscillators. The selected oscillator signal is then divided by a factor of either 2000 or 3000 and used to synthesize a sinusoidal output signal. Therefore, teleprinter data effectively shifts the frequency of the output signal from a normal rest frequency (Mark) to a higher frequency (Space). Control is provided so that the frequency shift with data input is either 170 Hz or 850 Hz, switch selectable. Additionally, the frequency can be shifted upward by 100 Hz with an external key closure to provide for CW identification of the RTTY signal. Crystals can be ordered for two sets of output tones, "high tones" or "low tones". The high tones are: 2125 Hz (Mark), 2295 Hz (170 Hz Shift Space), 2975 Hz (850 Hz Shift Space), and 2225 Hz (CW ID). The low tones are: 1275 Hz (Mark), 1445 Hz (170 Hz Shift Space), 2125 Hz (850 Hz Shift Space), and 1375 Hz (CW ID). The choice between "high tones" or "low tones" must be made upon ordering since different crystals are required for each set.

The input keying requirements of the XTK-100 are compatible with the FSK output signals of the HAL ST-6 and ST-5 demodulators and can be easily keyed from other sources of low-voltage serial teleprinter data. Both high-level (0 dBm) and low-level (-32 dBm) audio outputs are furnished by the XTK-100, providing a great deal of flexibility in interfacing the oscillator to various radio transmitter inputs. Active low-pass filtering of the output signal prevents generation of spurious signals in the form of harmonics of the original tones. The keying circuits of the oscillator do not generate any phase discontinuities in the output signal.

The entire oscillator assembly is contained on one 2-7/8" x 5-7/8" (7.3 x 15 cm) circuit board which plugs into a 12 pin edge connector. The XTK-100 is a direct substitute for the HAL AK-1 AFSK with the exception that the high-level output of the XTK-100 is of the order of 0.75 volt rms while the AK-1 high-level output is 100 mV rms. The XTK-100 is available as an option in the factory-wired ST-6 demodulator.

Dear XTK-100 Owner: Note the following changes in your manual:

- (1) All references to the crystals used in the CW-ID oscillator circuit should be changed to indicate the frequencies shown below. This change has been made to allow the CW-ID circuit to shift 100 Hz LOWER than the mark frequency --a much more desirable type of operation than was previously possible with the original CW-ID oscillator crystal frequencies.

High tones -- Old CW-ID crystal: 4450.0 kHz. Changed to 4050.0 kHz.
Low tones -- Old CW-ID crystal: 4125.0 kHz. Changed to 3525.0 kHz.

You should make this change in your manual in each place where reference is made to the CW-ID oscillator crystal frequency.

- (2) Make the following corrections in the preliminary parts list given in part 8 of the manual:
 - (a) Under resistors, change the number of 100 k-ohm resistors indicated from 3 to 2. Also, add one 22 k-ohm resistor to the list.
 - (b) Correct the crystal frequencies under the crystals section of the parts list, as indicated above.
 - (c) Under capacitors, add two 0.001 uF disc ceramic capacitors to the list.
- (3) On the schematic diagram given in part 7, one of the components, a 4017 IC, is mislabeled as 19. Change this to the correct designation of 17.

THANK YOU! HAL COMMUNICATIONS CORP.

2. SPECIFICATIONS

Output Frequencies

High Tones:	
Mark (all shifts)	2125 Hz
Space (170 Hz Shift)	2295 Hz
Space (850 Hz Shift)	2975 Hz
CW ID (key down)	2225 Hz
Low Tones:	
Mark (all shifts)	1275 Hz
Space (170 Hz shift)	1445 Hz
Space (850 Hz shift)	2125 Hz
CW ID (key down)	1375 Hz

Frequency Stability and Accuracy $\pm 0.05\%$

Output Amplitude
High Level 0 dBm \pm 2 dB
(0.77 V @ 600 ohms)
Low Level -32 dBm \pm 4 dB
(19.5 mV @ 600 ohms)

Output Impedance (both outputs) 600 ohms \pm 10%

Output Harmonic Content (below 9th harmonic) . . . -40 dB from fundamental

Input Voltage Requirements (EIA Compatible)

Mark -3 to -15 volts
Space +3 to +15 volts
(Adaptable for 0 to +12 volt input or simple key closure)

CW Shift 0 to +3 V, closed
+8 to +12 V, open

(Intended to interface to a hand-key closure or solid-state switch to ground.)

Power Requirements 12 \pm 1 volt dc @ 40 ma

Size 2-7/8 x 5-7/8 inches
(7.3 x 15 cm)

Weight 3 oz (86 gm)

Connector (supplied) 12 pin single-readout,
0.156 " pin spacing

3. OPERATION OF THE XTK-100

The circuit of the XTK-100 is made up of five basic sections: oscillators, keyer, divider, D/A converter, and low-pass filter. Refer to the schematic diagram, Figure 1 on page for the following description of each section.

Four separate crystal controlled oscillators are used to generate the four output frequencies required (mark, space-narrow shift, space-wide shift, and CW ID). The fundamental crystal frequencies have been selected to all be in the frequency range of 3.5 to 6.5 MHz. Crystal frequencies for the "high-tone" frequency set are exactly 2000 times the required output frequency; for "low-tones", crystal frequencies are 3000 times the desired output frequency. For example, the mark crystal for "high-tones" has a fundamental frequency of $2000 \times 2.125 \text{ kHz} = 4250.000 \text{ kHz}$. Similarly, the mark crystal for "low-tones" has a fundamental frequency of $3000 \times 1.275 \text{ kHz} = 3825.000 \text{ kHz}$. The four oscillators each use one section of integrated circuit 4, a 4049 Hex Inverter. All four oscillators operate at all times.

Integrated circuit gates 2A, 2B, 2C, and 2D are used to select which of the four oscillator signals are passed on to the divider chain. Grounding of pin 7 of the edge connector by a CW ID key will enable gate 2C, allowing the CW ID oscillator signal to pass on through gate 1B to the dividers. Conversely, the outputs of the other three oscillators are suppressed since gates 3A, 3B, 3C and therefore 2A, 2B, and 2D are disabled by a grounded key line. If pin 7 of the edge connector is not grounded, the CW ID signal is suppressed and the mark or space oscillator may be selected.

Frequency shift keying of the tone is accomplished by alternate gating of either the mark or ONE of the space oscillators. The selection of which of the two space oscillators is keyed is controlled by gate 4C in conjunction with gates 3A and 3B. When pin 9 is low (grounded), gates 3B and 2A are disabled, suppressing the wide-shift space oscillator output; gate 3A may be enabled by the FSK keying signal to allow transmission of the narrow-shift space tone. Conversely, when pin 9 is high (open circuit), the narrow-shift space signal is suppressed and the wide-shift space signal may be enabled by the FSK data.

The FSK data is connected to pin 6 of the edge connector and buffered and inverted by circuit 1A. Application of a negative voltage will enable gates 3C and 2B, allowing transmission of the mark signal to the divider chain; gates 3B and 3A are disabled, suppressing the space signals. When a positive voltage is applied to pin 6, either gate 3A or 3B is enabled (depending upon the shift selected), allowing transmission of the space signal. Gate 3C is disabled, suppressing the mark signal.

The gated oscillator signals are combined in gate 1B. The two sections of IC 9 can be connected with jumpers on the circuit board to divide the oscillator frequencies by a factor of either two or three. If "low-tone"

frequencies are used, the dividing factor is three; for "high-tones", the factor is two. The output frequency from IC 9 is a factor of 1000 times the final output frequency for either "low" or "high" tones. IC 8 and IC 7 are both decade dividers; the signal delivered to IC 6 is at a frequency of 10 times the final output frequency.

IC 6 and its associated resistor network are used as a Digital-to-Analog converter to synthesize a pseudo-sinewave at the output frequency. Note that the power terminals of IC 6 are connected between +12 volts and a derived +6 volt reference rather than between +12 volts and ground. The resistors between IC 6 and pin 2 of IC 5 have been specially chosen to synthesize a ten-step sinewave approximation. IC 5 is used as an active low-pass filter as well as an output amplifier. The output level of 0 dBm is available directly from IC 5 and the -32 dBm output is derived in a resistive divider. The output impedance of either output is 600 ohms.

Particular design attention has been given to minimizing the power consumption of the XTK-100 to assure full compatibility with existing ST-6 and ST-5 demodulators already using the HAL AK-1 AFSK oscillator. Low power consumption C-MOS integrated circuits are used throughout the oscillator circuit, with the exception of IC 5, a type 741 operational amplifier.

4. ASSEMBLY INSTRUCTIONS

Construction of the XTK-100 will be carried out in two steps:

1. Assemble the circuit board.
2. Install and interconnect the board and connectors in the cabinet.

Before starting construction, check the parts received against the parts list. It will simplify assembly if you separate the parts by type into small boxes as you check them off the list -- that is, resistors in one box, semiconductors in another, etc.

Your kit was carefully checked for quality and completeness before shipment. Should you find any parts missing or damaged, please notify the factory in writing so that a replacement can be supplied.

Since the construction of the XTK-100 involves many soldered connections, it is important that you make each one carefully. It is assumed that the builder has some prior experience in kit construction and is acquainted with good soldering practices. If not, it would be well to practice on scrap components, preferably with the help of an experienced individual, before starting work on the kit. It will also be helpful to keep the following points in mind:

1. Since most of the components are small, only a moderate amount of heat is needed to make good solder joints. Use a 15 to 25 watt iron with a pencil tip or small (1/8") chisel tip.
2. When soldering components to the printed circuit boards, avoid overheating the connections. Although high-grade epoxy-glass boards are supplied, excessive heat can cause the printed conductors to separate from the board and can also damage components. Be careful not to allow the solder to bridge between closely-spaced adjacent conductors and solder pads. Also, be careful to prevent solder splashes from falling on the board.
3. When soldering the IC socket terminal strips, be particularly careful not to use too much solder or heat. Excess solder with enough heat can be transferred through the board hole and onto the socket pins themselves.
4. If you make an error and find it necessary to remove a component from the board, heat each connection with the iron and use a suction desoldering tool or solder wicking (copper braid) to remove the excess solder. The component can then

usually be lifted from the board without applying additional heat. In the case of inexpensive components, it may be better to break the component and remove the leads one at a time than to risk damaging the board by overheating it. Replacement parts may be obtained locally in most cases.

4.1 Circuit Board Assembly

Before assembling any components on the circuit board, carefully inspect the board itself for defects in etching and plating. Although all boards have been inspected before shipping, it is far easier to find and correct such problems before assembly than after.

First, mount all integrated circuits on the board in the positions shown. Be careful to observe the correct orientation as indicated in Figure 2.

NOTE: the location of pin 1 of the integrated circuits may be indicated by a small indentation near pin 1 on the top of the IC or by a notch in the top end of the IC adjacent to pin 1 or sometimes both, depending upon the IC manufacturer. CAUTION: The MOS integrated circuits can be damaged by static electricity. ALWAYS be sure that the tip of the soldering iron is grounded and that the circuit board is placed on a good insulated surface or a well grounded surface. DO NOT handle the IC's around non-conductive plastic materials (most plastic bags and parts bins) or in any area of high static electricity (carpeting, particularly in periods of low relative humidity).

Secondly, mount all of the resistors in the locations shown in Figure 2. Continue to observe static electricity precautions for this and all other assembly steps.

Next, mount all of the diodes and capacitors with the exception of capacitor C6. Be sure to observe proper diode and electrolytic capacitor orientation.

The following parts values depend upon whether "high" or "low-tone" operation of the XTK-100 is desired. The frequencies of the tones generated for these two modes are listed in the specifications on page 2 of this manual. Unless transmitter frequency response prohibits their use, it is recommended that the XTK-100 be assembled for operation with the "high-tone" set of frequencies. Choose the appropriate value for C6 (0.0015 ufd for high tones, 0.0022 for low tones) and install it on the circuit board. Select the correct frequency crystals and mount them in the locations indicated in Figure 2. After the crystal has been connected, use lengths of uninsulated wire to secure it to the circuit board. DO NOT solder the wire to the crystal holder. Finally, install a jumper near the middle of the board in either the "B" to "C" location (High Tones) or "A" to "C" location (Low Tones). Use a piece of uninsulated wire to make a ground test clip and install it as shown near the top edge of the circuit board. The assembly of the circuit board is now complete. Set the board aside until provisions have been made for the connectors, shift switch, and power supply.

4.2 Installation of the Circuit Board

Since the XTK-100 is designed to be used in conjunction with other RTTY equipment, it does not have a self-contained power supply and must therefore be furnished with +12 volts dc at 40 ma. This voltage can be obtained from the demodulator (such as the ST-5 or ST-6) or other low-voltage source. Whatever the source, the +12 volts furnished to the XTK-100 should be well filtered (free of hum and noise) and reasonably well regulated (zener regulation is quite adequate).

The circuit board of the XTK-100 should be mounted in a metallic container (for shielding), away from obvious sources of heat and hum. When the XTK-100 is used with the ST-6, a circuit board location has been reserved in the demodulator for either the AK-1 OR XTK-100 AFSK Oscillator. The XTK-100 can be used as a direct replacement for all AK-1 Oscillators previously furnished by HAL Communications Corp. with the ST-6 demodulator. Edge connector pin numbers and functions are identical between the XTK-100 and AK-1.

A 12 pin edge connector is supplied with the XTK-100 to make connection with the circuit board, but this can be deleted, if desired, and connections made directly to the circuit board. Approximately 3/4" of overall length can be saved with this technique, but it is not recommended unless absolutely necessary. Typical connections to the XTK-100 are shown in Figure 4.

5. INTERCONNECTION OF THE XTK-100 WITH OTHER EQUIPMENT

Since the XTK-100 is a direct replacement for the HAL AK-1 AFSK Oscillator, the interconnections for the two pieces of equipment are the same. In order to expedite delivery of early XTK-100's, a complete AK-1 manual is included. All information presented in Chapter 5 of the AK-1 manual and in Figures 4 through 12 also applies to the XTK-100. Please disregard all data in other sections of the AK-1 manual. Note that the high-level audio output of the XTK-100 is 750 mV rms, not 100 mV as specified for the AK-1.

6. TEST

Refer to the schematic diagram (Figure 1) and the circuit board layout (Figure 2) to locate the test points mentioned in the following procedures. Minimum test equipment required is an oscilloscope (DC to 10 MHz, triggered sweep model preferred), a VOM (20,000 ohms-per-volt), and a frequency counter (10 MHz).

1. Apply +12 volts ($\pm 10\%$) between pin 1 (-) and pin 5 (+). Current drain should be 40 ma ($\pm 10\%$).
2. The dc voltage at pins 8, 13, and 15 of IC 6 as well as pin 3 of IC 5 should be approximately one-half the supply voltage, 6 vdc $\pm 10\%$.
3. With the oscilloscope and counter check that all four oscillators are generating the correct frequencies as per the table below:

<u>IC 4</u> <u>Pin No.</u>	<u>Function</u>	<u>"High Tones"</u> <u>Frequency</u>	<u>"Low Tones"</u> <u>Frequency</u>
2	Mark	4250 kHz	3825 kHz
15	Space (Wide)	5950 kHz	6375 kHz
12	Space (Narrow)	4590 kHz	4335 kHz
10	CW ID	4450 kHz	4125 kHz

All frequencies should check to within $\pm 0.05\%$ (± 3.2 kHz maximum).

4. Test the operation of the control circuitry by connecting the oscilloscope and counter to pin 13 of IC 1. With no connection to edge connector pins 7 and 9 and with pin 6 grounded, a signal of the mark frequency (see above table) should be observed. Unground pin 6 and connect it to +12 vdc and observe the narrow-shift space signal. With pin 6 still connected to +12 vdc, ground pin 7 and observe the wide-shift space signal. Finally, ground pin 7 and observe the CW ID signal. All frequencies measured should agree with those measured in step 3.
5. Connect the oscilloscope and counter to pin 14 of IC 8. With no connections to pins 7 and 9 of the edge connector and with pin 6 grounded, measure 2125 kHz ("High Tones") or 1275 kHz ("Low Tones"). IC 9 acts as either a divide-by-two ("High Tones") or a divide-by-three ("Low-Tones"), depending upon how the circuit board jumper is connected.
6. Check to see that IC 8 and IC 7 both function as divide-by-ten stages. Measure the output frequencies at pin 12 of IC 8 and at pin 12 of IC 7.

7. Verify that IC 6 is functioning correctly by measuring the frequency at pin 12. It should be the desired output mark frequency, 2125 Hz for "high tones" or 1275 Hz for "low tones".
8. The resistor network between IC 6 and pin 2 of IC 5 is used to synthesize a sine waveform from the individual pulses on pins 1 through 7 and 9 through 11 of IC 6. With the oscilloscope, check to see that pulses are indeed present on all 10 output pins of IC 6. The voltage at pin 2 of IC 5 is too small to reliably measure with the oscilloscope.
9. Connect the oscilloscope and counter to pin 8 of the edge connector and perform all of the tests outlined in step 4. The output signals should be sinusoidal and the frequencies should agree with the table below (± 1 Hz):

<u>Condition</u>	<u>"High Tones" Frequency</u>	<u>"Low Tones" Frequency</u>
MARK	2125 Hz	1275 Hz
SPACE	2295 Hz	1445 Hz (170 Hz Shift)
SPACE	2975 Hz	2125 Hz (850 Hz Shift)
CW ID	2225 Hz	1375 Hz

10. This completes the testing of the XTK-100. Install the XTK-100 in your TTY system.

7. DIAGRAMS AND PHOTOGRAPHS

The schematic diagram and circuit board layout are shown on the following pages. Please refer to Figures 4 through 12 of the AK-1 manual for inter-connection and installation diagrams. A complete XTK-100 set of diagrams will be furnished as soon as it is available. The preliminary parts list for the XTK-100 is attached.

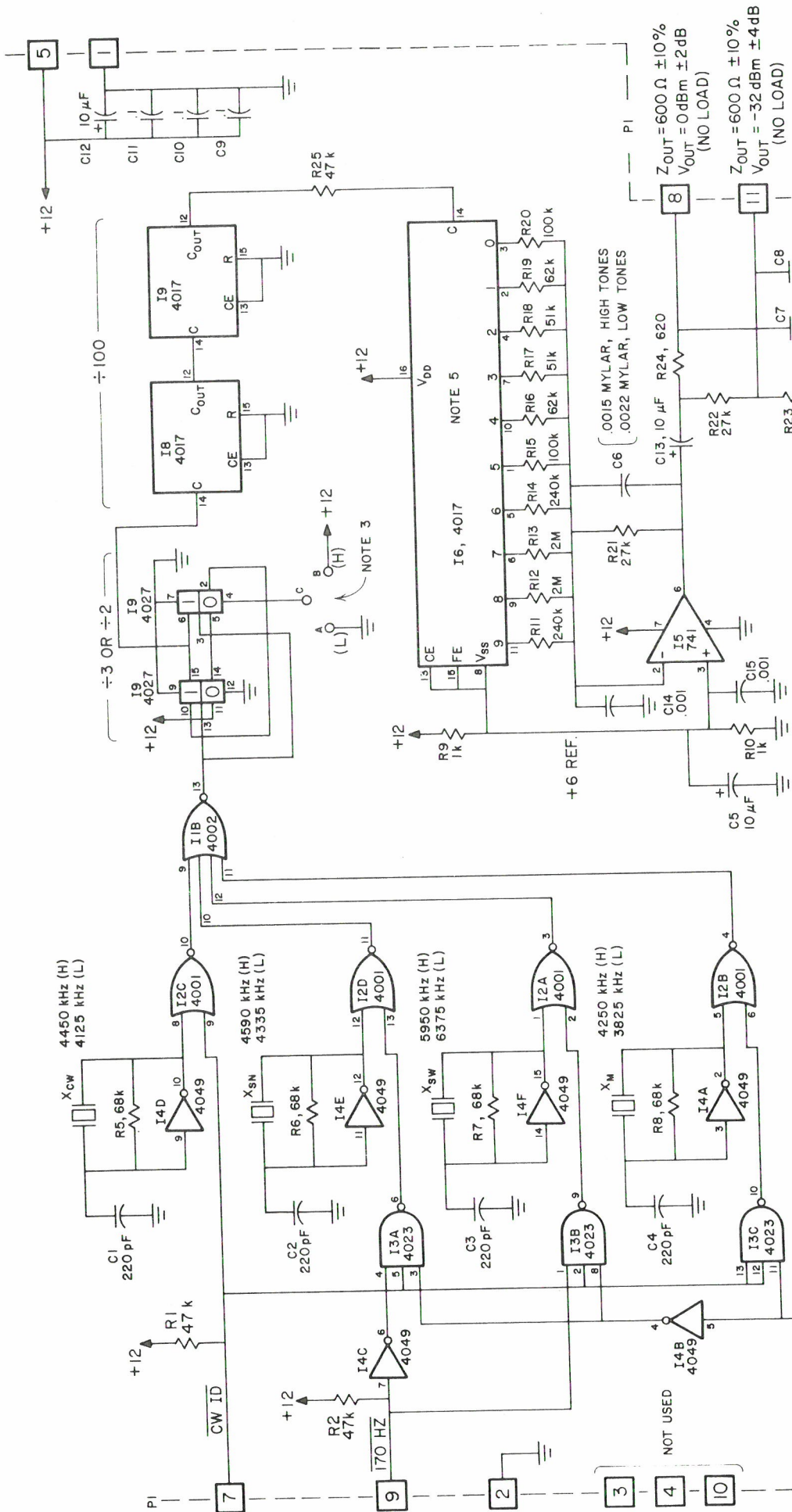

- NOTE: 1. ALL RESISTORS ARE $\frac{1}{4}$ W $\pm 5\%$, ALL CAPACITOR VALUES ARE IN μ F UNLESS OTHERWISE SPECIFIED
2. CIRCUIT TYPE 4009 CAN BE SUBSTITUTED FOR TYPE 4049 (I14)
3. JUMPER A-C FOR LOW TONE SET, B-C FOR HIGH TONE SET
4. LOW TONE CRYSTALS ARE 3000 TIMES AUDIO TONE AND HIGH TONE CRYSTALS ARE 2000 TIMES AUDIO TONE
5. I6(4017) POWER TERMINALS ARE CONNECTED TO +12V AND +6V (DERIVED FROM 1k RESISTORS) IN ORDER TO BIAS OUTPUTS TO +6V REFERENCE

REV. C: JUN. 13, 1975

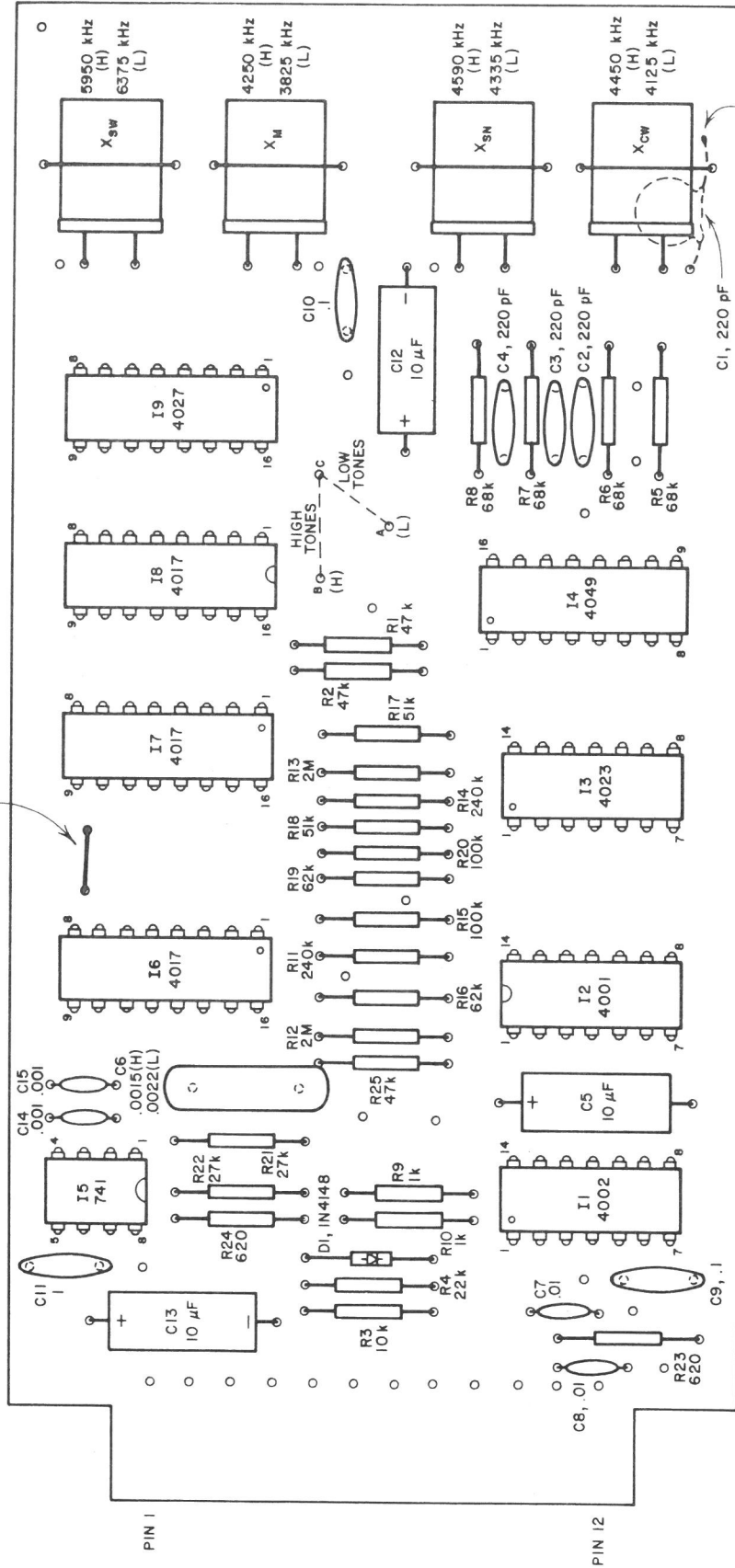
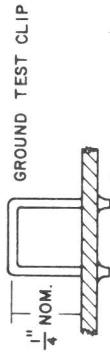

- NOTE: 1. ALL RESISTORS ARE $\frac{1}{4}$ W $\pm 5\%$
 2. ALL CAPACITOR VALUES ARE IN μ F UNLESS OTHERWISE SPECIFIED
 3. COMPONENT VALUES THAT CHANGE WITH HIGH-LOW TONE OPTION ARE INDICATED BY:
 (H) — "HIGH TONES"
 (L) — "LOW TONES"

REV. A: JUN. 13, 1975
 REV. B: OCT. 20, 1975

XTK-100 AFSK OSCILLATOR
 CIRCUIT BOARD
 APR. 22, 1975 B1029A

XTK-100 Owner's Manual Addendum

7-15-81

The attached drawings complete section 7 of the XTK-100 manual. Reference to the AK-1 manual is no longer necessary. Please note that all references on these drawings to AK-1 may be changed to read XTK-100.

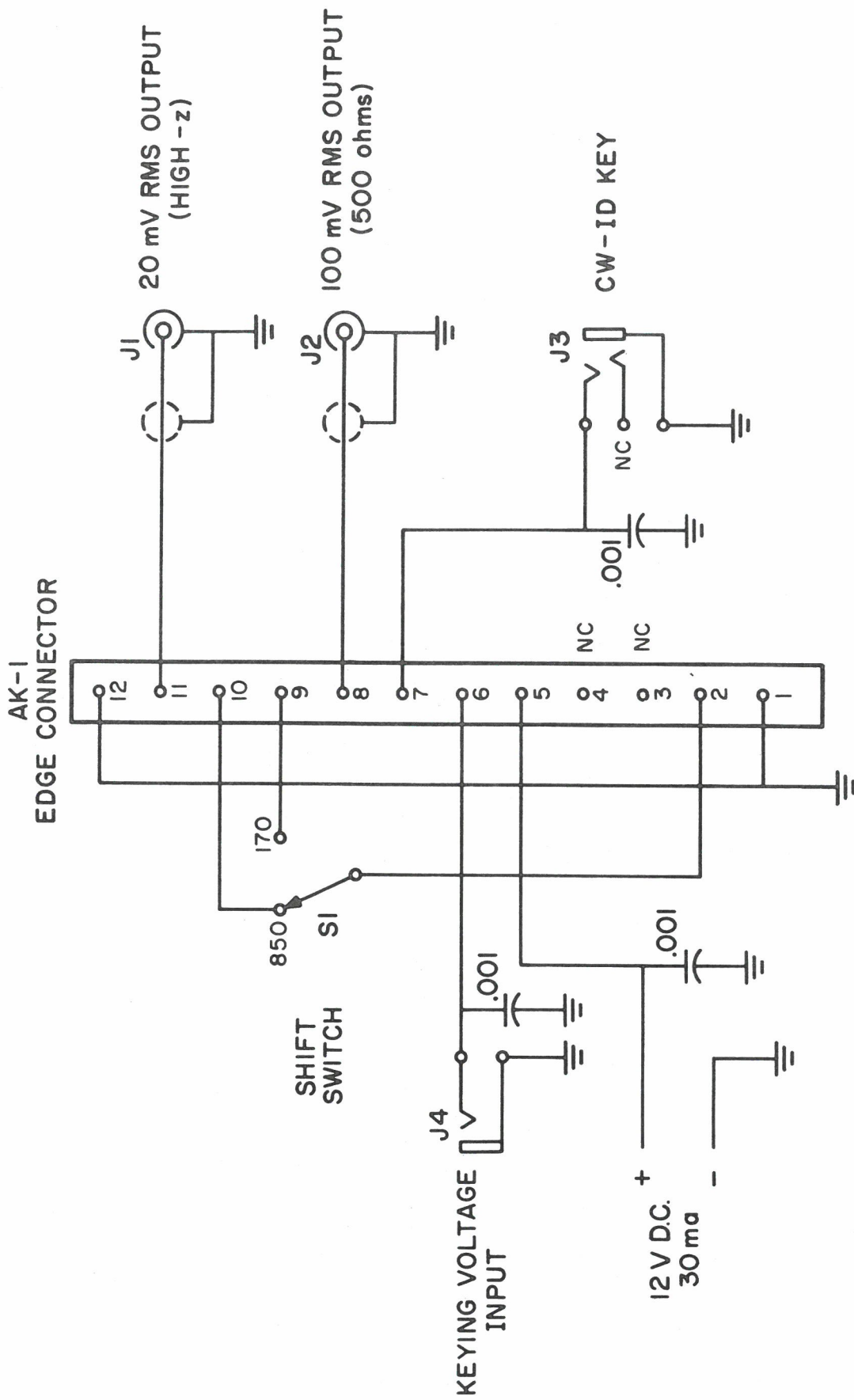

Figure 4 Typical Connections to AK-1

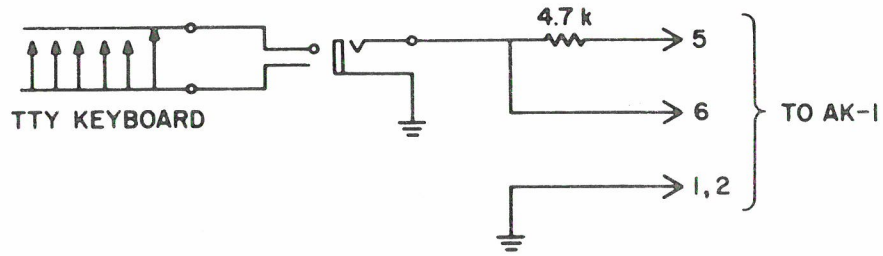

Figure 5 Direct TTY Keyboard Connection to AK-I

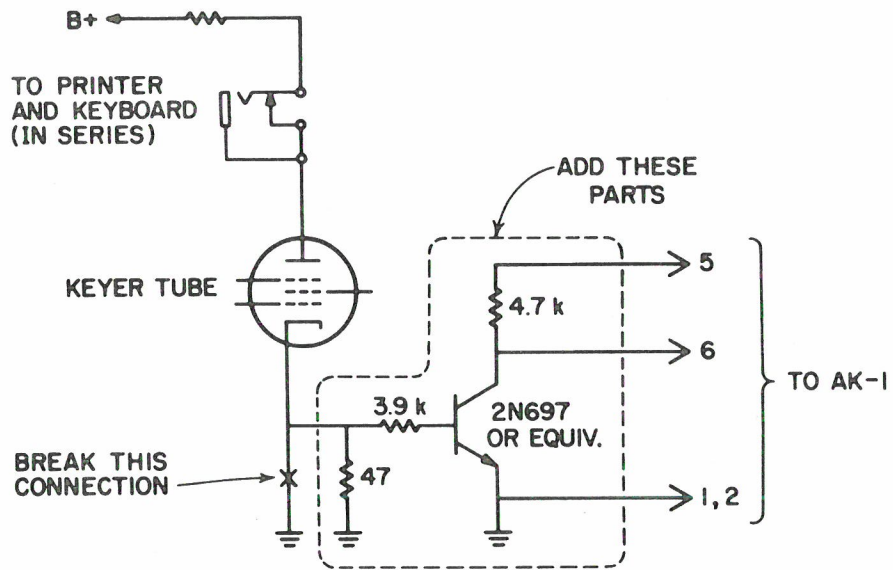

Figure 6 AK-I Connection to Tube-type Demodulator

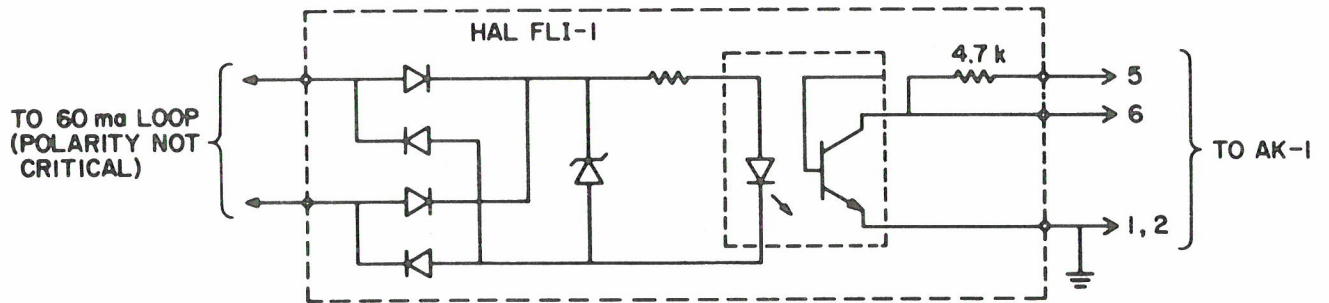

Figure 7 Direct Loop Connection of AK-I

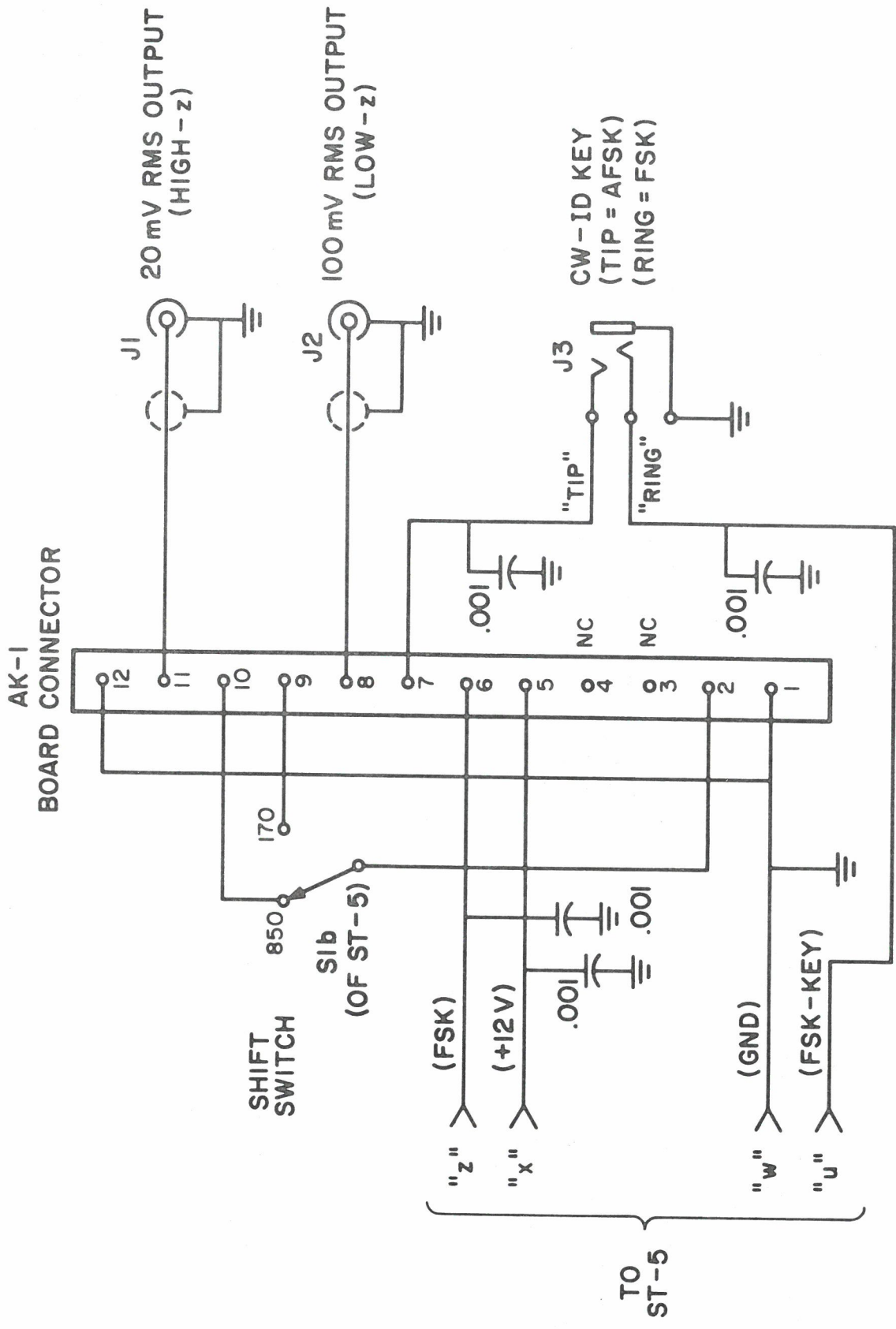
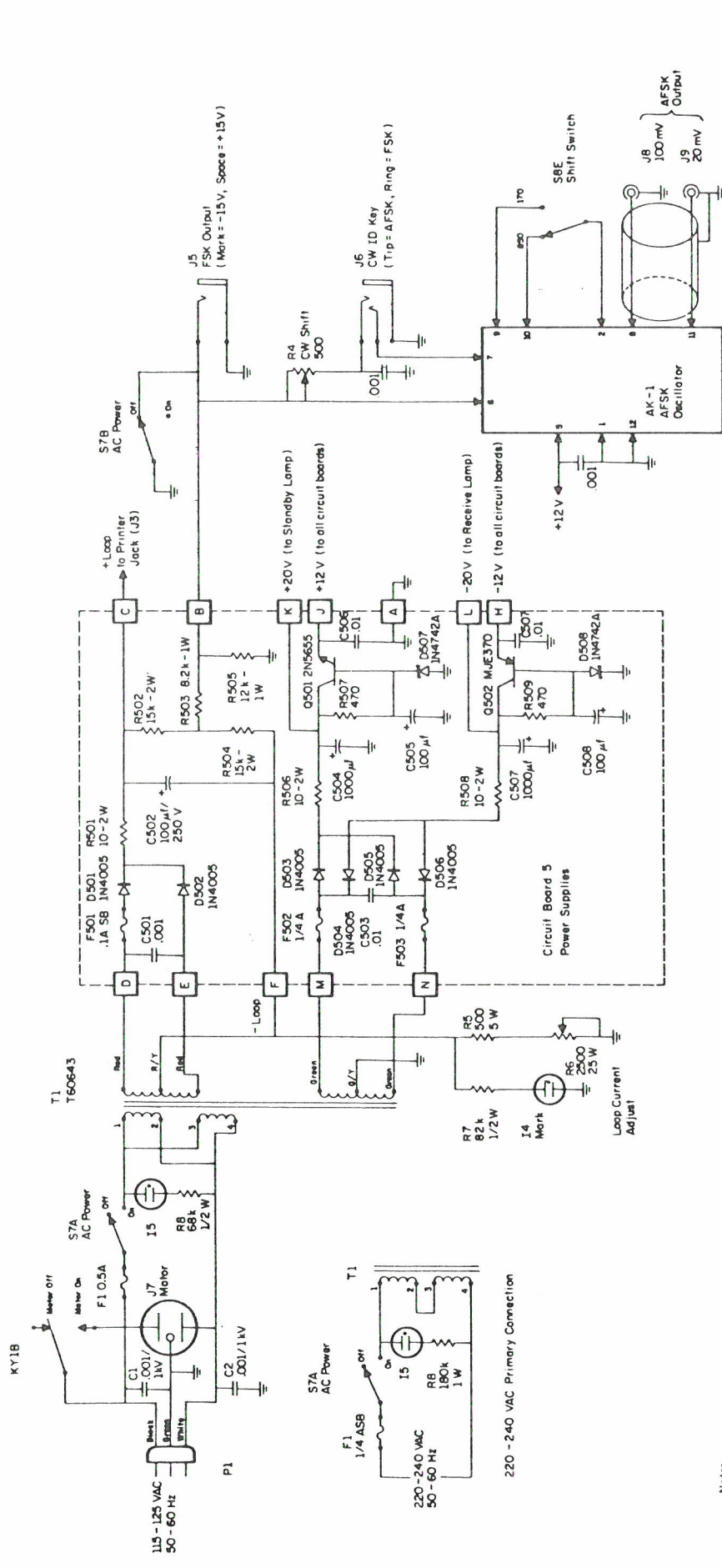

Figure 8 AK-1 Connections to ST-5



- NOTE:**
1. All resistors 1/4 W unless otherwise noted.
 2. Resistor R8 dissipates 9 Watts under Mark conditions and should be heat-sunk by mounting on metallic panel.
 3. I-3, I-4, & I-5 are NE-2 type neon lamps.
 4. Component Numbering System
X001 - X099, Main Frame
X501 - X599, Circuit Board 5

COMMUNICATIONS CORP. BOX 368, URBANA, ILLINOIS, 61801	
ST-6 Demodulator Circuit Board 5	
DATE	July 8, 1972
APPROVED	SCALE
No.	ST-6, S3

Figure 9. AK-1 Connections to St-6

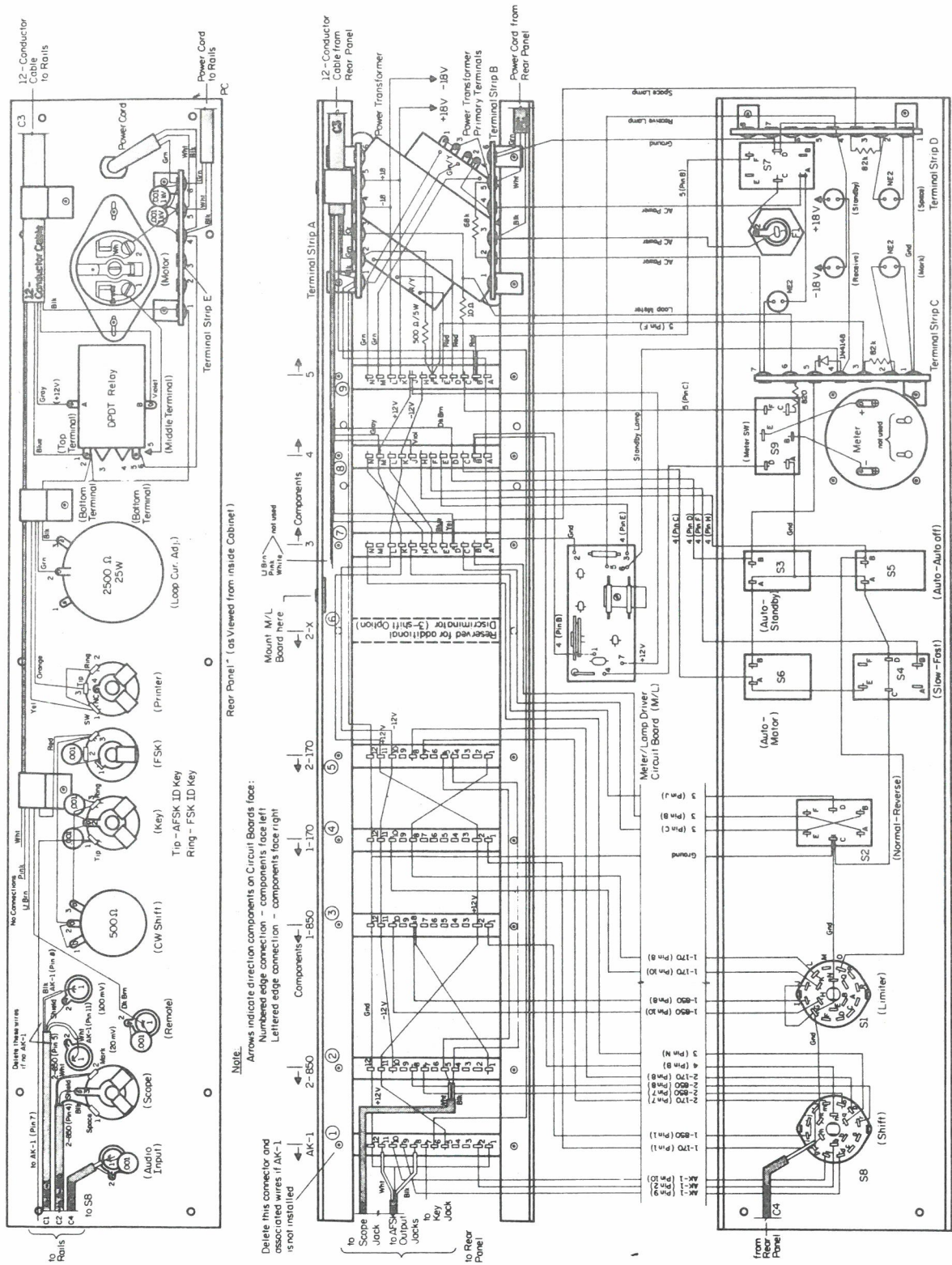

Front Panel (as viewed from inside)

HAILE COMMUNICATIONS CORP. BOX 365, URBANA, ILLINOIS, 61801	
DATE	August B, 1972
APPROVED	G. W. H.
SCALE	---
No.	ST-6, W1

ST-6 Wiring Diagram

Figure 10. AK-1 Wiring in ST-6 Cabinet

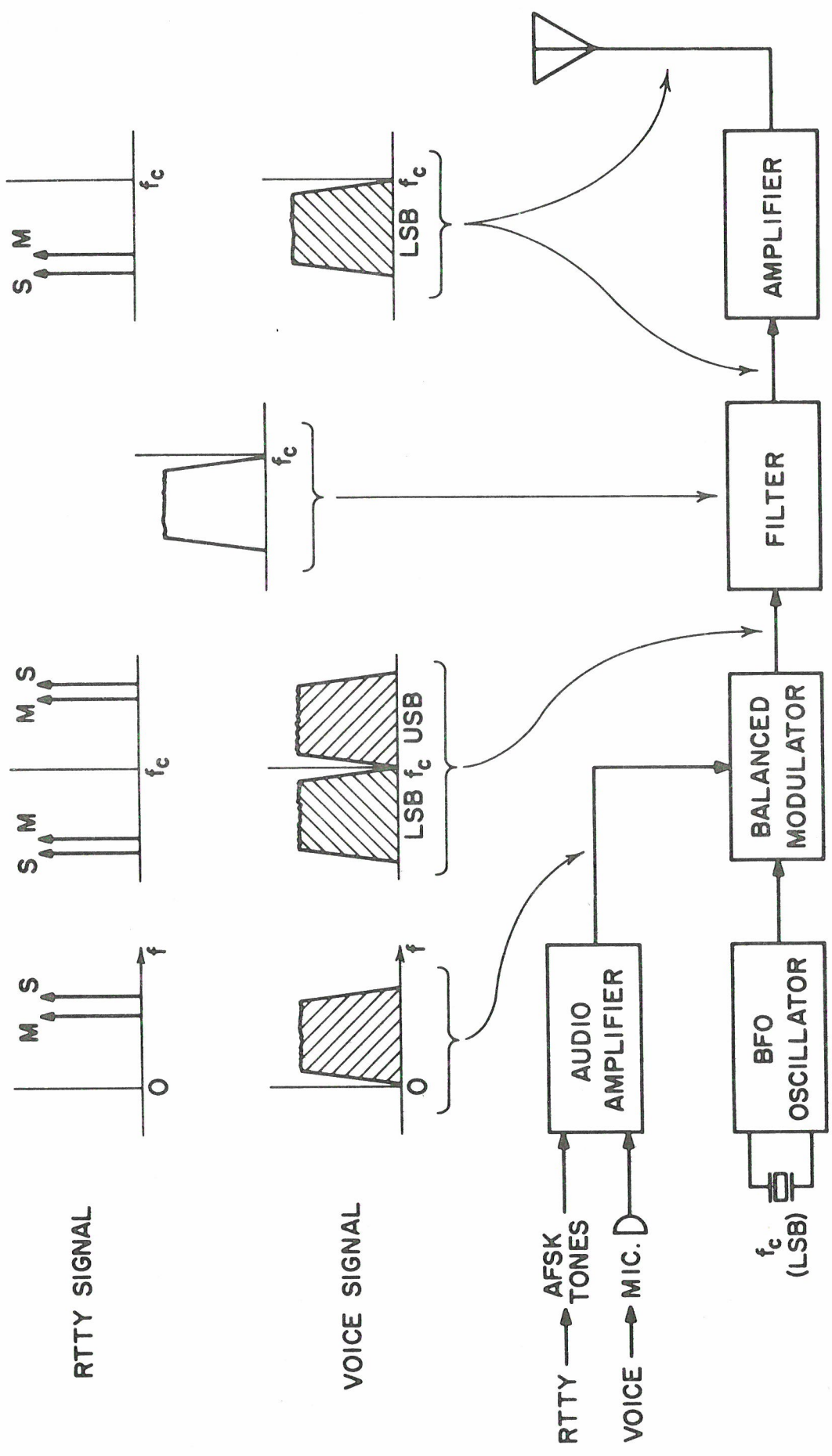

Figure 11 Use of AFSK with a Typical SSB Transmitter

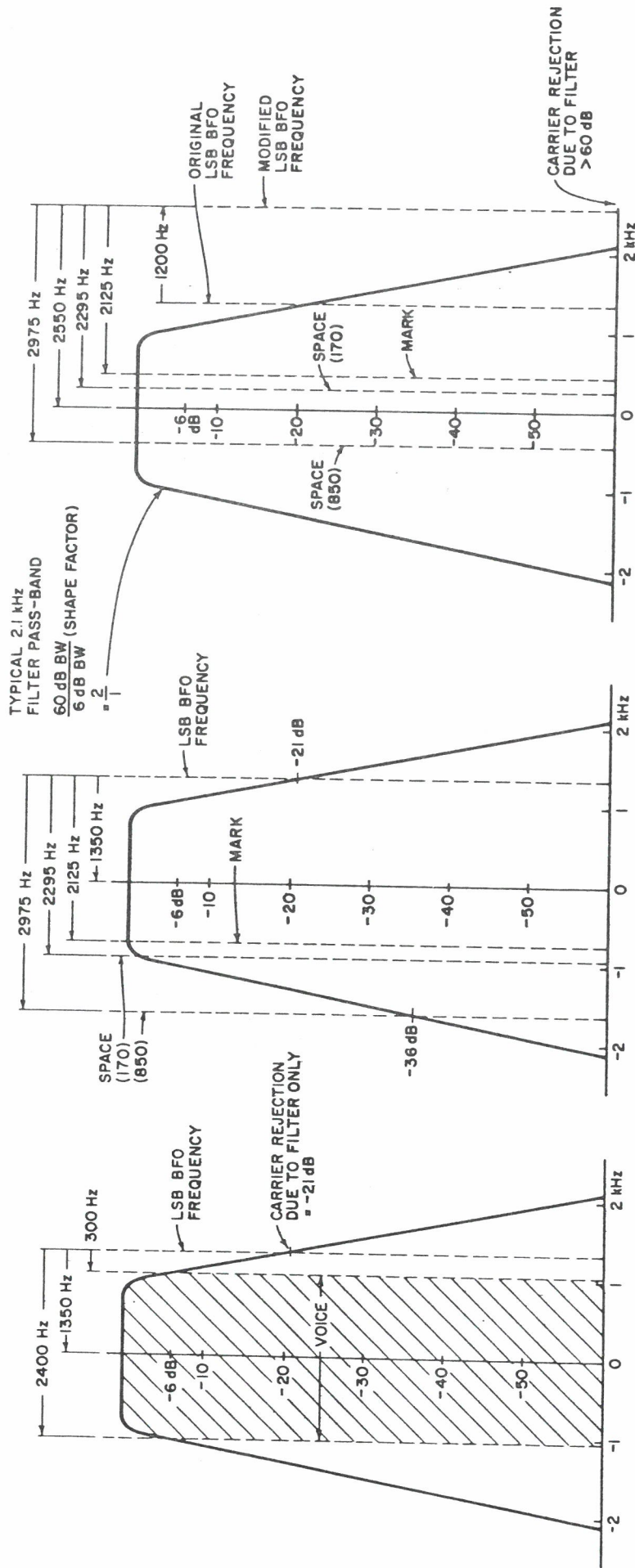

Figure 12 Spectra of Signals Generated by SSB Transmitter

8. PRELIMINARY PARTS LIST XTK-100

(April 1975)

Resistors (1/4 watt, 5%)

2	620 ohm
2	1,000 ohm
1	10 K ohm
2	27 K ohm
3	47 K ohm
2	51 K ohm
2	62 K ohm
4	68 K ohm
3	100 K ohm
2	240 K ohm
2	2.0 Meg ohm

Crystals

"High Tones"

1	4250.0 kHz
1	4450.0 kHz
1	4590.0 kHz
1	5950.0 kHz

"Low Tones"

1	3825.0 kHz
1	4125.0 kHz
1	4335.0 kHz
1	6375.0 kHz

Capacitors

4	220 pf disc ceramic
1	0.0015 ufd mylar ("High Tones")
1	0.0022 ufd mylar ("Low Tones")
2	0.01 ufd disc ceramic
3	0.1 ufd disc ceramic
3	10 ufd, 16 V electrolytic

Semiconductors

1	741 IC
1	4001 IC
1	4002 IC
3	4017 IC
1	4023 IC
1	4027 IC
1	4049 IC
1	1N4148 Silicon Diode

Miscellaneous

1	D1026B Circuit Board
1	12-pin edge connector
2	phono jacks
2	phono pin plugs

HAL COMMUNICATIONS CORP
P.O. BOX 365
URBANA, IL 61801

LIMITED WARRANTY

HAL Communications Corp of Urbana, Illinois, hereby warrants to the original purchaser only that any new equipment manufactured by HAL Communications Corp shall be free from defects in materials and workmanship for a period of one year from the date of original purchase. In the case of parts kits, this warranty applies only to materials and not to workmanship in kit assembly.

In the event of a defect in materials or workmanship during the warranty period, HAL Communications Corp will, at its own expense, repair the defective unit and replace any defective parts. Costs of shipping the unit to HAL Communications Corp shall be paid by the purchaser, as well as costs of removal and reinstallation of the unit. HAL Communications Corp will bear the shipping costs incurred in returning the unit to the purchaser.

To obtain service under this warranty, the original purchaser should do the following:

1. Notify, as soon as possible, the Customer Service Department at HAL Communications Corp, Urbana, Illinois, either in writing or by telephone, of the existence of a possible defect;
2. At the time of notification, identify the model or serial number, the approximate date of purchase, the place of purchase, and the possible defect;
3. Hold the unit until a written return authorization is received.
4. Return the unit, freight prepaid, upon the receipt of the written return authorization.

Correct installation, use, maintenance, and repair are essential for proper performance of this product. The purchaser should carefully read the technical manual.

This warranty does not apply to any defect which HAL Communications Corp determines is due to any of the following:

1. Improper maintenance or repair, including the installation of parts or accessories that do not conform to the quality and specifications of the original parts;
2. Misuse, abuse, neglect, improper installation, or improper operation (including operation without a proper safety ground connection);
3. Accidental or intentional damage.

All implied warranties, if any, are limited in duration to a period of one year from the date of original purchase. Some states do not allow limitations on how long an implied warranty lasts, so the above limitation may not apply to you.

HAL Communications Corp disclaims any liability for incidental or consequential damages arising out of the use of, or inability to use, this product. Some states do not allow the exclusion or limitation of incidental or consequential damages, so the above limitation or exclusion may not apply to you.

This warranty gives you specific legal rights, and you may also have other rights which vary from state to state.