TONO

COMMUNICATIONS COMPUTER

Θ - 7000E

INSTRUCTION MANUAL

TONO CORPORATION

230 MOTOSOJA-MACHI, MAEBASHI-SHI, 371. JAPAN

TABLE OF CONTENTS

1. Features & Precautions	1
2. Location and Function of controls	4
i) Front panel (Keyboard)	
ii) Back panel	
3. Accessories supplied	7
4. Connection	7
4-1. Basic System	7
i) Power Supply	
ii) TV set	
iii) Transceiver	
4-2. Expanded System	10
i) Oscilloscope	
ii) Printer	
5. Operation	
i) Preliminary Setting	11
ii) Procedure to Power Up Equipment	11
iii) Speed and Weight Setting	12
iv) Tuning	13
v) Transmission	16
1. Buffer Memory	
2. Correction of Miswritten Characters	
3. Automatic Key Repeat	
vi) Functions	17
1. Channel Memory	
2. SEND Function	
3. Split Screen	
4. Stop of Transmission	
5. "Stand-by" Procedure	
6. CW Identification	
7. Other Function Keys	
8. Indications	
vii) Using a Tape Recorder for Storage	22
6. Application of a Microcomputer as an Intelligent Terminal	23
7. How to Set Cells for the Battery Backed-up Memory	23
Key function and display	24
Special Character ASCII 00-1F	27
Specifications	28
Input/ Output Circuit	29

1. FEATURES & PRECAUTIONS

Features:

1. Communications Computer Θ -7000E
Due to the most up-to-date computer technology, one piece of equipment can now handle both transmitting and receiving in CW, RTTY and ASCII.
2. VHF and Composite video output provided:
Both a home TV set and video monitor outputs are provided for display purposes.
3. Printer interface
Centronics para. Compatible interface enables easy connection of a low-cost dot printer for hard copies.
4. Wide range of transmitting and receiving speeds
10 communication speeds for transmitting (with automatic CW speed adjustment of receive) and 9 communication speeds for transmitting and receiving in RTTY and ASCII. The multiple speed feature makes the Θ -7000E ideal for Amateur, business and commercial use.
5. Built-in demodulator for high performance
Three-step shift (either 170 Hz, 425 Hz, 850 Hz) can be obtained using either High Tone or Low Tones. Manual adjustment is available by FINE TUNING control.
6. Crystal controlled modulator
A transceiver without FSK function can transmit in RTTY mode by utilizing the high stability crystal-controlled modulator controlled by the computer.
7. Convenient ASCII key arrangement
The keyboard layout is the same as a regular typewriter and automatic insertion of LTR/FIG code makes operation a breeze.
8. Large capacity display memory
The two-page display memory contains 32 characters \times 16 lines per page. Page selection is operated via the keyboard.
9. Split-screen
With a keyboard command, the first page can be divided in two; the upper half for transmit and the lower half for receive. Sentences can be edited whilst receiving.
10. Automatic Transmit/Receive switch
The transmit/receive switch is controlled by the microprocessor. (Manual operation is also available.) Built-in remote control key function controls the transmit/receive switch of the transceiver.
11. Anti-noise
A new anti-noise circuit prevents garbled messages when there is no signal.
12. Battery backed-up memory
Data in the battery backed-up memory is retained when the external power source is removed. The Θ -7000E has provision for 64 characters \times 7 channels in the non-volatile memory. Data from a memory can be repeated 1–9 times from a keyboard instruction. Every channel can read out continuously. The channel number in use is displayed in the buffer.
13. SEND function
The SEND function sends data displayed on the screen, including any channel data after instruction from the keyboard. The message can be stopped and restarted.
14. Buffer memory
A 53-character-buffer-memory is displayed on the 17th and 18th lines on the screen. The characters move to the left erasing one by one as soon as they are transmitted. Data in the channels can be displayed in the buffer.
15. Rub out function
Mistakes can be erased whilst the information is still in the buffer memory. If the mistake has already been sent a correcting code will be transmitted.

16. Simultaneous access of the memory
Whilst receiving, it is possible to write into the channel memory and the buffer memory from the keyboard. When sending from the channel memory or the screen it is possible to write into the buffer memory.
17. Pre-loading function
The buffer memory can momentarily store data and release it on an instruction from the keyboard.
18. Channel No., Page No., and Case No.
Channel No., Page No., and Case (LTR/FIG) in RTTY are displayed in the 17th line of the screen.
19. CR (Carriage return)/LF (line feed) cancel function
When receiving CR or LF, they are replaced by = (equal) and _ (underline) respectively for effective use of the screen.
20. Cursor control function
Full cursor control (up/down-left/right) is available from the keyboard.
21. WORD MODE operation
Characters can be transmitted by word groupings.
22. Automatic CR/LF
While sending, CR/LF are automatically inserted once every 72 (64 or 80) characters.
23. Automatic LETTER code insertion
With LETTER switch ON, LETTER code can be transmitted continuously while transmitting from the keyboard is stopped.
24. ECHO-BACK function
With a keyboard instruction, received data can be read and sent out at the time. A cassette tape can be used as the source data.
25. WORD-WRAP-AROUND function
In receive mode word-wrap-around prevents the last word of the line from splitting in two. This function is released with a keyboard instruction.
26. Transmit/receive in ASCII mode in RTTY
On instruction from the keyboard, the same AFSK signals as used in RTTY are transmitted in ASCII mode.
27. CW Identification function
Keyboard controlled CW identification is available if required.
28. MARK-AND-BREAK (SPACE-AND-BREAK) system
Either mark or space tone can be used to copy RTTY.
29. Monitor circuit
A built-in-monitor circuit with an automatic transmit/receive switch enables checking of the transmitting and receiving state. In receive mode it is possible to check the output of the mark filter, the space filter and AGC amplifier prior to the filters.
30. CW practice function
The Ø-7000E reads data from the key and displays the characters on the screen.
31. Variable CW weights
For CW transmission, weights (ratio of dot to dash) can be changed within the limits of 1:3–1:6.
32. Cross-pattern checking output terminal
Provision has been made for attachment of an oscilloscope to aid tuning. This supplements the tuning LED and audio monitor provided in the system.
33. Log-computer output provided
The Ø-7000E has an output terminal for connection to a log-keeping computer.
34. Test message function
"RY" and "QBF" test messages can be repeated with this function.

Precautions:

1. Before operating the set, please read this INSTRUCTION MANUAL thoroughly.
2. Before using with a transceiver practice with a TV set.
3. Adjust SWR between the transceiver and antenna as follows:

OUTPUT	SWR
10 W	≤1.5
10...100 W	≤1.3
100...500 W	≤1.1

4. Take care to properly connect in. the connection to the input circuits and output circuits. Input signal and load should be within the ratings.
5. Voltage of DC power supply should be within the range of DC 11...14 V.
6. Where the Input impedance of the TV set is 300 ohms (not 75 ohms) put a matching transformer of 75 Ω : 300 Ω between the Θ-7000E and the TV set.
7. DC power supply for the Θ-7000E should not be connected to other sets.
8. The Θ-7000E should be installed at a well-ventilated dry place not exposed to the direct rays of the sun with special care for heat radiation.
9. While automatic CR/LF insertion function is working, CR/LF is inserted automatically at space which is written anywhere but in the last five letters of line.
10. Use RTTY modem at 150 Baud less.

2. LOCATION AND FUNCTION OF CONTROLS

i) Front panel (Keyboard)

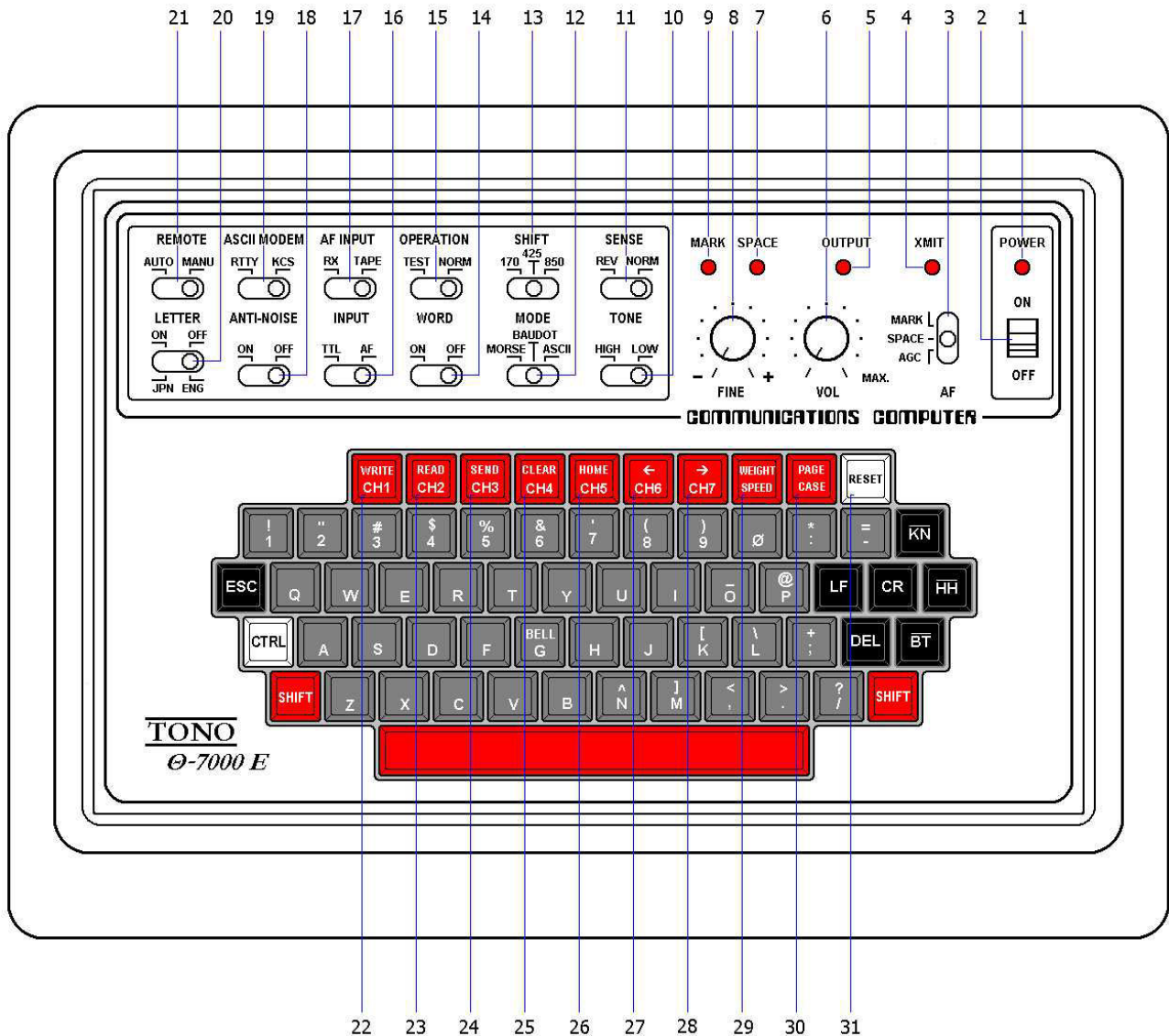

1. POWER pilot LED: lights when the POWER switch is turned ON.
2. POWER switch
3. AF switch: [AGC] output from AGC can be monitored
[MARK] or [SPACE] output from respective filters can be monitored.
4. XMIT indicating LED: turns on and off with **SHIFT X** operated when the REMOTE switch is set at MANUAL; turns on and off corresponding to key operation while at AUTO.
5. OUTPUT indicating LED: indicates output level. It lights at the time of "mark" and does not light at the time of "space". V.V.
6. VOL: controls the volume of a monitor speaker.
7. SPACE indicating LED: Indicates space of input signal.
8. FINE tuning control: provides the fine tuning of shift width in receiving in BAUDOT mode and RTTY of ASCII.
9. MARK indicating LED: Indicates mark of input signal.
10. TONE switch: indicates High Tone or Low Tone in RTTY.
11. SENSE switch: changes the polarity of mark/space in input and output.
12. MODE switch: for mode selection.
13. SHIFT switch: sets shift width in RTTY
14. WORD switch: transmits characters in the buffer memory by word groupings by pushing **SPACE** (or LF or CR).

- 15. OPERATION switch: controls the state of the keying circuit.
- 16. INPUT switch: [TTL] obtains input from TTL LEVEL IN jack.
[AF] obtains input from others.
- 17. AF INPUT switch: relates to AF INPUT jacks on the back panel.
- 18. ANTI-NOISE switch: Helps to prevent garble when there is no signal.
- 19. ASCII MODEM switch: relates to AF INPUT KCS and RX/TAPE on the back panel.
- 20. LETTER switch: LETTER code is transmitted when transmitting in RTTY.
- 21. REMOTE switch: puts the transceiver in transmitting state by pushing any key (AUTO) or **SHIFT X** (MANUAL).

- 22. **WRITE | CH1** key
 - 23. **READ | CH2** key
 - 24. **SEND | CH3** key
 - 25. **CLEAR | CH4** key
 - 26. **HOME | CH5** key
 - 27. **← | CH6** key
 - 28. **→ | CH7** key
 - 29. **WEIGHT | SPEED** key
 - 30. **PAGE | CASE** key
 - 31. **[RESET]** key: put the set in the initial state.
- } Refer to page 22

ii) Back panel

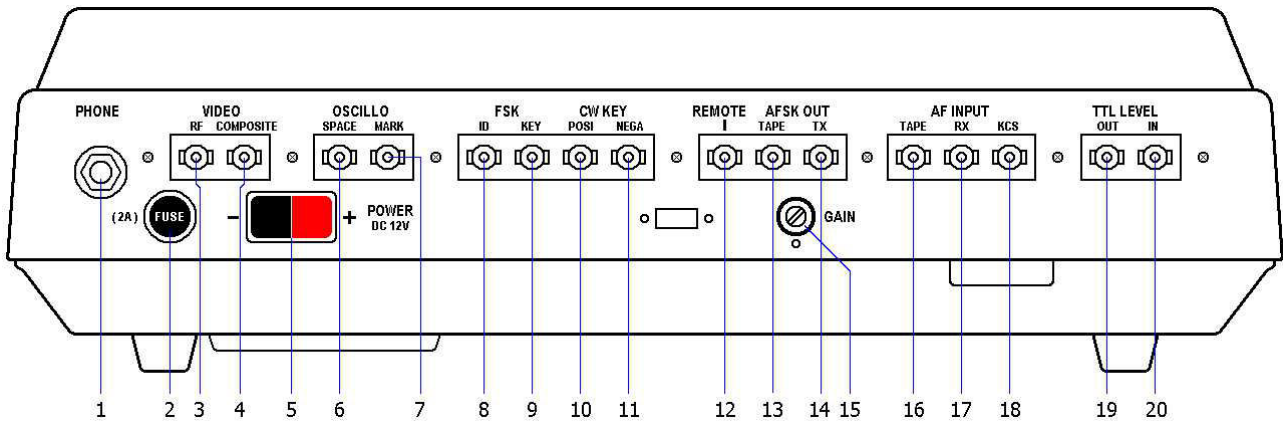

1. PHONE jack: Connect with an earphone
2. FUSE: 2 A
3. VIDEO RF jack: Connect with a home TV set.
4. VIDEO COMPOSITE jack: Connect with a video monitor.
5. POWER supply jack: DC 12 V in
6. OSCILLO SPACE jack: Oscilloscope should be connected to this jack for the space output for cross pattern.
7. OSCILLO MARK jack: Oscilloscope should be connected to this jack for the mark output for cross pattern.
8. FSK ID jack: Connect 100 k Ω – 200 k Ω resistor for CW identification.
9. FSK KEY jack: Connect with RTTY keying terminal of the transceiver for FSK function in RTTY.
10. CW KEY POSI jack: Connect to the transceiver for CW (refer to page 8)
11. CW KEY NEGA jack:
12. REMOTE jack: Connect to PTT terminal of the transceiver for remote control.
13. AFSK OUT TAPE jack: Connect to MIC terminal of the cassette tape recorder.
14. GAIN control: Controls the AFSK output level.
15. AFSK OUT TX jack: Connect to MIC terminal of the transceiver.
16. AF INPUT TAPE jack: Connect to EARPHONE terminal of the tape recorder.
17. AF INPUT RX jack: Connect to EXT SP terminal or line output of the transceiver.
18. AF INPUT KCS jack: Connect to EARPHONE terminal of the tape recorder.
19. TTL LEVEL OUT jack: For output in TTL level without modulation.
20. TTL LEVEL IN jack: For non-modulated signals in CW, BAUDOT or ASCII and when using with a hand key.
21. PRINTER CABLE OUTLET

3. ACCESSORIES SUPPLIED

Instruction manual	1
Pin plug	16
Headphone plug	1
Power source cord	1
Coaxial cable	4 m
Connector for printer	1

4. CONNECTION

4-1 Basic System

F

i) Power supply

Before connecting a power lead to your DC power supply, the setting of the voltage must be within the range of DC 11 V – 14 V.

After confirming that the DC source switch and POWER switch of the Θ -7000E indicates OFF, connect a plus (+) of POWER supply jack of the Θ -7000E with the plus (+) terminal of DC source; minus (-) with minus (-) terminal.

ii) TV set

1. Solder an ancillary coaxial cable and a pin plug as shown in Fig. 3. After having soldered, connect the pin plug to the RF pin jack of the Θ -7000E and the other end of the coaxial cable to an antenna terminal of a home TV set. Tune TV set to CH3 or CH4,

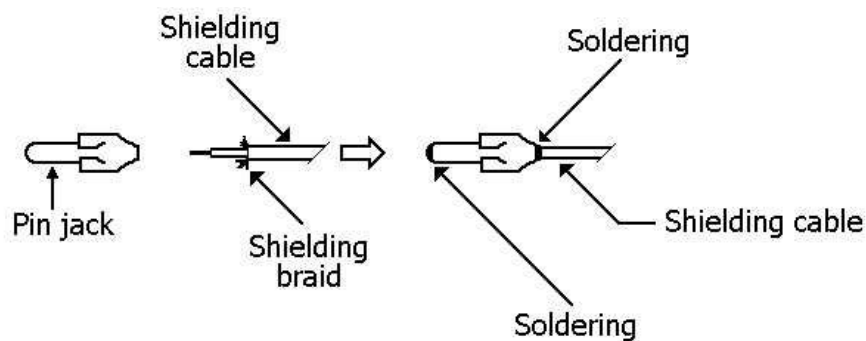

ig. 3

or 2. Connect the pin plug to COMPOSITE pin jack for a display monitor.

We recommend you TONO display monitor model: CRT-12,, which is specially designed for Amateur radio communications and has very stable display without being interfered by a electric wave.

iii) Transceiver

Make sure SWR is as follows; to enable correct operation.

T

OUTPUT	SWR
10 W	≤ 1.5
10...100 W	≤ 1.3
100...500 W	≤ 1.1

able 1

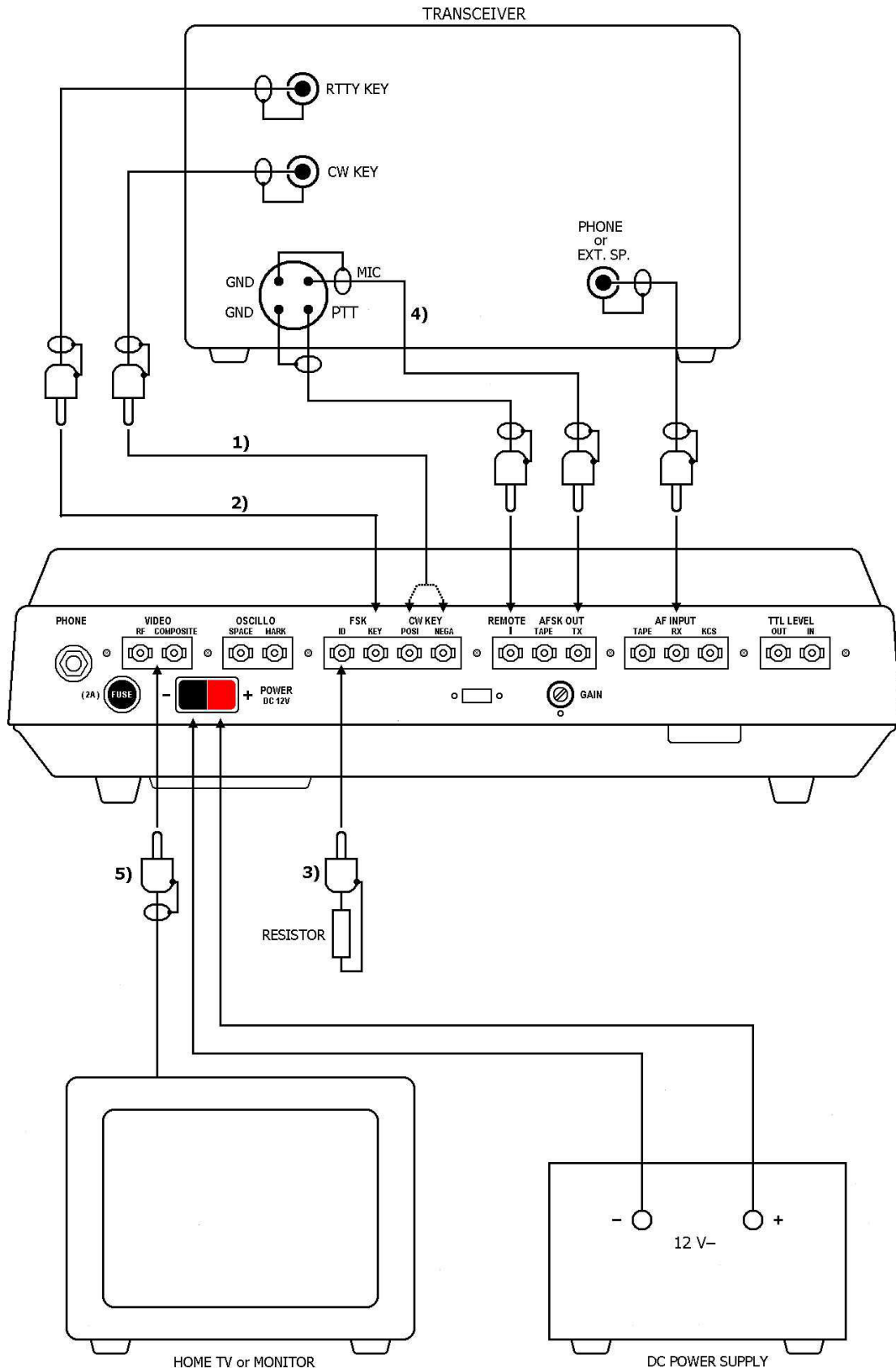

F

ig. 4

- NOTE: 1) Check the polarity against the ground by the tester and connect with the respective jack.
 2) No need to connect when using with AFSK function of Θ -7000E.
 3) Only for CW identification with FSK function of the transceiver.
 4) No need to connect when using with FSK function of the transceiver.
 5) For Home TV set "RF"; for Monitor set "COMPOSITE".

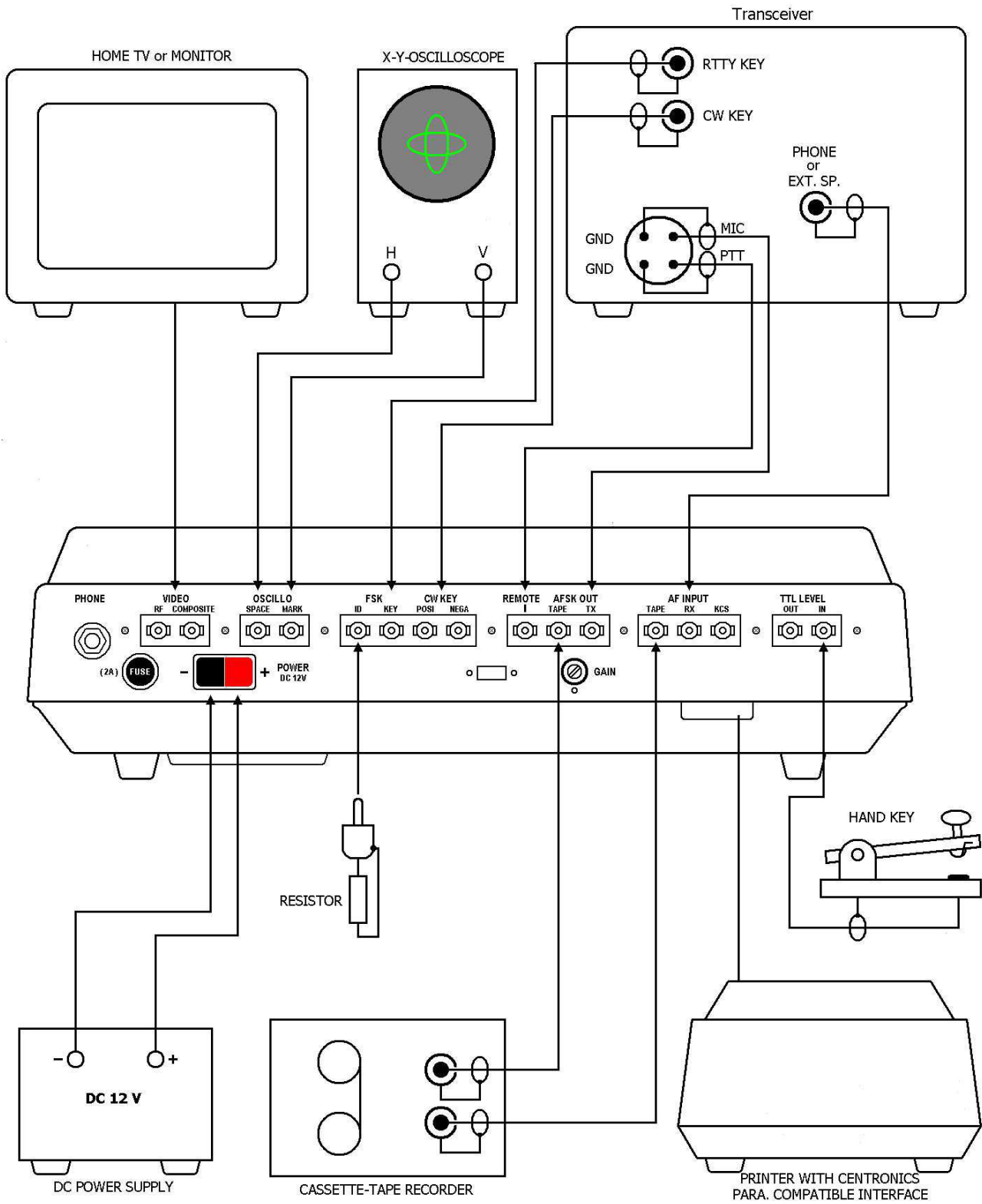

ig. 5

4-2 Expanded System

Refer to page 9 for detail.

i) Oscilloscope

As output impedance for oscilloscope is 200 kΩ, use an oscilloscope whose input impedance is over 1 MΩ. As output for oscilloscope is about 1.2 V_{PP}, large cross pattern cannot be obtained without an amplifier in horizontal-amplifier of the oscilloscope.

ii) Printer

A printer which has Centronics compatible interface can be connected directly with the Θ-7000E.

We recommend the TONO printer model HC-800, which is easy to connect because of its supplied cable with connector for the Θ-7000E.

Connector CN8 on the CPU board is a connector for a printer. The function of each pin is as follows. The fan-out of each pin is 5 standard TTL loads. Avoid overload! Connect any of them to your printer is required.

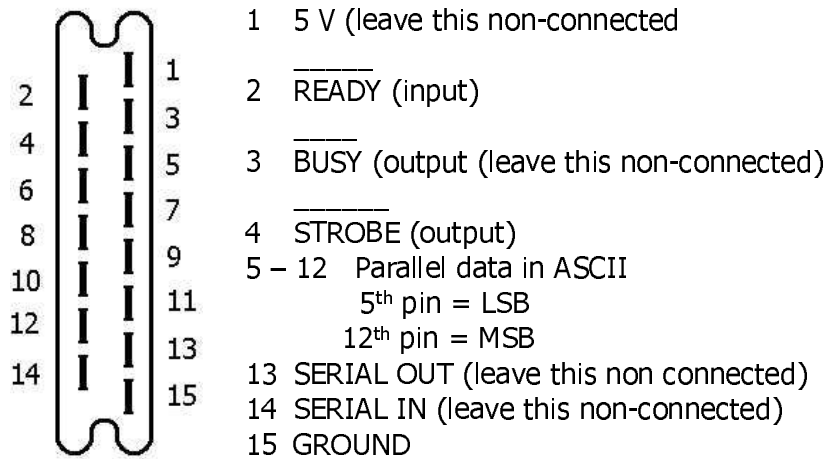

ig. 6

When $\overline{\text{READY}}$ is "L" level, timing of data for printer is as follows:

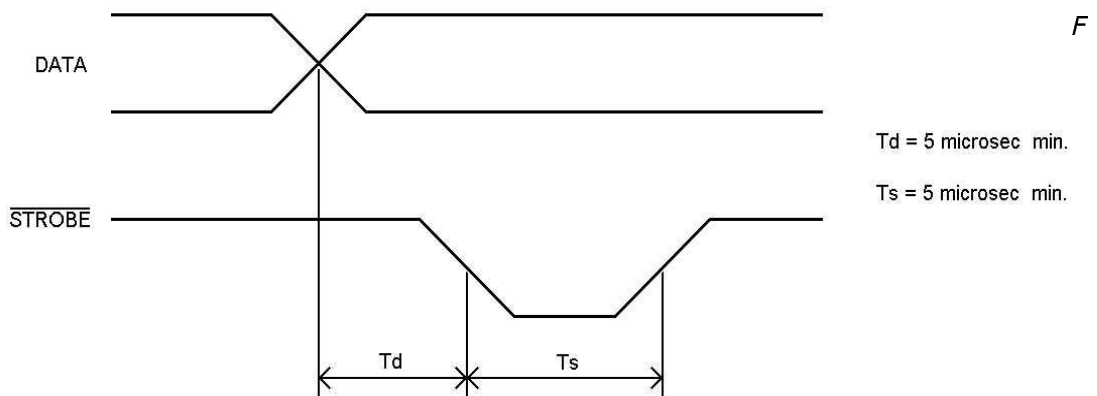

ig. 7

When $\overline{\text{READY}}$ is "H" level, the port for printer holds the previous data. The printer should print and make CR/LF with LF instruction or CR instruction.

5. OPERATION

T

i) Preliminary Setting

Theta-7000E		
Front Panel	POWER <i>w</i>	OFF
	VOL <i>uning control</i>	medium
	MODE sw	—
	OPERATION <i>w</i>	NORM
	SENSE sw	NORM
	REMOTE sw	—
	ASCII MODEM <i>w</i>	KSC
	AF INPUT <i>w</i>	RX
	LETTER <i>w</i>	—
	ANTI-NOISE <i>w</i>	—
	INPUT <i>w</i>	AF
	WORD <i>w</i>	—
	AF <i>w</i>	AGC
	FINE <i>uning control</i>	medium
	SHIFT <i>w</i>	(any place) when in BAUDOT mode select the proper shift
Back Panel	AFSK GAIN <i>ontrol</i>	around medium

DC power supply	
POWER <i>w</i>	OFF

TV set	
POWER <i>w</i>	OFF
VHF channel (Home TV)	CH 4 (Australia & Continental) CH 3 (USA)

Transceiver	
MODE sw	according to the MODE sw setting of the Θ-7000E. <u>w/o FSK function</u> LSB setting is required for RTTY.
POWER sw	OFF
AF volume	Set it so as to make the input voltage into the Θ-7000E ranging from 50 mV to 1 V (ordinary listening volume)

--- : as required

able 2

ii) Procedure to power up equipment

- Put the power switch ON of:
1. TV set
 2. DC power supply
 3. The Θ-7000E
 4. Transceiver

When you get POWER pilot LED light and indications on the TV screen as shown in Fig. 8, your Θ-7000E is all ready to go!

If using RF input, it may be necessary to find correct channel – either 3 or 4 – and adjust fine tuning.

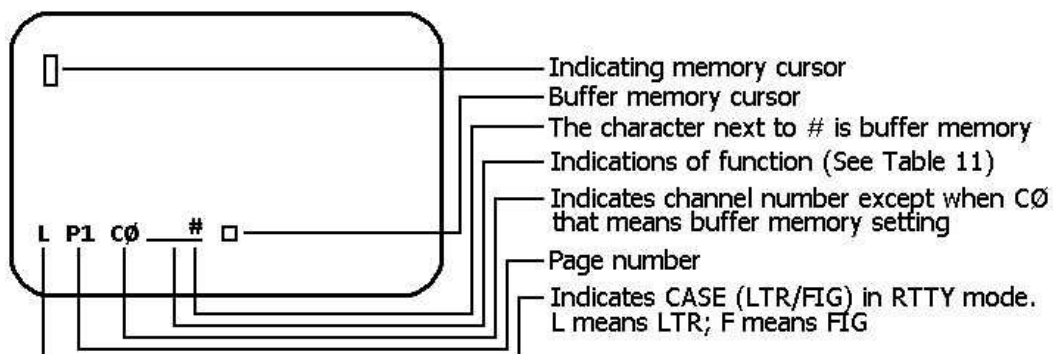

ig. 8

F

iii) Speed and Weight Setting

[1] CW (MORSE)

RECEIVING SPEED

Receiving speed is automatically determined. Dots which are less than 20 msec may be regarded as noise. However, when slow CW is received right after rather fast CW, 2–4 characters are required before synchronization is achieved.

➤ For the faster sync, in high speed

WEIGHT | SPEED → **H**
 (Push) (and then push)

➤ For the faster sync, in low speed

WEIGHT | SPEED → **L**

When the receiving speed of signals suddenly diminishes to less than half, it will sometimes happen that 8–12 characters are read as E or T by mistake. However, correct reading will be obtained with the continuation of the CW signals at the new rate.

TRANSMITTING SPEED

Transmitting speed is automatically set at the speed of about 50 characters per minute in the initial state.*

(* Pushing POWER switch ON or [RESET] key makes the initial state.)

T

➤ For the speed change

WEIGHT | SPEED → **∅ ~) | 9**

There are ten speeds to be selected as shown in Table 3.

∅	about 25 char./min.	% 5	about 87 char./min.
! 1	about 32 char./min.	& 6	about 113 char./min.
" 2	about 41 char./min.	' 7	about 147 char./min.
# 3	about 52 char./min.	(8	about 188 char./min.
\$ 4	about 68 char./min.) 9	about 250 char./min.

able 3

WEIGHT SETTING

Weight (ratio of dot to dash) is automatically set at 1:3 in the initial state.

➤ For the weight change

SHIFT | WEIGHT | SPEED → **∅ ~) | 9**

There are ten steps within the limits of 1:3 ~ 1:6.

[2] RTTY (BAUDOT)

Transmitting/receiving speed is automatically set at 45.45 baud in the initial state.

➤ For the speed change

WEIGHT | SPEED → **∅** ~ **) | 9**

Selection will be obtained as shown in Table 4.

∅	45.45 Baud	% 5	110 Baud
! 1	50 Baud	& 6	150 Baud
" 2	56.88 Baud	' 7	200 Baud
# 3	74.2 Baud	(8	300 Baud
\$ 4	100 Baud) 9	300 Baud

able 4

NOTE: 45.45 Baud is popular among Amateurs and 50 Baud is usually used in business communications.

➤ For the adjustment

SHIFT **Z** speed up (the length of a bit becomes about 0.16 msec shorter per time)

SHIFT **S** speed down (about 0.16 msec shorter per time)

[3] ASCII

Transmitting/receiving speed is automatically set at 110 baud in the initial state.

For speed change and selection, refer to RTTY.

[4] Mode change under running condition

Speed setting is necessary. Be sure to push **[RESET]** key when BAUDOT or ASCII mode is changed into CW mode; otherwise the tone frequency of AFSK is set at "Mark" frequency of BAUDOT/ASCII mode.

iv) Tuning

TRANSMITTING

[1] CW (MORSE)

Tune the transceiver when keying output is ON and with OPERATION switch at TEST and SENSE switch at NORM. After tuning, set OPERATION switch to NORM (refer to page 21).

[2] RTTY

In RTTY when using AFSK complete tuning by adjustment of microphone-gain of the transceiver, avoiding excess modulation and over drive.

RECEIVING

[1] CW (MORSE)

Using LED indicator

1. Receive CW with the transceiver.
2. SPACE indicating LED lights when the CW signals from the transceiver pass through the band-pass-filter of which the central frequency is 830 Hz.
3. Tune VFO or RIT of the transceiver so as to make this SPACE indicating LED have maximum brightness.

Using audio level

1. Set AF switch to SPACE.
2. Output of the band-pass-filter can be heard.
3. Adjust the transceiver to have the maximum sound level.

If the SPACE indicating LED begins to flicker corresponding to signals, the Θ -7000E reads properly and will display on the TV screen. Special characters are displayed as shown in Table 5.

CW special character	Display
$\overline{\text{BT}}$	=
$\overline{\text{KN}}$	(
$\overline{\text{HH}}$	>
$\overline{\text{AR}}$	+
$\overline{\text{AS}}$	^
$\overline{\text{VA}}$;
$\overline{\text{AA}}$	@

Table 5

[2] RTTY (BAUDOT)

1. Tune in RTTY signals with the transceiver.
2. Increase the AF output frequency gradually from the lower value with the VFO or RIT until MARK indicating LED lights.
3. Continue increasing the frequency.
4. Stop increasing the frequency when the MARK indicating LED lights again and comes to light at maximum brightness.

5. SPACE indicating LED lights at this moment if the shift width of RTTY signal agrees with the setting of the Θ -7000E.

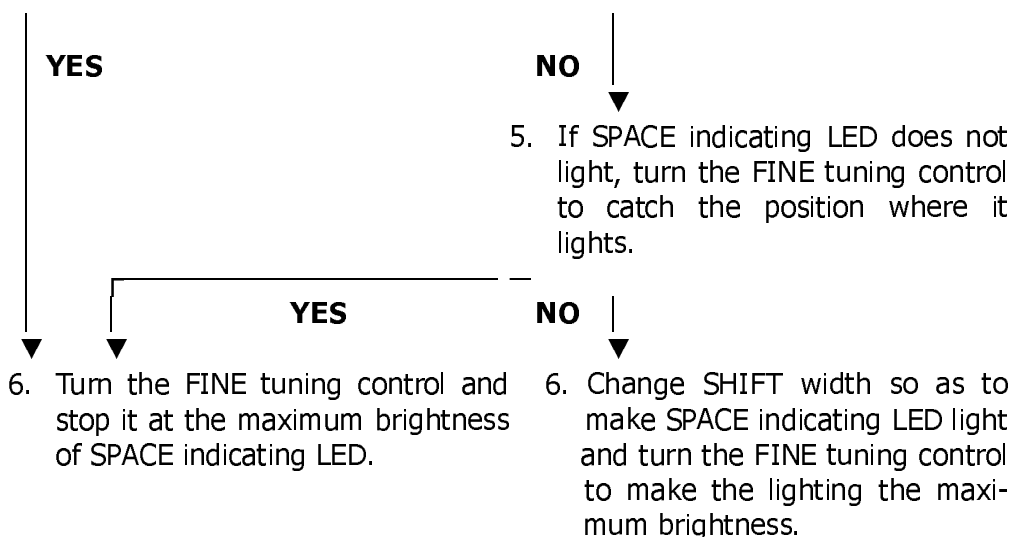

When tuning is completed, right characters will be displayed on the screen.

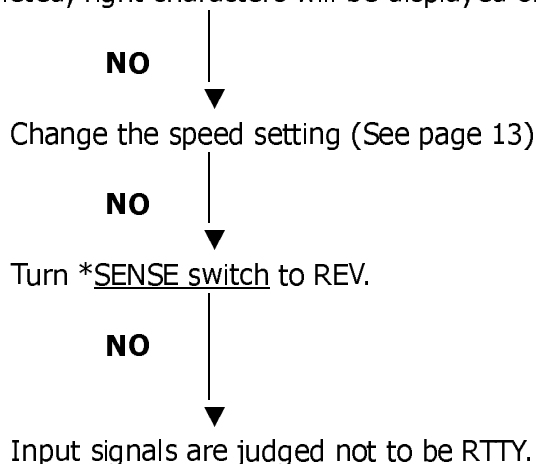

For amateur communications, 170 Hz shift is most commonly used; for business communications, 850 Hz and 425 Hz shift is usually used. In addition, monitoring of the output of MARK filter and that of SPACE filter are obtainable by tuning AF switch to MARK and SPACE respectively. The output of MARK filter and SPACE filter can function in lieu of MARK indicating LED and SPACE indicating LED.

SHIFT SWITCH	HIGH TONE		LOW TONE	
	MARK	SPACE	MARK	SPACE
170 Hz	2125 Hz	2295 Hz	1275 Hz	1445 Hz
425 Hz	2125 Hz	2550 Hz	1275 Hz	1700 Hz
850 Hz	2125 Hz	2975 Hz	1275 Hz	2125 Hz

Table 6

➤ Tuning by cross pattern

In the case of tuning with a cross pattern made on the oscilloscope, adjust VFO and RIT of a transceiver and FINE tuning control of the Θ -7000E to make amplitude both in V-direction and in H-direction the maximum.

[3] ASCII

- When using KCS

Tuning by watching the LEDs or by listening the transmitting sound from the speaker is not available in this mode.

Receive signals of 2400 Hz for mark and 1200 Hz for space in accordance with KCS (Kansas City Standard) from a tape recorder or a microcomputer.

- When using RTTY (ASCII)

Tuning is the same as in BAUDOT mode.

[4] NOISE

- ANTI-NOISE circuit

When there are too many errors caused by noise when there is no signal, set the ANTI-NOISE switch ON. This circuit may make mistakes with high speed CW (Morse) of which a dot is shorter than 20 msec.

- UNSHIFT-ON-SPACE function (only in BAUDOT)

When error in CASE (LTR or FIG) is often made with a lot of noise, push **SHIFT** **Y** UNSHIFT-ON-SPACE function works and leads the LTR case when space is received.

is replaced by * on the 17th line. To release this function push these keys again.

v) Transmission

Procedure	CW (MORSE)	BAUDOT (RTTY)	ASCII
1. Setting	The transceiver can be made to transmit by any of the three ways below: a) Automatic └ with REMOTE terminal of the Θ-7000E when connected to PTT b) Manual └ terminal of the transceiver. c) Manual change by the switch on the transceiver or Semi-break-in state with VOX turned ON		or tape recorder in recording state or microcomputer in receiving state
2. Transmission	Operate the keyboard, when characters corresponding to the respective keys as in Table 12 are displayed on the screen.		
3. OUTPUT indicating LED lights at	mark	space	space
4. The transmitting sound	heard	heard	heard
5. Setting	The transceiver can be returned to the receiving state by any of the three ways below: a) Automatic └ with REMOTE terminal of the Θ-7000E when connected to PTT b) Manual └ terminal of the transceiver. c) Manual change by the switch on the transceiver		

1. BUFFER MEMORY

Characters written in buffer memory are transmitted in order of writing. If the typing speed exceeds the transmitting speed, characters are stored in the buffer memory up to 53 characters. With 53 characters being stored, the cursor disappears, gives a sound signal and inputs from the key are rejected.

For loading of characters in the buffer memory **SHIFT** **V**. **V** will be displayed on the screen. To release the loaded information, push these keys again.

2. CORRECTION OF MISWRITTEN CHARACTERS

By pushing the **HH** key, mistakes can be erased, whilst the information is still in the buffer memory, and correcting code will be transmitted if the mistake has already been set.

If the **HH** key is pushed when the buffer memory is empty, characters shown in Table 8 are transmitted:

CW	$\overline{\text{HH}}$
BAUDOT	/
ASCII	{BS}

F

Table 8

3. AUTOMATIC KEY REPEAT

The same signal is repeated when you hold the key pressed. This applies to any key if it is held depressed.

vi) Functions

1. CHANNEL MEMORY

Data in this memory is retained even when the external power source is removed. The Θ-7000E has provision for 64 characters × 7 channels in the nonvolatile memory. And Channel 7 can be divided in 4 parts as shown in Fig. 9.

0	16	32	48	63
---	----	----	----	----

Fig. 9

No. 1 reads from the first character to the last you have written in Channel 7; No. 2 from the 16th character, No. 3 from the 32nd character, No. 4 from the 48th character.

[Writing]

1. **WRITE | CH1** ~ **→ | CH7** Select a channel by pushing the desired CH1 – 7 key. Selected channel number is shown at the 17th line on the screen.
2. **SHIFT | WRITE | CH1**
 1. NOTE: When you write in CH7, select desired part from **! | 1** to **\$ | 4** after operating these keys.
3. Type on the keys to write in desired data. A audio signal is heard after 64 characters are written in. Characters from the keyboard are thereafter to be written on the 64th character. The 64th character is not displayed on the screen, although it is written in the memory.

4. **HH** for correction of mistake
5. **SHIFT | READ | CH2** By pushing these keys Channel number at the 17th line should indicate **0**.

Example: "CQ DX CQ DX DE DC7XJ K" in CH1

1. **WRITE | CH1**
2. **SHIFT | WRITE | CH1**
3.

C	Q	space	D	X	space	C	Q	space	D	X	space	D	E	space	D	C
'	7	X	J	space	K											
4. **SHIFT | READ | CH2**

[OUTPUT]

1. **WRITE | CH1** ~ **→ | CH7** Select a channel by pushing. Selected channel number is displayed on the 17th line on the screen. (To cancel the selected channel push any key except for **! | 1** ~ **) | 9**)
2. **! | 1** ~ **) | 9** Designate the number of times you want to send. And channels will be displayed in the buffer memory.

Example: CH1 × 3, CH6 × 5, CH3 × 1, CH7 (4)

WRITE | CH1 **# | 3** **← | CH6** **% | 5** **→ | CH7** **\$ | 4**

NOTE: Channel 7 can NOT be repeated. After designating channels and the number of times the cursors will be displayed in the buffer memory.

3. Writing in the buffer memory is possible also during output from the channel memory.

2. SEND FUNCTION

SHIFT | SEND | CH3 Characters from the Characters from the head of the screen up to one before the cursor are transmitted. It can send whatever you can write on the screen. In other words, special characters such as DEL, ESC, CR or LF cannot be transmitted.

SHIFT | BT However in BAUDOT mode, CR is transmitted replaced by **=** (equal) displayed on the screen and LF by **_** (underline). This function also works in receiving in BAUDOT mode, received sentences can be immediately repeated to transmit by SEND function While this function is working, **=** will be displayed on the screen. (See Table 11). To release this function, push these keys again.

As soon as transmission of the sentences on the screen finishes, transmission from the buffer memory begins. In the case you want to insert characters from the keyboard while sending by SEND function, write " \" in the place you want to stop beforehand.

While stopping at "\", characters from the keyboard are not displayed, although they are transmitted.

To restart it push **SHIFT | space** or **SHIFT | SEND | CH3**.

3. SPLIT SCREEN

SHIFT B The first page can be divided in two. The lower half works as a regular display. When its space is filled, the information will be scrolled in the second page automatically. (NOTE: The second page cannot be divided.)

➤ How to write

SHIFT WRITE CH1 Then write the information from the keyboard. The channels can be also called here. Select the channel No. and the number of times to send. Selected channels will be displayed as the cursor (█) on the screen. To stop it mid-way, write "\". However, channels cannot be written right after "\". It needs at least one character including space between "\" and channels.

Push **SHIFT READ CH2** when you finish writing the whole message.

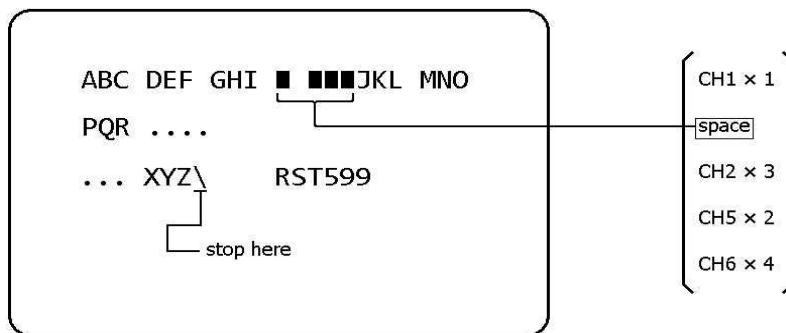

ig. 10

➤ How to send

SHIFT SEND CH3 See SEND function.

While stopping at "\", the information from the keyboard is transmitted and also displayed in the lower half. To release this function, push **SHIFT B** again.

4. STOP OF TRANSMISSION

SHIFT ESC Push when you need to stop transmission on the way. Transmission stops on the completion of transmitting the character that was being transmitted when the keys are pushed.

NOTE: In the case of transmission from the buffer memory, the whole buffer memory will be cleared at the same time as termination of transmission by pushing the keys once or twice.

5. "STAND-BY" PROCEDURE

When OPERATION switch is set to TEST position, a "stand-by" condition is provided by breaking circuit between the CPU (Central Processing Unit) and input circuit (demodulator and TTL IN) and between CPU and keying output circuit. However AFSK output continues. It is possible in this condition to write sentences in the buffer memory, channel memory or on the screen.

At "TEST", CPU demodulator is cut off and receiving is disable. The keying circuit holds its state as follows:

	SENSE	NORM	REV
MODE			
MORSE		ON	OFF
ASCII BAUDOT		OFF	ON

able 9

6. CW IDENTIFICATION

FSK keying: Connect 100 k Ω – 200 k Ω resistor with FSK ID jack.

AFSK keying: There is no need to connect the resistor. The space frequency is mark + 100 Hz.

➤ Procedure

Write the message in the channel. – See the method of Selecting channel.

➤ Operation

1. **SHIFT I** CW identification is available when operating in RTTY.
2. Transmit the identification from the channel. Or type the keyboard.
3. Push **SHIFT I** again to stop this function.

7. OTHER FUNCTION KEYS

SHIFT B The same page will be divided in two; the upper half for transmit and the lower half for transmit/receive data display. (Works page 1 only.) To stop this function, push these keys again.

SHIFT C Automatic CR/LF.

0	= no insertion
1	= 64
2	= 72 (the initial state)
3	= 80

SHIFT D Moves the cursor down. To move the cursor continuously you hold this keys pushed.

SHIFT I CW identification.

SHIFT Q QBF test message: THE QUICK BROWN FOX JUMPS OVER THE LAZY DOG 1234567890 DE _____ . (The 4th part of CH7 can be read in the underlined place.) To stop this function push any key.

SHIFT R RY test message. To release this function push any key.

SHIFT S For speed down of transmit/receive in BAUDOT or ASCII.

SHIFT U Moves the cursor up. To move cursor continuously you hold these keys pushed.

SHIFT V Loads the information in the buffer memory. (Refer to page 17.)

SHIFT X Can put the transceiver in the transmitting state by remote control with XMIT indicating LED lighting and the REMOTE jack connected with PTT terminal of the transceiver when REMOTE switch is at MANUAL. To return the transceiver to the receiving state push these keys again.

SHIFT Y UNSHIFT-ON-SPACE function. (See page 16.)

SHIFT Z For speed-up of transmit/receive in BAUDOT or ASCII.

SHIFT WRITE CH1 To write in channel memory. (See page 18.)

SHIFT READ CH2 To read channel memory. (See page 19.)

SHIFT SEND CH3 To send the sentences of the screen. (Refer to page 19.)

SHIFT | CLEAR | CH4

Clears the page shown on the screen at the time and returns the cursor to the head of the screen.

SHIFT | HOME | CH5

Returns the cursor to the head of the screen.

SHIFT | ← | CH6

The cursor goes back for one character. (To move cursor continuously you hold these keys pushed.)

SHIFT | → | CH7

The cursor advances for one character. (To move cursor continuously you hold these keys pushed.)

WEIGHT | SPEED

For the speed adjusting. (Refer to page 12 – 13.)

SPEED | WEIGHT | SPEED

For the weight change. (See page 13.)

PAGE | CASE

To change CASE (LTR/FIG) manually in receiving in BAUDOT mode.

SPEED | PAGE | CASE

To change the page on the screen.

SHIFT | ESC

To stop transmitting. (See page 20.)

[CTRL] | CLEAR | CH4

To clear the upper half of the split screen. (To clear the lower half and the 2nd page push **SHIFT | CLEAR | CH4** .)

[CTRL] | ! | 1 ~ & | 6

Sends ASCII control signal.

[CTRL] | A ~ Z

SHIFT | T

Enables transmitting/receiving of 300 Bd ASCII with the optional part. **0** is displayed on the 17th line.

SHIFT | W

To stop word-wrap-around function in receiving. Push these keys again to work this function.

8. INDICATIONS

Key	Indications	Function	Release
SHIFT V	V	Load the information in the buffer memory	SHIFT V
SHIFT E	E	Echo-back	SHIFT E
SHIFT B	B	Split screen	SHIFT B
SHIFT BT	=	Replacement of CR/LF	SHIFT BT
SHIFT Y	#→*	UNSHIFT-ON-SPACE	SHIFT Y
SHIFT T	0	Transmitting/receiving of 300 Bd ASCII	SHIFT T

able 11

T

➤ CW practice

1. Connect a hand key with TTL LEVEL IN jack on the back panel.
2. Set MODE switch to MORSE, OPERATION switch to NORM and INPUT switch at TTL.
3. Manipulate the key and reading is gained and displayed on the screen.
4. Keying output turns ON and OFF corresponding to the working of key. For monitoring the transmitting sound push **SHIFT E**.

vii) Using a tape recorder for storage ("paper tape")

[1] As an external memory for transmitting

* Sentence Recording *

1. Set the mode and speed
2. Set GAIN control of the back panel to the medium level in order to prevent excess input to a tape recorder.
3. Put the recorder in recording condition, leave it run for several seconds so as to get feed.
4. Send whatever you want to record from the Θ-7000E.
5. After sending out sentences, let it run for several seconds so as to get feed then stop it.

* Transmitting with SEND function *

1. Set the mode and speed as recorded in the tape recorder.
2. Clear the screen.
3. Adjust the volume of the tape recorder to make output level about 1 V_{PP} when connected. The tone adjustment should be at high at this time.
4. Sentences are read and displayed on the screen when playback starts.
5. Set the switches on the front panel to the proper positions.

* Transmitting with ECHO-BACK function *

SHIFT E and operate the tape recorder in play back. In this way a cassette tape can be used as paper tape of telex. To stop this function push these keys again.

[2] Receding of received signals

➤ For recording signals during receiving

with PHONE jack Recording is enabled by connecting PHONE jack of the Θ-7000E with the microphone terminal of a tape recorder.
or

SHIFT E Connect the microphone terminal of a tape recorder with AFSK OUT TAPE jack of the Θ-7000E. **E** is displayed on the screen.

6. APPLICATION OF A MICROCOMPUTER AS AN INTELLIGENT TERMINAL

CONNECTION

The easiest connection of the Θ -7000E and a microcomputer is as follows:

1. In the event that serial input and serial output of a microcomputer module are compatible TTL, TTL LEVEL OUT and TTL LEVEL IN, the Θ -7000E can be used as an intelligent terminal of a microcomputer module by connecting them respectively to serial output of the microcomputer module.
2. They can be connected in KCS modem if the microcomputer has KCS.
3. To do Hand Shake Operation with the Θ -7000E, connect pins of connector for printer as follows:

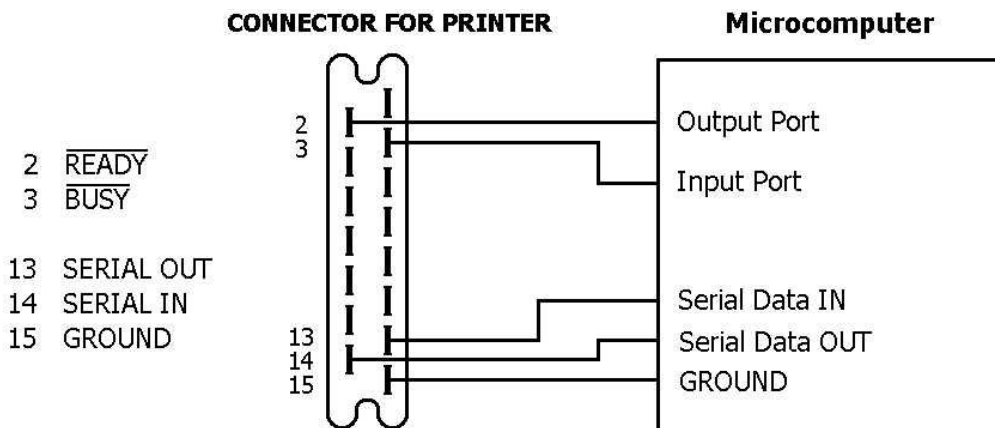

ig. 11

Note: I/O of the microcomputer should be TTL Compatible

➤ Operation for Connection 3 (above).

SHIFT E puts it in Log mode. Set the speed at 300 baud. When $\overline{\text{READY}}$ of the Θ -7000E becomes "H" level, the Θ -7000E is put in receiving state. It receives the data from the microcomputer but does not transmit.

When $\overline{\text{READY}}$ of the Θ -7000E becomes "L" level, the Θ -7000E is put in transmitting state. While transmitting, $\overline{\text{BUSY}}$ of the Θ -7000E becomes "L" level, and it doesn't receive the data from the microcomputer.

If CR is pushed at the end of the data transmitted from the Θ -7000E, the following data from the keyboard are ignored until it receives "EOT" from the microcomputer.

CR LF or LF are necessary to be put at the head of the data from the microcomputer.

7. HOW TO SET CELLS FOR THE BATTERY BACKED-UP MEMORY

1. Supply new battery at least once every year.
2. Use two (2) ALKALINE MANGANESE BATTERY CELLS (IEC No. LR6, 1.5 V, 14.5 mm in diameter and 50 mm in length) for this. It's the best to use this kind of battery, however, you can use two (2) CARBON-ZINC BATTERY CELLS (UM-3, 1.5 V, 14.5 mm in diameter and 50 in length) instead, but need more frequent exchange of battery in this case.
3. Take off the bottom plate by removing six M4 screws.
4. Put the cells in the battery holder. Do not make mistakes in polarity agreement.

able 12

KEY	CW	BAUDOT	ASCII	BUFFER	DISPLAY
!	SP 1	! 1	! 1	! 1	! 1
"	" 2	" 2	" 2	" 2	" 2
#	SP 3	# 3	# 3	# 3	# 3
\$	\$ 4	\$ 4	\$ 4	\$ 4	\$ 4
%	SP 5	LTR 5	% 5	% 5	% 5
&	SP 6	& 6	& 6	& 6	& 6
'	' 7	' 7	' 7	' 7	' 7
((,KN 8	(8	(8	(8	(8
)) 9) 9) 9) 9) 9
ø	ø	ø	ø	ø	ø
*	SP :	LTR :	* :	* :	* :
=	=,BT -	LTR -	= -	= -	= -
Q	Function key Q	Function key Q	Function key Q	Q	Q
W	W	W	W	W	W
E	Function key E	Function key E	Function key E	E	E
R	Function key R	Function key R	Function key R	R	R
T	Function key T	Function key T	Function key T	T	T
Y	Y	Function key Y	Y	Y	Y
U	Cursor move U	Cursor move U	Cursor move U	U	U
I	I	Function key I	I	I	I
0	SP 0	LTR 0	0	0	0
@	AA P	LTR P	@ P	@ P	@ P

A	A	A	A	A	A
S	S	Function key S	Function key S	S	S
D	Cursor move D	Cursor move D	Cursor move D	D	D
F	F	F	F	F	F
BELL G	G	BELL G	BELL G	G	(SOUND SIG.) G
H	SP H	LTR H	H	H	(BACK SPACE) H
J	SP J	LTR J	VT J	K J	J
(K	SP K	LTR K	[K	[K	[K
\ L	SP L	LTR L	\ L	\ L	\ L
+ ;	+, <u>AR</u> <u>VA</u>	LTR ;	+ ;	+ ;	+ ;
Z	Z	Function key Z	Function key Z	Z	Z
X	Function key X	Function key X	Function key X	X	X
C	C	Function key C	C	C	C
V	Function key V	Function key V	Function key V	V	V
B	Function key B	Function key B	Function key B	B	B
^ N	<u>AS</u> N	LTR N	^ N	^ N	^ N
) M	SP M	LTR M] M] M] M
< ,	<u>HH</u> ,	LTR ,	< ,	< ,	< ,
> .	SP .	LTR .	> .	> .	> .
? /	? /	? /	? /	? /	? /
LF	SP	LF	LF	J	LF, *_
CR	Cursor move SP	Cursor move CR	Cursor move CR	M	CR and LF Return.=*
DEL	SP	LTR	DEL	?	

ESC	STOP XMIT SP	STOP XMIT LTR	STOP XMIT ESC	[
BT	<u>BT</u> , =	Function key LTR	=	=	=
KN	<u>KN</u> , (((((
HH	<u>HH</u>	/	BS	<,/,H	<,/,BS
SPACE BAR	Function key SP	Function key SP	Function key SP	SP	SP

- NOTE: 1. Characters in lower part of each column are obtained by pushing each key only; characters or functions in upper part are obtained by pushing each with **SHIFT** key.
2. *; Function obtained when CR. LF CANCEL function works.

Special Character ASCII 00–1F

Following special characters are obtained by pushing respective keys with [CTRL] key.

Key	Special Character	
& 6	00	NUL
A	01	SOH
B	02	STX
C	03	ETX
D	04	EOT
E	05	ENQ
F	06	ACK
BELL G	07	BEL
H	08	BS
I	09	HT
J	0A	LF
(K	0B	VT
\ L	0C	FF
) M	0D	CR
^ N	0E	SO
- O	0F	SI

Key	Special Character	
@ P	10	DLE
Q	11	DC1
R	12	DC2
S	13	DC3
T	14	DC4
U	15	NAK
V	16	SYN
W	17	ETB
X	18	CAN
Y	19	EM
Z	1A	SUB
! 1	1B	ESC
" 2	1C	FS
# 3	1D	GS
\$ 4	1E	RS
% 5	1F	US

SPECIFICATIONS

1. Code:
CW (Morse), RTTY (Baudot Code), ASCII
2. Character:
Alphabet, Katakana, Figures, Symbols, Special characters
3. Communication Speed:
CW receiving: 25...250 Characters/Min., (Automatic follow)
CW transmitting: 25...250 Characters/Min., Weight; 1:3 ~ 1:6
RTTY and ASCII: 45.45, 50, 56.88, 74.2, 100, 110, 150, 200, 300 Baud
(Fine adjustment available)
4. Input:
AF Input CW, RTTY Input Impedance 500 Ω
ASCII Input Impedance 100 Ω
TTL Level Input (common to CW, RTTY, ASCII)
5. AF Input Frequency:
CW: 830 Hz
RTTY: Mark: 1275 Hz (Low Tone), 2125 Hz (High Tone),
Shift: 170 Hz, 425 Hz, 850 Hz and Fine Tuning or rev.
ASCII: Mark: 2400 Hz, Space: 1200 Hz or rev.
6. Output:
Keying: CW Keying (posi) 100 mA, 300 V
CW Keying (nega) 100 mA, -300 V
FSK Keying 100 mA, 300 V
FSK Keying (ID) 100 mA, 300 V
AFSK Output Impedance 500 Ω (common to CW, RTTY, ASCII)
TTL Level Output (common to CW, RTTY, ASCII)
7. AFSK Output Frequency:
CW: 830 Hz
RTTY: Mark: 1275 Hz (Low Tone), 2125 Hz (High Tone) or rev.
Shift: 170 Hz, 425 Hz, 850 Hz
ASCII: Mark: 2400 Hz, Space: 1200 Hz or rev.
8. Display Output:
VHF Output Impedance 75 Ω
Composite video signals, Output Impedance 75 Ω
9. Interface for a printer:
Centronics para, compatible
10. Remote Control Keyer:
Capacity: 300 mA, 50 V
11. Number of Characters and Number of Pages to be displayed:
512 characters (32 characters \times 16 lines)/page \times 2 pages (Total 1024 Characters)
12. Battery backed-up Memory:
64 characters \times 7 channels
13. Buffer Memory:
53 characters
14. Output for Oscilloscope:
Output Impedance 200 kilo-ohms
15. AF Output:
150 mW, Output Impedance 8 ohms
16. Power Supply:
DC +12 V, 1 A
17. Dimension:
400 mm \times 300 mm \times 120 mm – 57 mm

Specifications are subject to change without notice!

I/O CIRCUIT

