

Q - 9000E

COMMUNICATIONS TERMINAL

TABLE OF CONTENTS

1. FEATURES & PRECAUTIONS

1-1	Features	1
1-2	Precautions	7

2. INSTALLATION

2-1	Keyboard Introduction	8
2-2	Rear Apron Connections	9
2-3	Jack and Connector on CPU Board	10
2-4	Mode and Function Programming	10
2-5	Outline of Screen	10

3. CONNECTION

3-1	Power Supply	13
3-2	Video Monitor	13
3-3	Transceiver	13
3-4	Oscilloscope	13
3-5	Printer	14

4. SET UP

4-1	Preliminary Setting	16
4-2	Procedure to Power-up the Equipment	16

5. OPERATION

5-1	CW Mode (MORSE)	17
5-2	RTTY Mode (BAUDOT)	22
5-3	ASCII Mode	27

6. DATA TRANSMISSION

6-1	Classification of the Data Transmission	30
6-2	Buffer Transmission	30
6-3	Channel Memory Transmission	30
6-4	Screen Transmission ("SEND" Function)	33
6-5	Echo-Back Transmission	33
6-6	Test Message Transmission	34

7. VARIOUS FUNCTIONS

7-1	Split-Screen Mode	35
7-2	Graphic Mode	35
7-3	Control Code Output	37
7-4	Selective Calling System	37
7-5	Full Duplex Mode	39

8. WORD PROCESSOR MODE

8-1	Introduction	43
8-2	Various Functions	46
8-3	Channel Memory	53
8-4	Application	54

9. INTRODUCTION TO ALL THE FUNCTION KEYS

9-1	MORSE, BAUDOT and ASCII Mode	57
9-2	Word Processor Mode	60

10. APPLICATION

10-1 Connection to a Cassette Tape Recorder 63
10-2 Connection to the Equipment with RS232C Input/Output . 63

11. MAINTENANCE

11-1 Battery Replacement for the Battery-Backed-Up Memory . 63
11-2 Fuse Replacement 63
11-3 Light Pen 63

Code Tables 64

Input/Output Circuit 67

Block Diagram 68

1. FEATURES & PRECAUTIONS

1-1 Features

1. Communications Terminal

As a result of the most up-to-date microprocessor technology, just one piece of equipment can accomplish complete automatic send/receive of Morse code (CW), Baudot code (RTTY) and ASCII code (RTTY & KCS). By using a light pen, it can also handle send/receive of graphic patterns and characters freely.

2. Word Processor Function

Helps with easy generation of documents or letters. With cassette tape recorder storage, the document can be stored and modified.

3. Selective Calling System

With a keyboard command, SELCAL mode becomes active. Upon receipt of the signal corresponding to your own "SELCAL Characters" (stored in CMOS-Battery-Back-Up memory), the Θ -9000E begins to receive the message. And your own "End of Text" will terminate the reception. Also capable of calling up the specified distant station.

4. Two Display Format and Large Capacity Display Memory

Provides two different display format: 80 characters \times 24 lines and 40 characters \times 24 lines. Manually changeable with the keyboard command. Display memory covers up to 14,000 characters. The scroll feature enables to display of all the characters.

5. Graphic Function

Using the accessory light pen, graphic pattern can be drawn on the screen and easily transmitted and received.

6. Full Duplex Function

You may select full duplex mode when the Θ -9000E is used for ASCII mode. Capable of using as CRT terminal by RS232C serial interface. You can handle up to 9600 baud in send/receive.

7. Built-in Demodulator for High Performance

Three-step shift selects either 170 Hz, 425 Hz or 850 Hz shift with a manual fine tune control of the space channel for odd shifts. HIGH (Mark Frequency 2125 Hz) / LOW (Mark Frequency 1275 Hz) tone pairs available. Mark only or Space only copy capability for selective fading.

8. Crystal Controlled AFSK Modulator

A transceiver without direct FSK inputs can transmit in RTTY mode by utilizing the high stability crystal-controlled modulator, controlled by the microprocessor.

9. Optoisolator CW, FSK keyer built in

Very high-voltage, high-current optoisolator keyer is provided for CW, FSK keying.

10. Automatic Transmit/Receive

The transmit/receive switch is controlled by the microprocessor. Built-in remote control key function automatically controls the transmit/receive circuitry of the transceiver. manual operation is also available.

11. Convenient ASCII Key Arrangement

The keyboard layout is ASCII arrangement with function keys. Automatic insertion of LTR/FIG code.

12. Two Modes in ASCII

In ASCII, both KCS (Kansas City Standard) and RTTY mode tone sets are available.

13. Battery-Back-Up Memory

Data in the battery-back-up memory, covering 256 characters × 7 channels, is retained even when the external power source is removed. Channel 6 is divided into 16 subsections containing 32 characters, any of which may be used individually. Messages can be repeated 1–9 times from a keyboard command and any channel can read out continuously. You can store messages into any channel while receiving.

14. Anti-Noise Circuit

Well designed anti-noise circuit prevents garbled message in the absence of signal.

15. Screen Display Type-Ahead Buffer Memory

A 3120-character-buffer-memory is displayed on the lower part on the screen. The characters move to the left erasing one by one as soon as they are transmitted. The operator is free to prepare messages while another document is received.

16. Function Display System

Each parameter of operation (mode, channel number, speed and so on) is displayed on the screen.

17. "SEND" Function

Allows to send the transmitted text displayed on the screen, including the data stored in every channel of the Battery-back-up memory with an instruction from the keyboard. It is possible to interrupt the transmission and resume it.

18. Split Screen

With a keyboard command, the same screen format can be divided in two; the upper half for receive and the lower for transmit, While receiving, you can compose text for transmission in the Buffer Memory with the Pre-load function, which is to be taken over by the SEND function.

19. Composite Video Signal Output

Composite Video Signal Output is provided for Video monitor display.

20. Printer Interface

Centronics Parallel Compatible interface enables easy connection of a low-cost dot-matrix printer for hard copies.

21. Wide range of transmitting and receiving speeds

10 communications speed for transmitting (with AUTOTRACK on receive) in Morse Code and 14 communication speeds with Fine Adjustments for transmitting and receiving in Baudot and ASCII. The multiple speed feature makes the Θ-9000E ideal for amateur, business and commercial use.

22. Pre-load function

The Buffer Memory can store the messages written from the keyboard instead of sending them immediately. The stored messages can then be sent with a keyboard command.

23. "RUB-OUT" function

You can correct mistakes while writing messages in the Buffer Memory and misspellings can be erased while the information is still in the Buffer Memory.

24. Automatic CR/LF

While transmitting, CR/LF is automatically sent every 64, 72 or 80 characters.

25. WORD MODE operation

Characters can be transmitted in word groupings from the Buffer Memory. Keyboard-Selectable.

26. LINE MODE operation

Characters can be transmitted in line groupings from the Buffer Memory. Keyboard-Selectable.

27. WORD-WRAP-AROUND

In receive mode, WORD-WRAP-AROUND prevents the last word on a line from becoming split in two and provides you a readable screen.

28. Automatic Idle Signal Insertion

In RTTY mode, idle signal can be automatically inserted in a pause of transmitting.

29. "ECHO" function

With a keyboard instruction, received data can be read and resent at the same time. This function enables the cassette tape recorder to be used as the back-up memory and a system can be created as effective as paper tape storage.

30. Cursor Control function

Full cursor control (up/down-left/right) is available from the keyboard.

31. Test Message function

Two built-in test messages, "RY" and "QBF" are keyboard selectable.

32. CW Identification function

In RTTY (Baudot & ASCII) mode, keyboard-controlled CW identification is available if required.

33. MARK-AND-BREAK (SPACE-AND-BREAK) system

Mark only or Space only copy capability for selective fading.

34. Variable CW weights

For CW transmission, weights (ratio of dot to dash) can be changed within the range of 1:3 to 1:6 in ten steps.

35. Audio Monitor Circuit

A built-in audio monitor circuit with an automatic transmit/receive switch enables checking of the transmitting and receiving states. In receiving mode, it is possible to monitor the output of the mark channel, the space channel and incoming audio from AGC amplifier prior to the channel filters.

36. CW practice function

The Θ-9000E reads data from the hand key and displays the characters on the screen. CW keying output circuit works according to the key operation.

37. CW Random Generator

Output of random CW signal can be used as CW copy practice.

38. Cross-hatch checking output terminal

The oscilloscope may be connected to display the traditional cross-hatch tuning indicator. This supplements the tuning LEDs and audio monitor provided in the system.

SPECIFICATIONS

1. Code

Morse Code (CW), Baudot Code (RTTY) and ASCII (RTTY & KCS)

2. Characters

Alphabet, Figures, Symbol and Special Characters

3. Speed

Morse: Receiving 5–50 Words/Minute (Automatic Track)
Transmitting 5–50 Words/Minute (Weight 1:3 ~ 1:6)

Baudot/ASCII: 45.45, 50, 56.88, 74.2, 100, 110, 150, 200, 300, 600, 1200, 2400, 4800, 9600 Baud

NOTE: Details are mentioned in 2-1. 8.

4. Input

AF Input Impedance: CW, RTTY and ASCII: 500 ohms
KCS Input Impedance: 500 Ohms
TTL Level Input: Common to CW, RTTY and ASCII
RS232C Input: Common to CW, RTTY and ASCII

5. AF Frequency

MORSE: 830 Hz
RTTY (Baudot/ASCII): Mark 1275 Hz (Low-Tone), 2125 Hz (High-Tone)
Shift 170 Hz, 425 Hz, 850 Hz + Fine Tuning
KCS: Mark 2400 Hz
Space 1200 Hz

6. Output

Keying Output: CW 80 mA, 200 V (Optoisolator)
FSK 80 mA, 200 V (Optoisolator)
REMOTE 200 mA, 100 V (Optoisolator)
PTT 100 mA, 100 V (Optoisolator)
AFSK Output Impedance: 500 ohms (Common to CW, RTTY and ASCII)
RS232C Output: Common to CW, RTTY and ASCII

7. AFSK Output Frequency

MORSE: 830 Hz
RTTY (Baudot/ASCII) Mark 1275 Hz (Low-Tone), 2125 Hz (High-Tone)
Shift 170 Hz, 425 Hz, 850 Hz + Fine Tuning
KCS Mark 2400 Hz
Space 1200 Hz

8. Display Output

Composite Video Signal Output Impedance: 75 ohms

9. Interface for Printer

Centronics Compatible Parallel Interface

10. Number of Characters Displayed

Screen format (Keyboard-selectable): 80 characters × 24 lines = 1920 characters
40 characters × 24 lines = 960 characters

11. Battery-back-up Memory: 256 characters × 7 channels

12. Buffer memory: 3120 characters

13. Output Impedance for Oscilloscope: 200 kΩ

14. AF Output: 150 mW @ 8 ohms

15. Power Supply Requirement: 12 VDC, 1.3 A

16. Dimension: 415 mm × 245 mm × 45 mm ~ 78 mm

17. Accessories

Instruction Manual	1×
Pin Plug	13×
Fuse	1×
Coaxial Cable	4 m
Light Pen	1×
3P Connector	1×

The specifications are subject to change without prior notice.

1-2 Precautions

1. You should plan to read this OPERATOR'S MANUAL thoroughly to become familiar with your Θ -9000E.
2. Before making connection to a transceiver, practice is recommended with a CRT display.
3. Adjust for minimum SWR between the transceiver and antenna as follows:

OUTPUT	SWR
< 10 W	Maximum 1.5
10 W \cdots 100 W	Maximum 1.3
100 W \cdots 500 W	Maximum 1.1

Table 1 SWR Adjustment

4. Be sure that the connection to the input circuits and output circuits are appropriate. Input signal and load should be within the range mentioned in the Specifications.
5. Voltage of DC power supply should be within the range of DC 11 V \sim 14 V.
6. DC power supply for the Θ -9000E should not be connected to other equipment if any interaction is noticed.
7. It is suggested that the Θ -9000E is put at a well-ventilated dry place not exposed to the direct sun with special care for intense heat.
8. Notice the maximum speed as follows:
In full duplex mode, the available speed is up to 9600 baud and in RTTY modem, up to 150 baud. When you connect to the cassette tape recorder in KCS mode, the maximum baud rate is variable according to its characteristic. In good condition, you can handle up to 1200 baud. Other modes are usually up to 9600 baud.
9. In order to prevent the possibility of receiver interference from the microprocessor clock, it is recommended that the receiving antenna not be adjacent to the Θ -9000E terminal. The transmitting antenna should be well matched and also should not be located adjacent to the terminal to prevent R.F. interference to the logic and video generating circuits of the unit. This terminal is well bypassed and is designed in a metal enclosure to minimize any interference problem.

New Federal Communications Commission (Part 15) regulations require that the following caution notice be published:

Warning: This equipment generates, uses and can radiate radio frequency energy and if not installed and used in accordance with the instructions manual, may cause interference to radio communications. As temporarily permitted by regulation, it has not been tested for compliance with the limits for Class A computing devices pursuant to Subpart J of Part 15 of the FCC rules which are designed to provide reasonable protection against such interference. Operation of this equipment in a residential area is likely to cause interference in which case the user at his own expense will be required to take whatever measures may be required to correct the interference.

2. INSTALLATION

2-1 Keyboard Introduction

This section will assist you in becoming familiar with the keyboard controls.



1. POWER LED: indicates power is on.
2. SPACE LED: indicates tuning of the space filter.
3. MARK LED: indicates tuning of the mark filter.
4. FINE TUNING: Fine adjustment of the shift width while receiving BAUDOT RTTY or ASCII RTTY.
5. VOL: controls the volume of the monitor speaker.
6. LP: This is used for Graphic mode (using light pen).
7. RESET: initializes the microprocessor.
- 8 – 21: Function Keys - - - Refer to page 57.

2-2 Rear Apron Connections

This section will introduce you to the rear apron connections on this terminal. Refer to Figure 2 for the legend of the rear apron.

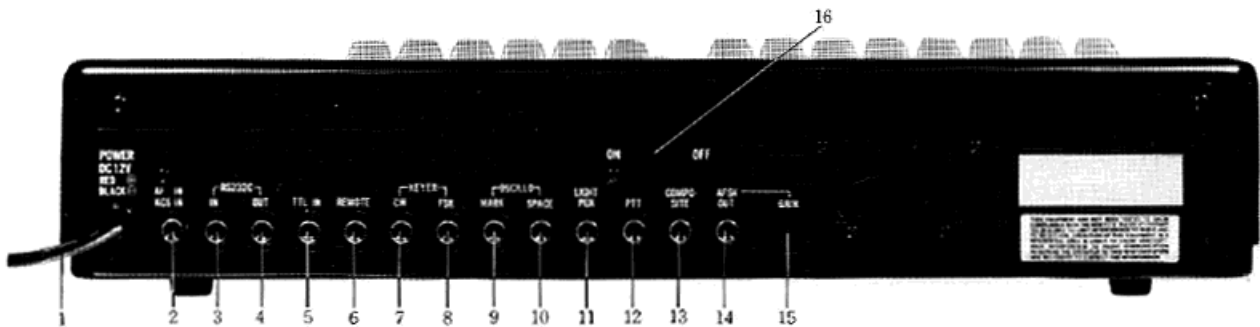

1. POWER SUPPLY CORD: 12 V DC. Red is positive, black is GND.
2. AF IN: This is an audio input from EARPHONE terminal of the tape recorder or EXT SP terminal of the transceiver.
3. RS232C IN: Connects to the serial input of RS232C level.
4. RS232C OUT: Connects to the serial output of RS232C level.
5. TTL IN: This is an input accepting TTL LEVEL of non-modulated signals in CW, BAUDOT or ASCII.
6. REMOTE: Activates or deactivates the remote-control jack for external equipment. When you are called up in SEL-CAL mode, the REMOTE line becomes active. End of SEL-CAL releases this function automatically. With the keystroke **ESC & 6**, this jack can be turned ON/OFF regardless of the SEL-CAL mode.
7. CW: \uparrow
8. FSK: \downarrow
Connects to the keying terminal of the transceiver in CW or RTTY mode. Outputs to collector of optoisolator.
NOTE CW: When in Normal position, this jack is ON in RTTY SPACE or CW MARK and OFF in RTTY MARK or CW SPACE.
FSK: When in Normal position, this jack is ON in RTTY MARK or CW SPACE and OFF in RTTY SPACE or CW MARK.
9. MARK: Connects to the Oscilloscope for MARK output of cross hatch.
10. SPACE: Connects to the Oscilloscope for SPACE output of cross hatch.
11. LIGHT PEN: Connects to the accessory light pen when using the Graphic (light pen) mode.
12. PTT: Connects to the PTT terminal of the transceiver for remote control.
13. COMPOSITE; Feeds to a video monitor.
14. AFSK OUT: This is an audio output from the AFSK generator and may be used to feed the AUDIO INPUT of a tape recorder or a transceiver.
15. GAIN: Adjusts the output level of the AFSK output jacks.
16. Power Switch

2-3 Jack and Connector on CPU Board

On CPU board, you may find the earphone jack and 3P connector (used for full duplex mode). Follow the procedure below:

(1) Remove two M4 screws on rear panel and two M4 screws on the bottom.

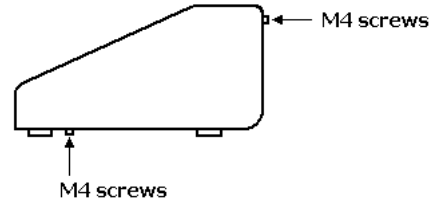

(2) Connect the earphone jack or 3P connector if necessary.

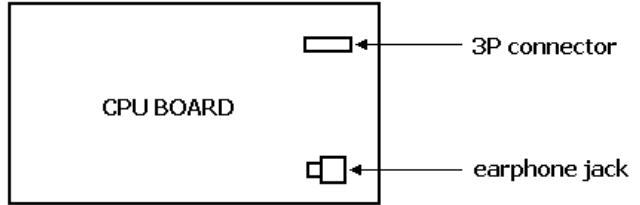

2-4 Mode and Function Programming

Modes and functions are set according to instructions from keyboard. Press **ESC M** so that the state of MODE, TONE, TYPING MODE, AUDIO, CR/LF AUTOMATIC INSERTION, SPEED, INPUT or SENSE is retained even if the power is removed. When the power is applied again, the microprocessor is reset to the same state as one just before the power was removed. Press **ESC ? /** to initialize the unit. Notice nothing changes on your screen unless the power is removed or [**RESET**] is pressed.

2-5 Outline of Screen

2-5-1 Screen format

(1) 80 × 24 Screen Format
One Screen Format contains 80 characters × 24 lines (1920 characters).

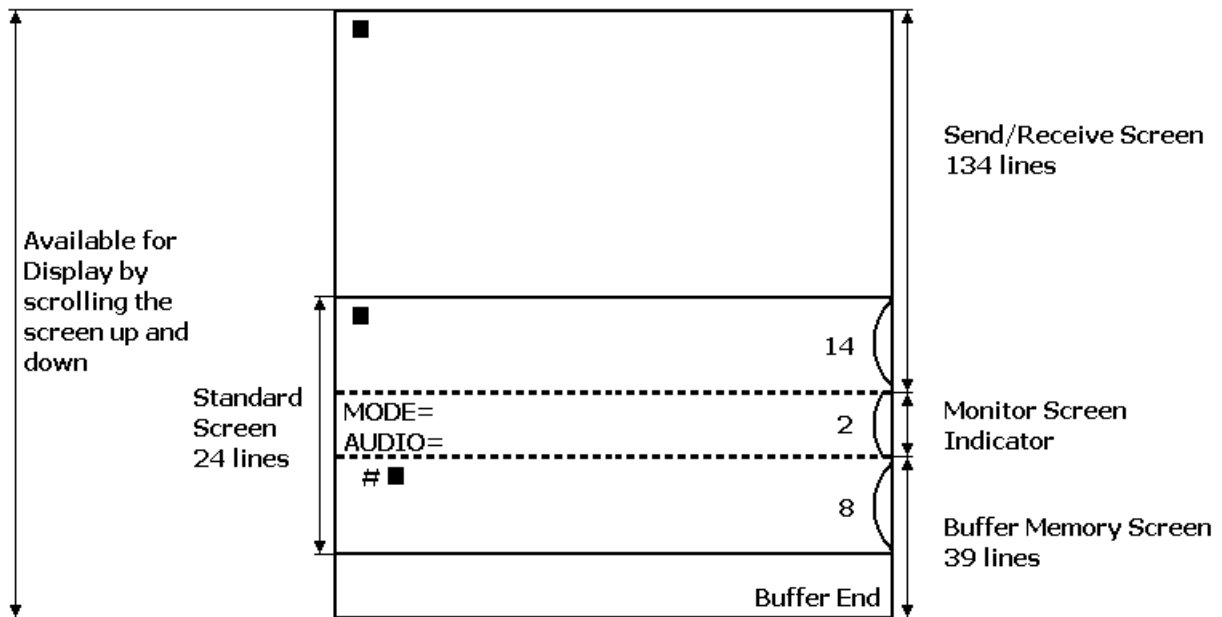

Figure 3-1 80 × 24 Screen Format

* The Send/Receive Screen includes 134 lines (10,720 char.)
* The Buffer Memory Screen includes 39 lines (3,120 char.)

- (2) 40 × 24 Screen Format
 One Screen format contains 40 characters × 24 lines (960 characters).

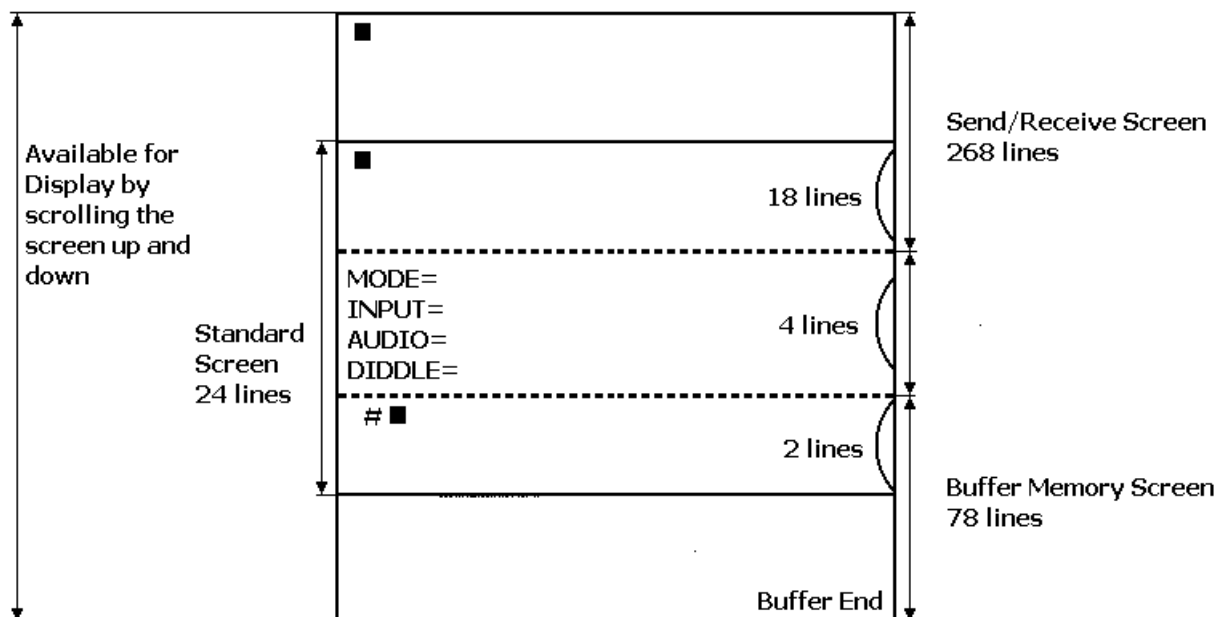

Figure 3-2 40 × 24 Screen Format

- * The Send/Receive Screen includes 268 lines (10,720 char.)
- * The Buffer Memory Screen includes 78 lines (3,120 char.)

2-5-2 Screen format in Graphic Mode

Screen Format in Graphic mode using a light pen is a display matrix 80 elements wide by 72 elements high = 5,760 elements.

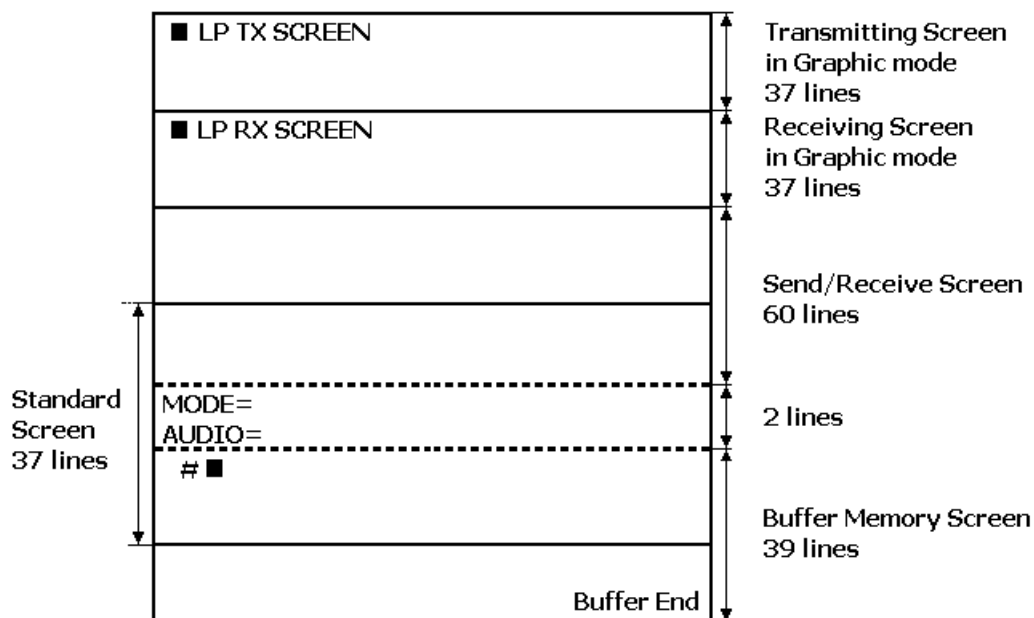

Figure 4 Screen Format in Graphic Mode

2-5-3 Screen format in Split Screen Mode

(1) 80 × 24 Screen Format

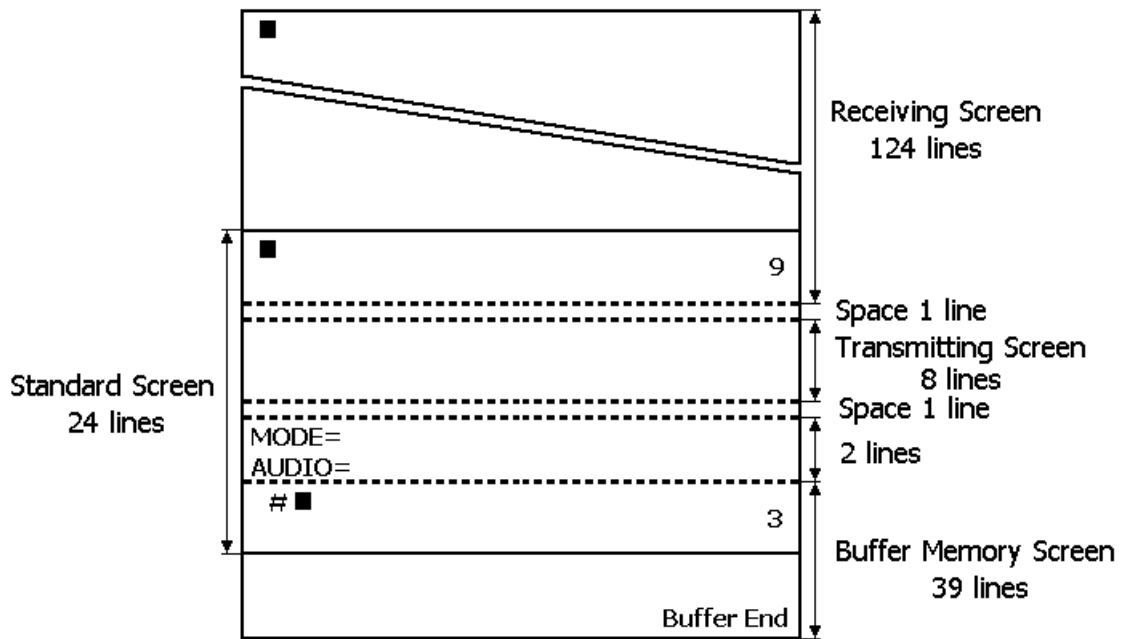

Figure 5-1 80 × 24 Screen Format in Split Screen Mode

(2) 40 × 24 Screen Format

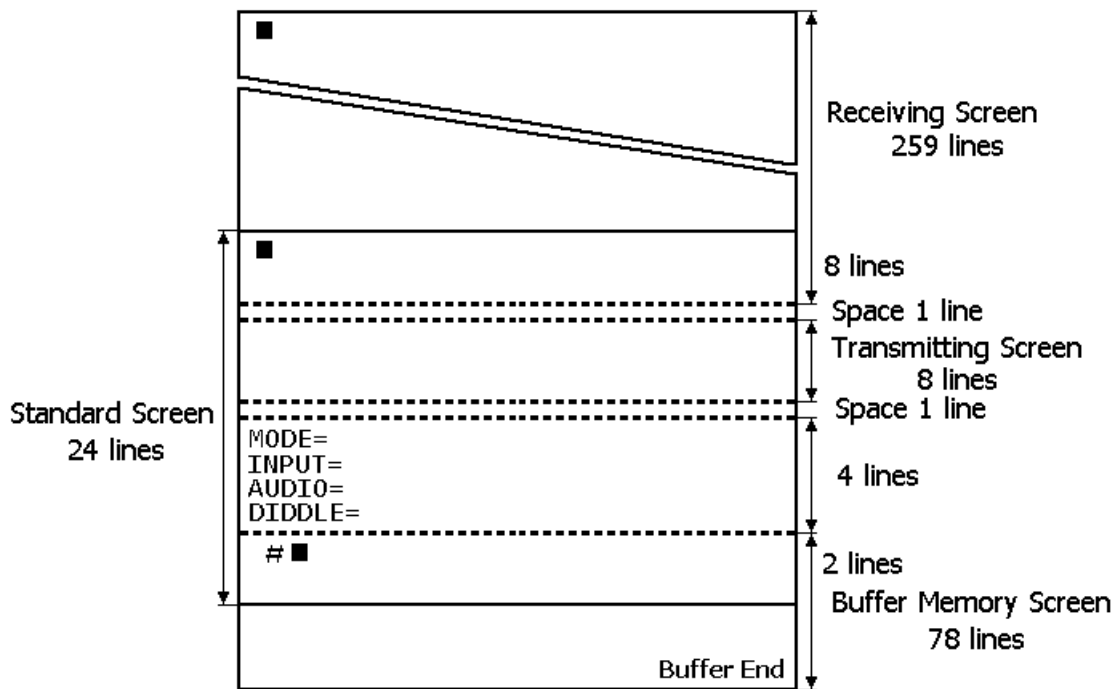

Figure 5-2 40 × 24 Screen Format in Split Screen Mode

3. CONNECTION

3-1 Power Supply

Before connecting power lead to your DC power supply, make sure the voltage is within the range of DC 11 -- 14 V.

3-2 Video Monitor

Solder an ancillary coaxial cable and a pin plug as shown in FIG. 6, and connect the pin plug to COMPOSITE jack of the Θ -9000E.

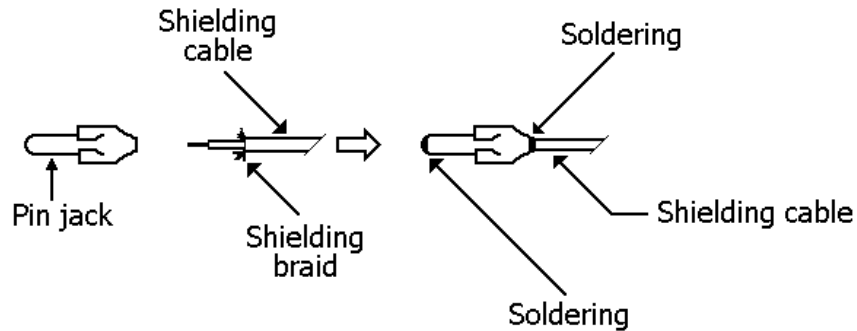

Figure 6 How to solder coaxial cable to pin plug

3-3 Transceiver

Adjust the SWR as shown in Table 1 (page 7) to assure normal operation. For connections, refer to FIG. 8

3-4 Oscilloscope

The output impedance for OSCILLO (MARK, SPACE) is 200 k Ω (maximum amplitude is 3.5 Vpp approx.). Use an oscilloscope whose input impedance is over 1 M Ω .

3-5 Printer

Connector CN1 on the CPU board is a connector for a printer. Each pin drives five standard TTL loads. Avoid overload.

- (1) When $\overline{\text{READY}}$ is set LOW, Timing of DATA for printer is as follows:

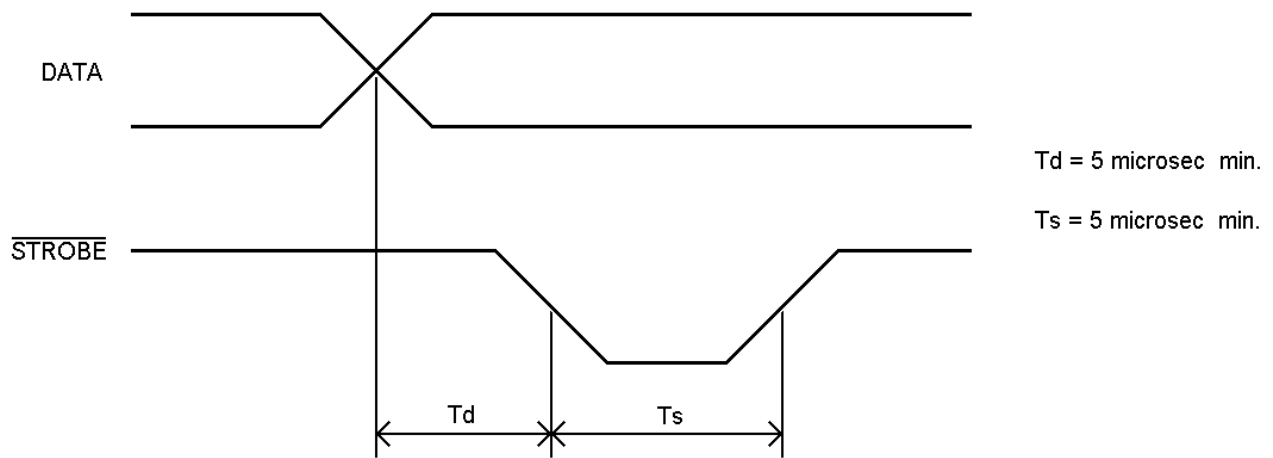

Figure 7. Timing of data for printer

When $\overline{\text{READY}}$ is set HIGH, the port for printer holds the previous data.

- (2) A printer with Centronics Compatible interface can be connected directly to the Θ -9000E.
- (3) Refer to FIG. 19 for Pin Connections.

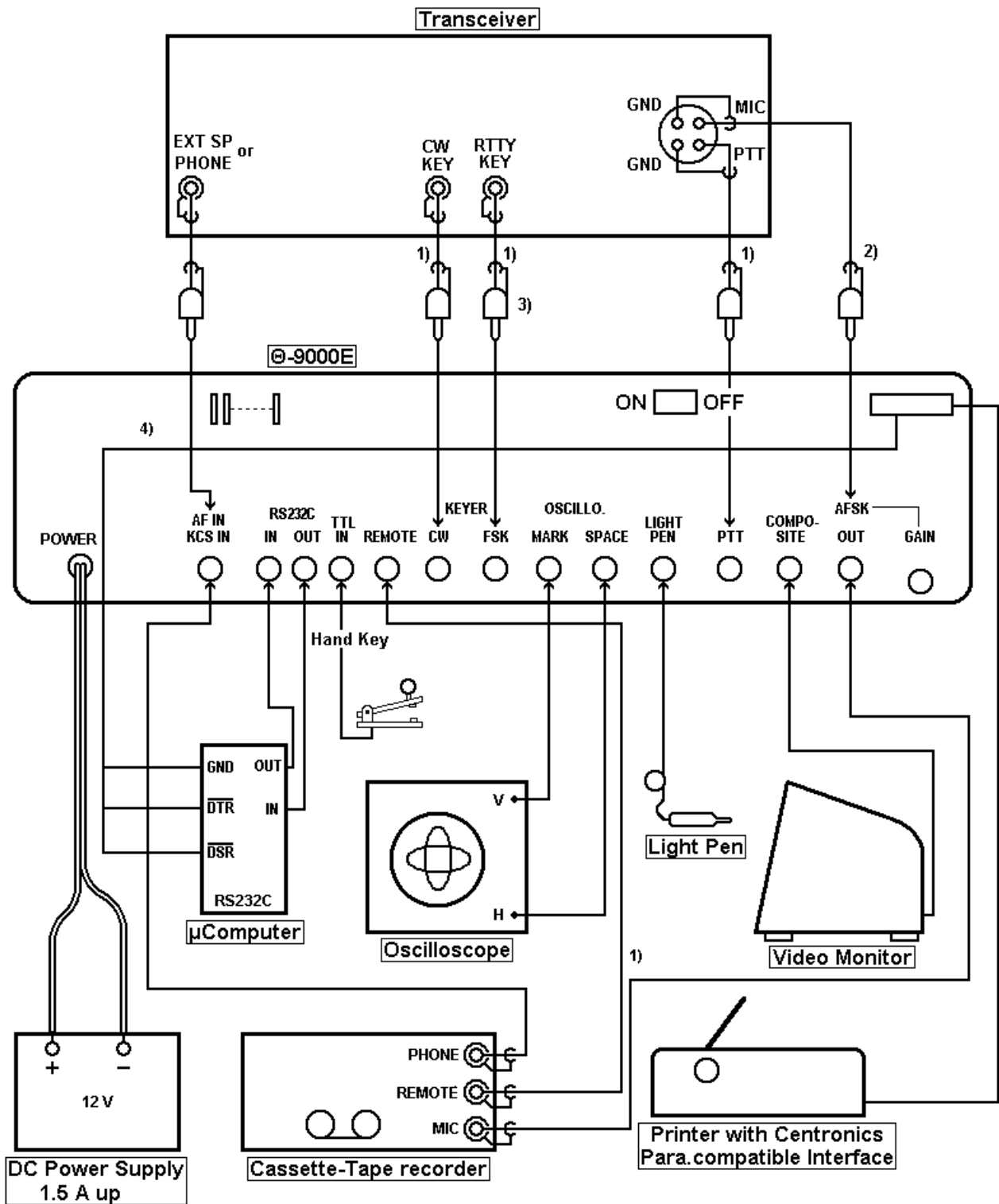

Figure 8 Connections to the peripheral equipment

NOTES:

- 1) Check the polarity first with a meter. Make sure the center pin in the plug always has the highest voltage.
- 2) Connect to the Θ -9000E when used with AFSK function. No need to use for FSK function.
- 3) Connect to the Θ -9000E when used with FSK function. No need to use for AFSK function.
- 4) Connect to the internal CPU board with accessory 3P connector.

4. SET UP

4-1 Preliminary Setting

Θ-9000E		
FRONT PANEL	VOL	Adjust the volume properly
	FINE	Medium
REAR PANEL	GAIN	Medium
	Power supply SW	OFF

DC Power Supply	
Power Supply SW	OFF

Transceiver	
MODE SW	Same mode as the Θ-9000E; RTTY or LSB when using the AFSK function
Power Supply SW	OFF
AF VOL	Adjust the volume so that the audio input level to the Θ-9000E is set to 0.1 to 1 Vpp

4-2 Procedure to Power-up the Equipment

Set the power switches ON --- 1. DC Power Supply --- 2. the Θ-9000E --- 3. Video Monitor --- 4. Transceiver. When the POWER pilot LED is lit and the indications shown in FIG. 9 is displayed on the screen, your Θ-9000E is ready.

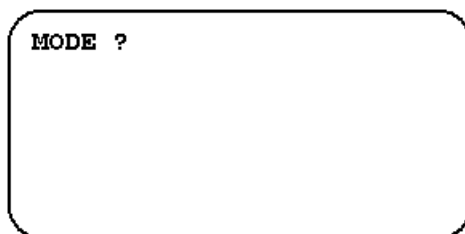

Figure 9 Initial Screen Indicator

Modes	Keys
CW (MORSE)	MORSE
RTTY (BAUDOT)	BAUDOT
ASCII	ASCII
WORD PROCESSOR	CTRL ASCII

Table 3 Mode Selection

NOTE: **CTRL ASCII** means that hold **CTRL** key down and tap **ASCII**.

5. OPERATION

5-1 CW Mode (MORSE)

When the key **MORSE** is depressed, CW mode becomes active. The indications on the screen are as follows:

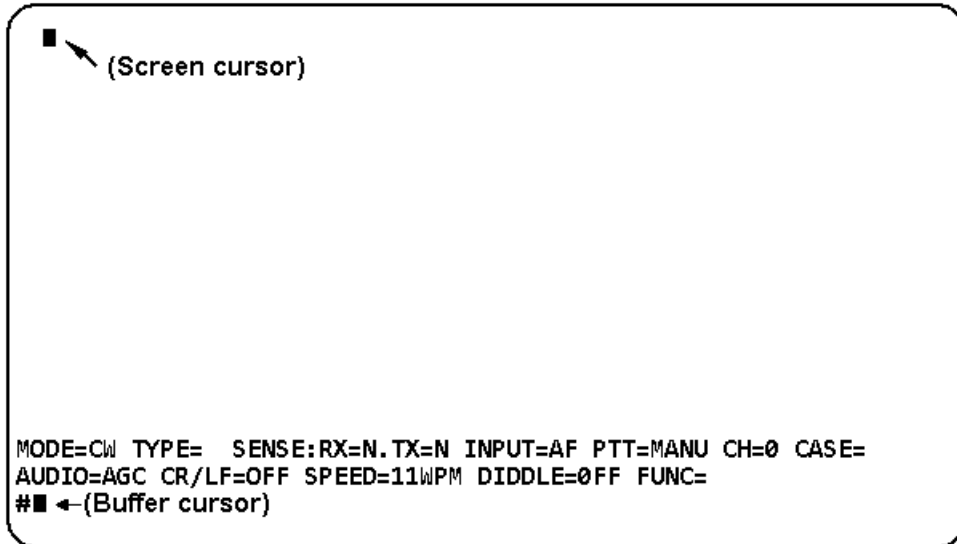

Figure 10-1 Screen Indicators in CW mode (80 × 24)

Screen Format (80 × 24, 40 × 24) is changeable with the keystroke **ESC** (·8). You should now see the following text when using 40 × 24 format:

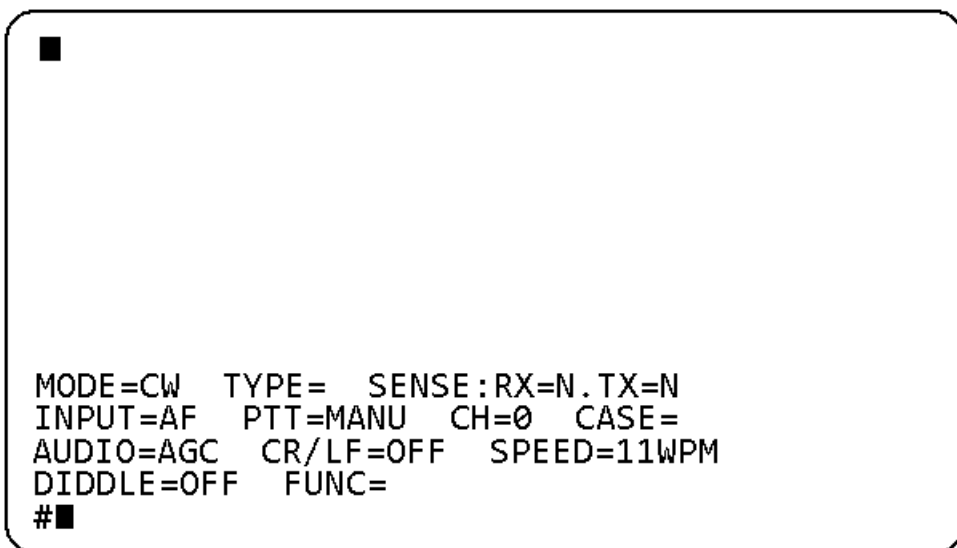

Figure 10-2 Screen Indicators in CW mode (40 × 24)

5-1-1 Introduction to the Screen Indicators

- (1) **MODE=CW** indicates CW mode.
- (2) **CH=0** indicating which channel memory is selected.
- (3) **TYPE=LINE** If you desire to select LINE mode, depress **SHIFT** | **TYPE·SENSE** followed by the key **RETURN**. Every time **RETURN** or **LINE FEED** is pressed, the buffer memory is transmitted.

TYPE=WORD

If you desire to select WORD mode, depress **SHIFT | TYPE·SENSE** followed by the key **SPACE**. Every time **RETURN**, **LINE FEED** or **SPACE** is depressed, the buffer memory is transmitted. To return to normal transmission press **SHIFT | TYPE·SENSE** followed by any of the data keys except for **RETURN**, **LINE FEED** or **SPACE**.

- (4) **SENSE:RX=N.TX=N**
SENSE:RX=R.TX=N

indicates the polarity of Send/Receive.

By depressing **TYPE·SENSE !·1**, **RX=R** is indicated on the screen and the polarity of the receiving is reversed.

To cancel it, re-depress **TYPE·SENSE !·1**.

SENSE:RX=N.TX=R

By depressing **TYPE·SENSE "·2**, **TX=R** is indicated on the screen and polarity for transmitting is reversed.

To cancel it, re-depress **TYPE·SENSE "·2**.

- (5) **INPUT=AF**

indicating which input jack is selected.

Select any key **!·1** ~ **%·5** after pressing **SHIFT | INPUT·CASE**.

Key	Indicator	
!·1	INPUT=AF	Selects AF IN, RTTY MODEM input (the initial state)
"·2	INPUT=TTL	Selects TTL IN input
#·3	INPUT=232C	Selects RS232C IN input
\$·4	INPUT=KCS	Selects AF IN (KCS MODEM) (This is active when in ASCII mode)
%·5	INPUT=ANTI	Applies AF IN to anti-noise circuit and selects AF IN (It is used when noise is present)

Table 4 Input jack selection

- (6) **PTT=MANU**
PTT=AUTO

With this indicator on, ON/OFF of PTT jack is manually switched.

By depressing **DIDDLE·PTT**, automatic ON/OFF for PTT jack is available. To return to manual operation, **DIDDLE·PTT** should be re-depressed.

- (7) **AUDIO=AGC**

indicates the monitor sound of input signal.

Select any key **!·1** ~ **#·3** after pressing **CR/LF·AUDIO**.

Key	Indicator	
!·1	AUDIO=AGC	Monitor output of AGC (initial state)
"·2	AUDIO=SPACE	Monitor output of Space filter
#·3	AUDIO=MARK	Monitor output of Mark filter

Table 5 Monitor Sound

- (8) **CASE=**

not used with CW mode.

- (9) **CR/LF=OFF**

not used with CW mode.

- (10) **SPEED=11WPM**

indicates that transmitting speed is automatically set at 11 WORDS PER MINUTE in the initial state.

If you desire a different speed, depress **WEIGHT·SPEED** followed by **0** ~ **)·9**.

Key	Indicator	Key	Indicator
0	SPEED=5 WPM	%·5	SPEED=18 WPM
!·1	SPEED=6 WPM	&·6	SPEED=23 WPM
"·2	SPEED=8 WPM	'·7	SPEED=30 WPM
#·3	SPEED=11 WPM	(·8	SPEED=39 WPM
\$·4	SPEED=14 WPM)·9	SPEED=50 WPM

Table 6 CW Speed Chart

(11) **DIDDLE=OFF** Not used in CW mode

(12) **FUNC=** indicates the other functions.

NOTE: When you finish the preliminary setting in MORSE mode, press **ESC M** to store every parameter in memory. **ESC ?·/** initializes the unit.

5-1-2 Weight Setting in CW

Select **0 ~)·9** after depressing **SHIFT | WEIGHT·SPEED**. Ten steps within the limits of 1:3 to 1:6 are selectable (**0** 1:3, **)·9** 1:6).

5-1-3 Operation by using Hand Key

- (1) Connect the hand keys to TTL IN jack as shown in Fig. 8.
- (2) Set to **INPUT=TTL** (refer to 5-1-1 (5)).
- (3) Depress **ESC E** (**FUNC=E** is displayed on the screen).
- (4) When you manipulate the key, a reading and transmission are available at the same time. CW.FSK jack is switched ON or OFF corresponding to the operation of the key. You can transmit by switching the key terminal of transceiver.
- (5) To return to the receive mode, perform **INPUT=AF** following the procedure of 5-1-1 (5).

5-1-4 Receiving Speed

Since this unit will automatically track receiving speed on CW, you are now ready to receive.

Dots which are less than 20 ms may be regarded as noise. However, when slow CW is received right after rather fast CW, 2–4 characters are required before synchronization is achieved.

5-1-5 Fine Adjustment of Speed

The keystroke **ESC Z** increases the speed and the keystroke **ESC A** decreases the speed. Every time the key is depressed, the speed is increased (or decreased) by 1/64 the previous speed. Note that the speed indicator on the screen remains unchanged.

5-1-6 Receiving/Transmitting Operation

For Connecting to the transceiver, refer to FIG. 8.

(1) Receiving

Using the LED indicator

- i) Receive CW (MORSE) with the transceiver.
- ii) SPACE indicating LED lights when the CW signal from the transceiver pass through the band-pass-filter of which the center frequency is 830 Hz.
- iii) Tune VFO or RIT of the transceiver so as to make this SPACE indicating LED have maximum brightness.

Using the monitor sound

- i) Press **CR/LF · AUDIO** " · 2 so as to monitor the output of SPACE filter. At this moment, **AUDIO=SPACE** is displayed on the screen.
- ii) Adjust the transceiver to have the maximum sound level. At this moment, SPACE indicating LED will also light at the maximum brightness.
- iii) If the SPACE indicating LED begins to flicker corresponding to signals, Θ-9000E reads properly, displaying on the screen and printing characters.

(2) Transmission

To enable automatic transmission, press **DIDDLE · PTT** and ascertain **PTT=AUTO** on the screen. Re-depress **DIDDLE · PTT** to switch it to the manual transmission.

In order to operate the transceiver follow this procedure:

- i) **Setting**
The transceiver can be made to transmit by any of the three ways below:
 - a) **Automatic** with PTT terminal of the Θ-9000E when connected to PTT terminal of the transceiver. **PTT=AUTO** is indicated on the screen while transmitting.
 - b) **Manual** Connection is same as the automatic operation. When **ESC X** is pressed, PTT jack turns on.
 - c) **Manual** Change by the switch on the transceiver. Or Semi-break-in state with VOX turned ON.
- ii) **Transmission**
Operate the keyboard. Characters corresponding to their respective keys as in Table 14-1 and 14-2 will be displayed on the screen.
- iii) **Setting**
The transceiver can be returned to the receiving state by any of the three ways below:
 - a) **Automatic** press **ESC F** or **ESC X** (PTT jack turns OFF).
 - b) **Manual** press **ESC X** (PTT jack turns OFF)
 - c) **Manual** changing the switch on the transceiver.

5-1-7 Function of the Manual and Automatic Transmission

With manual transmission (**PTT=MANU** is indicated on the screen), if you press **ESC X**, PTT jack turns ON. Another **ESC X** turns PTT jack OFF.

With automatic transmission (**PTT=AUTO** is displayed on the screen), if you press any key on the keyboard, PTT jack is automatically turned ON.

When **ESC F** is depressed at the end of the transmission, **X** is written in the buffer memory. When the transmission concludes at **X**, PTT jack turns OFF.

While PTT jack is ON, the cursor is displayed as **PTT=MANU ■** or **PTT=AUTO ■** on the screen.

Example

To transmit CQ CQ DE by automatic, type **C Q SPACE C Q SPACE D E** and at the end, press **ESC F** ([X] is displayed in the buffer).

5-1-8 Receive of Special Characters

Upon receipt of special characters ($\overline{\text{KN}}$, $\overline{\text{AR}}$, $\overline{\text{VA}}$), the Θ -9000E performs CR and LF on the screen, transmitting CR+LF signal to the printer.

Signal	Display
$\overline{\text{KN}}$ -	(
$\overline{\text{AR}}$	+
$\overline{\text{VA}}$ -	;

5-2 RTTY Mode (BAUDOT)

Press the key **BAUDOT** to activate RTTY mode. The indicators on the screen are as follows:

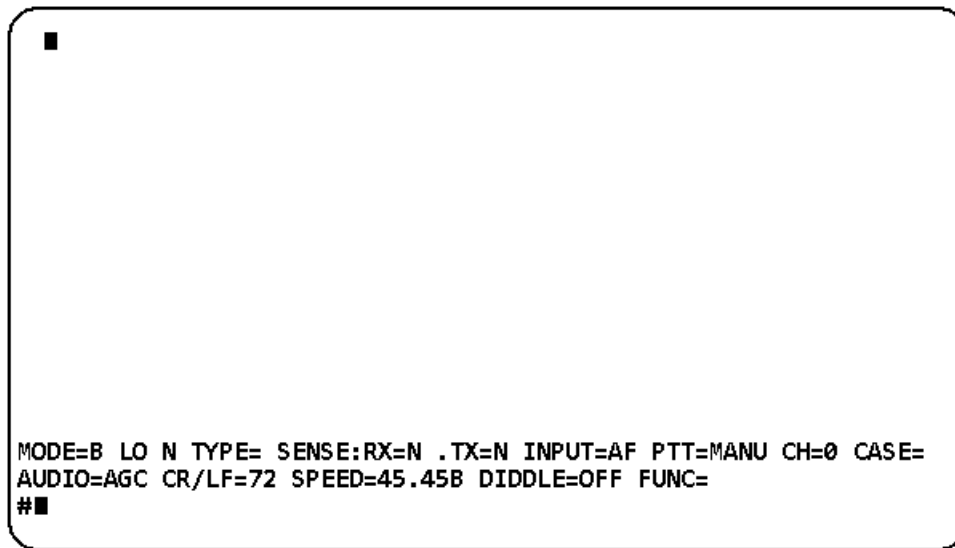

Figure 11 Screen Indicators in RTTY (BAUDOT) mode

To enable a 40 × 24 screen format, press **ESC** (**.8**).

5-2-1 Introduction to the screen indicators

- (1) **MODE=B LO N** indicates LOW tones, shift width 170 Hz (N) in RTTY (BAUDOT)
 Press **SHIFT | TONE · CH** followed by **! · 1** ~ **& · 6** to select the shift width and LOW tones or HIGH tones.

KEY	INDICATOR	MARK Frequency	SPACE Frequency	TONE , SHIFT Width
! · 1	MODE=B LO N	1275 Hz	1445 Hz	LO tone, 170 Hz
" · 2	MODE=B LO M	1275 Hz	1700 Hz	LO tone, 425 Hz
# · 3	MODE=B LO W	1275 Hz	2125 Hz	LO tone, 850 Hz
\$ · 4	MODE=B HI N	2125 Hz	2295 Hz	HI tone, 170 Hz
% · 5	MODE=B HI M	2125 Hz	2550 Hz	HI tone, 425 Hz
& · 6	MODE=B HI W	2125 Hz	2975 Hz	HI tone, 850 Hz

Table 7 Shift Width

- (2) **CH=0** indicating which channel memory is selected.
- (3) **TYPE=LINE** If you desire to select LINE mode, depress **SHIFT | TYPE · SENSE** followed by the key **RETURN**.
 Each time **RETURN** or **LINE FEED** is depressed, the buffer memory is transmitted.
- TYPE=WORD** If you desire to select WORD mode, depress **SHIFT | TYPE · SENSE** followed by the key **SPACE**.
 Each time **RETURN** or **LINE FEED** or **SPACE** is pressed, the buffer memory is transmitted.

To return to normal transmitting mode, press **SHIFT | TYPE · SENSE** followed by any data key except for **RETURN**, **LINE FEED** or **SPACE**.

- (4) **SENSE:RX=N.TX=N**
SENSE:RX=R.TX=N

indicates the polarity of Send/Receive.

By depressing **TYPE · SENSE ! · 1**, RX=R is indicated on the screen and polarity of receiving is reversed.

To cancel it, re-depress **TYPE · SENSE ! · 1**.

- SENSE:RX=N.TX=R**

By depressing **TYPE · SENSE " · 2**, TX=R is displayed on the screen and the polarity of transmitting is reversed.

To cancel it, re-depress **TYPE · SENSE " · 2**.

- (5) **INPUT=AF**

indicating which input jack is selected.

Select any key **! · 1** ~ **% · 5** after depressing **SHIFT | INPUT · CASE** (refer to 5-1-1 (5)).

- (6) **PTT=MANU**

With this indicator on, ON/OFF of PTT jack is manually switched.

- PTT=AUTO**

By depressing **DIDDLE · PTT**, automatic ON/OFF for PTT jack is available.

To return to manual operation, **DIDDLE · PTT** must be re-depressed.

- (7) **AUDIO=AGC**

indicates the monitoring of input signal. Select any key **! · 1** ~ **# · 3** after depressing **CR/LF · AUDIO** (refer to 5-1-1 (7)).

- (8) **CASE=**
CASE=L
CASE=F

indicates the status of transmitting/receiving

indicates "LETTERS" case is being received (or transmitted).

indicates "FIGURES" case is being received (or transmitted).

You may manually change the case with the keystroke

INPUT · CASE.

- (9) **CR/LF=72**

Carriage returns and Line feeds are automatically inserted 72 characters after the last carriage return. This feature may be changed with the keystroke **SHIFT | CR/LF · AUDIO** followed by **0** or **! · 1** ~ **# · 3**. In BAUDOT mode, CR/LF code is automatically inserted and transmitted. However, this process is not seen on your screen.

KEY	INDICATOR	
0	CR/LF=OFF	defeat automatic CR/LF
! · 1	CR/LF=64	automatic CR/LF after 64 characters
" · 2	CR/LF=72	automatic CR/LF after 72 characters (initial state)
# · 3	CR/LF=80	automatic CR/LF after 80 characters

Table 8 CR/LF Chart

- (10) **SPEED=45.45B**

indicates that transmitting/receiving speed is automatically set at 45.45 baud in the initial state.

If you desire a different speed, depress **WEIGHT · SPEED** followed by **0** ~ **) · 9** **Q** **W** **E** **R**. A chart of available speeds is in Table 9.

KEY	INDICATOR	KEY	INDICATOR	KEY	INDICATOR
0	SPEED=45.45B	% · 5	SPEED=110B	Q	SPEED=1200B
! · 1	SPEED=50B	& · 6	SPEED=150B	W	SPEED=2400B
" · 2	SPEED=56.88B	' · 7	SPEED=200B	E	SPEED=4800B
# · 3	SPEED=74.2B	(· 8	SPEED=300B	R	SPEED=9600B
\$ · 4	SPEED=100B) · 9	SPEED=600B		

Table 9 RTTY (BAUDOT) Speed Chart

NOTE: 45.45 baud is the initial state and is popular among amateurs and 50 baud is usually used in business communications.

- (11) **DIDDLE=OFF** "Idle" signals are not inserted while the keyboard is idle. This is activated or deactivated with the keystroke **SHIFT | DIDDLE · PTT**.
- (12) **FUNC=** indicates other function.

NOTE: 1. When you finish the preliminary setting in BAUDOT mode, press **ESC M** to store every parameter in memory. **ESC ? · /** initializes the unit.
 2. Blank signal in BAUDOT mode is available with **CTRL ' · @**.

5-2-2 UNSHIFT-ON-SPACE Function

When weak signals and noise cause errors, press **ESC Y** to activate UNSHIFT-ON-SPACE mode. This will cause the terminal to return to the "LETTERS" case upon receipt of a space signal (screen indicates **FUNC=Y**). Another **ESC Y** disables the function.

5-2-3 Fine Adjustment of Speed

The keystroke **ESC Z** increases the speed and the keystroke **ESC A** decreases the speed. Each time the key is depressed, the speed is increased (or decreased) by 1/64 the previous speed. Note that the speed indicator on the screen remains unchanged.

5-2-4 CW ID Function

Before using CW ID, data must be written in Channel 7-8. **ESC I** being depressed, **C** is written in the buffer memory regarding as one unit of data. When transmission arrives at **C**, CW ID function is activated automatically and the sentence **CW ID FOLLOWS** is displayed on the screen. Then the data written in Channel 7-8 follows this sentence and transmitted. You are returned to RTTY mode automatically right after CW ID is completed.

5-2-5 Receiving/Transmitting Operation

For connections to the transceiver, refer to FIG. 8.

- (1) Receiving
 Using LED indicator
- i) Receive RTTY signals with the transceiver.
 - ii) Follow the procedure of 5-2-1 (1), select the tone and the shift width. Ascertain MODE indication on the screen. Follow the procedure of 5-2-1 (10) so as to set the Baud rate properly. Ascertain SPEED indication on the screen.

- iii) Increase the AF output frequency gradually from the lower tone with the VFO or RIT.
- iv) MARK indicating LED lights
- v) Continue increasing the frequency.
- vi) Stop increasing the frequency when the MARK indicating LED lights again and comes to light at maximum brightness.
- vii) SPACE indicating LED lights at this moment if the shift width of RTTY signal agrees with the setting of the Θ-9000E.

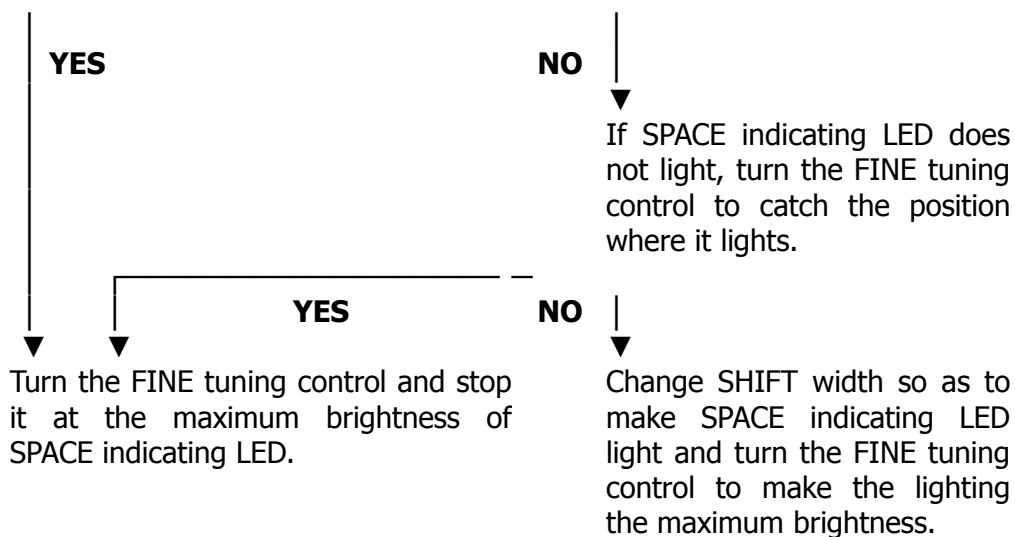

When tuning is completed, correct characters will be displayed on the screen.

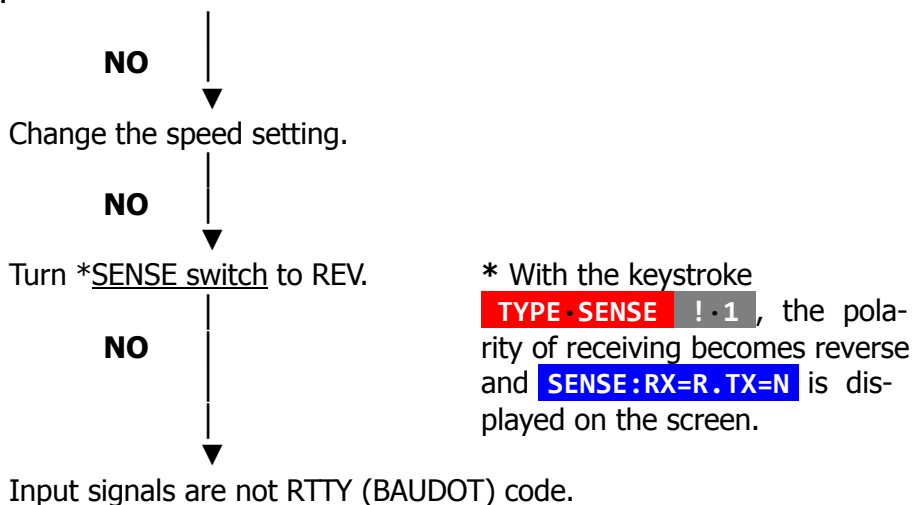

For amateur communications, 170 Hz shift is most commonly used; for business communications, 850 Hz and 425 Hz shift is usually used. In addition, monitoring of the output of MARK filter and that of SPACE filter are obtainable by changing AUDIO switches. Depress **CR/LF·AUDIO** followed by **"·2** or **#·3** to MARK and SPACE respectively.

The output of MARK filter and SPACE filter can function in lieu of MARK indicating LED and SPACE indicating LED.

SHIFT SWITCH	HIGH TONE		LOW TONE	
	MARK	SPACE	MARK	SPACE
170 Hz	2125 Hz	2295 Hz	1275 Hz	1445 Hz
425 Hz	2125 Hz	2550 Hz	1275 Hz	1700 Hz
850 Hz	2125 Hz	2975 Hz	1275 Hz	2125 Hz

Table 10

Using Cross Hatch Display

If tuning with a cross hatch display on the oscilloscope, adjust VFO and RIT of a transceiver and FINE tuning control of the Θ-9000E to make amplitude both in V-direction and in H-direction the maximum.

(2) Transmission

For automatic transmission, press **DIDDLE · PTT** and ascertain **PTT=AUTO** is on screen. Re-depress **DIDDLE · PTT** key to switch it to the manual transmission.

In order to operate the transceiver, follow the procedure:

i) Setting

The transceiver can be made to transmit by any of the three ways below:

- a) Automatic With PTT terminal of the Θ-9000E when connected to PTT terminal of the transceiver. **PTT=AUTO** is displayed on the screen while transmitting.
- b) Manual Connecting is same as automatic operation.
- c) Manual Changing the switch on the transceiver.

ii) Transmission

Operate the keyboard. Characters corresponding to the respective keys as in Table 14-1 and 14-2 are displayed on the screen.

iii) Setting

The transceiver can be returned to the receiving state by any of the three ways below:

- a) Automatic press **ESC F** or **ESC X** (PTT jack turns OFF).
- b) Manual press **ESC X** (PTT jack turns OFF).
- c) Manual changing the switch on the transceiver.

5-3 ASCII Mode

To use the Θ-9000E for ASCII, press **ASCII**. You will have screen indicators as follows:

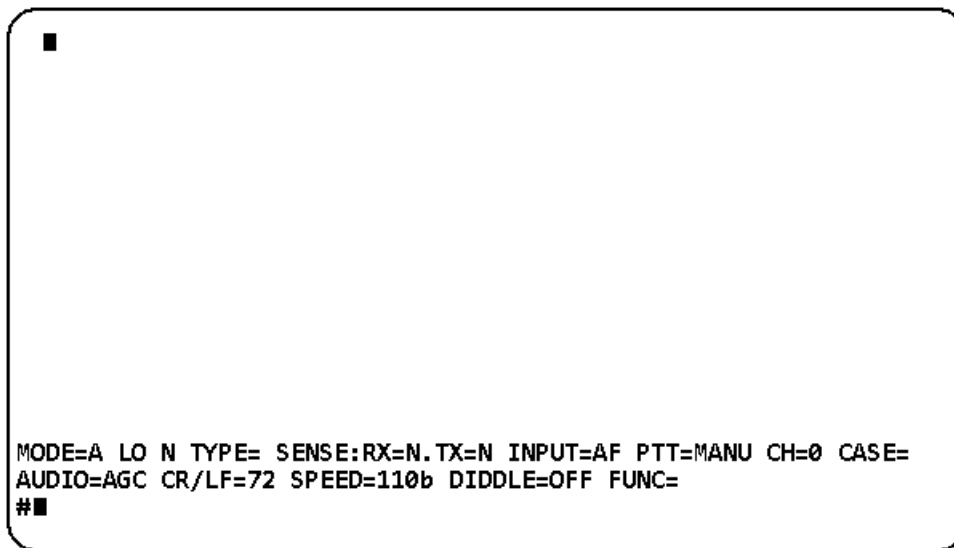

Figure 12 Screen Indicators in ASCII mode (80 × 24)

Screen format (40 × 24 or 80 × 24) is selectable with **ESC** (·8).

5-3-1 Introduction to the screen Indicators

- (1) **MODE=A LO N** indicates ASCII mode. Shift width is 170 Hz (N) in RTTY (ASCII) mode. To select the shift width of LOW tone and HI tone, refer to table 7.
- (2) **CH=0** indicating which channel memory is selected.
- (3) **TYPE=LINE** If you desire to select LINE mode, depress **SHIFT | TYPE · SENSE** followed by the key **RETURN**. Each time **RETURN** or **LINE FEED** is depressed, the buffer memory is transmitted.

TYPE=WORD If you desire to select WORD mode, depress **SHIFT | TYPE · SENSE** followed by the key **SPACE**. Each time **RETURN** or **LINE FEED** or **SPACE** is pressed, the buffer memory is transmitted. To return to the normal transmission mode, press **SHIFT | TYPE · SENSE** followed by any data key except for **RETURN**, **LINE FEED** or **SPACE**.
- (4) **SENSE:RX=N.TX=N** indicates the polarity of Send/Receive.
SENSE:RX=R.TX=N By depressing **TYPE · SENSE !·1**, RX=R is indicated on the screen and polarity of receiving is reversed. To cancel it, re-depress **TYPE · SENSE !·1**.
SENSE:RX=N.TX=R By depressing **TYPE · SENSE "·2**, TX=R is displayed on the screen and the polarity of transmitting is reversed. To cancel it, re-depress **TYPE · SENSE "·2**.
- (5) **INPUT=AF** indicating which input jack is selected. Select any key **!·1 ~ %·5** after pressing **SHIFT | INPUT · CASE**. Select any key **!·1** thru **%·5**, after depressing **SHIFT | INPUT · CASE**, **INPUT=KCS** is seen on the screen. At the same time **MODE=A LO N** change to **MODE=A KCS**.

- (6) **PTT=MANU**
PTT=AUTO With this indicator on, ON/OFF of PTT jack is manually switched. With the keystroke **DIDDLE · PTT**, automatic ON/OFF for PTT jack is available. To return to manual operation, **DIDDLE · PTT** should be re-depressed.
- (7) **AUDIO=AGC** indicates the monitor sound of input signal. Select any key **! · 1** ~ **# · 3** after pressing **CR/LF · AUDIO**.
- (8) **CASE=** not used in ASCII mode.
- (9) **CR/LF=72** Carriage returns and line feeds are inserted in ASCII mode.
- (10) **SPEED=110B** indicates that transmitting/receiving speed. Automatically set at 110 baud in the initial state. A chart of available speeds is in Table 9.
- (11) **FUNC=** indicates other functions.

NOTE: When you finish the preliminary setting in ASCII mode, press **ESC M** to store every parameter in memory. **ESC ? · /** initializes the unit.

5-3-2 Operation with KCS mode in ASCII

When using ASCII mode, modem is automatically set at RTTY mode (LOW TONE, NARROW SHIFT) in the initial state. To switch the modem from RTTY mode to KCS mode, press **SHIFT | INPUT · CASE** **\$ · 4**. At this moment, **MODE=A KCS** etc. are displayed on the screen. You may manually change the mode to RTTY with the keystroke **ASCII** or **SHIFT | TONE · CH** **! · 1** ~ **& · 6** and switch INPUT and AUDIO properly.

NOTE: DO NOT transmit KCS tones unless you determine that it is legal for you to transmit the 1200 Hz frequency shift. Amateur radio operators in the United States are presently limited to shifts of 900 Hz or less.

5-3-3 Small Letter Mode and Capital Letter Mode

The initial state in ASCII mode is normally a small letter mode. If you desire a capital letter mode, press **SHIFT A** ~ **SHIFT Z**. Or the keystroke **[CAPS · LOCK]** followed by **A** ~ **Z** also change to a capital letter mode. Notice that the keyboard entry of **[CAPS · LOCK]** switches Small/Capital alternately.

The screen indicator is as follows: Small letter mode: ■■■, Capital letter mode: ■■■.

5-3-4 Fine Adjustment

The keystroke **ESC A** increases the speed and the keystroke **ESC Z** decreases the speed. Each time the key is depressed, the speed is increased (or decreased) by 1/64 the previous speed. Notice that the speed indicator on the screen remains unchanged.

5-3-5 Receiving/Transmitting Operation

For the connection to transceiver, refer to FIG. 8.

(1) Receiving

- i) The Baud rate should be determined in the same way as in the RTTY mode. Ascertain the SPEED indication on the screen.
- ii) No tuning is necessary in the KCS (Kansas City Standard) mode. Follow the instruction in 5-1-1 (5) to adjust the audio input to the KCS tone. Ascertain the **INPUT=KCS** on the screen. Input the KCS signals of MARK (2400 Hz) and SPACE (1200 Hz).

- iii) When you transmit or receive ASCII signals in the RTTY mode, refer to the instruction of 5-2-5.

(2) Transmission

For automatic transmission, press **DIDDLE · PTT** and ascertain **PTT=AUTO** on the screen. Re-depress **DIDDLE · PTT** to switch it to manual transmission. To operate the transceiver, follow the procedure below:

- i) Setting
 - a) Automatic with PTT terminal of the Θ-9000E when connected to PTT terminal of the transceiver. **PTT=AUTO** is indicated on the screen while transmitting.
 - b) Manual Connection is same as automatic operation. With the key stroke **ESC X**, PTT jack turns ON.
 - c) Manual Changing the switch on the transceiver.

NOTE: Transmission of ASCII signals should be permitted by law!

- ii) Transmission
Operate the keyboard. Characters corresponding to the respective keys as in Table 14-1 and 14-2 are displayed.

- iii) Setting
The transceiver can be returned to the receiving state by any of the three ways below:

- a) Automatic press **ESC F** or **ESC X** (PTT jack turns OFF).
- b) Manual press **ESC X** (PTT jack turns OFF).
- c) Manual changing the switch on the transceiver.

6. DATA TRANSMISSION

6-1 Classification of the Data Transmission

- 6-1-1 Buffer Transmission: transmits the data stored in the Buffer Memory.
- 6-1-2 Channel Memory Transmission: transmits the data stored in channel memory (battery back-up).
- 6-1-3 Screen Transmission ("SEND" Function): transmits the data displayed on the screen.
- 6-1-4 Echo-back Transmission: The data from the external input (cassette tape recorder, hand key, microcomputer etc.) can be read and re-sent at the same time.
- 6-15 Test Message Transmission: transmits "RY", CW random signal and "QBF".

6-2 Buffer Transmission

The data from the keyboard is stored temporarily in the Buffer memory and transmitted one by one. Buffer memory is allocated 3120 characters.

- i) When the key **ESC V** is depressed, **FUNC=V**, which indicates a hold on the type-ahead keyboard buffer, is displayed on the screen. Release with a keyboard entry of **ESC V**.
- ii) By selecting LINE mode or WORD mode, the transmission is activated after every line or every word (refer to 5-1-1 (3)).
- iii) The two keystrokes **SHIFT | SPACE** disable the Buffer Transmission and the data in the Buffer memory is all cleared.
- iv) Miswritten data in the buffer memory can be erased while the information is still in the Buffer memory. This is activated with the keystroke **ESC | DEL** (RUB OUT function).

6-3 Channel Memory Transmission

Data in the memory is retained, even when external power is removed, when battery-back-up cells are installed. Seven channels (256 character/channel) are provided in the battery back-up memory. The 0-9000E has provision for 256 characters × 7 channels. Channel 6 has 16 subsections (16 characters × 16) and channel 7 has 8 subsections (32 characters × 8).

6-3-1 How to Program in Channel 1 thru 5 and Channels Usage

- A) In order to program a memory in Channels 1 thru 5 follow this procedure:
1. Press **TONE · CH**.
 2. Press the desired channel number key (**! · 1** ~ **% · 5**).
 3. Press **READ · WRITE**.
 4. Enter text up to 256 characters (including spaces, CR and LF).
 5. Press **SHIFT | READ · WRITE**.

EXAMPLE: To write " CQ CQ DE DC7XJ " in channel 3

TONE · CH # · 3 READ · WRITE C Q SPACE C Q SPACE
D E SPACE D C ' · 7 X J SHIFT READ · WRITE

Note: ESC | DEL allows you to edit any miswritten characters.

B) The transmission of the memory message in Channels 1 thru 5 can be repeated up to 9 times. Use the following procedure:

1. Press TONE · CH .
2. Press the channel number key you will transmit (! · 1 ~ % · 5).
3. Press one of ! · 1 thru) · 9 to instruct the repeating times.

EXAMPLE: How to transmit channel 1 three times, channel 5 nine times

TONE · CH ! · 1 # · 3 TONE · CH % · 5) · 9

6-3-2 How to Program in Channel 6 and the Channels Usage

A) Memory Channel 6 is divided into 16 subsections.

Section 1 is position 0–14	Section 9 is position 128–142
Section 2 is position 16–30	Section Q is position 144–158
Section 3 is position 32–46	Section W is position 160–174
Section 4 is position 48–62	Section E is position 176–190
Section 5 is position 64–78	Section R is position 192–206
Section 6 is position 80–94	Section T is position 208–222
Section 7 is position 96–110	Section Y is position 224–238
Section 8 is position 112–126	Section U is position 240–255

B) In order to program a memory in Channel 6, use the following procedure:

1. Press TONE · CH .
2. Press & · 6 .
3. Press READ · WRITE .
4. Press the desired section number key (! · 1 thru U).
5. Enter text up to 15 characters. If the text exceeds 15 characters, it is overwritten into the following sections. For instance, when you start writing in section 1, you can overwrite into section 2 thru section U to complete a text including up to 256 characters.
6. Press SHIFT | READ · WRITE .

EXAMPLE: To write " RST 599 " in channel 6-3

TONE · CH & · 6 READ · WRITE # · 3 R S T SPACE
% · 5) · 9 |) · 9 SHIFT | READ · WRITE

EXAMPLE: To write " CQ DX CQ DX THIS IS DC7XJ " in channel 6-R

TONE · CH & · 6 READ · WRITE R C Q SPACE D X
 SPACE C Q SPACE D X SPACE T H I S
 SPACE I S SPACE D C ' · 7 X J
 SHIFT | READ · WRITE

NOTE: Use CH6-1 ~ 6-8 for SEL-CAL.

- C) Memory Channel 6 is called once for each key entry. Follow this procedure:
1. Press **ESC D**.
 2. Press the desired section number key (**! · 1** thru **U**). When you call the section overwritten into, only a part of the text will be called.
- D) The transmission of the memory message in Section 1 of Channel 6 can be repeated up to 9 times. Follow the procedure:
1. Press **TONE · CH**.
 2. Press **& · 6**.
 3. Press one of **! · 1** thru **) · 9** to instruct the repeating times.

EXAMPLE: How to transmit Channel 6-1 three times an 6-Q, 6-8 and 6-1 once

TONE · CH & · 6 # · 3 ESC D Q ESC D (· 8 ESC D
 ! · 1

6-3-3 How to Program in Channel 7 and Channels Usage

- A) Memory Channel 7 is divided into 8 subsections.
- | | |
|------------------------------|-------------------------------|
| Section 1 is position 0–30 | Section 5 is position 128–158 |
| Section 2 is position 32–62 | Section 6 is position 160–190 |
| Section 3 is position 64–94 | Section 7 is position 192–220 |
| Section 4 is position 96–126 | Section 8 is position 222–255 |
- B) Follow this procedure to program a memory in Channel 7:
1. Press **TONE · CH**.
 2. Press **' · 7**.
 3. Press **READ · WRITE**.
 4. Press the desire section number key (**! · 1** thru **(· 8**)
 5. Enter text up to 31 characters. The text including over 31 characters will be overwritten into the following sections.
 6. Press **SHIFT | READ · WRITE**.

EXAMPLE: To write " MY ANT IS 15M " in Channel 7-2

TONE · CH ' · 7 READ · WRITE " · 2 M Y SPACE A
 N T SPACE ! · 1 % · 5 M SHIFT | READ · WRITE

NOTE: Test message "QBF" is written in Channel 7-7. CW ID transmits the data written in Channel 7-8.

C) Each section of Channel 7 is transmitted once for each key entry. Follow this procedure:

1. Press **TONE · CH**.
2. Press **' · 7**.
3. Press the desired section number key (**! · 1** thru **(· 8**)

EXAMPLE: To transmit Channel 7-2 once, Channel 7-8 once
TONE · CH **' · 7** **" · 2** **TONE · CH** **' · 7** **(· 8**

6-4 Screen Transmission ("SEND" function)

By depressing **ESC S**, characters from the head of the screen up to one before the cursor are transmitted. If you want to stop transmitting, write " \ ", before, in the place you want to stop. To transmit again:

- (1) Depress **ESC S** if you want to transmit from the head of the screen.
- (2) Depress **ESC SPACE** if you want to transmit from the one after " \ ".
- (3) By putting the new data from the keyboard, you can transmit from the Buffer.

NOTE: Buffer transmission during a standstill at " \ " is not displayed on the screen.

In Split Screen mode, depress **ESC S ! · 1** to transmit the receiving screen, and depress **ESC S " · 2** to transmit the sending screen. It is possible to interrupt the transmission by performing **SHIFT | SPACE**.

6-5 Echo-Back Transmission

The Θ-9000E provides AF IN, RS232C IN, TTL IN and KCS IN as the external input. By pressing **ESC E**, you can obtain a mode which reads the input and retransmits at the same time.

6-5-1 Transmission from a Cassette Tape Recorder

Put the output of the cassette tape recorder into AF IN or KCS IN of this unit (See FIG. 8). Select the appropriate input by depressing **SHIFT | INPUT · CASE ! · 1** or **\$ · 4**. With the keystroke **ESC E**, input data is retransmitted at the same time. **FUNC=E** will be indicated on the screen.

6-5-2 Hand Key Transmission

Connect the hand key to TTL IN (see FIG. 8). Set the input in TTL IN in CW mode. By depressing **ESC E**, you can transmit at the same time as displaying. The transmission is always available as long as **FUNC=E** is indicated on the screen. To return to the receiving state while **FUNC=E** is displayed on the screen, press **SHIFT | INPUT · CASE ! · 1** and **FUNC=E** will disappear.

With the keystroke **SHIFT | INPUT · CASE** **" · 2**, TTL IN is selected and **FUNC=E** will appear again on the screen. Perform another **ESC E** to release this function.

NOTE: Now you may see that connection to any external equipment is available in Echo-Back transmission.

6-6 Test Message Transmission

6-6-1 "QBF" Transmission

With the keystroke **ESC Q**, "QBF" test message is transmitted.
THE QUICK BROWN FOX JUMPS OVER THE LAZY DOG 1234567890 DE _____
data written in channel 7-7 is transmitted _____↑

6-6-2 "RY", CW Random Signal Transmission

ESC	R	! · 1	transmits "RY" test message.
ESC	R	" · 2	transmits CW Random signals (useful for CW copy practice).

6-6-3 Interruption

You can stop the transmission when part way thru by pressing any key on the keyboard.

7. VARIOUS FUNCTIONS

7-1 Split-Screen Mode (Separation of the Receiving Screen and the Sending Screen)

By depressing **ESC B**, the screen appears to be as the FIG. 13 shown below (**FUNC=B** is indicated).

NOTE: The various functions are to be indicated depending on the mode.

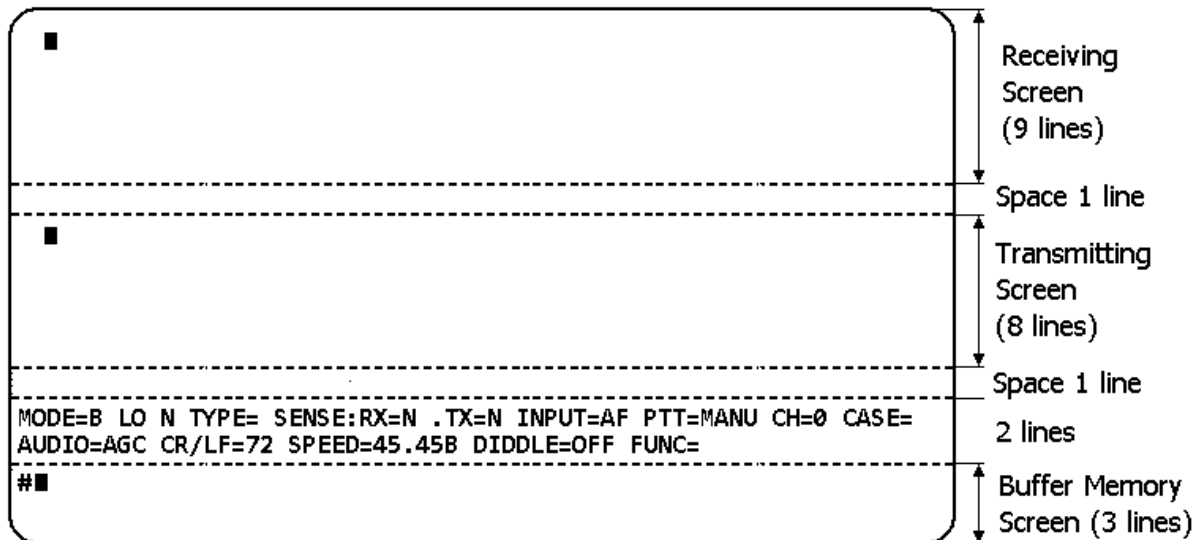

FIG. 13 Screen Indicators in Split Screen mode

NOTE: 40 × 24 screen format is shown in FIG. 5-2. You can change it by performing **ESC (·8)**.

7-1-1 Receiving data is displayed on the receiving screen. The receiving screen is provided for an extra 115 lines (225 lines in case of 40 × 24 screen format) on the upper screen. It holds 9200 characters all together.

7-1-2 Sending data is displayed on the transmitting screen (8 lines). Buffer memory is provided for an extra 36 lines on the lower screen. It holds 3120 characters all together.

7-1-3 To transmit the data on the receiving screen, depress **ESC S !·1**, transmitting screen **ESC R "·2** (see 6-4).

7-1-4 To clear the receiving screen, depress **HOME·CLEAR !·1**, transmitting screen **HOME·CLEAR "·2**.

7-1-5 To release this function, depress **ESC B**.

7-2 Graphic Mode

Press **ESC L** and the Θ -9000E is present for graphic mode (**FUNC=LP** is displayed). This allows you to create any characters or graphic patterns at you will. It is possible to send/receive the graphic patterns freely. **NOTE:** see below

7-2-1 Correction for Focus of the Light Pen

(1) Connect the light pen to the unit as shown in FIG. 8.

- (2) Press **ESC W** and small graphic elements are displayed on the whole screen.
- (3) Put the light pen vertically against the screen and move it up and down or right and left while keeping **[LP]** key on the keyboard pressed. Every dot or element touched by the light pen is changed as **XXX → XXX**. If it is not changed, intensify the brightness of the monitor T.V.
- (4) If the dot touched by the light pen does not change, press **ESC C**. Every time the key is pressed, the dot shifts to the right by one.
- (5) Press **ESC C** a few times until the dot correctly identifies the touched one. If the dot is on the right of the touched one, press **ESC C** until the dot comes to the left of the touched one.
- (6) Press **ESC P** to invert the screen. Put the light pen against the screen while keeping **[LP]** key pressed again and the dot is to disappear.
- (7) Re-press **ESC W** and return the screen to the state in (2). Repeat the procedures of (5) and (6) until the dot is corrected on the point of the light pen. Once it is corrected, no more modification is necessary.

7-2-2 How to Send Graphic Patterns

- (1) Press **ESC W** to display cursors on the screen. With **[LP]** pressed, draw graphic patterns on the screen with the light pen.
- (2) Press **ESC P** to reverse the screen. In this state you can make a modification on the screen by putting the light pen against the screen while keeping **[LP]** key pressed.
- (3) Press **ESC O** and the patterns on the screen will be transmitted. The transmission is done in order.
- (4) To stop the transmission any time, press **SHIFT | SPACE**.
- (5) To clear the transmitting screen, press **ESC W**.

NOTE: The graphic function is not used in CW (MORSE) mode. Displayed pattern will only re-displayed on another Θ-9000E also set in the graphic mode.

7-2-3 How to Switch in the Screen Mode

In the Graphic Mode, press either of **!·1**, **"·2**, **#·3** after pressing **ESC H** and the screen mode is switched as shown in Table 11. For scrolling the screen up or down, press **DOWN·UP** or **SHIFT | DOWN·UP** (refer to 2-4-2 Fig. 4).

Key	Screen Mode
!·1	Standard Screen Mode
"·2	Graphic Receive Screen Mode
#·3	Graphic Transmit Screen Mode

Table 11

7-2-4 How to Receive Graphic Patterns

When signals of graphic patterns are received in the Graphic Mode, the screen is switched automatically to the Graphic Receive Screen Mode. Practice transmitting or receiving graphic patterns with a cassette tape recorder and the like.

7-3 Control Code Output

When you press **'·@** **A** to **Z** **{·[** **!·1** **}·]** **~·^** **BS _** while pressing **CTRL**, the corresponding control code is transmitted. The serial output (every jack output of CW, FSK, AFSK OUT, RS232C OUT) varies depending on the mode used.

	Serial Output	Printer port
CW (MORSE)	No output	Every control code is sent.
RTTY (BAUDOT)	CTRL G , CTRL J or CTRL M transmits control codes. The others transmit LETTER code.	
ASCII	Every control code is transmitted.	

Table 12

Main Control Codes

CTRL H returns the cursor one step to the left (same as **SHIFT BS _**).

CTRL I shifts the cursor 8 steps (for 8 character spaces) to the right.

CTRL J shifts the cursor to a new line (same as **LINE FEED**).

CTRL M shifts the cursor to the line head (same as **RETURN**).

CTRL G transmits BEL code, making a pulse sound.

CTRL {·[transmits ESC (1BH) code.

CTRL | ESC transmits ESC (1BH) code. No signal is transmitted when only **ESC** is pressed.

When the control codes are received, they offer the same function as mentioned above.

For all control codes associated with the keys, refer to Table 16.

7-4 Selective Calling System

7-4-1 Introduction

It is possible to use Selective Calling System in every mode. The keystroke **ESC "·2** activates the function and **FUNC=SEL** is displayed on the screen.

When using the SEL-CAL system, your own "SEL-CAL Characters" and "End of Text" should be stored in channel 6 prior to the operation.

Receipt of your own "SEL-CAL Characters" causes the storage of text in memory and the text may be displayed on the screen and printed out to the printer. At this moment, the REMOTE jack is turned ON.

Upon receipt of your own "End of Text", the message stored in channel 6-1 ~ 6-2 is automatically transmitted. This is the Answer Back Data which notifies the end of receiving. Be sure that PTT jack turns ON during the transmission.

After the process, no more message is received nor displayed nor printed out. The the REMOTE jack is turned OFF.

NOTE: It is required to store "SEL-CAL Characters" in channel 6-3 ~ 6-4 and "End of Text" in channel 6-5 ~ 6-6. Avoid to overwrite the text into the following sections. If you use in MORSE mode, DO NOT use space in the text.

CH6-1	CH6-2	CH6-3	CH-4	CH-5	CH-6	CH6-7	CH6-8
"Answer Back Data"	"SEL-CAL Characters"			"End of Text"		applied for resistor while receiving	

When you call up the distant station, it is recommended that the "SEL-CAL Characters" and "End of Text" of the specified distant station may be stored in other memory channels. In this case, use any channel except CH6-1 ~ CH6-8.

Another **ESC** ". 2" cancels the function.

7-4-2 Connection to the peripheral equipment in SEL-CAL system

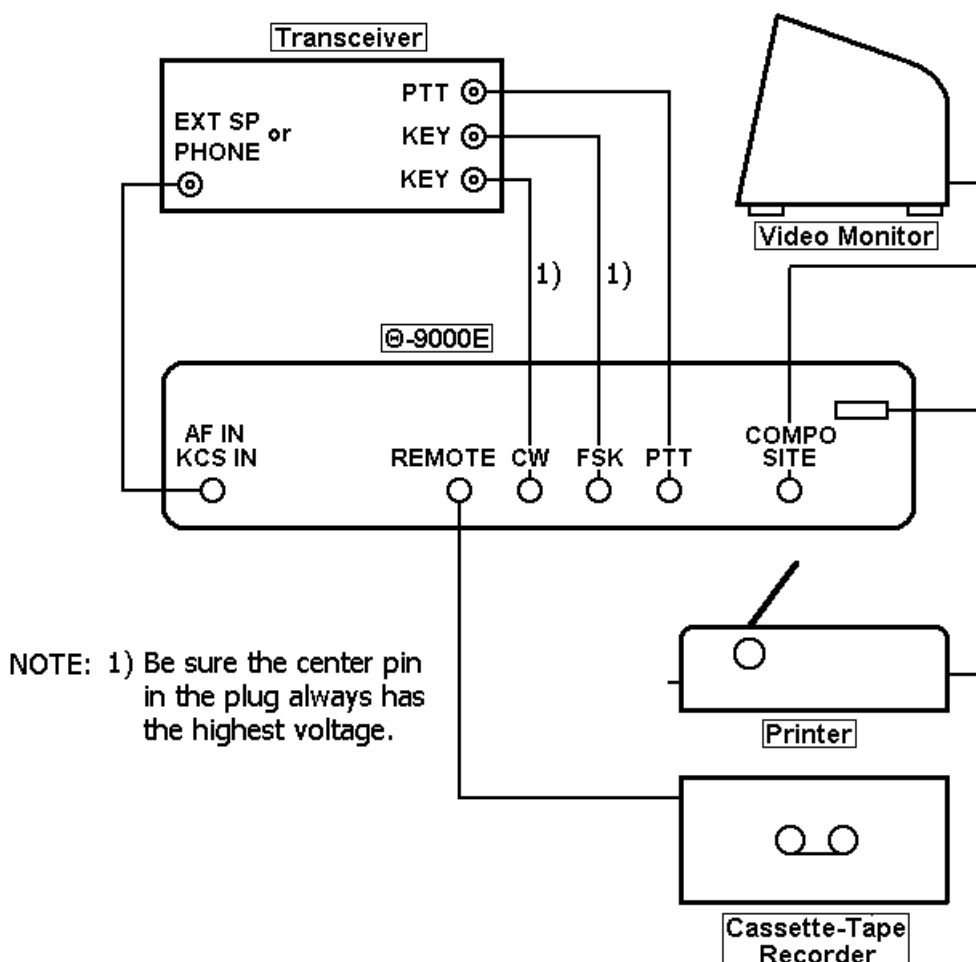

Figure 14 Connections in SEL-CAL mode

7-4-3 Operation

Press **ESC** "·2 so that SEL-CAL system is activated. Then you should see **FUNC=SEL** on the screen.

- (1) When you receive signal which corresponds to your own "SEL-CAL Characters" stored in channel 6-3 ~ 6-4, received text is displayed on the screen and printed out to the printer.
- (2) The REMOTE jack is turned ON. If the peripheral equipment (such as cassette tape recorder) is DC 100 V/200 mA or less, you can control it.
- (3) When you receive the signal which corresponds to your "End of Text" stored in channel 6-5 ~ 6-6 (the REMOTE jack is turned ON), the message stored in channel 6-1 ~ 6-2 is automatically transmitted as "Answer Back Data". Be sure that PTT jack is ON during the transmission.
- (4) After the transmission of "Answer Back Data", PTT jack is turned OFF.
- (5) Now, further signal is not received.
- (6) ' / ' is transmitted 6 Times before the transmit of "Answer Back Data".

7-5 Full Duplex Mode

When the Θ-9000E is used for ASCII mode, you may select a full duplex mode of operation.

With a full duplex mode, the receive and transmit data circuits are completely separated so that the Θ-9000E can receive and transmit simultaneously.

You may manually change the mode with the keystroke **ESC** %·5 . Notice that **FUNC=FULL** is displayed while using in full duplex mode.

NOTE: You may not be able to select full duplex mode in CW and BAUDOT mode.

7-5-1 Using as CRT Terminal by RS232C serial interface

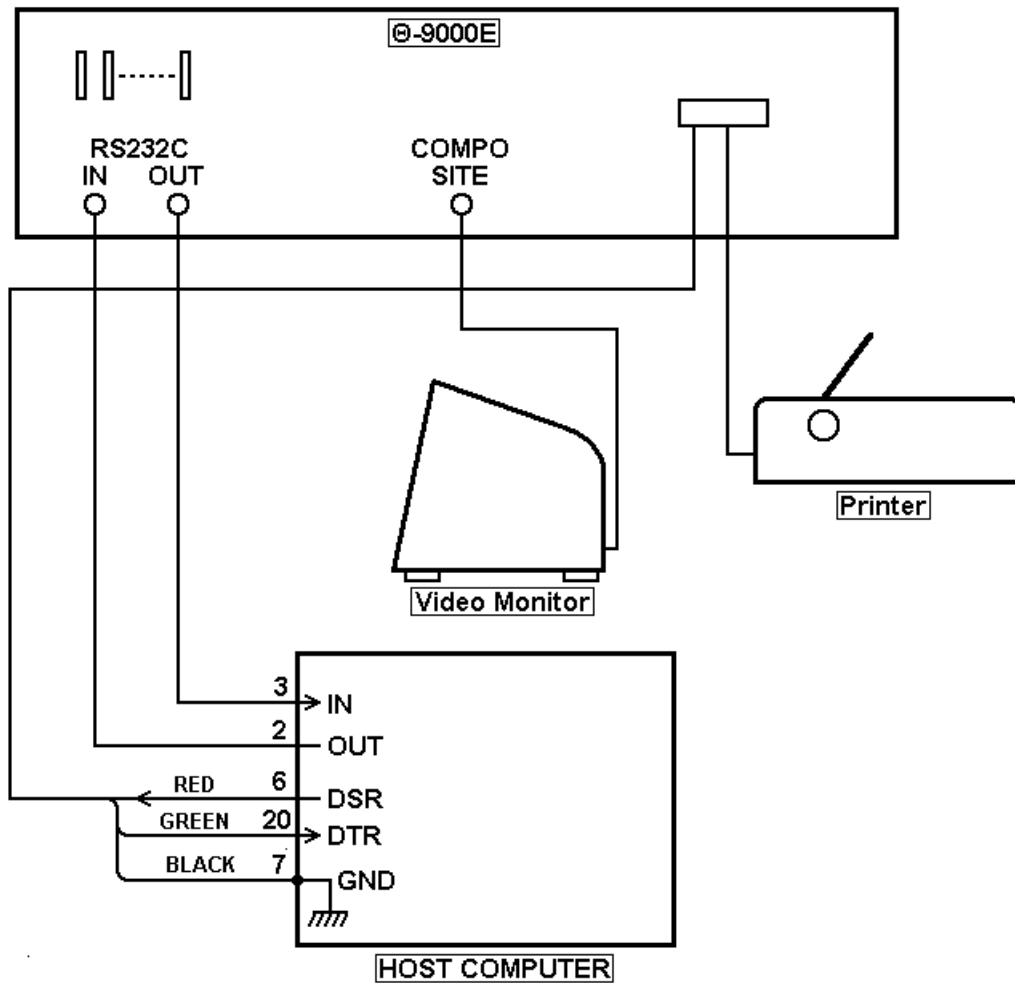
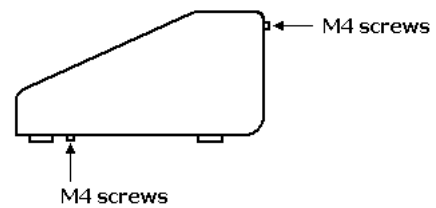

Figure 15 Using as CRT terminal by RS232C

7-5-2 How to Connect 3P Connector

- (1) Remove two M4 screws on rear panel and two M4 screws on the bottom.



- (2) Connect the accessory 3P Connector to 3P Connector on the CPU board as follows:

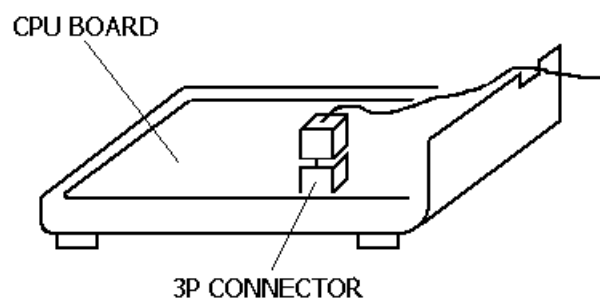
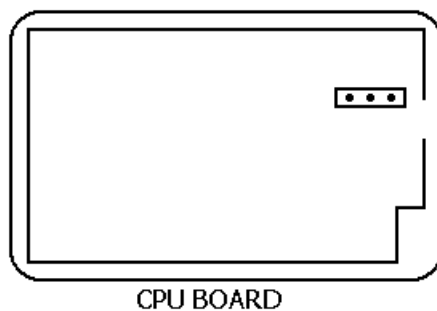

- (3) The lead wire of 3P Connector should be pulled out of the hole on rear panel.

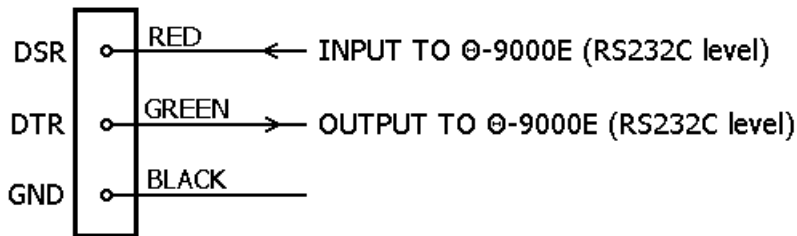

7-5-3 Connection to Host Computer

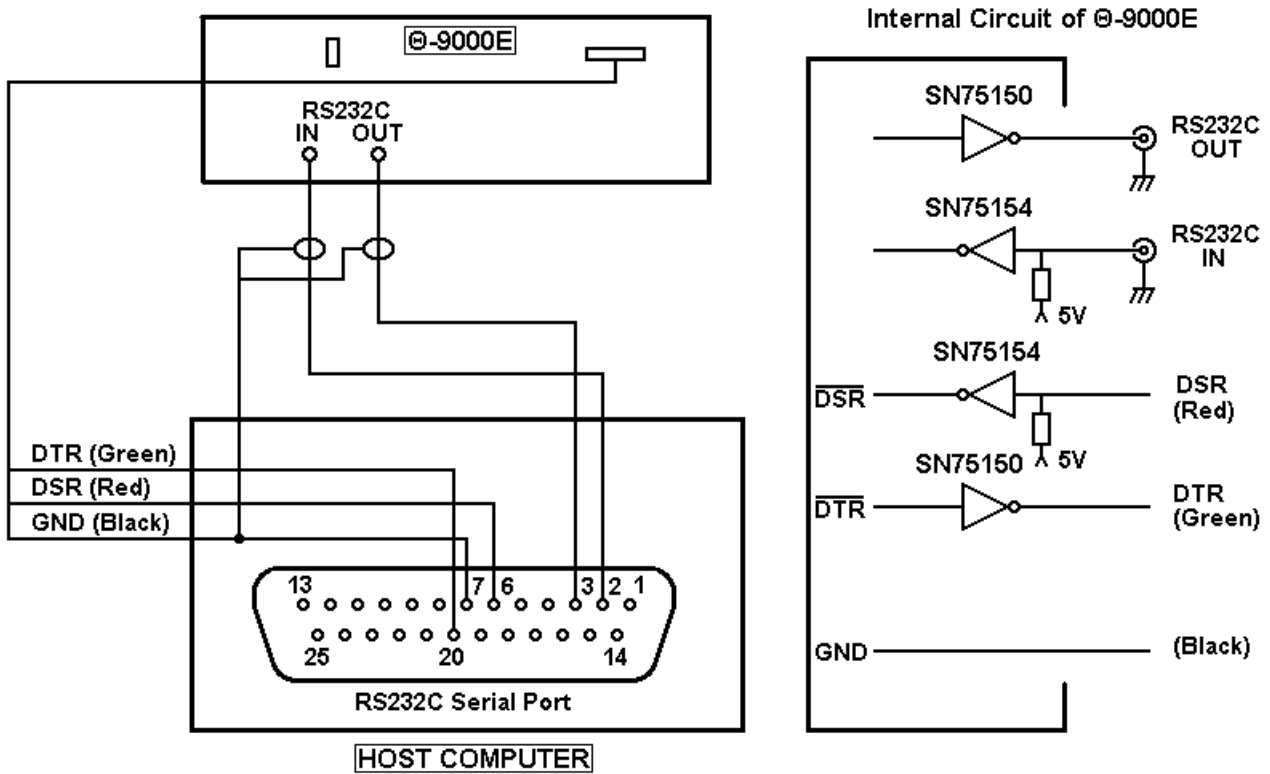

Figure 16 Connection to Host computer

7-5-4 Procedures before Operation

- (1) Press **ASCII**.
- (2) Press **ESC % 5** to activate full duplex mode.
- (3) Correspond the baud rate of the Θ-9000E to that of the host computer. For instance, if you desire to select 4800 baud, **E** should be pressed after the keystroke **WEIGHT SPEED**.

- (4) The bit format of one word of the Θ-9000E should be corresponded to that of the host computer.

EXAMPLE: Format of serial output (RS232C OUT) in the Θ-9000E (in case of A=41H)

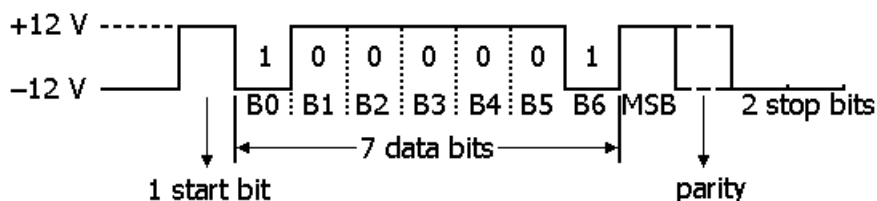

* Follow the procedure below to select the parity bit and Most Significant Bit (MSB).

Depress **ESC !.1** followed by the keystroke **!.1 ~ &.6**.

Key	Indicator	Format of RS232C serial output (in case of A=41H)	MSB	Parity	Total Bits
!.1	FUNC=FULL (initial state)		O	X	11
".2	FUNC=8E FULL		O	even	12
#.3	FUNC=80 FULL		O	odd	12
\$.4	FUNC=7 FULL		X	X	10
%.5	FUNC=7E FULL		X	even	11
&.6	FUNC=70 FULL		X	odd	11

Table 13

NOTE: ST=Start bit, Sp=Stop bit, M=MSB, P=Parity

7-5-5 Using Printer

In full duplex mode the Θ-9000E receives output data from the Host computer and displays it on the screen.

When you desire to print out the received text to the printer, press **CTRL P**. Then **FUNC=FULL P** is displayed on the screen.

The printing function is active while **FUNC=FULL P** is seen on the screen.

You can stop printing by depressing **CTRL P**. Now the screen indicator is returned to **FUNC=FULL**.

Be sure that the transmitted data may not be printed out in full duplex mode.

8. WORD PROCESSOR MODE

With the keystroke **CTRL ASCII**, the Word Processor mode becomes active.

Transmit/Receive baud rate: 300 baud
ASCII code: 1 start bit, 8 data bits, 2 stop bits
AFSK OUT: KCS (2400 Hz MARK and 1200 Hz SPACE)

8-1 Introduction

8-1-1 Screen Format in Word Processor Mode

One screen format consists of 3 pages and each page includes 60 lines. Capable of displaying 24 lines, with 80 characters in each line.

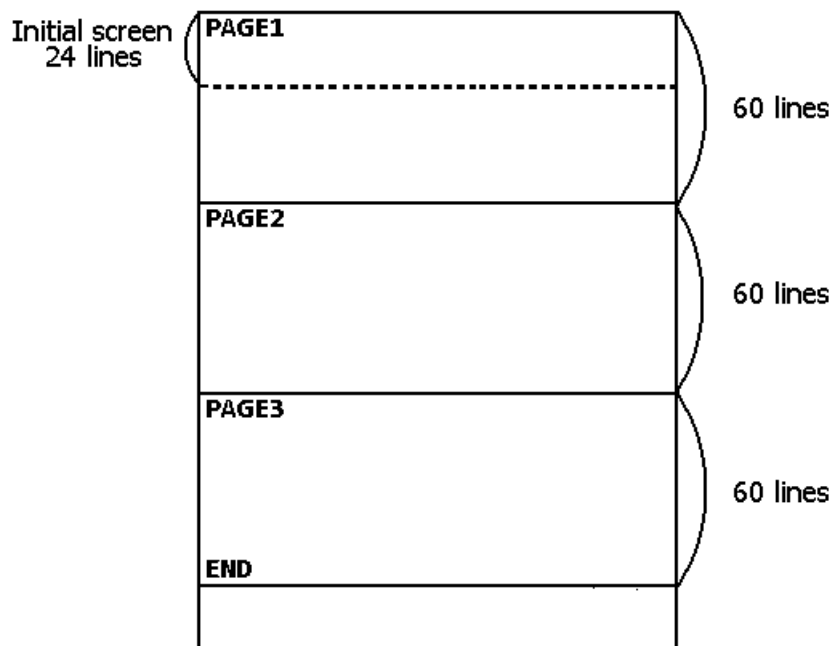

* Note that each page consists of two major components: Data area and Operation area.

72 characters × 60 lines are provided for Data area. Operation area provides a special area for operator's command not to be output.

Indicators in the initial state are as follows:

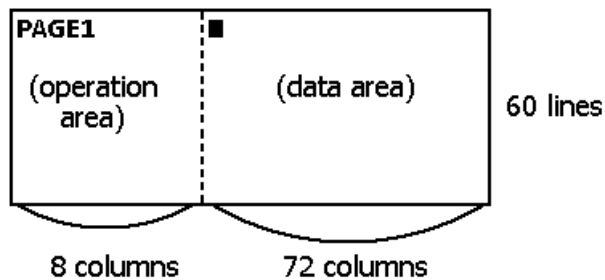

Ascertain that the cursor is always located on the left margin of the operation area whenever you give a command to the Θ-9000E.

8-1-2 Connections to the peripheral Equipment

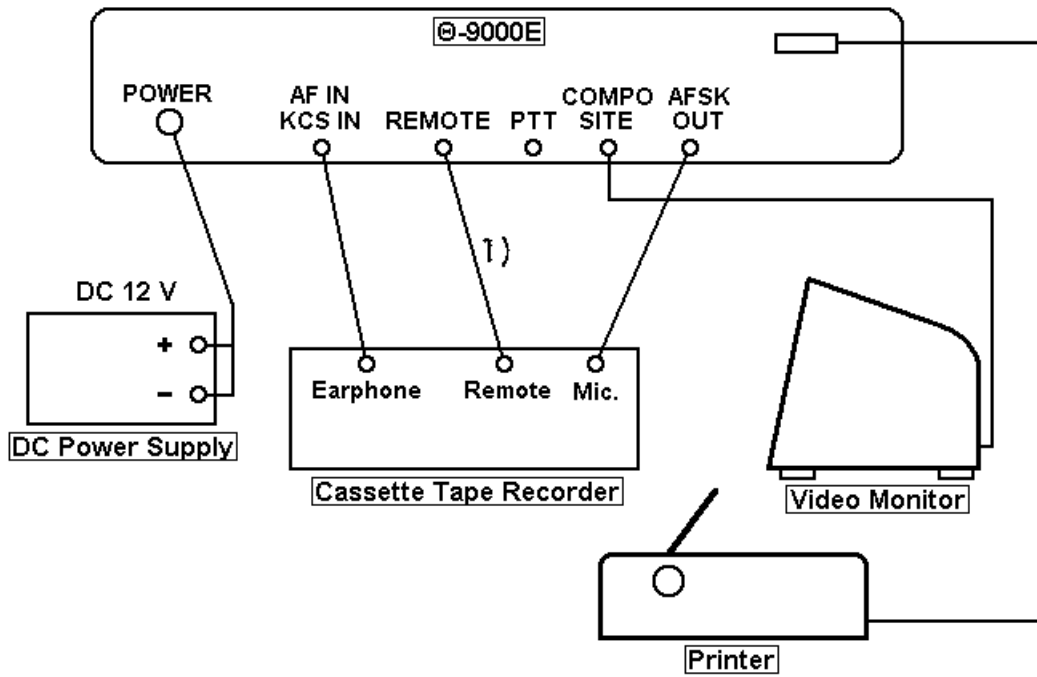

NOTE: Be sure the center pin in the plug always has the highest voltage. DO NOT connect unless necessary.

Figure 17 Connections in Word Processor mode

8-1-3 Basic Operation

A) How to write sentences

EXAMPLE

```

PAGE 1

Theta-9000E
WORD-PROCESSOR
MODE■
    
```

In order to perform the above, press the keys

LINE	FEDD	SHIFT	T	H	E	T	A	=	-)	.	9	0	0	0
SHIFT	E	RETURN	[CAPS	LOCK]	W	O	R	D	=	-	P	R	O	C	E
S	S	O	R	RETURN	M	O	D	E							

B) How to move the cursor

The cursor can be moved by depressing any of the key below:

← →, **SHIFT | ← →**, **↑ ↓**, **SHIFT | ↑ ↓**, **RETURN**, **LINE FEED**,
SHIFT | BS · _, **SHIFT | HOME · CLEAR**, **A n** **SHIFT | RETURN**
B n **SHIFT | RETURN**, **SHIFT | RETURN**, **TAB** etc.

NOTE: n identifies a number from 1 to 99.

If you desire to move the cursor to the head of a line (the left margin of the operation area), press **SHIFT | RETURN**.

C) How to move the cursor up or down

To move upward

- i) Move the cursor to the head of a line (Press **SHIFT | RETURN**)
- ii) Press **B n** **SHIFT | RETURN** to move the cursor n lines upward ($n = 1$ thru 99).

To move downward

- i) Move the cursor to the head of a line (Press **SHIFT | RETURN**)
- ii) Press **A n** **SHIFT | RETURN** to move the cursor n lines downward ($n = 1$ thru 99).

When you press **A** **SHIFT | RETURN** or **B** **SHIFT | RETURN** the cursor moves 1 line down or up.

D) How to scroll the screen

Either of the keystroke below enables to scroll the screen:

DOWN · UP or **SHIFT | DOWN · UP**.

E) How to clear the page

The keystroke **HOME · CLEAR** **! · 1** clears a text written in page 1.
The keystroke **HOME · CLEAR** **" · 2** clears a text written in page 2.
The keystroke **HOME · CLEAR** **# · 3** clears a text written in page 3.

F) How to switch the page

This is activated with the keystroke **ESC C** **! · 1** ~ **# · 3**.

ESC C **! · 1** displays the first 24 lines of page 1.
ESC C **" · 2** displays the first 24 lines of page 2.
ESC C **# · 3** displays the first 24 lines of page 3.

G) How to move text among the pages

Follow the procedure below:

- i) Move the cursor to the head of a line (Press **SHIFT | RETURN**).
- ii) Press **M** *n1 n2* **SHIFT | RETURN** (*n1* and *n2* are corresponding to the key **!·1** ~ **#·3**. *n1* identifies a page which is replaced with another page and *n2* identifies a page to which the text is moved.)

EXAMPLE: How to move text from page 2 to page 3:

Move the cursor to the head of a line.

Press **M** **"·2** **#·3** **SHIFT | RETURN**.

H) How to modify a command before it is carried out, press **ESC X**.

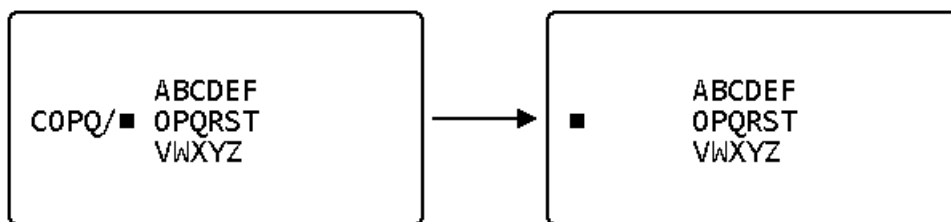

Sorry, the following page of the original manual is missing !

.....

- ii) **K** *n* **SHIFT | RETURN** (*n*=1 thru 99)

This keystroke allows the desired lines to be deleted and the space of line to be closed up.

EXAMPLE:

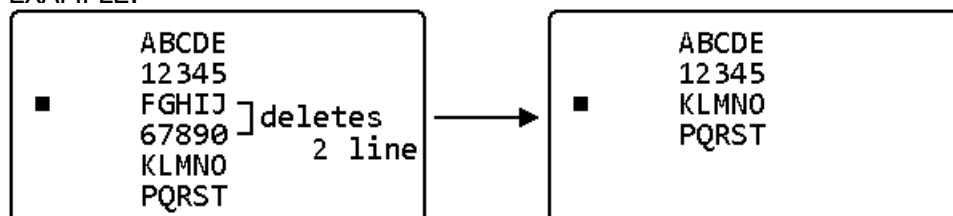

Follow the procedure below:

- (a) Move the cursor to the head of FGHIJ line.
- (b) Press the Keys **K** **2** **SHIFT | RETURN**.

NOTE: **K** **1** **SHIFT | RETURN** is equivalent to **K** **SHIFT | RETURN**

8-2-2 Data Search Function

Allows search for a desired character sequence among the sentences which are located under the cursor.

This capability is activated with the keystroke **F** *characters* **SHIFT | RETURN**.

EXAMPLE:

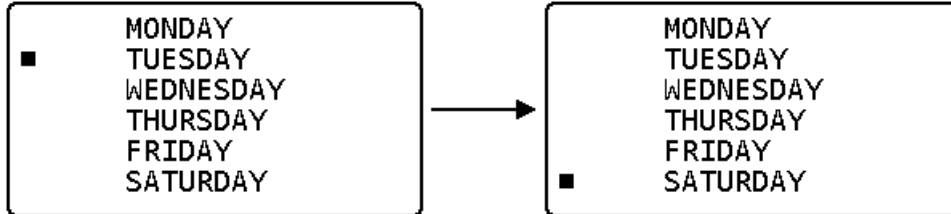

Press **F** **A** **T** **U** **R** **SHIFT | RETURN**.

If a characters sequence **ATUR** can be found on the screen, the cursor moves to the head of the line which includes the character sequence requested.

In the case that the desired characters are not displayed, the screen is automatically scrolled until the desired characters are viewed on the screen.

If the desired characters are not in the stored data, **NO DATA** is displayed on the screen.

Either with a new command or the keystroke **ESC X** erases **NO DATA**.

8-2-3 Data Substitution and Deletion

(1) Data Substitution

C *data 1* / *data 2* **SHIFT | RETURN** enables to substitute *data 2* for *data 1* with in the line where the cursor is located.

EXAMPLE:

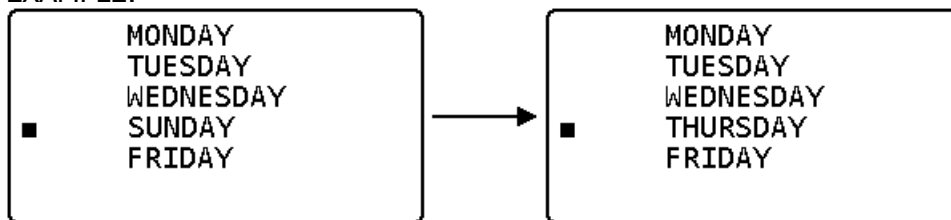

(a) Move the cursor to a head of SUNDAY line.

(b) Press **C** **S** **U** **N** **?./** **T** **H** **U** **R** **S** **SHIFT | RETURN**.

If desired data is not in the line where the cursor is located, **NO DATA** is displayed on the screen.

(2) Data Deletion

This activity permits an operator to delete the desired data with the keystroke **C** *data* **/** **SHIFT** **RETURN**.

EXAMPLE:

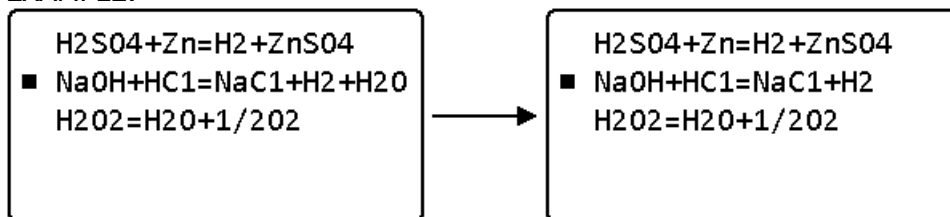

(a) Move the cursor to the head of a line which includes the desired data.

(b) Press **C** **SHIFT** **+·;** **H** **2** **?·/** **SHIFT** **RETURN**

If the data is not found on the line, **NO DATA** is displayed on the screen.

8-2-4 Margin Justification

(1) Left Margin Justification

This function allows the head of a line or a word to be left justified.

EXAMPLE 1

With the keystroke **ESC** **SPACE**, the head of the line shifts to the same position at which the cursor is located.

(a) Move the cursor to the desired place.

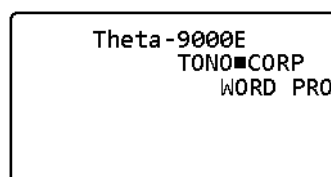

(b) Press the keys **ESC** **SPACE**. The the data, which is located to the left side of the cursor, shifts to rightward.

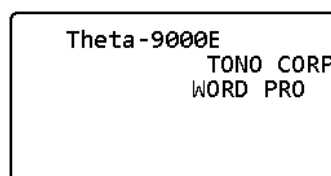

(c) Another keystroke **ESC** **SPACE** enables to shift the next data rightward.

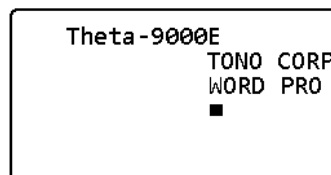

EXAMPLE 2-1

The head of the line shifts to the same position where the cursor is located.

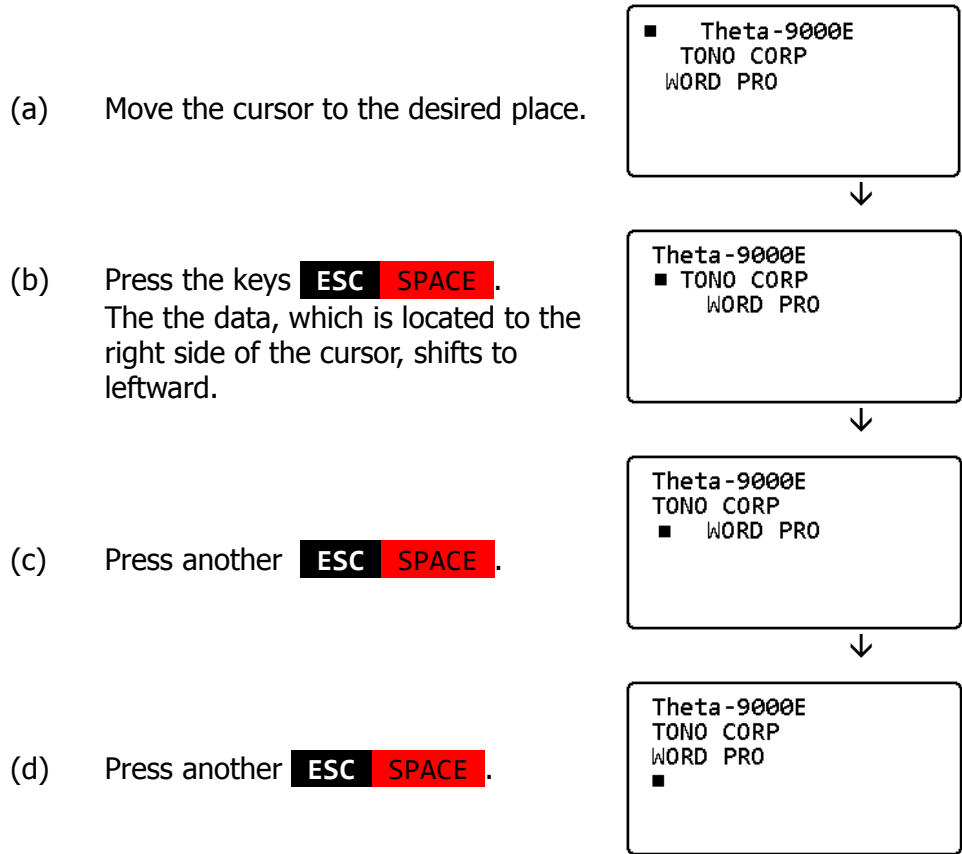

EXAMPLE 2-2

With the keystroke **ESC Z**, the head of a character sequence which is located to the right side of cursor shifts to the same position where the cursor is placed.

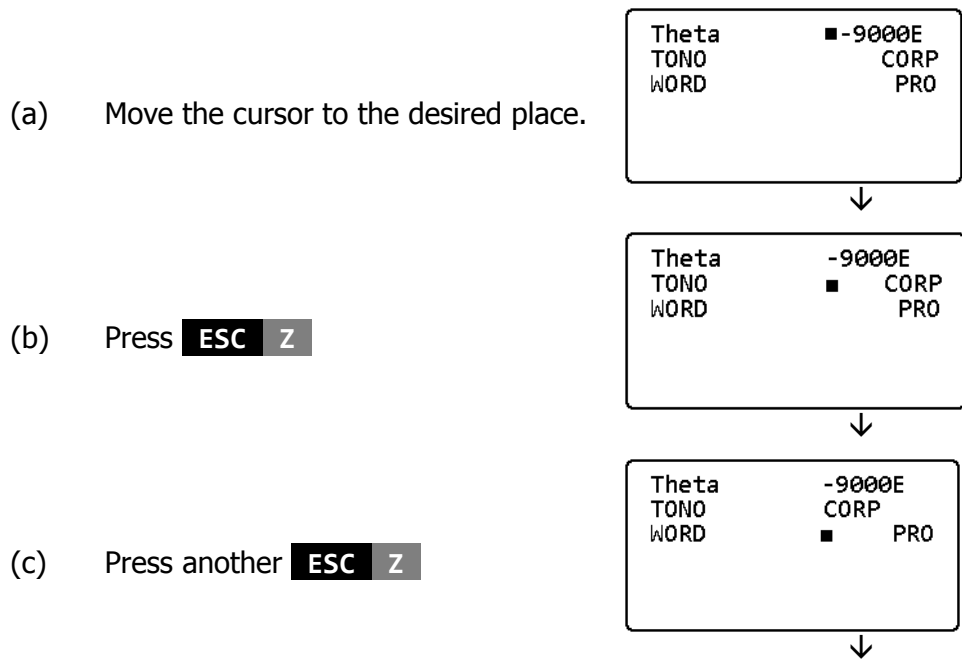

- (d) Press another **ESC Z**

```

Theta      -9000E
TONO      CORP
WORD      PRO
          ■
  
```

(2) Right Margin Justification

Allows to adjust word (or numeric) endings.

EXAMPLE 1

If one word (or numerics) is in the cursor, the keystroke **ESC | TAB** enable to move the end of the word (or numeric) to where the cursor is placed.

- (a) Move the cursor to the desired place.

```

ABCD      550
EFG       23
HIJ      1234
          ■
  
```



- (b) Press **ESC | TAB**

```

ABCD      550
EFG       23
HIJ      1234
          ■
  
```



- (c) Press another **ESC | TAB**

```

ABCD      550
EFG       23
HIJ      1234
          ■
  
```



- (d) Press another **ESC | TAB**

```

ABCD      550
EFG       23
HIJ      1234
          ■
  
```

EXAMPLE 2

If a word (or numeric) is outside the cursor, the keystroke **ESC | TAB** enable to move the closest left-hand word from the cursor rightward to adjust word (or numeric) endings.

- (a) Move the cursor to the desired place.

```

ABCD      550
EFG       23
HIJ      1234
          ■
  
```



- (b) Press **ESC Z**

```

ABCD      550
EFG       23
HIJ      1234
          ■
  
```



(c) Press another **ESC Z**

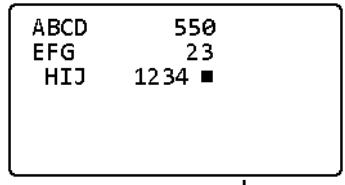

(d) Press another **ESC Z**

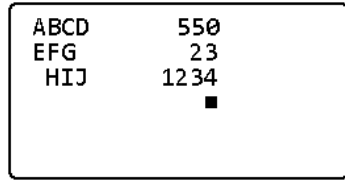

8-2-5 Space Control

(1) How to add spaces

(a) Move the cursor to the desired place.

(b) When **ESC I** is pressed, the text to the right of the cursor moves right by ones and one space is made next to the cursor.

(c) When you make more than two spaces, repeat pressing **ESC I**.

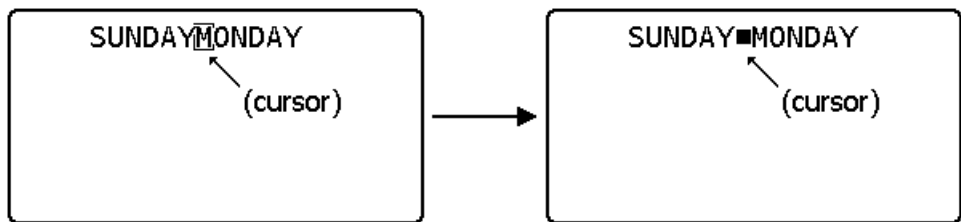

(2) How to close spaces

(a) Move the cursor to the desired place.

(b) When **ESC K** is pressed, one character to the right of the cursor is erased. The rest of the text is moved left by ones and one space is closed.

(c) To erase more than two characters, repeat the keystroke **ESC K**.

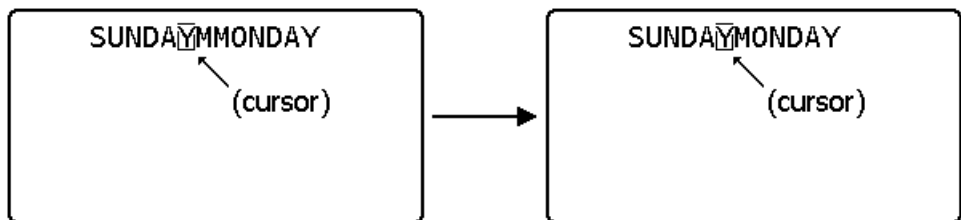

8-2-6 Vertical Lines and Horizontal Lines

(1) Vertical lines

- (a) To draw vertical line, move the cursor where you start drawing a line.
- (b) Press **ESC V** *n* and vertical lines (|) are drawn *n* lines downward from the place of the cursor (*n* identifies the figure key 1 thru 9 or every key input, Q, W, E, R, T, Y, U).

<i>n</i>	Number of line	<i>n</i>	Number of line
1	1	E	30
2	2	R	40
∫	∫	T	50
9	9	Y	60
Q	10	U	70
W	20		

EXAMPLE: How to draw 4 vertical lines

- (a) Move the cursor to the desired place.
- (b) Press **ESC V 4**

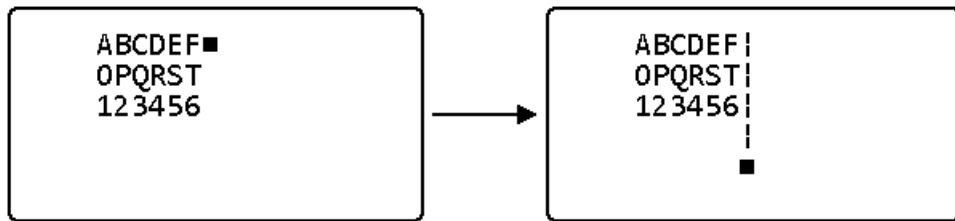

(2) Horizontal lines

- (a) To draw horizontal line, move the cursor where you start drawing line.
- (b) Press **ESC H** *n* and horizontal lines (_) are drawn *n* characters left (*n* identifies the figure key 1 thru 9 or every key input, Q, W, E, R, T, Y, U).

EXAMPLE: How to draw 6 horizontal lines

- (a) Move the cursor to the desired lines.
- (b) Press **ESC H 6**.

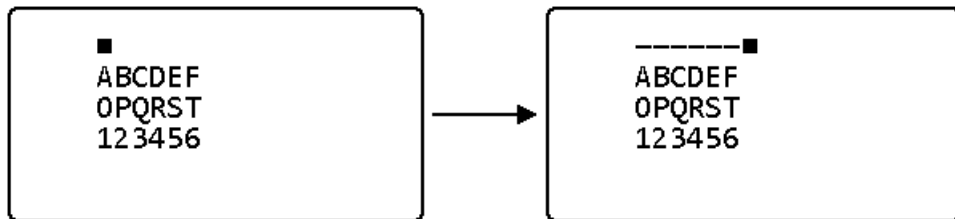

8-3 Channel Memory

The channel memory is useful for the memory of phrases. You can read or write programs in channels 1 thru 6, but not in channel 7.

8-3-1 How to write into channels 1 thru 5

Channels 1 thru 5 are continuous. If channel 1 is selected and it is filled out, the left-over text is automatically overwritten into channel 2 or the others.

- (a) Write a text on the screen
- (b) Press **TONE · CH** *n* **ESC** **W** (*n* identifies the channel number 1 thru 5).
- (c) The text on the screen is written into the channels.

8-3-2 How to display the text memorized in channels 1 thru 5

- (a) Press **TONE · CH** *n* **ESC** **D** (*n* identifies the channel number 1 thru 5).
- (b) The text in the selected channel is displayed, starting from the location of the cursor on the screen.

8-3-3 How to program a memory in channel 6

The method of writing into channel 6 is the same as that in CW, BAUDOT or ASCII mode.

In order to program a memory in channel 6, follow the procedure below:

- (a) Press **TONE · CH** .
- (b) Press **& · 6** .
- (c) Press **READ · WRITE** .
- (d) Press the desired section number key **! · 1** thru **U** .
- (e) Enter text up to 15 characters. If text exceeds 15 characters, it is overwritten into the following sections. For instance, when you start writing in section 1, you can overwrite into section 2 thru section U to complete a text including up to 256 characters.
- (f) Press **SHIFT | READ · WRITE** .

EXAMPLE 1: To write " RST 599 " in channel 6-3, press

TONE · CH **& · 6** **READ · WRITE** **# · 3** **R** **S** **T** **SPACE** **% · 5** **) · 9** **) · 9**
SHIFT | READ · WRITE

EXAMPLE 2: To write " CQ DX CQ DX THIS IS DC7XJ " in channel 6-R

TONE · CH **& · 6** **READ · WRITE** **R** **C** **Q** **SPACE** **D** **X** **SPACE** **C** **Q**
SPACE **D** **X** **SPACE** **T** **H** **I** **S** **SPACE** **I** **S** **SPACE**
D **C** **' · 7** **X** **J** **SHIFT | READ · WRITE**

8-3-4 How to display the text memorized in channel 6

Channel 6 is divided into 16 subsections of 16 characters. When you read out the text in each subsection, press **ESC** **D** **!.1** **).9** **Q** **~** **U** and the program in every subsection is displayed, starting from the present cursor location. This procedure is the same as that in CW, BAUDOT or ASCII.

8-4 **Application**

8-4-1 Printer

This section will instruct you how to output a text written on a page to a printer.

- (a) Connect a printer to the printer port of the Θ-9000E.
- (b) Set the printer to a selected state.
- (c) Move the cursor to the head of a line (press **SHIFT** **RETURN**).
- (d) Press **P** *n* *m* **SHIFT** **RETURN** (*n* identifies the key **!.1** **".2** **#.3** and selects the page.) When **P** **G** *m* **SHIFT** **RETURN** , the displayed screen is transmitted to the printer (*m* identifies a number from 1 to 99 and selects the number of times the page is to be printed. When *m* is omitted, *m* is equivalent to 1).
- (e) Press **ESC** **D** to stop the operation on the way.

EXAMPLE 1 How to transmit page 2 to a printer 15 times

- (a) Move the cursor to the head of a line.
- (b) Press **P** **".2** **!.1** **%.5** **SHIFT** **RETURN**

EXAMPLE 2 How to transmit the displayed screen to a printer 30 times

- (a) Move the cursor to the head of a line.
- (b) Press **P** **G** **#.3** **0** **SHIFT** **RETURN**

If you desire to change the printing specification, follow the procedure below:

You should write the control code on the screen previously so that the Θ-9000E can transmit the control signal and the typed text simultaneously to the printer.

EXAMPLE 1 Emphasized character print

Press **CTRL | ESC** (1BH code) and **SHIFT | !.1** (21H code) to activate emphasized character sequence which you desire to emphasize. This command continues until **CTRL | ESC** (1BH code) and **SHIFT | ".2** (22H code) are pressed.

```
ABCDE
·!12345·"
```

EXAMPLE 2: Under Line

The character sequence inserted between the keystroke **CTRL | ESC** (1BH) **X** (58H) and **CTRL | ESC** (1BH) **Y** (59H) can be underlined.

```
ABCDE
·X12345·Y
```

EXAMPLE 3: Elongated character print

Put the character sequence between the keystroke **CTRL | N** (0EH) and **CTRL | O** (0FH) to elongate characters you desire.

```
ABCDE
·12345·
```

EXAMPLE 4: Line Feed pitch

'·B' shows that **CTRL | ESC** **B** are pressed and 1/8" line feed pitch mode is active. After pressing **CTRL | ESC** **A**, 1/6" line feed pitch mode becomes active.

```
ABCDE
·BFGHIJ
12345
67890·A
abcde
fghij
```

NOTE: The above-mentioned control code is shown as **■** on the screen. The control signal varies with each printer, so follow your printer's instruction manual before operation. Be sure that control code is transmitted to the printer, but not printer out.

8-4-2 Tape recorder

(1) How to record a completed text with a tape recorder

The output signal in ASCII code (1 start bit, 8 data bits and 2 stop bits), 300 baud and KCS modulation, is available from the AFSK OUT jack.

- (a) Connect a tape recorder to the Θ -9000E (refer to Figure 17).
- (b) Move the cursor to the head of a line.
- (c) Press **T** *n* **SHIFT | RETURN** (*n* identifies keys **!.1** thru **#.3** and selects the page).
- (d) **TITLE ?** is displayed on the screen.
- (e) Enter a title of six characters or less on the keyboard.
- (f) Press **SHIFT | RETURN** to record the text in the tape recorder.

(g) At this moment, REMOTE jack is turned ON.

(h) When output of data is completed, REMOTE jack is automatically turned OFF,

EXAMPLE: How to write a title " REC1Ø " in a text written in page 2 and then record on tape recorder

(a) Move the cursor to the head of a line.

(b) Press **T** **"·2** **SHIFT | RETURN** .

(c) After **TITEL ?** is displayed on the screen. press **R** **E** **C** **!·1** **Ø** **SHIFT | RETURN** .

(2) How to read out the text from the tape recorder

This section instructs you how to display the text, recorded on the tape recorder, on the screen.

(a) Connect the tape recorder to the Ø-9000E (refer to Figure 17).

(b) Move the cursor to the head of a line.

(c) Press **L** *title* **SHIFT | RETURN** and the text so titled is displayed on page 1.

(d) The keystroke **ESC** **X** cancels the function.

(e) When using REMOTE jack, press **ESC** **X** at the end (REMOTE jack turns OFF).

EXAMPLE: How to display the text titled **REC1Ø**

(a) Move the cursor to the head of a line.

(b) Press **L** **R** **E** **C** **!·1** **Ø** **SHIFT | RETURN** .

(3) How to pick up and display *title* from tape recorder

When you desire to pick up and display the title only from the text already recorded on tape recorder,

(a) Move the cursor to the head of a line.

(b) Press **L** **D** **SHIFT | RETURN** .

(c) Now, the titled is displayed. In case there are some texts in a tape, all the titles are displayed.

(d) When using REMOTE jack, **ESC** **X** at the end (REMOTE jack turns OFF).

NOTE: Whenever you record a text on a tape recorder, please do not "D" as a title.

9. INTRODUCTION TO ALL THE FUNCTION KEYS

9-1 MORSE, BAUDOT, ASCII

HOME · CLEAR	clears the screen. In split screen mode, HOME · CLEAR !·1 clears the receiving screen and HOME · CLEAR "·2 clears the transmitting screen (see 7-1).	
SHIFT HOME · CLEAR	moves the cursor to the top of the screen.	
↑ ↓ or SHIFT ↑ ↓	moves the cursor up and down.	
← → , SHIFT ← →	moves the cursor right or left.	
TONE · CH !·1 ~ '·7	selects the channel memory.	
SHIFT TONE · CH !·1 ~ &·6	changes LOW/HI tone and shift width in RTTY mode.	
READ · WRITE	should be depressed before data is written in channel memory.	
SHIFT READ · WRITE	should be depressed after data is written in channel memory.	
DOWN · UP	scrolls the screen one line up.	
SHIFT DOWN · UP	scrolls the screen one line down.	
WEIGHT · SPEED 0 ~)·9	selects the sending speed in CW mode	
WEIGHT · SPEED 0 ~)·9 Q W E R	selects baud rate in BAUDOT and ASCII.	
SHIFT WEIGHT · SPEED 0 ~)·9	allows you to set the weight (dot-to-dash ratio) of CW within the range of 1:3 to 1:6.	
CR/LF · AUDIO !·1 ~ #·3	change the monitor source.	
SHIFT CR/LF · AUDIO !·1 ~ #·3	selects the intervals of automatic CR/LF insertion.	
MORSE	activates CW (MORSE) mode.	} switching is available during the operation (see Table 3)
BAUDOT	activates RTTY (BAUDOT) mode.	
ASCII	activate RTTY (ASCII) mode.	
CTRL ASCII	activates WORD PROCESSOR mode.	

TYPE · SENSE	changes the polarity of sending/receiving signals.
TYPE · SENSE ! · 1	switches the polarity of receiving.
TYPE · SENSE " · 2	switches the polarity of sending.
SHIFT TYPE · SENSE	changes buffer transmission mode.
SHIFT TYPE · SENSE RETURN SHIFT TYPE · SENSE SPACE	enables the LINE mode and enables the WORD mode. Depress any key except RETURN , SPACE or LINE FEED after SHIFT TYPE · SENSE for the normal buffer transmission.
INPUT · CASE	You may manually change the case of LETTER/FIGURE in RTTY (BAUDOT) with this keystroke.
SHIFT INPUT · CASE ! · 1 ~ % · 5	enables the input jack switching.
DIDDLE · PTT	With this key, automatic ON/OFF for PTT jack is available. For manual operation redepres it.
SHIFT DIDDLE · PTT	activates or deactivates automatic "IDLE signal" insertion in RTTY (BAUDOT and ASCII).
[RESET]	initializes the microprocessor.
SHIFT SPACE	interrupts buffer transmission or screen transmission ("SEND" function when part way thru).
CTRL	Hold this key down and tap the other key when control codes are desired.
[CAPS LOCK]	should be depressed when small letters are used. Another keystroke changes to the capital letter mode.
[BREAK]	interrupts output signals. To resume transmission, redepres.
DEL	transmits control code 'DEL' (7FH).
SHIFT DEL	allows you to edit any errors in the buffer memory and in the channel memory (RUB OUT function).
[LP]	Hold this key down while drawing the graphics on the screen with the light pen (see 7-2).
TAB	transmits control code (09H).
ESC A	In CW mode, it decreases the sending speed (see 5-1-5). In BAUDOT and ASCII mode, it decreases the sending speed and the receiving speed (see 5-2-3).
ESC B	enables and disables the split screen mode (see 7-1).

ESC C	revises focus of the light pen (see 7-2-1).
ESC D !·1 ~)·9 Q W E R T Y U	selects each subsection of channel 6 and transmits it (see 6-3-2).
ESC E	activates or deactivates ECHO-BACK function. Cassette tape recorder etc. can be used like punched paper tape. FUNC=E will be indicated (see 6-5).
ESC F	should be depressed at the end of data in automatic transmission. PTT jack is automatically switched OFF (see 5-1-6 (2)).
ESC H	indicates the standard screen in light pen mode.
ESC H !·1 ~ #·3	changes the screen (see 7-2-3).
ESC I	enables the CW ID operation in RTTY (BAUDOT & ASCII). CW ID function is automatically released at the end of the operation.
ESC L	activates the Graphic mode (see 7-2).
ESC M	memorizes the function status. When power is turned ON after being turned OFF, the Θ-9000E retains the previous status without resetting mode. Press ESC ?·/ to release this function (see 2-4).
ESC O	transmits the graphic patterns in the Graphic mode.
ESC P	displays the graphic patterns in the Graphic mode.
ESC Q	transmits the following test message:

THE QUICK BROWN FOX JUMPS OVER THE LAZY DOG 1234567890 DE mmmm

(*mmmm* are the data written in channel 7-7) Depress any key to stop the test message transmission.

ESC R !·1 transmits the RY test message. Press any key to interrupt the transmission.

ESC R "·2 generates the practice signals in CW mode. It is also used for CW listening practice. Press any key to stop the random signals.

ESC S transmits the screen from the top. In split screen mode, **ESC S !·1** transmits the receiving screen while **ESC S "·2** transmits the sending screen (see 6-4).

ESC V stops the buffer transmission temporarily and stores data in the buffer (see 6-2). **FUNC=V** should be indicated.

ESC W	should be pressed for writing in Graphic mode (see 7-2).
ESC X	operates the ON/OFF switching of PTT jack in PTT manual mode (see 5-1-6 (2), 5-2-5 (2) and 5-3-5 (2)). Turns PTT jack OFF in PTT automatic mode.
ESC Y	activates and releases the UNSHIFT-ON-SPACE function (see 5-2-2). FUNC=Y will be indicated.
ESC Z	increases the sending speed in CW mode (see 5-1-5). In RTTY (BAUDOT and ASCII) mode, the sending and receiving speed is increased (see 5-2-3 and 5-3-4).
ESC " 2	activates or deactivates the selective-Calling mode (see 7-5).
ESC % 5	selects full duplex mode (see 7-5).
ESC ! 1 0 ! 1 ~ & 6	determines a word format of serial data in full duplex mode (see 7-5-4).
ESC & 6	turns the remote jack ON or OFF regardless of SEL-CAL mode.
ESC (8	You can select either 80×24 or 40×24 screen format by this keystroke.
CTRL P	activates or deactivates the printing when full duplex mode (see 7-5-5).

9-2 Word Processor mode

CTRL ASCII	activates the Word Processor Mode.
SHIFT HOME CLEAR	moves the cursor to the top of the screen.
↑ ↓ or SHIFT ↑ ↓	moves the cursor up and down.
← → or SHIFT ← →	moves the cursor right or left.
SHIFT BS _	returns the cursor to the top of the screen.
TAB	shifts the cursor 8 steps to the right.
LINE FEED	shifts the cursor to a new line.
A <i>n</i> SHIFT RETURN	moves the cursor <i>n</i> line downwards (<i>n</i> = 1 thru 99).
B <i>n</i> SHIFT RETURN	moves the cursor <i>n</i> line upwards (<i>n</i> = 1 thru 99).
DOWN UP or SHIFT DOWN UP	enables to scroll the screen up and down.
HOME CLEAR ! 1 ~ # 3	clears a text written in page 1 thru 3.

ESC C !·1 ~ #·3	displays the first 24 lines of page 1, page 2 or page 3.
ESC H <i>n</i>	allows you to draw <i>n</i> horizontal lines.
ESC I	adds the spaces between characters.
ESC K	closes the spaces between characters.
ESC V <i>n</i>	allows you to draw <i>n</i> vertical lines.
ESC X	cancels every command.
ESC Z	is used for left margin justification.
ESC SPACE	is used for left margin justification.
ESC TAB	activates right margin justification.
ESC D !·1 ~ U	displays the text written in the subsections of CH6.
TONE·CH <i>n</i> ESC W	is used when you write in channel <i>n</i> memory (<i>n</i> = 1 thru 5).
TONE·CH <i>n</i> ESC D	displays the text written in channel <i>n</i> memory (<i>n</i> = 1 thru 5).
READ·WRITE	should be depressed before data is written in channel memory
SHIFT READ·WRITE	should be depressed after data is written in channel memory.
C <i>data1</i> / <i>data2</i> SHIFT RETURN	enables to substitute <i>data2</i> for <i>data1</i> .
C <i>data</i> / SHIFT RETURN	deletes the data.
D <i>n</i> SHIFT RETURN	causes the deletion of <i>n</i> lines (<i>n</i> = 1 thru 99).
F <i>characters</i> SHIFT RETURN	activates the data search function.
K <i>n</i> SHIFT RETURN	deletes <i>n</i> lines and closed up the space of lines.
I SHIFT RETURN	causes the insertion of line.
L <i>title</i> SHIFT RETURN	displays the text recorded on the tape recorder.
L D SHIFT RETURN	picks up and displays the title recorded on the tape recorder.
M <i>n1</i> <i>n2</i> SHIFT RETURN	moves the text among the page (refer to 8-1-3 G).
P <i>n</i> <i>m</i> SHIFT RETURN	transmits the text written on page <i>n</i> <i>m</i> times to a printer (<i>n</i> = 1 thru 3, <i>m</i> = 1 thru 99).

P **G** m **SHIFT** **RETURN**

transmits the text displayed on the screen m times to the printer ($m = 1$ thru 99).

T n **SHIFT** **RETURN**

is used for recording the text on the tape recorder.

10. APPLICATION

10-1 Connection to a Cassette Tape Recorder

10-1-1 Recording

- (1) Set the mode and speed.
- (2) Connect AFSK OUT jack to the microphone terminal of the recorder.
- (3) Set GAIN control of the back panel to the medium level so as to prevent excess input to a tape recorder.
- (4) Put the recorder in recording mode.
- (5) Send the data which you want to record from the Θ -9000E.
- (6) Stop the cassette tape recorder after the data transmission is completed. Make sure to let the cassette tape run for a few seconds before stopping.

10-1-2 Play back of the data

- (1) Adjust the mode and speed to the recording state of cassette tape recorder.
- (2) Clear the screen if required.
- (3) Connect the speaker terminal to AF IN jack in CW, RTTY mode and connect to KCS IN jack when using with ASCII KCS mode.
- (4) Adjust the volume of the cassette tape recorder to make output level about 100 mV \sim 1 Vpp when connected. Any tone adjustment should be at HIGH at this moment.
- (5) Sentences are read and displayed on the screen when play back starts.
Depressing **ESC E**, outputs the received data to AFSK OUT, CW, FSK, RS232C OUT jacks at the same time as the reading. You can use another tape recorder for storage. To release this function, re-depress **ESC X**.

10-2 Connection to the equipment with RS232C Input/Output

- (1) The Θ -9000E provides the input/output terminal of RS232C.
SHIFT | INPUT CASE #·3 should be depressed. Operate the unit in INPUT=RS232C status.
- (2) When you desire to use as CRT terminal, refer to 7-5.

11. MAINTENANCE

11-1 Battery replacement for the battery-backed-up memory

- i) Battery should be replaced once a year.
- ii) Two dry batteries of SUM-(3) 1.5 V should be used.
- iii) Remove two M4 screws at the bottom and two M4 screws in the back of this unit and set the battery in the battery holder on the CPU circuit board.

Pay attention to the polarity!

11-2 Fuse replacement

If the fuse burns out, replace it with the spare provided. The fuse holder is on the electric power circuit board.

11-3 Light pen

Keep the lens in the tip of the light pen clean.

KEY	CW (MORSE)	RTTY (BAUDOT)	ASCII	Buffer Display	Screen Display
!		!			
1		1			
"		"			
2		2			
#	SP		#		
3	3		3		
\$		\$			
4		4			
%	Sp	LTR	%		
5	5	5			
&	Sp		&		
6	6		6		
'		'			
7		7			
((, (KN)		(
8	8		8		
))			
9		9			
ø		ø			
=	= (BT)	LTR	=		
-	-	-			
~	^ (AS)	LTR	~		
^		LTR	^		
	Sp	LTR			
\	SP	LTR	\		
BS		LTR	BS		
-	SP	LTR	-		
Q		Q			
W		W			
E		E			
R		R			
T		T			
Y		Y			
U		U			
I		I	[C]	I	
O		O			
P		P			
@	SP @ (AA)	LTR @	@		
[SP SP	LTR LTR	[
A		A			

KEY	CW (MORSE)	RTTY (BAUDOT)	ASCII	Buffer Display	Screen Display
S		S			
D		D			
F		F			
G		G			
H		H			
J		J			
K		K			
L		L			
+	+ (AR)	LTR	+		
;	;(VA)	;	;		
*	SP	LTR	*		
:	:	:	:		
}	SP		}		
]	SP]		
Z		Z			
X		X			
C		C			
V		V			
B		B			
N		N			
M		M			
<	< (HH)	LTR	<		
,	,	,	,		
.	SP	LTR	.		
.	.	.	.		
?		?			
/		/			
RETURN	SP	CR	CR	␣	CR
LINE FEED	SP	LF	LF	␣	LF
DEL	SP	LTR	DEL		
TAB	SP	LTR	HT	␣	HT

Table 14

NOTE: Under columns = Key shifted only
 Up columns = Keys shifted pushing **SHIFT** key
 SP = Space output
 LTR = LETTER code output

CW Output and Display

KEY	Display	Signals	KEY	Display	Signals	KEY	Display	Signals	KEY	Display	Signals
!	!	BS	-		A	A	..	X	X
1	1	-	-		S	S	...	C	C
"	"	Q	Q	----	D	D	...	V	V
2	2	W	W	---	E	E	.	B	B
#	#	E	E	.	R	R	...	N	N	..
3	3	T	T	-	H	H	M	M	--
\$	\$	Y	Y	----	J	J	<	< (HH)
4	4	U	U	...	K	K	---	,	,
%	%	I	I	..	L	L	>	>
5	5	O	O	---	+	+ (AR)
&	&	P	P	;	;(VA)	?	?
'	'	\	@ (AA)	*	*	/	/
7	7	{	{		:	:	ESC		
((.....	[[}	}		TAB		
8	8	Z	Z	---]]		DEL		
))									
9	9									
ø	ø									
=	=									
-	-									
~	~ (AS)									
^	^ (AS)									
\	\										

Table 15

NOTE: Upon receipt of KN, AR, VA, carriage return and line feed are performed.

CONTROL CODES

The following keys should be depressed at the same time as the **CTRL** key is depressed.

KEY	Special Character	
@	00H	NUL
A	01H	SOH
B	02H	STX
C	03H	ETX
D	04H	EOT
E	05H	ENQ
F	06H	ACK
G	07H	BEL
H	08H	BS
I	09H	HT
J	0AH	LF
K	0BH	VT
L	0CH	FF
M	0DH	CR
N	0EH	SO
O	0FH	SI

KEY	Special Charater	
P	10H	DLE
Q	11H	DC1
R	12H	DC2
S	13H	DC3
T	14H	DC4
U	15H	NAK
V	16H	SYN
W	17H	ETB
X	18H	CAN
Y	19H	EM
Z	1AH	SUB
{·[1BH	ESC
 ·\	1CH	FS
}·]	1DH	GS
~·^	1EH	RS
BS·-	1FH	US

Table 16

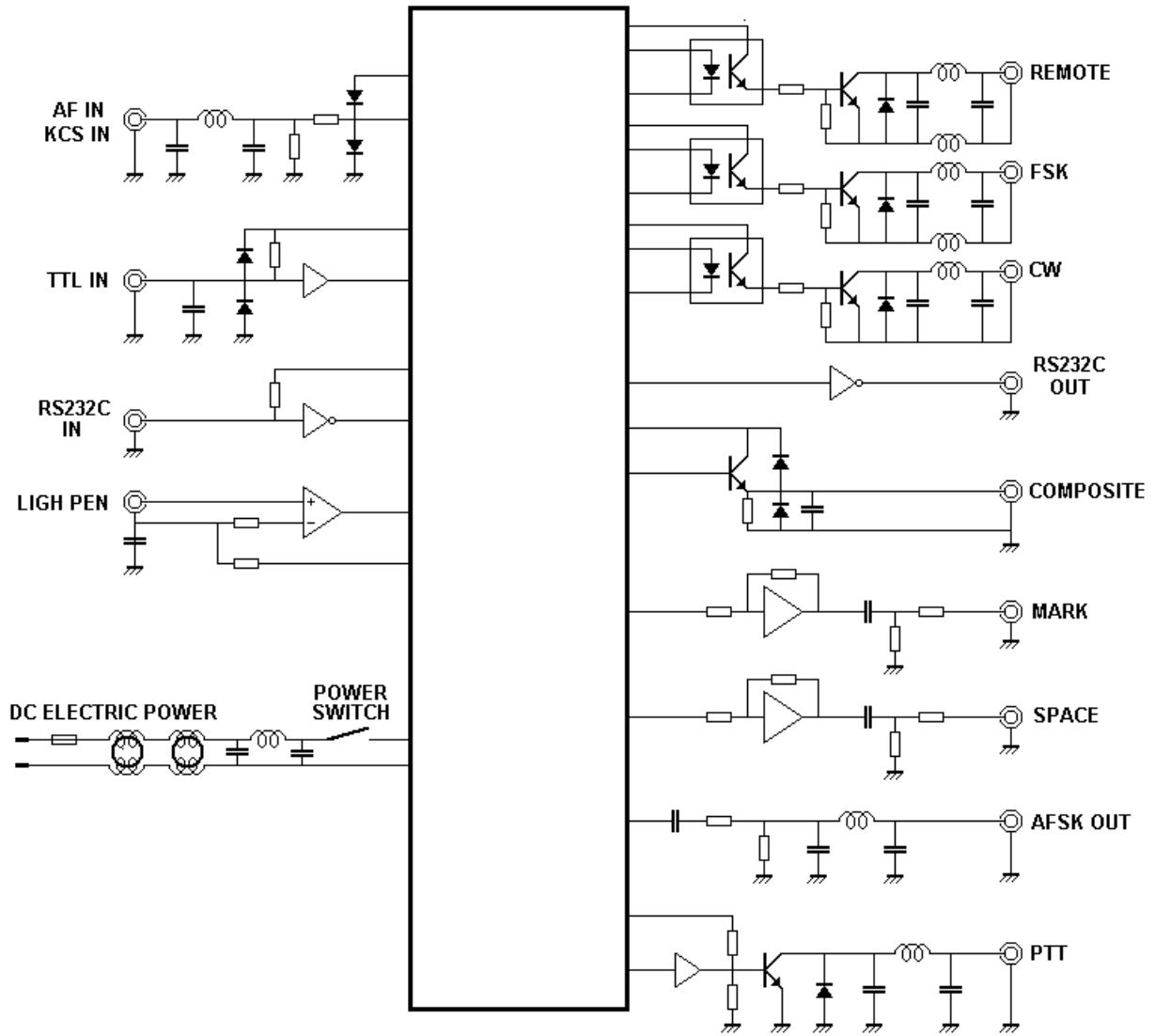

FIG. 18 Input-Output Circuit Diagram

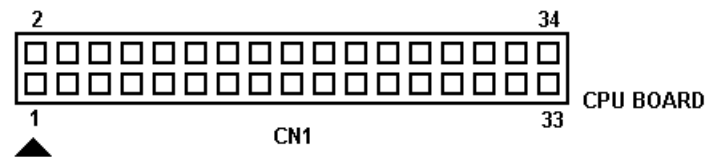
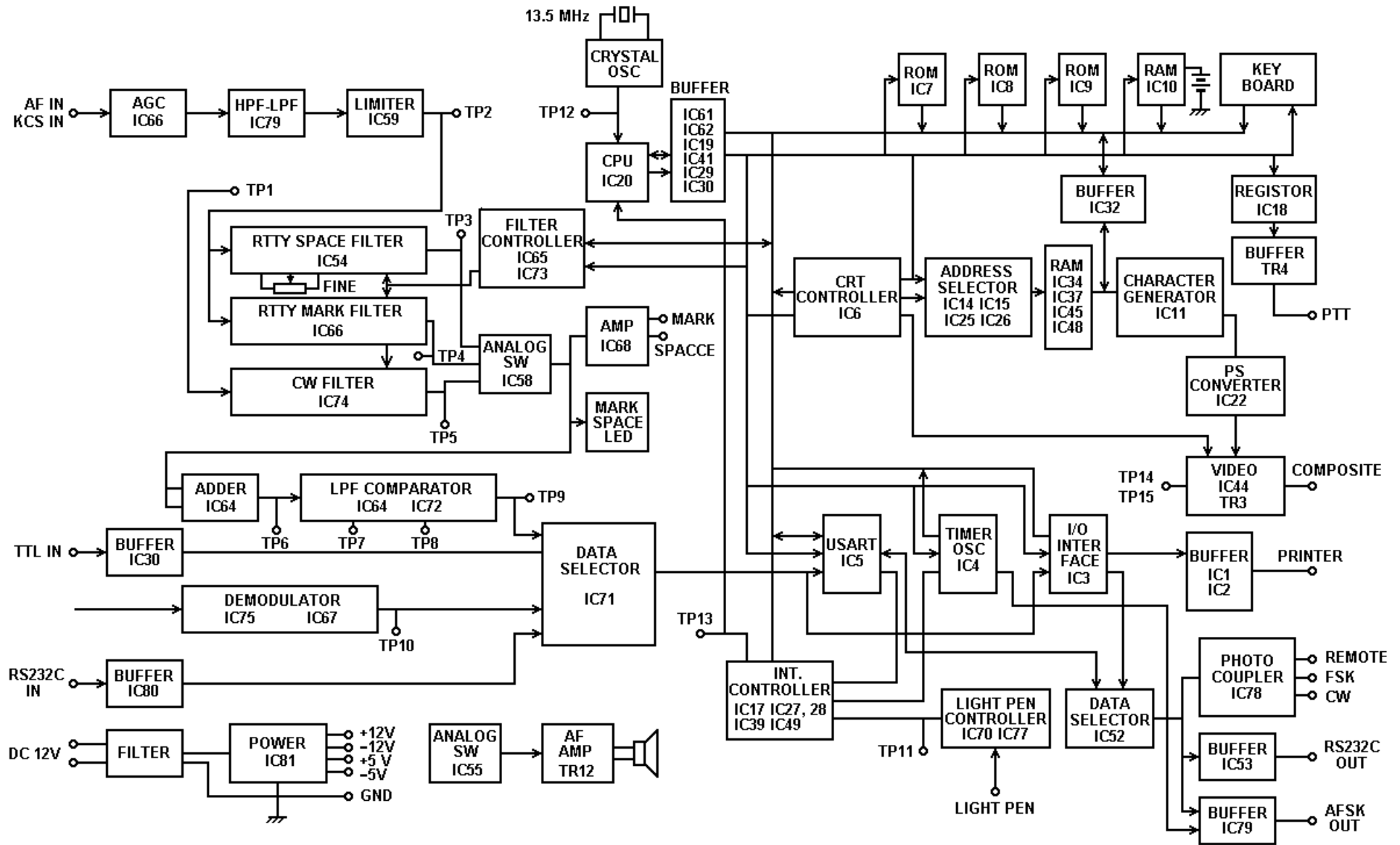

Fig. 19 Printer Port

PIN		PIN	
1	DATA STROBE	2	GND
3	DATA 0	4	GND
5	DATA 1	6	GND
7	DATA 2	8	GND
9	DATA 3	10	GND
11	DATA 4	12	GND
13	DATA 5	14	GND
15	DATA 6	16	GND
17	DATA 7	18	GND
19	ACKNOWLEDGE	20	GND
21	READY	22	GND
23	NC	24	GND
25	NC	26	NC
27	GND	28	NC
29	NC	30	GND
31	GND	32	NC
33	NC	34	NC



Q-9000E BLOCK DIAGRAM