



**1504**

**Isolated Variable AC Line Supply**

**Instruction Manual**

## TABLE OF CONTENTS

INTRODUCTION	PAGE 1
INITIAL INSPECTION	PAGE 2
SPECIFICATIONS	PAGE 3
DESCRIPTION	PAGE 4
OPERATING INSTRUCTIONS	PAGE 5
PART LIST & SCHEMATICS	PAGE 6
CIRCUIT DIAGRAM	PAGE
SERVICE & WARRANTY	PAGE

## **INTRODUCTION**

### **ISOLATED VARIABLE AC LINE SUPPLY : MODEL 1504**

The 1504 Isolated Variable AC Source cum leakage current tester is designed for modern electronics laboratories which need a clean, electrostatically and galvanically isolated variable line supply.

The unit is designed to provide isolated output variable from 0 to 150 V AC/4 Amps Max. The output voltage and load current can be monitored on a 3 digit DPM. The variable isolated output voltage capability makes this unit very convenient to use for either incoming or outgoing quality control testing. It is also useful in servicing or circuit design work application, when checking operation at voltage higher or lower than normal. The unit consists of a super isolation transformer which is triple shielded from the line to protect against shock hazards.

The 1504 can measure power line leakage current by means of a probe and a switch selected range of the output DPM. It can measure leakage currents upto 9.99 mA.

The unit is overload protected by means of an input fuse.

## **INITIAL INSPECTION**

Before shipping, the 1504 power supply has been tested thoroughly and found free of mechanical and electrical defects. As soon as it is unpacked, inspect for any damage that may have occurred during transit. Particular attention should be paid to the meters. Also check the packing material for any signs of severe stress (may be indicative of internal damage). Save all the packing material. Read the INSTRUCTION MANUAL carefully for any unusual input requirements and if found so, arrange to comply with the same.

## **SPECIFICATIONS**

OUTPUT VOLTAGE	: 0 to 150 VAC
INPUT VOLTAGE	: 115 VAC $\pm$ 10%
INPUT FREQUENCY	: 47 to 63 Hz.
METERING	: 3 digit DPM to read 1) Output Voltage. 2) Load Current and 3) Leakage current upto 9.99 mA.
METER ACCURACY	: $\pm$ 3 counts.
OUTPUT-LINE ISOLATION	: Capacitive coupling less than 0.0005 pF.
LINE & OUTPUT LEAKAGE	: Less than 10 mA.
NOISE REJECTION	: Better than 120 db (common mode noise).
DIMENSIONS	: 298 mm(W) x 133 mm(H) x 270 mm(D)
WEIGHT	: 16 kgs.

## DESCRIPTION

### **INPUT AND OUTPUT TERMINATION :**

The unit works from 115 V AC/47-63 Hz single phase supply. The input is provided through a mains cable with a three pin plug. The use of a three core cable enables the cabinet of the unit to be properly grounded.

Output is provided on a three-pin socket and is clearly marked 0-150 V AC/4 Amps max.

### **METERING :**

One 3-digit DPM is provided to measure

- 1) Output voltage
- 2) Leakage current and
- 3) Load current

Meter function is switch selectable

### **ON-OFF SWITCH AND FUSE :**

The power ON-OFF switch is provided on the front panel. Fuse is also provided on the front panel. Fuse rating is clearly marked.

### **PANEL CONTROLS :**

A voltage adjust knob allows adjustment of output AC voltage from 0 to 150 V AC. Three meter function push switches are provided to select the quantity to be displayed on the meter.

### **CIRCUIT DESCRIPTION :**

The circuit uses a single phase variable autotransformer to obtain an output voltage variable from zero to 150 V AC max. This is followed by a triple shielded isolation transformer which provides electrostatic and galvanic isolation.

Multiple shielding technique reduces primary to secondary static coupling to below 0.005pF. The DC isolation is over 1000 M Ohms. Line leakage current to load is 10mA or less.

## OPERATING INSTRUCTIONS

### TURN ON PROCEDURE :

#### a) 1504 as Isolated Variable Ac Supply.

Set output voltage to 'O' volt by turning the knob to minimum position. Depress push switch marked 'V'.

Set power on switch. Adjust the voltage control till the desired voltage is indicated on the 3-digit DPM. Connect the load at the output. Depress push switch marked A. The DPM will now read the load current. The total load current should not exceed 4 Amps for continuous operation.

#### b) 1504 as Line Leakage Tester.

Set output voltage to 'O' volt by turning the knob to minimum position. Depress push switch marked 'V'. Set power on switch. Adjust the voltage control till the desired voltage at which leakage current is to be measured is available at the output socket, and is indicated on the DPM.

Depress push switch marked 'mA'. Connect unit under test (U. U. T) to output socket. Connect U. U. T. earth to banana socket marked 'leakage test'. The DPM now reads the leakage current of the unit under test in milliamperes.

## PART LIST & SCHEMATICS

This section contains information for ordering replacement parts. Part list describes parts by reference designator used in circuit diagram & provides the following information :

- a) Reference Designators, refer to Table 4.1
- b) Description Refer to Table 4.2
- c) Location indicator Refer to Table 4.3

### ORDERING INFORMATION

To order replacement parts address order or enquiry to your local agent or ourselves. Specify following information for each part : Model complete serial number, Part number Circuit Reference Designator and Description. To order part not listed in Table 4.4 give complete description of the part, its function, and its location.

TABLE 4.1 REFERENCE DESIGNATOR

C	CAPACITOR	IC	INTERGRATEDCIRCUIT
CR	DIODE	F	FUSE
Q	TRANSISTOR	J	JACK, CONNECTOR
R	RESISTOR	L	INDUCTOR
SW	SWITCH	Z	ZENER DIODE
IX	TRANSFORMER	PR	PERSET

TABLE 4.2 DESCRIPTION ABBREVIATION

CD	CERAMIC DISC	MFR	METAL FILM RESISTOR
MP	METALISED POLYESTER	CFR	CARBON FILM RESISTOR
TAN	TANTALUM	HVR	HIGH VOLTAGE RESISTOR
SM	SILVER MICA	K	KILO
ML	MULTILAYER	M	MEGA
ELEC	ELECTROLYTIC	E	OHM
mF	MICRO FARAD	mH	MILLIHENRY
pF	PICO FARAD	mH	MICROHENRY
WW	WIRE WOUND	MO	METAL OXIDE

TABLE 4.3 LOCATION KEY

LOCATION	NO
DIGITAL PANEL METER SWITCH PCB (909A-DPM-SW-0594)	1
RECTIFIER PCB (GLB-1504-0694)	2
DIGITAL PANEL METER PCB (DPM-0893)	3

# SERVICE AND WARRANTY INFORMATION

## FACTORY SERVICE AND REPAIR

Global Specialties will service and repair this instrument free of charge for a period of one full year, subject to the warranty conditions stated below.

To obtain a return merchandise authorisation (RMA) required for all returns, phone our Customer Service Department for a RMA and all shipping instructions :

Tel. **800-572-1028** or write :

**GLOBAL SPECIALTIES**  
22820 Savi Ranch Parkway  
Yorba Linda, 92887

TEL.: (203) 466 6103  
FAX.: (203) 468 0060  
Email : eblaur@aol.com

## WARRANTY

Global Specialties warrants this device to be free from defective material or workmanship for a period of one full year from the date of original purchase.

Global Specialties under this warranty is limited to repairing the defective device when returned to the factory, shipping charges prepaid, within one full year from the date of original purchase.

Units returned to Global Specialties that have been subject to abuse, misuse damage or accident, or have been connected, installed or adjusted contrary to the instructions furnished by Global Specialties, or that have been repaired by unauthorized persons will not be covered by this warranty.

Global Specialties reserves the right to discontinue models, change specifications price or design of this device at any time without incurring any obligation whatsoever.

The purchaser agrees to assume all liabilities for any damages and/or bodily injury which may result from the use or misuse of this device by the purchaser, his employees or agents.

This warranty is in lieu of all other representations or warranties expressed or implied and no agent or representative of Global Specialties is authorized to assume any other obligation in connection with the sale and purchase of this device.

**GLOBAL  
SPECIALTIES**

Specifications subject to change without notice.

® and TM trademarks are the property of INTERPLEX ELECTRONICS, INC, New Haven, CT, 1994.

## **CASE DISASSEMBLY AND ASSEMBLY**

### **WARNING**

Potentially lethal AC power is present whenever the line cord is plugged into the AC outlet, even when the power switch is OFF. Always disconnect the power cord when opening the case. Avoid touching the fuse post on the inside of the unit.

Should access to the inside of the unit be required, proceed as follows :

1. Remove the line cord from the AC outlet before disassembly.
2. To disassemble the case, remove the screws that secure the cover to the chassis and lift the cover off.
3. To reassemble the case, place the cover on the chassis, line up the screw holes, and replace the screws.

## **MAINTENANCE AND RECALIBRATION**

### **ADJUSTMENTS**

All circuitry is factory-calibrated. No user adjustments are required.

### **FUSE REPLACEMENT**

Remove the line cord from the AC outlet before changing fuses. Using a screwdriver, remove the fuse holder cap. Replace the fuse with another fuse of identical type and current rating. Replace the fuse holder cap.

RESISTORS : All resistors are 0.25W, +/- 5%, MFR unless otherwise specified.

Reference Designator	Part Description	Location Key	Reference Designator	Part Description	Location Key
R1	1.3K	1	R1	39K	3
R2	91E	1	R2	470K	3
R3	1K	1	R3	1M	3
R4	7.5K	1	R4	Not used	3
R5	SHORT-INGLINK	1	R5	2.4K	3
R6	SHORT-INGLINK	1	R6	2.7K	3
R7	SHORT-INGLINK	1	R7	39K	3
R1	10k	2	R8	8.2K	3
R2	Not used	2	R9	100E	3
R3	10M	2	R10	12K	3
R4	100K	2	R11	20K	3
R5	8.2M	2	R12	100E	3
R6	4.7K	2	R13	330E	3
R7	10K	2	R14	330E	3
R8	470K	2			
PRESETS					
PR2	100E	1	PR1	100K	2
PR3	250E	1	VR1	2.2K	3
Reference	Part	Location	Reference	Part	Location

Designator	Description	Key	Designator	Description	Key
CAPACITORS (CD +/- 20%, TAN +/- 10%, SM +/- 5%, ELEC +/- 20% unless otherwise specified)					
C1	220mf	2	C4	0.47mf	3
C2	ELEC 50V 220mf	2	C5	MP100V 0.22mf	3
C3	ELEC 16V 0.1mf MP	2	C6	10mf EL- EC 50V	3
C4	100V 1mf ELEC	2	C7	0.1mf MP100V	3
C5	50V 0.22mf MP	2	C8	0.1mf CD 50V	3
C6	100V 1mf ELEC	2	C9	Not Used	3
C1	50V 220pf CD	3	C10	470mf ELEC	3
C2	100V 0.1mf MP	3	C11	25V 2.2mF	3
C3	100V 0.01mf CD	3		ELEC 50V	
Reference	Part	Location	Reference	Part	Location

Designator	Description	Key	Designator	Description	Key
DIODES					
D1	1N4148	2	D1	1N4148	3
D2	1N4148	2	D2	1N4148	3
CR1	1N4003	1	D3 TO D6	1N4003	3
TRANSISTORS/FET'S					
Q1	TL430	3	Q3	LM7805	3
Q2	MPSA12	3			
IC'S					
IC1	ICL 7660	2	IC3	CA3160	2
IC2	LM 741	2	U1	LM7107	
LED'S					
LED1	3mm	3	LED2	3mm	3
	GREEN			GREEN	
FND'S					
DS1	LT542	3	DS3	LT542	3
DS2	LT542	3	DS4	LT542	3
Reference Designator	Part Description	Location Key	Reference Designator	Part Description	Location Key

SWITCHES	tion			tion	
SW1 TO	4 Pole	1	SW4	1801	7
SW3	2WAY			ON/OFF	
TRANSFORMERS					
T1	Isolation	6	T3	DPM	6
T2	Current	6	T4	0-120V/	7
				4A	
FUSE				Variable	
F1	8Amp	7			
RELAY					
RL1	2/P 2CO	1			
	6V/6A				

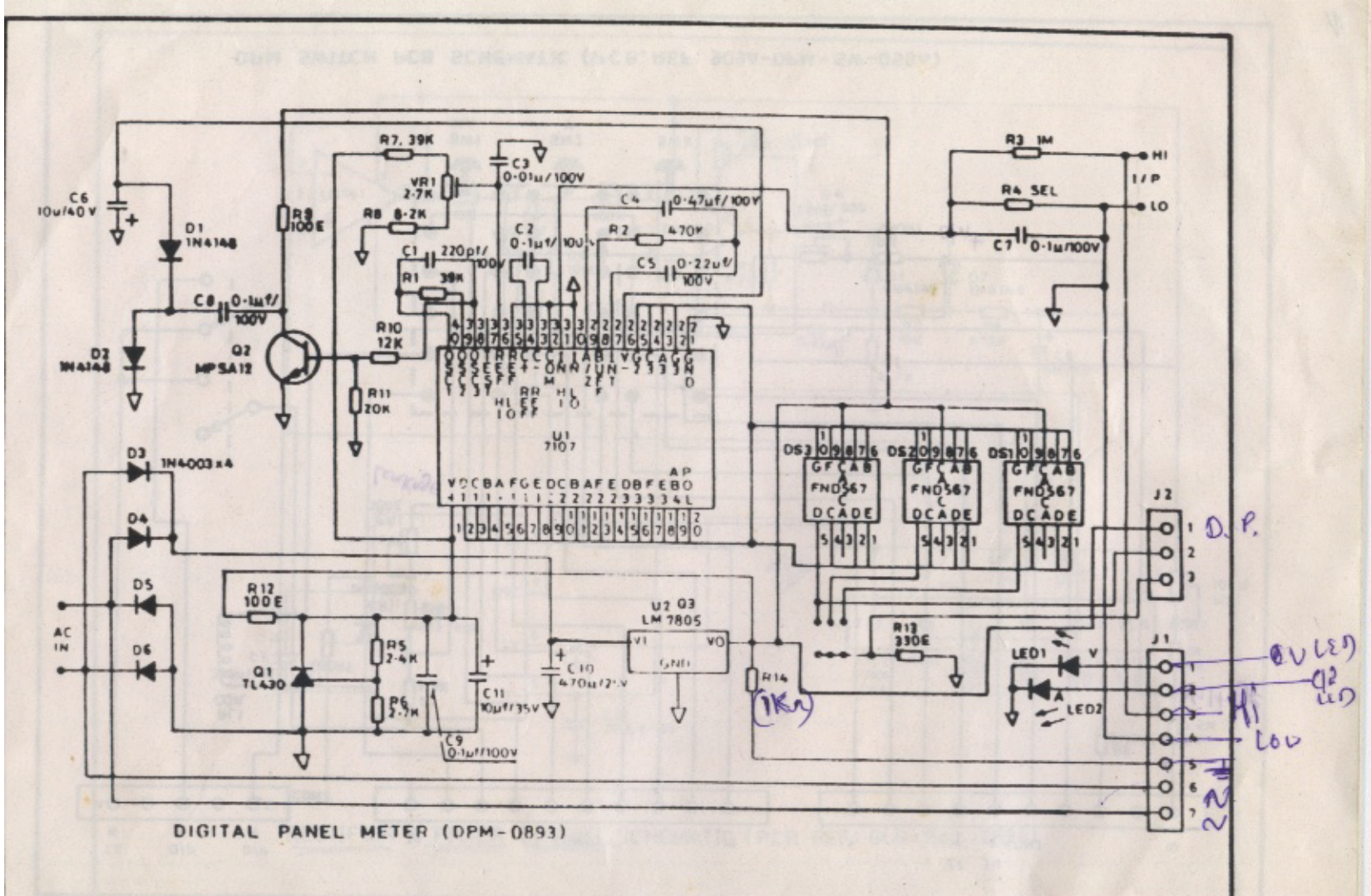

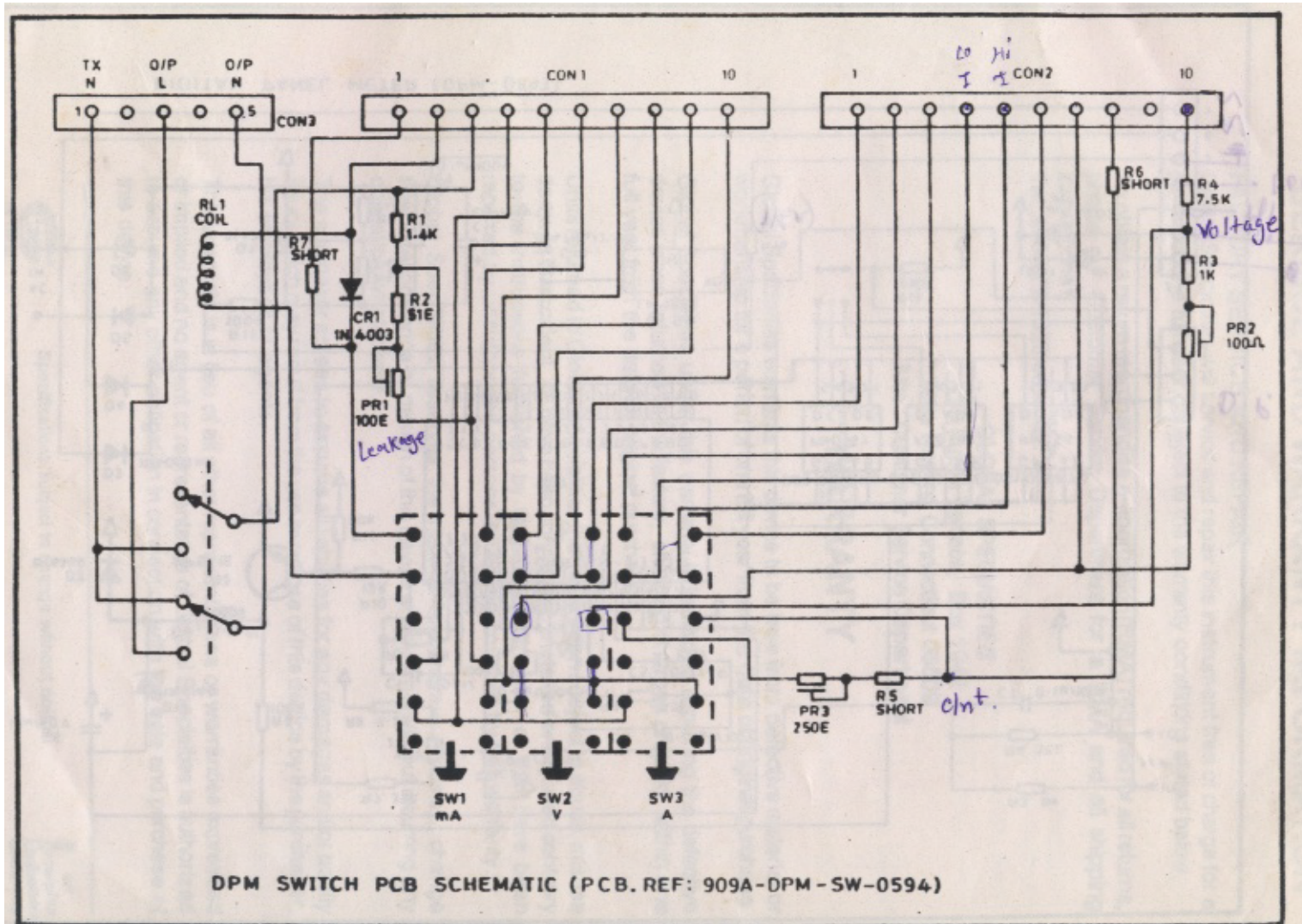

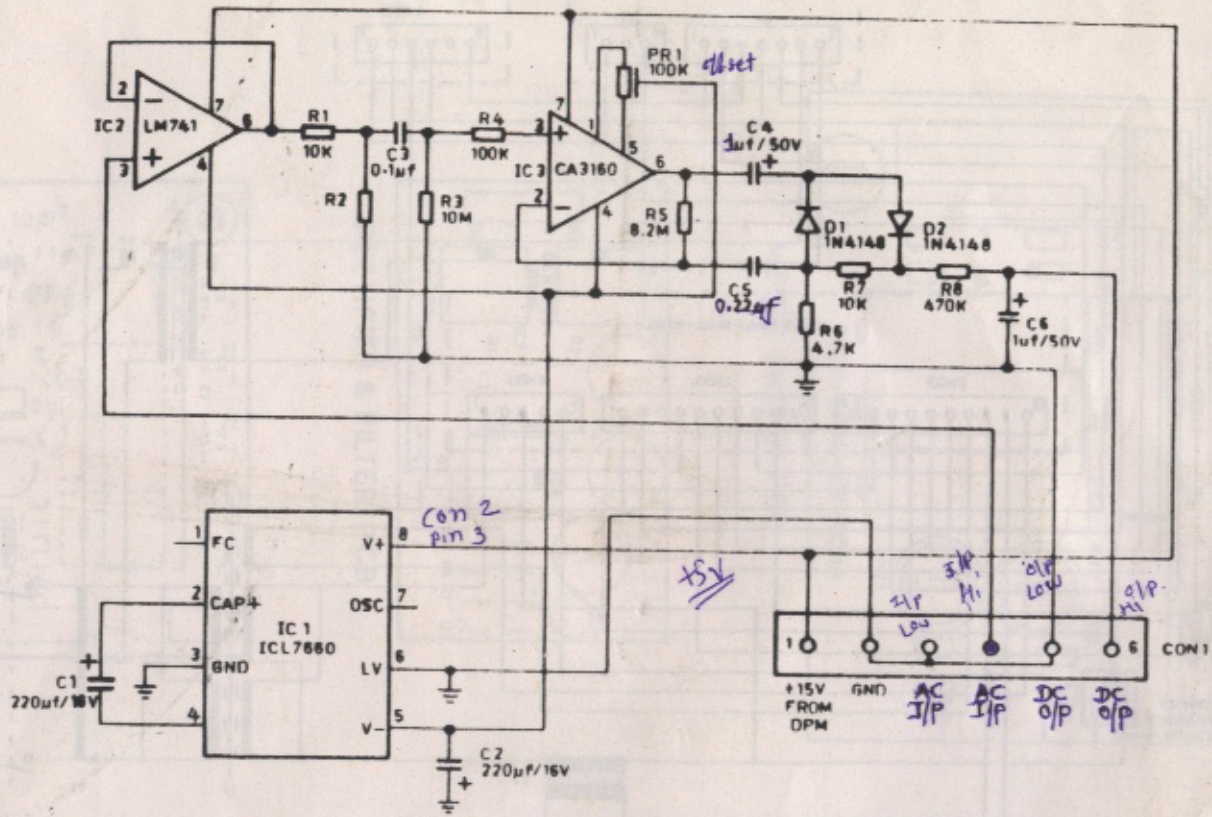

RECTIFIER & FILTER CIRCUIT SCHEMATIC (PCB. REF: GLB-1504-0694)

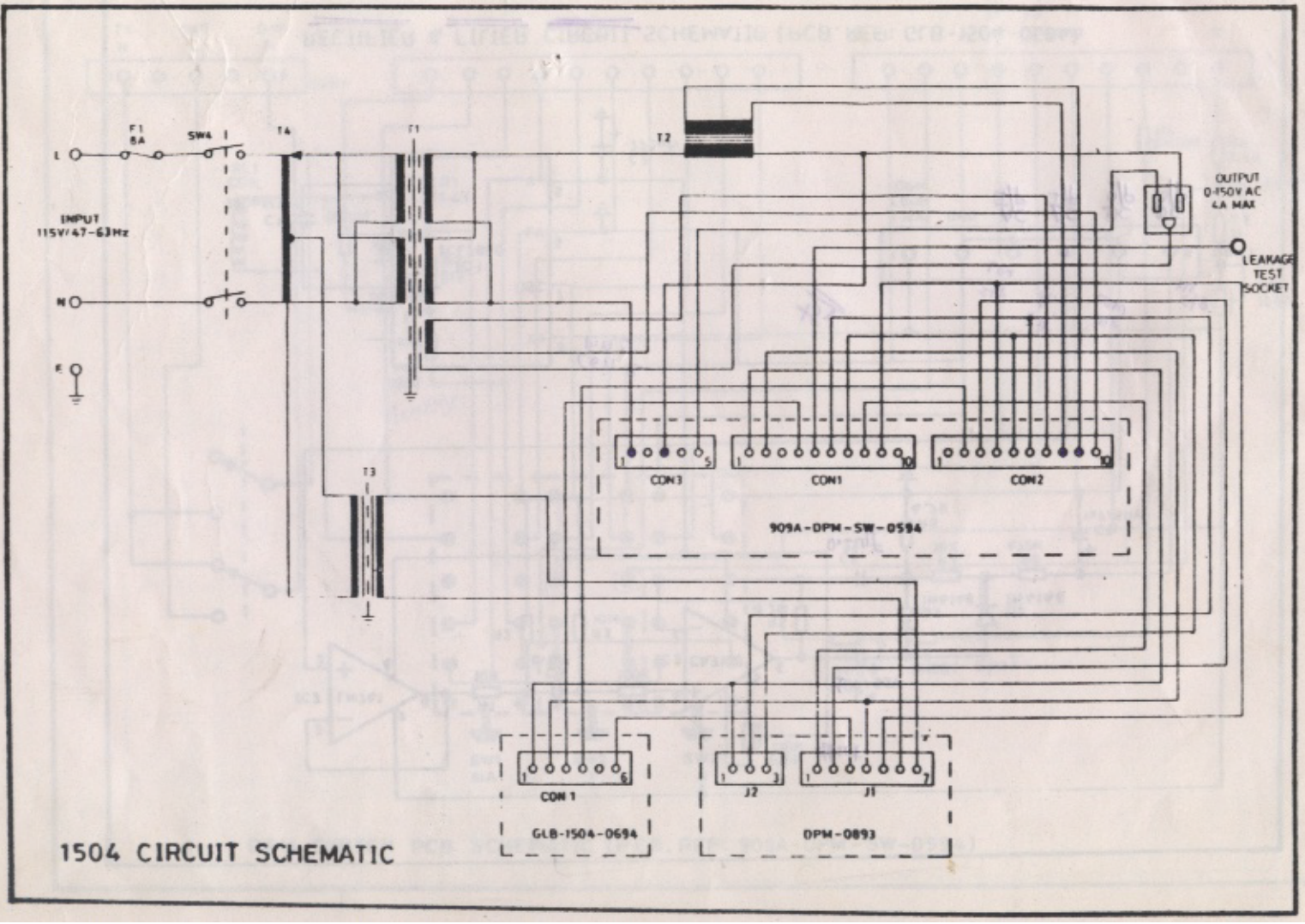

1504 CIRCUIT SCHEMATIC

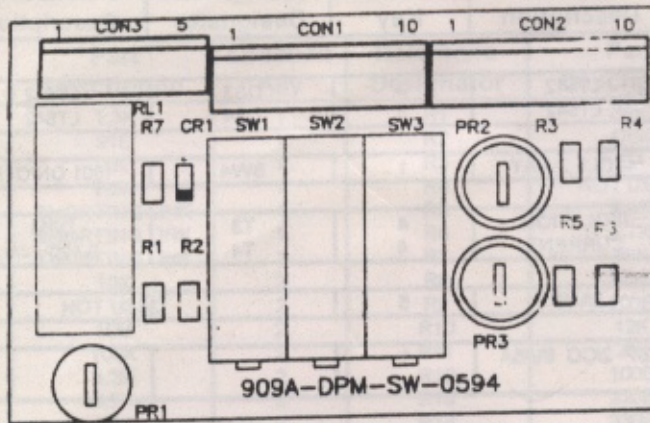

METER SWITCH PCB

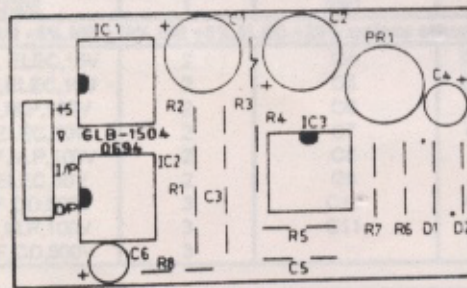

RECTIFIER & FILTER PCB

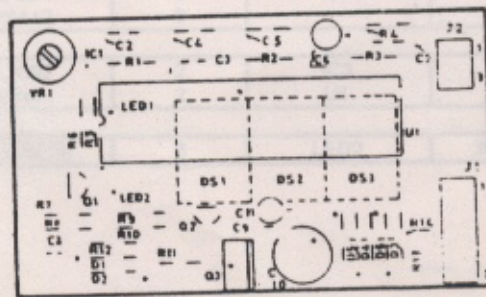

DIGITAL PANEL METER PCB