



GoPower

Powering Solutions

















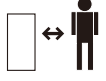

DIESEL GENERATOR

OPERATIONAL MANUAL



ORIGINAL INSTRUCTION

THE IMPORTANCE OF THE SECURITY LABEL

| | | | |
|---|---|---|--|
|  | caution |  | risk of electric shock |
|  | stay away from the the heat source |  | do not remove the pads moving parts |
|  | read before using the user manual. |  | do not use in the rain. do not wash with water jet |
|  | earthing terminal |  | do not use in a non ventilated the risk of death |
|  | conduct interviews |  | don't put out a fire oil and water |
|  | - safety distance |  | toxic exhaust gas the risk of death |
|  | protection against the noise) |  | HOT SURFACE |
|  | don't let a child without surveillance autour de l'appareil around the device |  | Do not spilling out when fueling. Remember to stop generator before fueling. |
|  | within the e u, this symbol indicates that this product is not on the waste can be disposed of. contain valuable recyclable waste materials, a recycling should be chan nelled towards and around the environment and the human health from uncontrolled waste disposal not to damage. please dispose of waste therefore, appropriate collection systems or send the device to dispose of the body when you bought it. this is the device of recycling. | | |
|  | Disconnection Electronic machinery | | |



ATTENTION

1. Kids should be kept in safe distance to generator.
2. Don't touch the engine and muffler while generator is working or just be turned down to avoid empyrosis. Please pay attention to warning sticker on generator.
3. Electrical equipment (including cable and plug connecting component) should be in good condition before starting.
4. New circuit breaker must be under same level performance, characteristic and parameters with the former for replacement.
5. Due to high mechanical stress, only rubber sheath cables or parity products are allowed to be used.
6. When using extension wire or mobile distribution cabinets, wire with 1.5 square millimetre cross section should not be longer than 60 metres; for 2.5 millimetre cross section, wire should not be longer than 100 metres.
7. With the engine of manual starting, the danger of change rotating direction suddenly should be prevented.
8. On standard working condition of circumstance, the generator could only load on rated output. If the working condition of circumstance is not standard, the generator should be run at lower output. When temperature, altitude and humidity is higher than standard working condition of circumstance, the generator would reduce the output.
9. Before checking and maintenance of generator, the engine must be stopped. To disassemble the spark plug and key starting to make sure the engine would not be started improperly. Then check and maintain the generator on the scheduled calendar of repair.
10. Except the daily maintenance and cleaning, the checking and readjustment should be conducted by authorized professional person and source the requested components by them. (contact with local dealers).
11. The new or just overhauled machine must endure the breaking-in period at 30hours at least, the output should not exceed 75% of rated output.



CONTENTS

| | |
|---|----|
| 1. INTRODUCTION..... | 1 |
| 2. APPERANCE PICTURE OF DIESEL GENERATOR SERIES..... | 2 |
| 3. CHAPTER 1 MAIN TECHNICAL SPECIFICATION AND DATA..... | 3 |
| 4. CHAPTER 2 OPERATION OF GENERATOR..... | 10 |
| 5. CHAPTER 3 PERIODIC CHECKS AND MAINTENANCE..... | 25 |
| 6. CHAPTER 4 MAINTENANCE AND REMEDY OF GENERATOR SET... | 28 |
| 7. APPENDIX..... | 29 |



INTRODUCTION

Thank you for purchasing our products.

This product is guaranteed against faulty manufacture for a period of 12 months from the date of purchase. Please keep your receipt as proof of purchase.

This guarantee is invalid if the product is found to have been abused or tampered with in any way, or not used for the purpose for which it was intended. Faulty goods should be returned to their place of purchase, no product can be returned to us without prior permission. This guarantee does not effect your statutory rights.

PLEASE SEE ENGINE MANUAL FOR WARRANTY

Diesel generator possesses the following features:

This series diesel generator adopts super-light type, air cooled, 4-stroke direct injection diesel engine and has two starting ways for option, that is, recoil start and electric start . They are equipped with large capacity fuel tank, circuit protector, A.C & D.C double voltage output device, low oil pressure alarm and automatic stop device. So it is more convenient for you to use the machine.

The diesel generator serves as an UPS stand-by power supply in bank, stockexchange and design studio, etc. , It is absolutely necessary for the moving powersupply of merchant ship and warship, for the moving power supply of open working site, construction site and field army, for emergency power of poultry farm, fishery, forestry, garden, hotel, shop, decoration site, office, place of entertainment,house and ballroom, etc..This operation manual tells you how to operate and service your new diesel generator. Please read it before using the diesel generator to ensure proper handling and operation. Follow the instruction carefully to keep your diesel generator in the best running condition which is helpful to prolong the using life of diesel generator.

If you have any question concerning this manual, or any suggestion, please contact our dealer or our corporation directly.

★ Stating that tampering with the engine voids the EU type-approval of that particular engine.



Appearance picture of diesel generator



SILENT POWER GENERATOR

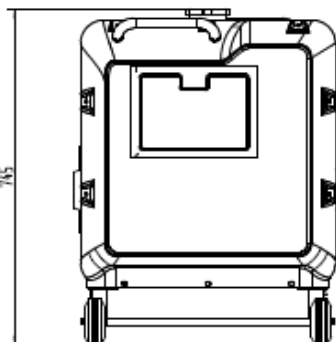
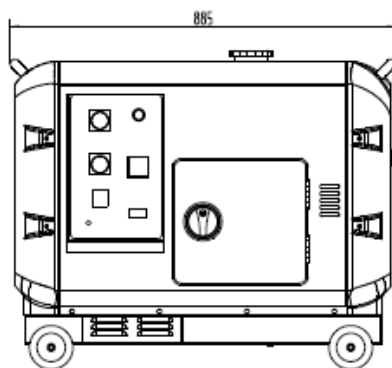



CHAPTER 1 Main technical specifications and data

1-1 Main technical specifications and data of generator set series

| model | | 2200 | 3600 | 5000 | 6000 | 6500 | 7500 | 8000 | |
|---------------------------------|-------------------------------|--|------------------|-------------------------------------|------------------------------------|-------------------------|---------|---------|---------|
| Item | | | | | | | | | |
| Generator | Type | Single phase A.C generator | | | | | | | |
| | Frequency (Hz) | 50/60 | | | | | | | |
| | Rated power (kW) | 1.7/2.0 | 2.7/3.0 | 4.2/4.6 | 4.5/5.0 | 5.0/5.5 | 5.5/6.0 | 6.0/6.5 | |
| | Max. power (kW) | 1.9/2.2 | 3.0/3.3 | 4.6/5.0 | 5.0/5.5 | 5.5/6.0 | 6.0/6.6 | 6.5/7.0 | |
| | Voltage (A.C) (V) | 110, 115, 120, 220, 230, 240, 110/220, 115/230, 120/240 | | | | | | | |
| | Voltage (D.C) (V) | 12 | | | | | | | |
| | Current (D.C) (A) | 6 | | | | | | | |
| | Power factor | 1.0 | | | | | | | |
| | Phase number | Single phase | | | | | | | |
| | Pole number | 2 | | | | | | | |
| | Excitation | Self-excitation type | | | | | | | |
| | Insulation | G1 | | | | | | | |
| | Voltage regulation system | Condenser compensating system | | | | | | | |
| Engine | Engine type | 170F(Add travel) | 178F(Add travel) | 186F(Add travel) EURO 5-LA186FAG | 186F Add travel EURO 5-LA186FAG | 188F EURO 5LA188FG | 188F | 192F | |
| | Type | 4-stroke, single cylinder, air cooling, direct injection diesel engine | | | | | | | |
| | Speed (rpm/min) | 3000/3600 EURO 5 :3000 | | | | | | | |
| | Cont.output (kW) | 2.5/2.8 | 3.68/4.0 | 5.7/6.3(EURO 5:5.7) | | 6.6/7.2 (EURO 5:6.3) | 6.6/7.2 | 6.9/7.6 | |
| | Bore x Stroke (mm) | 70x55 | 78x62 | 86x70 | 86x72 | 88x78 | | 92x75 | |
| | Displacement (L) | 0.211(0.219) | 0.296(0.306) | 0.406(0.418) | 0.418 | 0.474 | | 0.499 | |
| | Cooling system | Forced air-cooled system | | | | | | | |
| | Lubrication system | Forced lubrication | | | | | | | |
| | Lube oil capacity (L) | 0.75 | 1.10 | 1.65 | | | | | |
| | Start system | Recoil start / Electric start | | | | | | | |
| | Fuel oil | Diesel oil | | | | | | | |
| | Fuel oil tank capacity (L) | Genset Type(1) | 2.5 | 3.5 | 5.5 | 5.5 | 5.5 | | |
| | | Genset Type(2-5) | 12.5 | | | | | | |
| | | Genset Type(6) | | | 45 | | | | |
| | Low oil pressure alarm system | Have | | | | | | | |
| Unit | Operation capacity (hr) | Genset Type(1) | 2.8/2.4 | 2.6/2.3 | 2.7/2.5 | 2.5/2.3 | 2.5/2.2 | | |
| | | Genset Type(2-5) | 14/12 | 9/8 | 6.2/5.6 | 5.7/5.2 | 5.6/5.1 | 5.1/4.7 | 5.1/4.7 |
| | | Genset Type(6) | | | 22/20 | 21/19 | 20/18 | 18/17 | |
| | Acid battery capacity (AH) | 24-36 | | | | | | | |
| Care free battery capacity (AH) | 17-36 | | | | | | | | |



CHAPTER 1 Main technical specifications and data

1-1 Main technical specifications and data of generator set series

| model | | 3600-3 | 5000-3 | 6000-3 | 6500-3 | 7500-3 | 8000-3 | | |
|---------------------------------|-------------------------------|--|-------------------------------------|------------------------------------|--------------------------|-------------------------|---------|---------|---------|
| Item | | | | | | | | | |
| Generator | Type | Three phase A.C generator | | | | | | | |
| | Frequency (Hz) | 50/60 | | | | | | | |
| | Rated power (kVA) | 3.37/3.75 | 5.2/5.7 | 5.6/6.2 | 6.3/6.9 | 6.8/7.5 | 7.5/8.1 | | |
| | Max. power (kVA) | 3.75/4.13 | 5.7/6.3 | 6.2/6.8 | 6.9/7.5 | 7.5/8.2 | 8.1/8.8 | | |
| | Voltage (A.C) (V) | 127/220 , 220/380 , 230/400 , 240/415 | | | | | | | |
| | Voltage (D.C) (V) | 12 | | | | | | | |
| | Current (D.C) (A) | 6 | | | | | | | |
| | Power factor | 0.8 | | | | | | | |
| | Phase number | Three phase | | | | | | | |
| | Pole number | 2 | | | | | | | |
| | Excitation | Self-excitation type | | | | | | | |
| | Insulation | G1 | | | | | | | |
| | Voltage regulation system | Condenser compensating system | | | | | | | |
| Engine | Engine type | 178F(Add travel) | 186F(Add travel) EURO 5 LA186FAG | 186F Add travel EURO 5 LA186FAG | 188F (EURO 5 LA188FG) | 188F | 192F | | |
| | Type | 4-stroke, single cylinder, air cooling, direct injection diesel engine | | | | | | | |
| | Speed (rpm/min) | 3000/3600 EURO 5 :3000 | | | | | | | |
| | Cont.output (kW) | 3.68/4.0 | 5.7/6.3(EURO 5:5.7) | | | 6.6/7.2 (EURO 5:6.3) | 6.6/7.2 | 6.9/7.6 | |
| | Bore x Stroke (mm) | 78x62 | 86x70 | 86x72 | 88x78 | | 92x75 | | |
| | Displacement (L) | 0.296(0.306) | 0.406(0.418) | 0.418 | 0.474 | | 0.499 | | |
| | Cooling system | Forced air- cooled system | | | | | | | |
| | Lubrication system | Forced lubrication | | | | | | | |
| | Lube oil capacity (L) | 1.10 | 1.65 | | | | | | |
| | Start system | Recoil start / Electric start | | | | | | | |
| | Fuel oil | Diesel oil | | | | | | | |
| | Fuel oil tank capacity (L) | Genset Type(1) | 3.5 | 5.5 | 5.5 | 5.5 | / | / | |
| | | Genset Type(2-5) | 12.5 | | | | | | |
| | | Genset Type(6) | / | 45 | | | | / | |
| | Low oil pressure alarm system | Have | | | | | | | |
| | Unit | Operation capacity (hr) | Genset Type(1) | 2.6/2.3 | 2.7/2.5 | 2.5/2.3 | 2.5/2.2 | / | / |
| | | | Genset Type(2-5) | 9/8 | 6.2/5.6 | 5.7/5.2 | 5.6/5.1 | 5.1/4.7 | 5.1/4.7 |
| Genset Type(6) | | | / | 22/20 | 21/19 | 20/18 | 18/17 | / | |
| Acid battery capacity (AH) | | 24-36 | | | | | | | |
| Care free battery capacity (AH) | 17-36 | | | | | | | | |



| model | | Item | | | | | | |
|-------------------------------|---------------------------------|--|---------------------|--------------------------------------|-------------------------------------|--------------------------|----------|----------|
| | | 3600S | 5000S | 6000S | 6500S | 7500S | 8000S | |
| Generator | Type | Single phase A.C generator | | | | | | |
| | Frequency (Hz) | 50/60 | | | | | | |
| | Rated power (kW) | 2.7/3.0 | 4.2/4.6 | 4.5/5.0 | 5.0/5.5 | 5.5/6.0 | 6.0/6.5 | |
| | Max. power (kW) | 3.0/3.3 | 4.6/5.0 | 5.0/5.5 | 5.5/6.0 | 6.0/6.6 | 6.5/7.0 | |
| | Voltage (A.C) (V) | 110, 115, 120, 220, 230, 240, 110/220, 115/230, 120/240 | | | | | | |
| | Voltage (D.C) (V) | 12 | | | | | | |
| | Current (D.C) (A) | 6 | | | | | | |
| | Power factor | 1.0 | | | | | | |
| | Phase number | Single phase | | | | | | |
| | Pole number | 2 | | | | | | |
| | Excitation | Self-excitation type | | | | | | |
| | Insulation | G1 | | | | | | |
| | Voltage regulation system | Condenser compensating system | | | | | | |
| | Engine | Engine type | 178F(Add travel) | 186F(Add travel) EURO 5 :LA186FAG | 186F Add travel EURO 5 :LA186FAG | 188F (EURO 5:LA188FG) | 188F | 192F |
| Type | | 4-stroke, single cylinder, air cooling, direct injection diesel engine | | | | | | |
| Speed (rpm/min) | | 3000/3600 EURO 5 :3000 | | | | | | |
| Cont.output (kW) | | 3.68/4.0 | 5.7/6.3(EURO 5:5.7) | | 6.6/7.2 (EURO 5:6.3) | 6.6/7.2 | 6.9/7.6 | |
| Bore x Stroke (mm) | | 78x62 | 86x70 | 86x72 | 88x78 | | 92x75 | |
| Displacement (L) | | 0.296(0.306) | 0.406(0.418) | 0.418 | 0.474 | | 0.499 | |
| Cooling system | | Forced air-cooled system | | | | | | |
| Lubrication system | | Forced lubrication | | | | | | |
| Lube oil capacity (L) | | 1.10 | 1.65 | | | | | |
| Start system | | Electric start | | | | | | |
| Fuel oil | | Diesel oil | | | | | | |
| Fuel oil tank capacity (L) | | Genset Type(7-9) | 16 | | | | | |
| | | Genset Type(10) | | 25 | | | | |
| Low oil pressure alarm system | | Have | | | | | | |
| Unit | Operation capacity (hr) | Genset Type(7-9) | 11.7/10.5 | 7.9/7.2 | 7.4/6.6 | 7.2/6.5 | 6.5/6.0 | 6.5/6.0 |
| | | Genset Type(10) | | 12.4/11.3 | 11.5/10.4 | 11.2/10.2 | 10.2/9.3 | 10.2/9.4 |
| | Acid battery capacity (AH) | 24~36 | | | | | | |
| | Care free battery capacity (AH) | 17~36 | | | | | | |



| model | | Item | | | | | | |
|-------------------------------|---------------------------------|--|---------------------|--------------------------------------|-------------------------------------|--------------------------|----------|----------|
| | | 3600S-3 | 5000S-3 | 6000S-3 | 6500S-3 | 7500S-3 | 8000S-3 | |
| Generator | Type | Three phase A.C generator | | | | | | |
| | Frequency (Hz) | 50/60 | | | | | | |
| | Rated power (kVA) | 3.37/3.75 | 5.2/5.7 | 5.6/6.2 | 6.3/6.9 | 6.8/7.5 | 7.5/8.1 | |
| | Max. power (kVA) | 3.75/4.13 | 5.7/6.3 | 6.2/6.8 | 6.9/7.5 | 7.5/8.2 | 8.1/8.8 | |
| | Voltage (A.C) (V) | 127/220 , 220/380 , 230/400 , 240/415 | | | | | | |
| | Voltage (D.C) (V) | 12 | | | | | | |
| | Current (D.C) (A) | 6 | | | | | | |
| | Power factor | 0.8 | | | | | | |
| | Phase number | Three phase | | | | | | |
| | Pole number | 2 | | | | | | |
| | Excitation | Self-excitation type | | | | | | |
| | Insulation | G1 | | | | | | |
| | Voltage regulation system | Condenser compensating system | | | | | | |
| | Engine | Engine type | 178F(Add travel) | 186F(Add travel) EURO 5 :LA186FAG | 186F Add travel EURO 5 :LA186FAG | 188F (EURO 5:LA188FG) | 188F | 192F |
| Type | | 4-stroke, single cylinder, air cooling, direct injection diesel engine | | | | | | |
| Speed (rpm/min) | | 3000/3600 EURO 5 :3000 | | | | | | |
| Cont.output (kW) | | 3.68/4.0 | 5.7/6.3(EURO 5:5.7) | | 6.6/7.2 (EURO 5:6.3) | 6.6/7.2 | 6.9/7.6 | |
| Bore x Stroke (mm) | | 78x62 | 86x70 | 86x72 | 88x78 | | 92x75 | |
| Displacement (L) | | 0.296(0.306) | 0.406(0.418) | 0.418 | 0.474 | | 0.499 | |
| Cooling system | | Forced air- cooled system | | | | | | |
| Lubrication system | | Forced lubrication | | | | | | |
| Lube oil capacity (L) | | 1.10 | 1.65 | | | | | |
| Start system | | Electric start | | | | | | |
| Fuel oil | | Diesel oil | | | | | | |
| Fuel oil tank capacity (L) | | Genset Type(7-9) | 16 | | | | | |
| | | Genset Type(10) | | 25 | | | | |
| Low oil pressure alarm system | | Have | | | | | | |
| Unit | Operation capacity (hr) | Genset Type(7-9) | 11.7/10.5 | 7.9/7.2 | 7.4/6.6 | 7.2/6.5 | 6.5/6.0 | 6.5/6.0 |
| | | Genset Type(10) | | 12.4/11.3 | 11.5/10.4 | 11.2/10.2 | 10.2/9.3 | 10.2/9.4 |
| | Acid battery capacity (AH) | 24~36 | | | | | | |
| | Care free battery capacity (AH) | 17~36 | | | | | | |



1-3.2 Outline and installation DIM. of diesel generator. (silent type)

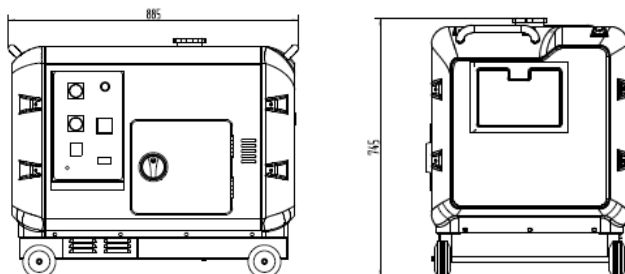

Outline and data of diesel generator

unit: mm

Genset Type(7)

Genset Type(8)

Genset Type(9)

| MODEL | N.W(kg) | L | W | H | MODEL | N.W(kg) | L | W | H | MODEL | N.W(kg) | L | W | H |
|-------|---------|-----|-----|-----|-------|---------|------|-----|-----|-------|---------|-----|-----|-----|
| 3600S | 108 | 820 | 520 | 700 | 5000S | 145 | 1060 | 535 | 740 | 5000S | 145 | 885 | 550 | 745 |
| 5000S | 140 | 900 | 520 | 700 | 6000S | 155 | 1060 | 535 | 740 | 6000S | 155 | 885 | 550 | 745 |
| 6000S | 150 | 900 | 520 | 700 | 6500S | 160 | 1060 | 535 | 740 | 6500S | 160 | 885 | 550 | 745 |
| 6500S | 154 | 900 | 520 | 700 | | | | | | 7500S | 165 | 885 | 550 | 745 |
| 7500S | 159 | 900 | 520 | 700 | | | | | | | | | | |
| 8000S | 160 | 900 | 520 | 700 | | | | | | | | | | |

Genset Type(10)

| MODEL | N.W(kg) | L | W | H | MODEL | N.W(kg) | L | W | H |
|-------|---------|-----|-----|-----|-------|---------|-----|-----|-----|
| 5000S | 141 | 960 | 560 | 755 | 7500S | 160 | 960 | 560 | 755 |
| 6000S | 151 | 960 | 560 | 755 | 8000S | 165 | 960 | 560 | 755 |
| 6500S | 155 | 960 | 560 | 755 | | | | | |

1-3.3 Type and Code of diesel generator

Open frame type

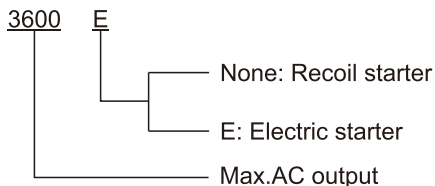

Silent type

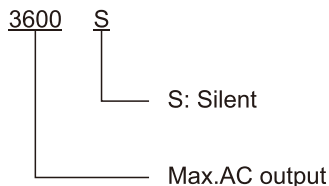

1-4 Parts names

1-4.1 Parts names of the open frame type diesel generator

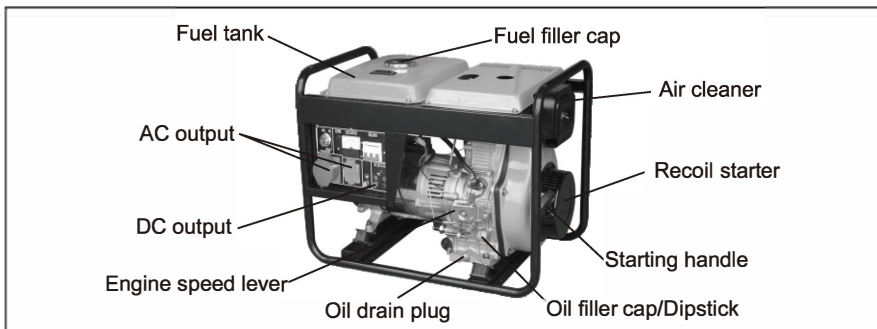

1-4.2 Parts names of the silent type generator

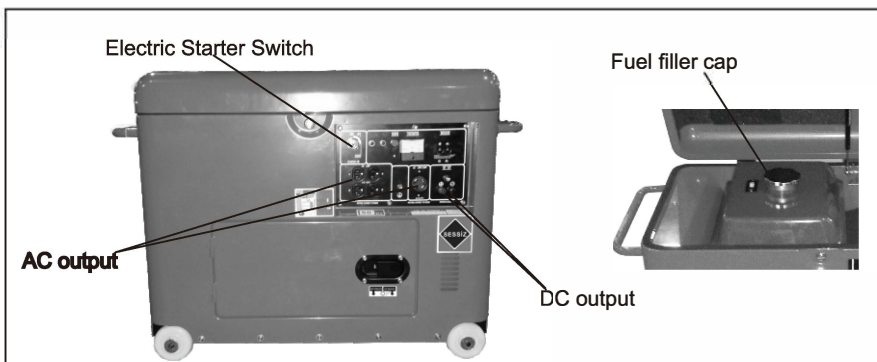
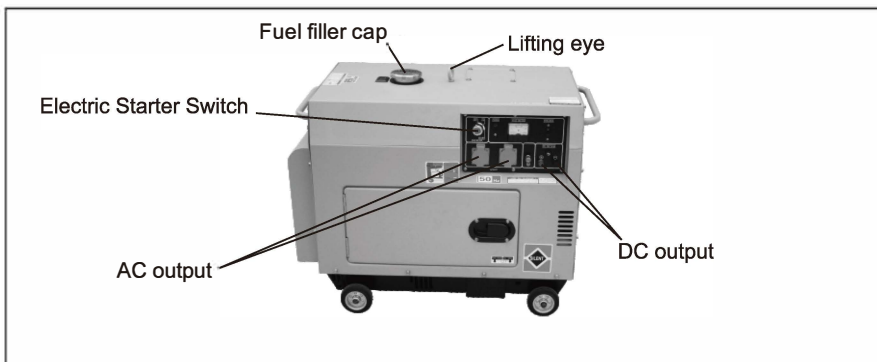



CHAPTER 2 Operation of generator

2-1 Main points and attentions

Please read and understand this operation manual to insure safe operation, and pay high attention to the following main points of operation otherwise it may cause personal injury and damage to equipment.

2-1.1 Preventing fires

The fuel of diesel engine is light diesel fuel, so gasoline, kerosene etc. must not be used.

Wipe away all fuel spills with a clean cloth. Keep gasoline, kerosene, matches and other explosives and inflammables away from the generator, because the temperature around the exhaust muffler is very high during operation. To prevent fire hazards and to provide adequate ventilation, keep the generator at least 1.5 meter away from buildings and other equipment during operation.

Operate the generator on a level surface, there may be fuel spillage if the generator is tilted.

2-1.2 Preventing exhaust gas inhalation

Exhaust gas contains poisonous carbon monoxide. Never use the generator in poorly ventilated locations. If indoor operation is unavoidable, provide proper ventilation so that people and cattle will not be affected.

2-1.3 Preventing burns

Never touch the muffler, muffler cover while the engine is running or hot.

2-1.4 Electric shocks, short circuits

In order to avoid electric shocks or short circuit, do not touch the generator, when either it or your hands are wet.

This generator is not waterproof , so it should not be used in a place exposed to rain, snow or water sprays.

Caution: Most appliance motors require more than their rated wattage for start up. Do not exceeded the current limit specified for any one socket .

The generator should be ground to prevent electric shocks. Please connect a length of heavy wire between the generator's ground terminal and an external ground device. **Please see Fig2-1, Fig2-2.**



Fig2-1

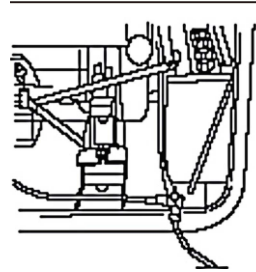

Fig2-2

Do not connect other equipment to the generator before start it.

2-1.5 Other safe main points

Know how to stop the generator quickly, and understand how operate all of the controls. Never permit anyone to operate the generator without proper instruction.

Always wear a helmet and safety shoes and proper clothes, keep pets and children away from the generator when it is in operation.

2-1.6 Charging the battery

Battery electrolyte contains sulphuric acid. Protect your eyes, skin and clothing. In case of contact, flush thoroughly with water and get prompt attention, especially if your eyes are affected.

Batteries generate hydrogen gas, which can flames or sparks near a battery, especially during charging.

Charge the battery in a fully ventilated pl.

When a peripheral device uses a flywheel generator power, do not disconnect the battery connections from the engine, or it may give the peripheral damage.



2-2 Preparation before start

2-2.1 Selection and handling fuel

Fuel tank: Only light diesel fuel can be used. The fuel must be filtered. Fuel should be free of water or dust because these cause trouble in the fuel injection pump and nozzle.

Caution: Over fill the tank beyond the top of the red plug inside the fuel tank filter.

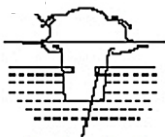

Air cleaner element:
Don't wash the air cleaner element with detergent. Replace the element when its output decreases or a bad exhaust color is noticed.

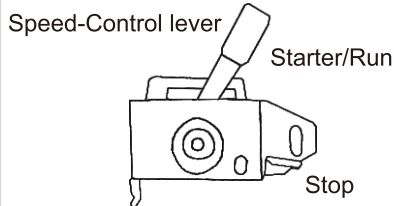
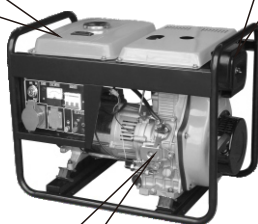

Caution

- Don't smoke and allow sparks in the area where the engine is refueled or where gasoline is stored.
- Don't spill fuel when refueling, make sure the filter cap is securely closed.

- After purchasing fuel; Allow drum to stand 3~4 days.
- After 3~4 days: Put a suction pipe halfway into the drum. (Water and dust accumulate in the lower portion of the drum.)

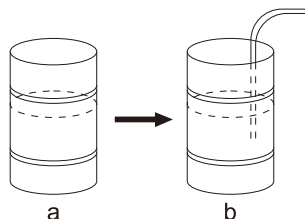



2-2.2 Selection and handling of lube oil

Inlet of lubricant:

Set the generator on the level, fill the engine oil into the inlet of lubricant.

To check the oil level, simply dip the dipstick into the pan. Do not screw the dipstick.

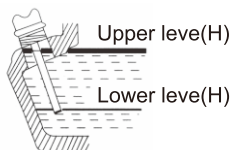

A.P.I. Maintenance classification for the diesel engine.

We recommend A.P.I. CC or CD

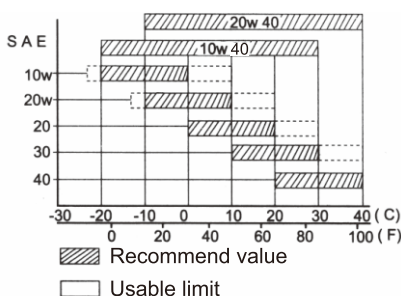

| Type | 170 | 178 | 186 | 188 | 192 |
|-------------|--------|--------|--------|--------|--------|
| Capacity | | | | | |
| Capacity(L) | 0.75 | 1.1 | 1.65 | 1.65 | 1.65 |
| UK gallon | (0.16) | (0.24) | (0.35) | (0.35) | (0.35) |

Nothing affects the performance and durability of generator more than the lube oil you use. If inferior oil is used up or if your engine oil is not changed regularly, the risk of piston seizure, piston ring sticking and accelerated wear of the cylinder liner, bearing and other moving components increases significantly. Your generator's life may be seriously shortened.

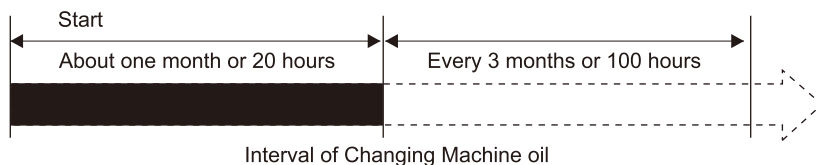

Make sure to check the oil level and to refill with oil to the specified level before starting the generator, even though it is equipped with a low oil pressure warning system.

Be sure to drain the oil while the engine is warm. It is difficult to drain the oil completely after cooling.

Caution: Do not add oil into the machine when the engine is running.

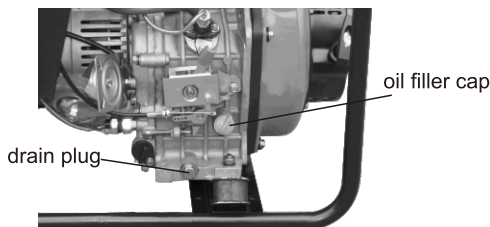

2-2.3 Check air cleaner element

(1) Loosen the wing nut, detach the cover of air cleaner and remove the element. Do not wash air cleaner element with detergent .

The air cleaner element must be changed when the output of engine decreases or the color of exhaust is abnormal.

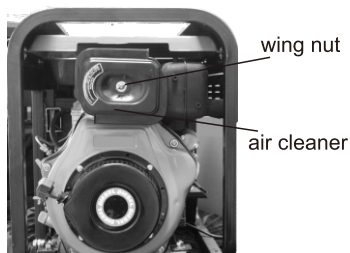

Never run the generator without the air cleaner element. This may cause rapid engine wear.

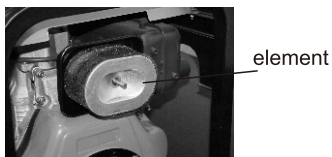

(2) Reattach the cover of air cleaner and tighten the wing nut.



2-2.4 Check generator

Turn off the main switch and any other loads

(Such as the light and motor switches)

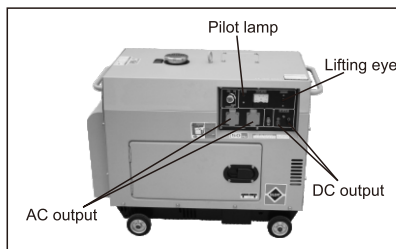
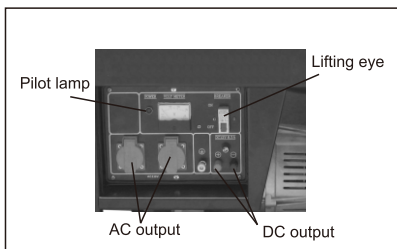

Be sure to turn off the main switch before starting the generator. If the switch is not on the “off ” position, sudden application of load could be very dangerous, when the diesel engine is started.

The generator should be earthed to prevent electric shocks.



2-2.5 Handling of dual voltage type generator

Operation of change over switch.

The circuit breaker on the control box must be used when application AC power, the air switch must be set at "OFF" position before run the machine. After start the genset, the speed reach rated speed so turn the switch at "ON" position, so that the two sockets can be used for output of rated voltage.

Set the main switch at "OFF" position when use 12v power for charge.

The terminal of 12v output can be used for 12v voltage charge, user can provide a charge switch for switch on or switch off.

2-2.6 The fuel and engine oil already drained off before ex-factory

To check oil pipeline, and find whether there is air mixed into the pipeline, if yes, drain away the air from the pipeline before refuel and start the diesel engine.

The actual method is that, loosen the connection nut between injecting pump and pipeline and then drain off the air until no air bubble from the fuel.

2-3 Inspection and operation of diesel engine

2-3.1 Low oil warning system/stop device.

The device works to stop the engine automatically when the oil pressure falls below the regulatory level and to prevent engine seizure when lube oil is running short.

The oil temperature will rise too high if the engine is operated with insufficient lubrication oil. On the other hand , too much oil is dangerous because the oil may combust and cause a sudden and excessive rise in engine rpm, so before operating the machine, be sure to check the oil and supply oil to the specified level.

2-3.2 How to open the cabinet door and cover (diesel generator)

(1) Opening the cabinet door and raise the door and check daily.



GS



(2) Loosen the bolt & open the cover to check the air cleaner.



air cleaner inspection cover

(3) Checking the outside cover of nozzle, loosen the thumb nut and open the cover.



2-3.3 Break-in operation

While your generator is still new, application of heavy loads may shorten the life of the engine. Follow the break-in procedures during the first 20 hours.

(1) Avoid applying any heavy load during the break-in period.

(2) Change engine oil regularly.

Change the engine oil every 20 hours or one month after the initial use, and every 3 months or 100 hours thereafter.

2-4 Starting the generator

2-4.1 Recoil starting (manual start)

The engine is started in the manner described below.

(1) Open the fuel cock (at the "ON" position).



(2) Put the engine speed lever in the "RUN" position.

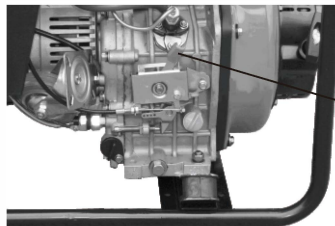

engine speed lever

(3) Pull out the recoil starting handle.

1. Pull out the handle to the point where your hands feel strong resistant and then return it to the initial position.



2. Push down the decompression lever. (It will return automatically when the recoil starter is pulled).



3. Pull out the recoil starting handle briskly with both hands.

Do not allow the handle grip to snap back against the engine. Return it gently to prevent damage to the starter, when starting (or after start).

Caution: Never pull out the start handle when diesel engine is running , otherwise it will damage the engine.

4. In cold weather, when diesel engine is difficult to start, remove the plug from the rocker arm cover and add 2 cc of engine oil.

Replace the plug before starting.

Keep the plug in the cover except when adding oil, otherwise rain, dirt and other contaminants may enter the engine and cause accelerated wear of internal parts. This can cause serious problems.

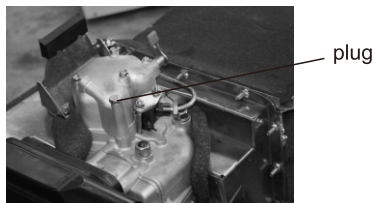

2-4.2 Electric starting

1. Starting (The preparation for electric starting is same as recoil start).

(1) Open the fuel cock.

(2) Let the engine speed lever at "RUN" position.

(3) Turn the starting key at clockwise to "Start" position.

(4) Remove your hand from the key as soon as the engine starts and let the key return automatically to initial position.

(5) If the starting motor doesn't start after 10 seconds, please wait for about 15 seconds before attempting to start again.

Caution:

If the starting motor is run for too long, the battery will go fault.

Always leave the starting key turned on, in the "ON" position, while the engine is running.

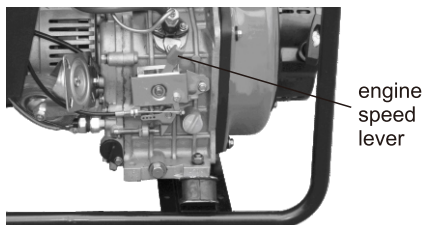

2. Battery

Check the level of the fluid in the battery once every month. when the level has dropped to the lower upper mark, replenish with distilled water up to the upper mark.

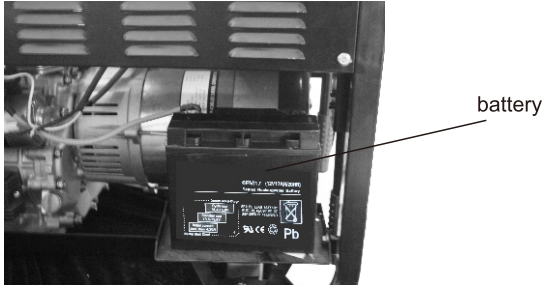

If battery fluid is short, the engine may fail to start because too little electricity is reaching the starter motor. Always keep the fluid level between the upper level and lower level.

If too much battery fluid is supplied, the fluid may spill and corrode the surrounding parts.

When a peripheral device uses a flywheel generator power, do not disconnect the battery connections from the engine, or it may give the peripheral damage.

2-5 Starting sequence of generator

This starting sequence is only suitable for open frame type diesel generator recoil start.

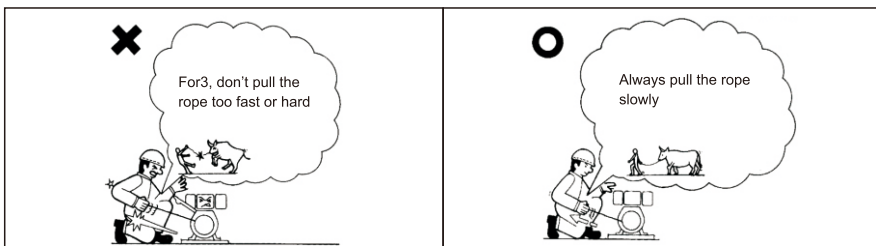
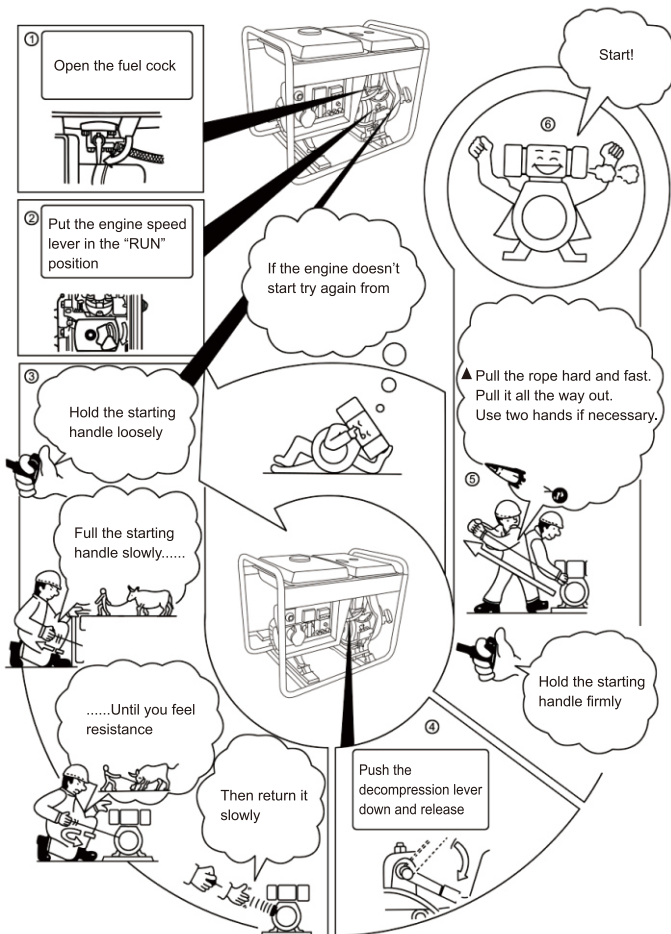

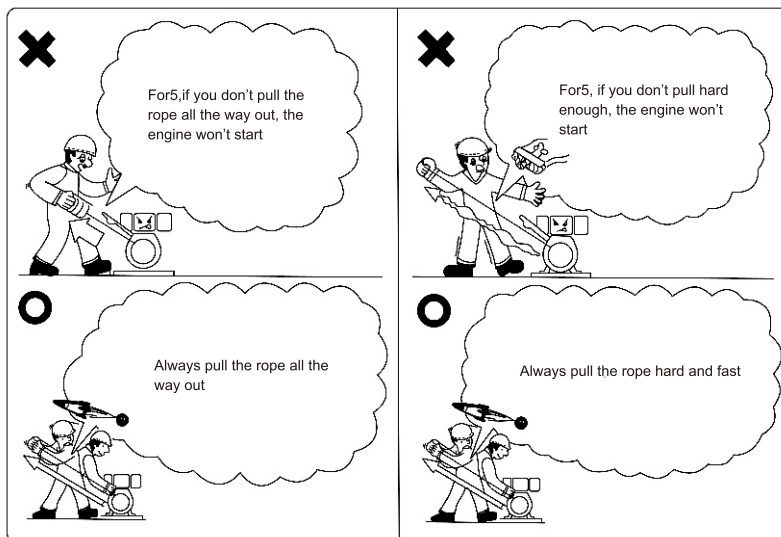

2-6 How to operate generator in correct way

2-6.1 Operating your generator

- (1) Warm up the engine without load for about 3 minutes.
- (2) Our generator is equipped with low oil warning system. The engine will stop automatically in case of low oil pressure or a lubrication oil shortage. The engine will stop immediately if restarted without a lubrication oil refill. To check the oil level and refill.
- (3) Do not loosen or readjust either the engine speed limiting bolt or fuel injection limiting bolt (They had been already well adjusted before ex-factory) otherwise, performance may be affected.

2-6.2 Check during operation

- (1) Any abnormal sound or vibration?
- (2) The engine misfiring or running rough.
- (3) What about the color of the exhaust gas? (Is it black or too white?)

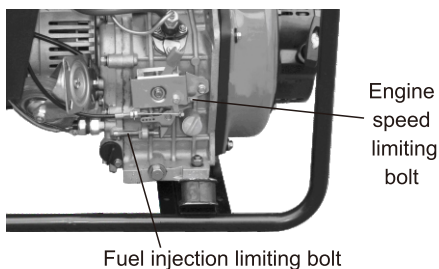

If you notice any of the above phenomenon, stop the engine and consult your nearest dealer or contact with our company.



2-7 Load

2-7.1 Load

To add load according to specified parameter. For electric principle diagram of generator, please refer to the following drawing.

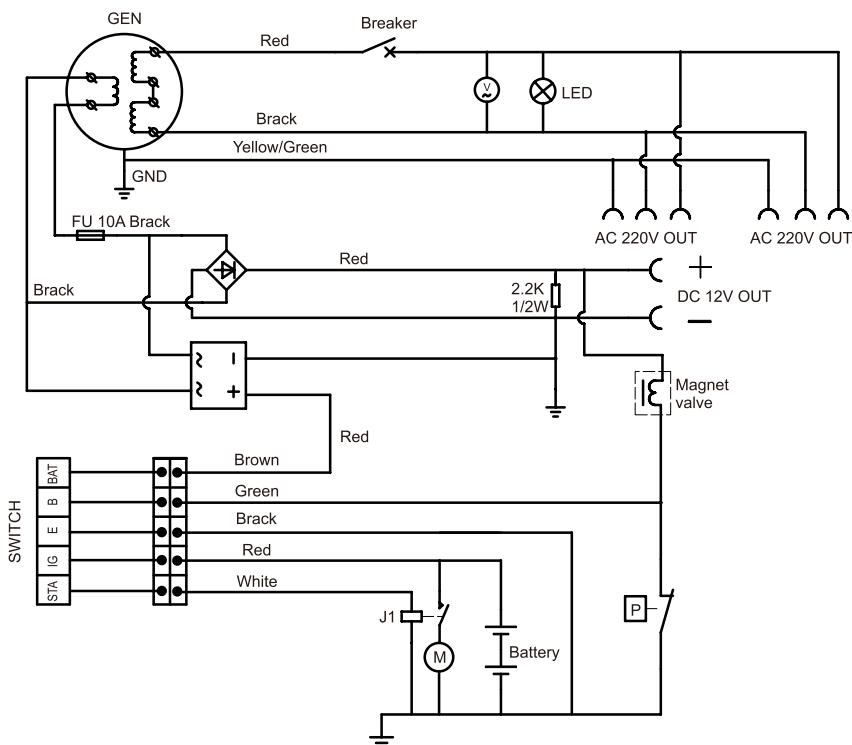

SWITCH

| | IG | BAT | STA | E | B |
|-------|-----|-----|-----|-----|---|
| OFF | | | | ○—○ | |
| ON | ○—○ | | | | |
| START | ○—○ | ○—○ | ○—○ | | |



2-7.2 A.C application

- (1) Start the engine and make sure the pilot lamp turns on. If it does not, the filament may be burnt out.
- (2) The speed of generator must reach rated speed (lever at top). For rated speed of generator, please see main technical specifications and parameter at chapter 1 1-1. & 1-2. Section.
- (3) Generator can load when the indicator of voltmeter shows at $230 \pm 10\%$ (50Hz) on the panel of control box.
- (4) Plug in the appliance.

Caution: Do not start two or more machines simultaneously. Start them one by one. Do not use floodlights together with other machines.

| Load Type | | Incandescent lights electric appliances | The machine using commutator motor | The machine using an induction motor (Condenser start type) (1:3) | | |
|------------------------|---------------|---|------------------------------------|---|--------------|--------------|
| | | Electric heater (1:1) projector | Drills, grinder (1:2) etc. | Water pump, compressors etc. | | |
| | | | | Load | 50Hz | 60Hz |
| Single phase generator | 2200 | Within 1700/2000W | Within 850/1000W | 400W or 250W | 1 units 2 | 1 units 2 |
| | 3600 3600S | Within 2700/3000W | Within 1350/1500W | 400W or 250W | 2 3 | 2 4 |
| | 5000 5000S | Within 4200/4600W | Within 2100/2300W | 400W or 250W | 3 5 | 3 6 |
| | 6000 6000S | Within 4500/5000W | Within 2250/2500W | 400W or 250W | 3 6 | 4 6 |
| | 6500 6500S | Within 5000/5300W | Within 2500/2650W | 400W or 250W | 4 6 | 4 7 |
| | 7500 7500S | Within 5500/6000W | Within 2750/3000W | 400W or 250W | 4 7 | 5 8 |
| | 8000 8000S | Within 6000/6500W | Within 3000/3250W | 400W or 250W | 5 8 | 5 8 |

The speed of generator (50Hz) must reach the rated speed 3000r/min.



(5) Be sure that all appliances are in good working condition before connecting them to the generator, if an appliance begins to operate abnormally. Becomes sluggish, or stops suddenly, turn off the generator immediately. Then disconnect the appliance and examine it for signs of malfunction.

If overloading of the circuit trips the AC circuit protector, reduce the electrical load on the circuit, and wait a few minutes before resuming operation.

If the indication of voltmeter is too low or too high, stop the machine and examine it for cause of malfunction.

2-7.3 DC application

The DC terminal may be used for charging 12 volt automotive-type batteries only.

(1) When using automotive-type batteries with battery cables, be sure to disconnect the minus pole battery cable from the battery before charging.

(2) Start the engine.

(3) Connect the charging cable to the battery terminals and the DC terminals of generator.

Connect the positive battery terminal to the positive generator terminal. Do not reverse the charging cables, or serious damage to the generator and/or battery may occur.

Do not allow the free ends of the cable to touch each other. If this occurs, it will be short circuit the battery.

When a large capacity battery is charged, excessive current flows(the value varies depending on the discharging condition), and the fuse for the direct current will burn out.

(4) Batteries produce explosive gases. Keep sparks, flames and cigarettes well away. To prevent the possibility of creating a spark near the battery, always connect the charging cables to battery first and only then to the generator. When disconnecting, you should disconnect the cables at the generator first.

(5) Charge the battery in a well ventilated place. Before charging, remove the cap from each cell of the battery.

Discontinue charging if the electrolyte temperature exceeds 45°C.

Caution: Do not attempt to start an automobile engine while the generator is still connected to the battery.
Do not use D.C 12 volt and A.C at the same time.



2-8 Stopping generator

2-8.1 Turn off the main switch of the generator

2-8.2 Set the engine speed lever at the “RUN” position, operate the engine without load for about 3 minutes, do not stop the engine suddenly because this may cause the temperature to rise abnormal and cause the nozzle to seizure, finally damage the engine.

- (1) Push down the stop lever.
- (2) Turn the key to “OFF” when using the electric starter.

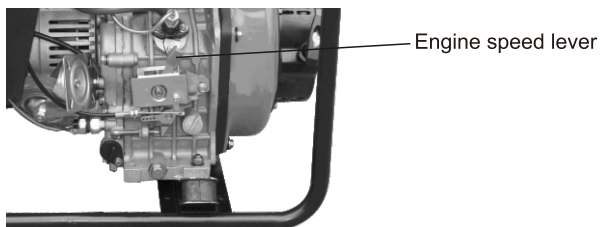

- (3) Set the fuel cock lever to the “S”(closed) position

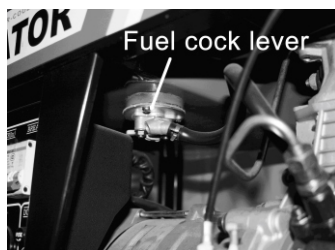

- (4) Slowly pull out the recoil handle until pressure is felt (that is, to the point in the compression stroke where the intake and exhaust valves are closed), and leave the handle in this position. This prevents rust from forming while the engine is not in use.

Caution: If the engine keeps on running even after the speed lever is laced at the “Stop” position, turn the fuel oil cock to the “Close” position to stop the engine. Do not stop the engine with the decompression lever.



CHAPTER 3 Periodic checks and maintenance

3-1 Periodic checks and maintenance

Periodic check and maintenance are very important for keeping the engine in good condition and durable. The generator consists of diesel engine, alternator, control box and frame, etc.. Please read the detailed description of operating manual for each part.

Shut off the engine before performing and maintenance. If the engine must run, make sure the area is well ventilated. The exhaust contains poisonous carbon monoxide gas.

After engine has been used, clean it immediately with a cloth to prevent corrosion and remove sediment.

| Item \ Service period regular | Daily check | First month or 20 Hrs | Every 3 months or 100 Hrs | Every 6 months or 300 Hrs | Every year or 1000 Hrs |
|--|--|-----------------------|---------------------------|---------------------------|------------------------|
| Check and replenish fuel | ○ | | | | |
| Drain fuel F.O. tank | | ○ | | | |
| Check and replenish lube oil | ○ | | | | |
| Check for oil leakage | ○ | | | | |
| Check and tighten each parts engine | ○ | | | ● Tighten head bolts | |
| Chang lube oil | | ○ (1st time) | ○ (2nd and thereafter) | | |
| Clean oil filter | | | ○ (Clean) | ○ (Replace) | |
| Air cleaner element replacement | Service more frequently when used in dusty areas | | | ○ (Replace) | |
| Clean fuel filter | | | | ○ (Clean) | ● (Replace) |
| Check fuel injection pump | | | | ● | |
| Check fuel injection nozzle | | | | ● | |
| Check fuel pipe | | | | ● (Replace if necessary) | |
| Adjust valve clearance for intake and exhaust valves | | ● (1st time) | | | |
| Lap intake and exhaust valves | | | | | ● |
| Replace piston rings | | | | | ● |
| Check battery fluid | (Monthly) | | | | |

“○” The chart above indicates what checks to make and when to make them, the mark (●) indicates that special tools and skills are required, consult your dealer.



3-1.1 Changing engine oil (Every 100Hrs)

Remove the oil filler cap. Remove the drain plug and drain the used oil while the engine is still warm. The plug is located on the bottom of the cylinder block. Tighten the drain plug and refill with the recommended oil.

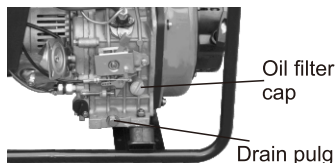

3-1.2 Cleaning the oil filter

| | |
|----------------------|-----------------------------|
| Clean | Every 6 months or 300 hours |
| Replace if necessary | |

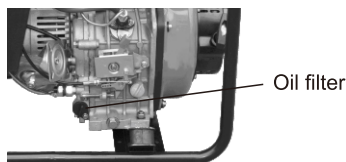

3-1.3 Changing the air cleaner element

Do not wash the air cleaner element with detergent because this is a dry type element.

| | |
|--------|--|
| Change | Every 6 months or 300 hours (or earlier if dirty) |
|--------|--|

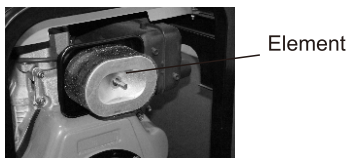

Caution: Never start the engine without the element, or with a defective element. Change the element in time.

3-1.4 Cleaning and replacing the fuel filter

The fuel filter also has to be cleaned regularly to insure maximum engine output .

(1) Drain the fuel oil from the fuel tank.

| | |
|---------|-----------------------------|
| Clean | Every 6 months or 300 hours |
| Replace | Every year or 1000 hours |

(2) Loosen the small screws of the fuel cock and pull out the filter from the F.O. tank. Wash the filter thoroughly with diesel fuel .Remove the lock nut, end cap and diffuser discs and clean the carbon deposit.

3-1.5 Tightening cylinder head bolts (Refer to the manual of diesel engine) requires a special tool. Don't try it yourself

3-1.6 Checking the injection nozzle, injection pump, etc.

(1) Adjusting the valve head clearance for the intake and exhaust valves.

(2) Lapping of intake and exhaust valve.



(3) Replacing piston ring.

All these require special tools and skills. Do not perform the injection nozzle test near an open fire or any other kind of fire. The fuel spray may ignite. Do not expose bare skin to the fuel spray. The fuel may penetrate the skin and cause injury to the body. Always keep your body away from the nozzle.

3-1.7 Checking and replenishing battery fluid and charging and battery

This diesel engine uses a 12v battery. The battery fluid will be lost through continuous charging and discharging.

Before starting, check for physical damage to the battery and also the electrolyte level, and replenish with distilled water up to the upper mark if necessary. When actual damage is discovered, replace the battery.

| | |
|---------------------|---------|
| Battery fluid check | Monthly |
|---------------------|---------|

3-2 Maintenance for a long time storage

If your generator should be stored in long time, the following preparation should be made.

3-2.1 Operate the diesel engine about 3 minutes, and stop it

3-2.2 Stop the diesel engine when the diesel engine is still hot, drain old lubricate of diesel engine oil out, then refill new one

3-2.3 Pull out the plug at the cover of diesel engine and add 2ml of lubricate in cylinder, and finally put the plug on its original place

3-2.4 Maintenance of starting position

(1) Manual starting

Press the pressure-reduce handle (non-compression position), pull the recoil handle 2-3 times. (Don't start diesel engine).

(2) Electric starting

When the starting handle is in the position of non-compression position, operate the diesel engine 2-3 seconds. When the switch is in the position of start, don't start the diesel engine.

3-2.5 Pull the pressure-reduce handle out, pull the recoil starter slowly

When you feel the fastness, stop the pulling. (At this time the intake and exhaust valve is at the status of close, it is suitable to prevent from rust).

3-2.6 Clean and store it in a dry place.



Chapter 4 Maintenance and remedy of generator set

4-1 Maintenance and remedy

| | Cause | Remedy |
|---------------------------------|---|---|
| The diesel engine can not start | Fuel oil is not enough | Add fuel oil |
| | The switch is not at "ON" position | Turn it to "ON" position |
| | The pump of high pressure and oil nozzle can not inject oil or the oil amount is not enough | Remove the oil nozzle out and repair it at test table |
| | The control lever of speed is not at "RUN" position | Put the control level to "RUN" position |
| | Check the level of lubricant | The specified oil level should be between upper level "H" and lower level "L" |
| | The speed and force to pull the recoil starter is not enough | Start the diesel engine according to the requirements of operating procedure of start |
| | The oil nozzle is dirty | Clean the oil nozzle |
| | The battery has no electricity | Charge it or replace it with a new one |
| The generator can not generate | Main switch is not closed | Put the main switch to the "ON" position |
| | The contact of socket is not good | Adjust the feet of socket |
| | The rated speed of generator can not be reached | Adjust it according to the requirements |

When welding, if find the electricity is too big to be welded, or the engine is shutdown by overload during welding, it may cause by the AVR's regulator damage or short circuit.

If electricity is not generated, take the generator to dealer.

4-2 Question and problems

If you have any question or problem when you meet in your operation, please contact with our company or our dealer and tell the following information:

(1) The type of diesel generator sets, the No. and type of diesel engine and the No. and type of generator.

(2) Status.

What problem had taken when operation and explain how much speed it is operated.

(3) Time of operation

(4) The other detailed condition, for example, when the problem took and how often, etc.

For details, please fill the sheet of soliciting opinions from the customers and send it to our company.



APPENDIX

1. List of accessory and spare parts with this machine

| No. | Name | Unit | Qty | Remarks |
|-----|------------------------|-------|-----|---------|
| 1 | Diesel generator | Set | 1 | |
| 2 | Kit | Piece | 1 | |
| 3 | Plastic cover | Piece | 1 | |
| 4 | Certificate of quality | Piece | 1 | |

2. Technical documents

| No. | Name | Unit | Qty | Remarks |
|-----|--------------------------------|-------|-----|---------|
| 1 | Manual of diesel engine series | Set | 1 | |
| 2 | Manual of generator set series | Piece | 1 | |
| 3 | Bag of plastic document | Piece | 1 | |

3. Service Part Kit (option)

| No. | Name | Unit | Qty | Remarks |
|-----|--------------|-------|-----|---------|
| 1 | Wrench 10-12 | Set | 1 | |
| 2 | Wrench 14-17 | Piece | 1 | |
| 3 | Screw | Piece | 1 | |
| 4 | Plastic Bag | Piece | 1 | |

“Original Instructions”, “the business name and full address of the manufacturer and the authorized representative within EU” are added on cover page.

Intended use:

- 1) This product is only intended for use outdoors in a well ventilated area.
- 2) The product is intended for generating electricity.
- 3) The product should not be used underground.
- 4) The product should not be used in a potentially explosive atmosphere.
- 5) The product can not be connected directly to power supply.

Noise Declaration

Sound power level = 95 dB(A)

Sound measurement uncertainty = 1.5dB

Measured in accordance with ISO 8528-10 and EN ISO 3744.

NOTE

When operating the engine, ear protection shall be worn.

