

Heathkit of the Month #67:
by Bob Eckweiler, AF6C



ELECTRONIC TEST EQUIPMENT
Heathkit IP-32
High Voltage Power Supply

Introduction:

When vacuum tubes were the common active electronic component, a variable high voltage power supply was a standard piece of equipment on the electronic designer's bench. This device normally can supply a B+ voltage in the 100 to 500 volt range, often continuously variable and sometimes adjustable down to zero volts. The device also provides filament voltage (usually 6.3 VAC) at a reasonable current to light-up up to a dozen tubes. Some supplies also provide a negative bias voltage at minimal current to provide tube bias.

Over the years Heathkit manufactured at least seven different bench HV power supplies (See Table I). This article will focus on the IP-32 (Figure 1) as it is the one I used in school for many experiments.

Heathkit PS-1:

Heathkit released their first bench HV power supply, the PS-1, in September 1950 for \$29.50. In those days, September was the normal release date for new and upgraded kits. Figure 2 shows the PS-1 advertisement in a 1951 Heathkit flyer.

The PS-1 provides unregulated B+ voltage that is variable between 50 and 300 VDC. I could not find any specification for the maximum B+ current; however the meter is scaled for 200 ma full-scale, so 150 ma would be a good guess. The PS-1 also provides 6.3 VAC for filaments at a hearty 4.5 amperes. There is no bias voltage provision. In 1952 a change was made to the



Figure 1: Heathkit IP-32 HV Power Supply

PS-1. Binding posts replaced screw terminals for B+ and filament output on the front panel.

Three tubes are used in the PS-1. A 5Y3GT rectifier tube and two paralleled 1619 series regulator tubes. The 1619 was a common tube that was mass produced during WWII. In 1971 TAB sold surplus 1619 tubes at 5 for a dollar. Heath probably obtained them at even a lower price. They might have been included in the mass surplus component buys Heathkit made in their early days. The 1619 has a 2.5 V filament requiring a separate transformer or isolated winding. Since the filament or cathode in these circuits is at a high voltage this requirement is universal across the various family of kits.



Figure 2: PS-1 Ad from 1951 Heathkit Flyer

MODEL	From	To	B+	Filament	Bias	Comments
PS-1	9/1950	9/1952	50 - 300 VDC @ 150 (?) ma	6.3 VAC @4.5A	none	Unregulated; Primary tapped xfmr.
PS-2	9/1952	5/1954	160 - 450 VDC @15 - 150 ma	6.3 VAC @4.0A	none	See Table II
PS-3	5/1954	1957	0 - 500 VDC @ 10 - 130 ma	6.3 VAC @4.0A	none	See Table II
PS-4	1957	1962	0 - 400 VDC @ 100 ma	6.3 VAC @4.0A	Neg. 0 - 100 V @ 1 ma	Dual meters, 125 ma intermittent
IP-32	1962	1967	0 - 400 VDC @ 100 ma	6.3 VAC @4.0A	Neg. 0 - 100 V @ 1 ma	Dual meters, 125 ma intermittent
IP-17	1968	1977	0 - 400 VDC @ 100 ma	6.3 VAC @4.0A	Neg. 0 - 100 V @ 1 ma	Dual meters, 125 ma intermittent
IP-2717	1977	1982	0 - 400 VDC @ 100 ma	6.3 VAC @4.0A 12.6 VAC @2.0A	Neg. 0 - 100 V @ 1 ma	Dual meters, 125 ma intermittent

Table I: Power Supply Specifications

An interesting feature of the power transformer in the PS-1 is a primary tap switch built right on the transformer that allows adjustment for varying line voltages around, the then nominal, 117 VAC. This unusual feature might be because Heath acquired a bunch of these transformers in one of their surplus buys.

The PS-1 has four front panel controls, an **OFF - ON** power slide switch, a **STAND-BY** slide switch that removes the B+ but leaves the filament power on, the **VOLTAGE** control potentiometer and a meter switch that selects whether the meter reads the output **VOLTS** or output **MA**. Also on the front panel are a jeweled pilot light, a meter with 0 - 500 volt and 0 - 200 MA scales, and two two-screw output terminals - **6.3 VAC** and - **H.V. +**. (Later units have binding posts).

The PS-1 was produced until late 1952 when it was updated to the PS-2.

Heathkit PS-2:

The PS-2 was released in September of 1952. It originally sold for \$29.50, but in the 1954 catalog the price had risen to \$33.50. The PS-2 improved on the basic circuit of the PS-1, adding voltage regulation and shifting the output voltage range higher, up to 160 to 450 VDC. Maximum current output varies with the chosen voltage. At 400 VDC the maximum draw is 15 ma increasing to 130 ma at 200 VDC.

A pair of paralleled 1619 tubes remain as the series regulator tubes. The rectifier was upgraded to a 5V4, and a 6SJ7 control amplifier tube and an 0C3 voltage reference tube were

Heathkit LABORATORY

REGULATED POWER SUPPLY KIT

Here is a new Heathkit Laboratory Power Supply with many outstanding features that thoroughly qualify it for laboratory and service shop application. The regulated voltage output is continuously variable and constant under wide load variations. A 4 1/2" Simpson plastic cased panel mounted meter constantly monitors the laboratory power supply output for either voltage or current measurements. Linear, variable DC output voltage with excellent regulation is readily available. Panel terminals provide a separate 6.3 volt AC supply of 4 amperes for necessary filament voltage requirements. The DC voltage output is completely isolated from the chassis and therefore can be conveniently used for AC-DC circuit work. Ripple component is exceptionally low; .03 volt ripple at 250 volts under 50 milliamperere load conditions for a percentage of .012%.

These highly desirable features admirably qualify the Heathkit Laboratory Power Supply for experimental high gain audio applications—as a spare source of DC supply for service work—laboratory experimental work—plotting tube characteristics, etc.



MODEL PS-2
\$33⁵⁰
 SHIPPING WEIGHT
 20 LBS.

Figure 3: PS-2 Ad from the 1954 Heathkit Catalog

added. These tubes control the regulation by comparing the output voltage to a steady reference voltage provided by the 0C3 reference tube, adjusting the regulator tube grid bias to keep the output voltage nearly constant.

The PS-2 front panel features a similar meter to the PS-1, and the panel nomenclature is identical, with the following exceptions: The two slide switches, are now marked **POWER** above the switch and **OFF - ON** below, and **STAND-BY** above the switch and **OFF - ON** below; the filament output binding posts now also show the maximum current - **6.3 V 4A AC**.

The PS-2 remained in the Heathkit stable until the PS-3 was released in May of 1954.

Heathkit PS-3:

The PS-3, introduced in June of 1954 for \$35.50, offers regulated B+ voltage control from zero to 500 VDC. It still uses two 1619 tubes as the series regulators, but the 0C3 was replaced by two 0A2 VR tubes and a second rectifier tube was added to provide negative 150V and 300V to allow the series regulator tubes to operate all the way down to zero volts. The PS-3 uses a transformer that has the same voltages and color codes as the earlier PS-2 and may be identical. I don't have the part numbers to confirm that. Current output is a function of the voltage the supply is set to; this is shown in Table II.

The PS-3 also features a larger meter and changed styling, which uses gray knobs, a dark gray front panel and a flat wrinkled lighter gray cabinet.

The PS-3 appears in the summer catalog for 1956. It remained in production into 1960, according to Chuck Penson's book *Heathkit Test Equipment Products*. I have no 1959 nor 1960 catalogs to refer to, which is sad since my first ham license arrived in July 1959.

Heathkit PS-4:

The first catalog I have that shows the PS-4 is in 1961, though sources say it appeared as early

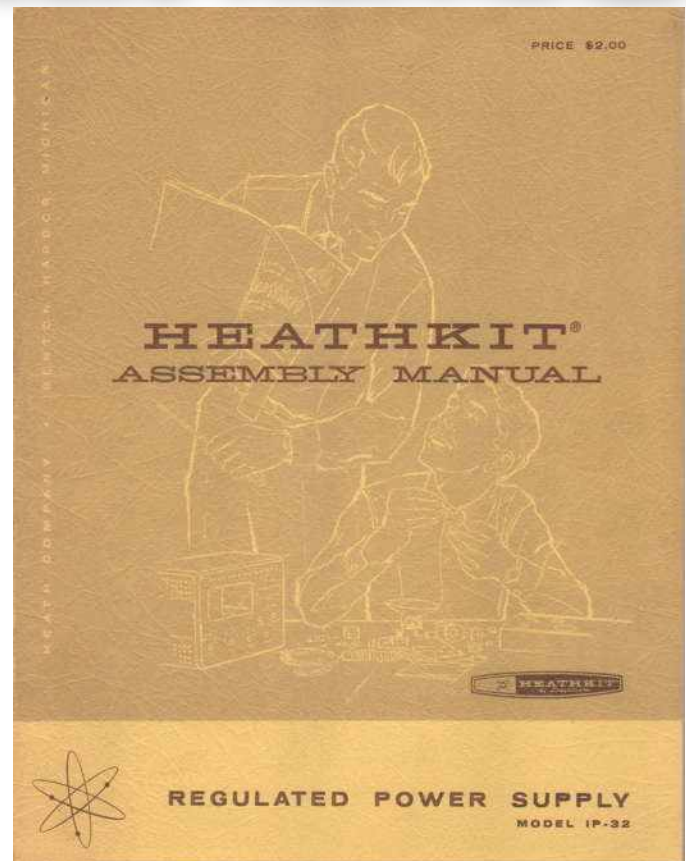

Figure 4: IP-32 Manual Cover

as late 1957 and was sold concurrently with the PS-3. The 1961 catalog has the price at \$56.95 as a kit and \$82.50 factory assembled. The increase in price is due to the PS-4 being a complete redesign. The PS-4 features separate filament and power transformers, dual meters and a new tube lineup that allows current output independent of the voltage setting. The PS-4 design is the basis for the IP-32, IP-17 and IP-2717 power supplies with only styling and minor circuit changes. The PS-4 is identical to the IP-32 except for styling, so circuit details will be provided in the featured IP-32 section.

Heathkit IP-32 HV Regulated Lab Power Supply: The IP-32 was introduced in 1962. It is identical to the PS-4 except for new styling, which Chuck Penson refers to as the **Classic II** style. (dark gray front panel with silver nomenclature and trim, lighter gray cabinet and black knobs with silver inserts and white pointers).

IP-32 Physical Specifications:

The IP-32 measures 13”W x 8-1/2”H x 7”D and weights 12 lbs. (Shipping weight is 16 lbs.) The front panel is laid out in rows. Left to right the top row contains the **D.C. OUTPUT VOLTAGE** meter, a pilot light and the **D.C. OUTPUT CURRENT** meter. Directly below the pilot light is a three position rotary power switch marked **OFF, STANDBY, ON**. Below the voltmeter is the bias supply potentiometer control marked **C- OUTPUT** with a clockwise arrow. Below the power switch is a slide **METER SWITCH** for switching the voltmeter between B+ (0 - 400 V full-scale) and bias (0 to -100 V full-scale). Below the current meter is the **B+ OUTPUT** potentiometer control with a clockwise arrow. Centered horizontally below the meter switch near the bottom of the front panel are seven binding posts marked: **0 TO - 100V AT 1 MA, COMMON, 6.3V AC 4 AMPS** (using two terminals), chassis **GND., COMMON, 0 - 400V. AT 100 MA 125 MA MAX..** The rear panel has a fuse holder (3 ampere) and a Heyco type clamp for the AC power cord exit.

IP-32 Circuit Description:

Figure 4 is a block diagram of the IP-32, and figure 7 is the schematic. The circuit may be broken down into seven blocks: filament power; negative/bias power supply; B+ power supply; screen power supply for the regulator tubes; the control circuit; series regulator and the metering circuit. The circuit uses six tubes, six silicon rectifier diodes and two selenium rectifiers. The tubes are two 0A2 150 V regulator tubes, a 6BH6 control amplifier tube, a 6X4 bias rectifier tube and two 6L6 series regulator tubes.

Tube Heater Power:

On most vacuum tubes the spacing is normally very close between the heater and cathode. Hence most tubes have a low maximum voltage rating between these two tube elements. In this circuit, even though all the tube filaments are rated at 6.3 VAC, the cathodes of the tube are at different high voltages. While the cathode of the 6X4 bias rectifier is near zero, the regulator

V out	PS-2	PS-3	PS-4, IP-32, IP-17, IP-2717
500 V	n/a	n.s.	n/a
450 V	n/a	10 ma	n/a
400 V	15 ma	20 ma	100 ma*
350 V	40 ma	40 ma	100 ma*
300 V	70 ma	70 ma	100 ma*
250 V	100 ma	100 ma	100 ma*
200 V	130 ma	130 ma	100 ma*
n.s. = not specified; * 125 ma intermittent max.			

Table II: Power Supply Current Ratings

tube cathodes are at whatever the output voltage is set at and the control tube cathode is at negative 150 volts. All heater power is provided by a separate transformer with four isolated and well insulated windings. One winding (2A) powers the two 6L6 tubes, a second (0.6A) powers the 6X4 rectifier, a third (0.15A) powers the 6BH6 and a fourth (4.15A) powers the pilot lamp and the external 6.3 VAC terminals. One side of each heater power winding is also connected directly to its associated cathode.

B+ Power Supply:

Power for three high voltage power supplies is provided by a separate second transformer. The primaries of the two transformers are wired to the three position power switch. In the standby position only the filament transformer receives AC line power, and in the on position both receive AC line power.

The B+ power comes from a 210 volt winding that feeds a full wave voltage doubler. Rectification is provided by two series-pairs of silicon diodes. No load voltage is on the order of 600 volts. This voltage is applied to the plates of the 6L6 regulator tubes and the low side is connected to the common output through a

jumper in one of the 0A2 regulator tube; the jumper will be discussed in the negative/bias power section.

Regulator Screen Power Supply:

A second winding of 175 volts on the power transformer provides power for the screen grid of the 6L6 regulator tubes. The voltage is half-wave rectified by two selenium rectifiers in series and filtered. The supply develops about 230VDC that is fed to the screen grid of the two 6L6 tubes. The common side of this power supply is connected directly to the cathode, so the screen grids remain 230 volts positive with respect to the cathode, independent of the cathode voltage.

Negative Bias Power Supply:

A third winding on the power transformer of 600 VCT is rectified by a 6X4 dual diode rectifier tube in a full-wave configuration. This voltage, approximately 380 volts is filtered and then current limited by R21 and regulated by two 0A2 150 volt regulator tubes. The positive side of this power supply is connected to common through a jumper in one of the 0A2 VR tubes. This supply then produces two voltages regulated at -150 and -300 volts with respect to circuit common.

The voltage regulator (VR) 0A2 tube is constructed with internal jumpers, the anode connected to pins 1 and 6 and the cathode connected to pins 2, 4 and 7. These multiple pin jumpers allow the prevention of unregulated voltage from reaching the circuit should a VR tube be removed. This feature is incorporated in the circuit for both 0A2 tubes.

The -150 V regulated power connects to the cathode of the 6BH6 control tube, allowing the tube to operate even with a plate voltage near zero. The -150 volt supply also is fed through the C- OUTPUT potentiometer and a current limiting resistor and further filtering to the 0 TO -100V AT 1 MA, and associated COMMON binding posts.

The -300 volt supply provides a reference for the control tube as well as a bleeder return for the output of the series regulator. These will be covered in a later paragraph.

Series Regulator Circuit:

A pair of 6L6 tubes, wired in parallel, are used as the series regulator. These tubes drop the +600 volts (at no load) from the B+ power supply to the desired voltage set by the front panel B+ OUTPUT control. The tubes act as active resistors keeping the voltage at their cathodes constant as the current drawn through the tubes fluctuates. Each tube's screen is connected to the screen supply via a 100 ohm parasite suppression resistor. These tubes are controlled by the control amplifier tube discussed next. The control amplifier output is connected to each 6L6 control grid through a 1K ohm suppression resistor. The plates, cathodes and heaters of the 6L6 tubes are directly connected to each other.

This type of series regulator loses control when the current draw drops below a certain value. To prevent this from happening, four 27K ohm 2-watt bleeder resistors are connected in series from the 6L6 cathodes to the -300 volt supply. This assures a minimum current draw about 3 ma even when the B+ OUTPUT control is set to zero.

The Control Circuit:

The heart of the IP-32 is the control circuit. The cathode of the 6BH6 control tube is connected to the regulated -150 volt source, and the plate is connected to the output of the series regulator tubes through a 470k ohm resistor. The plate is also connected to the control grids of the series regulator tubes. Any change in current through the control tube changes the output voltage.

A voltage divider chain, made up of two variable resistors, two fixed resistors and one potentiometer (R10 to R14), is connected between the regulated -300 volt source and the output voltage. The two variable resistors are at

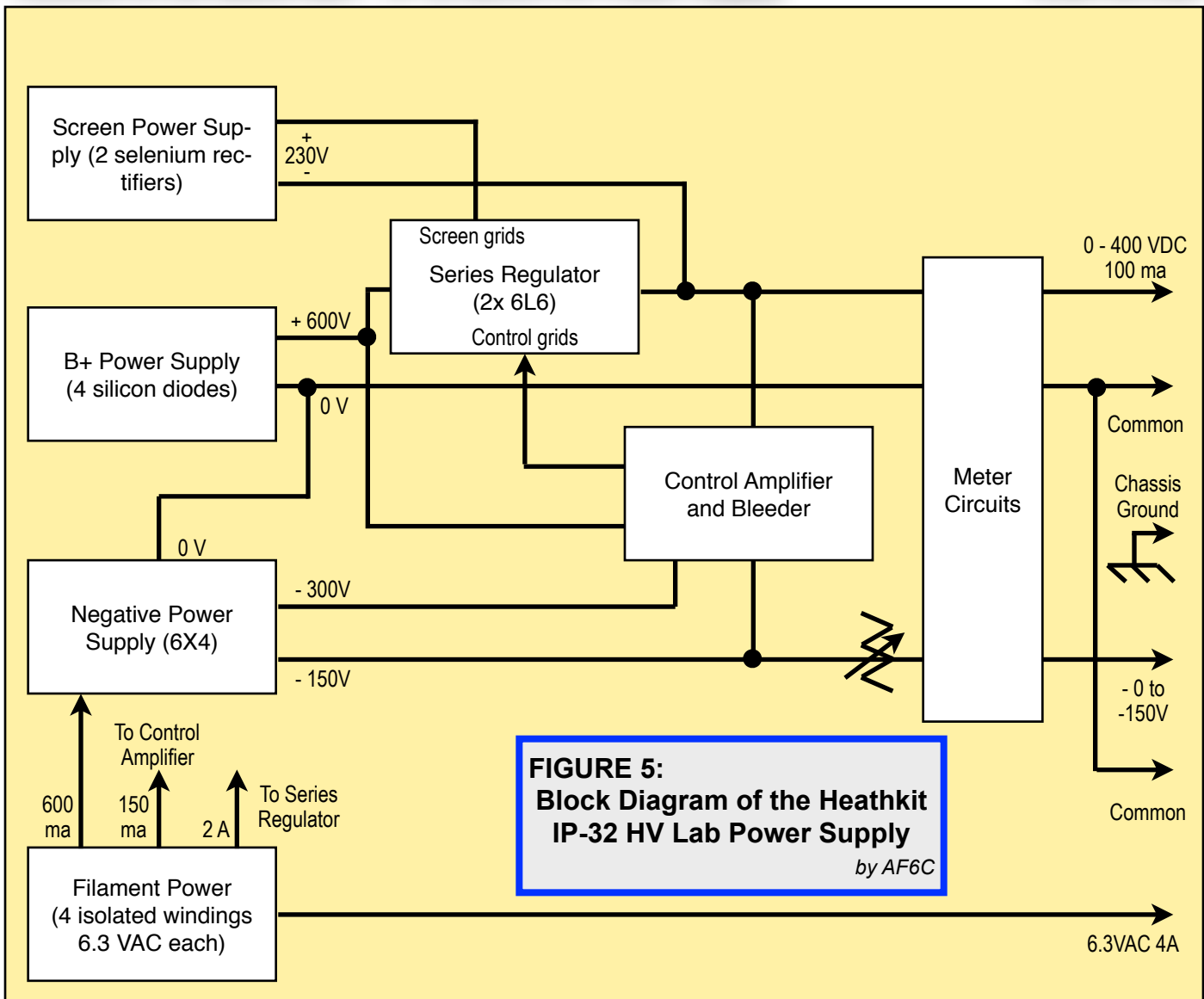

FIGURE 5:
Block Diagram of the Heathkit
IP-32 HV Lab Power Supply
by AF6C

each end of the resistor chain and set the zero point and the 400 volt output point. They are internal adjustments. The potentiometer, in the center of the chain, is the B+ OUTPUT control. Its wiper connection is filtered to remove any noise and applied to the grid of the control tube. This potentiometer sets the output voltage. Should the voltage change due to added current draw, the grid of the control tube senses the change and adjusts the series regulator tubes to return the voltage to the set value.

Additionally, the screen grid of the control tube is connected via a voltage divider from the raw B+ voltage to the -150 regulated voltage. Thus any sag in the raw voltage is detected by the

control tube. This divider controls the output impedance of the power supply. It is set to make the impedance close to zero. The IP-32 output impedance is specified to be less than 10 ohms from 1 Hz to 1 MHz.

Metering Circuit:

The IP-32 has two meters so the user may monitor the output voltages and the B+ current draw simultaneously. The current meter is a 150 ma full-scale meter with a series resistance of 0.66 ohms and is placed in line with the B+ output. No provision is provided to monitor the C- OUTPUT current since it is very low and current limited internally.



Figure 6: Heathkit IP-17 (top) shown with the IP-27 Low Voltage companion power supply (bottom) from the 810/68 1968 Catalog

The voltage of both the B+ OUTPUT and the C- OUTPUT is monitored on a 1 ma meter with the proper series resistors. A DPDT slide **METER SWITCH** selects the correct resistor and changes the meter polarity to read full-scale 0 to -150 volts on the C- OUTPUT ($R_{25} = 150\text{ K}\Omega$ 1%) and 0 to +400 volts on the B+ OUTPUT ($R_{24} = 400\text{ K}\Omega$ 1%).

Heathkit IP-17

The IP-17 (Fig. 6) is a totally restyled version of the IP-32. It is now in a low-profile cabinet measuring 13-3/8"W x 11-1/4"D x 5-1/2"H. Electrical changes to the PI-17 are minor. 6.3 or 12.6 VAC is available for external heaters at a total load of 25 VA. The selenium screen rectifiers were replaced by silicon diodes. A third pole has been added to the meter switch and two neon lamps indicate whether the voltmeter is reading C- or B+ volts. Also the primary and transformers have been updated so the IP-17 may be wired for 120 or 240 volt operation. A three wire AC plug has also been incorporated.

The IP-17 came out in 1967, too late for the main catalog. It sold for \$59.95 in kit form and \$89.95 wired (IPW-17).

Heathkit IP-2717

In 1977 the IP-17 was replaced by the nearly identical IP-2717 which featured only some

small styling changes (mainly colors) and a price of \$109.95. A factory wired version continued to be available at \$210. The IP-2717 continued to appear in catalogs into the mid-eighties when it was phased out and no replacement was released.

Summary:

If you dabble at all in vacuum tube circuits, a HV power supply that can provide filament and B+ voltage for your prototyping is a handy tool to have on the bench.

When Heathkit finally settled on a standard circuit with the PS-4, it and the models that followed have ratings of $\pm 1\%$ load regulation from no load to full load from 100 to 400 VDC and $\pm 1/2$ volt change for a 10 volt change in line voltage. Ripple, jitter and noise are less than 10 mV and the output impedance is below 10 ohms.

During my school years the physics department bought some IP-32 power supply kits and a few of us were given the task to each assemble one. By that time I had assembled numerous Heathkits and found the IP-32 not at all challenging, but probably the best homework assignment ever!

I'm busily looking over some Heathkits to find one in the ham category. I'm slowly piecing together information to feature the HW-32 et al. that have been an often requested topic. I also have an IP-27 Low Voltage Power Supply, an IM-4180 FM Deviation meter, an AA-14 Stereo Amplifier and an SK-107 Stereo Synthesizer in the queue.

73, from AF6C



This article originally appeared in the August 2015 issue of RF, the newsletter of the Orange County Amateur Radio Club - W6ZE.

Remember, if you are getting rid of any old Heathkit Manuals or Catalogs, please pass them along to me for my research.

Thanks - AF6C

