



March 2021

SERVICE MANUAL ERRATA

IC-705

Please note the following corrections and refer to the replaced pages.

ERRATA

• SECTION 5 ADJUSTMENT PROCEDURES

HEADING	DESCRIPTION	MISTAKE	CORRECTION	Page
5-1 PREPARATION	In the "REQUIRED EQUIPMENT" table.	Ammeter was not in the table.	Ammeter is added.	5-1
5-4 HF TRANSMIT ADJUSTMENT	Adjustment value for the [HF TX Total Gain] item	0.5 W	5.0 W	5-6
5-10 VHF BAND RECEIVE ADJUSTMENT	SSG frequency for the [VHF Tuned-BPF 1] item	72.2015 MHz	75.2015 MHz	5-17
5-11 UHF BAND RECEIVE ADJUSTMENT	SSG frequency for the [UHF Tuned-BPF 1] item	402.2015 MHz	400.2015 MHz	5-19

NOTE: Corrected parts on each replaced page are underlined.

REPLACED CONTENTS

SECTION 5 ADJUSTMENT PROCEDURES 5-1a~5-19a

SECTION 5 ADJUSTMENT PROCEDURES

The underlined parts have been updated from the previous version of the addendum, or from the original page.

5-1 PREPARATION

■ REQUIRED EQUIPMENT

EQUIPMENT	GRADE AND RANGE	EQUIPMENT	GRADE AND RANGE
DC power supplies	Output voltage: 13.8 V DC Current capacity: 5 A or more	Standard signal generator (SSG)	Frequency range: 10 kHz~600 MHz Output level: 0.1 μ V~32 mV (-127 to -17 dBm)
<u>Ammeter</u>	<u>Current range: 500 mA ~ 5 A</u>		
Frequency counter	Frequency range: 0.1~600 MHz Frequency accuracy: ± 1 ppm or better Sensitivity: 100 mV or better	RF power meter	Measuring range: 0.1~20 W Frequency range: 0.1~600 MHz SWR: Less than 1.2 : 1
Audio generator (AG)	Frequency range: 300~3000 Hz Output level: 1~500 mV	SWR 2 dummy load	Rated input: At least 10 W SWR: 2.0 : 1
AC millivoltmeter	Measuring range: 1 mV to 10 V	JIG plug	See "CONNECTIONS" for details.

■ CONNECTIONS

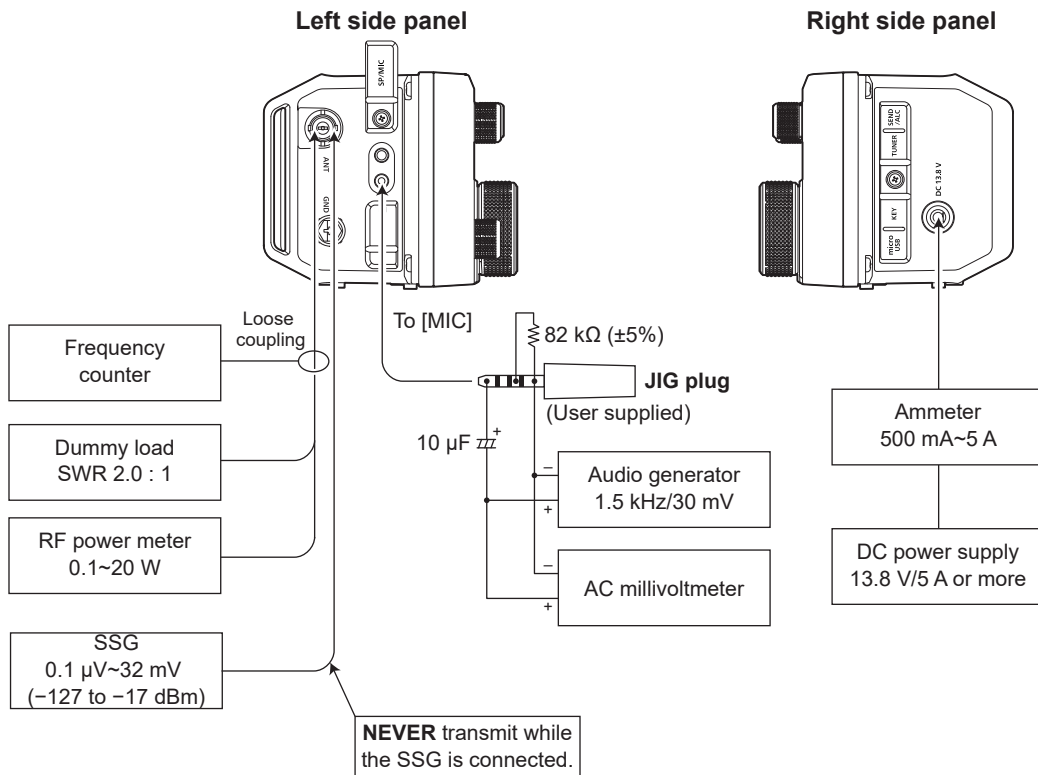

The underlined parts have been updated from the previous version of the addendum, or from the original page.

ENTERING THE ADJUST MODE

1. Turn OFF the power.
2. Connect the JIG plug to the [MIC] jack.

Left side panel

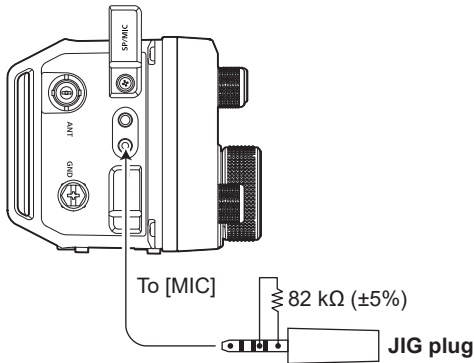

3. While holding down both [MENU] and [FUNC], turn ON to enter the adjust mode.

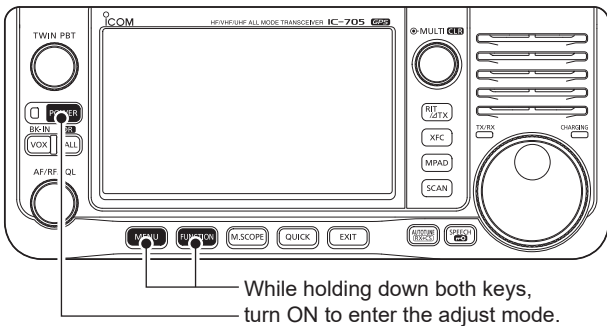

4. The Adjust Mode Main menu is displayed.



KEY ASSIGNMENTS FOR THE ADJUST MODE

- Touch [▼] to select the next adjustment item, touch [▲] to select the previous adjustment item.
- While holding down [QUICK], rotate [MAIN DIAL] to set or modify the adjustment value. (for only TX/ID adjustment)
 - Rotate [MAIN DIAL] to set or modify the adjustment value. (for other than TX/ID adjustment)
- Touch [SET] to start automatic adjustment, or store the adjusted value, and select the next adjustment item.
- Push [EXIT] to return to the previous screen.

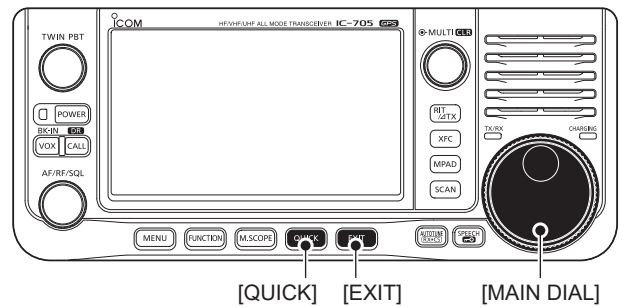
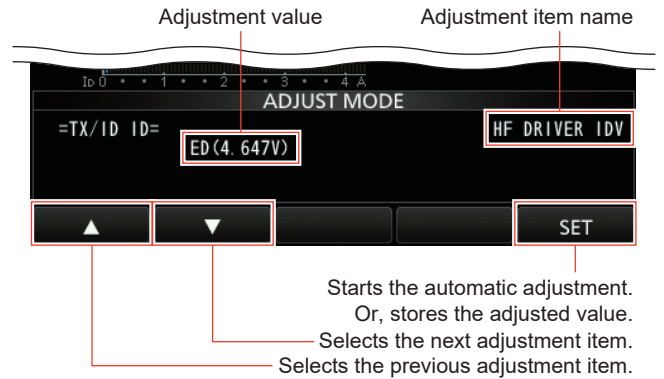

The underlined parts have been updated from the previous version of the addendum, or from the original page.

ADJUST MODE SCREENS

• MAIN MENU



Enter the FRONT key verification menu.
 Enter the TX/ID adjust menu.
 Enter the REF adjust menu.
 Enter the RX adjust menu.

• FRONT KEY VERIFICATION MENU

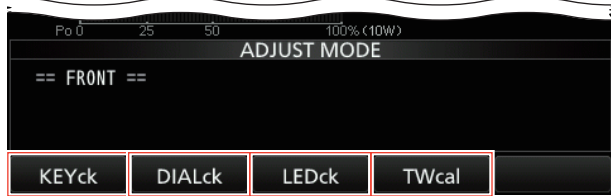

Starts the key verification.
 Starts the dial verification.
 Starts the LED verification.
 Starts the touch screen calibration.

• TX/ID ADJUST MENU

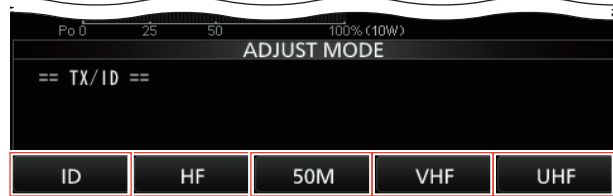

Starts the idling current adjustment.
 Starts the HF transmit adjustment.
 Starts the 50 MHz band transmit adjustment.
 Starts the VHF band transmit adjustment.
 Starts the UHF band transmit adjustment.

• REF ADJUST MENU



Starts the reference frequency adjustment.

• RX ADJUST MENU

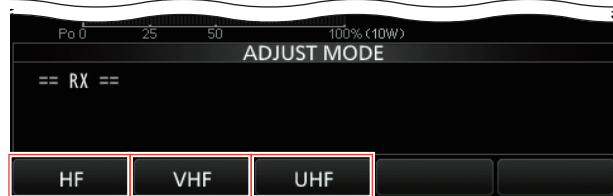

Starts the HF/50 MHz bands receive adjustment.
 Starts the VHF band receive adjustment.
 Starts the UHF band receive adjustment.

The underlined parts have been updated from the previous version of the addendum, or from the original page.

5-2 FRONT PANEL OPERATION VERIFICATION

1. Touch [FRONT] on the Adjust Mode Main menu.
2. Touch [KEYck] to enter to the Key Operation Verification mode.
3. Follow the instructions displayed on the screen, and push the corresponding key or knob.
4. Follow the instructions displayed on the screen, and rotate the corresponding dial and sensor.

NOTE: Verification items "25. PHOTO DARK" and "26. PHOTO BRIGHT" check the illuminance sensor. The sensor is built in to the area that assigned with a dotted red circle of the behind of the FRONT panel. (See the figure below)
 So, when verifying "25. PHOTO DARK," hide the sensor such as by covering it with your finger. When verifying "26. PHOTO BRIGHT," face the front panel to a light.

The illuminance sensor is built in here.

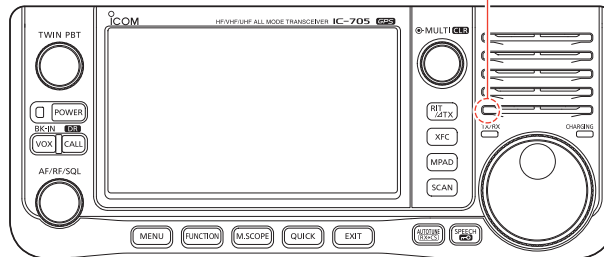

5. Follow the instructions displayed on the screen, and verify the corresponding LED is lit.
6. Push the [XFC] key, and verify the LCD screen changes in order of black, red, green, blue, minimum, and maximum backlight brightness.
7. Push the [XFC] key to start the touch screen calibration, and touch the dot in order of the instructions displayed on the screen.
 - After 2 short beeps sound, it automatically return to the Adjust Mode Main menu.

The underlined parts have been updated from the previous version of the addendum, or from the original page.

5-3 IDLING ADJUSTMENT

Touch [TX/ID] on the adjustment mode main menu.

ADJUSTMENT		ADJUSTMENT ITEM DISPLAY	SETTING CONDITION	OPERATION
IDLING - Preparation -	1	-	<ul style="list-style-type: none"> Connect the 13.8 V DC power source to [DC 13.8 V]. Connect the ammeter between the 13.8 V DC power source and the transceiver. 	Touch [ID] to enter the ID adjustment mode.
REFERENCE VOLTAGE LOADING	2	VDL IDL SET	<ul style="list-style-type: none"> Receive 	Touch [SET]. (The transceiver briefly transmits and then 3 short beeps sound.)
HF ~ FINAL IDLING CURRENT ~	3	HF FINAL ID SET		Touch [SET].
~ DRIVER IDLING CURRENT ~	4	HF FINAL IDV	<ul style="list-style-type: none"> Automatically transmits. 	Touch [SET]. (2 short beeps sound.)
	5	HF DRIVER ID		While holding down [QUICK], perform the following: Rotate [MAIN DIAL] to set the adjustment value to "00" and note the current flow as the reference. Then rotate [MAIN DIAL] to set the adjustment value so that the current flow is 60 mA (within ±5 mA) higher than the reference current, and then touch [SET].
50 MHz BAND ~ FINAL IDLING CURRENT ~	6	50M FINAL ID SET	<ul style="list-style-type: none"> Return to receive. 	Touch [SET]. (The transceiver briefly transmits and then 3 short beeps sound.)
~ DRIVER IDLING CURRENT ~	7	50M FINAL IDV	<ul style="list-style-type: none"> Automatically transmits. 	Touch [SET].
	8	50M DRIVER IDV		While holding down [QUICK], perform the following: Rotate [MAIN DIAL] to set the adjustment value to "EA," and then touch [SET].
70 MHz BAND ~ FINAL IDLING CURRENT ~	9	70M FINAL ID SET	<ul style="list-style-type: none"> Return to receive. 	Touch [▼] to skip the adjustment.
~ DRIVER IDLING CURRENT ~	10	70M FINAL IDV	<ul style="list-style-type: none"> Automatically transmits. 	
	11	70M DRIVER IDV		
VHF BAND ~ FINAL IDLING CURRENT ~	12	VHF FINAL ID SET	<ul style="list-style-type: none"> Return to receive. 	Touch [SET]. (The transceiver briefly transmits and then 3 short beeps sound.)
~ DRIVER IDLING CURRENT ~	13	VHF FINAL IDV	<ul style="list-style-type: none"> Automatically transmits. 	Touch [SET].
	14	VHF DRIVER IDV		While holding down [QUICK], perform the following: Rotate [MAIN DIAL] to set the adjustment value to "EE," and then touch [SET].
UHF BAND ~ FINAL IDLING CURRENT ~	15	UHF FINAL ID SET	<ul style="list-style-type: none"> Return to receive. 	Touch [SET]. (The transceiver briefly transmits and then 3 short beeps sound.)
~ DRIVER IDLING CURRENT~	16	UHF FINAL IDV	<ul style="list-style-type: none"> Automatically transmits. 	Touch [SET].
	17	UHF DRIVER IDV		While holding down [QUICK], perform the following: Rotate [MAIN DIAL] to set the adjustment value to "EA," and then touch [SET].

The underlined parts have been updated from the previous version of the addendum, or from the original page.

5-4 HF TRANSMIT ADJUSTMENT

Touch [TX/ID] on the adjustment mode main menu.

ADJUSTMENT	ADJUSTMENT ITEM DISPLAY	SETTING CONDITION	OPERATION	
HF TRANSMIT - Preparation -	1 -	<ul style="list-style-type: none"> Connect the 13.8 V DC power source to [DC 13.8 V]. Connect the RF power meter to the antenna connector. Connect the audio generator and the AC millivoltmeter to the JIG plug, and set the audio generator to: Frequency: 1.5 kHz Wave form: Sine wave Level: 30 mVrms 	<ul style="list-style-type: none"> When adjusting following from the idling adjustment, touch [SET]. When adjusting the HF transmit items from the TX/ID Adjust menu, touch [HF]. 	
HF POWER	2 HF TX	• Receive	Touch [SET]. (2 short beeps sound.)	
	3 HF POWER SET			
	4 HF TX Total Gain	• Automatically transmits.	Rotate [MAIN DIAL] to set to <u>5.0 W</u> , and then touch [SET].	
	5 HF Power MIN		Rotate [MAIN DIAL] to set to 0.1 W, and then touch [SET]. Note the adjustment value as the reference.	
	6 HF Power 1%		Rotate [MAIN DIAL] to set the adjustment value to the same as the reference, and then touch [SET].	
	7 HF Power 5%		Rotate [MAIN DIAL] to set to 0.5 W, and then touch [SET].	
	8 HF Power 10%		Rotate [MAIN DIAL] to set to 1.0 W, and then touch [SET].	
	9 HF Power 25%		Rotate [MAIN DIAL] to set to 2.5 W, and then touch [SET].	
	10 HF Power 50%		Rotate [MAIN DIAL] to set to 5.0 W, and then touch [SET].	
	11 HF Power 100%		Rotate [MAIN DIAL] to set to 10.0 W, and then touch [SET].	
	12 HF Power TUNE		Rotate [MAIN DIAL] to set to 10.0 W, and then touch [SET].	
	HF POWER BALANCE		13 HF Power Balance SET	• Return to receive.
14 HF 1.91M Power 100%			• Automatically transmits.	Rotate [MAIN DIAL] to set to 10.0 W, and then touch [SET].
15 HF 3.56M Power 100%				
16 HF 5.30M Power 100%				
17 HF 7.1M Power 100%				
18 HF 10.1M Power 100%				
19 HF 18.1M Power 100%				
20 HF 21.2M Power 100%				
21 HF 24.9M Power 100%				
22 HF 28.5M Power 100%				

Continued on the next page...

The underlined parts have been updated from the previous version of the addendum, or from the original page.

5-4 HF TRANSMIT ADJUSTMENT (continued)

ADJUSTMENT		ADJUSTMENT ITEM DISPLAY	SETTING CONDITION	OPERATION
HF AM POWER	23	HF POWER AM Ratio	• Return to receive.	Touch [SET]. (2 short beeps sound.)
	24		• Automatically transmits.	Rotate [MAIN DIAL] to set to 2.5 W, and then touch [SET].
HF ALC ADJUSTMENT	25	HF ALC	• Return to receive.	Touch [SET]. (1 short beep sounds.)
	26		• Automatically transmits.	Starts automatic adjustment. When the adjustment is completed, 2 short beeps sound and selects the next adjustment item.
HF DRIVE GAIN ADJUSTMENT	27	HF Drive	• Return to receive.	Touch [SET]. (1 short beep sounds.)
	28		• Automatically transmits.	Starts automatic adjustment. When the adjustment is completed, 2 short beeps sound and selects the next adjustment item.
ID-APC	29	ID-APC	• Return to receive.	Touch [SET]. (The transceiver briefly transmits and then 3 short beeps sound.)

The underlined parts have been updated from the previous version of the addendum, or from the original page.

5-5 50 MHz BAND TRANSMIT ADJUSTMENT

Touch [TX/ID] on the adjustment mode main menu.

ADJUSTMENT		ADJUSTMENT ITEM DISPLAY	SETTING CONDITION	OPERATION
50 MHz BAND TRANSMIT - Preparation -	1	–	<ul style="list-style-type: none"> Connect the 13.8 V DC power source to [DC 13.8 V]. Connect the RF power meter to the antenna connector. Connect the audio generator and the AC millivoltmeter to the JIG plug, and set the audio generator to: Frequency: 1.5 kHz Wave form: Sine wave Level: 30 mVrms 	<ul style="list-style-type: none"> When adjusting following from the HF transmit adjustment, touch [SET]. When adjusting the 50 MHz band transmit items from the TX/ID Adjust menu, touch [50M] and then [SET].
50 MHz BAND POWER	2	50M TX Total Gain	<ul style="list-style-type: none"> Automatically transmits. 	Rotate [MAIN DIAL] to set to 5.0 W, and then touch [SET].
	3	50M2 Power MIN		Rotate [MAIN DIAL] to set to 0.1 W, and then touch [SET]. Note the adjustment value as the reference.
	4	50M2 Power 1%		Rotate [MAIN DIAL] to set the adjustment value to the same as the reference, and then touch [SET].
	5	50M2 Power 5%		Rotate [MAIN DIAL] to set to 0.5 W, and then touch [SET].
	6	50M2 Power 10%		Rotate [MAIN DIAL] to set to 1.0 W, and then touch [SET].
	7	50M2 Power 25%		Rotate [MAIN DIAL] to set to 2.5 W, and then touch [SET].
	8	50M2 Power 50%		Rotate [MAIN DIAL] to set to 5.0 W, and then touch [SET].
	9	50M2 Power 100%		Rotate [MAIN DIAL] to set to 10.0 W, and then touch [SET].
	10	50M2 Power TUNE		Rotate [MAIN DIAL] to set to 10.0 W, and then touch [SET].
50 MHz BAND POWER BALANCE	11	50M Power Balance SET	<ul style="list-style-type: none"> Return to receive. 	Touch [SET]. (2 short beeps sound.)
	12	50M1 Power 100%	<ul style="list-style-type: none"> Automatically transmits. 	Rotate [MAIN DIAL] to set to 10.0 W, and then touch [SET].
	13	50M3 Power 100%		
50 MHz BAND AM POWER	14	50M POWER AM Ratio	<ul style="list-style-type: none"> Return to receive. 	Touch [SET]. (2 short beeps sound.)
	15		<ul style="list-style-type: none"> Automatically transmits. 	Rotate [MAIN DIAL] to set to 2.5 W, and then touch [SET].

Continued on the next page...

The underlined parts have been updated from the previous version of the addendum, or from the original page.

5-5 50 MHz BAND TRANSMIT ADJUSTMENT (continued)

ADJUSTMENT	ADJUSTMENT ITEM DISPLAY	SETTING CONDITION	OPERATION
50 MHz BAND ALC	16	50M ALC	• Return to receive. Touch [SET]. (1 short beep sounds.)
	17		• Automatically transmits. Starts automatic adjustment. When the adjustment is completed, 2 short beeps sound and selects the next adjustment item.
50 MHz BAND DRIVE GAIN	18	50M Drive	• Return to receive. Touch [SET]. (1 short beep sounds.)
	19		• Automatically transmits. Starts automatic adjustment. When the adjustment is completed, 2 short beeps sound and selects the next adjustment item.
70 MHz BAND TRANSMIT - Preparation -	20	70M TX POWER SET	– Touch [▼] to skip the adjustment.
70 MHz BAND POWER	21	70M TX Total Gain	• Automatically transmits.
	23	70M Power MIN	
	24	70M Power 1%	
	25	70M Power 5%	
	26	70M Power 10%	
	27	70M Power 25%	
	28	70M Power 50%	
	29	70M Power 100%	
	30	70M Power TUNE	
70 MHz BAND AM POWER	31	70M POWER AM Ratio	• Return to receive.
	32		• Automatically transmits.
70 MHz BAND ALC	33	70M ALC	• Return to receive.
	34		• Automatically transmits.
70 MHz BAND DRIVE GAIN	35	70M Drive	• Return to receive.
	36		• Automatically transmits.
SWR METER -Preparation -	37	–	• Connect the SWR 2.0:1 (impedance: 100 Ω or 25 Ω) dummy load to the antenna connector. –
- Adjustment - ~ HF BANDS ~	38	HF SWR2	• Return to receive. Touch [SET]. (1 short beep sounds.)
	39		• Automatically transmits. Starts automatic adjustment. When the adjustment is completed, 2 short beeps sound and selects the next adjustment item.
~ 50 MHz BAND ~	40	50M SWR2	• Return to receive. Touch [SET]. (1 short beep sounds.)
	41		• Automatically transmits. Starts automatic adjustment. When the adjustment is completed, 2 short beeps sound and selects the next adjustment item.
~ 70 MHz BAND ~	42	70M SWR2	• Return to receive. Touch [▼] to skip the adjustment.
	43		• Automatically transmits.

The underlined parts have been updated from the previous version of the addendum, or from the original page.

5-6 VHF BAND TRANSMIT ADJUSTMENT

Touch [TX/ID] on the adjustment mode main menu.

ADJUSTMENT	ADJUSTMENT ITEM DISPLAY	SETTING CONDITION	OPERATION
VHF BAND TRANSMIT - Preparation -	1 -	<ul style="list-style-type: none"> Connect the 13.8 V DC power source to [DC 13.8 V]. Connect the RF power meter to the antenna connector. Connect the audio generator and the AC millivoltmeter to the JIG plug, and set the audio generator to: Frequency: 1.5 kHz Wave form: Sine wave Level: 30 mVrms 	<ul style="list-style-type: none"> When adjusting following from the 50 MHz band transmit adjustment, touch [SET]. When adjusting the VHF band transmit items from the TX/ID Adjust menu, touch [VHF] and then [SET].
VHF BAND POWER	2 VHF TX Total Gain	• Automatically transmits.	Rotate [MAIN DIAL] to set to 5.0 W, and then touch [SET].
	3 VHF2 Power MIN		Rotate [MAIN DIAL] to set to 0.1 W, and then touch [SET]. Note the adjustment value as the reference.
	4 VHF2 Power 1%		Rotate [MAIN DIAL] to set the adjustment value to the same as the reference, and then touch [SET].
	5 VHF2 Power 5%		Rotate [MAIN DIAL] to set to 0.5 W, and then touch [SET].
	6 VHF2 Power 10%		Rotate [MAIN DIAL] to set to 1.0 W, and then touch [SET].
	7 VHF2 Power 25%		Rotate [MAIN DIAL] to set to 2.5 W, and then touch [SET].
	8 VHF2 Power 50%		Rotate [MAIN DIAL] to set to 5.0 W, and then touch [SET].
	9 VHF2 Power 100%		Rotate [MAIN DIAL] to set to 10.0 W, and then touch [SET].
VHF BAND POWER BALANCE	10 VHF Power Balance SET	• Return to receive.	Touch [SET]. (2 short beeps sound.)
	11 VHF1 Power 100% 12 VHF3 Power 100%	• Automatically transmits.	Rotate [MAIN DIAL] to set to 10.0 W, and then touch [SET].
VHF BAND AM POWER	13 VHF POWER AM Ratio	• Return to receive.	Touch [SET]. (2 short beeps sound.)
	14	• Automatically transmits.	Rotate [MAIN DIAL] to set to 2.5 W, and then touch [SET].
VHF BAND ALC	15 VHF ALC	• Return to receive.	Touch [SET]. (1 short beep sounds.)
	16	• Automatically transmits.	Starts automatic adjustment. When the adjustment is completed, 2 short beeps sound and selects the next adjustment item.

Continued on the next page...

The underlined parts have been updated from the previous version of the addendum, or from the original page.

5-6 VHF BAND TRANSMIT ADJUSTMENT (continued)

ADJUSTMENT		ADJUSTMENT ITEM DISPLAY	SETTING CONDITION	OPERATION
VHF BAND DRIVE GAIN	17	VHF Drive	• Return to receive.	Touch [SET]. (1 short beep sounds.)
	18		• Automatically transmits.	Starts automatic adjustment. When the adjustment is completed, 2 short beeps sound and selects the next adjustment item.
SWR METER - Preparation -	19	–	• Connect the SWR 2.0:1 (impedance: 100 Ω or 25 Ω) dummy load to the antenna connector.	–
- Adjustment -	20	VHF SWR2	• Return to receive.	Touch [SET]. (1 short beep sounds.)
	21		• Automatically transmits.	Starts automatic adjustment. When the adjustment is completed, 2 short beeps sound and selects the next adjustment item.

The underlined parts have been updated from the previous version of the addendum, or from the original page.

5-7 UHF BAND TRANSMIT ADJUSTMENT

Touch [TX/ID] on the adjustment mode main menu.

ADJUSTMENT		ADJUSTMENT ITEM DISPLAY	SETTING CONDITION	OPERATION
UHF BAND TRANSMIT - Preparation -	1	–	<ul style="list-style-type: none"> Connect the 13.8 V DC power source to [DC 13.8 V]. Connect the RF power meter to the antenna connector. Connect the audio generator and the AC millivoltmeter to the JIG plug, and set the audio generator to: Frequency: 1.5 kHz Wave form: Sine wave Level: 30 mVrms 	<ul style="list-style-type: none"> When adjusting following from the VHF band transmit adjustment, touch [SET]. When adjusting the UHF band transmit items from the TX/ID Adjust menu, touch [UHF], and then [SET].
UHF BAND POWER	2	UHF TX Total Gain	• Automatically transmits.	Rotate [MAIN DIAL] to set to 5.0 W, and then touch [SET].
	3	UHF2 Power MIN		Rotate [MAIN DIAL] to set to 0.1 W, and then touch [SET]. Note the adjustment value as the reference.
	4	UHF2 Power 1%		Rotate [MAIN DIAL] to set the adjustment value to the same as the reference, and then touch [SET].
	5	UHF2 Power 5%		Rotate [MAIN DIAL] to set to 0.5 W, and then touch [SET].
	6	UHF2 Power 10%		Rotate [MAIN DIAL] to set to 1.0 W, and then touch [SET].
	7	UHF2 Power 25%		Rotate [MAIN DIAL] to set to 2.5 W, and then touch [SET].
	8	UHF2 Power 50%		Rotate [MAIN DIAL] to set to 5.0 W, and then touch [SET].
	9	UHF2 Power 100%		Rotate [MAIN DIAL] to set to 10.0 W, and then touch [SET].
UHF BAND POWER BALANCE	10	UHF Power Balance SET	• Return to receive.	Touch [SET]. (2 short beeps sound.)
	11	UHF1 Power 100%	• Automatically transmits.	Rotate [MAIN DIAL] to set to 10.0 W, and then touch [SET].
	12	UHF3 Power 100%		
	13	UHF4 Power 100%		
UHF BAND AM POWER	14	UHF POWER AM Ratio	• Return to receive.	Touch [SET]. (2 short beeps sound.)
	15		• Automatically transmits.	Rotate [MAIN DIAL] to set to 2.5 W, and then touch [SET].
UHF BAND ALC	16	UHF ALC	• Return to receive.	Touch [SET]. (1 short beep sounds.)
	17		• Automatically transmits.	Starts automatic adjustment. When the adjustment is completed, 2 short beeps sound and selects the next adjustment item.

Continued on the next page...

The underlined parts have been updated from the previous version of the addendum, or from the original page.

5-7 UHF BAND TRANSMIT ADJUSTMENT (continued)

ADJUSTMENT		ADJUSTMENT ITEM DISPLAY	SETTING CONDITION	OPERATION
UHF BAND DRIVE GAIN	18	UHF Drive	• Return to receive.	Touch [SET]. (1 short beep sounds.)
	19		• Automatically transmits.	Starts automatic adjustment. When the adjustment is completed, 2 short beeps sound and selects the next adjustment item.
SWR METER - Preparation -	20	–	• Connect the SWR 2.0:1 (impedance: 100 Ω or 25 Ω) dummy load to the antenna connector.	–
- Adjustment -	21	UHF SWR2	• Return to receive.	Touch [SET]. (1 short beep sounds.)
	22		• Automatically transmits.	Starts automatic adjustment. When the adjustment is completed, 2 short beeps sound and returns to the TX/ID adjustment screen.

The underlined parts have been updated from the previous version of the addendum, or from the original page.

5-8 REFERENCE FREQUENCY ADJUSTMENT

Touch [REF] on the adjustment mode main menu.

ADJUSTMENT		ADJUSTMENT ITEM DISPLAY	SETTING CONDITION	OPERATION
REFERENCE FREQUENCY - Preparation -	1	-	<ul style="list-style-type: none"> • Connect the 13.8 V DC power source to [DC 13.8 V]. • Connect the RF power meter or dummy load to the antenna connector. • Loosely couple the frequency counter to the antenna connector. 	Touch [REF] to enter the Reference Frequency Adjustment mode.
- Adjustment -	2	REF OSC	• Receive	Touch [SET]. (2 short beeps sound.)
	3		• Automatically transmits.	Rotate [MAIN DIAL] to set to 435.000000 MHz (within ± 30 Hz), and then touch [SET]. Return to the reference frequency adjust menu.

The underlined parts have been updated from the previous version of the addendum, or from the original page.

5-9 HF/50 MHz BANDS RECEIVE ADJUSTMENT

Touch [RX] on the adjustment mode main menu.

ADJUSTMENT	ADJUSTMENT ITEM DISPLAY	SETTING CONDITION	OPERATION	
HF RECEIVE - Preparation - ----- - Adjustment - ----- ~ S0 LEVEL ~ ----- ~ S9 LEVEL ~ ----- ~ S9+60 LEVEL ~	1	–	• Connect the 13.8 V DC power source to [DC 13.8 V]. • Connect the SSG to the antenna connector and set it to: Frequency: 14.1515 MHz	Touch [HF] to enter the HF receive adjustment mode.
	2	HF Total Gain PRE OFF ref	• Set the SSG to: Level: 34 dBμ* (–73 dBm)	Touch [SET]. (1 short beep sounds.)
	3		• Receive	Starts automatic adjustment. When the adjustment is completed, 2 short beeps sound and selects the next adjustment item.
	4	HF Total Gain PRE OFF set	• Set the SSG to: Level: OFF	Touch [SET]. (1 short beep sounds.)
	5		• Receive	Starts automatic adjustment. When the adjustment is completed, 2 short beeps sound and selects the next adjustment item.
	6	HF Total Gain PRE1 ref	• Set the SSG to: Level: 34 dBμ* (–73 dBm)	Touch [SET]. (1 short beep sounds.)
	7		• Receive	Starts automatic adjustment. When the adjustment is completed, 2 short beeps sound and selects the next adjustment item.
	8	HF Total Gain PRE1 set	• Set the SSG to: Level: OFF	Touch [SET]. (1 short beep sounds.)
	9		• Receive	Starts automatic adjustment. When the adjustment is completed, 2 short beeps sound and selects the next adjustment item.
	10	HF S0 LEVEL	• Set the SSG to: Level: 10 dBμ* (–97 dBm)	Touch [SET]. (1 short beep sounds.)
	11		• Receive	Starts automatic adjustment. When the adjustment is completed, 2 short beeps sound and selects the next adjustment item.
	12	HF S9 LEVEL	• Set the SSG to: Level: 34 dBμ* (–73 dBm)	Touch [SET]. (1 short beep sounds.)
	13		• Receive	Starts automatic adjustment. When the adjustment is completed, 2 short beeps sound and selects the next adjustment item.
	14	HF S9+60 LEVEL	• Set the SSG to: Level: 94 dBμ* (–13 dBm)	Touch [SET]. (1 short beep sounds.)
	15		• Receive	Starts automatic adjustment. When the adjustment is completed, 2 short beeps sound and selects the next adjustment item.

*The output level of the standard signal generator (SSG) is measured at the load end (PD).

Continued on the next page...

The underlined parts have been updated from the previous version of the addendum, or from the original page.

5-9 HF/50 MHz BANDS RECEIVE ADJUSTMENT (continued)

ADJUSTMENT	ADJUSTMENT ITEM DISPLAY	SETTING CONDITION	OPERATION		
50 MHz BAND RECEIVE - Preparation - - Adjustment -	16	–	–		
	17	50M Total Gain PRE OFF ref	<ul style="list-style-type: none"> • Connect the SSG to the antenna connector and set it to: Frequency: 52.0215 MHz • Set the SSG to: Level: 34 dBμ* (–73 dBm) • Receive 	Touch [SET]. (1 short beep sounds.)	
				Starts automatic adjustment. When the adjustment is completed, 2 short beeps sound and selects the next adjustment item.	
	19	50M Total Gain PRE OFF set	<ul style="list-style-type: none"> • Set the SSG to: Level: OFF • Receive 	Touch [SET]. (1 short beep sounds.)	
				Starts automatic adjustment. When the adjustment is completed, 2 short beeps sound and selects the next adjustment item.	
	21	50M Total Gain PRE1 ref	<ul style="list-style-type: none"> • Set the SSG to: Level: 34 dBμ* (–73 dBm) • Receive 	Touch [SET]. (1 short beep sounds.)	
				Starts automatic adjustment. When the adjustment is completed, 2 short beeps sound and selects the next adjustment item.	
	23	50M Total Gain PRE1 set	<ul style="list-style-type: none"> • Set the SSG to: Level: OFF • Receive 	Touch [SET]. (1 short beep sounds.)	
				Starts automatic adjustment. When the adjustment is completed, 2 short beeps sound and selects the next adjustment item.	
	50 MHz BAND S-METER ~ S0 LEVEL ~	25	50M S0 LEVEL	<ul style="list-style-type: none"> • Set the SSG to: Level: 12 dBμ* (–95 dBm) • Receive 	Touch [SET]. (1 short beep sounds.)
26				Starts automatic adjustment. When the adjustment is completed, 2 short beeps sound and selects the next adjustment item.	
~ S9 LEVEL ~		27	50M S9 LEVEL	<ul style="list-style-type: none"> • Set the SSG to: Level: 34 dBμ* (–73 dBm) • Receive 	Touch [SET]. (1 short beep sounds.)
					28
~ S9+60 LEVEL ~	29	50M S9+60 LEVEL	<ul style="list-style-type: none"> • Set the SSG to: Level: 94 dBμ* (–13 dBm) • Receive 	Touch [SET]. (1 short beep sounds.)	
				30	Starts automatic adjustment. When the adjustment is completed, 2 short beeps sound and selects the next adjustment item.
IF TRAP	31	IF Trap1	<ul style="list-style-type: none"> • Set the SSG to: Frequency: 39.3485 MHz Level: 70 dBμ* (–37 dBm) 	Touch [SET]. (1 short beep sounds.)	
				32	Starts automatic adjustment. When the adjustment is completed, 2 short beeps sound and selects the next adjustment item.
	33	IF Trap2	<ul style="list-style-type: none"> • Set the SSG to: Frequency: 38.8485 MHz 	Touch [SET]. (1 short beep sounds.)	
				34	Starts automatic adjustment. When the adjustment is completed, 2 short beeps sound and selects the next adjustment item.
	35	IF Trap3	<ul style="list-style-type: none"> • Set the SSG to: Frequency: 38.3485 MHz 	Touch [SET]. (1 short beep sounds.)	
				36	Starts automatic adjustment. When the adjustment is completed, 2 short beeps sound and selects the next adjustment item.

*The output level of the standard signal generator (SSG) is measured at the load end (PD).

The underlined parts have been updated from the previous version of the addendum, or from the original page.

5-10 VHF BAND RECEIVE ADJUSTMENT

Touch [RX] on the adjustment mode main menu.

ADJUSTMENT	ADJUSTMENT ITEM DISPLAY	SETTING CONDITION	OPERATION
VHF BAND RECEIVE - Preparation -	1	-	<ul style="list-style-type: none"> Connect the 13.8 V DC power source to [DC 13.8 V]. Connect the SSG to the antenna connector.
	- Adjustment -		
	2	VHF Tuned-BPF 1	<ul style="list-style-type: none"> Set the SSG to: Frequency: <u>75.2015 MHz</u> Level: 10 dBμ* (-97 dBm)
	3		Touch [SET]. (1 short beep sounds.) Starts automatic adjustment. When the adjustment is completed, 2 short beeps sound and selects the next adjustment item.
	4	VHF Tuned-BPF 2	<ul style="list-style-type: none"> Set the SSG to: Frequency: 90.2015 MHz
	5		Touch [SET]. (1 short beep sounds.) Starts automatic adjustment. When the adjustment is completed, 2 short beeps sound and selects the next adjustment item.
	6	VHF Tuned-BPF 3	<ul style="list-style-type: none"> Set the SSG to: Frequency: 108.2015 MHz
	7		Touch [SET]. (1 short beep sounds.) Starts automatic adjustment. When the adjustment is completed, 2 short beeps sound and selects the next adjustment item.
	8	VHF Tuned-BPF 4	<ul style="list-style-type: none"> Set the SSG to: Frequency: 146.2015 MHz
	9		Touch [SET]. (1 short beep sounds.) Starts automatic adjustment. When the adjustment is completed, 2 short beeps sound and selects the next adjustment item.
	10	VHF Tuned-BPF 5	<ul style="list-style-type: none"> Set the SSG to: Frequency: 199.8015 MHz
	11		Touch [SET]. (1 short beep sounds.) Starts automatic adjustment. When the adjustment is completed, 2 short beeps sound and selects the next adjustment item.
	12	VHF Total Gain PRE OFF ref	<ul style="list-style-type: none"> Set the SSG to: Frequency: 146.0215 MHz
	13		Touch [SET]. (1 short beep sounds.) Starts automatic adjustment. When the adjustment is completed, 2 short beeps sound and selects the next adjustment item.
	14	VHF Total Gain PRE OFF set	<ul style="list-style-type: none"> Set the SSG to: Level: OFF
	15		Touch [SET]. (1 short beep sounds.) Starts automatic adjustment. When the adjustment is completed, 2 short beeps sound and selects the next adjustment item.
	16	VHF Total Gain PRE1 ref	<ul style="list-style-type: none"> Set the SSG to: Level: 10 dBμ* (-97 dBm)
	17		Touch [SET]. (1 short beep sounds.) Starts automatic adjustment. When the adjustment is completed, 2 short beeps sound and selects the next adjustment item.
	18	VHF Total Gain PRE1 set	<ul style="list-style-type: none"> Set the SSG to: Level: OFF
	19		Touch [SET]. (1 short beep sounds.) Starts automatic adjustment. When the adjustment is completed, 2 short beeps sound and selects the next adjustment item.

*The output level of the standard signal generator (SSG) is measured at the load end (PD).

Continued on the next page...

The underlined parts have been updated from the previous version of the addendum, or from the original page.

5-10 VHF BAND RECEIVE ADJUSTMENT (continued)

ADJUSTMENT	ADJUSTMENT ITEM DISPLAY	SETTING CONDITION	OPERATION
VHF S-METER ~ S0 LEVEL ~	20	VHF S0 LEVEL • Set the SSG to: Level: -13 dBμ* (-120 dBm)	Touch [SET]. (1 short beep sounds.)
	21		Starts automatic adjustment. When the adjustment is completed, 2 short beeps sound and selects the next adjustment item.
~ S9 LEVEL ~	22	VHF S9 LEVEL • Set the SSG to: Level: 10 dBμ* (-97 dBm)	Touch [SET]. (1 short beep sounds.)
	23		Starts automatic adjustment. When the adjustment is completed, 2 short beeps sound and selects the next adjustment item.
~ S9+60 LEVEL ~	24	VHF S9+60 LEVEL • Set the SSG to: Level: 70 dBμ* (-37 dBm)	Touch [SET]. (1 short beep sounds.)
	25		Starts automatic adjustment. When the adjustment is completed, 2 short beeps sound and selects the next adjustment item.

*The output level of the standard signal generator (SSG) is measured at the load end (PD).

The underlined parts have been updated from the previous version of the addendum, or from the original page.

5-11 UHF BAND RECEIVE ADJUSTMENT

Touch [RX] on the adjustment mode main menu.

ADJUSTMENT	ADJUSTMENT ITEM DISPLAY	SETTING CONDITION	OPERATION	
UHF BAND RECEIVE - Preparation - ----- - Adjustment -	1	-	<ul style="list-style-type: none"> Connect the 13.8 V DC power source to [DC 13.8 V]. Connect the SSG to the antenna connector. 	<ul style="list-style-type: none"> When adjusting following from the VHF band receive adjustment, touch [SET]. When adjusting the UHF band receive items from the RX Adjust menu, touch [UHF], and then [SET].
	2	UHF Tuned-BPF 1	<ul style="list-style-type: none"> Set the SSG to: Frequency: <u>400.2015 MHz</u> Level: 20 dBμ* (-87 dBm) 	Touch [SET]. (1 short beep sounds.)
				Starts automatic adjustment. When the adjustment is completed, 2 short beeps sound and selects the next adjustment item.
	4	UHF Tuned-BPF 2	<ul style="list-style-type: none"> Set the SSG to: Frequency: 435.0215 MHz 	Touch [SET]. (1 short beep sounds.)
				Starts automatic adjustment. When the adjustment is completed, 2 short beeps sound and selects the next adjustment item.
	6	UHF Tuned-BPF 3	<ul style="list-style-type: none"> Set the SSG to: Frequency: 469.8015 MHz 	Touch [SET]. (1 short beep sounds.)
				Starts automatic adjustment. When the adjustment is completed, 2 short beeps sound and selects the next adjustment item.
	8	UHF Total Gain PRE OFF ref	<ul style="list-style-type: none"> Set the SSG to: Frequency: 435.0215 MHz 	Touch [SET]. (1 short beep sounds.)
				Starts automatic adjustment. When the adjustment is completed, 2 short beeps sound and selects the next adjustment item.
	10	UHF Total Gain PRE OFF set	<ul style="list-style-type: none"> Set the SSG to: Level: OFF 	Touch [SET]. (1 short beep sounds.)
				Starts automatic adjustment. When the adjustment is completed, 2 short beeps sound and selects the next adjustment item.
	12	UHF Total Gain PRE1 ref	<ul style="list-style-type: none"> Set the SSG to: Level: 10 dBμ* (-97 dBm) 	Touch [SET]. (1 short beep sounds.)
				Starts automatic adjustment. When the adjustment is completed, 2 short beeps sound and selects the next adjustment item.
	14	UHF Total Gain PRE1 set	<ul style="list-style-type: none"> Set the SSG to: Level: OFF 	Touch [SET]. (1 short beep sounds.)
				Starts automatic adjustment. When the adjustment is completed, 2 short beeps sound and selects the next adjustment item.
16	UHF S0 LEVEL	<ul style="list-style-type: none"> Set the SSG to: Level: -13 dBμ* (-120 dBm) 	Touch [SET]. (1 short beep sounds.)	
			Starts automatic adjustment. When the adjustment is completed, 2 short beeps sound and selects the next adjustment item.	
~ S9 LEVEL ~	UHF S9 LEVEL	<ul style="list-style-type: none"> Set the SSG to: Level: 10 dBμ* (-97 dBm) 	Touch [SET]. (1 short beep sounds.)	
			Starts automatic adjustment. When the adjustment is completed, 2 short beeps sound and selects the next adjustment item.	
~ S9+60 LEVEL ~	UHF S9+60 LEVEL	<ul style="list-style-type: none"> Set the SSG to: Level: 70 dBμ* (-37 dBm) 	Touch [SET]. (1 short beep sounds.)	
			Starts automatic adjustment. When the adjustment is completed, 2 short beeps sound and returns to the RX Adjust menu.	

*The output level of the standard signal generator (SSG) is measured at the load end (PD).



SERVICE MANUAL

HF/VHF/UHF ALL MODE
TRANSCEIVER

IC-705

S-15707XZ-C1
October 2020

Icom Inc.

INTRODUCTION

This service manual describes the latest technical information for the following versions of the IC-705 HF/VHF/UHF ALL MODE TRANSCEIVER at the time of publication.

MODEL	VERSION	VERSION NUMBER	OUTPUT POWER
IC-705	USA	#12	10 W
	EUR	#13	

To upgrade quality, any electrical or mechanical parts and internal circuits are subject to change without notice or obligation.

SERVICE CAUTION

NEVER connect the transceiver to an AC outlet or to a DC power supply that outputs more than the specified voltage. This will ruin the transceiver.

DO NOT expose the transceiver to rain, snow or liquids.

DO NOT reverse the polarity of the DC power cable when directly connecting to the transceiver.

DO NOT apply an RF signal of more than 20 dBm (100 mW) to the antenna connector. This could damage the transceiver's front-end.



ORDERING PARTS

Be sure to include the following four points when ordering replacement parts:

1. 10-digit Icom part number
2. Component name
3. Equipment model name and unit name
4. Quantity required

<ORDER EXAMPLE>

1180005550	NJM2831	IC-705	MAIN	5 pieces
8930103000	4075 JACK CAP	IC-705	CHASSIS	1 piece

Addresses are provided on the inside back cover for your convenience.

REPAIR NOTES

1. Make sure that the problem is internal before disassembling the transceiver.
2. **DO NOT** open the transceiver until the transceiver is disconnected from its power source.
3. **DO NOT** force any of the variable components. Turn them slowly and smoothly.
4. **DO NOT** short any circuits or electronic parts. An insulated tuning tool **MUST** be used for all adjustments.
5. **DO NOT** keep power ON for a long time when the transceiver is defective.
6. **NEVER** directly transmit power into any test equipment such as Standard Signal Generator or a Sweep Generator, otherwise the RF power may damage them.
7. **ALWAYS** connect a 40 dB to 50 dB attenuator between the transceiver and such test equipment.
8. **READ** the instructions of the test equipment thoroughly before connecting it to the transceiver.

TABLE OF CONTENTS

SECTION 1	SPECIFICATIONS	1-1
SECTION 2	INSIDE VIEWS	2-1
SECTION 3	DISASSEMBLY INSTRUCTION.....	3-1
SECTION 4	INTERFACE INFORMATION	4-1
SECTION 5	ADJUSTMENT PROCEDURES	5-1
5-1	PREPARATION	5-1
5-2	FRONT PANEL OPERATION VERIFICATION	5-4
5-3	IDLING ADJUSTMENT	5-5
5-4	HF TRANSMIT ADJUSTMENT	5-6
5-5	50 MHz BAND TRANSMIT ADJUSTMENT	5-8
5-6	VHF BAND TRANSMIT ADJUSTMENT	5-10
5-7	UHF BAND TRNSMIT ADJUSTMENT	5-12
5-8	REFERENCE FREQUENCY AJJUSTMENT	5-14
5-9	HF/50 MHz BANDS RECEIVE ADJUSTMENT	5-15
5-10	VHF BAND RECEIVE ADJUSTMENT	5-17
5-11	UHF BAND RECEIVE ADJUSTMENT	5-19
SECTION 6	SPARE PARTS AND UNITS	6-1
SECTION 7	MECHANICAL PARTS	7-1
SECTION 8	BOARD LAYOUT	8-1
SECTION 9	WIRING DIAGRAM	9-1
SECTION 10	BLOCK DIAGRAM	10-1
SECTION 11	SCHEMATIC DIAGRAM	11-1

SECTION 1

SPECIFICATIONS

GENERAL

- Frequency coverage (unit: MHz):

	USA version	EUR version
Receiver	0.030000 ~ 199.999999*	0.030000 ~ 199.999999*
	400.000000 ~ 470.000000*	400.000000 ~ 470.000000*
Transmitter	1.800000 ~ 1.999999	1.810000 ~ 1.999999
	3.500000 ~ 3.999999	3.500000 ~ 3.800000
	5.255000 ~ 5.405000	–
	7.000000 ~ 7.300000	7.000000 ~ 7.200000
	10.100000 ~ 10.150000	10.100000 ~ 10.150000
	14.000000 ~ 14.350000	14.000000 ~ 14.350000
	18.068000 ~ 18.168000	18.068000 ~ 18.168000
	21.000000 ~ 21.450000	21.000000 ~ 21.450000
	24.890000 ~ 24.990000	24.890000 ~ 24.990000
	28.000000 ~ 29.700000	28.000000 ~ 29.700000
	50.000000 ~ 54.000000	50.000000 ~ 52.000000
144.000000 ~ 148.000000	144.000000 ~ 146.000000	
430.000000 ~ 450.000000	430.000000 ~ 440.000000	

* Some frequency ranges are not guaranteed.

- Operating modes: USB/LSB (J3E), CW (A1A), RTTY (F1B), AM (A3E), FM/WFM* (F2D/F3E), and DV (F7W)
* WFM: RX only
- Number of memory channels: 500 channels (in 100 groups)
- Number of program scan channels: 25 channels (2 edge frequencies in each channel)
- Number of call channels: 4 channels (2 channels × 2 bands (144 MHz and 430 MHz))
- Number of repeater memories: 2500
- Number of GPS memories: 300
- Antenna impedance: 50 Ω unbalanced
- Antenna connector: BNC (50 Ω)
- Power supply requirement: 13.8 V DC (within ±15%) for external DC power
7.4 V DC specified Icom's battery pack
- Operating temperature range: –10°C ~ +60°C, 14°F ~ 140°F
- Frequency stability: Less than ±0.5 ppm (–10°C ~ +60°C, 14°F ~ 140°F)
- Frequency resolution: 1 Hz (minimum)
- Power consumption:
 - Using external DC power (13.8 V DC)

Receive	Standby	0.3 A (typical)
	Maximum audio	0.5 A (typical)
Transmit	Maximum power (10 W)	Less than 3.0 A
 - Using specified Icom's battery pack (7.4 V DC)

Receive	Standby	0.5 A (typical)
	Maximum audio	0.8 A (typical)
Transmit	Maximum power (5 W)	Less than 2.5 A
- Dimensions (projections not included): 200.0 (W) × 83.5 (H) × 82.0 (D) mm, 7.9 (W) × 3.3 (H) × 3.2 (D) in
- Weight (approximate): 1.1 kg, 2.4 lb (including BP-272)

■ TRANSMITTER

- Transmit output power:
 - Using external DC power (13.8 V DC)
 - SSB, CW, FM, RTTY, DV 0.1 ~ 10 W
 - AM 0.025 ~ 2.5 W
 - Using specified Icom's battery pack (7.4 V DC)
 - SSB, CW, FM, RTTY, DV 0.1 ~ 5 W
 - AM 0.025 ~ 1.25 W
- SAR 10g: 0.643 W/kg
- Modulation system:
 - SSB Digital PSN modulation
 - FM Digital Reactance modulation
 - AM Digital Low power modulation
 - DV Digital GMSK modulation
- Spurious emission:
 - Harmonics
 - 1.8 ~ 28 MHz band Less than -50 dB
 - 50 MHz band Less than -60 dB
 - 144/430 MHz band Less than -60 dB
 - Out-of-band emission
 - 1.8 ~ 28 MHz band Less than -40 dB
 - 50 MHz band Less than -60 dB
 - 144/430 MHz band Less than -60 dB
- Carrier suppression: More than 50 dB
- Unwanted sideband suppression: More than 50 dB
- Microphone impedance: 2.2 k Ω

RECEIVER

- Receive system:
 - 0.03 ~ 24.999999 MHz RF Direct Sampling
 - 25 ~ 199.999999 MHz, 400 ~ 470 MHz Down Conversion IF Sampling
- Intermediate frequency (only 25 ~ 199.999999 MHz, 400 ~ 470 MHz):
 - 38.85 MHz \pm 0.5 MHz
- Sensitivity:
 - SSB/CW (SSB: BW=2.4 kHz, Filter: SOFT, 10 dB S/N CW: BW=500 Hz, Filter: SHARP, 10 dB S/N)
 - 1.8 ~ 29.999999 MHz Less than -14 dB μ V (0.20 μ V) ^{*1}
 - 50 MHz band Less than -16 dB μ V (0.15 μ V) ^{*2}
 - 144/430 MHz band Less than -19 dB μ V (0.11 μ V) ^{*3}
 - AM (BW=6 kHz, 10 dB S/N)
 - 0.5 ~ 1.799999 MHz Less than 22 dB μ V (13.0 μ V) ^{*1}
 - 1.8 ~ 29.999999 MHz Less than 6 dB μ V (2.0 μ V) ^{*1}
 - 50 MHz band Less than 0 dB μ V (1.0 μ V) ^{*2}
 - 108.0 ~ 137.0 MHz Less than 0 dB μ V (1.0 μ V) ^{*3}
 - 144/430 MHz band Less than 0 dB μ V (1.0 μ V) ^{*3}
 - FM (at 12 dB SINAD)
 - 28.0 ~ 29.7 MHz Less than -6 dB μ V (0.5 μ V) ^{*1}
 - 50 MHz band Less than -12 dB μ V (0.25 μ V) ^{*2}
 - 144/430 MHz band Less than -15 dB μ V (0.18 μ V) ^{*3}
 - WFM (at 12 dB SINAD)
 - 76.0 ~ 108 MHz Less than -3 dB μ V (0.71 μ V) ^{*3}
 - DV (1% BER (PN9))
 - 28.0 ~ 29.7 MHz Less than 0 dB μ V (1.0 μ V) ^{*1}
 - 50 MHz band Less than -4 dB μ V (0.63 μ V) ^{*2}
 - 144/430 MHz band Less than -9 dB μ V (0.35 μ V) ^{*3}

^{*1} Preamp 1 is ON, ^{*2} Preamp 2 is ON, ^{*3} Preamp is ON
- Sensitivity for the European version:
 - SSB/CW (BW=2.4 kHz, 12 dB SINAD)
 - 1.8 ~ 2.999999 MHz Less than 10 dB μ V emf ^{*1}
 - 3.0 ~ 29.999999 MHz Less than 0 dB μ V emf ^{*1}
 - 50 MHz band Less than -6 dB μ V emf ^{*2}
 - 144/430 MHz band Less than -6 dB μ V emf ^{*3}
 - AM (BW=4 kHz, 60% Modulation, 12 dB SINAD)
 - 1.8 ~ 2.999999 MHz Less than 16 dB μ V emf ^{*1}
 - 3.0 ~ 29.999999 MHz Less than 6 dB μ V emf ^{*1}
 - 50 MHz band Less than 0 dB μ V emf ^{*2}
 - 144/430 MHz band Less than 0 dB μ V emf ^{*3}
 - FM (BW=7 kHz, 60% Modulation, 12 dB SINAD)
 - 28.0 ~ 29.7 MHz Less than 0 dB μ V emf ^{*1}
 - 50 MHz band Less than -6 dB μ V emf ^{*2}
 - 144/430 MHz band Less than -6 dB μ V emf ^{*3}

^{*1} Preamp 1 is ON, ^{*2} Preamp 2 is ON, ^{*3} Preamp is ON
- Selectivity (Filter: SHARP):
 - SSB (BW=2.4 kHz)
 - More than 2.4 kHz/-6 dB
 - Less than 3.4 kHz/-40 dB
 - CW (BW=500 Hz)
 - More than 500 Hz/-6 dB
 - Less than 700 Hz/-40 dB
 - RTTY (BW=500 Hz)
 - More than 500 Hz/-6 dB
 - Less than 800 Hz/-40 dB
 - AM (BW=6 kHz)
 - More than 6.0 kHz/-6 dB
 - Less than 10 kHz/-40 dB
 - FM (BW=15 kHz)
 - More than 12.0 kHz/-6 dB
 - Less than 22 kHz/-40 dB
 - DV (Channel spacing=12.5 kHz)
 - More than -50 dB
- Spurious and image rejection:
 - SSB/CW/AM/FM
 - HF band More than 70 dB* (except for ADC aliasing)
 - 50 MHz band More than 70 dB*
 - 144 MHz band More than 65 dB
 - 430 MHz band More than 54 dB

* At Intermediate frequency in 25 ~ 30 MHz or 50 ~ 54 MHz: More than 50 dB
- Audio output power:
 - Internal speaker More than 0.53 W (12 Ω load, 1 kHz, 10% distortion)
 - External speaker More than 0.2 W (8 Ω load, 1 kHz, 10% distortion)
- AF output impedance:
 - 8 Ω
- RIT variable range:
 - \pm 9.999 kHz
- ANF attenuation:
 - More than 30 dB (with 1 kHz single tone)
- MNF attenuation:
 - More than 70 dB
- NR attenuation:
 - More than 6 dB (noise rejection in SSB)

■ WIRELESS LAN

- Wireless LAN standard: IEEE802.11 b/g/n
- Authentication and Encryption: WEP (64/128 bit), WPA-PSK (TKIP), WPA2-PSK (AES)
- Channels: 1 to 13 (2.4 GHz band)
(May differ depending on the country of use.)
- Protocol: TCP/IP
- Output power: Less than 10 mW/MHz

■ BLUETOOTH

- Version: Bluetooth Version 4.2
- Transmission Output: Class 2
- Profile: HFP, HSP, SPP, GATT (Serial) over LE
- The maximum number of paired Bluetooth devices:
5 devices
(Either headsets or data devices are maximum 4 devices,
and the combination is 5 devices in total.)
- Device Name: ICOM BT(IC-705)
(default value)
- Passkey: 0000 (four zeros)

All stated specifications are subject to change without notice or obligation.

• DISPLAY UNIT

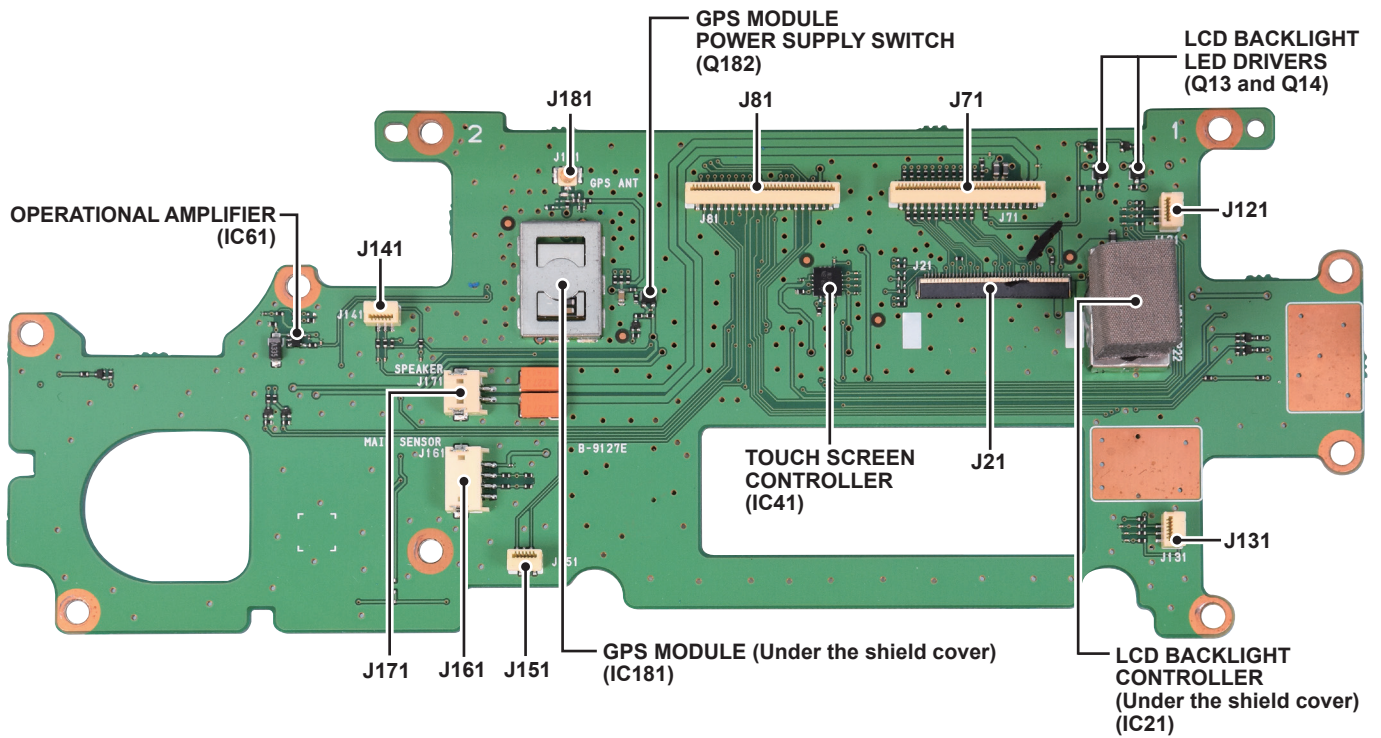

• MAIN UNIT (TOP VIEW)

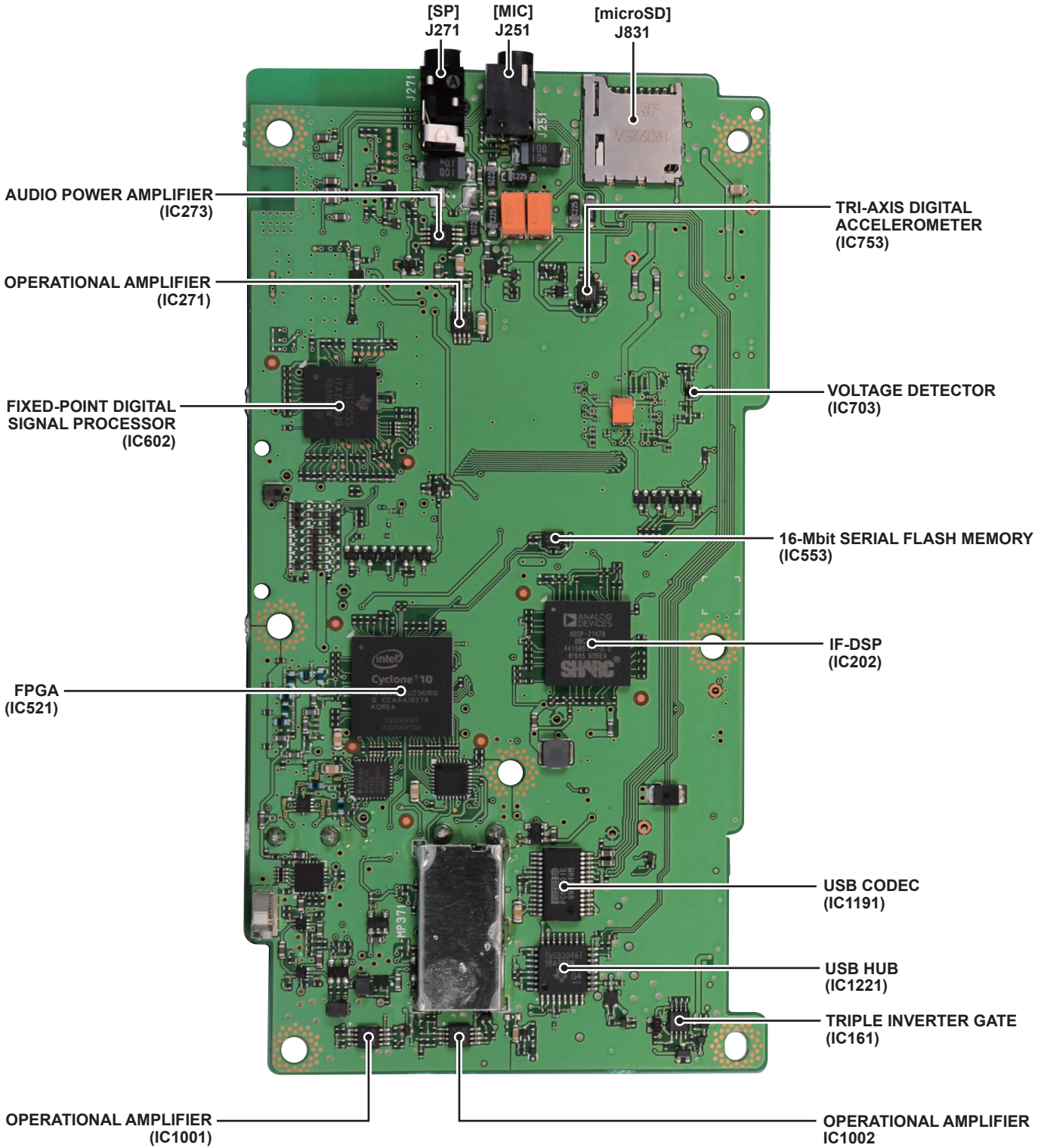

• RF UNIT

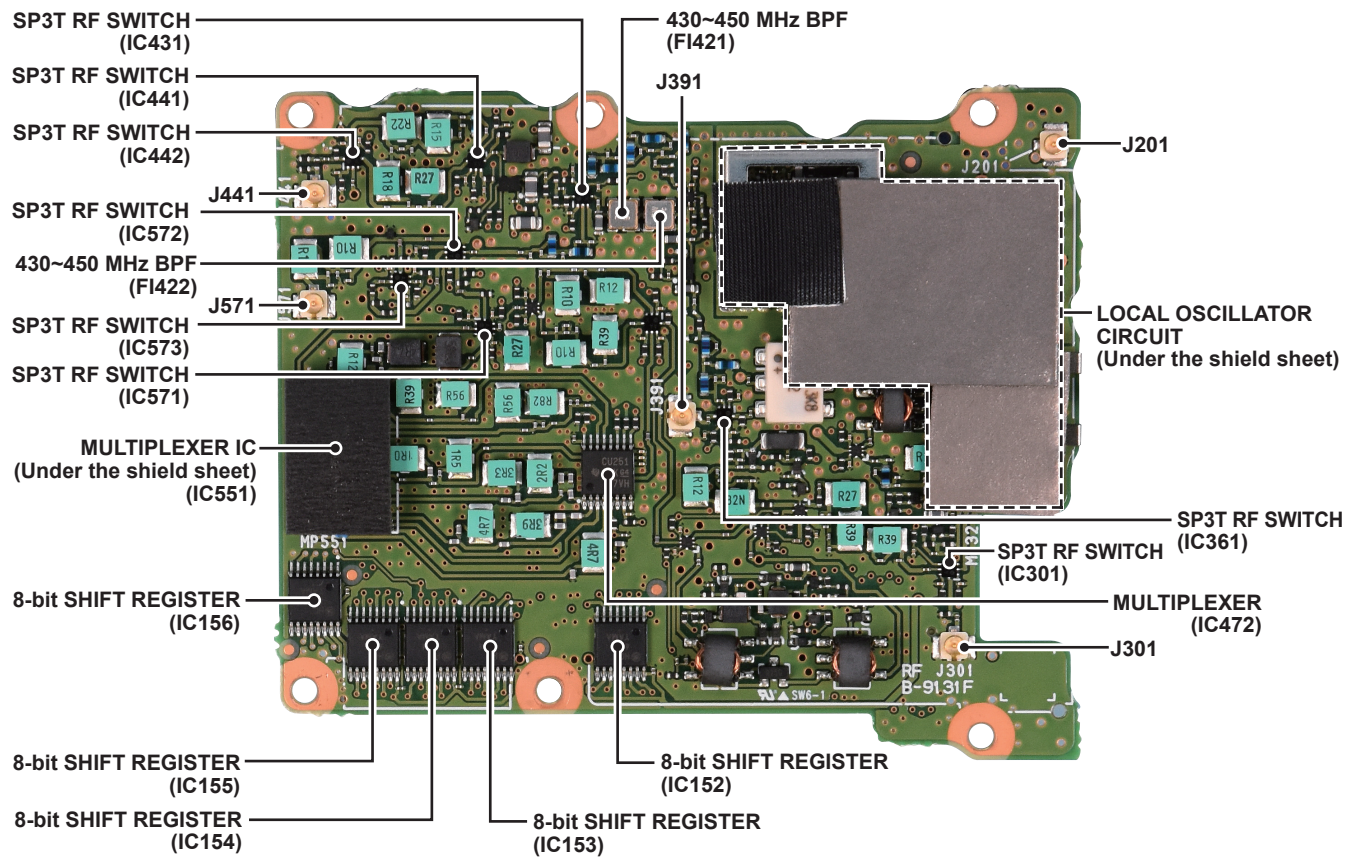

• FILTER UNIT

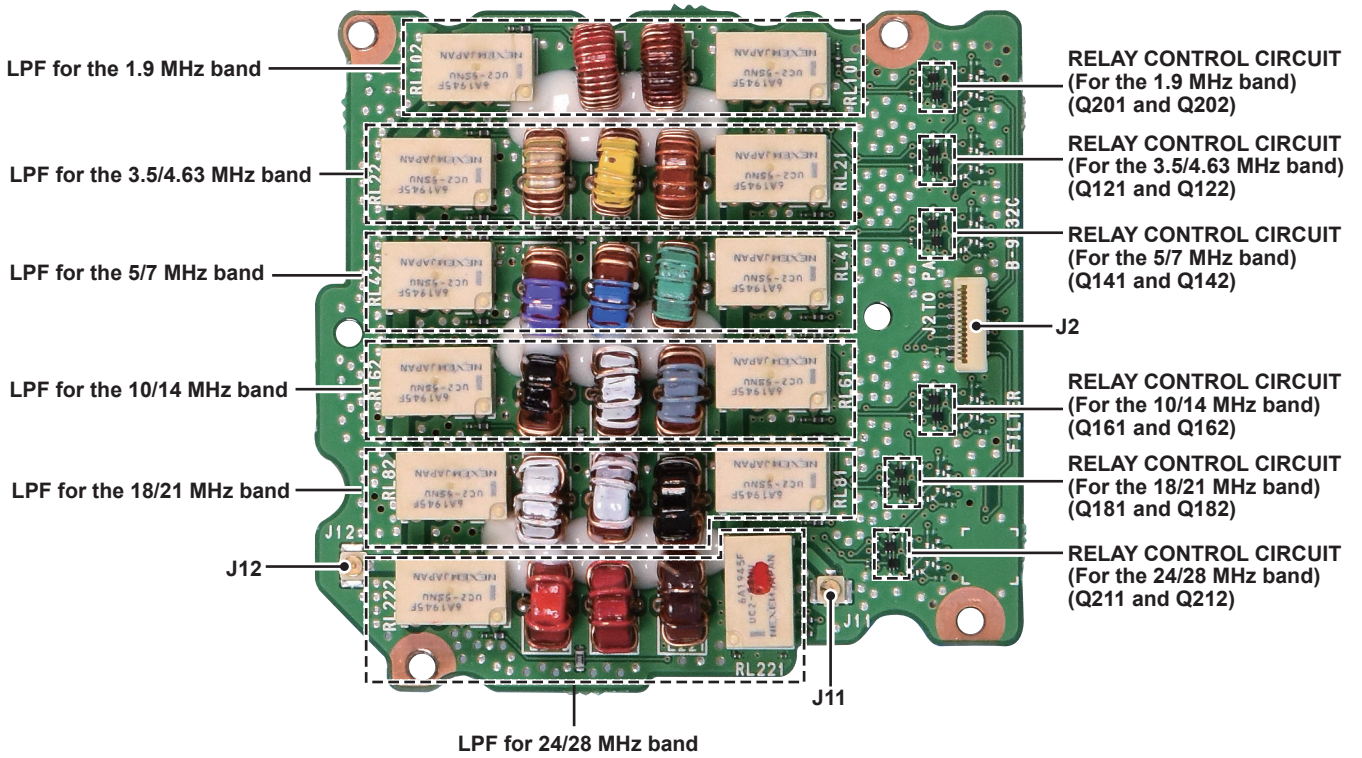

• PA-A UNIT

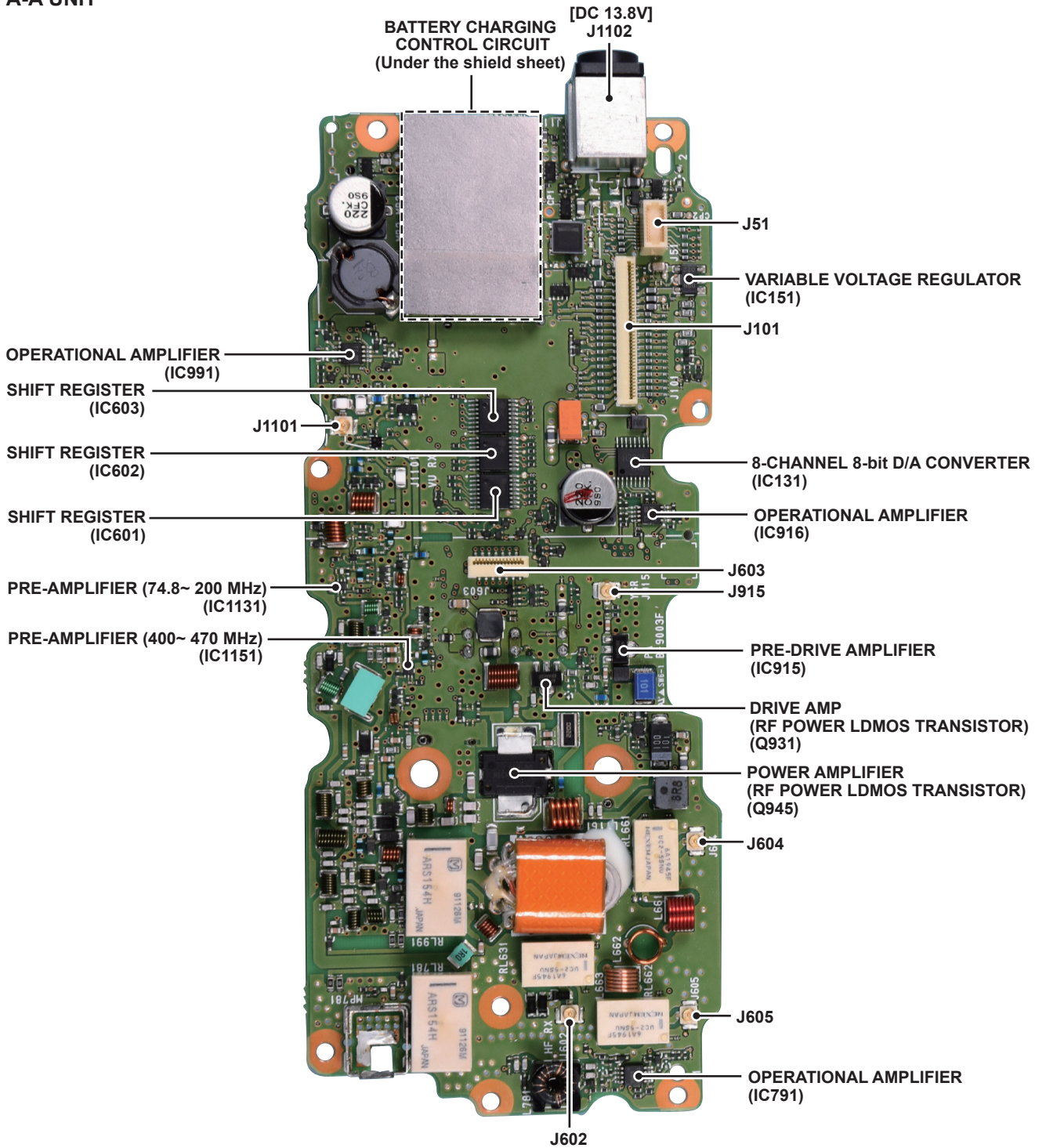

SECTION 3 DISASSEMBLY INSTRUCTION

1. Removing the front panel

- 1) Remove the battery pack if attached.
- 2) Remove the 4 screws from the rear panel, 1 screw each from the top and bottom of the transceiver.

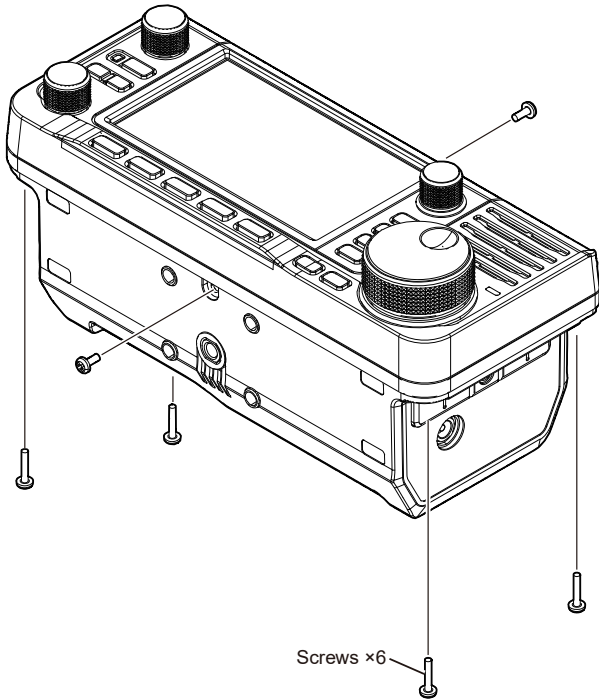

- 2) Separate the front panel from the rear assembly in the direction of the arrow.
Disconnect 2 flat cables from the PCB, as illustrated below.

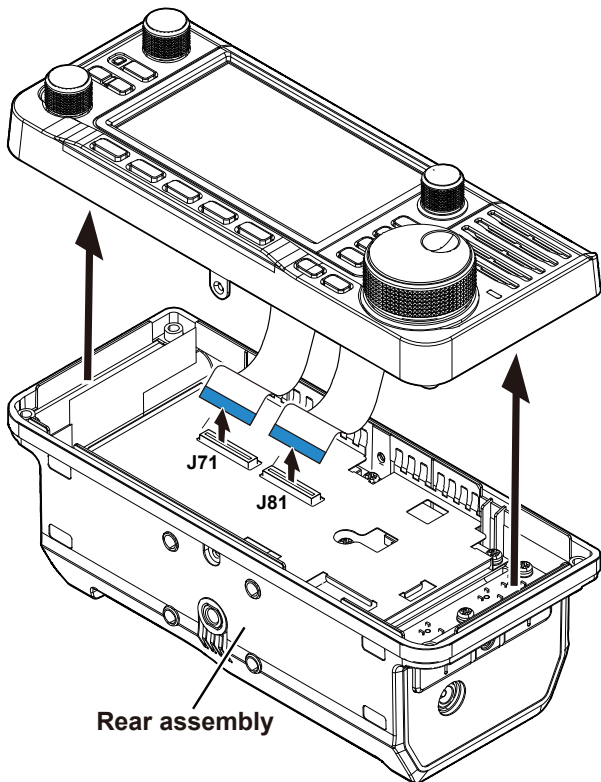

2. Removing the DISPLAY UNIT

- 1) Pull the 4 dial knobs to remove them from the front panel.

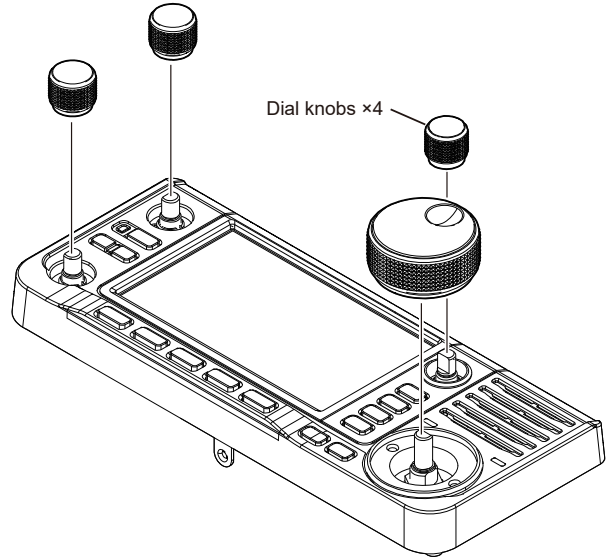

- 2) Disconnect the 4 flat cables, encoder cable, speaker cable and 1 coaxial cable from the DISPLAY UNIT, as illustrated below.

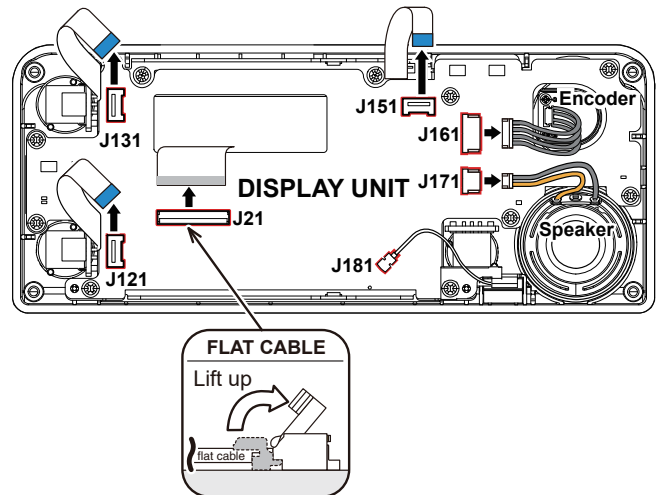

- 3) Remove the 9 screws from the DISPLAY UNIT, then take the DISPLAY UNIT from the front panel.

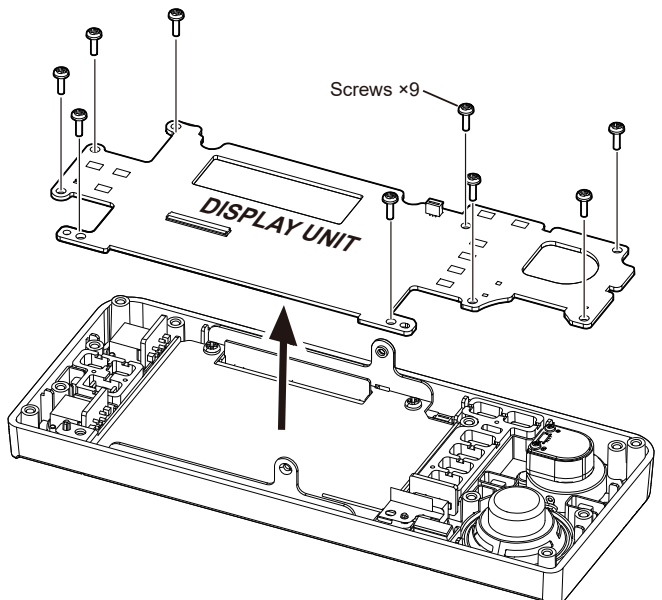

3. Removing the CONNECT UNIT

1) Disconnect 1 flat cable, and remove the 3 screws from the CONNECT UNIT.

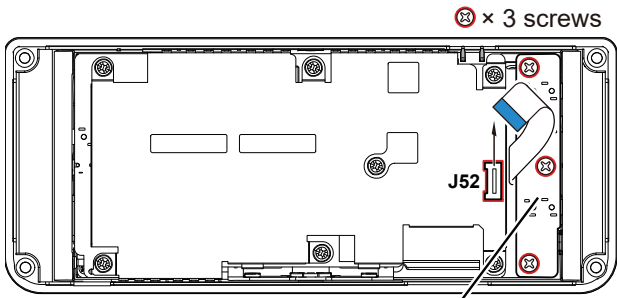

2) Remove the CONNECT UNIT in the direction of the arrow.

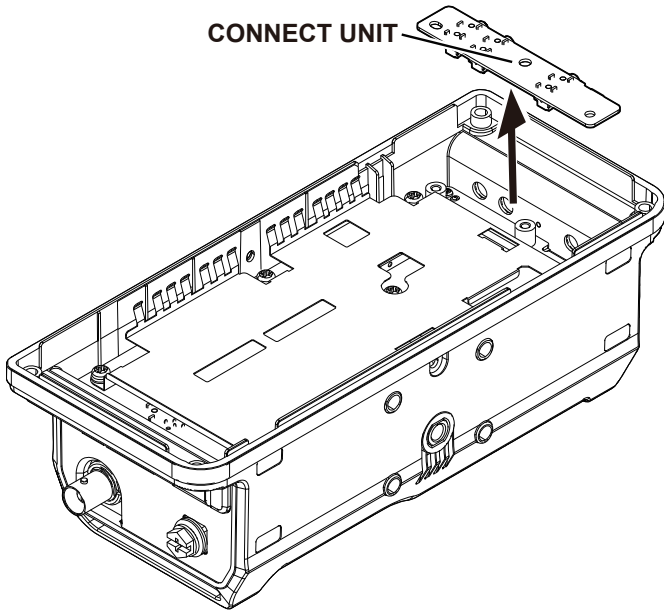

4. Removing the MAIN UNIT

1) Remove the 6 screws from the shield plate.

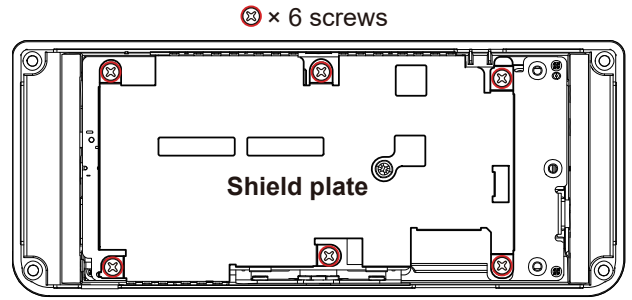

2) Remove the shield plate in the direction of the arrow. (The MAIN UNIT appears.)

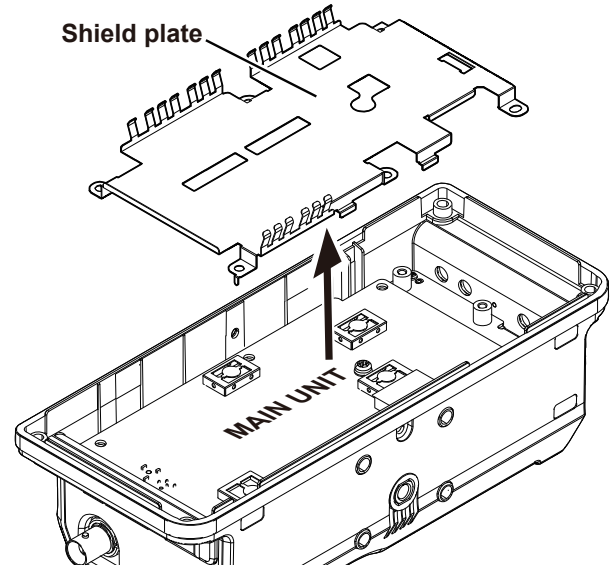

3) Disconnect the 1 flat cable and 2 coaxial cables, and remove a screw from the MAIN UNIT, as illustrated below.

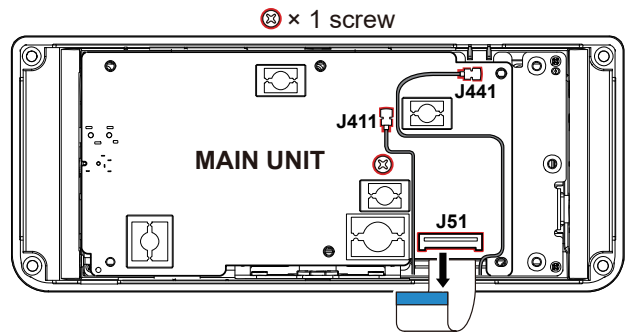

4) Remove the MAIN UNIT in the direction of the arrow.

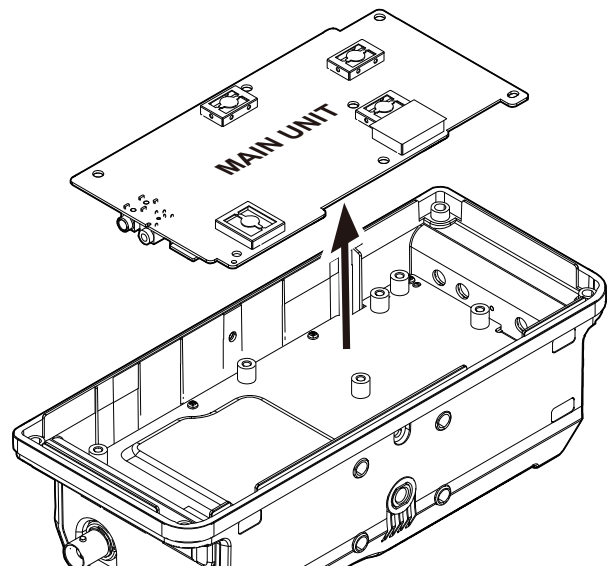

5. Removing the FILTER UNIT and RF UNIT

1) Remove the 8 screws from the shield plate.

⊗ × 8 screws

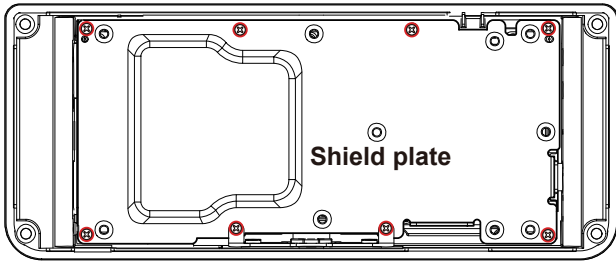

2) Remove the shield plate in the direction of the arrow.
(The FILTER UNIT appears.)

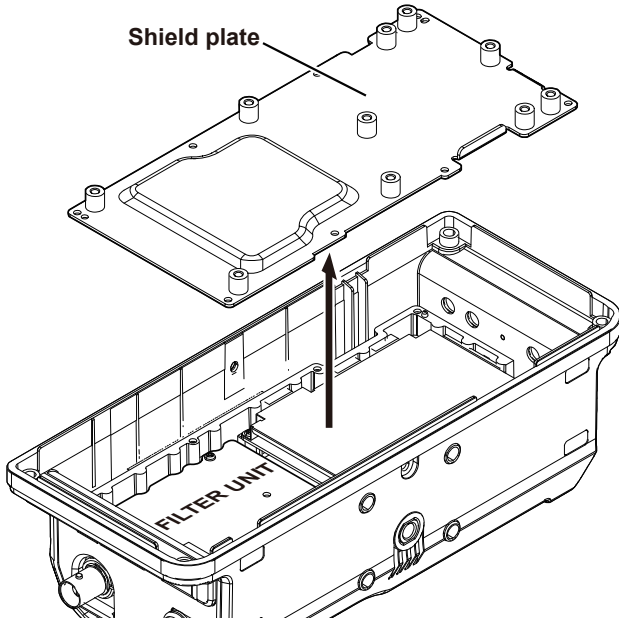

3) Disconnect the 2 coaxial cables and 1 flat cable, and remove the 4 screws from the FILTER UNIT, as illustrated below.

⊗ × 4 screws

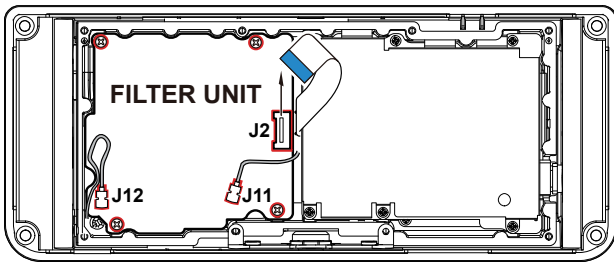

4) Remove the FILTER UNIT in the direction of the arrow.

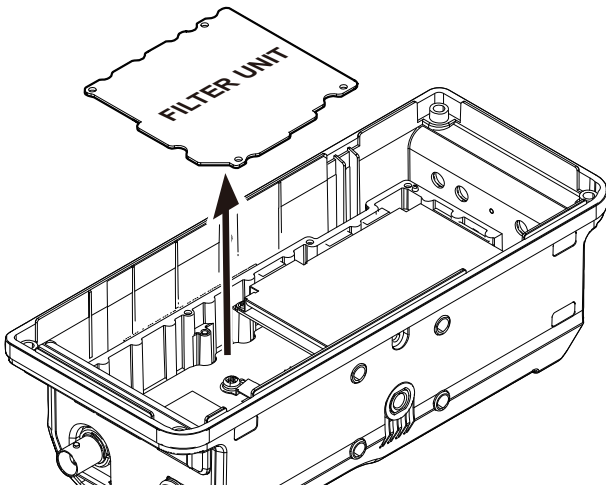

(Continued on the right above)

5) Remove the 4 screws from the shield plate.

⊗ × 4 screws

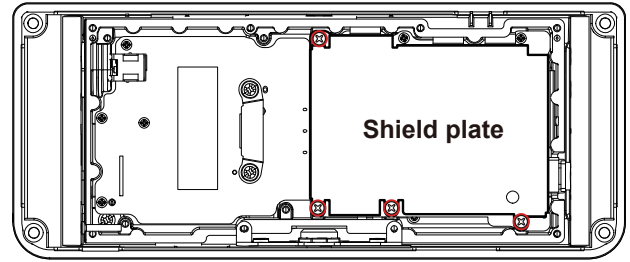

6) Remove the shield plate in the direction of the arrow.
(The RF UNIT appears.)

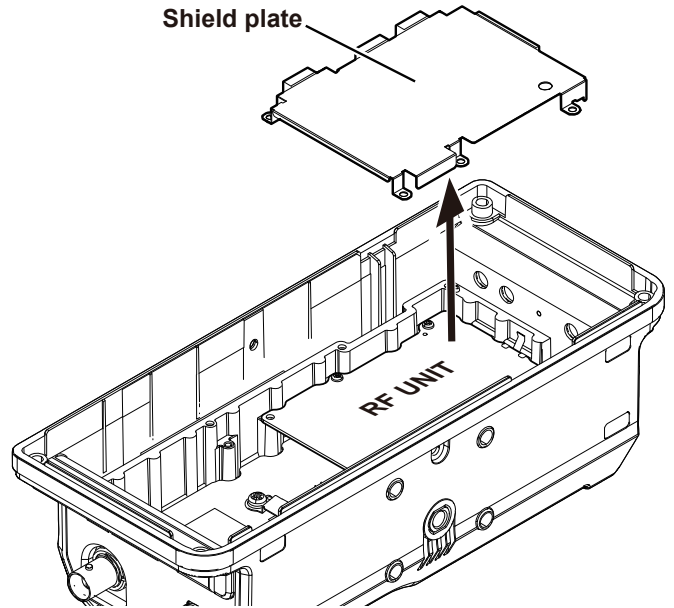

7) Disconnect the 5 coaxial cables, and remove the 2 screws from the RF UNIT, as illustrated below.

⊗ × 2 screws

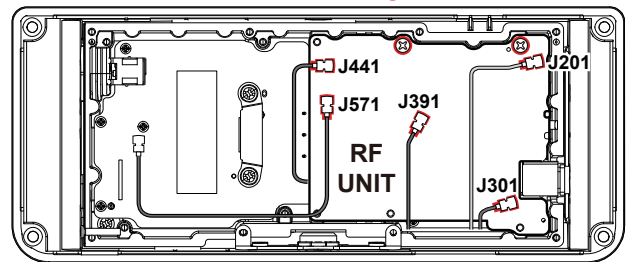

8) Remove the RF UNIT in the direction of the arrow.

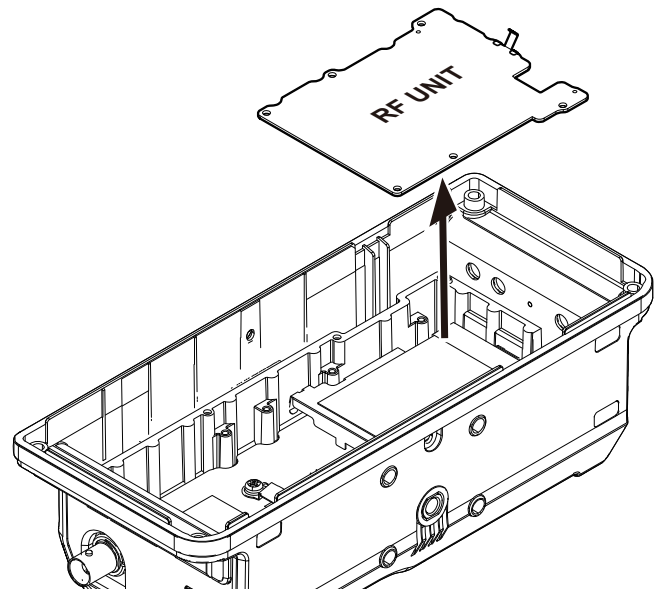

6. Removing the PA-A UNIT

1) Remove the shield plate from the PA-A UNIT.

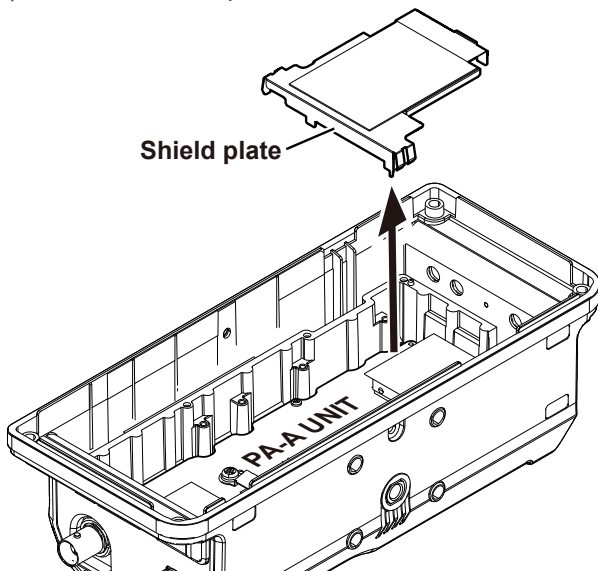

2) Remove the solder from the shield cover to remove it, then remove the solder from the antenna connector.

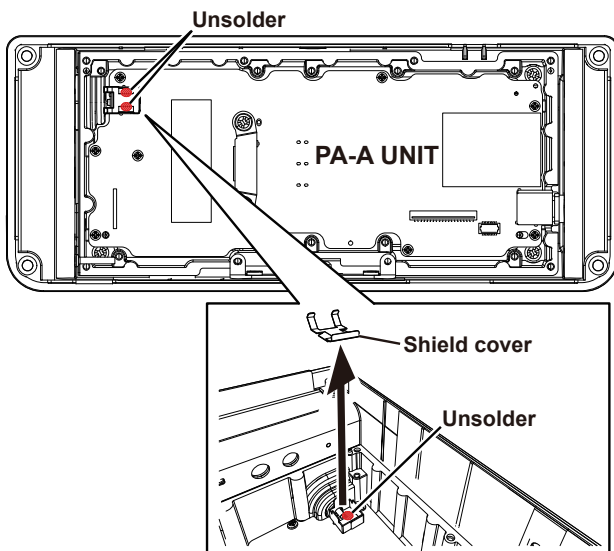

3) Remove the 10 screws from the PA-A UNIT, as illustrated below.

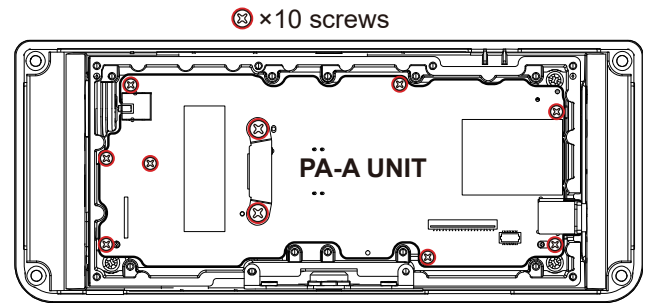

4) Remove the PA-A UNIT in the direction of the arrow. (The binding plate is also removed.)

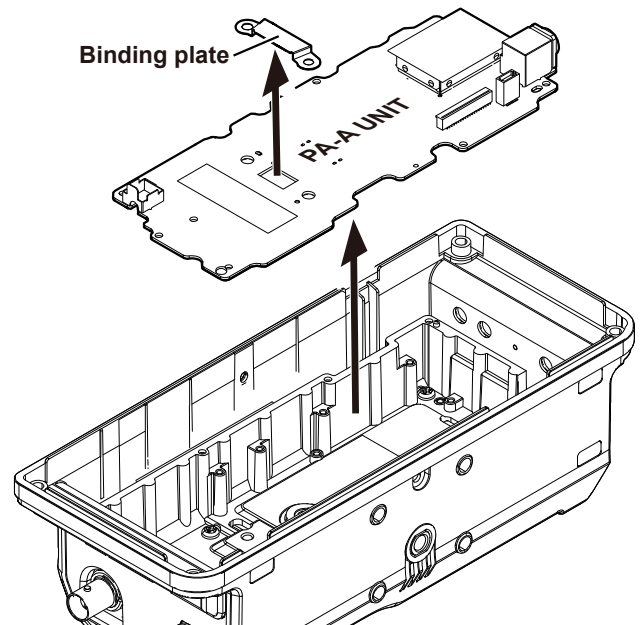

(Continued on the right above)

SECTION 4 INTERFACE INFORMATION

•SIDE PANEL

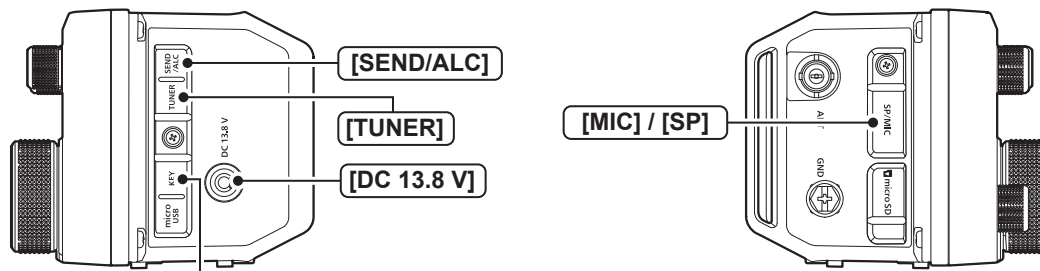

[SEND/ALC]

SEND/ALC	Pin name	Description	Specification
	SEND (I/O)	This terminal goes low when the transceiver transmits, to control an external device such as a non-Icom linear amplifier.	—
	ALC	Input ALC voltage from the linear amplifier, when operating with a non-Icom linear amplifier.	-4 ~ 0 V
	GND	Ground	—

[KEY]

KEY	Pin name	Description	Specification
<ul style="list-style-type: none"> • Paddle key 	Dot	—	—
	Common	—	—
	Dash	—	—
<ul style="list-style-type: none"> • Straight key 	+	—	—
	-	—	—

[SP]

SP	Pin name	Description	Specification
	Left channel	AF output (Left channel)	Output level: More than 0.2 W (at 8 Ω load)
	Right channel	AF output (Right channel)	
	GND	Ground	—

[MIC]

MIC	Pin name	Description	Specification
	Microphone/PTT input	MIC signal input and superimposed PTT	—
	+3.3 V/8 V	DC voltage output	—
	Microphone key input	Key input signal from HM-243	—
	GND	Ground	—

[DC 13.8 V]

DC 13.8 V	Pin name	Description	Specification
	DC IN	Power supply input	13.8 V DC (±15%, 5 A or more)
	GND	Ground	—

[TUNER]

TUNER	Pin name	Description	Specification
	Key	External antenna tuner control signal	—
	Start		—
	GND	Ground	—

SECTION 5 ADJUSTMENT PROCEDURES

5-1 PREPARATION

REQUIRED EQUIPMENT

EQUIPMENT	GRADE AND RANGE	EQUIPMENT	GRADE AND RANGE
DC power supplies	Output voltage: 13.8 V DC Current capacity: 5 A or more	Standard signal generator (SSG)	Frequency range: 10 kHz~600 MHz Output level: 0.1 μ V~32 mV (-127 to -17 dBm)
Frequency counter	Frequency range: 0.1~600 MHz Frequency accuracy: \pm 1 ppm or better Sensitivity: 100 mV or better	RF power meter	Measuring range: 0.1~20 W Frequency range: 0.1~600 MHz SWR: Less than 1.2 : 1
Audio generator (AG)	Frequency range: 300~3000 Hz Output level: 1~500 mV	SWR 2 dummy load	Rated input: At least 10 W SWR: 2.0 : 1
AC millivoltmeter	Measuring range: 1 mV to 10 V	JIG plug	See "CONNECTIONS" for details.

CONNECTIONS

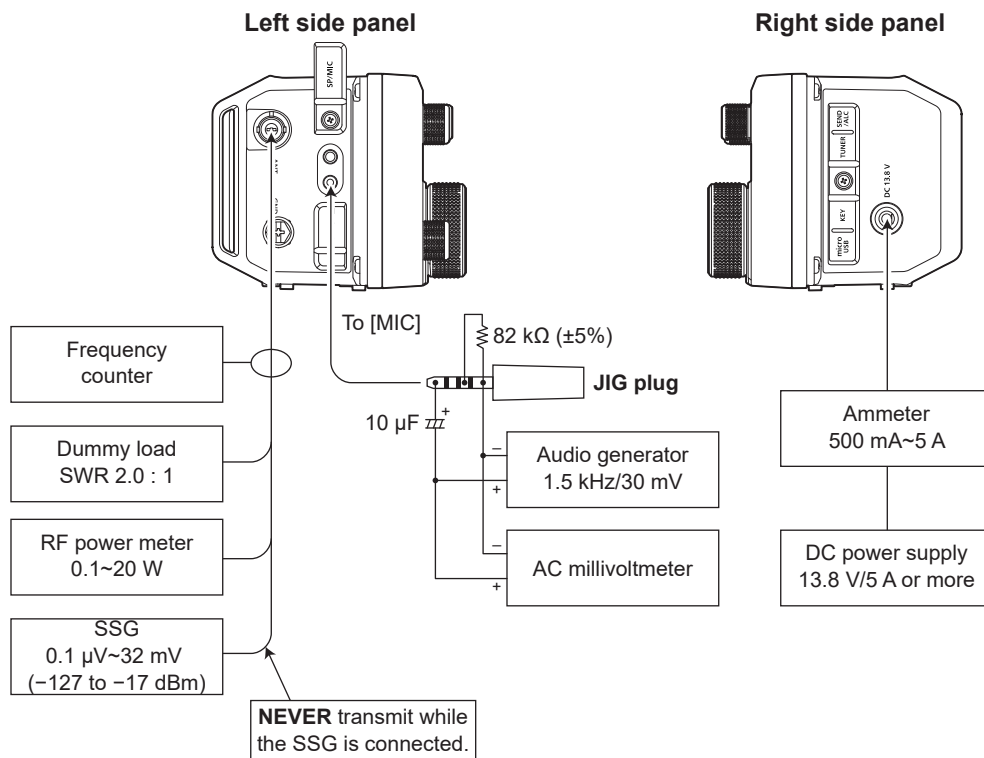

ENTERING THE ADJUST MODE

1. Turn OFF the power.
2. Connect the JIG plug to the [MIC] jack.

Left side panel

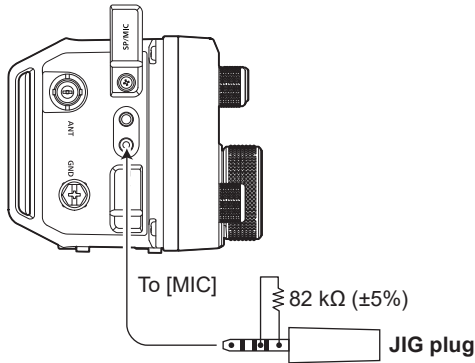

3. While holding down both [MENU] and [FUNC], turn ON to enter the adjust mode.

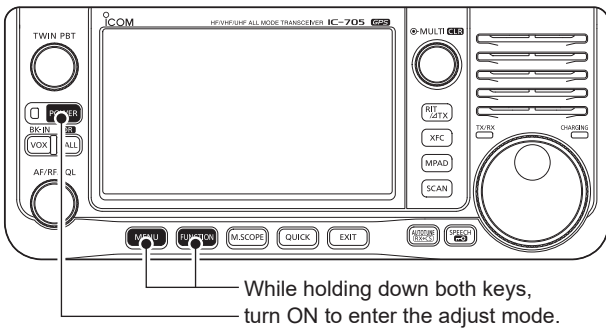

4. The Adjust Mode Main menu is displayed.



KEY ASSIGNMENTS FOR THE ADJUST MODE

- Touch [▼] to select the next adjustment item, touch [▲] to select the previous adjustment item.
- While holding down [QUICK], rotate [MAIN DIAL] to set or modify the adjustment value. (for only TX/ID adjustment)
 - Rotate [MAIN DIAL] to set or modify the adjustment value. (for other than TX/ID adjustment)
- Touch [SET] to start automatic adjustment, or store the adjusted value, and select the next adjustment item.
- Push [EXIT] to return to the previous screen.

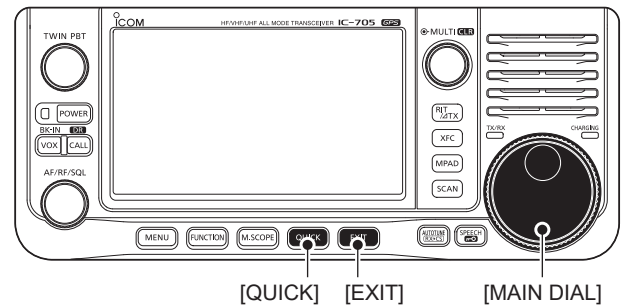
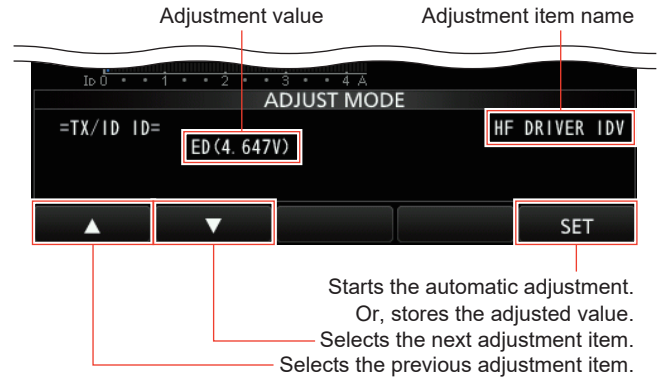

■ ADJUST MODE SCREENS

• MAIN MENU



Enter the FRONT key verification menu.
 Enter the TX/ID adjust menu.
 Enter the REF adjust menu.
 Enter the RX adjust menu.

• FRONT KEY VERIFICATION MENU

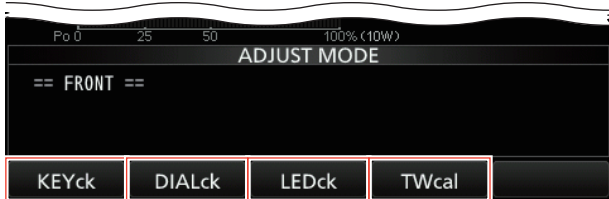

Starts the key verification.
 Starts the dial verification.
 Starts the LED verification.
 Starts the touch screen calibration.

• TX/ID ADJUST MENU

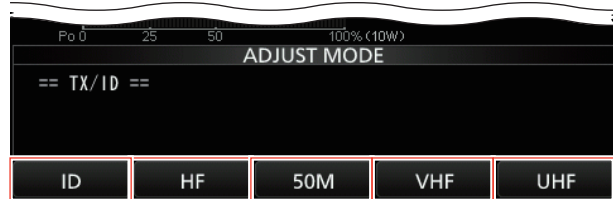

Starts the idling current adjustment.
 Starts the HF transmit adjustment.
 Starts the 50 MHz band transmit adjustment.
 Starts the VHF band transmit adjustment.
 Starts the UHF band transmit adjustment.

• REF ADJUST MENU



Starts the reference frequency adjustment.

• RX ADJUST MENU

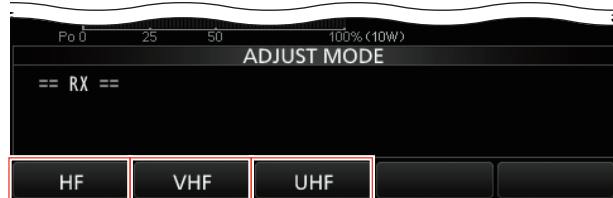

Starts the HF/50 MHz bands receive adjustment.
 Starts the VHF band receive adjustment.
 Starts the UHF band receive adjustment.

5-2 FRONT PANEL OPERATION VERIFICATION

1. Touch [FRONT] on the Adjust Mode Main menu.
2. Touch [KEYck] to enter to the Key Operation Verification mode.
3. Follow the instructions displayed on the screen, and push the corresponding key or knob.
4. Follow the instructions displayed on the screen, and rotate the corresponding dial and sensor.

NOTE: Verification items "25. PHOTO DARK" and "26. PHOTO BRIGHT" check the illuminance sensor. The sensor is built in to the area that assigned with a dotted red circle of the behind of the FRONT panel. (See the figure below)
So, when verifying "25. PHOTO DARK," hide the sensor such as by covering it with your finger. When verifying "26. PHOTO BRIGHT," face the front panel to a light.

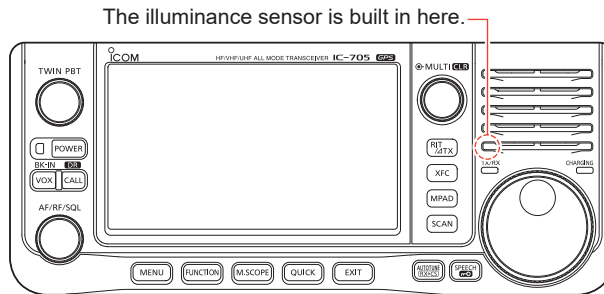

5. Follow the instructions displayed on the screen, and verify the corresponding LED is lit.
6. Push the [XFC] key, and verify the LCD screen changes in order of black, red, green, blue, minimum, and maximum backlight brightness.
7. Push the [XFC] key to start the touch screen calibration, and touch the dot in order of the instructions displayed on the screen.
- After 2 short beeps sound, it automatically return to the Adjust Mode Main menu.

5-3 IDLING ADJUSTMENT

Touch [TX/ID] on the adjustment mode main menu.

ADJUSTMENT		ADJUSTMENT ITEM DISPLAY	SETTING CONDITION	OPERATION
IDLING - Preparation -	1	—	<ul style="list-style-type: none"> Connect the 13.8 V DC power source to [DC 13.8 V]. Connect the ammeter between the 13.8 V DC power source and the transceiver. 	Touch [ID] to enter the ID adjustment mode.
REFERENCE VOLTAGE LOADING	2	VDL IDL SET	<ul style="list-style-type: none"> Receive 	Touch [SET]. (The transceiver briefly transmits and then 3 short beeps sound.)
HF ~ FINAL IDLING CURRENT ~ ~ DRIVER IDLING CURRENT ~	3	HF FINAL ID SET		Touch [SET].
	4	HF FINAL IDV	<ul style="list-style-type: none"> Automatically transmits. 	Touch [SET]. (2 short beeps sound.)
	5	HF DRIVER ID		While holding down [QUICK], perform the following: Rotate [MAIN DIAL] to set the adjustment value to "00" and note the current flow as the reference. Then rotate [MAIN DIAL] to set the adjustment value so that the current flow is 60 mA (within ±5 mA) higher than the reference current, and then touch [SET].
50 MHz BAND ~ FINAL IDLING CURRENT ~ ~ DRIVER IDLING CURRENT ~	6	50M FINAL ID SET	<ul style="list-style-type: none"> Return to receive. 	Touch [SET]. (The transceiver briefly transmits and then 3 short beeps sound.)
	7	50M FINAL IDV	<ul style="list-style-type: none"> Automatically transmits. 	Touch [SET].
	8	50M DRIVER IDV		While holding down [QUICK], perform the following: Rotate [MAIN DIAL] to set the adjustment value to "EA," and then touch [SET].
70 MHz BAND ~ FINAL IDLING CURRENT ~ ~ DRIVER IDLING CURRENT ~	9	70M FINAL ID SET	<ul style="list-style-type: none"> Return to receive. 	Touch [▼] to skip the adjustment.
	10	70M FINAL IDV	<ul style="list-style-type: none"> Automatically transmits. 	
	11	70M DRIVER IDV		
VHF BAND ~ FINAL IDLING CURRENT ~ ~ DRIVER IDLING CURRENT ~	12	VHF FINAL ID SET	<ul style="list-style-type: none"> Return to receive. 	Touch [SET]. (The transceiver briefly transmits and then 3 short beeps sound.)
	13	VHF FINAL IDV	<ul style="list-style-type: none"> Automatically transmits. 	Touch [SET].
	14	VHF DRIVER IDV		While holding down [QUICK], perform the following: Rotate [MAIN DIAL] to set the adjustment value to "EE," and then touch [SET].
UHF BAND ~ FINAL IDLING CURRENT ~ ~ DRIVER IDLING CURRENT ~	15	UHF FINAL ID SET	<ul style="list-style-type: none"> Return to receive. 	Touch [SET]. (The transceiver briefly transmits and then 3 short beeps sound.)
	16	UHF FINAL IDV	<ul style="list-style-type: none"> Automatically transmits. 	Touch [SET].
	17	UHF DRIVER IDV		While holding down [QUICK], perform the following: Rotate [MAIN DIAL] to set the adjustment value to "EA," and then touch [SET].

5-4 HF TRANSMIT ADJUSTMENT

Touch [TX/ID] on the adjustment mode main menu.

ADJUSTMENT	ADJUSTMENT ITEM DISPLAY	SETTING CONDITION	OPERATION
HF TRANSMIT - Preparation -	1 -	<ul style="list-style-type: none"> Connect the 13.8 V DC power source to [DC 13.8 V]. Connect the RF power meter to the antenna connector. Connect the audio generator and the AC millivoltmeter to the JIG plug, and set the audio generator to: Frequency: 1.5 kHz Wave form: Sine wave Level: 30 mVrms 	<ul style="list-style-type: none"> When adjusting following from the idling adjustment, touch [SET]. When adjusting the HF transmit items from the TX/ID Adjust menu, touch [HF].
HF POWER	2 HF TX	• Receive	Touch [SET]. (2 short beeps sound.)
	3 HF POWER SET		
	4 HF TX Total Gain	• Automatically transmits.	While holding down [QUICK], perform the following: Rotate [MAIN DIAL] to set to 0.5 W, and then touch [SET].
	5 HF Power MIN		While holding down [QUICK], perform the following: Rotate [MAIN DIAL] to set to 0.1 W, and then touch [SET]. Note the adjustment value as the reference.
	6 HF Power 1%		While holding down [QUICK], perform the following: Rotate [MAIN DIAL] to set the adjustment value to the same as the reference, and then touch [SET].
	7 HF Power 5%		While holding down [QUICK], perform the following: Rotate [MAIN DIAL] to set to 0.5 W, and then touch [SET].
	8 HF Power 10%		While holding down [QUICK], perform the following: Rotate [MAIN DIAL] to set to 1.0 W, and then touch [SET].
	9 HF Power 25%		While holding down [QUICK], perform the following: Rotate [MAIN DIAL] to set to 2.5 W, and then touch [SET].
	10 HF Power 50%		While holding down [QUICK], perform the following: Rotate [MAIN DIAL] to set to 5.0 W, and then touch [SET].
	11 HF Power 100%		While holding down [QUICK], perform the following: Rotate [MAIN DIAL] to set to 10.0 W, and then touch [SET].
	12 HF Power TUNE		While holding down [QUICK], perform the following: Rotate [MAIN DIAL] to set to 10.0 W, and then touch [SET].
	HF POWER BALANCE	13 HF Power Balance SET	• Return to receive.
14 HF 1.91M Power 100%		• Automatically transmits.	While holding down [QUICK], perform the following: Rotate [MAIN DIAL] to set to 10.0 W, and then touch [SET].
15 HF 3.56M Power 100%			
16 HF 5.30M Power 100%			
17 HF 7.1M Power 100%			
18 HF 10.1M Power 100%			
19 HF 18.1M Power 100%			
20 HF 21.2M Power 100%			
21 HF 24.9M Power 100%			
22 HF 28.5M Power 100%			

Continued on the next page...

5-4 HF TRANSMIT ADJUSTMENT (continued)

ADJUSTMENT		ADJUSTMENT ITEM DISPLAY	SETTING CONDITION	OPERATION
HF AM POWER	23	HF POWER AM Ratio	• Return to receive.	Touch [SET]. (2 short beeps sound.)
	24	HF POWER AM Ratio	• Automatically transmits.	While holding down [QUICK], perform the following: Rotate [MAIN DIAL] to set to 2.5 W, and then touch [SET].
HF ALC ADJUSTMENT	25	HF ALC	• Return to receive.	Touch [SET]. (1 short beep sounds.)
	26		• Automatically transmits.	Starts automatic adjustment. When the adjustment is completed, 2 short beeps sound and selects the next adjustment item.
HF DRIVE GAIN ADJUSTMENT	27	HF Drive	• Return to receive.	Touch [SET]. (1 short beep sounds.)
	28		• Automatically transmits.	Starts automatic adjustment. When the adjustment is completed, 2 short beeps sound and selects the next adjustment item.
ID-APC	29	ID-APC	• Return to receive.	Touch [SET]. (The transceiver briefly transmits and then 3 short beeps sound.)

5-5 50 MHz BAND TRANSMIT ADJUSTMENT

Touch [TX/ID] on the adjustment mode main menu.

ADJUSTMENT	ADJUSTMENT ITEM DISPLAY	SETTING CONDITION	OPERATION	
50 MHz BAND TRANSMIT - Preparation -	1	–	<ul style="list-style-type: none"> Connect the 13.8 V DC power source to [DC 13.8 V]. Connect the RF power meter to the antenna connector. Connect the audio generator and the AC millivoltmeter to the JIG plug, and set the audio generator to: Frequency: 1.5 kHz Wave form: Sine wave Level: 30 mVrms 	<ul style="list-style-type: none"> When adjusting following from the HF transmit adjustment, touch [SET]. When adjusting the 50 MHz band transmit items from the TX/ID Adjust menu, touch [50M] and then [SET].
	2	50M TX Total Gain	<ul style="list-style-type: none"> Automatically transmits. 	While holding down [QUICK], perform the following: Rotate [MAIN DIAL] to set to 5.0 W, and then touch [SET].
50 MHz BAND POWER	3	50M2 Power MIN		While holding down [QUICK], perform the following: Rotate [MAIN DIAL] to set to 0.1 W, and then touch [SET]. Note the adjustment value as the reference.
	4	50M2 Power 1%		While holding down [QUICK], perform the following: Rotate [MAIN DIAL] to set the adjustment value to the same as the reference, and then touch [SET].
	5	50M2 Power 5%		While holding down [QUICK], perform the following: Rotate [MAIN DIAL] to set to 0.5 W, and then touch [SET].
	6	50M2 Power 10%		While holding down [QUICK], perform the following: Rotate [MAIN DIAL] to set to 1.0 W, and then touch [SET].
	7	50M2 Power 25%		While holding down [QUICK], perform the following: Rotate [MAIN DIAL] to set to 2.5 W, and then touch [SET].
	8	50M2 Power 50%		While holding down [QUICK], perform the following: Rotate [MAIN DIAL] to set to 5.0 W, and then touch [SET].
	9	50M2 Power 100%		While holding down [QUICK], perform the following: Rotate [MAIN DIAL] to set to 10.0 W, and then touch [SET].
	10	50M2 Power TUNE		While holding down [QUICK], perform the following: Rotate [MAIN DIAL] to set to 10.0 W, and then touch [SET].
50 MHz BAND POWER BALANCE	11	50M Power Balance SET	<ul style="list-style-type: none"> Return to receive. 	Touch [SET]. (2 short beeps sound.)
	12	50M1 Power 100%	<ul style="list-style-type: none"> Automatically transmits. 	While holding down [QUICK], perform the following: Rotate [MAIN DIAL] to set to 10.0 W, and then touch [SET].
50 MHz BAND AM POWER	13	50M3 Power 100%		
	14	50M POWER AM Ratio	<ul style="list-style-type: none"> Return to receive. 	Touch [SET]. (2 short beeps sound.)
	15		<ul style="list-style-type: none"> Automatically transmits. 	While holding down [QUICK], perform the following: Rotate [MAIN DIAL] to set to 2.5 W, and then touch [SET].

Continued on the next page...

5-5 50 MHz BAND TRANSMIT ADJUSTMENT (continued)

ADJUSTMENT	ADJUSTMENT ITEM DISPLAY	SETTING CONDITION	OPERATION
50 MHz BAND ALC	16	50M ALC	• Return to receive. Touch [SET]. (1 short beep sounds.)
	17		• Automatically transmits. Starts automatic adjustment. When the adjustment is completed, 2 short beeps sound and selects the next adjustment item.
50 MHz BAND DRIVE GAIN	18	50M Drive	• Return to receive. Touch [SET]. (1 short beep sounds.)
	19		• Automatically transmits. Starts automatic adjustment. When the adjustment is completed, 2 short beeps sound and selects the next adjustment item.
70 MHz BAND TRANSMIT - Preparation -	20	70M TX POWER SET	– Touch [▼] to skip the adjustment.
70 MHz BAND POWER	21	70M TX Total Gain	• Automatically transmits.
	23	70M Power MIN	
	24	70M Power 1%	
	25	70M Power 5%	
	26	70M Power 10%	
	27	70M Power 25%	
	28	70M Power 50%	
	29	70M Power 100%	
	30	70M Power TUNE	
70 MHz BAND AM POWER	31	70M POWER AM Ratio	• Return to receive.
	32		• Automatically transmits.
70 MHz BAND ALC	33	70M ALC	• Return to receive.
	34		• Automatically transmits.
70 MHz BAND DRIVE GAIN	55	70M Drive	• Return to receive.
	36		• Automatically transmits.
SWR METER -Preparation -	37	–	–
- Adjustment - ~ HF BANDS ~	38	HF SWR2	• Return to receive. Touch [SET]. (1 short beep sounds.)
	39		• Automatically transmits. Starts automatic adjustment. When the adjustment is completed, 2 short beeps sound and selects the next adjustment item.
~ 50 MHz BAND ~	40	50M SWR2	• Return to receive. Touch [SET]. (1 short beep sounds.)
	41		• Automatically transmits. Starts automatic adjustment. When the adjustment is completed, 2 short beeps sound and selects the next adjustment item.
~ 70 MHz BAND ~	42	70M SWR2	• Return to receive. Touch [▼] to skip the adjustment.
	43		• Automatically transmits.

5-6 VHF BAND TRANSMIT ADJUSTMENT

Touch [TX/ID] on the adjustment mode main menu.

ADJUSTMENT	ADJUSTMENT ITEM DISPLAY	SETTING CONDITION	OPERATION	
VHF BAND TRANSMIT - Preparation -	1	–	<ul style="list-style-type: none"> • Connect the 13.8 V DC power source to [DC 13.8 V]. • Connect the RF power meter to the antenna connector. • Connect the audio generator and the AC millivoltmeter to the JIG plug, and set the audio generator to: Frequency: 1.5 kHz Wave form: Sine wave Level: 30 mVrms 	<ul style="list-style-type: none"> • When adjusting following from the 50 MHz band transmit adjustment, touch [SET]. • When adjusting the VHF band transmit items from the TX/ID Adjust menu, touch [VHF] and then [SET].
VHF BAND POWER	2	VHF TX Total Gain	• Automatically transmits.	While holding down [QUICK], perform the following: Rotate [MAIN DIAL] to set to 5.0 W, and then touch [SET].
	3	VHF2 Power MIN		While holding down [QUICK], perform the following: Rotate [MAIN DIAL] to set to 0.1 W, and then touch [SET]. Note the adjustment value as the reference.
	4	VHF2 Power 1%		While holding down [QUICK], perform the following: Rotate [MAIN DIAL] to set the adjustment value to the same as the reference, and then touch [SET].
	5	VHF2 Power 5%		While holding down [QUICK], perform the following: Rotate [MAIN DIAL] to set to 0.5 W, and then touch [SET].
	6	VHF2 Power 10%		While holding down [QUICK], perform the following: Rotate [MAIN DIAL] to set to 1.0 W, and then touch [SET].
	7	VHF2 Power 25%		While holding down [QUICK], perform the following: Rotate [MAIN DIAL] to set to 2.5 W, and then touch [SET].
	8	VHF2 Power 50%		While holding down [QUICK], perform the following: Rotate [MAIN DIAL] to set to 5.0 W, and then touch [SET].
	9	VHF2 Power 100%		While holding down [QUICK], perform the following: Rotate [MAIN DIAL] to set to 10.0 W, and then touch [SET].
	VHF BAND POWER BALANCE	10	VHF Power Balance SET	• Return to receive.
11		VHF1 Power 100%	• Automatically transmits.	While holding down [QUICK], perform the following: Rotate [MAIN DIAL] to set to 10.0 W, and then touch [SET].
12		VHF3 Power 100%		
VHF BAND AM POWER	13	VHF POWER AM Ratio	• Return to receive.	Touch [SET]. (2 short beeps sound.)
	14		• Automatically transmits.	While holding down [QUICK], perform the following: Rotate [MAIN DIAL] to set to 2.5 W, and then touch [SET].
VHF BAND ALC	15	VHF ALC	• Return to receive.	Touch [SET]. (1 short beep sounds.)
	16		• Automatically transmits.	Starts automatic adjustment. When the adjustment is completed, 2 short beeps sound and selects the next adjustment item.

Continued on the next page...

5-6 VHF BAND TRANSMIT ADJUSTMENT (continued)

ADJUSTMENT	ADJUSTMENT ITEM DISPLAY	SETTING CONDITION	OPERATION
VHF BAND DRIVE GAIN	17	VHF Drive	• Return to receive. Touch [SET]. (1 short beep sounds.)
	18		• Automatically transmits. Starts automatic adjustment. When the adjustment is completed, 2 short beeps sound and selects the next adjustment item.
SWR METER - Preparation -	19	–	–
- Adjustment -	20	VHF SWR2	• Return to receive. Touch [SET]. (1 short beep sounds.)
	21		• Automatically transmits. Starts automatic adjustment. When the adjustment is completed, 2 short beeps sound and selects the next adjustment item.

5-7 UHF BAND TRANSMIT ADJUSTMENT

Touch [TX/ID] on the adjustment mode main menu.

ADJUSTMENT	ADJUSTMENT ITEM DISPLAY	SETTING CONDITION	OPERATION	
UHF BAND TRANSMIT - Preparation -	1	–	<ul style="list-style-type: none"> • Connect the 13.8 V DC power source to [DC 13.8 V]. • Connect the RF power meter to the antenna connector. • Connect the audio generator and the AC millivoltmeter to the JIG plug, and set the audio generator to: Frequency: 1.5 kHz Wave form: Sine wave Level: 30 mVrms 	<ul style="list-style-type: none"> • When adjusting following from the VHF band transmit adjustment, touch [SET]. • When adjusting the UHF band transmit items from the TX/ID Adjust menu, touch [UHF], and then [SET].
UHF BAND POWER	2	UHF TX Total Gain	• Automatically transmits.	While holding down [QUICK], perform the following: Rotate [MAIN DIAL] to set to 5.0 W, and then touch [SET].
	3	UHF2 Power MIN		While holding down [QUICK], perform the following: Rotate [MAIN DIAL] to set to 0.1 W, and then touch [SET]. Note the adjustment value as the reference.
	4	UHF2 Power 1%		While holding down [QUICK], perform the following: Rotate [MAIN DIAL] to set the adjustment value to the same as the reference, and then touch [SET].
	5	UHF2 Power 5%		While holding down [QUICK], perform the following: Rotate [MAIN DIAL] to set to 0.5 W, and then touch [SET].
	6	UHF2 Power 10%		While holding down [QUICK], perform the following: Rotate [MAIN DIAL] to set to 1.0 W, and then touch [SET].
	7	UHF2 Power 25%		While holding down [QUICK], perform the following: Rotate [MAIN DIAL] to set to 2.5 W, and then touch [SET].
	8	UHF2 Power 50%		While holding down [QUICK], perform the following: Rotate [MAIN DIAL] to set to 5.0 W, and then touch [SET].
	9	UHF2 Power 100%		While holding down [QUICK], perform the following: Rotate [MAIN DIAL] to set to 10.0 W, and then touch [SET].
UHF BAND POWER BALANCE	10	UHF Power Balance SET	• Return to receive.	Touch [SET]. (2 short beeps sound.)
	11	UHF1 Power 100%	• Automatically transmits.	While holding down [QUICK], perform the following: Rotate [MAIN DIAL] to set to 10.0 W, and then touch [SET].
	12	UHF3 Power 100%		
	13	UHF4 Power 100%		
UHF BAND AM POWER	14	UHF POWER AM Ratio	• Return to receive.	Touch [SET]. (2 short beeps sound.)
	15		• Automatically transmits.	While holding down [QUICK], perform the following: Rotate [MAIN DIAL] to set to 2.5 W, and then touch [SET].
UHF BAND ALC	16	UHF ALC	• Return to receive.	Touch [SET]. (1 short beep sounds.)
	17		• Automatically transmits.	Starts automatic adjustment. When the adjustment is completed, 2 short beeps sound and selects the next adjustment item.

Continued on the next page...

5-7 UHF BAND TRANSMIT ADJUSTMENT (continued)

ADJUSTMENT		ADJUSTMENT ITEM DISPLAY	SETTING CONDITION	OPERATION
UHF BAND DRIVE GAIN	18	UHF Drive	• Return to receive.	Touch [SET]. (1 short beep sounds.)
	19		• Automatically transmits.	Starts automatic adjustment. When the adjustment is completed, 2 short beeps sound and selects the next adjustment item.
SWR METER - Preparation -	20	–	• Connect the SWR 2.0:1 (impedance: 100 Ω or 25 Ω) dummy load to the antenna connector.	–
- Adjustment -	21	UHF SWR2	• Return to receive.	Touch [SET]. (1 short beep sounds.)
	22		• Automatically transmits.	Starts automatic adjustment. When the adjustment is completed, 2 short beeps sound and returns to the TX/ID adjustment screen.

5-8 REFERENCE FREQUENCY AJUSTMENT

Touch [REF] on the adjustment mode main menu.

ADJUSTMENT		ADJUSTMENT ITEM DISPLAY	SETTING CONDITION	OPERATION
REFERENCE FREQUENCY - Preparation -	1	–	<ul style="list-style-type: none"> • Connect the 13.8 V DC power source to [DC 13.8 V]. • Connect the RF power meter or dummy load to the antenna connector. • Loosely couple the frequency counter to the antenna connector. 	Touch [REF] to enter the Reference Frequency Adjustment mode.
	- Adjustment -	2	REF OSC	<ul style="list-style-type: none"> • Receive
	3		<ul style="list-style-type: none"> • Automatically transmits. 	Rotate [MAIN DIAL] to set to 435.000000 MHz (within ± 30 Hz), and then touch [SET]. Return to the reference frequency adjust menu.

5-9 HF/50 MHz BANDS RECEIVE ADJUSTMENT

Touch [RX] on the adjustment mode main menu.

ADJUSTMENT	ADJUSTMENT ITEM DISPLAY	SETTING CONDITION	OPERATION
HF RECEIVE - Preparation -	1	-	Touch [HF] to enter the HF receive adjustment mode.
- Adjustment -	2	HF Total Gain PRE OFF ref	• Set the SSG to: Level: 34 dB μ * (-73 dBm)
	3		• Receive
	4	HF Total Gain PRE OFF set	• Set the SSG to: Level: OFF
	5		• Receive
	6	HF Total Gain PRE1 ref	• Set the SSG to: Level: 34 dB μ * (-73 dBm)
	7		• Receive
	8	HF Total Gain PRE1 set	• Set the SSG to: Level: OFF
	9		• Receive
	HF S-METER ~ S0 LEVEL ~	10	HF S0 LEVEL
11			• Receive
~ S9 LEVEL ~	12	HF S9 LEVEL	• Set the SSG to: Level: 34 dB μ * (-73 dBm)
	13		• Receive
~ S9+60 LEVEL ~	14	HF S9+60 LEVEL	• Set the SSG to: Level: 94 dB μ * (-13 dBm)
	15		• Receive

Continued on the next page...

5-9 HF/50 MHz BANDS RECEIVE ADJUSTMENT (continued)

ADJUSTMENT	ADJUSTMENT ITEM DISPLAY	SETTING CONDITION	OPERATION	
50 MHz BAND RECEIVE - Preparation - - Adjustment -	16	–	–	
	17	50M Total Gain PRE OFF ref	• Set the SSG to: Level: 34 dB μ * (–73 dBm)	Touch [SET]. (1 short beep sounds.)
	18		• Receive	Starts automatic adjustment. When the adjustment is completed, 2 short beeps sound and selects the next adjustment item.
	19	50M Total Gain PRE OFF set	• Set the SSG to: Level: OFF	Touch [SET]. (1 short beep sounds.)
	20		• Receive	Starts automatic adjustment. When the adjustment is completed, 2 short beeps sound and selects the next adjustment item.
	21	50M Total Gain PRE1 ref	• Set the SSG to: Level: 34 dB μ * (–73 dBm)	Touch [SET]. (1 short beep sounds.)
	22		• Receive	Starts automatic adjustment. When the adjustment is completed, 2 short beeps sound and selects the next adjustment item.
	23	50M Total Gain PRE1 set	• Set the SSG to: Level: OFF	Touch [SET]. (1 short beep sounds.)
	24		• Receive	Starts automatic adjustment. When the adjustment is completed, 2 short beeps sound and selects the next adjustment item.
	50 MHz BAND S-METER ~ S0 LEVEL ~ ~ S9 LEVEL ~ ~ S9+60 LEVEL ~	25	50M S0 LEVEL	• Set the SSG to: Level: 12 dB μ * (–95 dBm)
26			• Receive	Starts automatic adjustment. When the adjustment is completed, 2 short beeps sound and selects the next adjustment item.
27		50M S9 LEVEL	• Set the SSG to: Level: 34 dB μ * (–73 dBm)	Touch [SET]. (1 short beep sounds.)
28			• Receive	Starts automatic adjustment. When the adjustment is completed, 2 short beeps sound and selects the next adjustment item.
29		50M S9+60 LEVEL	• Set the SSG to: Level: 94 dB μ * (–13 dBm)	Touch [SET]. (1 short beep sounds.)
30			• Receive	Starts automatic adjustment. When the adjustment is completed, 2 short beeps sound and selects the next adjustment item.
IF TRAP	31	IF Trap1	• Set the SSG to: Frequency: 39.3485 MHz	Touch [SET]. (1 short beep sounds.)
	32		Level: 70 dB μ * (–37 dBm)	Starts automatic adjustment. When the adjustment is completed, 2 short beeps sound and selects the next adjustment item.
	33	IF Trap2	• Set the SSG to: Frequency: 38.8485 MHz	Touch [SET]. (1 short beep sounds.)
	34			Starts automatic adjustment. When the adjustment is completed, 2 short beeps sound and selects the next adjustment item.
	35	IF Trap3	• Set the SSG to: Frequency: 38.3485 MHz	Touch [SET]. (1 short beep sounds.)
	36			Starts automatic adjustment. When the adjustment is completed, 2 short beeps sound and selects the next adjustment item.

5-10 VHF BAND RECEIVE ADJUSTMENT

Touch [RX] on the adjustment mode main menu.

ADJUSTMENT	ADJUSTMENT ITEM DISPLAY	SETTING CONDITION	OPERATION	
VHF BAND RECEIVE - Preparation -	1	–	<ul style="list-style-type: none"> • Connect the 13.8 V DC power source to [DC 13.8 V]. • Connect the SSG to the antenna connector. 	<ul style="list-style-type: none"> • When adjusting following from the HF band receive adjustment, touch [SET]. • When adjusting the VHF band receive items from the RX Adjust menu, touch [VHF], and then [SET].
	- Adjustment -			
	2	VHF Tuned-BPF 1	<ul style="list-style-type: none"> • Set the SSG to: Frequency: 72.2015 MHz Level: 10 dBμ* (-97 dBm) 	Touch [SET]. (1 short beep sounds.)
	3			Starts automatic adjustment. When the adjustment is completed, 2 short beeps sound and selects the next adjustment item.
	4	VHF Tuned-BPF 2	<ul style="list-style-type: none"> • Set the SSG to: Frequency: 90.2015 MHz 	Touch [SET]. (1 short beep sounds.)
	5			Starts automatic adjustment. When the adjustment is completed, 2 short beeps sound and selects the next adjustment item.
	6	VHF Tuned-BPF 3	<ul style="list-style-type: none"> • Set the SSG to: Frequency: 108.2015 MHz 	Touch [SET]. (1 short beep sounds.)
	7			Starts automatic adjustment. When the adjustment is completed, 2 short beeps sound and selects the next adjustment item.
	8	VHF Tuned-BPF 4	<ul style="list-style-type: none"> • Set the SSG to: Frequency: 146.2015 MHz 	Touch [SET]. (1 short beep sounds.)
	9			Starts automatic adjustment. When the adjustment is completed, 2 short beeps sound and selects the next adjustment item.
	10	VHF Tuned-BPF 5	<ul style="list-style-type: none"> • Set the SSG to: Frequency: 199.8015 MHz 	Touch [SET]. (1 short beep sounds.)
	11			Starts automatic adjustment. When the adjustment is completed, 2 short beeps sound and selects the next adjustment item.
	12	VHF Total Gain PRE OFF ref	<ul style="list-style-type: none"> • Set the SSG to: Frequency: 146.0215 MHz 	Touch [SET]. (1 short beep sounds.)
	13			Starts automatic adjustment. When the adjustment is completed, 2 short beeps sound and selects the next adjustment item.
	14	VHF Total Gain PRE OFF set	<ul style="list-style-type: none"> • Set the SSG to: Level: OFF 	Touch [SET]. (1 short beep sounds.)
	15			Starts automatic adjustment. When the adjustment is completed, 2 short beeps sound and selects the next adjustment item.
	16	VHF Total Gain PRE1 ref	<ul style="list-style-type: none"> • Set the SSG to: Level: 10 dBμ* (-97 dBm) 	Touch [SET]. (1 short beep sounds.)
	17			Starts automatic adjustment. When the adjustment is completed, 2 short beeps sound and selects the next adjustment item.
	18	VHF Total Gain PRE1 set	<ul style="list-style-type: none"> • Set the SSG to: Level: OFF 	Touch [SET]. (1 short beep sounds.)
	19			Starts automatic adjustment. When the adjustment is completed, 2 short beeps sound and selects the next adjustment item.

Continued on the next page...

5-10 VHF BAND RECEIVE ADJUSTMENT (continued)

ADJUSTMENT	ADJUSTMENT ITEM DISPLAY	SETTING CONDITION	OPERATION
VHF S-METER ~ S0 LEVEL ~	20	VHF S0 LEVEL • Set the SSG to: Level: $-13 \text{ dB}\mu^*$ (-120 dBm)	Touch [SET]. (1 short beep sounds.)
	21		Starts automatic adjustment. When the adjustment is completed, 2 short beeps sound and selects the next adjustment item.
~ S9 LEVEL ~	22	VHF S9 LEVEL • Set the SSG to: Level: $10 \text{ dB}\mu^*$ (-97 dBm)	Touch [SET]. (1 short beep sounds.)
	23		Starts automatic adjustment. When the adjustment is completed, 2 short beeps sound and selects the next adjustment item.
~ S9+60 LEVEL ~	24	VHF S9+60 LEVEL • Set the SSG to: Level: $70 \text{ dB}\mu^*$ (-37 dBm)	Touch [SET]. (1 short beep sounds.)
	25		Starts automatic adjustment. When the adjustment is completed, 2 short beeps sound and selects the next adjustment item.

5-11 UHF BAND RECEIVE ADJUSTMENT

Touch [RX] on the adjustment mode main menu.

ADJUSTMENT	ADJUSTMENT ITEM DISPLAY	SETTING CONDITION	OPERATION	
UHF BAND RECEIVE - Preparation - ----- - Adjustment -	1	–	<ul style="list-style-type: none"> Connect the 13.8 V DC power source to [DC 13.8 V]. Connect the SSG to the antenna connector. 	<ul style="list-style-type: none"> When adjusting following from the VHF band receive adjustment, touch [SET]. When adjusting the UHF band receive items from the RX Adjust menu, touch [UHF], and then [SET].
	2	UHF Tuned-BPF 1	<ul style="list-style-type: none"> Set the SSG to: Frequency: 402.2015 MHz Level: 20 dBμ* (–87 dBm) 	Touch [SET]. (1 short beep sounds.)
	3			Starts automatic adjustment. When the adjustment is completed, 2 short beeps sound and selects the next adjustment item.
	4	UHF Tuned-BPF 2		Touch [SET]. (1 short beep sounds.)
	5			Starts automatic adjustment. When the adjustment is completed, 2 short beeps sound and selects the next adjustment item.
	6	UHF Tuned-BPF 3	<ul style="list-style-type: none"> Set the SSG to: Frequency: 469.8015 MHz 	Touch [SET]. (1 short beep sounds.)
	7			Starts automatic adjustment. When the adjustment is completed, 2 short beeps sound and selects the next adjustment item.
	8	UHF Total Gain PRE OFF ref	<ul style="list-style-type: none"> Set the SSG to: Frequency: 435.0215 MHz 	Touch [SET]. (1 short beep sounds.)
	9			Starts automatic adjustment. When the adjustment is completed, 2 short beeps sound and selects the next adjustment item.
	10	UHF Total Gain PRE OFF set	<ul style="list-style-type: none"> Set the SSG to: Level: OFF 	Touch [SET]. (1 short beep sounds.)
	11			Starts automatic adjustment. When the adjustment is completed, 2 short beeps sound and selects the next adjustment item.
	12	UHF Total Gain PRE1 ref	<ul style="list-style-type: none"> Set the SSG to: Level: 10 dBμ* (–97 dBm) 	Touch [SET]. (1 short beep sounds.)
	13			Starts automatic adjustment. When the adjustment is completed, 2 short beeps sound and selects the next adjustment item.
	14	UHF Total Gain PRE1 set	<ul style="list-style-type: none"> Set the SSG to: Level: OFF 	Touch [SET]. (1 short beep sounds.)
	15			Starts automatic adjustment. When the adjustment is completed, 2 short beeps sound and selects the next adjustment item.
UHF S-METER ~ S0 LEVEL ~	16	UHF S0 LEVEL	<ul style="list-style-type: none"> Set the SSG to: Level: –13 dBμ* (–120 dBm) 	Touch [SET]. (1 short beep sounds.)
	17			Starts automatic adjustment. When the adjustment is completed, 2 short beeps sound and selects the next adjustment item.
~ S9 LEVEL ~	18	UHF S9 LEVEL	<ul style="list-style-type: none"> Set the SSG to: Level: 10 dBμ* (–97 dBm) 	Touch [SET]. (1 short beep sounds.)
	19			Starts automatic adjustment. When the adjustment is completed, 2 short beeps sound and selects the next adjustment item.
~ S9+60 LEVEL ~	20	UHF S9+60 LEVEL	<ul style="list-style-type: none"> Set the SSG to: Level: 70 dBμ* (–37 dBm) 	Touch [SET]. (1 short beep sounds.)
	21			Starts automatic adjustment. When the adjustment is completed, 2 short beeps sound and returns to the RX Adjust menu.

SECTION 6 SPARE PARTS AND UNITS

ASSEMBLED FRONT UNIT

Spare unit name	Order Number	Applicable Versions	Remarks
C 705 #12 FRONT	0340751201	#12 [USA]	-
C 705 #13 FRONT	0340751301	#13 [EUR]	-

See the illustrations below for the individual parts in the unit.

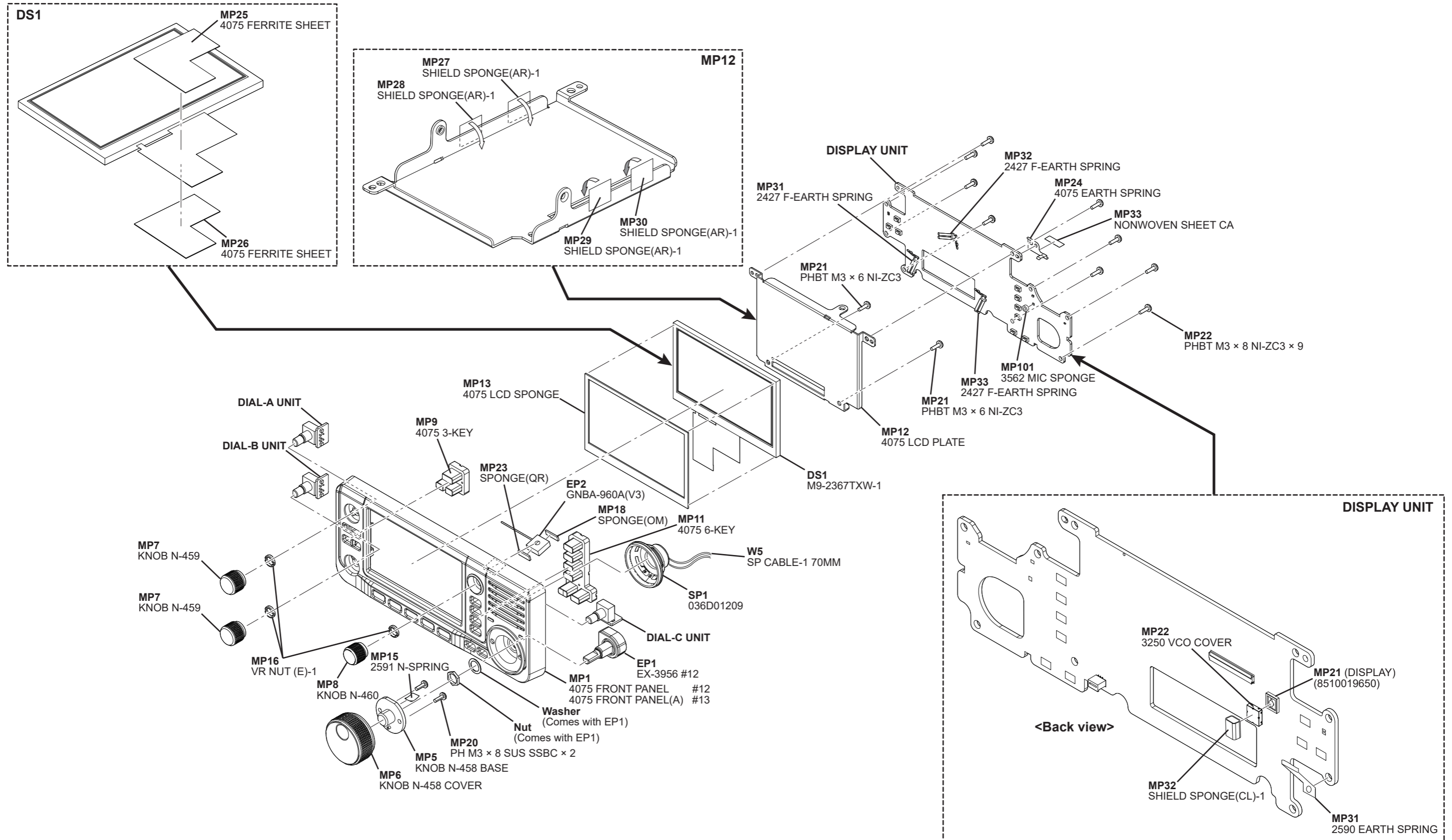

■ ASSEMBLED DISPLAY UNIT

Spare unit name	Order Number	Applicable Versions	Remarks
C 705 #12 DISPLAY	0340751207	#12 [USA]	-
C 705 #13 DISPLAY	0340751307	#13 [EUR]	-

See the illustrations below for the individual parts in the unit.

<Front view>

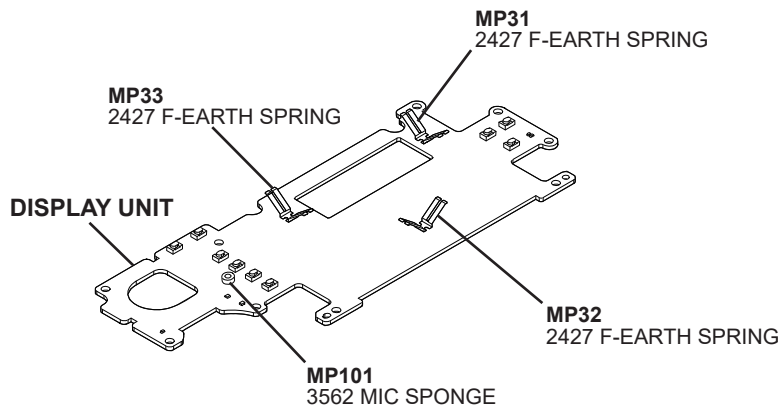

<Back view>

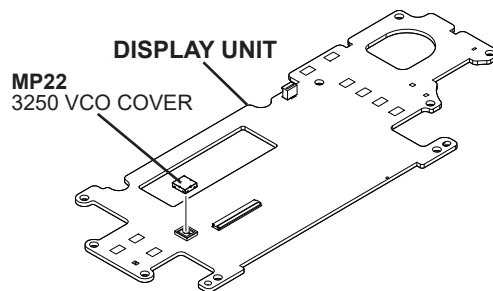

■ ASSEMBLED MAIN UNIT

Spare unit name	Order Number	Applicable Versions	Remarks
C 705 #12 MAIN	0340751202	#12 [USA]	-
C 705 #13 MAIN	0340751302	#13 [EUR]	-

See the illustrations below for the individual parts in the unit.

<Front view>

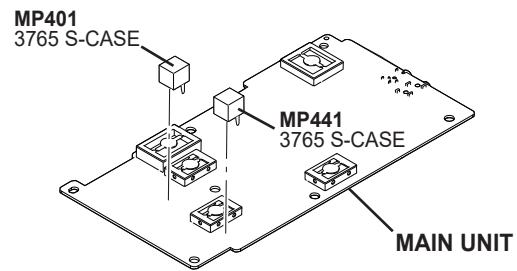

<Back view>

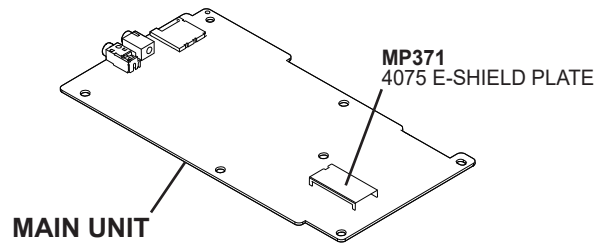

■ ASSEMBLED CONNECT UNIT

Spare unit name	Order Number	Applicable Versions	Remarks
C 705 #12 CONNECT	0340751208	#12 [USA]	-
C 705 #13 CONNECT	0340751308	#13 [EUR]	-

See the illustrations below for the individual parts in the unit.

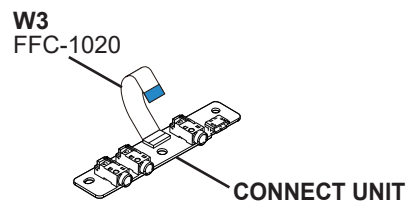

■ ASSEMBLED RF UNIT

Spare unit name	Order Number	Applicable Versions	Remarks
C 705 #12 RF	0340751204	#12 [USA]	-
C 705 #13 RF	0340751304	#13 [EUR]	-

See the illustrations below for the individual parts in the unit.

<Front view>

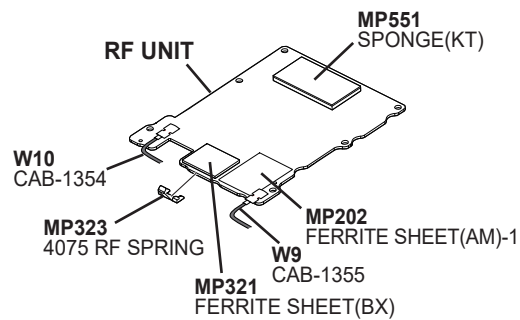

<Back view>

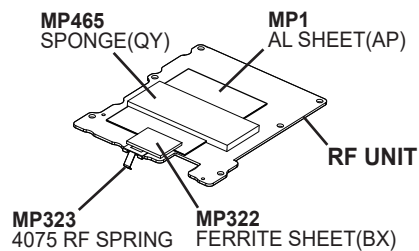

■ ASSEMBLED FILTER UNIT

Spare unit name	Order Number	Applicable Versions	Remarks
C 705 #12 FILTER	0340751205	#12 [USA]	-
C 705 #13 FILTER	0340751305	#13 [EUR]	-

FILTER UNIT

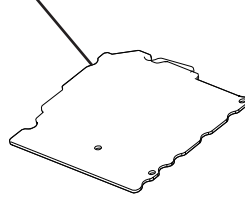

■ ASSEMBLED PA-A UNIT

Spare unit name	Order Number	Applicable Versions	Remarks
C 705 #12 PA-A	0340751203	#12 [USA]	-
C 705 #13 PA-A	0340751303	#13 [EUR]	-

See the illustrations below for the individual parts in the unit.

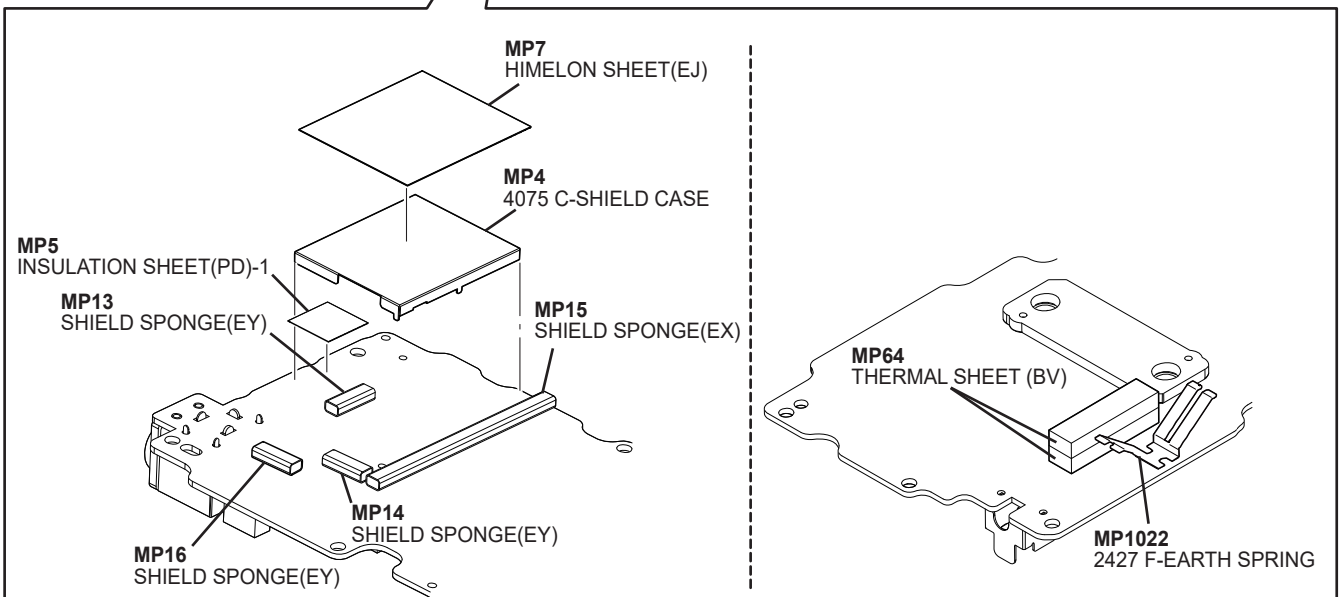
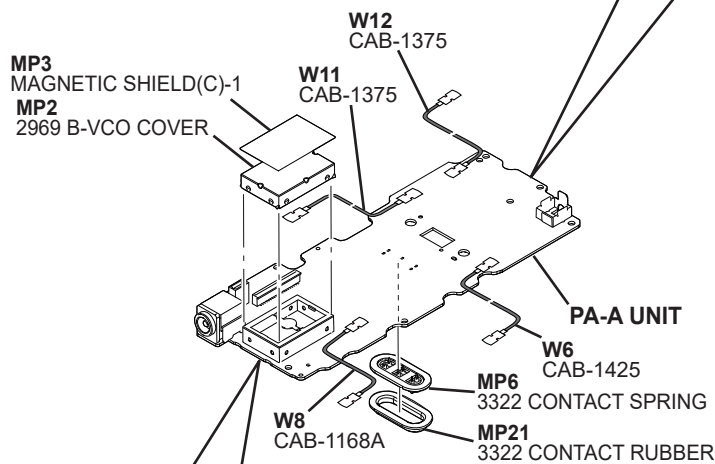
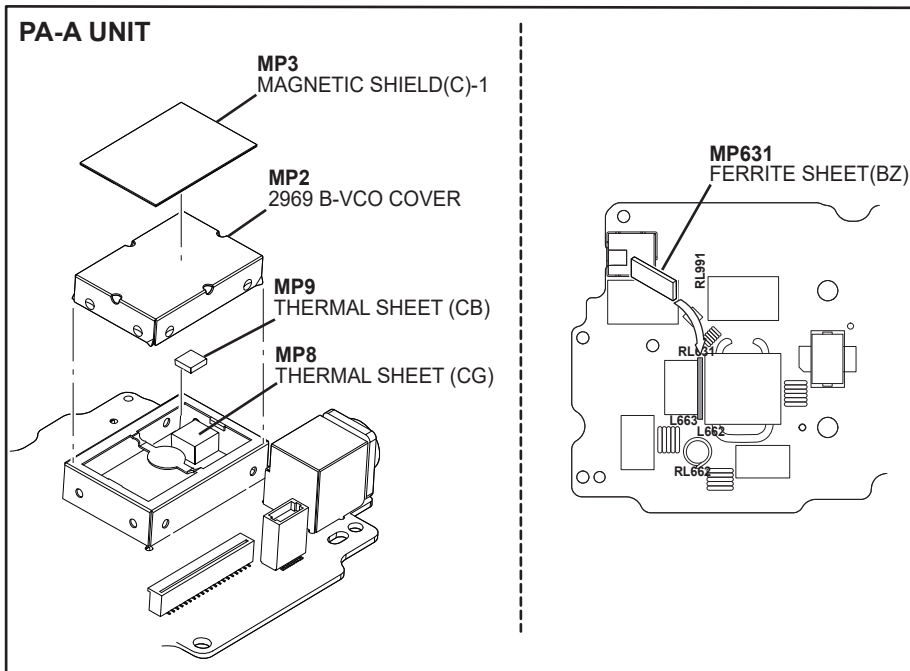

■ ASSEMBLED MAIN DIAL

Spare unit name	Order Number	Applicable Versions	Remarks
IC-705 MAIN DIAL SENSOR	-	#12 [USA], #13 [EUR]	-



IC-705 MAIN DIAL SENSOR

SPARE PARTS INFORMATION

	Reference number	Parts name	Order Number	Applicable Versions
Rotary encoder	S1	RE1107CM1-V03-5391	2250001110	#12 [USA], #13 [EUR]
GPS antenna	EP2	GNBA-960A(V3)	3310005571	#12 [USA], #13 [EUR]
LCD	DS1	M9-2367TXW-1	5030004620	#12 [USA], #13 [EUR]
Front panel	MP1	4075 FRONT PANEL ASSY	8210035100	#12 [USA]
Front panel	MP1	4075 FRONT PANEL(A)ASSY	8210035360	#12 [USA]
Dial knob	MP6	KNOB N-458 COVER	8610016570	#12 [USA], #13 [EUR]
Dial knob	MP7	KNOB N-459	8610016580	#12 [USA], #13 [EUR]
Dial knob	MP8	KNOB N-460	8610016590	#12 [USA], #13 [EUR]
Key pad	MP9	4075 3-KEY	8930103030	#12 [USA], #13 [EUR]
Key pad	MP11	4075 6-KEY	8930103050	#12 [USA], #13 [EUR]
Screw	MP16	VR NUT(E)-1	8830000551	#12 [USA], #13 [EUR]
Speaker	SP1	036D01209	2510002160	#12 [USA], #13 [EUR]

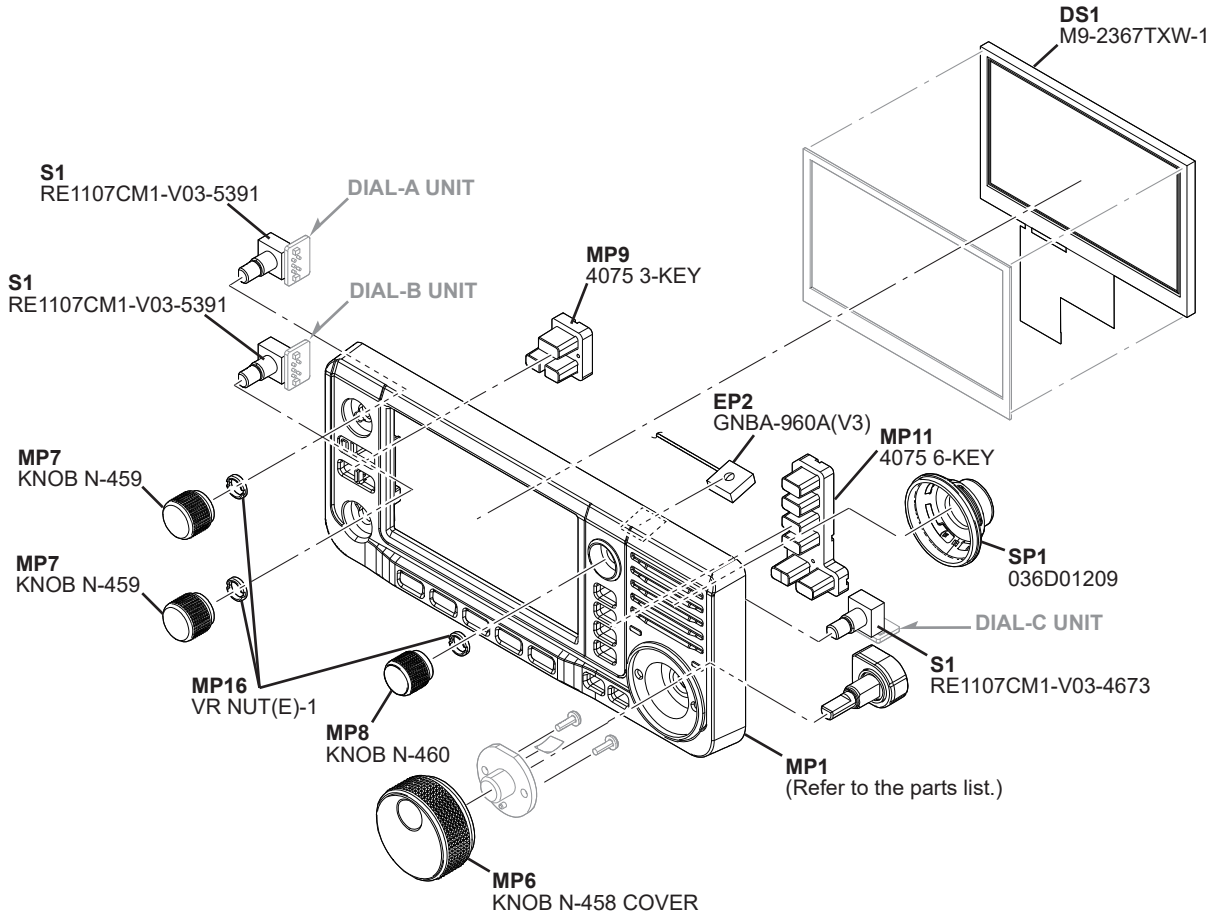

NOTE: The parts that are not listed are indicated in gray.

■ SPARE PARTS INFORMATION (CONTINUED)

	Reference number	Parts name	Order Number	Applicable Versions
Push switch	S101	LS8J2M-T	2260002740	#12 [USA], #13 [EUR]
Push switch	S102	LS8J2M-T	2260002740	#12 [USA], #13 [EUR]
Push switch	S103	LS8J2M-T	2260002740	#12 [USA], #13 [EUR]
Push switch	S104	LS8J2M-T	2260002740	#12 [USA], #13 [EUR]
Push switch	S105	LS8J2M-T	2260002740	#12 [USA], #13 [EUR]
Push switch	S106	LS8J2M-T	2260002740	#12 [USA], #13 [EUR]
Push switch	S107	LS8J2M-T	2260002740	#12 [USA], #13 [EUR]
Push switch	S108	LS8J2M-T	2260002740	#12 [USA], #13 [EUR]
Push switch	S109	LS8J2M-T	2260002740	#12 [USA], #13 [EUR]

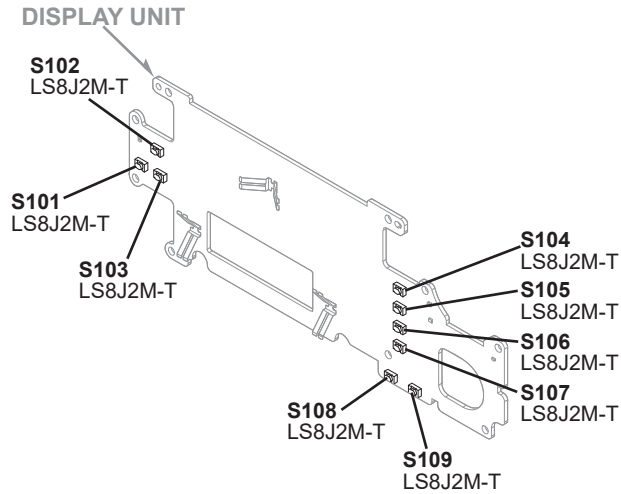

NOTE: The parts that are not listed are indicated in gray.

■ SPARE PARTS INFORMATION (CONTINUED)

	Reference number	Parts name	Order Number	Applicable Versions
BNC connector	J1	BNC-R4066	6510032950	#12 [USA], #13 [EUR]
Rear case	MP2	4075 CASE ASSY	8010025310	#12 [USA], #13 [EUR]
Protection cap	MP3	4075 JACK CAP	8930103000	#12 [USA], #13 [EUR]
Protection cap	MP4	4075 MIC CAP	8930103010	#12 [USA], #13 [EUR]
Protection cap	MP5	4075 SD CAP	8930103020	#12 [USA], #13 [EUR]
Contact	MP6	3322 CONTACT SPRING	8950007850	#12 [USA], #13 [EUR]
Nut	MP7	4075 ANT NUT	8830004680	#12 [USA], #13 [EUR]
Screw	MP32	TAPPING SCREW B0 2X4 SUS SSBC	8810011830	#12 [USA], #13 [EUR]
Shield sheet	MP37	4075 AL A-SHEET	8930104550	#12 [USA], #13 [EUR]
Shield sheet	MP38	4075 AL B-SHEET	8930104560	#12 [USA], #13 [EUR]
Shield sheet	MP48	4075 AL C-SHEET	8930104930	#12 [USA], #13 [EUR]
Screw	MP51	PH BT M3X12 NI-ZK3	8810009371	#12 [USA], #13 [EUR]
Screw	MP52	PH M3X6 ZK3 B	8810012030	#12 [USA], #13 [EUR]

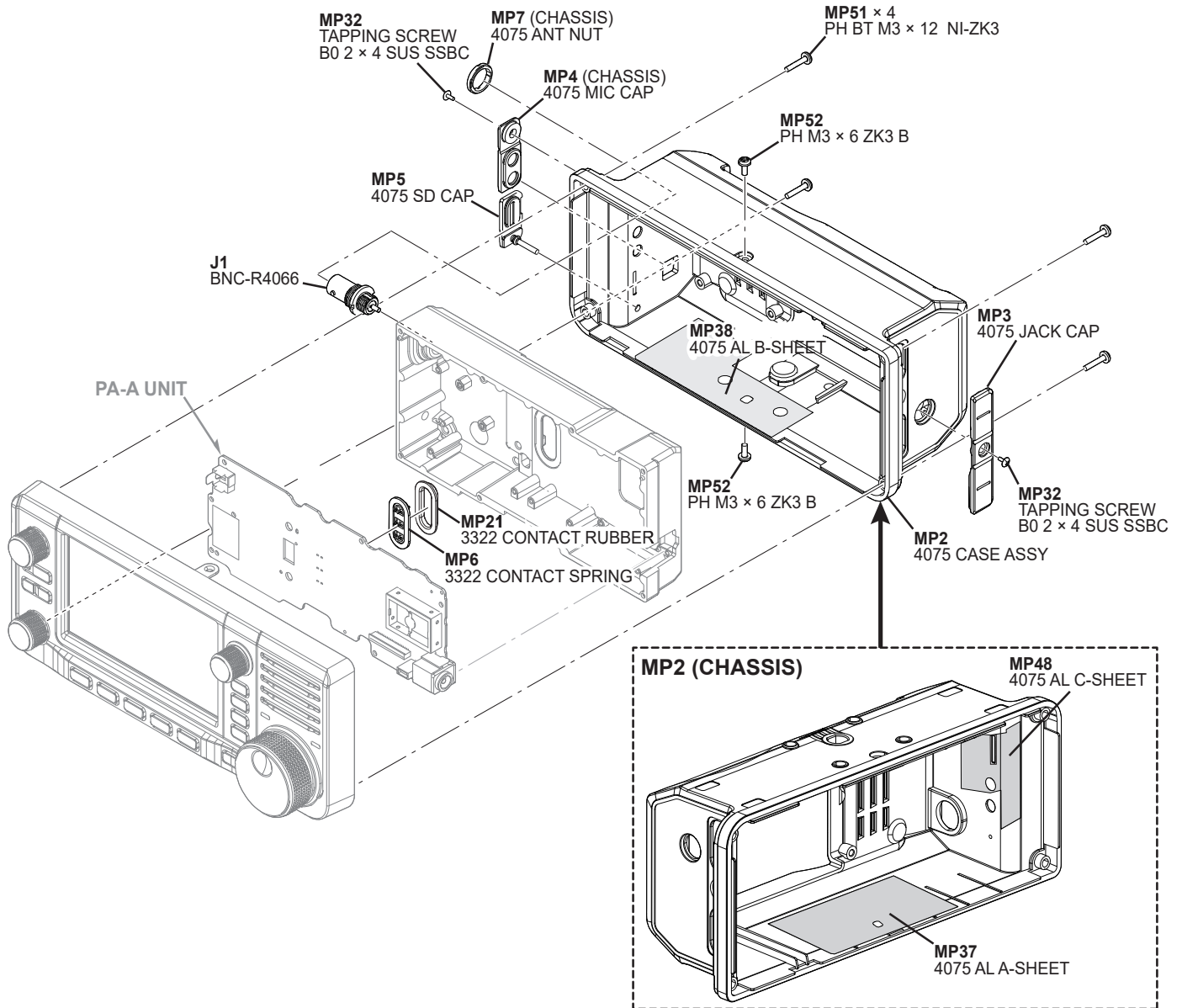

NOTE: The parts that are not listed are indicated in gray.

■ SPARE PARTS INFORMATION (CONTINUED)

	Reference number	Parts name	Order Number	Applicable Versions
Jack	J251	ASJ-190-A	6450002690	#12 [USA], #13 [EUR]
Jack	J271	HSJ4456-010320	6450002530	#12 [USA], #13 [EUR]
SDcard slot	J831	SDHL-8BNS-K-363-A0-ETB	6510028170	#12 [USA], #13 [EUR]

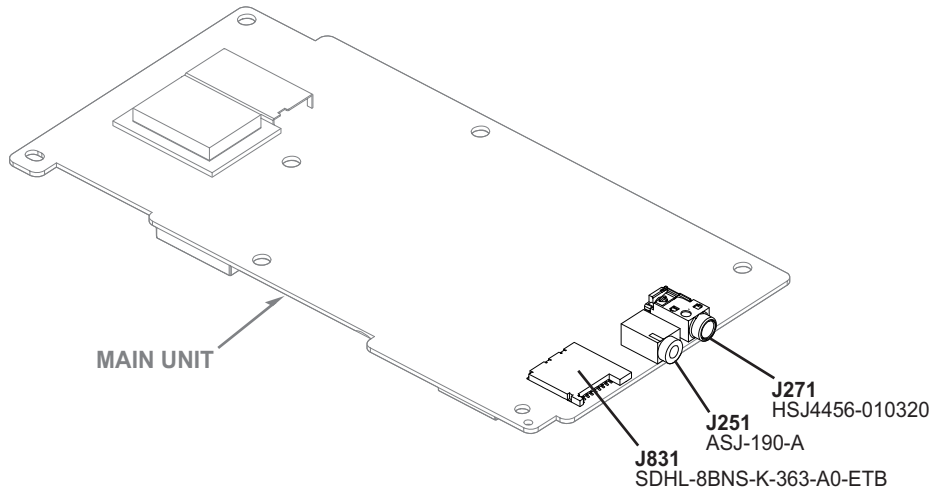

	Reference number	Parts name	Order Number	Applicable Versions
Jack	J31	HSJ4456-010320	6450002530	#12 [USA], #13 [EUR]
Jack	J41	HSJ4456-010320	6450002530	#12 [USA], #13 [EUR]
Jack	J51	HSJ4456-010320	6450002530	#12 [USA], #13 [EUR]

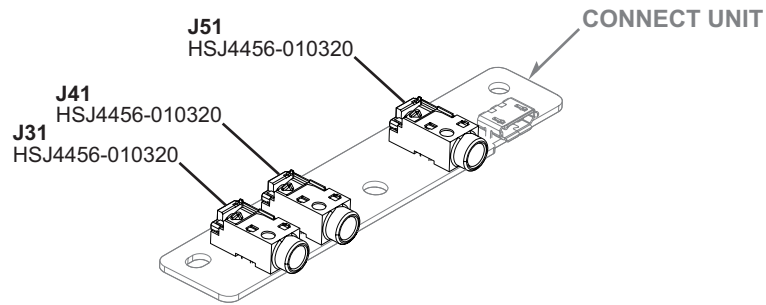

NOTE: The parts that are not listed are indicated in gray.

■ SPARE PARTS INFORMATION (CONTINUED)

	Reference number	Parts name	Order Number	Applicable Versions
RF POWER TRANSISTOR	IC915	MMG3H21NT1	1110009820	#12 [USA], #13 [EUR]
POWER SWITCHING FET	Q1	TPCF8107	1550000241	#12 [USA], #13 [EUR]
RF POWER TRANSISTOR	Q931	AFT05MS003NT1	1560002580	#12 [USA], #13 [EUR]
RF POWER TRANSISTOR	Q945	AFT05MS031NR1	1560002590	#12 [USA], #13 [EUR]

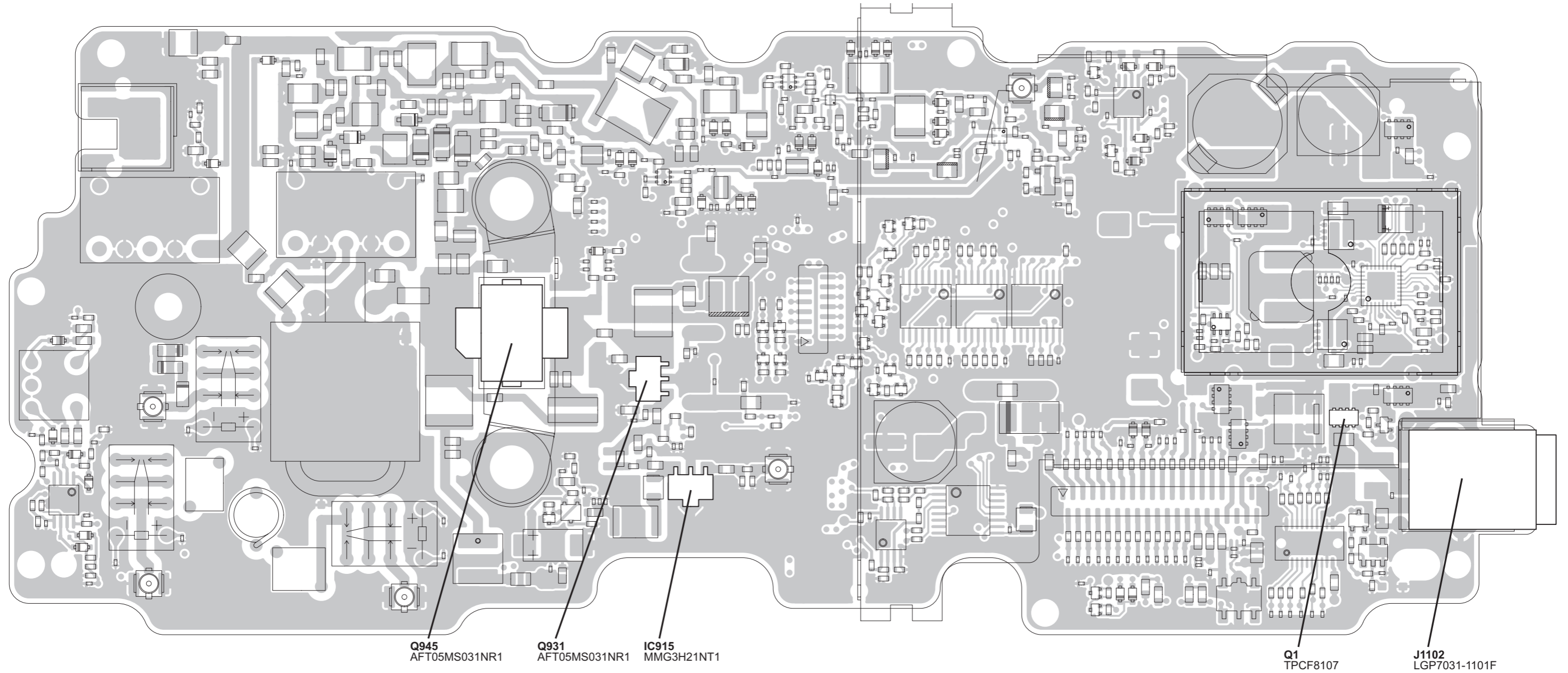

■ SPARE PARTS INFORMATION (CONTINUED)

	Reference number	Parts name	Order Number	Applicable Versions
Zener diode	D1	DZ2J180M0L	1750002000	#12 [USA], #13 [EUR]

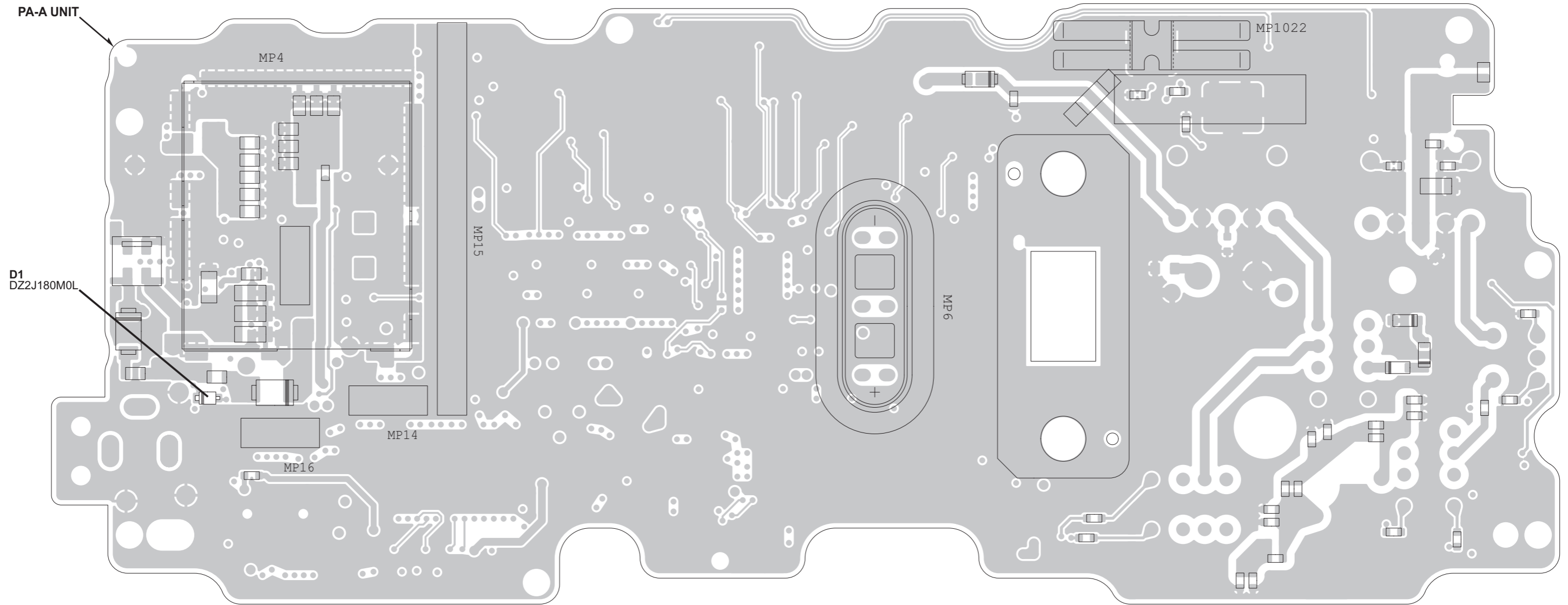

■ SPARE PARTS INFORMATION (CONTINUED)

	Reference number	Parts name	Order Number	Applicable Versions
Supplied accessory	MP2	4075 MIC PLATE	8930104120	#12 [USA], #13 [EUR]



SECTION 7

MECHANICAL PARTS

[CHASSIS UNIT]

REF NO.	PART NO.	DESCRIPTION	QTY.
J1	6510032950	BNC-R4066	1
W1**	8910000180	FFC-1020	1
W2**	8910000520	FFC-1056	1
W3**	8910000180	FFC-1020	1
W4**	8910000520	FFC-1056	1
W5**	8910000520	FFC-1056	1
W6**	8920003430	CAB-1425	1
W7**	8920003110	CAB-1354	1
W8**	8920002370	CAB-1168A	1
W9**	8920003120	CAB-1355	1
W10**	8920003110	CAB-1354	1
W11**	8920003080	CAB-1375	1
W12**	8920003080	CAB-1375	1
MP1	8010025231	4075 CHASSIS-1	1
MP2	8010025310	4075 CASE ASSEMBLY	1
MP3	8930103000	4075 JACK CAP	1
MP4	8930103010	4075 MIC CAP	1
MP5	8930103020	4075 SD CAP	1
MP6	8510023102	4075 SHIELD PLATE-2	1
MP7	8830004680	4075 ANT NUT	1
MP8	8930103410	4075 BRACKET PLATE	1
MP21	8930083140	3322 CONTACT RUBBER	1
MP22	8930096240	3740 SPONGE	2
MP23	8850003250	PLAIN WASHER (AU)	2
MP24	8810007131	SET SCREW H M3 x 6 ZC3 2K	3
MP25	8810007131	SET SCREW H M3 x 6 ZC3 2K	2
MP26	8810009050	SET SCREW H M3 x 10 NI	7
MP27	8810008661	PHBT M3 x 8 NI-ZC3	5
MP28	8810009511	PHBT M2 x 4 NI-ZC3	8
MP29	8810009511	PHBT M2 x 4 NI-ZC3	6
MP30	8810009511	PHBT M2 x 4 NI-ZC3	4
MP31	8810009561	PHBT M2 x 6 NI-ZK3	8
MP32	8810011830	TAPPING SCREW B0 2 x 4 SUS SSBC	2
MP33	8820000530	FLANGE BOLT M4 x 8 NI	1
MP34	8850000430	S-WASHER M4 NI	1
MP35	8850001800	FLAT WASHER M4 (4 x 12 x 0.8) SUS	2
MP37	8930104550	4075 AL A-SHEET	1
MP38	8930104560	4075 AL B-SHEET	1
MP39	8510023280	4075 C-SHIELD PLATE	1
MP40	8930075581	SHIELD SPONGE (CH)-1	1
MP41	8930067291	SHIELD SPONGE (AR)-1	1
MP42	8930067291	SHIELD SPONGE (AR)-1	1
MP43	8510023270	4075 B-SHIELD PLATE	1
MP44	8930104500	MAGNETIC SHIELD (D)	1
MP45	8930088331	FERRITE SHEET (AM)-1	1
MP46	8930104510	HIMELON SHEET (EI)	1
MP47	8930070691	SHIELD SPONGE (BH)-1	1
MP48	8930104930	4075 AL C-SHEET	1
MP49	8930063971	SHIELD SPONGE (AM)-1	1
MP51	8810009371	PHBT M3 x 12 NI-ZK3	4
MP52	8810012030	SCREW PH M3 x 6 ZK3	2
MP53	8930085980	SHIELD TAPE (Z)	3
MP61	8930080760	SPONGE (KT)	1
MP62	8510023290	4075 D-SHIELD PLATE	1
MP63	8930097340	FERRITE SHEET (BG)	2
MP64	8930080830	THERMAL SHEET (BV)	2
MP65	8930065741	2590 D-EARTH SPRING-1	1
MP66	8930098400	FERRITE SHEET (BK)	1
MP67	8930097310	FERRITE SHEET (BE)	1
MP68	8930055982	SHIELD SPONGE (F)-2	1
MP69	8930105430	SHIELD SPONGE (FA)	1
MP70	8930070691	SHIELD SPONGE (BH)-1	1
MP71	8930105070	FERRITE SHEET (BW)	1
MP72	8930055982	SHIELD SPONGE (F)-2	1
MP73	8930105430	SHIELD SPONGE (FA)	1
MP74	8930105430	SHIELD SPONGE (FA)	1
MP631	8930105440	FERRITE SHEET (BZ)	1
MP662	8930088331	FERRITE SHEET (AM)-1	1
MP782	8510023380	4075 ANT SHIELD COVER	1
MP945	8510023360	4075 F-SHIELD PLATE	1

[RF UNIT]

REF NO.	PART NO.	DESCRIPTION	QTY.
J161*	6510024930	20RF-JMCSG1BTBF	1
J201*	6510032350	20279-001E-01	1
J301*	6510032350	20279-001E-01	1
J391*	6510032350	20279-001E-01	1
J441*	6510032350	20279-001E-01	1
J571*	6510032350	20279-001E-01	1
MP1	8930075990	AL SHEET (AP)	1
MP201*	8510019611	3254 VCO CASE-1	1
MP202	8930088331	FERRITE SHEET (AM)-1	1
MP211*	8510019611	3254 VCO CASE-1	1
MP321	8930105150	FERRITE SHEET (BX)	1
MP322	8930105150	FERRITE SHEET (BX)	1
MP323	8930105240	4075 RF SPRING	1
MP401	8930105150	FERRITE SHEET (BX)	1
MP402	8930080760	FERRITE SHEET (BX)	1
MP465	8930104570	SPONGE (QY)	1
MP551	8930080760	SPONGE (KT)	1

[MAIN UNIT]

REF NO.	PART NO.	DESCRIPTION	QTY.
J51*	6510022472	40FLT-SM2-TB	1
J52*	6510022022	14FLT-SM2-TB	1
J71*	6510022472	40FLT-SM2-TB	1
J81*	6510022472	40FLT-SM2-TB	1
J201*	6510025142	10FLT-SM2-TB	1
J251*	6450002690	ASJ-190-A	1
J271*	6450002530	HSJ4456-010320	1
J411*	6510032350	20279-001E-01	1
J441*	6510032350	20279-001E-01	1
J551*	6510025142	10FLT-SM2-TB	1
J552*	6510025142	10FLT-SM2-TB	1
J601*	6510025142	10FLT-SM2-TB	1
J701*	6510025142	10FLT-SM2-TB	1
J831*	6510028170	SDHL-8BNS-K-363-A0-ETB	1
J901*	6510025142	10FLT-SM2-TB	1
J1101*	6510030950	MM8030-2610RJ3	1
S701*	2230001480	LS37J2-T	1
BT751*	3020000390	ML414HIV01E	1
EP1101*	3310005410	AH316M245001-T	1
MP1*	8510023320	4075 B-SHIELD CASE	1
MP2*	8510023310	4075 A-SHIELD CASE	1
MP41*	8510019650	3250 VCO CASE	1
MP251*	8510021210	OGSC-402030	1
MP252*	8510021050	OG-603070	1
MP371	8510023340	4075 E-SHIELD PLATE	1
MP401	8510021830	3765 S-CASE	1
MP412*	8510019650	3250 VCO CASE	1
MP413	8510019660	3250 VCO COVER	1
MP441	8510021830	3765 S-CASE	1
MP442*	8510021050	OG-603070	1
MP501*	8510019650	3250 VCO CASE	1

[FILTER UNIT]

REF NO.	PART NO.	DESCRIPTION	QTY.
J2*	6510022022	14FLT-SM2-TB	1
J11*	6510032350	20279-001E-01	1
J12*	6510032350	20279-001E-01	1

[PA-A UNIT]

REF NO.	PART NO.	DESCRIPTION	QTY.
J51*	6510028350	20P10.0-JMCS-G-B-TF	1
J101*	6510022472	40FLT-SM2-TB	1
J602*	6510032350	20279-001E-01	1
J603*	6510022022	14FLT-SM2-TB	1
J604*	6510032350	20279-001E-01	1
J605*	6510032350	20279-001E-01	1
J915*	6510032350	20279-001E-01	1
J1101*	6510032350	20279-001E-01	1
J1102*	6450002660	LGP7031-1101F	1
W1021*	7030010840	MJP-0.2-T	1
MP1*	8510021680	3697 VCO CASE	1
MP2	8510018160	2969 B-VCO COVER	1
MP3	8930104041	MAGNETIC SHIELD (C)-1	1
MP4	8510023330	4075 C-SHIELD CASE	1
MP5	8930104531	INSULATION SHEET (PD)-1	1
MP6	8950007850	3322 CONTACT SPRING	1
MP7	8930103520	HIMELON SHEET (EJ)	1
MP8	8930086210	THERMAL SHEET (CG)	1
MP9	8930084910	THERMAL SHEET (CB)	1
MP13	8930104980	SHIELD SPONGE (EY)	1
MP14	8930104980	SHIELD SPONGE (EY)	1
MP15	8930104950	SHIELD SPONGE (EX)	1
MP16	8930104980	SHIELD SPONGE (EY)	1
MP781	8510023370	4075 ANT SHIELD CASE	1
MP945*	8410003220	3913 B-CU HEATSINK	1
MP1022	8930071160	2427 F-EARTH SPRING	1
MP1102	8510023300	4075 DC SHIELD	1

*: Refer to "BOARD LAYOUTS" for the location. **: Refer to "GENERAL WIRING" for the connection

Screw abbreviations A, B0, BT: Self-tapping PH: Pan head ZK: Black NI-ZU: Nickel-Zinc SUS: Stainless

[FRONT UNIT]

REF NO.	PART NO.	DESCRIPTION	QTY.
DS1	5030004620	M9-2367TXW-1	1
SP1	2510002160	036D01209	1
W1**	8910000070	FFC-1008 (P0.5N6L50)	1
W2**	8910000070	FFC-1008 (P0.5N6L50)	1
W3**	8910000070	FFC-1008 (P0.5N6L50)	1
W4**	8910000070	FFC-1008 (P0.5N6L50)	1
W5**	8600037590	SP CABLE 70MM	1
EP1	0880004930	EX-3956 #12	1
EP2	3310005571	GNBA-960A	1
MP1	8210035100	4075 FRONT PANEL ASSEMBLY	1
	8210035360	4075 FRONT PANEL (A) ASSEMBLY	1
MP5	8610016560	KNOB N-458 BASE	1
MP6	8610016570	KNOB N-458 COVER	1
MP7	8610016580	KNOB N-459	2
MP8	8610016590	KNOB N-460	1
MP9	8930103030	4075 3-KEY	1
MP11	8930103050	4075 6-KEY	1
MP12	8930103400	4075 LCD PLATE	1
MP13	8930103390	4075 LCD SPONGE	1
MP15	8930060190	2591 N-SPRING	1
MP16	8830000551	VR NUT (E)-1	3
MP18	8930095360	SPONGE (OM)	1
MP20	8810005561	PH M3 x 8 SUS SSBC	2
MP21	8810008631	PHBT M3 x 6 NI-ZC3	2
MP22	8810008661	PHBT M3 x 8 NI-ZC3	9
MP23	8930103680	SPONGE (QR)	1
MP24	8930104660	4075 EARTH SPRING	1
MP25	8930104940	4075 FERRITE SHEET	1
MP26	8930104940	4075 FERRITE SHEET	1
MP27	8930067291	SHIELD SPONGE (AR)-1	1
MP28	8930067291	SHIELD SPONGE (AR)-1	1
MP29	8930067291	SHIELD SPONGE (AR)-1	1
MP30	8930067291	SHIELD SPONGE (AR)-1	1
MP31	8930063270	2590 EARTH SPRING	1
MP32	8930078381	SHIELD SPONGE (CL)-1	1
MP33	8930049260	NONWOVEN SHEET CA	1

[DISPLAY UNIT]

REF NO.	PART NO.	DESCRIPTION	QTY.
J21*	6510031070	AYF534035	1
J71*	6510022472	40FLT-SM2-TB	1
J81*	6510022472	40FLT-SM2-TB	1
J121*	6510022692	06FLT-SM2-TB	1
J131*	6510022692	06FLT-SM2-TB	1
J141*	6510022692	06FLT-SM2-TB	1
J151*	6510022692	06FLT-SM2-TB	1
J161*	6510023801	S4B-ZR-SM4A-TF	1
J171*	6510018301	S2B-ZR-SM4A-TF	1
J181*	6510032350	20279-001E-01	1
S101*	2260002740	LS8J2M-T	1
S102*	2260002740	LS8J2M-T	1
S103*	2260002740	LS8J2M-T	1
S104*	2260002740	LS8J2M-T	1
S105*	2260002740	LS8J2M-T	1
S106*	2260002740	LS8J2M-T	1
S107*	2260002740	LS8J2M-T	1
S108*	2260002740	LS8J2M-T	1
S109*	2260002740	LS8J2M-T	1
MP21*	8510019650	3250 VCO CASE	1
MP22	8510019660	3250 VCO COVER	1
MP31	8930071160	2427 F-EARTH SPRING	1
MP32	8930071160	2427 F-EARTH SPRING	1
MP33	8930071160	2427 F-EARTH SPRING	1
MP101	8930089670	3562 MIC SPONGE	1
MP181*	8510022450	3754 GPS CASE	1

[DIAL-A UNIT]

REF NO.	PART NO.	DESCRIPTION	QTY.
J1*	6510022692	06FLT-SM2-TB	1
S1	2250001110	RE1107CM1-V03-5391	1

[DIAL-B UNIT]

REF NO.	PART NO.	DESCRIPTION	QTY.
J1*	6510022692	06FLT-SM2-TB	1
S1	2250001110	RE1107CM1-V03-5391	1

[DIAL-C UNIT]

REF NO.	PART NO.	DESCRIPTION	QTY.
J1*	6510022692	06FLT-SM2-TB	1
S1	2250001030	RE1107CM1-V03-4673	1

[CONNECT UNIT]

REF NO.	PART NO.	DESCRIPTION	QTY.
J1*	6510028230	IMSA-9681S-14Y901	1
J31*	6450002530	HSJ4456-010320	1
J41*	6450002530	HSJ4456-010320	1
J51*	6450002530	HSJ4456-010320	1
J61*	6510030041	CSS5005-4R11FSZ	1

[ACCESSORIES]

REF NO.	PART NO.	DESCRIPTION	QTY.
P1	5610000750	MP-013MS-R	1
F1	5210000131	FGB 4A PBF	2
MC1	-	HM-243†	1
W1	-	OPC-2421†	1
EP2	-	BP-272†	1
MP1	8930103510	LEG CUSHION (S)	1
MP2	8930104120	4075 MIC PLATE	1

†: Sold as an option.

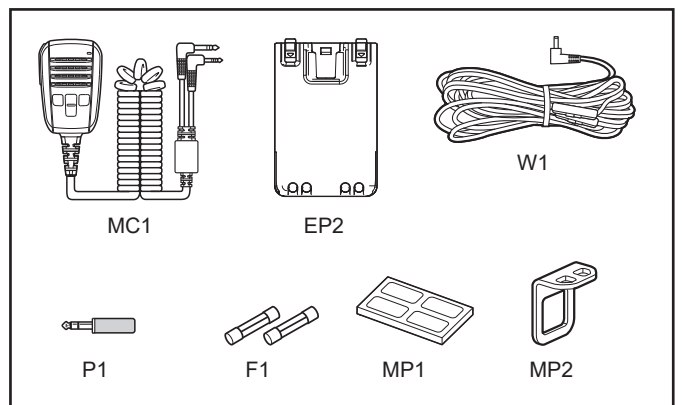

*: Refer to "BOARD LAYOUTS" for the location. **: Refer to "GENERAL WIRING" for the connection
Screw abbreviations A, B0, BT: Self-tapping PH: Pan head ZK: Black NI-ZU: Nickel-Zinc SUS: Stainless

• FRONT ASSEMBLY

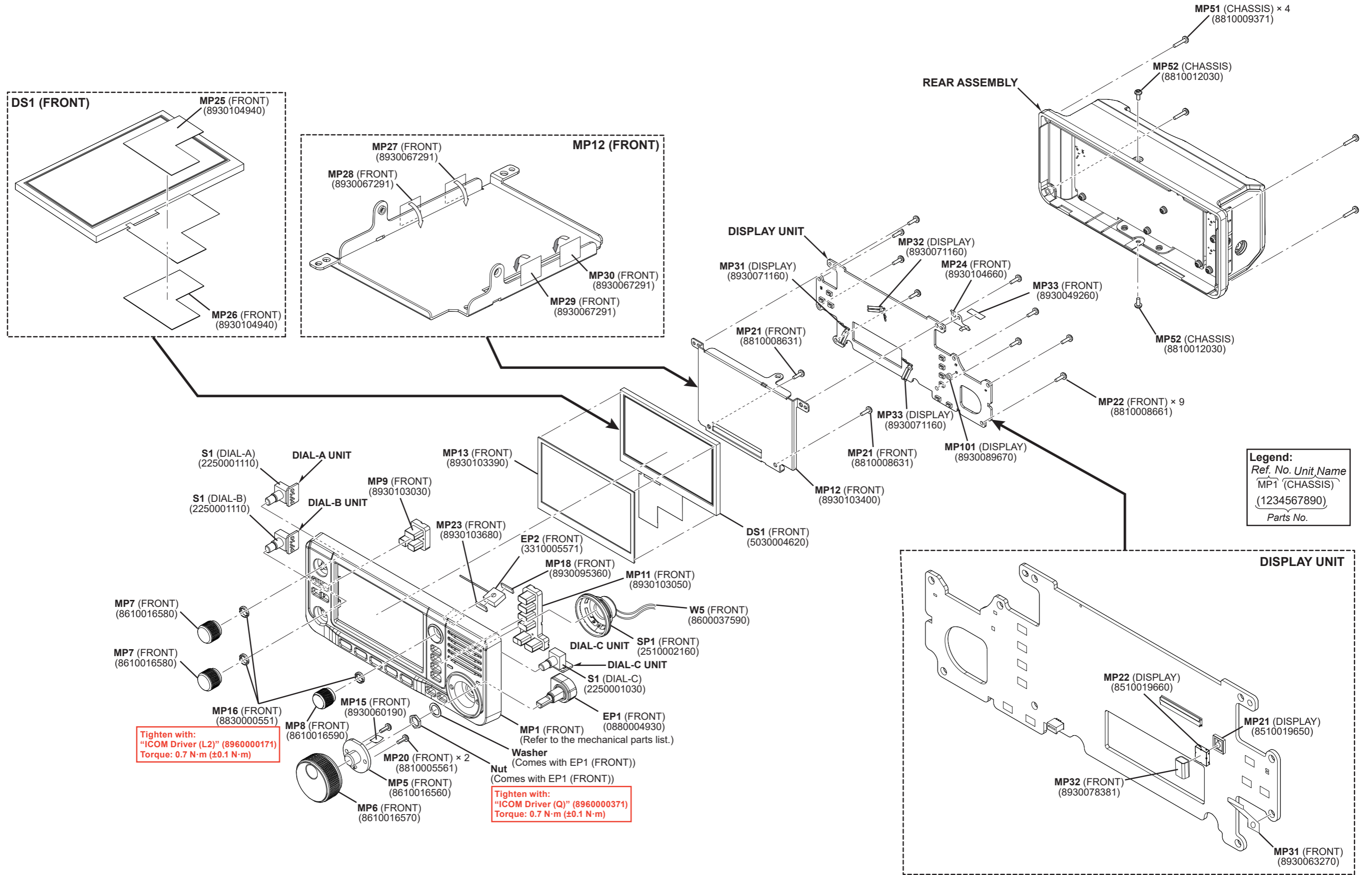

Unless otherwise noted, the tighten to torque is 0.5 N·m (±0.07 N·m).

NOTE: When replacing a flat cable, form the new one in the same shape as the original.

• REAR ASSEMBLY

PA-A UNIT

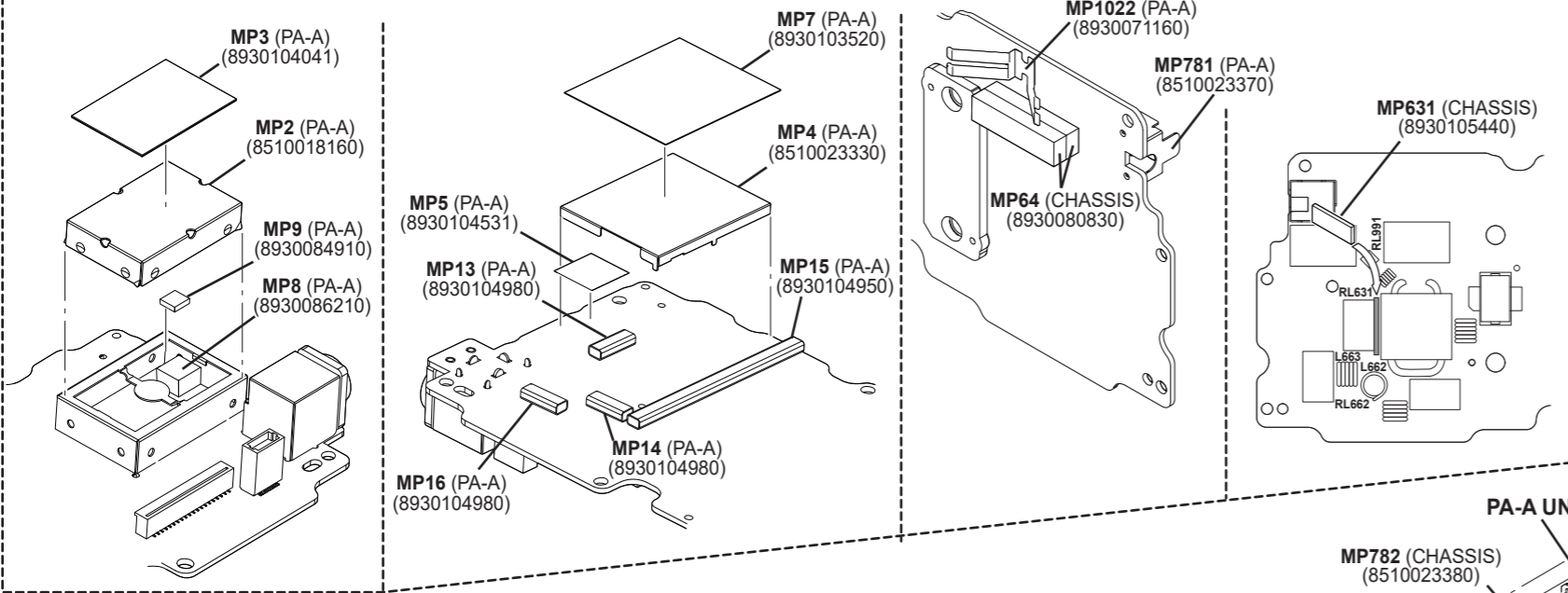

MAIN UNIT

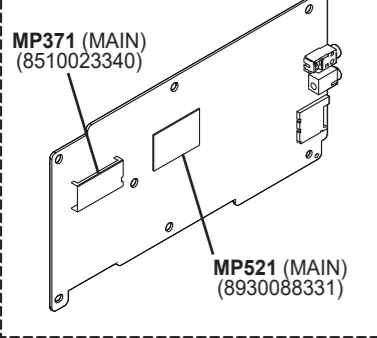

MAIN UNIT

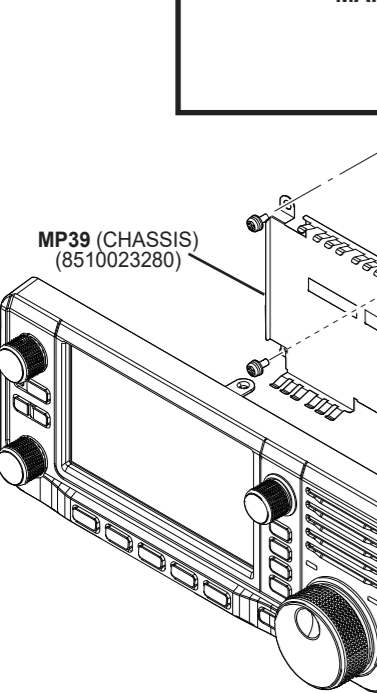

FRONT ASSEMBLY

FILTER UNIT

RF UNIT

CONNECT UNIT

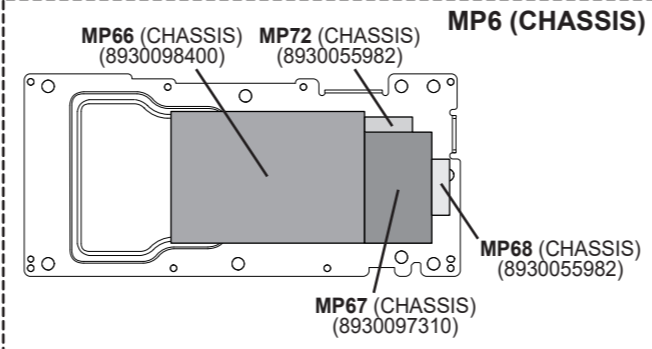

MP43 (CHASSIS)

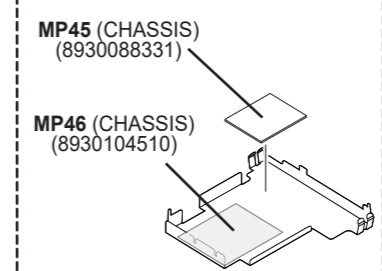

RF UNIT

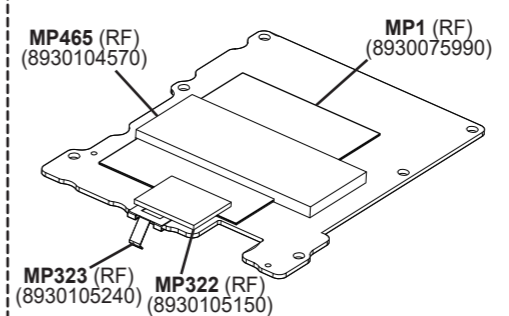

MP2 (CHASSIS)

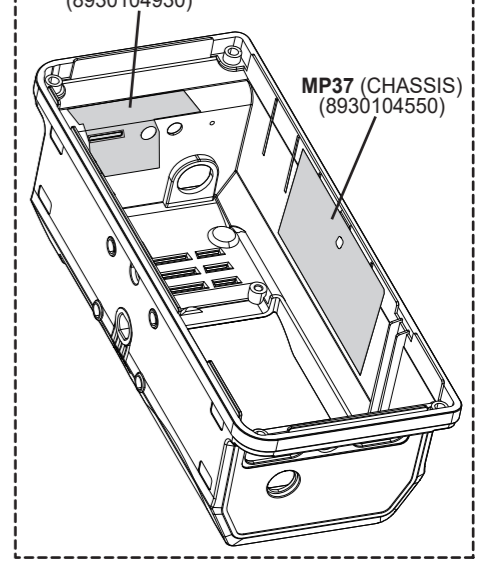

MP1 (CHASSIS)

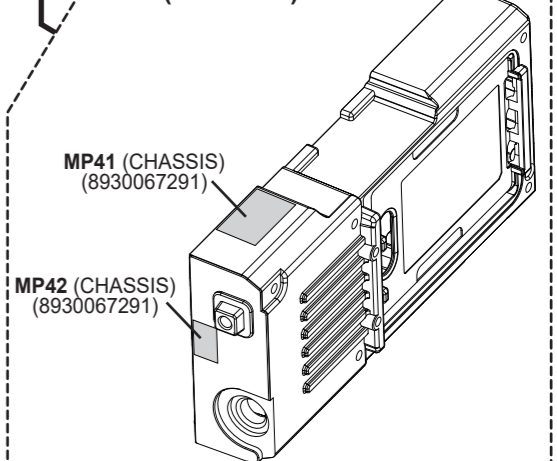

Legend:

Ref. No.	Unit Name
MP1	(CHASSIS)
(1234567890)	
	Parts No.

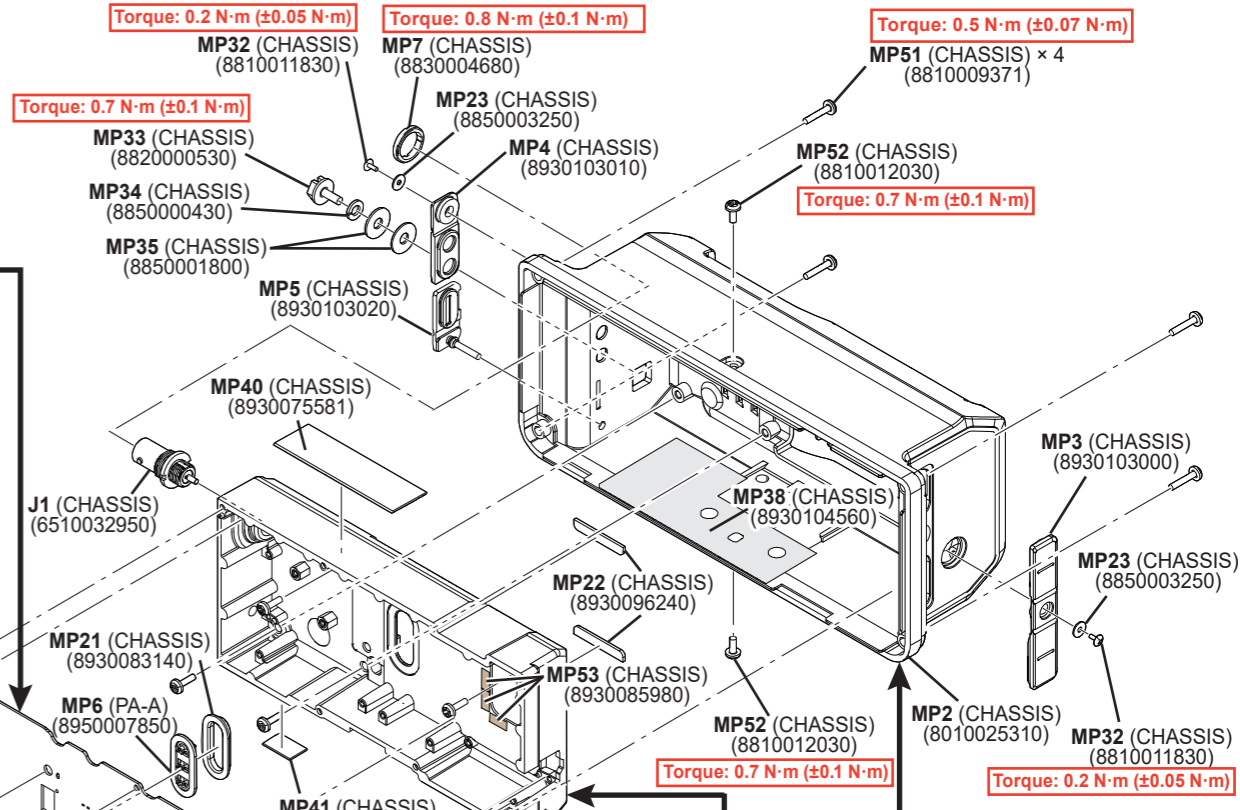

Torque: 0.5 N·m (±0.07 N·m)

Torque: 0.7 N·m (±0.1 N·m)

Torque: 0.5 N·m (±0.07 N·m)

Torque: 0.7 N·m (±0.1 N·m)

Unless otherwise noted, the tighten to torque is 0.35 N·m (±0.05 N·m).

NOTE: When replacing a flat cable, form the new one in the same shape as the original.

• DISPLAY UNIT (B-9127E: Top view)

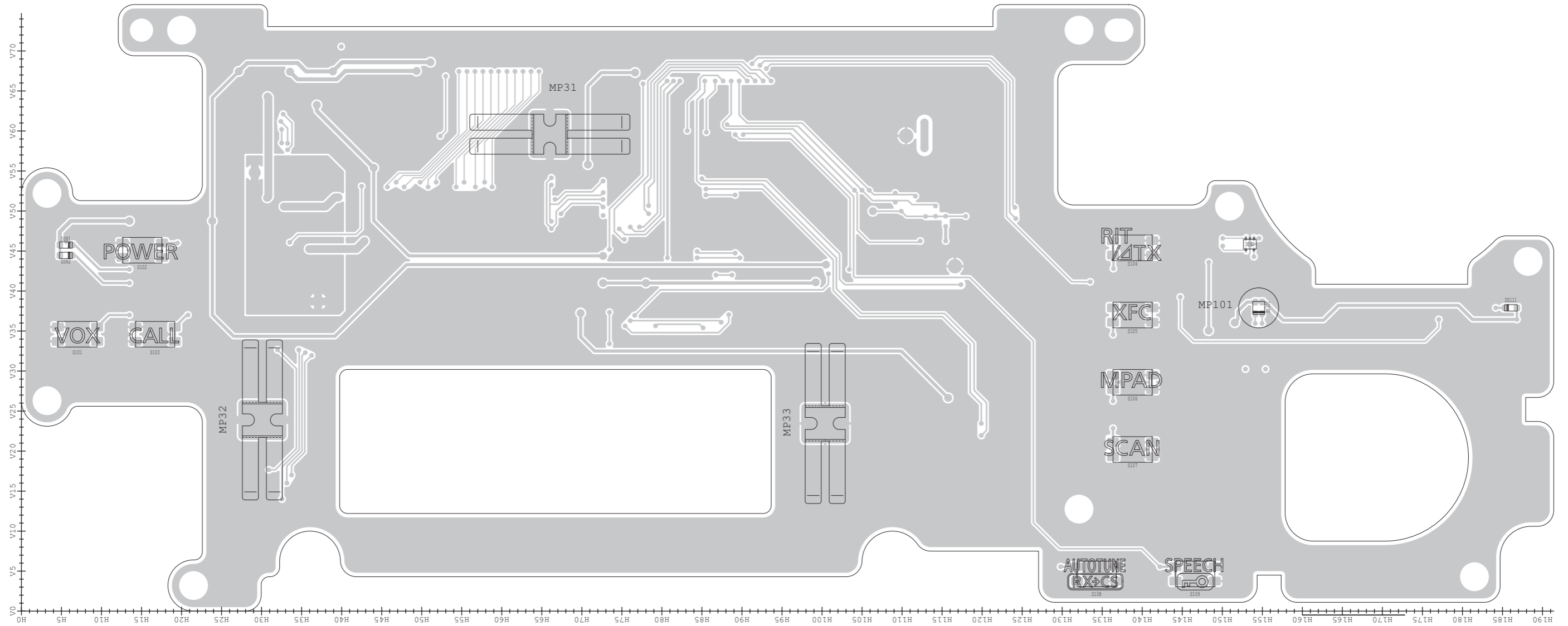

• DISPLAY UNIT (B-9127E: Bottom view)

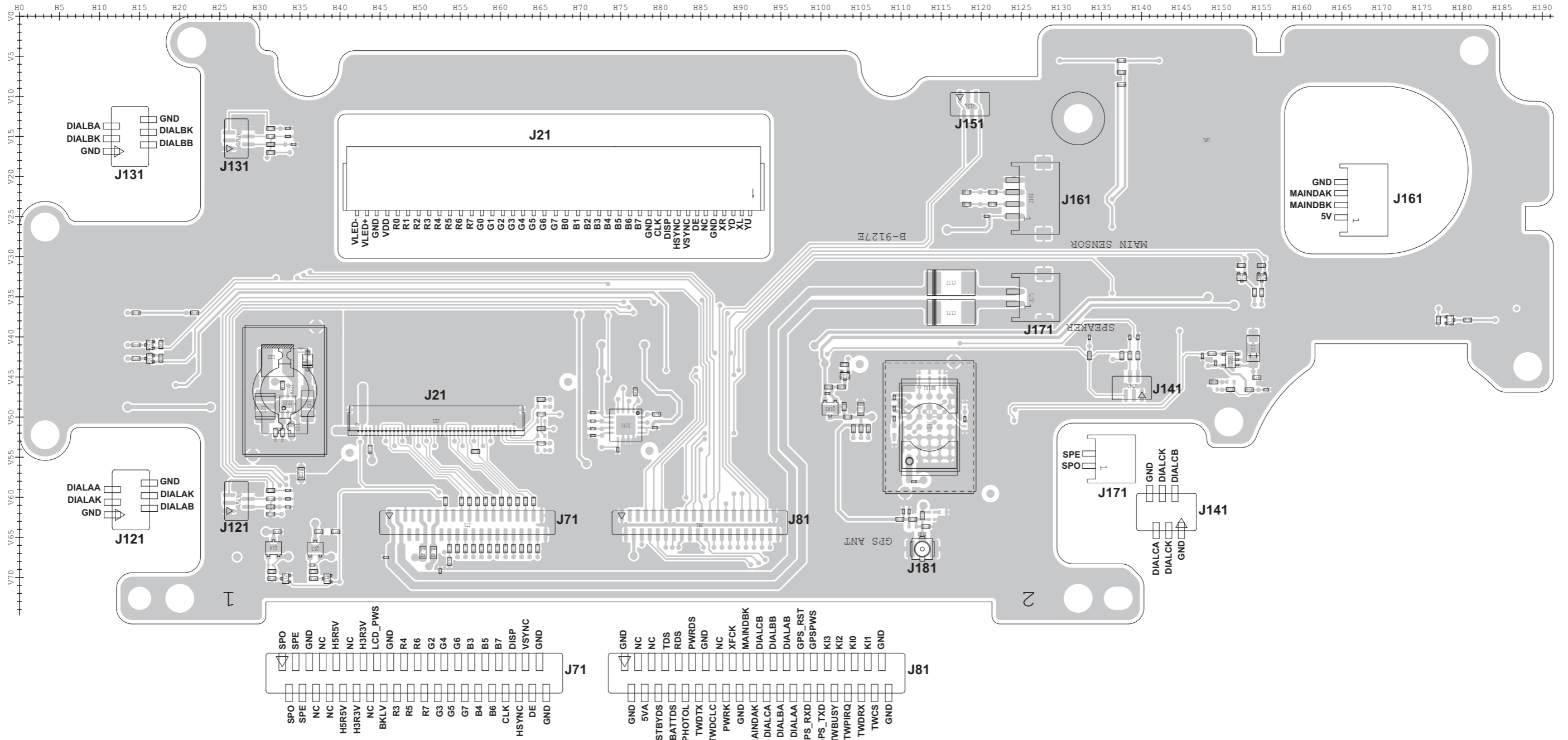

• **DIAL-A UNIT (B-9152A)**
(Top view)

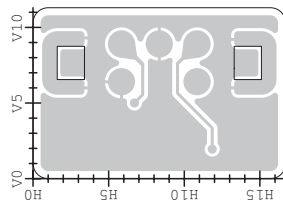

(Bottom view)

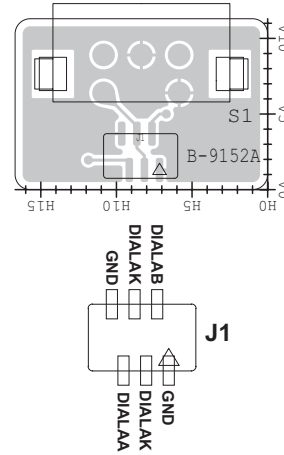

• **DIAL-B UNIT (B-9152A)**
(Top view)

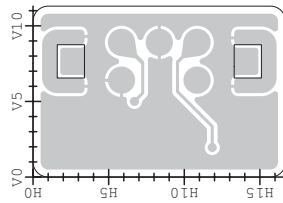

(Bottom view)

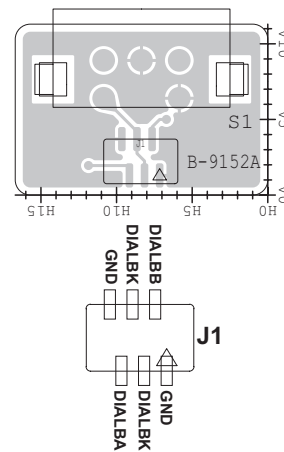

• **DIAL-C UNIT (B-9154B)**
(Top view)

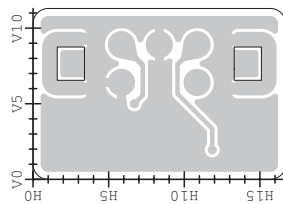

(Bottom view)

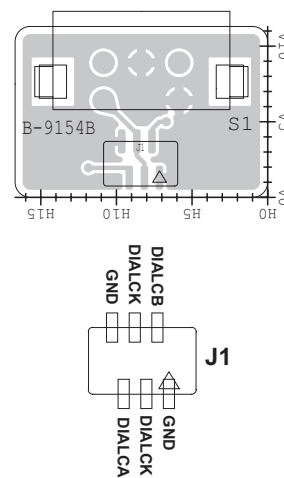

• MAIN UNIT (B-8984G: Top view)

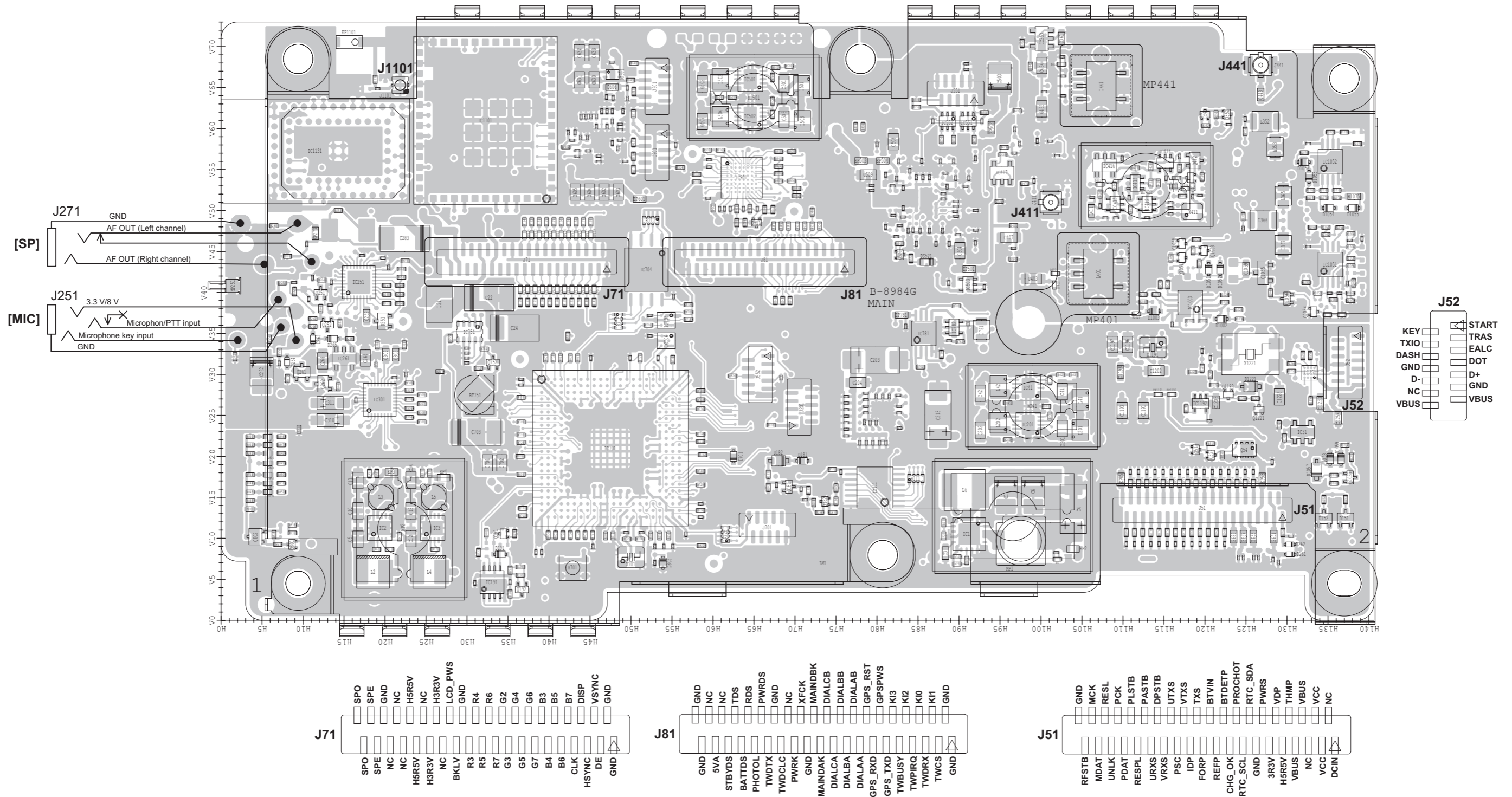

The serial numbers of transceivers that use the PCB (B-8984G).

Model Name	Version Number	Serial Numbers
IC-705	#12	12001001 to 12003650
	#13	-

• MAIN UNIT (B-8984G: Bottom view)

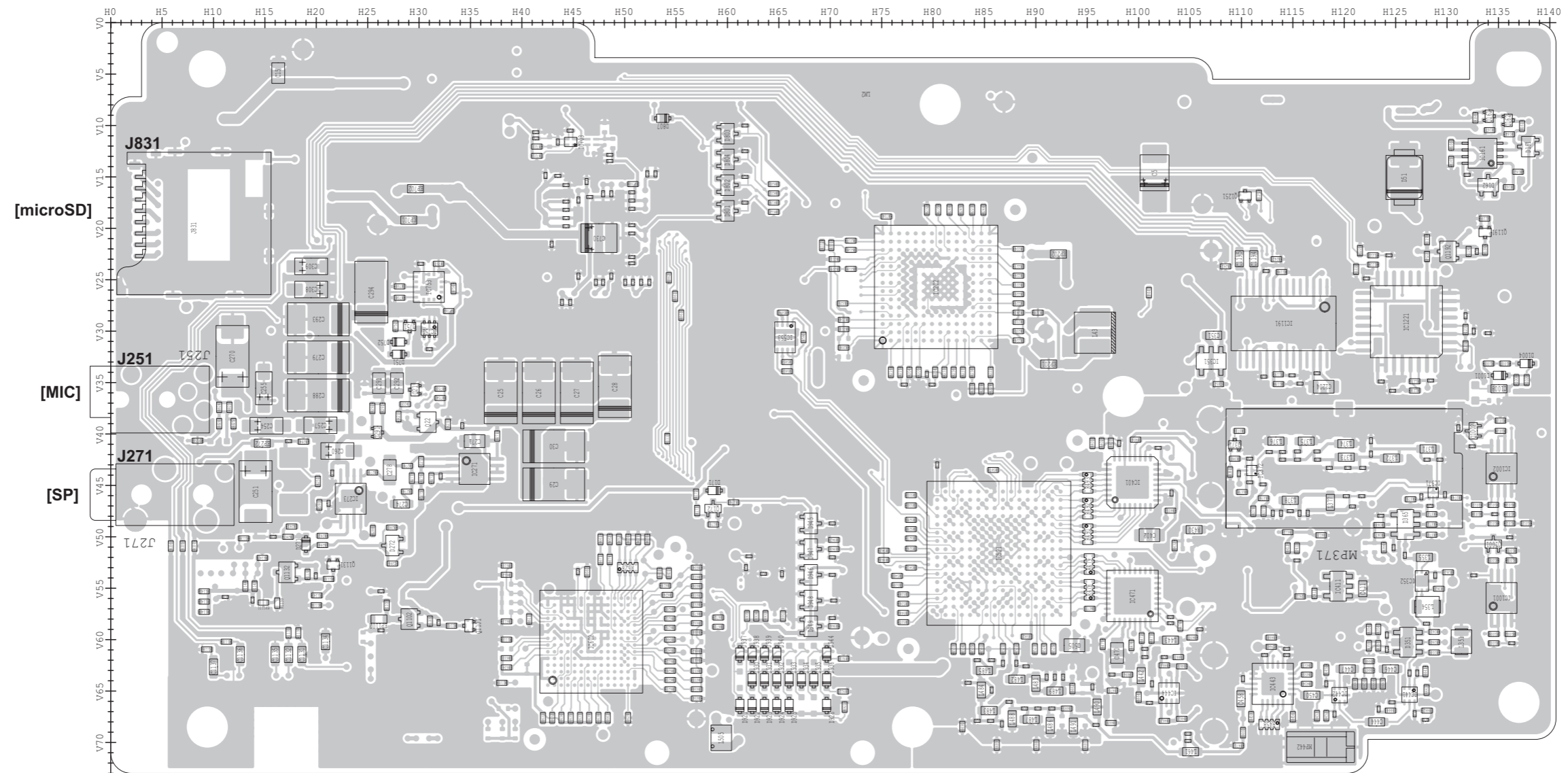

• MAIN UNIT (B-8984H: Top view)

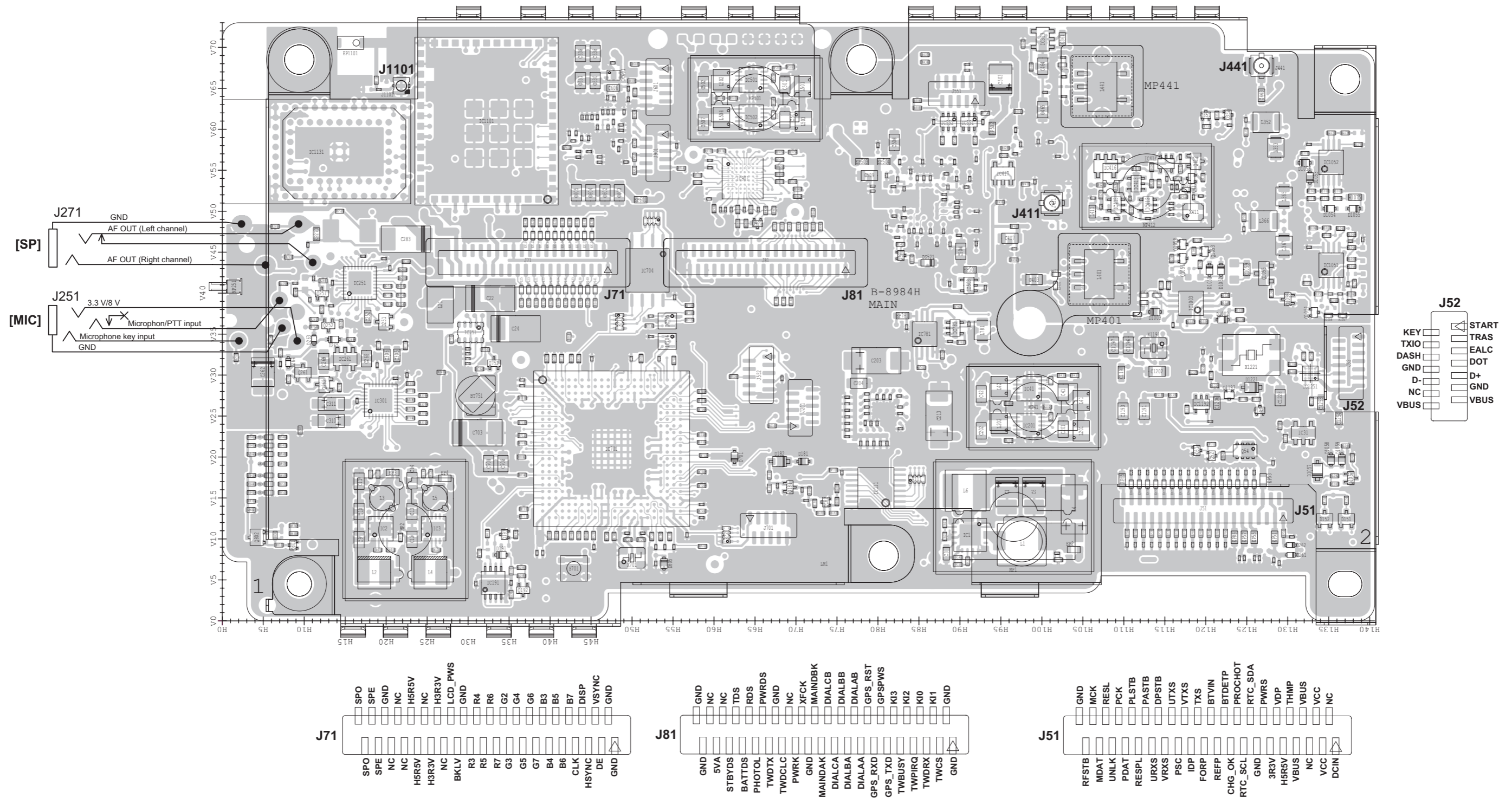

The serial numbers of transceivers that use the PCB (B-8984H).

Model Name	Version Number	Serial Numbers
IC-705	#12	12003651 to 12005000
	#13	13003101 to 13003100

• MAIN UNIT (B-8984H: Bottom view)

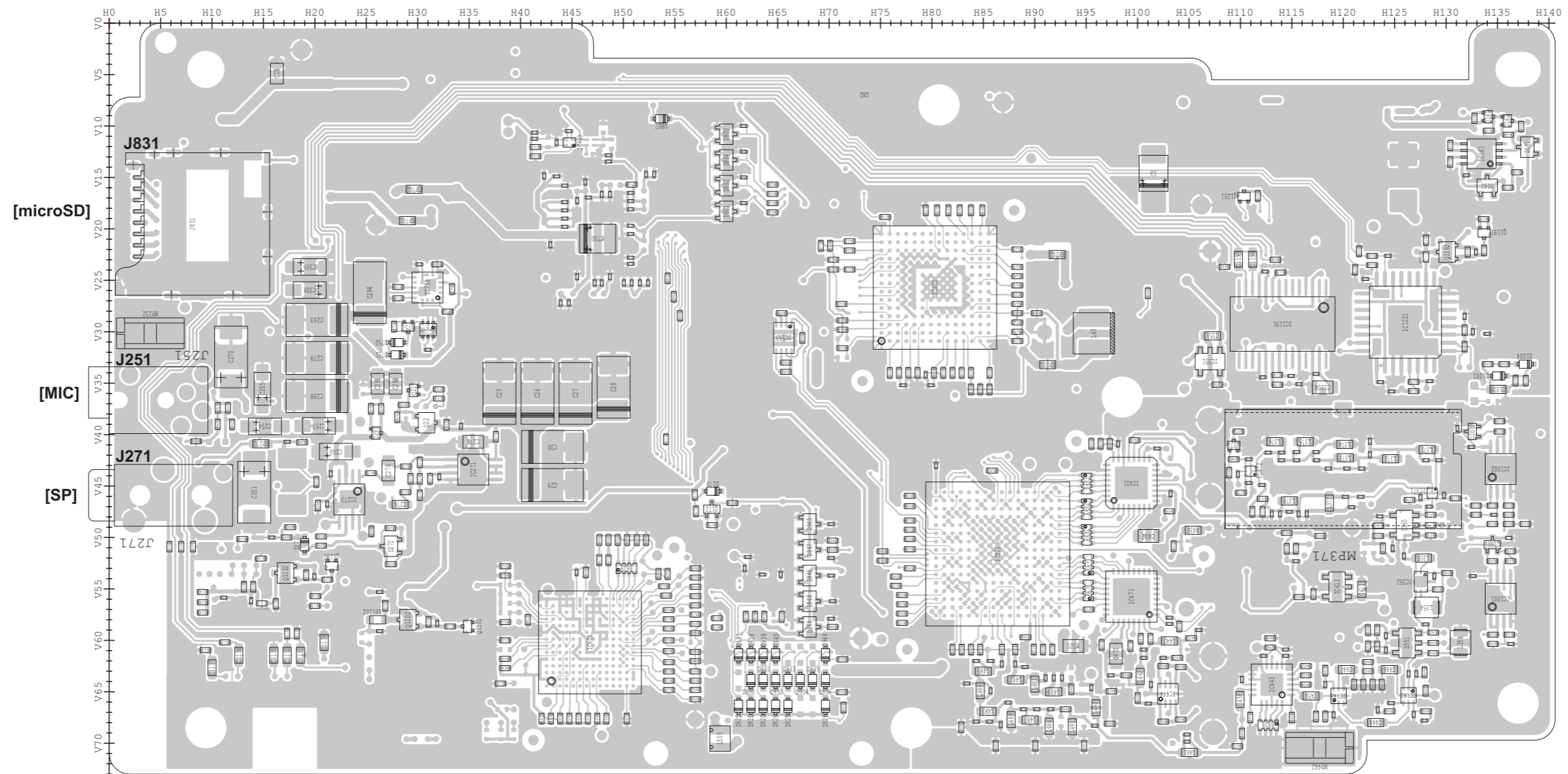

• MAIN UNIT (B-8984I: Top view)

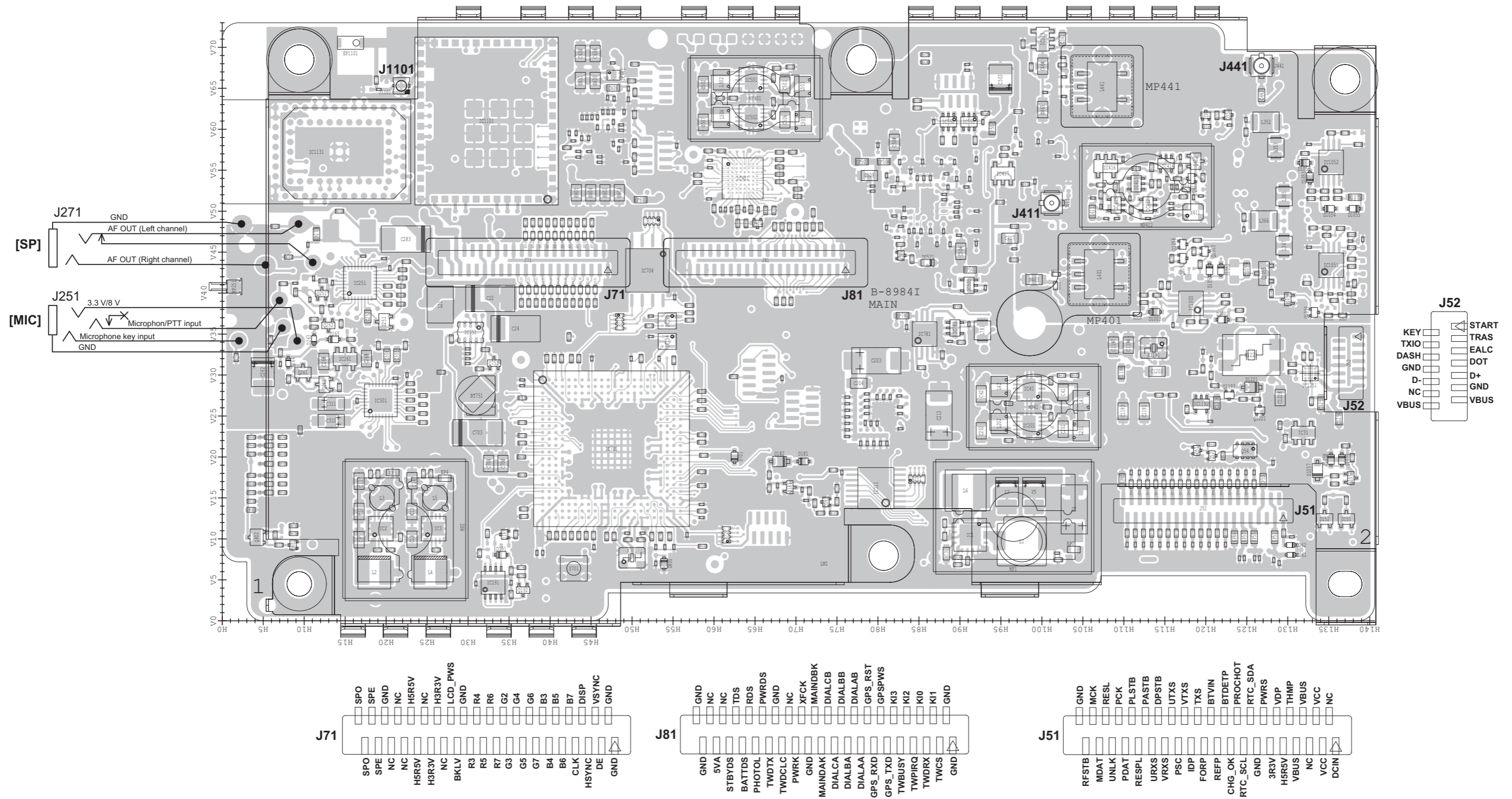

The serial numbers of transceivers that use the PCB (B-8984I).

Model Name	Version Number	Serial Numbers
IC-705	#12	12005001 and above
	#13	13003101 and above

• **CONNECT UNIT (B-9128B)**
(Top view)

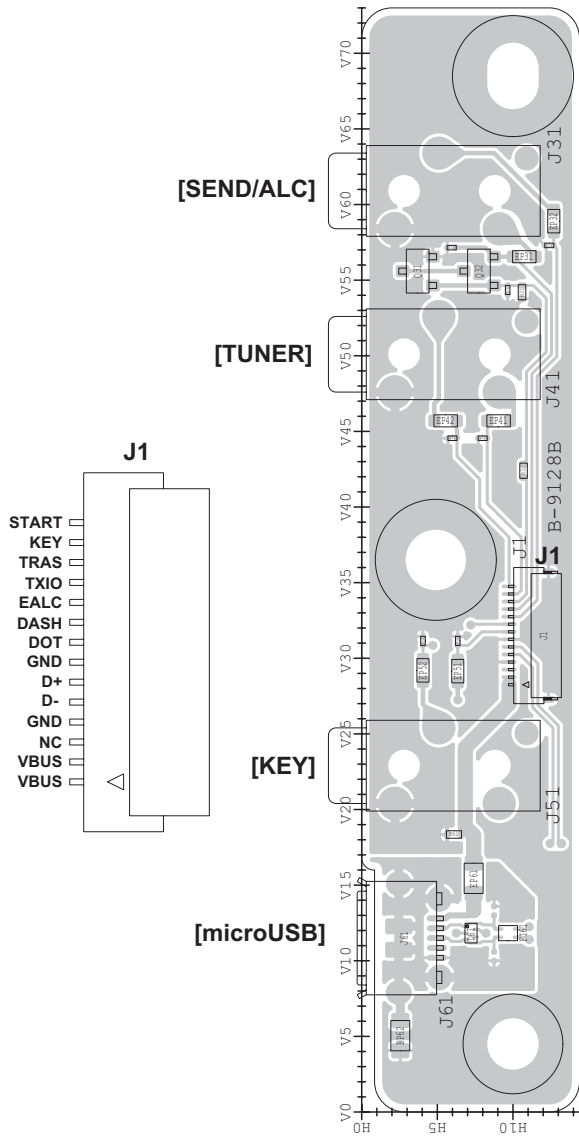

(Bottom view)

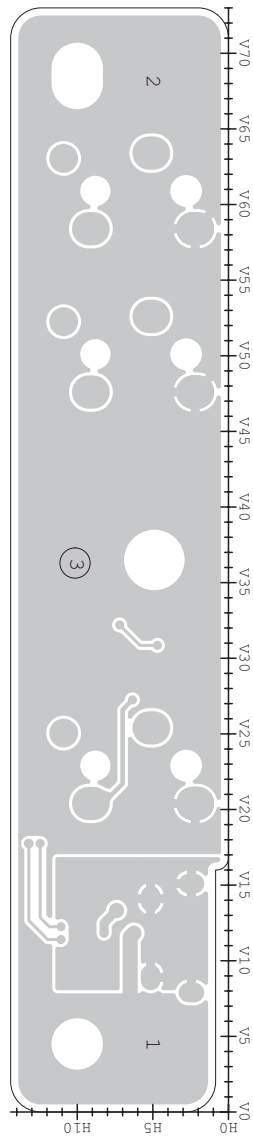

• RF UNIT (B-9131G)
(Top view)

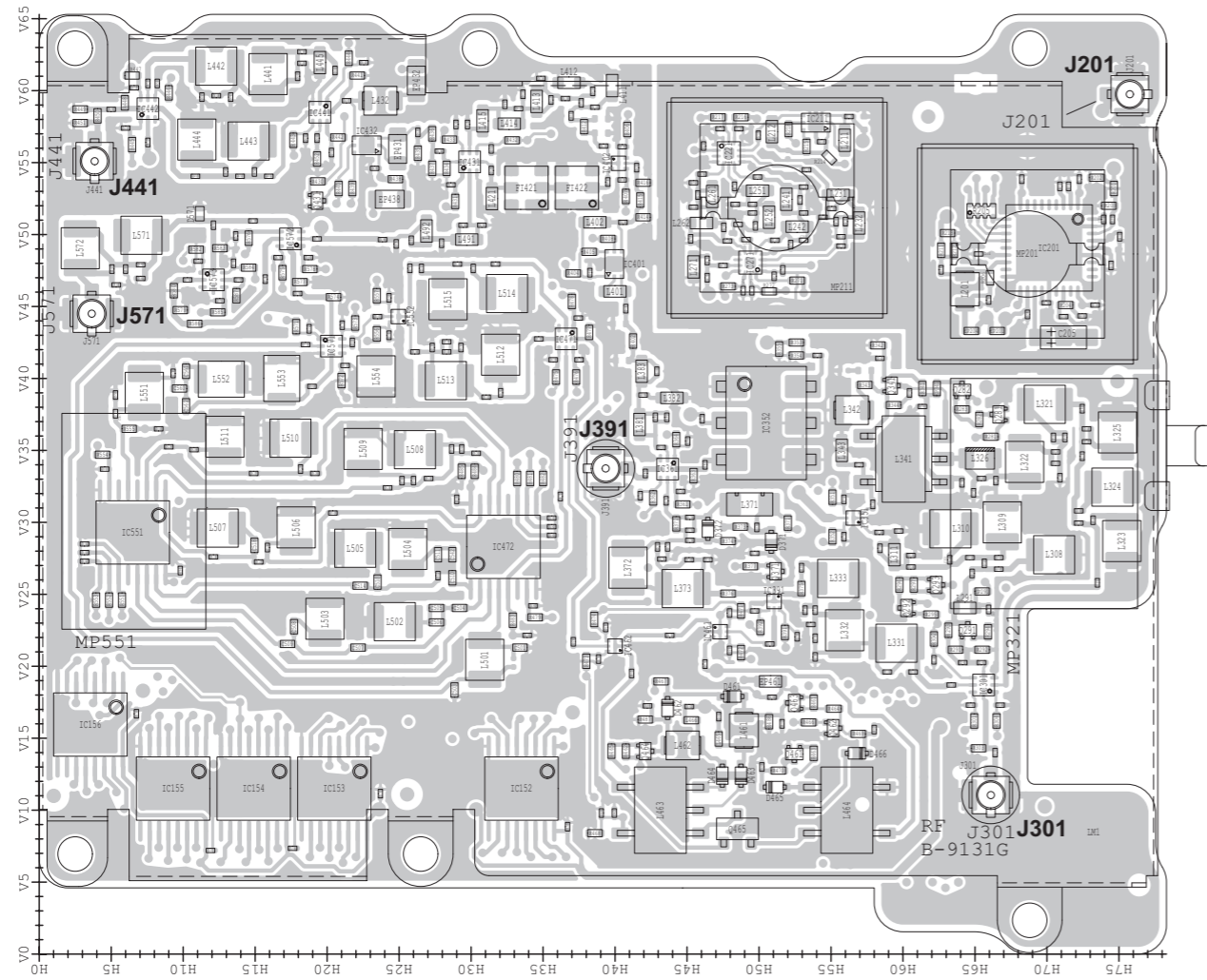

(Bottom view)

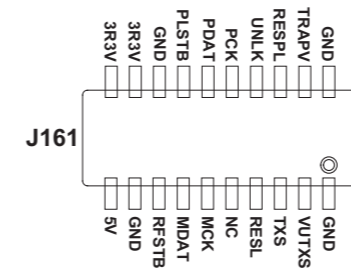
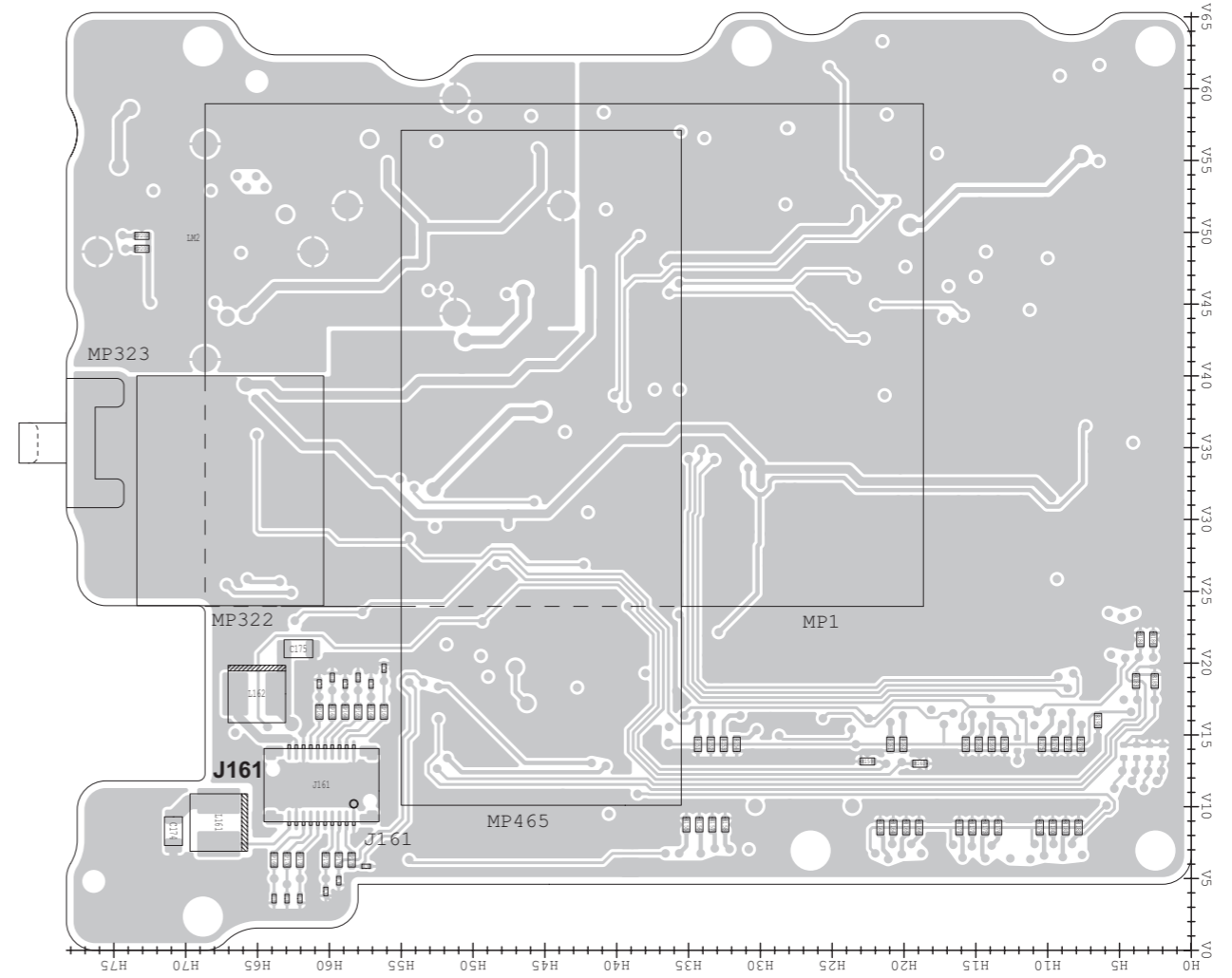

• **FILTER UNIT (B-9132C)**
(Top view)

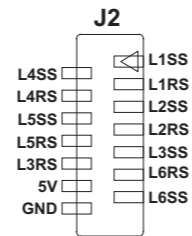
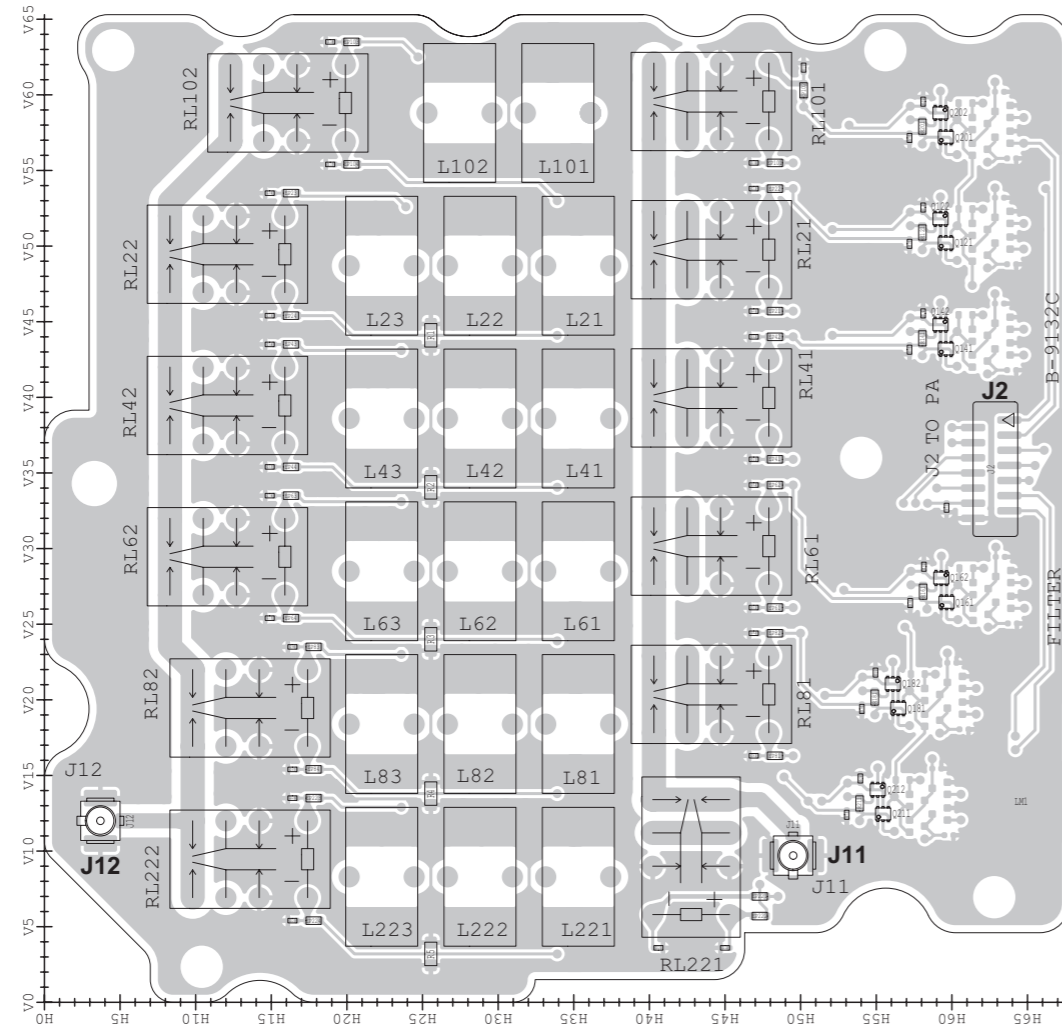

(Bottom view)

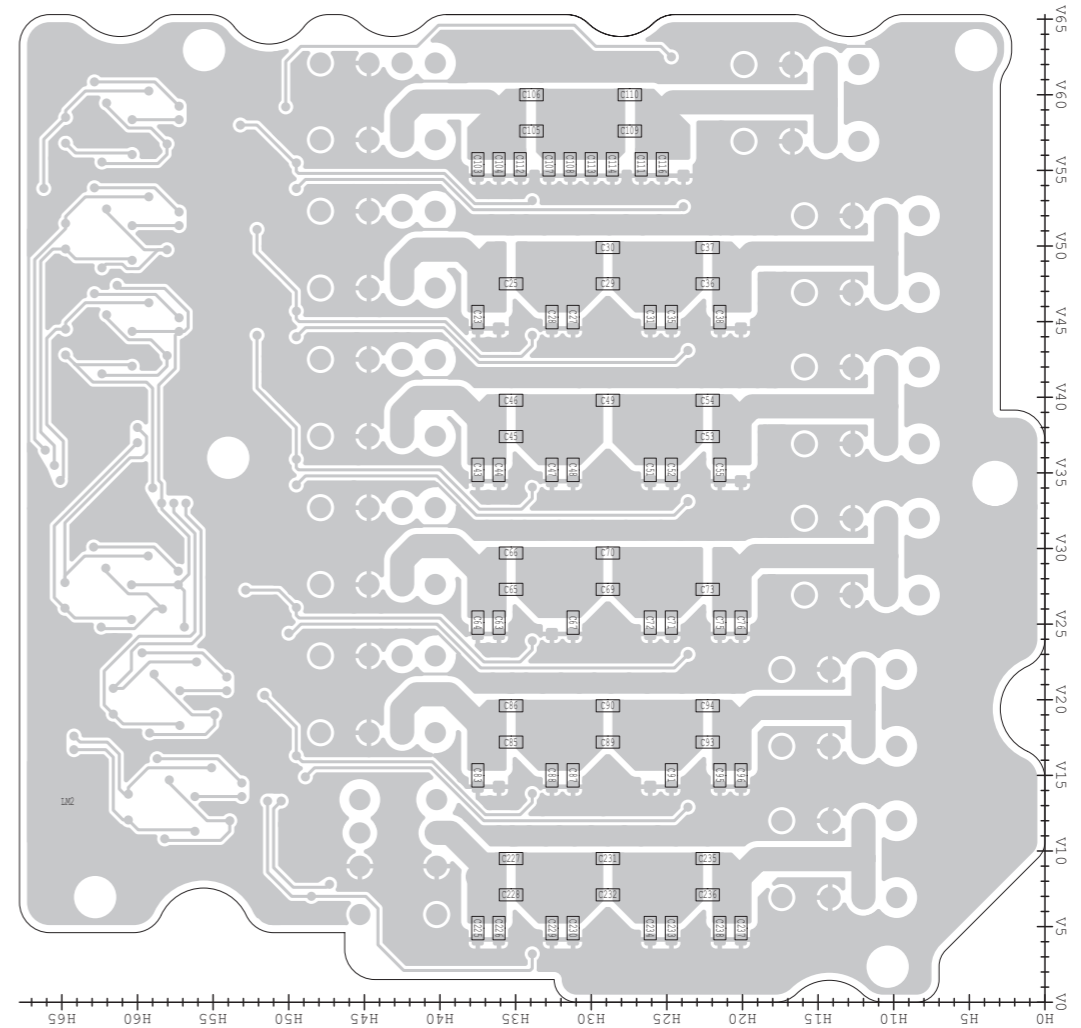

• PA-A UNIT (B-9003G: Top view)

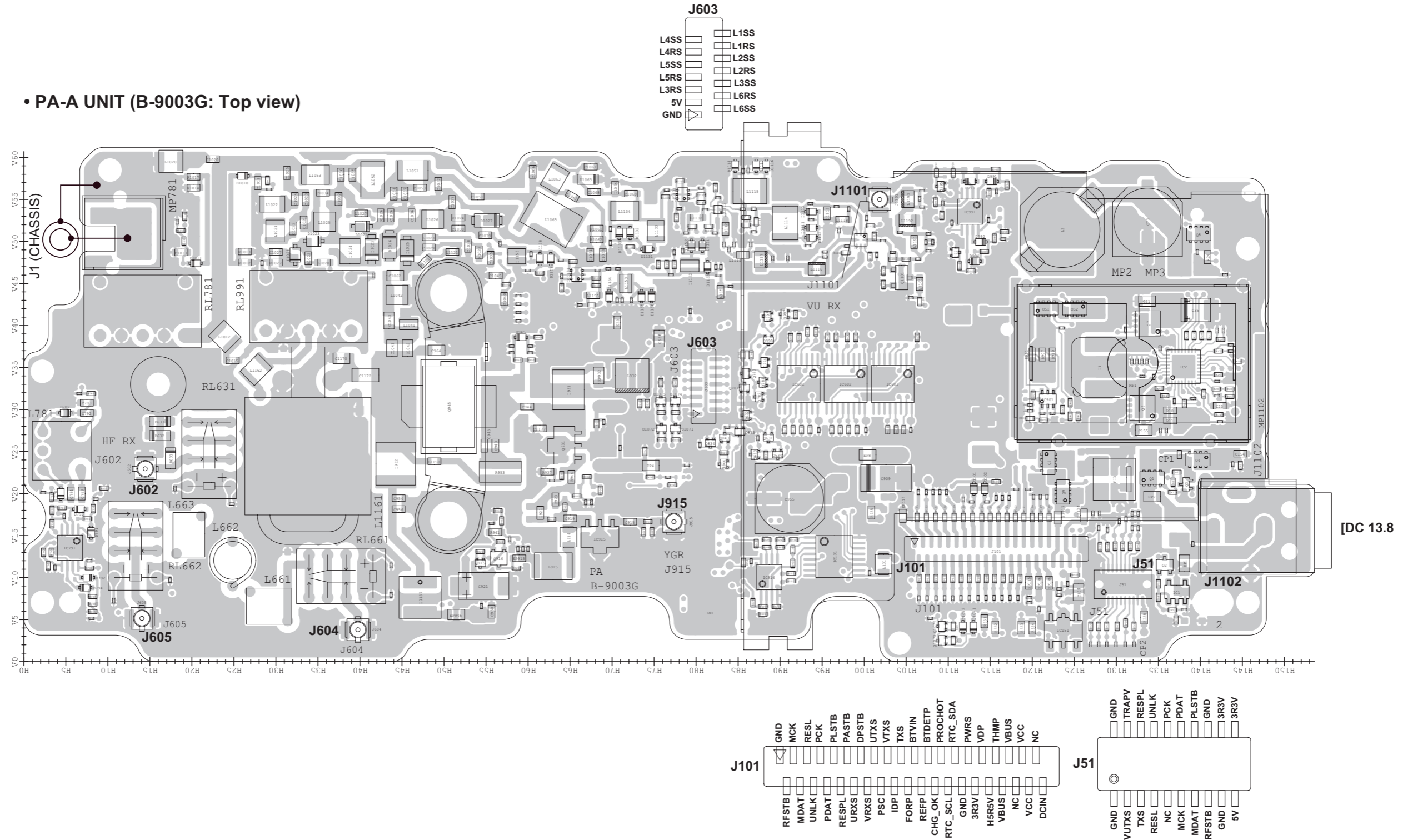

The serial numbers of transceivers that use the PCB (B-9003G).

Model Name	Version Number	Serial Numbers
IC-705	#12	12001001 to 12003650
	#13	-

• PA-A UNIT (B-9003G: Bottom view)

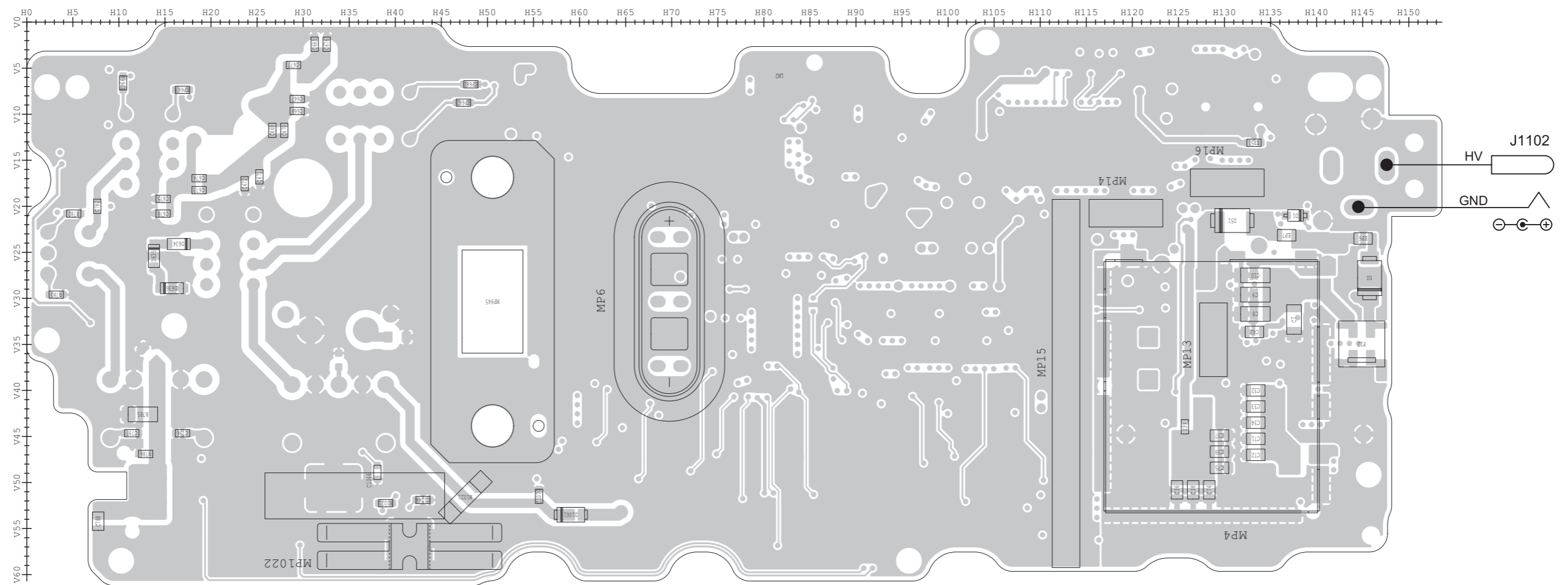

• PA-A UNIT (B-9003H: Top view)

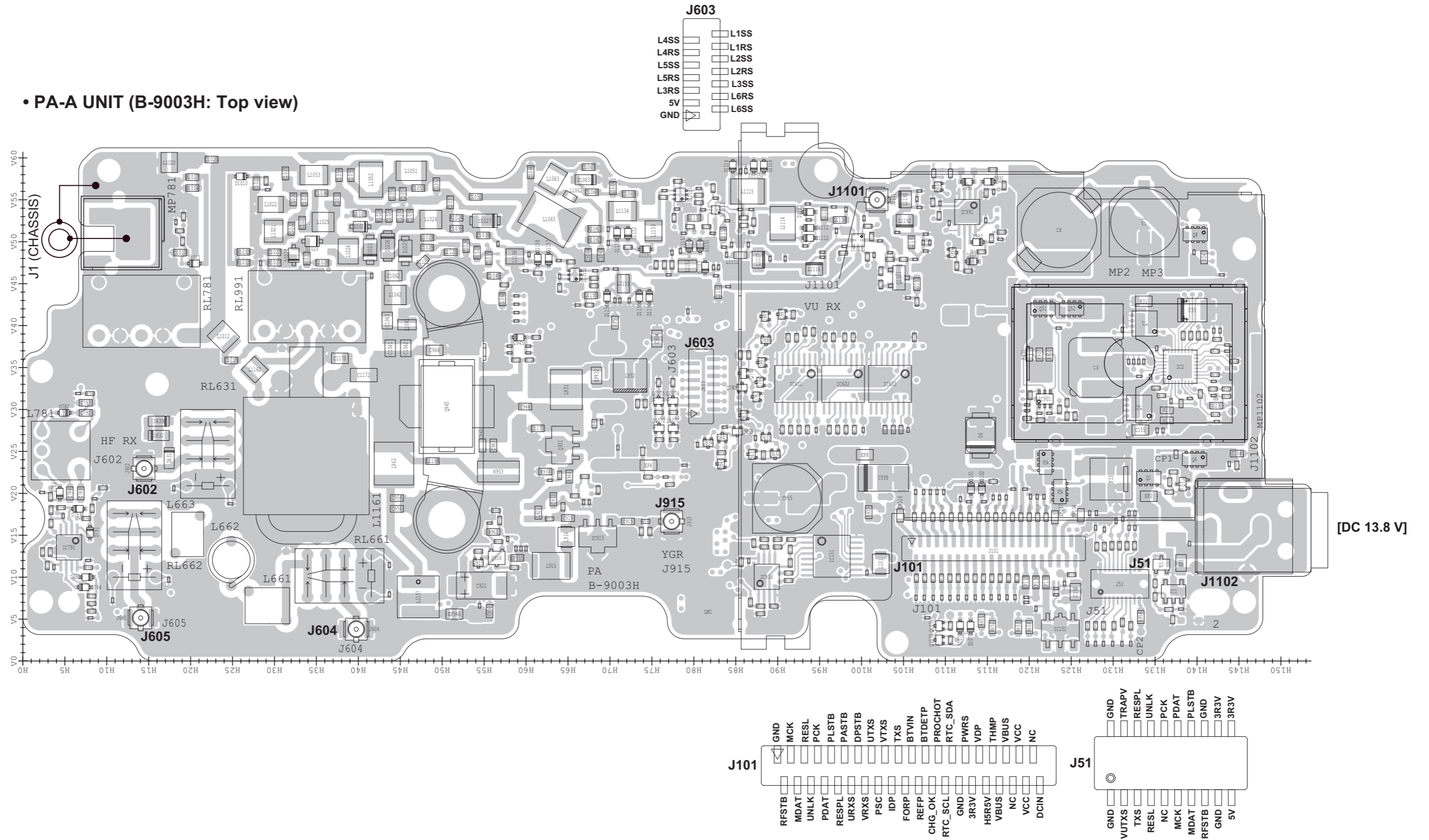

The serial numbers of transceivers that use the PCB (B-9003H).

Model Name	Version Number	Serial Numbers
IC-705	#12	12003651 to 12005000
	#13	-

• PA-A UNIT (B-9003H: Bottom view)

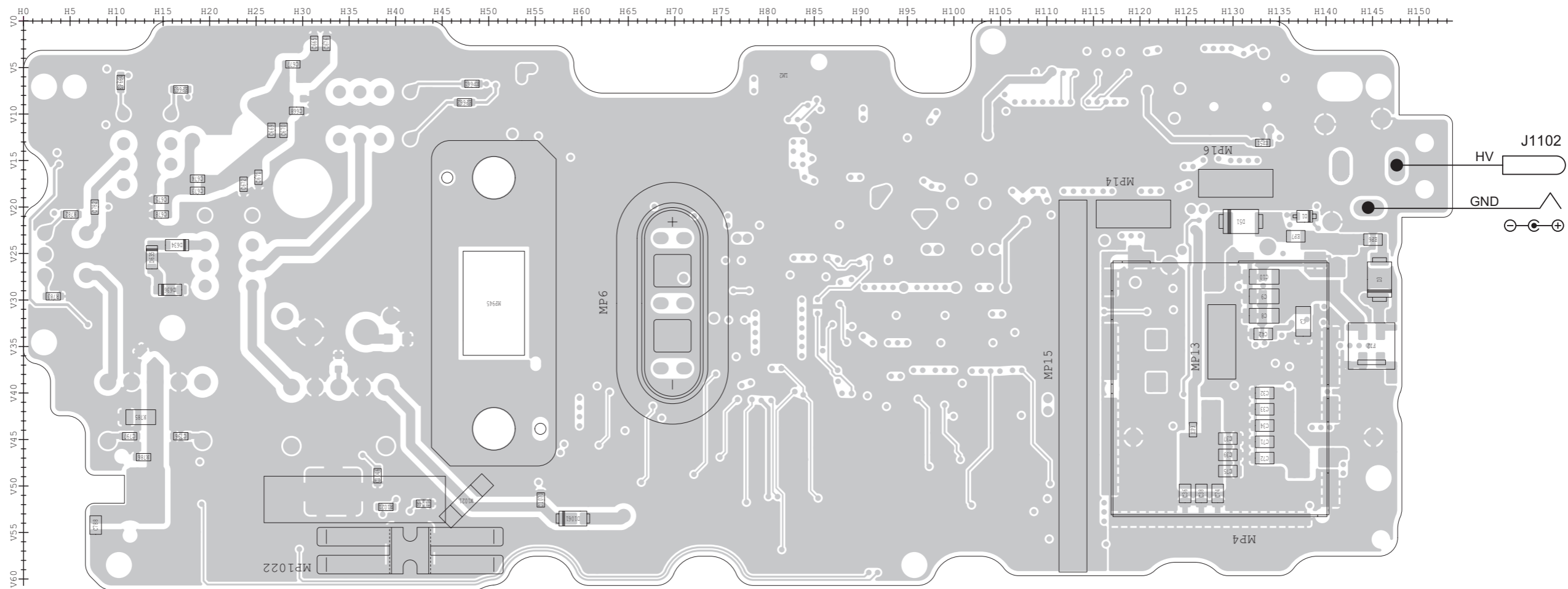

• PA-A UNIT (B-9328: Top view)

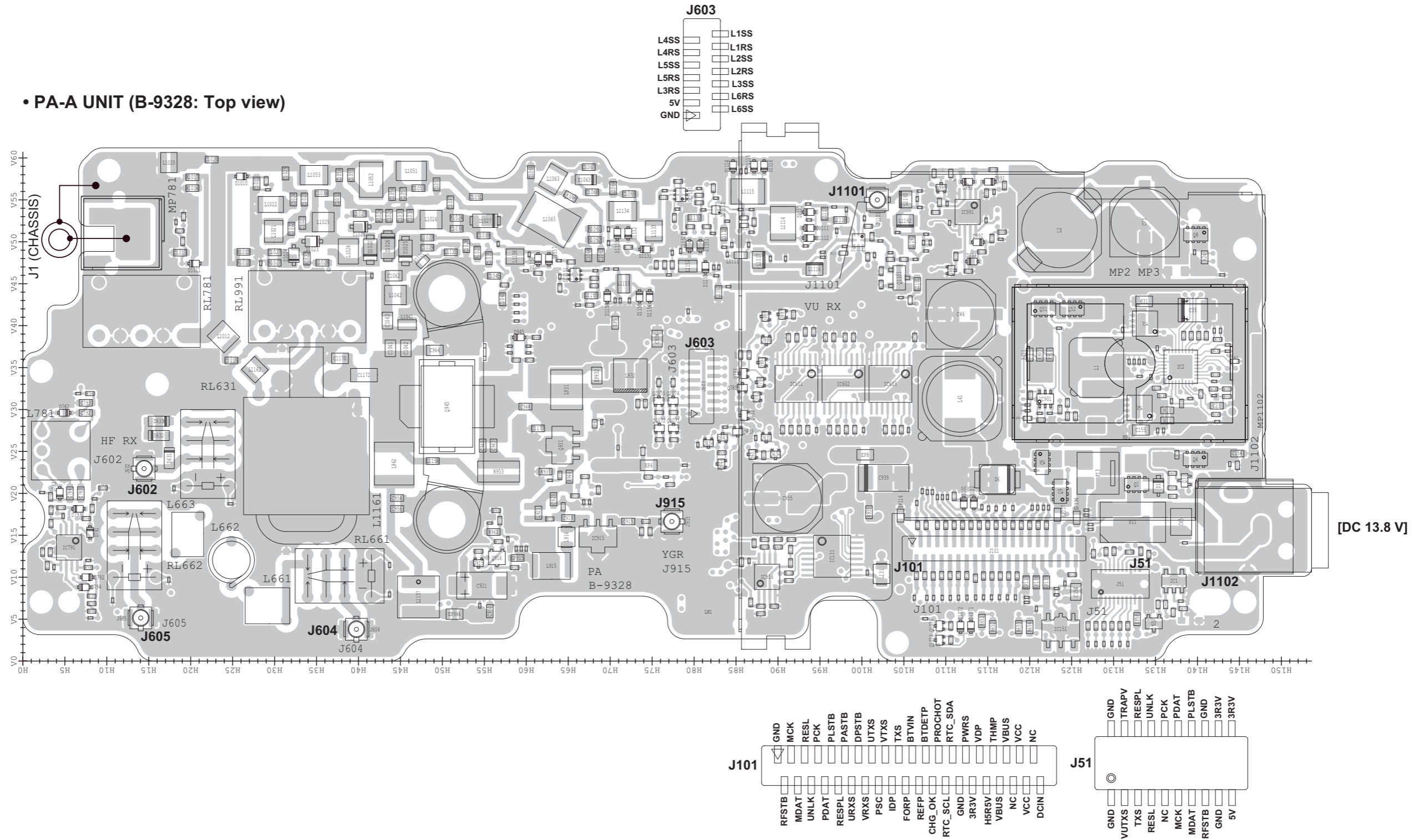

The serial numbers of transceivers that use the PCB (B-9328).

Model Name	Version Number	Serial Numbers
IC-705	#12	12005001 and above
	#13	13001001 and above

• PA-A UNIT (B-9328: Bottom view)

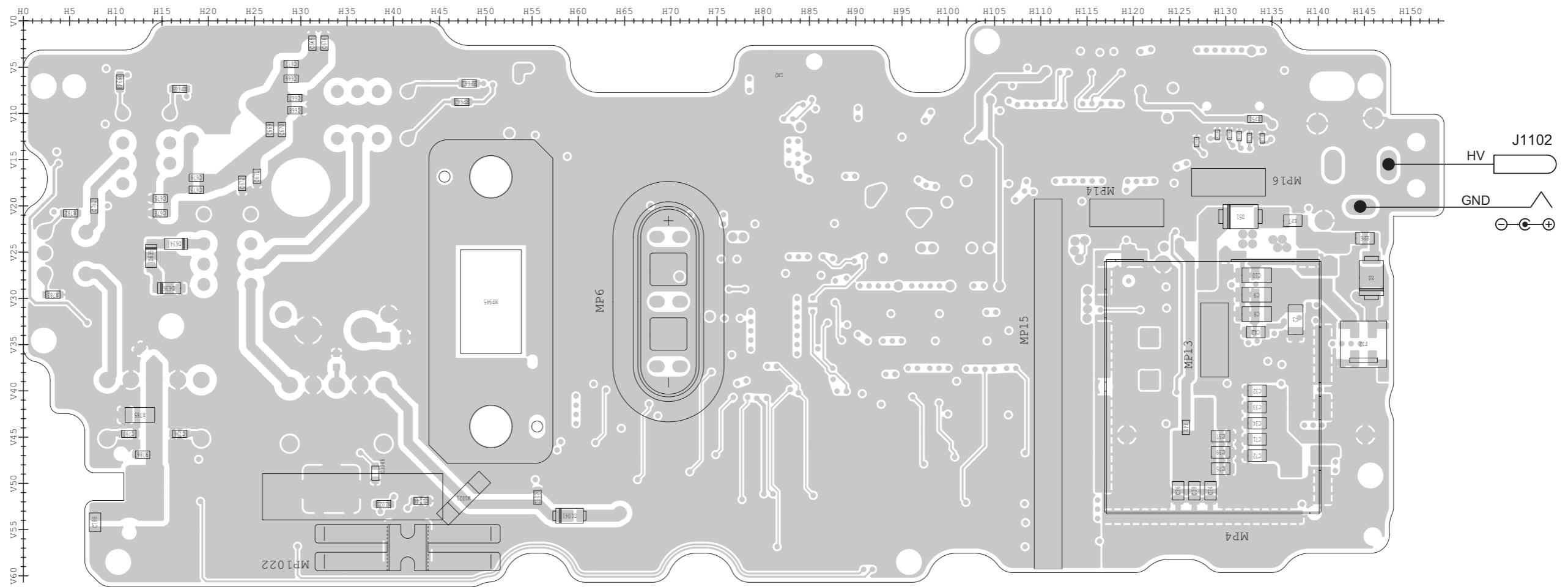

FRONT UNIT

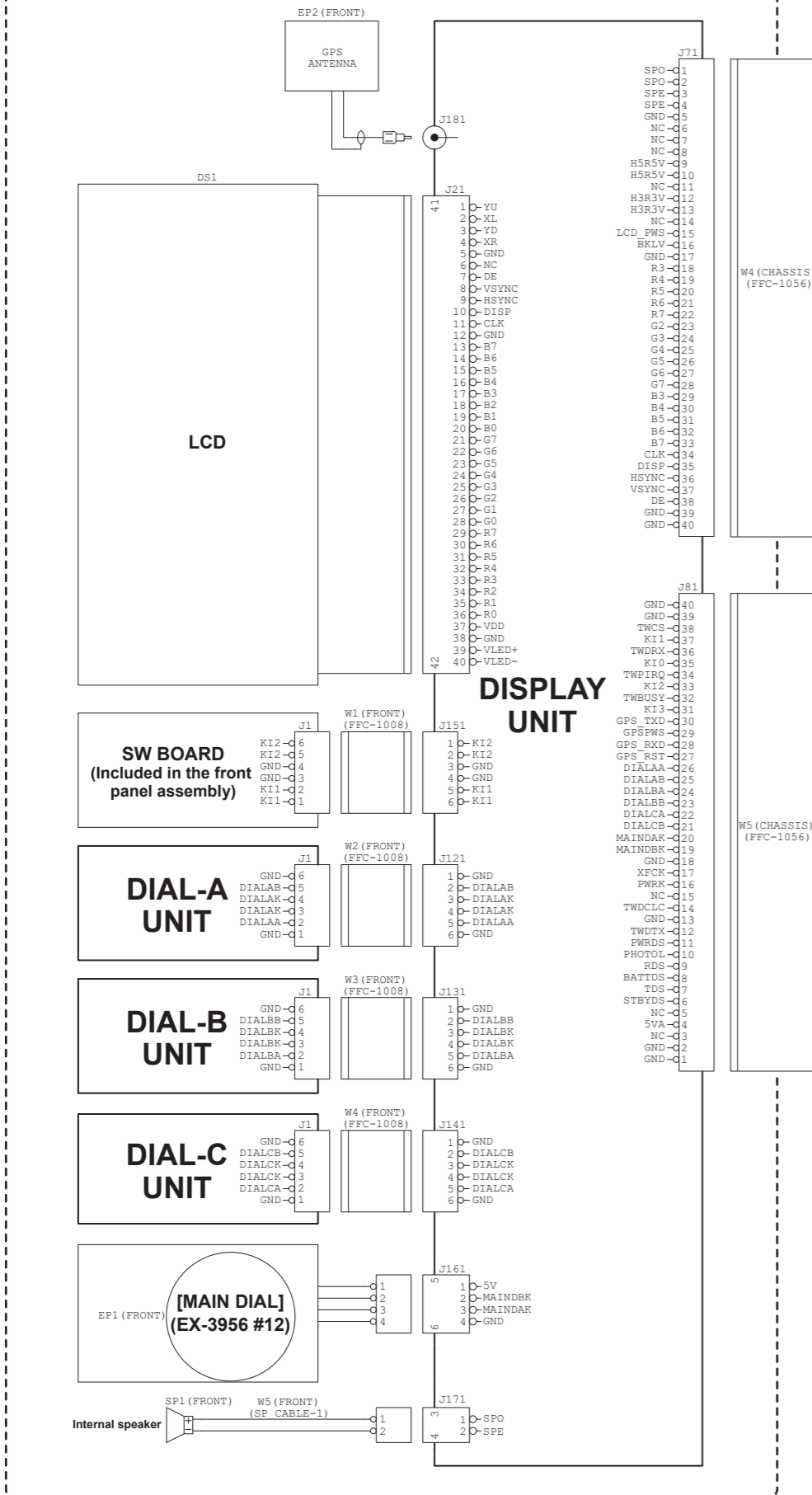

[MIC] [SP]

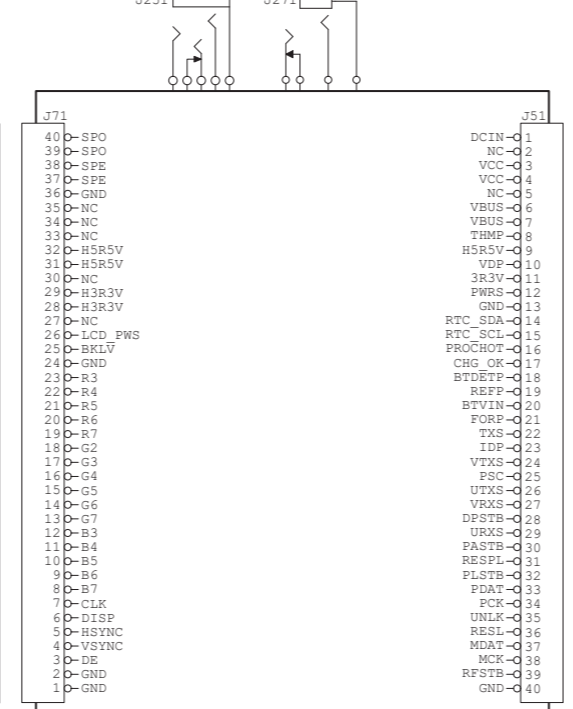

MAIN UNIT

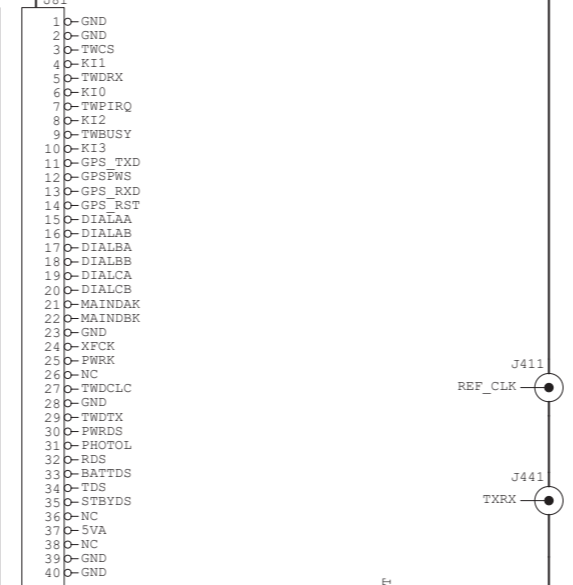

CONNECT UNIT

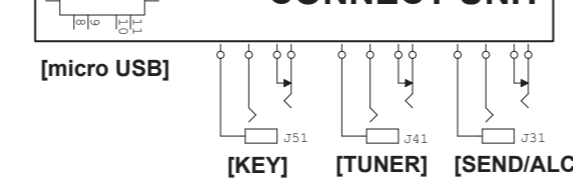

[ANT]

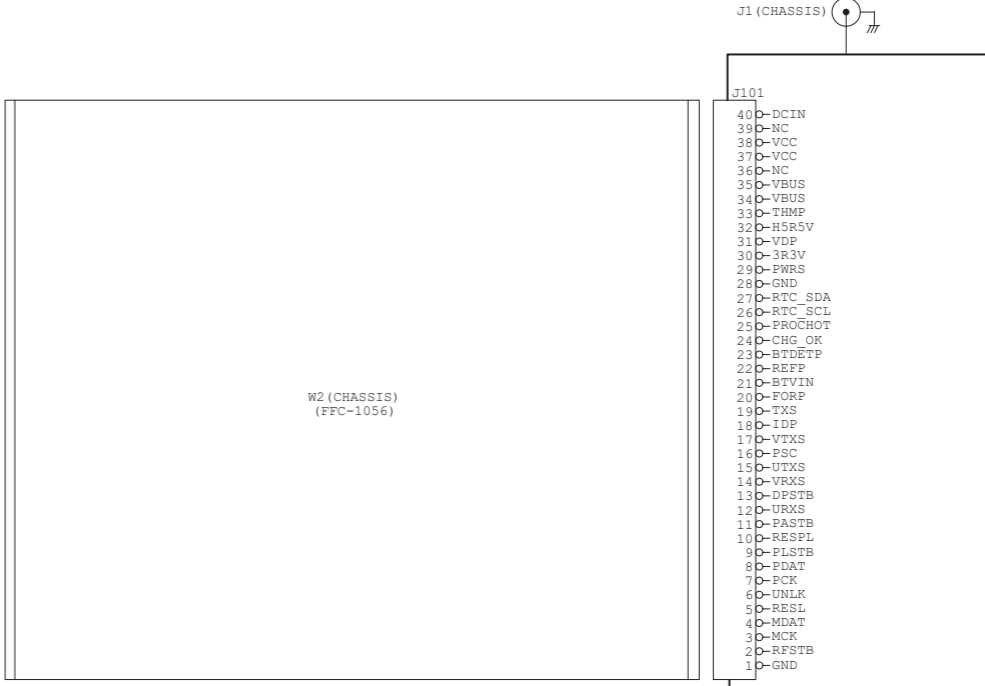

RF UNIT

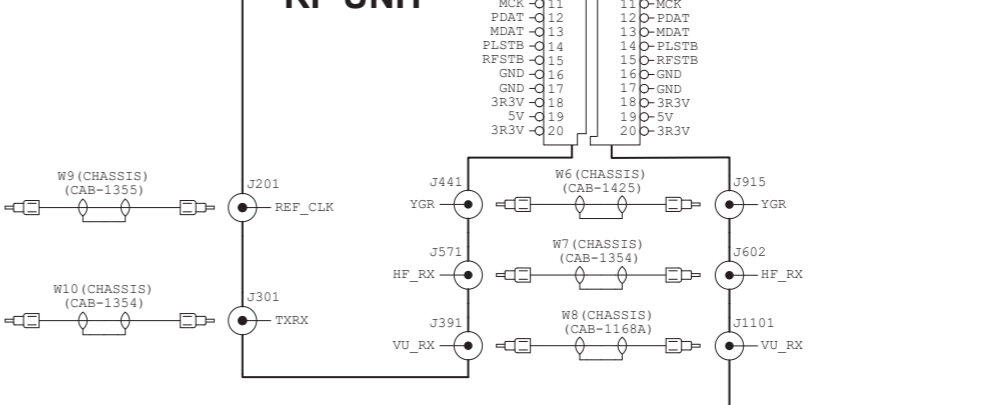

PA-A UNIT

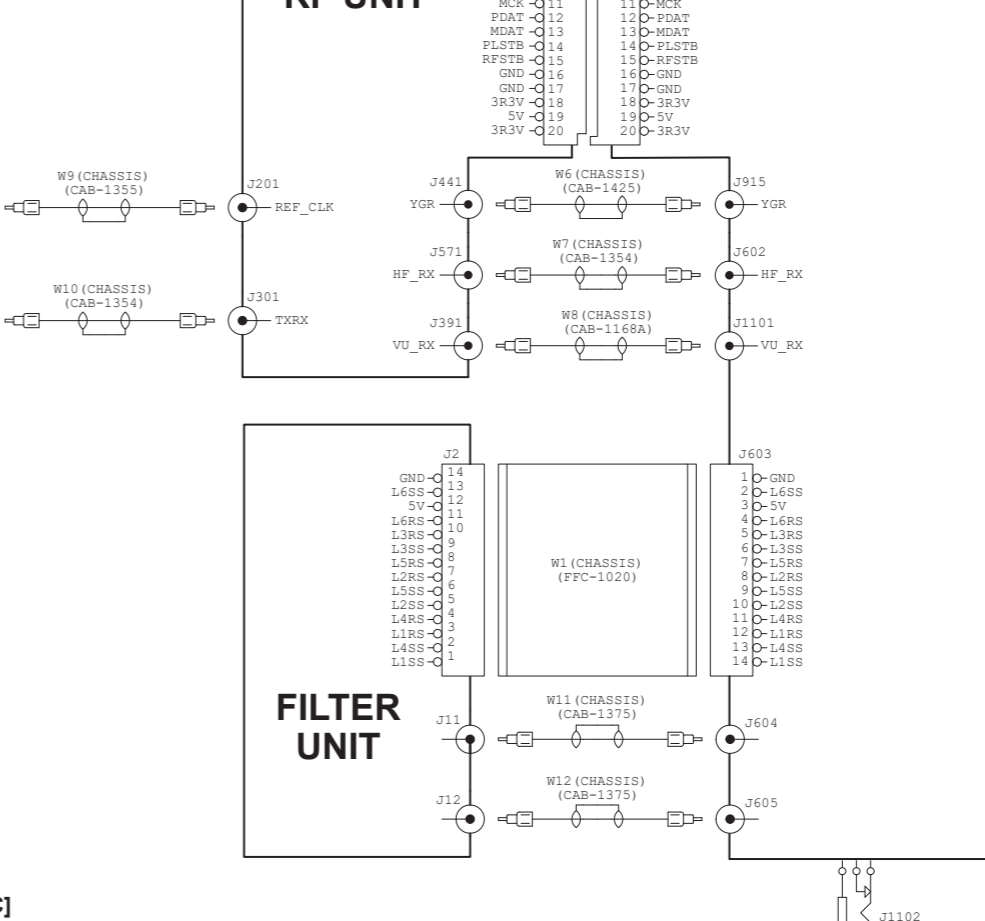

FILTER UNIT

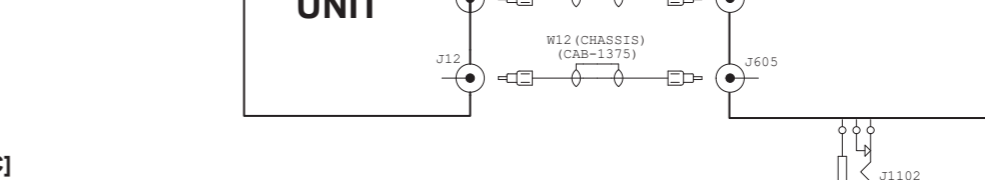

[DC 13.8 V]

SECTION 10

BLOCK DIAGRAM

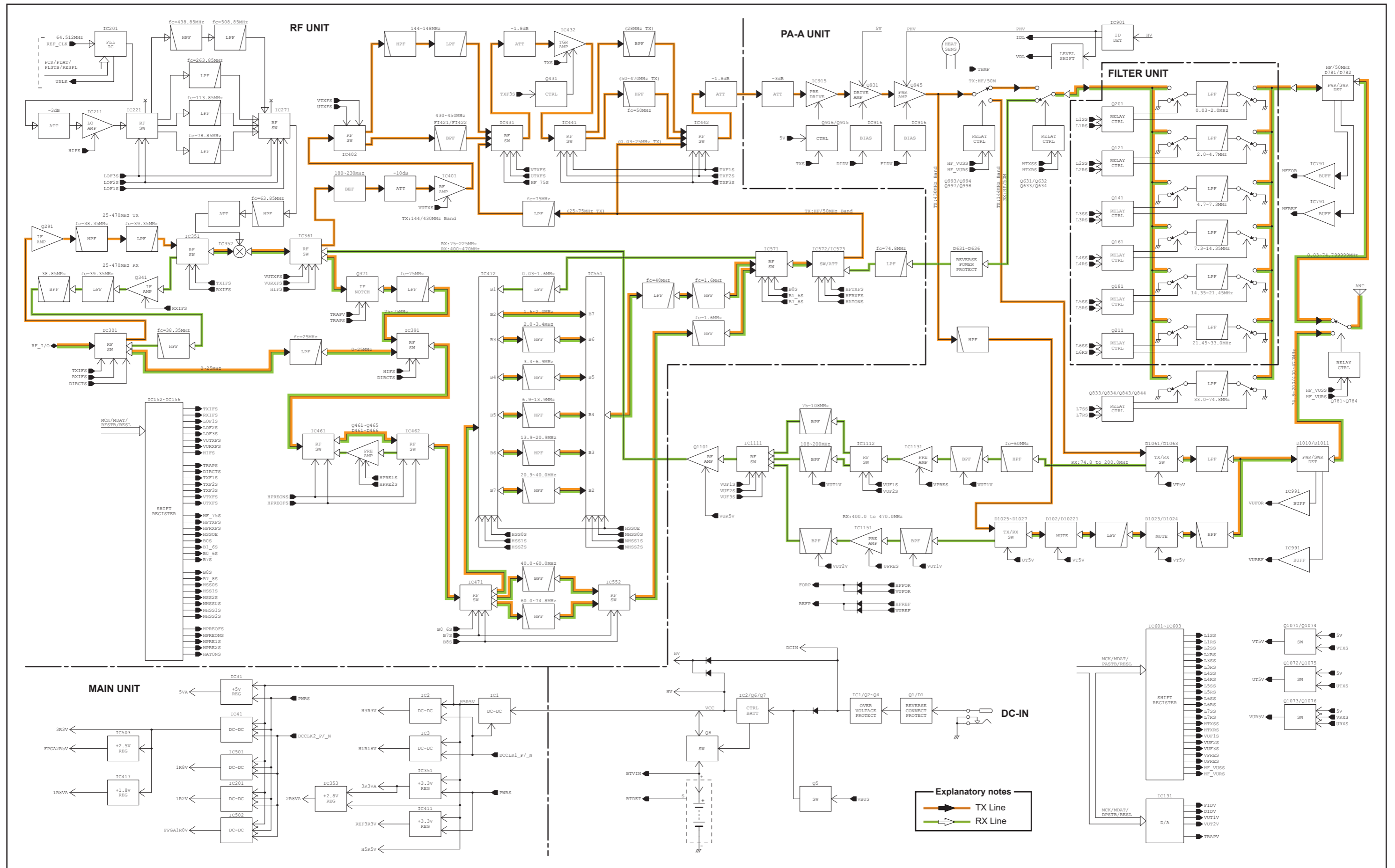

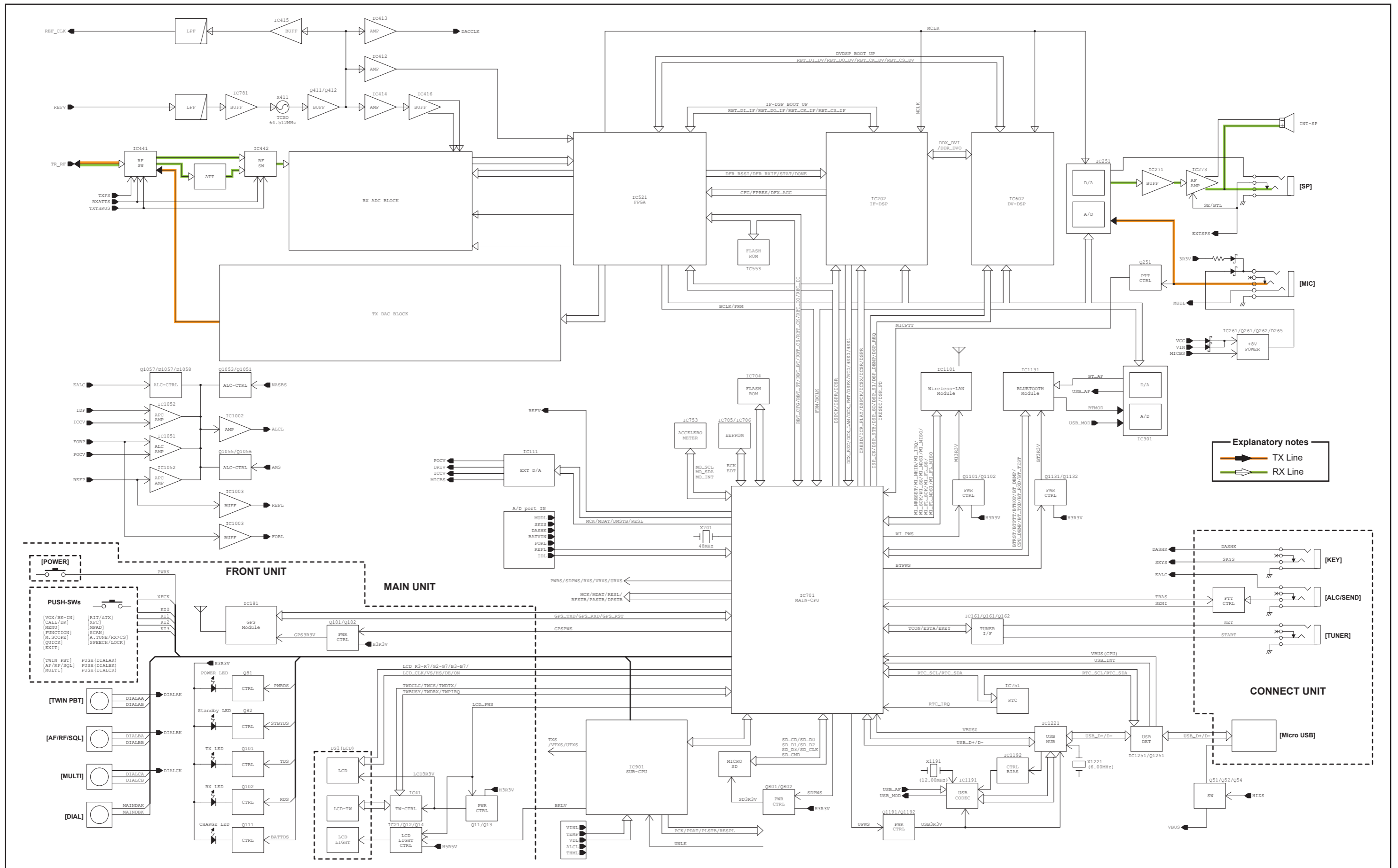

• FRONT UNIT

• DIAL-A UNIT

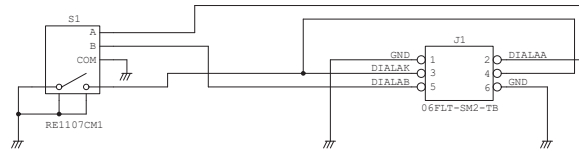

• DIAL-B UNIT

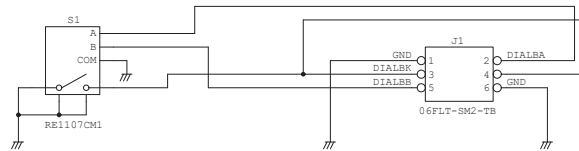

• DIAL-C UNIT

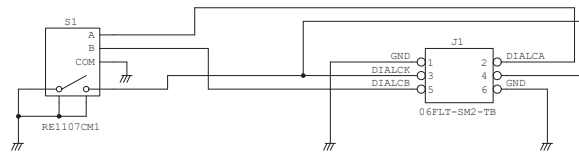

• MAIN UNIT (2/8)

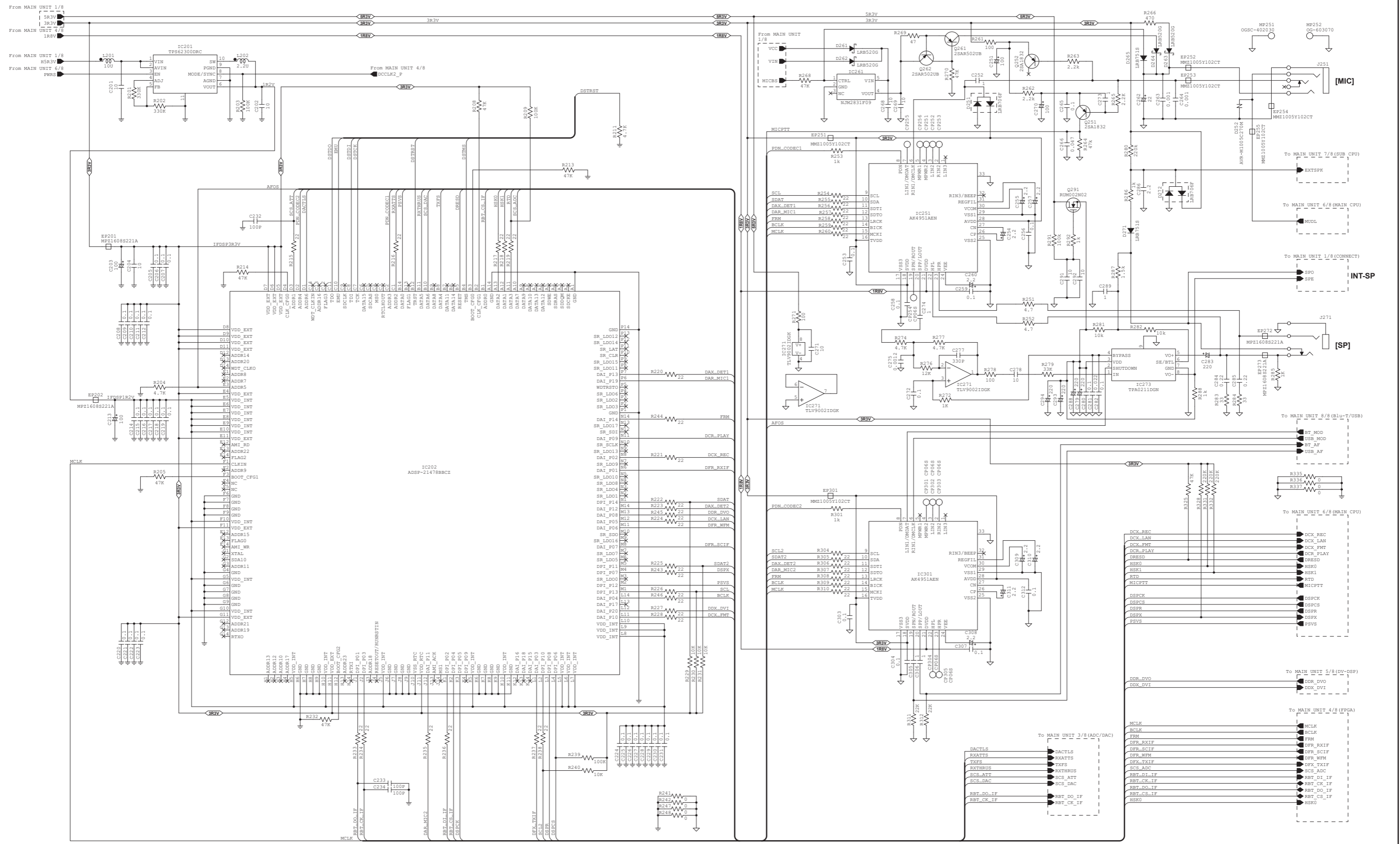

• MAIN UNIT (3/8)

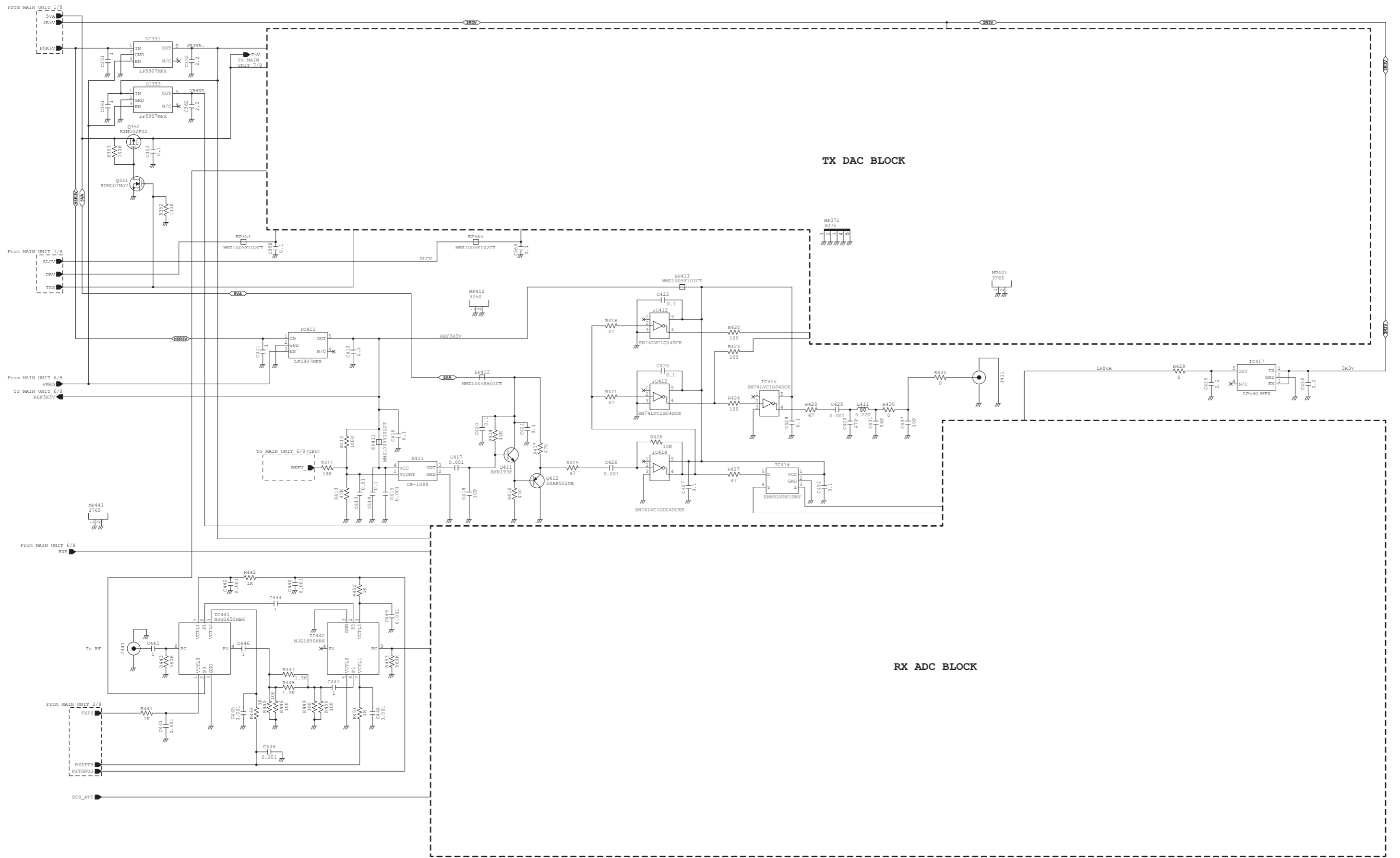

• MAIN UNIT (6/8)

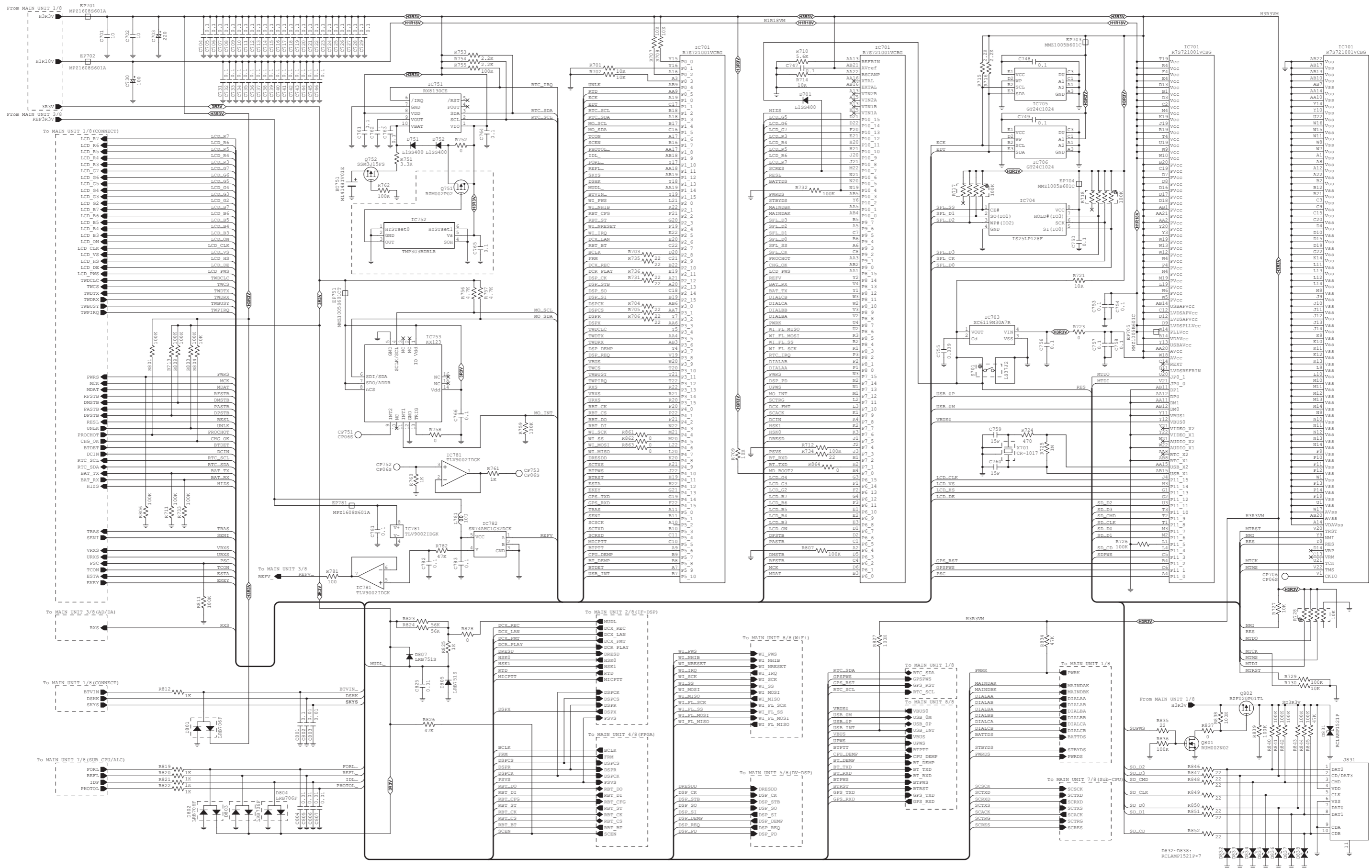

• MAIN UNIT (7/8)

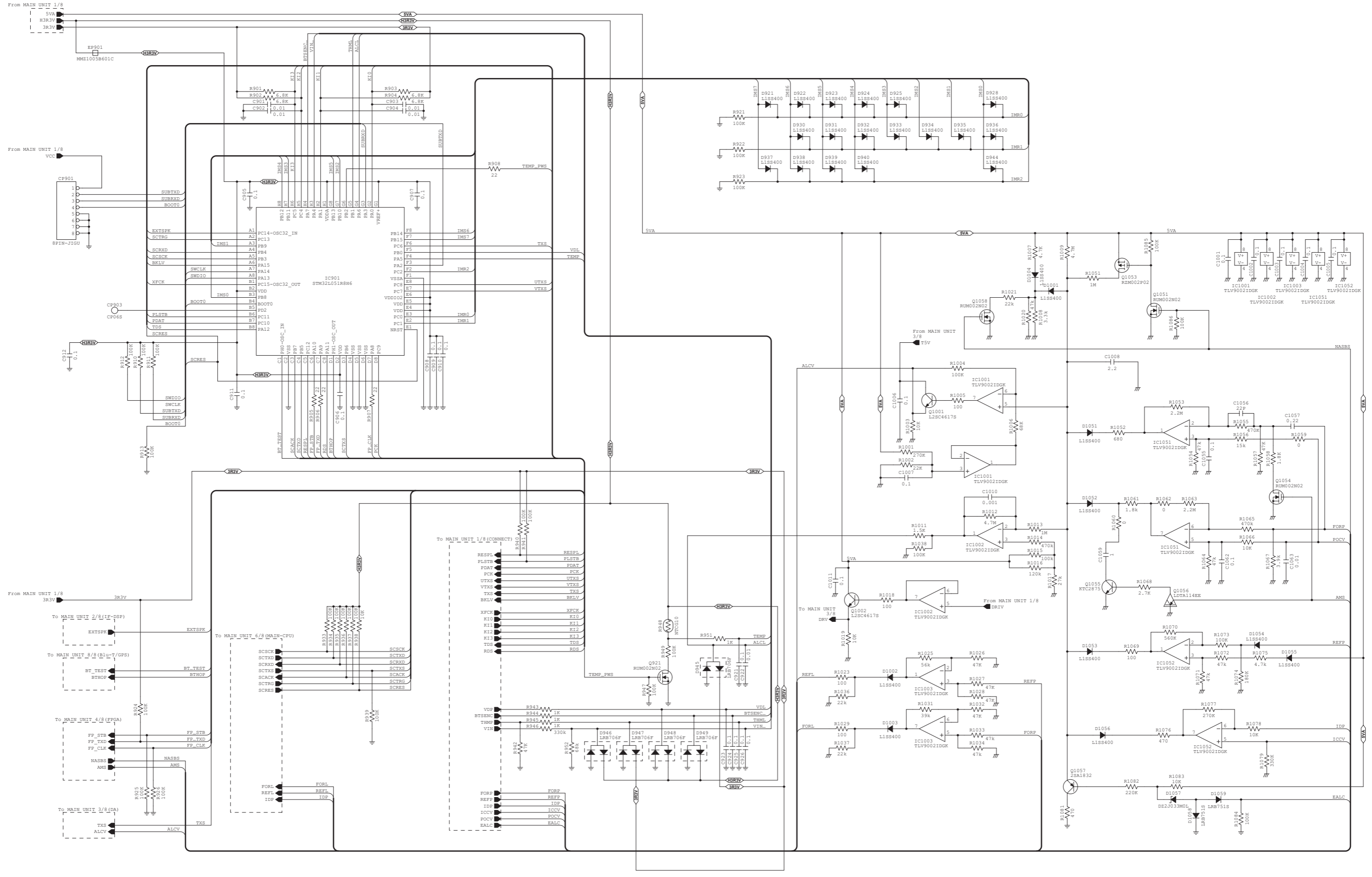

• MAIN UNIT (8/8)

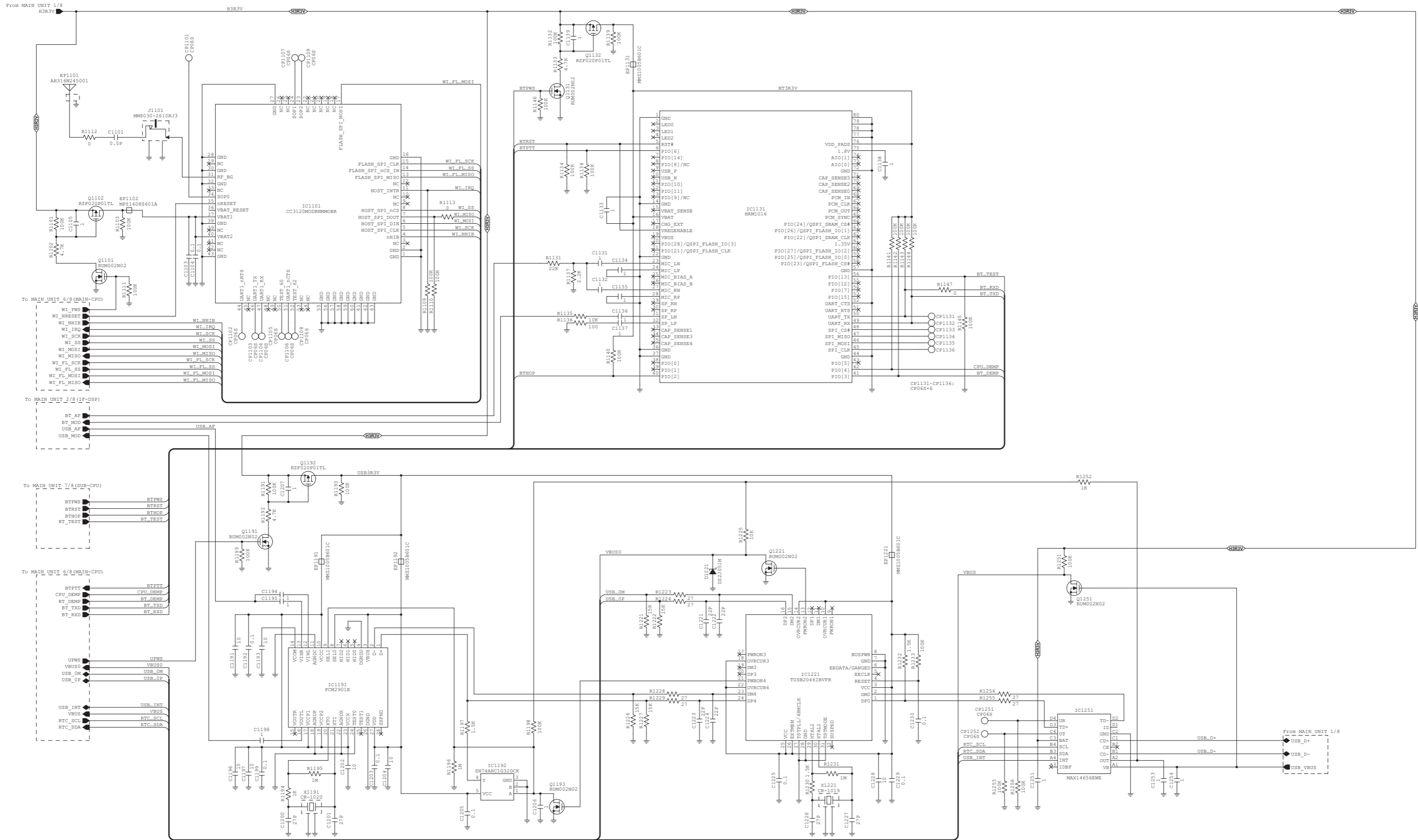

• CONNECT UNIT

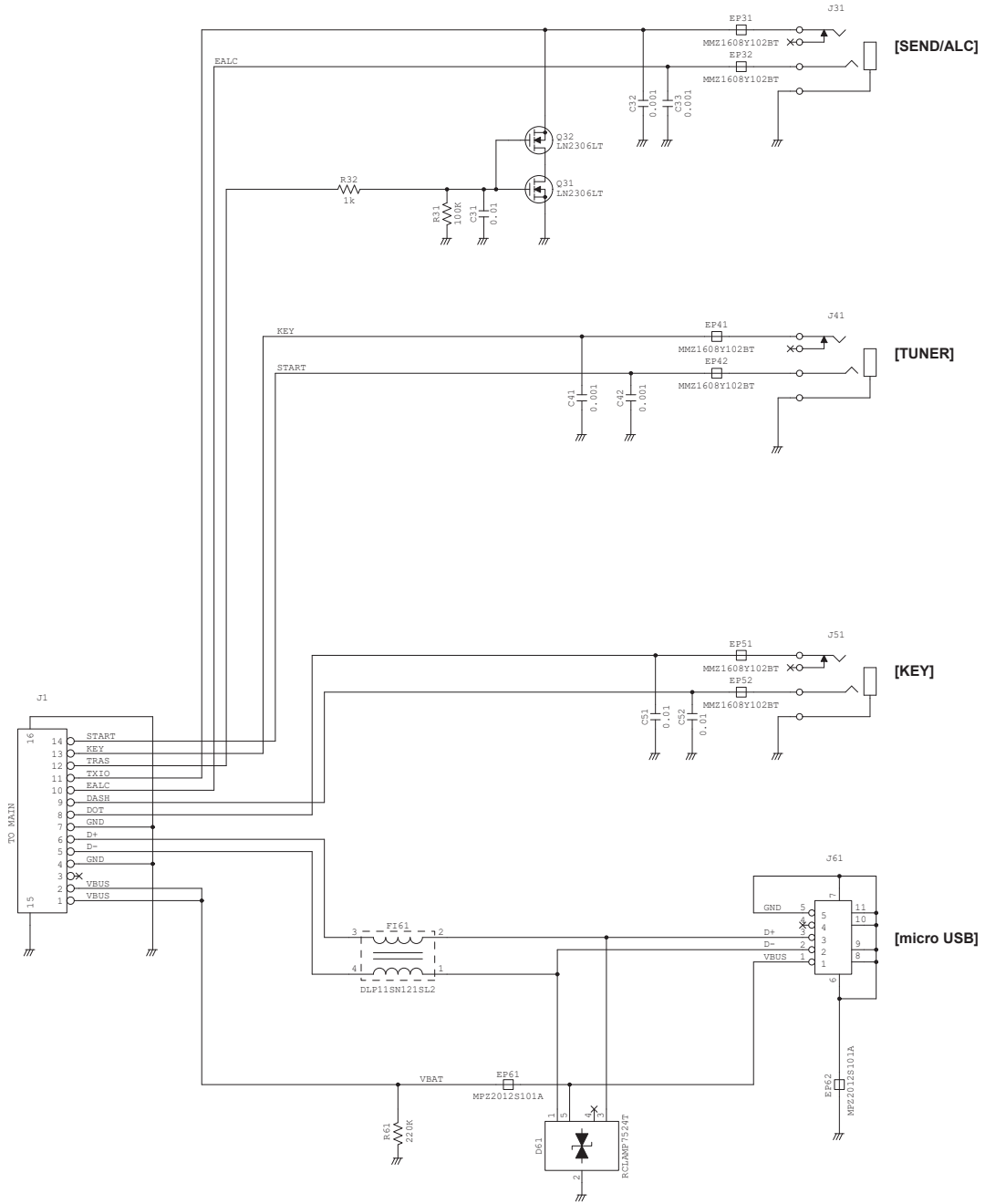

• RF UNIT (1/3)

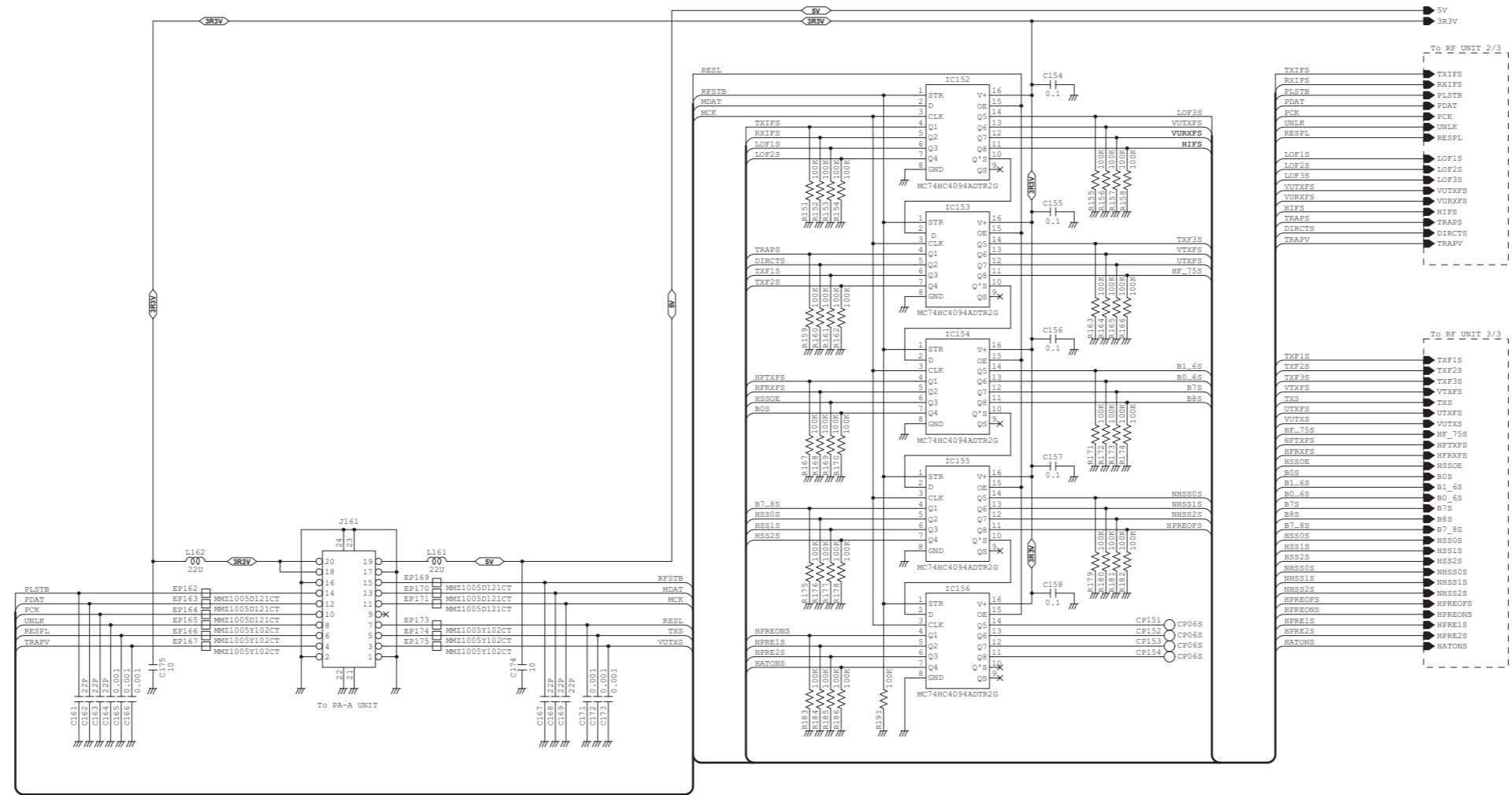

• RF UNIT (3/3)

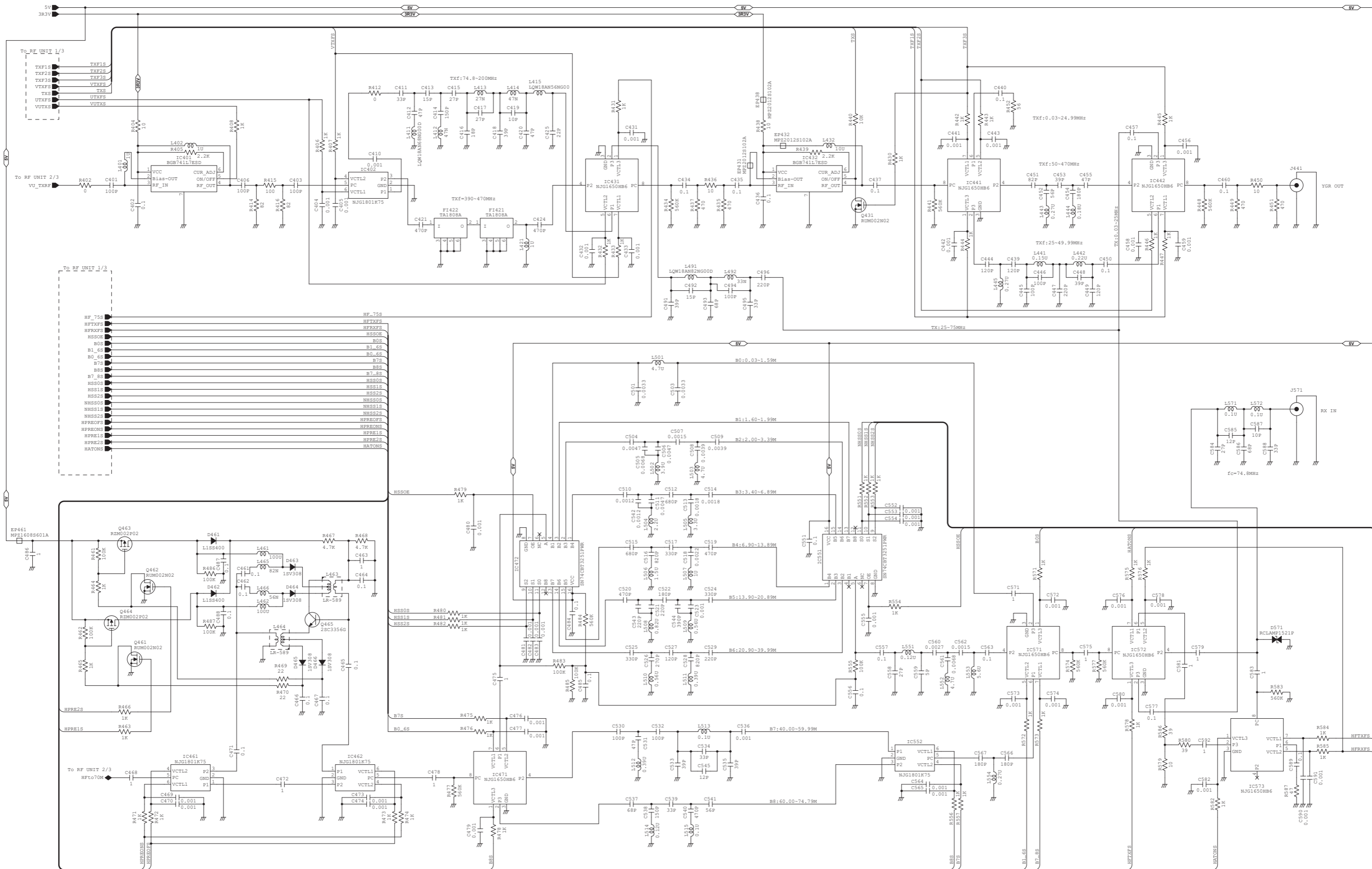

• PA-A UNIT (1/3)

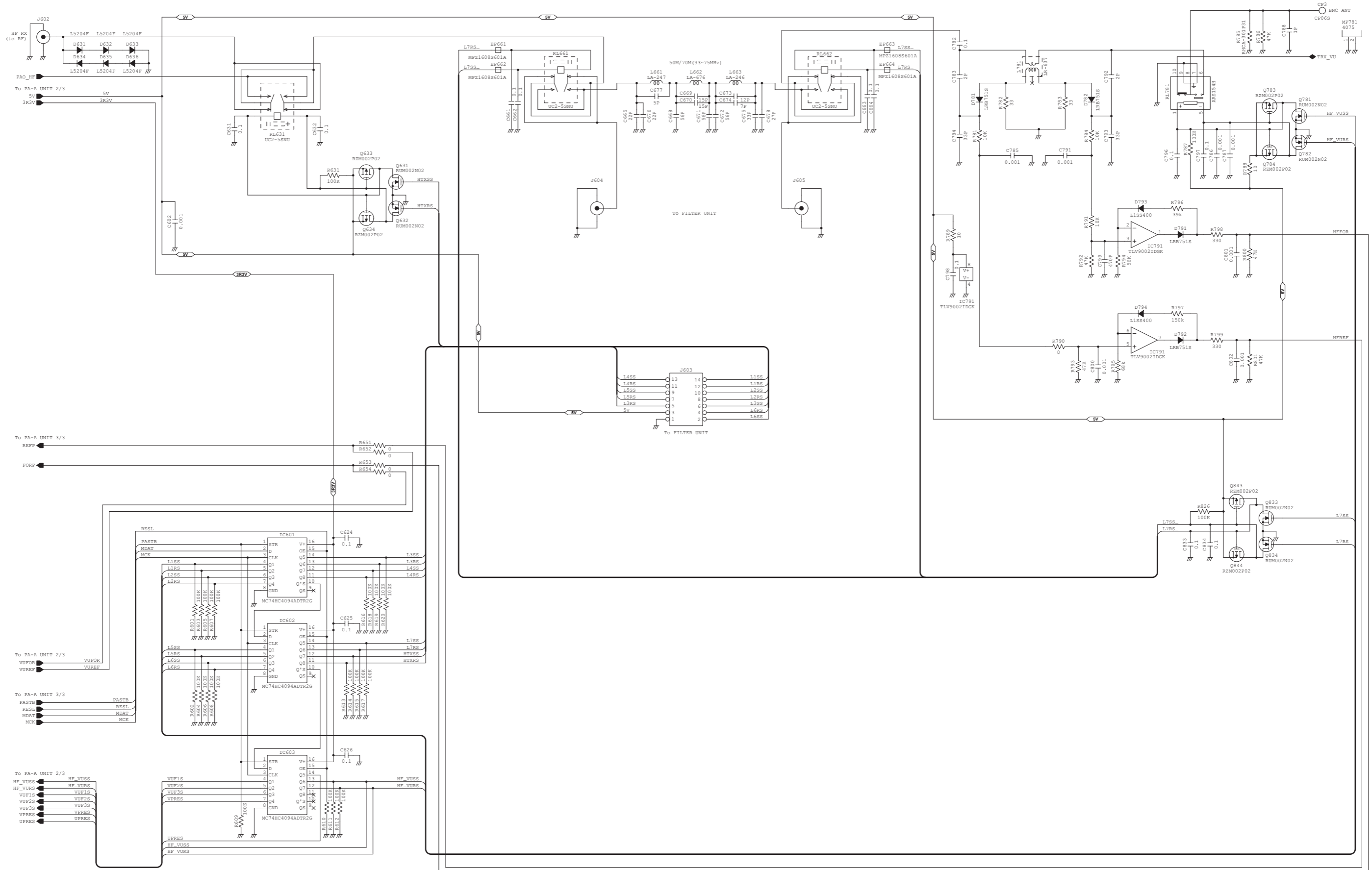

• PA-A UNIT (3/3)

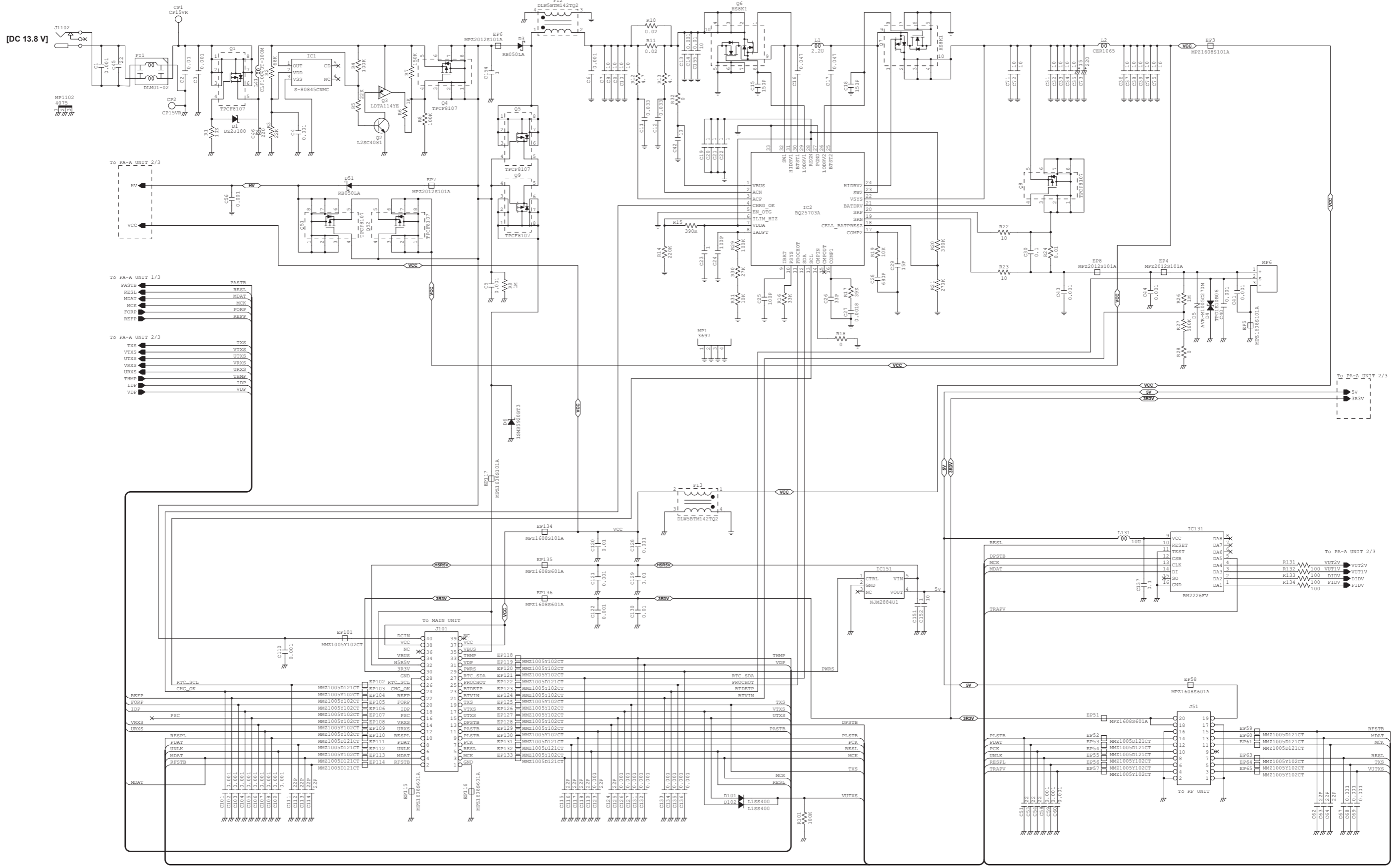

If you have any inquiries regarding service, contact your distributor. The contact number or E-mail address of your distributor can be found on our website.

<https://www.icomjapan.com/>

Count on us!