



INSTRUCTION MANUAL

HF/50 MHz TRANSCEIVER **IC-7200**



IMPORTANT

READ THIS INSTRUCTION MANUAL CAREFULLY before attempting to operate the transceiver.

SAVE THIS INSTRUCTION MANUAL. This manual contains important safety and operating instructions for the IC-7200.

FOREWORD

We understand that you have a choice of many different radios in the market place. We want to thank you for making the IC-7200 your radio of choice, and hope you agree with Icom's philosophy of "technology first." Many hours of research and development went into the design of your IC-7200.

◆ FEATURES

- IF DSP features
- Digital Twin PBT
- Manual notch function
- ± 0.5 ppm of high frequency stability
- Simple operation
- Tough and compact body
- Standard voice synthesizer

EXPLICIT DEFINITIONS

WORD	DEFINITION
⚠ DANGER!	Personal death, serious injury or an explosion may occur.
⚠ WARNING!	Personal injury, fire hazard or electric shock may occur.
CAUTION	Equipment damage may occur.
NOTE	If disregarded, inconvenience only. No risk of personal injury, fire or electric shock.

Spurious signals may be received near the following frequencies when the transceiver is connected to a PC via an USB cable.

These are generated in the internal circuit and does not indicate a transceiver malfunction:

21.0295 MHz, 51.0910 MHz, 51.0957 MHz

Icom, Icom Inc. and the Icom logo are registered trademarks of Icom Incorporated (Japan) in Japan, the United States, the United Kingdom, Germany, France, Spain, Russia and/or other countries.

Microsoft, Windows and Windows Vista are registered trademarks of Microsoft Corporation in the United States and/or other countries.

All other products or brands are registered trademarks or trademarks of their respective holders.

SUPPLIED ACCESSORIES

The transceiver comes with the following accessories.

- ① Hand microphone (HM-36) 1
- ② DC power cable (OPC-1457) 1
- ③ Spare fuse (ATC 5 A) 1
- ④ Spare fuse (ATC 30 A) 2
- ⑤ Jack cap (for [PHONES]) 1
- ⑥ ACC cable 1
- ⑦ 3.5 (d) mm plug 1
- ⑧ 6.3 (d) mm Electronic keyer plug 1
- ⑨ CD 1

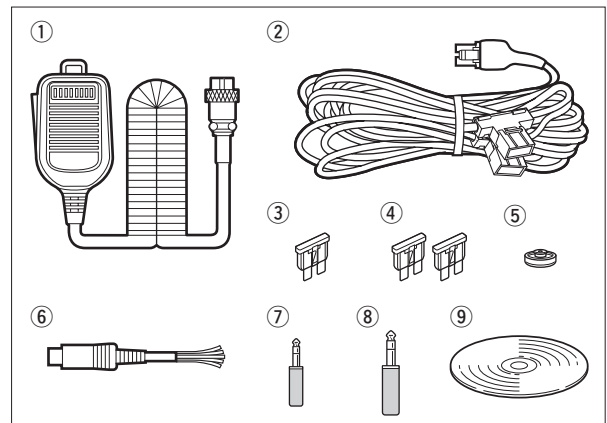

FCC INFORMATION

• FOR CLASS B UNINTENTIONAL RADIATORS:

This equipment has been tested and found to comply with the limits for a Class B digital device, pursuant to part 15 of the FCC Rules. These limits are designed to provide reasonable protection against harmful interference in a residential installation. This equipment generates, uses, and can radiate radio frequency energy and, if not installed and used in accordance with the instructions, may cause harmful interference to radio communications. However, there is no guarantee that interference will not occur in a particular installation. If this equipment does cause harmful interference to radio or television reception, which can be determined by turning the equipment off and on, the user is encouraged to try to correct the interference by one or more of the following measures:

- Reorient or relocate the receiving antenna.
- Increase the separation between the equipment and receiver.
- Connect the equipment into an outlet on a circuit different from that to which the receiver is connected.
- Consult the dealer or an experienced radio/TV technician for help.

Caution: Changes or modifications to this transceiver, not expressly approved by Icom Inc., could void your authority to operate this transceiver under FCC regulations.

PRECAUTIONS

⚠ **DANGER HIGH RF VOLTAGE! NEVER** attach an antenna or internal antenna connector during transmission. This may result in an electrical shock or burn.

⚠ **WARNING! NEVER** operate the transceiver while driving a vehicle. Safe driving requires your full attention—anything less may result in an accident.

⚠ **WARNING! NEVER** operate the transceiver with a headset or other audio accessories at high volume levels. Hearing experts advise against continuous high volume operation. If you experience a ringing in your ears, reduce the volume or discontinue use.

⚠ **WARNING! NEVER** operate or touch the transceiver with wet hands. This may result in an electric shock or damage to the transceiver.

⚠ **WARNING! NEVER** apply AC power to the [DC13.8V] socket on the transceiver rear panel. This could cause a fire or damage the transceiver.

⚠ **WARNING! NEVER** apply more than 16 V DC to the [DC13.8V] socket on the transceiver rear panel, or use reverse polarity. This could cause a fire or damage the transceiver.

⚠ **WARNING! NEVER** cut the DC power cable between the DC plug and fuse holder. If an incorrect connection is made after cutting, the transceiver may be damaged.

⚠ **WARNING! NEVER** let metal, wire or other objects protrude into the transceiver or into connectors on the rear panel. This may result in an electric shock.

⚠ **WARNING!** Immediately turn OFF the transceiver power and remove the power cable if it emits an abnormal odor, sound or smoke. Contact your Icom dealer or distributor for advice.

⚠ **WARNING! NEVER** put the transceiver in any unstable place (such as on a slanted surface or vibrated place). This may cause injury and/or damage to the transceiver.

CAUTION: NEVER change the internal settings of the transceiver. This may reduce transceiver performance and/or damage to the transceiver.

In particular, incorrect settings for transmitter circuits, such as output power, idling current, etc., might damage the expensive final devices.

The transceiver warranty does not cover any problems caused by unauthorized internal adjustment.

CAUTION: NEVER install the transceiver in a place without adequate ventilation. Heat dissipation may be reduced, and the transceiver may be damaged.

CAUTION: NEVER block any cooling vents on the top, rear, sides or bottom of the transceiver.

CAUTION: NEVER expose the transceiver to rain, snow or any liquids.

DO NOT use harsh solvents such as benzine or alcohol when cleaning, as they will damage the transceiver surfaces.

DO NOT push the PTT switch when you don't actually desire to transmit.

DO NOT use or place the transceiver in areas with temperatures below -10°C ($+14^{\circ}\text{F}$) or above $+60^{\circ}\text{C}$ ($+140^{\circ}\text{F}$).

DO NOT place the transceiver in excessively dusty environments or in direct sunlight.

DO NOT place the transceiver against walls or putting anything on top of the transceiver. This may overheat the transceiver.

Always place unit in a secure place to avoid inadvertent use by children.

BE CAREFUL! If you use a linear amplifier, set the transceiver's RF output power to less than the linear amplifier's maximum input level, otherwise, the linear amplifier will be damaged.

BE CAREFUL! The rear panel will become hot when operating the transceiver continuously for long periods of time.

USE only the specified microphone. Other manufacturers' microphones have different pin assignments, and connection to the IC-7200 may damage the transceiver or microphone.

During maritime mobile operation, keep the transceiver and microphone as far away as possible from the magnetic navigation compass to prevent erroneous indications.

PRECAUTIONS (CONTINUED)

During mobile operation, **NEVER** place the transceiver where air bag deployment may be obstructed.

During mobile operation, **DO NOT** place the transceiver where hot or cold air blows directly onto it.

During mobile operation, **DO NOT** operate the transceiver without running the vehicle's engine. When the transceiver's power is ON and your vehicle's engine is OFF, the vehicle's battery will quickly become exhausted.

Make sure the transceiver power is OFF before starting the vehicle engine. This will avoid possible damage to the transceiver by ignition voltage spikes.

Turn OFF the transceiver's power and/or disconnect the DC power cable when you will not use the transceiver for long period of time.

ABOUT THE SUPPLIED CD

The following Instructions, Installers and Schematic diagrams are included in the CD.

- **Instruction manual**
Instructions for the basic operation, the same as this manual
- **Advanced Instructions**
Instructions for the advanced operations and more details are described than in this manual.
- **HAM radio Terms**
The glossary of HAM radio terms
- **Schematic Diagrams**
The Block diagram and schematic diagrams.
- **Adobe® Reader® Installer**
Installer for Adobe® Reader®

To read the guide or instructions, Adobe® Reader® is required. If you have not installed it, please install the Adobe® Reader® in the CD or downloaded it from Adobe Systems Incorporated's website.

A PC with the following Operating System is required.

- Microsoft® Windows® 7, Microsoft® Windows Vista® or Microsoft® Windows® XP

◇ Starting the CD

- ① Insert the CD into the CD drive.
 - The Menu screen shown below is automatically displayed. If it doesn't appear, double click "Autorun.exe" in the CD.
- ② Click the desired button to open the file.
 - To close the Menu screen, click [Quit].

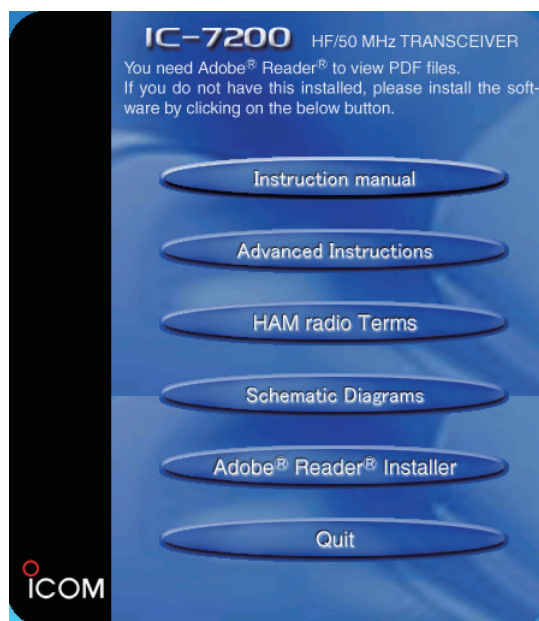
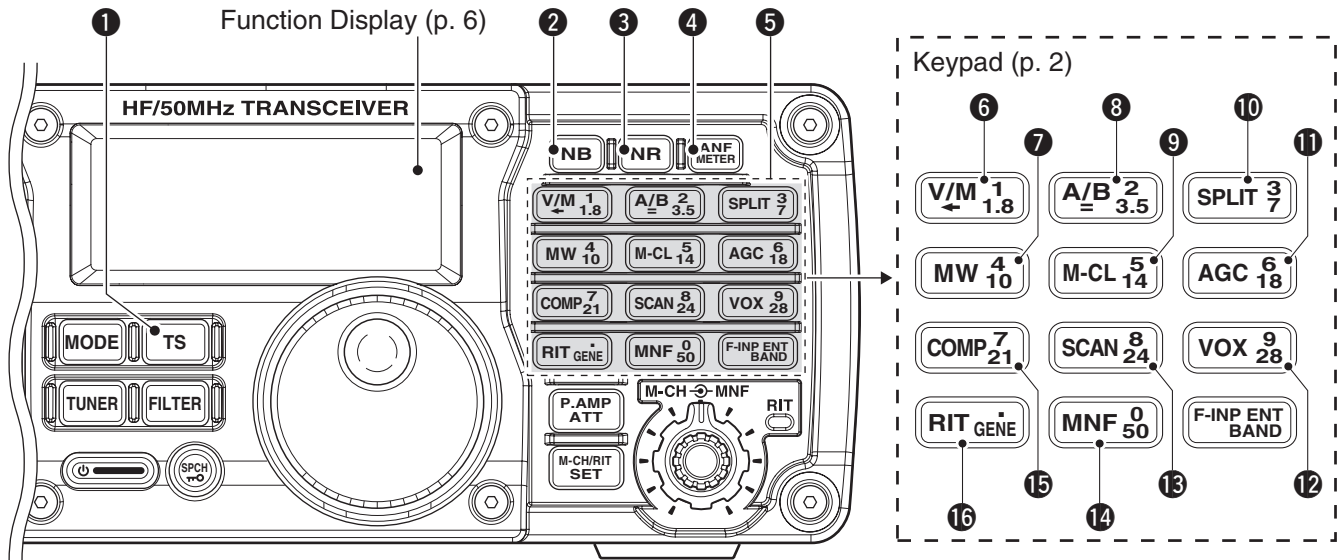

TABLE OF CONTENTS

IMPORTANT	i	4 MEMORY OPERATION.....	21–22
FOREWORD	i	■ About the Memory channels	21
EXPLICIT DEFINITIONS.....	i	■ Selecting Memory channels.....	21
SUPPLIED ACCESSORIES.....	i	■ Programming Memory channels	22
FCC INFORMATION	i	◇ Programming in the VFO mode	22
PRECAUTIONS.....	ii	◇ Programming in the Memory mode.....	22
ABOUT THE SUPPLIED CD	iii	5 SCAN OPERATION.....	23–24
TABLE OF CONTENTS.....	iv	■ Scan types	23
1 PANEL DESCRIPTION.....	1–7	■ Preparation.....	23
■ Front panel	1	■ Scanning between programmed channels (VFO mode)	24
■ Function display	6	■ Scanning Memory channels (Memory mode).....	24
■ Rear panel.....	7	6 SET MODE	25–34
2 INSTALLATION AND CONNECTIONS.....	8–12	■ General	25
■ Unpacking	8	◇ Using the Quick Set mode	25
■ Selecting a location	8	◇ Using the Set mode	25
■ Grounding	8	■ Items in the Quick Set mode	26
■ Connecting an antenna.....	8	■ Items in the Set mode	26
■ Basic connections	9	■ Quick Set mode.....	28
■ Power supply connections.....	10	■ Set mode.....	29
■ Connecting the DC Power Supply.....	10	◇ Connect a paddle to the [MIC] connector ...	34
■ External antenna tuners.....	11	7 MAINTENANCE	35–37
■ Battery connections.....	11	■ Fuse replacement	35
■ Connecting a CW keyer	12	■ DC power cable fuse replacement	35
3 OPERATION	13–20	■ Circuitry fuse replacement	35
■ Before first applying power.....	13	■ Memory backup.....	35
■ Applying power.....	13	■ Cleaning.....	35
■ Selecting the VFO and memory modes	13	■ Troubleshooting	36
■ Selecting VFO A/B	13	■ Resetting the CPU	37
◇ Selecting VFO A/B	13	8 OPTION INSTALLATIONS	38
◇ Equalizing the VFOs	13	■ Installing the MB-116 HANDLES.....	38
■ Setting the operating frequency	14	■ Installing the MB-117 CARRYING HANDLE.....	38
◇ Selecting an operating band	14	■ Installing the MB-118 MOBILE MOUNTING BRACKET	38
◇ Quick tuning function	14	9 SPECIFICATIONS	39
◇ Selecting 'kHz' step	15	■ General	39
◇ Selecting the 1 Hz and 10 Hz tuning steps.	15	■ Transmitter.....	39
■ Entering a frequency from the keypad	16	■ Receiver	39
■ Selecting operating mode	16	10 OPTIONS.....	40
■ Adjusting the audio volume	17		
■ Using RF gain and Squelch control.....	17		
■ Locking the Dial.....	18		
■ Basic transmit operation.....	18		
◇ Transmitting.....	18		
◇ Output power setting.....	18		
◇ Microphone gain setting.....	19		
■ Measuring SWR	19		
■ About the optional AH-4 AUTOMATIC ANTENNA TUNER	20		
◇ Operating the AH-4	20		



Front panel



1 TUNING STEP KEY **TS** (pp. 14, 15)

- ➔ Push to turn the Quick tuning function ON or OFF.
 - “▼” appears above the 1 kHz icon when the Quick tuning function is turned ON and the frequency is changed in ‘kHz’ steps.
- ➔ “▼” appears when the Quick tuning function is turned ON. Hold down for 1 second to enter tuning step Set mode. After selecting a step, push again to return to normal operation.
 - 0.1, 1, 5, 9 and 10 kHz tuning steps are selectable.
- ➔ While the Quick tuning function is turned OFF, hold down for 1 second to turn the 1 Hz step ON or OFF.
 - 1 Hz indication appears, and the frequency is changed in 1 Hz steps.

2 NOISE BLANKER KEY **NB**

- ➔ Push to turn the noise blanker function ON or OFF.
 - “**NB**” appears when the noise blanker function is ON.
- ➔ Hold down for 1 second to enter the noise blanker Set mode. Rotate [M-CH] to select, then rotate [DIAL] to set the noise blanker level and blank width; push again to return to normal operation.
 - When entering the noise blanker Set mode, the noise blanker function is automatically turned ON.

✓ What is the noise blanker?

The noise blanker reduces pulse-type noise such as that generated by automobile ignition systems. This function is not effective against non pulse-type noise.

3 NR KEY **NR**

- ➔ Push to turn the noise reduction function ON or OFF.
 - “**NR**” appears when the noise reduction function is ON.
- ➔ Hold down for 1 second to enter the noise reduction level Set mode. Rotate [DIAL] to set the NR level; push again to return to normal operation.
 - When entering the noise reduction Set mode, the noise reduction function is automatically turned ON.

✓ What is the Noise Reduction function?

The Noise Reduction (NR) function removes random noise from the receiver passband. The level is adjustable to allow maximum clarity without harming the intelligibility of the desired signal. Noise Reduction should generally not be used in the digital modes.

4 ANF/METER KEY **ANF/METER**

- ➔ Push to turn the Automatic Notch Filter function ON or OFF in the SSB and AM modes.
 - “**ANF**” appears when the automatic notch filter function is ON.
- ➔ Hold down for 1 second to toggle the meter function.
 - PO → SWR → ALC
 - **PO** : Displays the relative RF output power.
 - **SWR** : Displays the SWR of the antenna. (p. 19)
 - **ALC** : Displays ALC level. (p. 19)

✓ What is the Automatic Notch Filter?

The Automatic Notch Filter is a narrow DSP filter that automatically identifies and attenuates beat tones, tuning signals, CW, and so on, even if they are moving. It removes them from the receiver passband while preserving the desired signal’s audio frequency response.

5 KEYPAD

- ➔ After pushing **F-INP ENT BAND**, push a key on the keypad to enter a frequency. After entering, push **F-INP ENT BAND**. (p. 16)
 - For example To enter 14.195 MHz;
 - Push **F-INP ENT BAND**, **1.8**, **4.10**, **GENE**, **1.8**, **9.28**, **5.14**
 - and **F-INP ENT BAND**.
- ➔ After holding down **F-INP ENT BAND** for 1 second, push a key on the keypad to select the operating band. (p. 14)
 - After the band has been used once, the last used frequency is recalled when the band is selected again.
 - **GENE** selects the general coverage receive band.
- ➔ Push or hold down a key to turn the specified function ON or OFF, as described in **6** to **16**.

6 VFO/MEMORY/1/1.8 MHz BAND KEY

- V/M** ➔ Push to toggle the operating mode between the VFO mode and the memory mode. (pp. 13, 21)
 - ➔ Hold down for 1 second to copy the memory contents to the VFO.

7 MEMORY WRITE/4/10 MHz BAND KEY

- MW** Hold down for 1 second to store the displayed VFO frequency and operating mode into the selected memory channel. (p. 21)

8 VFO SELECT/EQUALIZATION/2/3.5 MHz BAND KEY

- A/B =** ➔ Push to toggle between VFO A and VFO B. (p. 13)
 - ➔ Hold down for 1 second to equalize the frequency and operating mode of the two VFOs. (p. 13)
 - The undisplayed VFO frequency and operating mode are set to the same frequency and operating mode as the displayed VFO.

9 MEMORY CLEAR/5/14 MHz BAND KEY

- M-CL** ➔ Hold down for 1 second to clear the displayed frequency and operating mode in the selected memory channel.
 - **BLANK** appears above the memory channel number.
- ➔ Hold down for 1 second, to select a default option or value when in the Set mode or the Quick Set mode. (p. 25)

10 SPLIT/3/7 MHz BAND KEY

- SPLIT** ➔ Push to turn the split function ON or OFF.
 - **SPLIT** appears when the split function is ON.
- ➔ Hold down for 1 second to activate the quick split function.
 - VFO B's frequency and operating mode are set to the same frequency and operating mode as the VFO A.
 - The quick split function can be disabled in the Set mode. (p. 30)

11 AGC/6/18 MHz BAND KEY

- AGC** ➔ Push to toggle the time constant for the AGC circuit between fast and slow.
 - **F.AGC** appears when fast AGC is selected; no indication appears when slow AGC is selected
- ➔ Hold down for 1 second to turn OFF the AGC function.
 - **AGC-OFF** appears.

12 VOX/9/28 MHz BAND KEY

- VOX** ➔ Push to turn the VOX function ON or OFF.
 - ➔ Hold down for 1 second to enter the VOX Set mode; push again to return to normal operation.

✓ What is the VOX function?

The VOX function (Voice-Operated Transmission) activates the transmitter when you speak into the microphone and automatically returns to receive when you stop speaking.

13 SCAN/8/24 MHz BAND KEY

- SCAN** Push to start/stop the programmed/memory scan in the VFO/memory mode. (p. 24)
 - **SCAN** appears during a scan.

14 MANUAL NOTCH FILTER/0/50 MHz BAND KEY

- MNF** ➔ Push to turn the manual notch filter function ON or OFF.
 - **MNF** appears when the manual notch filter function is ON.
- ➔ Hold down for 1 second to enter the manual notch Set mode. Push again to return to normal operation.

15 SPEECH COMPRESSOR/7/21 MHz BAND KEY

- COMP** ➔ Push to turn the speech compressor function ON or OFF.
 - **COMP** appears when the speech compressor function is ON.
- ➔ Hold down for 1 second to enter the speech compression level Set mode.
 - Rotate [DIAL] to set the compression level.
 - Push again to return to normal operation.

16 RIT/•/GENERAL BAND KEY

- RIT** ➔ Push to turn the RIT (Receiver Incremental Tuning) function ON or OFF.
 - **RIT** appears when the RIT function is ON.
 - The RIT frequency can be adjusted with [M-CH] control when the RIT mode is selected.
- ➔ Hold down for 1 second to add the RIT frequency shift to the operating frequency.
 - Selectable only when the XFC (transmit frequency check function) is turned OFF.

1 PANEL DESCRIPTION

■ Front panel (Continued)

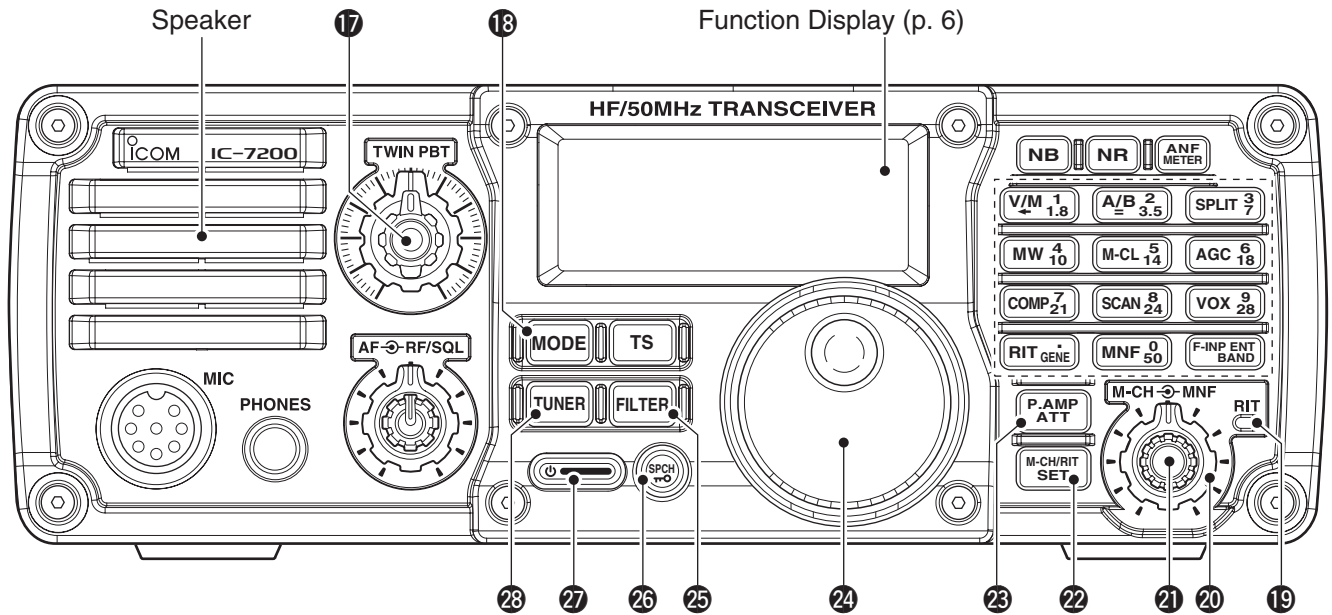

17 PASSBAND TUNING CONTROLS [TWIN PBT]

Adjust the receiver's DSP filter passband width.

- The limit of the variable range depends on the passband width and operating mode. The limit of the variable range is half of the passband width, and PBT is adjustable in 200 Hz (AM) or 50 Hz (other modes) steps.
- Rotating both [TWIN PBT] controls (PBT1 and PBT2) to the same position shifts the IF higher or lower.

✓ What is the PBT control?

Generally, the PBT electronically narrows the IF passband width to reject interference. This transceiver uses the DSP circuit for the PBT function.

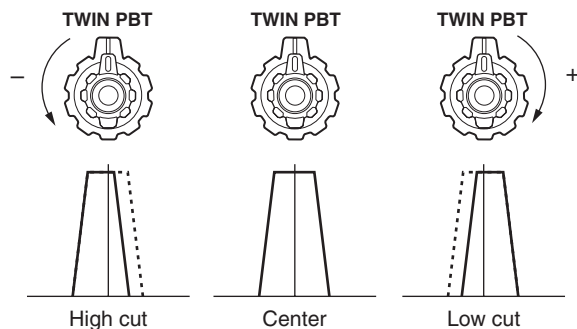
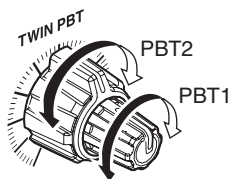

18 MODE KEY [MODE] (p. 16)

- Push to cycle through the operating modes:
USB/LSB → CW/CW-R → RTTY/RTTY-R → AM
- Hold down for 1 second to toggle the following operating modes:
USB ↔ LSB
CW ↔ CW-R (Reverse)
RTTY ↔ RTTY-R (Reverse)
- "CW-R" or "RTTY-R" appears when the reverse mode is selected.

▨ You can temporarily disable modes you do not want to be selectable, in the Set mode. (pp. 33, 34)

19 RIT CONTROL INDICATOR

Lights orange when the [M-CH] control (21) is selected as the RIT control.

20 MANUAL NOTCH FILTER CONTROL [MNF]

(outer control)

Rotate to adjust the notch filter frequency to reject an interfering signal when while the manual notch function is ON.

- Select the narrow, mid or wide filter width in the manual notch filter Set mode.

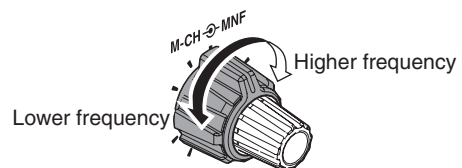

✓ What is the Manual Notch Filter?

The Manual Notch Filter is an adjustable narrow DSP filter that removes tones from CW, SSB, AM or RTTY or other signals, while preserving the desired signal's frequency response.

21 M-CH/RIT CONTROL [M-CH] (inner control)

- ➔ While in the Set mode/Quick Set mode, rotate to select the Set mode item. (p. 25)
- ➔ This control can be set as the memory channel control or the RIT control.
 - The RIT function should be turned ON first to activate this control as the RIT control.
 - “[RIT]” appears when the RIT function is ON.
 - The RIT control indicator (19) lights orange when this control is activated as the RIT control.

When [M-CH] acts as the M-CH control:

Rotate to select a memory channel (p. 21).

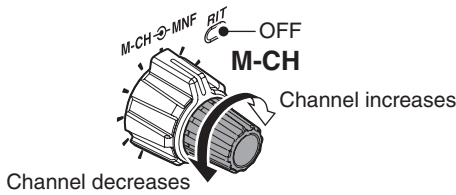

When [M-CH] acts as an RIT control:

Rotate to shift the receive frequency.

- Rotate the control clockwise to increase the frequency, or rotate the control counterclockwise to decrease the frequency.
- The frequency shift range is ± 9.999 kHz in 1 Hz steps or ± 9.99 kHz in 10 Hz steps, depending on the 1 Hz or 10 Hz tuning steps settings.

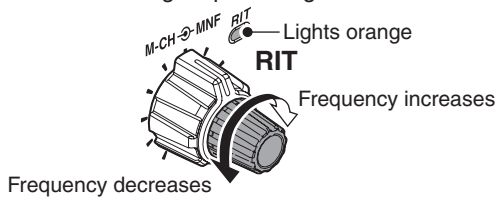

✓ What is the RIT function?

The RIT (Receiver Incremental Tuning) shifts the receive frequency without shifting the transmit frequency. This is useful for fine tuning stations calling you off frequency, or when you prefer to listen to slightly different sounding audio characteristics.

- About the [M-CH] control activation:

		RIT control indicator (19 on p. 3)	
		Lights	OFF
[RIT] icon (4 on p. 6)	Appears	Acts as the RIT control	Acts as the memory channel control
	Disappears	N/A	

22 M-CH/RIT•SET KEY [M-CH/RIT SET]

- ➔ Push to toggle the [M-CH] control between the memory channel control and the RIT control.
 - The RIT function should be turned ON first.
 - The RIT control indicator (19) lights orange when the [M-CH] control functions as the RIT control.
- ➔ Hold down for 1 second to enter the Quick Set mode. (p. 25)
- ➔ In the Quick Set mode, hold down for 1 second to enter the Set mode (p. 25)
- ➔ In the Quick Set mode or Set mode, push to return to normal operation. (p. 25)

23 PREAMP/ATTENUATOR KEY [P.AMP ATT]

- ➔ Push to turn the preamp ON or OFF.
 - “[P.AMP]” appears when the preamp is ON.
- ➔ Hold down for 1 second to turn ON the 20 dB attenuator; push to turn OFF the attenuator.
 - “[ATT]” appears when the attenuator is ON.

✓ What is the preamp?

The preamp amplifies signals in the receiver front end (input) circuit to improve the sensitivity. Turn ON the preamp when receiving weak signals.

✓ What is the attenuator?

The attenuator prevents a strong undesired signal near the desired frequency or near your location, such as from a broadcast station, from causing distortion or spurious signals.

24 MAIN DIAL [DIAL]

Changes the displayed frequency and selects values for selected Set mode/Quick Set mode items.

25 FILTER KEY [FILTER]

- ➔ Push to select the wide, mid or narrow IF filter setting for the selected band.
- ➔ Hold down for 1 second to enter the filter Set mode.
 - Rotate [DIAL] to adjust the filter width, then push the key to return to normal operation.

26 SPCH•LOCK KEY [SPCH LOCK]

- ➔ Push to announce the displayed frequency and S-meter level by the speech synthesizer.
 - The items to be announced can be selected in the Set mode. (p. 31)
- ➔ Hold down for 1 second to turn the dial lock function ON or OFF. (p. 18)
 - The dial lock function electronically locks the main dial.
 - “[LOCK]” appears while the dial lock function is ON.

27 POWER KEY [POWER]

- ➔ Push to turn ON power.
 - First turn ON the DC power supply.
- ➔ Hold down for 1 second to turn OFF power.

28 TUNER KEY [TUNER] (p. 20)

- ➔ Push to turn the automatic antenna tuner function ON or OFF.
 - An optional antenna tuner must be connected.
 - “[TUNE]” appears when the automatic antenna tuner function is ON.
- ➔ Hold down for 1 second to start the antenna tuner.
 - An optional antenna tuner must be connected.
 - When the tuner cannot tune the antenna within 20 seconds, the tuning circuit is automatically bypassed.

1 PANEL DESCRIPTION

■ Front panel (Continued)

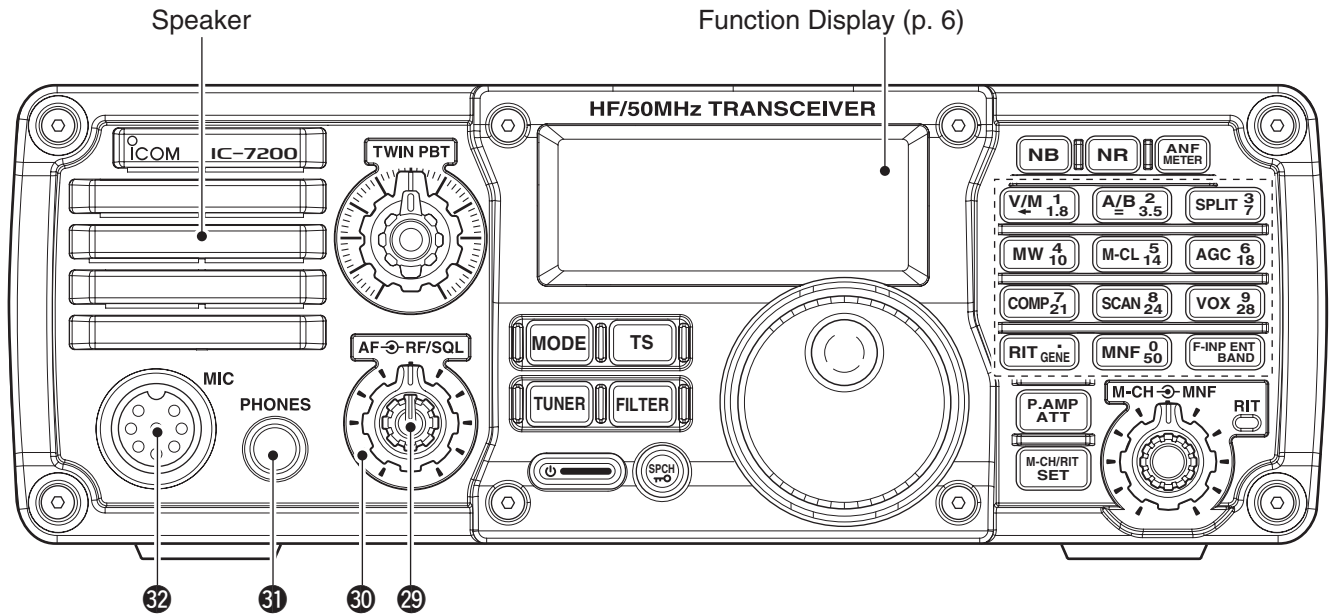

- 29 AF CONTROL [AF]** (inner control; p. 17)
 Rotate clockwise to increase the audio output level; counterclockwise to decrease it.

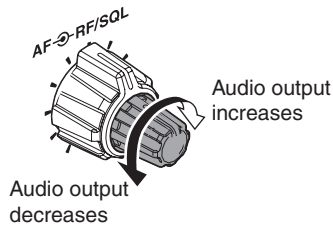

- 30 RF GAIN/SQUELCH CONTROL [RF/SQL]**
 (outer control; p. 17)

➔ Adjusts the RF gain and squelch threshold level.

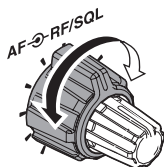

- ➔ The squelch removes noise output from the speaker (closed) when no signal is received.
- The squelch is usable in all modes.
 - The control can be set as the squelch plus RF gain controls, squelch control only (RF gain is fixed at maximum) or Auto (RF gain control in SSB, CW and RTTY; squelch control in AM) in the Set mode.

MODE	SET MODE SETTING		
	AUTO	SQL	RF + SQL
SSB, CW RTTY	RF GAIN	SQL	RF GAIN + SQL
AM	SQL	SQL	RF GAIN + SQL

- When functioning as the RF GAIN/SQL control

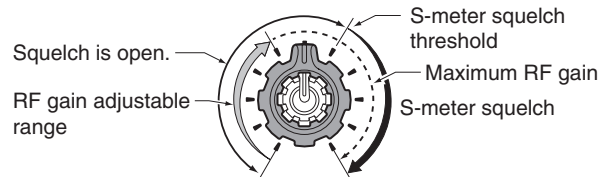

- When functioning as the RF GAIN control (Squelch is fixed open; SSB, CW, RTTY only)

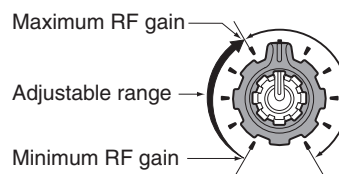

- When functioning as the SQL control (RF gain is fixed at maximum.)

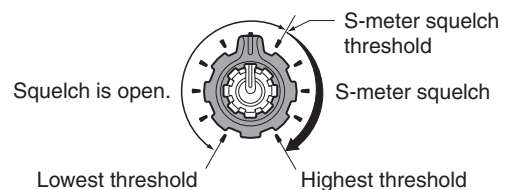

- 31 HEADPHONE JACK [PHONES]**

- Accepts headphones with 8–16 Ω impedance.
- Output power: 5 mW with an 8 Ω load.
- When headphones are connected, the speaker audio is disabled.

- 32 MICROPHONE CONNECTOR [MIC]**

- Accepts the supplied and optional microphones.
- See page 40 for appropriate microphones.

■ Function display

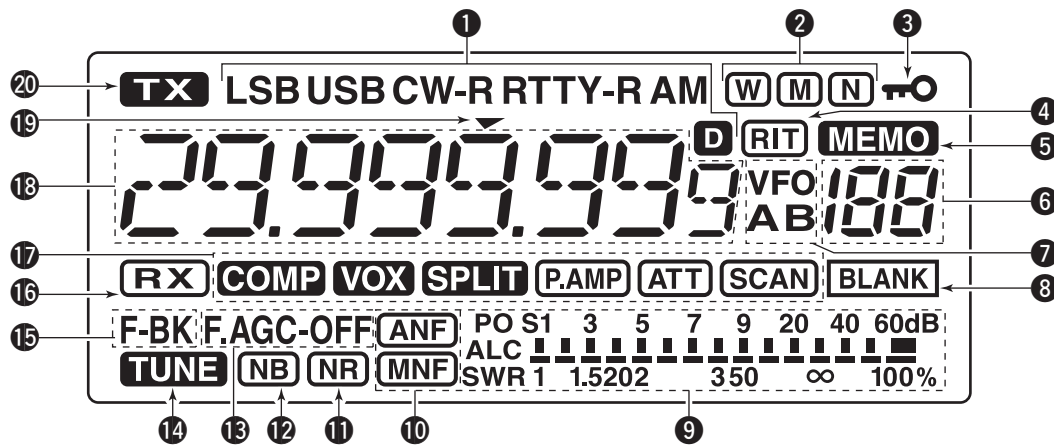

1 MODE ICONS

Shows the selected operating mode.

- “D” appears when the SSB/AM data mode is selected.
- “-R” appears when the CW reverse or RTTY reverse mode is selected. (p. 16)

2 IF FILTER ICONS

Shows the selected IF filter.

- ➔ “W” appears when the wide IF filter is selected.
- ➔ “M” appears when the mid IF filter is selected.
- ➔ “N” appears when the narrow IF filter is selected.

3 LOCK ICON (p. 18)

Appears when the dial lock function is ON.

4 RIT ICON

Appears when the RIT function is ON.

5 MEMORY ICON (p. 21)

Appears when in the memory mode is selected.

6 MEMORY CHANNEL NUMBER READOUT

(p. 21)

Shows the selected memory channel number.

7 VFO ICONS (p. 13)

“VFO A” or “VFO B” appears when the VFO mode is selected.

8 BLANK ICON

Appears when the selected memory channel is blank.

- This icon appears in both the VFO and memory modes.

9 S/RF METER

- ➔ Displays the receiving signal strength.
- ➔ Displays either the transmit power (PO), SWR or ALC while transmitting. (p. 19)

10 NOTCH ICONS

- ➔ “ANF” appears when the automatic notch function is ON.
- ➔ “MNF” appears when the manual notch function is ON.

11 NOISE REDUCTION ICON

Appears when the noise reduction function is ON.

12 NOISE BLANKER ICON

Appears when the noise blanker is ON.

13 AGC ICONS

Displays the selected AGC time constant.

- “F.AGC” for AGC fast; “AGC-OFF” for AGC OFF; no icon for AGC slow.

14 TUNE ICON (p. 20)

- ➔ Appears when an automatic antenna tuner is activated.
- ➔ Blinks while tuning.

15 BREAK-IN ICONS

- ➔ “BK” appears when the semi break-in function is ON.
- ➔ “F-BK” appears when the full break-in function is ON.

16 RECEIVE ICON

Appears while receiving a signal or when the squelch is open.

17 FUNCTION ICONS

- ➔ “COMP” appears when the speech compressor is ON in the SSB mode.
- ➔ “VOX” appears when the VOX function is ON.
- ➔ “SPLIT” appears when the Split function is ON.
- ➔ “P.AMP” appears when preamp is ON.
- ➔ “ATT” appears when the attenuator is ON.
- ➔ “SCAN” appears during a scan.
 - Blinks when the scan is paused.

18 FREQUENCY READOUT

Displays the operating frequency.

19 QUICK TUNING STEP ICON

Appears when the Quick tuning function is selected. (p. 14)

20 TRANSMIT ICON

Appears while transmitting.

■ Rear panel

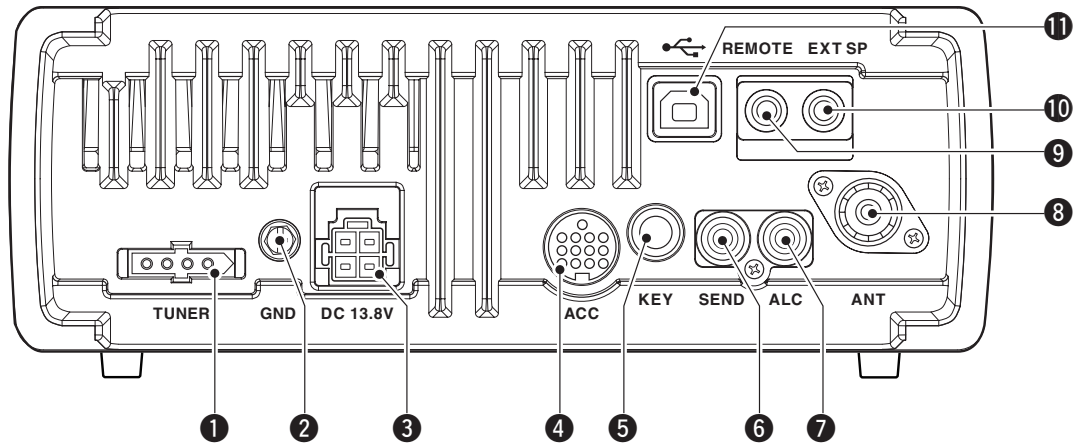

- 1 TUNER CONTROL SOCKET [TUNER]** (p. 11)
Accepts the control cable from an optional antenna tuner.
- 2 GROUND TERMINAL [GND]** (p. 8)
Connects to a ground to prevent electrical shocks, TVI, BCI and other problems.
- 3 DC POWER SOCKET [DC 13.8V]** (p. 10)
Accepts 13.8 V DC through the supplied DC power cable.

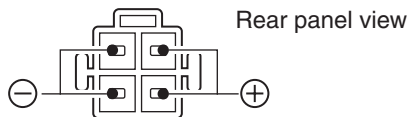

- 4 ACCESSORY SOCKET [ACC]**
Enables connection to external equipment such as a TNC for data communications, a linear amplifier or an automatic antenna tuner, and so on.
• See the PDF type Advanced Instructions for socket wiring information.
- 5 ELECTRONIC KEYS JACK [KEY]**
Accepts a key or paddle connector for the internal electronic keyer.
• The keyer type selection between the internal electronic keyer and straight key operation can be made in the Set mode. (p. 33)

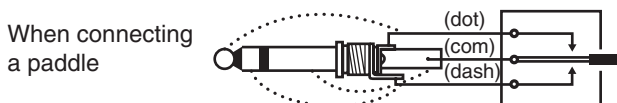

▨ If you use an external electronic keyer, make sure the output voltage of the keyer is less than 0.4 V when keying the transmitter.

- 6 SEND CONTROL JACK [SEND]**
Goes to ground while transmitting to control external equipment such as a linear amplifier.
• Max. control level: 16 V DC/0.5 A
- 7 ALC INPUT JACK [ALC]**
Connects to the ALC output jack of a non-Icom linear amplifier.
- 8 ANTENNA CONNECTOR [ANT]** (p. 8)
Accepts a PL-259 connector and a 50 Ω coaxial cable from an antenna tuner or an antenna.
- 9 CI-V REMOTE CONTROL JACK [REMOTE]**
➔ Designed for use with a PC for remote control of the transceiver functions.
➔ Used for transceiver operation with another Icom CI-V transceiver or receiver.
- 10 EXTERNAL SPEAKER JACK [EXT SP]**
Connects a 4–8 Ω external speaker.
• When an external speaker is connected, the internal speaker is disabled.
- 11 USB (Universal Serial Bus) PORT []**
Connects a USB cable for transceiver modulation input, the transceiver operation with a PC, and the received audio sent to the PC.

▨ **About the USB driver:**

The USB driver and the installation guide can be downloaded from our website.
➔ <http://www.icom.co.jp/world/>

■ Unpacking

After unpacking, immediately report any damage to the delivering carrier or dealer. Keep the shipping cartons.

For a description and a diagram of accessory equipment included with the IC-7200, see 'Supplied accessories' on page i of this manual.

■ Selecting a location

Select a location for the transceiver that allows adequate air circulation, is free from extreme heat, cold, or vibrations, and away from TV sets, TV antenna elements, radios and other electromagnetic sources.

The base of the transceiver has an adjustable stand for desktop use. Set the stand to one of two angles, depending on your operating conditions.

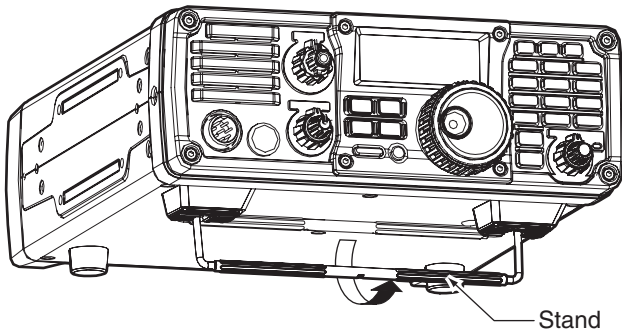

Stand

■ Grounding

To prevent electrical shock, television interference (TVI), broadcast interference (BCI) and other problems, ground the transceiver through the GROUND terminal on the rear panel.

For best results, connect a copper or copper-plated ground rod driven into the earth. Make the distance between the [GND] terminal and ground as short and straight as possible.

⚠ WARNING! NEVER connect the [GND] terminal to a gas or electric conduit, since the connection could cause an explosion or electric shock.

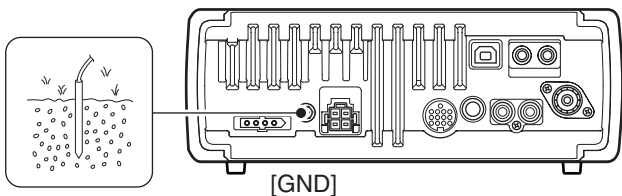

[GND]

■ Connecting an antenna

For radio communications, the antenna is of critical importance for output power and sensitivity. Use well-matched 50 Ω antennas and coaxial feedline. An SWR (standing wave ratio) of 1.5:1 or lower is recommended when transmitting.

⚠ CAUTION: Protect your transceiver from lightning by using a lightning arrestor.

PL-259 CONNECTOR INSTALLATION EXAMPLE

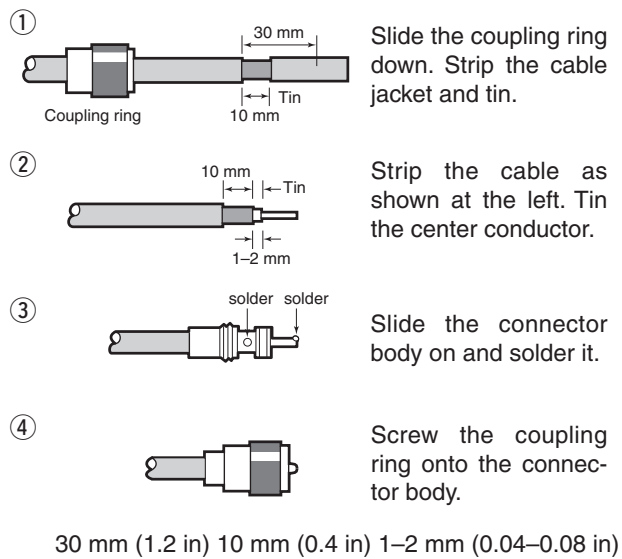

Antenna SWR

Each antenna is tuned for a specified frequency range and the SWR may increase out-of-range. When the SWR is higher than approximately 2.0:1, the transceiver's power drops to protect the final transistors. In this case, an optional antenna tuner is useful to match the transceiver and antenna. Low SWR allows full power for transmitting, even when using the antenna tuner. The IC-7200 has an SWR meter to continuously monitor the antenna SWR.

Basic connections

• Front panel

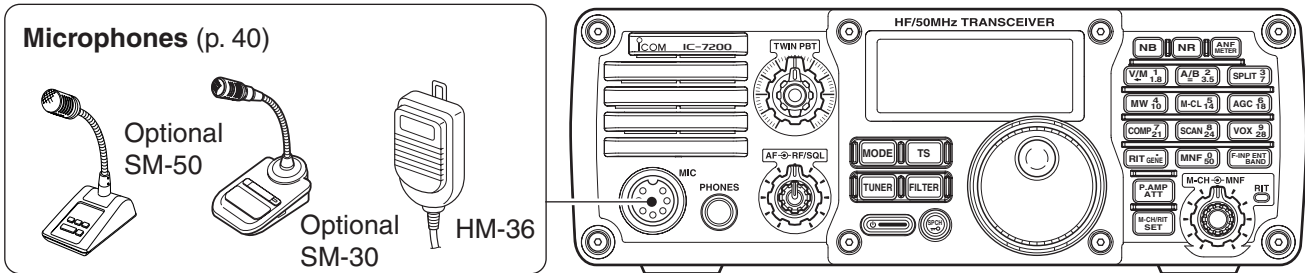

• Rear panel

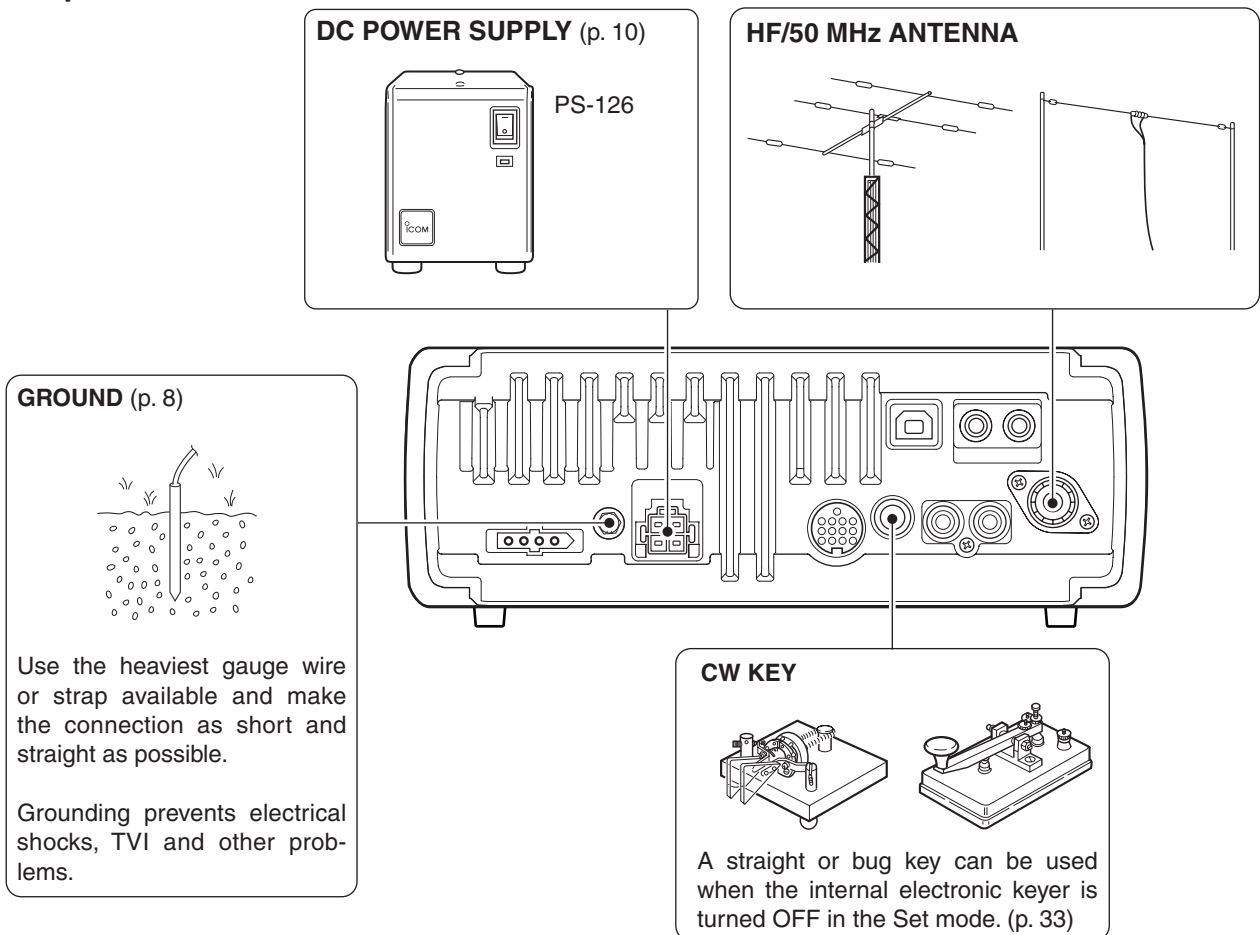

■ Power supply connections

Use a DC power supply with at least a 22 A capacity when operating the transceiver with AC power. Refer to the diagrams below.

CAUTION: Before connecting the DC power cable, check the following important items. Make sure:

- The  switch is OFF.
- Output voltage of the power source is 12–15 V.
- DC power cable polarity is correct.
 - Red : Positive ⊕ terminal
 - Black : Negative ⊖ terminal

■ Connecting the DC Power Supply

CONNECTING THE PS-126 DC POWER SUPPLY

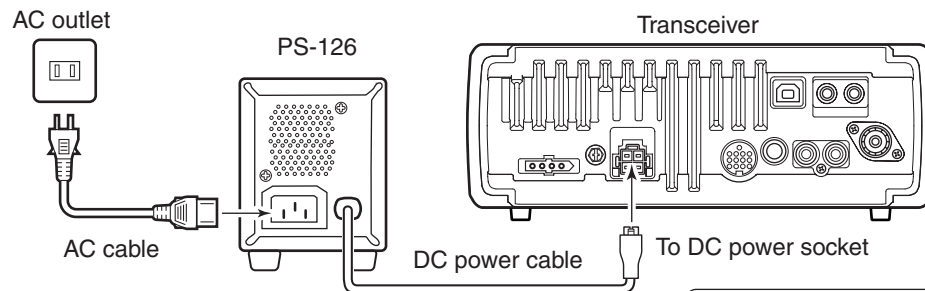

CAUTION: The rear panel will become hot when continuously operating the transceiver for long periods.

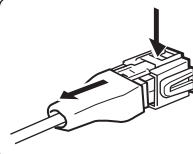

BE CAREFUL when disconnecting the DC power cable because the connector is tightly locked. Use a small tool, such as a flat-bladed screwdriver, to disengage the locking tab.

CONNECTING A NON-ICOM DC POWER SUPPLY

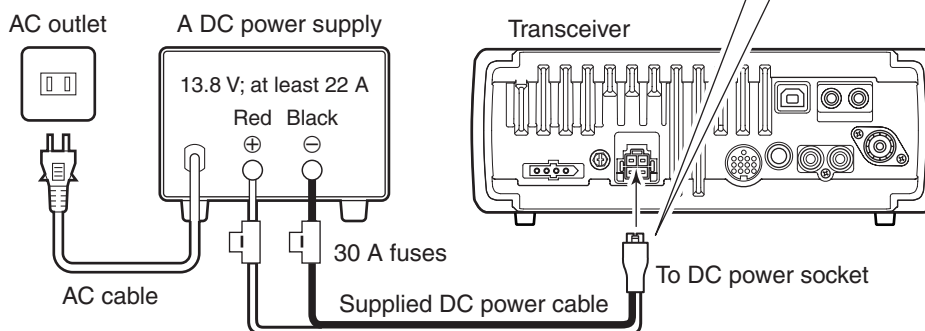

CAUTION: The rear panel will become hot when continuously operating the transceiver for long periods.

Battery connections

- **⚠ WARNING NEVER** connect to a battery without supplying a DC fuse, otherwise a fire hazard could occur.
- **NEVER** connect the transceiver to a 24 V battery.

The transceiver may not receive well on some frequencies when installed in a hybrid vehicle, or any type of electric vehicle (fuel cell vehicle). This is because vehicle's electric components such as the inverter system generate a lot of electric noise.

- **DO NOT** use a cigarette lighter socket as a power source when operating in a vehicle. The plug may cause voltage drops and ignition noise may be superimposed onto transmit or receive audio.
- Use a rubber grommet when passing the DC power cable through a metal plate to prevent a short circuit.

The IC-7200 is not certified for vehicle installation in European countries.

CONNECTING A VEHICLE BATTERY

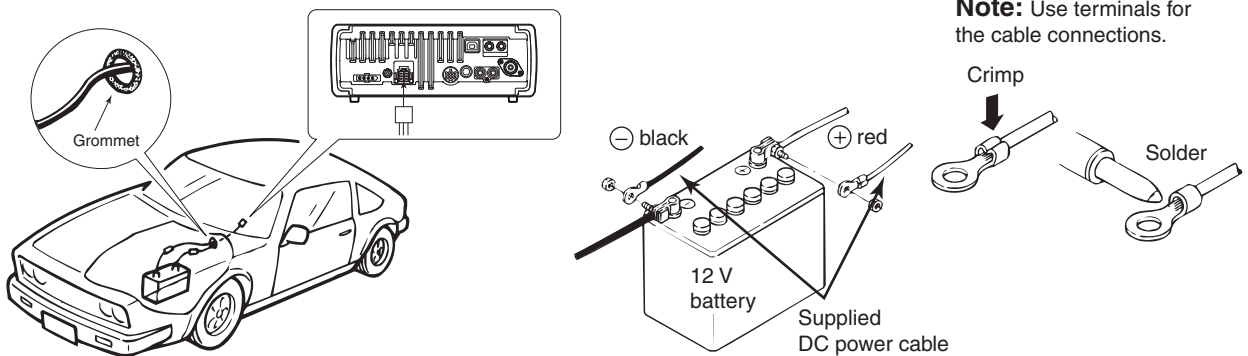

External antenna tuners

CONNECTING an AH-4

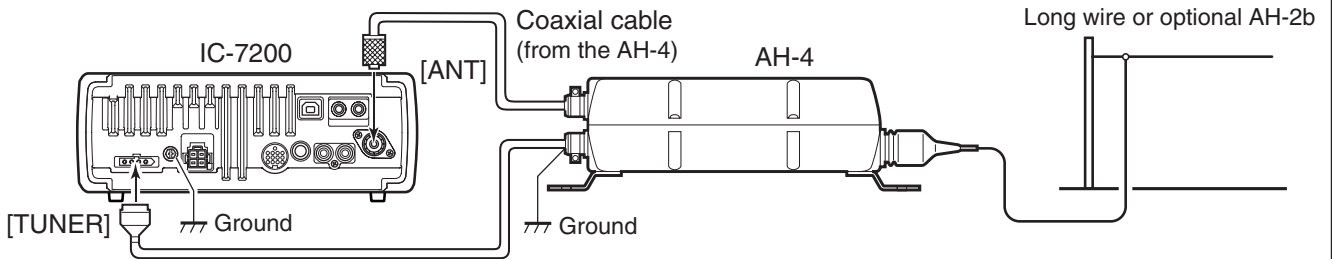

CONNECTING an AT-180

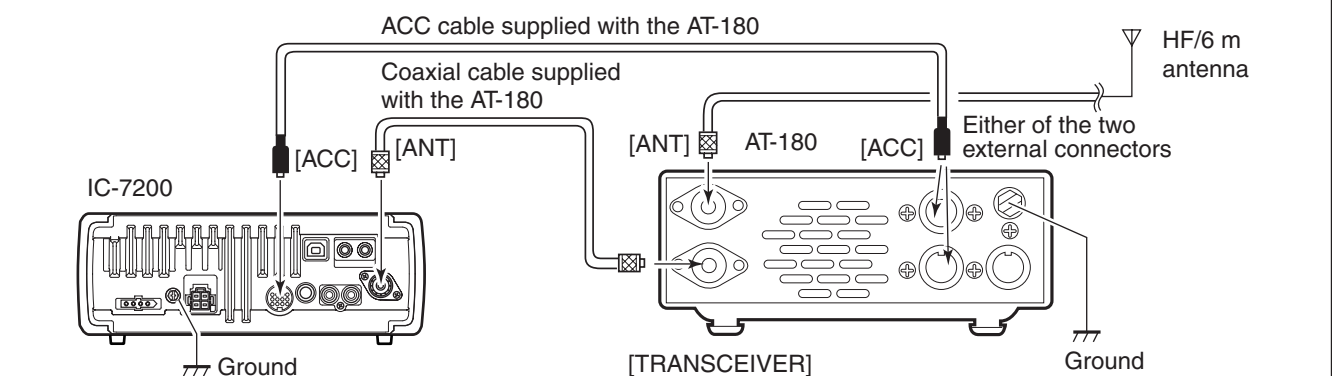

- Turn the IC-7200's power OFF when connecting the AT-180, otherwise, the CPU may malfunction and the AT-180 may not function properly.

■ Connecting a CW keyer

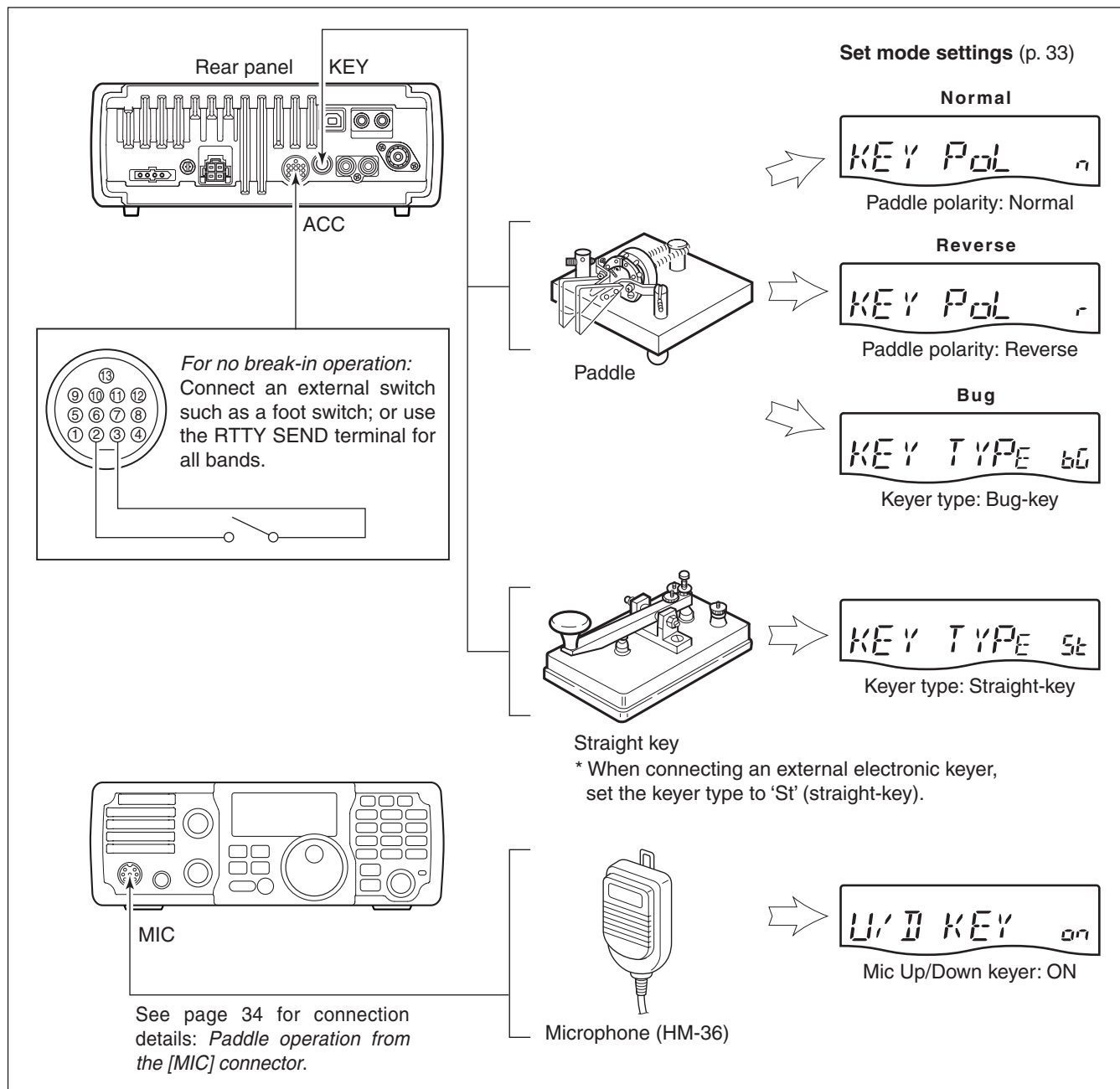

Before first applying power

Before first applying power, make sure all connections required for your system are complete by referring to Chapter 2 or the PDF type Advanced Instructions.

After all connections have been done, set controls and switch as shown in the figure below.

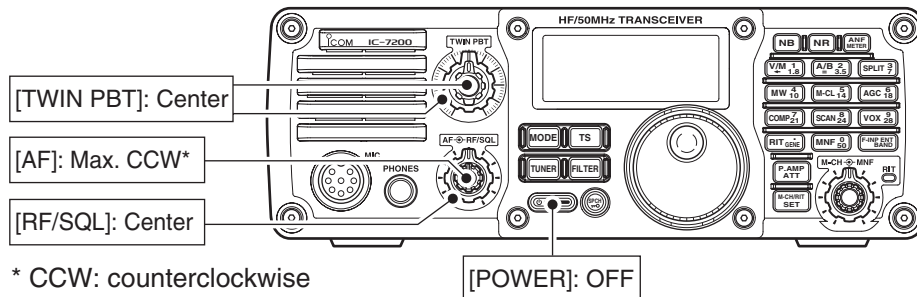

Applying power

First applying power:

Reset the transceiver using the following procedure.

Resetting **CLEARs** all programmed contents in memory channels and returns to their default values in Quick Set mode and Set mode.

- ① Make sure the transceiver power is OFF.
- ② While holding down **F-INP ENT BAND** and **M-CL**, push **POWER** to turn ON power.
 - The internal CPU is reset.
 - The transceiver displays its initial VFO frequencies when resetting is complete.
- ③ All Quick Set mode and Set mode settings are returned to their default values. (pp. 26, 27)

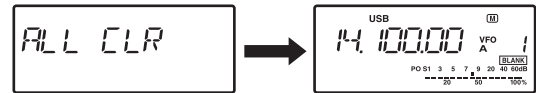
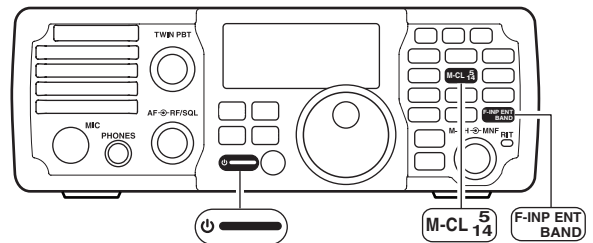

Normal applying power:

Push **POWER** to turn ON power, then check the display. If any of icons appear, turn them OFF if necessary. (See the appropriate page for details).

Under cooler temperatures, the LCD may appear dark and unstable after turning ON power. This is normal and does not indicate an equipment malfunction.

Selecting the VFO and memory modes

Push **V/M** to toggle between the VFO and memory modes.

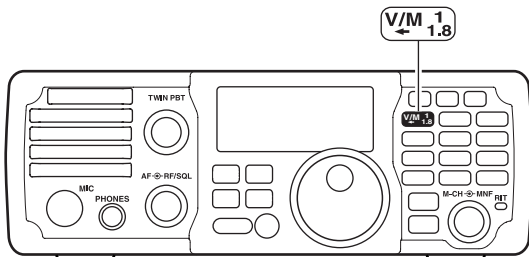

Selecting VFO A/B

Selecting VFO A/B

Push **A/B** to select either VFO A or VFO B.

Either "VFO A" or "VFO B" appears. **A/B 2 3.5**

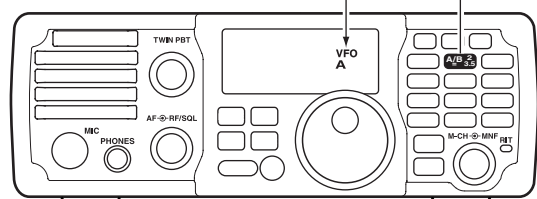

Equalizing the VFOs

Hold down **A/B** for 1 second to set the undisplayed VFO frequency and mode to the displayed VFO frequency

- 3 beeps sound when the VFO equalization is completed.

■ Setting the operating frequency

◇ Selecting an operating band

The transceiver has a band stacking register. This function automatically memorizes the last operating frequency and mode used on a particular band. This is convenient for contest operation.

See the table below for a list of the bands available and the default settings for each register.

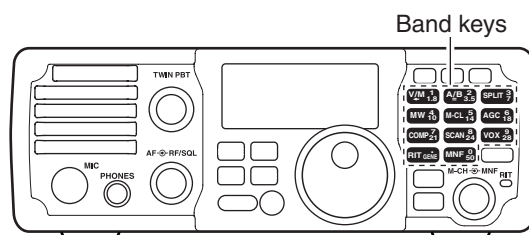

BAND	REGISTER	BAND	REGISTER
1.8 MHz	1.900000 MHz CW	21 MHz	21.200000 MHz USB
3.5 MHz	3.550000 MHz LSB	24 MHz	24.950000 MHz USB
7 MHz	7.050000 MHz LSB	28 MHz	28.500000 MHz USB
10 MHz	10.120000 MHz CW	50 MHz	50.100000 MHz USB
14 MHz	14.100000 MHz USB	General	15.000000 MHz USB
18 MHz	18.100000 MHz USB		

• Operation example

- Hold down **F-INP ENT BAND** for 1 second to enter the band selection mode.
- Push the desired band key to select the corresponding band.
(Example: Push **5**/**14** to select 14 MHz band.)
 - The last operated frequency and mode are memorized.
- Rotate **[DIAL]** to set the desired frequency.

[Example]: 14 MHz band

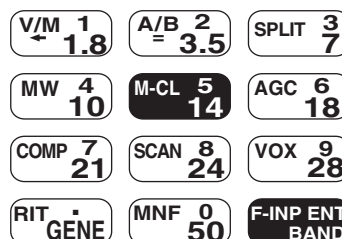

◇ Quick tuning function

The operating frequency can be changed in steps of (0.1, 1, 5, 9 or 10 kHz selectable) for quick tuning.

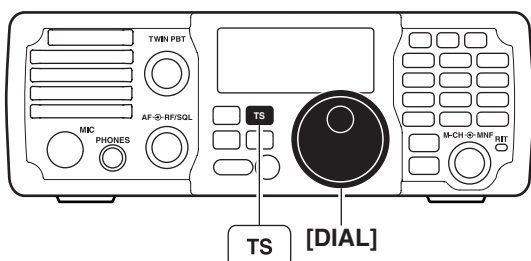

- Push **TS** to turn ON the Quick tuning function.
 - “▼” appears.

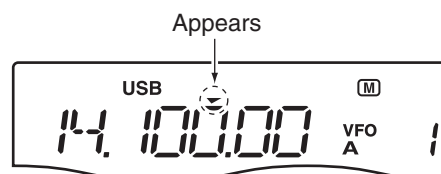

- Rotate **[DIAL]** to change the frequency in programmed kHz steps.
- Push **TS** again to turn OFF the Quick tuning function.
 - “▼” disappears.
- Rotate **[DIAL]** for normal tuning, if desired.

◇ Selecting 'kHz' step

When the Quick tuning function is selected, the frequency can be changed in the selected 'kHz' steps.
 • 0.1, 1, 5, 9 or 10 kHz are selectable.

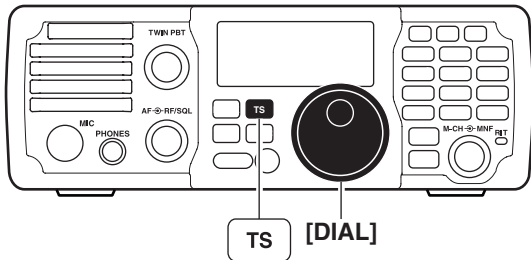

- ① Push **[TS]** to turn ON the Quick tuning function.
 • “▼” appears.

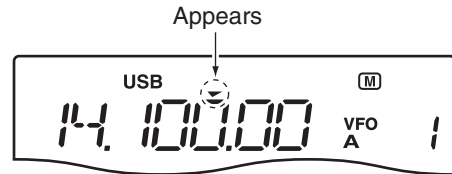

- ② Hold down **[TS]** for 1 second to enter the tuning step Set mode.



- ③ Rotate **[DIAL]** to select the desired tuning step of 0.1, 1, 5, 9 or 10 kHz.
- ④ Push **[TS]** to exit the tuning step Set mode.
- ⑤ Rotate **[DIAL]** to change the frequency according to the set tuning step.
- ⑥ Push **[TS]** to turn OFF the Quick tuning function.
 • “▼” disappears.

◇ Selecting the 1 Hz and 10 Hz tuning steps

When the Quick tuning step icon, “▼,” disappears, rotating **[DIAL]** changes the frequency in increments of 1 or 10 Hz.

NOTE: The frequency is changed in 50 Hz steps when the **[UP]/[DN]** switches of the microphone are used for the frequency setting (when the Quick tuning step is not selected, “▼” disappears.)

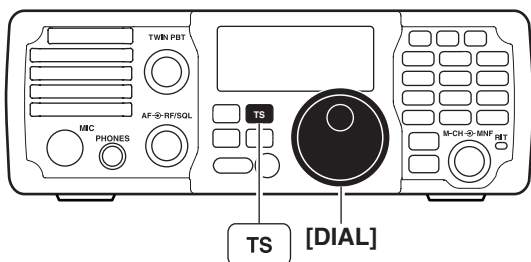

- ➔ Hold down **[TS]** for 1 second to toggle between the 1 Hz and 10 Hz step settings.
 - When the 1 Hz step is selected, the 1 Hz digit appears in the frequency display; when the 10 Hz step is selected, the 1 Hz digit disappears from the frequency display.
 - Rotating **[DIAL]** changes the frequency in 1 Hz or 10 Hz tuning step.

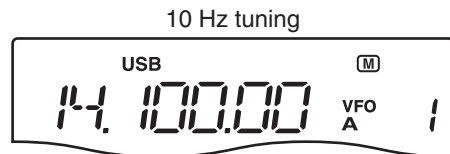

Rotating **[DIAL]** changes the frequency in 10 Hz steps.

Hold down **[TS]** for 1 second

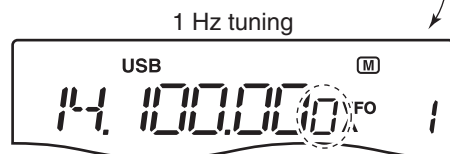

Rotating **[DIAL]** changes the frequency in 1 Hz steps.

■ Entering a frequency from the keypad

The transceiver has a keypad for direct frequency entry, as described to the right.

- ① Push **F-INP ENT BAND**.
- ② Input the desired frequency with the numeric keys on the keypad.
 - Push **GENE** to input “• (decimal point)” between the MHz digits and kHz digits.
- ③ Push **F-INP ENT BAND** to set the input frequency.
 - To cancel the input, push **M-CH/RIT SET** (or any key except a keypad key).

[EXAMPLE]

• 14.025 MHz

• 706 kHz

• 21.280 MHz → 21.245 MHz

3

■ Selecting operating mode

The following modes are selectable in the IC-7200: SSB (USB/LSB), SSB data (USB data/LSB data), CW, CW-R (CW Reverse), RTTY, RTTY-R (RTTY Reverse), AM and AM data modes.

- ➔ Push **MODE** one or more times to select a desired operation mode.
 - The selected mode icon is displayed in the display.
- ➔ In the SSB mode, hold down **MODE** for 1 second to toggle between USB and LSB.
- ➔ In the CW mode, hold down **MODE** for 1 second to toggle between CW and CW Reverse.
- ➔ In the RTTY mode, hold down **MODE** for 1 second to toggle between RTTY and RTTY Reverse.
- ➔ SSB data (USB data/LSB data) or AM data mode can be selected in the Quick Set mode. (p. 28)

NOTE: If a desired operating mode cannot be selected, it may be disabled in the Set mode. (pp. 33, 34)

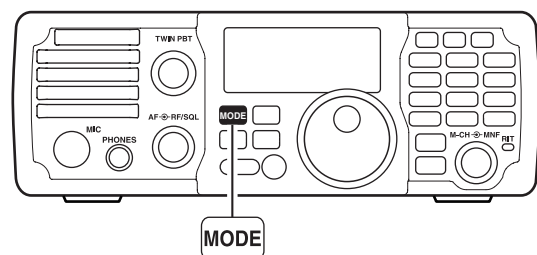

OPERATING MODE SELECTION

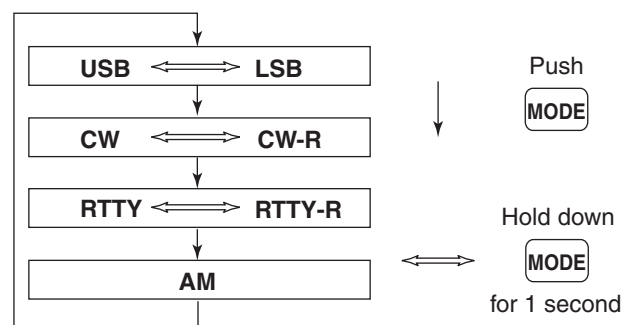

■ Adjusting the audio volume

Rotate the [AF] control clockwise to increase the audio output level; counterclockwise to decrease it.

- Set a suitable audio level.

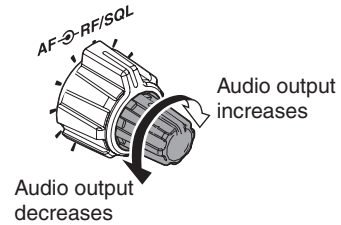
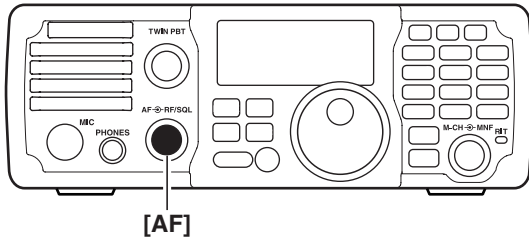

■ Using RF gain and Squelch control

The [RF/SQL] control adjusts the RF gain and squelch threshold level. The squelch stops noise output from the speaker (closed position) when no signal is received.

- The 12 o'clock position is recommended for any setting of the [RF/SQL] control.
- The [RF/SQL] control can be set as the RF gain control only (squelch is fixed open) or squelch control (RF gain is fixed at maximum) in the Set mode (p. 29).

MODE	SET MODE SETTING		
	AUTO	SQL	RF + SQL
SSB, CW RTTY	RF GAIN	SQL	RF GAIN + SQL
AM	SQL	SQL	RF GAIN + SQL

○ Adjusting the RF gain (Receive sensitivity)

Normally, the [RF/SQL] control is set to the 12 o'clock position.

Rotate the [RF/SQL] control to the 11 o'clock position for maximum sensitivity.

- Rotate the [RF/SQL] control clockwise to increase the receiver sensitivity, counterclockwise to decrease it.
- The S-meter indicates receive sensitivity.

○ Adjusting the squelch (Removing non-signal noise)

Rotate the [RF/SQL] control to the 1 o'clock position to invoke the S-meter squelch— this allows you to set the minimum signal level needed to open the squelch.

- A segment appears in the S-meter to indicate the S-meter squelch level.

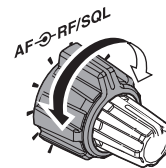
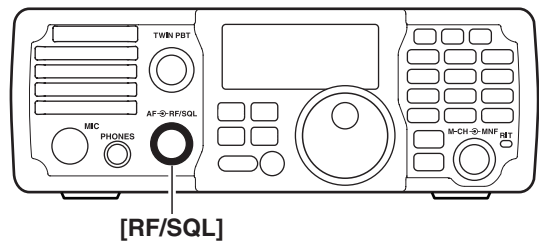

• When functioning as an RF GAIN/SQL control

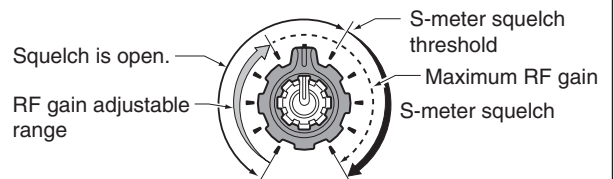

• When functioning as an RF GAIN control

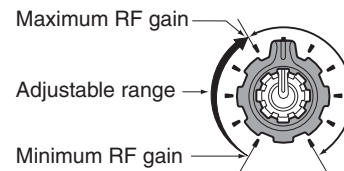

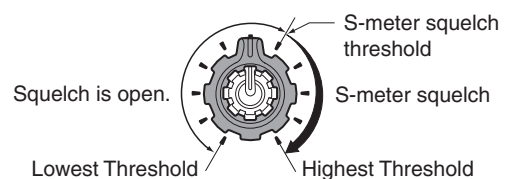

• When functioning as a SQL control

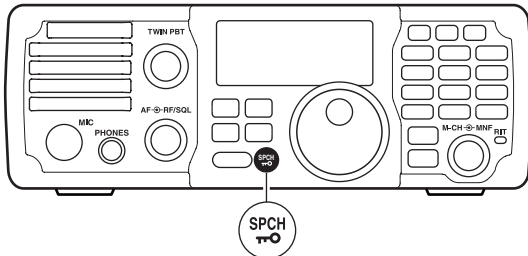

■ Locking the Dial

The dial lock function prevents accidental changes by [DIAL] being rotated.



➔ Hold down  for 1 second to turn the dial lock function ON or OFF.

- “” appears when the dial lock function is ON.



■ Basic transmit operation

Before transmitting, monitor your selected operating frequency to make sure transmitting won't cause interference to other stations on the same frequency.

It's good Amateur practice to listen first. On the HF bands, even if nothing is heard, ask “is the frequency in use” once or twice, before you begin operating on that frequency.

◇ Transmitting



- ① Push [PTT] (microphone) to transmit.
 - “**TX**” appears.
- ② Release [PTT] to return to receive.
 - “**TX**” disappears.

Appears while transmitting



◇ Output power setting

If a linear amplifier is connected, such as the IC-PW1/EURO, set the output power using the ALC meter to the ALC zone (see “Microphone gain setting” below.) The ALC meter reading should be within this zone, otherwise the linear amplifier will not work properly.

- ① Hold down  for 1 second to enter the Quick Set mode.
- ② Rotate [M-CH] to select “RF POWER.”
- ③ Rotate [DIAL] to select the desired output level.
 - Output power is displayed in 101 steps (Low, 1–100.)
- ④ Push  to exit the Quick Set mode.

• Available power

SSB/CW/RTTY : 2–100 W
 AM : 1–25 W* (*Carrier power)

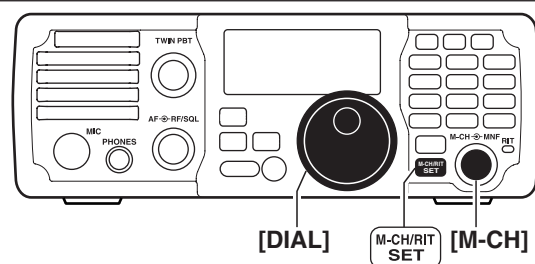

When maximum output power “100” is selected (default)

3 OPERATION

■ Basic transmit operation (Continued)

◇ Microphone gain setting

Microphone gain must be adjusted properly so that your signal does not distort when transmitted.

- ① Select the SSB or AM mode.
- ② Hold down **ANF METER** for 1 second once or twice to select the ALC meter.
- ③ Hold down **M-CH/RIT SET** for 1 second to enter the Quick Set mode.
- ④ Rotate **[M-CH]** to select “**MIC GAIN.**”
- ⑤ Push **[PTT]** to transmit.
 - Speak into the microphone at your normal voice level.
- ⑥ While speaking into the microphone, rotate **[DIAL]** so that the ALC meter reading stays within the ALC zone.
 - Microphone gain is adjusted in 1% steps (0% to 100%).
- ⑦ Release **[PTT]** to receive.
- ⑧ Push **M-CH/RIT SET** to exit the Quick Set mode.

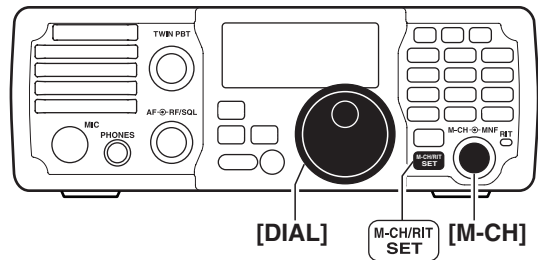

When “50” is selected (default)

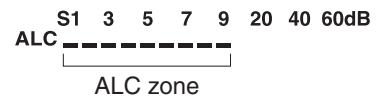

■ Measuring SWR

The IC-7200 has a built-in circuit for measuring antenna SWR—no external equipment is necessary.

- ① Push **MODE** to select the RTTY mode.
- ② Set the output power to 30 watts or more. (p. 18)
- ③ Hold down **ANF METER** for 1 second several times to select the SWR meter.
- ④ Push **[PTT]** to transmit, then read the actual SWR on the meter.
 - ≤ 1.5 well-matched antenna
 - > 1.5 may indicate your antenna is out of its well-matched frequency range. If over 2.0, check antenna and cable connections.

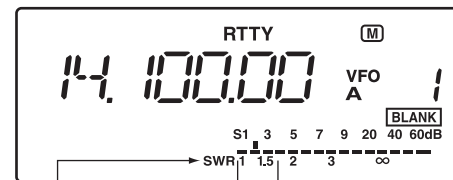
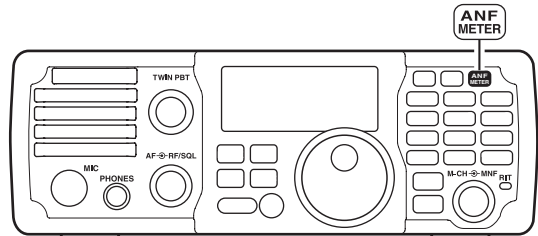

Appears The best match is in this range.

Refer to the PDF type Advanced instructions for transmission details on the CW/RTTY modes.

■ About the optional AH-4 AUTOMATIC ANTENNA TUNER

The AH-4 matches the IC-7200 to a long wire antenna more than 7 m/23 ft long (3.5 MHz and above).

- See page 14 for connection.
- See the AH-4 instruction manual for AH-4 installation and antenna connection details.

AH-4 setting example:

For mobile operation

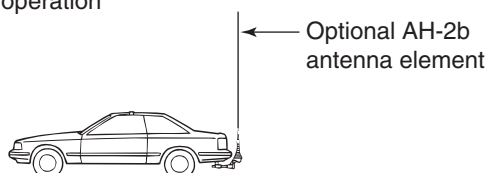

For outdoor operation

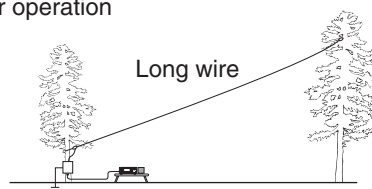

⚠ DANGER HIGH VOLTAGE!

NEVER touch the antenna element while tuning or transmitting.

NEVER operate the AH-4 without an antenna connected. The tuner and transceiver will be damaged.

NEVER operate the AH-4 when it is ungrounded.

Transmitting before tuning may damage the transceiver. Note that the AH-4 cannot tune when using a $\frac{1}{2}\lambda$ long wire or on a multiple of that frequency.

◇ Operating the AH-4

Tuning is required for each frequency. **Be sure** to retune the antenna before transmitting when you change the frequency—even slightly.

- ① Set a desired frequency in an HF band.
 - The AH-4 will not operate on frequencies outside of the ham bands.
- ② Hold down **TUNER** for 1 second.
 - “**TUNE**” blinks while tuning.
- ③ “**TUNE**” is still ON after the tuning is completed.
 - When the connected wire cannot be tuned, “**TUNE**” goes out, the AH-4 is bypassed and the antenna wire is directly connected.
- ④ Push **TUNER** to manually bypass the AH-4.
 - “**TUNE**” goes out.

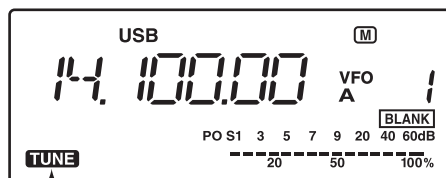

Appears when the antenna tuner is ON.
Blinks while tuning.

CONVENIENT

• PTT tune function (p. 30)

The AH-4 always tunes when [PTT] is pushed after the frequency is changed (more than 1%). This function replaces the “hold down **TUNER**” operation and is activated on the first transmission on the new frequency. Turn ON this function in the Set mode.

About the Memory channels

The transceiver has 201 memory channels, including 2 scan edge channels.

The Memory mode is very useful to quickly select often-used frequencies.

All 201 memory channels are tunable, which means the programmed frequency can be tuned temporarily by rotating [DIAL], even, in the memory mode.

MEMORY CHANNEL	MEMORY CHANNEL NUMBER	CAPABILITY	COPY TO VFO	OVER-WRITING	CLEAR
Regular memory channels	1-199	Independent transmit and receive frequencies and mode in each memory channel.	Yes	Yes	Yes
Scan edge memory channels	P1, P2	One frequency and one mode in each memory channel to use as scan edges for a programmed scan.	Yes	Yes	No

Selecting Memory channels

- Push **V/M** to select the Memory mode.
 - “MEMO” appears.
- Rotate [M-CH] to select the desired memory channel.
 - If the RIT control indicator is bright orange, push **M-CH/RIT SET** to turn OFF the RIT and set the [M-CH] control to memory channel control. (See details below.)
 - All memory channels, including blank channels, can be selected.
 - Pushing [UP]/[DN] on the microphone also selects the memory channels. Only programmed memory channels are selectable using the microphone buttons.

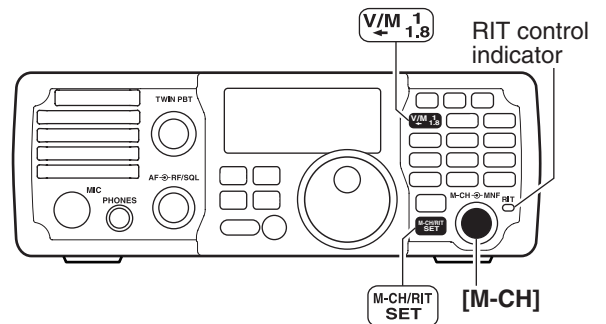
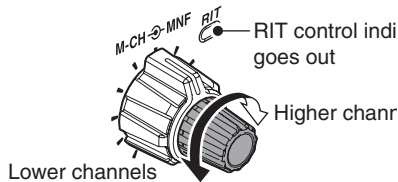

[EXAMPLE]: Selecting memory channel 17.

VFO mode



Memory mode



Channel 17 is selected.

About the [M-CH] control:

When the RIT control indicator lights orange, the memory channels cannot be selected by rotating the [M-CH] control because the [M-CH] control acts as the RIT control. Push **M-CH/RIT SET** to set the [M-CH] control to memory channel control (RIT control indicator goes out).

■ Programming Memory channels

You can program the Memory channels in either the VFO mode or the Memory mode.

◇ Programming in the VFO mode

- ① Push **[V/M]** to select the VFO mode.
- ② Rotate [DIAL] to set the desired frequency, and then push **[MODE]** to set the operating mode.
- ③ Rotate [M-CH] to select the desired memory channel.
 - If the RIT control indicator lights orange, push **[M-CH/RIT SET]**.
 - "BLANK" appears if the selected memory channel is a blank channel (one without any stored data).

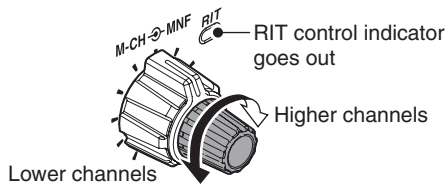

- ④ Hold down **[MW]** for 1 second to enter the displayed frequency and operating mode into the selected memory channel.
 - Three beeps sound when memory entry is completed.

[EXAMPLE]: Programming 7.088 MHz/LSB into channel 12.

VFO mode

Push **[V/M]** ¹/_{1.8}

CW (M) VFO A 2

14020.00

Rotate [DIAL]

Push **[MODE]**

LSB (M) VFO A 2

7088.00

Rotate [M-CH]

LSB (M) VFO A 12

7088.00

Hold down **[MW]** ⁴/₁₀

7.088 MHz/LSB are programmed into channel 12.

◇ Programming in the Memory mode

- ① Push **[V/M]** to select the Memory mode.
- ② Rotate [M-CH] to select the desired memory channel.
 - If the RIT control indicator lights orange, push **[M-CH/RIT SET]**.
 - Memory channel contents appear in the display.

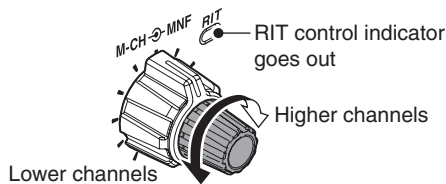

- ③ Rotate [DIAL] to set the desired frequency, and push **[MODE]** to set the operating mode.
 - To program a blank channel, directly enter the frequency entry with the keypad. (p. 16)
- ④ Hold down **[MW]** for 1 second to enter the displayed frequency and operating mode into the memory channel.
 - Three beeps sound when memory entry is completed

[EXAMPLE]: Programming 21.280 MHz/USB into channel 18.

Memory mode

Push **[V/M]** ¹/_{1.8}

USB (M) MEMO 1

14100.00

Rotate [M-CH]

Current frequency and mode in channel 18

LSB (M) MEMO 18

3550.00

Rotate [DIAL]

Push **[MODE]**

New frequency and mode entered

USB (M) MEMO 18

21280.00

Hold down **[MW]** ⁴/₁₀

Write new data into channel 18

USB (M) MEMO 18

21280.00

21.280 MHz/USB are now in channel 18.

■ Scan types

Scanning automatically searches for signals and makes it easier to locate new stations for contact or listening purposes. The IC-7200 has two scan types; Programmed scan and Memory scan.

PROGRAMMED SCAN

Repeatedly scans between two scan edge frequencies (scan edge memory channels P1 and P2).

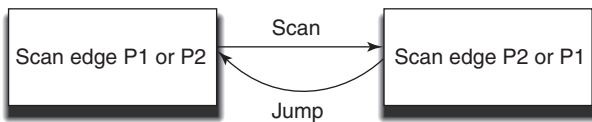

This scan is for the VFO mode.

MEMORY SCAN

Repeatedly scans all programmed memory channels that are not blank.

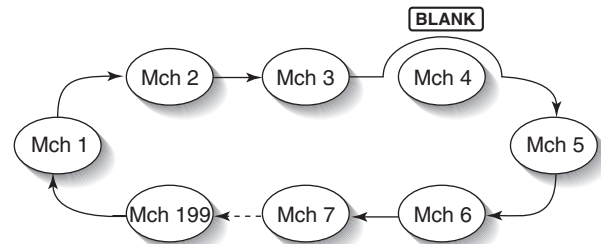

This scan is for the memory mode.

■ Preparation

• Channels

For a programmed scan:

Program scan edge frequencies into scan edge memory channels P1 and P2.

For a memory scan:

Program two or more memory channels other than scan edge memory channels.

• Scan resume ON/OFF

In the Set mode, you can select the scan to resume or cancel when a signal is detected.

Scan resume must be set to ON or OFF before starting a scan. See page 31 for ON/OFF setting and scan resume details.

• Scan speed

You can select High or Low scan speeds in the Set mode. See page 31 for details.

• Squelch status

○ Scan starts with the squelch open

For a programmed scan:

When the tuning step is 1 kHz or less:

The scan continues until it is manually stopped by pushing **[SCAN]**, and does not pause*, even if signals are detected.

* The scan pauses when the squelch is closed and then opens (Scan resumes after 10 seconds has passed when the scan resume is ON. The scan is cancelled when resume is OFF).

When the tuning step is more than 5 kHz:

The scan pauses on each step when the scan resume is ON; not applicable when resume is OFF.

For a memory scan:

The scan pauses on each channel when the scan resume is ON; not applicable when it is OFF.

○ Scan starts with squelch closed

The scan stops when a signal is detected.

If you set scan resume ON in the Set mode, the scan pauses for 10 seconds when detecting a signal, then resumes. When a signal disappears while the scan is paused, scanning resumes 2 seconds later.

NOTE: If the [RF/SQL] control function is set to "AUTO," the squelch is always open in the SSB, CW and RTTY modes. (pp. 5, 17, 29)

■ Scanning between programmed channels (VFO mode)

A programmed scan searches for signals between scan edge memory channels P1 and P2.

The default frequencies for these memories are 0.500000 MHz and 29.99999 MHz.

See the PDF type Advanced Instructions for scan edges programming details.

- ① Push **V/M** to select the VFO mode.
- ② Push **MODE** to select the desired operating mode.
 - The operating mode can be changed while scanning.
- ③ Push **TS** to select a tuning step.
 - The tuning step cannot be changed while scanning. (The programmed tuning function can be turned ON or OFF while scanning.)
- ④ Set the **[RF/SQL]** control open or closed.
 - See the previous page for squelch status details.
- ⑤ Push **SCAN** to start the scan.
 - “**SCAN**” appears while scanning.
- ⑥ When the scan detects a signal, the scan either ignores it, pauses or the scan stops, depending on the resume setting and the squelch status.
- ⑦ To cancel the scan, push **SCAN**.

NOTE: If the same frequencies are programmed into both scan edge memory channels P1 and P2, programmed scan cannot start.

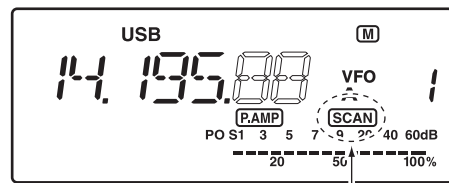
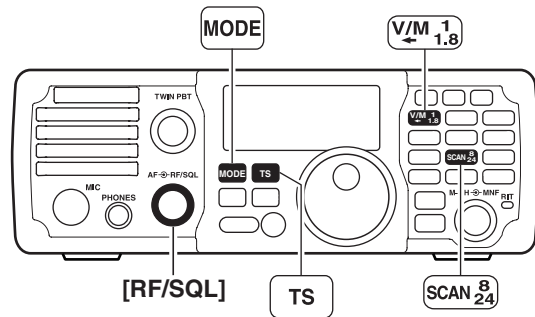

Appears

■ Scanning Memory channels (Memory mode)

A memory scan searches through memory channel 1 to 199 for signals. Blank (unprogrammed) memory channels are skipped.

- ① Push **V/M** to select the Memory mode.
- ② Close the squelch with the **[RF/SQL]** control.
- ③ Push **SCAN** to start the scan.
 - “**SCAN**” appears while scanning.
- ④ When the scan detects a signal, the scan stops or pauses depending on the resume setting.
- ⑤ To cancel the scan push **SCAN**.
 - Rotating **[DIAL]** during scan also cancels the scan.

NOTE: Two or more different memory channels must be programmed for a memory scan to start.

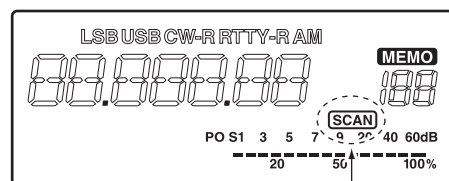
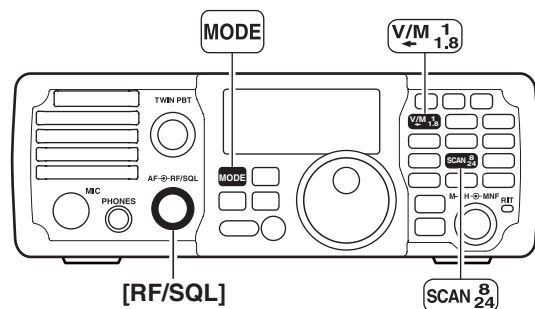

Appears

■ General

The Set mode is for programming infrequently changed values or functions.

The IC-7200 has two separate Set modes: the **Quick Set mode** and the **Set mode**.

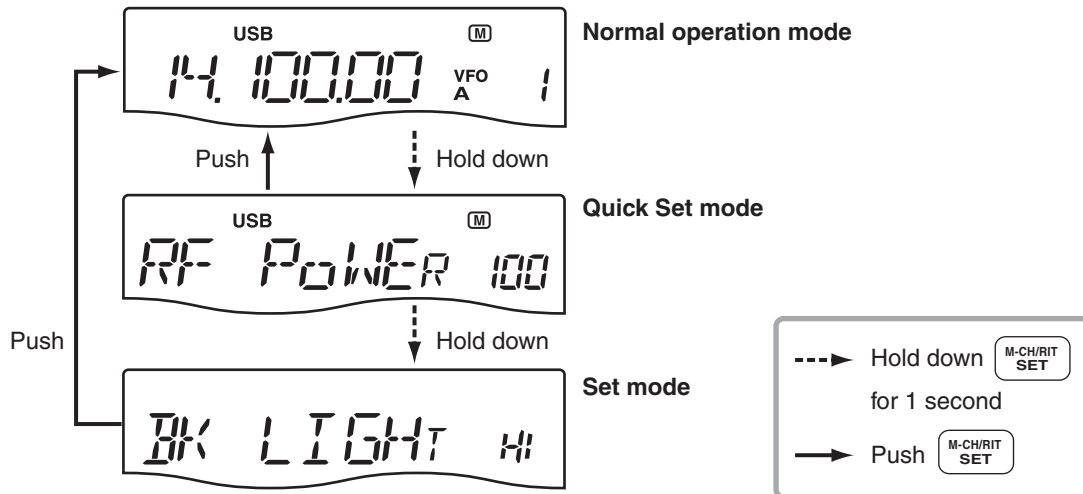

◇ Using the Quick Set mode

- ① Hold down **M-CH/RT SET** for 1 second to enter the Quick Set mode.
- ② Rotate **[M-CH]** to select the desired item.
- ③ Set the desired option or value using **[DIAL]**.
 - Hold down **M-CL** for 1 second to select the default option or value.
- ④ Repeat ② and ③ to set other items.
- ⑤ Push **M-CH/RT SET** to exit the Quick Set mode.

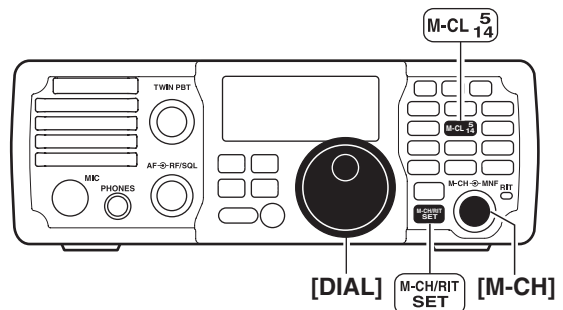

◇ Using the Set mode

- ① Hold down **M-CH/RT SET** for 1 second to enter the Quick Set mode.
- ② Hold down **M-CH/RT SET** for 1 second again to enter the Set mode.
- ③ Rotate **[M-CH]** to select the desired item.
- ④ Set the desired option or value using **[DIAL]**.
 - Hold down **M-CL** for 1 second to select the default option or value.
- ⑤ Repeat ③ and ④ to set other items.
- ⑥ Push **M-CH/RT SET** to exit the Set mode.

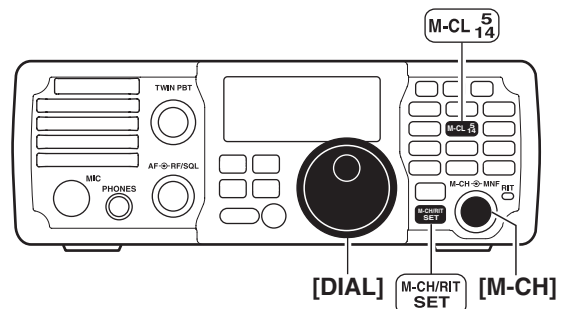

■ Items in the Quick Set mode

Refer to pages 28, 29 for details.

Item	Range or Value (Default is shown in bold)	Operating Mode			
		SSB	CW	RTTY	AM
RF POWER	L (Low) and 1 to 100% , in 1 % steps	✓	✓	✓	✓
MIC GAIN	0 ~ 50 ~ 100%, in 1 % steps	✓	-	-	✓
DATA MODE	on or oF	✓	-	-	✓
KEY SPEED	6 ~ 20 ~ 60* wpm (words per minute). * 39, 43, 45, 47, 49, 51, 53, 55, 56, 58 and 59 cannot be selected.	-	✓	-	-
CW TONE PITCH	300 ~ 600 ~ 900 Hz, in 10 Hz steps	-	✓	-	-
SIDE TONE LEVEL	0% ~ 30 ~ 100%, in 1% steps	-	✓	-	-
SIDE TONE LIMIT	on or oF	-	✓	-	-
TWIN PEAK FILTER	on or oF NOTE: The RTTY mark frequency (2125 Hz) and shift width (170 Hz) are automatically set when the twin peak filter is ON.	-	-	✓	-
RTTY MARK TONE	1275, 1615 or 2125 Hz	-	-	✓	-
RTTY SHIFT	170 , 200, 425 or 850 Hz	-	-	✓	-
RTTY KEY POLARITY	n (Normal) or r (Reverse)	-	-	✓	-

■ Items in the Set mode

Item	Range or Value (Default is shown in bold)	Descriptions	Refer
LCD BACKLIGHT	HI (High), Lo (Low) or oF (Off)	Sets the brightness of the LCD.	p. 29
BEEP	on or oF	Turns the Confirmation beep ON or OFF.	
BAND EDGE BEEP	on or oF	Turns the Band edge beep ON or OFF.	
BEEP LEVEL	0 ~ 50 ~ 100%, in 1% steps	Sets the maximum volume level for the confirmation beep and band edge beep tones.	
BEEP LEVEL LIMIT	on or oF	Turns the beep tones output level limiting ON or OFF.	
RF/SQL CONTROL	rS (RF+SQL), Sq (SQL) or At (AUTO)	Selects the RF/SQL Control function.	
METER PEAK HOLD	on or oF	Turns the meter peak hold function ON or OFF.	p. 30
QUICK SPLIT	on or oF	Turns the Quick split function ON or OFF.	
SPLIT LOCK	on or oF	Turns the Split Lock function ON or OFF.	
XFC	on or oF	Turns the XFC (transmit frequency check) function ON or OFF.	
AUTO TUNE	on or oF	Turns the Auto tune function ON or OFF.	
PTT TUNE	on or oF	Turns the PTT Tune function ON or OFF.	
MODULATION INPUT (DATA OFF)	M (MIC), A (ACC), MA (MIC/ACC) or U (USB)	Selects the input connector for modulation signals on the SSB/AM mode. (Data mode is OFF.)	p. 31
MODULATION INPUT (DATA ON)	M (MIC), A (ACC), MA (MIC/ACC) or U (USB)	Selects the input connector for modulation signals on the SSB data/AM data mode. (Data mode is ON.)	
USB LEVEL	0 ~ 50 ~ 100%, in 1% steps	Sets the input modulation level of the USB jack.	

6 SET MODE

■ Items in the Set mode (Continued)

Item	Range or Value (Default is shown in bold)	Descriptions	Refer
SPEECH LEVEL	0 ~ 50 ~ 100%, in 1% steps	Sets the volume level of the speech function.	p. 31
SPEECH LANGUAGE	En (English) or JP (Japanese)	Selects English or Japanese as the language of the speech function.	
SPEECH SPEED	HI (faster) or Lo (slower)	Selects the speech speed.	
SPEECH S-LEVEL	on or oF	Turns the S-Level Speech announcement function ON or OFF.	
SPEECH [MODE] KEY	on or oF	Turns the Speech [MODE] key function ON or OFF.	
SCAN SPEED	HI (faster) or Lo (slower)	Sets the rate at which channels or frequencies are scanned during scanning.	
SCAN RESUME	on or oF	Turns the Scan resume function ON or OFF.	p. 32
MAIN DIAL AUTO TS	HI (Fastest), Lo (Faster) or oF (OFF)	Set the Main Dial automatic tuning speed when rotating [DIAL] rapidly.	
DIAL ¼	on or oF	Turn the ¼-speed tuning function ON or OFF in the CW, RTTY and SSB data modes.	
MIC UP/DOWN SPEED	HI (faster) or Lo (slower)	Sets the rate at which frequencies are scanned when the microphone [UP]/[DN] keys are held down.	
SSB/CW SYNCHRONOUS TUNING	on or oF	Turns the displayed frequency shift function ON or OFF.	
CW NORMAL SIDE	L (LSB) or U (USB)	Select the carrier point of CW mode between LSB and USB.	
BREAK-IN	oF (OFF), SE (Semi) or FL (Full)	Selects the CW break-in type.	p. 33
BREAK-IN DELAY	0.2 ~ 7.5 ~ 13.0 (dots), in 0.1 dots steps	Sets the break-in delay time for CW semi break-in operation.	
DOT/DASH RATIO	1:1:2.8 ~ 1:1:3.0 ~ 1:1:4.5, in 0.1 unit steps	Sets the internal electronic keyer dot/dash ratio.	
PADDLE POLARITY	n (Normal) or r (Reverse)	Sets the paddle polarity.	
KEYER TYPE	EL (ELEC-KEY), bG (BUG-KEY) or St (Straight key)	Selects the keyer type for the [KEY] connector on the rear panel.	
MIC UP/DOWN KEYER	on or oF	Sets the activation of the microphone [UP]/[DN] switches as a paddle.	
MODE SELECT (SSB)	on or oF	Turns the SSB (LSB/USB) mode selection ON or OFF.	p. 34
MODE SELECT (CW)	on or oF	Turns the CW/CW-R mode selection ON or OFF.	
MODE SELECT (RTTY)	on or oF	Turns the RTTY/RTTY-R mode selection ON or OFF.	
MODE SELECT (AM)	on or oF	Turns the AM mode selection ON or OFF.	
CI-V BAUD RATE	300, 1200, 4800, 9600, 19200 bps or Auto	Sets the CI-V data transfer rate.	
CI-V ADDRESS	01h ~ 76h ~ 7Fh	Sets the CI-V address.	
CI-V TRANSCEIVE	on or oF	Turn the CI-V "Transceive" function ON or OFF.	p. 34
REFERENCE FREQUENCY ADJUSTMENT	0 ~ 100%, in 1% steps (Default setting is different for each transceiver.)	Adjusts the internal reference signal frequency.	

■ Quick Set mode

RF power	(all modes)	<i>RF POWER 100</i>	100% (default)
Adjusts the RF output power to between L (Low), and 1% to 100%, in 1% steps.			
Mic gain	(SSB/AM modes)	<i>MIC GAIN 50</i>	50% (default)
Adjusts microphone gain to between 0% and 100%, in 1% steps.			
Data mode	(SSB/AM modes)	<i>DATA oF</i>	OFF (default)
Turn the data mode ON or OFF. When the data mode is turned ON, the audio input from the [ACC] connector, the [MIC] connector, or the [USB] connector is, used, depending on the selection in the Set Mode. (p. 31). The speech compressor function is turned OFF. on : Data mode operation is enabled. (“ D ” appears.) oF : Data mode operation is disabled. (“ D ” disappears.)			
Key speed	(CW mode)	<i>KEY SPD 20</i>	20 wpm (default)
Adjusts the CW key speed to between 6 and 60* wpm (words per minute). * 39, 43, 45, 47, 49, 51, 53, 55, 56, 58 and 59 cannot be selected.			
CW tone pitch	(CW mode)	<i>CW PITCH 60</i>	600 Hz (default)
Adjusts the CW receive tone pitch to between 300 and 900 Hz, in 10 Hz steps.			
Side tone level	(CW mode)	<i>SIDE LVL 30</i>	30% (default)
Adjusts the CW side tone level to between 0% and 100%, in 1% steps.			
Side tone level limit	(CW mode)	<i>SIDE LMT on</i>	ON (default)
Turn the CW side tones output level limiting capability ON or OFF. When this item is set to ON, the CW side tone is linked to the [AF] control until rotation of the [AF] control reaches to the specified level—further rotation will not increase the volume of the CW side tones. on : The CW side tone level is limited with the [AF] control. oF : The CW side tone level is linked to the [AF] control.			
Twin peak filter	(RTTY mode)	<i>TPF oF</i>	OFF (default)
Turn the twin peak filter ON or OFF. on : The Twin peak filter is ON. oF : The Twin peak filter is OFF. /// NOTE: The RTTY mark frequency (2125 Hz) and shift width (170 Hz) are automatically set when the twin peak filter is ON.			
RTTY mark tone	(RTTY mode)	<i>TON 2125</i>	2125 Hz (default)
Sets the RTTY mark frequency to 1275, 1615 or 2125 Hz. /// NOTE: 2125 Hz is automatically set when the twin peak filter is ON.			

6 SET MODE

■ Quick Set mode (Continued)

RTTY shift width	(RTTY mode)	<i>SFT 170</i>	170 Hz (default)
Sets the RTTY shift width to 170, 200, 425 or 850 Hz.			
⚡ NOTE: 170 Hz is automatically set when the twin peak filter is ON.			

RTTY key polarity	(RTTY mode)	<i>RTTY KEY n</i>	NORMAL (default)
Sets the RTTY keying polarity to normal or reverse. When reverse polarity is selected, Mark and Space are reversed.			
n (normal) : Key open/close = Mark/Space			
r (reverse) : Key open/close = Space/Mark			

■ Set mode

LCD Backlight		<i>BK LIGHT H</i>	High (default)
Set the brightness of the LCD to HI (High), Lo (Low) or oF (Off).			

Beep		<i>BEEP on</i>	ON (default)
A beep sounds each time a key is pushed. This function can be turned OFF for silent operation.			
on : The Confirmation beep is ON. ; oF : The Confirmation beep is OFF.			
The volume level can be set in “Beep Level,” as described below.			

Band Edge Beep		<i>BAND BEP on</i>	ON (default)
A beep sounds when an operating frequency enters or exits an amateur band. This function is independent from the “Beep” setting described above.			
on : The Band edge beep is ON. ; oF : The Band edge beep is OFF.			
The volume level can be set in “Beep Level,” as described below.			

Beep Level		<i>BEEP LVL 50</i>	50% (default)
Set the maximum volume level for the confirmation beep and band edge beep tones to between 0% and 100%, in 1% steps.			
When beep tones are set to OFF, this setting has no effect.			

Beep Level Limit		<i>BEEP LMT on</i>	ON (default)
Turn the beep tones output level limiting ON or OFF for the confirmation and band edge beep tones.			
When this item is set to ON, the beep tones are linked to the [AF] control until rotation of the [AF] control reaches to the specified level—further rotation will not increase the volume of the beep tones.			
on : The Beep level is limited with the [AF] control. ; oF : The Beep level is linked to the [AF] control.			

RF/SQL Control		<i>RF / SQL rS</i>	RF + SQL (default)
Set as the RF/squelch control, the squelch control only (RF gain is fixed at maximum) or Auto (RF gain control in SSB, CW and RTTY; squelch control in AM).			
See pages 4, 31 for details.			
rS (RF+SQL) : The [RF/SQL] control is set as the RF/squelch control.			
Sq (SQL) : The [RF/SQL] control is set as the squelch control.			
At (AUTO) : The [RF/SQL] control is set as the RF gain control in SSB, CW and RTTY; squelch control in AM.			

Meter Peak Hold	<i>P-HOLD</i> <input type="checkbox"/>	ON (default)
<p>Turn the meter peak hold function ON or OFF.</p> <p>on : The highest activated segment of the meter remains visible for 0.5 seconds. oF : The meter functions normally.</p>		

Quick Split	<i>Q-SPLIT</i> <input type="checkbox"/>	ON (default)
<p>Turn the quick split function ON or OFF.</p> <p>When this item is set to ON, hold down [SPLIT] for 1 second to set the undisplayed VFO frequency and operating mode are set the same as the displayed VFO frequency and operating mode.</p> <p>on : The quick split function is ON. ; oF : The quick split function is OFF.</p>		

Split Lock	<i>SPLIT LK</i> <input type="checkbox"/>	OFF (default)
<p>Turn the Split Lock function ON or OFF.</p> <p>When this item is set to ON, the transmit frequency can be adjusted by rotating [DIAL] while holding down [RIT]*, even if the lock function is turned ON.</p> <p>* The transmit frequency check function ("XFC"; as shown below) must be turned ON first. See the PDF type Advanced Instructions for split frequency operation details.</p> <p>NOTE: When the split lock function is ON, the transmit frequency cannot be adjusted by rotating [DIAL] while holding down [PTT] even if the lock function is not turned ON.</p> <p>on : The split lock function is ON. ; oF : The split lock function is OFF.</p>		

XFC	<i>XFC</i> <input type="checkbox"/>	OFF (default)
<p>Turn the XFC (transmit frequency check) function ON or OFF.</p> <p>on : The transmit frequency can be monitored while holding down [RIT].</p> <p>oF : The transmit frequency check function is OFF.</p> <p>NOTE: When the XFC function is ON, the RIT calculation function is disabled.</p>		

Auto Tune	<i>AT-TUNE</i> <input type="checkbox"/>	OFF (default)
<p>Turns the Auto tune function ON or OFF. The AT-180 ANTENNA TUNER has an automatic start capability which starts tuning if the SWR is higher than 1.5:1.</p> <p>on : The automatic tune starts even when the tuner is turned OFF during HF band operation. oF : The tuner remains OFF even when the SWR is poor (1.5:1).</p>		

PTT Tune	<i>PTT TUNE</i> <input type="checkbox"/>	OFF (default)
<p>Turns the PTT Tune function ON or OFF. Tuning of the antenna tuner can be automatically started at the moment [PTT] is pushed after the operating frequency is changed more than 1% from the last-tuned frequency. When an AT-180 ANTENNA TUNER is connected, the tuner function must be turned ON first.</p> <p>on : Tuning starts when [PTT] is pushed on a new frequency. ; oF : Tuning starts only when [TUNER] is pushed.</p>		

Modulation input (Data OFF)	<i>MOD</i> <input type="checkbox"/>	MIC/ACC (default)
<p>Selects the desired connector(s) for modulation input when SSB data/AM data mode is not in use.</p> <p>M (MIC) : Use the signals from [MIC]. A (ACC) : Use the signals from [ACC] (pin 11). M A (MIC/ACC) : Use the signals from [MIC] and [ACC] (pin 11). U (USB) : Use the signals from [USB].</p>		

6 SET MODE

■ Set mode (Continued)

Modulation input (Data ON)	<i>D--MOD</i>	<i>A</i>	ACC (default)
Selects the desired connector(s) for modulation input when SSB data/AM data mode is in use.			
M (MIC) : Use the signals from [MIC].			
A (ACC) : Use the signals from [ACC] (pin11).			
M A (MIC/ACC) : Use the signals from [MIC] and [ACC] (pin11).			
U (USB) : Use the signals from [USB].			
USB Level	<i>USB LVL</i>	<i>50</i>	50% (default)
Sets the input modulation level of the USB jack to between 0% to 100% in 1% steps.			
Speech Level	<i>SP LVL</i>	<i>50</i>	50% (default)
Adjusts the volume level of the speech function to between 0% and 100%, in 1% steps.			
Speech Language	<i>SP LANG</i>	<i>En</i>	English (default)
Selects English or Japanese as the language of the speech function.			
En : English ; JP : Japanese			
Speech Speed	<i>SP SPD</i>	<i>H</i>	High (default)
Selects HI (faster) or Lo (slower) as the speech speed.			
HI (High) : Faster announcement ; Lo (Low) : Slower announcement			
Speech S-level	<i>SP S-LVL</i>	<i>on</i>	ON (default)
The received signal level, frequency and mode can be announced by the voice synthesizer. The signal level announcement can be turned OFF if desired.			
When "oF" is selected, the signal level is not announced.			
on : The Signal level is announced. ; oF : The signal level is not announced.			
Speech [MODE] Key	<i>SP MODE</i>	<i>oF</i>	OFF (default)
Selects whether the operating mode is announced with the speech synthesizer when [MODE] is pushed.			
When "on" is selected, the operating mode is announced when you push [MODE] .			
on : The operating mode is announced when pushing [MODE] .			
oF : The operating mode is not announced when pushing [MODE] .			
Scan Speed	<i>SCAN SPD</i>	<i>H</i>	High (default)
Sets the speed at which channels or frequencies are scanned during scanning.			
High and low can be selected.			
HI : Fast scan ; Lo : Slow scan			
Scan Resume	<i>SCAN RES</i>	<i>on</i>	ON (default)
This item turns the scan resume function ON or OFF.			
on : Scan resumes 10 seconds after stopping on a signal (or 2 seconds after a signal disappears).			
oF : Scan does not resume after stopping on a signal.			

Main Dial Auto TS	<i>AUTO TS HI</i>	High (default)
<p>Sets the auto tuning step function so that when rotating [DIAL] rapidly, the tuning step rate adapts as selected. Set either HI (Fastest), Lo (Faster) tuning speed, or to oF (OFF).</p> <p>HI : Approximately 5 times faster when the tuning step is set to 1 kHz or smaller steps; approximately 2 times faster when the tuning step is set to 5 kHz or larger steps.</p> <p>Lo : Approximately 2 times faster.</p> <p>oF : Auto tuning step is turned OFF.</p>		

Dial ¼	<i>DIAL 1/4 oF</i>	OFF (default)
<p>Turn the ¼-speed tuning function ON or OFF in the CW, RTTY and SSB data modes.</p> <p>on : The ¼-speed tuning function is ON for critical tuning. While operating in the CW/RTTY/SSB data modes, the dial sensitivity is reduced to ¼ of normal.</p> <p>oF : The ¼-speed tuning function is OFF.</p> <p>⚡ NOTE: This function is only usable when the programmable tuning step is OFF (p. 14).</p>		

Mic Up/Down Speed	<i>U/D SPD HI</i>	High (default)
<p>Sets the rate at which frequencies are scanned when the microphone [UP]/[DN] keys are used.</p> <p>HI : High speed (50 tuning steps/second) ; Lo : Low speed (25 tuning steps/second)</p>		

SSB/CW Synchronous Tuning	<i>SYNC TUN oF</i>	OFF (default)
<p>Turns the displayed frequency shift function ON or OFF.</p> <p>When this function is set to ON, the received signal will remain the same even when the operating mode is changed between SSB and CW.</p> <p>The amount of frequency shift will change according to the CW tone pitch setting.</p> <p>on : The displayed frequency shifts when the operating mode is changed between SSB and CW.</p> <p>oF : The displayed frequency does not shift.</p>		

CW Normal Side	<i>CW NORM L</i>	LSB (default)
<p>Select the carrier point of CW mode between LSB and USB.</p> <p>L (LSB) : LSB is the normal mode. ; U (USB) : USB is the normal mode.</p>		

Break-In	<i>BK-IN oF</i>	OFF (default)
<p>Selects the CW break-in type.</p> <p>Full break-in (QSK) activates the receiver between transmitted dots and dashes. This is useful when operating contests, when “fast responses” are common.</p> <p>Semi break-in keeps the receiver quiet between dots and dashes, and automatically returns to receive after a pre-set time after you stop keying.</p> <p>When break-in is turned off, the key or paddle can generate side tones, selectable in the Quick Set mode, but will not transmit.</p> <p>oF : No break-in operation ; SE (Semi) : Semi break-in operation ; FL (Full) : Full break-in operation</p>		

Break-In Delay	<i>BK-DELAY 7.5</i>	7.5 dots (default)
<p>Adjusts break-in delay time for CW semi break-in operation between 0.2 and 13.0 (dots), in 0.1 (dots) steps.</p>		

6 SET MODE

■ Set mode (Continued)

Dot/Dash Ratio	<i>KEY RAT</i> 30	1:1:3.0 (default)
Sets the internal electronic keyer dot/dash ratio between 1:1:2.8 and 1:1:4.5, in 0.1 unit steps.		
<p>Keying weight example: Morse code "K"</p> <p>Weight setting: 1:1:3 (default)</p> <p>Weight setting: Adjusted</p> <p>Adjustable range SPACE (Fixed*)</p> <p>*SPACE and DOT length can be adjusted only with the "Key speed" in the Quick Set mode.</p>		

Paddle Polarity	<i>KEY Pol</i> n	Normal (default)
Sets the paddle polarity.		
n (Normal) : Normal polarity ; r (Reverse) : Reverse polarity		

Keyer Type	<i>KEY TYPE</i> EL	ELEC-KEY (default)
Selects the keyer type for the [KEY] connector on the rear panel.		
EL : The internal electronic keyer is selected.		
bG : The internal electronic keyer is set for a BUG key.		
St : The internal electronic keyer is turned OFF, and a straight key or external electronic keyer can be used.		

Mic Up/Down Keyer	<i>U/D KEY</i> oF	OFF (default)
Sets the microphone [UP]/[DN] switches to be used as a paddle.		
on : [UP]/[DN] switches can be used as a paddle for CW mode operation.		
oF : [UP]/[DN] switches cannot be used as a paddle for CW mode operation.		
<p>/// NOTE: When "ON" is selected, the frequency and memory channel cannot be changed using the [UP]/[DN] switches.</p>		
See page 33 for the CW paddle connection to the MIC connector.		

Mode Select (SSB)	<i>MODE SSB</i> on	ON (default)
Disables the selection of the SSB (LSB/USB) modes, to simplify operation.		
For example if you are operating mobile and plan on using only the AM mode, set all other modes (SSB, CW, RTTY) to OFF, thereby making selection of AM quick and easy.		
on : The SSB modes are selectable. ; oF : The SSB modes are disabled.		

Mode Select (CW)	<i>MODE CW</i> on	ON (default)
Disables the selection of the CW/CW-R modes, to simplify operation.		
on : The CW modes are selectable. ; oF : The CW modes are disabled.		

Mode Select (RTTY) MODE RTTY on ON (default)

Disables the selection of the RTTY/RTTY-R modes, to simplify operation.
 on : The RTTY modes are selectable. ; oF : The RTTY modes are disabled.

Mode Select (AM) MODE AM on ON (default)

Disables the selection of the AM mode, to simplify operation.
 on : AM modes are selectable. ; oF : AM modes are disabled.

CI-V Baud Rate CIV BAUD At Auto (default)

Sets the CI-V data transfer rate to 300, 1200, 4800, 9600, 19200 bps or Auto.
 When Auto is selected, the baud rate is automatically set according to the controller or remote controller.

CI-V Address CIV ADDR 76 76h (default)

To distinguish equipment, each CI-V transceiver has its own Icom standard address in hexadecimal code.
 The IC-7200's address is 76h.
 When two or more IC-7200s are connected to an optional CT-17 CI-V LEVEL CONVERTER, rotate [DIAL] to select a different address for each IC-7200 in the range 01h to 7Fh.
 76 : Set address to 76h

CI-V Transceive CIV TRN on ON (default)

“Transceive” operation is possible with the IC-7200 connected to other Icom HF transceivers or receivers through a CT-17.
 When “ON” is selected, changing the frequency, operating mode, and so on, on the IC-7200, automatically changes those of the other transceivers or receivers, and vice versa.
 on : Transceive is ON. ; oF : Transceive is OFF.

Reference Frequency Adjustment REF ADJ 50

Adjusts the internal reference signal frequency between 0% and 100%, in 1% steps, during frequency calibration.
 // NOTE: Default setting is different for each transceiver.

◇ **Connect a paddle to the [MIC] connector**

Connect a CW paddle as shown to the right to operate an electronic keyer from the [MIC] connector.

- Be sure to set the “Paddle Polarity,” “Keyer Type” and “Mic Up/Down Keyer” in the Set mode. (p. 33)
- Connect a straight key to the “DOT” side.
- Push both of “DOT” and “DASH” to turn ON the squeeze operation.

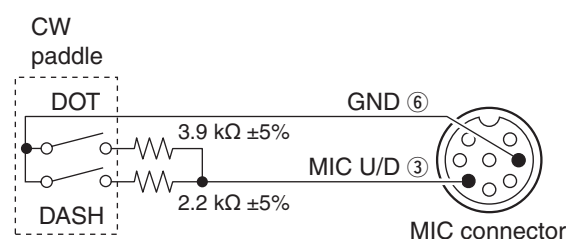

■ Fuse replacement

If a fuse blows, or the transceiver stops functioning, try to find the source of the problem, first repair the problem. Then replace the damaged fuse with a new, adequately rated fuse.

CAUTION: Disconnect the DC power cable from the transceiver when changing a fuse.

The IC-7200 has two fuses (DC power cable fuses) installed for transceiver protection.

- DC power cable fuses ATC 30 A
- Circuitry fuse ATC 5 A

◇ Circuitry fuse replacement

13.8 V DC from the DC power cable is applied to all units in the IC-7200, except the power amplifier, through the circuitry fuse. This fuse is installed in the PA unit.

- ① Remove the 11 screws, then remove the bottom cover and the PA shielding plate.

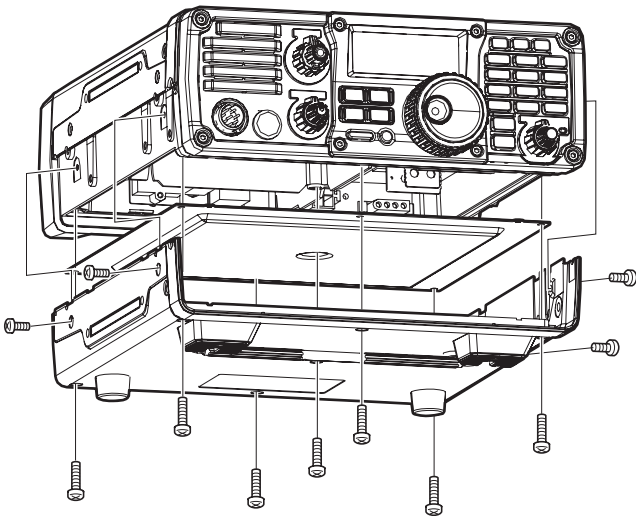

◇ DC power cable fuse replacement

Refer to the illustration to replace the DC power cable fuses.

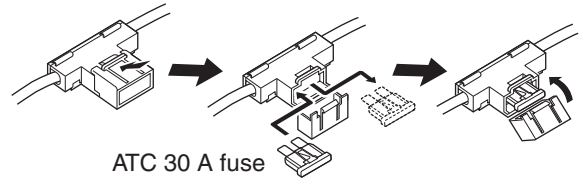

- ② Replace the circuitry fuse as shown.

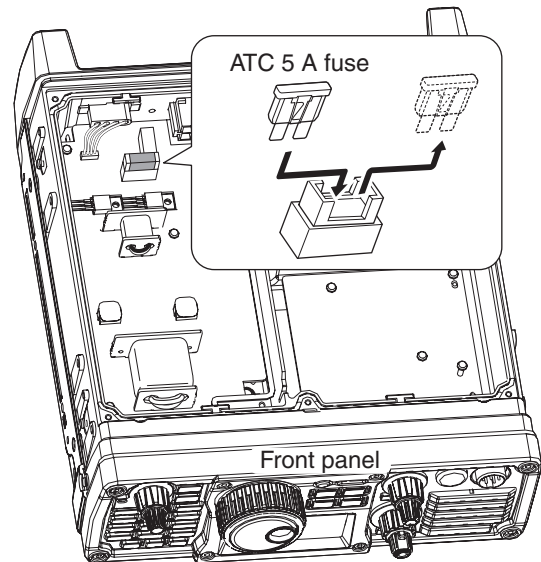

- ③ Replace the PA shielding plate, bottom cover and screws to their original position.

Be sure the gasket is seated correctly, and does not protrude from the PA shielding plate.

■ Memory backup

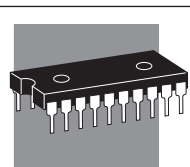

All of the CPU's memory is backed up in an EEPROM (Electrically-Erasable Programmable Read-Only Memory). All data you set, such as VFO, memory, Set mode contents, and so on, are stored in this EEPROM. There is no internal battery.

■ Cleaning







If the transceiver becomes dusty or dirty, wipe it clean with a dry, soft cloth.



DO NOT use harsh solvents such as benzene or alcohol when cleaning, as they will damage the transceiver surfaces.

■ Troubleshooting

The following chart is designed to help you correct problems which are not equipment malfunctions. If you are unable to locate the cause of a problem or solve it through the use of this chart, contact your nearest Icom Dealer or Service Center.

	PROBLEM	POSSIBLE CAUSE	SOLUTION	REF.
POWER SUPPLY	Power does not come on when  is pushed.	<ul style="list-style-type: none"> • DC power cable is improperly connected. • Fuse is blown. • Battery is exhausted if you are using a 12 V battery as the power source. 	<ul style="list-style-type: none"> • Reconnect the power cable correctly. • Check for the cause, repair it, then replace the fuse with a similar rate one. (Fuse is installed in the DC power cable) • Check the battery voltage. 	<p>p. 10</p> <p>p. 35</p> <p>—</p>
	RECEIVE	No sound comes from the speaker.	<ul style="list-style-type: none"> • Volume level is set too low. • The squelch level is closed. • The transceiver is in the transmit mode. • An external speaker or headphones are connected. 	<ul style="list-style-type: none"> • Rotate [AF] clockwise to obtain a suitable listening level. • Rotate [RF/SQL] to 12 o'clock position to open the squelch. • Release [PTT] on the microphone or check the SEND line of an external unit, if connected. • Check the external speaker or headphones plug connection.
Sensitivity is too low, and only strong signals are audible.		<ul style="list-style-type: none"> • The antenna is not properly connected. • The antenna feed line is cut or shorted. • The antenna is not properly tuned. • The attenuator function is ON. • The antenna for another band is selected. 	<ul style="list-style-type: none"> • Reconnect the antenna. • Check the feed line and correct any improper conditions. • Push  to manually tune the antenna. • Push  to turn OFF the function. • Select an antenna suitable for the operating frequency. 	<p>—</p> <p>—</p> <p>p. 20</p> <p>p. 4</p> <p>—</p>
Receive audio is distorted.		<ul style="list-style-type: none"> • The operating mode is not selected correctly. 	<ul style="list-style-type: none"> • Select a suitable operating mode. 	p. 16
Receive signal is distorted by strong signals.		<ul style="list-style-type: none"> • The noise reduction is ON and the noise reduction level is too high. • The noise blanker function is ON. • The preamp is ON. 	<ul style="list-style-type: none"> • Set the noise reduction level for maximum readability. • Push  to turn OFF the function. • Push  to turn OFF the function. 	<p>p. 1</p> <p>p. 1</p> <p>p. 4</p>
The frequency shift of the RIT function cannot be added/subtracted.		<ul style="list-style-type: none"> • The XFC (transmit frequency check function) is turned ON. 	<ul style="list-style-type: none"> • Turn the XFC OFF in the Set mode. 	p. 30

■ Troubleshooting (Continued)

	PROBLEM	POSSIBLE CASE	SOLUTION	REF.
TRANSMIT	Transmitting is impossible.	• The operating frequency is not in a ham band.	• Set the frequency in a ham band.	p. 16
	Output power is too low.	• Power is set to a lower power than maximum.	• Set the output power in Quick Set mode.	p. 18
		• Microphone gain is set too low.	• Set microphone gain to a suitable level in Quick Set mode.	p. 19
		• The antenna is not connected properly. • The antenna feed line is cut or shorted. • The antenna is not properly tuned. • The antenna for another band is selected.	• Reconnect the antenna. • Check the feed line and correct any improper conditions. • Push TUNER to manually tune the antenna or test with dummy load. • Select an antenna suitable for the operating band.	— — p. 20 —
No contact possible with other stations.	• RIT function is ON. • Split function is ON.	• Push RIT to turn OFF the function. • Push SPLIT to turn OFF the function	p. 2 p. 2	
DISPLAY	Transmitted signals are distorted.	• Microphone gain is set too high.	• Set microphone gain to a suitable level in Quick Set mode.	p. 19
		• The compression level is set too high with the speech compressor ON.	• Set compression to a suitable level.	p. 2
SCAN	Displayed frequency does not change properly.	• The dial lock function is ON. • The internal CPU has malfunctioned.	• Hold down SPCH for 1 second to turn OFF the function. • Reset the CPU.	p. 18 Below
	Programmed scan does not stop.	• [RF/SQ] is assigned to RF gain control and squelch is open.	• Change the [RF/SQ] control assignment and set it to the proper threshold point.	p. 29
MEMORY	Programmed scan does not start.	• The same frequencies have been programmed in scan edge memory channels.	• Program different frequencies into scan edge memory channels.	p. 22
	Memory scan does not start.	• Two or more memory channels have not been programmed.	• Program two or more memory channels.	p. 22
	The memory channels cannot be selected with rotating the [M-CH] control.	• The [M-CH] control acts as the RIT control mode.	• Push M-CH/RIT SET to set the [M-CH] control to memory channel control. (RIT control indicator goes out).	p. 21

■ Resetting the CPU

- ① Make sure the transceiver power is OFF.
- ② While holding down **F-INP ENT BAND** and **M-CL**, push **POWER** to turn ON power.
 - The internal CPU is reset, and all memory data are cleared.
 - The transceiver displays its initial VFO frequencies when resetting is complete.
- ③ All Quick Set mode/Set mode settings are returned to their default values. (pp. 26, 27)

Resetting **CLEARs** all programmed contents in memory channels and returns to their default values in Quick Set mode and Set mode.

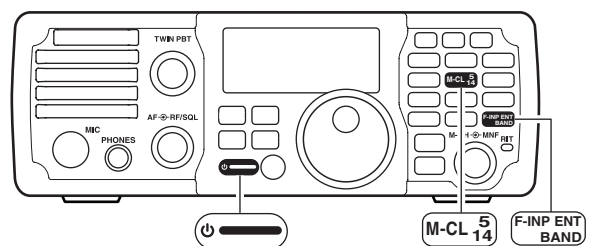

■ Installing the MB-116 HANDLES

The optional MB-116 HANDLES are convenient when moving the transceiver and can protect the face and radio knobs during transport.

- ➔ Attach the MB-116 to the both sides of the transceiver with the supplied M4 × 9 screws.

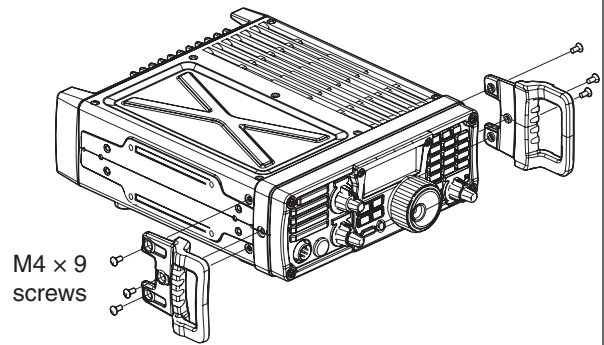

■ Installing the MB-117 CARRYING HANDLE

The optional MB-117 CARRYING HANDLE is convenient when carrying the transceiver for DX-peditions, field operation, and so on.

- ① Attach the rubber feet to the [FOOT] holes on the right side of the transceiver with the supplied M4 × 12 screws.
- ② Attach the MB-117 to the [CARRYING HANDLE] holes on the left side of the transceiver with the supplied M3 × 10 screws.

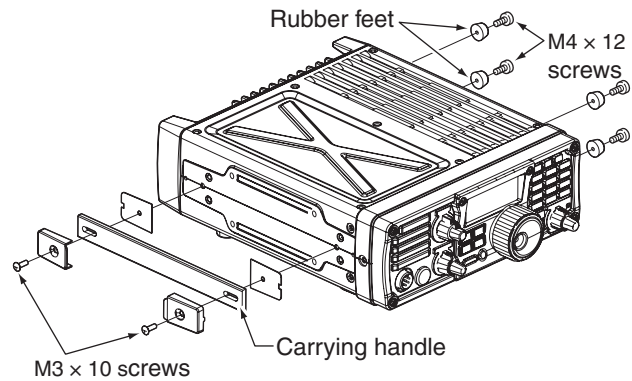

■ Installing the MB-118 MOBILE MOUNTING BRACKET

The universal mounting bracket allows overhead mounting.

- Mount the transceiver securely with the 4 supplied screws (5 × 20) to a thick surface which can support more than 5.5 kg (12.1 lb).

CAUTION: Non-supplied bolts (longer than 8 mm) may damage the internal units.
NEVER install the MB-118 with non-supplied screws and bolts.

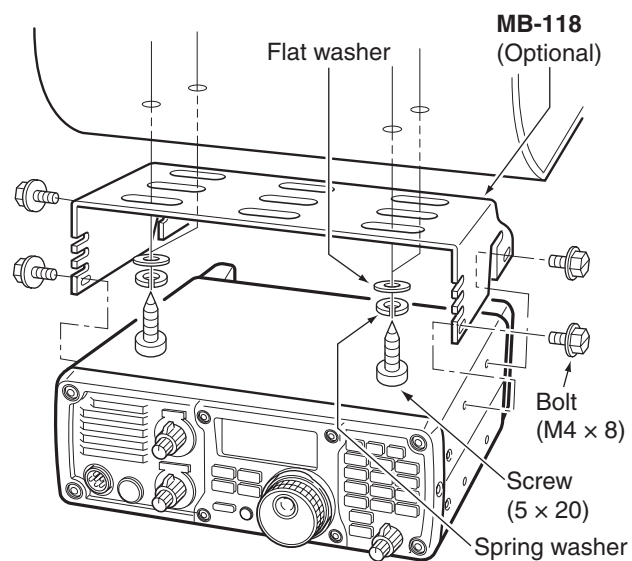

■ General

- Frequency coverage :
 - Receive
30 kHz–60.000000 MHz*1*2
 - Transmit
1.800–1.999999 MHz*2, 3.500–3.999999 MHz*2
5.33200*3, 5.34800*3, 5.35850*3,
5.37300*3, 5.40500*3,
7.000–7.300 MHz*2, 10.100–10.150 MHz,
14.000–14.350 MHz, 18.068–18.168 MHz,
21.000–21.450 MHz, 24.890–24.990 MHz,
28.000–29.700 MHz, 50.000–54.000 MHz*2,
*1Some frequency bands are not guaranteed.
*2Depending on version. *3USA version only.
- Mode : SSB, CW, RTTY, AM
- Number of memory CH : 201 (split memory: 199; scan edges: 2) channels
- Antenna connector : SO-239
- Antenna impedance : 50 Ω (unbalanced)
- Usable temperature : –10°C to +60°C (+14°F to +140°F) range
- Frequency stability : Less than ±0.5 ppm
- Power supply : 13.8 V DC±15% (negative ground) requirement
- Current drain : Transmit (at 100 W) 22 A
Receive squelched 1.3 A
max. audio 2.0 A
- Dimensions : 241(W) × 84(H) × 281(D) mm,
(projections not included) 9.5(W) × 3.3(H) × 11.1(D) in
- Weight (approximately) : 5.5 kg (12.1 lb)
- CI-V connector : 2-conductor 3.5 (d) mm (1/8")
- ACC connector : 13-pin

■ Transmitter

- Output power
 - SSB, CW, RTTY : 2–100 W
 - AM : 1–25 W* (*Carrier power)
- Modulation system
 - SSB : Digital PSN modulation
 - AM : Digital Low power modulation
- Spurious emissions
 - HF bands : Less than –50 dB
 - 50 MHz band : Less than –63 dB
- Carrier suppression : More than 50 dB
- Unwanted sideband : More than 50 dB
- Microphone : 8-pin connector (600 Ω) connector
- KEY connector : 3-conductor 6.3 (d) mm (1/4")

■ Receiver

- Receive system : Triple-conversion superheterodyne
- Intermediate frequencies
 - 1st : 64.455 MHz
 - 2nd : 455 kHz
 - 3rd : 15.625 kHz
- Sensitivity (10dB S/N, preamp: ON, Filter shape: sharp)
 - SSB, CW : Less than 0.16 μV
(1.8–29.7 MHz)
Less than 0.13 μV
(50 MHz band)
 - AM : Less than 13 μV
(0.5–1.799 MHz)
Less than 2 μV
(1.8–29.7 MHz)
Less than 1 μV
(50 MHz band)
- Squelch sensitivity (SSB, threshold, preamp ON) : Less than 5.6 μV
- Selectivity
 - SSB* (BW=2.4 kHz) : More than 2.4 kHz/–6 dB
Less than 3.6 kHz/–60 dB
 - CW* (BW=500 Hz) : More than 500 Hz/–6 dB
Less than 900 Hz/–60 dB
 - RTTY (BW=350 Hz) : More than 360 Hz/–6 dB
Less than 650 Hz/–60 dB
 - AM (BW=6 kHz) : More than 6.0 kHz/–6 dB
Less than 15.0 kHz/–60 dB
*IF filter shape is set to SHARP.
- Spurious and image rejection ratio : More than 70 dB
(except 1/2 IF through on 50 MHz band)
- Audio output power : More than 2.0 W at 10% distortion with an 8 Ω load (at 13.8 V DC)
- RIT variable range : ±9.999 kHz
- PHONES connector : 3-conductor 6.3 (d) mm (1/4")/8 Ω
- EXT SP connector : 2-conductor 3.5 (d) mm (1/8")/8 Ω

AT-180 HF/50 MHz AUTOMATIC ANTENNA TUNER



Fully automatic antenna tuner with preset memories for each 100 kHz. Unique "automatic tuner on" function is available. See the PDF type Advanced Instructions for AT-180 specifications.

AH-4 HF AUTOMATIC ANTENNA TUNER



Specially designed to tune a long wire antenna for portable or mobile HF/50 MHz operation. The "PTT tune" function provides simple operation.

- Input power rating: 150 W

AH-2b ANTENNA ELEMENT



A 2.5 m long antenna element for mobile operation with the AH-4.

- Frequency coverage 7–54 MHz band with the AH-4

PS-126 DC POWER SUPPLY



- Output voltage : 13.8 V DC
- Max. output current : 25 A

SM-30 DESKTOP MICROPHONE



Includes a low frequency cut function.

SM-50 DESKTOP MICROPHONE



Unidirectional, dynamic microphone for base station operation. Includes [UP]/[DOWN] switches, a low cut switch and mic gain control.

HM-36 HAND MICROPHONE



Hand microphone equipped with [UP]/[DOWN] switches.

CT-17 CI-V LEVEL CONVERTER UNIT



For remote transceiver control using a personal computer equipped with an RS-232C port. You can change frequencies, operating mode, memory channels, and so on with your computer.

SP-10 EXTERNAL SPEAKER



External speakers suitable for mobile operation.

SP-10: Compact-type; 4 Ω/5 W

SP-21 EXTERNAL SPEAKER



Designed for base station operation.

- Input impedance: 8 Ω
- Max. input power: 5 W

SP-34 EXTERNAL SPEAKER



4 audio filters; headphone jack; can connect to 2 transceivers.

- Input impedance: 8 Ω
- Max. input power: 5 W

MB-116 HANDLE



Convenient when moving the transceiver and provides front panel protection during transport.

10 OPTIONS

MB-117 CARRYING HANDLE



Convenient when carrying the transceiver.

MB-118 MOBILE MOUNTING BRACKET

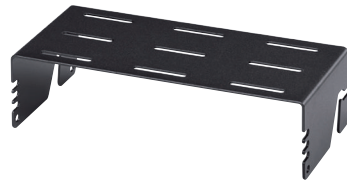

For mounting the transceiver in a vehicle.

OPC-598 ACC 13-PIN CABLE



Required when using the AT-180.
• 7 m (22 ft)

OPC-599 ADAPTOR CABLE



13-pin, ACC connector to 7-pin and 8-pin ACC connectors.

AH-710 FOLDED DIPOLE ANTENNA

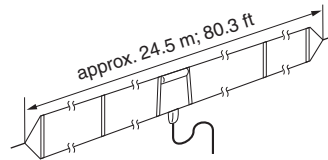

Covers all bands from 1.9 to 30 MHz. Has an SO-239 connector. 30 m (98.4 ft) coaxial cable with PL-259 connector is supplied.

RS-BA1 IP REMOTE CONTROL SOFTWARE

To remotely control radios using the RS-BA1, **BE SURE** that you comply with your local regulations.

IC-PW1/EURO HF/50 MHz ALL BAND 1 kW LINEAR AMPLIFIER



Full-duty 1 kW linear amplifier including an automatic antenna tuner. Has automatic tuning and band selection capability. Full break-in (QSK) operation is possible. The amplifier/power supply unit and the remote control unit are separated. An optional OPC-599 is required for connection.

Approved Icom optional equipment is designed for optimal performance when used with an Icom transceiver. Icom is not responsible for the destruction or damage to an Icom transceiver in the event the Icom transceiver is used with equipment that is not manufactured or approved by Icom.

FOR EUROPEAN VERSIONS

• Installation Notes

For amateur base station installations it is recommended that the forward clearance in front of the antenna array is calculated relative to the EIRP (Effective Isotropic Radiated Power). The clearance height below the antenna array can be determined in most cases from the RF power at the antenna input terminals.

As different exposure limits have been recommended for different frequencies, a relative table shows a guideline for installation considerations.

Below 30 MHz, the recommended limits are specified in terms of V/m or A/m fields as they are likely to fall within the near-field region. Similarly, the antennas may be physically short in terms of electrical length and that the installation will require some antenna matching device which can create local, high intensity magnetic fields. Analysis of such MF installations is best considered in association with published guidance notes such as the FCC OET Bulletin 65 Edition 97-01 and its annexes relative to amateur transmitter installations.

The EC recommended limits are almost identical to the FCC specified 'uncontrolled' limits and tables exist that show pre-calculated safe distances for different antenna types for different frequency bands. Further information can be found at <http://www.arrl.org/>.

• Typical amateur radio installation

Exposure distance assumes that the predominant radiation pattern is forward and that radiation vertically downwards is at unity gain (sidelobe suppression is equal to main lobe gain). This is true of almost every gain antenna today. Exposed persons are assumed to be beneath the antenna array and have a typical height of 1.8 m.

The figures assume the worst case emission of a constant carrier.

For the bands 10 MHz and higher the following power density limits have been recommended:

10–50 MHz 2 W/sq m

Vertical clearance by EIRP output

1 Watts	2.1 m
10 Watts	2.8 m
25 Watts	3.4 m
100 Watts	5 m
1000 Watts	12 m

Forward clearance by EIRP output

100 Watts	2 m
1000 Watts	6.5 m
10,000 Watts	20 m
100,000 Watts	65 m

In all cases any possible risk depends on the transmitter being activated for long periods. (actual recommendation limits are specified as an average during 6 minutes) Normally the transmitter is not active for long periods of time. Some radio licenses will require that a timer circuit automatically cuts off the transmitter after 1–2 minutes or so.

Similarly some modes of transmission, like SSB, CW and AM, have a lower 'average' output power and the assessed risk is even lower.

• Country codes List (ISO 3166-1)

	Country	Codes		Country	Codes
1	Austria	AT	18	Liechtenstein	LI
2	Belgium	BE	19	Lithuania	LT
3	Bulgaria	BG	20	Luxembourg	LU
4	Croatia	HR	21	Malta	MT
5	Czech Republic	CZ	22	Netherlands	NL
6	Cyprus	CY	23	Norway	NO
7	Denmark	DK	24	Poland	PL
8	Estonia	EE	25	Portugal	PT
9	Finland	FI	26	Romania	RO
10	France	FR	27	Slovakia	SK
11	Germany	DE	28	Slovenia	SI
12	Greece	GR	29	Spain	ES
13	Hungary	HU	30	Sweden	SE
14	Iceland	IS	31	Switzerland	CH
15	Ireland	IE	32	Turkey	TR
16	Italy	IT	33	United Kingdom	GB
17	Latvia	LV			

IC-7200 #03
(Europe)

< Intended Country of Use >
AT BE CY CZ DK EE
FI FR DE GR HU IE
IT LV LT LU MT NL
PL PT SK SI ES SE
GB IS LI NO CH BG
RO TR HR

IC-7200 #04
(France)

< Intended Country of Use >
AT BE CY CZ DK EE
FI FR DE GR HU IE
IT LV LT LU MT NL
PL PT SK SI ES SE
GB IS LI NO CH BG
RO TR HR

IC-7200 #05
(Italy)

< Intended Country of Use >
AT BE CY CZ DK EE
FI FR DE GR HU IE
IT LV LT LU MT NL
PL PT SK SI ES SE
GB IS LI NO CH BG
RO TR HR

IC-7200 #06
(Spain)

< Intended Country of Use >
AT BE CY CZ DK EE
FI FR DE GR HU IE
IT LV LT LU MT NL
PL PT SK SI ES SE
GB IS LI NO CH BG
RO TR HR

IC-7200 #07
(Europe-1)

< Intended Country of Use >
AT BE CY CZ DK EE
FI FR DE GR HU IE
IT LV LT LU MT NL
PL PT SK SI ES SE
GB IS LI NO CH BG
RO TR HR