



INSTRUCTION MANUAL

HF/50 MHz TRANSCEIVER **IC-7600**



FOREWORD

Thank you for making the IC-7600 your radio of choice. We hope you agree with Icom's philosophy of "technology first." Many hours of research and development went into the design of your IC-7600.

FEATURES

- *Ultimate receiver performance: third-order intercept (IP3) of +30 dBm (HF bands only)*
- *Built-in Baudot RTTY and PSK modulator/demodulator and direct PC keyboard connection capability for RTTY and PSK operations without a PC*
- *High resolution spectrum scope— center frequency and fixed frequency modes, plus mini-scope displays*
- *USB connectors on front and rear panels*
- *Large LCD with LED backlight*

IMPORTANT

READ THIS INSTRUCTION MANUAL CAREFULLY before attempting to operate the transceiver.

SAVE THIS INSTRUCTION MANUAL. This manual contains important safety and operating instructions for the IC-7600.

EXPLICIT DEFINITIONS

WORD	DEFINITION
⚠ DANGER	Personal death, serious injury or an explosion may occur.
⚠ WARNING	Personal injury, fire hazard or electric shock may occur.
CAUTION	Equipment damage may occur.
NOTE	If disregarded, inconvenience only. No risk of personal injury, fire or electric shock.

Spurious signals may be received near the following frequencies. These are made in the internal circuit and does not indicate a transceiver malfunction.
10.4923MHz, 24.576MHz

Icom, Icom Inc. and Icom logo are registered trademarks of Icom Incorporated (Japan) in Japan, the United States, the United Kingdom, Germany, France, Spain, Russia, Australia, New Zealand, and/or other countries.

Microsoft, Windows and Windows Vista are registered trademarks of Microsoft Corporation in the United States and/or other countries. All other products or brands are registered trademarks or trademarks of their respective holders.

SUPPLIED ACCESSORIES

The transceiver comes with the following accessories.

	Qty.
① Hand microphone	1
② DC power cable	1
③ CD (Instruction manual, Schematic diagram)	1
④ Spare fuse (5 A)	1
⑤ Spare fuse (30 A)	2
⑥ 6.35 (d) mm plug	1

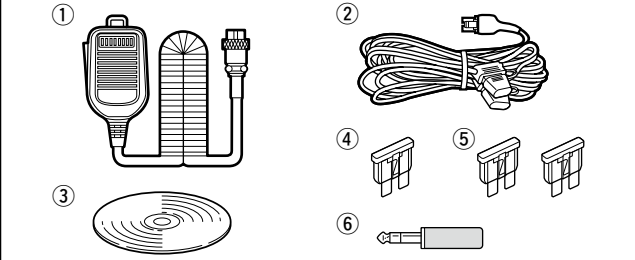

FCC INFORMATION

• FOR CLASS B UNINTENTIONAL RADIATORS:

This equipment has been tested and found to comply with the limits for a Class B digital device, pursuant to part 15 of the FCC Rules. These limits are designed to provide reasonable protection against harmful interference in a residential installation. This equipment generates, uses and can radiate radio frequency energy and, if not installed and used in accordance with the instructions, may cause harmful interference to radio communications. However, there is no guarantee that interference will not occur in a particular installation. If this equipment does cause harmful interference to radio or television reception, which can be determined by turning the equipment off and on, the user is encouraged to try to correct the interference by one or more of the following measures:

- Reorient or relocate the receiving antenna.
- Increase the separation between the equipment and receiver.
- Connect the equipment into an outlet on a circuit different from that to which the receiver is connected.
- Consult the dealer or an experienced radio/TV technician for help.

DISPOSAL



The crossed-out wheeled-bin symbol on your product, literature, or packaging reminds you that in the European Union, all electrical and electronic products, batteries, and accumulators (rechargeable batteries) must be taken to designated collection locations at the end of their working life. Do not dispose of these products as unsorted municipal waste. Dispose of them according to the laws in your area.

PRECAUTIONS

⚠ WARNING HIGH RF VOLTAGE! NEVER attach an antenna or internal antenna connector during transmission. This may result in an electrical shock or burn.

⚠ WARNING! NEVER operate the radio with a headset or other audio accessories at high volume levels. The continuous high volume operation may cause a ringing in your ears. If you experience the ringing, reduce the volume level or discontinue use.

⚠ WARNING! NEVER operate or touch the radio with wet hands. This may result in an electric shock or damage to the radio.

⚠ WARNING! NEVER let metal, wire or other objects protrude into the radio or into connectors on the rear panel. This may result in an electric shock.

⚠ WARNING! Immediately turn the radio power OFF and remove the power cable if it emits an abnormal odor, sound or smoke. Contact your Icom dealer or distributor for advice.

⚠ WARNING! NEVER put the radio in any unstable place (such as on a slanted surface or vibrated place). This may cause injury and/or damage to the radio.

⚠ WARNING! NEVER apply AC power to the [DC13.8V] connector on the radio rear panel. This could cause a fire or damage the radio.

⚠ WARNING! NEVER apply more than 16 V DC to the [DC13.8V] connector on the radio rear panel. This could cause a fire or damage the radio.

CAUTION: NEVER change the internal settings of the radio. This may reduce radio performance and/or damage to the radio.

In particular, incorrect settings for transmitter circuits, such as output power, idling current, etc., might damage the expensive final devices.

The radio warranty does not cover any problems caused by unauthorized internal adjustment.

CAUTION: NEVER block any cooling vents on the top, rear or bottom of the radio.

CAUTION: NEVER expose the radio to rain, snow or any liquids.

CAUTION: NEVER install the radio in a place without adequate ventilation. Heat dissipation may be reduced, and the radio may be damaged.

DO NOT use harsh solvents such as benzene or alcohol when cleaning, as they can damage the radio's surfaces.

DO NOT push the PTT switch when you don't actually desire to transmit.

DO NOT operate or place the radio in areas with temperatures below $\pm 0^{\circ}\text{C}$ ($+32^{\circ}\text{F}$) or above $+50^{\circ}\text{C}$ ($+122^{\circ}\text{F}$).

DO NOT place the radio in excessively dusty environments or in direct sunlight.

DO NOT place the radio against walls or putting anything on top of the radio. This may overheat the radio.

Always place unit in a secure place to avoid inadvertent use by children.

BE CAREFUL! If you use a linear amplifier, set the radio's RF output power to less than the linear amplifier's maximum input level, otherwise, the linear amplifier will be damaged.

BE CAREFUL! The rear panel will become hot when operating the radio continuously for long periods of time.

Use Icom microphones only (supplied or optional). Other manufacturers' microphones have different pin assignments, and connection to the IC-7600 may damage the radio or microphone.

The LCD display may have cosmetic imperfections that appear as small dark or light spots. This is not a malfunction or defect, but a normal characteristic of LCD displays.

During maritime mobile operation, keep the radio and microphone as far away as possible from the magnetic navigation compass to prevent erroneous indications.

Turn the radio power OFF and/or disconnect the DC power cable when you will not use the radio for long period of time.

For U.S.A. only

CAUTION: Changes or modifications to this device, not expressly approved by Icom Inc., could void your authority to operate this device under FCC regulations.

ABOUT THE SUPPLIED CD

The following instructions and installer are included on the CD.

- **Instruction manual**

Instructions for full operations, the same as this manual

- **Schematic diagram**

Includes the schematic and block diagrams

- **HAM radio Terms**

A glossary of HAM radio terms

- **Adobe® Reader® Installer**

Installer for Adobe® Reader®

To read the Instruction manual or Schematic diagram, Adobe® Reader® is required. If you have not installed it, please install the Adobe® Reader® on the CD or downloaded it from Adobe Systems Incorporated's website.

A PC with the following Operating System is required.

- Microsoft® Windows® 8.1, Microsoft® Windows® 8, Microsoft® Windows® 7, or Microsoft® Windows Vista®

◇ Starting the CD

- ① Insert the CD into the CD drive.
 - Double click "Menu.exe" on the CD.
 - Depending on the PC setting, the Menu screen shown below is automatically displayed.
- ② Click the desired button to open the file.
 - To close the Menu screen, click [Quit].

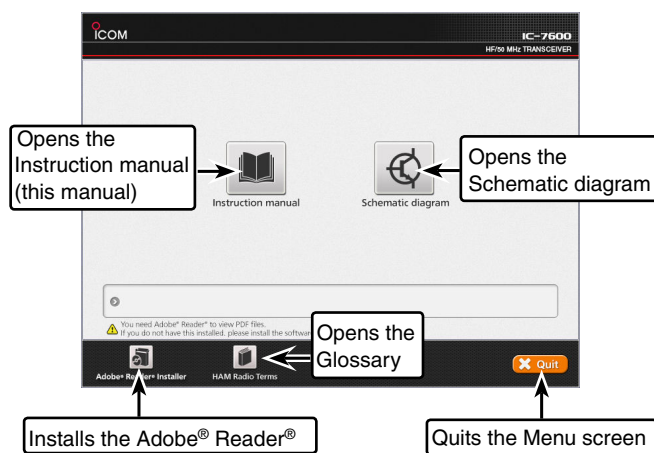

FUNCTIONS AND FEATURES OF ADOBE® READER®

The following functions and features can be used with Adobe® Reader®.

• Keyword search

Click “Find (Ctrl+F)” or “Advanced Search (Shift+Ctrl+F)” in the Edit menu to open the search screen. This is convenient when searching for a particular word or phrase in this manual.

*The Menu screen may differ, depending on the Adobe® Reader® version.

Click to open the Find or Search screen or Advanced search screen.

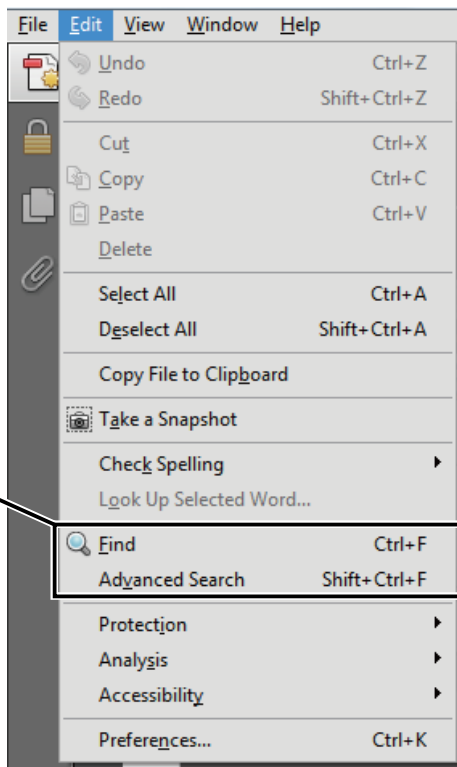

• Find screen

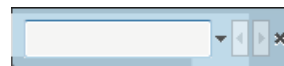

• Advanced search screen

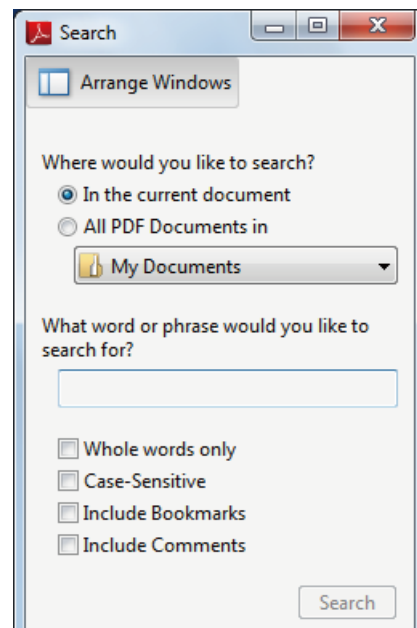

• Printing out the desired pages.

Click “Print...(Ctrl+P)” in File menu, and then select the paper size and page numbers you want to print.

*The printing setup may differ, depending on the printer. Refer to your printer’s instruction manual for details.

*Select “A4” size to print out the page in the equal-sized size.

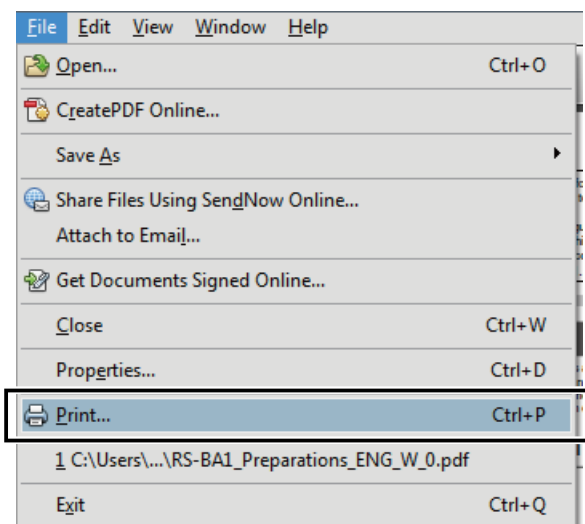

• Read Out Loud feature.

The Read Out Loud feature reads aloud the text in this Instruction Manual.

Refer to the Adobe® Reader® Help for the details.

(This feature may not be usable, depending on your PC environment including the operating system.)

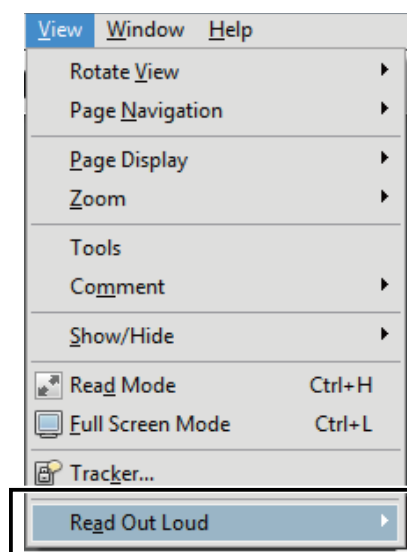

*The screen may differ, depending on the Adobe® Reader® version.

TABLE OF CONTENTS

FOREWORD	i	3 BASIC OPERATION	27–41
IMPORTANT	i	■ Before first applying power.....	27
EXPLICIT DEFINITIONS.....	i	■ Applying power (CPU resetting).....	27
SUPPLIED ACCESSORIES.....	i	■ Selecting VFO/memory mode.....	28
FCC INFORMATION	i	■ Main/Sub band selection.....	28
DISPOSAL.....	i	◇ Main/Sub band switching	28
PRECAUTIONS.....	ii	◇ Main/Sub band equalization	28
ABOUT THE SUPPLIED CD	iii	■ Selecting an operating band	29
FUNCTIONS AND FEATURES of Adobe® Reader® ..iv		◇ Using the band stacking registers	29
ABOUT THESE ADVANCED INSTRUCTIONS		■ Frequency setting	30
(PDF FORMAT)	v	◇ Tuning with the main dial.....	30
TABLE OF CONTENTS.....	vi	◇ Direct frequency entry with the keypad	30
		◇ About the 5 MHz band operation	
1 PANEL DESCRIPTION	1–15	(USA version only)	31
■ Front panel.....	1	◇ Quick tuning step.....	32
■ Rear panel	11	◇ Selecting “kHz” step	32
■ LCD display.....	13	◇ Selecting 1 Hz step	32
■ Screen menu arrangement	15	◇ Auto tuning step function.....	33
		◇ 1/4 tuning step function.....	33
		◇ Band edge warning beep	34
2 INSTALLATION AND CONNECTIONS	16–26	■ Operating mode selection	36
■ Unpacking.....	16	■ Squelch and receive (RF) sensitivity.....	37
■ Selecting a location.....	16	■ Volume setting	38
■ Grounding	16	■ Meter Display selection.....	38
■ Antenna connection	16	◇ Multi-function digital meter	38
■ Required connections	17	◇ Meter type selection	39
◇ Front panel	17	■ Voice synthesizer operation	39
◇ Rear panel.....	17	■ Basic transmit operation	40
■ Advanced connections.....	18	◇ Transmitting	40
◇ Front panel	18	◇ Microphone gain adjustment	40
◇ Rear panel— 1	18	◇ Drive gain adjustment.....	41
◇ Rear panel— 2	19		
■ USB connection	19	4 RECEIVE AND TRANSMIT.....	42–97
■ Power supply connections	20	■ Functions for CW operation	42
■ External antenna tuner connection	21	◇ About CW reverse mode	42
◇ Connecting an AH-4.....	21	◇ About CW pitch control.....	42
◇ Connecting an AH-740.....	21	◇ CW sidetone function	42
■ Linear amplifier connections	22	◇ APF (Audio Peak Filter) operation.....	43
◇ Connecting the IC-PW1/EURO	22	■ Electronic keyer functions	44
◇ Connecting a non-Icom linear amplifier.....	22	◇ Memory keyer screen.....	45
■ Transverter jack information.....	23	◇ Editing a memory keyer.....	46
■ FSK and AFSK connections	23	◇ Contest number set mode.....	47
◇ When using the ACC socket or the		◇ Keyer set mode	48
microphone connector	23		
◇ When connecting to the USB connector	23		
■ Microphone connector information.....	24		
■ Microphones	24		
◇ HM-36.....	24		
◇ SM-50.....	25		
◇ SM-30.....	25		
■ Accessory socket information	26		

■ RTTY (FSK) operation	50	■ Dualwatch operation	87
◇ About RTTY reverse mode	51	■ Noise blanker	89
◇ Twin peak filter	51	◇ NB set mode	89
◇ Functions of the RTTY decoder display	52	■ Noise reduction	90
◇ Setting the decoder threshold level	52	■ Dial lock function	90
◇ RTTY memory transmission	53	■ Notch function	91
◇ Automatic transmission/reception setting	53	■ Auto tune function	91
◇ Editing RTTY memory	54	■ VOX function	92
◇ RTTY decode set mode	55	◇ Using the VOX function	92
◇ Data saving	57	◇ Adjusting the VOX function	92
■ PSK operation	58	■ Break-in function	93
◇ About BPSK and QPSK modes	59	◇ Semi break-in operation	93
◇ Functions of the PSK decoder display	60	◇ Full break-in operation	93
◇ Setting the decoder threshold level	60	■ Speech compressor	94
◇ PSK memory transmission	61	■ Transmit filter width setting	94
◇ Automatic transmission/reception setting	61	■ ΔTX function	95
◇ Editing PSK memory	62	◇ ΔTX monitor function	95
◇ PSK decode set mode	63	■ Monitor function	95
◇ Data saving	65	■ Split frequency operation	96
■ Repeater operation	66	■ Quick split function	97
◇ Repeater access tone frequency setting	66	◇ Split lock function	97
■ Tone squelch operation	67		
■ Data mode (AFSK) operation	68	5 VOICE RECORDER FUNCTIONS	98–106
■ Spectrum scope screen	69	■ About digital voice recorder	98
◇ Using the Spectrum scope	70	■ Recording a received audio	99
◇ Center mode	71	◇ Basic recording	99
◇ Fixed mode	72	◇ One-touch recording	99
◇ Mini scope screen	73	■ Playing the recorded audio	100
◇ Scope attenuator	73	◇ Basic playing	100
◇ Scope set mode	74	◇ One-touch playing	100
◇ USB mouse operation	79	■ Protect the recorded contents	101
■ Preamplifier	80	■ Erasing the recorded contents	101
■ Attenuator	80	■ Recording a message for transmit	102
■ RIT function	81	◇ Recording	102
◇ RIT monitor function	81	◇ Confirming a message for transmit	102
■ AGC function	82	■ Programming a memory name	103
◇ Selecting the preset value	82	■ Sending a recorded message	104
◇ Setting the AGC time constant preset value	82	◇ Transmit level setting	104
■ Twin PBT operation	83	■ Voice set mode	105
■ IF filter selection	84	■ Saving a voice message into the	
◇ IF filter selection	84	USB-Memory	106
◇ Filter passband width setting		◇ Saving the received audio memory	106
(except the FM mode)	84	◇ Saving the TX memory	106
◇ Roofing filter selection	85		
◇ DSP filter shape	85		
◇ Filter shape set mode	86		

1
2
3
4
5
6
7
8
9
10
11
12
13
14
15

TABLE OF CONTENTS

6 MEMORY OPERATION	107–112	9 CLOCK AND TIMERS.....	123–125
■ Memory channels	107	■ Clock set mode	123
■ Memory channel selection	107	■ Daily timer setting	124
◇ Using the [▲]/[▼] keys.....	107	■ Setting sleep timer	125
◇ Using the keypad.....	107	■ Timer operation.....	125
■ Memory list screen.....	108	10 SET MODE.....	126–151
◇ Selecting a memory channel using the		■ Set mode description	126
memory list screen.....	108	◇ Set mode operation	126
◇ Confirming programmed memory		◇ Screen arrangement.....	127
channels.....	108	■ Level set mode.....	128
■ Memory channel programming.....	109	■ ACC set mode.....	132
◇ Programming in the VFO mode.....	109	■ Display set mode	134
◇ Programming in the memory mode.....	109	■ Others set mode	136
■ Frequency transfers	110	■ USB-Memory set menu	144
◇ Transferring in the VFO mode.....	110	◇ USB-Memory set screen arrangement.....	144
◇ Transferring in the memory mode	110	■ File loading	145
■ Memory names.....	111	◇ Load option set mode.....	146
◇ Editing (programming) memory names.....	111	■ File saving.....	147
■ Memory clearing	111	◇ Save option set mode.....	148
■ Memo pads	112	■ Changing a file name.....	149
◇ Writing frequencies and operating modes		■ Deleting a file	150
into memo pads.....	112	■ Unmounting USB-Memory.....	150
◇ Calling up a frequency and operating mode		■ Formatting the USB-Memory	151
from a memo pad.....	112	11 MAINTENANCE.....	152–158
7 SCANS.....	113–119	■ Troubleshooting.....	152
■ Scan types	113	◇ Transceiver power	152
■ Preparation	113	◇ Transmit and receive	152
■ Scan set mode.....	114	◇ Scanning	153
■ Programmed scan operation.....	115	◇ Display.....	153
■ Δ F scan operation.....	115	◇ Format USB-Memory	153
■ Fine programmed scan/Fine Δ F scan.....	116	■ Main dial brake adjustment.....	153
■ Memory scan operation	117	■ SWR reading.....	154
■ Select memory scan operation	117	■ Screen type and font selections.....	154
■ Setting select memory channels.....	118	■ Frequency calibration (approximate).....	155
◇ Setting in scan screen.....	118	■ Opening the transceiver's case.....	156
◇ Setting in memory list screen.....	118	■ Clock backup battery replacement.....	156
◇ Erasing the select scan setting.....	118	■ Fuse replacement	157
■ Tone scan.....	119	◇ DC power cable fuse replacement	157
8 ANTENNA TUNER OPERATION.....	120–122	◇ Circuitry fuse replacement	157
■ Automatic antenna selection.....	120	■ Resetting the CPU	157
■ Antenna tuner operation	121	■ About protection displays.....	158
◇ Tuner operation	121	■ Screen saver function	158
◇ Manual tuning.....	121		
■ Optional external tuner operation.....	122		
◇ Before operating the AH-4 or AH-740	122		
◇ Operating the AH-4 or AH-740.....	122		
◇ Antenna tuner of the IC-PW1/EURO.....	122		

12CONTROL COMMAND.....	159–169
■ Remote jack (CI-V) information.....	159
◇ CI-V connection.....	159
◇ Preparing.....	159
◇ Data format.....	159
◇ Command table	160
◇ Data content description	166
13SPECIFICATIONS AND OPTIONS.....	170–172
■ General	170
■ Transmitter	170
■ Receiver.....	170
■ Antenna tuner	170
■ Options	171
14UPDATING THE FIRMWARE.....	173–176
■ General	173
◇ Firmware confirmation.....	173
■ Caution	173
■ Preparation	174
◇ File downloading	174
■ Firmware update.....	175
15CE	177
INDEX.....	178–182

1
2
3
4
5
6
7
8
9
10
11
12
13
14
15

Front panel

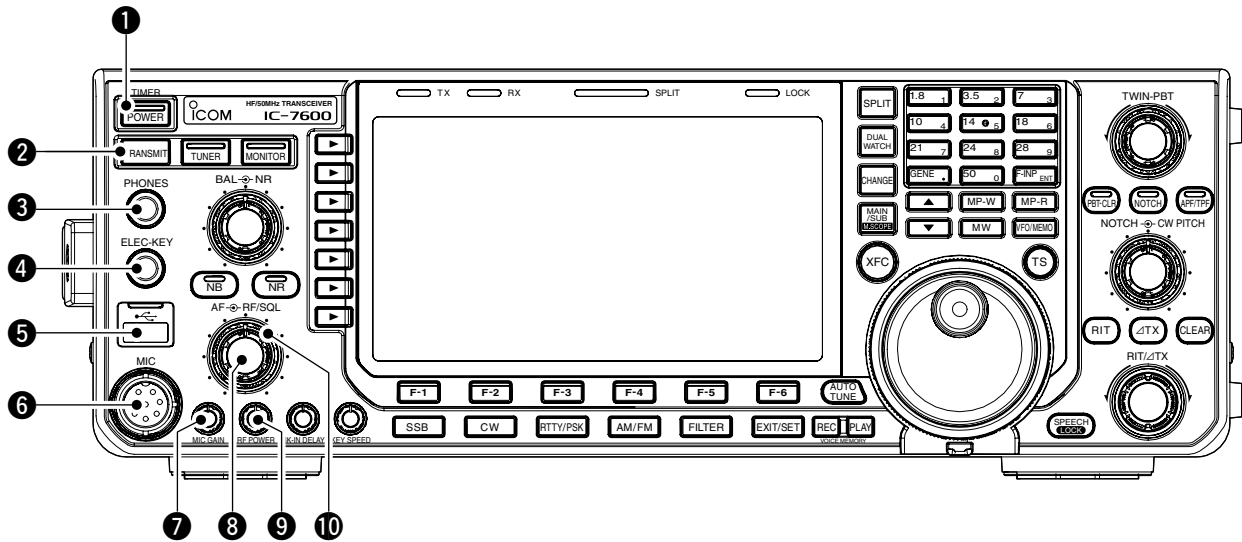

1 POWER SWITCH [POWER•TIMER] (p. 27)

When the transceiver's power is OFF:

- Push to turn the transceiver power ON.
 - Turn the optional DC power supply ON in advance.
 - The indicator on this switch lights green when powered ON.

When the transceiver's power is ON:

- Push the switch momentarily to toggle the timer function ON or OFF. (p. 125)
 - The timer indicator appears when the timer function is ON. (If the transceiver's power is OFF, the indicator on this switch lights red.)
- Hold down for 1 second to turn the transceiver power OFF.

2 TRANSMIT SWITCH [TRANSMIT]

Selects transmit or receive.

- The [TX] indicator lights red while transmitting and the [RX] indicator lights green when the squelch is open.

3 HEADPHONE JACK [PHONES]

Accepts standard stereo headphones.
(impedance: 8 to 16 Ω)

- Output power: 5 mW with an 8 Ω load.
- When headphones are connected, the internal speaker or connected external speaker is disabled.

4 ELECTRONIC KEYS JACK [ELEC-KEY]

Accepts a paddle to activate the internal electronic keyer for CW operation. (p. 17)

- You can select the internal electronic keyer, bug-key or straight key operation in the keyer set mode screen. (p. 48)
- A straight key jack is located on the rear panel. See [KEY] on page 12.
- Keyer polarity (dot and dash) can be reversed in the keyer set mode screen. (p. 49)
- A 4-channel memory keyer is available for your convenience. (p. 45)

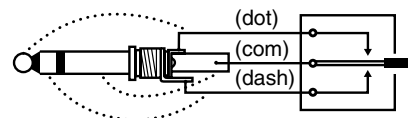

5 USB (Universal Serial Bus) CONNECTOR (A type) [USB] (A) (p. 19)

- Insert a USB-Memory* for both reading and storing a wide variety of the transceiver's information and data.
 - The indicator above the connector lights or blinks when the transceiver reads or writes to the memory data.
 - An unmount operation should be performed before removing the USB-Memory*. (p. 150)
 - Connects a PC keyboard for RTTY and PSK operations, etc.
 - Only USB keyboards* are supported.
- *: A USB-Memory and USB keyboard are not supplied by Icom.

6 MICROPHONE CONNECTOR [MIC]

Accepts the supplied or an optional microphone.
 • See page 171 for appropriate microphones.
 • See page 24 for microphone connector information.

7 MIC GAIN CONTROL [MIC GAIN] (p. 40)

Adjusts the microphone gain.
 • The transmit audio tone in the SSB, AM and FM modes can be adjusted independently in the level set mode. (p. 128)

✓ How to set the microphone gain.

Set the [MIC GAIN] control so that the ALC meter swings within the ALC range during normal voice level transmission, in the SSB or AM modes. (The ALC meter must be selected.)

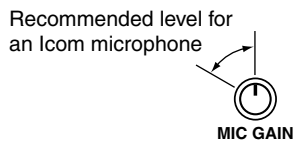
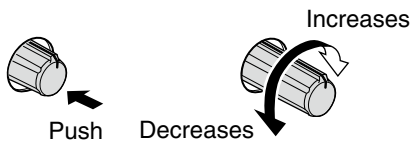

8 AF CONTROL [AF] (inner control; p. 38)

Varies the audio output level of the speaker or headphones.

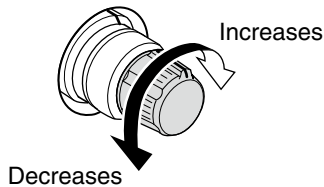

9 RF POWER CONTROL [RF POWER] (p. 40)

Continuously varies the RF output power from a minimum of 2 W* to a maximum of 100 W*.

*AM mode: 1 W to 30 W

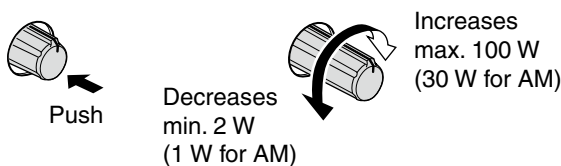

10 RF GAIN CONTROL/SQUELCH CONTROL [RF/SQL] (outer control; p. 37)

Adjusts the RF gain and squelch threshold level. The squelch removes noise output from the speaker (closed condition) when no signal is received.

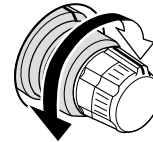

- The squelch is particularly effective for FM. It is also available for other modes.
- The 12 to 1 o'clock position is recommended for the most effective use of the [RF/SQL] control.
- The control can be set as 'Auto' (RF gain control in SSB, CW, RTTY and PSK. Squelch control in AM and FM) or squelch control (RF gain is fixed at maximum) in the set mode as follows. (p. 136)

MODE	SET MODE SETTING		
	AUTO	SQL	RF GAIN + SQL
SSB, CW RTTY/PSK	RF GAIN	SQL	RF GAIN + SQL
AM, FM	SQL	SQL	RF GAIN + SQL

• When setting as an RF gain/squelch control

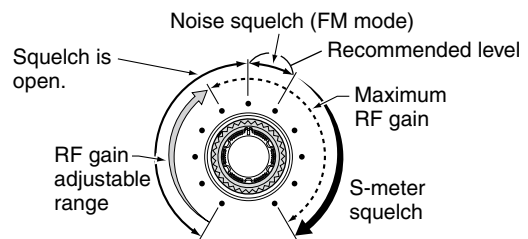

• When functioning as an RF gain control

(Squelch is fixed open; SSB, CW, RTTY and PSK only)

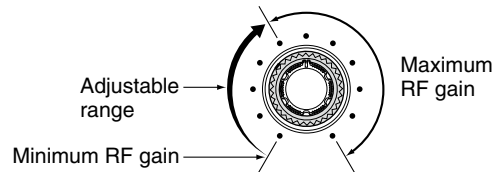

• When functioning as a squelch control

(RF gain is fixed at maximum.)

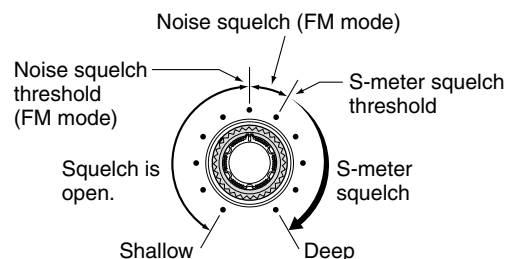

While rotating the RF gain control, noise may be heard. This comes from the DSP unit and does not indicate an equipment malfunction.

1 PANEL DESCRIPTION

■ Front panel (continued)

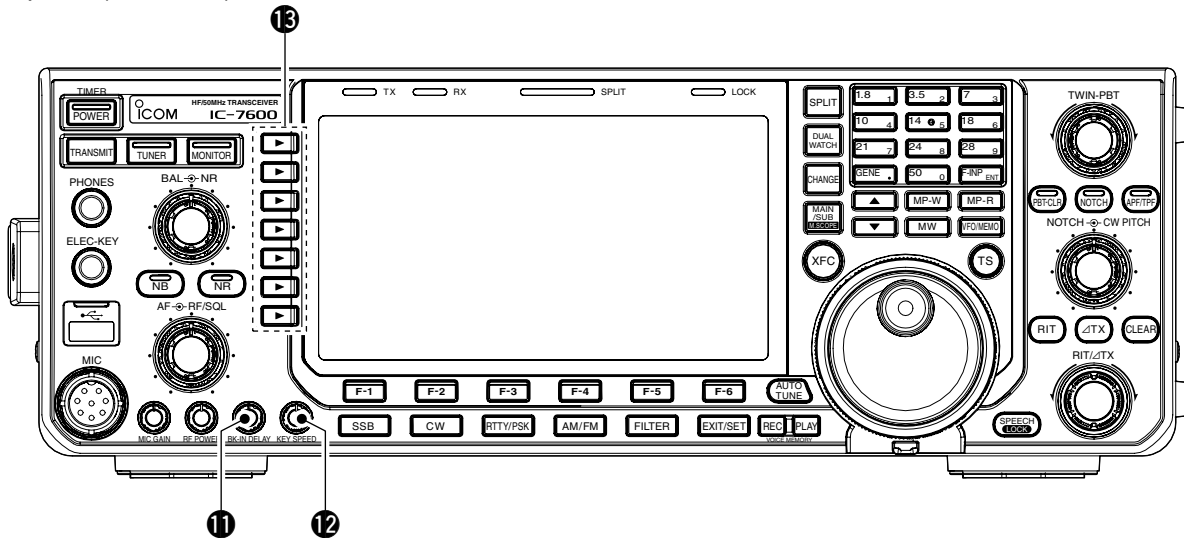

① BREAK-IN DELAY CONTROL

[BK-IN DELAY] (p. 93)

Adjusts the transmit-to-receive switching delay time for CW semi-break-in operations.

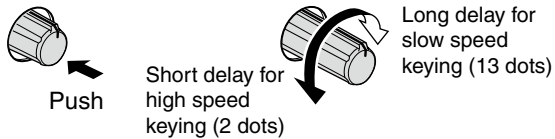

⑫ ELECTRONIC CW KEYSPEED CONTROL

[KEY SPEED] (p. 93)

Adjusts keying speed for the internal electronic CW keyer from 6 wpm (min.) to 48 wpm (max.).

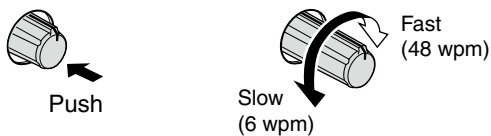

⑬ MULTI-FUNCTION SWITCHES

Push to select the functions indicated in the LCD display to the right of these switches.

- Functions vary, depending on the operating condition.

MF1 (MULTI-FUNCTION 1 SWITCH) ANT SWITCH (ANT)



- ➔ Selects the antenna connector between ANT1 and ANT2 when pushed. (p. 120)
- ➔ Turns the **[RX ANT]** (receive antenna) ON or OFF when held down for 1 second.
 - When the receive antenna is activated, the antenna connected to **[ANT1]** or **[ANT2]** is used for transmitting only.
- ⚡ When a transverter is in use, **[ANT]** does not function and 'TRV' appears.

MF2 (MULTI-FUNCTION 2 SWITCH) METER SWITCH (METER) (p. 38)

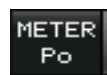

- ➔ Selects the RF power (Po), SWR, ALC, COMP, Vd or Id metering functions during transmit.
- ➔ Switches the multi-function digital meter ON or OFF when held down for 1 second.

MF3 (MULTI-FUNCTION 3 SWITCH)

P.AMP SWITCH (P.AMP) (p. 80)

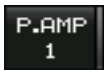

- ➔ Selects one of 2 receive RF preamps or bypasses them.
 - “P. AMP1” activates a 10 dB preamp.
 - “P. AMP2” activates a 16 dB high-gain preamp.
 - “P. AMP OFF” can also be selected.
- ➔ Turns the preamp function OFF when held down for 1 second.

✓ **What is the preamp?**

The preamp amplifies signals in the front end to improve the S/N ratio and sensitivity. Select “P. AMP1” or “P. AMP2” when receiving weak signals.

MF4 (MULTI-FUNCTION 4 SWITCH)

ATT SWITCH (ATT) (p. 80)



- ➔ Selects a 6 dB, 12 dB or 18 dB attenuator when pushed.
 - “ATT OFF” can also be selected.
- ➔ Turns the attenuator function OFF when held down for 1 second.

✓ **What is the attenuator?**

The attenuator prevents a desired signal from being distorted when very strong signals are near it, or when very strong electromagnetic fields, such as from a broadcasting station, are near your location.

MF5 (MULTI-FUNCTION 5 SWITCH)

AGC SWITCH (AGC) (p. 82)

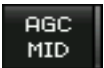

- ➔ Activates and selects a fast, middle or slow AGC time constant when pushed.
 - In the FM mode, only “FAST” is available.
- ➔ Selects the AGC set mode when held down for 1 second.
- ▨ The AGC time constant can be set between 0.1 and 8.0 seconds (depending on the mode), or turned OFF. When the AGC is OFF, the S-meter does not function.

✓ **What is the AGC?**

The AGC controls the receiver gain to produce a constant audio output level, even when the received signal strength varies dramatically. Select “FAST” for tuning and then select “MID” or “SLOW,” depending on the receiving condition.

MF6 (MULTI-FUNCTION 6 SWITCH)

VOX SWITCH (VOX) (p. 92)

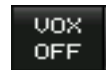

- ➔ Push to turn the VOX function ON or OFF during the SSB, AM and FM mode operation.
- ➔ Hold down for 1 second to select the VOX set mode.

✓ **What is the VOX function?**

The VOX function (voice operated transmission) activates transmission without pushing the transmit switch or PTT switch when you speak into the microphone, then automatically returns to receive when you stop speaking.

BK-IN SWITCH (BK-IN) (p. 93)

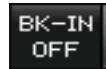

- ➔ Selects semi break-in, full break-in operation in the CW mode, or turns the break-in operation OFF when pushed.

✓ **What is the break-in function?**

The break-in function switches transmit and receive with CW keying. Full break-in function (QSK), you can monitor the receive signal during keying.

MF7 (MULTI-FUNCTION 7 SWITCH)

COMP SWITCH (COMP) (p. 94)



- ➔ Turns the speech compressor ON or OFF in the SSB mode.
- ➔ Selects the compression between narrow, mid or wide when held down for 1 second.

✓ **What is the speech compressor?**

The speech compressor compresses the transmitter audio input to increase the average audio output level, in order to increase talk power. This function is effective for long-distance communication, or when propagation conditions are poor.

1/4 SWITCH (1/4) (p. 33)



- ➔ Turns the 1/4 speed tuning function ON or OFF in the SSB data, CW, RTTY and PSK modes.
 - The 1/4 function sets the dial speed to 1/4 of it's normal speed for fine tuning.

TONE SWITCH (TONE) (pp. 66, 67)



- ➔ Switches between the tone encoder, tone squelch function and no-tone operation when pushed in the FM mode.
- ➔ Selects the tone set mode when held down for 1 second in the FM mode.

1 PANEL DESCRIPTION

■ Front panel (continued)

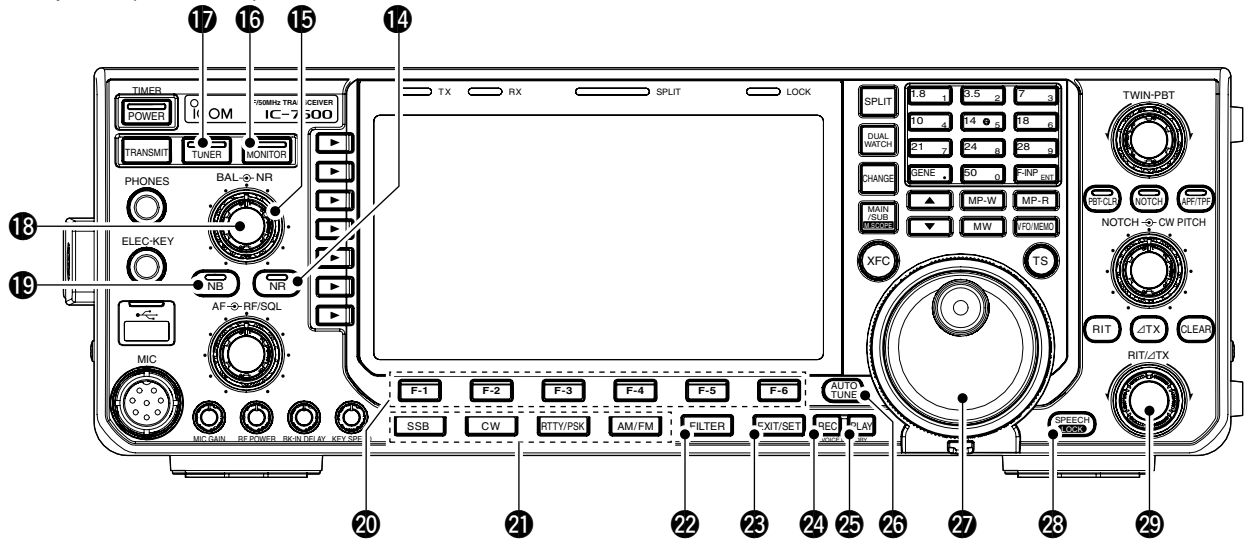

- 14 NOISE REDUCTION SWITCH [NR]** (p. 90)
Push to switch DSP noise reduction ON or OFF.
• The indicator on this switch lights green when the function is activated.

- 15 NOISE REDUCTION LEVEL CONTROL [NR]**
(outer control; p. 90)
Adjusts the DSP noise reduction level when the noise reduction function is in use. Set for maximum readability.
• To use this control, push [NR] (14) in advance.

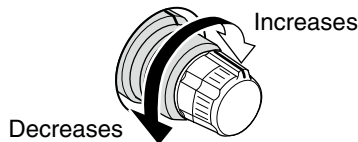

- 16 MONITOR SWITCH [MONITOR]** (p. 95)
Push to monitor your transmitted signal.
• The CW sidetone functions regardless of the [MONITOR] switch setting in the CW mode.
• The indicator on this switch lights green while the function is activated.

- 17 ANTENNA TUNER SWITCH [TUNER]** (p. 121)
➤ Turns the internal antenna tuner ON or OFF (bypass) when pushed momentarily.
• The indicator on this switch lights green when the tuner is turned ON, goes off when tuner is turned OFF (bypassed).
➤ Allows you to tune the antenna tuner manually, when held down for 1 second.
• The indicator on this switch blinks red during manual tuning.
• When the tuner cannot tune the antenna, the tuning circuit is automatically bypassed after 20 seconds.

- 18 BALANCE CONTROL [BAL]** (inner control; p. 87)
Adjusts the audio output balance between main and sub readout frequencies while in dualwatch.

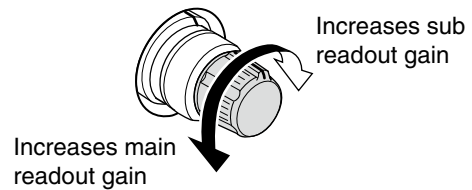

- 19 NOISE BLANKER SWITCH [NB]** (p. 89)
➤ Switches the noise blanker ON or OFF when pushed. The noise blanker reduces pulse-type noise such as that generated by automobile ignition systems. This function cannot be used in the FM mode, and is not effective for non-pulse-type noise.
• The indicator on this switch lights green while the function is activated.
➤ Selects the noise blanker level set mode when held down for 1 second.

- 20 LCD FUNCTION SWITCHES [F-1] to [F-6]**
Push to select the function indicated in the LCD display above these switches.
• Functions vary, depending on the operating condition.

21 MODE SWITCHES

Selects the desired mode. (p. 36)

- Announces the selected mode via the speech synthesizer. (p. 39)

[SSB]

- ➔ Selects the USB and LSB modes alternately when pushed.
- ➔ Selects the SSB data mode (USB-D, LSB-D) when held down for 1 second in the SSB mode.
 - In the SSB data mode, push to return to the SSB mode.
- ➔ Switches D1, D2 and D3 when held down for 1 second in the SSB data mode.

[CW]

Alternately selects the CW and CW-R (CW reverse) modes when pushed.

[RTTY/PSK]

- ➔ Alternately selects the RTTY and PSK modes when pushed.
- ➔ Switches the RTTY and RTTY-R (RTTY reverse) mode when held down for 1 second in the RTTY mode.
- ➔ Switches the PSK and PSK-R (PSK reverse) mode when held down for 1 second in PSK mode.

[AM/FM]

- ➔ Alternately selects the AM and FM modes.
- ➔ Selects the AM or FM data mode (AM-D/FM-D) when held down for 1 second in the AM or FM mode, respectively.
 - In the AM or FM data mode, push to return to the AM or FM mode, respectively.
- ➔ Switches D1, D2 and D3 when held down for 1 second in the AM or FM data mode.

22 FILTER SWITCH [FILTER] (p. 84)

- ➔ Push to select one of 3 IF filter settings.
- ➔ Hold down for 1 second to display the filter set screen.

23 EXIT/SET SWITCH [EXIT/SET]

- ➔ Push to exit, or return to the previous screen display during spectrum scope, memory, scan or set mode screen display.
- ➔ Hold down for 1 second to display the set mode menu screen.

24 VOICE MEMORY RECORD SWITCH [REC] (p. 99)

- ➔ Push to store the previous received signal for the preset time period.
 - The preset time period can be set in the voice set mode. (p. 105)
- ➔ Hold down for 1 second to start recording the received signal until the recording is stopped.
 - Push this switch momentarily to stop recording.
 - The memory records the latest 30 seconds of audio.

25 VOICE MEMORY PLAYBACK SWITCH [PLAY]

(p. 98)

- ➔ Push to playback the selected voice memory in the RX memory screen for the preset time period.
 - When the RX memory screen is not displayed, the previously recorded audio is played back for the preset time period.
- ➔ Hold down for 1 second to playback all of the selected voice memory in the RX memory screen.
 - When the RX memory screen is not displayed, all of the previously recorded audio is played back.

26 AUTOMATIC TUNING SWITCH [AUTO TUNE]

(p. 91)

Turns the automatic tuning function ON or OFF in the CW and AM modes.

IMPORTANT!

When receiving a weak signal, or receiving a signal with interference, the automatic tuning function may tune the receiver to an undesired signal.

27 MAIN DIAL

Changes the displayed frequency, selects the set mode setting, etc.

28 SPEECH/LOCK SWITCH [SPEECH/LOCK]

- ➔ Push to audibly announce the S-meter display, the displayed frequency and the operating mode. (p. 39)
 - The parameters to be announced can be selected in the Others set mode. (p. 139)
- ➔ Hold down for 1 second to turn the dial lock function ON or OFF. (p. 90)
 - The dial lock function electronically locks the main dial.
 - The lock indicator lights while the dial lock function is activated.

NOTE: The [SPEECH/LOCK] switch operation to activate the voice synthesizer or the dial lock functions can be replaced in the Others set mode. (p. 139)

29 RIT/ Δ TX CONTROL [RIT/ Δ TX] (pp. 81, 95)

Shifts the receive and/or transmit frequency without changing the transmit and/or receive frequency shown on the main VFO while the RIT and/or Δ TX functions are/is ON.

- Rotate the control clockwise to increase the frequency, or rotate the control counterclockwise to decrease the frequency. The RIT or Δ TX functions must be ON.
- The shift frequency range is ± 9.999 kHz in 1 Hz steps (or ± 9.99 kHz in 10 Hz steps).

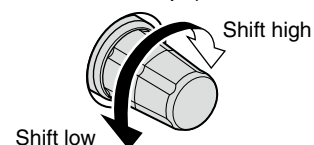

1 PANEL DESCRIPTION

■ Front panel (continued)

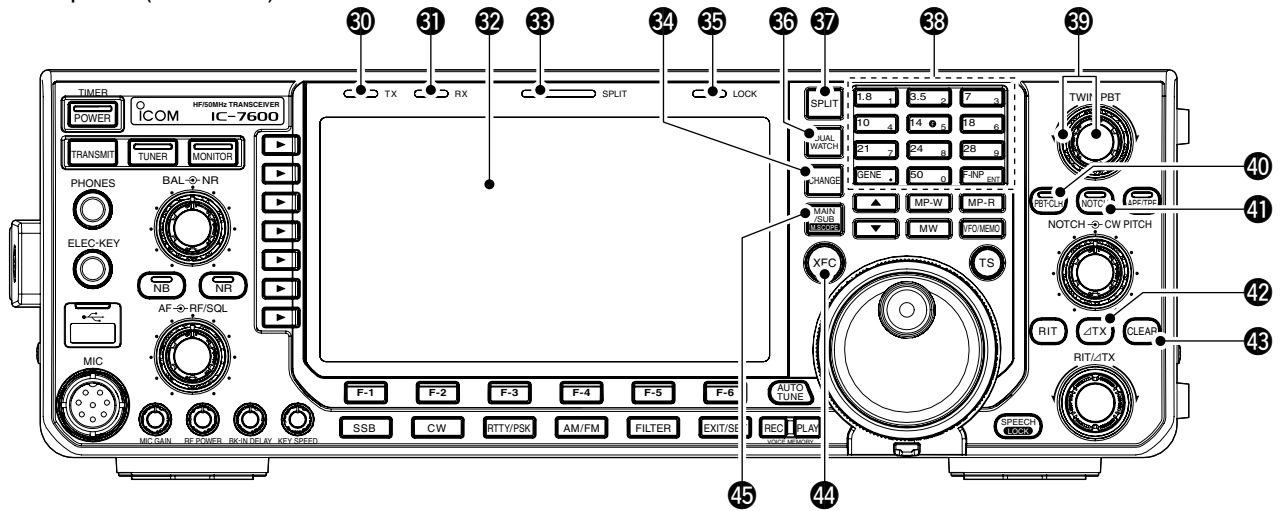

30 TRANSMIT INDICATOR [TX]

Lights red while transmitting.

31 RECEIVE INDICATOR [RX]

Lights green while receiving a signal and when the squelch is open.

32 LCD FUNCTION DISPLAY (p. 13)

Shows the operating frequency, function switch menus, spectrum scope screen, memory list screen, set mode settings, etc.

33 SPLIT OPERATION INDICATOR [SPLIT] (p. 96)

Lights during split frequency operation.

34 MAIN/SUB CHANGE SWITCH [CHANGE]

- Switches the frequency and selected memory channel between main and sub readouts when pushed.
 - Switches between transmit frequency and receive frequency when the split frequency function is ON. (p. 96)
- Equalizes the sub readout frequency to the main readout frequency when held down for 1 second.

35 LOCK INDICATOR [LOCK] (p. 90)

Lights when the dial lock function is activated.

36 DUALWATCH SWITCH [DUALWATCH] (p. 87)

- Push to turn the dualwatch function ON or OFF.
 - “**DUAL-W**” appears when the dualwatch function ON.
- Hold down for 1 second to turn the dualwatch function ON and equalize the sub readout frequency to the main readout. (Quick dualwatch function)
 - The quick dualwatch function can be turned OFF in the Others set mode. (p. 137)

37 SPLIT SWITCH [SPLIT] (p. 96)

- Push to turn the split function ON or OFF.
 - “**SPLIT**” appears when the split function is in use.
- Hold down for 1 second to activate the quick split function.
 - Turns the split function ON and equalizes the sub readout frequency to the main readout and sets the sub readout for frequency input in the non-FM modes. (p. 97)
 - The offset frequency is shifted from the selected VFO frequency in the FM mode. (p. 137)
 - The tone encoder function is turned ON in the FM mode.
 - The quick split function can be turned OFF in the Others set mode. (p. 137)

38 KEYPAD

- Pushing a key selects the operating band. (p. 29)
 - [GEN •] selects the general coverage band.
- Pushing the same key 2 or 3 times calls up other stacked frequencies in the band. (p. 29)
 - Icom’s triple band stacking register memorizes 3 frequencies in each band.
- After pushing [F-INP ENT], push a key on the keypad to enter a numeric frequency. After entering, push [F-INP ENT] to select the desired frequency directly (p. 30)
 - For example, to enter 14.195 MHz: Push [F-INP ENT] [1] [4] [•] [1] [9] [5] [F-INP ENT].
- After pushing [F-INP ENT], push a key on the keypad to enter a memory channel. After entering, push [▲] or [▼] to directly select the desired memory channel. (p. 107)

39 PASSBAND TUNING CONTROLS [TWIN-PBT]

(p. 83)

Adjusts the receiver's IF filter passband width via the DSP.

- Passband width and shift frequency are displayed in the multi-function display.
- Hold down [PBT-CLR] for 1 second to clear the PBT settings.
- Adjustment range is set to half of the IF filter passband width. 25 Hz steps and 100 Hz steps are available.

✓ **What is the PBT control?**

The PBT function electronically modifies the IF passband width to reject interference. This transceiver uses the DSP circuit for the PBT function.

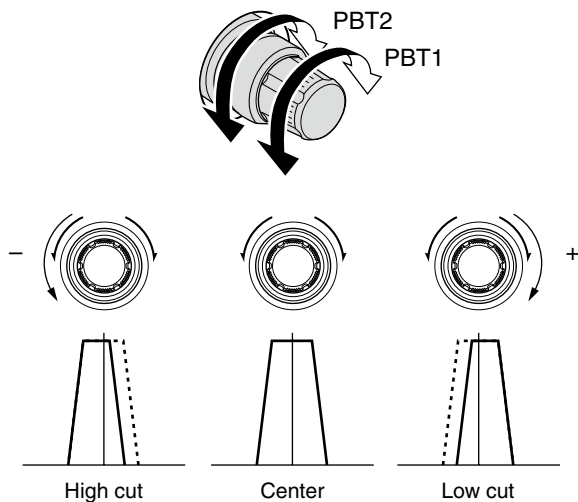

40 PBT CLEAR SWITCH [PBT-CLR] (p. 83)

Hold down for 1 second to clear the PBT settings.

- The indicator on this switch lights green when PBT is in use.

41 NOTCH SWITCH [NOTCH] (p. 91)

- ➔ Switches the notch function between auto, manual and OFF in the SSB and AM modes.
 - Either auto or manual notch function can be deactivated in the Others set mode. (p. 140)
- ➔ Turns the manual notch function ON or OFF when pushed in the CW, RTTY or PSK mode.
- ➔ Turns the auto notch function ON or OFF when pushed in the FM mode.
 - “**MN**” appears when manual notch is in use.
 - “**AN**” appears when auto notch is in use.
 - No indicator appears when the notch function is OFF.
- ➔ Hold down for 1 second to switch the manual notch characteristics from wide, middle and narrow when manual notch function is activated.
 - The indicator on this switch lights green when the function is activated.

✓ **What is the notch function?**

The notch function is a narrow filter that eliminates unwanted CW or AM carrier tones while preserving the desired voice signal. The DSP circuit automatically adjusts the notch frequency to effectively eliminate unwanted tones.

42 ΔTX SWITCH [ΔTX] (p. 95)

- ➔ Push to turn the ΔTX function ON or OFF.
 - Use [RIT/ΔTX] control to vary the ΔTX frequency.
- ➔ Hold down for 1 second to add the ΔTX shift frequency to the operating frequency.

✓ **What is the ΔTX function?**

ΔTX shifts the transmit frequency without shifting the receive frequency. This is useful for simple split frequency operation in CW, etc.

43 CLEAR SWITCH [CLEAR] (pp. 81, 95)

Push, or hold down for 1 second* to clear the RIT/ΔTX shift frequency.

- * Depending on the quick RIT/ΔTX clear function setting. (p. 140)

44 TRANSMIT FREQUENCY CHECK SWITCH [XFC]

- ➔ Directly monitors the transmit frequency (including ΔTX frequency offset) when held down during split frequency operation. (p. 95)
 - While holding down this switch, the transmit frequency can be changed with the main dial, keypad, memo pad or [▲]/[▼] switches.
 - When the split lock function is turned ON, pushing [XFC] cancels the dial lock function. (pp. 95, 137)
- ➔ Monitors the operating frequency directly when held down when the RIT function is turned ON. (RIT is temporarily cancelled.) (p. 81)

45 MAIN/SUB•M.SCOPE SWITCH [MAIN/SUB M.SCOPE]

- ➔ Push to select access to the main or sub readout. (p. 28)
 - The selected readout frequency is displayed clearly. The sub readout functions only during split operation or dualwatch.
- ➔ Hold down for 1 second to turn the mini spectrum scope screen display ON or OFF. (p. 73)
 - The mini spectrum scope screen can be displayed with another screen, such as memory, set mode screen, simultaneously.

1 PANEL DESCRIPTION

■ Front panel (continued)

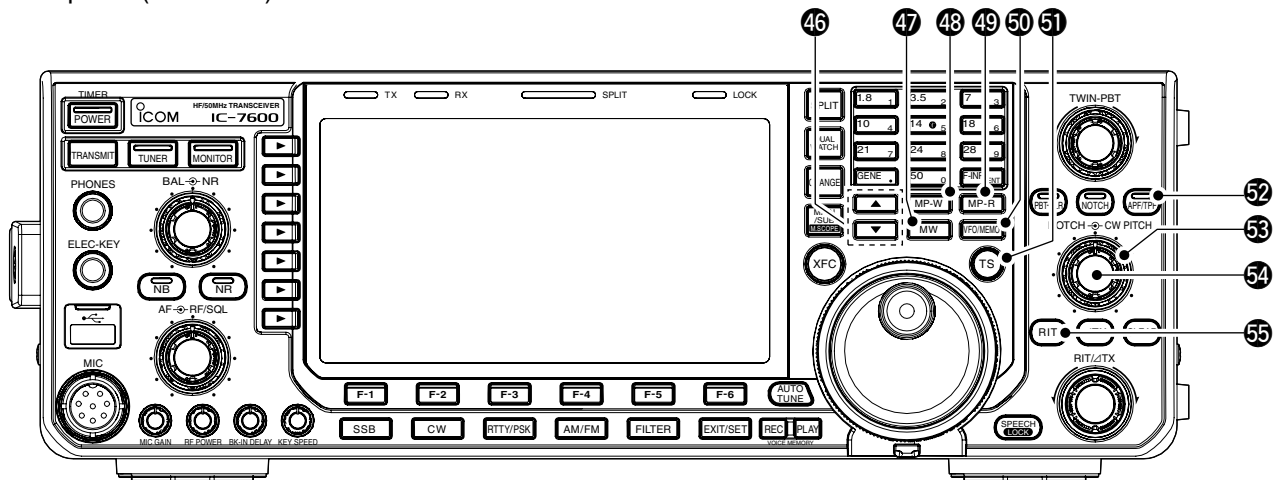

46 MEMORY UP/DOWN SWITCHES [▲]/[▼] (p. 107)

- Push to select the desired memory channel.
 - Memory channels can be selected in both the VFO and memory modes.
- Push to directly select the desired memory channel after pushing [F-INP ENT] and a memory channel number.

47 MEMORY WRITE SWITCH [MW] (p. 109)

- Stores the selected readout frequency and operating mode into the displayed memory channel when held down for 1 second.
- This function is available both in VFO and memory modes.

48 MEMO PAD-WRITE SWITCH [MP-W] (p. 112)

- Programs the displayed readout frequency and operating mode into a memo pad.
- The 5 most recent entries remain in memo pads.
 - The memo pad capacity can be expanded from 5 to 10 in the Others set mode. (p. 140)

49 MEMO PAD-READ SWITCH [MP-R] (p. 112)

- Each push calls up a frequency and operating mode in a memo pad. The 5 (or 10) most recently programmed frequencies and operating modes can be recalled, starting from the most recent.
- The memo pad capacity can be expanded from 5 to 10 in the Others set mode. (p. 140)

50 VFO/MEMORY SWITCH [VFO/MEMO]

- Switches the selected readout operating mode between the VFO and memory when pushed. (pp. 28, 107)
- Transfers the memory contents to VFO when held down for 1 second. (p. 110)

51 QUICK TUNING SWITCH [TS]

- Turns the quick tuning step ON or OFF. (p. 32)
 - While the quick tuning indicator, “▼,” is displayed above the frequency display, the frequency can be changed in programmed kHz steps.
 - 0.1, 1, 5, 9, 10, 12.5, 20 and 25 kHz steps are selectable for each operating mode independently.
- When the quick tuning step is ON, hold down for 1 second to select the quick tuning step set mode. (p. 32)
- When the quick tuning step is OFF, hold down for 1 second to turn the 1 Hz tuning step ON or OFF. (p. 32)

52 AUDIO PEAK FILTER/TWIN PEAK FILTER SWITCH [APF/TPF]

During CW mode operation (p. 43)

- Push to turn the audio peak filter ON or OFF.
 - “APF” appears when audio peak filter is in use.
- When the audio peak filter is ON, hold down for 1 second to select the APF passband width between WIDE, MID and NAR or between 320, 160 and 80 Hz, depending on APF type setting (SOFT or SHARP).

During RTTY mode operation (p. 51)

- Push to turn the twin peak filter ON or OFF.
 - “TPF” appears when twin peak filter is in use.
 - The indicator on this switch lights green when the function is activated.

53 CW PITCH CONTROL [CW PITCH]

(outer control; p. 42)

Shifts the received CW audio pitch and the CW side-tone pitch without changing the operating frequency.

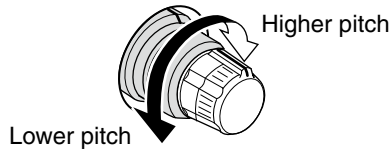

54 MANUAL NOTCH FILTER CONTROL [NOTCH]

(inner control; p. 91)

Varies the notch frequency of the manual notch filter to reject an interfering signal while the manual notch function is ON.

• Notch filter center frequency:

LSB/RTTY/PSK-R : -1040 Hz to +4060 Hz

USB/RTTY-R/PSK : -1060 Hz to +4040 Hz

CW : CW pitch freq. -2540 Hz to

CW pitch freq. +2540 Hz

AM : -5100 Hz to +5100 Hz

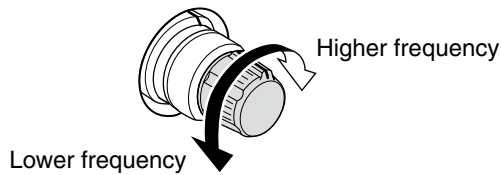

55 RIT SWITCH [RIT] (p. 81)

- ➔ Push to turn the RIT function ON or OFF.
 - Use [RIT/ΔTX] control to vary the RIT frequency.
- ➔ Hold down for 1 second to add the RIT shift frequency to the operating frequency.

✓ What is the RIT function?

The RIT (Receiver Incremental Tuning) shifts the receive frequency without shifting the transmit frequency.

This is useful for fine tuning stations calling you off-frequency or when you prefer to listen to slightly different-sounding voice characteristics, etc.

■ Rear panel

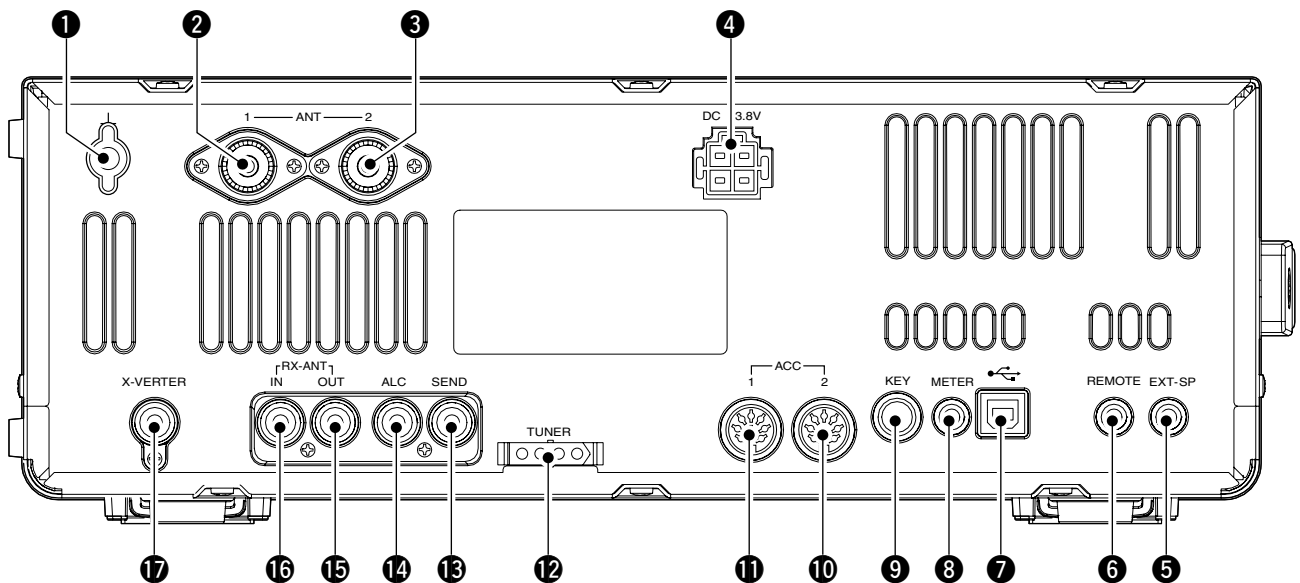

- 1 GROUND TERMINAL [GND]** (p. 16)
Connect this terminal to a ground to prevent electrical shocks, TVI, BCI and other problems.
- 2 ANTENNA CONNECTOR 1 [ANT1]**
- 3 ANTENNA CONNECTOR 2 [ANT2]** (pp. 17, 120)
Accepts a 50 Ω antenna with a PL-259 plug connector.
When using an optional AH-4 HF/50 MHz AUTOMATIC ANTENNA TUNER, connect it to the [ANT1] connector. The internal antenna tuner activates for [ANT2] and deactivates for [ANT1] when connecting the AH-4.
- 4 DC POWER SOCKET [DC 13.8V]** (p. 20)
Accepts 13.8 V DC through the supplied DC power cable.

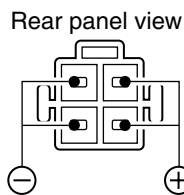

- 5 EXTERNAL SPEAKER JACK [EXT-SP]** (p. 18)
Connects to an external speaker (4–8 Ω), if desired.
- 6 CI-V REMOTE CONTROL JACK [REMOTE]** (pp. 18, 159)
 - ➔ Connects to a PC, using the optional CT-17 CI-V LEVEL CONVERTER, for external control of the transceiver.
 - ➔ Used for transceive operation with another Icom CI-V transceiver or receiver.

- 7 USB (Universal Serial Bus) CONNECTOR (B type) [USB] (B)**
Connects to a PC, using a USB cable, to do the following:
 - Input the modulation (p. 132)
 - Remotely control the transceiver using CI-V commands (p. 159)
 - Send the received audio to the PC (p. 132)
 - Send the decoded characters to the PC (pp. 141, 142)
- CAUTION:**
NEVER connect the USB cable between the transceiver and the PC until **AFTER** the USB driver has been installed.

About the USB driver:

The USB driver and the installation guide can be downloaded from our website.
<http://www.icom.co.jp/world/index.html>

The following items are required:

- PC**
 - Microsoft® Windows® 8/8.1 (32/64 bit)*, Microsoft® Windows® 7 (32/64 bit), or Microsoft® Windows Vista® (32/64 bit) OS
 - *Except for Microsoft® Windows® RT.
- A USB 1.1, 2.0 or 3.0 port

Other items

- USB cable (user supplied)
- PC software

About the modulation input:

Select “USB” in the ACC set mode item ‘DATA OFF MOD,’ ‘DATA1 MOD,’ ‘DATA2 MOD’ or ‘DATA3 MOD.’ And the modulation input level from USB jack can be set in the ACC set mode item ‘USB MOD Level.’ (p. 132)

8 METER JACK [METER] (p. 19)

Outputs a signal showing received signal strength, transmit output power, VSWR, ALC, speech compression, VD or ID level for external meter display.

9 STRAIGHT KEY JACK [KEY] (p. 17)

Accepts a straight key or external electronic keyer output using a standard 1/4 inch plug.

- [ELEC-KEY] on the front panel can be used for a straight key or external electronic keyer. Deactivate the internal electronic keyer in the keyer set mode. (p. 49)

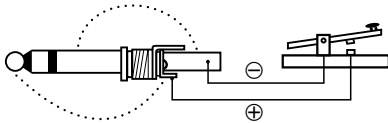

10 ACCESSORY SOCKET 2 [ACC 2]

11 ACCESSORY SOCKET 1 [ACC 1]

Enable connection of external equipment such as a linear amplifier, an automatic antenna selector/tuner, a TNC for data communications, etc.

- See page 26 for socket information.

12 TUNER CONTROL SOCKET [TUNER] (p. 18)

Accepts the control cable from an optional AH-4 HF/50 MHz AUTOMATIC ANTENNA TUNER.

13 SEND CONTROL JACK [SEND] (p. 18)

Connects to ground when transmitting to control an external unit, such as a non-Icom linear amplifier.

NOTE: T/R control voltage and current must be less than 16 V DC/0.5 A (or 250 V AC, 200 mA with MOSFET switching).

14 ALC INPUT JACK [ALC] (p. 18)

Connects to the ALC output jack of a non-Icom linear amplifier.

15 RECEIVE ANTENNA OUT [RX ANT- OUT]

16 RECEIVE ANTENNA IN [RX ANT- IN]

Located between the transmit/receive switching circuit and receiver's RF stage.

Connects an external unit, such as preamplifier or RF filter, using RCA connectors, if desired.

In this case, the antenna connector must be selected as "ANT 1/R" or "ANT 2/R." (p. 120)

- When no external unit is connected, "ANT 1" or "ANT 2" must be selected.

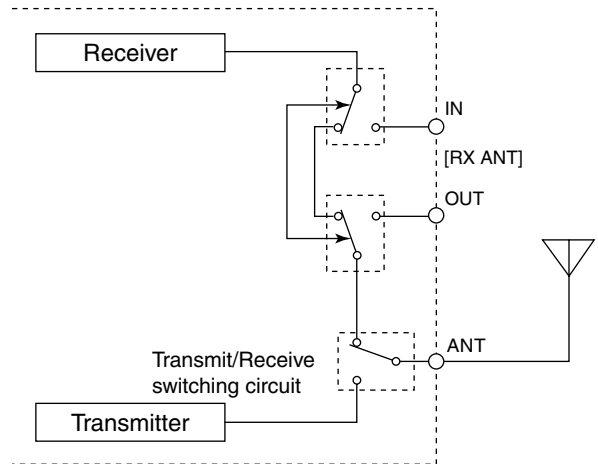

17 TRANSVERTER CONNECTOR [X-VERTER]

(p. 18)

External transverter input/output connector.

Activated by voltage applied to [ACC 2] pin 6, or when the transverter function is in use. (p. 26)

■ LCD display

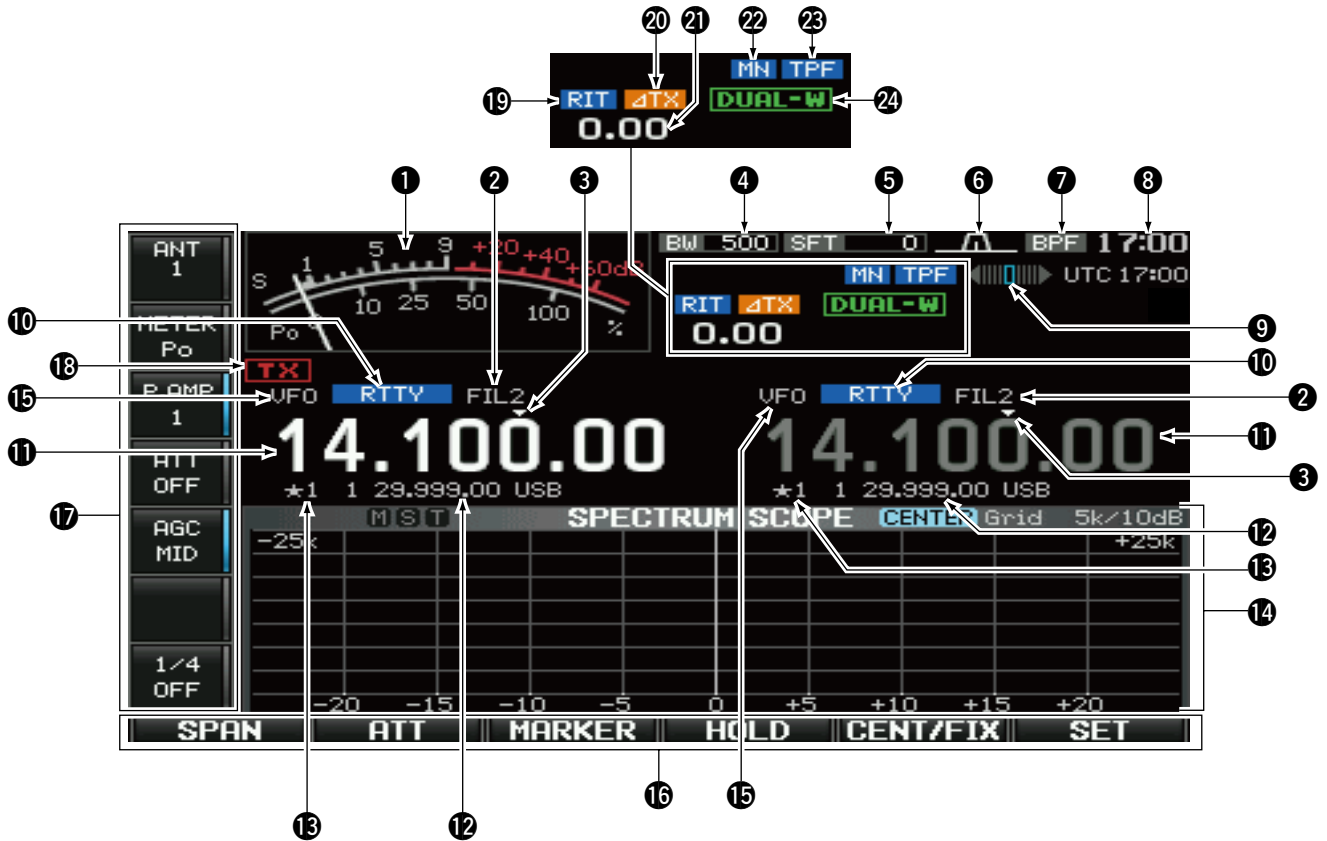

1 S/Rf METER (pp. 38, 134)

Shows the signal strength while receiving. Shows the relative output power, SWR, ALC, VD, ID or compression levels while transmitting.

- A total of 3 meter types are available.

- Standard meter

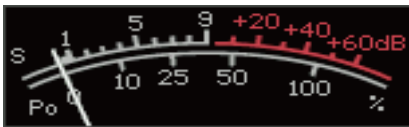

- Edgewise meter

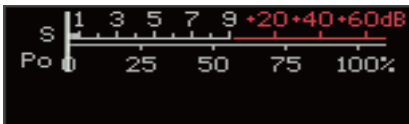

- Bar meter

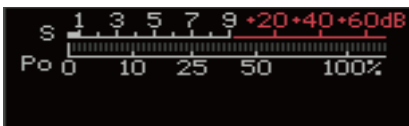

2 IF FILTER INDICATOR (p. 84)

Shows the selected IF filter number.

3 QUICK TUNING INDICATOR (p. 32)

Appears when the quick tuning step function is in use.

4 BANDWIDTH INDICATOR (p. 83)

Shows the passband width of the IF filter.

5 SHIFT FREQUENCY INDICATOR (p. 83)

Shows the shift frequency of the IF filter.

6 PASSBAND WIDTH INDICATOR (p. 83)

Graphically displays the passband width for twin PBT operation and the center frequency for IF shift operation.

7 BANDPASS FILTER INDICATOR

Appears when the narrow filter (500 Hz or less) is selected during SSB, CW, RTTY or PSK operation.

8 CLOCK READOUT

Shows the current time.

Local and UTC time can be displayed at the same time.

- Offset time period for UTC time can be set in the time set mode. (p. 123)

9 RTTY TUNING INDICATOR

Shows the tuning condition in the RTTY mode.

10 MODE INDICATOR

Shows the selected mode.

11 FREQUENCY READOUTS

Shows the operating frequency.

- Gray characters are used for not-selected readout.

12 MEMORY CHANNEL READOUTS

- Shows the selected memory channel contents in VFO mode.
- Shows the VFO contents in memory mode.

13 SELECT MEMORY CHANNEL INDICATOR (p. 117)

Displays the displayed memory channel is set as a select memory channel.

The select memory channels are used in the select scan operation. The desired memory channels can be assigned to 3 select groups, for fast, convenient scanning.

14 MULTI-FUNCTION SCREEN

Shows the screens for the multi-function digital meter, spectrum scope, voice recorder, memory list, scan, memory keyer, RTTY decoder, PSK decoder, IF filter selection, or set modes.

15 VFO/MEMORY CHANNEL INDICATOR (p. 28)

Displays the VFO mode or selected memory channel number.

16 LCD FUNCTION SWITCH GUIDE

Displays the function of the LCD function switches ([F-1] to [F-6]).

17 MULTI-FUNCTION SWITCH GUIDE

Displays the function of the multi-function switches.

18 TX INDICATOR

- “**TX**” appears while transmitting. (p. 40)
- Displays the frequency readout for transmit.
 - “**TX**” appears during an operating frequency is not in an amateur band. When the band edge warning beep is set to “OFF” (p. 34), “**TX**” does not appear.
 - Appears on the sub band readout when the split function is turned ON.

19 RIT INDICATOR

“**RIT**” appears when RIT function is in use.

20 ΔTX INDICATOR

“**ΔTX**” appears when ΔTX function is in use.

21 RIT/ΔTX SHIFT FREQUENCY INDICATOR

Shows the shift frequency for the RIT or ΔTX function.

22 NOTCH INDICATOR (p. 91)

- “**MN**” appears when the manual notch function is in use. This function is available in the SSB, CW, RTTY, PSK and AM modes.
- “**AN**” appears when the auto notch function is in use. This function is available in the SSB, AM and FM modes.

23 APF/TPF INDICATOR

- “**APF**” appears when the audio peak filter function is in use. This function is available in the CW mode. (p. 43)
- “**TPF**” appears when the twin peak filter function is in use. This function is available in the RTTY mode. (p. 51)

24 DUAL WATCH INDICATOR

“**DUAL-W**” appears when the dualwatch function is in use.

Screen menu arrangement

The following screens can be selected from the start-up screen. Choose the desired screen using the following chart.

Pushing [EXIT/SET] several times returns to the start-up screen. See page 127 for set mode arrangement.

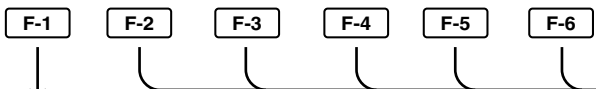

• Spectrum scope screen (p. 69)

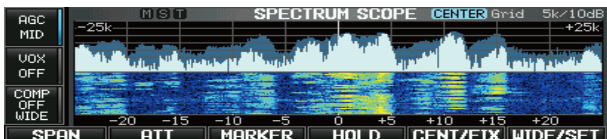

• Voice recorder screen* (p. 99)



• Memory keyer screen (CW mode; p. 44)



• RTTY decoder screen (RTTY mode; p. 50)



• PSK decoder screen (PSK mode; p. 58)



• Memory list screen (p. 108)



• Scan screen (VFO mode; p. 115)



• Scan screen (Memory mode; p. 117)

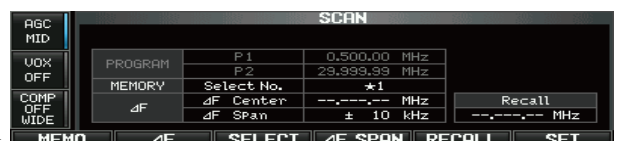

• Set mode menu screen (p. 126)

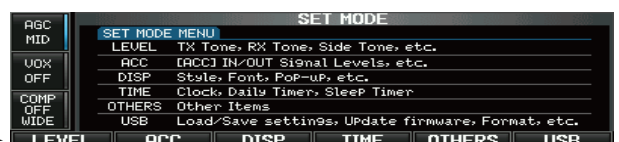

*Previously selected screen, TX or RX memory, is displayed. Push [T/R] (F-6) to switch the screen.

■ Unpacking

After unpacking, immediately report any damage to the delivering carrier or dealer. Keep the shipping cartons.

For a description and a diagram of accessory equipment included with the IC-7600, see 'Supplied accessories' on p. i of this manual.

■ Selecting a location

Select a location for the transceiver that allows adequate air circulation, free from extreme heat, cold, or vibrations, and away from TV sets, TV antenna elements, radios and other electromagnetic sources.

The base of the transceiver has adjustable feet for desktop use. Set the feet to one of two angles depending on your operating preference.

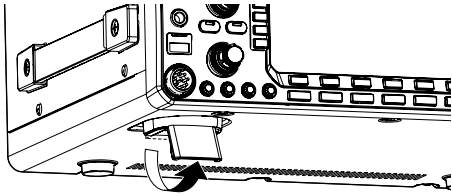

■ Grounding

To prevent electrical shock, television interference (TVI), broadcast interference (BCI) and other problems, ground the transceiver through the GROUND terminal on the rear panel.

For best results, connect a heavy gauge wire or strap to a long ground rod. Make the distance between the [GND] terminal and ground as short as possible.

⚠ **WARNING! NEVER** connect the [GND] terminal to a gas or electric pipe, since the connection could cause an explosion or electric shock.

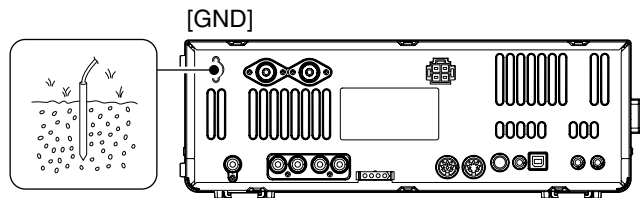

■ Antenna connection

For radio communications, the antenna is of critical importance, along with output power and receiver sensitivity. Select antenna(s), such as a well-matched 50 Ω antenna, and feedline. We recommend 1.5:1 or better of Voltage Standing Wave Ratio (VSWR) on your operating bands. The transmission line should be a coaxial cable.

When using a single antenna, use the [ANT1] connector.

⚡ **CAUTION:** Help protect your transceiver from lightning by using a lightning arrestor.

Antenna SWR

Each antenna is tuned for a specified frequency range and SWR may be increased out-of-range. When the SWR is higher than approximately 2.0:1, the transceiver's power drops to protect the final transistors. In this case, an antenna tuner is useful to match the transceiver and antenna. Low SWR allows full power for transmitting. The IC-7600 has an SWR meter to monitor the antenna SWR continuously.

Required connections

Front panel

CW KEY

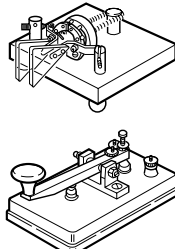

A straight key can be used when the internal electronic keyer is turned OFF in keyer set mode. (p. 49)

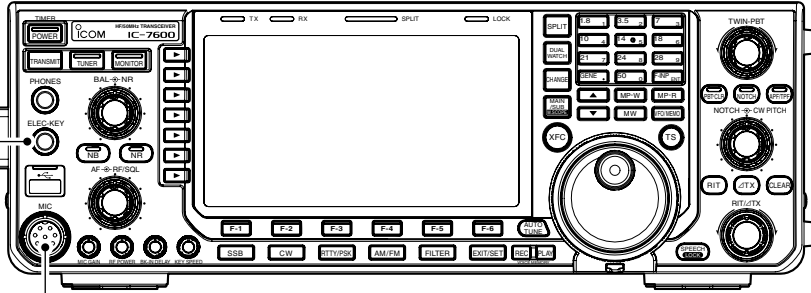

MICROPHONES (pp. 24, 25)

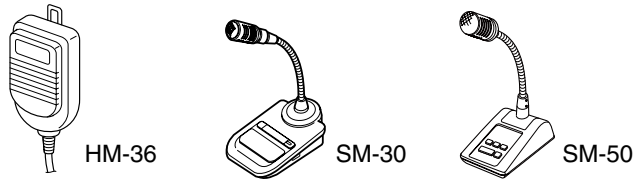

HM-36 SM-30 SM-50

Rear panel

ANTENNA 1, 2 (p. 16)
 [Example]: ANT1 for 1.8–18 MHz bands
 ANT 2 for 21–28 MHz bands

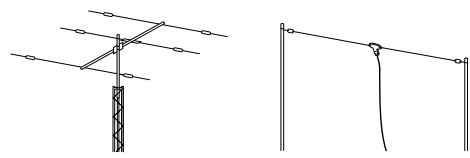

DC POWER SUPPLY (p. 20)

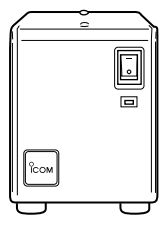

PS-126

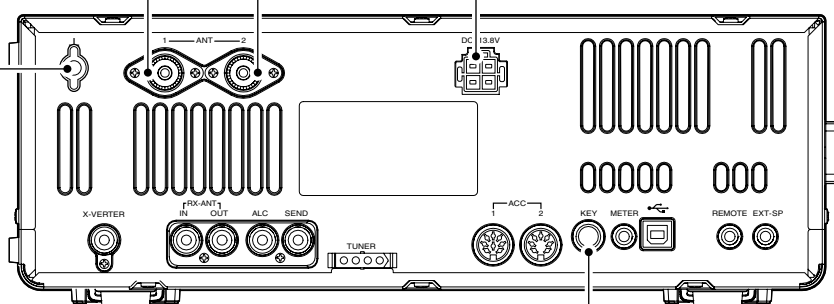

Labels on rear panel: ANT 1, ANT 2, DC 12.6V, X-VERTER, F/RX-ANT1 IN, OUT, ALC, SEND, TUNER, ACC 2, KEY, METER, REMOTE EXT-SP.

GROUND (p. 16)

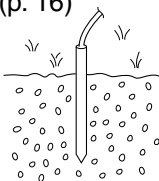

Use the heaviest gauge wire or strap available and make the connection as short as possible.

Grounding prevents electrical shocks, TVI and other problems.

STRAIGHT KEY

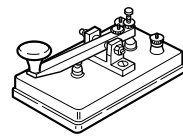

Advanced connections

Front panel

USB-MEMORY

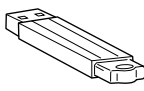

MOUSE

KEYBOARD
Connect a USB type PC keyboard for direct RTTY/PSK operation, as well as other text edit operations.



MIC
The AFSK modulation signal can also be input to [MIC].

HEADPHONES

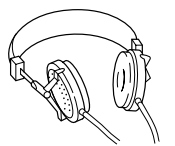

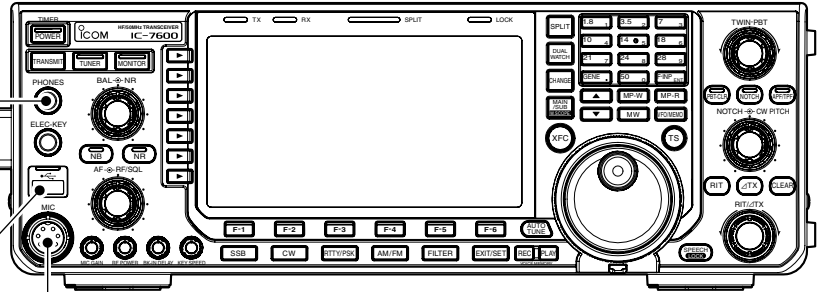

EXTERNAL KEYPAD
Connect an external keypad for direct voice memory, keyer memory, RTTY TX memory and PSK TX memory controls.

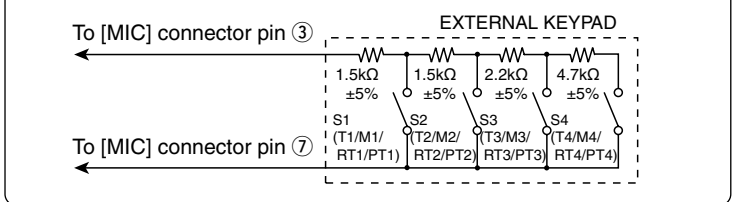

The diagram shows an external keypad with four switches (S1, S2, S3, S4) connected to the [MIC] connector pins 3 and 7. Each switch has a resistor in series: S1 (1.5kΩ ±5%), S2 (1.5kΩ ±5%), S3 (2.2kΩ ±5%), and S4 (4.7kΩ ±5%). The switches are labeled with their functions: S1 (T1/M1/RT1/PT1), S2 (T2/M2/RT2/PT2), S3 (T3/M3/RT3/PT3), and S4 (T4/M4/RT4/PT4).

Rear panel— 1

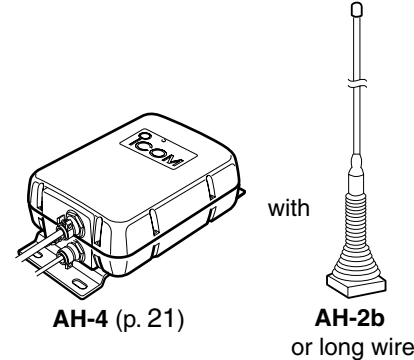

with

AH-4 (p. 21)

AH-2b
or long wire

[REMOTE] (p. 159)
Used for computer control and transceive operation. The optional CT-17 is required when connecting a PC to [REMOTE].

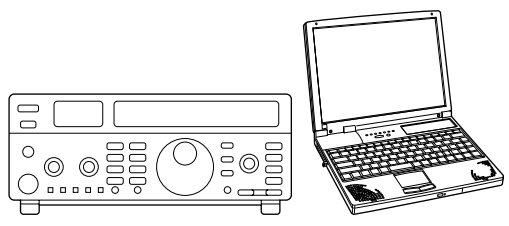

ANTENNA 1, 2 (p. 120)
Connect a linear amplifier, antenna selector, etc.

[X-VERTER]
Connect a transverter for VHF, UHF or other band use.

RX ANT IN/OUT
Connect an external preamp or lowpass filter.

The antenna connector must be selected as "ANT 1/R" or "ANT 2/R." (p. 3)

ACC SOCKETS 1, 2
(pp. 22, 26)

[ALC], [SEND] (p. 22)
Used to connect a non-com linear amplifier.

EXTERNAL SPEAKER
(p. 171)

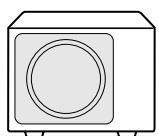

SP-23 (option)

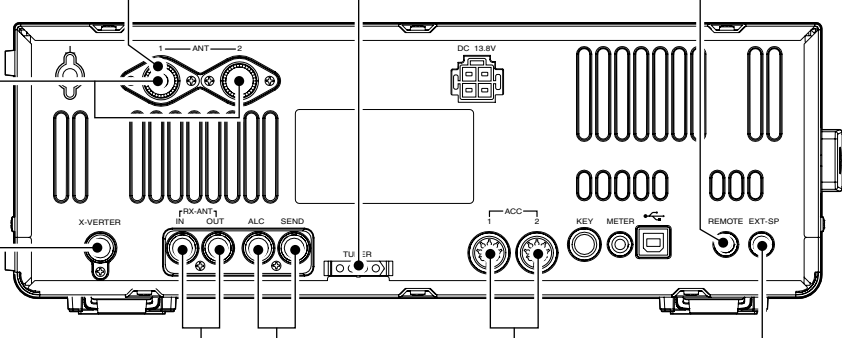

◇ Rear panel— 2

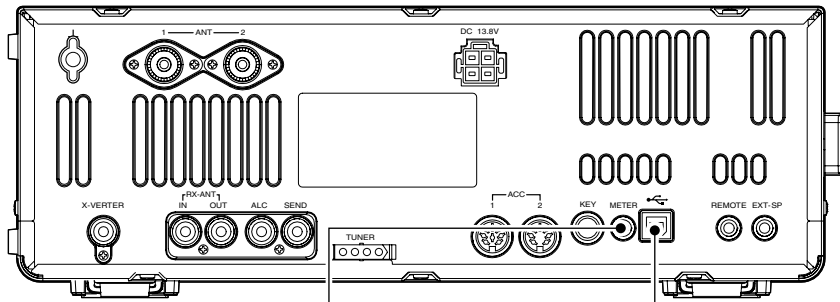

[METER]

Connect an external meter, etc.

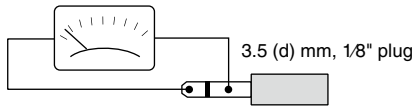

Output impedance : 4.7 kΩ
 Output voltage (open circuit) : 2.5 V (default)
 Output voltage can be adjusted 0 to 5 V
 in ACC set mode. (p. 133)

[USB] (B)

When the transceiver is connected to a PC, a USB cable (user supplied) should be connected to the USB connector (B type) on the rear panel. (p. 11)

■ USB connection

Connect the USB-Memory* to the USB connector (A type) on the front panel.

- Unmount operation is recommended before removing the USB-Memory*. (p.150)

/// Be sure to connect the USB-Memory correctly.
 /// **NEVER** connect or remove the USB-Memory when the read/write indicator is lit or blinks.

/// A USB keyboard* or a USB hub* can also be connected to the USB connector.

* USB-Memory, USB keyboard and USB hub are not supplied by Icom.

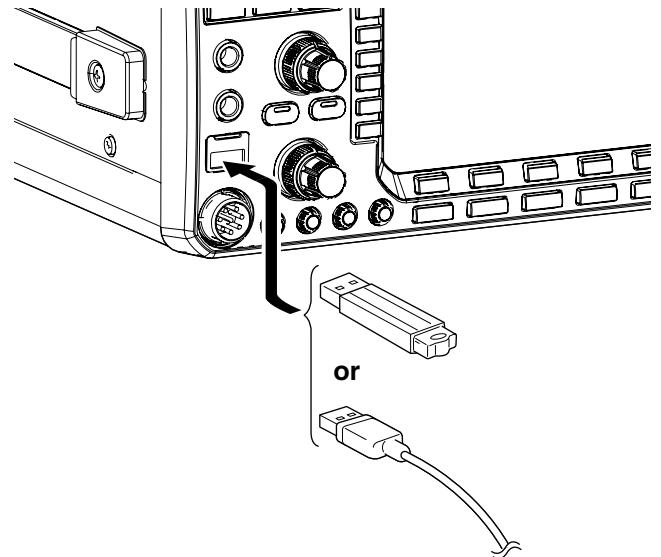

■ Power supply connections

Connect the optional PS-126 to the transceiver.
 If you use a non-Icom power supply, be sure that the output voltage of the power supply is 13.8 V DC \pm 15% with 23 A capacity at least.

CAUTION: Before connecting the DC power cable, check the following important items. Make sure:

- The **[POWER]** switch is OFF.
- DC power cable polarity is correct.
 Red: Positive \oplus terminal
 Black: Negative \ominus terminal

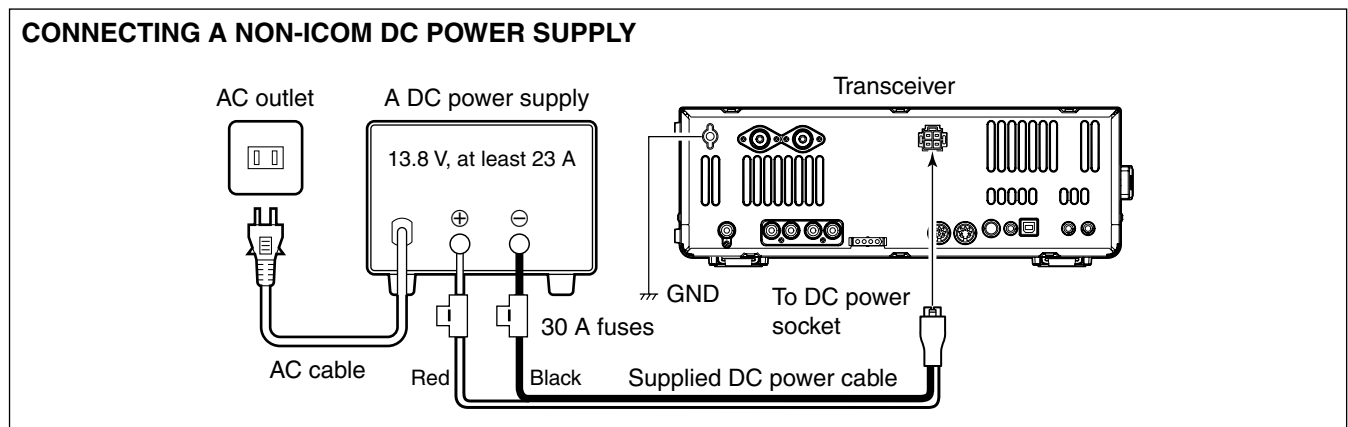
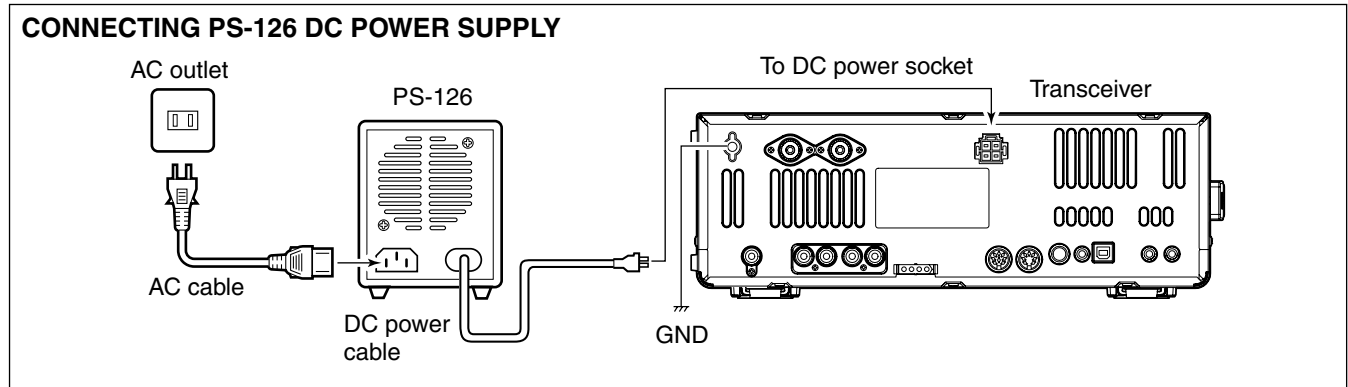

External antenna tuner connection

The AH-4 and AH-740 Automatic antenna tuner automatically matches the IC-7600 to the connected antenna.

NOTE: Before connecting, be sure to turn OFF the transceiver's power.

Connecting an AH-4

The optional AH-4 matches the IC-7600 to a long wire antenna more than 7 m/23 ft long (3.5 MHz and above).

- See page 122 for operation.
- See the AH-4 instruction manual for installation and connection details.

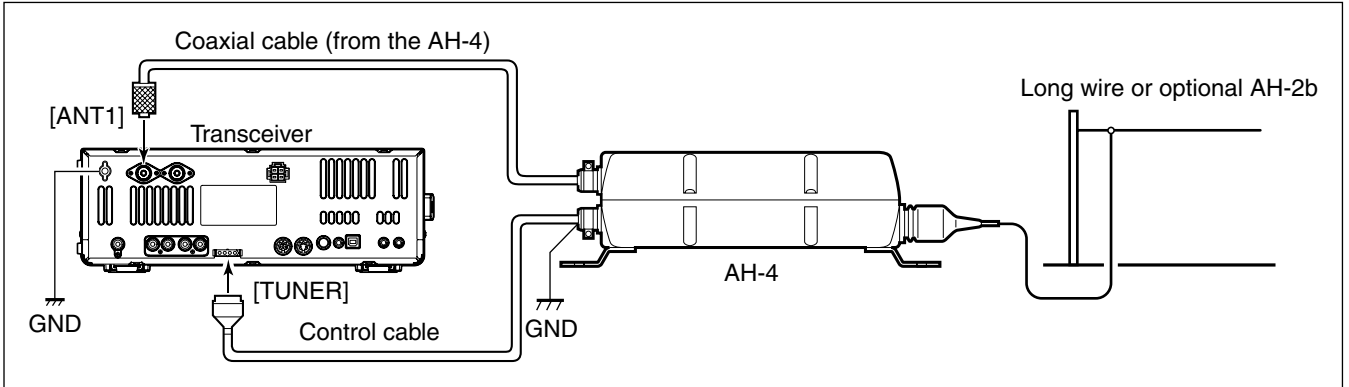

Connecting an AH-740

The optional AH-740 covers 2.5 to 30 MHz range with a supplied whip antenna element. Or when using with the optional NVIS kit, it covers 2.2 to 30 MHz range.

- See page 122 for operation.
- See the AH-740 instruction manual for the installation and connection details.

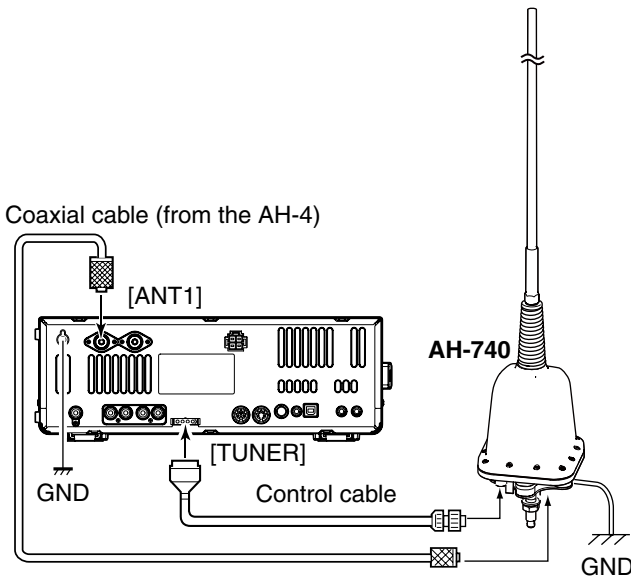

The coaxial cable is supplied with the AH-740. The OPC-2321 Controls cable is optional.

Coaxial cable and control cable connections

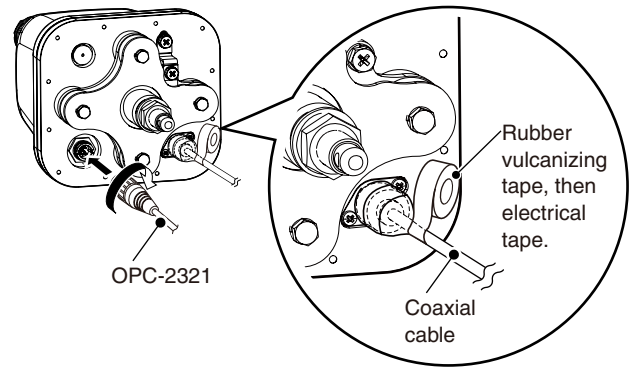

About the ground strap connection

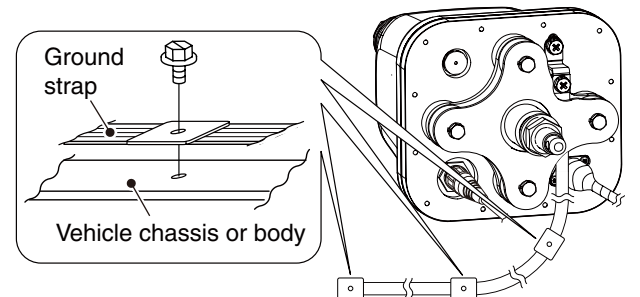

Linear amplifier connections

Connecting the IC-PW1/EURO

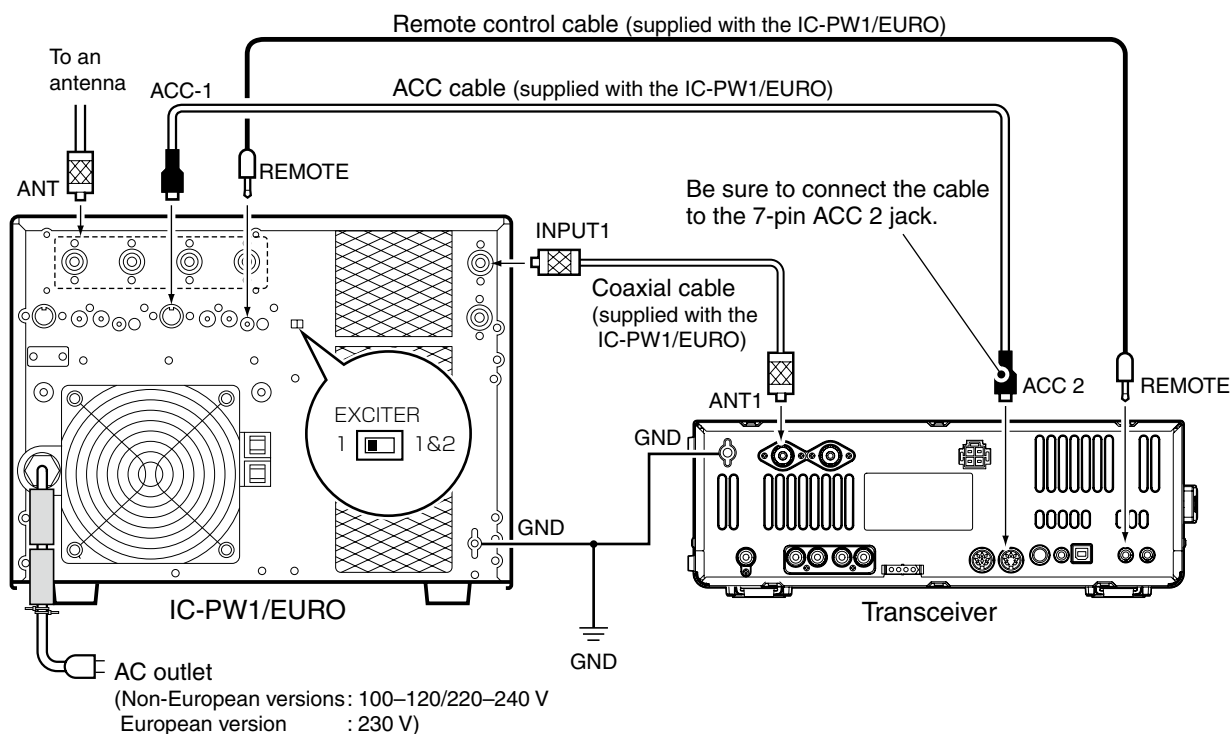

Connecting a non-Icom linear amplifier

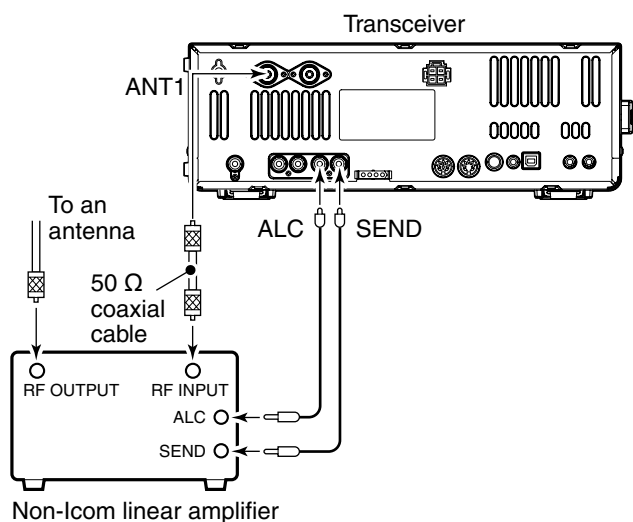

⚠ WARNING!

Set the transceiver output power and linear amplifier ALC output level after referring to the linear amplifier instruction manual.

The ALC input level must be in the range 0 V to -4 V. The transceiver does not accept positive voltage. Non-matched ALC and RF power settings could overheat or damage the linear amplifier.

The maximum signal level of [SEND] jack is 16 V/ 0.5 A DC with initial setting, and 250 V/ 200 mA with "MOSFET" setting (see page 133 for details). Use an external relay unit if your non-Icom linear amplifier requires control voltage and/or current greater than specified.

When using a linear amplifier that has a time delay between receiving and transmitting, a high SWR might cause the linear amplifier to malfunction. To prevent this, slow the TX Delay the "TX Delay (HF), (50M)" settings in the others set mode. (pp. 136, 137)

■ Transverter jack information

When 2 to 13.8 V is applied to pin 6 of [ACC 2], the [X-VERTER] connector is activated for transverter operation and the antenna connectors do not receive or transmit any signals.

While receiving, the [X-VERTER] connector can be activated as an input terminal from an external transverter.

While transmitting, the [X-VERTER] connector outputs signals of the displayed frequency at -20 dBm (22 mV) as signals for the external transverter.

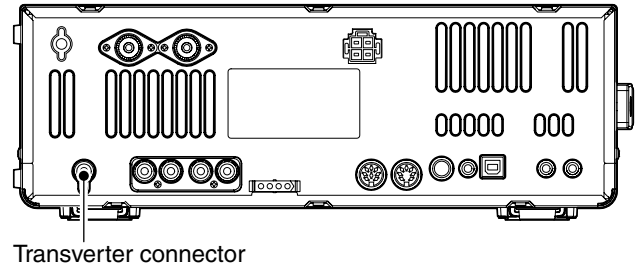

■ FSK and AFSK connections

The transceiver has a Modem function for RTTY and PSK. However, if you want to use a PC to operate these digital modes, it is necessary to prepare the following interface circuit, or use a similar 3rd party device.

Refer to the instruction manual for the device prior to connecting it.

◇ When using the ACC socket or the microphone connector

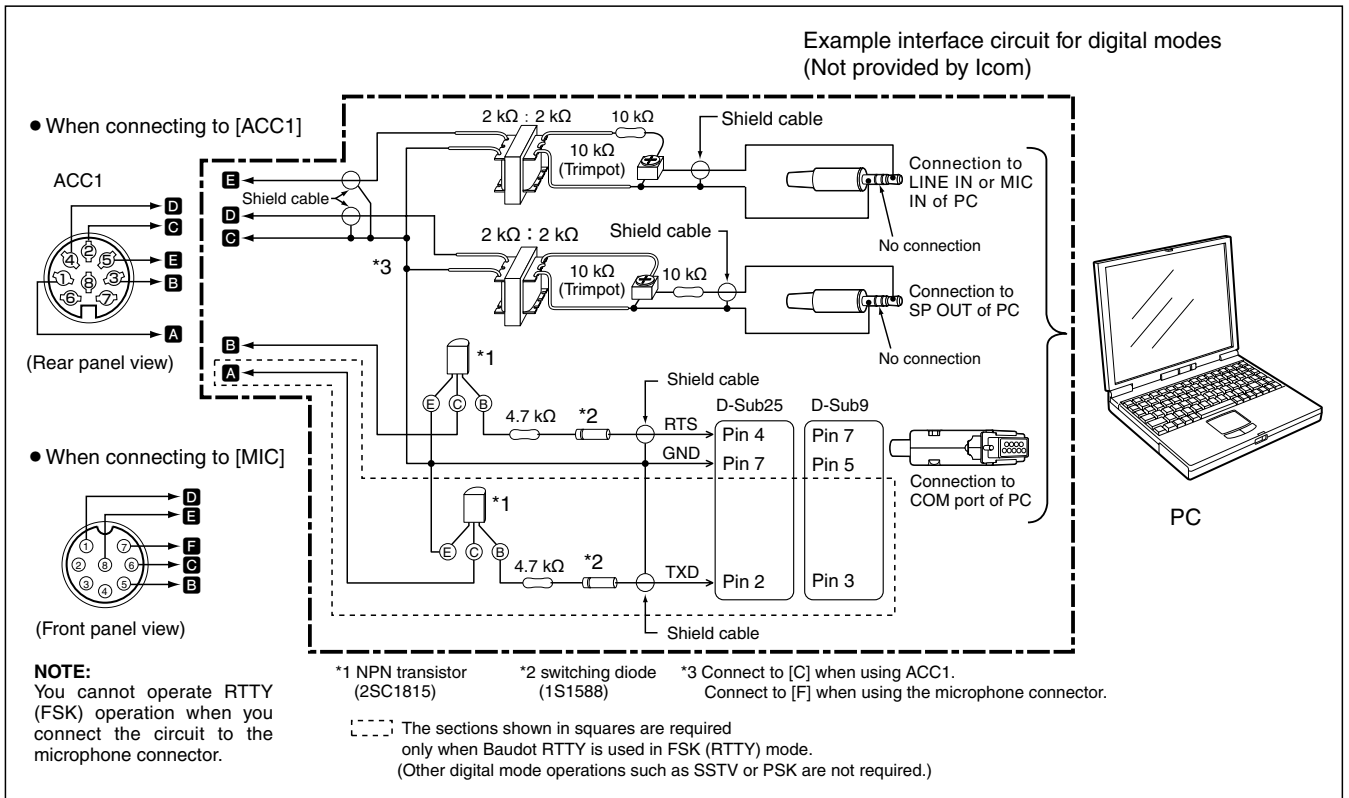

◇ When connecting to the USB connector

Connect a USB cable (user supplied) between the transceiver's USB connector [USB] (B) on the rear panel and the PC. (p. 19)

• The USB driver and the installation guide can be downloaded from our website (<http://www.icom.co.jp/world/index.html>).

Microphone connector information

(Front panel view)

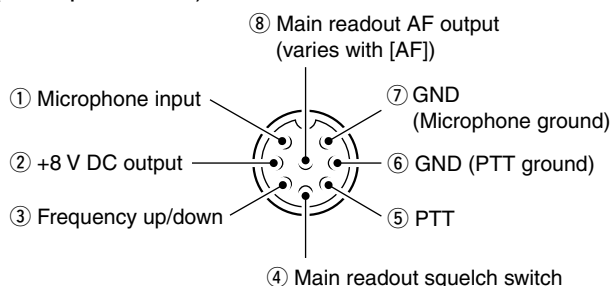

[MIC] Pin No.	FUNCTION	DESCRIPTION
②	+8 V DC output	Max. 10 mA
③	Frequency up	Ground
	Frequency down	Ground through 470 Ω
④	Squelch open	"Low" level
	Squelch closed	"High" level

CAUTION: DO NOT short pin 2 to ground as this can damage the internal 8 V regulator. DC voltage is applied to pin 1 for microphone operation. Use caution when using a non-Icom microphone.

Microphones

◇ HM-36

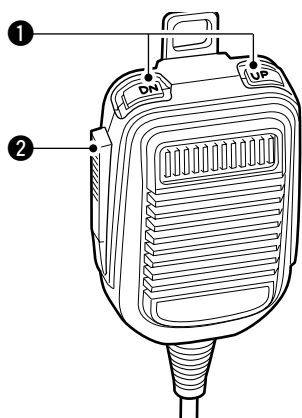

① UP AND DOWN SWITCHES [UP]/[DN]

Change the selected readout frequency or memory channel.

- Holding down continuously changes the frequency or memory channel.
- While holding down [XFC], the transmit readout frequency can be controlled while in the split frequency mode.
- The [UP] and [DN] switches can simulate a key paddle. Preset in the keyer set mode. (p. 49)

② PTT SWITCH

Hold down to transmit, release to receive.

2 INSTALLATION AND CONNECTIONS

■ Microphones (Continued)

◇ SM-50

TOP VIEW

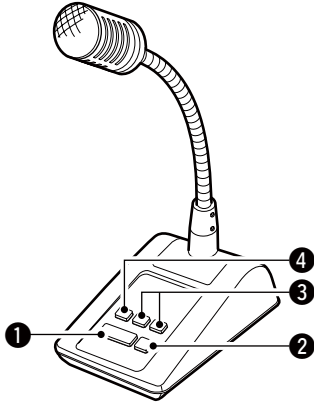

BOTTOM VIEW

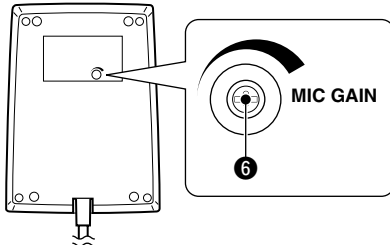

① PTT SWITCH

Hold down to transmit, release to receive.

② PTT LOCK SWITCH

Push to lock the PTT switch in the transmit mode.

③ UP/DOWN SWITCHES [UP]/[DN]

Change the selected readout frequency or memory channel.

- Holding down continuously changes the frequency or memory channel.
- While holding down [XFC], the transmit readout frequency can be controlled while in the split frequency mode.
- The [UP]/[DN] switch can simulate a key paddle. Preset in the keyer set mode. (p. 49)

④ LOW CUT SWITCH

Push (SM-50)/Slide (SM-30) to cut out the low frequency components of input voice signals.

⑤ PTT LOCK INDICATOR [LOCK]

(Only for the SM-30)

Lights red when the PTT lock switch (②) is ON.

⑥ MIC GAIN VOLUME [MIC GAIN]

Rotate to adjust the microphone output level.

- Use this control as an addition to the microphone gain setting of the transceiver.

Rotating the control too far clockwise may result in an output level that is too high and transmit signal distortion.

◇ SM-30

TOP VIEW

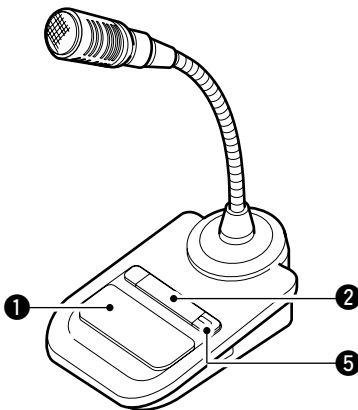

BOTTOM VIEW

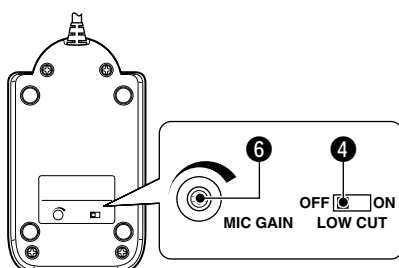

■ Accessory socket information

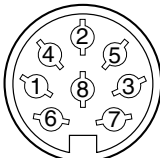
ACC 1	PIN No.	NAME	DESCRIPTION	SPECIFICATIONS	
	1	RTTY	Controls RTTY keying	“High” level : More than 2.4 V “Low” level : Less than 0.6 V Output current : Less than 2 mA	
	2	GND	Connects to ground.	Connected in parallel with ACC 2 pin 2.	
	3	SEND*	Input/output pin. Connected in parallel with ACC 2 pin 3.	An external equipment controls the transceiver. When this pin goes low, the transceiver transmits. The pin outputs a low level signal when the transceiver transmits.	Input voltage (TX) : 2.0 V to 20.0 V Input voltage (RX) : -0.5 V to 0.8 V Current flow : Max. 20 mA Output voltage (TX) : Less than 0.1 V Current flow : Max. 200 mA
	4	MOD	Modulator input. Connects to the internal modulator circuit.	Input impedance : 10 kΩ Output level : Approximately 100 mV rms	
	5	AF	AF detector output. Fixed, regardless of [AF] position in default settings. (see NOTE below)	Output impedance : 4.7 kΩ Output level : 100–300 mV rms	
	6	SQLS	Squelch output. Grounded when the squelch opens.	SQL open : Less than 0.3 V/5 mA SQL closed : More than 6.0 V/100 μA	
	7	13.8 V	13.8 V output when power is ON. Connected in parallel with ACC 2 pin 7.	Output current : Max. 1 A	
	8	ALC	ALC voltage input. Connected in parallel with ACC 2 pin 5.	Input impedance : More than 10 kΩ Input level : -4 V to 0 V	

NOTE: If the CW sidetone level limit or beep level limit is in use, the CW sidetone or beep tone decreases from the fixed level when the [AF] control is rotated above a specified level. (p. 130)

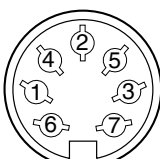
ACC 2	PIN No.	NAME	DESCRIPTION	SPECIFICATIONS
	1	8 V	Regulated 8 V output.	Output voltage : 8.0 V ±0.3 V Output current : Less than 10 mA
	2	GND	Same as ACC 1 pin 2.	
	3	SEND*	Same as ACC 1 pin 3.	
	4	BAND	Band voltage output. (Varies with selected amateur band)	Output voltage : 0 V to 8.0 V
	5	ALC	Same as ACC 1 pin 8.	
	6	TRV	Activates [X-VERTER] input/output when “HIGH” voltage is applied.	Input impedance : More than 10 kΩ Input voltage : 2 V to 13.8 V
	7	13.8 V	Same as ACC 1 pin 7.	

* When the SEND terminal controls the inductive load (such as a relay), a counter-electromotive force can cause the transceiver’s malfunction or damage. To prevent this, we recommend adding a switching diode, such as an “1SS133,” on the load side of the circuit to the counter-electromotive force absorption. When the diode is added, a switching delay of the relay may occur. Be sure to check its switching action before operation.

[Example]

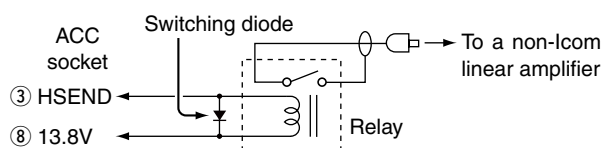

■ Before first applying power

Before first applying power, make sure all connections required for your system are complete by referring to Chapter 2.

After all connections have been done, set controls and switches as shown in the figure below.

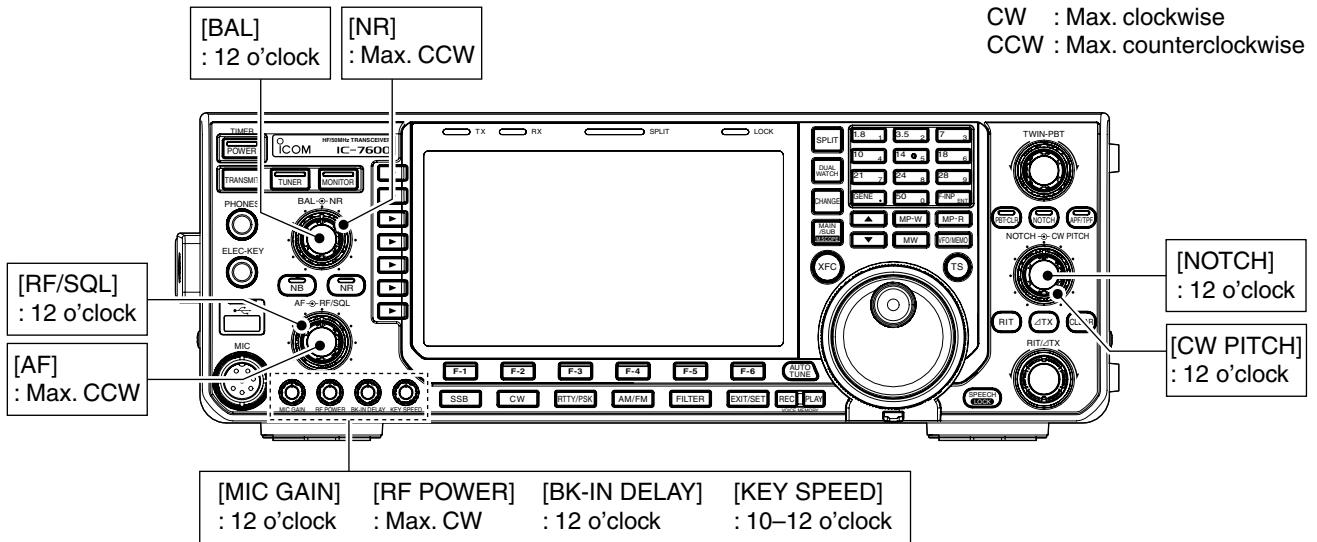

■ Applying power (CPU resetting)

First applying power:

Reset the transceiver using the following procedure.

Resetting **CLEARs** all programmed contents in memory channels and returns programmed values in the set mode to default values.

- ① Make sure the transceiver power is OFF.
- ② While holding down [F-INP ENT] and [MW], push [POWER] to turn power ON.
 - The CPU is reset.
 - The CPU start-up takes approximately 5 seconds.
 - The transceiver displays its initial VFO frequencies when resetting is complete.
- ③ Change the set mode settings after resetting, if desired.

Normal applying power:

Push [POWER] to turn power ON, then check the display. When any of indicators appear, turn them OFF if necessary. (See the appropriate page for details.)

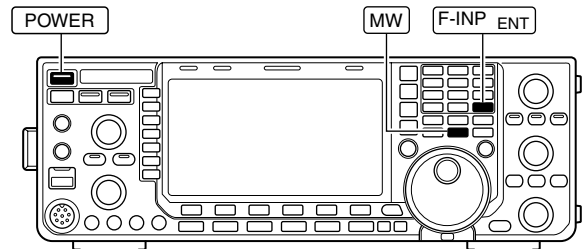

■ Selecting VFO/memory mode

- ➔ Push **[VFO/MEMO]** to switch between VFO and memory modes.
 - “VFO” appears when in VFO mode, or the selected memory channel number appears when in memory mode.
 - Holding down **[VFO/MEMO]** for 1 second transfers the contents of the selected memory channel to VFO mode. (p. 110)

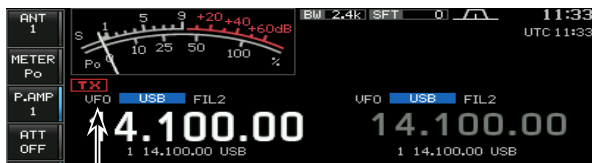

“VFO” indicator

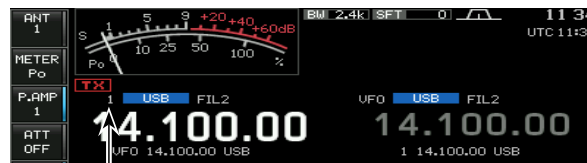
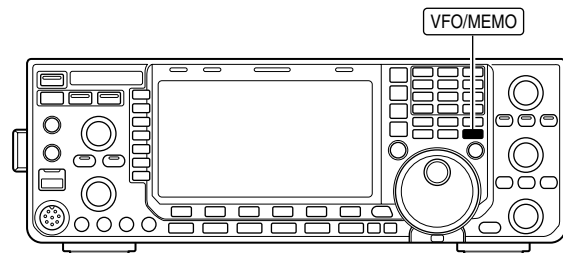

Memory channel number

3

■ Main/Sub band selection

The IC-7600 has a main and a sub band. The main band is displayed on the left hand side, and the sub band is displayed on the right hand side of the LCD. Some functions can only be applied to the selected band, and transmission occurs on only the main band (except during split frequency operation).

- ➔ Push **[MAIN/SUB M.SCOPE]** to select access to the main or sub band readout.
 - The selected readout frequency is displayed clearly. The sub readout functions only during split operation or dualwatch.

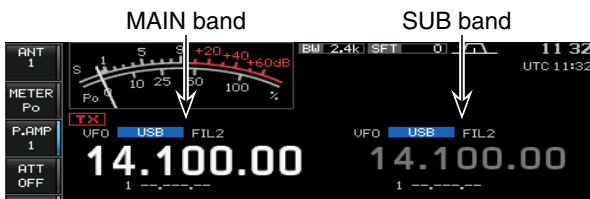
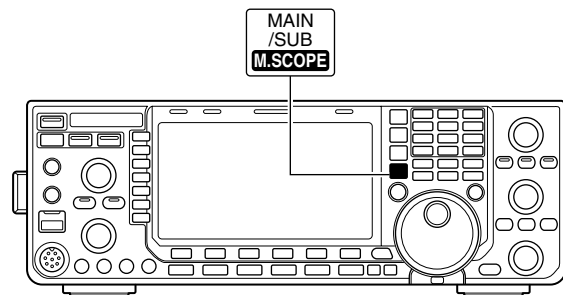

Access to MAIN band

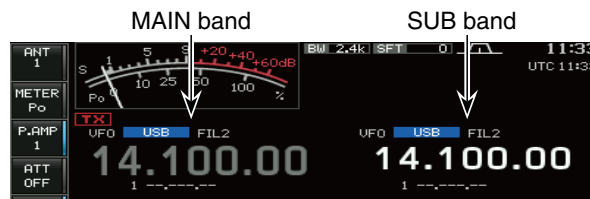

Access to SUB band

◇ Main/Sub band switching

- ➔ Push **[CHANGE]** to switch the frequency and selected memory channel between main and sub readouts.
 - Switches between transmit frequency and receive frequency when the split frequency function is ON. (p. 96)

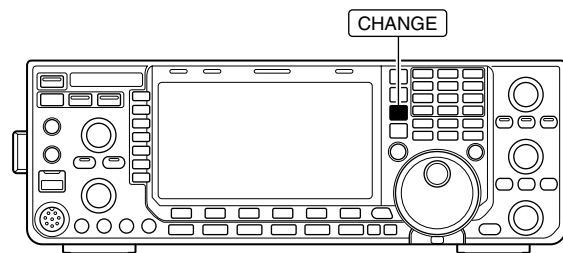

◇ Main/Sub band equalization

- ➔ Hold down **[CHANGE]** for 1 second to equalizes the sub band readout to the main band readout.

■ Selecting an operating band

The triple band stacking register provides 3 memories for each band key, for storing frequency and mode information.

This function is convenient when you operate 3 operating modes on one band. For example, one register is used for a CW frequency, another for a SSB frequency and the other one for a RTTY frequency.

If a band key is pushed once, the frequency and operating mode last used are called up. When the key is pushed again, another stored frequency and operating mode are called up.

See the table below for a list of the bands available and the default settings for each band.

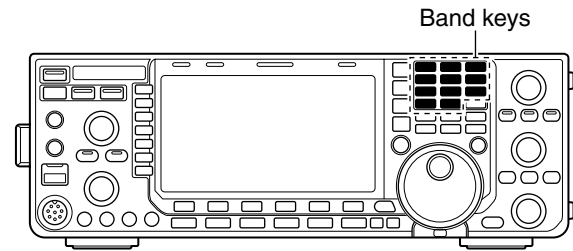

BAND	REGISTER 1	REGISTER 2	REGISTER 3
1.8 MHz	1.900000 MHz CW	1.910000 MHz CW	1.915000 MHz CW
3.5 MHz	3.550000 MHz LSB	3.560000 MHz LSB	3.580000 MHz LSB
7 MHz	7.050000 MHz LSB	7.060000 MHz LSB	7.020000 MHz CW
10 MHz	10.120000 MHz CW	10.130000 MHz CW	10.140000 MHz CW
14 MHz	14.100000 MHz USB	14.200000 MHz USB	14.050000 MHz CW
18 MHz	18.100000 MHz USB	18.130000 MHz USB	18.150000 MHz USB
21 MHz	21.200000 MHz USB	21.300000 MHz USB	21.050000 MHz CW
24 MHz	24.950000 MHz USB	24.980000 MHz USB	24.900000 MHz CW
28 MHz	28.500000 MHz USB	29.500000 MHz USB	28.100000 MHz CW
50 MHz	50.100000 MHz USB	50.200000 MHz USB	51.000000 MHz FM
General	15.000000 MHz USB	15.100000 MHz USB	15.200000 MHz USB

◇ Using the band stacking registers

[Example]: 14 MHz band

- ① Push **[14 5]**, then select a frequency and an operating mode.
 - The previously selected frequency and an operating mode are memorized in the first band stacking register of that band.
- ② Push **[14 5]** again, then select another frequency and operating mode.
 - The frequency and operating mode that is selected in step ① are memorized in the 14 MHz's first band stacking register.
- ③ Push **[14 5]** again, then select another frequency and operating mode.
 - The frequency and operating mode that is selected in step ② are memorized in the 14 MHz's second band stacking register.
- ④ Push **[14 5]** again, then select another frequency and operating mode.
 - The frequency and operating mode that is selected in step ③ are memorized in the 14 MHz's third band stacking register.
 - When **[14 5]** is pushed again, the first band stacking register set in step ②, is overwritten.

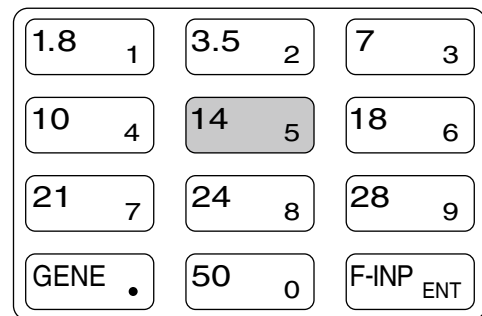

Frequency setting

The transceiver has several tuning methods for convenient frequency tuning.

◇ Tuning with the main dial

- ① Push the desired band key on the keypad 1–3 times.
 - 3 different frequencies can be selected on each band with the band key. (See previous page “Using the band stacking registers.”)
- ② Rotate the main dial to set the desired frequency.

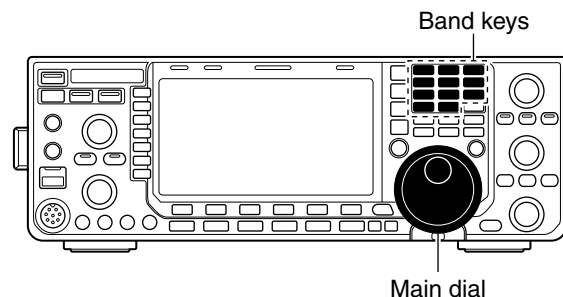

If the dial lock function is activated, the lock indicator lights, and the main dial does not function. In this case, hold down **[SPEECH/LOCK]** for 1 second to deactivate the lock function. (p. 90) When “LOCK/SPEECH” is selected in “[SPEECH/LOCK] Switch” item in the Others set mode, pushing **[SPEECH/LOCK]** deactivates the lock function. (see page 139 for details)

◇ Direct frequency entry with the keypad

The transceiver has a keypad for direct frequency entry as described below.

- ① Push **[F-INP ENT]**.
 - “**F-INP**” indicator appears.
- ② Input the desired frequency.
 - Push **[GENE •]** to input “.” (decimal point) between the MHz units and kHz units.
- ③ Push **[F-INP ENT]** to set the input frequency.
 - To cancel the input, push **[EXIT/SET]**.

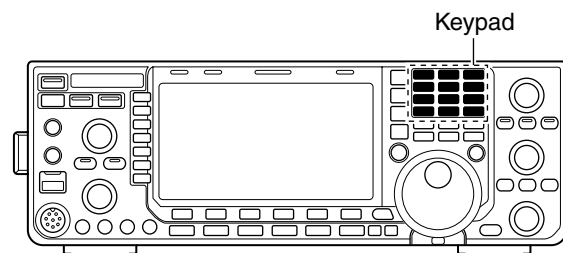

[EXAMPLE]

14.025 MHz

[F-INP ENT] [1.8 1] [10 4] [GENE •] [50 0] [3.5 2] [14 5] [F-INP ENT]

18.0725 MHz

[F-INP ENT] [1.8 1] [24 8] [GENE •] [50 0] [21 7] [3.5 2] [14 5] [F-INP ENT]

706 kHz

[F-INP ENT] [50 0] [GENE •] [21 7] [50 0] [18 6] [F-INP ENT]

5.100 MHz

[F-INP ENT] [14 5] [GENE •] [1.8 1] [F-INP ENT]

7.000 MHz

[F-INP ENT] [21 7] [F-INP ENT]

21.280 MHz ↔ 21.245 MHz

[F-INP ENT] [GENE •] [3.5 2] [10 4] [14 5] [F-INP ENT]

◇ **About the 5 MHz band operation (USA version only)**

Operation on the 5 MHz frequency band is allowed on 5 discrete frequencies and must adhere to the following:

- The USB, USB Data, CW and PSK modes
- Maximum of 100 watts ERP (Effective Radiated Power)
- 2.8 kHz bandwidth (maximum)

It is your responsibility to set all controls so that transmission in this frequency band meets the stringent conditions under which amateur operations may use these frequencies.

/// **NOTE:** We recommend that you store these frequencies, modes and filter settings into memory channels, for easy recall.

To assist you in operating within the rules specified by the FCC, transmission is illegal on any frequencies other than the five shown in the tables to the right.

• **For the USB and USB Data modes**

The FCC specifies center frequencies on the 5 MHz frequency band. However, the transceiver displays carrier frequency. Therefore, tune the transceiver to 1.5 kHz below the specified FCC channel center frequency.

Transceiver Displayed Frequency	FCC Channel Center Frequency
5.33050 MHz	5.33200 MHz
5.34650 MHz	5.34800 MHz
5.35700 MHz	5.35850 MHz
5.37150 MHz	5.37300 MHz
5.40350 MHz	5.40500 MHz

• **For the CW and PSK modes**

The transceiver displays the center frequency. Therefore, tune the transceiver to the specified FCC channel frequency when you operate in these modes.

Transceiver Displayed Frequency	FCC Channel Center Frequency
5.33200 MHz	5.33200 MHz
5.34800 MHz	5.34800 MHz
5.35850 MHz	5.35850 MHz
5.37300 MHz	5.37300 MHz
5.40500 MHz	5.40500 MHz

◇ Quick tuning step

The operating frequency can be changed in larger steps (0.1, 1, 5, 9, 10, 12.5, 20 or 25 kHz selectable) for quick tuning.

- ① Push **[TS]** to turn the quick tuning function ON.
 - “▼” appears when the quick tuning function is ON.
- ② Rotate the main dial to change the frequency in programmed kHz steps.
- ③ Push **[TS]** again to turn the quick tuning function OFF.
 - “▼” disappears.
- ④ Rotate the main dial for normal tuning, if desired.

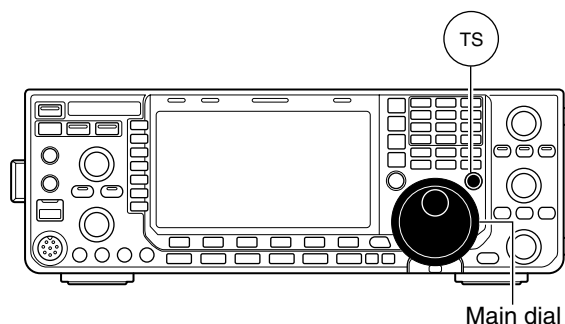

◇ Selecting “kHz” step

- ① Push **[TS]** to turn the quick tuning function ON.
 - “▼” appears when the quick tuning function is ON.
- ② Hold down **[TS]** for 1 second to select the quick tuning step set mode.
 - Selected tuning steps for all modes appear.
- ③ Select the desired operating mode.
- ④ Rotate the main dial to select the desired tuning step.
 - Hold down **[DEF] (F-4)** for 1 second to return to the default setting, if desired.
- ⑤ Repeat steps ③ and ④ to select quick tuning steps for other modes, if desired.
- ⑥ Push **[EXIT/SET]** to exit the setting display.

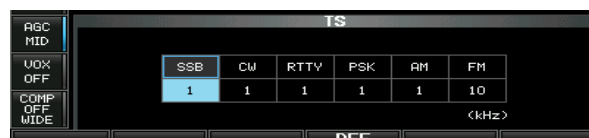
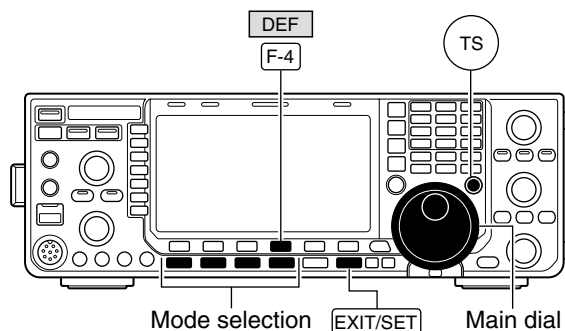

NOTE: When entering the quick tuning step set mode, the quick tuning function must be activated first.

◇ Selecting 1 Hz step

A minimum tuning step of 1 Hz can be used for fine tuning.

- ① Push **[TS]** to turn the quick tuning function OFF.
- ② Hold down **[TS]** for 1 second to turn the 1 Hz tuning step ON or OFF.

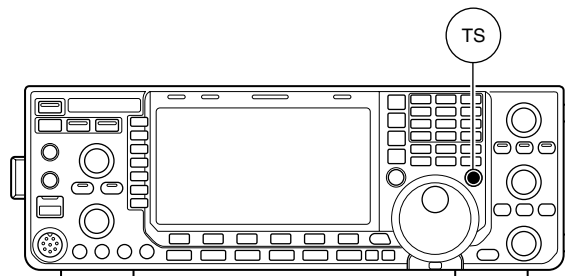

NOTE:

- RIT and/or Δ TX also functions in 1 Hz tuning steps when used.
- The frequency is changed in 50 Hz steps when the **[UP]/[DN]** switches of the microphone are used for the frequency setting (when the programmable tuning step is not selected.)

1 Hz step indicator

3 BASIC OPERATION

◇ Auto tuning step function

When rotating the main dial rapidly, the tuning speed automatically accelerates, as selected.

- ① Push **[EXIT/SET]** several times to close any multi-function screens, if necessary.
- ② Push **[SET] (F-6)** to select the set mode menu screen.
 - Holding down **[EXIT/SET]** for 1 second also selects the set mode menu screen.
- ③ Push **[OTHERS] (F-5)** to select the Others set mode.
- ④ Push **[▲] (F-1)** or **[▼] (F-2)** to select "MAIN DIAL Auto TS."
- ⑤ Rotate the main dial to select the desired tuning speed, between HIGH, LOW and OFF.
 - **HIGH** : Approximately 5 times faster when the tuning step is set to 1 kHz or smaller steps.
Approximately 2 times faster when the tuning step is set to 5 kHz or larger steps.
 - **LOW** : Approximately 2 times faster
 - **OFF** : Auto tuning step is turned OFF.
- ⑥ Push **[EXIT/SET]** to exit the set mode.

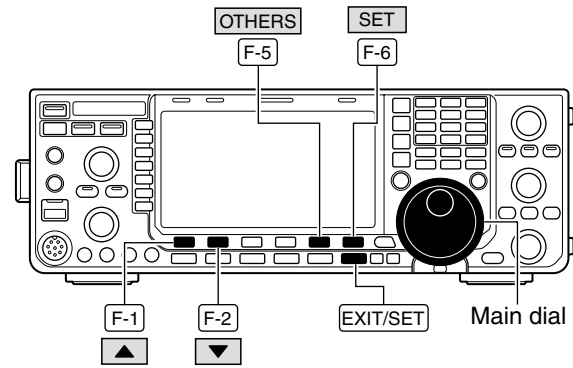

HIGH (default)

◇ 1/4 tuning step function

When operating in SSB data, CW, RTTY or PSK, the 1/4 tuning function is available. Dial speed is reduced to 1/4 of the normal speed when the 1/4 tuning function is ON, for finer tuning control.

- Push **[1/4] (MF7)** to toggle the 1/4 tuning function ON or OFF.
 - "**1/4**" appears when the 1/4 tuning function is ON.

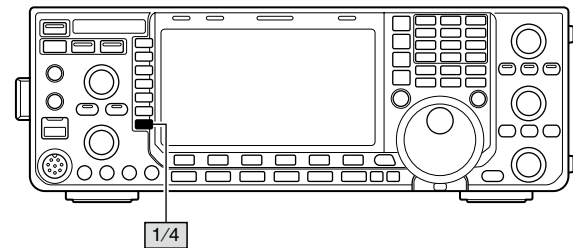

1/4 tuning step OFF



1/4 tuning step ON

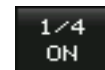

◇ Band edge warning beep

This function allows you to hear a beep tone when you tune in or out of an amateur band's frequency range. A regular beep sounds when you tune into a range, and a lower tone error beep will sound when you tune out of a range. Also, the TX indicator shows if the selected frequency is in or out of an amateur band, when an option other than "OFF" is set.

- A TX indicator with a dotted, "TX" is displayed, instead of the regular "TX" TX indicator, when a frequency outside of an amateur band frequency range is selected.

- ① Push **[EXIT/SET]** several times to close any multi-function screens, if necessary.
- ② Push **[SET] (F-6)** to select the set mode menu screen.
 - Holding down **[EXIT/SET]** for 1 second also selects the set mode menu screen.
- ③ Push **[OTHERS] (F-5)** to select the Others set mode.
- ④ Push **[▲] (F-1)** or **[▼] (F-2)** to select "Beep (Band Edge)."
- ⑤ Rotate the main dial to select the desired band edge warning beep setting.
 - OFF : Band edge beep is OFF.
 - ON (Default) : A low beep sounds when you tune out of, and a high beeps sound when you tune into the set band. (default)
 - ON (User) : A low beep sounds when you tune out of, and a high beep sounds when you tune into the user set band.
 - ON (User) & TX Limit : A low beep sounds when you tune out of, and a high beep sounds when you tune into the user set band. Also, the solid border around "TX" becomes a dotted border.
- ⑥ Push **[EXIT/SET]** to exit the set mode.

▨ The beep output level can be set in the level set mode. (p. 131)

When the transverter function is in use, the band edge warning beep sounds with the default setting.

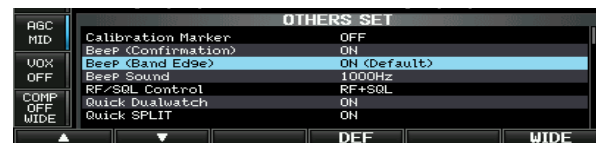
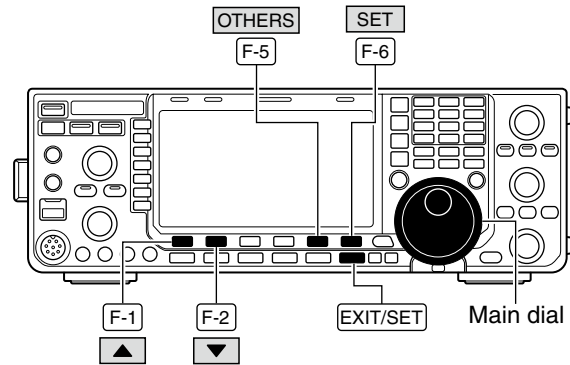

ON (Default)

Appears when "ON (User)" or "ON (User) & TX Limit" is selected,

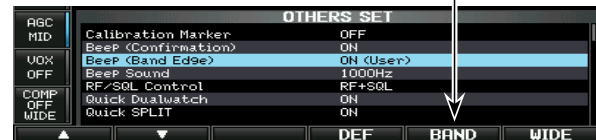

ON (User)

☞ Continued on the next page.

3 BASIC OPERATION

◇ Band edge warning beep (Continued)

To programming the band edge:

- ① Perform the steps ① to ⑤ as shown above, then select either “ON (User)” or “ON (User) & TX Limit” setting.
 - **[BAND]** appears above the function switch (F-5).
- ② Push **[BAND] (F-5)** to open the band edge screen.
- ③ Push **[▲] (F-1)** or **[▼] (F-2)** to select the desired band edge.
 - Push **[◀ ▶] (F-3)** to select the upper and lower band edge frequency entry cell.
 - Push **[INS] (MF6)** to insert a new blank band edge line.
 - Hold down **[DEL] (MF7)** for 1 second to delete the selected band edge line.
- ④ Input the desired frequency with the keypad, then push **[F-INP•ENT]**.
 - Push **[GENE •]** to input decimal point (“.”) between the MHz and kHz digits.
 - Program each channel from left to right and each frequency must be higher than the preceding frequency.
 - The frequency that is duplicated, or out of an amateur band, cannot be programmed.
 - If you want to return the band edge frequencies to their default (initial) value, hold down **[DEF] (F-4)** for 1 second. The band edge initialize screen appears, then hold down **[OK] (F-5)** for 1 second to initialize all band edge frequency settings.
- ⑤ Push **[EXIT/SET]** to exit the set mode.

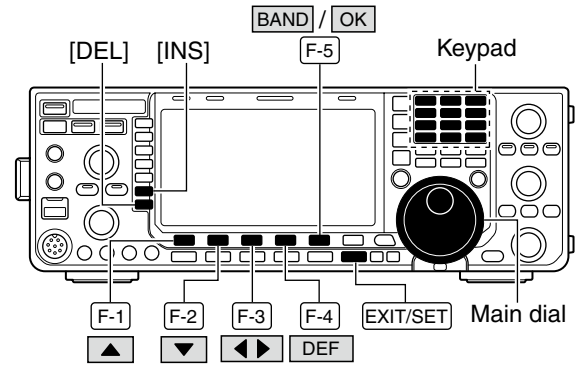

• Band edge screen



NOTE: All frequency ranges are set to default. So you should delete or change it to add the desired band edge frequency.

■ Operating mode selection

SSB (USB/LSB), SSB data (USB data/LSB data), CW, CW reverse (CW-R), RTTY, RTTY reverse (RTTY-R), PSK, PSK reverse (PSK-R), AM, AM data, FM and FM data modes are available in the IC-7600. Push the desired mode switch to select a mode of operation.

See the diagram as at right for the order of selection.

Microphone signals are muted when data mode is selected depending on the set mode settings (p. 132).

• Selecting SSB mode

- ➔ Push **[SSB]** to select USB or LSB.
 - USB is selected first when above 10 MHz, LSB is selected first when below 10 MHz operation.
 - After USB or LSB is selected, push **[SSB]** to toggle between USB and LSB.
 - After USB or LSB is selected, hold down **[SSB]** for 1 second to select the USB or LSB data mode, respectively.
 - After the USB or LSB data mode is selected, hold down **[SSB]** for 1 second to select data 1, 2 and 3, in sequence.
 - In the USB or LSB data mode, push **[SSB]** to return to the USB or LSB mode, respectively.

• Selecting CW mode

- ➔ Push **[CW]** to select CW.
 - After CW is selected, push **[CW]** to toggle between the CW and CW reverse mode.

• Selecting RTTY/PSK mode

- ➔ Push **[RTTY/PSK]** to select RTTY or PSK.
 - After RTTY or PSK is selected, push **[RTTY/PSK]** to toggle between RTTY and PSK.
 - After RTTY or PSK is selected, hold down **[RTTY/PSK]** for 1 second to toggle between RTTY and RTTY reverse, or, PSK and PSK reverse mode, respectively.

• Selecting AM/FM mode

- ➔ Push **[AM/FM]** to select AM or FM.
 - After AM or FM is selected, push **[AM/FM]** to toggle between AM and FM.
 - After AM or FM is selected, hold down **[AM/FM]** for 1 second to select AM or FM data mode, respectively.
 - After AM or FM data mode is selected, hold down **[AM/FM]** for 1 second to select data 1, 2 and 3, in sequence.
 - In AM or FM data mode, push **[AM/FM]** to return to the AM or FM mode, respectively.

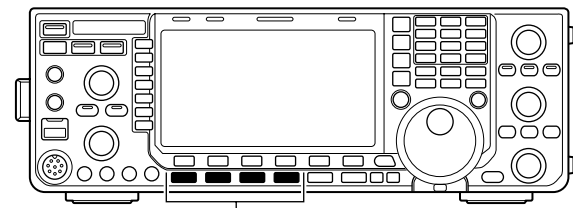

Mode switches

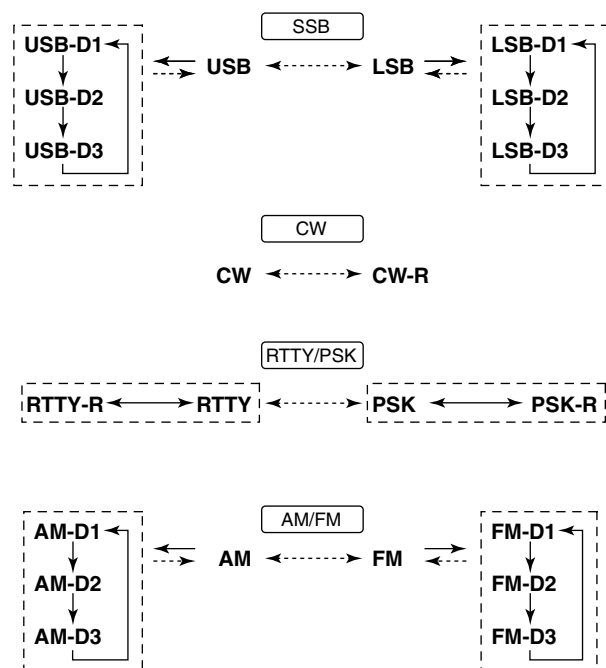

⋯→ : Push mode switch momentary.

→ : Push and hold mode switch for 1 sec.

■ Squelch and receive (RF) sensitivity

Adjusts the RF gain and squelch threshold level.

The squelch removes noise output from the speaker (closed position) when no signal is received.

- The squelch is particularly effective for AM and FM. It is also available for other modes.
- 12 to 1 o'clock position is recommended for any setting of the **[RF/SQL]** control.
- The control can be set as 'Auto' (RF gain control in SSB, CW, RTTY and PSK. Squelch control in AM and FM) or squelch control (RF gain is fixed at maximum) in the Others set mode, as follows. (p. 136)

SET MODE	OPERATION
RF+SQL (default)	Can be used in all modes. Functions as noise squelch or S-meter squelch in the FM modes, S-meter squelch only in other modes.
SQL	Operates as a squelch control. • RF gain is fixed at maximum sensitivity.
AUTO	Operates as an RF gain control in the SSB, CW, RTTY and PSK modes. • Squelch is fixed open. Operates as a squelch control in the AM and FM modes. • RF gain is fixed at maximum sensitivity.

○ Adjusting RF gain (Receive sensitivity)

Normally, **[RF/SQL]** is set to the 11 o'clock position. Rotate **[RF/SQL]** to the 11 o'clock position for maximum sensitivity.

- Rotating counterclockwise from the maximum position reduces sensitivity.
- The S-meter indicates receive sensitivity.

○ Adjusting squelch (Removing non-signal noise)

Rotate **[RF/SQL]** clockwise when receiving no signal, until the noise just disappears.

- **[RX]** indicator light goes out.
- Rotating **[RF/SQL]** past the threshold point invokes the S-meter squelch— this allows you to set a minimum signal level needed to open the squelch.

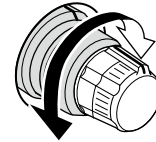
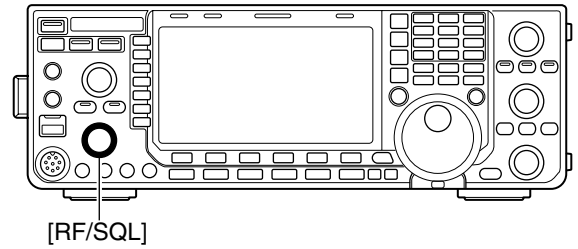

• When setting as RF gain/squelch control

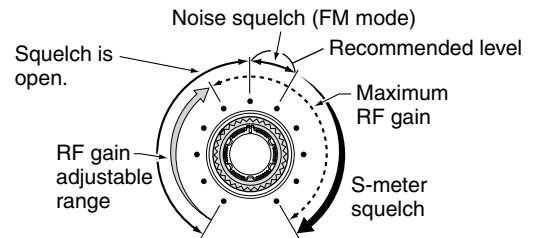

• When functioning as RF gain control (Squelch is fixed open: SSB, CW, RTTY, PSK only)

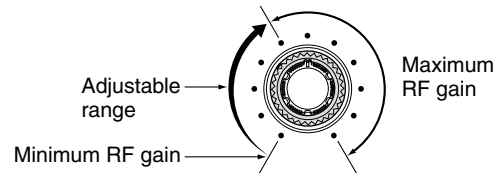

• When functioning as squelch control (RF gain is fixed at maximum.)

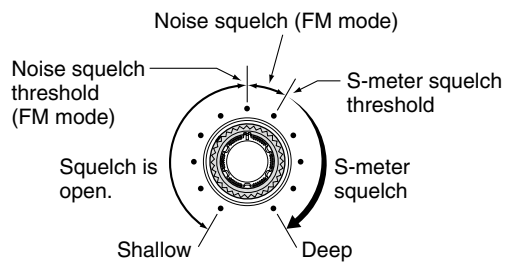

While rotating the RF gain control, noise may be heard. This comes from the DSP unit and does not indicate an equipment malfunction.

Volume setting

- ➔ Rotate **[AF]** control clockwise to increase the audio output level, counterclockwise to decrease it.

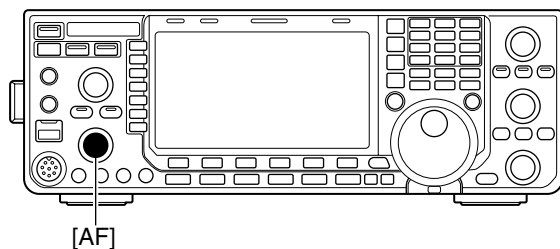
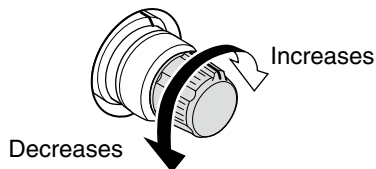

Meter Display selection

The transceiver has 6 transmit meter functions for your convenience.

- ➔ Push **[METER] (MF2)** several times to select the desired meter.

- METER Po** Displays the RF output power in % (percent).
- METER SWR** Displays the SWR on the transmission line.
- METER ALC** Displays the ALC level. When the meter movement shows the input signal level exceeds the allowable level, the ALC limits the RF power. In such cases, reduce the **[MIC GAIN]** control.
- METER COMP** Displays the compression level when the speech compressor is in use.
- METER Id** Displays the drain current of the final amplifier MOSFETs.
- METER Ud** Displays the drain terminal voltage of the final amplifier MOSFETs.

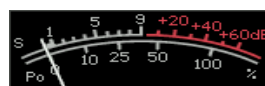
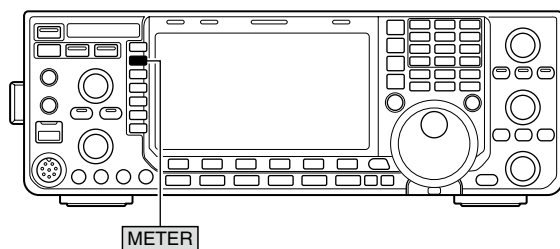

Power level readout

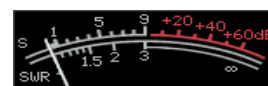

SWR readout

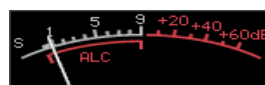

ALC level readout

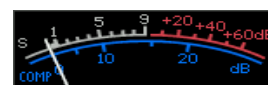

Compression level readout

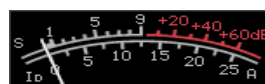

Id readout

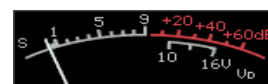

Vd readout

Multi-function digital meter

The IC-7600 can display the multi-function digital meter on the LCD display. This meter displays all transmit parameters simultaneously.

- ① Hold down **[METER] (MF2)** for 1 second to turn the multi-function digital meter ON.
- ② Push **[P-HOLD] (F-1)** to toggle the peak level hold function ON.
 - “P-HOLD” appears on the window title when the peak level hold function is ON.
- ③ Hold down **[METER] (MF2)** for 1 second, or push **[EXIT/SET]** to turn the multi-function digital meter OFF.

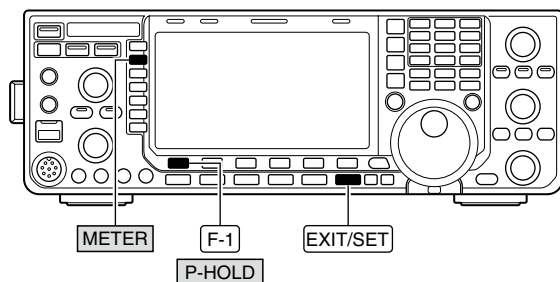

“P-HOLD” indicator

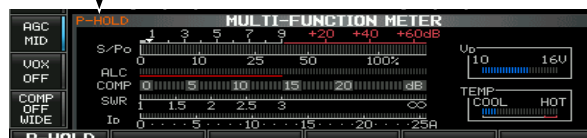

3 BASIC OPERATION

◇ Meter type selection

A total of 3 meter types are available in the IC-7600—Standard, Edgewise and Bar meters.

Follow the instructions below for the meter type selection.

- ① Push **[EXIT/SET]** several times to return to the normal screen, if necessary.
- ② Push **[SET]** (F-6), then push **[DISP]** (F-3) to select the display set mode.
- ③ Push **[▲]** (F-1) or **[▼]** (F-2) to select “Meter type (Normal Screen)” item.
- ④ Rotate the main dial to select the desired meter type between “Standard,” “Edgewise” and “Bar.”
- ⑤ Push **[EXIT/SET]** to exit the display set mode.

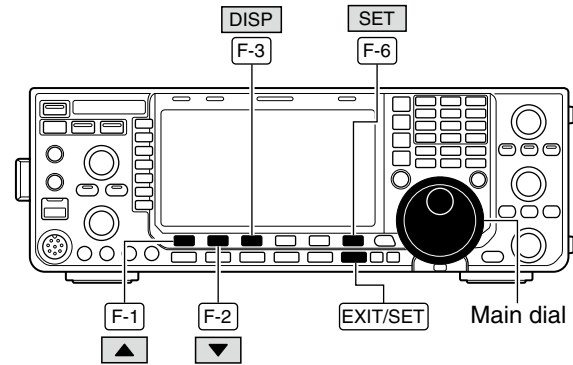

• Standard meter

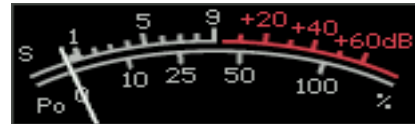

• Edgewise meter

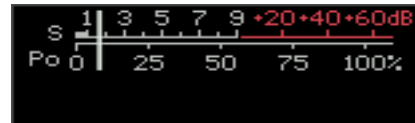

• Bar meter

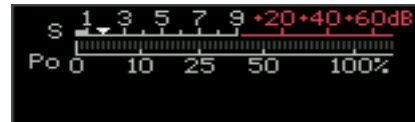

■ Voice synthesizer operation

The IC-7600 has a built-in voice synthesizer to announce the operating frequency, mode* and S-meter* in clear, electronically-generated voice, in English (or Japanese).

First, select the desired parameters to be announced, such as audio level, speed, language, contents, in the Others set mode. (p. 139)

- ➔ Push **[SPEECH/LOCK]** to announce the currently selected frequency, mode* and S-meter level*.
- ➔ Push a mode switch to announce the appropriate mode*.

* The S-meter level and operating mode announcements can be deactivated, respectively. (p.139)

NOTE: When “LOCK/SPEECH” is selected in [[SPEECH/LOCK] Switch] item in the Others set mode, holding down **[SPEECH/LOCK]** activates the voice synthesizer. (p. 139)

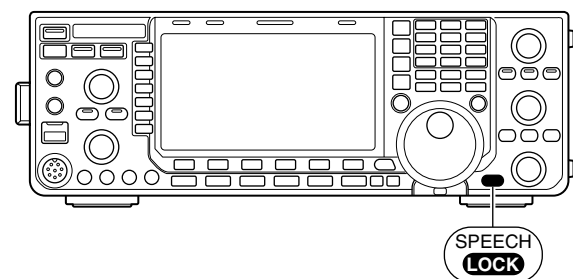

■ Basic transmit operation

Before transmitting, monitor your selected operating frequency to make sure transmitting won't cause interference to other stations on the same frequency. It's good amateur practice to listen first, and then, even if nothing is heard, ask "Is the frequency in use?" once or twice, before you begin operating on that frequency.

◇ Transmitting

Before transmitting, monitor your selected operating frequency to make sure transmitting won't cause interference to other stations on the same frequency.

- ① Push **[TRANSMIT]** or **[PTT]** (microphone) to transmit.
 - The **[TX]** indicator lights red.
 - "**TX**" appears while transmitting.
- ② Push **[TRANSMIT]** again or release **[PTT]** (microphone) to return to receive.

✓ Adjusting the transmit output power

- ➔ Rotate **[RF POWER]**.
 - Adjustable range : 2 W to 100 W
(The AM mode: 1 W to 30 W)

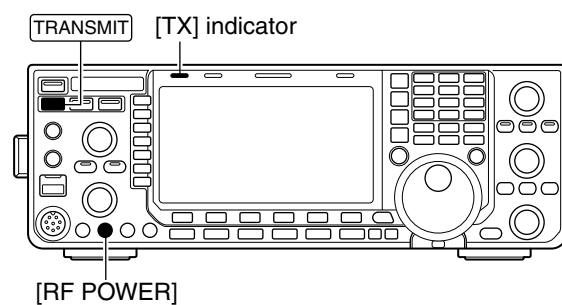
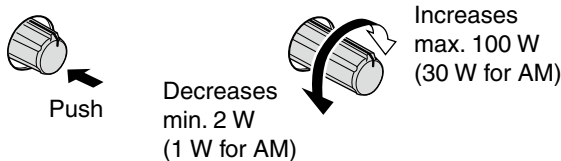

◇ Microphone gain adjustment

Before transmitting, monitor your selected operating frequency to make sure transmitting won't cause interference to other stations on the same frequency.

- ① Push **[SSB]** to select the SSB mode.
- ② Push **[METER]** (**MF2**) to select the ALC meter.
- ③ Push **[PTT]** (microphone) to transmit.
 - Talk into the microphone at your normal voice level.
- ④ While talking into the microphone, rotate **[MIC GAIN]** so that the ALC meter reading doesn't go outside the ALC zone. (see at right)

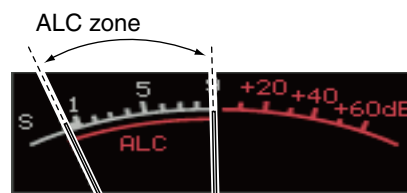
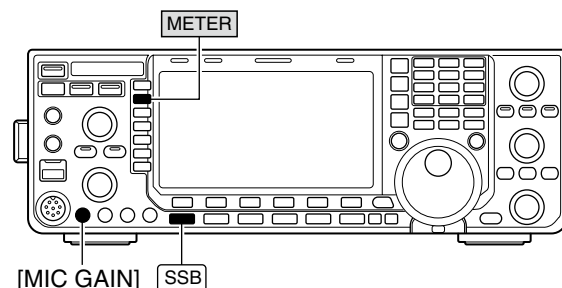
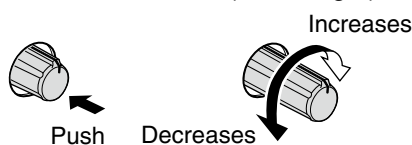

- ⑤ Release **[PTT]** (microphone) to return to receive.

In addition, the transceiver can display the multi-function digital meter in the LCD, which displays all transmit meters simultaneously.

3 BASIC OPERATION

◇ Drive gain adjustment

The drive gain is active for all modes, other than the SSB mode with speech compressor OFF.

Before transmitting, monitor your selected operating frequency to make sure transmitting won't cause interference to other stations on the same frequency.

- ① Push **[EXIT/SET]** several times to return to the normal screen, if necessary.
- ② Push **[SET]** (F-6), then push **[LEVEL]** (F-1) to select the level set mode.
- ③ Push **[▲]** (F-1) or **[▼]** (F-2) to select "Drive Gain" item.
- ④ Push **[METER]** (MF2) to select the ALC meter.
- ⑤ Push **[PTT]** (microphone in SSB with **[COMP]** ON, AM or FM), key down (CW) or push **[TRANSMIT]** (RTTY or PSK) to transmit.
 - ⑥ While talking into the microphone, keying down or transmitting, rotate the main dial so that the ALC meter reading is within 30% to 50% of the ALC scale. (p. 36)
 - Talk into the microphone at your normal voice level.
- ⑦ Release **[PTT]**, stop keying or push **[TRANSMIT]** again to return to receive.
- ⑧ Push **[EXIT/SET]** to exit the display set mode.

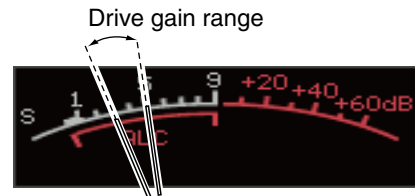
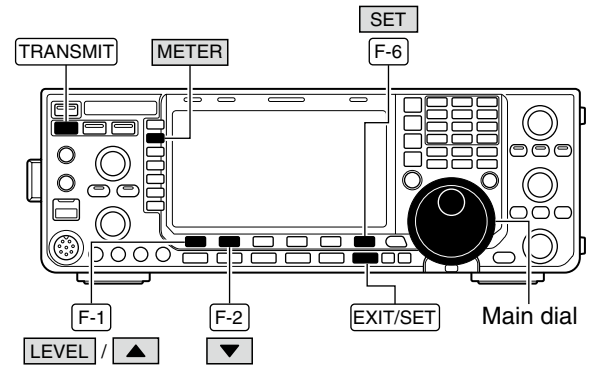

■ Functions for CW operation

◇ About CW reverse mode

CW-R (CW Reverse) mode uses the opposite side band to receive CW signals. Use when interfering signals are near a desired signal and you want to use CW-R to reduce the interference.

- ➔ During the CW mode, push **[CW]** to select the CW or CW-R mode.

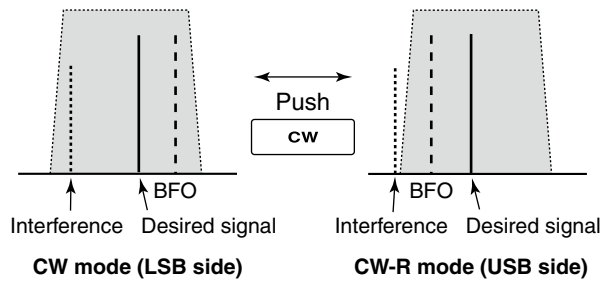

◇ About CW pitch control

The received CW audio pitch and CW sidetone can be adjusted to suit your preference (from 300 to 900 Hz in 5 Hz steps). This does not change the operating frequency.

- ➔ Rotate **[CW PITCH]** to suit your preference.
 - Adjustable from 300 to 900 Hz.

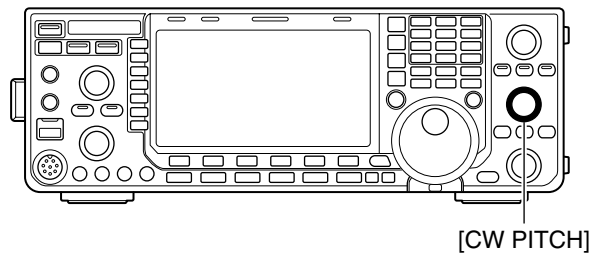

The filter set screen graphically displays the CW pitch operations. (See at right.)

- ➔ Hold down **[FILTER]** for 1 second to access the filter set screen.
 - The CW pitch frequency is graphically changed in 5 Hz steps when the selected IF filter passband width is below 500Hz (“**BPF**” appears), or in 25 Hz steps when the selected IF filter passband width is above 600Hz (“**BPF**” disappears).
 - Push **[EXIT/SET]** or hold down **[FILTER]** for 1 second to return to the previous screen.

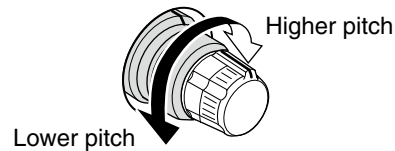

• Filter set screen



CW pitch frequency (Example: 700 Hz)

◇ CW sidetone function

When the transceiver is in receive (and the break-in function is OFF— p. 93) you can listen to the CW sidetone without actually transmitting.

This allows you to match your transmit frequency exactly to another station's by matching the audio tone. You can also use the CW sidetone (be sure to turn OFF break-in!) to practice CW sending. CW sidetone level can be adjusted in the level set mode. (p. 130)

- ➊ Push **[SET]** (F-6), then push **[LEVEL]** (F-1) to select the level set mode.
- ➋ Push **[▲]** (F-1) or **[▼]** (F-2) to select the “Side Tone Level” item.
- ➌ Rotate the main dial to adjust the sidetone level.
 - Sidetone level is adjustable within 0 to 100% in 1% steps.
- ➍ Push **[EXIT/SET]** to exit the display set mode.

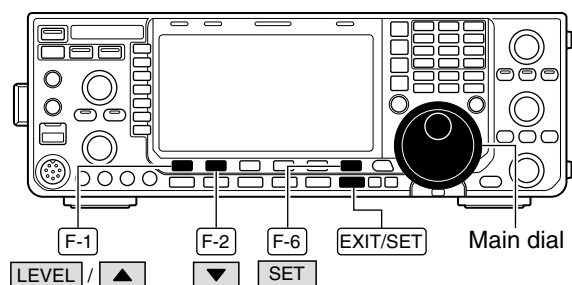

Matching the frequency of a transmitted and received signal is called “Zero beat.”

◇ **APF (Audio Peak Filter) operation**

The APF changes the audio frequency response by boosting a particular frequency to enhance a desired CW signal.

- ① During the CW mode, push **[APF/TPF]** to turn the audio peak filter ON or OFF.
 - “**APF**” appears in the display and the indicator on this switch lights green when the audio peak filter is ON.
- ② Hold down **[APF/TPF]** for 1 second several times to select the desired audio filter width.
 - WIDE, MID and NAR filters, or 320, 160 and 80 Hz filters are selectable, depending on [APF type] item setting in the Others set mode. (p. 141)

The APF (Audio Peak Filter) type is also selectable from “SOFT” and “SHARP” in [APF type] item in the Others set mode (p. 141).

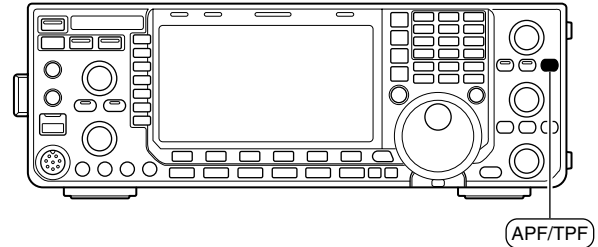

Electronic keyer functions

The IC-7600 has a number of convenient functions for the built-in electronic keyer that can be accessed from the memory keyer menu.

- ① During the CW mode, push [EXIT/SET] several times to return to the normal screen, if necessary.
- ② Push [KEYER] (F-3) to select the memory keyer screen.
- ③ Push [EXIT/SET] to select the memory keyer menu screen.
- ④ Push [SEND] (F-1), [EDIT] (F-2), [001] (F-3) or [CW KEY] (F-4) to select the desired menu. See the diagram below.
 - Push [EXIT/SET] to return to the previous display.

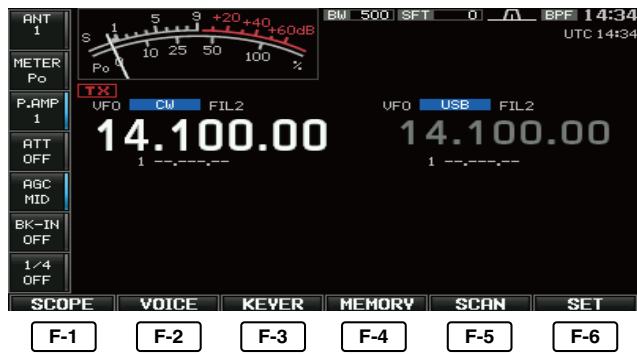
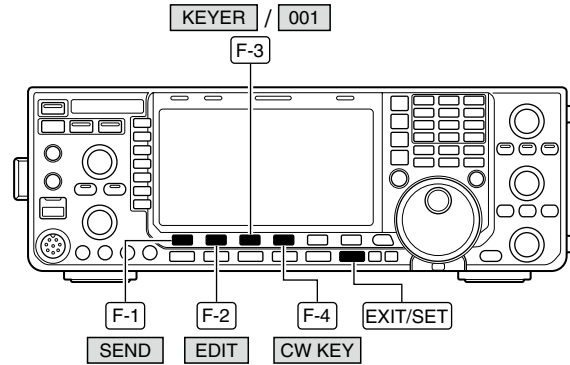

• Memory keyer screen (p. 45)



• Memory keyer edit screen (p. 46)



• Memory keyer menu screen

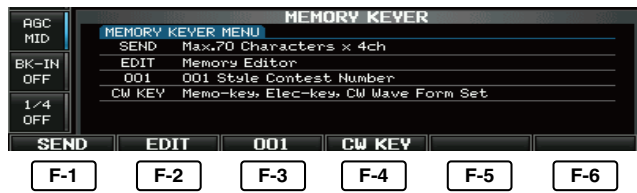

• Contest number set mode (p. 47)



• Keyer set mode screen (p. 48)



◇ **Memory keyer screen**

Pre-set characters can be sent using the keyer send menu. Contents of the memory keyer are set using the edit menu.

• **Transmitting**

- ① During the CW mode operation, push **[KEYER] (F-3)** to select the memory keyer screen.
- ② Push **[TRANSMIT]** to set the transceiver to transmit, or set the break-in function ON (p. 93).
- ③ Push one of the function keys (**[M1] (F-1)** to **[M4] (F-4)**) to send the contents of the memory keyer.
 - Hold down a function key that is pushed in step ① for 1 second, or push **[REPEAT] (F-6)** while sending the contents of the memory keyer to send repeatedly.
 - Push any function key to cancel the transmission.
 - “” appears while transmitting repeatedly.
 - The contest serial number counter counts each time the contents are sent.
 - Push **[-1] (F-5)** to reduce the contest serial number count by 1 before sending the contents of the memory keyer to a station a second time.
 - “M1”–“M4” are highlighted while transmitting.
 - Set the repeat interval of the memory keyer to 1–60 seconds (1 second steps). See page 48 for the keyer set mode.
- ④ Push **[EXIT/SET]** twice to return to the the normal screen.

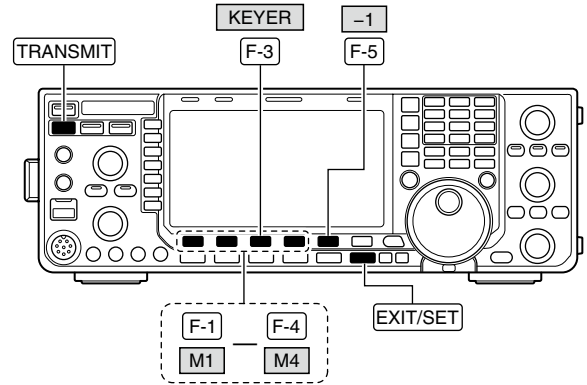

• **Memory keyer screen**



During transmitting:

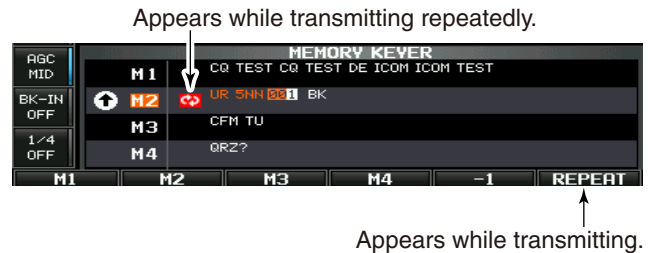

For your information

- When an external keypad or keyboard is connected, the programmed contents, M1 to M4, can be transmitted without selecting the memory keyer screen.
- See pages 18, 141, 142 for details.
- The programmed contents, M1 to M4, are transmitted once when momentarily pushing one of four switches on the external keypad that is connected to **[MIC]** connector on the front panel. Or, the programmed contents are transmitted repeatedly when holding down a switch.
 - The programmed contents, M1 to M4, are transmitted once when pushing one of **[F1]** to **[F4]** key of the keyboard that is connected to the **[USB] (A)** connector on the front panel. Or, the programmed contents are transmitted repeatedly when pushing a key while holding down the **[SHIFT]** key.

◇ Editing a memory keyer

The contents of the memory keyer memories can be set, using the memory keyer edit menu. The memory keyer can memorize and re-transmit 4 CW key codes for often-used CW sentences, contest serial numbers, etc. Total capacity of the memory keyer is 70 characters per memory channel.

• Programming contents

- ① During the CW mode operation, push **[KEYER] (F-3)** to select memory keyer screen.
- ② Push **[EXIT/SET]** to select memory keyer menu, then push **[EDIT] (F-2)** to select keyer edit screen.
 - Memory keyer contents of Channel 1 (M1) is selected.
- ③ Push **[M1..M4] (F-6)** several times to select the desired memory keyer channel to be edited.
- ④ Push **[ABC] (MF6)** or **[123]/[Symbol] (MF7)** to select the character group, then rotate the main dial to select the character, or push the keypad for number input.
 - **[Symbol]** appears when **[123] (MF7)** is pushed when “123” character group is selected.
 - Selectable characters (using the main dial):

Key selection	Characters
ABC	A to Z (capital letters)
123	0 to 9 (numbers)
Symbol	/ ? ^ . , @ *

NOTE:

“^” is used to transmit a string of characters with no inter-character space. Put “^” before a text string such as ^AR, and the string “AR” is sent with no space.
 “*” is used to insert the CW contest serial number. The serial number automatically increments by 1. This function is available only for one memory keyer channel at a time. Memory keyer channel M2 uses “*” by default.

- ⑤ Push **[◀] (F-1)** or **[▶] (F-2)** to move the cursor backwards or forwards, respectively.
 - Pushing **[DEL] (F-3)** deletes a character and **[SPACE] (F-4)** inserts a space.
- ⑥ Repeat steps ④ and ⑤ to input the desired characters.
- ⑦ Push **[EXIT/SET]** twice to return to the normal screen.

✓ For your convenience

When a PC keyboard is connected to [USB] (A) connector on the front panel, the memory keyer contents can also be edited from the keyboard.

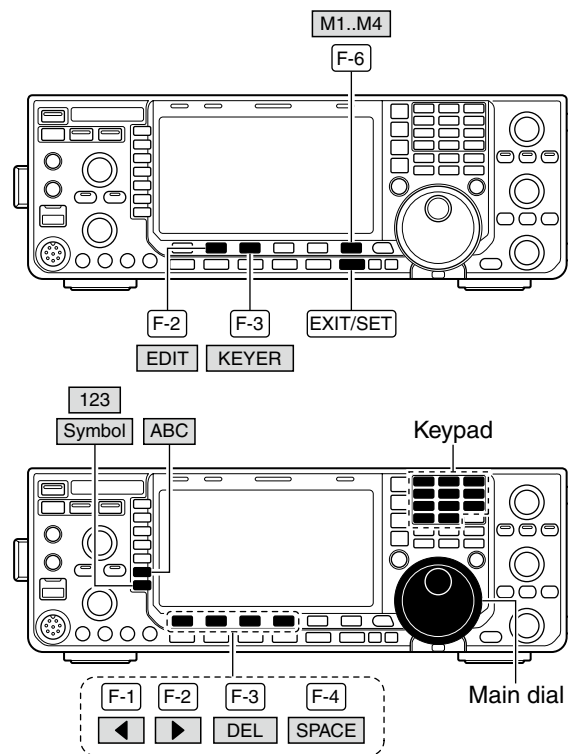

• Memory keyer edit screen



• Example— entered “QSL TU DE JA3YUA TEST” into memory keyer channel 3



• Pre-programmed contents

CH	Contents
M1	CQ TEST CQ TEST DE ICOM ICOM TEST
M2	UR 5NN* BK
M3	CFM TU
M4	QRZ?

◇ **Contest number set mode**

This menu is used to set the contest (serial) number and count-up trigger, etc.

• **Setting contents**

- ① During the CW mode operation, push **[KEYER] (F-3)** to select memory keyer screen.
- ② Push **[EXIT/SET]** to select memory keyer menu, then push **[001] (F-3)** to select the contest serial number set mode.
- ③ Push **[▲] (F-1)** or **[▼] (F-2)** to select the desired set item.
- ④ Set the desired condition using the main dial.
 - Hold down **[DEF] (F-4)** for 1 second to select the default condition or value.
- ⑤ Push **[EXIT/SET]** twice to return to the normal screen.

• **Contest number set mode screen**

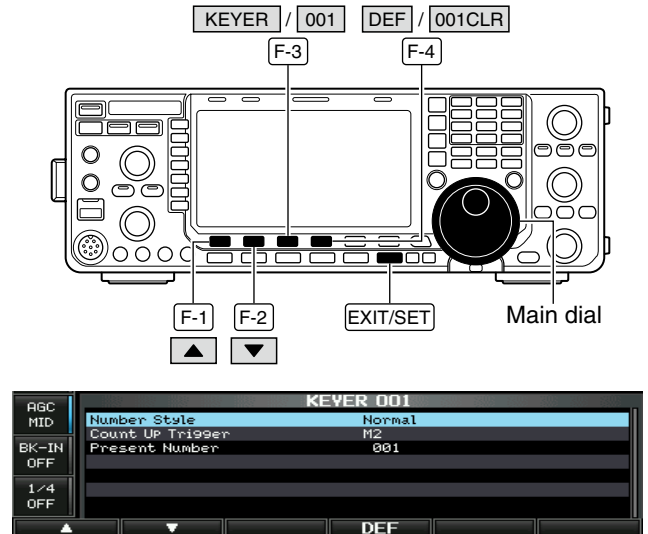

Number Style

This item sets the numbering system used for contest (serial) numbers— normal or short morse numbers.

Short morse numbers are also referred to as “cut” numbers.

Normal

- Normal : Does not use short morse numbers (default)
- 190→ANO : Sets 1 as A, 9 as N and 0 as O.
- 190→ANT : Sets 1 as A, 9 as N and 0 as T.
- 90→ NO : Sets 9 as N and 0 as O.
- 90→ NT : Sets 9 as N and 0 as T.

Count Up Trigger

The count-up trigger allows the contest serial number to automatically increment after each complete serial number exchange is sent.

M2

- M1, M2, M3 and M4 can be set. (default: M2)

Present Number

This item shows the current number for the count-up trigger channel set above.

001

- Rotate the main dial to change the number, or hold down **[001CLR] (F-4)** for 1 second to reset the current number to 001.

◇ Keyer set mode

This set mode is used to set the memory keyer repeat time, dash weight, paddle specifications, keyer type, etc.

• **Setting contents**

- ① During the CW mode operation, push **[KEYER] (F-3)** to select the memory keyer screen.
- ② Push **[EXIT/SET]** to select the memory keyer menu, then push **[CW KEY] (F-4)** to select the keyer set mode.
- ③ Push **[▲] (F-1)** or **[▼] (F-2)** to select the desired set item.
- ④ Set the desired condition using the main dial.
 - Hold down **[DEF] (F-4)** for 1 second to select the default condition or value.
- ⑤ Push **[EXIT/SET]** twice to return to the normal screen.

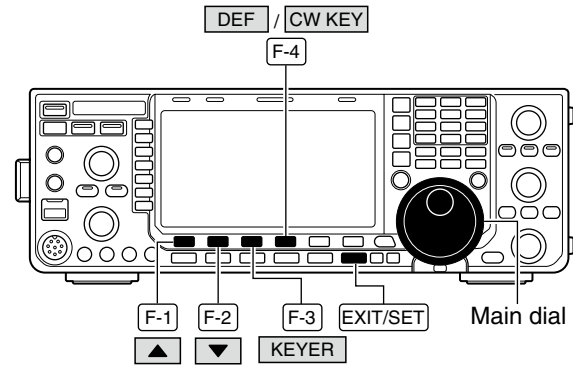

• **Keyer set mode screen**



Keyer Repeat Time	2s
When sending CW using the repeat timer, this item sets the time between transmission.	<ul style="list-style-type: none"> • 1 to 60 seconds in 1 second steps can be selected. (default: 2 seconds)

Dot/Dash Ratio	1:1:3.0
This item sets the dot/dash ratio.	<ul style="list-style-type: none"> • 1:1:2.8 to 1:1:4.5 (in 0.1 steps) can be selected. (default: 1:1:3.0)
Keying weight example: Morse code "K"	
<p style="font-size: small;">*SPACE and DOT length can be adjusted with [KEY SPEED] only.</p>	

Rise Time	4ms
This item sets the rise time of the transmitted CW waveform.	<ul style="list-style-type: none"> • 2, 4, 6, 8 or 10 milliseconds can be selected. (default: 4 milliseconds)
<ul style="list-style-type: none"> • About rise time 	<ul style="list-style-type: none"> ▨ Key clicks on nearby frequencies can be generated if the rise time of a CW waveform is too short.

Continued on the next page.

4 RECEIVE AND TRANSMIT

◇ Keyer set mode (continued)

Paddle Polarity	Normal
This item sets the paddle dot-dash polarity.	• Normal and reverse polarity can be selected.
Keyer Type	ELEC-KEY
This item selects the keyer type for the [ELEC-KEY] connector on the front panel.	• Straight key, BUG-KEY and ELEC-KEY can be selected. (default: ELEC-KEY)
MIC Up/Down Keyer (Microphone's [UP]/[DN] switches keyer) This item allows you to set the microphone [UP]/[DN] switches to be used as a paddle. (The microphone [UP]/[DN] switches do not work as a 'squeeze key'.)	OFF • ON : [UP]/[DN] switches can be used for CW. • OFF : [UP]/[DN] switches cannot be used for CW. // NOTE: When "ON" is selected, the frequency and memory channel cannot be changed using the [UP]/[DN] switches.

■ RTTY (FSK) operation

A DSP-based high-quality Baudot RTTY encoder/decoder is built-in to the IC-7600. When connecting a PC keyboard (pp. 18, 19), you can operate RTTY without an external RTTY terminal or PC.

If you would rather use your RTTY terminal, consult the equipment manual.

Before transmitting, monitor your selected operating frequency to make sure you don't cause interference to other stations on the same frequency.

- ① Push a band key to select the desired band.
- ② Push **[RTTY/PSK]** to select RTTY.
 - After the RTTY mode is selected, hold down **[RTTY/PSK]** for 1 second to toggle between the RTTY and RTTY-R modes.
 - "RTTY" or "RTTY-R" appears.
 - The RTTY tuning indicator appears.
- ③ Push **[DECODE] (F-3)** to display the decode screen.
 - The IC-7600 has a built-in Baudot decoder.
- ④ Rotate the main dial to tune the desired signal.
 - Aim for a symmetrical waveform, and ensure the peak points align with the mark (2125 Hz) and shift (170 Hz) frequency lines in the FFT scope.
 - The S-meter displays the received signal strength, when a signal is received.
- ⑤ Push **[F12]** on the connected PC's keyboard to transmit.
 - [TX] indicator lights red.
- ⑥ Type on the keyboard to enter the contents that you want to transmit.
 - The typewritten contents are indicated in the TX buffer screen and transmitted immediately.
 - The text color will change when transmitted.
 - Push one of **[F1]–[F8]** on the keyboard to transmit the TX memory contents.
- ⑦ Push **[F12]** on the keyboard to return to receive.

✓ For your convenience

The transmission contents can be typed before being transmitted.

- ① Perform the steps ① to ④ above.
- ② Type on the connected keyboard to enter the message that you want to transmit.
 - The typewritten contents are displayed on the TX buffer screen.
- ③ Push **[F12]** of the connected keyboard to transmit the typewritten contents.
 - The color of displayed text, in the TX buffer screen, will change when transmitted.
 - To cancel the transmission, push **[F12]** twice.
- ④ Push **[F12]** of the keyboard to return to receive.

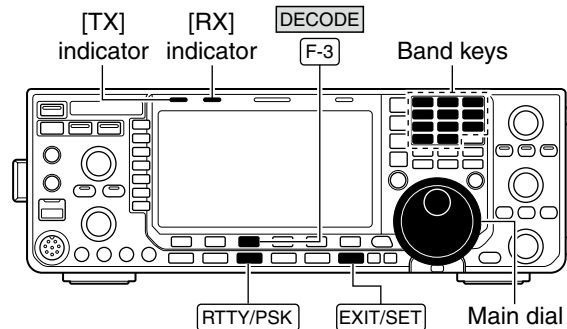

• Waterfall display

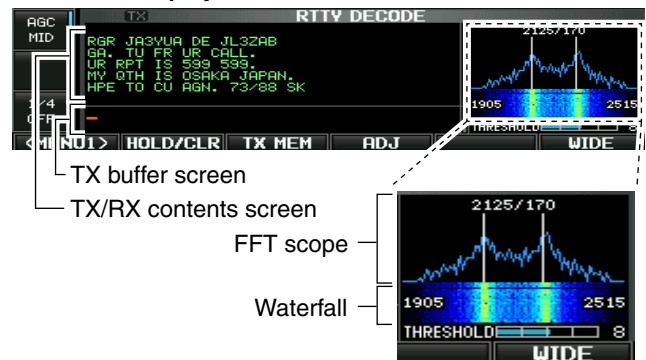

◇ About RTTY reverse mode

Received characters are occasionally garbled when the received signal is reversed between Mark and Space tones. This reversal can be caused by incorrect TNC connections, setting, commands, etc.

To receive a reversed RTTY signals correctly, select the RTTY-R (RTTY Reverse) mode.

- ➔ During the RTTY mode, hold down **[RTTY/PSK]** for 1 second to select the RTTY-R mode.
 - Check the received signal.

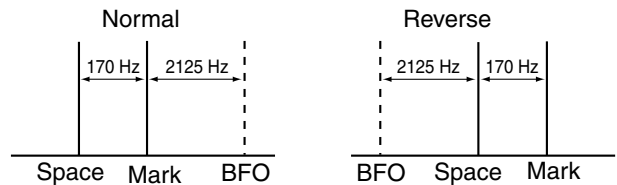

◇ Twin peak filter

The twin peak filter changes the audio frequency response by boosting the mark and space frequencies (2125 and 2295 Hz) for better reception of RTTY signals.

- ➔ During the RTTY mode, push **[APF/TPF]** to turn the twin peak filter ON or OFF.
 - “**TPF**” appears in the LCD and the indicator on this switch lights green while the filter is in use.

/// **NOTE:** When the twin peak filter is in use, the received audio output may increase. This is a normal, not a malfunction.

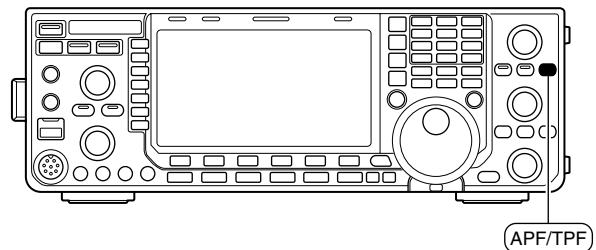

◆ Functions of the RTTY decoder display

- ① Push a band key to select the desired band.
- ② Push **[RTTY/PSK]** to select RTTY.
 - After RTTY is selected, hold down **[RTTY/PSK]** for 1 second to toggle between the RTTY and RTTY-R modes.
 - “RTTY” or “RTTY-R” appears.
- ③ Push **[DECODE]** (F-3) to display the decode screen.
 - When tuned into an RTTY signal, decoded characters are displayed in the RX contents screen.
- ④ Push **[HOLD/CLR]** (F-2) to freeze the current screen.
 - “**HOLD**” appears while the function is in use.
 - Push **[HOLD/CLR]** (F-2) again to cancel the function.
- ⑤ Hold down **[HOLD/CLR]** (F-2) for 1 second to clear the displayed characters.
 - The “**HOLD**” indicator disappears at the same time as the displayed characters are cleared. (The hold function is cancelled.)
- ⑥ Push **[WIDE]** (F-6) to toggle the RTTY decode screen size between normal and wide.
 - The S/Rf meter type during wide screen display can be selected in the display set mode. (p. 134)
- ⑦ Push **[EXIT/SET]** to close the RTTY decode screen.

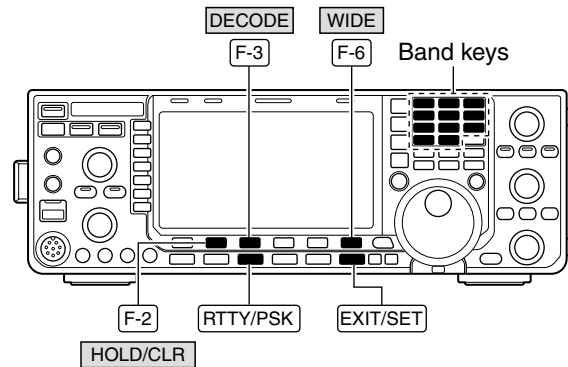

• RTTY Decode screen (Normal)



• RTTY Decode screen (Wide)



◆ Setting the decoder threshold level

Adjust the RTTY decoder threshold level if some characters are displayed when no signal is received.

- ① Select the RTTY decode screen as described above.
- ② Push **[ADJ]** (F-4) to select the threshold level setting condition.
- ③ Rotate the main dial to adjust the RTTY decoder threshold level.
 - Hold down **[DEF]** (F-5) for 1 second to select the default setting.
- ④ Push **[ADJ]** (F-4) to exit from the threshold level setting condition.

▨ The UnShift On Space (USOS) function and new line code can be set in the RTTY set mode. (p. 55)

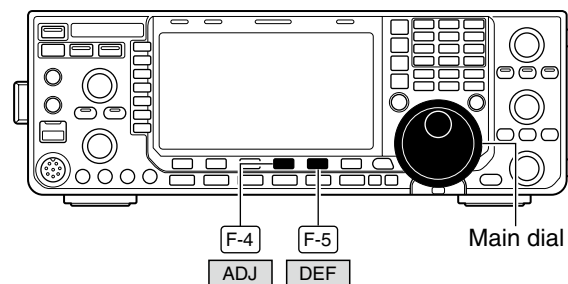

Threshold level indicator bar

◆ **RTTY memory transmission**

Previously entered characters can be sent using the RTTY memory. Contents of the memory are set using the edit menu.

- ① During the RTTY mode operation, push **[DECODE] (F-3)** to select the RTTY decode screen.
- ② Push **[TX MEM] (F-3)** to select the RTTY memory screen.
- ③ Push **[1-4/5-8] (F-6)** to select the memory bank, and then push one of the function keys (**[RT1] (F-1)** to **[RT4] (F-4)** or **[RT5] (F-1)** to **[RT8] (F-4)**).
 - When no keyboard is connected, the selected memory contents will be transmitted immediately.
 - When a keyboard is connected, the memory contents will be transmitted immediately when **[F1]** to **[F8]** on the connected keyboard is pressed, or transmitted after **[F12]** is pressed, depending on auto transmission/reception setting (see below).
 - The transmission date, time, reception date and/or time may be displayed in RX contents screen, depending on setting.

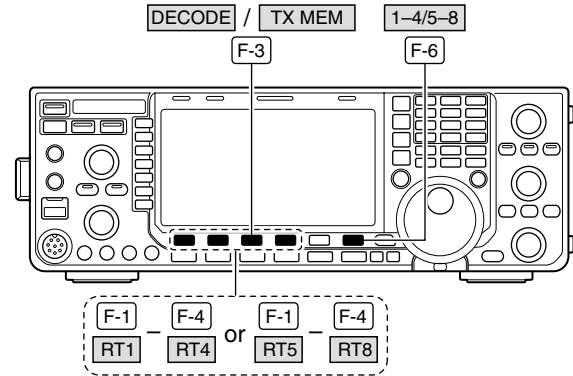

• **RTTY memory screen**

RTTY MEMORY			
AGC MID	RT1	-DE ICOM ICOM K-	AUTO TX/RX
	RT2	-DE ICOM ICOM ICOM K-	AUTO TX/RX
	RT3	-QSL UR 599-599 BK-	AUTO TX/RX
1/4 OFF	RT4	-QSL DE ICOM ICOM UR 599-599 BK-	AUTO TX/RX
	RT1	RT2	RT3
	RT4	EDIT	1-4/5-8

▨ **For your information**

When an external keypad is connected to [MIC] connector on the front panel, one of RT1 to RT4 RTTY memory contents can be transmitted while the RTTY decode screen is selected in the RTTY mode. (pp. 18, 141)

◆ **Automatic transmission/reception setting**

- ① During the RTTY mode operation, push **[DECODE] (F-3)** to select the RTTY decode screen.
- ② Push **[TX MEM] (F-3)** to select the RTTY memory screen, then push **[EDIT] (F-5)** to select the RTTY memory edit screen.
 - RTTY memory contents of the Channel 1 (RT1) is selected.
- ③ Push **[RT1..RT8] (F-6)** several times to select the desired RTTY memory.
- ④ Push **[AUTO TX] (F-5)** several times to select the desired operating option as follow.
 - **AUTO TX/RX** : Automatically transmits the selected memory contents, and returns to receive after the transmission.
 - **AUTO TX** : Automatically transmits the selected memory contents. To return to receive, push **[F12]** on the keyboard.
 - **AUTO RX** : Push **[F12]** on the keyboard to transmit the selected memory contents. Automatically returns to receive after the transmission.
 - **No indication** : Push **[F12]** on the keyboard to transmit the selected memory contents, and push **[F12]** again to return to receive.
- ⑤ Push **[EXIT/SET]** to exit the RTTY memory edit condition.

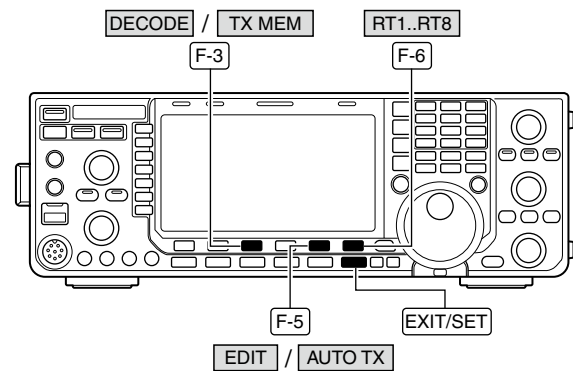

Auto TX/RX settings

RTTY MEMORY EDIT			
ABC	RT1	-DE ICOM ICOM K-	AUTO TX/RX
ABC	RT2	-DE ICOM ICOM ICOM K-	AUTO TX/RX
	RT3	-QSL UR 599-599 BK-	AUTO TX/RX
123	RT4	-QSL DE ICOM ICOM UR 599-599 BK-	AUTO TX/RX
		DEL	SPACE
		AUTO TX	RT1..RT8

▨ **NOTE:** The transceiver always functions in the “AUTO TX/RX” setting when no keyboard is connected.

◇ Editing RTTY memory

The contents of the RTTY memories can be set using the memory edit menu. The memory can store and re-transmit 8 RTTY message for often-used RTTY information. Total capacity of the memory is 70 characters per memory channel.

• Programming contents

- ① During the RTTY mode operation, push **[DECODE]** (F-3) to select the RTTY decode screen.
- ② Push **[TX MEM]** (F-3) to select the RTTY memory screen, then push **[EDIT]** (F-5) to select the RTTY memory edit screen.
 - RTTY memory contents of Channel 1 (RT1) is selected.
- ③ Push **[RT1..RT8]** (F-6) several times to select the desired RTTY memory channel to be edited.
- ④ Push **[ABC]** (MF6) or **[123]/[Symbol]** (MF7) to select the character group, then rotate the main dial to select the character, or push the keypad for number input.
 - **[Symbol]** (MF7) appears when **[123]** (MF7) is pushed when "123" character group is selected.
 - Selectable characters (using the main dial):

Key selection	Characters
ABC	A to Z (capital letters)
123	0 to 9 (numbers)
Symbol	! \$ & ? " ' - / . , ; : () ↵

- ⑤ Push **[◀]** (F-1) or **[▶]** (F-2) to move the cursor backwards or forwards, respectively.
 - Pushing **[DEL]** (F-3) deletes a character and **[SPACE]** (F-4) inserts a space.
- ⑥ Repeat steps ④ and ⑤ to input the desired characters.
- ⑦ Push **[EXIT/SET]** to set the contents and exit the RTTY memory edit screen.

✓ For your convenience

When a PC keyboard is connected to the [USB] connector on the front panel, the RTTY memory contents can also be edited from the keyboard.

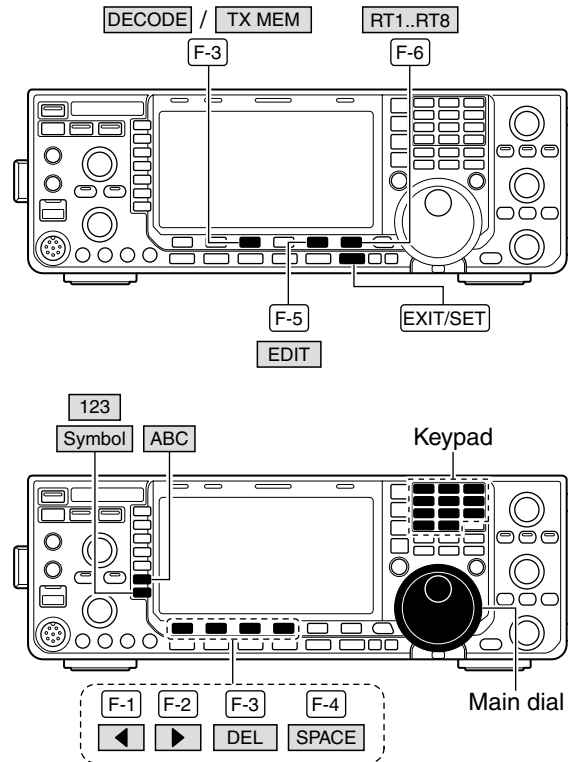

• RTTY memory edit screen



• Pre-programmed contents

CH	Contents
RT1	↵DE ICOM ICOM K↵
RT2	↵DE ICOM ICOM ICOM K↵
RT3	↵QSL UR 599-599 BK↵
RT4	↵QSL DE ICOM ICOM UR 599-599 BK↵
RT5	↵73 GL SK↵
RT6	↵CQ CQ CQ DE ICOM ICOM ICOM K↵
RT7	↵JMY TRANSCEIVER IS IC-7600 & ANTENNA IS A 3-ELEMENT TRIBAND YAGI..↵
RT8	↵JMY RTTY EQUIPMENT IS INTERNAL FSK UNIT & DEMODULATOR OF THE IC-7600..↵

◇ RTTY decode set mode

This set mode is used to set the decode USOS function, time stamp setting, etc.

• Setting contents

- ① During the RTTY mode operation, push [DECODE] (F-3) to select the RTTY decode screen.
- ② Push [<MENU1>] (F-1) to select the second RTTY decode menu, then push [SET] (F-5) to select the RTTY decode set mode.
 - Push [WIDE] (F-6) to toggle the screen size between normal and wide.
- ③ Push [▲] (F-1) or [▼] (F-2) to select the desired set item.
- ④ Set the desired condition using the main dial.
 - Hold down [DEF] (F-4) for 1 second to select a default condition or value.
 - Push [◀ ▶] (F-3) to select the set contents for some items.
- ⑤ Push [EXIT/SET] to exit from the set mode.

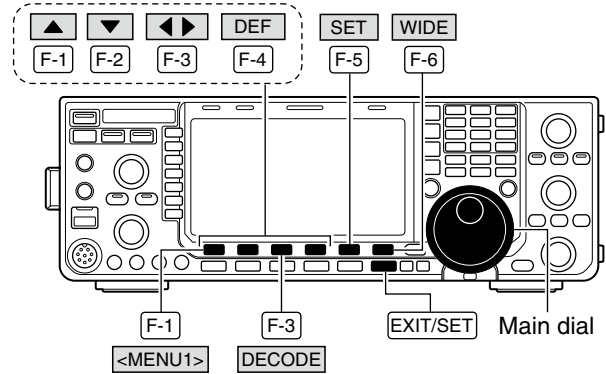

• RTTY decode set mode screen



<p>RTTY FFT Scope Averaging</p>	<p>OFF</p>
<p>Select the FFT scope waveform averaging function from 2 to 4 and OFF. (default: OFF)</p>	<p>Recommendation! If you use the FFT scope waveform for tuning, the default or smaller averaging setting is recommended.</p>
<p>RTTY FFT Scope Waveform Color</p>	<p></p>
<p>Set the color for the FFT scope waveform.</p> <ul style="list-style-type: none"> • The color is set in RGB format. • The set color is shown in the box beside the RGB scale. 	<ul style="list-style-type: none"> • Push [◀ ▶] (F-3) to select R (Red), G (Green) and B (Blue), and then rotate the main dial to set the ratio from 0 to 255.
<p>RTTY Decode USOS</p>	<p>ON</p>
<p>Turn the capability of letter code decoding after receiving a “space” (USOS: UnShift On Space function) ON or OFF.</p>	<ul style="list-style-type: none"> • ON : Decode as a letter code. • OFF : Decode as a character code.
<p>RTTY Decode New Line Code</p>	<p>CR,LF,CR+LF</p>
<p>Selects the new line code of the internal RTTY decoder. CR: Carriage Return, LF: Line Feed</p>	<ul style="list-style-type: none"> • CR,LF,CR+LF : Makes a new line with any codes. • CR+LF : Makes a new line with CR+LF code only.
<p>RTTY Diddle</p>	<p>BLANK</p>
<p>Selects the diddle condition.</p>	<ul style="list-style-type: none"> • OFF : Turns the diddle function OFF. • BLANK : Transmits blank code during no code transmission. • LTRS : Transmits letter code during no code transmission.

RTTY TX USOS	ON
Explicitly inserts the FIGS character, even though it is not required by the receiving station.	<ul style="list-style-type: none"> • ON : Inserts FIGS. • OFF : Does not insert FIGS.

RTTY Auto CR+LF by TX	ON
Selects the automatic new line code (CR+LF) transmission capability.	<ul style="list-style-type: none"> • ON : Transmits CR+LF code once. • OFF : Transmits no CR+LF code.

RTTY Time Stamp	ON
Turn the time stamp (date, transmission or reception time) indication ON or OFF.	<ul style="list-style-type: none"> • ON : Displays the time stamp. • OFF : No time stamp indication.

RTTY Time Stamp (Time)	Local
Selects the clock indication for time stamp usage.	<ul style="list-style-type: none"> • Local : Selects the time that is set in "Time (Now)." • UTC* : Selects the time that is set in "CLOCK2." <p>*The name of choice may differ, according to "CLOCK2 Name" setting (p. 123). "UTC" is the default name of CLOCK2.</p>
NOTE: The time won't be displayed when "OFF" is selected in "RTTY Time Stamp," as explained above.	

RTTY Time Stamp (Frequency)	OFF
Selects the operating frequency display for time stamp usage.	<ul style="list-style-type: none"> • ON : Displays the operating frequency. • OFF : No operating frequency display.
NOTE: The frequency won't be displayed when "OFF" is selected in "RTTY Time Stamp," as explained above.	

RTTY Font Color (Receive)	
Set the text color for received characters.	<ul style="list-style-type: none"> • Push [◀ ▶] (F-3) to select R (Red), G (Green) and B (Blue), and then rotate the main dial to set the ratio from 0 to 255.
<ul style="list-style-type: none"> • The color is set in RGB format. • The set color is shown in the box beside the RGB scale. 	

RTTY Font Color (Transmit)	
Set the text color for transmitted characters.	<ul style="list-style-type: none"> • Push [◀ ▶] (F-3) to select R (Red), G (Green) and B (Blue), and then rotate the main dial to set the ratio from 0 to 255.
<ul style="list-style-type: none"> • The color is set in RGB format. • The set color is shown in the box beside the RGB scale. 	

RTTY Font Color (Time Stamp)	
Set the text color for time stamp indication.	<ul style="list-style-type: none"> • Push [◀ ▶] (F-3) to select R (Red), G (Green) and B (Blue), and then rotate the main dial to set the ratio from 0 to 255.
<ul style="list-style-type: none"> • The color is set in RGB format. • The set color is shown in the box beside the RGB scale. 	

RTTY Font Color (TX Buffer)	
Set the text color in the TX buffer screen.	<ul style="list-style-type: none"> • Push [◀ ▶] (F-3) to select R (Red), G (Green) and B (Blue), and then rotate the main dial to set the ratio from 0 to 255.
<ul style="list-style-type: none"> • The color is set in RGB format. • The set color is shown in the box beside the RGB scale. 	

◇ **Data saving**

The contents of the RTTY memory/received signal can be saved into USB-Memory.

- ① During the RTTY decode screen display, push [**<MENU1>**] (F-1) to select the RTTY decode second menu.
- ② Push [**SAVE**] (F-4) to select the decode file save screen.
- ③ Change the following conditions, if desired.

• **File name:**

- ① Push [**EDIT**] (F-4) to select the file name edit option.
 - Push [**DIR/FILE**] (F-1) several times to select the file name, if necessary.
- ② Push [**ABC**] (MF6) or [**123**]/[**Symbol**] (MF7) to select the character group, then rotate the main dial to select the character.
 - [**ABC**] (MF6): A to Z (capital letters), [**123**] (MF7): 0 to 9 (numerals), [**Symbol**] (MF7): ! # \$ % & ' ` ^ - () { } _ - @ can be selected.
 - Push [**◀**] (F-1) to move the cursor left, push [**▶**] (F-2) to move the cursor right, [**DEL**] (F-3) delete a character and push [**SPACE**] (F-4) to insert a space.
- ③ Push [**EXIT/SET**] to store the file name.

• **File format**

- ① Hold down [**SAVE/OPT**] (F-5) for 1 second to select the save option screen.
- ② Rotate the main dial to select the saving format between Text to HTML.
 - "Text" is the default setting.
 - Hold down [**DEF**] (F-4) for 1 second to select the default setting.
- ③ Push [**EXIT/SET**] to return to the previous display.

• **Saving location**

- ① Push [**DIR/FILE**] (F-1) to select the tree view screen.
- ② Select the desired directory or folder on the USB-Memory.
 - Push [**◀▶**] (F-4) to select the upper directory.
 - Push [**▲**] (F-2) or [**▼**] (F-3) to select folder in the same directory.
 - Hold down [**◀▶**] (F-4) for 1 second to select a folder in the directory.
 - Push [**REN**] (MF5) to rename the folder.
 - Hold down [**DEL**] (MF6) for 1 second to delete the folder.
 - Hold down [**MAKE**] (MF7) for 1 second to making a new folder. (Edit the name in the same manner as the "• File name" above.)
- ③ Push [**DIR/FILE**] (F-1) twice to select the file name.

- ④ Push [**SAVE/OPT**] (F-5).
 - After saving is completed, automatically returns to the RTTY decode second menu.

✓ **For your convenience!**

Two data formats, Text and HTML, are available for PC data storage.

The USB-Memory is not supplied by Icom.

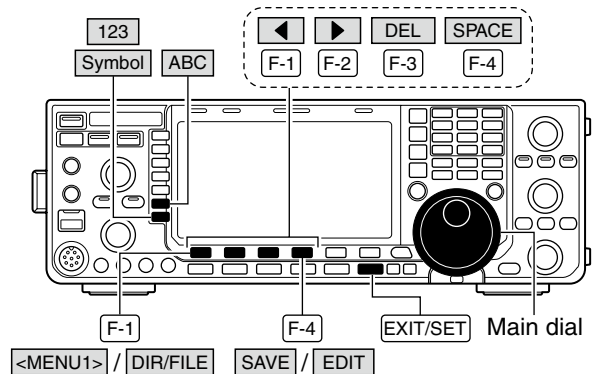

• **Decode file save screen— file name edit**

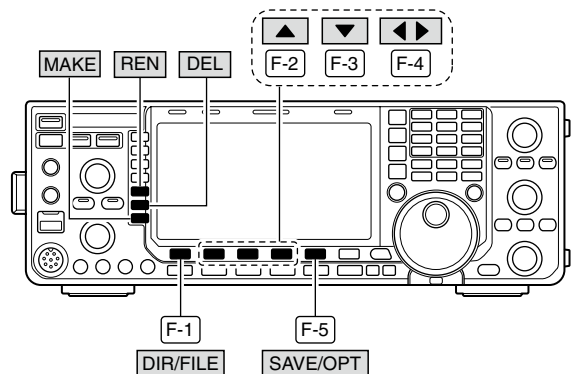
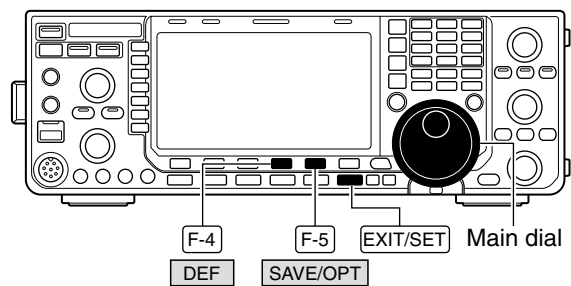
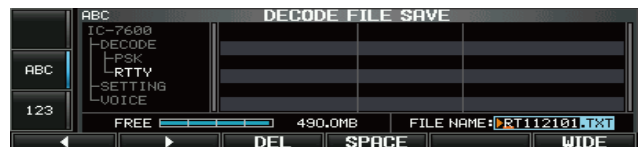

• **Save option screen**

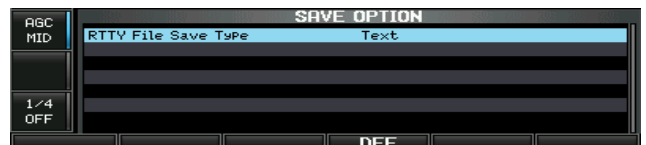

When a PC keyboard is connected to the [USB] (A) connector on the front panel, the file name can also be edited from the keyboard. In this case, a USB hub is required.

■ PSK operation

A high-quality DSP-based PSK encoder/decoder is built-in to the IC-7600. When connecting a PC keyboard (pp. 18, 19), PSK operation can be performed without PSK software installed on your PC. If desired, you can also use your PSK software. Consult the manual that comes with the software.

- ① Push a band key to select the desired band.
- ② Push **[RTTY/PSK]** to select PSK.
 - After the PSK mode is selected, hold down **[RTTY/PSK]** for 1 second to toggle between the PSK and PSK-R modes.
 - “PSK” or “PSK-R” appears.
- ③ Push **[DECODE] (F-3)** to display the decode screen.
 - The IC-7600 has a built-in PSK decoder.
- ④ Tune to the desired signal with the main dial.
 - The signal is properly tuned when the radiated lines in the vector tuning indicator narrow, as show in the example below.
 - The radiated lines in the vector tuning indicator may be displayed sporadically.
 - When a PSK signal is received, the water-fall display is activated.
 - The water-fall display shows the signals within the passband. Received PSK signals appear as vertical lines.
- ⑤ Push **[F12]** of the connected keyboard to transmit.
 - [TX] indicator lights red.
- ⑥ Type on the connected keyboard to enter the message that you want to transmit.
 - The typewritten contents are displayed in the TX buffer screen and transmitted immediately.
 - The text color will change when transmitted.
 - Push one of **[F1]–[F8]** to transmit the TX memory contents.
- ⑦ Push **[F12]** of the keyboard to return to receive.

✓ For your convenience

The transmission contents can be typed before being transmitted.

- ① Perform the steps ① to ④ above.
- ② Type on the connected keyboard to enter the message that you want to transmit.
 - The message is shown in the TX buffer screen.
- ③ Push **[F12]** of the connected keyboard to transmit the message.
 - The color of displayed text, in the TX buffer screen, will be changed when transmitted.
 - To cancel the transmission, push **[F12]** twice.
- ④ Push **[F12]** of the keyboard to return to receive.

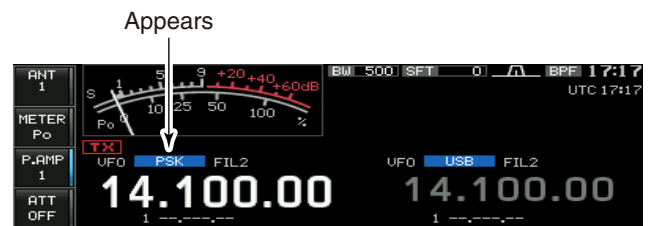
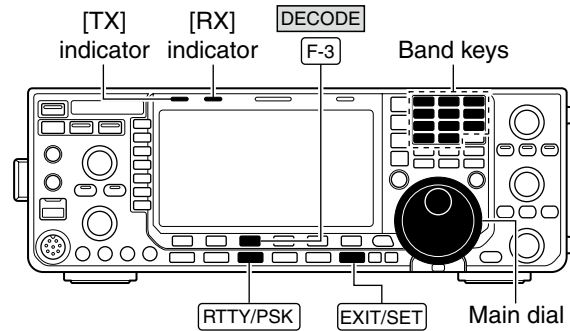

• Waterfall display

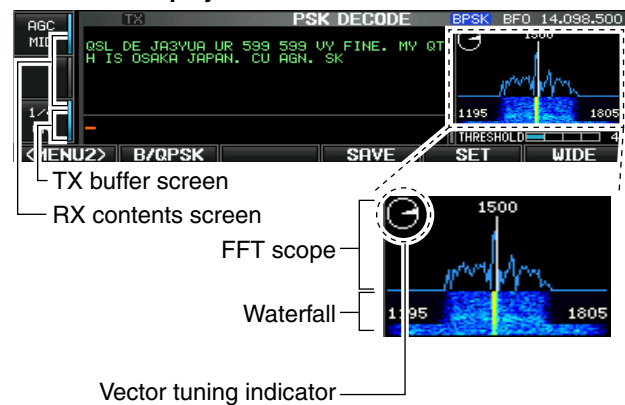

• Vector tuning indicator display example

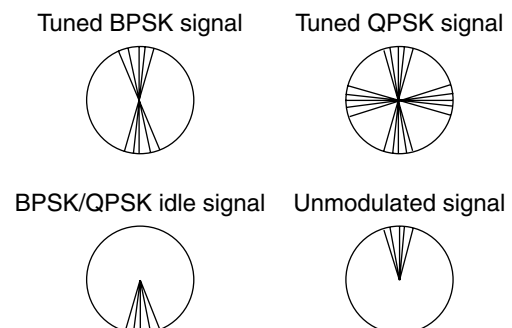

◆ **About BPSK and QPSK modes**

The BPSK and QPSK modes are available for PSK.

- The BPSK (Binary Phase Shift Keying) mode is the most commonly used mode.
- The QPSK (Quadrature Phase Shift Keying) mode has error correction capability to provide better decoding than the BPSK mode in marginal condition.

- ① During the PSK mode selection, push [**DECODE**] (**F-3**) to display the PSK decode screen.
- ② Push [**<MENU1>**] (**F-1**) to select the PSK decode second menu.
- ③ Push [**B/QPSK**] (**F-2**) to toggle between the BPSK and QPSK mode alternately.

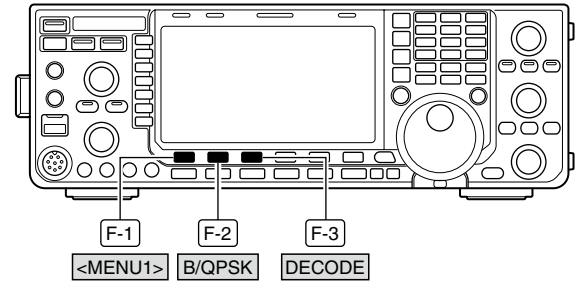

• **PSK decode screen— in the BPSK mode**



• **PSK decode screen— in the QPSK mode**



◆ Functions of the PSK decoder display

- ① Push a band key to select the desired band.
- ② Push **[RTTY/PSK]** to select PSK.
 - After the PSK mode is selected, hold down **[RTTY/PSK]** for 1 second to toggle between the PSK and PSK-R modes.
 - “PSK” or “PSK-R” appears.
- ③ Push **[DECODE] (F-3)** to display the decode screen.
 - When tuned into a PSK signal, decoded characters are displayed in the RX contents screen.
- ④ Push **[HOLD/CLR] (F-2)** to freeze the current screen.
 - “**HOLD**” appears while the function is in use.
 - Push **[HOLD/CLR] (F-2)** again to release the function.
- ⑤ Hold down **[HOLD/CLR] (F-2)** for 1 second to clear the displayed characters.
 - The “**HOLD**” indicator disappears at the same time as the displayed characters are cleared. (The hold function is cancelled.)
- ⑥ Push **[WIDE] (F-6)** to toggle the PSK decode screen size between normal and wide.
 - S/Rf meter type during wide screen display can be selected in the display set mode. (p. 134)
- ⑦ Push **[AFC/NET] (F-5)** to turn the AFC function ON.
 - “**AFC**” appears.
 - If a PSK signal is received within the AFC tuning range, the decoder automatically tunes into the signal and the offset frequency is displayed.
 - The AFC tuning range is set to ± 15 Hz as the default. Optional ± 8 Hz setting is available in the PSK decode set mode. (p. 63)

NOTE: The AFC function may not tune the signal properly when a weak PSK signal is received.

- ⑧ Push **[AFC/NET] (F-5)** again to turn the NET function ON.
 - “**NET**” appears.
- ⑨ Hold down **[AFC/NET] (F-5)** for 1 second to add the offset frequency to the displayed frequency.
- ⑩ Push **[EXIT/SET]** to close the PSK decode screen.

◆ Setting the decoder threshold level

Adjust the PSK decoder threshold level if some characters are displayed when no signal is received.

- ① Call up the PSK decode screen as described above.
- ② Push **[ADJ] (F-4)** to select the threshold level setting condition.
- ③ Rotate the main dial to adjust the PSK decoder threshold level.
 - Hold down **[DEF] (F-5)** for 1 second to select the default setting.
- ④ Push **[ADJ] (F-4)** to exit from the threshold level setting condition.

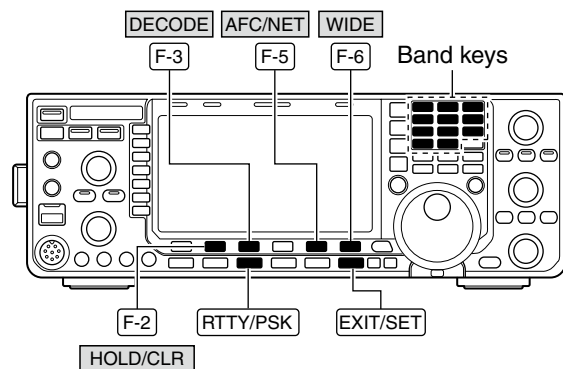

• AFC/NET indicators



“AFC” and “NET” Offset frequency indicators

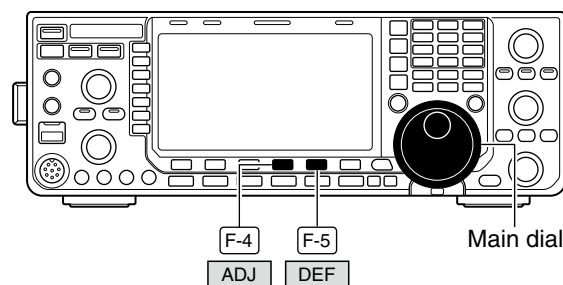

Threshold level indicator bar

◆ **PSK memory transmission**

Previously entered characters can be sent using the PSK memory. Contents of the memory are set using the edit menu.

- ① During the PSK mode operation, push [**DECODE**] (**F-3**) to select the PSK decode screen.
- ② Push [**TX MEM**] (**F-3**) to select the PSK memory screen.
- ③ Push [**1-4/5-8**] (**F-6**) to select memory bank then push one of the function keys ([**PT1**] (**F-1**) to [**PT4**] (**F-4**) or [**PT5**] (**F-1**) to [**PT8**] (**F-4**)).
 - When no keyboard is connected, the selected memory contents will be transmitted immediately.
 - When a keyboard is connected, the memory contents will be transmitted immediately when [**F1**] to [**F8**] on the connected keyboard is pressed, or transmitted after [**F12**] is pressed, depending on auto transmission/reception setting (see below).
 - The transmission date, time, reception date and/or time may be displayed in RX contents screen, depending on setting.

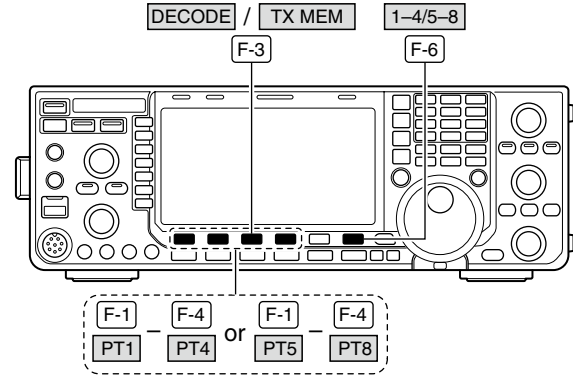

PSK MEMORY			
PT1	-DE Icom Icom K-	AUTO TX/RX	
PT2	-DE Icom Icom Icom K-	AUTO TX/RX	
PT3	-QSL UR 599 599 BK-	AUTO TX/RX	
PT4	-QSL DE Icom Icom UR 599 599 BK-	AUTO TX/RX	
PT1	PT2	PT3	PT4
			EDIT
			1-4/5-8

/// **For your information**

When an external keypad is connected to [MIC] connector on the front panel, one of PT1 to PT4 PSK memory contents can be transmitted while the PSK decode screen is selected in PSK mode. (pp. 18, 141)

◆ **Automatic transmission/reception setting**

- ① During the PSK mode operation, push [**DECODE**] (**F-3**) to select the PSK decode screen.
- ② Push [**TX MEM**] (**F-3**) to select the PSK memory screen, then push [**EDIT**] (**F-5**) to select the PSK memory edit screen.
 - PSK memory contents of Channel 1 (PT1) is selected.
- ③ Push [**PT1..PT8**] (**F-6**) several times to select the desired PSK memory.
- ④ Push [**AUTO TX**] (**F-5**) several times to select the desired operating option, as follows.
 - **AUTO TX/RX**: Automatically transmits the selected memory contents, and returns to receive after the transmission.
 - **AUTO TX** : Automatically transmits the selected memory contents. To return to receive, push [**F12**] on the keyboard.
 - **AUTO RX** : Push [**F12**] on the keyboard to transmit the selected memory contents. Automatically returns to receive after the transmission.
 - **No indication** : Push [**F12**] on the keyboard to transmit the selected memory contents and push [**F12**] again to return to receive.
- ⑤ Push [**EXIT/SET**] to return to exit from the PSK memory edit condition.

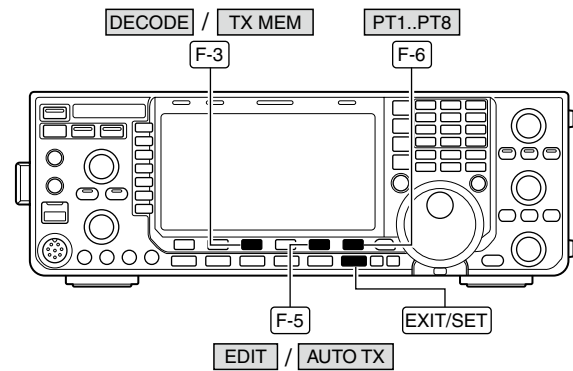

Auto TX/RX settings

PSK MEMORY EDIT			
PT1	-DE Icom Icom K-	AUTO TX/RX	
PT2	-DE Icom Icom Icom K-	AUTO TX/RX	
PT3	-QSL UR 599 599 BK-	AUTO TX/RX	
PT4	-QSL DE Icom Icom UR 599 599 BK-	AUTO TX/RX	
			DEF SPACE AUTO TX PT1..PT8

/// **NOTE:** The transceiver always functions in the “AUTO TX/RX” setting when no keyboard is connected.

◆ Editing PSK memory

The contents of the PSK memories can be set using the memory edit menu. The memory can store and re-transmit 8 PSK message for often-used PSK information. Total capacity of the memory is 70 characters per memory channel.

• Programming contents

- ① During the PSK mode operation, push **[DECODE]** (F-3) to select the PSK decode screen.
- ② Push **[TX MEM]** (F-3) to select the PSK memory screen, then push **[EDIT]** (F-5) to select the PSK memory edit screen.
 - PSK memory contents of Channel 1 (PT1) is selected.
- ③ Push **[PT1..PT8]** (F-6) several times to select the desired PSK memory channel to be edited.
- ④ Push **[ABC]/[abc]** (MF6) or **[123]/[Symbol]** (MF7) to select the character group, then rotate the main dial to select the character, or push the keypad for number input.
 - **[abc]** (MF6) appears when **[ABC]** (MF6) is pushed when “ABC” character group is selected. and **[Symbol]** (MF7) appears when **[123]** (MF7) is pushed when “123” character group is selected.
 - Selectable characters (using the main dial):

Key selection	Characters
ABC	A to Z (capital letters)
abc	a to z (small letters)
123	0 to 9 (numbers)
Symbol	! # \$ % & ¥ ? " ' ` ^ + - * / . , : ; = < > () [] { } _ - @ ↵

- ⑤ Push **[◀]** (F-1) or **[▶]** (F-2) to move the cursor backwards or forwards, respectively.
 - Pushing **[DEL]** (F-3) deletes a character and **[SPACE]** (F-4) inserts a space.
- ⑥ Repeat steps ④ and ⑤ to input the desired characters.
- ⑦ Push **[EXIT/SET]** to set the contents and exit the PSK memory edit screen.

✓ For your convenience

When a PC keyboard is connected to the [USB] connector on the front panel, the PSK memory contents can also be edited from the keyboard.

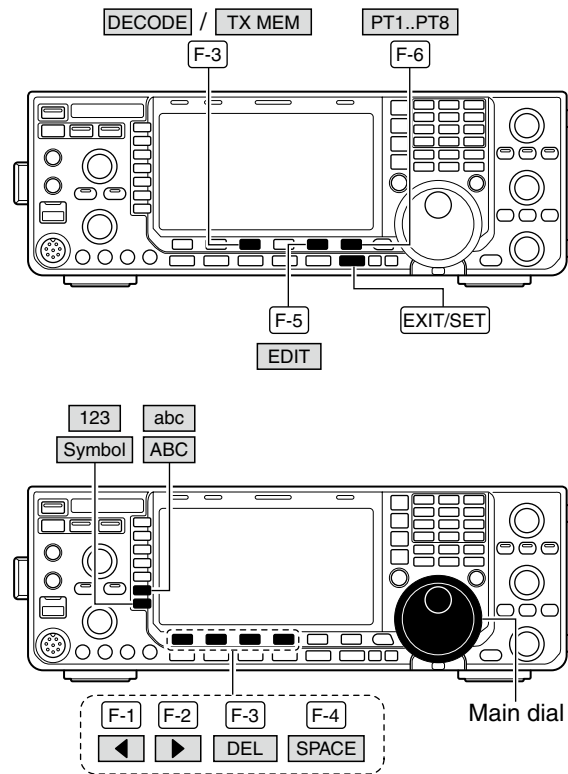

• PSK memory edit screen



• Pre-programmed contents

CH	Contents
PT1	↓DE Icom Icom K↓
PT2	↓DE Icom Icom Icom K↓
PT3	↓QSL UR 599 599 BK↓
PT4	↓QSL DE Icom Icom UR 599 599 BK↓
PT5	↓73 GL SK↓
PT6	↓CQ CQ CQ DE Icom Icom Icom K↓
PT7	↓My transceiver is IC-7600 & Antenna is a 3-element triband yagi.↓
PT8	↓My PSK equipment is internal modulator & demodulator of the IC-7600.↓

◇ **PSK decode set mode**

This set mode is used to set the PSK AFC range, time stamp setting, etc.

• **Setting contents**

- ① During the PSK mode operation, push [DECODE] (F-3) to select the PSK decode screen.
- ② Push [<MENU1>] (F-1) to select the second PSK decode menu, then push [SET] (F-5) to select the PSK decode set mode.
 - Push [WIDE] (F-6) to toggle the screen size between normal and wide.
- ③ Push [▲] (F-1) or [▼] (F-2) to select the desired set item.
- ④ Set the desired condition using the main dial.
 - Hold down [DEF] (F-4) for 1 second to select a default condition or value.
 - Push [◀▶] (F-3) to select the set contents for some items.
- ⑤ Push [EXIT/SET] to exit from the set mode.

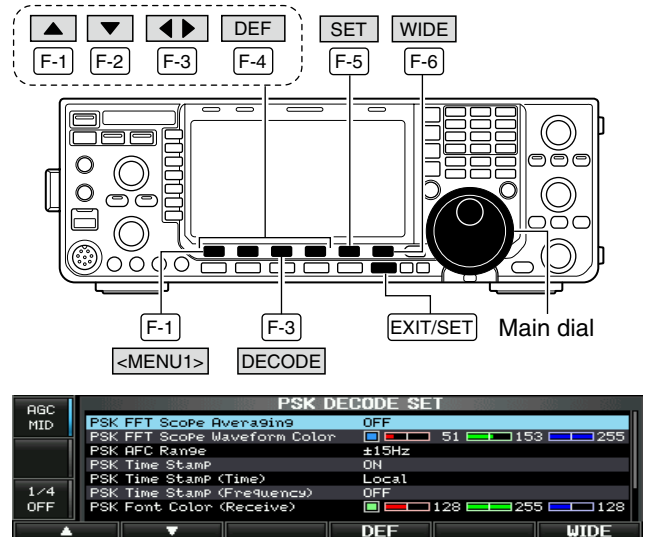



PSK FFT Scope Averaging	OFF
Select the FFT scope waveform averaging function from 2 to 4 and OFF. (default: OFF)	Recommendation! If you use the FFT scope waveform for tuning, using the default or smaller averaging setting is recommended.
PSK FFT Scope Waveform Color	
Set the color for the FFT scope waveform. <ul style="list-style-type: none"> • The color is set in RGB format. • The set color is shown in the box beside the RGB scale. 	<ul style="list-style-type: none"> • Push [◀▶] (F-3) to select R (Red), G (Green) and B (Blue), and then rotate the main dial to set the ratio from 0 to 255.
PSK AFC Range	±15Hz
Select the AFC (Automatic Frequency Control) function operating range from ±15 Hz (default) and ±8 Hz.	NOTE: The AFC function may not tune the signal properly when a weak PSK signal is received.
PSK Time Stamp	ON
Turn the time stamp (date, transmission or reception time) display ON or OFF.	<ul style="list-style-type: none"> • ON : Displays the time stamp. • OFF : No time stamp display.
PSK Time Stamp (Time)	Local
Selects the clock display for time stamp usage.	<ul style="list-style-type: none"> • Local: Selects the time that set in “Time (Now).” • UTC*: Selects the time that set in “CLOCK2.” <p>*The name of choice may differ according to “CLOCK2 Name” setting (p. 123). “UTC” is the default name of CLOCK2.</p>
NOTE: The time won't be displayed when “OFF” is selected in “PSK Time Stamp” as shown above.	

PSK Time Stamp (Frequency)	OFF
<p>Selects the operating frequency display for time stamp usage.</p> <p>NOTE: The frequency won't be displayed when "OFF" is selected in "PSK Time Stamp" as shown below left.</p>	<ul style="list-style-type: none"> • ON : Displays the operating frequency. • OFF : No operating frequency display.

PSK Font Color (Receive)	
<p>Set the text color for received characters.</p> <ul style="list-style-type: none"> • The color is set in RGB format. • The set color is shown in the box beside the RGB scale. 	<ul style="list-style-type: none"> • Push [◀ ▶] (F-3) to select R (Red), G (Green) and B (Blue), and then rotate the main dial to set the ratio from 0 to 255.

PSK Font Color (Transmit)	
<p>Set the text color for transmitted characters.</p> <ul style="list-style-type: none"> • The color is set in RGB format. • The set color is shown in the box beside the RGB scale. 	<ul style="list-style-type: none"> • Push [◀ ▶] (F-3) to select R (Red), G (Green) and B (Blue), and then rotate the main dial to set the ratio from 0 to 255.

PSK Font Color (Time Stamp)	
<p>Set the text color for time stamp indication.</p> <ul style="list-style-type: none"> • The color is set in RGB format. • The set color is shown in the box beside the RGB scale. 	<ul style="list-style-type: none"> • Push [◀ ▶] (F-3) to select R (Red), G (Green) and B (Blue), and then rotate the main dial to set the ratio from 0 to 255.

PSK Font Color (TX Buffer)	
<p>Set the text color in the TX buffer screen.</p> <ul style="list-style-type: none"> • The color is set in RGB format. • The set color is shown in the box beside the RGB scale. 	<ul style="list-style-type: none"> • Push [◀ ▶] (F-3) to select R (Red), G (Green) and B (Blue), and then rotate the main dial to set the ratio from 0 to 255.

◇ **Data saving**

The contents of the PSK memory/received signal can be saved into USB-Memory.

- ① During the PSK decode screen display, push [**<MENU1>**] (F-1) to select the PSK decode second menu.
- ② Push [**SAVE**] (F-4) to select decode file save screen.
- ③ Change the following conditions if desired.

• **File name:**

- ① Push [**EDIT**] (F-4) to select file name edit condition.
 - Push [**DIR/FILE**] (F-1) several times to select the file name, if necessary.
- ② Push [**ABC**] (MF6) or [**123**]/[**Symbol**] (MF7) to select the character group, then rotate the main dial to select the character.
 - [**ABC**] (MF6): A to Z (capital letters), [**123**] (MF7): 0 to 9 (numerals), [**Symbol**] (MF7): ! # \$ % & ' ` ^ - () { } _ - @ can be selected.
 - Push [**◀**] (F-1) to move the cursor left, push [**▶**] (F-2) to move the cursor right, [**DEL**] (F-3) delete a character and push [**SPACE**] (F-4) to insert a space.
- ③ Push [**EXIT/SET**] to store the file name.

• **File format**

- ① Hold down [**SAVE/OPT**] (F-5) for 1 second to select the save option screen.
- ② Rotate the main dial to select the saving format between Text to HTML.
 - “Text” is the default setting.
 - Hold down [**DEF**] (F-4) for 1 second to select the default setting.
- ③ Push [**EXIT/SET**] to return to the previous display.

• **Saving location**

- ① Push [**DIR/FILE**] (F-1) to select tree view screen.
- ② Select the desired directory or folder on the USB-Memory.
 - Push [**◀▶**] (F-4) to select the upper directory.
 - Push [**▲**] (F-2) or [**▼**] (F-3) to select folder in the same directory.
 - Hold down [**◀▶**] (F-4) for 1 second to select a folder in the directory.
 - Push [**REN**] (MF5) to rename the folder.
 - Hold down [**DEL**] (MF6) for 1 second to delete the folder.
 - Hold down [**MAKE**] (MF7) for 1 second to making a new folder. (Edit the name with the same manner as the “• File name” above.)
- ③ Push [**DIR/FILE**] (F-1) twice to select the file name.

- ④ Push [**SAVE/OPT**] (F-5).
 - After saving is completed, returns to the PSK decode second menu automatically.

✓ **For your convenience!**

Two data formats, Text and HTML, are available for PC data storage.

The USB-Memory is not supplied by Icom.

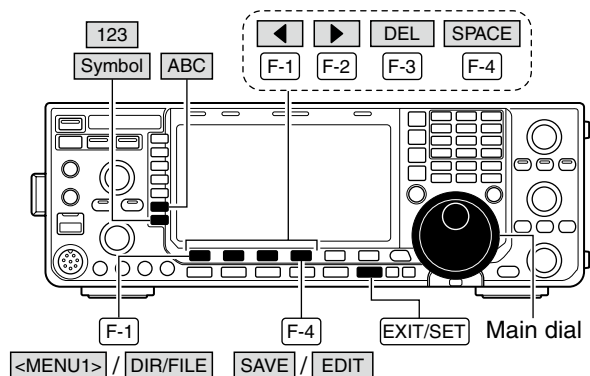

• **Decode file save screen— file name edit**

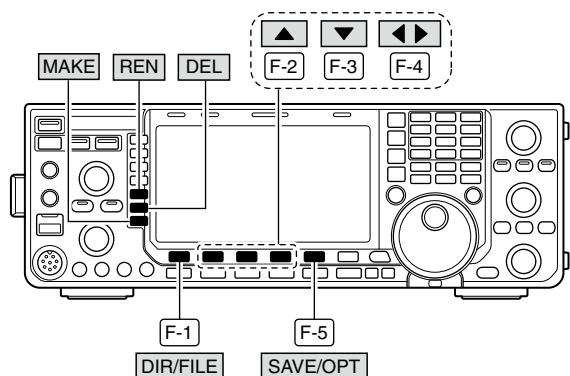
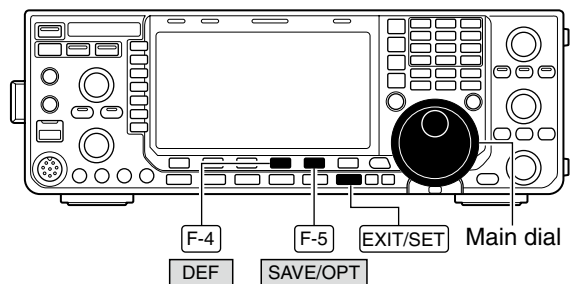
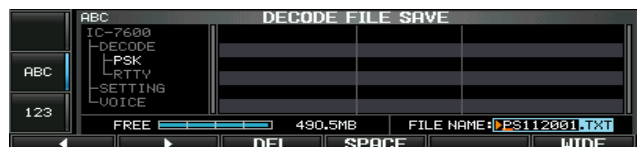

• **Save option screen**



When a PC keyboard is connected to the [USB] connector on the front panel, the file name can also be edited from the keyboard. In this case, a USB hub is required.

■ Repeater operation

A repeater retransmits a received signal on a different frequency. When using a repeater, the transmit frequency is shifted from the receive frequency by an offset frequency. A repeater can be accessed using split frequency operation with the transmit frequency shifted to the repeater's receive frequency.

For accessing a repeater which requires an access tone, set the tone frequency in the tone frequency set mode as described below.

- ① First, set the offset frequency for HF and 50 MHz bands in "FM SPLIT Offset (HF)" and "FM SPLIT Offset (50M)," and set the quick split function to ON in "Quick SPLIT" in the Others set mode. (p. 137)
- ② Push **[VFO/MEMO]** to select the VFO mode.
- ③ Push the desired band key, then set the receive frequency (repeater output frequency).
- ④ Push **[AM/FM]** several times to select the FM mode.
- ⑤ Hold down **[SPLIT]** for 1 second to start repeater operation.
 - Repeater tone is turned ON automatically.
 - **[SPLIT]** indicator lights and "**SPLIT**" appears on the LCD.
 - The tone encoder function is turned ON in the FM mode.
 - Shifted transmit frequency and "TX" appear in the sub band.
 - The transmit frequency can be monitored while holding down **[XFC]**.
- ⑥ Hold down **[PTT]** to transmit, release to receive.
- ⑦ To return to simplex, push **[SPLIT]** momentarily.

◇ Repeater access tone frequency setting

Some repeaters require subaudible tones to be accessed. Subaudible tones are superimposed on your normal signal and must be set in advance. The transceiver has 50 tones from 67.0 Hz to 254.1 Hz.

- ① During FM mode operation, hold down **[TONE] (MF7)** for 1 second to select the tone frequency set mode.
- ② Push **[▲] (F-1)** or **[▼] (F-2)** to select REPEATER TONE item.
- ③ Rotate the main dial to select the desired repeater tone frequency.
 - Hold down **[DEF] (F-4)** for 1 second to select the default setting.
- ④ Push **[EXIT/SET]** to return to the previous display.

• Available tone frequencies (unit: Hz)

67.0	85.4	107.2	136.5	165.5	186.2	210.7	254.1
69.3	88.5	110.9	141.3	167.9	189.9	218.1	
71.9	91.5	114.8	146.2	171.3	192.8	225.7	
74.4	94.8	118.8	151.4	173.8	196.6	229.1	
77.0	97.4	123.0	156.7	177.3	199.5	233.6	
79.7	100.0	127.3	159.8	179.9	203.5	241.8	
82.5	103.5	131.8	162.2	183.5	206.5	250.3	

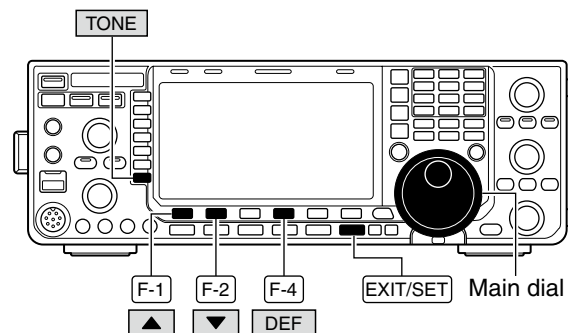
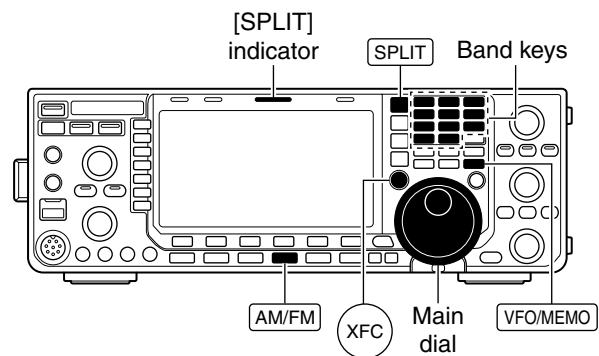

• Tone frequency set mode



■ Tone squelch operation

The tone squelch opens only when receiving a signal containing a matching subaudible tone. You can silently wait for calls from group members using the same tone.

- ① Set the desired frequency band and select the FM mode.
- ② Push **[TONE] (MF7)** several times to turn the tone squelch function ON.
 - “**TSQL**” appears
- ③ Hold down **[TONE] (MF7)** for 1 second to select the tone frequency set mode.
- ④ Push **[▲] (F-1)** or **[▼] (F-2)** to select T-SQL TONE item.
- ⑤ Rotate the main dial to select the desired tone squelch frequency.
 - Hold down **[DEF] (F-4)** for 1 second to select the default setting.
- ⑥ Push **[EXIT/SET]** to return to the previous display.
- ⑦ When the received signal includes a matching tone, squelch opens and the signal can be heard.
 - When the received signal’s tone does not match, tone squelch does not open. However, the S-indicator shows signal strength.
 - To open the squelch manually, push **[XFC]**.
- ⑧ Operate the transceiver in the normal way.
- ⑨ To cancel the tone squelch, push **[TONE] (MF7)** to clear “TSQL.”

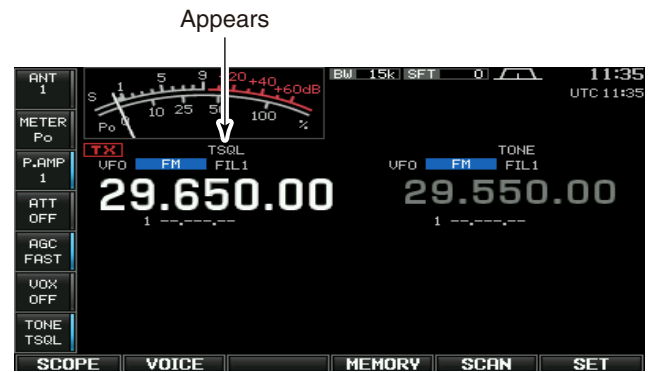
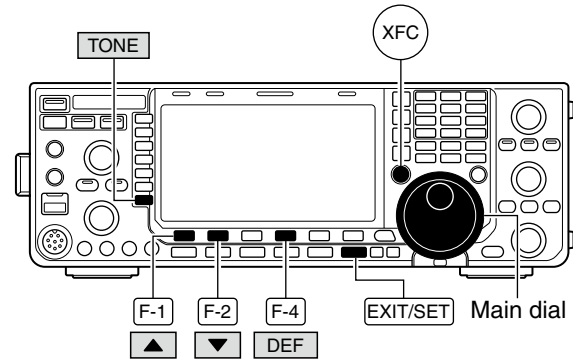

• Tone frequency set mode



• Available tone frequencies (unit: Hz)

67.0	85.4	107.2	136.5	165.5	186.2	210.7	254.1
69.3	88.5	110.9	141.3	167.9	189.9	218.1	
71.9	91.5	114.8	146.2	171.3	192.8	225.7	
74.4	94.8	118.8	151.4	173.8	196.6	229.1	
77.0	97.4	123.0	156.7	177.3	199.5	233.6	
79.7	100.0	127.3	159.8	179.9	203.5	241.8	
82.5	103.5	131.8	162.2	183.5	206.5	250.3	

■ Data mode (AFSK) operation

When operating RTTY, SSTV, AMTOR or PACKET with your TNC and/or PC software in the AFSK mode, consult the manual that comes with the TNC and/or the software.

- ① Connect a PC and TNC to the transceiver. (p. 23)
- ② Push a band key to select the desired band.
- ③ Push **[SSB]** or **[AM/FM]** to select the desired operating mode.
- ④ Hold down **[SSB]** or **[AM/FM]** that is pushed in step ③ for 1 second to turn the data mode ON.
 - One of “-D1,” “-D2” or “-D3” is additionally appears.
 - During data mode selection, hold down **[SSB]** or **[AM/FM]** for 1 second to select data mode 1 (D1), 2 (D2) and 3 (D3) in sequence.
- ⑤ Rotate the main dial to tune to the desired signal and decode it correctly.
 - Also use the tuning indicator of the TNC or software.
 - During the SSB data mode, the 1/4 tuning function can be used for critical tuning.
- ⑥ Operate the PC (software) or TNC to transmit.
 - When operating in the SSB data mode, adjust the TNC output level so that the ALC meter reading doesn't go outside the ALC zone.

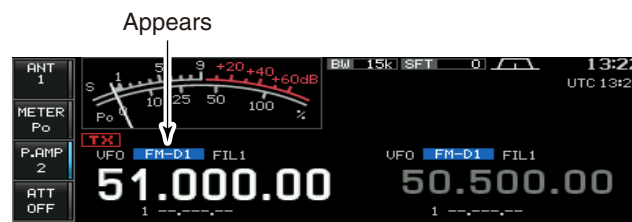
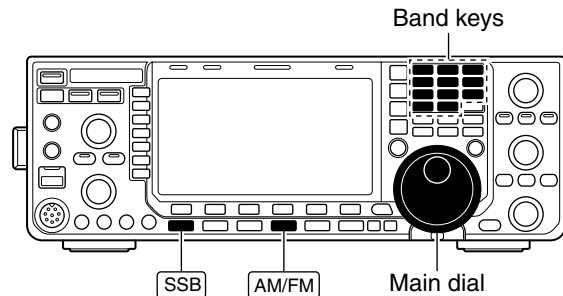

NOTE: When data mode is selected, the audio input from the [ACC1] (pin 4) is used for transmission instead of the [MIC]'s depending on the set mode settings. Modulation input connector can be changed in the ACC set mode. (p. 132)
 The fixed condition is used for SSB data transmission as follows:

- [COMP] : OFF
- Tx bandwidth : MID*
- Tx Tone (Bass) : 0
- Tx Tone (Treble) : 0

*Fixed to the default value (lower: 300, higher: 2700). (p. 130)

✓ For your information

Carrier frequency is displayed when the SSB data mode is selected.
 See the diagram to the right for the tone-pair example.

• Mark and Space tones of RTTY in the AFSK mode operated in the LSB mode

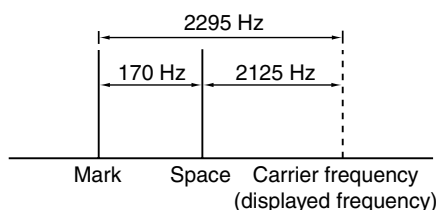

■ Spectrum scope screen

This DSP-based spectrum scope allows you to display the activity on the selected band, as well as the relative strengths of various signals.

The IC-7600 has two spectrum scope modes. One is the center mode, and another one is the fixed mode. You can also turn the waterfall display ON or OFF for your convenience.

In addition, there is a mini scope screen to save screen space.

• Center mode screen

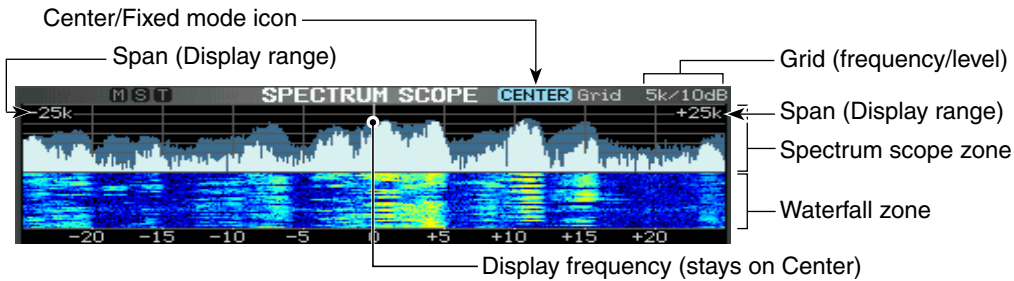

• Fixed mode screen

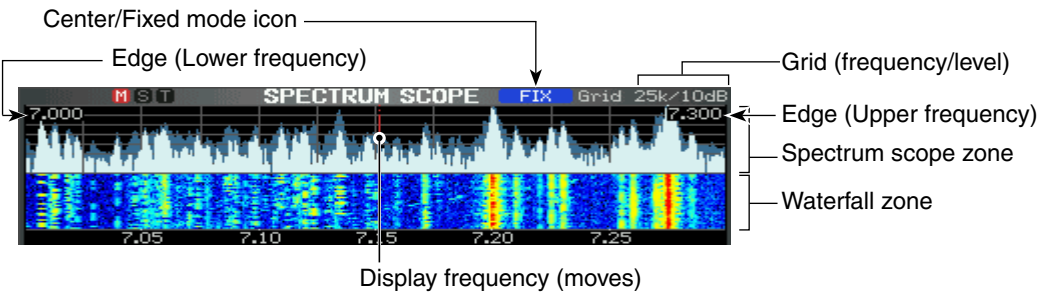

• Center mode screen (Wide screen)

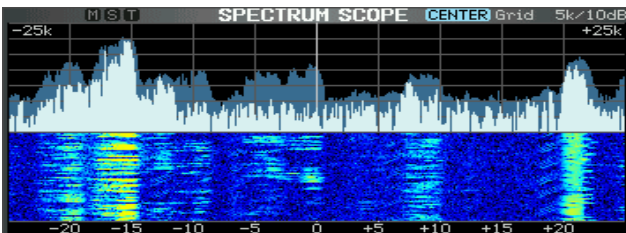

• Fixed mode screen (Waterfall OFF)

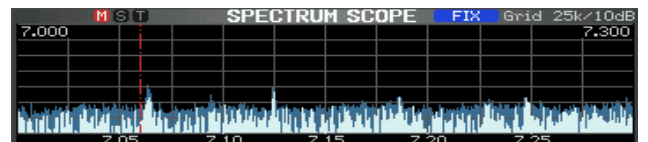

◆ Using the Spectrum scope

- ① Push [EXIT/SET] several times to close any multi-function screens, if necessary.
- ② Push [SCOPE](F-1).
 - The Spectrum scope screen is displayed.

Function	Action	
SPAN (F-1)	When the center mode is selected, selects the scope span. • Selectable spans: ±2.5, 5.0, 10, 25, 50, 100 and 250 kHz • Hold down for 1 second to select the ±2.5 kHz span.	
ATT (F-2)	Push	Selects the scope attenuator. • OFF, 10 dB, 20 dB, 30dB
	Hold down	Turns OFF the attenuator.
MARKER (F-3)	Selects the marker.	
HOLD (F-4)	Push	Turns the hold function ON or OFF.
	Hold down	Clears the peak hold level.
CENT/FIX (F-5)	Selects the center or fixed mode.	
WIDE/SET (F-6)	Push	Selects the wide or normal screen.
	Hold down	Enters the scope set screen.

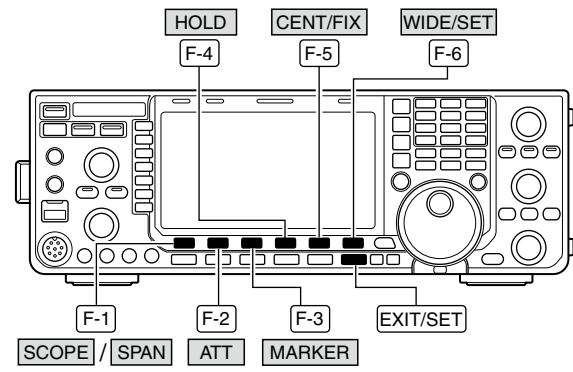

• Spectrum scope screen

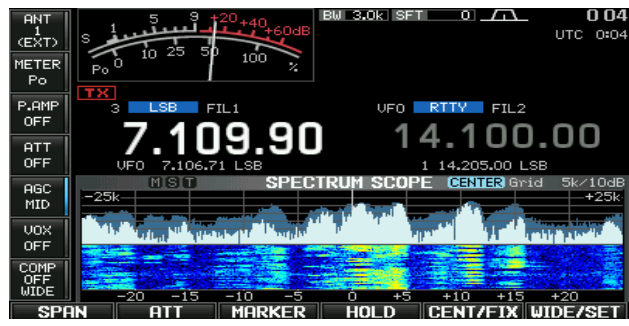

- ③ To exit the spectrum scope screen, push [EXIT/SET].

NOTE: If a strong signal is received, a ghost waveform may appear. If it appears, push [ATT](F-2) several times to enable the scope attenuator.

• Scope spurious signal example

Spurious signal waveforms may be displayed. They are generated in the internal scope circuit and do not indicate a transceiver malfunction.

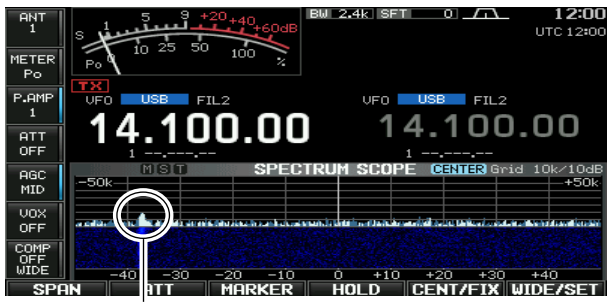

Scope spurious example

◆ **Center mode**

Displays signals around the operating frequency within the selected span. The operating frequency is always displayed in the center of the screen.

- ① Push **[EXIT/SET]** several times to close any multi-function screens, if necessary.
- ② Push **[SCOPE](F-1)** to select the scope screen.
- ③ Push **[CENT/FIX](F-5)** to select the center mode.
 - “**CENTER**” is displayed when the center mode is selected.
 - Push **[CENT/FIX](F-5)** to toggle between the center and fixed modes.
- ④ Push **[SPAN](F-1)** several times to select the desired scope span.
 - Selectable spans $\pm 2.5, 5.0, 10, 25, 50, 100,$ and 250 kHz
 - Hold down **[SPAN](F-1)** for 1second to select the ± 2.5 kHz span.
 - The sweep speed is selectable for each span independently in the scope set mode. (pp. 74, 75)
- ⑤ To exit the spectrum scope screen, push **[EXIT/SET]**.

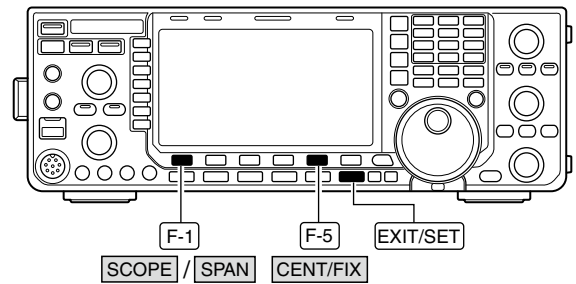

• **Center mode screen**

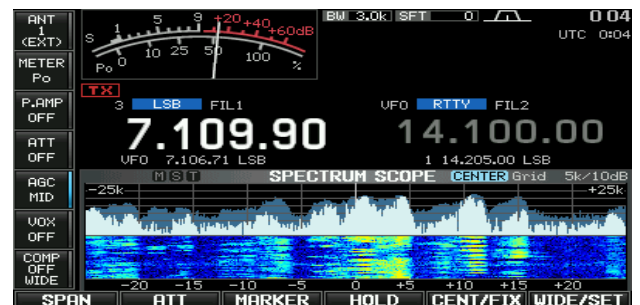

• **Center mode screen (Example: Span ± 250 kHz)**

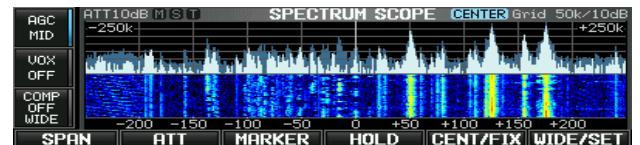

The Marker display in the center mode

The marker displays the operating frequency of the sub band in the spectrum scope screen. The main band frequency stays on the center of the screen when the center mode is selected. Thus, the transceiver does not display the main maker in the center mode.

- When the hold function is ON, the main maker is displayed to indicate the operating frequency’s position.

• **Marker types**

- M** : The main marker indicates the operating frequency of the main band.
- S** : The sub marker indicates the operating frequency of the sub band.
- T** : The TX marker indicates the transmit frequency.

- ➔ Push **[MARKER](F-3)** to select the desired marker.
 - SUB, TX, TX/SUB, or OFF

- When the maker is displayed and the frequency is out of range, “<<” or “>>” appears at the upper side corners of the spectrum scope screen.
 - <<: The operating frequency is too low.
 - >>: The operating frequency is too high.

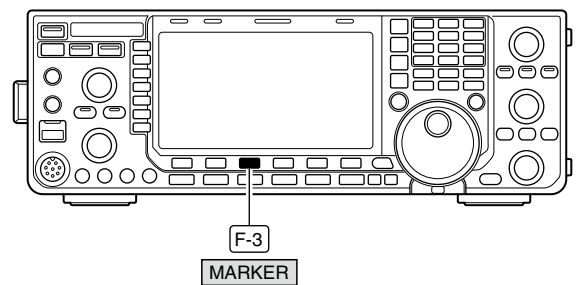

• **TX marker is ON**

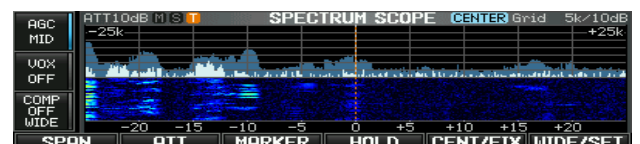

◇ Fixed mode

Displays signals within a specified frequency range. The selected frequency band activity can be observed at a glance when using this mode.

- ① Push **[EXIT/SET]** several times to close any multi-function screens, if necessary.
- ② Push **[SCOPE](F-1)** to select the scope screen.
- ③ Push **[CENT/FIX](F-5)** to select the fixed mode.
 - “**FIX**” is displayed when the fixed mode is selected.
 - Push **[CENT/FIX](F-5)** to toggle between the center and fixed modes.
 - When the operating frequency moves past the upper or lower edge frequency, “<<” or “>>” appears at the upper side corners of the screen.
 - <<: The frequency is too low.
 - >>: The frequency is too high.
- ④ To exit the spectrum scope screen, push **[EXIT/SET]**.

▨ The scope bandwidth can be specified for each frequency band independently in the scope set mode. (pp. 76 to 78)

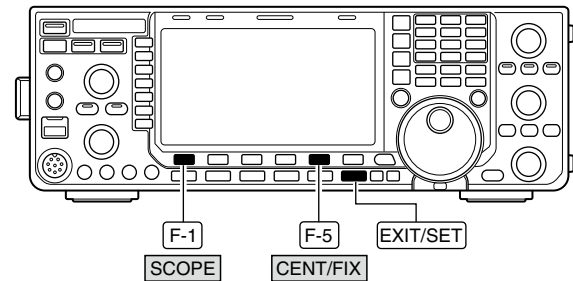

• Fixed mode screen

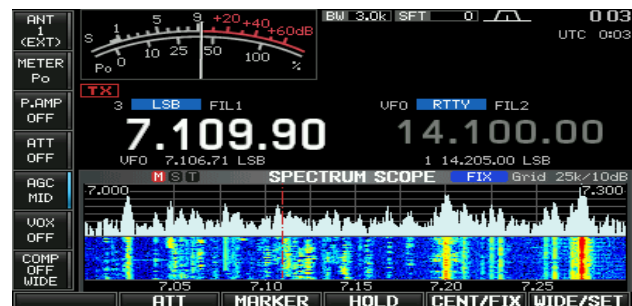

The Marker display in the fixed mode

In the fixed mode, the marker displays the operating frequency. So, the transceiver always displays the main marker.

• Marker types

- M**: The main marker indicates the operating frequency of the main band.
- S**: The sub marker indicates the operating frequency of the sub band.
- T**: The TX marker indicates the transmit frequency.

- ➔ Push **[MARKER](F-3)** to select the desired marker.
 - MAIN/SUB, MAIN/TX, MAIN/SUB/TX, or only MAIN

- When the marker is displayed and the frequency is out of range, “<<” or “>>” appears at the upper side corners of the spectrum scope screen.
 - <<: The operating frequency is too low.
 - >>: The operating frequency is too high.

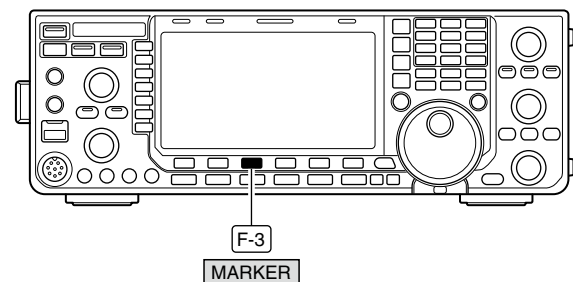

• The SUB maker is out of range (“>>” appears)

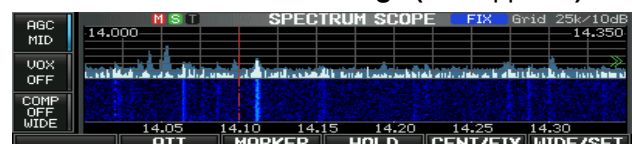

◆ **Mini scope screen**

The mini scope screen can be simultaneously displayed with other multi-function displays, such as a set mode menu, RTTY/PSK decode screen, or memory list screen.

- ➔ Hold down **[M.SCOPE]** for 1 second to turn the mini scope screen ON or OFF.
 - When the mini scope screen is displayed with the scope set screen, you can select the settings by verifying the spectrum.
 - However, you cannot make changes using the function keys, such as the scope attenuator setting, center/fixed mode selection.
 - In the display set mode (Meter Type (Wide Screen) item), you can select the S/RF meter type displayed in the mini scope screen. (p. 134)

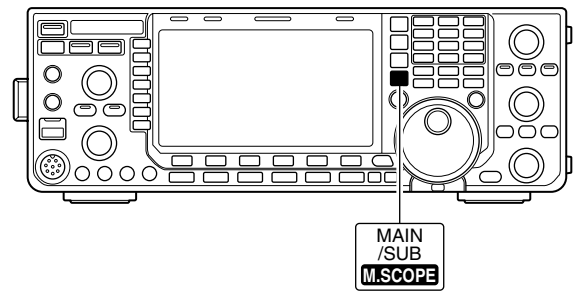

• **Mini scope screen with the set mode menu screen**

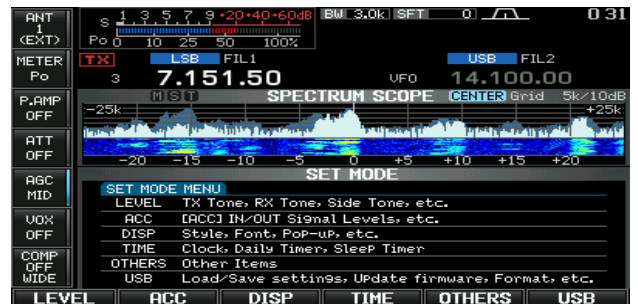

• **Mini scope screen with the RTTY decode screen**



◆ **Scope attenuator**

While operating in a band with a high noise floor, activate the scope attenuator to reduce the noise level.

- Even if the scope attenuator is ON, it does not affect the receiver sensitivity.
- ① Push **[EXIT/SET]** several times to close any multi-function screens, if necessary.
 - ② Push **[SCOPE](F-1)** to select the scope screen.
 - ③ Push **[ATT](F-2)** several times to select the desired scope attenuator level.
 - Selectable levels: 10 dB, 20 dB, 30 dB, and OFF.
 - Hold down **[ATT](F-2)** for 1 second to turn the scope attenuator OFF.
 - ④ To exit the spectrum scope screen, push **[EXIT/SET]**.

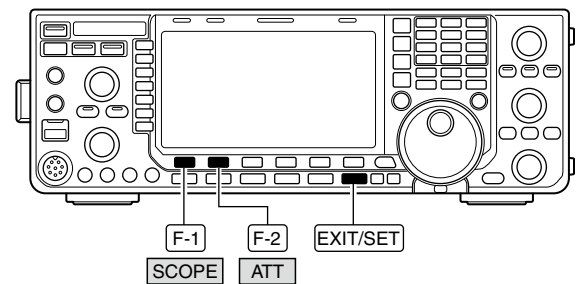

• **Scope attenuator (OFF)**

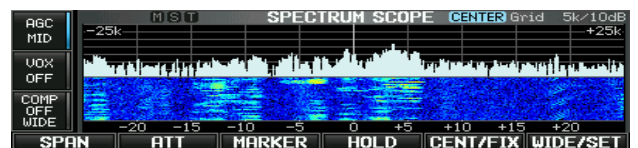

• **Scope attenuator (20 dB)**

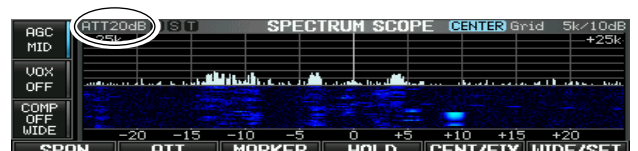

◇ **Scope set mode**

This set mode is used to set the waveform color, sweeping speed, scope range for fixed mode, etc.

- ① During spectrum scope display ON, hold down **[WIDE/SET] (F-6)** for 1 second to select the scope set mode screen.
 - Push **[WIDE/SET] (F-6)** to toggle the screen size between normal and wide.
- ② Push **[▲] (F-1)** or **[▼] (F-2)** to select the desired set item.
- ③ Set the desired condition using the main dial.
 - Hold down **[DEF] (F-4)** for 1 second to select the default condition or value.
 - Push **[◀ ▶] (F-3)** to select the set contents for some items.
- ④ Push **[EXIT/SET]** to exit from the set mode.

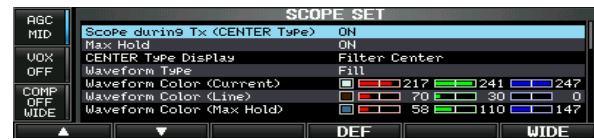
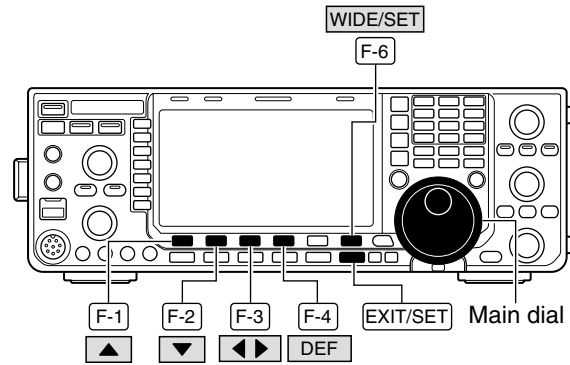

Scope during Tx (CENTER Type)	ON
Turn display of the transmit signal ON or OFF.	NOTE: Transmit signal display is available for the center mode only.

Max Hold	ON
Turn the peak level hold function ON or OFF.	

CENTER Type Display	Filter Center
Select the center frequency of the spectrum scope display (center mode only).	<ul style="list-style-type: none"> • Filter Center : Shows the selected filter's center frequency at the center. • Carrier Point Center : Shows the selected operating mode carrier point frequency at the center. • Carrier Point Center (Abs. Freq.) : In addition to the carrier point center setting above, the actual frequency is displayed at the bottom of the scope.

Waveform Type	Fill
Select the outline waveform display type for the Spectrum scope.	<ul style="list-style-type: none"> • Fill : The waveform is drawn only in color. • Fill + Line : The waveform is drawn in color with an outline.

◇ Scope set mode (continued)

Waveform Color (Current)	
Set the waveform color for the currently received signals.	<ul style="list-style-type: none"> • The color is set in RGB format. • Push [◀ ▶] (F-3) to select R (Red), G (Green) and B (Blue), and rotate the main dial to adjust the ratio from 0 to 255. • The color is displayed in the box beside the RGB scale.

Waveform Color (Line)	
Set the waveform outline color for the currently received signals.	<ul style="list-style-type: none"> • The color is set in RGB format. • Push [◀ ▶] (F-3) to select R (Red), G (Green) and B (Blue), and rotate the main dial to adjust the ratio from 0 to 255. • The color is displayed in the box beside the RGB scale.

Waveform Color (Max Hold)	
Set the waveform color for the received signals maximum level.	<ul style="list-style-type: none"> • The color is set in RGB format. • Push [◀ ▶] (F-3) to select R (Red), G (Green) and B (Blue), and rotate the main dial to adjust the ratio from 0 to 255. • The color is displayed in the box beside the RGB scale.

Waterfall Display	ON
Turn the Waterfall display ON or OFF for the normal scope or Mini scope screen. (In the wide screen, the Waterfall is always displayed, regardless of this setting.)	<ul style="list-style-type: none"> • OFF : Turns OFF the Waterfall display. • ON : Turns ON the Waterfall display.

Waterfall Peak Color Level	Grid 7
Select the signal level that the Waterfall displays a peak color from Grid 1 to Grid 7.	Higher signal levels are Red, Yellow, Green, Light-blue, Blue and Black in order.

Sweep Speed (± 2.5k)	MID
Select the sweep speed for the ±2.5 kHz span selection from SLOW, MID and FAST.	NOTE: Signals may be displayed incorrectly with "FAST" setting.

Sweep Speed (± 5k)	MID
Select the sweep speed for the ±5 kHz span selection from SLOW, MID and FAST.	NOTE: Signals may be displayed incorrectly with "FAST" setting.

Sweep Speed (± 10k)	FAST
Select the sweep speed for the ±10 kHz span selection from SLOW, MID and FAST.	

Sweep Speed	(± 25k)	FAST
Select the sweep speed for the ±25 kHz span selection from SLOW, MID and FAST.		

Sweep Speed	(± 50k)	FAST
Select the sweep speed for the ±50 kHz span selection from SLOW, MID and FAST.		

Sweep Speed	(± 100k)	FAST
Select the sweep speed for the ±100 kHz span selection from SLOW, MID and FAST.		

Sweep Speed	(± 250k)	FAST
Select the sweep speed for the ±250 kHz span selection from SLOW, MID and FAST.		

Fixed Edges	(0.03 – 1.60)	0.750 – 1.250 MHz
Set the scope edge frequencies for fixed mode for bands below 1.6 MHz.		
		<ul style="list-style-type: none"> • Set the frequencies within 0.030 to 1.600 MHz range in 1 kHz steps. ▨ As edge frequencies are set, the other edge frequency will be automatically set for a display band width of 5 kHz to a maximum of 500 kHz.

Fixed Edges	(1.60 – 2.00)	1.800 – 2.000 MHz
Set the scope edge frequencies for fixed mode scope when the 1.6 to 2 MHz band is selected.		
		<ul style="list-style-type: none"> • Set the frequencies within 1.600 to 2.000 MHz range in 1 kHz steps.

Fixed Edges	(2.00 – 6.00)	3.500 – 4.000 MHz
Set the scope edge frequencies for fixed mode scope when the 2 to 6 MHz band is selected.		
		<ul style="list-style-type: none"> • Set the frequencies within 2.000 to 6.000 MHz range in 1 kHz steps. ▨ As edge frequencies are set, the other edge frequency will be automatically set for a display band width of 5 kHz to a maximum of 500 kHz.

Fixed Edges	(6.00 – 8.00)	7.000 – 7.300 MHz
Set the scope edge frequencies for fixed mode scope when the 6 to 8 MHz band is selected.		
		<ul style="list-style-type: none"> • Set the frequencies within 6.000 to 8.000 MHz range in 1 kHz steps. ▨ As edge frequencies are set, the other edge frequency will be automatically set for a display band width of 5 kHz to a maximum of 500 kHz.

◇ Scope set mode (continued)

<p>Fixed Edges (8.00 – 11.00)</p> <p>Set the scope edge frequencies for fixed mode scope when the 8 to 11 MHz band is selected.</p>	<p>10.100 – 10.150 MHz</p> <ul style="list-style-type: none"> • Set the frequencies within 8.000 to 11.000 MHz range in 1 kHz steps. /// As edge frequencies are set, the other edge frequency will be automatically set for a display band width of 5 kHz to a maximum of 500 kHz.
<p>Fixed Edges (11.00 – 15.00)</p> <p>Set the scope edge frequencies for fixed mode scope when the 11 to 15 MHz band is selected.</p>	<p>14.000 – 14.350 MHz</p> <ul style="list-style-type: none"> • Set the frequencies within 11.000 to 15.000 MHz range in 1 kHz steps. /// As edge frequencies are set, the other edge frequency will be automatically set for a display band width of 5 kHz to a maximum of 500 kHz.
<p>Fixed Edges (15.00 – 20.00)</p> <p>Set the scope edge frequencies for fixed mode scope when the 15 to 20 MHz band is selected.</p>	<p>18.068 – 18.168 MHz</p> <ul style="list-style-type: none"> • Set the frequencies within 15.000 to 20.000 MHz range in 1 kHz steps. /// As edge frequencies are set, the other edge frequency will be automatically set for a display band width of 5 kHz to a maximum of 500 kHz.
<p>Fixed Edges (20.00 – 22.00)</p> <p>Set the scope edge frequencies for fixed mode scope when the 20 to 22 MHz band is selected.</p>	<p>21.000 – 21.450 MHz</p> <ul style="list-style-type: none"> • Set the frequencies within 20.000 to 22.000 MHz range in 1 kHz steps. /// As edge frequencies are set, the other edge frequency will be automatically set for a display band width of 5 kHz to a maximum of 500 kHz.
<p>Fixed Edges (22.00 – 26.00)</p> <p>Set the scope edge frequencies for fixed mode scope when the 22 to 26 MHz band is selected.</p>	<p>24.890 – 24.990 MHz</p> <ul style="list-style-type: none"> • Set the frequencies within 22.000 to 26.000 MHz range in 1 kHz steps. /// As edge frequencies are set, the other edge frequency will be automatically set for a display band width of 5 kHz to a maximum of 500 kHz.
<p>Fixed Edges (26.00 – 30.00)</p> <p>Set the scope edge frequencies for fixed mode scope when the 26 to 30 MHz band is selected.</p>	<p>28.000 – 28.500 MHz</p> <ul style="list-style-type: none"> • Set the frequencies within 26.000 to 30.000 MHz range in 1 kHz steps. /// As edge frequencies are set, the other edge frequency will be automatically set for a display band width of 5 kHz to a maximum of 500 kHz.

Fixed Edges (30.00 – 45.00)

Set the scope edge frequencies for fixed mode scope when the 30 to 45 MHz band is selected.

30.000 – 30.500 MHz

- Set the frequencies within 30.000 to 45.000 MHz range in 1 kHz steps.

/// As edge frequencies are set, the other edge frequency will be automatically set for a display band width of 5 kHz to a maximum of 500 kHz.

Fixed Edges (45.00 – 60.00)

Set the scope edge frequencies for fixed mode scope when the 45 to 60 MHz band is selected.

50.000 – 50.500 MHz

- Set the frequencies within 45.000 to 60.000 MHz range in 1 kHz steps.

/// As edge frequencies are set, the other edge frequency will be automatically set for a display band width of 5 kHz to a maximum of 500 kHz.

◆ **USB mouse operation**

If you connect a USB mouse to the transceiver, a mouse pointer appears on the spectrum scope screen.

Now, you can change the frequency by using the mouse.

☐ Clicking while holding down **[XFC]** changes the transmit frequency.

• **Mouse operation on the center mode screen**

Button	Operation	Description
Left	Click	The frequency changes to the clicked point and the mouse pointer moves to the center of the screen.
	Drag	The frequency changes to the clicked point and the mouse pointer moves to the center of the screen, and then the frequency increases or decreases.
Right	Click/Drag	The right button temporarily changes the frequency. While holding the button, same action as the left button, but release it to return to the original frequency.

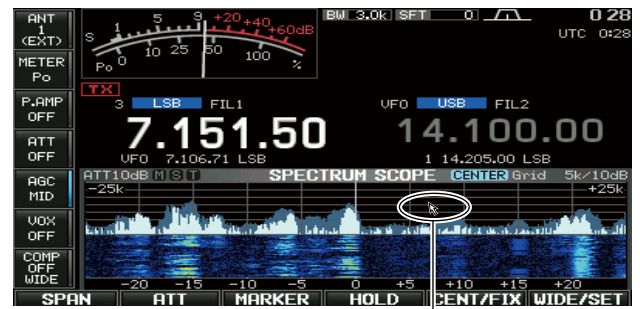

Mouse pointer

• **Mouse operation on the fixed mode screen**

Button	Operation	Description
Left	Click	The frequency and marker change to the clicked point
	Drag	The frequency and marker change to the clicked point and then the frequency increases or decreases.
Right	Click/Drag	The right button temporarily changes the frequency. While holding the button, same action as the left button, but release it to return to the original frequency.

☐ Changing frequencies in the drag operation differ, depending on the tuning step settings.

■ Preamplifier

The preamp amplifies received signals in the receiver front end, to improve the S/N ratio and sensitivity. Set this to preamp 1 or preamp 2 when receiving weak signals.

- ➔ Push **[P.AMP] (MF3)** several times to set the preamp OFF, preamp 1 ON or preamp 2 ON.
- ➔ Hold down **[P.AMP] (MF3)** for 1 second to turn the preamp function OFF.

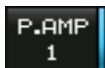

For all HF and 50 MHz bands

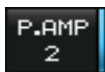

High-gain preamp for 24 MHz band and above (Available for all HF and 50 MHz bands)

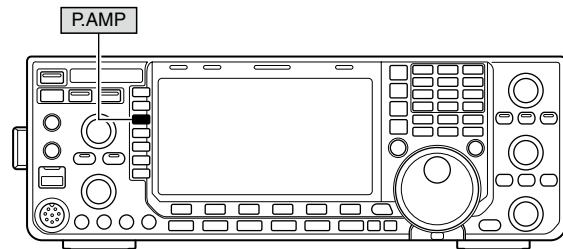

✓ About the "P.AMP2"

The "P.AMP 2" is a high gain receive amplifier. When the "P.AMP 2" is used in the presence of strong electromagnetic fields, distortion sometimes results. In such cases, use the transceiver with the "P.AMP 1" or "P.AMP OFF" setting.

The "P.AMP 2" is most effective when:

- Used on bands above 24 MHz and when signals are weak.
- Receive sensitivity is insufficient when using low-gain antennas, or while using a narrow band antenna (such as small loop, a Beverage antenna or a short Yagi antenna).

4

■ Attenuator

The attenuator prevents a desired signal from being distorted when very strong signals are near the desired frequency or when very strong electromagnetic fields, such as from broadcast stations near your location.

- ➔ Push **[ATT] (MF4)** several times to set the attenuator 6 dB, 12 dB, 18 dB or attenuator OFF.
- ➔ Hold down **[ATT] (MF4)** for 1 second to turn the attenuator function OFF.



6 dB attenuation



12 dB attenuation



18 dB attenuation

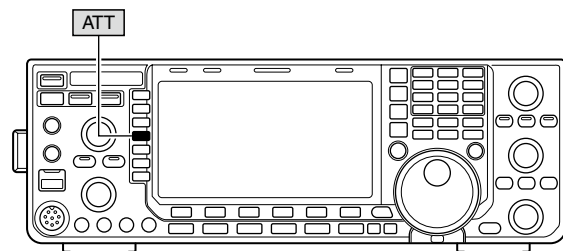

■ RIT function

The RIT (Receive Increment Tuning) function compensates for off-frequency operation of the received station.

The function shifts the receive frequency up to ± 9.999 kHz in 1 Hz steps (10 Hz steps when cancelling the 1 Hz step readout) without moving the transmit frequency.

- ① Push **[RIT]** to turn the RIT function ON and OFF.
 - “**RIT**” and the shifting frequency appear when the function is ON.
- ② Rotate the **[RIT/ΔTX]** control.
 - Hold down **[CLEAR]** for 1 second to reset the RIT frequency.
 - Push **[CLEAR]** momentarily to reset the RIT frequency when the quick RIT/ΔTX clear function is ON. (p. 140)
 - Hold down **[RIT]** for 1 second to add the shift frequency to the operating frequency.

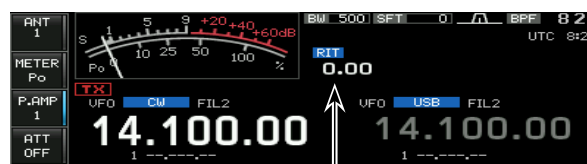
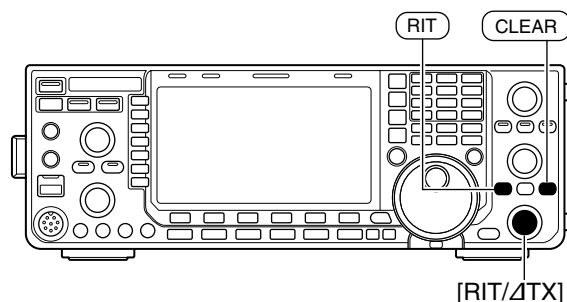

RIT shifting frequency

◇ RIT monitor function

When the RIT function is ON, holding down **[XFC]** allows you to monitor the operating frequency directly (RIT is temporarily cancelled).

✓ For your convenience— Calculate function

The frequency shift of the RIT function can be added/subtracted to the displayed frequency.

- ➡ While displaying the RIT shift frequency, hold down **[RIT]** for 1 second.

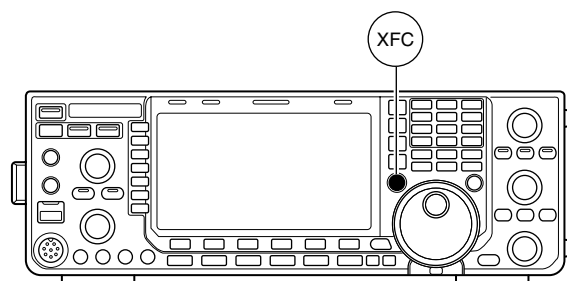

AGC function

The AGC (auto gain control) controls receiver gain to produce a constant audio output level even when the received signal strength varies greatly.

The transceiver has 3 preset AGC characteristics (time constant: fast, mid, slow) for non-FM modes.

▨ The FM mode AGC time constant is fixed as 'FAST' (0.1 seconds) and AGC time constant cannot be changed.

◆ Selecting the preset value

- ① Select any non-FM mode.
- ② Push **[AGC] (MF5)** several times to select AGC fast, AGC medium (MID) or AGC slow.

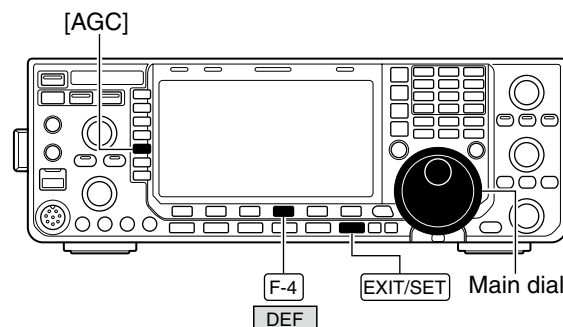

◆ Setting the AGC time constant preset value

- ① Select any non-FM mode.
- ② Hold down **[AGC] (MF5)** for 1 second to select the AGC set mode.
- ③ Push **[AGC] (MF5)** several times to select FAST time constant.
 - ④ Rotate the main dial to set the desired time constant for 'AGC FAST.'
 - AGC time constant can be set between 0.1 to 8.0 seconds (depends on mode) or turned OFF.
 - Hold down **[DEF] (F-4)** for 1 second to select a default value.
- ⑤ Push **[AGC] (MF5)** to select medium time constant.
- ⑥ Rotate the main dial to set the desired time constant for 'AGC MID.'
 - AGC time constant can be set between 0.1 to 8.0 seconds (depends on mode) or turned OFF.
 - Hold down **[DEF] (F-4)** for 1 second to select a default value.
- ⑦ Push **[AGC] (MF5)** to select slow time constant.
- ⑧ Rotate the main dial to set the desired time constant for 'AGC SLOW.'
 - AGC time constant can be set between 0.1 to 8.0 seconds (depends on mode) or turned OFF.
 - Hold down **[DEF] (F-4)** for 1 second to select a default value.
- ⑨ Select another non-FM mode, then repeat steps ③ to ⑧ if desired.
- ⑩ Push **[EXIT/SET]** to exit the AGC set mode screen.

• AGC set mode screen

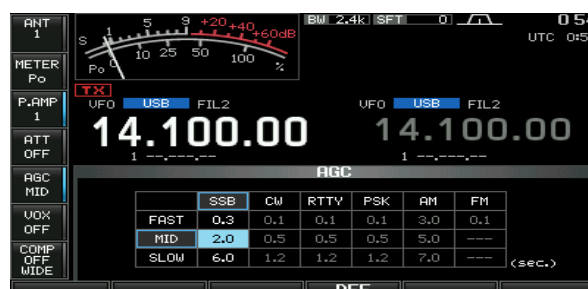

• Selectable AGC time constant (unit: second)

Mode	Default	Selectable AGC time constant
SSB	0.3 (FAST)	OFF, 0.1, 0.2, 0.3, 0.5, 0.8, 1.2, 1.6, 2.0, 2.5, 3.0, 4.0, 5.0, 6.0
	2.0 (MID)	
	6.0 (SLOW)	
CW	0.1 (FAST)	OFF, 0.1, 0.2, 0.3, 0.5, 0.8, 1.2, 1.6, 2.0, 2.5, 3.0, 4.0, 5.0, 6.0
	0.5 (MID)	
	1.2 (SLOW)	
RTTY PSK	0.1 (FAST)	OFF, 0.1, 0.2, 0.3, 0.5, 0.8, 1.2, 1.6, 2.0, 2.5, 3.0, 4.0, 5.0, 6.0
	0.5 (MID)	
	1.2 (SLOW)	
AM	3.0 (FAST)	OFF, 0.3, 0.5, 0.8, 1.2, 1.6, 2.0, 2.5, 3.0, 4.0, 5.0, 6.0, 7.0, 8.0
	5.0 (MID)	
	7.0 (SLOW)	
FM	0.1 (FAST)	Fixed

■ Twin PBT operation

<MODE> SSB/CW/RTTY/PSK/AM

In general, the PBT (Passband Tuning) electronically narrows the IF passband width by shifting the IF frequency to slightly outside of the IF filter passband, to reject interference. The IC-7600 uses DSP for the PBT function.

/// You can watch the nearby intended signal using the spectrum scope. (p. 69)

- ① Rotate **[PBT1]** (inner control) and **[PBT2]** (outer control) to the opposite direction from each other to narrow the IF passband width.
 - Before rotating, the PBT settings of **[PBT1]** and **[PBT2]** should be cleared.
 - Rejects interference of both higher and lower passbands. If you rotate the control too much, the received audio may not be heard because the passband width is too narrow.
 - Displays the passband width and shift frequency.
 - The indicator on the **[PBT-CLR]** switch lights.
 - Hold down **[PBT-CLR]** for 1 second to clear the PBT setting. In that case, indicator on the **[PBT-CLR]** switch goes OFF.
 - The variable range depends on the passband width and the operating mode. The edge of the variable range is half of the passband width. The PBT is adjustable in 25 Hz steps in the SSB/CW/RTTY/PSK modes, and 100 Hz in the AM mode.
 - Moving both **[TWIN PBT]** controls to the same position shifts the IF left or right.
- ② Hold down **[FILTER]** for 1 second.
 - The Filter screen is displayed. The current passband width and shift frequency are displayed.
- ③ Push **[EXIT/SET]**.
 - Exits the Filter screen.

/// **NOTE:** While rotating the **[TWIN PBT]** controls, noise may be heard. This comes from the DSP unit and does not indicate an equipment malfunction.

• PBT operation example

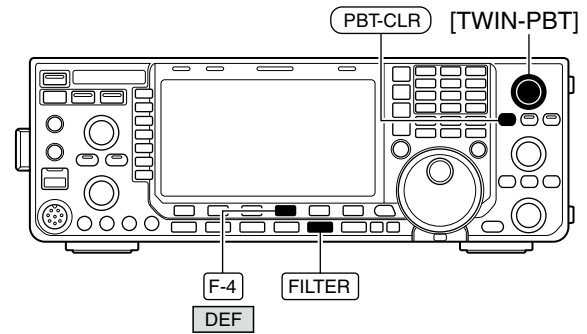
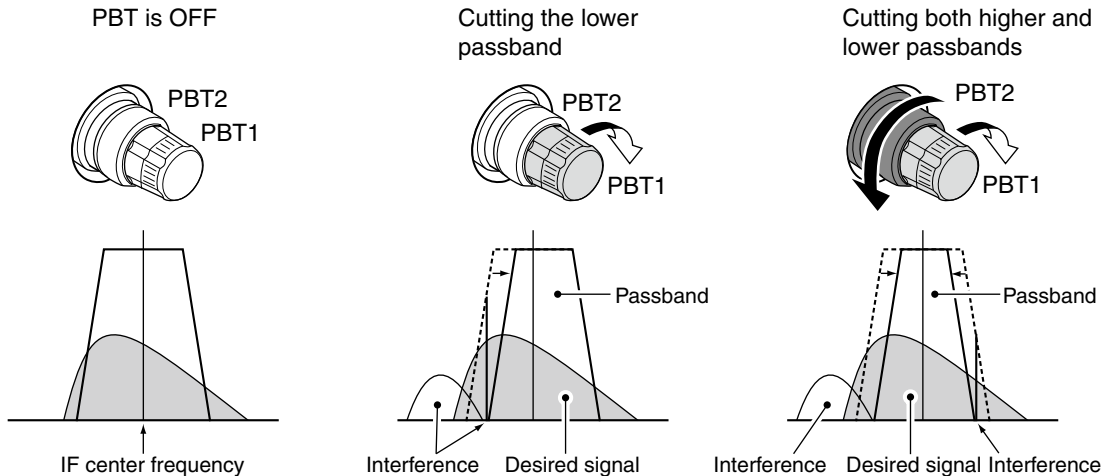

• When operating **[TWIN PBT]**

Shows filter width, shifting value and condition

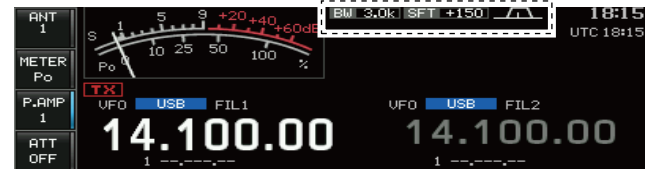

• Filter screen when operating **[TWIN PBT]**

"SHARP" is selected.



• About Passband width and Shift value on the screen

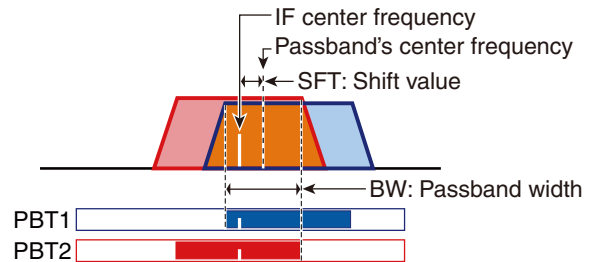

IF filter selection

The transceiver has 3 passband width IF filters for each mode.

For the SSB, CW and PSK modes, the passband width can be set between 50 and 3600 Hz in 50 or 100 Hz steps.

A total of 41 passband widths are available.

For the RTTY mode, the passband width can be set between 50 and 2700 Hz in 50 or 100 Hz steps.

A total of 32 passband widths are available.

For the AM mode, the passband width can be set between 200 Hz and 10 kHz in 200 Hz steps.

A total of 50 passband widths are available.

For the FM mode, the passband width is fixed and 3 passband widths are available.

▨ The filter selection is automatically memorized in each mode.

▨ The PBT shift frequencies are automatically memorized in each filter.

IF filter selection

- ① Select the desired mode.
- ② Push **[FILTER]** several times to select the IF filter 1, 2 or 3.
 - The selected passband width and filter number is displayed in the LCD.

Filter passband width setting (except the FM mode)

- ① Hold down **[FILTER]** for 1 second to select the filter set screen.
- ② Select any mode except FM.
 - Passband widths for the FM modes are fixed and cannot be set.
- ③ Push **[FILTER]** several times to select the desired IF filter.
- ④ Push **[BW]** (**F-1**), then rotate the main dial to adjust the desired passband width. Then push **[BW]** (**F-1**) to set.
 - While holding down **[BW]** (**F-1**), rotating the main dial also adjusts the passband width. After adjustment, release **[BW]** (**F-1**) to set.
 - In the SSB, CW and PSK modes, the passband width can be set within the following range.

50 to 500 Hz	50 Hz steps
600 to 3600 Hz	100 Hz steps
 - In the RTTY mode, the passband width can be set within the following range.

50 to 500 Hz	50 Hz steps
600 to 2700 Hz	100 Hz steps
 - In the AM mode, the passband width can be set within the following range.

200 Hz to 10 kHz	200 Hz steps
------------------	--------------
 - Hold down **[DEF]** (**F-4**) for 1 second to select a default value. (Roofing filter setting also selects a default value.)
- ⑤ Repeat steps ② to ④ if desired for other modes.
- ⑥ Push **[EXIT/SET]** to exit filter set screen.

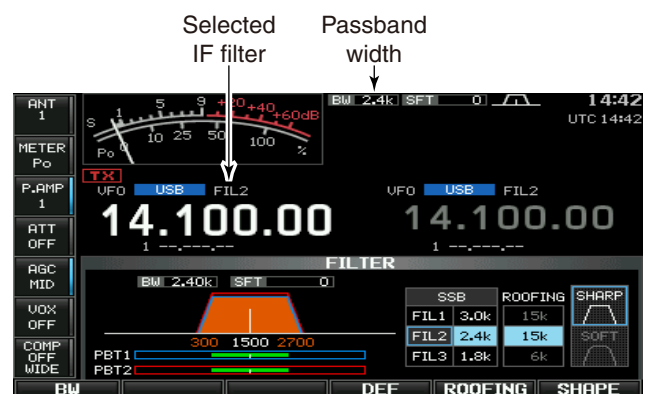
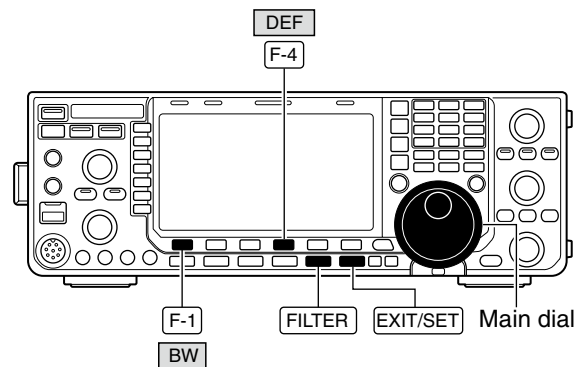

During the passband width setting



▨ The PBT shift frequencies are cleared when the passband width is changed.

▨ This filter set screen graphically displays the PBT shift frequencies and CW pitch operations.

◆ **Roofing filter selection**

The IC-7600 has 3, 6 and 15 kHz roofing filters at the 1st IF frequency. The roofing filter provides interference reduction from nearby strong signals.

- ① Hold down **[FILTER]** for 1 second to select the filter set screen.
- ② Select any mode except FM.
- ③ Push **[ROOFING] (F-5)** to select the desired filter width from 15 kHz, 6 kHz and 3 kHz.
 - Hold down **[DEF] (F-4)** for 1 second to select a default value. (Filter passband width setting also selects a default value.)
- ④ Push **[EXIT/SET]** to exit filter set screen.

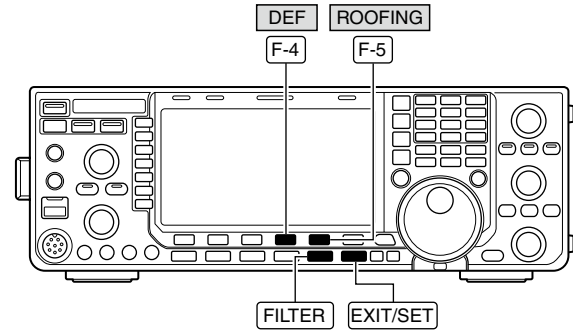

• **Filter set screen**

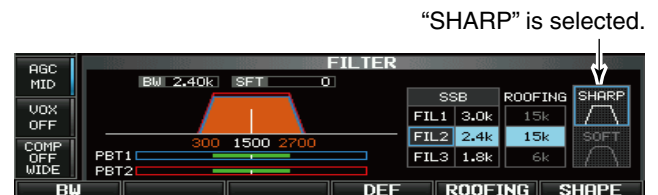

• **Default roofing filter**

(unit: kHz)

Mode	FIL1	FIL2	FIL3	Mode	FIL1	FIL2	FIL3
SSB	15	15	6	RTTY	15	6	6
SSB-D	6	6	6	PSK	6	6	6
CW	6	6	6	AM	15	15	15

◆ **DSP filter shape**

The type of DSP filter shape for each SSB, SSB data and CW can be selected independently from soft and sharp.

- ① Hold down **[FILTER]** for 1 second to select the filter set screen.
- ② Select the SSB, SSB data or CW mode.
- ③ Push **[SHAPE] (F-6)** several times to select the desired filter shape from soft and sharp.
- ④ Push **[EXIT/SET]** to exit filter set screen.

The filter shape can be set for each band (HF and 50 MHz bands), mode, as well as the passband width setting (CW only) independently from your default setting in the filter shape set mode.

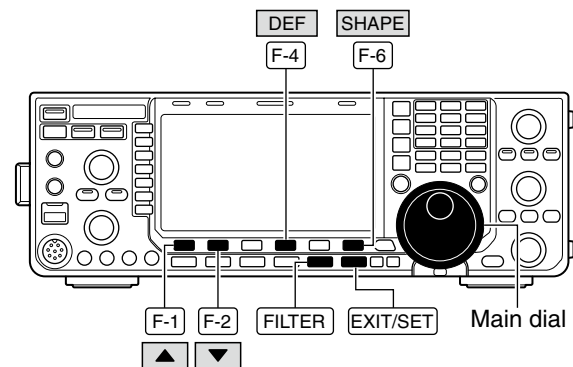

◇ **Filter shape set mode**

The type of DSP filter shape for SSB, SSB data and CW can be selected independently from soft and sharp.

- ① Hold down [FILTER] for 1 second to select the filter set screen.
- ② Hold down [SHAPE] (F-6) for 1 second to select the filter shape set mode.
- ③ Select the desired item using [▲] (F-1) or [▼] (F-2).
- ④ Rotate the main dial to select the filter shape from soft and sharp.
 - Hold down [DEF] (F-4) for 1 second to select a default value.
- ⑤ Push [EXIT/SET] to exit filter shape set mode.

• **Filter shape set mode**



HF SSB (600Hz -)	SHARP
Select the filter shape for the SSB mode in HF bands.	▨ The set filter shape is automatically used only when the IF filter is set to 600 Hz or wider.

SSB-(600Hz -)	SHARP
Select the filter shape for the SSB data mode in HF bands.	▨ The set filter shape is automatically used only when the IF filter is set to 600 Hz or wider.

CW (- 500Hz)	SHARP
Select the filter shape for the CW mode in HF bands.	▨ The set filter shape is automatically used only when the IF filter is set to 500 Hz or narrower.

CW (600Hz -)	SHARP
Select the filter shape for the CW mode in HF bands.	▨ The set filter shape is automatically used only when the IF filter is set to 600 Hz or wider.

50M SSB (600Hz -)	SOFT
Select the filter shape for the SSB mode in 50 MHz band.	▨ The set filter shape is automatically used only when the IF filter is set to 600 Hz or wider.

SSB-(600Hz -)	SHARP
Select the filter shape for the SSB data mode in 50 MHz band.	▨ The set filter shape is automatically used only when the IF filter is set to 600 Hz or wider.

CW (- 500Hz)	SHARP
Select the filter shape for the CW mode in 50 MHz band.	▨ The set filter shape is automatically used only when the IF filter is set to 500 Hz or narrower.

CW (600Hz -)	SHARP
Select the filter shape for the CW mode in 50 MHz band.	▨ The set filter shape is automatically used only when the IF filter is set to 600 Hz or wider.

■ Dualwatch operation

Dualwatch monitors 2 frequencies with the same mode simultaneously.
 During dualwatch, both frequencies should be on the same band, because the bandpass filter in the RF circuit is selected for the main readout frequency.

- ① Set a desired frequency into the main band.
- ② Hold down **[DUALWATCH]** for 1 second.
 - “**DUAL-W**” appears.
 - The sub readout operating mode is equalized to the main readout.
 - Equalized receive frequency appears on the sub band frequency readout. This quick dualwatch function can be turned OFF in the Others set mode. (p. 137)
 - Pushing **[DUALWATCH]** momentarily activates the dualwatch with the previously operated frequency.
- ③ Rotate the main dial to set another desired frequency.
- ④ Push **[MAIN/SUB M.SCOPE]** to enables the sub band access when changing the frequency, etc. in sub band.
 - Push **[MAIN/SUB M.SCOPE]** again for the main band access.
- ⑤ Adjust the **[BAL]** control to set a suitable signal strength balance between the main and sub readout frequencies.
 - S-meter shows the combined signal strength.
- ⑥ To transmit on the sub readout frequency, push **[CHANGE]** or **[SPLIT]**.

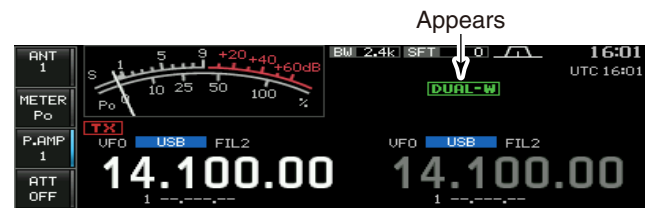
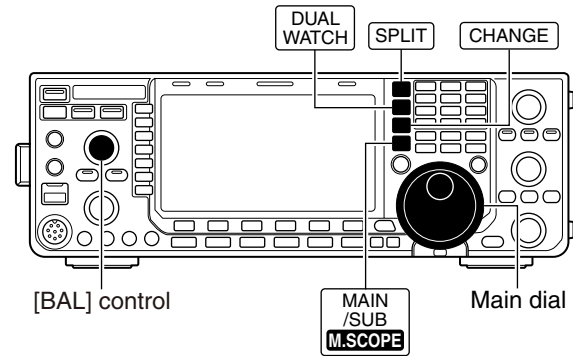

NOTE:

- A beat note may be heard depending on the frequency combination.
- The RIT function can be used for the main readout only.
- The ΔTX function can be used for the transmit readout (main readout when the split function OFF, sub readout when the split function ON).

• **Scanning during dualwatch**

Scanning operates only for the main readout.

To operate the scan during dualwatch, scan on the main readout and use the sub readout for your QSO using both dualwatch and split frequency operation.

- ① Program the desired programmed scan edges in the same amateur band.
See page 109 for programming.
 - If you plan to operate a ΔF scan, programming the scan edges may not be necessary.
- ② Push **[SPLIT]** to turn the split frequency function ON.
 - “**SPLIT**” appears.
- ③ Select VFO mode for the main readout.
- ④ Set the desired operating frequency for the main readout.
- ⑤ Hold down **[DUALWATCH]** for 1 second.
 - “**DUAL-W**” appears.
 - Equalized receive frequency and operating mode appear on the sub band readout and the dualwatch function is turned ON.
- ⑥ Push **[SCAN] (F-5)** to select the scan screen.
 - Push **[EXIT/SET]** several times to close any multi-function screens, if necessary.
- ⑦ Push **[PROG] (F-1)** or **[ΔF] (F-2)** to start the programmed scan or ΔF scan, respectively.
 - Scan activates on the main readout between the programmed scan edges or within the ΔF span.
 - Transmitting on the sub readout stops the scan.
- ⑧ To cancel the scan, push **[EXIT/SET]**.

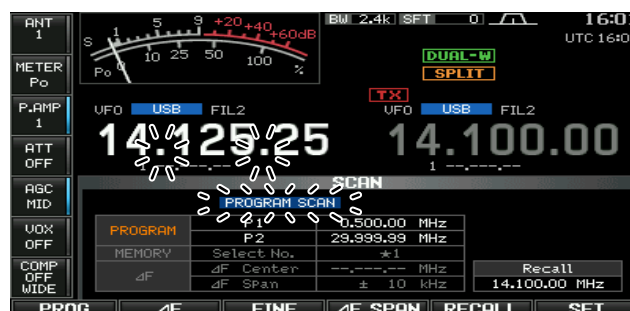
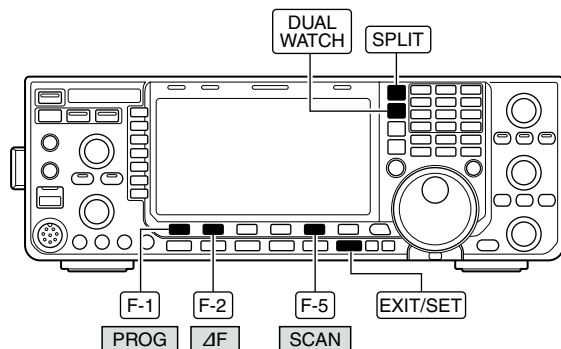

■ Noise blanker

<MODE> SSB/CW/RTTY/PSK/AM

The noise blanker eliminates pulse-type noise such as the noise from car ignitions.

The noise blanker is not available for the FM mode.

➔ Push **[NB]** to turn the noise blanker function ON or OFF.

- The indicator on this switch lights green when the noise blanker is ON.

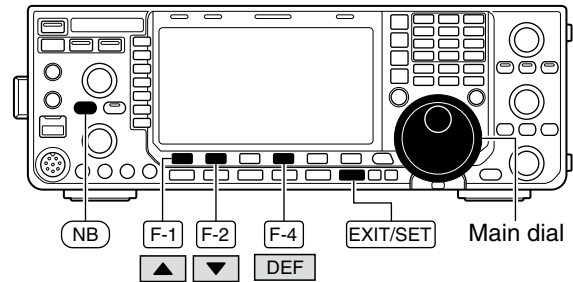

When using the noise blanker, received signals may be distorted if they are excessively strong or for other types of noise than impulse.

Turn the noise blanker OFF, or set the noise blanker threshold level (see below) to a shallow position in this case.

◇ NB set mode

To deal with various type of noise, attenuation level and noise blanking duration can be set in the NB set mode.

- ① Hold down **[NB]** for 1 second to select the NB set mode.
- ② Select the desired item using **[▲]** (F-1) or **[▼]** (F-2).
- ③ Rotate the main dial to the desired set value or condition.
 - Hold down **[DEF]** (F-4) for 1 second to select a default value.
- ④ Push **[EXIT/SET]** to exit the NB set mode.

• NB set mode

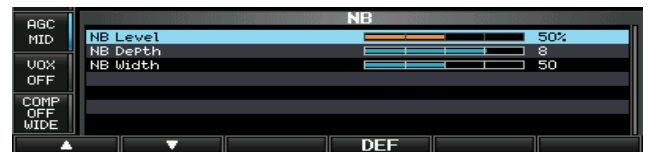

NB Level  **50%**

Set the noise blanker threshold level from 0% to 100%.

NB Depth  **8**

Set the noise attenuation level from 1 to 10.

NB Width  **50**

Set the blanking duration from 1 to 100.

■ Noise reduction

The noise reduction function reduces random noise components and enhances desired signals which are buried in noise.

The DSP performs the random noise reduction function.

- ① Push **[NR]** to turn the noise reduction ON.
 - The indicator on this switch lights green.
- ② Rotate the **[NR]** control to adjust the noise reduction level.
- ③ Push **[NR]** to turn the noise reduction OFF.
 - The indicator goes off.

Large rotations of the **[NR]** control results in audio signal masking or distortion. Set the **[NR]** control for maximum readability.

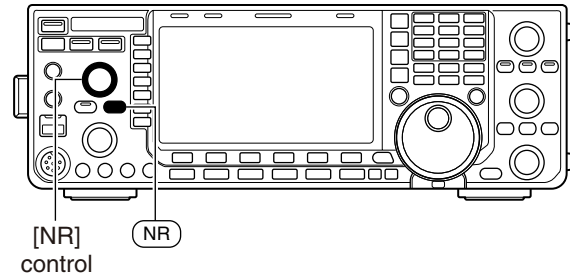

Noise reduction OFF

Noise components

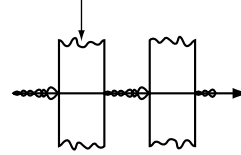

Noise reduction activated

Desired signal (CW)

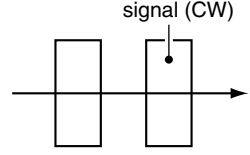

■ Dial lock function

The dial lock function prevents frequency changes by accidental movement of the tuning dial.

The lock function electronically locks the dial.

- ➔ Hold down **[SPEECH/LOCK]** for 1 second to turn the dial lock function ON or OFF.
 - The **[LOCK]** indicator lights when the dial lock function is in use.
 - While split frequency operation is ON, the split lock function may be turned ON. (p. 96)

NOTE: When "LOCK/SPEECH" is selected in [[SPEECH/LOCK] Switch] item in the Others set mode, pushing **[SPEECH/LOCK]** activates the dial lock function. (p. 139)

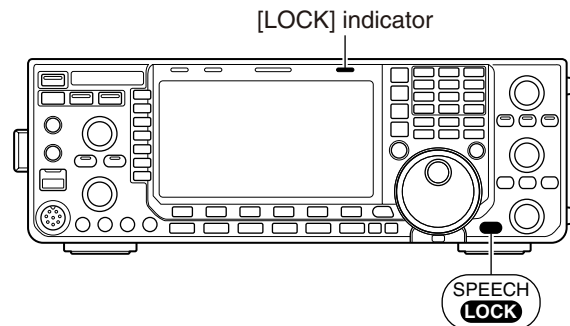

Notch function

This transceiver has auto and manual notch functions. The auto notch function uses DSP to automatically attenuate beat tones, tuning signals, etc., even if they are moving. The manual notch can be set to attenuate a frequency via the **[NOTCH]** control.

The auto notch can be used in the SSB, AM and FM mode.

The manual notch can be used in the SSB, CW, RTTY, PSK and AM modes.

- Push **[NOTCH]** to toggle the notch function between auto, manual and OFF in the SSB and AM modes.
 - Either auto or manual notch function can be deactivated in the Others set mode. (p. 140)
- Push **[NOTCH]** to turn the manual notch function ON or OFF in the CW, RTTY, PSK modes.
- Push **[NOTCH]** to turn the auto notch function ON or OFF in the FM mode.
 - The indicator on this switch lights green when the auto or manual notch function is ON.
 - When the manual notch function is ON, hold down **[NOTCH]** for 1 second to select the notch filter width for manual notch from wide, middle and narrow.
 - Set to attenuate a frequency for manual notch via the **[NOTCH]** control.
 - “**AN**” appears when auto notch is in use.
 - “**MN**” appears when manual notch is in use.

While tuning the manual notch, noise may be heard. This comes from the DSP unit and does not indicate an equipment malfunction.

Auto tune function

<MODE> CW/AM

The automatic tuning function tunes the displayed frequency automatically when an off-frequency signal is received within the range ± 500 Hz (CW) or ± 5 kHz (AM).

This function is active while in CW or AM is selected.

- Push **[AUTO TUNE]** to toggle the auto tune function ON or OFF.
 - “**AUTOTUNE**” blinks when auto tune function is activated.
 - After 2 seconds has passed, the auto tune function stops tuning automatically even it's still off-frequency.
 - If **[AUTO TUNE]** is pushed when the RIT function is ON, the auto tune function changes the RIT frequency, not the displayed frequency.

IMPORTANT!

When receiving a weak signal, or receiving a signal with interference, the automatic tuning function may tune the receiver to an undesired signal.

NOTE: The automatic tuning function does not active on the sub band.

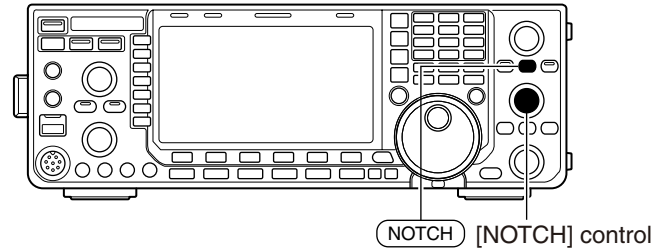

Auto notch indication

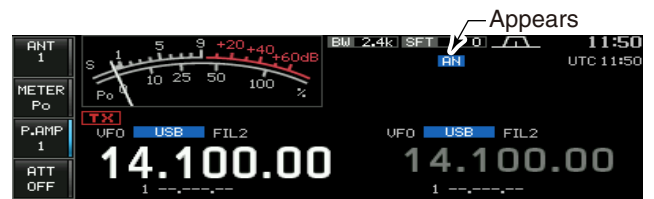

Manual notch indication

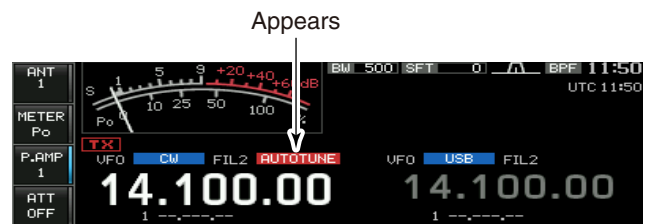
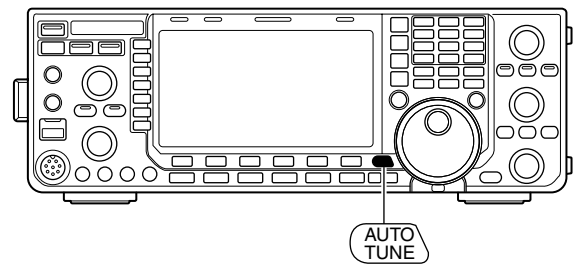
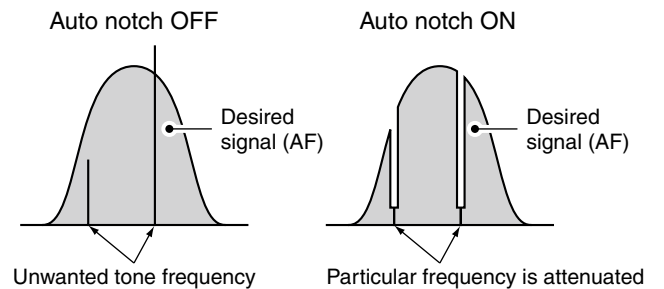

■ VOX function

<MODE> SSB/AM/FM

The VOX (Voice-Operated Transmission) function switches between transmit and receive with your voice. This function provides “hands-free” operation.

◇ Using the VOX function

- ① Select a phone mode (SSB, AM, FM).
- ② Push **[VOX] (MF6)** to turn the VOX function ON or OFF.
 - “VOX” appears while the VOX is in use.

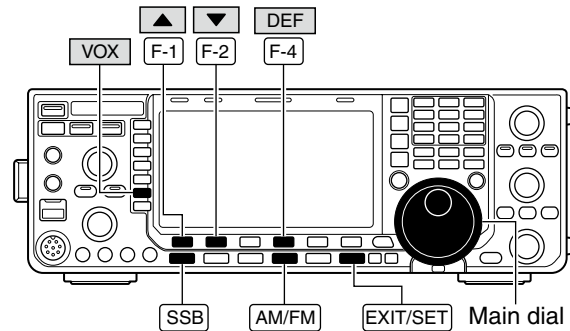

◇ Adjusting the VOX function

- ① Push **[SSB]** or **[AM/FM]** to select a phone mode (SSB, AM, FM).
- ② Hold down **[VOX] (MF6)** for 1 second to select the VOX set mode.
- ③ Select the VOX gain item using **[▲] (F-1)** or **[▼] (F-2)**.
- ④ While speaking into the microphone, rotate the main dial to the point where the transceiver is continuously transmitting.
- ⑤ If the receive audio from the speaker causes the VOX circuit to switch to, adjust the anti-VOX setting to the point where speaker audio does not activate the VOX.
 - Select the Anti-VOX item using **[▲] (F-1)** or **[▼] (F-2)**.
 - Rotate the main dial.
- ⑥ Adjust the VOX delay for a convenient interval before returning to receive.
- ⑦ Set the VOX voice delay if desired.
- ⑧ Push **[EXIT/SET]** to exit the VOX set mode.

• VOX set mode screen



Hold down for 1 second to select a default value.

VOX Gain

50%

This item adjusts the VOX gain for the VOX function. Higher values make the VOX function more sensitive to your voice.

This setting can be adjusted from 0% to 100% in 1% steps.

Anti-VOX

50%

This item adjusts the ANTI-VOX gain for the VOX function. Higher values make the VOX function less sensitive to receiver output audio from a speaker or headphones.

This setting can be adjusted from 0% to 100% in 1% steps.

VOX Delay

0.2s

Set the VOX delay for a convenient interval before returning to receive within 0.0 to 2.0 seconds range.

VOX Voice Delay

OFF

Set the VOX voice delay to prevent clipping of the first few syllables of a transmission when switching to transmit.
OFF, Short, Mid and Long settings are available.

When using the VOX voice delay, turn the TX monitor function OFF to prevent transmitted audio from be echoed.

■ Break-in function

<MODE> CW

The break-in function is used in the CW mode to automatically toggle the transceiver between transmit and receive when keying. The IC-7600 is capable of full break-in or semi break-in.

◇ Semi break-in operation

During semi break-in operation, the transceiver immediately transmits when keying, then returns to receive after a pre-set delay time has passed from when you stop keying.

- ① Push **[CW]** to select the CW or CW-R mode.
- ② Push **[BK-IN] (MF6)** once or twice to turn the semi break-in function ON.
 - “BKIN” appears.
- ③ Rotate **[BK-IN DELAY]** to set the break-in delay time (the delay from transmit to receive).

▨ When using a paddle, rotate **[KEY SPEED]** to adjust the keying speed.

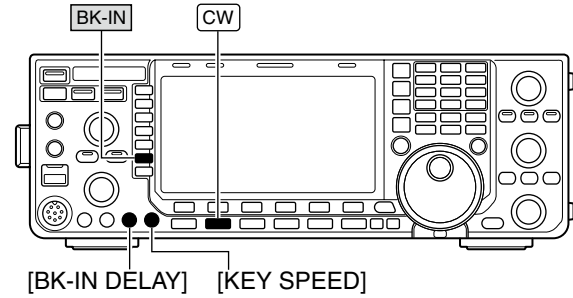

Appears

◇ Full break-in operation

During full break-in operation, the transceiver immediately transmits when keying, then returns to receive after you stop keying.

- ① Push **[CW]** to select the CW or CW-R mode.
- ② Push **[BK-IN] (MF6)** once or twice to turn the full break-in function ON.
 - “F-BKIN” appears.

▨ When using a paddle, rotate **[KEY SPEED]** to adjust the keying speed.

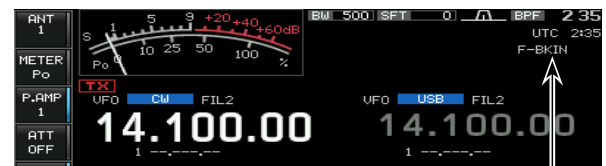
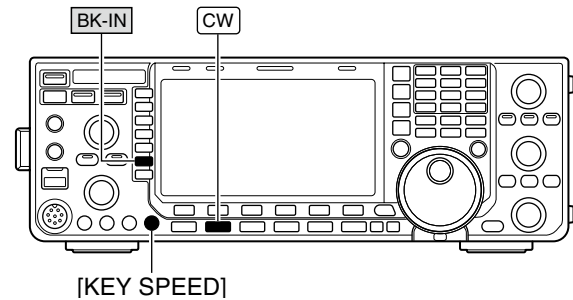

Appears

Speech compressor

<MODE> SSB

The speech compressor increases average RF output power, improving signal strength and readability.

- ① Push **[SSB]** to select the USB or LSB mode.
- ② Hold down **[COMP] (MF7)** for 1 second to select the COMP TBW set screen.
- ③ Adjust the **[MIC GAIN]** control so that the ALC meter reads within the ALC zone, whether or not you speak softly or loudly.
- ④ Push **[COMP] (MF7)** to turn the speech compressor ON.
- ⑤ While speaking into the microphone, rotate the main dial, so that the COMP meter reads within the COMP zone (10 to 20 dB range) for your normal voice level.
 When the COMP meter peaks exceed 20 dB, your transmitted voice may be distorted.
- ⑥ Push **[COMP] (MF7)** or **[EXIT/SET]** to exit COMP TBW set screen.
- ⑦ Adjust the drive gain to set the ALC meter reading within the 30 to 50% range of the ALC scale. (p. 38)

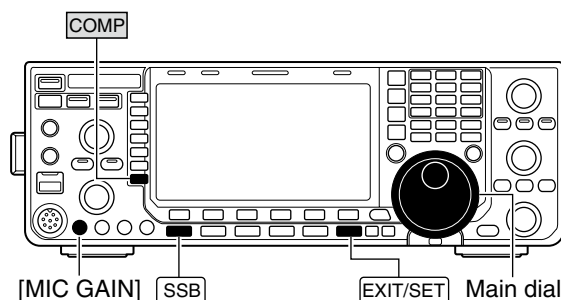

• COMP/TBW set screen



Transmit filter width setting

<MODE> SSB

The transmit filter width for the SSB mode can be selected between wide, middle and narrow.

- ① Push **[SSB]** to select the USB or LSB mode.
- ② Hold down **[COMP] (MF7)** for 1 second to select the COMP TBW set screen.
- ③ Push **[COMP] (MF7)** to turn the speech compressor ON or OFF.
- ④ Push **[TBW] (F-3)** several times to select the desired transmit filter width between wide, middle and narrow.
 - The filter can be independently set on the speech compressor function is ON or OFF.
 - The following filters are specified as the default. Each of the filter width can be re-set in the level set mode. (p. 130)
- ⑤ Push **[COMP] (MF7)** or **[EXIT/SET]** to exit COMP TBW set screen.

- WIDE : 100 Hz to 2.9 kHz
- MI : 300 Hz to 2.7 kHz
- NAR : 500 Hz to 2.5 kHz

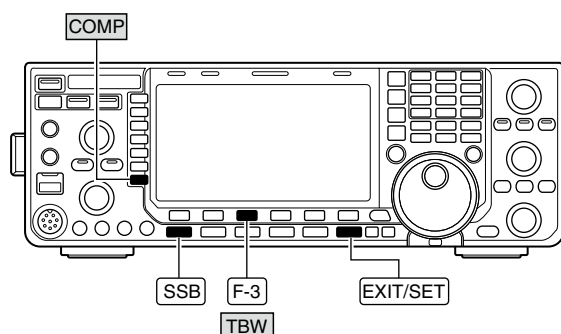

■ ΔTX function

The ΔTX function shifts the transmit frequency up to ±9.999 kHz in 1 Hz steps (10 Hz steps when cancelling the 1 Hz step readout) without moving the receive frequency.

- ① Push [**ΔTX**] to turn ΔTX function ON.
 - “**ΔTX**” and the shifting frequency appear when the function is ON.
- ② Rotate the [**RIT/ΔTX**] control.
- ③ To reset the ΔTX frequency, hold down [**CLEAR**] for 1 second.
 - Push [**CLEAR**] momentarily to reset the ΔTX frequency when the quick RIT/ΔTX clear function is ON. (p. 140)
- ④ To cancel the ΔTX function, push [**ΔTX**] again.
 - “**ΔTX**” and the shifting frequency disappears.

When RIT and ΔTX are ON at the same time, the [**RIT/ΔTX**] control shifts both the transmit and receive frequencies from the displayed frequency at the same time.

◇ ΔTX monitor function

When the ΔTX function is ON, holding down [**XFC**] allows you to monitor the operating frequency directly.

✓ **For your convenience— Calculate function**
 The frequency shift of the ΔTX function can be added/subtracted to the displayed frequency.

While displaying the ΔTX shift frequency, hold down [**ΔTX**] for 1 second.

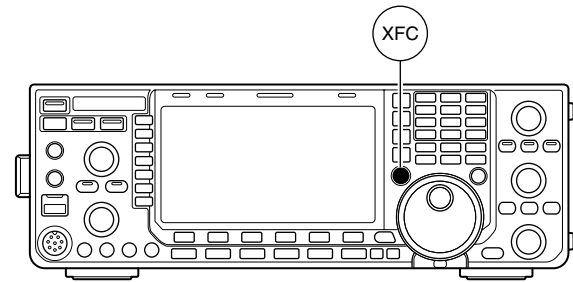
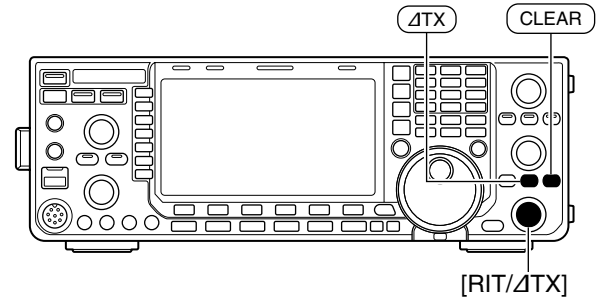

■ Monitor function

The monitor function allows you to monitor your transmit IF signals in any mode. Use this to check voice characteristics while adjusting SSB transmit parameter (p. 139).

The CW sidetone functions regardless of the [**MONITOR**] switch setting.

- ① Push [**MONITOR**] to turn the monitor function ON and OFF.
 - The indicator on this switch lights green when the monitor function is ON.
- ② Hold down [**MONITOR**] to the monitor set mode.
- ③ Rotate the main dial to adjust the monitor level.
 - Hold down [**DEF**] (F-4) for 1 second to select a default value.
- ④ Push [**EXIT/SET**] to exit the monitor set mode.

NOTE: When using the VOX voice delay, turn the monitor function OFF, or transmitted audio will be echoed.

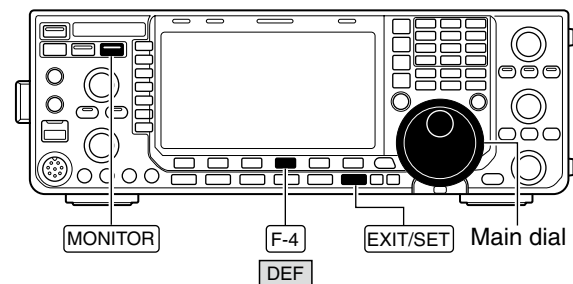

• Monitor set mode



Split frequency operation

Split frequency operation allows you to transmit and receive in the same mode on two different frequencies. Split frequency operation is performed using 2 frequencies on the main and sub readouts. The following is an example of setting 21.290 MHz for receiving and 21.310 MHz for transmitting.

- ① Set 21.290 MHz (USB) in VFO mode.
- ② Push **[SPLIT]**, then hold down **[CHANGE]** for 1 second.
 - The quick split function is much more convenient for selecting the transmit frequency. See the next section for details.
 - The equalized transmit frequency and “**SPLIT**” appear on the LCD.
 - **[SPLIT]** indicator lights.
 - “**TX**” appears to show the transmit frequency readout.
- ③ While holding down **[XFC]**, rotate the main dial to set the transmit frequency to 21.310 MHz.
 - The transmit frequency can be monitored while pushing **[XFC]**.
- ④ Now you can receive on 21.290 MHz and transmit on 21.310 MHz.

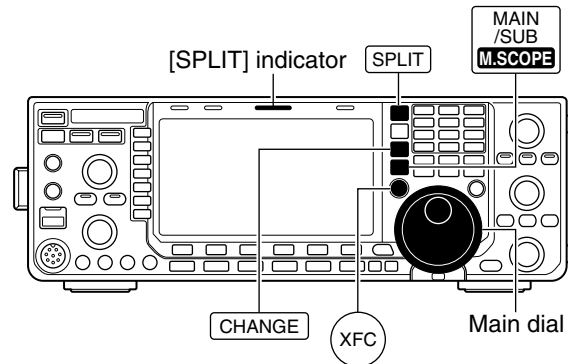

When the split function ON



When [XFC] is pushed

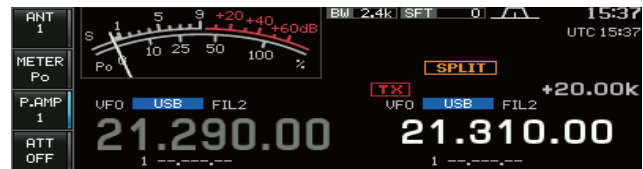

The split frequency operation is ready

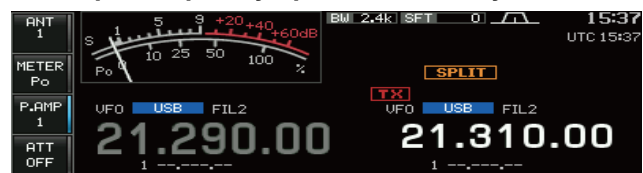

To change the transmit and receive frequencies, push **[CHANGE]** to exchange the main and sub readouts.

✓ CONVENIENT

Direct shift frequency input

The shift frequency can be entered directly.

- ① Push **[F-INP ENT]**.
- ② Enter the desired shift frequency with the digit keys.
 - 1 kHz to 9.999 MHz can be set.
 - When you require a negative shift direction, push **[GENE •]** in advance.
- ③ Push **[SPLIT]** to input the shift frequency in the sub readout and the split function is turned ON.

Dualwatch function

The dualwatch function is convenient for tuning the transmit frequency while monitoring both frequencies used for transmitting and receiving.

Split lock function (p. 137)

Accidentally releasing **[XFC]** while rotating the main dial changes the receive frequency. To prevent this, use both the split lock and dial lock functions to change the transmit frequency only. The split lock function cancels the dial lock function while pushing **[XFC]** during split frequency operation. The split lock function is OFF by default, but can be turned ON in the Others set mode.

■ Quick split function

When you find a DX station, an important consideration is how to set the split frequency. When you hold down the **[SPLIT]** switch for 1 second, the split frequency operation is turned ON, and the sub readout frequency and operating mode is equalized to the main readout, then enters standby for transmit frequency input.

This shortens the time needed to begin split frequency operation.

The quick split function is ON by default.

For your convenience, it can be turned OFF in the Others set mode. (p. 137)

In this case, the **[SPLIT]** switch does not equalize the main and sub readout frequencies.

- ① Suppose you are operating at 21.290 MHz (USB) in VFO mode.
- ② Hold down **[SPLIT]** for 1 second.
 - Split frequency operation is turned ON.
 - **[SPLIT]** indicator lights.
 - The sub readout frequency and operating mode is equalized to the main readout.
 - The sub readout enters standby for transmit frequency input and "**F-INP**" appears.
 - During FM mode operation, the sub readout frequency shifts from the main readout frequency according to the Others set mode setting. (p. 137)
 - The tone encoder function is turned ON in the FM mode.
- ③ Rotate the main dial to set the transmit frequency, or input the transmit frequency using the keypad and **[F-INP ENT]**, or input a shift frequency using the keypad and **[SPLIT]**.
 - "**F-INP**" disappears when **[F-INP ENT]** is pushed.
 - Offset frequency setting with the keypad and **[SPLIT]**.
[Example]
To transmit on 1 kHz higher frequency:
- Push **[1.8 1]** then **[SPLIT]**.
To transmit on 3 kHz lower frequency:
- Push **[GENE •]**, **[7 3]** then **[SPLIT]**.

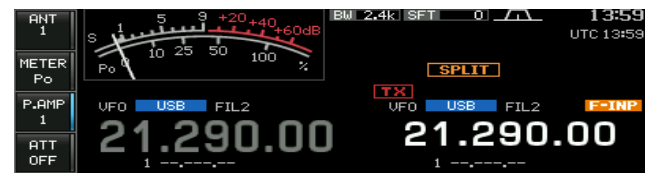
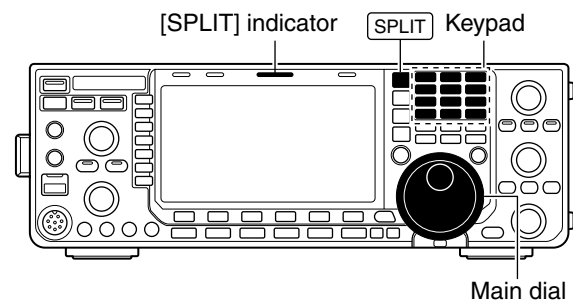

◇ Split lock function

The split lock function is convenient for changing only the transmit frequency. When the split lock function is not used, accidentally releasing **[XFC]** while rotating the main dial, changes the receive frequency.

The split lock function is OFF by default, but can be turned ON in the Others set mode. (p. 137)

- ① While split frequency operation is ON, hold down **[SPEECH/LOCK]** for 1 second to activate the split lock function.
 - **[LOCK]** indicator lights.
- ② While holding down **[XFC]**, rotate the main dial to change the transmit frequency.
 - If you accidentally release **[XFC]** while rotating the main dial, the receive frequency does NOT change.

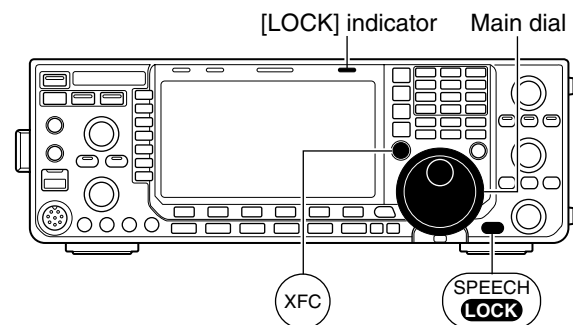

■ About digital voice recorder

The IC-7600 has digital voice memories, up to 4 messages for transmit, and up to 20 messages for receive.

A maximum message length of 30 seconds can be recorded into receive memory (total message length for all channels of up to 209 seconds) and a total message length of up to 99 seconds can be recorded in transmit memory.

The transmit memory is very convenient for repeated CQ and exchange transmissions in contests, as well as when making repeated calls to DX'peditions.

- ① Select any mode.
- ② Push **[VOICE] (F-2)** to display voice recorder screen.
- ③ Push **[EXIT/SET]** to display voice recorder menu.
- ④ Push **[PLAY] (F-1)** or **[MIC REC] (F-2)** to select the desired memory channel screen, then record audio or playback the contents.
- ⑤ Push **[EXIT/SET]** twice to exit voice recorder screen.

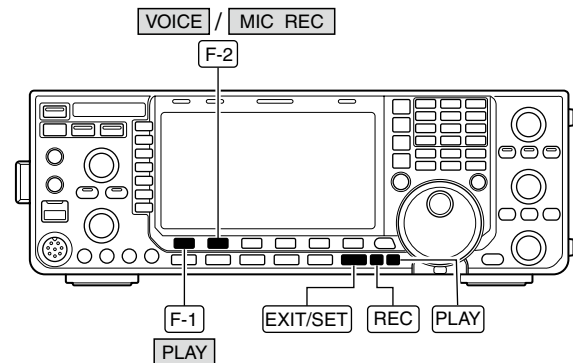

4
5

About recording received audio and playing back the contents

• Example— When [REC] is held down for 1 second.

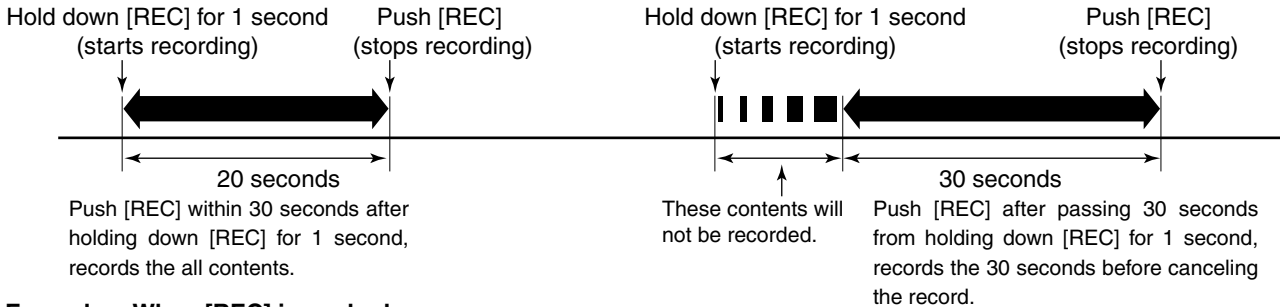

• Example— When [REC] is pushed.

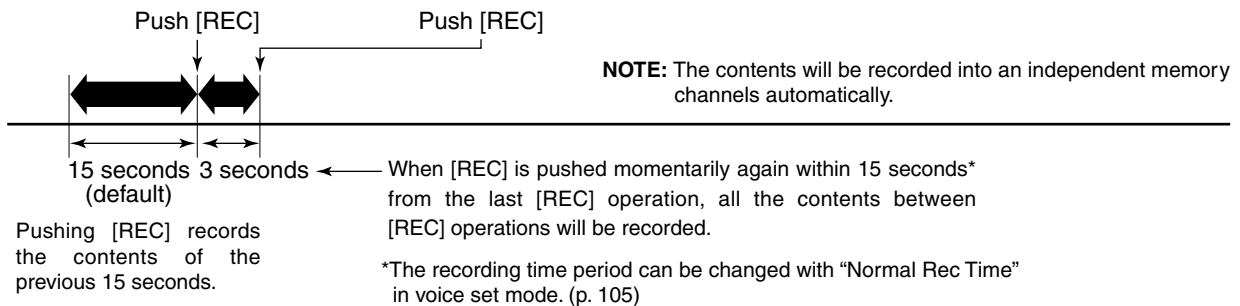

• Playing back the all contents in a channel

Push **[PLAY] (F-1)**.
Or, hold down **[PLAY]** for 1 second.

• Playing back the last 5 seconds* in a channel

Push **[PLAY]**.

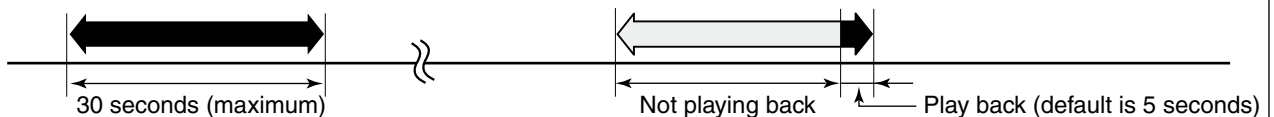

*The playing back time period can be changed with "Short Play Time" in voice set mode. (p. 105)

■ Recording a received audio

Up to 20 receive voice memories can be recorded in the IC-7600. A total of 209 seconds of audio can be recorded in receive messages.

However, the maximum recordable length of a single message is 30 seconds.

This voice recorder records not only the received audio, but also the information such as operating frequency, mode, and the recording time for your future reference.

◇ Basic recording

- ① Push **[EXIT/SET]** several times to close any multi-function screens, if necessary.
- ② Select the desired mode.
- ③ Push **[VOICE] (F-2)** to call up the voice recorder screen.
 - Previously selected screen, TX or RX memory, is displayed. If the TX memory channel (T1–T4) appears, push **[T/R] (F-6)** to select an RX memory channel.
- ④ Hold down **[REC]** for 1 second to start recording.
 - The operating frequency, mode and current time are automatically programmed as the memory names.
- ⑤ Push **[REC]** momentarily to stop recording.

IMPORTANT!

Push **[REC]** to stop recording before, or when 30 seconds has elapsed from the start of recording.

The voice recorder memory records 30 seconds (max.) of audio before **[REC]** is pushed.

For example, when recording 40 seconds of audio, the first 10 seconds audio will be overwritten with the last 10 seconds, so that the total of audio recorded is only 30 seconds.

When you record the 21st audio message, or when the total audio length exceeds 209 seconds, the oldest recorded audio is automatically erased to make room for the new audio.

- ⑥ Push **[EXIT/SET]** twice to exit the voice recorder screen.

NOTE: When transmit (or **[PTT]** is pushed) while recording, no audio will be recorded.

◇ One-touch recording

To record the received signal immediately, one-touch voice recording is available.

- ➔ Push **[REC]** momentarily to store the previous 15 seconds audio.
 - The recordable time period can be set in the voice set mode. (p. 105)

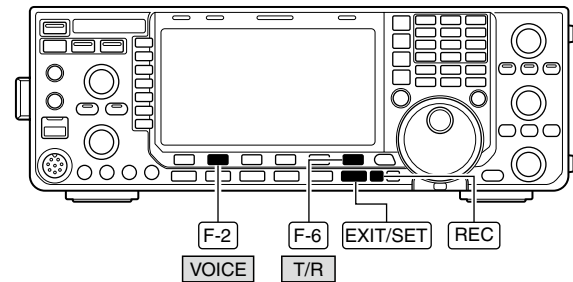

The remaining time for recording is displayed.

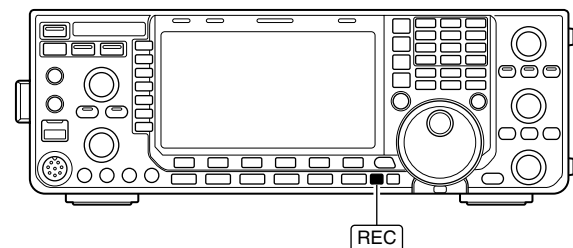

■ Playing the recorded audio

◇ Basic playing

- ① Push **[EXIT/SET]** several times to close any multi-function screens, if necessary.
- ② Push **[VOICE] (F-2)** to call up the voice recorder screen.
 - Previously selected screen, TX or RX memory, is displayed. If the TX memory message (T1–T4) appears, push **[T/R] (F-6)** to select RX memory message.
- ③ Push **[▲] (F-1)** or **[▼] (F-2)** to select the desired voice memory to playback.
- ④ Push **[PLAY] (F-3)** to start playback.
 - “▶PLAY” indicators appear and the timer counts down.
- ⑤ Push **[PLAY] (F-3)** again to stop playback if desired.
 - Playback is terminated automatically when all of the recorded contents in the message are played.
- ⑥ Push **[EXIT/SET]** twice to exit the voice recorder screen.

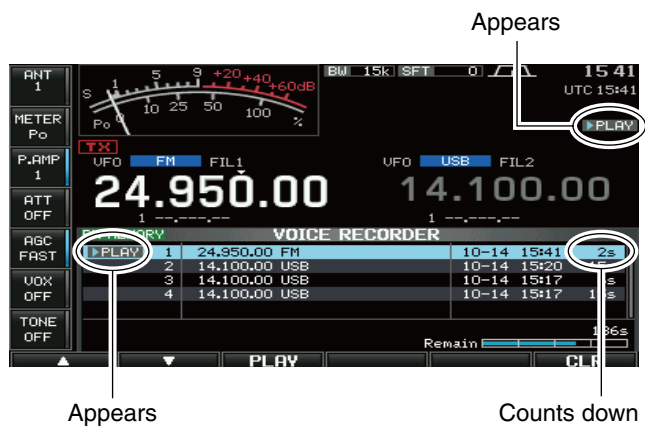
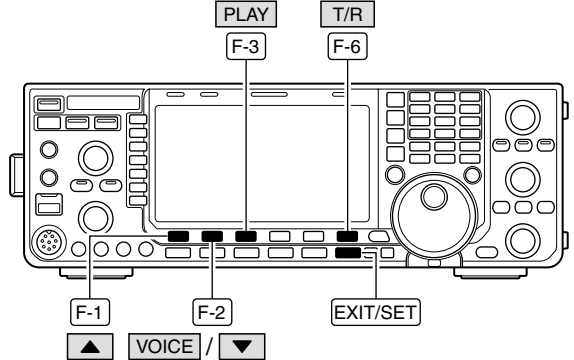

◇ One-touch playing

The previously recorded audio in message 1 can be played back without selecting voice recorder screen.

- ➔ Push **[PLAY]** momentarily to playback the last 5 seconds of the previously recorded audio.
 - To playback all contents of the previously recorded audio, hold down **[PLAY]** for 1 second.
 - “▶PLAY” indicator appears.
 - Playback is terminated automatically when all of the recorded contents in the message are played, or after 5 seconds.
 - The playback time period can be set in the voice set mode. (p. 105)

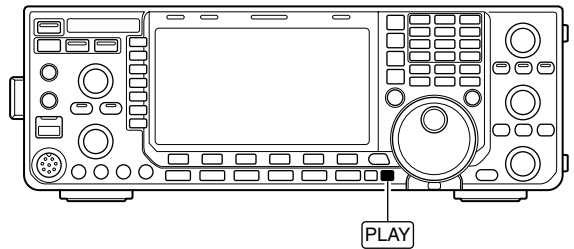

■ Protect the recorded contents

The protect function is available to protect the recorded contents from accidental erasure, such as over-writing, etc.

- ① Call up the voice recorder screen, RX memory.
- ② Push **[▲] (F-1)** or **[▼] (F-2)** to select the desired voice message.
- ③ Push **[PROTECT] (F-4)** to turn the protect function ON or OFF.
 - “” indicator appears when the contents is protected.
- ④ Push **[EXIT/SET]** twice to exit the voice recorder screen.

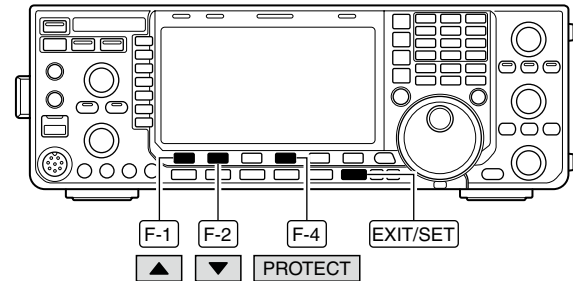

■ Erasing the recorded contents

The recorded contents can be erased independently by message.

- ① Call up the voice recorder screen, RX memory.
- ② Push **[▲] (F-1)** or **[▼] (F-2)** to select the desired voice message to be erased.
- ③ Push **[PLAY] (F-3)** to start playback.
 - “PLAY” indicators appear and the timer counts down.
- ④ Hold down **[CLR] (F-6)** for 1 second to erase the contents.
 - Push **[PROTECT] (F-4)** to release the protection in advance if necessary.
- ⑤ Push **[EXIT/SET]** twice to exit the voice recorder screen.

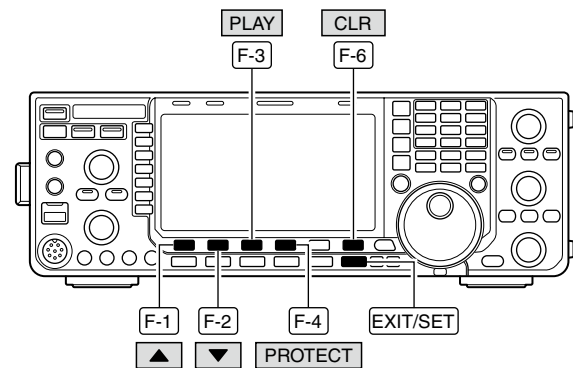

■ Recording a message for transmit

To transmit a message using the voice recorder, record the desired message in advance as described below.

The IC-7600 has digital voice memories for transmission, up to 4 messages and a total message length of up to 99 seconds can be recorded.

◇ Recording

- ① Push **[EXIT/SET]** several times to close any multi-function screens, if necessary.
- ② Push **[VOICE] (F-2)** to call up the voice recorder screen.
- ③ Push **[EXIT/SET]** to select voice recorder menu.
- ④ Push **[MIC REC] (F-2)** to select the voice mic. record screen.
- ⑤ Push **[▲] (F-1)** or **[▼] (F-2)** to select the desired message.
- ⑥ While speaking into the microphone with your normal voice level, adjust the **[MIC GAIN]** control so that the **[MIC-REC LEVEL]** indicator reads within 100%.
- ⑦ Hold down **[REC] (F-4)** for 1 second to start recording.
 - “**REC**” indicator appears.
 - Speak into the microphone without pushing **[PTT]**.
 - Previously recorded contents are cleared.
 - Audio output from the internal speaker is automatically muted.
- ⑧ Push **[REC] (F-4)** momentarily to stop recording.
 - The recording is terminated automatically when the remaining time becomes 0 second.
- ⑨ Push **[EXIT/SET]** twice to exit the voice recorder screen.

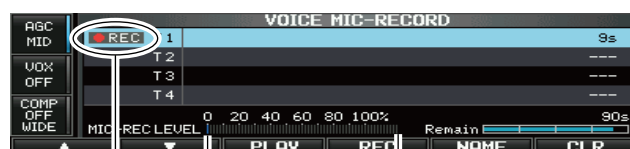
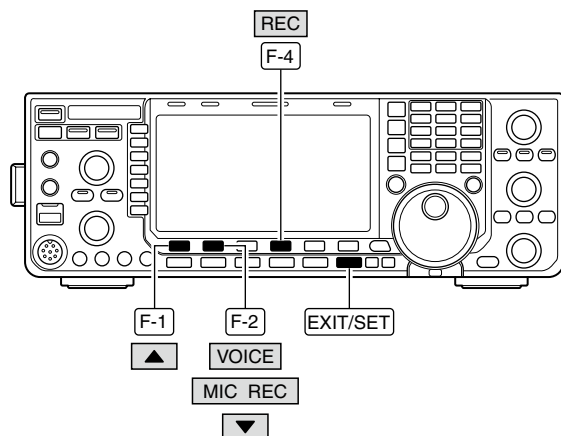

Appears Adjust **[MIC GAIN]** control so that this indicator reads within 100%.

◇ Confirming a message for transmit

- ① Perform the steps ① to ④ as “◇ Recording” above.
- ② Push **[▲] (F-1)** or **[▼] (F-2)** to select the desired message.
- ③ Push **[PLAY] (F-3)** to playback the recorded contents.
 - “**PLAY**” indicator appears.
 - Hold down **[CLR] (F-6)** for 1 second to erase the contents.
- ④ Push **[PLAY] (F-3)** again to stop playback.
 - Playback is terminated automatically when all of the recorded contents in the message are played.
- ⑤ Push **[EXIT/SET]** twice to exit the voice recorder screen.

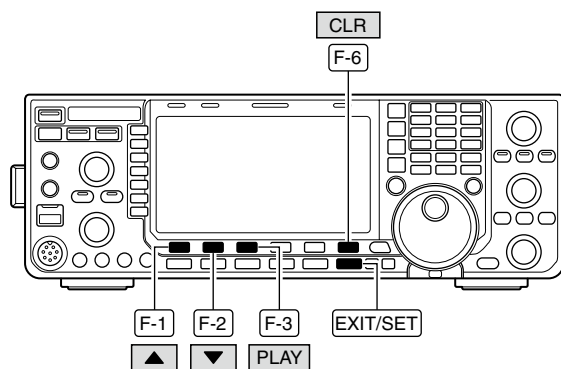

■ Programming a memory name

Memory messages can be tagged with alphanumeric names of up to 30 characters each.

Capital letters, small letters, numerals, some symbols (! # \$ % & ¥ ? " ' ` ^ + - * / . , ; = < > () [] { } | _ - @) and spaces can be used. (See the table below.)

- ① Record a message as described in page 102.
- ② During the voice mic. record screen display, push **[NAME] (F-5)** to enter memory name edit condition.
 - A cursor appears and blinks.
- ③ Push **[T1..T4] (F-6)** several times to select the desired voice message.
 - Push **[ABC] (MF6)** or **[abc] (MF6)** to toggle capital and small letters.
 - Push **[123] (MF7)** or **[Symbol] (MF7)** to toggle numerals and symbols.
 - Push **[◀] (F-1)** or **[▶] (F-2)** for cursor movement.
 - Push **[DEL] (F-3)** to delete the selected character.
 - Push **[SPACE] (F-4)** to input a space.
 - Pushing the transceiver's keypad, [0]–[9] and [,] can also enter numerals.
- ⑤ Push **[EXIT/SET]** to input and set the name.
 - The cursor disappears.
- ⑥ Repeat steps ③ to ⑤ to program another voice message's name, if desired.
- ⑦ Push **[EXIT/SET]** twice to exit the voice recorder screen.

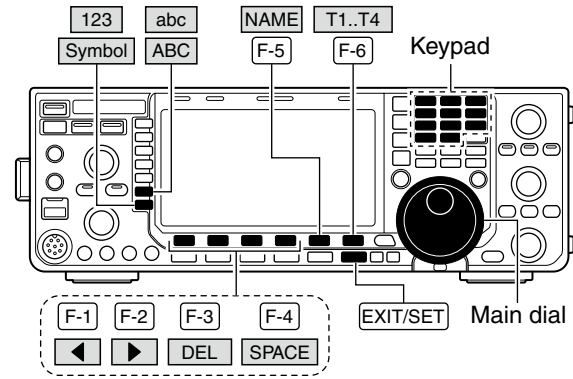

• Voice mic. record screen



• Usable characters

Key selection	Editable characters
ABC	A to Z (capital letters)
abc	a to z (small letters)
123	0 to 9 (numerals)
Symbol	! # \$ % & ¥ ? " ' ` ^ + - * / . , ; = < > () [] { } _ - @

Voice memory name editing example

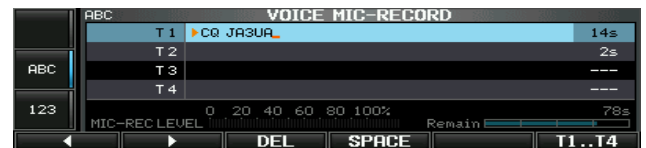

✓ For your convenience

When a PC keyboard is connected to [USB] (A) connector on the front panel, the memory name can also be edited from the keyboard.

■ Voice set mode

Sets the automatic monitor function, short play and normal recording times for voice recorder.

- ① Push **[EXIT/SET]** several times to close any multi-function screens, if necessary.
- ② Push **[VOICE] (F-2)** to call up the voice recorder screen.
- ③ Push **[EXIT/SET]** to select voice recorder menu.
- ④ Push **[SET] (F-6)** to select the voice set mode screen.
- ⑤ Push **[▲] (F-1)** or **[▼] (F-2)** to select the desired item.
- ⑥ Rotate the main dial to set the desired condition or value.
 - Hold down **[DEF] (F-4)** for 1 second to select the default condition or value.
- ⑦ Push **[EXIT/SET]** to exit the voice set mode screen.

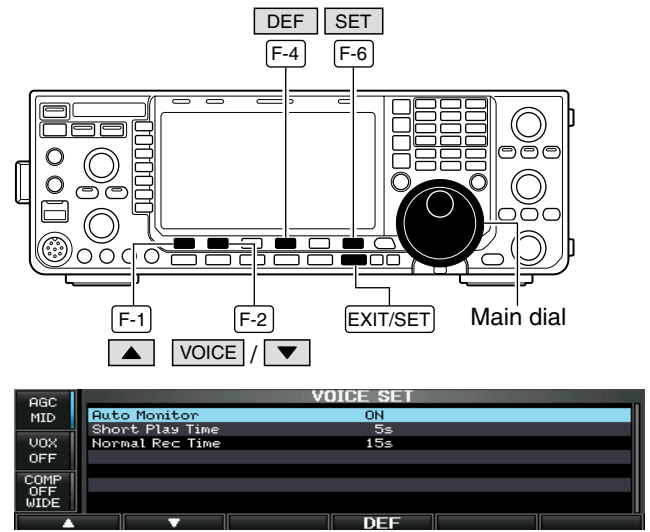

Auto Monitor	ON
Turn on the automatic monitor function for recorded audio contents transmission.	<ul style="list-style-type: none"> • ON : Monitors transmit audio automatically when sending a recorded audio. • OFF : Monitors transmit audio only when the monitor function is in use.
Short Play Time	5s
Set the desired time period for one-touch playback (when [PLAY] is pushed momentarily).	<ul style="list-style-type: none"> • 3 to 10 seconds in 1 second steps can be set. (default: 5 seconds)
Normal Rec Time	15s
Set the desired time period for one-touch recording (when [REC] is pushed momentarily).	<ul style="list-style-type: none"> • 5 to 15 seconds in 1 second steps can be set. (default: 15 seconds)

■ Saving a voice message into the USB-Memory

◇ Saving the received audio memory

The recorded RX memory contents can be saved into the USB-Memory.

- ① During voice recorder RX memory screen display, push **[SAVE] (F-5)** to select voice file save screen.
 - Previously selected screen, TX or RX memory, is displayed. If the TX message (T1–T4) appears, push **[T/R] (F-6)** to select RX message.

② Change the following conditions if desired.

• **File name:**

- 1 Push **[EDIT] (F-4)** to select file name edit condition.
 - Push **[DIR/FILE] (F-1)** several times to select the file name, if necessary.
- 2 Push **[ABC] (MF6)**, **[123] (MF7)** or **[Symbol] (MF7)** to select the character group, then rotate the main dial to select the character.
 - **[ABC] (MF6)** : A to Z (capital letters), **[123] (MF7)** : 0 to 9 (numerals), **[Symbol] (MF7)** : ! # \$ % & ' ^ - () { } _ - @ can be selected.
 - Push **[◀] (F-1)** to move the cursor left, push **[▶] (F-2)** to move the cursor right, push **[DEL] (F-3)** to delete a character and push **[SPACE] (F-4)** to insert a space.

3 Push **[EXIT/SET]** to set the file name.

• **Saving location**

- 1 Push **[DIR/FILE] (F-1)** to select tree view screen.
- 2 Select the desired directory or folder in the USB-Memory.
 - Push **[◀▶] (F-4)** to select the upper directory.
 - Push **[▲] (F-2)** or **[▼] (F-3)** to select folder in the same directory.
 - Hold down **[◀▶] (F-4)** for 1 second to select a folder in the directory.
 - Push **[REN] (MF5)** to rename the folder.
 - Hold down **[DEL] (MF6)** for 1 second to delete the folder.
 - Hold down **[MAKE] (MF7)** for 1 second to making a new folder. (Edit the name with the same manner as the “• File name” above.)

3 Push **[DIR/FILE] (F-1)** twice to select the file name.

③ Push **[SAVE] (F-5)**.

- After the saving is completed, return to voice recorder RX memory screen automatically.

◇ Saving the TX memory

The TX memory contents can also be saved into the USB-Memory. However, the contents are saved with the message list, set mode conditions, etc. at the same time. See page 147 for details.

The USB-Memory is not supplied by Icom.

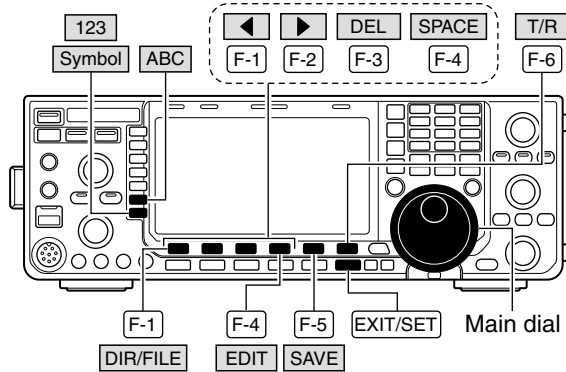

• Voice recorder RX memory screen



• Voice file save screen— file name edit

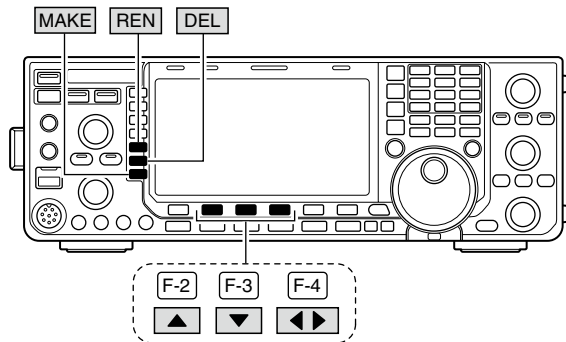

• While saving

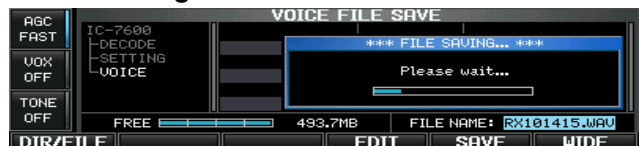

When a PC keyboard is connected to the [USB] connector on the front panel, the file name can also be edited from the keyboard. In this case, a USB hub is required.

Memory channels

The transceiver has 101 memory channels. The Memory mode is very useful to quickly change to often-used frequencies.

All 101 memory channels are tunable, which means the programmed frequency can be tuned temporarily with the main dial, etc. in memory mode.

MEMORY CHANNEL	MEMORY CHANNEL NUMBER	CAPABILITY	TRANSFER TO VFO	OVER-WRITING	CLEAR
Regular memory channels	1–99	One frequency and one mode in each memory channel.	Yes	Yes	Yes
Scan edge memory channels	P1, P2	One frequency and one mode in each memory channel as scan edges for programmed scan.	Yes	Yes	No

Memory channel selection

Using the [▲]/[▼] keys

- ① Push [VFO/MEMO] to select the memory mode.
- ② Push [▲]/[▼] several times to select the desired memory channel.
 - Hold down [▲]/[▼] for continuous scrolling.
 - [UP] and [DN] on the microphone can also be used.
- ③ To return to VFO mode, push [VFO/MEMO] again.

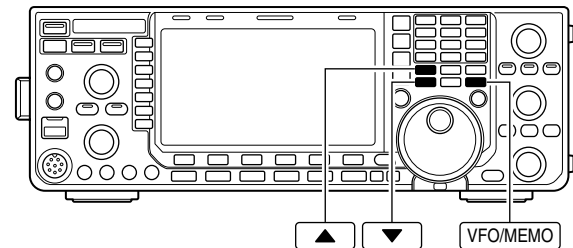

Using the keypad

- ① Push [VFO/MEMO] to select the memory mode.
- ② Push [F-INP ENT].
- ③ Enter the desired memory channel number using the keypad.
 - Enter 100 or 101 to select scan edge channel P1 or P2, respectively.
- ④ Push [▲] or [▼] to set the memory channel.

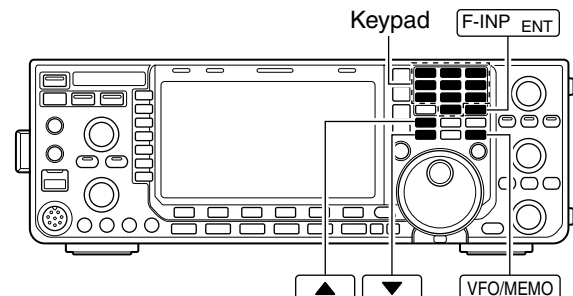

[EXAMPLE]

To select memory channel 3:

- ➔ Push [F-INP ENT], [7 3], then push [▲] or [▼].

To select memory channel 12:

- ➔ Push [F-INP ENT], [1.8 1], [3.5 2], then push [▲] or [▼].

To select the scan edge channel P1:

- ➔ Push [F-INP ENT], [1.8 1], [50 0], [50 0], then push [▲] or [▼].

To select the scan edge channel P2:

- ➔ Push [F-INP ENT], [1.8 1], [50 0], [1.8 1], then push [▲] or [▼].

■ Memory list screen

The memory list screen simultaneously shows 7 memory channels and their programmed contents. 13 memory channels can be displayed in the wide memory list screen.

You can select a desired memory channel from the memory list screen.

◇ Selecting a memory channel using the memory list screen

- ① Push **[EXIT/SET]** several times to close any multi-function screens.
- ② Push **[MEMORY] (F-4)** to select the memory list screen.
 - Push **[WIDE] (F-6)** to switch between the standard and wide screens.
- ③ While holding down **[SET] (F-2)**, rotate the main dial to select the desired memory channel.
 - **[▲]** and **[▼]** can also be used.
- ④ Push **[EXIT/SET]** to exit the memory list screen.

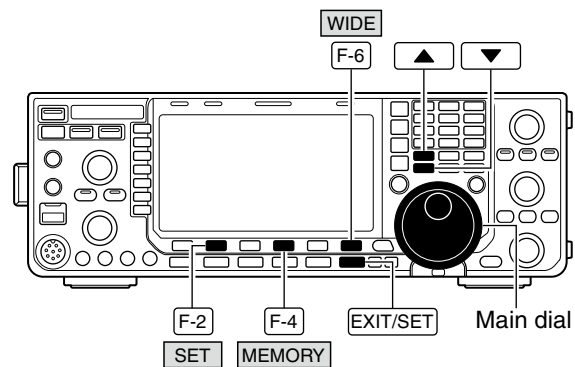

• Memory list screen

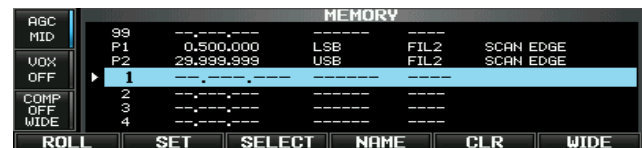

◇ Confirming programmed memory channels

- ① Select the memory list screen as described above.
- ② While pushing **[ROLL] (F-1)**, rotate the main dial to scroll the screen.
- ③ Push **[SET] (F-2)** to select the highlighted memory channel.
 - “▶” appears beside the selected memory channel number in the memory list screen and the selected memory channel contents are displayed below the frequency readout.
- ④ Push **[EXIT/SET]** to exit the memory list screen.

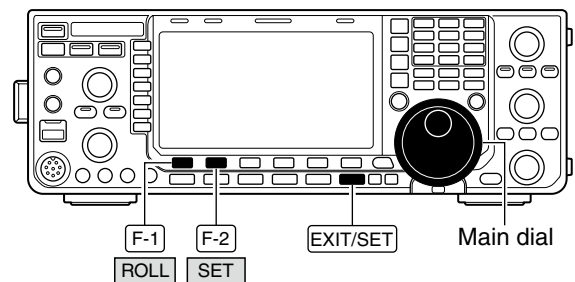

Memory channel programming

Memory channel can be programmed in either the VFO mode or the memory mode.

Programming in the VFO mode

- ① Set the desired frequency, operating mode and filter width in the VFO mode.
- ② Push [▲]/[▼] several times to select the desired memory channel.
 - The Memory list screen is convenient for selecting the desired channel. (p. 108)
 - Memory channel contents appear in the memory channel readout (below the frequency readout).
 - “-.-.-.-” appears if the selected memory channel is a blank channel (and does not have any contents).
- ③ Hold down [MW] for 1 second to program the displayed frequency, operating mode, etc., into the memory channel.

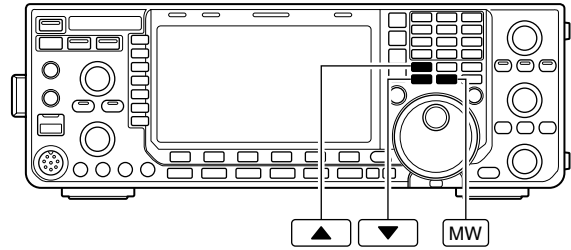

[EXAMPLE]:
Programming 7.088 MHz/LSB into memory channel 12.



Programming in the memory mode

- ① Select the desired memory channel with [▲]/[▼] in the memory mode.
 - Memory channel contents appear in the memory channel readout instead of the frequency readout.
 - Nothing is displayed if the selected memory channel is an empty channel.
- ② Set the desired frequency and operating mode.
 - To program a blank channel, use direct frequency entry with the keypad or memo pads, etc. (p. 30)
- ③ Hold down [MW] for 1 second to program the displayed frequency and operating mode into the memory channel.

[EXAMPLE]:
Programming 21.280 MHz/USB into memory channel 19.

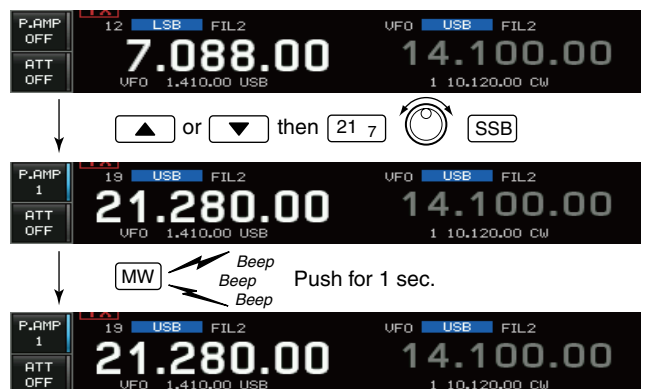

Frequency transfers

The frequency and operating mode in a memory channel can be transferred to the VFO in either VFO mode or memory mode.

◇ Transferring in the VFO mode

This is useful for transferring programmed contents to a VFO.

- ① Select the VFO mode by pushing [VFO/MEMO].
- ② Select the memory channel to be transferred with [▲]/[▼].
 - The Memory list screen is convenient for selecting the desired channel.
 - Memory channel contents appear in the memory channel readout (below the frequency readout).
 - “---,---,---” appears if the selected memory channel is a blank channel. In this case transferring is not possible.
- ③ Hold down [VFO/MEMO] for 1 second to transfer the frequency and operating mode.
 - Transferred frequency and operating mode appear on the frequency readout.

TRANSFER EXAMPLE IN VFO MODE

Operating frequency : 21.320 MHz/USB (VFO)
 Contents of M-ch 16 : 14.018 MHz/CW

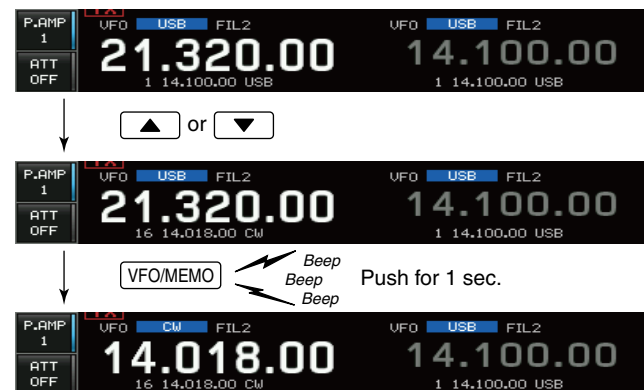

◇ Transferring in the memory mode

This is useful for transferring the frequency and operating mode while operating in the memory mode.

- When you have changed the frequency or operating mode in the selected memory channel:
- **Displayed** frequency, mode and filter setting are transferred.
 - **Programmed** frequency, mode and filter in the memory channel are not transferred, and they remain in the memory channel.

- ① Select the memory channel to be transferred with [▲]/[▼] in memory mode.
 - Then, set the frequency or operating mode if required.
- ② Hold down [VFO/MEMO] for 1 second to transfer the frequency, mode and filter.
 - Displayed frequency, mode and filter are transferred to the VFO.
- ③ To return to VFO mode, push [VFO/MEMO] momentarily.

TRANSFER EXAMPLE IN MEMORY MODE

VFO frequency : 21.320 MHz/USB
 Contents of M-ch 16 : 14.018 MHz/CW

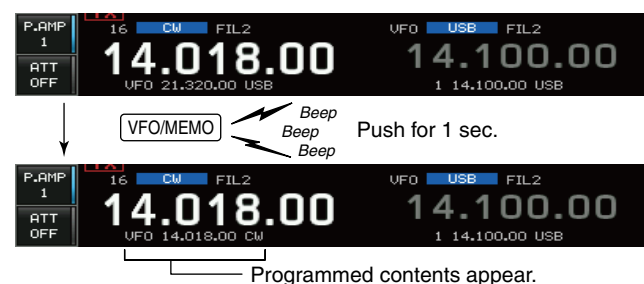

Memory names

All memory channels (including scan edges) can be tagged with alphanumeric names of up to 10 characters each.

Capital letters, small letters, numerals, some symbols (! # \$ % & ¥ ? " ' ` ^ + - * / . , ; = < > () [] { } | _ - @) and space can be used.

Editing (programming) memory names

- ① Push **[EXIT/SET]** several times to close any multi-function screens, if necessary.
- ② Push **[MEMORY] (F-4)** to select memory list screen.
- ③ Select the desired memory channel with **[▲]/[▼]**.
- ④ Push **[NAME] (F-4)** to edit memory channel name.
 - A cursor appears and blinks.
 - Memory channel names of blank channels cannot be edited.
- ⑤ Input the desired character by rotating the main dial or by pushing the keypad for number input.
 - Push **[ABC]** or **[abc]** to toggle capital and small letters.
 - Push **[123]** or **[Symbol]** to toggle numerals and symbols.
 - Push **[◀] (F-1)** or **[▶] (F-2)** for cursor movement.
 - Push **[DEL] (F-3)** to delete the selected character.
 - Push **[SPACE] (F-4)** to input a space.
 - Pushing the transceiver's keypad, **[0]–[9]** and **[.]** can also enter numerals.
- ⑥ Push **[EXIT/SET]** to input and set the name.
 - The cursor disappears.
- ⑦ Repeat steps ③ to ⑥ to program another memory channel's name, if desired.
- ⑧ Push **[EXIT/SET]** to exit memory list screen.

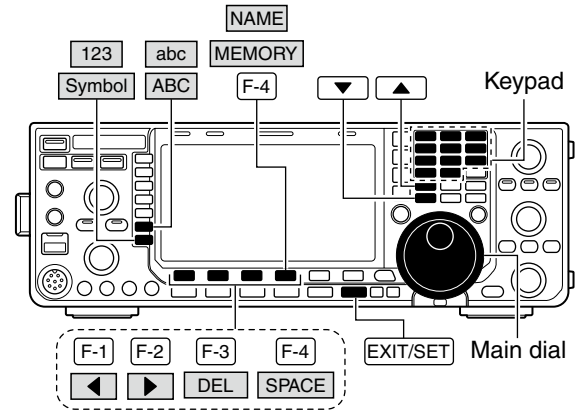

For your convenience

When a PC keyboard is connected to a [USB] (A) connector on the front panel, the memory name can also be edited from the keyboard.

Memory clearing

Any unused memory channels can be cleared. The cleared memory channels become blank channels.

- ① Select memory mode with **[VFO/MEMO]**.
- ② Push **[MEMORY] (F-4)** to select memory list screen.
- ③ Select the desired memory channel with **[▲]/[▼]**.
- ④ Hold down **[CLR] (F-5)** for 1 second to clear the contents.
 - The programmed frequency, operating mode and filter disappear.
- ⑤ To clear other memory channels, repeat steps ③ and ④.

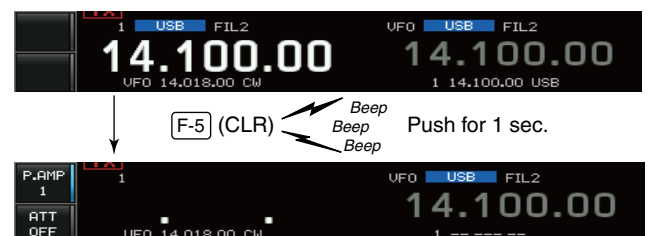
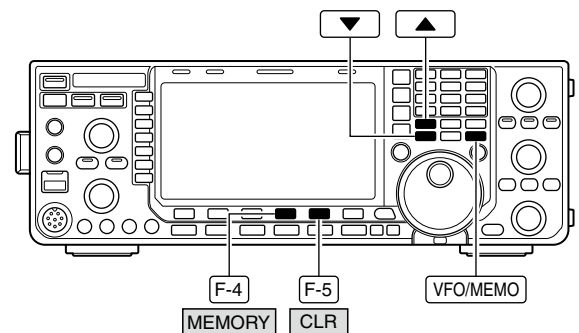

■ Memo pads

The transceiver has a memo pad function to store frequency and operating mode for easy writing and recalling. The memo pads are separate from the memory channels.

The default number of memo pads is 5. If desired, however, this can be increased to 10 in the set mode. (p. 140)

Memo pads are convenient when you want to memorize a frequency and operating mode temporarily, such as when you find a DX station in a pile-up, or when a desired station is busy for a long time and you want to temporarily search for other stations.

Use the transceiver's memo pads instead of relying on hastily scribbled notes that are easily misplaced.

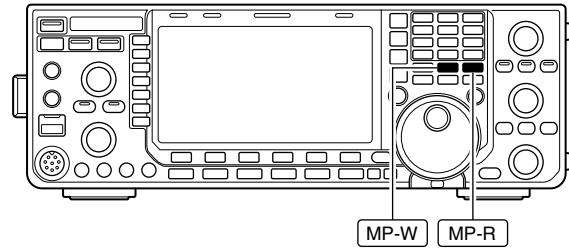

◇ Writing frequencies and operating modes into memo pads

You can store the readout frequency and operating mode by pushing **[MP-W]**.

When you store the 6th frequency and operating mode, the oldest stored entries are automatically erased, to make room for the new settings.

- ▨ Each memo pad must have its own unique combination of frequency and operating mode.
- ▨ Memo pads having identical settings cannot be written.

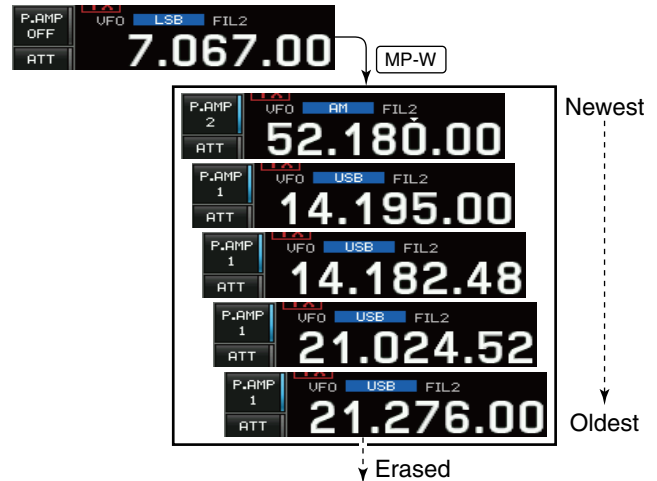

In this example, 21.276 MHz (USB) will be erased when 7.067 MHz (LSB) is written.

◇ Calling up a frequency and operating mode from a memo pad

You can call up the desired contents of a memo pad by pushing **[MP-R]** several times.

- Both VFO and memory modes can be used.
- The frequency and operating mode are called up, starting from the most recently written.

When you call up the memo pads with **[MP-R]**, the previously displayed frequency and operating mode are automatically stored in a temporary pad. The temporary pad can be recalled by pushing **[MP-R]** several times.

- You may think there are 6 memo pads because 6 different frequencies (5 are in memo pads and 1 is in the temporary pad) are called up by **[MP-R]**.

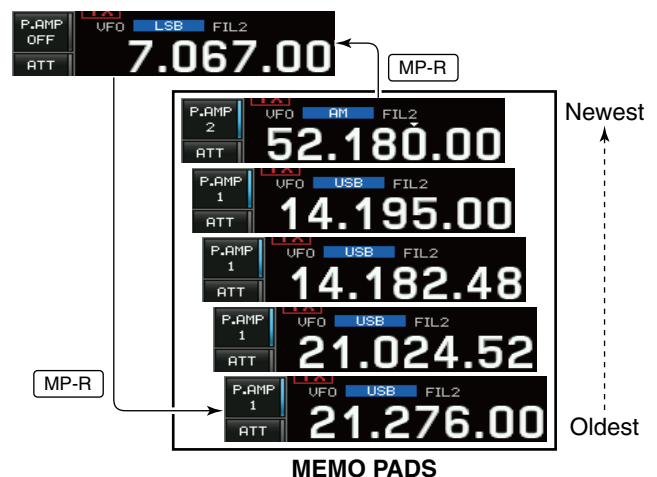

- ▨ If you change the frequency or operating mode called up from a memo pad with the main dial, those in the temporary pad are erased.

Scan types

PROGRAMMED SCAN

Repeatedly scans between two scan edge frequencies (scan edge memory channels P1 and P2).

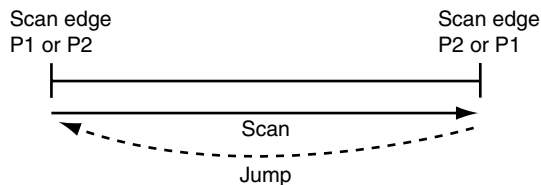

This scan operates in the VFO mode.

MEMORY SCAN

Repeatedly scans all programmed memory channels.

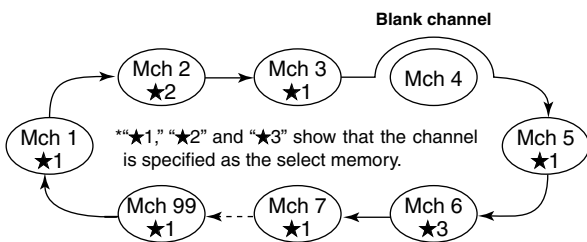

This scan operates in the memory mode.

- The scan function can be used on the main readout only.
- You can perform a scan while operating on a frequency using the dualwatch or split functions.

ΔF SCAN

Repeatedly scans within ΔF span area.

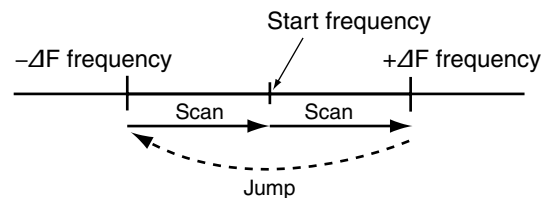

This scan operates in both the VFO and memory modes.

SELECT MEMORY SCAN

Repeatedly scans all or one of 3 select memory channels.

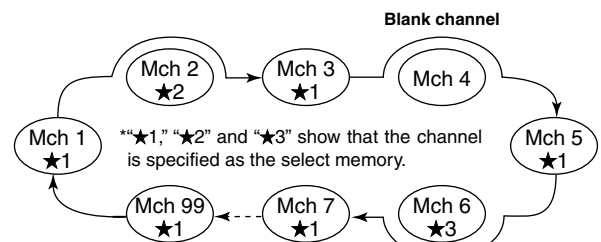

This scan operates in the memory mode.

Preparation

• Channels

For programmed scan:

Program scan edge frequencies into scan edge memory channels P1 and P2. (p. 109)

For ΔF scan:

Set the ΔF span (ΔF scan range) in the scan screen.

For memory scan:

Program 2 or more memory channels except scan edge memory channels.

For select memory scan:

Designate 2 or more memory channels as Select memory channels. To designate the channel as a Select memory channel, choose a memory channel, then push [SELECT] (F-3) in the scan screen (memory mode) or in the memory list screen.

• Scan resume ON/OFF

You can select the scan to resume or cancel when detecting a signal in the scan set mode. Scan resume ON/OFF must be set before performing a scan. See page 114 for ON/OFF setting and scan resume condition details.

• Scan speed

Scan speed can be selected from 2 levels, high or low, in the scan set mode. See page 114 for details.

• Squelch condition

○ Scan starts with the squelch open

For programmed scan:

When the tuning step is 1 kHz or less:

The scan continues until it is stopped manually—it does not pause* even if signals are detected.

* The scan is paused when the squelch is closed and then opened (scan resumes after 10 seconds has passed when the scan resume is ON, or the scan is cancelled when the scan resume is OFF).

When the tuning step is more than 5 kHz:

The scan pauses on each step when the scan resume is ON. This is not applicable when the scan resume is OFF.

For memory scan:

Scan pauses on each channel when the scan resume is ON. This is not applicable when the scan resume is OFF.

○ Scan starts with squelch closed

Scan stops when a signal is detected.

- If the scan resume is set to ON in the scan set mode, the scan pauses for 10 seconds when detecting a signal, then resumes. When a signal disappears while scan is paused, scan resumes 2 seconds later.

■ Scan set mode

The scan speed and the scan resume condition can be set using the scan set mode.

- ① Push **[SCAN] (F-5)** to select scan screen.
- ② Push **[SET] (F-6)** to select the scan set mode.
- ③ Push **[▲] (F-1)** or **[▼] (F-2)** to select the desired item.
- ④ Rotate the main dial to select the desired condition.
 - Hold down **[DEF] (F-4)** for 1 second to select the default setting.
- ⑤ Push **[EXIT/SET]** to return to scan menu.

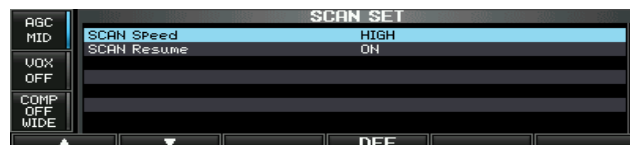
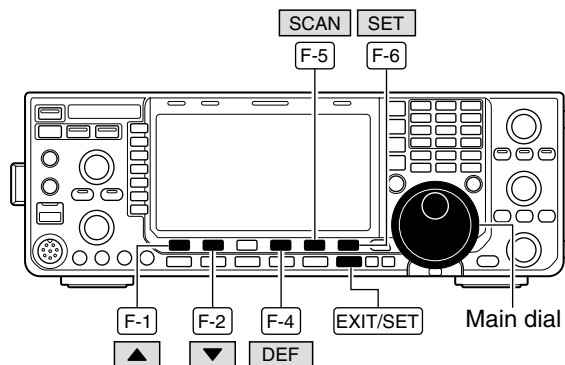

Scan Speed	HIGH
Select the desired scan speed between high and low.	<ul style="list-style-type: none"> • HIGH : scan is faster. • LOW : scan is slower.
Scan Resume	ON
Set the scan resume function ON or OFF.	<ul style="list-style-type: none"> • ON : When detecting a signal, scan pauses for 10 seconds, then resumes. When a signal disappears, scan resumes 2 seconds later. • OFF : When detecting a signal, cancels scanning.

Programmed scan operation

- ① Push **[EXIT/SET]** several times to close any multi-function screens, if necessary.
- ② Select the VFO mode.
- ③ Select the desired operating mode.
 - The operating mode can also be changed while scanning.
- ④ Push **[SCAN] (F-5)** to select the scan screen.
- ⑤ Set **[RF/SQL]** open or closed.
 - See page 113 for squelch condition.
 - If the **[RF/SQL]** control function is set as “AUTO,” the squelch is always open in the SSB, CW, RTTY and PSK modes. (pp. 2, 37, 136)
- ⑥ Push **[PROG] (F-1)** to start the programmed scan.
 - “**PROGRAM SCAN**” and decimal points blink while scanning.
- ⑦ When the scan detects a signal, scan stops, pauses or ignores it depending on the resume setting and the squelch status.
- ⑧ To cancel the scan, push **[PROG] (F-1)**.
 - Rotating the main dial also cancels the scan.
- ⑨ Hold down **[RECALL] (F-5)** for 1 second to recall the frequency that is set before starting the scan, if desired.

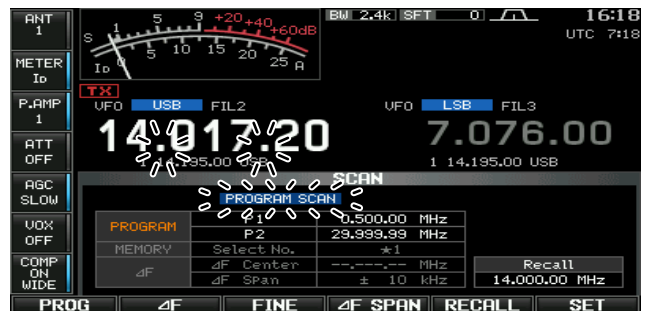
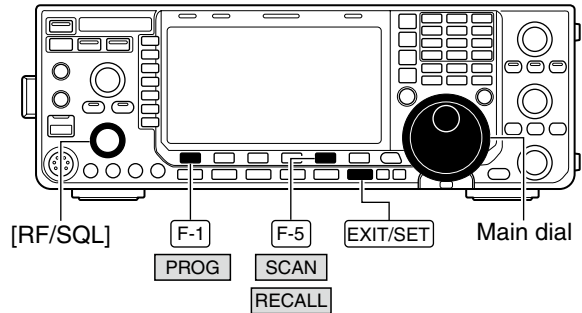

▨ If the same frequencies are programmed into the scan edge memory channel P1 and P2, programmed scan will not start.

ΔF scan operation

- ① Push **[EXIT/SET]** several times to close any multi-function screens, if necessary.
- ② Select VFO mode or a memory channel.
- ③ Select the desired operating mode.
 - The operating mode can also be changed while scanning.
- ④ Push **[SCAN] (F-5)** to select the scan screen.
- ⑤ Set **[RF/SQL]** open or closed.
 - See page 113 for squelch condition.
 - If the **[RF/SQL]** control function is set as “AUTO,” the squelch is always open in the SSB, CW, RTTY and PSK modes. (pp. 2, 37, 136)
- ⑥ Set the ΔF span by pushing **[ΔF SPAN] (F-4)**.
 - ± 5 kHz, ± 10 kHz, ± 20 kHz, ± 50 kHz, ± 100 kHz, ± 500 kHz and ± 1000 kHz are selectable.
- ⑦ Rotate the main dial to set a center frequency of the ΔF span.
- ⑧ Push **[ΔF] (F-2)** to start the ΔF scan.
 - “ **ΔF SCAN**” and decimal points blink while scanning.
- ⑨ When the scan detects a signal, the scan stops, pauses or ignores it depending on the resume setting and the squelch status.
- ⑩ To cancel the scan, push **[ΔF] (F-2)**.
 - Rotating the main dial also cancels the scan.
- ⑪ Hold down **[RECALL] (F-5)** for 1 second to recall the frequency that was set before starting the scan.

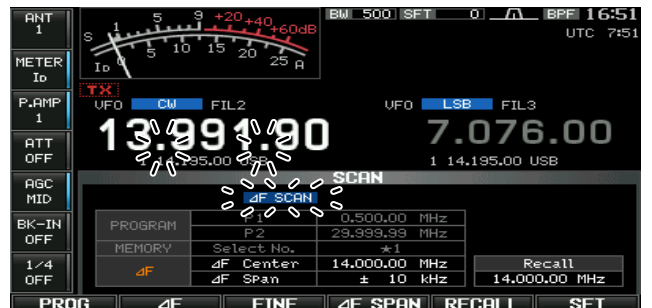
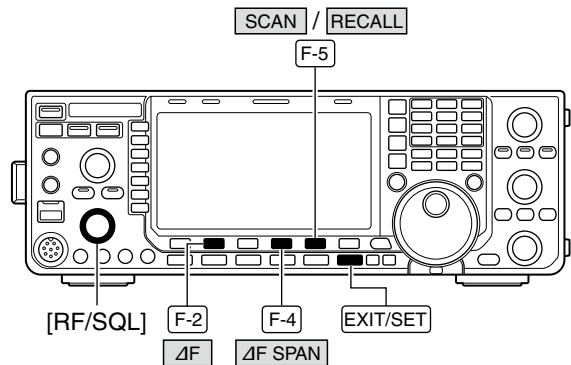

■ Fine programmed scan/Fine ΔF scan

In fine scan (programmed or ΔF), the scan speed decreases when the squelch opens, but the transceiver keeps scanning. The scanning tuning step shifts from 50 Hz to 10 Hz when the squelch opens.

- ① Push **[EXIT/SET]** several times to close any multi-function screens, if necessary.
- ② Push **[SCAN] (F-5)** to select the scan screen.
- ③ Set for programmed scan or ΔF scan as described on the previous page.
- ④ Push **[PROG] (F-1)** or **[ΔF] (F-2)** to start a scan.
 - “PROGRAM SCAN” or “ΔF SCAN” and decimal points blink while scanning.
- ⑤ Push **[FINE] (F-3)** to start a fine scan.
 - “FINE PROGRAM SCAN” or “FINE ΔF SCAN” blinks instead of “PROGRAM SCAN” or “ΔF SCAN,” respectively.
- ⑥ When the scan detects a signal, the scan speed decreases but scan does not stop.
- ⑦ Push **[PROG] (F-1)** or **[ΔF] (F-2)** to stop the scan, push **[FINE] (F-3)** to cancel the fine scan.
 - Rotating the main dial also cancels the scan.
- ⑧ Hold down **[RECALL] (F-5)** for 1 second to recall the frequency that is set before starting the scan, if desired.

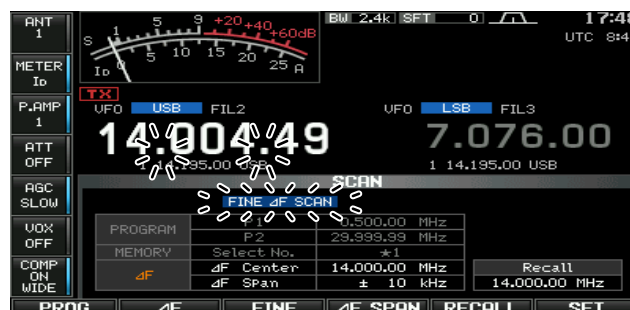
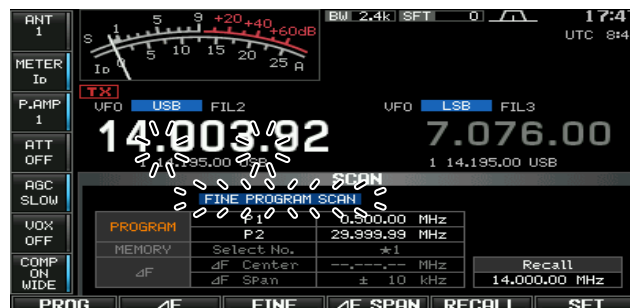
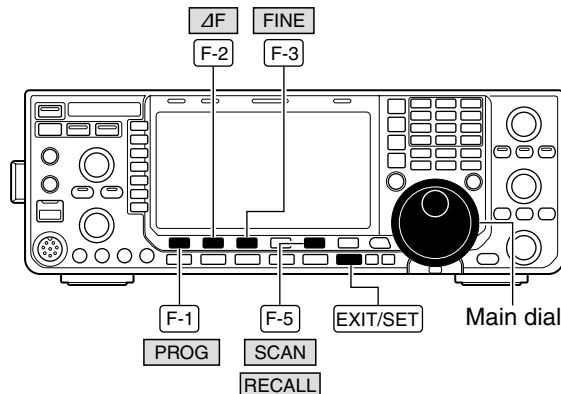

Memory scan operation

- ① Push **[EXIT/SET]** several times to close any multi-function screens, if necessary.
- ② Select memory mode.
- ③ Push **[SCAN] (F-5)** to select the scan screen.
- ④ Set **[RF/SQL]** open or closed.
 - See page 113 for squelch condition.
 - If the **[RF/SQL]** control function is set as “AUTO,” the squelch is always open in the SSB, CW, RTTY and PSK modes. (pp. 2, 37, 136)
- ⑤ Push **[MEMO] (F-1)** to start the memory scan.
 - “**MEMORY SCAN**” and decimal points blink while scanning.
- ⑥ When the scan detects a signal, the scan stops, pauses or ignores it depending on the resume setting and the squelch condition.
- ⑦ To cancel the scan, push **[MEMO] (F-1)**.
 - Rotating the main dial also cancels the scan.

2 or more memory channels must be programmed for a memory scan to start.

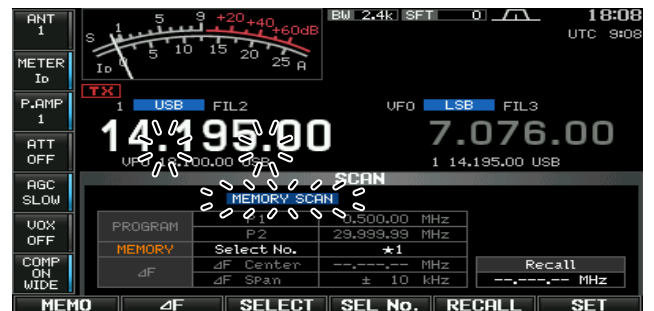
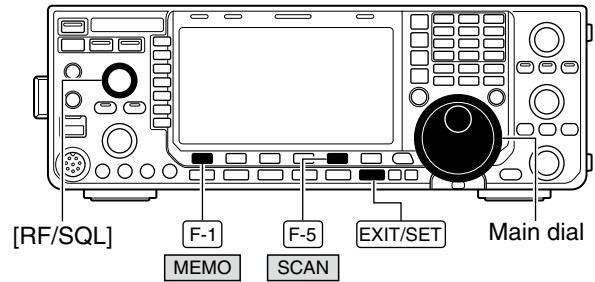

Select memory scan operation

- ① Push **[EXIT/SET]** several times to close any multi-function screens, if necessary.
- ② Select memory mode.
- ③ Push **[SCAN] (F-5)** to select the scan screen.
- ④ Set **[RF/SQL]** open or closed.
 - See page 113 for squelch condition.
 - If the **[RF/SQL]** control function is set as “AUTO,” the squelch is always open in the SSB, CW, RTTY and PSK modes. (pp. 2, 37, 136)
- ⑤ Push **[MEMO] (F-1)** to start the memory scan.
 - “**MEMORY SCAN**” and decimal points blink while scanning.
- ⑥ Push **[SEL No.] (F-4)** several times to select the select scan number from ★1, ★2, ★3 and ★1,2,3.
- ⑦ Push **[SELECT] (F-3)** to start select memory scan, push **[SELECT] (F-3)** again to return to memory scan, if desired.
 - “**SELECT MEMORY SCAN**” blinks instead of “**MEMORY SCAN**” during a select memory scan.
- ⑧ When the scan detects a signal, the scan stops, pauses or ignores it depending on the resume setting and the squelch condition.
- ⑨ To cancel the scan, push **[MEMO] (F-1)**.
 - Rotating the main dial also cancels the scan.

2 or more memory channels must be designated as select memory channels, as well as the same select scan channel number, for select memory scan to start.

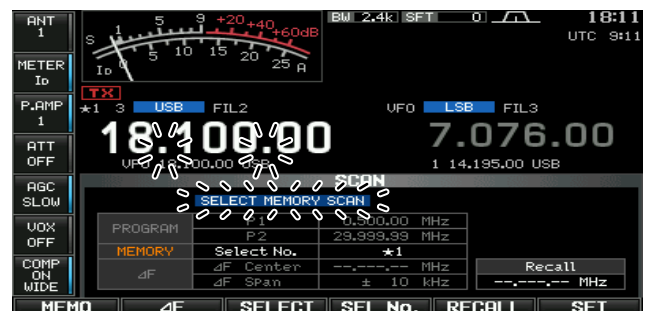
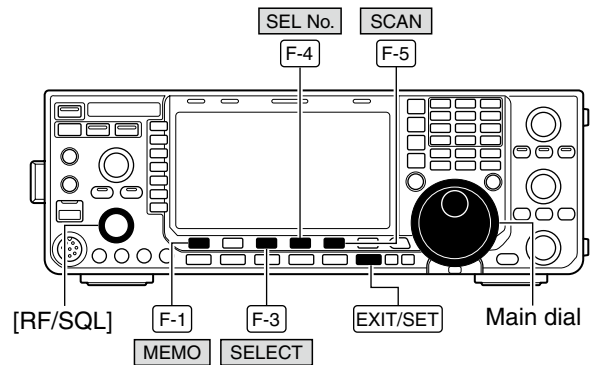

■ Setting select memory channels

◇ Setting in scan screen

- ① Push **[EXIT/SET]** several times to close any multi-function screens, if necessary.
- ② Select memory mode.
- ③ Push **[SCAN] (F-5)** to select the scan screen.
- ④ Select the desired memory channel to set as a select memory channel.
 - **[▲]/[▼]** keys and direct keypad selections can be used. (p. 107)
- ⑤ Push **[SELECT] (F-3)** several times to set the memory channel as a select memory **★1, ★2, ★3** or not.
 - “★1,” “★2” or “★3” appears on the LCD to show that the channel is specified as the select memory.
- ⑥ Repeat steps ④ to ⑤ to program another memory channel as a select memory channel.
- ⑦ Push **[EXIT/SET]** to exit the scan screen.

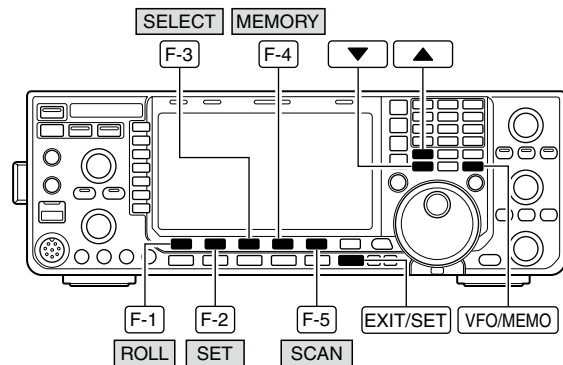

• Scan screen



◇ Setting in memory list screen

- ① Push **[EXIT/SET]** several times to close any multi-function screens, if necessary.
- ② Push **[MEMORY] (F-4)** to select memory list screen.
- ③ Rotate the main dial while pushing **[ROLL] (F-1)** or **[SET] (F-2)** to select the desired memory channel.
 - **[▲]/[▼]** keys and direct keypad selections can be used. (p. 107)
- ④ Push **[SELECT] (F-3)** several times to set the memory channel as a select memory **★1, ★2, ★3** or not.
 - “★1,” “★2” or “★3” appears on the LCD to show that the channel is specified as the select memory.
- ⑤ Repeat steps ③ to ④ to program another memory channel as a select memory channel.
- ⑥ Push **[EXIT/SET]** to exit the memory list screen.

• Memory list screen



◇ Erasing the select scan setting

- ① Push **[EXIT/SET]** several times to close any multi-function screens, if necessary.
- ② Push **[MEMORY] (F-4)** to select memory list screen, or push **[SCAN] (F-5)** to select scan screen.
- ③ Hold down **[SELECT] (F-3)** for 1 second to display memory select all clear window.
- ④ Push one of the following keys to clear all select scan settings.
 - [★1] (F-1)** : Clears all ★1 settings.
 - [★2] (F-2)** : Clears all ★2 settings.
 - [★3] (F-3)** : Clears all ★3 settings.
 - [★1,2,3] (F-4)** : Clears all select settings.
- ⑤ Push **[EXIT/SET]** to exit the memory list screen.

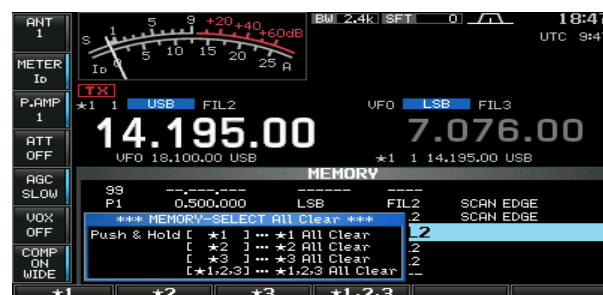
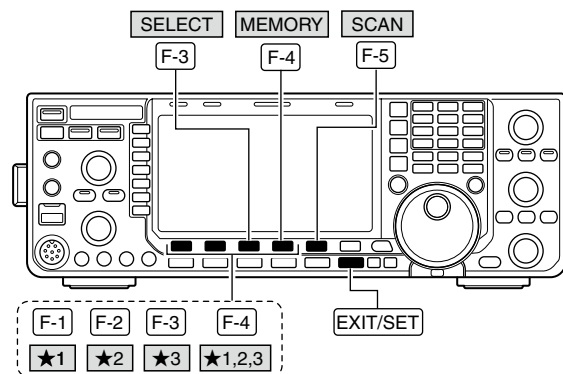

■ Tone scan

The transceiver can detect subaudible tones in a received signal. By monitoring a signal that is being transmitted on a repeater input frequency, you can determine the tone frequency required to access the repeater.

- ① Set the desired frequency or memory channel to be checked for a tone frequency.
- ② Push **[AM/FM]** several times to select the FM mode.
- ③ Hold down **[TONE] (MF7)** for 1 second to select the tone frequency screen.
- ④ Push **[▲] (F-1)** or **[▼] (F-2)** to check the repeater tone frequency or tone squelch frequency, respectively.
- ⑤ Push **[T-SCAN] (F-6)** to start the tone scan.
 - “SCAN” blinks while scanning.
- ⑥ When a matching tone frequency is detected, the tone scan pauses.
 - The tone frequency is set temporarily on a memory channel. Program the memory channel to store the tone frequency permanently.
 - The decoded tone frequency is used for the repeater tone frequency or tone squelch frequency.
- ⑦ To stop the scan, push **[T-SCAN] (F-6)**.
 - Hold down **[DEF] (F-4)** for 1 second to select the default frequency.
- ⑧ Push **[EXIT/SET]** to exit tone frequency screen.

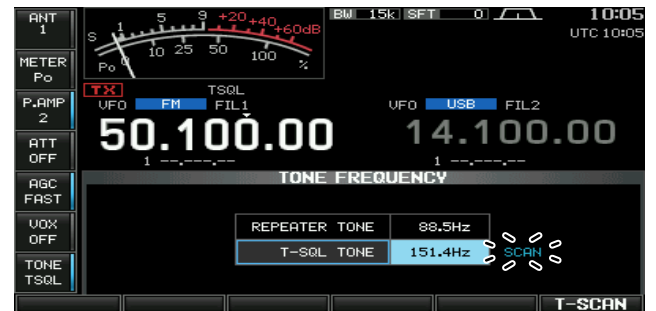
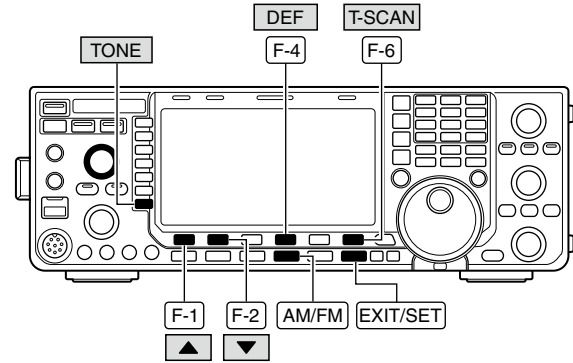

■ Automatic antenna selection

The transceiver covers 0.03–60 MHz over 10 bands. Each band key has a band memory which can memorize a selected antenna (ANT1, ANT2, ANT1/RX antenna and ANT2/RX antenna).

When you change the operating frequency beyond a band, the previously used antenna is automatically selected. This function is convenient when you use 2 or 3 antennas.

To use the band memory, select the set mode and confirm that “Auto” is selected as the [ANT] switch option. (p. 138)

• Antenna selection mode: “Auto” (default)

The antenna tuner ON/OFF condition is also memorized in the band memory.

[Example]: a 3.5/7 MHz antenna is connected to [ANT1], a 21/28/50 MHz antenna is connected to [ANT2].

When the antenna selector function is set to “Auto,” an antenna is automatically selected when the transceiver changes bands.

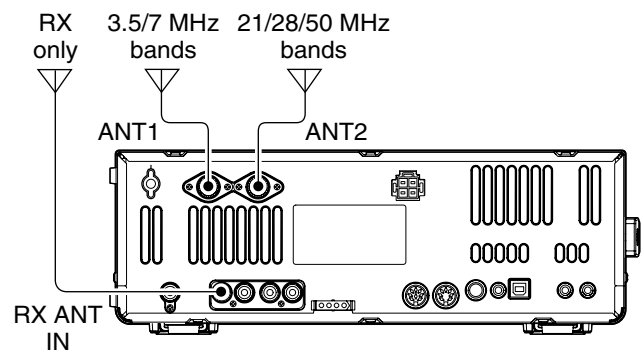

• Antenna selection mode: “Manual”

[ANT] (MF1) functions, however, band memory does not function. In this case, you must select an antenna manually.

When using an external antenna selector for more than 3 antennas (except for a receive antenna), “Manual” should be selected as the [ANT] switch the set mode item. (p. 138)

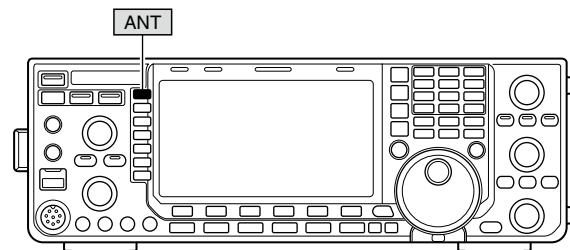

NOTE: When “Auto” or “Manual” is selected, the antenna tuner ON/OFF condition is consistent with [ANT] (MF1).

• Antenna selection mode: “OFF”

[ANT] (MF1) does not function and [ANT1] is always selected.

■ Antenna tuner operation

The internal automatic antenna tuner automatically matches the transceiver to the connected antenna. After the tuner matches an antenna, the variable capacitor settings are memorized as a preset point for each frequency range (100 kHz steps). Therefore, when you change the frequency range, the variable capacitors are automatically preset to the memorized setting.

CAUTION: NEVER transmit with the tuner ON when no antenna is connected. This will damage the transceiver. Be careful of the antenna selection.

✓ For your convenience

When you purchase a brand-new antenna, or you want to change the antenna settings, you can erase the all of the internal antenna tuner preset points with “Tuner Preset Memory Clear” in the Others set mode. (p. 138)

◇ Tuner operation

- ➔ Push **[TUNER]** to turn the internal antenna tuner ON. The antenna is automatically tuned when the antenna SWR is higher than 1.5:1.
 - When the tuner is ON, the indicator on the switch lights green.
 - While tuning, the indicator on the switch blinks.

◇ Manual tuning

During SSB operation at low voice levels, the internal tuner may not automatically tune correctly. In such cases, manual tuning is helpful.

- ➔ Hold down **[TUNER]** for 1 second, to start manual tuning.
 - A sidetone is emitted and the indicator on the switch blinks red while tuning.
 - If the tuner cannot reduce the SWR to less than 1.5:1 after 20 seconds of tuning, the indicator on the switch goes out.

○ If the tuner cannot tune the antenna, check the following and try again:

- the **[ANT]** connector selection.
- the antenna connection and feedline.
- the untuned antenna SWR. (Less than 3:1 for HF bands. Less than 2.5:1 for 50 MHz band)
- the transmit power. (8 W for HF bands, 15 W for 50 MHz band)
- the power source voltage/capacity.

If the tuner cannot reduce the SWR to less than 1.5:1 after checking the above, perform the following:

- repeat manual tuning several times.
- adjust the antenna feedline length. (This is effective for higher frequencies in some cases.)

Even if the manual tune does not tune the antenna and the tuner turns OFF the first time, it may tune the antenna the second time.

NOTES:

- NEVER transmit without an antenna properly connected to antenna port in use.
- When 2 antennas are connected, select the antenna to be used with **[ANT] (MF1)**.
- If the SWR is higher than about 1.5:1 when tuning farther than 100 kHz from an antenna's programmed preset point, hold down **[TUNER]** for 1 second to start manual tuning.
- The internal tuner may not be able to tune in the AM mode. In such cases, hold down **[TUNER]** for 1 second to manually tune.

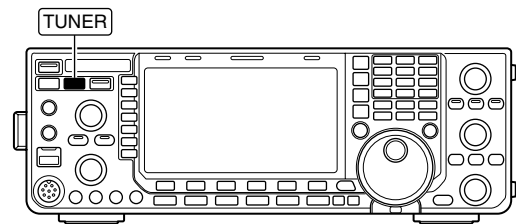

○ Tuning a narrow bandwidth antenna

Some antennas, especially for the low bands, have a narrow bandwidth. These antennas may not be tuned beyond the edge of their operating bandwidth, therefore, tune such an antenna as follows:

[Example]: Suppose you have an antenna which has an SWR of 1.5:1 at 3.55 MHz and an SWR of 3:1 at 3.8 MHz.

- ① Set 3.55 MHz and hold down **[TUNER]** for 1 second to start manual tuning.
- ② Set 3.80 MHz and hold down **[TUNER]** for 1 second to start manual tuning.

- **Automatic tuner start** (HF bands only)
If you want to deactivate the tuner under conditions of VSWR 1.5:1 or less, use the auto tuner start function and turn the tuner OFF. This function activates the tuner automatically when the SWR is high, and is controlled in set mode. (p. 138)
- The tuner may not be activated if the TX power is not output stably longer than the specified time period as the SSB or CW mode operation.
- **PTT tuner start**
Tuning of the internal*/external antenna tuner starts when [PTT] is pushed on a new frequency (more than 1% away from the last-tuned frequency). This function removes the “hold down [TUNER]” operation and activates for the first transmission on a new frequency.
*Tuning starts if the internal antenna tuner is ON. This function is turned ON in set mode. (p. 138)

■ Optional external tuner operation

◇ **Before operating the AH-4 or AH-740**
 // ⚠ **DANGER! HIGH VOLTAGE!**
 // **NEVER** touch the antenna element while tuning or transmitting. Always place it in a secure place.

NEVER operate the AH-4 or AH-740 without an antenna connected. The tuner and transceiver will be damaged.

NEVER operate the AH-4 or AH-740 when it is ungrounded.

Transmitting before tuning may damage the transceiver.

Note that the AH-4 or AH-740 cannot tune when using a $\frac{1}{2} \lambda$ long wire or on a multiple of that frequency.

See page 21 for the transceiver and AH-4 or AH-740 connection.

◇ **Operating the AH-4 or AH-740**
Tuning is required for each frequency. Be sure to retune the antenna before transmitting when you change the frequency— even slightly.

- ① Set the desired frequency in an HF or 50 MHz band for use with the AH-4 or AH-740.
 - The AH-4 or AH-740 will not operate on frequencies outside of ham bands.
- ② Hold down [TUNER] for 1 second.
 - The indicator on the switch blinks while tuning.

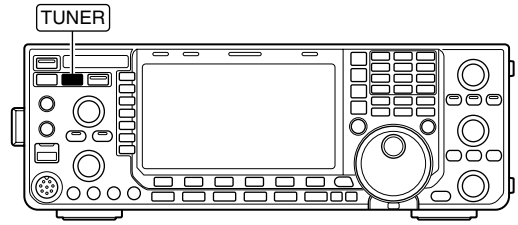

- ③ The indicator on the switch lights constantly when tuning is complete.
 - When the connected wire cannot be tuned, the indicator on the switch goes out and the AH-4 or AH-740 is bypassed. At that point the antenna wire connection is to the transceiver directly, and not via the AH-4 or AH-740 antenna tuner.
- ④ To bypass the AH-4 or AH-740 manually, push [TUNER].

// **NOTE:** PTT tuner function is also available.
 // See page 138 for details.

◇ **Antenna tuner of the IC-PW1/EURO**
When using an external antenna tuner such as the IC-PW1/EURO's tuner, tune with the external antenna tuner, while the internal tuner is turned OFF. After tuning is completed, turn the internal tuner ON. Otherwise, both tuners tune simultaneously and correct tuning may not be obtained. See the instruction manual included with each antenna tuner for their respective operations.

■ Clock set mode

The IC-7600 has a built-in calendar and 24-hour clock (accuracy ± 75 seconds per month) with daily power ON/OFF timer functions. Before operating these timer functions, set the current date and time.

- ① Push **[EXIT/SET]** several times to close multi-function screen, if necessary.
- ② Push **[SET] (F-6)** to select the set mode menu screen.
- ③ Push **[TIME] (F-4)** to select the time set mode.
- ④ Push **[CLOCK] (F-1)** to select the clock set mode.
- ⑤ Push **[▲] (F-1)** or **[▼] (F-2)** to select the desired item, then rotate the main dial to set or select the desired value or condition.
 - Pushing **[◀ ▶] (F-3)** may be necessary for some items.
 - Hold down **[DEF] (F-4)** to select a default condition or value.
- ⑥ Push **[EXIT/SET]** to exit the time set mode.

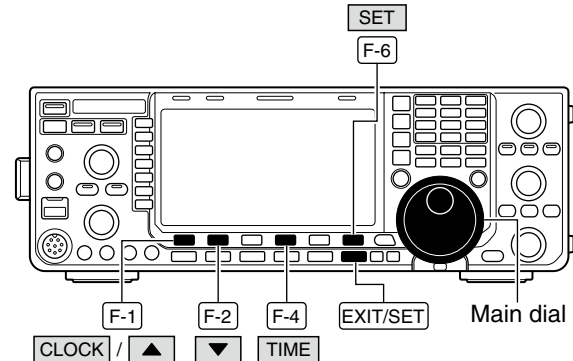

Date	2000 – 1 – 1 (Sat)
Sets the date.	<ol style="list-style-type: none"> ① Push [◀ ▶] (F-3) to select between the year and the month/day, then rotate the main dial to select them. <ul style="list-style-type: none"> • The date setting and “DATE-set Push [SET]” indicators blink. ② Push [SET] (F-5) to set the date.
Time (Now)	0:00
Sets the local time.	<ol style="list-style-type: none"> ① Rotate the main dial to set the local time. <ul style="list-style-type: none"> • The time setting and “TIME-set Push [SET]” indicators blink. ② Push [SET] (F-5) to set the time.
CLOCK2 Function	ON
Turns the CLOCK2 indicator ON and OFF. CLOCK2 is convenient to display UTC or other country's local time, etc.	<ul style="list-style-type: none"> • ON : The CLOCK2 indicator is displayed below the local time display. • OFF : The CLOCK2 indicator does not display.
CLOCK2 Offset	± 0:00
Sets the desired off-set time period for CLOCK2 display within –24:00 to +24:00 in 5 minute steps.	
CLOCK2 Name	UTC
Sets the desired 3-character name for CLOCK2. Capital letters, small letters, numerals, some symbols (! # \$ % & ¥ ? " ' ` ^ + - * / . , ; = < > () [] { } _ - @) and spaces can be used.	<ol style="list-style-type: none"> ① Push [EDIT] (F-5) to select the name edit condition. <ul style="list-style-type: none"> • The cursor under the 1st character blinks. ② Push [ABC]/[abc] (MF6) or [123]/[Symbol] (MF7) to select the character group, then rotate the main dial to select the character. <ul style="list-style-type: none"> • Push [ABC] or [abc] to toggle capital and small letters. • Push [123] or [Symbol] to toggle numerals and symbols. • Push [◀] (F-1) or [▶] (F-2) for cursor movement. • Push [DEL] (F-3) to delete the selected character. • Push [SPACE] (F-4) to input a space. • Pushing the transceiver's keypad, [0]–[9] and [.] can also enter numerals. ③ Push [EXIT/SET] to set the name.

■ Daily timer setting

The transceiver turns power ON and/or OFF automatically on the specified day and time, with the specified frequency settings.

- ① Push **[EXIT/SET]** several times to close multi-function screen, if necessary.
- ② Push **[SET] (F-6)** to select the set mode menu screen.
- ③ Push **[TIME] (F-4)** to select the time set mode.
- ④ Push **[TIMER] (F-2)** to select the timer set mode.
- ⑤ Push one of **[TIMER1] (F-1)** to **[TIMER5] (F-5)** to select the desired timer.
- ⑥ Rotate the main dial to select the timer action ON or OFF.
- ⑦ Push **[▶] (F-2)** to select the “DAY” cell, then rotate the main dial to select the desired day of the week.
 - Select “---” not to specify the day of the week. The timer will function every day in this case.
 - Once a day of the week is selected, push **[CLR] (F-4)** to select “---”.
- ⑧ Push **[▶] (F-2)** to select the “REPEAT” cell, then rotate the main dial to select the repeat function ON or OFF.
 - ON : The timer functions every selected day of the week (repeats).
 - OFF : The timer does not repeat.
- ⑨ Push **[▶] (F-2)** to select the “ON” cell, then rotate the main dial to set the desired transceiver power ON time.
 - When using power OFF timer only, push **[CLR] (F-4)** to select “---”. This setting cannot be set when the power OFF timer is set to “---”.
- ⑩ Push **[▶] (F-2)** to select the “OFF” cell, then rotate the main dial to set the desired transceiver power OFF time.
 - When using power ON timer only, push **[CLR] (F-4)** to select “---”. This setting cannot be set when the power ON timer is set to “---”.
- ⑪ Push **[▶] (F-2)** to select the “Mch” cell, then rotate the main dial to select the desired memory channel number.
 - If using the currently set VFO condition, push **[CLR] (F-4)** to select “---”.
- ⑫ Push **[SET] (F-6)** to set the timer.
 - The timer indicator appears.
- ⑬ Repeat steps ⑤ to ⑫ to set other timers, if desired.
- ⑭ Push **[EXIT/SET]** to exit timer set screen.

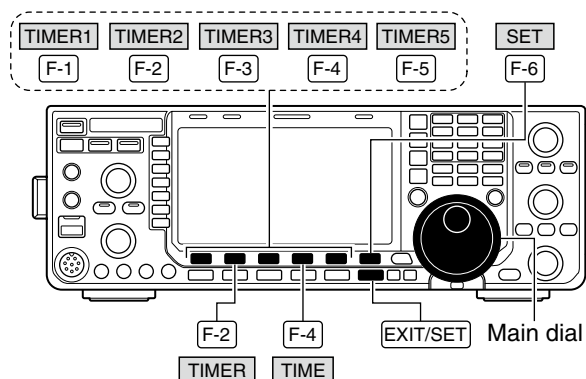

• Timer set mode screen

AGC	DAILY TIMER						TIMER				
MID	ACT	DAY	REPEAT	ON	OFF	Mch					
1	OFF	---	OFF	0:00	---	---					
2	OFF	---	OFF	0:00	---	---					
3	OFF	---	OFF	0:00	---	---					
4	OFF	---	OFF	0:00	---	---					
5	OFF	---	OFF	0:00	---	---					
2008-10- 8 (Wed) 16:12							SLEEP --- min				
TIMER1							TIMER2	TIMER3	TIMER4	TIMER5	SLEEP

• During [Timer1] is selected

AGC	DAILY TIMER						TIMER
MID	ACT	DAY	REPEAT	ON	OFF	Mch	
1	OFF	---	OFF	0:00	---	---	
2	OFF	---	OFF	0:00	---	---	
3	OFF	---	OFF	0:00	---	---	
4	OFF	---	OFF	0:00	---	---	
5	OFF	---	OFF	0:00	---	---	
2008-10- 8 (Wed) 16:12							SLEEP --- min
							CLR

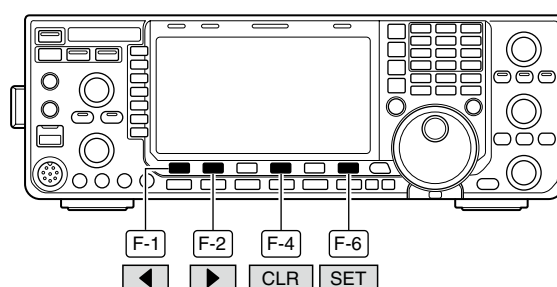

■ Setting sleep timer

The sleep timer turns the transceiver power OFF automatically after passing the set period. The timer can be set to 5–120 minutes in 5 minute steps.

▨ The sleep timer function counts the ‘minute’ units, and does not count the ‘second’ units. For example, when the sleep timer is started at 12:00 59, First one minute past for just 1 second The maximum error is therefore 59 seconds. This is normal, not a malfunction.

- ① Push **[EXIT/SET]** several times to close the multi-function screen, if necessary.
- ② Push **[SET] (F-6)** to select the set mode menu screen.
- ③ Push **[TIME] (F-4)** to select the time set mode.
- ④ Push **[TIMER] (F-2)** to select the timer set mode.
- ⑤ Push **[SLEEP] (F-6)** to select the sleep timer set screen.
 - “-- --” blinks.
- ⑥ Set the desired time period using the main dial.
 - “TIMER–set Push [SET]” blinks.
 - Push **[CLR] (F-4)** to select “-- --” to cancel the setting.
- ⑦ Push **[SET] (F-6)** to set the time.
 - Push **[EXIT/SET]** to cancel the setting.
 - The timer indicator appears.
- ⑧ Push **[EXIT/SET]** to exit timer set screen.
- ⑨ The transceiver sounds 10 beeps and turns OFF after the sleep timer period elapses.
 - The timer indicator blinks while beeping.
 - Push **[POWER]** momentarily to cancel the sleep timer.

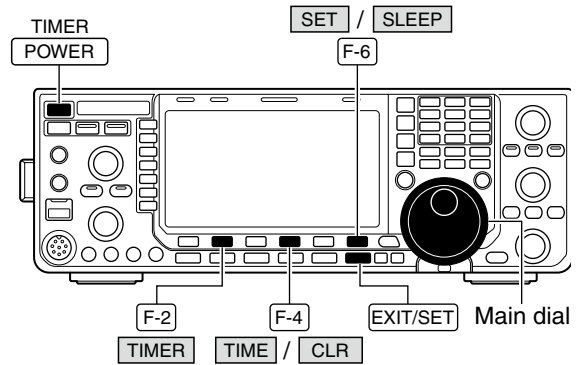

• Sleep timer set condition



■ Timer operation

- ① Preset the daily timer as described previously to turn the timer function ON.
 - The timer indicator appears.
- ② Hold down **[POWER]** for 1 second to turn the power OFF.
 - The indicator on this switch lights red when the timer function is ON.
- ③ When the set time arrives, the power is automatically turned ON.
- ④ The transceiver sounds 10 beeps and turns OFF after the power-off period elapses.
 - The timer indicator blinks while beeping.
 - Push **[POWER]** momentarily to turn the timer function OFF, if desired.

▨ Timer action in the timer set screen must be set to ON to enable the timer operation, described in page 124 step ⑥.

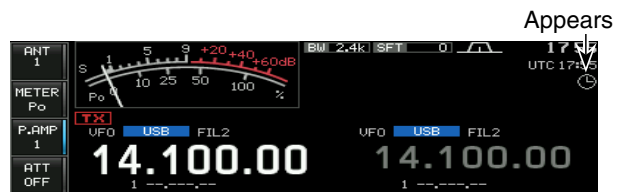
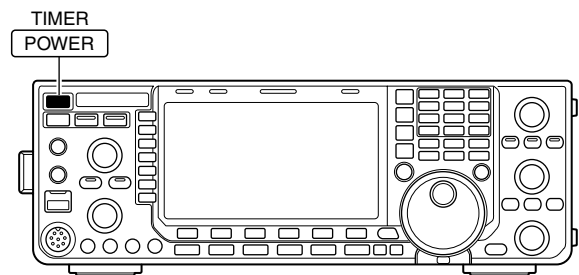

■ Set mode description

The set mode is used for programming infrequently changed values or conditions of functions. The IC-7600 has a level set mode, display set mode, time set mode, accessory set mode, others set mode and USB-Memory set menu.

◇ Set mode operation

- ① Push **[EXIT/SET]** several times to close any multi-function screens, if necessary.
- ② Push **[SET] (F-6)** to select the set mode menu screen.
 - Holding down **[EXIT/SET]** for 1 second also selects the set mode menu screen.
- ③ Push **[LEVEL] (F-1)**, **[ACC] (F-2)**, **[DISP] (F-3)**, **[TIME] (F-4)**, **[OTHERS] (F-5)** or **[USB] (F-6)** to select the desired set mode.
- ④ For level, accessory, display and Others set mode, push **[WIDE] (F-6)** to toggle wide and normal screen.
- ⑤ Push **[▲] (F-1)** or **[▼] (F-2)** to select the desired item, then rotate the main dial to adjust/select the desired value or condition.
 - Pushing **[◀ ▶] (F-3)** operation may be necessary for some items.
 - Hold down **[DEF] (F-4)** select a default condition or value.
- ⑥ Push **[EXIT/SET]** twice to exit the set mode.

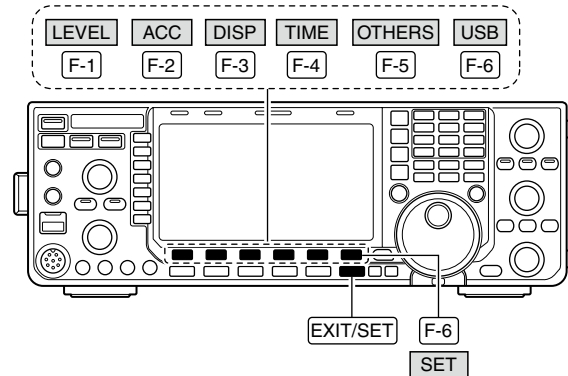

• Set mode screen

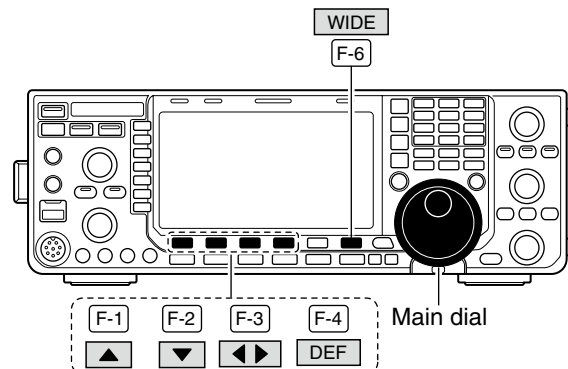

◆ Screen arrangement



• Display set mode (p. 134)



• Set mode menu screen (p. 126)

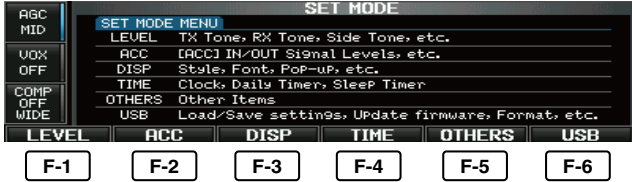

• Time set mode (p. 123)



• Level set mode (p. 128)



• Others set mode (p. 136)



• ACC set mode (p. 132)



• USB-Memory set menu (p. 144)



F-2

F-6

F-3

F-4

F-5

■ Level set mode

SSB RX HPF/LPF

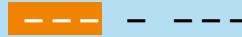

Sets the high-pass filter (100 to 2000 Hz) and low-pass filter (500 to 2400 Hz) of the receive audio in 100 Hz steps in the SSB mode. (default: OFF)
 // NOTE: When this setting is active, below 2 items will be reset to default value, '0.'

SSB RX Tone (Bass)



0

Sets the bass level of the receive audio tone in the SSB mode from -5 to +5. (default: 0)

SSB RX Tone (Treble)



0

Sets the treble level of the receive audio tone in the SSB mode from -5 to +5. (default: 0)

AM RX HPF/LPF



Sets the high-pass filter (100 to 2000 Hz) and low-pass filter (500 to 2400 Hz) of the receive audio in 100 Hz steps in the AM mode. (default: OFF)
 // NOTE: When this setting is active, below 2 items will be reset to default value, '0.'

AM RX Tone (Bass)



0

Sets the bass level of the receive audio tone in the AM mode from -5 to +5. (default: 0)

AM RX Tone (Treble)



0

Sets the treble level of the receive audio tone in the AM mode from -5 to +5. (default: 0)

FM RX HPF/LPF



Sets the high-pass filter (100 to 2000 Hz) and low-pass filter (500 to 2400 Hz) of the receive audio in 100 Hz steps in the FM mode. (default: OFF)
 // NOTE: When this setting is active, below 2 items will be reset to default value, '0.'

FM RX Tone (Bass)



0

Sets the bass level of the receive audio tone in the FM mode from -5 to +5. (default: 0)

FM RX Tone (Treble)



0

Sets the treble level of the receive audio tone in the FM mode from -5 to +5. (default: 0)

Continued on the next page.

10 SET MODE

■ Level set mode (Continued)

CW RX HPF/LPF

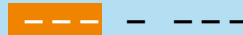

Sets the high-pass filter (100 to 2000 Hz) and low-pass filter (500 to 2400 Hz) of the receive audio in 100 Hz steps in the CW mode. (default: OFF)

RTTY RX HPF/LPF



Sets the high-pass filter (100 to 2000 Hz) and low-pass filter (500 to 2400 Hz) of the receive audio in 100 Hz steps in the RTTY mode. (default: OFF)

PSK RX HPF/LPF



Sets the high-pass filter (100 to 2000 Hz) and low-pass filter (500 to 2400 Hz) of the receive audio in 100 Hz steps in the PSK mode. (default: OFF)

SSB TX Tone (Bass)



Sets the bass level of the transmit audio tone in the SSB mode from -5 to +5. (default: 0)

SSB TX Tone (Treble)



Sets the treble level of the transmit audio tone in the SSB mode from -5 to +5. (default: 0)

AM TX Tone (Bass)



Sets the bass level of the transmit audio tone in the AM mode from -5 to +5. (default: 0)

AM TX Tone (Treble)



Sets the treble level of the transmit audio tone in the AM mode from -5 to +5. (default: 0)

FM TX Tone (Bass)



Sets the bass level of the transmit audio tone in the FM mode from -5 to +5. (default: 0)

FM TX Tone (Treble)





Sets the treble level of the transmit audio tone in the FM mode from -5 to +5. (default: 0)

SSB TBW (WIDE)		100 – 2900
<p>Sets the transmission passband width to a wide setting by changing the lower and higher cut-off frequencies.</p>	<ul style="list-style-type: none"> • Lower freq. : 100 (default), 200, 300 and 500 Hz • Higher freq. : 2500, 2700, 2800 and 2900 Hz (default) 	

SSB TBW (MID)		300 – 2700
<p>Sets the transmission passband width to a middle setting by changing the lower and higher cut-off frequencies.</p>	<ul style="list-style-type: none"> • Lower freq. : 100, 200, 300 (default) and 500 Hz • Higher freq. : 2500, 2700 (default), 2800 and 2900 Hz 	

SSB TBW (NAR)		500 – 2500
<p>Sets the transmission passband width to a narrow setting by changing the lower and higher cut-off frequencies.</p>	<ul style="list-style-type: none"> • Lower freq. : 100, 200, 300 and 500 Hz (default) • Higher freq. : 2500 (default), 2700, 2800 and 2900 Hz 	

Drive Gain		 50%
<p>Sets the drive gain level from 0% to 100% in 1% steps. (default: 50%)</p> <p>While talking into the microphone, keying down or transmitting, rotate the main dial so that the ALC meter reading is between 30% to 50% of the ALC scale. (p. 38)</p> <p>The drive gain is active for all modes other than the SSB mode with speech compressor OFF.</p>		

Speech Level		 50%
<p>Sets the voice synthesizer audio output level from 0% to 100% in 1% steps. (default: 50%)</p>		

Side Tone Level		 50%
<p>Sets the sidetone output level from 0% to 100% in 1% steps. (default: 50%)</p>		

Side Tone Level Limit		ON
<p>Turns the sidetone output level limiting capability ON or OFF. (default: ON)</p> <p>When this item is set to ON, the CW sidetone is linked to the [AF] control until rotation of the [AF] control reaches to the specified level—further rotation will not increase the volume of the CW sidetones.</p>	<ul style="list-style-type: none"> • OFF : The CW sidetone level is linked to the [AF] control. • ON : The CW sidetone level is limited with the [AF] control. 	

■ Level set mode (Continued)

APF AF Level	0 dB
Sets the audio level for the audio peak filter in the CW mode from 0 to +6 dB in 1 dB steps.	
Beep Level	 50%
Sets the beep output level from 0% to 100% in 1% steps. (default: 50%)	
Beep Level Limit	ON
Turns the beep tone output level limiting capability ON or OFF for the confirmation and band edge beep tones. (default: ON)	<ul style="list-style-type: none">• OFF : Beep level is linked to the [AF] control.• ON : Beep level is limited with the [AF] control.
When this item is set to ON, the beep tones are linked to the [AF] control until rotation of the [AF] control reaches to the specified level—further rotation will not increase the volume of the beep tones.	

■ ACC set mode

USB Audio SQL	OFF (OPEN)
<p>Sets the squelch condition of the USB audio which is output from the [USB] (B) connector on the rear panel.</p> <p>The same audio signals are output from [USB] (B) and the ACC sockets.</p> <ul style="list-style-type: none"> • The beep tones and the voice synthesizer announcements are not output. • The received audio output level cannot be adjusted with the [AF] control. 	<ul style="list-style-type: none"> • OFF (OPEN): The received audio is always output regardless of the squelch condition. (default) • ON : The received audio is output according to the squelch condition (open/close).

USB MOD Level	 50%
<p>Sets the input modulation level of the [USB] (B) connector from 0% to 100% in 1% steps. (default: 50%)</p>	

DATA OFF MOD	MIC,ACC
<p>Selects the desired connector(s) for modulation input when data mode is not in use.</p>	<ul style="list-style-type: none"> • MIC : Use the signals from [MIC]. • ACC : Use the signals from [ACC1] (pin 4). • MIC,ACC : Use the signals from [MIC] and [ACC1] (pin 4). (default) • USB : Use the signals from [USB] (B).

DATA1 MOD	ACC
<p>Selects the desired connector(s) for modulation input when data 1 mode (D1) is in use.</p>	<ul style="list-style-type: none"> • MIC : Use the signals from [MIC]. • ACC : Use the signals from [ACC1] (pin 4). (default) • MIC,ACC : Use the signals from [MIC] and [ACC1] (pin 4). • USB : Use the signals from [USB] (B).

DATA2 MOD	MIC,ACC
<p>Selects the desired connector(s) for modulation input when data 2 mode (D2) is in use.</p>	<ul style="list-style-type: none"> • MIC : Use the signals from [MIC]. • ACC : Use the signals from [ACC1] (pin 4). • MIC,ACC : Use the signals from [MIC] and [ACC1] (pin 4). (default) • USB : Use the signals from [USB] (B).

DATA3 MOD	MIC
<p>Selects the desired connector(s) for modulation input when data 3 mode (D3) is in use.</p>	<ul style="list-style-type: none"> • MIC : Use the signals from [MIC]. (default) • ACC : Use the signals from [ACC1] (pin 4). • MIC,ACC : Use the signals from [MIC] and [ACC1] (pin 4). • USB : Use the signals from [USB] (B).



Continued on the next page.

■ ACC set mode (Continued)

SEND Relay Type	MOS-FET
<p>Selects the switching relay type for [RELAY] from Reed and MOS-FET. Select the suitable relay type when connecting a non-linear amplifier.</p>	<ul style="list-style-type: none"> • Reed : Use mechanical relay. (16 V DC/0.5 A max.: default) • MOS-FET : Use semiconductor type relay. (250 V/200 mA max.)

External Meter Output	Auto
<p>Selects the desired item for an external meter indication.</p>	<ul style="list-style-type: none"> • Auto : Outputs the receiving signal strength level during receive, and outputs the selected level (selected with [METER]), during transmit. (default) • S : Outputs the receiving signal strength level during receive. • Po : Outputs the transmitting power level during transmit. • SWR : Outputs the VSWR level during transmit. • ALC : Outputs the ALC level during transmit. • COMP : Outputs the compression level during transmit. • V : Outputs the drain terminal voltage of the final amplifier MOSFETs. • I : Outputs the drain current of the final amplifier MOSFETs.

External Meter Level	 50%
<p>Sets the output level for an external meter indication with in 0% to 100% range in 1% steps.</p> <ul style="list-style-type: none"> • Approximately 2.5 V at 50% (default) setting for full-scale indication. (4.7 kΩ impedance) 	

REF Adjust	 50 % (Example)
<p>Adjusts the internal reference signal frequency within 0% to 100% range in 1% steps during frequency calibration.</p> <p> NOTE: Default setting is different for each transceiver.</p>	

■ Display set mode

<p>Bright (LCD)</p> <p>Adjusts the LCD unit brightness from 0% (dark) to 100% (bright) range in 1% steps. (default: 50%)</p>	 <p>50%</p> <p>NOTE: When you set the LCD brightness to 0%, nothing may appear on the screen. Adjust the LCD brightness until some indicators appear on the screen, then set it to your desired level.</p>
<p>Backlight (Switches)</p> <p>Adjusts the switch indicators brightness from 1 (dark) to 100 (bright) range in 1 steps. (default: 80)</p>	 <p>80</p>
<p>Display Type</p> <p>Selects the desired display type from A (Black back) and B (Blue back). (default: A) See page 154 for details.</p>	<p>A</p>
<p>Display Font</p> <p>Selects the desired font for frequency readout from Basic, Italic and Round. (default: Basic) See page 154 for details.</p>	<p>Basic</p>
<p>Meter Response</p> <p>Set meter needle response from SLOW, MID and FAST. (default: MID) This setting is effective for the standard and edgewise meter type selections only.</p>	<p>MID</p>
<p>Meter Type (Normal Screen)</p> <p>Selects the desired S/RF meter type during normal screen display from Standard, Edgewise and Bar. (default: Standard)</p>	<p>Standard</p>
<p>Meter Type (Wide Screen)</p> <p>Selects the desired S/RF meter type during wide screen or mini scope display from Edgewise and Bar. (default: Bar)</p>	<p>Bar</p>
<p>Meter Peak Hold (Bar)</p> <p>Turns the meter peak hold function ON or OFF. (default: ON) This function is used for the bar meter only.</p>	<p>ON</p>
<p>Memory Name</p> <p>Sets the memory name display, during memory mode operation, ON or OFF. (default: ON)</p>	<p>ON</p> <ul style="list-style-type: none"> • OFF : No memory name is displayed even a memory name is programmed. • ON : The programmed memory name is displayed above the frequency display.

Continued on the next page.

10 SET MODE

■ Display set mode (Continued)

APF-Width Popup (APF OFF→ON) ON

Selects the pop-up display for the APF filter width from ON or OFF. (default: ON)

MN-Q Popup (MN OFF→ON) ON

Enables the pop-up display capability when the notch filter width is changed from ON to OFF. (default: ON)

Screen Saver Function 60min

Turns the screen saver function ON (15, 30 or 60 minutes) and OFF. (default: 60 min.)

The screen saver will activate when no operation is performed for the selected time period to protect the LCD from the “burn-in” effect.

Screen Saver Type Bound

Selects the screen saver type from “Bound,” “Rotation” and “Twist.” (default: Bound)

The screen saver pattern can be displayed for your reference while holding down [PREVIEW] (F-5).

Opening Message ON

Turns the opening message screen display capability ON or OFF. (default: ON)

My Call

Sets the introductory text, up to 10-character long, displayed in the opening screen.

Usually, you set your call sign for the opening screen.

Capital letters, numerals, some symbols (- / . @) and spaces can be used.

When a keyboard is connected to the [USB] connector on the front panel, the call sign can also be edited from the keyboard.

- 1 Push [EDIT] (F-5) to select the name edit condition.
 - The cursor under the 1st character blinks.
- 2 Push [ABC] (MF6), [123] (MF7) or [Symbol] (MF7) to select the character group, then rotate the main dial to select the character.
 - Push [123] (MF7) or [Symbol] (MF7) to toggle numerals and symbols.
 - Push [◀] (F-1) or [▶] (F-2) for cursor movement.
 - Push [DEL] (F-3) to delete the selected character.
 - Push [SPACE] (F-4) to input a space.
 - Pushing the transceiver’s keypad, [0]–[9] and [.] can also enter numerals.
- 3 Push [EXIT/SET] to set the name.

Others set mode

<p>Calibration Marker</p> <p>This item is used for a simple frequency check of the transceiver. See page 155 for calibration procedure.</p>	<p>OFF</p> <ul style="list-style-type: none"> • OFF : Calibration marker OFF (default) • ON : Calibration marker ON <p>/// NOTE: Turn the calibration marker OFF after checking the frequency of the transceiver.</p>
<p>Beep (Confirmation)</p> <p>A beep sounds each time a switch is pushed to confirm it. This function can be turned OFF for silent operation. The beep output level can be set in the level set mode. (p. 131)</p>	<p>ON</p> <ul style="list-style-type: none"> • OFF : Confirmation beep OFF • ON : Confirmation beep ON (default)
<p>Beep (Band Edge)</p> <p>When you tune into or out of an amateur band's frequency range, a beep sounds. This functions independently of the confirmation beep setting (as described above). The beep output level can be set in the level set mode. (p. 131) When "ON (User)" or "ON (User) & TX Limit" is selected, [BAND] appears in the display above the function switch (F-5). Up to 30 band edge frequencies can be programmed in band edge screen. (See page 35 for programming details.)</p>	<p>ON (Default)</p> <ul style="list-style-type: none"> • OFF : Band edge beep is OFF • ON (Default) : When you tune into or out of the default amateur band's frequency range, a beep sounds. (default) • ON (User) : When you tune outside of, or back into a user programmed amateur band's frequency range, a beep sounds. • ON (User) & TX Limit : When you tune outside of, or back into a user programmed amateur band's frequency range, a beep sounds. Transmission is also inhibited outside the programmed band.
<p>Beep Sound</p> <p>Sets the desired beep frequency within 500 to 2000 Hz in 10 Hz steps. (default: 1000 Hz)</p>	<p>1000Hz</p>
<p>RF/SQL Control</p> <p>The [RF/SQL] control can be set as the RF/squelch control (default), the squelch control only (RF gain is fixed at maximum) or 'Auto' (RF gain control in SSB, CW, RTTY and PSK, squelch control in AM and FM). See pages 2 and 37 for details. (default: RF+SQL)</p>	<p>RF+SQL</p> <ul style="list-style-type: none"> • AUTO : [RF/SQL] control as RF gain control in SSB, CW, RTTY and PSK, squelch control in AM and FM • SQL : [RF/SQL] control as squelch control • RF+SQL : [RF/SQL] control as RF/squelch control
<p>TX Delay (HF)</p> <p>If the transceiver transmits power before the external device, such as a linear amplifier, is ready to operate, the transmitted power will be reflected back and can damage the transceiver. Therefore a time delay can be set to delay the transceiver output until the external device is ready.</p>	<p>OFF</p> <p>Set the TX delay time on the HF bands to 10, 15, 20, 25, or 30 milliseconds, or select "OFF" for no delay time, depending on the needs of your external device. (default: OFF)</p>

■ Others set mode (Continued)

<p>TX Delay (50M)</p> <p>If the transceiver transmits power before an external device, such as a linear amplifier, is ready to operate, the transmitted power will be reflected back and can damage the transceiver. Therefore a time delay can be set to delay the transceiver output until the external device is ready.</p>	<p>OFF</p> <p>Set the TX delay time on the 50 MHz band to 10, 15, 20, 25, or 30 milliseconds, or select "OFF" for no delay time, depending on the needs of your external device. (default: OFF)</p>
<p>Time-Out Timer (CI-V)</p> <p>If a continuous transmission exceeds the selected time period, this function will cut off the transmission, to prevent a prolonged transmission. Set the Time-Out Timer function to ON, and select a time of 3, 5, 10, 20 or 30 minutes, or turn the function OFF. (default: OFF)</p>	<p>OFF</p> <p>/// NOTE: This function will be activated only when you transmit using CI-V commands, or pushing [TRANSMIT] on the transceiver.</p>
<p>Quick Dualwatch</p> <p>When this item is set to ON, holding down [DUALWATCH] for 1 second sets the sub readout frequency to the main readout frequency, and activates dualwatch operation.</p>	<p>ON</p> <ul style="list-style-type: none"> • OFF : Quick dualwatch OFF • ON : Quick dualwatch ON (default)
<p>Quick SPLIT</p> <p>When this item is set to ON, holding down [SPLIT] for 1 second sets the unselected VFO's readout frequency and operating mode to the selected VFO's readout, and activates split operation. (default: ON) See page 97 for details.</p>	<p>ON</p> <ul style="list-style-type: none"> • OFF : Quick split OFF • ON : Quick split ON
<p>FM SPLIT Offset (HF)</p> <p>Sets the offset (difference between transmit and receive frequencies) for the quick split function. This setting is used for HF bands in the FM mode only and is used to input the repeater offset for an HF band. The offset frequency can be set from -9.999 to +9.999 MHz in 1 kHz steps. (default: -0.100 MHz)</p>	<p>-0.100MHz</p>
<p>FM SPLIT Offset (50M)</p> <p>Sets the offset (difference between transmit and receive frequencies) for the quick split function. This setting is used for 50 MHz band FM mode only, and is used to input the repeater offset for the 50 MHz band. The offset frequency can be set from -9.999 to +9.999 MHz in 1 kHz steps. (default: -0.500 MHz)</p>	<p>-0.500MHz</p>
<p>SPLIT LOCK</p> <p>When this item is ON, the main dial can be used to adjust the transmit frequency while pushing [XFC], even while the lock function is activated. (default: OFF)</p>	<p>OFF</p> <ul style="list-style-type: none"> • OFF : Split lock OFF • ON : Split lock ON <p>See pages 96 and 97 for split frequency operation details.</p>

<p>Tuner (Auto Start)</p> <p>The internal antenna tuner has an automatic start capability, which starts tuning if the SWR is high. (default: OFF)</p>	<p>OFF</p> <ul style="list-style-type: none"> • OFF : The tuner remains OFF even when the SWR is high. • ON : Automatic tune starts even when the tuner is turned OFF during HF bands operation.
<p>Tuner (PTT Start)</p> <p>Tuning of the internal/external antenna tuner can be automatically started at the moment the [PTT] is pushed after the operating frequency is changed (more than 1% from last-tuned frequency). (default: OFF)</p>	<p>OFF</p> <ul style="list-style-type: none"> • OFF : Tuning starts only when [TUNER] is pushed. • ON : (Internal antenna tuner) Tuning starts when [PTT] is pushed on a new frequency (more than 1% from last-tuned frequency) if the internal antenna tuner is ON. (External antenna tuner) Tuning always starts when [PTT] is pushed on a new frequency (more than 1%) regardless of the external antenna tuner ON/OFF.
<p>Tuner Preset Memory Clear</p> <p>The preset memory* of the selected antenna can be cleared with pushing [CLR] (F-5). * The variable capacitor settings are memorized as a preset point for each frequency range (100 kHz steps) after the tuner matches an antenna.</p>	<ul style="list-style-type: none"> • ANT1 Push [CLR] : The preset memory of the antenna that is connected to [ANT 1] is cleared after pushing [CLR] (F-5). • ANT2 Push [CLR] : The preset memory of the antenna that is connected to [ANT 2] is cleared after pushing [CLR] (F-5).
<p>[ANT] Switch</p> <p>You can set the antenna connector selection to automatic, manual or non-selection (when using 1 antenna only). (default: Auto)</p>	<p>Auto</p> <ul style="list-style-type: none"> • OFF : Antenna switch is not activated and does not function. The [ANT1] connector is always selected. • Manual : Antenna switch is activated and manually selects an antenna. • Auto : Antenna switch is activated and the band memory memorizes the selected antenna. See page 120 for details.
<p>Transverter Function</p> <p>Selects the transverter operation condition from Auto and ON. (default: Auto)</p>	<p>Auto</p> <ul style="list-style-type: none"> • Auto : The transceiver turns into transverter operation condition when 2 to 13.8 V DC is applied to [ACC2] pin 6. • ON : Turn the transverter operation ON.
<p>Transverter Offset</p> <p>Sets the desired offset frequency for the transverter operation within 0.000 to 99.999 MHz in 1 kHz steps. (default: 16.000 MHz)</p>	<p>16.000MHz (14.100.0→30.100.0)</p>
<p>RTTY Mark Frequency</p> <p>Selects the RTTY mark frequency. RTTY mark frequency is switched between 1275, 1615 and 2125 Hz. (default: 2125 Hz)</p>	<p>2125</p> <p>2125 Hz is automatically selected when the internal RTTY decoder is used.</p>

■ Others set mode (Continued)

RTTY Shift Width	170
<p>Selects the RTTY shift width. There are 3 selectable values: 170, 200 and 425 Hz. (default: 170 Hz) 170 Hz is automatically selected when the internal RTTY decoder is used.</p>	
RTTY Keying Polarity	Normal
<p>Selects the RTTY keying polarity. Normal or reverse keying polarity can be selected. (default: Normal) When reverse polarity is selected, Mark and Space are reversed.</p> <ul style="list-style-type: none"> • Normal : Key open/close = Mark/Space • Reverse : Key open/close = Space/Mark 	
PSK Tone Frequency	1500
<p>Selects the desired PSK tone frequency for the PSK reception between 1000, 1500 and 2000 Hz. (default: 1500 Hz)</p>	
SPEECH Language	English
<p>Selects the speech language from English and Japanese. (default: English)</p>	
SPEECH Speed	HIGH
<p>Selects the speech speed from HIGH (faster) and LOW (slower). (default: HIGH)</p>	
SPEECH S-Level	ON
<p>The IC-7600 speech processor can announce frequency, mode and signal level. Signal level announcement can be deactivated if desired. (default: ON) When "OFF" is selected, the signal level is not announced.</p> <ul style="list-style-type: none"> • OFF : Signal level is not announced. (Operating frequency and mode are announced.) • ON : Signal level, operating frequency and mode is announced. 	
SPEECH [MODE] Switch	OFF
<p>Selects the operating mode speech capability when a mode switch is pushed. (default: OFF)</p> <ul style="list-style-type: none"> • OFF : Operating mode speech capability OFF • ON : Operating mode speech capability ON The selected operating mode is verbally announced when a mode switch is pushed. 	
[SPEECH/LOCK] Switch	SPEECH/LOCK
<p>Selects the [SPEECH/LOCK] switch action. (default: SPEECH/LOCK)</p> <ul style="list-style-type: none"> • SPEECH/LOCK : (Push) The voice synthesizer function is activated. (Hold down) The dial lock function is turned ON or OFF. • LOCK/SPEECH : (Push) The dial lock function is turned ON or OFF. (Hold down) The voice synthesizer function is activated. 	

Memopad Numbers	5
Sets the number of memo pad channels available. 5 or 10 memo pads can be selected. (default: 5)	
MAIN DIAL Auto TS	HIGH
<p>Sets the auto tuning step function for the main dial. When rapidly rotating the main dial, the tuning step automatically changes several times as selected. There are 2 type of auto tuning steps: HIGH (Fastest) and LOW (Faster). (default: HIGH)</p>	<ul style="list-style-type: none"> • HIGH : Approximately 5 times faster when the tuning step is set to 1 kHz or smaller steps, approximately 2 times faster when the tuning step is set to 5 kHz or larger steps. • LOW : Approximately 2 times faster • OFF : Auto tuning step is turned OFF.
MIC Up/Down Speed	HIGH
<p>Sets the rate at which frequencies are scanned when the microphone [UP]/[DN] switches are held down. HIGH or LOW can be selected.</p>	<ul style="list-style-type: none"> • LOW : Low speed (25 tuning steps/second) • HIGH : High speed (50 tuning steps/second : default)
Quick RIT/ΔTX Clear	OFF
<p>Selects the RIT/ΔTX frequency clearing instruction with [CLEAR]. (default: OFF)</p>	<ul style="list-style-type: none"> • OFF : Clears the RIT/ΔTX frequency when [CLEAR] is held down for 1 second. • ON : Clears the RIT/ΔTX frequency when [CLEAR] is pushed momentarily.
[NOTCH] Switch (SSB)	Auto/Manual
<p>Selects notch functions for the SSB mode operation from Auto, Manual and Auto/Manual. (default: Auto/Manual)</p>	<ul style="list-style-type: none"> • Auto : Only the auto notch can be used. • Manual : Only the manual notch can be used. • Auto/Manual : Both the auto and manual notch can be used. (default)
[NOTCH] Switch (AM)	Auto/Manual
<p>Selects notch functions for the AM mode operation from Auto, Manual and Auto/Manual. (default: Auto/Manual)</p>	<ul style="list-style-type: none"> • Auto : Only the auto notch can be used. • Manual : Only the manual notch can be used. • Auto/Manual : Both the auto and manual notch can be used.
SSB/CW Synchronous Tuning	OFF
<p>Selects the displayed frequency shift function from ON and OFF. (default: OFF) When this function is activated, the audio pitch or tones of the received signal will remain the same even when the operating mode is changed between SSB and CW.</p> <p>/// The amount of frequency shift may differ according to the CW pitch setting.</p>	<ul style="list-style-type: none"> • OFF : The displayed frequency does not shift. • ON : The displayed frequency shifts when the operating mode is changed between SSB and CW.
CW Normal Side	LSB
<p>Selects the sideband used to receive CW in the CW normal mode from LSB and USB. (default: LSB)</p>	

■ Others set mode (Continued)

<p>APF Type</p> <p>Select audio filter shape for APF between SOFT and SHARP. (default: SOFT)</p>	<p>SOFT</p> <ul style="list-style-type: none"> • SHARP : The Sharp filter shape rejects interfering signals more aggressively. • SOFT : The Soft filter shape makes distinguishing noise and signals easier. The audio filter width is related to the CW pitch setting.
<p>External Keypad (VOICE)</p> <p>Sets the external keypad for voice message transmission capability ON or OFF. (default: OFF) See page 18 for the equivalent circuit of an external keypad and connection.</p>	<p>OFF</p> <ul style="list-style-type: none"> • OFF : The external keypad does not function. • ON : In the phone mode, pushing one of external keypad switches transmits the desired voice message contents.
<p>External Keypad (KEYER)</p> <p>Sets the external keypad for keyer memory transmission capability ON or OFF. (default: OFF) See page 18 for the equivalent circuit of an external keypad and connection.</p>	<p>OFF</p> <ul style="list-style-type: none"> • OFF : The external keypad does not function. • ON : In the CW mode, pushing one of external keypad switches transmits the desired keyer memory contents.
<p>External Keypad (RTTY)</p> <p>Sets the external keypad for RTTY memory transmission capability ON or OFF. (default: OFF)</p> <p>/// NOTE: Only RTTY memory channels RT1, RT2, RT3 and RT4 can be transmitted using with the external keypad.</p> <p>See page 18 for the equivalent circuit of an external keypad and connection details.</p>	<p>OFF</p> <ul style="list-style-type: none"> • OFF : The external keypad does not function. • ON : In the RTTY mode, and while the RTTY decode screen is active, pushing one of the external keypad switches transmits the desired RTTY memory contents.
<p>External Keypad (PSK)</p> <p>Sets the external keypad for PSK memory transmission capability ON or OFF. (default: OFF)</p> <p>/// NOTE: Only PSK memory channels PT1, PT2, PT3 and PT4 can be transmitted using with the external keypad.</p> <p>See page 18 for the equivalent circuit of an external keypad and connection details.</p>	<p>OFF</p> <ul style="list-style-type: none"> • OFF : The external keypad does not function. • ON : In the PSK mode, and while the PSK decode screen is active, pushing one of the external keypad switches transmits the desired PSK memory contents.
<p>Keyboard [F1]–[F4] (VOICE)</p> <p>Sets the voice message transmission capability ON or OFF when one of the [F1] to [F4] keys of the keyboard that is connected to the [USB] (A) connector on the front panel is pushed. (default: OFF)</p>	<p>OFF</p> <ul style="list-style-type: none"> • OFF : [F1] to [F4] keys do not function. • ON : Pushing one of the [F1] to [F4] keys transmits the desired voice message contents during a phone mode operation.

Keyboard [F1]–[F4] (KEYER)	OFF
<p>Sets the keyer memory transmission capability ON or OFF when one of the [F1] to [F4] key of the keyboard that is connected to the [USB] (A) connector on the front panel is pushed. (default: OFF)</p>	<ul style="list-style-type: none"> • OFF : [F1] to [F4] keys do not function. • ON : Pushing one of the [F1] to [F4] keys transmits the desired keyer memory contents during the CW mode operation. And while pushing the [SHIFT] key, push [F1] to [F4] key to repeatedly transmit the desired keyer memory contents.

Shutdown function	Shutdown
<p>Selects the shutdown option.</p> <p>○ When “Standby/Shutdown” is selected</p> <p>① Hold down [POWER] for approximately for 1 second to turn OFF the power.</p> <ul style="list-style-type: none"> • The shutdown option dialogue appears. <p>② Rotate the main dial to select the shutdown option.</p> <ul style="list-style-type: none"> • If you want to turn OFF the power immediately, select “Shutdown.” • If you want to remotely turn ON the power later, select “Standby (for Remote Control).” <ul style="list-style-type: none"> - The power indicator, which is located on the right above [POWER], slowly blinks Orange. - When the transceiver is remote standby mode, the transceiver accepts the power ON command only from the [REMOTE] jack. <p>③ Push [POWER].</p>	<ul style="list-style-type: none"> • Shutdown : Shuts down right after [POWER] has been held down for 1 second. • Standby/Shutdown : Enters the remote standby mode. If the remote standby mode is selected, the IC-7600 can be remotely turned ON later using the optional RS-BA1.

CI-V Baud Rate	Auto
<p>Sets the CI-V data transfer between 300, 1200, 4800, 9600, 19200 bps and “Auto.” (default: Auto)</p> <p>When “Auto” is selected, the baud rate is automatically set, according to the data rate of the connected controller.</p>	

CI-V Address	7Ah
<p>To distinguish equipment, each CI-V transceiver has its own Icom standard address in hexadecimal code. The IC-7600’s address is 7Ah.</p> <p>When 2 or more IC-7600’s are connected to an optional CT-17 CI-V LEVEL CONVERTER, rotate the main dial to select a different address for each IC-7600. The range is 01h to DFh.</p>	

CI-V Transceive	ON
<p>Transceive operation is possible with the IC-7600 connected to other Icom HF transceivers or receivers. (default: ON)</p>	<ul style="list-style-type: none"> • OFF : Transceive operation OFF • ON : Transceive operation ON <p>Changing the frequency, operating mode, etc. on the IC-7600 automatically changes those of other connected transceivers (or receivers) and vice versa.</p>

■ Others set mode (Continued)

CI-V Output (for ANT)	OFF
Enables to output the antenna controller status (frequency and so on) from [REMOTE].	<ul style="list-style-type: none"> • OFF : Turns OFF the function. • ON : Outputs the status.
USB Serial Function	CI-V
Selects the [USB] connector output data format between CI-V and Decode. (default: CI-V)	<ul style="list-style-type: none"> • CI-V : Outputs data in CI-V format. • Decode: Outputs decoded contents in ASCII code format.
Decode Baud Rate	9600
<p>Selects the data transmission speed (Baud rate) when “Decode” is selected in “USB Serial Function.”</p> <p>The settings are 300, 1200, 4800, 9600 and 19200 bps. (default: 9600)</p>	
Keyboard Type	English
<p>Selects the connected keyboard type between English, Japanese, United Kingdom, French, French (Canadian), German, Portuguese, Portuguese (Brazilian), Spanish, Spanish (Latin American) and Italian. (default: English)</p>	
Keyboard Repeat Delay	250ms
<p>Sets the time period for delay between 100 to 1000 milliseconds in 50 millisecond steps. (default: 250 ms)</p> <p>When a keyboard key is held down for the set period, the character is input continuously.</p>	
Keyboard Repeat Rate	10.9cps
<p>Sets the repeating rate for the keyboard within 2.0 to 30.0 cps. (default: 10.9 cps)</p> <p>*cps=character per second</p> <p>When a keyboard key is held down, the character is repeatedly input with the set speed.</p>	<ul style="list-style-type: none"> • Available repeating rate 2.0, 2.1, 2.3, 2.5, 2.7, 3.0, 3.3, 3.7, 4.0, 4.3, 4.6, 5.0, 5.5, 6.0, 6.7, 7.5, 8.0, 8.6, 9.2, 10.0, 10.9, 12.0, 13.3, 15.0, 16.0, 17.1, 18.5, 20.0, 21.8, 24.0, 26.7, 30.0

■ USB-Memory set menu

◇ USB-Memory set screen arrangement

• USB-Memory set menu

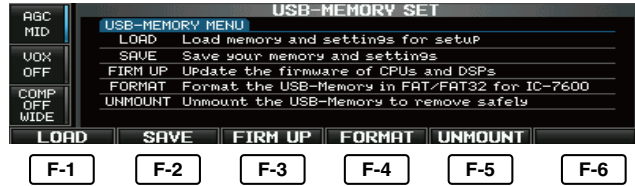

The USB-Memory is not supplied by Icom.

• Setting load screen (p. 145)

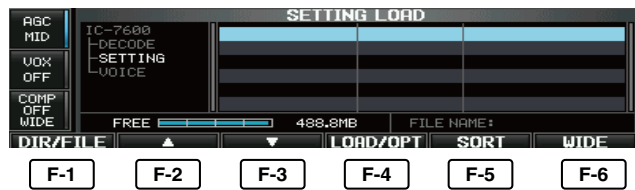

Hold down
for 1 second

• Load option set mode (p. 146)



• Setting save screen (p. 147)

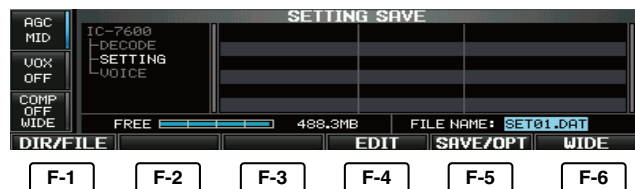

Hold down
for 1 second

• Save option set mode (p. 148)



• Firmware update (p. 175)

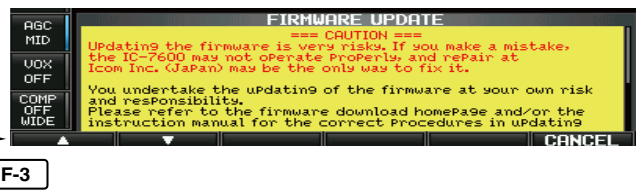

• Format menu (p. 151)



• Unmount USB-Memory (p. 150)



■ File loading

By loading the saved setting file from the USB-Memory, you can easily set up another IC-7600 or apply the several operators settings to one IC-7600.

- ① During the set mode menu screen display, push **[USB] (F-6)** to select the USB set menu screen.
- ② Push **[LOAD] (F-1)** to select setting load screen.
- ③ Hold down **[LOAD/OPT] (F-4)** for 1 second to select the load option set mode, then rotate the main dial to set the desired loading conditions, if desired.
 - See page 146 for details.
- ④ Push **[EXIT/SET]** to set.
- ⑤ Push **[▲] (F-2)** or **[▼] (F-3)** to select the desired setting file.
- ⑥ Push **[LOAD/OPT] (F-4)**.
 - Confirmation screen appears.
- ⑦ Push **[OK] (F-5)** to starts loading.
 - After the loading is completed, the message dialog, "Reboot the IC-7600," appears.
- ⑧ Turn the transceiver power OFF then ON to make the setting effective.

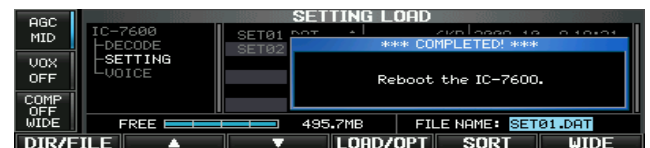
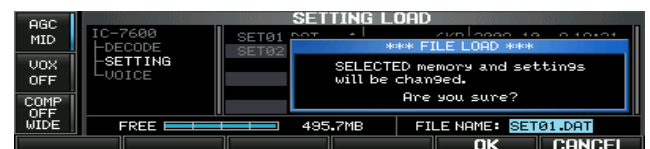
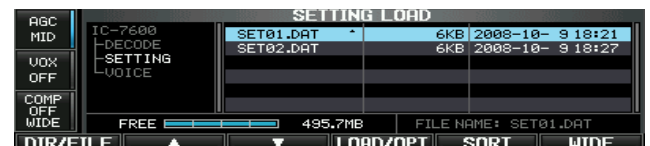
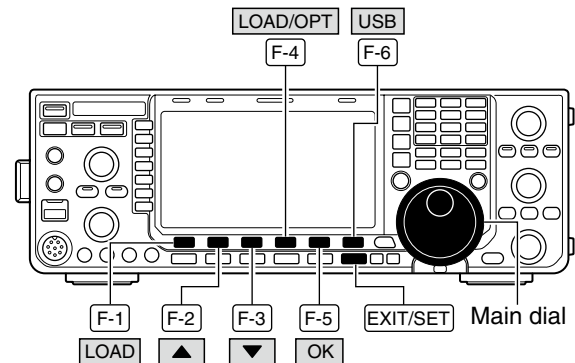

◇ Load option set mode

<p>LOAD Contents</p> <p>Selects file load condition from All and Select. (default: Select)</p>	<p>Select</p> <ul style="list-style-type: none"> • All : Loads and sets the all following contents. • Select : Loads and sets the selected contents only.
<p>ANT Memory</p> <p>Selects the antenna memory setting loading condition from YES or NO. (default: NO)</p>	<p>NO</p> <ul style="list-style-type: none"> • YES : Loads and sets the antenna memory. • NO : Use the original antenna memory setting.
<p>REF Adjust</p> <p>Selects the reference signal setting load condition from YES or NO. (default: NO)</p>	<p>NO</p> <ul style="list-style-type: none"> • YES : Loads and sets the reference signal setting. • NO : Use the original reference signal setting.
<p>CI-V Address</p> <p>Selects the CI-V address setting load condition from YES or NO. (default: NO).</p>	<p>NO</p> <ul style="list-style-type: none"> • YES : Loads and sets the CI-V address setting. • NO : Use the original CI-V address setting.
<p>Other Memory & Settings</p> <p>This setting is fixed “YES.”</p>	<p>YES</p> <ul style="list-style-type: none"> • YES : Loads and sets the memory channel contents and other settings.
<p>Voice TX Memory</p> <p>Selects the voice TX message load condition from YES or NO. (default: YES)</p>	<p>YES</p> <ul style="list-style-type: none"> • YES : Loads and sets the voice TX message. • NO : Use the original voice TX message.
<p>Voice RX Memory</p> <p>Selects the voice RX message load condition from YES or NO. (default: NO)</p>	<p>NO</p> <ul style="list-style-type: none"> • YES : Loads and sets the voice RX message. • NO : Use the original voice RX message.

File saving

Memory channel contents, set mode settings, etc. can be saved into the USB-Memory for backup.

- ① During the set mode menu screen display, push **[USB] (F-6)** to select the USB Memory set menu screen.
- ② Push **[SAVE] (F-2)** to select setting save screen.
- ③ Change the following conditions if desired.

• **File name:**

- ① Push **[EDIT] (F-4)** to select file name edit condition.
 - Push **[DIR/FILE] (F-1)** several times to select the file name, if necessary.
- ② Push **[ABC] (MF6)** or **[123]/[Symbol] (MF7)** to select the character group, then rotate the main dial to select the character.
 - **[ABC] (MF6)**: A to Z (capital letters), **[123] (MF7)**: 0 to 9 (numerals), **[Symbol] (MF7)**: ! # \$ % & ' ` ^ - () { } _ ~ @ can be selected.
 - Push **[◀] (F-1)** to move the cursor left, push **[▶] (F-2)** to move the cursor right, push **[DEL] (F-3)** to delete a character and push **[SPACE] (F-4)** to insert a space.
- ③ Push **[EXIT/SET]** to set the file name.

• **Save option**

- ① Hold down **[SAVE/OPT] (F-5)** for 1 second to select the save option set mode.
- ② Push **[▲] (F-1)** or **[▼] (F-2)** to select the item, then rotate the main dial to select the desired setting. (see page 148 for details)
 - Hold down **[DEF] (F-4)** for 1 second to select the default setting.
- ③ Push **[EXIT/SET]** to return to the previous display.

• **Saving location**

- ① Push **[DIR/FILE] (F-1)** to select tree view screen.
- ② Select the desired directory or folder in the USB-Memory.
 - Push **[◀▶] (F-4)** to select the upper directory.
 - Push **[▲] (F-2)** or **[▼] (F-3)** to select folder in the same directory.
 - Hold down **[◀▶] (F-4)** for 1 second to select a folder in the directory.
 - Push **[REN] (MF5)** to rename the folder.
 - Hold down **[DEL] (MF6)** for 1 second to delete the folder.
 - Hold down **[MAKE] (MF7)** for 1 second to making a new folder. (Edit the name with the same manner as the “• File name” above.)
- ③ Push **[DIR/FILE] (F-1)** twice to select the file name.
- ④ Push **[SAVE/OPT] (F-5)**.
 - Confirmation screen appears.
- ⑤ Push **[OK] (F-5)** to save.
 - After saving is completed, automatically return to USB-Memory set menu.

When a PC keyboard is connected to the [USB] connector on the front panel, the file name can also be edited from the keyboard. In this case, a USB hub is required.

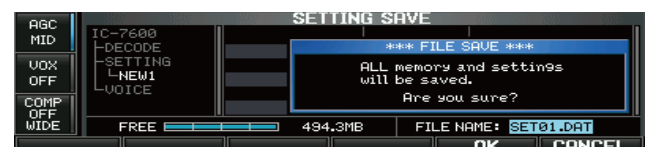
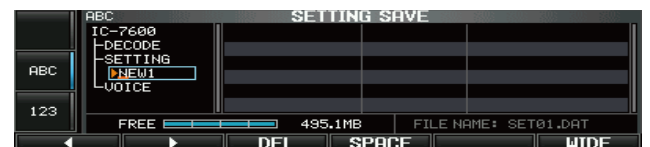
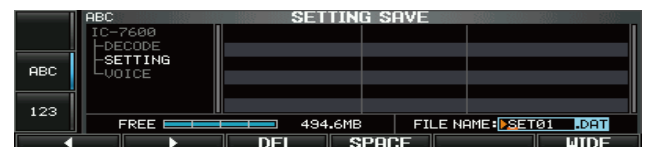
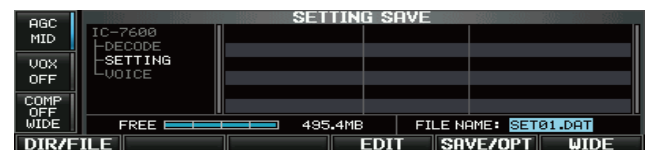
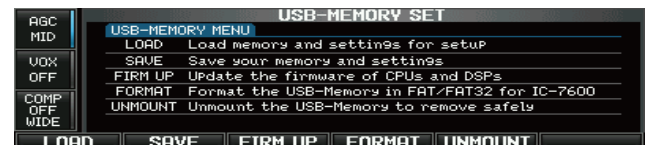
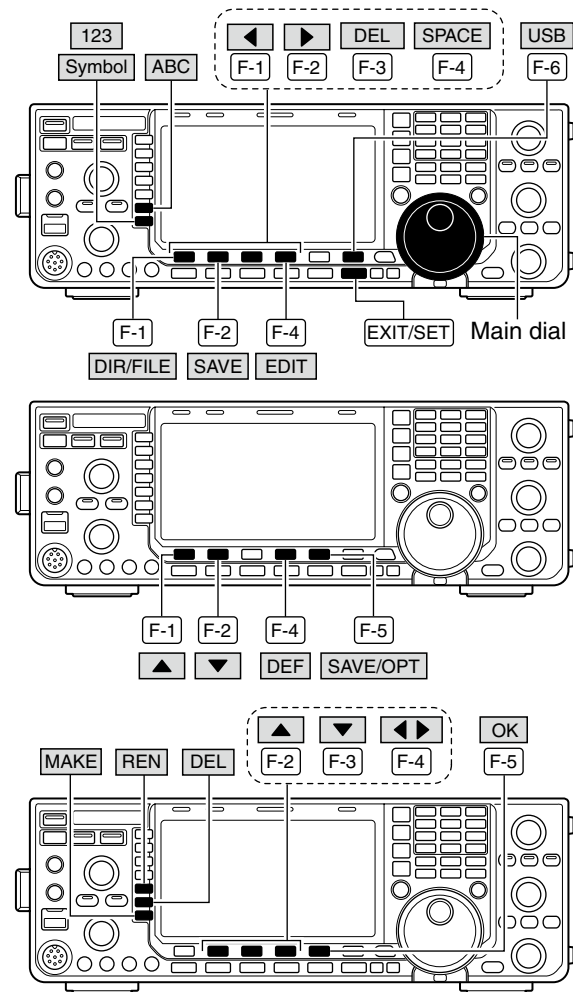

◇ Save option set mode

<p>SAVE Contents</p> <p>Selects the file save option from All or Select. (default: All)</p>	<p>All</p> <ul style="list-style-type: none"> • All : Saves all the following contents. • Select: Saves the selected contents only.
<p>Memory & Settings</p> <p>This setting is fixed “YES.”</p>	<p>YES</p> <ul style="list-style-type: none"> • YES : Saves memory channel contents and settings of set modes.
<p>Voice TX Memory</p> <p>Selects the voice TX message save option YES or NO. (default: YES)</p>	<p>YES</p> <ul style="list-style-type: none"> • YES : Saves the voice TX message. • NO : Does not save.
<p>Voice RX Memory</p> <p>Selects the voice RX message save option YES or NO. (default: NO)</p>	<p>NO</p> <ul style="list-style-type: none"> • YES : Saves the voice RX message. • NO : Does not save.
<p>SAVE Form</p> <p>Selects the file saving format between “Now Ver” and “Old Ver.” (default: Now Ver)</p> <p>To save settings and memory contents for backup or copying to another IC-7600, you must save the data in the firmware version format that matches the target IC-7600.</p> <p>Select “Now Ver” for the current version, or “Old Ver (xxx - xxx)” for the previous version.</p> <ul style="list-style-type: none"> • The previous versions are shown in brackets, and you can select the desired version by rotating the main dial. The file will be saved in the selected version. <p>See page 173 for confirming the firmware version of the IC-7600.</p>	<p>Now Ver</p> <ul style="list-style-type: none"> • Now Ver : Saves the file in the current firmware version format. • Old Ver : Saves the file in the firmware version format shown in brackets. <p>NOTE:</p> <ul style="list-style-type: none"> • You cannot write setting file that is saved in the current version format to an older firmware version IC-7600. • If the settings are saved in an older version format, the items added in version 2.00 or later are not saved.

■ Changing a file name

The file name, saved in the USB-Memory, can be re-named from the transceiver as desired.

- ① During the setting save screen display, push **[DIR/FILE] (F-1)** to select the tree view screen.
 - Push **[▲] (F-2)** or **[▼] (F-3)** to select the desired folder.
 - “DECODE,” “SETTING” and “VOICE” folders are available as the default.
 - After the folder is selected, hold down **[◀ ▶] (F-4)** for 1 second to display content folder(s), if available.
- ② Push **[DIR/FILE] (F-1)** to select the file list screen.
- ③ Push **[▲] (F-2)** or **[▼] (F-3)** to select the desired file.
- ④ Push **[REN] (MF5)** momentarily to select the file name edit mode.
- ⑤ Push **[ABC] (MF6)** or **[123]/[Symbol] (MF7)** to select the character group, then rotate the main dial to select the character.
 - **[ABC] (MF6)**: A to Z (capital letters), **[123] (MF7)**: 0 to 9 (numerals), **[Symbol] (MF7)**: ! # \$ % & ' ` ^ - () { } _ - @ can be selected.
 - Push **[◀] (F-1)** to move the cursor left, push **[▶] (F-2)** to move the cursor right, push **[DEL] (F-3)** to delete a character and push **[SPACE] (F-4)** to insert a space.
 - Pushing the transceiver’s keypad, [0]–[9] and [.] can also enter numerals.
- ⑥ Push **[EXIT/SET]** to store the file name.

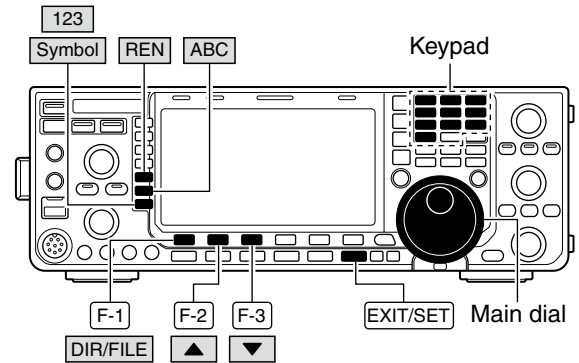

When a PC keyboard is connected to the [USB] connector on the front panel, the file name can also be edited from the keyboard. In this case, a USB hub is required.

■ Deleting a file

RECOMMENDATION: Deleting the setting file is irreversible.
Confirm the contents before deleting a setting file.

- ① During the setting save screen display, push **[DIR/FILE] (F-1)** to select the tree view screen.
 - Push **[▲] (F-2)** or **[▼] (F-3)** to select the desired folder.
 - “DECODE,” “SETTING” and “VOICE” folders are available as the default.
 - After the folder is selected, hold down **[◀ ▶] (F-4)** for 1 second to display content folder(s), if available.
- ② Push **[DIR/FILE] (F-1)** to select file list screen.
- ③ Push **[▲] (F-2)** or **[▼] (F-3)** to select the desired file to be deleted.
- ④ Hold down **[DEL] (MF6)** for 1 second.
 - Confirmation screen appears.
- ⑤ Push **[OK] (F-5)** to delete.
 - After the deleting, return to setting save screen automatically.

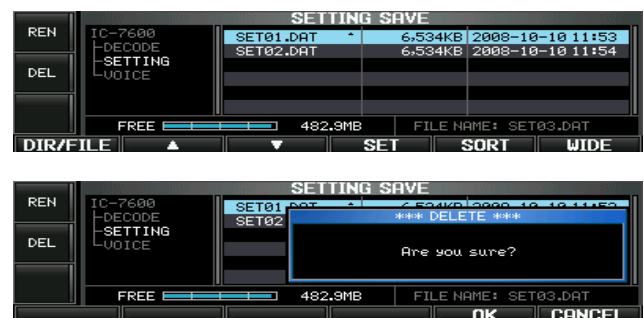
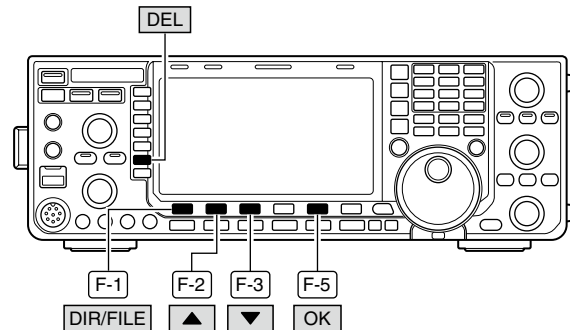

■ Unmounting USB-Memory

CAUTION: When removing the USB-Memory, unmount operation is recommended. If you do not unmount the memory, data on the USB-memory may be corrupted.

- ① During the USB Memory set menu screen display, hold down **[UNMOUNT] (F-5)** for 1 second.
 - A confirmation screen appears.
- ② Push **[OK] (F-5)** to unmount the USB-Memory.
- ③ After the indicator above **[USB] (A)** connector goes off, remove the USB-Memory.

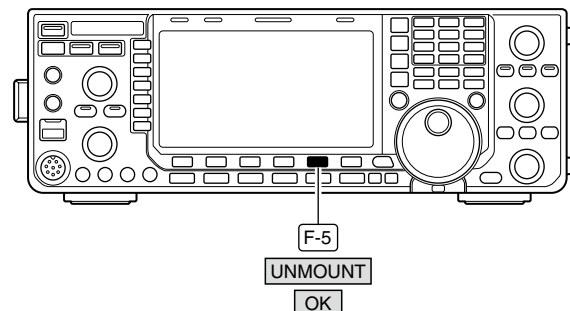

■ Formatting the USB-Memory

Saved data in the USB-Memory can be erased.

IMPORTANT! Formatting erases all saved data on the USB-Memory. Making a backup file on your PC is recommended.

- ① During the USB Memory set menu screen display, hold down **[FORMAT] (F-4)** for 1 second.
 - Confirmation screen appears.
- ② Push **[FAT] (F-5)** or **[FAT32] (F-6)** to select the format type, FAT or FAT32, respectively.
 - Confirmation screen appears.
- ③ Push **[OK] (F-5)** to format.
 - Push **[CANCEL] (F-6)** to cancel.
- ④ Automatically returns to the USB Memory set menu display.

NOTE: If no USB-Memory is inserted and **[FORMAT] (F-4)** is selected as in step ①, an error message appears as below.

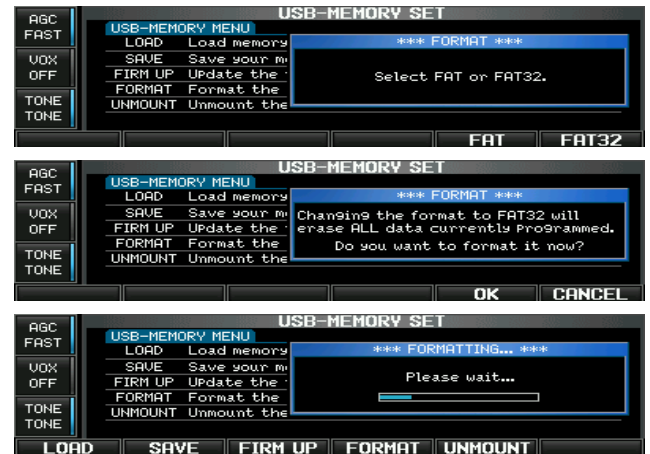
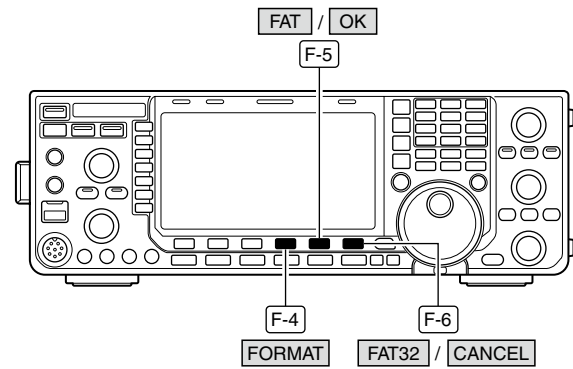

■ Troubleshooting

The following chart is designed to help you correct problems which are not equipment malfunctions.

If you are unable to locate the cause of a problem or solve it through the use of this chart, contact your nearest Icom Dealer or Service Center.

◇ Transceiver power

PROBLEM	POSSIBLE CAUSE	SOLUTION	REF.
Power does not come on when the [POWER] switch is pushed.	<ul style="list-style-type: none"> • Power cable is improperly connected. • Fuse is blown. 	<ul style="list-style-type: none"> • Re-connect the DC power cable correctly. • Check for the cause, then replace the fuse with the spare one. (Fuses are installed in the DC power cable and the internal PA unit.) 	<p>p. 20 p. 157</p>

◇ Transmit and receive

PROBLEM	POSSIBLE CAUSE	SOLUTION	REF.
No sounds from the speaker.	<ul style="list-style-type: none"> • Volume level is too low. • The squelch is closed. • The transceiver is in transmit. 	<ul style="list-style-type: none"> • Rotate the [AF] control clockwise to obtain a suitable listening level. • Rotate the [RF/SQL] control to 11 o'clock position to open the squelch. • Push [TRANSMIT] to receive or check the SEND line of an external unit, if connected. 	<p>p. 38 p. 37 p. 40</p>
Sensitivity is too low, and only strong signals are audible.	<ul style="list-style-type: none"> • The antenna is not connected properly. • The antenna for another band is selected. • The antenna is not properly tuned. • The attenuator is activated. 	<ul style="list-style-type: none"> • Re-connect to the antenna connector. • Select an antenna suitable for the operating frequency. • Hold down [TUNER] for 1 second to manually tune the antenna. • Push [ATT] (MF4) several times to select "ATT OFF." 	<p>— p. 120 p. 121 p. 80</p>
Received audio is unclear or distorted.	<ul style="list-style-type: none"> • Wrong operating mode is selected. • PBT function is activated. • Noise blanker is turned ON when receiving a strong signal. • Preamp is activated. • The noise reduction is activated and the [NR] control is too far clockwise. 	<ul style="list-style-type: none"> • Select a suitable operating mode. • Hold down [PBT-CLR] for 1 second to reset the function. • Push [NB] to turn the noise blanker OFF. • Push [P.AMP] (MF3) once or twice to turn the function OFF. • Set the [NR] control for maximum readability. 	<p>p. 36 p. 83 p. 89 p. 80 p. 90</p>
The [ANT] switch does not function	<ul style="list-style-type: none"> • The antenna switch has not been activated. 	<ul style="list-style-type: none"> • Set the antenna switch in the set mode to "Auto" or "Manual." 	<p>p. 138</p>
Transmitting is impossible.	<ul style="list-style-type: none"> • The operating frequency is not inside a ham band. 	<ul style="list-style-type: none"> • Set the frequency to be in a ham band. 	<p>p. 30</p>
Output power is too low.	<ul style="list-style-type: none"> • The [RF POWER] control is set too far counterclockwise • The drive gain level is set too high. • The [MIC GAIN] control is set too far counterclockwise • The antenna for another band is selected. • The antenna is not properly tuned. 	<ul style="list-style-type: none"> • Rotate the [RF POWER] control clockwise. • Set the drive gain level to a suitable level. • Set the [MIC GAIN] control to a suitable position. • Select an antenna suitable for the operating frequency. • Hold down [TUNER] for 1 second to manually tune the antenna. 	<p>p. 40 p. 41 p. 40 p. 120 p. 121</p>
No contact can be made with another station.	<ul style="list-style-type: none"> • RIT or ΔTX function is activated. • Split frequency function and/or dualwatch are/is activated. 	<ul style="list-style-type: none"> • Push [RIT] or [ΔTX] to turn the function OFF. • Push [SPLIT] and/or [DUALWATCH] to turn the function OFF. 	<p>pp. 73, 95 pp. 87, 96</p>
Transmit signal is unclear or distorted.	<ul style="list-style-type: none"> • The [MIC GAIN] control is set too far clockwise. • The speech compressor function is activated. 	<ul style="list-style-type: none"> • Set the [MIC GAIN] control to a suitable position. • Push [COMP] (MF7) to turn the function OFF. 	<p>p. 40 p. 94</p>
Repeater cannot be accessed.	<ul style="list-style-type: none"> • Split frequency function is not activated. • Programmed subaudible tone frequency is wrong. 	<ul style="list-style-type: none"> • Push [SPLIT] to turn the function ON • Reset the frequency using the set mode. 	<p>p. 96 p. 66</p>

◇ Scanning

PROBLEM	POSSIBLE CAUSE	SOLUTION	REF.
Programmed scan does not stop.	• Squelch is open.	• Set the [RF/SQL] control to the threshold point.	p. 37
Programmed scan does not start.	• The same frequencies have been programmed in scan edge memory channels P1 and P2.	• Program different frequencies in scan edge memory channel P1 and P2.	p. 109
Memory scan does not start.	• 2 or more memory channels have not been programmed.	• Program more than 2 memory channels.	p. 109
Select memory scan does not start.	• 2 or more memory channels have not been designated as select channels.	• Designate more than 2 memory channels as select channels for the scan.	p. 118

◇ Display

PROBLEM	POSSIBLE CAUSE	SOLUTION	REF.
The displayed frequency does not change properly.	• The dial lock function is activated.	• Hold down [SPEECH/LOCK] for 1 second to turn the function OFF.	p. 90
	• A set mode screen is selected.	• Push [EXIT/SET] several times to exit the set mode screen.	p. 126
	• The internal CPU has malfunctioned.	• Reset the CPU.	p. 157
The screen saver displays the IC-7600 with a “bound,” “rotating” or “twisting” configuration.	• The screen saver function is activated.	• Operate the transceiver. • Set the screen saver function in the set mode to “OFF.”	— p. 125

◇ Format USB-Memory

PROBLEM	POSSIBLE CAUSE	SOLUTION	REF.
Format error appears when formatting in FAT32	• The inserted USB-Memory capacity is smaller than 64 MB.	• Insert a USB-Memory larger than 64 MB, or select the FAT format.	p. 151
Format error appears when formatting in FAT	• The inserted USB-Memory capacity is larger than 2 GB.	• Insert a USB-Memory smaller than 2 GB, or select the FAT32 format.	p. 151

■ Main dial brake adjustment

The tension of the main dial may be adjusted to suit your preference. The brake adjustment is located on the bottom side of the front panel. See the figure at right. Slide the brake adjustment to a comfortable tension level while turning the dial continuously and evenly in one direction.

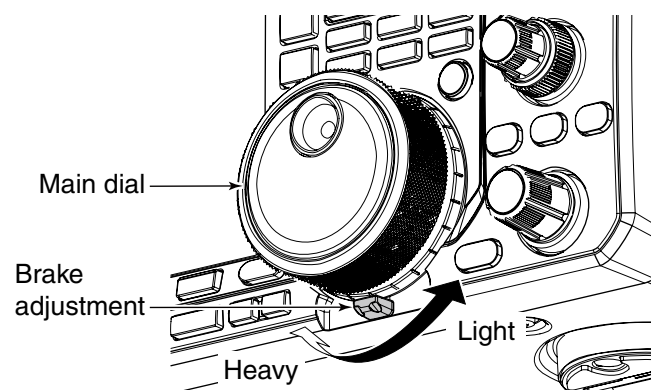

■ SWR reading

The SWR meter displays the SWR over the transmission line in all modes.

- ① Push **[TUNER]** to turn the antenna tuner OFF.
- ② Hold down **[METER] (MF2)** for 1 second to display multi-function meter.
- ③ Push **[RTTY/PSK]** once or twice to select the RTTY mode.
- ④ Push **[TRANSMIT]**.
- ⑤ Rotate **[RF POWER]** clockwise past the 12 o'clock position for more than 30 W output power.
- ⑥ Read the SWR on the SWR meter gage.
- ⑦ Push **[EXIT/SET]** to close multi-function meter.

The built-in antenna tuner matches the transmitter to the antenna when the SWR is lower than 3 : 1.

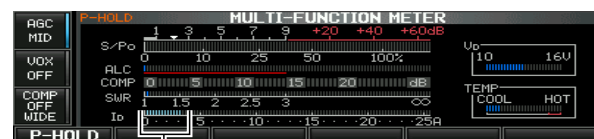
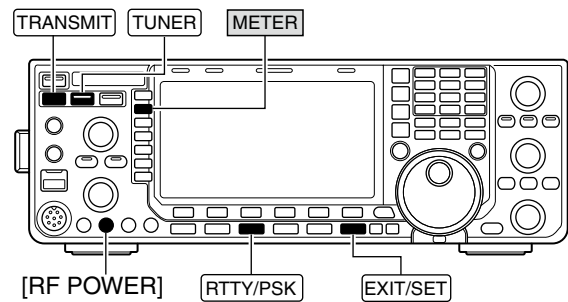

Better than 1.5:1

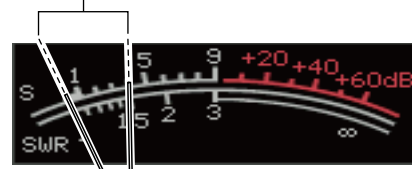

■ Screen type and font selections

2 types of screen images and 3 types of frequency readout display fonts are available in the IC-7600.

- ① Push **[EXIT/SET]** several times to close multi-function screen, if necessary.
- ② Push **[SET] (F-6)** to select the set mode menu screen.
- ③ Push **[DISP] (F-3)** to select the display set mode.
- ④ Push **[▲] (F-1)** or **[▼] (F-2)** to select “Display Type” item when selecting the screen image, select “Display Font” when selecting the frequency readout display font.
- ⑤ Rotate the main dial to select the desired screen image or font.
 - Screen image is selectable from A (Black back) and B (Blue back).
 - Basic, Italic and Round are available for the frequency readout font.
- ⑥ Push **[EXIT/SET]** twice to exit from the display set mode.

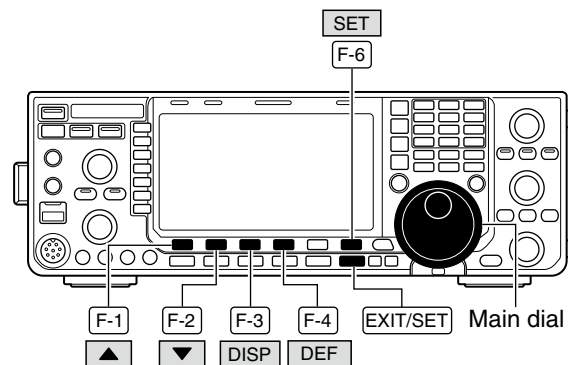

- **Screen image example—**
Display Type: B, Display Font: Italic

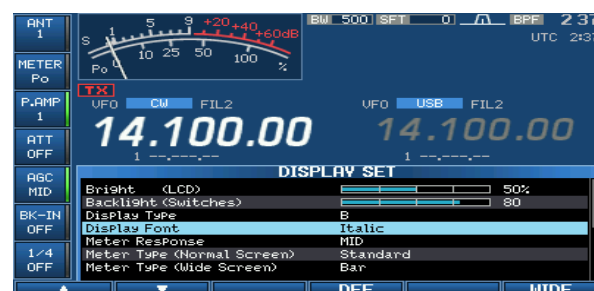

Frequency calibration (approximate)

A very accurate frequency counter is required to calibrate the frequency of the transceiver. However, a rough check may be performed by receiving radio station WWV, WWVH, or other standard frequency signals.

CAUTION: The IC-7600 has been thoroughly adjusted and tested at the factory before being shipped. You should not have to re-calibrate it.

- ① Push **[SSB]** to select the USB mode.
- ② Hold down **[PBT-CLR]** for 1 second to clear the PBT setting and make sure that the RIT/ Δ TX function is not activated.
- ③ Set the frequency to the standard frequency station minus 1 kHz.
 - When receiving WWV or WWVH (at 15.00000 MHz) as a standard frequency, set the operating frequency for 14.99900 MHz.
 - Other standard frequencies can be used.
- ④ Push **[EXIT/SET]** several times to close any multi-function screens, if necessary.
- ⑤ Push **[SET]** (F-6) to select the set mode menu screen.
- ⑥ Push **[OTHERS]** (F-5) to select the Others set mode.
- ⑦ Push **[▲]** (F-1) several times to select the “Calibration Marker” item.
- ⑧ Rotate the main dial clockwise to turn the calibration marker ON.
- ⑨ Push **[EXIT/SET]** once to return to the set mode menu screen.
- ⑩ Push **[ACC]** (F-2) to select the accessory set mode.
- ⑪ Push **[▼]** (F-2) several times to select the “REF Adjust” item.
- ⑫ Rotate the main dial to adjust for a zero beat with the received standard signal as shown at right.
 - Zero beat means that two signals are exactly the same frequency, resulting in a single tone being emitted.
- ⑬ Turn the calibration marker OFF in the Others set mode.
- ⑭ Push **[EXIT/SET]** twice to exit the set mode.

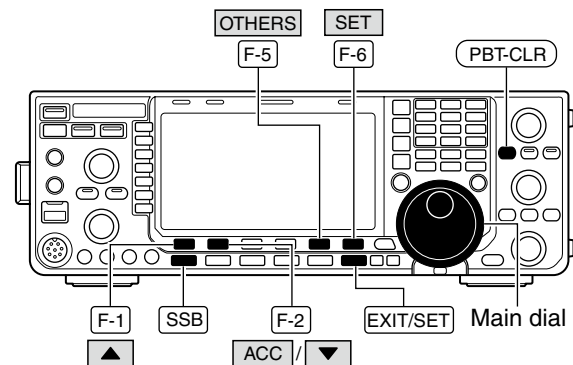

• Calibration marker item



• REF Adjust item

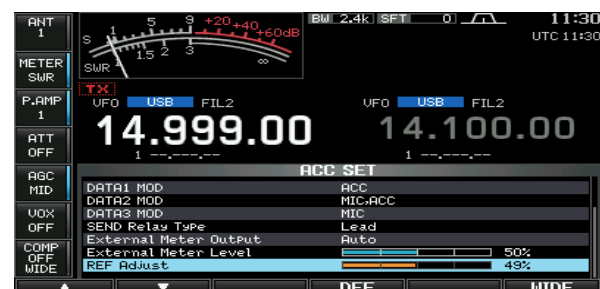

■ Opening the transceiver's case

Follow the case opening procedures shown here when you want to replace the clock backup battery or internal fuse.

CAUTION: Turn the power OFF and disconnect the DC power cable from the transceiver before performing any work on the transceiver. Otherwise, there is danger of electric shock and/or equipment damage.

- ① Remove the two screws from the carrying handle and remove the handle from the transceiver.
- ② Remove the 6 screws from the top of the transceiver and the 4 screws from the sides, then lift up the top cover.
- ③ Turn the transceiver upside-down.

CAUTION: NEVER HOLD THE MAIN DIAL OR ANY OTHER KNOBS when the transceiver is being turned upside down. This may damage them, or cause you to drop the transceiver.

- ④ Remove the 6 screws from the bottom, and then lift off the bottom cover.

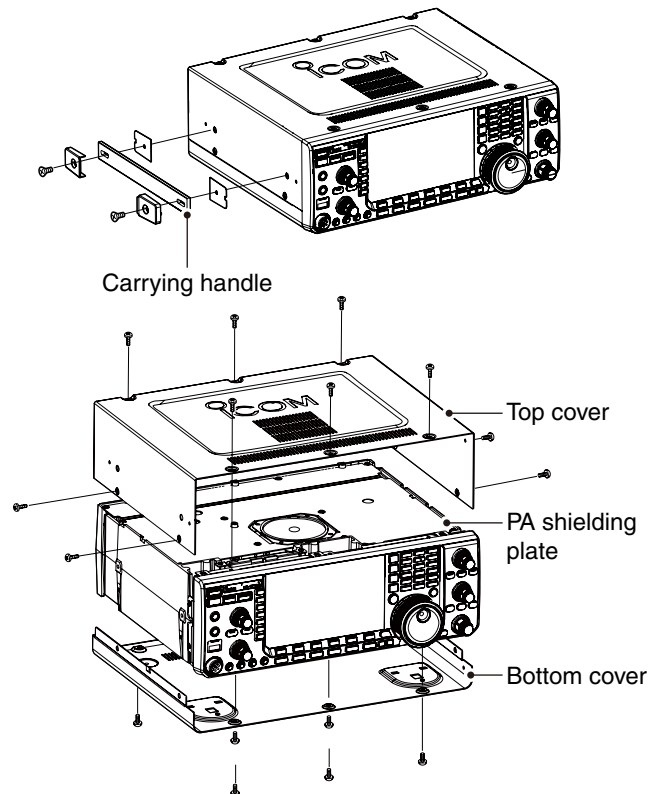

✓ About the leg pads

To detach the leg pads from the right side panel of the top/bottom cover, push them from the inner side of each cover after steps ① to ④ as above.

■ Clock backup battery replacement

The IC-7600 has a lithium backup battery (CR2032) inside for clock and timer functions. The usual life of the backup battery is approximately 2 years. When the backup battery is discharged, the transceiver transmits and receives normally but cannot retain the current time.

CAUTION: Turn the power OFF and disconnect the DC power cable from the transceiver before removing the transceiver's cover.

- ① Remove the bottom cover as shown above.
- ② Replace the clock backup battery, located on the front panel as illustrated to the right.
 - Make sure the battery polarity is correct.
- ③ Return the bottom cover to the original position.
- ④ Set the date and time in the time set mode. (p. 124)

For customers in California (U.S.A.)

The IC-7600 uses a Coin Lithium Battery which contains Perchlorate Material—special handling may apply. See <http://www.dtsc.ca.gov/hazardouswaste/perchlorate>

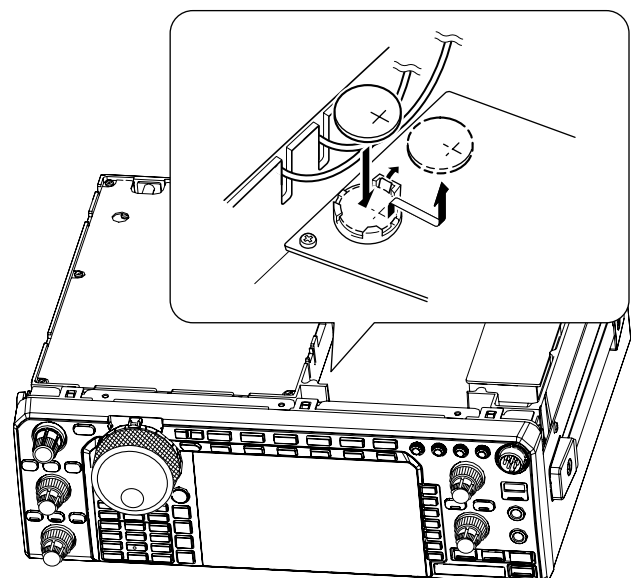

■ Fuse replacement

If a fuse blows, or the transceiver stops functioning, find the source of the problem, and repair it. Then replace the damaged fuse with a new, adequately rated fuse.

CAUTION: Turn the power OFF and disconnect the DC power cable from the transceiver before removing the transceiver's cover.

◇ DC power cable fuse replacement

Refer the figure illustrated at right for the DC power cable fuse replacement.

The IC-7600 has two fuse types installed for transceiver protection.

- DC power cable fuses 30 A
- Circuitry fuse 5 A

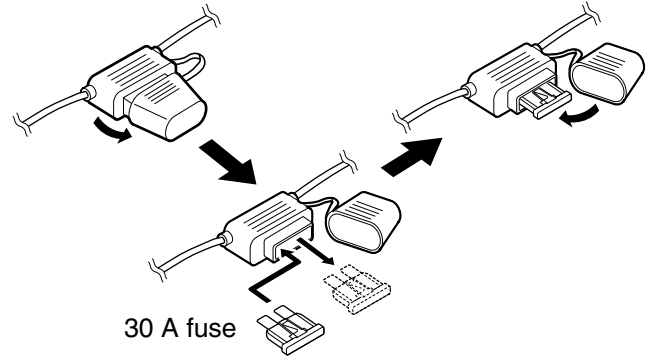

◇ Circuitry fuse replacement

Except for the power amplifier, the 13.8 V DC from the DC power cable is applied to all units in the IC-7600, through the circuitry fuse. This fuse is installed in the PA unit.

- ① Remove the top cover. (p. 158)
- ② Remove the 11 screws, then remove the bottom cover and the PA shielding plate as shown to the right.
- ③ Replace the circuitry fuse as shown in the diagram to the right.
- ④ Replace the PA shielding plate, top cover and screws to their original position.

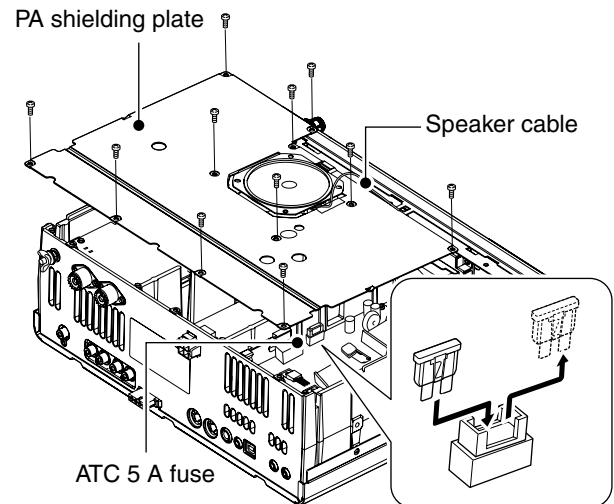

WARNING! DO NOT pull the speaker cable when removing or replacing the PA shielding plate. Otherwise, a fire, injury or damage the transceiver may occur.

■ Resetting the CPU

- ① First, turn the transceiver power OFF.
- ② While holding down [F-INP ENT] and [MW], push [POWER] to turn power ON.
 - The internal CPU is reset.
 - The CPU start-up takes approximately 5 seconds.
 - The transceiver displays its initial VFO frequencies when resetting is complete.
- ③ If desired, correct the set mode settings after resetting.

NOTE:

- Resetting **CLEARs** all programmed contents in memory channels and returns programmed values in the set mode to default values.
- When "Standby/Shutdown" is selected in "Shutdown Function" item (p. 142), hold down [POWER] for 1 second, then select "Shutdown" to turn OFF the power.

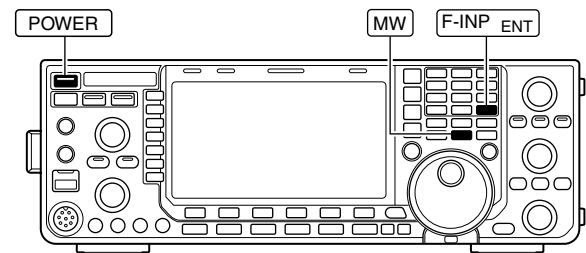

■ About protection displays

The IC-7600 has a 2-step protection function to protect the final power amplifiers.
The protector monitors the power amplifier temperature and activates when the temperature becomes extremely high.

- **Reduced power transmission**
Reduces the transmit output power to 50 W.
“LMT” appears beside the TX indicator (p. 14) during transmit.
- **Transmission inhibit**
Deactivates the transmitter.
The TX indicator (p. 14) is displayed in gray during transmit.

When the protector is activated, wait until the power amplifier cools down, using the transceiver in only stand-by or receive mode.

NOTE: DO NOT turn the transceiver power OFF when the protector is ON. If you do, the cooling fan will not function and it will take longer to cool the transceiver.

The power amplifier temperature can be monitored in the multi-function meter, TEMP gauge.

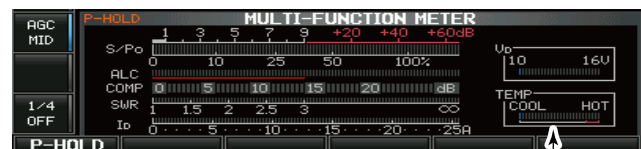

Check the temperature

■ Screen saver function

The IC-7600 has a screen saver function to protect the LCD from the “burn-in” effect.

- ① Push **[EXIT/SET]** several times to close any multi-function screens.
- ② Push **[SET] (F-6)** to select the set mode menu screen.
- ③ Push **[DISP] (F-3)** to select the display set mode.
- ④ Push **[▲] (F-1)** or **[▼] (F-2)** several times to select the “Screen Saver Function” item.
- ⑤ Rotate the main dial to select the desired time period for the screen saver activation from 15, 30, 60 minutes and OFF.
 - Deactivate the screen saver with “OFF” selection.
- ⑥ Push **[▼] (F-2)** to select the “Screen Saver Type” item.
- ⑦ Rotate the main dial to select the screen saver type from “Bound,” “Rotation” and “Twist.”
 - Hold down **[PREVIEW] (F-5)** to display the pattern for your reference.
- ⑧ Push **[EXIT/SET]** twice to exit the set mode.

NOTE: When the screen saver function is activated, the LCD unit brightness is set to dark (0%), and the indicator on the **[NR]** switch blinks.

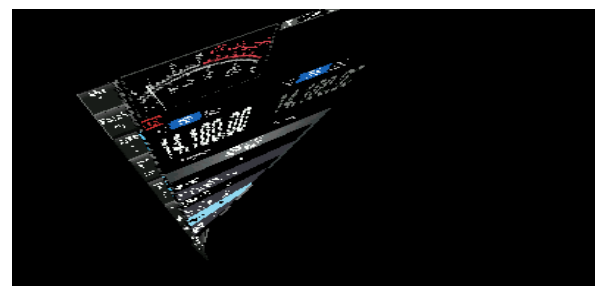
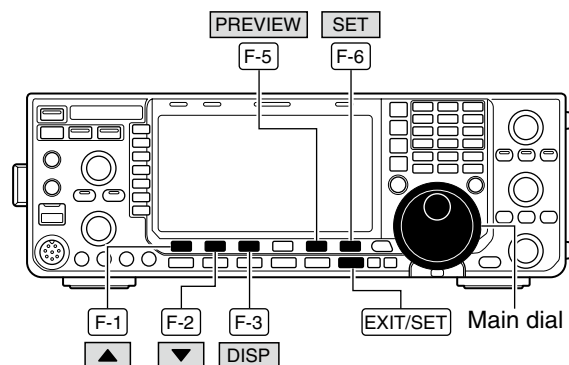

When “Twist” is selected

12 CONTROL COMMAND

Remote jack (CI-V) information

◇ CI-V connection

The transceiver's operating frequency, mode, VFO and memory selection, can be remotely controlled using the PC.

Choose the connection method from the following:

- A USB cable (A-B type, user supplied)
 - The required USB driver and driver install guide can be downloaded from Icom web site.
 - Access to "<http://www.icom.co.jp/world>," then click "Support," "Firmware Updates / Software downloads" in sequence.
 - The download procedure on the web page may be changed without notice.
- The optional CT-17 (CI-V level converter)
 - Connects to a PC with an RS-232C port.

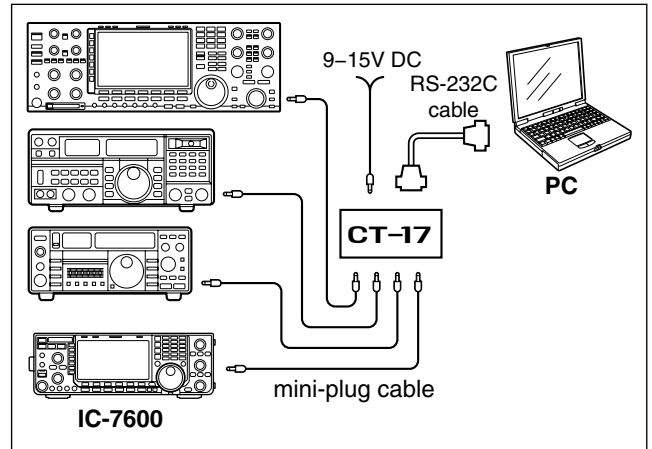

When the transceiver is connected to a PC with the USB cable (user supplied), the optional CT-17 is not required.

◇ Preparing

The Icom Communications Interface-V (CI-V) is used for remote control.

To control the transceiver, first set its address, data communication speed, and transceive function. These settings are set in Set mode. (p. 142)

◇ Data format

The CI-V system can be operated using the following data formats. Data formats differ according to command numbers. A data area or sub command is added for some commands.

Controller to IC-7600

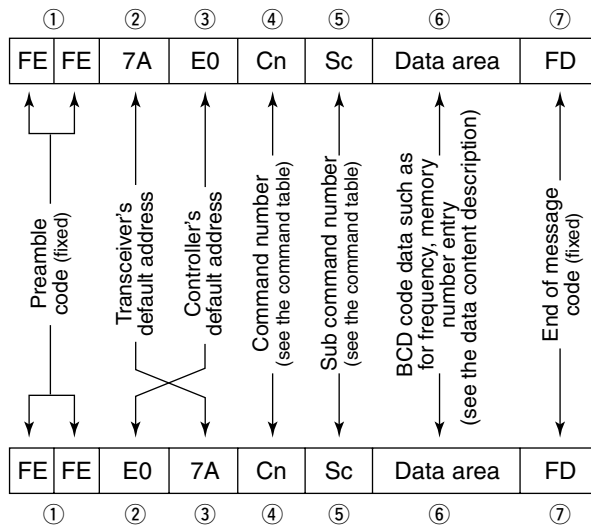

IC-7600 to controller

OK message to controller

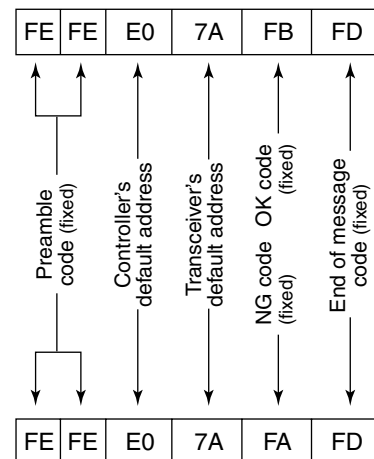

NG message to controller

◆ Command table

Cmd.	Sub cmd.	Data	Description	Cmd.	Sub cmd.	Data	Description		
00		see p. 166	Send frequency data for transceiver	14	01	0000 to 0255	Send/read [AF] level (0000=max. CCW, 0255=max. CW)		
01		see p. 166	Operating mode selection for transceiver		02	0000 to 0255	Send/read [RF] level (0000=max. CCW, 0255=11 o'clock)		
02		see p. 168	Read band edge frequencies		03	0000 to 0255	Send/read [SQL] level (0000=11 o'clock, 0255=max. CW)		
03		see p. 166	Read operating frequency		06	0000 to 0255	Send/read [NR] level (0000=0%, 0255=100%)		
04		see p. 166	Read operating mode		07	0000 to 0255	Send/read inner [TWIN PBT] position (0000=max. CCW, 0128=center, 0255=max. CW)		
05		see p. 166	Set operating frequency		08	0000 to 0255	Send/read outer [TWIN PBT] position (0000=max. CCW, 0128=center, 0255=max. CW)		
06		see p. 166	Operating mode selection		09	0000 to 0255	Send/read CW pitch (0000=300 Hz, 0128=600 Hz, 0255=900 Hz; 5 Hz steps)		
07			Select VFO mode		0A	0000 to 0255	Send/read [RF POWER] level (0000=max. CCW, 0255=max. CW)		
	B0		Exchange main and sub bands		0B	0000 to 0255	Send/read [MIC GAIN] level (0000=max. CCW, 0255=max. CW)		
	B1		Equalize main and sub bands		0C	0000 to 0255	Send/read [KEY SPEED] level (0000=max. CCW, 0255=max. CW)		
	C0		Turn the dualwatch OFF		0D	0000 to 0255	Send/read [NOTCH] position (0000=max. CCW, 0128=center, 0255=max. CW)		
	C1		Turn the dualwatch ON		0E	0000 to 0255	Send/read COMP level (0000=0, 0255=10)		
	C2	00	Send/read the dualwatch OFF		0F	0000 to 0255	Send/read [BK-IN DELAY] position (0000=max. CCW, 0255=max. CW)		
		01	Send/read the dualwatch ON		10	0000 to 0255	Send/read [BAL] position (0000=max. CCW, 0128=center, 0255=max. CW)		
	D0		Select main band		12	0000 to 0255	Send/read NB level (0000=0%, 0255=100%)		
	D1		Select sub band		14	0000 to 0255	Send/read DRIVE gain (0000=0%, 0255=100%)		
	D2	00	Send/read Main band selection		15	0000 to 0255	Send/read Monitor gain (0000=0%, 0255=100%)		
		01	Send/read Sub band selection		16	0000 to 0255	Send/read VOX gain (0000=0%, 0255=100%)		
08			Select memory mode		17	0000 to 0255	Send/read Anti VOX gain (0000=0%, 0255=100%)		
		0001 to 0099	Select memory channel (0001=M-CH01, 0099=M-CH99)		19	0000 to 0255	Send/read BRIGHT level (0000=0%, 0255=100%)		
		0100	Select program scan edge channel P1		15	01	00	Read squelch condition (squelch close)	
		0101	Select program scan edge channel P2				01	00	Read squelch condition (squelch open)
09			Memory write			02	0000 to 0255	Read S-meter level (0000=S0, 0120=S9, 0241=S9+60 dB)	
0A			Memory to VFO			05	00	01	Read various squelch (tone squelch, and so on) status (squelch close)
0B			Memory clear				01	00	Read various squelch (tone squelch, and so on) status (squelch open)
0E	00		Scan stop			11	0000 to 0255	Read RF power meter (0000=0%, 0143=50%, 0213=100%)	
	01		Programmed/memory scan start			12	0000 to 0255	Read SWR meter (0000=SWR1.0, 0048=SWR1.5, 0080=SWR2.0)	
	02		Programmed scan start			13	0000 to 0255	Read ALC meter (0000=0, 0120=Max.)	
	03		∇F scan start			14	0000 to 0255	Read COMP meter (0000=0 dB, 0130=15 dB, 0241=30 dB)	
	12		Fine programmed scan start			15	0000 to 0255	Read VD meter (0152=10 V, 0181=13 V, 0212=16 V)	
	13		Fine ∇F scan start			16	0000 to 0255	Read ID meter (0000=0 A, 0097=10 A, 0241=25 A)	
	22		Memory scan start						
	23		Select memory scan start						
	A1		Select ∇F scan span ±5 kHz						
	A2		Select ∇F scan span ±10 kHz						
	A3		Select ∇F scan span ±20 kHz						
	A4		Select ∇F scan span ±50 kHz						
	A5		Select ∇F scan span ±100 kHz						
	A6		Select ∇F scan span ±500 kHz						
	A7		Select ∇F scan span ±1 MHz						
	B0		Set as non-select channel						
	B1		Set as select channel (The previously set number by CI-V is set after turning power ON, or "1" is selected if no selection is performed.)						
		01	Set as select channel "★1"						
		02	Set as select channel "★2"						
		03	Set as select channel "★3"						
	B2	00	Set "ALL" for select memory scan						
		01	Set "★1" for select memory scan						
		02	Set "★2" for select memory scan						
		03	Set "★3" for select memory scan						
	D0		Set scan resume OFF						
	D3		Set scan resume ON						
0F			Read Split setting (00=OFF, 01=ON)						
10		00	Send/read 10 Hz (1 Hz) tuning step						
		01	Send/read 100 Hz tuning step						
		02	Send/read 1 kHz tuning step						
		03	Send/read 5 kHz tuning step						
		04	Send/read 9 kHz tuning step						
		05	Send/read 10 kHz tuning step						
		06	Send/read 12.5 kHz tuning step						
		07	Send/read 20 kHz tuning step						
11		00	Send/read attenuator OFF						
		06	Send/read 6 dB attenuator						
		12	Send/read 12 dB attenuator						
		18	Send/read 18 dB attenuator						
12		0000	Send/read ANT1 selection (RX ANT OFF)						
		0001	Send/read ANT1 selection (RX ANT ON)						
		0100	Send/read ANT2 selection (RX ANT OFF)						
		0101	Send/read ANT2 selection (RX ANT ON)						
13	00		Announce all data with voice synthesizer						
	01		Announce frequency and S-meter level with voice synthesizer						
	02		Announce receive mode with voice synthesizer						

12 CONTROL COMMAND

◇ Command table (continued)

Cmd.	Sub cmd.	Data	Description	Cmd.	Sub cmd.	Data	Description		
16	02	00	Preamp OFF	1A	05	0005	00 to 10	Send/read AM RX tone (Bass) level (00=-5, 10=+5)	
		01	Preamp 1 ON				0006	00 to 10	Send/read AM RX Tone (Treble) level (00=-5, 10=+5)
		02	Preamp 2 ON			0007		see p. 168	Send/read FM RX HPF/LPF
	12	00	AGC FAST selection			0008	00 to 10	Send/read FM RX tone (Bass) level (00=-5, 10=+5)	
		01	AGC MID selection				0009	00 to 10	Send/read FM RX Tone (Treble) level (00=-5, 10=+5)
		02	AGC SLOW selection			0010	see p. 168	Send/read CW RX HPF/LPF	
	22	00	Noise blanker OFF			0011	see p. 168	Send/read RTTY RX HPF/LPF	
		01	Noise blanker ON			0012	see p. 168	Send/read PSK RX HPF/LPF	
	32	00	Audio peak filter OFF			0013	00 to 10	Send/read SSB TX Tone (Bass) level (00=-5, 10=+5)	
		01	Audio peak filter WIDE ON (320 Hz is selected when SHARP APF is set)			0014	00 to 10	Send/read SSB TX Tone (Treble) level (00=-5, 10=+5)	
		02	Audio peak filter MID ON (160 Hz is selected when SHARP APF is set)			0015	00 to 10	Send/read AM TX Tone (Bass) level (00=-5, 10=+5)	
		03	Audio peak filter NAR ON (80 Hz is selected when SHARP APF is set)			0016	00 to 10	Send/read AM TX Tone (Treble) level (00=-5, 10=+5)	
	40	00	Noise reduction OFF			0017	00 to 10	Send/read FM TX Tone (Bass) level (00=-5, 10=+5)	
		01	Noise reduction ON			0018	00 to 10	Send/read FM TX Tone (Treble) level (00=-5, 10=+5)	
	41	00	Auto notch function OFF			0019	see p. 168	Send/read SSB TX bandwidth for WIDE	
		01	Auto notch function ON			0020	see p. 168	Send/read SSB TX bandwidth for MID	
	42	00	Repeater tone OFF			0021	see p. 168	Send/read SSB TX bandwidth for NARROW	
		01	Repeater tone ON			0022	0000 to 0255	Send/read DRIVE gain (0000=0%, 0255=100%)	
	43	00	Tone squelch OFF			0023	0000 to 0255	Send/read speech level (0000=0%, 0255=100%)	
		01	Tone squelch ON			0024	0000 to 0255	Send/read CW sidetone level (0000=0%, 0255=100%)	
		02	Full BK-IN function ON			0025	00 01	CW sidetone level limit OFF ON	
	44	00	Speech compressor OFF			0026	0000 to 0255	Send/read beep level (0000=0%, 0255=100%)	
		01	Speech compressor ON			0027	00 01	Beep level limit OFF ON	
	45	00	Monitor function OFF			0028	00 01	Squelch mute effect OFF (squelch is fixed open) for audio output from USB-B connector Squelch mute effect ON for audio output from USB-B connector	
		01	Monitor function ON			0029	0000 to 0255	Send/read modulation level for audio input to USB-B connector (0000=0%, 0255=100%)	
	46	00	VOX function OFF			0030	00 01 02 03	[MIC] selection for MOD input connector during DATA OFF [ACC] selection for MOD input connector during DATA OFF Both [MIC] and [ACC] selection for MOD input connector during DATA OFF [USB] selection for MOD input connector during DATA OFF	
		01	VOX function ON			0031	00 01 02 03	[MIC] selection for MOD input connector during DATA1 [ACC] selection for MOD input connector during DATA1 Both [MIC] and [ACC] selection for MOD input connector during DATA1 [USB] selection for MOD input connector during DATA1	
		02	Full BK-IN function ON			0032	00 01 02 03	[MIC] selection for MOD input connector during DATA2 [ACC] selection for MOD input connector during DATA2 Both [MIC] and [ACC] selection for MOD input connector during DATA2 [USB] selection for MOD input connector during DATA2	
	47	00	BK-IN function OFF			17*1	00	see p. 167	Send CW messages
		01	Semi BK-IN function ON				01	00	Turn OFF the transceiver
		02	Full BK-IN function ON				02	01	Turn ON the transceiver*2
	48	00	Manual notch function OFF			19	00	Read the transceiver ID	
		01	Manual notch function ON			1A	00	see p. 169	Send/read memory contents
	00	Twin peak filter OFF	01				see p. 166	Send/read band stacking register contents	
	01	Twin peak filter ON	02				see p. 166	Send/read memory keyer contents	
	02	Full BK-IN function ON	03				00 to 49	Send/read the selected filter width (SSB, CW, PSK: 00=50 Hz, 40=3600 Hz; RTTY: 00=50 Hz, 31=2700 Hz; AM: 00=200 Hz, 49=10 kHz)	
	50	00	Dial lock function OFF			04	00 to 13	Send/read the selected AGC time constant (00=OFF, 01=0.1/0.3 seconds, 13=6.0/8.0 seconds)	
		01	Dial lock function ON			05	0001	see p. 168	Send/read SSB RX HPF/LPF
		00	15 kHz roofing filter selection				0002	00 to 10	Send/read SSB RX Tone (Bass) level (00=-5, 10=+5)
	01	6 kHz roofing filter selection	0003				00 to 10	Send/read SSB RX Tone (Treble) level (00=-5, 10=+5)	
	02	3 kHz roofing filter selection	0004				see p. 168	Send/read AM RX HPF/LPF	
	56	00	SHARP selection for DSP filter type			18	00	00	Turn OFF the transceiver
		01	SOFT selection for DSP filter type				01	01	Turn ON the transceiver*2
	57	00	WIDE selection for manual notch width			19	00	00	Read the transceiver ID
		01	MID selection for manual notch width				01	00	Send/read memory contents
		02	NAR selection for manual notch width				02	01	Send/read band stacking register contents
	58	00	WIDE selection for SSB transmit bandwidth			03	00 to 49	Send/read the selected filter width (SSB, CW, PSK: 00=50 Hz, 40=3600 Hz; RTTY: 00=50 Hz, 31=2700 Hz; AM: 00=200 Hz, 49=10 kHz)	
01		MID selection for SSB transmit bandwidth	04	00 to 13	Send/read the selected AGC time constant (00=OFF, 01=0.1/0.3 seconds, 13=6.0/8.0 seconds)				
02		NAR selection for SSB transmit bandwidth	05	0001	see p. 168	Send/read SSB RX HPF/LPF			
00		WIDE selection for SSB transmit bandwidth	05	0002	00 to 10	Send/read SSB RX Tone (Bass) level (00=-5, 10=+5)			

*1 While transmitting in the CW mode, or if the Break-in function is ON, the transceiver transmits CW code when the PC sends this command.

*2 The power ON command (18 01) is available only when the transceiver is remote standby mode. The transceiver accepts the control command only from the [REMOTE] jack.

Cmd.	Sub cmd.	Data	Description
1A	05	0033	00 [MIC] selection for MOD input connector during DATA3
			01 [ACC] selection for MOD input connector during DATA3
			02 Both [MIC] and [ACC] selection for MOD input connector during DATA3
			03 [USB] selection for MOD input connector during DATA3
	0034	00	00 Reed selection for SEND relay type
			01 MOS-FET selection for SEND relay type
	0035	00	00 Auto selection for external meter output
			01 S (receiving signal strength) selection for external meter output
			02 Po (RF power) selection for external meter selection
			03 SWR selection for external meter output
			04 ALC selection for external meter output
			05 COMP selection for external meter output
			06 Vd selection for external meter output
	07 Id selection for external meter output		
	0036	0000 to 0255	Send/read external meter output level (see page 133)
	0037	0000 to 0255	Send/read reference frequency (0000=0%, 0255=100%)
	0038	0000 to 0255	Send/read LCD backlight brightness level (0000=0% (dark), 0255=100% (bright))
	0039	0000 to 0255	Send/read key backlight brightness level (0000=1 (dark), 0255=100 (bright))
	0040	00	00 Display type A selection
			01 Display type B selection
	0041	00	00 Basic font selection
			01 Italic font selection
			02 Round font selection
	0042	00	00 SLOW selection for meter response
			01 MID selection for meter response
			02 FAST selection for meter response
	0043	00	00 Standard meter selection for normal screen indication
			01 Edgewise meter selection for normal screen indication
			02 Bar meter selection for normal screen indication
	0044	00	00 Edgewise meter selection for wide screen indication
			01 Bar meter selection for wide screen indication
	0045	00	00 Meter peak hold function for Bar meter OFF
			01 Meter peak hold function for Bar meter ON
	0046	00	00 Memory name indication OFF
			01 Memory name indication ON
	0047	00	00 Audio peak filter width pop-up indication OFF
			01 Audio peak filter width pop-up indication ON
	0048	00	00 Manual notch filter width pop-up indication OFF
			01 Manual notch filter width pop-up indication ON
	0049	00	00 Screen saver OFF
			01 15 minutes selection for screen saver
			02 30 minutes selection for screen saver
			03 60 minutes selection for screen saver
	0050	00	00 Bound selection for screen saver type
			01 Round selection for screen saver type
			02 Twist selection for screen saver type
	0051	00	00 Opening screen indication OFF
			01 Opening screen indication ON
	0052	see p. 167	Send/read opening screen contents.
	0053	20000101 to 20991231	Send/read date (20000101=1st Jan. 2000, 20991231=31st Dec. 2099)
			0000 to 2359
	0055	00	00 Clock 2 OFF
			01 Clock 2 ON
0056	see p. 166	Send/read offset time for clock 2	
0057	see p. 167	Send/read clock 2 name (Up to 3 characters)	
0058	00	00 Calibration marker OFF	
		01 Calibration marker ON	
0059	00	00 Confirmation beep OFF	
		01 Confirmation beep ON	

Cmd.	Sub cmd.	Data	Description
1A	05	0060	00 Band edge beep OFF
			01 Band edge beep ON (Beep sounds with a default amateur band)
			02 Band edge beep with user setting ON
			03 Band edge beep with user setting/TX limit ON
	0061	0050 to 0200	Send/read beep audio frequency (0050=500 Hz, 0200=2000 Hz)
			0062
	0062	00	01 SQL selection for [RF/SQL]
			02 RF+SQL selection for [RF/SQL]
	0063	00	00 Quick dualwatch OFF
			01 Quick dualwatch ON
	0064	00	00 Quick split function OFF
			01 Quick split function ON
	0065	see p. 167	FM split offset frequency setting for HF
	0066	see p. 167	FM split offset frequency setting for 50 MHz
	0067	00	00 Split lock function OFF
			01 Split lock function ON
	0068	00	00 Tuner auto start OFF
			01 Tuner auto start ON
	0069	00	00 PTT tune OFF
			01 PTT tune ON
	0070	00	00 Antenna selection OFF
			01 Manual antenna selection
			02 Auto antenna selection
	0071	00	00 Transverter functions automatically
			01 Transverter function ON
	0072	see p. 167	Transverter offset frequency
	0073	00	00 1275 Hz selection for RTTY mark frequency
			01 1615 Hz selection for RTTY mark frequency
			02 2125 Hz selection for RTTY mark frequency
	0074	00	00 170 Hz selection for RTTY shift width
			01 200 Hz selection for RTTY shift width
			02 425 Hz selection for RTTY shift width
	0075	00	00 RTTY keying with normal polarity
			01 RTTY keying with reverse polarity
	0076	00	00 1000 Hz selection for PSK tone frequency
			01 1500 Hz selection for PSK tone frequency
			02 2000 Hz selection for PSK tone frequency
	0077	00	00 English selection for voice synthesizer speech language
			01 Japanese selection for voice synthesizer speech language
	0078	00	00 Speech speed slow
			01 Speech speed fast
	0079	00	00 S-meter level announcement OFF
			01 S-meter announcement ON
	0080	00	00 Operating mode announcement (after pushing mode switch) OFF
			01 Operating mode announcement (after pushing mode switch) ON
	0081	00	00 [SPEECH/LOCK] key function setting (Push momentarily=SPEECH, Hold down=LOCK)
			01 [SPEECH/LOCK] key function setting (Push momentarily=LOCK, Hold down=SPEECH)
	0082	00	00 Number of memo pad channels 5
			01 Number of memo pad channels 10
	0083	00	00 Auto TS for main dial OFF
			01 Auto TS for main dial ON with LOW
			02 Auto TS for main dial ON with HIGH
	0084	00	00 LOW selection for microphone Up/Down speed
01 HIGH selection for microphone Up/Down speed			
0085	00	00 Quick RIT/ΔTX clear OFF	
		01 Quick RIT/ΔTX clear ON	
0086	00	00 Auto notch selection for SSB operation	
		01 Manual notch selection for SSB operation	
		02 Auto/Manual notch selection for SSB operation	
0087	00	00 Auto notch selection for AM operation	
		01 Manual notch selection for AM operation	
0088	00	00 Auto/Manual notch selection for AM operation	
		01 SSB/CW synchronous tuning function OFF	
0088	00	01 SSB/CW synchronous tuning function ON	

12 CONTROL COMMAND

◇ Command table (continued)

Cmd.	Sub cmd.	Data	Description	Cmd.	Sub cmd.	Data	Description		
1A	05	0089	00	LSB selection for CW normal side set	1A	05	0109	00	SLOW selection for scope sweep speed in ±5 kHz span
		01	USB selection for CW normal side set	01			MID selection for scope sweep speed in ±5 kHz span		
	0090	00	SHARP selection for APF type	02		FAST selection for scope sweep speed in ±5 kHz span			
		01	SOFT selection for APF type	0110		00	SLOW selection for scope sweep speed in ±10 kHz span		
	0091	00	Voice memory transmission OFF with external keypad			01	MID selection for scope sweep speed in ±10 kHz span		
		01	Voice memory transmission ON with external keypad	02		FAST selection for scope sweep speed in ±10 kHz span			
	0092	00	Memory keyer transmission OFF with external keypad	0111		00	SLOW selection for scope sweep speed in ±25 kHz span		
		01	Memory keyer transmission ON with external keypad			01	MID selection for scope sweep speed in ±25 kHz span		
	0093	00	RTTY memory transmission OFF with external keypad	02		FAST selection for scope sweep speed in ±25 kHz span			
		01	RTTY memory transmission ON with external keypad	0112		00	SLOW selection for scope sweep speed in ±50 kHz span		
	0094	00	PSK memory transmission OFF with external keypad			01	MID selection for scope sweep speed in ±50 kHz span		
		01	PSK memory transmission ON with external keypad	02		FAST selection for scope sweep speed in ±50 kHz span			
	0095	00	Voice memory transmission OFF with [F1]–[F4] on the keyboard	0113		00	SLOW selection for scope sweep speed in ±100 kHz span		
		01	Voice memory transmission ON with [F1]–[F4] on the keyboard			01	MID selection for scope sweep speed in ±100 kHz span		
	0096	00	Memory keyer transmission OFF with [F1]–[F4] on the keyboard	02		FAST selection for scope sweep speed in ±100 kHz span			
		01	Memory keyer transmission ON with [F1]–[F4] on the keyboard	0114		00	SLOW selection for scope sweep speed in ±250 kHz span		
	0097	00	CI-V transceive OFF			01	MID selection for scope sweep speed in ±250 kHz span		
		01	CI-V transceive ON	02		FAST selection for scope sweep speed in ±250 kHz span			
	0098	00	CI-V selection for [USB-B] usage	0115		see p. 167	Scope edge frequencies for 0.03 to 1.60 MHz band		
		01	Decode selection for [USB-B] usage			0116	see p. 167	Scope edge frequencies for 1.60 MHz to 2.00 MHz band	
	0099	00	300 bps selection for decode speed	0117		see p. 167	Scope edge frequencies for 2.00 MHz to 6.00 MHz band		
		01	1200 bps selection for decode speed	0118		see p. 167	Scope edge frequencies for 6.00 MHz to 8.00 MHz band		
		02	4800 bps selection for decode speed	0119		see p. 167	Scope edge frequencies for 8.00 MHz to 11.00 MHz band		
		03	9600 bps selection for decode speed	0120		see p. 167	Scope edge frequencies for 11.00 MHz to 15.00 MHz band		
		04	19200 bps selection for decode speed	0121		see p. 167	Scope edge frequencies for 15.00 MHz to 20.00 MHz band		
	0100	00	English keyboard selection	0122		see p. 167	Scope edge frequencies for 20.00 MHz to 22.00 MHz band		
		01	Japanese keyboard selection	0123		see p. 167	Scope edge frequencies for 22.00 MHz to 26.00 MHz band		
		02	United Kingdom keyboard selection	0124		see p. 167	Scope edge frequencies for 26.00 MHz to 30.00 MHz band		
		03	French keyboard selection	0125		see p. 167	Scope edge frequencies for 30.00 MHz to 45.00 MHz band		
		04	French (Canadian) keyboard selection	0126		see p. 167	Scope edge frequencies for 45.00 MHz to 60.00 MHz band		
		05	German keyboard selection			0127	00	Auto monitor function OFF during voice memory transmission	
		06	Portuguese keyboard selection	01		Auto monitor function ON during voice memory transmission			
		07	Portuguese (Brazilian) keyboard selection	0128		03 to 10	Send/read voice memory short play time (03=3 seconds, 10=10 seconds)		
		08	Spanish keyboard selection			0129	05 to 15	Send/read voice memory normal record time (05=5 seconds, 15=15 seconds)	
		09	Spanish (Latin American) keyboard selection	0130			00	Normal selection for contest number style	
	10	Italian keyboard selection	01			"190 → ANO" selection for contest number style			
	0101	0010 to 0100	Send/read keyboard repeat delay (0010=100 milliseconds, 0100=1000 milliseconds, 50 millisecond steps)			02	"190 → ANT" selection for contest number style		
		00 to 31	Send/read keyboard repeat speed (00=2.0 cps, 31=30.0 cps)			03	"90 → NO" selection for contest number style		
	0103	00	Scope indication during TX OFF	04		"90 → NT" selection for contest number style			
	0104	01	Scope indication during TX ON						
		00	Scope max. hold function OFF						
	0105	01	Scope max. hold function ON						
		00	Filter center selection for scope center frequency (center mode only)						
		01	Carrier point center selection for scope center frequency (center mode only)						
		02	Carrier point center (Abs. Freq.) selection for scope center frequency (center mode only)						
	0106	see p. 167	Send/read waveform color for receiving signal						
	0107	see p. 167	Send/read waveform color for max. hold						
	0108	00	SLOW selection for scope sweep speed in ±2.5 kHz span						
		01	MID selection for scope sweep speed in ±2.5 kHz span						
		02	FAST selection for scope sweep speed in ±2.5 kHz span						

Cmd.	Sub cmd.	Data	Description
1A	05	0131	01 M1 selection for count up trigger channel
		02 M2 selection for count up trigger channel	
		03 M3 selection for count up trigger channel	
		04 M4 selection for count up trigger channel	
	0132	0001 to 9999	Send/read present number (0001=1, 9999=9999)
	0133	01 to 60	Send/read CW keyer repeat time (01=1 second, 60=60 seconds)
	0134	28 to 45	Send/read CW keyer dot/dash ratio (28=1:1.2:8, 45=1:1.4:5)
	0135	00	2 milliseconds selection for rise time of the transmitted CW envelope
		01	4 milliseconds selection for rise time of the transmitted CW envelope
		02	6 milliseconds selection for rise time of the transmitted CW envelope
		03	8 milliseconds selection for rise time of the transmitted CW envelope
	0136	00	Normal selection for paddle polarity
		01	Reverse selection for paddle polarity
	0137	00	Straight selection for keyer type
		01	BUG-KEY selection for keyer type
		02	ELEC-KEY selection for keyer type
	0138	00	Mic. up/down keyer function OFF
		01	Mic. up/down keyer function ON
	0139	00	RTTY decoder FFT scope averaging function OFF
		01	Number 2 selection for RTTY decoder FFT scope averaging function
		02	Number 3 selection for RTTY decoder FFT scope averaging function
		03	Number 4 selection for RTTY decoder FFT scope averaging function
	0140	see p. 167	Set/read FFT scope waveform color set for RTTY decoder
	0141	00	RTTY decode USOS function OFF
		01	RTTY decode USOS function ON
	0142	00	"CR,LF,CR+LF" selection for RTTY decode new line code
		01	"CR+LF" selection for RTTY decode new line code
	0143	00	OFF selection for RTTY diddle
		01	BLANK selection for RTTY diddle
		02	LTRS selection for RTTY diddle
	0144	00	RTTY encode USOS function OFF
		01	RTTY encode USOS function ON
	0145	00	RTTY auto CR+LF by keyboard's [F12] OFF
		01	RTTY auto CR+LF by keyboard's [F12] ON
	0146	00	RTTY time stamp OFF
		01	RTTY time stamp ON
	0147	00	Local time selection for RTTY time stamp
		01	Clock2 selection for RTTY time stamp
	0148	00	Frequency stamp for RTTY time stamp OFF
		01	Frequency stamp for RTTY time stamp ON
	0149	see p. 167	Send/read received text font color for RTTY decoder
	0150	see p. 167	Send/read transmitted text font color (RTTY)
	0151	see p. 167	Send/read time stamp text font color (RTTY)
	0152	see p. 167	Send/read text font color in TX buffer (RTTY)
	0153	00	PSK decoder FFT scope averaging function OFF
		01	Number 2 selection for PSK decoder FFT scope averaging function
		02	Number 3 selection for PSK decoder FFT scope averaging function
	0154	00	Set/read FFT scope waveform color set for PSK decoder
		01	Number 4 selection for PSK decoder FFT scope averaging function
	0155	00	±8 Hz selection for PSK AFC function tuning range
		01	±15 Hz selection for PSK AFC function tuning range

Cmd.	Sub cmd.	Data	Description	
1A	05	0156	00 PSK time stamp OFF	
		01 PSK time stamp ON		
	0157	00	Local time selection for PSK time stamp	
		01	Clock2 selection for PSK time stamp	
	0158	00	Frequency stamp for PSK time stamp OFF	
		01	Frequency stamp for PSK time stamp ON	
	0159	see p. 167	Send/read received text font color for PSK decoder	
	0160	see p. 167	Send/read transmitted text font color (PSK)	
	0161	see p. 167	Send/read time stamp text font color (PSK)	
	0162	see p. 167	Send/read text font color in TX buffer (PSK)	
	0163	00	LOW scan speed selection	
		01	HIGH scan speed selection	
	0164	00	Scan resume OFF	
		01	Scan resume ON	
	0165	0000 to 0255	Send/read VOX gain (0000=0%, 0255=100%)	
		0000 to 0255	Send/read ANTI-VOX gain (0000=0%, 0255=100%)	
	0167	00 to 20	Send/read VOX delay time (00=0.0 sec, 20=2.0 sec)	
	0168	00	VOX voice delay function OFF	
		01	Short selection for VOX voice delay	
		02	Mid selection for VOX voice delay	
	0169	0000 to 0255	Send/read NB level (0000=0%, 0255=100%)	
		00 to 09	Send/read NB depth (00=1, 09=10)	
	0171	0000 to 0255	Send/read NB width (0000=1, 0255=100)	
		0000 to 0255	Send/read MONITOR gain (0000=0%, 0255=100%)	
	0173	00 to 05	Send/read time-out timer (00=OFF, 01=3 min, 02=5 min, 03=10 min, 04=20 min, 05=30 min)	
	0174	00 to 06	Send/read audio output level at APF ON (00=0 dB, 06=+6 dB)	
	0175	00 to 05	Send/read the TX Delay setting (HF) (00=OFF, 01=10 ms, 02=15 ms, 03=20 ms, 04=25 ms, 05=30 ms)	
	0176	00 to 05	Send/read the TX Delay setting (50 M) (00=OFF, 01=10 ms, 02=15 ms, 03=20 ms, 04=25 ms, 05=30 ms)	
	0177	00	Send/read the Shutdown function is Shutdown	
		01	Send/read the Shutdown function is Standby/Shutdown	
	0178	00	Send/read command to disable to output the antenna controller status (frequency and so on) from [REMOTE].	
		01	Send/read command to enable to output the antenna controller status (frequency and so on) from [REMOTE].	
	0179	00	Send/read the spectrum display type is Fill	
		01	Send/read the spectrum display type is Fill+Line	
	0180	see p. 167	Send/read spectrum line color	
	0181	00	Send/read waterfall set for spectrum scope OFF	
		01	Send/read waterfall set for spectrum scope ON	
	0182	00 to 06	Send/read peak color level set for waterfall of the spectrum scope (00=Grid 1, 01=Grid 2, 02=Grid 3, 03=Grid 4, 04=Grid 5, 05=Grid 6, 06=Grid 7)	
	06	see p. 167	Send/read DATA mode with filter set	
	07	00	WIDE selection for SSB transmit bandwidth	
		01	MID selection for SSB transmit bandwidth	
		02	NAR selection for SSB transmit bandwidth	
	08	00	SHARP selection for DSP filter type	
		01	SOFT selection for DSP filter type	
	09	00	3 kHz roofing filter selection	
		01	6 kHz roofing filter selection	
		02	15 kHz roofing filter selection	
	0A	00	WIDE selection for manual notch width	
		01	MID selection for manual notch width	
		02	NAR selection for manual notch width	
	1B	00	see p. 168	Send/read repeater tone frequency
		01	see p. 168	Send/read tone squelch frequency

12 CONTROL COMMAND

◇ Command table (continued)

Cmd.	Sub cmd.	Data	Description	
1C	00	00	Send/read transceiver's status (RX) When "CI-V Output (for ANT)" (Command: 1C 04) is set to "ON," automatically outputs when changed.	
		01	Send/read transceiver's status (TX) When "CI-V Output (for ANT)" (Command: 1C 04) is set to "ON," automatically outputs when changed.	
	01	00	Antenna tuner OFF (through)	
		01	Antenna tuner ON	
		02	Tuning	
	02	00	Send/read transmit frequency monitor setting OFF	
		01	Send/read transmit frequency monitor setting ON	
	03	see p. 166	Read transmit frequency When "CI-V Output (for ANT)" (Command: 1C 04) is set to "ON," automatically outputs when changed.	
	04	00	Send/read command to disable to output the antenna controller status (frequency and so on) from [REMOTE].	
		01	Send/read command to enable to output the antenna controller status (frequency and so on) from [REMOTE].	
1E	00		Read number of available TX frequency band	
	01	see p. 168	Read TX band edge frequencies	
	02		Read number of user-set TX frequency band	
	03	see p. 168	Send/read user-set TX band edge frequencies	
21	00	see p. 168	Send/read RIT frequency	
		00	Send/read RIT setting is OFF	
	01	01	Send/read RIT setting is ON	
		02	00	Send/read ΔTX setting is OFF
			01	Send/read ΔTX setting is ON
25		see p. 168	Send/read the Main or Sub band frequency	
26		see p. 168	Send/read the selected operating mode and filter	

◇ Data content description

• Operating frequency

Command: 00, 03, 05, 1C 03

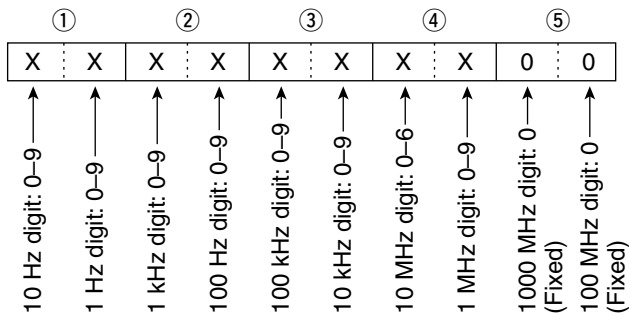

• Operating mode

Command: 01, 04, 06

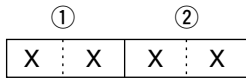

① Operating mode	② Filter setting
00: LSB	05: FM
01: USB	07: CW-R
02: AM	08: RTTY-R
03: CW	12: PSK
04: RTTY	13: PSK-R
	01: FIL1
	02: FIL2
	03: FIL3

Filter setting (②) can be skipped with command 01 and 06. In that case, "FIL1" is selected with command 01 and the default filter setting of the operating mode is selected with command 06, automatically.

• Memory keyer contents

Command: 1A 02

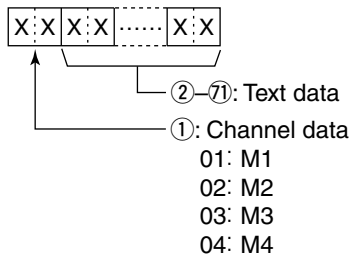

• Character's code

Character	ASCII code	Description
0-9	30-39	Numerals
A-Z	41-5A	Alphabetical characters
space	20	Word space
/	2F	Symbol
?	3F	Symbol
,	2C	Symbol
.	2E	Symbol
@	40	Symbol
^	5E	Example: To send BT, enter ^BT
*	2A	Inserts contest number (can be used for 1 channel only)

• Band stacking register

Command: 1A 01

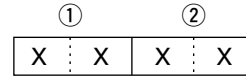

① Frequency band code

Code	Freq. band	Frequency range (unit: MHz)
01	1.8	1.800000- 1.999999
02	3.5	3.400000- 4.099999
03	7	6.900000- 7.499999
04	10	9.900000-10.499999
05	14	13.900000-14.499999
06	18	17.900000-18.499999
07	21	20.900000-21.499999
08	24	24.400000-25.099999
09	28	28.000000-29.999999
10	50	50.000000-54.000000
11	GENE	Other than above

② Register code

Code	Registered No.
01	1 (latest)
02	2
03	3 (oldest)

For example, when reading the oldest contents in the 21 MHz band, the code "0703" is used.

When sending the contents, the following code should be added after code ②.

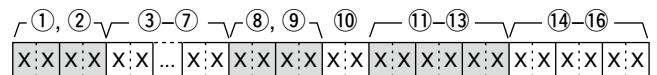

③-⑦ Operating frequency setting

See "• Operating frequency."

⑧, ⑨ Operating mode setting

See "• Operating mode."

⑩ Data mode setting

1 byte data (XX)

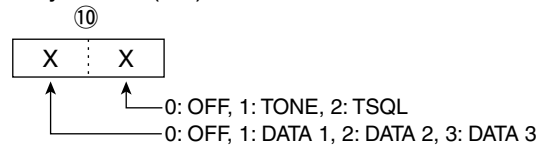

⑪-⑬ Repeater tone frequency setting

⑭-⑯ Tone squelch frequency setting

See "• Repeater tone/tone squelch setting."

• Clock 2 offset time setting

Command: 1A 05 0056

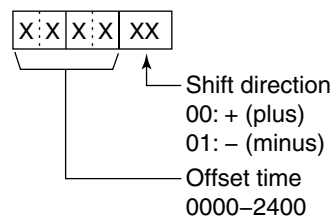

12 CONTROL COMMAND

◇ Data content description (continued)

• Offset frequency setting

Command: 1A 05 0065, 0066, 0072

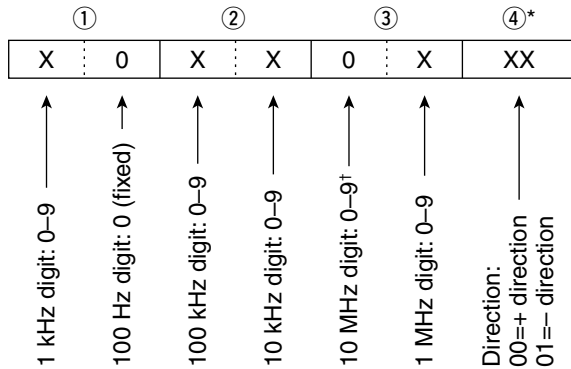

*No need to enter for transverter offset frequency setting.

†Transverter offset only. Fix to '0' for split offset setting.

• Codes for memory name, opening message and CLOCK2 name contents

Command: 1A 05 0052, 0057

To send or read the desired memory name settings, the character codes, instructed codes for memory keyer contents, and follows are used.

• Character's code— Alphabetical characters

Character	ASCII code	Character	ASCII code
a-z	61-7A	—	—

• Character's code— Symbols

Character	ASCII code	Character	ASCII code
!	21	#	23
\$	24	%	25
&	26	¥	5C
?	3F	"	22
'	27	`	60
+	2B	-	2D
:	3A	;	3B
=	3D	<	3C
>	3E	(28
)	29	[5B
]	5D	{	7B
}	7D		7C
~	5F	-	7E
@	40		

• Color setting

Command: 1A 05 0106, 0107, 0140, 0149, 0150, 0151, 0152, 0154, 0159, 0160, 0161, 0162, 0180

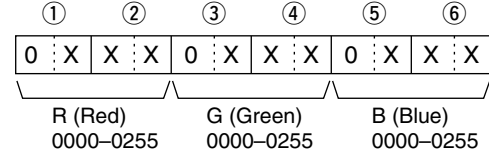

• Bandscope edge frequency setting

Command: 1A 05 0115, 0116, 0117, 0118, 0119, 0120, 0121, 0122, 0123, 0124, 0125, 0126

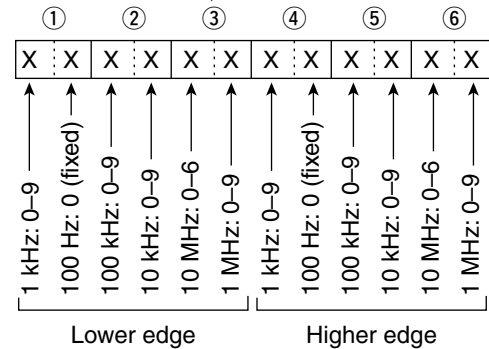

• Data mode with filter width setting

Command: 1A 06

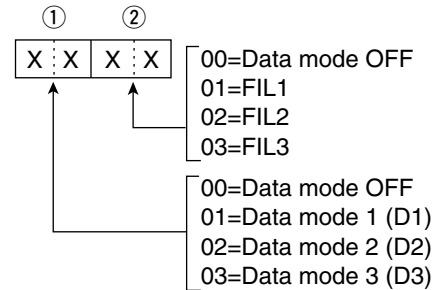

• Codes for CW message content

Command : 17 Up to 30 characters

To send CW messages, the following character codes are used.

- ▨ "FF" stops sending CW messages.
- ▨ "^" is used to transmit a string of characters with no inter-character space.

Character's code

Character	ASCII code	Character	ASCII code
0-9	30-39	'	27
A-Z	41-5A	(28
a-z	61-7A)	29
/	2F	=	3D
?	3F	+	2B
.	2E	"	22
-	2D	@	40
,	2C	Space	20
:	3A		

Command	Set item/Available characters
1A00	Memory name All characters are available.
1A05 0052	Opening message Capital letters, numerals, some symbols (- / . @) and space are available.
1A05 0057	CLOCK 2 name Capital letters, small letters, numerals, some symbols (! # \$ % & ¥ ? " ' ` ^ + - * / . , ; = < > () [] { } _ ~ @) and space are available.

• Repeater tone/tone squelch frequency setting

Command: 1B 00, 1B 01

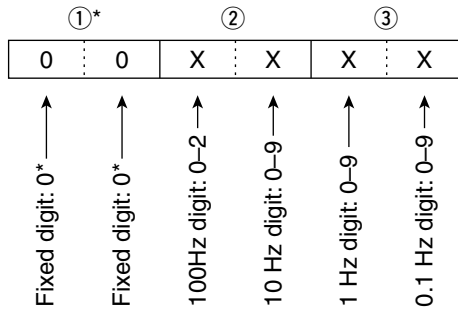

*Not necessary when setting a frequency.

• Band edge frequency setting

Command 02*, 1E 01, 1E 03

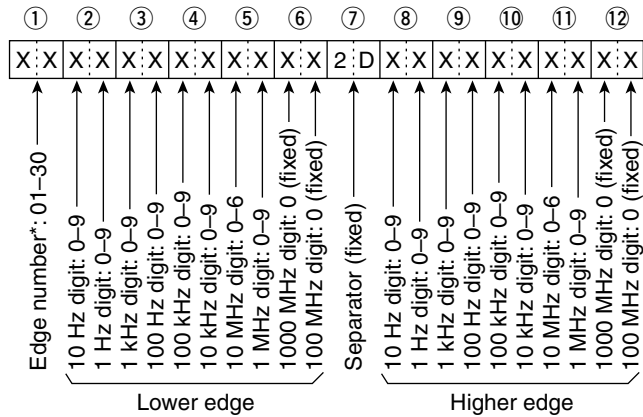

* Edge number setting is not necessary with command 02.

• RIT frequency settings

Command : 21 00

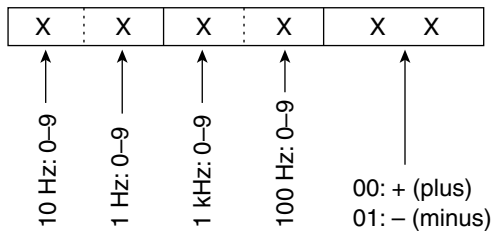

• Main or Sub band's frequency settings

Command : 25

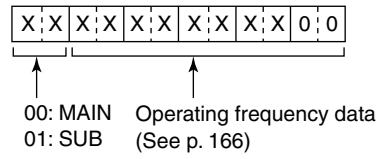

• Main or Sub band's operating mode and filter settings

Command : 26

Both data and filter settings can be skipped. In that case, "DATA OFF" and the default filter setting of the operating mode is automatically selected.

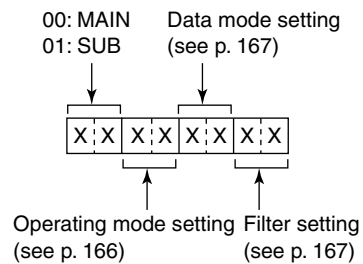

• RX HPF/LPF setting for each operating mode

Command : 1A 05 0001, 0004, 0007, 0010, 0011, 0012

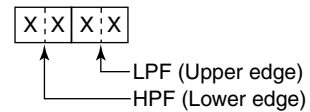

HPF	LPF
00: Through	05-24: 500~2400 Hz
01-20: 100~2000 Hz	25: Through

*The value of the HPF should be smaller than the LPF.

• SSB transmission passband width settings

Command : 1A 05 0019, 0020, 0021

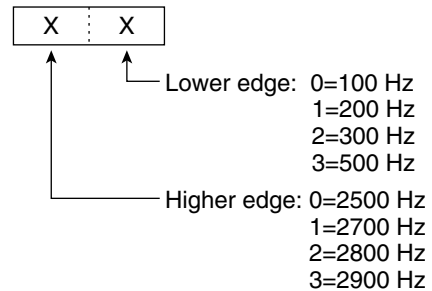

12 CONTROL COMMAND

◇ Data content description (continued)

• Memory content setting

Command: 1A 00

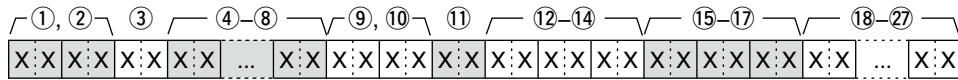

①, ② Memory channel number

0000–0099 : Memory channel 0 to 99

0100 : Programmed scan edge P1

0101 : Programmed scan edge P2

③ Select memory setting

00 : OFF

01 : ★1

02 : ★2

03 : ★3

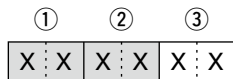

To program the blank channel, enter “FF” to ③ after the memory channel number (① and ②).

This completes the memory channel programming.

④–⑧ Operating frequency setting

See “• Operating frequency.”

⑨, ⑩ Operating mode setting

See “• Operating mode.”

⑪ Data mode setting

1 byte data (XX)

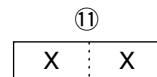

0: OFF, 1: TONE, 2: TSQ
0: OFF, 1: DATA 1, 2: DATA 2, 3: DATA 3

⑫–⑭ Repeater tone frequency setting

⑮–⑰ Tone squelch frequency setting

See “• Repeater tone/tone squelch setting.”

⑱–⑳ Memory name setting

Up to 10 characters.

See “• Codes for memory name, opening message and Clock 2 name contents.”

■ General

- Frequency coverage : (unit: MHz)
 - Receive : 0.030–60.000*1*2
 - Transmit :
 - 1.800–1.999*2, 3.500–3.999*2,
 - 5.33050*3, 5.34650*3, 5.36650*3,
 - 5.37150*3, 5.40350*3,
 - 7.000–7.300*2, 10.100–10.150*2,
 - 14.000–14.350*2, 18.068–18.168*2,
 - 21.000–21.450*2, 24.890–24.990*2,
 - 28.000–29.700*2, 50.000–54.000*2
- *1Some frequency bands are not guaranteed.
- *2Depending on version. *3USA version only.
- Mode : USB, LSB, CW, RTTY, PSK, AM, FM
- No. of memory channels : 101 (99 regular, 2 scan edges)
- Antenna connector type : SO-239 × 2 and phono jack (RCA, 50 Ω impedance)
- Temperature range : 0°C to +50°C (+32°F to +122°F)
- Frequency stability : Less than ±0.5 ppm 5 minutes after power ON. (0°C to +50°C: +32°F to +122°F)
- Frequency resolution : 1 Hz
- Power supply : 13.8 V DC ±15% (negative ground)
- Power consumption
 - Transmit : Max. power 23 A
 - Receive : Standby 3.0 A
Max. audio 3.5 A
- Dimensions : 340(W) × 116(H) × 279.3(D) mm (projections not included) 13³/₈(W) × 4⁹/₁₆(H) × 11(D) in
- Weight (approximately) : 10.0 kg (22 lb)
- ACC 1 connector : 8-pin DIN connector
- ACC 2 connector : 7-pin DIN connector
- CI-V connector : 2-conductor 3.5 (d) mm (1/8")
- Display : 5.8-inch (diagonal) TFT color LCD

■ Transmitter

- Output power (continuously adjustable)
 - SSB/CW/RTTY/FM : Less than 2 to 100 W
 - AM : Less than 1 to 30 W
- Modulation system
 - SSB : Digital PSN modulation
 - AM : Digital Low power modulation
 - FM : Digital Phase modulation
- Spurious emission
 - HF bands : Less than –50 dB
 - 50 MHz ban : Less than –63 dB
- Carrier suppression : More than 40 dB
- Unwanted sideband suppression : More than 55 dB
- ΔTX variable range : ±9.999 kHz
- Microphone connector : 8-pin connector (600 Ω)
- ELEC-KEY connector : 3-conductor 6.35(d) mm (1/4")
- KEY connector : 3-conductor 6.35(d) mm (1/4")
- SEND connector : Phono jack (RCA)
- ALC connector : Phono jack (RCA)

■ Receiver

- Receive system : Double superheterodyne system
- Intermediate frequencies
 - 1st : 64.455 MHz
 - 2n : 36 kHz
- Sensitivity (typical)
 - SSB, CW, RTTY : 0.15 μV (1.80–29.99 MHz)*1 (10 dB S/N) BW=2.4 kHz 0.12 μV (50.0–54.0 MHz)*2
 - AM (10 dB S/N) : 6.3 μV (0.1–1.799 MHz)*1 BW=6 kHz 2 μV (1.80–29.99 MHz)*1 1.6 μV (50.0–54.0 MHz)*2
 - FM (12 dB SINAD) : 0.5 μV (28.0–29.99 MHz)*1 BW=15 kHz 0.3 μV (50.0–54.0 MHz)*2
- *1Pre-amp 1 is ON. *2Pre-amp 2 is ON.
- Squelch sensitivity (Pre-amp: ON)
 - SSB : Less than 3.2 μV
 - FM : Less than 0.3 μV
- Selectivity (IF filter shape is set to SHARP.)
 - SSB (BW: 2.4 kHz) : More than 2.4 kHz/–6 dB Less than 3.8 kHz/–60 dB
 - CW (BW: 500 Hz) : More than 500 Hz/–6 dB Less than 900 Hz/–60 dB
 - RTTY (BW: 350 Hz) : More than 350 Hz/–6 dB Less than 650 Hz/–60 dB
 - AM (BW: 6 kHz) : More than 6.0 kHz/–6 dB Less than 15.0 kHz/–60 dB
 - FM (BW: 15 kHz) : More than 12.0 kHz/–6 dB Less than 20.0 kHz/–60 dB
- Spurious and image rejection ratio : More than 70 dB (except IF through on 50 MHz band)
- AF output power : More than 2.0 W at 10% distortion with an 8 Ω load
- RIT variable range : ±9.999 kHz
- PHONES connector : 3-conductor 6.35 (d) mm (1/4")
- External SP connector : 2-conductor 3.5 (d) mm (1/8")/8 Ω
- DSP ANF attenuation : More than 30 dB (with 1 kHz single tone)
- DSP NR attenuation : More than 6 dB (noise rejection in SSB)

■ Antenna tuner

- Matching impedance range
 - HF bands : 16.7 to 150 Ω unbalanced (Less than VSWR 3:1)
 - 50 MHz ban : 20 to 125 Ω unbalanced (Less than VSWR 2.5:1)
- Minimum operating input power : 8 W (HF bands) 15 W (50MHz band)
- Tuning accuracy : VSWR 1.5:1 or less
- Insertion loss : Less than 1.0 dB (after tuning at RF power 100W)

Spurious signals may be displayed on the spectrum scope screen regardless of the transceiver's state (Tx or Rx). They are generated in the scope circuit. This does not indicate a transceiver malfunction.

All stated specifications are typical and subject to change without notice or obligation.

Options

IC-PW1/EURO HF/50 MHz ALL BAND 1 kW LINEAR AMPLIFIER



Full-duty 1 kW linear amplifier including an automatic antenna tuner. Has automatic tuning and band selection capability. Full break-in (QSK) operation is possible. The amplifier/power supply unit and the remote control unit are separated.

AH-4 HF AUTOMATIC ANTENNA TUNER



Specially designed to tune a long wire antenna for HF/50 MHz bands particularly in portable or mobile operation. The "PTT tune" function provides simple operation.

- Input power rating: 120 W

PS-126 DC POWER SUPPLY



- Output voltage : 13.8 V DC
- Max. output current : 25 A

SP-23 EXTERNAL SPEAKER



- 4 audio filters, headphone jack, can be connected to 2 transceivers.
- Input impedance: 8 Ω
 - Max. input power: 4 W

AH-2b ANTENNA ELEMENT



A 2.5 m long antenna element for mobile operation with the AH-4.

- Frequency coverage 7–54 MHz band with the AH-4

HM-36 HAND MICROPHONE



Hand microphone equipped with [UP]/[DOWN] switches.

SM-30 DESKTOP MICROPHONE



Unidirectional, electret microphone for base station operation. Includes a low cut switch and mic gain control.

AH-740 AUTOMATIC TUNING ANTENNA

High performance, automatic high-speed tuning antenna.

- Frequency coverage
With 1.54 m whip antenna: 2.5 MHz–29.9999 MHz
With AH-5NV (NVIS kit): 2.2 MHz–29.9999 MHz



SM-50 DESKTOP MICROPHONE



Unidirectional, dynamic microphone for base station operation. Includes [UP]/[DOWN] switches, a low cut switch and mic gain control.

CT-17 CI-V LEVEL CONVERTER UNIT



For remote transceiver control using a personal computer equipped with an RS-232C port. You can change frequencies, operating mode, memory channels, etc., via your computer.

- **MB-121** CARRYING HANDLE

Convenient when carrying the transceiver.
The same as that attached to the transceiver.

- **SP-33** EXTERNAL SPEAKER

Designed for base station operation.
Input impedance: 8 Ω
Maximum input power: 5 W

- **RS-BA1** IP REMOTE CONTROL SOFTWARE

/// To remotely control radios using the RS-BA1, BE SURE
/// that you comply with your local regulations. Approved
/// Icom optional equipment is designed for optimal
/// performance when used with an Icom transceiver.

Icom is not responsible for the destruction or damage to an Icom transceiver in the event the Icom transceiver is used with equipment that is not manufactured or approved by Icom.

14 UPDATING THE FIRMWARE

■ General

The IC-7600's firmware can be updated if desired. By updating the firmware, new function(s) can be added and the improvement of performance parameters can be obtained.

Refer to ■ Preparation (p. 174) and ■ Firmware update (p. 175) for details.

Ask your dealer or distributor about how to update the firmware if you have no PC.

The downloaded firmware data (Example: 7600_110.dat) should be copied to the USB-Memory (in the "IC-7600" folder) using an available USB port (a USB hub may be required, user supplied).

◇ Firmware confirmation

The firmware version of the IC-7600 can be confirmed during turning power ON.

- The firmware version appears at the right bottom corner.



Firmware version

■ Caution

CAUTION: NEVER turn the transceiver power OFF while updating the firmware.

You can turn the transceiver power OFF only when the transceiver displays that rebooting is required. If you turn the transceiver power OFF, or if a power failure occurs during updating, the transceiver firmware will be corrupted and you will have to send the transceiver back to the nearest Icom distributor for repair. This type of repair is out of warranty even if the warranty period is still valid.

✓ Recommendation!

Backing up the settings and/or memory contents to the USB-Memory before starting the firmware update is recommended.

Settings and/or memory contents will be lost or returned to default settings when the firmware update is performed.

■ Preparation

◇ File downloading

✓ Information

The downloaded firmware data (Example: 7600_110.dat) should be copied to the USB-Memory (in the “IC-7600” folder) using an available USB port (a USB hub may be required, user supplied).

- ① Access the following URL.
http://www.icom.co.jp/world/index.html
- ② Click the [Support] button.
- ③ Click the “Firmware Updates/Software Downloads” link.
- ④ Click the desired firmware file link in the IC-7600 group.
- ⑤ Read “Regarding this Download Service” carefully, and then click [Agree].

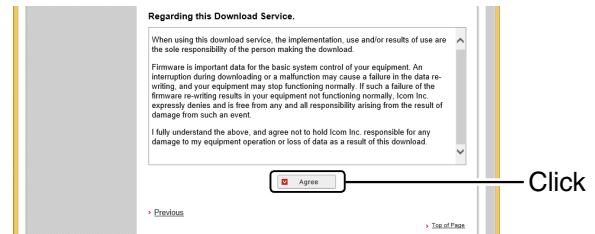

- ⑥ Click [Save as] in the displayed File Download dialog.

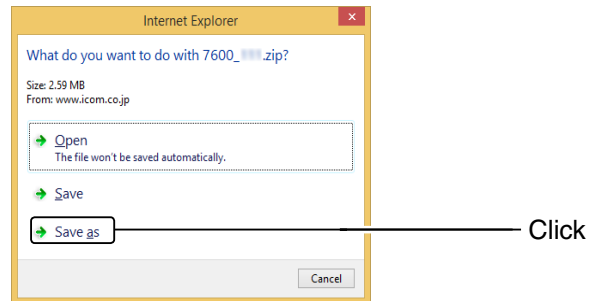

- ⑦ Select the desired location where you want to save the firmware, and then click [Save] in the displayed File Download dialog.
 - File download starts.
- ⑧ After the download is completed, extract the file.
 - The firmware and the firm utility are compressed in the “zip” format.
 - When updating the transceiver using the USB-Memory, copy the extracted firmware to the IC-7600 folder.

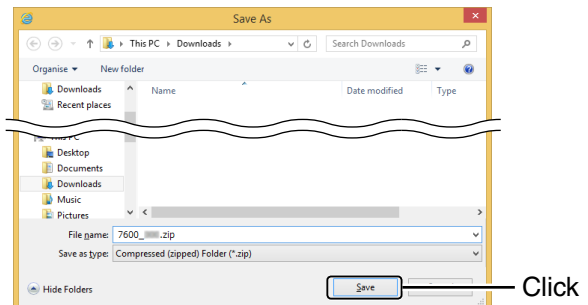

Firmware update

The transceiver displays its firmware version information after turning power ON, if the opening message screen indication capability is ON. (p. 135)

- ① Copy the downloaded firmware data into the "IC-7600" folder of the USB-Memory.
 - The USB-Memory must have been formatted by the IC-7600.
- ② Insert the USB-Memory into the [USB] (A) connector on the front panel.
- ③ Push [EXIT/SET] several times to close any multi-function screens, if necessary.
- ④ Push [SET] (F-6) to select the set mode menu screen.
- ⑤ Push [USB] (F-6) to select the USB Memory set menu.
- ⑥ Hold down [FIRM UP] (F-3) for 1 second.
- ⑦ Read the displayed precaution carefully.
 - Push [▲] (F-1) or [▼] (F-2) to scroll the display.
 - Push [CANCEL] (F-6) to cancel the firmware updating.
- ⑧ After you read and understand all of the precautions, push [OK] (F-5).
 - [OK] (F-5) appears only following the precautions.
 - Push [CANCEL] (F-6) to cancel the firmware updating.
- ⑨ Push [▲] (F-2) or [▼] (F-3) to select the firmware file, then push [FIRM UP] (F-4).
- ⑩ Read the displayed precautions carefully.
- ⑪ If you agree, hold down [OK] (F-5) for 1 second to start the firmware update.
 - Push [CANCEL] (F-6) to cancel the firmware updating.
- ⑫ While loading the firmware from the USB-Memory, the dialog to the right is displayed.

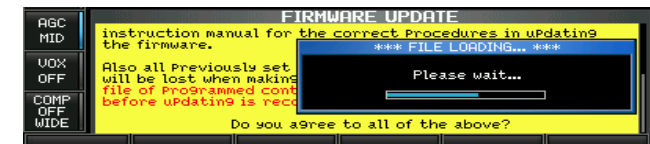
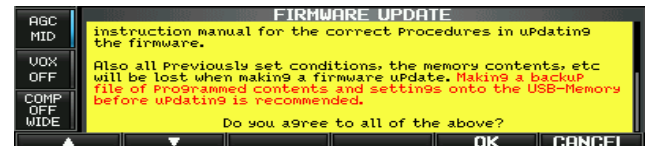
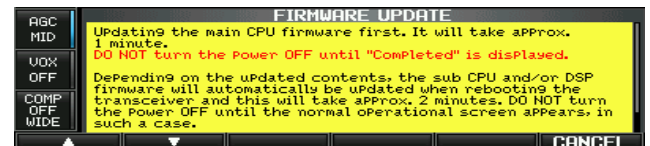
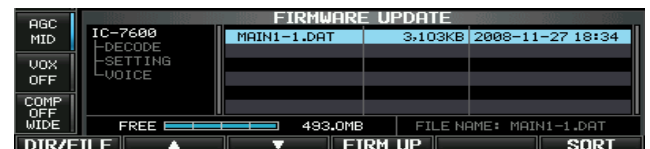
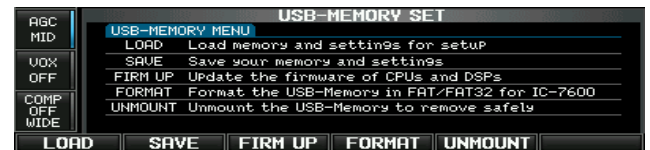
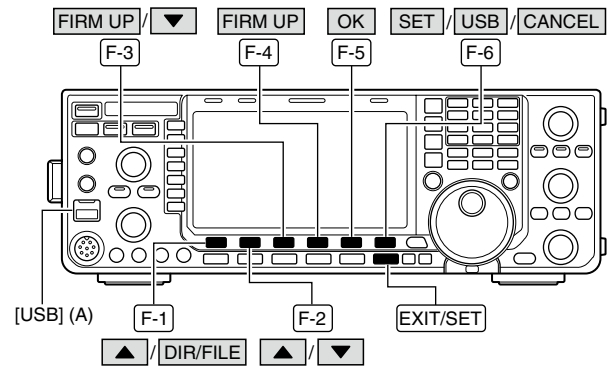

⑬ After the firmware loading is completed, the transceiver automatically starts the update, and the dialog at right is displayed.

⚠ **WARNING! NEVER** turn the IC-7600 power OFF at this stage.
 The transceiver firmware will be corrupted.

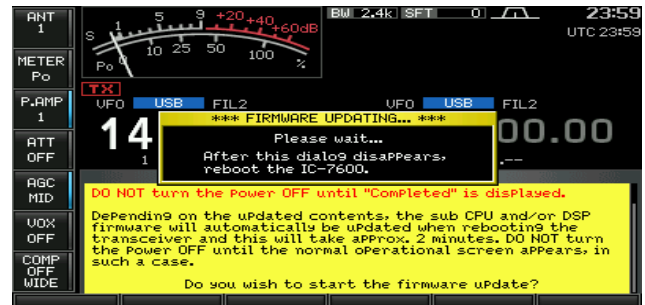

⑭ When the dialog disappears, the precaution to the right is displayed.

⑮ Read the precaution carefully, and then push **[OK] (F-5)**.
 • Return to the USB Memory set menu.

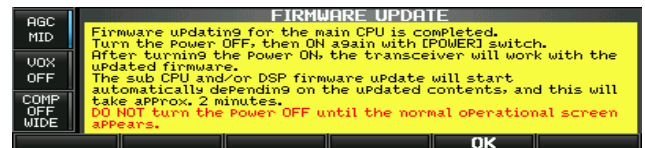

⑯ Push **[POWER]** to turn the IC-7600 power OFF, then ON again.

⑰ Depending on the update, one or two dialog boxes to the right appear in sequence.

⚠ **WARNING! NEVER** turn the IC-7600 power OFF at this stage.
 The transceiver firmware will be corrupted.

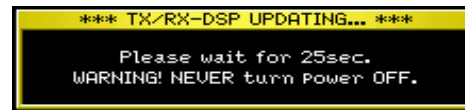
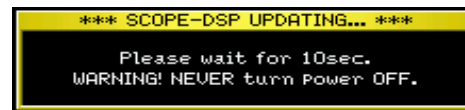

⑱ After the dialog disappears, the firmware updating is completed and the normal operation screen appears.

INSTALLATION NOTES

For amateur base station installations it is recommended that the forward clearance in front of the antenna array is calculated relative to the EIRP (Effective Isotropic Radiated Power). The clearance height below the antenna array can be determined in most cases from the RF power at the antenna input terminals.

As different exposure limits have been recommended for different frequencies, a relative table shows a guideline for installation considerations.

Below 30 MHz, the recommended limits are specified in terms of V/m or A/m fields as they are likely to fall within the near-field region. Similarly, the antennas may be physically short in terms of electrical length and that the installation will require some antenna matching device which can create local, high intensity magnetic fields. Analysis of such MF installations is best considered in association with published guidance notes such as the FCC OET Bulletin 65 Edition 97-01 and its annexes relative to amateur transmitter installations.

The EC recommended limits are almost identical to the FCC specified 'uncontrolled' limits and tables exist that show pre-calculated safe distances for different antenna types for different frequency bands. Further information can be found at <http://www.arrl.org/>.

• Typical amateur radio installation

Exposure distance assumes that the predominant radiation pattern is forward and that radiation vertically downwards is at unity gain (sidelobe suppression is equal to main lobe gain). This is true of almost every gain antenna today. Exposed persons are assumed to be beneath the antenna array and have a typical height of 1.8 m.

The figures assume the worst case emission of a constant carrier.

For the bands 10 MHz and higher the following power density limits have been recommended:

10–50 MHz 2 W/sq m

Vertical clearance by EIRP output

1 Watts	2.1 m
10 Watts	2.8 m
25 Watts	3.4 m
100 Watts	5 m
1000 Watts	12 m

Forward clearance by EIRP output

100 Watts	2 m
1000 Watts	6.5 m
10,000 Watts	20 m
100,000 Watts	65 m

In all cases any possible risk depends on the transmitter being activated for long periods. (actual recommendation limits are specified as an average during 6 minutes) Normally the transmitter is not active for long periods of time. Some radio licenses will require that a timer circuit automatically cuts off the transmitter after 1–2 minutes etc.

Similarly some modes of transmission, SSB, CW, AM etc. have a lower 'average' output power and the assessed risk is even lower.

• List of Country codes (ISO 3166-1)

	Country	Codes		Country	Codes
1	Austria	AT	18	Liechtenstein	LI
2	Belgium	BE	19	Lithuania	LT
3	Bulgaria	BG	20	Luxembourg	LU
4	Croatia	HR	21	Malta	MT
5	Czech Republic	CZ	22	Netherlands	NL
6	Cyprus	CY	23	Norway	NO
7	Denmark	DK	24	Poland	PL
8	Estonia	EE	25	Portugal	PT
9	Finland	FI	26	Romania	RO
10	France	FR	27	Slovakia	SK
11	Germany	DE	28	Slovenia	SI
12	Greece	GR	29	Spain	ES
13	Hungary	HU	30	Sweden	SE
14	Iceland	IS	31	Switzerland	CH
15	Ireland	IE	32	Turkey	TR
16	Italy	IT	33	United Kingdom	GB
17	Latvia	LV			

Symbol	
Δ F scan operation	115
Δ TX function.....	95
Δ TX monitor function.....	95

Number	
1/4 tuning step function.....	33

A

Accessory socket information.....	26
ACC set mode	132
AGC function	82
Selectable AGC time constant.....	82
Setting the AGC time constant preset value.....	82
AFSK connection.....	23
AM mode selection.....	36
Antenna connection.....	16
Antenna tuner	120
Antenna tuner of the IC-PW1/EURO.....	122
Automatic antenna selection	120
Automatic tuner start	122
Manual tuning.....	121
Operation.....	121
Operating the AH-4 or AH-740	122
PTT tuner start	122
Specifications	170
Tuner operation.....	121
Tuning a narrow bandwidth antenna.....	121
APF (Audio Peak Filter) operation	43
Attenuator.....	80
Automatic transmission/reception setting	53, 61
Auto tune function.....	91
Auto tuning step function	33

B

Band edge warning beep.....	34
Band edge programming.....	35
Band stacking registers	29
Basic operation.....	27
BPSK and QPSK modes	59
Break-in function.....	93
Full break-in operation.....	93
Semi break-in operation	93

C

Center mode.....	71
CI-V	
Control command	159
Command table	160
Data content description.....	166
Data format.....	159
Remote jack (CI-V) information	159
Clock.....	123
Clock set mode.....	123
Clock backup battery replacement	156
Command table	160
Connection	
Advanced connections	18
Antenna connection.....	16
External antenna tuner connection.....	21
Connecting an AH-4	21
Connecting an AH-740	21
FSK and AFSK connections	23
When using the ACC socket or the microphone connector	23
When connecting to the USB connector.....	23
Grounding.....	16
Linear amplifier connections.....	22
Connecting a non-Icom linear amplifier	22
Connecting the IC-PW1/EURO.....	22
Power supply connections	20
Connecting a non-Icom DC power supply	20
Connecting PS-126.....	20
Required connections.....	17
CPU resetting	27, 157
CW operation.....	42
CW pitch control	42
CW reverse mode.....	42
CW sidetone function	42
CW mode selection	36

D

Daily timer setting	124
Data mode (AFSK) operation	68
Dial lock function	90
Digital voice recorder.....	98
Display set mode	134
Disposal.....	i
Drive gain adjustment.....	41
DSP filter shape.....	85
Dualwatch operation.....	87
Scanning during dualwatch	88

INDEX

E		K	
Electronic keyer functions.....	44	Keyer set mode.....	48
Editing a memory keyer.....	46	L	
Contest number set mode.....	47	LCD display.....	13
Memory keyer screen.....	45	Level set mode.....	128
EXPLICIT DEFINITIONS.....	i	Linear amplifier connections.....	22
External antenna tuner connection.....	21	Connecting a non-Icom linear amplifier.....	22
Connecting an AH-4.....	21	Connecting the IC-PW1/EURO.....	22
Connecting an AH-740.....	21	Load option set mode.....	146
F		M	
FCC INFORMATION.....	i	Main dial brake adjustment.....	153
FEATURES.....	i	Main/Sub band	
File		Equalization.....	28
Changing a file name.....	149	Selection.....	28
Deleting.....	150	Switching.....	28
Loading.....	145	MAINTENANCE.....	152
Saving.....	147	Memo pads.....	112
Fine Δ F scan.....	116	Calling up a frequency and operating mode.....	112
Fine programmed scan.....	116	Writing frequencies and operating modes into	
Firmware		memo pads.....	112
Confirmation.....	173	Memory keyer screen.....	45
Update.....	175	Memory channels.....	107
Fixed mode.....	72	Clearing.....	111
FM mode selection.....	36	Frequency transfers.....	110
FOREWORD.....	i	Transferring in the memory mode.....	110
Formatting the USB-Memory.....	151	Transferring in the VFO mode.....	110
Frequency calibration (approximate).....	155	Memory channel programming.....	109
Frequency setting.....	30	Programming in the memory mode.....	109
5 MHz band operation.....	31	Programming in the VFO mode.....	109
Direct frequency entry with the keypad.....	30	Memory list screen.....	108
Frequency transfers.....	110	Confirming programmed memory channels..	108
Selecting 1 Hz step.....	32	Memory names.....	111
Selecting "kHz" step.....	32	Editing.....	111
Tuning with the main dial.....	30	Operation.....	107
Front panel.....	1	Selection.....	107
FSK connection.....	23	Using the [▲]/[▼] keys.....	107
Full break-in operation.....	93	Using the keypad.....	107
Fuse replacement.....	157	Using the memory list screen.....	108
Circuitry fuse replacement.....	157	Setting select memory channels.....	118
DC power cable fuse replacement.....	157	Setting in scan screen.....	118
G		Setting in memory list screen.....	118
Grounding.....	16	Erasing the select scan setting.....	118
H		Memory mode selection.....	28
HM-36.....	24	Memory scan operation.....	117
I		Meter Display selection.....	38
IF filter.....	84	Meter type selection.....	39
Selection.....	84	Microphones.....	24
Filter passband width setting.....	84	Connector information.....	24
Filter shape set mode.....	86	Gain adjustment.....	40
Roofing filter selection.....	85	HM-36.....	24
IMPORTANT.....	i	SM-30.....	25
Installation.....	16	SM-50.....	25
Selecting a location.....	16	Mini scope screen.....	73
		Monitor function.....	95
		Multi-function digital meter.....	38

N		R	
NB set mode.....	89	Rear panel.....	11
Noise blanker.....	89	RECEIVE AND TRANSMIT.....	42
Noise reduction.....	90	Recording	
Notch function.....	91	Erasing the recorded contents.....	101
O		Protect the recorded contents.....	101
Opening the transceiver's case.....	156	Recording a message for transmit.....	102
Operating band selection.....	29	Recording.....	102
Using the band stacking registers.....	29	Confirming.....	102
Operating mode selection.....	36	Recording a received audio.....	99
Options.....	171	Basic recording.....	99
Others set mode.....	136	One-touch recording.....	99
P		Saving a voice message into the USB-Memory.....	106
PANEL DESCRIPTION.....	1	Saving the received audio memory.....	106
Screen menu arrangement.....	15	Saving the TX memory.....	106
Playing the recorded audio.....	100	Sending a recorded message.....	104
Basic playing.....	100	Transmit level setting.....	104
One-touch playing.....	100	Remote jack (CI-V) information.....	159
Power		Repeater operation.....	66
Applying power.....	27	Repeater access tone frequency setting.....	66
Before first applying power.....	27	Resetting the CPU.....	157
Power supply.....	20	RF gain adjusting.....	37
Non-Icom DC power supply.....	20	RIT function.....	81
PS-126.....	20	RIT monitor function.....	81
Preamplifier.....	80	Roofing filter selection.....	85
PRECAUTIONS.....	ii	RTTY	
Protection displays.....	158	Data saving.....	57
PSK operation.....	58	Editing RTTY memory.....	54
Data saving.....	65	Functions of the RTTY decoder display.....	52
Editing PSK memory.....	62	RTTY Decode screen (Normal).....	52
Functions of the PSK decoder display.....	60	RTTY Decode screen (Wide).....	52
PSK decode screen—the BPSK mode.....	59	RTTY decode set mode.....	55
PSK decode screen—the QPSK mode.....	59	RTTY (FSK) operation.....	50
PSK decode set mode.....	63	RTTY memory transmission.....	53
PSK memory edit screen.....	62	RTTY reverse mode.....	51
PSK memory transmission.....	61	RTTY mode selection.....	36
PSK mode selection.....	36	Setting the decoder threshold level.....	52
Setting the decoder threshold level.....	60		
Vector tuning indicator display example.....	58		
PTT tuner start.....	122		
Q			
Quick split function.....	97		
Quick tuning step.....	32		

INDEX

S	
Save option set mode	148
SCANS	113
Channels	113
Fine Δ F scan	116
Fine programmed scan.....	116
Memory scan operation.....	117
Preparation.....	113
Programmed scan operation	115
Scan set mode	114
Scan speed	113
Scan types.....	113
Scan resume ON/OFF.....	113
Select memory scan operation.....	117
Squelch condition	113
Tone scan	119
Screen saver function.....	158
Screen type and font selections	154
Semi break-in operation	93
SET MODE.....	126
ACC set mode	132
Clock set mode.....	123
Contest number set mode	47
Display set mode.....	134
Filter shape set mode	86
Keyer set mode.....	48
Level set mode	128
Load option set mode.....	146
NB set mode.....	89
Others set mode.....	136
Save option set mode.....	148
Set mode description.....	126
Set mode operation	126
Scan set mode	114
Scope set mode	74
Screen arrangement.....	127
Voice set mode	105
SM-30	25
SM-50	25
SPECIFICATIONS	170
Antenna tuner.....	170
General.....	170
Receiver	170
Transmitter.....	170
Spectrum scope screen.....	69
Center mode.....	71
Fixed mode.....	72
Marker display in the Center mode.....	71
Marker display in the Fixed mode.....	72
Mini scope screen	73
Scope attenuator	73
Scope set mode	74
USB mouse operation	79
Using the Spectrum scope	70
Speech compressor.....	94
Split frequency operation.....	96
Direct shift frequency input.....	96
Dualwatch function	96
Split lock function.....	96, 97
Quick split function	97
Squelch and receive (RF) sensitivity	37
Squelch adjusting	37
SSB mode selection	36
SUPPLIED ACCESSORIES.....	i
SWR reading	154
T	
TABLE OF CONTENTS.....	vi
Timer	123
Daily timer setting.....	124
Operation.....	125
Setting sleep timer.....	125
Tone scan	119
Tone squelch operation	67
Transmit filter width setting	94
Transmitting	40
Adjusting the transmit output power	40
Transverter jack information	23
Troubleshooting	152
Display.....	153
Format USB-Memory	153
Scanning	153
Transceiver power.....	152
Transmit and receive	152
Tuner operation.....	121
Tuning a narrow bandwidth antenna.....	121
Tuning with the main dial	30
Twin PBT operation	83
About Passband width and Shift value on the screen.....	83
PBT operation example	83
Twin peak filter.....	51
U	
Unpacking.....	16
Updating the firmware	173
Caution	173
File downloading.....	174
Preparation.....	174
USB connection.....	19
USB-Memory	
Saving a voice message.....	106
Unmounting	150
USB-Memory set menu	144
USB-Memory set screen arrangement.....	144
USB mouse operation	79

V

Vector tuning indicator display example	58
VFO mode selection	28
VOICE RECORDER FUNCTIONS	98
Playing the recorded audio	100
Basic playing	100
One-touch playing	100
Programming a memory name	103
Recording	
Erasing the recorded contents	101
Protect the recorded contents	101
Recording a message for transmit	102
Recording	102
Confirming	102
Recording a received audio	99
Basic recording	99
One-touch recording	99
Saving the received audio memory	106
Saving the TX memory	106
Sending a recorded message	104
Transmit level setting	104
Saving a voice message into the USB-Memory..	106
Voice set mode	105
Voice synthesizer operation	39
Volume setting	38
VOX function	92
Adjusting	92
Using	92

IC-7600 #03
(Europe)

< Intended Country of Use >
AT BE CY CZ DK EE
FI FR DE GR HU IE
IT LV LT LU MT NL
PL PT SK SI ES SE
GB IS LI NO CH BG
RO TR HR

IC-7600 #04
(Europe-1)

< Intended Country of Use >
AT BE CY CZ DK EE
FI FR DE GR HU IE
IT LV LT LU MT NL
PL PT SK SI ES SE
GB IS LI NO CH BG
RO TR HR

IC-7600 #05
(Spain)

< Intended Country of Use >
AT BE CY CZ DK EE
FI FR DE GR HU IE
IT LV LT LU MT NL
PL PT SK SI ES SE
GB IS LI NO CH BG
RO TR HR

IC-7600 #09
(Italy)

< Intended Country of Use >
AT BE CY CZ DK EE
FI FR DE GR HU IE
IT LV LT LU MT NL
PL PT SK SI ES SE
GB IS LI NO CH BG
RO TR HR

IC-7600 #10
(France)

< Intended Country of Use >
AT BE CY CZ DK EE
FI FR DE GR HU IE
IT LV LT LU MT NL
PL PT SK SI ES SE
GB IS LI NO CH BG
RO TR HR