

  
**ICOM**

144, 430, 1200, 2400, 5600 MHz +10 GHz  
ALL MODE TRANSCEIVER

**IC-905**

# Aim Higher!

VHF, UHF, and Explore  
the World of Microwave



\* 10 GHz band operations require the optional CX-10G.

\* Above photo uses some non-Icom genuine brackets for shooting purpose.

**DIGITAL**

# Industry First Multi-Band 144 MHz

## 144, 430, 1200, 2400, 5600 MHz & 10 GHz

### Explore the World of Microwave

The IC-905 is the industry's first microwave rig in the 144, 430, 1200, 2400, 5600 MHz and 10 GHz\* bands. Multi-mode operation including SSB, CW, AM, FM, RTTY, D-STAR DV/DD, and FM-TV (Amateur TV). Output power is 10 W on 144, 430, 1200 MHz, 2 W on 2400, 5600 MHz, and 0.5 W on 10 GHz.

\* CX-10G is required for 10 GHz operation.

### GPS-Controlled Oscillator for Ultimate Frequency Stability

Frequency accuracy and stability are required for SHF band operation. Even with a high-performance OCXO, the frequency gradually changes due to temperature and aging. To solve this problem, the IC-905 uses a high-precision 1 pulse-per-second (1 PPS) clock signal from an internal GPS (GNSS) receiver to enable advanced frequency control.

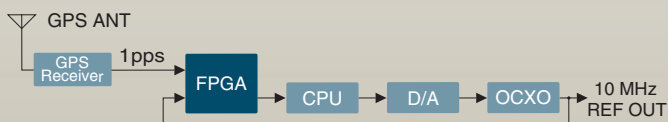

High Precision Frequency Oscillator using GPS

### Separate Controller and RF Unit Configuration

The IC-905 is the industry's first super efficient microwave base station with the RF unit designed to be at the base of the antenna, rather than in the shack. This design eliminates signal loss due to costly, long coax feed line runs found in legacy SHF designs. Optional 50 m (164 ft) or 20 m (65.6 ft) controller cable is available with the IC-905.

### Less Signal Loss

With the RF unit mounted at the antenna, transmit and receive signals are at their maximum efficiency as the coax feed line is measured in centimeters rather than meters, keep signal loss to a minimum. This is possible due to the controller cable providing digital communications between the controller and RF units.

### Power Supplied through the Controller Cable

The DC power is supplied from the controller to the RF unit through the controller cable, making it possible to supply power with a low loss. Moreover, optional CX-10G's power is supplied from the IC-905 RF unit.

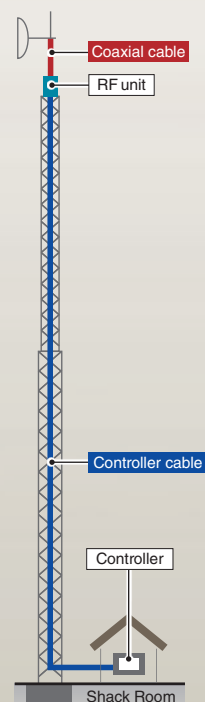

Controller

# to Microwave Transceiver!



RF Unit

## Wideband 50 MHz Span Real-time Spectrum Scope

A high-performance real-time spectrum scope and waterfall display are built in. The real-time spectrum scope can be adjusted for Center, Fixed, and Scroll mode, and it covers a wide band-width of up to 50 MHz span.

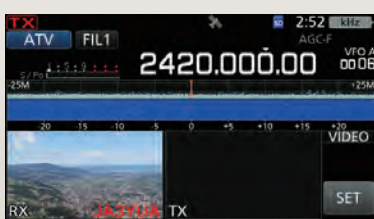

## ATV (Amateur TV) Mode

The IC-905 is compatible with the ATV (FM-TV, NTSC, PAL or SECAM) mode. With an analog camera connected, the IC-905 can transmit video, and receive a real-time video.

Furthermore, received videos can be shown on the display with composite video input.

## Icom Common User Interface

The controller of the IC-905 was designed based on the compact IC-705 and utilizes Icom's Common User Interface system used in Icom's touch screen transceivers.



## Full D-STAR Functions

DV, DD mode, DR function, Terminal mode, and Access Point mode enable easy use of D-STAR. It is also possible to send, receive, and view received pictures with the IC-905.

## Optional 10 GHz Transverter, CX-10G



CX-10G

The CX-10G transverter provides 10 GHz operation by converting to a 2400 MHz IF signal. 10 GHz operation becomes more approachable and easier to work. The CX-10G is in bypass mode when the use of the 2400 MHz band.

## A Variety of Optional Antennas

Optional Collinear antennas for 2400 MHz, 5600 MHz, and 10 GHz, are available. Additionally, a high-performance parabolic antenna for 10 GHz is also available.



Collinear antenna  
AH-24 for 2400 MHz  
AH-56 for 5600 MHz  
AH-100 for 10 GHz



Parabolic antenna  
AH-109PB for 10 GHz  
The CX-10G can be installed  
in the back of the antenna

## Other Features

- SD card slot
- USB Type-C™ connection for PC and mobile connectors
- Power Amp thermal protection function
- Δ TX and AFC (Automatic Frequency Control) function
- One-Touch FT8 mode preset
- Quick Data mode setting for SSTV, RTTY, PSK31, JT65B and FT8
- AMPS hole pattern and 1/4-20 tripod mount for controller unit
- Two call channels for each band (2 × 6 band)
- 500 memory channels divided into up to 100 groups
- 50 scan edges, 2500 repeater memories and 300 GPS memories

144, 430, 1200, 2400, 5600 MHz +10 GHz  
ALL MODE TRANSCEIVER

# IC-905

SPECIFICATIONS

GENERAL		
Frequency coverage (Varies by country.)	IC-905	144 – 146, 430 – 440, 1240 – 1300, 2300 – 2450, 5650 – 5850 MHz
	CX-10G	10,000 – 10,500 GHz
Mode		SSB, CW, AM, FM, RTTY, DV, DD*, ATV**
Power supply requirement	IC-905	13.8 V DC ±15% (Controller unit)
	CX-10G	12.0 V DC ±15% (Power supplied from the IC-905 RF unit)
Antenna impedance		50 Ω
Operating temperature range	Controller unit	0°C – 50°C, 32°F – 122°F
	RF unit, & CX-10G	-10°C – 55°C, 14°F – 131°F
Frequency stability		Less than ±65 ppb (Total deviation) GPS-Controlled Oscillator
Current drain (at 13.8 V DC)	RX Max. audio/Standby	Less than 3 A / 2 A (typical)
	TX Max. power	Less than 5.5 A
Dimensions (W × H × D) (Projections not included)	Controller unit	200 × 83.5 × 82 mm, 7.9 × 3.3 × 3.2 in
	RF unit	172 × 87 × 210 mm, 6.8 × 3.4 × 8.3 in
	CX-10G	181 × 115 × 64 mm, 7.1 × 4.5 × 2.5 in
Weight (Approximate)	Controller unit	940 g, 2.1 lb (supplied accessories not included)
	RF unit	3.2 kg, 7.1 lb (supplied accessories not included)
	CX-10G	13.4 kg, 2.9 lb (supplied accessories not included)

\*\* 1200 MHz and above.

TRANSMITTER		
Output power	144, 430 MHz	SSB, CW, FM, RTTY, DV : 10 W AM : 2.5 W
	1200 MHz	SSB, CW, FM, RTTY, DV, DD, ATV : 10 W AM : 2.5 W
	2400, 5600 MHz	SSB, CW, FM, RTTY, DV, DD, ATV : 2 W AM : 0.5 W
	10 GHz (with CX-10G)	SSB, CW, FM, RTTY, DV, DD, ATV : 0.5 W typ. AM : 0.125 W typ.
Modulation system	SSB	Digital PSN modulation
	FM	Digital Reactance modulation
	AM	Digital Low Power modulation
	DV, DD	Digital GMSK modulation
	ATV	Digital Reactance modulation
Spurious emission	144, 430 MHz	Less than -60 dBc
	1200 MHz	Less than -53 dBc
	2400, 5600 MHz	Less than -46 dBc
	10 GHz (with CX-10G)	Less than 50 μW
Microphone impedance		2.2 kΩ
CX-10G conversion gain		7 dB (typical)

RECEIVER		
Receiver system	144, 430 MHz	RF Direct Sampling
	1200, 2400, 5600 MHz	Down Conversion IF Sampling
	10 GHz (with CX-10G)	2400 MHz Transverter + Down Conversion IF Sampling
IF frequency	1200 MHz	1st IF: 331 – 371 MHz
	2400, 5600 MHz	1st IF: 914 MHz band, 2nd IF: 346 MHz band
	10 GHz (with CX-10G)	2400 – 2450 MHz (2400 MHz IF connector)
Sensitivity (Less than)	144, 430, 1200, 2400 MHz bands	5600 MHz band (with CX-10G)
	SSB, CW (Filter: SOFT) (at 10 dB S/N)	-19 dBμV (0.11 μV)
	AM (at 10 dB S/N)	0 dBμV (1.0 μV)
	FM (at 12 dB SINAD)	-15 dBμV (0.17 μV)
	DV (at 1% BER (PN9))	-9 dBμV (0.35 μV)
	DD (at 1% BER (PN9))	4 dBμV (1.58 μV)**
		10 GHz band (with CX-10G)
		-17 dBμV (0.14 μV)**
		1 dBμV (1.1 μV)**
		-13 dBμV (0.22 μV)**
		(Not specified)
		(Not specified)

Specifying PREAMP ON in 144, 430, and 1200 MHz bands. No PREAMP ON/OFF in 2400 and 5600 MHz bands. \*\* 1200, 2400 MHz bands only. \* Cable loss between the IC-905 and CX-10G is less than 1 dB.

Sensitivity (for EUR version)	144, 430, 1200, 2400 MHz bands	5600 MHz bands
	SSB, CW (at 12 dB SINAD)	Less than -6 dBμV emf (BW= 2.4 kHz, Filter: SOFT)
	AM (at 12 dB SINAD)	Less than 0 dBμV emf (BW= 4 kHz, modulation 60%)
	FM (at 12 dB SINAD)	Less than -6 dBμV emf (BW= 7 kHz, modulation 60%)
Specifying PREAMP ON in 144, 430, and 1200 MHz bands. No PREAMP ON/OFF in 2400 and 5600 MHz bands.		
Selectivity	SSB (BW=2.4 kHz, Filter: SHARP)	More than 2.4 kHz/-3 dB
	CW (BW=500 Hz)	More than 500 Hz/-3 dB
	RTTY (BW=500 Hz)	More than 500 Hz/-3 dB
	AM (BW=6 kHz)	More than 6.0 kHz/-3 dB
	FM (BW=15 kHz)	More than 12.0 kHz/-6 dB
	DV (Ch. Spacing=12.5 kHz)	Less than -50 dB
	DD (Ch. Spacing=300 kHz)	Less than -40 dB
Audio output power	Internal SP	More than 530 mW (12 Ω, 1 kHz, 10% distortion)
	External SP	More than 200 mW (8 Ω, 1 kHz, 10% distortion)
	AV-OUT	More than -6 dBV (600 Ω, Max. power)
		1 V p-p typ. (Composite video output)
AF output impedance	External SP	8 Ω
	AV-OUT	600 Ω (Audio), 75 Ω (Video)
CX-10G conversion gain		6 dB (typical)

All stated specifications are subject to change without notice or obligation.

Icom, and the Icom logo are registered trademarks of Icom Incorporated (Japan) in Japan, the United States, the United Kingdom, Germany, France, Spain, Russia, Australia, New Zealand, and/or other countries. D-STAR (Digital Smart Technology for Amateur Radio) is a digital radio protocol developed by JARL (Japan Amateur Radio League). USB Type-C is a trademark of USB Implementers Forum, Inc. Windows is a trademark of the Microsoft group of companies. All other trademarks are the properties of their respective holders. This product includes "zlib", "libpng" and real-time OS "RTX" open source software, and is licensed according to the open source software license. This software is based in part on the work of the Independent JPEG Group, and is licensed according to the open source software license.

Les spécifications et informations données dans ce document peuvent être modifiées sans préavis.

Controller

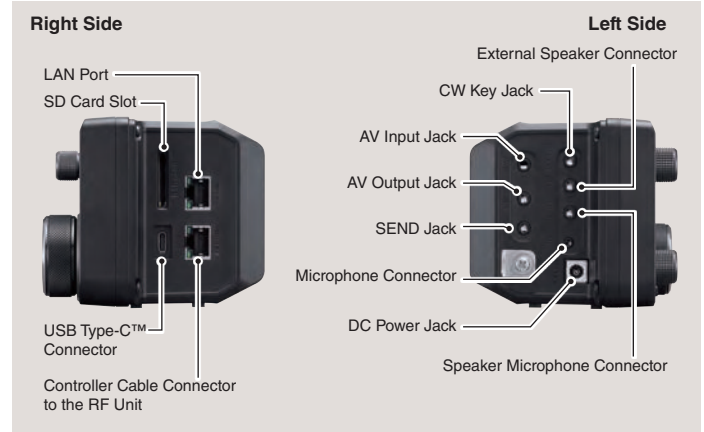

RF Unit

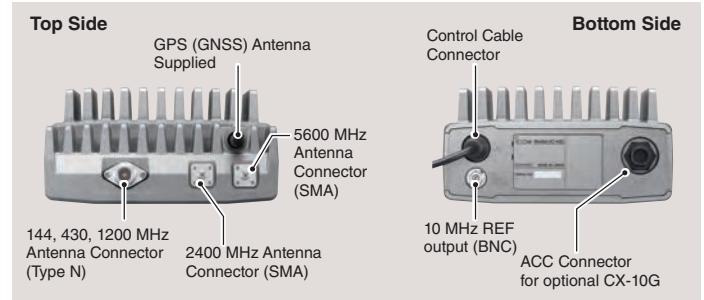

IC-905 SUPPLIED ACCESSORIES

- Accessory connector
- OPC-2488, DC power cable
- GPS antenna
- Cushion sheet
- U-bolt clamp kit
- CW KEY PLUG
- Controller cable (5 m, 16.4 feet)
- HM-243, Speaker-microphone
- RF unit bracket kit
- Spare fuse

OPTIONAL ACCESSORIES

- **CS-905** PROGRAMMING SOFTWARE  
Download free software for Windows™ PC
- **CX-10G** 10 GHz TRANSVERTER
- **HM-243** SPEAKER-MICROPHONE (Same as supplied)
- **AH-24** 2400 MHz BAND COLLINEAR ANTENNA
- **AH-56** 5600 MHz BAND COLLINEAR ANTENNA
- **AH-100** 10 GHz BAND COLLINEAR ANTENNA (for CX-10G)
- **AH-109PB** 10 GHz PARABOLIC ANTENNA (for CX-10G)
- **OPC-2513** CONTROLLER CABLE (20 m, 65.6 feet)
- **OPC-2509** CONTROLLER CABLE (50 m, 164.0 feet)
- **RS-BA1** Version 2 IP REMOTE CONTROL SOFTWARE (Available soon)

The optional accessories are subject to change without notice.

CX-10G SUPPLIED ACCESSORIES

- BNC coaxial cable (2 m, 6.5 feet)
- Mounting bracket kit
- Control cable (2 m, 6.5 feet)
- U-bolt clamp kit

Icom France s.a.s.

Zac de la Plaine - 1, Rue Brindejonn des Moulinais  
 BP 45804 - 31505 TOULOUSE CEDEX 5  
 Tél : +33 (0)5 61 36 03 03 - Fax : +33 (0)5 61 36 03 00  
 WEB ICOM : <http://www.icomfrance.com>  
 E-mail : [icom@icomfrance.com](mailto:icom@icomfrance.com)



Flash code

DISTRIBUTEUR AGRÉÉ ICOM :