

Connecting the RF unit and the controller

Connect the RF unit and the controller, as shown below.

- ① Prepare antennas and cables, suitable for your operating environment.

NOTE: Attach the connector cap when no equipment is connected.

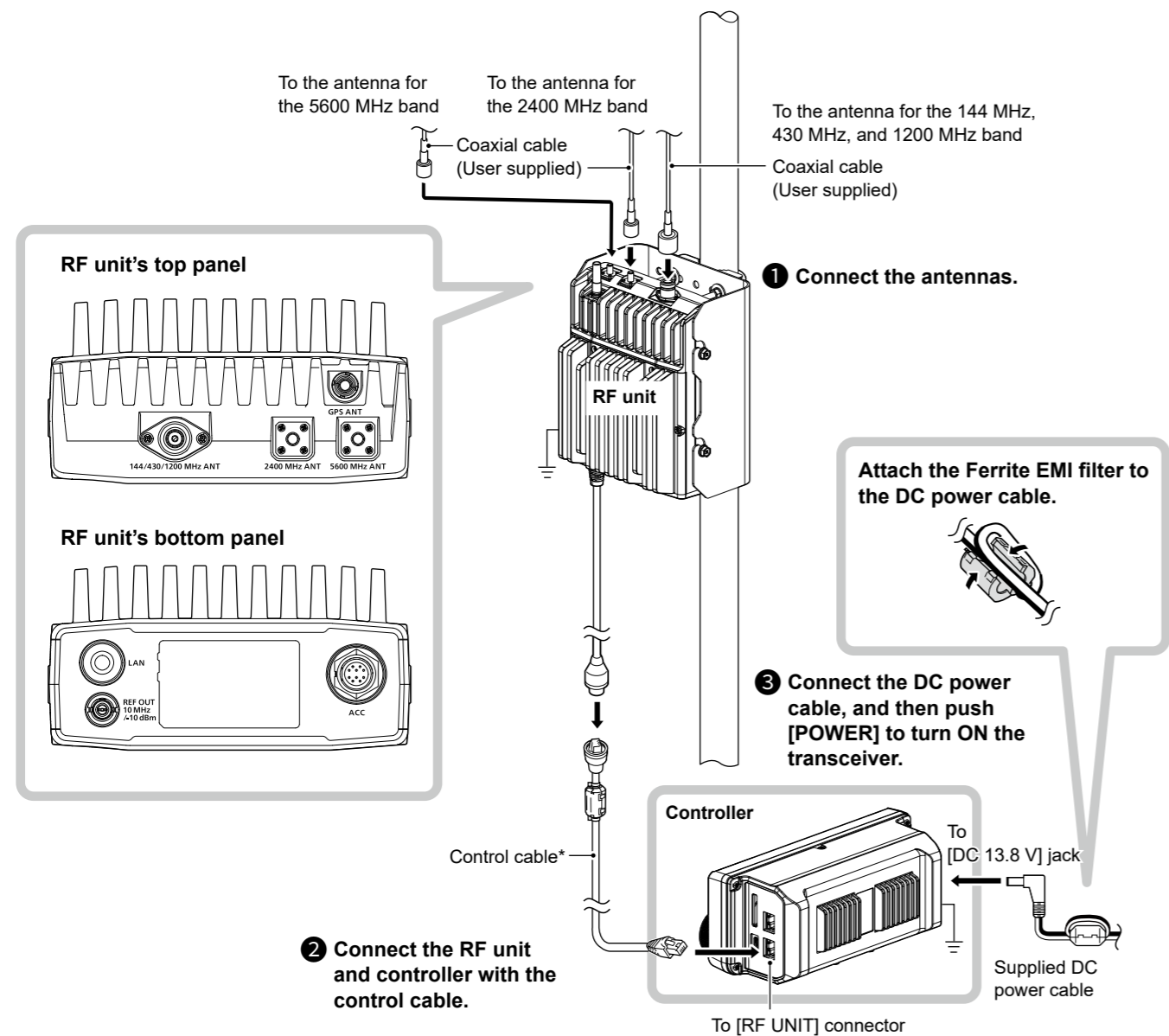

* The following cables are usable, depending on your operating environment.
 Supplied control cable: 5 m (16.4 feet)
 Optional OPC-2513 control cable: 20 m (65.6 feet)
 Optional OPC-2509 control cable: 50 m (164.0 feet)

TIP:

To prevent water from seeping into the connection
 After connecting, cover the connectors and Ferrite EMI filter with the supplied or user supplied rubber vulcanizing tape.

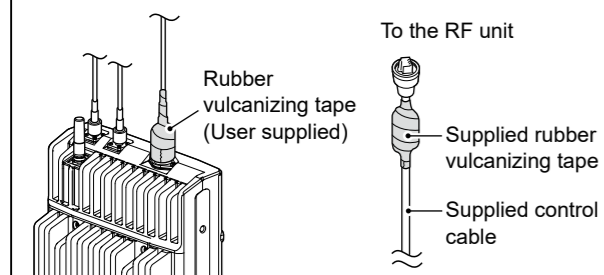

About an external DC power supply

The transceiver needs:

- 13.8 V DC
- A power supply with an over current protective line, and low voltage fluctuation or ripple.

- ① Confirm that the power supply is OFF before connecting the DC power cable.

ICOM CONNECTION GUIDE

ALL MODE TRANSCEIVER IC-905

Thank you for choosing this Icom product.
READ ALL INSTRUCTIONS carefully and completely before using this product.

Important

FIRST, CAREFULLY READ BASIC MANUAL that is boxed with the transceiver.

SAVE THESE INSTRUCTIONS— These instructions contain installation instructions for the IC-905.

The Connection Guide for German, Spanish, French, and Italian is at the end of the Basic manual for each respective language.

BE CAREFUL! When you install the IC-905's RF unit and antenna, wear gloves to avoid cutting your hand on the sharp edges of the metal parts or antenna.

Icom is not responsible for any building breakage, any damage resulting from a drop of the mounting bracket from a high place or unstable site, or any personal injury or any accident in any other case. Be sure to consult an expert engineer for installation help.

Requirements for attaching and connecting

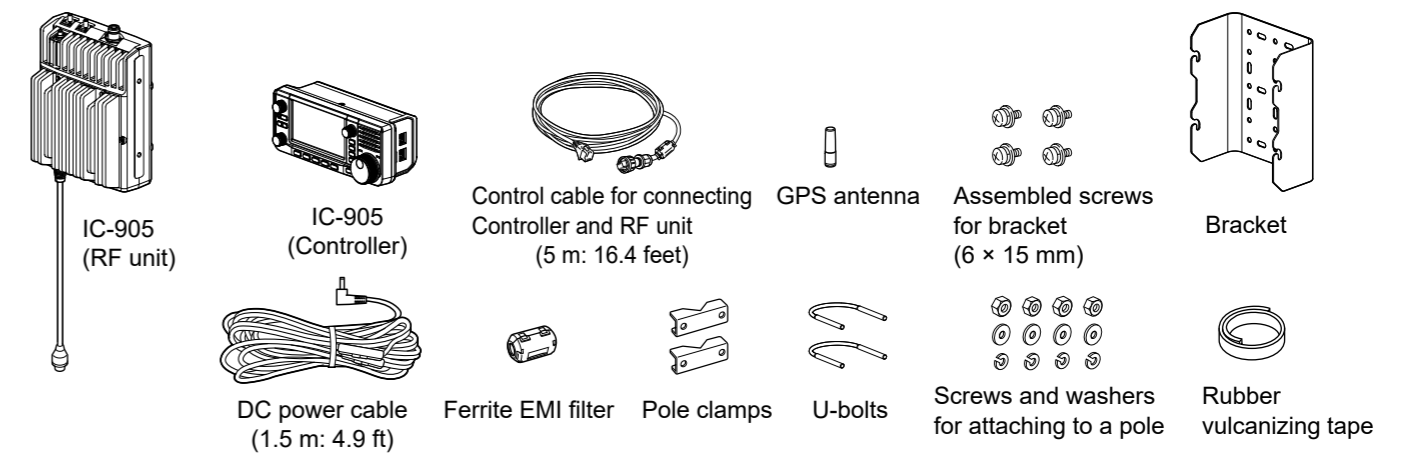

Important notes

⚠ **WARNING! NEVER** disassemble, modify, or repair the transceiver. This may result in an electrical shock, cause a fire or damage the transceiver.

- **NEVER** use the RF unit without securing the cables so that they cannot be pulled or stretched.
- Attach the RF unit in a vertical position with the ACC connector down. The water jet resistance cannot be guaranteed if you attach the RF unit upside down.
- **NEVER** immerse the RF unit in water. The RF unit meets IP55* requirements for dust-protection and water jet resistance. However, once the RF unit has been dropped, dust-protection and water jet resistance cannot be guaranteed due to the fact that the RF unit may be cracked or the waterproof seal damaged, and so on.
* Only when the connector covers are attached.
- **BE SURE** to check your local regulations or laws to select the appropriate operating frequency.

Selecting a location

NEVER place the transceiver and antenna in areas such as:

- The RF unit and controller cannot be connected using the supplied or optional control cable.
 - ① Operation cannot be guaranteed if you:
 - Cut or extend the control cable.
 - Use other than the specified cable.
 - ② The RF unit accepts the power through the control cable.
- A place without adequate ventilation or that gets wet with rain. (Only for the controller)
 - ① The controller does not have the dust-protection and water jet resistance.
- An unstable place that slopes or vibrates.
- Too close to each other or other devices, such as TV antennas.
- Near a radio tower emitting strong radio waves.
- Near a metal structure, such as warehouses.
 - ① If there is a metal wall, handrail, or pillar where the radio wave from the antenna travels, the radio wave may be reflected irregularly.
- A place without direct lightning protection, such as lightning rods.
- A place without grounding.
- A place that the transceiver cannot receive signals from the GPS satellites.
 - ① The IC-905 automatically adjusts the internal reference frequency using the received GPS data as the default setting.

NOTE:

- Make the connection as short as possible.
- Use a coaxial cable (user supplied) that is as low loss as possible.
- **DO NOT** bend the coaxial cable more than the allowable bending radius. This may cause more losses.

Attaching the RF unit to a pole

Attach the RF unit to a pole, as shown below.

CAUTION: Attach the RF unit in a vertical position with the ACC connector down. The water jet resistance cannot be guaranteed if you attach the RF unit upside down.

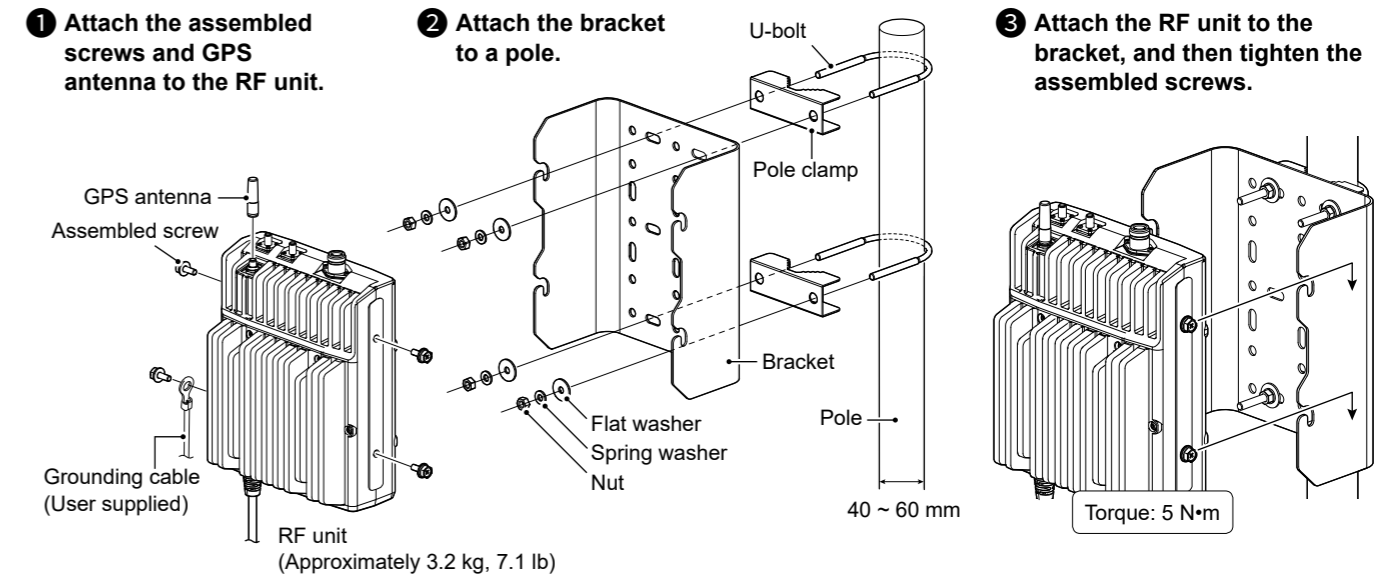

Dimensions

IC-905 RF unit with the bracket unit: mm (inch)

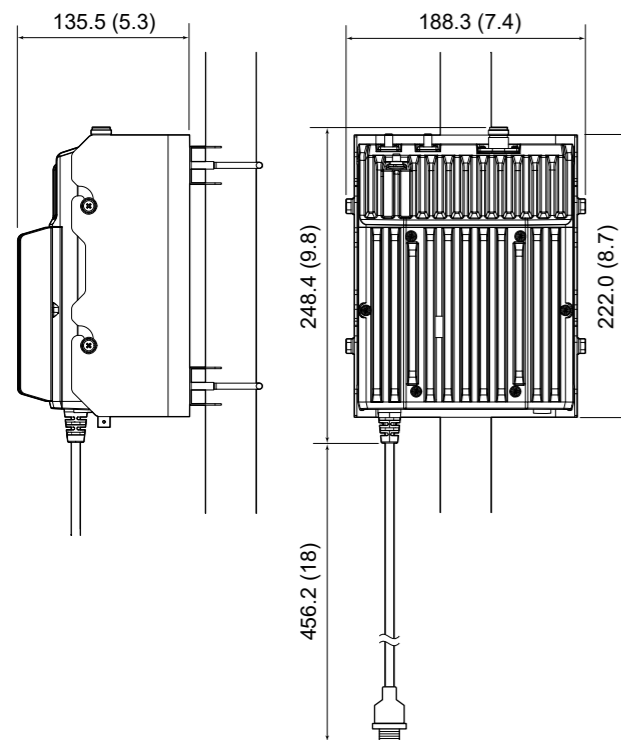

About the operating environment

- Communication may be temporarily unavailable or interrupted when:
 - The received signal is too weak.
 - There is heavy rain or snow.
 - Snow or ice accumulates on the RF unit or external devices.
- When using in a cold location, **DO NOT** bend, pull, or move the cable if the cable is hardened. This may damage the cable.

Grounding

To prevent electrical shock, television interference (TVI), broadcast interference (BCI) and other problems, ground the RF unit and controller.

For best results, connect a heavy gauge wire or strap to a long ground rod. Make the distance between the ground terminal and ground as short as possible.

⚠ **WARNING! NEVER** connect the ground terminal to a gas or electric pipe, since the connection could cause an explosion or electric shock.

