



SERVICE MANUAL

ALL MODE TRANSCEIVER

IC-905

S-15913XZ-C1
May 2023

Icom Inc.

INTRODUCTION

We will supply spare units for the IC-905 (only #12) described in this service manual.
Accordingly, this service manual focuses on the spare units that can be supplied, consumable parts and parts that are considered necessary in case of physical damage, instead of those on the individual electronic parts list.

This service manual describes the latest technical information for the IC-905 ALL MODE TRANSCEIVER at the time of publication.

Model	Version	Version Number	TX output power
IC-905	USA	#12	VHF, UHF, and 1.2 GHz bands: 10 W 2.4 GHz and 5.6 GHz bands: 2 W
	EUR	#13	

To upgrade quality, any electrical or mechanical parts and internal circuits are subject to change without notice or obligation.

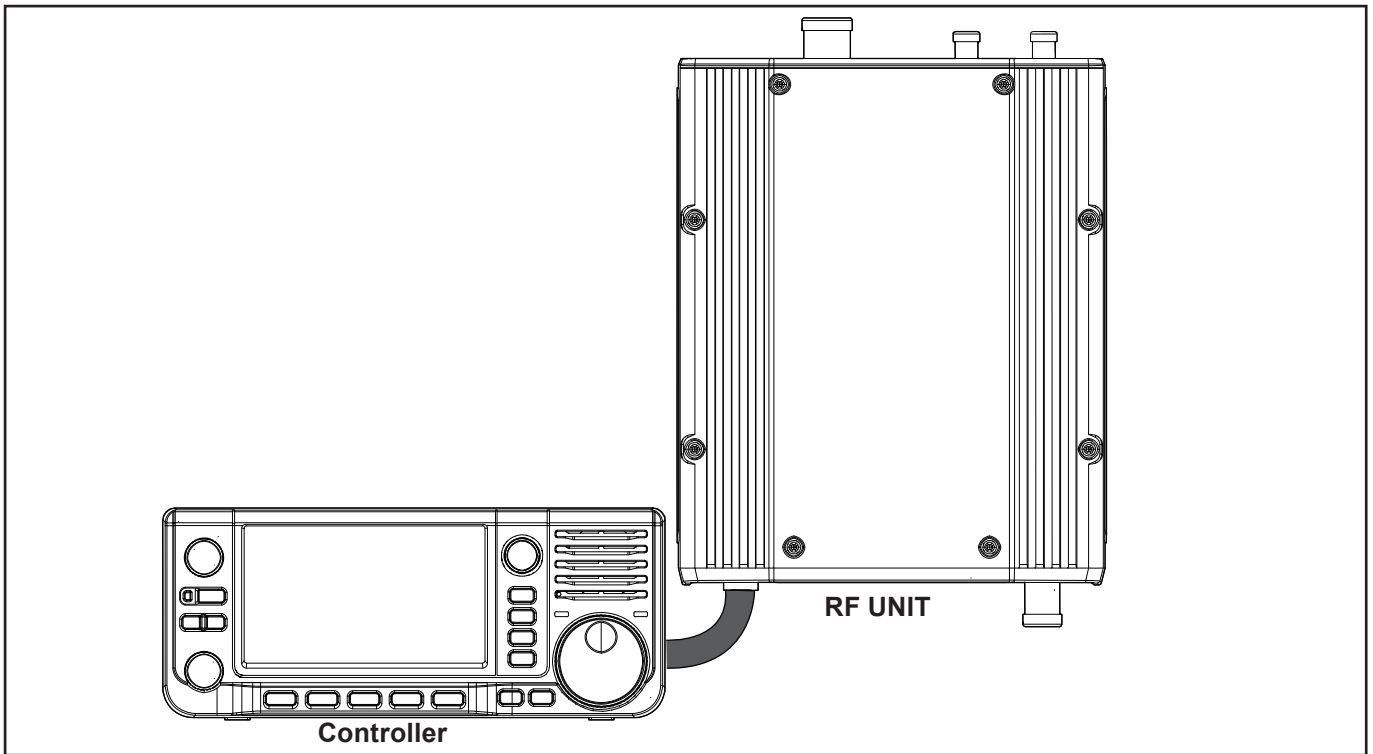

ORDERING PARTS

Be sure to include the following four points when ordering replacement parts:

1. 10-digit Icom part number
2. Component name
3. Equipment model name and unit name
4. Quantity required

<ORDER EXAMPLE>

0342091202 C 905 #12 MAIN IC-905 MAIN UNIT 1 piece
8010026180 4209 CHASSIS IC-905 CHASSIS 1 piece

SERVICE CAUTION

NEVER connect the DUT to an AC outlet or to a DC power supply that uses more than the specified voltage. This will ruin the DUT.

DO NOT expose the DUT to rain, snow or liquids.

DO NOT reverse the polarity of the DC power cable when directly applying power to the DUT/circuit.

DO NOT apply an RF signal of more than 20 dBm (100 mW) to the antenna connector. This could damage the DUT's front-end.

REPAIR NOTES

1. Make sure that the problem is internal before disassembling the DUT.
2. **DO NOT** open the DUT until the DUT is disconnected from its power source.
3. **DO NOT** short any circuits or electronic parts.
4. **DO NOT** keep power ON for a long time when the DUT is defective.
5. **NEVER** transmit power into a Standard Signal Generator or a Sweep Generator. Otherwise the RF power may damage them.
6. **ALWAYS** connect a 30 dB to 40 dB attenuator between the DUT and such test equipment.
7. **READ** the instructions of the test equipment thoroughly before connecting it to the DUT.

TABLE OF CONTENTS

SECTION 1 SPECIFICATIONS

SECTION 2 INSIDE VIEW

SECTION 3 DISASSEMBLY INSTRUCTION

SECTION 4 INTERFACE INFORMATION

SECTION 5 ADJUSTMENT PROCEDURE

5-1	PREPARATION	5-1
5-2	FRONT PANEL OPERATION VERIFICATION	5-5
5-3	IDLING ADJUSTMENT	5-6
5-4	VHF BAND TRANSMIT ADJUSTMENT	5-7
5-5	UHF BAND TRANSMIT ADJUSTMENT	5-8
5-6	1.2 GHz BAND TRANSMIT ADJUSTMENT	5-9
5-7	2.4 GHz BAND TRANSMIT ADJUSTMENT	5-10
5-8	5.6 GHz BAND TRANSMIT ADJUSTMENT	5-11
5-9	REFERENCE FREQUENCY ADJUSTMENT	5-12
5-10	VHF BAND RECEIVE ADJUSTMENT	5-13
5-11	UHF BAND RECEIVE ADJUSTMENT	5-14
5-12	1.2 GHz BAND RECEIVE ADJUSTMENT	5-15
5-13	2.4 GHz BAND RECEIVE ADJUSTMENT	5-16
5-14	5.6 GHz BAND RECEIVE ADJUSTMENT	5-17
5-15	CX-10G TRANSMIT ADJUSTMENT.....	5-18
5-16	CX-10G RECEIVE ADJUSTMENT	5-20
5-17	CX-10G TRANSMIT VERIFICATION	5-21

SECTION 6 SPARE PARTS AND UNITS

SECTION 7 MECHANICAL PARTS

SECTION 8 BOARD LAYOUT

SECTION 9 GENERAL WIRING

SECTION 10 BLOCK DIAGRAM

SECTION 11 SCHEMATIC DIAGRAM

■ GENERAL

- Frequency coverage (unit: MHz):

USA version

Receiver/Transmitter	144.000000 ~ 148.000000
	430.000000 ~ 450.000000
	1240.000000 ~ 1300.000000
	2300.000000 ~ 2309.999999
	2390.000001 ~ 2450.000000
	5650.000000 ~ 5925.000000

EUR version

Receiver/Transmitter	144.000000 ~ 146.000000
	430.000000 ~ 440.000000
	1240.000000 ~ 1300.000000
	2300.000000 ~ 2450.000000
	5650.000000 ~ 5850.000000

① **BE SURE** to check your local regulations or laws to select the appropriate operating frequency.

- Operating modes: USB/LSB (J3E), CW (A1A), RTTY (F1B), AM (A3E), FM (F2D/F3E), DV (F7W), DD (F1D), and ATV (F3F/F8W)
- Number of memory channels: 500 channels (in up to 100 groups)
- Number of program scan channels: 25 channels (2 edge frequencies in each channel)
- Number of call channels: 12 channels (2 channels in each of the 6 bands)
- Number of repeater memories: 2500
- Number of GPS memories: 300
- Antenna impedance: 50 Ω unbalanced
- Antenna connector: SMA (50 Ω) \times 2 (for the 2400/5600 MHz band)
Type-N \times 1 (for the 144/430/1200 MHz band)
- Power source requirement:

Controller	13.8 V DC (\pm 15%)
------------	------------------------
- Operating temperature range:

Controller	0°C ~ 50°C, 32°F ~ 122°F
RF UNIT	-10°C ~ +55°C, 14°F ~ 131°F
- Frequency stability: \pm 65 ppb or less
(Total deviation including variations in operating temperature.)
- Frequency resolution: 1 Hz (minimum)
- Power consumption:

Receive	Standby	2 A (typical)
	Maximum audio	3 A or less
Transmit	Maximum power	5.5 A or less

 (When using an external DC power (13.8 V DC) and supplied control cable)
- Dimensions (projections not included):

Controller	200.0 (W) \times 83.5 (H) \times 82.0 (D) mm, 7.9 (W) \times 3.3 (H) \times 3.2 (D) in
RF unit	172.0 (W) \times 87.0 (H) \times 210.0 (D) mm, 6.8 (W) \times 3.4 (H) \times 8.3 (D) in
- Weight (approximate, without the supplied accessories):

Controller	940 g, 2.1 lb
RF UNIT	3.2 kg, 7.1 lb

■ TRANSMITTER

- Transmit output power:
 - 144/430 MHz band
 - SSB, CW, FM, RTTY, DV 10 W
 - AM 2.5 W
 - 1200 MHz band
 - SSB, CW, FM, RTTY, DV, DD, ATV 10 W
 - AM 2.5 W
 - 2400/5600 MHz band
 - SSB, CW, FM, RTTY, DV, DD, ATV 2 W
 - AM 0.5 W
- Modulation system:
 - SSB Digital PSN modulation
 - FM Digital Reactance modulation
 - AM Digital Low power modulation
 - DV and DD Digital GMSK modulation
 - ATV Digital Reactance modulation
- Spurious emission:
 - Spurious
 - 144 MHz band -60 dBc or less
 - 430 MHz band -60 dBc or less
 - 1200 MHz band -53 dBc or less
 - 2400 MHz band -46 dBc or less
 - 5600 MHz band -46 dBc or less
 - Out-of-band
 - 144 MHz band -60 dBc or less
 - 430 MHz band -60 dBc or less
 - 1200 MHz band -50 dBc or less
 - 2400 MHz band -43 dBc or less
 - 5600 MHz band -43 dBc or less
- Carrier suppression: 50 dB or more
- Unwanted sideband suppression: 50 dB or more
- Microphone impedance: 2.2 k Ω (When using PTT by the [MIC] jack, 1.2 k Ω)
- Video signal input level: 1 Vp-p (typical, at 75 Ω)
- Video signal input impedance: 75 Ω

■ RECEIVER

- Receive system:

144/430 MHz band	RF Direct Sampling
1200/2400/5600 MHz band	Down Conversion IF Sampling
- Intermediate frequencies:

1200 MHz band	1st 331 ~ 371 MHz
2400/5600 MHz band	1st 914 MHz band, 2nd 346 MHz band
- Sensitivity:

SSB/CW (Filter: SOFT, 10 dB S/N)	
144/430/1200/2400 MHz band	-19 dB μ V (PD) (0.11 μ V) or less
5600 MHz band	-16 dB μ V (PD) (0.15 μ V) or less
AM (at 10 dB S/N)	
144/430/1200/2400 MHz band	0 dB μ V (PD) (1.0 μ V) or less
5600 MHz band	+3 dB μ V (PD) (1.4 μ V) or less
FM (at 12 dB SINAD)	
144/430/1200/2400 MHz band	-15 dB μ V (PD) (0.17 μ V) or less
5600 MHz band	-12 dB μ V (PD) (0.25 μ V) or less
DV (1% BER (PN9))	
144/430/1200/2400 MHz band	-9 dB μ V (PD) (0.35 μ V) or less
5600 MHz band	-6 dB μ V (PD) (0.50 μ V) or less
DD (1% BER (PN9))	
1200/2400 MHz band	+4 dB μ V (PD) (1.58 μ V) or less
5600 MHz band	+7 dB μ V (PD) (2.23 μ V) or less

① Preamp is ON in the 144 MHz, 430 MHz, and 1200 MHz bands.
- Sensitivity for the European version:

SSB/CW (BW=2.4 kHz, Filter: SOFT, 12 dB SINAD)	
144/430/1200/2400/5600 MHz band	-6 dB μ V emf or less
AM (BW=4 kHz, 60% deviation, 12 dB SINAD)	
144/430/1200/2400/5600 MHz band	0 dB μ V emf or less
FM (BW=7 kHz, 60% deviation, 12 dB SINAD)	
144/430/1200/2400/5600 MHz band	-6 dB μ V emf or less

① Preamp is ON in the 144 MHz, 430 MHz, and 1200 MHz bands.
- Selectivity (Filter: SHARP):

SSB (BW=2.4 kHz)	2.4 kHz/-3 dB or more, 3.6 kHz/-60 dB or less
CW (BW=500 Hz)	500 Hz/-3 dB or more, 700 Hz/-60 dB or less
RTTY (BW=500 Hz)	500 Hz/-3 dB or more, 700 Hz/-60 dB or less
AM (BW=6 kHz)	6.0 kHz/-3 dB or more, 15 kHz/-60 dB or less
FM (BW=15 kHz)	12.0 kHz/-6 dB or more, 20 kHz/-60 dB or less
DV (Channel spacing=12.5 kHz)	-50 dB or less
DD (Channel spacing=300 kHz)	-40 dB or less
- Spurious and image rejection:

SSB/CW	
144/430 MHz band	70 dB or more
1200/2400/5600 MHz band	50 dB or more
AM/FM/DV	
144/430 MHz band	60 dB or more
1200/2400/5600 MHz band	50 dB or more
DD	
1200/2400/5600 MHz band	50 dB or more
- Audio output power:

Internal speaker	0.53 W or more (12 Ω load, 1 kHz, 10% distortion)
External speaker	0.2 W or more (8 Ω load, 1 kHz, 10% distortion)
[AV-OUT] jack	-6 dBV or more (maximum audio, 600 Ω load) (audio), 1 Vp-p (test pattern) (video)
- Output impedance:

[EXT-SP] jack	8 Ω
[AV-OUT] jack	600 Ω (audio), 75 Ω (video)
- RIT variable range: \pm 9.999 kHz
- ANF attenuation: 30 dB or more (with 1 kHz single tone)
- MNF attenuation: 70 dB or more
- NR attenuation: 6 dB or more (noise rejection in SSB)

① All stated specifications are typical and subject to change without notice or obligation.

① See the optional CX-10G service manual about the specifications on the 10 GHz band.

SECTION 2

INSIDE VIEW

• CONTROLLER

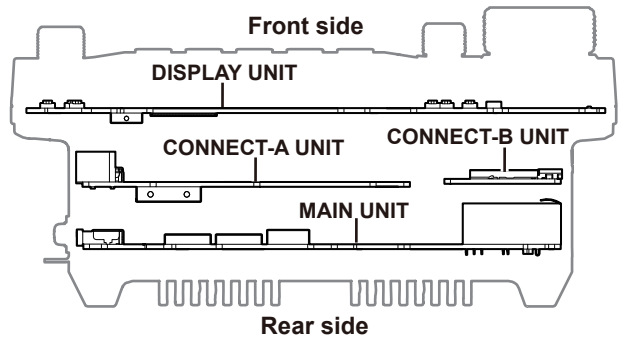
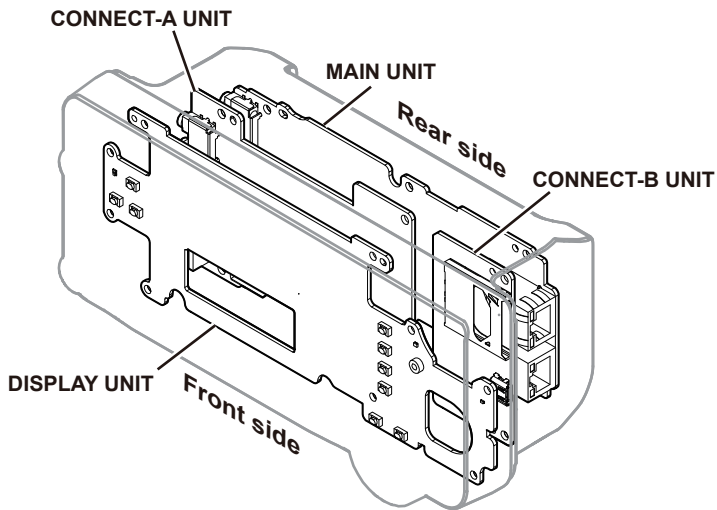

• RF UNIT

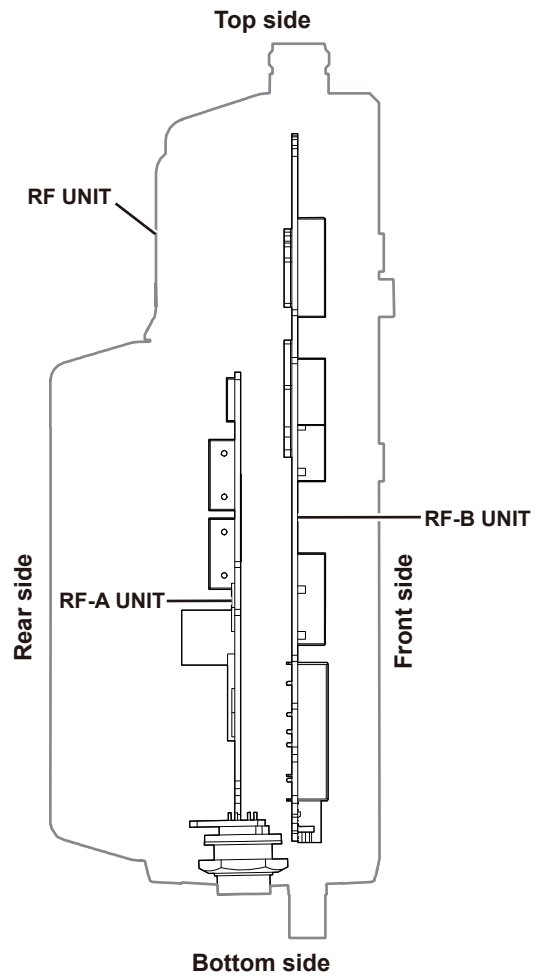
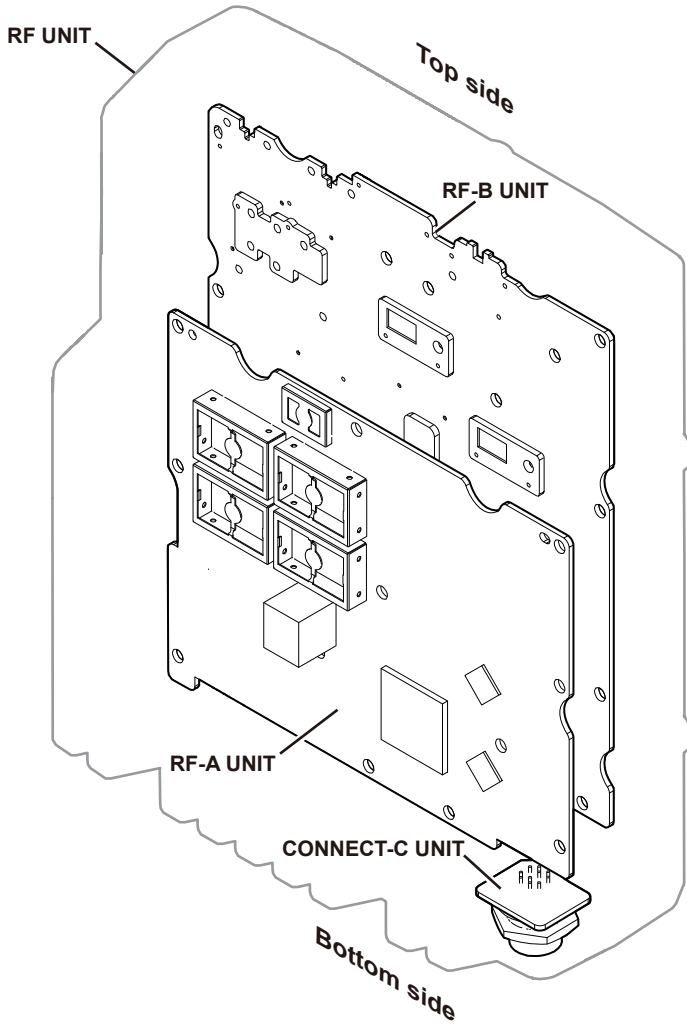

• DISPLAY UNIT

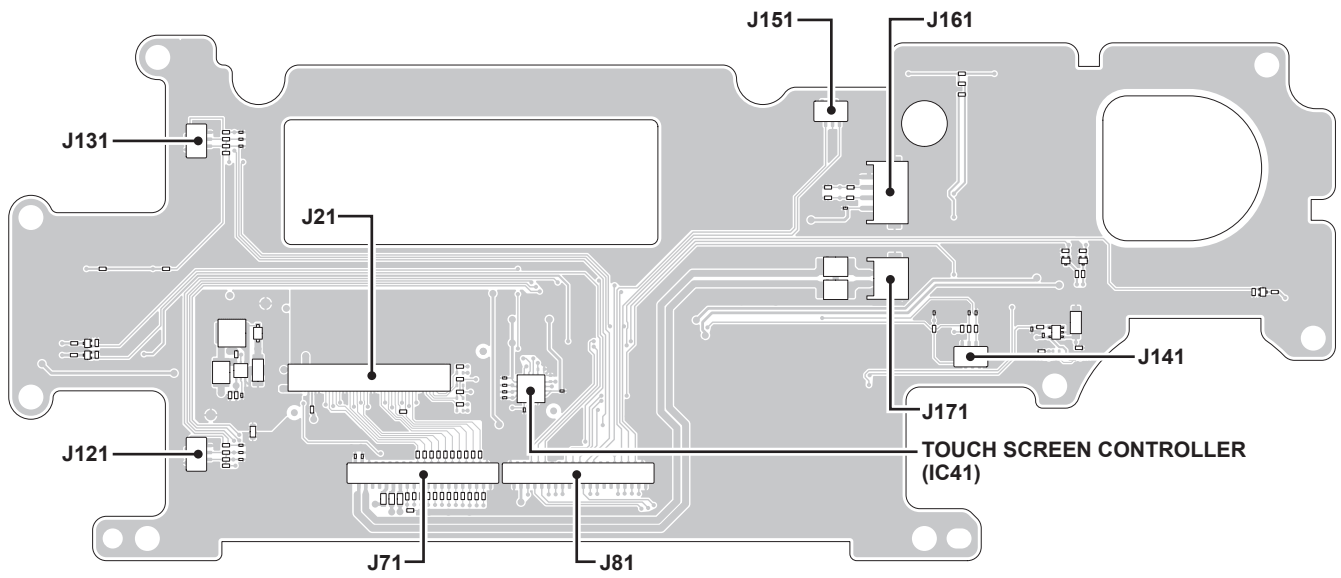

• MAIN UNIT (Top view)

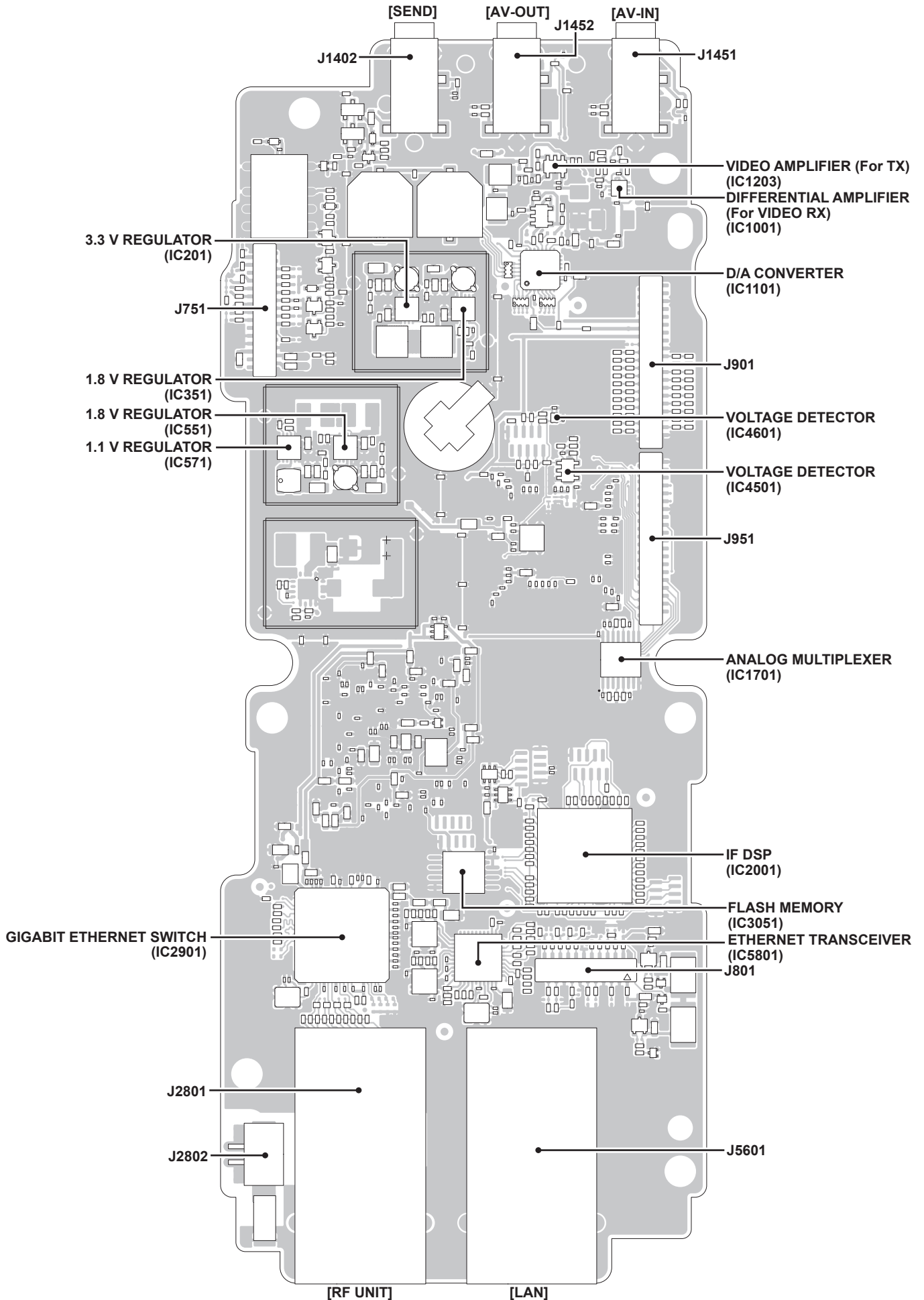

• MAIN UNIT (Bottom view)

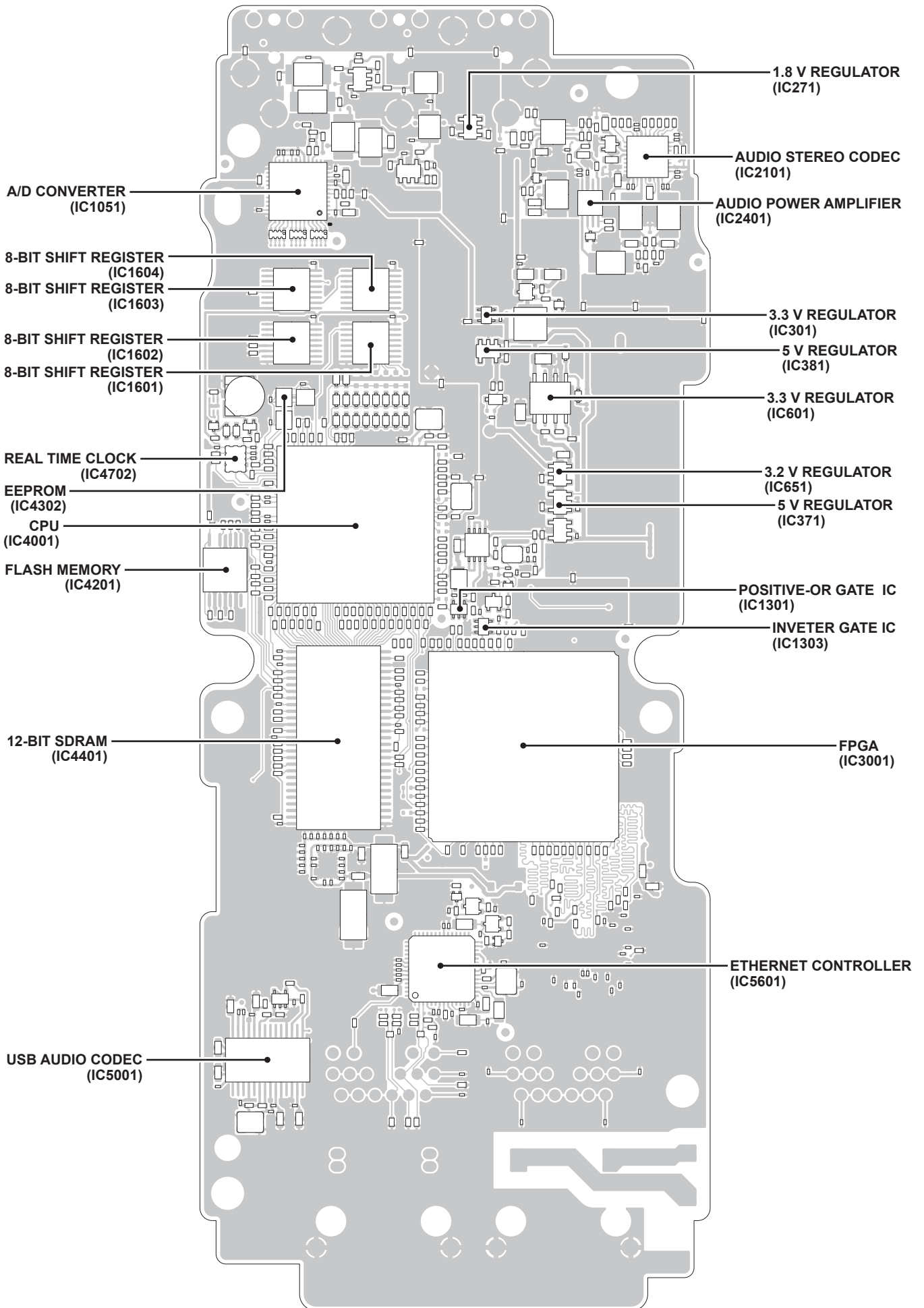

• RF-A UNIT (Top view)

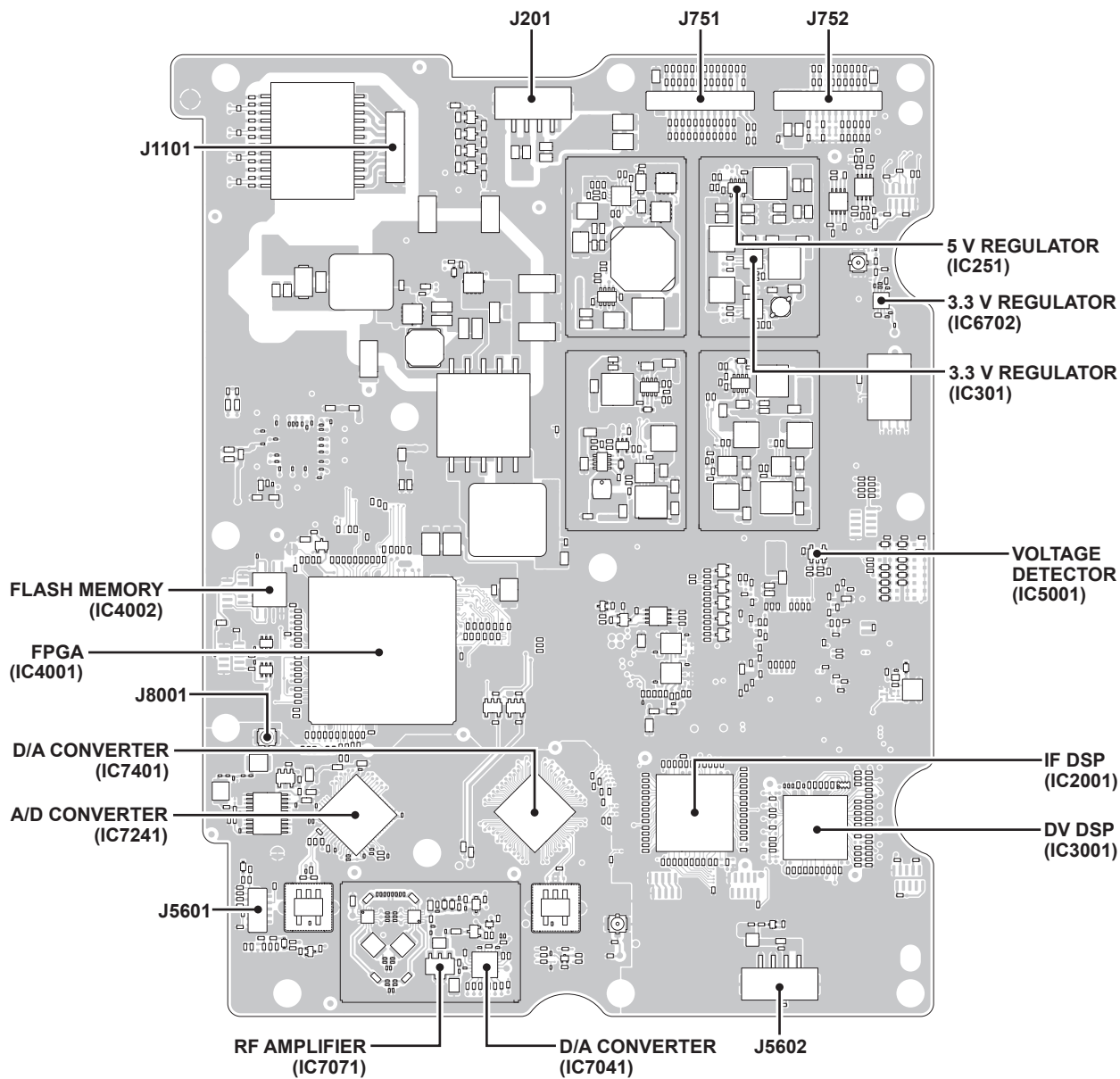

• RF-A UNIT (Bottom view)

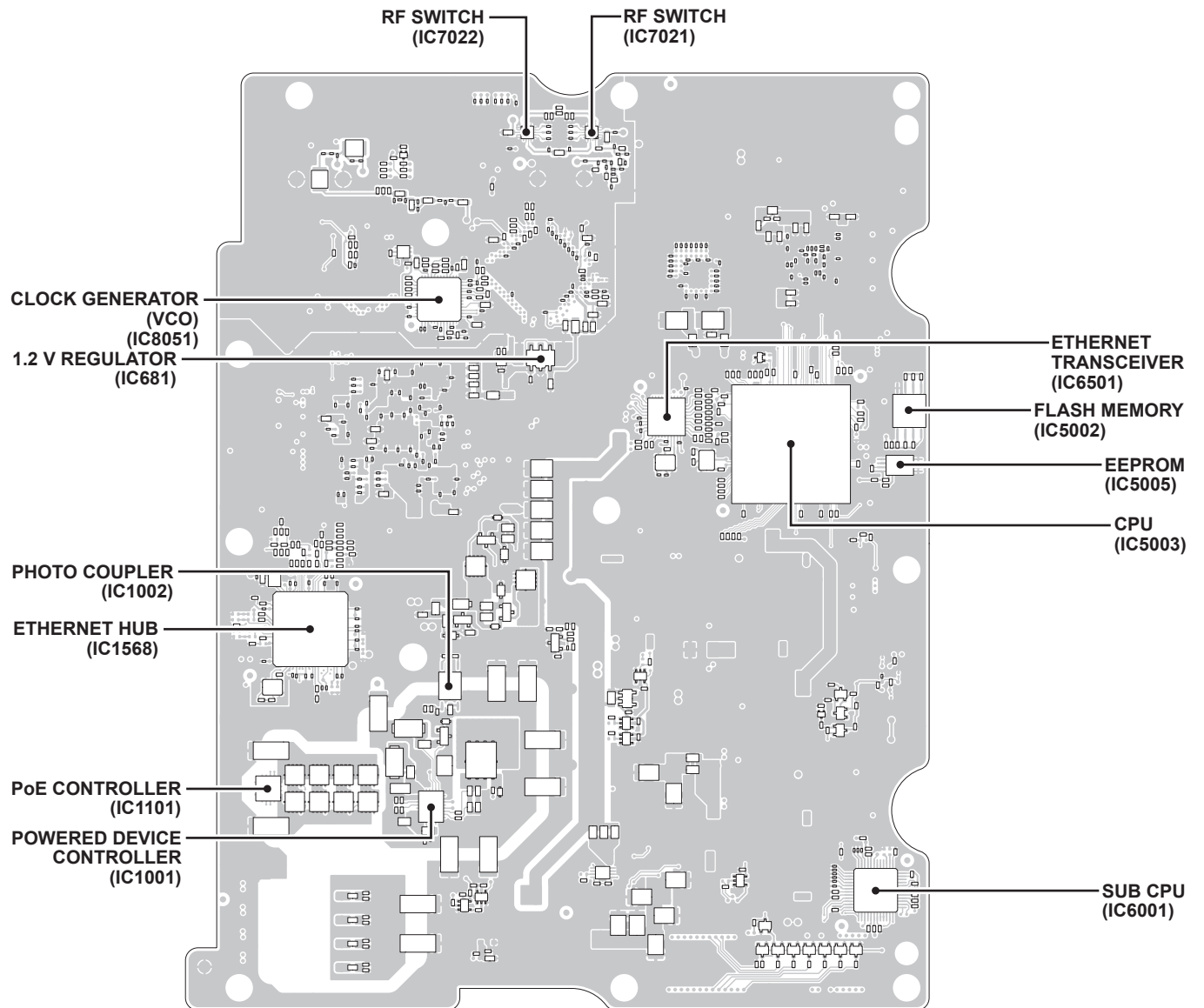

• RF-B UNIT (Top view)

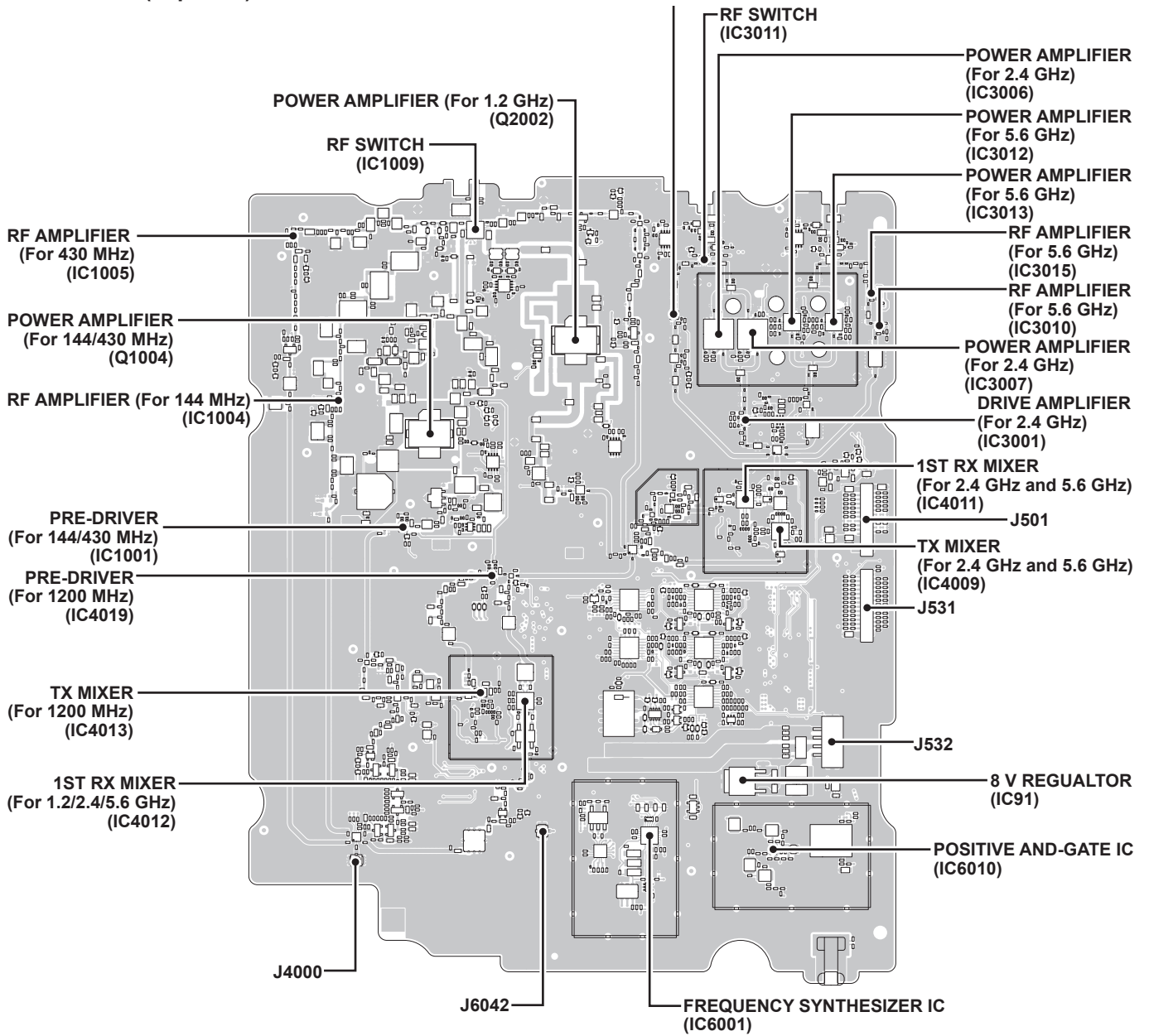

• RF-B UNIT (Bottom view)

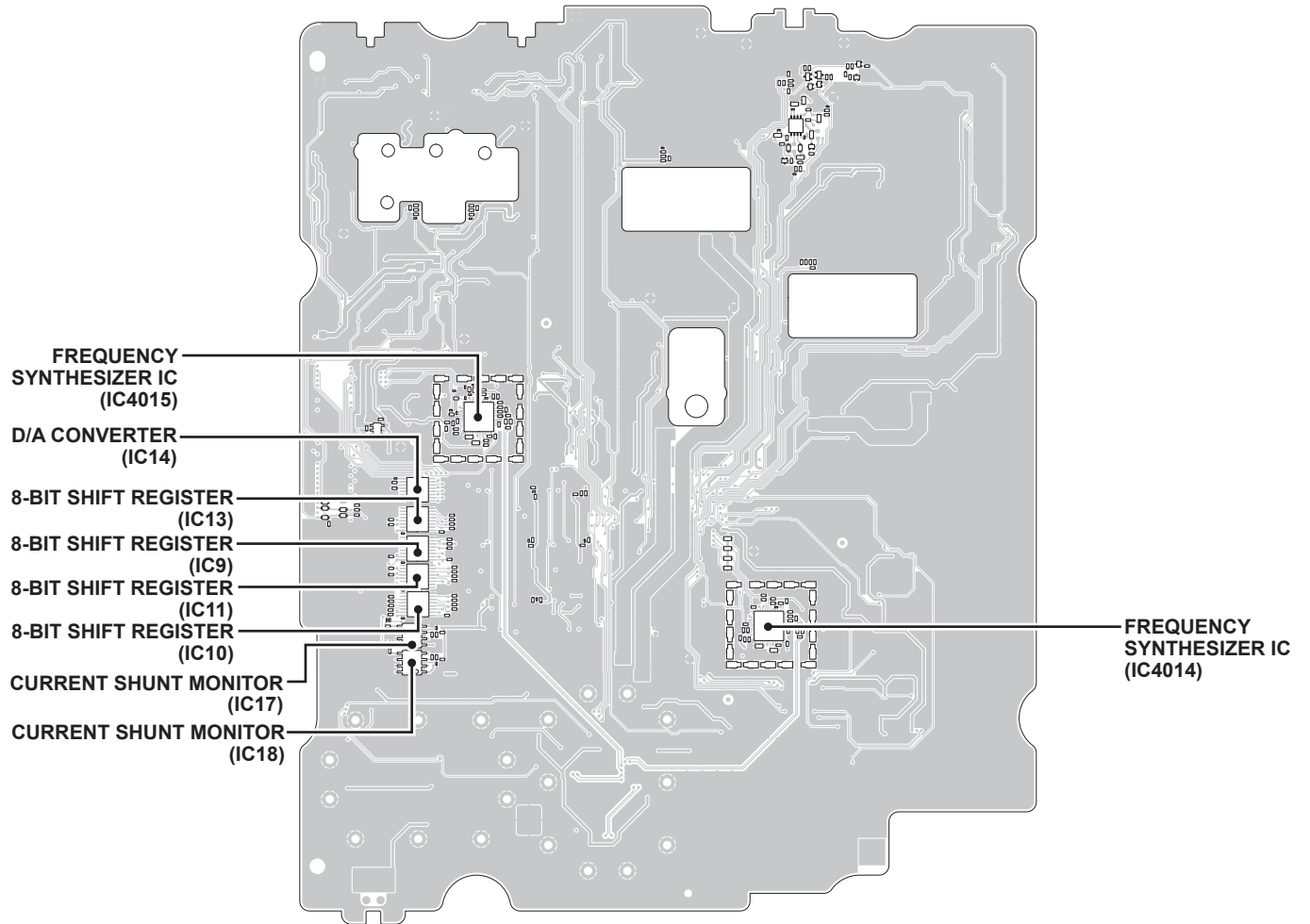

SECTION 3 DISASSEMBLY INSTRUCTION

1. Removing the front panel assembly

- 1) Remove the 4 screws from the rear panel, 1 screw each from the top and bottom of the controller.

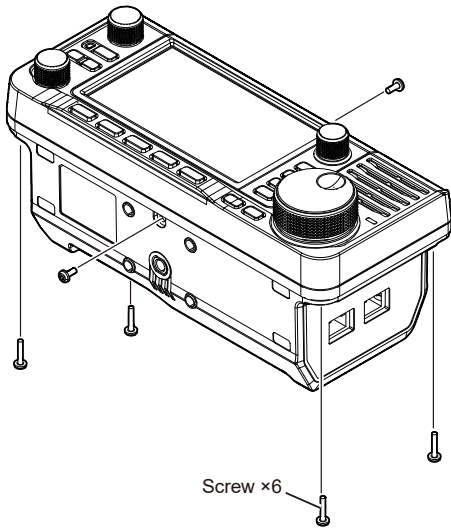

- 2) Separate the front assembly from the rear assembly in the direction of the arrow.

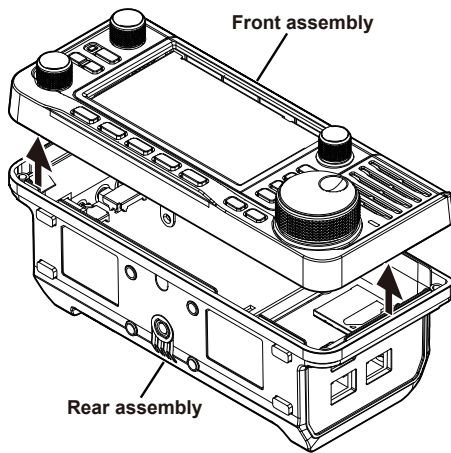

- 3) Disconnect 2 flat cables from the PCB as illustrated below.

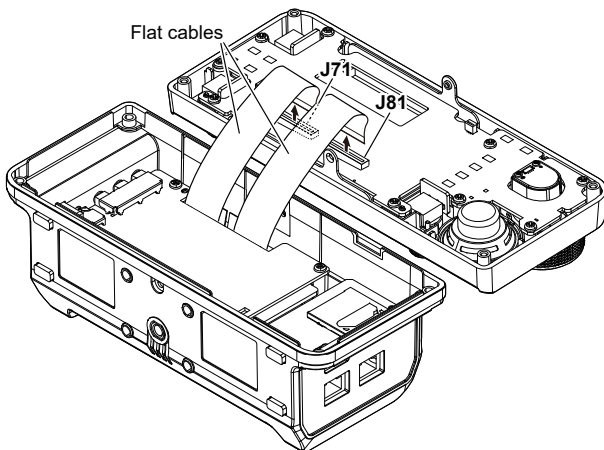

2. Removing the DISPLAY UNIT

- 1) Pull the 4 dial knobs to remove them from the front panel.

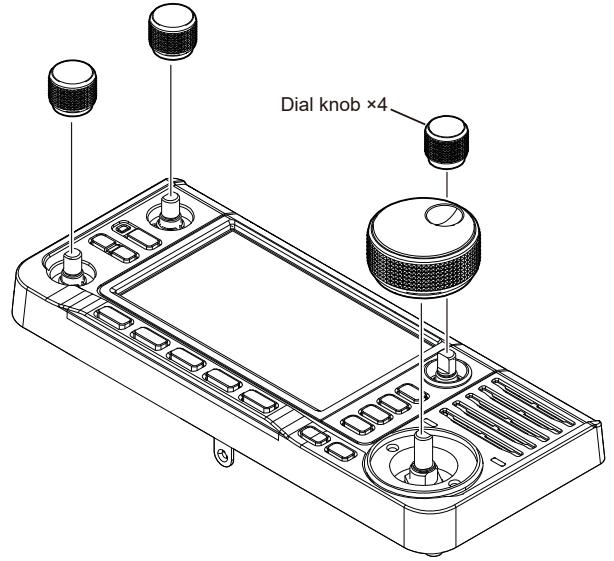

- 2) Disconnect the 5 flat cables, encoder cable, and speaker cable from the DISPLAY UNIT, as illustrated below.

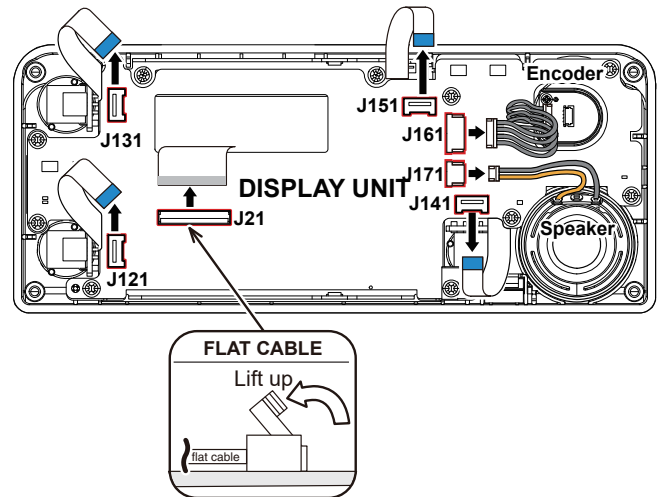

- 3) Remove the 9 screws from the DISPLAY UNIT, then take the DISPLAY UNIT from the front panel.

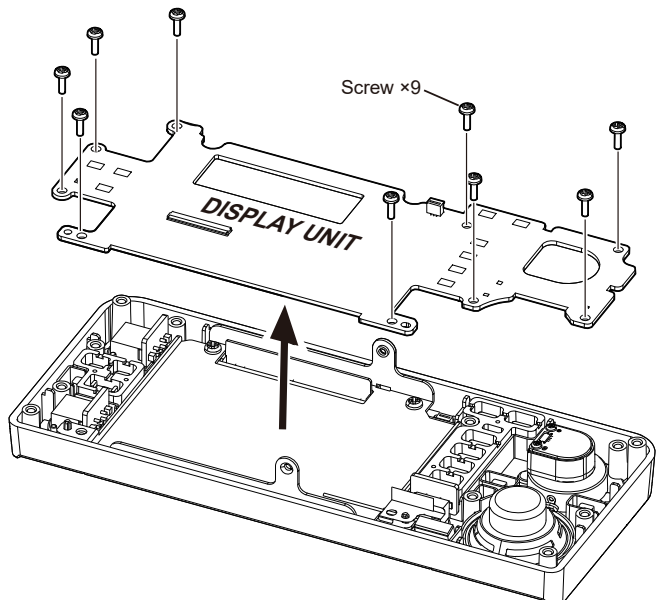

3. Removing the CONNECT-B UNIT

- 1) Disconnect 1 flat cable, and remove the 2 screws from the CONNECT-B UNIT.

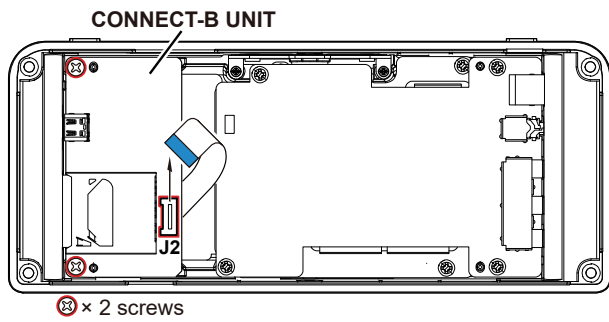

- 2) Remove the CONNECT-B UNIT in the direction of the arrow.

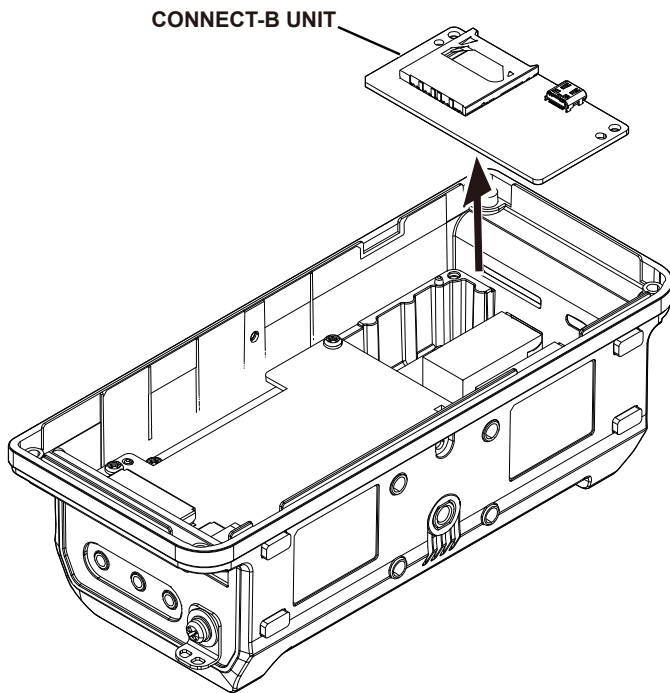

4. Removing the CONNECT-A UNIT

- 1) Remove the 4 screws, a DC power cable and a flat cable from the CONNECT-A UNIT.

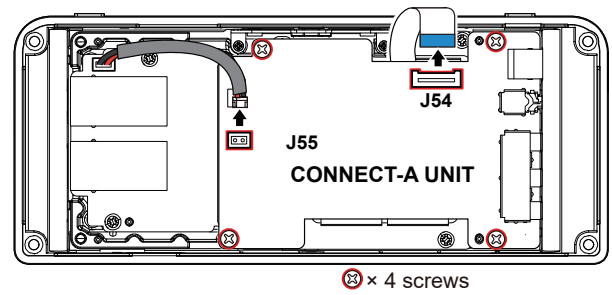

- 2) Remove the CONNECT-A UNIT in the direction of the arrow.

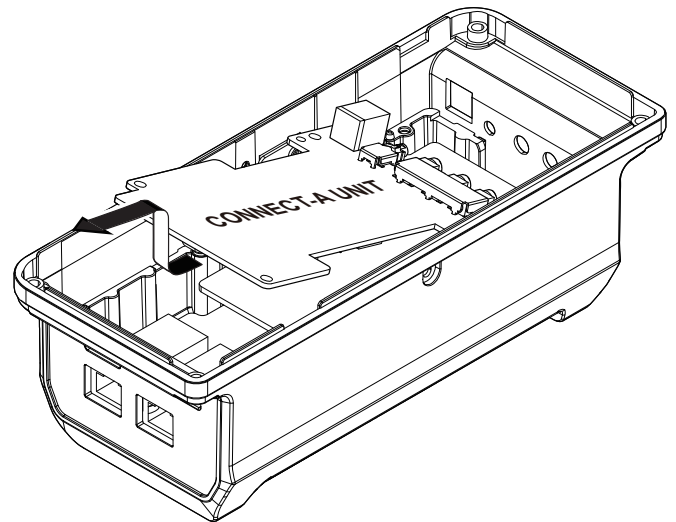

5. Removing the MAIN UNIT

1) Remove the 4 screws from the shield plate.

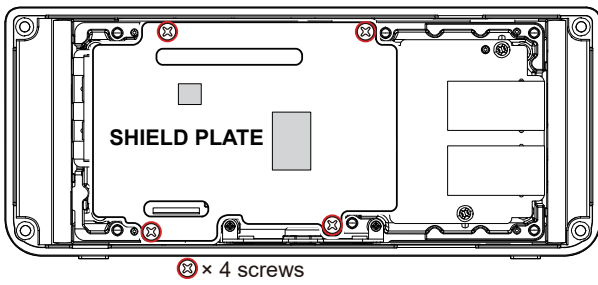

3) Remove the 6 screws from the MAIN UNIT.

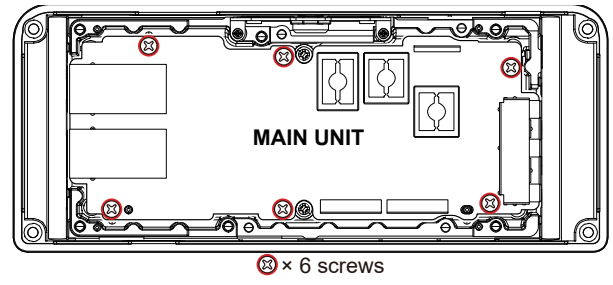

2) Remove the shield plate in the direction of the arrow.
(The MAIN UNIT appears.)

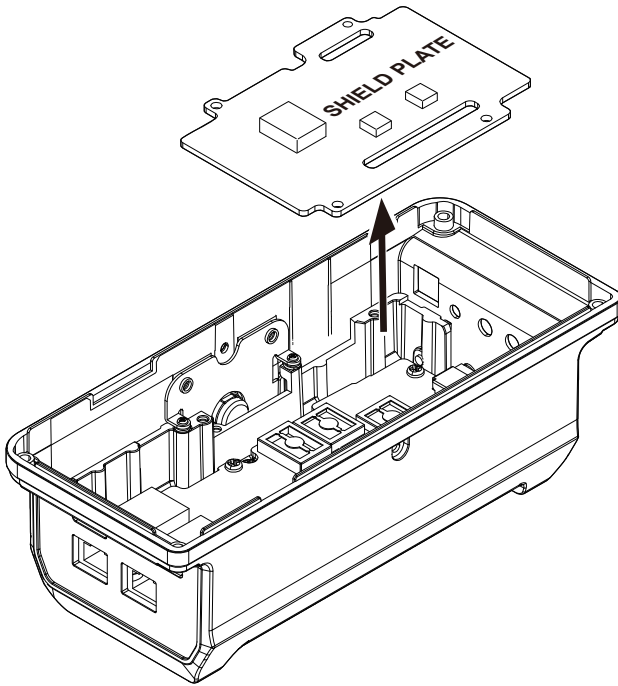

4) Remove the MAIN UNIT in the direction of the arrow.

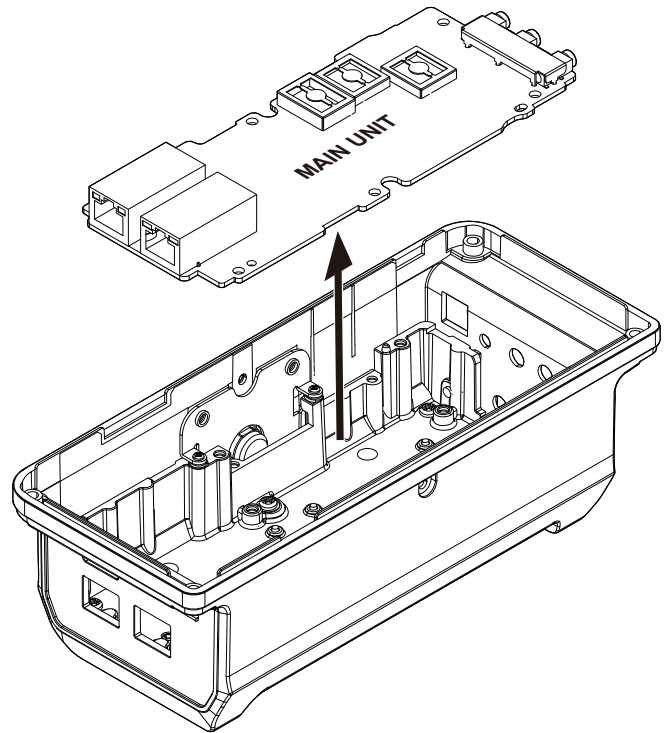

(Continued on the right above)

6. Removing the RF-A UNIT

1) Remove the cover from the RF UNIT.

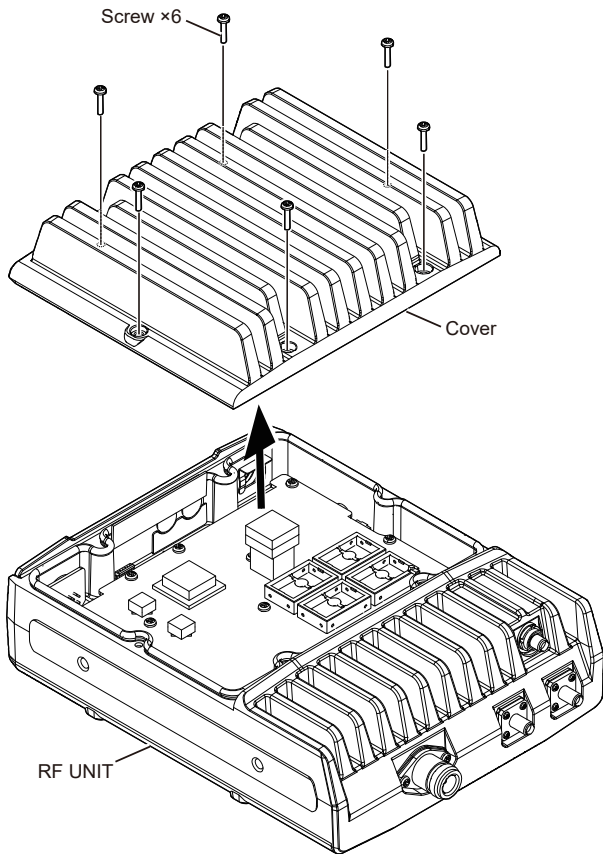

2) Remove the 3 cables, 3 flat cables, and 3 coaxial cables from the RF-A UNIT.

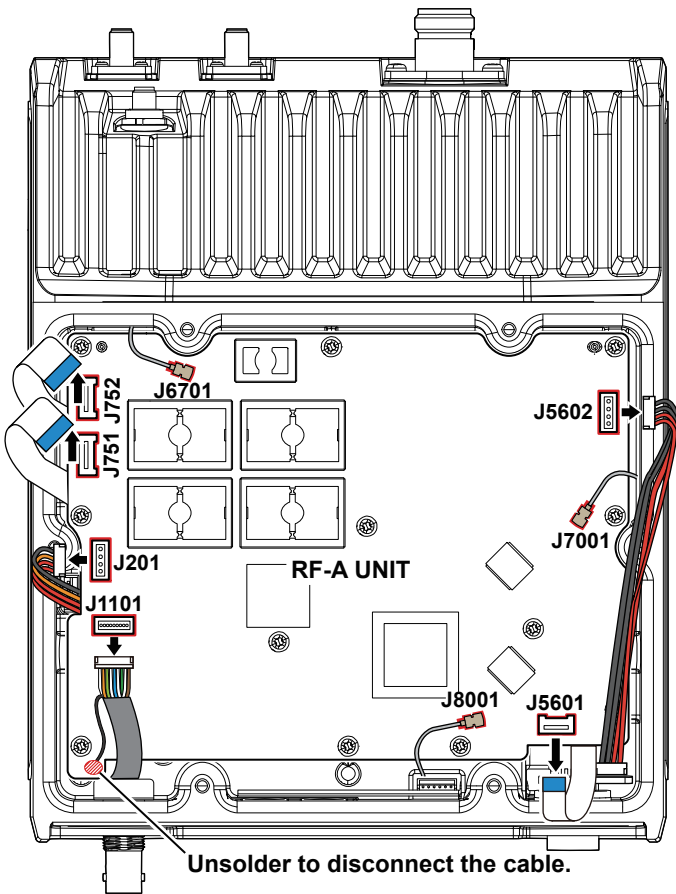

(Continued on the right above)

3) Remove the 12 screws from the RF-A UNIT.

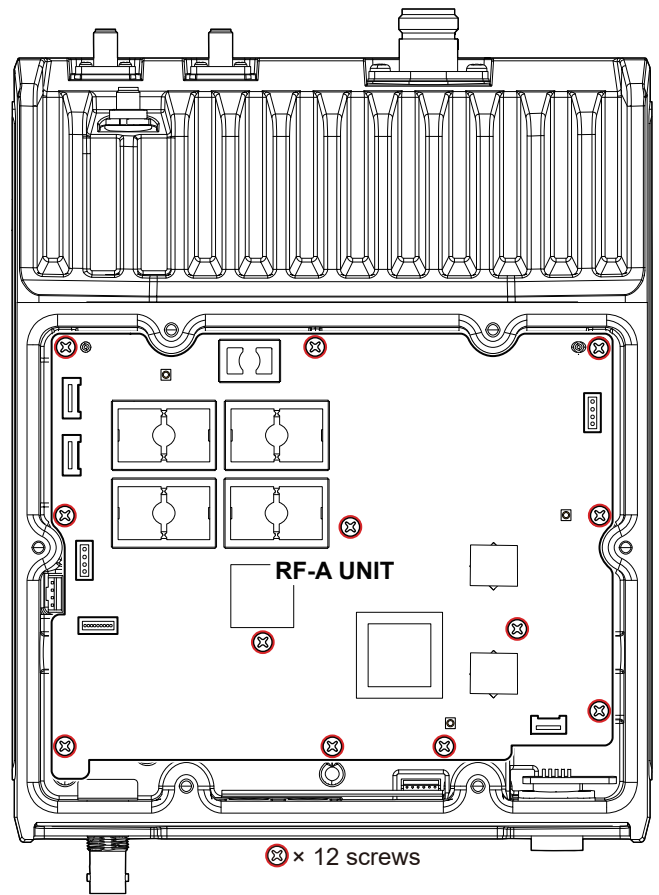

4) Remove the RF-A UNIT in the direction of the arrow.

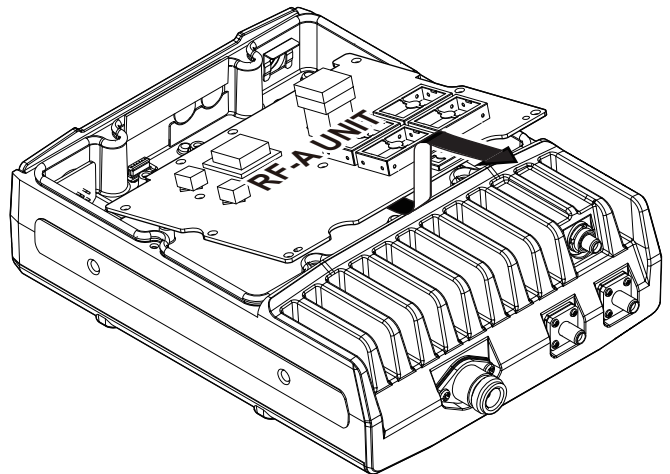

7. Removing the RF-B UNIT

- 1) Remove the 8 screws from the cover, then remove the cover from the RF UNIT.

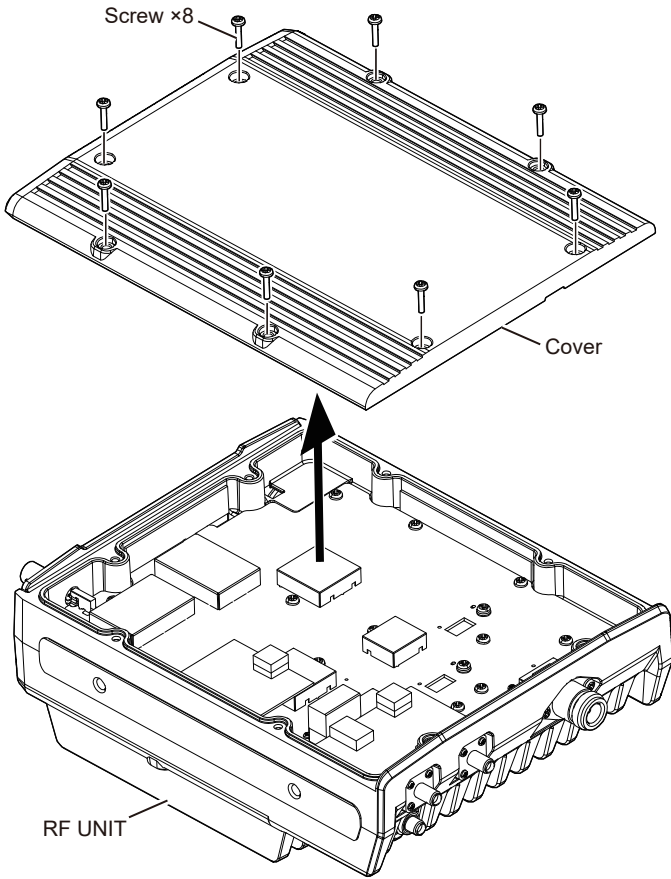

- 2) Remove the 2 ferrite sheets and 1 shield sponge from the RF-B UNIT.

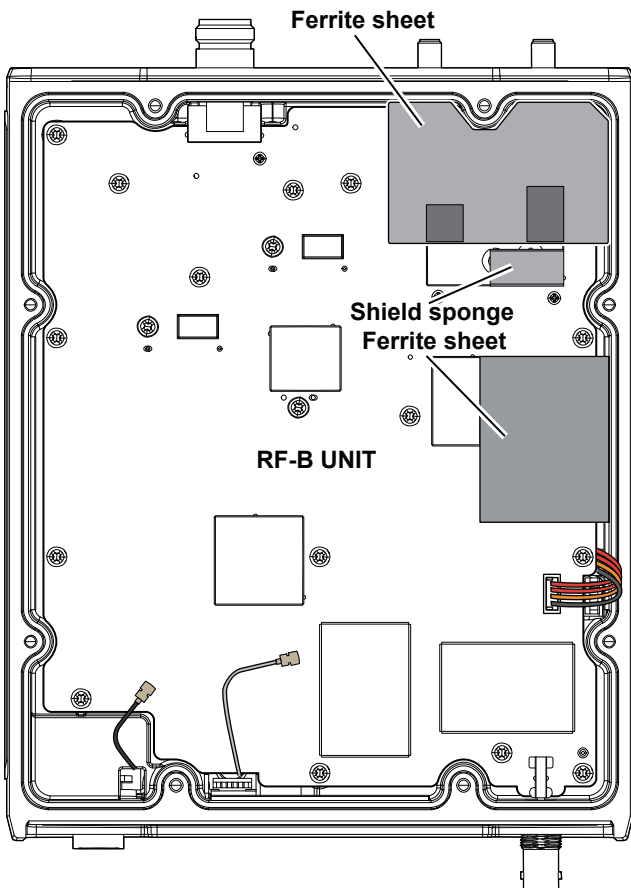

- 3) Remove the 1 cable, 2 flat cables, and 2 coaxial cables from the RF-B UNIT.

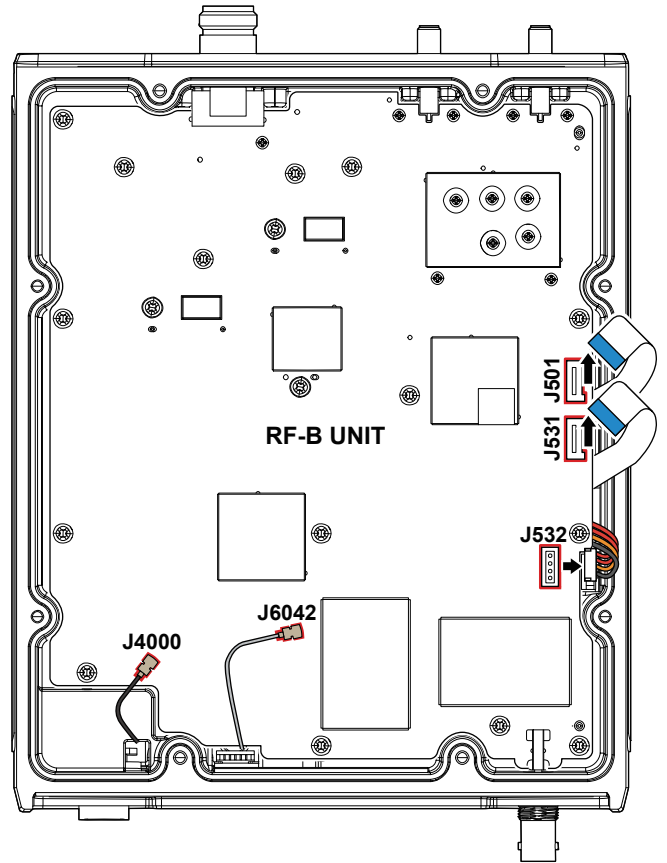

- 4) Remove the solder from total of 11 points on the RF-B UNIT.

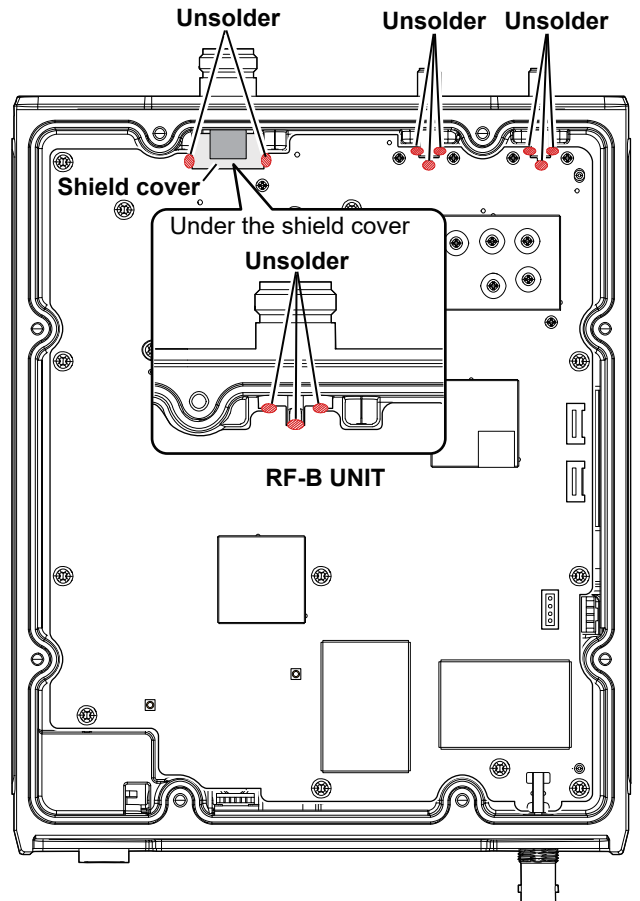

(Continued on the next page)

(Continued on the right above)

7. Removing the RF-B UNIT (continued)

5) Remove the total of 30 screws from the RF-B UNIT.

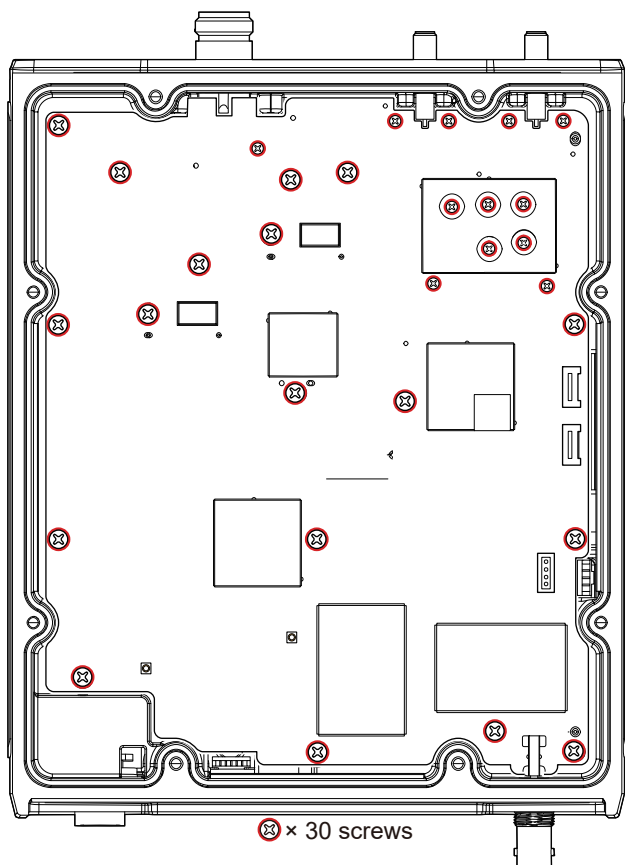

6) Remove the RF-B UNIT in the direction of the arrow.

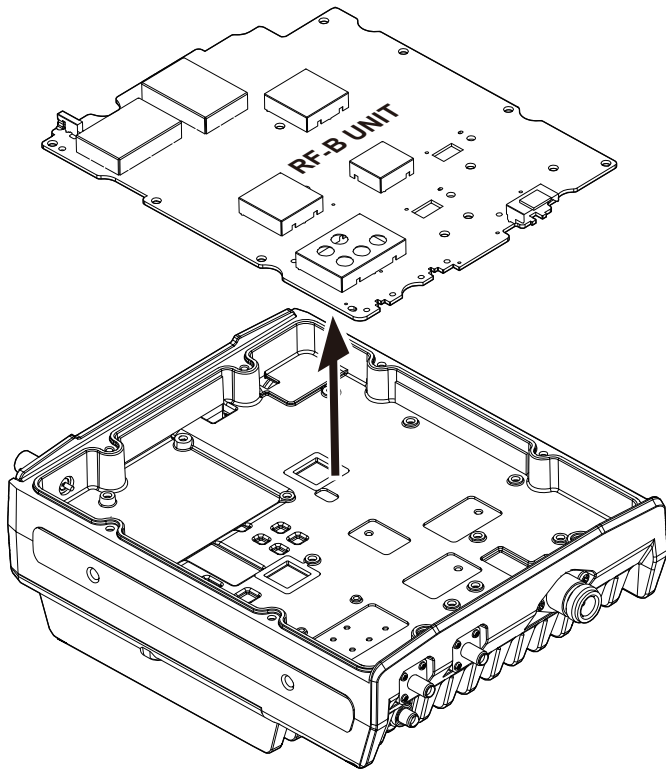

SECTION 4 INTERFACE INFORMATION

• CONTROLLER

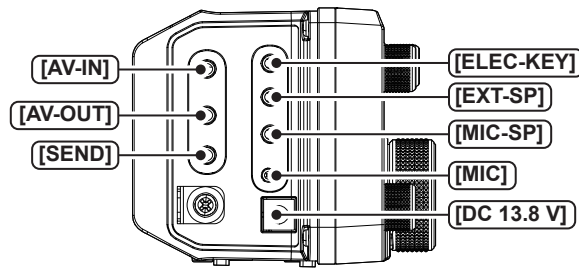

[ELEC-KEY]

ELEC-KEY	Pin name	Description	Specification
• Paddle key 	Dot	–	–
	Common	–	–
	Dash	–	–
• Straight key 	+	–	–
	–	–	–

[EXT-SP]

EXT-SP	Pin name	Description	Specification
	Left channel	AF output (Left channel)	When using the amplifier for a speaker: <ul style="list-style-type: none"> • Output impedance: 8 Ω • Output level: 200 mW or more (8 Ω load, 10% distortion) When using the amplifier for a headset: <ul style="list-style-type: none"> • Output impedance: 16 Ω • Output level: 5 mW or more (16 Ω load, 10% distortion)
	Right channel	AF output (Right channel)	
	GND	Ground	–

[MIC-SP]

MIC-SP	Pin name	Description	Specification
	AF	AF output	Output level: 150 mW or more (at 8 Ω load, 10% distortion)
	GND	Ground	–

[MIC]

MIC	Pin name	Description	Specification
	Microphone + PTT	MIC signal input and superimposed PTT	–
	+3.3 V/8 V	DC voltage output	+3.3 V (through 470 Ω) or +8.0 V (maximum 10 mA)
	Microphone key	Key input signal from HM-243	–
	GND	Ground	–

[DC 13.8 V]

DC 13.8 V	Pin name	Description	Specification
	DC IN	Power supply input	13.8 V DC (±15%, 5.5 A or more)
	GND	Ground	–

• CONTROLLER (CONTINUED)

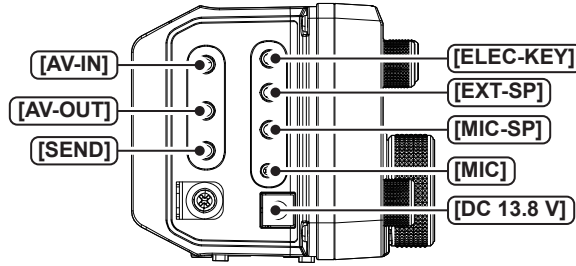

[AV-IN]

AV-IN	Pin name	Description	Specification
	Video input	Video signal	Input impedance: 75 Ω
	Audio input	Audio signal	Input impedance: 600 Ω Input level: -10 dBV ±3 dB
	GND	Ground	-

[AV-OUT]

AV-OUT	Pin name	Description	Specification
	Video output	Video signal	Output impedance: 75 Ω
	Audio output	Audio signal	Output impedance: 600 Ω Output level: -10 dBV ±3 dB
	GND	Ground	-

[SEND]

SEND	Pin name	Description	Specification
	Input pin	When this pin goes to ground, the transceiver transmits.	Input: • Input voltage (RX): 2.0 ~ 20.0 V • Input voltage (TX): -0.5 ~ +0.8 V • Current flow: Maximum 20 mA Output: • Output voltage (TX): 0.1 V or less • Current flow: Maximum 200 mA
	Output pin	This pin goes low when the transceiver transmits.	
	GND	Ground	-

• RF UNIT

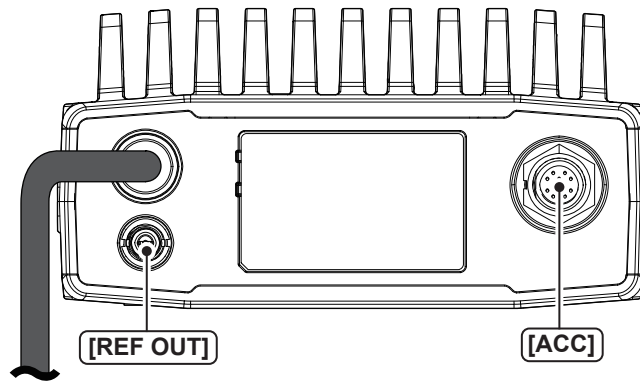

[ACC]

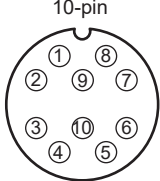
ACC	Pin No.	Port name	Description	Specification	
 <p>10-pin Bottom panel view</p>	1	NC	–	–	
	2	NC	–	–	
	3	GND	Connects to ground.	–	
	4	NC	–	–	
	5	NC	–	–	
	6	NC	–	–	
	7	ALC	ALC voltage input.	Input impedance: 10 kΩ or more Input level: –4 ~ 0 V Input voltage: 30 V or less Input current: 0.5 mA or less	
	8	GND	Connects to ground.	–	
	9	SEND	Input	When this pin goes to ground, the transceiver transmits.	Voltage: 30 V or less Reverse voltage: 80 V Open circuit voltage: 5 V
			Output	This pin goes low when the transceiver transmits.	Voltage (TX): –0.5 ~ +0.8 V Current flow: Maximum 2.27 mA
10	NC	–	–		

[REF OUT 10 MHz/–10 dBm]

REF OUT 10 MHz/–10 dBm	Description	Specification
 <p>BNC</p>	Outputs the 10 MHz signal as a reference frequency signal.	<ul style="list-style-type: none"> • Output frequency: 10 MHz • Output impedance: 50 Ω (unbalanced) • Output level: –10 dBm (approximate)

SECTION 5 ADJUSTMENT PROCEDURES

5-1 PREPARATION

■ REQUIRED EQUIPMENT

EQUIPMENT	GRADE AND RANGE	EQUIPMENT	GRADE AND RANGE
DC power supply	Output voltage: 13.8 V DC Rated output current: 6 A or more	Standard signal generator (SSG)	Frequency range: Up to 15 GHz Output level: -20 dBμV~90 dBμV (-127 dBm~-17 dBm)
Ammeter	Current range: 500 mA to 6 A	RF power meter (50 Ω terminated)	Measuring range: 10 mW to 20 W Frequency range: Up to 15 GHz
Frequency counter	Frequency range: Up to 6 GHz Measuring accuracy: ±1 ppb or better	SWR 2 dummy load	Rated input power: 10 W or more Impedance: 25 Ω
Audio generator (AG)	Frequency range: Up to 3000 Hz Output level: 1~500 mV	Attenuator	Power attenuation: 30 dB Rated input power: 3 W or more
Spectrum analyzer	Measuring range: Up to 26 GHz	AC millivoltmeter	Measuring range: 1 mV to 10 V
Dummy load	Impedance: 50 Ω Rated input power: 10 W or more	JIG plug	See the illustration below.

■ CONNECTIONS

• For IC-905 adjustment

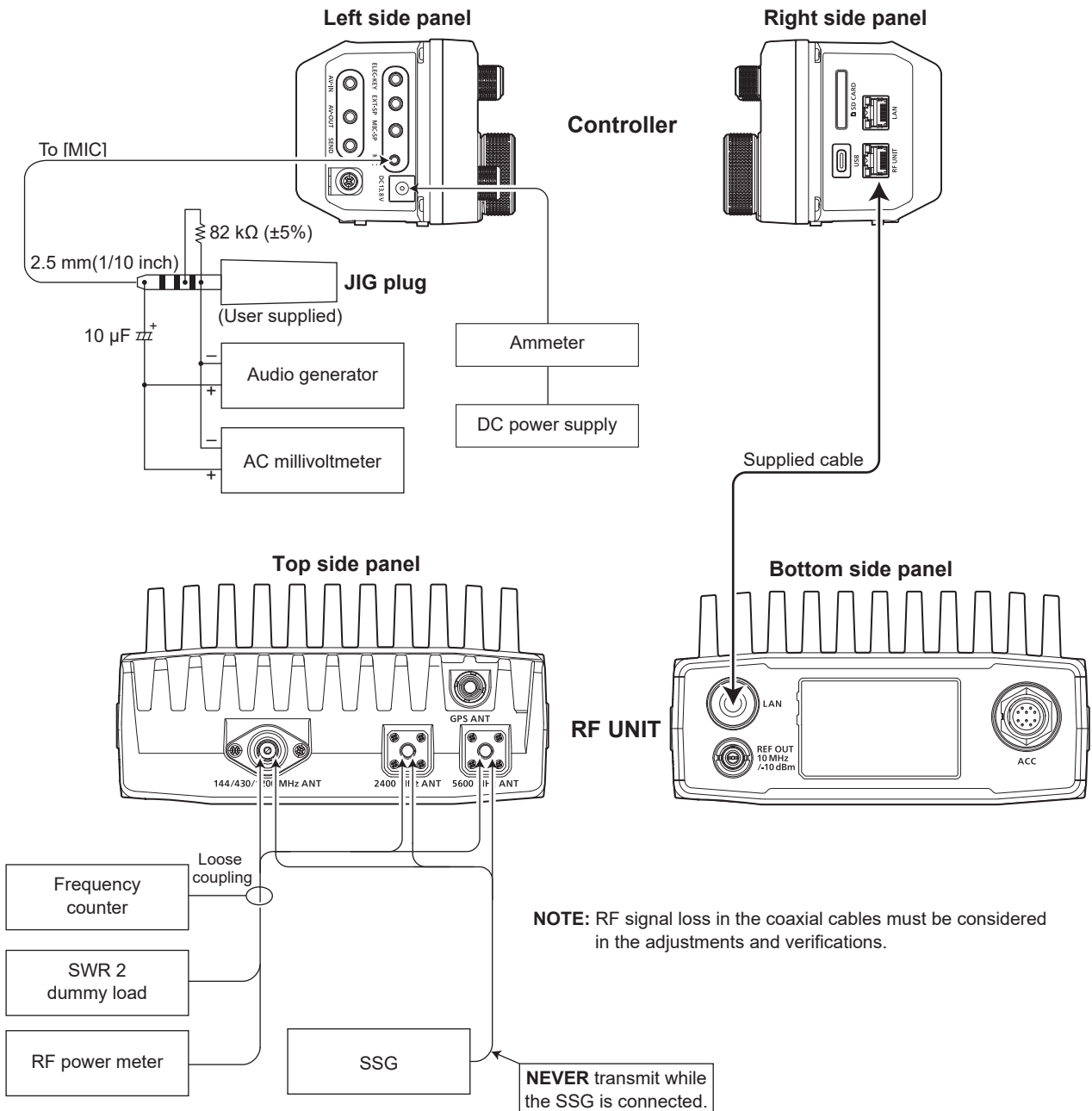

■ CONNECTIONS (CONTINUED)

- For CX-10G (Optional product) adjustment (See page 5-18)

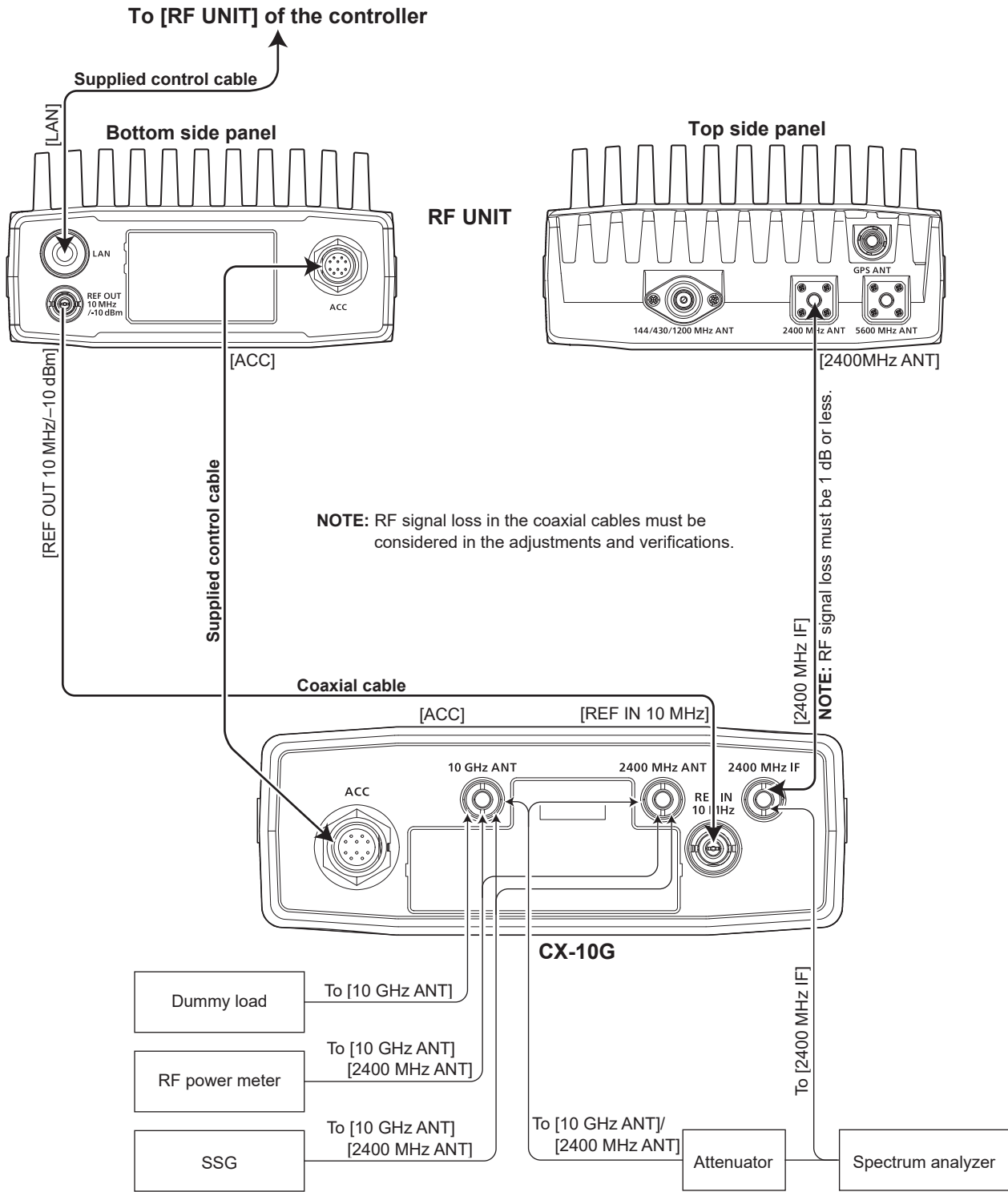

ENTERING THE ADJUST MODE

1. Turn OFF the power.
2. Connect the JIG plug to the [MIC] jack.

Left side panel

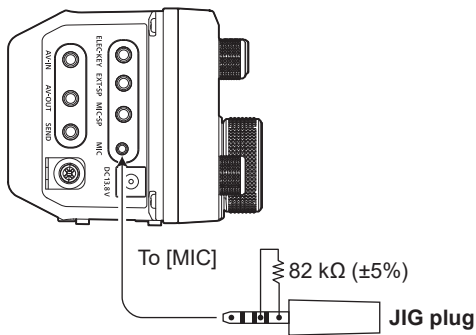

3. While holding down both [MENU] and [FUNC], turn ON to enter the adjust mode.

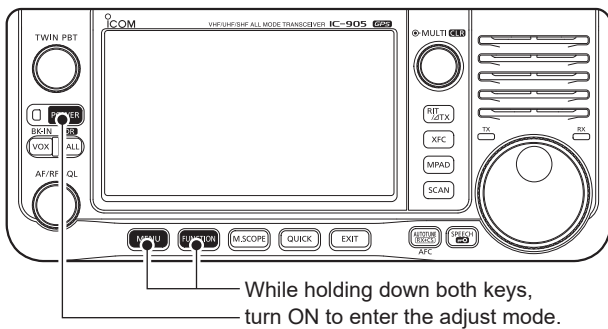

4. The Adjust Mode Main menu is displayed.

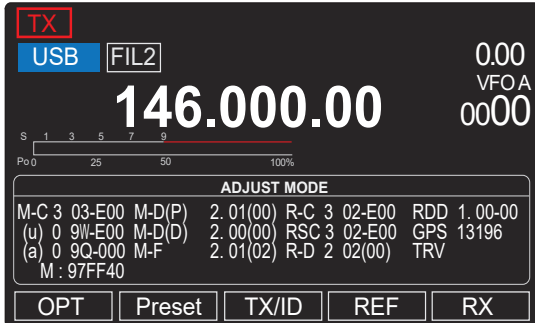

(This screen is an example.)

KEY ASSIGNMENTS FOR THE ADJUST MODE

- Touch [▼] to select the next adjustment item, touch [▲] to select the previous adjustment item.
- Rotate [MAIN DIAL] to set or modify the adjustment value.
- Touch [SET] to start automatic adjustment, or store the adjusted value, and select the next adjustment item.
- Push [EXIT] to exit from the adjustment item.

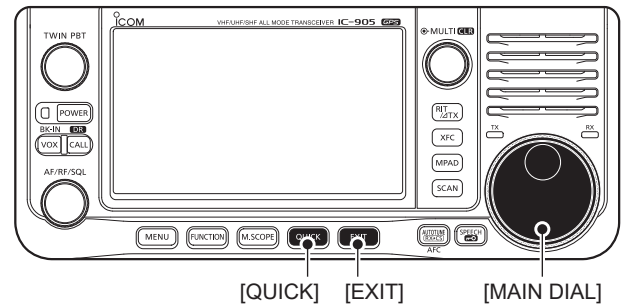

■ ADJUST MODE SCREENS

• MAIN MENU

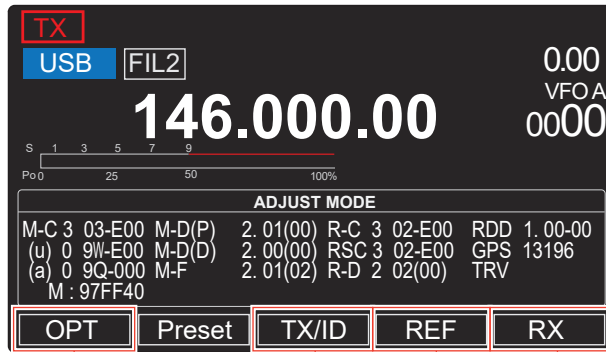

- Enter the FRONT key verification or CX-10G (optional product) adjust menu.
- Enter the TX/ID adjust menu.
- Enter the REF adjust menu.
- Enter the RX adjust menu.

• FRONT PANEL/CX-10G ADJUST MENU

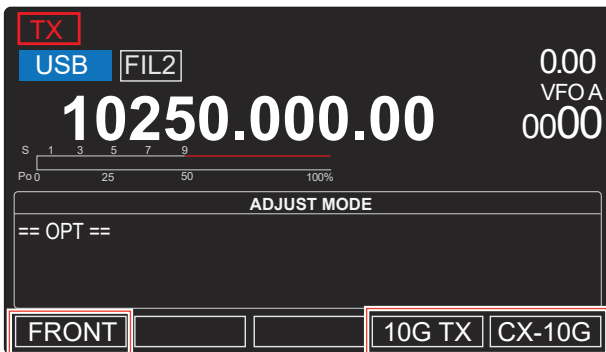

Enter the FRONT key verification menu. CX-10G adjustments

• TX/ID ADJUST MENU

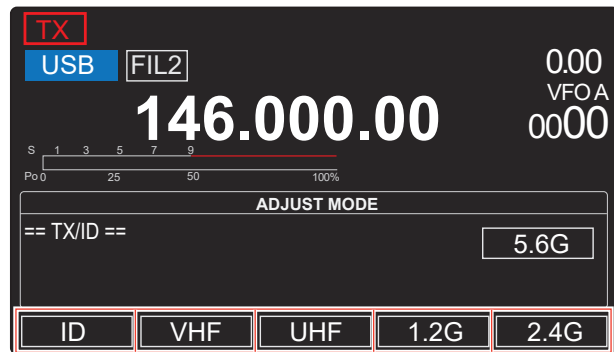

- Starts the idling current adjustment.
- Starts the VHF band transmit adjustment.
- Starts the UHF band transmit adjustment.
- Starts the 1.2 GHz band transmit adjustment.
- Starts the 2.4 GHz band transmit adjustment.

• FRONT KEY VERIFICATION MENU

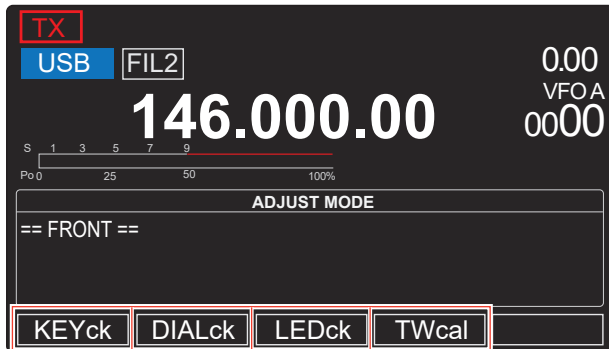

- Starts the key verification.
- Starts the dial verification.
- Starts the LED verification.
- Starts the touch screen calibration.

• RX ADJUST MENU

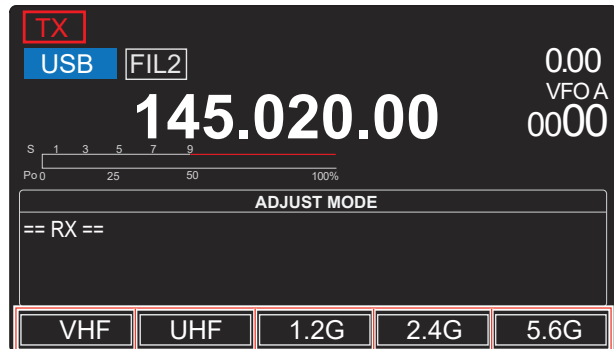

- Starts the VHF band receive adjustment.
- Starts the UHF band receive adjustment.
- Starts the 1.2 GHz band receive adjustment.
- Starts the 2.4 GHz band receive adjustment.
- Starts the 5.6 GHz band receive adjustment.

• REF ADJUST MENU

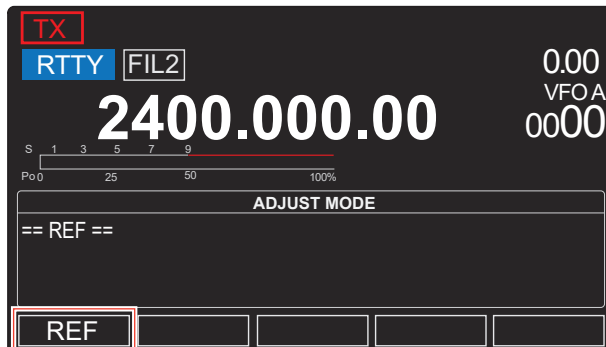

Starts the reference frequency adjustment.

NOTE: These screens are example.

5-2 FRONT PANEL OPERATION VERIFICATION

1. Touch [OPT] on the Adjust mode Main menu.
2. Touch [FRONT] on the OPT Adjust Mode menu.
3. Touch [KEYck] to enter to the Key Operation Verification mode.
4. Follow the instructions displayed on the screen, and push the corresponding key or knob.
5. Follow the instructions displayed on the screen, and rotate the corresponding dial and sensor.

NOTE: Verification items "25. PHOTO DARK" and "26. PHOTO BRIGHT" check the illuminance sensor. The sensor is built in to the area that assigned with a dotted red circle of the behind of the FRONT panel. (See the figure below)
So, when verifying "25. PHOTO DARK," hide the sensor such as by covering it with your finger. When verifying "26. PHOTO BRIGHT," face the front panel to a light.

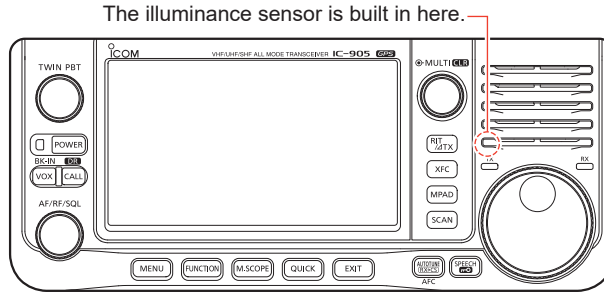

6. Follow the instructions displayed on the screen, and verify the corresponding LED is lit.
7. Push the [XFC] key, and verify the LCD screen changes in order of black, red, green, blue, minimum, and maximum backlight brightness.
8. Push the [XFC] key to start the touch screen calibration, and touch the dot in order of the instructions displayed on the screen.
- After 2 beeps sound, it automatically Returns to the Adjust Mode Main menu.

5-3 IDLING ADJUSTMENT

Touch [TX/ID] on the adjustment mode main menu.

ADJUSTMENT	ADJUSTMENT ITEM DISPLAY	SETTING CONDITION	OPERATION
IDLING	1	–	• Connect the 13.8 V DC power source to [DC 13.8 V]. • Connect the ammeter between the 13.8 V DC power source and the CONTROLLER.
			Touch [ID] to enter the ID adjustment menu.
REFERENCE VOLTAGE LOADING	2	VHF/UHF IDL SET	• Receive
	3	1.2G IDL SET	
	4	2.4G/5.6G IDL SET	
			Touch [SET]. (The IC-905 briefly transmits and then 3 beeps sound.)
VHF BAND	5	VHF ID SET	–
~ FINAL IDLING CURRENT ~	6	VHF FIDV	• Automatically transmits.
~ DRIVER IDLING CURRENT ~	7	VHF DIDV	
			Touch [SET]. Touch [SET]. (2 beeps sound.)
UHF BAND	8	UHF ID SET	• Returns to receive.
~ FINAL IDLING CURRENT ~	9	UHF FIDV	• Automatically transmits.
~ DRIVER IDLING CURRENT ~	10	UHF DIDV	
			Touch [SET]. Touch [SET]. (2 beeps sound.)
1.2 GHz BAND	11	1.2G ID SET	• Returns to receive.
~ FINAL IDLING CURRENT ~	12	1.2G FIDV	• Automatically transmits.
			Touch [SET]. Touch [SET]. (2 beeps sound.)

5-4 VHF BAND TRANSMIT ADJUSTMENT

Touch [TX/ID] on the adjustment mode main menu.

ADJUSTMENT	ADJUSTMENT ITEM DISPLAY	SETTING CONDITION	OPERATION			
TRANSMIT	1	–	<ul style="list-style-type: none"> • Connect the 13.8 V DC power source to [DC 13.8 V]. • Connect the RF power meter to [144/430/1200 MHz ANT] of RF UNIT. • Connect the audio generator and the AC millivoltmeter to the JIG plug, and set it to: Frequency: 1.5 kHz Waveform: Sine wave Level: 30 mVrms 	<ul style="list-style-type: none"> • When adjusting following from the idling adjustment, touch [SET]. • When adjusting the VHF band transmit items from the TX/ID Adjust menu, touch [VHF]. 		
TX OUTPUT POWER	2	TX VHF	<ul style="list-style-type: none"> • Receive 	Touch [SET]. (2 beeps sound.)		
	3	TX POWER VHF SET				
	4	TX Total VHF Gain			<ul style="list-style-type: none"> • Automatically transmits. 	Rotate [MAIN DIAL] to set to 5.0 W, and then touch [SET].
	5	POWER VHF2 MIN				Rotate [MAIN DIAL] to set to 0.1 W, and then touch [SET]. Note the adjustment value as the reference.
	6	POWER VHF2 1%				Rotate [MAIN DIAL] to set the adjustment value to the same as the reference, and then touch [SET].
	7	POWER VHF2 10%				Rotate [MAIN DIAL] to set to 1.0 W, and then touch [SET].
	8	POWER VHF2 50%				Rotate [MAIN DIAL] to set to 5.0 W, and then touch [SET].
9	POWER VHF2 100%	Rotate [MAIN DIAL] to set to 10.0 W, and then touch [SET].				
TX OUTPUT POWER BALANCE	10	POWER VHF Balance SET	<ul style="list-style-type: none"> • Returns to receive. 	Touch [SET]. (2 beeps sound.)		
	11	POWER VHF1 100%			<ul style="list-style-type: none"> • Automatically transmits. 	Rotate [MAIN DIAL] to set to 10.0 W, and then touch [SET].
	12	POWER VHF3 100%				
AM TX OUTPUT POWER	13	POWER AM Ratio VHF	<ul style="list-style-type: none"> • Returns to receive. 	Touch [SET]. (2 beeps sound.)		
	14				<ul style="list-style-type: none"> • Automatically transmits. 	Rotate [MAIN DIAL] to set to 2.5 W, and then touch [SET].
ALC	15	ALC VHF	<ul style="list-style-type: none"> • Returns to receive. • Automatically transmits. 	Touch [SET]. (A beep sound.) The automatic adjustment starts. When the adjustment is completed, 2 beeps sound and selects the next adjustment item.		
	16					
DRIVE GAIN	17	DRIVE VHF	<ul style="list-style-type: none"> • Returns to receive. • Automatically transmits. 	Touch [SET]. (A beep sound.) The automatic adjustment starts. When the adjustment is completed, 2 beeps sound and selects the next adjustment item.		
	18					
SWR METER	19	SWR2(VHF)	<ul style="list-style-type: none"> • Connect the SWR 2 dummy load to Connect the RF power meter to [144/430/1200 MHz ANT] of RF UNIT. • Automatically transmits. 	Touch [SET]. (A beep sound.) The automatic adjustment starts. When the adjustment is completed, 2 beeps sound and selects the next adjustment item.		
	20					

5-5 UHF BAND TRANSMIT ADJUSTMENT

Touch [TX/ID] on the adjustment mode main menu.

ADJUSTMENT	ADJUSTMENT ITEM DISPLAY	SETTING CONDITION	OPERATION	
TRANSMIT	1	–	<ul style="list-style-type: none"> • Connect the 13.8 V DC power source to [DC 13.8 V]. • Connect the RF power meter to [144/430/1200 MHz ANT] of RF UNIT. • Connect the audio generator and the AC millivoltmeter to the JIG plug, and set it to: Frequency: 1.5 kHz Waveform: Sine wave Level: 30 mVrms 	<ul style="list-style-type: none"> • When adjusting following from the idling adjustment, touch [SET]. • When adjusting the UHF band transmit items from the TX/ID Adjust menu, touch [UHF].
TX OUTPUT POWER	2	TX POWER UHF SET	• Receive	Touch [SET]. (2 beeps sound.)
	3	TX Total UHF Gain	• Automatically transmits.	Rotate [MAIN DIAL] to set to 5.0 W, and then touch [SET].
	4	POWER UHF2 MIN		Rotate [MAIN DIAL] to set to 0.1 W, and then touch [SET]. Note the adjustment value as the reference.
	5	POWER UHF2 1%		Rotate [MAIN DIAL] to set the adjustment value to the same as the reference, and then touch [SET].
	6	POWER UHF2 10%		Rotate [MAIN DIAL] to set to 1.0 W, and then touch [SET].
	7	POWER UHF2 50%		Rotate [MAIN DIAL] to set to 5.0 W, and then touch [SET].
	8	POWER UHF2 100%		Rotate [MAIN DIAL] to set to 10.0 W, and then touch [SET].
	TX OUTPUT POWER BALANCE	9	POWER UHF Balance SET	• Returns to receive.
10		POWER UHF1 100%	• Automatically transmits.	Rotate [MAIN DIAL] to set to 10.0 W, and then touch [SET].
11		POWER UHF3 100%		
12		POWER UHF4 100%		
AM TX OUTPUT POWER	13	POWER UHF AM Ratio	• Returns to receive.	Touch [SET]. (2 beeps sound.)
	14		• Automatically transmits.	Rotate [MAIN DIAL] to set to 2.5 W, and then touch [SET].
ALC	15	ALC UHF	• Returns to receive.	Touch [SET]. (A beep sound.)
	16		• Automatically transmits.	The automatic adjustment starts. When the adjustment is completed, 2 beeps sound and selects the next adjustment item.
UHF DRIVE GAIN	17	DRIVE UHF	• Returns to receive.	Touch [SET]. (A beep sound.)
	18		• Automatically transmits.	The automatic adjustment starts. When the adjustment is completed, 2 beeps sound and selects the next adjustment item.
SWR METER	19	SWR2(UHF)	• Connect the SWR 2 dummy load to [144/430/1200 MHz ANT] of RF UNIT.	Touch [SET]. (A beep sound.)
	20		• Automatically transmits.	The automatic adjustment starts. When the adjustment is completed, 2 beeps sound and selects the next adjustment item.

5-6 1.2 GHZ BAND TRANSMIT ADJUSTMENT

Touch [TX/ID] on the adjustment mode main menu.

ADJUSTMENT	ADJUSTMENT ITEM DISPLAY	SETTING CONDITION	OPERATION	
TRANSMIT	1	–	<ul style="list-style-type: none"> • Connect the 13.8 V DC power source to [DC 13.8 V]. • Connect the RF power meter to [144/430/1200 MHz ANT] of RF UNIT. • Connect the audio generator and the AC millivoltmeter to the JIG plug, and set it to: Frequency: 1.5 kHz Waveform: Sine wave Level: 30 mVrms 	<ul style="list-style-type: none"> • When adjusting following from the idling adjustment, touch [SET]. • When adjusting the 1.2 GHz band transmit items from the TX/ID Adjust menu, touch [1.2G].
TX OUTPUT POWER	2	TX POWER 1.2G SET	• Receive	Touch [SET]. (2 beeps sound.)
	3	TX Total 1.2G Gain	• Automatically transmits.	Rotate [MAIN DIAL] to set to 5.0 W, and then touch [SET].
	4	POWER 1.2G3 MIN		Rotate [MAIN DIAL] to set to 0.1 W, and then touch [SET]. Note the adjustment value as the reference.
	5	POWER 1.2G3 1%		Rotate [MAIN DIAL] to set the adjustment value to the same as the reference, and then touch [SET].
	6	POWER 1.2G3 10%		Rotate [MAIN DIAL] to set to 1.0 W, and then touch [SET].
	7	POWER 1.2G3 50%		Rotate [MAIN DIAL] to set to 5.0 W, and then touch [SET].
	8	POWER 1.2G3 100%		Rotate [MAIN DIAL] to set to 10.0 W, and then touch [SET].
TX OUTPUT POWER BALANCE	9	POWER 1.2G Balance SET	• Returns to receive.	Touch [SET]. (2 beeps sound.)
	10	POWER 1.2G1 100%	• Automatically transmits.	Rotate [MAIN DIAL] to set to 10.0 W, and then touch [SET].
	11	POWER 1.2G2 100%		
	12	POWER 1.2G4 100%		
AM TX OUTPUT POWER	13	POWER AM Ratio 1.2G	• Returns to receive.	Touch [SET]. (2 beeps sound.)
	14		• Automatically transmits.	Rotate [MAIN DIAL] to set to 2.5 W, and then touch [SET].
ALC	15	ALC 1.2G	• Returns to receive.	Touch [SET]. (A beep sound.)
	16		• Automatically transmits.	The automatic adjustment starts. When the adjustment is completed, 2 beeps sound and selects the next adjustment item.
DRIVE GAIN	17	DRIVE 1.2G	• Returns to receive.	Touch [SET]. (A beep sound.)
	18		• Automatically transmits.	The automatic adjustment starts. When the adjustment is completed, 2 beeps sound and selects the next adjustment item.
SWR METER	19	SWR2(1.2G)	• Connect the SWR 2 dummy load to [144/430/1200 MHz ANT] of RF UNIT.	Touch [SET]. (A beep sound.)
	20		• Automatically transmits.	The automatic adjustment starts. When the adjustment is completed, 2 beeps sound and selects the next adjustment item.

5-7 2.4 GHZ BAND TRANSMIT ADJUSTMENT

Touch [TX/ID] on the adjustment mode main menu.

ADJUSTMENT	ADJUSTMENT ITEM DISPLAY	SETTING CONDITION	OPERATION
TRANSMIT	1	–	<ul style="list-style-type: none"> • Connect the 13.8 V DC power source to [DC 13.8 V]. • Connect the RF power meter to [2400 MHz ANT] of RF UNIT. • Connect the audio generator and the AC millivoltmeter to the JIG plug, and set it to: Frequency: 1.5 kHz Waveform: Sine wave Level: 30 mVrms <ul style="list-style-type: none"> • When adjusting following from the idling adjustment, touch [SET]. • When adjusting the 2.4 GHz band transmit items from the TX/ID Adjust menu, touch [2.4G].
TX OUTPUT POWER	2	TX POWER 2.4G SET	<ul style="list-style-type: none"> • Receive <p style="text-align: center;">Touch [SET]. (2 beeps sound.)</p>
	3	TX Total 2.4G Gain	<ul style="list-style-type: none"> • Automatically transmits. <p>Rotate [MAIN DIAL] to set to 1.0 W, and then touch [SET].</p>
	4	POWER 2.4G2 MIN	<p>Rotate [MAIN DIAL] to set to 0.02 W, and then touch [SET]. Note the adjustment value as the reference.</p>
	5	POWER 2.4G2 1%	<p>Rotate [MAIN DIAL] to set the adjustment value to the same as the reference, and then touch [SET].</p>
	6	POWER 2.4G2 10%	<p>Rotate [MAIN DIAL] to set to 0.2 W, and then touch [SET].</p>
	7	POWER 2.4G2 50%	<p>Rotate [MAIN DIAL] to set to 1.0 W, and then touch [SET].</p>
TX OUTPUT POWER BALANCE	8	POWER 2.4G2 100%	<p>Rotate [MAIN DIAL] to set to 2.0 W, and then touch [SET].</p>
	9	POWER 2.4G Balance SET	<ul style="list-style-type: none"> • Returns to receive. <p style="text-align: center;">Touch [SET]. (2 beeps sound.)</p>
	10	POWER 2.4G1 100%	<ul style="list-style-type: none"> • Automatically transmits. <p>Rotate [MAIN DIAL] to set to 2.0 W, and then touch [SET].</p>
AM TX OUTPUT POWER	11	POWER 2.4G3 100%	
	12	POWER AM Ratio 2.4G	<ul style="list-style-type: none"> • Returns to receive. <p style="text-align: center;">Touch [SET]. (2 beeps sound.)</p>
ALC	13		<ul style="list-style-type: none"> • Automatically transmits. <p>Rotate [MAIN DIAL] to set to 0.5 W, and then touch [SET].</p>
	14	ALC 2.4G	<ul style="list-style-type: none"> • Returns to receive. <p style="text-align: center;">Touch [SET]. (A beep sound.)</p>
DRIVE GAIN	15		<ul style="list-style-type: none"> • Automatically transmits. <p>The automatic adjustment starts. When the adjustment is completed, 2 beeps sound and selects the next adjustment item.</p>
	16	DRIVE 2.4G	<ul style="list-style-type: none"> • Returns to receive. <p style="text-align: center;">Touch [SET]. (A beep sound.)</p>
SWR METER	17		<ul style="list-style-type: none"> • Automatically transmits. <p>The automatic adjustment starts. When the adjustment is completed, 2 beeps sound and selects the next adjustment item.</p>
	18	SWR2(2.4G)	<ul style="list-style-type: none"> • Connect the SWR 2 dummy load to [2400 MHz ANT] of RF UNIT. <p style="text-align: center;">Touch [SET]. (A beep sound.)</p>
	19		<ul style="list-style-type: none"> • Automatically transmits. <p>The automatic adjustment starts. When the adjustment is completed, 2 beeps sound and selects the next adjustment item.</p>

5-8 5.6 GHZ BAND TRANSMIT ADJUSTMENT

Touch [TX/ID] on the adjustment mode main menu.

ADJUSTMENT	ADJUSTMENT ITEM DISPLAY	SETTING CONDITION	OPERATION
TRANSMIT	1	–	<ul style="list-style-type: none"> • Connect the 13.8 V DC power source to [DC 13.8 V]. • Connect the RF power meter to [5600 MHz ANT] of RF UNIT. • Connect the audio generator and the AC millivoltmeter to the JIG plug, and set it to: Frequency: 1.5 kHz Waveform: Sine wave Level: 30 mVrms <ul style="list-style-type: none"> • When adjusting following from the idling adjustment, touch [SET]. • When adjusting the 5.6 GHz band transmit items from the TX/ID Adjust menu, touch [5.6G].
TX OUTPUT POWER	2	TX POWER 5.6G SET	<ul style="list-style-type: none"> • Receive <p style="text-align: center;">Touch [SET]. (2 beeps sound.)</p>
	3	TX Total 5.6G Gain	<ul style="list-style-type: none"> • Automatically transmits. <p>Rotate [MAIN DIAL] to set to 1.0 W, and then touch [SET].</p>
	4	POWER 5.6G2 MIN	<p>Rotate [MAIN DIAL] to set to 0.02 W, and then touch [SET]. Note the adjustment value as the reference.</p>
	5	POWER 5.6G2 1%	<p>Rotate [MAIN DIAL] to set the adjustment value to the same as the reference, and then touch [SET].</p>
	6	POWER 5.6G2 10%	<p>Rotate [MAIN DIAL] to set to 0.2 W, and then touch [SET].</p>
	7	POWER 5.6G2 50%	<p>Rotate [MAIN DIAL] to set to 1.0 W, and then touch [SET].</p>
	8	POWER 5.6G2 100%	<p>Rotate [MAIN DIAL] to set to 2.0 W, and then touch [SET].</p>
TX OUTPUT POWER BALANCE	9	POWER 5.6G Balance SET	<ul style="list-style-type: none"> • Returns to receive. <p style="text-align: center;">Touch [SET]. (2 beeps sound.)</p>
	10	POWER 5.6G1 100%	<ul style="list-style-type: none"> • Automatically transmits. <p>Rotate [MAIN DIAL] to set to 2.0 W, and then touch [SET].</p>
	11	POWER 5.6G3 100%	
	12	POWER 5.6G4 100%	
AM TX OUTPUT POWER	13	POWER AM Ratio 5.6G	<ul style="list-style-type: none"> • Returns to receive. <p style="text-align: center;">Touch [SET]. (2 beeps sound.)</p>
	14		<ul style="list-style-type: none"> • Automatically transmits. <p>Rotate [MAIN DIAL] to set to 0.5 W, and then touch [SET].</p>
ALC	15	ALC 5.6G	<ul style="list-style-type: none"> • Returns to receive. <p style="text-align: center;">Touch [SET]. (A beep sound.)</p>
	16		<ul style="list-style-type: none"> • Automatically transmits. <p>The automatic adjustment starts. When the adjustment is completed, 2 beeps sound and selects the next adjustment item.</p>
DRIVE GAIN	17	DRIVE 5.6G	<ul style="list-style-type: none"> • Returns to receive. <p style="text-align: center;">Touch [SET]. (A beep sound.)</p>
	18		<ul style="list-style-type: none"> • Automatically transmits. <p>The automatic adjustment starts. When the adjustment is completed, 2 beeps sound and selects the next adjustment item.</p>
SWR METER	19	SWR2(5.6G)	<ul style="list-style-type: none"> • Connect the SWR 2 dummy load to [5600 MHz ANT] of RF UNIT. <p style="text-align: center;">Touch [SET]. (A beep sound.)</p>
	20		<ul style="list-style-type: none"> • Automatically transmits. <p>The automatic adjustment starts. When the adjustment is completed, 2 beeps sound and returns to the TX/ID adjustment screen.</p>

5-9 REFERENCE FREQUENCY ADJUSTMENT

Touch [REF] on the adjustment mode main menu.

ADJUSTMENT	ADJUSTMENT ITEM DISPLAY	SETTING CONDITION	OPERATION
REFERENCE FREQUENCY	1	–	• Connect the 13.8 V DC power source to [DC 13.8 V]. • Connect the RF power meter to [2400 MHz ANT] of RF UNIT. • Loosely couple the frequency counter to [2400 MHz ANT] of RF UNIT.
	2	REF OSC 1	• Receive
	3		• Automatically transmits.
	4	REF OSC 2	• Receive
	5		• Automatically transmits.
			Touch [REF] to enter the Reference Frequency Adjustment menu.
			Touch [SET]. (2 beeps sound.)
			Rotate [MAIN DIAL] to set to 2400.000000 MHz (within ± 4 Hz), and then touch [SET].
			Touch [SET]. (2 beeps sound.)
			Rotate [MAIN DIAL] to set to 2400.000000 MHz (within ± 1 Hz), and then touch [SET].
			Returns to the reference frequency adjust menu.

5-10 VHF BAND RECEIVE ADJUSTMENT

Touch [RX] on the adjustment mode main menu.

ADJUSTMENT	ADJUSTMENT ITEM DISPLAY	SETTING CONDITION	OPERATION	
RECEIVE SENSITIVITY	1	–	<ul style="list-style-type: none"> • Connect the 13.8 V DC power source to [DC 13.8 V]. • Connect the SSG to [144/430/1200 MHz ANT] of RF UNIT. 	<ul style="list-style-type: none"> • When adjusting following from the VHF band receive adjustment, touch [SET]. • When adjusting the VHF band receive items from the RX Adjust menu, touch [VHF], and then [SET].
	2	Total Gain VHF PRE OFF ref	<ul style="list-style-type: none"> • Set the SSG to: Frequency: 145.0215 MHz Level: +10 dBμ (PD) (–97 dBm) Modulation: OFF 	Touch [SET]. (A beep sound.)
	3			The automatic adjustment starts. When the adjustment is completed, 2 beeps sound and selects the next adjustment item.
	4	Total Gain VHF PRE OFF set	<ul style="list-style-type: none"> • Set the SSG to: Level: OFF 	Touch [SET]. (A beep sound.)
	5			The automatic adjustment starts. When the adjustment is completed, 2 beeps sound and selects the next adjustment item.
	6	Total Gain VHF PRE ON ref	<ul style="list-style-type: none"> • Set the SSG to: Level: +10 dBμ (PD) (–97 dBm) 	Touch [SET]. (A beep sound.)
	7			The automatic adjustment starts. When the adjustment is completed, 2 beeps sound and selects the next adjustment item.
	8	Total Gain VHF PRE ON set	<ul style="list-style-type: none"> • Set the SSG to: Level: OFF 	Touch [SET]. (A beep sound.)
9		The automatic adjustment starts. When the adjustment is completed, 2 beeps sound and selects the next adjustment item.		
S-METER ~ S0 LEVEL ~	10	VHF S0 LEVEL	<ul style="list-style-type: none"> • Set the SSG to: Level: –13 dBμ (PD) (–120 dBm) 	Touch [SET]. (A beep sound.)
	11			The automatic adjustment starts. When the adjustment is completed, 2 beeps sound and selects the next adjustment item.
~ S9 LEVEL ~	12	VHF S9 LEVEL	<ul style="list-style-type: none"> • Set the SSG to: Level: +10 dBμ (PD) (–97 dBm) 	Touch [SET]. (A beep sound.)
	13			The automatic adjustment starts. When the adjustment is completed, 2 beeps sound and selects the next adjustment item.
~ S9+60 LEVEL ~	14	VHF S9+60 LEVEL	<ul style="list-style-type: none"> • Set the SSG to: Level: +70 dBμ (PD) (–37 dBm) 	Touch [SET]. (A beep sound.)
	15			The automatic adjustment starts. When the adjustment is completed, 2 beeps sound and selects the next adjustment item.

5-11 UHF BAND RECEIVE ADJUSTMENT

Touch [RX] on the adjustment mode main menu.

ADJUSTMENT	ADJUSTMENT ITEM DISPLAY	SETTING CONDITION	OPERATION	
RECEIVE SENSITIVITY	1	–	<ul style="list-style-type: none"> • Connect the 13.8 V DC power source to [DC 13.8 V]. • Connect the SSG to [144/430/1200 MHz ANT] of RF UNIT. 	<ul style="list-style-type: none"> • When adjusting following from the UHF band receive adjustment, touch [SET]. • When adjusting the UHF band receive items from the RX Adjust menu, touch [UHF], and then [SET].
	2	Total Gain UHF PRE OFF ref	<ul style="list-style-type: none"> • Set the SSG to: Frequency: 435.0215 MHz Level: +10 dBμ (PD) (–97 dBm) Modulation: OFF 	Touch [SET]. (A beep sound.)
	3			The automatic adjustment starts. When the adjustment is completed, 2 beeps sound and selects the next adjustment item.
	4	Total Gain UHF PRE OFF set	<ul style="list-style-type: none"> • Set the SSG to: Level: OFF 	Touch [SET]. (A beep sound.)
	5			The automatic adjustment starts. When the adjustment is completed, 2 beeps sound and selects the next adjustment item.
	6	Total Gain UHF PRE ON ref	<ul style="list-style-type: none"> • Set the SSG to: Level: +10 dBμ (PD) (–97 dBm) 	Touch [SET]. (A beep sound.)
	7			The automatic adjustment starts. When the adjustment is completed, 2 beeps sound and selects the next adjustment item.
	8	Total Gain UHF PRE ON set	<ul style="list-style-type: none"> • Set the SSG to: Level: OFF 	Touch [SET]. (A beep sound.)
9		The automatic adjustment starts. When the adjustment is completed, 2 beeps sound and selects the next adjustment item.		
S-METER ~ S0 LEVEL ~	10	UHF S0 LEVEL	<ul style="list-style-type: none"> • Set the SSG to: Level: –13 dBμ (PD) (–120 dBm) 	Touch [SET]. (A beep sound.)
	11			The automatic adjustment starts. When the adjustment is completed, 2 beeps sound and selects the next adjustment item.
~ S9 LEVEL ~	12	UHF S9 LEVEL	<ul style="list-style-type: none"> • Set the SSG to: Level: +10 dBμ (PD) (–97 dBm) 	Touch [SET]. (A beep sound.)
	13			The automatic adjustment starts. When the adjustment is completed, 2 beeps sound and selects the next adjustment item.
~ S9+60 LEVEL ~	14	UHF S9+60 LEVEL	<ul style="list-style-type: none"> • Set the SSG to: Level: +70 dBμ (PD) (–37 dBm) 	Touch [SET]. (A beep sound.)
	15			The automatic adjustment starts. When the adjustment is completed, 2 beeps sound and selects the next adjustment item.

5-12 1.2 GHz BAND RECEIVE ADJUSTMENT

Touch [RX] on the adjustment mode main menu.

ADJUSTMENT	ADJUSTMENT ITEM DISPLAY	SETTING CONDITION	OPERATION	
RECEIVE SENSITIVITY	1	–	<ul style="list-style-type: none"> • Connect the 13.8 V DC power source to [DC 13.8 V]. • Connect the SSG to [144/430/1200 MHz ANT] of RF UNIT. 	<ul style="list-style-type: none"> • When adjusting following from the 1.2 GHz band receive adjustment, touch [SET]. • When adjusting the 1.2 GHz band receive items from the RX Adjust menu, touch [1.2G], and then [SET].
	2	Total Gain 1.2G PRE OFF ref	<ul style="list-style-type: none"> • Set the SSG to: Frequency: 1280.0215 MHz Level: +10 dBμ (PD) (–97 dBm) Modulation: OFF 	Touch [SET]. (A beep sound.)
	3			The automatic adjustment starts. When the adjustment is completed, 2 beeps sound and selects the next adjustment item.
	4	Total Gain 1.2G PRE OFF set	<ul style="list-style-type: none"> • Set the SSG to: Level: OFF 	Touch [SET]. (A beep sound.)
	5			The automatic adjustment starts. When the adjustment is completed, 2 beeps sound and selects the next adjustment item.
	6	Total Gain 1.2G PRE ON ref	<ul style="list-style-type: none"> • Set the SSG to: Level: +10 dBμ (PD) (–97 dBm) 	Touch [SET]. (A beep sound.)
	7			The automatic adjustment starts. When the adjustment is completed, 2 beeps sound and selects the next adjustment item.
	8	Total Gain 1.2G PRE ON set	<ul style="list-style-type: none"> • Set the SSG to: Level: OFF 	Touch [SET]. (A beep sound.)
9		The automatic adjustment starts. When the adjustment is completed, 2 beeps sound and selects the next adjustment item.		
S-METER ~ S0 LEVEL ~	10	1.2G S0 LEVEL	<ul style="list-style-type: none"> • Set the SSG to: Level: –13 dBμ (PD) (–120 dBm) 	Touch [SET]. (A beep sound.)
	11			The automatic adjustment starts. When the adjustment is completed, 2 beeps sound and selects the next adjustment item.
~ S9 LEVEL ~	12	1.2G S9 LEVEL	<ul style="list-style-type: none"> • Set the SSG to: Level: +10 dBμ (PD) (–97 dBm) 	Touch [SET]. (A beep sound.)
	13			The automatic adjustment starts. When the adjustment is completed, 2 beeps sound and selects the next adjustment item.
~ S9+60 LEVEL ~	14	1.2G S9+60 LEVEL	<ul style="list-style-type: none"> • Set the SSG to: Level: +70 dBμ (PD) (–37 dBm) 	Touch [SET]. (A beep sound.)
	15			The automatic adjustment starts. When the adjustment is completed, 2 beeps sound and selects the next adjustment item.

5-13 2.4 GHz BAND RECEIVE ADJUSTMENT

Touch [RX] on the adjustment mode main menu.

ADJUSTMENT	ADJUSTMENT ITEM DISPLAY	SETTING CONDITION	OPERATION	
RECEIVE SENSITIVITY	1	–	<ul style="list-style-type: none"> • Connect the 13.8 V DC power source to [DC 13.8 V]. • Connect the SSG to [2400 MHz ANT] of RF UNIT. 	<ul style="list-style-type: none"> • When adjusting following from the 2.4 GHz band receive adjustment, touch [SET]. • When adjusting the 2.4 GHz band receive items from the RX Adjust menu, touch [2.4G], and then [SET].
	2	Total Gain 2.4G ref	<ul style="list-style-type: none"> • Set the SSG to: Frequency: 2400.0215 MHz Level: +10 dBμ (PD) (–97 dBm) Modulation: OFF 	Touch [SET]. (A beep sound.)
	3			The automatic adjustment starts. When the adjustment is completed, 2 beeps sound and selects the next adjustment item.
	4	2.4G Total Gain set	<ul style="list-style-type: none"> • Set the SSG to: Level: OFF 	Touch [SET]. (A beep sound.)
	5			The automatic adjustment starts. When the adjustment is completed, 2 beeps sound and selects the next adjustment item.
S-METER ~ S0 LEVEL ~	6	2.4G S0 LEVEL	<ul style="list-style-type: none"> • Set the SSG to: Level: –13 dBμ (PD) (–120 dBm) 	Touch [SET]. (A beep sound.)
	7			The automatic adjustment starts. When the adjustment is completed, 2 beeps sound and selects the next adjustment item.
~ S9 LEVEL ~	8	2.4G S9 LEVEL	<ul style="list-style-type: none"> • Set the SSG to: Level: +10 dBμ (PD) (–97 dBm) 	Touch [SET]. (A beep sound.)
	9			The automatic adjustment starts. When the adjustment is completed, 2 beeps sound and selects the next adjustment item.
~ S9+60 LEVEL ~	10	2.4G S9+60 LEVEL	<ul style="list-style-type: none"> • Set the SSG to: Level: +70 dBμ (PD) (–37 dBm) 	Touch [SET]. (A beep sound.)
	11			The automatic adjustment starts. When the adjustment is completed, 2 beeps sound and selects the next adjustment item.

5-14 5.6 GHz BAND RECEIVE ADJUSTMENT

Touch [RX] on the adjustment mode main menu.

ADJUSTMENT	ADJUSTMENT ITEM DISPLAY	SETTING CONDITION	OPERATION	
RECEIVE SENSITIVITY	1	–	<ul style="list-style-type: none"> • Connect the 13.8 V DC power source to [DC 13.8 V]. • Connect the SSG to [5600 MHz ANT] of RF UNIT. 	<ul style="list-style-type: none"> • When adjusting following from the 5.6 GHz band receive adjustment, touch [SET]. • When adjusting the 5.6 GHz band receive items from the RX Adjust menu, touch [5.6G], and then [SET].
	2	Total Gain 5.6G ref	<ul style="list-style-type: none"> • Set the SSG to: Frequency: 5750.0415 MHz Level: +10 dBμ (PD) (–97 dBm) Modulation: OFF 	Touch [SET]. (A beep sound.)
	3			The automatic adjustment starts. When the adjustment is completed, 2 beeps sound and selects the next adjustment item.
	4	Total Gain 5.6G set	<ul style="list-style-type: none"> • Set the SSG to: Level: OFF 	Touch [SET]. (A beep sound.)
	5			The automatic adjustment starts. When the adjustment is completed, 2 beeps sound and selects the next adjustment item.
S-METER ~ S0 LEVEL ~	6	5.6G S0 LEVEL	<ul style="list-style-type: none"> • Set the SSG to: Level: –13 dBμ (PD) (–120 dBm) 	Touch [SET]. (A beep sound.)
	7			The automatic adjustment starts. When the adjustment is completed, 2 beeps sound and selects the next adjustment item.
~ S9 LEVEL ~	8	5.6G S9 LEVEL	<ul style="list-style-type: none"> • Set the SSG to: Level: +10 dBμ (PD) (–97 dBm) 	Touch [SET]. (A beep sound.)
	9			The automatic adjustment starts. When the adjustment is completed, 2 beeps sound and selects the next adjustment item.
~ S9+60 LEVEL ~	10	5.6G S9+60 LEVEL	<ul style="list-style-type: none"> • Set the SSG to: Level: +70 dBμ (PD) (–37 dBm) 	Touch [SET]. (A beep sound.)
	11			The automatic adjustment starts. When the adjustment is completed, 2 beeps sound and returns to the RX adjustment screen.

5-15 CX-10G TRANSMIT ADJUSTMENT

Touch [OPT] on the adjustment main menu.

ADJUSTMENT	ADJUSTMENT ITEM DISPLAY	SETTING CONDITION	OPERATION
TX OUTPUT POWER	1	–	• Connect the RF power meter to [10 GHz ANT]. • Connect the audio generator and the AC millivoltmeter to the JIG plug, and set it to: Frequency: 1.5 kHz Waveform: Sine wave Level: 30 mVrms
	2	10G TX POWER SET (905 Side)	• Automatically transmits.
	3	10G TX Total Gain (905 Total)	• Automatically transmits.
ALC	4	10G ALC for DRIVE ADJ	• Returns to receive.
	5		• Automatically transmits.
DRIVE GAIN	6	10G Drive	• Returns to receive.
	7		• Automatically transmits.
REFERENCE VOLTAGE LOADING	1	–	• Connect the audio generator and the AC millivoltmeter to the JIG plug, and set it to: Frequency: 1.5 kHz Waveform: Sine wave Level: 30 mVrms • Connect the dummy load (50 Ω) to [10 GHz ANT].
10 GHz BAND ~ FINAL IDLING CURRENT ~	2	10G FINAL ID SET	• Returns to receive.
	3	10G FINAL IDV	• Automatically transmits.
	4		

Touch [10G TX] to enter the 10G TX adjustment screen. ([OPT] > [10G TX])

Touch [SET]. (2 beeps sound.)

Rotate [MAIN DIAL] to set to 0.25 W, and then touch [SET].

Touch [SET]. (A beep sound.)

The automatic adjustment starts.
When the adjustment is completed, 2 beeps sound and selects the next adjustment item.

Touch [SET]. (A beep sound.)

The automatic adjustment starts.
When the adjustment is completed, 2 beeps sound returns to the 10G TX adjustment screen.

• Touch [CX-10G], [TX/ID] then [ID] to enter the ID adjustment mode. ([OPT] > [CX-10G] > [TX/ID] > [ID])

Touch [SET]. (A beep sound)

Touch [SET]. (A beep sound)

The automatic adjustment starts.
When the adjustment is completed, 2 beeps sound and selects the next adjustment item.

5-15 CX-10G TRANSMIT ADJUSTMENT (CONTINUED)

Touch [OPT] on the adjustment main menu.

ADJUSTMENT	ADJUSTMENT ITEM DISPLAY	SETTING CONDITION	OPERATION	
2.4 GHz BAND CARRIER OUTPUT	1	–	<ul style="list-style-type: none"> • Connect the RF power meter to [2400 MHz ANT] (IC-905). • Connect the audio generator and the AC millivoltmeter to the JIG plug, and set it to: Frequency: 1.5 kHz Waveform: Sine wave Level: 30 mVrms 	<ul style="list-style-type: none"> • When adjusting following from the idling adjustment, touch [SET]. • When adjusting the CX-10G transmit items from the TX/ID adjust screen, touch [10G TX]. ([OPT] > [CX-10G] > [TX-ID] > [10G TX])
	2	2.4G TX Po ADJ	<ul style="list-style-type: none"> • Automatically transmits. 	Touch [SET]. (2 beeps sound.)
	3			Rotate [MAIN DIAL] to set the 2400 MHz output level to 65 mW, and then touch [SET].
10 GHz BAND TX OUTPUT POWER	4	10G TX Total Gain SET	<ul style="list-style-type: none"> • Returns to receive. • Connect the RF power meter to [10 GHz ANT]. • Connect the SSG to [2400 MHz IF], and set it to: Frequency: 2.400 GHz Level: +124 dBμ (PD) (+17 dBm) Modulation: OFF 	Touch [SET]. (2 beeps sound.)
	5	10G1 TX Total Gain	<ul style="list-style-type: none"> • Automatically transmits. 	Rotate [MAIN DIAL] to set to +24 dBm (within ± 0.5 dB), and then touch [SET].
	6	10G2 TX Total Gain	<ul style="list-style-type: none"> • Set the SSG to: Frequency: 2.405 GHz 	
	7	10G3 TX Total Gain	<ul style="list-style-type: none"> • Set the SSG to: Frequency: 2.410 GHz 	
	8	10G POWER SET	<ul style="list-style-type: none"> • Returns to receive. 	Touch [SET]. (2 beeps sound.)
	9	10G2 Po 0%(MIN)	<ul style="list-style-type: none"> • Automatically transmits. 	Rotate [MAIN DIAL] to set to 25 mW (within ± 2 mW), and then touch [SET]. Note the adjustment value as the reference.
	10	10G2 Po 1%		Rotate [MAIN DIAL] to set the adjustment value to the same as the reference, and then touch [SET].
	11	10G2 Po 10%		Rotate [MAIN DIAL] to set to 50 mW (within ± 4 mW), and then touch [SET].
	12	10G2 Po 50%		Rotate [MAIN DIAL] to set to 0.25 W (within ± 0.015 W), and then touch [SET].
	13	10G2 Po 100%		Rotate [MAIN DIAL] to set to 0.5 W (within ± 0.015 W), and then touch [SET].
10 GHz BAND TX OUTPUT POWER BALANCE	14	10G POWER Balance SET	<ul style="list-style-type: none"> • Returns to receive. 	Touch [SET]. (2 beeps sound.)
	15	10G1 Po 100%	<ul style="list-style-type: none"> • Automatically transmits. 	Rotate [MAIN DIAL] to set to 0.5 W (within ± 0.015 W), and then touch [SET].
	16	10G3 Po 100%		
10 GHz BAND AM TX OUTPUT POWER	17	10G POWER AM Ratio	<ul style="list-style-type: none"> • Returns to receive. 	Touch [SET]. (2 beeps sound.)
	18		<ul style="list-style-type: none"> • Automatically transmits. 	Rotate [MAIN DIAL] to set to 0.125 W (within ± 0.01 W), and then touch [SET].
10 GHz BAND ALC	19	10G ALC	<ul style="list-style-type: none"> • Returns to receive. 	Touch [SET]. (A beep sound.)
	20		<ul style="list-style-type: none"> • Automatically transmits. 	The automatic adjustment starts. When the adjustment is completed, 2 beeps sound and selects the next adjustment item.

5-16 CX-10G RECEIVE ADJUSTMENT

Touch [OPT] on the adjustment main menu.

ADJUSTMENT	ADJUSTMENT ITEM DISPLAY	SETTING CONDITION	OPERATION
RECEIVE SENSITIVITY	1	–	<ul style="list-style-type: none"> • Touch [CX-10G], and then touch [RX]. ([OPT] > [CX-10G] > [RX]) • Rotate [MAIN DIAL] to set the 2400 MHz IF signal level to –19 dBm (within ±0.5 dB), and then touch [SET].
	2	10G1 RX Total Gain	
	3	10G2 RX Total Gain	
	4	10G3 RX Total Gain	
		<ul style="list-style-type: none"> • Connect the spectrum analyzer to [2400 MHz IF]. • Connect the SSG to [10 GHz ANT], and set it to: Frequency: 10.000 GHz Level: +82 dBμ (PD) (–25 dBm) Modulation: OFF • Set the SSG to: Frequency: 10.250 GHz • Set the SSG to: Frequency: 10.500 GHz 	

5-17 CX-10G TRANSMIT VERIFICATION

Turn OFF the UDT, then turn ON it again to exit from the adjustment mode.

ADJUSTMENT	DUT'S CONDITION	SETTING CONDITION	Value
SPURIOUS EMISSIONS (at 10.25 GHz) - Out-of-band -	1 • Frequency: 10.250 GHz • Mode: FM • Transmitting	• Connect the spectrum analyzer to [10 GHz ANT], through the attenuator, and set it to: Start frequency: 10.24925 GHz Stop frequency: 10.24998 GHz RBW: 300 Hz VBW: 300 Hz Detector mode: Sampling Video averaging: OFF	-10 dBm or less
		2 • Set the spectrum analyzer to: Start frequency: 10.25002 GHz Stop frequency: 10.25075 GHz	
- Spurious -	1 • Frequency: 10.250 GHz • Mode: FM • Transmitting	• Connect the spectrum analyzer to [10 GHz ANT], through the attenuator, and set it to: Start frequency: 0.03 GHz Stop frequency: 1 GHz RBW: 1 MHz VBW: 1 MHz Detector mode: Positive peak Video averaging: OFF	-13 dBm or less
		2 • Set the spectrum analyzer to: Start frequency: 1 GHz Stop frequency: 4 GHz	
		3 • Set the spectrum analyzer to: Start frequency: 4 GHz Stop frequency: 7 GHz	
		4 • Set the spectrum analyzer to: Start frequency: 7 GHz Stop frequency: 13 GHz	
		5 • Set the spectrum analyzer to: Start frequency: 13 GHz Stop frequency: 19 GHz	
		6 • Set the spectrum analyzer to: Start frequency: 19 GHz Stop frequency: 26 GHz	
		7 • Set the spectrum analyzer to: Start frequency: 10.24000 GHz Stop frequency: 10.24925 GHz RBW: 30 kHz VBW: 30 kHz Video averaging: ON (15 times)	
		8 • Set the spectrum analyzer to: Start frequency: 10.25075 GHz Stop frequency: 10.26000 GHz	

5-17 CX-10G TRANSMIT VERIFICATION (CONTINUED)

ADJUSTMENT	DUT'S CONDITION	SETTING CONDITION	Value
SPURIOUS EMISSIONS (at 10.5 GHz) - Spurious -	1 • Frequency: 10.500 GHz • Mode: FM • Transmitting	• Connect the spectrum analyzer to [10 GHz ANT], through the attenuator, and set it to: Start frequency: 7 GHz Stop frequency: 13 GHz RBW: 1 MHz VBW: 1 MHz Detector mode: Positive peak Video averaging: OFF	-13 dBm or less
SPURIOUS EMISSIONS (at 2.420 GHz) - Out-of-band -	1 • Frequency: 2.420 GHz • Mode: FM • Transmitting	• Connect the spectrum analyzer to [2400 MHz ANT] (CX-10G), through the attenuator, and set it to: Start frequency: 2.41975 GHz Stop frequency: 2.41998 GHz RBW: 300 Hz VBW: 300 Hz Detector mode: Sampling Video averaging: OFF	-10 dBm or less
	2	• Set the spectrum analyzer to: Start frequency: 2.42002 GHz Stop frequency: 2.42025 GHz	
SPURIOUS EMISSIONS (at 2.420 GHz) - Spurious -	1 • Frequency: 2.420 GHz • Mode: FM • Transmitting	• Connect the spectrum analyzer to [2400 MHz ANT] (CX-10G), through the attenuator, and set it to: Start frequency: 0.03 GHz Stop frequency: 1 GHz RBW: 1 MHz VBW: 1 MHz Detector: Positive Peak Video averaging: OFF	-13 dBm or less
	2	• Set the spectrum analyzer to: Start frequency: 1 GHz Stop frequency: 4 GHz	
	3	• Set the spectrum analyzer to: Start frequency: 4 GHz Stop frequency: 7 GHz	
	4	• Set the spectrum analyzer to: Start frequency: 7 GHz Stop frequency: 13 GHz	
	5	• Set the spectrum analyzer to: Start frequency: 2.41000 GHz Stop frequency: 2.41975 GHz RBW: 30 kHz VBW: 30 kHz Video averaging: ON (15 times)	
	6	• Set the spectrum analyzer to: Start frequency: 2.42025 GHz Stop frequency: 2.43000 GHz	

5-17 CX-10G TRANSMIT VERIFICATION (CONTINUED)

ADJUSTMENT		DUT'S CONDITION	SETTING CONDITION	Value
LO LEAKAGE IN RECEIVING (at [10 GHz ANT])	1	<ul style="list-style-type: none"> • Frequency: 10.250 GHz • Mode: FM • Stand-by 	<ul style="list-style-type: none"> • Connect the spectrum analyzer to [10 GHz ANT]. 	2 nW or less
(at [2400 MHz ANT])	2		<ul style="list-style-type: none"> • Connect the spectrum analyzer to [2400 MHz ANT] (CX-10G). 	

SECTION 6 SPARE PARTS AND UNITS

■ ABOUT SPARE UNITS

Information about ordering spare units for the IC-905 (only #12) is described in this section.

The mechanical parts information for each unit is also shown in exploded illustrations.

When you order a part that is not described in this section, see SECTION 7 MECHANICAL PARTS for details.

■ COMPOSED ASSEMBLED UNITS

The name of the IC-905's assembled units are shown below.

UNIT NAME
FRONT UNIT
DISPLAY UNIT
MAIN UNIT
CONNECT-A UNIT
CONNECT-B UNIT
RF-A UNIT
RF-B UNIT
MAIN DIAL

■ ASSEMBLED FRONT UNIT

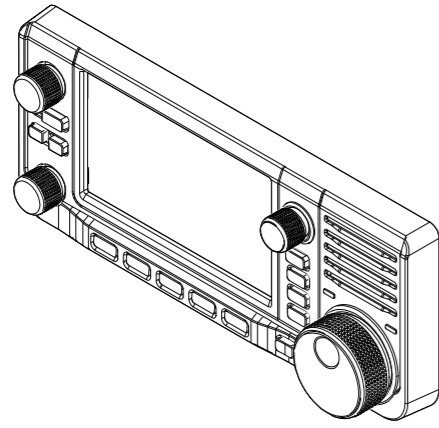

Assembled front unit image

Spare unit name	Order Number	Remarks
C 905 #12 FRONT	0342091201	-

See the illustrations below for the individual parts in the unit.

• Individual parts illustrations

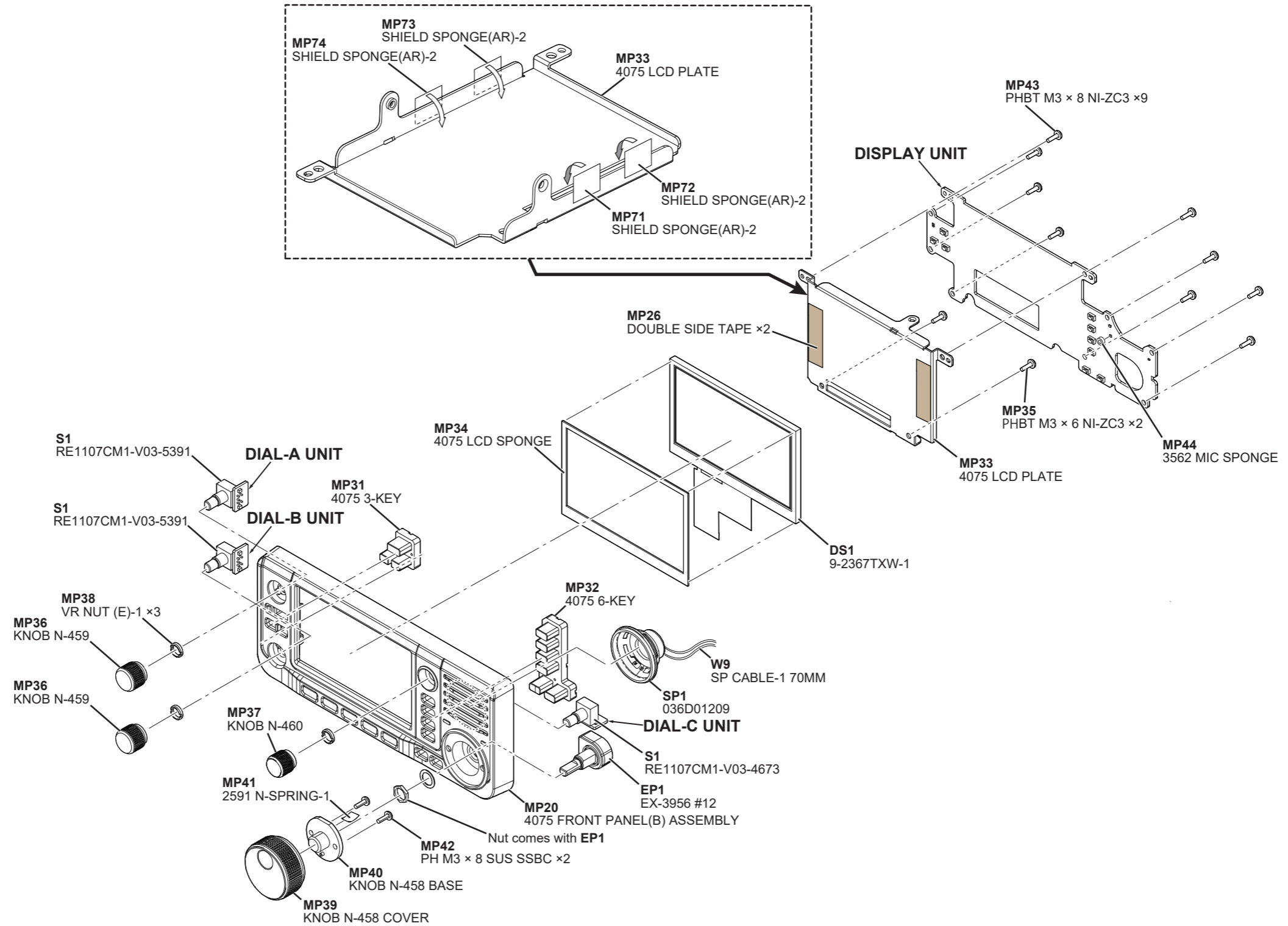

■ ASSEMBLED DISPLAY UNIT

Spare unit name	Order Number	Remarks
C 905 #12 DISPLAY	0342091205	—

See the illustrations below for the individual parts in the unit.

• Individual parts illustrations

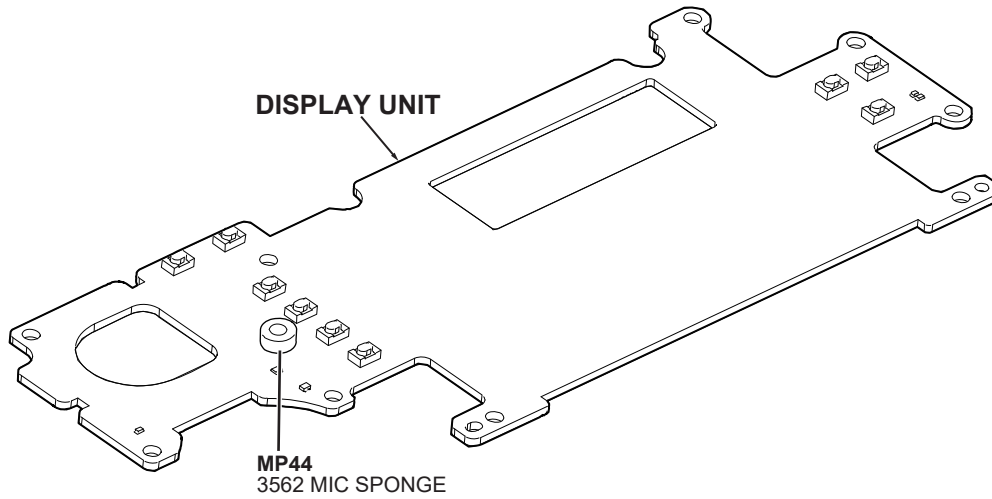

NOTE: The LCD (DS1, FRONT UNIT) is not included in the DISPLAY UNIT.
Therefore, order the LCD separately, if necessary.

■ ASSEMBLED MAIN UNIT

Spare unit name	Order Number	Remarks
C 905 #12 MAIN	0342091202	—

See the illustrations below for the individual parts in the unit.

• Individual parts illustrations

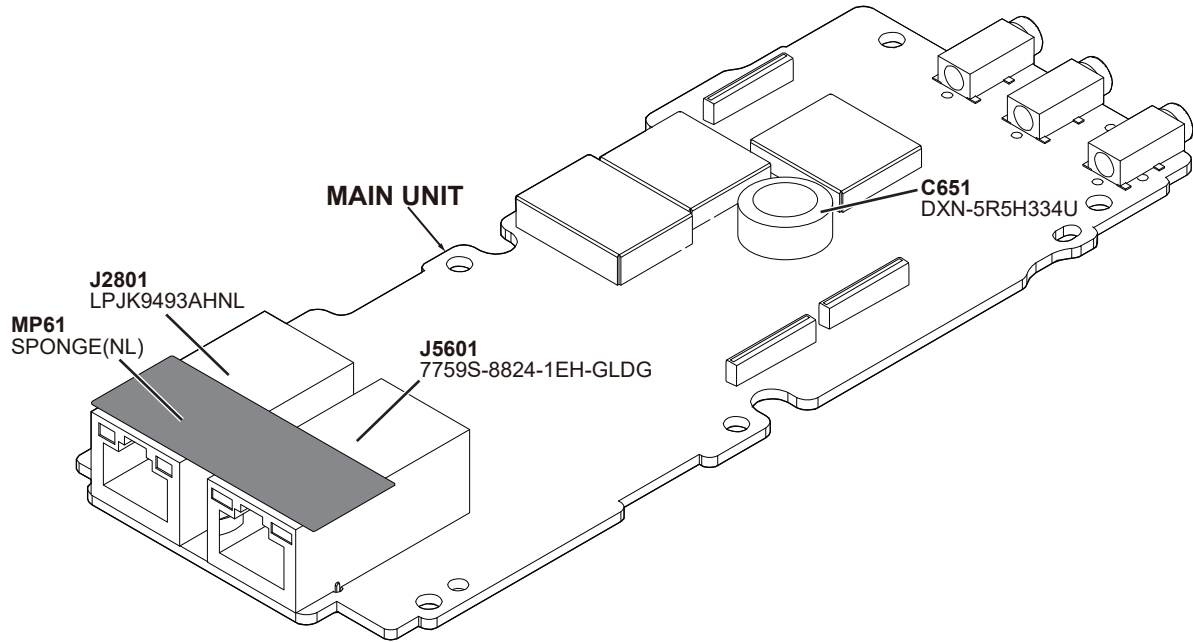

■ ASSEMBLED CONNECT-A UNIT

Spare unit name	Order Number	Remarks
C 905 #12 CONNECT-A	0342091203	-

See the illustrations below for the individual parts in the unit.

• Individual parts illustrations

<Top view>

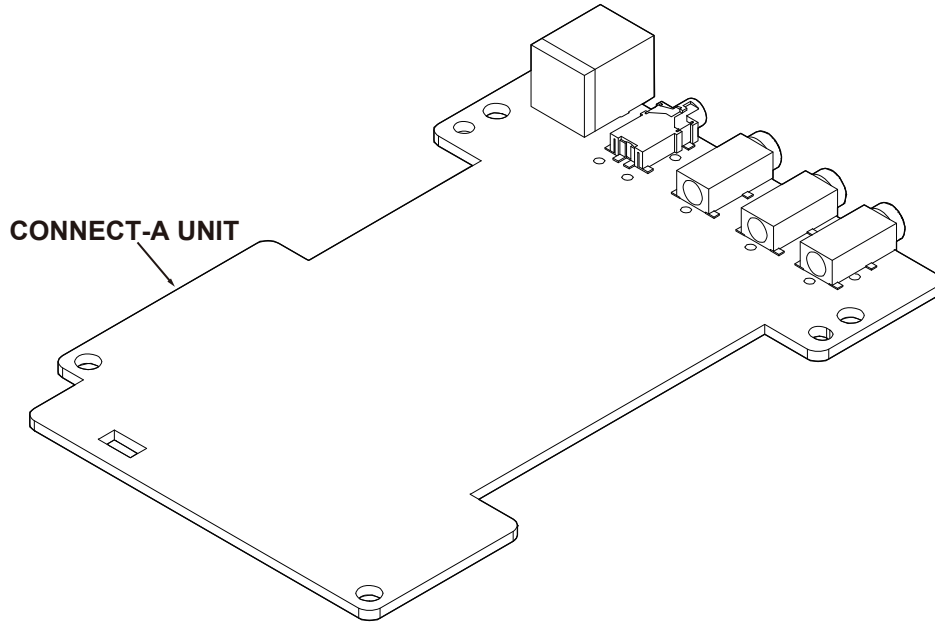

<Bottom view>

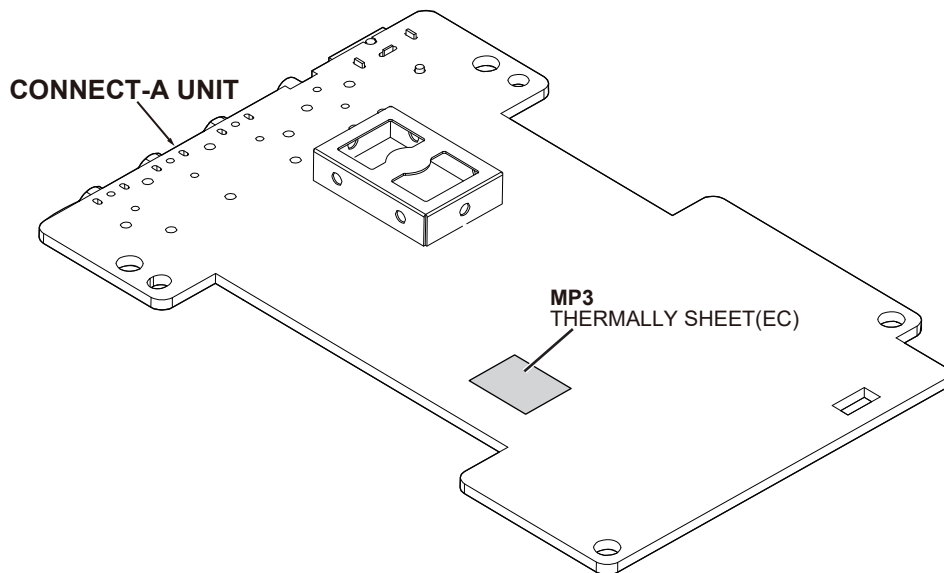

■ ASSEMBLED CONNECT-B UNIT

Spare unit name	Order Number	Remarks
C 905 #12 CONNECT-B	0342091204	—

See the illustrations below for the individual parts in the unit.

• Individual parts illustrations

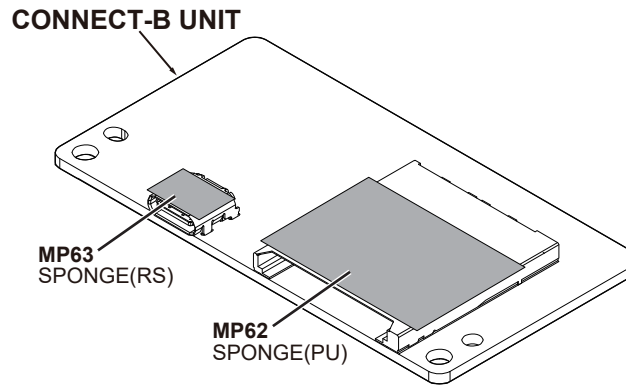

■ ASSEMBLED RF-A UNIT

Spare unit name	Order Number	Remarks
C 905 #12 RF-A	0342091207	-

See the illustrations below for the individual parts in the unit.

• Individual parts illustrations

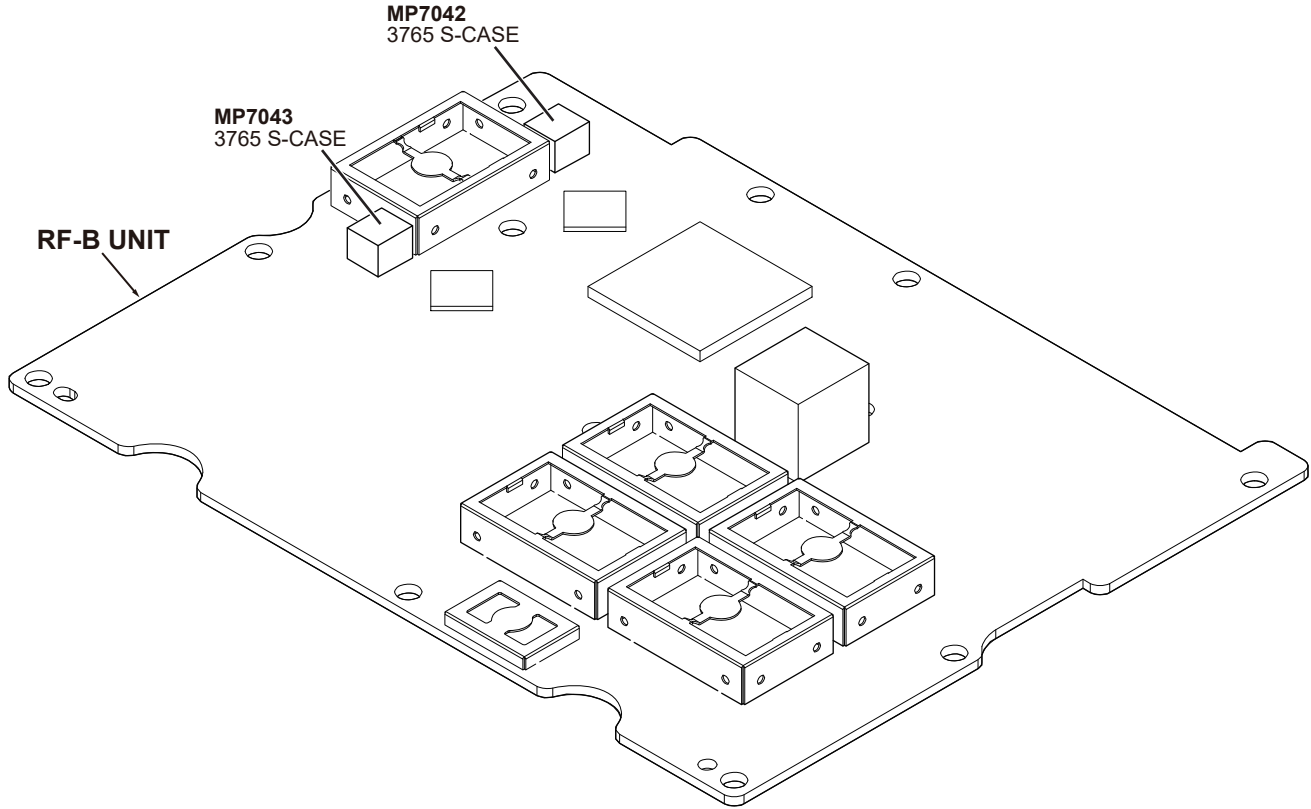

■ ASSEMBLED RF-B UNIT

Spare unit name	Order Number	Remarks
C 905 #12 RF-B	0342091208	-

See the illustrations below for the individual parts in the unit.

• Individual parts illustrations

<Top view>

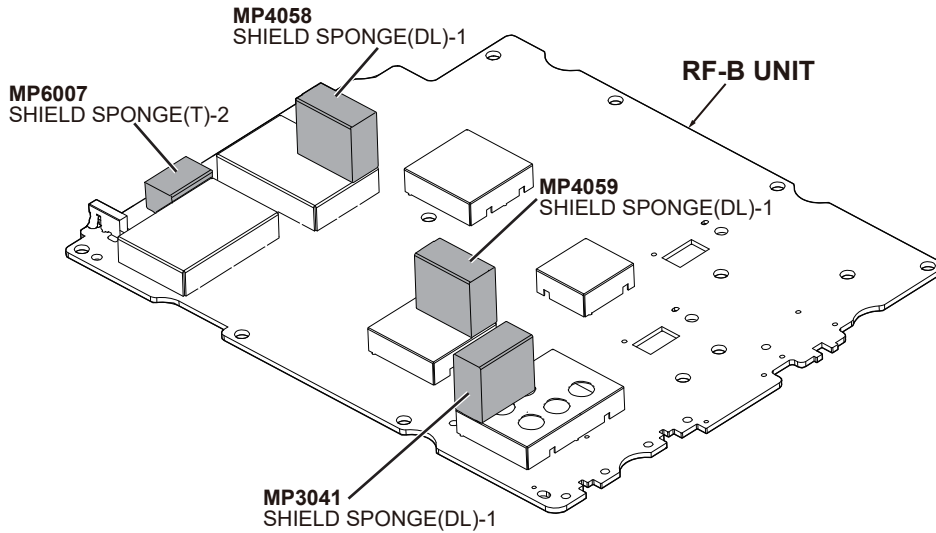

<Bottom view>

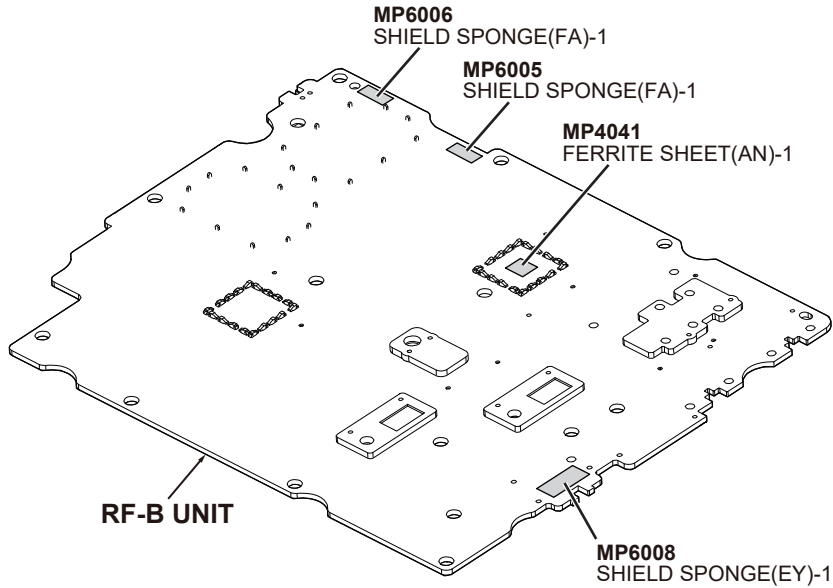

■ ASSEMBLED MAIN DIAL

Spare unit name	Order Number	Remarks
C 905 #12 SENSOR	0342091206	-

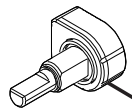

IC-905 MAIN DIAL SENSOR

■ SPARE PARTS INFORMATION

• For the MAIN UNIT

	Reference number	Parts name	Order Number	Remarks
CAPACITOR	C651	DXN-5R5H334U	4510010460	—
CONNECTOR	J1402	03-935H1-72BKA	6510025771	—
CONNECTOR	J1451	03-935H1-72BKA	6510025771	—
CONNECTOR	J1452	03-935H1-72BKA	6510025771	—
CONNECTOR	J2801	LPJK9493AHNL	6510035130	—
CONNECTOR	J5601	7759S-8824-1EH-GLDG	6510034850	—

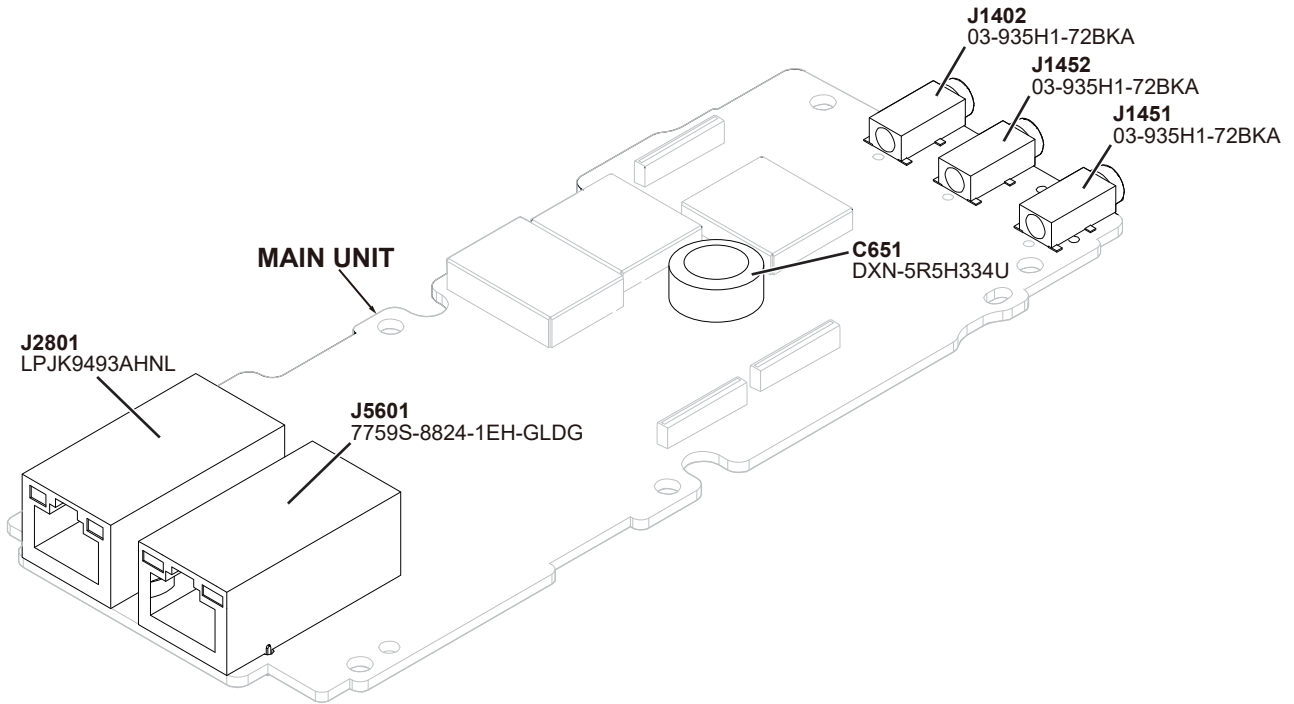

• Electronic part

REF NO.	PART NO.	DESCRIPTION	M.	H/V LOCATION
IC2401	1110007610	S.IC TPA0211DGNR	B	23.9/14.5

M.=Mounted side (T: Mounted on the Top side, B: Mounted on the Bottom side)
H/V LOCATION=See the BOARD LAYOUTS for details.

NOTE: The parts that are not listed are indicated in gray.

■ SPARE PARTS INFORMATION (CONTINUED)

• For the FRONT UNIT

	Reference number	Parts name	Order Number	Remarks
LCD	DS1	M9-2367TXW-1	5030004620	-
SPEAKER	SP1	036D01209	2510002160	-
PANEL	MP20	4075 FRONT PANEL(B) ASSEMBLY	8210036660	-
KEYPAD	MP31	4075 3-KEY	8930103030	-
KEYPAD	MP32	4075 6-KEY	8930103050	-
SPONGE	MP34	4075 LCD SPONGE	8930103390	-
SCREW	MP35	PHBT M3 × 6 NI-ZC3	8810008631	Quantity: 2*
KNOB	MP36	KNOB N-459 M1200	8610016580	-
KNOB	MP37	KNOB N-460 M600	8610016590	-
NUT	MP38	VR NUT (E)-1	8830000551	Quantity: 3*
KEYPAD	MP39	KNOB N-458 COVER	8610016570	-
KEYPAD	MP40	KNOB N-458 BASE	8610016560	-
SPRING	MP41	2591 N-SPRING-1	8930060191	-
SCREW	MP42	PH M3 × 8 SUS SSBC	8810005561	Quantity: 2*
SCREW	MP43	PHBT M3 × 8 NI-ZC3	8810008661	Quantity: 9*
SPONGE	MP71	SHIELD SPONGE(AR)-2	8930067292	-
SPONGE	MP72	SHIELD SPONGE(AR)-2	8930067292	-
SPONGE	MP73	SHIELD SPONGE(AR)-2	8930067292	-
SPONGE	MP74	SHIELD SPONGE(AR)-2	8930067292	-
CABLE	W9	SP CABLE-1 70MM	8600037590	-
FFC	W5	FFC-1008	8910000070	-
FFC	W6	FFC-1008	8910000070	-
FFC	W7	FFC-1008	8910000070	-
FFC	W8	FFC-1008	8910000070	-

*When you order a quantity of 1, you will receive one item.

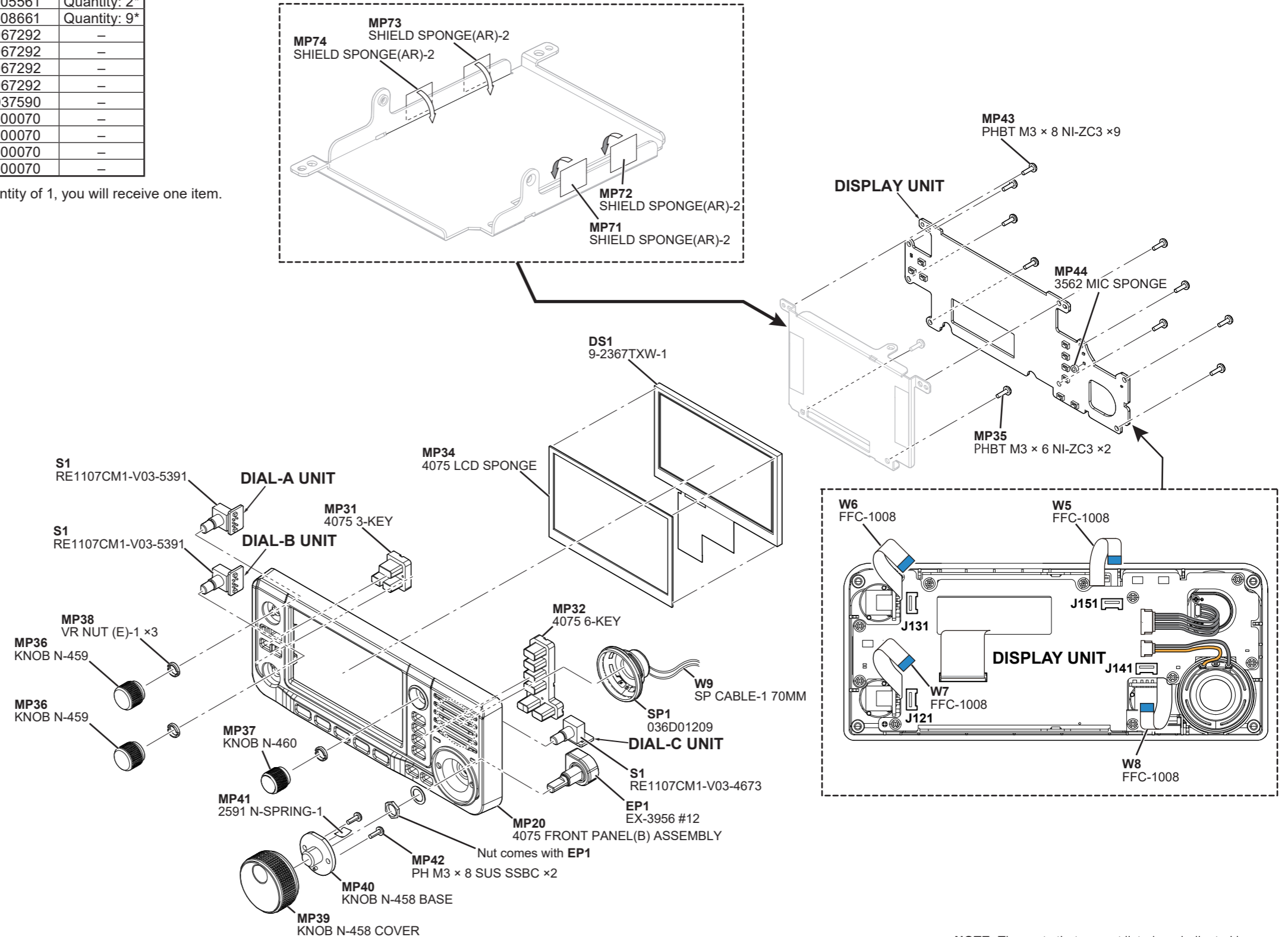

NOTE: The parts that are not listed are indicated in gray.

■ SPARE PARTS INFORMATION (CONTINUED)

• For the controller

	Reference number	Parts name	Order Number	Remarks
CHASSIS	MP1	4209 CHASSIS	8010026180	-
CASE	MP2	4209 CASE ASSEMBLY	8010026200	-
PLATE	MP4	4075 BRACKET PLATE	8930103410	-
SCREW	MP5	PHBT M2 × 6 NI-ZK3	8810009561	Quantity: 2*
SCREW	MP6	PHBT M3 × 8 NI-ZC3	8810008661	Quantity: 6*
PLATE	MP7	4075 MIC PLATE	8930104120	-
SCREW	MP8	SETSCREW (H) 4X12 SUS	8810012240	-
SCREW	MP9	FLAT WASHER M4 (4X12X0.8) SUS	8850001800	-
SCREW	MP10	PHBT M3 × 8 NI-ZC3	8810008661	Quantity: 10*
SCREW	MP11	PHBT M3 × 8 NI-ZC3	8810008661	Quantity: 2*
SCREW	MP12	PHBT M3 × 8 NI-ZC3	8810008661	Quantity: 6*
SCREW	MP50	PHBT M3 × 12 NI-ZK3	8810009371	Quantity: 4*
SCREW	MP51	PHBT M3 × 6 ZK3 B	8810012030	Quantity: 2*
SCREW	MP53	PHBT M3 × 8 NI-ZC3	8810008661	Quantity: 2*
SCREW	MP54	FLAT M2.6 × 6 ZK3	8810009611	Quantity: 8*
HEATSINK	MP56	4209 C-HEATSINK	8410003480	Quantity: 2*
WIRE	MP57	CS-2 (COATING CLIP)	8950003640	-
SHEET	MP59	THERMALLY SHEET(EC)	8930110230	-
SHEET	MP60	THERMALLY SHEET DS TC-500CAT(8X12)	8930101020	-
SPONGE	MP61	SPONGE(NL)	8930092830	-
SPONGE	MP62	SPONGE(PU)	8930100110	-
SPONGE	MP63	SPONGE(RS)	8930106010	-
STICKER	MP64	4209 B CAUTION STICKER	8310107890	-
STICKER	MP65	4209 STICKER	8310107870	-
SPONGE	MP75	SHIELD SPONGE(AR)-2	8930067292	-
SPONGE	MP76	SHIELD SPONGE(AR)-2	8930067292	-
SPONGE	MP77	SHIELD SPONGE(AR)-2	8930067292	-
SPONGE	MP78	SHIELD SPONGE(AR)-2	8930067292	-
SHEET	MP79	4209 AL A-SHEET	8930111430	-
SHEET	MP80	4209 AL B-SHEET	8930111440	-
SPONGE	MP81	SHIELD SPONGE(AR)-2	8930067292	-
SPONGE	MP82	SHIELD SPONGE(AR)-2	8930067292	-
FFC	W11	FFC-1056	8910000520	-
FFC	W12	FFC-1056	8910000520	-
CABLE	W13	OPC-519A	8900014750	-
CABLE	W15	CAB-1708	8920005760	-
FFC	W16	FFC-1066(P0.5.N22.L70)	8910000610	-

*When you order a quantity of 1, you will receive one item.

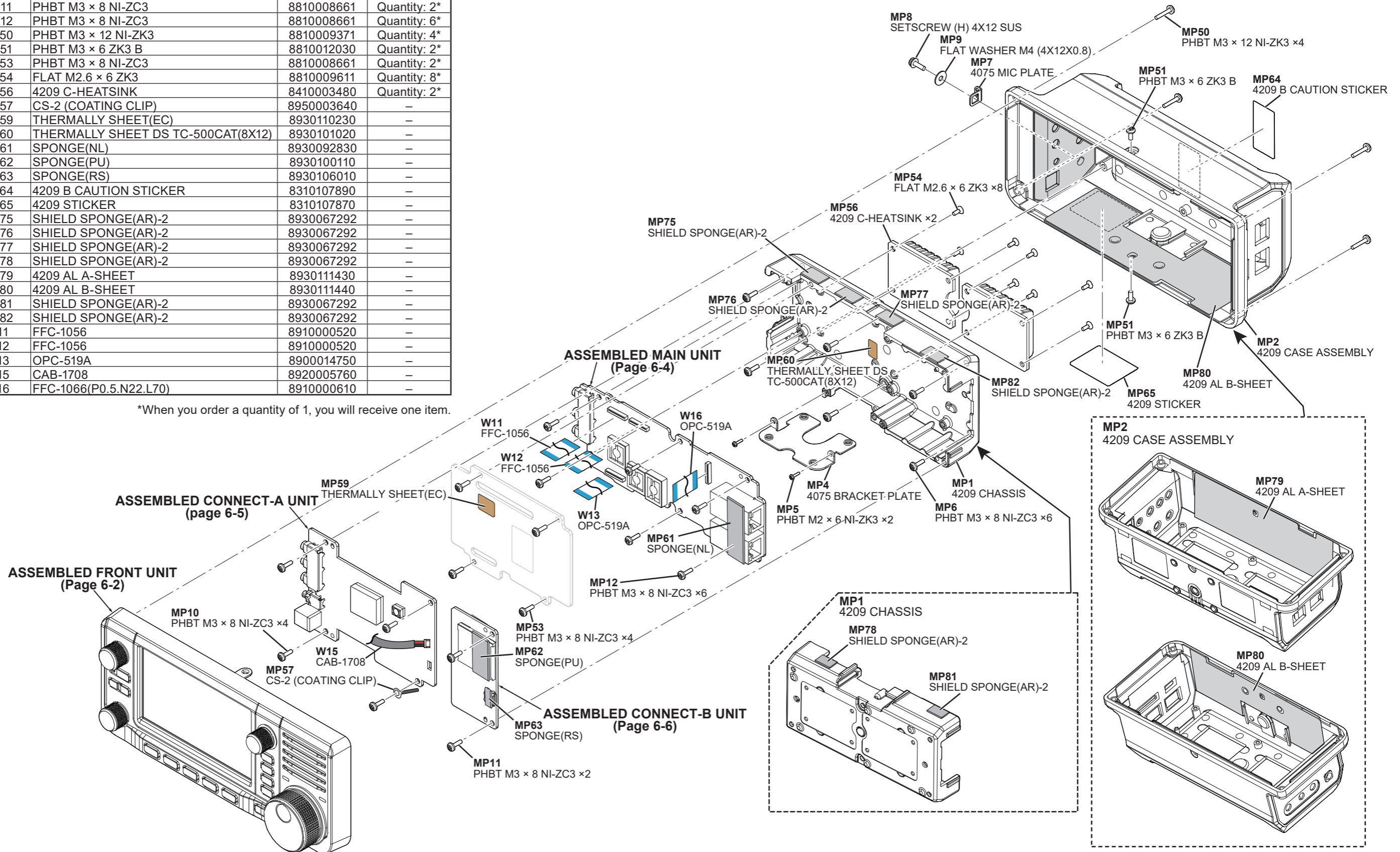

■ SPARE PARTS INFORMATION (CONTINUED)

• For the DISPLAY UNIT

	Reference number	Parts name	Order Number	Remarks
SPONGE	MP44	3562 MIC SPONGE	8930089670	—

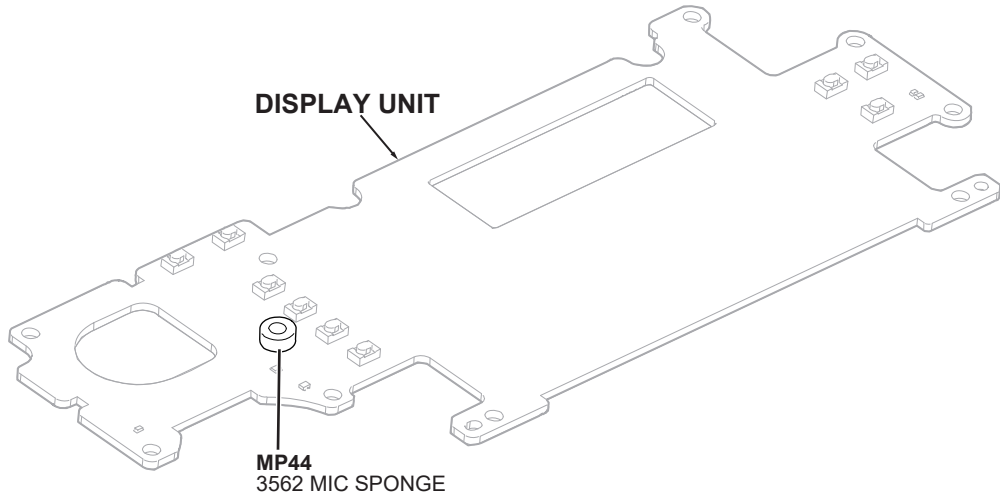

NOTE: The parts that are not listed are indicated in gray.

■ SPARE PARTS INFORMATION (CONTINUED)

• For the CONNECT-A UNIT

	Reference number	Parts name	Order Number	Remarks
CONNECTOR	J51	03-935H1-72BKA	6510025771	—
CONNECTOR	J52	03-935H1-72BKA	6510025771	—
CONNECTOR	J301	03-935H1-72BKA	6510025771	—
SHEET	MP3	THERMALLY SHEET(EC)	8930110230	—

<Top view>

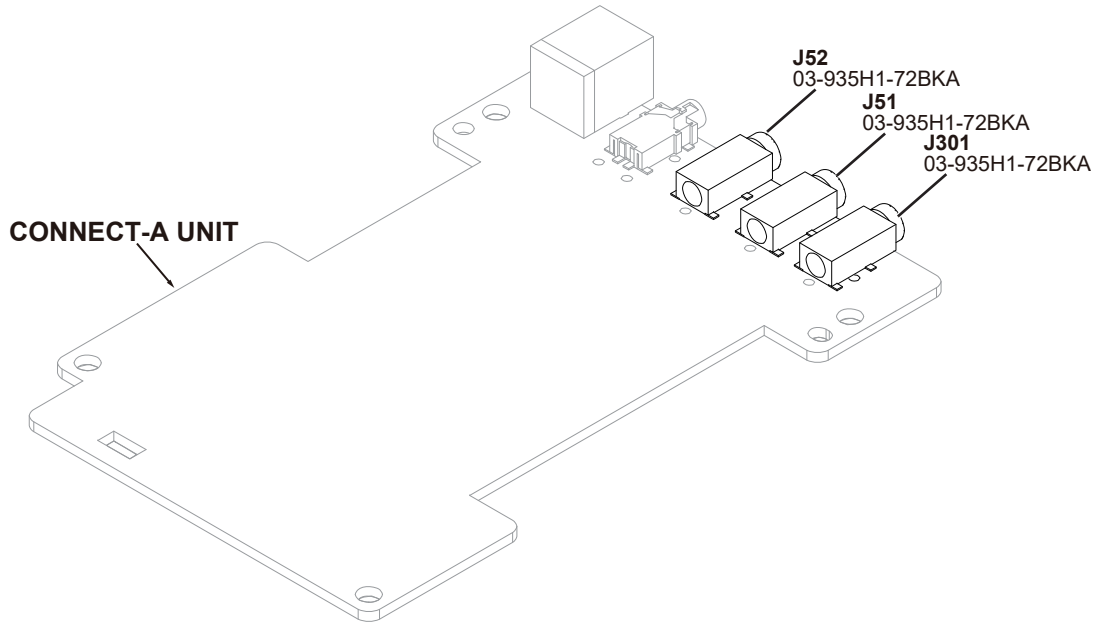

<Bottom view>

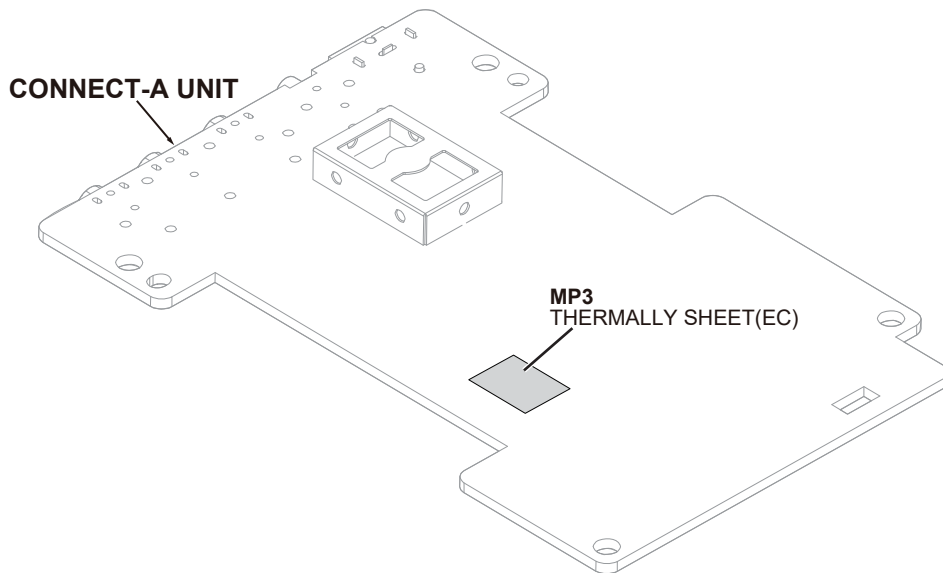

NOTE: The parts that are not listed are indicated in gray.

■ SPARE PARTS INFORMATION (CONTINUED)

• For the CONNECT-C UNIT

	Reference number	Parts name	Order Number	Remarks
CONNECTOR	J1	ICOM-CCBPM10MBB	6510031421	—

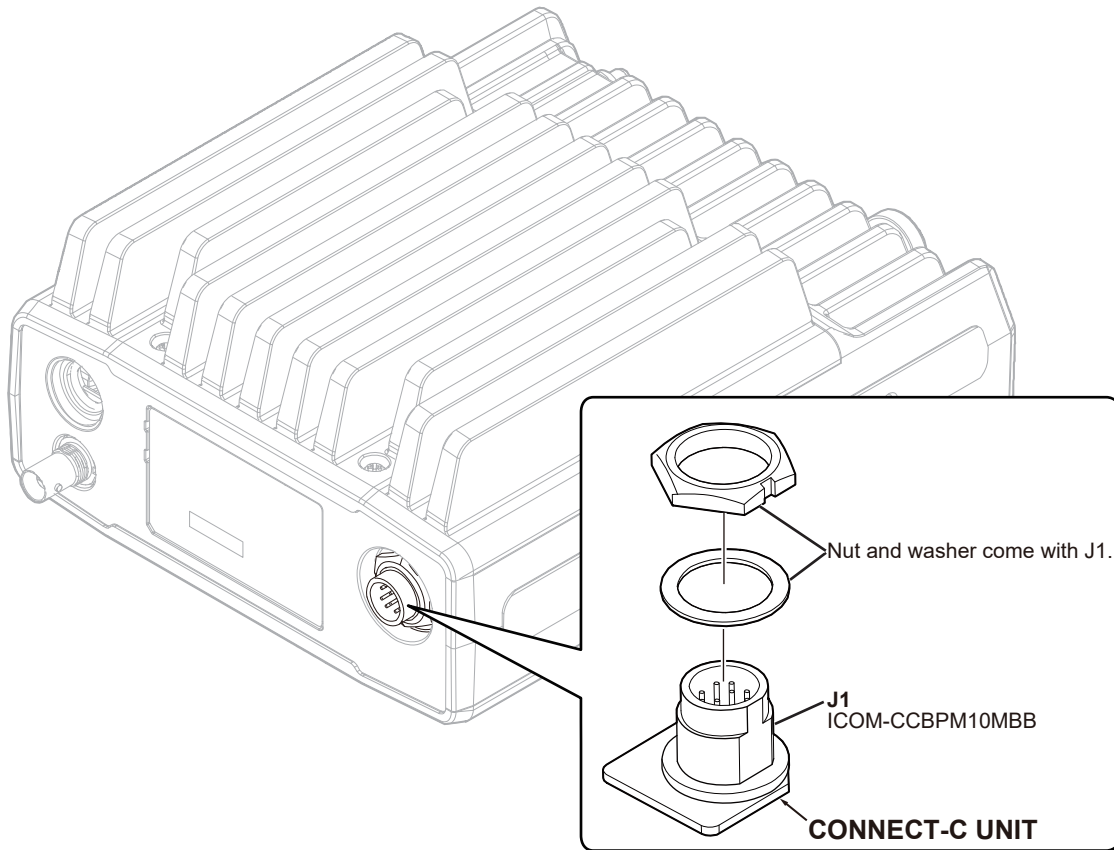

NOTE: The parts that are not listed are indicated in gray.

■ SPARE PARTS INFORMATION (CONTINUED)

• For the RF UNIT (RF-A UNIT side)

	Reference number	Parts name	Order Number	Remarks
CONNECTOR	J1	BNC-R4066	6510032950	-
CONNECTOR	J2	NR-DS-E 01	6510004910	-
CONNECTOR	J3	SMA-R26.9ICW	6510035330	-
CONNECTOR	J4	SMA-R26.9ICW	6510035330	-
CABLE	W22	CAB-1367	8920002950	-
CABLE	W23	CAB-1727	8920006060	-
SCREW	MP9	PH B0 M3 × 8 SUS S (BT)	8810010610	Quantity: 2*
COVER	MP11	4209 RF-A A-COVER	8110012550	-
SEAL	MP12	4209 RF-A SEAL (TOP)	8930109360	-
SCREW	MP13	PHBT M3 × 8 NI-ZC3	8810008661	Quantity: 12*
SCREW	MP24	PHBT M3 × 12 SUS	8810012610	Quantity: 6*
PLATE	MP25	3803 BUSH PLATE	8930094980	-
SEAL	MP26	4209 CONNECTOR SEAL	8930109950	-
CHASSIS	MP28	4209 RF CHASSIS	8010026190	-
SEAL	MP33	O-RING(DV) (TOP)	8930094800	-
SHEET	MP34	2438 SHEET	8930055070	-
SEAL	MP39	O-RING(DV)	8930109960	-
SHEET	MP41	THERMALLY SHEET (EC)	8930110230	-
SHEET	MP43	THERMALLY SHEET (EB) RM-5(30) 29X29XT5	8930110140	-
HEATSINK	MP44	4209 A-HEATSINK	8410003490	-
SCREW	MP45	SET SCREW C M3 × 6 ZC3	8810003361	Quantity: 4*
SHEET	MP48	THERMALLY SHEET DT TC-200CAT-20(8X12)	8930101210	-
SHEET	MP49	THERMALLY SHEET DS TC-500CAT(8X12)	8930101020	-
SHEET	MP50	THERMALLY SHEET (DI) TC250CAT20(18X18)	8930098010	-
SHEET	MP51	THERMALLY SHEET (CP) TC150CAT(17X17)	8930091000	-
SCREW	MP52	PHBT M2 × 6 SUS	8810012600	Quantity: 8*
SHEET	MP53	THERMALLY SHEET DT TC-200CAT-20(8X12)	8930101210	-
SHEET	MP54	THERMALLY SHEET DS TC-500CAT(8X12)	8930101020	-
SHEET	MP55	THERMALLY SHEET (DI) TC250CAT20(18X18)	8930098010	-
SHEET	MP56	THERMALLY SHEET (CP) TC150CAT(17X17)	8930091000	-
CABLE	W25	CAB-1741	8920006170	-
FFC	W26	OPC-2283	8900021240	-

• Electronic part

REF NO.	PART NO.	DESCRIPTION	M.	H/V LOCATION
IC6701	1190005440	S.IC GSU-141A-103A	T	51.9/112.1

M.=Mounted side (T: Mounted on the Top side, B: Mounted on the Bottom side)
H/V LOCATION=See the BOARD LAYOUTS for details.

Viewing from RF-A UNIT side

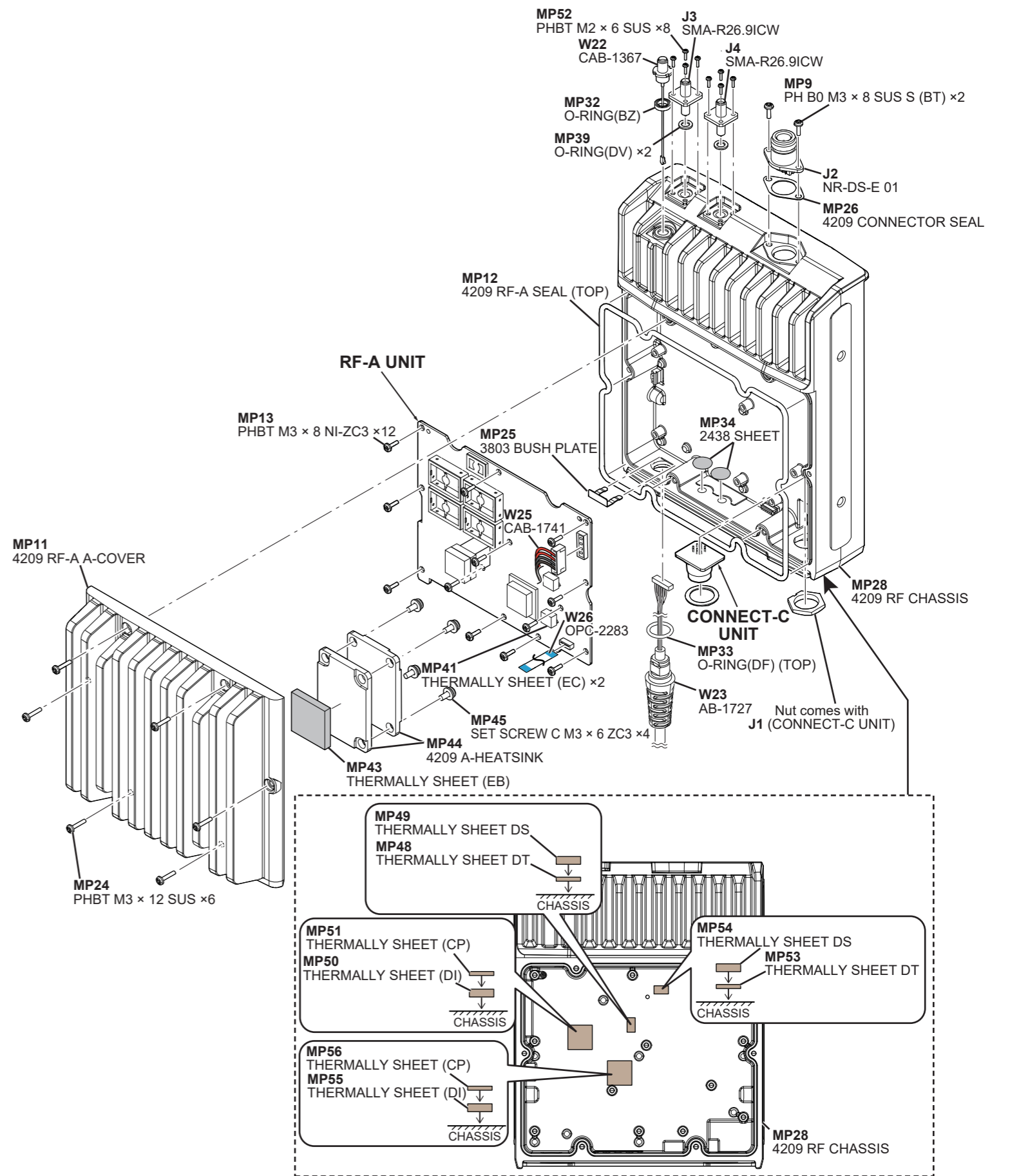

■ SPARE PARTS INFORMATION (CONTINUED)

• For the RF UNIT (RF-B UNIT side)

	Reference number	Parts name	Order Number	Remarks
CONNECTOR	J1	BNC-R4066	6510032950	-
CONNECTOR	J2	NR-DS-E 01	6510004910	-
CONNECTOR	J3	SMA-R26.9ICW	6510035330	-
CONNECTOR	J4	SMA-R26.9ICW	6510035330	-
CABLE	W22	CAB-1367	8920002950	-
SCREW	MP9	PH B0 M3 × 8 SUS S (BT) ×2	8810010610	Quantity: 2*
SCREW	MP14	PHBT M3 × 8 NI-ZC3	8810008661	Quantity: 15*
COVER	MP15	4209 RF-B COVER	8110012470	-
SEAL	MP16	4209 RF-B SEAL (TOP)	8930109370	-
SCREW	MP22	SET SCREW M3 × 10 NI	8810009050	Quantity: 3*
SCREW	MP23	PHBT M2 × 8 NI-ZC3	8810008761	Quantity: 12*
SCREW	MP24	PHBT M3 × 12 SUS	8810012610	Quantity: 8*
SEAL	MP26	4209 CONNECTOR SEAL	8930109950	-
CHASSIS	MP28	4209 RF CHASSIS	8010026190	-
SEAL	MP29	O-RING(DS)	8930109710	-
SEAL	MP32	O-RING(BZ)	8930075620	-
SEAL	MP39	O-RING(DV)	8930109960	Quantity: 2*
SHEET	MP40	THERMALLY SHEET (CP) TC150CAT(17X17)	8930091000	-
SHEET	MP101	THERMALLY SHEET (CP) TC150CAT(17X17)	8930091000	-
SHEET	MP111	FERRITE SHEET (AH)-1	8930084711	-
CABLE	W17	CAB-1354	8920003110	-
CABLE	W18	CAB-1480	8920003740	-
CABLE	W19	CAB-1709	8920005770	-
FFC	W20	FFC-1015-1	8910000141	-
FFC	W21	FFC-1015-1	8910000141	-

Viewing from RF-B UNIT side

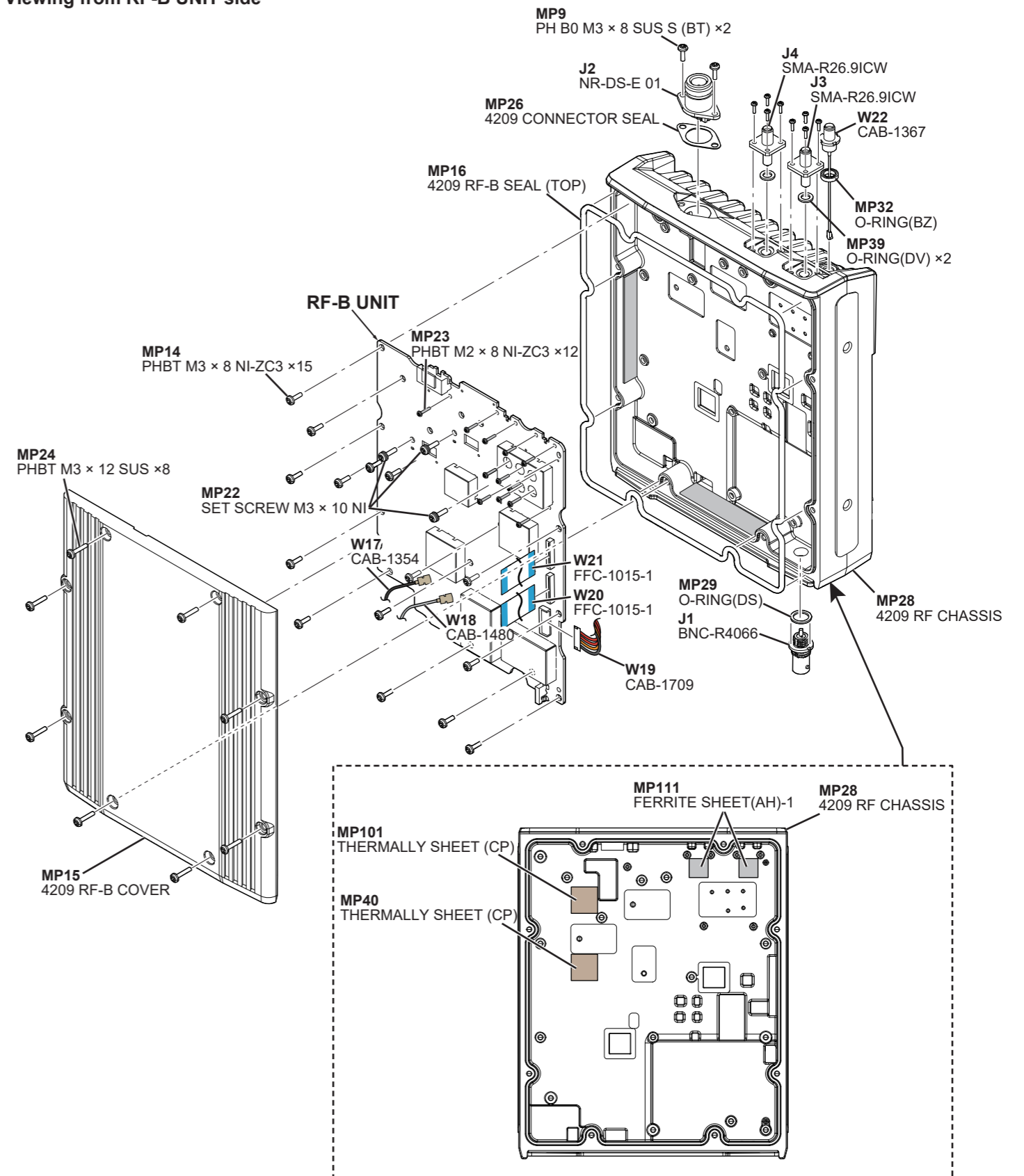

NOTE: The parts that are not listed are indicated in gray.

■ SPARE PARTS INFORMATION (CONTINUED)

• For the RF-B UNIT

	Reference number	Parts name	Order Number	Remarks
SHEET	MP3042	4209 FERRITE SHEET	8930111240	—
SPONGE	MP3044	SPONGE(JJ)	8930071240	—
SPONGE	MP6102	SPONGE(JJ)	8930071240	—

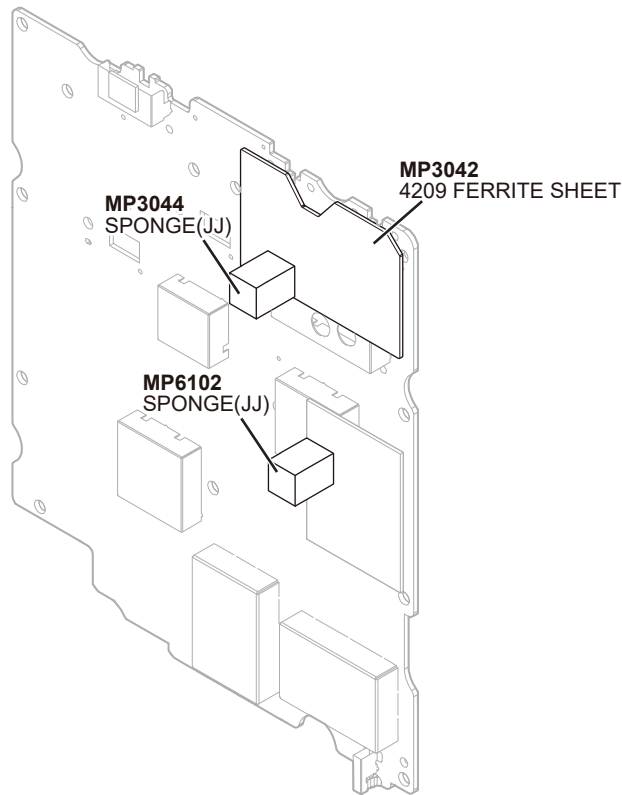

NOTE: The parts that are not listed are indicated in gray.

• Electronic parts

REF NO.	PART NO.	DESCRIPTION	M.	H/V LOCATION
IC1001	1110009950	S.IC TRF37C75IDSGR	T	36.7/105.8
IC2001	1110009950	S.IC TRF37C75IDSGR	T	76.8/114.5
IC2003	1110010910	S.IC GRF5115-TR	T	67.2/118.3
IC2005	1110008550	S.IC NJM2904CRB1-TE1	T	84.9/124.6
IC3001	1110009950	S.IC TRF37C75IDSGR	T	115.2/130.5
IC3004	1110009950	S.IC TRF37C75IDSGR	T	98.7/145
IC3005	1110010830	S.IC GRF2093-TR	T	129.3/134.3
IC3006	1110010820	S.IC TQP9224	T	108.9/150.6
IC3007	1110010820	S.IC TQP9224	T	116.8/150.6
IC3010	1110010830	S.IC GRF2093-TR	T	145.8/152.3
IC3012	1110010880	S.IC SE5004L-R	T	126.0/153.4
IC3013	1110010880	S.IC SE5004L-R	T	135.7/153.4
IC3015	1110010830	S.IC GRF2093-TR	T	144.1/160.1
IC4019	1110009950	S.IC TRF37C75IDSGR	T	56.4/94.7
IC4200	1110009950	S.IC TRF37C75IDSGR	T	97.5/110.1

M.=Mounted side (T: Mounted on the Top side, B: Mounted on the Bottom side)
H/V LOCATION=See the BOARD LAYOUTS for details.

SECTION 7

MECHANICAL PARTS

[MAIN UNIT]

REF NO.	PART NO.	DESCRIPTION	QTY.
J751*	6510021722	30FLT-SM2-TB (LF) (SN) (M)	1
J801*	6510026101	22FLT-SM2-TB (LF) (SN) (M)	1
J901*	6510022472	40FLT-SM2-TB (LF) (SN) (M)	1
J951*	6510022472	40FLT-SM2-TB (LF) (SN) (M)	1
J1402*	6510025771	03-935H1-72BKA	1
J1451*	6510025771	03-935H1-72BKA	1
J1452*	6510025771	03-935H1-72BKA	1
J2801*	6510035130	LPJK9493AHNL	1
J2802*	6510018961	B2B-PH-SM4-TB (LF) (SN)	1
J5601*	6510034850	7759S-8824-1EH-GLDG	1
T5801*	5920001110	ALT3232M-151-T001	1
T5802*	5920001110	ALT3232M-151-T001	1
BT4701*	3020000390	ML414HIV01E	1
MP1	8930109390	4209 C-JACK HOLDER	1
MP201*	8510023310	4075 A-SHIELD CASE	1
MP501*	8510023320	4075 B-SHIELD CASE	1
MP551*	8510023310	4075 A-SHIELD CASE	1

[CONTROL UNIT]

REF NO.	PART NO.	DESCRIPTION	QTY.
MP63	8930106010	SPONGE (RS)	Only [#12] 1
MP64	8310107890	4209 B CAUTION STICKER	1
MP65	8310107870	4209 CAUTION STICKER	1
MP71	89300067292	SHIELD SPONGE (AR)-2	Only [#12] 1
MP72	89300067292	SHIELD SPONGE (AR)-2	Only [#12] 1
MP73	89300067292	SHIELD SPONGE (AR)-2	Only [#12] 1
MP74	89300067292	SHIELD SPONGE (AR)-2	Only [#12] 1
MP75	89300067292	SHIELD SPONGE (AR)-2	Only [#12] 1
MP76	89300067292	SHIELD SPONGE (AR)-2	Only [#12] 1
MP77	89300067292	SHIELD SPONGE (AR)-2	Only [#12] 1
MP78	89300067292	SHIELD SPONGE (AR)-2	Only [#12] 1
MP79	8930111430	4209 AL A-SHEET	Only [#12] 1
MP80	8930111440	4209 AL B-SHEET	Only [#12] 1
MP81	89300067292	SHIELD SPONGE (AR)-2	Only [#12] 1
MP82	89300067292	SHIELD SPONGE (AR)-2	Only [#12] 1
MP83	8930111460	4209 AL C-SHEET	Only [#12] 1
MP84	8930111450	4209 AL D-SHEET	Only [#12] 1
MP85	8930072062	SHIELD SPONGE (BU)-2	Only [#12] 1
MP86	8930072062	SHIELD SPONGE (BU)-2	Only [#12] 1
MP87	8930072062	SHIELD SPONGE (BU)-2	Only [#12] 1
MP88	8930072062	SHIELD SPONGE (BU)-2	Only [#12] 1
MP89	8930095181	FERRITE SHEET (BB)-1	Only [#12] 1
MP90	8930088331	FERRITE SHEET (AM)-1	Only [#12] 1

[CONTROL UNIT]

REF NO.	PART NO.	DESCRIPTION	QTY.
P1	6510009580	ZHR-2	Only [#13] 1
DS1	5030004620	M9-2367TXW-1	1
SP1	2510002160	036D01209	1
W5**	8910000070	FFC-1008 (P0.5N6L50)	1
W6**	8910000070	FFC-1008 (P0.5N6L50)	1
W7**	8910000070	FFC-1008 (P0.5N6L50)	1
W8**	8910000070	FFC-1008 (P0.5N6L50)	1
W9	8600037590	SP CABLE-1 70MM	1
W11	8910000520	FFC-1056 (P0.5N40L100 S)	1
W12	8910000520	FFC-1056 (P0.5N40L100 S)	1
W13	8900014750	OPC-519A (P0.5N30L55)	1
W15	8920005760	CAB-1708	1
W16	8910000610	FFC-1066 (P0.5.N22.L70)	1
EP1	0880004930	EX-3956 #12	1
MP1	8010026180	4209 CHASSIS	1
MP2	8010026200	4209 CASE ASSEMBLY	1
MP4	8930103410	4075 BRACKET PLATE	1
MP5	8810009561	PHBT M2 x 6 NI-ZK3	2
MP6	8810008661	PHBT M3 x 8 NI-ZC3	6
MP7	8930104120	4075 MIC PLATE	1
MP8	8810012240	SET SCREW (H) 4 x 12 SUS	1
MP9	8850001800	FLAT WASHER M4 (4X12X0.8)SUS	1
MP10	8810008661	PHBT M3 x 8 NI-ZC3	4
MP11	8810008661	PHBT M3 x 8 NI-ZC3	2
MP12	8810008661	PHBT M3 x 8 NI-ZC3	6
MP20	8210036660	4075 FRONT PANEL (B) ASSEMBLY	1
MP26	8930057950	DOUBLE SIDE TAPE (AH)	2
MP31	8930103030	4075 3-KEY	1
MP32	8930103050	4075 6-KEY	1
MP33	8930103400	4075 LCD PLATE	1
MP34	8930103390	4075 LCD SPONGE	1
MP35	8810008631	PHBT M3 x 6 NI-ZC3	2
MP36	8610016580	KNOB N-459	2
MP37	8610016590	KNOB N-460	1
MP38	8830000551	VRNUT (E)-1	3
MP39	8610016570	KNOB N-458 COVER	1
MP40	8610016560	KNOB N-458 BASE	1
MP41	8930060191	2591 N-SPRING-1	1
MP42	8810005561	PH M3 x 8 SUS SSBC	2
MP43	8810008661	PHBT M3 x 8 NI-ZC3	9
MP50	8810009371	PHBT M3 x 12 NI-ZK3	4
MP51	8810012030	SCREW PH M3 x 6 ZK3	2
MP52	8930110050	4209 AL PLATE	1
MP53	8810008661	PHBT M3 x 8 NI-ZC3	4
MP54	8810009611	FLAT M2.6 x 6 ZK3	8
MP55	8930102100	THERMAL SHEET (DV) TC400CAT 13.8X18.5	1
MP56	8410003480	4209 C-HEATSINK	2
MP57	8950003640	CS-2 (COATING CLIP) UL	1
MP59	8930110230	THERMALLY SHEET (EC)	1
MP60	8930101020	THERMAL SHEET DS TC-500CAT	Only [#12] 1
MP61	8930092830	SPONGE (NL)	Only [#12] 1
MP62	8930100110	SPONGE (PU)	Only [#12] 1

[DISPLAY UNIT]

REF NO.	PART NO.	DESCRIPTION	QTY.
J21*	6510033810	AYF564035	1
J71*	6510022472	40FLT-SM2-TB (LF) (SN) (M)	1
J81*	6510022472	40FLT-SM2-TB (LF) (SN) (M)	1
J121*	6510022692	06FLT-SM2-TB (LF) (SN) (M)	1
J131*	6510022692	06FLT-SM2-TB (LF) (SN) (M)	1
J141*	6510022692	06FLT-SM2-TB (LF) (SN) (M)	1
J151*	6510022692	06FLT-SM2-TB (LF) (SN) (M)	1
J161*	6510023801	S4B-ZR-SM4A-TF (LF) (SN)	1
J171*	6510018301	S2B-ZR-SM4A-TF (LF) (SN)	1
S101*	2260002740	LS8J2M-T	1
S102*	2260002740	LS8J2M-T	1
S103*	2260002740	LS8J2M-T	1
S104*	2260002740	LS8J2M-T	1
S105*	2260002740	LS8J2M-T	1
S106*	2260002740	LS8J2M-T	1
S107*	2260002740	LS8J2M-T	1
S108*	2260002740	LS8J2M-T	1
S109*	2260002740	LS8J2M-T	1
MP21*	8510019650	3250 VCO CASE	1
MP44	8930089670	3562 MIC SPONGE	1

[DIAL-A UNIT]

REF NO.	PART NO.	DESCRIPTION	QTY.
J1*	6510022692	06FLT-SM2-TB (LF) (SN) (M)	1
S1	2250001110	RE1107CM1-V03-5391	1

[DIAL-B UNIT]

REF NO.	PART NO.	DESCRIPTION	QTY.
J1*	6510022692	06FLT-SM2-TB (LF) (SN) (M)	1
S1	2250001110	RE1107CM1-V03-5391	1

[DIAL-C UNIT]

REF NO.	PART NO.	DESCRIPTION	QTY.
J1*	6510022692	06FLT-SM2-TB (LF) (SN) (M)	1
S1	2250001030	RE1107CM1-V03-4673	1

*: Refer to "BOARD LAYOUTS" for the location.

** : Refer to "GENERAL WIRING" for the connection

Screw abbreviations A, B0, BT: Self-tapping PH: Pan head BS: Brass NI: Nickel ZU: Zinc SUS: Stainless

[CONNECT-A UNIT]

REF NO.	PART NO.	DESCRIPTION	QTY.
J51*	6510025771	03-935H1-72BKA	1
J52*	6510025771	03-935H1-72BKA	1
J53*	6450002950	02-909B0-66BKY	1
J54*	6510021722	30FLT-SM2-TB (LF) (SN) (M)	1
J55*	6510018961	B2B-PH-SM4-TB (LF) (SN)	1
J101*	6450003000	DC0146B-BH100AS01	1
J301*	6510025771	03-935H1-72BKA	1
F101*	5210001170	ERBRE2R50V	1
F102*	5210001250	ERBRE1R25V ATEX	1
T2501*	5910001470	750342911	1
MP1	8930109340	4209 A-JACK HOLDER	1
MP2	8930109350	4209 B-JACK HOLDER	1
MP3	8930110230	THERMALLY SHEET (EC)	1
MP201*	8510022610	3913 SHIELD CASE	1

[CONNECT-B UNIT]

REF NO.	PART NO.	DESCRIPTION	QTY.
J1*	6510035110	SDK-9BNS-K13-GS-TB (LF) (SN)	1
J2*	6510026101	22FLT-SM2-TB (LF) (SN) (M)	1
J3*	6510033720	DX07S024JA1R1300	1

[RF UNIT]

REF NO.	PART NO.	DESCRIPTION	QTY.
J1	6510032950	BNC-R4066	1
J2	6510004910	NR-DS-E 01	1
J3	6510035330	SMA-R26.9ICW	1
J4	6510035330	SMA-R26.9ICW	1
W17	8920003110	CAB-1354 (822Z82150000000101)	1
W18	8920003740	CAB-1480 (822Z83090000000101)	1
W19	8920005770	CAB-1709	1
W20	8910000141	FFC-1015-1 (P0.5N30L80)	1
W21	8910000141	FFC-1015-1 (P0.5N30L80)	1
W22	8920002950	CAB-1367 (CA20410113000070G)	1
W23	8920006060	CAB-1727	1
W25	8920006170	CAB-1741	1
W26	8900021240	OPC-2283 (P0.5N10L31)	1
	8910000300	FFC-1036 (P0.5N10L30)	1
MP9	8810010610	PHB0 M3 x 8 SUS S (BT)	2
MP11	8110012550	4209 RF-A A-COVER	1
	8110012460	4209 RF-A COVER	1
MP12	8930109360	4209 RF-A SEAL (TOP)	1
MP13	8810008661	PHBT M3 x 8 NI-ZC3	12
	8810010620	PHB0 M3 x 12 SUS S	6
MP14	8810008661	PHBT M3 x 8 NI-ZC3	15
MP15	8110012470	4209 RF-B COVER	1
MP16	8930109370	4209 RF-B SEAL (TOP)	1
MP22	8810009050	SET SCREWH M3 x 10 NI	3
MP23	8810008761	PHBT M2 x 8 NI-ZC3	12
MP24	8810012610	PHBT M3 x 12 SUS	14
	8810008661	PHBT M3 x 8 NI-ZC3	14
MP25	8930094980	3803 BUSH PLATE	1
MP26	8930109950	4209 CONNECTOR SEAL	1
MP28	8010026190	4209 RF CHASSIS	1
MP29	8930109710	O-RING (DS)	1
MP31	8310108150	4209 RF LABEL (B)	1
	8310105990	4209 RF LABEL	1
MP32	8930075620	O-RING (BZ)	1
MP33	8930094800	O-RING (DF) (TOP)	1
MP34	8930055070	2438 SHEET	2
MP35	8930109780	4209 BNC CAP (TOP)	1
MP36	8930109790	4209 CAP (TOP)	1
MP37	8930109800	4209 SMA CAP (TOP)	2
MP38	6910030560	ICOM-CPBPPMCKN71	1
	8930055041	2438 CAP-1 (KOB)	1
MP39	8930109960	O-RING (DV)	2
MP40	8930091000	THERMAL SHEET (CP) TC150CAT (17X17)	1
MP41*	8930110230	THERMALLY SHEET (EC)	2
MP42*	8930092980	THERMAL SHEET (CX) TC500CAT 16.8X16.8	1
MP43	8930110140	THERMAL SHEET (EB) RM-5 (30) 29X29XT5	1
MP44	8410003490	4209 A-HEATSINK	2
MP45	8810003361	SET SCREWC M3 x 6 ZC3	4
MP48	8930101210	THERMAL SHEET DT TC-200CAT-20 (8X12)	1
MP49	8930101020	THERMAL SHEET DS TC-500CAT (8X12)	1
MP50	8930098010	THERMAL SHEET (DI) TC250CAT20 18X18	1
MP51	8930091000	THERMAL SHEET (CP) TC150CAT (17X17)	1
MP52	8810012600	PHBT M2 x 6 SUS	8
	8810010750	PHBT M2 x 6 SUS SSBC	8
MP53	8930101210	THERMAL SHEET DT TC-200CAT-20 (8X12)	1
MP54	8930101020	THERMAL SHEET DS TC-500CAT (8X12)	1

[RF UNIT]

REF NO.	PART NO.	DESCRIPTION	QTY.
MP55	8930098010	THERMAL (DI) TC250CAT20 18X18	1
MP56	8930091000	THERMAL SHEET (CP) TC150CAT (17X17)	1
MP101	8930091000	THERMAL SHEET (CP) TC150CAT (17X17)	1
MP107	8930092980	THERMAL SHEET (CX) TC500CAT (16.8X16.8)	2
MP111	8930084711	FERRITE SHEET (AH)-1	2
MP112	8930109550	FERRITE SHEET (CJ)	1
MP121	8930111410	FERRITE SHEET (CP)	1
MP122	8930111410	FERRITE SHEET (CP)	1
MP123	8930111410	FERRITE SHEET (CP)	1
MP124	8930111420	FERRITE SHEET (CQ)	1
MP125	8930111420	FERRITE SHEET (CQ)	1

[RF-A UNIT]

REF NO.	PART NO.	DESCRIPTION	QTY.
J201*	6510018971	B4B-PH-SM4-TB (LF) (SN)	1
J751*	6510021722	30FLT-SM2-TB (LF) (SN) (M)	1
J752*	6510021722	30FLT-SM2-TB (LF) (SN) (M)	1
J1101*	6510030190	BM09B-SRSS-TBT (LF) (SN)	1
J5601*	6510025142	10FLT-SM2-TB (LF) (SN) (M)	1
J5602*	6510018971	B4B-PH-SM4-TB (LF) (SN)	1
J6701*	6510032350	20279-001E-01	1
J7001*	6510032350	20279-001E-01	1
J8001*	6510032350	20279-001E-01	1
F5601*	5210001500	0686F4000-01	1
T1001*	5910001440	POE72PR-12ED	1
T1101*	5910001460	VP6150M HF	1
T6501*	5920001110	ALT3232M-151-T001	1
T6502*	5920001110	ALT3232M-151-T001	1
MP101*	8510021680	3697 VCO CASE	1
MP102*	8510021680	3697 VCO CASE	1
MP103*	8510021680	3697 VCO CASE	1
MP104*	8510021680	3697 VCO CASE	1
MP6701*	8510022450	3754 GPS CASE	1
MP7041*	8510021680	3697 VCO CASE	1
MP7042*	8510021830	3765 S-CASE	1
MP7043*	8510021830	3765 S-CASE	1
MP7101*	8930109550	FERRITE SHEET (CJ)	1

*: Refer to "BOARD LAYOUTS" for the location.

***: Refer to "GENERAL WIRING" for the connection

Screw abbreviations A, B0, BT: Self-tapping PH: Pan head BS: Brass NI: Nickel ZU: Zinc SUS: Stainless

[RF-B UNIT]

REF NO.	PART NO.	DESCRIPTION	QTY.
J501*	6510021722	30FLT-SM2-TB (LF) (SN) (M)	1
J531*	6510021722	30FLT-SM2-TB (LF) (SN) (M)	1
J532*	6510018971	B4B-PH-SM4-TB (LF) (SN)	1
J4000*	6510032350	20279-001E-01	1
J6042*	6510032350	20279-001E-01	1
EP2004*	6910030160	X4C20K1-20SR1	1
EP2005*	6910030160	X4C20K1-20SR1	1
EP3003*	6910029730	C2327J5003AHF	1
EP3011*	6910029730	C2327J5003AHF	1
EP3012*	6910029720	C5060J5003AHF	1
EP3021*	6910029790	X4C20J1-20G-R	1
EP3026*	6910029720	C5060J5003AHF	1
EP3027*	6910029790	X4C20J1-20G-R	1
EP3028*	6910029760	X4C60J1-20G-R	1
EP3029*	6910029760	X4C60J1-20G-R	1
MP1001*	8410003140	4048 HEATSINK	1
MP1010	8510024590	4209 A-ANT SHIELD	Only [#12] 1
MP2002*	8410003140	4048 HEATSINK	1
MP2010*	8510024220	4209 C-SHIELD CASE	Only [#13] 1
MP2014*	8410003390	4171 P-HEATSINK	1
MP3040*	8510024120	4209 A-SHIELD CASE	1
MP3041	8930091981	SHIELD SPONGE (DL)-1	1
MP3042	8930111240	4209 FERRITE SHEET	Only [#12] 1
MP3043	8930094670	SPONGE (OD)	Only [#12] 1
MP3044	8930071240	SPONGE (JJ)	Only [#12] 1
MP3100*	8410003410	4209 HEATSINK	1
MP4001*	8510022290	E01J1113Y	1
MP4002*	8510022290	E01J1113Y	1
MP4003*	8510022290	E01J1113Y	1
MP4004*	8510022290	E01J1113Y	1
MP4005*	8510022290	E01J1113Y	1
MP4006*	8510022290	E01J1113Y	1
MP4007*	8510022290	E01J1113Y	1
MP4008*	8510022290	E01J1113Y	1
MP4009*	8510022290	E01J1113Y	1
MP4010*	8510022290	E01J1113Y	1
MP4011*	8510022290	E01J1113Y	1
MP4012*	8510022290	E01J1113Y	1
MP4013*	8510022290	E01J1113Y	1
MP4014*	8510022290	E01J1113Y	1
MP4015*	8510022290	E01J1113Y	1
MP4016*	8510022290	E01J1113Y	1
MP4017*	8510022290	E01J1113Y	1
MP4018*	8510022290	E01J1113Y	1
MP4021*	8510022290	E01J1113Y	1
MP4022*	8510022290	E01J1113Y	1
MP4023*	8510022290	E01J1113Y	1
MP4024*	8510022290	E01J1113Y	1
MP4025*	8510022290	E01J1113Y	1
MP4026*	8510022290	E01J1113Y	1
MP4027*	8510022290	E01J1113Y	1
MP4028*	8510022290	E01J1113Y	1
MP4029*	8510022290	E01J1113Y	1
MP4030*	8510022290	E01J1113Y	1
MP4031*	8510022290	E01J1113Y	1
MP4032*	8510022290	E01J1113Y	1
MP4033*	8510022290	E01J1113Y	1
MP4034*	8510022290	E01J1113Y	1
MP4035*	8510022290	E01J1113Y	1
MP4036*	8510022290	E01J1113Y	1
MP4037*	8510022290	E01J1113Y	1
MP4038*	8510022290	E01J1113Y	1
MP4041	8930088691	FERRITE SHEET (AN)-1	Only [#12] 1
MP4055*	8510024210	4209 B-SHIELD CASE	1
MP4057*	8510024210	4209 B-SHIELD CASE	1
MP4058	8930091981	SHIELD SPONGE (DL)-1	1
MP4059	8930091981	SHIELD SPONGE (DL)-1	1
MP6001*	8510020100	3182 DC-DC CASE	1
MP6002*	8510020100	3182 DC-DC CASE	1
MP6003*	8930109380	4209 ANT SPRING	1
MP6005	8930105431	SHIELD SPONGE (FA)-1	1
MP6006	8930105431	SHIELD SPONGE (FA)-1	1
MP6007	8930058842	SHIELD SPONGE (T)-2	1
MP6101	8930097300	FERRITE SHEET (BD)	Only [#12] 1
MP6102	8930071240	SPONGE (JJ)	Only [#12] 1

[CONNECT-C UNIT]

REF NO.	PART NO.	DESCRIPTION	QTY.
J1	6510031421	ICOM-CCBPM10MBB	1
J2*	6510018971	B4B-PH-SM4-TB (LF) (SN)	1
J4*	6510025142	10FLT-SM2-TB (LF) (SN) (M)	1

[SUPPLIED ACCESSORIES UNIT]

REF NO.	PART NO.	DESCRIPTION	QTY.
P1	5610000960	ICOM-CCBDF10FBB	1
P2	5610000750	MP-013MS-R	1
F1	5210001610	FGBO-A 250V 8A PBF	2
MC1	-	HM-243†	1
W1	8900023240	OPC-2488	1
W2	8900023420	OPC-2508	[#12] 1
	8900019882	OPC-2102A-1	[#13] 1
EP1	3310005760	YH1111004	[#12] 1
	3310005710	YH1101101A	[#13] 1
EP2	6910013530	ZCAT2035-0930A-BK	Only [#12] 1
MP1	8930103510	LEG CUSHION (S)	1
MP101	8930109930	4209 BRACKET (NC)	1
MP102	8810012620	SET SCREW (K) M6 × 15 SUS GEOMET	[#12] 4
	8810011010	SET SCREW (K) M6 × 15 SUS	[#13] 4
MP103	8010000010	BRACKET EX143	[#12] 2
MP104	8820000440	UBOLT A SUS	2
MP105	8830000260	NUT M6 SUS	4
MP106	8850000510	S-WASHER M6 SUS	4
MP107	8850000200	FLAT WASHER M6 (6X20X1.5) SUS	4
MP108	8950007580	RUBBER VULCANIZING TAPE NO.11 L=500MM	Only [#12] 1

†Sold as an option.

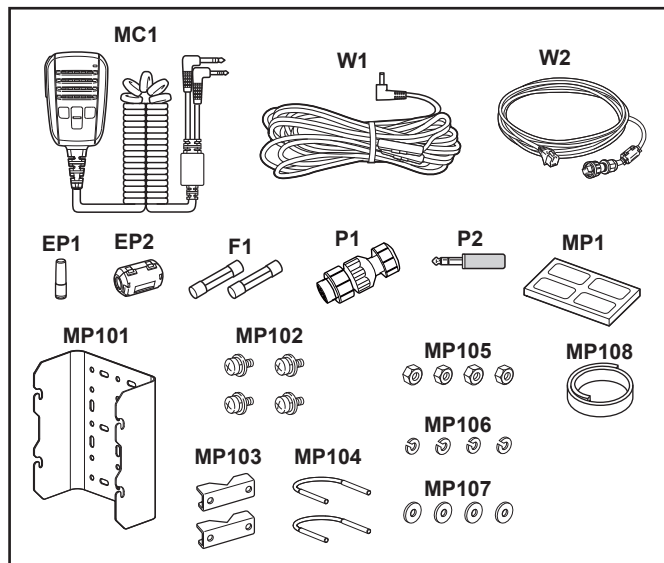

*: Refer to "BOARD LAYOUTS" for the location.

** : Refer to "GENERAL WIRING" for the connection

Screw abbreviations A, B0, BT: Self-tapping PH: Pan head BS: Brass NI: Nickel ZU: Zinc SUS: Stainless

• CONTROLLER (Front assembly)

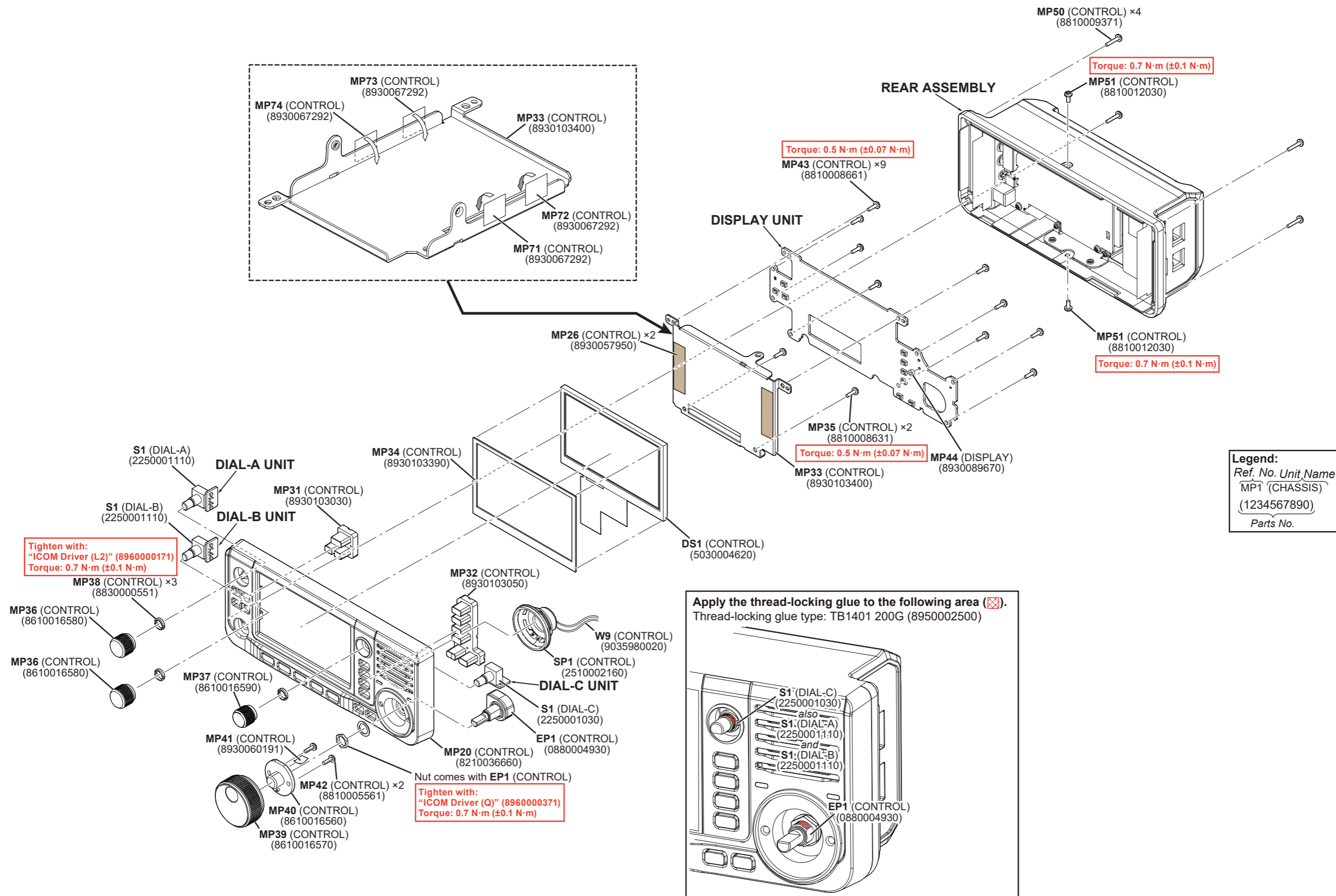

Legend:

Ref. No.	Unit Name
MP1	(CHASSIS)
(1234567890)	
	Parts No.

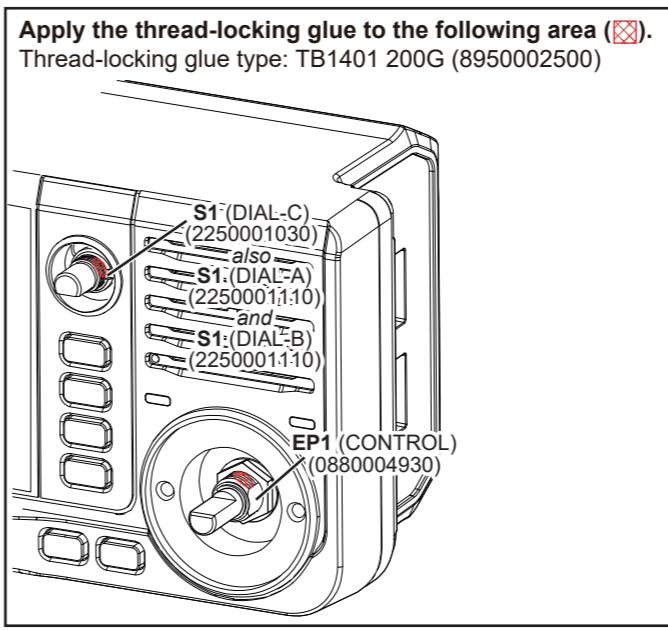

Unless otherwise noted, the tighten to torque is 0.5 N·m (±0.07 N·m).

NOTE: When replacing a flat cable, form the new one in the same shape as the original.

*Refer to the Mechanical Parts list.

• CONTROLLER (Rear assembly)

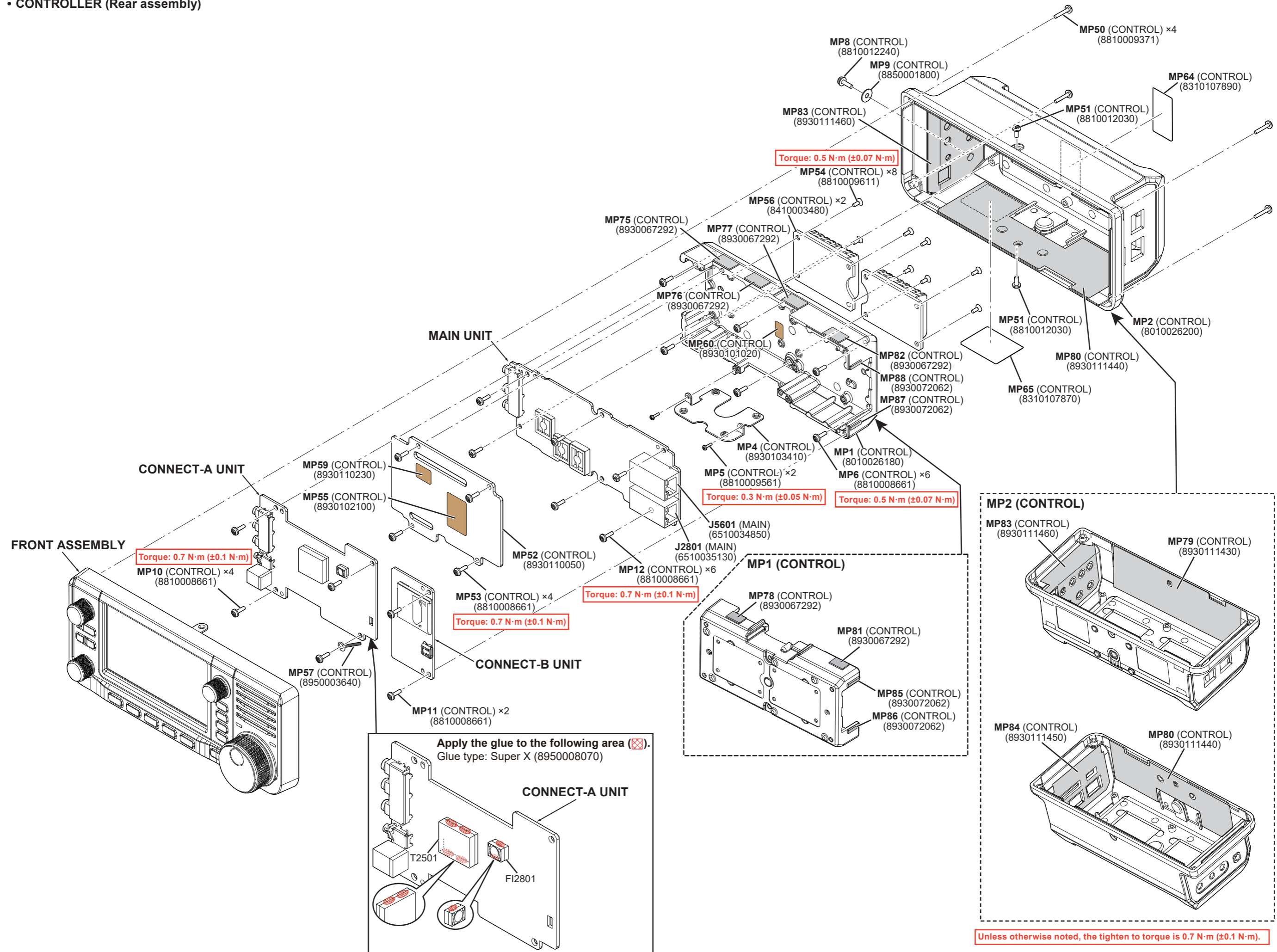

*Refer to the Mechanical Parts list.

• RF UNIT

Viewing from RF-A UNIT side

Apply the thread-locking glue to the following area (☒).
Thread-locking glue type: TB1401 200G (8950002500)

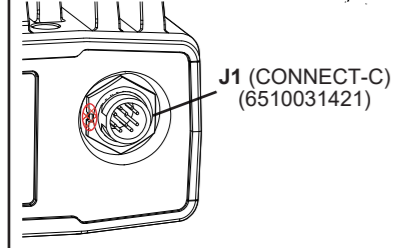

Apply the thread-locking glue to the following area (☒).
Thread-locking glue type: 638-250ML (8950007110)

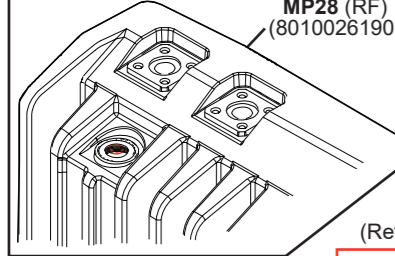

MP11 (RF)
(Refer to the parts list.)

MP107 (RF) × 2
(8930092980)

MP13 (RF) × 12
(Refer to the parts list.)
Torque: 0.7 N·m (±0.1 N·m)

RF-A UNIT

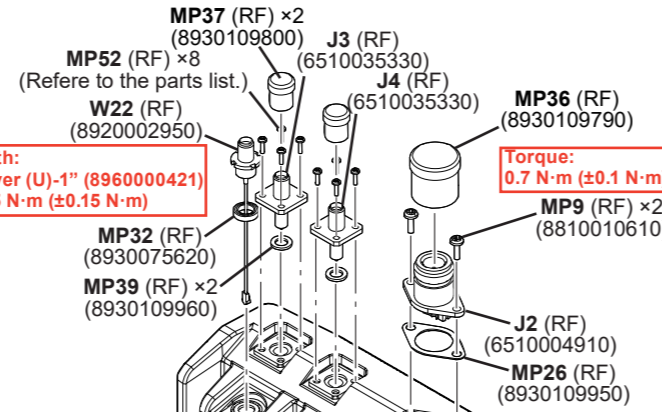

MP12 (RF)
(8930109360)

MP34 (RF)
(8930055070)

MP25 (RF)
(8930094980)

CONNECT-C UNIT

MP33 (RF)
(8930094800)

W23 (RF)
(8920006060)

MP45 (RF) × 4
(8810003361)

Nut comes with
J1 (CONNECT-C UNIT)

Tighten with:
"ICOM Driver (V)-1" (8960000431)
Torque: 1.0 N·m (±0.15 N·m)

MP49 (RF)
(8930101020)

MP48 (RF)
(8930101210)

MP51 (RF)
(8930091000)

MP50 (RF)
(8930098010)

MP54 (RF)
(8930101020)

MP53 (RF)
(8930101210)

MP56 (RF)
(8930091000)

MP55 (RF)
(8930098010)

MP28 (RF)
(8010026190)

MP122 (RF)
(8930111410)

MP11 (RF)
(Refer to the parts list.)

MP24 (RF) × 6
(Refer to the parts list.)
Torque: 0.65 N·m (±0.07 N·m)

Viewing from RF-B UNIT side

Apply the glue to the following area (☒).
Glue type: TB1401 200G (8950002500)

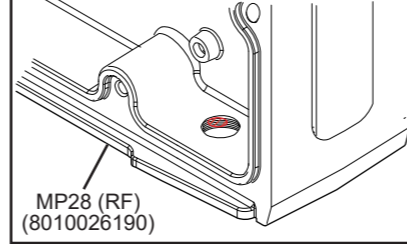

RF-B UNIT

Torque: 0.7 N·m (±0.1 N·m)

MP14 (RF) × 15
(8810008661)

MP23 (RF) × 12
(8810008761)

Torque: 0.65 N·m (±0.07 N·m)

MP24 (RF) × 8
(Refer to the parts list.)

Torque: 0.7 N·m (±0.1 N·m)

MP22 (RF)
(8810009050)

MP15 (RF)
(8110012470)

MP123 (RF)
(8930111410)

MP15 (RF)
(8110012470)

MP36 (RF)
(8930109790)
Torque: 0.7 N·m (±0.1 N·m)

MP9 (RF) × 2
(8810010610)

J2 (RF)
(6510004910)

MP26 (RF)
(8930109950)

MP16 (RF)
(8930109370)

MP124 (RF)
(8930111420)

MP121 (RF)
(8930111410)

MP29 (RF)
(8930109710)

J1 (RF)
(6510032950)

Tighten with:
"ICOM Driver (Y)-1" (8960000461)
Torque: 1.5 N·m (±0.15 N·m)

MP35 (RF)
(8930109780)

Apply the glue to the following area (☒).
Glue type: SL320W (8950009140)

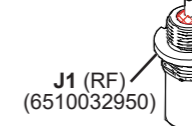

J2 (RF)
(6510004910)

MP101 (RF)
(8930091000)

MP40 (RF)
(8930091000)

MP111 (RF)
(8930084711)

MP28 (RF)
(8010026190)

MP125 (RF)
(8930111420)

MP121 (RF)
(8930111410)

Unless otherwise noted, the tighten to torque is 0.3 N·m (±0.05 N·m).

*Refer to the Mechanical Parts list.

• DISPLAY UNIT (B-9551B: Top view)

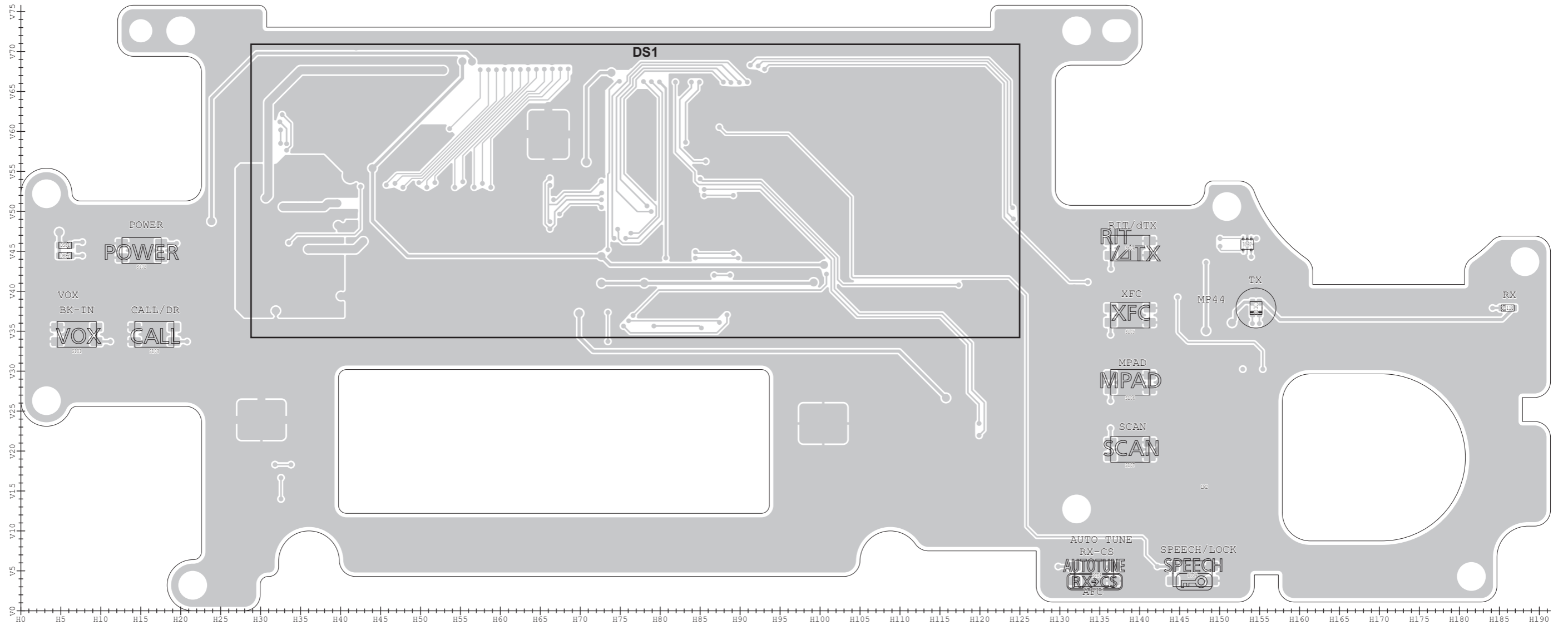

NOTE: Some parts may not be mounted on the PCB, depending on the transceiver version.

• DISPLAY UNIT (B-9551B: Bottom view)

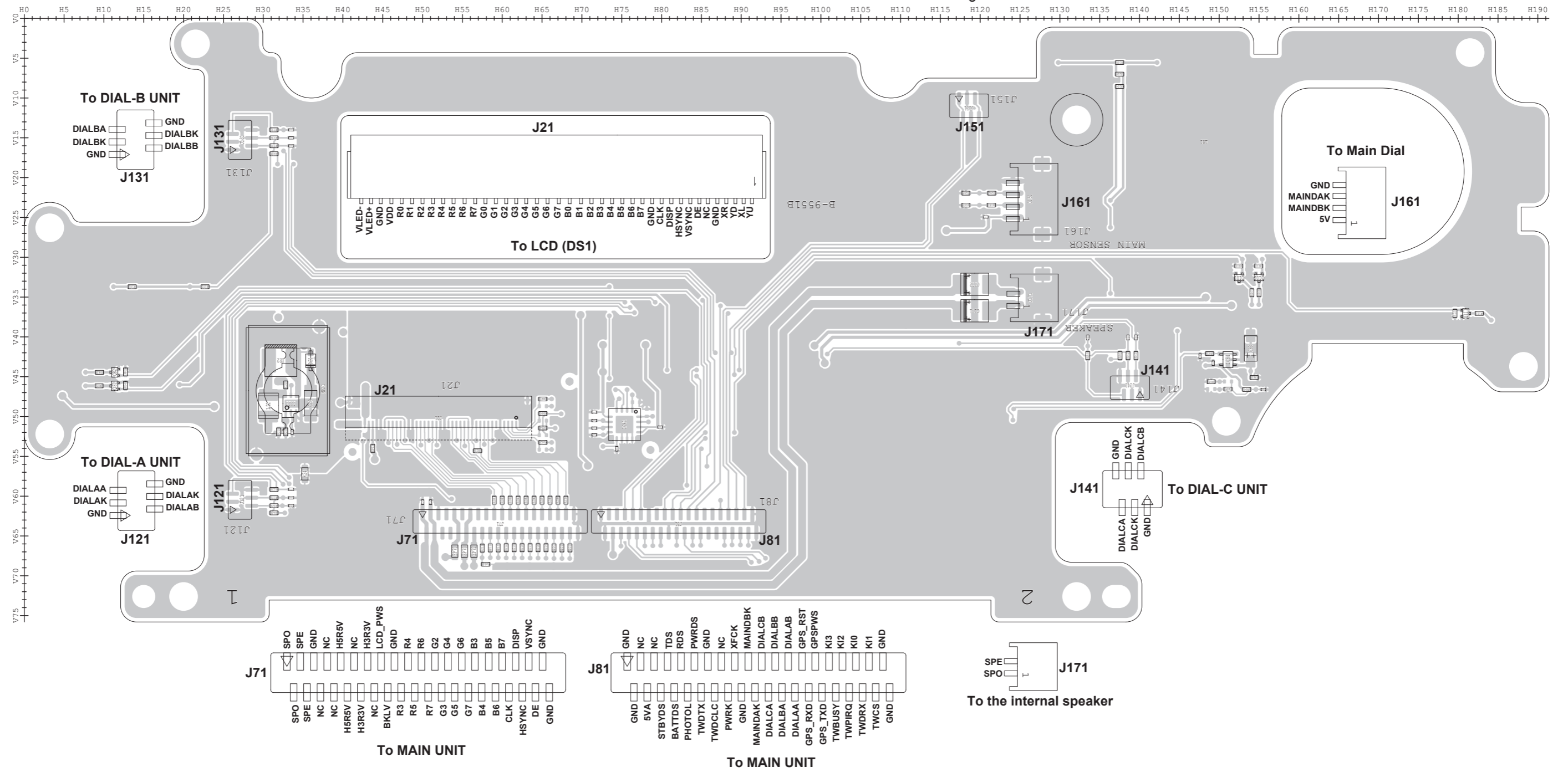

NOTE: Some parts may not be mounted on the PCB, depending on the transceiver version.

• **DIAL-A UNIT (B-9553)**
(Top view)

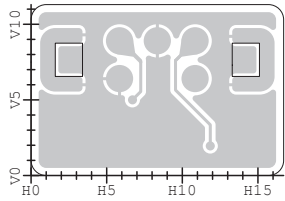

(Bottom view)

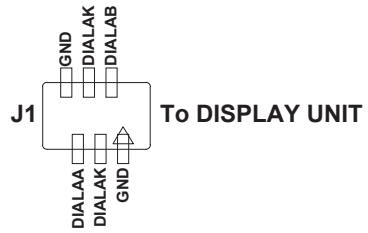
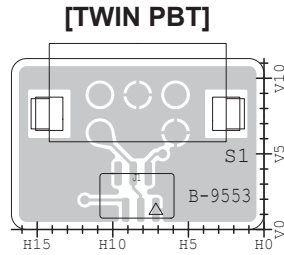

• **DIAL-B UNIT (B-9553)**
(Top view)

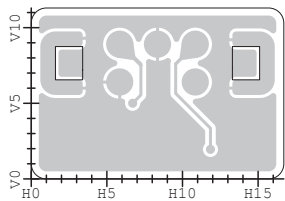

(Bottom view)

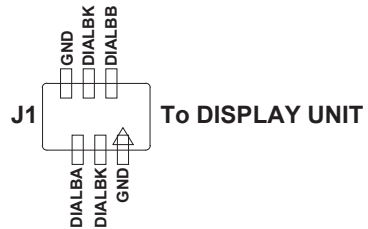
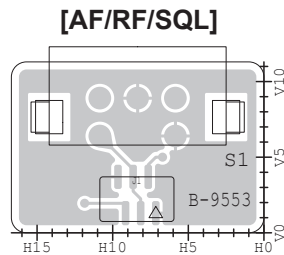

• **DIAL-C UNIT (B-9555)**
(Top view)

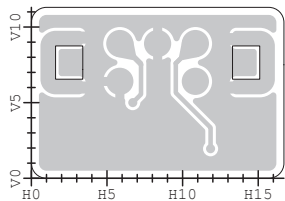

(Bottom view)

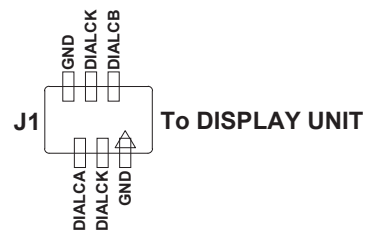
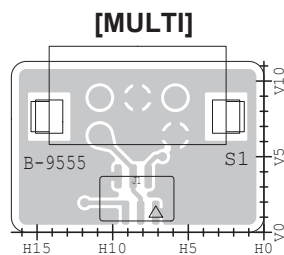

NOTE: Some parts may not be mounted on the PCB, depending on the transceiver version.

• MAIN UNIT (B-9550D)
(Top view)

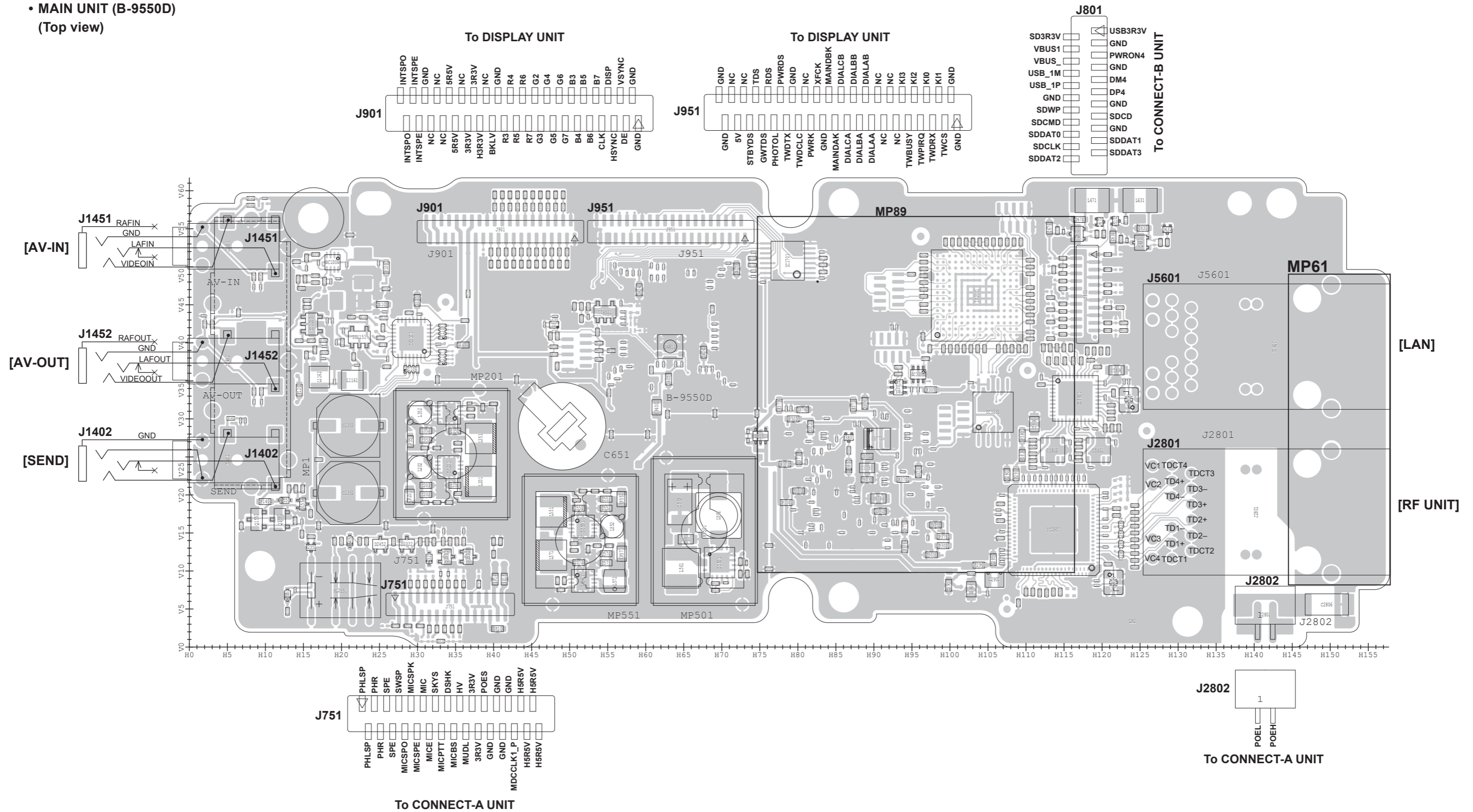

NOTE: Some parts may not be mounted on the PCB, depending on the transceiver version.

• MAIN UNIT (B-9550D)
(Bottom view)

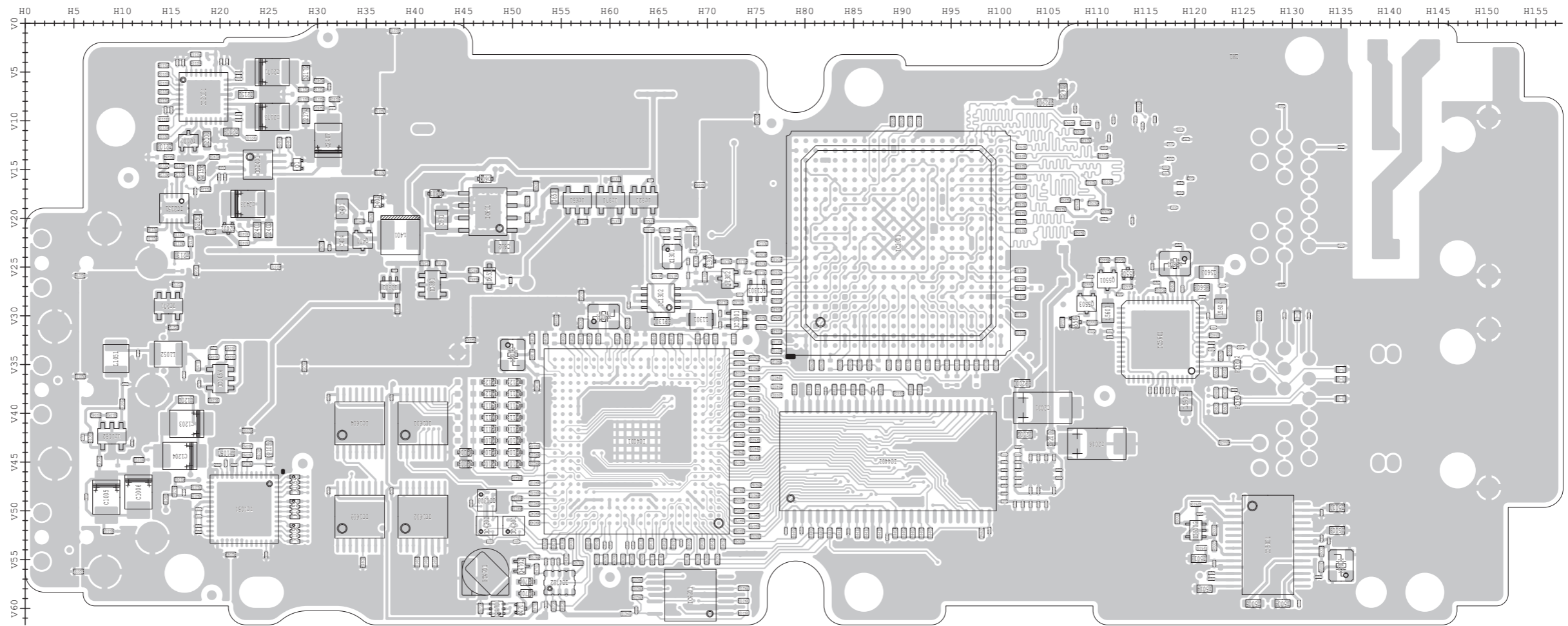

NOTE: Some parts may not be mounted on the PCB, depending on the transceiver version.

• CONNECT-A UNIT (B-9556D)
(Top view)

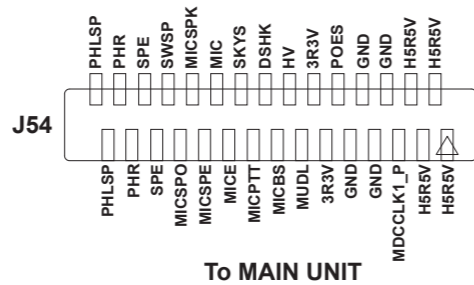
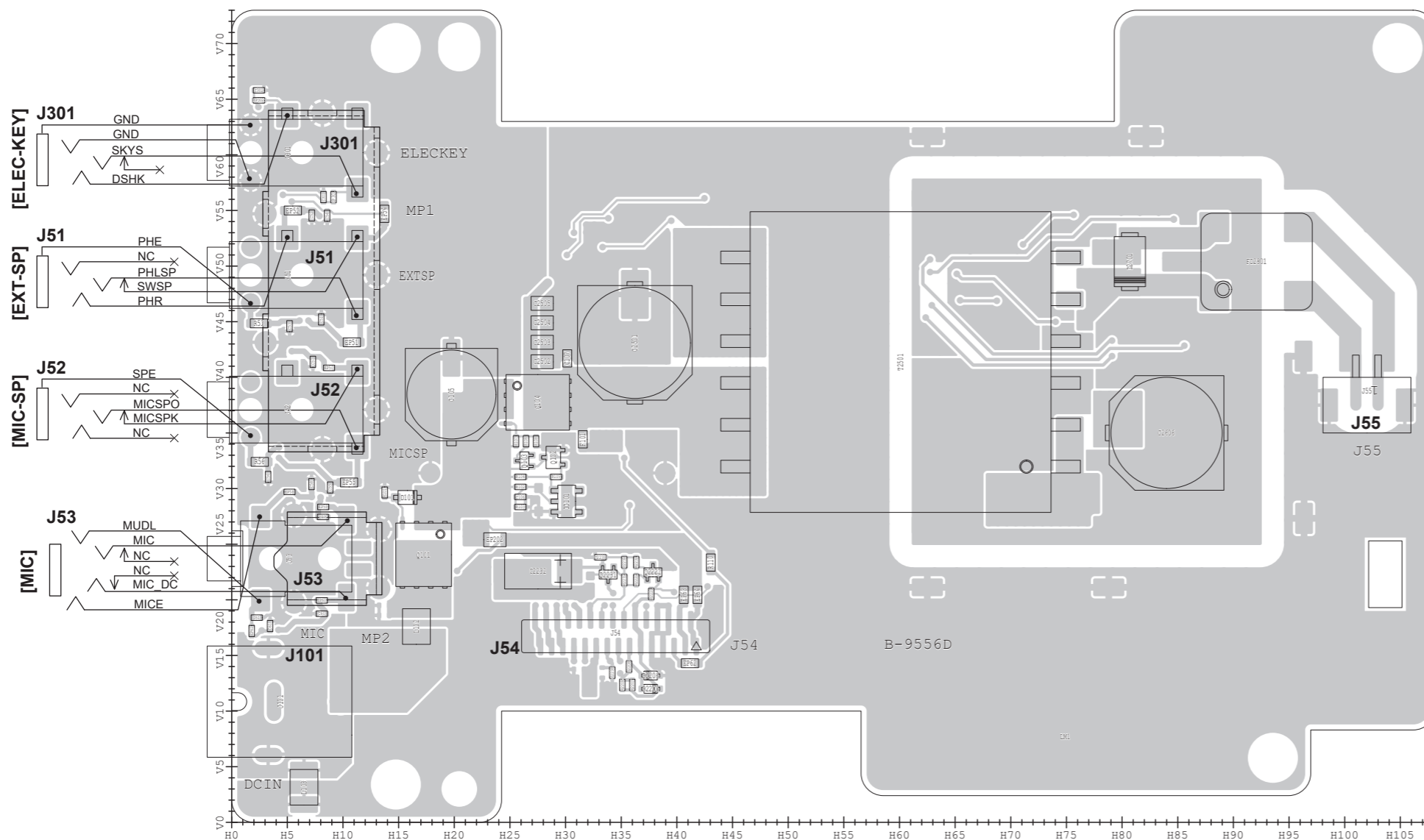

• CONNECT-B UNIT (B-9557B)
(Top view)

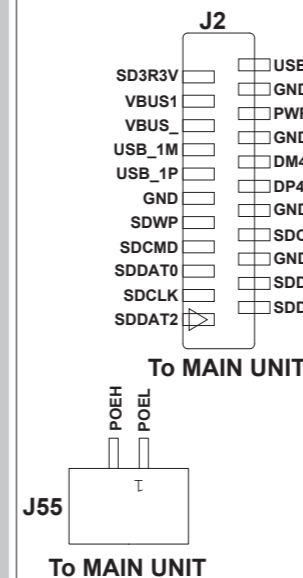
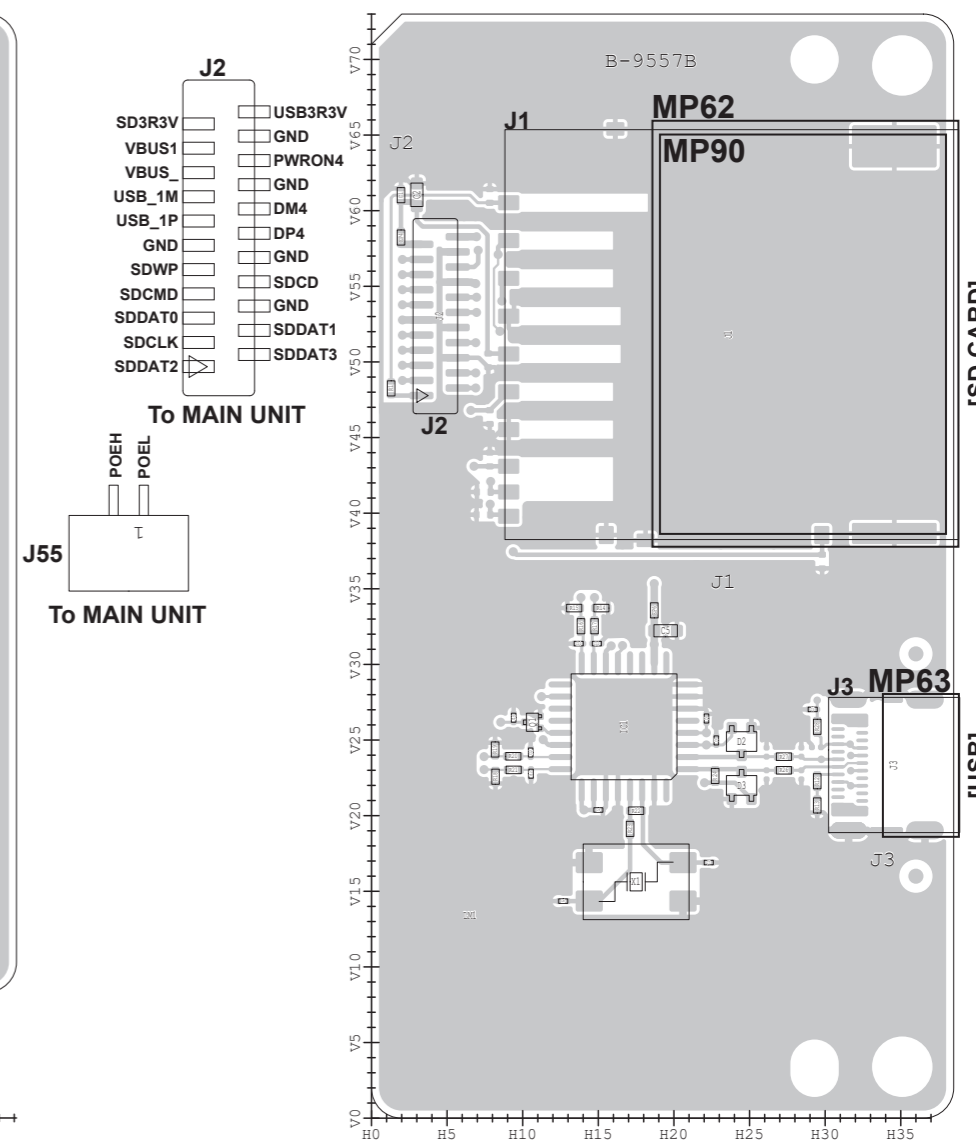

• CONNECT-C UNIT (B-9700A)
(Top view)

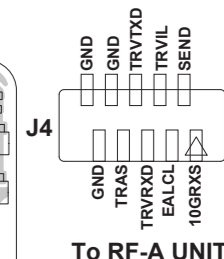
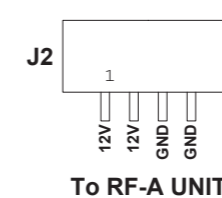
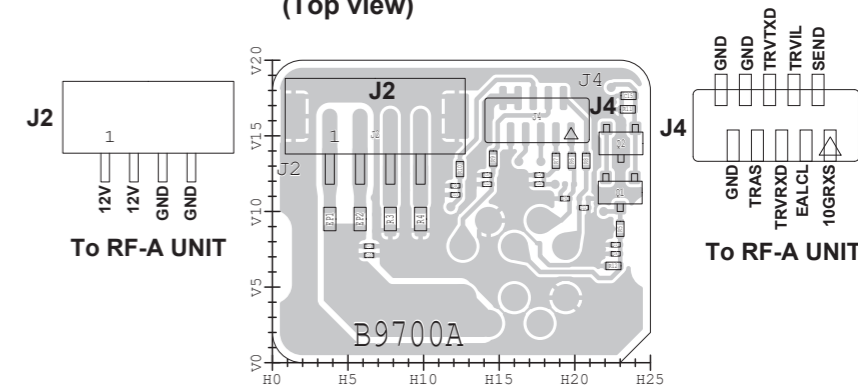

NOTE: Some parts may not be mounted on the PCB, depending on the transceiver version.

• **CONNECT-A UNIT (B-9556D)**
(Bottom view)

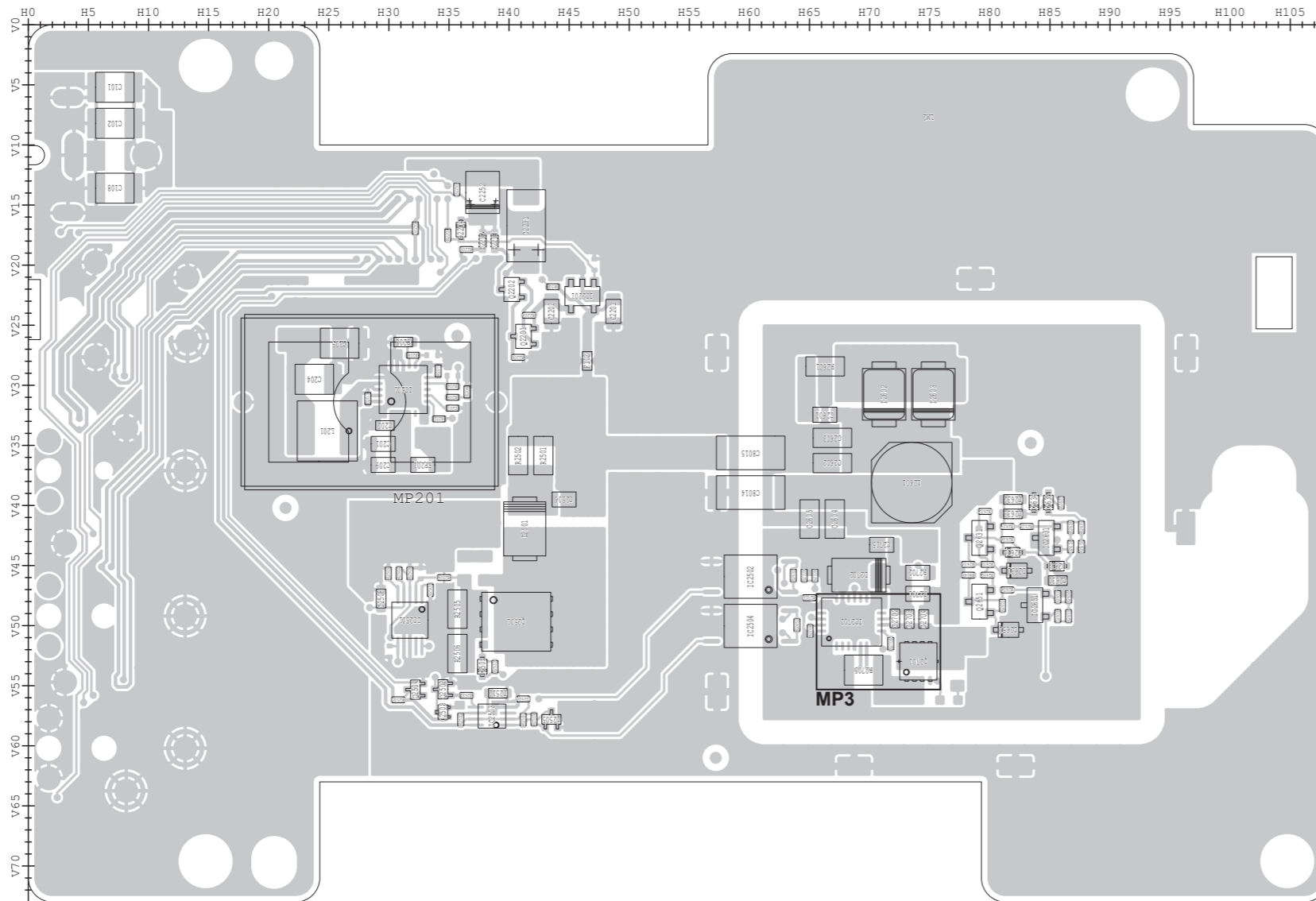

• **CONNECT-C UNIT (B-9700A)**
(Bottom view)

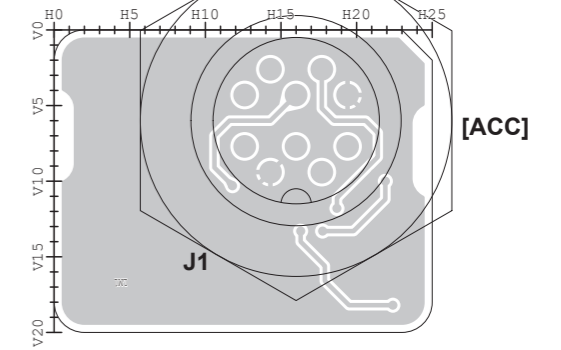

• **CONNECT-B UNIT (B-9557B)**
(Bottom view)

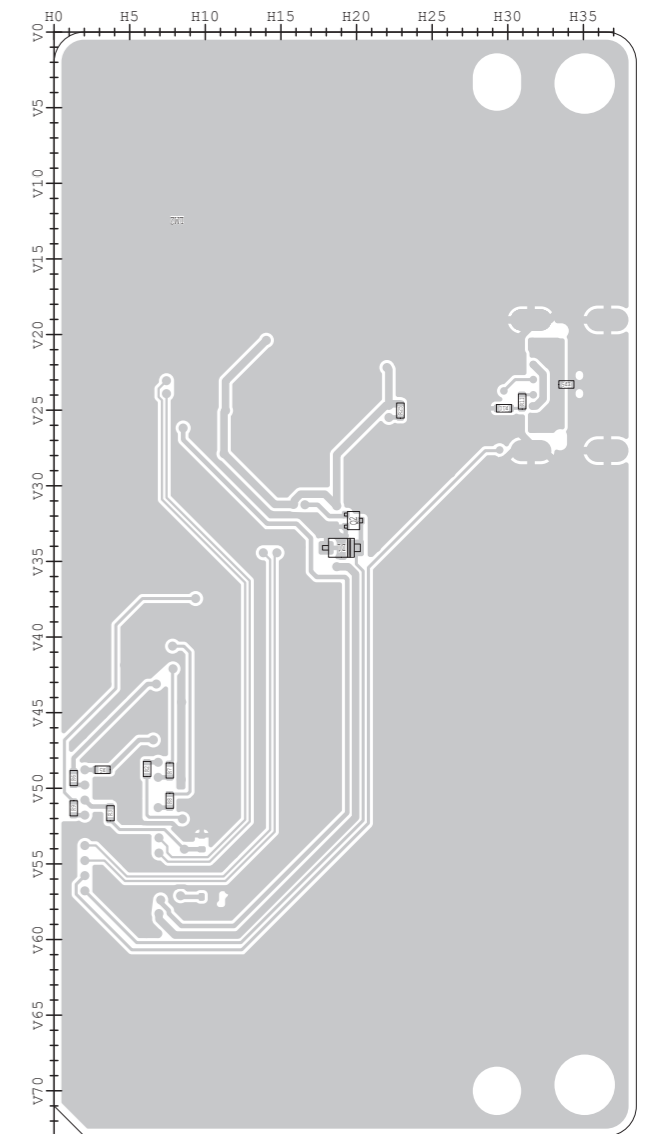

NOTE: Some parts may not be mounted on the PCB, depending on the transceiver version.

• RF-A UNIT (B-9558F)
(Top view)

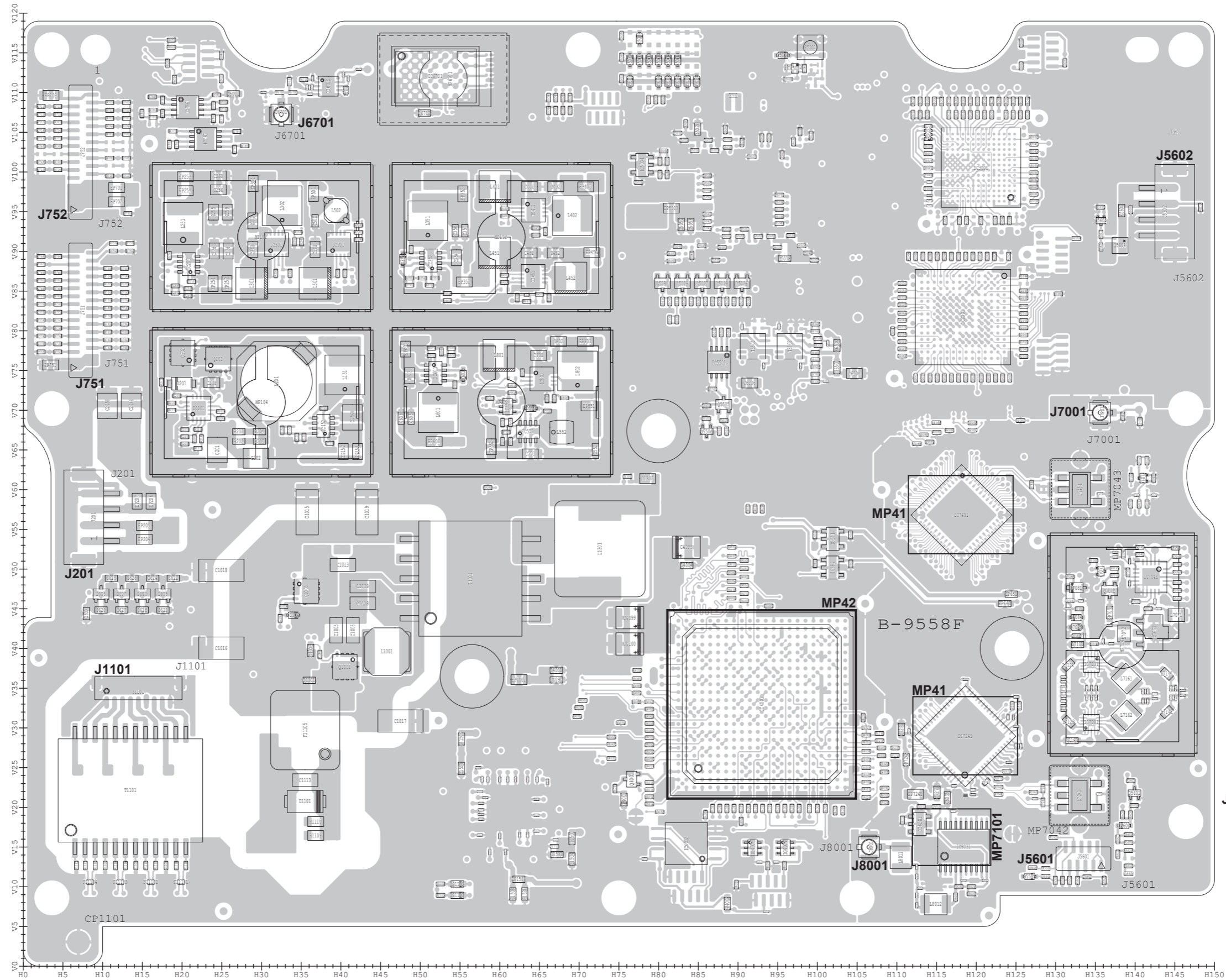
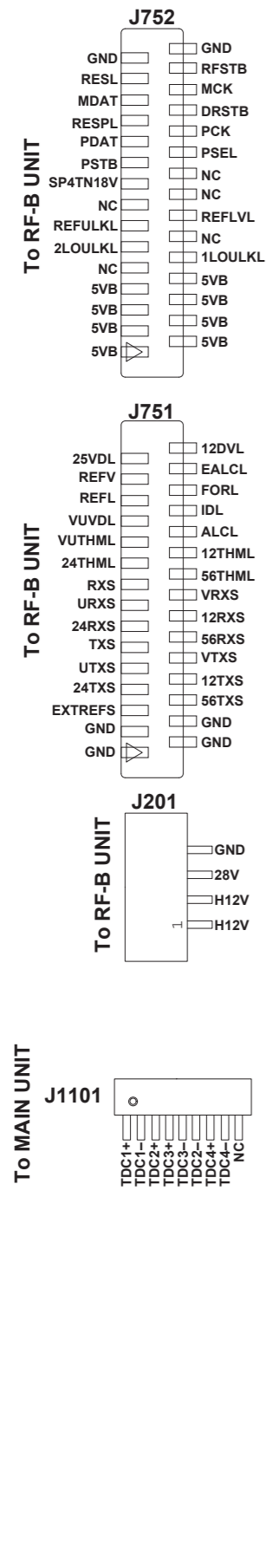

NOTE: Some parts may not be mounted on the PCB, depending on the transceiver version.

• RF-A UNIT (B-9558F)
(Bottom view)

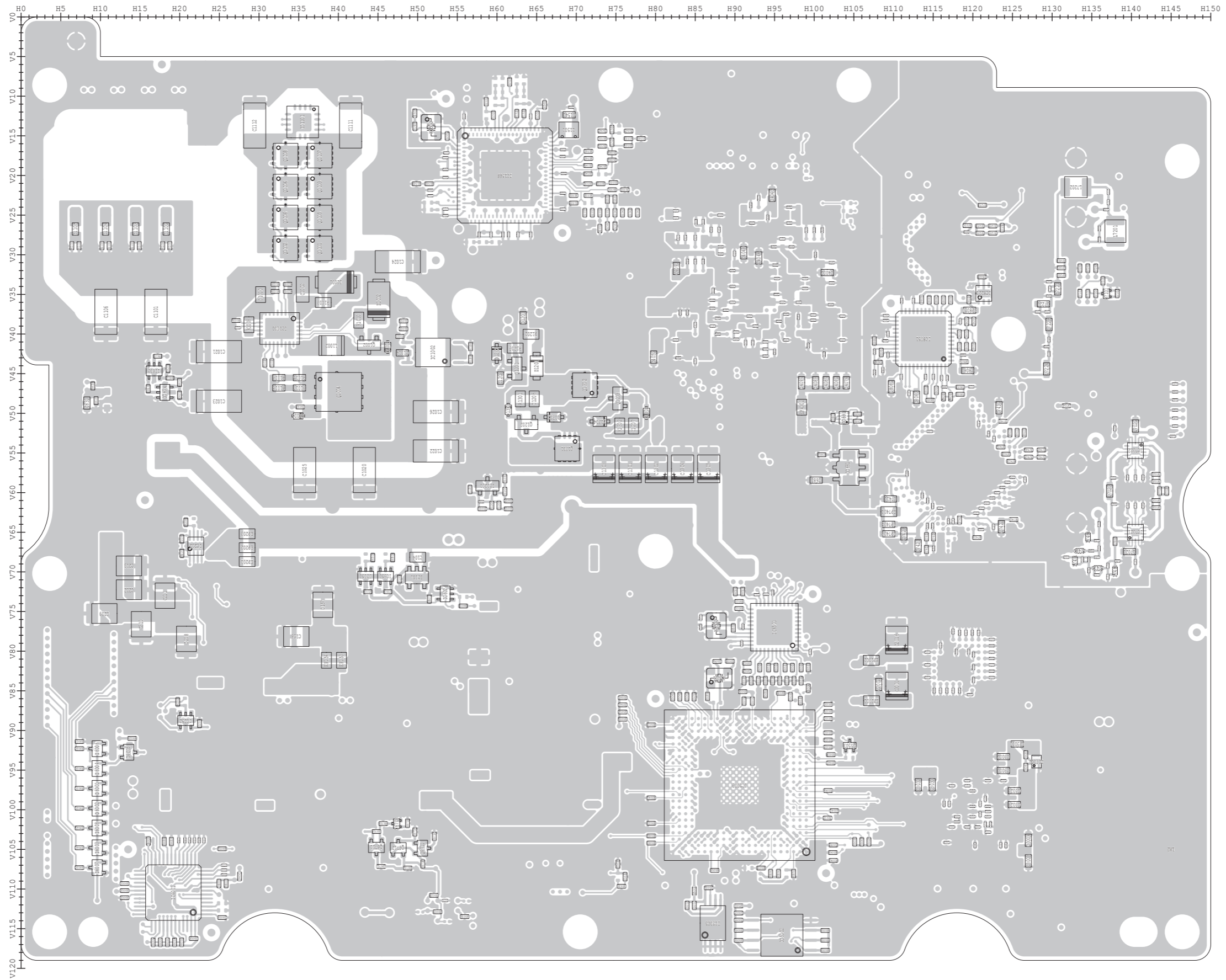

NOTE: Some parts may not be mounted on the PCB, depending on the transceiver version.

• RF-B UNIT (B-9559D)
(Bottom view)

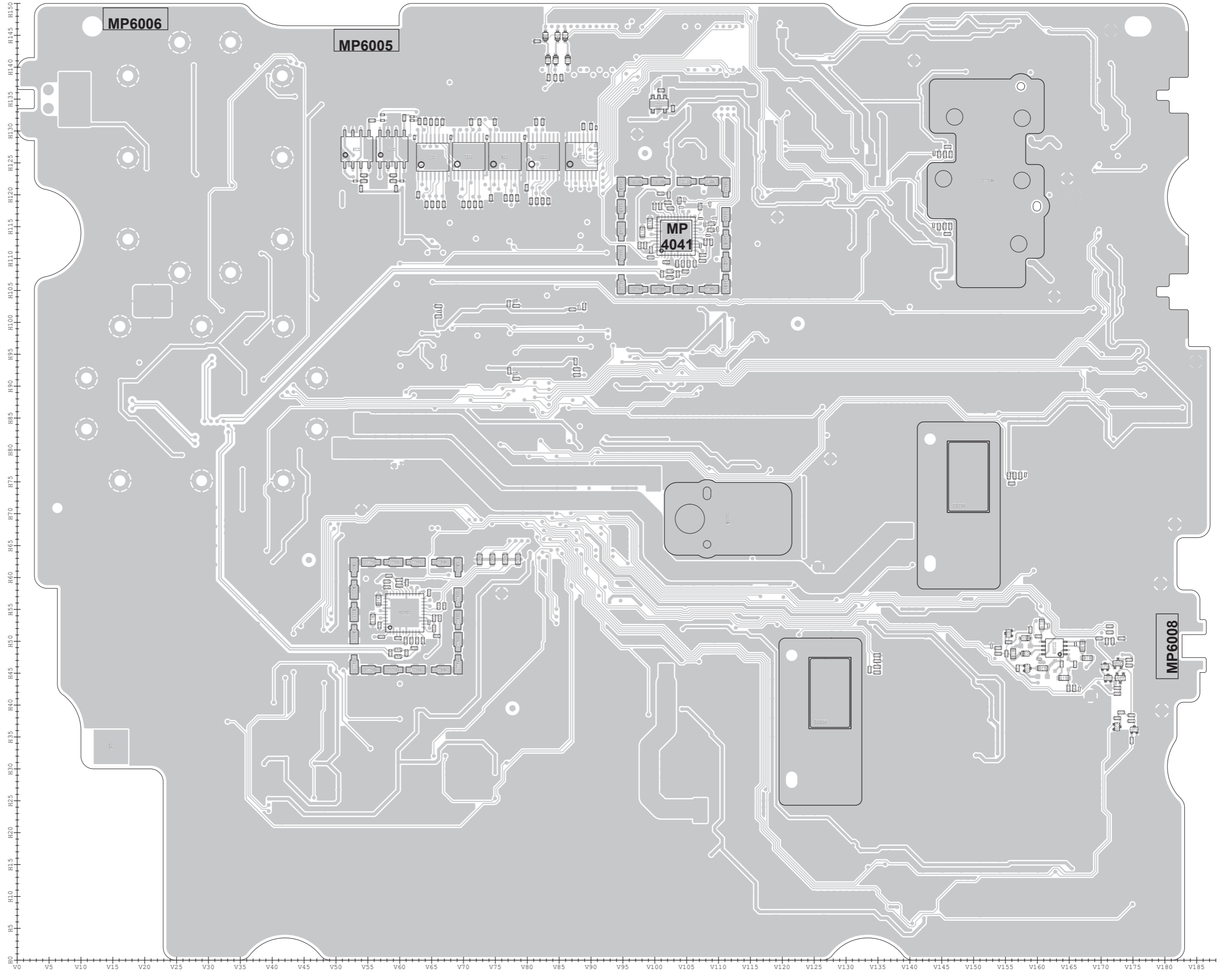

NOTE: Some parts may not be mounted on the PCB, depending on the transceiver version.

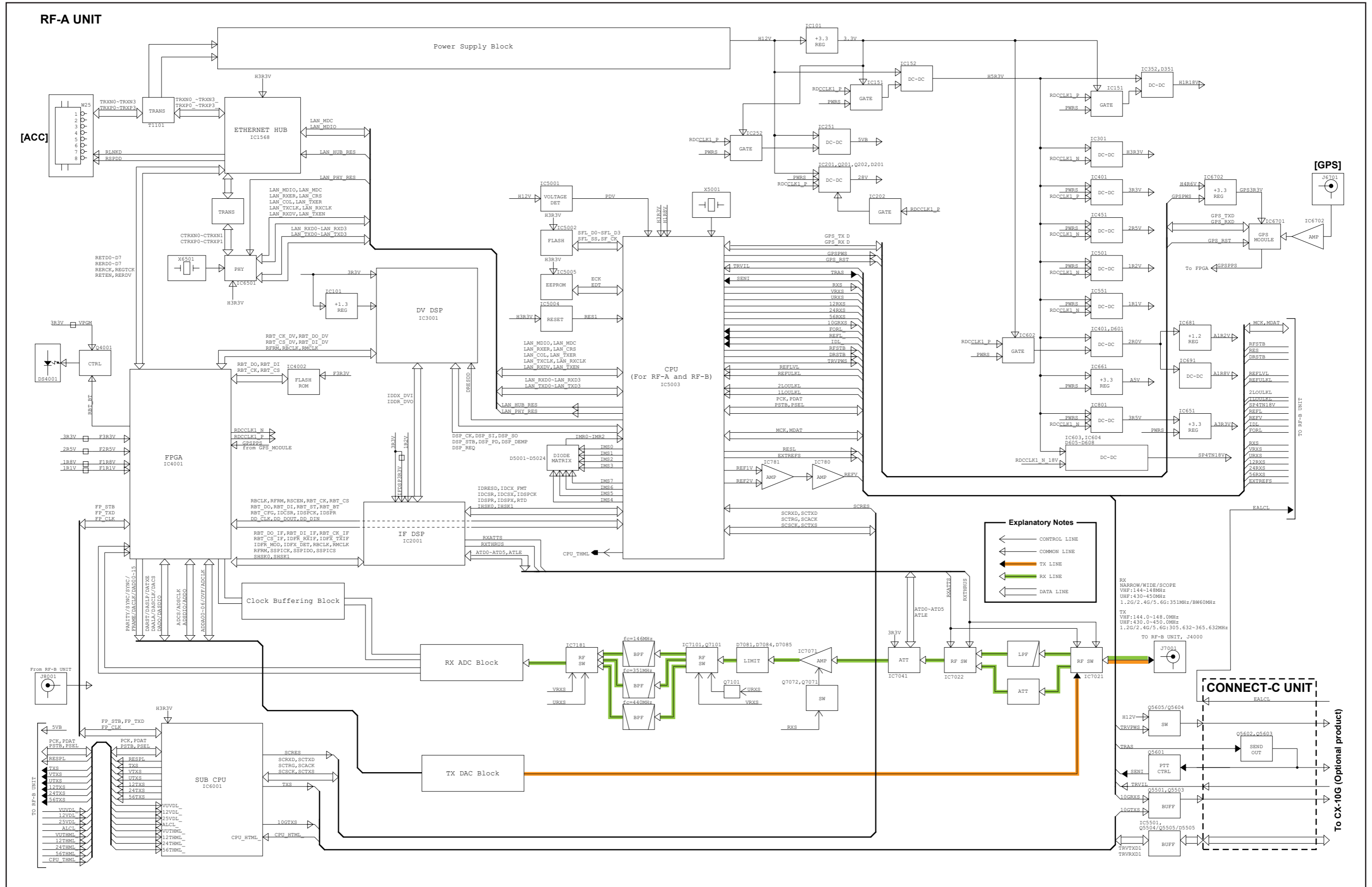

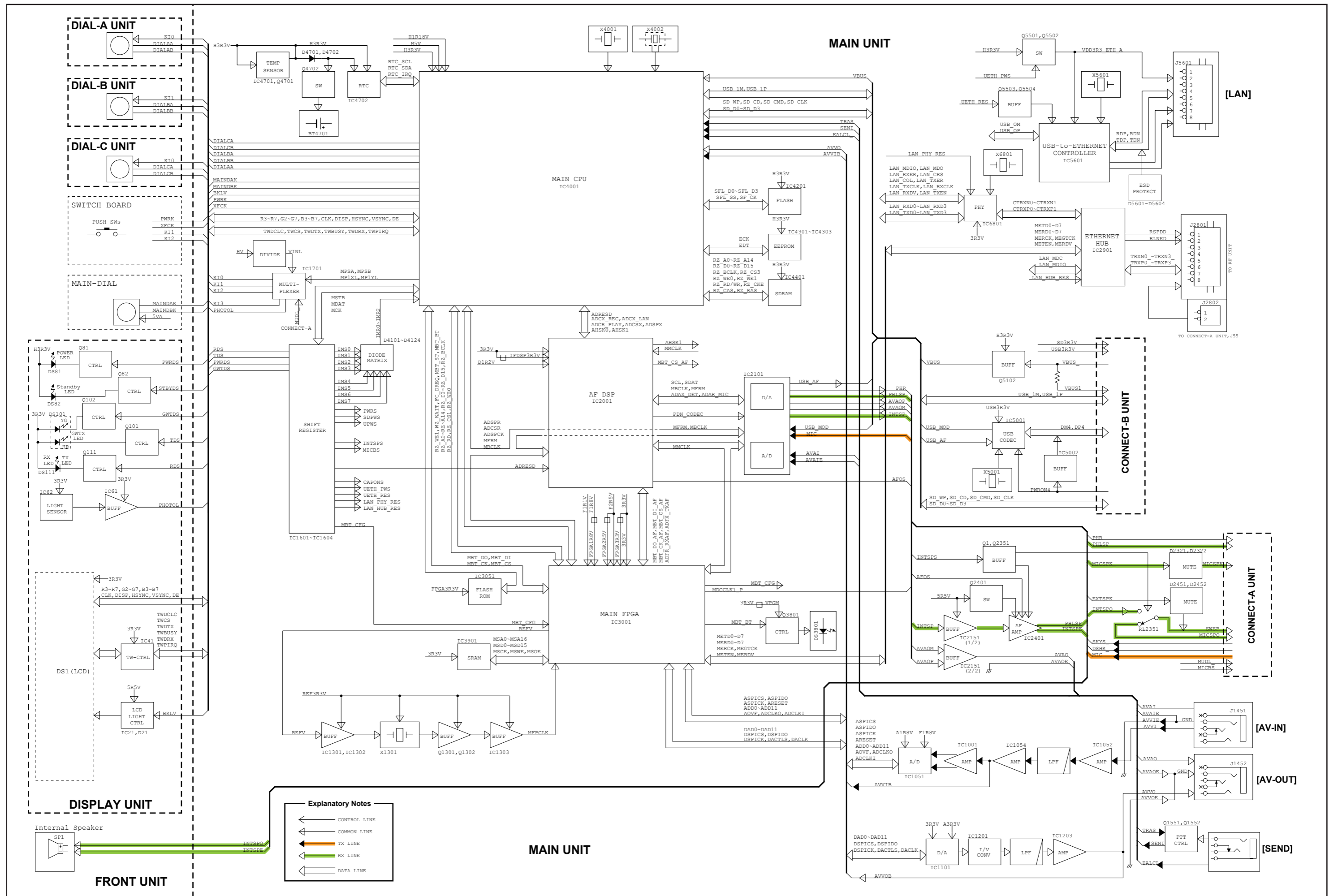

Explanatory Notes

- ← CONTROL LINE
- ← COMMON LINE
- ← TX LINE
- ← RX LINE
- ← DATA LINE

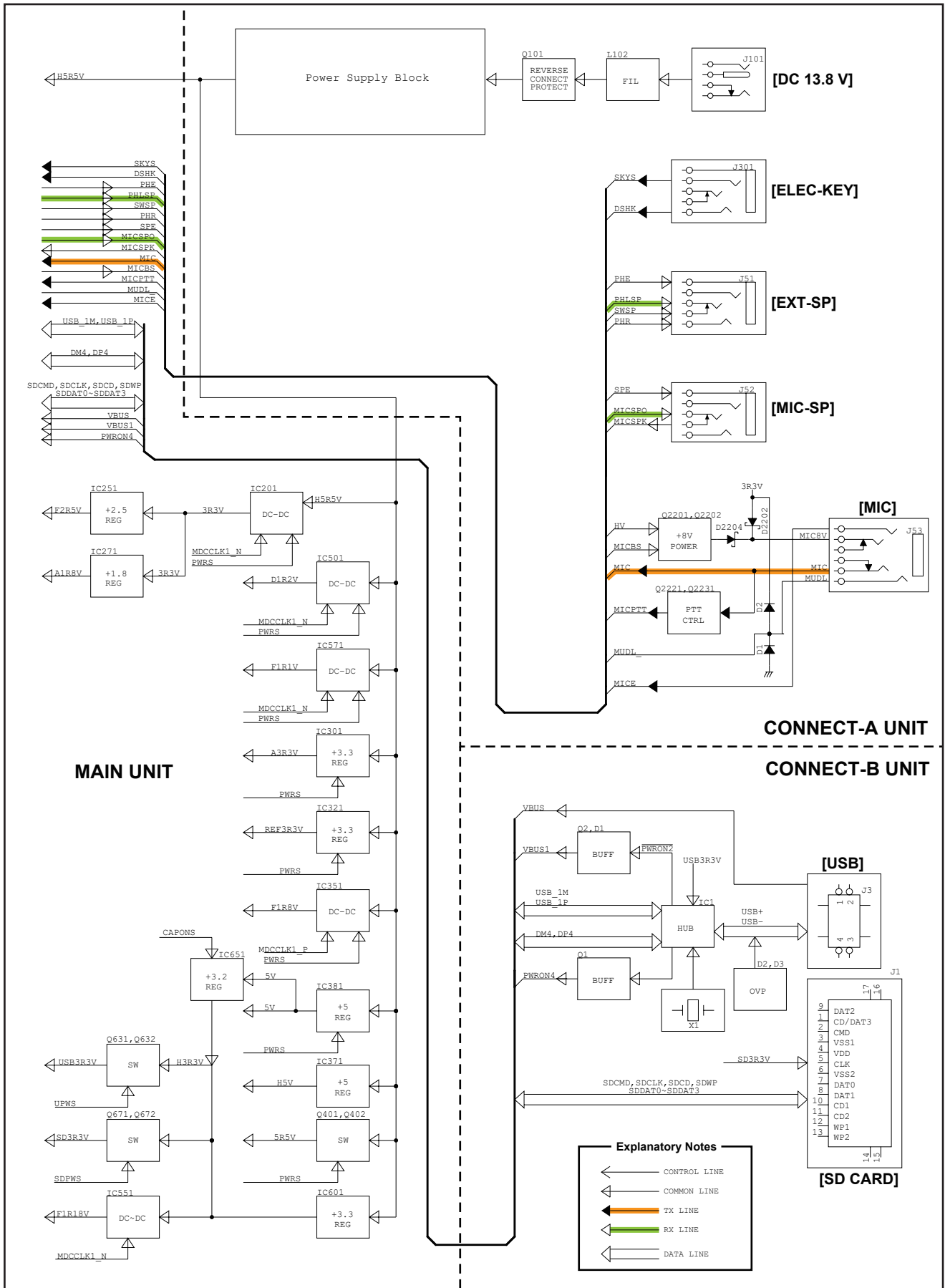

SECTION 11 SCHEMATIC DIAGRAM

• DISPLAY UNIT

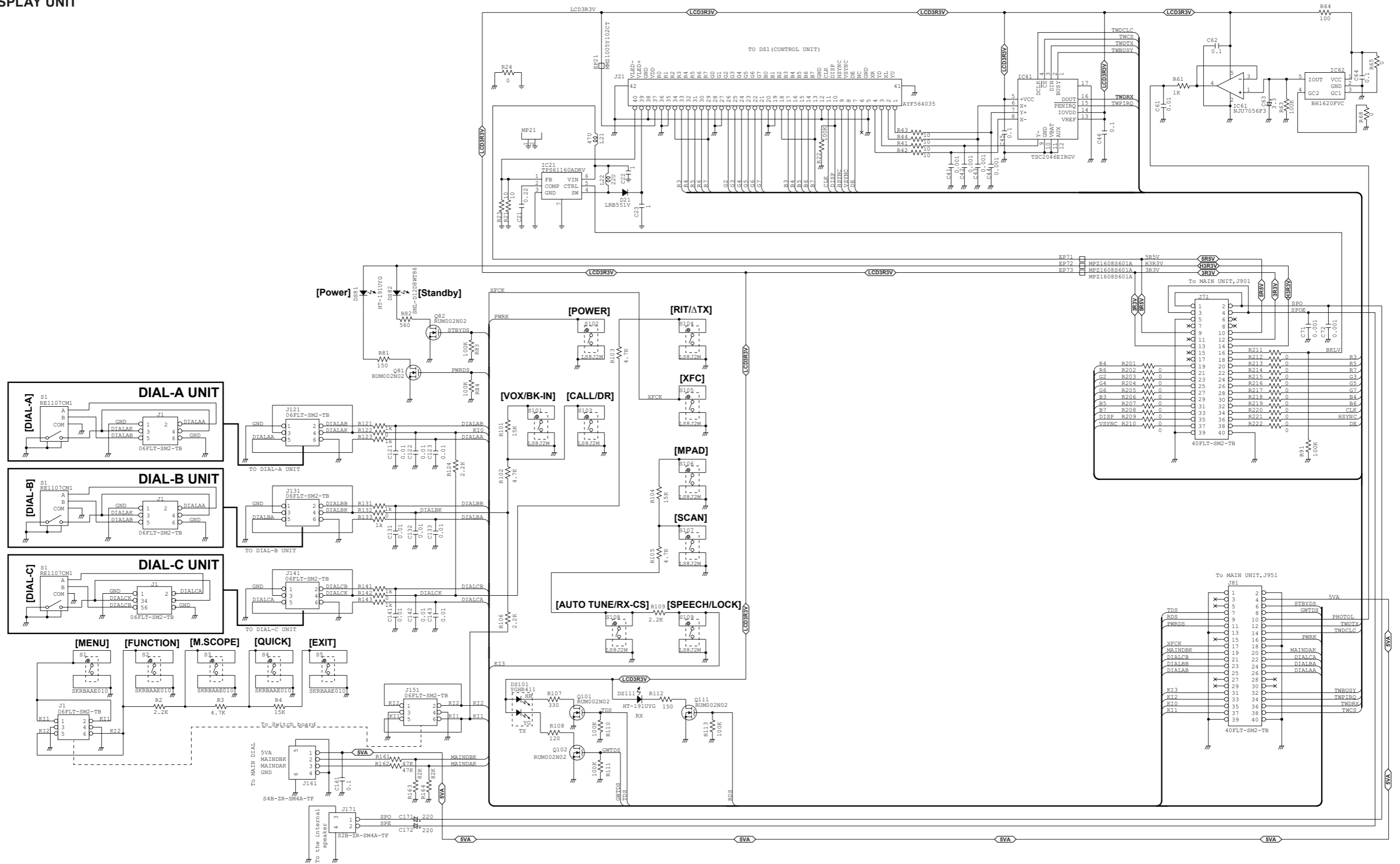

• MAIN UNIT (1/7)

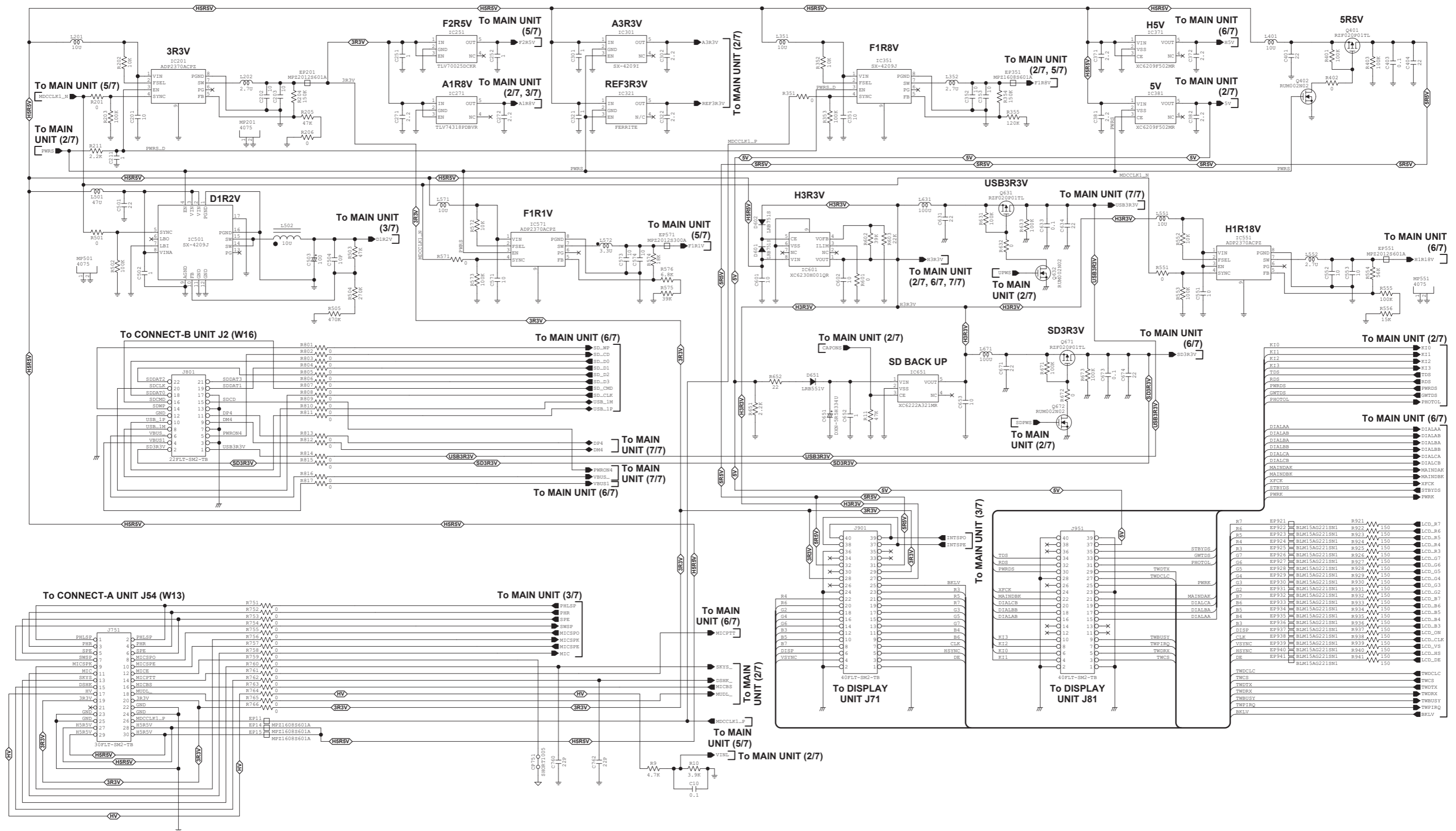

• MAIN UNIT (3/7)

To MAIN UNIT (1/7)

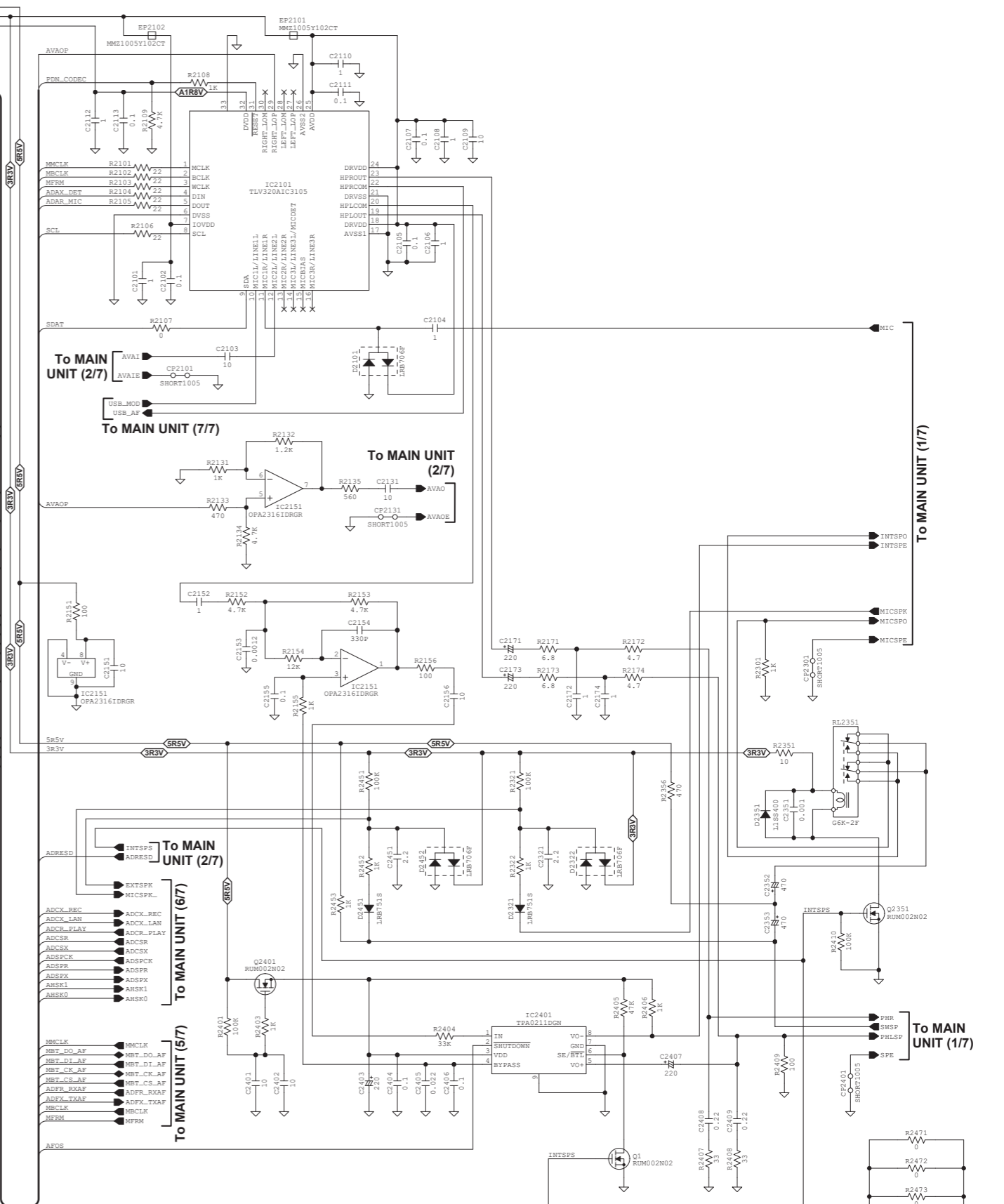
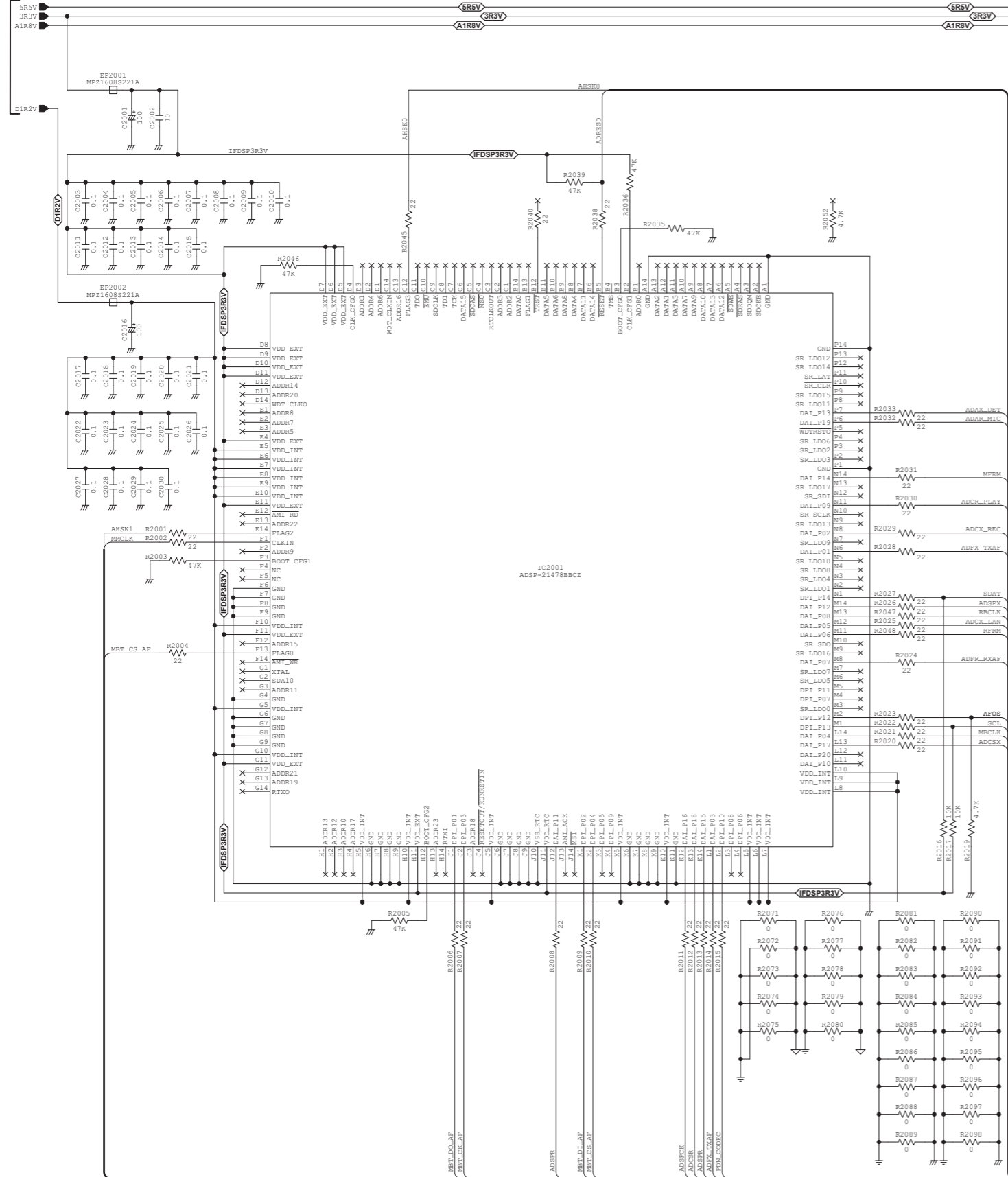

• MAIN UNIT (5/7)

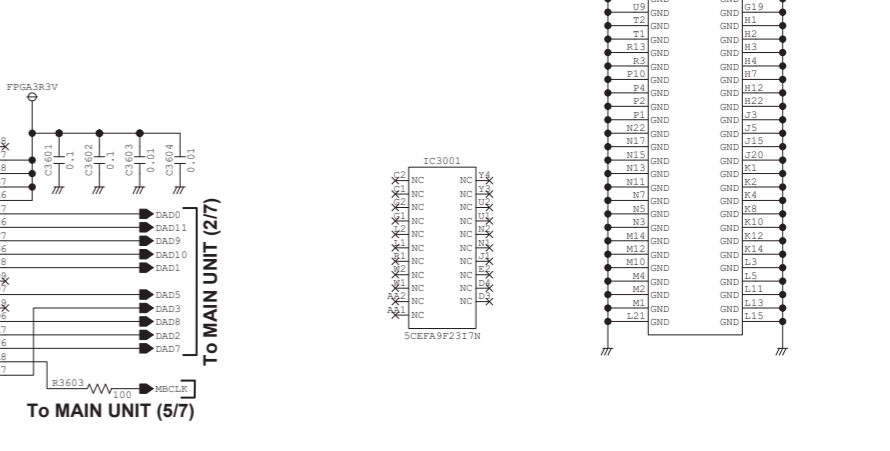
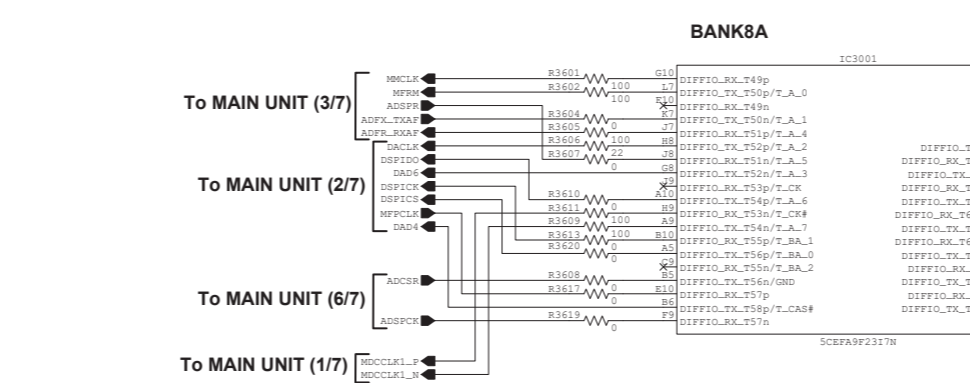
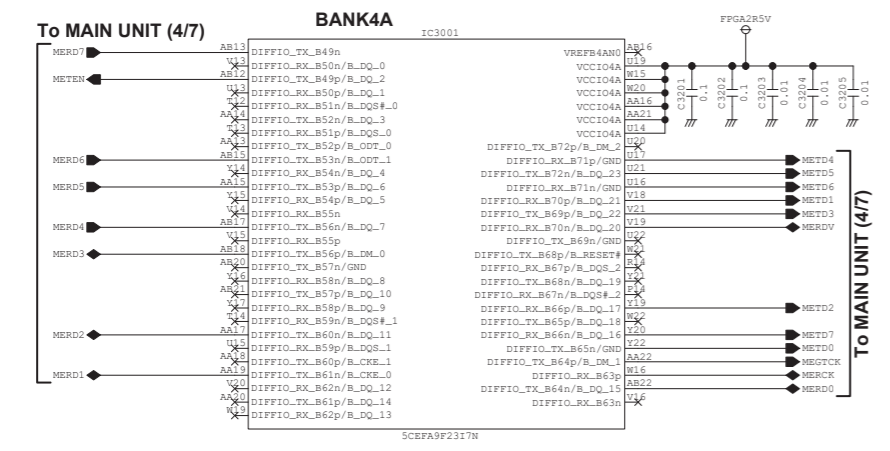
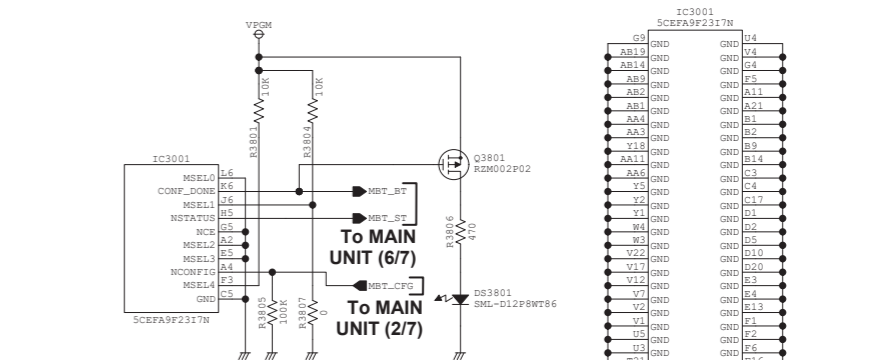
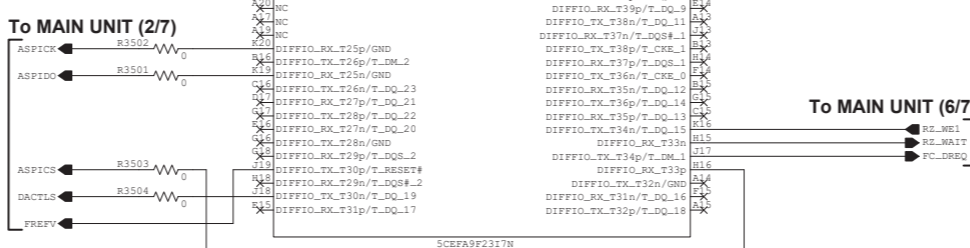
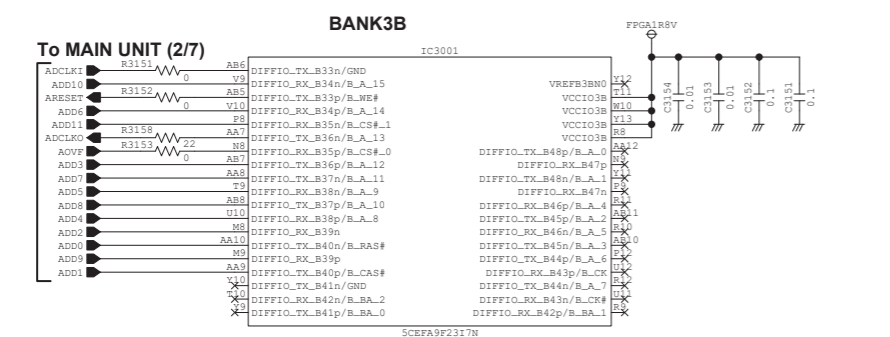
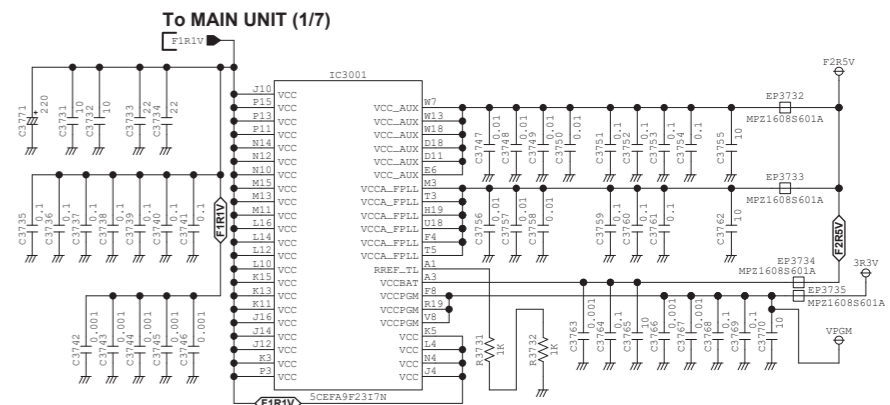
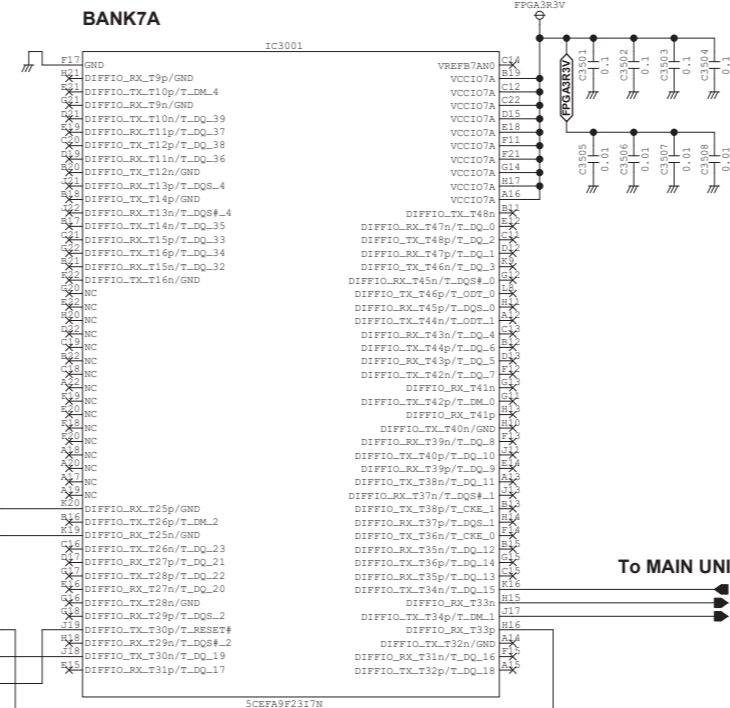
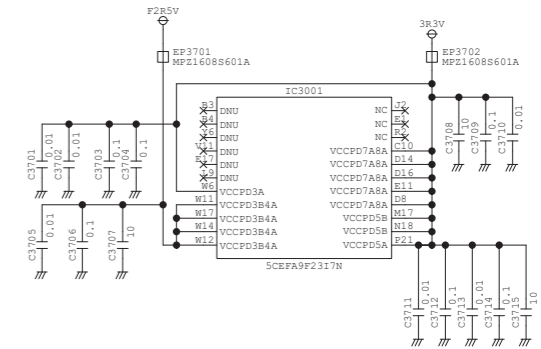
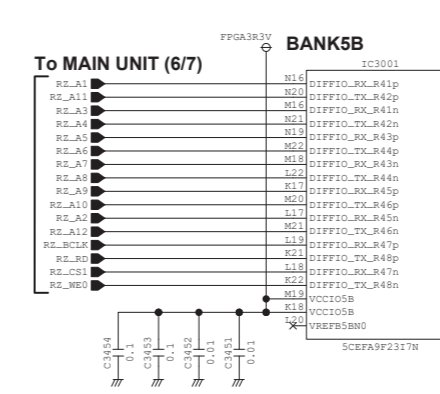
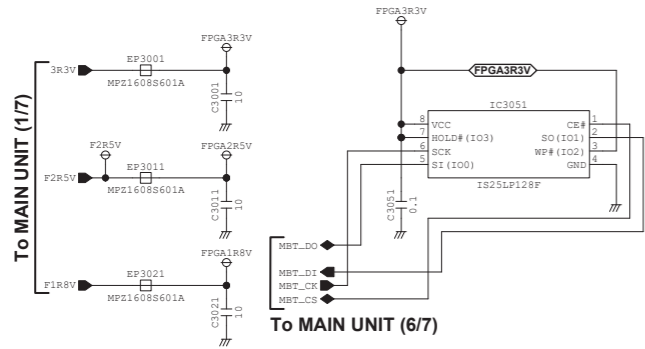

• MAIN UNIT (7/7)

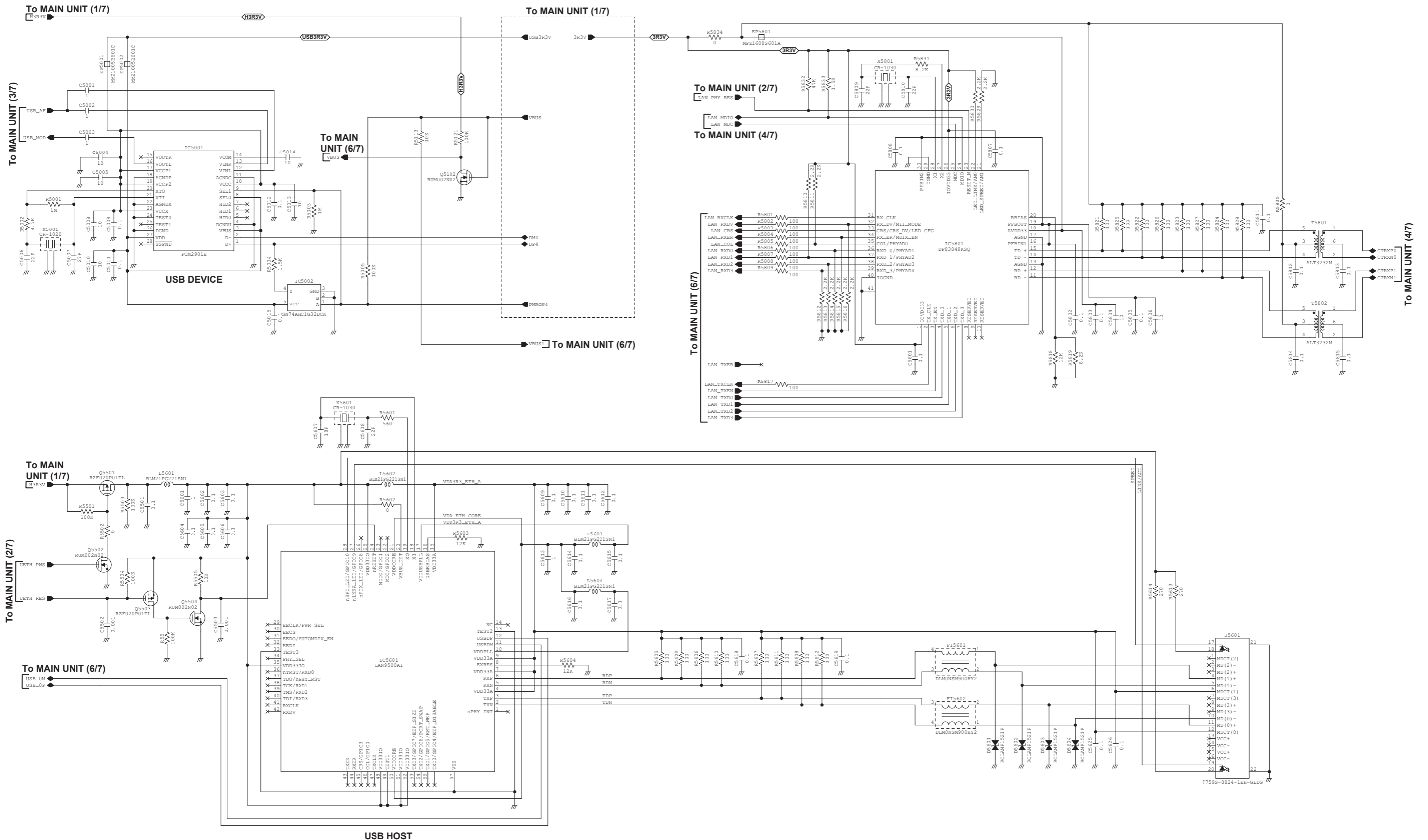

• CONNECT-A UNIT

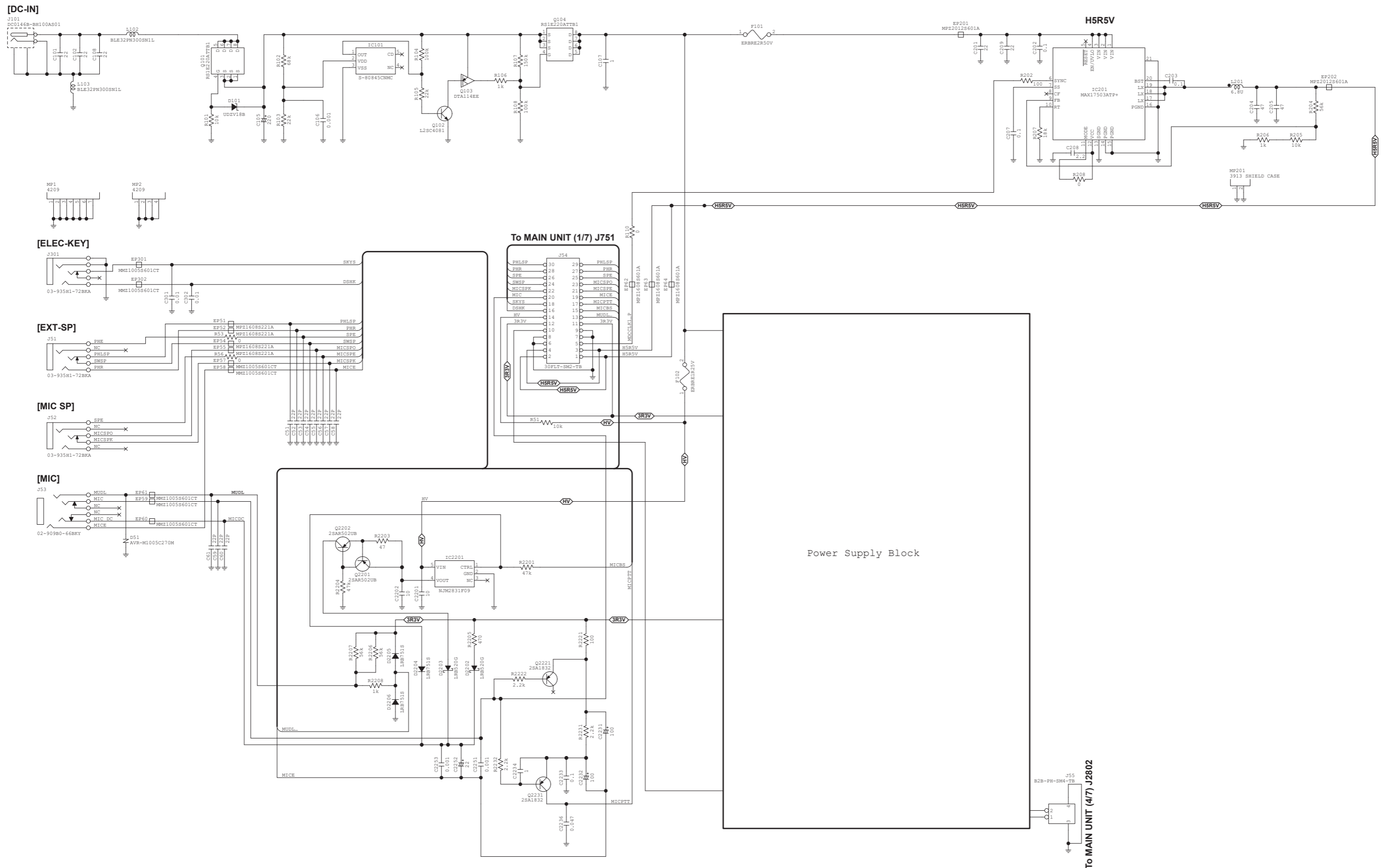

• CONNECT-B UNIT

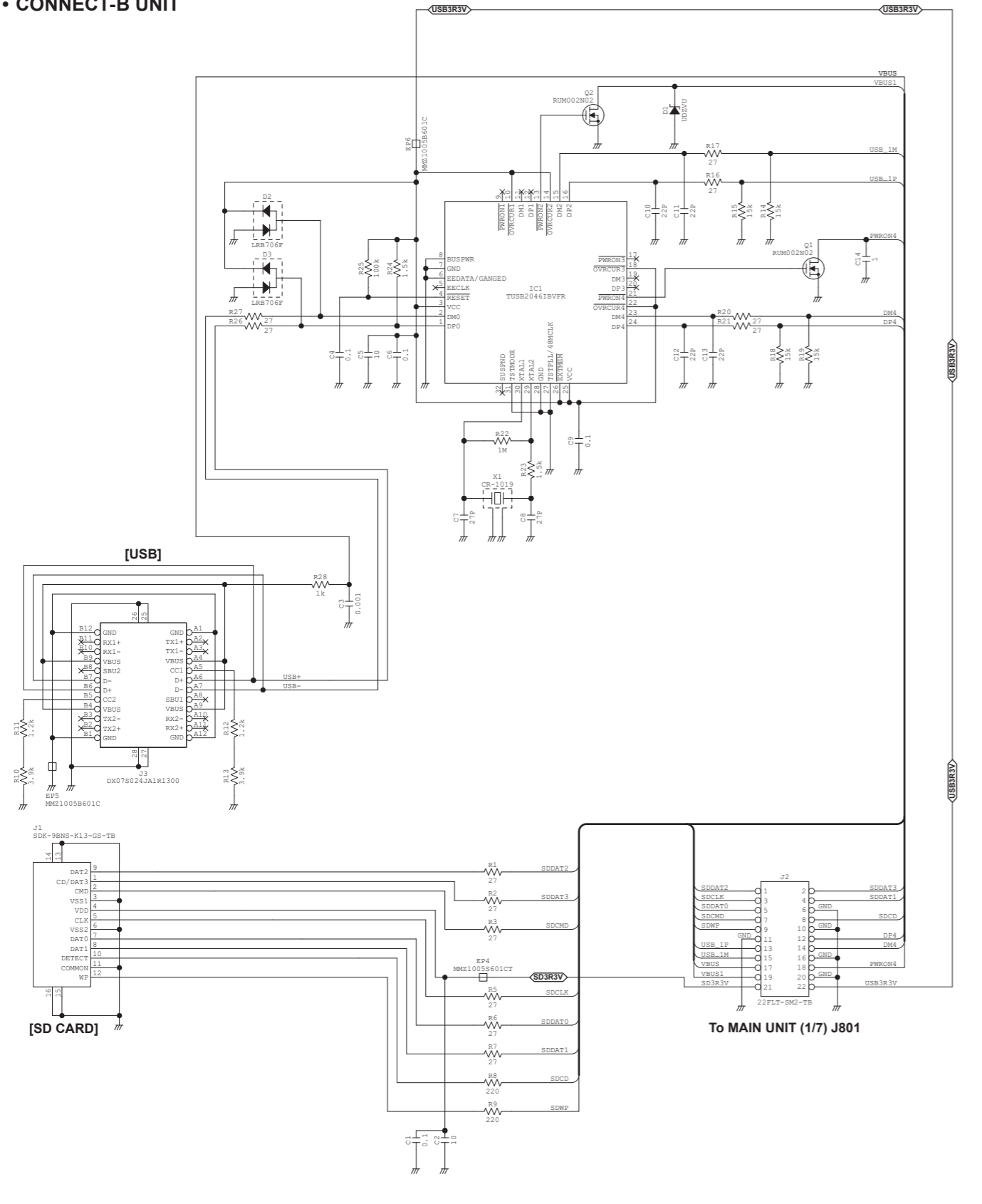

• CONNECT-C UNIT

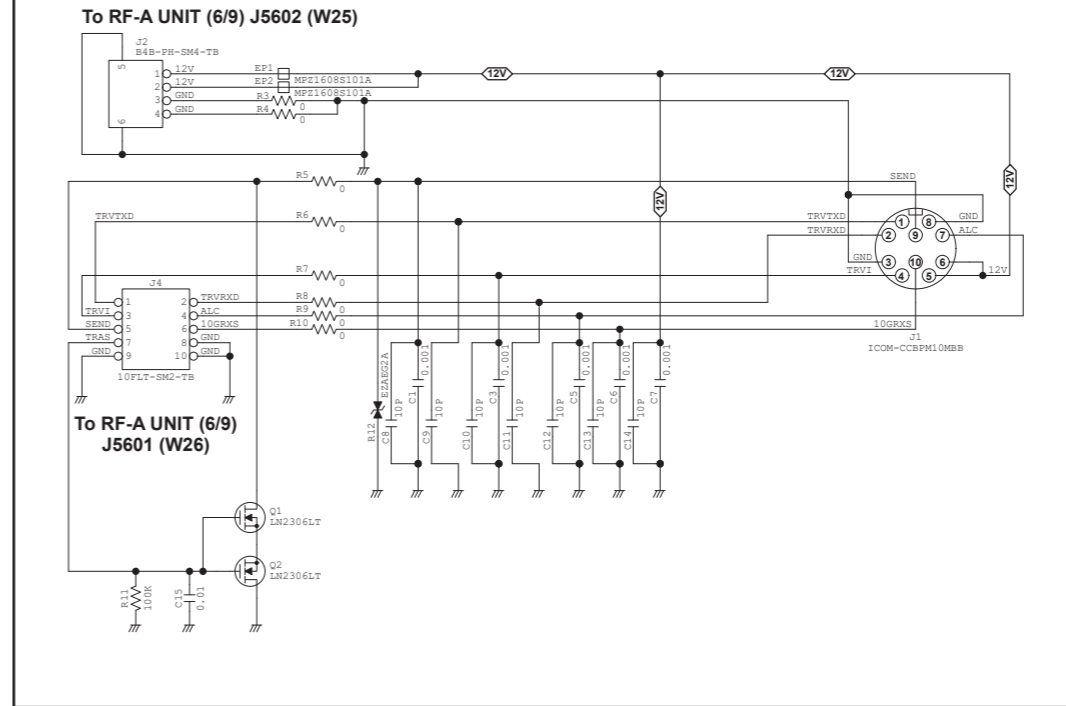

• RF-A UNIT (2/9)

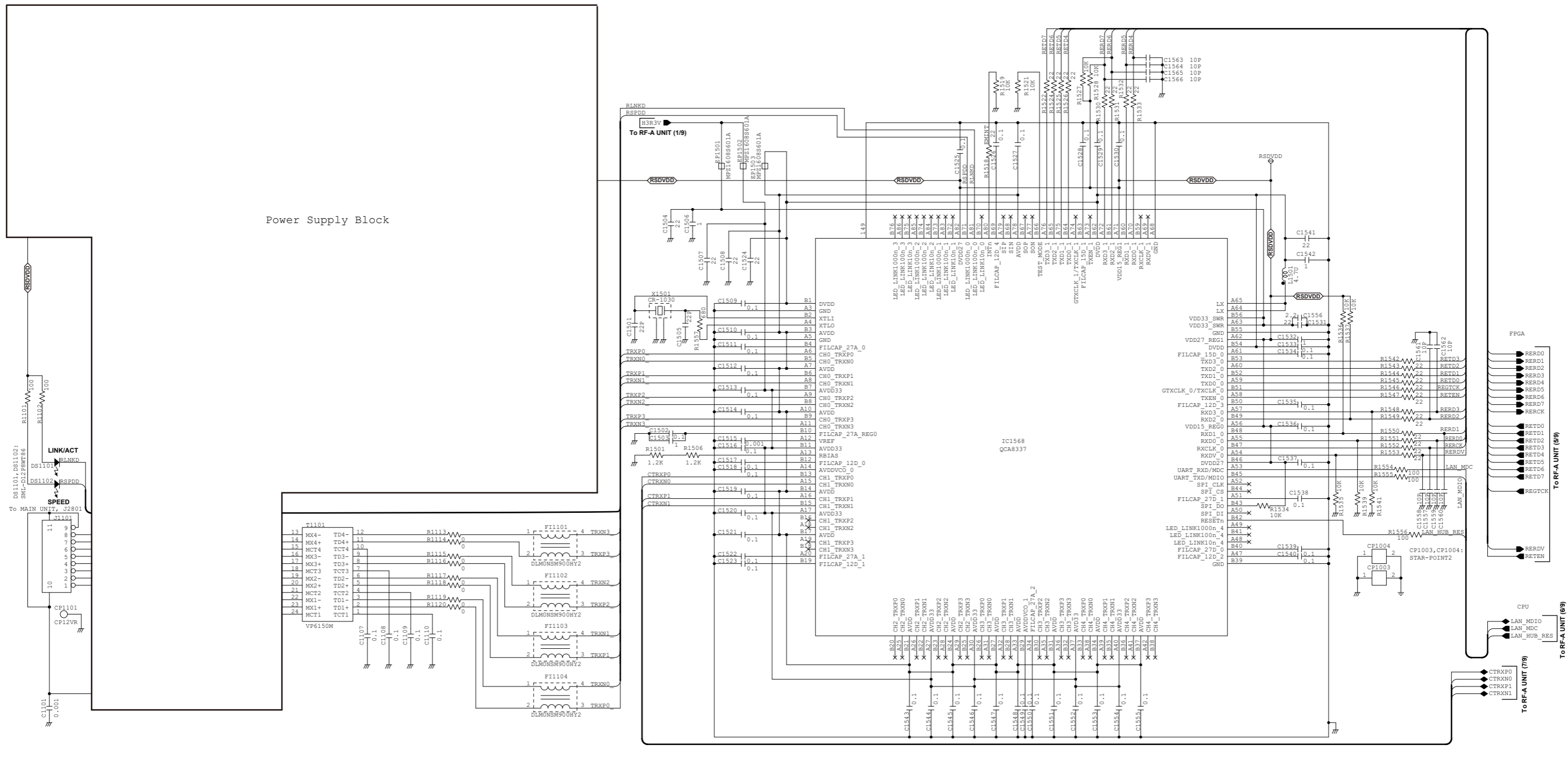

Power Supply Block

• RF-A UNIT (3/9)

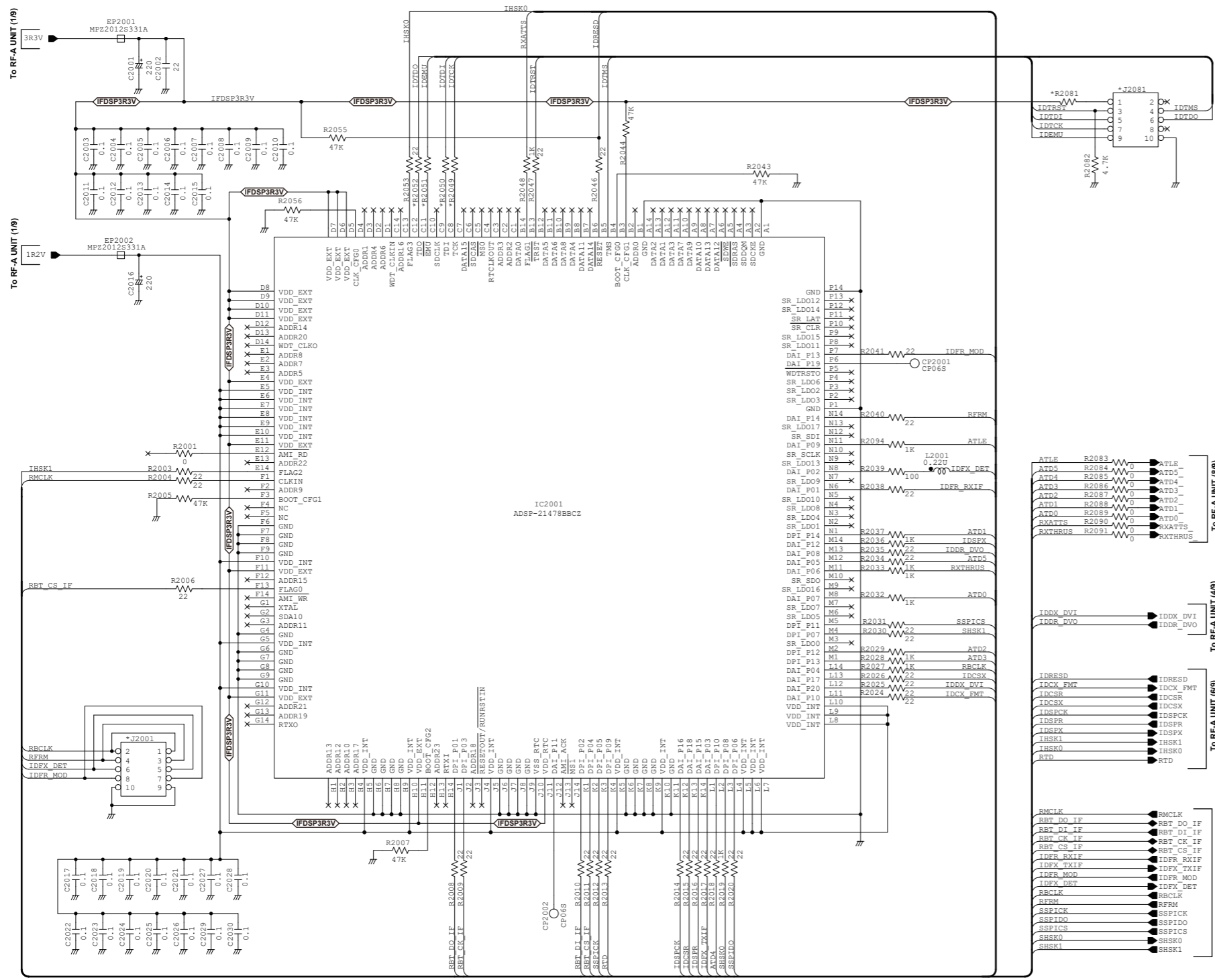

• RF-A UNIT (4/9)

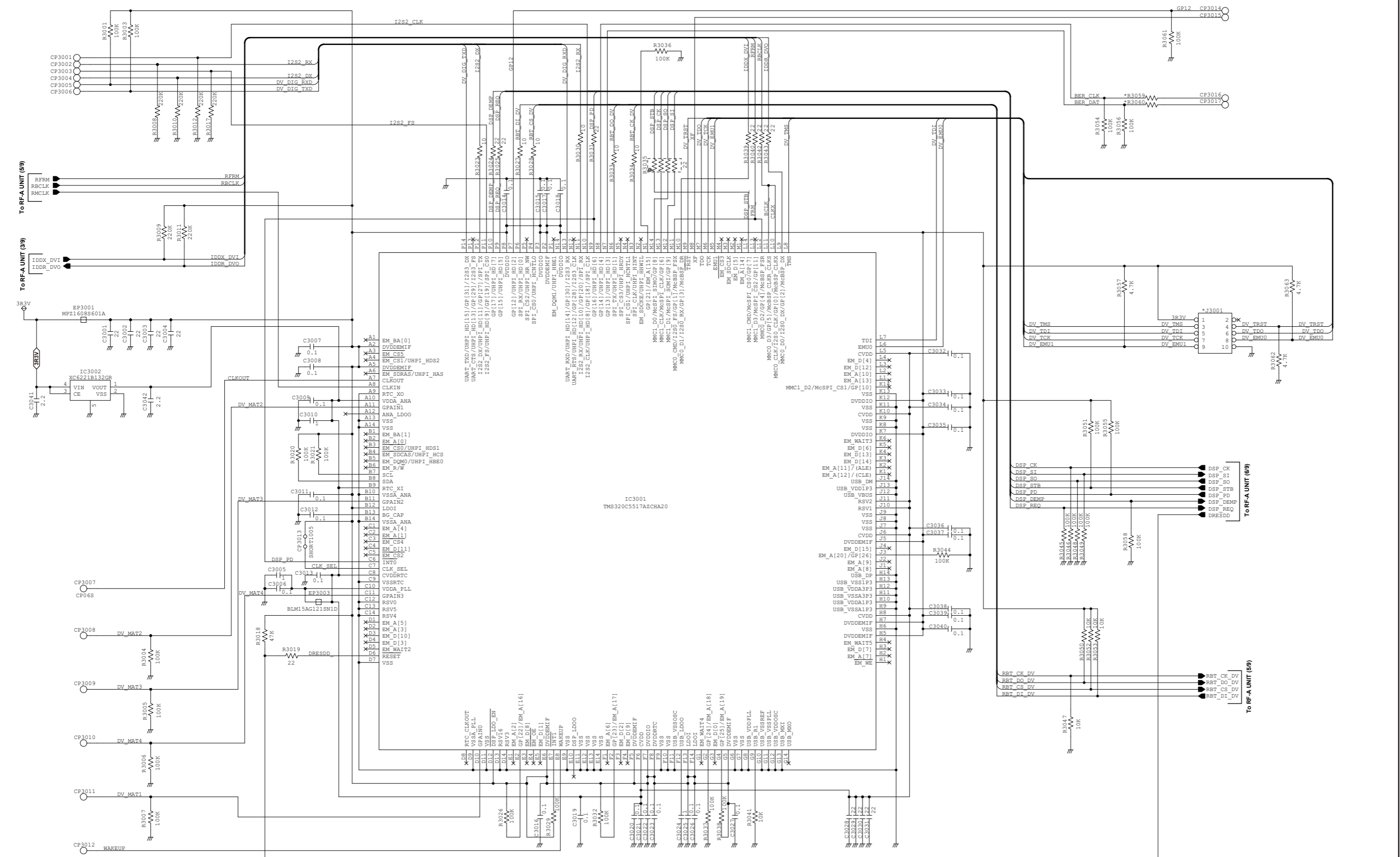

• RF-A UNIT (6/9)

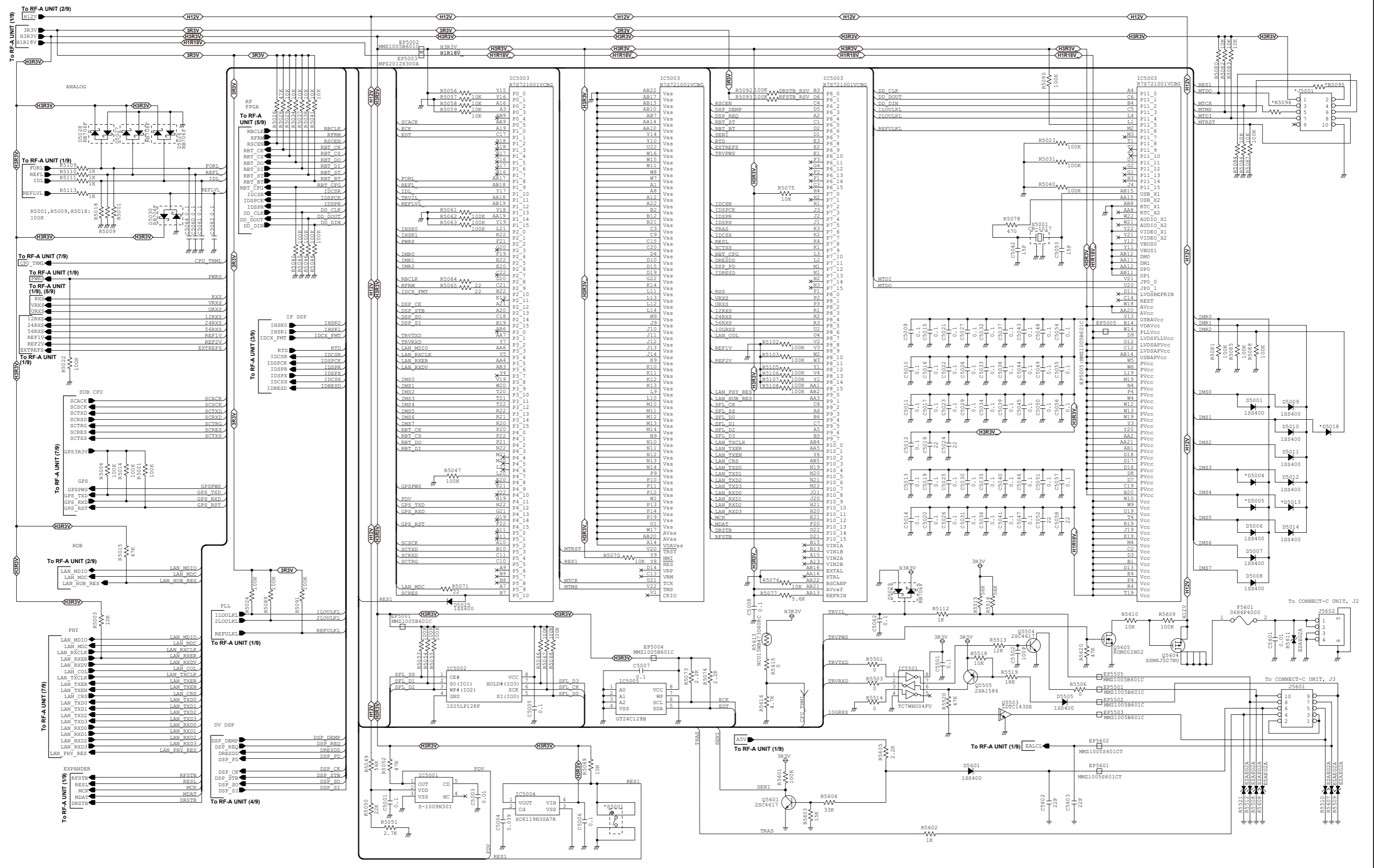

• RF-A UNIT (7/9)

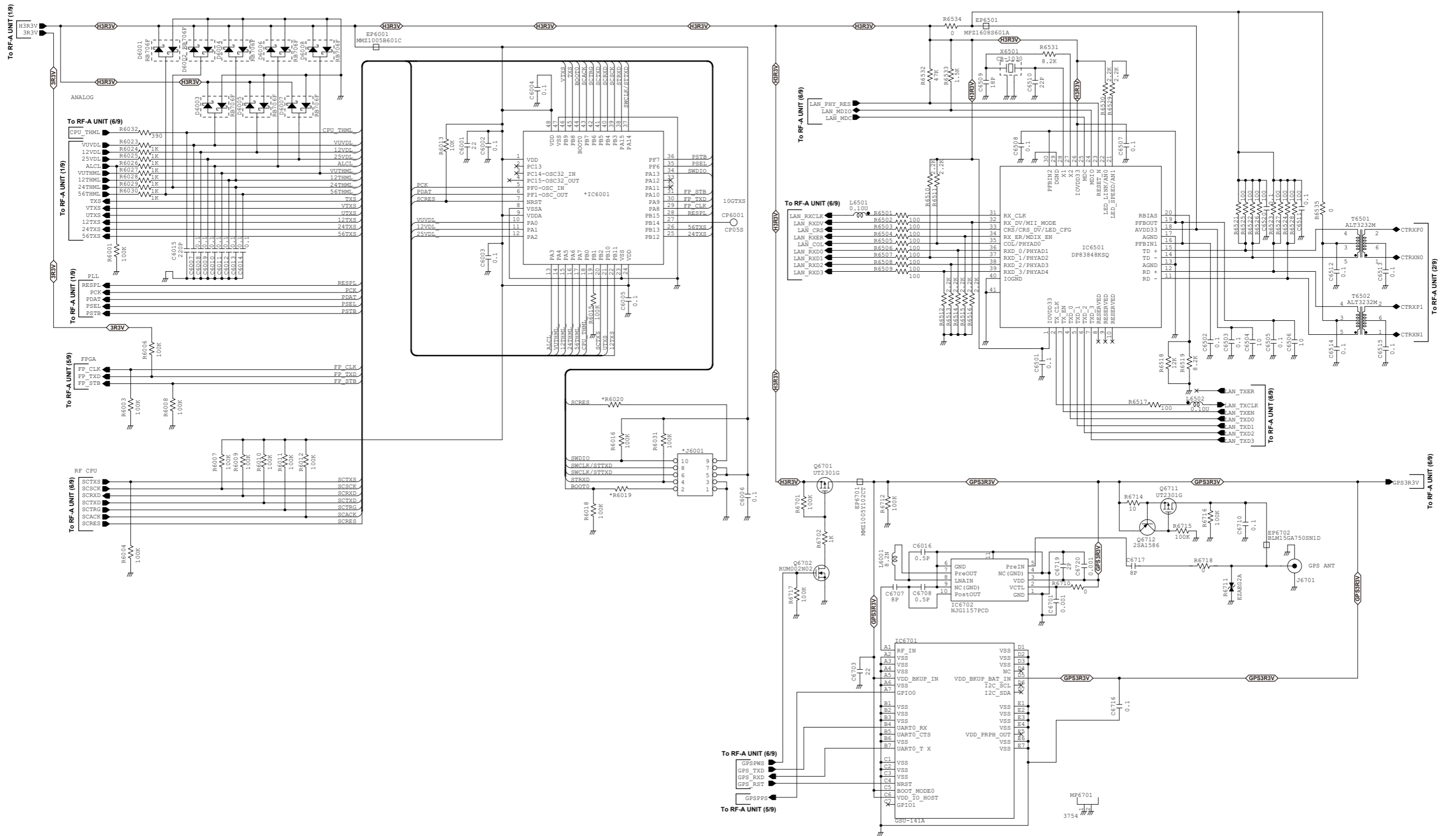

• RF-A UNIT (8/9)

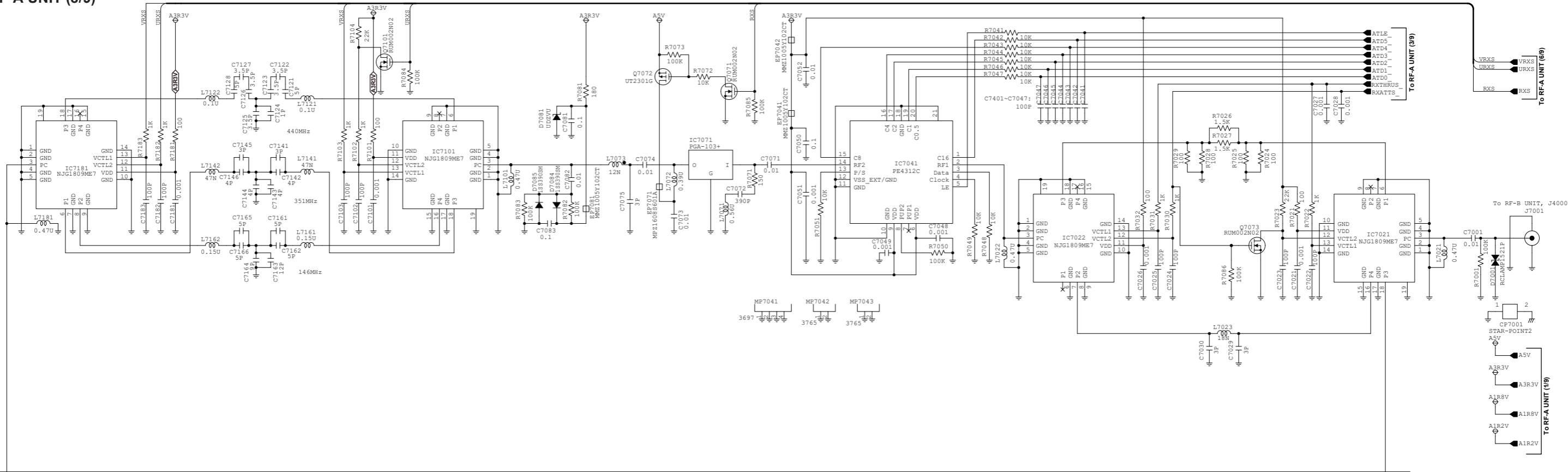

RF TRX Block

• RF-A UNIT (9/9)

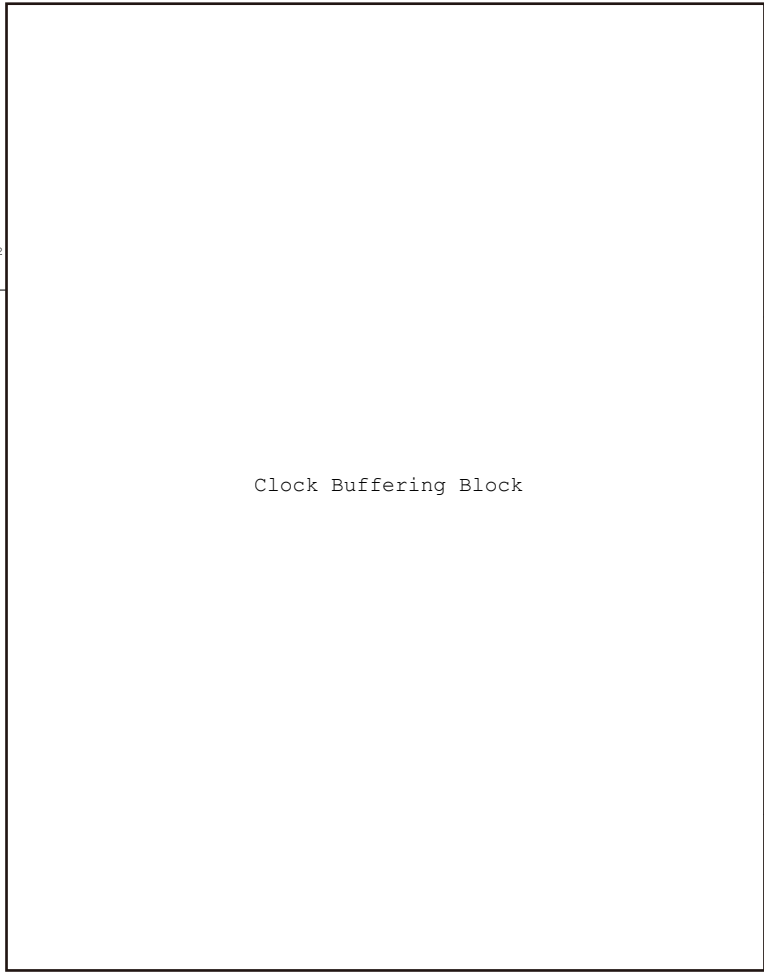
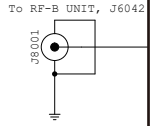

Clock Buffering Block

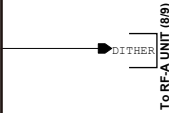
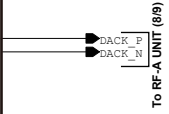
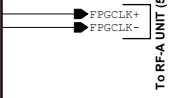
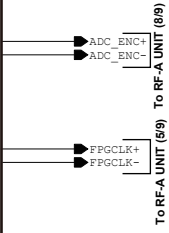

• RF-B UNIT (1/8)

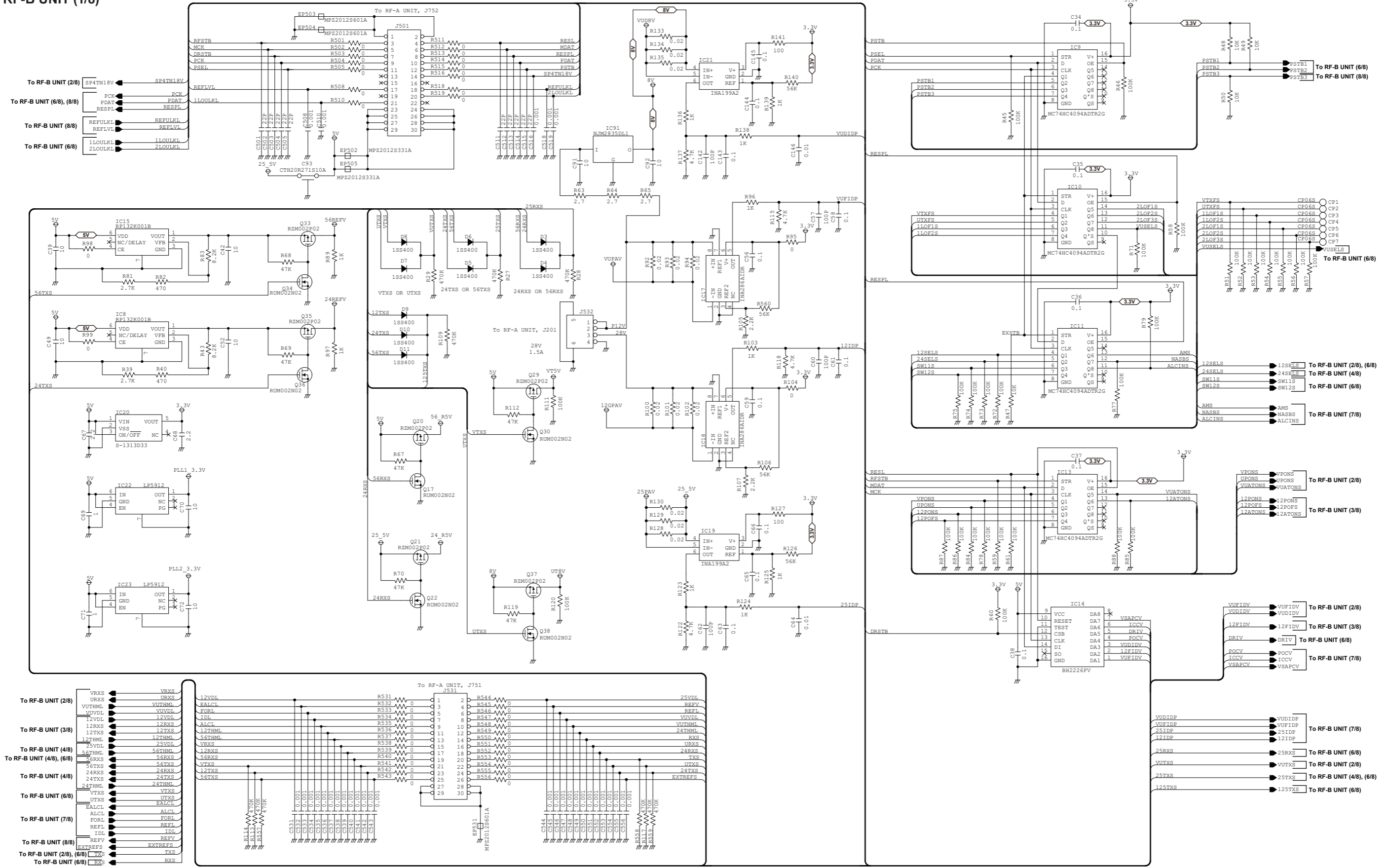

• RF-B UNIT (3/8)

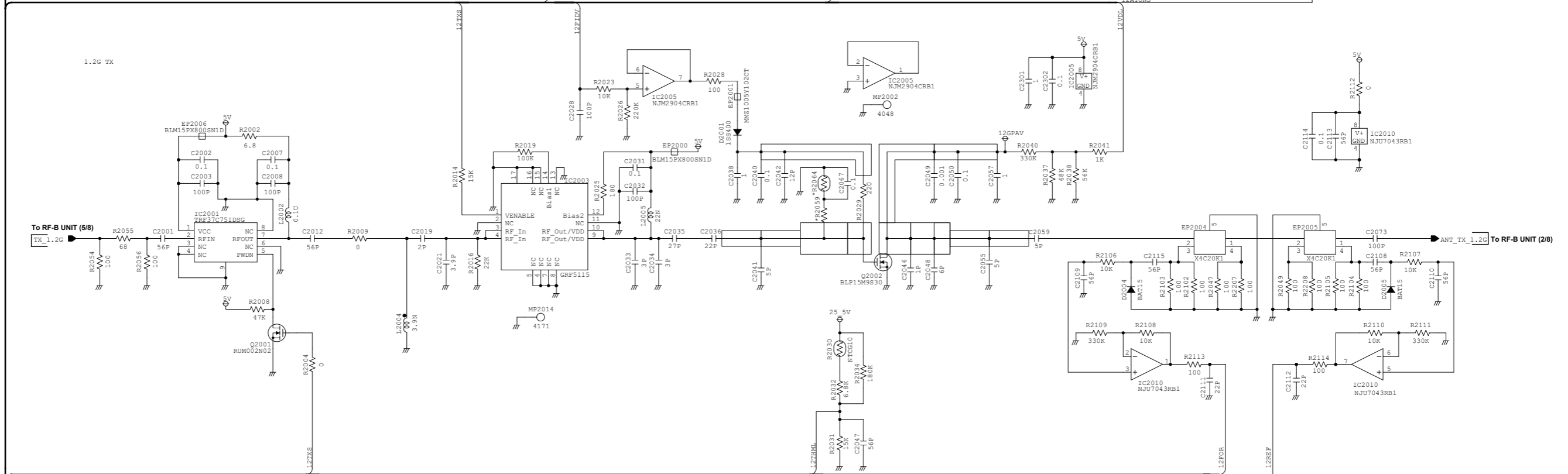
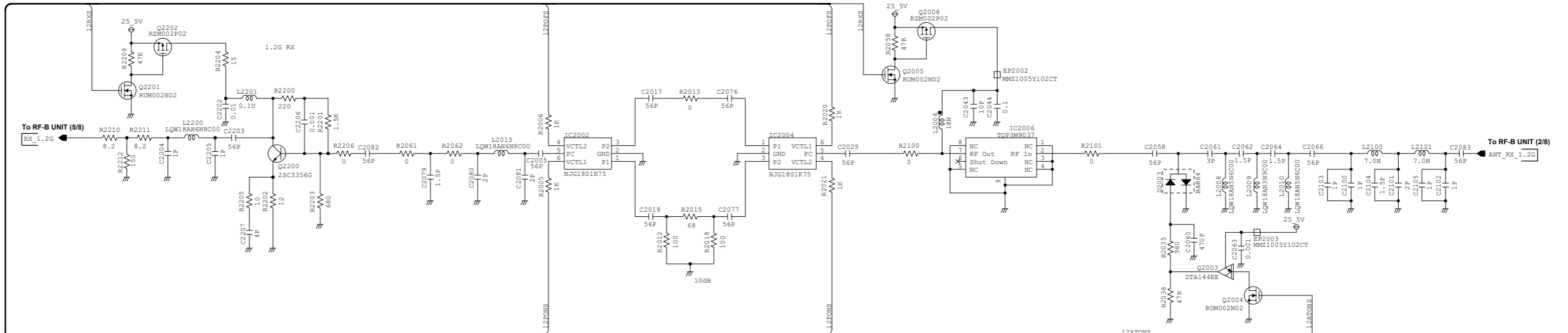

- To RF-B UNIT (7/8)
 - 12FOR
 - 12REF
- To RF-B UNIT (1/8)
 - 12VDD
 - 12ATONS
 - 12FIDV
 - 12POFS
 - 12PONS
 - 12RXS
 - 12THML
 - 12TXS

• RF-B UNIT (4/8)

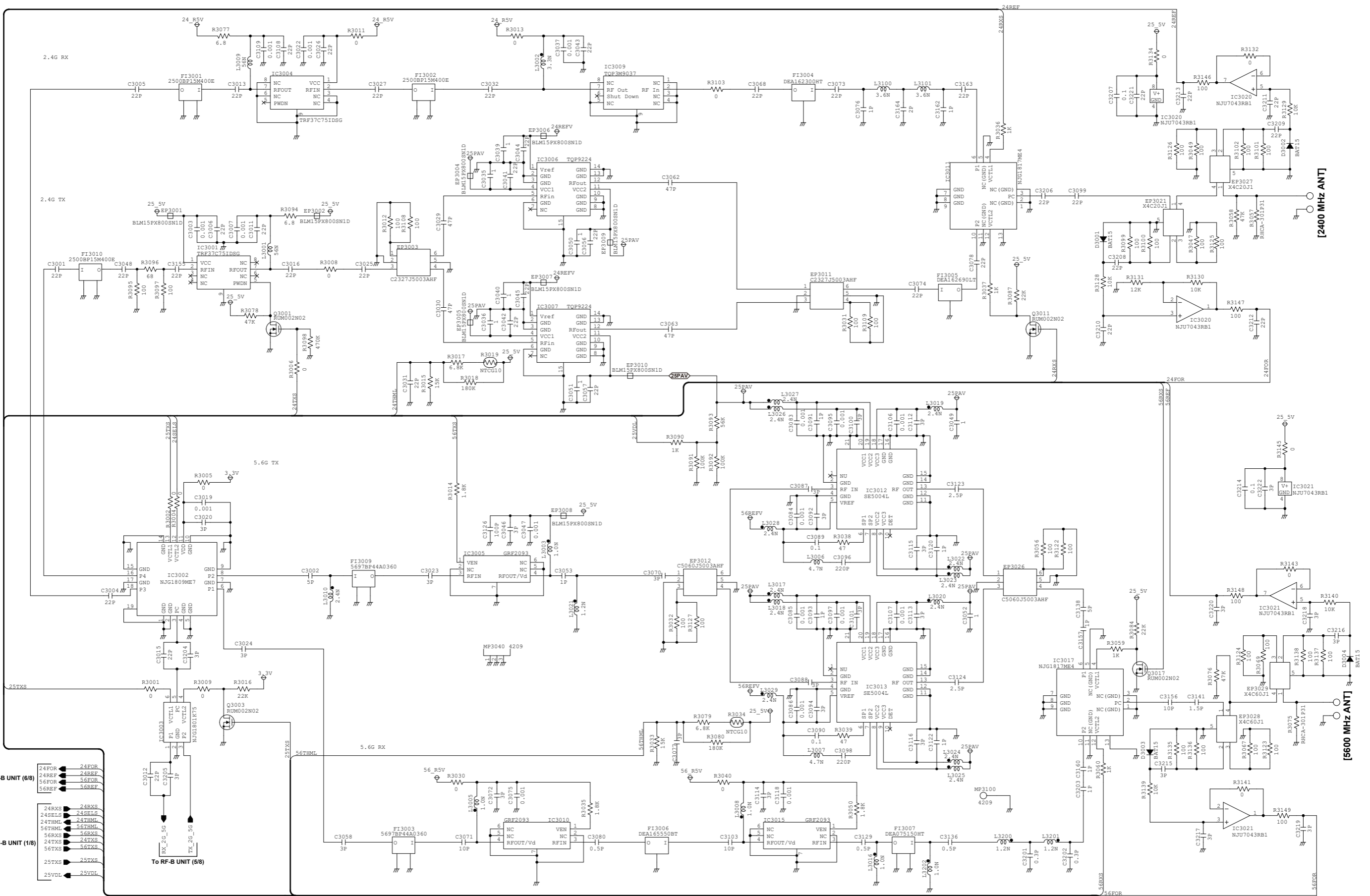

To RF-B UNIT (6/8)

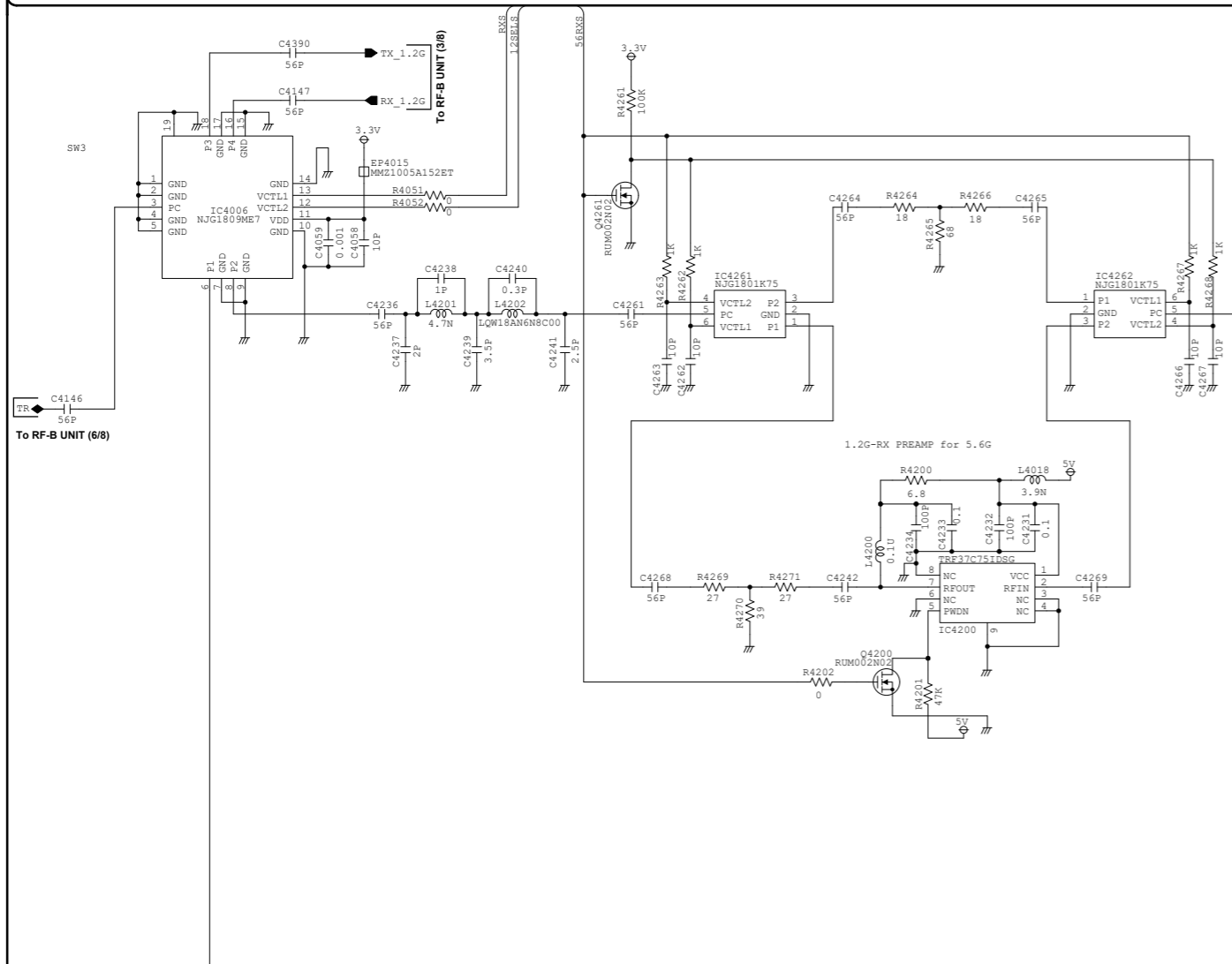

PLL Block
(TX 2nd Mixer Block)

• RF-B UNIT (6/8)

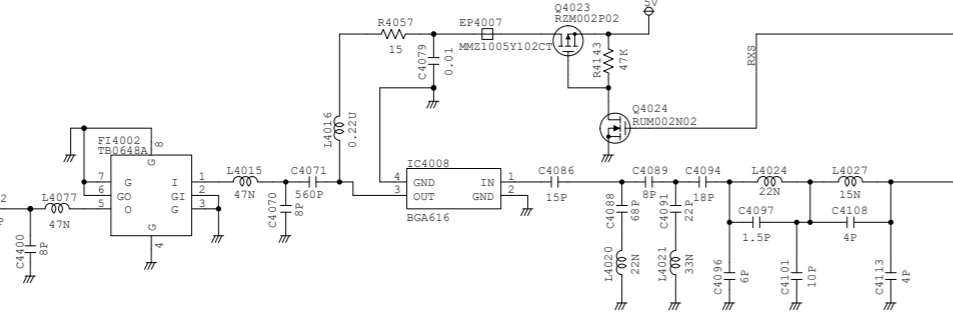
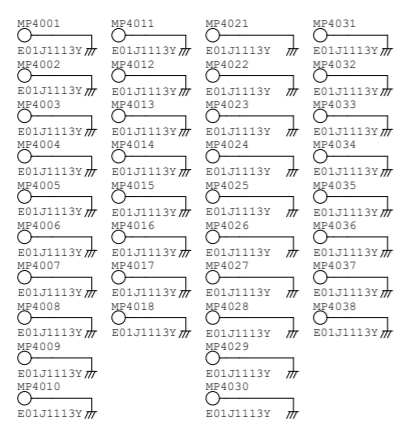
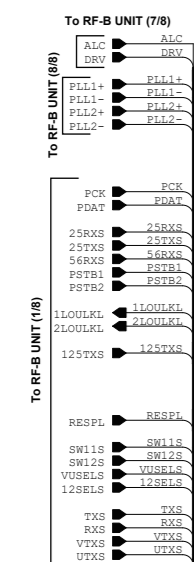
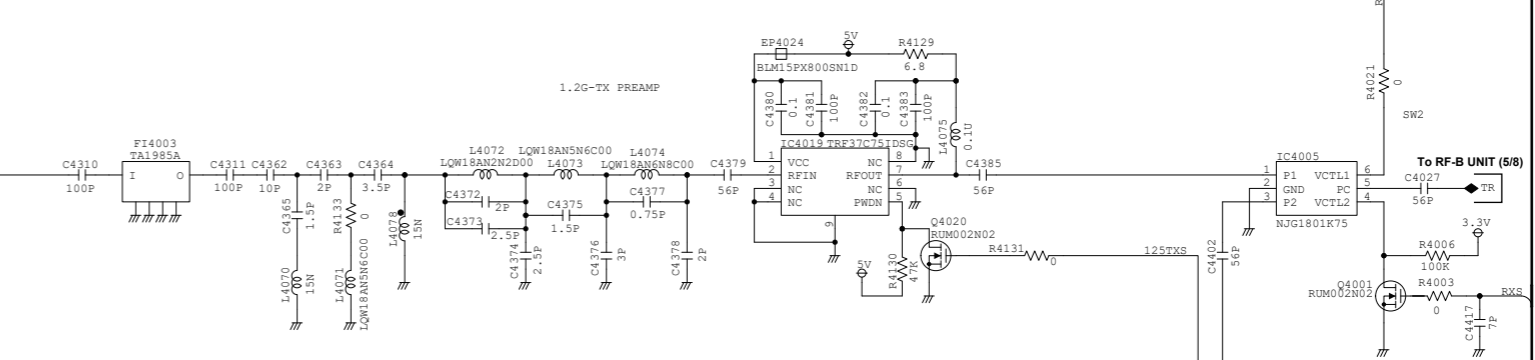
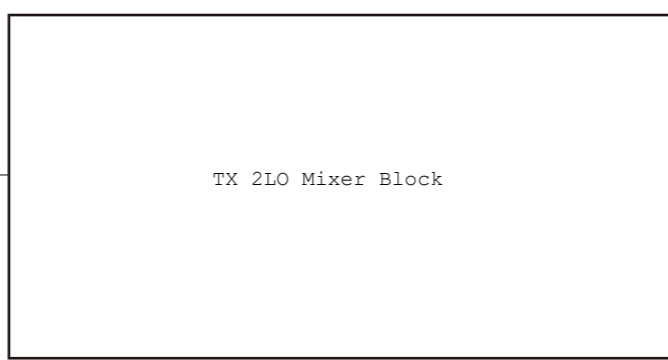
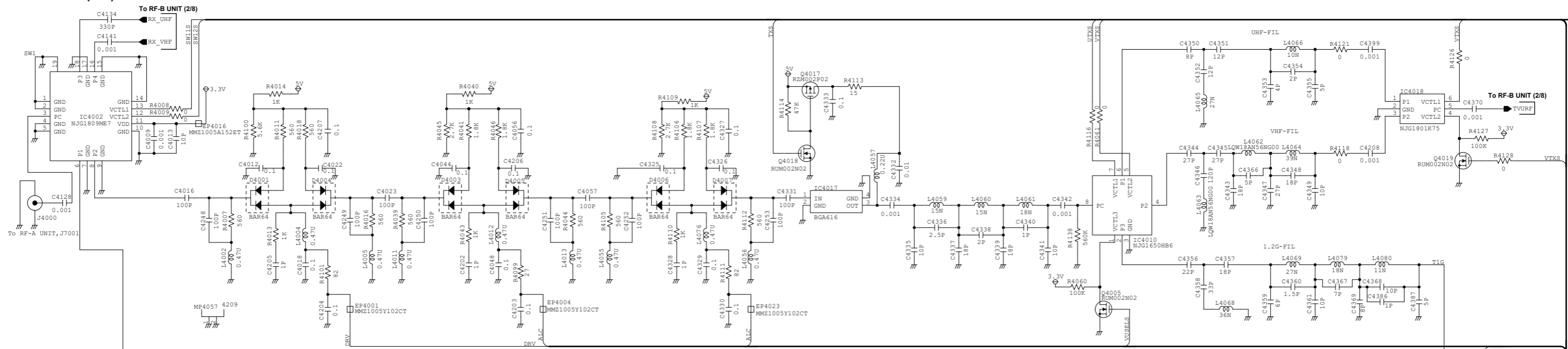

To RF-B UNIT (5/8)

• RF-B UNIT (7/8)

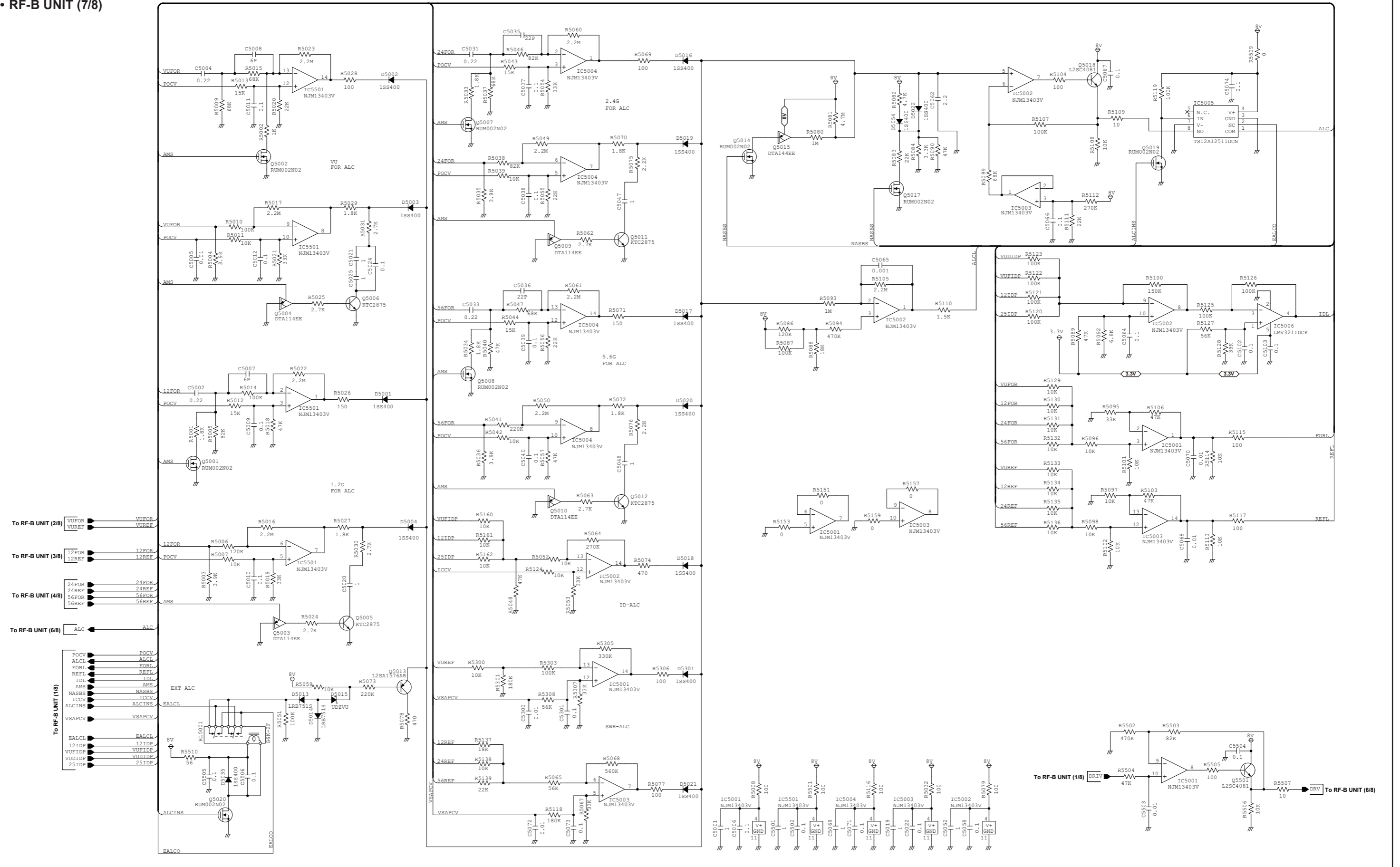

• RF-B UNIT (8/8)

Clock Generator Block

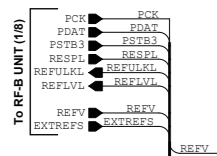

To RF-A UNIT, J8001

J6042

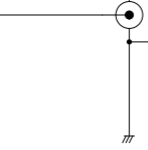

[REF OUT 10MHz/-10dBm]

MP6003

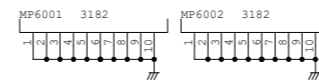

If you have any inquiries regarding service, contact your distributor. The contact number or E-mail address of your distributor can be found on our website.

<https://www.icomjapan.com/>

