



SERVICE MANUAL

DUAL BAND FM TRANSCEIVER

IC-X2A

IC-X2E

SECTION 1 ADJUSTMENT PROCEDURES

1-1 PREPARATION BEFORE SERVICING

■ REQUIRED TEST EQUIPMENT

EQUIPMENT	GRADE AND RANGE	EQUIPMENT	GRADE AND RANGE
DC power supply	Output voltage : 12.5 V DC Current capacity : 3 A or more	Audio generator	Frequency range : 300~3000 Hz Output level : 1~500 mV
RF power meter (terminated type)	Measuring range : 1~10 W Frequency range : 400~1300 MHz Impedance : 50 Ω SWR : Less than 1.2:1	Attenuator	Power attenuation : 40 or 50 dB Capacity : 10 W or more
Frequency counter	Frequency range : 400~1300 MHz Frequency accuracy : ±1 ppm or better Sensitivity : 100 mV or better	DC voltmeter	Input impedance : 50 kΩ/DC or better
Distortion meter	Frequency range : 1 kHz ± 10 Hz Measuring range : 1~100 %	AC millivoltmeter	Measuring range : 10 mV~10 V
Standard signal generator (SSG)	Frequency range : 400~1300 MHz Output level : -127~-17 dBm (0.1 μV~32 mV)	External speaker	Impedance : 8 Ω
		FM deviation meter	Frequency minimum : 1300 MHz Measuring range : 0~±5 kHz
		Digital multimeter or oscilloscope	Input impedance : 1 MΩ/DC or better

CP: check point CCW: counterclockwise

■ CONNECTION

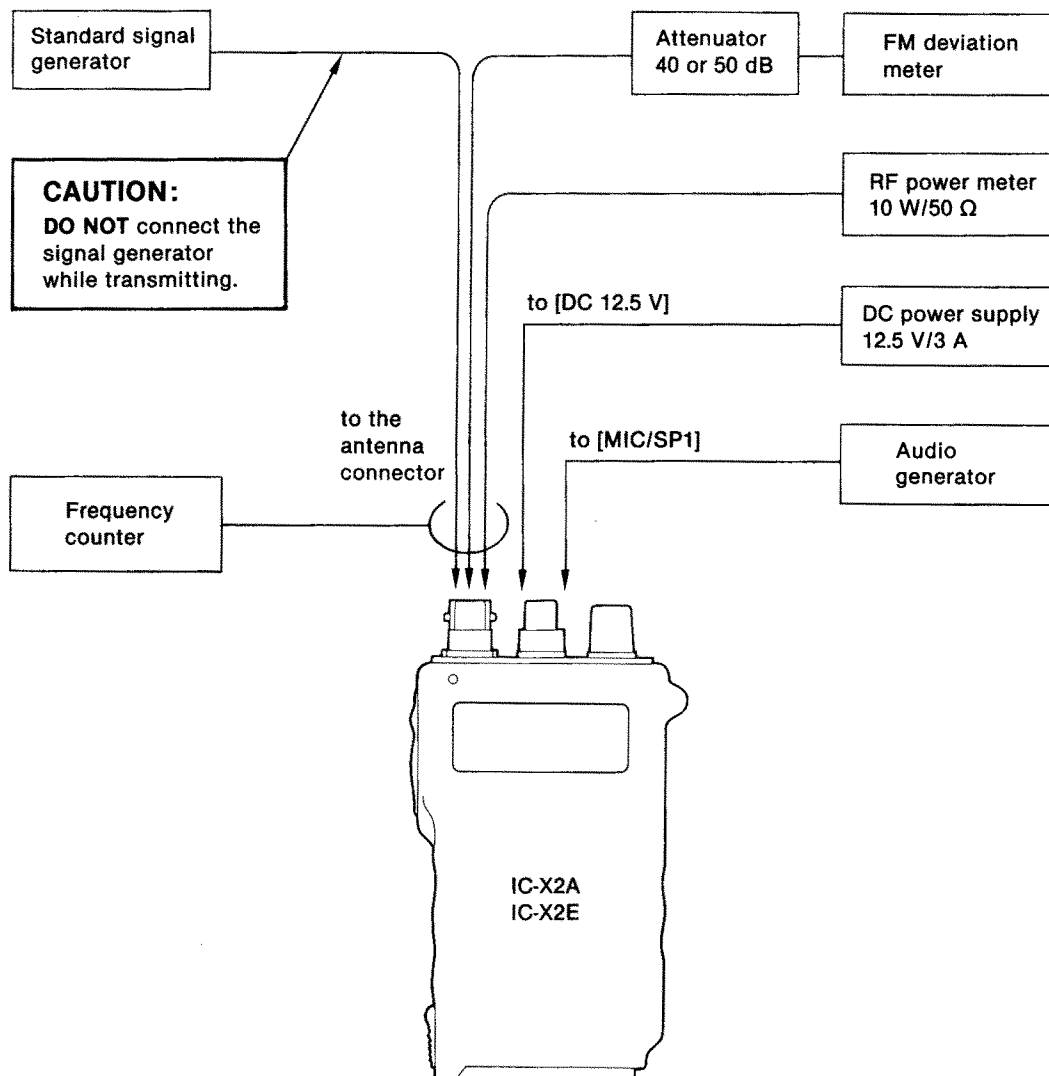

1-2 PLL ADJUSTMENT

ADJUSTMENT		ADJUSTMENT CONDITIONS	MEASUREMENT		VALUE	ADJUSTMENT POINT	
			UNIT	LOCATION		UNIT	ADJUST
440 MHz LOCK VOLTAGE	1	<ul style="list-style-type: none"> • Displayed frequency: 450.00 MHz (USA version) 440.00 MHz (All other versions) • Simplex • Transmitting and receiving 	440 RF	Connect the digital multimeter or oscilloscope to LV CP.	3.0 V DC on the higher voltage at transmitting or receiving	U VCO	C3
440 MHz REFERENCE FREQUENCY	1	<ul style="list-style-type: none"> • Displayed frequency: 440.00 MHz • Connect the RF power meter or a 50 Ω dummy load to the antenna connector. • Transmitting 	Top panel	Loosely couple the frequency counter to the antenna connector.	440.0000 MHz	440 RF	C61
1200 MHz LOCK VOLTAGE	1	<ul style="list-style-type: none"> • Displayed frequency: 1300.00 MHz • Simplex • Transmitting and receiving 	12 RF	Connect the digital multimeter or oscilloscope to LV CP.	4.1 V DC on the higher voltage at transmitting or receiving	12 VCO	C3
1200 MHz REFERENCE FREQUENCY	1	<ul style="list-style-type: none"> • Displayed frequency: 1300.00 MHz • Connect the RF power meter or a 50 Ω dummy load to the antenna connector. • Transmitting 	Top panel	Loosely couple the frequency counter to the antenna connector.	1300.0000 MHz	12 RF	C38

• 440 RF UNIT

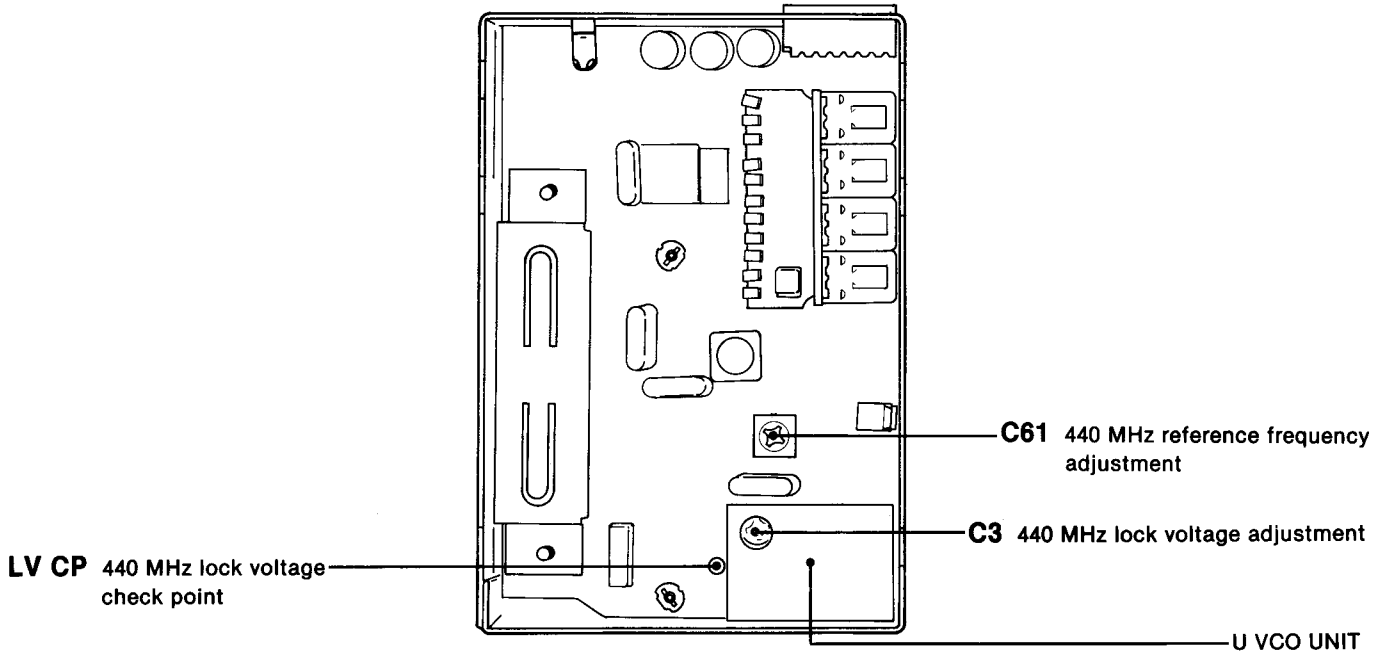

• 12 RF UNIT

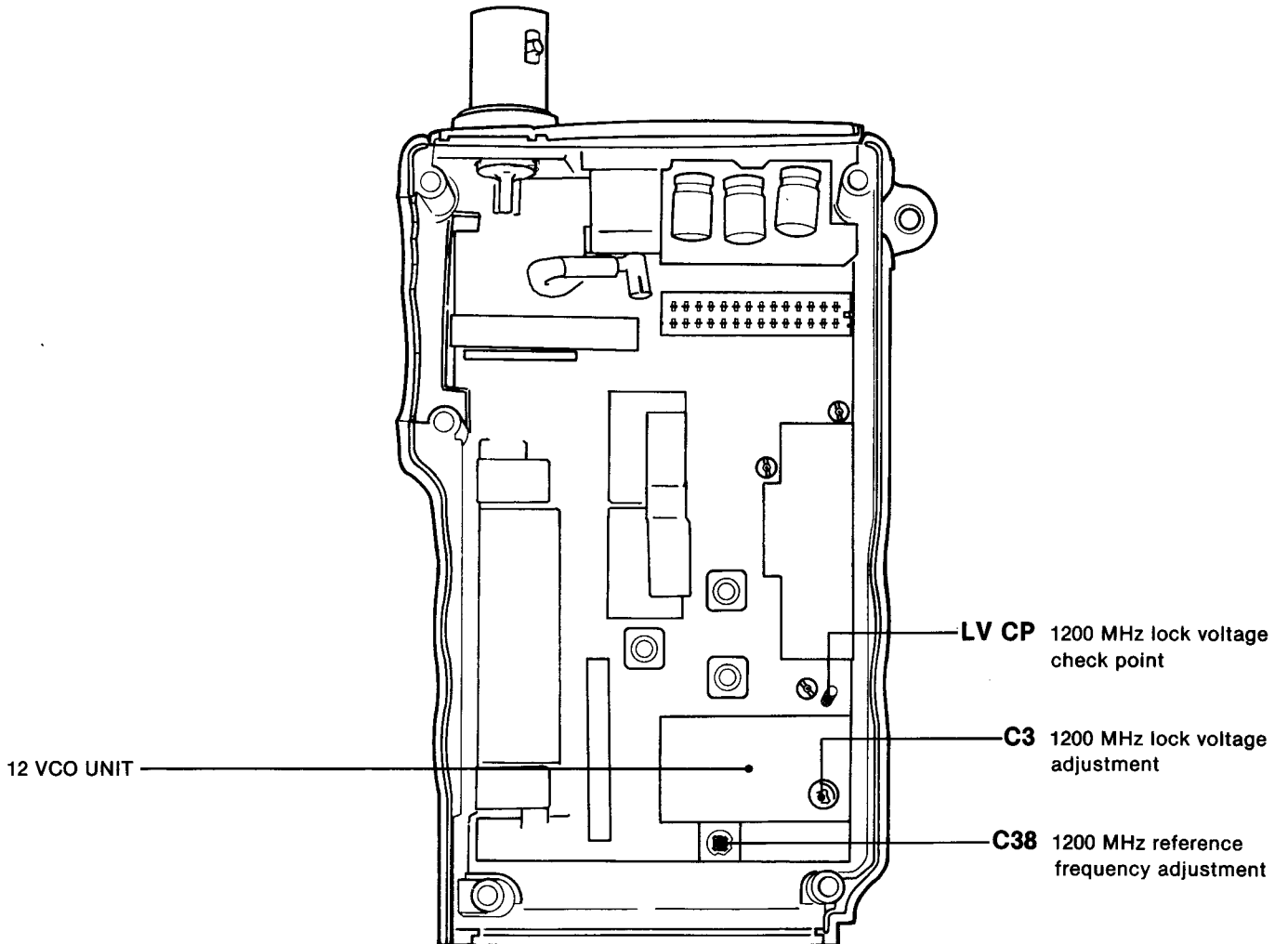

1-3 RECEIVER ADJUSTMENT

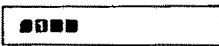
ADJUSTMENT		ADJUSTMENT CONDITIONS	MEASUREMENT		VALUE	ADJUSTMENT POINT	
			UNIT	LOCATION		UNIT	ADJUST
440 MHz SENSITIVITY	1	<ul style="list-style-type: none"> • Displayed frequency: 446.00 MHz (USA version) 436.00 MHz (All other versions) • [400 SQL] control: Max. CCW • Connect the SSG to the antenna connector and set as: Level : 0.32 μV^* (-117 dBm) Modulation: 1 kHz Deviation : ± 3.5 kHz • Receiving 	440 RF	Connect the DC voltmeter to J1 (LSD) line.	Maximum	U RF B	L1 IN, L2 OUT
	2	<ul style="list-style-type: none"> • Displayed frequency: 440.5 MHz (USA version) 430.5 MHz (All other versions) 					L1 OUT, L2 IN
							440 RF
440 MHz S-METER	1	<ul style="list-style-type: none"> • Displayed frequency: 445.00 MHz (USA version) 435.00 MHz (All other versions) • Connect the SSG to the antenna connector and set as: Level : 0.32 μV^* (-117 dBm) Modulation: 1 kHz Deviation : ± 3.5 kHz • Receiving 	Function display	S/RF indicator	4 dots (S3) 	440 RF	R4
1200 MHz SENSITIVITY	1	<ul style="list-style-type: none"> • Displayed frequency: 1280.00 MHz • [1200 SQL] control: Max. CCW • Connect the SSG to the antenna connector and set as: Level : 0.32 μV^* (-117 dBm) Modulation: 1 kHz Deviation : ± 3.5 kHz • Receiving 	12 RF	Connect the digital multimeter or oscilloscope to J6 (HSD) line.	Maximum	12 RF	Adjust in sequence L3, L4, L5
1200 MHz S-METER	1	<ul style="list-style-type: none"> • Displayed frequency: 1280.00 MHz • Connect the SSG to the antenna connector and set as: Level : 1.0 μV^* (-107 dBm) Modulation: 1 kHz Deviation : ± 3.5 kHz • Receiving 	Function display	S/RF indicator	4 dots (S3) 	12 RF	R5

* This output level of the standard signal generator (SSG) is indicated as the SSG's open circuit.

• 440 RF UNIT

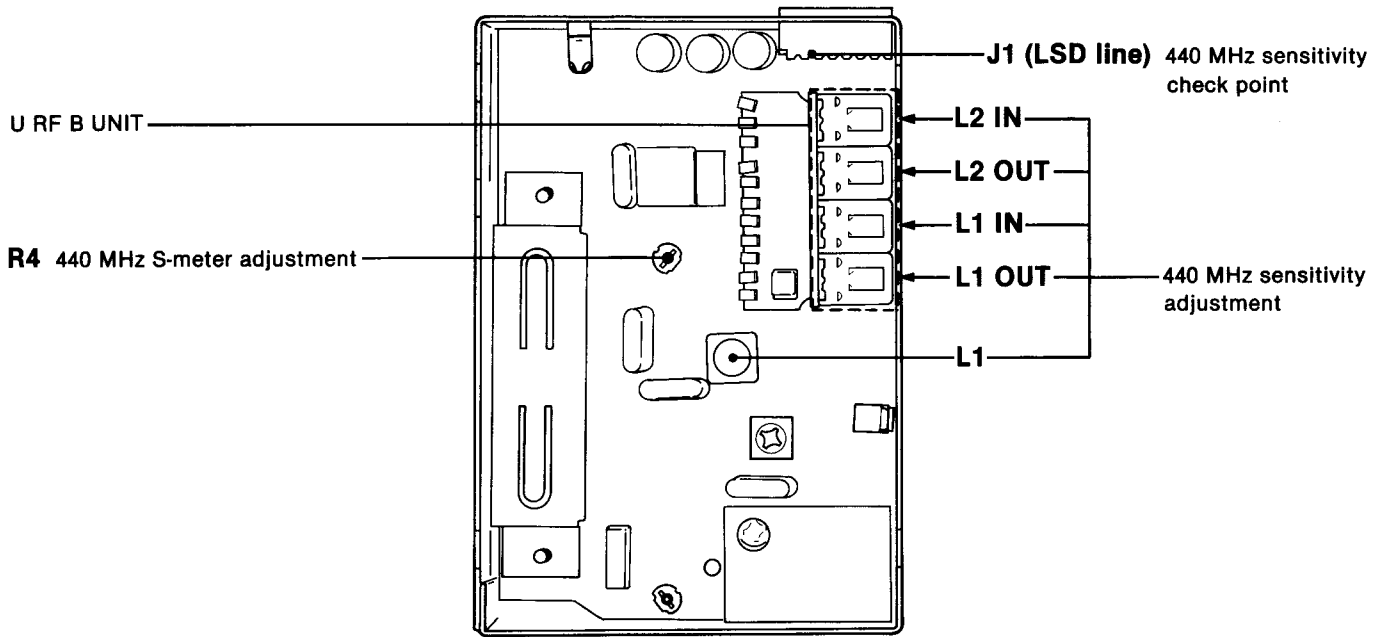

• 12 RF UNIT

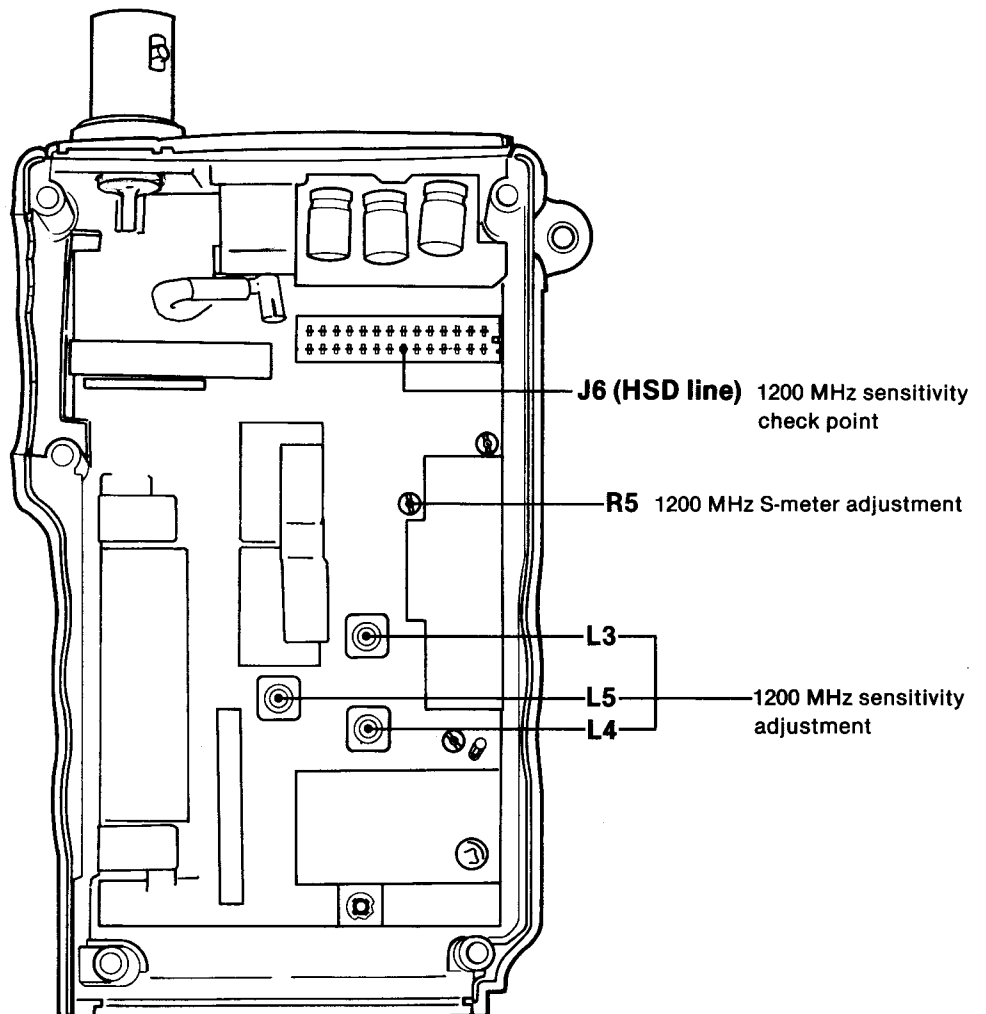

1-4 TRANSMITTER ADJUSTMENT

ADJUSTMENT	ADJUSTMENT CONDITIONS	MEASUREMENT		VALUE	ADJUSTMENT POINT			
		UNIT	LOCATION		UNIT	ADJUST		
440 MHz OUTPUT POWER	1	<ul style="list-style-type: none"> • Displayed frequency: 445.00 MHz (USA version) 435.00 MHz (All other versions) • Output power : HIGH • Simplex • Transmitting 	Top panel	Connect the RF power meter to the antenna connector.	5.0 W	440 RF	R42	
	2	<ul style="list-style-type: none"> • Output power : LOW 1 					0.15~0.75 W	Verify
	3	<ul style="list-style-type: none"> • Output power : LOW 2 					Approx. 1.5 W	Verify
	4	<ul style="list-style-type: none"> • Output power : LOW 3 					Approx. 3.5 W	Verify
440 MHz FREQUENCY DEVIATION	1	<ul style="list-style-type: none"> • Displayed frequency: 445.00 MHz (USA version) 435.00 MHz (All other versions) • Output power : HIGH • Connect the audio generator to the [MIC] jack and set as: 160 mV/1.0 kHz (USA version) 80 mV/1.0 kHz (All other versions) • Set the FM deviation meter as: HPF : 50 Hz LPF : 20 kHz De-emphasis: OFF Detector : (P-P)/2 • Transmitting 	Top panel	Connect the FM deviation meter to the antenna connector via the attenuator.	±4.8 kHz	440 RF	R73	
1200 MHz OUTPUT POWER	1	<ul style="list-style-type: none"> • Displayed frequency: 1280.00 MHz • Output power : HIGH • Simplex • Transmitting 	Top panel	Connect the RF power meter to the antenna connector.	1.0 W	12 RF	R27	
	2	<ul style="list-style-type: none"> • Output power : LOW 					50~250 mW	Verify
1200 MHz FREQUENCY DEVIATION	1	<ul style="list-style-type: none"> • Displayed frequency: 1280.00 MHz • Output power : HIGH • Connect the audio generator to the [MIC] jack and set as: 160 mV/1.0 kHz (USA version) 80 mV/1.0 kHz (All other versions) • Set the FM deviation meter as: HPF : 50 Hz LPF : 20 kHz De-emphasis: OFF Detector : (P-P)/2 • Transmitting 	Top panel	Connect the FM deviation meter to the antenna connector via the attenuator.	±4.8 kHz	12 RF	R93	

• 440 RF UNIT

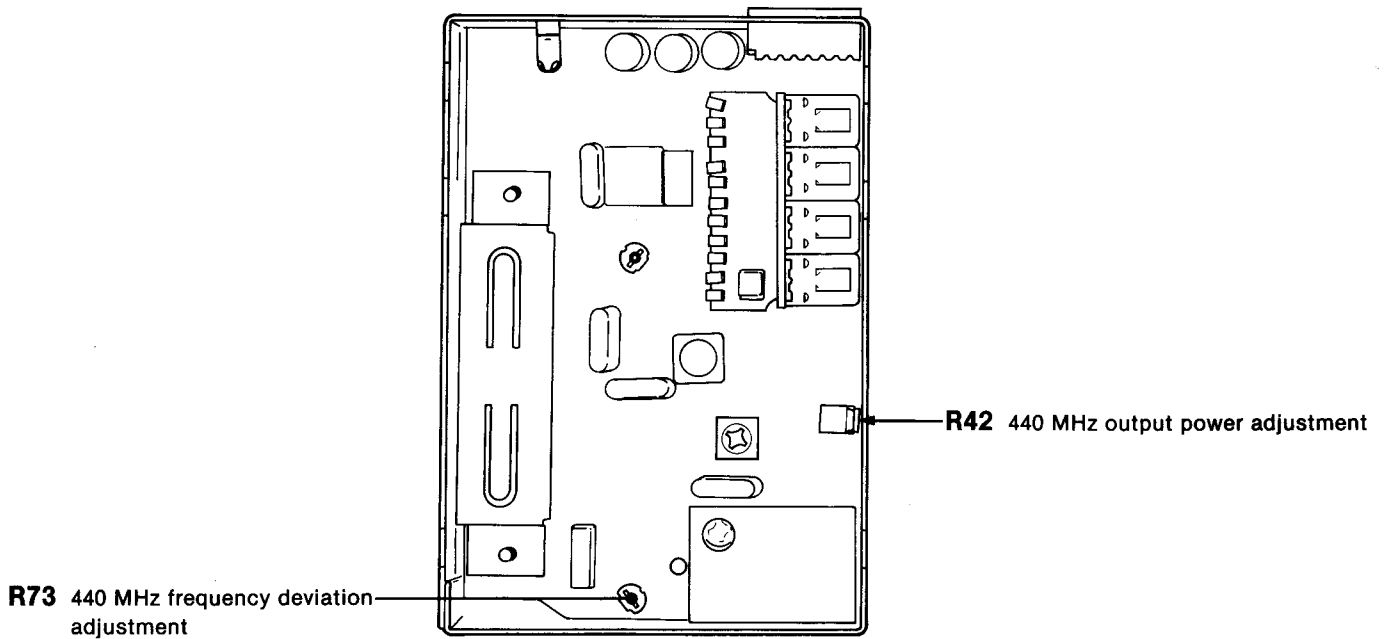

• 12 RF UNIT

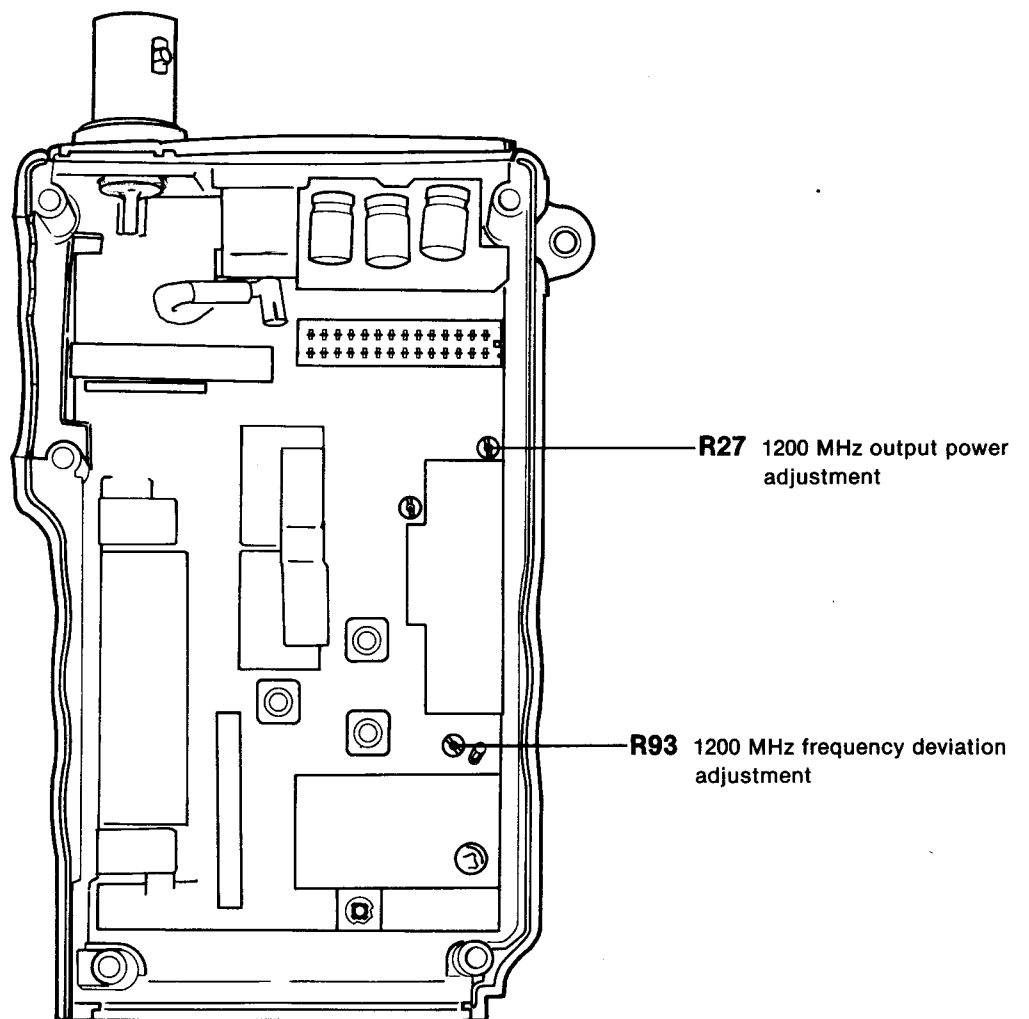

TRANSMITTER ADJUSTMENT (CONTINUED)

ADJUSTMENT	ADJUSTMENT CONDITIONS	MEASUREMENT		VALUE	ADJUSTMENT POINT	
		UNIT	LOCATION		UNIT	ADJUST
DTMF TONE FREQUENCY DEVIATION	1 <ul style="list-style-type: none"> • Displayed frequency: 445.00 MHz (USA version) 435.00 MHz (All other versions) • While pushing the [PTT] switch, push the desired digit key. 	Top panel	Connect the FM deviation meter to the antenna connector via the attenuator.	± 3.5 kHz	LOGIC	R4
TONE CALL FREQUENCY DEVIATION (IC-X2E only)	1 <ul style="list-style-type: none"> • Displayed frequency: 435.00 MHz • While pushing the [PTT] switch, push and hold [400] key. 	Top panel	Connect the FM deviation meter to the antenna connector via the attenuator.	± 3.5 kHz	LOGIC	R128

• LOGIC UNIT

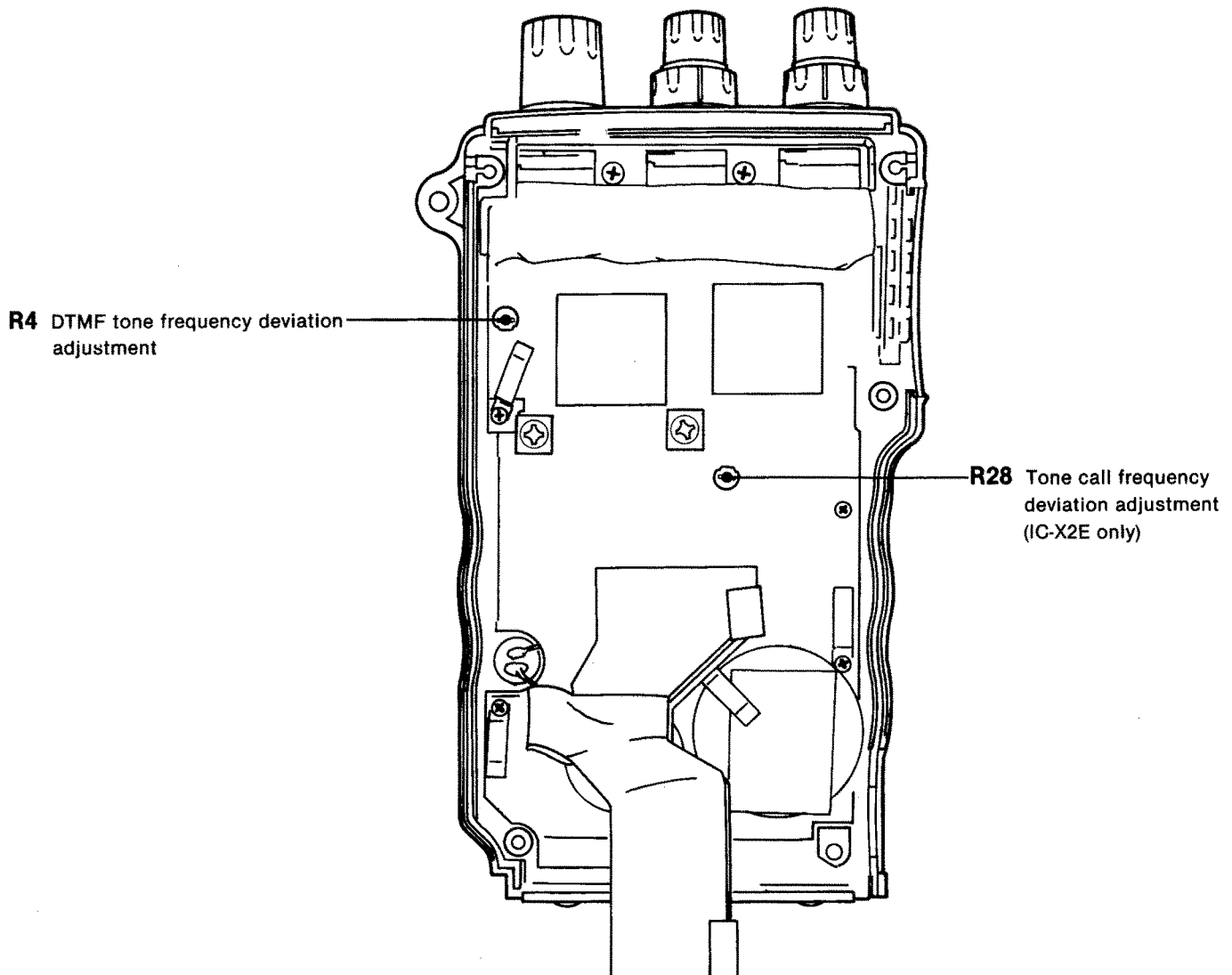

SECTION 2 PARTS LIST

[440 RF UNIT]

REF. NO.	ORDER NO.	DESCRIPTION	
IC1	1110002200	S. IC	MC3372MR
IC3	1110001971	S. IC	μPC1676G-T1
IC4	1130000830	S. IC	μPD4094BG-T1
IC6	1130005700	S. IC	M56760FP
IC7	1110001971	S. IC	μPC1676G-T1
IC8	1110002490	S. IC	M5218FP-73A
IC10	1180000050	IC	S-81250HG
IC11	1150000970	IC	SC1143
IC12	1130003760	S. IC	TC4S81F (TE85R)
IC13	1130003760	S. IC	TC4S81F (TE85R)
IC14	1130003760	S. IC	TC4S81F (TE85R)
Q1	1530002020	S. TRANSISTOR	2SC3770-3-TA
Q2	1530002560	S. TRANSISTOR	2SC4403-3-TR
Q3	1590000720	S. TRANSISTOR	DTA144EU T107
Q6	1530002640	S. TRANSISTOR	2SC3583 R34-T2B
Q7	1590000970	S. TRANSISTOR	FMA2 T148
Q8	1510000510	S. TRANSISTOR	2SA1576 T107 R
Q9	1590000430	S. TRANSISTOR	DTC144EU T107
Q10	1590000720	S. TRANSISTOR	DTA144EU T107
Q11	1590000660	S. TRANSISTOR	DTC144TU T107
Q12	1590000910	S. TRANSISTOR	IMZ2 T108
Q13	1590001160	S. TRANSISTOR	XP1401- (TX) .AB
Q14	1590000430	S. TRANSISTOR	DTC144EU T107
Q15	1530002560	S. TRANSISTOR	2SC4403-3-TR
Q16	1530002280	S. TRANSISTOR	2SC4081 T107 S
Q17	1510000620	S. TRANSISTOR	2SA1576 T107 S
Q18	1530002280	S. TRANSISTOR	2SC4081 T107 S
Q19	1510000620	S. TRANSISTOR	2SA1576 T107 S
Q20	1530002280	S. TRANSISTOR	2SC4081 T107 S
Q21	1520000200	S. TRANSISTOR	2SB798-T2 DK
Q22	1530002280	S. TRANSISTOR	2SC4081 T107 S
Q23	1520000080	TRANSISTOR	2SB909M R
Q24	1590001160	S. TRANSISTOR	XP1401- (TX) .AB
Q25	1530002280	S. TRANSISTOR	2SC4081 T107 S
Q26	1510000620	S. TRANSISTOR	2SA1576 T107 S
Q27	1530000371	S. TRANSISTOR	2SC3356 R25-T2B
Q28	1530002560	S. TRANSISTOR	2SC4403-3-TR
Q29	1590000440	S. TRANSISTOR	DTA143ZU T107
Q30	1590000430	S. TRANSISTOR	DTC144EU T107
Q31	1590001170	S. TRANSISTOR	XP1501- (TX) .AB
Q32	1590000430	S. TRANSISTOR	DTC144EU T107
Q33	1530002560	S. TRANSISTOR	2SC4403-3-TR
Q34	1530002560	S. TRANSISTOR	2SC4403-3-TR
D2	1790000450	S. DIODE	MA862 (TX)
D3	1790000450	S. DIODE	MA862 (TX)
D4	1790000620	S. DIODE	MA77 (TW)
D6	1790000450	S. DIODE	MA862 (TX)
D7	1790000450	S. DIODE	MA862 (TX)
D9	1790000450	S. DIODE	MA862 (TX)
D10	1750000130	S. DIODE	DA204U T107
D11	1790000590	S. DIODE	MA110 (TW)
D12	1750000160	S. DIODE	DA114 T107
D13	1750000160	S. DIODE	DA114 T107
D14	1790000590	S. DIODE	MA110 (TW)
D15	1160000060	S. DIODE	DAN202U T107
D16	1790000660	S. DIODE	MA728 (TW)
D17	1790000590	S. DIODE	MA110 (TW)
D18	1790000660	S. DIODE	MA728 (TW)

[440 RF UNIT]

REF. NO.	ORDER NO.	DESCRIPTION	
D19	1790000450	S. DIODE	MA862 (TX)
D20	1790000620	S. DIODE	MA77 (TW)
D21	1790000620	S. DIODE	MA77 (TW)
D22	1790000620	S. DIODE	MA77 (TW)
X1	6070000080	DISCRIMINATOR	CDBM455C16
X2	6050007220	XTAL	CR-328 UM-1/T 35.34510MHZ
X3	6050007230	XTAL	CR-329 UM-1/T 12.80000MHZ
F11	2020000550	CERAMIC	CFUM455E
F12	2010001230	FILTER	35M15B 35.8000M (FL-152)
L1	6150003210	COIL	LS-319
L5	6200000720	S. COIL	LQN 2A 10NM
L7	6200000720	S. COIL	LQN 2A 10NM
L8	6200000100	S. COIL	LQN 2A 22NM
L9	6110001990	COIL	LA-223
L10	6110001990	COIL	LA-223
L11	6110001520	COIL	LA-232
L12	6110001520	COIL	LA-232
L13	6110002110	COIL	LA-382
L14	6110001990	COIL	LA-223
L15	6110001990	COIL	LA-223
L16	6200000100	S. COIL	LQN 2A 22NM
L17	6200001640	S. COIL	ELJNC 10NK-F
L18	6200001520	S. COIL	MLF2012D R82K-T
L19	6200001060	S. COIL	MLF2012D 47NM-T
L20	6110001990	COIL	LA-223
L21	6200000090	S. COIL	LQN 2A 18NM
R1	7030003520	S. RESISTOR	ERJ3GEYJ 472 V (4.7 kΩ)
R2	7030003200	S. RESISTOR	ERJ3GEYJ 100 V (10 Ω)
R3	7030003640	S. RESISTOR	ERJ3GEYJ 473 V (47 kΩ)
R4	7310002590	S. TRIMMER	RV-109 (RH03A3AJ3X0BA) 222
R5	7030003400	S. RESISTOR	ERJ3GEYJ 471 V (470 Ω)
R6	7030003680	S. RESISTOR	ERJ3GEYJ 104 V (100 kΩ)
R7	7030003680	S. RESISTOR	ERJ3GEYJ 104 V (100 kΩ)
R8	7030003520	S. RESISTOR	ERJ3GEYJ 472 V (4.7 kΩ)
R9	7030003460	S. RESISTOR	ERJ3GEYJ 152 V (1.5 kΩ)
R10	7030003430	S. RESISTOR	ERJ3GEYJ 821 V (820 Ω)
R11	7030003670	S. RESISTOR	ERJ3GEYJ 823 V (82 kΩ)
R12	7030003400	S. RESISTOR	ERJ3GEYJ 471 V (470 Ω)
R13	7030003410	S. RESISTOR	ERJ3GEYJ 561 V (560 Ω)
R14	7030003440	S. RESISTOR	ERJ3GEYJ 102 V (1 kΩ)
R15	7030003680	S. RESISTOR	ERJ3GEYJ 104 V (100 kΩ)
R16	7030003700	S. RESISTOR	ERJ3GEYJ 154 V (150 kΩ)
R17	7030003520	S. RESISTOR	ERJ3GEYJ 472 V (4.7 kΩ)
R18	7030003660	S. RESISTOR	ERJ3GEYJ 683 V (68 kΩ)
R19	7030003200	S. RESISTOR	ERJ3GEYJ 100 V (10 Ω)
R27	7030003520	S. RESISTOR	ERJ3GEYJ 472 V (4.7 kΩ)
R28	7030003520	S. RESISTOR	ERJ3GEYJ 472 V (4.7 kΩ)
R29	7030003520	S. RESISTOR	ERJ3GEYJ 472 V (4.7 kΩ)
R30	7030003520	S. RESISTOR	ERJ3GEYJ 472 V (4.7 kΩ)
R31	7030003520	S. RESISTOR	ERJ3GEYJ 472 V (4.7 kΩ)
R32	7030003300	S. RESISTOR	ERJ3GEYJ 680 V (68 Ω)

S. = Surface mount

[440 RF UNIT]

REF. NO.	ORDER NO.	DESCRIPTION
R33	7030003440	S. RESISTOR ERJ3GEYJ 102 V (1 kΩ)
R34	7030003680	S. RESISTOR ERJ3GEYJ 104 V (100 kΩ)
R35	7030003720	S. RESISTOR ERJ3GEYJ 224 V (220 kΩ)
R37	7030003560	S. RESISTOR ERJ3GEYJ 103 V (10 kΩ)
R38	7030003700	S. RESISTOR ERJ3GEYJ 154 V (150 kΩ)
R39	7030003680	S. RESISTOR ERJ3GEYJ 104 V (100 kΩ)
R40	7030003720	S. RESISTOR ERJ3GEYJ 224 V (220 kΩ)
R41	7030003620	S. RESISTOR ERJ3GEYJ 333 V (33 kΩ)
R42	7310003520	S. TRIMMER RV-224 (RH03AVA15) 104
R44	7030003680	S. RESISTOR ERJ3GEYJ 104 V (100 kΩ)
R45	7030003400	S. RESISTOR ERJ3GEYJ 471 V (470 Ω)
R46	7030003560	S. RESISTOR ERJ3GEYJ 103 V (10 kΩ)
R47	7030003560	S. RESISTOR ERJ3GEYJ 103 V (10 kΩ)
R48	7030003480	S. RESISTOR ERJ3GEYJ 222 V (2.2 kΩ)
R49	7030003460	S. RESISTOR ERJ3GEYJ 152 V (1.5 kΩ)
R50	7030003460	S. RESISTOR ERJ3GEYJ 152 V (1.5 kΩ)
R51	7030003680	S. RESISTOR ERJ3GEYJ 104 V (100 kΩ)
R52	7030003440	S. RESISTOR ERJ3GEYJ 102 V (1 kΩ)
R53	7030003650	S. RESISTOR ERJ3GEYJ 563 V (56 kΩ)
R54	7030003320	S. RESISTOR ERJ3GEYJ 101 V (100 Ω)
R55	7030003380	S. RESISTOR ERJ3GEYJ 331 V (330 Ω)
R56	7030003290	S. RESISTOR ERJ3GEYJ 560 V (56 Ω)
R57	7030003520	S. RESISTOR ERJ3GEYJ 472 V (4.7 kΩ)
R58	7030003440	S. RESISTOR ERJ3GEYJ 102 V (1 kΩ)
R59	7030003710	S. RESISTOR ERJ3GEYJ 184 V (180 kΩ)
R60	7030003880	S. RESISTOR ERJ3GEYJ 244 V (240 kΩ)
R61	7030003370	S. RESISTOR ERJ3GEYJ 271 V (270 Ω)
R62	7030003620	S. RESISTOR ERJ3GEYJ 333 V (33 kΩ)
	7030003660	S. RESISTOR ERJ3GEYJ 683 V (68 kΩ) (USA, USA-1) (EUR-1, EUR-2, UK, AUS, SEA)
R63	7030003670	S. RESISTOR ERJ3GEYJ 823 V (82 kΩ)
R64	7030003740	S. RESISTOR ERJ3GEYJ 334 V (330 kΩ)
R65	7030003680	S. RESISTOR ERJ3GEYJ 104 V (100 kΩ)
R66	7030003760	S. RESISTOR ERJ3GEYJ 474 V (470 kΩ)
R67	7030003630	S. RESISTOR ERJ3GEYJ 393 V (39 kΩ)
R68	7030003630	S. RESISTOR ERJ3GEYJ 393 V (39 kΩ)
R69	7030003570	S. RESISTOR ERJ3GEYJ 123 V (12 kΩ)
R70	7510000180	S. THERMISTOR DTN-T203S223LS (T)
R71	7030003560	S. RESISTOR ERJ3GEYJ 103 V (10 kΩ)
R72	7030003540	S. RESISTOR ERJ3GEYJ 682 V (6.8 kΩ)
R73	7310002600	S. TRIMMER RV-110 (RH03A3AS4X0AA) 473
R74	7030003640	S. RESISTOR ERJ3GEYJ 473 V (47 kΩ)
R75	7030003660	S. RESISTOR ERJ3GEYJ 683 V (68 kΩ)
R76	7030003400	S. RESISTOR ERJ3GEYJ 471 V (470 Ω)
R77	7030003480	S. RESISTOR ERJ3GEYJ 222 V (2.2 kΩ)
R78	7030003520	S. RESISTOR ERJ3GEYJ 472 V (4.7 kΩ)
R79	7030003560	S. RESISTOR ERJ3GEYJ 103 V (10 kΩ)
R80	7030003560	S. RESISTOR ERJ3GEYJ 103 V (10 kΩ)
R81	7030003520	S. RESISTOR ERJ3GEYJ 472 V (4.7 kΩ)
R82	7030003280	S. RESISTOR ERJ3GEYJ 470 V (47 Ω)
R83	7030003240	S. RESISTOR ERJ3GEYJ 220 V (22 Ω)
R84	7030003230	S. RESISTOR ERJ3GEYJ 180 V (18 Ω)
R85	7030003210	S. RESISTOR ERJ3GEYJ 120 V (12 Ω)
R86	7030003340	S. RESISTOR ERJ3GEYJ 151 V (150 Ω)
R87	7030003680	S. RESISTOR ERJ3GEYJ 104 V (100 kΩ)
R88	7030003400	S. RESISTOR ERJ3GEYJ 471 V (470 Ω)
R89	7030003460	S. RESISTOR ERJ3GEYJ 152 V (1.5 kΩ)
R90	7030003460	S. RESISTOR ERJ3GEYJ 152 V (1.5 kΩ)
R91	7030003550	S. RESISTOR ERJ3GEYJ 822 V (8.2 kΩ)
R92	7030003400	S. RESISTOR ERJ3GEYJ 471 V (470 Ω)
R93	7030003340	S. RESISTOR ERJ3GEYJ 151 V (150 Ω)
R94	7510000200	S. THERMISTOR DTN-T203U473LS (T)
R95	7030003570	S. RESISTOR ERJ3GEYJ 123 V (12 kΩ)
R96	7030003440	S. RESISTOR ERJ3GEYJ 102 V (1 kΩ)

[440 RF UNIT]

REF. NO.	ORDER NO.	DESCRIPTION
R97	7030003670	S. RESISTOR ERJ3GEYJ 823 V (82 kΩ)
R98	7030003600	S. RESISTOR ERJ3GEYJ 223 V (22 kΩ)
R99	7030003600	S. RESISTOR ERJ3GEYJ 223 V (22 kΩ)
R100	7030003770	S. RESISTOR ERJ3GEYJ 564 V (560 kΩ)
R101	7030003520	S. RESISTOR ERJ3GEYJ 472 V (4.7 kΩ)
R102	7030000440	S. RESISTOR MCR10EZHZ 3.3 kΩ (332)
R103	7030003400	S. RESISTOR ERJ3GEYJ 471 V (470 Ω)
R104	7030003520	S. RESISTOR ERJ3GEYJ 472 V (4.7 kΩ)
R106	7510000430	S. THERMISTOR DTN-T203K202LS (T)
R107	7030003400	S. RESISTOR ERJ3GEYJ 471 V (470 Ω)
R108	7030003650	S. RESISTOR ERJ3GEYJ 563 V (56 kΩ)
R109	7030003660	S. RESISTOR ERJ3GEYJ 683 V (68 kΩ)
R110	7030003650	S. RESISTOR ERJ3GEYJ 563 V (56 kΩ)
R111	7030003410	S. RESISTOR ERJ3GEYJ 561 V (560 Ω)
R112	7030003410	S. RESISTOR ERJ3GEYJ 561 V (560 Ω)
R113	7030003520	S. RESISTOR ERJ3GEYJ 472 V (4.7 kΩ)
R114	7030003320	S. RESISTOR ERJ3GEYJ 101 V (100 Ω)
C1	4030006860	S. CERAMIC C1608 JB 1H 102K-T-A
C2	4030006830	S. CERAMIC C1608 JF 1C 104Z-T-A
C3	4030006670	S. CERAMIC C1608 SL 1H 270J-T-A
C4	4030006830	S. CERAMIC C1608 JF 1C 104Z-T-A
C6	4030006830	S. CERAMIC C1608 JF 1C 104Z-T-A
C7	4030006640	S. CERAMIC C1608 SL 1H 180J-T-A
C8	4030006710	S. CERAMIC C1608 SL 1H 470J-T-A
C9	4030006860	S. CERAMIC C1608 JB 1H 102K-T-A
C10	4030006830	S. CERAMIC C1608 JF 1C 104Z-T-A
C11	4030006830	S. CERAMIC C1608 JF 1C 104Z-T-A
C12	4030006860	S. CERAMIC C1608 JB 1H 102K-T-A
C13	4030006900	S. CERAMIC C1608 JB 1E 103K-T-A
C14	4030006830	S. CERAMIC C1608 SL 1H 150J-T-A
C15	4030006860	S. CERAMIC C1608 JB 1H 102K-T-A
C16	4030006660	S. CERAMIC C1608 SL 1H 220J-T-A
C18	4030009570	S. CERAMIC C1608 CH 1H 0R3B-T-A
C19	4030006570	S. CERAMIC C1608 SL 1H 060D-T-A
C26	4030006860	S. CERAMIC C1608 JB 1H 102K-T-A
C27	4030006860	S. CERAMIC C1608 JB 1H 102K-T-A
C29	4030006520	S. CERAMIC C1608 SL 1H 010C-T-A
C30	4030006600	S. CERAMIC C1608 SL 1H 090D-T-A
C31	4030006530	S. CERAMIC C1608 SL 1H 020C-T-A
C32	4030006560	S. CERAMIC C1608 SL 1H 050C-T-A
C33	4030006860	S. CERAMIC C1608 JB 1H 102K-T-A
C34	4030006860	S. CERAMIC C1608 JB 1H 102K-T-A
C35	4030006900	S. CERAMIC C1608 JB 1E 103K-T-A
C36	4030006860	S. CERAMIC C1608 JB 1H 102K-T-A
C37	4030006860	S. CERAMIC C1608 JB 1H 102K-T-A
C38	4030006850	S. CERAMIC C1608 JB 1H 471K-T-A
C39	4030006860	S. CERAMIC C1608 JB 1H 102K-T-A
C41	4030006560	S. CERAMIC C1608 SL 1H 050C-T-A
C42	4030006610	S. CERAMIC C1608 SL 1H 100D-T-A
C43	4030006730	S. CERAMIC C1608 SL 1H 680J-T-A
C44	4030006600	S. CERAMIC C1608 SL 1H 090D-T-A
C45	4030006550	S. CERAMIC C1608 SL 1H 040C-T-A
C46	4030006870	S. CERAMIC C1608 SL 1H R75C-T-A
C47	4030006600	S. CERAMIC C1608 SL 1H 090D-T-A
C48	4030008440	S. CERAMIC C1608 SL 1H 1R5C-T-A
C49	4030006590	S. CERAMIC C1608 SL 1H 080D-T-A
C50	4030006530	S. CERAMIC C1608 SL 1H 020C-T-A
C51	4030006510	S. CERAMIC C1608 SL 1H 0R5C-T-A
C52	4030008440	S. CERAMIC C1608 SL 1H 1R5C-T-A
C53	4030006570	S. CERAMIC C1608 SL 1H 060D-T-A
C54	4030006850	S. CERAMIC C1608 JB 1H 471K-T-A
C56	4030007120	S. CERAMIC C1608 CH 1H 820J-T-A
C57	4030006960	S. CERAMIC C2012 JB 1C 104K-T-A
C59	4030006830	S. CERAMIC C1608 JF 1C 104Z-T-A
C60	4030007030	S. CERAMIC C1608 CH 1H 150J-T-A

S.=Surface mount

[440 RF UNIT]

REF. NO.	ORDER NO.	DESCRIPTION	
C61	4610001260	S. TRIMMER	ECR-JA020 E12W
C62	4030006850	S. CERAMIC	C1608 JB 1H 471K-T-A
C63	4030008630	S. CERAMIC	C1608 JF 1C 104Z-T-A
C64	4030006860	S. CERAMIC	C1608 JB 1H 102K-T-A
C65	4030006580	S. CERAMIC	C1608 SL 1H 070D-T-A
C66	4030006860	S. CERAMIC	C1608 JB 1H 102K-T-A
C67	4030006610	S. CERAMIC	C1608 SL 1H 100D-T-A
C68	4550002950	S. TANTALUM	TESVA 0J 335M1-8L
C69	4030009000	S. CERAMIC	C2012 JB 1C 224K-T-A
C70	4550000270	S. TANTALUM	TESVA 1E 474M1-8L
C71	4030006860	S. CERAMIC	C1608 JB 1H 102K-T-A
C72	4030006860	S. CERAMIC	C1608 JB 1H 102K-T-A
C74	4030006860	S. CERAMIC	C1608 JB 1H 102K-T-A
C75	4030006900	S. CERAMIC	C1608 JB 1E 103K-T-A
C76	4030006860	S. CERAMIC	C1608 JB 1H 102K-T-A
C77	4030006880	S. CERAMIC	C1608 JB 1H 472K-T-A
C78	4550003030	S. TANTALUM	TEMSVA 0J 475M-8L
C79	4030006850	S. CERAMIC	C1608 JB 1H 471K-T-A
C80	4030008960	S. CERAMIC	C2012 JB 1C 104K-T-A
C81	4030006850	S. CERAMIC	C1608 JB 1H 471K-T-A
C82	4030006860	S. CERAMIC	C1608 JB 1H 102K-T-A
C83	4030008470	S. CERAMIC	C1608 JB 1H 272K-T-A
C84	4030006760	S. CERAMIC	C1608 SL 1H 121J-T-A
C85	4030006900	S. CERAMIC	C1608 JB 1E 103K-T-A
C86	4030006900	S. CERAMIC	C1608 JB 1E 103K-T-A
C87	4030006860	S. CERAMIC	C1608 JB 1H 102K-T-A
C88	4030006850	S. CERAMIC	C1608 JB 1H 471K-T-A
C89	4510004430	S. ELECTROL	ECEV1CV220WR
C90	4030006850	S. CERAMIC	C1608 JB 1H 471K-T-A
C91	4030006850	S. CERAMIC	C1608 JB 1H 471K-T-A
C93	4510004420	S. ELECTROL	ECEV0JV330SR
C94	4550003030	S. TANTALUM	TEMSVA 0J 475M-8L
C95	4030006850	S. CERAMIC	C1608 JB 1H 471K-T-A
C96	4030006860	S. CERAMIC	C1608 JB 1H 102K-T-A
C97	4550000550	S. TANTALUM	TESVA 1V 224M1-8L
C98	4030006860	S. CERAMIC	C1608 JB 1H 102K-T-A
C99	4550000550	S. TANTALUM	TESVA 1V 224M1-8L
C100	4030006860	S. CERAMIC	C1608 JB 1H 102K-T-A
C101	4550000550	S. TANTALUM	TESVA 1V 224M1-8L
C102	4030006860	S. CERAMIC	C1608 JB 1H 102K-T-A
C103	4550003040	S. TANTALUM	TEMSVB2 0J 106M-8L
C104	4030008630	S. CERAMIC	C1608 JF 1C 104Z-T-A
C105	4030006850	S. CERAMIC	C1608 JB 1H 471K-T-A
C106	4030006850	S. CERAMIC	C1608 JB 1H 471K-T-A
C108	4030006850	S. CERAMIC	C1608 JB 1H 471K-T-A
C109	4030006850	S. CERAMIC	C1608 JB 1H 471K-T-A
C110	4550003030	S. TANTALUM	TEMSVA 0J 475M-8L
C111	4030006850	S. CERAMIC	C1608 JB 1H 471K-T-A
C112	4030006850	S. CERAMIC	C1608 JB 1H 471K-T-A
C113	4030006860	S. CERAMIC	C1608 JB 1H 102K-T-A
C114	4030006860	S. CERAMIC	C1608 JB 1H 102K-T-A
C116	4030006860	S. CERAMIC	C1608 JB 1H 102K-T-A
C117	4510004430	S. ELECTROL	ECEV1CV220WR
C118	4030006860	S. CERAMIC	C1608 JB 1H 102K-T-A
C119	4030006550	S. CERAMIC	C1608 SL 1H 040C-T-A
C120	4030006860	S. CERAMIC	C1608 JB 1H 102K-T-A
C121	4030006860	S. CERAMIC	C1608 JB 1H 102K-T-A
C122	4030006560	S. CERAMIC	C1608 SL 1H 050C-T-A
C123	4030006860	S. CERAMIC	C1608 JB 1H 102K-T-A
C124	4030006570	S. CERAMIC	C1608 SL 1H 060D-T-A
C125	4030006860	S. CERAMIC	C1608 JB 1H 102K-T-A
C126	4030006710	S. CERAMIC	C1608 SL 1H 470J-T-A
C127	4030006860	S. CERAMIC	C1608 JB 1H 102K-T-A
C128	4030007130	S. CERAMIC	C1608 CH 1H 101J-T-A
C129	4030006520	S. CERAMIC	C1608 SL 1H 010C-T-A
C130	4030006520	S. CERAMIC	C1608 SL 1H 010C-T-A
C131	4030006900	S. CERAMIC	C1608 JB 1E 103K-T-A

[440 RF UNIT]

REF. NO.	ORDER NO.	DESCRIPTION	
C132	4030006900	S. CERAMIC	C1608 JB 1E 103K-T-A
C133	4030008440	S. CERAMIC	C1608 SL 1H 1R5C-T-A
C134	4030006610	S. CERAMIC	C1608 SL 1H 100D-T-A
C135	4030006590	S. CERAMIC	C1608 SL 1H 080D-T-A
C136	4030006560	S. CERAMIC	C1608 SL 1H 050C-T-A
C137	4030006860	S. CERAMIC	C1608 JB 1H 102K-T-A
C138	4030006860	S. CERAMIC	C1608 JB 1H 102K-T-A
C139	4030006860	S. CERAMIC	C1608 JB 1H 102K-T-A
C140	4030006860	S. CERAMIC	C1608 JB 1H 102K-T-A
C141	4030009170	S. CERAMIC	GRM40 F 105Z 16PT
C142	4030006860	S. CERAMIC	C1608 JB 1H 102K-T-A
C143	4030006860	S. CERAMIC	C1608 JB 1H 102K-T-A
C145	4030006850	S. CERAMIC	C1608 JB 1H 471K-T-A
C146	4030006860	S. CERAMIC	C1608 JB 1H 102K-T-A
C147	4030006850	S. CERAMIC	C1608 JB 1H 471K-T-A
J1	6510012710	CONNECTOR	53020-1210
J2	6510013800	CONNECTOR	MM3326-2506
W1	7030003860	S. JUMPER	ERJ3GE JPW V
W2	7030003860	S. JUMPER	ERJ3GE JPW V
W3	7030003860	S. JUMPER	ERJ3GE JPW V
W4	7030003860	S. JUMPER	ERJ3GE JPW V
W6	7030003860	S. JUMPER	ERJ3GE JPW V
W7	7030003860	S. JUMPER	ERJ3GE JPW V
W8	7030003860	S. JUMPER	ERJ3GE JPW V
W9	7030003860	S. JUMPER	ERJ3GE JPW V
EP2	0910033611	PCB	B 3391A (440 RF)

[U RF A UNIT]

REF. NO.	ORDER NO.	DESCRIPTION	
Q1	1530002640	S. TRANSISTOR	2SC3583 R34-T2B
Q2	1530002620	S. TRANSISTOR	2SC3585 R44-T2B
D1	1790000620	S. DIODE	MA77 (TW)
D2	1790000620	S. DIODE	MA77 (TW)
R1	7030003280	S. RESISTOR	ERJ3GEYJ 470 V (47 Ω)
R2	7030003400	S. RESISTOR	ERJ3GEYJ 471 V (470 Ω)
R3	7030003280	S. RESISTOR	ERJ3GEYJ 470 V (47 Ω)
R4	7030003600	S. RESISTOR	ERJ3GEYJ 223 V (22 kΩ)
R5	7030003280	S. RESISTOR	ERJ3GEYJ 470 V (47 Ω)
R6	7030003600	S. RESISTOR	ERJ3GEYJ 223 V (22 kΩ)
R7	7030003520	S. RESISTOR	ERJ3GEYJ 472 V (4.7 kΩ)
R8	7030003520	S. RESISTOR	ERJ3GEYJ 472 V (4.7 kΩ)
C1	4030006850	S. CERAMIC	C1608 JB 1H 471K-T-A
C2	4030006860	S. CERAMIC	C1608 JB 1H 102K-T-A
C3	4030006860	S. CERAMIC	C1608 JB 1H 102K-T-A

S.=Surface mount

[U RF A UNIT]

REF. NO.	ORDER NO.	DESCRIPTION	
C4	4030006630	S. CERAMIC	C1608 SL 1H 150J-T-A
C5	4030006860	S. CERAMIC	C1608 JB 1H 102K-T-A
C6	4030006860	S. CERAMIC	C1608 JB 1H 102K-T-A
C7	4030006860	S. CERAMIC	C1608 JB 1H 102K-T-A
W1	7030003860	S. JUMPER	ERJ3GE JPW V
EP1	0910036260	PCB	B 3616 (U RF A)
EP2	6510008580	LEADFRAME	PT2.0-0.7-16.5 (K)

[U VCO UNIT]

REF. NO.	ORDER NO.	DESCRIPTION	
C1	4030006860	S. CERAMIC	C1608 JB 1H 102K-T-A
C2	4030006590	S. CERAMIC	C1608 SL 1H 080D-T-A
C3	4610001270	S. TRIMMER	ECR-JA010 A12W
C4	4030006540	S. CERAMIC	C1608 SL 1H 030C-T-A
C5	4030006520	S. CERAMIC	C1608 SL 1H 010C-T-A
C6	4030006520	S. CERAMIC	C1608 SL 1H 010C-T-A
C7	4030006860	S. CERAMIC	C1608 JB 1H 102K-T-A
C8	4030006860	S. CERAMIC	C1608 JB 1H 102K-T-A
C9	4030006510	S. CERAMIC	C1608 SL 1H 0R5C-T-A
C10	4030006550	S. CERAMIC	C1608 SL 1H 040C-T-A
C11	4030006850	S. CERAMIC	C1608 JB 1H 471K-T-A
C12	4030006860	S. CERAMIC	C1608 JB 1H 102K-T-A
C14	4030006710	S. CERAMIC	C1608 SL 1H 470J-T-A
W1	6910001230	CONNECTOR	HARNESS TERMINAL
W2	6910001230	CONNECTOR	HARNESS TERMINAL
W3	6910001230	CONNECTOR	HARNESS TERMINAL
W4	6910001230	CONNECTOR	HARNESS TERMINAL
W5	6910001230	CONNECTOR	HARNESS TERMINAL
EP1	0910026991	PCB	B 2720A (U VCO)

[U RF B UNIT]

REF. NO.	ORDER NO.	DESCRIPTION	
L1	6190000320	COIL	5HW-F367PN-157A
L2	6190000320	COIL	5HW-F367PN-157A
EP1	0910020033	PCB	B 1916C (U RF B)

[12 RF UNIT]

REF. NO.	ORDER NO.	DESCRIPTION	
IC1	1110002780	S. IC	MC3371DR
IC3	1150001100	S. IC	M66321GP-30AD
IC4	1140001890	S. IC	MB1502PF-G-BND
IC5	1150001120	IC	SC1197
IC7	1180000050	IC	S-81250HG
IC8	1130003760	S. IC	TC4S81F (TE85R)
IC9	1130003760	S. IC	TC4S81F (TE85R)
IC10	1130003760	S. IC	TC4S81F (TE85R)
Q1	1560000550	S. FET	2SK882-Y (TE85R)
Q2	1530002940	S. TRANSISTOR	2SC4228-T2 R44
Q3	1530002180	S. TRANSISTOR	2SC4095-T2
Q4	1530002180	S. TRANSISTOR	2SC4095-T2
Q5	1590000720	S. TRANSISTOR	DTA144EU T107
Q6	1590000430	S. TRANSISTOR	DTC144EU T107
Q7	1590000430	S. TRANSISTOR	DTC144EU T107
Q8	1530002280	S. TRANSISTOR	2SC4081 T107 S
Q9	1510000620	S. TRANSISTOR	2SA1576 T107 S
Q10	1590000440	S. TRANSISTOR	DTA143ZU T107
Q11	1590000430	S. TRANSISTOR	DTC144EU T107
Q12	1530003000	S. TRANSISTOR	2SC4117-BL (TE85R)
Q13	1510000830	S. TRANSISTOR	2SA1587-GR (TE85R)
Q14	1530003110	S. TRANSISTOR	2SC4226-T2 (R24/R25)
Q16	1530003110	S. TRANSISTOR	2SC4226-T2 (R24/R25)
Q17	1530003110	S. TRANSISTOR	2SC4226-T2 (R24/R25)
Q18	1590000620	S. TRANSISTOR	FMS1 T148
Q19	1530002060	S. TRANSISTOR	2SC4081 T107 R
Q20	1530002060	S. TRANSISTOR	2SC4081 T107 R
Q21	1520000200	S. TRANSISTOR	2SB798-T2 DK

[U VCO UNIT]

REF. NO.	ORDER NO.	DESCRIPTION	
Q1	1530000371	S. TRANSISTOR	2SC3356 R25-T2B
Q2	1530000371	S. TRANSISTOR	2SC3356 R25-T2B
D1	1790000530	S. VARICAP	MA333 (TW)
D2	1790000620	S. DIODE	MA77 (TW)
L1	6200001520	S. COIL	MLF2012D R82K-T
L2	6110001990	COIL	LA-223
R1	7030003360	S. RESISTOR	ERJ3GEYJ 221 V (220 Ω)
R2	7030003320	S. RESISTOR	ERJ3GEYJ 101 V (100 Ω)
R3	7030003550	S. RESISTOR	ERJ3GEYJ 822 V (8.2 kΩ)
R4	7030003360	S. RESISTOR	ERJ3GEYJ 221 V (220 Ω)
R5	7030003550	S. RESISTOR	ERJ3GEYJ 822 V (8.2 kΩ)
R6	7030003650	S. RESISTOR	ERJ3GEYJ 563 V (56 kΩ)
R7	7030003460	S. RESISTOR	ERJ3GEYJ 152 V (1.5 kΩ)
R8	7030003320	S. RESISTOR	ERJ3GEYJ 101 V (100 Ω)
R9	7030003720	S. RESISTOR	ERJ3GEYJ 224 V (220 kΩ)

S.=Surface mount

[12 RF UNIT]

REF. NO.	ORDER NO.	DESCRIPTION	
Q22	1520000200	S. TRANSISTOR	2SB798-T2 DK
Q23	1530003110	S. TRANSISTOR	2SC4226-T2 (R24/R25)
Q24	1530003110	S. TRANSISTOR	2SC4226-T2 (R24/R25)
Q25	1530002280	S. TRANSISTOR	2SC4081 T107 S
Q26	1510000620	S. TRANSISTOR	2SA1576 T107 S
Q27	1530002280	S. TRANSISTOR	2SC4081 T107 S
Q28	1510000620	S. TRANSISTOR	2SA1576 T107 S
Q29	1530002280	S. TRANSISTOR	2SC4081 T107 S
Q30	1510000620	S. TRANSISTOR	2SA1576 T107 S
Q31	1530002280	S. TRANSISTOR	2SC4081 T107 S
Q32	1520000200	S. TRANSISTOR	2SB798-T2 DK
Q33	1530003000	S. TRANSISTOR	2SC4117-BL (TE85FR)
D1	1790000450	S. DIODE	MA862 (TX)
D2	1790000640	S. VARICAP	MA363B (TX)
D3	1790000620	S. DIODE	MA77 (TW)
D4	1790000620	S. DIODE	MA77 (TW)
D5	1730000540	S. ZENER	RD3.3M-T2B1
D6	1790000590	S. DIODE	MA110 (TW)
D7	1790000590	S. DIODE	MA110 (TW)
D8	1790000590	S. DIODE	MA110 (TW)
D9	1790000590	S. DIODE	MA110 (TW)
D10	1790000620	S. DIODE	MA77 (TW)
D11	1790000680	S. DIODE	SB20-03P-TD
D12	1790000620	S. DIODE	MA77 (TW)
D13	1790000620	S. DIODE	MA77 (TW)
X1	6070000100	DISCRIMINATOR	CDBM455C18
X2	6050007950	XTAL	CR-376
X3	6050007940	XTAL	CR-366
F11	2020000550	CERAMIC	CFUM455E
F12	2010001370	MONOLITHIC	72M15B2 (FL-165)
F13	2040000370	DIELECTR	EZF-MC70 BM12
F14	2040000370	DIELECTR	EZF-MC70 BM12
L2	6200001520	S. COIL	MLF2012D R82K-T
L3	6150003830	S. COIL	LS-438 (CHIP REEL)
L4	6150003830	S. COIL	LS-438 (CHIP REEL)
L5	6150003830	S. COIL	LS-438 (CHIP REEL)
L6	6200001630	S. COIL	ELJNC R10K-F
L8	6200001650	S. COIL	ELJNC 18NK-F
L9	6110001980	COIL	LA-222
L10	6110001980	COIL	LA-222
L11	6110001980	COIL	LA-222
R1	7030003400	S. RESISTOR	ERJ3GEYJ 471 V (470 Ω)
R2	7030003540	S. RESISTOR	ERJ3GEYJ 682 V (6.8 kΩ)
R4	7030003340	S. RESISTOR	ERJ3GEYJ 151 V (150 Ω)
R5	7310003720	S. TRIMMER	EVM-1XSX50 B23 (202)
R6	7030003680	S. RESISTOR	ERJ3GEYJ 104 V (100 kΩ)
R7	7030003500	S. RESISTOR	ERJ3GEYJ 332 V (3.3 kΩ)
R8	7030003460	S. RESISTOR	ERJ3GEYJ 152 V (1.5 kΩ)
R9	7030003320	S. RESISTOR	ERJ3GEYJ 101 V (100 Ω)
R10	7030003320	S. RESISTOR	ERJ3GEYJ 101 V (100 Ω)
R11	7030003560	S. RESISTOR	ERJ3GEYJ 103 V (10 kΩ)
R12	7030003560	S. RESISTOR	ERJ3GEYJ 103 V (10 kΩ)
R13	7030003330	S. RESISTOR	ERJ3GEYJ 121 V (120 Ω)
R14	7030003420	S. RESISTOR	ERJ3GEYJ 681 V (680 Ω)
R15	7030003720	S. RESISTOR	ERJ3GEYJ 224 V (220 kΩ)
R17	7030003320	S. RESISTOR	ERJ3GEYJ 101 V (100 Ω)
R18	7030003480	S. RESISTOR	ERJ3GEYJ 222 V (2.2 kΩ)

[12 RF UNIT]

REF. NO.	ORDER NO.	DESCRIPTION	
R19	7030003600	S. RESISTOR	ERJ3GEYJ 223 V (22 kΩ)
R20	7030003550	S. RESISTOR	ERJ3GEYJ 822 V (8.2 kΩ)
R23	7030003320	S. RESISTOR	ERJ3GEYJ 101 V (100 Ω)
R24	7030003600	S. RESISTOR	ERJ3GEYJ 223 V (22 kΩ)
R25	7030003550	S. RESISTOR	ERJ3GEYJ 822 V (8.2 kΩ)
R26	7030003620	S. RESISTOR	ERJ3GEYJ 333 V (33 kΩ)
R27	7310003580	S. TRIMMER	EVM-1XSX50 B15 (104)
R28	7030000340	S. RESISTOR	MCR10EZHJ 470 Ω (471)
R29	7030003720	S. RESISTOR	ERJ3GEYJ 224 V (220 kΩ)
R30	7030003680	S. RESISTOR	ERJ3GEYJ 104 V (100 kΩ)
R31	7030003680	S. RESISTOR	ERJ3GEYJ 104 V (100 kΩ)
R32	7030003720	S. RESISTOR	ERJ3GEYJ 224 V (220 kΩ)
R33	7030003750	S. RESISTOR	ERJ3GEYJ 394 V (390 kΩ)
R34	7030003790	S. RESISTOR	ERJ3GEYJ 824 V (820 kΩ)
R35	7030003680	S. RESISTOR	ERJ3GEYJ 104 V (100 kΩ)
R36	7030003680	S. RESISTOR	ERJ3GEYJ 104 V (100 kΩ)
R37	7030003680	S. RESISTOR	ERJ3GEYJ 104 V (100 kΩ)
R38	7030003680	S. RESISTOR	ERJ3GEYJ 104 V (100 kΩ)
R39	7030003560	S. RESISTOR	ERJ3GEYJ 103 V (10 kΩ)
R41	7030003480	S. RESISTOR	ERJ3GEYJ 222 V (2.2 kΩ)
R42	7030003440	S. RESISTOR	ERJ3GEYJ 102 V (1 kΩ)
R43	7030003560	S. RESISTOR	ERJ3GEYJ 103 V (10 kΩ)
R45	7030003680	S. RESISTOR	ERJ3GEYJ 104 V (100 kΩ)
R46	7030003680	S. RESISTOR	ERJ3GEYJ 104 V (100 kΩ)
R47	7030003570	S. RESISTOR	ERJ3GEYJ 123 V (12 kΩ)
R48	7030003560	S. RESISTOR	ERJ3GEYJ 103 V (10 kΩ)
R49	7030003570	S. RESISTOR	ERJ3GEYJ 123 V (12 kΩ)
R50	7030003490	S. RESISTOR	ERJ3GEYJ 272 V (2.7 kΩ)
R51	7030003560	S. RESISTOR	ERJ3GEYJ 103 V (10 kΩ)
R52	7030003320	S. RESISTOR	ERJ3GEYJ 101 V (100 Ω)
R53	7030003360	S. RESISTOR	ERJ3GEYJ 221 V (220 Ω)
R54	7030003660	S. RESISTOR	ERJ3GEYJ 683 V (68 kΩ)
R55	7030003470	S. RESISTOR	ERJ3GEYJ 182 V (1.8 kΩ)
R59	7030003440	S. RESISTOR	ERJ3GEYJ 102 V (1 kΩ)
R60	7030003500	S. RESISTOR	ERJ3GEYJ 332 V (3.3 kΩ)
R61	7030003660	S. RESISTOR	ERJ3GEYJ 683 V (68 kΩ)
R62	7030003320	S. RESISTOR	ERJ3GEYJ 101 V (100 Ω)
R63	7030003340	S. RESISTOR	ERJ3GEYJ 151 V (150 Ω)
R64	7030003600	S. RESISTOR	ERJ3GEYJ 223 V (22 kΩ)
R65	7030003490	S. RESISTOR	ERJ3GEYJ 272 V (2.7 kΩ)
R66	7030003540	S. RESISTOR	ERJ3GEYJ 682 V (6.8 kΩ)
R67	7030003440	S. RESISTOR	ERJ3GEYJ 102 V (1 kΩ)
R68	7030003280	S. RESISTOR	ERJ3GEYJ 470 V (47 Ω)
R69	7030003540	S. RESISTOR	ERJ3GEYJ 682 V (6.8 kΩ)
R70	7030003670	S. RESISTOR	ERJ3GEYJ 823 V (82 kΩ)
R71	7030003720	S. RESISTOR	ERJ3GEYJ 224 V (220 kΩ)
R72	7030003450	S. RESISTOR	ERJ3GEYJ 122 V (1.2 kΩ)
R73	7030003600	S. RESISTOR	ERJ3GEYJ 223 V (22 kΩ)
R74	7030003600	S. RESISTOR	ERJ3GEYJ 223 V (22 kΩ)
R75	7030003320	S. RESISTOR	ERJ3GEYJ 101 V (100 Ω)
R76	7030003410	S. RESISTOR	ERJ3GEYJ 561 V (560 Ω)
R93	7310003600	S. TRIMMER	EVM-1XSX50 B54 (503)
R94	7030003720	S. RESISTOR	ERJ3GEYJ 224 V (220 kΩ)
R96	7030003400	S. RESISTOR	ERJ3GEYJ 471 V (470 Ω)
R97	7030003520	S. RESISTOR	ERJ3GEYJ 472 V (4.7 kΩ)
R99	7030003560	S. RESISTOR	ERJ3GEYJ 103 V (10 kΩ)
R100	7030003560	S. RESISTOR	ERJ3GEYJ 103 V (10 kΩ)
R101	7030003520	S. RESISTOR	ERJ3GEYJ 472 V (4.7 kΩ)
R102	7030003460	S. RESISTOR	ERJ3GEYJ 152 V (1.5 kΩ)
R103	7030003400	S. RESISTOR	ERJ3GEYJ 471 V (470 Ω)
R104	7030003680	S. RESISTOR	ERJ3GEYJ 104 V (100 kΩ)
R105	7030003550	S. RESISTOR	ERJ3GEYJ 822 V (8.2 kΩ)
R107	7030003240	S. RESISTOR	ERJ3GEYJ 220 V (22 Ω)
R108	7030003360	S. RESISTOR	ERJ3GEYJ 221 V (220 Ω)
R109	7030003360	S. RESISTOR	ERJ3GEYJ 221 V (220 Ω)
R110	7030003470	S. RESISTOR	ERJ3GEYJ 182 V (1.8 kΩ)
R111	7030003680	S. RESISTOR	ERJ3GEYJ 104 V (100 kΩ)

S.=Surface mount

[12 RF UNIT]

REF. NO.	ORDER NO.	DESCRIPTION	
R113	7030003680	S. RESISTOR	ERJ3GEYJ 104 V (100 kΩ)
R115	7030003280	S. RESISTOR	ERJ3GEYJ 470 V (47 Ω)
R116	7030003620	S. RESISTOR	ERJ3GEYJ 333 V (33 kΩ)
R117	7030003680	S. RESISTOR	ERJ3GEYJ 104 V (100 kΩ)
R118	7030003560	S. RESISTOR	ERJ3GEYJ 103 V (10 kΩ)
C1	4030008960	S. CERAMIC	C2012 JB 1C 104K-T-A
C2	4030008630	S. CERAMIC	C1608 JF 1C 104Z-T-A
C3	4030008630	S. CERAMIC	C1608 JF 1C 104Z-T-A
C5	4030008630	S. CERAMIC	C1608 JF 1C 104Z-T-A
C6	4030008630	S. CERAMIC	C1608 JF 1C 104Z-T-A
C7	4030006550	S. CERAMIC	C1608 SL 1H 040C-T-A
C8	4030006660	S. CERAMIC	C1608 SL 1H 220J-T-A
C9	4030008630	S. CERAMIC	C1608 JF 1C 104Z-T-A
C10	4030006860	S. CERAMIC	C1608 JB 1H 102K-T-A
C11	4030006860	S. CERAMIC	C1608 JB 1H 102K-T-A
C12	4030006900	S. CERAMIC	C1608 JB 1E 103K-T-A
C13	4030006900	S. CERAMIC	C1608 JB 1E 103K-T-A
C14	4030006660	S. CERAMIC	C1608 SL 1H 220J-T-A
C15	4030006660	S. CERAMIC	C1608 SL 1H 220J-T-A
C16	4030006850	S. CERAMIC	C1608 JB 1H 471K-T-A
C17	4030006850	S. CERAMIC	C1608 JB 1H 471K-T-A
C18	4030006660	S. CERAMIC	C1608 SL 1H 220J-T-A
C20	4030006850	S. CERAMIC	C1608 JB 1H 471K-T-A
C21	4030009540	S. CERAMIC	C1608 CH 1H 1R5B-T-A
C22	4030009350	S. CERAMIC	C1608 CH 1H 3R5B-T-A
C23	4030006850	S. CERAMIC	C1608 JB 1H 471K-T-A
C24	4030009520	S. CERAMIC	C1608 CH 1H 020B-T-A
C25	4030006850	S. CERAMIC	C1608 JB 1H 471K-T-A
C26	4030006850	S. CERAMIC	C1608 JB 1H 471K-T-A
C27	4030006640	S. CERAMIC	C1608 SL 1H 180J-T-A
C28	4030006550	S. CERAMIC	C1608 SL 1H 040C-T-A
C29	4010000460	CERAMIC	DD104 B 471K 50V
C31	4030009540	S. CERAMIC	C1608 CH 1H 1R5B-T-A
C35	4030006860	S. CERAMIC	C1608 JB 1H 102K-T-A
C36	4030006860	S. CERAMIC	C1608 JB 1H 102K-T-A
C37	4030007030	S. CERAMIC	C1608 CH 1H 150J-T-A
C38	4610000520	S. TRIMMER	TZB04N100BA006
C41	4030007020	S. CERAMIC	C1608 CH 1H 120J-T-A
C42	4550002950	S. TANTALUM	TESVA 0J 335M1-8L
C43	4030006860	S. CERAMIC	C1608 JB 1H 102K-T-A
C44	4030008630	S. CERAMIC	C1608 JF 1C 104Z-T-A
C45	4550002950	S. TANTALUM	TESVA 0J 335M1-8L
C47	4550002950	S. TANTALUM	TESVA 0J 335M1-8L
C48	4030008630	S. CERAMIC	C1608 JF 1C 104Z-T-A
C49	4030008660	S. CERAMIC	C1608 JB 1H 102K-T-A
C50	4030006630	S. CERAMIC	C1608 SL 1H 150J-T-A
C51	4030006860	S. CERAMIC	C1608 JB 1H 102K-T-A
C52	4030006580	S. CERAMIC	C1608 SL 1H 070D-T-A
C53	4030006850	S. CERAMIC	C1608 JB 1H 471K-T-A
C54	4030006860	S. CERAMIC	C1608 JB 1H 102K-T-A
C55	4030006860	S. CERAMIC	C1608 JB 1H 102K-T-A
C56	4030006860	S. CERAMIC	C1608 JB 1H 102K-T-A
C57	4030006860	S. CERAMIC	C1608 JB 1H 102K-T-A
C58	4030006860	S. CERAMIC	C1608 JB 1H 102K-T-A
C59	4030006860	S. CERAMIC	C1608 JB 1H 102K-T-A
C60	4030006860	S. CERAMIC	C1608 JB 1H 102K-T-A
C61	4030006660	S. CERAMIC	C1608 SL 1H 220J-T-A
C62	4030006860	S. CERAMIC	C1608 JB 1H 102K-T-A
C63	4030006850	S. CERAMIC	C1608 JB 1H 471K-T-A
C64	4030006550	S. CERAMIC	C1608 SL 1H 040C-T-A
C65	4030009520	S. CERAMIC	C1608 CH 1H 020B-T-A
C71	4030006850	S. CERAMIC	C1608 JB 1H 471K-T-A
C72	4030006850	S. CERAMIC	C1608 JB 1H 471K-T-A
C73	4030006850	S. CERAMIC	C1608 JB 1H 471K-T-A
C74	4550003030	S. TANTALUM	TEMSVA 0J 475M-8L

[12 RF UNIT]

REF. NO.	ORDER NO.	DESCRIPTION	
C75	4030006850	S. CERAMIC	C1608 JB 1H 471K-T-A
C76	4030006850	S. CERAMIC	C1608 JB 1H 471K-T-A
C77	4030006850	S. CERAMIC	C1608 JB 1H 471K-T-A
C78	4030006850	S. CERAMIC	C1608 JB 1H 471K-T-A
C79	4550002890	S. TANTALUM	TESVA 1A 225M1-8L
C80	4030006620	S. CERAMIC	C1608 SL 1H 120J-T-A
C81	4030006510	S. CERAMIC	C1608 SL 1H 0R5C-T-A
C82	4030009520	S. CERAMIC	C1608 CH 1H 020B-T-A
C83	4030006850	S. CERAMIC	C1608 JB 1H 471K-T-A
C84	4030009520	S. CERAMIC	C1608 CH 1H 020B-T-A
C85	4030009500	S. CERAMIC	C1608 CH 1H 0R5B-T-A
C86	4030009500	S. CERAMIC	C1608 CH 1H 0R5B-T-A
C87	4030006850	S. CERAMIC	C1608 JB 1H 471K-T-A
C88	4030009520	S. CERAMIC	C1608 CH 1H 020B-T-A
C89	4030006850	S. CERAMIC	C1608 JB 1H 471K-T-A
C90	4550000460	S. TANTALUM	TESVA 1C 105M1-8L
C91	4030006850	S. CERAMIC	C1608 JB 1H 471K-T-A
C92	4550000460	S. TANTALUM	TESVA 1C 105M1-8L
C93	4030006850	S. CERAMIC	C1608 JB 1H 471K-T-A
C94	4030006570	S. CERAMIC	C1608 SL 1H 060D-T-A
C95	4030006630	S. CERAMIC	C1608 SL 1H 150J-T-A
C96	4030009520	S. CERAMIC	C1608 CH 1H 020B-T-A
C97	4030006640	S. CERAMIC	C1608 SL 1H 180J-T-A
C98	4030009540	S. CERAMIC	C1608 CH 1H 1R5B-T-A
C99	4030006540	S. CERAMIC	C1608 SL 1H 030C-T-A
C100	4030009500	S. CERAMIC	C1608 CH 1H 0R5B-T-A
C101	4030006560	S. CERAMIC	C1608 SL 1H 050C-T-A
C102	4030009500	S. CERAMIC	C1608 CH 1H 0R5B-T-A
C103	4030006550	S. CERAMIC	C1608 SL 1H 040C-T-A
C104	4510004430	S. ELECTROL	ECEV1CV220WR
C105	4030006850	S. CERAMIC	C1608 JB 1H 471K-T-A
C107	4030006860	S. CERAMIC	C1608 JB 1H 102K-T-A
C108	4510004420	S. ELECTROL	ECEV0JV330SR
C109	4510004420	S. ELECTROL	ECEV0JV330SR
C110	4030006850	S. CERAMIC	C1608 JB 1H 471K-T-A
C111	4030006850	S. CERAMIC	C1608 JB 1H 471K-T-A
C112	4550003030	S. TANTALUM	TEMSVA 0J 475M-8L
C114	4550002890	S. TANTALUM	TESVA 1A 225M1-8L
C115	4030006850	S. CERAMIC	C1608 JB 1H 471K-T-A
C116	4550002890	S. TANTALUM	TESVA 1A 225M1-8L
C117	4030006850	S. CERAMIC	C1608 JB 1H 471K-T-A
C118	4550003030	S. TANTALUM	TEMSVA 0J 475M-8L
C119	4030006850	S. CERAMIC	C1608 JB 1H 471K-T-A
C122	4030006850	S. CERAMIC	C1608 JB 1H 471K-T-A
C124	4030006860	S. CERAMIC	C1608 JB 1H 102K-T-A
C125	4030006860	S. CERAMIC	C1608 JB 1H 102K-T-A
C126	4030008960	S. CERAMIC	C2012 JB 1C 104K-T-A
C128	4030006850	S. CERAMIC	C1608 JB 1H 471K-T-A
C130	4030007010	S. CERAMIC	C1608 CH 1H 100D-T-A
C131	4030007130	S. CERAMIC	C1608 CH 1H 101J-T-A
C132	4030007100	S. CERAMIC	C1608 CH 1H 560J-T-A
C133	4030006670	S. CERAMIC	C1608 SL 1H 270J-T-A
C134	4030006860	S. CERAMIC	C1608 JB 1H 102K-T-A
C135	4030006850	S. CERAMIC	C1608 JB 1H 471K-T-A
C136	4030006850	S. CERAMIC	C1608 JB 1H 471K-T-A
C137	4030006850	S. CERAMIC	C1608 JB 1H 471K-T-A
J1	6450001060	CONNECTOR	HSJ1493-01-010 [SP2]
J2	6450001060	CONNECTOR	HSJ1493-01-010 [MIC/SP1]
J3	6450001080	CONNECTOR	HEC3800-01-010 [DC 12.5 V]
J4	6510013530	CONNECTOR	BNC-R000 [ANTENNA]
J5	6510013550	S. CONNECTOR	DF9A-9P-1V
J6	6510012660	CONNECTOR	52022-2810
W1	7030003860	S. JUMPER	ERJ3GE JPW V

S.=Surface mount

[12 RF UNIT]

REF. NO.	ORDER NO.	DESCRIPTION	
W2	7030003860	S. JUMPER	ERJ3GE JPW V
W4	7030003860	S. JUMPER	ERJ3GE JPW V
W5	8900003410	CABLE	OPC-358
W6	7030003860	S. JUMPER	ERJ3GE JPW V
EP1	0910031844	PCB	B 3206D (12 RF)

[ANT SW UNIT]

REF. NO.	ORDER NO.	DESCRIPTION	
D1	1790000620	S. DIODE	MA77 (TW)
D2	1790000620	S. DIODE	MA77 (TW)
D3	1790000620	S. DIODE	MA77 (TW)
D4	1790000620	S. DIODE	MA77 (TW)
L1	6200001640	S. COIL	ELJNC 10NK-F
C1	4030006860	S. CERAMIC	C1608 JB 1H 102K-T-A
C2	4030006860	S. CERAMIC	C1608 JB 1H 102K-T-A
W1	7030003860	S. JUMPER	ERJ3GE JPW V
W2	7030003860	S. JUMPER	ERJ3GE JPW V
EP1	0910031393	PCB	B 3166C (ANT SW)
EP2	6910006410	LEADFRAME	HFB2.0-0.55-8 (N)

[LPF UNIT]

REF. NO.	ORDER NO.	DESCRIPTION	
D1	1790000660	S. DIODE	MA728 (TW)
R1	7030003660	S. RESISTOR	ERJ3GEYJ 683 V (68 kΩ)
C1	4030009350	S. CERAMIC	C1608 CH 1H 3R5B-T-A
C2	4030009520	S. CERAMIC	C1608 CH 1H 020B-T-A
C3	4030008440	S. CERAMIC	C1608 SL 1H 1R5C-T-A
C4	4030006550	S. CERAMIC	C1608 SL 1H 040C-T-A
C5	4030009520	S. CERAMIC	C1608 CH 1H 020B-T-A
EP1	0910031362	PCB	B 3162B (LPF)

[12 VCO UNIT]

REF. NO.	ORDER NO.	DESCRIPTION	
Q1	1530003110	S. TRANSISTOR	2SC4226-T2 (R24/R25)
Q2	1530002940	S. TRANSISTOR	2SC4228-T2 R44
D1	1790000640	S. VARICAP	MA363B (TX)
D2	1790000620	S. DIODE	MA77 (TW)
D3	1790000640	S. VARICAP	MA363B (TX)
L1	6110001990	COIL	LA-223
L2	6200001700	S. COIL	MLF2012D R47K-T
L4	6200000090	S. COIL	LQN 2A 18NM
R1	7030003660	S. RESISTOR	ERJ3GEYJ 683 V (68 kΩ)
R2	7030003380	S. RESISTOR	ERJ3GEYJ 331 V (330 Ω)
R3	7030003720	S. RESISTOR	ERJ3GEYJ 224 V (220 kΩ)
R4	7030003580	S. RESISTOR	ERJ3GEYJ 153 V (15 kΩ)
R5	7030003580	S. RESISTOR	ERJ3GEYJ 153 V (15 kΩ)
R6	7030003640	S. RESISTOR	ERJ3GEYJ 473 V (47 kΩ)
R7	7030003550	S. RESISTOR	ERJ3GEYJ 822 V (8.2 kΩ)
R8	7030003340	S. RESISTOR	ERJ3GEYJ 151 V (150 Ω)
R9	7030003520	S. RESISTOR	ERJ3GEYJ 472 V (4.7 kΩ)
R10	7030003340	S. RESISTOR	ERJ3GEYJ 151 V (150 Ω)
R11	7030003220	S. RESISTOR	ERJ3GEYJ 150 V (15 Ω)
R12	7030003220	S. RESISTOR	ERJ3GEYJ 150 V (15 Ω)
R13	7030003220	S. RESISTOR	ERJ3GEYJ 150 V (15 Ω)
R15	7030003440	S. RESISTOR	ERJ3GEYJ 102 V (1 kΩ)
C2	4030006900	S. CERAMIC	C1608 JB 1E 103K-T-A
C3	4610000530	S. TRIMMER	TZB04Z060BA006
C4	4030006990	S. CERAMIC	C1608 CH 1H 080D-T-A
C5	4030006980	S. CERAMIC	C1608 CH 1H 070D-T-A

[BPF UNIT]

REF. NO.	ORDER NO.	DESCRIPTION	
C1	4030008570	S. CERAMIC	C1608 SL 1H R75C-T-A
C2	4030009510	S. CERAMIC	C1608 CH 1H 010B-T-A
C3	4030006540	S. CERAMIC	C1608 SL 1H 030C-T-A
C4	4030008570	S. CERAMIC	C1608 SL 1H R75C-T-A
C5	4030006540	S. CERAMIC	C1608 SL 1H 030C-T-A
C6	4030006540	S. CERAMIC	C1608 SL 1H 030C-T-A
C7	4030006660	S. CERAMIC	C1608 SL 1H 220J-T-A
C8	4030009540	S. CERAMIC	C1608 CH 1H 1R5B-T-A
C9	4030006620	S. CERAMIC	C1608 SL 1H 120J-T-A
C10	4030009560	S. CERAMIC	C1608 CH 1H R75B-T-A
EP1	0910031462	PCB	B 3177B (BPF)

S.=Surface mount

[12 VCO UNIT]

REF. NO.	ORDER NO.	DESCRIPTION	
C6	4030006850	S. CERAMIC	C1608 JB 1H 471K-T-A
C7	4030006980	S. CERAMIC	C1608 CH 1H 070D-T-A
C8	4030006850	S. CERAMIC	C1608 JB 1H 471K-T-A
C9	4030009170	S. CERAMIC	GRM40 F 105Z 16PT
C10	4030007030	S. CERAMIC	C1608 CH 1H 150J-T-A
C11	4550002950	S. TANTALUM	TESVA 0J 335M1-8L
C12	4030007030	S. CERAMIC	C1608 CH 1H 150J-T-A
C13	4030006930	S. CERAMIC	C1608 CH 1H 020C-T-A
C15	4030006960	S. CERAMIC	C1608 CH 1H 050C-T-A
C18	4030006590	S. CERAMIC	C1608 SL 1H 080D-T-A
C19	4030006910	S. CERAMIC	C1608 CH 1H 0R5C-T-A
C20	4030006850	S. CERAMIC	C1608 JB 1H 471K-T-A
C21	4030006850	S. CERAMIC	C1608 JB 1H 471K-T-A
W1	6910001230	CONNECTOR	HARNESS TERMINAL
W2	6910001230	CONNECTOR	HARNESS TERMINAL
W3	6910001230	CONNECTOR	HARNESS TERMINAL
W4	6910001230	CONNECTOR	HARNESS TERMINAL
W5	6910001230	CONNECTOR	HARNESS TERMINAL
W6	6910001230	CONNECTOR	HARNESS TERMINAL
W7	7030003860	S. JUMPER	ERJ3GE JPW V
EP1	0910031662	PCB	B 3188B (12 VCO)

[AF UNIT]

REF. NO.	ORDER NO.	DESCRIPTION	
C6	4550002960	S. TANTALUM	TESVA 1C 155M1-8L
C7	4030006850	S. CERAMIC	C1608 JB 1H 471K-T-A
C8	4550002960	S. TANTALUM	TESVA 1C 155M1-8L
C9	4030008920	S. CERAMIC	C1608 JB 1C 473K-T-A
C10	4030006850	S. CERAMIC	C1608 JB 1H 471K-T-A
C11	4030008920	S. CERAMIC	C1608 JB 1C 473K-T-A
C12	4510003180	ELECTROLYTIC	6.3 RC2 100 μF (D=5.0)
C13	4030006850	S. CERAMIC	C1608 JB 1H 471K-T-A
C14	4030006850	S. CERAMIC	C1608 JB 1H 471K-T-A
EP1	6910003420	LEADFRAME	AR1.27-0.7-12.3
EP2	0910034753	PCB	B 2870C (AF)

[MIC UNIT]

REF. NO.	ORDER NO.	DESCRIPTION	
IC1	1110002490	S. IC	M5218FP-73A
R1	7030003640	S. RESISTOR	ERJ3GEYJ 473 V (47 kΩ)
R2	7030003880	S. RESISTOR	ERJ3GEYJ 244 V (240 kΩ)
R3	7030003370	S. RESISTOR	ERJ3GEYJ 271 V (270 Ω)
R4	7030003710	S. RESISTOR	ERJ3GEYJ 184 V (180 kΩ)
R5	7030003440	S. RESISTOR	ERJ3GEYJ 102 V (1 kΩ)
R6	7030003670	S. RESISTOR	ERJ3GEYJ 823 V (82 kΩ)
R7	7030003740	S. RESISTOR	ERJ3GEYJ 334 V (330 kΩ)
R8	7030003680	S. RESISTOR	ERJ3GEYJ 104 V (100 kΩ)
R9	7030003760	S. RESISTOR	ERJ3GEYJ 474 V (470 kΩ)
R10	7030003630	S. RESISTOR	ERJ3GEYJ 393 V (39 kΩ)
R11	7030003630	S. RESISTOR	ERJ3GEYJ 393 V (39 kΩ)
R12	7030003560	S. RESISTOR	ERJ3GEYJ 103 V (10 kΩ)
R13	7030003570	S. RESISTOR	ERJ3GEYJ 123 V (12 kΩ)
R14	7510000180	S. THERMISTOR	DTN-T203S223LS (T)
R15	7030003540	S. RESISTOR	ERJ3GEYJ 682 V (6.8 kΩ)
R16	7030003620	S. RESISTOR	ERJ3GEYJ 333 V (33 kΩ) (USA, USA-1)
	7030003660	S. RESISTOR	ERJ3GEYJ 683 V (68 kΩ) (EUR-1, EUR-2, UK, AUS, SEA)
C1	4030006900	S. CERAMIC	C1608 JB 1E 103K-T-A
C2	4030006860	S. CERAMIC	C1608 JB 1H 102K-T-A
C3	4030006880	S. CERAMIC	C1608 JB 1H 472K-T-A
C4	4030006850	S. CERAMIC	C1608 JB 1H 471K-T-A
C5	4550003030	S. TANTALUM	TEMSVA 0J 475M-8L
C6	4030008960	S. CERAMIC	C2012 JB 1C 104K-T-A
C7	4030006850	S. CERAMIC	C1608 JB 1H 471K-T-A
C8	4030006860	S. CERAMIC	C1608 JB 1H 102K-T-A
C9	4030008470	S. CERAMIC	C1608 JB 1H 272K-T-A
C10	4030006900	S. CERAMIC	C1608 JB 1E 103K-T-A
C11	4030006760	S. CERAMIC	C1608 SL 1H 121J-T-A
C12	4030006900	S. CERAMIC	C1608 JB 1E 103K-T-A

[AF UNIT]

REF. NO.	ORDER NO.	DESCRIPTION	
IC1	1110002420	S. IC	NJM2073M (T1)
Q1	1590001170	S. TRANSISTOR	XP1501- (TX) .AB
Q2	1520000270	S. TRANSISTOR	2SB1182 TL Q
R1	7030003200	S. RESISTOR	ERJ3GEYJ 100 V (10 Ω)
R2	7030003200	S. RESISTOR	ERJ3GEYJ 100 V (10 Ω)
R3	7030003570	S. RESISTOR	ERJ3GEYJ 123 V (12 kΩ)
R4	7030003570	S. RESISTOR	ERJ3GEYJ 123 V (12 kΩ)
R5	7030003330	S. RESISTOR	ERJ3GEYJ 121 V (120 Ω)
R6	7030003330	S. RESISTOR	ERJ3GEYJ 121 V (120 Ω)
R7	7030003570	S. RESISTOR	ERJ3GEYJ 123 V (12 kΩ)
R8	7030003570	S. RESISTOR	ERJ3GEYJ 123 V (12 kΩ)
R9	7030003560	S. RESISTOR	ERJ3GEYJ 103 V (10 kΩ)
R10	7030003450	S. RESISTOR	ERJ3GEYJ 122 V (1.2 kΩ)
R11	7030003790	S. RESISTOR	ERJ3GEYJ 824 V (820 kΩ)
R12	7030003460	S. RESISTOR	ERJ3GEYJ 152 V (1.5 kΩ)
C1	4030008920	S. CERAMIC	C1608 JB 1C 473K-T-A
C2	4030008920	S. CERAMIC	C1608 JB 1C 473K-T-A
C3	4030008920	S. CERAMIC	C1608 JB 1C 473K-T-A
C4	4510003180	ELECTROLYTIC	6.3 RC2 100 μF (D=5.0)
C5	4510003180	ELECTROLYTIC	6.3 RC2 100 μF (D=5.0)

S. =Surface mount

[MIC UNIT]

REF. NO.	ORDER NO.	DESCRIPTION
J1	6510013560	S. CONNECTOR DF9A-9S-1V
EP1	0910031820	PCB B 3220 (MIC)

[PRT UNIT]

REF. NO.	ORDER NO.	DESCRIPTION
Q1	1520000200	S. TRANSISTOR 2SB798-T2 DK
Q2	1530002280	S. TRANSISTOR 2SC4081 T107 S
D1	1790000680	S. DIODE SB20-03P-TD
D2	1790000670	S. DIODE SB07-03C-TA
D5	1790000590	S. DIODE MA110 (TW)
D6	1730002160	S. ZENER 02CZ5.1-Z (TE85R)
R1	7030003250	S. RESISTOR ERJ3GEYJ 270 V (27 Ω)
R2	7030003380	S. RESISTOR ERJ3GEYJ 331 V (330 Ω)
R3	7030003440	S. RESISTOR ERJ3GEYJ 102 V (1 kΩ)
R4	7030003600	S. RESISTOR ERJ3GEYJ 223 V (22 kΩ)
R5	7030003470	S. RESISTOR ERJ3GEYJ 182 V (1.8 kΩ)
R6	7030003520	S. RESISTOR ERJ3GEYJ 472 V (4.7 kΩ)
R7	7030003320	S. RESISTOR ERJ3GEYJ 101 V (100 Ω)
R8	7030003440	S. RESISTOR ERJ3GEYJ 102 V (1 kΩ)
R9	7030003250	S. RESISTOR ERJ3GEYJ 270 V (27 Ω)
C1	4030006860	S. CERAMIC C1608 JB 1H 102K-T-A
C2	4030006860	S. CERAMIC C1608 JB 1H 102K-T-A
C3	4030006710	S. CERAMIC C1608 SL 1H 470J-T-A
C4	4030006860	S. CERAMIC C1608 JB 1H 102K-T-A
C5	4030006860	S. CERAMIC C1608 JB 1H 102K-T-A
C6	4030006860	S. CERAMIC C1608 JB 1H 102K-T-A
EP1	0910034770	PCB B 2874 (PRT)

[LOGIC UNIT]

REF. NO.	ORDER NO.	DESCRIPTION
IC1	1140002490	S. IC SC-4618H A23
IC2	1140002470	S. IC SC-L4808H B58
IC3	1130005640	S. IC TC4W53F (TE12L)
IC6	1110002400	S. IC NJM2107F (TE1)
IC7	1110002400	S. IC NJM2107F (TE1)

[LOGIC UNIT]

REF. NO.	ORDER NO.	DESCRIPTION
IC8	1110002410	S. IC NJM2406F (TE1)
IC9	1110002410	S. IC NJM2406F (TE1)
IC10	1130003710	S. IC TC4S71F (TE85R)
IC11	1180000680	S. IC S-87050EF-VR-T1
IC12	1130003760	S. IC TC4S81F (TE85R)
IC13	1130004330	S. IC LC7385M
IC14	1130005640	S. IC TC4W53F (TE12L)
IC15	1130003610	S. IC TC4SU69F (TE85R)
IC16	1130003610	S. IC TC4SU69F (TE85R)
IC17	1130003610	S. IC TC4SU69F (TE85R)
IC18	1130004200	S. IC TC4S66F (TE85R)
IC19	1130004170	S. IC TC4S01F (TE85R)
IC20	1110002400	S. IC NJM2107F (TE1)
Q1	1540000350	S. TRANSISTOR 2SD2216-S (TX)
Q2	1540000350	S. TRANSISTOR 2SD2216-S (TX)
Q3	1510000510	S. TRANSISTOR 2SA1576 T107 R
Q4	1590001130	S. TRANSISTOR UN9110 (TX)
Q5	1590001150	S. TRANSISTOR UN9211 (TX)
Q10	1540000350	S. TRANSISTOR 2SD2216-S (TX)
Q11	1540000350	S. TRANSISTOR 2SD2216-S (TX)
Q12	1540000350	S. TRANSISTOR 2SD2216-S (TX)
Q13	1590001170	S. TRANSISTOR XP1501- (TX) .AB
Q18	1590001180	S. TRANSISTOR XP1210 (TX)
Q19	1590001180	S. TRANSISTOR XP1210 (TX)
Q20	1590001180	S. TRANSISTOR XP1210 (TX)
Q21	1590001180	S. TRANSISTOR XP1210 (TX)
Q23	1590001140	S. TRANSISTOR UN9210 (TX)
Q24	1590001140	S. TRANSISTOR UN9210 (TX)
Q25	1590001130	S. TRANSISTOR UN9110 (TX)
Q26	1520000430	S. TRANSISTOR 2SB1462-R (TX)
Q27	1540000350	S. TRANSISTOR 2SD2216-S (TX)
Q28	1510000510	S. TRANSISTOR 2SA1576 T107 R
Q29	1540000350	S. TRANSISTOR 2SD2216-S (TX)
Q30	1540000350	S. TRANSISTOR 2SD2216-S (TX)
Q31	1590001140	S. TRANSISTOR UN9210 (TX)
Q32	1590001130	S. TRANSISTOR UN9110 (TX)
Q33	1590001140	S. TRANSISTOR UN9210 (TX)
D3	1790000860	S. DIODE MA133 (TX)
D4	1790000590	S. DIODE MA110 (TW)
D5	1790000820	S. DIODE MA132K (TX)
D6	1790000840	S. DIODE MA132WA (TX)
D7	1790000870	S. DIODE MA1S121 (TX)
D8	1790000840	S. DIODE MA132WA (TX)
D9	1790000840	S. DIODE MA132WA (TX)
D10	1790000840	S. DIODE MA132WA (TX)
D11	1790000840	S. DIODE MA132WA (TX)
D12	1790000840	S. DIODE MA132WA (TX)
D13	1790000840	S. DIODE MA132WA (TX)
D14	1790000840	S. DIODE MA132WA (TX)
D15	1790000820	S. DIODE MA132K (TX)
	1790000830	S. DIODE (EUR-1, UK, AUS) MA132HK (TX)
	1790000850	S. DIODE (USA, USA-1) MA132WK (TX) (SEA)
D16	1790000830	S. DIODE (EUR-2, USA, USA-1, AUS, SEA) MA132HK (TX)
D18	1790000830	S. DIODE MA132HK (TX)
D19	1790000860	S. DIODE MA133 (TX)
D22	1790000810	S. DIODE MA132A (TX)
D25	1750000190	S. DIODE 1SS322 (TE85R)
D26	1790000810	S. DIODE MA132A (TX)
D27	1790000850	S. DIODE MA132WK (TX)

S. = Surface mount

[LOGIC UNIT]

[LOGIC UNIT]

REF. NO.	ORDER NO.	DESCRIPTION	
D28	1790000490	S. DIODE	HSM88AS-TR
D29	1790000490	S. DIODE	HSM88AS-TR
D30	1790000850	S. DIODE	MA132WK (TX)
D31	1790000860	S. DIODE	MA133 (TX)
D32	1790000850	S. DIODE	MA132WK (TX)
D33	1790000860	S. DIODE	MA133 (TX)
D34	1790000860	S. DIODE	MA133 (TX)
D35	1790000860	S. DIODE	MA133 (TX)
D36	1790000660	S. DIODE	MA728 (TW)
D37	1790000860	S. DIODE	MA133 (TX)
D38	1790000860	S. DIODE	MA133 (TX)
X1	6060000391	CERAMIC	CSB800J201T
X2	6060000391	CERAMIC	CSB800J201T
X3	6050005800	XTAL	DT-26S 32.768KHZ
X4	6060000150	S. CERAMIC	CSAC3.58MGC300CD
R1	7410000610	S. ARRAY	EXB-V4V 153JV
R3	7030003800	S. RESISTOR	ERJ3GEYJ 105 V (1 MΩ)
R4	7310002600	S. TRIMMER	RV-110 (RH03A3AS4X0AA) 473
R8	7030003560	S. RESISTOR	ERJ3GEYJ 103 V (10 kΩ)
R9	7030003580	S. RESISTOR	ERJ3GEYJ 153 V (15 kΩ)
R11	7030003800	S. RESISTOR	ERJ3GEYJ 105 V (1 MΩ)
R12	7030003550	S. RESISTOR	ERJ3GEYJ 822 V (8.2 kΩ)
R13	7410000610	S. ARRAY	EXB-V4V 153JV
R15	7030003480	S. RESISTOR	ERJ3GEYJ 222 V (2.2 kΩ)
R16	7030003720	S. RESISTOR	ERJ3GEYJ 224 V (220 kΩ)
R17	7030003760	S. RESISTOR	ERJ3GEYJ 474 V (470 kΩ)
R18	7030003620	S. RESISTOR	ERJ3GEYJ 333 V (33 kΩ)
R19	7030003440	S. RESISTOR	ERJ3GEYJ 102 V (1 kΩ)
R20	7030003450	S. RESISTOR	ERJ3GEYJ 122 V (1.2 kΩ)
R21	7030003560	S. RESISTOR	ERJ3GEYJ 103 V (10 kΩ)
R22	7030003440	S. RESISTOR	ERJ3GEYJ 102 V (1 kΩ)
R23	7030003800	S. RESISTOR	ERJ3GEYJ 105 V (1 MΩ)
	7030003840	S. RESISTOR	(USA, USA-1) ERJ3GEYJ 225 V (2.2 MΩ) (EUR-1, EUR-2, UK, AUS, SEA)
R24	7030003400	S. RESISTOR	ERJ3GEYJ 471 V (470 Ω)
R25	7030003720	S. RESISTOR	ERJ3GEYJ 224 V (220 kΩ)
R26	7030003720	S. RESISTOR	ERJ3GEYJ 224 V (220 kΩ)
R27	7030003440	S. RESISTOR	ERJ3GEYJ 102 V (1 kΩ)
R28	7030003720	S. RESISTOR	ERJ3GEYJ 224 V (220 kΩ)
R29	7030003800	S. RESISTOR	ERJ3GEYJ 105 V (1 MΩ)
R30	7030003720	S. RESISTOR	ERJ3GEYJ 224 V (220 kΩ)
R31	7030003580	S. RESISTOR	ERJ3GEYJ 153 V (15 kΩ)
R32	7030003680	S. RESISTOR	ERJ3GEYJ 104 V (100 kΩ)
R33	7030003620	S. RESISTOR	ERJ3GEYJ 333 V (33 kΩ)
R34	7030003600	S. RESISTOR	ERJ3GEYJ 223 V (22 kΩ)
R35	7030003610	S. RESISTOR	ERJ3GEYJ 273 V (27 kΩ)
R36	7030003580	S. RESISTOR	ERJ3GEYJ 153 V (15 kΩ)
R41	7030003200	S. RESISTOR	ERJ3GEYJ 100 V (10 Ω)
R42	7030003360	S. RESISTOR	ERJ3GEYJ 221 V (220 Ω)
R43	7030003360	S. RESISTOR	ERJ3GEYJ 221 V (220 Ω)
R44	7030003520	S. RESISTOR	ERJ3GEYJ 472 V (4.7 kΩ)
R45	7030003550	S. RESISTOR	ERJ3GEYJ 822 V (8.2 kΩ)
R46	7030003330	S. RESISTOR	ERJ3GEYJ 121 V (120 Ω)
R47	7030003600	S. RESISTOR	ERJ3GEYJ 223 V (22 kΩ)
R48	7030003600	S. RESISTOR	ERJ3GEYJ 223 V (22 kΩ)
R63	7030003760	S. RESISTOR	ERJ3GEYJ 474 V (470 kΩ)
R64	7030003880	S. RESISTOR	ERJ3GEYJ 244 V (240 kΩ)
R65	7030003690	S. RESISTOR	ERJ3GEYJ 124 V (120 kΩ)
R66	7030003720	S. RESISTOR	ERJ3GEYJ 224 V (220 kΩ)
R67	7030003800	S. RESISTOR	ERJ3GEYJ 105 V (1 MΩ)

REF. NO.	ORDER NO.	DESCRIPTION	
R68	7030003800	S. RESISTOR	ERJ3GEYJ 105 V (1 MΩ)
R69	7410000560	S. ARRAY	EXB-V4V 474JV
R73	7030003800	S. RESISTOR	ERJ3GEYJ 105 V (1 MΩ)
R74	7410000590	S. ARRAY	EXB-V4V 473JV
R76	7410000590	S. ARRAY	EXB-V4V 473JV
R78	7410000590	S. ARRAY	EXB-V4V 473JV
R80	7030003620	S. RESISTOR	ERJ3GEYJ 333 V (33 kΩ)
R81	7410000560	S. ARRAY	EXB-V4V 474JV
R83	7030003880	S. RESISTOR	ERJ3GEYJ 244 V (240 kΩ)
R84	7030003730	S. RESISTOR	ERJ3GEYJ 274 V (270 kΩ)
R85	7030003880	S. RESISTOR	ERJ3GEYJ 244 V (240 kΩ)
R86	7030003520	S. RESISTOR	ERJ3GEYJ 472 V (4.7 kΩ)
R87	7030003880	S. RESISTOR	ERJ3GEYJ 244 V (240 kΩ)
R88	7030003730	S. RESISTOR	ERJ3GEYJ 274 V (270 kΩ)
R89	7030003880	S. RESISTOR	ERJ3GEYJ 244 V (240 kΩ)
R90	7030003520	S. RESISTOR	ERJ3GEYJ 472 V (4.7 kΩ)
R91	7410000560	S. ARRAY	EXB-V4V 474JV
R92	7410000580	S. ARRAY	EXB-V4V 224JV
R93	7410000560	S. ARRAY	EXB-V4V 474JV (IC-X2E)
R95	7410000600	S. ARRAY	EXB-V4V 222JV
R97	7030003560	S. RESISTOR	ERJ3GEYJ 103 V (10 kΩ)
R98	7030003560	S. RESISTOR	ERJ3GEYJ 103 V (10 kΩ)
R99	7030003800	S. RESISTOR	ERJ3GEYJ 105 V (1 MΩ)
R100	7030003720	S. RESISTOR	ERJ3GEYJ 224 V (220 kΩ)
R101	7030003620	S. RESISTOR	ERJ3GEYJ 333 V (33 kΩ)
R102	7030003760	S. RESISTOR	ERJ3GEYJ 474 V (470 kΩ)
R103	7030003680	S. RESISTOR	ERJ3GEYJ 104 V (100 kΩ)
R104	7030004020	S. RESISTOR	ERJ3GEYG 243 V (24 kΩ)
R105	7030003360	S. RESISTOR	ERJ3GEYJ 221 V (220 Ω)
R106	7030003360	S. RESISTOR	ERJ3GEYJ 221 V (220 Ω)
R107	7030003800	S. RESISTOR	ERJ3GEYJ 105 V (1 MΩ)
R108	7030003800	S. RESISTOR	ERJ3GEYJ 105 V (1 MΩ)
R109	7030003800	S. RESISTOR	ERJ3GEYJ 105 V (1 MΩ)
R110	7030003560	S. RESISTOR	ERJ3GEYJ 103 V (10 kΩ)
R111	7030003560	S. RESISTOR	ERJ3GEYJ 103 V (10 kΩ)
R112	7030003560	S. RESISTOR	ERJ3GEYJ 103 V (10 kΩ)
R113	7030003680	S. RESISTOR	ERJ3GEYJ 104 V (100 kΩ)
R114	7030003680	S. RESISTOR	ERJ3GEYJ 104 V (100 kΩ)
R115	7030003740	S. RESISTOR	ERJ3GEYJ 334 V (330 kΩ)
R116	7030003700	S. RESISTOR	ERJ3GEYJ 154 V (150 kΩ)
R117	7030003720	S. RESISTOR	ERJ3GEYJ 224 V (220 kΩ)
R118	7030003640	S. RESISTOR	ERJ3GEYJ 473 V (47 kΩ)
R121	7410000570	S. ARRAY	EXB-V8V 474JV
R122	7410000570	S. ARRAY	EXB-V8V 474JV
R123	7410000570	S. ARRAY	EXB-V8V 474JV
R124	7410000570	S. ARRAY	EXB-V8V 474JV
R127	7030003800	S. RESISTOR	ERJ3GEYJ 105 V (1 MΩ)
R128	7310002600	S. TRIMMER	RV-110 (RH03A3AS4X0AA) 473 (IC-X2E)
R130	7030003840	S. RESISTOR	ERJ3GEYJ 225 V (2.2 MΩ) (IC-X2E)
R131	7030003600	S. RESISTOR	ERJ3GEYJ 223 V (22 kΩ)
R132	7030003800	S. RESISTOR	ERJ3GEYJ 105 V (1 MΩ)
R134	7030003690	S. RESISTOR	ERJ3GEYJ 124 V (120 kΩ)
R135	7030003680	S. RESISTOR	ERJ3GEYJ 104 V (100 kΩ)
R136	7030003680	S. RESISTOR	ERJ3GEYJ 104 V (100 kΩ)
R137	7030003800	S. RESISTOR	ERJ3GEYJ 105 V (1 MΩ)
R138	7030003600	S. RESISTOR	ERJ3GEYJ 223 V (22 kΩ)
R139	7030003800	S. RESISTOR	ERJ3GEYJ 105 V (1 MΩ)
R140	7030003690	S. RESISTOR	ERJ3GEYJ 124 V (120 kΩ)
R141	7030003680	S. RESISTOR	ERJ3GEYJ 104 V (100 kΩ)
R142	7030003680	S. RESISTOR	ERJ3GEYJ 104 V (100 kΩ)
R143	7030003800	S. RESISTOR	ERJ3GEYJ 105 V (1 MΩ)
R144	7030003800	S. RESISTOR	ERJ3GEYJ 105 V (1 MΩ)
R145	7410000560	S. ARRAY	EXB-V4V 474JV
R146	7030003520	S. RESISTOR	ERJ3GEYJ 472 V (4.7 kΩ)
R147	7030003640	S. RESISTOR	ERJ3GEYJ 473 V (47 kΩ)

S.=Surface mount

[LOGIC UNIT]

REF. NO.	ORDER NO.	DESCRIPTION	
R148	7030003600	S. RESISTOR	ERJ3GEYJ 223 V (22 kΩ)
R149	7030003620	S. RESISTOR	ERJ3GEYJ 333 V (33 kΩ)
R150	7030003760	S. RESISTOR	ERJ3GEYJ 474 V (470 kΩ)
R151	7030003620	S. RESISTOR	ERJ3GEYJ 333 V (33 kΩ)
R152	7030003690	S. RESISTOR	ERJ3GEYJ 124 V (120 kΩ)
R153	7030003880	S. RESISTOR	ERJ3GEYJ 244 V (240 kΩ)
R154	7030003760	S. RESISTOR	ERJ3GEYJ 474 V (470 kΩ)
R155	7030003200	S. RESISTOR	ERJ3GEYJ 100 V (10 Ω)
R156	7030003650	S. RESISTOR	ERJ3GEYJ 563 V (56 kΩ)
R157	7030003650	S. RESISTOR	ERJ3GEYJ 563 V (56 kΩ)
R158	7030003520	S. RESISTOR	ERJ3GEYJ 472 V (4.7 kΩ)
R159	7030003520	S. RESISTOR	ERJ3GEYJ 472 V (4.7 kΩ)
R160	7030003800	S. RESISTOR	ERJ3GEYJ 105 V (1 MΩ)
R161	7030003800	S. RESISTOR	ERJ3GEYJ 105 V (1 MΩ)
R163	7030003760	S. RESISTOR	ERJ3GEYJ 474 V (470 kΩ)
R164	7030003800	S. RESISTOR	ERJ3GEYJ 105 V (1 MΩ)
R165	7030003520	S. RESISTOR	ERJ3GEYJ 472 V (4.7 kΩ)
R167	7030003560	S. RESISTOR	ERJ3GEYJ 103 V (10 kΩ)
R168	7030003800	S. RESISTOR	ERJ3GEYJ 105 V (1 MΩ)
R170	7030003680	S. RESISTOR	ERJ3GEYJ 104 V (100 kΩ)
R171	7030003800	S. RESISTOR	ERJ3GEYJ 105 V (1 MΩ)
R172	7030003560	S. RESISTOR	ERJ3GEYJ 103 V (10 kΩ)
C2	4030006860	S. CERAMIC	C1608 JB 1H 102K-T-A
C3	4030006740	S. CERAMIC	C1608 SL 1H 820J-T-A
C4	4030006800	S. CERAMIC	C1608 SL 1H 221J-T-A
C6	4030008960	S. CERAMIC	C2012 JB 1C 104K-T-A
C7	4030006740	S. CERAMIC	C1608 SL 1H 820J-T-A
C8	4030006800	S. CERAMIC	C1608 SL 1H 221J-T-A
C9	4030007030	S. CERAMIC	C1608 CH 1H 150J-T-A
C10	4030007030	S. CERAMIC	C1608 CH 1H 150J-T-A
C11	4030008920	S. CERAMIC	C1608 JB 1C 473K-T-A
C12	4550003040	S. TANTALUM	TEMSVB2 0J 106M-8L
C13	4030006860	S. CERAMIC	C1608 JB 1H 102K-T-A
C14	4030006860	S. CERAMIC	C1608 JB 1H 102K-T-A
C15	4030006860	S. CERAMIC	C1608 JB 1H 102K-T-A
C16	4030008920	S. CERAMIC	C1608 JB 1C 473K-T-A
C17	4030008920	S. CERAMIC	C1608 JB 1C 473K-T-A
C18	4030008920	S. CERAMIC	C1608 JB 1C 473K-T-A
C19	4030008880	S. CERAMIC	C1608 JB 1C 223K-T-A
C20	4030008880	S. CERAMIC	C1608 JB 1C 223K-T-A
C21	4550003030	S. TANTALUM	TEMSVA 0J 475M-8L
C22	4030006860	S. CERAMIC	C1608 JB 1H 102K-T-A
C23	4030008920	S. CERAMIC	C1608 JB 1C 473K-T-A
C28	4030006860	S. CERAMIC	C1608 JB 1H 102K-T-A
C30	4030006860	S. CERAMIC	C1608 JB 1H 102K-T-A
C31	4030006690	S. CERAMIC	C1608 SL 1H 330J-T-A
C32	4030006860	S. CERAMIC	C1608 JB 1H 102K-T-A
C33	4030009220	S. CERAMIC	GRM39 B 681K 50PT
C34	4030006860	S. CERAMIC	C1608 JB 1H 102K-T-A
C35	4030006690	S. CERAMIC	C1608 SL 1H 330J-T-A
C36	4030006860	S. CERAMIC	C1608 JB 1H 102K-T-A
C37	4030006850	S. CERAMIC	C1608 JB 1H 471K-T-A
C38	4030006900	S. CERAMIC	C1608 JB 1E 103K-T-A
C39	4030006900	S. CERAMIC	C1608 JB 1E 103K-T-A
C40	4030008900	S. CERAMIC	C1608 JB 1C 333K-T-A
C41	4030008900	S. CERAMIC	C1608 JB 1C 333K-T-A
C42	4030006800	S. CERAMIC	C1608 SL 1H 221J-T-A
C43	4550003060	S. TANTALUM	TEMSVC 0J 336M-12L
C44	4030008960	S. CERAMIC	C2012 JB 1C 104K-T-A
C45	4030008960	S. CERAMIC	C2012 JB 1C 104K-T-A
C46	4550004000	S. TANTALUM	TEMSVD 0J 686M-12L
C47	4030006860	S. CERAMIC	C1608 JB 1H 102K-T-A
C48	4030006860	S. CERAMIC	C1608 JB 1H 102K-T-A
C49	4550004020	S. TANTALUM	TEMSVD 1C 336M-12L
C50	4550003040	S. TANTALUM	TEMSVB2 0J 106M-8L

[LOGIC UNIT]

REF. NO.	ORDER NO.	DESCRIPTION	
C51	4030006860	S. CERAMIC	C1608 JB 1H 102K-T-A
C52	4550000790	S. TANTALUM	TESVD 0J 476M-12L
C53	4030006690	S. CERAMIC	C1608 SL 1H 330J-T-A
C54	4030006700	S. CERAMIC	C1608 SL 1H 390J-T-A
C55	4030008630	S. CERAMIC	C1608 JF 1C 104Z-T-A
C56	4030008630	S. CERAMIC	C1608 JF 1C 104Z-T-A
C57	4030006860	S. CERAMIC	C1608 JB 1H 102K-T-A
C58	4030006850	S. CERAMIC	C1608 JB 1H 471K-T-A
C60	4030006850	S. CERAMIC	C1608 JB 1H 471K-T-A
C62	4030006850	S. CERAMIC	C1608 JB 1H 471K-T-A
C63	4030006850	S. CERAMIC	C1608 JB 1H 471K-T-A
C64	4030008960	S. CERAMIC	C2012 JB 1C 104K-T-A
C65	4030008960	S. CERAMIC	C2012 JB 1C 104K-T-A
C68	4030008880	S. CERAMIC	C1608 JB 1C 223K-T-A
C69	4030008880	S. CERAMIC	C1608 JB 1C 223K-T-A
C70	4030008960	S. CERAMIC	C2012 JB 1C 104K-T-A
C71	4030008960	S. CERAMIC	C2012 JB 1C 104K-T-A
C72	4030006860	S. CERAMIC	C1608 JB 1H 102K-T-A
C73	4030008630	S. CERAMIC	C1608 JF 1C 104Z-T-A
C74	4030008960	S. CERAMIC	C2012 JB 1C 104K-T-A
C75	4030008960	S. CERAMIC	C2012 JB 1C 104K-T-A
C76	4030008630	S. CERAMIC	C1608 JF 1C 104Z-T-A
C77	4030008630	S. CERAMIC	C1608 JF 1C 104Z-T-A
C79	4550003030	S. TANTALUM	TEMSVA 0J 475M-8L
C80	4550003030	S. TANTALUM	TEMSVA 0J 475M-8L
C81	4030006900	S. CERAMIC	C1608 JB 1E 103K-T-A
C82	4030006900	S. CERAMIC	C1608 JB 1E 103K-T-A
C83	4030006860	S. CERAMIC	C1608 JB 1H 102K-T-A
C84	4030006690	S. CERAMIC	C1608 SL 1H 330J-T-A
C85	4030006900	S. CERAMIC	C1608 JB 1E 103K-T-A
C87	4030006860	S. CERAMIC	C1608 JB 1H 102K-T-A
DS1	5030000630	LCD	LD-BU5192J (E-5395)
DS2	5040001110	S. LED	SLM-23VMWS T97B
DS3	5040000880	S. LED	SLM-13MWS T97B
DS4	5040000880	S. LED	SLM-13MWS T97B
BT1	3020000160	LITHIUM	VL2020-1VC
MC1	7700000861	MICROPHONE	WM-62A103
SP1	2510000530	SPEAKER	T028S14I0810
J1	6910005830	CONNECTOR	IMSA-9208B-1-04A-T
J2	6910005840	CONNECTOR	IMSA-9208B-1-05A-T
J3	6510012880	S. CONNECTOR	CEW9114-0201
W9	7030003860	S. JUMPER	ERJ3GE JPW V
EP1	8930025920	LCD CONTACT	SRCN-935W
EP2	8930020160	CONTACT	SRCN-873
EP3	0910034782	PCB	B 3390B (LOGIC)
EP4	0910028842	PCB	B 2873B (10-KEY)

S.=Surface mount

[PTT UNIT]

REF. NO.	ORDER NO.	DESCRIPTION	
R1	7210001910	VARIABLE	RV-199 (RK0972210) 10KB/10KA [SQL/VOL] 400
R2	7210001910	VARIABLE	RV-199 (RK0972210) 10KB/10KA [SQL/VOL] 1200
S1	2260001320	S. SWITCH	SW-121 (SKHUPF) [PTT]
S2	2260001320	S. SWITCH	SW-121 (SKHUPF) [F]
S3	2260001400	ENCODER	SW-122 (RK097103H) [DIAL]
EP1	0910034763	PCB	B 2871C (PTT)
EP2	0910036251	FPC	B 3614A

[CONNECTOR UNIT]

REF. NO.	ORDER NO.	DESCRIPTION	
R1	7030003560	S. RESISTOR	ERJ3GEYJ 103 V (10 kΩ)
R2	7030003600	S. RESISTOR	ERJ3GEYJ 223 V (22 kΩ)
R3	7030003560	S. RESISTOR	ERJ3GEYJ 103 V (10 kΩ)
C1	4550000460	S. TANTALUM	TESVA 1C 105M1-8L
C2	4030006860	S. CERAMIC	C1608 JB 1H 102K-T-A
C3	4030006860	S. CERAMIC	C1608 JB 1H 102K-T-A
C4	4030006860	S. CERAMIC	C1608 JB 1H 102K-T-A
C5	4030006860	S. CERAMIC	C1608 JB 1H 102K-T-A
C6	4030006860	S. CERAMIC	C1608 JB 1H 102K-T-A
C7	4030006860	S. CERAMIC	C1608 JB 1H 102K-T-A
C8	4030006860	S. CERAMIC	C1608 JB 1H 102K-T-A
C9	4030006750	S. CERAMIC	C1608 SL 1H 101J-T-A
J1	6510012790	CONNECTOR	53020-2810
J2	6510012590	CONNECTOR	52022-1210
EP1	0910031863	PCB	B 3221C (CONNECTOR)
EP2	0910032330	FPC	B 3223

[AF FIL UNIT]

REF. NO.	ORDER NO.	DESCRIPTION	
Q4	1540000350	S. TRANSISTOR	2SD2216-S (TX)
Q5	1590001170	S. TRANSISTOR	XP1501- (TX) .AB
Q6	1590001190	S. TRANSISTOR	XP6501- (TX) .AB
D1	1790000860	S. DIODE	MA133 (TX)
D2	1790000860	S. DIODE	MA133 (TX)
D3	1790000830	S. DIODE	MA132HK (TX)
D4	1790000860	S. DIODE	MA133 (TX)
R2	7030003600	S. RESISTOR	ERJ3GEYJ 223 V (22 kΩ)
R3	7030003560	S. RESISTOR	ERJ3GEYJ 103 V (10 kΩ)
R4	7030003560	S. RESISTOR	ERJ3GEYJ 103 V (10 kΩ)
R5	7030003520	S. RESISTOR	ERJ3GEYJ 472 V (4.7 kΩ)
R6	7030003520	S. RESISTOR	ERJ3GEYJ 472 V (4.7 kΩ)
R7	7030003520	S. RESISTOR	ERJ3GEYJ 472 V (4.7 kΩ)
R8	7030003630	S. RESISTOR	ERJ3GEYJ 393 V (39 kΩ)
R9	7030003630	S. RESISTOR	ERJ3GEYJ 393 V (39 kΩ)
R10	7030003480	S. RESISTOR	ERJ3GEYJ 222 V (2.2 kΩ)
R11	7030003550	S. RESISTOR	ERJ3GEYJ 822 V (8.2 kΩ)
R12	7030003760	S. RESISTOR	ERJ3GEYJ 474 V (470 kΩ)
R13	7030003700	S. RESISTOR	ERJ3GEYJ 154 V (150 kΩ)
R14	7030003580	S. RESISTOR	ERJ3GEYJ 153 V (15 kΩ)
R16	7030003600	S. RESISTOR	ERJ3GEYJ 223 V (22 kΩ)
R17	7030003560	S. RESISTOR	ERJ3GEYJ 103 V (10 kΩ)
R18	7030003560	S. RESISTOR	ERJ3GEYJ 103 V (10 kΩ)
R19	7030003520	S. RESISTOR	ERJ3GEYJ 472 V (4.7 kΩ)
R20	7030003520	S. RESISTOR	ERJ3GEYJ 472 V (4.7 kΩ)
R21	7030003520	S. RESISTOR	ERJ3GEYJ 472 V (4.7 kΩ)
R22	7030003630	S. RESISTOR	ERJ3GEYJ 393 V (39 kΩ)
R23	7030003630	S. RESISTOR	ERJ3GEYJ 393 V (39 kΩ)
R24	7030003480	S. RESISTOR	ERJ3GEYJ 222 V (2.2 kΩ)
R25	7030003550	S. RESISTOR	ERJ3GEYJ 822 V (8.2 kΩ)
R26	7030003760	S. RESISTOR	ERJ3GEYJ 474 V (470 kΩ)
R27	7030003700	S. RESISTOR	ERJ3GEYJ 154 V (150 kΩ)
R28	7030003580	S. RESISTOR	ERJ3GEYJ 153 V (15 kΩ)
R29	7030003520	S. RESISTOR	ERJ3GEYJ 472 V (4.7 kΩ)
R30	7030003520	S. RESISTOR	ERJ3GEYJ 472 V (4.7 kΩ)
C1	45500004010	S. TANTALUM	TEMSVA2 1A 105M-8L
C2	4030008960	S. CERAMIC	C2012 JB 1C 104K-T-A
C3	4030006860	S. CERAMIC	C1608 JB 1H 102K-T-A
C4	4030006870	S. CERAMIC	C1608 JB 1H 222K-T-A
C5	4030006900	S. CERAMIC	C1608 JB 1E 103K-T-A
C6	4030006900	S. CERAMIC	C1608 JB 1E 103K-T-A
C7	45500004010	S. TANTALUM	TEMSVA2 1A 105M-8L
C8	4030008960	S. CERAMIC	C2012 JB 1C 104K-T-A
C9	4030006860	S. CERAMIC	C1608 JB 1H 102K-T-A
C10	4030006870	S. CERAMIC	C1608 JB 1H 222K-T-A
C11	4030006900	S. CERAMIC	C1608 JB 1E 103K-T-A
C12	4030006900	S. CERAMIC	C1608 JB 1E 103K-T-A
C13	4030006860	S. CERAMIC	C1608 JB 1H 102K-T-A
C14	4030008960	S. CERAMIC	C2012 JB 1C 104K-T-A
C15	4030006860	S. CERAMIC	C1608 JB 1H 102K-T-A
C16	4030008960	S. CERAMIC	C2012 JB 1C 104K-T-A
EP1	0910028941	PCB	B 2925A (AF FIL)

[AF FIL UNIT]

REF. NO.	ORDER NO.	DESCRIPTION	
Q1	1540000350	S. TRANSISTOR	2SD2216-S (TX)
Q2	1590001170	S. TRANSISTOR	XP1501- (TX) .AB
Q3	1590001190	S. TRANSISTOR	XP6501- (TX) .AB

S.=Surface mount

[T. SQL UNIT] (USA-1 only) (Optional UT-63)

REF. NO.	ORDER NO.	DESCRIPTION	
IC1	1130005100	S. IC	FX365LG
IC2	1130005100	S. IC	FX365LG
IC3	1130003610	S. IC	TC4SU69F (TE85R)
Q1	1590000430	S. TRANSISTOR	DTC144EU T107
Q2	1510000580	S. TRANSISTOR	2SA1362-GR (TE85R)
Q3	1590000430	S. TRANSISTOR	DTC144EU T107
Q4	1510000580	S. TRANSISTOR	2SA1362-GR (TE85R)
Q5	1530002280	S. TRANSISTOR	2SC4081 T107 S
Q6	1530002280	S. TRANSISTOR	2SC4081 T107 S
Q7	1530002280	S. TRANSISTOR	2SC4081 T107 S
D1	1790000590	S. DIODE	MA110 (TW)
D2	1790000590	S. DIODE	MA110 (TW)
D3	1790000870	S. DIODE	MA1S121 (TX)
D4	1160000060	S. DIODE	DAN202U T107
D5	1790000870	S. DIODE	MA1S121 (TX)
X1	6060000480	CERAMIC	CSB1000J221T
R1	7030003570	S. RESISTOR	ERJ3GEYJ 123 V (12 kΩ)
R2	7030003700	S. RESISTOR	ERJ3GEYJ 154 V (150 kΩ)
R3	7030003840	S. RESISTOR	ERJ3GEYJ 225 V (2.2 MΩ)
R4	7030003740	S. RESISTOR	ERJ3GEYJ 334 V (330 kΩ)
R5	7030003600	S. RESISTOR	ERJ3GEYJ 223 V (22 kΩ)
R6	7030003680	S. RESISTOR	ERJ3GEYJ 104 V (100 kΩ)
R7	7030003800	S. RESISTOR	ERJ3GEYJ 105 V (1 MΩ)
R9	7030003570	S. RESISTOR	ERJ3GEYJ 123 V (12 kΩ)
R10	7030003700	S. RESISTOR	ERJ3GEYJ 154 V (150 kΩ)
R11	7030003560	S. RESISTOR	ERJ3GEYJ 103 V (10 kΩ)
R12	7030003560	S. RESISTOR	ERJ3GEYJ 103 V (10 kΩ)
R13	7310003550	S. TRIMMER	MVR32HXBR N473
R14	7030003480	S. RESISTOR	ERJ3GEYJ 222 V (2.2 kΩ)
R15	7030003740	S. RESISTOR	ERJ3GEYJ 334 V (330 kΩ)
R16	7030003600	S. RESISTOR	ERJ3GEYJ 223 V (22 kΩ)
R17	7030003680	S. RESISTOR	ERJ3GEYJ 104 V (100 kΩ)
R18	7030003780	S. RESISTOR	ERJ3GEYJ 684 V (680 kΩ)
R19	7030003680	S. RESISTOR	ERJ3GEYJ 104 V (100 kΩ)
R20	7030003800	S. RESISTOR	ERJ3GEYJ 105 V (1 MΩ)
R21	7030003800	S. RESISTOR	ERJ3GEYJ 105 V (1 MΩ)
R22	7030003800	S. RESISTOR	ERJ3GEYJ 105 V (1 MΩ)
R23	7030003480	S. RESISTOR	ERJ3GEYJ 222 V (2.2 kΩ)
R24	7030003520	S. RESISTOR	ERJ3GEYJ 472 V (4.7 kΩ)
R25	7030003480	S. RESISTOR	ERJ3GEYJ 222 V (2.2 kΩ)
R26	7030003780	S. RESISTOR	ERJ3GEYJ 684 V (680 kΩ)
R27	7030003800	S. RESISTOR	ERJ3GEYJ 105 V (1 MΩ)
R28	7030003800	S. RESISTOR	ERJ3GEYJ 105 V (1 MΩ)
R29	7030003800	S. RESISTOR	ERJ3GEYJ 105 V (1 MΩ)
R30	7030003680	S. RESISTOR	ERJ3GEYJ 104 V (100 kΩ)
R31	7030003640	S. RESISTOR	ERJ3GEYJ 473 V (47 kΩ)
R32	7030003710	S. RESISTOR	ERJ3GEYJ 184 V (180 kΩ)
R33	7030003710	S. RESISTOR	ERJ3GEYJ 184 V (180 kΩ)
R34	7030003580	S. RESISTOR	ERJ3GEYJ 153 V (15 kΩ)
C1	4030008920	S. CERAMIC	C1608 JB 1C 473K-T-A
C2	4030006850	S. CERAMIC	C1608 JB 1H 471K-T-A
C3	4030006900	S. CERAMIC	C1608 JB 1E 103K-T-A
C4	4550000420	S. TANTALUM	TESVA 1A 105M1-8L
C5	4550000530	S. TANTALUM	TESVA 1V 104M1-8L
C6	4030006540	S. CERAMIC	C1608 SL 1H 030C-T-A
C7	4550002950	S. TANTALUM	TESVA 0J 335M1-8L
C8	4030007170	S. CERAMIC	C1608 CH 1H 221J-T-A

[T. SQL UNIT] (USA-1 only) (Optional UT-63)

REF. NO.	ORDER NO.	DESCRIPTION	
C9	4030007170	S. CERAMIC	C1608 CH 1H 221J-T-A
C10	4030008920	S. CERAMIC	C1608 JB 1C 473K-T-A
C11	4030006850	S. CERAMIC	C1608 JB 1H 471K-T-A
C12	4030006900	S. CERAMIC	C1608 JB 1E 103K-T-A
C13	4550000420	S. TANTALUM	TESVA 1A 105M1-8L
C15	4030006540	S. CERAMIC	C1608 SL 1H 030C-T-A
C16	4550000530	S. TANTALUM	TESVA 1V 104M1-8L
C17	4550002950	S. TANTALUM	TESVA 0J 335M1-8L
C18	4030008920	S. CERAMIC	C1608 JB 1C 473K-T-A
C19	4030008920	S. CERAMIC	C1608 JB 1C 473K-T-A
C20	4030006860	S. CERAMIC	C1608 JB 1H 102K-T-A
W1	7030003860	S. JUMPER	ERJ3GE JPW V
EP1	0910030531	PCB	B 3110A (T. SQL)

S.=Surface mount

SECTION 3 MECHANICAL PARTS AND DISASSEMBLY

• CHASSIS PARTS

LABEL NUMBER	ORDER NO.	DESCRIPTION	QTY.	LABEL NUMBER	ORDER NO.	DESCRIPTION	QTY.
①	8610006780	Knob N161 [VOL]	2	③⑨	8930018080	SP ring	1
②	8610006790	Knob N162 [SQL]	2	④⑩	2510000530	Speaker T028S14I0810	1
③	8610006800	Knob N163 [DIAL]	1	⑪	8510006960	873 shield	1
④	8830000570	Nut (A)	3	⑫	8930020160	Contact SRCN-873	1
⑤	8210006490	Top panel	1	⑬	8010010700	Keyboard	1
⑥	8930021890	VR seal	1	⑭	8510006880	Key shield	1
⑦	8010012140	Top chassis	1	⑮	8930019780	LED lens	1
⑧	8930023620	935 PTT plate	1	⑯	8930020240	873 spring	1
⑨	8810004870	Screw PH No. 0 M2×2.5	4		8210006570	Front panel (J) (incl. window plate) (IC-X2A)	1
⑩	8930025660	935 VR shield	1		8210006580	Front panel (K) (incl. window plate) (IC-X2E)	1
⑪	7210001910	RV-199 (RK0972210) 10KB/10KA [SQL/VOL] 400	1	⑰	8930019861	PTT rubber-1	1
⑫	7210001910	RV-199 (RK0972210) 10KB/10KA [SQL/VOL] 1200	1	⑱	8930019850	Release button	1
⑬	2260001400	SW-122 (RK097103H) [DIAL]	1	⑲	8510006890	Top shield	1
⑭	8930020211	Connector seal-1	1	⑳	8930022480	932 M holder	1
⑮	6510013530	BNC-R000 (incl. nut) [ANTENNA]	1	㉑	8930020930	930 plate	1
⑯	8810005700	Screw PH No. 0 M2×4 ZK	1	㉒	8510006860	Unit case	1
⑰	8930021880	Jack panel	1	㉓	8930023610	935 under plate	1
⑱	8930021901	ANT seal-1	1	㉔	8810005580	Screw FH No. 0 M2×2.5	6
⑲	8810007500	Screw FH No. 0 M2×3 NI ZK metallic	2	㉕	8950002070	Electrical tape No. 1245 60×13	1
⑳	8510007530	935 top shield	1	㉖	8510005940	752 VCO case	1
㉑	8930010790	Insulate plate AQ	1	㉗	8810000530	Screw PH No. 0 M2×5 ZK	4
㉒	8810001720	Screw PH B0 No. 0-3 M1.4×4	6	㉘	8510006870	Bottom shield	1
㉓	8930017200	752 ground spring	4	㉙	8930023590	935 connector plate	1
㉔	7700000861	Microphone WM-62A103	1	㉚	8810004870	Screw PH No. 0 M2×2.5	1
㉕	8930014940	752 microphone holder	1	㉛	8810007020	Screw PH No. 0 M2×11	8
㉖	8930018810	Sheet AA	1	㉜	8930023600	935 side plate	1
㉗	8930014971	752 contact holder-1	1	㉝	8010011500	Center chassis	1
㉘	8930016560	Terminal rubber	3	㉞	8900003410	Cable OPC-358	1
㉙	8930014852	752 battery terminal-2	3	㉟	8930023630	935 shield plate	1
㉚	8930025680	935 LCD sheet	1	㊱	8930023640	SW shield plate	1
㉛	8930025670	935 LCD shield	1	㊲	8930014140	Ground spring (D)	1
㉜	8010010690	Reflector	1	㊳	8010012130	BPF case	1
㉝	8930025920	LCD contact SRCN-935W	1	㊴	8510007410	935 VCO case	1
㉞	5030000630	LCD LD-BU5192J (E-5395)	1	㊵	8950002470	Electrical tape No. 1245 42×13	1
㉟	8930019930	LCD holder	1	㊶	8010011490	935 rear panel	1
㊱	8810001700	Screw PH B0 No. 0-3 M1.4×3	7	㊷	8810006490	Screw PH B0 M2×25 ZK	5
㊲	8930020250	CPU-seal	1	㊸	8820000620	873 screw	1
㊳	8930025910	935 CPU shield	1				

Screw abbreviations B0: Self-tapping screw PH: Pan head FH: Flat head NI: Nickel ZK: Black

• ACCESSORIES

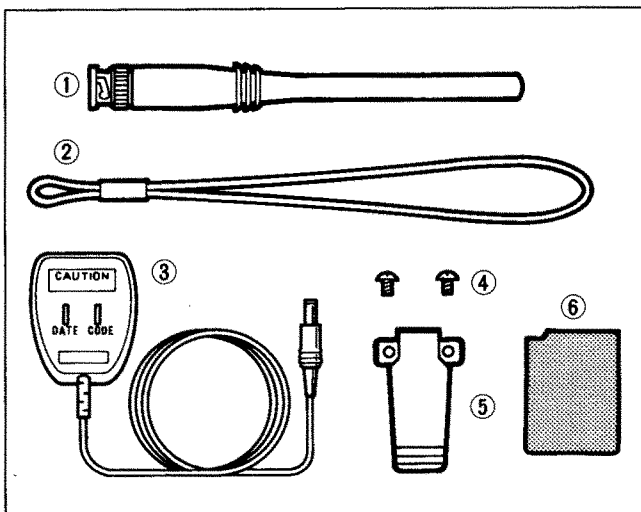

LABEL NUMBER	ORDER NO.	DESCRIPTION	QTY.
①	Optional product	FA-4312BA FLEXIBLE ANTENNA	1
②	8010011960	Strap belt HK-005	1
③	Optional product	BC-77A WALL CHARGER (USA, USA-1)	1
		BC-77D WALL CHARGER (EUR-1)	1
		BC-77E WALL CHARGER (UK, EUR-2)	1
		BC-77V WALL CHARGER (AUS)	1
④	8810005730	Screw BuH M3×3 ZK BS	2
⑤	8010008620	752 belt clip	1
⑥	Optional product	BP-82 BATTERY PACK (AUS)	1
		BP-83 BATTERY PACK (IC-X2E)	1
		BP-84 BATTERY PACK (USA, USA-1)	1
		BP-90 BATTERY CASE (SEA)	1

Screw abbreviations BuH: Button head BS: Brass ZK: Black

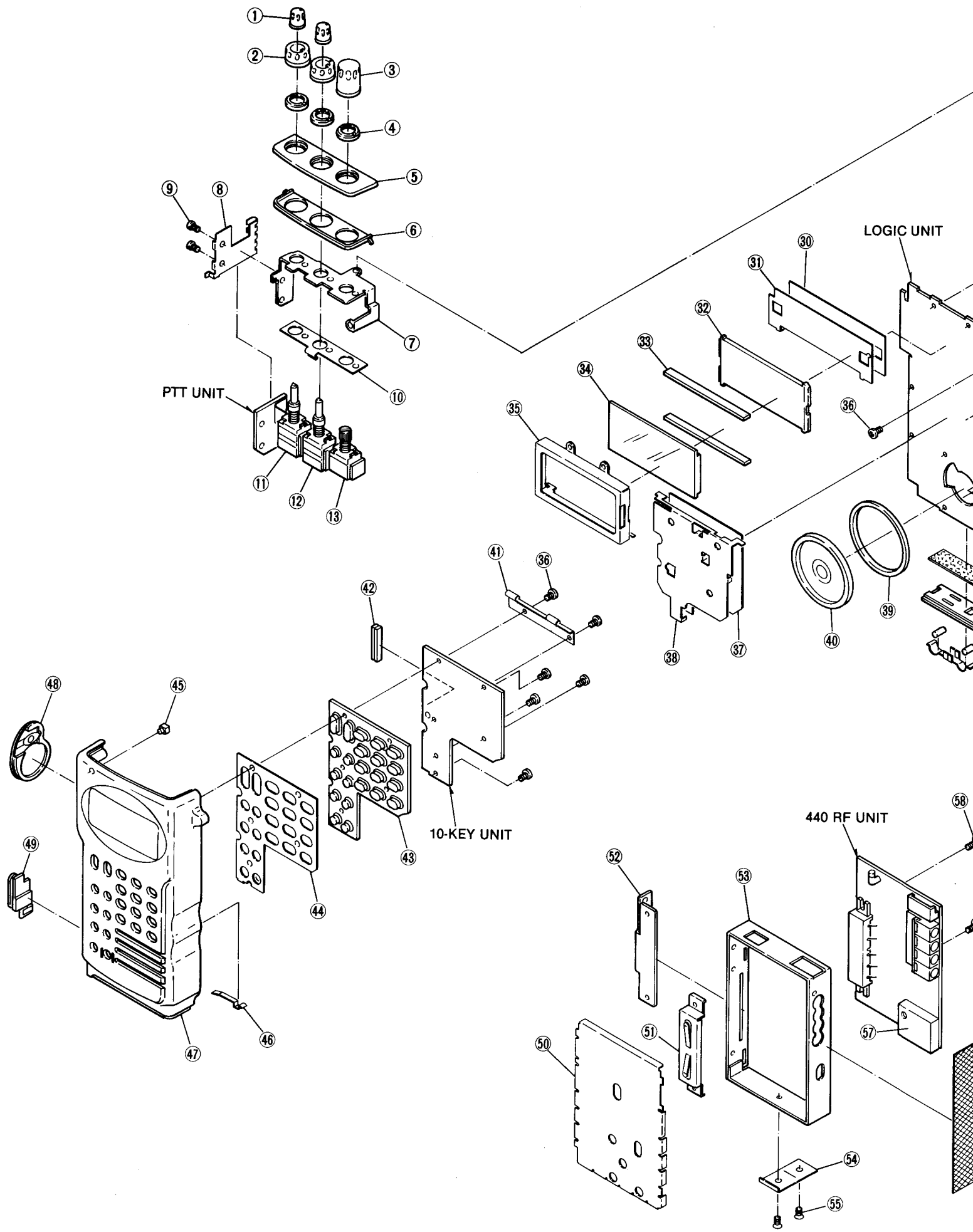

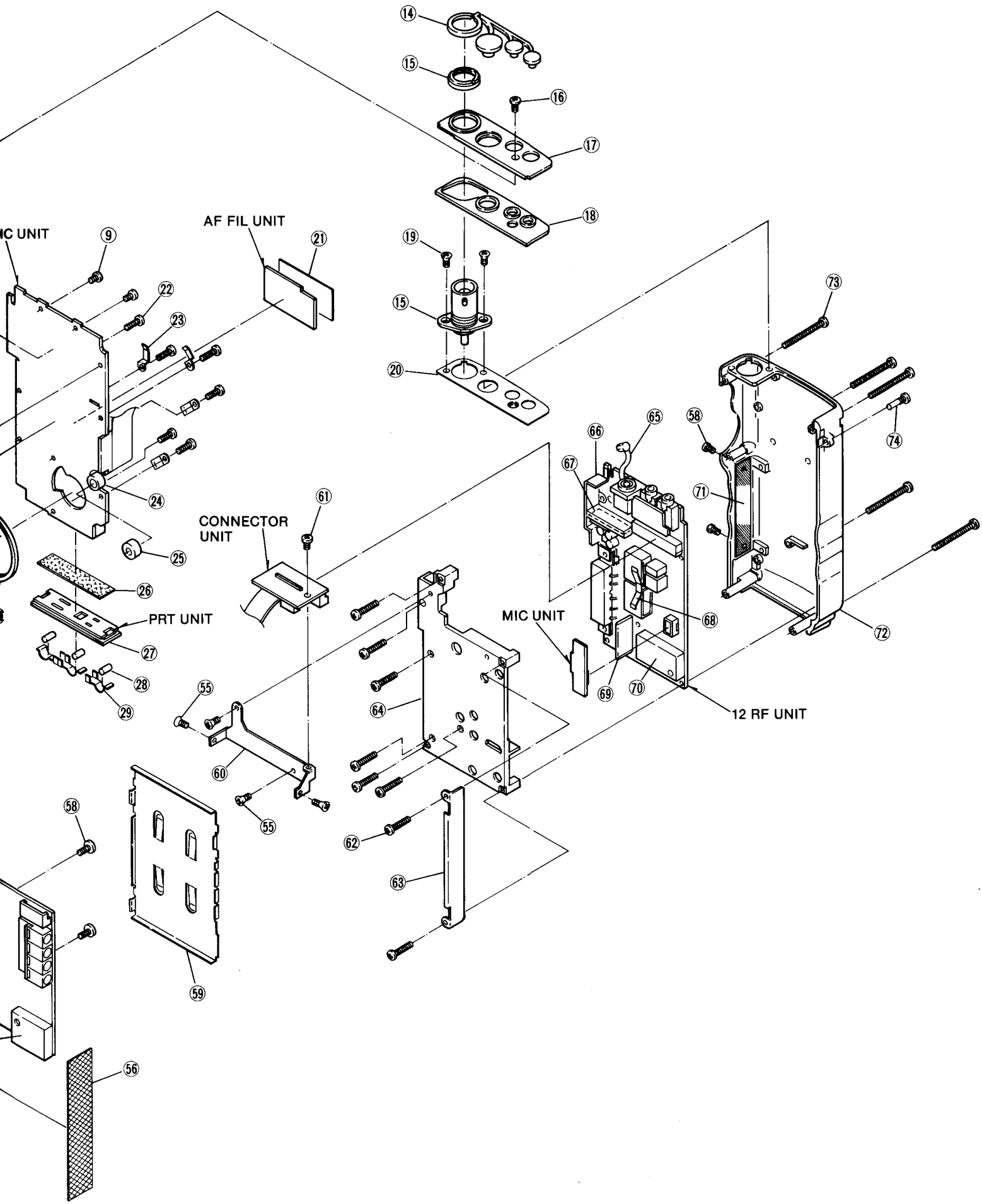

SECTION 4 BOARD LAYOUTS

4-1 LOGIC, 10-KEY, PTT AND AF FIL UNITS

• 10-KEY UNIT

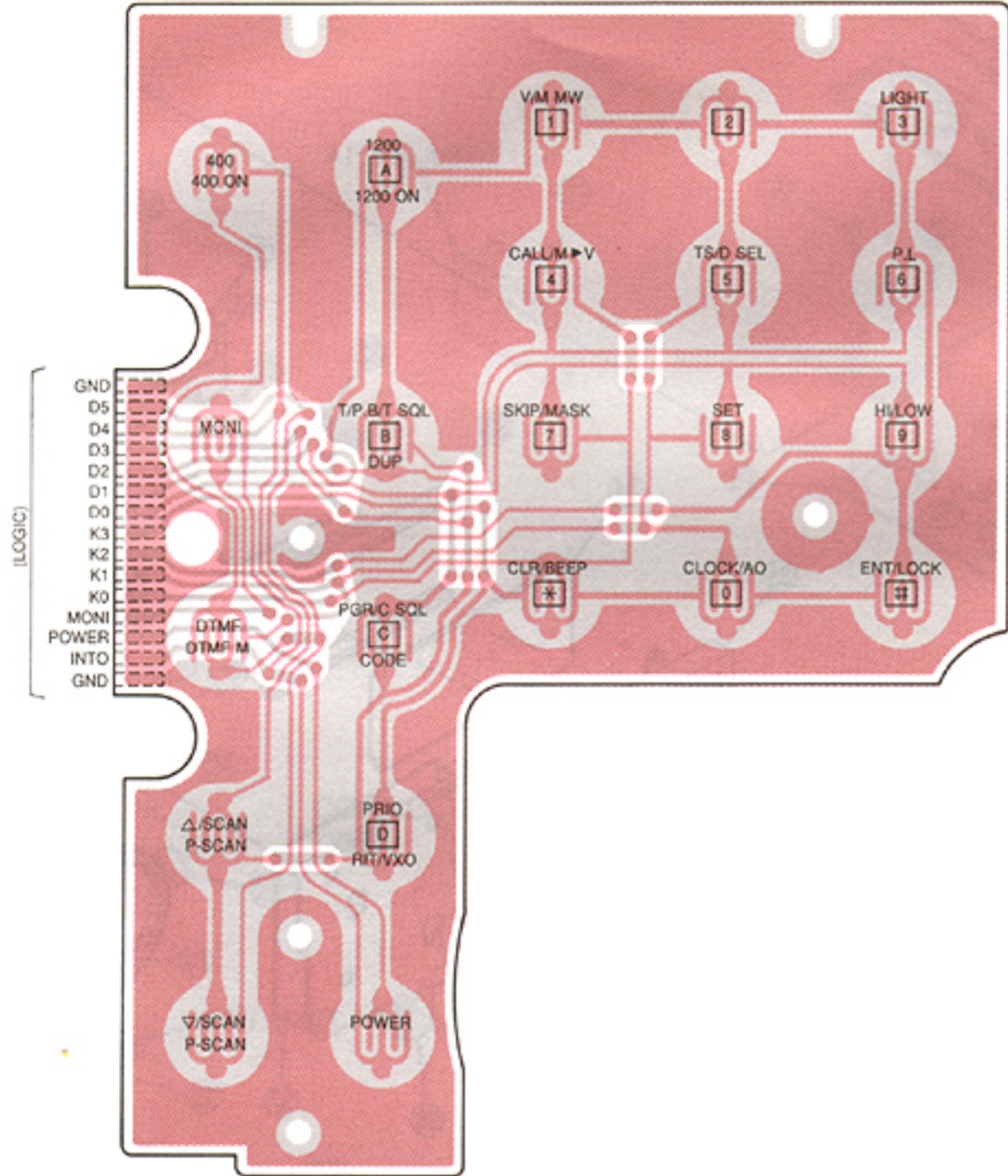

• PTT UNIT

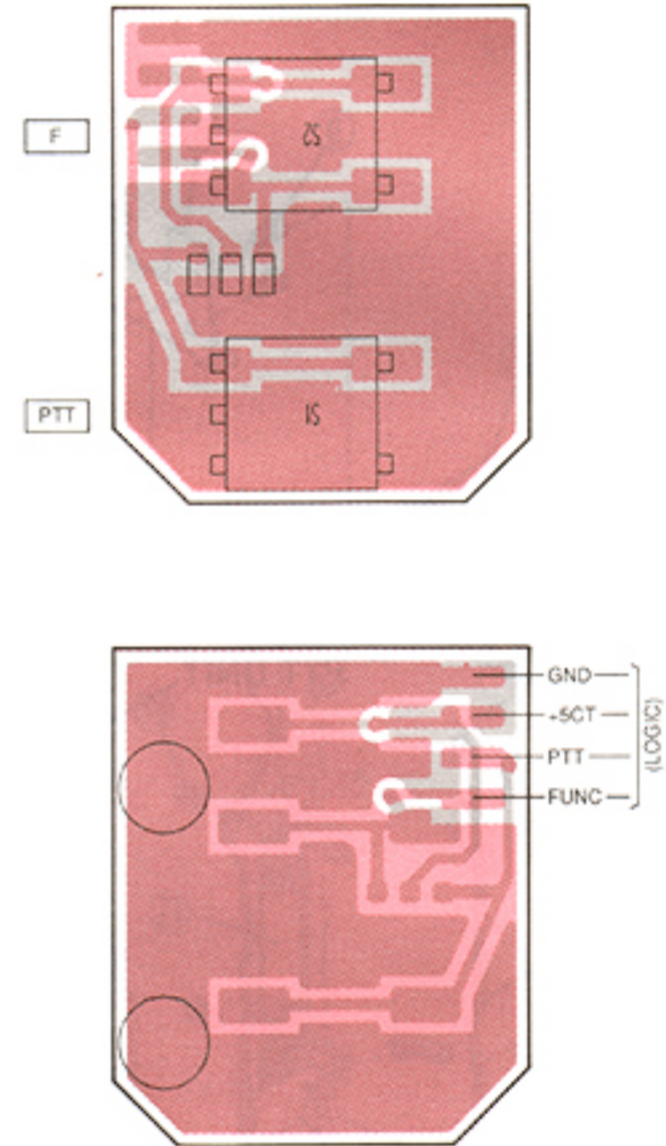

• AF FIL UNIT

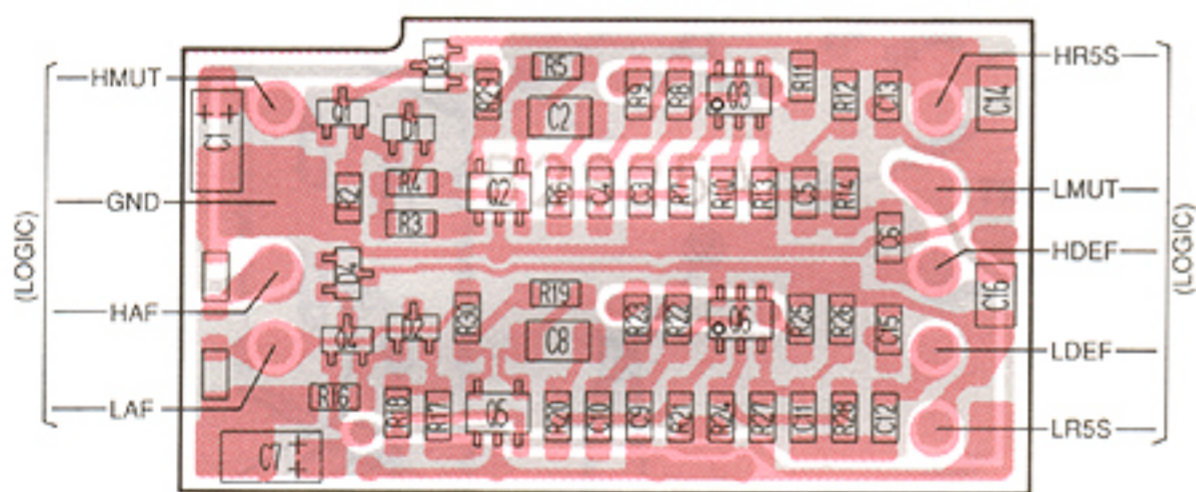

2SD2216 S
(Symbol: 5)

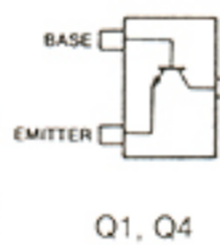

XP1501
(Symbol: 5R)

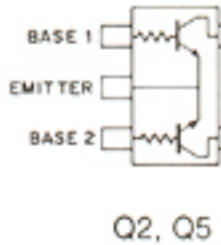

XP6501
(Symbol: 5N)

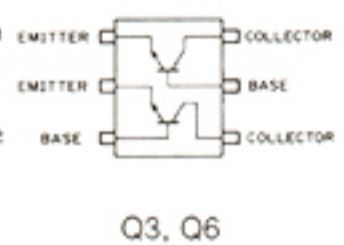

MA133
(Symbol: MP)

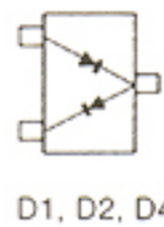

MA132HK
(Symbol: M3N)



• LOGIC UNIT

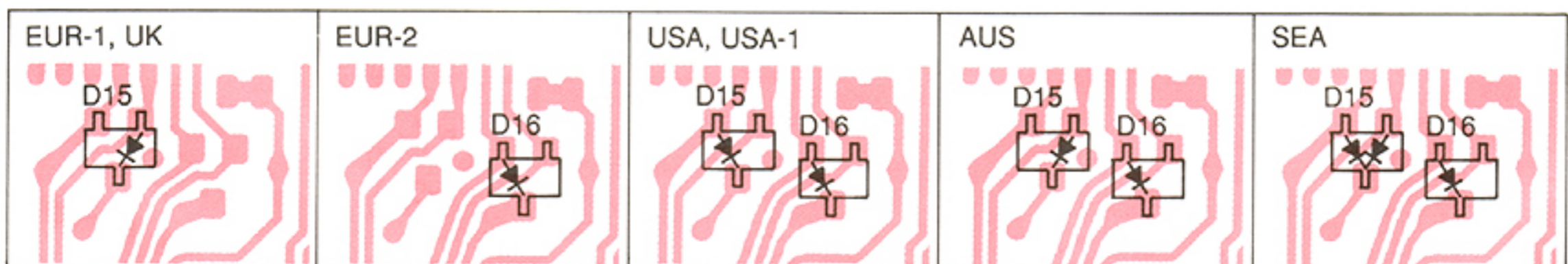

• LOGIC UNIT

The combination of this page and the next page show the unit layout in the same configuration as the actual P.C. Board.

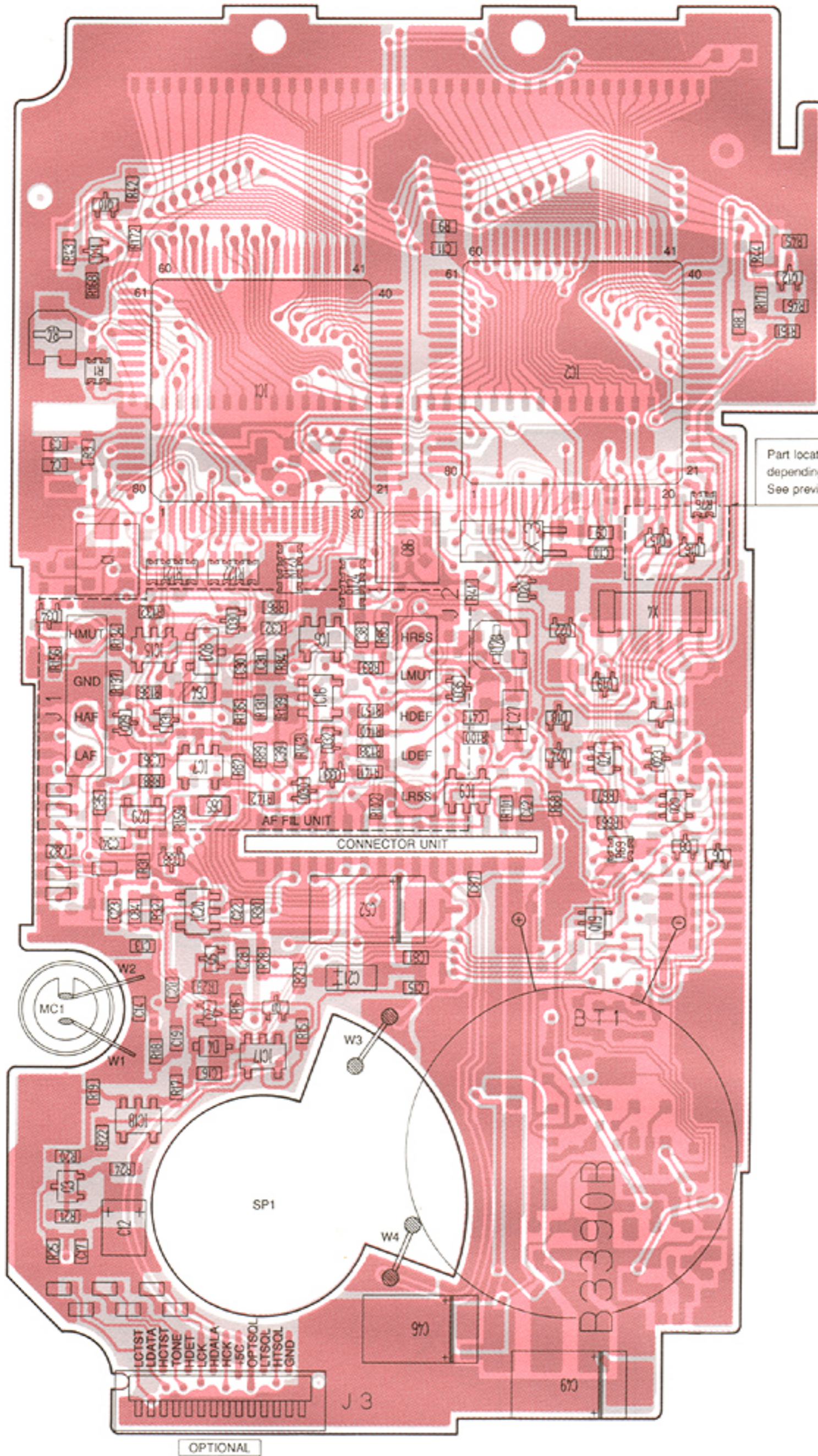

2SD2216 S
(Symbol: 5)

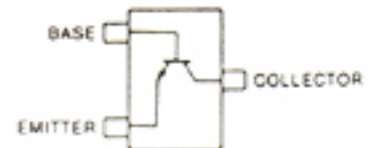

Q1, Q2, Q10, Q11, Q12,
Q29, Q30

2SA1576 R
(Symbol: FR)



Q3

UN9211
(Symbol: 8A)

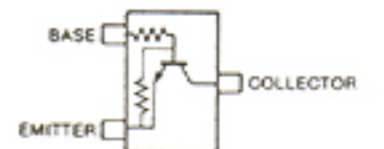

Q5

XP1210
(Symbol: AC)

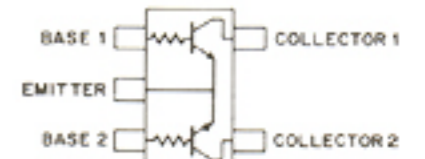

Q19, Q20, Q21

UN9210
(Symbol: 8L)

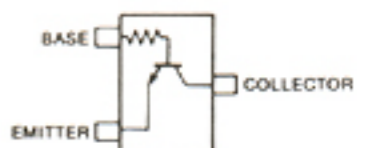

Q23, Q24

MA132WA
(Symbol: M0)

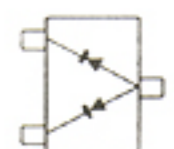

D6, D8

MA132K
(Symbol: M1)

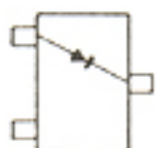

D15 (EUR-1, UK, AUS)

MA132HK
(Symbol: M3N)

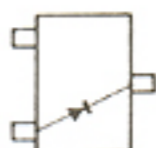

D15 (USA, USA-1),
D16 (EUR-2, USA,
USA-1, AUS, SEA), D18

MA132WK
(Symbol: MU)

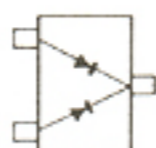

D15 (SEA), D30, D32

MA133
(Symbol: MP)

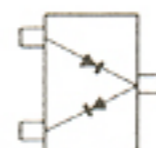

D19, D31, D33, D34,
D35, D38

MA132A
(Symbol: MB)

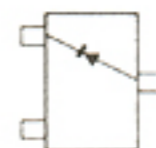

D22

HSM88AS
(Symbol: C1)

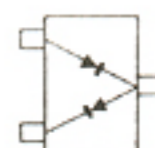

D28, D29

4-2 CONNECTOR, AF, U RF A, PRT AND U VCO UNITS

• CONNECTOR UNIT

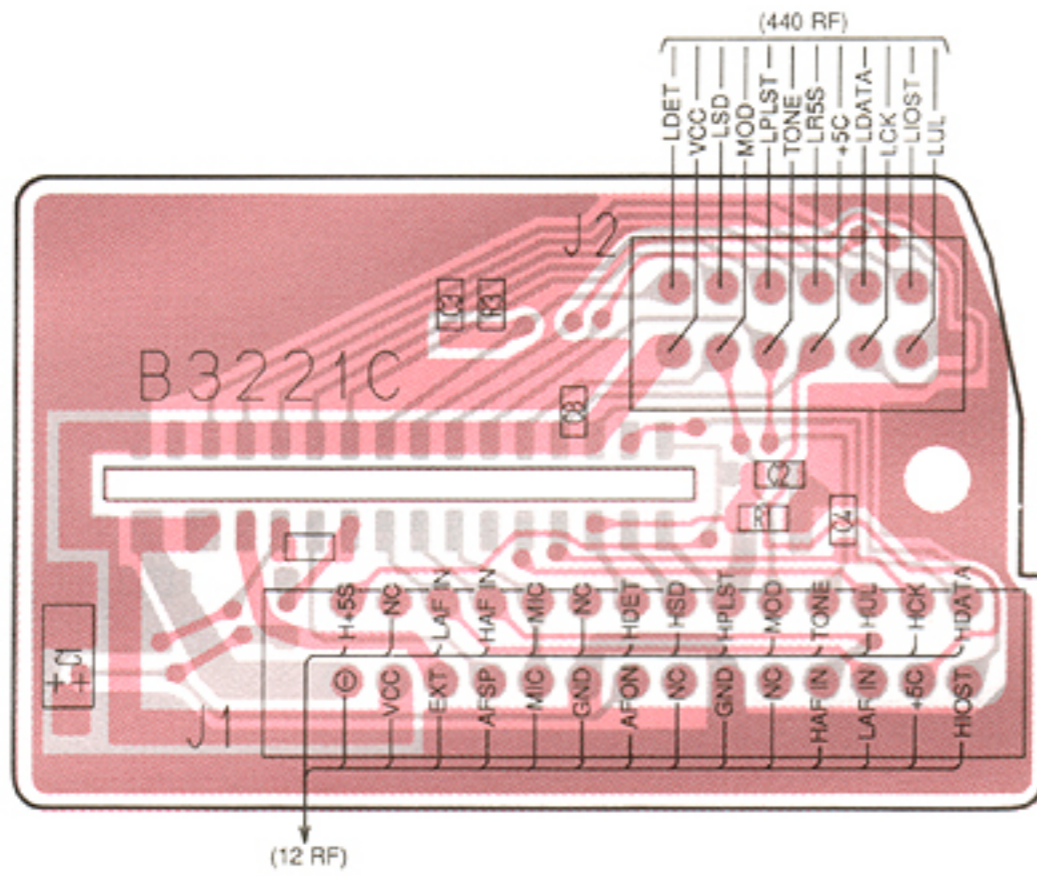

• AF UNIT

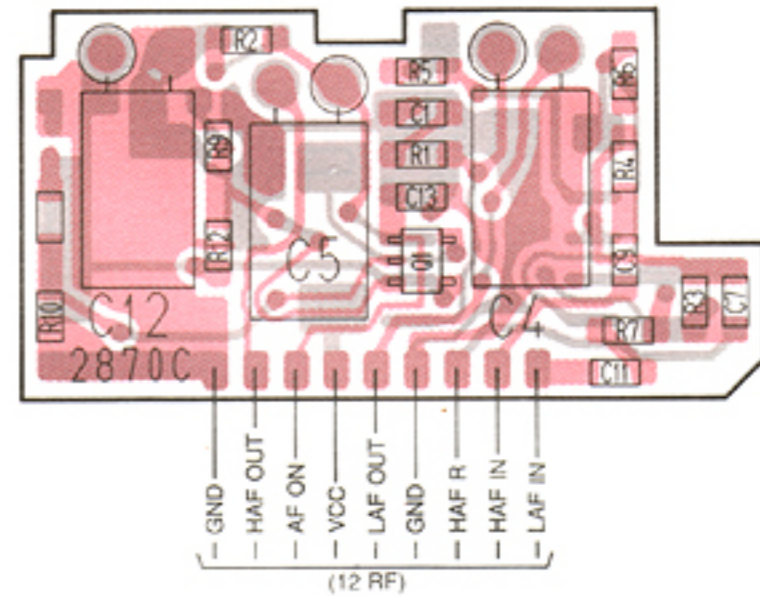

XP1501
(Symbol: 5R)

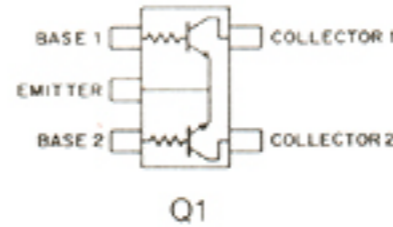

• U RF A UNIT

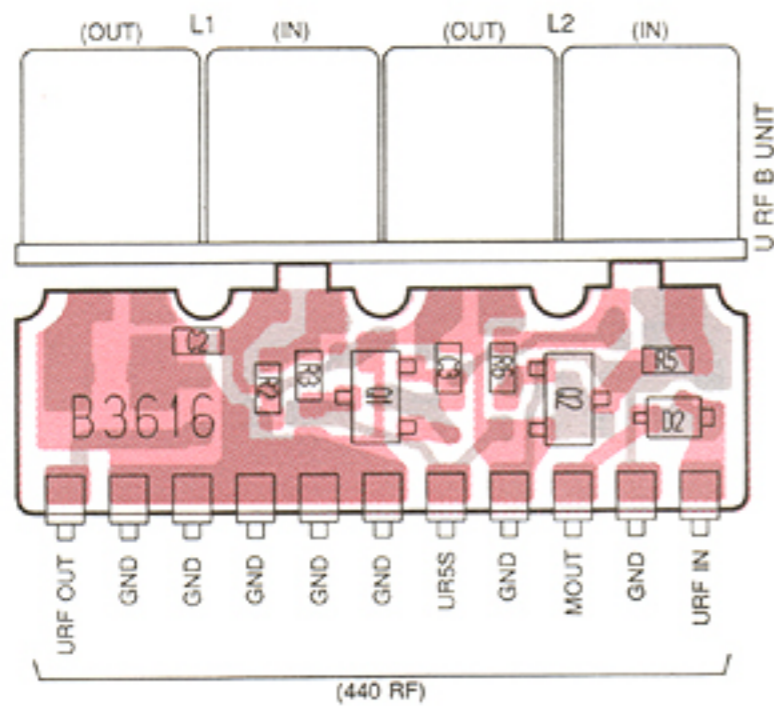

The combination of this page and the next page show the CONNECTOR, AF and U RF A units layout in the same configuration as the actual P.C. Board.

2SC3583 R34
(Symbol: R34)

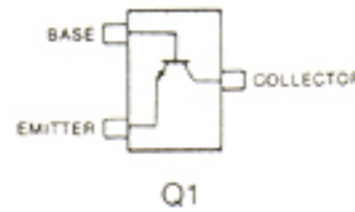

2SC3585 R44
(Symbol: R44)

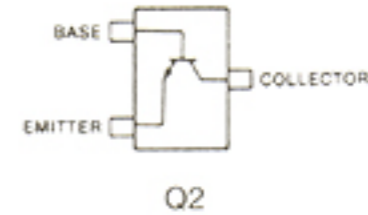

• PRT UNIT

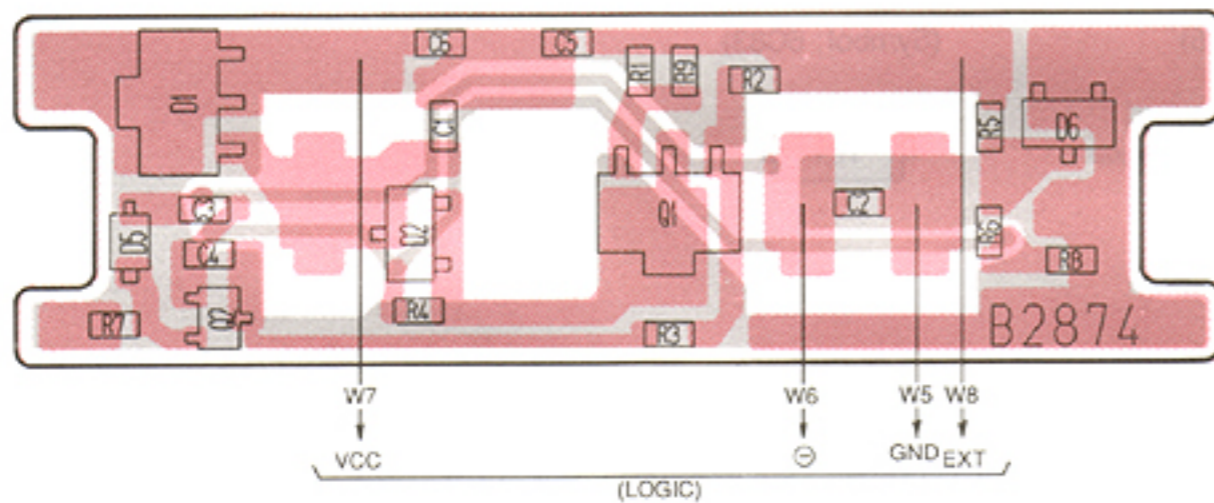

2SB798 DK
(Symbol: DK)

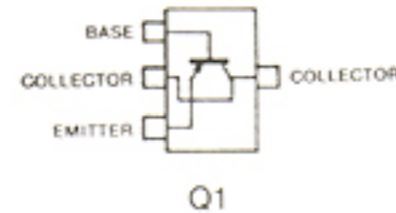

2SC4081 S
(Symbol: BS)

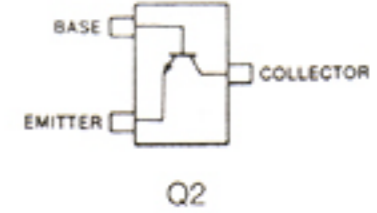

SB20 03P
(Symbol: SC)



SB07 03C
(Symbol: J)

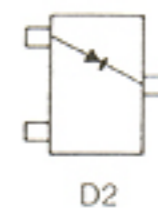

02CZ5.1 Z
(Symbol: 5.1Z)

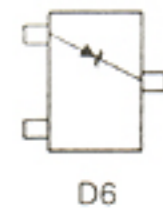

• AF UNIT

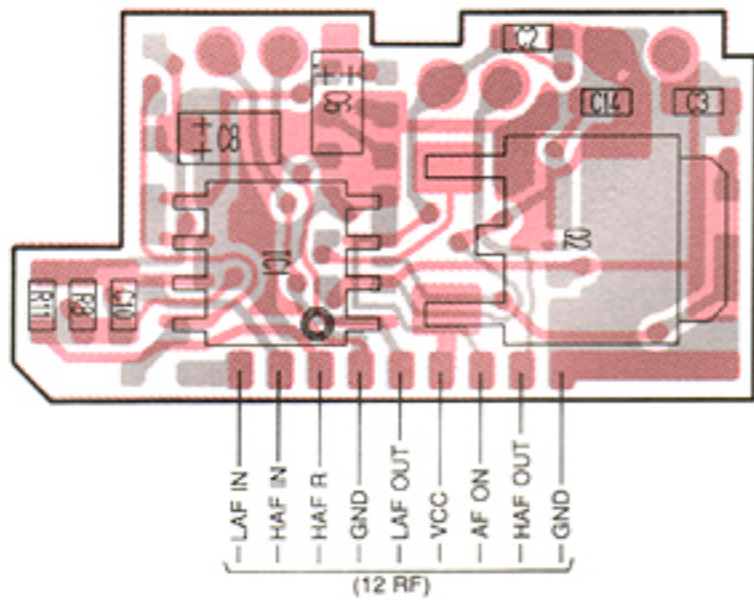

2SB1182 Q
(Symbol: B1182)

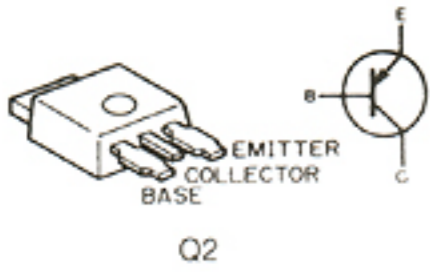

• CONNECTOR UNIT

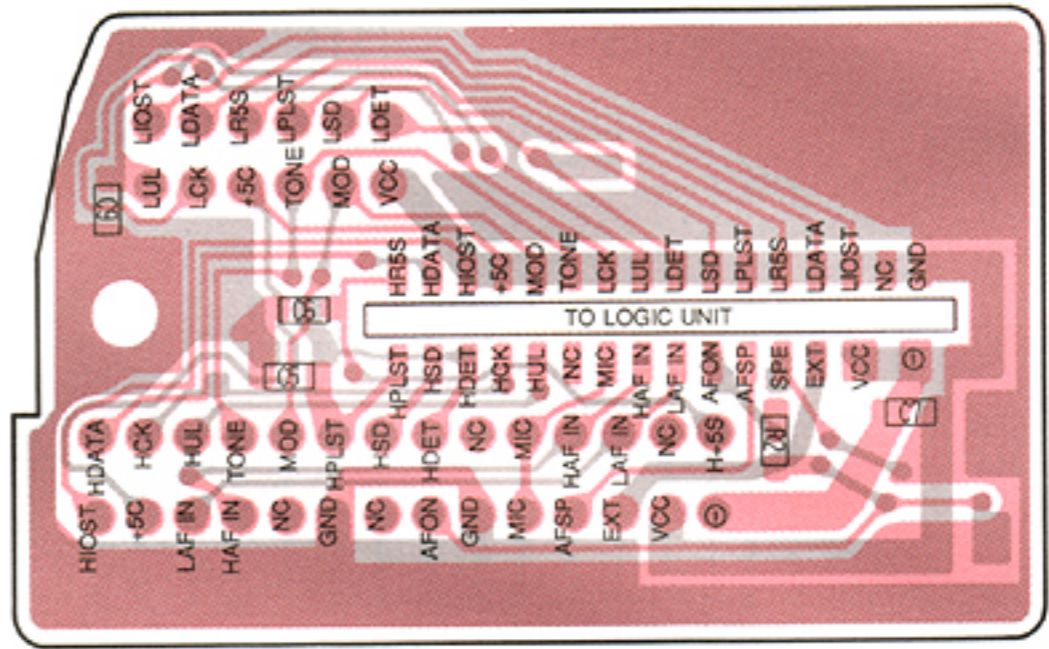

• U RF A UNIT

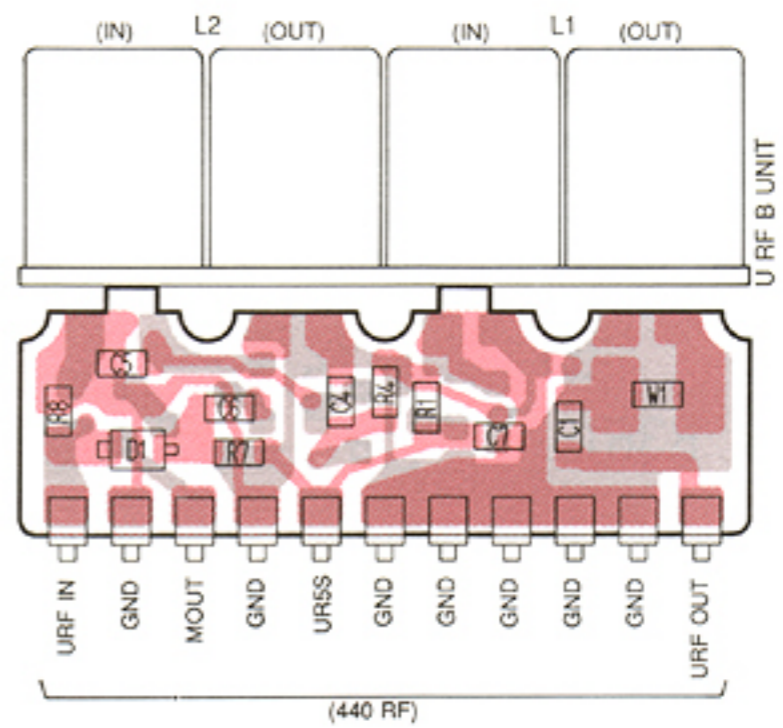

• U VCO UNIT

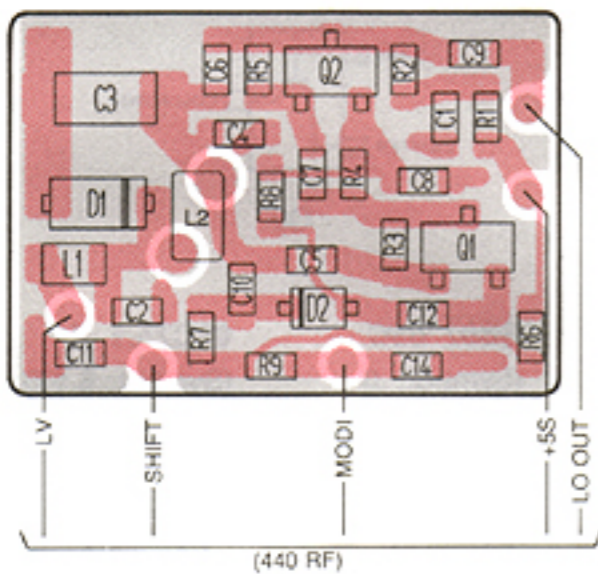

2SC3356 R25
(Symbol: R25)

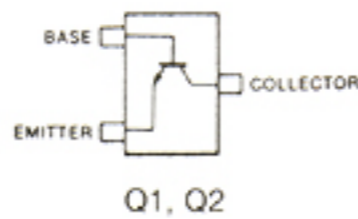

MA333
(Symbol: 6C83)

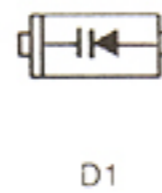

4-3 440 RF UNIT

• 440 RF UNIT

The combination of this page and the next page show the unit layout in the same configuration as the actual P.C. Board.

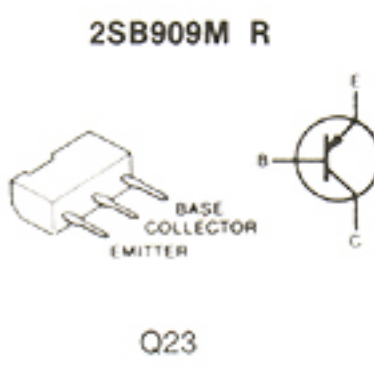
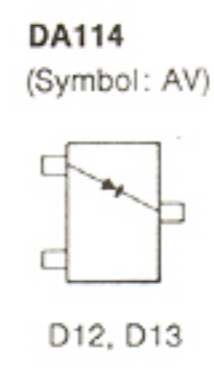
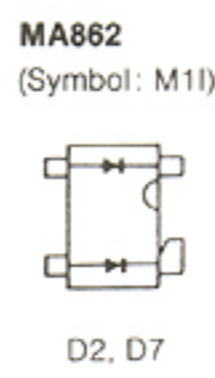
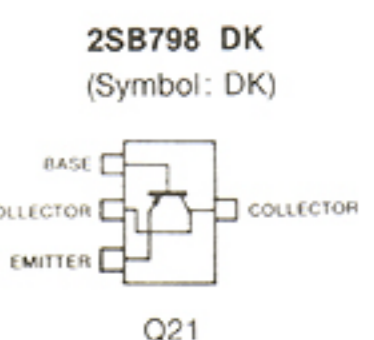
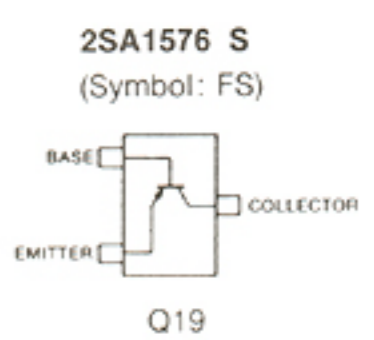
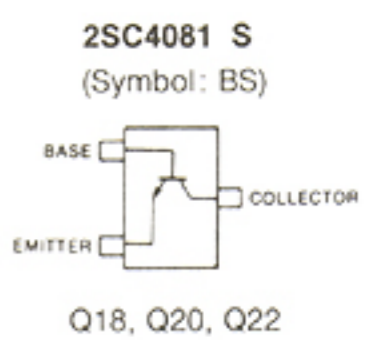
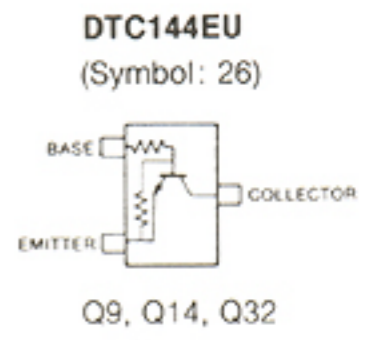
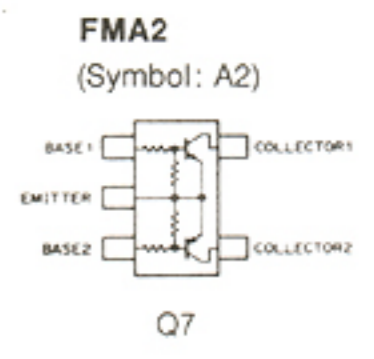
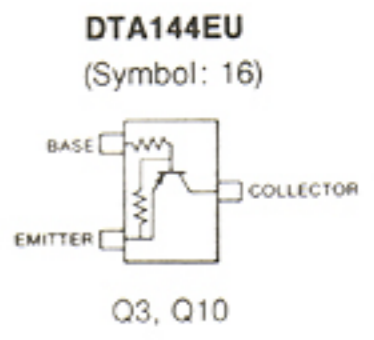
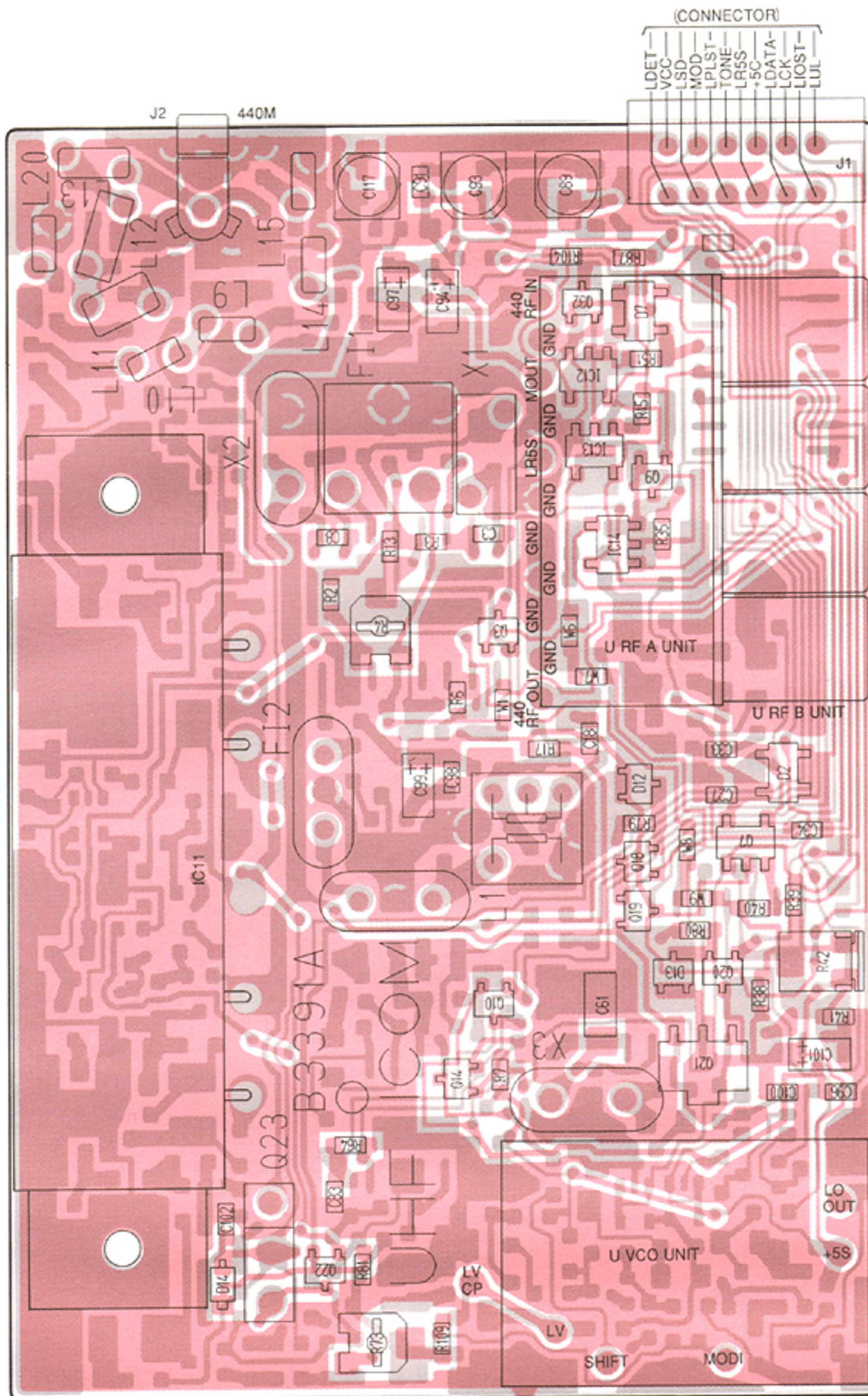

• 440 RF UNIT

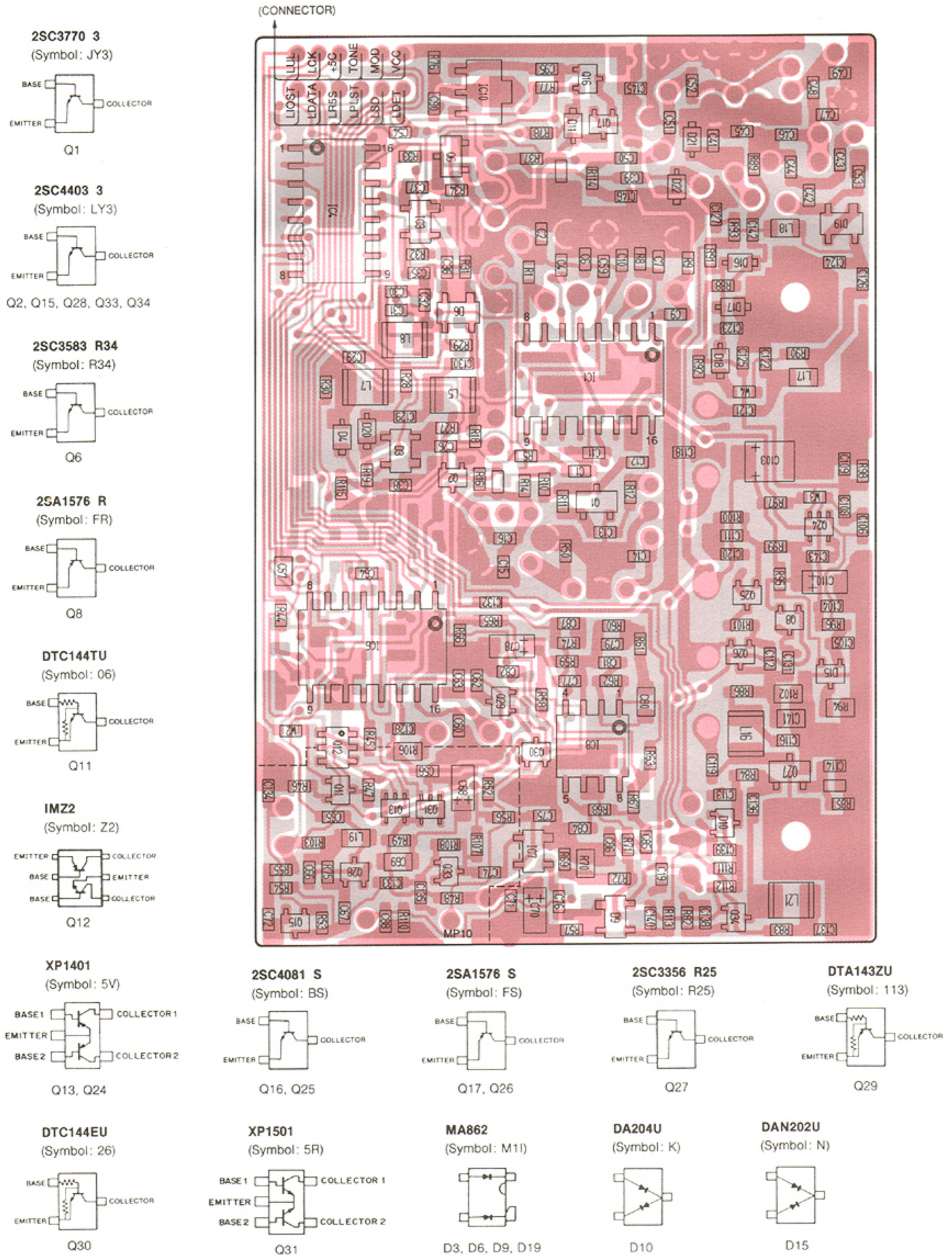

• 12 RF UNIT

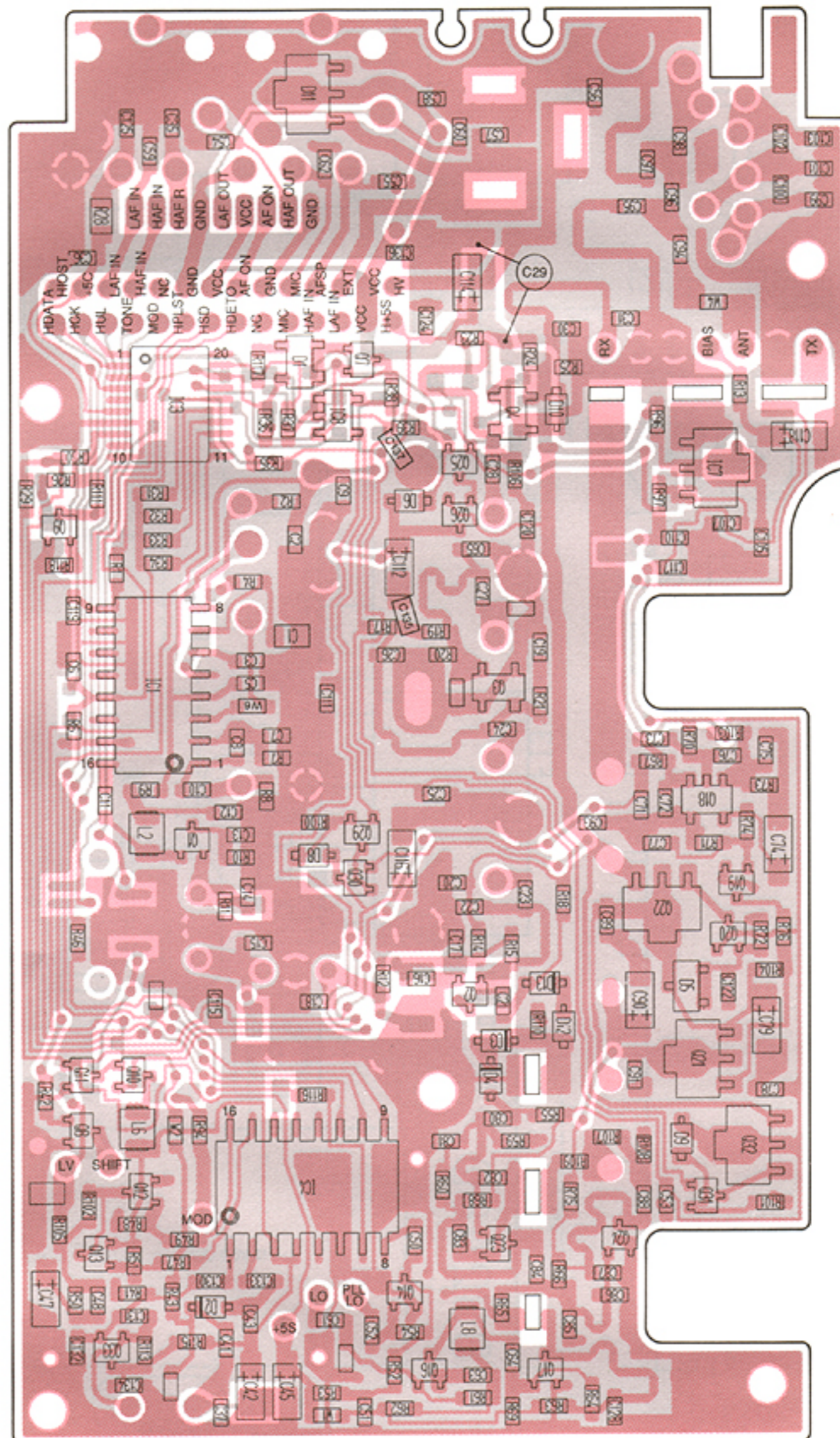
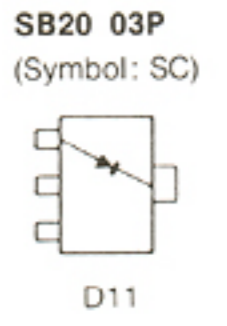
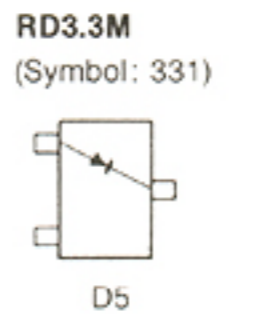
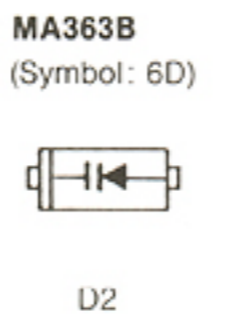
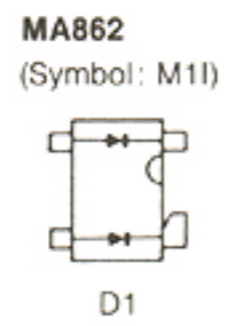
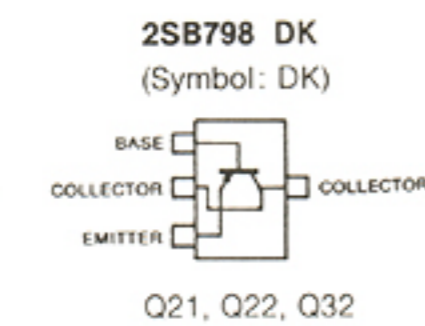
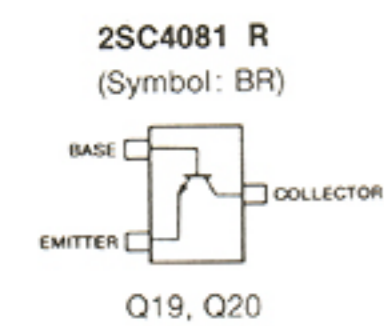
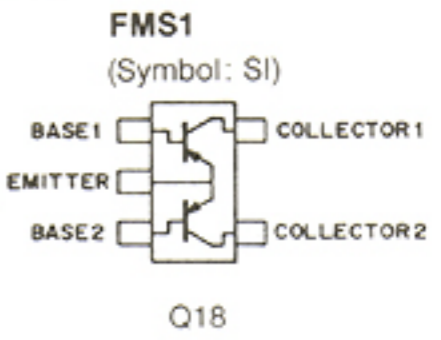
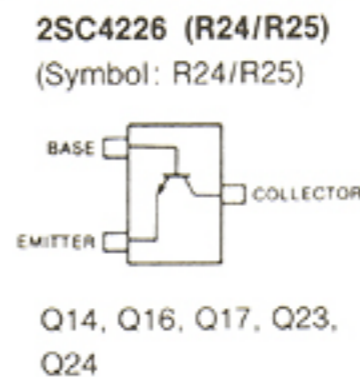
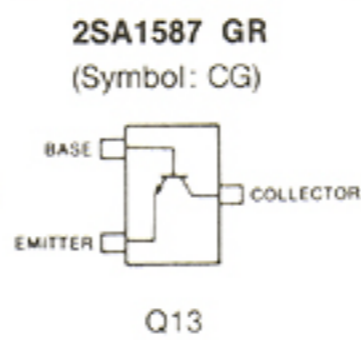
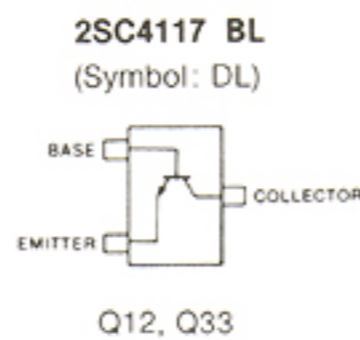
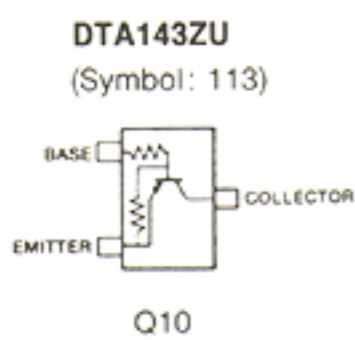
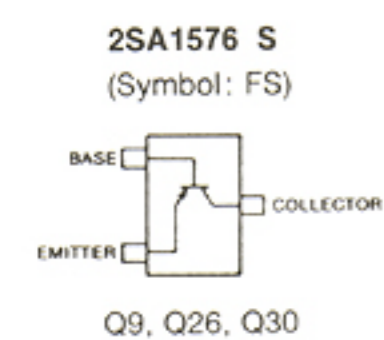
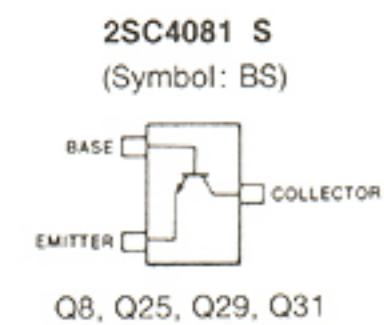
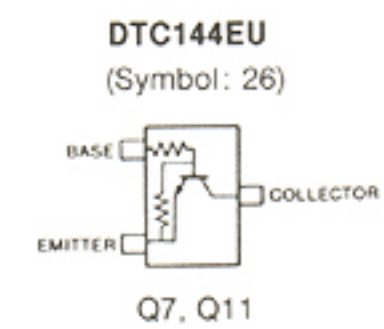
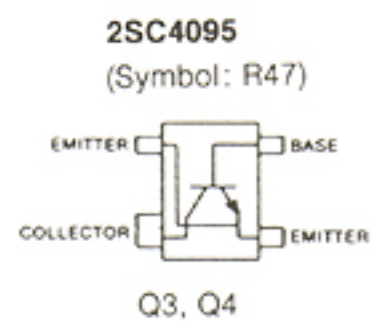
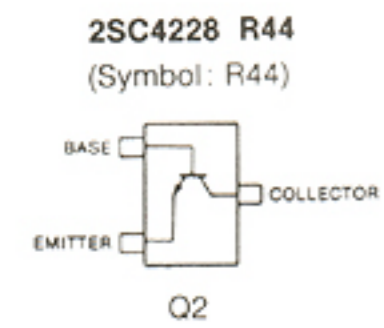
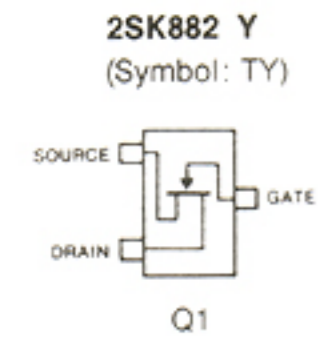

4-5 LPF, BPF AND SW UNITS

- LPF UNIT

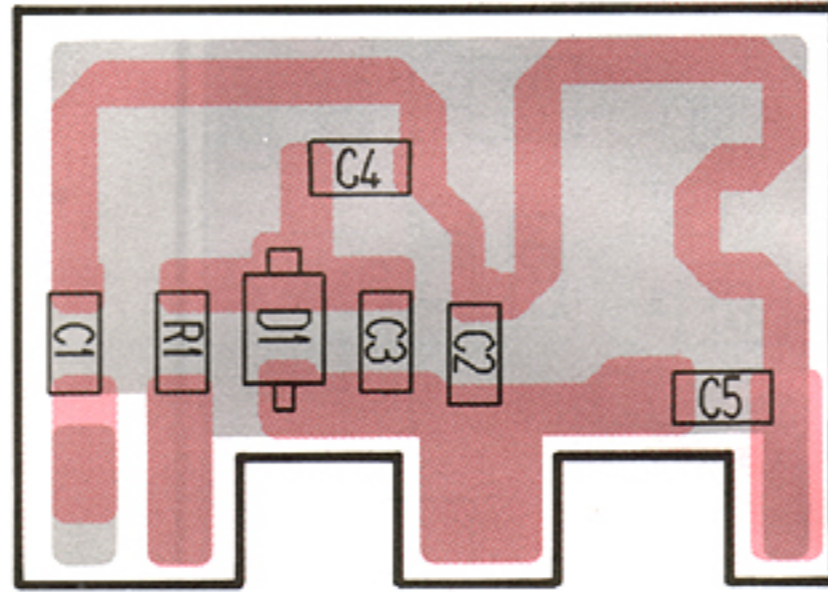

- BPF UNIT

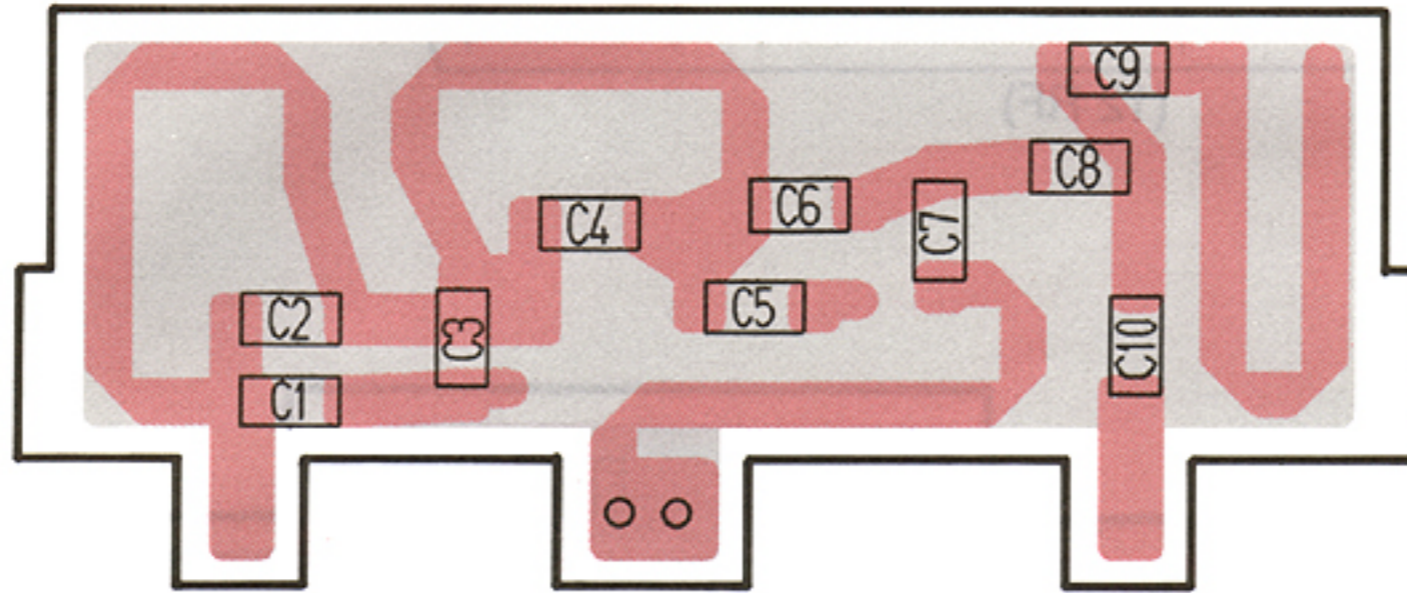

- ANT SW UNIT

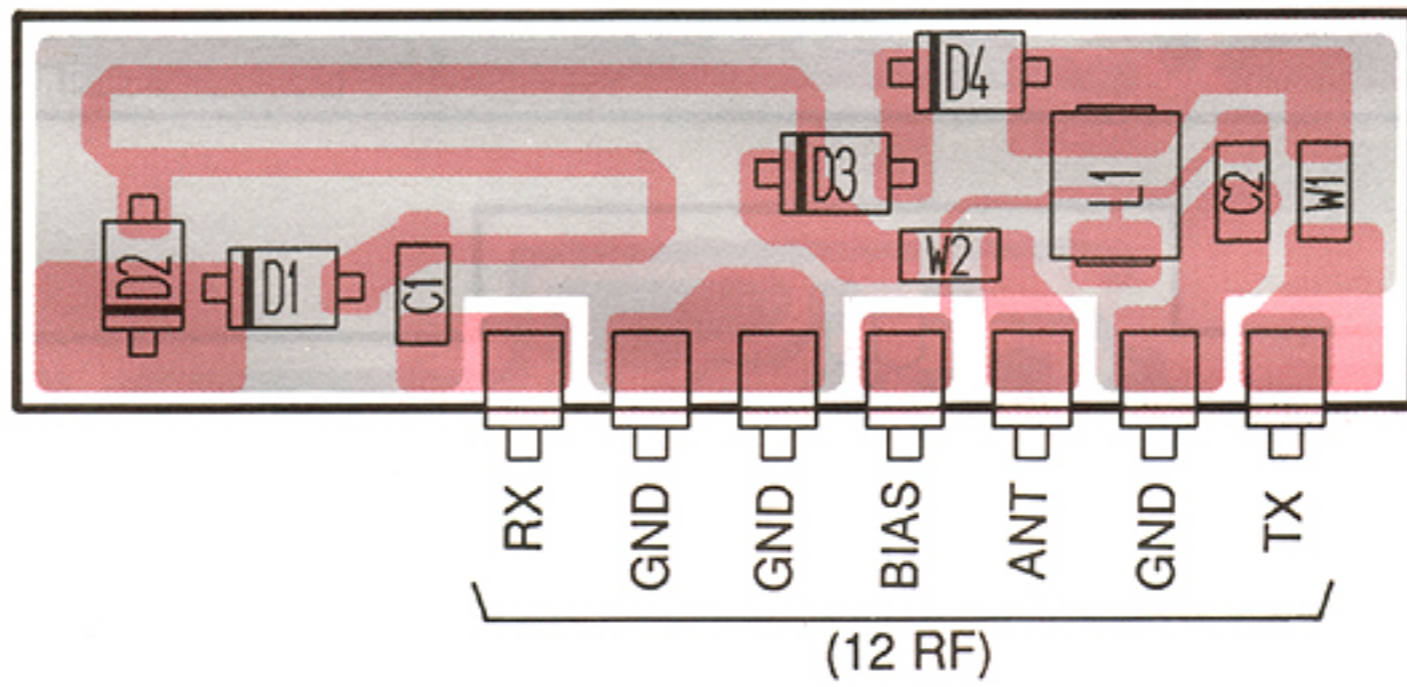

4-6 12 VCO AND MIC UNITS

• 12 VCO UNIT

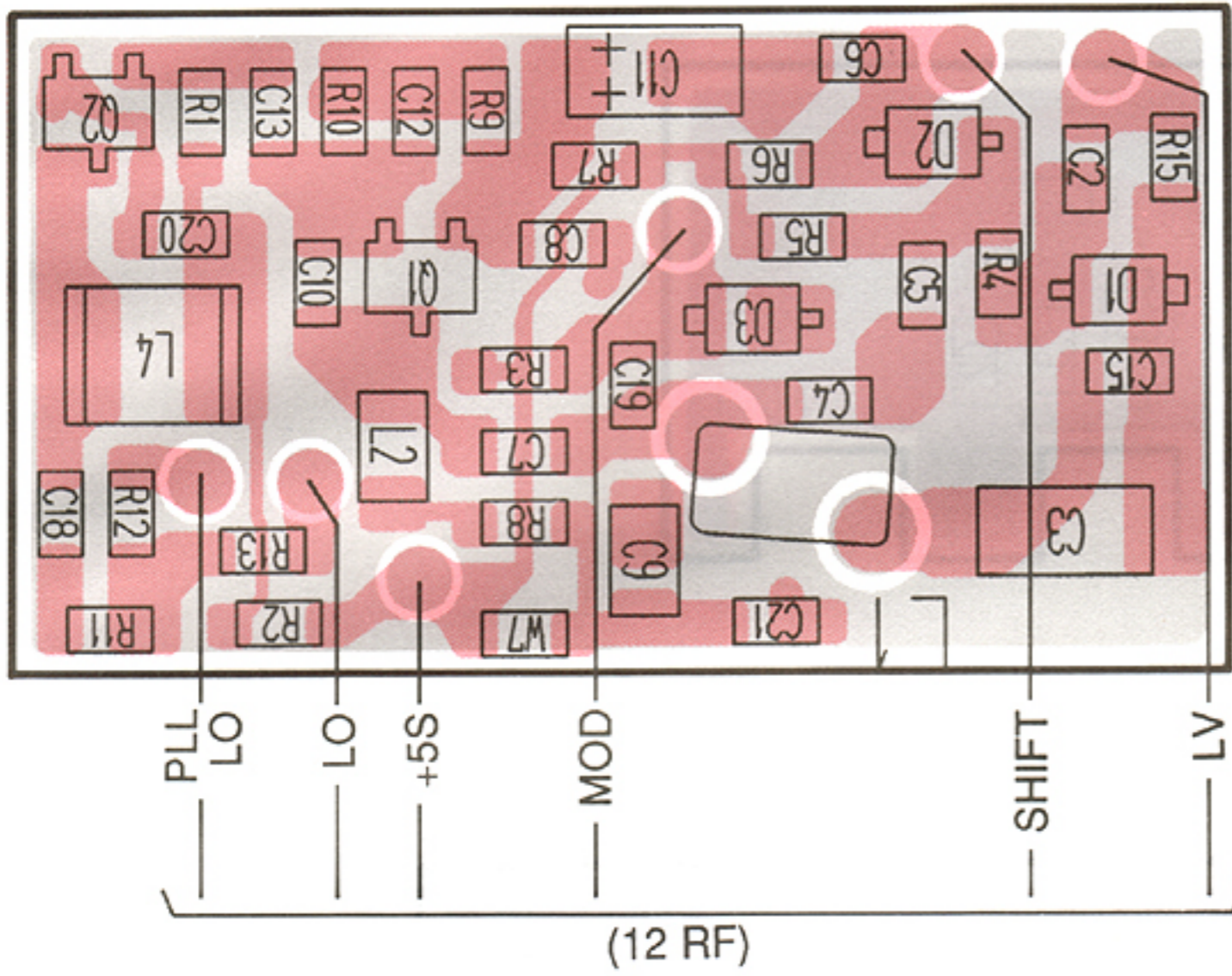

2SC4226
(Symbol: R24/R)

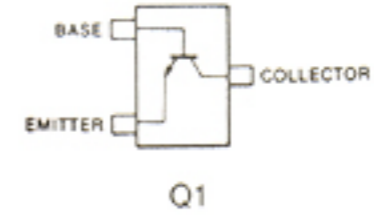

2SC4228
(Symbol: R44)

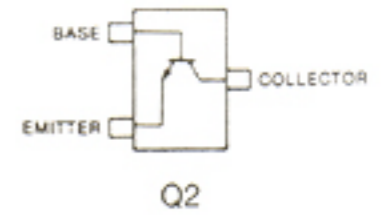

MA363B
(Symbol: 6D)



D1, D3

• MIC UNIT

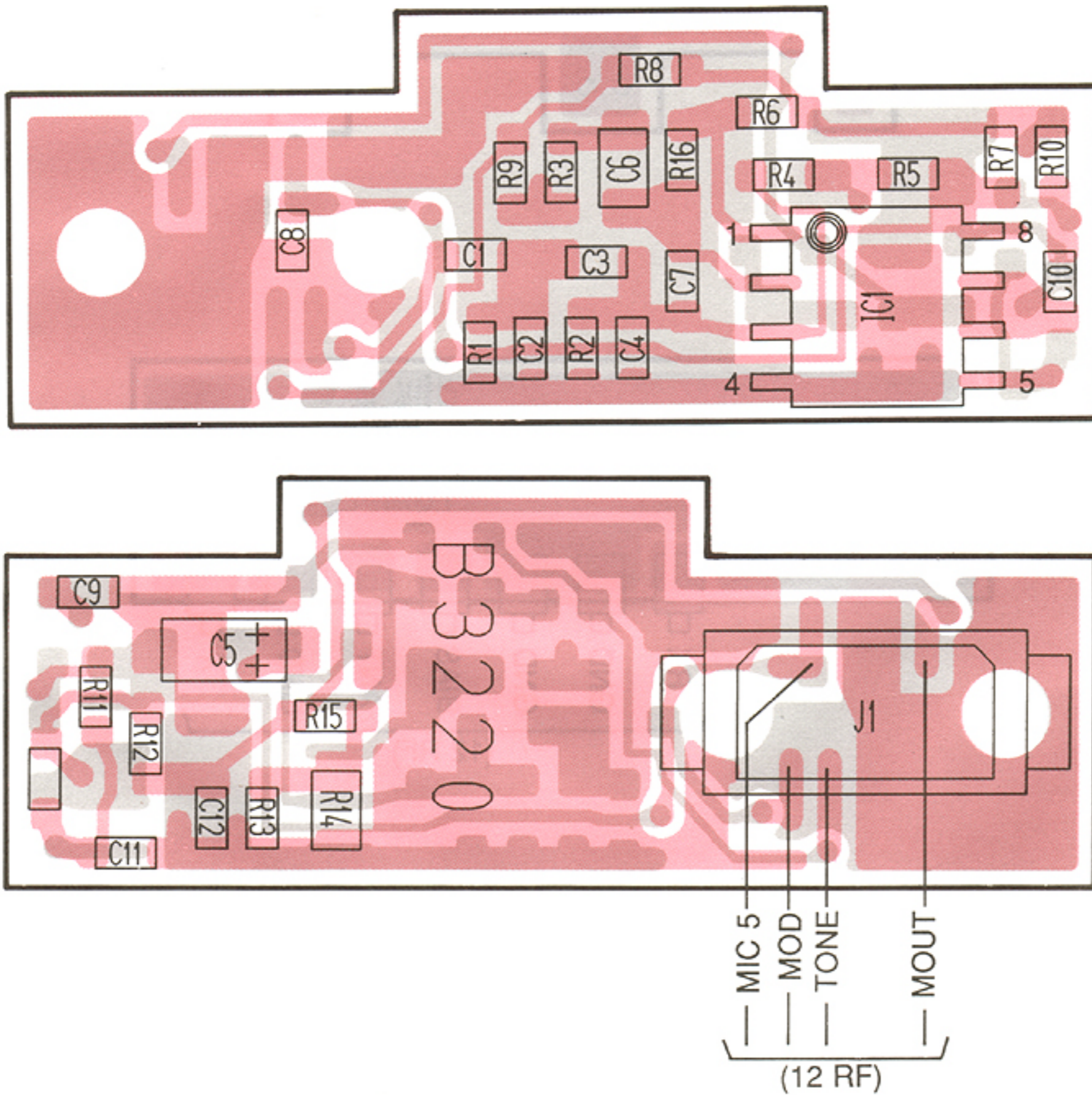

ICOM

IC-X2A IC-X2

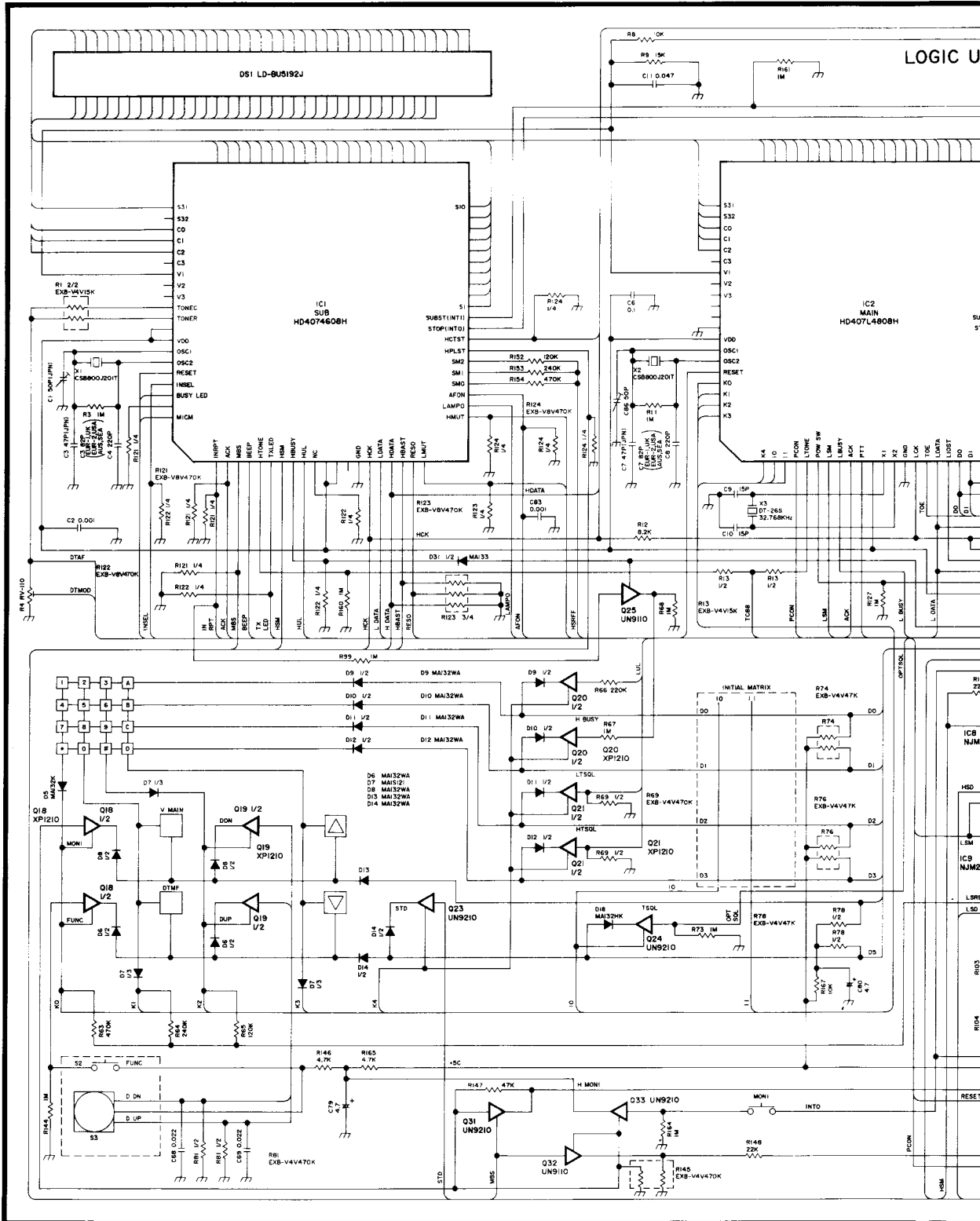
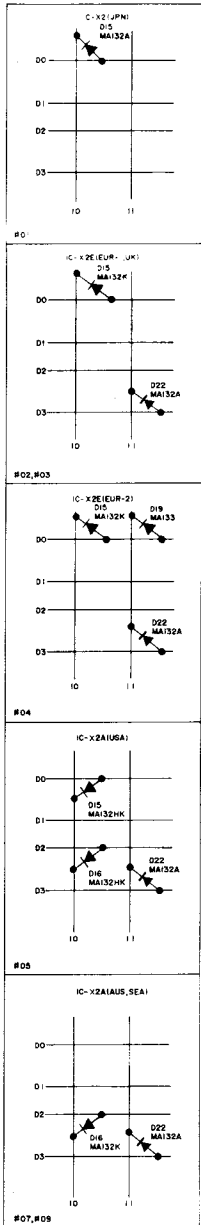

-X2E

SCHEMATIC DIAGRAM

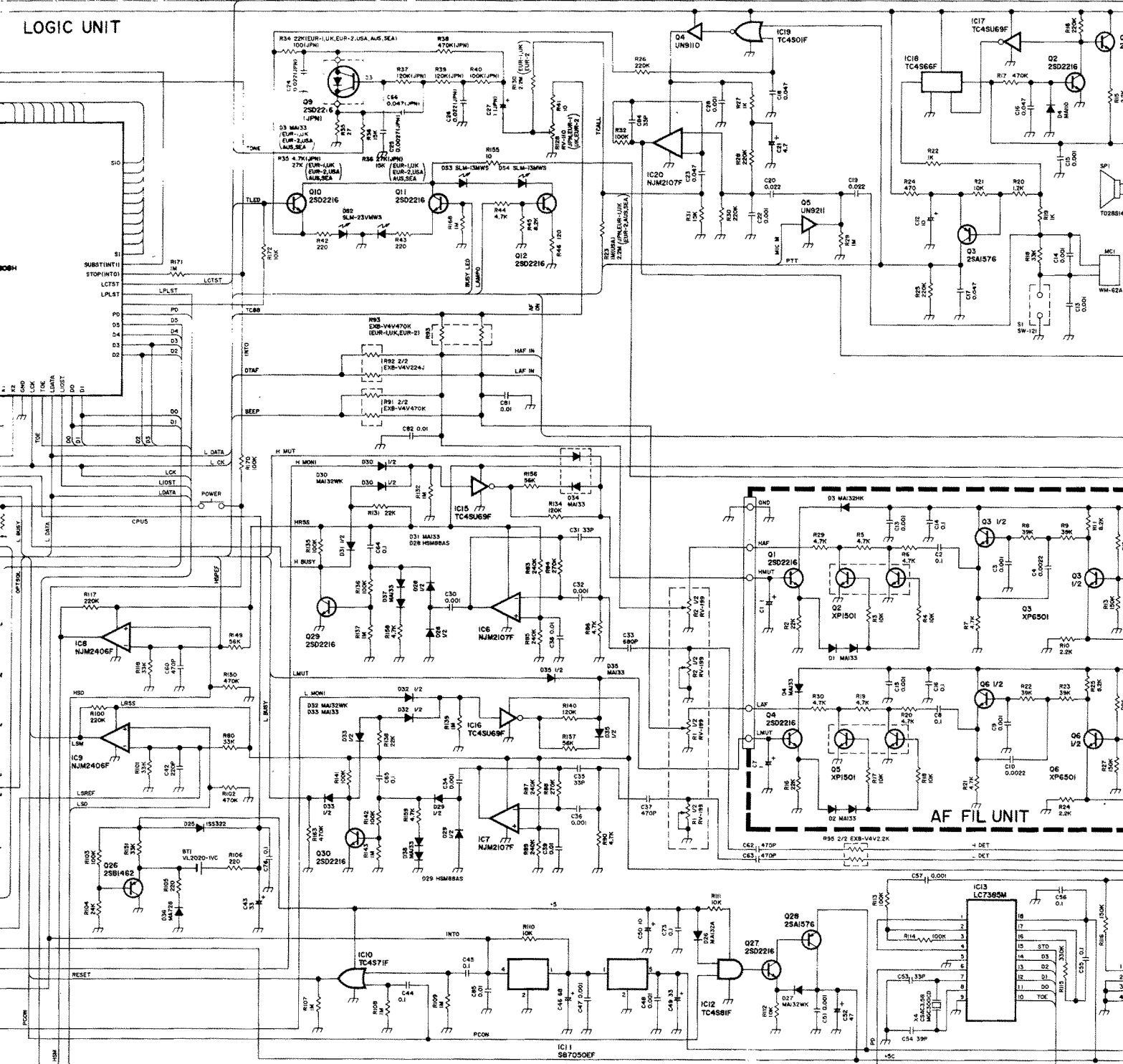

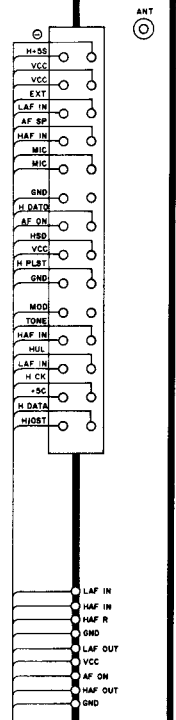
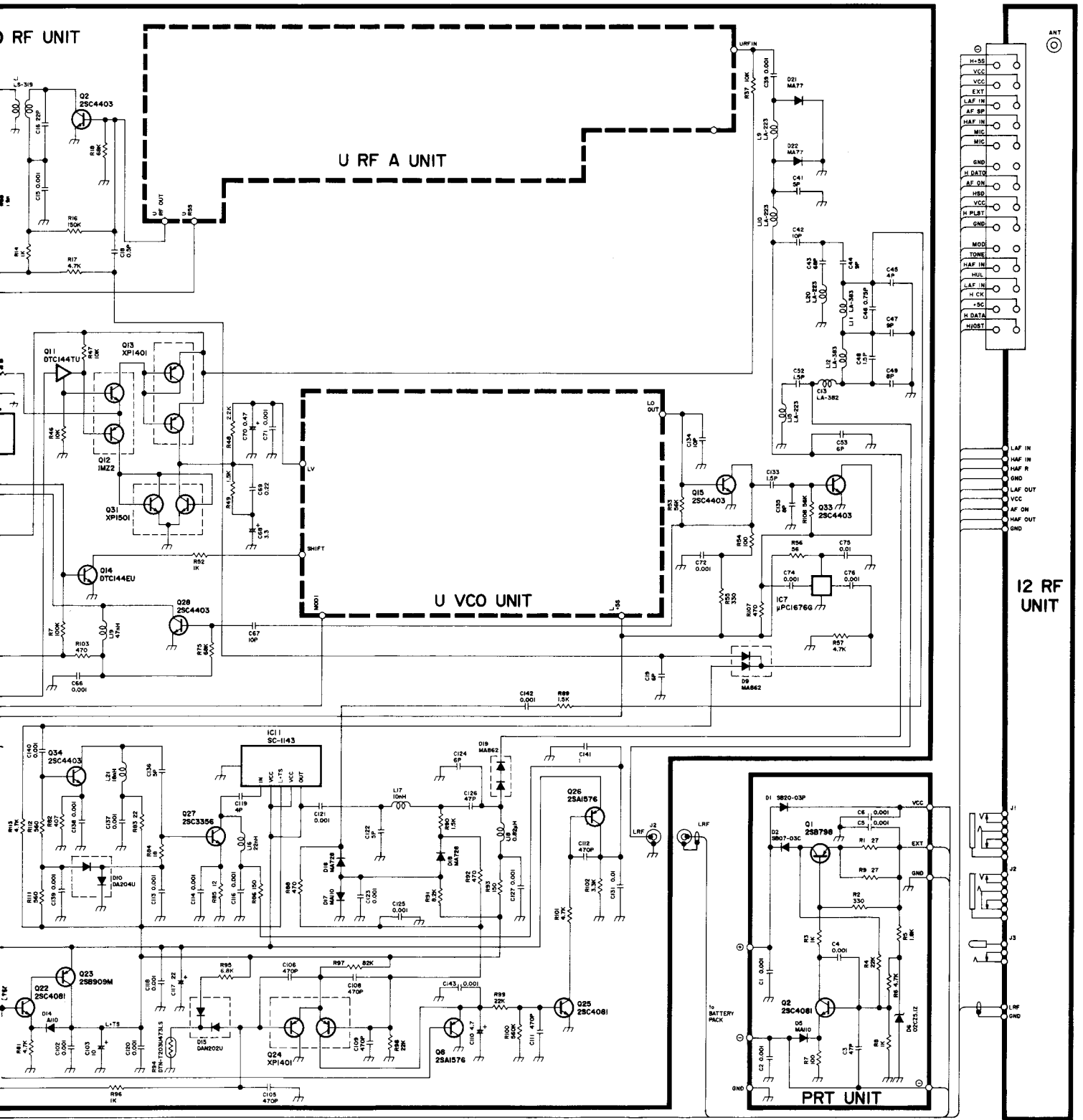

12 RF UNIT

To upgrade quality, some components may be subject to change without notice.

A-5185S-2EX
 Printed in Japan
 Copyright © 1991 by Icom Inc.

Icom Inc.

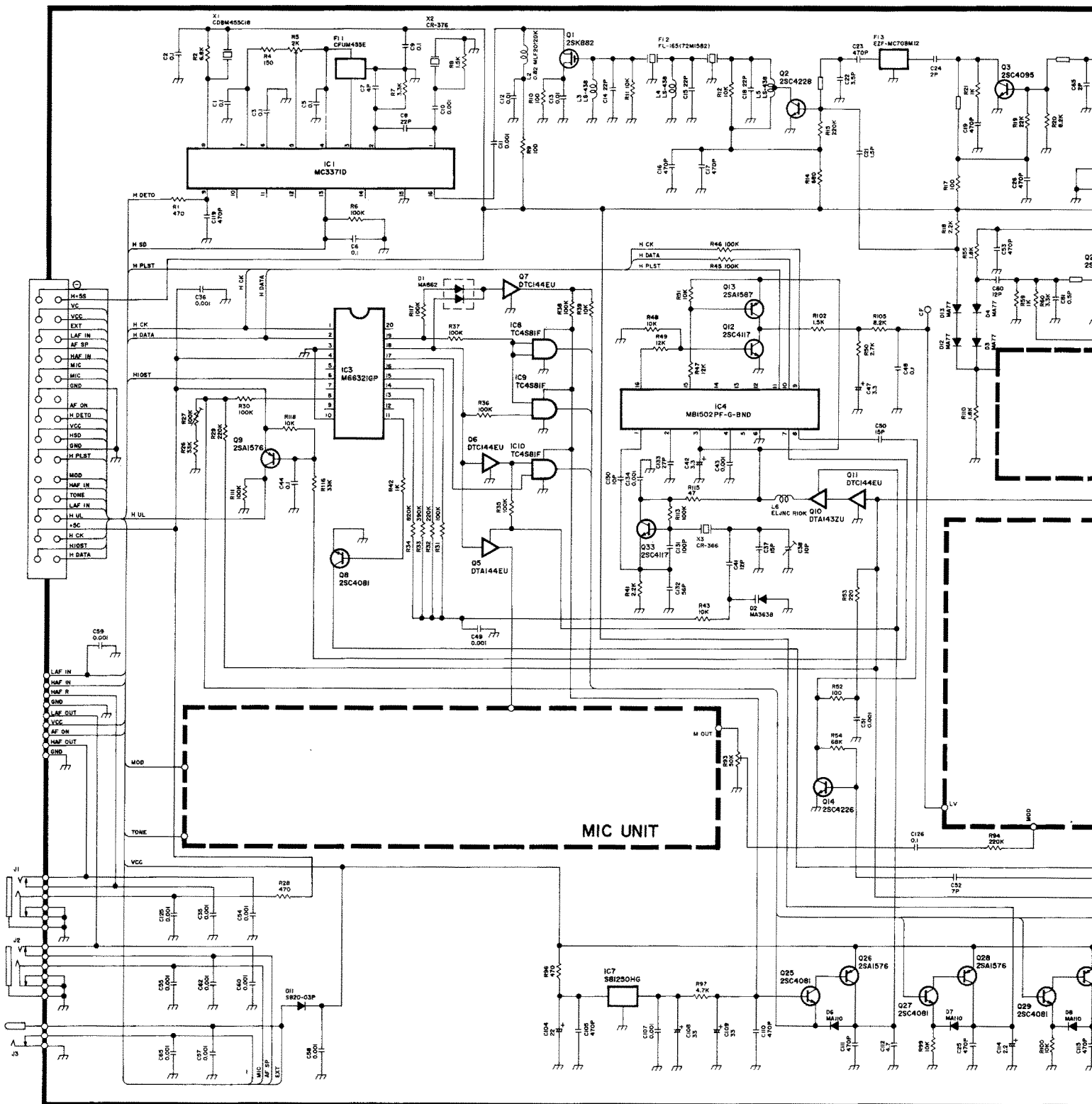

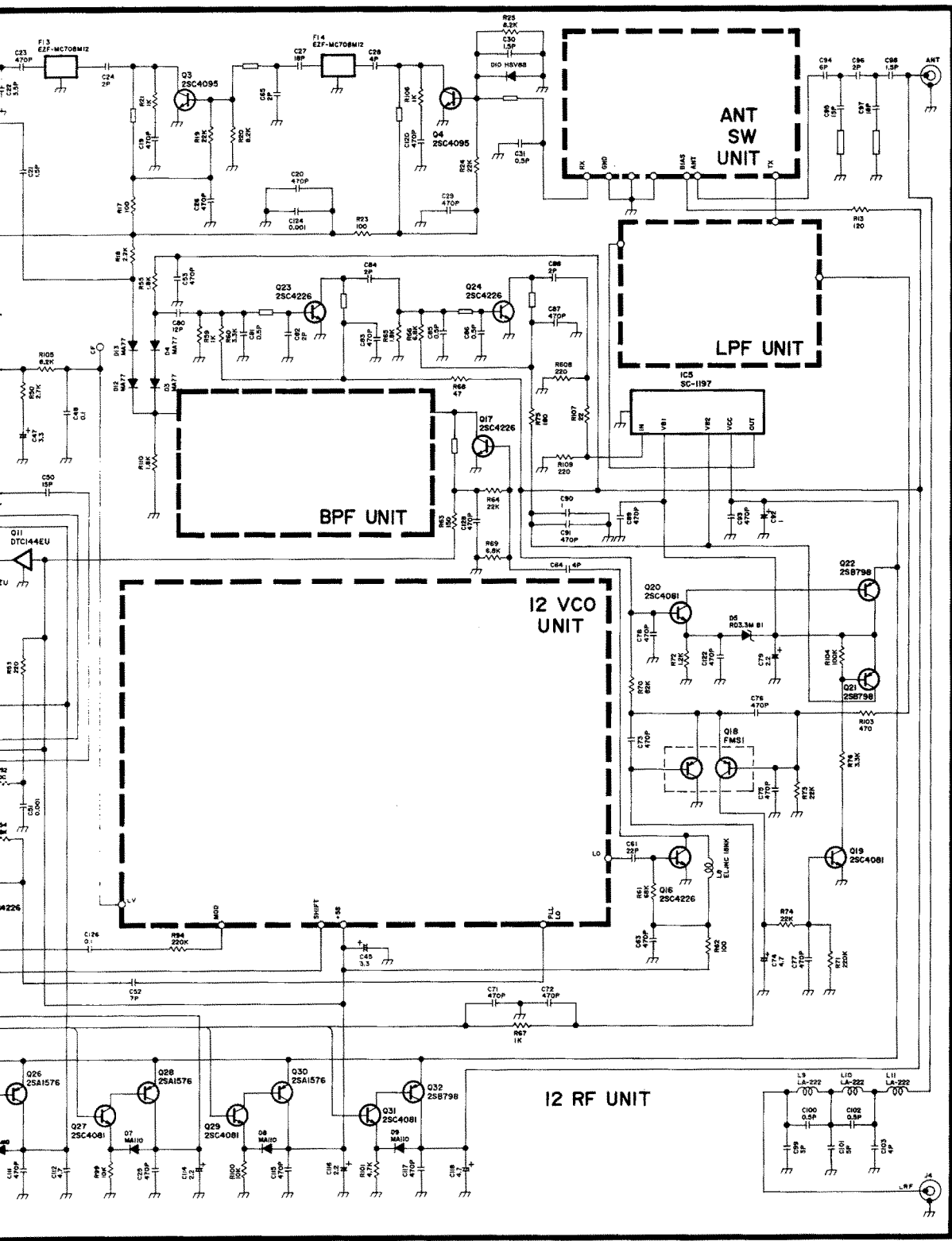

BLOCK DIAGRAM

LOGIC UNIT

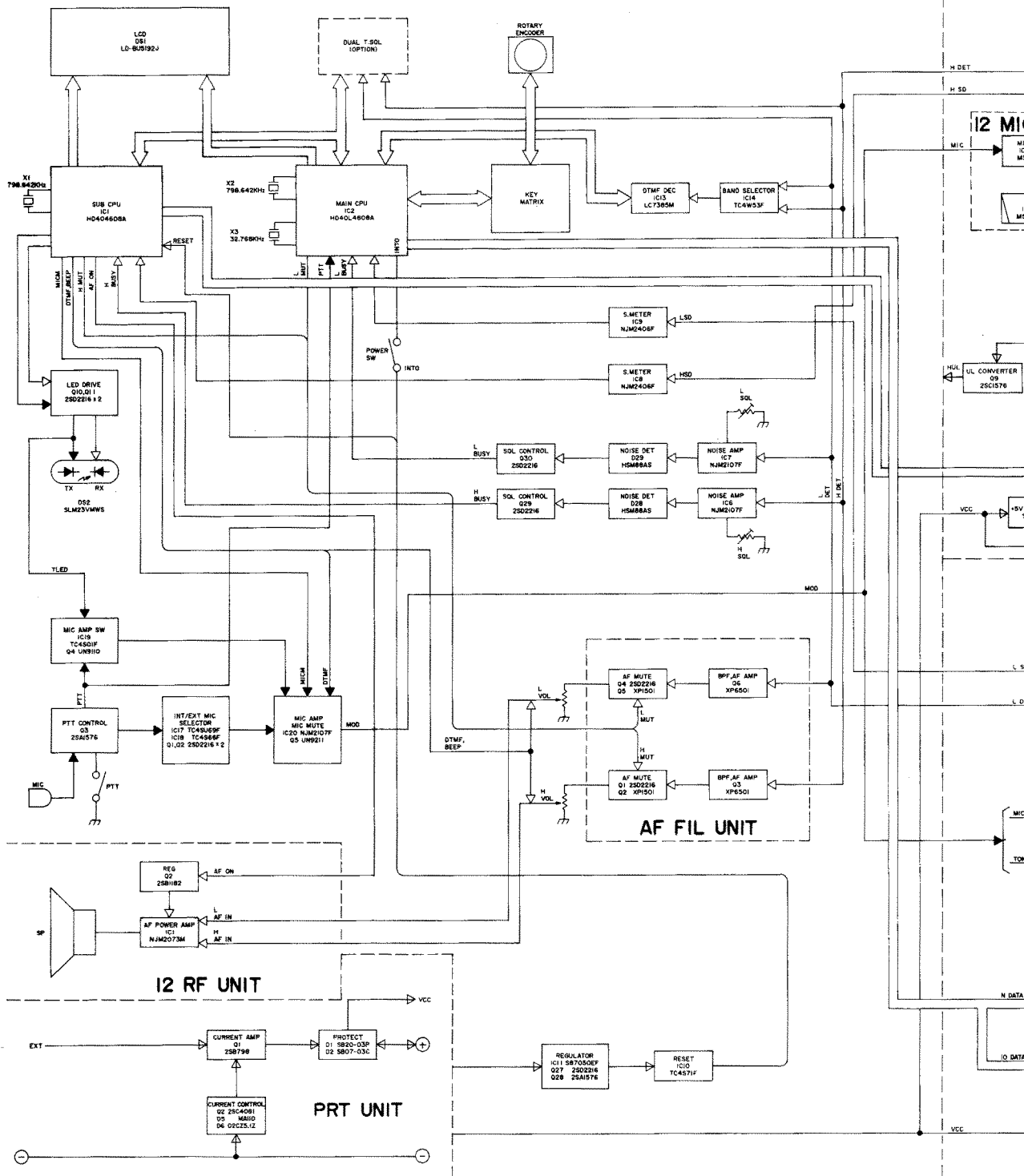

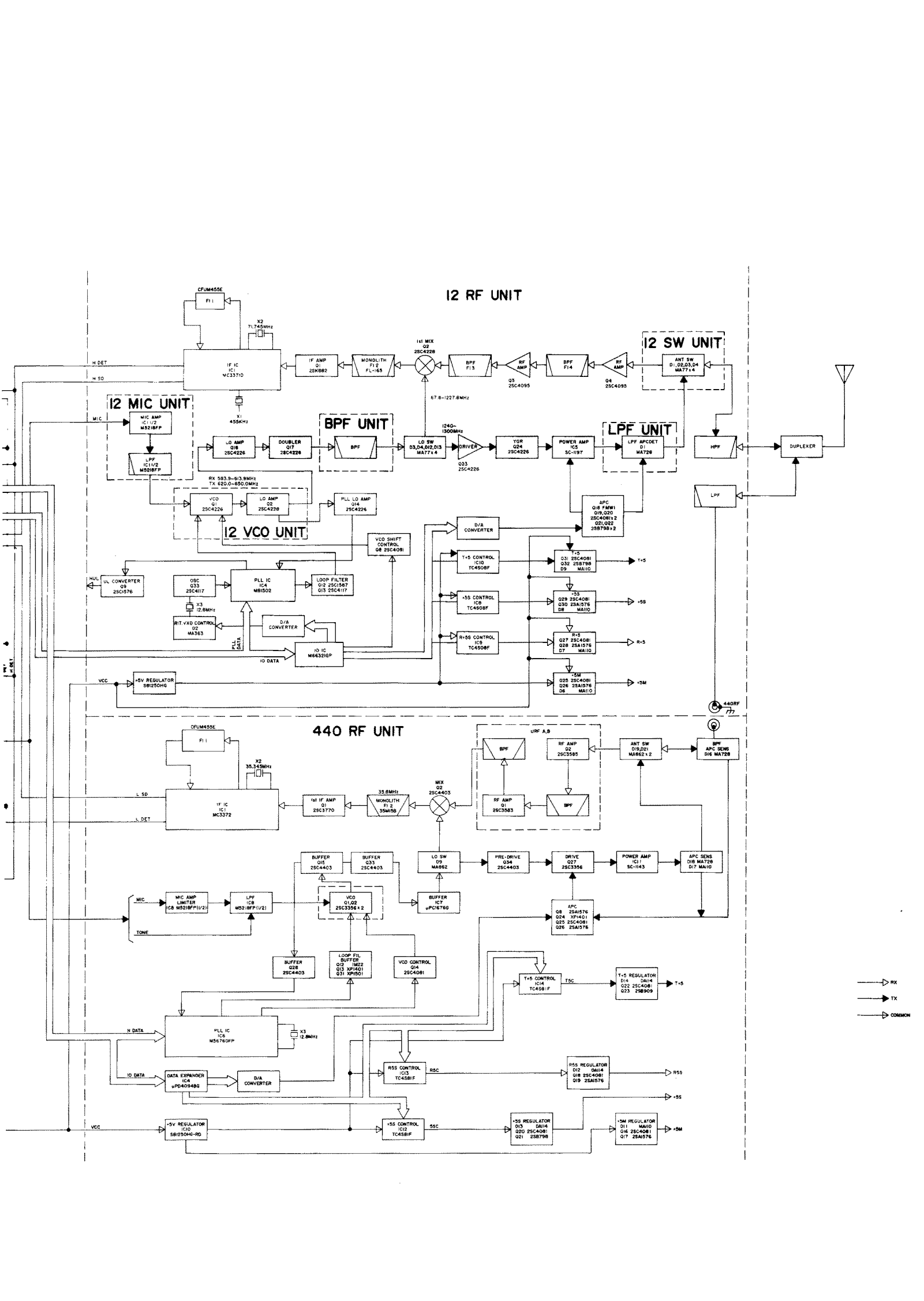

Icom Inc.

6-9-16, Kamihigashi, Hirano-ku, Osaka 547, Japan

Phone: 06 793 5302

Fax : 06 793 0013

Telex : 05277822 ICOMTR J

Icom America Inc.

<Corporate Headquarters>

2380 116th Avenue N.E., Bellevue, WA 98004, U.S.A.

Phone: (206) 454-8155

Fax : (206) 454-1509

Telex : 152210 ICOM AMER BVUE

<Customer Service>

Phone: (206) 454-7619

<Regional Customer Service Centers>

18102 Sky Park South, Suite 52-B, Irvine, CA 92714, U.S.A.

Phone: (714) 852-8026

Fax : (714) 852-8716

1777 Phoenix Parkway, Suite 201, Atlanta, GA 30349, U.S.A.

Phone: (404) 991-6166

Fax : (404) 991-6327

Icom Canada

A Division of Icom America Inc.

3071 #5 Road, Unit 9, Richmond, B.C., V6X 2T4, Canada

Phone: (604) 273-7400

Fax : (604) 273-1900

Icom (Europe) GmbH

Communication Equipment

Himmelgeister Str. 100, 4000 Düsseldorf 1, F.R.G.

Phone: 0211 346047

Fax : 0211 333639

Telex : 8588082 ICOM D

Icom (Australia) Pty. Ltd.

A.C.N 006 092 575

7 Duke Street, Windsor, Victoria, 3181, Australia

Phone: 03 529 7582

Fax : 03 529 8485

Telex : AA 35521 ICOM AS

Icom (UK) Ltd.

Unit 9, Sea St., Herne Bay, Kent, CT6 8LD, U.K.

Phone: 0227 741741

Fax : 0227 741742

Telex : 965179 ICOM G

Icom France S.a

Zac de la Plaine, Rue Brindejonc des Moulinais

BP 5804, 31505 Toulouse Cedex, France

Phone: 61. 36. 03. 03 Fax : 61. 34. 05. 91

Telex : 521515 ICOM FRA

