

TM-941A

SERVICE MANUAL

KENWOOD

*Bryan@BryanFields.net
Bryan Fields, W9CR*

©1990-10 PRINTED IN JAPAN -
B51-8079-00(A) 582



A	KNOB (CALL) K27-3081-04	KNOB (SHIFT) K27-3089-04	KNOB(REV) K27-3085-04	KNOB(LOW) K27-3087-04
B	KNOB (F) K27-3082-04	KNOB (TONE) K27-3084-04	KNOB (DTSS) K27-3086-04	KNOB (MUTE) K27-3088-04

*Refer to parts list on page 41.

CONTENTS

CIRCUIT DESCRIPTION	2
DESCRIPTION OF COMPONENTS	27
SEMICONDUCTOR DATA	36
PARTS LIST	38
EXPLODED VIEW	60
PACKING	61
ADJUSTMENT	62
PC BOARD VIEWS	
CONTROL UNIT (X53-3310-11)	70
144MHz TX-RX UNIT (X57-3580-XX)	72
430MHz TX-RX UNIT (X57-3590-XX)	74
1200 MHz TX-RX UNIT (X57-3600-11)	76

LEVEL DIAGRAM	79
SCHEMATIC DIAGRAM	81
BLOCK DIAGRAM	89
DTU-2 (DTMF UNIT)	91
PG-4K/L (PANEL SEPARATE KIT K:4m, L:7m)	93
TSU-7 (CTCSS UNIT)	94
MC-45 (MULTI FUNCTION MICROPHONE)	96
MC-45DM (MULTI FUNCTION MICROPHONE WITH AUTOPATCH)	97
SPECIFICATIONS	BACK COVER

Manual Scan

I hope this service manual is of use to you. Kenwood does not make this available as a PDF and all other available copies are of poor quality.

Each page is captured at 600 DPI, and as 24-bit color, 8-bit grayscale or black and white and at the proper page size, up to 11x34 inches in many cases. OCR has been performed on the document, even on the large pages. The document is condensed into one single PDF with text overlay. You should be able to print the larger sheets on 11x17 or tile them onto 8.5x11 if needed.

Please do not charge for access to this, or put it on a pay-wall site. Please don't pay for access to any such sites, they are against the ethos of hacking, and it only encourages them to profit off the hard work of others which has been shared openly. Please don't change this/recompress it; this defeats the point of capturing this at high resolution.

If something is incorrect here, or unreadable please reach out; I likely have the original lossless compressed images. In the final PDF that's color or grayscale will be JPEG 2000 format with highest quality selected. B&W images will be compressed using CCITT Group 4. This is quite close to the source material, but there may be some artifacts due to lossy compression. If there's a choice between file size and image quality, image quality will win. It's 2021 and storage and bandwidth is cheap.

This was captured on a Canon DR-G2140 scanner which is a ~7500 USD unit circa 2021. You may note some artifacts and lines in on the scans, these are due to scratches on the sensor glass, and are minor. The replacement glass is about 250 USD if you're feeling generous :-)

If you have a hard to find/out of print manual and would like to make it available please reach out, I may be able to scan and return it to you.

Thank you,

Bryan Fields, W9CR
bryan@bryanfields.net

CIRCUIT DESCRIPTION

144 TX-RX Unit Frequency Configuration

The 144 MHz unit incorporates a digital variable-frequency oscillator (VFO) that can freely select a channel step of 5, 10, 12.5, 15, 20, or 25 kHz with a Phase-Locked-Loop (PLL) synthesizer system.

The frequency in the receive signal channel is mixed with a first local oscillation frequency of 133.300-137.295 MHz to produce a first intermediate frequency of 10.7

MHz. This frequency is then mixed with a second local oscillation frequency of 10.245 MHz to produce a second intermediate frequency of 455 kHz. This is called a double-conversion system.

The signal in the transmission channel is directly oscillated and frequency-divided by a PLL circuit, amplified by a straight amplifier, then transmitted.

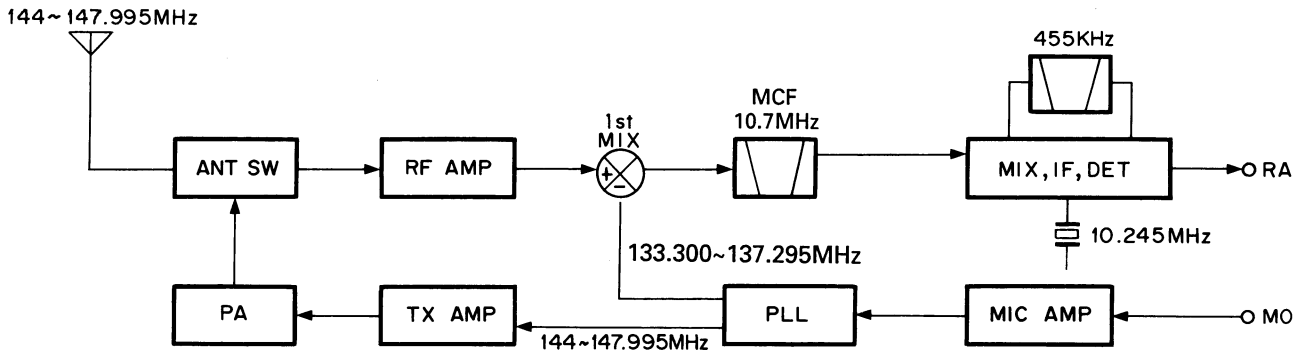

Fig. 1 Frequency configuration

144 TX-RX Unit Receive Signal Channel

- Outline

For the 144 MHz unit, the received signal from an antenna is passed through a low-pass filter in the final transmission stage and sent through a transmission/reception selection diode switch to the receiving front end. The signal is then passed through an antenna matching coil and amplified to high frequencies by a

GaAs (gallium arsenide) field-effect transistor. The unwanted components of the signal are eliminated by a bandpass filter consisting of a three-stage variable capacitor. The resultant signal is sent to the first mixer, mixed with the first local signal from a PLL circuit, then converted to a first intermediate frequency of 10.7 MHz. The unwanted near-by signal components are then eliminated by a two-stage MCF.

Item	Rating
Nominal center frequency (fo)	10.7MHz
Pass band width	±7.5kHz or less at 3dB
Attenuation band width	±25kHz or less at 40dB ±45kHz or less at 60dB
Ripple	1.0dB or less
Insertion loss	1.5dB or less
Guaranteed attenuation	70dB or more within ±1MHz (Spurious : 40dB or more at fo ~ fo + 500kHz) 80dB or more at fo - (900 - 920kHz)
Terminating impedance	3kΩ/0pF

Table 1 MCF (L71-0228-05) (144 TX-RX unit XF1)

Item	Rating
Nominal center frequency	455kHz ± 1kHz
6dB bandwidth	±6kHz or more (from 455kHz)
50dB bandwidth	±12.5kHz or less (from 455kHz)
Ripple (within ±4kHz of 455kHz)	3dB or less
Insertion loss	6dB or less
Guaranteed attenuation (within ±100kHz of 455kHz)	35dB or more
I/O matching impedance	2.0kΩ

Table 2 Ceramic filter CFWM455F (L72-0372-05) (144 TX-RX unit CF1)

CIRCUIT DESCRIPTION

The first intermediate-frequency signal is amplified and input to FM IF HIC IC5 (KCD04). This signal is then mixed with a second local oscillation frequency of 10.245MHz to produce a second intermediate-frequency signal of 455 kHz. The unwanted near-by signal components are then eliminated by an FM ceramic filter. The resultant signal is input to IC5 again, amplified to a second intermediate-frequency signal, and detected to produce an audio signal.

- **Signal-strength meter**

The signal-strength meter output voltage of FM IF HIC IC5 (KCD04) is supplied to the control unit.

- **Shift-register circuit**

The ES, CK, and DT serial data from the control unit are sent to IC1 (BU4094BF) to perform the control operation outlined in the following table:

Pin NO.	Name	Function	Pin No.	Name	Function
1	Strobe	Enable input	9	Q _s	
2	Data	Serial data input	10	Q' _s	
3	Clock	Clock input	11	Q8	TX/RX selection. "H" when TX is set.
4	Q1	TX/RX selection. "L" when TX is set	12	Q7	439/144 MHz selection. "H" when 144MHz is set.
5	Q2	TX power selection. "L" when middle and low. "H" when high.	13	Q6	
6	Q3	TX power selection. "L" when high and low. "H" when middle.	14	Q5	
7	Q4		15	OE	8V
8	V _{ss}	GND	16	V _{DD}	8V

Table 3

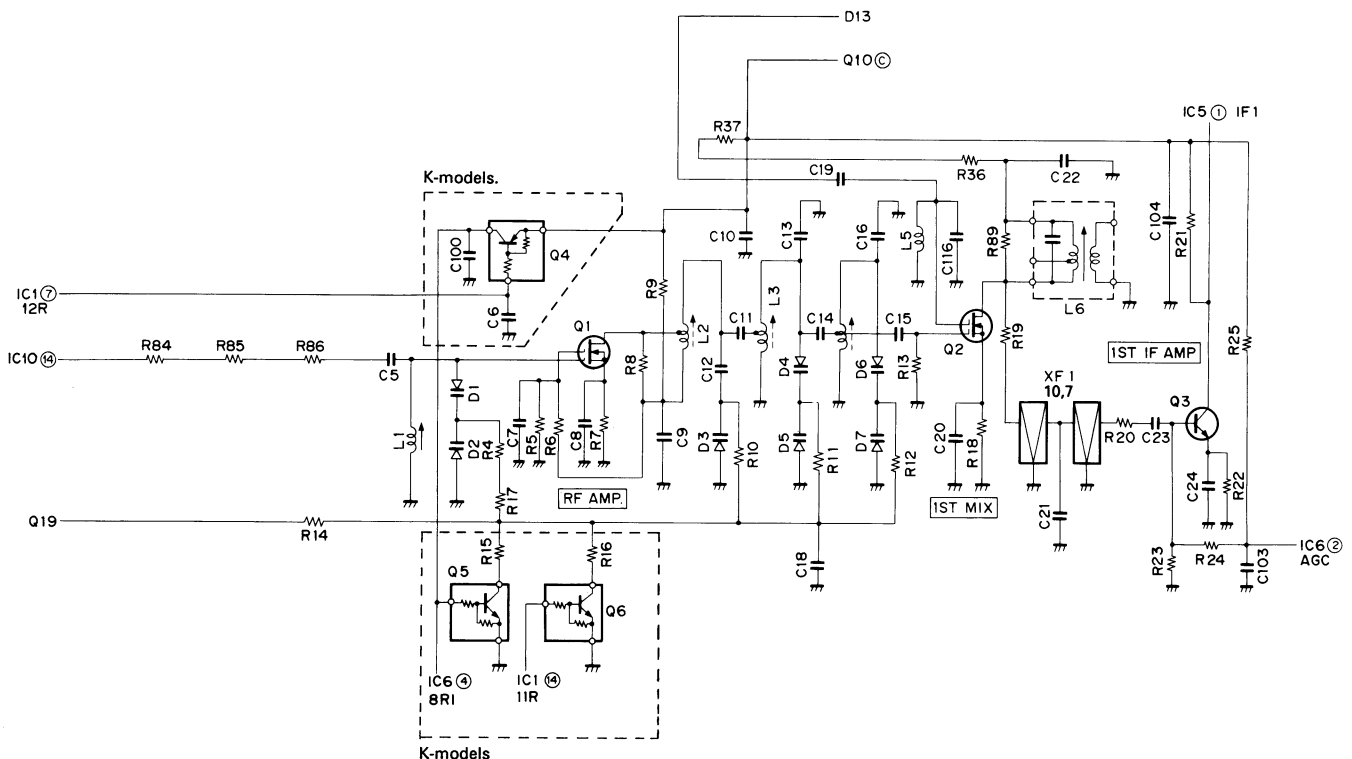

Fig. 2

CIRCUIT DESCRIPTION

144 TX-RX Unit Transmit Signal Channel

- **Outline**

In the transmission channel, the desired frequency is directly oscillated and directly frequency modulated by means of a varicap diode.

- **Modulator circuit**

The audio signal from the control unit is input to microphone amplifier HIC IC7 (KCA04). IC4 consists of a preemphasis circuit, amplifier, limiter, and splatter circuit that eliminate unwanted high-frequency components. The voltage-controlled oscillator (VCO) signal is directly frequency modulated by means of a varicap diode in the frequency modulator circuit.

- **Younger-stage circuit**

The signal output from the VCO is input to drive circuit HIC IC8 (KCB11). The amplifier can obtain a stable drive output without adjustment because it has a wide band. An APC circuit controls the collector voltage in the younger final stage.

- **Power amplifier circuit**

A drive signal is input to power module IC10 and amplified to the specified level.

- **APC circuit**

The automatic transmission output control circuit (APC) detects and partially amplifies the power module output with a diode and controls the output control voltage. The control voltage is output in inverse proportion to the output, so the control voltage output is always constant. To protect the set against excessive temperature rise, the high-power unit has a thermal switch. The high-power unit is automatically set to a low power by the thermal switch when it exceeds the specified temperature.

144 TX-RX Unit PLL Synthesizer

The VCO and PLL circuit are housed in a solid shielding case as a hybrid integrated circuit. Comparison frequencies of 6.25 kHz and 5 kHz are produced by dividing a 12.8 MHz reference oscillation frequency by 2048 and 2560 to correspond to 5, 10, 12.5, 15, 20, and 25 kHz channel steps.

For 144 MHz, the relationship between f_{VCO} (Rx) and each frequency division ratio is given by $f_{VCO} = (144 - 10.7) = \{(n \times 128) + A\} \times f_{OSC} \div R$
 Where: f_{VCO} = VCO output frequency
 n : Binary 10-bit programmable counter setting value
 A : Binary 7-bit programmable counter setting value
 f_{OSC} : Reference oscillation frequency of 12.8 MHz

R: Binary 14-bit programmable counter setting value 2048

In this case, n is 208, and A is 36.

$$\begin{aligned} \text{Therefore, } f_{VCO} &= \{(208 \times 128) + 36\} \times 12800 / 2560 \\ &= \{26624 + 37\} \times 5 \\ &= 133300 \text{ kHz} = 133.300 \text{ MHz} \end{aligned}$$

The following table lists the pin functions of the PLL circuit:

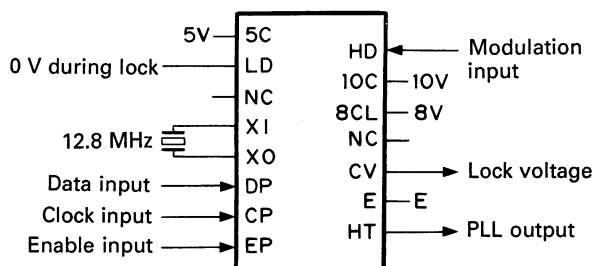

Pin name	Function	Pin name	Function
5C	5V	MO	Modulation signal input
LD	Lock signal (on during lock)	10C	10V
NC	Unused	8CL	8V (ripple filter)
XI	12.8 MHz crystal oscillation	NC	Unused
XO		CV	Lock voltage output
DP	Data input	E	GND
CP	Clock input	HT	VCO output
EP	Enable input		

Table 4

CIRCUIT DESCRIPTION

• 8T (8 V during transmission) and unlock signal

A 0.7 V voltage is applied to the base of Q13 during reception, Q13 is set on, Q14 is set off, and Q11 is set off. No voltage appears at the collector (8T) of Q11. Serial data is output from the control unit during transmission and input to shift register IC1. Pin 4 of IC1 is then set low. Therefore, Q13 is changed from on to off, Q14 from off to on, and Q11 from off to on. An 8 V

voltage is applied to the collector (8T) of Q11.

An unlock circuit is activated only during transmission. The LD signal output from the PLL circuit is ORed with the signal at pin 4 of IC1 using D11 as shown in the figure, so the LD signal is set high during unlock. Therefore, no voltage appears at the collector (8T) of Q11 and no transmission wave is output to the reception state.

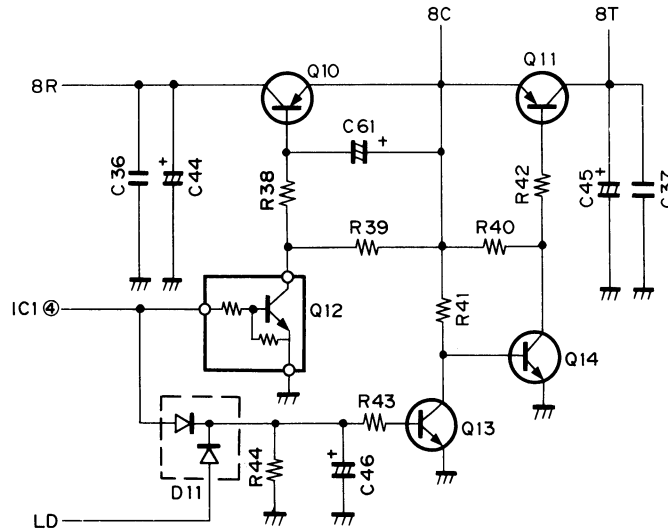

Fig. 4

430 TX-RX Unit Frequency Configuration

The 430 MHz unit incorporates a digital variable-frequency oscillator (VFO) that can freely select a channel step of 5, 10, 12.5, 15, 20, or 25 kHz with a PLL synthesizer system. The frequency in the receive signal channel is mixed with a first local oscillation frequency of 451.6-461.595 MHz (459.6-471.595 MHz for K-models) to produce a first intermediate frequency

of 21.6 MHz. The frequency is then mixed with a second local oscillation frequency of 21.145 MHz to produce a second intermediate frequency of 455 kHz. This is called a double-conversion system.

The signal in the transmission channel is directly oscillated and frequency-divided by a PLL circuit, amplified by a straight amplifier, then transmitted.

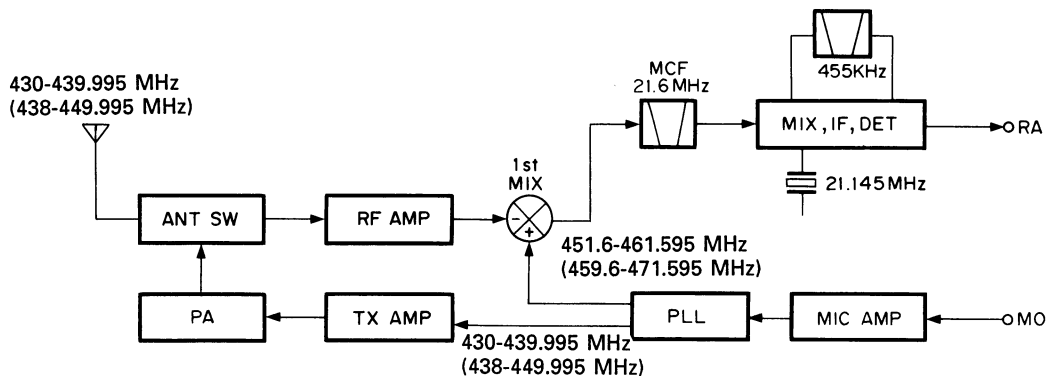

* The alphanumeric characters enclosed in parentheses are used for K-models.

Fig. 5 Frequency Configuration

CIRCUIT DESCRIPTION

430 TX-RX Unit Receive Signal Channel

- **Outline**

A 430 MHz band antenna input signal is passed through the antenna selection diode in the final stage and sent through a front-stage antenna matching coil to the high-frequency two-stage amplifier and helical block of a GaAs (gallium arsenide) FET and junction FET. The signal is then input to the first mixer. The first mixer input signal is mixed with the first local signal from the PLL circuit and converted to a first intermediate-frequency signal of 21.6 MHz. The unwanted near-by signal components are then eliminated by a two-stage MCF.

The first intermediate-frequency signal is amplified and input to FM IF HIC IC1 (KCD04). This signal is then mixed with a second local oscillation frequency of

21.145 kHz to produce a second intermediate frequency of 455 kHz. The unwanted near-by components of the intermediate-frequency signal are eliminated by an FM ceramic filter. The intermediate-frequency signal is input to IC1 again. The second intermediate-frequency signal is amplified and detected by IC1 to produce an audio signal.

- **Signal-strength meter**

The signal-strength meter output voltage of FM IF HIC IC1 (KCD04) is supplied to the control unit.

- **Shift-register circuit**

The ES, CK, and DT serial data from the control unit are sent to IC3 (BU4094BF) to perform the control operation outlined in the following table:

Pin No.	Name	Function	Pin No.	Name	Function
1	Strobe	Enable input	9	Q _s	
2	Data	Serial data input	10	Q' _s	
3	Clock	Clock input	11	Q8	
4	Q1	TX/RX selection. "L" when TX is set	12	Q7	
5	Q2	TX power selection. "L" when middle and low. "H" when high.	13	Q6	
6	Q3	TX power selection. "L" when high and low. "H" when middle.	14	Q5	
7	Q4		15	OE	8V
8	V _{ss}	GND	16	V _{DD}	8V

Table 5

CIRCUIT DESCRIPTION

430 TX-RX Unit Transmit Signal Channel

- **Outline**

In the transmission channel, the desired frequency is directly oscillated and directly frequency modulated by means of a varicap diode.

- **Modulator circuit**

The audio signal from the control unit is input to microphone amplifier HIC IC2 (KCA04). IC4 consists of a preemphasis circuit, amplifier, limiter, and splatter circuit that eliminate unwanted high-frequency components. The VCO signal is directly frequency modulated by a varicap diode in the frequency modulator circuit.

- **Younger-stage circuit**

The signal output from the VCO is input to drive circuit HIC IC6 (KCB14). The amplifier can obtain a stable drive output without adjustment because it has a wide

band. An APC circuit controls the collector voltage in the younger final stage.

- **Power amplifier circuit**

A drive signal is input to power module IC7 and amplified to the specified level.

- **APC circuit**

The automatic transmission output control circuit (APC) detects and partially amplifies the power module output with a diode and controls the output control voltage. The control voltage is output in inverse proportion to the output, so the control voltage output is always constant. To protect the set against excessive temperature rise, the high-power unit has a thermal switch. The high-power unit is automatically set to a low power by the thermal switch when it exceeds the specified temperature.

430 TX-RX Unit PLL Synthesizer

The VCO and PLL circuit are housed in a solid shielding case as a hybrid integrated circuit. Comparison frequencies of 6.25 and 5 kHz are produced by dividing a 12.8 MHz reference oscillation frequency by 2048 and 2560 to correspond to 5, 10, 12.5, 15, 20, or 25 kHz channel steps.

For 430 MHz, the relationship between f_{VCO} (RX) and each frequency division ratio is given by

$$f_{VCO} = (430 + 21.6) = \{(n \times 128) + A\} \times f_{osc} + R$$

Where: f_{VCO} = VCO output frequency

n: Binary 10-bit programmable counter setting value

A: Binary 7-bit programmable counter setting value

f_{osc} = Reference oscillation frequency of 12.8 MHz

R: Binary 14-bit programmable counter setting value

2560 (in 5, 10, 15, and 20 kHz steps)

2048 (in 12.5 and 25 kHz steps)

In 5, 10, 15, and 20 kHz steps, n is 705 and A is 80.

Therefore, $f_{VCO} = \{705 \times 128\} \times 12800 / 2560$

$$= \{90240 + 80\} \times 5$$

$$= 451600$$

$$= 451.6 \text{ MHz}$$

See the 144 MHz band unit (X57-3580-00) for the function of each pin of IC10 in the PLL circuit.

- **8T (8 V during transmission) and unlock signal**

See the 144 TX/RX unit description on page 5. (The figure on the under indicates the 430 MHz unit.)

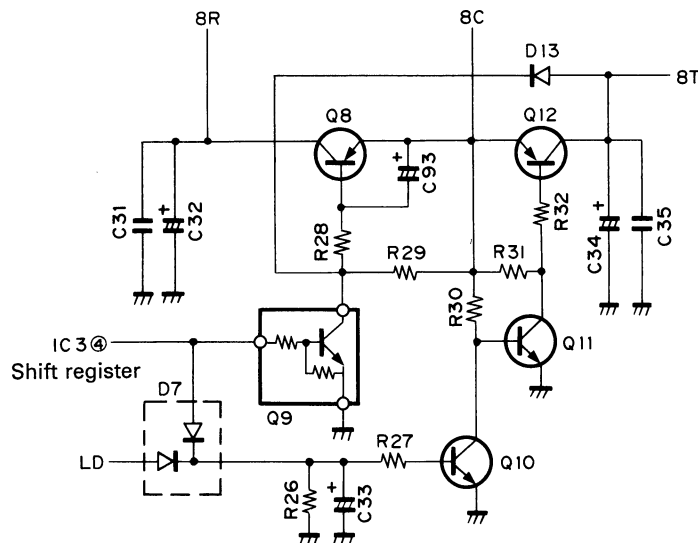

Fig. 6

CIRCUIT DESCRIPTION

1200 TX-RX Unit Frequency Configuration

The 1200 MHz unit incorporates a digital variable-frequency oscillator (VFO) that freely can select a channel step of 10, 12.5, 20, or 25 kHz with a PLL synthesizer system.

The frequency in the receive signal channel is mixed with a frequency of 1200.3 to 1240.20 MHz obtained when a first local oscillation frequency of 600.15 to 620.145 MHz is multiplied by 2 to produce a first

intermediate frequency of 59.7 MHz. This frequency is then mixed with a second local oscillation frequency of 59.245 MHz to produce a second intermediate frequency of 455 kHz. This is called a double-conversion system.

The signal in the transmission channel is oscillated and frequency-divided by a PLL circuit, then multiplies the frequency of 630 to 649.995 MHz by two to produce a frequency of 1260 to 1299.99 MHz. This signal is amplified by a straight amplifier, then transmitted.

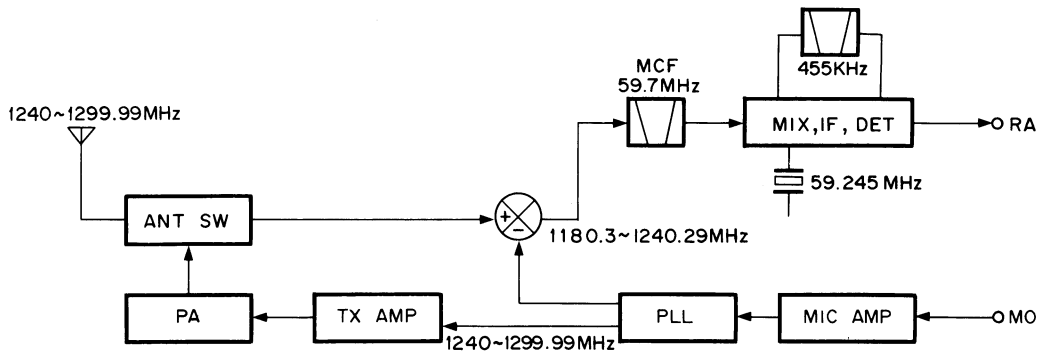

Fig. 7 Frequency Configuration

1200 TX-RX Unit Receive Signal Channel

● Outline

The received signal from an antenna is passed through a low-pass filter in the transmission final stage and sent through a transmission/reception selection diode switch to the receiving front end. The signal is then amplified to high frequencies by a microwave GaAs (gallium arsenide) FET and sent to a dielectric filter. The unwanted components of the signal are eliminated by a microwave transistor in another stage and the dielectric filter. The resultant signal is input to the first mixer. The front end block is matched by a microstrip line to ensure high sensitivity and high reliability. A GaAs FET is used in the first mixer to obtain a good two-signal characteristic. This signal is mixed with the first local signal from a PLL circuit by the first mixer and converted to a first intermediate frequency of 59.7 MHz. The unwanted near-by signal components are eliminated by a two-stage MCF. The

resultant signal is produced as a first intermediate-frequency signal.

The first intermediate-frequency signal is amplified and input to FM IF HIC IC2 (KCD04). This signal is then mixed with a second local oscillation frequency of 59.245 kHz to produce a second intermediate frequency of 455 kHz. The intermediate-frequency signal is passed through a ceramic filter to obtain a sharp characteristic. The signal is then input to an HIC again, amplified, then demodulated and output from the HIC.

● Signal-strength meter

The signal-strength meter output voltage of FM IF HIC IC2 (KCD04) is supplied to the control unit.

● Shift-register circuit

The FS, CK, and DT serial data from the control unit are sent to IC5 (BU4094BF) to perform the control operation outlined in the following table:

CIRCUIT DESCRIPTION

Pin No.	Name	Function	Pin No.	Name	Function
1	Strobe	Enable input	9	Q _s	
2	Data	Serial data input	10	Q' _s	
3	Clock	Clock input	11	Q8	TX/RX selection. "L" when TX is set (Set low faster than Q1).
4	Q1	TX/RX selection. "L" when TX is set	12	Q7	ALT. "H" when on.
5	Q2	TX power selection. "L" when middle and low. "H" when high.	13	Q6	
6	Q3	TX power selection. "L" when high and low. "H" when middle.	14	Q5	
7	Q4		15	QE	8V
8	V _{ss}	GND	16	V _{DD}	8V

Table 6

1200 TX-RX Unit Transmit Signal Channel

- **Outline**

In the transmission channel, the desired frequency is oscillated by half and directly frequency modulated by means of a varicap diode.

- **Modulator circuit**

The audio signal from the control unit is input to microphone amplifier HIC IC4 (KCA04). IC4 consists of a preemphasis circuit, amplifier, limiter, and splatter circuit that eliminate unwanted high-frequency components. The VCO signal is directly frequency modulated by means of a varicap diode in the frequency modulator circuit.

- **Younger-stage circuit**

The signal output from the VCO is input to predrive circuit IC7 (KCB09). The amplifier can obtain a stable drive output without adjustment because it has a wide band.

- **Power amplifier circuit**

The signal amplified in the predrive stage is amplified again by drive circuit HIC IC8 (KCB10), then input to power module IC10 and amplified to the specified level.

- **APC circuit**

The automatic transmission output control circuit (APC) detects and partially amplifies the power module output with a diode and controls the output control voltage. The control voltage is output in inverse proportion to the output, so the control voltage output is always constant.

- **Antenna selection circuit**

Figure 8 shows the antenna selection circuit. The receiver circuit obtains a low insertion loss and isolation with a two-stage breaker circuit consisting of a $\lambda/4$ strip circuit.

The pin diode used as a switching device has a low junction capacitance. The high-frequency capacitance of the diode does not depend on the reverse bias voltage.

Figure 9 shows the equivalent circuit during transmission. A current flows through each diode using 8T. The impedance becomes very low. At that time, the receiver side uses a $\lambda/4$ strip circuit. Therefore, the impedance becomes very high when the receiver side is viewed from point (A). The voltage from a power module is transferred to the antenna. Figure 10 shows the equivalent circuit during reception. The bias is switched off, so each diode is in a high-resistance state. The antenna and receiving circuit are connected by a strip line.

CIRCUIT DESCRIPTION

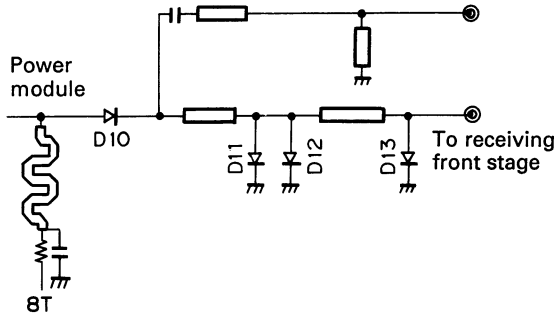

Fig. 8 Antenna Selection Circuit

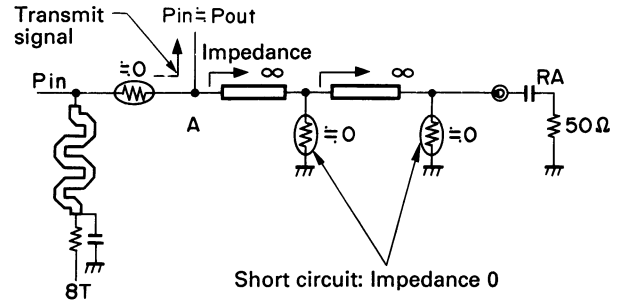

Fig. 9 Equivalent Circuit during Transmission

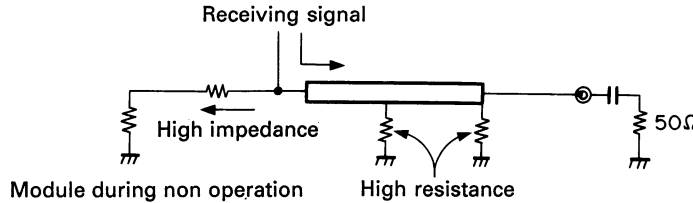

Fig. 10 Equivalent Circuit during Reception

1200 TX-RX Unit PLL Synthesizer

The VCO and PLL are housed in 2 solid shielding case as a hybrid integrated circuit. This reduces the electrical and mechanical influence and ensures frequency stability.

The VCO and PLL circuit double the higher harmonics by oscillating and locking a 600 MHz frequency to produce a 1200 MHz band frequency. Comparison frequencies of 5 kHz and 6.25 kHz are produced by dividing a 12.8 MHz frequency of the TCXD by 2560 and 2048 to correspond to 10, 12.5, 20, and 25 kHz channel steps.

The relationship between $f_{VCO} (RX)$ and each frequency division is given by

$$f_{VCO} (RX) = (f_{RX} - 59.7) / 2 = \{(n \times 128) + A\} \times f_{OSC} + R$$

Where: $f_{VCO} (RX)$ = Previous output frequency that is multiplied by 2 during VCO reception

f_{RX} : Reception frequency

n : Binary 10-bit programmable counter setting value

A : Binary 7-bit programmable counter setting value

f_{OSC} : Reference oscillation frequency of 12.8 MHz (TXCO)

R : Binary 14-bit programmable reference counter setting value

2048 (in 12.5 and 25 kHz steps)

2560 (in 10 and 20 kHz steps)

For 1260 MHz,

$$f_{VCO} (RX) = (1260 - 59.7)$$

$$= \{(n \times 180) + A\} \times 12800 + 2560$$

$$= 600.15 \text{ MHz}$$

In this case, n is 937 and A is 94.

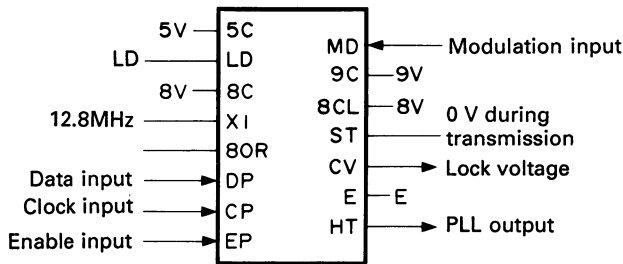

The same as for the 144 MHz unit except 8 V shown in the figure above.

Fig. 11 PLL pin description

Pin name	Function	Pin name	Function
5C	5V	MO	Modulation signal input
LD	Lock signal (on during lock)	10V	10V
NC	Unused	8CL	8V (ripple filter)
XI	12.8 MHz crystal oscillation	ST	0 V during transmission
XO		CV	Lock voltage
DP	Data input	E	GND
CP	Clock input	HT	VCO output
EP	Enable input		

Table 7

CIRCUIT DESCRIPTION

- **Unlock circuit**

When a PLL circuit is unlocked during transmission, the LD pin of a IC11 set low and Q12 is set off. Q11 is then set on. The 8T line is not activated when 8T switching control circuit Q13 is set off.

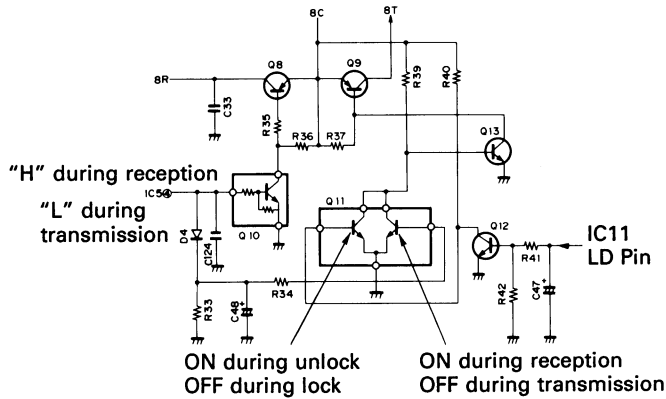

Fig. 12 Unlock Circuit

Digital Control Block

- **Outline**

The digital control block is classified into a panel block and control unit block. The panel block consists of a key, rotary encoder input circuit, and display circuit. The control unit block consists of reset and backup circuits, a tone output circuit, and a microphone tone input circuit.

- **Panel and control unit data communication circuit**

Figure 13 shows the panel and control unit data communication circuit. The S0 pin indicates serial data output and the S1 pin serial data input. An inverter is inserted for microcomputer port protection.

The data communication system is asynchronous, and the communication data rate is 19,200 bps. This data rate is about 16 times that of RC-20 and about 4 times those of other companies. The connection is checked every 0.5 second by a microcomputer on the control unit. Therefore, the power is switched off when the panel block is removed.

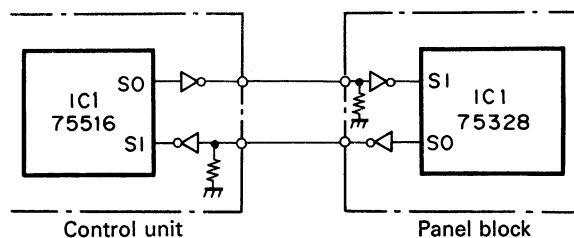

Fig. 13

- **Predrive circuit HIC (KCB09)**

The VCO output is amplified by Q22, then input to pre-drive circuit HIC IC7. An average 22 to 23 dBm output is obtained by inputting 0 dBm through three-stage (2SC4093 and 2SC3357 x 2) amplification. An alumina board and hybrid integrated circuit are used to ensure stable circuit operation.

- **Drive circuit HIC (KCB10)**

The VCO output is amplified by KCB09, then input to drive circuit HIC. An average 29 dBm output is obtained by inputting 20 dBm through one-stage (2SC3814) amplification. An integrated radiation plate and alumina board are used to attain a stable output against heating.

- **ALT**

It is almost the same circuit construction as the TM-531A/E.

Refer to page 6 in the TM-531A/E service manual for more information.

Panel Block

- **Key and rotary encoder input circuit**

For keys on the panel block, one key entry data item is input to one port. A pull-up resistor is inserted by software. The rotary encoder is directly connected to a microcomputer.

- **Display circuits**

The display circuits are on the panel block and are processed by a microcomputer on the panel. The display circuits consist of two LCD drivers and their peripheral circuit.

The LCD indicators dynamically light at a duty ratio of 1/2. The LCD ON data is transferred in series from the BP5, BP6, and BP7 pins of the CPU to the LCD driver. The number of segments is 137.

CIRCUIT DESCRIPTION

• Dimmer circuit

The dimmer circuit can change the lamp brightness in four steps. Figure 14 shows the dimmer circuit. Q2 is an error amplifier of the regulated power supply. A 5 V voltage is used as a reference voltage. P52 and P53 are open drains of a microcomputer. A four-step voltage can be output by connecting the P52 and P53 ports to ground. P50 connected to the emitter of A3 is also an open drain. When the P50 port is open, Q3 is set off and no lamp voltage is output. When the P50 port is connected to ground, Q3 is activated and the lamp goes on.

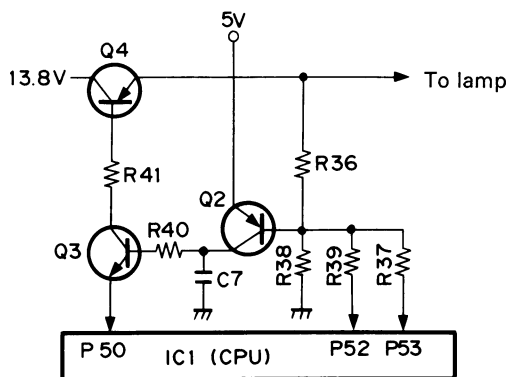

Fig. 14 Dimmer circuit

• Reset and backup circuits

A low pulse of about 3 ms is output from the reset circuit when the power is switched on. This low pulse is input to the RESET pin of the microcomputer. A power on reset is then made.

Control Unit Block

• Microphone key input circuit

Microphone UP/DOWN keys and function keys are connected to the analog input pins of a microcomputer. Each function is activated by the voltage generated when the keys are set on.

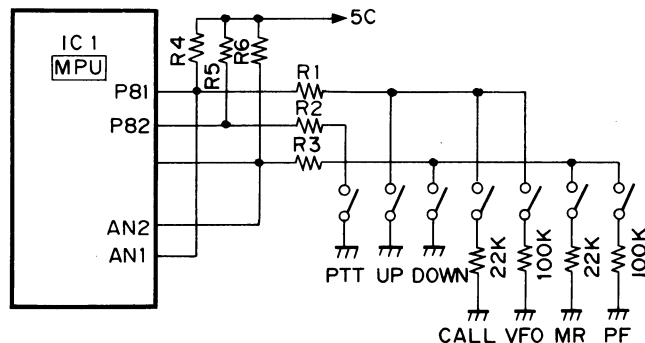

Fig. 15 Microphone key Input Circuit

A drop in the 13.8 V line voltage is detected by the backup circuit when the power is switched off. The INT4 pin of the microcomputer is then set high. Consequently, the microcomputer enters the backup state.

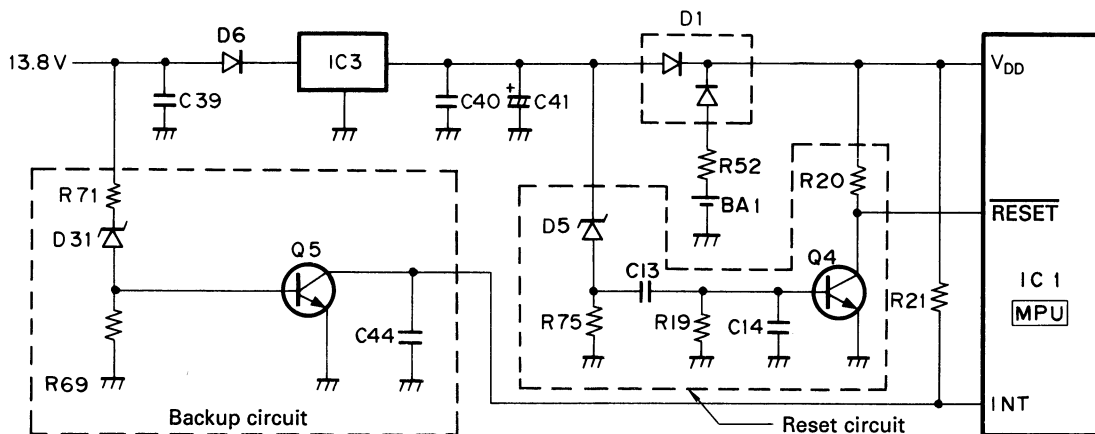

Fig. 16 Reset and Backup Circuits

CIRCUIT DESCRIPTION

- **Shift-register circuit**

The serial data from the microcomputer is passed through IC6 and IC7 (BU4094BF) to perform the following control operation.

Shift-Register Port Specification List (Common)

Shift-register A 4094

S.Reg Port	Pin No.	Port data	SA VE	Back up	Function	Pin name
Q1	4	PD_BZA			BAND A beep 0: Sounds 1: Does not sound	BZA
Q2	5	PD_BZA			BAND B beep 0: Sounds 1: Does not sound	BZB
Q3	6	PD_BZA			BAND C beep 0: Sounds 1: Does not sound	BZC
Q4	7	PD_MUTEA			BAND A MUTE 0: OFF 1: ON	MUTEA
Q5	14	PD_MUTEB			BAND B MUTE 0: OFF 1: ON	MUTEB
Q6	13	PD_MUTE C			BAND C MUTE 0: OFF 1: ON	MUTE C
Q7						
Q8	11	PD_BANK			SRAM A12 0: Normal 1: Abnormal	BANK

Shift-register B 4094

S.Reg Port	Pin No.	Port data	SA VE	Back up	Function	Pin name
Q1	4	PD_CTC1			CTCSS operation unit selection *1	CTC1
Q2	5	PD_CTC2			CTCSS operation unit selection *1	CTC2
Q3	6	PD_RD1			Detection output connection unit selection *3	RD1
Q4	7	PD_RD2			Detection output connection unit selection *3	RD2
Q5	14	PD_DTS1			DTSS operation unit selection *2	DTS1
Q6	13	PD_DTS2			DTSS operation unit selection *2	DTS2
Q7	12					
Q8	11	PD_DTSEL			DTSS input selection 0: Detection output 1: MIC	DTSEL

*1, *2, *3

CTC2	CTC1	CTCSS operation unit
DTS2	DTS1	DTSS operation unit
RD2	RD1	Detection output connection unit
0	0	A
0	1	B
1	x	C

CIRCUIT DESCRIPTION

I/O Port Specification List

μPD75516 I/O port list

μCOM Port	Port	I/O	Pull Up	Back up	Description	Pin name
INT4 P00	P_VF	I			Power check 0: Operation 1: Backup	
SCK0 P01	P_RFMID	I	○		Lower-power unit TX power selection 0: Three stages (middle stage) 1: Two stages (no middle stage)	
SO0/SB0 P02	P_SO	O	○		Panel microcomputer SI	
S10/SB1 P03	P_SI	I	○		Panel microcomputer SO	
INT0 P10		I		I		
INT1 P11	P_CTCSS	I		I	CTCSS detection 0: Tone coincides 1: Tone does not coincide	SDO
INT2 P12	P_STD	I		I	DTMF detection (LC7385 standard) 0: No signal 1: Signal detected	DV
T10 P13	P_DTSCCHK	I		I	DTSS connection check 0: No connection 1: Connection	VCK
PTO0 P20	P_BEEP	O		L	Beep sound output pin (effect sound) Set low when no beep sound is output.	BZ
P21	P_DTOE	O		L	DTMF receiver LC7385 TOE	EN
PCL P22	P_DTCE	O		L	DTMF tone generator TP5088 CE	CE
BUZ P23	P_CLK	O		L	CTCSS unit/shift register/electronic volume clock	CK
P30	P_ET	O I		I	CTCSS unit enable connection check 0: Connection 1: No connection	ET
P31						
P32	P_FANDL0	I	Δ	I	FAN delay time setting input *1	
P33	P_FANDL1	I	Δ	I	FAN delay time setting input *1	
P40	P_DAT0	I/O	●	I	External RAM, I/O expander data, and DTMF data (D0/Q1)	
P41	P_DAT1	I/O	●	I	↑ (D1/Q2)	
P42	P_DAT2	I/O	●	I	↑ (D2/Q3)	
P43	P_DAT3	I/O	●	I	↑ (D3/Q4)	
P50	P_DAT4	I/O	●	I	External RAM and I/O expander data	

CIRCUIT DESCRIPTION

μPD75516 I/O List

μCOM Port	Port	I/O	Pull Up	Back up	Description	Pin name
P51	P_DAT5	I/O	•		↑	
P52	P_DAT6	I/O	•		↑	
P53	P_DAT7	I/O	•		↑	
KR0 P60	P_TONE	O			Subtone output bit 0	
KR1 P61	P_TONE	O			Subtone output bit 1	
KR2 P62	P_TONE	O			Subtone output bit 2	
KR3 P63	P_TONE	O			Subtone output bit 3	
KR4 P70	P_TONE	O			Subtone output bit 4	
KR5 P71	P_TONE	O			Subtone output bit 5	
KR6 P72	P_TONE	O			Subtone output bit 6	
KR7 P73	P_TONE	O			Subtone output bit 7	
PPO P80						
SCK P81	P_UP	I	•		Microphone up	
SO1 P82	P_PTT	I	•		Microphone PTT	
S11 P83	P_DOWN	I	•		Microphone down	
P90	P_A0	O			External RAM and I/O expander address (IOEADR)	
P91	P_A1	O			↑ (RAMADR1)	
P92	P_A2	O			↑	
P93	P_A3	O			External RAM address	
P100	P_A4	O			↑ (RAMADR4)	
P101	P_A5	O			↑	
P102	P_A6	O			↑	
P103	P_A7	O			↑	

CIRCUIT DESCRIPTION

μPD75516 I/O Port List

μCOM Port	Port	I/O	Pull Up	Back up	Description	Pin name
P110	P_A8	O		I	↑	
P111	P_A9	O		I	↑	
P112	P_A10	O		I	↑	
P113	P_A11	O		L	↑	
P120	P_RAMOE	O	●	H	External RAM OE (L) L: Read	OE
P121	P_RAMRW	O	●	H	External RAM R/W L: Write H: Normal	R/W
P122	P_RAMCE2	O	●	L	External RAM CE2 L: Backup	CE2
P123	P_10CS	O	●	L	I/O Expander CS(L)	CS
P130	P_10RD	O	●	I	I/O Expander RD(L)	RD
P131	P_10WR	O	●	I	I/O Expander WR(L)	WR
P132	P_VOLEN1	O	●	I	Electronic volume enable 1 L: Buzzer R: Band C	EV1
P133	P_VOLEN2	O	●	I	Electronic volume enable 2 L: Band B R: Band A	EV2
P140	P_ES	O		I	Shift Register Enable	ES
P141	P_MMUTE	O		I	Mic MUTE 0: MUTE OFF 1: MUTE ON	
P142	P_PSW	O		I	POWER switch 0: Power on 1: Power off	PSW
P143	P_DAT	O		I	CTCSS unit, shift register, and electronic volume data	DT
AN0	P_DNAN	I			DOWN, MR, PF key input	
AN1	P_UPAN	I			UP, CALL, and VFO key input	
AN2	P_SMA	I			Band unit A signal-strength meter input	
AN3	P_ALTA	I			Band unit A ALT input	
AN4 P150	P_SMB	I			Band unit B signal-strength meter input	
AN5 P151	P_ALTB	I			Band unit B ALT input	
AN6 P152	P_SMC	I			Band unit C signal-strength meter input	
AN7 P153	P_ALTC	I			Band unit C ALT input	

- Δ : Pulled up by software during check (note that P_ET is set high during check).
 O : Pulled up by software at all times.
 ● : Pulled up by hardware.

*1 FAN delay time setting input

FAN control	P_FANDL1	P_FANDL0
Always on during power-on sequence	0	0
On during transmission	0	1
On during transmission and for 1 minute after transmission	1	0
On during transmission and on for 2 minutes after transmission	1	1

CIRCUIT DESCRIPTION

I/O Expander Port Specification List

CXD1095Q I/O port list

Port	I/O	Back up	Description	Pin name	
PA0	I/O		BAND Unit C PLL Enable *3	EPC	
PA1			BAND Unit C PLL/Shift Register Clock *3	CKC	
PA2			BAND Unit C PLL/Shift Register Data *3	DTC	
PA3			BAND Unit C Shift Register Enable	ESC	
PA4		I		BAND Unit A busy input 0: Busy 1: Close	SCA
PA5				BAND Unit B busy input 0: Busy 1: Close	SCB
PA6				BAND Unit C busy input 0: Busy 1: Close	SCC
PA7					
PB0	O		BAND Unit C SQ Out bit0	SQC0	
PB1			BAND Unit C SQ Out bit1	SQC1	
PB2			BAND Unit C SQ Out bit2	SQC2	
PB3			BAND Unit C SQ Out bit3	SQC3	
PB4			BAND Unit B SQ Out bit0	SQB0	
PB5			BAND Unit B SQ Out bit1	SQB1	
PB6			BAND Unit B SQ Out bit2	SQB2	
PB7			BAND Unit B SQ Out bit3	SQB3	
PC0	O		BAND Unit A SQ Out bit0	SQA0	
PC1	O		BAND Unit A SQ Out bit1	SQA1	
PC2	O		BAND Unit A SQ Out bit2	SQA2	
PC3	O		BAND Unit A SQ Out bit3	SQA3	
PC4	O		BAND Unit A SQ Out bit4	SQA4	
PC5	O		BAND Unit A SQ Out bit5	SQA5	
PC6	O		BAND Unit B SQ Out bit4	SQB4	
PC7	O		BAND Unit B SQ Out bit5	SQB5	
PD0	I/O		BAND Unit A PLL Enable *1	EPA	
PD1			BAND Unit A PLL/Shift Register Clock *1	CKA	
PD2			BAND Unit A PLL/Shift Register Data *1	DTA	
PD3			BAND Unit A Shift Register Enable	ESA	
PD4			BAND Unit B PLL Enable *2	EPB	
PD5			BAND Unit B PLL/Shift Register Clock *2	CKB	
PD6			BAND Unit B PLL/Shift Register Data *2	DTB	
PD7			BAND Unit B Shift Register Enable	ESB	
PE0	O		FAN ON/OFF 0: OFF 1: ON	FANSW	
PE1			PSW other than 5C	OSW2	
PE2			BAND Unit C SQ Out bit4	SQC4	
PE3			BAND Unit C SQ Out bit5	SQC5	

TM-941A

CIRCUIT DESCRIPTION

*1, *2, *3 Type of band unit

BAND Unit	DT _x	CK _x	EP _x	Unit No.	No. of data items after conversion
No unit	0	0	0	0	0
	1	0	0	4	1
	1	1	0	6	2
144MHz BAND	0	1	1	3	3
220MHz BAND	0	1	0	2	4
430MHz BAND	1	0	1	5	5
1200MHz BAND	0	0	1	1	6
	1	1	1	7	7

Note:

An x indicates A, B, or C. The number of data items after conversion indicates the data used in a program.

CIRCUIT DESCRIPTION

I/O Port Specification List

μPD75328 I/O port list

μCOM Port	Port	I/O	Pull up	Back up	Description	Pin name
INT4 P00	P_VF	I			Power check 0: Stop mode 1: Operation	
SCK P01	P_IF	I	Δ		IF selection check (430 MHz band only) 0: 21.8 MHz 1: 21.6 MHz (initial value)	
SO/SB0 P02	P_SO	O			Main microcomputer SI	
S1/SB1 P03	P_SI	I			Main microcomputer SO	
INT0 P10	↑	I	○		Connected to P_SI.	
INT1 P11	P_ENCA	I	○		Encoder clock (interrupt)	
INT2 P12	P_ENCB	I	○		Encoder data	
T10 P13	P_KEY17	I	○		BAND SEL C Key	
PTO0 P20	P_KEY16	I	○		BAND SEL B Key	
P21	P_KEY15	I	○		BAND SEL A Key	
PCL P22	P_KEY14	I	○		CONT SEL C Key	
BUZ P23	P_KEY13	I	○		CONT SEL B Key	
LCDCL P30	P_KEY12	I	○		CONT SEL A Key	
SYNC P31	P_KEY11	I	○		MUTE Key	
P32	P_KEY11	I	○		LOW Key	
P33	P_KEY9	I	○		DTSS Key	
P40	P_LEDTB	O			BAND Unit B control LED	
P41	P_LED RB	O			BAND Unit B LED	
P42	P_LEDTC	O			BAND Unit C control LED	
P43	P_LEDRC	O			BAND Unit C LED	
P50	P_PSW	O			Power off during APO 0: Power on (during power on) 1: Power off	

CIRCUIT DESCRIPTION

μPD75328 I/O Port List

μCOM Port	Port	I/O	Pull up	Back up	Description	Pin name
P51	P_PSW	O			↑	
P52	P_DIM0	O			Dimmer selection *1	
P53	P_DIM1	O			Dimmer selection *1	
KR0 P60	P_KEY8	I	O		REV Key	
KR1 P61	P_KEY7	I	O		TONE (CTCSS) Key	
KR2 P62	P_KEY6	I	O		BELL [SHIFT] Key	
KR3 P63	P_KEY5	I	O		F Key	
KR4 P70	P_KEY4	I	O		CALL Key	
KR5 P71	P_KEY3	I	O		MHz Key	
KR6 P72	P_KEY2	I	O		MR/M Key	
KR7 P73	P_KEY1	I	O		VFO Key	
P80	P_B0	I	O		Destination input b0	
P81	P_B1	I	O		Destination input b1	
P82	P_B2	I	O		Destination input b2	
P83	P_B3	I	O		Destination input b3	
S24 BP0	P_BLANK	O			LCD Driver MSM5265 BLANK	BLANK
S25 BP1	P_LEDTA	O			BAND Unit A Control LED	
S26 BP2	P_LEDRA	O			BAND Unit A LED	
S27 BP3	P_FDSP	O			Function display 0: Others 1: Function mode	
S28 BP4	P_TEST	O			LCD Driver MSM5265 SEG-TEST	TEST
S29 BP5	P_LCDDT	O			LCD Driver MSM5265 DATA	DL

CIRCUIT DESCRIPTION

μPD75328 I/O Port List

μCOM Port	Port	I/O	Pull up	Back up	Description	Pin name
S30 BP6	P_LCDCK	O			LCD Driver MSM5265 CLOCK	CL
S31 BP7	P_LCDCLD	O			LCD Driver MSM5265 LOAD	EL
AN0	P_VOLA				BAND Unit A VOL Input	VOLA
AN1	P_SQA				BAND Unit A SQ Input	SQA
AN2	P_VOLB				BAND Unit B VOL Input	VOLB
AN3	P_SQB				BAND Unit B SQ Input	SQB
AN4	P_VOLC				BAND Unit C VOL Input	VOLC
AN5	P_SQC				BAND Unit C SQ Input	SQC

O: Always pulled up by software.

Δ: Pulled up by software during check

*1 Dimmer selection

Brightness	DIM1	DIM0
Lightest	0	0
Normal	0	1
Dark	1	0
Darkest	1	1

Initial value 01 (normal)

CIRCUIT DESCRIPTION

• Tone output circuit

The tone output signal is input from the P60 through P63 and P70 through P73 ports of the microcomputer to ladder resistor R8 and converted from digital to analog. The 38 waves in 67.0 to 250.3 MHz are then produced. Figure 17 shows the internal configuration of R8.

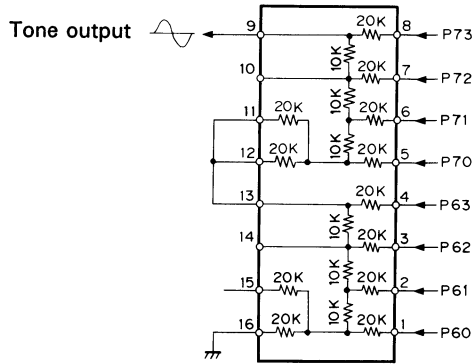

Fig. 17 Internal Configuration of Ladder Resistor (KRR-C001)

• CTCSS unit input and output (TSU-7 (option))

The data input to the CTCSS unit is output from P30, P23, and P143. P30 is also used for connection check. Data is input to P30 when the power is switched on. The data is output from P30 after a connection check is completed. The CTCSS unit is not set on when no connection is performed.

Figure 19 shows the data transfer format, and figure 20 shows the data configuration. A low signal is input to the P11 pin of the microcomputer when the tone detected from the CTCSS unit coincides. The squelch is then opened.

One CTCSS unit can correspond to three bands by switching detection signal RD output from a band unit.

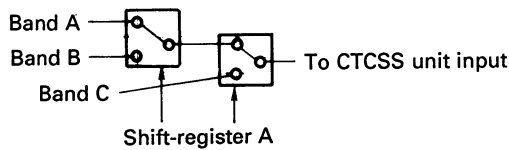

Fig. 18

As the figure above shows, the analog switch is selected with two-bit data.

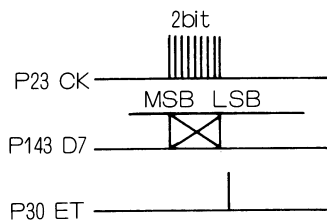

Fig. 19 CTCSS Data Transfer Format

Tone frequency selection data of CTCSS FX365

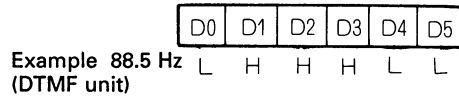

Fig. 20 CTCSS Data Configuration

• DTMF unit input and output (DTU-2 (option))

Data input to the DTMF unit is output from P21, P22, and P40 through P43 of the microcomputer. An encoder is activated when P40 through P43 output data and when P2 is high.

Similar to the CTCSS unit, when a decoder selects a detection signal and detects the input signal, a high signal is input to P12, P21 is set high, and data is input to P40 through P43. The microcomputer then judges whether the data coincides with a DTSS code.

• PLL data output

The PLL data is passed through I/O expander IC101 (CXD1095Q) from the microcomputer and output to each band unit with EP, CK, and DT signals and three serial data items.

A PLL IC (M56760FP) is used in common with the 144 and 430 TX/RX units. Figure 21 shows the data configuration. Figure 22 shows the PLL data transfer format.

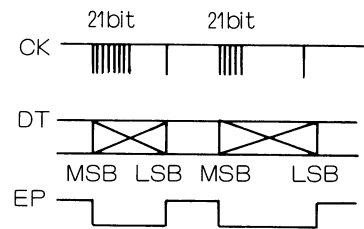
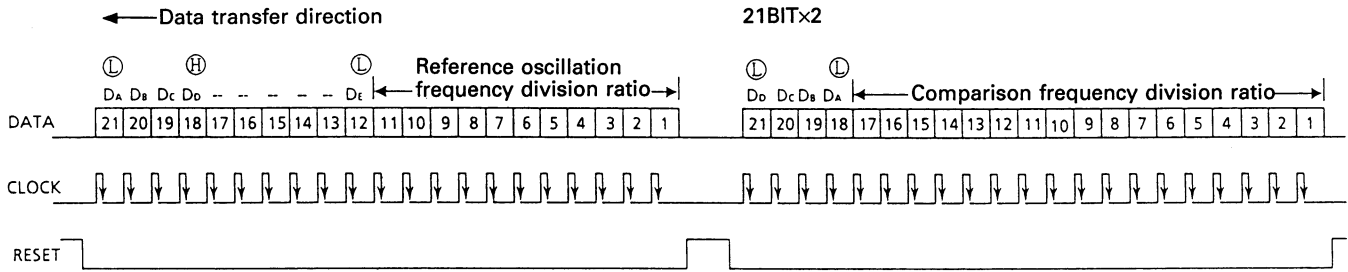

Fig. 21 PLL Data Configuration

CIRCUIT DESCRIPTION



$$f_{REF} = 12800 + (8 \times \text{Reference oscillation frequency division ratio})$$

Reference oscillation frequency division ratio = $16000 / f_{REF}$ (kHz)

5 kHz P = 320
6.25 kHz P = 256

Reference oscillation frequency division ratio

1 2 3 4 5 6 7 8 9 10 11
0 0 0 0 0 0 1 0 1 0 0 (320)
0 0 0 0 0 0 0 0 1 0 0 (256)

17 16 15 14 13 12 11 10 9 8 7 6 5 4 3 2 1
0 0 0 0 0 0 0 0 1 0 1 0 0 0 0 0 0 0 0 1 40 5 kHz
0 0 0 0 0 0 0 0 1 0 0 0 0 0 0 0 0 0 0 1 00 5.25 kHz

Special bit function

Bit	Name	H	L
D _A	Data latch selection	Reference	Comparison
D _B	SW2	H: OFF	L: ON
D _C	SW1	H: OFF	L: ON
D _D	POWER switch	OFF	ON
D _E	Test	Test	Normal

PLL data-to-bit relationship

ADD	BIT			
	0	1	2	3
1BH	1	2	3	4
1CH	5	6	7	8
1DH	9	10	11	12
1BH	13	14	15	16
1FH	17	-	-	-

Fig. 22 M56760 PLL DATA

1F	1E	1D	1C	1B	1A
-	6	10	14	18	1
-	7	11	15	19	2
-	8	12	16	20	3
5	9	13	17	21	4

Data	State
D _E	POWER switch
L	Normal
H	Test

Data	PLL
D _E	POWER switch
L	ON
H	OFF

1F	1E	1D	1C	1B	1A
-	2 ¹⁵	2 ¹¹	2 ⁷	2 ³	D _D
-	2 ¹⁴	2 ¹⁰	2 ⁶	2 ²	D _C
-	2 ¹³	2 ⁹	2 ⁵	2 ¹	D _B
2 ¹⁶	2 ¹²	2 ⁸	2 ⁴	2 ⁰	D _A

For frequency division ratio setting

Data		Output port	
D _H	D _C	SW2	SW1
L	L	ON	ON
H	L	OFF	ON
L	H	ON	OFF
H	H	OFF	OFF

1F	1E	1D	1C	1B	1A
-	x	D _E	2 ⁷	2 ³	D _D
-	x	2 ¹⁰	2 ⁶	2 ²	D _C
-	x	2 ⁹	2 ⁵	2 ¹	D _B
x	x	2 ⁸	2 ⁴	2 ⁰	D _A

For comparison frequency

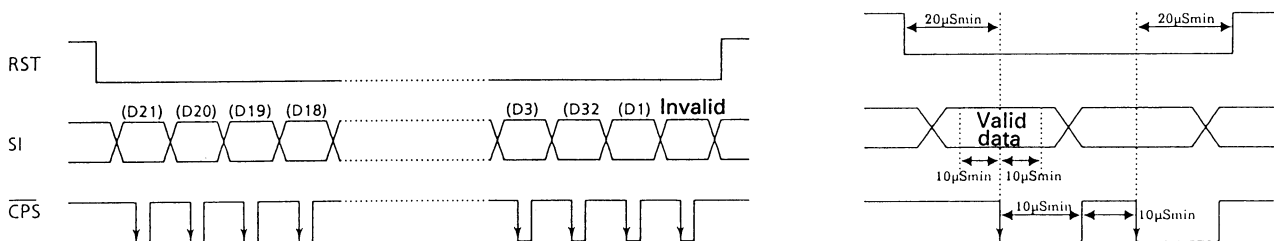

Fig. 23 M56760 PLL DATA OUTPUT

CIRCUIT DESCRIPTION

The PLL and reference frequency-division ratio data input to the 1200 TX/RX unit are output from P21 (CK), P22 (DT), and P23 (EP1) of the CPU. The reference frequency-division ratio data (R) is output only when the power is switched on and when 10 and 12.5 kHz reference frequencies are changed.

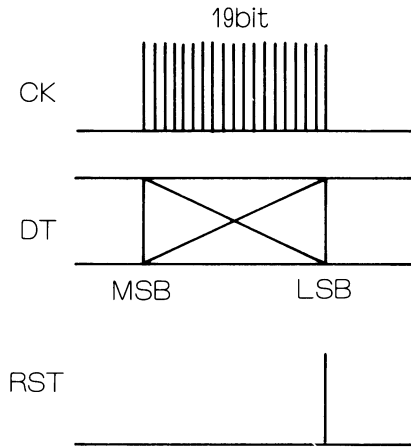

Fig. 24 PLL Frequency-Division Ratio Data Transfer Format

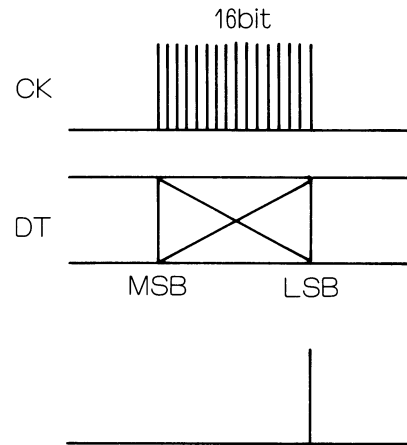

Fig. 25 Reference Frequency-Division Ratio Data Transfer Format

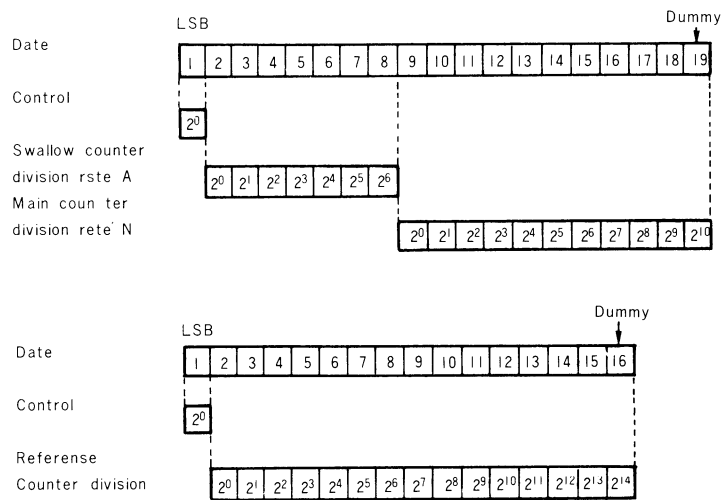

Fig. 26 Data Configuration

CIRCUIT DESCRIPTION

AF Signal Channel

- **Outline**

Detection signal RA from each band unit is passed through an electronic volume control and output to the power amplifier and speaker through a mute circuit, buzzer circuit, and speaker selection circuit.

Each band has an independent AF signal that can be output from the speaker in accordance with the speaker jack insertion position.

- **Volume control circuit**

The angle data of each band volume control on the panel is analog-to-digital converted by a microcomputer on the panel and converted to 5-bit data. The data from the panel block is sent to the microcomputer of the control unit, then converted. Serial data is then output from P132, P133, P23, and P143. Each band has an independent volume control. See the device function for the channel-to-band unit relationship. The data transfer format is the same as that for IF-20.

- **Buzzer circuit**

A pulse is output from P20 of IC1 to sound a buzzer when keys are pressed. The pulse is mixed with the DTMF unit output signal as a monitor pulse during DTSS operation.

After that, the pulse is passed through the electronic volume control and mixed with the AF signal in a mute circuit corresponding to each band before it is mixed with the AF signal line in each band.

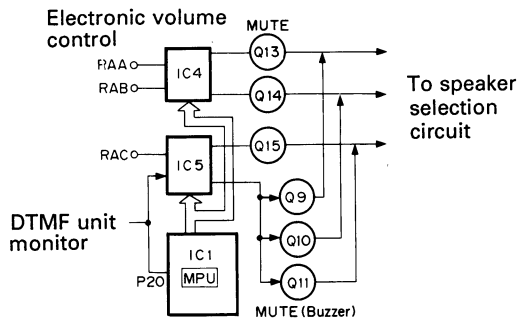

Fig. 27 Volume and Buzzer Circuits

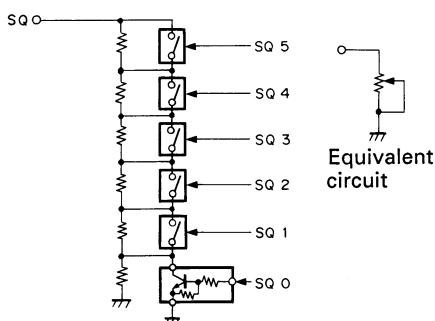

Fig. 29 Squelch D/A Converter Circuit

- **Speaker selection circuit**

Each band unit has three speaker jacks (on rear panel), and the control unit has one speaker jack (on side panel). When a speaker is connected to a speaker jack on the band unit, the corresponding band AF signal is output.

The speaker jack on the control unit outputs a remaining mixed AF signal. The mixed signal is output from an internal speaker when a speaker is not connected to this speaker jack. Figure 28 shows the speaker selection circuit.

A signal is input to adder IC103 when no speaker is connected. The signal level does not fluctuate even if one to three signals are input to the adder.

For example, band B can mix bands A and C with one speaker and output the mixed signal from another speaker by connecting the band B jack and control unit jack.

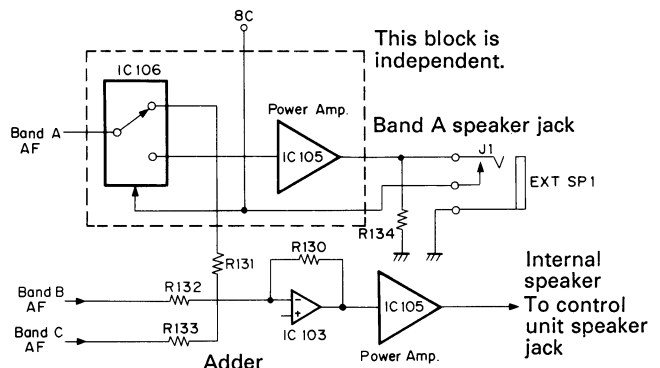

Fig. 28 Speaker Selection Circuit

- **Squelch circuit**

The angle data of each band squelch volume control on the panel is analog-to-digital converted and converted to 6-bit data.

The data from the panel block is sent to the microcomputer of the control unit and passed through I/O expander IC101 from the microcomputer. The data is then digital-to-analog converted by the analog switch shown in Figure 29. Each band in the circuit shown in Figure 29 is independent.

CIRCUIT DESCRIPTION

Connector Connecting the Band Unit and Control Unit

- Outline**

The pin assignments of the connector that connects the control unit and band unit are common in three

bands. The band unit is also used to check which band unit is connected.

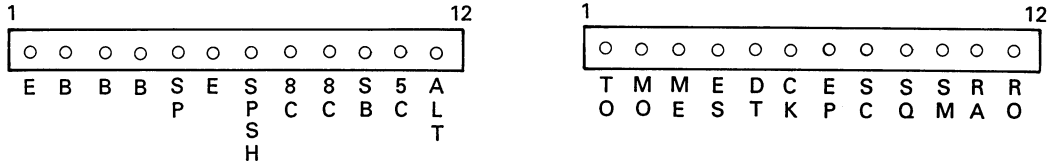

Fig. 30 Connector Connecting the Band Unit and Control Unit

Pin No.	Name	Function	Pin No.	Name	Function
1	E	GND	1	TO	67.0 to 250.3 Hz subtone output
2	B	13.8 V input	2	MO	Audio signal from microphone (including DTMF)
3	B		3	ME	Microphone ground
4	B		4	ES	Shift-register enable output
5	SP	AF signal is output when speaker jack is connected.	5	CK	Shift-register PLL clock
6	E	GND	6	DT	Shift-register PLL data
7	SPSW	Speaker jack connection and detection. "H" during connection.	7	EP	PLL enable
8	8C	8 V is output during the power-on sequence.	8	SC	"L" when squelch input is busy.
9	8C		9	SQ	50 k ohms when squelch D/A output is tight.
10	SB	13.8 V is output during the power-on sequence.	10	SM	Signal-strength meter voltage input
11	SC	5 V is output during the power-on sequence.	11	RA	Detection input (squelch circuit)
12	ACT	ALT voltage input	12	RD	Detection input (no squelch circuit)

Table 8 Pin functions (as viewed from the control unit)

- Band retrieval**

Each band is retrieved through the EP, CK, and DT pins. Data is input for retrieval when the power is switched on and when the memory is cleared. Data is then output again.

The control unit is pulled down as shown in Figure 31. Therefore, the DT, CK, and EP pins are set low when no band unit is connected. Pins set high as listed in Table 14 are pulled up when any band unit is connected. The type of connected band unit is then judged.

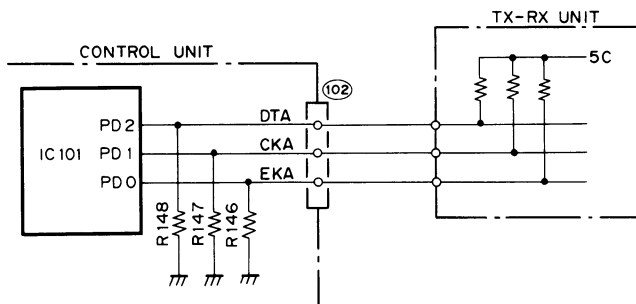

Fig. 31 Retrieval System

BAND Unit	DT	CK	EP
No Unit	L	L	L
144	L	H	H
430	H	L	H
1200	L	L	H

Table 9 Band Retrieval

DESCRIPTION OF COMPONENTS

Control Unit (X53-3310-XX)

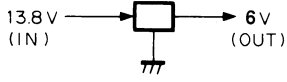
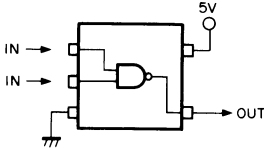
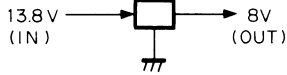
Reference No.	Function	Description
IC1	Microcomputer	See the circuit description.
IC2	SRAM memory backup	
IC3	6V AVR	Three-terminal regulator 
IC4, IC5	Electronic volume control	IC4 R-CH band A volume control IC4 L-CH band B volume control IC5 R-CH band C volume control IC5 L-CH BZ common volume control (Used in common) ③ L-CH input ⑥ L-CH output ⑪ R-CH output ⑭ R-CH input
IC6, IC7	Shift register	See the circuit description.
IC8, IC9	Analog switch	CTCSS, DTSS, or microphone RD band selection (See the circuit description.)
IC10	Low-frequency amplification and adder	Microphone amplifier and DTMF modulation adder
IC11, IC12	Serial data inverter buffer	
IC101	I/O expander	See the circuit description.
IC102	8V AVR	Three-terminal regulator 
IC103	Adder	Used for internal speaker and level compensation.
IC104, IC105	Low-frequency amplification	① Input (IC104: Band B, IC105: Common) ⑥ Output (IC104: Band B, IC105: Common) ⑦ 13.8 V ④ ⑩ ⑫ Ground ⑧ Output (IC104: Band C, IC105: Band A) ⑬ Input (IC104: Band C, IC105: Band A)
IC106	Speaker selection analog switch	④ Band C AF input ⑭ Band A AF input ⑮ Band B AF input ② Band B internal SP output ⑤ Band C internal SP output ⑫ Band A internal SP output ① Band B external SP output ③ Band C external SP output ⑬ Band A external SP output ⑪ Band A selection input ⑩ Band B selection input ⑨ Band C selection input ⑨ to ⑪ Internal SP when "L"
IC107~IC110	Analog switch	Used for squelch. (See the circuit description.)

DESCRIPTION OF COMPONENTS

Reference No.	Function	Description
Q1	Low-frequency amplification	Microphone amplifier
Q2	Buffer amplification	Used for microphone RD.
Q3	Microphone line muting	Microphone muting when power is ON (DTMF signal transmission).
Q4	RESET switch	RESET switch for IC1
Q5	BACKUP switch	ON when power is supplied
Q6, Q7, Q8	Low-frequency amplification	Q6 Band A Q7 Band B Q8 Band C
Q9, Q10, Q11	Beep sound muting	Q9 Band A Q10 Band B Q11 Band C A beep sounds from the corresponding band when OFF.
Q13, Q14, Q15	AF muting	Q13 Band A Q14 Band B Q15 Band C Muted when power is on (squelch ON, CTCSS, DTSS, etc.)
Q16	5 V POWER switch	5 V is output when power is ON.
Q17	Low-frequency amplification	Used for DTMF signal monitor.
Q101, Q102	SB POWER switch	Q101 and Q102 are set ON when power is ON. Q101 and Q102 are set OFF when power is OFF.
Q103	Fan motor switch	Rotates when power is ON. Does not rotate when power is OFF.
Q104, Q105	Squelch switch	Same as for IC107 through IC110. (See the circuit description.)
Q106, Q108	MUTE switch	Power amplifier muting Q106 is instantaneously set ON when power is switched ON. Q108 is instantaneously set ON when power is switched OFF.
Q107	RESET switch	RESET switch for IC101
D1	Antireverse current lithium cell selection	Lithium cell is OFF when power is supplied.
D2	Voltage compensation	
D3	Backup detection	
D4	Antireverse current	
D5	Reset detection	
D6, D101 ~ D103	Antireverse current	

DESCRIPTION OF COMPONENTS

144TX-RX Unit (X57-3580-XX)

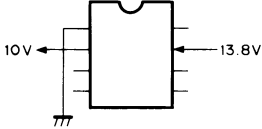
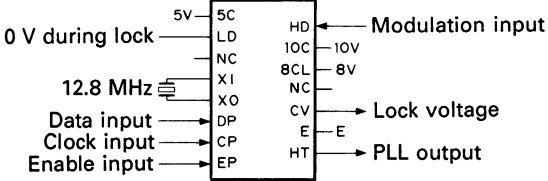
Reference No.	Function	Description
IC1	Shift register	See the circuit description.
IC2	10V AVR	
IC5	Second local oscillation, mixer, IF amplification, detection, low-frequency amplification, noise amplification, noise detection, and squelch switching	① 10.7 MHz first IF input ③, ④ 10.245 MHz second local oscillation ⑨ 0 V when scan control and busy signals are busy. ⑩ Noise detection voltage output (DC) ⑪ Signal-strength meter output ⑫ Detection output ⑭ RD output ⑮ AF output
IC7	Low-frequency amplification and limiter	Microphone amplifier
IC8	144 MHz band transmission driver	Operation during transmission. 144 to 148 MHz band ⑭ Input ① Output
IC9	APC	
IC10	Power module	
IC11	VCO.PLL	
Q1	High-frequency amplification	Operation during reception. 144 MHz band
Q2	First mixer	Operation during reception
Q3	First IF amplification	Operation during reception. 10.7 MHz

DESCRIPTION OF COMPONENTS

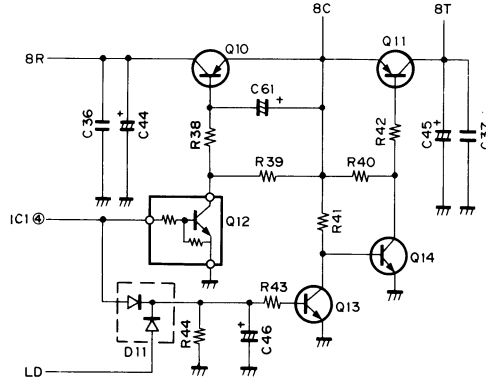
Reference No.	Function	Description
Q10 ~ Q14	Transmission and reception power selection	 <p>(0 V during lock)</p> <p>(Q10, Q12, and Q13 are set "OFF" during transmission. Q11 and Q14 are set "ON" during transmission. Q10, Q12, and Q13 are set "ON" during reception. Q11 and Q14 are set "OFF" during reception.)</p>
Q15, Q16, Q17	Inverter	
Q18	Modulation muting	ON during reception
Q19	CV line buffer	144 MHz band
Q20	PLL output amplification	
Q21	PLL 8 V ripple filter	
Q22	Middle/low POWER switch	Middle and low POWER switches are set ON when high.
Q23	APC control	Operation during transmission
Q24	Squelch hysteresis switch	OFF when busy
D1 ~ D7	Varicap diode tuning	
D11	Antireverse current	
D12	Antireverse current	
D13	PLL output switch	
D14	Temperature compensation	APC
D15, D16	Antenna transmission and reception selection	ON during transmission. OFF during reception.
D17, D18	Power detection	APC
D19	Power reverse connection protection	

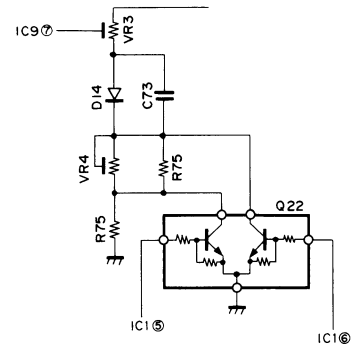

DESCRIPTION OF COMPONENTS

430TX-RX Unit (X57-3590-XX)

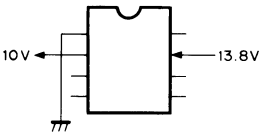
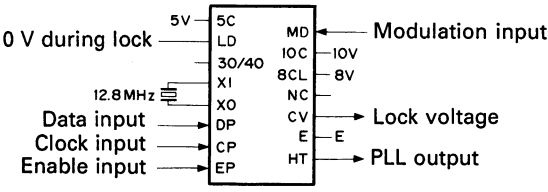
Reference No.	Function	Description
IC1	Second local oscillation, mixer, IF amplification, detection, low-frequency amplification, noise amplification, noise detection, and squelch switching	① 21.6 MHz first IF input ③, ④ 21.145 MHz second local oscillation ⑨ 0 V when scan control and busy signals are busy. ⑩ Noise detection voltage output (DC) ⑪ Signal-strength meter output ⑫ Detection output ⑭ RD output ⑮ AF output
IC2	Low-frequency amplification and limiter	Microphone amplifier
IC3	Shift register	See the circuit description.
IC4	10V AVR	
IC5	APC	
IC6	430 MHz band transmission driver	① Output ⑮ Input
IC7	Power module	
IC10	VCO.PLL	
Q1, Q2	High-frequency amplification	Operation during reception
Q3	First mixer	Operation during reception
Q5	First IF amplification	Operation during reception. 21.6 MHz

DESCRIPTION OF COMPONENTS

Reference No.	Function	Description
Q8~Q12	Transmission/reception power selection	<p>(0V during transmission) (0 V during lock)</p> <p>(Q8, Q9, and Q10 are set "OFF" during transmission.) (Q11 and Q12 are set "ON" during transmission.) (Q8, Q9, and Q10 are set "ON" during reception.) (Q11 and Q12 are set "OFF" during reception.)</p>
Q13, Q14, Q15	Inverter	
Q16	Modulation muting	ON during reception
Q17	PLL 8 V ripple filter	
Q18	PLL output amplification	
Q19	Middle/low POWER switch	Middle and low POWER switches are ON when high.
Q20	APC control	Operation during transmission
Q21	Squelch hysteresis switch	OFF when busy
D1	Antenna switch	OFF during reception
D4	PLL output switch	
D5	Temperature compensation	APC
D6, D7	Antireverse current	
D8, D9	Antenna transmission/reception selection	ON during transmission
D10, D11	Power detection	APC
D12	Power reverse connection protection	
D13	Antireverse current	8T pulse rise is faster during transmission and reception.
D14	IF level limiter	

DESCRIPTION OF COMPONENTS

1200TX-RX Unit (X57-3600-11)

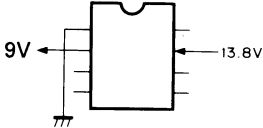
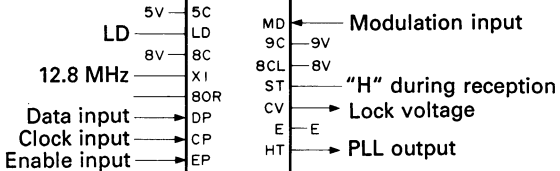
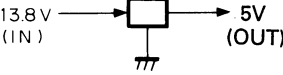
Reference No.	Function	Description
IC2	Second local oscillation, mixer, IF amplification, detection, low-frequency amplification, noise amplification, noise detection, and squelch switching	① 59.7 MHz first IF input ③, ④ 59.245 MHz second local oscillation ⑨ 0 V when scan control and busy signals are busy. ⑩ Noise detection voltage output (DC) ⑪ Signal-strength meter output ⑫ Detection output ⑭ RD output ⑮ AF output
IC3	ALT	② 8 V ③ "H" during ALT ⑩ Detection input (DC)
IC4	Low-frequency amplification and limiter	Microphone amplifier
IC5	Shift register	See the circuit description.
IC6	9V AVR	
IC7	Predrive	⑩ Input ① Output
IC8	Drive	① Output ③ Input
IC9	APC	
IC10	Power module	
IC11	VCO.PLL	
IC12	5V AVR	Three-terminal regulator 
Q1, Q2	High-frequency amplification	Operation during reception
Q3	First mixer	Operation during reception
Q6	Receiving PLL output amplification	Operation during reception
Q7	First IF amplification	Operation during reception. 59.7 MHz

DESCRIPTION OF COMPONENTS

Reference No.	Function	Description
Q8 ~ Q13	Transmission/reception power selection	<p>0 V during transmission</p> <p>During lock</p> <p>Q8, Q10, and Q11 (b) are set "OFF" during transmission. Q9, Q12, and Q13 are set "ON" during transmission. Q8, Q10, Q11 (b), and Q12 are set "ON" during reception. Q9, Q11 (a), and Q13 are set "OFF" during reception.</p>
Q15, Q16, Q17	Inverter	
Q18	Modulation muting	ON during reception
Q19, Q20	8T voltage selection	OFF when low
Q21	PLL output amplification	
Q22	Transmitting PLL output amplification	Operation during transmission
Q23	8 V ripple filter	
Q24	APC control	Operation during transmission
Q25	Lower-power switch	ON when high
Q26	Squelch hysteresis switch	OFF when busy
Q28	Q1 POWER switch	ON during transmission
D3	IF level limiter	
D4, D17	Antireverse current	
D5, D15	Constant voltage circuit	
D6	Temperature compensation	APC
D7	Temperature compensation	Drive
D8	Oversvoltage prevention	
D9	Power detection	APC
D10 ~ D13	Antenna switch	ON during transmission
D14	Power reverse connection protection	

DESCRIPTION OF COMPONENTS

LCD ASSY (B38-034X-05)

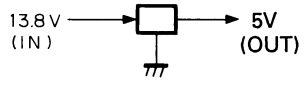
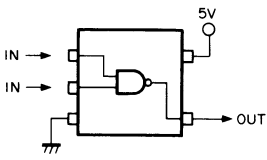
Reference No.	Function	Description
IC1	Microcomputer	See the circuit description.
IC2, IC3	LCD driver	
IC4	5V AVR	Three-terminal regulator 
IC5, IC6	Serial data inverter buffer	Same as IC11 and IC12 (X53-3310-XX) 
IC7	Reset IC	
Q1	RESET switch	
Q2	Lamp AVR error amplification	
Q3	Lamp AVR switch	
Q4	Lamp AVR	
Q5	5 V POWER switch	ON when power is on. OFF when APO is off.
Q6 ~ Q11	Control band LED switch	Q6, Q9, and Q11 are set "ON" when A. Q7, Q8, and Q10 are set "OFF" when A. Q7, Q8, and Q11 are set "ON" when B. Q6, Q9, and Q10 are set "OFF" when B. Q7, Q9, and Q10 are set "ON" when C. Q6, Q8, and Q11 are set "OFF" when C.
Q12	Function LED switch	ON during function

SEMICONDUCTOR DATA

Power module S-AV17 (144 TX-RX UNIT)

• Equivalent circuit diagram

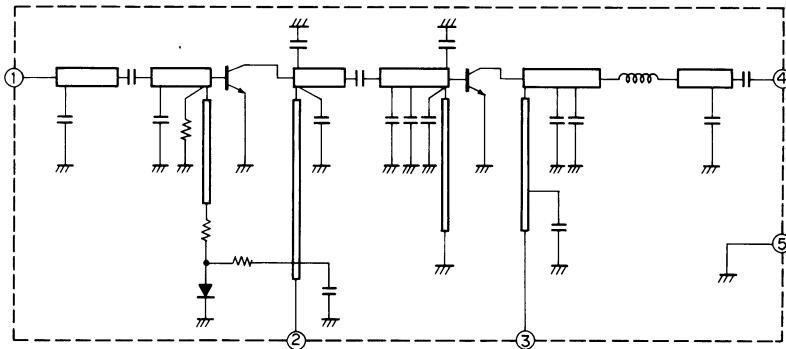

• External view

- ① Input terminal
- ② First power supply terminal
- ③ End power supply terminal
- ④ Output terminal
- ⑤ Fin (earth)

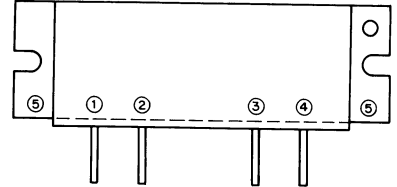

• Electrical characteristics

Item	Symbol	Tc (°C)	Conditions	Standard value			Unit
				Minimum	Standard	Maximum	
Frequency	f			144		148	MHz
Output power	Po	25	Vcc = 12.5V, Pin = 400mW, Zg = Zl = 50Ω			65	W
Combined efficiency	ηT	25	Same as above	45			%
Harmonics	HRM	25	Same as above		-30	-25	dB

Power module M5778M (430 TX-RX UNIT)

• Equivalent circuit diagram

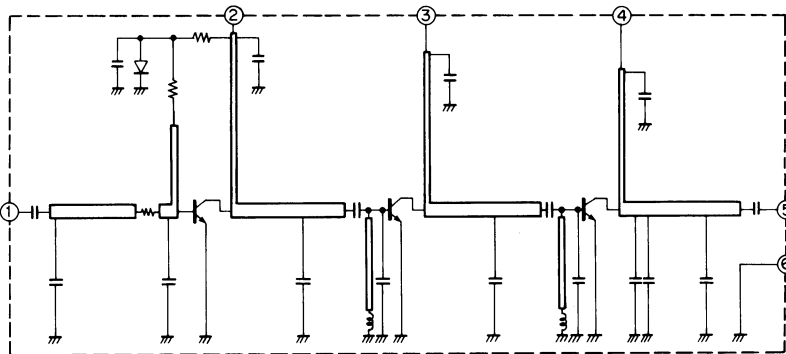

• External view

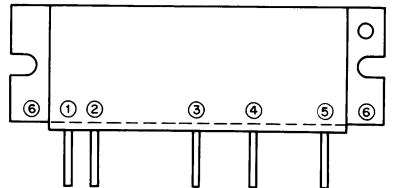

- ① Input terminal
- ② First power supply terminal
- ③ Driver power supply terminal
- ④ End power supply terminal
- ⑤ Output terminal
- ⑥ Fin (earth)

• Electrical characteristics

Item	Symbol	Tc (°C)	Conditions	Standard value			Unit
				Minimum	Standard	Maximum	
Frequency	f			430		450	MHz
Output power	Po	25	Vcc = 12.5V, Pin = 400mW, Zg = Zl = 50Ω	40	45		W
Combined efficiency	ηT	25	Same as above	40	45		%
Secondary spurious strength		25	Same as above			-30	dB
Tertiary spurious strength		25	Same as above			-30	dB

SEMICONDUCTOR DATA

Power module M67711 (1200 TX-RX UNIT)

• Equivalent circuit diagram

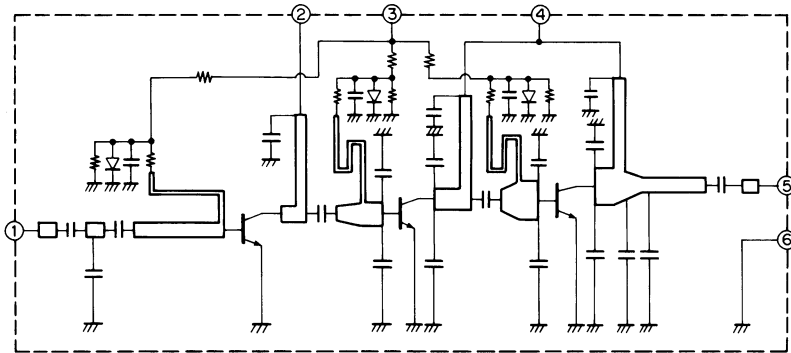

• External view

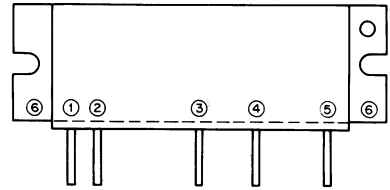

- ① Input terminal
- ② First power supply terminal
- ③ Bias power supply terminal
- ④ End power supply terminal
- ⑤ Output terminal
- ⑥ Fin (earth)

• Electrical characteristics

Item	Symbol	Tc (°C)	Conditions	Standard value			Unit
				Minimum	Standard	Maximum	
Frequency	f			1.24		1.3	GHz
Output power	Po	25	Vcc = 12.5V, Vbb = 10V, Pin = 1W, Zg = Zl = 50Ω	16	17		W
Combined efficiency	ηT	25	Same as above	30	35		%
Secondary spurious strength		25	Same as above			-45	dB

PARTS LIST

CAPACITORS

CC 45 TH 1H 220 J
 1 2 3 4 5 6

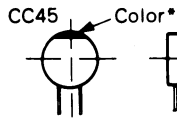

• Capacitor value

1 0 3 = 0.01 μ F

- 1 = Type ceramic, electrolytic, etc.
- 2 = Shape round, square, etc.
- 3 = Temp. coefficient
- 4 = Voltage rating
- 5 = Value
- 6 = Tolerance

- 0 1 0 = 1pF
- 1 0 0 = 10pF
- 1 0 1 = 100pF
- 1 0 2 = 1000pF = 0.001 μ F

2 2 0 = 22pF
 1st number | Multiplier
 2nd number

1st Word	C	L	P	R	S	T	U
Color*	Black	Red	Orange	Yellow	Green	Blue	Violet
ppm/°C	0	-80	-150	-220	-330	-470	-750

2nd Word	G	H	J	K	L
ppm/°C	± 30	± 60	± 120	± 250	± 500

Example CC45TH = -470 \pm 60 ppm/°C

• Tolerance

Code	C	D	G	J	K	M	X	Z	P	No code
(%)	± 0.25	± 0.5	± 2	± 5	± 10	± 20	+40 -20	+80 -20	+100 -0	More than Less than 10 μ F-10~+50 4.7 μ F-10~+75

Code	B	C	D	F	G
(pF)	± 0.1	± 0.25	± 0.5	± 1	± 2

Less than 10 pF

• Rating voltage

1st word	2nd word										
	A	B	C	D	E	F	G	H	J	K	V
0	1.0	1.25	1.6	2.0	2.5	3.15	4.0	5.0	6.3	8.0	-
1	10	12.5	16	20	25	31.5	40	50	63	80	35
2	100	125	160	200	250	315	400	500	630	800	-
3	1000	1250	1600	2000	2500	3150	4000	5000	6300	8000	-

• Chip capacitors

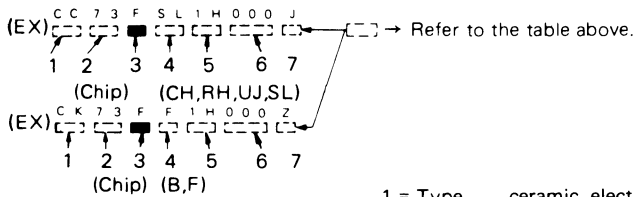

Dimension

Dimension code	L	W	T
Empty	5.6 \pm 0.5	5.0 \pm 0.5	Less than 2.0
E	3.2 \pm 0.2	1.6 \pm 0.2	Less than 1.25
F	2.0 \pm 0.3	1.25 \pm 0.2	Less than 1.25

Dimension

Dimension code	L	W	T	Wattage
E	3.2 \pm 0.2	1.6 \pm 0.2	0.57	2B
F	2.0 \pm 0.3	1.25 \pm 0.2	0.45	2A

Rating wattage

Cord	Wattage	Cord	Wattage	Cord	Wattage
2A	1/10W	2E	1/4W	3A	1W
2B	1/8W	2H	1/2W	3D	2W
2C	1/6W				

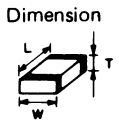

RESISTORS

• Chip resistor (Carbon)

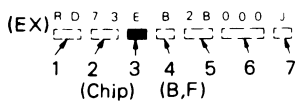

- 1 = Type ceramic, electrolytic, etc.
- 2 = Shape round, square, etc.
- 3 = Dimension
- 4 = Temp. coefficient
- 5 = Voltage rating
- 6 = Value
- 7 = Tolerance.

• Carbon resistor (Normal type)



PARTS LIST

× New Parts

Parts without Parts No. are not supplied.

Les articles non mentionnés dans le Parts No. ne sont pas fournis.

Telle ohne Parts No. werden nicht geliefert.

TM-941A

Ref. No. 参照番号	Address 位置	New Parts 新	Parts No. 部品番号	Description 部品名 / 規格	Desti- nation 仕向	Re- marks 備考
TM-941A						
1	1C	*	A01-2006-03	METALLIC CABINET(UPSIDE)		
2	4B	*	A01-2007-03	METALLIC CABINET(BOTTOM)		
3	4B	*	A62-0021-03	PANEL ASSY		
4	3B	*	A82-0001-02	BACK PANEL		
5	4A	*	B03-0562-04	DRESSING PLATE		
-		*	B11-0487-08	FILTER		
-		*	B11-0488-08	FILTER		
-		*	B11-0500-08	FILTER		
10	3A	*	B11-1002-04	FILTER		
11	4B	*	B38-0341-05	LCD ASSY	K, P	
11	4B	*	B38-0342-05	LCD ASSY	M	
12	3A	*	B38-0345-08	LCD		
13	4B	*	B41-0679-04	LABEL (FCC)		
14	1B	*	B42-2455-04	LABEL		
15	2C	*	B42-3343-04	LABEL (S/NO)		
15-1	1C	*	B42-3394-04	LABEL (FCC)	K, P	
16	1C	*	B42-3412-04	LABEL (SP, ANT)	M	
16	1C	*	B42-3440-04	LABEL (SP, ANT)	K, P	
17	1E	*	B46-0410-20	WARRANTY CARD	K	
17	1E	*	B46-0422-00	WARRANTY CARD	P	
20	1D	*	B62-0010-00	INSTRUCTION MANUAL		
21	2C	*	B72-0021-04	MODEL NAME PLATE	K, P	
21	2C	*	B72-0022-04	MODEL NAME PLATE	M	
23	2A	*	B58-1001-00	CAUTION CARD		
24	4B	*	D10-0607-04	LEVER		
25	4B	*	D32-0415-04	STOPPER		
26	2B	*	E23-0657-04	TERMINAL		
27	-	*	E29-0488-08	CONNECTOR		
28	-	*	E30-3005-05	CONNECTING WIRE(COMON-PANEL)		
-		*	E30-3006-08	CURL CORD		
30	2D	*	E30-3034-05	DC CORD (ACSY)		
31	2A	*	E37-0006-05	CONNECTING WIRE(SP)		
32	2A	*	E37-0007-05	FLAT CABLE (COMON)		
33	3D	*	F05-1531-05	FUSE (ACSY)		
35	2C	*	F05-2036-05	FUSE (20A)		
37	2C	*	F07-1203-03	COVER (FAN)		
38	3B	*	F07-1204-04	COVER (PANEL)		
39	4B	*	G01-0854-04	COMPRESSION SPRING		
40	4A	*	G02-0505-05	LEAF SPRING		
41	2A	*	G02-0701-04	FLAT SPRING (SP)		
42	4A	*	G09-0405-05	SPRING		
43	2B	*	G10-0635-04	NON-WOVEN FABRIC(19X9)		
44	2A	*	G10-0700-04	NON-WOVEN FABRIC(60X10)		
45	1C	*	G10-0663-04	NON-WOVEN FABRIC		
-		*	G10-0668-04	NON-WOVEN FABRIC		
47	4C	*	G10-0684-04	NON-WOVEN FABRIC(130X10)		
-		*	G10-0694-04	NON-WOVEN FABRIC		
49	3B	*	G11-0651-04	CUSHION		
50	3B	*	G11-0652-03	CUSHION		
51	3B	*	G11-0653-04	CUSHION		
52	3A	*	G13-0967-04	CUSHION (3KEY)		
53	4A	*	G13-0968-04	CUSHION (8KEY)		

E: Scandinavia & Europe K: USA P: Canada W: Europe

U: PX(Far East, Hawaii) T: England M: Other Areas

UE: AAFES(Europe) X: Australia

 indicates safety critical components.

PARTS LIST

× New Parts

Parts without Parts No. are not supplied.

Les articles non mentionnés dans le Parts No. ne sont pas fournis.

Teile ohne Parts No. werden nicht geliefert.

TM-941A

Ref. No. 参照番号	Address 位置	New Parts 新	Parts No. 部品番号	Description 部品名 / 規格	Desti- nation 仕 向	Re- marks 備考
54	4A	*	G13-0969-04	CUSHION (3KEY)		
55	2A	*	G13-1302-04	CUSHION (COMMON)		
56	3A	*	G11-0658-04	CUSHION (15X10)		
57	4C		G53-0508-04	NON-WOVEN FABRIC (30X10)		
58	1A		G53-0511-04	NON-WOVEN FABRIC (COMMON)		
59	3D	*	H10-2696-02	POLYSTYREN FOAMED FIXTURE		
60	1D		H11-0830-04	PACKING FIXTURE		
61	2E		H25-0723-04	PROTECTION BAG (230X400)		
62	2D		H25-0079-04	PROTECTION BAG (200X200)		
63	3E	*	H52-0015-04	ITEM CARTON BOX	K, P	
63	3E	*	H52-0016-04	ITEM CARTON BOX	M	
64	2D		H25-0029-04	PROTECTION BAG (MIC HOOK SCREW)		
65	2D		J20-0319-24	MIC HOOK (ACSY)	K, P	
66	4A	*	J19-1477-04	HOLDER (LED)		
67	2C	*	J21-4308-04	MOUNTING HARDWARE (FAN)		
68	3B	*	J21-4309-14	MOUNTING HARDWARE (LEVER)		
-	-	*	J21-4311-08	MOUNTING HARDWARE		
70	2E	*	J29-0454-03	BRACKET (ACSY)		
71	3B	*	J42-0470-03	BUSHING (MIC)		
72	4C	*	J42-0473-04	BUSHING (NUT)		
73	4A	*	K27-3078-04	KNOB (BUTTON) VFO		
74	4A	*	K27-3079-04	KNOB (BUTTON) MR		
75	4A	*	K27-3080-04	KNOB (BUTTON) MHZ		
76	4A	*	K27-3081-04	KNOB (BUTTON) CALL		
77	4A	*	K27-3082-04	KNOB (BUTTON) F		
78	4A	*	K27-3089-04	KNOB (BUTTON) SHIFT		
79	4A	*	K27-3084-04	KNOB (BUTTON) TONE		
80	4A	*	K27-3085-04	KNOB (BUTTON) REV		
81	4A	*	K27-3086-04	KNOB (BUTTON) DTSS		
82	4A	*	K27-3087-04	KNOB (BUTTON) LOW		
83	4A	*	K27-3088-04	KNOB (BUTTON) MUTE		
84	4B	*	K27-3090-04	KNOB (BUTTON)		
85	4A	*	K27-3091-04	KNOB (BUTTON) POWER		
86	4A	*	K27-3092-04	KNOB (BUTTON) RELEASE		
87	4A		K29-3156-04	KNOB		
88	4A	*	K29-4575-04	KNOB VOL		
89	4A	*	K29-4576-04	KNOB SQL		
-	-	*	L15-0022-05	COIL		
A	3B		N09-2036-05	SCREW RELEASE		
B	2B		N09-2084-05	MACHINE SCREW (+ TERMINAL)		
C	3B	*	N09-2130-05	SCREW PANEL		
D	4C		N10-2030-46	HEXAGON NUT (BAND UNIT CONNEX)		
E	2B	*	N30-3040-46	MACHINE SCREW (UNIT)		
F	1B, 1C		N33-2606-45	MACHINE SCREW (CASE, FAN)		
G	1C	*	N33-2614-45	MACHINE SCREW (FAN)		
H	2D		N46-3010-46	TAPPING SCREW (MIC HOOK)		
I	4B, 4C		N86-2606-45	SCREW		
J	1A, 3C		N87-2606-46	TAPTITE SCREW (COMMON UNIT)		
K	1A		N87-2608-46	TAPTITE SCREW (HEAT SINK)		
L	1B, 2A		N88-2606-46	FLAT HEAD TAPTITE SCREW (TX-RX)		
M	3D		N99-0331-05	SCREW SET (ACSY)		
SP1	2A	*	T07-0268-05	SPEAKER		
MFAN	2C	*	T42-0307-15	DC MOTOR ASSY (FAN)		

E: Scandinavia & Europe K: USA P: Canada W: Europe

U: PX (Far East, Hawaii) T: England M: Other Areas

UE: AAFES (Europe) X: Australia

⚠ indicates safety critical components.

PARTS LIST

× New Parts

Parts without Parts No. are not supplied.

Les articles non mentionnes dans le Parts No. ne sont pas fournis.

Telle ohne Parts No. werden nicht geliefert.

TM941A
CONTROL UNIT (X53-3310-11)

Ref. No. 参照番号	Address 位置	New Parts 新	Parts No. 部品番号	Description 部品名 / 規格	Desti- nation 仕 向	Re- marks 備考
92	1D	*	T91-0396-05	MICROPHONE (ACSY)	M	
92	1D	*	T91-0397-05	MICROPHONE (ACSY)	K, P	
95	2D		W01-0414-04	SPANNER (ACSY)		
97	2B, 3B	*	X53-3310-11	CONTROL UNIT		
99	2B	*	X57-3580-11	TX-RX UNIT (144 50W)	K	
99	2B	*	X57-3580-21	TX-RX UNIT (144 50W)	M, P	
102	3C	*	X57-3590-11	TX-RX UNIT (440 35W)	K, P	
102	3C	*	X57-3590-21	TX-RX UNIT (440 35W)	M	
105	4C	*	X57-3600-11	TX-RX UNIT (1200 10W)		
CONTROL UNIT (X53-3310-11)						
C1 -4			CK73FB1H102K	CHIP C 1000PF K		
C5			CK73FB1E104K	CHIP C 0.10UF K		
C6		*	CK73FF1C105Z	CHIP C 1.0UF Z		
C7			CK73FB1E223K	CHIP C 0.022UF K		
C8			CK73FB1H102K	CHIP C 1000PF K		
C9			CK73FB1E104K	CHIP C 0.10UF K		
C10			CK73FB1H102K	CHIP C 1000PF K		
C11		*	CK73FF1C105Z	CHIP C 1.0UF Z		
C12			CK73FB1H102K	CHIP C 1000PF K		
C13			CK73FB1E223K	CHIP C 0.022UF K		
C14			CK73FB1H102K	CHIP C 1000PF K		
C15 ,16			CC73FCH1H330J	CHIP C 33PF J		
C17 -19			C92-0005-05	CHIP-TAN 2.2UF 6.3WV		
C20 -28			CK73FB1E104K	CHIP C 0.10UF K		
C29		*	CK73FF1C105Z	CHIP C 1.0UF Z		
C30			CK73FB1E104K	CHIP C 0.10UF K		
C31			C92-0507-05	CHIP-TAN 4.7UF 6.3WV		
C32 -35			CK73FB1H102K	CHIP C 1000PF K		
C36 ,37			CC73FSL1H101J	CHIP C 100PF J		
C38 -40			CK73FB1H102K	CHIP C 1000PF K		
C41			CE04EW1A101M	ELECTRO 100UF 10WV		
C42		*	CK73FF1C105Z	CHIP C 1.0UF Z		
C43			CK73FB1H102K	CHIP C 1000PF K		
C44			CK73FB1E103K	CHIP C 0.01UF K		
C45 ,46			CK73FB1H102K	CHIP C 1000PF K		
C47 -49			CK73FB1E104K	CHIP C 0.10UF K		
C50		*	CK73FF1C105Z	CHIP C 1.0UF Z		
C51			CC73FSL1H101J	CHIP C 100PF J		
C101-103			CK73FB1H102K	CHIP C 1000PF K		
C104			CE04EW1C470M	ELECTRO 47UF 16WV		
C105			CK73FB1H102K	CHIP C 1000PF K		
C106			CE04EW1A470M	ELECTRO 47UF 10WV		
C107,108			CK73FB1E123K	CHIP C 0.012UF K		
C109			C92-0507-05	CHIP-TAN 4.7UF 6.3WV		
C110			CK73FB1H682K	CHIP C 6800PF K		
C111		*	CK73FF1C105Z	CHIP C 1.0UF Z		
C112-115			CK73FB1E104K	CHIP C 0.10UF K		
C116			CE04EW1A471M	ELECTRO 470UF 10WV		
C117-120			CE04EW1A470M	ELECTRO 47UF 10WV		
C121			CE04EW1C101M	ELECTRO 100UF 16WV		
C122-125			CE04EW1A470M	ELECTRO 47UF 10WV		
C126			CE04EW1C101M	ELECTRO 100UF 16WV		
C127-129			CK73FB1E104K	CHIP C 0.10UF K		

E: Scandinavia & Europe K: USA P: Canada W: Europe

U: PX(Far East, Hawaii) T: England M: Other Areas

UE: AAFES(Europe) X: Australia

 indicates safety critical components.

PARTS LIST

× New Parts

Parts without Parts No. are not supplied.

Les articles non mentionnés dans le Parts No. ne sont pas fournis.

Telle ohne Parts No. werden nicht geliefert.

CONTROL UNIT (X53-3310-11)

Ref. No. 参照番号	Address 位置	New Parts 新	Parts No. 部品番号	Description 部品名 / 規格	Desti- nation 向	Re- marks 備考
C130, 131 C132 C133-135 C136 C137			CK73FB1H102K CE04EW1C101M CE04EW1A471M CK73FB1H102K CK73FB1E123K	CHIP C 1000PF K ELECTRO 100UF 16WV ELECTRO 470UF 10WV CHIP C 1000PF K CHIP C 0.012UF K		
C138 C139 C140, 141 C142, 143 C144			CE04EW1C470M CK73FB1E223K CK73FB1E103K CK73FB1H102K CC73FSL1H101J	ELECTRO 47UF 16WV CHIP C 0.022UF K CHIP C 0.01UF K CHIP C 1000PF K CHIP C 100PF J		
C145, 146		*	CK73FF1C105Z	CHIP C 1.0UF Z		
CN1 ,2 CN3 CN4 CN5 CN6		*	E40-5417-05 E40-3246-05 E40-3248-05 E40-5188-05 E40-5183-05	PIN ASSY 13P PIN CONNECTOR 2P(SP) PIN ASSY 4P(PANEL) PIN ASSY 11P(DTSS) PIN ASSY 6P(DTSS)		
CN7 CN8 CN101-106 CN107, 108 CN109		*	E40-5343-05 E40-5224-05 E40-5452-05 E40-5400-05 E40-5224-05	PIN ASSY 9P(CTCSS) PIN CONNECTOR 16P PIN ASSY 12P PIN ASSY 13P PIN CONNECTOR 16P		
CN110 J1 J2 W1		*	E40-3237-05 E11-0425-05 E08-0876-05 E33-1871-15	PIN CONNECTOR 2P(FAN) PHONE JACK (3.5D) MODULER JACK (MIC JACK) FINISHED WIRE SET		
X1			L77-1333-05	CRYSTAL RESONATOR (4.19MHZ)		
R1 -3 R4 -6 R7 R8			RK73FB2A393J RK73FB2A102J RK73FB2A473J RK73FB2A102J R90-0711-05	CHIP R 39K J 1/10W CHIP R 1.0K J 1/10W CHIP R 47K J 1/10W CHIP R 1.0K J 1/10W MULTI-COMP R		
R9 R10 R11 R12 R13			RK73FB2A102J RK73FB2A154J RK73FB2A333J RK73FB2A102J RK73FB2A392J	CHIP R 1.0K J 1/10W CHIP R 150K J 1/10W CHIP R 33K J 1/10W CHIP R 1.0K J 1/10W CHIP R 3.9K J 1/10W		
R14 R15 R16 R17 R18			RK73FB2A332J RK73FB2A183J RK73FB2A104J RK73FB2A182J RK73FB2A221J	CHIP R 3.3K J 1/10W CHIP R 18K J 1/10W CHIP R 100K J 1/10W CHIP R 1.8K J 1/10W CHIP R 220 J 1/10W		
R19 R20 ,21 R22 R23 -28 R29			RK73FB2A563J RK73FB2A473J RK73FB2A472J RK73FB2A153J RK73FB2A684J	CHIP R 56K J 1/10W CHIP R 47K J 1/10W CHIP R 4.7K J 1/10W CHIP R 15K J 1/10W CHIP R 680K J 1/10W		
R30 R31 R32 R33 R34			RK73FB2A272J RK73FB2A102J RK73FB2A684J RK73FB2A272J RK73FB2A102J	CHIP R 2.7K J 1/10W CHIP R 1.0K J 1/10W CHIP R 680K J 1/10W CHIP R 2.7K J 1/10W CHIP R 1.0K J 1/10W		
R35 R36			RK73FB2A684J RK73FB2A272J	CHIP R 680K J 1/10W CHIP R 2.7K J 1/10W		

E: Scandinavia & Europe K: USA P: Canada W: Europe

U: PX(Far East, Hawaii) T: England M: Other Areas

UE: AAFES(Europe) X: Australia

 indicates safety critical components.

PARTS LIST

× New Parts

Parts without **Parts No.** are not supplied.

Les articles non mentionnes dans le **Parts No.** ne sont pas fournis.

Telle ohne **Parts No.** werden nicht geliefert.

CONTROL UNIT (X53-3310-11)

Ref. No. 参照番号	Address 位置	New Parts 新	Parts No. 部品番号	Description 部品名 / 規格	Desti- nation 仕向	Re- marks 備考
R37			RK73FB2A102J	CHIP R 1.0K J 1/10W		
R38 -40			RK73FB2A104J	CHIP R 100K J 1/10W		
R41			RK73FB2A103J	CHIP R 10K J 1/10W		
R42			RK73FB2A105J	CHIP R 1.0M J 1/10W		
R43			RK73FB2A123J	CHIP R 12K J 1/10W		
R44 -47			RK73FB2A103J	CHIP R 10K J 1/10W		
R48			RK73FB2A683J	CHIP R 68K J 1/10W		
R49			RK73FB2A473J	CHIP R 47K J 1/10W		
R50			RK73FB2A474J	CHIP R 470K J 1/10W		
R51			RK73FB2A124J	CHIP R 120K J 1/10W		
R52			RK73FB2A472J	CHIP R 4.7K J 1/10W		
R53			RK73FB2A224J	CHIP R 220K J 1/10W		
R54			RK73FB2A184J	CHIP R 180K J 1/10W		
R55			RK73FB2A474J	CHIP R 470K J 1/10W		
R56			R92-0670-05	CHIP R 0 ΩHM		
R57			RK73FB2A223J	CHIP R 22K J 1/10W		
R58			R92-0670-05	CHIP R 0 ΩHM		
R60			R92-0670-05	CHIP R 0 ΩHM		
R61 -63			RK73FB2A474J	CHIP R 470K J 1/10W		
R64 -67			RK73FB2A473J	CHIP R 47K J 1/10W		
R68			RK73FB2A472J	CHIP R 4.7K J 1/10W		
R69			RK73FB2A103J	CHIP R 10K J 1/10W		
R70			RK73FB2A473J	CHIP R 47K J 1/10W		
R71			RK73FB2A472J	CHIP R 4.7K J 1/10W		
R72			RK73FB2A822J	CHIP R 8.2K J 1/10W		
R73			RK73FB2A153J	CHIP R 15K J 1/10W		
R74			RK73FB2A473J	CHIP R 47K J 1/10W		
R75 ,76			RK73FB2A102J	CHIP R 1.0K J 1/10W		
R77			RK73FB2A105J	CHIP R 1.0M J 1/10W		
R78			RK73FB2A471J	CHIP R 470 J 1/10W		
R79			RK73FB2A272J	CHIP R 2.7K J 1/10W		
R101			RK73FB2A273J	CHIP R 27K J 1/10W		
R102			RK73FB2A123J	CHIP R 12K J 1/10W		
R103			RK73FB2A562J	CHIP R 5.6K J 1/10W		
R104			RK73FB2A272J	CHIP R 2.7K J 1/10W		
R105			RK73FB2A122J	CHIP R 1.2K J 1/10W		
R106			RK73FB2A561J	CHIP R 560 J 1/10W		
R107			RK73FB2A273J	CHIP R 27K J 1/10W		
R108			RK73FB2A123J	CHIP R 12K J 1/10W		
R109			RK73FB2A562J	CHIP R 5.6K J 1/10W		
R110			RK73FB2A272J	CHIP R 2.7K J 1/10W		
R111			RK73FB2A122J	CHIP R 1.2K J 1/10W		
R112			RK73FB2A561J	CHIP R 560 J 1/10W		
R113			RK73FB2A273J	CHIP R 27K J 1/10W		
R114			RK73FB2A123J	CHIP R 12K J 1/10W		
R115			RK73FB2A562J	CHIP R 5.6K J 1/10W		
R116			RK73FB2A272J	CHIP R 2.7K J 1/10W		
R117			RK73FB2A122J	CHIP R 1.2K J 1/10W		
R118			RK73FB2A561J	CHIP R 560 J 1/10W		
R119			RK73FB2A472J	CHIP R 4.7K J 1/10W		
R120			RK73FB2A103J	CHIP R 10K J 1/10W		
R121			R92-1215-05	CHIP R 470 J 1/2W		
R122-124			RK73FB2A473J	CHIP R 47K J 1/10W		
R125-127			RK73FB2A474J	CHIP R 470K J 1/10W		
R128,129			RK73FB2A104J	CHIP R 100K J 1/10W		

E: Scandinavia & Europe K: USA P: Canada W: Europe

U: PX(Far East, Hawaii) T: England M: Other Areas

UE: AAFES(Europe) X: Australia

 indicates safety critical components.

PARTS LIST

× New Parts

Parts without Parts No. are not supplied.

Les articles non mentionnés dans le Parts No. ne sont pas fournis.

Telle ohne Parts No. werden nicht geliefert.

CONTROL UNIT (X53-3310-11)

Ref. No. 参照番号	Address 位置	New Parts 新	Parts No. 部品番号	Description 部品名 / 規格	Desti- nation 仕向	Re- marks 備考
R130-133			RK73FB2A183J	CHIP R 18K J 1/10W		
R134			RK73FB2A4R7J	CHIP R 4.7 J 1/10W		
R135			RK73FB2A473J	CHIP R 47K J 1/10W		
R136, 137			RK73FB2A101J	CHIP R 100 J 1/10W		
R138, 139			RK73FB2A473J	CHIP R 47K J 1/10W		
R140, 141			RK73FB2A101J	CHIP R 100 J 1/10W		
R142			RK73FB2A473J	CHIP R 47K J 1/10W		
R143-145			RK73FB2A4R7J	CHIP R 4.7 J 1/10W		
R146			RK73FB2A474J	CHIP R 470K J 1/10W		
R147, 148			RK73FB2A183J	CHIP R 18K J 1/10W		
R149			RK73FB2A332J	CHIP R 3.3K J 1/10W		
R150			RK73FB2A474J	CHIP R 470K J 1/10W		
R151, 152			RK73FB2A183J	CHIP R 18K J 1/10W		
R153			RK73FB2A332J	CHIP R 3.3K J 1/10W		
R154-156			RK73FB2A474J	CHIP R 470K J 1/10W		
R157			RK73FB2A332J	CHIP R 3.3K J 1/10W		
R158, 159			RK73FB2A473J	CHIP R 47K J 1/10W		
R160			R92-0685-05	CHIP R 22 J 1/2W		
R161			RK73FB2A472J	CHIP R 4.7K J 1/10W		
R162-169			RK73FB2A473J	CHIP R 47K J 1/10W		
R170			RK73FB2A563J	CHIP R 56K J 1/10W		
R171			RK73FB2A103J	CHIP R 10K J 1/10W		
R172			RK73FB2A473J	CHIP R 47K J 1/10W		
R173, 174			RK73FB2A472J	CHIP R 4.7K J 1/10W		
R175-177			RK73FB2A102J	CHIP R 1.0K J 1/10W		
D1			1SS184	DIODE		
D2		*	LFB01	DIODE		
D3			02CZ7.5(X)	DIODE		
D4		*	LFB01	DIODE		
D5			02CZ3.0(Z)	DIODE		
D6		*	LFB01	DIODE		
D101-103			1SS184	DIODE		
IC1		*	75516GF-189-3B9	IC(UPD)		
IC2		*	LC3564PML-12,15	IC(64K RAM)		
IC3			TA78L06F	IC(6V AVR)		
IC4 ,5			TC9154AP	IC(2CH ELECTRONIC VOLUME)		
IC6 ,7			BU4094BF	IC		
IC8 ,9			BU4053BF	IC		
IC10		*	NJM4558E	IC		
IC11,12			TC4S11F	IC(2 INPUT NAND GATE)		
IC101			CXD1095Q	IC		
IC102		*	MC78T08CT	IC(8V AVR)		
IC103		*	NJM4558E	IC		
IC104, 105			LA4446	IC(AF PA)		
IC106			BU4053BF	IC		
IC107-110			BU4066BF	IC(ANALOG SWITCH X4)		
Q1			2SC3324(G)	TRANSISTOR		
Q2			2SC2712(Y)	TRANSISTOR		
Q3			DTC114EK	DIGITAL TRANSISTOR		
Q4 -8			2SC2712(Y)	TRANSISTOR		
Q9 -11			DTC114EK	DIGITAL TRANSISTOR		
Q12 -15			2SD1757(K)	TRANSISTOR		
Q16			2SA1519	TRANSISTOR		
Q17			2SC2712(Y)	TRANSISTOR		
Q101			2SC2712(Y)	TRANSISTOR		

E: Scandinavia & Europe K: USA P: Canada W: Europe

U: PX(Far East, Hawaii) T: England M: Other Areas

UE: AAFES(Europe) X: Australia

 indicates safety critical components.

PARTS LIST

× New Parts

Parts without **Parts No.** are not supplied.

Les articles non mentionnés dans le **Parts No.** ne sont pas fournis.

Telle ohne **Parts No.** werden nicht geliefert.

CONTROL UNIT (X53-3310-11)

TX-RX UNIT/144 (X53-3580-XX)

Ref. No. 参照番号	Address 位置	New Parts 新	Parts No. 部品番号	Description 部品名 / 規格	Desti- nation 仕 向	Re- marks 備考
Q102 Q103 Q104,105 Q106 Q107		*	2SA1641(S,T) DTD143EK DTC114EK DTC144EK 2SC2712(Y)	TRANSISTOR DIGITAL TRANSISTOR DIGITAL TRANSISTOR DIGITAL TRANSISTOR TRANSISTOR		
Q108			DTA144EK	DIGITAL TRANSISTOR		
BA1		*	W09-0573-05	LITHUM BATTERY		
TX-RX UNIT/144 (X53-3580-XX) -11:K, -21:M, P						
C5			CC73FCH1H040C	CHIP C 4PF C		
C6 -9			CK73FB1H102K	CHIP C 1000PF K		
C10			CK73FB1E103K	CHIP C 0.01UF K		
C11			CC73FCH1HOR5C	CHIP C 0.5PF C		
C12			CC73FCH1H151J	CHIP C 150PF J		
C13			CC73FCH1H030C	CHIP C 3PF C		
C14			CC73FCH1HOR5C	CHIP C 0.5PF C		
C15			CC73FCH1H150J	CHIP C 15PF J		
C16			CC73FCH1H020C	CHIP C 2.0PF C		
C18			CK73FB1H102K	CHIP C 1000PF K		
C19			CC73FCH1H060D	CHIP C 6PF D		
C20			CK73FB1H102K	CHIP C 1000PF K		
C21			CC73FCH1H050C	CHIP C 5PF C		
C22			CK73FB1E103K	CHIP C 0.01UF K		
C23			CK73FB1H102K	CHIP C 1000PF K		
C24			CK73FB1E103K	CHIP C 0.01UF K		
C26			CK73FB1H102K	CHIP C 1000PF K		
C29			CK73FB1E103K	CHIP C 0.01UF K		
C30			CC73FCH1H390J	CHIP C 39PF J		
C31			CC73FCH1H101J	CHIP C 100PF J		
C32			CK73FB1H102K	CHIP C 1000PF K	K	
C33			CK73FB1E104K	CHIP C 0.10UF K		
C34 ,35			CK73EF1C105Z	CHIP C 1.0UF Z		
C36 ,37			CK73FB1E103K	CHIP C 0.01UF K		
C44 ,45			CE04NW1C470M	ELECTRO 47UF 16WV		
C46			C92-0504-05	CHIP-TAN 0.68UF 20WV		
C47			CE04NW1C470M	ELECTRO 47UF 16WV		
C48			C92-0003-05	CHIP-TAN 0.47UF 25WV		
C49			CE04NW1E100M	ELECTRO 10UF 25WV	K	
C50			CE04NW1C470M	ELECTRO 47UF 16WV		
C51 ,52			CK73FB1E103K	CHIP C 0.01UF K		
C53 ,54			CK73FB1H102K	CHIP C 1000PF K		
C55			CK73EF1C105Z	CHIP C 1.0UF Z		
C56			CC73FUJ1H150J	CHIP C 15PF J		
C57			CK73FB1H102K	CHIP C 1000PF K		
C58			CC73FUJ1H220J	CHIP C 22PF J		
C59 ,60			CK73FB1H102K	CHIP C 1000PF K		
C61			CE04NW1C470M	ELECTRO 47UF 16WV		
C62			CK73FB1H102K	CHIP C 1000PF K		
C63			CK73FB1E103K	CHIP C 0.01UF K		
C64			CE04NW1E100M	ELECTRO 10UF 25WV		
C65		*	CE04NW1A330M	ELECTRO 33UF 10WV		
C66			CK73FB1E103K	CHIP C 0.01UF K		
C67			CK73FB1H102K	CHIP C 1000PF K		
C68 ,69			CC73FCH1H100D	CHIP C 10PF D		

E: Scandinavia & Europe K: USA P: Canada W: Europe

U: PX(Far East, Hawaii) T: England M: Other Areas

UE: AAFES(Europe) X: Australia

 indicates safety critical components.

PARTS LIST

× New Parts

Parts without Parts No. are not supplied.

Les articles non mentionnes dans le Parts No. ne sont pas fournis.

Teile ohne Parts No. werden nicht geliefert.

TX-RX UNIT/144 (X53-3580-XX)

Ref. No. 参照番号	Address 位置	New Parts 新	Parts No. 部品番号	Description 部品名 / 規格	Desti- nation 仕向	Re- marks 備考
C70			CK73FB1E103K	CHIP C 0.01UF K		
C71 -73			CK73FB1H102K	CHIP C 1000PF K		
C74			CK73FB1H223K	CHIP C 0.022UF K		
C75			CE04NW1C101M	ELECTRO 100UF 16WV		
C76			CK73EF1C105Z	CHIP C 1.0UF Z		
C77 ,78			CK73FB1H102K	CHIP C 1000PF K		
C79			CK73EF1C105Z	CHIP C 1.0UF Z		
C80			CC73FCH1H050C	CHIP C 5PF C		
C81			CC45SL2H120J	CERAMIC 12PF J		
C82			CK73FB1H102K	CHIP C 0.001UF K		
C83			CK45B2H102K	CERAMIC 1000PF K		
C84			CM73F2H330J	CHIP C 33PF J		
C85			CC73FCH1H220J	CHIP C 22PF J		
C86			CC73FCH1H0R5C	CHIP C 0.5PF C		
C87			CC73FCH1H020C	CHIP C 2.0PF C		
C88			CC45SL2H560J	CERAMIC 56PF J		
C89			CC45SL2H470J	CERAMIC 47PF J		
C90 -92			CK73FB1H102K	CHIP C 1000PF K		
C93			CC73FCH1H0R5C	CHIP C 0.5PF C		
C94			CM73F2H300J	CHIP C 30PF J		
C95			CC73FCH1H020C	CHIP C 2.0PF C		
C96			CK73FB1E103K	CHIP C 0.01UF K		
C98			CK73FB1H102K	CHIP C 1000PF K		
C99			CE04NW1E100M	ELECTRO 10UF 25WV		
C100			CK73FB1H102K	CHIP C 1000PF K	K	
C101			CE04NW1E100M	ELECTRO 10UF 25WV		
C103			CK73FB1H102K	CHIP C 1000PF K		
C104			CK73FB1E103K	CHIP C 0.01UF K		
C105			CK73FB1H223K	CHIP C 0.022UF K		
C110			CC73FCH1H030C	CHIP C 3PF C		
C111			CK73FB1E103K	CHIP C 0.01UF K		
C112			CE04NW1A221M	ELECTRO 220UF 10WV		
C113			CC73FCH1H100D	CHIP C 10PF D		
C114,115			CC73FSL1H101J	CHIP C 100PF J		
C116			CC73FCH1H080D	CHIP C 8PF D		
C119			CE04NW1E100M	ELECTRO 10UF 25WV		
C120-127			CC73FSL1H101J	CHIP C 100PF J		
C128,129			CK73FB1H102K	CHIP C 1000PF K		
C130			CE04EW1C102M	ELECTRO 1000UF 16WV		
TC1			C05-0345-05	TRIMMING CAP 10PF		
110	2C	*	E22-0672-04	TERMINAL BOARD		
110	2C	*	E22-0673-04	TERMINAL BOARD		
110	2C	*	E30-2145-05	ANT CABLE		
110	2C	*	E40-5461-05	PIN ASSY		
110	2C	*	E11-0442-05	PHONE JACK		
115	1B	*	F10-1444-03	SHIELDING COVER		
115	1B	*	F10-1446-04	SHIELDING PLATE		
115	1B	*	F10-1457-04	SHIELDING CASE (VC0-PLL)		
115	1B	*	G02-0600-04	FLAT SPRING (THERMAL SWITCH)		
115	1B	*	G02-0705-04	FLAT SPRING		
115	1B	*	G11-0660-04	SHEET (VC0 25X10)		
115	1B	*	G11-0661-04	INSULATION SHEET(APC TR)		
115	1B	*	G13-0841-04	CUSHION (CRYSTAL)		
115	1B	*	G13-1319-04	CUSHION (VC0 22X15)		

E: Scandinavia & Europe K: USA P: Canada W: Europe

U: PX(Far East, Hawaii) T: England M: Other Areas

UE: AAFES(Europe) X: Australia

▲ indicates safety critical components.

PARTS LIST

× New Parts

Parts without **Parts No.** are not supplied.

Les articles non mentionnés dans le **Parts No.** ne sont pas fournis.

Telle ohne **Parts No.** werden nicht geliefert.

TX-RX UNIT/144 (X53-3580-XX)

Ref. No. 参照番号	Address 位置	New Parts 新	Parts No. 部品番号	Description 部品名 / 規格	Desti- nation 仕 向	Re- marks 備考
			G53-0508-04	NON-WOVEN FABRIC		
CD1			L79-1013-05	FILTER		
CF1			L72-0372-05	CERAMIC FILTER (CFWM455F)		
L1 -4		*	L34-4252-05	COIL		
L5			L40-1582-19	SMALL FIXED INDUCTOR (0.15UH)		
L6		*	L34-4251-05	COIL		
L8 ,9			L34-1185-05	COIL (2.5T)		
L10			L40-3382-19	SMALL FIXED INDUCTOR (0.33UH)		
L11			L34-1239-05	COIL (10.5T)		
L12			L34-0895-05	COIL (6T)		
L13			L34-0742-05	COIL (6T)		
L14			L34-0908-05	COIL (9.5T)		
L15 -17			L34-0499-05	COIL (4T)		
L19			L40-8272-48	SMALL FIXED INDUCTOR (82NH)		
L20			L40-1001-19	SMALL FIXED INDUCTOR (10UH)		
X1			L77-1405-05	CRYSTAL RESONATOR (12.8MHZ)		
X2			L77-0946-15	CRYSTAL RESONATOR (10.245MHZ)		
XF1			L71-0228-05	CRYSTAL FILTER (10.7MHZ)		
N	2B		N09-0623-04	SCREW (MODULE)		
J	2B		N87-2606-46	TAPTITE SCREW(PCB,ANT)		
L	1B		N88-2606-46	TAPTITE SCREW(COVER,THERMAL SW)		
R4			RK73FB2A103J	CHIP R 10K J 1/10W		
R5			RK73FB2A333J	CHIP R 33K J 1/10W		
R6			RK73FB2A274J	CHIP R 270K J 1/10W		
R7			RK73FB2A101J	CHIP R 100 J 1/10W		
R8			RK73FB2A103J	CHIP R 10K J 1/10W		
R9			RK73FB2A101J	CHIP R 100 J 1/10W		
R10 -12			RK73FB2A103J	CHIP R 10K J 1/10W		
R13			RK73FB2A473J	CHIP R 47K J 1/10W		
R14			RK73FB2A104J	CHIP R 100K J 1/10W		
R15			RK73FB2A683J	CHIP R 68K J 1/10W	K	
R16			RK73FB2A823J	CHIP R 82K J 1/10W	K	
R17			R92-0670-05	CHIP R 0 OHM		
R18			RK73FB2A470J	CHIP R 47 J 1/10W		
R19			RK73FB2A102J	CHIP R 1.0K J 1/10W		
R20			RK73FB2A152J	CHIP R 1.5K J 1/10W		
R21			RK73FB2A471J	CHIP R 470 J 1/10W		
R22			RK73FB2A101J	CHIP R 100 J 1/10W		
R23			RK73FB2A103J	CHIP R 10K J 1/10W		
R24			RK73FB2A473J	CHIP R 47K J 1/10W		
R25			RK73FB2A103J	CHIP R 10K J 1/10W		
R30			R92-0670-05	CHIP R 0 OHM		K
R31			RK73FB2A394J	CHIP R 390K J 1/10W		
R33 ,34			R92-0670-05	CHIP R 0 OHM		
R35			RK73FB2A222J	CHIP R 2.2K J 1/10W		
R36			RK73FB2A101J	CHIP R 100 J 1/10W		
R37			R92-0670-05	CHIP R 0 OHM		
R38			RK73FB2A182J	CHIP R 1.8K J 1/10W		
R39 -41			RK73FB2A103J	CHIP R 10K J 1/10W		
R42			RK73FB2A182J	CHIP R 1.8K J 1/10W		
R43			RK73FB2A223J	CHIP R 22K J 1/10W		
R44			RK73FB2A273J	CHIP R 27K J 1/10W		
R45			RK73FB2A473J	CHIP R 47K J 1/10W		

E: Scandinavia & Europe K: USA P: Canada W: Europe

U: PX(Far East, Hawaii) T: England M: Other Areas

UE: AAFES(Europe) X: Australia

▲ indicates safety critical components.

PARTS LIST

× New Parts

Parts without Parts No. are not supplied.

Les articles non mentionnés dans le Parts No. ne sont pas fournis.

Teile ohne Parts No. werden nicht geliefert.

TX-RX UNIT/144 (X53-3580-XX)

Ref. No. 参照番号	Address 位置	New Parts 新	Parts No. 部品番号	Description 部品名 / 規格	Desti- nation 仕向	Re- marks 備考
R46			RK73FB2A472J	CHIP R 4.7K J 1/10W		
R47			R92-0670-05	CHIP R 0 ΩHM		
R49			RK73FB2A223J	CHIP R 22K J 1/10W		
R50			RK73FB2A124J	CHIP R 120K J 1/10W		
R52 -54			RK73FB2A473J	CHIP R 47K J 1/10W		
R55			RK73FB2A471J	CHIP R 470 J 1/10W		
R56			RK73FB2A104J	CHIP R 100K J 1/10W		
R57			RK73FB2A105J	CHIP R 1.0M J 1/10W		
R58			RK73FB2A473J	CHIP R 47K J 1/10W		
R59			R92-0670-05	CHIP R 0 ΩHM		
R60			RK73FB2A103J	CHIP R 10K J 1/10W		
R61			RK73FB2A471J	CHIP R 470 J 1/10W		
R62			R92-0670-05	CHIP R 0 ΩHM		
R63 ,64			RK73FB2A222J	CHIP R 2.2K J 1/10W		
R65 ,66			R92-0670-05	CHIP R 0 ΩHM		
R67			RK73FB2A122J	CHIP R 1.2K J 1/10W		
R68			RK73FB2A220J	CHIP R 22 J 1/10W		
R69			RK73FB2A470J	CHIP R 47 J 1/10W		
R71			R92-0670-05	CHIP R 0 ΩHM		
R73			RK73FB2A104J	CHIP R 100K J 1/10W		
R75			RK73FB2A103J	CHIP R 10K J 1/10W		
R76			R92-0670-05	CHIP R 0 ΩHM		
R78			R92-1213-05	CARBON 100 J 1/2W		
R79 ,80			RK73FB2A223J	CHIP R 22K J 1/10W		
R81			RK73FB2A471J	CHIP R 470 J 1/10W		
R82			R92-0685-05	CHIP R 22 J 1/2W		
R83			R92-0670-05	CHIP R 0 ΩHM		
R84 -86			R92-0670-05	CHIP R 0 ΩHM		
R89			RK73FB2A332J	CHIP R 3.3K J 1/10W		
R90			RK73FB2A221J	CHIP R 220 J 1/10W		
R91			RK73FB2A473J	CHIP R 47K J 1/10W		
R93			RK73FB2A104J	CHIP R 100K J 1/10W		
R98 ,99			RK73FB2A103J	CHIP R 10K J 1/10W		
VR1			R12-6429-05	TRIM POT. 100K		
VR2			R12-6427-05	TRIM POT. 47K		
VR3 ,4			R12-6423-05	TRIM POT. 10K		
TS1		*	S79-0401-05	THERMAL SWITCH 95°C		
D1			1SV164	DIODE		
D2			1SV166	DIODE		
D3 ,4			1SV164	DIODE		
D5			1SV166	DIODE		
D6			1SV164	DIODE		
D7			1SV166	DIODE		
D11			1SS184	DIODE		
D12			1SS184	DIODE		
D13			DAN235(K)	DIODE		
D14			1SS181	DIODE		
D15			MI407	DIODE		
D16			MI308	DIODE		
D17 ,18			1SS226	DIODE		
D19			DSA3A1	DIODE		
IC1			BU4094BF	IC		
IC2			LA5010M	IC(LOW SATURATION REGULATOR)		

E: Scandinavia & Europe K: USA P: Canada W: Europe

U: PX(Far East, Hawaii) T: England M: Other Areas

UE: AAFES(Europe) X: Australia

⚠ indicates safety critical components.

PARTS LIST

※ New Parts

Parts without Parts No. are not supplied.

Les articles non mentionnes dans le Parts No. ne sont pas fournis.

Teile ohne Parts No. werden nicht geliefert.

TX-RX UNIT/144 (X53-3580-XX)

TX-RX UNIT/440 (X57-3590-XX)

Ref. No. 参照番号	Address 位置	New Parts 新	Parts No. 部品番号	Description 部品名 / 規格	Desti- nation 仕向	Re- marks 備考
IC5			KCD04	IC(FM IF)		
IC6		*	KCD05	IC(AM IF)	K	
IC7		*	KCA04	IC(MIC AMP)		
IC8		*	KCB11	IC(DRIVE)		
IC9		*	KCC04	IC(APC)		
IC10			S-AV17	IC(POWER MODULE FOR 144MHZ)		
IC11		*	KCH05	IC(144 PLL-VCO)		
Q1			3SK184(S)	FET		
Q2			3SK179(L)	FET		
Q3			2SC2714(Y)	TRANSISTOR		
Q4			DTA114YK	DIGITAL TRANSISTOR	K	
Q5 ,6			DTC123JK	DIGITAL TRANSISTOR	K	
Q7			DTC143EK	DIGITAL TRANSISTOR	K	
Q10			2SA1362(Y)	TRANSISTOR		
Q11			2SB1119S	TRANSISTOR		
Q12			DTC144WK	DIGITAL TRANSISTOR		
Q13 ,14			2SC2712(Y)	TRANSISTOR		
Q15 -17			DTC144EK	DIGITAL TRANSISTOR		
Q18			2SD1757(K)	TRANSISTOR		
Q19			2SK208(Y)	FET		
Q20			2SC2714(Y)	TRANSISTOR		
Q21			2SC2712(Y)	TRANSISTOR		
Q22			FMG1	TRANSISTOR		
Q23		*	2SD1902R	TRANSISTOR		
Q24			2SJ106(GR)	FET		
TX-RX UNIT/440 (X57-3590-XX) -11:K, P, -21:M						
C2 -4			CK73FB1H102K	CHIP C 1000PF K		
C5			CC73FCH1H1R5C	CHIP C 1.5PF C		
C6			CC73FCH1H390J	CHIP C 39PF J		
C7			CK73FB1H102K	CHIP C 1000PF K		
C9			CC73FCH1H010C	CHIP C 1.0PF C		
C10			CC73FCH1H390J	CHIP C 39PF J		
C11			CK73FB1H102K	CHIP C 0.001UF K		
C13 ,14			CK73FB1H102K	CHIP C 1000PF K		
C15			CC73FCH1H050C	CHIP C 5PF C		
C16 ,17			CK73FB1H102K	CHIP C 1000PF K		
C18			CC73FCH1H060D	CHIP C 6PF D		
C19 ,20			CK73FB1H102K	CHIP C 1000PF K		
C20 ,21			CC73FCH1H330J	CHIP C 33PF J	M	
C21			CC73FCH1H560J	CHIP C 56PF J	K, P	
C22			CC73FCH1H180J	CHIP C 18PF J	K, P	
C22			CC73FCH1H330J	CHIP C 33PF J	M	
C23			CK73FB1H102K	CHIP C 1000PF K		
C24			CE04NW1C470M	ELECTRO 47UF 16WV		
C25			CK73FB1H102K	CHIP C 1000PF K		
C26		*	CK73FF1C105Z	CHIP C 1.0UF Z		
C27			C92-0003-05	CHIP-TAN 0.47UF 25WV		
C28 ,29		*	CK73FF1C105Z	CHIP C 1.0UF Z		
C31			CK73FB1H102K	CHIP C 1000PF K		
C32			CE04NW1C470M	ELECTRO 47UF 16WV		
C33			C92-0504-05	CHIP-TAN 0.68UF 20WV		
C34			CE04NW1C470M	ELECTRO 47UF 16WV		

E: Scandinavia & Europe K: USA P: Canada W: Europe

U: PX(Far East, Hawaii) T: England M: Other Areas

UE: AAFES(Europe) X: Australia

 indicates safety critical components.

PARTS LIST

× New Parts

Parts without **Parts No.** are not supplied.

Les articles non mentionnés dans le **Parts No.** ne sont pas fournis.

Teile ohne **Parts No.** werden nicht geliefert.

TX-RX UNIT/440 (X57-3590-XX)

Ref. No. 参照番号	Address 位置	New Parts 新	Parts No. 部品番号	Description 部品名 / 規格	Desti- nation 仕 向	Re- marks 備考
C35			CK73FB1H102K	CHIP C 1000PF K		
C36			CE04NW1C470M	ELECTRO 47UF 16WV		
C37			CK73FB1H102K	CHIP C 1000PF K		
C38			CK73FB1H822K	CHIP C 8200PF K		
C39			CK73FB1H102K	CHIP C 1000PF K		
C40		*	CK73FF1C105Z	CHIP C 1.0UF Z		
C41			CC73FUJ1H330J	CHIP C 33PF J		
C42			CC73FUJ1H100D	CHIP C 10PF D		
C43			CK73FB1H102K	CHIP C 1000PF K		
C44			CC73FCH1H060D	CHIP C 6PF D		
C45			CK73FB1H102K	CHIP C 1000PF K		
C46			CC73FCH1H060D	CHIP C 6PF D		
C47			CK73FB1H102K	CHIP C 1000PF K		
C48			CE04NW1C101M	ELECTRO 100UF 16WV		
C49			CK73FB1H102K	CHIP C 1000PF K		
C50		*	CE04NW1A330M	ELECTRO 33UF 10WV		
C51 ,52			CK73FB1H102K	CHIP C 1000PF K		
C53			CE04NW1C101M	ELECTRO 100UF 16WV		
C54 -58			CK73FB1H102K	CHIP C 1000PF K		
C59			CC73FCH1H040C	CHIP C 4PF C		
C60			CE04NW1C220M	ELECTRO 22UF 16WV		
C62			CK73FB1H102K	CHIP C 1000PF K		
C64 ,65			CK73FB1H102K	CHIP C 1000PF K		
C66			CM73F2H030D	CHIP C 3.00F D	K, P	
C66			CM73F2H060D	CHIP C 6.0PF D	M	
C67			CC73FCH1H070D	CHIP C 7PF D		
C68			CC45SL2H150J	CERAMIC 15PF J		
C69			CC45SL2H180J	CERAMIC 18PF J		
C70			CC45SL2H220J	CERAMIC 22PF J		
C71			CC73FCH1H0R5C	CHIP C 0.5PF C		
C72			CC73FCH1H020C	CHIP C 2.0PF C		
C73			CC45SL2H080D	CERAMIC 8.0PF D		
C74			CC45SL2H100D	CERAMIC 10PF D		
C75			CC73FCH1H0R5C	CHIP C 0.5PF C		
C76			CC73FCH1H020C	CHIP C 2.0PF C		
C77			CM73F2H060D	CHIP C 6.0PF D		
C78 -80			CK73FB1H102K	CHIP C 1000PF K		
C81			C90-2092-05	ELECTRO 1800PF 16WV		
C82 -85			CC73FSL1H101J	CHIP C 100PF J		
C86			CK73FB1H102K	CHIP C 1000PF K		
C87			CK73FB1H333K	CHIP C 0.033UF K		
C88			CE04NW1A221M	ELECTRO 220UF 10WV		
C92			CK73FB1H471K	CHIP C 470PF K		
C93			CE04NW1C470M	ELECTRO 47UF 16WV		
C94 ,95			CC73FCH1H030C	CHIP C 3PF C		
C96			CK73FB1H102K	CHIP C 1000PF K		
C97			CK73FB1E104K	CHIP C 0.10UF K		
C98			CC73FCH1H040C	CHIP C 4PF C		
C99			CC73FCH1H020C	CHIP C 2.0PF C		
C100			CC73FCH1H070D	CHIP C 7PF D		
C102			CE04NW1C100M	ELECTRO 10UF 16WV		
C103,104			CK73FB1H102K	CHIP C 1000PF K		
C105-110			CC73FSL1H101J	CHIP C 100PF J		
C111			CK73FB1H103K	CHIP C 0.010UF K		
C112			CK73FB1H102K	CHIP C 1000PF K		

E: Scandinavia & Europe K: USA P: Canada W: Europe

U: PX(Far East, Hawaii) T: England M: Other Areas

UE: AAFES(Europe) X: Australia

 indicates safety critical components.

PARTS LIST

× New Parts

Parts without Parts No. are not supplied.

Les articles non mentionnes dans le Parts No. ne sont pas fournis.

Telle ohne Parts No. werden nicht geliefert.

TX-RX UNIT/440 (X57-3590-XX)

Ref. No. 参照番号	Address 位置	New Parts 新	Parts No. 部品番号	Description 部品名 / 規格	Desti- nation 仕 向	Re- marks 備考
C113			CC73FCH1H020C	CHIP C 2.0PF C		
C114			CK73FB1E223K	CHIP C 0.022UF K		
C115-117			CK73FB1H102K	CHIP C 0.001UF K		
C118			CC73FCH1H150J	CHIP C 15PF J	K, P	
TC1 ,2			C05-0346-05	TRIM CAP 6PF		
TC3			C05-0371-05	TRIM CAP 10PF		
		*	E22-0672-04	TERMINAL BOARD		
		*	E22-0673-04	TERMINAL BOARD		
119	2C	*	E30-3007-05	DC CORD		
120	2C	*	E30-3009-05	ANT CABLE (M TYPE COVER)		
CN1 ,2		*	E40-5461-05	PIN ASSY (12P)		
J1		*	E11-0442-05	PHONE JACK		
TP1			E04-0154-05	RF COAXIAL CABLE RECEPTACLE		
			F05-1531-05	FUSE (10A)		
125	2C	*	F10-1444-03	SHIELDING PLATE (UPSIDE)		
		*	F10-1446-04	SHIELDING PLATE (MODULE)		
		*	F10-1457-04	SHIELDING CASE (VCO-PLL)		
		*	F10-1477-14	SHIELDING PLATE (MIX)		
		*	G02-0599-04	FLAT SPRING (DB TR)		
		*	G02-0600-04	SPRING (THERMAL SWITCH)		
		*	G02-0704-04	SPRING		
		*	G02-0705-04	SPRING		
		*	G09-0426-05	SPRING (DC CORD)		
			G11-0660-04	SHEET (VCO 25X10)		
		*	G11-0661-04	INSULATION SHEET(DB TR)		
		*	G11-0654-04	SHEET (VCO 30X20)		
		*	G11-0655-04	SHEET (CN1,2 55X8)		
		*	G11-0656-14	CONDUCTIVE SHEET(MCF)		
			G13-0841-04	CUSHION (12.8M XTAL)		
			G13-1319-04	CUSHION (VCO 22X15)		
			G53-0508-04	NON-WOVEN FABRIC		
CD1			L79-1013-05	FILTER		
CF1			L72-0372-05	CERAMIC FILTER (CFWM455F)		
L1			L40-1872-80	SMALL FIXED INDUCTOR (18NH)		
L2			L40-1572-48	SMALL FIXED INDUCTOR (15NH)		
L3		*	L79-1016-05	FILTER		
L4		*	L79-1017-05	FILTER (430)	M	
L4		*	L79-1018-05	FILTER (440)	K, P	
L5			L40-2272-48	SMALL FIXED INDUCTOR (22NH)	K, P	
L5			L40-3372-48	SMALL FIXED INDUCTOR (33NH)	M	
L6			L40-3372-48	SMALL FIXED INDUCTOR (33NH)		
L7		*	L34-4250-05	COIL		
L8			L40-2272-48	SMALL FIXED INDUCTOR (22NH)		
L9			L34-1238-05	COIL (9.5T)		
L10			L34-1185-05	COIL (2.5T)		
L11			L34-1032-05	COIL (3.5T)		
L12			L34-1226-05	COIL (1.5T)		
L13			L34-1238-05	COIL (9.5T)		
L14			L34-1226-05	COIL (1.5T)		
L15			L40-1872-48	SMALL FIXED INDUCTOR (18NH)		
L16			L40-1001-19	SMALL FIXED INDUCTOR (10UH)		
X1		*	L77-1445-05	CRYSTAL RESONATOR (21.145MHZ)		
X2		*	L77-1405-05	CRYSTAL RESONATOR (12.8MHZ)		
XF1		*	L71-0411-05	MCF (21.6MHZ)		

E: Scandinavia & Europe K: USA P: Canada W: Europe

U: PX(Far East, Hawaii) T: England M: Other Areas

UE: AAFES(Europe) X: Australia

△ indicates safety critical components.

PARTS LIST

× New Parts

Parts without Parts No. are not supplied.

Les articles non mentionnes dans le Parts No. ne sont pas fournis.

Teile ohne Parts No. werden nicht geliefert.

TX-RX UNIT/440 (X57-3590-XX)
TX-RX UNIT/1200 (X57-3600-11)

Ref. No. 参照番号	Address 位置	New Parts 新	Parts No. 部品番号	Description 部品名 / 規格	Desti- nation 仕 向	Re- marks 備考
VR3 ,4			R12-6423-05	TRIM POT. 10K		
TS1		*	S59-0444-05	THERMAL SWITCH 90°C		
D1			HSK277	DIODE		
D4			MA862	DIODE		
D5			1SS181	DIODE		
D6			1SS184	DIODE		
D7			1SS184	DIODE		
D8			MI407	DIODE		
D9			MI808	DIODE		
D10 ,11			MA716	DIODE		
D12			DSA3A1	DIODE		
D13			1SS184	DIODE		
D14			MA716	DIODE		
D15			MA862	DIODE		
IC1			KCD04	IC(FM IF)		
IC2		*	KCA04	IC(MIC AMP)		
IC3			BU4094BF	IC		
IC4			LA5010M	IC(LOW SATURATION REGULATOR)		
IC5		*	KCC04	IC(APC)		
IC6		*	KCB14	IC(DRIVE)		
IC7			M57788M	IC(POWER MODULE/ 430-450MHZ)		
IC10		*	KCH07	IC(VCO-PLL 430)		
Q1			3SK184(S)	FET		
Q2			2SK582	FET		
Q3			3SK184(S)	FET		
Q5			2SC2714(Y)	TRANSISTOR		
Q8			2SA1362(Y)	TRANSISTOR		
Q9			DTC144WK	DIGITAL TRANSISTOR		
Q10 ,11			2SC2712(Y)	TRANSISTOR		
Q12			2SB1119S	TRANSISTOR		
Q13 -15			DTC144EK	DIGITAL TRANSISTOR		
Q16			2SD1757(K)	TRANSISTOR		
Q17			2SC2712(Y)	TRANSISTOR		
Q18			2SC3123	TRANSISTOR		
Q19			FMG1	TRANSISTOR		
Q20		*	2SD1760(Q)	TRANSISTOR		
Q21			2SJ106(GR)	FET		
TX-RX UNIT/1200 (X57-3600-11)						
C1			CC73FCH1H220J	CHIP C 22PF J		
C2 -5			CK73FB1H471K	CHIP C 470PF K		
C7			CC73FCH1H100D	CHIP C 10PF D		
C8			CC73FSL1H101J	CHIP C 100PF J		
C9		*	CC73FCH1H1R5B	CHIP C 1.5PF B		
C10 ,11			CC73FCH1H470J	CHIP C 47PF J		
C12			CK73FB1E103K	CHIP C 0.01UF K		
C13		*	CC73FCH1H1R5B	CHIP C 1.5PF B		
C14			CC73FSL1H101J	CHIP C 100PF J		
C15			CK73FB1H471K	CHIP C 470PF K		
C17			CC73FSL1H101J	CHIP C 100PF J		
C18		*	CC73FCH1H1R5B	CHIP C 1.5PF B		
C19			CE04NW1C470M	ELECTRO 47UF 16WV		
C21 ,22			CK73FB1H471K	CHIP C 470PF K		
C23			CC73FCH1H030C	CHIP C 3PF C		

E: Scandinavia & Europe K: USA P: Canada W: Europe

U: PX(Far East, Hawaii) T: England M: Other Areas

UE: AAFES(Europe) X: Australia

 indicates safety critical components.

PARTS LIST

× New Parts

Parts without Parts No. are not supplied.

Les articles non mentionnes dans le Parts No. ne sont pas fournis.

Telle ohne Parts No. werden nicht geliefert.

TX-RX UNIT/440 (X57-3590-XX)

Ref. No. 参照番号	Address 位置	New Parts 新	Parts No. 部品番号	Description 部品名 / 規格	Desti- nation 仕向	Re- marks 備考
P	-		N09-2077-05	SCREW (MODULE)		
J	3C		N87-2606-46	TAPTITE SCREW(PCB, ANT)		
L	2C, 3C		N88-2606-46	TAPTITE SCREW(COVER, THERMAL SW)		
R2			RK73FB2A104J	CHIP R 100K J 1/10W		
R3			RK73FB2A333J	CHIP R 33K J 1/10W		
R4	, 5		RK73FB2A101J	CHIP R 100 J 1/10W		
R6			RK73FB2A470J	CHIP R 47 J 1/10W		
R7			RK73FB2A220J	CHIP R 22 J 1/10W		
R9			R92-0670-05	CHIP R 0 ΩHM		
R10			RK73FB2A223J	CHIP R 22K J 1/10W		
R11			RK73FB2A102J	CHIP R 1.0K J 1/10W		
R12	, 13		R92-0670-05	CHIP R 0 ΩHM		
R14	, 15		RK73FB2A102J	CHIP R 1.0K J 1/10W		
R17			RK73FB2A221J	CHIP R 220 J 1/10W		
R18			RK73FB2A222J	CHIP R 2.2K J 1/10W		
R19			RK73FB2A470J	CHIP R 47 J 1/10W		
R20			R92-0670-05	CHIP R 0 ΩHM		
R21			RK73FB2A122J	CHIP R 1.2K J 1/10W		
R22			RK73FB2A334J	CHIP R 330K J 1/10W		
R24			RK73FB2A102J	CHIP R 1.0K J 1/10W		
R25			RK73FB2A471J	CHIP R 470 J 1/10W		
R26			RK73FB2A473J	CHIP R 47K J 1/10W		
R27			RK73FB2A223J	CHIP R 22K J 1/10W		
R28			RK73FB2A182J	CHIP R 1.8K J 1/10W		
R29	- 31		RK73FB2A103J	CHIP R 10K J 1/10W		
R32			RK73FB2A182J	CHIP R 1.8K J 1/10W		
R33	- 35		RK73FB2A473J	CHIP R 47K J 1/10W		
R36			RK73FB2A154J	CHIP R 150K J 1/10W		
R37			RK73FB2A273J	CHIP R 27K J 1/10W		
R38			RK73FB2A152J	CHIP R 1.5K J 1/10W		
R40			RK73FB2A221J	CHIP R 220 J 1/10W		
R42			R92-0670-05	CHIP R 0 ΩHM		
R43			RK73FB2A471J	CHIP R 470 J 1/10W		
R44			RK73FB2A103J	CHIP R 10K J 1/10W		
R45	, 46		RK73FB2A222J	CHIP R 2.2K J 1/10W		
R47			RK73EB2B220J	CHIP R 22 J 1/8W		
R48			R92-0670-05	CHIP R 0 ΩHM		
R49			RK73FB2A102J	CHIP R 1.0K J 1/10W		
R51			RK73FB2A562J	CHIP R 5.6K J 1/10W		
R52			RK73FB2A104J	CHIP R 100K J 1/10W		
R53			R92-0685-05	CHIP R 22 J 1/2W		
R55			R92-0670-05	CHIP R 0 ΩHM		
R58			R92-0679-05	CHIP R 0 ΩHM		
R59			R92-1214-05	CHIP R 120 J 1/2W		
R60	, 61		RK73FB2A103J	CHIP R 10K J 1/10W		
R62			RK73FB2A221J	CHIP R 220 J 1/10W		
R63			RK73FB2A473J	CHIP R 47K J 1/10W		
R64			RK73FB2A104J	CHIP R 100K J 1/10W		
R65			RK73FB2A472J	CHIP R 4.7K J 1/10W		
R66			RK73FB2A473J	CHIP R 47K J 1/10W		
R67	, 68		RK73FB2A103J	CHIP R 10K J 1/10W		
R69			RK73FB2A474J	CHIP R 470K J 1/10W	K, P	
VR1			R12-6429-05	TRIMMING POT. 100K		
VR2			R12-6427-05	TRIM POT. 47K		

E: Scandinavia & Europe K: USA P: Canada W: Europe

U: PX(Far East, Hawaii) T: England M: Other Areas

UE: AAFES(Europe) X: Australia

△ indicates safety critical components.

PARTS LIST

× New Parts

Parts without Parts No. are not supplied.

Les articles non mentionnés dans le Parts No. ne sont pas fournis.

Teile ohne Parts No. werden nicht geliefert.

TX-RX UNIT/1200 (X57-3600-11)

Ref. No. 参照番号	Address 位置	New Parts 新	Parts No. 部品番号	Description 部品名 / 規格	Desti- nation 仕 向	Re- marks 備考
C24			CC73FCH1H1R5C	CHIP C 1.5PF C		
C25			CK73FB1H102K	CHIP C 1000PF K		
C26			CK73FB1H471K	CHIP C 470PF K		
C27			CK73FB1E223K	CHIP C 0.022UF K		
C28			CC73FCH1H080D	CHIP C 8PF D		
C29			CK73FB1E103K	CHIP C 0.01UF K		
C30			CC73FCH1H030C	CHIP C 3PF C		
C31			CC73FSL1H101J	CHIP C 100PF J		
C32			CC73FCH1H030C	CHIP C 3PF C		
C33			CK73FB1H471K	CHIP C 470PF K		
C34			CK73FB1H472K	CHIP C 4700PF K		
C35			CK73FB1H102K	CHIP C 1000PF K		
C36			CC73FCH1H150J	CHIP C 15PF J		
C37			CC73FCH1H220J	CHIP C 22PF J		
C38 -41			CK73FB1E103K	CHIP C 0.01UF K		
C42			CE04NW1C470M	ELECTRØ 47UF 16WV		
C43 ,44			CK73EF1C105Z	CHIP C 1.0UF Z		
C45			C92-0002-05	CHIP-TAN 0.22UF 35WV		
C46			CK73FB1E104K	CHIP C 0.10UF K		
C47			CK73FB1H471K	CHIP C 470PF K		
C48			C92-0504-05	CHIP-TAN 0.68UF 20WV		
C49			C92-0004-05	CHIP-TAN 1.0UF 10WV		
C50			CK73FB1E223K	CHIP C 0.022UF K		
C51			CK73EF1C105Z	CHIP C 1.0UF Z		
C52			CC73FCH1H030C	CHIP C 3PF C		
C53			CK73FB1E473K	CHIP C 0.047UF K		
C54			CE04NW1C470M	ELECTRØ 47UF 16WV		
C55			CK73EF1C105Z	CHIP C 1.0UF Z		
C56			CK73FB1E223K	CHIP C 0.022UF K		
C57			CK73FB1H471K	CHIP C 470PF K		
C58 ,59			CE04NW1C101M	ELECTRØ 100UF 16WV		
C60			CK73FB1H471K	CHIP C 470PF K		
C61		*	CE04NW1A330M	ELECTRØ 33UF 10WV		
C62 ,63			CK73FB1E103K	CHIP C 0.01UF K		
C64			CE04NW1C101M	ELECTRØ 100UF 16WV		
C65			CC73GCH1H030C	CHIP C 3PF C		
C66			CC73GCH1H101J	CHIP C 100PF J		
C67 ,68			CC73GCH1H020C	CHIP C 2.0PF C		
C69			CC73GCH1H101J	CHIP C 100PF J		
C70			CC73GCH1H050C	CHIP C 5PF C		
C71			CK73EF1C105Z	CHIP C 1.0UF Z		
C72			CE04NW1E100M	ELECTRØ 10UF 25WV		
C73 ,74			CK73FB1H471K	CHIP C 470PF K		
C75			CK73GB1H471K	CHIP C 470PF K		
C76			CK73FB1H471K	CHIP C 470PF K		
C77			CK73FB1E103K	CHIP C 0.01UF K		
C78 -80			CK73FB1H471K	CHIP C 470PF K		
C81			CK73EF1C105Z	CHIP C 1.0UF Z		
C82 -84			CK73FB1H471K	CHIP C 470PF K		
C85			CE04NW1E100M	ELECTRØ 10UF 25WV		
C86			CK73EF1C105Z	CHIP C 1.0UF Z		
C87 ,88			CK73GB1H471K	CHIP C 470PF K		
C89 ,90			CK73FB1H471K	CHIP C 470PF K		
C91			CE04NW1C470M	ELECTRØ 47UF 16WV		
C92			CC73FCH1H470J	CHIP C 47PF J		

E: Scandinavia & Europe K: USA P: Canada W: Europe

U: PX(Far East, Hawaii) T: England M: Other Areas

UE: AAFES(Europe) X: Australia

▲ indicates safety critical components.

PARTS LIST

※ New Parts

Parts without Parts No. are not supplied.

Les articles non mentionnes dans le Parts No. ne sont pas fournis.

Teile ohne Parts No. werden nicht geliefert.

TX-RX UNIT/1200 (X57-3600-11)

Ref. No. 参照番号	Address 位置	New Parts 新	Parts No. 部品番号	Description 部品名 / 規格	Desti- nation 仕向	Re- marks 備考
C93 ,94			CK73FB1H471K	CHIP C 470PF K		
C95			CC73FCH1H010C	CHIP C 1PF C		
C96			CC73FCH1H100D	CHIP C 10PF D		
C97			CK73FB1H471K	CHIP C 470PF K		
C98			CM73F2H470J	CHIP C 47PF J		
C99			CC73FSL1H101J	CHIP C 100PF J		
C100			CK73FB1E103K	CHIP C 0.01UF K		
C101			CC73FCH1H080D	CHIP C 8PF D		
C102-104			CK73FB1H471K	CHIP C 470PF K		
C105		*	CC73FCH1HR75B	CHIP C 0.75PF B		
C106			CK73FB1H471K	CHIP C 470PF K		
C107			CC73FSL1H101J	CHIP C 100PF J		
C108-110			CK73FB1H471K	CHIP C 470PF K		
C111			CC73FSL1H101J	CHIP C 100PF J		
C112			CK73FB1H471K	CHIP C 470PF K		
C113			CK73FB1H102K	CHIP C 1000PF K		
C114-116			CK73FB1H471K	CHIP C 470PF K		
C117			CK73GB1H102K	CHIP C 1000PF K		
C118			CK73FB1E103K	CHIP C 0.01UF K		
C119			CC73FSL1H101J	CHIP C 100PF J		
C120			CC73FUJ1H221J	CHIP C 220PF J		
C123-130			CK73FB1H471K	CHIP C 470PF K		
C131			CK73GB1H103K	CHIP C 0.01UF K		
C132			CK73GB1H471K	CHIP C 470PF K		
C133			CK73FB1E103K	CHIP C 0.01UF K		
C134-137			CK73FB1H471K	CHIP C 470PF K		
C138			CE04NWOJ470M	ELECTRO 47UF 6.3WV		
C139			CC73FSL1H101J	CHIP C 100PF J		
C140			CK73FB1E104K	CHIP C 0.10UF K		
C141, 142			CK73FB1H471K	CHIP C 470PF K		
C144, 145			CC73FSL1H101J	CHIP C 100PF J		
C147-156			CC73GCH1H101J	CHIP C 100PF J		
C157			CK73GB1H102K	CHIP C 0.001UF K		
C158			CK73FB1H102K	CHIP C 0.001UF K		
130	3C	*	E22-0672-04	TERMINAL BOARD		
CN1 ,2		*	E22-0673-04	TERMINAL BOARD		
J1		*	E30-3011-05	ANT CABLE		
		*	E40-5461-05	PIN ASSY (12P)		
		*	E11-0442-05	PHONE JACK		
135	3C	*	F10-1444-03	SHIELDING PLATE (UPSIDE)		
		*	F10-1445-04	SHIELDING PLATE (VCO)		
		*	F10-1446-04	SHIELDING PLATE (MODULE)		
		*	F10-1457-04	SHIELDING PLATE		
		*	F10-1475-04	SHIELDING PLATE (MODULE)		
		*	G02-0599-04	FLAT SPRING (IC)		
		*	G02-0706-04	SPRING		
		*	G11-0661-04	INSULATION SHEET (IC)		
		*	G11-0654-04	SHEET (VCO 30X20)		
		*	G11-0655-04	SHEET (CN1,2 55X8)		
			G11-0660-04	SHEET (VCO 25X10)		
			G13-1319-04	CUSHON (VCO 22X15)		
			G53-0508-04	NON-WOVEN FABRIC		
		*	J42-0471-04	BUSHING (DC CABLE)		

E: Scandinavia & Europe K: USA P: Canada W: Europe

U: PX(Far East, Hawaii) T: England M: Other Areas

UE: AAFES(Europe) X: Australia

 indicates safety critical components.

PARTS LIST

× New Parts

Parts without Parts No. are not supplied.

Les articles non mentionnés dans le Parts No. ne sont pas fournis.

Telle ohne Parts No. werden nicht geliefert.

TX-RX UNIT/1200 (X57-3600-11)

Ref. No. 参照番号	Address 位置	New Parts 新	Parts No. 部品番号	Description 部品名 / 規格	Desti- nation 仕 向	Re- marks 備考
CD1			L79-1013-05	FILTER		
CF1			L72-0366-05	CERAMIC FILTER (CFWM455E)		
L1 ,2		*	L79-1015-05	FILTER		
L4		*	L34-4259-05	COIL		
L5			L71-0280-05	MCF		
L6			L34-2034-05	COIL		
L7		*	L40-3982-19	SMALL FIXED INDUCTOR (0.39UH)		
L8			L40-5682-19	SMALL FIXED INDUCTOR (0.56UH)		
X1			L77-1375-05	CRYSTAL RESONATOR (59.245MHZ)		
X2			L77-1376-25	TCXO (12.8MHZ)		
P	-		N09-2077-05	SCREW		
J	3C		N87-2606-46	TAPTITE SCREW(PCB,ANT)		
L	3C		N88-2606-46	TAPTITE SCREW(COVER)		
R1 ,2			RK73FB2A222J	CHIP R 2.2K J 1/10W		
R4			RK73FB2A473J	CHIP R 47K J 1/10W		
R5			RK73GB1J473J	CHIP R 47K J 1/16W		
R6			RK73FB2A560J	CHIP R 56 J 1/10W		
R7			RK73FB2A221J	CHIP R 220 J 1/10W		
R9			RK73FB2A472J	CHIP R 4.7K J 1/10W		
R10			RK73FB2A153J	CHIP R 15K J 1/10W		
R11			RK73FB2A471J	CHIP R 470 J 1/10W		
R13			R92-0670-05	CHIP R 0 OHM		
R14			RK73GB1J180J	CHIP R 18 J 1/16W		
R15			RK73FB2A101J	CHIP R 100 J 1/10W		
R16			RK73FB2A331J	CHIP R 330 J 1/10W		
R17			RK73FB2A100J	CHIP R 10 J 1/10W		
R19			RK73FB2A151J	CHIP R 150 J 1/10W		
R20			RK73FB2A101J	CHIP R 100 J 1/10W		
R21			R92-0670-05	CHIP R 0 OHM		
R22			RK73FB2A331J	CHIP R 330 J 1/10W		
R23			RK73FB2A224J	CHIP R 220K J 1/10W		
R24			RK73FB2A561J	CHIP R 560 J 1/10W		
R25			RK73FB2A103J	CHIP R 10K J 1/10W		
R26			RK73FB2A473J	CHIP R 47K J 1/10W		
R27			RK73FB2A471J	CHIP R 470 J 1/10W		
R29			R92-0670-05	CHIP R 0 OHM		
R30			RK73FB2A221J	CHIP R 220 J 1/10W		
R31			RK73FB2A472J	CHIP R 4.7K J 1/10W		
R32			RK73FB2A222J	CHIP R 2.2K J 1/10W		
R33			RK73FB2A334J	CHIP R 330K J 1/10W		
R34			RK73FB2A223J	CHIP R 22K J 1/10W		
R35			RK73FB2A182J	CHIP R 1.8K J 1/10W		
R36 ,37			RK73FB2A103J	CHIP R 10K J 1/10W		
R38			RK73FB2A102J	CHIP R 1.0K J 1/10W		
R39 -41			RK73FB2A103J	CHIP R 10K J 1/10W		
R42			RK73FB2A474J	CHIP R 470K J 1/10W		
R43 -45			RK73GB1J472J	CHIP R 4.7K J 1/16W		
R46			RK73FB2A684J	CHIP R 680K J 1/10W		
R47			RK73FB2A823J	CHIP R 82K J 1/10W		
R48			RK73FB2A331J	CHIP R 330 J 1/10W		
R49			RK73FB2A102J	CHIP R 1.0K J 1/10W		
R50			RK73FB2A472J	CHIP R 4.7K J 1/10W		
R51			RK73FB2A102J	CHIP R 1.0K J 1/10W		
R52			RK73FB2A560J	CHIP R 56 J 1/10W		

E: Scandinavia & Europe K: USA P: Canada W: Europe

U: PX(Far East, Hawaii) T: England M: Other Areas

UE: AAFES(Europe) X: Australia

 indicates safety critical components.

PARTS LIST

※ New Parts

Parts without Parts No. are not supplied.

Les articles non mentionnes dans le Parts No. ne sont pas fournis.

Telle ohne Parts No. werden nicht geliefert.

TX-RX UNIT/1200 (X57-3600-11)

Ref. No. 参照番号	Address 位置	New Parts 新	Parts No. 部品番号	Description 部品名 / 規格	Desti- nation 仕 向	Re- marks 備考
R53			RK73GB1J470J	CHIP R 47 J 1/16W		
R54			RK73GB1J103J	CHIP R 10K J 1/16W		
R55			RK73GB1J222J	CHIP R 2.2K J 1/16W		
R56			RK73GB1J471J	CHIP R 470 J 1/16W		
R57			RK73FB2A100J	CHIP R 10 J 1/10W		
R58			RK73FB2A152J	CHIP R 1.5K J 1/10W		
R59			RK73FB2A683J	CHIP R 68K J 1/10W		
R60			R92-0670-05	CHIP R 0 ΩHM		
R61 ,62			RK73FB2A220J	CHIP R 22 J 1/10W		
R63			RK73GB1J472J	CHIP R 4.7K J 1/16W		
R64			RK73GB1J222J	CHIP R 2.2K J 1/16W		
R65			RK73GB1J471J	CHIP R 470 J 1/16W		
R66 ,67			RK73FB2A180J	CHIP R 18 J 1/10W		
R68			R92-0670-05	CHIP R 0 ΩHM		
R69			RK73FB2A333J	CHIP R 33K J 1/10W		
R70			R92-1201-05	SILID 220 1/2W		
R71			R92-0670-05	CHIP R 0 ΩHM		
R72		*	R92-1264-05	RESISTOR 5.6 1W		
R73			RK73FB2A472J	CHIP R 4.7K J 1/10W		
R74			R92-0700-05	CHIP R 180 1/2W		
R75			RK73FB2A470J	CHIP R 47 J 1/10W		
R76			RK73FB2A222J	CHIP R 2.2K J 1/10W		
R77			R92-0670-05	CHIP R 0 ΩHM		
R79 ,80			RK73FB2A103J	CHIP R 10K J 1/10W		
R81			RK73FB2A471J	CHIP R 470 J 1/10W		
R82			R92-0670-05	CHIP R 0 ΩHM		
R83			RK73FB2A4R7J	CHIP R 4.7 J 1/10W		
VR1			R12-6429-05	TRIMMING POT. 100K		
VR2			R12-6421-05	TRIM POT. 4.7K		
VR3			R12-6427-05	TRIM POT. 47K		
VR4			R12-6423-05	TRIM POT. 10K		
VR5			R12-6427-05	TRIM POT. 47K		
D1			MA862	DIODE		
D3			MA716	DIODE		
D4			1SS193	DIODE		
D5			02CZ6.2(X,Y)	DIODE		
D6			1SS193	DIODE		
D7			1SS187	DIODE		
D8			02CZ12(X,Y)	DIODE		
D9			HSK151	DIODE		
D10 -13			MI808	DIODE		
D14			DSA3A1	DIODE		
D15			02CZ3.6(Y,Z)	DIODE		
D17			DAP202U	DIODE		
IC2			KCD04	IC(IF)		
IC3		*	KCX03	IC(ALT)		
IC4		*	KCA04	IC(MIC)		
IC5			BU4094BF	IC		
IC6			LA5009M	IC		
IC7		*	KCB09	IC(PRE DRIVE)		
IC8		*	KCB10	IC(DRIVE)		
IC9		*	KCC04	IC(APC)		
IC10			M67711	IC(POWER MODULE/ 1.24-1.3BHZ)		
IC11		*	KCH03	IC(PLL)		

E: Scandinavia & Europe K: USA P: Canada W: Europe

U: PX(Far East, Hawaii) T: England M: Other Areas

UE: AAFES(Europe) X: Australia

⚠ indicates safety critical components.

PARTS LIST

× New Parts

Parts without Parts No. are not supplied.

Les articles non mentionnes dans le Parts No. ne sont pas fournis.

Teile ohne Parts No. werden nicht geliefert.

TX-RX UNIT/1200 (X57-3600-11)
LCD ASSY (B38-034X-XX)

Ref. No. 参照番号	Address 位置	New Parts 新	Parts No. 部品番号	Description 部品名 / 規格	Desti- nation 仕 向	Re- marks 備考
IC12			NJM78L05UA	IC		
Q1			MGF1502	IC		
Q2			2SC4095(R47.6)	TRANSISTOR		
Q3			3SK184(S)	FET		
Q6			2SC3356	TRANSISTOR		
Q7			2SC3120	TRANSISTOR		
Q8			2SA1362(Y)	TRANSISTOR		
Q9			2SB1302S	TRANSISTOR		
Q10			DTC144WK	DIGITAL TRANSISTOR		
Q11			FMW1	TRANSISTOR		
Q12 ,13			2SC2712(Y)	TRANSISTOR		
Q15 -17			DTC144EU	DIGITAL TRANSISTOR		
Q18			2SD1757(K)	TRANSISTOR		
Q19			2SA1362(Y)	TRANSISTOR		
Q20			DTC124EK	DIGITAL TRANSISTOR		
Q21 ,22			2SC4226(R23,24)	TRANSISTOR		
Q23			2SC2712(Y)	TRANSISTOR		
Q24		*	2SD1760(Q)	TRANSISTOR		
Q25			FMG1	TRANSISTOR		
Q26			2SJ106(GR)	FET		
Q28			DTC114EK	DIGITAL TRANSISTOR		
LCD ASSY (B38-034X-XX) 1-05:K, P, 2-05:M						
D1 -6		*	B30-0892-05	LED(RED)		
D7		*	B30-0894-05	LED(ORG)		
D8		*	B30-0893-05	LED(GREEN)		
D9		*	B30-0894-05	LED(ORG)		
D10		*	B30-0893-05	LED(GREEN)		
D11		*	B30-0894-05	LED(ORG)		
D12		*	B30-0893-05	LED(GREEN)		
PL1 -6			B30-0865-05	LAMP		
C1 ,2			CC73ECH1H330J	CHIP C 33PF J		
C3			CK73EB1H223K	CHIP C 0.022UF K		
C4			CK73EB1H102K	CHIP C 1000PF K		
C5			CK73EB1H103K	CHIP C 0.01UF K		
C6			CK73EB1H102K	CHIP C 1000PF K		
C7			CK73EB1H223K	CHIP C 0.022UF K		
C8			CE04CW1C220M	ELECTRO 22UF 16WV		
C9			CK73EB1H102K	CHIP C 1000PF K		
C10 ,11			CC73ESL1H101J	CHIP C 100PF J		
C12			CE04CW1C220M	ELECTRO 22UF 16WV		
C13 -16			CK73EB1H102K	CHIP C 1000PF K		
C17			CK73EB1H223K	CHIP C 0.022UF K		
C18 -31			CK73EB1H103K	CHIP C 0.01UF K		
C32 ,33			CK73EB1H102K	CHIP C 1000PF K		
CN1			E40-3262-05	CONNECTOR		
CN2 -4		*	E40-5392-05	CONNECTOR (5P)		
CN5 -7		*	E40-5409-05	CONNECTOR (5P VR SIDE)		
X1			L77-1333-05	XTAL(4.19MHZ)		
R1			RK73EB2B473J	CHIP R 47K J 1/8W		
R2			RK73EB2B105J	CHIP R 1.0M J 1/8W		
R3			RK73EB2B103J	CHIP R 10K J 1/8W		
R4			RK73EB2B563J	CHIP R 56K J 1/8W		
R5			RK73EB2B104J	CHIP R 100K J 1/8W		

E: Scandinavia & Europe K: USA P: Canada W: Europe

U: PX(Far East, Hawaii) T: England M: Other Areas

UE: AAFES(Europe) X: Australia

 indicates safety critical components.

PARTS LIST

× New Parts

Parts without Parts No. are not supplied.

Les articles non mentionnes dans le Parts No. ne sont pas fournis.

Telle ohne Parts No. werden nicht geliefert.

LCD ASSY (B38-034X-XX)

Ref. No. 参照番号	Address 位置	New Parts 新	Parts No. 部品番号	Description 部品名 / 規格	Desti- nation 仕向	Re- marks 備考
R6			RK73EB2B105J	CHIP R 1.0M J 1/8W		
R7			RK73EB2B223J	CHIP R 22K J 1/8W		
R8 ,9			RK73EB2B222J	CHIP R 2.2K J 1/8W		
R10 -13			RK73EB2B100J	CHIP R 10 J 1/8W		
R14 -17			RK73EB2B473J	CHIP R 47K J 1/8W		
R19			R92-0679-05	CHIP R 0 0HM		
R20			R92-0679-05	CHIP R 0 0HM	K,P	
R21 ,22			R92-0679-05	CHIP R 0 0HM		
R23 -25			RK73EB2B100J	CHIP R 10 J 1/8W		
R26 -31			RK73EB2B151J	CHIP R 150 J 1/8W		
R32 -34			RK73EB2B221J	CHIP R 220 J 1/8W		
R35			RK73EB2B473J	CHIP R 47K J 1/8W		
R36			RK73EB2B222J	CHIP R 2.2K J 1/8W		
R37			RK73EB2B272J	CHIP R 2.7K J 1/8W		
R38			RK73EB2B472J	CHIP R 4.7K J 1/8W		
R39			RK73EB2B123J	CHIP R 12K J 1/8W		
R40			RK73EB2B102J	CHIP R 1.0K J 1/8W		
R41			RK73EB2B222J	CHIP R 2.2K J 1/8W		
R42			R92-0686-05	CHIP R 33 J 1/2W		
R43			R92-1211-05	SOLID R 5.6K J 1/2W		
R44			RK73EB2B331J	CHIP R 330 J 1/8W		
VR1 -3	4B	*	R23-9407-05	POTENTIAL M. (SQ,VOL)		
S1			S40-1079-05	TACT SWITCH		
S2 -14			S40-1086-05	TACT SWITCH		
S15			S40-2458-05	PUSH SWITCH (POWER SW)		
IC1			75328GC-093-3B9	IC(UPD)		
IC2 ,3			MSM5265GS-V1K	IC		
IC4		*	TA78L05F	IC(VOLTAGE REGULATOR/ +5V)		
IC5 ,6			TC4S11F	IC(2 INPUT NAND GATE)		
IC7			S-8054ALR	IC(VOLTAGE DETECTOR)		
Q1			2SC2712(Y)	TRANSISTOR		
Q2			2SA1162(Y)	TRANSISTOR		
Q3			2SC2712(Y)	TRANSISTOR		
Q4			2SA1307(Y)	TRANSISTOR		
Q5			2SB815	TRANSISTOR		
Q6 -12			DTA114EK	DIGITAL TRANSISTOR		
S16	4A		W02-0388-05	ENCODER		

E: Scandinavia & Europe K: USA P: Canada W: Europe

U: PX(Far East, Hawaii) T: England M: Other Areas

UE: AAFES(Europe) X: Australia

 indicates safety critical components.

TM-941A

EXPLODED VIEW

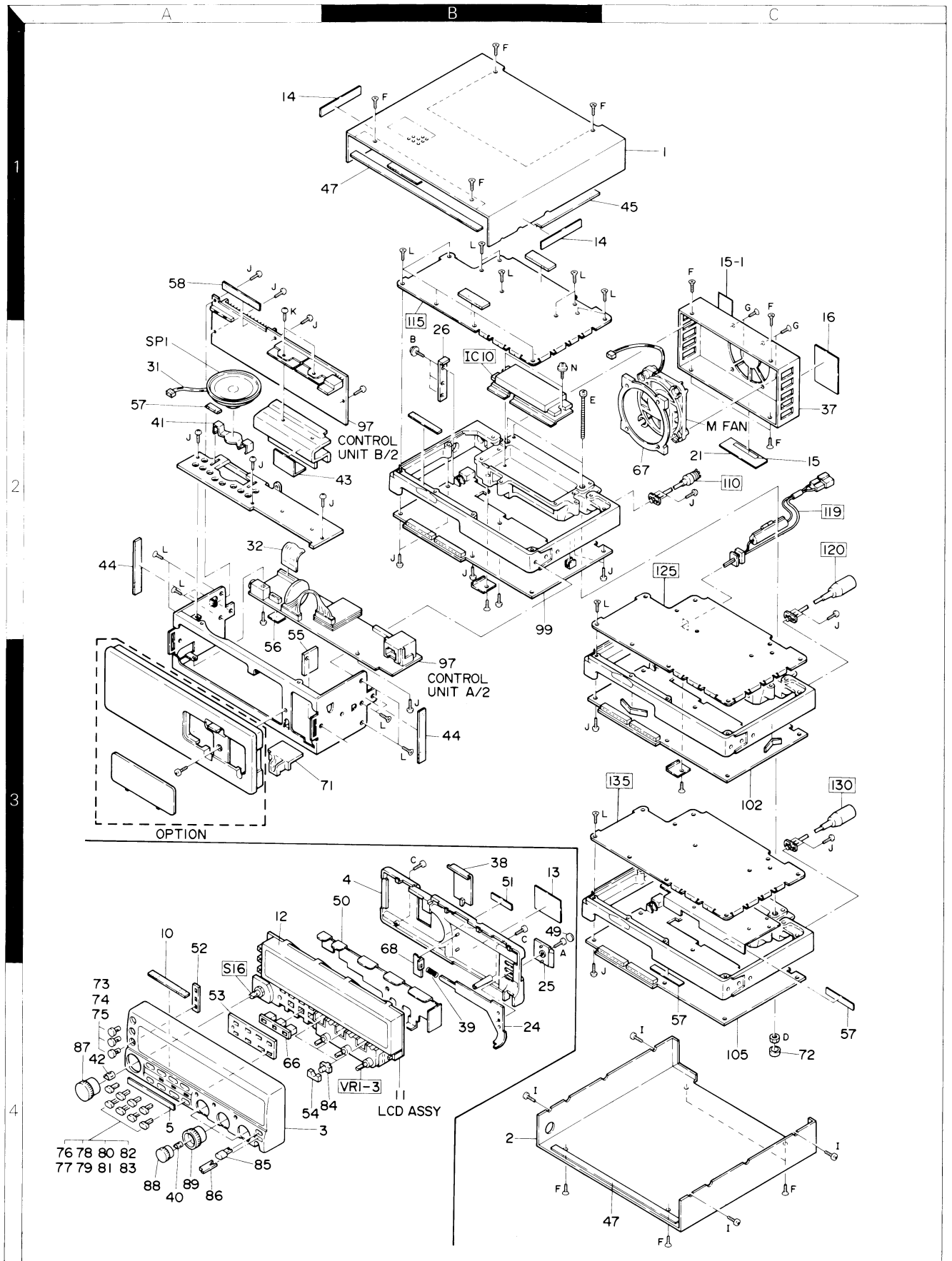

PACKING

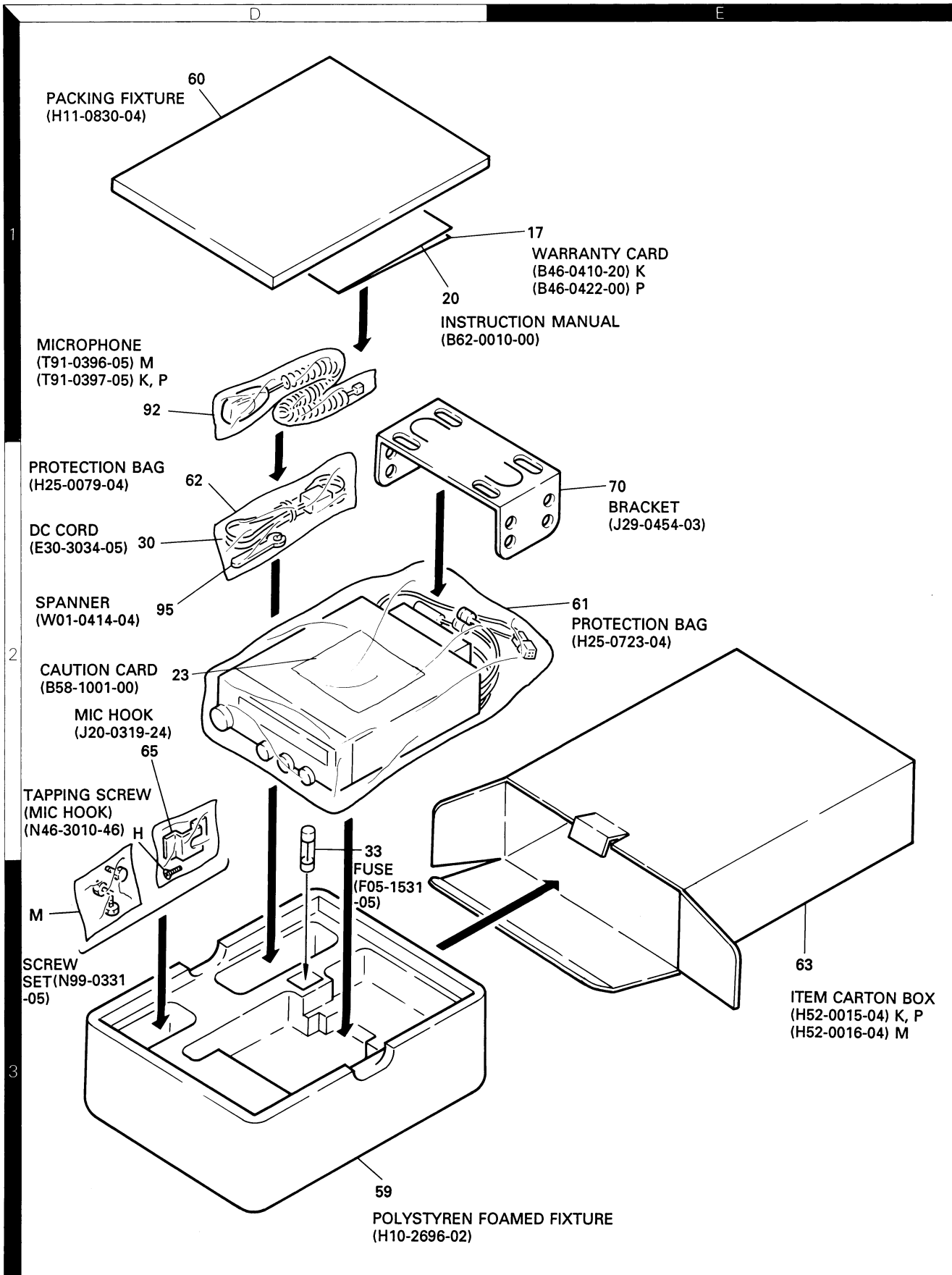

ADJUSTMENT

Required Test Equipment

- 1. Tester and DC V.M**
Use a tester with high input impedance.
- 2. RF VTVM (RF VM)**
Input impedance: 1 M ohms or more, 2 pF or less
Voltage range: FS = 10 mV to 300 V
Measurable frequency: 1,300 MHz (maximum)
- 3. Frequency counter (F counter)**
Input sensitivity: Approximately 50 mV
Measurable frequency: 1,300 MHz or more
- 4. DC power supply**
Voltage: 10 to 17 V (variable)
Current: 12 A or more
- 5. Power meter**
Power measurement ranges : 100 W, 50 W, and 15 W
Input impedance: 50 ohms
Measurable frequency: 1,300 MHz
- 6. AF vacuum voltmeter (AF VM)**
Input impedance: 1 M ohms or more
Voltage range: FS= 1 mV to 30 V
Measurable frequency: 50 Hz to 10 kHz
- 7. AF generator (AG)**
Output frequency: 100 Hz to 10 kHz
Output voltage: 0.5 mV to 1 V
- 8. Linear detector**
Measurable frequency: 1,300 MHz
- 9. Spectrum analyzer**
Measurable frequency: 1,300 MHz
- 10. Directional coupler**
- 11. Oscilloscope**
Use a high-sensitivity oscilloscope with horizontal input socket.
- 12. SSG**
Use an SSG that produces a frequency of 144 to 1,300 MHz with amplitude and frequency modulation.
Output level: 0.1µV to 100 mV
- 13. Dummy resistor**
Use an 8-ohm resistor exceeding the rated value in each band.

14. Noise generator

Use a noise generator whose output contains a high-frequency component of more than 1,300 MHz (near ignition noise).

15. Sweep generator

Use a sweep generator that can sweep the 1,300 MHz band.

16. Tracking generator

Preparation

- Set controls to the position shown in Table 10 unless otherwise specified.

POWER SW	ON	CALL SW	OFF
AF VOL VR	MIN	BELL/ALERT	OFF
SQL VOL VR	MIN	TONE, SHIFT	OFF
VFO, MR/M	OFF	REW, STEP	OFF
VFO, MR/M	VFO	DRS	OFF

Table 10

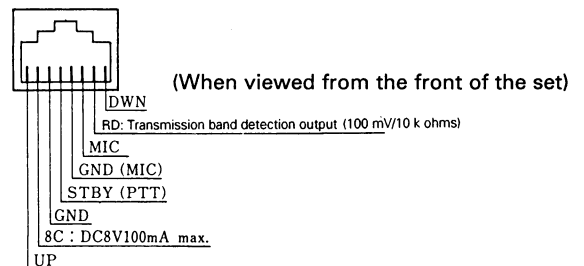

Fig. 32 Microphone Socket (on Front Panel)

- Use an insulated tool such as a plastic tool during adjustment (especially trimmer coil adjustment).
- For SSG protection, do not connect a microphone to the microphone socket during receiver block adjustment.
- Check that the power switch is off before the power cord is connected.
- The SSG output level is displayed at the release end.
- Check that the display and LCD display are as shown in Figure 33 after controls are set as in shown in Table 10.

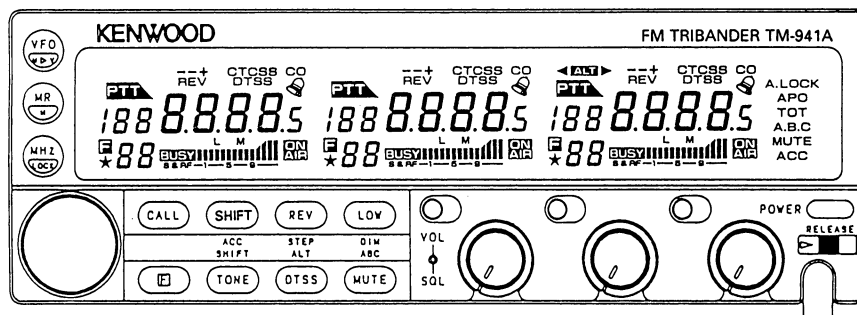

Fig. 33

ADJUSTMENT

Removing the TM-941A

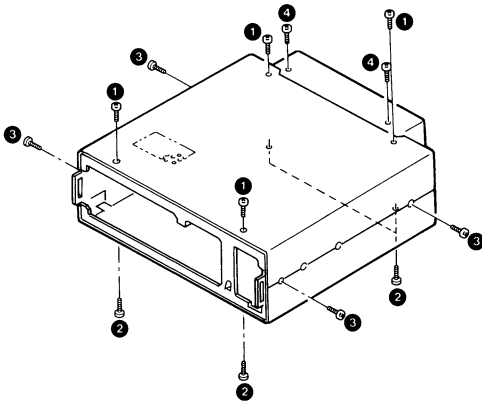

Fig. 34

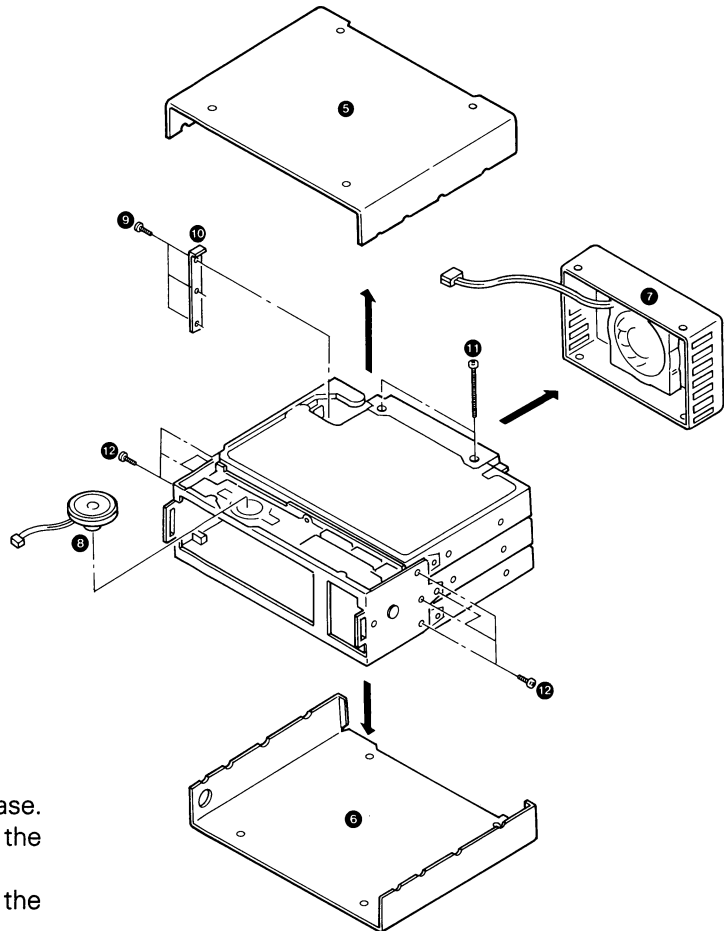

Fig. 35

1. Removing the case

- 1) Remove four screws ① in the top half of the case.
- 2) Remove four screws ② in the bottom half of the case.
- 3) Remove each two screws ③ in each side of the case.
- 4) Remove the top half ⑤ of the case in the direction of the arrow.
- 5) Remove the bottom half ⑥ of the case in the direction of the arrow.
- 6) Unplug the speaker connector from the common unit so that the speaker leads will not break off.

2. Removing the fan

- 1) Remove the two upper and lower fan fixing screws. ④
- 2) Unplug the power cord connector.
- 3) Pull the fan cover ⑦ backward to remove it.

3. Removing the TX-RX units

- 1) Remove the three screws ⑨ by inserting a screwdriver through the hole in the rear left of each TX-RX unit. Pull the power connector ⑩ of each TX-RX unit upward to remove it.
- 2) Remove the two screws ⑪ holding the TX-RX units together.
- 3) Remove the four screws ⑫ right and left connectin the common unit and TX-RX units.
- 4) Fix the common unit ⑬ so it cannot move, then pull out the TX-RX unit ⑭, ⑮, ⑯ in the direction of the arrow.

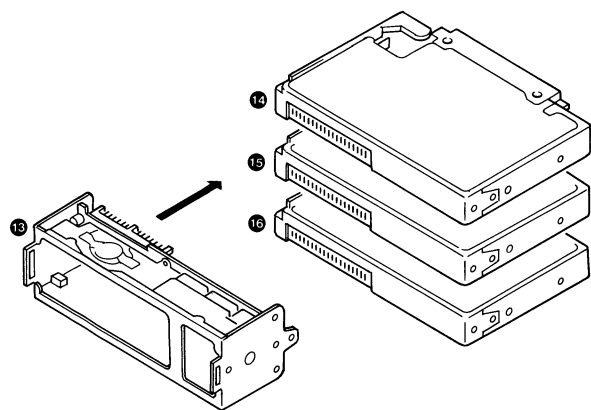

Fig. 36

ADJUSTMENT

● 144 MHz Band

Common Section Adjustment

Item	Condition	Measurement point			Adjustment point			Specification
		Test equipment	Unit	Terminal	Unit	Parts	Method	
1. Lock voltage check	1. Frequency: 146.000 MHz Receive	Digital voltmeter					Check the lock voltage.	2.3 ~ 2.7V
	2. Frequency: 147.995 MHz Transmit	Digital voltmeter powermeter					Check the lock voltage.	3.4 ~ 4.1V
	3. Frequency: 144.000 MHz Receive	Digital voltmeter					Check the lock voltage.	2.0 V or more

The DC power supply must be set to the rated voltage.

Receiver Section Adjustment

Item	Condition	Measurement point			Adjustment point			Specification		
		Test equipment	Unit	Terminal	Unit	Parts	Method			
1. Bandpass filter (BPF) adjustment	1. Frequency: 144.040 MHz SSG output: 0 dB μ Modulation: 1 KHz Deviation: 3 KHz Receive	Digital voltmeter SSG			TX-RX	L1-4	Adjust so that the voltmeter reading is maximum.	Voltmeter reading is maximum.		
2. Receive sensitivity	1. Frequency: 144.040 MHz 145.940 MHz 147.940 MHz SSG output: 0.16 μ V (-10dB μ) Modulation: 1 KHz Deviation: 3 KHz	Distortion meter Millivoltmeter Oscilloscope SSG	Rear panel	EXT.SP			Check	12 dB SINAD or more		
	2. AM sensitivity (K and P models only) Frequency: 118.040 MHz SSG output: 9 μ V (25dB μ) Modulation: 1 KHz Deviation: 30%								Press the MHz key and check that the frequency is set to 118.040 with an encoder.	12 dB SINAD or more
	Press the MR key									
3. Distortion factor	1. Frequency: 145.040 MHz SSG output: 52 μ V (40dB μ) Modulation: 1 KHz Deviation: 3 KHz AF output: 4 V/8 ohms	Distortion factor Oscilloscope SSG	Rear panel	EXT.SP	TX-RX	L6	Minimize the distortion factor.	5% or less		
4. Signal strength meter adjustment	1. Frequency: 146.040 MHz SSG output: 6.3 μ V (22dB μ) Modulation: 1 KHz Deviation: 3 KHz	SSG			TX-RX	VR1	Adjust so that all LEDs go on, then one LED goes off.	The SSG output is 20 \pm 6 dB μ .		
	2. SSG output: 6.8 μ V (23dB μ)						Adjust the SSG output so that all signal strength meter LEDs go on.			
5. Squelch check	1. Frequency: 146.040 MHz SSG output: Off Modulation: 1 KHz Deviation: 3 KHz	SSG	Rear panel	EXT.SP			1. Set the SQL knob to the closed position when the SSG output is off.	The SQL knob position is between 8 o'clock and 11 o'clock. The BUSY LED goes off.		
	2. SSG output: 0.1 μ V (-14dB μ)							The squelch is open. The BUSY LED goes on.		

ADJUSTMENT

Transmitter Section Adjustment

Item	Condition	Measurement point			Adjustment point			Specification
		Test equipment	Unit	Terminal	Unit	Parts	Method	
1. Power adjustment	1. Maximum power check Frequency: 146.000 MHz Transmit	Powermeter Ammeter	Rear panel	ANT	TX-RX	VR3	Check.	57 W or more
	2. High-power adjustment Frequency: 146.000 MHz Transmit				TX-RX	VR3	Adjust. 54W	48 to 59 W (11.5 A or less)
	3. Medium-power adjustment Note: This adjustment does not apply to the TM-941. Frequency: 146.000 MHz Transmit				TX-RX	VR4	Adjust. 12W	10 to 14 W
	4. Low-power check Frequency: 146.000 MHz Transmit						Check.	3 to 8 W
2. Deviation adjustment	1. Frequency: 146.000 MHz AG: 1 KHz, 50 mV Transmit	DC detector Oscilloscope	Rear panel	ANT	TX-RX	VR2	Adjust (in the higher + or - direction). 4.2 KHz	± 4.0 to 5.0 KHz
	2. Frequency: 146.000 MHz AG: 1 KHz, 5.0 mV Transmit						Check.	± 2.2 to 3.6 KHz
3. Tone check	1. Frequency: 145.220 MHz Tone: On Transmit	DC detector Oscilloscope	Rear panel	ANT			Check	± 0.5 to 1.5 KHz
4. Protection check	1. Frequency: 147.980 MHz Antenna: Open Transmit	Ammeter					Check	12.0 A or less
5. Frequency check	1. Frequency: 146.000 MHz Transmit	Frequency counter powermeter			TX-RX	TC1	146.000 MHz	± 100 Hz

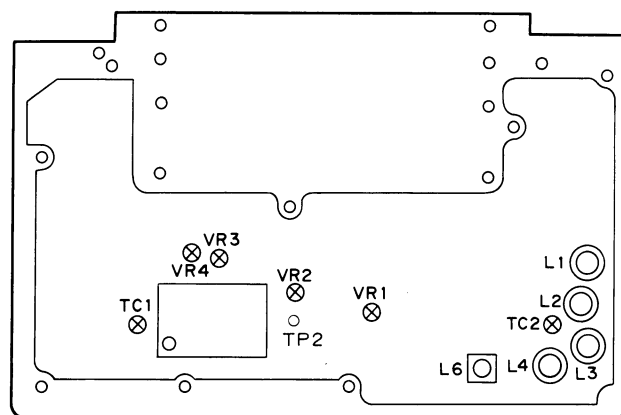

Fig. 37 144 MHz band adjustment: Component layout (upper view)

Note: Use an adjustment tool with a ceramic or plastic tip 1.5 mm square.



ADJUSTMENT

● 430 MHz Band

Common Section Adjustment

Item	Condition	Measurement point			Adjustment point			Specification
		Test equipment	Unit	Terminal	Unit	Parts	Method	
1. Lock voltage check	1. Frequency: 440.000 MHz (K and P models) 430.000 MHz (M model) Receive	Digital voltmeter					Check the lock voltage.	3.9 ~ 4.9V
	2. Frequency: 440.000 MHz (K and P models) 430.000 MHz (M model) Transmit	Digital voltmeter powermeter					Check the lock voltage.	2.0 ~ 3.0V
	3. Frequency: 449.975 MHz (K and P models) 439.975 MHz (M model)	Digital voltmeter					Check the lock voltage.	4.4 ~ 5.6V

Receiver Section Adjustment

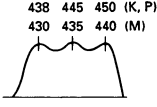
Item	Condition	Measurement point			Adjustment point			Specification	
		Test equipment	Unit	Terminal	Unit	Parts	Method		
1. Helical scanning adjustment	1. Frequency: 445.050 MHz (K and P models) 435.050 MHz (M model) Spectrum analyzer: Center of above frequency Tracking generator: Output: -30 dBm	Digital voltmeter Spectrum analyzer Tracking generator			TX-RX	TC1, TC2, L3, L4X3		Adjust each frequency as shown in the figure.	
2. Receive sensitivity	1. Frequency: 445.050 MHz (K and P models) 435.050 MHz (M model) SSG output: 0.18μV (-9 dBμ) Modulation: 1 KHz Deviation: 3 KHz	Distortion meter Millivoltmeter Oscilloscope SSG	Rear panel	EXT.SP			Check.	12 dB SINAD or more	
3. Distortion factor	1. Frequency: 445.050 MHz (K and P models) 435.050 MHz (M model) SSG output: 52μV (40 dBμ) Modulation: 1 KHz Deviation: 3 KHz AF output: 4 V/8 ohms	Distortion meter Oscilloscope SSG	Rear panel	EXT.SP	TX-RX	L7	Minimize the distortion factor.	5% or less	
4. Signal strength meter adjustment (check)	1. Frequency: 445.050 MHz (K and P models) 435.050 MHz (M model) SSG output: 6.8μV (23 dBμ) Modulation: 1 KHz Deviation: 3 KHz	SSG			TX-RX	VR1		Adjust so that all LEDs go on, then one LED goes off.	
	2. SSG output: 8.3μV (24 dBμ)							Adjust the SSG output so that all signal strength meter LEDs go on.	The SSG output is 20 ± 6 dBμ.
5. Squelch check	1. Frequency: 445.050 MHz (K and P models) 435.050 MHz (M model) SSG output: Off Modulation: 1 KHz Deviation: 3 KHz	SSG	Rear panel	EXT.SP				1. Set the SQL knob to the closed position when the SSG output is off.	The knob position is between 8 o'clock and 11 o'clock. The BUSY LED goes off.
	2. SSG output: 0.1μV (-14 dBu)								The squelch is open. The BUSY LED goes on.

ADJUSTMENT

Transmitter Section Adjustment

Item	Condition	Measurement point			Adjustment point			Specification
		Test equipment	Unit	Terminal	Unit	Parts	Method	
1. Power adjustment	1. Maximum power check Frequency: 445.000 MHz (K and P models) 435.000 MHz (M model) Transmit	Powermeter Ammeter	Rear panel	ANT	TX-RX	VR3	Check.	38 W or more
	2. High-power adjustment Frequency: 445.000 MHz (K and P models) 435.000 MHz (M model) Transmit				TX-RX	VR3	Adjust. 37W	33 to 42 W (10 A or less)
	3. Medium-power adjustment Frequency: 445.000 MHz (K and P models) 435.000 MHz (M model) Transmit				TX-RX	VR4	Adjust. 13W	10 to 14 W
	4. Low-power check Frequency: 445.000 MHz (K and P models) 435.000 MHz (M model) Transmit						Check.	3 to 8 W
2. Deviation adjustment	1. Frequency: 445.000 MHz (K and P models) 435.000 MHz (M model) AG: 1 KHz, 50 mV Transmit	DC detector Oscilloscope	Rear panel	ANT	TX-RX	VR2	Adjust (in the higher + or - direction). 4.2 KHz	± 4.0 to 5.0 KHz
	2. Frequency: 445.000 MHz (K and P models) 435.000 MHz (M model) AG: 1 KHz, 5.0 mV Transmit						Check.	± 2.2 to 3.6 KHz
3. Tone check	1. Frequency: 438.200 MHz Tone: On Transmit	DC detector Oscilloscope	Rear panel	ANT			Check.	± 0.5 to 1.5 KHz
4. Protection check	1. Frequency: 449.980 MHz (K and P models) 439.980 MHz (M model) Antenna: Open Transmit	Ammeter					Check.	10 A or less
5. Frequency check	1. Frequency: 445.000 MHz (K and P models) 435.000 MHz (M model) Transmit	Frequency counter powermeter			TX-RX	TC1	445.000 MHz K, P 435.000 MHz M	± 100 Hz

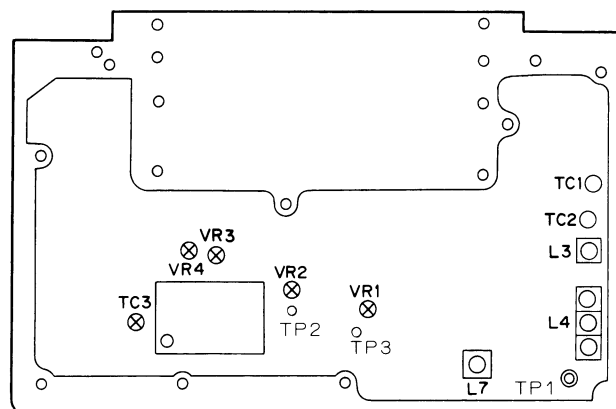

To adjust the 430 MHz band, remove the 144 MHz band unit from the control unit.

Fig. 38 430 MHz band adjustment: Component layout (upper view)

ADJUSTMENT

• 1200 MHz Band

Common Section Adjustment

Item	Condition	Measurement point			Adjustment point			Specification
		Test equipment	Unit	Terminal	Unit	Parts	Method	
1. Lock voltage check	1. Frequency: 1270.000 MHz Receive	Digital voltmeter					Check the lock voltage.	6.5 ~ 7.5V
	2. Frequency: 1299.975 MHz Transmit	Digital voltmeter Wattmeter					Check the lock voltage.	6.0 ~ 7.0V
	3. Frequency: 1240.000 MHz Receive	Digital voltmeter					Check the lock voltage.	1.2 V or more

Receiver Section Adjustment

Item	Condition	Measurement point			Adjustment point			Specification		
		Test equipment	Unit	Terminal	Unit	Parts	Method			
1. ALT adjustment	1. Frequency: 1270.100 MHz	Digital voltmeter SSG					Check the voltage.	AV		
	2. The same as the above frequency. SSG: Off						TX-RX	VR2	Adjust so that the voltage is 0.1 V higher than above.	AV + 0.1V
	3. The same as the above frequency. SSG output: 0.5 μ V (0 dB μ) Modulation: 1 KHz Deviation: 3 KHz						TX-RX	L6	Check that the voltage is 0.3 V higher than above when ALT is on, then turn ALT off.	(A + 0.1) V + 0.3V
2. Receive sensitivity	1. Frequency: 1270.100 MHz SSG output: 0.19 μ V (-8.5 dB μ) Modulation: 1 KHz Deviation: 3 KHz	Distortion meter Millivoltmeter Oscilloscope SSG	Rear panel	EXT.SP			Check.	12 dB SINAD or more		
3. Distortion adjustment	1. Frequency: 1270.100 MHz SSG output: 52 μ V (40 dB μ) Modulation: 1 KHz Deviation: 3 KHz AF output: 4 V/8 ohms	Distortion meter Oscilloscope SSG	Rear panel	EXT.SP	TX-RX	L4	Minimize the distortion factor.	5% or less		
4. Signal strength meter adjustment (check)	1. Frequency: 1270.100 MHz SSG output: 8 μ V (24 dB μ) Modulation: 1 KHz Deviation: 3 KHz	SSG			TX-RX	VR1		Adjust so that all LEDs go on, then one LED goes off.		
	2. SSG output: 9 μ V (25 dB μ)							Adjust the SSG output so that all signal strength meter LEDs go on.	The SSG output is 20 \pm 6 dB μ .	
5. Squelch check	1. Frequency: 1270.100 MHz SSG output: Off Modulation: 1 KHz Deviation: 3 KHz	SSG	Rear panel	EXT.SP			1. Set the SQL knob to the closed position when the SSG output is off.	The knob position is between 8 o'clock and 11 o'clock. The BUSY LED goes off.		
	2. SSG output: 0.1 μ V (-14 dB μ)							Check	The squelch is open. The BUSY LED goes on.	

ADJUSTMENT

Transmitter Section Adjustment

Item	Condition	Measurement point			Adjustment point			Specification
		Test equipment	Unit	Terminal	Unit	Parts	Method	
1. Power adjustment	1. Maximum power check Frequency: 1270.000 MHz Transmit	Powermeter Ammeter	Rear panel	ANT	TX-RX	VR4	Check.	11 W or more
	2. High-power adjustment Frequency: 1270.000 MHz Transmit				TX-RX	VR4	Adjust. 10W	9 to 14 W (6.0 A or less)
	3. Low-power check Frequency: 1270.000 MHz Transmit				TX-RX	VR5	Check.	0.7 to 1.4 W
2. Deviation adjustment	1. Frequency: 1270.000 MHz AG: 1 KHz, 50 mV Transmit	DC detector Oscilloscope	Rear panel	ANT	TX-RX	VR3	Adjust (in the higher + or - direction). 4.2KHz	± 4.0 to 5.0 KHz
	2. Frequency: 1270.000 MHz AG: 1 KHz, 5.0 mV Transmit						Check.	± 2.2 to 3.6 KHz
3. Tone check	1. Frequency: 1282.200 MHz Tone: On Transmit	DC detector Oscilloscope	Rear panel	ANT			Check.	± 0.5 to 1.5 KHz
4. Protection check	1. TM-941 Frequency: 1240.000 MHz 1270.000 MHz 1299.980 MHz Antenna: Open Transmit	Ammeter					Check.	8.5 A or less
5. Frequency check	1. Frequency: 1270.000 MHz Transmit	Frequency counter Powermeter					1270.000 MHz	± 1KHz

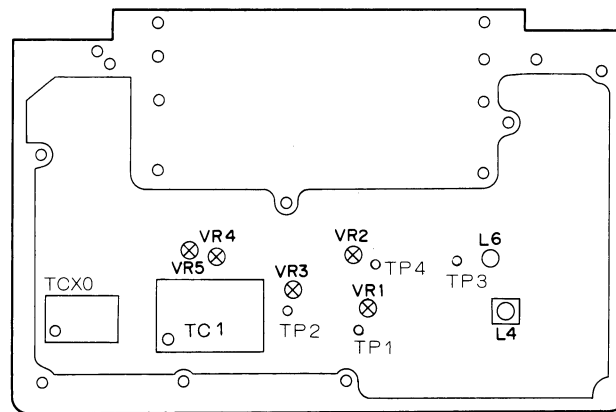

To adjust the 1200 MHz band, remove 144 and 430 MHz band units from the control unit and install a 1200 MHz band unit in the 430 MHz band position (center section). Supply the power with a power cord with alligator clips. Make sure there is no short circuit between the clips and the case.

Fig. 39 1200 MHz band adjustment: Component layout (upper view)

TM-941A

PC BOARD VIEW

CONTROL UNIT (X53-3310-11)

Component side view

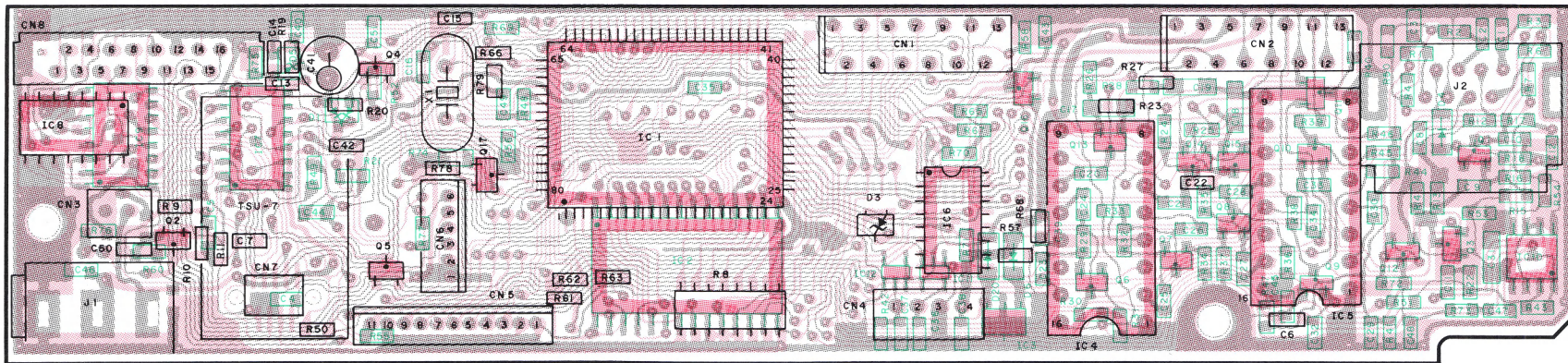

IC1:75516GF-189-3B9 IC2:LC3564PML-12, 15 IC3:TA78L06F IC4, 5:TC9154AP IC6, 7:BU4094BF IC8, 9:BU4053BF IC10:NJM4558E IC11, 12:TC4S11F
 Q1:2SC3324 (G) Q2, 4-8, 17:2SC2712(Y) Q3,9~11:DTC114EK Q12~15:2SD175 (K) Q16:2SA1519
 D1:1SS184 D2, 4, 6:LFB01 D3:02CZ7.5(X) D5:02CZ3.0(Z)

IC101:CXD1095Q IC102:MC78T08CT IC103:NJM4558E IC104,105:LA4446 IC106:BU4053BF IC107~110:BU4066BF
 Q101,107:2SC2712(Y) Q102:2SA1641(S, T) Q103:DTD143EK Q104,105:DTC114EK Q106:DTC144EK Q108:DTA144EK
 D101~103:1SS184

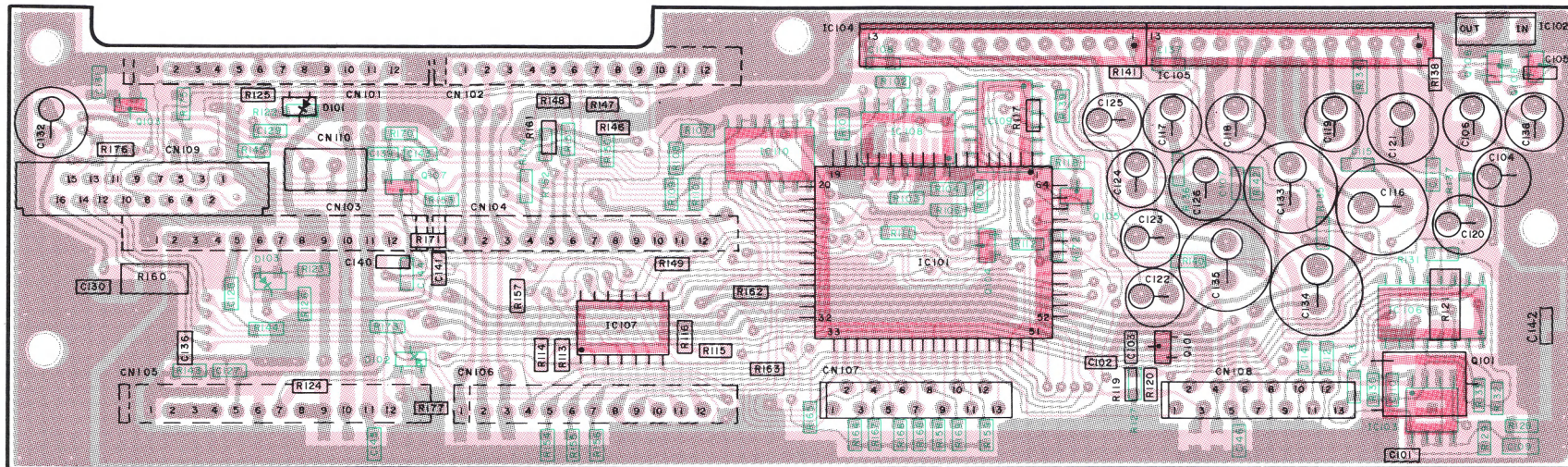

Component side pattern
 Foil side pattern

TM-941A

PC BOARD VIEW

CONTROL UNIT (X53-3310-11)

Foil side view

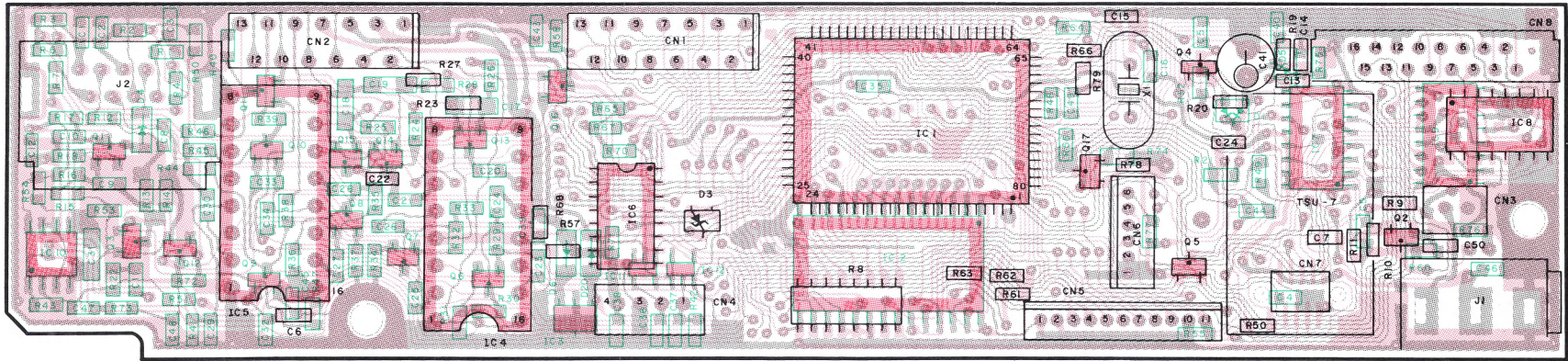

IC1:75516GF-189-3B9 IC2:LC3564PML-12,15 IC3:TA78L06F IC4, 5:TC9154AP IC6, 7:BU4094BF IC8, 9:BU4053BF IC10:NJM4558E IC11, 12:TC4S11F
 Q1:2SC3324(G) Q2, 4~8, 17:2SC2712(Y) Q3, 9~11:DTC114EK Q12~15:SD1757(K) Q16:2SA1519
 D1:1SS184 D2, 4, 6:LFB01 D3:02CZ7.5(X) D5:020Z3.0(Z)

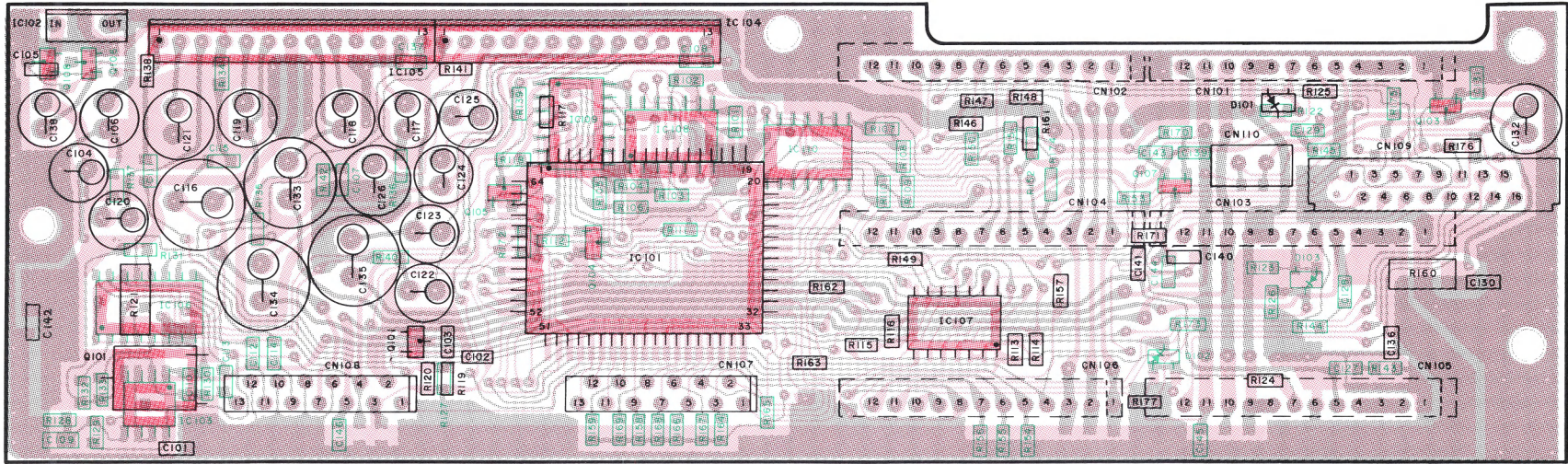

IC101:CXD1095Q IC102:MC78T08CT IC103:NJM4558E IC104, 105:LA4446 IC106:BU4053BF IC107~110:BU4066BF
 Q101, 107:2SC2712(Y) Q102:2SA1641(S, T) Q103:DTD143EK Q104, 105:DTC114EK Q106:DTC144EK Q108:DTA144EK
 D101~103:1SS184

Component side pattern : Foil side pattern

TM-941A

PC BOARD VIEW

144MHz TX-RX UNIT (X57-3580-XX)

Component side view

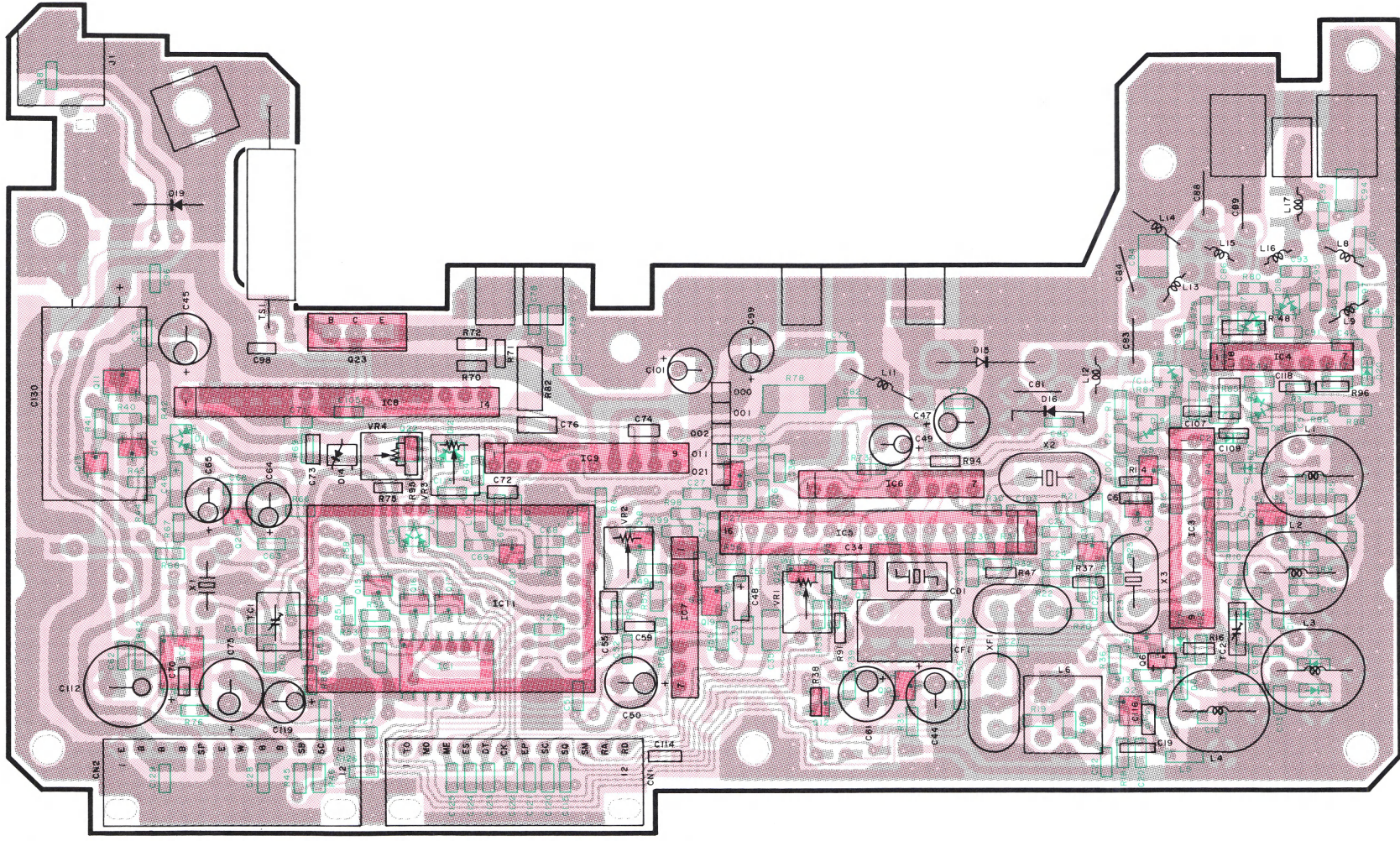

IC1:BU4094BF IC2:LA5010M IC5:KCD04 IC6:KCD05 IC7:KCA04 IC8:KCB11 IC9:KCC04 IC10:S-AV17 IC11:KCH05
Q1:3KS184(S) Q2:3SK179(L) Q3, 20:2SC2714(Y) Q4:DTA114YK Q5, 6:DTC123JK Q7:DTC143EK Q10:2SA1362(Y) Q11:2SB1119S Q12:DTC144WK
Q13, 14, 21:2SC2712(Y) Q15-17:DTC144EK Q18:2SD1757(K) Q19:2SK208(Y) Q22:FMG1 Q23:2SD1902R Q24:2SJ106(GR)
D1, 3, 4, 6:1SV164 D2, 5, 7:1SV166 D11, 12:1SS184 D13:DAN235(K) D14:1SS181 D15:MI407 D16:MI308 D17, 18:1SS226 D19:DSA3A1

Component side pattern : Foil side pattern

TM-941A

PC BOARD VIEW

144MHz TX-RX UNIT (X57-3580-XX)

Foil side view

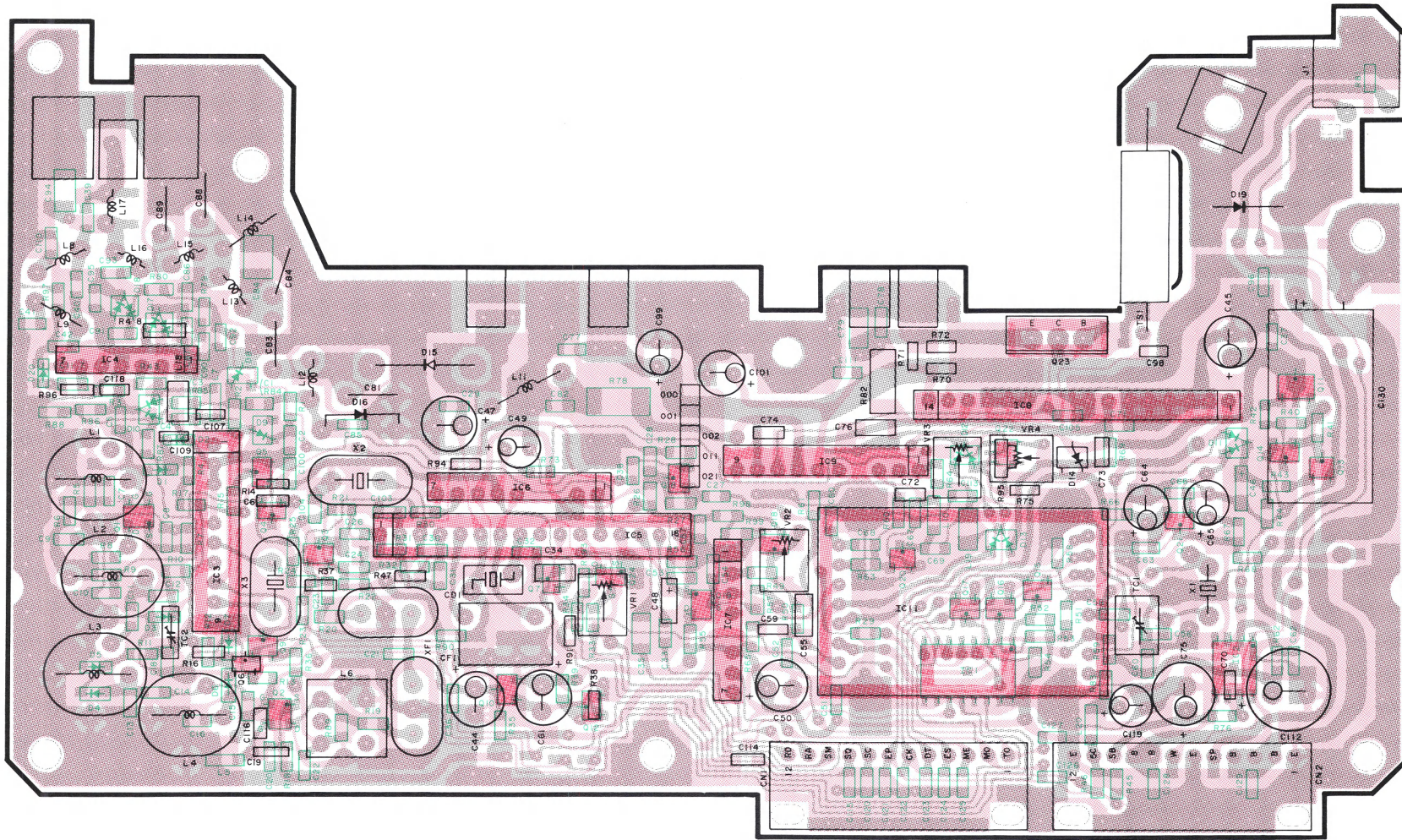

IC1:BU4094BF IC2:LA5010M IC5:KCD04 IC6:KCD05 IC7:KCA04 IC8:KCB11 IC9:KCC04 IC10:S-AV17 IC11:KCH05
 Q1:3SK184(S) Q2:3SK179(L) Q3, 20:2SC2714(Y) Q4:DTA114YK Q5, 6:DTC123JK Q7:DTC143EK Q10:2SA1362(Y) Q11:2SB1119S Q12:DTC144WK
 Q13, 14, 21:2SC2712(Y) Q15~17:DTC144EK Q18:2SD1757(K) Q19:2SK208(Y) Q22:FMG1 Q23:2SD1902R Q24:2SJ106(GR)
 D1, 3, 4, 6:1SV164 D2, 5, 7:1SV166 D11, 12:1SS184 D13:DAN235(K) D14:1SS81 D15:MI407 D16: MI308 D17, 18:1SS226 D19:DSA3A1

: Component side pattern

: Foil side pattern

TM-941A

PC BOARD VIEW

430MHz TX-RX UNIT (X57-3590-XX)

Component side view

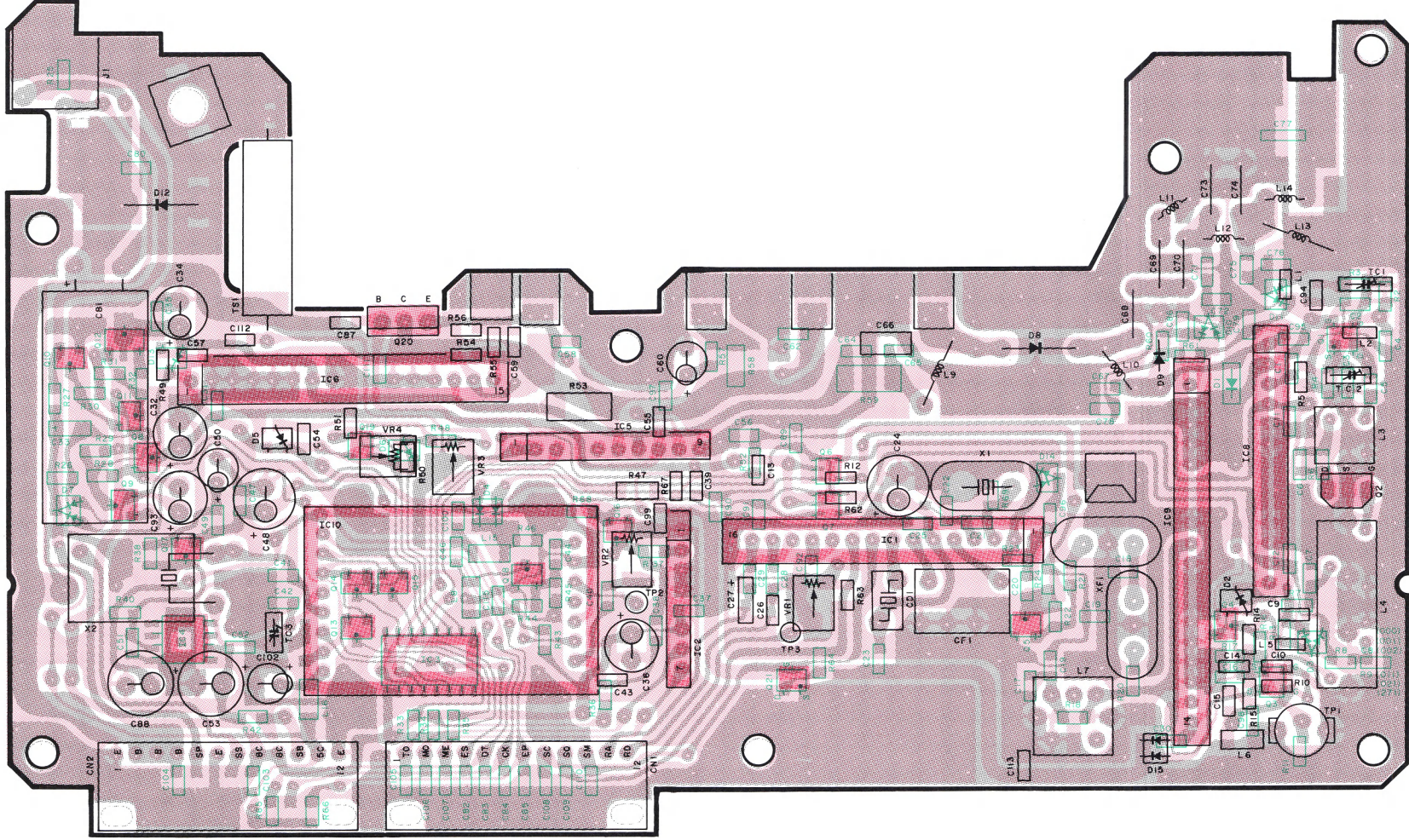

IC1:KCD04 IC2:KCA04 IC3:BU4094BF IC4:LA5010M IC5:KCC04 IC6:KCB14 IC7:M57788M IC10:KCH07
Q1,3:3SK184(S) Q2:2SK582 Q5:2SC2714(Y) Q8:2SA1362(Y) Q9:DTC144WK Q10,11,17:2SC2712(Y) Q12:2SB1119S Q13-15:DTC144EK
Q16:2SD1757(K) Q18:2SC3123 Q19:FMG1 Q20:2SD1760(Q) Q21:2SJ106(GR)
D1:HSK277 D4,15:MA862 D5:1SS181 D6, 7, 13:1SS184 D8:MI407 D9:MI808 D10,11,14:MA716 D12:DSA3A1

TM-941A

PC BOARD VIEW

430MHz TX-RX UNIT (X57-3590-XX)

Foil side view

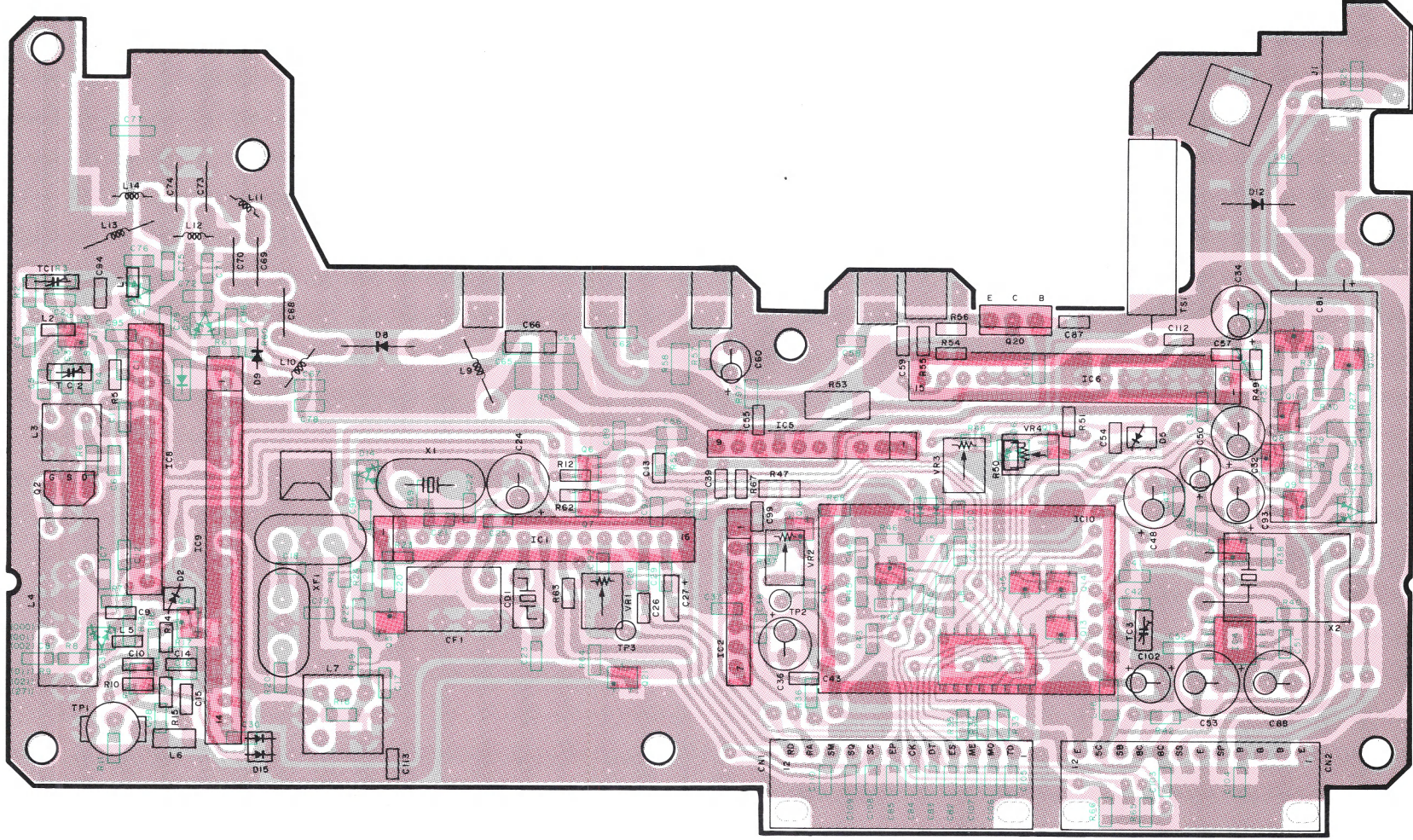

IC1:KCD04 IC2:KCA04 IC3:BU4094BF IC4:LA5010M IC5:KCC04 IC6:KCB14 IC7:M57788M IC10:KCH07
Q1,3:3SK184(S) Q2:2SK582 Q5:2SC2714(Y) Q8:2SA1362(Y) Q9:DTC144WK Q10,11,17:2SC2712(Y) Q12:2SB1119S Q13-15:DTC144EK
Q16:2SD1757(K) Q18:2SC3123 Q19:FMG1 Q20:2SD1760(Q) Q21:2SJ106(GR)
D1:HSK277 D4,15:MA862 D5:1SS181 D6, 7, 13:1SS184 D8:MI407 D9:MI808 D10,11,14:MA716 D12:DSA3A1

■ : Component side pattern
■ : Foil side pattern

TM-941A

PC BOARD VIEW

1200MHz TX-RX UNIT (X57-3600-11)

Component side view

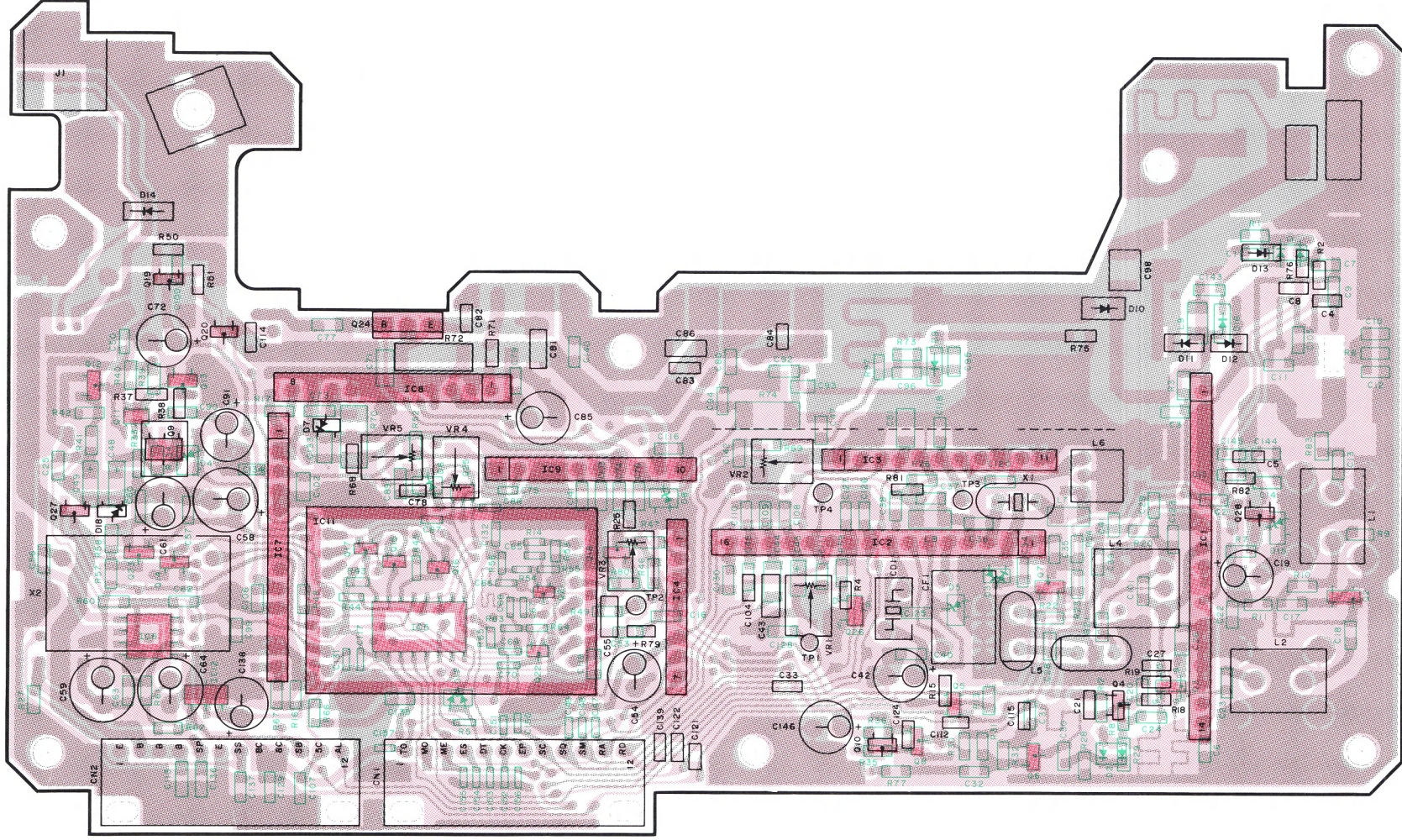

IC2:KCD04 IC3:KCX03 IC4:KCA04 IC5:BU4094BF IC6:LA5009M IC7:KCB09 IC8:KCB10 IC9:KCC04 IC10:M67711 IC11:KCH03 IC12:NUM78L05UA
Q1:MGF1502 Q2:2SC4095(R47.6) Q3:3SK184(S) Q6:2SC3356 Q7:2SC3120 Q8,19:2SA1362(Y) Q9:2SB1302S Q10:DTC144WK
Q11:FMW1 Q12, 13, 23:2SC2712(Y) Q15-17:DTC144EU Q18:2SD1757(K) Q20:2S124EK Q21,22:2SC4226(R23, 24)
Q24:2SD1760(Q) Q25:FMG1 Q26:2SJ106(GR) Q28:DTC114EK
D1:MA862 D3:MA716 D4,6:1SS193 D5:02CZ6.2(X, Y) D7,18:1SS187 D8:02CZ12(X, Y) D9:HSK151 D10-13:MI808 D14:DSA3A1 D15:02CZ3.6(Y, Z)
D17:DAP202U

Component side pattern
Foil side pattern

PC BOARD VIEW

1200MHz TX-RX UNIT (X57-3600-11)
Foil side view

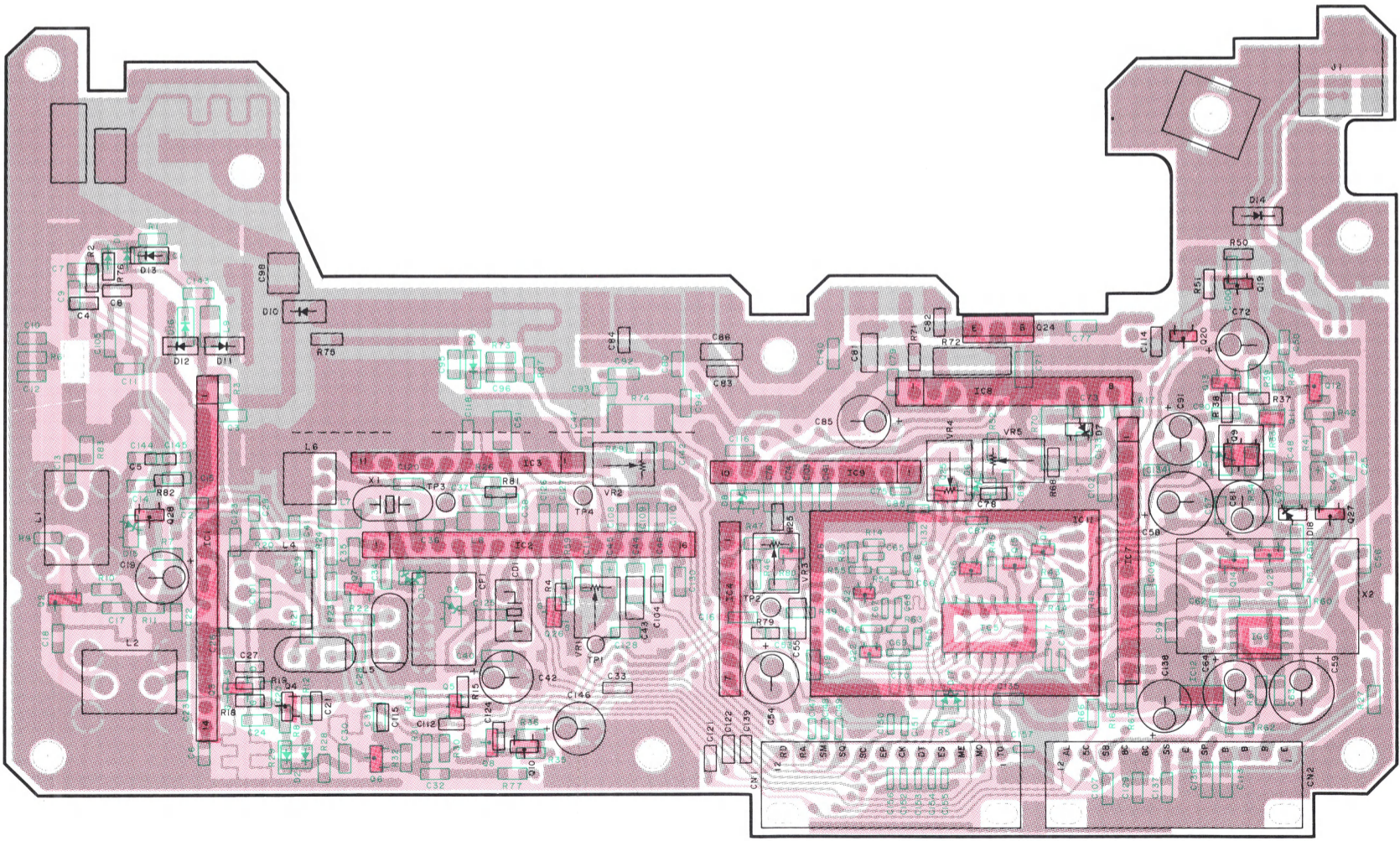

IC2:KCD04 IC3:KCX03 IC4:KCA04 IC5:BU4094BF IC6:LA5009M IC7:KCB09 IC8:KCB10 IC9:KCC04 IC10:M67711 IC11:KCH03 IC12:NJM78L05UA
 Q1:MGF1502 Q2:2SC4095(R47.6) Q3:3SK184(S) Q6:2SC3356 Q7:2SC3120 Q8,19:2SA1362(Y) Q9:2SB1302S Q10:DTC144WK
 Q11:FMW1 Q12, 13, 23:2SC2712(Y) Q28:DTC114EK Q15~17:DTC144EU Q18:2SD1757(K) Q20:DTC124EK Q21,22:2SC4226(R23, 24)
 Q24:2SD1760(Q) Q25:FMG1 Q26:2SJ106(GR) Q28:DTC114EK
 D1:MA862 D3:MA716 D4,6:1SS193 D5:02CZ6.2(X, Y) D7:1SS187 D8:02CZ12(X, Y) D9:HSK151 D10~13:MI808 D14:DSA3A1 D15:02CZ3.6(Y, Z)
 D17:DAP202U

■ : Component side pattern
 ■ : Foil side pattern

SCHEMATIC DIAGRAM (2/2)

— Signal line - - - - Control line — Common DC line

①	USED
②	NO

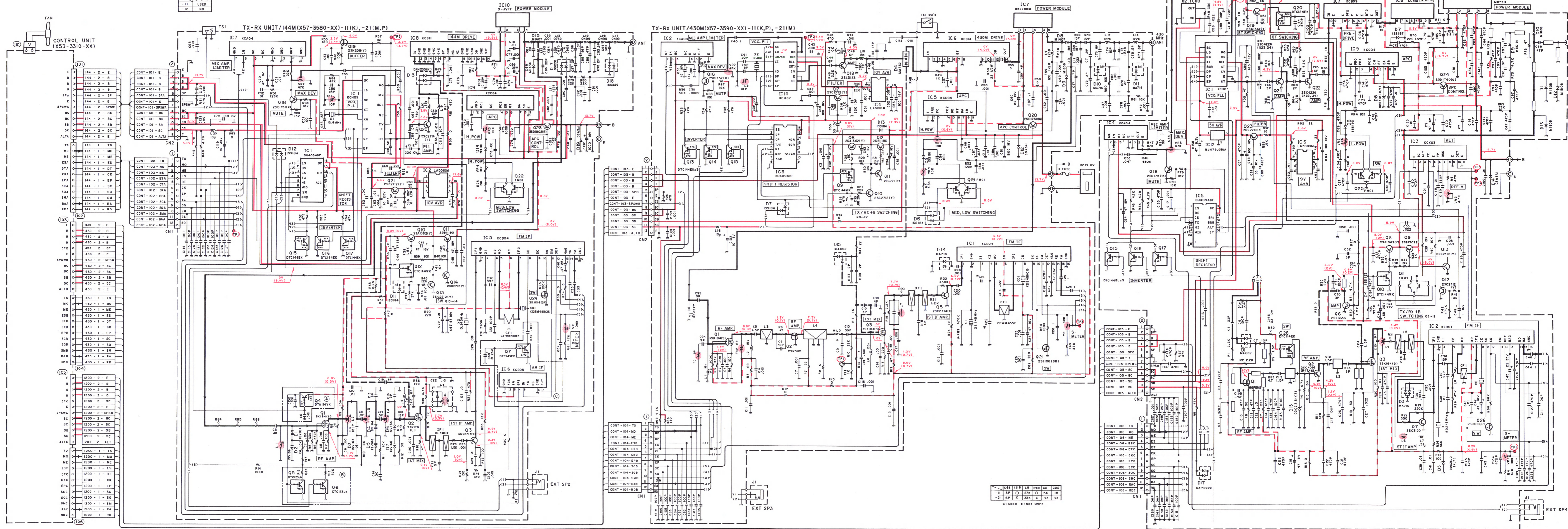

BLOCK DIAGRAM

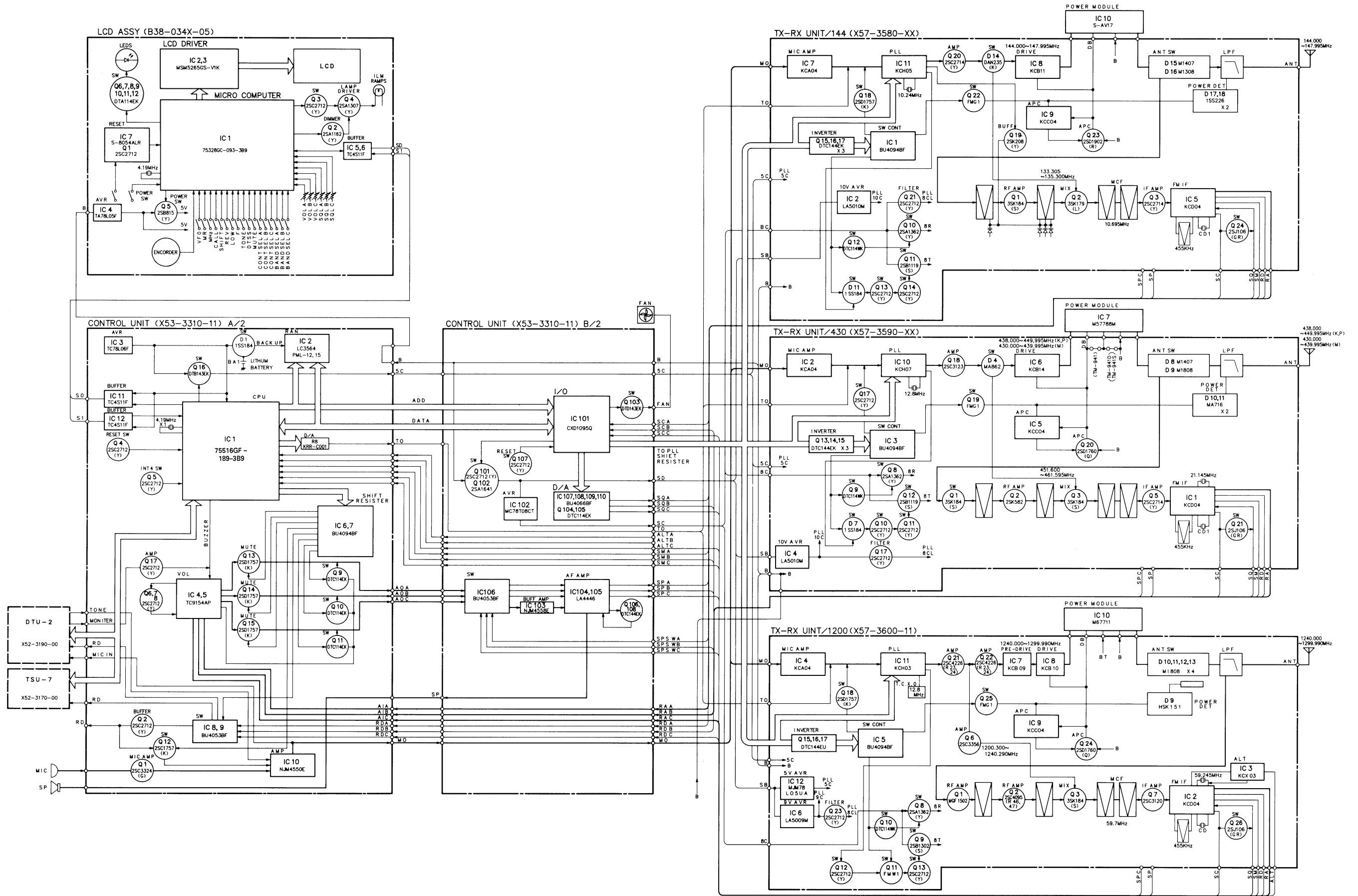

DTU-2 (DTMF UNIT)

DTU-2 EXTERNAL VIEW

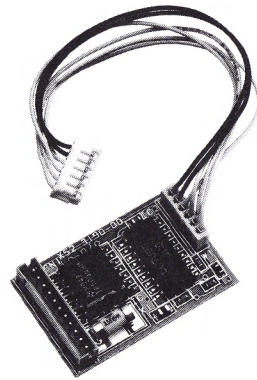

DTU-2 PC BOARD VIEWS

Component side view

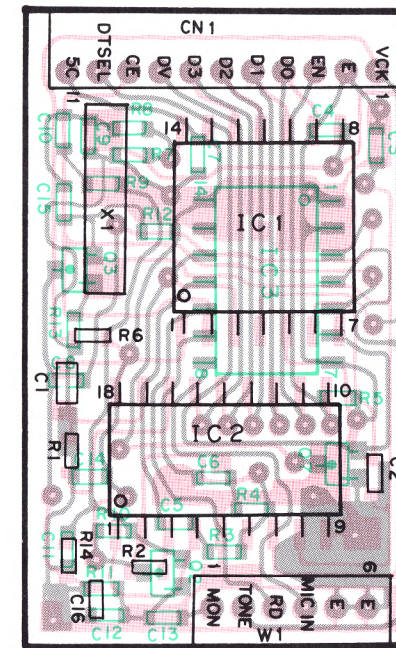

Foil side view

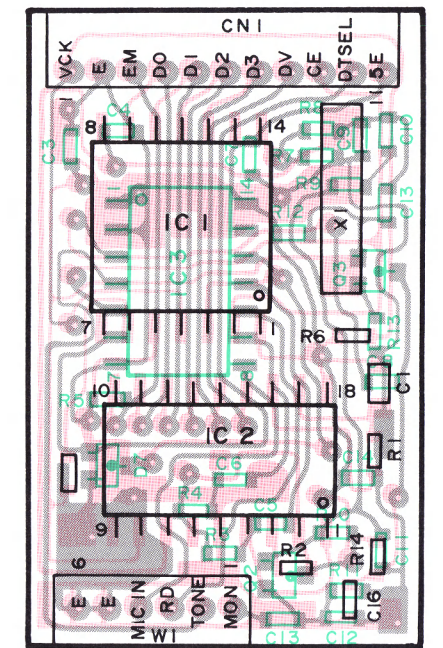

Component side
Foil side

DTU-2 PARTS LIST

* NEW PARTS

Ref. No.	New parts	Parts No.	Description
C1		CK73FB1E104K	Chip C 0.1μF K
C2		CC73GCH1H100D	Chip C 10pF D
C3, 4		CC73GCH1H330J	Chip C 33pF J
C5~8, 10		CK73GB1E103K	Chip C 0.01μF K
C13~16		CK73GB1E103K	Chip C 0.01μF K
C9		CK73GB1E822K	Chip C 0.0082μF K
C10		CK73GB1E322K	Chip C 0.0032μF K
C11		CC73GSL1H101J	Chip C 100pF J
		E37-0033-05	Connecting cable (6P)
		E40-5188-05	Pin ass'y socket (11P)
X1		L78-0061-05	CERAMIC RESONATOR (3.58MHz)
R1~14		RK73GB1JxxxJ	Chip R
Q1		DTC114EU	Digital transistor
Q2, 3		2SC4116 (Y)	Digital transistor
IC1		TP5088WM	IC
IC2		LC7385M	IC
IC3		BU4066BF	IC

DTU-2 CIRCUIT DIAGRAM

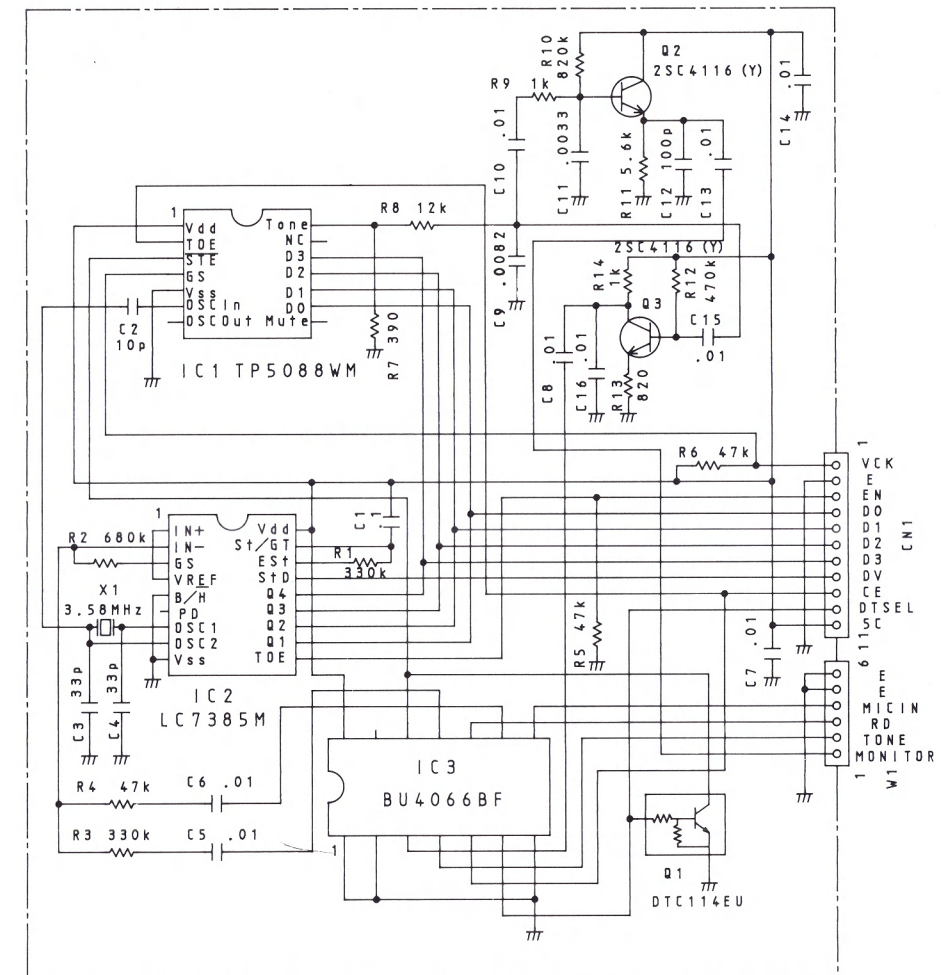

PG-4K/L (PANEL SEPARATE KIT K:4M, L:7M)

PG-4K EXTERNAL VIEW

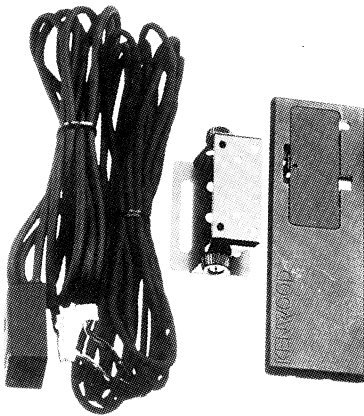

PG-4L EXTERNAL VIEW

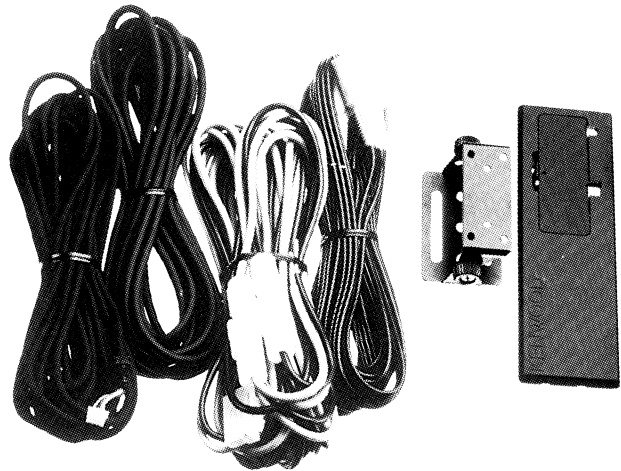

PG-4K MAIN EXTERNAL DIMENSIONS

- Panel

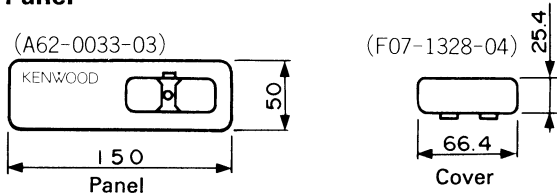

- Panel cable (E30-3012-05)

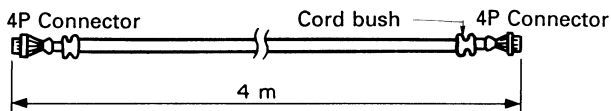

- Microphone cable (E30-3013-05)

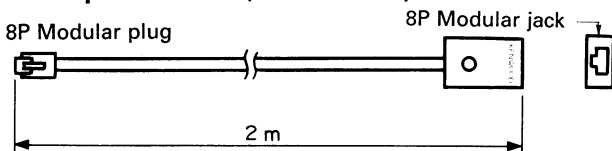

- Screw set (N99-0347-05)

PG-4L MAIN EXTERNAL DIMENSIONS

- Panel

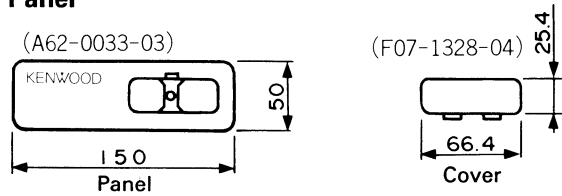

- Panel cable (E30-3014-05)

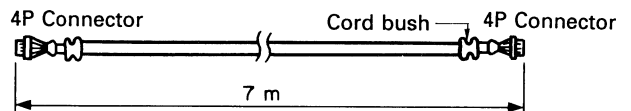

- Microphone cable (E30-3015-05)

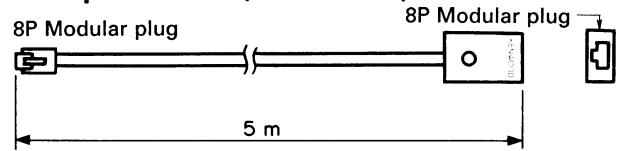

- Speaker cable (E30-3016-05)

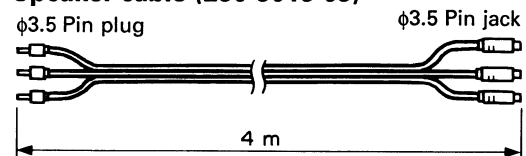

- DC cord (E30-3032-05)

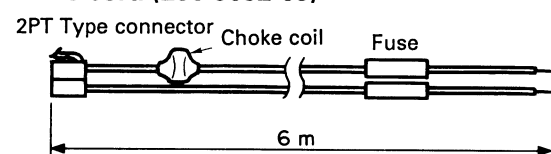

- DC cord (N99-0347-05)

TM-941A

TSU-7 (CTCSS UNIT)

TSU-7 EXTERNAL VIEW

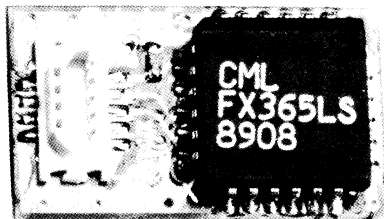

TSU-7 PARTS LIST

Ref. No	Address	Rart	Rarts No.	Description	Desti- nation	Re- marks
TSU-7 (X52-3170-00)						
X1			G10-0692-04	CUTTON		
IC1			H21-0704-04	CUTTON		
D1			L78-0062-05	STAL (1MHz)		
CN1			FX365LS	IC		
VR1			DAN202U	DIODE		
R1			E40-5341-05			
R2			R12-6526-05	TRIM. POT. (47K)		
R4			RK73BG1J274J	CHIP R J 270K		
R5			RK73BG1J824J	CHIP R J 820K		
R6			RK73BF1J103J	CHIP R J 10K		
C1			RK73BG1J105J	CHIP R J 1M		
C2			RK73BG1J473J	CHIP R J 47K		
C4-6			CK73GB1H471K	CHIP C K 470pF		
C7			C92-0521-05	CHIP TAN 20W		
C8.9			CK73FB1E104K	CHIP C K 0.1UF		
			CK73GB1H471K	CHIP C K 470pF		
			CC73GCH1H221J	CHIP C J 220pF		

TM-941A

MC-45 (MULTI FUNCTION MICROPHONE)

EXTERNAL VIEW



PARTS LIST

Ref. No.	Address	New Parts	Parts No.	Description	Destination	Remarks
			A02-0896-08	CASE (FRONT)		
			A02-0900-08	CASE (REAR)		
			E30-3006-08	CURL CORD ASSY		
			G13-0933-08	CUSHION (UP,DWN)		
			K29-3165-08	KNOB PTT		
			K29-3168-08	KNOB UP		
			K29-3169-08	KNOB DWN		
			K29-3170-08	KNOB CALL,VFO, MR,PF		
S3-6			S59-1409-28	SWITCH ASSY UP,DWN		
S7,8			S40-1431-08	TACT SWITCH CALL,VFO, MR,PF		
SW1		*	S40-1437-08	TACT SWITCH UP,DWN		
SW2			S50-1431-08	MICRO SWITCH LOCK		
			S31-1422-08	SLIDE SWITCH LOCK		
			T91-0383-08	MICROPHONE ELEMENT		

SCHEMATIC DIAGRAM

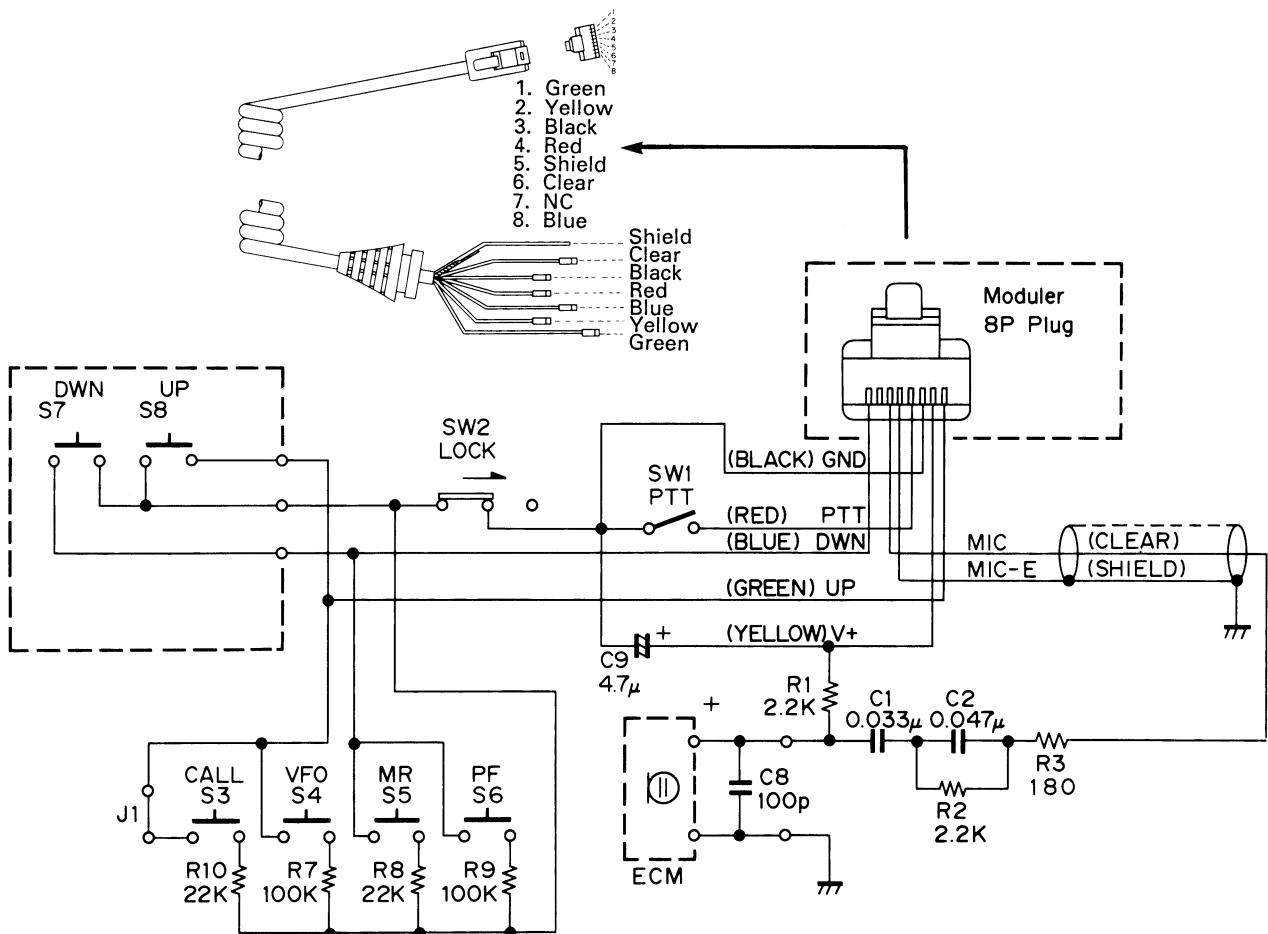

MC-45DM (MULTI FUNCTION MICROPHONE WITH AUTOPATCH)

EXTERNAL VIEW



PARTS LIST

Ref. No.	Address	New Parts	Parts No.	Description	Destination	Remarks
			A02-0898-08	CASE (FRONT)		
			A02-0901-08	CASE (REAR)		
			E30-3006-08	CURL CORD ASSY		
			G13-0933-08	CUSHION (UP,DWN)		
			K29-3165-08	KNOB PTT		
			K29-3167-08	KEY TOP DTMF		
			K29-3168-18	KNOB UP		
			K29-3169-18	KNOB DOWN		
S7, 8		*	S59-1409-28	SWITCH ASSY UP,DWN		
SW1			S40-1437-08	TACT SWITCH UP,DWN		
SW2			S50-1431-08	MICRO SWITCH PTT		
			S31-1422-08	SLIDE SWITCH LOCK		
			T91-0393-08	MICROPHONE ELEMENT		

SCHEMATIC DIAGRAM

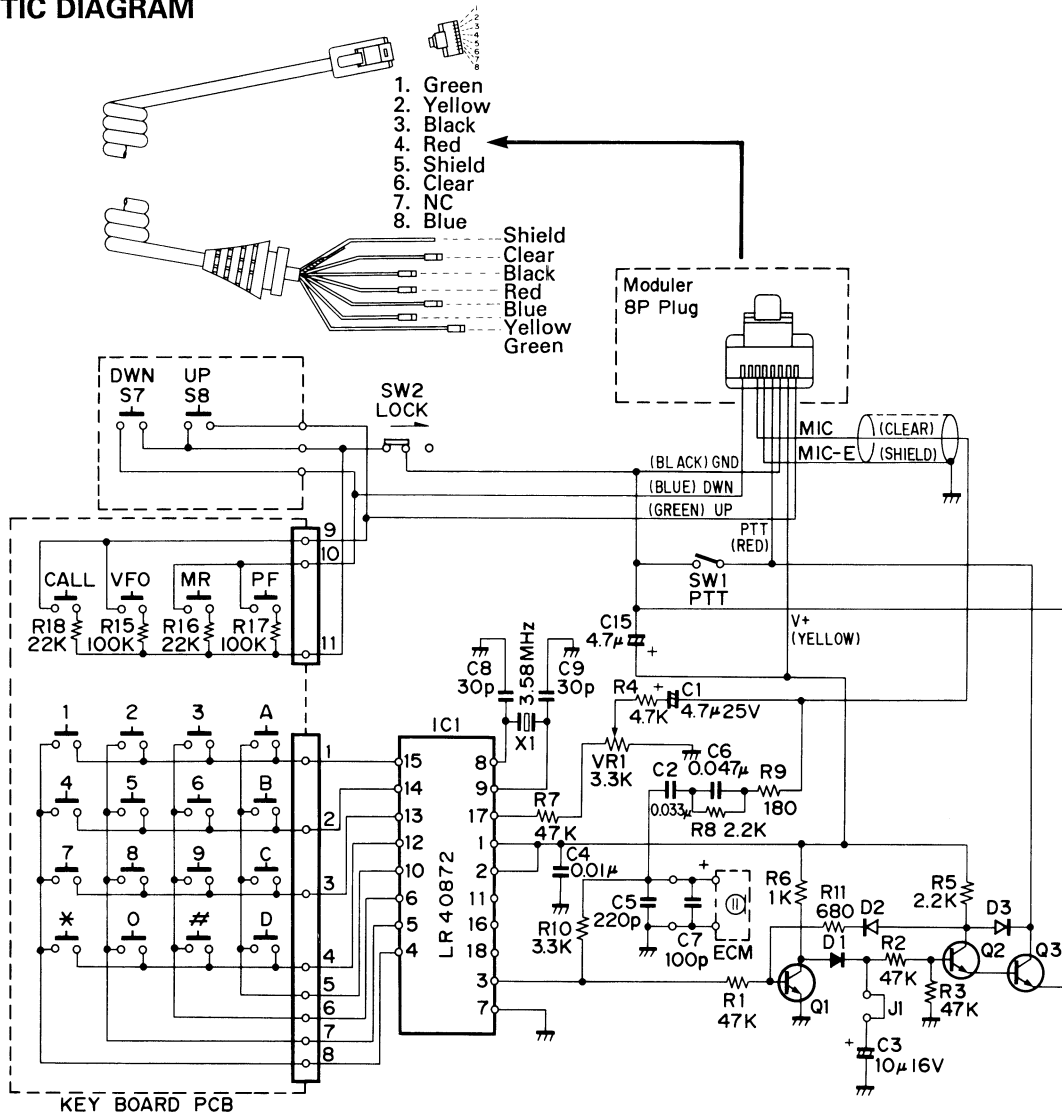

SPECIFICATIONS

		144 MHz Band	440 MHz Band	1200 MHz Band	
GENERAL	Frequency range MHz	144 ~ 148	438 ~ 450	1240 ~ 1300	
	Mode	F3E(PM)			
	Antenna impedance	50Ω			
	Operating temperature	-20°C ~ +60°C (-4°F ~ +140°F)			
	Power requirements	13.8 VDC ± 15 % (11.7 ~ 15.8V)			
	Ground	Negative			
	Current drain	Transmit mode	Less than 11.5A	Less than 10.0A	Less than 6.0A
		Receiver mode	Less than 1.2A	Less than 1.2A	Less than 1.2A
	Frequency stability	± 10ppm			
Dimensions (WxHxD)	150 x 50 x 175 mm				
Weight	1.9 kg				
TRANSMITTER	Output power	HI	50W	35W	10W
		MID	10W	10W	—
		LOW	Approx. 5W	Approx. 5W	1W
	Modulation	Reactance modulation			
	Spurious radiation	Less than -60 dB		Less than -50 dB	
	Maximum frequency deviation	±5kHz			
	Audio distortion (at 60% modulation)	Less than 3%			
	Microphone impedance	600Ω			
RECEIVER	Circuitry	Double conversion superheterodyne			
	Intermediate frequency 1st/2nd	10.7 MHz/455 kHz	21.6 MHz/455 kHz	59.7 MHz/455 kHz	
	Sensitivity (12 dB S NAD)	Less than 0.16 μV (-10 dBμ)*			
	Selectivity -6 dB	More than 12 kHz			
	Selectivity -60 dB	Less than 24 kHz	Less than 36 kHz		
	Squelch sensitivity	Less than 0.1 μV (-14 dBμ)			
	Output (5% distortion)	More than 2 W (8Ω load) (5% distortion)			
	External speaker impedance	8Ω			

* 1240 MHz to 1260 MHz Less than 0.22 μV (-7 dBμ)

Notes:

1. Circuit and ratings are subject to change without notice due to advancements in technology.
2. Recommended duty cycle : 1 minute Transmit, 3 minutes Reception.

KENWOOD CORPORATION

Shionogi Shibuya Building, 17-5, 2-chome Shibuya, Shibuya-ku, Tokyo 150, Japan

KENWOOD U.S.A. CORPORATION

COMMUNICATIONS & TEST EQUIPMENT GROUP

P.O. BOX 22745, 2201 East Dominguez St., Long Beach, CA 90801-5745, U.S.A.

KENWOOD ELECTRONICS DEUTSCHLAND GMBH

Rembrücker Str. 15, 6056 Heusenstamm, West Germany

KENWOOD ELECTRONICS BENELUX N.V.

Mechelsesteenweg 418 B-1930 Zaventem, Belgium

TRIO-KENWOOD FRANCE S.A.

13, Boulevard Ney, 75018 Paris, France

KENWOOD LINEAR S.P.A.

20125, Milano-via Arbe, 50, Italy

KENWOOD ELECTRONICS AUSTRALIA PTY. LTD.

P.O. BOX504, 8 Figtree Drive, Australia Centre, Homebush N.S.W. 2140, Australia

KENWOOD & LEE ELECTRONICS, LTD.

Wang Kee Building, 5th Floor, 34-37, Connaught Road, Central, Hong Kong

KENWOOD ELECTRONICS CANADA INC.

P.O. BOX 1075, 959 Gana Court, Mississauga, Ontario, Canada L4T 4C2

PARTS LIST

× New Parts

 Parts without **Parts No.** are not supplied.
 Les articles non mentionnés dans le **Parts No.** ne sont pas fournis.
 Teile ohne **Parts No.** werden nicht geliefert.

Ref. No.	Address	New Parts	Parts No.	Description	Desti- nation	Re- marks
参照番号	位置	新	部品番号	部品名 / 規格	仕	向備考
LCD ASS'Y (B38-034X-XX) 1-05: K,P 2-05: M 3-05: E						
PL1	-6		B30-0865-05	LAMP		
C1	,2		CC73EB1H330J	CHIP C 33PF J		
C3			CK73EB1H223K	CHIP C 0.022UF K		
C4			CK73EB1H102K	CHIP C 1000PF K		
C5			CK73EB1H103K	CHIP C 0.01UF K		
C6			CK73EB1H102K	CHIP C 1000PF K		
C7			CK73EB1H223K	CHIP C 0.022UF K		
C8			CE04CW1C220M	ELECTRØ 22UF 16WV		
C9			CK73EB1H102K	CHIP C 1000PF K		
C10	,11		CC73BSL1H101J	CHIP C 100PF J		
C12			CE04CW1C220M	ELECTRØ 22UF 16WV		
C13	-16		CK73EB1H102K	CHIP C 1000PF K		
C17			CK73EB1H223K	CHIP C 0.022UF K		
C18	-31		CK73EB1H103K	CHIP C 0.01UF K		
C32	,33		CK73EB1H102K	CHIP C 1000PF K		
CN1			E40-3262-05	CONNECTOR		
CN2	-4		E40-5392-05	CONNECTOR (5P)		
CN5	-7		E40-5409-05	CONNECTOR (5P VR SIDE)		
X1			L77-1333-05	XTAL(4.19MHZ)		
R1			RK73EB2B473J	CHIP R 47K J 1/8W		
R2			RK73EB2B105J	CHIP R 1.0M J 1/8W		
R3			RK73EB2B103J	CHIP R 10K J 1/8W		
R4			RK73EB2B563J	CHIP R 56K J 1/8W		
R5			RK73EB2B104J	CHIP R 100K J 1/8W		
R6			RK73EB2B105J	CHIP R 1.0M J 1/8W		
R7			RK73EB2B223J	CHIP R 22K J 1/8W		
R8	,9		RK73EB2B222J	CHIP R 2.2K J 1/8W		
R10	-13		RK73EB2B100J	CHIP R 10 J 1/8W		
R14	-17		RK73EB2B473J	CHIP R 47K J 1/8W		
R19			R92-0679-05	CHIP R 0 ØHM		K, P, E
R20			R92-0679-05	CHIP R 0 ØHM		K, P, M
R21			R92-0679-05	CHIP R 0 ØHM		
R22			R92-0679-05	CHIP R 0 ØHM		
R23	-25		RK73EB2B100J	CHIP R 10 J 1/8W		
R26	-31		RK73EB2B151J	CHIP R 150 J 1/8W		
R32	-34		RK73EB2B221J	CHIP R 220 J 1/8W		
R35			RK73EB2B473J	CHIP R 47K J 1/8W		
R36			RK73EB2B222J	CHIP R 2.2K J 1/8W		
R37			RK73EB2B272J	CHIP R 2.7K J 1/8W		
R38			RK73EB2B472J	CHIP R 4.7K J 1/8W		
R39			RK73EB2B123J	CHIP R 12K J 1/8W		
R40			RK73EB2B102J	CHIP R 1.0K J 1/8W		
R41			RK73EB2B222J	CHIP R 2.2K J 1/8W		
R42			R92-0686-05	CHIP R 33 J 1/2W		
R43			R92-1211-05	SØLID R 5.6K J 1/2W		
R44			RK73EB2B331J	CHIP R 330 J 1/8W		
VR1	-3	4B	R23-9407-05	PØTENTIØ M. (SQ,VØL)		
S1			S40-1079-05	TACT SWITCH		
S2	-14		S40-1086-05	TACT SWITCH		
S15			S40-2458-05	PUSH SWITCH (POWER SW)		

 L:Scandinavia K:USA P:Canada
 Y:PX(Far East, Hawaii) T:England E:Europe
 A:AFES(Europe) X:Australia M:Other Areas

▲ indicates safety critical components. 6

PARTS LIST

× New Parts

 Parts without **Parts No.** are not supplied.
 Les articles non mentionnés dans le **Parts No.** ne sont pas fournis.
 Teile ohne **Parts No.** werden nicht geliefert.

Ref. No.	Address	New Parts	Parts No.	Description	Desti- nation	Re- marks
参照番号	位置	新	部品番号	部品名 / 規格	仕	向備考
D1	-6		B30-0892-05	LED(RED)		
D7			B30-0894-05	LED(ØRG)		
D8			B30-0893-05	LED(GREEN)		
D9			B30-0894-05	LED(ØRG)		
D10			B30-0893-05	LED(GREEN)		
D11			B30-0894-05	LED(ØRG)		
D12			B30-0893-05	LED(GREEN)		
IC1			753280C-093-3B9	IC(UPD)		
IC2	,3		MSM5265GS-V1K	IC(LCD DRIVER)		
IC4			TA78L05F	IC(VØLTAGE REGULATØR/ +5V)		
IC5	,6		TC4S11F	IC(2 INPUT NAND GATE)		
IC7			S-8054ALR	IC(VØLTAGE DETECTØR)		
Q1			2SC2712(Y)	TRANSISTØR		
Q2			2SA1162(Y)	TRANSISTØR		
Q3			2SC2712(Y)	TRANSISTØR		
Q4			2SA1307(Y)	TRANSISTØR		
Q5			2SB815	TRANSISTØR		
Q6	-12		DTA114EK	DIGITAL TRANSISTØR		
S16	4A		W02-0388-05	ENCØDER		

 L:Scandinavia K:USA P:Canada
 Y:PX(Far East, Hawaii) T:England E:Europe
 A:AFES(Europe) X:Australia M:Other Areas

▲ indicates safety critical components. 7

LCD ASS'Y (B38-034X-XX)



A	KNOB (CALL) K27-3081-04	KNOB (SHIFT) K27-3089-04	KNOB(REV) K27-3085-04	KNOB(LOW) K27-3087-04
B	KNOB (F) K27-3082-04	KNOB (TONE) K27-3084-04	KNOB (DTSS) K27-3086-04	KNOB (MUTE) K27-3088-04

This manual is issued for a supplementary reference of the LCD Assembly. For further information, please refer to the service manual (B51-8079-00).

KENWOOD CORPORATION

 Shionogi Shibuya Building, 17-5, 2-chome Shibuya, Shibuya-ku, Tokyo 150, Japan
KENWOOD U.S.A. CORPORATION
 COMMUNICATIONS & TEST EQUIPMENT GROUP
 P.O. BOX 22745, 2201 East Dominguez St., Long Beach, CA 90801-5745, U.S.A.
KENWOOD ELECTRONICS DEUTSCHLAND GMBH
 Rembrücker Str. 15, 6056 Heusenstamm, Germany
TRIO-KENWOOD U.K. LIMITED
 KENWOOD House, Dwight Road, Watford, Herts., WD1 8EB United Kingdom
KENWOOD ELECTRONICS BENELUX N.V.
 Mechelsesteenweg 418 B-1930 Zaventem, Belgium
TRIO-KENWOOD FRANCE S.A.
 13, Boulevard Ney, 75018 Paris, France
KENWOOD LINEAR S.P.A.
 20125, Milano-via Arbe, 50, Italy
KENWOOD ELECTRONICS AUSTRALIA PTY. LTD.
 P.O. Box 504, 8 Figtree Drive, Australia Centre, Homebush, N.S.W. 2140, Australia
KENWOOD & LEE ELECTRONICS, LTD.
 Wang Kee Building, 5th Floor, 34-37, Connaught Road, Central, Hong Kong
KENWOOD ELECTRONICS CANADA INC.
 6070 Kestrel Road, Mississauga, Ontario, Canada L5T 1S8

PC BOARD VIEW

LCD ASS'Y (B38-034X-XX) 1-05: K,P 2-05: M 3-05: E

Component side view

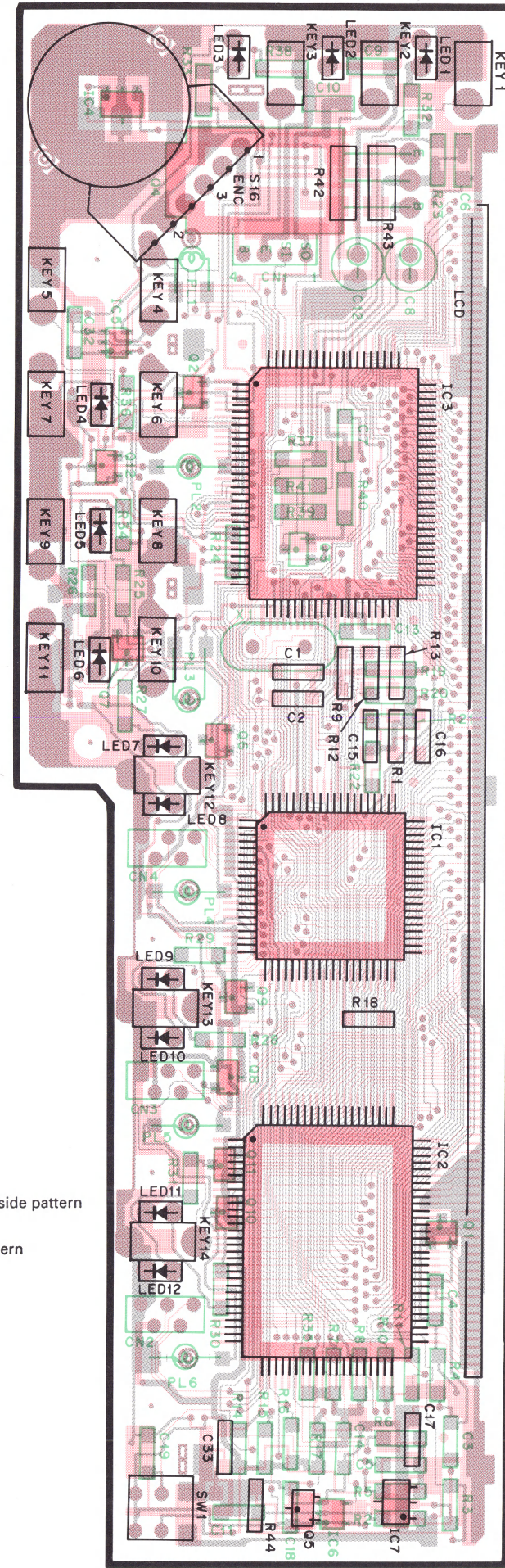

- IC1: 753280C-093-389 IC2,3: MSM5265GS-VIK IC4: TA78L05F IC5,6: TC4511F
- IC7: S-8054LR Q1: 2SC2712(Y) Q2: 2SA1162(Y) Q3: 2SC2712(Y) Q4: 2SA1307(Y)
- Q5: 2SB815 Q6-12: DTA114EK D1-6: B30-0892-05 D7: B30-0894-05 D8: B30-0893-05
- D9: B30-0894-05 D10: B30-0893-05 D11: B30-0894-05 D12: B30-0893-05

Component side pattern
Foil side pattern

PC BOARD VIEW

Foil side view

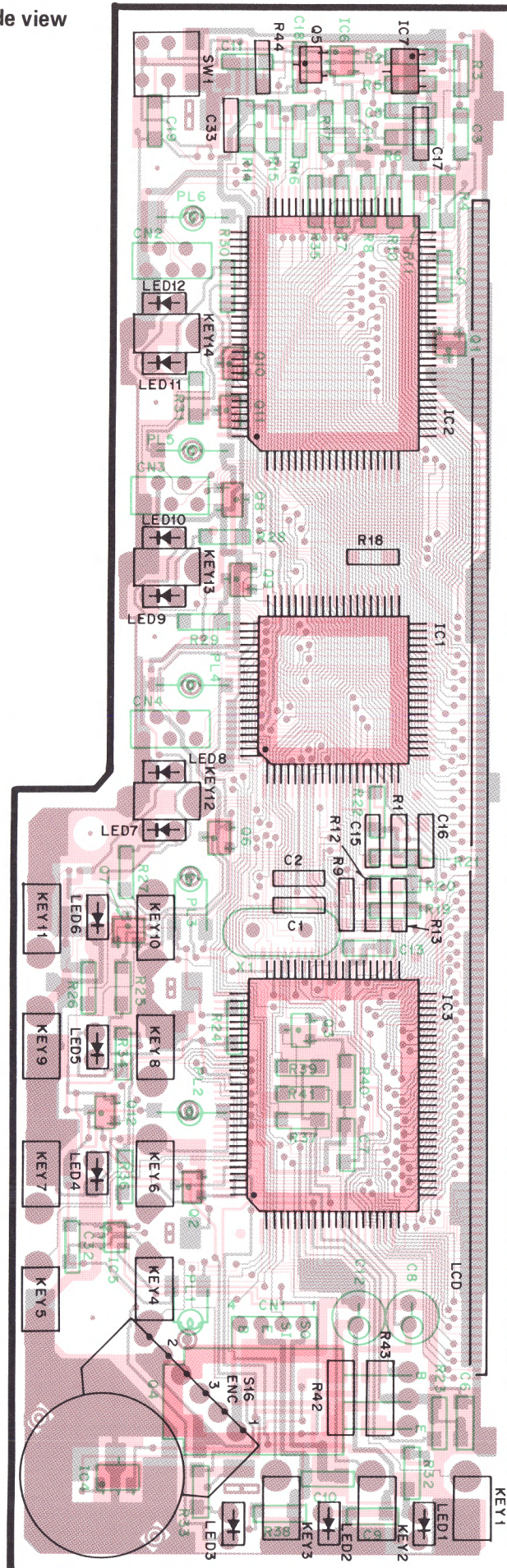

SCHEMATIC DIAGRAM

LCD ASSY (B38-034X-XX) 1-05: K,P 2-05: M 3-05: E

— Signal line - - - Control line — Common DC line

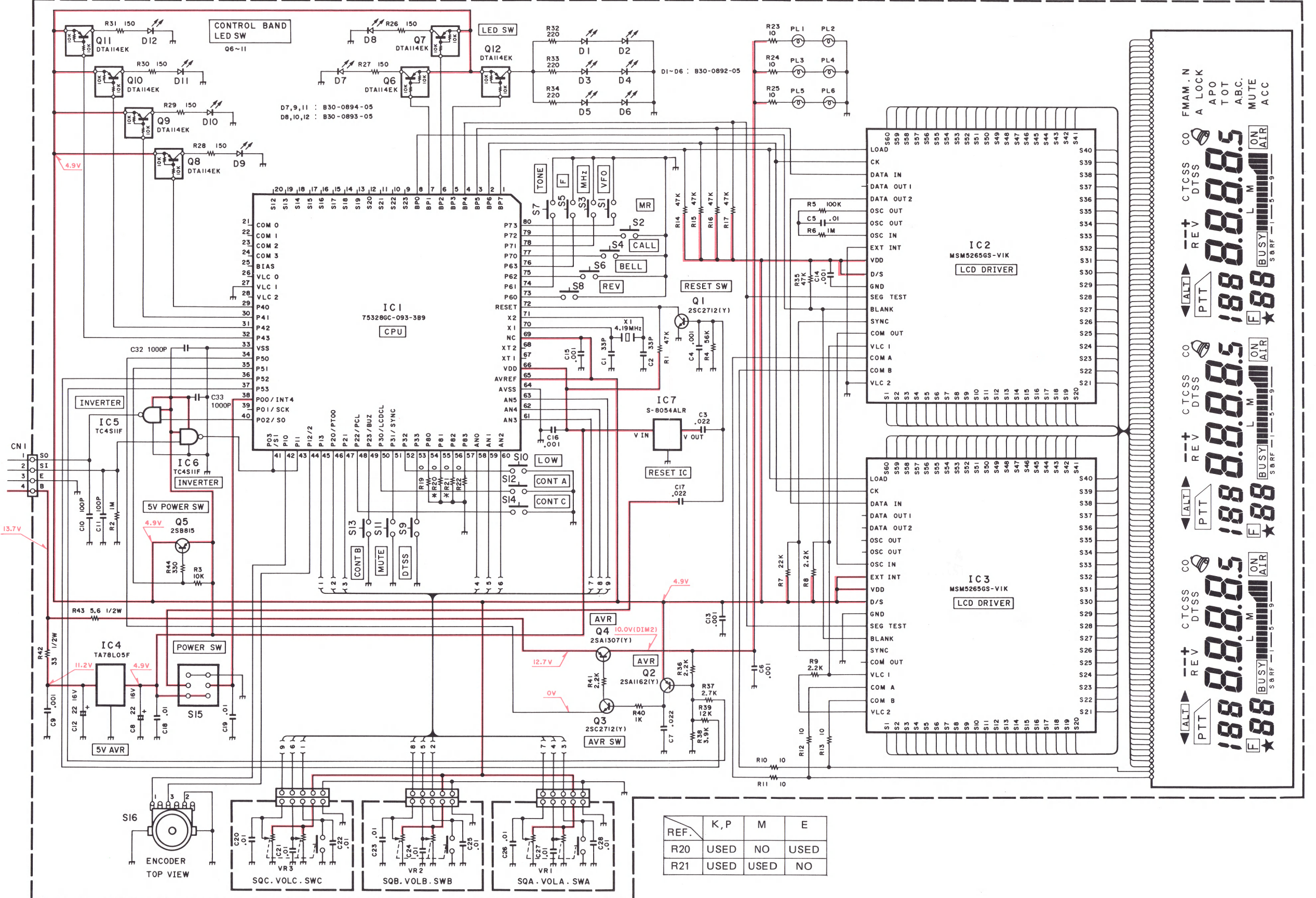

REF.	K, P	M	E
R20	USED	NO	USED
R21	USED	USED	NO

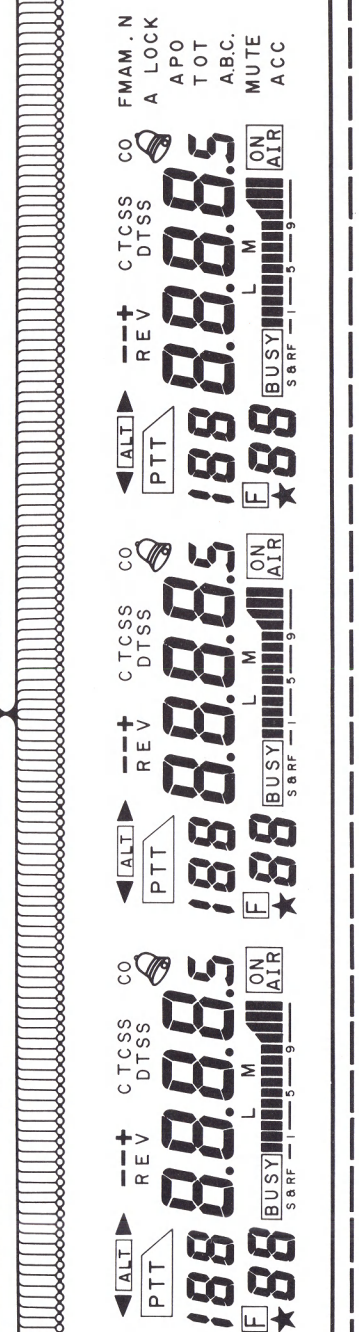

TM-941A/E