

Service Manual

Radio

FM-AM-SW_{1~6} 8-BAND
PORTABLE RADIO

RF-2200BA

- * This service manual includes only the changes of the RF-2200BS service manual (ORDER NO. RD7701-1412).
- * This manual should be filed with the service manual for model RF-2200BS (ORDER NO. RD7701-1412).
- * When servicing model RF-2200BA, this service manual and the RF-2200BS service manual should be used together.

CHANGES

■ SPECIFICATIONS

Frequency Range: FM 87.5~108 MHz
Sensitivity: FM 2 μ V for 50 mW Output
Power Source: AC 110~125V/220~240V
50-60 Hz or 6V (Four "D" Size Flashlight Batteries)
(National UM-1 or equivalent)
(Model RF-2200BS)



FM 88~108 MHz
FM 3 μ V for S/N 6 dB
AC 240V 50 Hz or 6V (Four "D" Size Flashlight Batteries)
(National UM-1 or equivalent)
(Model RF-2200BA)

■ REPLACEMENT PARTS LIST

Ref. No.	Change of Part No.		Description	Per Set	Remarks	Price
	RF-2200BS	RF-2200BA				
D _{50,51}	RVD10E1LF	—	Removed			
T ₁₂	RLT5J199	RLT5J191	Power Transformer	1	○X	
S ₁₀	RSR2A01Z-A	—	Removed			
C _{510,511}	ECKV1H103ZF	—	Removed			
	RYMF2200BSXG	RYMF2200N	Cabinet Assembly	1	○X	
	RYF2F2200BSX	RYF2F2200BAX	Cabinet Cover Assembly (Rear)	1	○X	
	RYF2F2200BSI	—	Removed			
	RYPF2200BSXG	RYPF2200BAXA	Front Panel Assembly	1	○X	
CH ₂	RJJ30Z-H	RJJ29Z-H	Jack, EXT Power Source	1	Y	
	RXEF2200BSXG	RXEF2200BAXA	Dial Drive Assembly	1	○X	
	RJA20Z-K	RJA26Z-K	Power Cord, AC	1	Y	
A ₁	RQX6071Z	RQX6072Z	Instruction Book	1	○Y	

■ SCHEMATIC DIAGRAM

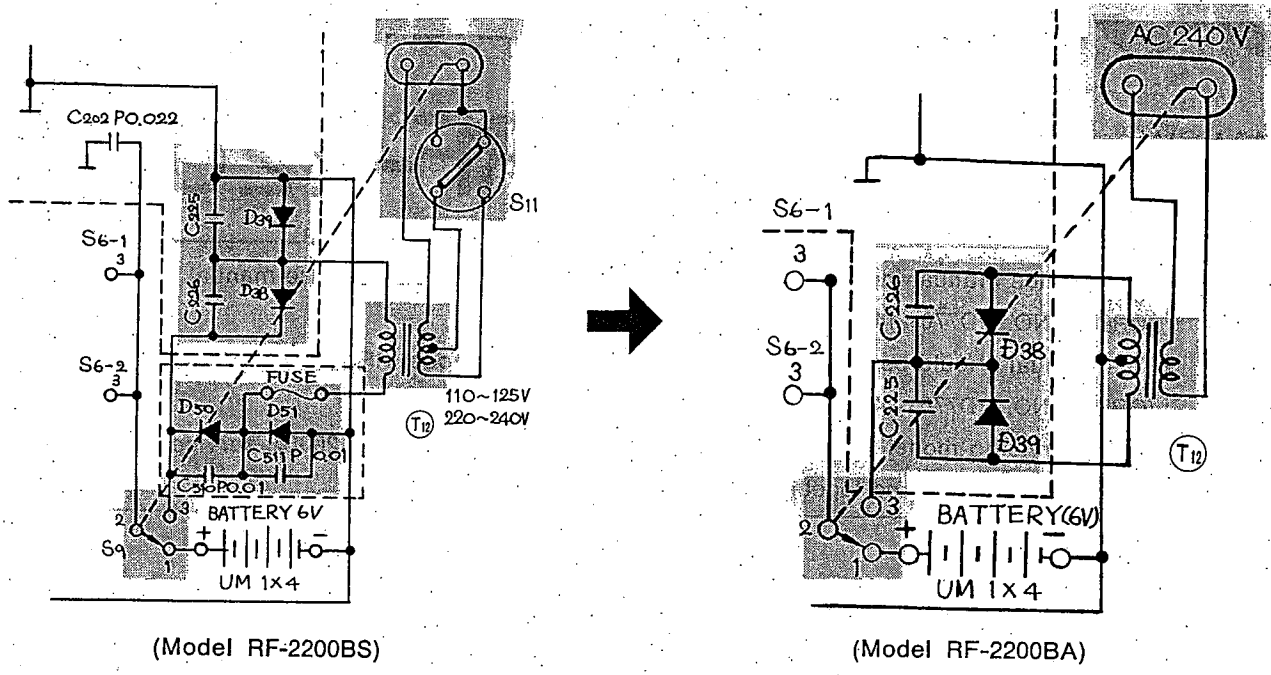

■ CIRCUIT BOARD WIRING VIEW

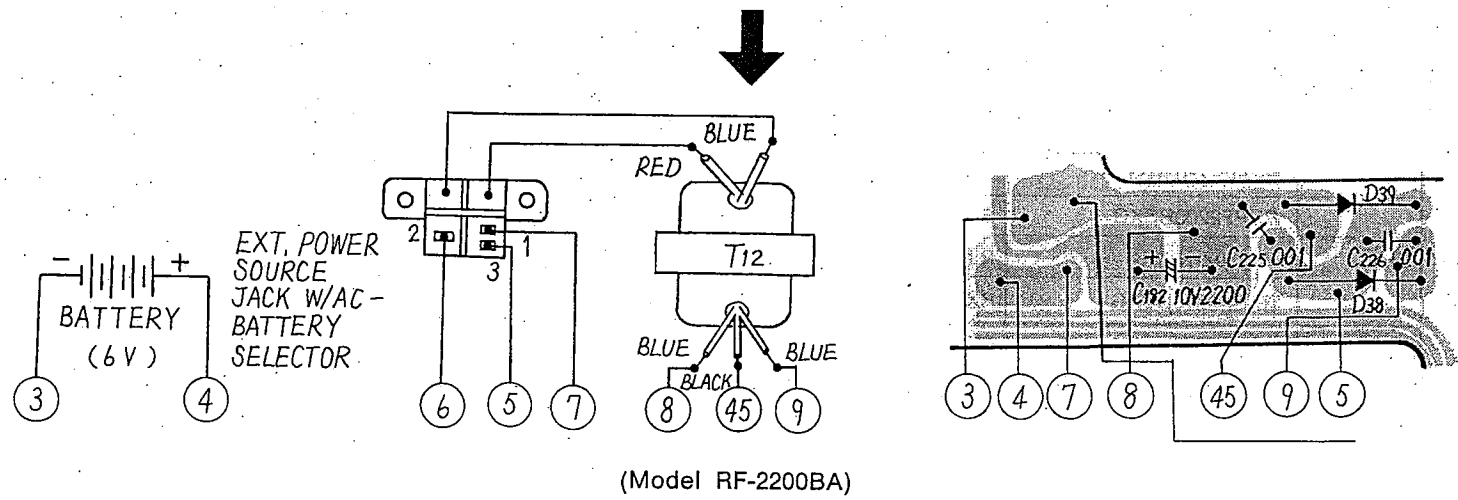
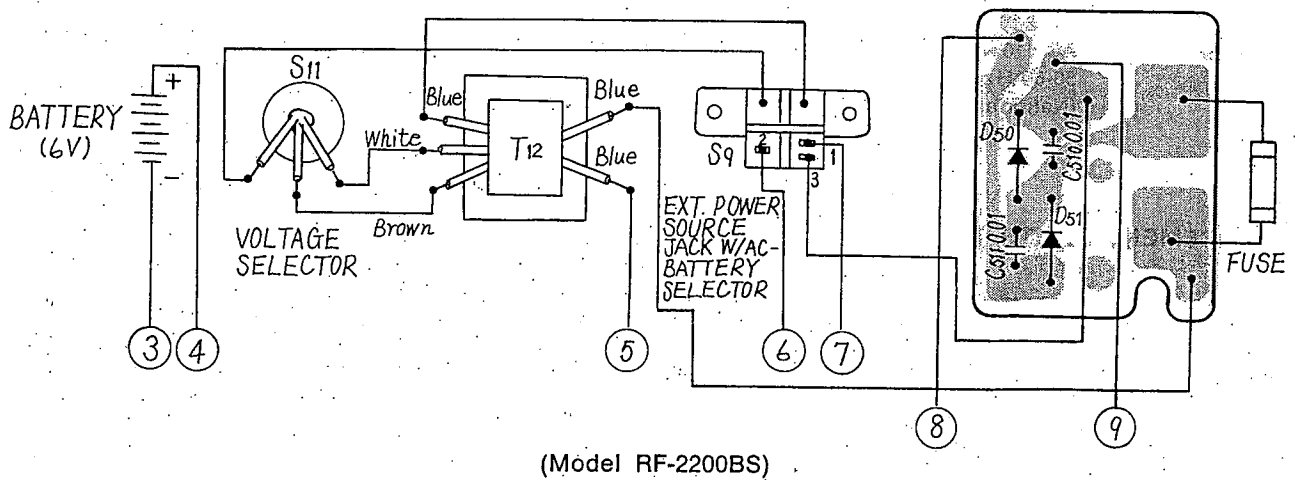

Service Manual

Radio

FM-AM-SW_{1~6} 8-BAND
PORTABLE RADIO

RF-2200BS



■ SPECIFICATIONS

Frequency Range:	FM 87.5~108 MHz	SW ₅ 0.3 μ V for 50 mW Output
	MW 525~1610 kHz (571~186m)	SW ₆ 0.3 μ V for 50 mW Output
	SW ₁ 3.9~8 MHz (76.9~37.5m)	Power Output:
	SW ₂ 8~12 MHz (37.5~25m)	3W (DC Max.)
	SW ₃ 12~16 MHz (25~18.8m)	2.4W (MPO)
	SW ₄ 16~20 MHz (18.8~15m)	Power Source:
	SW ₅ 20~24 MHz (15~12.5m)	AC 110—125/220—240V 50/60 Hz or
	SW ₆ 24~28 MHz (12.5~10.7m)	6V (Four "D" Size Flashlight
Intermediate Frequency:	FM 10.7 MHz	Batteries)
	MW & SW 2nd 455 kHz	(Panasonic UM-1 or equivalent)
	SW 1st 1.985 MHz	Power Consumption:
Sensitivity:	FM 2 μ V (S/N 6 dB)/50 mW Output	7W (AC Only)
	MW 14 μ V/m for 50 mW Output	Speaker:
	SW ₁ 0.5 μ V for 50 mW Output	10 cm (4") PM Dynamic Speaker
	SW ₂ 0.5 μ V for 50 mW Output	Dimensions:
	SW ₃ 0.5 μ V for 50 mW Output	12 $\frac{1}{2}$ " (Wide) x 7 $\frac{1}{2}$ " (High) x
	SW ₄ 0.5 μ V for 50 mW Output	3 $\frac{1}{8}$ " (Deep)
		(318 x 188 x 100 mm)
		Weight:
		3 kg (6 lb. 9.8 oz.) without batteries
		Impedance:
		Speaker8 Ω
		Earphone Jack8 Ω
		Recording Out Jack3k Ω

Specifications are subject to change without notice for further improvement.

 **National Panasonic**

Matsushita Electric Trading Co., Ltd.
P.O. Box 288, Central Osaka, Japan

■ TO REMOVE FRONT AND REAR COVER

1. Set dial scale to minimum frequency.
2. Remove the ten (10) knobs for the FM AFC, X-TAL MARKER, VOLUME, BASS, TREBLE, TUNING SPEED, BAND and MW/SW RF GAIN.
3. Lift up the gyro antenna.
4. Remove the battery cover and pull out the batteries.
5. Remove the six (6) screws for the cabinet cover, as shown in fig. 1.
6. Remove the rear cover.
7. Remove the sockets from chassis.
8. Push the catch in the direction of arrow, as shown in fig. 2 and remove the front cover.
9. Remove the sockets from chassis.
10. To reassemble, reverse the above procedure and note the following.
 1. Set power and AFC switch to "ON" position.
 2. Set X-TAL marker and BFO switch to "OFF" positions.

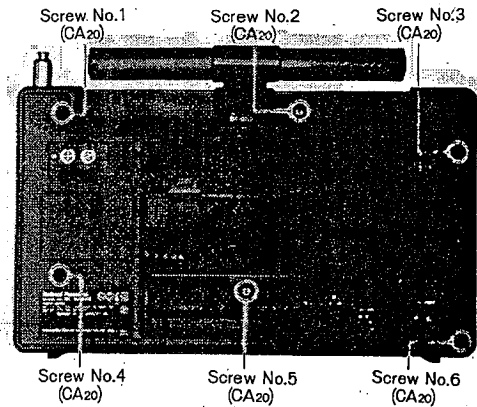

Fig. 1

■ TO REMOVE DIAL DRIVE ASSEMBLY

1. Set band switch to "SW-SW₁" position.
2. Remove the cabinet covers. (Refer to cabinet cover removal instruction.)
3. Remove the four (4) screws (nos. 1~4) for the dial drive assembly, as shown in fig. 3.
4. Turn the tuning shaft to clockwise and set the two (2) screws at the position, as shown in fig. 4.
5. Loosen the one (1) screw (no. 2) for the variable capacitor shaft, as shown in fig. 4.
6. Turn tuning shaft fully counter-clockwise.
7. Loosen the one (1) screw (no. 1) for the variable capacitor shaft, as shown in fig. 4.
8. Remove the tuning knob.
9. Push the catch in the direction of arrow ① and remove the front panel in the direction of arrow ②, as shown in fig. 5.
10. Remove the six (6) screws (nos. 1~6) for the dial drive assembly, as shown in fig. 6.
11. Remove the dial drive assembly.
12. To reassemble, reverse the above procedure and note the following.
 1. Set the band switch shaft at the position (SW, SW₁), as shown in fig. 7.
 2. Set the band switch shaft of dial drive assembly at the position, as shown in fig. 8.
 3. Set the "0" point of dial scale to pointer of front panel, as shown in fig. 8.
 4. Set tuning capacitor to maximum capacity.
 5. Insert the dial drive assembly in chassis.
 6. Turn the shaft of band selector drum with a pliers and set the indicator of band selector drum to "SW₁" position, as shown in fig. 8.

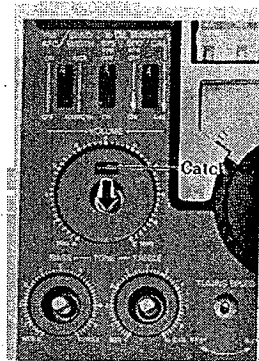

Fig. 2

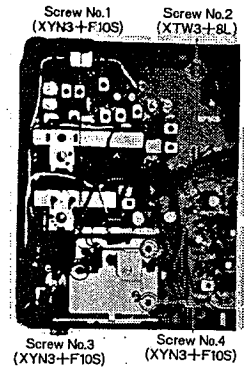

Fig. 3

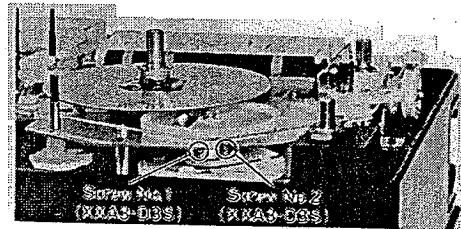

Fig. 4

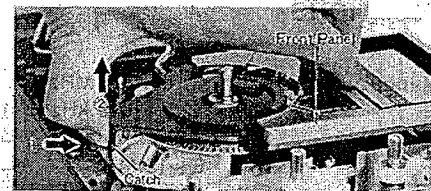

Fig. 5

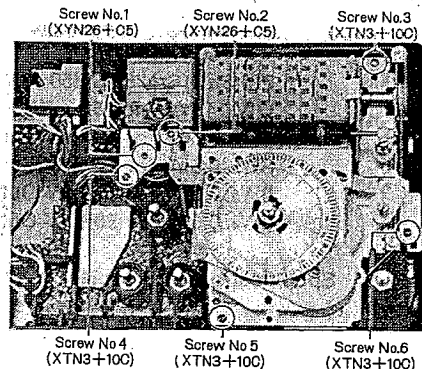

Fig. 6

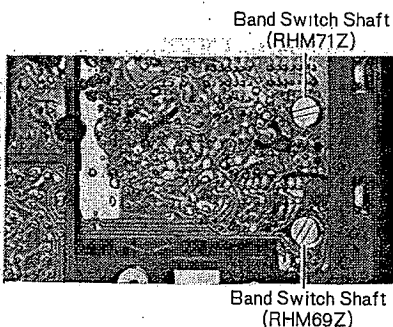

Fig. 7

■ DIAL CORD INSTALLATION GUIDE

1. Remove dial drive assembly. (Refer to dial drive assembly removal instruction.)
2. Remove spread dial.
3. Loosen the one (1) screw for the drum shaft, as shown in fig. 8.
4. Set the dial drum at the position, as shown in fig. 9.
5. Turn tuning shaft fully counter-clockwise.
6. Cord length is 100 cm (39 $\frac{3}{8}$ "').
7. Arrows (1~12) indicate correct order and direction of dial cord installation, as shown in fig. 9.
8. Cement dial cord ends.
9. Set the "0" point of dial scale to pointer of front panel. (Refer to dial scale mounting instruction.)

■ TO MOUNT DIAL SCALE

1. Remove the front cover. (Refer to cabinet cover removal instruction.)
2. Remove the front panel. (Refer to dial drive assembly removal instruction.)
3. Loosen the one (1) screw for the drum shaft, as shown in fig. 10.
4. When removed the rollers, set the roller no. 1 and 2 at the position, as shown in fig. 11.
5. Wind the dial scale onto roller no. 2 shown in fig. 10 and secure the gear of roller no. 2 on the catch of roller no. 1, as shown in fig. 10.
6. Mount the front panel to chassis.
7. Turn the tuning shaft fully counter-clockwise.
8. Turn the roller gear, shown in fig. 12 and set the "0" point of dial scale to the pointer of front panel, as shown in fig. 8. Tighten the one (1) screw for the drum shaft, as shown in fig. 8.

■ TO REMOVE POWER, LIGHT AND BFO SWITCH

1. Remove the cabinet covers. (Refer to cabinet cover removal instruction.)
2. Push the four (4) catches in the direction of arrow shown in fig. 13 and remove the switch.
3. To reassemble, reverse the above procedure.

■ TO REMOVE BASS, TREBLE, VOLUME AND RF GAIN CONTROL

1. Remove the cabinet covers. (Refer to cabinet cover removal instruction.)
2. Remove the dial drive assembly. (Refer to dial drive assembly removal instruction.)
3. Set variable capacitor to maximum capacity.
4. Unsolder the lead wire of RF gain control from chassis.
5. Remove the meter and dial lamp.
6. Remove the power, light and BFO switch. (Refer to switch removal instruction.)
7. Remove the FM AFC and X-TAL marker switch.
8. Remove the three (3) red screws (nos. 1~3) for the PC board, as shown in fig. 14.
9. Remove the two (2) screws (nos. 4 & 5) for the lead wires, as shown in fig. 14.
10. Remove the four (4) nuts (nos. 1, 3, 4 & 5) for the controls, as shown in fig. 15.
11. Remove the one (1) screw (no. 2) for sub PC board, shown in fig. 15 and remove sub PC board.
12. Push the eight (8) catches for the PC board, shown in fig. 15 and remove PC board.
13. Unsolder the controls, as shown in fig. 16.

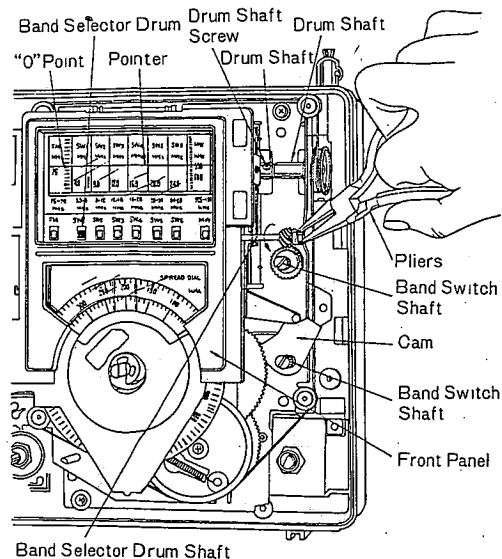

Fig. 8

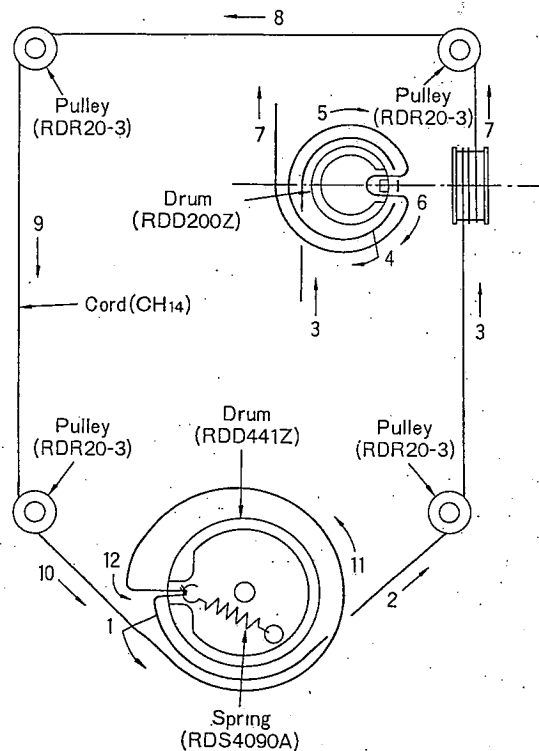

Fig. 9

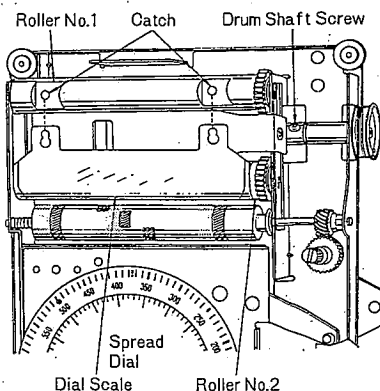

Fig. 10

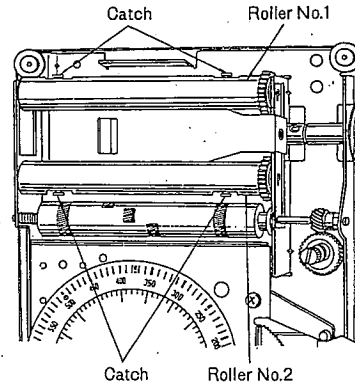

Fig. 11

■ TO REMOVE GYRO ANTENNA CASE ASSEMBLY

1. Remove the rear cover. (Refer to cabinet cover removal instruction.)
2. Unsolder the lead wire of gyro antenna from PC board.
3. Remove the circlip in the direction of arrow, as shown in fig. 17.
4. Remove the gyro antenna case.
5. To reassemble, reverse the above procedure.

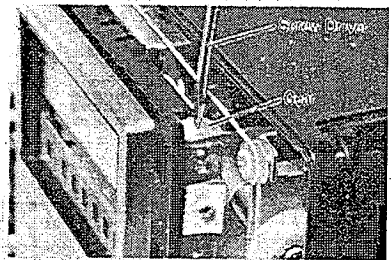

Fig. 12

■ TO REMOVE SHIELD PLATE

1. Remove the front cover. (Refer to cabinet cover removal instruction.)
2. Remove the power, light and BFO switch. (Refer to switch removal instruction.)
3. Unsolder the shield plate, as shown in fig. 18.
4. To reassemble, reverse the above procedure.

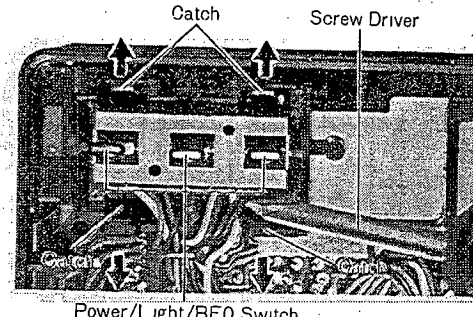

Fig. 13

■ TO REMOVE CORE ANTENNA

1. Remove the gyro antenna cover in the direction of arrow, as shown in fig. 19.
2. Unsolder lead wires from core antenna, as shown in fig. 20.
3. To reassemble, reverse the above procedure.

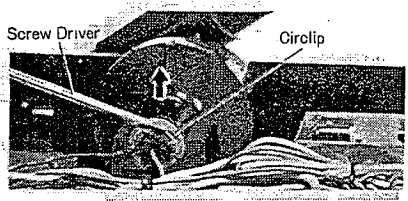

Fig. 17

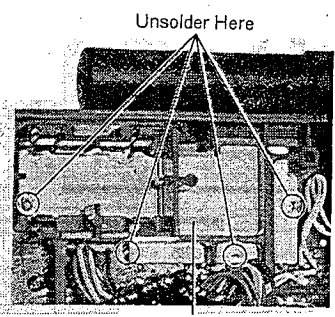

Fig. 18

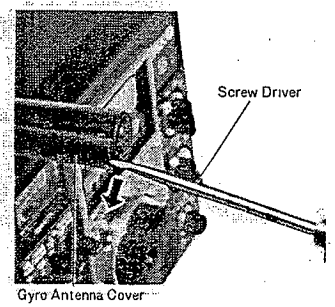

Fig. 19

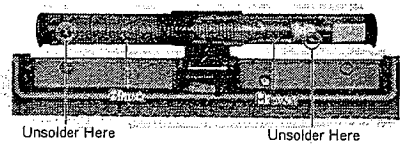

Fig. 20

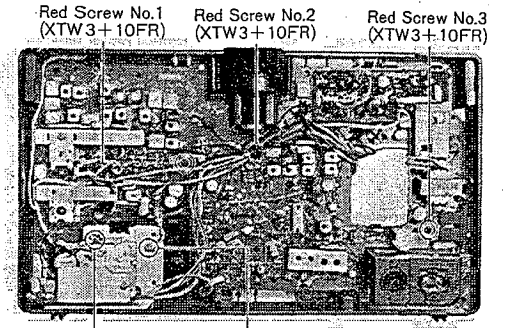

Fig. 14

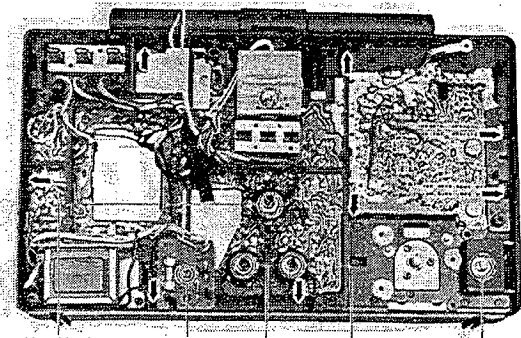

Fig. 15

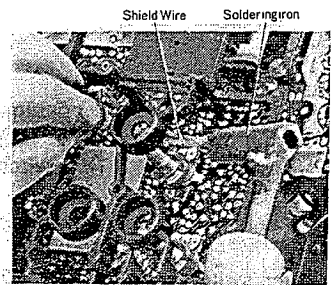
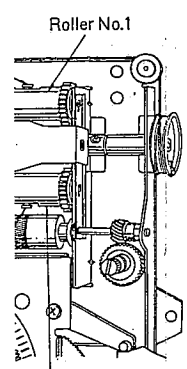

Fig. 16

ch

tch

el



Roller No.2

1

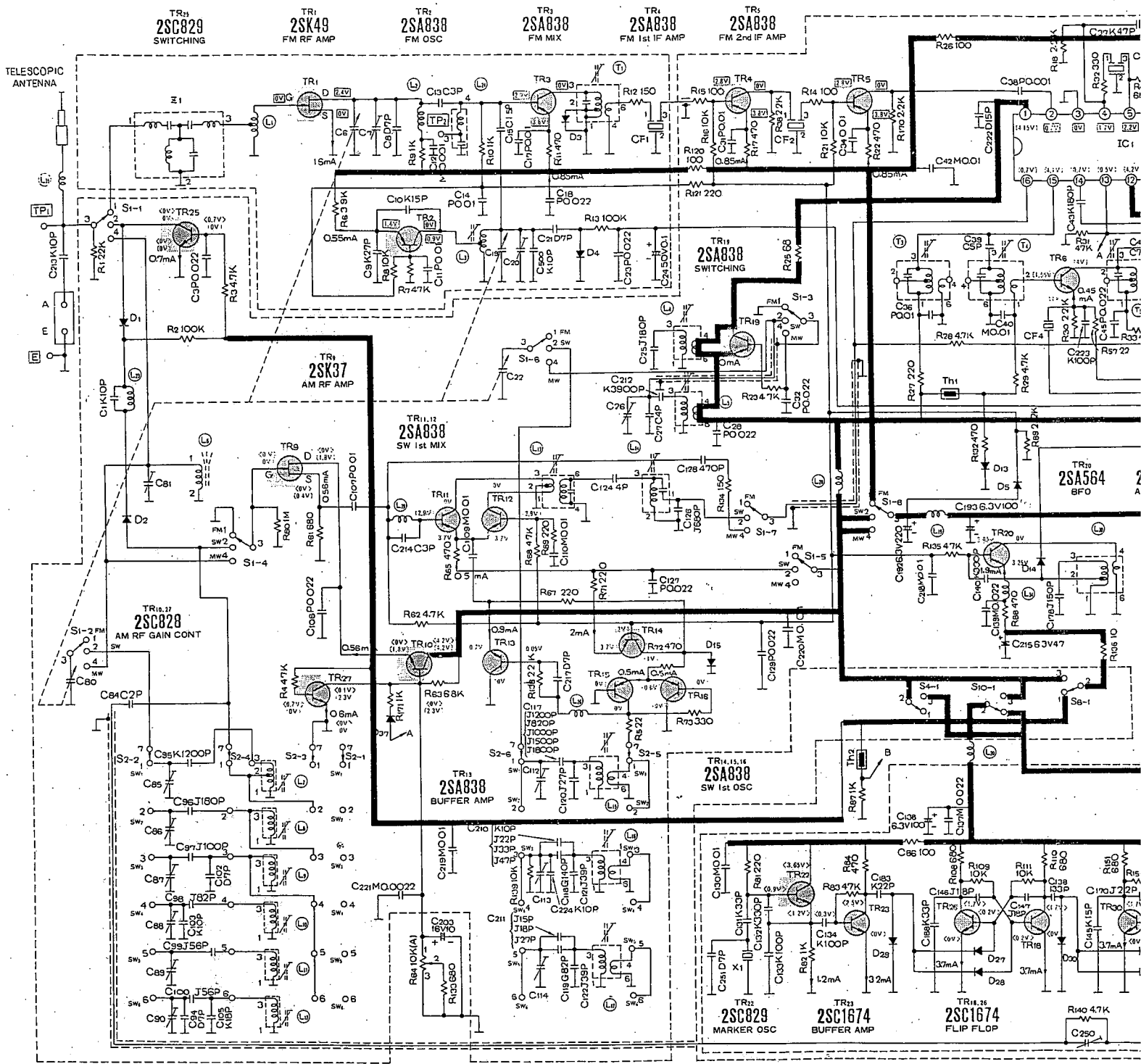

C	213	1	3	227	8	9	8	10	11	12	13	14	15	17	22	19	50	20	21	18	23	24	25	26	27	212	28	31	32	35	34	36	222	42	39	216	38	40	43	223	45	37	4		
R	80	84	81	85-90	95-100	102	103	105	83	94	106	107	221	214	171	203	219	109	210	211	112	113	114	110	117-124	217	251	126-134	220	183	136	192	188	146	137	193	139	215	140	147	138	170	250	145	17
	1	2	3				6	8	7	9	10		11	13	12	15	16	121	120	17	38	23	25	14	21	22	27	170	26	28	132	29	83	30	31	32	57	18	2						
					60	4	61					62	63	64	65	133	139	68	138	69	67	71			5	72	73	134	81	113	82	98	83	84	87	85	135	108	109	86	111	110	140	136	11

- Notes:**
- S1-1~S1-8: Band switch in "FM" position.
 - S2-1~S2-6: SW band switch in "SW1" position.
 - S3-1, S3-2: FM AFC/BAND WIDTH switch in "OFF", "NARROW" position.
 - S4-1, S4-2: X-TAL MARKER/125 kHz switch in "OFF" position.
 - S6-1, S6-2: Power switch in "OFF" position.
 - S7: Dial Light switch in "OFF" position.
 - S8-1, S8-2: BFO switch in "OFF" position.
 - S9: AC-BATTERY switch in "BATTERY" position.
 - S10-1, S10-2: X-TAL MARKER/500 kHz switch in "OFF" position.
 - S11: Voltage selector in "110~125V" position
 - DC voltage measurements are taken with circuit tester 10kΩ/V from negative side of batteries.
 - []...FM position
 - []...MW & SW position
 - ()...SW position
 - < >...CAL-ON position
 - TR20...BFO-ON position
 12. 1) IC2 with B rank w
2) IC2 with C rank R
3) IC2 with D rank R
 13. Battery current: No : Max

5 RF-2200BS

IMPORTANT
THE SHADED AREA () INCORPORATES SPE FOR SAFETY WHEN SERVICING THE CRITICAL AREAS OF THE SCHE

am-Model RF-2200BS

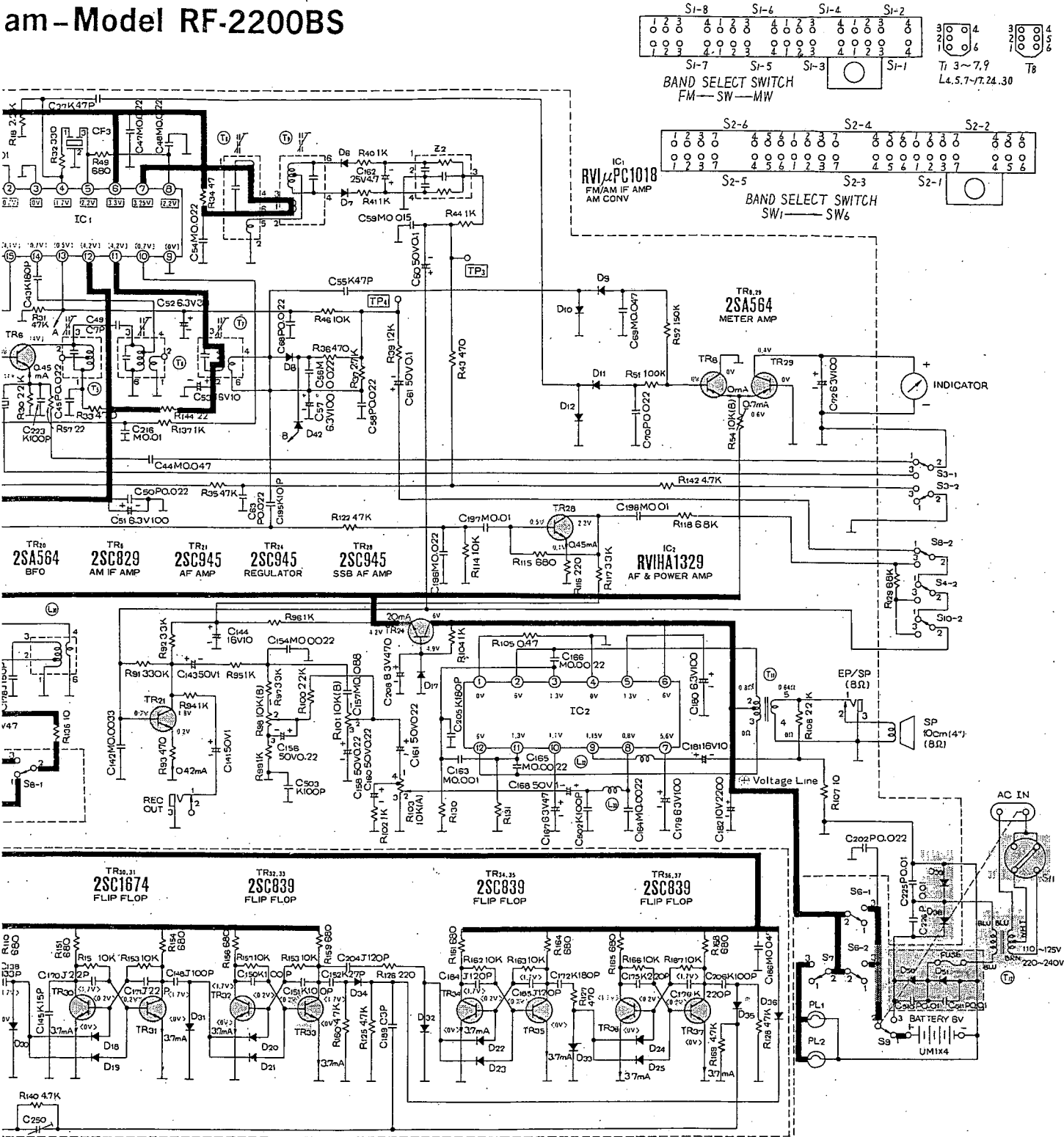

43	223	45	37	49	50	51	47	48	216	44	52	54	53	63	195	68	50	58	57	55	162	58	59	60	61	196	197	502	198	69	70	72													
17	138	170	250	145	170	142	171	148	143	141	144	150	154	156	151	152	163	158	157	160	204	205	206	161	184	163	185	172	165	167	173	166	168	175	164	502	206	176	179	190	161	166	162	202	
30	31	32	57	18	49	33	144	137	34	35	46	36	37	40	41	122	39	43	44	114	115	116	117	51	142	53	118	54	52	129															
110	140	136	151	152	153	154	91	92	93	156	94	95	157	98	99	97	158	159	160	96	100	125	101	102	103	126	130	104	151	162	131	105	163	164	127	165	166	167	168	169	128	106	107	226	225

ith B rank without R130, R131.
 th C rank R130, R131.....22 kΩ.
 th D rank R130, R131.....15 kΩ.
 urrent: No signal 60mA
 Maximum output650mA

IMPORTANT SAFETY NOTICE
 SHADED AREA ON THIS SCHEMATIC DIAGRAM
 INCORPORATES SPECIAL FEATURES IMPORTANT
 SAFETY
 ON SERVICING IT IS ESSENTIAL THAT ONLY
 MANUFACTURER'S SPECIFIED PARTS BE USED FOR
 CRITICAL COMPONENTS IN THE SHADED
 AREA OF THE SCHEMATIC.

D1, 2	RV0SD113	SWITCHING
D3	RVD1K110	FM AGC
D4	RV0SD113	FM AFC
D5, 13	RVDVD1250M	AOC
D6, 7	2-OA90	FM DET
D8	QA90	AM DET
D9, 10	QA90	AM METER RECT
D11, 12	QA90	FM METER RECT

D14	RVD1K110	SSB DET
D15	RVDVD1252L	AOC
D17	RVDMZA205	ZENER
D18~25	MA150	TRIGGER
D27~33	MA150	TRIGGER
D34, 35	QA90	DET
D36, 37, 42	MA150	SWITCHING
D38, 39	RVD10E1LF	RECT

■ BLOCK DIAGRAM

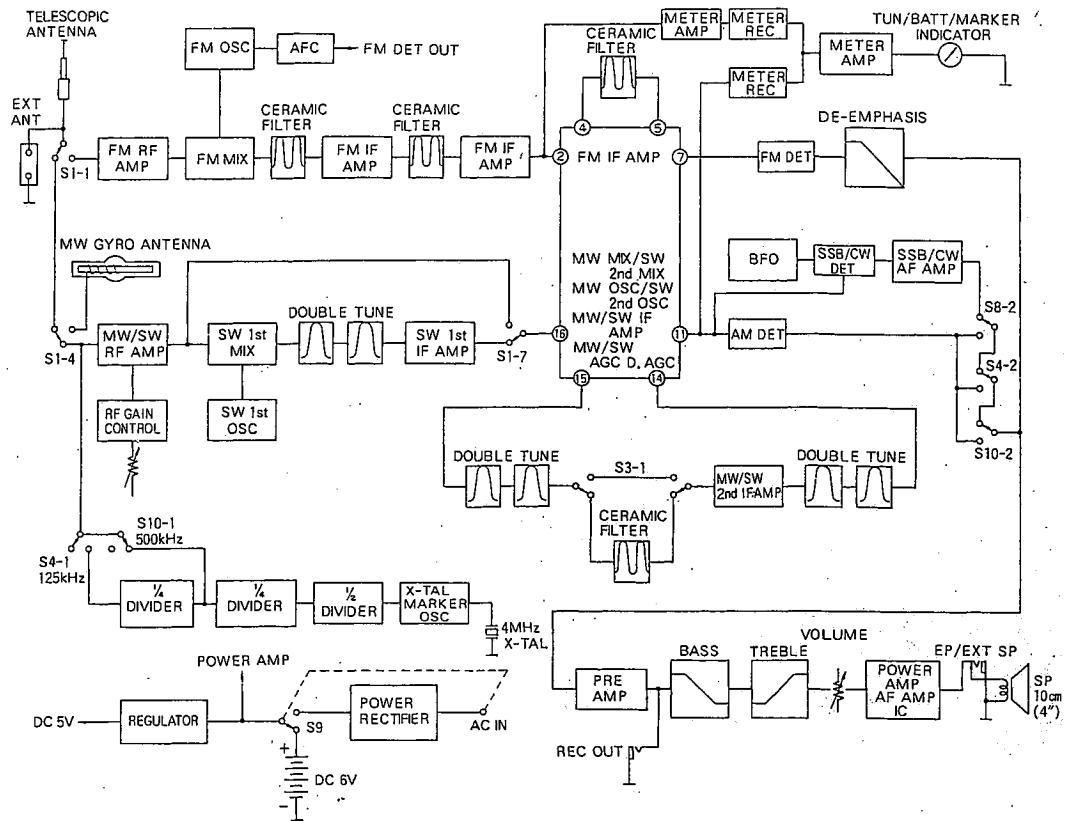

Fig. 21

■ ALIGNMENT POINTS

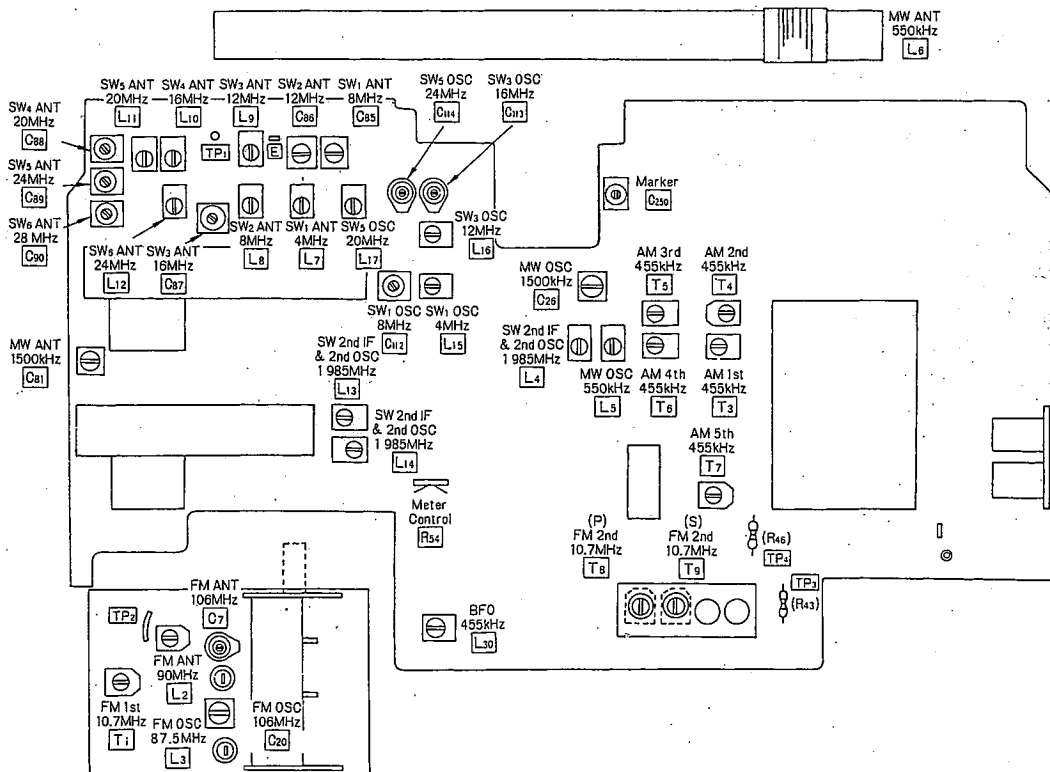

Fig. 22

■ TUNING/BATTERY/MARKER METER ADJUSTMENT

1. RADIO RECEIVER SETTING

- Set band switch to MW.
- Set volume control to MIN.
- Set power source voltage to DC 6V.

2. REMARKS

- Adjust R₅₄ so that the pointer of level meter stays as shown in fig. 23.

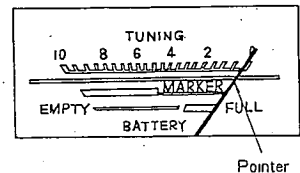

Fig. 23

S
C
D
E

C
B
E
I

■ ALIGNMENT INSTRUCTIONS

10

READ CAREFULLY BEFORE ATTEMPTING ALIGNMENT

1. Set volume control to maximum.
2. Set power switch to ON.
3. Set bass and treble control to maximum.
4. Set band switch to MW, SW or FM.
5. Set SW band switch to SW₁, SW₂, SW₃, SW₄, SW₅ or SW₆.
6. Set MW/SW RF gain control to high.
7. Set FM AFC/Band width switch to narrow, OFF position for the BFO and FM adjustment, and to wide ON position for other adjustment.
8. Set X-TAL Marker switch to OFF.
9. Set BFO switch to ON position for BFO adjustment, and to OFF position for other adjustment.
10. Output of signal generator should be no higher than necessary to obtain an output reading.

■ MW, SW ALIGNMENT

BAND	SIGNAL GENERATOR or SWEEP GENERATOR		RADIO DIAL SETTING	INDICATOR (VTVM or SCOPE)	ADJUSTMENT	REMARKS
	CONNECTIONS	FREQUENCY				
AM-IF ALIGNMENT						
(1) MW	Fashion loop of several turns of wire and radiate signal into loop of receiver.	455 kHz 30% Mod. at 400 Hz	Point of non-interference.	Output meter across voice coil.	T ₃ (AM 1st IFT) T ₄ (AM 2nd IFT) T ₅ (AM 3rd IFT) T ₆ (AM 4th IFT) T ₇ (AM 5th IFT)	1. Set band width switch to narrow and adjust for maximum output. 2. Set band width switch to wide. 3. Adjust for maximum output.
BFO ALIGNMENT						
(2) MW	"	455 kHz	"	Audio output from speaker.	L ₃₀ (BFO OSC Coil)	Adjust for zero beat.
MW-RF ALIGNMENT						
(3) MW	"	550 kHz	550 kHz (Refer to fig.30)	Output meter across voice coil	L ₅ (MW OSC Coil) L ₆ (MW ANT Coil)	Adjust for maximum output.
(4) MW	"	1500 kHz	1500 kHz (Refer to fig.31)	"	C ₂₆ (MW OSC Trimmer) C ₈₁ (MW ANT Trimmer)	Adjust for maximum output. Repeat steps (3) and (4).
SW-1st IF and 2nd OSC ALIGNMENT						
(5) SW1	Connect to test point [TP] through ceramic capacitor (10PF). Negative side to point [E]	1.985 MHz	Point of non-interference.	"	L ₄ (2nd OSC Coil) L ₁₃ (SW 1st IF Coil) L ₁₄ (SW 1st IF Coil)	Adjust for maximum output.

■ PADDING ALIGNMENT

• When you change variable capacitor please adjust as follows.

1. Solder padding capacitors at the position, as shown in fig. 26 according to the following table.

Ref. No.	Part No.	Description
C ₁₁₇ (SW ₁)	ECQS05122JZ	1200 PF, 50 WV, ±5%, Styrol
C ₂₁₀ (SW ₃)	ECMS05270JH	27 PF, 50WV, ±5%, Mica
C ₂₁₁ (SW ₅)	ECCD1H100KC	10 PF, 50WV, ±10%, Ceramic

2. Adjust the RF circuit of SW₁, SW₃ and SW₅.

3. Set 125 marker switch to ON position and then check zero beat as following frequencies.

Band	Zero Beat Frequency	Radio Dial Setting
SW ₁	6 MHz	Turn spread dial two times from 4 MHz position and set it to 0 kHz.
SW ₃	14 MHz	Turn spread dial two times from 12 MHz position and set it to 0 kHz.
SW ₅	22 MHz	Turn spread dial two times from 20 MHz position and set it to 0 kHz.

4. If there is difference between spread dial indication and the frequency of following table, please change proper capacitor.

Band	Ref. No.	Spread Dial	Part No.	Description
SW ₁	C ₁₁₇	less than 960 kHz	ECQS05821JZ	820 PF, 50WV, ±5% Styrol
		960~980 kHz	ECQS05102JZ	1000PF, 50WV, ±5%, Styrol
		20~40 kHz	ECMS05152JZ	1500PF, 50WV, ±5%, Mica
		more than 40 kHz	ECQS05182JZ	1800PF, 50WV, ±5%, Styrol
SW ₃	C ₂₁₀	less than 960 kHz	ECCE1H100KC	10PF, 50WV, ±10%, Ceramic
		960~980 kHz	ECMS05220JH	22PF, 50WV, ±5%, Mica
		20~40 kHz	ECMS05330JH	33PF, 50WV, ±5%, Mica
		more than 40 kHz	ECMS05470JH	47PF, 50WV, ±5%, Mica
SW ₅	C ₂₁₁	less than 920 kHz	ECCD1H040C	4PF, 50WV, ±0.25PF, Ceramic
		920~960 kHz	ECCD1H070DC	7PF, 50WV, ±0.5PF, Ceramic
		40~80 kHz	ECMS05150JH	15PF, 50WV, ±5%, Mica
		more than 80 kHz	ECMS05180JH	18PF, 50WV, ±5%, Mica

■ SW RF ALIGNMENT

BAND	SIGNAL GENERATOR or SWEEP GENERATOR		RADIO DIAL SETTING	INDICATOR (VTVM or SCOPE)	ADJUSTMENT	REMARKS	
	CONNECTIONS	FREQUENCY					
SW1-RF ALIGNMENT							
(1)	SW1	Connect to test point [TP] through ceramic capacitor (10PF) Negative side to point [E]	4 MHz	4 MHz Refer to note 1.	Output meter across voice coil.	L ₁₅ (SW1 OSC Coil) L ₇ (SW1 ANT Coil)	Adjust for maximum output.
(2)	SW1	"	8 MHz	8 MHz Refer to note 2.	"	C ₁₁₂ (SW1 OSC Trimmer) C ₈₅ (SW1 ANT Trimmer)	Adjust for maximum output. Repeat steps (1) and (2).
SW2-RF ALIGNMENT							
(3)	SW2	"	8 MHz	8 MHz Refer to note 1.	"	L ₈ (SW2 ANT Coil)	Adjust for maximum output.
(4)	SW2	"	12 MHz	12 MHz Refer to note 2.	"	C ₈₆ (SW2 ANT Trimmer)	Adjust for maximum output. Repeat steps (3) and (4).
SW3-RF ALIGNMENT							
(5)	SW3	"	12 MHz	12 MHz Refer to note 1.	"	L ₁₆ (SW3 OSC Coil) L ₉ (SW3 ANT Coil)	Adjust for maximum output.
(6)	SW3	"	16 MHz	16 MHz Refer to note 2.	"	C ₁₁₃ (SW3 OSC Trimmer) C ₈₇ (SW3 ANT Trimmer)	Adjust for maximum output. Repeat steps (5) and (6).
SW4-RF ALIGNMENT							
(7)	SW4	"	16 MHz	16 MHz Refer to note 1.	"	L ₁₀ (SW4 ANT Coil)	Adjust for maximum output.
(8)	SW4	"	20 MHz	20 MHz Refer to note 2.	"	C ₈₈ (SW4 ANT Trimmer)	Adjust for maximum output. Repeat steps (7) and (8).
SW5-RF ALIGNMENT							
(9)	SW5	"	20 MHz	20 MHz Refer to note 1.	"	L ₁₇ (SW5 OSC Coil) L ₁₁ (SW5 ANT Coil)	Adjust for maximum output.
(10)	SW5	"	24 MHz	24 MHz Refer to note 2.	"	C ₁₁₄ (SW5 OSC Trimmer) C ₈₉ (SW5 ANT Trimmer)	Adjust for maximum output. Repeat steps (9) and (10).
SW6-RF ALIGNMENT							
(11)	SW6	"	24 MHz	24 MHz Refer to note 1.	"	L ₁₂ (SW6 ANT Coil)	Adjust for maximum output.
(12)	SW6	"	28 MHz	28 MHz Refer to note 2.	"	C ₉₀ (SW6 ANT Trimmer)	Adjust for maximum output. Repeat steps (11) and (12).

Notes:

1. Set tuning capacitor to maximum capacity (minimum frequency), tuning knob to fully counter-clockwise, spread dial to 435 kHz, as shown in fig. 24. Then set tuning knob to clockwise and set spread dial to 0 kHz, as shown in fig. 25.

2. Set spread dial to 0 kHz by turning 4 times to clockwise from the position of note 1.

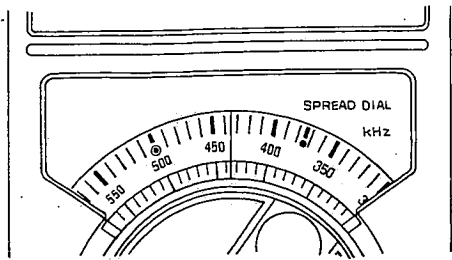

Fig. 24

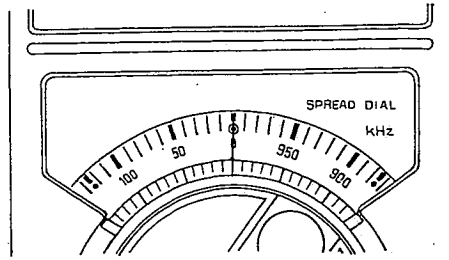

Fig. 25

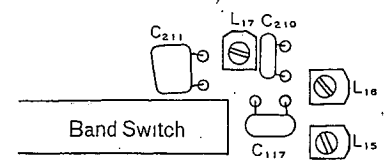

Fig. 26

MARKER ALIGNMENT

1. Set trimmer capacitor (C₂₅₀) to maximum capacity.
2. Check zero beat at the position of 24 MHz (SW₅).
3. Set 125, 500 kHz marker to ON. For the image beat of 24.03 MHz, set spread dial to 24.03 MHz and adjust C₂₅₀ so that the meter indicates 4 scale or less.

FM ALIGNMENT INSTRUCTIONS

SIGNAL GENERATOR or SWEEP GENERATOR		RADIO DIAL SETTING	INDICATOR (VTVM or SCOPE)	ADJUSTMENT	REMARKS	
CONNECTIONS	FREQUENCY					
FM-IF ALIGNMENT						
(1)	High side thru. 0.001 μ F to point [TP ₂]. Negative side to point [E].	10.7 MHz (400 kHz SWP.)	Point of non-interference. (on/about 90 MHz).	Connect vert. amp. of scope to point [TP ₃]. Negative side to point [E].	T ₁ (FM 1st IFT) T ₈ (FM 2nd IFT) (Primary)	Adjust for maximum amplitude. (Refer to fig. 27).
(2)	"	"	"	"	T ₉ (FM 2nd IFT) (Secondary)	Adjust for maximum amplitude. (Refer to fig. 28).
FM-RF ALIGNMENT						
(3)	Connect to test point [TP ₁] through FM dummy antenna. Negative side to point [E]. (Refer to fig. 29).	87.5 MHz	Variable capacitor fully closed.	Output meter across voice coil.	L ₃ (FM OSC Coil)	Adjust for maximum output.
(4)	"	90 MHz	90 MHz (Refer to fig. 32)	"	L ₂ (FM Tuning Coil)	Adjust for maximum output.
(5)	"	106 MHz	106 MHz (Refer to fig. 33)	"	C ₂₀ (FM OSC Trimmer) C ₇ (FM ANT Trimmer)	Adjust for maximum output. Repeat steps (3) and (4).

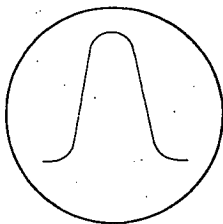

Fig. 27

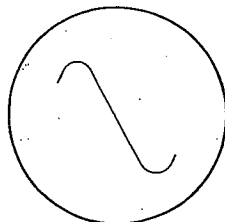

Fig. 28

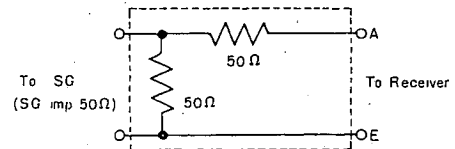

Fig. 29 FM Dummy Antenna

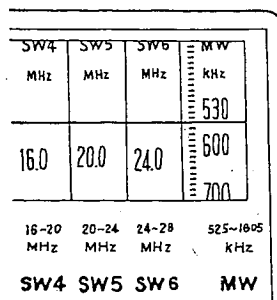
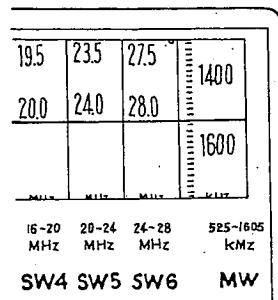

Fig. 30 550 kHz



(MW) Fig. 31 1500 kHz

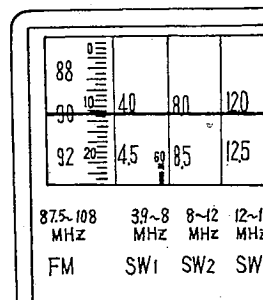

Fig. 32 90 MHz

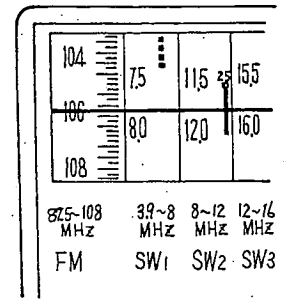
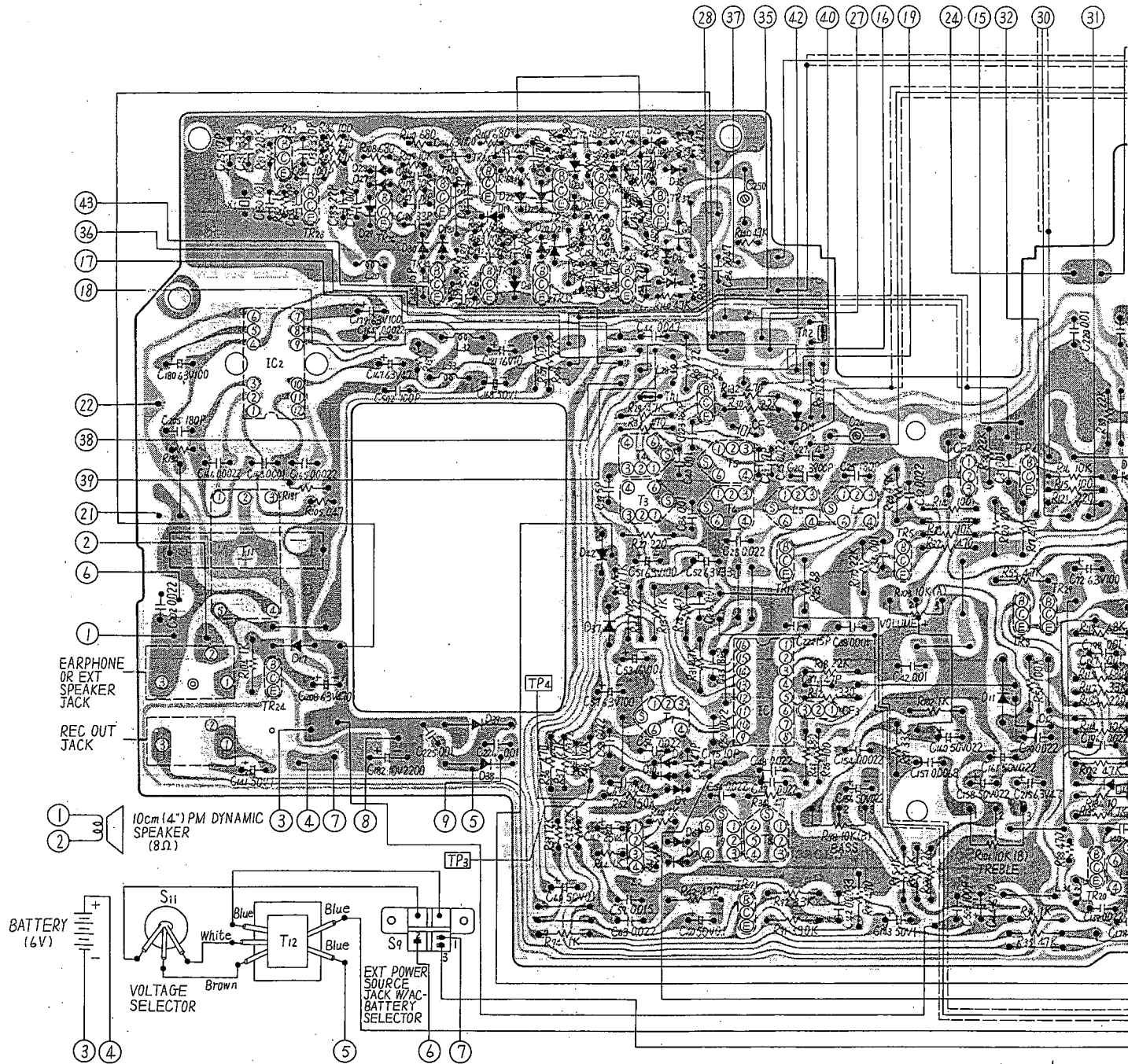

Fig. 33 106 MHz



TR, D & IC	IC ₂	TR ₂₂	TR ₂₃	D ₂₈	D ₂₇	D ₂₉	TR ₂₆	D ₃₀	TR ₃₀	D ₁₈	TR ₃₁	D ₁₉	TR ₃₄	D ₃₁	D ₂₂	D ₂₃	D ₂₀	D ₃₂	TR ₃₂	D ₂₁	TR ₃₅	D ₃₃	TR ₃₆	D ₂₄	TR ₃₃	D ₂₅	TR ₃₇	D ₂₆	D ₃₄	D ₃₅					
		D ₁₇								D ₃₉	D ₃₈			D ₄₂	D ₃₇	D ₈	D ₁₀	D ₆	D ₇	TR ₆	TR ₂₁	IC ₁	TR ₁₉	D ₁₃		TR ₅		D ₁₁	D ₁₂	TR ₈	TR ₄	TR ₂₉	TR ₂₀	D ₁₄	D ₅
T & L	T ₁₁	T ₁₂	L ₂₀					L ₃₃	L ₃₂					T ₄	T ₃	L ₂₈	T ₇			T ₅	T ₆	T ₉	T ₈	L ₅		L ₄						L ₃₄			

TR1	TR2	TR3	TR4	TR5	TR6	TR8	TR9	TR10
FM	FM	FM	FM	FM	MW & SW	C 0V	MW & SW CAL-ON	MW & SW CAL
S 0V	C 0V	C 0V	C 0V	C 0V	C 4V	B 0V	S 0.4V 0V	C 4.2V 4
G 0V	B 0.9V	B 2.9V	B 2.8V	B 2.8V	B 1.55V	E 0.6V	G 0V 0V	B 2.3V 0
D 2.4V	E 1.4V	E 3.6V	E 3.8V	E 3.8V	E 1V	Ic 0mA	D 1.8V 0V	E 1.8V 0
Ic 1.6mA	Ic 0.55mA	Ic 0.85mA	Ic 0.85mA	Ic 0.85mA	Ic 0.45mA		I _s 0.56mA 0mA	Ic 0.56mA 0
TR21	TR22	TR23	TR24	TR25	TR26	TR27	TR28	TR29
C 1.8V	CAL-ON	CAL-ON	C 6V	SW CAL-ON	CAL-ON	SW CAL-ON	C 2.2V	C 0.4V
B 0.7V	C 3.65V	C 2.5V	B 4.9V	C 0V 0V	C 1.7V	C 2.3V 0.1V	B 0.5V	B 0V
E 0.2V	B 0.9V	B 0.3V	E 4.2V	B 0V 0.7V	B 0.2V	B 0V 0.7V	E 0.1V	E 0.6V
Ic 0.42mA	E 1.2V	E 0V	Ic 20mA	E 0V 0V	E 0V	E 0V 0V	Ic 0.45mA	Ic 0.75mA
	Ic 1.2mA	Ic 3.2mA		Ic 0mA 0.7mA	Ic 3.7mA	Ic 0mA 0.6mA		

1g View-Model RF-2200BS

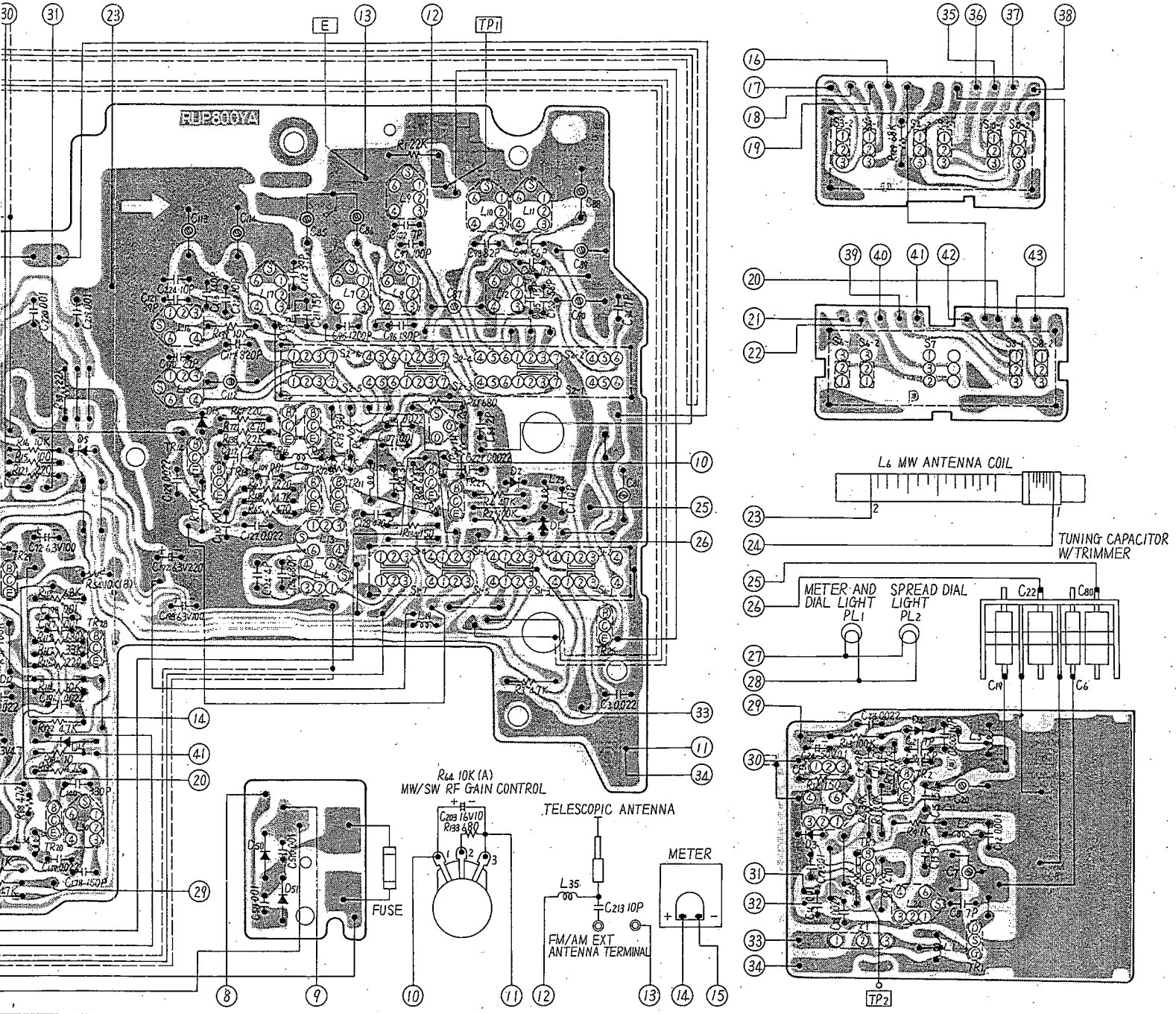

TR29 TR20 Di4 D5 TR28	TR14 D15 TR13 TR16 TR15 TR12 TR11 D50 D51	TR10 TR9 TR27	D2	D1	D3	TR3	TR2	D4	TR1
L34 L30	L16 L15	L17 L26	L13 L14 L7 L29 L8 L9 L19	L10 L12 L11	L23	L35	T1	L6 L24	L1 L3

TR10	
MW & SW	CAL-ON
4.2V	4.2V
2.3V	0V
1.8V	0V
0.56mA	0mA

TR11	
SW	
C	0V
B	2.9V
E	3.7V
Ic	0.5mA

TR12	
SW	
C	0V
B	2.9V
E	3.7V
Ic	0.5mA

TR13	
SW	
C	0V
B	0.05V
E	0.7V
Ic	0.9mA

TR14	
SW	
C	1V
B	3V
E	3.7V
Ic	2mA

TR15	
SW	
C	0V
B	0V
E	0.6V
Ic	0.5mA

TR16	
SW	
C	0V
B	0V
E	0.6V
Ic	0.5mA

TR18	
CAL-ON	
C	1.7V
B	0.2V
E	0V
Ic	3.7mA

TR19	
C	—
B	—
E	—
Ic	—

TR20	
BFO-ON	
C	0V
B	2.85V
E	3.25V
Ic	1.9mA

TR29	
C	0.4V
B	0V
E	0.5V
Ic	0.75mA

TR30-37	
C	CAL-ON
B	1.7V
E	0.2V
Ic	3.7mA

IC1			
FM		MW & SW	
2	0.7V	9	4.15V
3	0V	9	0V
4	1.7V	10	0.7V
5	2.2V	11	4.2V
6	3.3V	12	4.2V
7	3.25V	13	0.5V
8	2.2V	14	0.7V
15	4.1V		
16	0.7V		

IC2			
1	0V	7	5.6V
2	6V	8	0.8V
3	1.3V	9	1.15V
4	0V	10	1.1V
5	1.3V	11	1.3V
6	6V	12	6V

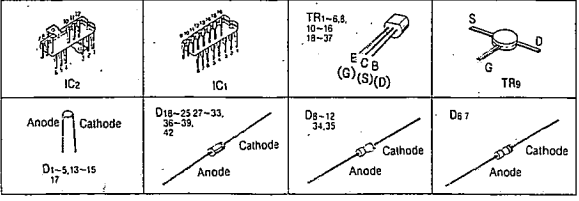

■ CABINET PARTS LOCATION

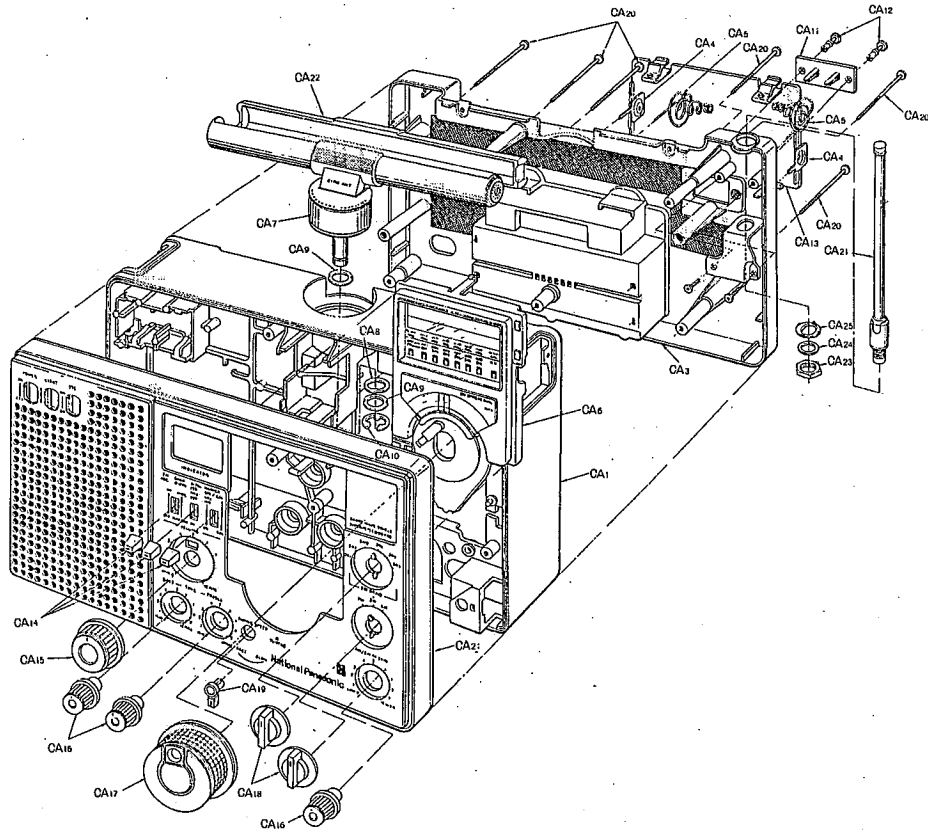

Fig. 34

■ PACKING MATERIALS AND ACCESSORIES

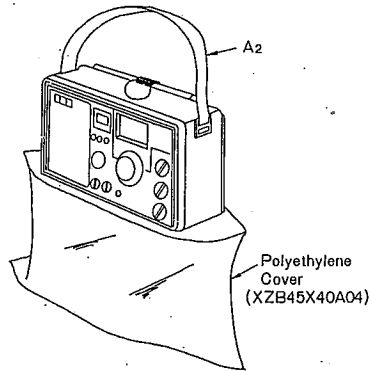

Fig. 35

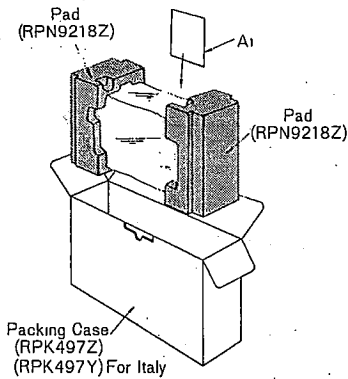

Fig. 36

■ CHASSIS PARTS LOCATIONS

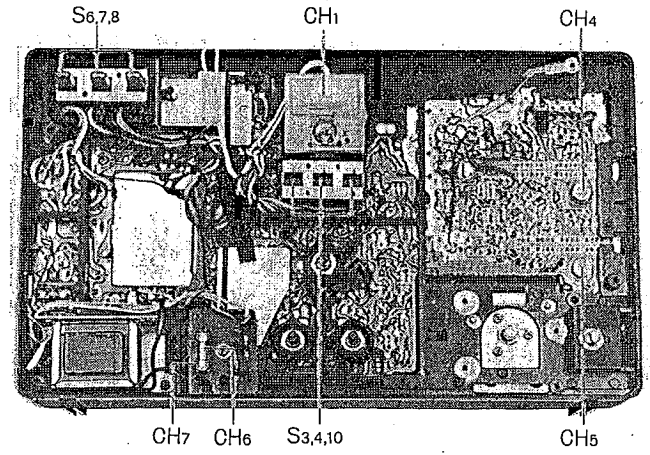

Fig. 37

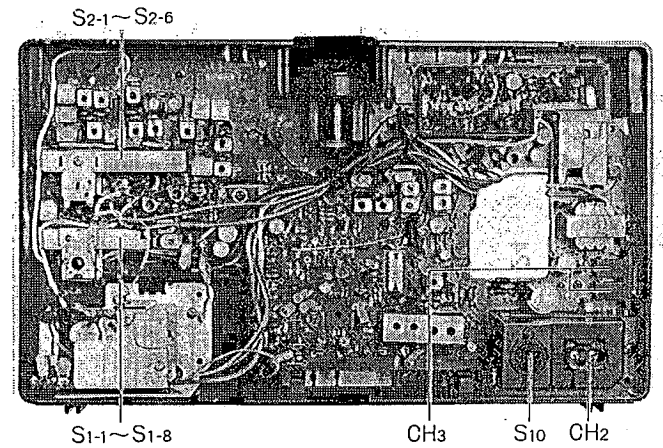

Fig. 38

■ DIAL DRIVE ASSEMBLY PARTS LOCATIONS

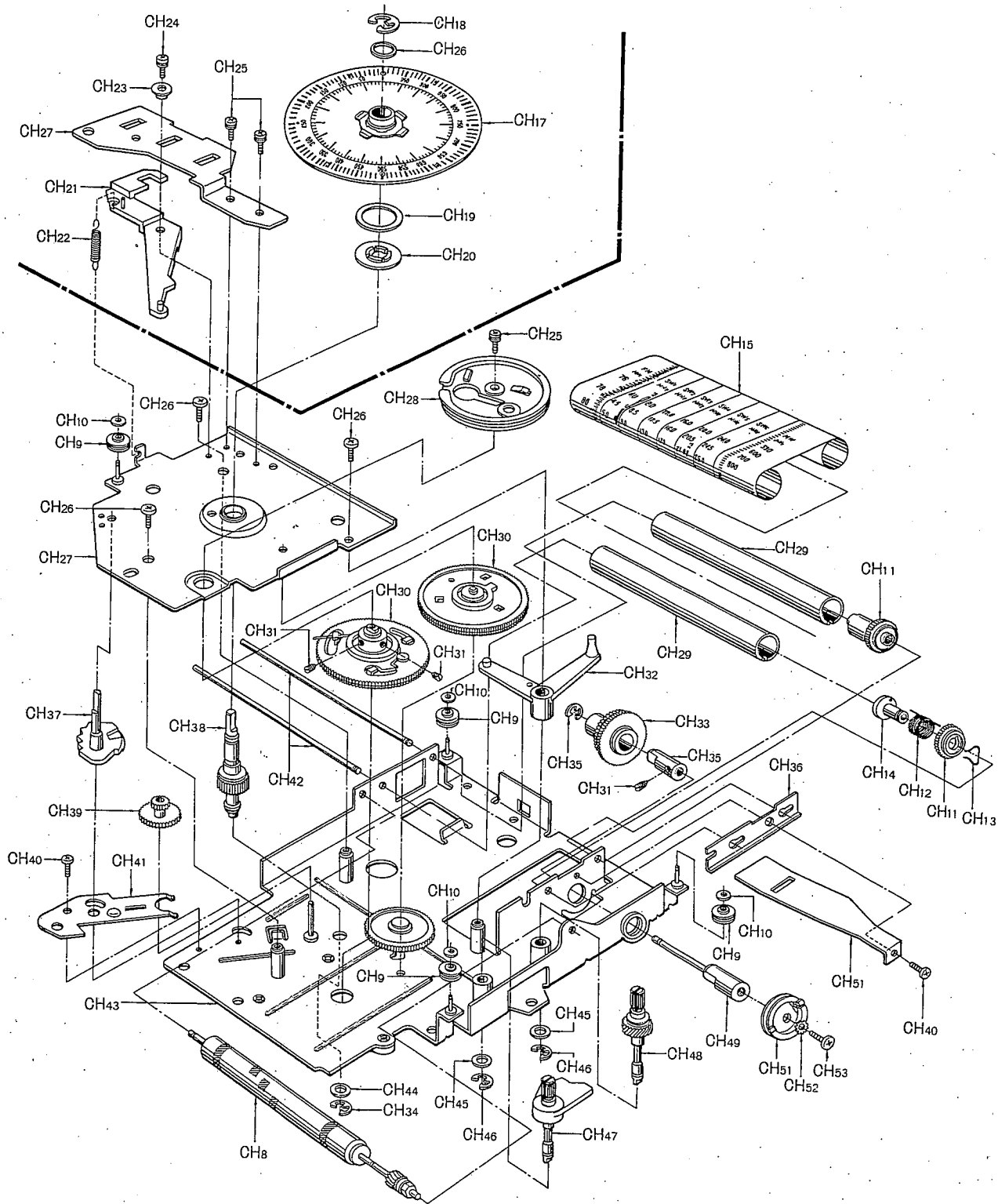

Fig. 39

REPLACEMENT PARTS LIST..... Model RF-2200BS (RD7702-1412)

NOTES 1. Part numbers are indicated on most mechanical parts.
Please use this part number for parts orders.
2. X-Z rank: X rank parts will cover 80% of repair needs.
X+Y rank parts will cover 95% of repair needs.
Z rank parts are less necessary.
3. Components identified by shaded area have special characteristic important for safety. When replacing any of these components use only manufacture's special parts.
4. Part numbers shown in bold letters are service standard parts and may differ from production parts.
5. The O mark is used by the manufacturing plant only.

Ref. No.	Part No.	Part Name & Description	Per Set	Remarks
INTEGRATED CIRCUITS, TRANSISTORS AND DIODES				
IC1	RVI μ PC1018	IC, FM/AM IF AMP., AM Converter	1	X
IC2	RVIHA1329	IC, AF & Power Amp.	1	X
TR1	2SK49	Transistor(Si), FM RF Amp.	1	X
TR2,3,4,5,11, 12,13,14, 15,16,19	2SA838	Transistor(Ge), FM OSC, FM MIX, FM IF AMP., SW MIX, Buffer Amp., SW OSC, Switching	11	X
TR6,22,25	2SC829	Transistor(Si), AM IF Amp., Marker OSC, Switching	3	X
TR8,20,29	2SA564	Transistor(Ge), Meter AMP., BFO	3	X
TR9	2SK37	Transistor(Si), AM RF AMP.	1	X
TR10,27	2SC828	Transistor(Si), AM RF Gain Control	2	X
TR18,23,26, 30,31	2SC1674	Transistor(Si), Flip Flop, Buffer Amp.	5	X
TR21,24,28	2SC945	Transistor(Si), AF Amp., Regulator, SSB AF Amp.	3	X
TR32,33,34, 35,36,37	2SC839	Transistor(Si), Flip Flop.	6	X
D1,2,4	RVDS113	Diode(Si), FM AGC, Switching	3	X
D3,14	RVD1K110	Diode(Si), FM AGC, SSB Det.	2	X
D5,13	RVDVD1250M	Diode(Si), Operation Compensator	2	X
D6,7	2-OA90	Diode(Ge), FM Detector	2	X
D8,9,10,11,12 34,35	OA90	Diode(Ge), Detector, AM Meter r Rect. Marker	7	X
D15	RVDVD1252L	Diode(Si), Operation Compensator	1	X
D17	RVDMZA205	Diode(Si), Zener	1	X
D18,19,20,21, 22,23,24,25, 27,28,29,30, 31,32,33,36, 37,42	MA150	Diode(Si), Triger, Switching	18	X
D38,39,50,51	RVD10E1LF	Diode(Si), Rectifier	4	X

Ref. No.	Part No.	Part Name & Description	Per Set	Remarks
CRYSTAL AND THERMISTORS				
X1 Th1,2	RVCX4000Q5Z RRT262	Crystal Temperature Compensator	1 2	X X
CERAMIC FILTERS, COILS AND TRANSFORMERS				
CF1,2,3	RVPCF10S12FR	Ceramic Filter	3	X
CF4	RVFBFB455C1	Ceramic Filter	1	X
L1	RLA4Y6	Antenna Coil, FM	1	X
L2	RLD4N33	Coil, Tuning	1	OX
L3	RLO4N27	Oscillator Coil, FM(RLO4N27-O)	1	X
L4	RLO9M4	Oscillator Coil, 2nd Local	1	OX
L5	RLO2M16	Oscillator Coil, MW	1	OX
L6	RLF2G38	Antenna Coil, MW	1	OX
L7	RLA3M19	Antenna Coil, SW1	1	OX
L8	RLA3M20	Antenna Coil, SW2	1	OX
L9	RLA3M21	Antenna Coil, SW3	1	OX
L10	RLA3M22	Antenna Coil, SW4	1	OX
L11	RLA3M23	Antenna Coil, SW5	1	OX
L12	RLA3M24	Antenna Coil, SW6	1	OX
L13	RLI9M3	IFT, SW 2nd IF	1	OX
L14	RLI9M4	IFT, SW 2nd IF	1	OX
L15	RLO3M37	Oscillator Coil, SW1	1	OX
L16	RLO3M38	Oscillator Coil, SW3	1	OX
L17	RLO3M39	Oscillator Coil, SW5,6	1	OX
L24	RLI4M103	Coil, IF Trap	1	X
L30	RLO9M5	Oscillator Coil, BFO	1	OX
T1	RLI4M101	IFT, FM 1st	1	X
T3,5	RLI2M212	IFT, AM 1st, 3rd(RLI2M212-K)	2	X
T4,6	RLI2M208	IFT, AM 2nd, 4th	2	X
T7	RLI2M402	IFT, AM 5th	1	X
T8	RLI4M504	IFT, FM 2nd(Primary)	1	X
T9	RLI4M506	IFT, FM 2nd(Secondary)	1	X
T11	RLT2H32	Output Transformer, P=20Q, S=8Q (RLT2H32-V, RLT2H32-W)	1	OX
T12	RLT5J199	Power Transformer	1	OX
VARIABLE RESISTORS				
R64	EVH0MA095A14	10K Ω (A), RF Gain Control	1	X
R103	EVH8XAF25A14	10K Ω (A), Volume Control	1	X
R98,101	EVH7XAF25B14	10K Ω (B), Tone Control	2	X
R54	EVL0AA00B14	10K Ω (B), Pre Set, Meter Control	1	Y
VARIABLE CAPACITORS				
G6,9,22,80	RCVCV45D112	Tuning Capacitor	1	OX
G85,86	RCVCTY21D17	Trimmer Capacitor	1	Y

Ref. No.	Part No	Part Name & Description	Per Set	Remarks
C20,26,81,250	RCV1PX15AG	Trimmer Capacitor	4	Y
C87,88,89,90	RCV1PX20AG	Trimmer Capacitor	4	Y
C112,113,114	RCV1PX30AG	Trimmer Capacitor	3	Y
C7	ECV1ZW10X32	Trimmer Capacitor	1	Y
COMPONENT COMBINATIONS				
Z1	RXABPF10801H	Component Combination, Coils & Capacitors	1	Y
Z2	EXA5DLO4C	Component Combination, 330PF×3, 4.7KΩ×2	1	Y
SPEAKER				
SP	EAS10P57SA	Speaker, Imp.8Ω, PM Dynamic	1	OX
SWITCHES				
S1-1~S1-8	RSR3HO2Z-H	Switch, Band	1	OX
S2-1~S2-6	RSR6FO1Z-P	Switch, SW Band	1	OX
S3,4,10	RSTX003Z-A	Switch, FM AFC, X-TAL MARKER	1	OX
S6,7,8	RSTX002Z-M	Switch, Power Light, BFO	1	OX
S11	RSR2A01Z-H	Switch, Voltage Selector	1	OX
RESISTORS				
R27,67,69,71,116,121,126	ERD25TJ221	220Ω, ½Watt, ±5%, Carbon	7	Z
R11,17,22,33,36,65,72,84,88,93,127,132	ERD25TJ471	470Ω, ½Watt, ±5%, Carbon	12	Z
R49,61,108,110,151,154,156,159,161,164,165,168	ERD25TJ681	680Ω, ½Watt, ±5%, Carbon	12	Z
R14,15,26,86,120	ERD25TJ101	100Ω, ½Watt, ±5%, Carbon	5	Z
R9,10,40,41,44,82,87,94,95,96,99,102,104,137,171,172	ERD25TJ102	1KΩ, ½Watt, ±5%, Carbon	16	Z
R3,4,7,23,28,29,62,68,122,125,128,135,140,160,169	ERD25TJ472	4.7KΩ, ½Watt, ±5%, Carbon	15	Z

Ref. No	Part No.	Part Name & Description	Per Set	Remarks
R8,16,21,46,109,111,114,139,152,153,157,158,162,163,166,167	ERD25TJ103	10KΩ, ½Watt, ±5%, Carbon	16	Z
R130,131	ERD25TJ153	15KΩ, ½Watt, ±5%, Carbon	2	Z
R1,130,131	ERD25TJ223	22KΩ, ½Watt, ±5%, Carbon	3	Z
R31,35,83	ERD25TJ473	47KΩ, ½Watt, ±5%, Carbon	3	Z
R81	ERD25TJ224	220KΩ, ½Watt, ±5%, Carbon	1	Z
R107,136	ERD25TJ100	10Ω, ½Watt, ±5%, Carbon	2	Z
R5,57,144	ERD25TJ220	22Ω, ½Watt, ±5%, Carbon	3	Z
R34	ERD25TJ470	47Ω, ½Watt, ±5%, Carbon	1	Z
R25	ERD25TJ680	68Ω, ½Watt, ±5%, Carbon	1	Z
R12,134	ERD25TJ151	150Ω, ½Watt, ±5%, Carbon	2	Z
R32,73	ERD25TJ331	330Ω, ½Watt, ±5%, Carbon	2	Z
R6	ERD25TJ392	3.9KΩ, ½Watt, ±5%, Carbon	1	Z
R18,30,38,89,100,106,138,170	ERD25TJ222	2.2KΩ, ½Watt, ±5%, Carbon	8	Z
R37	ERD25TJ272	2.7KΩ, ½Watt, ±5%, Carbon	1	Z
R92,97,117	ERD25TJ332	3.3KΩ, ½Watt, ±5%, Carbon	3	Z
R63,118	ERD25TJ682	6.8KΩ, ½Watt, ±5%, Carbon	2	Z
R129	ERD25TJ683	68KΩ, ½Watt, ±5%, Carbon	1	Z
R39	ERD25TJ123	12KΩ, ½Watt, ±5%, Carbon	1	Z
R52	ERD25TJ154	150KΩ, ½Watt, ±5%, Carbon	1	Z
R2,13,51	ERD25TJ104	100KΩ, ½Watt, ±5%, Carbon	3	Z
R91	ERD25TJ334	330KΩ, ½Watt, ±5%, Carbon	1	Z
R43	ERD25TJ474	470KΩ, ½Watt, ±5%, Carbon	1	Z
R115	ERD25TJ684	680KΩ, ½Watt, ±5%, Carbon	1	Z
R60	ERD25TJ105	1MΩ, ½Watt, ±5%, Carbon	1	Z
R105	ERX1ANJR47U	0.47Ω, 1Watt, ±5%, Metal Oxide	1	Z
R133	ERD25TJ681	680Ω, ½Watt, ±5%, Carbon	1	Z
CAPACITORS				
C15	ECCD1H1R5C	1.5PF, 50WV, ±0.25PF, Ceramic	1	Z
C84	ECCD1H020C	2PF, 50WV, ±0.25PF, Ceramic	1	Z
C13,189,214	ECCD1H030C	3PF, 50WV, ±0.25PF, Ceramic	3	Z
C27,124,211	ECCD1H040C	4PF, 50WV, ±0.25PF, Ceramic	3	Z
C39	ECCD1H050CC	5PF, 50WV, ±0.25PF, Ceramic	1	Z
C8,21,49,94,102,217,251	ECCD1H070DC	7PF, 50WV, ±0.5PF, Ceramic	7	Z
C1,103,195,213,500	ECCD1H100KC	10PF, 50WV, ±10%, Ceramic	5	Z
C10,145,222	ECCD1H150KC	15PF, 50WV, ±10%, Ceramic	3	Z
C105	ECCD1H180KC	18PF, 50WV, ±10%, Ceramic	1	Z
C183	ECCD1H220KC	22PF, 50WV, ±10%, Ceramic	1	Z
C9,152	ECCD1H270KC	27PF, 50WV, ±10%, Ceramic	2	Z
C131,188	ECCD1H330KC	33PF, 50WV, ±10%, Ceramic	2	Z
C37,55	ECCD1H470KC	47PF, 50WV, ±10%, Ceramic	2	Z
C38	ECKD1H102ZF	0.001μF, 50WV, ±20%, Ceramic	1	Z
C133,134,150,151,206,223,502,503,210	ECCD1H101K	100PF, 50WV, ±10%, Ceramic	9	Z

Ref. No.	Part No.	Part Name & Description	Per Set	Remarks
C43,172,205	ECGD1H181K	180PF, 50WV,±10%, Ceramic	3	Z
C175,176	ECGD1H221K	220PF, 50WV,±10%, Ceramic	2	Z
C132,140	ECKV1H331KB	330PF, 50WV,±10%, Ceramic	2	Z
C122	ECGD1H390JU	39PF, 50WV,±5%, Ceramic	1	Z
C11,14,17, 107,225,510 511	ECKV1H103ZF	0.01μF, 50WV,±20%, Ceramic	7	Z
C31,34,36, 226	ECKT1H103ZF	0.01μF, 50WV,±20%, Ceramic	4	Z
C18,23,32,45, 68,127	ECKV1H223ZF	0.022μF, 50WV,±20%, Ceramic	6	Z
C3,28,50,58, 63,70,106, 129,202	ECKT1H223ZF	0.022μF, 50WV,±20%, Ceramic	8	Z
C128	ECKD1H471MD	470PF, 50WV,±20%, Ceramic	1	Z
C12,163	ECKD1H102MD	0.001μF, 50WV,±20%, Ceramic	2	Z
C154,165,166 164,221	ECKD1H222MD	0.0022μF, 50WV,±20%, Ceramic	5	Z
C142	ECKD1H332MD	0.0033μF, 50WV,±20%, Ceramic	1	Z
C157	ECKD1H682MD	0.0068μF, 50WV,±20%, Ceramic	1	Z
C40,42,110, 130,198,219 220,218 109,197,216	ECKD1H103MD	0.01μF, 50WV,±20%, Ceramic	11	Z
C146,147	ECMS05180JH	18PF, 50WV,±5%, Mica	2	Z
C170,171	ECMS05220JH	22PF, 50WV,±5%, Mica	2	Z
C120	ECMS05270JH	27PF, 50WV,±5%, Mica	1	Z
C138	ECMS05330JH	33PF, 50WV,±5%, Mica	1	Z
C121	ECMS05390JH	39PF, 50WV,±5%, Mica	1	Z
C99,100	ECMS05560JH	56PF, 50WV,±5%, Mica	2	Z
C98	ECMS05820JH	82PF, 50WV,±5%, Mica	1	Z
C97,148	ECMS05101JH	100PF, 50WV,±5%, Mica	2	Z
C184,185,204	ECMS05121JH	120PF, 50WV,±5%, Mica	3	Z
C25,96	ECMS05181JH	180PF, 50WV,±5%, Mica	2	Z
C119	ECMS05820GH	82PF, 50WV,±2%, Mica	1	Z
G118	ECMS05141GH	140PF, 50WV,±2%, Mica	1	Z
C211	ECMS05120JH	12PF, 50WV,±5%, Mica	1	Z
C126	ECQS05102JZ	1000PF, 50WV,±5%, Styrol	1	Z
C95	ECQS05122KZ	1200PF, 50WV,±10%, Styrol	1	Z
C212	ECQS05392KZ	3900PF, 50WV,±10%, Styrol	1	Z
C178	ECQS1151JZ	150PF, 50WV,±5%, Styrol	1	Z
C117	ECQS05821JZ	820PF, 50WV,±5%, Styrol	1	Z
C59	ECFVD153MD	0.015μF, 50WV,±20%, Semi-Conductor	1	Z
C47,54,56, 137,196,228	ECFVD223MD	0.022μF, 50WV,±20%, Semi-Conductor	6	Z
C44,186	ECFTD473MD	0.047μF, 50WV,±20%, Semi-Conductor	2	Z
C69	ECFVD473MD	0.047μF, 50WV,±20%, Semi-Conductor	1	Z
C48,139	ECFTD223MD	0.022μF, 50WV,±20%, Semi-Conductor	2	Z
C52	ECEA16V33	33μF, 16WV, Electrolytic	1	Y
C167,215	ECEA16V47	47μF, 16WV, Electrolytic	2	Y
C51,72,180, 193,57,136, 179	ECEA10V100	100μF, 10WV, Electrolytic	7	Y
C208	ECEA6V470	470μF, 6.3WV, Electrolytic	1	
C192	ECEA6V220	220μF, 6.3WV, Electrolytic	1	

Ref. No.	Part No.	Part Name & Description	Per Set	Remarks
C182	ECEA10V2200	2200μF, 10WV, Electrolytic	1	Y
C203,53,144, 181	ECEA16V10	10μF, 16WV, Electrolytic	4	Y
C162	ECEA35V4R7B	4.7μF, 35WV, Electrolytic	1	Y
C24,60,61	ECEA50ZR1E	1μF, 50WV, Electrolytic	3	Y
C158,143, 156,160	ECEA50ZR22	0.22μF, 50WV, Electrolytic	4	Y
C141,168	ECEA50V1	1μF, 50WV, Electrolytic	2	Y
CABINET				
CA1	RYMF2200BSXG	Cabinet Assembly	1	OX
CA2	RYF1F2200BSX	Cabinet Cover Assembly (Front)	1	OX
CA3	RYF2F2200BSX	Cabinet Cover Assembly (Rear)	1	OX
CA3	RYF2F2200BSI	Cabinet Cover Assembly (Rear), For Italy	1	OX
CA4	RJC111A	Terminal, Battery ⊕ Side	2	Y
CA5	RJC505Z	Terminal Spring, Battery ⊖ Side	2	Y
CA6	RYPF2200BSXG	Front Panel Assembly	1	OX
CA7	RYEF2200N	Gyro Antenna Case Assembly	1	OX
CA8	RUS238Z	Spring, Gyro Antenna	1	Z
CA9	RHB6021Z	Washer, Gyro Antenna	3	Z
CA10	XUC9FY	Circlip, Gyro Antenna	1	Z
CA11	RJF1044Z	Terminal, EXT. Antenna	1	Y
CA12	SHRA403	Latch, EXT. Antenna Terminal M'tg	2	Z
CA13	RKK114Z	Cover, Battery Compartment	1	OY
CA14	RBE13Z	Knob, FM AFC, BAND WIDTH	3	OX
CA15	RBN379Z	Knob, Volume	1	OX
CA16	RBN381Z	Knob, Bass, Treble, RF Gain	3	OX
CA17	RBN380Z	Knob, Tuning	1	OX
CA18	RBS103ZK	Knob, Band	2	OX
CA19	RBS104Z	Knob, Tuning Speed	1	OX
CA20	XTB3+50CFN	Screw, Cabinet Back Cover M'tg	6	Z
CA21	XEART160GDY	Telescopic Antenna, 7 Steps, 963mm	1	X
CA22	RKE140Z	Cover, Core Antenna	1	Y
CHASSIS				
	XAMR46T200	Pilot Lamp, Dial & Meter, 6V, 40mA	2	X
CH1	RSM2614Z-K	Meter, Tune, Battery, Marker	1	OX
CH2	RJJ30Z-H	Jack, EXT. Power Source	1	Y
CH3	RJJ80A-C	Jack, Earphone & Rec. Out	1	Y
	RUS279Z	Spring, Band Switch Shaft	2	OZ
	RNW423Z	Washer, Band Switch Shaft	2	OZ
CH4	RHM71Z	Shaft, SW Band Switch	1	OZ
CH5	RHM69Z	Shaft, Band Switch	1	OZ
	RJE10Z	Cover, EXT. Power Source Jack	1	Y

Ref. No.	Part No.	Part Name & Description	Per Set	Remarks
CH6	XBA200BTRO	Fuse, 250V, 800mA	1	X
CH7	RJF7A	Holder, Fuse	2	X
	XTW3+10FR	Red Screw, P.C. Board M'tg	3	Z
	RXEF2200BSXG	Dial Drive Assembly	1	OX
CH8	RXB6F2200N	Selector Drum Assembly	1	OX
CH9	RDR20-3	Pulley, Dial	4	Z
CH10	RNW150-2	Washer, Dial	4	Z
CH11	RDG5649Z	Gear, Roller	1	OZ
CH12	RDS5050Z	Spring, Gear	1	OZ
CH13	RUS273Z	Spring, Gear	1	OZ
CH14	RDE88Z	Shaft, Gear	1	OZ
CH15	RKD423Y	Scale, Dial	1	OY
CH16 (Fig.9)	RDZ05Z	Cord(500m), Dial	1Roll	Z
CH17	RXE11F2200N	Spread Dial Assembly	1	OX
CH18	XUC6FW	Circlip, Spread Dial M'tg	1	Z
CH19	RUS283Z	Spring, Spread Dial M'tg	1	OZ
CH20	RDE99Z	Washer, Tuning Shaft M'tg	1	OZ
CH21	RUB145Z	Lever, Calibrator	1	OZ
CH22	RDS3120A	Spring, Calibrator Lever	1	Z
CH23	RHM68Z	Spacer, Calibrator Lever	1	OZ
ACCESSORIES				
A1	XEH1A1-P	Magnetic Earphone	1	Y
	RJA20Z-K	Power Cord, AC	1	Y
	RQX6071Z	Instruction Book	1	OY
A2	RQC9011Z	Belt	1	Y