

SONY®

FM/AM MULTI-BAND RECEIVER

ICF-5900W



Operating Instructions

Page 2

Mode d'emploi

Page 17

Manual de instrucciones

Página 33

Bedienungsanleitung

Seite 49

- Before operating the set, please read this manual thoroughly.
- This manual should be retained for future reference.

TABLE OF CONTENTS

Main features.....	2
Precautions	3
Location and function of controls	4
Power sources	5
FM/MW reception	7
SW reception	8
SSB/CW reception.....	11
To attach the shoulder strap.....	11
External antennas and grounds.....	12
Specifications.....	15
Troubleshooting guide.....	16

MAIN FEATURES

- The Sony ICF-5900W offers you listening pleasure in the FM, MW and 3 SW bands (including SSB/CW).
- Accurate SW tuning is possible because of the crystal marker and the easily read SW bandsread dial.
- Tuner section provides high AM selectivity and good FM reception.
- Separate tone controls for precise adjustment of tonal quality.
- AM sensitivity switch rejects interference signals, ensuring excellent AM reception.
- The telescopic antenna (aerial) pops out at the turn of a lever.
- Three different power sources; standard batteries, house current and 12 V car battery.

PRECAUTIONS

- Do not open the cabinet. Refer servicing to qualified personnel only.
- Operate the set only on 4.5 V dc. For operation from house current (mains outlet), use the ac power adaptor recommended for this set. For car battery operation, use the car battery cord recommended for this set. Do not use any other ac power adaptor or car battery cord.
- The marking indicating operating voltage, etc. is located on the rear exterior.
- Disconnect the ac power adaptor from the wall (mains) outlet when the set is not to be used for an extended period of time.
- Do not install the set in a location near heat sources such as radiators or airducts, or in a place subject to direct sunlight, excessive dust, moisture, rain, mechanical vibration or shock.
- When the set is not to be used for a long period of time or is to be operated extensively on other power sources, remove the batteries to avoid set damage from battery leakage.
- Should any liquid or solid object fall into the mechanism, remove the batteries and disconnect the ac power adaptor, and have the set checked by qualified personnel before operating it any further.
- When the cabinet becomes soiled, clean it with a soft cloth dampened with a mild detergent solution. Never use abrasive cleansers or chemical solvents, as they will mar the cabinet.
- Although the set is ruggedly built to withstand normal usage, care should be taken not to drop it or handle it carelessly, since the case or internal portions may be damaged. Do not place the set on a sloping shelf unless properly secured.
- Keep cassette tapes away from the rear panel of the set to avoid erasing the recorded contents, since a strong magnet is used for the speaker.

- When an outdoor external antenna (aerial) is used, disconnect it from the antenna terminals of the set during a lightning storm, unless the installation incorporates a suitable lightning arrestor.
- Never connect a ground wire to a gas pipe.
- If you have any question or problem concerning your set that is not covered in this booklet, please consult your nearest Sony dealer.

LOCATION AND FUNCTION OF CONTROLS

1 POWER Switch: Set to ON to turn on the power. After using, turn the power off.

2 VOLUME Control: Turn clockwise for more volume.

3 TONE Controls [BASS] and [TREBLE]: Turn clockwise for more bass and treble.

4 Telescopic Antenna (Aerial) [POP UP ANT]: Used for FM and SW reception. See page 7.

Turn the lever fully to the left to pop up the top of the Telescopic Antenna. Pull out the antenna until the movable base joint comes out.

When retracting the antenna, be sure to position the antenna perpendicularly to the set and then push it back into the set until it locks.

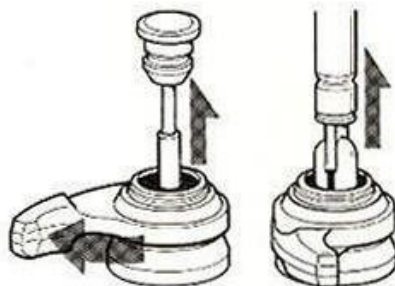

5 Dial Light Button [LIGHT]: While operating, depress the button to illuminate the Dial Scale and SW BAND SPREAD DIAL, when necessary.

6 Antenna (Aerial) Terminals [EXT ANT]: Used for FM, MW and SW reception. For external antenna connection, see page 12.

7 Crystal Marker Switch [X-TAL MARKER]: Normally set the switch to OFF. Set it to ON for setting the SW dial calibration. See "SW RECEPTION" page 8.

8 TUNING & BATT METER: Used as a tuning meter, battery meter (page 5) and marker meter (page 8).

9 MAIN TUNING Knob and Dial Scale: Turn to select the frequency of the desired station, as marked on the Dial Scale so that the pointer of the TUNING & BATT METER swings to the right as far as possible.

10 Band Selector [BAND SELECT]: Choose the desired band; FM, MW, SW3, SW2 or SW1.

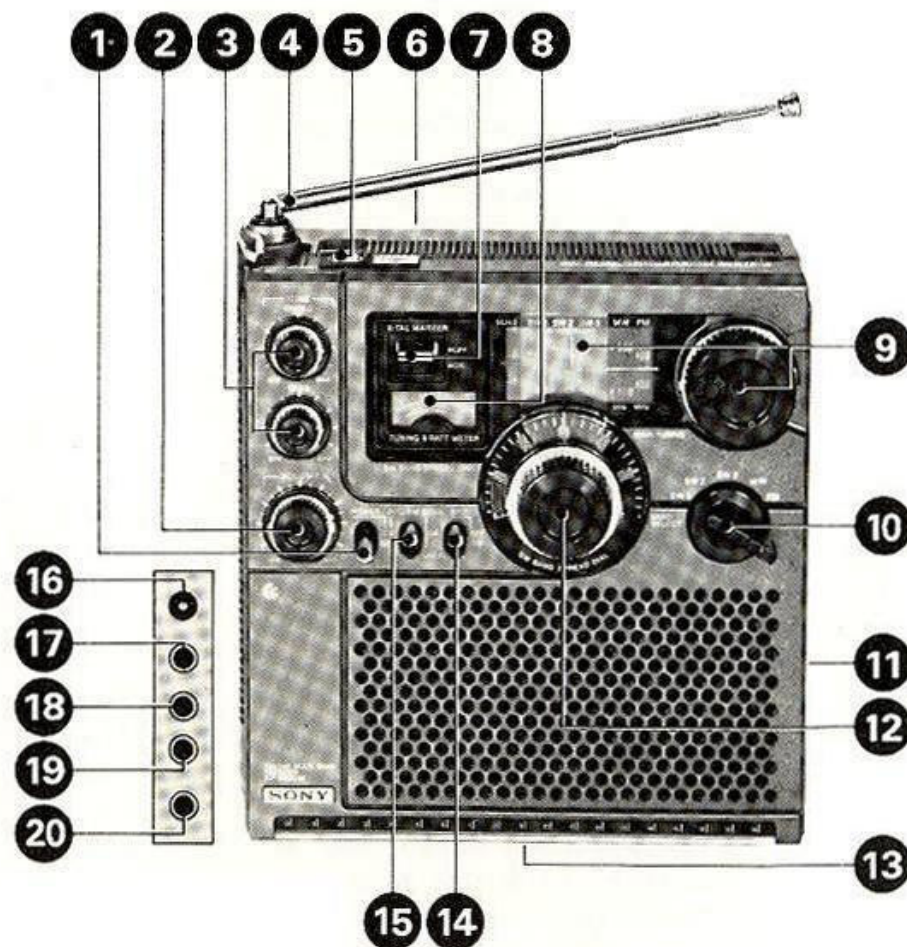

⑪ **EARPHONE POCKET:** Store the supplied earphone in this pocket.

⑫ **SW BAND SPREAD DIAL Knob:** Used for precise tuning in SW reception after using the MAIN TUNING knob.

⑬ **Battery Compartment:** See right.

⑭ **Beat Frequency Oscillator Switch [BFO]:** Normally set the switch to OFF. For SSB or CW reception, set the switch to ON. See page 11.

⑮ **Automatic Frequency Control/AM Sensitivity Switch [AFC/AM SENS]:** For FM reception, used as Automatic Frequency Control (page 7). For MW and SW reception, used as AM Sensitivity Switch (page 7).

⑯ **DC Input Jack [EXT POWER IN DC 4.5 V]:** For operation on house current or a car battery. See page 6.

⑰ **External Timer In Jack [EXT TIMER IN]:** For turning the radio on or off automatically at the desired time using a suitable timer.

⑱ **Recording Jack [RECORD]:** For recording radio programs with a tape recorder. Connect this jack to the microphone input jack of your tape recorder with a suitable cord. In the case of a Sony tape recorder, use the Sony Connecting Cord RK-69H (optional).
● The volume or tone control setting of the radio has no effect on the recording.

⑲ **Multiplex Output Jack [MPX OUT]:** For listening to FM stereo sound using a suitable stereo adaptor. Such stereo adaptors are not currently produced by Sony.

⑳ **Earphone Jack [EHPH]:** For private listening with an earphone. When the earphone is plugged in, the built-in speaker is disconnected automatically.

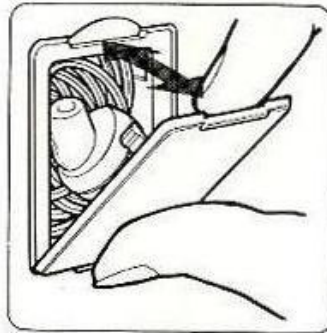

POWER SOURCES

BATTERIES

Battery installation:

① Push and open.
(bottom)

② Insert three size D batteries, with correct polarity.
The flat side of the battery presses against the left battery.

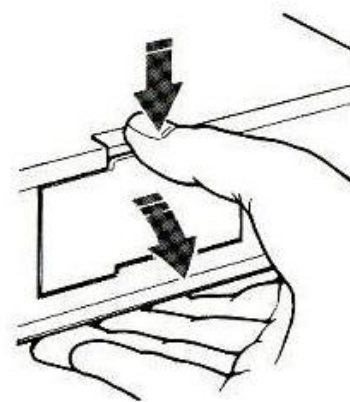

Lay the ribbon underneath the batteries. The ribbon aids in removing the batteries.

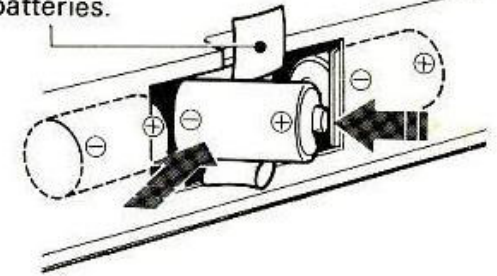

③ Close the lid by placing the bottom of the lid into the lower portion of the compartment opening, and pivot the cover down until the tab snaps closed.

● The set cannot be operated on the internal batteries when either the ac power adaptor or optional car battery cord is connected to the set.

● When the set is not to be used for a long period of time or is to be operated on other power sources, remove the batteries to avoid set damage caused by battery leakage and corrosion.

To check battery condition: Set the POWER switch to ON. Turn the MAIN TUNING knob and select a position where no broadcasting station is being received. If the pointer of the TUNING & BATT METER stays out of the bold white zone, the batteries are discharged.

In such a case replace all the batteries with fresh new ones. Weak and distorted sound also indicates that the batteries are discharged.



good battery condition



Replace the batteries.

HOUSE CURRENT (MAINS SUPPLY)

When connecting the ICF-5900W to a wall (mains) outlet, use the appropriate ac power adaptor listed below, available in the countries where the unit is used.

Where used.	AC Power Adaptor
Europe	AC-456C
The United Kingdom	AC-14A
Other countries	AC-3A

Connect the ac power adaptor as illustrated.

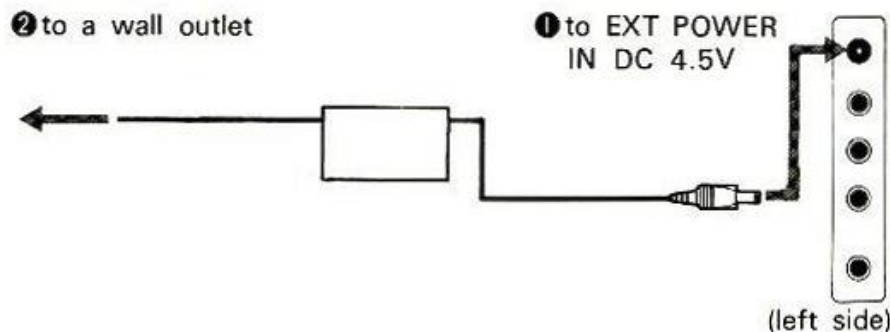

● Before connecting, be sure to read the instruction manual for the adaptor.

● When the ac power adaptor is connected to the radio EXT POWER IN DC 4.5 V jack, the internal batteries (if present) are automatically disconnected.

12 V CAR BATTERY

Use the Sony Car Battery Cord DCC-127H (optional), and connect the radio EXT POWER IN DC 4.5 V jack to the cigarette lighter socket of a car.

For further details, refer to the instruction manual of the DCC-127H.

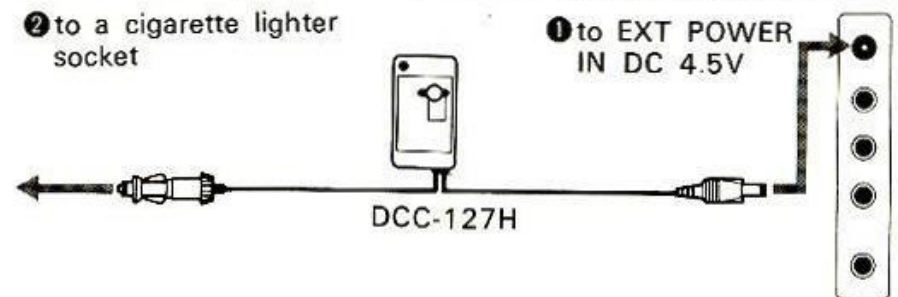

FM/MW RECEPTION

- Follow in the order numbered.

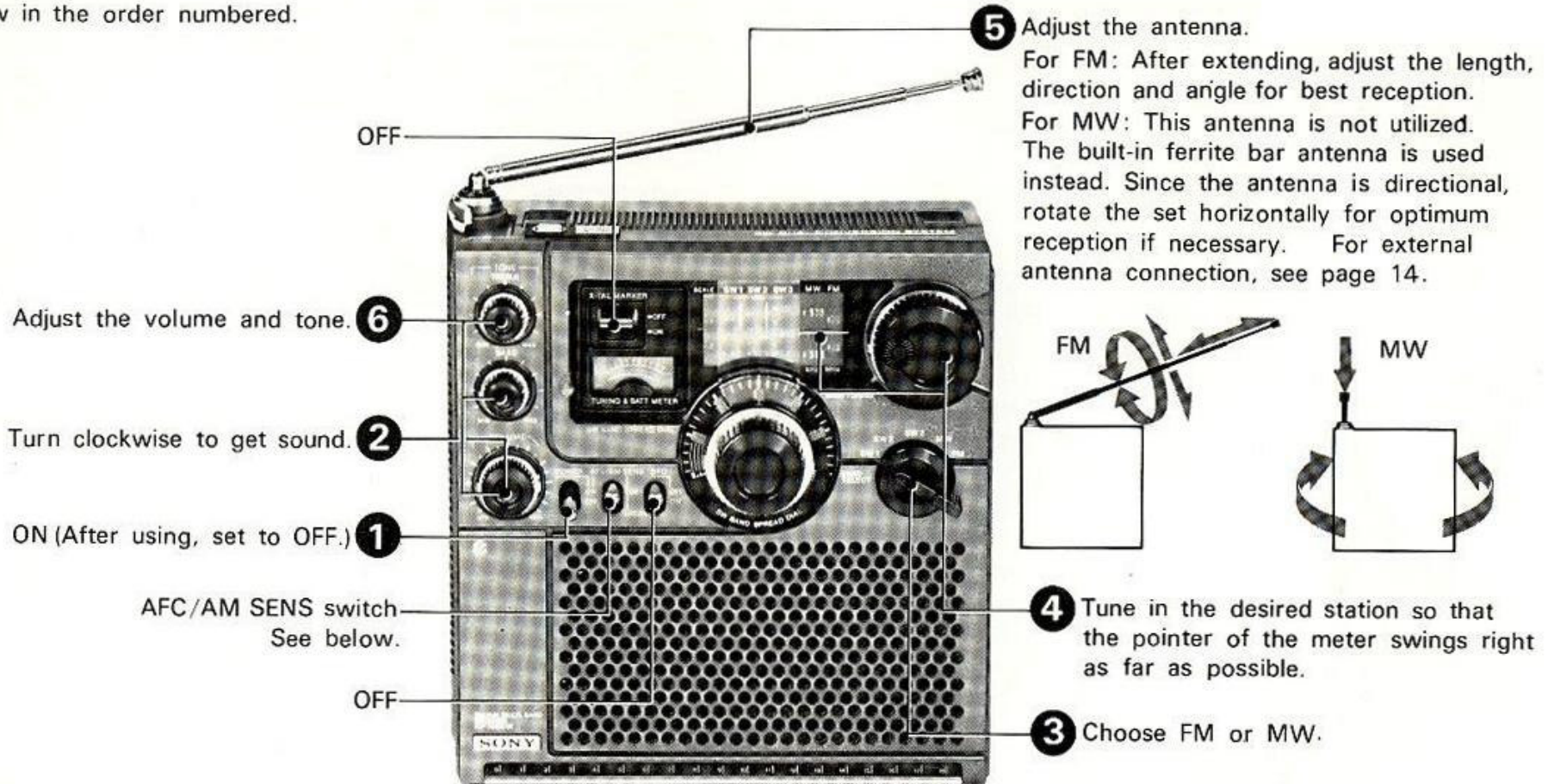

AFC/AM SENS switch:

Used as the Automatic Frequency Control switch for FM reception. Set the switch to OFF and tune in the desired FM station precisely and then set it to ON. This assures stable FM reception. For MW and SW reception used as the AM Sensitivity switch.

Usually keep this switch to DX position. However, set this switch to LOCAL when receiving a strong-signal station, or at night when it is difficult to pick up a local station signal because adjacent signals of far-away stations are heard.

SW RECEPTION

MAIN TUNING knob and SW BAND SPREAD DIAL:

Each graduation of the calibrated SW Dial Scale (main) indicates 0.25 MHz (250 kHz).

For example, the range of 15.00 – 16.00 MHz on the SW Dial Scale is graduated as illustrated.

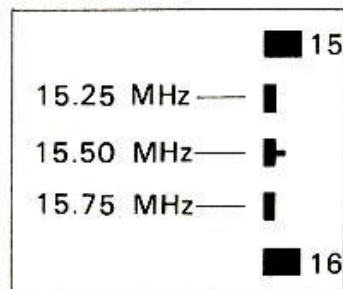

The frequencies on either side of these major calibration points can be easily located with the use of the SW BAND SPREAD DIAL, which covers a range of 130 kHz above and below the major calibration points. First, a major calibration point is precisely set with the aid of the X-TAL MARKER (see "TO TUNE IN THE DESIRED SW STATION"). Thereafter, the precise frequency of the desired station can be read on the SW BAND SPREAD DIAL which is graduated in intervals of .01 MHz (10 kHz).

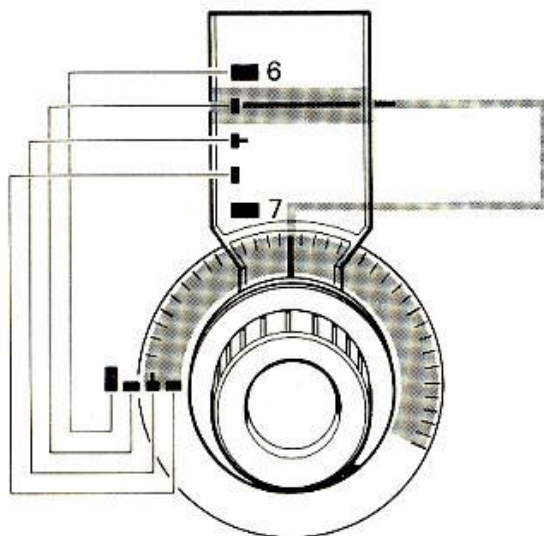

There are four scales on the SW BAND SPREAD DIAL, which are used in conjunction with the major calibration points. (See left illustration.) For example, any integral major calibration from 4 to 26 MHz is used in conjunction with the topmost scale with a "0" center. Any major calibration point with a value ending in .25 would be used with the next lower scale with its center at ".250". Similarly, major calibration points with a value ending in .5 or .75 MHz would be used with the third and fourth scales from the top, which have a center at ".500" and ".750" respectively. Turn clockwise from center for a higher frequency than the major calibration point, and counterclockwise for lower frequencies.

First general rule: To locate any station within the frequency range of the ICF-5900W, first set the main SW Dial Scale to a major calibration point (as previously explained) within 130 kHz of the desired frequency.

Second general rule: After choosing the appropriate major calibration point, select the corresponding row of SPREAD DIAL calibrations (as previously explained), and set the SW BAND SPREAD DIAL to the exact frequency desired. Intervals of less than .01 MHz (10 kHz) must be estimated.

Example: To tune in 4.11 MHz (4,110 kHz)

Set and crystal calibrate the SW Dial Scale at 4.0 MHz. Use the top SW BAND SPREAD DIAL scale and set to .110.

Example: To tune in 15.21 MHz (15,210 kHz)

As before, set and crystal calibrate at 15.25 MHz. Tune to .210 on the second lower spread dial.

Example: To tune in 18.62 MHz (18,620 kHz)

As before, set and crystal calibrate at 18.5 MHz. Tune to .620 on the third lower spread dial.

Example: To tune in 24.65 MHz (24,650 kHz)

As before, set and crystal calibrate at 24.75 MHz. Tune to .650 on the lowest spread dial.

Note: For fast tuning of powerful stations, only the main SW Dial Scale can be used (with the SW BAND SPREAD DIAL centered at 0.250). However, for precise tuning or for receiving a weak signal, it is desirable to use both the main SW Dial Scale and the SW BAND SPREAD DIAL in conjunction with the crystal calibration function as described above.

Note: When an external antenna is used, a beat noise may occur at places on the dial other than the .25 MHz major calibration marks. This is interference from very strong signals, and should be ignored.

TO TUNE IN THE DESIRED SW STATION

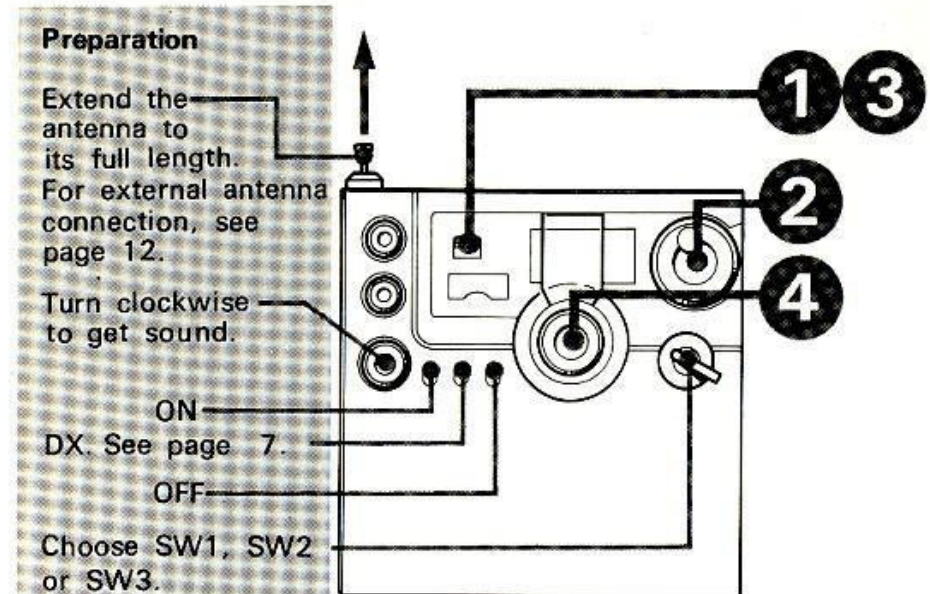

● Follow the numbered sequence. Refer to the above illustration.

❶ Set the X-TAL MARKER switch to ON.

When the switch is set to ON, a beat noise will come on when a SW frequency of 0.25 MHz interval is tuned in by turning the MAIN TUNING knob for calibration.

❷ Set the pointer of the SW Dial Scale to the frequency adjacent (within .130 MHz) to the desired SW station by turning the MAIN TUNING knob. Turn the MAIN TUNING knob slowly so that the beat noise comes on and the pointer of the meter swings right as far as possible.

● It is unnecessary to set the SW BAND SPREAD DIAL knob to "0" because when the X-TAL MARKER switch is set to ON, the SW BAND SPREAD DIAL is rendered inoperative during the calibration process.

- ③ Return the X-TAL MARKER switch to OFF.
- ④ Set the green line of the SW BAND SPREAD DIAL knob to the frequency of the desired station as previously explained. Turn the knob slowly so that the pointer of the meter swings right as far as possible, which indicates the best tuning point.

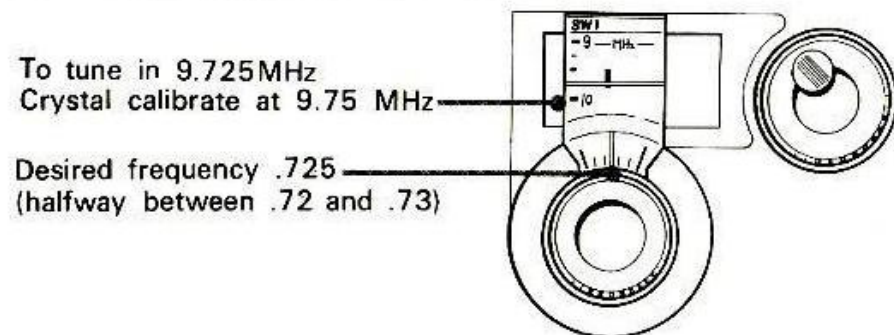

CHART

The chart below shows the most commonly used international short wave bands, the MAIN TUNING setting, and the range of received frequencies within each band.

meter band	receiving frequency	MAIN TUNING setting
75	3.37 – 4.13	4.0
60	4.62 – 4.88	4.75
60	4.87 – 5.13	5.0
49	5.87 – 6.13	6.0
49	6.12 – 6.38	6.25
41	6.87 – 7.13	7.0
41	7.12 – 7.38	7.25
31	9.37 – 9.63	9.5
31	9.62 – 9.88	9.75
25	11.62 – 11.88	11.75
25	11.87 – 12.13	12.0
19	14.87 – 15.13	15.0
19	15.12 – 15.38	15.25
19	15.37 – 15.63	15.5
16	17.62 – 17.88	17.75
16	17.87 – 18.13	18.0
13	21.37 – 21.63	21.5
13	21.62 – 21.88	21.75
11	25.37 – 25.63	25.5
11	25.62 – 25.88	25.75
11	25.87 – 26.13	26.0

SSB AND CW RECEPTION

SSB (Single Side Band) is a type of broadcasting used for military, marine, aviation, amateur (ham) and even CB (Citizens Band) communications.

An SSB signal will be obtained in one of the two possible sideband positions depending on how the SSB signal was broadcast.

This set covers ham frequencies of from 7.0 – 7.3 MHz, 14.0 – 14.35 MHz or 21.0 – 21.45 MHz. Generally, in these ham frequencies the USB (upper sideband) is used for frequencies higher than 10 MHz and the LSB (lower sideband) for frequencies lower than 10 MHz.

CW (Continuous Wave) is transmitted by means of Morse code. This system is used for commercial, military, scientific, marine, aviation and ham telegraphy.

The operating procedures for SSB/CW reception are the same as for ordinary SW reception, except for the following:

- 1 Set the BFO switch to ON.
- 2 Turn the SW BAND SPREAD DIAL knob more slowly than you would for ordinary SW reception.
- 3 If you receive the unclear voice by turning the SW BAND SPREAD DIAL knob, turn the knob counterclockwise (for LSB) or clockwise (for USB) very slowly until the signal can be heard clearly. For CW reception, if an unclear signal can be heard, turn the SW BAND SPREAD DIAL knob clockwise or counterclockwise very slowly until the signal can be heard clearly.
- 4 For stable SSB or CW reception, turn the SW BAND SPREAD DIAL knob, 2 or 3 minutes after turning the MAIN TUNING knob.

TO ATTACH THE SHOULDER STRAP

Refer to the illustration.

- 1 Remove the button at the end of the strap, and insert the strap with the seamless side up around the pin on one side of the set.
- 2 Let the strap pass through the buckle.
- 3 Insert the end of the strap around the pin at the other side of the set.
- 4 Insert the button.

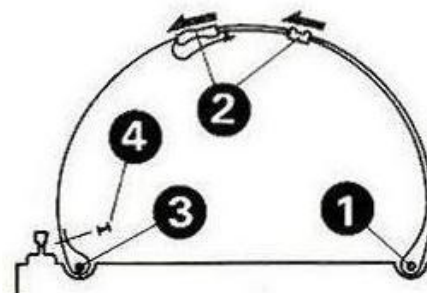

EXTERNAL ANTENNAS AND GROUNDS

FOR SW RECEPTION

Ordinarily, the receiver's own telescopic antenna is enough to pull in usable signals. However the use of an external antenna will greatly improve the reception of weak signals and give more stable SW reception when the receiver is located inside a building. Ideally, the length of the antenna wire should be matched to the reception frequency. Although you will probably listen on many different frequencies, select the antenna length on the basis of the wavelength that you listen to the most.

Refer to the following formula to determine the antenna length.

$$L \text{ (meters)} = 0.475\lambda = \frac{143}{\text{frequency (MHz)}}$$

L (meters).....length of antenna wire in meters

λ wavelength

Extend the antenna wire outdoors as high as possible and keep it from touching other metal or trees. Keep it far away from high-voltage power-transmission lines and noisy electrical machinery. Also, position the antenna at right angles to power lines, electrical wiring, or any other antennas.

Long wire antenna

This is the simplest one to build. You can string it between handy trees or the buildings around you.

The higher the antenna support, the more effective the antenna is for reception.

If you use bare wire for the antenna, you must insulate it where the antenna wire passes through the wall of a building.

Since the antenna impedance is high, connect the lead-in wire directly to the telescopic antenna or to the antenna terminal of the radio.

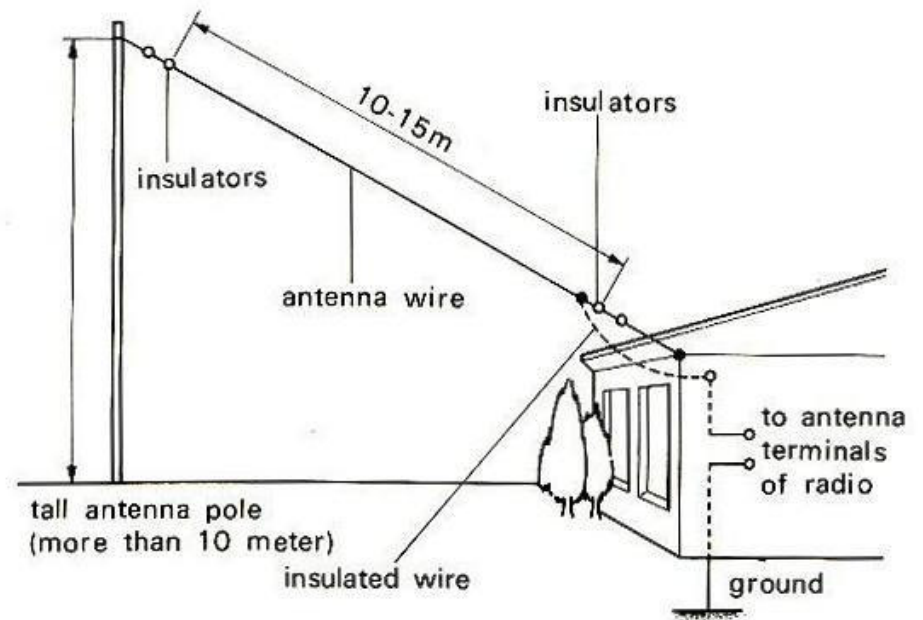

Doublet antenna

You can get comparatively good low-noise reception from this type antenna when the antenna is cut to one-half wavelength at the signal frequency.

The antenna length can be obtained from the formula on page 12. If the antenna length is tailored to the desired wavelength, very good reception can be obtained at the desired frequency, though results will not be as good at other frequencies.

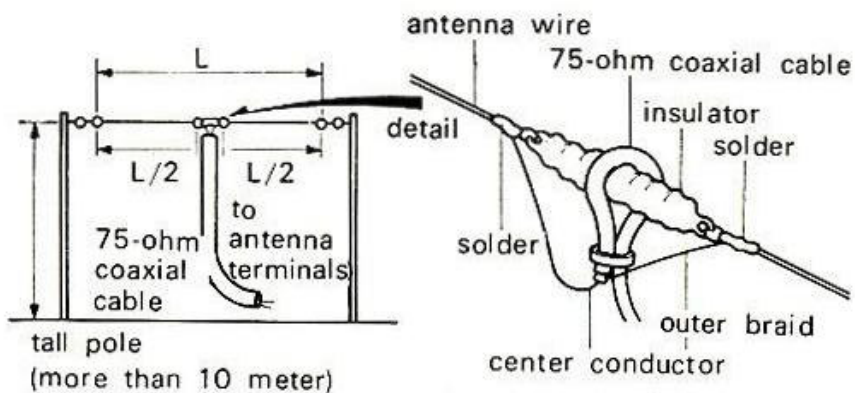

Twin doublet antenna (all wave antenna)

The twin doublet antenna shown below is the best one to cover the wide frequency range of SW reception. It is similar to the doublet just described, but you can get wider frequency coverage by use of the 2 elements. Typically, you can get good reception from 6 MHz to 17 MHz with the antenna shown below.

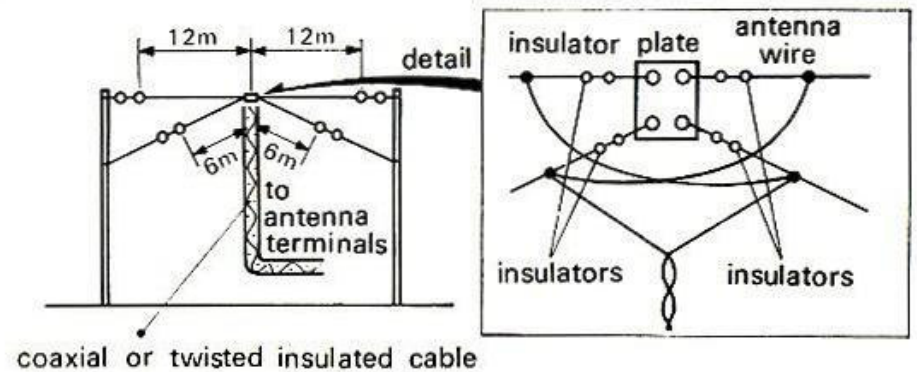

Connection to the Antenna Terminals

Connect the antenna wire or 75-ohm coaxial cable to the Antenna Terminals on the rear of the set as illustrated.

Loosen the Antenna Terminal screws, wind the wires, or center conductor and braid round the terminals and tighten the screws.

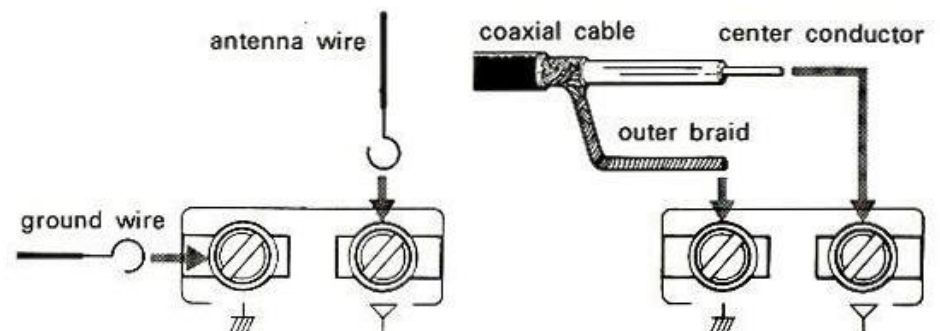

Antenna directivity

Ordinarily, the parallel doublet antenna picks up signals from both front and rear equally well. It has little response to signals traveling in a direction in line with the antenna axis.

Therefore, orient the antenna wire at right angles to the incoming signals to get the best reception. Refer to a Great Circle Map centered on or near the city in which you live to determine how to orient the antenna for a particular country.

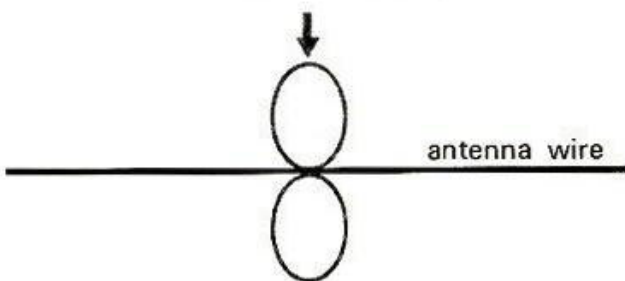

Grounding

For almost all cases, there is no need to use a ground wire for SW reception. However a ground connection will sometimes reduce noise and provide better reception.

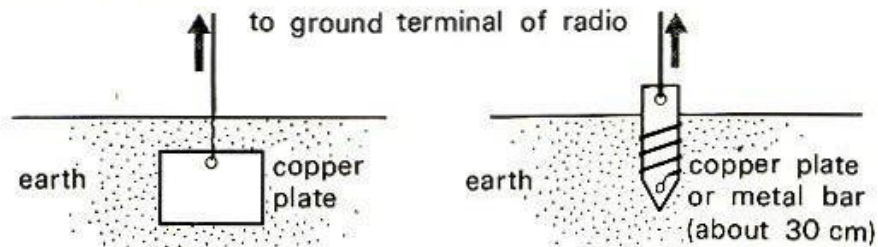

FOR FM AND MW RECEPTION

In a steel-frame building, a mountainous area, or at a distance from the transmitter, reception may be unsatisfactory.

In that case, the use of an external antenna is recommended.

For FM: Connect any commercially available external FM antenna or feeder antenna to the Antenna Terminals [Ψ] [⚡] at the rear.

For MW: Connect an antenna wire more than 5 m (15 feet) long to the Antenna Terminal [Ψ] at the rear. Extend the wire outdoors if possible.

The use of a ground wire will eliminate hum and noise and provide better reception. Connect the end of the ground wire to the Antenna Terminal [⚡], and the other end directly to a convenient earth ground.

Note: Never connect the ground wire to a gas pipe.

Note: The use of a suitable lightning arrester is recommended if the antenna is extended out-of-doors.

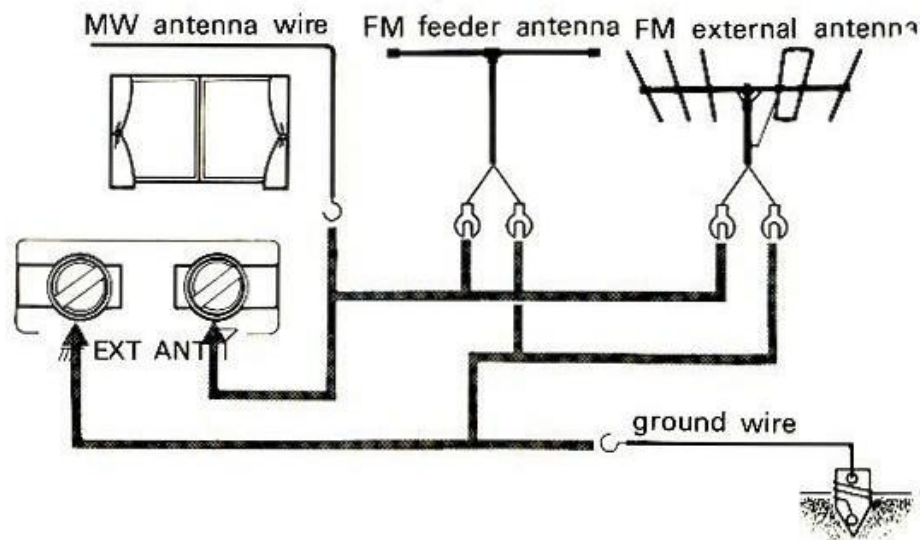

SPECIFICATIONS

Power requirements	4.5 V dc, three batteries size D (IEC Designation R20) 110 or 220 V ac \sim adjustable, 50/60 Hz with optional Sony Power Pack AC-456C... for European model 240 V ac \sim , 50 Hz with optional Sony AC Adaptor AC-14A... for the United Kingdom model 110, 120, 220 or 240 V ac adjustable, 50/60 Hz with optional Sony AC Power Adaptor AC-3A... for the model available in other countries 120 V ac \sim (110, 220 or 240 V adjustable by the Sony personnel), 50/60 Hz with optional Sony AC Power Adaptor AC-3A... for tourist model in Japan or 12 V car battery with optional Sony Car Battery Cord DCC-127H
Power requirements	1,900 mW (Total harmonic Distortion 10 %)
Power consumption	9 VA (with the AC-456C) 9W (with the AC-14A) 7.4 VA at 50 Hz (with the AC-3A) 6.8 VA at 60 Hz (with the AC-3A)
Circuit systems	FM/MW: Superheterodyne SW: Dual conversion superheterodyne
Frequency range	FM 87.5 – 108 MHz SW ₁ 3.9 – 10 MHz (77 – 30 m) SW ₂ 11.7 – 20 MHz (25.6 – 15 m) SW ₃ 20 – 28 MHz (15 – 10.7 m) MW 530 – 1,605 kHz
Antennas	FM/SW: Telescopic antenna, external antenna terminals

Speaker	MW: Built-in ferrite bar antenna, external antenna terminal 10 cm (4 inches) dia.
Dimensions	Approx. 223 × 234 × 102 mm (w/h/d) (8 ³ / ₄ × 9 ¹ / ₄ × 4 inches) including projecting parts and controls
Weight	Approx. 2.2 kg (4 lb 7 oz) including batteries
Accessories supplied	Earphone ME-20H Shoulder Strap
Optional accessories	AC Power Pack AC-456C (available in European countries) AC Adaptor AC-14A (available in the United Kingdom) AC Power Adaptor AC-3A (available in other countries)

Whilst the information given is true at the time of printing small production changes in the course of our company's policy of improvement through research, and design might not necessarily be indicated in the specifications. We would ask you to check with your appointed Sony dealer if clarification on any point is required.

Your dealer may not handle some of the above listed optional accessories. Please ask the dealer for detailed information about the optional accessories available in your country.

TROUBLESHOOTING GUIDE

Should any problem occur with the set, make the following simple tests to determine whether or not servicing is required. If the problem persists after you have made these tests, consult the nearest Sony dealer for further information.

Sound does not come on at all when the POWER switch is set to ON.

- The batteries are exhausted.
- Incorrect polarity of batteries.
- The ac power adaptor is not connected firmly (on ac operation).
- Battery operation is attempted while the ac power adaptor is connected to the radio but not to the wall outlet.
- The VOLUME control is turned down completely.
- The earphone is plugged in.

MW or SW broadcasts is not heard, but beat noises come on.

- The X-TAL MARKER switch is set to ON.
- The BFO switch is set to ON.

Very weak or interrupted sound, or unsatisfactory reception.

- Improper tuning.
- Weak batteries.
- Improper adjustment of the antenna.