

YUPITERU

Multi-band Receiver

MVT-3300EU

Instruction Manual



Thank you for purchasing the MVT-3300EU multi-band receiver.

⚠ IMPORTANT

Please read the complete manual to familiarize yourself with the entire unit before using. This manual is to assist the user toward a better understanding of the MVT-3300EU. Keep it in a convenient place so you can consult it quickly as necessary.

YUPITERU INDUSTRIES CO., LTD.

Before You Begin

This manual is a detailed guide to the operation of the MVT-3300EU multi-band receiver.

INTRODUCTION

Describes safety practices and preparatory steps for operation.

If this unit is your first multi-band receiver, this section helps you understand how a multi-band receiver works.

VFO MODE

Describes basic operation of the MVT-3300EU.

Those who know how to operate a multi-band receiver can start reading from here.

SEARCH

Describes how to locate radio transmission frequencies automatically.

MEMORY AND SCAN

Describes how to store channels and use scan to access them efficiently.

OTHER FUNCTIONS

Describes convenient functions and settings necessary to receive special frequencies. A complete understanding enables you to make use of the various functions of the unit.

USEFUL INFORMATION

Quick reference diagrams and the Troubleshooting Guide can be consulted when you have problems.

NAMES AND FUNCTIONS

Refer to this page as necessary while you read the instructions.

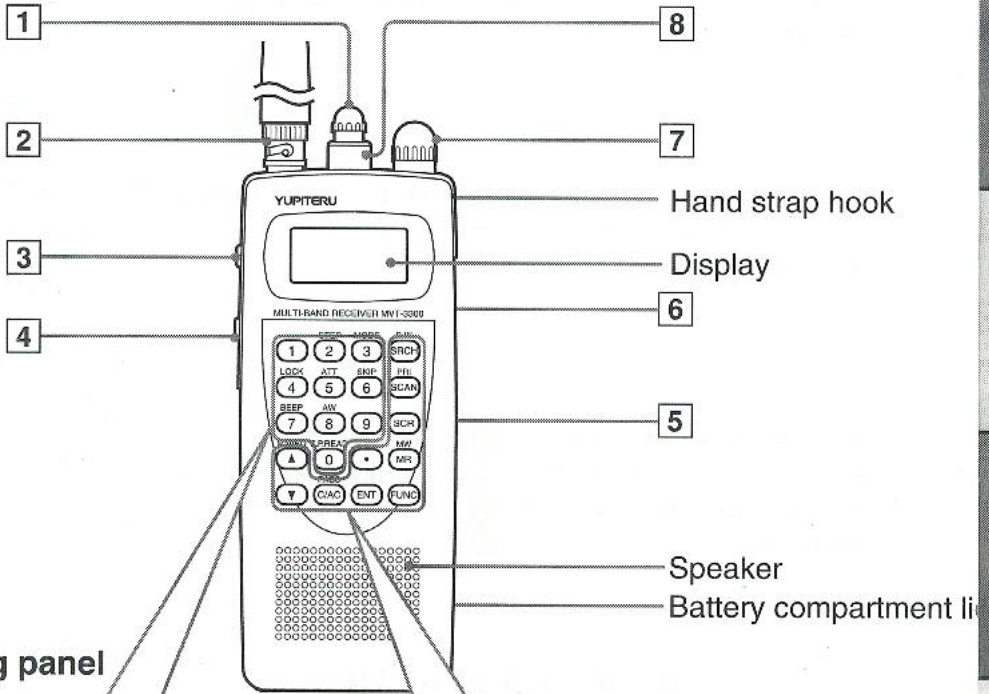

Operating panel buttons

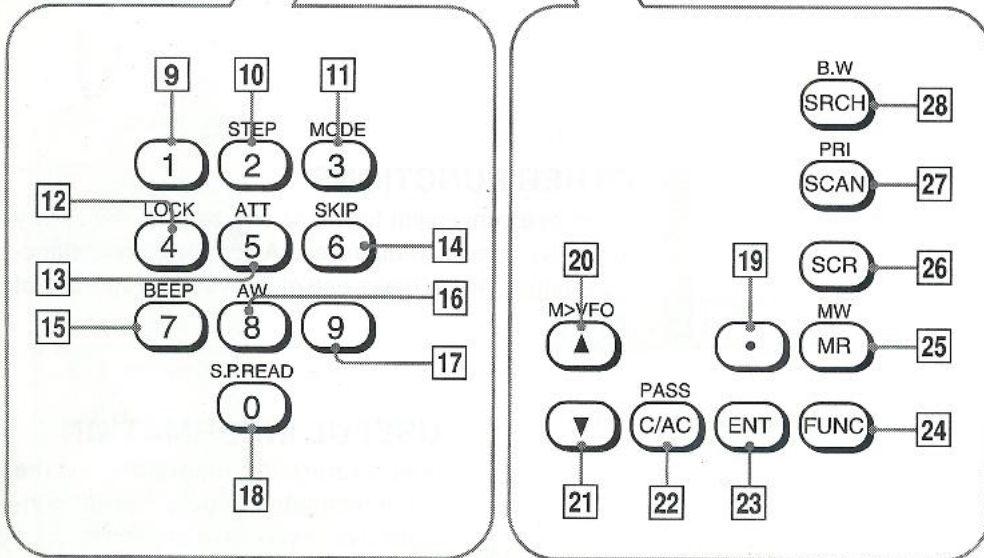

FEATURES

High-speed scanning and searching

Scans / searches as many as 40 channels / 50 steps per second.

10-channel priority memory

You won't miss important radio transmissions while receiving lower priority ones.

Descrambler

The unit contains descrambler circuitry capable of deciphering and restoring scrambled transmissions.

Time-saving presetting function

Once channels and modes are preset, reception is possible with a simple operation.

10-band searching

Of a maximum of 10 bands, the unit comes with 5 major bands, including the police band, already stored so you can tune into them without first having to find their frequencies. Band frequency can be changed as desired.

200-channel memory

Frequencies of up to 200 channels can be stored in memory. These channels can be quickly received by using memory scanning and bank scanning.

3-way power supply allows use anywhere

Built-in universal adapter can accommodate dry cells and Ni-Cd batteries for portable use, an AC adapter for home use, and a cigarette-lighter plug (12 V cigarette-lighter socket) for use in the car.

SAFETY PRECAUTIONS

For safe operation of the receiver, read and follow all warnings and cautions. In this manual, warnings and cautions identify conditions or practices that could result in personal injury or damage to the equipment or other property.

WARNINGS

:Warnings indicate a danger of personal injury or loss of life if not observed.

CAUTION

:Cautions indicate the possibility of minor personal injury or property damage if not observed.

Symbol Key



These symbols () indicate cautionary advice.



These symbols () indicate DON'Ts.



These symbols () indicate DOs and instructions that must be followed.

WARNINGS



Do not get the receiver wet. Do not handle the receiver with wet hands.

Failure to observe this warning may result in fire or electrical damage or injury.



Do not use the receiver while bathing. Do not connect or disconnect the power plug with wet hands.

Failure to observe this warning may result in personal injury from electric shock.



Do not operate the receiver at voltage other than that indicated on the receiver.

Failure to observe this warning may result in fire or electrical damage or injury.



Do not damage, forcibly bend, or modify the power cord. Do not use a damaged power cord.

Failure to observe this warning may result in personal injury from electric shock or fire due to short circuit.



Do not plug the receiver power cord into an outlet where too many devices are connected.











Failure to observe this warning may result in equipment damage or fire due to overheating. This receiver is designed for use with a negative grounded car power supply. When connecting to the car power supply, connect with the correct polarity.



When using an AC adapter or cigarette lighter plug, plug it into the socket securely.

A loose connection could result in fire.

WARNINGS

-  **Keep the blades of the AC adapter and the tip of the cigarette lighter plug clean.**
A dirty contact point may result in fire.
-  **Do not use an AC adapter or cigarette lighter plug other than the one that came with the receiver.**
Failure to observe this warning may result in fire or electrical damage or injury.
-  **Do not put a metallic object such as a pin or wire into a hole or slot in the receiver.**
Failure to observe this warning may result in fire or electrical damage or injury.
-  **Do not modify the receiver and/or its accessories.**
Failure to observe this warning may result in fire or electrical damage or injury.
-  **If the housing is damaged, immediately disconnect the AC adapter or cigarette lighter plug.**
Continued operation may result in fire or electrical damage or injury.
-  **Do not use the receiver during an electrical storm.**
Personal injury from electric shock may result.
-  **Troubleshooting and disassembling of the receiver and its accessories should only be carried out by a qualified service engineer.**
Failure to observe this warning may result in electrical damage or injury. Refer inspection, adjustment or troubleshooting to your local distributor.
-  **Do not operate the receiver while driving.**
Not concentrating on driving can result in a serious traffic accident.
-  **When using the receiver in a car, do not install the receiver where it will disturb the driver or hinder access to driving controls (brake, steering wheel, etc.).**
Poor installation might cause a traffic accident.
-  **When using the receiver in a car, do not install the receiver or run the wiring near the air bag on the seat next to the driver.**
The inflating air bag has sufficient energy to throw the receiver and cause severe injury. Also, the power cord of the receiver can disturb the operation of the air bag.
-  **Do not operate the receiver if it seems defective (emanating smoke or a nasty smell).**
Disconnect the AC adapter or the cigarette lighter plug to prevent fire. Return the receiver to the local distributor for repair.

SAFETY PRECAUTIONS



CAUTION



Do not run the power cord close to a heat generating device.

A melted cord cover can result in fire or electric shock.



Do not place the receiver on unstable or vibrating surfaces or places where it may be hit.

If the receiver falls or is dropped it can cause injury or be damaged.



When disconnecting the receiver from the power source, do not tug on the power cord, grab the plug itself.

A damaged cord may result in injury from electric shock or fire from a short circuit.



When moving the receiver, first disconnect the AC adapter or cigarette lighter plug.

A damaged cord may result in injury from electric shock or fire from a short circuit.



Install the batteries with the correct polarity.

Reversing polarity may cause the battery to explode or leak electrolyte, resulting in fire, injury, or contamination of the surroundings.



Do not use batteries other than those specified. Do not use new and old batteries together.

Failure to follow this instruction may result in the explosion of the battery or leakage of electrolyte, which can cause fire, injury, or contamination of the surroundings.



Do not throw used batteries into fire.

Failure to follow this instruction may result in injury from burns and/or fire.



Disconnect the AC adapter or cigarette lighter plug before carrying out maintenance of the receiver.

Failure to follow this instruction may result in injury from electric shock.



Disconnect the AC adapter or cigarette lighter plug when the receiver is not going to be used for an extended period.

Failure to follow this instruction may result in personal injury from electric shock due to deteriorated insulation or fire due to leakage.



Remove the batteries when the receiver is not going to be used for an extended period.

Electrolyte leakage may result in contamination.



Adjust the audio level when listening through earphones or a headset.

Failure to observe this recommendation may result in earache.



Do not use the receiver in an airplane.

RF energy from the receiver may interfere with navigation instruments.



Do not use the receiver in a hospital.

Radio frequency energy radiated from the receiver may interfere with electrical medical equipment.

CONSIDERATIONS ON USING THE RECEIVER

Handling Considerations

- When cleaning the receiver, use a soft cloth.
Do not use benzine, thinner, detergent, or a cloth that is prone to build up static, such as polyester.
- Being a wide bandwidth receiver, spurious radiation inside the receiver may mask some incoming transmissions or generate noise. It may also interfere with radio receivers and TV sets operating nearby.
- The receiver may pick up noise from radio or television receivers, PCs and other digital devices, or equipment installed in the car.
- As damage could result, avoid using or storing the receiver in the following places:
 - where exposed to high temperatures (such as in direct sunlight, near heating units, in a hot car, etc.)
 - places with high humidity
 - places with poor ventilation
 - places with excessive dust or greasy fumes
 - extremely cold places

Power Supply

- Use a Ni-Cd battery fully charged with a battery charger (a commercially available charger can be used).
- With alkaline dry cells the unit can be operated continuously for approx. 14 hours (lamp off, volume at moderate level), depending on receiving conditions.

Encoded Transmissions

- The receiver cannot decode some encrypted information (e.g. digital data).

Memory

- The receiver will store the operating configuration at the time it is turned off by pressing the PWR button. Unless the stored data is erased by cutting the external power source or removing the batteries while the unit is on, the next power up will be with the configuration stored when the receiver was previously turned off. When using a car's power, always turn off the receiver when not in use to keep the configuration stored in memory.

Antenna

- The sensitivity of the receiver depends on the receiving location and the antenna used.
- In addition to the unit's flexible antenna, commercially available antennae for amateur wireless use can be used; when doing so, use an antenna that matches the target frequency. Do not use an antenna with a booster as it can damage the receiver circuitry.
- The ANT terminal is a 50 ohm impedance BNC terminal.
- A high power transmission from a TV broadcasting station could interfere with the receiver, depending on the location of the receiver and the antenna being used.

Transmission Contents

- By law, a third party may listen to, but not pass on, the contents of a transmission.

If the receiver isn't working properly, immediately discontinue use and consult your local distributor or service center.

NAMES AND FUNCTIONS

Controls

1 PWR/VOL knob (power/volume)

Turning clockwise turns on the unit then gradually increases the sound level.

2 ANT socket (antenna socket)

Socket for the attachment of an antenna.

3 LAMP button (illumination)

Illuminates the display and keyboard.

Press this button when you cannot see the display or keyboard.

4 MONI button (monitor)

Improves reception for weak or intermittent transmissions.

5 12 V DC socket (external power socket)

For attachment of the unit's AC adapter or cigarette lighter plug.

6 EAR terminal (external speaker)

For attachment of an external speaker or earphones. This socket, once engaged, disables the internal speaker.

7 DIAL knob (tuning)

Switches between frequency or channel memory.

Adjusts descrambling level on a signal currently being received.

8 SQL knob (squelch)

Mutes static when there is no signal. When properly adjusted, provides noiseless tuning.

Keypad

Each key has two functions if used in conjunction with the FUNC key [24].

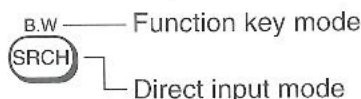

Direct input mode

When the FUNC key [24] is not pressed.

	Key	Function
9	1	Numeric key (1)
10	STEP 2	Numeric key (2)
11	MODE 3	Numeric key (3)
12	LOCK 4	Numeric key (4)
13	ATT 5	Numeric key (5)
14	SKIP 6	Numeric key (6)
15	DEEP 7	Numeric key (7)
16	AW 8	Numeric key (8)
17	9	Numeric key (9)
18	S.PREAD 0	Numeric key (0)
19	•	Decimal point key
20	MV/FC ▲	Up key
21	▼	Down key
22	PASS C/AC	Clear/all clear key
23	ENT	Enter key
24	FUNC	Function key
25	MW MR	Memory read key
26	SCR	Scramble key
27	PRI SCAN	Scan key
28	B.W SRCH	Search key

Function mode

Press the FUNC key [24], causing "FUNC" to light up, and press another key.

Key		Function
[24] → [10]	FUNC ▶ STEP 2	Step key
[24] → [11]	FUNC ▶ MODE 3	Mode key
[24] → [12]	FUNC ▶ LOCK 4	Lock key
[24] → [13]	FUNC ▶ ATT 5	Attenuator key
[24] → [14]	FUNC ▶ SKIP 6	Skip key
[24] → [15]	FUNC ▶ BEEP 7	Beep key
[24] → [16]	FUNC ▶ AW 8	Auto write key
[24] → [18]	FUNC ▶ SPREAD 0	Search pass read key
[24] → [20]	FUNC ▶ M-VFO ▲	Memory to VFO copy key
[24] → [22]	FUNC ▶ PASS C/IAC	Pass key
[24] → [25]	FUNC ▶ MW MR	Memory write key
[24] → [27]	FUNC ▶ PRI SCAN	Priority key
[24] → [28]	FUNC ▶ B.W SRCH	Band write key

Display



Frequency readings

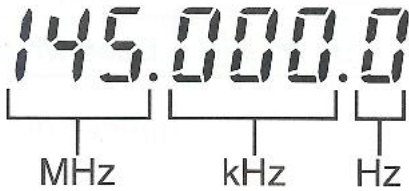

1 Function

[FUNC] is displayed while in function mode.

2 Frequency step/channel memory field

Indicates the frequency step while in search or VFO mode.

Indicates the channel number while scanning.

The second digit is [\overline{P}] (priority channel) if a priority channel is being received.

3 Frequency

Displays the selected frequency or digits being input.

4 Lock

[$\rightarrow \circ$] is displayed when locked.

5 Setting

Displays the current setting.

6 Low battery

[BATT] is displayed when the batteries need to be recharged or replaced.

7 Signal Strength (S meter)

Displays signal strength. When a signal is being received, [BUSY] is displayed.

8 Operation mode

Indicates the current operation mode (search, scan, etc.).

9 Band/Bank Number

Indicates the selected band or bank number.

10 Reception mode

Indicates current reception mode (type of transmission).

POWER SUPPLY

The receiver can be operated with an external power source (in the home or car) via AC adapter or cigarette lighter plug, or with an alkaline or Ni-Cd battery.

Using an External Power Supply

- 1 Connect the AC adapter or cigarette lighter plug to the 12 V DC socket [5].

Always turn off the power before attaching the AC adaptor or cigarette lighter plug.

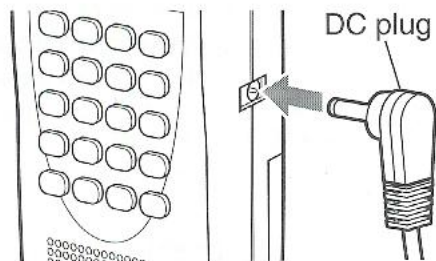

- 2 Plug the AC adapter into an AC outlet; or plug the cigarette lighter plug into the cigarette lighter socket (12 V DC).

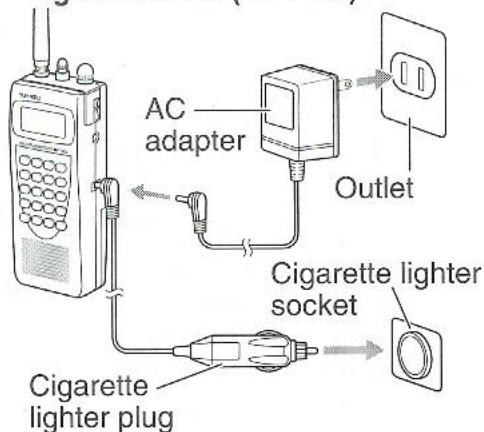

- The cigarette lighter plug is designed to connect to a 12 V car power supply whose negative rail is grounded. Do not connect the plug to a socket supplying 24 V DC (used in large vehicles such as busses and heavy trucks).
- If the fuse inside the cigarette lighter plug is blown, replace it with a 1A fuse. If the fuse is blown immediately, discontinue use, disconnect the cigarette lighter plug, and consult your local distributor or service center.

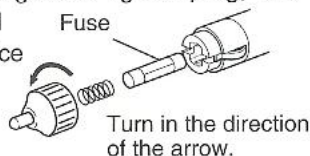

Using alkaline or Ni-Cd batteries

Putting in batteries

- 1 Remove the battery compartment lid.

Always turn off the receiver before changing the batteries.

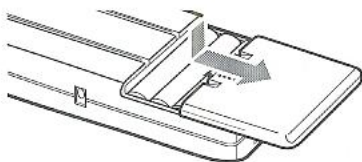

- 2 Install 4 batteries as indicated in the battery compartment. Close the lid.

When using Ni-Cd batteries, use fully charged ones since the unit has no re-charging circuit.

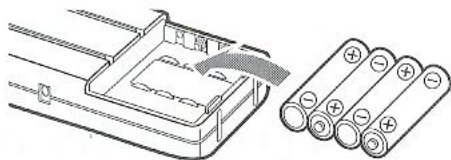

- Do not use batteries of different types at the same time. Do not use new and old batteries together.
- Remove the batteries when the receiver is not going to be used for an extended period.

Low Battery Indicator

When battery power is low, [BATT] is displayed.

Replace with new or fully recharged batteries.

- When the batteries have no power, the display goes dead.

PREPARATION

- 1 Turn the SQL knob **8** counterclockwise all the way.



- 2 Turn on the power.

Turn the PWR/VOL knob **1** clockwise until it clicks.



- When turned on initially, the receiver enters VFO mode.

- 3 Adjust volume.

Adjust the PWR/VOL knob **1** for the desired audio level.

- 4 Adjust reception (squelch).

When there is static, turn the SQL knob **8** clockwise until the static is muted. While adjusting, do not press the MONI button **4** (see Monitor, page 34). The SQL knob should be set about midway while receiving a transmission.

- Turning the SQL knob **8** clockwise too far makes reception of weak signals difficult, but turning it too far counterclockwise increases static. Adjust as required for the signal you wish to receive.



RECEIVING IN VFO MODE

In VFO mode, frequencies can be entered or changed with the numeric keys, ▲ key [20], ▼ key [21], or DIAL knob [7]. In this mode, [PRI] and the operation mode ([SEARCH] or [SCAN]) are not displayed; neither are channel number and [P]. Frequency step shows up in the frequency step/channel memory display field. When you turn on the unit for the first time, you will be in VFO mode.

Entering VFO Mode

VFO mode can be selected in any of the following four ways.

While [SEARCH] is displayed,

Press the SRCH key [28]

While [SCAN] is displayed,

Press the MR key [25] twice

While channel number is displayed,

Press the MR key [25]

While [P] is displayed,

Press the FUNC key [24] then the SCAN key [27].

Preset

The assignment of reception modes (transmission type) and frequency step (frequency interval) varies with purpose and band width. The receiver is programmed for normal radio service operation, but reception modes and frequency steps are user reprogrammable.

<Band Preset List>

Band	Edge Frequency (MHz)		Step (kHz)	Reception mode
	Lower limit	Upper limit		
1	68.0000	88.0000	5	FM
2	108.0000	136.0000	25	AM
3	136.0000	180.0000	5	FM
4	320.0000	470.0000	12.5	FM
5	808.0000	1000.0000	12.5	FM
6-9, 0	68.0000	1000.0000	5	FM

TUNING

Tuning using Numeric Keys

In VFO mode, you can enter frequencies with the numeric keys.

1 Enter the desired frequency starting with the highest digit:

In other words, MHz, [.), KHz, then Hz. The value being entered blinks.

2 Press the ENT key [23].

The entered value stops blinking.

- Up to 4 digits can be entered in the MHz field. If the 5th digit is entered without first pressing the decimal point key (.) [19], the 1st digit is deleted. Enter up to 5 digits in the kHz and Hz fields. Pressing a 6th numeric key following the decimal point causes an error, indicated with a popping sound, and the entry is ignored.
- The entered frequency might be adjusted to fit the preset frequency step range, reception mode, etc. If the entered frequency is outside the range of the receiver, a popping sound is generated and [Error] flashes; then the display returns to the previous screen.
- When entering the frequency, if a key is not pressed for 10 seconds the display returns to the previous screen.

Examples of frequency setting

① For the input: (3) (4) (5) (ENT)

Key pressed	Display
3	----- 3-
4	----- 3.4-
5	----- 34.5-
ENT	345.000.00

② For the input:

(2) (1) (0) (0) (0) (ENT)

Key pressed	Display
2	----- 2-
1	----- 2.1-
0	----- 21.0-
0	----- 210.0-
0	----- 100.0-
ENT	1000.000.00 (2 is ignored.)

③ For the input: (8) (7) (6) (.) (9) (8) (7) (6) (5) (4) (ENT)

Key pressed	Display
8	----- 8-
7	----- 87-
6	----- 876-
.	-876.----
9	-876.9--
8	-876.98--
7	-876.987.-
6	-876.987.6-
5	-876.987.65
4	-876.987.65 (Generates an error and 4 is not accepted.)
ENT	876.980.0

The frequency varies with the channel and preset frequency step. In this example, the recognized frequency is 876.980.0.

Changing or Correcting a Frequency being Entered

When entering a frequency, any digit in the string can be changed.

1 Press the C/AC key [22].

The digit entered last will blink at a faster rate.



- Press the C/CA key [22] again to return to VFO mode.

2 Select the desired digit by using the ▲ key [20] or ▼ key [21].

The digit blinking at a faster rate can be changed.

3 Input the correct value.

Use the DIAL knob [7] or the numeric keys.

4 Press the ENT key [23].

Returns to input mode. If there are more digits, the next digit may be entered.

- If a key is not pressed within 10 seconds, the display returns to the previous screen.

5 Press the ENT key [23] again.

The input value is accepted.

Tuning with the DIAL Knob

In VFO mode, turning the DIAL knob [7] increments or decrements the current frequency one designated frequency step at a time.

To increase frequency

Turn the DIAL knob [7] clockwise.



To decrease frequency

Turn the DIAL knob [7] counterclockwise.



VFO MODE

Tuning with the ▲ and ▼ keys

In VFO mode, pressing the ▲ key [20] or ▼ key [21] respectively increments or decrements the frequency one designated frequency step.

To increase frequency

Press the ▲ key [20].



To decrease frequency

Press the ▼ key [21].



Pressing and holding the ▲ key [20] or ▼ key [21] for more than a second increments or decrements frequency at a faster rate.

DECIPHERING ENCRYPTED (SCRAMBLED) TRANSMISSIONS

In cordless communications, it is common for transmitters to transmit a scrambled signal for descrambling upon reception. Such signals are just noise unless descrambled. The MVT-3300EU is provided with a descrambler for transmissions of this type.

1 When receiving a scrambled transmission, press the SCR key **[26]**.

[SCR] is displayed and the transmission is descrambled.

2 Tune with the DIAL knob **[7]**.

- The descrambler can only decode or decrypt transmissions encrypted in the normal way.
- Do not press the SCR key **[26]** except when receiving scrambled transmissions.
- Descrambling a transmission can change its sound quality.

To return to normal, press the SCR key **[26] again.**

* Turning the DIAL knob **[7]** has no effect while [SCR] is displayed.

VFO SEARCH MODE

In VFO mode, a search starts at the displayed frequency.

VFO Searching

Press the SRCH key [28].

[SEARCH] is displayed, indicating the start of the search.

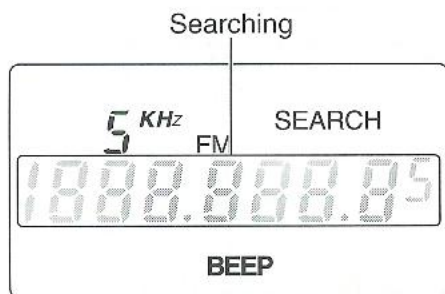

Press the SRCH key [28] again to abort search.

[SEARCH] will no longer be displayed.

- Operating the DIAL knob [7], ▲ key [20] or ▼ key [21] while search is suspended (i.e. while receiving) resumes searching.

Changing Search Direction

Use the DIAL knob [7], ▲ key [20] or ▼ key [21].

Upward search

Turn the DIAL knob [7] clockwise, or press the ▲ key [20].



Downward search

Turn the DIAL knob [7] counterclockwise, or press the ▼ key [21].



BAND SEARCH MODE

Even when the frequency of a station is unknown, if its operating band is known, you can search the entire band (or up to four bands) for it. Up to 10 user-reprogrammable search bands can be stored in the unit.

<Band Preset List>

Band	Edge Frequency (MHz)		Step (kHz)	Reception mode
	Lower limit	Upper limit		
1	68.0000	88.0000	5	FM
2	108.0000	136.0000	25	AM
3	136.0000	180.0000	5	FM
4	320.0000	470.0000	12.5	FM
5	808.0000	1000.0000	12.5	FM
6-9, 0	68.0000	1000.0000	5	FM

1 Using numeric keys, enter the band number (band selection).

Up to 4 bands can be selected.

2 Press the SRCH key [28].

[SEARCH] and the selected band number are displayed while searching. The blinking band number indicates the search has been completed.

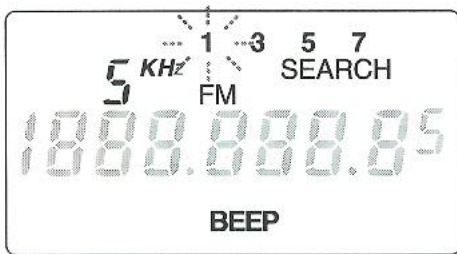

To exit band search mode, press the SRCH key [28]. [SEARCH] will no longer be displayed.

- To resume searching, use the DIAL knob [7], ▲ key [20] or ▼ key [21].
- Searching always starts with the lowest of the selected bands (0 = band 10).

- If all of the frequencies in a selected band are specified as search pass, a popping sound is generated and [ALL PASS] is displayed for about a second.
- Entered band ranges can be changed. Refer to Entering/Changing Band Ranges (page 33).

SEARCH PASS MEMORY Continued on next page

By designating unwanted frequencies as search pass, more efficient searching is possible because the designated frequencies are bypassed.

Designating Frequencies as Search Pass

1 Tune to an unwanted frequency.

Use VFO or search mode. Below is an example of what the display looks like when in search mode.



2 Press the FUNC key [24].

3 Press the C/AC key [22].

Two short beeps indicate the frequency has been designated as search pass and the search resumes. Thereafter the designated frequency will be bypassed when searching.



- Up to 100 frequencies can be entered. Once full, trying to make another entry generates a popping sound and [FULL] is displayed for about a second; the entry is ignored.

Accessing Search Pass Memory

Designated search pass frequencies can be retrieved and verified.

1 Press the FUNC key [24].

2 Press numeric key (0) [18].

[P] will start blinking and reception will be at the lowest of the frequencies higher than the one currently being received. (The search is from lower to higher frequencies.)



- If there are no search pass designations, a popping sound is generated and [P] is displayed for about a second.

3 Selecting a Frequency from Search Pass Memory

Use the DIAL knob [7], ▲ key [20] or ▼ key [21].

For a faster search, press and hold the ▲ key [20] or ▼ key [21] for more than 1 second.

To abort, press the C/AC key [22] or press the FUNC key [24], then numeric key (0) [18].

Cancelling Search Pass Designations

Frequencies can be removed from search pass memory.

1 Retrieve the frequency to be removed.

Retrieve as per Accessing Search Pass Memory.

2 Press the FUNC key [24].

3 Press the C/AC key [22].

Two beeps indicates that the frequency is no longer designated search pass.

- Once an entry is deleted, the next higher search pass frequency is displayed.
- If all of the search pass entries are deleted, two beeps are generated, [ny !!] is displayed for about a second, and you return to the mode prior to accessing search pass memory.



ny !!

Frequencies to which you often listen can be stored in channel memory.

The stored channels can be retrieved (scanned) automatically. Refer to Scanning (page 28).

Data that can be entered

The following data can be entered for each channel.

- Frequency
- Frequency step
- Reception mode

Storing a Frequency in Channel Memory

1 Find the frequency to be stored.

Use VFO or search mode.



2 Input the channel number.

Enter a channel number (from 0 to 199) for the frequency with the numeric keys.

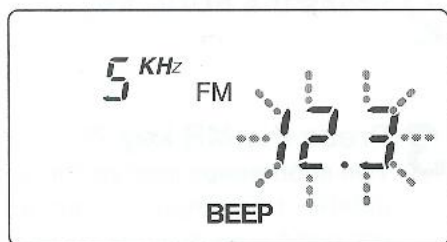

- The frequency can also be stored without entering a channel number. In this case, the next available channel number higher than the most recently displayed channel number is assigned automatically.
- Reassigning a channel number will overwrite the previously entered channel.

3 Press the FUNC key [24].

4 Press the MR key [25].

Two beeps are generated and the channel number is displayed for about a second.



- If an invalid channel number is entered, a popping sound is generated and [Error] is displayed for about a second.

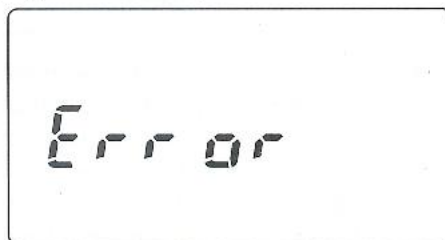

CAUTION Auto Write (page 31) will overwrite channels 180 to 199.

- Channels 200-209 are priority channels (see page 30).

Accessing Channel Memory

Channels can be retrieved from channel memory.

1 Enter the channel number to be retrieved.

Use the numeric keys to enter the channel number (0-199).

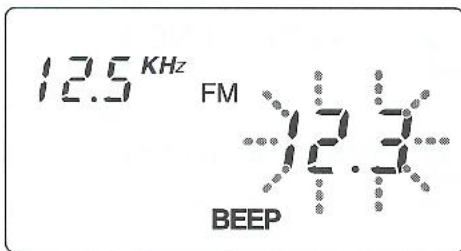

2 Press the MR key [25].

The channel is retrieved from channel memory.



- If there is no data for the channel number selected, the frequency 000.000.0 is displayed, but the receiver continues to receive the frequency to which it was tuned before the operation.
- If the MR key [25] is pressed without first specifying a channel number, the most recently retrieved channel is retrieved again.
- Entering an invalid channel number results in an error: a popping sound is generated and [Error] is displayed for about a second.

3 Retrieving another channel from memory.

Use the DIAL knob [7], ▲ key [20] or ▼ key [21].

Pressing and holding the ▲ key [20] or ▼ key [21] for more than 1 second allows fast scanning.

To abort, press the MR key [25] to return to VFO mode.

Deleting an Entry from Channel Memory

1 Retrieve the channel to be deleted.

Retrieve as per Accessing Channel Memory.

2 Press the FUNC key [24].

3 Press the MR key [25].

Two short beeps indicate the entry is deleted from channel memory and 000.000.0 is displayed as the frequency (although reception continues).



Designating Channels as Scan Pass

By designating certain channels in channel memory as scan pass, they can be skipped when scanning.

1 Retrieve the channel to be skipped.

Retrieve as per Channel Memory Retrieval or by scanning.

2 Press the FUNC key [24].

3 Press the C/AC key [22].

Two short beeps indicate the channel has been designated scan pass; [CH] starts to blink.

Subsequent scanning will bypass the channel.

- A channel that has been designated scan pass can be retrieved as per Channel Memory Retrieval. This causes [CH] to blink.
- Priority channels cannot be designated scan pass.
- Removing a channel that is being received from channel memory causes scanning to commence. If all entries are deleted from channel memory, a popping sound is generated and [no !!] is displayed for about a second.
- Designating a channel that is being received as scan pass causes scanning to commence. If all channels are designated as scan pass, a popping sound is generated and [ALL PASS] is displayed for about a second.

Scan Pass Designation Cancellation

A scan pass designation can be cancelled.

1 Retrieve the channel.

Retrieve as per Accessing Channel Memory.

2 Press the FUNC key [24].

3 Press the C/AC key [22].

The channel is no longer designated scan pass.

- [CH] stops blinking.

Using a Channel Frequency in VFO Mode

A channel's frequency can be used in VFO mode.

1 Retrieve the channel to be used.

Retrieve as per Accessing Channel Memory or by scanning.

2 Press the FUNC key [24].

3 Press the ▲ key [20].

Sets the unit to VFO mode with the channel's frequency.

- Priority channel frequencies can also be used in VFO mode.

SCANNING

The scanning function retrieves channels from channel memory and uses them in turn to search for stations.

About Scanning

The MVT-3300EU is capable of two types of scanning, sequential and bank scanning.

The unit can store up to 200 channels in 10 banks, 20 channels per bank.

Channel No.	Bank	BankSelection Key
0 - 19	1	(1)
20 - 39	2	(2)
40 - 59	3	(3)
60 - 79	4	(4)
80 - 99	5	(5)
100 - 119	6	(6)
120 - 139	7	(7)
140 - 159	8	(8)
160 - 179	9	(9)
180 - 199	0	(0)

- Bank 0 (channels 180-199) also serves as the auto write bank (See Auto Write, page 31).

Sequential Scanning

The MVT-3300EU scans channels in channel memory from lowest to highest and locks onto the signal of the first station it locates.

Press the SCAN key [27].

[SCAN] is displayed, indicating the start of scanning.

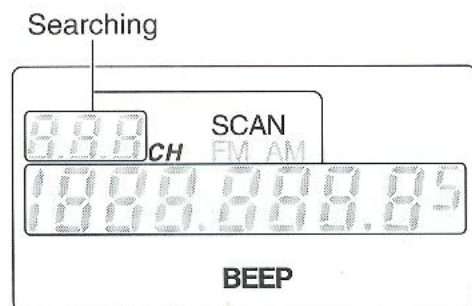

To abort, press the SCAN key [27] or the MR key [25].

[SCAN] is no longer displayed and the unit enters channel memory retrieval mode.

Selecting Scanning Direction

Use the DIAL knob [7], ▲ key [20] or ▼ key [21].

Scanning Channels in Increasing Order

Turn the DIAL knob [7] clockwise, or press the ▲ key [20].



Scanning Channels in Decreasing Order

Turn the DIAL knob [7] counterclockwise, or press the ▼ key [21].

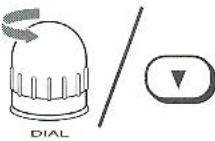

- Using the DIAL knob [7], ▲ key [20] or ▼ key [21] while receiving a station causes scanning to commence.

Bank Scanning

Scanning starts with the lowest channel of the specified bank.

1 Use the numeric keys to select the banks to be scanned (bank selection).

Up to 4 banks can be specified.

2 Press the SCAN key [27].

[SCAN] is displayed and bank scanning commences.

To stop scanning, press the SCAN key [27] or MR key [25].

[SCAN] ceases to be displayed and the receiver returns to channel memory retrieval mode.

- Scanning always starts with the lowest channel.
- If all of the channels in the specified bank have been designated scan pass, a popping sound is generated and [ALL PASS] is displayed for about a second.

PRIORITY

While receiving in VFO, search, scan, or channel memory access modes, priority channels are scanned sequentially in 5 second intervals.

Priority Channel Designation

- 1** Retrieve the frequency to be designated a priority channel.
- 2** Enter the channel number.
Enter a channel number (from 200 to 209) for the frequency with the numeric keys.
- 3** Press the FUNC key [24].
- 4** Press the MR key [25].
Two beeps are generated and the assigned channel number is displayed for about a second.
The maximum number of priority channels is 10.



Channel No.	Display
200CH	P0
201CH	P1
202CH	P2
208CH	P8
209CH	P9

To delete a priority channel, retrieve as per Accessing Channel Memory and carry out steps 3 and 4.

Scanning Priority Channels Using Numeric Keys

For this purpose, up to 4 channels can be specified.

- 1** Enter the channel numbers to be scanned.

Enter the channel numbers (from 200 to 209) using the numeric keys.

Numeric key	Channel No.
0	200CH
1	201CH
2	202CH
8	208CH
9	209CH

- The lowest channel is scanned first. The same channel number can be specified more than once for scanning.
- Channel numbers need not be entered. This allows scanning of all priority channels.

- 2** Press the FUNC key [24].

- 3** Press the SCAN key [27].

[PRI] is displayed indicating the start of priority channel scanning.

To cancel priority channel scanning, repeat steps 2 and 3.

- A channel number may be selected even if the channel is not designated a priority channel. However, if none of the selected channels are designated priority channels, a popping sound is generated and [ru |] appears for about a second.

Skip

Skip causes searching / scanning to resume about 4 seconds after locating a frequency.

1 Press the FUNC key [24].

2 Press numeric key (6) [14].

[SKIP] is displayed.

Starting a search or scan activates the skipping function.



To disable the Skip function, press the FUNC key [24], then numeric key (6) [14].

- This function won't work while a priority channel is being received.

Auto Write

Frequencies found with a search can be stored in channel memory automatically.

Up to 20 channels can be automatically stored in bank 0 (channel numbers 180 to 199) of the channel memory.

1 Press the FUNC key [24].

2 Press numeric key (8) [16].

[AW] is displayed and the receiver enters auto write mode.

3 Press the SRCH key [28].

A search is initiated and the located frequencies are stored in channel memory starting with channel 180.

To abort, press the SRCH key [28] again.

- By pressing the SRCH key [28], the channels in Bank 0 stored prior to the auto write are deleted.
- When all 20 channels are stored, two beeps are generated and the searching sequence ends.
- When the searching sequence stops, auto write is disabled.

CHANGING RECEPTION MODE OR FREQUENCY STEP

Changing Reception Mode

The reception mode can be changed while in VFO or search mode.

1 Press the FUNC key [24].

2 Press numeric key (3) [11].
The new reception mode is displayed.



Changing Frequency Step

The frequency step can be changed while in VFO or search mode.

1 Press the FUNC key [24].
[FUNC] is displayed.

2 Press numeric key (2) [10].
The current frequency step starts blinking.



3 Select the new frequency step.

Use the DIAL knob [7], ▲ key [20] or ▼ key [21].

Note that the width of the frequency step depends on the reception mode.

Possible frequency steps

5kHz, 6.25kHz, 10kHz, 12.5kHz, 25kHz

4 Press the ENT key [23].

The frequency step is displayed and is changed to the one selected.

ENTERING/CHANGING BAND RANGES

Search Band Memory

While in VFO mode, the search band range can be entered or changed. On bands 1 to 9 and 0, previously specified band ranges can also be changed.

1 Press the FUNC key [24].
[FUNC] is displayed.

2 Press the SRCH key [28].
The band number for band 1 begins blinking and the lower and upper limits of its frequency range are alternately displayed.



3 Select the band whose contents are to be entered (changed).

Use the DIAL knob [7], ▲ key [20] or ▼ key [21].

4 Press the ENT key [23].
The lower limit of the frequency range is displayed.

5 Enter the lower limit of the frequency range with the numeric keys.

The lower limit of the frequency range is displayed in the frequency display field.

6 Press the ENT key [23].
The lower limit is set and the upper limit of the frequency range is displayed in the frequency display field.

7 Enter the upper limit of the frequency range with the numeric keys.

The upper limit of the frequency range is displayed in the frequency display field (as shown in the diagram).

8 Press the ENT key [23].
The upper and lower limits of the frequency range are saved.
For each frequency band, the frequencies entered are adjusted to come into alignment with previously set frequency steps.

- When entering the upper or lower limits of the frequency range, pressing the C/AC key [22] returns to step 3.
- If the upper limit is lower than the lower limit of the frequency range, [E R R O R] is displayed and you return to step 3.

9 Upon entering the search band range, you return to reception/frequency step mode.

CONVENIENT FEATURES

Monitor

The monitor function enables clearer reception of a fading or interrupted signal.

Press and hold the MONI button [4].

As long as the button is held down, the monitor function is enabled and reception is clearer.

When the button is released, the monitor function is disabled.

- If the MONI button [4] is pressed while searching or scanning, the search or scan is suspended until the button is released.
- Do not press the MONI button [4] while adjusting squelch.

Lamp

Illuminates the display and keys when it is dark.

Lamp works in either the following two ways.

Pressing the LAMP button [3] once:

The lamp stays on for about 5 seconds. If keys are pressed while the lamp is on, it stays on for about 5 seconds after the last key pressed.

- The PWR/VOL knob [1] and SQL knob [8] are not illuminated by the lamp.

Pressing the FUNC key [24] then the LAMP button [3]:

[LAMP] is displayed and the lamp remains on.

To turn off the lamp, press the FUNC key [24] then the LAMP button [3].

The lamp is turned off and [LAMP] is no longer displayed.

Attenuator

When there is interference, such as TV broadcasting station signals, or static, the attenuator can be used to improve reception.

1 Press the FUNC key [24].

2 Press numeric key (5) [13].

[ATT] is displayed and the attenuator is activated.

To disable the attenuator, repeat steps 1 and 2.



- When the attenuator is enabled, it decreases the decibel level by about 13 dB (at 300 MHz).
- When the attenuator is enabled, reception of weak signals is not possible so use the attenuator only when it is needed.

Key Lock

Keys can be disabled to avoid accidental activation. However, the FUNC key, PWR/VOL, SQL, and DIAL knobs, and LAMP and MONI buttons cannot be disabled.

1 Press the FUNC key [24].

2 Press numeric key (4) [12].



[] is displayed, indicating that the lock is activated.

To unlock, repeat steps 1 and 2.

Muting Beeps

When operating the keys, beeps are generated to enable verification.

Correct operation: two short beeps
Wrong operation: a popping sound

The beep function is initially enabled but can be disabled.

1 Press the FUNC key [24].
[FUNC] blinks.

2 Press numeric key (7) [15].
[BEEP] is no longer displayed, indicating that beeps will be muted.



To reenale the beep function, repeat steps 1 and 2.

INITIALIZATION

Reset function (memory all clear)

This function clears memory and returns to the default configuration.

While holding the C/AC key [22] and ENT key [23], turn the PWR/VOL knob [1] clockwise (turn on the unit).



After displaying [CLEAR], the unit is set to VFO mode.

■ Function Default Settings

Parameter	Default
Operating Mode	VFO mode: 144.000.00MHz
Beep	ON
Key Lock	OFF
Skip	OFF
AW	OFF
PRI Scan	OFF
ATT	OFF
SCR	OFF
SCR Tuning Setting	3.1kHz
Channel Memory	Blank
PRI Channel Memory	P0:350.1MHz P1-P9: blank
Search Pass Memory	Blank
Current Channel Number	000CH

* STEP frequencies and reception modes for each band are according to PRESET settings.

TROUBLESHOOTING GUIDE

Before taking the unit in for repairs, check it yourself using the table below. If you are unable to remedy the problem even when using the table, consult your local distributor or service center.

Problem	Possible cause	Remedy
Nothing shows up on the display	The battery is exhausted	Recharge or replace the battery (page 15).
Sometimes PCH is displayed.	The priority function is activated.	Disable the priority function (page 30).
"P" is blinking.	The search pass memory is being accessed.	Abort search pass memory access (page 23).
Reception is interrupted	Poor squelch adjustment	Readjust the squelch (page 16).
	The signal is too weak.	Press the MONI button (page 34).
	The attenuator is activated.	Disable the attenuator (page 34).
Reception is not possible due to poor sound quality	The descrambler is on.	Press the SCR key. (page 20).
Nothing happens when a key is pressed	The key lock is on.	Turn off key lock (page 35).
Frequency input is not accepted.	The entered frequency is outside the unit's reception range.	Input a valid frequency.
Cannot search	Poor squelch adjustment.	Readjust the squelch (page 16).
	The MONI button is being held down.	Release the MONI button (page 34).
	All channels in the specified band are designated search pass.	Cancel search pass designation (page 24).
Cannot scan	Poor squelch adjustment.	Readjust the squelch (page 16).
	The MONI button is being held down.	Release the button (page 34).
	All channels are designated scan pass.	Cancel scan pass designation (page 27).
	No channels are stored in channel memory.	Store some channels in channel memory (page 25).

SPECIFICATIONS

Frequency range:	66-88 MHz 108-180 MHz 320-470 MHz 808-1000MHz
Reception mode:	NFM/AM (Selectable)
Frequency step :	5, 6.25, 10, 12.5, 25 kHz (Selectable)
Memory type:	Channel memory...200 Band memory...10 (rewritable) Priority channel memory ...10 Search pass memory...100
Sensitivity:	AM 0.7 μ V (S/N ratio 10 dB or better) NFM 0.5 μ V (12 dB SINAD)
Scan/search speed:	approx. 40 channels/50 steps per second
Impedance and antenna connection:	50 Ω /BNC
Power supply:	Alkaline dry cells (1.5V x 4, 6 V) Ni-Cd batteries (1.2V x 4, 4.8 V) External power source: 12 V DC (cannot be used for recharging internal batteries)
Audio output :	100 mW or more (4.8 V 8 Ω at 10% THD)
Current consumption:	Max. output power 170 mA Standby 72 mA
Guaranteed operating temperature:	0-50°C
External dimensions:	59.0 (W) x 152.0 (H) x 32.0 (D) mm (projection excluded)
Weight:	Approx. 310 g (incl. antenna and batteries)
Accessories:	Antenna, hand strap, earphones, instruction manual

*Specifications subject to change without notice.

QUICK REFERENCE CHARTS

SCANNING

Priority scanning

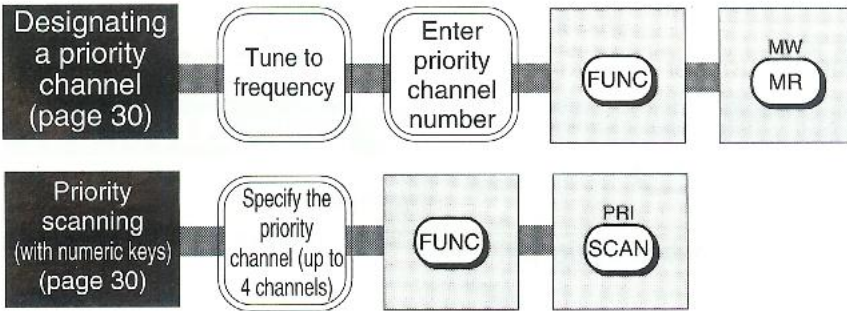

OTHER FUNCTIONS

Optional Functions for Searching and Scanning

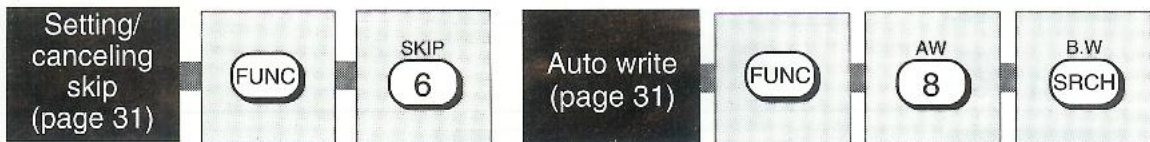

Special Transmissions

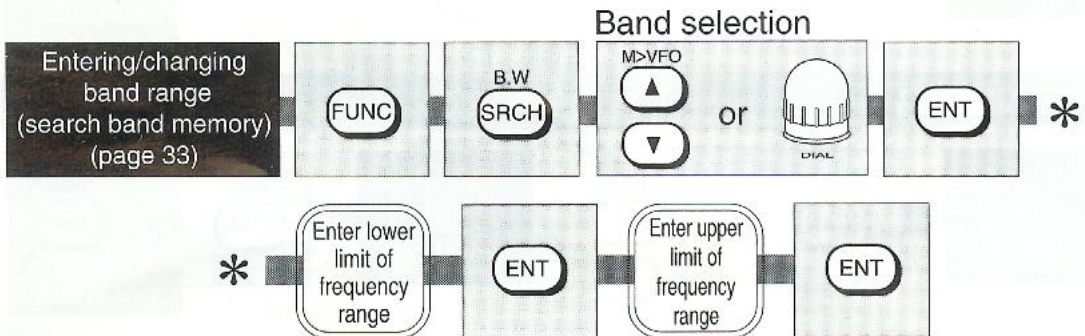

CONVENIENT FEATURES

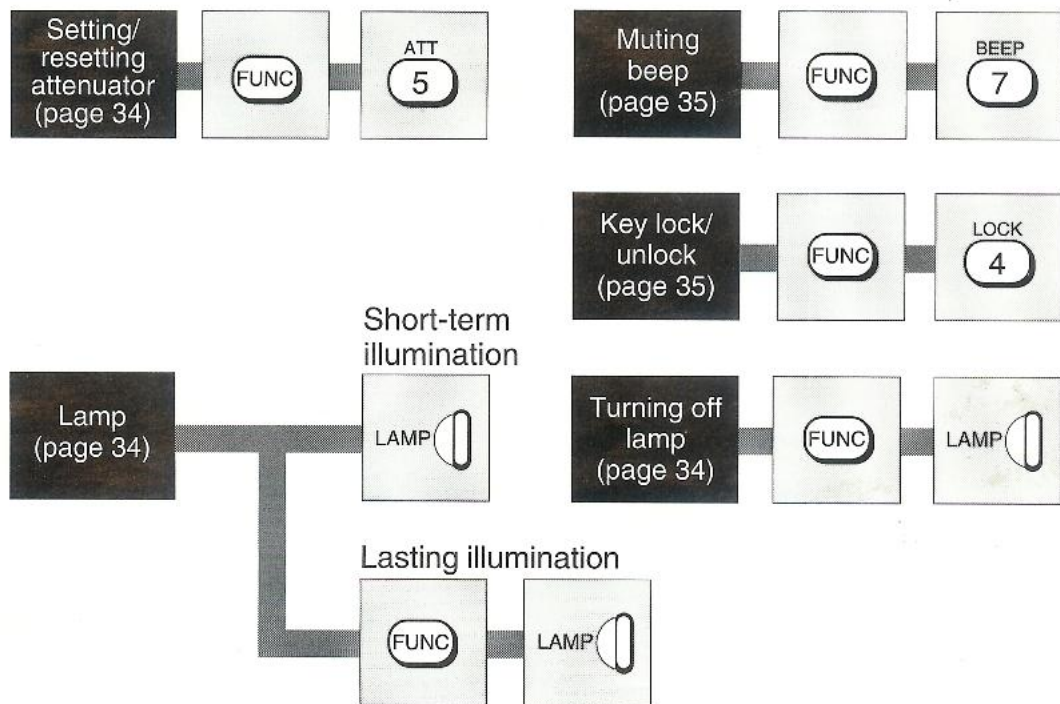

MVT-3300EU

YUPITERU INDUSTRIES CO., LTD.