

T M 1 1 - 6 6 2 5 - 2 9 5 8 - 1 4 & P

TECHNICAL MANUAL

OPERATOR'S, ORGANIZATIONAL,
DIRECT SUPPORT AND GENERAL SUPPORT

MAINTENANCE MANUAL

(INCLUDING REPAIR PARTS
AND SPECIAL TOOLS LIST)

FOR

POWER SUPPLY PP-7545/U

(HEWLETT-PACKARD MODEL 6269B)

(NSN 6130-00-148-1796)

HEADQUARTERS, DEPARTMENT OF THE ARMY

21 AUGUST 1980



5

SAFETY STEPS TO FOLLOW IF SOMEONE
IS THE VICTIM OF ELECTRICAL SHOCK

1

DO NOT TRY TO PULL OR GRAB THE INDIVIDUAL

2

IF POSSIBLE , TURN OFF THE ELECTRICAL POWER

3

IF YOU CANNOT TURN OFF THE ELECTRICAL
POWER, PULL, PUSH, OR LIFT THE PERSON TO
SAFETY USING A WOODEN POLE OR A ROPE OR
SOME OTHER INSULATING MATERIAL

4

SEND FOR HELP AS SOON AS POSSIBLE

5

AFTER THE INJURED PERSON IS FREE OF
CONTACT WITH THE SOURCE OF ELECTRICAL
SHOCK, MOVE THE PERSON A SHORT DISTANCE
AWAY AND IMMEDIATELY START ARTIFICIAL
RESUSCITATION

This manual includes copyright material reproduced by permission of the HEWLETT-PACKARD Company.

TM 11-6625-2958-14&P

TECHNICAL MANUAL

No. 11-6625-2958-14&P

**HEADQUARTERS
DEPARTMENT OF THE ARMY**

Washington DC, 21 August 1980

**OPERATOR'S, ORGANIZATIONAL, DIRECT SUPPORT AND
GENERAL SUPPORT MAINTENANCE MANUAL
(INCLUDING REPAIR PARTS AND SPECIAL TOOLS LISTS)**

FOR

DC POWER SUPPLY PP-7545/U

(HEWLETT-PACKARD MODEL 6269B)

(NSN 6130-00-148-1796)

FOR SERIALS 1027A00101 AND ABOVE*

REPORTING OF ERRORS

You can improve this manual by recommending improvements using DA Form 2028-2 located in the back of the manual. Simply tear out the self-addressed form, fill it out as shown on the sample, fold it where shown, and drop it in the mail.

If there are no blank DA Forms 2028-2 in the back of your manual, use the standard DA Form 2028 (Recommended Changes to Publications and Blank Forms) and forward to Commander, US Army Communications and Electronics Materiel Readiness Command, ATTN: DRSEL-ME-MQ, Fort Monmouth, NJ 07703.

In either case a reply will be forwarded direct to you.

This manual is an authentication of the manufacturer's commercial literature which, through usage, has been found to cover the data required to operate and maintain this equipment. Since the manual was not prepared in accordance with military specifications and AR 310-3, the format has not been structured to consider levels of maintenance.

TABLE OF CONTENTS

Section	Page No.	Section	Page No.
0	INSTRUCTIONS	6-1	
0-1	Scope	0-1	
0-2	Indexes of Publications	0-1	
0-3	Forms and Records	0-1	
0-4	Reporting Equipment Improvement Recommendations (EIR)	0-1	
0-5	Administrative Storage	0-1	
0-6	Destruction of Army Electronics Materiel	0-1	
I	GENERAL INFORMATION.	1-1	
1-1	Description	1-1	
1-7	Specifications	1-2	
1-9	Options	1-2	
1-11	Instrument/Manual Identification	1-2	
1-14	Ordering Additional Manuals	1-3	
II	INSTALLATION	2-1	
2-1	Initial Inspection	2-1	
2-3	Mechanical Check	2-1	
2-5	Electrical Check	2-1	
2-7	Installation Data	2-1	
2-9	Location	2-1	
2-11	Outline Diagram	2-1	
2-13	Rack Mounting	2-1	
2-15	Input Power Requirements	2-1	
2-17	Connections for 208 Volt Operation (Model 6259B, 6261B, or 6268B)	2-1	
2-19	Connections for 208 Volt Operation (Model 6260B and 6269B)	2-2	
2-21	Connections for 115 Volt Operation (Model 6259B, 6261B, and 6268B)	2-3	
2-23	Connections for 115 Volt Operation (Model 6260B)	2-3	
2-25	Connections for 50Hz Operation	2-4	
2-27	Power Cable	2-4	
2-29	Repackaging for Shipment	2-4	
III	OPERATING INSTRUCTIONS	3-1	
3-1	Turn-On Checkout Procedure	3-1	
3-3	Operating Modes	3-1	
3-5	Normal Operating Mode	3-1	
3-7	Constant Voltage	3-2	
3-9	Constant Current	3-2	
3-11	Overvoltage Trip Point Adjustment	3-2	
3-14	Connecting Load	3-2	
3-18	No Load Operation	3-2	
3-20	Operation Beyond Rated Output	3-3	
3-22	Optional Operating Modes	3-3	
3-23	Remote Programming, Constant Voltage	3-3	
3-32	Remote Programming, Constant Current	3-4	
3-41	Remote Sensing	3-5	
3-46	Auto-Parallel Operation	3-6	
3-50	Auto-Series Operation	3-7	
3-55	Auto-Tracking Operation	3-8	
3-59	Special Operating Considerations	3-8	
3-60	Pulse Loading	3-8	
3-62	Output Capacitance	3-9	
3-65	Reverse Voltage Loading	3-9	
3-67	Reverse Current Loading	3-9	
IV	PRINCIPLES OF OPERATION.	4-1	
4-1	Overall Block Diagram Discussion	4-1	
4-16	Detailed Circuit Analysis	4-3	
4-17	Preregulator Control Circuit	4-3	
4-27	Series Regulator and Driver	4-4	
4-29	Short Circuit Protection	4-4	
4-31	Constant Voltage Comparator	4-5	
4-38	Constant Current Comparator	4-5	
4-43	Voltage Clamp Circuit	4-6	
4-46	Mixer and Error Amplifiers	4-6	
4-50	Overvoltage Protection Crowbar	4-6	
4-56	Turn-On Control Circuit	4-7	
4-59	Reference Regulator	4-7	
4-64	Meter Circuit	4-7	
4-68	Additional Protection Features	4-8	
v	MAINTENANCE	5-1	
5-1	Introduction	5-1	
5-3	Test Equipment Required	5-1	
5-5	performance Test	5-2	
5-7	Constant Voltage Tests	5-2	
5-40	Constant Current Tests	5-7	
5-51	Troubleshooting	5-9	
5-56	Overall Troubleshooting Procedure	5-10	
5-62	Disassembly Procedures	5-15	
5-71	Repair and Replacement	5-16	
5-73	Adjustment and Calibration	5-18	
5-75	Meter Zero	5-18	
5-77	Voltmeter Calibration	5-18	
5-79	Ammeter Calibration	5-18	
5-81	Constant Voltage Programming Current	5-19	
5-90	Constant Current Programming Current	5-20	
5-99	Transient Recovery Time	5-20	
5-101	Ripple Imbalance 150 and 60Hz Operation)	5-20	

TABLE OF CONTENTS (Continued)

Section	Page No.	Section	Page No.
V MAINTANCE . . . Continued		5-111 Crowbar Disablement	5-22
5-103 Preregulator Tracking (5 O and 60Hz Operation)	5-21	VI REPLACEABLE PARTS	6-1
5-105 50Hz Operation (Option 005)	5-21	6-1 Introduction	6-1
5-107 Crowbar Trip Voltage	5-21	6-4 Ordering Information	6-1
5-109 Maximum Crowbar Trip Voltage	5-22	VII CIRCUIT DIAGRAMS & COMPONENT LOCATION DIAGRAMS	7-1
APPENDIX			Page No.
	A.	References	A-1
	B.	Components of End Item List	
Section	I.	Introduction	B-1
	II.	Integral Components of End Item	B-2
	III.	Basic Issue Items	B-2
APPENDIX	c.	Additional Authorization List (N/A)	
	D.	Maintenance Allocation Chart	D-1
Section	I.	Introduction	D-1
	II.	Maintenance Allocation Chart	D-3
	111.	Tools and Test Equipment Required	D-4
	IV.	Remarks	D-5

LIST OF TABLES

Table	Page No
1-1	Specifications 1-3
5-1	Test Equipment Required 5-1
5-2	Reference and Bias Voltages. 5-10
5-3	Overall Troubleshooting 5-10
5-4	Feedback Loop Isolation 5-12
5-5	Series Regulator Troubleshooting, High Voltage Condition 5-13
5-6	Series Regulator Troubleshooting, Low Voltage Condition. 5-13
5-7	Preregulator Troubleshooting 5-14
5-8	Checks and Adjustments After Replacement of Semiconductor Devices 5-17
6-1	Reference Designators. 6-1
6-2	Description Abbreviations 6-1
6-3	Code List of Manufacturers 6-2
6-4	Replaceable Parts. 6-5
6-5	Part Number-National Stock Number Cross Reference Index 6-12

MANUAL CHANGES

Check the serial number of your power supply. Then refer to the manual changes at the rear of this technical manual and make changes as required so that your power supply can be correctly serviced.

LIST OF ILLUSTRATIONS

Figure	Page No.
1-1 DC Power Supply, Model 6259B, 6260B, 6261B, 6268B, or 6269B	I-I
2-1 Outline Diagram	2-1
2-2 Bias Transformer Primary Connections for 208Vac and 115Vac Operation	2-2
2-3 Power Transformer Primary Connections for 208Vac and 115Vac Operation	2-2
2-4 Power Transformer T1 Primary Connections for 208Vac Operation.	2-3
2-5 RF I Choke (A2L1A/A2L1B) Connections for 115Vac Operation	2-3
3-1 Front Panel Controls and Indicators	3-1
3-2 Normal Strapping Pattern	3-2
3-3 Remote Resistance Programming (Constant Voltage)	3-3
3-4 Remote Voltage Programming, Unity Gain (Constant Voltage)	3-3
3-5 Remote Voltage Programming, Non-Unity Gain (Constant Voltage).	3-4
3-6 Remote Resistance Programming (Constant Current)	3-4
3-7 Remote Voltage Programming, Unity Gain (Constant Current)	3-5
3-8 Remote Voltage Programming, Non-Unity Gain (Constant Current).	3-5
3-9 Remote Sensing.	3-5
3-10 Auto-Parallel Operation, Two and Three Units	3-6
3-11 Auto-Series Operation, Two and Three Units	3-7
3-12 Auto-Tracking, Two and Three Units	3-8
4-1 Overall Block Diagram	4-1
4-2 Operating Locus of a CV/CC Power Supply	4-2
4-3 Triac Phase Control Over AC Input Amplitude	4-3
4-4 Preregulator Control Circuit Waveforms	4-4
5-1 Differential Voltmeter Substitute Test Setup	5-2
5-2 Constant Voltage Load Regulation Test Setup	5-3
5-3 Ripple Test Setup	5-4
5-4 Noise Spike Measurement Test Setup	5-5
5-5 Transient Recovery Time Test Setup	5-6
5-6 Transient Recovery Time Waveforms	5-6
5-7 Current Sampling Resistor Connections	5-8
5-8 Constant Current Load Regulation Test Setup	5-8
5-9 Constant Current Ripple and Noise Test Setup	5-9
5-10 "ZERO ADJUST" Section of Main Circuit Board	5-19
7-1 A2 RFI Assembly Component Location Diagram	7-2
7-2 A3 Interconnection Circuit Board Assembly Component Location Diagram.	7-2
7-3 Top Front Chassis Assembly Component Location Diagram	7-3
7-4 Bottom Front Chassis Assembly Component Location Diagram	7-4
7-5 Bottom Rear Chassis Assembly Component Location Diagram	7-5
7-6 Series Regulator Emitter Resistor Assembly Component Location Diagram	7-6
7-7 A4 Heat Sink Assembly Component Location Diagram (Top View)	7-6
7-8 A4 Heat Sink Assembly Component Location Diagram (End View)	7-7
7-9 Preregulator Control Circuit Waveforms	7-7
7-10 A1 Main Printed Circuit Board Component Location Diagram.	7-8
7-11 Schematic Diagram	Foldout

SECTION O INTRODUCTION

0-1. SCOPE.

a. This manual describes DC Power Supply PP-7545/U (fig. 1-1) and provides maintenance instructions. Throughout this manual, PP-7545/U is referred to as the Hewlett-Packard (HP) Model 6269B DC Power supply.

0-2. INDEXES OF PUBLICATIONS.

a. DA Pam 310-4. Refer to the latest issue of DA Pam 310-4 to determine whether there are new editions, changes, additional publications pertaining to the equipment.

b. DA Pam 310-7: Refer to DA Pam 310-7 to determine whether there are modification work orders (MWO's) pertaining to the equipment.

0-3. FORMS AND RECORDS.

a. *Reports of Maintenance and Unsatisfactory Equipment.* Maintenance forms, records, and reports which are to be used by maintenance personnel at all maintenance levels are listed in and prescribed by TM 38-750.

b. *Report of Packaging and Handling Deficiencies.* Fill out and forward DD Form 6 (Packaging Improvement Report) as prescribed in AR 735-11-2/NAVUPINST4440.127E/AFR 400-54/MCO

4430.3E and DSAR 4140.55.

c. *Discrepancy in Shipment Report (DISREP) (SF 361).* Fill out and forward Discrepancy in Shipment Report (DISREP) (SF 361) as prescribed in AR 55-38/NAVSUPINST 4610.33B/AFR 75-18\MCO P4610.19C and DLAR 4500.15.

0-4. REPORTING EQUIPMENT IMPROVEMENT RECOMMENDATIONS (EIR).

EIR's will be prepared using SF 368 (Quality Deficiency Report). Instructions for preparing EIR's are provided in TM 38-750, the Army Maintenance Management System. EIR's should be mailed direct to Commander, US Army Communication and Electronics Materiel Readiness Command, ATTN: DRSEL-ME-MQ, Fort Monmouth, NJ 07703. A reply will be furnished direct to you.

0-5. ADMINISTRATIVE STORAGE.

Administrative storage of equipment issued to and used by Army activities shall be in accordance with TM 740-90-1 and paragraph 2-8.

0-6. DESTRUCTION OF ARMY ELECTRONICS MATERIEL.

Destruction of Army electronics materiel to prevent enemy use shall be in accordance with TM 750-244-2.

SAFETY PRECAUTIONS.

A periodic review of safety precautions in TB 385-4 is recommended. When the equipment is operated with covers removed while performing maintenance, DO NOT TOUCH exposed connections or components. MAKE CERTAIN you are not grounded when making connections or adjusting components inside the power supply.

WARNING

HIGH VOLTAGE is used during the "performance of maintenance as instructed in this manual. DEATH ON CONTACT may result if personnel fail to observe safety precautions.

SECTION I GENERAL INFORMATION

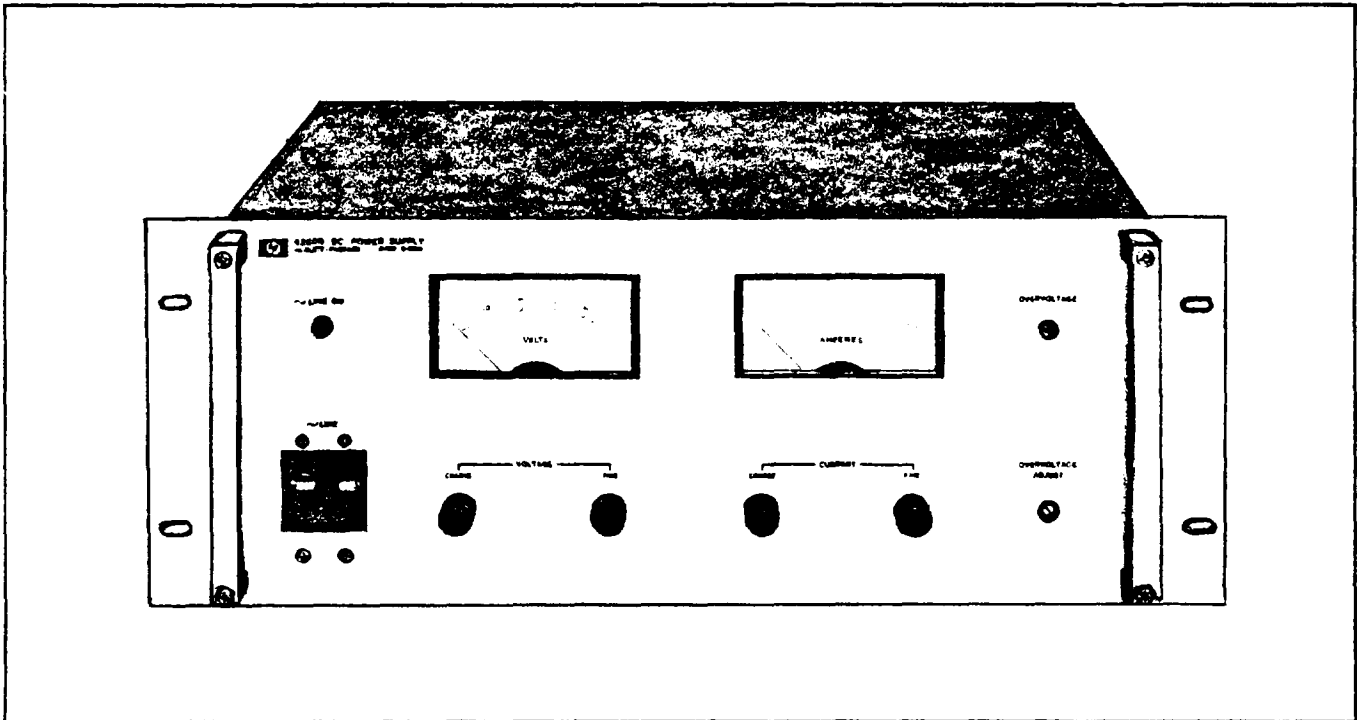

Figure 1-1. DC Power Supply, Model 6259B, 6260B, 6261B, 6268B, or 6269B

1-1 DESCRIPTION

1-2 This power supply, Figure 1-1, is completely transistorized and suitable for either bench or relay rack operation. It is a well-regulated, constant voltage/constant current supply that will furnish full rated output voltage at the maximum rated output current or can be continuously adjusted throughout the output range. The front panel CURRENT controls can be used to establish the output current limit (overload or short circuit) when the supply is used as a constant voltage source and the VOLTAGE controls can be used to establish the voltage limit (ceiling) when the supply is used as a constant current source. The supply will automatically cross over from constant voltage to constant current operation and vice versa if the output current or voltage exceeds these preset limits.

1-3 The power supply contains an added feature for protection of delicate loads. A limit can be set on the output voltage. If this limit is exceeded the output will automatically be shorted.

1-4 The power supply has rear output terminals. Either the positive or negative output terminal may be grounded or the power supply can be operated floating at up to a maximum of 300 volts above ground.

1-5 Output voltage and current are continuously monitored on two front panel meters.

1-6 Terminals located at the rear of the unit allow access to various control points within the unit to expand the operating capabilities of the power supply. A brief description of these capabilities is given below:

a. Remote Programming. The power supply output voltage or current may be programmed (controlled) from a remote location by means of an external voltage source or resistance.

b. Remote-Sensing. The degradation in regulation which occurs at the load due to voltage drop in the load leads can be reduced by using the power supply in the remote sensing mode of operation.

c. Auto-Series Operation. Power supplies

may be used in series when a higher output voltage is required in the constant voltage mode of operation or when greater voltage compliance is required in the constant current mode of operation. Auto-Series operation permits one-knob control of the total output voltage from a "master" supply.

d. Auto-Parallel Operation. The power supply may be operated in parallel with a similar unit when greater output current capability is required. Auto-Parallel operation permits one-knob control of the total output current from a "master" supply.

e. Auto-Tracking. The power supply may be used as a "master" supply controlling one or more "slave" supplies furnishing various voltages for a system.

1-7 SPECIFICATIONS

1-8 Detailed specifications for the power supply are given in Table 1-1 on Page 1-3.

1-9 OPTIONS

1-10 Options are customer-requested factory modifications of a standard instrument. The following options are available for the instrument covered by this manual. Where necessary, detailed coverage of the options is included throughout the manual.

<u>Option No.</u>	<u>Description</u>
005	<u>50Hz Regulator Realignment:</u> Standard instruments are designed for 57 to 63 Hz operation. Option 005 (factory realignment) is necessary when the instrument is to be operated from a 50Hz ac source. The option consists of changing a resistor in the preregulator circuit and adjusting the preregulator tracking.
007	<u>Ten-Turn Output Voltage Control:</u> A single control that replaces the coarse voltage control and allows greater resolution in setting the output voltage.
008	<u>Ten-Turn Output Current Control:</u> A single control that replaces the coarse current control and allows greater resolution in setting the output current.
009	<u>Ten-Turn Output Voltage and Current Controls:</u> Options 007 and 008 on the same instrument.
010	<u>Chassis Slides:</u> Enables convenient access to power supply interior for maintenance purposes.
013	<u>Three Digit Graduated Decadial Voltage Control:</u> A single control that replaces the coarse voltage control and allows accurate resetting of the output voltage.

<u>Option No.</u>	<u>Description</u>
014	<u>Three Digit Graduated Decadial Current Control:</u> A single control that replaces the coarse current control and allows accurate resetting of the output current. <u>Rewire for 115Vac Input (6260B only):</u> Consists of replacing the input power transformer and circuit breaker, and reconnecting the bias transformer, RFI choke, and fans for 115Vac operation.
020	<u>Voltage Programming Adjustment:</u> Two rear panel mounted, screwdriver-adjustable controls that allow accurately setting the zero volt output and the constant voltage programming coefficient.
021	<u>Current Programming Adjustment:</u> Two rear panel mounted, screwdriver-adjustable controls that allow accurately setting the zero current output and the constant current programming coefficient.
022	<u>Voltage and Current Programming Adjustments:</u> Options 020 and 021 on the same instrument. <u>Rewire for 115Vac Input (6259B, 6261B, and 6268B only):</u> Consists of replacing the line circuit breaker, and reconnecting the input power transformer, bias transformer, RFI choke, and fans for 115Vac operation.
027	<u>Rewire for 208Vac Input:</u> Consists of reconnecting the input power transformer and bias transformer for 208V ac operation.

1-11 INSTRUMENT/MANUAL IDENTIFICATION

1-12 Hewlett-Packard power supplies are identified by a two-part serial number. The first part is the serial number prefix, a number-letter combination that denotes the date of a significant design change and the country of manufacture. The first two digits indicate the year (10= 1970, 11= 1971, etc.), the second two digits indicate the week, and the letter "A" designates the U.S.A. as the country of manufacture. The second part is the power supply serial number; a different sequential number is assigned to each power supply, starting with 00101.

1-13 If the serial number on your instrument does not agree with those on the title page of the manual, Change Sheets supplied with the manual or Manual Backdating Changes in Appendix A define the differences between your instrument and the instrument described by this manual.

1-14 ORDERING ADDITIONAL MANUALS

1-15 One manual is shipped with each power supply. Additional manuals may be purchased from

your local Hewlett-Packard field office (see list at rear of this manual for addresses). Specify the model number, serial number prefix, and HP part number shown on the title page.

Table 1-1. Specifications

<p>INPUT: 230Vac *10%, single phase, 57-63 Hz, 18A, 2500W @ 230V.</p> <p>OUTPUT : 0-40 volts @ 0-50 amperes.</p> <p>LOAD REGULATION: <u>Constant Voltage</u> - Less than 0.01% plus 200µV for a load current change equal to the current rating of the supply. <u>Constant Current</u> - Less than 0.02% plus 2mA for a load voltage change equal to the voltage rating of the supply.</p> <p>LINE REGULATION : <u>Constant Voltage</u> - Less than 0.01% plus 200µV for a change in line voltage from 207 to 253 volts at any output voltage and current within rating. <u>Constant Current</u> - Less than 0.02% plus 2mA for a change in line voltage from 207 to 253 volts at any output voltage and current within rating.</p> <p>RIPPLE AND NOISE: <u>Constant Voltage</u> - Less than 1mV rms, 5mV P-P (dc to 20MHz). <u>Constant Current</u> - Less than 25mA rms.</p> <p>TEMPERATURE RATINGS: Operating: 0 to 55°C. Storage: -40 to +75°C.</p> <p>TEMPERATURE COEFFICIENT: <u>Constant Voltage</u> - Less than 0.01% plus 200µV change in output per degree Centigrade change in ambient following 30 minutes warm-up. <u>Constant Current</u> - Less than 0.01% plus 4mA change in output per degree Centigrade change in ambient following 30 minutes warm-up.</p> <p>STABILITY : <u>Constant Voltage</u> - Less than 0.03% plus 2mV total drift for 8 hours following 30 minutes warm-up under constant ambient conditions. <u>Constant Current</u> - Less than 0.03% plus 10mA total drift for 8 hours following 30 minutes warm-up under constant ambient conditions.</p> <p>TRANSIENT RECOVERY TIME: Less than 50µsec is required for output voltage recovery (in constant voltage operation) to within 10mV of the nominal output voltage following a 5 ampere change in output current.</p>	<p>METERS: A front panel voltmeter (0-50V) and ammeter (0-60A) is provided. (Accurate within 2% of full scale.)</p> <p>OUTPUT CONTROLS: Single-turn coarse and fine voltage and current controls are included on the front panel.</p> <p>OUTPUT TERMINALS: Output bus bars are located on the rear of the chassis. Both bus bars are isolated from the chassis and either the positive or negative bus bar may be connected to the chassis through a separate, adjacent ground terminal.</p> <p>REMOTE VOLTAGE PROGRAMMING: All programming terminals are on a rear barrier strip. <u>Constant Voltage</u> - 1V/volt (accuracy: 1%). <u>Constant Current</u> - 10mV/amp (Accuracy 10%).</p> <p>REMOTE RESISTANCE PROGRAMMING: All programming terminals are on a rear barrier strip. <u>Constant Voltage</u> -200 ohms/volt (Accuracy: 1%). <u>Constant Current</u> -4 ohms/ampere (Accuracy 10%).</p> <p>OVERVOLTAGE PROTECTION CROWBAR: The minimum crowbar trip setting above the desired operating output voltage” to prevent false crowbar tripping is 5% of output voltage setting plus 2 volts. Range is 4 to 45Vdc.</p> <p>COOLING: Forced air cooling is employed. The supply has two cooling fans.</p> <p>WEIGHT: 95 lbs. (43.0 kg.) net. 120 lbs. (54.5 kg.) shipping.</p> <p>SIZE: 7.0” (17.8cm) H x 17.511 (44.4cm) D x 19.0” (48, 3 cm) W. The unit can be mounted in a standard 19” rack panel.</p> <p>FINISH: Light gray front panel with dark gray case.</p>
---	---

SECTION II INSTALLATION

2-1 INITIAL INSPECTION

2-2 Before shipment, this instrument was inspected and found to be free of mechanical and electrical defects. As soon as the instrument is unpacked, inspect for any damage that may have occurred in transit. Save all packing materials until the inspection is completed. If damage is found, file a claim with the carrier immediately. Hewlett-Packard Sales and Service office should be notified.

2-3 MECHANICAL CHECK

2-4 This check should confirm that there are no broken knobs or connectors, that the cabinet and panel surfaces are free of dents and scratches, and that the meters are not scratched or cracked.

2-5 ELECTRICAL CHECK

2-6 The instrument should be checked against its electrical specifications. Section V includes a n "in-cabinet" performance check to verify proper instrument operation.

2-7 INSTALLATION DATA

2-8 The instrument is shipped ready for bench operation. It is necessary only to connect the instrument to a source of power and it is ready for operation.

2-9 LOCATION

2-10 This instrument is fan cooled. Sufficient space should be allotted so that a free flow of cooling air can reach the sides of the instrument when it is in operation. It should be used in an area where the ambient temperature does not exceed 55°C.

2-11 OUTLINE DIAGRAM

2-12 Figure 2-1 illustrates the outline shape and dimensions of Models 6259B, 6260B, 6261B, 6268B, and 6269B.

2-13 RACK MOUNTING

2-14 This instrument is full rack size and can be easily rack mounted in a conventional 19 inch rack panel using standard mounting screws,

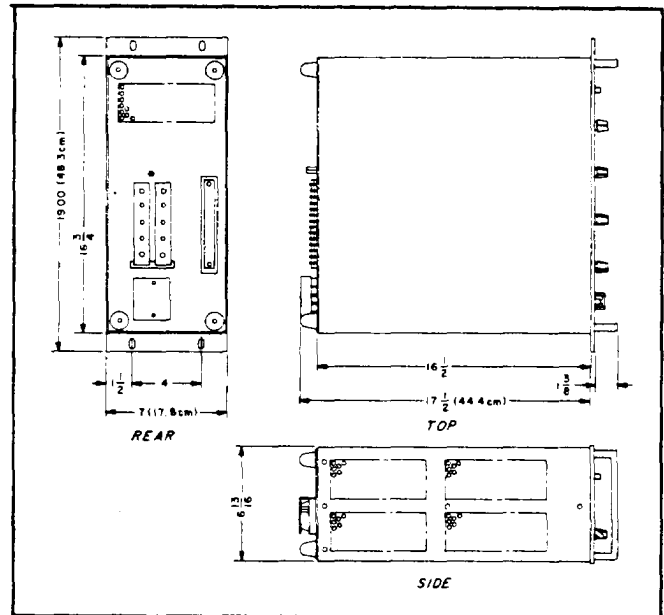

Figure 2-1. Outline Diagram

2-15 INPUT POWER REQUIREMENTS

2-16 Model 6259B, 6260B, 6261B, or 6268B power supply may be operated continuously from either a nominal 230 volt, 208 volt, or 115 volt 57-63Hz power source. Model 6269B may be operated from a 230 volt or 208 volt, 57-63Hz power source only. The instrument as shipped from the factory is wired for 230 volt operation. The input power when operated from a 230 volt power source at full load is:

Model	Input Current	Input Power
6259B	6A	850W
6260B	12A	1600W
6261B	11A	1500W
6268B	11A	1600W
6269B	18A	2500W

2-17 CONNECTIONS FOR 208 VOLT OPERATION (Model 6259B, 6261B, or 6268B: Option 027)

2-18 To convert Model 6259B, 6261B, or 6268B to operation from a 208Vac source, taps on the power and bias transformers must be changed as follows:

- a. Remove RFI assembly as described in Steps (a) through (c) of Paragraph 5-67. Access is now provided to bias transformer A3T2. (See Figure 7-2.)

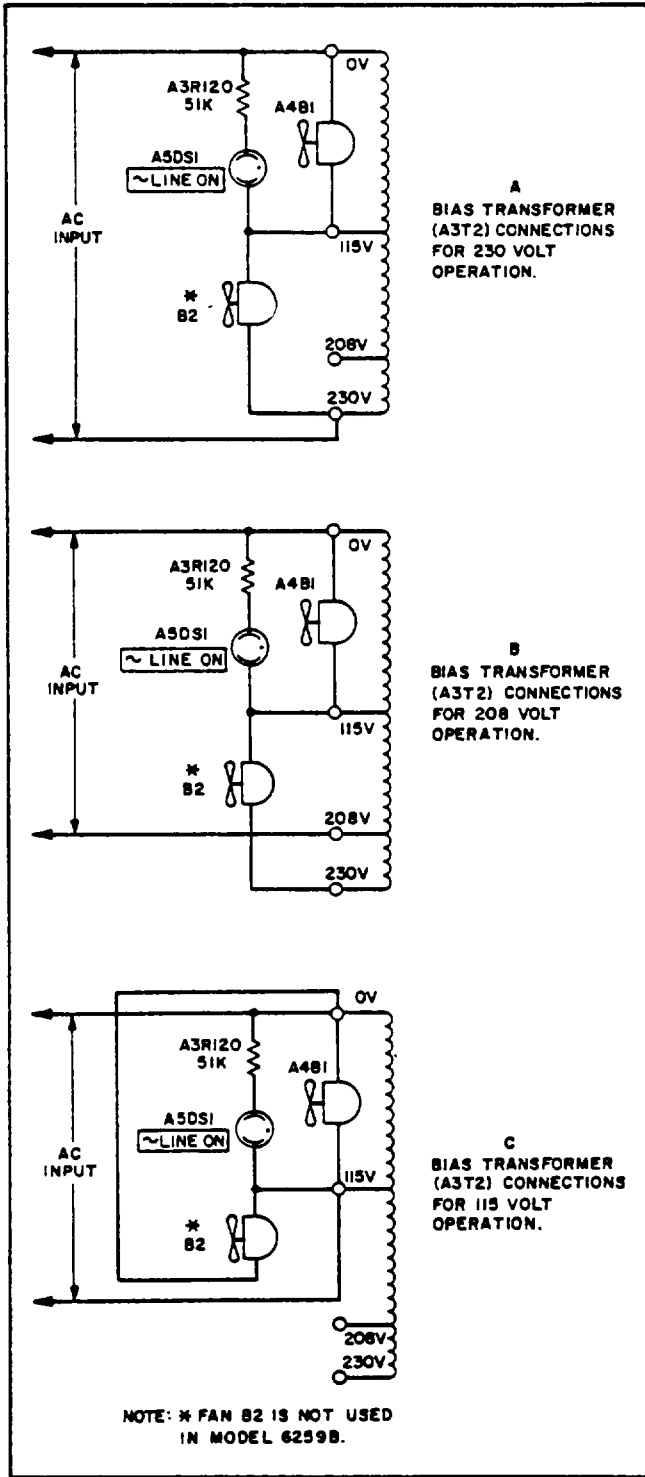

Figure 2-2. Bias Transformer Primary Connections for 208Vac Operation (Model 6259B, 6260B, 6261B, 6268B, and 6269B) and 115Vac Operation (Except Model 6269B)

b. Unsolder wire from circuit breaker A5CB1 connected to "230V" terminal of bias transformer A3T2 and solder it instead to "208V" terminal of

transformer (see Figure 2-2 B). Leave wire from fan B2 (not used in 62599) soldered to "230V" terminal.

c. Re-install RFI assembly by reversing procedure of Step (a).

d. Unsolder wire connected to terminal 5 of power transformer T1 (see Figure 7-4) and solder it instead to terminal 4 of transformer (see Figure 2-3 B).

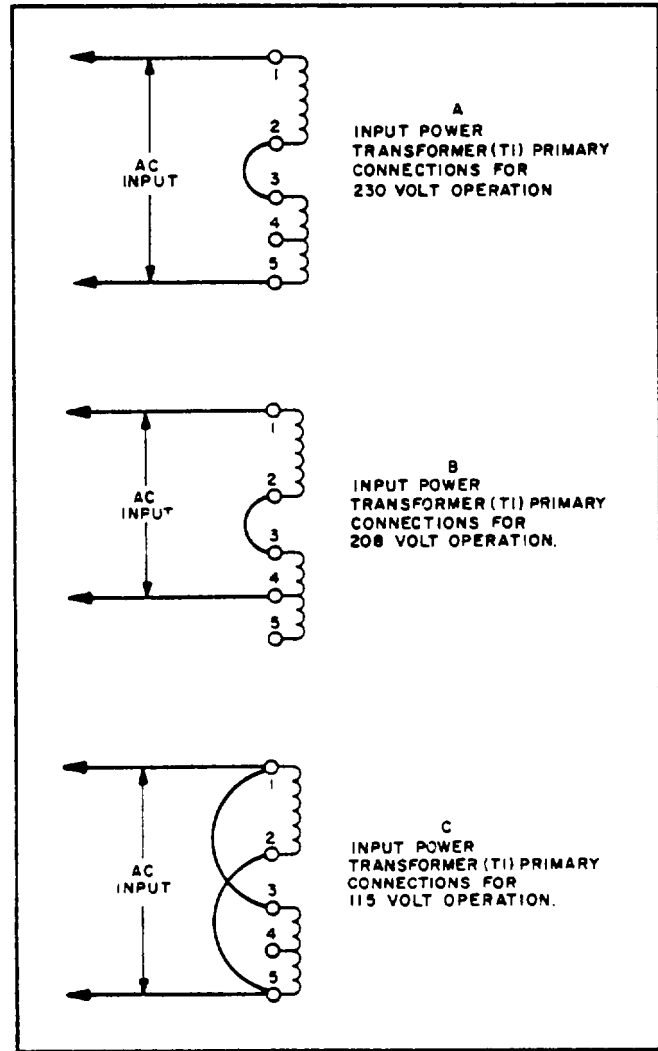

Figure 2-3. Power Transformer Primary Connections for 208Vac and 115Vac Operation . (Model 6259B, 6261B, and 6268B)

2-19 CONNECTIONS FOR 208 VOLT OPERATION (Model 6260B and 6269B: Option 027)

2-20 To convert Model 6260B or 6269B to operation from a 208Vac source, taps on the power and bias transformers must be changed as follows:

- a. Perform Steps (a) through (c) of Paragraph 2-18.
- b. Unsolder wire connected to "230V" terminal

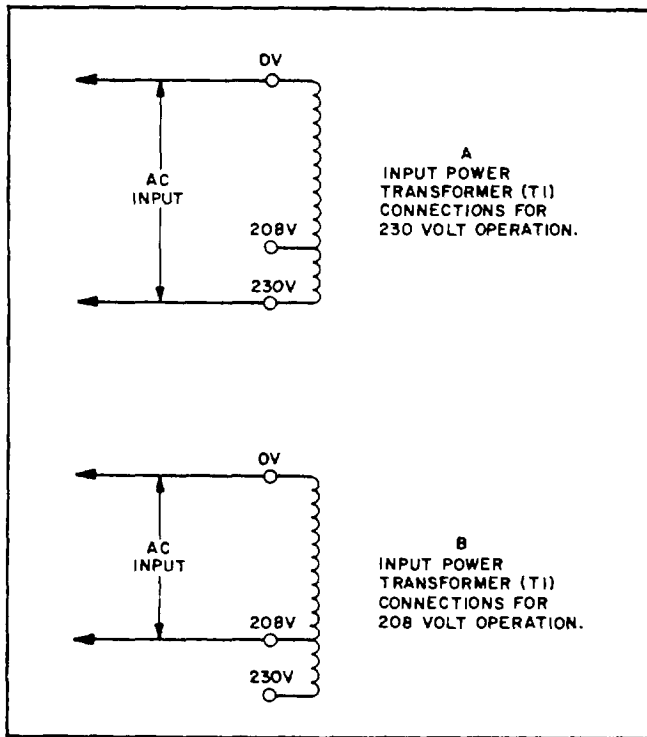

Figure 2-4. Power Transformer T1 Primary Connections for 208Vac Operation (Model 6260B and 6269B)

of power transformer T1 (see Figure 7-4) and solder it instead to "208V" terminal of transformer (see Figure 2-4 B).

2-21 CONNECTIONS FOR 115 VOLT OPERATION
(Model -6259B, 6261B, and 6268B: Option 026)

2-22 To convert Model 6259B, 6261B, or 6268B to operation from a 115Vac source, a new circuit breaker must be installed and taps must be changed on the bias transformer, power transformer, and RFI choke as follows:

- a. Obtain and install new LINE circuit breaker (A5CB1). Connections to new circuit breaker are same as old connections. Refer to Option 026 in Table 6-4 (Replaceable Parts) for current rating and HP Part Number.
- b. Remove and partially disassemble RFI assembly as described in Steps (a) through (d) of Paragraph 5-67.
- c. Unsolder jumper between terminals 2 and 3 of RFI choke mounting board and solder jumpers between terminals 1 and 3, 2 and 4 (see Figure 2-5 B). Replace cover on RFI assembly.
- d. Unsolder wires from circuit breaker A5CB1 and fan B2 connected to "230V" terminal of bias transformer A3T2 (see Figure 7-2). Solder wire from circuit breaker to "115V" terminal of transformer, and solder wire from fan to "0V" terminal of transformer (see Figure 2-2 C). Note that

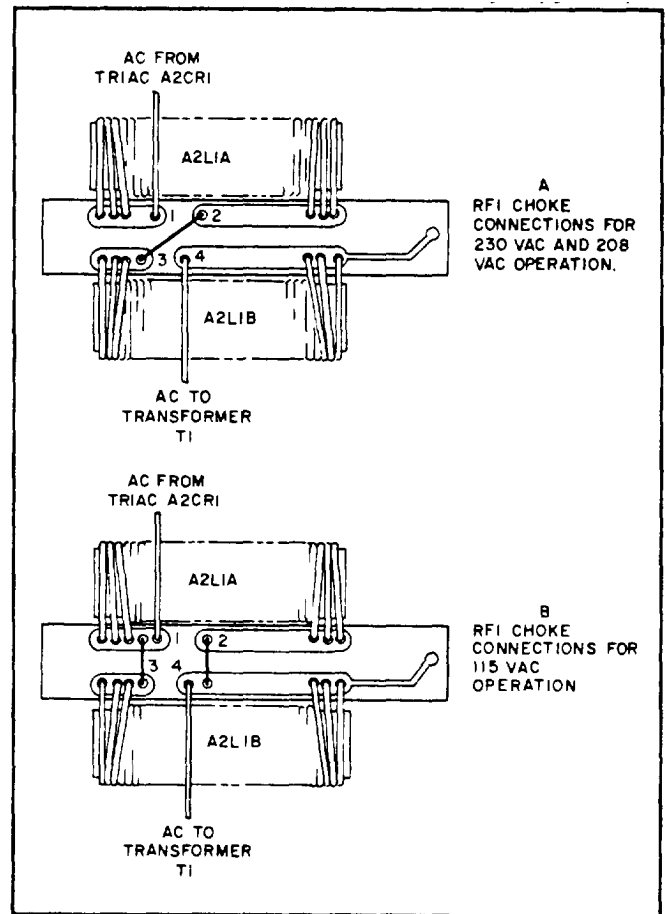

Figure 2-5. RFI Choke (A2L1A/A2L1B) Connections for 115Vac Operation (Model 6259B, 6260B, 6261B, and 6268B)

fan B2 is not used in Model 6259B.

- e. Re-install RFI assembly by reversing procedure of Step (b).
- f. Unsolder jumper connecting terminals 2 and 3 of power transformer T1 (see Figure 7-4) and solder jumpers between terminals 1 and 3, 2 and 5 (see Figure 2-3 C).

2-23 CONNECTIONS FOR 115 VOLT OPERATION
(Model 6260B: Option 016)

2-24 To convert Model 6260B to operation from a 115Vac source, a new power transformer and circuit breaker must be installed and taps must be changed on the RFI choke and bias transformer as follows:

- a. Obtain and install new power transformer (T1) and new circuit breaker (A5CB1). Refer to Option 016 in Table 6-4 (Replaceable Parts) for power ratings and HP Part Numbers. New transformer has two primary terminals. Transfer wire from old transformer "0V" terminal to new transformer "0V" terminal, and wire from old transformer "230V" terminal to new transformer "115V" terminal. New circuit breaker connections are same as old.

b. Perform Steps (b) through (e) of Paragraph 2-22.

2-25 CONNECTIONS FOR 50Hz OPERATION

2-26 For operation from a 50Hz ac input, R82 must be replaced with a 240 Ω , $\pm 5\%$, $\frac{1}{2}$ watt resistor as specified under Option 005 in Table 6-4 (Replaceable Parts). In addition, it is necessary to readjust the voltage drop across the series regulator ("Preregulator Tracking", Paragraph 5-103) and to check the ripple imbalance as described in Steps (a) through (e) of Paragraph 5-101.

2-27 POWER CABLE

2-28 A power cable is not supplied with the instrument. It is recommended that the user-supplied power cable have three conductors (third conductor

grounded) and be of sufficient wire size to handle the input current drawn by the supply (see Paragraph 2-16). Note that when the supply is operated from a 115Vac source, the input current is approximately double that shown in Paragraph 2-16.

2-29 REPACKAGING FOR SHIPMENT

2-30 To insure safe shipment of the instrument, it is recommended that the package designed for the instrument be used. The original packaging material is reusable. If it is not available, contact your local Hewlett-Packard field office to obtain the materials. This office will also furnish the address of the nearest service center to which the instrument can be shipped. Be sure to attach a tag to the instrument specifying the owner, model number, full serial number, and service required, or a brief description of the trouble.

SECTION III OPERATING INSTRUCTIONS

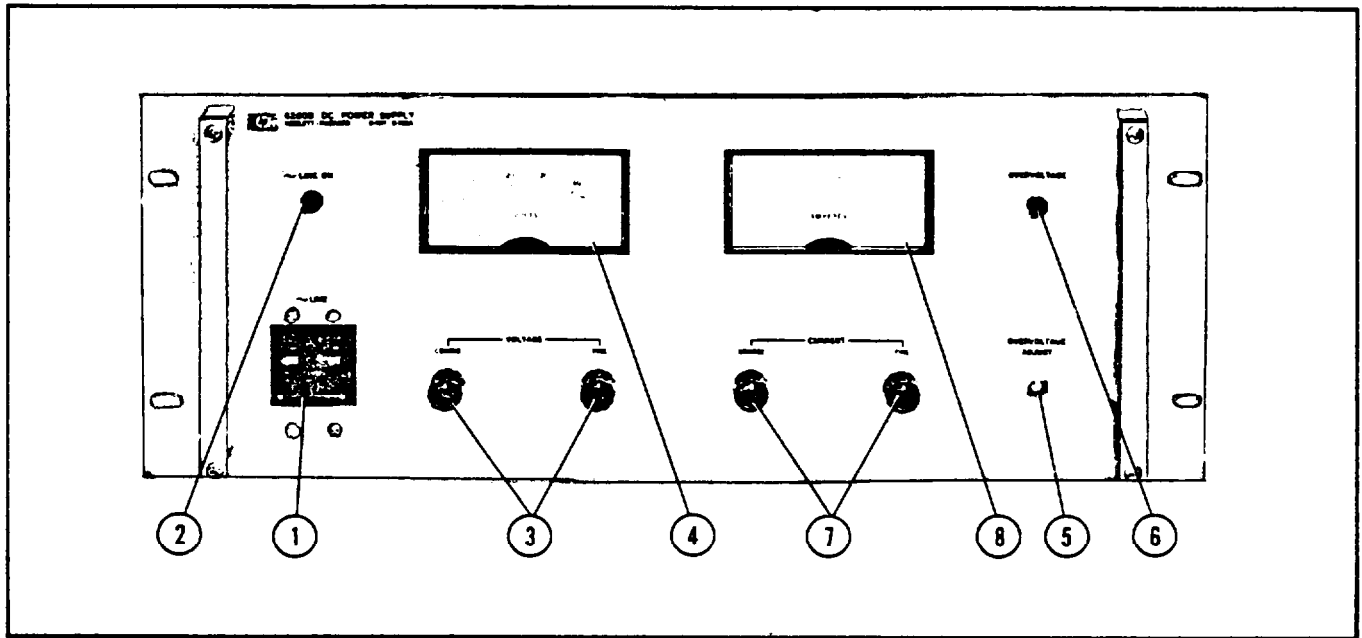

Figure 3-1. Front Panel Controls and Indicators, Modal 6259B, 6260B, 6261B, 6268B or 6269B

3-1 TURN-ON CHECKOUT PROCEDURE

3-2 The following checkout procedure describes the use of the front panel controls and indicators (Figure 3-1) and ensures that the supply is operational.

- a. Set LINE circuit breaker ① to ON, and observe that pilot light ② lights.
- b. Adjust VOLTAGE controls ③ until desired voltage is indicated on voltmeter ④.
- c. To ensure that overvoltage crowbar circuit is operational, rotate OVERVOLTAGE ADJUST control ⑤ (screwdriver adjust) counterclockwise until unit crowbars. Overvoltage lamp ⑥ will light and output voltage will fall to zero volts.
- d. To deactivate crowbar, return OVERVOLTAGE ADJUST control to its maximum clockwise position and turn off supply. Turn supply back on and voltage should again be value obtained in step (b).
- e. To check out constant current circuit, turn off supply. Short circuit rear output terminals and turn on supply.
- f. Adjust CURRENT controls ⑦ until desired output current is indicated on ammeter ⑧.
- g. Remove short circuit and read following paragraphs before connecting actual load to supply.

3-3 OPERATING MODES

3-4 The power supply is designed so that its mode of operation can be selected by making strapping connections between particular terminals on the terminal strip at the rear of the power supply. The terminal designations are stenciled in white on the power supply below their respective terminals. The following paragraphs describe the procedures for utilizing the various operational capabilities of the power supply. A more theoretical description concerning the operational features of this supply is contained in Application Note 90, Power Supply Handbook (available at no charge from your local Hewlett-Packard sales office). Sales office addresses appear at the rear of the manual.

3-5 NORMAL OPERATING MODE

3-6 The power supply is normally shipped with its rear terminal strapping connections arranged for constant voltage/constant current, local sensing, local programming, single unit mode of operation. This strapping pattern is illustrated in Figure 3-2. The operator selects either a constant voltage or a constant current output using the front panel controls (local programming; no strapping changes are necessary).

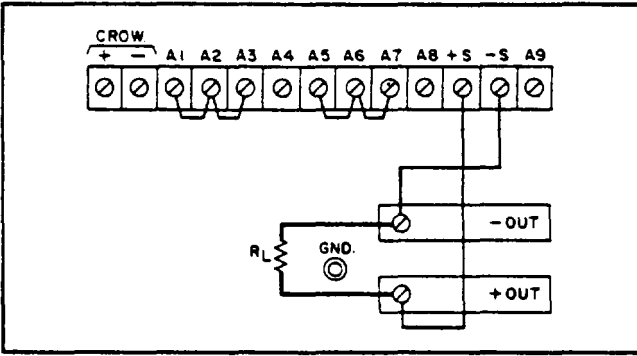

Figure 3-2. Normal Strapping Pattern

3-7 CONSTANT VOLTAGE

3-8 To select a constant voltage output, proceed as follows:

- a. Turn on power supply and adjust VOLTAGE controls for desired output voltage with output terminals open.
- b. Short circuit output terminals and adjust CURRENT controls for maximum output current allowable (current limit), as determined by load conditions. If a load change causes the current limit to be exceeded, the power supply will automatically cross over to constant current output at the preset current limit and the output voltage will drop proportionately. In setting the current limit, allowance must be made for high peak currents which can cause unwanted crossover. (Refer to Paragraph 3-60.)

3-9 CONSTANT CURRENT

3-10 To select a constant current output, proceed as follows:

- a. Short circuit output terminals and adjust CURRENT controls for desired output current.
- b. Open output terminals and adjust VOLTAGE controls for maximum output voltage allowable (voltage limit), as determined by load conditions. If a load change causes the voltage limit to be exceeded, the power supply will automatically cross over to constant voltage output at the preset voltage limit and the output current will drop proportionately. In setting the voltage limit, allowance must be made for high peak voltages which can cause unwanted crossover. (Refer to Paragraph 3-60.)

3-11 OVERVOLTAGE TRIP POINT ADJUSTMENT

3-12 The crowbar trip voltage can be adjusted by using the screwdriver control on the front panel. The trip voltage range is as follows:
 6259B, 6260B 6261B 6268B, 6269B
 2 to 12Vdc 2 to 23Vdc 4 to 45Vdc
 When the crowbar trips, the output is shorted and the amber indicator on the front panel lights.

Clockwise rotation of the control produces higher trip voltages. The factory sets the control fully clockwise. The crowbar may be disabled completely if desired. (Refer to Paragraph 5-11 1.)

3-13 False crowbar tripping must be considered when adjusting the trip point. If the trip voltage is set too close to the operating output voltage of the supply, a transient in the output will falsely trip the crowbar. It is recommended that the crowbar be set higher than the output voltage by 5% of the output voltage plus 2 volts. However, if occasional crowbar tripping on unloading can be tolerated, the crowbar trip point can be set much closer to the operating output voltage of the supply.

3-14 CONNECTING LOAD

3-15 Each load should be connected to the power supply output terminals using separate pairs of connecting wires. This will minimize mutual coupling effects between loads and will retain full advantage of the low output impedance of the power supply. Each pair of connecting wires should be as short as possible and twisted or shielded to reduce noise pickup. (If a shielded pair is used, connect one end of the shield to ground at the power supply and leave the other end unconnected.)

3-16 If load considerations require that the output power distribution terminals be remotely located from the power supply, then the power supply output terminals should be connected to the remote distribution terminals via a pair of twisted or shielded wires and each load should be separately connected to the remote distribution terminals. For this case, remote sensing should be used. (Refer to Paragraph 3-4 1.)

3-17 Positive or negative voltages can be obtained from this supply by grounding either one of the output terminals or one end of the load. Always use two leads to connect the load to the supply, regardless of where the setup is grounded. This will eliminate any possibility of output current return paths through the power source ground which would damage the line cord plug. This supply can also be operated up to 300Vdc above ground, if neither output terminal is grounded.

3-18 NO LOAD OPERATION

3-19 When the supply is operated without a load, down-programming speed is considerably slower than in normal loaded operation. This slower programming speed is evident when using any method of down-programming - either turning the VOLTAGE controls fully counterclockwise, activating the crowbar, or throwing the LINE circuit breaker to OFF. Under any of these conditions, the supply output will rapidly fall to approximately two volts,

then proceed at a slower rate towards zero. The actual time required for the output to fall from two volts to zero will vary from several seconds to several minutes, depending upon which down-programming method is used.

3-20 OPERATION BEYOND RATED OUTPUT

3-21 The shaded area on the front panel meter face indicates the approximate amount of output voltage or current that may be available in excess of the normal rated output. Although the supply can be operated in this shaded region without being damaged, it cannot be guaranteed to meet all of its performance specifications.

3-22 OPTIONAL OPERATING MODES

3-23 REMOTE PROGRAMMING, CONSTANT VOLTAGE

3-24 The constant voltage output of the power supply can be programmed (controlled) from a remote location if required. Either a resistance or voltage source can be used as the programming device. The wires connecting the programming terminals of the supply to the remote programming device should be twisted or shielded to reduce noise pickup. The VOLTAGE controls on the front panel are automatically disabled in the following procedures.

3-25 Resistance Programming (Figure 3-3). In this mode, the output voltage will vary at a rate determined by the voltage programming coefficient of 200 ohms/volt. The programming coefficient is determined by the programming current. This current is factory adjusted to within 1% of 5mA. If greater programming accuracy is required, it may be achieved by either adjusting R3 as discussed in Paragraph 5-88, or, if the instrument is equipped with Option 020, by adjusting potentiometer R112 as discussed in Paragraph 5-89.

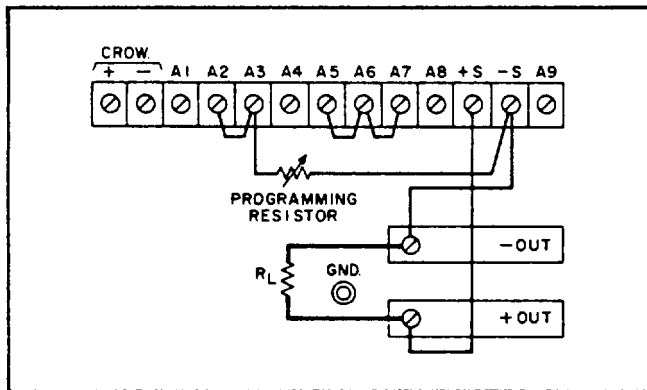

Figure 3-3. Remote Resistance Programming (Constant Voltage)

3-26 The output voltage of the supply should be $-15\text{mV} \pm 5\text{mV}$ when zero ohms is connected across the programming terminals. If a zero ohm voltage closer to zero than this is required, it may be achieved by inserting and adjusting R110 as discussed in Paragraph 5-83, or, if the instrument is equipped with Option 020, by adjusting potentiometer R113 as discussed in Paragraph 5-85.

3-27 To maintain the stability and temperature coefficient of the power supply, use programming resistors that have stable, low noise, and low temperature coefficient (less than 30ppm per degree Centigrade) characteristics. A switch can be used in conjunction with various resistance values in order to obtain discrete output voltages. The switch should have make-before-break contacts to avoid momentarily opening the programming terminals during the switching interval.

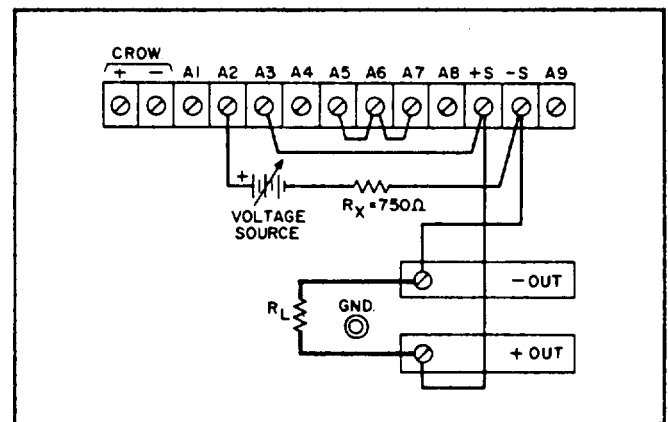

Figure 3-4. Remote Voltage Programming, Unity Gain (Constant Voltage)

3-28 Voltage Programming, Unity Gain (Figure 3-4). Employ the strapping pattern shown in Figure 3-4 for voltage programming with unity gain. In this mode, the output voltage will vary in a 1 to 1 ratio with the programming voltage (reference voltage) and the load on the programming voltage source will not exceed 20 microampere. Impedance matching resistor (R_x) is required to maintain the temperature coefficient and stability specifications of the supply.

3-29 Voltage Programming, Non-Unity Gain (Figure 3-5). The strapping pattern shown in Figure 3-5 can be utilized for programming the power supply using an external voltage source with a variable voltage gain. The output voltage in this configuration is found by multiplying the external voltage source by (R_p/RR) .

3-30 External resistors R_p and R_R should have stable, low noise, and low temperature coefficient

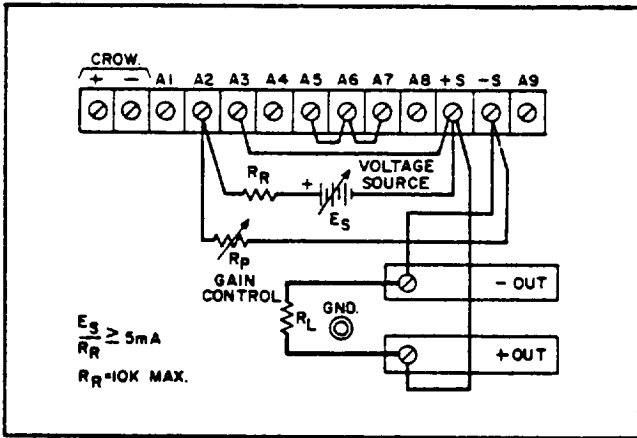

Figure 3-5. Remote Voltage Programming, Non-Unity Gain (Constant Voltage)

(less than 30ppm Per degree Centigrade) characteristics in order to maintain the Supply's temperature and stability specifications. Reference resistor R_R should not exceed 10K. Note that it is possible to use the front panel voltage control already in the supply (A5R121) as the voltage gain control (R_P) by simply removing the external R_P and strapping terminals A1 and A2 together.

3-31 The output voltage of the supply may be adjusted to exactly zero when the external programming voltage is zero by either inserting and adjusting R111 as discussed in Paragraph 5-84, or, if the instrument is equipped with Option 020, by adjusting potentiometer R112 as discussed in Paragraph 5-86.

3-32 REMOTE PROGRAMMING, CONSTANT CURRENT

3-33 Either a resistance or a voltage source can be used to control the constant current output of the supply. The CURRENT controls on the front panel are automatically disabled in the following procedures.

3-34 Resistance Programming (Figure 3-6). In this mode, the output current varies at a rate determined by the *programming* coefficient as follows:

Model	Programming Coefficient
6259B	4 ohms/ampere
6260B	2 ohms/ampere
6261B	4 ohms/ampere
6268B	6 ohms/ampere
6269B	4 ohms/ampere

The programming coefficient is determined by the constant current programming current which is adjusted to within 10% of 2.5mA at the factory. If greater programming accuracy is required, it may be achieved by either adjusting R30 as discussed in Paragraph 5-97, or, if the instrument is equipped

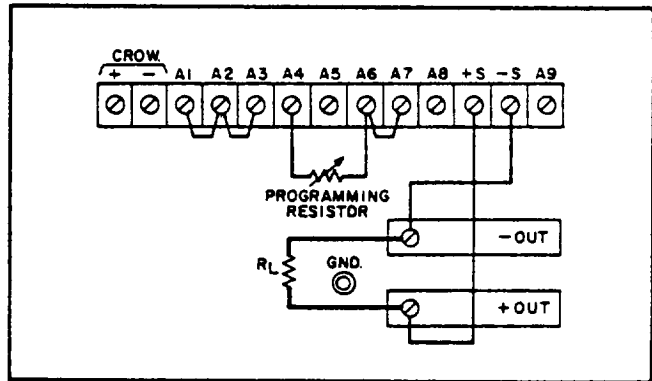

Figure 3-6. Remote Resistance Programming (Constant Current)

with Option 021, by adjusting potentiometer R116 as discussed in Paragraph 5-98. The output current of the supply when zero ohms is placed across the programming terminals *may* be set to exactly zero by either inserting and adjusting R117 as discussed in Paragraph 5-92, or, if the instrument is equipped with Option 021, by adjusting potentiometer R119 as discussed in Paragraph 5-94.

3-35 Use stable, low noise, low temperature coefficient (less than 30ppm/°C) programming resistors to maintain the power supply temperature coefficient and stability specifications. A switch may be used to set discrete values of output current. A make-before-break type of switch should be used since the output current will exceed the maximum rating of the power supply if the switch contacts open during the switching interval.

C A U T I O N

If the programming terminals (A4 and A 6) should open at any time during the remote resistance programming mode, the output current will rise to a value that may damage the power supply and/or the load. If, in the particular programming configuration in use, there is a chance that the terminals might become open, it is suggested that a 200 ohm resistor be connected across the programming terminals. Like the programming resistor, this resistor should be a low noise, low temperature coefficient type. Note that when this resistor is used, the resistance value actually programming the supply is the parallel combination of the remote programming resistance and the resistor across the programming terminals.

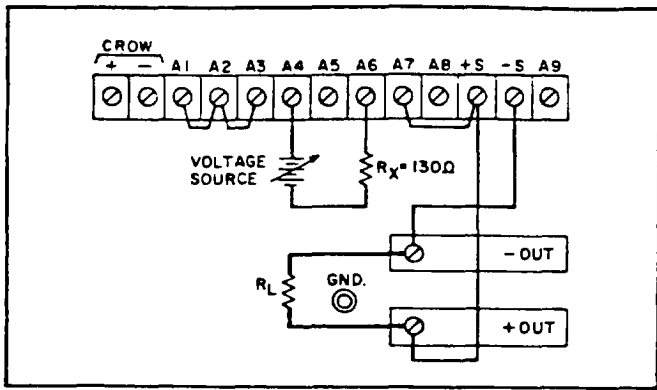

Figure 3-7. Remote Voltage Programming, Unity Gain (Constant Current)

3-36 Voltage Programming, Unity Gain (Figure 3-7). In this mode, the output current will vary linearly with changes in the programming voltage. The programming voltage should not exceed 0.6 volts. Voltage in excess of 0.6 volts will result in excessive power dissipation in the instrument and possible damage.

3-37 The output current varies at a rate determined by the programming coefficient as follows:

Model	Programming Coefficient
6259B	10.0mV/ampere
6260B	5.0mV/ampere
6261B	10.0mV/ampere
6268B	16.7mV/ampere
6269B	10.0mV/ampere

The current required from the voltage source will be less than 20μA. Impedance matching resistor R_x is required to maintain the temperature coefficient and stability specifications of the supply.

3-38 Voltage Programming, Non-Unity Gain (Figure 3-8). The power supply output current can be

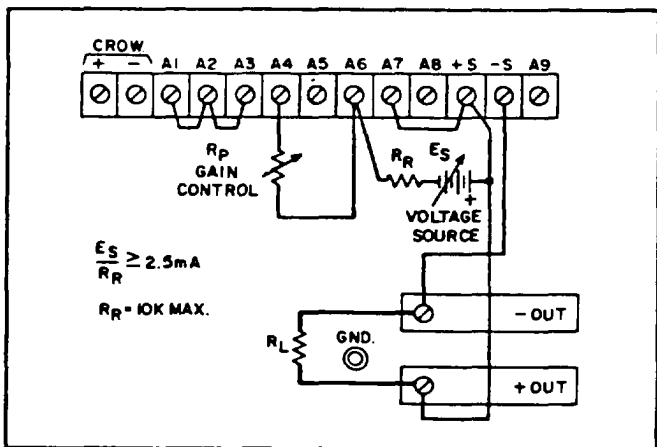

Figure 3-8. Remote Voltage Programming, Non-Unity Gain (Constant Current)

programmed using an external voltage source with variable gain by utilizing the strapping pattern shown in Figure 3-8. In this mode, the output current is found by multiplying the external voltage source (E_s) by $[R_p/(R_R \times K_p)]$, where K_p is the constant current voltage programming coefficient as given in Paragraph 3-37. The value of reference resistor R_R and programming voltage source E_s should be such that the value of E_s/R_R is equal to or greater than 2.5mA.

3-39 External resistors R_p and R_R should have stable, low noise, and low temperature coefficient (less than 30ppm per degree Centigrade) characteristics in order to maintain the stability and temperature specifications of the Power supply. Reference resistor R_R should not exceed 10K. Note that it is possible to use the front panel current control already in the supply (A5R123) as the gain control (R_p) by simply removing the external R_p and strapping terminals AS and A6 together.

3-40 The output current of the supply may be adjusted to exactly zero when the external programming voltage is zero by either inserting and adjusting R115 as discussed in Paragraph 5-93, or, if the instrument is equipped with Option 021, by adjusting potentiometer R116 as discussed in Paragraph 5-95.

3-41 REMOTE SENSING (Figure 3-9)

3-42 Remote sensing is used to maintain good regulation at the load and reduce the degradation of regulation which would occur due to the voltage drop in the leads between the power supply and the load. Remote sensing is accomplished by utilizing the strapping pattern shown in Figure 3-9. The Power supply should be turned off before changing strapping patterns. The leads from the sensing ($\pm S$) terminals to the load will carry much less current than the load leads and it is not required that these leads be as heavy as the load leads. However, they must be twisted or shielded to minimize noise pickup.

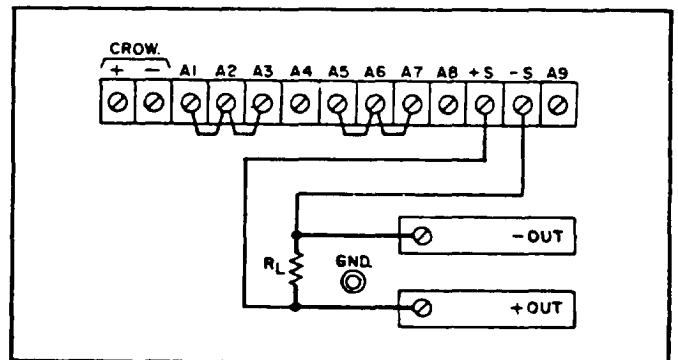

Figure 3-9. Remote Sensing

3-43 For reasonable load lead lengths, remote sensing greatly improves the performance of the supply. However, if the load is located a considerable distance from the supply, added precautions must be observed to obtain satisfactory operation. Notice that the voltage drop in the load leads subtracts directly from the available output voltage and also reduces the amplitude of the feedback error signals that are developed within the unit. Because of these factors it is recommended that the drop in each load lead not exceed 0.5 volt. If a larger drop must be tolerated, please consult an HP Sales Engineer.

NOTE

Due to the voltage drop in the load leads, it may be necessary to readjust the current limit in the remote sensing mode.

3-44 Observance of the precautions in Paragraph 3-43 will result in a low dc output impedance at the load. However, another factor that must be considered is the inductance of long load leads. This causes a high ac impedance and could affect the stability of the feedback loop seriously enough to cause oscillation. If this is the case, it is recommended that the following actions be taken:

a. Adjust equalization control R47 to remove oscillation, or to achieve best possible transient response for given long load lead configuration. Refer to Paragraph 5-27 for discussion of transient response measurement.

b. If performing adjustment in step (a) above does not remove oscillation, disconnect output capacitor A3C3 and connect a capacitor having similar characteristics (approximately the same capacitance, the same voltage rating or greater, and having good high frequency characteristics) directly across load using short leads. Readjust equalization control R47 as in step (a) above after making this change. In order to gain access to capacitor A3C3, it is necessary to remove the RFI assembly as described in steps (a) through (c) of Paragraph 5-67. Lead from positive side of capacitor (shown arrowed in Figure 7-2) can then be unsoldered from A3 interconnection circuit board.

3-45 To employ remote sensing with any method of remote programming or with any method of combining more than one supply discussed in the preceding or following paragraphs, use the following procedure:

a. Remove the two external leads connecting the sensing terminals ($\pm S$) to the output bus bars ($\pm OUT$).

b. Connect a lead from the +S terminal to the positive side of the load, and connect another lead

from the -S terminal to the negative side of the load. Note that there may be more than one lead connected to the +S and -S terminals.

3-46 AUTO-PARALLEL OPERATION (Figure 3-10)

3-47 Two or more power supplies can be connected in an Auto-Parallel arrangement to obtain an output

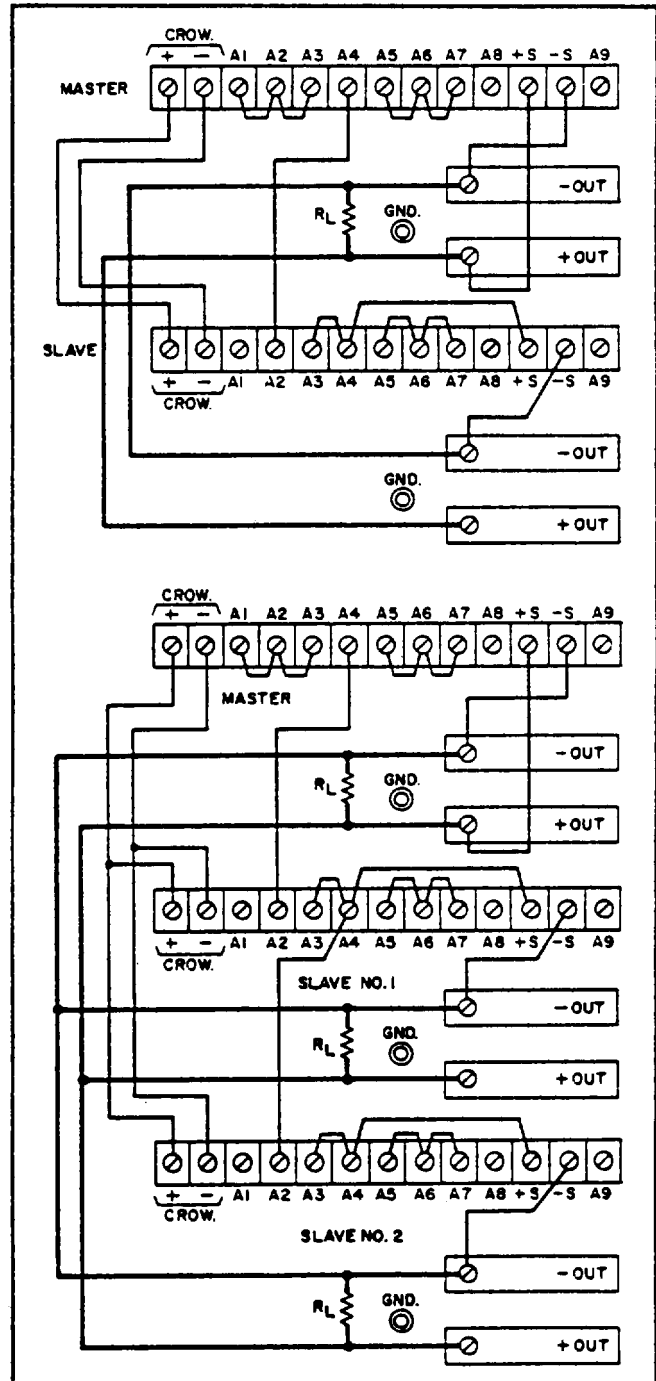

Figure 3-10. Auto-Parallel Operation, Two and Three Units

current greater than that available from one supply. Auto-Parallel operation permits equal current sharing under all load conditions, and allows complete control of the output current from one master power supply. The output current of each slave will be approximately equal to the master's output current regardless of the load conditions. Because the output current controls of each slave are operative, they should be set to maximum to prevent the slave reverting to constant current operation; this would occur if the master output current setting exceeded the slave's.

3-48 Additional slave supplies may be added in parallel with the master/slave combination as shown in the bottom half of Figure 3-10. All the connections between the master and slave #1 are duplicated between slave #1 and the added slave supply. In addition, the strapping pattern of the added slave should be the same as slave #1. Remote sensing and programming can be used, though the strapping arrangements shown in Figure 3-10 show local sensing and programming.

3-49 Overvoltage protection is controlled by the crowbar circuit in the master supply which monitors the voltage across the load and fires the SCR's in both units if an overvoltage condition occurs. The firing pulses are fed to the slave supply from transformer T90 (winding 5-6) of the master supply through the "EXT. CROWBAR TRIGGER" terminals on the rear panel of the master supply. Correct polarity must be observed in connecting the crowbars together. The overvoltage trip point is adjusted on the master supply, The OVERVOLTAGE ADJUST potentiometer on the slave supply should be set to maximum [clockwise] so that the master crowbar will control the slave.

3-50 AUTO-SERIES OPERATION (Figure 3-11)

3-51 Two or more power supplies can be operated in Auto-Series to obtain a higher voltage than that available from a single supply. When this connection is used, the output voltage of each slave supply varies in accordance with that of the master supply. At maximum output voltage, the voltage of the slaves is determined by the setting of the front panel VOLTAGE controls on the master. The master supply must be the most positive supply of the series. The output CURRENT controls of all series units are operative and the current limit is equal to the lowest control setting. If any of the output CURRENT controls are set too low, automatic cross-over to constant current operation will occur and the output voltage will drop. Remote sensing and programming can be used, though the strapping arrangements shown in Figure 3-11 show local sensing and programming.

3-52 In order to maintain the temperature coeffi-

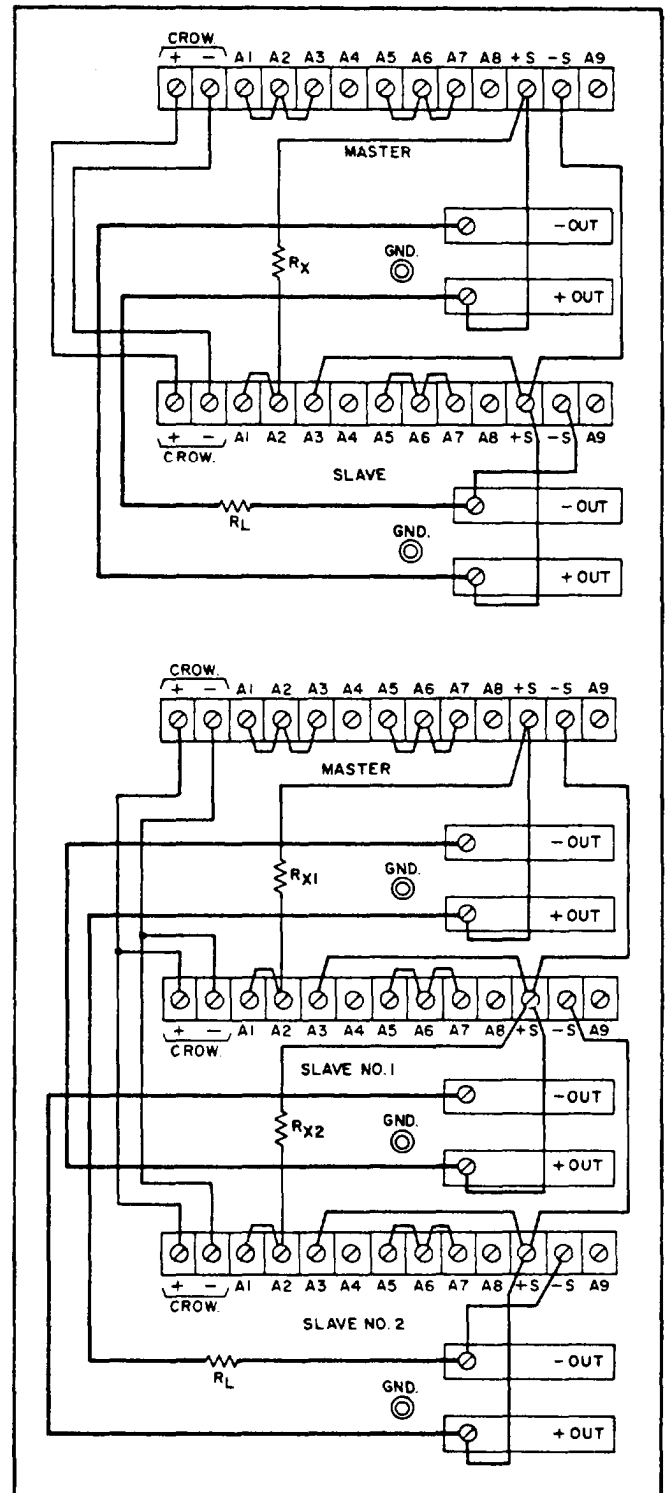

Figure 3-11. Auto-Series Operation, Two and Three Units

cient and stability specifications of the power supply, the external resistors (Rx) shown in Figure 3-11 should be stable, low noise, low temperature coefficient (less than 30ppm per degree Centigrade) resistors. The value of each resistor is dependent

on the maximum voltage rating of the "master" supply. The value of R_x is this voltage divided by the voltage programming current of the slave supply ($1/K_p$ where K_p is the voltage programming coefficient). The voltage contribution of the slave is determined by its voltage control setting.

3-53 Overvoltage protection is provided in Auto-Series operation by connecting the crowbars in parallel with correct polarity as in Auto-Parallel operation (see Paragraph 3-49). The OVERVOLTAGE ADJUST potentiometer in each supply should be adjusted so that it trips at a point slightly above the output voltage that the supply will contribute.

3-54 When the center tap of an Auto-Series combination is grounded, coordinated positive and negative voltages result. This technique is commonly referred to as "robber-banding" and an external reference source may be employed if desired. Any change of the internal or external reference source (e.g. drift, ripple) will cause an equal percentage change in the outputs of both the master and slave supplies. This feature can be of considerable use in analog computer and other applications, where the load requires a positive and a negative power supply and is less susceptible to an output voltage change occurring simultaneously in both supplies than to a change in either supply alone.

3-55 AUTO-TRACKING OPERATION (Figure 3-12)

3-56 The Auto-Tracking configuration is used when several different voltages referred to a common bus must vary in proportion to the setting of a particular instrument (the control or master). A fraction of the master's output voltage is fed to the comparison amplifier of the slave supply, thus controlling the slave's output. The master must have the largest output voltage of any power supply in the group. It must be the most positive supply in the example shown on Figure 3-12.

3-57 The output voltage of the slave (E_s) is a percentage of the master's output voltage (E_M), and is determined by the voltage divider consisting of R_x and the voltage control of the slave supply, R_p , where $E_s = E_M [R_p / (R_x + R_p)]$. Remote sensing and programming can be used (each supply senses at its own load), though the strapping patterns given in Figure 3-12 show only local sensing and programming. In order to maintain the temperature coefficient and stability specifications of the power supply, the external resistors should be stable, low noise, low temperature coefficient (less than 30ppm per degree Centigrade) resistors.

3-58 The overvoltage protection circuit in each unit is operable and independently monitors the voltage across its own load. Notice that if the master supply crowbars, the output voltage of

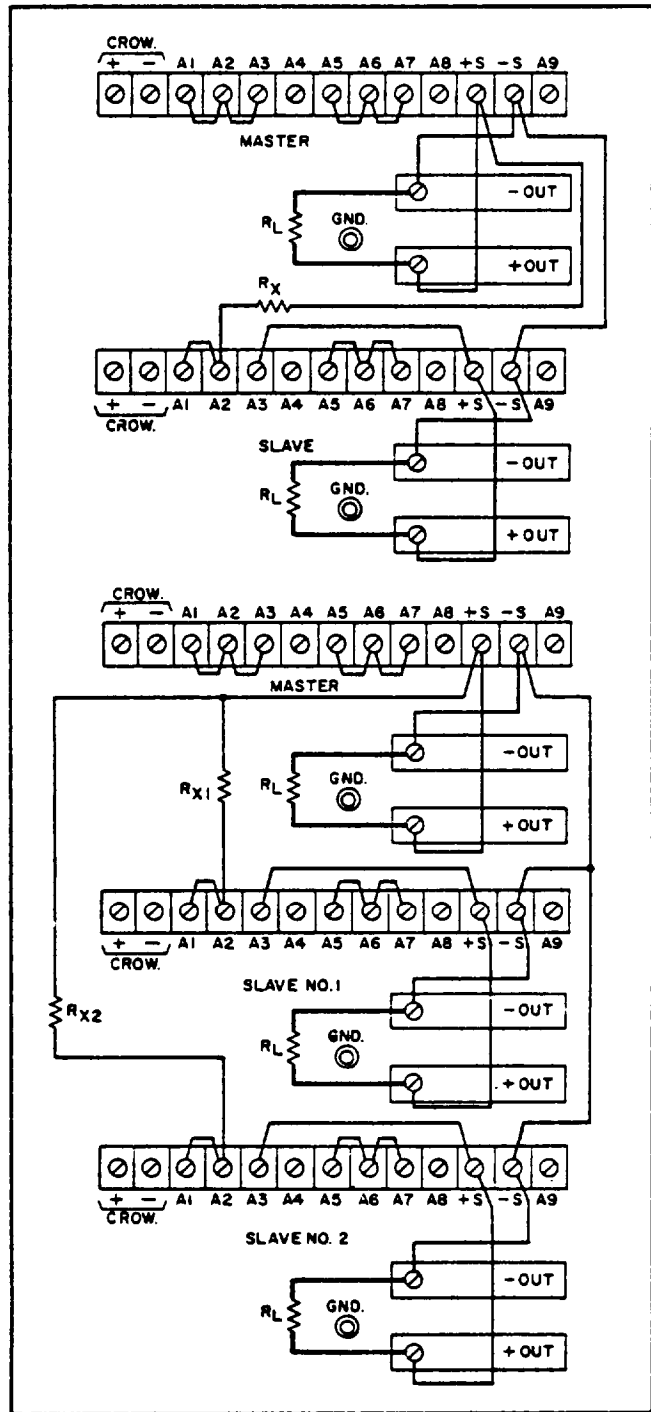

Figure 3-12. Auto-Tracking, Two and Three Units

each slave will also decrease. However, the reverse is not true. If one of the slave units crowbars, the other supplies in the ensemble will not be affected.

3-59 SPECIAL OPERATING CONSIDERATIONS

3-60 "PULSE LOADING

3-61 The power supply will automatically cross

over from constant voltage to constant current operation, or the reverse, in response to an increase (over the preset limit) in the output current or voltage, respectively. Although the preset limit may be set higher than the average output current or voltage, high peak currents or voltages (as occur in pulse loading) may exceed the preset limit and cause crossover to occur. If this crossover limiting is not desired, set the preset limit for the peak requirement and not the average.

3-62 OUTPUT CAPACITANCE

3-63 An internal capacitor (A3C3) connected across the output terminals of the power supply, helps to supply high-current pulses of short duration during constant voltage operation. Any capacitance added externally will improve the pulse current capability, but will decrease the safety provided by the constant current circuit. A high-current pulse may damage load components before the average output current is large enough to cause the constant current circuit to operate.

3-64 The effects of the output capacitor during constant current operation are as follows:

- a. The output impedance of the power supply decreases with increasing frequency.
- b. The recovery time of the output voltage is longer for load resistance changes.

c. A large surge current causing a high power dissipation in the load occurs when the load resistance is reduced rapidly.

3-65 REVERSE VOLTAGE LOADING

3-66 A diode (A4CR106) is connected across the output terminals. Under normal operation conditions, the diode is reverse biased (anode connected to the negative terminal). If a reverse voltage is applied to the output terminals (positive voltage applied to the negative terminal), the diode will conduct, shunting current across the output terminals and limiting the voltage across the output terminals to the forward voltage drop of the diode. This diode protects the series transistors and the output electrolytic capacitors.

3-67 REVERSE CURRENT LOADING

3-68 Active loads connected to the power supply may actually deliver a reverse current to the power supply during a portion of its operating cycle. An external source cannot be allowed to pump current into the supply without loss of regulation and possible damage to the output capacitor. To avoid these effects, it is necessary to preload the supply with a dummy load resistor so that the power supply delivers current through the entire operation cycle of the load device.

4-6 The feedback signals controlling the conduction of the series regulator originate within the constant voltage or constant current comparator. During constant voltage operation the constant voltage comparator continuously compares the output voltage of the supply with the drop across the VOLTAGE controls. If these voltages are not equal, the comparator produces an amplified error signal which is further amplified by the error amplifier and then fed back to the series regulator in the correct phase and amplitude to counteract the difference. In this manner, the constant voltage comparator helps to maintain a constant output voltage and also generates the error signals necessary to set the output voltage at the level established by the VOLTAGE controls.

4-7 During constant current operation, the constant current comparator detects any difference between the voltage drop developed by the load current flowing through the current sampling resistor and the voltage across the CURRENT controls. If the two inputs to the comparator are momentarily unequal, an error signal is generated which (after amplification) alters the conduction of the series regulator by the amount necessary to reduce the error voltage at the comparator input to zero. Hence, the IR drop across the current sampling resistor, and therefore the output current, is maintained at a constant value.

4-8 Since the constant voltage comparator tends to achieve zero output impedance and alters the output current whenever the load resistance changes, while the constant current comparator causes the output impedance to be infinite and changes the output voltage in response to any load resistance change, it is obvious that the two comparison amplifiers cannot operate simultaneously. For any-given value of load resistance, the power supply must act either as a constant voltage source or as a constant current source - it cannot be both.

4-9 Figure 4-2 shows the output characteristic of a constant voltage/constant current power supply. With no load attached ($R_L = \infty$), $I_{OUT} = 0$, and $E_{OUT} = E_S$, the front panel voltage control setting. When a load resistance is applied to the output terminals of the power supply, the output current increases, while the output voltage remains constant; point D thus represents a typical constant voltage operating point. Further decreases in load resistance are accompanied by further increases in I_{OUT} with no change in the output voltage until the output current reaches I_S , a value equal to the front panel current control setting. At this point the supply automatically changes its mode of operation and becomes a constant current source; still further decreases in the value of load resistance are accompanied by a drop in the supply output voltage with no accompanying change in the output current

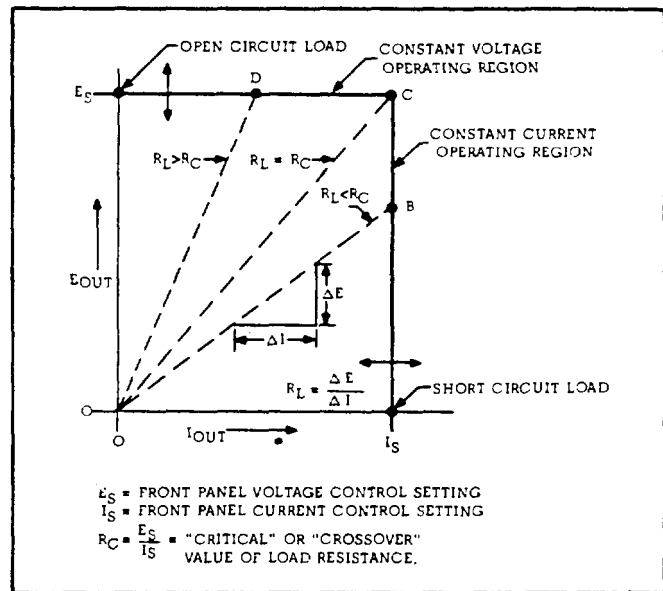

Figure 4-2. Operating Locus of a CV/CC Power Supply

value. With a short circuit across the output load terminals, $I_{OUT} = I_S$ and $E_{OUT} = 0$.

4-10 The "Crossover" value of load resistance can be defined as $R_C = E_S / I_S$. Adjustment of the front panel voltage and current controls permits this "crossover" resistance R_C to be set to any desired value from 0 to ∞ . If R_L is greater than R_C , the supply is in constant voltage operation, while if R_L is less than R_C , the supply is in constant current operation.

4-11 The short circuit protection circuit (see Figure 4-1) protects the series regulator in the event of a shorted output when the controls are set to a high output voltage and current. The protection circuit monitors the voltage drop across the series regulator. If the drop rises above a preset level, the protection circuit limits the current through the series regulator until the preregulator can reduce the voltage across the series regulator. Once this voltage returns to normal, the short circuit protection circuit is turned off and has no effect on normal operation of the supply.

4-12 The overvoltage protection crowbar monitors the output of the supply, and if it exceeds a preset (adjustable) threshold, fires an SCR which short circuits the supply. The circuit also sends a turn-down signal to the preregulator control circuit.

4-13 The overvoltage limit circuit protects the main rectifier diodes and filter capacitors from damage that might occur if the series regulator transistors were shorted or the voltage programming pot were opened. The circuit monitors the output voltage of

the supply and, if it exceeds approximately 120% of maximum rated output, sends a turn-down signal to the preregulator control circuit. Hence, the output voltage of the supply is limited to a "safe" value despite any possible failure in the series regulator feedback loop.

4-14 The turn-on control circuit is a long time constant network which allows the supply to achieve a gradual turn-on characteristic. The slow turn-on feature protects the preregulator triac and the series regulator from damage which might occur when ac power is first applied to the unit. At turn-on, the control circuit sends inhibiting voltages to the preregulator *control* circuit and the series regulator (via the error and driver amplifiers). A short time after the unit is in operation, the inhibiting voltages are removed and the circuit no longer exercises any control over the operation of the supply.

4-15 The reference supply provides stable reference voltages used by the constant voltage and current comparators. Less critical operating voltages are obtained *from* the bias supply.

4-16 DETAILED CIRCUIT ANALYSIS (See Figure 7-11)

4-17 PREREGULATOR CONTROL CIRCUIT

4-18 The preregulator minimizes changes in the power dissipated by the series regulating transistors due to output *voltage or* input line voltage variations. Preregulation is accomplished by means of a phase control circuit utilizing triac A2CR1 as the switching element.

4-19 In order to understand the operation of the preregulator, it is important to understand the operation of the triac. The triac is a bi-directional device, that is, it can conduct current in either direction. Hence, the device fires whenever it receives a gating pulse regardless of the polarity of the input ac that is applied to it. The triac is fired once during each half-cycle (8.33 milliseconds) of the input ac (see Figure 4-3). Notice that when the triac is fired at an early point during the half-cycle, the ac level applied to the power transformer is relatively high. When the triac is fired later during the half-cycle, the ac level is relatively low.

4-20 Normally the ac input signal must be at a certain minimum potential before the triac will conduct. However, A2R1 and A2C1 provide a holding current that allows the triac to conduct at any time during the ac input cycle. RFI choke A2L1A/A2L1B (in series with the triac) slows down the turn-on of the triac in order to minimize spikes at the output of the supply. Components A2CR1, A2R1, A2L1A/A2L1B, and A2C1 are all mounted inside a shielded

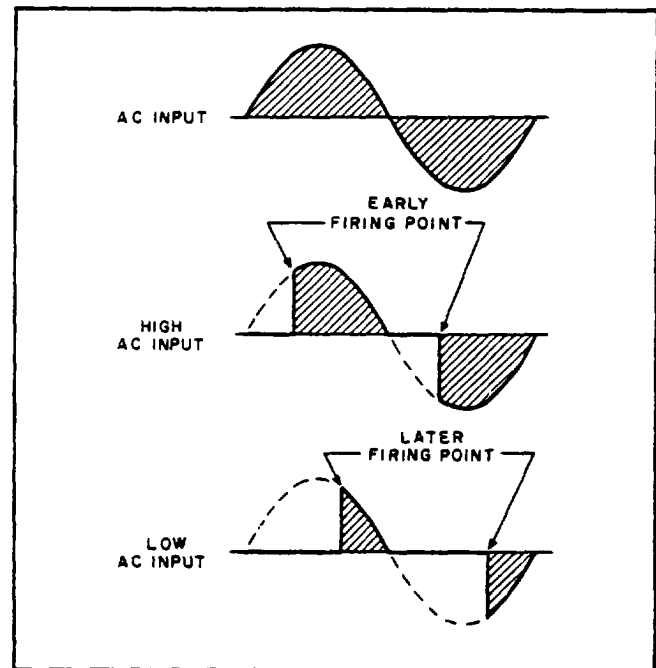

Figure 4-3. Triac Phase Control Over AC Input Amplitude

box (assembly A2) to minimize radiated and reflected RFI. Further RFI suppression is provided by bypass capacitors C110 and C111.

4-21 The preregulator control circuit samples the input line voltage, the output voltage, and the voltage across the series regulator transistors. It generates firing pulses, at the time required, to fire the triac. This action maintains the ac input voltage across the primary winding of T1 at the desired level.

4-22 The inputs to the control circuit are algebraically summed across capacitor C70. All inputs contribute to the time required to charge C70. The input line voltage is rectified by CR81, CR82, CR83, and CR84, attenuated by voltage divider R86 and R83, and applied to the summing point at the collector of Q71 (TP81) via capacitor C70. Capacitor C73 is used for smoothing purposes.

4-23 Transistor Q71, connected in a common base configuration, provides a charging current for the summing capacitor varying in accordance with the input signals applied to its emitter. Resistor R78, connected between the negative output line and the emitter of Q71, furnishes a signal which is *proportional* to the output voltage. Resistors R75 and R76 sample the voltage across, and the current through, the series regulator. Capacitor C72 and resistor R82 stabilize the entire preregulator feedback loop. Resistors R70 and R80 are the source of a *constant* offset current which sustains a net negative charge

TM 11-6625-2958-14&P
 ing current to the summing point, ensuring that the triac will fire at low output "voltages.

4-24 The summation of the input signals results in the generation of a voltage waveform at TP80 similar to that shown in waveform (A) of Figure 4-4. When the linear ramp portion of the waveform reaches a certain negative threshold voltage, diodes CR74 and CR75 become forward biased. The negative voltage is then coupled to the base of transistor Q72. Transistors Q72 and Q73 form a squaring circuit resembling a Schmitt trigger configuration. Q72 is conducting prior to firing time due to the positive bias connected to its base through R84, Transistor Q73 is cut off at this time because its base is driven negative by the collector of Q72.

4-25 When the negative threshold voltage is reached, transistor Q72 is turned off and Q73 is turned on. The conduction of Q73 allows capacitor C71 to discharge rapidly through pulse transformer T70 resulting in the generation of a firing pulse across the secondary winding of T70. As shown in

waveform (C) of Figure 4-4, the firing pulse is quite narrow because Q73 saturates rapidly, causing the magnetic field surrounding T70 to collapse. Diode CR76 damps out positive overshoot.

4-26 Reset of the control circuit occurs once every 8.33 milliseconds when the rectified ac voltage at the junction of CR77, CR78, and CR79 (TP82) increases to a level at which diode CR78 becomes forward biased. Summing capacitor C70 is then allowed to discharge through CR78. Diodes CR74 and CR75 become reverse biased at reset and transistor Q72 reverts to its "on" state. Consequently, Q73 is turned off and capacitor C71 charges up through R79 at a comparatively slow rate until the collector voltage of Q73 reaches approximately +11 volts. The above action causes the small positive spike that appears across the windings of pulse transformer at T70 at reset time.

4-27 SERIES REGULATOR AND DRIVER

4-28 The series regulator consists of transistors A4Q103 through A4Q108 connected in parallel. The transistors serve as the series or "pass" element which provides precise and rapid control of the output. Resistors A4R150 through A4R155 allow high output currents to be equally shared by the series regulator transistors. The conduction of the series regulator transistors is controlled by signals obtained from driver A4Q102, which is connected in a Darlington configuration with the parallel-connected series regulator transistors. Thermal switch A4TS101 opens if the heat sink assembly temperature exceeds approximately 230°F, thus turning off the series regulator transistors. This feature protects critical components of the supply from excessive temperatures which could occur if cooling fan A4B1 failed. Diode CR50 provides a discharge path for the output capacitors when the supply is rapidly down-programmed; R57 limits the discharge current flowing through the diode and through error amplifier A4Q101. Diode A4CR105, connected across the regulator circuit, protects the series elements from reverse voltages that could develop across them during parallel operation if one supply is turned on before the other.

4-29 SHORT CIRCUIT PROTECTION

4-30 This circuit acts to initially protect the series regulator against a simultaneous full-voltage, full-current conditions such as might occur if the output were shorted when the controls were set to deliver a high output voltage and current. Under this condition, Q20 goes into heavy conduction due to the increased voltage across the series regulator, putting R26 in parallel with the current controls and thus limiting the current to less than 10% of the supply's rating. Within 10 milliseconds after the short circuit is imposed, the preregulator shuts off.

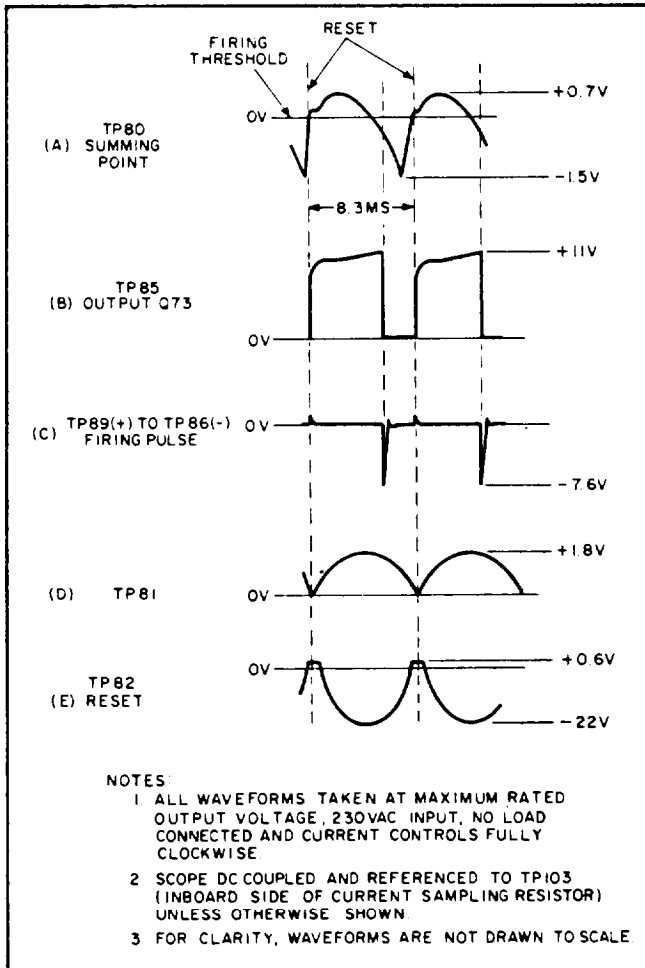

Figure 4-4. Preregulator Control Circuit Waveforms

The input capacitor then begins to discharge through the series regulator, and the voltage across the regulator decreases until Q20 turns off. The discharge time (typically ½ to 4 seconds) depends on the voltage and current ratings of the supply, the main filter capacitor, and the control settings. Once this recovery time has elapsed, the output current will return to the level set by the current controls, and the preregulator will return the voltage across the series regulator to the normal 3.5V level, thus limiting the power dissipated by the series regulator.

4-31 CONSTANT VOLTAGE COMPARATOR

4-32 This circuit consists of the programming resistors (A5R121 and A5R122) and a differential amplifier stage (Z1 and associated components). An integrated circuit is used for the differential amplifier to minimize differential voltages due to mismatched transistors and thermal differentials.

4-33 The constant voltage comparator continuously compares the voltage drop across the VOLTAGE controls with the output voltage and, if a difference exists, produces an error voltage whose amplitude is proportional to this difference. The error signal ultimately alters the conduction of the series regulator which, in turn, alters the output current so that the output voltage becomes equal to the voltage drop across the VOLTAGE controls. Hence, through feedback action, the difference between the two inputs to Z1 is held at zero volts.

4-34 One input of the differential amplifier (pin 10) is connected to the output voltage sensing terminal of the supply (+S) through impedance equalizing resistor R23. Resistors R1 and optional resistor R110 are used to zero bias the input. If the supply is equipped with Option 020, resistor R114 and potentiometer R 113 provide a variable input bias that allows the output voltage to be adjusted to exactly zero volts when the supply is programmed for zero output. The other input of the differential amplifier (pin 1) is connected to a summing point (terminal A2) at the junction of the programming resistors and the current pullout resistors R3, R4, and R5. Instantaneous changes in the output voltage or changes in the voltage at the summing point due to manipulation of the VOLTAGE controls produce a difference voltage between the two inputs of the differential amplifier. This difference voltage is amplified and appears at the output of the differential amplifier (pin 12) as an error voltage which ultimately varies the conduction of the series regulator.

4-3 S Resistor R6, in series with the summing-point input to the differential amplifier, limits the current through the programming resistors during rapid voltage turn-down. Diode CR7 prevents excessive current drain from the +6.2 volt reference supply

during rapid down-programming; diodes CR5 and CR6 prevent excessive voltage excursions from over-driving the differential amplifier. Capacitor C2 prevents the gain of the feedback loop from changing during manipulation of the VOLTAGE controls. Resistor R2 limits the discharge current through C2. Resistors Z2F, Z2M, and Z2N bias the differential amplifier; diode CR4 provides temperature compensation.

4-36 During constant voltage operation, the programming current flowing through the programming resistors (VOLTAGE controls) is held constant because the value of shunt resistor R3 is factory selected to allow all of the +6.2 volt reference to be dropped across R3, R4, and RS. Linear constant voltage programming is thus assured with a constant current flowing through A5R121 and A5R122. If the supply is equipped with Option 020, resistor R111 and potentiometer R 112 allow the programming current to be adjusted by varying the bias applied to the summing point.

4-37 Main output capacitor A3C3 stabilizes the series regulator feedback loop and helps supply high-current pulses of short duration during constant voltage pulse loading operation. An additional output capacitor (C 19), connected directly across the output bus bars, helps maintain a low ac output impedance by compensating for the inductive reactance of the main output capacitor at high frequencies. C19 also prevents any spikes in the output from reaching the load.

4-38 CONSTANT CURRENT COMPARATOR

4-39 This circuit is similar in appearance and operation to the constant voltage comparator circuit. It consists of the coarse and fine current controls (A5R123 and A5R124) and a differential amplifier stage (Z 1 and associated components). As in the constant voltage comparator, an integrated circuit is used for the differential amplifier to minimize differential voltages due to mismatched transistors and thermal differentials.

4-40 The constant current comparator circuit continuously compares the voltage drop across the CURRENT controls with the voltage drop across the current sampling resistor, A4R123. If a difference exists, the differential amplifier produces an error signal which is proportional to this difference. The remaining components in the feedback loop (mixer amplifier, error amplifiers, and the series regulator) function to maintain the voltage drop across the current sampling resistors, and hence the output current, at a constant value.

4-41 One input of the differential amplifier (pin 7) is connected to the output bus through impedance equalizing resistor R20 and is zero-biased by R21

and optional resistor R 117. The other input of the differential amplifier (pin 4) is connected to a summing point (terminal A6) at the junction of the programming resistors and the current pullout resistors R30 and R31. Changes in the output current due to load changes or changes in the voltage at the summing point due to manipulation of the CURRENT controls produce a difference voltage between the two inputs of the differential amplifier. This difference voltage is amplified and appears at the output of the differential amplifier (pin 6) as an error voltage which ultimately varies the conduction of the series regulator.

4-42 Resistor R30 serves as a trimming adjustment for the programming current flowing through A5R123 and A5R124. If the supply is equipped with Option 021, resistor R115 and potentiometer R116 provide a means of adjusting the programming current. As in the constant voltage comparator circuit, a variable input bias (from resistor R118 and potentiometer R119) is provided to allow the output current to be adjusted to exactly zero when the supply is programmed for zero output. Diode CR21 limits excessive voltage excursions at the summing-point input to the differential amplifier.

4-43 VOLTAGE CLAMP CIRCUIT

4-44 The voltage clamp circuit keeps the constant voltage programming current relatively constant when the power supply is operating in the constant current mode. This is accomplished by clamping terminal A2, the voltage summing point, to a fixed bias voltage. During constant current operation the constant voltage programming resistors are a shunt load across the output terminals of the power supply. When the output voltage changes, the current through these resistors also tends to change. Since this programming current flows through the current sampling resistor, it is erroneously interpreted as a load change by the current comparator circuit. The clamp circuit eliminates this undesirable effect by maintaining this programming current at a constant level.

4-45 The voltage divider, Z2A, Z2B, and VR1, back biases CR2 and Q1 during constant voltage operation. When the power supply goes into constant current operation, CR2 becomes forward biased by the voltage at pin 12 of Z 1. This results in conduction of Q1 and the clamping of the summing point at a potential only slightly more negative than the normal constant voltage potential. Clamping this voltage at approximately the same potential that exists in constant voltage operation results in a constant voltage across, and consequently a constant current through, the current pullout resistors R3, R4, and R5.

4-46 MIXER AND ERROR AMPLIFIERS

4-47 The mixer and error amplifiers amplify the error signal from the constant voltage or constant current input circuit to a level sufficient to drive the series regulating transistors. Mixer amplifier Q41 receives the error voltage input from either the constant voltage or constant current comparator via the OR-gate diode (CR1 or CR20) that is conducting at the time. Diode CR1 is forward biased and CR20 reverse biased during constant voltage operation. The reverse is true during constant current operation.

4-48 Transistor Q40 provides a constant current to the collector of Q41 and also generates a negative going turn-off signal for the series regulator when the unit is first turned off. Feedback network C41, R47, and R53 shapes the high frequency rolloff in the loop gain response in order to stabilize the series regulator feedback loop.

4-49 Error amplifiers Q42 and A4Q101 serve as the predriver elements for the series regulator. In addition, transistor A4Q101 allows faster down-programming by providing a discharge path for output capacitors A3C3 and C19, and by supplying a bleed current for the series regulator (thus keeping it in its linear, active region) when the supply is set for zero output current. Diode CR44, in the base circuit of transistor A4Q101, prevents the base from going more negative than -3 volts. This action limits the current through R57 to a relatively low level, thus protecting A4Q101 from damage in the event a voltage higher than the programmed output voltage is placed across the output terminals (such as might occur in Auto-Parallel or battery charging applications).

4-50 OVERVOLTAGE PROTECTION CROWBAR

4-51 The overvoltage protection circuit protects delicate loads from high voltage conditions such as might result from the failure of the series regulator transistor. It accomplishes this by shorting the output of the supply. Under normal operation (no overvoltage), Q92 is conducting since CR91 is reverse biased and Q91 is off. Thus no trigger signal is received by SCR A4CR110 and it acts as an open circuit, having no effect on normal output voltage.

4-52 A5R125 (OVERVOLTAGE ADJUST) adjusts the bias of Q92 with relation to -S. It establishes the point at which CR91 becomes forward biased and Q92 is turned off. Zener diode VR90 provides a stable reference voltage with which the -S potential is compared; R95 sets the upper crowbar trip limit. When Q92 turns off, Q91 begins to conduct, sending a positive going trigger pulse to A4CR110, causing it to create a near short circuit across the

output. When A4CR110 is fired, overvoltage lamp A5DS2 is tuned on, completing a path for a + 11V unregulated holding current through A5DS2. This current holds A4CR110 on even after the output voltage has fallen. A4 CR110 will remain in conduction until the supply is turned off. R92 supplies the holding current if lamp A5DS2 should open. R106 protects A4CR108 and A4CR110 from the large surge current that occurs when A4CR110 is first fired. CR93 damps out positive overshoot in the trigger pulse.

4-53 The firing of SCR A4CR110 biases Q90 into conduction, placing approximately +11 volts on the cathode of CR74 in the preregulator control circuit and thus reverse biasing CR74 and CR75. This action, by preventing transistor Q 72 from turning off, prevents the generation of any trigger pulses and turns off the preregulator. This prevents the series regulator from experiencing a full-voltage, full-current condition.

4-54 The crowbar circuit creates an extra current path during normal operation of the supply, thus changing the current that flows through the sampling resistor. Diode CR92 keeps this extra current at a fixed level for which compensation can then be made in the constant current comparator circuit.

4-55 A slaving arrangement of crowbar circuits in more than one unit is made possible by an extra secondary winding (terminals 5 and 6) on transformer T90. Terminals on the rear barrier strip (\pm EXT. CROWBAR TRIGGER) allow easy connection to this winding. Connecting these windings in parallel when operating in a multiple-supply configuration will result in all the crowbars being activated if one of the crowbars is tripped. To reset the crowbars in this arrangement, all of the units must be turned off and then on. Correct polarity must be observed when connecting the windings in parallel. Figures 3-10 and 3-11 (Auto-Parallel and Auto-Series) demonstrate these connections.

4-56 TURN-ON CONTROL CIRCUIT

4-57 This circuit is a long time-constant network which protects the triac and the series regulator from possible damage during turn-on. When the supply is first tuned on, C35 provides a positive voltage to the anodes of CR35 and CR36. The voltage from CR35 is connected to the cathode of diode CR74 in the preregulator control circuit to ensure that it is initially reverse biased. After C35 becomes sufficiently charged, diode CR35 becomes reverse biased and the preregulator control circuit is permitted to fire the triac.

4-58 Diode CR36 performs a similar function for the series regulator. CR36 initially couples a positive voltage to Q41 where it is inverted and ap-

plied to the series regulator. This negative voltage keeps the regulator cut off until C35 charges up. Diode CR37 provides a discharge path for C35 when the supply is turned off.

4-59 REFERENCE REGULATOR

4-60 The reference circuit is a feedback power supply similar to the main supply. It provides stable reference voltages used throughout the unit. AH the reference *voltages are* derived from dc obtained from full wave rectifier CR61-CR62 and filter capacitor C61. The total output of the reference circuit is 18.6V. Zener diodes VR60 and VR61 establish moderately well regulated potentials of +6.2V and -6.2V respectively from the common point +S, while the regulator circuit establishes a very well regulated potential of +12.4 volts from +S. Resistor R63 limits the current through the Zener diodes to establish an optimum bias level.

4-61 The regulating circuit consists of s crie's regulating transistor Q60, driver Q61, and differential amplifier Q62 and Q63. The voltage across Zener diode VR60 (+6.2 volts with respect to +S) and the voltage at the junction of divider Z2L-R69B and Z2J are compared, and any difference is amplified by Q 62 and Q63. The error voltage thus appearing at the collector of Q62 is amplified by driver stage Q61 and applied to series regulator Q60 in the correct phase and amplitude to maintain the +12.4 volt output at a constant level.

4-62 Diode CR60, connected from voltage divider R66 and R67 to the base of Q61, serves as a turn-on circuit for series regulator transistor Q60. When the supply is first turned on, CR60 biases driver Q61 on, thus turning on the series regulator. When the reference supply reaches normal output, the base voltage of Q61 is sufficient to reverse bias CR60, thus effectively removing it from the circuit. Capacitor C60, connected across the output of the reference supply, removes spikes and stabilizes the reference regulator loop.

4-63 Unregulated 11Vdc is supplied from a separate winding on transformer A3T2 by diodes CR53 and CR54 and filter capacitor C44. Additional lightly regulated reference voltages of -4V and -2.4V are provided by diodes CR45-CR46 and CR47-CR48-CR49 respectively. Diode CR43 prevents reverse current flow from damaging the main supply series regulator transistors. Diode CR7, shown in the schematic near the current pullout resistors (R3, R4, and RS), protects the Zener diodes in the reference circuit by providing a path for surge currents which occur during rapid down programming.

4-64 METER CIRCUIT

4-65 The meter circuit provides continuous indica-

tions of output voltage and current on the dc voltmeter and ammeter. Both meter movements can withstand an overload of many times the maximum rated output without damage.

4-66 The ammeter together with its series resistors (R101, R105) is connected across current sampling resistor A4R123. As mentioned previously, the voltage drop across the current sampling resistor varies in proportion to the output current. Potentiometer R101 is adjusted for full scale deflection (calibration) of the ammeter.

4-67 The voltmeter, in series with R103 and R104 and shunted by R102 and R106, is connected directly across the output terminals of the supply. Potentiometer R106 permits calibration of the voltmeter.

4-68 ADDITIONAL PROTECTION FEATURES

4-69 The supply contains several "special purpose" components which protect the supply in the event of unusual circumstances. One of these components is diode A4CR106. Connected across the output terminals of the supply, it prevents internal damage from reverse voltages that might be applied across the supply. This could occur, for example, during Auto-Series operation if one supply was turned on before the other.

4-70 Resistors R108 and R109 limit the output of the supply if the connections between both output buses and the sensing terminals (+S and -S) are inadvertently removed.

4-71 Diode A4CR105, previously mentioned in the series regulator description, protects the regulating transistor from the effects of reverse voltages.

**SECTION V
MAINTENANCE**

5-1 INTRODUCTION

5-2 Upon receipt of the power supply, the performance check (Paragraph 5-5) should be made. This check is suitable for incoming inspection. If a fault is detected in the power supply while making the performance check or during normal operation, proceed to the troubleshooting procedures (Paragraph 5-51). After troubleshooting and repair (Paragraph 5-71), perform any necessary adjustments and calibrations (Paragraph 5-73). Before

returning the power supply to normal operation, repeat the performance check to ensure that the fault has been properly corrected and that no other faults exist. Before performing any maintenance checks, turn on the power supply and allow a half-hour warm-up.

5-3 TEST EQUIPMENT REQUIRED

5-4 Table 5-1 lists the test equipment required to perform the various procedures described in this section.

Table 5-1. Test Equipment Required

TYPE	REQUIRED CHARACTERISTICS	USE	RECOMMENDED MODEL
Differential Voltmeter	Sensitivity: 1mV full scale (min.) Input impedance: 10M Ω (rein.)	Measure dc voltages; calibration procedures.	Ⓢ 3420A/B (See Note on Page 5-2)
Oscilloscope	Sensitivity and bandwidth; 100μV/cm and 400KHz for all measurements except noise spike; 5mV sensitivity and 20 MHz bandwidth for noise spike measurement.	Measure ripple; display transient recovery waveform; measure noise spikes.	Ⓢ 140A with 1423A time base and 1400A vertical plug-in; 1402A plug-in for spike measurement.
Variable Voltage Transformer	Range: 207-253Vac. Recommended minimum output current: 12A, 6259B; 22A, 6261B and 6268B; 24A, 6260B: 36A, 6269B.	Vary ac input for line regulation measurement.	----
AC Voltmeter	Sensitivity: 1mV full scale deflection (min). Accuracy: 2%.	Measure ac voltages and ripple.	Ⓢ 403B
DC Voltmeter	Sensitivity: 1mV full scale deflection (rein). Accuracy: 1%.	Measure dc voltages.	Ⓢ 412A
Repetitive Load Switch	Switching rate: 60-400Hz Rise time: 2μsec.	Measure transient recovery time.	See Figure 5-5.
Resistive Loads	Values: see Figures 5-2 and 5-5.	Power supply load resistors.	----
Current Sampling Resistors	Values: see Figure 5-8.	Measure output current; calibrate ammeter.	A4R123; A4R123A-A4R123B, 6260B only; see Replaceable Parts Table.

Table 5-1. Test Equipment Required (Continued)

TYPE	REQUIRED CHARACTERISTICS	USE	RECOMMENDED MODEL
Terminating Resistors	Value: 50 ohms, 1/2 watt, ±5%, non-inductive. (Four required.)	Noise spike measurement.	----
Blocking Capacitors	Value: 0.01µF, 100Vdc. (Two required.)	Noise spike measurement.	----

NOTE

A satisfactory substitute for a differential voltmeter is a reference voltage source and null detector arranged as shown in Figure 5-1. The reference voltage source is adjusted so that the voltage difference between the supply being measured and the reference voltage will have the required resolution for the measurement being made. The voltage difference will be a function of the null detector that is used. Examples of satisfactory null detectors are:  419A null detector, a dc coupled oscilloscope utilizing differential input, or a 50mV meter movement with a 100 division scale. For the latter, a 2mV change in voltage will result in a meter deflection of four divisions.

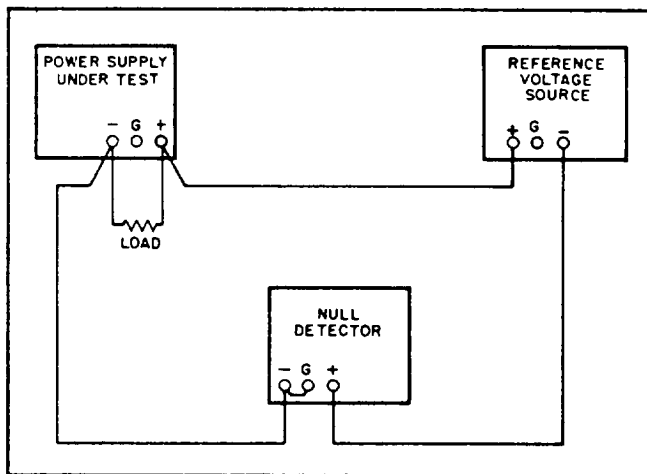

Figure 5-1. Differential Voltmeter Substitute Test Setup

CAUTION

Care must be exercised to avoid ground loops and circulating currents when using an electronic null detector in which one input terminal is grounded.

5-5 PERFORMANCE TEST

5-6 The following test can be used as an incoming inspection check and appropriate portions of the test can be repeated either to check the operation of the instrument after repairs or for periodic maintenance tests. The tests are performed using a 230V ac, 60 Hz, single phase input power source. If the correct result is not obtained for a particular check, do not adjust any internal controls; proceed to troubleshooting (Paragraph 5-5 1).

5-7 CONSTANT VOLTAGE TESTS

5-8 If maximum accuracy is to be obtained in the following measurements, the measuring devices must be connected as close to the output terminals as possible. This is particularly important when measuring the transient response, regulation, or ripple of the power supply. A measurement made across the load includes the impedance of the leads to the load and such lead lengths can easily have an impedance several orders of magnitude greater than the supply impedance, thus invalidating the measurement.

5-9 To avoid mutual coupling effects, each monitoring device must be connected to the output terminals by a separate pair of leads. Twisted pairs or shielded two-wire cables should be used to avoid pickup on the measuring leads. The load resistor should be connected across the output terminals as close to the supply as possible. When measuring the constant voltage performance specifications, the current controls should be set well above (at least 10%) the maximum output current which the supply will draw, since the onset of constant current action will cause a drop in output voltage, increased ripple, and other performance changes not properly ascribed to the constant voltage operation of the supply .

5-10 Voltage Output and Voltmeter Accuracy. To check the output voltage, proceed as follows:

- a. Connect load resistor (R_L) indicated in Figure 5-2 across output terminals of supply.
- b. Connect differential voltmeter across +OUT and -OUT terminals of supply, observing

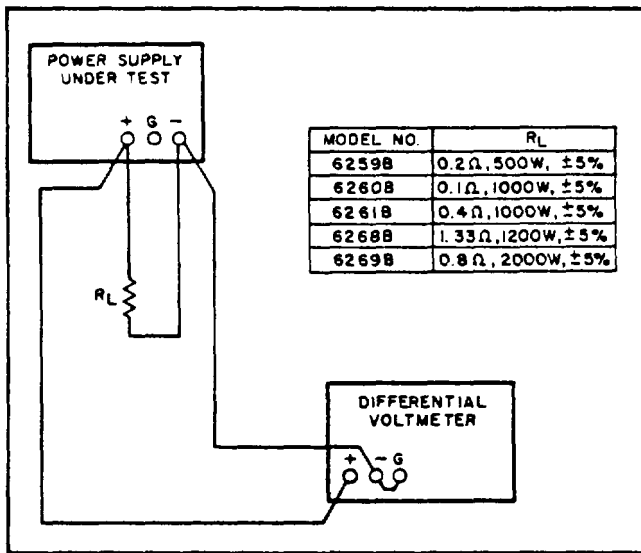

Figure 5-2. Constant Voltage Load Regulation Test Setup

correct polarity.

c. Turn CURRENT controls fully clockwise.

d. Turn on supply and adjust VOLTAGE controls until front panel meter indicates exactly maximum rated output voltage.

e. Differential voltmeter should indicate the following:

6259B, 6260B	10 ±0.2Vdc
6261B	20 ±0.4Vdc
6268B, 6269B	40 ±0.8Vdc

5-11 Load Regulation.

Definition: The change ΔE_{OUT} in the static value of dc output voltage resulting from a change in load resistance from open circuit to a value which yields maximum rated output current (or vice versa).

5-12 To check the constant voltage load regulation, proceed as follows:

a. Connect test setup shown in Figure 5-2.

b. Turn CURRENT controls fully clockwise.

c. Turn on supply and adjust VOLTAGE controls until front panel meter indicates exactly maximum rated output current.

d. Read and record voltage indicated on differential voltmeter.

e. Disconnect load resistor.

f. Reading on differential voltmeter should not vary from reading recorded in Step (d) by more than the following:

6259B, 6260B	1.2mV
6261B	2.2mV
6268B, 6269B	4.2mV

5-13 Line Regulation.

Definition: The change ΔE_{OUT} in the static value of dc output voltage resulting from a change in ac input voltage over the specified range from low line (usually 207 volts) to high line (usually 253 volts), or from high line to low line.

5-14 To check the line regulation, proceed as follows :

a. Connect test setup shown in Figure 5-2.

b. Connect variable auto transformer between input power source and power supply power input.

c. Adjust variable auto transformer for 207 volts a c input.

d. Turn CURRENT controls fully clockwise.

e. Turn on supply and adjust VOLTAGE controls until front panel meter indicates exactly maximum rated output voltage.

f. Read and record voltage indicated on differential voltmeter.

g. Adjust variable auto transformer for 253V ac input.

h. Reading on differential voltmeter should not vary from reading recorded in Step (f) by more than the following:

6259B, 6260B	1.2mV
6261B	2.2mV
6268B, 6269B	4.2mV

5-15 Ripple and Noise.

Definition: The residual ac voltage superimposed on the dc output of a regulated power supply. Ripple and noise may be specified and measured in terms of its RIMS or (preferably) peak-to-peak value.

Ripple and noise measurement can be made at any input ac line voltage combined with any dc output voltage and load current within the supply's rating.

5-16 The amount of ripple and noise that is present in the power supply output is measured either in terms of the RMS or (preferably) peak-to-peak value. The peak-to-peak measurement is particularly important for applications where noise spikes could be detrimental to a sensitive load, such as logic circuitry. The RMS measurement is not an ideal representation of the noise, since fairly high output noise spikes of short duration can be present in the ripple without appreciably increasing the RMS value,

5-17 Ripple Measurements. Figure 5-3A shows an incorrect method of measuring p-p ripple. Note that a continuous ground loop exists from the third wire of the input power cord of the supply to the third wire of the input power cord of the oscilloscope via the grounded power supply case, the

wire between the negative output terminal of the power supply and the vertical input of the scope, and the grounded scope case. Any ground current circulating in this loop as a result of the difference in potential E_G between the two ground points causes an IR drop which is in series with the scope input. This IR drop, normally having a 60Hz line frequency fundamental, plus any pickup on the unshielded leads interconnecting the power supply and scope, appears on the face of the CRT. The magnitude of this resulting noise signal can easily be much greater than the true ripple developed between the plus and minus output terminals of the power supply, and can completely invalidate the measurement.

5-18 The same ground current and pickup problems can exist if an RMS voltmeter is substituted in place of the oscilloscope in Figure 5-3. However, the oscilloscope display, unlike the true RMS meter reading, tells the observer immediately whether the fundamental period of the signal displayed is 8.3 milliseconds (1/120 Hz) or 16.7 milliseconds (1/60 Hz). Since the fundamental ripple frequency present on the output of an ϕ supply is 120Hz (due to full-wave rectification), an oscilloscope display showing a 120Hz fundamental component is indicative of a "clean" measurement set-up, while the presence of a 60Hz fundamental usually means that an improved setup will result in a more accurate (and lower) value of measured ripple.

5-19 Although the method shown in Figure 5-3A is not recommended for ripple measurements, it may prove satisfactory in some instances provided certain precautionary measures are taken. One method of minimizing the effects of ground current (I_G) flow is to ensure that both the supply and the test instrument are plugged into the same ac power buss.

5-20 To minimize pick up, a twisted pair or (preferably) a shielded two-wire cable should be used to connect the output terminals of the power supply to the vertical input terminals of the scope. When using a twisted pair, care must be taken that one of the two wires is connected both to the grounded terminal of the power supply and the grounded input terminal of the oscilloscope. When using shielded two-wire cable, it is essential for the shield to be connected to ground at one end only to prevent any ground current flowing through this shield from inducing a signal in the shielded leads.

5-21 To verify that the oscilloscope is not displaying ripple that is induced in the leads or picked up from the grounds, the (+) scope lead should be shorted to the (-) scope lead at the power supply terminals. The ripple value obtained when the leads are shorted should be subtracted from the

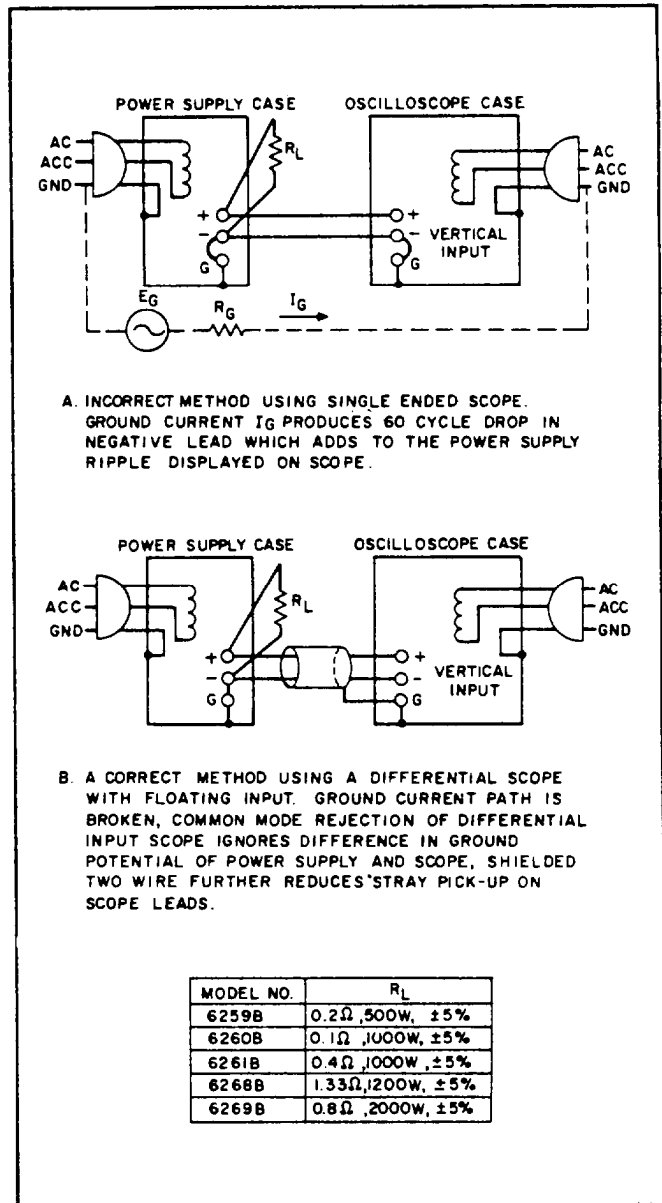

Figure 5-3. Ripple Test Setup

actual ripple measurement.

5-22 If the foregoing measures are used, the single-ended scope of Figure 5-3A may be adequate to eliminate non-real components of ripple so that a satisfactory measurement can be obtained. However, in stubborn cases or in measurement situations where it is essential that both the power supply case and the oscilloscope case be connected to ground (e. g. if both are rack-mounted), it may be necessary to use a differential scope with floating input as shown in Figure 5-3B. If desired, two single-conductor shielded cables may be substituted in place of the shielded two-wire cable with equal success.

Because of its common mode rejection, a differential oscilloscope displays only the difference in signal between its two vertical input terminals, thus ignoring the effects of any common mode signal produced by the difference in the ac potential between the power supply case and scope case. Before using a differential input scope in this manner, however, it is imperative that the common mode rejection capability of the scope be verified by shorting together its two input leads at the power supply and observing the trace on the CRT. If this trace is a straight line, then the scope is properly ignoring any common mode signal present. If this trace is not a straight line, then the scope is not rejecting the ground signal and must be realigned in accordance with the manufacturer's instructions until proper common mode rejection is attained.

5-23 To check the ripple output, proceed as follows :

- a. Connect oscilloscope or RMS voltmeter as shown in Figures 5-3A or 5-3B.
- b. Turn CURRENT controls fully clockwise.
- c. Adjust VOLTAGE controls until front panel meter indicates maximum rated output voltage.
- d. The observed ripple should be less than the following:

6259B, 6260B, 6261B	500 μ Vrms and 5mV p-p
6268B, 6269B	1mVrms and 5mV p-p

5-24 Noise Spike Measurement. When a high frequency spike measurement is being made, an instrument of sufficient bandwidth must be used; an oscilloscope with a bandwidth of 20 MHz or more is adequate. Measuring noise with an instrument that has insufficient bandwidth may conceal high frequency spikes detrimental to the load.

5-25 The test setup illustrated in Figure 5-3A is generally not acceptable for measuring spikes; a differential oscilloscope is necessary. Furthermore, the measurement concept of Figure 5-3B must be modified if accurate spike measurement is to be achieved

1. As shown in Figure 5-4, two coax cables must be substituted for the shielded two-wire cable.
2. Impedance matching resistors must be included to eliminate standing waves and cable ringing, and capacitors must be inserted to block the dc current path.
3. The length of the test leads outside the coax is critical and must be kept as short as possible; the blocking capacitor and the impedance matching resistor should be connected directly from the inner conductor of the cable to the power supply terminals.
4. Notice that the shields of the power supply end of the two coax cables are not connected to the power supply ground, since such a connection would give rise to a ground current path through the

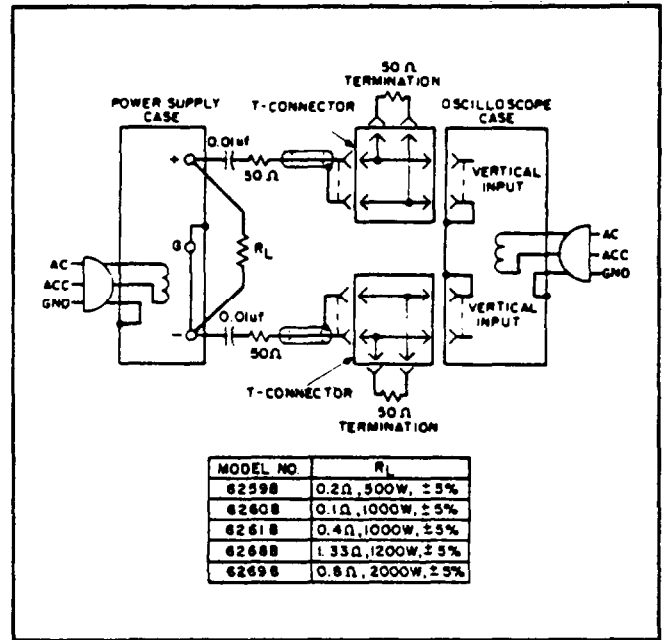

Figure 5-4. Noise Spike Measurement Test Setup

coax shield, resulting in an erroneous measurement.

5. Since the impedance matching resistors constitute a 2-to-1 attenuator, the noise spikes observed on the oscilloscope should be less than 2.5mV p-p instead of 5mV p-p.

5-26 The circuit of Figure 5-4 can also be used for the normal measurement of low frequency ripple: simply remove the four terminating resistors and the blocking capacitors and substitute a higher gain vertical plug-in in place of the wide-band plug-in required for spike measurements. Notice that with these changes, Figure 5-4 becomes a two-cable version of Figure 5-3B.

5-27 Transient Recovery Time.

Definition: The time "X" for the output voltage recovery to within "Y" millivolts of the nominal output voltage following a "Z" amp step change in load current, where: "Y" is specified as 10mV, the nominal output Voltage is defined as the dc level halfway between the static output voltage before and after the imposed load change, and "Z" is the specified load current change of S amps or the full load current rating of the supply, whichever is less.

5-28 Transient recovery time may be measured at any input line voltage combined with any output voltage and load current within rating,

5-29 Reasonable care must be taken in switching the load resistance on and off. A hand-operated

switch in series with the load is not adequate, since the resulting one-shot displays are difficult to observe on most oscilloscopes, and the arc energy occurring during switching action completely masks the display with a noise burst. Transistor load switching devices are expensive if reasonably rapid load current changes are to be achieved.

5-30 A mercury-wetted relay, as connected in the load switching circuit of Figure 5-5 should be used for loading and unloading the supply. When this load switch is connected to a 60Hz ac input, the mercury-wetted relay will open and close 60 times per second. Adjustment of the 25K control permits adjustment of the duty cycle of the load current switching and reduction in jitter of the oscilloscope display.

5-31 The load resistances shown in Figure 5-5 are the minimum resistances that must be used in order to preserve the mercury-wetted relay contacts. Switching of larger load currents can be accomplished with mercury pool relays; with this technique fast rise times can still be obtained, but the large inertia of mercury pool relays limits the maximum repetition rate of load switching and makes the clear display of the transient recovery characteristic on oscilloscope more difficult.

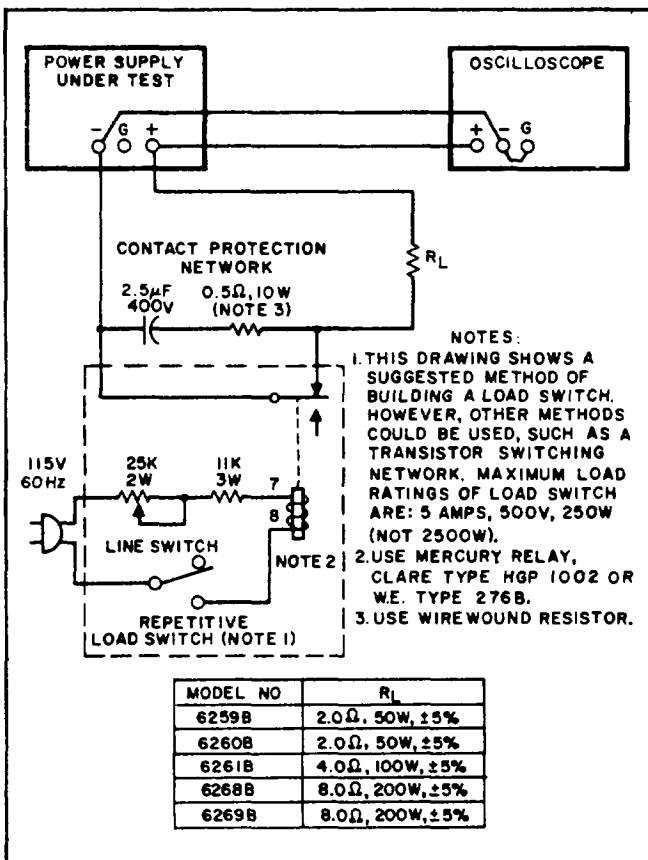

Figure 5-5. Transient Recovery Time Test Setup

5-32 To check the transient recovery time, proceed as follows:

- Connect test setup shown in Figure 5-5.
- Turn CURRENT controls fully clockwise.
- Turn on supply and adjust VOLTAGE controls until front panel ammeter indicates 5 amps output current.
- Close line switch on repetitive load switch setup.
- Set oscilloscope for internal sync and lock on either positive or negative load transient spike.
- Set vertical input of oscilloscope for ac coupling so that small dc level changes in power supply output voltage will not cause display to shift.
- Adjust the vertical centering on the scope so that the tail ends of the no load and full load waveforms are symmetrically displayed about the horizontal center line of the oscilloscope. This center line now represents the nominal output voltage defined in the specification.
- Adjust the horizontal positioning control so that the trace starts at a point coincident with a major graticule division. This point is then representative of time zero.
- Increase the sweep rate so that a single transient spike can be examined in detail.
- Adjust the sync controls separately for the positive and negative going transients so that not only the recovery waveshape but also as much as possible of the rise time of the transient is displayed.
- Starting from the major graticule division representative of time zero, count to the right 50µsec and vertically 10mV. Recovery should be within these tolerances as illustrated in Figure 5-6.

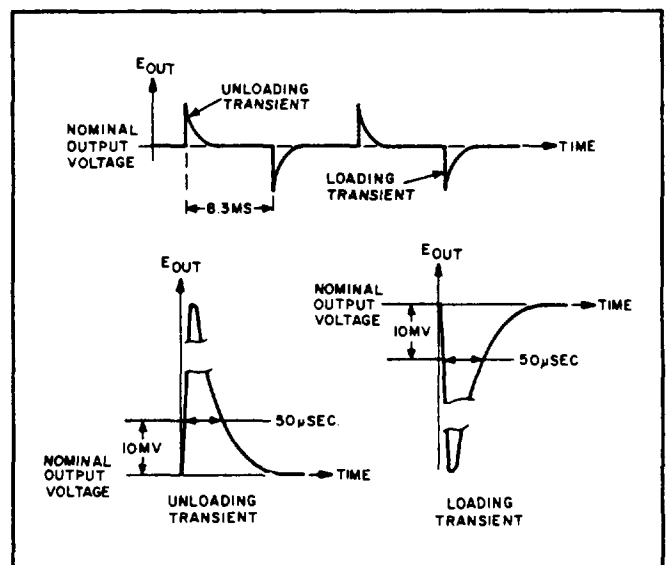

Figure 5-6. Transient Recovery Time Waveforms

5-33 Temperature Coefficient.

Definition: The change in output voltage per degree Centigrade change in the ambient temperature under conditions of constant input ac line voltage, output voltage setting, and load resistance.

5-34 The temperature coefficient of a power supply is measured by placing the power supply in an oven and varying it over any temperature span within its rating. (Most HP power supplies are rated for operation from 0°C to 55°C.) The power supply must be allowed to thermally stabilize for a sufficient period of time at each measurement temperature.

5-35 The temperature coefficient given in the specifications is the maximum temperature-dependent output voltage change which will result over any one degree Centigrade interval. The differential voltmeter or digital voltmeter used to measure the output voltage change of the supply should be placed outside the oven and should have a long term stability adequate to insure that its drift will not affect the overall measurement accuracy.

5-36 To check the temperature coefficient, proceed as follows:

- a. Connect load resistance and differential voltmeter as illustrated in Figure 5-2.
- b. Turn CURRENT controls fully clockwise.
- c. Adjust front panel VOLTAGE controls until front panel voltmeter indicates maximum rated output voltage.
- d. Place power supply in temperature-controlled oven (differential voltmeter remains outside oven). Set temperature to 30°C and allow 30 minutes warm-up.
- e. Record differential voltmeter reading.
- f. Raise temperature to 40°C and allow 30 minutes warm-up.
- g. Observe differential voltmeter reading.

Difference in voltage reading between Step (e) and (g) should be less than the following:

62599,62600	12mV
6261B	22mV
6268B, 6269B	42mV

5-37 Output Stability.

Definition: The change in output voltage for the first eight hours following a 30-minute warm-up period. During the interval of measurement all parameters, such as load resistance, ambient temperature, and input line voltage are held constant.

5-38 This measurement is made by monitoring the output of the power supply on a differential voltmeter or digital voltmeter over the stated measurement interval; a strip chart recorder can be used to

provide a permanent record. A thermometer should be placed near the supply to verify that the ambient temperature remains constant during the period of measurement. The supply should be put in a location immune from stray air currents (open doors or windows, air conditioning vents); if possible, the supply should be placed in an oven which is held at a constant temperature. Care must be taken that the measuring instrument has a stability over the eight hour interval which is at least an order of magnitude better than the stability specification of the power supply being measured. Typically, a supply may drift less over the eight hour measurement interval than during the half-hour warm-up.

5-39 To check the output stability, proceed as follows :

- a. Connect load resistance and differential voltmeter as illustrated in Figure 5-2.
- b. Turn CURRENT controls fully clockwise.
- c. Adjust front panel VOLTAGE controls until differential voltmeter indicates maximum rated output voltage.
- d. Allow 30 minutes warm-up, then record differential voltmeter reading.
- e. After 8 hours, differential voltmeter should change from reading recorded in Step (d) by less than the following:

6259B, 62600	5.0mV
6261B, 6268B	8.0mV
6269B	14.0mV

5-40 CONSTANT CURRENT TESTS

5-41 The instruments, methods, and precautions for the proper measurement of constant current power supply characteristics are for the most part identical to those already described for the measurement of constant voltage power supplies. There **are**, however, two main differences: first, the power supply performance will be checked between short circuit and full load rather than open circuit and full load. Second, a current monitoring resistor is inserted between the output of the power supply and the load.

5-42 For all output current measurements the current sampling resistor must be treated as a four terminal device. In the manner of a meter shunt, the load current is fed to the extremes of the wire leading to the resistor while the sampling terminals are located as close as possible to the resistance portion itself (see Figure 5-7). Generally, any **current** sampling resistor should be of the low noise, low temperature coefficient (less than 30ppm/°C) type and should be used at no more than 5% of its rated power so that its temperature rise will be minimized, If difficulty is experienced in obtaining a low resistance, high current resistor suitable for current sampling, a duplicate of the sampling resistor used in this unit (A4R123 or A4R123A-A4R123B)

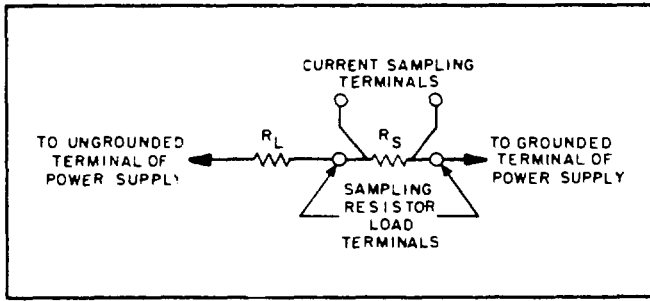

Figure 5-7. Current Sampling Resistor Connections

NOTE

When using the HP current sampling resistor recommended for this instrument, an external fan must be employed to cool the resistor. This precaution will maintain the sampling resistance at a constant value.

may be obtained from the factory.

5-43 Rated Output and Meter Accuracy.

- Connect test setup shown in Figure 5-8.
- Turn VOLTAGE controls fully clockwise.
- Turn on supply and adjust CURRENT controls until front panel ammeter indicates maximum rated output current.
- Differential voltmeter should read $0.5 \pm 0.01V_{dc}$.

5-44 Load Regulation.

Definition: The change ΔI_{OUT} in the static value of the dc output current resulting from a change in load resistance from short circuit to a value which yields maximum rated output voltage.

5-45 To check the constant current load regulation, proceed as follows:

- Connect test setup shown in Figure 5-8.
- Turn VOLTAGE controls fully clockwise.
- Adjust CURRENT controls until front panel meter reads exactly maximum rated out voltage.
- Read and record voltage indicated on differential voltmeter.
- Short circuit load resistor (R_L).
- Reading on differential voltmeter should not vary from reading recorded in Step (d) by more than the following:

6259B	110 μ v
6260B	110 μ v
6261B	110 μ v
6268B	134 μ v
6269B	120 μ v

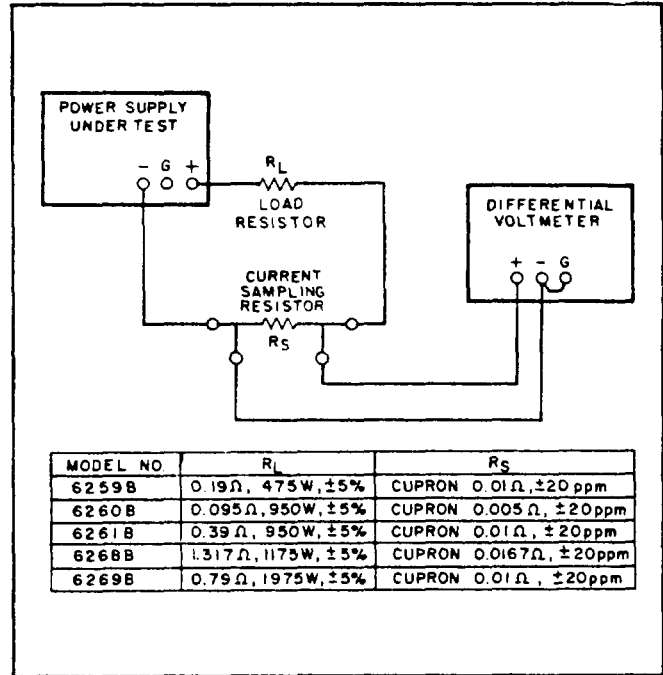

Figure 5-8. Constant Current Load Regulation Test Setup

5-46 Line Regulation.

Definition: The change ΔI_{OUT} in the static value of dc output current resulting from a change in ac input voltage over the specified range from low line (usually 207 volts) to high line (usually 253 volts), or from high line to low line.

5-47 To check the line regulation, proceed as follows:

- Utilize test setup shown in Figure 5-8.
- Connect variable auto transformer between input power source and power supply power input.
- Adjust auto transformer for 207Vac input.
- Turn VOLTAGE controls fully clockwise.
- Adjust CURRENT controls until front panel ammeter reads exactly maximum rated output current.
- Read and record voltage indicated on differential voltmeter.
- Adjust variable auto transformer for 253V ac input.
- Reading on differential voltmeter should not vary from reading recorded in Step (f) by more than the following:

6259B, 6269B	120 μ v
6260B, 6261B	110 μ v
6268B	134 μ v

5-48 Ripple and Noise.

Definition: The residual ac current which is superimposed on the dc output current

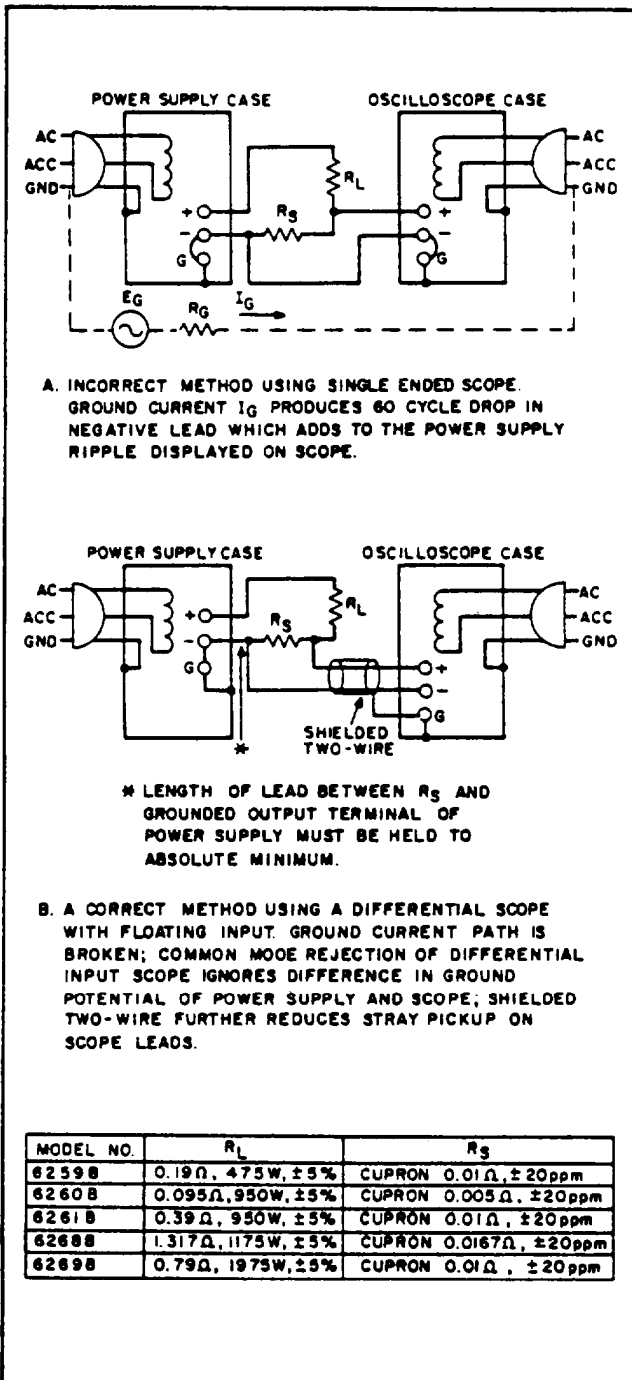

Figure 5-9. Constant Current Ripple and Noise Test Setup

of a regulated power supply. AC ripple and noise current is usually specified and measured in terms of its RMS value.

s-49 Most of the instructions pertaining to the ground loop and pickup problem-s associated with constant voltage ripple and noise measurement

also apply to the measurement of constant current ripple and noise. Figure 5-9 illustrates the most important precautions to be observed when measuring the ripple and noise of a constant current supply. The presence of a 120Hz waveform on the oscilloscope is normally indicative of a correct measurement method. A waveshape having 60Hz as its fundamental component is typically associated with an incorrect measurement setup.

5-50 Ripple and Noise Measurement. To check the ripple and noise, proceed as follows:

- a. Connect oscilloscope or RMS voltmeter as shown in Figures 5-9A or 5-9B.
- b. Turn VOLTAGE controls fully clockwise.
- c. Adjust CURRENT controls until front panel 1 ammeter reads exactly maximum rated output current.
- d. The observed ripple and noise should be less than:

6259B	250 μ Vrms
6260B	250 μ Vrms
6261B	250 μ Vrms
6268B	334 μ Vrms
6269B	250 μ Vrms

5-51 TROUBLESHOOTING

5-52 Before attempting to troubleshoot this instrument, ensure that the fault is with the instrument and not with an associated circuit. The performance test (Paragraph 5-5) enables this to be determined without having to remove the instrument from the cabinet.

5-53 A good understanding of the principles of operation is a helpful aid in troubleshooting, and it is recommended that the reader review Section IV of the manual before attempting to troubleshoot the unit in detail. Once the principles of operation are understood, refer to the overall troubleshooting procedures in Paragraph S-S 6 to locate the symptom and probable cause.

5-54 The schematic diagram at the rear of the manual (Figure 7-11) contains normal voltage readings taken at various points within the circuits. These voltages are positioned adjacent to the applicable test points (identified by encircled numbers). The component location diagrams (Figures 7-1 through 7-8, and Figure 7-10) at the rear of the manual should be consulted to determine the location of components and test points.

5-55 If a defective component is located, replace it and re-conduct the performance test. When a component is replaced, refer to the repair and replacements (Paragraph 5-71) and adjustment and calibration (Paragraph 5-73) sections of this manual

5-57 To locate the cause of trouble, follow Steps 1, 2, and 3 in sequence:

(1) Check for obvious troubles such as tripped circuit breaker, defective power cord, incorrectly strapped rear terminals, input power failure or defective meter. Next, remove the top and bottom covers and inspect for open connections, charred components, etc., paying particular attention to both sides of the main circuit board. (Refer to Paragraph 5-64 for the main circuit board removal procedure.)

If the trouble source cannot be detected by visual inspection, re-install the main circuit board and proceed to Step (2).

(2) In almost all cases, the trouble can be caused by incorrect dc bias or reference voltages; thus, it is a good practice to check the voltages in Table 5-2 before proceeding with Step (3). Refer to Figure 7-10 for the location of the test points listed in Table 5-2.

(3) Disconnect load and examine Table 5-3 to determine your symptom and its probable cause.

Table 5-2. Reference and Bias Voltages
(Refer to Schematic and Figure 7-10 for test point locations)

STEP	METER COMMON	METER POSITIVE	NORMAL VDC	NORMAL RIPPLE (P-P)	PROBABLE CAUSE
1	+S	TP63	+12.4 ± 7%	2.0mV	CR61, CR62, Q60, Q61, Q62, Q63
2	+S	TP64	+6.2 ±5%	0.5mV	VR60, VR61, Q62, Q63
3	+S	TP65	-6.2 ±5%	2.0mV	VR60, VR61, Q62, Q63
4	+S	TP66	+11 ±15%	2.0V	C44, CR53, CR54
5	+S	TP67	-4.0 ±12.5%	0.8V	C44, CR53, CR54, CR45, CR46, CR47, CR48, CR49
6	+S	TP68	-2.4±12.5%	0.4V	CR54, CR45, CR46, CR47, CR48, CR49

Table 5-3. Overall Trouble shooting

SYMPTOM	PROBABLE CAUSE
Low or no output voltage (Overvoltage lamp may be on or off)	a. Front panel meter defective. b. Crowbar not reset or defective. Refer to Table 5-4. c. Series regulator or preregulator feedback loop defective. Refer to Table 5-4.
High output voltage	a. Front panel meter defective. b. Open circuit between sensing terminals (*S) and output terminals (*OUT). Refer to Table 5-4. c. Series regulator or preregulator loop defective. If crowbar does not trip, it also is faulty. Refer to Table 5-4.
High ripple	a. Ground loops in operating setup. Refer to Paragraph 5-15. b. Incorrect reference and/or bias voltages. Refer to Table 5-2. c. Supply crossing over to constant current operation under loaded conditions. Check current limit setting or constant

Table 5-3. Overall Troubleshooting (Continued)

SYMPTOM	PROBABLE CAUSE
High ripple (continued)	current comparator circuit (Z1 and associated components).
Poor line regulation	a. Improper measurement technique. Refer to Paragraph 5-13. b. Incorrect reference and/or bias voltages. Refer to Table 5-2.
Poor load regulation (Constant voltage)	a. Improper measurement technique. Refer to Paragraph 5-11. b. Incorrect reference and/or bias voltages. Refer to Table 5-2. c. Supply current limiting. Check constant current comparator circuit (Z1 and associated components).
Poor load regulation (Constant current)	a. Improper measurement technique. Refer to Paragraph 5-44. b. Incorrect reference and/or bias voltages. Refer to Table 5-2. c. Supply voltage limiting. Check constant voltage comparator circuit (Z1 and associated components) and voltage clamp circuit, Q1. d. Leaky C19, A3C3.
Oscillates (Constant current\constant voltage)	a. Adjustment of R47. Refer to Paragraph 5-99. b. Faulty C40, C41, C19, A3C3, R50. c. Open sensing lead (+S).
Instability (Constant current/constant voltage)	a. Incorrect reference and/or bias voltages; CR92 defective. Refer to Table 5-2. b. Noisy voltage or current controls (A5R121, A5R122, or A5R123, A5R124); noisy VR60 or VR61. c. Integrated circuit Z1 defective. d. CR4, CR5, CR6, or CR21 leaky. e. R2, R3, R4, R5, R6, R22, R30, R31, C2 noisy or drifting.
Cannot reach maximum output	a. Q20 shorted. One or more of series regulator transistors (A4Q103 through A4Q108) open,

5-58 Table 5-3 contains symptoms and probable causes of many possible troubles. If either high or low output voltage is a symptom, Table 5-4 contains the steps necessary to isolate the trouble to one of the feedback loops and instructions directing the tester to the proper table for further isolation. Because of the interaction between feedback loops, it is necessary to refer to Table 5-4 before proceeding to Tables 5-5, 5-6, or 5-7.

5-59 Tables 5-5, 5-6, and 5-7 contain troubleshooting methods for the series regulator and preregulator feedback loops once the fault has been

isolated to either one. Tables 5-5 and 5-6 contain instructions for driving each stage of the series regulator feedback loop into conduction or cut-off. By following the steps in these tables, the fault can be isolated to a circuit or to a component.

5-60 Table 5-7 contains troubleshooting procedures for the preregulator feedback loop. The troubleshooting method is based upon comparing the waveforms shown in Figure 7-9 with those actually found at the various test points in the preregulator control circuit. As indicated in Table

5-7, the circuit is checked by starting with the output waveform and tracing backwards.

5-61 Performing the tests given in Table 5-5, 5-6, and 5-7 will usually require partial disassembly of

the supply in order to gain access to components (such as the series regulator transistors) that are not mounted on the main circuit board. If this is the case, refer as necessary to Paragraphs 5-65 through 5-70 for disassembly procedures.

Table 5-4. Feedback Loop Isolation

STEP	ACTION	RESPONSE	PROBABLE CAUSE
1	<p>NOTE: After each step, crowbar should be reset by turning supply off and then on.</p> <p>Inspect LINE circuit breaker.</p>	<p>a. Tripped.</p> <p>b. Not tripped; High voltage output.</p> <p>c. Not tripped; Low voltage output.</p>	<p>a. Check rectifier, filter, and triac for short. Faulty pre-regulator. Proceed to Step 3.</p> <p>b. Series regulator loop in high voltage condition. Proceed to Step 2.</p> <p>c. Proceed to Step 2.</p>
2	<p>Inspect overvoltage lamp on front pane 1.</p>	<p>a. On.</p> <p>b. Off; High voltage output.</p> <p>c. off; Low voltage output.</p>	<p>a. Check setting of overvoltage adjust (A5R125). Check A4CR110 for short. Series regulator loop in high voltage condition. Proceed to Step 3.</p> <p>b. Check setting of overvoltage adjust (A5R125). Check A4CR110 for open, Q91 for open, Q92 for short. Series regulator loop in high voltage condition. Proceed to Step 3.</p> <p>c. Check overvoltage adjust (A5R125). Check A4CR110 for short. Check Q20 for short. Proceed to Step 3.</p>
3	<p>Isolate fault to either series regulator or preregulator by using the following steps:</p> <p>(1) Open the gate lead to triac A2CR1 by disconnecting either end of resistor R88 (TP87 or TP88).</p> <p>(2) Place a small dc power supply across the input capacitors (C 101 through C104). A 0-10V, 2A supply is sufficient.</p> <p>(3) Set external supply to ten volts.</p> <p>(4) Vary front panel voltage controls.</p>	<p>a. Output voltage normal. Variable from 0 volts to about 9 volts.</p> <p>b. Output voltage high. Varying controls has little or no effect.</p> <p>c. Output voltage low, Varying controls has little or no effect.</p>	<p>a. Check each series regulator transistor (A4Q103 through A4Q108) for open. Then check preregulator by disconnecting source and proceeding to Table 5-7.</p> <p>b. High voltage condition in series regulator. Proceed to Table 5-5. Leave external source connected.</p> <p>c. Low voltage condition in series regulator loop. Proceed to Table 5-6. Leave external source connected.</p>

Table 5-5. Series Regulator Troubleshooting, High Voltage Condition

STEP	ACTION	RESPONSE	PROBABLE CAUSE
1	These tests should be made with external source connected as described in Table 5-4, Step 3. Check turn-off of series regulator transistors A4Q103 through A4Q108 by shorting base (TP101) to emitter (TP103).	a. Output voltage remains high. b. Output voltage decreases.	a. One or more of A4Q103 through A4Q108 shorted or A4CR105 shorted. Check A4R150-A4R155. b. Remove short. Proceed to Step 2.
2	Check turn-off of driver A4Q102 by shorting base (TP100) to emitter (TP101).	a. Output voltage remains high. b. Output voltage decreases.	a. A4Q102 shorted. b. Remove short. Proceed to Step 3.
3	Check conduction of error amplifier A4Q101 by connecting base (TP45) to cathode of CR45 (TP67) through a 100 Ω resistor.	a. Output voltage remains high. b. Output voltage decreases.	a. A4Q101 open. b. Remove resistor. Proceed to Step 4.
4	Check conduction of error amplifier Q42 by connecting base (TP44) to cathode of CR45 (TP67) through a 1K Ω resistor.	a. Output voltage remains high, b. Output voltage decreases.	a. Q42 open. b. Remove resistor. Proceed to Step S.
s	Check turn-off of mixer amplifier Q41 by connecting base (TP40) to +11 volt supply (TP66) through a 1K Ω resistor.	a. Output voltage remains high. b. Output voltage decreases.	a. Q41 shorted. b. Remove resistor. Proceed to Step 6.
6	Check turn-off of constant voltage comparator Z 1 by shunting R 1 with a 10K Ω resistor, or by installing a 10K Ω resistor in R1 position if resistor is not installed in the supply.	a. Output voltage remains high. b. Output voltage decreases.	a. Z1 defective, R110 shorted. b. R23 open, open strap between A 1 and A2, A5R121 or A5R122 open.

Table 5-6. Series Regulator Troubleshooting, Low Voltage Condition

STEP	ACTION	RESPONSE	PROBABLE CAUSE
1	These tests should be made with external source connected as described in Table 5-4, Step 3. Check conduction of series regulator transistors A4Q103 through A4Q108 by connecting base (TP101) to +11 volt supply (TP66) through a 100 ohm resistor.	a. Output voltage remains low. b. Output voltage rises.	a. A4Q103 through A4Q108 open and/or A4R150 through A4R155 open, A4CR106 shorted. b. Remove resistor. Proceed to Step 2.

Table 5-6. Series Regulator Troubleshooting, Low Voltage Condition (Continued)

STEP	ACTION	RESPONSE	PROBABLE CAUSE
2	Check conduction of driver A4Q102 by shorting A4Q101 emitter (TP100) to base (TP45).	a. Output voltage remains low. b. Output voltage rises.	a. A4Q102 open, thermal switch A4TS101 open. b. Remove short. Proceed to Step 3.
3	Check turn-off of error amplifier A4Q101 by connecting base (TP45) to Q42 base (TP44).	a. Output voltage remains low. b. Output voltage rises.	a. A4Q101 or CR44 shorted. b. Remove short. Proceed to Step 4.
4	Check turn-off of error amplifier Q42 by connecting base (TP44) to +11V supply (TP66) through a 1K Ω resistor.	a. Output voltage remains low, b. Output voltage rises.	a. Q42 shorted. b. Remove resistor. Proceed to Step 5.
5	Isolate fault to either constant voltage comparator or constant current comparator by opening the cathode of CR20.	a. Output voltage rises. b. Output voltage remains low.	a. Z1 defective, open strap between A6 and A7, or shorted A5R123 or A5R124. b. Reconnect lead and proceed to Step 6.
6	Check conduction of mixer amplifier Q41 by connecting base (TP40) to +S terminal.	a. Output voltage remains low. b. Output voltage rises.	a. Q41 or CR40 open, Q40 shorted. b. Remove short. Proceed to Step 7.
7	Check conduction of constant voltage comparator Z1 by shunting R110 with a 10K ohm resistor, or by installing a 10K Ω resistor in R110 position if resistor is not installed in the supply.	a. Output voltage remains low. b. Output voltage rises.	a. Z1 defective, R1 shorted. b. A5R121 and A5R122 shorted, open strap between AZ and A3, R5 open, C2 shorted, CR7 shorted.

Table 5-7. Preregulator Troubleshooting (Refer to Waveforms in Figure 7-9)

STEP	ACTION	RESPONSE	PROBABLE CAUSE
WARNING			
A differential oscilloscope <u>must be used</u> for these tests in order to avoid a potentially dangerous shock hazard. Floating a single-ended oscilloscope for these tests is not recommended, because it may result in the oscilloscope chassis being at 230Vac line potential.			
1	Connect oscilloscope between TP89 (+) and TP86 (-).	a. Normal waveform. b. Little or no voltage.	a. Defective A2CR1, R88, CR88, A2L1A/A2L1B, T1, A2C1, A2R1. b. Proceed to Step 2.

Table 5-7. Preregulator Troubleshooting (Continued)

STEP	ACTION	RESPONSE	PROBABLE CAUSE
2	Connect oscilloscope between TP85 (+) and TP103 (-).	a. Normal waveform. b. Little or no voltage.	a. Defective T70. b. Defective Q72, Q73, CR76, or C71. proceed to Step 3.
3	Connect oscilloscope between TP80 (+) and TP103 (-).	a. Amplitude incorrect. b. Period incorrect.	a. Defective Q71, C70, C72, CR74, CR75, R82, R75, or R78. b. CR78 defective. Proceed to Step 4.
4	Connect oscilloscope between TP82 (+) and TP103 (-).	a. Amplitude, dc reference or period incorrect.	a. Defective CR82, CR84, CR79, CR80, CR77, CR78. Check R87.
5	Connect oscilloscope between TP81 (+) and TP103 (-).	a. Amplitude, dc reference or period incorrect.	a. Defective CR81, CR83, R86, R83, C73.

5-62 DISASSEMBLY PROCEDURES

5-63 The following seven paragraphs describe procedures for removing and disassembling the five subassemblies in this supply (A1 main circuit board, A2 RFI assembly, A3 interconnection circuit board, A4 heat sink, and A5 front panel). These procedures are referenced throughout the manual wherever necessary. For example, in the instructions for converting the supply to 115Vac operation, reference is made to the RFI assembly removal procedure in order to allow access to the bias transformer (A3T2) primary connections.

5-64 Main Circuit Board (A1) Removal. To remove the main printed circuit board, proceed as follows:

- a. Unplug unit and remove top cover of supply.
- b. Remove six hold-down screws visible on component side of main circuit board (arrowed "A" through "F" in Figure 7-1 O).
- c. Unplug board from receptacle mounted on interconnection circuit board by gently pulling on finger hole in opposite end of circuit board. Only finger hole should be used to remove board; do not pull on board-mounted components to aid removal. Care must be taken that rear barrier strip clears opening in rear panel.

5-65 Front Panel (A5) Removal. To remove the front panel, proceed as follows:

- a. Unplug unit, turn supply upside down, and remove four screws holding handlers to front panel.

- b. Front panel may now be swung outward, hinging on wires to LINE circuit breaker. Access is provided to all panel-mounted components.

5-66 Main Filter Capacitor Bank Removal. To remove the main filter capacitors (C1 01 through C104), proceed as follows:

- a. Unplug unit, remove top and bottom covers of supply.
- b. Remove one long screw and hold-down bracket on top of supply (arrowed "A" in Figure 7-3), and one long screw and hold-down bracket on bottom of supply (arrowed "A" in Figure 7-4).
- c. Sufficient lead length is provided to allow capacitors to be lifted partially out of instrument.

5-67 RFI Assembly (A2) Removal. To remove the RFI assembly, proceed as follows:

- a. Unplug unit, turn supply upside down, and remove bottom cover.
- b. Remove four screws holding RFI heat sink to mounting brackets (arrowed "A" through "D" in Figure 7-5). Two of the screws are accessible through holes in chassis flanges.
- c. Lift out RFI assembly and turn over.
- d. Remove four screws holding cover to heat sink (screw holes are arrowed "A" through "D" in Figure 7-1). This allows access to A2R1, A2C1, and A2L1A/A2L1B with its jumpers for 115/230 volt operation.
- e. Remove four screws holding A2L1A/A2LIB mounting bracket to heat sink. (Two of the screws

are arrowed "E" and "F" in Figure 7-1.) Lifting brackets away from heat sink allows access to triac A2CR1. A magnetized screwdriver is useful in performing this step.

5-68 Heat Sink (A4) Removal. In order to gain access to the following components, it is necessary to remove the heat sink assembly. Transistors A4Q101 through A4Q108; diodes A4CR10I through A4CR106, A4CR108, and A4CR110; resistors A4R106, A4R123, and A4R150 through A4R155; capacitors A4C1 through A4C5; cooling fan A4B1; and thermal switch A4TS101. For the location of these components, see Figures 7-5, 7-6, 7-7, and 7-8. To remove the heat sink assembly, proceed as follows:

- a. Unplug unit, stand it on left side, and remove top and bottom covers.
- b. Remove main printed circuit board as described in Paragraph 5-64.
- c. Remove two screws holding upper edge of heat sink to upper chassis flange (arrowed "E" and "F" in Figure 7-D).
- d. Disengage two pins holding lower section of heat sink assembly to main circuit board support tray by sliding heat sink down about ½ inch and slightly away from chassis. Before fully removing heat sink assembly, observe lead dress so assembly may be returned easily to correct position.
- e. Maneuver heat sink assembly downwards and away from chassis until it is resting on table (sufficient lead length is provided). Gentle leverage with a thin screwdriver may be necessary to allow heat sink assembly to clear upper chassis flange. Access is now provided to all components mounted on heat sink except resistors A4R150 through A4R155, and A4R123,

5-69 Heat Sink (4) Disassembly. To gain access to resistors A4R123 and A4R150 through A4R155 (shown in Figures 7-6 and 7-8) it is necessary to disassemble the heat sink assembly by utilizing the following procedure:

- a. Remove heat sink assembly as described in Paragraph 5-68 above.
- b. Turn supply upside down and place heat sink assembly partially into chassis so fan (A4B1) is protruding above chassis.
- c. Remove four screws and four shoulder washers attaching fan mounting plate to heat sink. Do not remove fan from mounting plate. When re-assembling heat sink, do not overtighten these screws. Too much tension will damage the insulating rods.
- d. Remove two screws holding current sampling resistor A4R123 to topmost two portions of heat sink. If necessary, the resistor may be

unsoldered at this point.

- e. Remove mounting nuts from A4CR106 on left side of heat sink, and from A4CR108 on right side of heat sink. Remove mounting nuts, bolts and shoulder washers on transistor A4Q102 on right side of heat sink (see Figure 7-5).

- f. Slide top section of heat sink forward and off insulating rods.

- g. Remove four screws holding emitter resistor circuit board to bottom half of heat sink. A magnetized screwdriver is useful here. Access is now provided to series regulator emitter resistors A4R150 through A4R155 (see Figure 7-6).

- h. If necessary to completely remove emitter resistor circuit board, unsolder connections to board, marking wires to enable correct replacement, and remove board.

5-70 Interconnection Circuit Board (A3) Removal.

To replace capacitor A3C3 or transformer A3T2, (shown in Figure 7-2), it is necessary to remove the interconnection circuit board by utilizing the following procedure:

- a. Remove main circuit board, RFI assembly, and heat sink assembly as described in Paragraphs 5-64, 5-67, and 5-68 respectively.

- b. Remove six screws holding back panel to chassis frame.

- c. Stand supply on left side, and remove two screws holding main circuit board support tray to back panel. Move panel away from frame.

- d. Remove two screws holding main circuit board support tray to internal chassis divider.

- e. Working from top rear of supply, interconnection circuit board (still attached to main circuit board support tray) can be angled up enough to allow access.

- f. If necessary to completely remove interconnection circuit board, remove two screws holding board to support tray, one screw holding capacitor clamp (A3C3) to support tray, and two screws holding bias transformer (A3T2) to support tray. Unsolder connections to board, marking wires to enable correct replacement, and remove board.

5-71 REPAIR AND REPLACEMENT

5-72 Section VI of this manual contains a list of replaceable parts. If the part to be replaced does not have a standard manufacturers' part number, it is a "special" part and must be obtained directly from Hewlett-Packard. After replacing a semiconductor device, refer to Table 5-8 for checks and adjustments that may be necessary. All components listed in Table 5-8 without A-designators are on the main printed circuit board (A1).

Table 5-8. Checks and Adjustments After Replacement of Semiconductor Devices

REFERENCE	FUNCTION OR CIRCUIT	CHECK	ADJUST
Z1	Constant voltage and constant current differential amplifiers.	Constant voltage (CV) line and load regulation. Zero volt output. Constant current (CC) line and load regulation. Zero current output.	R110, or R113 (Option 020); R117, or R119 (Option 021)
Q1	Voltage clamp circuit.	CC load regulation.	---
Q20	Short circuit protection.	Output current, protection action.	---
Q40, Q41	Mixer amplifier.	CV/CC load regulation. CV transient response.	R47
Q42, A4Q101, A4Q102	Driver and error amplifiers.	CV/CC load regulation.	---
Q60, Q61, Q62, Q63	Reference regulator.	+12.4V, +6.2V, and -6.2V reference voltages and reference circuit line operation.	---
Q70	Overvoltage limit.	Limiting action and level.	---
Q71, Q72, Q73	Preregulator control circuit.	Output voltage, ripple imbalance, and preregulator waveforms.	R70, R82
Q90, Q91, Q92	Crowbar.	Crowbar action, trip voltage, voltage across series regulator when tripped.	A5R125
A4Q103 thru A4Q108	Series regulator.	CV/CC load regulation.	---
A42CR1	Preregulator.	Output voltage.	R70
CR1, CR20	CV/CC OR gate.	CV/CC crossover operation.	---
CR2, CR3	Voltage clamp circuit.	CC load regulation.	---
CR4, CR40, CR41	Temperature stabilizing diodes.	Temperature coefficient.	---
CR5, CR6, CR21	Limiting diodes.	CV/CC load regulation.	---
CR7, CR60, CR61, CR62	Reference regulator.	+12.4V, +6.2V, and -6.2V reference voltages.	---
CR35, CR36, CR37	Turn-on circuit.	Preregulator control turn-on delay.	---
CR43, CR45 thru CR49, CR53, CR54	Bias supply.	+11V, -4V, and -2.4V bias voltages.	---
CR44, CR50	Driver and error amplifier.	Down-programming speed, CV/CC load regulation.	---

Table 5-8. Checks and Adjustments After Replacement of Semiconductor Devices (Continued)

REFERANCE	FUNCTION OR CIRCUIT	CHECK	ADJUST
CR70, CR71	Overvoltage limit circuit.	Limiting action and level.	---
CR72, thru CR84, CR88	Preregulator control.	Output voltage, ripple imbalance, and preregulator waveforms.	R70, R82
CR90 thru CR93, A4CR108, A4CR110	Crowbar.	Trip voltage, voltage across series regulator when crowbar is tripped, supply stability.	R95, A5R125
A4CR101 thru A4CR104	Main rectifier diodes.	Voltage across main filter capacitors.	---
A4CR105 and A4CR106	Reverse voltage protection.	Output voltage.	---
VR1	Voltage clamp circuit.	CC load regulation.	---
VR40	Mixer amplifier stabilization diode.	CV transient response.	R47
VR60, VR61	Reference regulator.	+6.2V and -6.2V reference voltages.	---
VR90	Crowbar.	Trip voltage.	R95, A5R125

5-73 ADJUSTMENT AND CALIBRATION

5-74 Adjustment and calibration may be required after performance testing, troubleshooting, or repair and replacement. Perform only those adjustments that affect the operation of the faulty circuit and no others.

5-75 METER ZERO

5-76 The meter pointer must rest on the zero calibration mark on the meter scale when the instrument is at normal operating temperature, resting in its normal operating position, and turned off.

To zero set the meter proceed as follows:

- a. Connect load resistor of value shown in Figure 5-2.
- b. Turn on instrument and allow it to come up to normal operating temperature (about 30 minutes).
- c. Turn instrument off. Wait one minute for power supply capacitors to discharge completely.
- d. Insert sharp pointed object (pen point or awl) into small indentation near top of round black plastic disc located directly below meter face.
- e. Rotate plastic disc clockwise until meter reads zero, then rotate counterclockwise

slightly in order to free adjustment screw from meter suspension. Pointer should not move during latter part of adjustment.

5-77 VOLTMETER CALIBRATION

5-78 To calibrate the voltmeter, proceed as follows:

- a. Connect differential voltmeter across supply, observing correct polarity.
- b. Turn on supply and adjust VOLTAGE controls until differential voltmeter reads exactly the maximum rated output voltage.
- c. Adjust R106 until front panel voltmeter also indicates exactly the maximum rated output voltage.

5-79 AMMETER CALIBRATION

5-80 To calibrate the ammeter, proceed as follows:

- a. Connect test setup shown in Figure 5-8.
- b. Turn VOLTAGE controls fully clockwise.
- c. Turn on supply and adjust CURRENT controls until differential voltmeter reads 0.5Vdc.
- d. Adjust R101 until front panel ammeter indicates exactly maximum rated output current.

5-81 CONSTANT VOLTAGE PROGRAMMING CURRENT

5-82 Zero Output Voltage. To calibrate the zero voltage programming accuracy, proceed as directed in Paragraphs 5-83, 5-84, 5-85, or 5-86, whichever applies to your particular instrument.

5-83 Standard instrument with resistance or unity-gain voltage programming.

- a. Connect differential voltmeter between +OUT and -OUT bus bars.
- b. If unit is to be used in local programming mode, turn VOLTAGE controls fully counterclockwise. If unit is to be used in remote programming mode, connect remote programming setup (Figure 3-3 or 3-4) and adjust remote resistance or voltage to zero (minimum).
- c. Connect decade resistance box between pads of position marked for resistor R110 in "ZERO ADJUST" section of main circuit board (points "A" and "B" in Figure 5-10; also see Figure 7-10).
- d. Rotate CURRENT controls fully clockwise and turn on supply.
- e. Adjust decade resistance box until differential voltmeter reads exactly zero volts.
- f. Replace decade resistance box with fixed, metal film, 1%, 1/4 or 1/8 watt resistor of same value.

5-84 Standard instrument with non-unity gain voltage programming.

- a. Perform Steps (a) and (b) in Paragraph 5-83.
- b. Solder jumper between "wiper" pad and "+12.4V" pad of position marked for potentiometer R112 in "ZERO ADJUST" section of main circuit board (points "C" and "D" in Figure 5-10; also see Figure 7-10).
- c. Connect decade resistance box between pads marked for resistor R111 in "ZERO ADJUST" section of main circuit board (points "E" and "F" in Figure 5-10; also see Figure 7-10).
- d. Perform Steps (d) through (f) in Paragraph 5-83.

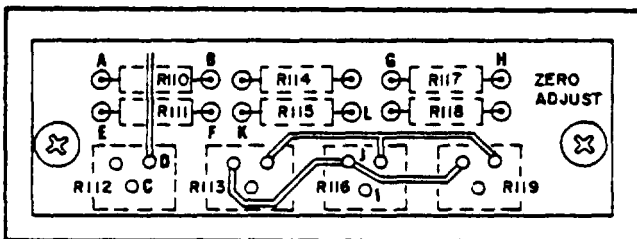

Figure 5-10. "ZERO ADJUST" Section of Main circuit Board

5-85 Option 020 with resistance or unity-gain

voltage programming.

- a. Perform Steps (a) and (b) in Paragraph 5-83.
 - b. Rotate CURRENT controls fully clockwise and turn on supply.
 - c. If reading on differential 1 voltmeter is not exactly zero volts, adjust potentiometer R113 (labeled "VOLTAGE ZERO" and accessible through hole in rear panel) until reading is exactly zero.
- 5-86 Option 020 with non-unity gain voltage programming.
- a. Perform Steps (a) and (b) in Paragraph 5-83.
 - b. Rotate CURRENT controls fully clockwise and turn on supply.
 - c. If reading on differential voltmeter is not exactly zero volts, adjust potentiometer R112 (labeled "VOLTAGE PROG" and accessible through hole in rear panel) until reading is exactly zero.

5-87 CV Programming Accuracy. To calibrate the constant voltage programming current, proceed as directed in Paragraphs 5-88 or 5-89, whichever applies to your particular instrument.

5-88 Standard instrument.

- a. Connect 0.1%, 1/8 watt resistor of value shown below between terminals -S and A3 on rear barrier strip.

Model	Value
62596	2K Ω
62606	2K Ω
62616	4K Ω
6268B	8K Ω
62696	8K Ω

- b. Disconnect strap between terminals A1 and A2 on rear barrier strip.
- c. Connect differential voltmeter between +OUT and -OUT bus bars.
- d. Connect decade resistance box in place of R3 (mounted on standoffs on main circuit board; see Figure 7-10).
- e. Rotate CURRENT controls fully clockwise and turn on supply.
- f. Adjust decade resistance box until differential voltmeter indicates exactly maximum rated output voltage.
- g. Replace decade resistance box with fixed, composition, 5%, 1/2 watt resistor of same value.

5-89 Option 020.

- a. Perform Steps (a) through (c) in Paragraph 5-88.
- b. Rotate CURRENT controls fully clockwise and turn on supply.
- c. Adjust potentiometer R112 (labeled "VOLTAGE PROG" and accessible through hole in rear panel) until differential voltmeter indicates

exactly maximum rated output voltage.

5-90 CONSTANT CURRENT PROGRAMMING
CURRENT

5-91 Zero Current OutPut. To calibrate the zero current programming accuracy, proceed as directed in Paragraphs 5-92, 5-93, 5-94, or 5-95, whichever applies to your particular instrument.

5-92 Standard instrument with resistance or unity-gain voltage programming.

- a. Connect test setup shown in Figure 5-8.
- b. If unit is to be used in local programming mode, turn CURRENT controls fully counter-clockwise. If unit is to be used in remote programming mode, connect remote programming setup (Figure 3-6 or 3-7) and adjust remote resistance or voltage to zero. (minimum).
- c. Connect decade resistance box between pads of position marked for resistor R117 in "ZERO ADJUST" section of main circuit board (points "G" and "H" in Figure 5-10; also see Figure 7-10).
- d. Rotate VOLTAGE controls fully clockwise and turn on supply.
- e. Adjust decade resistance box until differential voltmeter reads exactly zero volts.
- f. Replace decade resistance box with fixed, metal film, 1%, 1/4 or 1/8 watt resistor of same value.

5-93 Standard instrument with non-unity gain voltage programming.

- a. Perform Steps (a) and (b) in Paragraph 5-92.
- b. Solder jumper between "wiper" pad and "-6.2V" pad of position marked for potentiometer R116 in "ZERO ADJUST" section of main circuit board (points "I" and "J" in Figure 5-10; also see Figure 7-10).
- c. Connect decade resistance box between pads marked for resistor R115 in "ZERO ADJUST" section of main circuit board (points "K" and "L" in Figure 5-1 O; also see Figure 7-10).
- d. Perform Steps (d) through (f) in Paragraph 5-92.

5-94 Option 021 with resistance or unity-gain voltage programming.

- a. Perform Steps (a) and (b) in Paragraph 5-92.
- b. Rotate VOLTAGE controls fully clockwise and turn on supply.
- c. If reading on differential voltmeter is not exactly zero volts, adjust potentiometer R119 (labeled "CURRENT ZERO" and accessible through hole in rear panel) until reading is exactly zero.

5-95 Option 021 with non-unity gain voltage programming.

- a. Perform Steps (a) and (b) in Paragraph 5-92.

b. Rotate VOLTAGE controls fully clockwise and turn on supply.

c. If reading on differential voltmeter is not exactly zero volts, adjust potentiometer R116 (labeled "CURRENT PROG" and accessible through hole in rear panel) until reading is exactly zero.

5-96 CC Programming Accuracy. To calibrate the constant current programming current, proceed as directed in Paragraphs 5-97 or 5-98, whichever applies to your particular instrument.

5-97 Standard instrument.

- a. Connect test setup shown in Figure 5-8.
- b. Disconnect strap between terminals A5 and A6 on rear barrier strip.
- c. Connect 0.1%, 1/8 watt resistor of value shown below between terminals A4 and A6 on rear barrier strip.

<u>Mode 1</u>	<u>Value</u>
6259B	200 Ω
6260B	200 Ω
6261B	200 Ω
6268B	180 Ω
6269B	200 Ω

- d. Connect decade resistance box in place of R30 (mounted on standoffs on main circuit board; see Figure 7-1 O).
- e. Rotate VOLTAGE controls fully clockwise and turn on supply.
- f. Adjust decade resistance box until differential voltmeter indicates exactly 0.5Vdc.
- g. Replace decade resistance box with fixed, composition, 5%, 1/2 watt resistor of same value.

5-98 Option 021.

- a. Perform Steps (a) through (c) in Paragraph 5-97.
- b. Rotate VOLTAGE controls fully clockwise and turn on supply.
- c. Adjust potentiometer R116 (labeled "CURRENT PROG" and accessible through hole in rear panel) until differential voltmeter indicates exactly 0.5Vdc.

5-99 TRANSIENT RECOVERY TIME

5-100 To adjust the transient response, proceed as follows:

- a. Connect test setup shown in Figure 5-5.
- b. Repeat Steps (a) through (k) as outlined in Paragraph 5-32.
- c. Adjust R47 until transient response is within specification as shown in Figure 5-6.

5-101 RIPPLE IMBALANCE (50 and 60Hz Operation)

5-102 This procedure ensures balanced operation of the triac by ensuring that the conduction time

is equal in either direction (within 25%). To check for imbalance, proceed as follows:

a. Connect appropriate load resistance across rear output terminals of supply as follows:

<u>MODEL</u>	<u>Load Resistance</u>
6259B	0.2 Ω 500W, ±5%
6260B	0.1 Ω, 1000W, ±5%
62610	0.4 Ω, 1000W, ±5%
6268B	1.33 Ω, 1200W, ±5%
6269B	0.8 Ω, 2000W, ±5%

b. Connect variable auto transformer between input power source and power supply power input; adjust auto transformer for 230Vac input to supply.

c. Connect oscilloscope (ac coupled) between TP102 and TP103 (across series regulator).

d. Turn CURRENT controls fully clockwise, turn on supply, and adjust VOLTAGE controls for maximum rated output voltage.

e. Adjust oscilloscope to observe 120Hz sawtooth waveform. Peak amplitudes of adjacent sawtooth peaks should be within 25% of each other.

f. If amplitude difference is greater than 25%, turn off supply and replace R82 with decade resistance.

g. Turn on supply and adjust decade resistance to reduce imbalance to within 25%.

h. Vary input line voltage from 207 to 253V ac and insure that imbalance does not exist anywhere within this range. Replace decade box with equivalent resistor.

NOTE

If imbalance cannot be reduced to within 25%, check capacitors C70 and C72, and diodes CR79 through CR84. If these components test satisfactorily, the problem may be due to distortion present on the ac power line.

5-103 PREREGULATOR TRACKING (50 and 60Hz Operation)

5-104 To adjust the voltage drop across the series regulator, proceed as follows:

a. Connect appropriate load resistance across rear output terminals of supply as follows:

<u>Model</u>	<u>Load Resistance</u>
62S9B	0.2 Ω 500W, ±5%
6260B	0.1 Ω, 1000W, ±5%
6261B	0.4 Ω, 1000W, ±5%
6268B	1.33 Ω, 1200W, ±5%
6269B	0.8 Ω, 2000W, ±5%

b. Connect variable auto transformer between input power source and power supply power input adjust auto transformer for 230Vac input to supply.

Connect dc voltmeter across series regulator (TP102 and TP103).

d. Turn CURRENT controls fully clockwise.

e. To check voltage drop across regulator at low output voltage, short circuit load resistor and adjust VOLTAGE controls for maximum rated output current on front pane 1 ammeter.

f. Adjust R70 until voltmeter reads 3.5± 0.3Vdc.

g. To check the voltage drop at high output voltage, remove short circuit from across load resistor and adjust VOLTAGE controls for maximum rated output current. Voltmeter reading should again be 3.5 ± 0.3Vdc.

h. Vary input line voltage from 207 to 253V ac. Voltmeter reading should vary between 3.2 (minimum) and 3.8 (maximum) volts. If reading exceeds this range, proceed with Step (i).

i. Replace resistor R77 with decade resistance box. Vary input line voltage between 207 and 253Vac while adjusting decade box until voltmeter reading variation is minimal and within range of 3.2 to 3.8Vdc. Replace decade box with equivalent resistor.

5-105 50Hz OPERATION (Option 005)

5-106 If the supply is to be operated from a 50Hz ac input, the following modifications are required:

a. Replace resistor R82 with 240 Ω, ±5%, 1/2 watt resistor, and check ripple imbalance as described in Steps (a) through (e) of Paragraph 5-101.

b. Perform preregulator tracking adjustment described in Paragraph 5-103.

5-107 CROWBAR TRIP VOLTAGE

5-108 To adjust A5R125 (OVERVOLTAGE ADJUST), proceed as follows:

a. Turn screwdriver adjustment, A5R125, fully clockwise.

b. Turn on supply.

c. Set voltage output to desired trip voltage.

d. Turn A5R125 slowly counterclockwise until the crowbar is tripped (meter falls to zero volts).

e. Turn off supply and turn down output voltage.

f. Turn on supply and set desired operating output voltage.

NOTE

It is recommended that the crowbar be set to no less than 5% of the desired output voltage plus two volts, in order to avoid false tripping of the crowbar. However, if occasional crowbar tripping on unloading can be tolerated, the crowbar trip point can

TM 11-6625-2958-14&P
be set much closer to the operating
output voltage of the supply.

<u>Model</u>	<u>Value</u>
6261B	23Vdc
6268B	45Vdc
6269B	45Vdc

5-109 MAXIMUM CROWBAR TRIP VOLTAGE

5-110 To adjust the maximum voltage at which the crowbar trips, proceed as follows:

- a. Rotate A5R125 (OVERVOLTAGE ADJUST) and CURRENT controls fully clockwise.
- b. Disconnect either end of R72 (TP70 or TP71; see Figure 7-10).
- c. Connect decade resistance box in place of R95 (mounted on standoffs on main circuit board).
- d. Turn on supply and adjust VOLTAGE controls for output voltage shown below:

<u>Model</u>	<u>Value</u>
6259B	12Vdc
6260B	12Vdc

e. Adjust decade resistance box until crowbar trips (amber OVERVOLTAGE lamp lights up).

f. Replace decade resistance with appropriate value resistor in R95 position and reconnect resistor R72. Maximum crowbar trip voltage is now set at voltage given in Step (d).

5-111 CROWBAR DISABLEMENT

5-112 To disable the crowbar completely, disconnect either end of R98 (TP97 or TP98). This resistor is mounted on the main circuit board (see Figure 7-10).

**SECTION VI
REPLACEABLE PARTS**

6-1 INTRODUCTION

6-2 This section contains information for ordering replacement parts. Table 6-4 lists parts in alpha-numeric order by reference designators and provides the following information:

- a. Reference Designators. Refer to Table 6-1.
- b. Description. Refer to Table 6-2 for abbreviations.
- c. Total Quantity (TQ). Given only the first time the part number is listed except in instruments containing many sub-modular assemblies, in which case the TQ appears the first time the part number is listed in each assembly.
- d. Manufacturer's Part Number or Type.
- e. Manufacturer's Federal Supply Code Number. Refer to Table 6-3 for manufacturer's name and address.
- f. Hewlett-Packard Part Number.
- g. Recommended Spare Parts Quantity (RS) for complete maintenance of one instrument during one year of isolated service.
- h. Parts not identified by a reference designator are listed at the end of Table 6-4 under Mechanical and/or Miscellaneous. The former consists of parts belonging to and grouped by individual assemblies; the latter consists of all parts not immediately associated with an assembly.

6-3 ORDERING INFORMATION

6-4 Table 6-5 is a part number-national stock number cross reference index. The items on this cross reference index are source coded PAHZZ. Items that do not appear on this cross reference index are source coded XD and shall be procured using the FSCM and the NPN at the nearest wholesale level.

Table 6-1. Reference Designators

A = assembly	E = miscellaneous
B = blower (fan)	electronic part
C = capacitor	F = fuse
CB = circuit breaker	J = jack, jumper
CR = diode	K = relay
DS = device, signaling (lamp)	L = inductor
	M = meter

Table 6-1. Reference Designators (Continued)

P = plug	v = vacuum tube,
Q = transistor	neon bulb,
R = resistor	photocell, etc.
S = switch	VR = zener diode
T = transformer	x = socket
TB = terminal block	z = integrated circuit or network
TS = therms 1 switch	

Table 6-2. Description Abbreviations

A = ampere	mfr = manufacturer
ac = alternating current	mod. = modular or modified
assy. = assembly	mtg = mounting
bd = board	n = nano = 10 ⁻⁹
bkt = bracket	NC = normally closed
°C = degree Centigrade	NO = normally open
cd = card	NP = nickel-plated
coef = coefficient	W = ohm
comp = composition	obd = order by description
CRT = cathode-ray tube	OD = outside diameter
CT = center-tapped	p = pico = 10 ⁻¹²
dc = direct current	P.C. = printed circuit
DPDT = double pole, double throw	pot. = potentiometer
DPST = double pole, single throw	P-P = peak-to-peak
elect = electrolytic	ppm = parts per million
encap = encapsulated	pvr = peak reverse voltage
F = farad	rect = rectifier
OF = degree Fahrenheit	rms = root mean square
fxd = fixed	\$1 = silicon
Ge = germanium	SPDT = single pole, double throw
H = Henry	SPST = single pole, single throw
Hz = Hertz	SS = small signal
IC = integrated circuit	T = slow-blow
ID = inside diameter	tan. = tantalum
incnd = incandescent	T1 = titanium
k = kilo = 10 ³	V = volt
m = mini = 10 ⁻³	var = variable
M = mega = 10 ⁶	ww = wirewound
μ = micro = 10 ⁻⁶	w = Watt
met. = metal	

Table 6-3. Code List of Manufacturers

CODE NO.	MANUFACTURER	ADDRESS
00629	EBY Sales Co. , Inc.	Jamaica, N. Y.
00656	Aerovox Corp.	New Bedford, Mass.
00853	Sangamo Electric Co.	
	S. Carolina Div.	Pickens, S. C.
01121	Allen Bradley Co.	Milwaukee, Wis.
01255	Litton Industries, Inc.	Beverly Hills, Calif.
01281	TRW Semiconductors, Inc.	Lawndale, Calif.
01295	Texas Instruments, Inc.	
	Semiconductor-Components Div.	Dallas, Texas
01686	RCL Electronics, Inc.	Manchester, N. H.
01930	Amerock Corp.	Rockford, Ill.
02107	Sparta Mfg. Co.	Dover, Ohio
02114	Ferroxcube Corp.	Saugerties, N. Y.
02606	Fenwal Laboratories	Morton Grove, Ill.
02660	Amphenol Corp.	Broadview, Ill.
02735	Radio Corp. of America, Solid State and Receiving Tube Div.	Somerville, N. J.
03508	G. E. Semiconductor Products Dept.	Syracuse, N. Y.
03797	Eldema Corp.	Compton, Calif.
03877	Transitron Electronic Corp.	Wakefield, Mass.
03888	Pyrofilm Resistor Co. Inc.	
		Cedar Knolls, N. J.
04009	Arrow, Hart and Hegeman Electric Co.	Hartford, Conn.
04072	ADC Electronics, Inc.	Harbor City, Calif.
04213	Caddell & Bums Mfg. Co. Inc.	Mineola, N. Y.
04404	*Hewlett-Packard Co.	Palo Alto Div, Palo Alto, Calif.
04713	Motorola Semiconductor Prod. Inc.	Phoenix, Arizona
05277	Westinghouse Electric Corp.	
	Semiconductor Dept.	Youngwood, Pa.
05347	Ultronix, Inc.	Grand Junction, Colo.
05820	Wakefield Engr. Inc.	Wakefield, Mass.
06001	General Elect. Co. Electronic Capacitor & Battery Dept.	Irmo, S. C.
06004	Bassik Div. Stewart-Warner Corp.	Bridgeport, Conn.
06486	IRC Div. of TRW Inc.	
	Semiconductor Plant	Lynn, Mass.
06540	Amatom Electronic Hardware Co. Inc.	New Rochelle, N. Y.
06555	Beede Electrical Instrument Co.	Penacook, N. H.
06666	General Devices Co. Inc.	Indianapolis, Ind.
06751	Semcor Div. Components, Inc.	Phoenix, Arizona
06776	Robinson Nugent, Inc.	New Albany, Ind.
06812	Torrington Mfg. Co. , West Div.	Van Nuys, Calif.
07137	Transistor Electronics Corp.	Minneapolis, Minn.

CODE NO.	MANUFACTURER	ADDRESS
07138	Westinghouse Electric Corp.	
	Electronic Tube Div.	Elmira, N. Y.
07263	Fairchild Camera and Instrument Corp. Semiconductor Div.	Mountain View, Calif.
07387	Birtcher Corp.,The	Los Angeles, Calif.
07397	Sylvania Electric Prod. Inc.	
	Sylvania Electronic Systems Western Div.	Mountain View, Calif.
07716	IRC Div. of TRW Inc.	Burlington Plant Burlington, Iowa
07910	Continental Device Corp.	Hawthorne, Calif.
07933	Raytheon Co. Components Div. Semiconductor Operation	Mountain View, Calif.
08484	Breeze Corporations, Inc.	Union, N. J.
08530	Reliance Mica Corp.	Brooklyn, N. Y.
08717	Sloan Company, The	Sun Valley, Calif.
08730	Vemaline Products Co. Inc.	Wyckoff, N. J.
08806	General Elect. Co. Miniature Lamp Dept.	Cleveland, Ohio
08863	Nylomatic Corp.	Norrisville, Pa.
08919	RCH Supply Co.	Vernon, Calif.
09021	Airco Speer Electronic Components	Bradford, Pa.
09182	*Hewlett-Packard Co.	New Jersey Div. Rockaway, N. J.
09213	General Elect. Co. Semiconductor Prod. Dept.	Buffalo, N. Y.
09214	General Elect. Co. Semiconductor Prod. Dept.	Auburn, N. Y.
09353	C & K Components Inc.	Newton, Mass.
09922	Burdy Corp.	Norwalk, Conn.
11115	Wagner Electric Corp.	
	Tung-Sol Div.	Bloomfield, N. J.
11236	CTS of Berne, Inc.	Berne, Ind.
11237	Chicago Telephone of Cal. Inc.	So. Pasadena, Calif.
11502	IRC Div. of TRW Inc.	Boone Plant Boone, N.C.
11711	General Instrument Corp Rectifier Div.	Newark, N. J.
12136	Philadelphia Handle Co. Inc.	Camden, N. J.
12615	U. S. Terminals, Inc.	Cincinnati, Ohio
12617	Hamlin Inc.	Lake Mills, Wisconsin
12697	Clarostat Mfg. Co. Inc.	Dover, N. H.
13103	Thermally Co.	Dallas, Texas
14493	*Hewlett-Packard Co.	Loveland Div. Loveland, Colo.
14655	Comell-Dubilier Electronics Div. Federal Pacific Electric Co.	Newark, N. J.
14936	General Instrument Corp. Semiconductor Prod. Group	Hicksville, N. Y.
15801	Fenwal Elect.	Framingham, Mass.
16299	Corning Glass Works, Electronic Components Div.	Raleigh, N. C.

*Use Code 28480 assigned to Hewlett-Packard Co. , Palo Alto, California

Table 6-3. Code List of Manufacturers (Continued)

CODE NO.	MANUFACTURER	ADDRESS
16758	Delco Radio Div. of General Motors Corp.	Kokomo, I.nd.
17545	Atlantic Semiconductors, Inc.	Asbury Park, N. J.
17803	Fairchild Camera and Instrument Corp Semiconductor Div.	Transducer Plant Mountain View, Calif.
17870	Daven Div. Thomas A. Edison Industries McGraw-Edison Co.	Orange, N. J.
18324	Slngetics Corp.	Sunnyvale, Calif.
19315	Bendix Corp. The Navigation and Control Div.	Teterboro, N. J.
19701	Electra/Midland Corp.	Mineral Wells, Texas
21520	Fansteel Metallurgical Corp.	No. Chicago, Ill.
22229	Union Carbide Corp. Electronics Div.	Mountain View, Calif.
22753	UID Electronics Corp.	Hollywood, Fla.
23936	Pamotor, Inc.	Pampa, Texas
24446	General Electric Co.	Schenectady, N.Y.
24455	General Electric Co. Lamp Div. of Con- sumer Prod. Group	Nela Park, Cleveland, Ohio
24655	General Radio Co.	West Concord, Mass.
24681	LTV Electrosystems Inc Memcor/Com- ponents Operations	Huntington, Ind.
26982	Dynacool Mfg. Co. Inc. Saugerties, N.Y.	
27014	National Semiconductor Corp.	Santa Clara, Calif.
28480	Hewlett-Packard Co.	Palo Alto, Calif.
28520	Heyman Mfg. Co.	Kenilworth, N. J.
28875	IMC Magnetics Corp.	
	New Hampshire Div.	Rochester, N. H.
31514	SAE Advance Packaging, Inc.	Santa Ana, Calif.
31827	Budwig Mfg. Co.	Ramona, Calif.
33173	G. E. Co. Tube Dept.	Owensboro, Ky.
35434	Lectroh, Inc.	Chicago, Ill.
37942	P. R. Mallory & Co. Inc.	Indianapolis, Ind.
42190	Muter Co.	Chicago, 111.
43334	New Departure-Hyatt Bearings Div.	
	General Motors Corp.	Sanclusky, Ohio
44655	Ohmite Manufacturing Co.	Skokie, 111.
46384	Penn Engr. and Mfg. Corp.	Doylestown, Pa.
47904	Polaroid Corp.	Cambridge, Mass.
49956	Raytheon Co.	Lexington, Mass.
55026	Simpson Electric Co. Div. of American Gage and Machine Co.	Chicago, 111.
56289	Sprague Electric Co.	North Adams, Mass.
58474	Superior Electric Co.	Bristol, Corm.
58849	Syntron Div. of FMC Corp.	
	Homer City, Pa.	
59730	Thomas and Betts Co.	Philadelphia, Pa.
61637	Union Carbide Corp.	New York, N. Y.
63743	Ward Leonard Electric Co.	Mt. Vernon, N. Y.

CODE NO.	MANUFACTURE R	ADDRESS
70563	Amperite Co. Inc.	Union City, N. J.
70901	Beemer Engrg. Co.	Fort Washington, Pa.
70903	Belden Corp.	Chicago, Ill.
71218	Bud Radio, Inc.	Willoughby, Ohio
71279	Cambridge Thermionic Corp.	Cambridge, Mass.
71400	Bussmann Mfg. Div. of McGraw & Edison Co.	St. Louis, Mo.
71450	CTS Corp.	Elkhart, Ind.
71468	I. T. T. Cannon Electric Inc.	Los Angeles, Calif.
71590	Globe-Union Inc.	
	Centralab Div.	Milwaukee, Wis.
71700	General Cable Corp. Cornish Wire Co. Div.	Williams town, Mass.
71707	Coto Coil Co. Inc.	Providence, R. 1.
71744	Chicago Miniature Lamp Works	Chicago, Ill.
71785	Cinch Mfg. Co. and Howard B. Jones Div.	Chicago, Ill.
71984	Dow Coming Corp.	Midland, Mich.
72136	Electro Motive Mfg. Co. Inc.	Willimantic, Corm.
72619	Dialight Corp.	Brooklyn, N. Y.
72699	General Instrument Corp.	Newark, N. J.
72765	Drake Mfg. Co.	Harwood Heights, Ill.
72962	Elastic Stop Nut Div. of Amerace Esna Corp.	Union, N. J.
72982	Erie Technological Products Inc.	Erie, Pa.
73096	Hart Mfg. Co.	Hartford, Corm.
73138	Beckman Instruments Inc.	
	Helipot Div.	Fullerton, Calif.
73168	Fenwal, Inc.	Ashland, Mass.
73293	Hughes Aircraft Co. Elecmon Dynamics Div.	Torrance, Calif.
73445	Amperex Electronic Corp.	Hicksville, N. Y.
73506	Bradley Semiconductor Corp.	New Haven, Corm.
73559	Carling Electric, Inc.	Hartford, Corm.
73734	Federal Screw Products, Inc.	Chicago, Ill.
74193	Heinemann Electric Co.	Trenton, N. J.
74545	Hubbell Harvey Inc.	Bridgeport, Corm.
74868	Amphenol Corp. Amphenol RF Div.	Danbury, Corm.
	E. F. Johnson Co.	Waseca, Minn.
74970	IRC Div. of TRW, Inc.	Philadelphia, Pa.
75042	I Howard B. Jones Div. of Cinch Mfg. Corp.	New York, N. Y.
75183	Kurz and Kasch, Inc.	Dayton, Ohio
75376	Kilka Electric Corp.	Mt. Vernon, N. Y.
75382	Littlefuse, Inc.	Des Plaines, Ill.
75915	Minnesota Mining and Mfg. Co.	
76381		St. Paul, Minn.
76385	Minor Rubber Co. Inc.	Bloomfield, N.J.
76487	James Millen Mfg. Co. Inc.	
		Maiden, Mass.
76493	J. W. Miller Co.	Compton, Calif.

I Use Code 71785 assigned to Cinch Mfg. Co. , Chicago, Ill.

CODE NO.	MANUFACTURER	ADDRESS
76530	Cinch	City of Industry, Calif.
76854	Oak Mfg. Co. Div. of Oak	
77068	Electro/Netics Corp.	Crystal Lake, Ill.
	Bendix Corp. , Electroynamics Div.	No. Hollywood, Calif.
77122	Palnut Co.	Mountainside, N. J.
77147	Patton -Mac Guyer Co.	Providence, R. I.
77221	Phaostron Instrument and Electronic Co.	
		South Pasadena, Calif.
77252	Philadelphia Steel and Wire Corp.	Philadelphia, Pa.
77342	American Machine and Foundry Co.	
	Potter and Brumfield Div.	Princeton, Ind.
77630	TRW Electronic Components Div.	
		Camden, N. J.
77764	Resistance Products Co.	Harrisburg, Pa.
78189	Illinois Tool Works Inc. Shakeproof Div.	
		Elgin, Ill.
78452	Everlock Chicago, Inc.	Chicago, 111.
78488	Stackpole Carbon Co.	St. Marys, Pa.
78526	Stanwyck Winding Div.	San Fernando
	Electric Mfg. Co. Inc.	Newburgh, N.Y.
78553	Tinnerman Products, Inc.	Cleveland, Ohio
78584	Stewart Stamping Corp.	Yonkers, N. Y.
79136	Waldes Kohinoor, Inc.	L.I.C., N.Y.
79307	Whitehead Metals Inc.	New York, N. Y.
79727	Continental-Wirt Electronics Corp.	
		Philadelphia, Pa.
79963	Zierick Mfg. Co.	Mt. Kisco, N.Y.
80031	Mepco Div. of Sessions Clock Co.	
		Morristown, N. J.
80294	Bourns, Inc.	Riverside, Calif.
81042	Howard Industries Div. of Msl Ind. Inc.	
		Racine, Wis.
81073	Grayhiil, Inc.	La Grange, Ill.
81483	International Rectifier Corp.	
		El Segundo, Calif.
81751	Columbus Electronics Corp.	Yonkers, N. Y."
82099	Goodyear Sundries & Mechanical Co. Inc.	
		New York, N. Y.
82142	Airco Speer Electronic Components	
		Du Bois, Pa.
82219	Sylvania Electric Products Inc.	
	Electronic Tube Div. Receiving	
	Tube Operations	Emporium, Pa.
82389	Switchcraft, Inc.	Chicago, Ill.
82647	Metals and Controls Inc. Control	
	Products Group	Attleboro, Mass.
82866	Research Products Corp.	Madison, Wis.
82877	Rotron Inc.	Woodstock, N. Y.
82893	Vector Electronic Co.	Glendale, Calif.
83058	Cam Fastener Co.	Cambridge, Mass.
83186	Victory Engineering Corp.	
		Springfield, N. J.
83298	Bendix Corp. Electric Power Div.	
		Eatontown, N, J.
83330	Herman H. Smith, Inc.	Brooklyn, N. Y.
83385	Central Screw Co.	Chicago, Ill.
83501	Gavitt Wire and Cable Div. of	
	Amerace Esna Corp.	Brookfield, Mass.

CODE NO.	MANUFACTURER	ADDRESS
83508	Grant Pulley and Hardware Co.	
		West Nyack, N. Y.
83594	Burroughs Corp. Electronic	
	Components Div.	Plainfield, N.J.
83835	U. S. Radium Corp.	Morristown, N.J.
83877	Yardeny Laboratoriess, Inc.	
		New York, N.Y.
84171	Arco Electronics, Inc.	Great Neck, N.Y.
84411	TRW Capacitor Div.	Ogallala, Neb.
86684	RCA Corp. Electronic Components	
		Harrison, N. J.
86838	Rummel Fibre Co.	Newark, N, J.
87034	Marco & Oak Industries a Div. of Oak	
	Electro/netics Corp.	Anaheim; Calif.
87216	Philco Corp. Lansdale Div.	Lansdale, Pa.
87585	Stockwell Rubber Co. Inc.	
		Philadelphia, Pa.
87929	Tower-Olschan Corp.	Bridgeport, Corm.
88140	Cutler-Hammer Inc. Power Distribution	
	and Control Div. Lincoln Plant	
		Lincoln, Ill.
88245	Litton Precision Products Inc, USECO	
	Div. Litton Industries	Van Nuys, Calif.
90634	Gulton Industries Inc.	Metuchen, N,J.
90763	United-Car Inc.	Chicago, Ill.
91345	Miller Dial and Nameplate Co.	
		El Monte, Calif.
91418	Radio Materials Co.	Chicago, Ill.
91506	Augat, Inc.	Attleboro, Mass.
91637	Dale Electronics, Inc.	Columbus, Neb.
91662	Elco Corp.	Willow Grove, Pa.
91929	Honeywell Inc. Div. Micro Switch	
		Freeport, Ill.
92825	Whitso, Inc.	Schiller Pk. , Ill.
93332	Sylvania Electric Prod. Inc. Semi-	
	conductor Prod. Div.	Woburn, Mass.
93410	Essex Wire Corp. Stemco	
	Controls Div.	Mansfield, Ohio
94144	Raytheon Co. Components Div.	
	Ind. Components Oper.	Quincy, Mass.
94154	Wagner Electric Corp.	
	Tung-Sol Div.	Livingston, N. J.
94222	Southco Inc.	Lester, Pa.
95263	Leecraft Mfg. Co. Inc.	L.I.C., N.Y.
95354	Method Mfg. Co. Rolling Meadows, Ill,	
95712	Bendix Corp. Microwave	
	Devices Div.	Franklin, Ind.
35987	Weckesser Co. Inc.	Chicago, Ill.
96791	Amphenol Corp. Amphenol	
	Controls Div.	Janesville, Wis.
97464	Industrial Retaining Ring Co.	
		Irvington, N.J.
97702	IMC Magnetics Corp. Eastern Div.	
		Westbury, N. Y.
98291	Seaelectro Corp.	Mamaroneck, N. Y.
98410	ETC Inc.	Cleveland, Ohio
38978	'International Electronic Research Corp.	
		Burbank, Calif.
39934	Renbrandt, Inc.	Boston, Mass.

Table 6-4. Replaceable Parts

REF. DESIG.	DESCRIPTION	TQ	MFR. PART NO.	MFR. CODE	HP PART NO.	RS
	AI MAIN PRINTED CIRCUIT BOARD					
A1	Printed Circuit Board, Main	1		28480	5060-6189	
C1	fxd, mylar. 01μF 200V	1		28480	0160-0161	1
C2	fxd, elect. 5μF 50Vdc	3	30D505G050BB2	56289	0180-0301	1
C20	fxd, elect. 68μF 15Vdc	2	150D686X0015R2	56285	0180-1835	1
C35	fxd, elect. 20μF 50Vdc	1	30 D206G050C02	56289	0180-0049	1
C40, 41	fxd, mylar .022μF 200Vdc	2	192P22392	56289	0160-0162	1
C44	fxd, elect. 1,400μF 30Vdc	1		28480	0180-1860	1
C60	fxd, elect. 4.7μF 35Vdc	1	150D475X9035B2	56289	0180-0100	1
C61	fxd, elect. 325μF 35Vdc	1		28480	0180-0332	1
C70	fxd, elect. 1μF 35Vdc	1	150D105X9035A2	56289	0180-0291	1
C71	fxd, mylar .1μF 200Vdc	2	192P10492	56289	0160-0168	1
C72, 73	fxd, elect. 5μF 50Vdc		30D505G050BB2	56289	.0180-0301	
C90	fxd, mylar .1μF 200Vdc		192P10492	56289	0160-0168	
CR1-7,20, 21,35-37	Diode, Si. 200mA 200prv	38		28480	1901-0033	12
CR40	Stabistor	1		28480	1901-0460	1
CR41,43,44	Diode, Si 200mA 200prv			28480	1901-0033	
CR42,51,52	NOT ASSIGNED	-	-			
CR45-50, 53,54	Diode, Si.	8	1N5059	03508	1901-0327	6
CR60-62, 70-84,88, 90-93	Diode, Si. 200mA 200prv			28480	1901-0033	
Q1	SS PNP Si.	6		28480	1853-0099	6
Q20, 40	SS NPN Si.	9		28480	1854-0071	6
Q41, 42	SS PNP Si.			28480	1853-0099	
Q60	SS PNP Si	1		28480	1853-0041	1
Q61-Q63	SS NPN Si.			28480	1854-0071	
Q70, 71	SS PNP Si.			28480	1853-0099	
Q72, 73	SS NPN Si.			28480	1854-0071	
Q90	SS PNP Si.			28480	1853-009-9	
Q91, 92	SS NPN Si.			09182	1854-0071	
R1	fxd, met. film 1M Ω ±1% ¼ Ω	1	Type CEB T-O	07716	0757-0344	1
R2	fxd, comp 160 Ω ±5% ½ Ω	2	EB-1615	01121	0686-1615	1
R3	fxd, comp (selected) +5% ½ Ω	2	Type EB (obd)	01121	-	1
R4	fxd, ww 680 Ω ±5% 5W	1	243E6815	56289	0811-2099	1
R5	fxd, ww 600 Ω ± 5 % 5 W	1	243E6015	56289	0811-1869	1
R6	fxd, ww 1K Ω ± 5% 3W	1	242E1025	56289	0813-0001	1
R20	fxd, met. film 330 Ω ±1% 1/8W	1	Type CEA T-0	07716	0698-5663	1
R21	fxd, met. film 200k Ω ±1% 1/8W	1	Type CEA T-0	07716	0757-0472	1
R22	fxd, met. film 196 Ω ±1% 1/8W	1	Type CEA T-0	07716	0698-3440	1
R23	fxd, met. film 1.21k Ω ±1% 1/8W	2	Type CEA T-0	07716	0757-0274	1
R24	fxd, met. film 7.5K Ω ±1% 1/8W	3	Type CEA T-0	07716	0757-0440	1
R25	fxd, met. film 5.49K Ω ±1% 1/8W	2	Type CEA T-0	077,16	0698-3382	1
R26	fxd, met. film 21.5K Ω ±1% 1/8W	1	Type CEA T-0	07716	0698-3430	1
R27	fxd, comp 3.9M Ω ±5% ½W	1	EB-3955	01121	0686-3955	1
R28, 29	fxd, comp 3.3 Ω ±5% ½W	2	EB-0335	01121	0686-0335	1
R30	fxd, comp (Selected) ±5% ½W		Type EB (obd)	01121	-	
R31	fxd, ww 2.6K Ω ±5% 3W	1	242E2625	56289	0811-1808	1
R35, 36	fxd, comp 10k Ω ± 5 % ½ W	2	EB-1035	01121	0686-1035	1
R37	fxd, comp 180k Ω ± 5 % ½ W	1	EB-1845	01121	0686-1845	1
R40	fxd, comp 1.5K Ω ±5% ½W	1	EB-1525	01121	0686-1525	1

REF. DESIG.	DESCRIPTION	TQ	MFR. PART NO.	MFR. CODE	HP PART NO.	RS
R41	fxd, comp 510 Ω \pm 5% $\frac{1}{2}$ W	2	EB-5115	01121	0686-5115	1
R42	fxd, met. film 560 Ω \pm 1% $\frac{1}{4}$ W	1	Type CEB T-O	07716	0698-5146	1
R43	fxd, ww 50 Ω \pm 5% 5W	2	243E5005	56289	0811-1854	1
R44	fxd, met. oxide 22 Ω \pm 5% 2W	1	Type C42S	16299	0698-3609	1
R45	fxd, comp 820 Ω \pm 5% $\frac{1}{2}$ W	1	EB-8215	01121	0686-8215	1
R46	fxd, comp 1K Ω \pm 5% $\frac{1}{2}$ W	2	EB-1025	01121	0686-1025	1
R47	var. ww 5k Ω \pm 10%, Equalizer Adj.	2	Type 110-F4	11236	2100-1824	1
R48	fxd, comp 5.1k Ω \pm 5% $\frac{1}{2}$ W	1	EB-5125	01121	0686-5125	1
R49	fxd, comp 47 Ω \pm 5% $\frac{1}{2}$ W	1	EB-4705	01121	0686-4705	1
R50	fxd, comp 39 Ω \pm 5% $\frac{1}{2}$ W	1	EB-3905	01121	0686-3905	1
R51	fxd, comp 1k Ω \pm 5% $\frac{1}{2}$ W	1	EB-1025	01121	0686-1025	1
R52	fxd, met. film 61.9k Ω \pm 1% 1/8W	1	Type CEA T-O	07716	0757-0460	1
R53	fxd, comp 560 Ω \pm 5% $\frac{1}{2}$ W	1	EB-5615	01121	0686-5615	1
R54	fxd, ww 50 Ω \pm 5% 5W	1	243 E5005	56289	0811-1854	1
R56	fxd, comp 75 Ω \pm 5% $\frac{1}{2}$ W	1	EB-7505	01121	0686-7505	1
R57	fxd, ww 3.9 Ω 2W	1	Type BWH	07716	0811-1673	1
R58	fxd, ww 400 Ω \pm 5% 10W	1	Type 10XM	63743	0811-0942	1
R60	fxd, met. film 600 Ω \pm 1% 1/8W	1	Type CEA T-O	07716	0757-1100	1
R61	fxd, met. film 7.5K Ω \pm 1% 1/8W	1	Type CEA T-O	07716	0757-0440	1
R62	fxd, met. oxide 180 Ω \pm 5% 2W	1	Type C42S	16299	0698-3626	1
R63	fxd, met. film 499 Ω \pm 1% $\frac{1}{4}$ W	1	Type CEB T-O	07716	0698-3207	1
R64	fxd, met. film 2k Ω \pm 1% $\frac{1}{4}$ W	1	Type CEB T-O	07716	0757-0739	1
R65	fxd, comp 100k Ω \pm 5% $\frac{1}{2}$ W	2	EB-1045	01121	0686-1045	1
R66	fxd, comp 200k Ω \pm 5% $\frac{1}{2}$ W	3	EB-2045	01121	0686-2045	1
R67	fxd, comp 33k Ω \pm 5% $\frac{1}{2}$ W	1	EB-3335	01121	0686-3335	1
R68	fxd, met. film 5.49k Ω \pm 1% 1/8W	1	Type CEA T-O	07716	0698-3382	1
R69	fxd, met. film 7.5k Ω \pm 1% 1/8W	1	Type CEA T-O	07716	0757-0440	1
R69B	fxd, met. film 3.4k Ω \pm 1% 1/8W	1	Type CEA T-O	07716	0698-4440	1
R70	var, ww 5k Ω \pm 10%, Ramp Adjust.	1	Type 110-F4	11236	2100-1824	1
R71	fxd, met. film 12k Ω \pm 1% 1/8W	1	Type CEA T-O	07716	0698-5088	1
R72	fxd, met. film 45k Ω \pm 1% 1/8W	1	Type CEA T-O	07716	0698-5091	1
R73	fxd, comp 12k Ω \pm 5% $\frac{1}{2}$ W	1	EB-1235	01121	0686-1235	1
R74	fxd, comp 82k Ω \pm 5% $\frac{1}{2}$ W	1	EB-8235	01121	0686-8235	1
R75, 76	fxd, met. film 4,75k Ω \pm 1% 1/8W	2	Type CEA T-O	07716	0757-0437	1
R77	fxd, comp 430k Ω \pm 5% $\frac{1}{2}$ W	1	EB-4345	01121	0686-4345	1
R78	fxd, met. film 249k Ω \pm 1% 1/8W	1	Type CEA T-O	07716	0757-0270	1
R79	fxd, comp 3.9k Ω \pm 5% $\frac{1}{2}$ W	2	EB-3925	01121	0686-3925	1
R80	fxd, met. film 4.32k Ω \pm 1% 1/8W	1	Type CEA T-O	07716	0757-0436	1
R81	fxd, comp 4.7 Ω \pm 5% $\frac{1}{2}$ W	2	EB-47G5	01121	0698-0001	1
R82	fxd, comp 9.1k Ω \pm 5% $\frac{1}{2}$ W	2	EB-9125	01121	0686-9125	1
R83	fxd, comp 27 Ω \pm 5% $\frac{1}{2}$ W	1	EB-2705	01121	0686-2705	1
R84	fxd, comp 100k Ω \pm 5% $\frac{1}{2}$ W	1	EB-1045	01121	0686-1045	1
R85	fxd, comp 9.1k Ω \pm 5% $\frac{1}{2}$ W	1	EB-9125	01121	0686-9125	1
R86	fxd, met. oxide 270 Ω \pm 5% 2W	1	Type C42S	16299	0698-3629	1
R87	fxd, met. oxide 1.5k Ω \pm 5% 2w	1	Type C42S	16299	0698-3338	1
R88	fxd, comp 10 Ω \pm 5% $\frac{1}{2}$ W	2	EB-1005	01121	0686-1005	1
R90	fxd, met. oxide 820 Ω \pm 5% 2W	1	Type C42S	16299	0698-3637	1
R91	fxd, comp 180 Ω \pm 5% 1W	1	GB-1815	01121	0689-1815	1
R92	fxd, ww 220 Ω 2W	1	Type BWH	07716	0811-1763	1
R93	fxd, comp 3.9k Ω \pm 5% $\frac{1}{2}$ W	1	EB-3925	01121	0686-3925	1
R94	fxd, comp 510 Ω \pm 5% $\frac{1}{2}$ W	1	EB-5115	01121	0686-5115	1
R95	fxd, met. film 1.5k Ω \pm 1% 1/8W	2	Type CEA T-O	07716	0757-0427	1
R96	fxd, comp 200k Ω \pm 5% $\frac{1}{2}$ W	1	EB-2045	01121	0686-2045	1
R97	fxd, comp 4.7 Ω \pm 5% $\frac{1}{2}$ W	1	EB-47G5	01121	0698-0001	1
R98	fxd, comp 10 Ω \pm 5% $\frac{1}{2}$ W	1	EB-1005	01121	0686-1005	1
R99	fxd, comp 200k Ω \pm 5% $\frac{1}{2}$ W	1	EB-2045	01121	0686-2045	1
R101	var. ww 250 Ω \pm 10%, Ammeter Adj.	2	Type 110-F4	11236	2100-0439	1
R102	fxd, met. film 909 Ω \pm 1% 1/8W	1	Type CEA T-O	07716	0757-0422	1

REF. DESIG.	DESCRIPTION	TQ	MFR. PART NO.	MFR. CODE	HP PART NO.	RS
R103	fxd, met. film 1.5k Ω \pm 1% 1/8W		Type CEA 7-0	07716	0757-0427	
R104	fxd, met. film 19.1k Ω \pm 1% 1/8W	1	Type CEA T-O	07716	0698-4484	1
R105	fxd, met. film 422 Ω \pm 1% 1/4W	1	Type CEB T-O	07716	0698-4590	1
R106	var. ww 250 Ω \pm 10%, Voltmeter Adj.		Type 110-F4	11236	2100-0439	
R108, 109	fxd, comp 100 Ω \pm 5% 1/2W	2	EB-1015	01121	0686-1015	1
T70, 90	Pulse Transformer	2		28480	5080-7122	1
VR1, 40	Diode, zener 4.22V \pm 5%	2		28480	1902-3070	2
VR60, 61	Diode, zener 6.2V \pm 5%	2		28480	1902-1221	2
VR90	Diode, zener 6.19V \pm 5%	1		28480	1902-0049	1
Z1	Dual Differential Amplifier	1	CA3026	02735	1820-0240	1
22	Resistor Network	1		28480	1810-0042	1
A2 RFI FILTER ASSEMBLY						
A2	RFI Filter Assembly	1		28480	06269-60007	
C1	fxd, paper .22 μ F 600Vdc	1	Type 160P	56289	0160-2461	1
CR1	Triac, 40A 400prv	1	2N5445	02735	1884-0080	1
L1A/L1B	Filter Choke 1.5mH	1		28480	5080-7146	1
R1	fxd, met. oxide 270 Ω \pm 5% 2W	1	Type C42S	16299	0698-3629	1
A3 INTERCONNECTION BOARD						
A3	Interconnection Board Assembly	1		28480	5060-7906	
C3	fxd, elect. 5000 μ F 45Vdc	1		28480	0180-1919	1
J1	P.C. Board Edge Connector	1	64-718-22	76530	1251-1887	
R120	fxd, comp 51k Ω \pm 5% 1/2W	1	EB-5135	01121	0686-5135	1
T2	Bias Transformer	1		28480	9100-2607	1
A4 HEAT SINK ASSEMBLY						
A4	Heat Sink Assembly	1		28480	06269-60004	
B1	Fan	1	WS2107F	97702	3160-0056	1
C1-C4	fxd, ceramic .05 μ F 400V	4		28480	0150-0052	1
C5	fxd, elect. 15 μ F 50V	1		28480	0180-1834	1
CR101, 102	Rect. Si. 40A 50prv	4	1N1183AR	02577	1901-0316	4
CR103, 104	Rect. Si. 40A 50prv	3	1N1183A	02577	1901-0315	3
CR105	Rect. Si. 40A 50prv		1N1183AR	02577	1901-0316	
CR106	Rect. Si. 40A 50prv		1N1183A	02577	1901-0315	
CR108	Rect. Si. 40A 50prv		1N1183AR	28480	1901-0316	
CR110	SCR 35A 400prv	1		28480	1884-0058	1
Q101	Power PNP Si.	1		28480	1853-0063	1
Q102	Power NPN Si.	1		28480	1854-022S	1
Q103-Q108	Power NPN Si.	6		28480	1854-0458	6
R106	fxd, ww .125 Ω \pm 5% 5W	1		28480	0811-1846	1
R123	fxd, cupron 0.01 Ω 20ppm, Current Sampling	1		28480	5080-7144	1
R150-R155	Emitter Resistor Assembly	1		28480	06260-60023	1
	fxd, wire helix 0.1 Ω \pm 5% - Part of Emitter Resistor Assembly	6		28480	0811-2545	2

REF. DESIG.	DESCRIPTION	TQ	MFR. PART NO.	MFR. CODE	HP PART NO.	RS
TS101	Thermal Switch, open 230°F, close 200°F	1		28480	0440-0079	1
A5 FRONT PANEL ASSEMBLY						
A5	Front Panel Assembly	1		28480	06269-60005	
CB1	Circuit Breaker, 25A @ 250Vac max.	1	AM33 Curve 5	74193	2110-0213	1
DS1	Indicator Light, Neon, Red	1	599-124	72765	1450-0048	1
DS2	Overvoltage Indicator, 6V, Amber	1	MCL-A3-1730	07137	1450-0305	1
M1	Voltmeter, 0-50V	1		28480	1120-1173	1
M2	Ammeter, 0-60A	1		28480	1120-1181	1
R121	var. ww 10k Ω ±5%, Voltage Control, Coarse	2		28480	2100-1854	1
R122	var. ww 50 Ω ±5%, Voltage Control, Fine	2		28480	2100-1858	1
R123	var. ww 200 Ω ±5%, Current Control, Coarse	1		28480	2100-1856	1
R124	var. ww 10 Ω ±5%, Current Control, Fine	1		28480	2100-1857	1
R125	var. ww 10k Ω ±5%, Overvoltage Adjustment			28480	2100-1854	
CHASSIS - ELECTRICAL						
B 2	Fan	1	8500	23936	3160-0056	1
C19	fxd, elect. 15μF 50Vdc	1	150D156X0050R2	56289	0180-1834	1
C101-C104	fxd, elect. 50,000μF 50Vdc	4		28480	0180-2346	1
C110, 111	fxd, ceramic .01μF 300Vdc	2	41C21A5	56289	0160-2568	1
T1	Power Transformer	1		28480	06269-80091	1
CHASSIS ASSEMBLY- MECHANICAL						
	Chassis Assembly (Welded)	1		28480	5060-6186	
	Bracket, RFI Filter Mounting	2		28480	5000-6257	
	Standoff, Insulated, RFI Filter Mounting	4		28480	0380-0902	
	Grommet, 5/8" (Internal Chassis Divider)	1	1661	73734	0400-0062	
	Cover	2		28480	5000-6250	
	Chassis, Internal, Ckt. Board Tray	1		28480	5000-6248	
	Chassis, Internal, Capacitor Tray	1		28480	06269-00002	
	Bus Bar, C101-C102	2		28480	5000-6251	
	Bus Bar, C103-C104	2		28480	5000-6253	
	Clamp, C101-C104	3		28480	5000-6017	
	Bracket, Fan B2	2		28480	06269-00003	
	Rear Panel (Blank, with labeling)	1		28480	06260-60008	
	Cover, AC Input Barrier Block	1		28480	5000-6249	
	Cover, Rear Control Barrier Strip	1		28480	00712-20001	
	Bus Bar, Output	2		28480	5000-6252	
	Barrier Block, AC Input	1	603-3	75382	0360-1596	1
	Rubber Bumper	4	2097-W	87585	0403-0089	
	Spacer, Insulated, AC Input Barrier (2), Output Bus Bars (4)	6		28480	0380-0710	6
	Serial I.D. Plate	1		28480	7120-1111	

REF. DESIG.	DESCRIPTION	TQ	MFR. PART NO.	M R F . CODE	H P PART NO.	R S
	MISCELLANEOUS					
	Manual	1		28480	06269-90002	
	Carton, Packing	1		28480	9211-1181	
	Floater Pad, Packing	2		28480	9220-1402	
R82	OPTION 005 50Hz Operation fxd, comp 240 Ω ±5% ½W Label, Identification	1 1	EB-2415	01121	0686-2415 7124-1719	1
A5R121	OPTION 007 10-Turn Voltage Coarse Control var. ww 10k Ω ±5% 10-Turn	1		28480	2100-1866	1
A5R123	OPTION 008 10-Turn Current Coarse Control var. ww 200 Ω ±5% 10-Turn	1		28480	2100-1863	1
A5R121 A5R123	OPTION 009 10-Turn Voltage & Current Controls var. ww 10k Ω ±5% 10-Turn var. ww 200 Ω ±5% 10-Turn	1 1		28480 28480	2100-1866 2100-1863	1 1
	OPTION 010 Chassis Slides Slides, Chassis	1	CTS 120 E6			1
R3 A5R121	OPTION 013 Decadial Voltage Control fxd, comp (Selected) ±5% ½W var. ww 10k Ω ±5% 10-Turn Decadial Control	1 1 1	Type EB (obd) RD-411	01121 28480 07716	2100-1866 1140-0020	1 1
R30 A5R123	OPTION 014 Decadial Current Control fxd, comp (Selected) ±5% ½W var. ww 200 Ω ±5% 10-Turn Decadial Control	1 1 1	Type EB (obd) RD-411	01121 28480 07716	2100-1863 1140-0020	1 1
R111 R112,113 R114	OPTION 020 Voltage Programming Adjust fxd, met. film 221k Ω ±1% 1/8W var. ww 5k Ω fxd, met. film 249k Ω ±1% 1/8W Label, Identification	1 2 1 1	Type CEA T-O Type CEA T-O	07716 28480 07716	0757-0473 2100-0806 0757-0270 7124-1721	1 1 1
R115 R116 R118 R119	OPTION 021 Current Programming Adjust fxd, met. film 23K Ω ±1% 1/8W var. ww 5k Ω fxd, met. film 200k Ω ±1% 1/8W var. ww 5k Ω Label, Identification	1 2 1 1	Type CEA T-O Type CEA T-O	07716 28480 07716 28480	0698-3269 2100-0806 0757-0472 2100-0806 7124-1721	1 1 1

REF DESIGN	DESCRIPTION	TQ	MFR PART NO	MFR CODE	HP PART NO	RS
	OPTION 022 VOLTAGE & CURRENT PROGRAMMING ADJUST					
R111	FXD, MET. FILM 221KW ±1% 1/8W	1	TYPE CEA T-O	07716	0757-0473	1
R112,113	VAR. WW 5KΩ	4		28480	2100-0806	1
R114	FXD, MET. FILM 249KW ±1% 1/8W	1	TYPE CEA T-O	07716	0757-0270	1
R115	FXD, MET. FILM 23KW ±1% 1/8W	1	TYPE CEA T-O	07716	0698-3269	1
R116	VAR. WW 5KΩ			28480	2100-0806	
R118	FXD, MET. FILM 200KW ±1% 1/8W	1	TYPE CEA T-O	07716	0757-0472	1
R119	VAR. WW 5KW			28480	2100-0806	
	LABEL, IDENTIFICATION	1		28480	7124-1721	
	OPTION 027 208VAC INPUT					
	LABEL, IDENTIFICATION	1		28480	7124-1717	

TABLE 6-5. PART NUMBER - NATIONAL STOCK NUMBER
CROSS REFERENCE INDEX

PART NUMBER	FSCM	NATIONAL STOCK NUMBER	PART NUMBER	FSCM	NATIONAL STOCK NUMBER
0150-0052	28480	5910-00-797-4909	0757-0437	28480	5905-00-904-4404
0160-0161	28480	5910-00-911-9271	0757-0440	28480	5905-00-858-6795
0160-0162	28480	5910-00-850-2162	0757-0460	28480	5905-00-858-8959
0160-0168	28480	5910-00-917-0668	0757-0472	28480	5905-00-257-9210
0180-0049	28480	5910-00-781-9398	0757-0473	28480	5905-00-994-8480
0180-0100	28480	5910-00-752-4172	0757-0739	28480	5905-00-830-6078
0180-0291	28480	5910-00-931-7055	0757-1100	28480	5905-00-917-0586
0180-0332	28480	5910-00-943-6709	0813-0001	28480	5905-00-932-0413
0180-1860	28480	5910-00-931-7061	1N5059	03508	5961-00-088-8792
0686-1035	28480	5905-00-451-0540	1140-0020	28480	5355-00-584-0840
0686-1045	28480	5905-00-195-6761	1251-1887	28480	5935-00-147-7384
0686-1525	28480	5905-00-279-1757	137	83330	5940-00-321-4984
0686-3335	28480	5905-00-997-5436	1410-0052	28480	5895-00-061-2906
0686-4345	28480	5905-00-279-2518	1450-0048	28480	6210-00-761-8898
0686-5125	28480	5905-00-279-2019	150D105X9035A2	56289	5910-00-104-0144
0689-1815	28480	5905-00-403-9066	150D475X9035B2	56289	5910-00-177-4300
0698-0001	28480	5905-00-682-4247	1661	73734	5325-00-301-8656
0698-3338	28480	5905-00-431-6842	1810-0042	28480	5905-00-450-0107
0698-3430	28480	5905-00-420-7136	1853-0041	28480	5961-00-931-8259
0698-3440	28480	5905-00-828-0377	1853-0063	28480	5961-00-867-9319
0698-3629	28480	5905-00-405-3727	1853-0099	28480	5961-00-450-4689
0698-4440	28480	5905-00-431-6840	1854-0071	28480	5961-00-137-4608
0698-4484	28480	5905-00-140-5675	1854-0225	28480	5961-00-072-0094
0698-5088	28480	5905-00-469-2838	1901-0033	28480	5961-00-821-0710
0698-5146	28480	5905-00-431-6837	1901-0327	28480	5961-00-931-0213
0757-0270	28480	5905-00-491-4596	1901-0460	28480	5961-00-867-9206
0757-0274	28480	5905-00-858-9105	1902-0049	28480	5961-00-911-9277
0757-0344	28480	5905-00-269-2629	1902-3070	28480	5961-00-931-6989
0757-0422	28480	5905-00-728-9980	192P10492	56289	5910-00-728-8472
0757-0427	28480	5905-00-917-0578	192P22392	56289	5910-00-993-8308
0757-0436	28480	5905-00-858-6792	2100-0439	28480	5905-00-851-3924

PART NUMBER - NATIONAL STOCK NUMBER
CROSS REFERENCE INDEX

TM 11-6625-2958-14&P

PART NUMBER	FSCM	NATIONAL STOCK NUMBER	PART NUMBER	FSCM	NATIONAL STOCK NUMBER
2100-0806	28480	5905-00-929-0485			
2100-1824	28480	5905-00-892-9626			
2100-1857	28480	5905-00-575-8853			
2100-1866	28480	5905-00-110-0282			
242E1025	56289	5905-00-504-4892			
243E5005	56289	5905-00-950-5551			
2950-0034	28480	5310-00-903-8729			
30D505G050BB2	56289	5910-00-081-6159			
3160-0056	28480	4140-00-758-6113			
422-13-11-013	71785	5935-00-917-9079			
599-124	72765	6210-00-761-8898			
734	08530	5970-00-840-5109			

SECTION VII
CIRCUIT DIAGRAMS AND COMPONENT LOCATION DIAGRAMS

This section contains the circuit diagrams necessary for the operation and maintenance of this power supply. Included are:

a. Component location diagrams (Figures 7-1 through 7-8, and 7-10), showing the physical location and reference designators of parts mounted on the printed circuit boards and chassis.

b. Preregulator control circuit waveforms (Figure 7-9), showing the waveforms found at various points in the preregulator control circuit.

c. Schematic diagram (Figure 7-1 1), illustrating the circuitry for the entire power supply. Voltages are given adjacent to test points, which are identified by encircled numbers on the schematic.

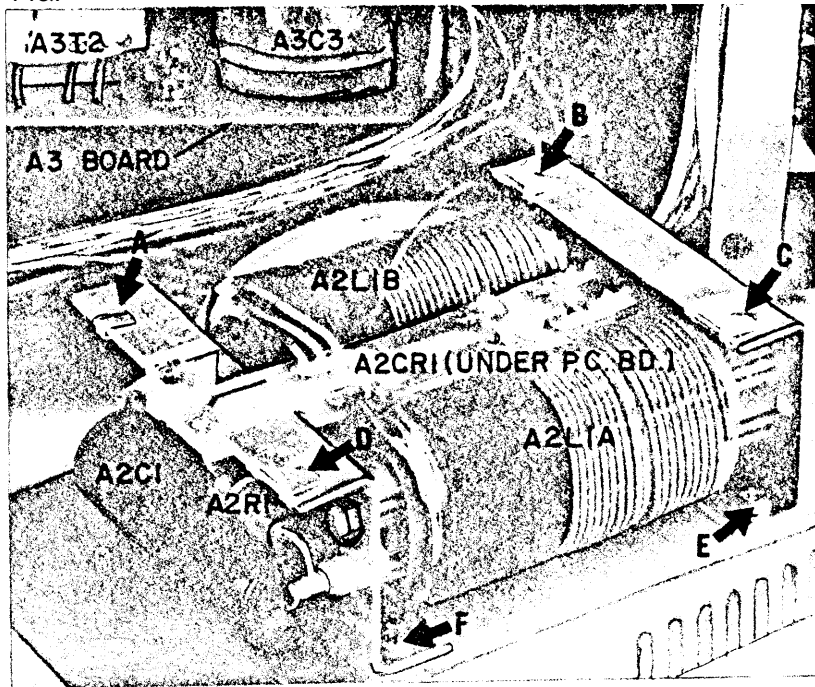

Figure 7-1. A2 RFI Assembly Component Location Diagram (Shown removed from supply with assembly cover off.)

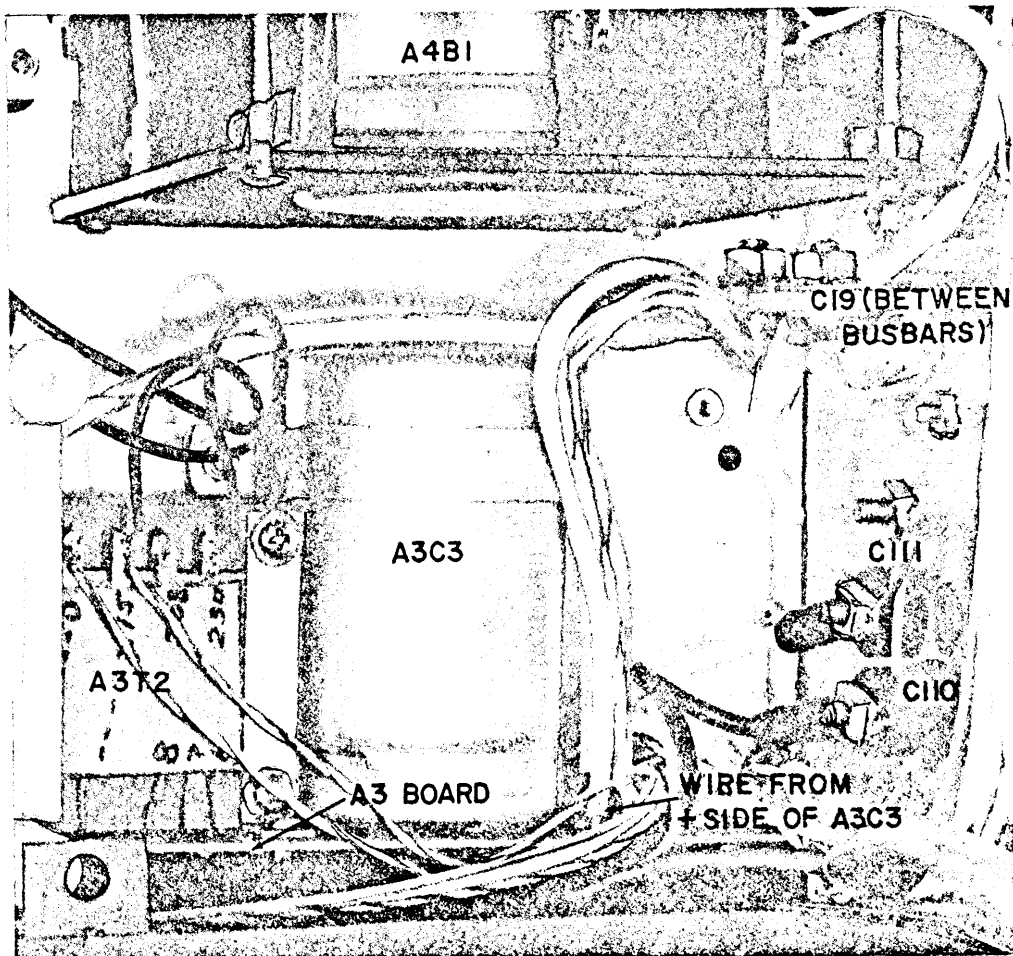

Figure 7-2. A3 Interconnection Circuit Board Assembly Component Location Diagram (Shown with A2 RFI assembly removed.)

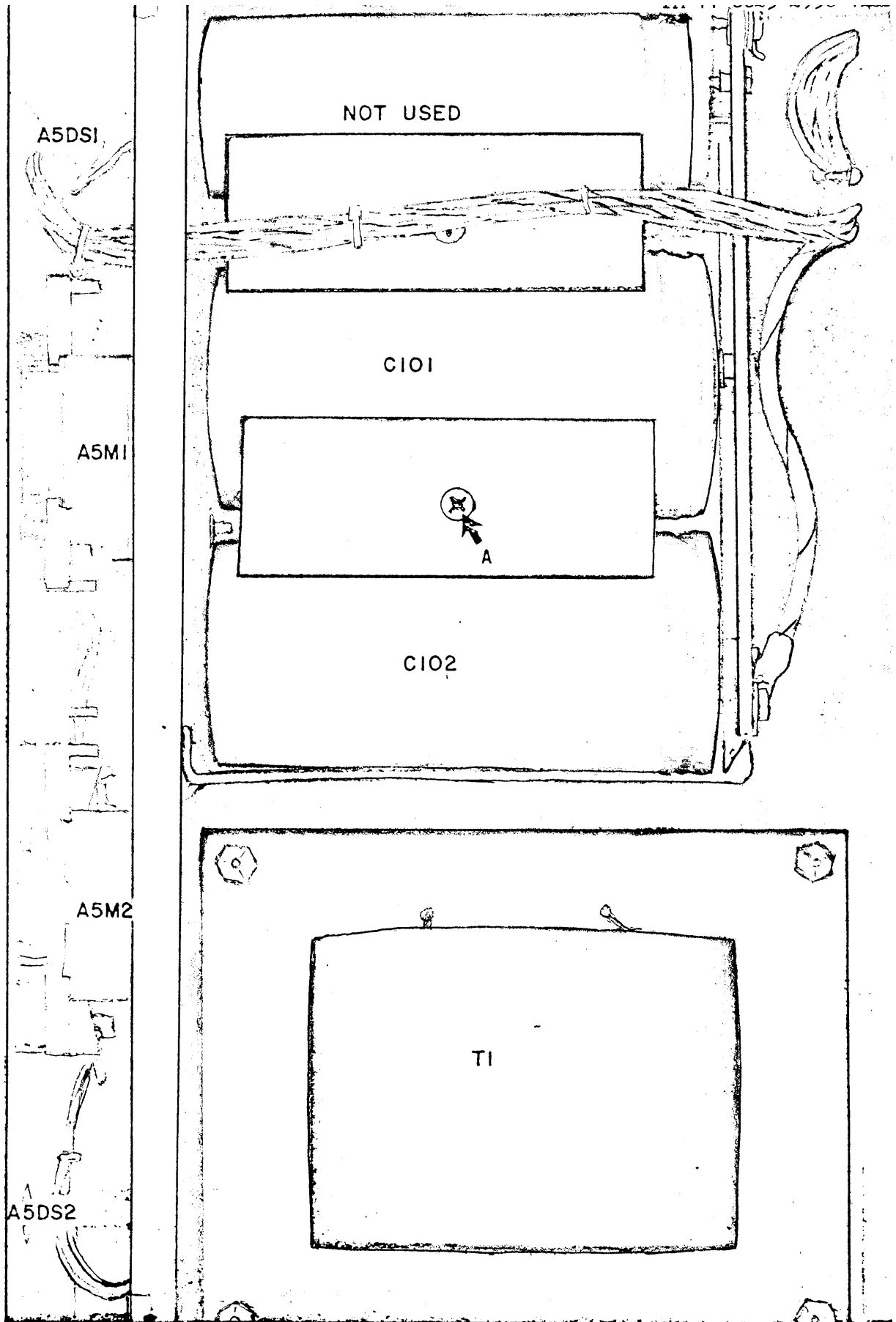

Figure 7-3. Top Front Chassis Assembly Component Location Diagram

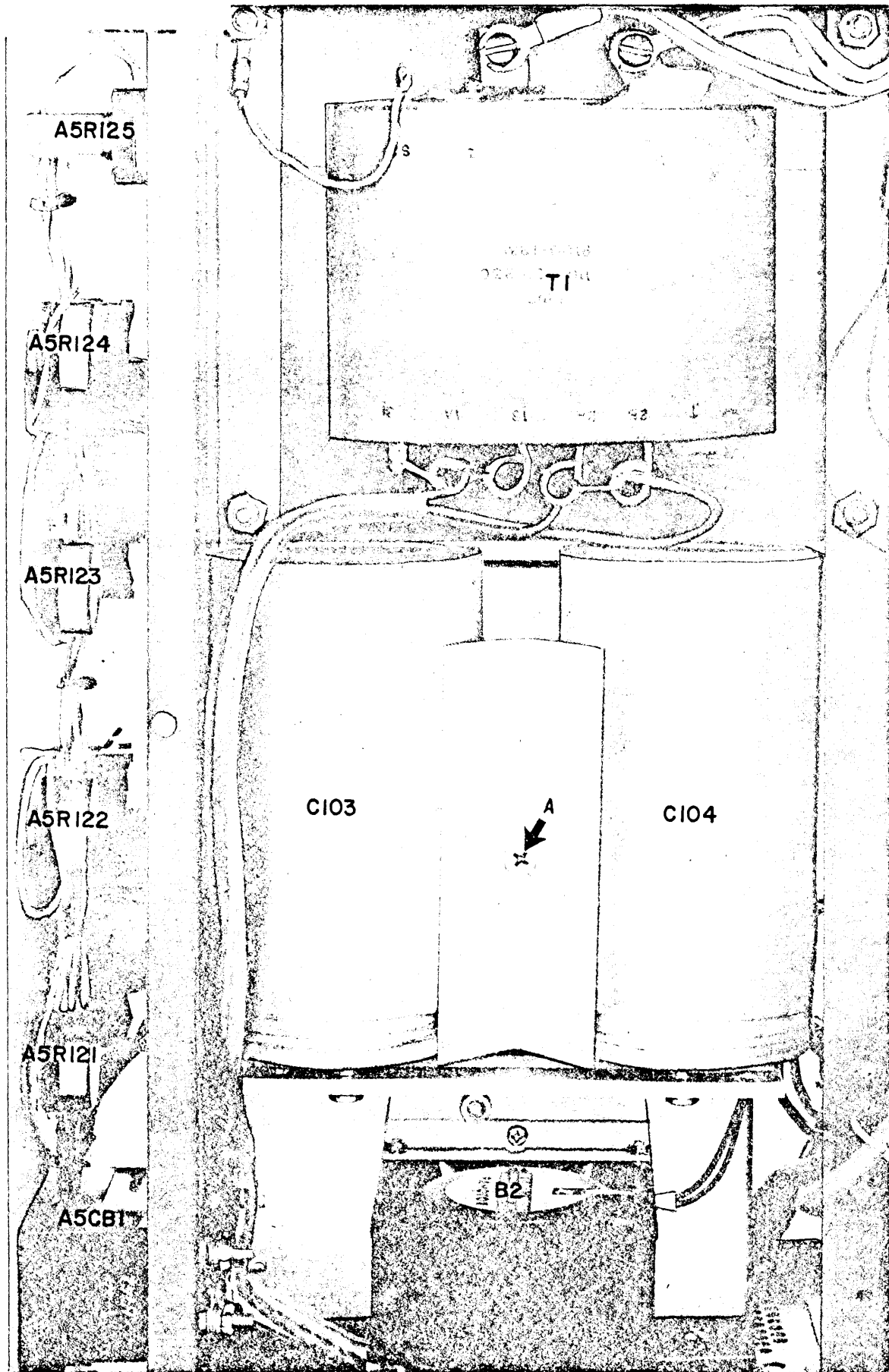

Figure 7-4. Bottom Front Chassis Assembly Component Location Diagram

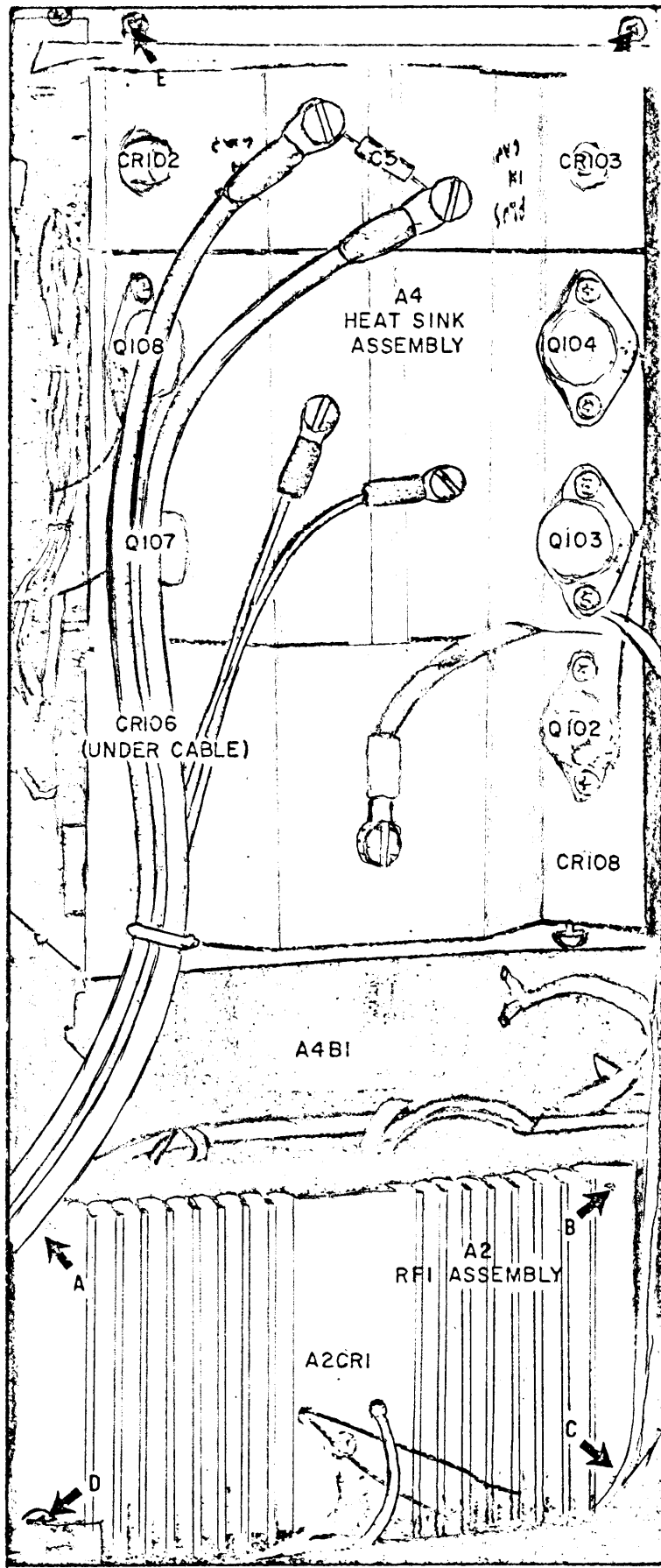

Figure 7-5. Bottom Rear Chassis Assembly Component Location Diagram

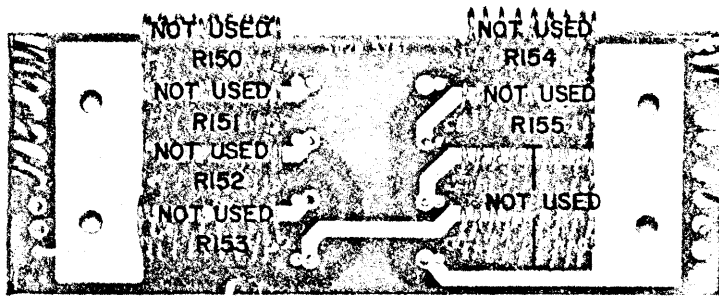

Figure 7-6. Series Regulator Emitter Resistor Assembly Component Location Diagram
(Circuit board is part of A4 heat sink assembly.)

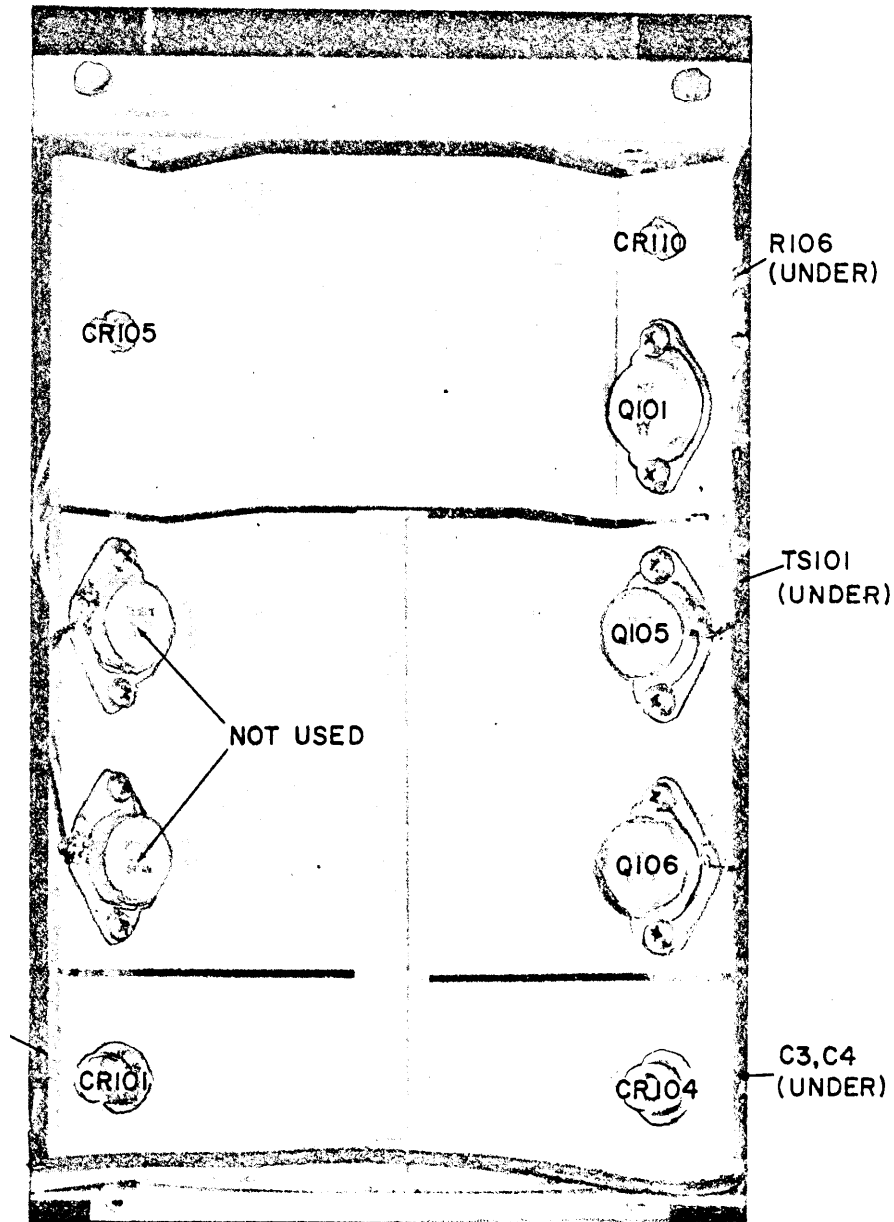

Figure 7-7. A4 Heat Sink Assembly Component Location Diagram
(Top view, assembly removed from supply.)

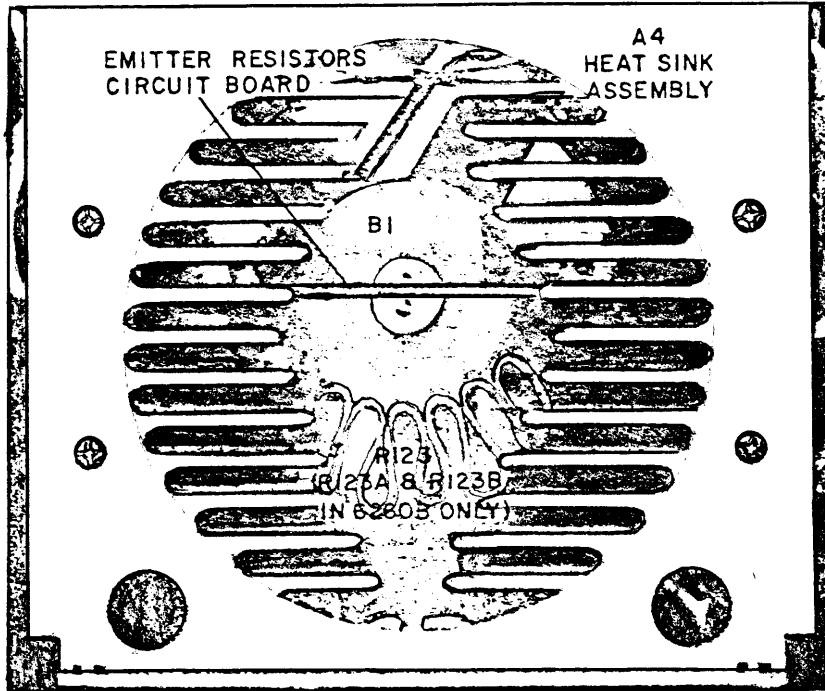
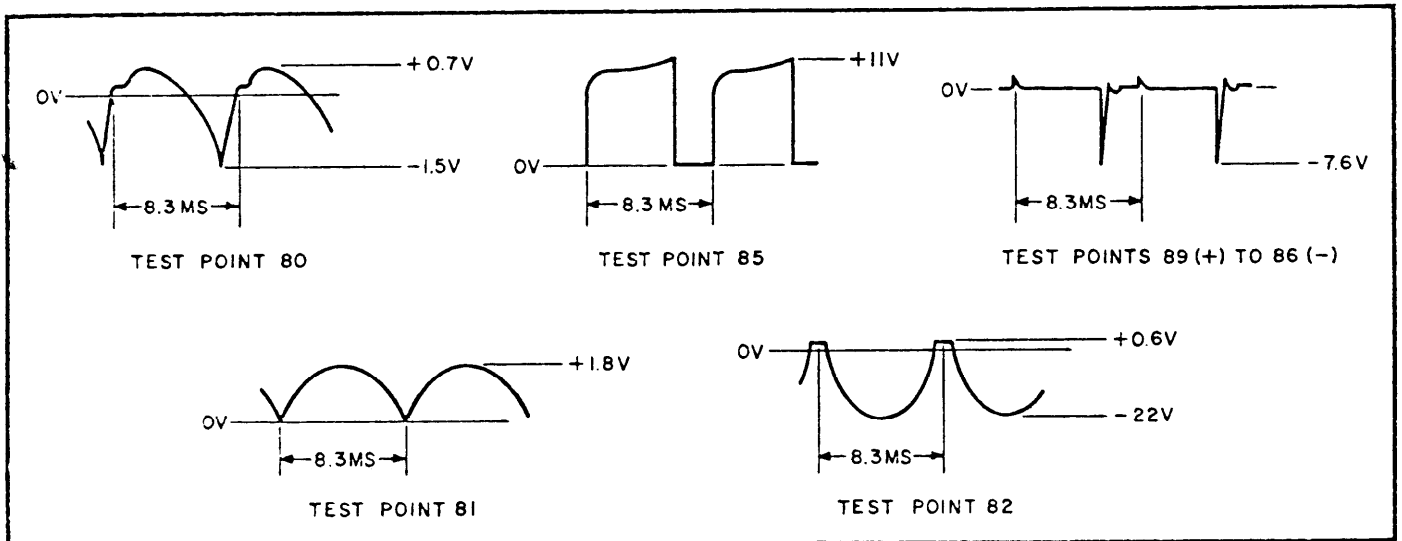

Figure 7-8. A4 Heat Sink Assembly Component Location Diagram (End view, assembly removed from supply.)



NOTES

1. ALL WAVEFORMS TAKEN AT MAXIMUM RATED OUTPUT VOLTAGE, 230 VAC INPUT, NO LOAD CONNECTED AND CURRENT CONTROLS FULLY CLOCKWISE.
2. SCOPE DC COUPLED AND REFERENCED TO TP103 (INBOARD SIDE OF CURRENT SAMPLING RESISTOR) UNLESS OTHERWISE SHOWN.
3. FOR CLARITY, WAVEFORMS ARE NOT DRAWN TO SCALE.

Figure 7-9. Preregulator Control Circuit Waveforms

Figure 7-10

This publication does not contain Figure 7-10.
Figure 7-10 does not exist in paper or digital form.

NOT DIGITIZED

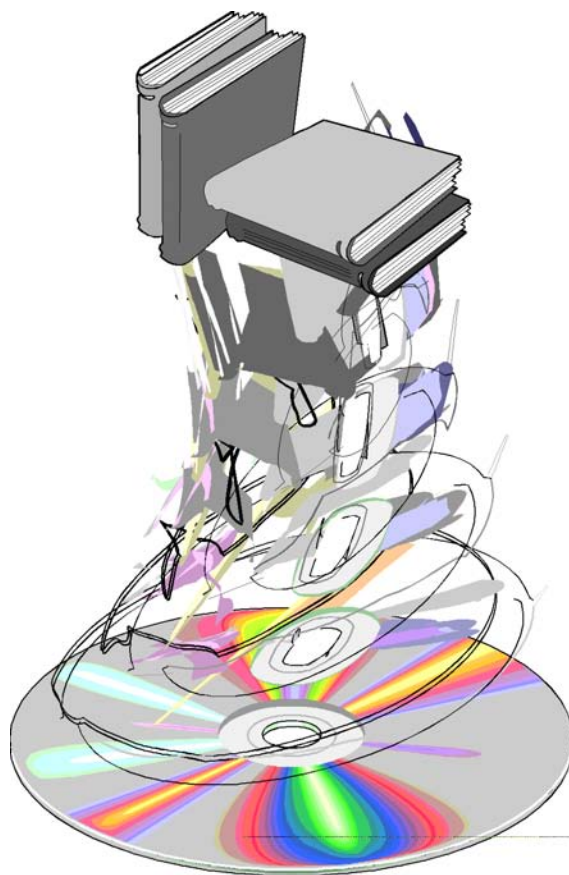

APPENDIX A

REFERENCES

DA Pam 310-4	Index of Technical Manuals, Technical Bulletins, Supply Manuals (Types 7, 8 and 9), Supply Bulletins, and Lubrication Orders.
DA Pam 310-7	Index of Modification Work Orders.
TM 38-750	The Army Maintenance Management System (TAMMS).
TM 740-90-1	Administrative Storage of Equipment.
TM '750-244-2	Procedures for Destruction of Electronics Materiel to Prevent Enemy Use (Electronics Command).
TB 43-180	Calibration Requirements for the Maintenance of Army Materiel.
TB 385-4	Safety Precautions for Maintenance of Electrical/ Electronic Equipment.

APPENDIX B
COMPONENTS OF END ITEM LIST

Section L INTRODUCTION

B-1. Scope

This appendix lists integral components of and basic issue items for the PP-7545/U to help you inventory items required for safe and efficient operation.

B-2. General

This Components of End Item List is divided into the following sections:

a. Section II. Integral Components of the End item. Not applicable. These items, when assembled, comprise the PP-7545/U and must accompany it whenever it is transferred or turned in. The illustrations will help you identify these items.

b. Section III. Basic Issue Items. Not applicable. These are the minimum essential items required to place the PP-7545/U in operation, to operate it, and to perform emergency repairs. Although shipped separately packed they must accompany the PP-7545/U during operation and whenever it is transferred between accountable officers. The illustrations will assist you with hard-to-identify items. This manual is your authority to requisition replacement BII, based on TOE/MTOE authorization of the end item.

B-3. Explanation of Columns

a. Illustration. This column is divided as follows:

(1) Figure number. Indicates the figure number of the illustration on which the item is shown.

(2) Item number. The number used to identify item called out in the illustration.

b. National Stock Number. Indicates the National stock number assigned to the item and which will be used for requisitioning.

c. Description. Indicates the Federal item name and, if required, a minimum description to identify the item. The part number indicates the primary number used by the manufacturer, which controls the design and characteristics of the item by means of its engineering drawings, specifications, standards, and inspection requirements to identify an item or range of items. Following the part number, the Federal Supply Code for Manufacturers (FSCM) is shown in parentheses.

d. Location. The physical location of each item listed is given in this column. The lists are designed to inventory all items in one area of the major item before moving on to an adjacent area.

e. Usable on Code. Not applicable.

f. Quantity Required (Qty Reqd). This column lists the quantity of each item required for a complete major item.

g. Quantity. This column is left blank for use during an inventory. Under the Rcvd column, list the quantity you actually receive on your major item. The Date columns are for your use when you inventory the major item.

(Next printed page is B-2.)

(1) ILLUSTRATION (A) (B) FIG ITEM NO NO		SECTION III BASIC ISSUE ITEMS (2) NATIONAL STOCK NUMBER (3) DESCRIPTION PART NUMBER		(4) LOCATION (FSCM)	(5) USABLE ON CODE	(6) QTY REQD	(7) QUANTITY RCVD DATE
1-1	N/A	6130-00-148-1796	PP-7545/U	28480		1	
			TM 11-6625-2958-14&P			1	

APPENDIX D

MAINTENANCE ALLOCATION

Section L INTRODUCTION**D-1. General**

This appendix provides a summary of the maintenance operations for the PP-7545/U. It authorizes categories of maintenance for specific maintenance functions on repairable items and components and the tools and equipment required to perform each function. This appendix may be used as an aid in planning maintenance operations.

D-2. Maintenance Function

Maintenance functions will be limited to and defined as follows:

- a. Inspect. To determine the serviceability of an item by comparing its physical, mechanical, and/or electrical characteristics with established standards through examination.
- b. Test. To verify serviceability and to detect incipient failure by measuring the mechanical or electrical characteristics of an item and comparing those characteristics with prescribed standards.
- c. Service. Operations required periodically to keep an item in proper operating conditions, i.e., to clean (decontaminate), to preserve, to drain, to paint, or to replenish fuel, lubricants, hydraulic fluids, or compressed air supplies.
- d. Adjust. To maintain, within prescribed limits, by bringing into proper or exact position, or by setting the operating characteristics to the specified parameters.
- e. Align. To adjust specified variable elements of an item to bring about optimum or desired performance.
- f. Calibrate. To determine and cause corrections to be made or to be adjusted on instruments or test measuring and diagnostic equipments used in precision measurement. Consists of comparisons of two instruments, one of which is a certified standard of known accuracy, to detect and adjust any discrepancy in the accuracy of the instrument being compared.
- g. install. The act of emplacing, seating, or fixing into position an item, part, module (component or assembly) in a manner to allow the proper functioning of the equipment or system.
- h. Replace. The act of substituting a serviceable like type part, subassembly, or module (component or assembly) for an unserviceable counterpart.
- i. Repair. The application of maintenance services (inspect, test, service, adjust, align, calibrate, replace) or other maintenance actions (welding, grinding, riveting, straightening, facing, remachining, or resurfacing) to restore serviceability to an item by correcting, specific damage, fault, malfunction, or failure in a part, subassembly, module (component or assembly), end item, or system.
- j. Overhaul. That maintenance effort (service/action) necessary to restore an item to a completely serviceable/operational condition as prescribed by maintenance standards (i.e., DMWR) in appropriate technical publications. Overhaul is normally the highest degree of maintenance performed by the Army. Overhaul does not normally return an item to like new condition.
- k. Rebuild. Consists of those services actions necessary for the restoration of unserviceable equipment to a like new condition in accordance with original manufacturing standards. Rebuild is the highest degree of materiel maintenance applied to Army equipment. The rebuild operation includes the act of returning to zero those age measurements (hours, miles, etc.) considered in classifying Army equipments/components.

D-3. Column Entries

u. Column 1, Group Number. Column 1 lists group numbers, the purpose of which is to identify components, assemblies, subassemblies, and modules with the next higher assembly.

b. Column 2, Component/Assembly. Column 2 contains the noun names of components, assemblies, subassemblies, and modules for which maintenance is authorized.

c. Column 3, Maintenance Functions. Column 3 lists the functions to be performed on the item listed in column 2. When items are listed without maintenance functions, it is solely for purpose of having the group numbers in the MAC and RPSTL coincide.

d. Column 4, Maintenance Category. Column 4 specifies, by the listing of a "worktime" figure in the appropriate subcolumn (s), the lowest level of maintenance authorized to perform the function listed in column 3. This figure represents the active time required to perform that maintenance function at the indicated category of maintenance. If the number or complexity of the tasks within the listed maintenance function vary at different maintenance categories, appropriate "worktime" figures will be shown for each category. The number of task-hours specified by the "worktime" figure represents the average time required to restore an item (assembly, subassembly, component, module, end item or system) to a serviceable condition under typical field operating conditions. This time includes preparation time, troubleshooting time, and quality assurance/quality control time in addition to the time required to perform the specific tasks identified for the maintenance functions authorized in the maintenance allocation chart. Subcolumns of column 4 are as follows:

- C - Operator/Crew
- O- Organizational
- F - Direct Support
- H - General Support
- D - Depot

e. Column 5, Tools and Equipment. Column 5 specifies by code, those common tool sets (not individual tools) and special tools, test, and support equipment required to perform the designated function.

f. Column 6, Remarks. Column 6 contains an alphabetic code which leads to the remark in section IV, Remarks, which is pertinent to the item opposite the particular code.

D-4. Tool and Test Equipment Requirement (sect III)

a. Tool or Test Equipment Reference Code. The numbers in this column coincide with the numbers used in the tools and equipment column of the MAC. The numbers indicate the applicable tool or test equipment for the maintenance functions.

b. Maintenance Category. The codes in this column indicate the maintenance category allocated the tool or test equipment.

c. Nomenclature. This column lists the noun name and nomenclature of the tools and test equipment required to perform the maintenance functions.

d. National/NATO Stock Number. This column lists the National, NATO stock number of the specified tool or test equipment.

e. Tool Number. This column lists the manufacturer's part number of the tool followed by the Federal Supply Code for manufacturers (5-digit) in parentheses.

D-5. Remarks (sect IV)

a. Reference Code. This code refers to the appropriate item in section II, column 6.

b. Remarks. This column provides the required explanatory information necessary to clarify items appearing in section II.

(1) GROUP NUMBER	(2) COMPONENT ASSEMBLY	(3) MAINTENANCE FUNCTION	(4) MAINTENANCE CATEGORY					(5) TOOLS AND EQPT.	(6) REMARKS
			C	O	F	H	D		
00	Power Supply PP-7545/U	Inspect		0.2				2	A A B C C D D D
		Service		0.2				1	
		Test		0.1					
		Inspect				0.3		3	
		Service				0.3		3	
Test				1.5		3-11			
Adjust				0.7		3-11			
Repair				1.5		3			
Overhaul						45	3-11		

SECTION III TOOL AND TEST EQUIPMENT REQUIREMENTS
FOR
POWER SUPPLY PP-7545/U

TOOL OR TEST EQUIPMENT REF CODE	MAINTENANCE CATEGORY	NOMENCLATURE	NATIONAL/NATO STOCK NUMBER	TOOL NUMBER
1	O	MULTIMETER AN/URM-105	6625-00-581-2036	
2	O	TOOL KIT, ELECTRONIC EQUIPMENT TK-101/G	5180-00-064-5178	
3	H, D	TOOL KIT, ELECTRONIC EQUIPMENT TK-105/G	5180-00-610-8177	
4	H, D	GENERATOR, SIGNAL SG-321/U	6625-00-880-5791	
5	H, D	MULTIMETER, AN/USM-223/U	6625-00-999-7465	
6	H, D	MULTIMETER, ELECTRONIC, ME-260/U	6625-00-913-9781	
7	H, D	OSCILLOSCOPE AN/USM-281	6625 00-106-9622	
8	H, D	RESISTANCE BRIDGE, ZM-4()/U	6625-00-500-9370	
9	H, D	TRANSFORMER, VARIABLE CN-16/U	5950-00-235-2086	
10	H, D	VOLTMETER DIGITAL, AN/GSM-64	6625-00-022-7894	
11	H, D	VOLTMETER DIGITAL, ME-202/U	6625-00-709-0288	

REFERENCE CODE	REMARKS
A	Exterior
B	Operational
C	Interior
D	All

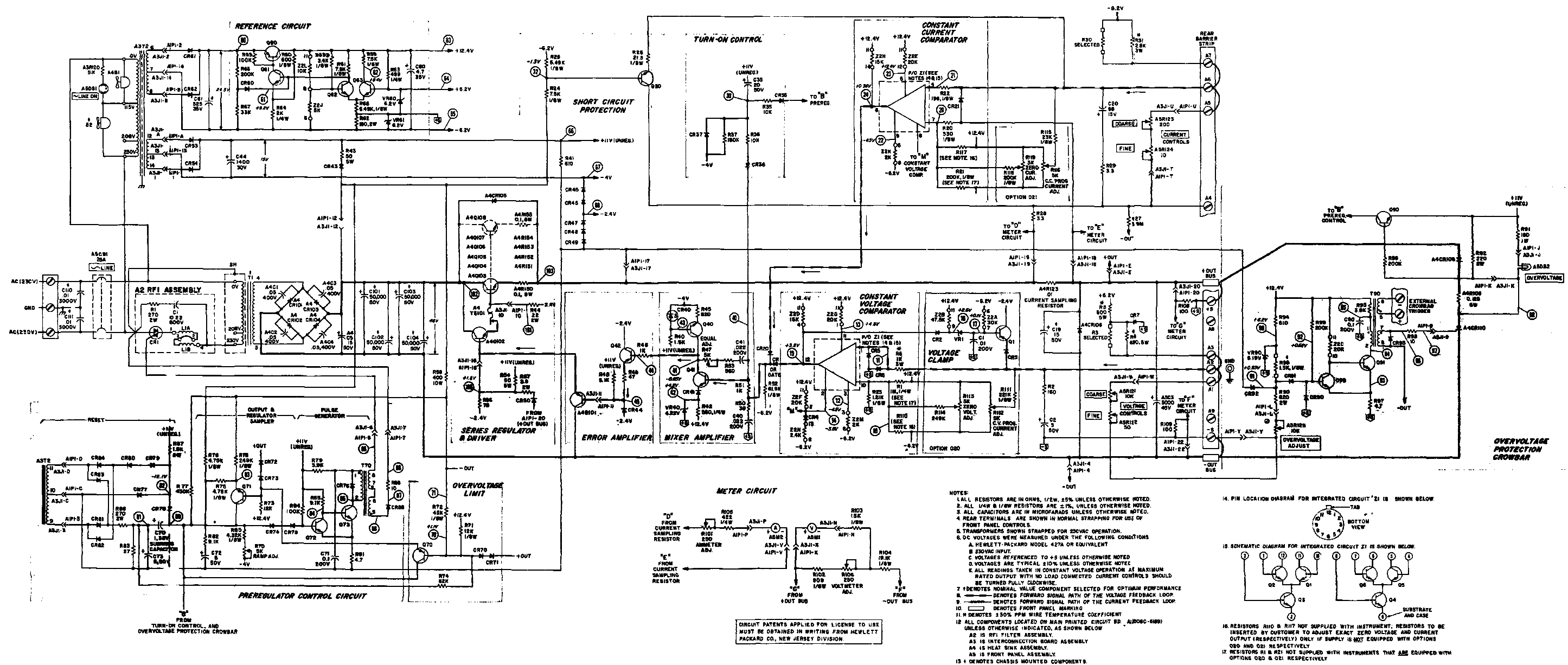

Figure 7-11. Schematic Diagram, Model 6269B

MANUAL CHANGES

Model 6269B DC Power Supply
Manual HP Part No. 06269-90002

Make all corrections in the manual according to errata below, then check the following table for your power supply serial number and enter any listed change(s) in the manual.

SERIAL		MAKE CHANGES
Prefix	Number	
ALL 1027A	0245, 0246, 0255	Errata 1
1027A	0236, 0239, 0241 - 0244, 0247, 0248, 0252 -0254, 0256-0305	1,2
1027A	0306 - 0355	1,2,3
1027A	0356 - 0380	1,2, 3,4
1027A	0381 - 0429	1 thru S
1027A	0430 - 0455	1 thru 6
1027A	0456 - 0540	1 thru 7
1027A	0541 - 0870	1 thru 8
1027A	0871 - 1080	1 thru 9
1027A	1081 - 1260	1 thru10
1436A	1261 - 1470	1 thru 11
1506A	1471 - 1510	1 thru 12
1513A	1511 - 1630	1 thru 13
1535A	1631 - up	1 thru 14

ERRATA:

In the Replaceable Parts List, make the following changes:

Knob, front panel, black: Change to HP Part No. 0370-0084.

Option 007: Add knob, HP Part No. 0370-0137, quantity 1.

Option 008: Add knob, HP Part No. 0370-0137, quantity 1.

Option 009: Add knob, HP Part No. 0370-0137, quantity 2.

Under AS-Mechanical:

Bezel, Gray Plastic: Change to HP Part No. 4040-0293 (Black).

Under Chassis Assembly-Mechanical

Bus Bar, C103-C104: Change to HP Part No. 5000-6251.

CHANGE 1:

Add new RC network (C2 and R2) on the RFI filter board assembly A2. On the schematic, C2 and R2 are connected directly across Triac CR1 (C2 is on the inboard side of CR1).

C2 and R2 prevent the misfiring (turning on too soon) of triac CR1 by slowing the rate of voltage increase across L1A/B (in series with T1) when the triac turns off.

In the Replaceable Parts list under AZ RFI Filter Assembly:

C2: Add, 0.047 μ F, 600V, HP Part No. 0160-0005.
R2: Add, 220 Ω , \pm 5%, 2W, HP Part No. 0811-1763.

In the Replaceable Parts list, make the following changes:

CR1: Delete Mfr. Part No. and change HP Part No. to 1884-0209.

Under A2-Mechanical:

Wafer, Insulated, CR1: Delete.

Shoulder Washer, CR1: Delete.

CHANGE 2:

In the Replaceable Parts List under A4 Heat Sink Assembly and on the Schematic, make the following changes:

A4R106 (in the Overvoltage Protection Crowbar):
Change to fxd, ww, 0.2 Ω , 12W, HP Part No. 0811-3081.

A4Q102 (in the Series Regulator and Driver Circuit): change to HP Part No. 1854-0458.

CHANGE 3:

In the Replaceable Parts list, make the following changes:

A1C71: Change to 0.22 μ F, 80V, HP Part No. 0160-2453.

A1R5: Change to 680 Ω , 5W, HP Part No. 0811-2099.

A1R79: Change to 1.8k, $\frac{1}{2}$ W, HP Part No. 0686-1825.

ERRATA :

In the Replaceable Parts List on Page 6-8, under Chassis-Electrical, change:

C110, C111 to 3000 Vdc.

On the schematic, Figure 7-11, connect the +S output terminal to the A8 terminal on the inboard side of the + OUT BUS (these terminals are internally connected).

CHANGE 4:

In the Replaceable Parts List and on the schematic make the following changes:

A2C1: Change C1 to 0.1 μ F, 400Vdc, HP Part No. 0160-0013.

A1C41: Change C41 to 0.01 μ F, 200Vdc, HP Part No. 0160-0161.

CHANGE 5:

The standard colors for this instrument are now mint gray (for front and rear panels) and olive, gray (for all top, bottom, side, and other external surfaces). Option X95 designates use of the former color scheme of light gray and blue gray. Option A85 designates use of a light gray front panel with olive gray used for all other external surfaces. New part numbers are shown below:

DESCRIPTION	HP PART NO.		
	STANDARD	OPTION A85	OPTION X95
Front Panel, Complete	06269-60005	←	←
Front Panel, Lettered	06269-60009	06269-60006	←
Rear Panel	5000-9475	←	5000-6247
Cover, Top and Bottom	5000-9476	←	5000-6250
Chassis, Assembly (welded)	5060-7972	←	5060-6186

CHANGE 6:

In the Replaceable Parts list and on the schematic, make the following changes:

A1R24: Change to 127k Ω , $\pm 25\%$, 1/8W, HP Part No. 0698-6659.

A1R25: Change to 90.9k Ω , $\pm 1\%$, 1/8W, HP Part No. 0757-0464.

These changes insure that the Short Circuit Protection circuit operates correctly.

CHANGE 7:

In the replaceable parts table under AI Main P. C. Board - Electrical and on the schematic (in the Overvoltage Protection Crowbar circuit), make the following changes:

C91: Add, 0.0047 μ F, 200V, HP Part No. 0160-0157.

R99: Change to 10k Ω , $\pm 5\%$, 1/2W, HP Part No. 0686-1035.

T70, T90: Change to HP Part No. 5080-7192.

The above changes have been made to improve the noise immunity of the overvoltage protection crowbar and thereby eliminate spurious triggering of the crowbar. Capacitor C91 is connected from between the collector of Q92 (which also connects to the base of Q91) and (+S). The top of R99 has been disconnected from +12.4V and connected instead to the junction of R94-R95 (the other end of R95 still connects to the base of Q92 through CR91).

In order to eliminate false triggering and ripple imbalance in the Preregulator Control Circuit, the following changes have been made:

Diode CR88 and resistor R88 are now in series

CHANGE 8:

In the replaceable parts table under A2 RFI Filter Assembly, change Triac CR1 HP Part No. to 1884-0218.

with the secondary winding of the new Pulse Generator Pulse Transformer T70 (HP Part No. 5080-7192) as shown below:

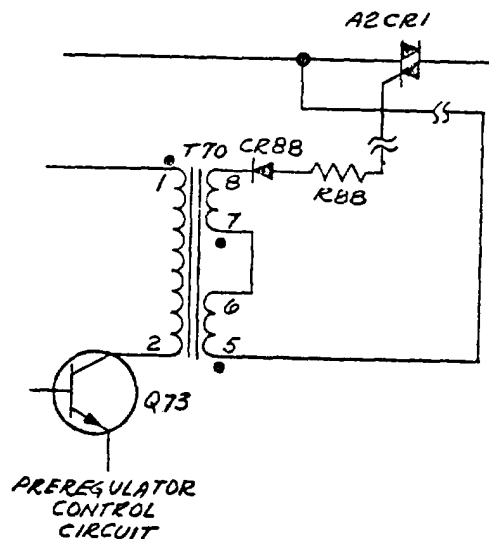

ERRATA :

In the parts list

Under A4 Mechanical, add Transistor Insulator, HP Part No. 0340-0795, quantity 2.
 Under AS Front Panel Assembly, change the HP Part No. of circuit breaker CB1 to 3105-0034.

CHANGE 9:

In the parts list under A4 Heat Sink Assembly, change the HP Part No. of CR101, 102, 105, and 108 to 1901-0318, and change CR103, 104, and 106 to 1901-0317.

CHANGE 10:

In the parts list under AS Front Panel Assembly, change R122 to 100 ohms, variable, HP Part No. 2100-1987.

CHANGE 11:

In the parts list and on the schematic, make the following additions and changes:

Under AS: Add C112, fxd, .01 μ F 3KV HP Part No. 0160-2568

Under A2: Add RV1, varistor, MOV HP Part No. 0837-0117

Change: C110 and C111 have been moved from chassis to the front panel assembly. Connect the added and changed components as shown below.

The following changes enable the master crowbar to trip the slave crowbar(s) when two or more units are connected in parallel. In the parts list under AI Main Printed Circuit Board and on the schematic, change A1C90 to .47 μ F 25Vdc HP Part No. 0160-0174. Also, add resistor A1R120, 4.7K 1/4W HP Part No. 0758-0005. Connect A1R20 in parallel with A1Z2C in the Overvoltage Protection Crowbar Circuit on schematic.

The following change prevents series regulator failure under short circuit conditions. On schematic, in the Constant Voltage Comparator Circuit disconnect anode of A1CR6 from A1Z1 pin 1 side of A1R6. Connect anode of A1CR6 to rear terminal A2 side of A1R6.

►CHANGE 13:

In the parts list under A4 Heat Sink Assembly, change the part number of CR101 and CR102 to 1901-0729 and change CR103 and CR104 to 1901-0730.

►CHANGE 14:

The RFI Assembly is changed to HP Part No. 06269-60010. This new RFI Assembly is completely interchangeable in all previously built 6269B power supplies.

In the parts list under A2-Mechanical make the following changes:

Change the Cover, RFI Assembly to 5020-2284.

Change the Heat Sink, RFI Filter Ass'y to 5020-2282.

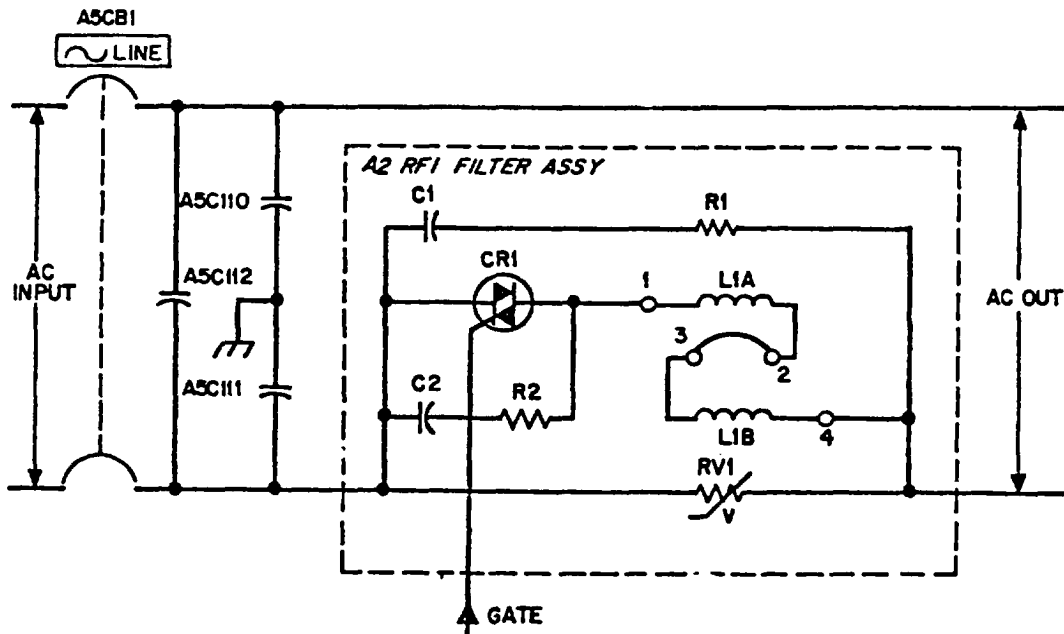

In the parts list, delete the entire listing under A2 RFI Filter Assembly and replace with the following.

A schematic of RFI Filter Assembly 06269-60010 is shown below. This schematic replaces the A2 Filter portion of the schematic shown in Change 11.

REF. DESIG.	DESCRIPTION	HP PART NO.
A2	RFI Filter Assembly	06269-60010
C1, C2	fxd, metalized paper, 0.1 μ F 250Vac	0160-4065
C3	fxd, metalized paper, .047 μ F 250v	0160-4323
C4	fxd mica, 5000pF, 1kV	0160-0899
CR1	Thyristor, Si. (Triac)	1884-0248
L1	Filter choke, 20A	5080-1782
R1, R2	fxd, metal oxide, 1.5k Ω 2W	0698-3338
R4	fxd, metal oxide, 220 Ω 2W	0698-3628
RV1	Varistor, MOV	0837-0117

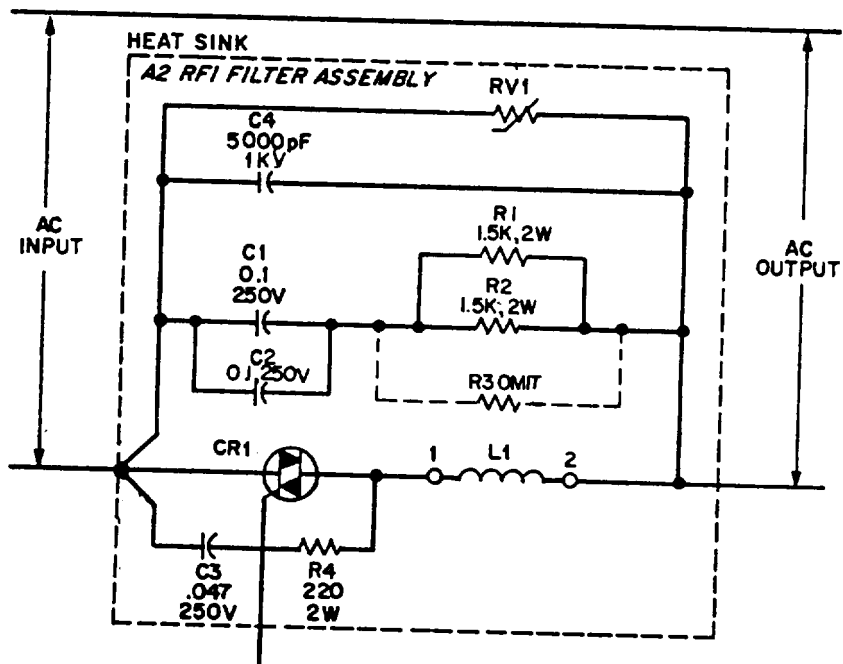

HEWLETT PACKARD

SALES & SERVICE OFFICES

AFRICA, ASIA, AUSTRALIA

ANGOLA
Telecisa
Empresa Técnica de Equipamentos Eléctricos, S.A.R.L.
R. Barbosa Rodrigues, 42-1 OT
Cais Postal 6487
Luanda
Tel: 355158
Cable TELETRA Luanda

AUSTRALIA
Hewlett-Packard Australia
Phy. Ltd
31-41 Joseph Street
Blackburn, Victoria 3130
P.O. Box 38
Doncaster East, Victoria 3109
Tel: 89-6351
Telex: 31-024
Cable HEWPAUD Melbourne
Hewlett-Packard Australia
Phy. Ltd
31 Bridge Street
Pyrmont
New South Wales, 2073
Tel: 449-6566
Telex: 21561
Cable HEWPAUD Sydney
Hewlett-Packard Australia
Phy. Ltd
153 Greenhill Road
Parkville, S.A. 5063
Tel: 272-5911
Telex: 82536 ADEL
Cable HEWPAUD ADELAID
Hewlett-Packard Australia
Phy. Ltd
141 Spring Highway
Needlands, W.A. 6009
Tel: 86-5455
Telex: 93859 PERTH
Cable HEWPAUD PERTH
Hewlett-Packard Australia
Phy. Ltd
121 Worongong Street
Pyrmont, A.C.T. 2608
Tel: 95-2733
Telex: 82656 Canberra
Cable HEWPAUD CANBERRA
Hewlett-Packard Australia
Phy. Ltd
5th Floor
Teachers Union Building
485-490 Boundary Street
Spring Hill, 4000 Queensland
Tel: 225-1544
Cable HEWPAUD Brisbane

GUAM
Medical/Pocket Calculators Only
Guam Medical Supply, Inc.
Jay East Building, Room 210
P.O. Box 8947
Tarranburg 96811
Tel: 648-4513
Cable EARNMED Guam

HONG KONG
Schmidt & Co. (Hong Kong) Ltd
P.O. Box 297
Connaught Centre
39th Floor
Connaught Road Central
Hong Kong
Tel: H-255231-5
Telex: 74766 SCHMC HK
Cable SCHMOTCO Hong Kong

INDIA
Blue Star Ltd
Kasturi Buildings
Janshree Tada Rd
Bombay 400 020
Tel: 29 50 21
Telex: 001-2156
Cable BLUEFROST
Blue Star Ltd
Sales
414 2 Vr Savarkar Marg
Prabhadevi
Bombay 400 025
Tel: 45 78 87
Telex: 011-4093
Cable FROSTBLUE
Blue Star Ltd
Band Box House
Prabhadevi
Bombay 400 025
Tel: 45 73 01
Telex: 011-3751
Cable BLUESTAR
Yokogawa-Hewlett-Packard Ltd
Blue Star Ltd
7 Mare Street
P.O. Box 506
Calcutta 700 001
Tel: 23-0131
Telex: 021-7655
Cable BLUESTAR
Blue Star Ltd
7th & 8th Floor
Bhambhani House
91 Nehru Place
New Delhi 110024
Tel: 634770 & 635166
Telex: 031-2483
Cable BLUESTAR
Blue Star Ltd
Blue Star House
11-11A Magarath Road
Bangalore 560 025
Tel: 55608
Telex: 04-3-430
Cable BLUESTAR
Blue Star Ltd
Messiah Mandran
100/1678 Mahatma Gandhi Rd
Coimbatore 682 018
Tel: 3208001 32181 32362
Telex: 0885-514
Cable BLUESTAR
Blue Star Ltd
1-1-117-1
Sardam Devi Road
Bengaluru 500 003
Tel: 70126, 70127
Cable BLUEFROST
Telex: 015-459

INDONESIA
BERCA Indonesia P.T.
J.K.Abdul Muis 82
Jasarah
Tel: 40389 49886 49255 356038
JKT 42895
Cable BERCAON
BERCA Indonesia P.T.
63 JL Raya Gubeng
Surabaya
Tel: 44309

ISRAEL
Electronics & Engineering Div
of Motorola Israel Ltd
17 Kremenatzki Street
P.O. Box 25016
Tel: 34973
Telex: 33569
Cable BASTEL Tel-Aviv

JAPAN
Yokogawa-Hewlett-Packard Ltd
Onashi Building
59-1 Yoyogi 1-Chome
Shibuya-ku, Tokyo 151
Tel: 03-370-2281 92
Telex: 232-2024YHP MARKET
TKM 23-724
Cable YHPMARKET
Blue Star Ltd
7th & 8th Floor
Bhambhani House
91 Nehru Place
New Delhi 110024
Tel: 634770 & 635166
Telex: 031-2483
Cable BLUESTAR
Blue Star Ltd
Blue Star House
11-11A Magarath Road
Bangalore 560 025
Tel: 55608
Telex: 04-3-430
Cable BLUESTAR
Blue Star Ltd
Messiah Mandran
100/1678 Mahatma Gandhi Rd
Coimbatore 682 018
Tel: 3208001 32181 32362
Telex: 0885-514
Cable BLUESTAR
Blue Star Ltd
1-1-117-1
Sardam Devi Road
Bengaluru 500 003
Tel: 70126, 70127
Cable BLUEFROST
Telex: 015-459

KENYA
Technical Engineering
Services/E A ILTD
P.O. Box 18311
Nairobi
Tel: 557726-558762
Cable PROTON
Medical Only
International Aeradio (E A) ILTD
P.O. Box 19012
Nairobi/Airport
Tel: 336055-56
Telex: 22201 22301
Cable INTAERIO Nairobi

KOREA
Samsung Electronics Co. Ltd
200, Fi. Dongbang Bldg 250 2-KA
C.P.O. Box 2775
Taepyeong-Ro, Chung-Ku
Seoul
Tel: (23) 8811
Telex: 22575
Cable ELEKSTAR Seoul

MALAYSIA
Terak Mutu Sdn Bhd
2 Lorong 13 BA
Section 13
Petaling Jaya Selangor
Tel: 54594 5498
Telex: MA 37605
Protin Engineering
P.O. Box 197
Lot 259 Satok Road
Kuching, Sarawak
Tel: 2400
Cable PROTEL ENG

MOZAMBIQUE
A.N. Goncalves Lda
182 1 Apt. 14 Av. D. Luis
Cais Postal 107
Lourenco Marques
Tel: 27091, 27114
Telex: 6-203 NEGON Mo
Cable NEGON

NEW ZEALAND
Hewlett-Packard (N.Z.) Ltd
P.O. Box 9443
Courtenay Place
Wellington
Tel: 877-199
Cable HEWPAUK Wellington
Hewlett-Packard (N.Z.) Ltd
Paikura Professional Centre
267 Paturanga Highway
Box 51092
Palustrana
Tel: 569-651
Cable HEWPAUK Auckland

Yokogawa-Hewlett-Packard Ltd
Kumagaya Asahi
Nakajima Building
4th Floor
3-4 Tsutsumi
Kumagaya, Satama 360
Tel: 0485-24-6563

ANALYTICAL MEDICAL ONLY
Medical Supplies N.Z. Ltd
Scientific Division
79 Carlton Gore Rd. Newmarket
P.O. Box 1234
Auckland
Tel: 75-289
Cable DENTAL Auckland
Analytical Medical Only
Medical Supplies N.Z. Ltd
P.O. Box 1994
147-161 Tory St
Wellington
Tel: 850-799
Telex: 3054
Cable DENTAL Wellington
Analytical Medical Only
Medical Supplies N.Z. Ltd
P.O. Box 309
239 Stanmore Road
Christchurch
Tel: 892-019
Cable DENTAL Christchurch
Analytical Medical Only
Medical Supplies N.Z. Ltd
303 Great King Street
P.O. Box 233
Dunedin
Tel: 88-817
Cable DENTAL Dunedin

NGERIA
The Electronics
Instrumentations Ltd
N68 770 Oyo Road
Ojodu House
P.M.B. 5402
Nisalan
Tel: 61577
Telex: 31231 TEIL Nigeria
Cable THETEL Ibadan
The Electronics Instrumentations
Lagos Ltd
144 Agege Motor Road, Mushin
P.O. Box 6645
Lagos
Cable THETEL Lagos

PAKISTAN
Mushko & Company Ltd
Osman Chambers
Abdullah Haroon Road
Karachi-3
Tel: 511027 512927
Telex: 2094
Cable COOPERATOR Karachi
Mushko & Company Ltd
36B Sakate Town
Rawalpindi
Tel: 53-7955 mu 9
Telex: 57-0006
Cable FEMUS Rawalpindi

PHILIPPINES
The Drive Advanced
Systems Corporation
Rico House
Amaroso cor. Herrera Str
Ligasan Village, Makati
Metro Manila
Tel: 85-35-81 85-34-91
Telex: 3274 ONLINE

RHODESIA
Field Technical Sales
45 Kelvin Road North
P.O. Box 3458
Salisbury
Tel: 705251 (5 lines)
Telex: RH 4122

SINGAPORE
Hewlett-Packard Singapore
(Pte) Ltd
1150 Depot Road
Alamanda P.O. Box 56
Singapore 4
Tel: 270-2355
Telex: HPSG RS 21486
Cable HEWPAUK Singapore

SOUTH AFRICA
Hewlett-Packard South Africa
(Pty) Ltd
Private Bag Windywood
Sandton, Transvaal 2144
Hewlett-Packard Centre
Daphne Street, Windywood
Sandton, Transvaal 2144
Tel: 802-1048
Telex: 6-4782
Cable HEWPAUK JOHANNESBURG
Service Department
Hewlett-Packard South Africa
(Pty) Ltd
P.O. Box 3325
Glenayre, Sandton 2018
451 Wynberg Extension 3
Sandton 2001
Tel: 536-8188 9
Telex: 6-2391
Hewlett-Packard South Africa
(Pty) Ltd
P.O. Box 120
Howard Place, Cape Province 7450
Pine Park Centre, Forest Drive
Riverside, Cape Province 7405
Tel: 53-7955 mu 9
Telex: 57-0006
Service Department
Hewlett-Packard South Africa
(Pty) Ltd
P.O. Box 37099
Overport, Durban 4087
Brady House
641 Ridge Road
Durban 4001
Tel: 88-7478
Telex: 6-7954

TAIWAN
Hewlett-Packard Far East Ltd
Tung Chung Hsiao West Road
Sec. 1, 7th Floor
Taipei
Tel: 3819160-4
Cable HEWPAUK TAIPEI
Hewlett-Packard Far East Ltd
Tawan Branch
68-2 Chung Cheng 3rd Road
Kaohsiung
Tel: (07) 242318-KAOSUNG
Analytical Only
San Kwong Instruments Co. Ltd
No. 20 Yung Su Road
Taipei
Tel: 3715071-4 (5 lines)
Telex: 22894 SANKWANG
Cable SANKWANG TAIPEI

TANZANIA
Medical Only
International Aeradio (E A) Ltd
P.O. Box 861
Dar es Salaam
Tel: 21251 Ext. 265
Telex: 41030

THAILAND
UNIMESA Co. Ltd
Ecom Research Building
2538 Sukhumvit Ave
Bangkok
Tel: 3532387, 3830338
Cable UNIMESA Bangkok

UGANDA
Medical Only
International Aeradio (E A) Ltd
P.O. Box 2577
Kampala
Tel: 54388
Cable INTAERIO Kampala

ZAMBIA
R.J. Tubory (Zambia) Ltd
P.O. Box 2792
Lusaka
Tel: 73793
Cable ARJAYTEE Lusaka

Blue Star Ltd
2-34 Kodambakkam High Road
Newmas 600034
Tel: 87055
Telex: 041-379
Cable BLUESTAR

INDONESIA
BERCA Indonesia P.T.
J.K.Abdul Muis 82
Jasarah
Tel: 40389 49886 49255 356038
JKT 42895
Cable BERCAON
BERCA Indonesia P.T.
63 JL Raya Gubeng
Surabaya
Tel: 44309

ISRAEL
Electronics & Engineering Div
of Motorola Israel Ltd
17 Kremenatzki Street
P.O. Box 25016
Tel: 34973
Telex: 33569
Cable BASTEL Tel-Aviv

JAPAN
Yokogawa-Hewlett-Packard Ltd
Onashi Building
59-1 Yoyogi 1-Chome
Shibuya-ku, Tokyo 151
Tel: 03-370-2281 92
Telex: 232-2024YHP MARKET
TKM 23-724
Cable YHPMARKET
Blue Star Ltd
7th & 8th Floor
Bhambhani House
91 Nehru Place
New Delhi 110024
Tel: 634770 & 635166
Telex: 031-2483
Cable BLUESTAR
Blue Star Ltd
Blue Star House
11-11A Magarath Road
Bangalore 560 025
Tel: 55608
Telex: 04-3-430
Cable BLUESTAR
Blue Star Ltd
Messiah Mandran
100/1678 Mahatma Gandhi Rd
Coimbatore 682 018
Tel: 3208001 32181 32362
Telex: 0885-514
Cable BLUESTAR
Blue Star Ltd
1-1-117-1
Sardam Devi Road
Bengaluru 500 003
Tel: 70126, 70127
Cable BLUEFROST
Telex: 015-459

KENYA
Technical Engineering
Services/E A ILTD
P.O. Box 18311
Nairobi
Tel: 557726-558762
Cable PROTON
Medical Only
International Aeradio (E A) ILTD
P.O. Box 19012
Nairobi/Airport
Tel: 336055-56
Telex: 22201 22301
Cable INTAERIO Nairobi

KOREA
Samsung Electronics Co. Ltd
200, Fi. Dongbang Bldg 250 2-KA
C.P.O. Box 2775
Taepyeong-Ro, Chung-Ku
Seoul
Tel: (23) 8811
Telex: 22575
Cable ELEKSTAR Seoul

MALAYSIA
Terak Mutu Sdn Bhd
2 Lorong 13 BA
Section 13
Petaling Jaya Selangor
Tel: 54594 5498
Telex: MA 37605
Protin Engineering
P.O. Box 197
Lot 259 Satok Road
Kuching, Sarawak
Tel: 2400
Cable PROTEL ENG

MOZAMBIQUE
A.N. Goncalves Lda
182 1 Apt. 14 Av. D. Luis
Cais Postal 107
Lourenco Marques
Tel: 27091, 27114
Telex: 6-203 NEGON Mo
Cable NEGON

NEW ZEALAND
Hewlett-Packard (N.Z.) Ltd
P.O. Box 9443
Courtenay Place
Wellington
Tel: 877-199
Cable HEWPAUK Wellington
Hewlett-Packard (N.Z.) Ltd
Paikura Professional Centre
267 Paturanga Highway
Box 51092
Palustrana
Tel: 569-651
Cable HEWPAUK Auckland

Yokogawa-Hewlett-Packard Ltd
Kumagaya Asahi
Nakajima Building
4th Floor
3-4 Tsutsumi
Kumagaya, Satama 360
Tel: 0485-24-6563

ANALYTICAL MEDICAL ONLY
Medical Supplies N.Z. Ltd
Scientific Division
79 Carlton Gore Rd. Newmarket
P.O. Box 1234
Auckland
Tel: 75-289
Cable DENTAL Auckland
Analytical Medical Only
Medical Supplies N.Z. Ltd
P.O. Box 1994
147-161 Tory St
Wellington
Tel: 850-799
Telex: 3054
Cable DENTAL Wellington
Analytical Medical Only
Medical Supplies N.Z. Ltd
P.O. Box 309
239 Stanmore Road
Christchurch
Tel: 892-019
Cable DENTAL Christchurch
Analytical Medical Only
Medical Supplies N.Z. Ltd
303 Great King Street
P.O. Box 233
Dunedin
Tel: 88-817
Cable DENTAL Dunedin

NGERIA
The Electronics
Instrumentations Ltd
N68 770 Oyo Road
Ojodu House
P.M.B. 5402
Nisalan
Tel: 61577
Telex: 31231 TEIL Nigeria
Cable THETEL Ibadan
The Electronics Instrumentations
Lagos Ltd
144 Agege Motor Road, Mushin
P.O. Box 6645
Lagos
Cable THETEL Lagos

PAKISTAN
Mushko & Company Ltd
Osman Chambers
Abdullah Haroon Road
Karachi-3
Tel: 511027 512927
Telex: 2094
Cable COOPERATOR Karachi
Mushko & Company Ltd
36B Sakate Town
Rawalpindi
Tel: 53-7955 mu 9
Telex: 57-0006
Cable FEMUS Rawalpindi

PHILIPPINES
The Drive Advanced
Systems Corporation
Rico House
Amaroso cor. Herrera Str
Ligasan Village, Makati
Metro Manila
Tel: 85-35-81 85-34-91
Telex: 3274 ONLINE

RHODESIA
Field Technical Sales
45 Kelvin Road North
P.O. Box 3458
Salisbury
Tel: 705251 (5 lines)
Telex: RH 4122

SINGAPORE
Hewlett-Packard Singapore
(Pte) Ltd
1150 Depot Road
Alamanda P.O. Box 56
Singapore 4
Tel: 270-2355
Telex: HPSG RS 21486
Cable HEWPAUK Singapore

SOUTH AFRICA
Hewlett-Packard South Africa
(Pty) Ltd
Private Bag Windywood
Sandton, Transvaal 2144
Hewlett-Packard Centre
Daphne Street, Windywood
Sandton, Transvaal 2144
Tel: 802-1048
Telex: 6-4782
Cable HEWPAUK JOHANNESBURG
Service Department
Hewlett-Packard South Africa
(Pty) Ltd
P.O. Box 3325
Glenayre, Sandton 2018
451 Wynberg Extension 3
Sandton 2001
Tel: 536-8188 9
Telex: 6-2391
Hewlett-Packard South Africa
(Pty) Ltd
P.O. Box 120
Howard Place, Cape Province 7450
Pine Park Centre, Forest Drive
Riverside, Cape Province 7405
Tel: 53-7955 mu 9
Telex: 57-0006
Service Department
Hewlett-Packard South Africa
(Pty) Ltd
P.O. Box 37099
Overport, Durban 4087
Brady House
641 Ridge Road
Durban 4001
Tel: 88-7478
Telex: 6-7954

TAIWAN
Hewlett-Packard Far East Ltd
Tung Chung Hsiao West Road
Sec. 1, 7th Floor
Taipei
Tel: 3819160-4
Cable HEWPAUK TAIPEI
Hewlett-Packard Far East Ltd
Tawan Branch
68-2 Chung Cheng 3rd Road
Kaohsiung
Tel: (07) 242318-KAOSUNG
Analytical Only
San Kwong Instruments Co. Ltd
No. 20 Yung Su Road
Taipei
Tel: 3715071-4 (5 lines)
Telex: 22894 SANKWANG
Cable SANKWANG TAIPEI

TANZANIA
Medical Only
International Aeradio (E A) Ltd
P.O. Box 861
Dar es Salaam
Tel: 21251 Ext. 265
Telex: 41030

THAILAND
UNIMESA Co. Ltd
Ecom Research Building
2538 Sukhumvit Ave
Bangkok
Tel: 3532387, 3830338
Cable UNIMESA Bangkok

UGANDA
Medical Only
International Aeradio (E A) Ltd
P.O. Box 2577
Kampala
Tel: 54388
Cable INTAERIO Kampala

ZAMBIA
R.J. Tubory (Zambia) Ltd
P.O. Box 2792
Lusaka
Tel: 73793
Cable ARJAYTEE Lusaka

OTHER AREAS NOT LISTED. CONTACT:
Hewlett-Packard International
C/A
Palo Alto, California 94304
Tel: (415) 493-1501
TWX: 910-373-1267
Cable HEWPAUK Palo Alto

CANADA

ALBERTA
Hewlett-Packard (Canada) Ltd
11620A - 188th Street
Edmonton T5M 3T9
Tel: (403) 432-9670
TWX: 810-631-2431

BRITISH COLUMBIA
Hewlett-Packard (Canada) Ltd
837 E Cordova Street
Vancouver V6A 3R2
Tel: (604) 253-2713
Telex: 80-82-82A

MANITOBA
Hewlett-Packard (Canada) Ltd
513 Century St
St. James
Winnipeg R3M 0L8
Tel: (204) 786-7581
TWX: 610-671-3531

NOVA SCOTIA
Hewlett-Packard (Canada) Ltd
800 Windmill Road
Dartmouth B3B 1L1
Tel: (902) 488-7820
TWX: 602-271-4482 HFX

ONTARIO
Hewlett-Packard (Canada) Ltd
1020 Morrison Dr
Ottawa K2M 8K7
Tel: (613) 820-6483
TWX: 610-563-1636

QUEBEC
Hewlett-Packard (Canada) Ltd
275 Hymus Blvd
Sainte-Claire H8R 1G7
Tel: (514) 697-4232
TWX: 810-422-3022
TLX: 805-821521 HPCL

FOR CANADIAN AREAS NOT LISTED:
Contact Hewlett-Packard (Canada)
Ltd in Mississauga

CENTRAL AND SOUTH AMERICA

ARGENTINA
Hewlett-Packard Argentina
S.A.
Av. Leandro N. Alem 622 - 12
1001 Buenos Aires
Tel: 31-6063 4 5 6 and 7
Telex: 322443 AR DICY
Cable HEWPAUK ARG

Hewlett-Packard do Brazil
I.E.C. Ltda
Rua Padre Chapas, 32
Copacabana
20000-Rio de Janeiro-RS
Tel: (0512) 22-2998, 22-5621
Cable HEWPAUK Porto Alegre
Hewlett-Packard do Brazil
I.E.C. Ltda
Rua Siqueira Campos, 53
Copacabana
20000-Rio de Janeiro
Tel: 257-80-94-000 (021)
Telex: 39-212-1905 HEWPP-BR
Cable HEWPAUK
Rio de Janeiro

BOLIVIA
Casa Kavin S.A.
Cable Potosi 1130
P.O. Box 500
La Paz
Tel: 41330, 53221
Telex: CWC BX 5298 IIT 3560062
Cable KAVLIN

BRAZIL
Hewlett-Packard do Brazil
I.E.C. Ltda
Avenida Rio Negro, 980
Apollonia
05000-Barueri SP
Tel: 429-3222

CHILE
Calcagra y Metcalf Ltda
Alameda 980-DI 807
Casilla 2118
Santiago, 1
Tel: 398013
Telex: 06000001 CALNET
Cable CALNET Santiago

COLOMBIA
Instrumentacion
Henna A. Langebeck & Kier S.A.
Carrera 7 No. 48-75
Apartado Aéreo 8267
Bogota, 1 D.E.
Tel: 69-88-77
Cable AARIS Bogota
Telex: 044-400

COSTA RICA
Ciencia Costarricense S.A.
Avenida 2, Calle 5
San Pedro de Montes de Oca
Apartado 10159
San Jose
Tel: 24-38-20 24-08-19
Telex: 2367 GALTUR CR
Cable GALTUR

ECUADOR
Calculators Only
Computadores y Equipos
Electrónicos
P.O. Box 6423 CCJ
Eloy Alfaro #1824 J. Piso
Quito
Tel: 453482
Telex: 02-2113 Sagita Ed
Cable Sagita-Quito

GUATEMALA
I.P.E.S.A.
Avenida La Reforma-3-48
Zona 9
Guatemala City
Tel: 53627 64786
Telex: 4192 Tietro Gu

MEXICO
Hewlett-Packard Mexicana
S.A. de C.V.
Av. Periférico Sur No. 6501
Tlalpam, Xochimilco
Mexico 23, D.F.
Tel: 905-678-4600

NICARAGUA
Roberto Terán G.
Apartado Postal 689
Managua
Tel: 25114, 23412, 23454
Cable ROTERAN Managua

PANAMA
Electrónica Balboa S.A.
P.O. Box 4929
Cable Samuel Lewis
Calle de Panamá
Tel: 64-2700
Telex: 3483103 Curunda
Cable Zone
Cable ELECTRON Panama

PERU
Compam Electro Medica S.A.
Los Flamencos 145
San Isidro Casilla 1030
Lima
Tel: 41-4325
Cable ELMED Lima

PUERTO RICO
Roberto Terán G.
Puerto Rico Branch Office
Calle 272
No. 203 Urb. Country Club
Carolina 00924
Tel: (809) 787-2255
Telex: 345 0514

URUGUAY
Pablo Ferrando S.A.
Comercial e Industrial
Avenida Italia 28
Casilla de Correo 370
Montevideo
Tel: 40-3102
Cable ELECTRON Montevideo

VENEZUELA
Hewlett-Packard de Venezuela
C.A.
P.O. Box 50933
Caracas 105
Los Ruices Norte
38 Transversal
Edificio Segre
Caracas 107
Tel: 35-00-11 (20 lines)
Telex: 25146 HEWPAUK
Cable HEWPAUK Caracas

FOR AREAS NOT LISTED. CONTACT:
Hewlett-Packard International
Inter-Américas
3200 Halybur Ave
Palo Alto, California 94304
Tel: (415) 493-1501
TWX: 910-373-1260
Cable HEWPAUK Palo Alto
Telex: 034-8300 034-6483

EUROPE, NORTH AFRICA AND MIDDLE EAST

AUSTRIA
Hewlett-Packard Ges m b H
Hundertss 52
P O Box 7
A-1205 Vienna
Tel (0222) 351621 to 27
Cable HEWPAC Vienna
Telex 75923 hewpak a

BELGIUM
Hewlett-Packard Benelux
S A N V
Avenue de Col-Vert 1
(Grootraklaan)
B-1170 Brussels
Tel (02) 872 22 40
Cable PALOBEN Brussels
Telex 23 494 paloben bru

CYPRUS
Kyprounics
19 Gregorios & Xenopoulos Rd
P O Box 1152
CY-Helios
Tel 45428-29
Cable KYPRONICS PANDEHIS
Telex 3018

CZECHOSLOVAKIA
Vývojová a Provozní Ústředna
Výzkumný Ústav v Bečovicích
CSSR-25097 Bečovice u Prahy
Tel 89 93 41
Telex 121333
Institute of Medical Sciences
Výzkumný Ústav Laboratorní Biologie
Jedlova 6
CS-88346 Bratislava-Kramarske
Tel 44-551-45-541

DDR
Entwicklungslabor der TU Dresden
Forschungsinstitut Messburg
DDR-7305
Waldheim-Messburg
Tel 37 667
Telex 11245
Export Contact AG Zuenen
Guenther Forster
Schneebergstrasse 15
1040 Berlin
Tel 42-74-12
Telex 111889

DENMARK
Hewlett-Packard A/S
Ostavis 52
DK-3480 Birkedam
Tel (02) 81 66 40
Cable HEWPACK AS
Telex 37409 hpas dk
Hewlett-Packard A/S
Naveris 1
DK-8650 Silkeborg
Tel (02) 82 71 66
Telex 37409 hpas dk
Cable HEWPACK AS

FINLAND
Hewlett-Packard Oy
Mantolousentie 5
P O Box 6
SF-00211 Helsinki 21
Tel (90) 6923031
Cable HEWPACKOY Helsinki
Telex 12-1563 HEWPA SF

FRANCE
Hewlett-Packard France
Quartier de Courtabouff
Boris Pasternak Rd 6
F-91401 Orsay Cedex
Tel (1) 907 78 25
Cable HEWPACK Orsay
Telex 50048
Hewlett-Packard France
Agence Regionale
La Saquin
Charm des Moulins
B P 102
F-69136 Ecly
Tel (78) 33 81 25
Cable HEWPACK Ecly
Telex 31 08 17

Hewlett-Packard France
Agence Regionale
Pavillon de la Capelle
Chemin de la Capelle 20
F-31300 Toulouse-Le Mirail
Tel (81) 40 11 12
Cable HEWPACK 51957
Telex 510957

Hewlett-Packard France
Agence Regionale
Aéroport principal de
Marseille-Mangane
F-13721 Mangane
Tel (91) 89 12 36
Cable HEWPACK MARGN
Telex 410770

Hewlett-Packard France
Agence Regionale
63 Avenue de Rochester
B P 1124
F-35014 Rennes Cedex
Tel (88) 35 23 20 21
Cable HEWPACK 74912
Telex 740912

Hewlett-Packard France
Agence Regionale
74 Alee de la Roberteau
F-67000 Strasbourg
Tel (88) 35 23 20 21
Cable HEWPACK STRBG
Telex 740912

Hewlett-Packard France
Agence Regionale
Centre Vauban
201 rue Colbert
F-59000 Lille
Tel (20) 51 44 14
Telex 820744
Hewlett-Packard France
Centre d Affaires Paris-Nord
Bâtiment Ampère
Rue de la Commune de Paris
8 P 300
F-93153 Le Blanc Mesnil Cedex
Tel (01) 931 88 50

**GERMAN FEDERAL
REPUBLIC**
Hewlett-Packard GmbH
Vertriebszentrale Frankfurt
Bernerstrasse 117
Postfach 560 140
D-6000 Frankfurt 56
Tel (069) 10 04-1
Cable HEWPACKSA Frankfurt
Tel (069) 10 04-1
Cable HEWPACKSA Frankfurt
Telex DA 13249 hpfrfd
Hewlett-Packard GmbH
Technisches Büro Böttingen
Hartenbergstrasse 110
D-7030 Böttingen Württemberg
Tel (07031) 867-1
Cable HEPAK Böttingen
Telex 07265739 bbn

Hewlett-Packard GmbH
Technisches Büro Dusseldorf
Emanuel-Leutze-Str 1 (Seester)
D-4000 Düsseldorf 11
Tel (0211) 59711
Telex 085-98 533 hodd d
Hewlett-Packard GmbH
Technisches Büro Hamburg
Wandstrasse 23
D-2000 Hamburg 1
Tel (040) 24 13 13-13
Cable HEWPACKSA Hamburg
Telex 21 63 032 hpnd d
Hewlett-Packard GmbH
Technisches Büro Hannover
Am Grossmarkt 6
D-3000 Hannover 01
Tel (0511) 46 60 01
Telex 092 3259

IRELAND
Hewlett-Packard Ltd
King Street Lane
GB-Winnerah, Wokingham
Berkts: RG11 5AR
Tel (0734) 78 47 74
Telex 847178-848179

Hewlett-Packard GmbH
Werk Grootzingen
Ohmstrasse 6
D-7500 Karlsruhe 41
Tel (0721) 69 40 06
Telex 07-825707

Hewlett-Packard GmbH
Technisches Büro Nuremberg
Neumayer Str 90
D-8500 Nuremberg
Tel (0911) 56 30 83 85
Telex 0623 862

Hewlett-Packard GmbH
Technisches Büro München
Unterhachinger Strasse 28
ISAR Center
D-8012 Osterbrunn
Tel (089) 801 30 61 7
Cable HEWPACKSA München
Telex 0524985

Hewlett-Packard GmbH
Technisches Büro Berlin
Karlstrasse 2-4
D-1000 Berlin 30
Tel (30) 24 90 86
Telex 18 3405 hpoin d

GREECE
Kostas Karayannis
08 Ormou Street
GR-Athens 133
Tel 3237731
Cable RAKAR Athens
Telex 21 59 621 gr
Analytical Only
INTECO G Papatheasou & Co
Mara 17
GR Athens 103
Tel 522 1915
Cable INTEKNIKA Athens
Telex 21 5329 INTE GR

HUNGARY
MTA
Műszaki és Méréstechnika
Szolgálat
Lavin Krt 67
1391 Budapest VI
Tel 42 03 38
D-8000 Frankfurt 56
Tel (069) 10 04-1
Cable HEWPACKSA Frankfurt
Tel (069) 10 04-1
Cable HEWPACKSA Frankfurt
Telex DA 13249 hpfrfd

ICELAND
Medical Only
Elding Trading Company Inc
Hafnarvirk - Hviggvartou
IS-Reykjavik
Tel 1 58 20
Cable ELIDING Reykjavik

IRAN
Hewlett-Packard Iran Ltd
No 12 Fourth St
Neyriz Avenue
PO Box 41/2419
IR-Tehran
Tel 851082-7
Telex 21 23 74 ktrm w

IRAQ
Hewlett-Packard Trading Co
41/8 Mansour City
Baghdad
Tel 5517827
Telex 2453 hparaq ir
Cable HEWPACDAD
Baghdad Iraq

IRELAND
Hewlett-Packard Ltd
King Street Lane
GB-Winnerah, Wokingham
Berkts: RG11 5AR
Tel (0734) 78 47 74
Telex 847178-848179

ITALY
Hewlett-Packard Italiana S p A
Via Amerigo Vesputcci 2
Casella postale 3645
I-20100 Milano
Tel (2) 6251 (10 lines)
Cable HEWPACKIT Milano
Telex 32046

Hewlett-Packard Italiana S p A
Via Pietro Marone 40
(ang. Via Visentini)
I-35100 Padova
Tel (49) 66 48 88
Telex 41612 Hewpacu
Medical only
Hewlett-Packard Italiana S p A
Via d Agnardi 7
I-56100 Pisa
Tel (050) 2 32 04
Telex 32046 via Milano

Hewlett-Packard Italiana S p A
Via G. Arimondi 10
I-00143 Roma
Tel (06) 54 69 6
Telex 61514
Cable HEWPACKIT Roma

Hewlett-Packard Italiana S p A
Corso Giovanni Lanza
I-10131 Torino
Tel (011) 682245-659308
Medical/Calculators Only
Hewlett-Packard Italiana S p A
Via Pinco Raccia 43 G C
I-96126 Catania
Tel (095) 37 05 04
Hewlett-Packard Italiana S p A
Via Amerigo Vesputcci 9
I-80142 Napoli
Tel (081) 33 77 11

Hewlett-Packard Italiana S p A
Via G. Arimondi 10
I-00143 Roma
Tel (06) 54 69 6
Telex 61514
Cable HEWPACKIT Roma

KUWAIT
Al-Khadry Trading &
Contracting Co
P O Box 830-Saft
Kuwait
Tel 424910-411728
Telex 2481 areg it
Cable VISDCUUT

LUXEMBURG
Hewlett-Packard Benelux
S A N V
Avenue de Col-Vert 1
(Grootraklaan)
B-1170 Brussels
Tel (02) 672 22 40
Cable PALOBEN Brussels
Telex 23 494

MOROCCO
Gereg
190 Blvd Brahim Roudah
Casablanca
Tel 25-16-76-25-90-99
Cable Gereg-Casa
Telex 23739

NETHERLANDS
Hewlett-Packard Benelux N V
Van Haven Goochthartan 12
P O Box 667
NL-1134 Amsterdam
Tel (020) 47 20 21
Cable PALOBEN Amsterdam
Telex 13 216 hppa nl

NORWAY
Hewlett-Packard Norge A/S
Hewlett 13
Box 149
N-1344 Haslum
Tel (02) 53 83 60
Telex 18621 hpnos n

POLAND
Biuro Informacja Techniczna
Hewlett-Packard
Ul. Stowus 2, 6P
00-969 Warszawa
Tel 395962-395187
Telex 81 24 53 hpa pl

PORTUGAL
Telectra-Empresa Técnica de
Equipamentos Eléctricos S a r l
Rua Rodrigo da Fonseca 103
P O Box 2531
P-Lisbon
Tel (19) 68 60 72
Cable TELECTRA Lisbon
Telex 12598
Medical only
Intercombin Mundial de Comércio
S a r l
Av A A de Aguiar 138
P O Box 2781
P-Lisbon
Tel (19) 53 21 31-7
Cable INTERCAMBIO Lisbon

RUMANIA
Hewlett-Packard Reprazentanta
Bd N Balcescu 16
Bucharest
Tel (602) 313885
Telex 10440
I I R U C
Intrinderea Pentru
Intretinera
S Reparatia Utilizator de Calcul
B-dul prof Dimitrie Pompei 6
Bucharest-Sectorul 2
Tel 12 64 30
Telex 11716

SAUDI ARABIA
Modern Electronic Establishment
King Abdul Aziz str (Head Office)
P O Box 1228
Jeddah
Tel 31173-332201
Cable ELECTRA
P O Box 2728 (Service center)
Riyadh
Tel 62596-68232
Cable SAUJPCO

SPAIN
Hewlett-Packard Española S A
Jerez, Calle 3
E-Madrid 16
Tel (1) 458 28 00 (10 lines)
Telex 23515 hpe
Hewlett-Packard Española S A
Edificio Sennia planta 9,
E-Barcelona 17
Tel (3) 203 6200 (5 lines)
Telex 52603 hpoe e
Hewlett-Packard Española S A
Av Ramón y Cajal 1
E-Barcelona
Tel 64 44 54 56
Hewlett-Packard Española S A
E-Bilbao
Tel 23 63 06 23 82 08

SWEDEN
Hewlett-Packard Sverige AB
Engelstravagen 1-3
Facs
S-102 20 Stockholm 20
Tel (08) 730 05 50
Cable MEASUREMENTS
Stockholm
Telex 10721
Hewlett-Packard Sverige AB
Ostra Vintergatan 22
S-102 40 Ostersund
Tel (019) 14 07 20
Hewlett-Packard Sverige AB
Frotisgatan 30
S-421 32 Västra Frölunda
Tel (031) 49 09 50
Telex 10721 Via Bromma Office

SWITZERLAND
Hewlett-Packard (Schweiz) AG
Zürcherstrasse 207
P O Box 307
CH-8952 Schönenwerd-Zürich
Tel (01) 730 32 40-730 18 21
Cable HEPAK CH
Telex 53533 hpag ch
Hewlett-Packard (schweiz) AG
Château Bloc 19
CH-1219 Le Lignon-Genève
Tel (022) 98 03 22
Cable HEWPACKAG Geneva
Telex 27 333 hpag ch

SYRIA
Medical/Calculator only
Sawah & Co
Place Arme
SIR-Damascus
Tel 16367-19897-14268
Cable SAWAH Damascus
Telex 30439

TURKEY
Telekom Engineering Bureau
P O Box 437
Beyoğlu
TR-Istanbul
Tel 49 40 40
Cable TELEMATON Istanbul
Telex 23609
Medical only
E M A
Muharrem Kalemli Sirketi
Adakale Sokak 41-6
TR-Ankara
Tel 175622
Analytical only
Yilmaz Özyürek
Meb Mühürata Cad No 16-6
Kuşluk
TR-Ankara
Tel 25 03 09
Telex 42576 ozek tr

UNITED KINGDOM
Hewlett-Packard Ltd
King Street Lane
GB-Winnerah, Wokingham
Berkts: RG11 5AR
Tel (0734) 78 47 74
Cable Hewpac London
Telex 847178-848179

Hewlett-Packard Ltd
Lyon Court
Hereward Rise
Dudley Road
Walswortham
West Midlands B62 8SD
Tel (021) 550 991
Telex 339105

UNITED STATES
Hewlett-Packard Ltd
Wedge House
799 Lodge Road
GB-Farnham Heath
Surrey CR4 6XL
Tel (01) 884 0103 B
Telex 94825

Hewlett-Packard Ltd
C/o Mairo
South Service Wholesale Centre
Wear Industrial Estate
Washington
GB-New Town County Durham
Tel Washington 484001 ext 57 58

Hewlett-Packard Ltd
1 Wallace Way
GB-Hatfield
Herts
Tel (0482) 52824-56704
Telex 825981
Hewlett-Packard Ltd
28 Avonby Industrial Estate
Long Mile Road
Dunblin 12
Tel Dublin 509458
Telex 30439

USSR
Hewlett-Packard
Representative Office USSR
Poborskiy Boulevard 417-KW 12
Moscow 101000
Tel 294-7222
Telex 2825 hewpak su

YUGOSLAVIA
Hera-standard/Hewlett-Packard
Miloševića 38 VII
61000 Ljubljana
Tel 31 58 79-32 16 74
Telex 31583

**SOCIALIST COUNTRIES
NOT SHOWN PLEASE
CONTACT:**
Hewlett-Packard Ges m b H
A-1205 Vienna Austria
Tel (0222) 35 16 21 20
Cable HEWPAC Vienna
Telex 75923 hewpak a

**MEDITERRANEAN AND
MIDDLE EAST COUNTRIES
NOT SHOWN PLEASE CONTACT:**
Hewlett-Packard Ges m b H
A-1205 Vienna Austria
Tel (0222) 35 16 21 20
Cable HEWPAC Vienna
Telex 75923 hewpak a

**FOR OTHER AREAS
NOT LISTED CONTACT
Hewlett-Packard S A
7 rue du Bois-du-Lan
P O Box
CH-1217 Meyrin 2 - Geneva
Switzerland
Tel (022) 82 70 00
Cable HEWPACKSA Geneva
Telex 2 24 86**

UNITED STATES

ALABAMA
8290 Whitesburg Dr S E
P O Box 4207
Montevallo 35082
Tel (205) 881-4581
Medical Only
228 W Valley Ave
Room 220
Birmingham 35209
Tel (205) 942-2081 2

ARIZONA
2306 E Magnolia St
Phoenix 85034
Tel (602) 244-1381
2424 East Aragon Rd
Tucson 85706
Tel (602) 294-3148

ARKANSAS
Medical Service Only
P O Box 5846
Brad Stano
Little Rock 72215
Tel (501) 378-1844

CALIFORNIA
1430 East Orangehorpe Ave
Fullerton 92631
Tel (714) 870-1000
3939 Lankershim Boulevard
North Hollywood 91604
Tel (213) 877-1282
TWX 910-498-2871
5400 West Rosecrans Blvd
P O Box 92105
World Way Postal Center
Low Angeles 90009
Tel (213) 970-7500
1400 Los Angeles
Tel (213) 778-7500
3003 Scott Boulevard
Santa Clara 95050
Tel (408) 249-7000
FWO 910-338-0518

*Ridgeway
Tel (714) 446-8165
648 W Norm Market Blvd
Sacramento 95834
Tel (916) 929-7222
9608 Aero Drive
P O Box 23333
Scottsdale 85269
Tel (312) 255-9800
TWX 910-687-2290

COLORADO
5600 South Ulster Parkway
Englewood 80110
Tel (303) 771-3455

CONNECTICUT
12 Lunar Drive
New Haven 06525
Tel (203) 389-6551
TWX 710-465-2029

FLORIDA
24210
2808 W Oakland Park Blvd
FL Lauderdale 33311
Tel (305) 731-2020
*Jacksonville
Medical Service Only
Tel (904) 598-0663
P O Box 8410
6177 Latta Eleanor Dr
Orlando 32809
Tel (305) 859-2900
P O Box 12826
Pensacola 32575
Tel (904) 478-8422

GEORGIA
P O Box 105005
Atlanta 30344
Tel (404) 955-1500
TWX 810-766-4880
Medical Service Only
*Aspenue 30993
Tel (404) 736-0592
P O Box 2103
Warner Robins 31098
Tel (912) 822-0449

HAWAII
2875 So King Street
Honolulu 96813
Tel (808) 955-4455
Telex 723-705

ILLINOIS
5201 Tolson Dr
Rolling Meadows 60008
Tel (312) 255-9800
TWX 910-687-2290

INDIANA
7301 North Shadeland Ave
Indianapolis 46250
Tel (317) 842-1000
TWX 810-280-1797

IOWA
2415 Heinz Road
Iowa City 52240
Tel (319) 338-9466

KENTUCKY
Medical Only
Atkinson Square
3901 Atkinson Dr
Suite 407 Atkinson Square
Louisville 40218
Tel (502) 458-1573

MICHIGAN
23855 Research Drive
Farmington Hills 48024
Tel (313) 478-6400
724 West Centre Ave
Kalamazoo 49002
Tel (606) 323-8362

MINNESOTA
2400 N Prior Ave
St Paul 55113
Tel (612) 638-0700

MISSISSIPPI
Jackson
Medical Service Only
Tel (601) 982-9363

MISSOURI
11313 Colorado Ave
Kansas City 64137
Tel (816) 783-8000
1024 Executive Parkway
St. Louis 63141
Tel (314) 878-0200

NEBRASKA
Medical Only
771 Mercy Road
Suite 10
Omaha 68106
Tel (402) 392-0948

NEW YORK
6 Automation Lane
Computer Park
Albany 12205
Tel (518) 458-1550
201 South Avenue
Poughkeepsie 12601
Tel (914) 454-7330
TWX 510-253-5981
850 Pennton Hill Office Park
Fairport 14450
Tel (716) 223-9950
5858 East Motley Road
Bryantown 13211
Tel (315) 454-2484
TWX 910-983-0580

NEW YORK
6 Automation Lane
Computer Park
Albany 12205
Tel (518) 458-1550
201 South Avenue
Poughkeepsie 12601
Tel (914) 454-7330
TWX 510-253-5981
850 Pennton Hill Office Park
Fairport 14450
Tel (716) 223-9950
5858 East Motley Road
Bryantown 13211
Tel (315) 454-2484
TWX 910-983-0580

NEW YORK
6 Automation Lane
Computer Park
Albany 12205
Tel (518) 458-1550
201 South Avenue
Poughkeepsie 12601
Tel (914) 454-7330
TWX 510-253-5981
850 Pennton Hill Office Park
Fairport 14450
Tel (716) 223-9950
5858 East Motley Road
Bryantown 13211
Tel (315) 454-2484
TWX 910-983-0580

NORTH CAROLINA
P O Box 5188
1923 North Main Street
High Point 27822
Tel (919) 885-8101

OHIO
16500 Sprague Road
Cleveland 44130
Tel (216) 243-7300
TWX 810-423-9430
330 Progress Rd
Dayton 45444
Tel (513) 859-8202
1041 Kingsmill Parkway
Columbus 43229
Tel (614) 436-1041

10535 Maroon Dr
Houston 77036
Tel (713) 776-8400
205 Billy Mitchell Road
San Antonio 78226
Tel (512) 334-8241

OKLAHOMA
P O Box 32008
Oklahoma City 73132
Tel (405) 721-0200

OREGON
17890 SW Lower Boones
Ferry Road
Tualatin 97062
Tel (503) 620-3350

PENNSYLVANIA
111 Zeta Drive
Pittsburgh 15238
Tel (412) 782-0400
1021 8th Avenue
King of Prussia Industrial Park
King of Prussia 19406
Tel (215) 265-7000
TWX 510-686-2670

SOUTH CAROLINA
6941-O N Trumbull Road
Columbia 29260
Tel (803) 782-6483

205 Billy Mitchell Road
San Antonio 78226
Tel (512) 334-8241
17800 SW Lower Boones
Ferry Road
Tualatin 97062
Tel (503) 620-3350

TENNESSEE
*Knoxville
Medical Service Only
Charleston
Tel (304) 345-1640

TEXAS
P O Box 1270
201 E Acapalo Rd
Richardson 75080
Tel (214) 321-8101

UTAH
2100 South 3270 West Street
Salt Lake City 84119
Tel (801) 972-4711

VIRGINIA
P O Box 12278
Hwy 7 Koger Escal Center
Suite 212
Harrison 23102
Tel (804) 461-4025-6
P O Box 9869
2914 Hungary Springs Road
Richmond 23228
Tel (804) 285-3431

WASHINGTON
Bellevue Office Pl
2203 114th Ave S E
Bellevue 98004
Tel (206) 454-3971
TWX 910-443-2448

WEST VIRGINIA
Medical/Analytical Only
Charleston
Tel (304) 345-1640

WISCONSIN
5004 West Lincoln Ave
West Allis 53227
Tel (414) 541-0550

FOR U.S. AREAS NOT LISTED:
CONTACT the regional office
nearest you. Atlanta, Georgia,
North Hollywood, California,
Rockville Maryland, Rolling Meadows
Illinois. Their complete
addresses are listed above.

By Order of the Secretary of the Army:

E. C. MEYER
General, United States Army
Chief of Staff

Official:

J. C. PENNINGTON
Major General, United States Army
The Adjutant General

Distribution:

Active Army:

TSG (1)	USAERDAA (1)
USAARENBD (1)	USAERDAW (1)
USAINSCOM (2)	Army Dep (1) except
TRADOC (2)	SAAD (20)
DARCOM (1)	TOAD (14)
TECOM (2)	SHAD (2)
OS Maj Cored (2)	USA Dep (1)
USACC (2)	Sig Sec USA Dep (1)
HISA (Ft Monmouth) (21)	Units org under fol TOE:
Armies (1)	(2 copies each unit)
USASIGS (10)	29-207
Svc Colleges (1)	29-610
Ft Richardson (CERCOM Ofc) (1)	(1 copy each unit)
Ft Carson (5)	29-134
Ft Gillem (10)	29-136
WSMR (1)	

ARNG: None

USAR: None

For explanation of abbreviations used, see AR 310-50.



SOMETHING WRONG WITH THIS MANUAL?

THEN... JOT DOWN THE DOPE ABOUT IT ON THIS FORM, TEAR IT OUT, FOLD IT AND DROP IT IN THE MAIL!

FROM: (YOUR UNIT'S COMPLETE ADDRESS)

Commander
Stateside Army Depot
ATTN: AMSTA-US
Stateside, N.J. 07703

DATE 4 April 1978

PUBLICATION NUMBER

TM 11-5840-340-14&P

DATE

23 Jan 74

TITLE

Radar Set W/PLC-76

BE EXACT... PIN-POINT WHERE IT IS

IN THIS SPACE TELL WHAT IS WRONG AND WHAT SHOULD BE DONE ABOUT IT:

TEAR ALONG DOTTED LINE

PAGE NO.	PARA-GRAPH	FIGURE NO.	TABLE NO.
2-25	2-28		
3-10	3-3		3-1
5-6	5-8		
E-5			
E-8		E-3	
E-9			

Recommend that the installation antenna alignment procedure be changed throughout to specify a 2° IFF antenna lag rather than 1°.

REASON: Experience has shown that with only a 1° lag, the antenna servo system is too sensitive to wind gusting in excess of 5 knots, and has a tendency to rapidly accelerate and decelerate as it hunts, causing strain to the drive train. Hunting is minimized by adjusting the lag to 2° without degradation of operation.

Item 5, Function column. Change "2 db" to "3db."

REASON: The adjustment procedure for the TRANS POWER FAULT indicator calls for a 3 db (500 watts) adjustment to light the TRANS POWER FAULT indicator.

Add new step f.1 to read, "Replace cover plate removed in step e.1, above."

REASON: To replace the cover plate.

For item 2, change the NSN to read: 5835-00-134-9186.

REASON: Accuracy.

Identify the cover on the junction box (item no. 5).

REASON: It is a separate item and is not called out on figure 19.

Add the cover of the junction box as an item in the listing for figure 19.

REASON: Same as above.

TYPED NAME, GRADE OR TITLE, AND TELEPHONE NUMBER

SSG I. M. DeSpirito 999-1776

SIGN HERE:

SSA I. M. DeSpirito

DA FORM 2028-2
1 AUG 74

P.S.--IF YOUR OUTFIT WANTS TO KNOW ABOUT YOUR MANUAL "FIND" MAKE A CARBON COPY OF THIS AND GIVE IT TO YOUR HEADQUARTERS.

FILL IN YOUR
UNIT'S ADDRESS

FOLD BACK

DEPARTMENT OF THE ARMY

OFFICIAL BUSINESS
PENALTY FOR PRIVATE USE, \$300

POSTAGE AND FEES PAID
DEPARTMENT OF THE ARMY
DOD-314



Commander
US Army Communications and
Electronics Materiel Readiness Command
ATTN: DRSEL-ME-MQ
Fort Monmouth, New Jersey 07703

TEAR ALONG DOTTED LINE

FOLD BACK

THE METRIC SYSTEM AND EQUIVALENTS

WEIGHT MEASURE

1 Centimeter = 10 Millimeters = 0.01 Meters = 0.3937 Inches
 1 Meter = 100 Centimeters = 1000 Millimeters = 39.37 Inches
 1 Kilometer = 1000 Meters = 0.621 Miles

WEIGHTS

1 Gram = 0.001 Kilograms = 1000 Milligrams = 0.035 Ounces
 1 Kilogram = 1000 Grams = 2.2 lb.
 1 Metric Ton = 1000 Kilograms = 1 Megagram = 1.1 Short Tons

LIQUID MEASURE

1 Milliliter = 0.001 Liters = 0.0338 Fluid Ounces
 1 Liter = 1000 Milliliters = 33.82 Fluid Ounces

SQUARE MEASURE

1 Sq. Centimeter = 100 Sq. Millimeters = 0.155 Sq. Inches
 1 Sq. Meter = 10,000 Sq. Centimeters = 10.76 Sq. Feet
 1 Sq. Kilometer = 1,000,000 Sq. Meters = 0.386 Sq. Miles

CUBIC MEASURE

1 Cu. Centimeter = 1000 Cu. Millimeters = 0.06 Cu. Inches
 1 Cu. Meter = 1,000,000 Cu. Centimeters = 35.31 Cu. Feet

TEMPERATURE

$5/9(^{\circ}\text{F} - 32) = ^{\circ}\text{C}$
 212° Fahrenheit is equivalent to 100° Celsius
 90° Fahrenheit is equivalent to 32.2° Celsius
 32° Fahrenheit is equivalent to 0° Celsius
 $9/5^{\circ}\text{C} + 32 = ^{\circ}\text{F}$

APPROXIMATE CONVERSION FACTORS

TO CHANGE	TO	MULTIPLY BY
Inches	Centimeters	2.540
Feet	Meters	0.305
Yards	Meters	0.914
Miles	Kilometers	1.609
Square Inches	Square Centimeters	6.451
Square Feet	Square Meters	0.093
Square Yards	Square Meters	0.836
Square Miles	Square Kilometers	2.590
Acres	Square Hectometers	0.405
Cubic Feet	Cubic Meters	0.028
Cubic Yards	Cubic Meters	0.765
Fluid Ounces	Milliliters	29.573
its	Liters	0.473
arts	Liters	0.946
allons	Liters	3.785
Ounces	Grams	28.349
Pounds	Kilograms	0.454
Short Tons	Metric Tons	0.907
Pound-Feet	Newton-Meters	1.356
Pounds per Square Inch	Kilopascals	6.895
Miles per Gallon	Kilometers per Liter	0.425
Miles per Hour	Kilometers per Hour	1.609

TO CHANGE	TO	MULTIPLY BY
Centimeters	Inches	0.394
Meters	Feet	3.280
Meters	Yards	1.094
Kilometers	Miles	0.621
Square Centimeters	Square Inches	0.155
Square Meters	Square Feet	10.764
Square Meters	Square Yards	1.196
Square Kilometers	Square Miles	0.386
Square Hectometers	Acres	2.471
Cubic Meters	Cubic Feet	35.315
Cubic Meters	Cubic Yards	1.308
Milliliters	Fluid Ounces	0.034
Liters	Pints	2.113
Liters	Quarts	1.057
ers	Gallons	0.264
ms	Ounces	0.035
ograms	Pounds	2.205
Metric Tons	Short Tons	1.102
Newton-Meters	Pounds-Feet	0.738
Kilopascals	Pounds per Square Inch	0.145
ometers per Liter	Miles per Gallon	2.354
ometers per Hour	Miles per Hour	0.621

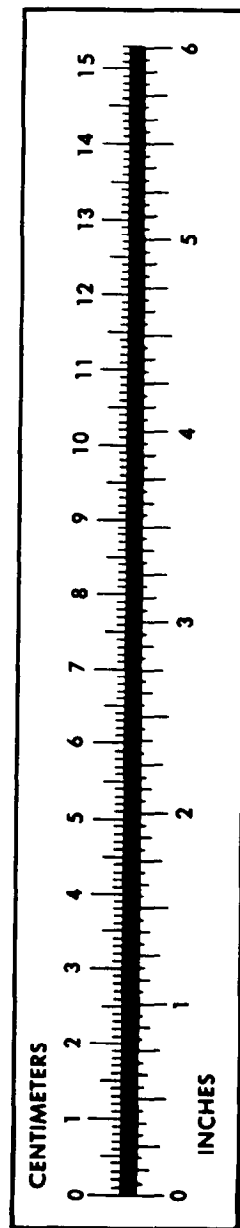

PIN: 046413-000