

KHF 950/990

HF Communications Transceiver **PILOT'S GUIDE** AND DIRECTORY OF HF SERVICES



INTRODUCTION
 KHF 950/990 COMMUNICATIONS TRANSCEIVERI
 SECTION I
 CHARACTERISTICS OF HF SSB WITH ALE1-1
 ACRONYMS AND DEFINITIONS1-1
 REFERENCES1-1
 HF SSB COMMUNICATIONS1-1
 FREQUENCY1-2
 SKYWAVE PROPAGATION1-3
 WHY SINGLE SIDEBAND IS IMPORTANT1-9
 AMPLITUDE MODULATION (AM)1-9
 SINGLE SIDEBAND OPERATION1-10
 SINGLE SIDEBAND (SSB)1-10
 SUPPRESSED CARRIER VS.
 REDUCED CARRIER1-10
 SIMPLEX & SEMI-DUPLEX OPERATION1-11
 AUTOMATIC LINK ESTABLISHMENT (ALE)1-11
 FUNCTIONS OF HF RADIO AUTOMATION1-11
 ALE ASSURES BEST COMM
 LINK AUTOMATICALLY1-12
 SECTION II
 KHF 950/990 SYSTEM DESCRIPTION.2-1
 KCU 1051 CONTROL DISPLAY UNIT2-1
 KFS 594 CONTROL DISPLAY UNIT2-3
 KCU 951 CONTROL DISPLAY UNIT2-5
 KHF 950 REMOTE UNITS2-6
 KAC 952 POWER AMPLIFIER/ANT COUPLER .2-6
 KTR 953 RECEIVER/EXITER2-7
 ADDITIONAL KHF 950 INSTALLATION OPTIONS .2-8
 SINGLE KHF 950 SYSTEM CONFIGURATION .2-9
 KHF 990 REMOTE UNITS2-10
 KAC 992 PROBE/ANTENNA COUPLER2-10
 KTR 993 RECEIVER/EXITER2-11
 SINGLE KHF 990 SYSTEM CONFIGURATION ..2-12

Table of Contents

SECTION III	
OPERATING THE KHF 950/990	3-1
KHF 950/990 GENERAL OPERATING INFORMATION	3-1
PREFLIGHT INSPECTION	3-1
ANTENNA TUNING	3-2
FAULT INDICATION	3-2
TUNING FAULTS	3-3
KHF 950/990 CONTROLS-GENERAL	3-3
KCU 1051 CONTROL DISPLAY UNIT OPERATION	3-4
KCU 1051 GENERAL OPERATING INFORMATION	3-4
KCU 1051 CONTROL DESCRIPTION	3-4
PUSH ON/VOL	3-4
SQUELCH	3-4
CURSOR	3-5
VAR/PUSH CHAR	3-5
CLEAR	3-6
ENTER	3-6
MESSAGE	3-7
SCAN	3-7
KCU 1051 DISPLAY AND CONTROL OPERATION	3-8
DISPLAY	3-8
PAGES	3-8
DATA STORE AND RECALL KEYS	3-10
CLR KEY	3-10
ENT KEY	3-10
MICROPHONE KEY OPERATION.	3-11
OPERATOR ALERTS	3-11
COMMON DISPLAY FORMATS	3-13
OPERATION / MODE FIELD	3-14
STATE / SELECTION-CATEGORY FIELD	3-14
RECEIVE./TRANSMIT STATE	3-14
MESSAGE/UNTUNED FLAG	3-14
SECOND LINE OF DISPLAY	3-14
LARGE DATA FIELDS	3-15
MANUAL MODE	3-15
FREQUENCY AGILE	3-16
ITU CHANNEL OPERATION	3-16
CHANGES TO ALE AND ITU CHANNELS	3-16
INITIAL MANUAL CHANNEL	3-17
MANUAL CHANNEL ENTRY	3-17

ALE MODE	3-18
ALE IDLE STATES	3-18
ALE MODE DISPLAYS	3-19
ALE IDLE SCANNING	3-20
ALE IDLE NOT SCANNING	3-20
ALE CALL IN PROGRESS	3-20
ALE LINKED TO ADDRESS	3-21
ALE RECEIVING AMD MESSAGE	3-21
ALE SOUND RECEIVED FROM ADDRESS	3-22
ALE SOUNDING USING ADDRESS	3-22
SEND PAGE	3-23
SEND PAGE DISPLAYS	3-23
SEND MESSAGE PAGE (TRANSMIT AMD MESSAGE)	3-23
SEND SOUND AS PAGE (BROADCAST A SOUND)	3-24
SEND LQA PAGE (PERFORM AN LQA)	3-24
SYSTEM TEST	3-25
TEST REPORT PAGE	3-25
SYSTEM REVNUM	3-26
SYSTEM LQA SCORE	3-26
LQA SCORE PAGE	3-26
SYSTEM PROGRAM	3-27
PROGRAM MESSAGES	3-29
EDIT TX (EDIT AMD TRANSMIT MESSAGES)	3-29
REV RX (REVIEW RECEIVED AMD MESSAGES)	3-30
DEL RX (DELETE AMD RECEIVED MESSAGE)	3-30
DEL RX (ALL SELECTED)	3-31
COPY RX	3-31
PROGRAM OPERATION	3-31
INTERVAL	3-32
ACTIVITY LIMIT TIME-OUT PERIOD	3-33
SCAN RATE	3-33
AUTOMATIC SOUNDING INTERVAL	3-33
CALLTIME	3-33

Table of Contents

ENABLES	3-34
ENABLE AUTOMATIC SOUNDING	3-35
ENABLE LQA IN CALL	3-35
ENABLE RECEPTION OF AMD MESSAGES	3-35
ENABLE RECEPTION OF ANYCALLS	3-35
ENABLE RECEPTION OF ALLCALLS	3-35
ENABLE RECEPTION OF WILDCARD CALLS	3-35
ENABLE NUMERIC DIGIT ROLL OVER	3-36
BRIGHTNESS SETTING	3-36
PROGRAM CHANNEL	3-37
ALE CHANNEL DATA	3-37
CHANNEL GROUPS (CHGRP)	3-38
SCAN-LIST (SCAN-LIST)	3-39
TUNE ALL UNTUNED CHANNELS (TUNE-ALL)	3-39
NEED TUNE COMPLETED	3-39
CLEAR TUNES FROM ALL TUNED CHANNELS	3-40
MARKING UNTUNED	3-40
PROGRAM ADDRESS	3-41
ALE ADDRESS ENTRY PAGE	3-41
SINGLE ADDRESS ENTRY	3-44
SELF ADDRESS	3-44
RESPONSE TIME	3-45
SPECIAL ADDRESS TYPES	3-45
MESSAGE PAGE	3-46
KCU 1051 OPERATIONS SUMMARY	3-48
KCU 951 CONTROL DISPLAY UNIT OPERATION	3-50
KCU 951 CONTROLS	3-50
OFF/VOLUME	3-50
SQUELCH/OPTIONAL SELCAL	3-51
CLARIFIER	3-52
MODE BUTTON	3-52
FREQ/CHAN BUTTON	3-53
DIRECT TUNING A FREQUENCY	3-54
CHANNEL OPERATION AND PROGRAMMING 1	3-55
CHANNEL OPERATION AND PROGRAMMING 2	3-56
RECEIVE-ONLY CHANNEL PROGRAMMING	3-57
SIMPLEX CHANNEL PROGRAMMING	3-59
SEMI-DUPLEX CHANNEL PROGRAMMING	3-60

KFS 594 CONTROL DISPLAY UNIT OPERATION 3-62

 KFS 594 CONTROLS 3-62

 OFF/VOLUME 3-62

 SQUELCH/OPTIONAL SELCAL 3-63

 MODE SELECTION 3-63

 USB MODE A3J MODE 3-63

 DIRECT TUNING A FREQUENCY 3-64

 CHANNEL OPERATION AND PROGRAMMING .. 3-66

 SIMPLEX CHANNEL PROGRAMMING 3-67

 SEMI-DUPLEX CHANNEL PROGRAMMING 3-68

 CLARIFIER 3-70

 MARITIME RADIOTELEPHONE NETWORK 3-71

 KFS 594 OPERATIONAL NOTES: 3-73

SECTION IV

 HF COMMUNICATIONS SERVICES DIRECTORY 4-1

SECTION V

 ICAO ENROUTE NETWORKS 5-1

 HF RADIOTELEPHONE NETWORKS MAP 5-3

SECTION VI

 ARINC OPERATIONAL CONTROL SERVICES 6-1

 DESCRIPTION OF SERVICES 6-1

 ARINC OPERATING PROCEDURES 6-2

 AUTHORIZED CONNECTIONS 6-2

 GROUND-TO-AIRCRAFT CALLS 6-3

 ARINC LONG DISTANCE CONTROL FACILITIES .. 6-5

SECTION VII

 ITU MARITIME RADIOTELEPHONE STATIONS 7-1

 DESCRIPTION OF SERVICES 7-1

 AT&T HIGH SEAS RADIOTELEPHONE SERVICE .. 7-2

 AT & T COAST STATION COVERAGE MAP 7-3

 COAST STATION COVERAGE & INFORMATION .. 7-3

 AIRCRAFT REGISTRATION 7-4

 USING THE HIGH SEAS RADIO NETWORK 7-4

 PLACING AIRCRAFT-TO-GROUND CALLS .. 7-4

 RECEIVING HIGH SEAS CALLS 7-5

 PLACING GROUND-TO-AIRCRAFT CALLS .. 7-5

 TELEPHONE SERVICES OFFERING 7-5

 HIGH SEA RATE STRUCTURE 7-6

 TRAFFIC LIST BROADCAST 7-6

Table of Contents

AT&T HIGH SEAS COAST STATIONS	7-6
A FEW VITAL FACTS	7-6
COAST STATION KMI-CALIFORNIA	7-7
COAST STATION WOO - NEW JERSEY	7-8
COAST STATION WOM - FLORIDA	7-9
MOBILE MARINE RADIO, INC.	7-11
WORLD WIDE LISTING OF PUBLIC CORRESPONDENCE STATIONS	7-12
MARITIME RADIO CHANNEL DESIGNATIONS	7-14
SECTION VIII	
TIME & FREQUENCY STANDARD	8-1
DESCRIPTION OF SERVICES	8-1
WWV AND WWVH	8-1
TIME ANNOUNCEMENTS	8-2
GEOPHYSICAL ALERTS ON WWV	8-3
OMEGA NAV SYSTEM STATUS REPORTS	8-5
GLOBAL POSITIONING SYSTEM (GPS) STATUS ANNOUNCEMENTS	8-5
MARINE STORM WARNINGS	8-5
TIME AND FREQUENCY SERVICES WORLDWIDE	8-7
SECTION IX	
VOLMETS	9-1
SECTION X	
EMERGENCY FREQUENCIES	10-1
INTERNATIONAL DISTRESS FREQUENCY	10-1
SECTION XI	
SHORTWAVE BROADCASTS	11-1
SECTION XII	
MANUAL AND ALE PROGRAMMING	12-1
MANUAL DATABASE PROGRAMMING	12-1
MANUAL CHANNEL PROGRAMMING	12-1
PROGRAMMING FREQUENCY	12-2
PROGRAMMING MODULATION TYPE	12-2
ALE DATABASE PROGRAMMING	12-2
SYSTEM PROGRAM PAGE	12-3
AMD TRANSMIT MESSAGES	12-5
OPERATION PARAMETERS	12-5
PROGRAMMING OPERATION PARAMETERS	12-6

ALE CHANNEL DATABASE12-7
PROGRAMMING ALE CHANNELS12-7
PROGRAMMING CHANNEL GROUPS ..12-7
PROGRAMMING THE SCAN LIST12-8
ALE ADDRESSES12-8
ALE ADDRESS PROGRAM PAGE12-9
PROGRAMMING A SELF ADDRESS ...12-9
PROGRAMMING A SINGLE ADDRESS .12-10
PROGRAMMING A STAR NETWORK
ADDRESS12-11
PROGRAMMING A GROUP ADDRESS .12-12
PROGRAMMING A SPECIAL ADDRESS
TYPE12-13

SECTION XIII

APPENDICES13-1
APPENDIX A: GEOPHYSICAL ALERT BROADCASTS 13-1
VOICE MESSAGE GEOPHYSICAL ALERTS ON WWV 13-1
GLOSSARY OF TERMS FOR THE SESC WWV
VOICE MESSAGE13-2
APPENDIX B: FREQUENCY STANDARD SERVICES 13-4
APPENDIX C: ADDITIONAL MATERIAL ON HF RADIO 13-5
APPENDIX D: FCC APPLICATION13-6

This Page Intentionally Left Blank

INTRODUCTION

KHF 950/990 COMMUNICATIONS TRANSCEIVER

High frequency (HF) communications made easy, that's what the King KHF 950/990 HF SSB Transceiver is all about.

The KHF 950/990 is a compact, lightweight system to provide an extensive range of operator benefits. It is designed with international flight operations in mind to provide superior long range communications.

A basic KHF 950/990 system consists of either three or four units including your choice of either a miniature Gold Crown III style (KFS 594) or two different Dzus rail-mounted control display units (KCU 951 & KCU 1051). Additional hardware is available to allow the KHF 950 system to tune most shunt and notch antennas used on some corporate jet aircraft. It can also be installed in a dual configuration sharing the same HF antenna, and yet provide a dual receive capability which many corporate users find highly desirable. The KCU 1051 will provide Automatic Link Establishment (ALE). This allows automatic selection of the optimum frequency and linking to another ALE system.

Microprocessor control of vital frequency selection functions provides an unprecedented number of programmable channels, greater ease of changing these channels on the ground or in the air, and direct access to a full 280,000 operating frequencies from 2.0 to 29.9999 MHz. The control heads provide extreme ease in fully utilizing the semi-duplex channels of the maritime radiotelephone (public correspondence) network.

There are three types of control heads available. The KCU 1051 control display unit provides Automatic Link Establishment (ALE) capability. The KCU 1051 is a Dzus rail-mounted unit with 200 programmable channels, 100 for manual channels and 100 for ALE channels, also all 245 ITU channels used by the maritime radiotelephone network are preprogrammed into non-volatile memory. No additional programming of ITU channels is ever required. With the KCU 951 Dzus rail-mounted control display unit, 99 pilot programmable channels are available. With the KFS 594 miniature control display unit and its associated remote adapter unit, 19 pilot programmable channels are available and, in addition, all 245 ITU channels used by the maritime radiotelephone network are preprogrammed into nonvolatile memory. When the KFS 594 Control Display Unit is used, no additional programming of ITU maritime radiotelephone network channels is ever required.

Introduction

High frequency radio opens a world of communication possibilities to the pilot and his passengers, including long range contact with air traffic control agencies over thousands of miles away, time and frequency standard broadcasts, Omega navigation station status reports, weather and marine storm warnings, radiotelephone service for personal messages and ARINC operational control services for messages relating to flying operations.

The first section of this pilot's guide deals with high frequency communications in general. A basic understanding of single sideband and some of the conditions which influence HF communications is important to using the KHF 950/990 effectively and obtaining the maximum benefit from its extensive capabilities.

The second section details the actual operation of the KHF 950/990 system and the final section of this pilot's guide covers the wide variety of HF communications services which are available to the pilot using the Bendix/King KHF 950/990.

SECTION I

CHARACTERISTICS OF HF SSB COMMUNICATIONS WITH AUTOMATIC LINK ESTABLISHMENT.

ACRONYMS AND DEFINITIONS

ALE	Automatic Link Establishment
AMD	Automatic Message Display
CDU	Control Display Unit
HF	High Frequency
KPN	King Part Number
LQA	Link Quality Analysis
PC	IBM compatible Personal Computer

REFERENCES

The following documents are referenced by this document.

MIL-STD-188-141A Appendix A Notice 2

Automatic Link Establishment System, 10 September 1993

Federal Standard 1045A

Telecommunications: HF Radio Automatic Link Establishment, 24 January 1990

HF SSB COMMUNICATIONS

High frequency single side band communications achieve reliable long range transmission and reception over distances of thousands of miles. The primary reason is due to skywave propagation which allows HF radio waves which are beamed toward outer space to be reflected back toward the earth's surface by the ionosphere. Another reason is because of a transmission process known as single side-band which puts all the transmitter's power into sending just a radio

Description

wave containing the intelligence to be communicated. Both of these make HF radio highly useful to aircraft flying over water or desolate land areas when they are out of reach of VHF communications which are limited to line of sight transmissions. A familiarization with frequency, skywave propagation, amplitude modulation, single sideband operation, suppressed carrier versus reduced carrier, simplex and semi-duplex operation, and automatic link establishment will make this pilot's guide easier to use and understand.

The following explanations will help provide a base to build on as you acquire experience in operating your KHF 950/990. If you have had experience with HF radio previously, the following material will serve as a review.

FREQUENCY

The frequency of a radio wave is the number of cycles of that radio wave which pass a given point within one second. The longer the wavelength, the lower the frequency. The frequency is often expressed as cycles per second, with one complete wave representing a cycle. The term **hertz** (Hz) is more commonly used today to represent one cycle per second. Expression of the measurement Hz has a shorthand of its own. When thousands of Hz are expressed, they are designated **kilohertz** (kHz), and millions of Hz as **megahertz** (MHz). Thus the notation 29.9999 MHz represents a signal which is passing a given point at 29,999, 900 cycles per second. Expressed in kHz, the same Figure would read 29,999.9 kHz representing 29,999.9 thousand cycles per second. In using HF, you will encounter both MHz and kHz notations for frequencies. KFS 594 and KCU 951 control display units always express frequencies in terms of kHz. The KCU1051 control display unit always expresses frequencies in terms of MHz.

The **high frequency** (HF) band, with which we are primarily concerned in this pilot's guide, covers from 2.0 MHz to 30 MHz (2,000 kHz to 30,000 kHz). The HF band lies between the medium frequency (MF) band and the very high frequency (VHF) band. Pilots are familiar with the characteristics of MF frequencies through the use of ADF equipment and know that these signals hug the ground and are sensitive to variations in terrain and to atmospheric disturbances. On the other hand, pilots know that VHF frequencies such as are used in VOR navigation and normal communications with Air Traffic Control facilities generally travel line-of-sight range and are not greatly affected by atmospheric disturbances. As will be discussed next, HF has its own characteristics which allow long range communications to take place.

SKYWAVE PROPAGATION - WHICH FREQUENCY TO USE?

As mentioned earlier, HF's primary method of travel or propagation is via skywaves which are radio waves that start out radiating into space and are reflected off the ionosphere back to the earth's surface. This reflecting of signals makes communications over very long distances-under ideal conditions more than 4,000 miles and typically in excess of 2,000 miles-possible. Because of variations in the ionosphere, HF communications require more analysis of conditions and operational decisions (such as frequency selection) than VHF communications.

The ionosphere is a multi-layered band of electrically charged particles surrounding the earth. It varies in height above the surface of the earth from approximately 30 to over 400 miles. The height and intensity varies from one location to the next and according to the season of the year and the time of day.

Because HF radio waves depend upon the ionosphere for reflection, their propagation is affected by changes in the ionosphere. It is changes in the density of the electrically charged particles in the ionosphere which cause propagation to improve or deteriorate. Since the ionosphere is formed primarily by the action of the sun's ultraviolet radiation, its thickness changes in relation to the amount of sunlight passing through it. Sunlight-induced ionization increases the particle density during the day and the absence of it reduces the particle density at night. At midday, when the sun's radiation is at its highest, the ionosphere's thickness may expand into four layers of ionized gas. During the nighttime hours, the ionosphere diminishes, normally merging into just one layer.

Solar disturbances including solar flares and magnetic storms can cause propagation of HF radio waves to deteriorate rapidly. HF signals can also suffer interference from such atmospheric disturbances as precipitation and thunderstorms.

The net result of all these factors is that because the ionospheric and atmospheric conditions are constantly changing, HF communications can vary in quality and strength. The signal received on the KHF 950/990 may be accompanied by a considerable amount of static from atmospheric disturbances, or it may fade in and out at times because each radio wave which hits the changing ionosphere may be reflected differently. Your reception and transmission success may vary from loud and clear to nonexistent depending on your selection of frequency and the conditions in the atmosphere and the ionos-

Description

phere. One of the best things the pilot can do to assure the best possible HF communications, based on existing HF propagation conditions, is to select the proper frequency. A good rule of thumb for the time of day is that the higher frequencies are best during daylight (10 to 29.9999 MHz) and lower frequencies work best at night (2 to 10 Mhz).

This rule of thumb can be explained by a mirror analogy. It is the electrically charged particles in the ionosphere which reflect or bend radio waves back toward earth like a mirror reflects light. Sunlight induces ionization and increases the density of these particles in the ionosphere during the day. The mirror becomes thicker and it reflects higher frequencies better. When the sun goes down the density of charged particles decreases and the ionosphere becomes a mirror that can only reflect lower frequencies in the HF band.

For any one particular frequency, as the angle at which an HF radio wave hits a layer of the ionosphere is increased, a **critical angle** will be reached from which the wave will just barely manage to be reflected back to earth (Figure 1-1). Waves entering at sharper angles than this will pass through this layer of the ionosphere and be lost in space (or may reflect off another layer of the ionosphere).

Changing the frequency under the same conditions will change the critical angle at which the HF radio waves will be reflected back to earth. The highest frequency which is reflected back to the earth is called the maximum useable frequency (MUF). The best HF communications are usually obtained using a frequency as close to the MUF as possible since radio waves higher than this frequency are not reflected and radio waves lower than this frequency will be partially absorbed by the ionosphere.

You should also be aware of the possibility that you or the ground station you are calling may be in a quiet zone. The linear distance from the point of transmission to the point where the skywave returns to earth is called the skip distance. There may be a quiet zone between the end of the ground wave and the return of the skywave. No communication can take place in this area. At any time, day or night, there is a "window" of useable frequencies created by the reflecting properties of the ionosphere. At night this "window" will normally be in the lower range of HF frequencies, and during the day it will be in the higher range of frequencies.

Normally you will not know what the MUF is at any particular time and location unless you have a table of propagation forecasts. Just remember that the higher frequencies in the "window" of useable fre-

quencies are likely to be the most effective. The closer a frequency is to the MUF, the better it is likely to be.

The effect of solar disturbances including solar flares and magnetic storms is to change the particle density in the ionosphere. Therefore, the “window” of useable frequencies may begin to close, with radio waves of frequencies in the lower range dropping out first as they are absorbed by the ionosphere.

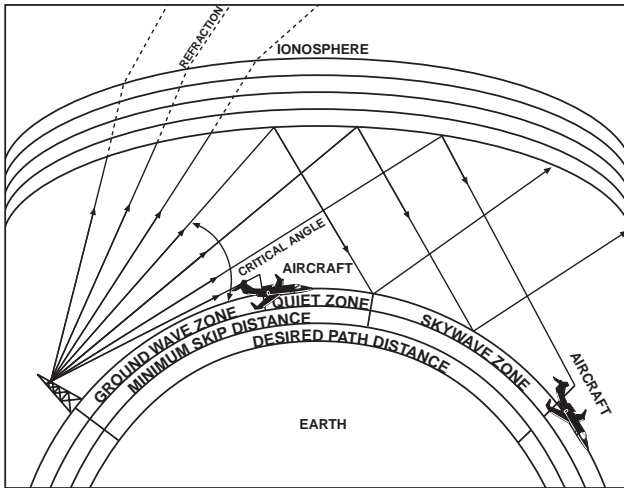

Figure 1-1 Effects Of Different Skywave Paths

Next, the radio waves of upper frequencies in the useable “window” may start to penetrate the ionosphere and go into outer space. It is even possible for the entire “window” to close, particularly if you are flying in a polar region in latitudes above 60 degrees north or 60 degrees south. Solar disturbances have the most negative effects on HF communications in these regions.

If you are flying in polar regions and are having difficulty raising any ground station located in the same region, remember this: even though the “window” of useable frequencies may have closed in the polar regions, another “window” may be open in regions closer to the equator which are less affected by solar disturbances. Try calling a station closer to the equator in latitudes lower than 60 degrees north or 60 degrees south, and use a higher frequency. If you can raise a station in these areas, that station may be able to relay your message.

Description

There are even times when solar disturbances improve the usability of higher frequencies in the HF band, particularly in equatorial regions. Another phenomenon which occurs during solar disturbances may allow you to communicate with a station even though the “window” is closed. This is known as scatter propagation, in which a radio wave is broken up in the ionosphere and scatters in various directions. Refer to the discussion of geophysical alerts in Appendix A for information on broadcasts which announce solar disturbance phenomena, and how to interpret these broadcasts.

Because frequency propagation cannot be predicted with total accuracy, ground stations responsible for aircraft HF communications will typically operate on several different frequencies within the HF band. The pilot is then able to choose the optimum communication frequency for the existing ionospheric conditions.

One feature that will be particularly useful when a trial and error method is used to find an HF frequency which is working well. This is the system’s capability to be programmed by the pilot with 99 channels (using the KCU 951 Control Display Unit), 100 channels (using the KCU1051 control display unit) or 19 (using the KFS 594 miniature control display unit). Rather than having to select the four to six digits each time you want to try another frequency, you can preprogram the frequencies you need to contact a particular ground station. Then if you call and fail to get through, you just change to another channel. (Automatic channel selection for optimum communications reliability is simplified with the addition of Automatic Link Establishment (ALE), available on the KCU 1051 Control Display Unit.

NOTE: It is advisable to program at least three frequencies for each station you plan to contact, in case one frequency suddenly becomes unusable. During times of solar disturbances, a useable frequency can fade out in less than a minute. And the “window” of useable frequencies can shift rapidly during solar disturbances or during sunset and sunrise when the level of ionization in the ionosphere is changing rapidly.

Tables 1-1 and 1-2 show typical propagation distances after one reflection from the ionosphere for various frequencies during different hours of the day and for different seasons of the year. It may prove helpful in selecting the optimum HF frequency for the communications distance your operation requires.

Frequency (kHz)								
4000			8000		12000		16000	
Propagation (Miles)								
	Min	Max	Min	Max	Min	Max	Min	Max
Hours After Sunset								
1	50	250	200	1000	500	3500	750	6000
2	100	600	250	1500	500	3500	750	6000
3	100	600	250	2000	500	3500		
4	100	800	250	2500				
5	100	1000	250	2500				
6	100	1500	400	3000				
7	100	1500	500	3500				
8	250	2000	750	4000				
9	250	2500	750	4000				
10	250	2500	750	4000				
11	100	1000	500	2500				
Hours After Sunrise								
1	100	500	400	2000				
2	0	100	400	2000				
3	0	100	250	1500				
4	0	100	250	1500	500	1000		
5	0	100	250	1500	500	1500		
6	0	100	250	1500	500	2500	750	4000
7	0	100	250	1500	500	3500	750	4000
8	0	100	250	1500	500	3500	750	4000
9	0	100	250	1500	500	3500	750	4000
10	0	100	250	1500	500	3500	750	4000
11	0	100	150	500	500	3500	750	6000
12	0	200	150	500	500	3500	750	6000
13	50	250	150	750	500	3500	750	6000

Table 1-1 Typical Frequency Propagation Spring And Summer

Description

Frequency (kHz)								
4000			8000		12000		16000	
Propagation (Miles)								
Min		Max	Min	Max	Min	Max	Min	Max
Hours After Sunset								
1	100	600	400	2000	500	3500	750	6000
2	100	800	400	2000	500	4000	750	6000
3	100	1000	400	2000	500	4000		
4	100	1000	400	2500	500	4000		
5	100	1000	400	3000	500	4000		
6	100	1500	400	3500				
7	250	2000	400	4000				
8	250	2500	500	4000				
9	500	3000	500	4000				
10	500	4000	500	4000				
11	500	3000	750	5000				
12	250	2500	750	5000				
13	250	1500	500	2500				
Hours After Sunrise								
1	100	1000	400	2000				
2	100	500	400	2000				
3	0	100	400	2000		3500	750	4000
4	0	100	400	2000	500	3500	750	4000
5	0	100	250	1500	500	3500	750	4000
6	0	100	250	1500	500	3500	750	4000
7	0	100	250	1500	500	4000	750	5000
8	0	100	250	1500	500	4000	750	5000
9	0	100	250	1500	500	4000	750	6000
10	0	100	250	1000	500	3500	750	6000
11	0	250	250	1500	500	3500	750	6000

Table 1-2 Typical Frequency Propagation For Fall And Winter

WHY SINGLE SIDEBAND IS IMPORTANT IN HF COMMUNICATIONS

As mentioned earlier, there are two characteristics of HF SSB communications which allow long range capability. Skywave propagation has been discussed in detail. The other characteristic is a transmission process known as single sideband. Single sideband (SSB) high frequency (HF) communications was developed in the early 1950's as a means of increasing the effective range of HF signals. The KHF 950/990 is capable of both amplitude modulation (AM) operation, such as is used in conventional VHF aircraft communications, and of SSB operation.

AMPLITUDE MODULATION (AM)

In order to understand SSB operation, a discussion of AM operation is helpful. Amplitude Modulation (AM) is a transmission process in which the selected frequency (called the carrier frequency) and two sidebands (which are frequencies above and below the carrier frequency) are generated and transmitted. (Figure 1-2.) It takes about two-thirds of the transmitter's power just to transmit the carrier frequency, yet the carrier does not contain any of the intelligence to be communicated. Each of these sidebands contains all the intelligence to be communicated. Standard broadcast stations (550-1600 kHz) and short-wave broadcasts use AM since it allows simpler receivers.

NOTE: The use of lower sideband isn't normally authorized for airborne HF use. It is normally disabled in the KHF 950/990, but can be enabled for those who are authorized to use it.

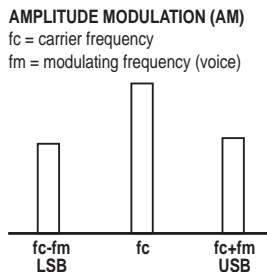

Figure 1-2 Amplitude Modulation

SINGLE SIDEBAND OPERATION

By electronically eliminating the carrier wave and one sideband, a single sideband transmitter manages to pack all of its power in transmitting the remaining single sideband. (Figure 1-3). Either the upper sideband (USB) or the lower sideband (LSB) can be used since each sideband contains all the required intelligence. However, from a practical standpoint the USB is used almost exclusively in airborne HF SSB operations and the LSB may be disabled. Upon receiving this SSB signal, the receiver then generates the carrier frequency internally and combines it with the one sideband in such a way that the intelligence (voice) can be heard and understood by the pilot.

SINGLE SIDEBAND (SSB)

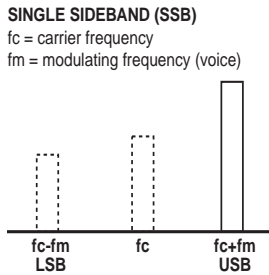

Figure 1-3 Single Sideband

The result is that an SSB system has the effective transmit power of AM units having many more times the transmitter power. Also, SSB communications allow the frequency band to be utilized more efficiently since the space or “bandwidth” of only one sideband rather than two sidebands is required to transmit the message.

SUPPRESSED CARRIER VS. REDUCED CARRIER

The single sideband (SSB) operation just described with the carrier frequency virtually eliminated is actually referred to as single sideband suppressed carrier and is designated A3J. If just a small portion of the carrier is transmitted along with the sideband, the operation is referred to as single sideband reduced carrier and is designated A3A. A3A was previously used in maritime radiotelephone but is not used currently. Regulations still require its inclusion in equipment used in conjunction with maritime radiotelephone. A3A is normally disabled on the KCU 1051, but is harness selectable. A3A is normally internally disabled on the KCU 951 Control Display Unit. If it has been enabled it is annunciated when both “AM” and “USB” are simultaneously displayed. The KFS 594 miniature control display unit allows the A3A mode to be selected by rotating the mode selector to the “A3A” position.

SIMPLEX AND SEMI-DUPLEX OPERATION

The KHF 950/990 is capable of both simplex and semi-duplex operation.

Simplex operation means that communication signals are transmitted and received on the same frequency. Simplex operations are used when communicating with Air Traffic Control (ATC), for example. Semi-duplex operation means that messages are transmitted on one frequency and received on another. The HF operator selects separate transmit and receive frequencies, then keys the microphone to transmit and releases the push-to-talk switch to receive. Semi-duplex operation is usually used for maritime radiotelephone (public correspondence) communications.

AUTOMATIC LINK ESTABLISHMENT (ALE)

ALE is an HF radio management system that selects the optimum frequency of transmission, places automatic or manual calls to link one or more users, and communicates digital messages. The ALE specification and waveform were adopted as standards by the US government in September, 1988 as MIL-STD 188-141A (Appendix A) for the military and as Federal Standard 1045 for civilian government agencies.

The advent of ALE technology has changed HF communications by allowing systematic and automatic real-time evaluation of HF communications paths, permitting automatic frequency selection. Because of this, the operation of an HF radio with Automatic Link Establishment is greatly simplified and the communications reliability is increased. A KCU 1051 CDU is required when Automatic Link Establishment features are desired.

FUNCTIONS OF HF RADIO AUTOMATION

There are many functions, that the HF Radio Automatic Link Establishment System performs for you. They are Selective Calling and Handshake, Scanning, Sounding, Polling, and Link Quality Analysis and Channel Selection

SELECTIVE CALLING AND HANDSHAKE - The selective calling and handshake function enables the establishment of a link between two radios. It includes digital address selective calling, followed by an exchange consisting of a response and acknowledgment, to produce a handshake (the establishment of a communications link).

Description

SCANNING - All available stations continuously and rapidly scan their receivers through their channels, seeking ALE calls. At any time, a calling station may slowly scan its transmitter through their channels, calling on each one, until answered on a channel that supports contact. This function enables the selection of a channel that successfully supports contact, despite variations in propagation, occupancy, and other traditional HF challenges.

SOUNDING - Sounding is a special beacon-like technique that assists all listening stations in measuring the propagation from the sounding station. The sounding station transmits its address on all channels, and the other stations measure the quality of the received signal. Sounding stations provide this service to other stations and do not use the information themselves.

POLLING - Polling enables two radios to measure the propagation characteristics for each channel's receive and transmit path. Then the information is stored in non-volatile memory.

LINK QUALITY ANALYSIS AND CHANNEL SELECTION - This function enables the radio to measure the quality of the received signals (and thus the available links) and to select the best channel for calling and communicating. This function allows a calling station to initiate calling on the best known working channel and thereby speed linking. It also minimizes unnecessary calling on marginal channels, when a transmitting station knows how well its signal is being received by the intended stations.

HOW ALE ASSURES THAT THE BEST COMMUNICATIONS LINK IS CHOSEN AUTOMATICALLY EVERY TIME

With Automatic Link Establishment on the job, the radio constantly scans the available channels for an ALE transmission. ALE transmissions are digitized HF signals. When an ALE transmission is detected, the signal-to-noise ratio of that signal is retained in memory. The next time a call is made, the radio uses that signal-to-noise ratio to determine the best channel to use. This way the best channel is always the one used, allowing you to have the best possible communications link all the time, in spite of the constantly changing thickness, density, and reflectivity of the ionosphere (a condition that is not controllable). Every frequency reacts a little differently to random changes in the ionosphere. The link quality for one frequency may increase while it may decrease for another for the same random changes.

ALE relieves you of the burden of trying to manually detect and compensate for random changes in the ionosphere and of searching for a good channel to use. It lets you concentrate on the message to be sent.

During the time when no call is present, the radio is squelched to reduce noise in the cockpit. After a call is received, a sound like a phone ringing is heard, the radio un-squelches, and you can commence a normal HF communication. **ALE relieves you of the burden of monitoring the radio for the presence of an HF call.**

This Page Intentionally Left Blank

SECTION II

KHF 950/990

SYSTEM DESCRIPTION.

The KHF 950/990 is a solid-state HF single sideband transceiver system. The KHF 950 system can be controlled by either a KCU 1051 Dzus rail-mounted control display unit, a KCU 951 Dzus rail-mounted control display unit, or a miniature KFS 594 Gold Crown III style control display unit. The KFS 594 requires an extra remote unit (KA 594) which contains electronics associated with this miniature panel-mounted control display unit. All the control units work in conjunction with a KAC 952 power amplifier/antenna coupler and a KTR 953 receiver/exciter.

The KHF 990 system can be controlled by either a KCU 1051 or the KFS 594 Control Display Unit. These control units work with the KAC 992 Antenna Coupler and a KTR 993 receiver/transmitter.

KCU 1051 CONTROL DISPLAY UNIT

The KCU 1051 Control Display Unit (Figure 2-1) adapts the existing KHF 950 and KHF 990 High Frequency Radio systems for use with Automatic Link Establishment, providing the pilot's display and control interface. Frequency, channel, mode, ALE address, audio gain, and squelch level selections are entered via its controls. Fault monitoring and fault annunciation are also provided by the KCU 1051.

The KCU 1051 provides the pilot access to 100 manual channels, 100 ALE channels, and 245 ITU channels to interface with maritime radiotelephone networks. The KCU 1051 uses a liquid crystal display to show frequency, channel, and mode of operation. The manual and ALE channels can be easily programmed by the pilot on the ground or in the air, and the nonvolatile memory stores this information even when the system is turned off.

Description

Display

The display screen is capable of displaying 2 lines of 16 (upper or lower case) characters. Information is presented in formatted pages. The main display pages are accessed by placing the cursor over the operations/mode field (ALE) and rotating the VAR knob until the desired page is displayed. To display a sub-page of a main page see Section III, Operation..

VOLUME knob

The VOLUME knob performs two functions. Rotate the VOLUME knob to control the audio output level. Push the VOLUME knob to the in position to apply power to the unit or pull the VOLUME knob to the out position to remove power from the unit.

VAR knob

The VAR knob performs two functions. Rotate knob to vary data under cursor. Toggle the momentary switch. VAR knob to the in position to select CHAR cursor mode and then toggle again to select FIELD cursor mode.

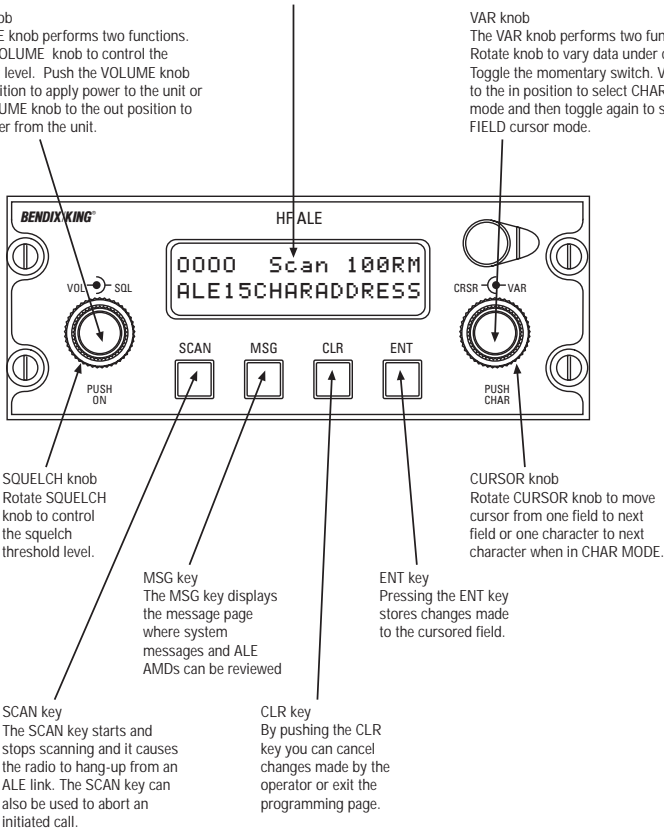

Figure 2-1 KCU 1051 Control Display Unit

KFS 594 CONTROL DISPLAY UNIT

The KFS 594 (Figure 2-2) provides the pilot with access to 19 programmable channels plus a full 280,000 operating frequencies in the 2.0 to 29.9999 MHz range. In addition, all 245 ITU maritime radiotelephone network (public correspondence) channels have been stored in nonvolatile memory along with the appropriately paired transmit and receive frequencies. Thus, to call up a radiotelephone channel, the pilot need only select "423" for WOM in Ft. Lauderdale, Fla., for example, rather than having to program 4425.6 kHz as the transmit frequency and 4131.2 kHz as the receive frequency (see WOM channel/frequency chart, Figure 7-3). The KFS 594 is a miniature Gold Crown III style control display unit which uses electronic gas discharge readouts to display frequency and channel information. All necessary controls for operation of the KHF 950/990 system, including programming of all preset channels, are on the KFS 594.

The 19 channels can be easily programmed by the pilot on the ground or in the air, and the nonvolatile memory stores this information and the 245 ITU maritime radiotelephone channels even when the system is turned off.

Description

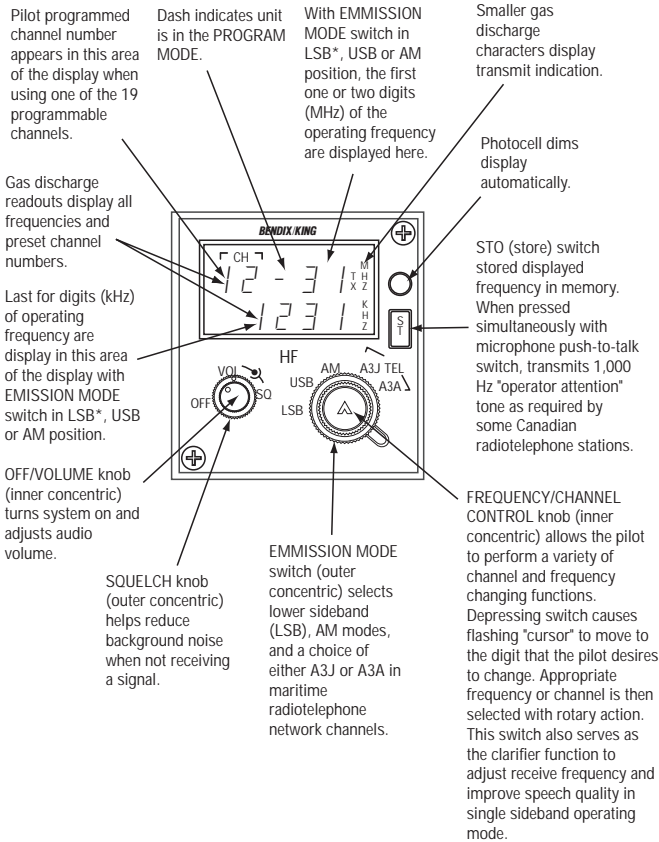

Figure 2-2 KFS 594 Control Display Unit
KFS 594 in A3J (or A3A) Mode

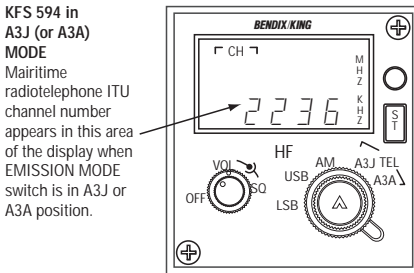

Figure 2-3 KFS 594 in A3J (or A3A) Mode

KCU 951 CONTROL DISPLAY UNIT

The KCU 951 (Figure 2-4) provides the pilot access to 99 programmable channels plus a full 280,000 operating frequencies in the 2.0 to 29.9999 MHz range. It provides semi-duplex capability through the 99 programmable channels to interface with maritime radiotelephone networks. A Dzus rail-mounted control display unit, the KCU 951, uses electronic gas discharge readouts to display frequency, channel and mode of operation. All necessary controls for operation of the KHF 950/990 system, including programming of all preset channels, are on the KCU 951. The 99 channels can be easily programmed by the pilot on the ground or in the air, and the nonvolatile memory stores this information even when the system is turned off.

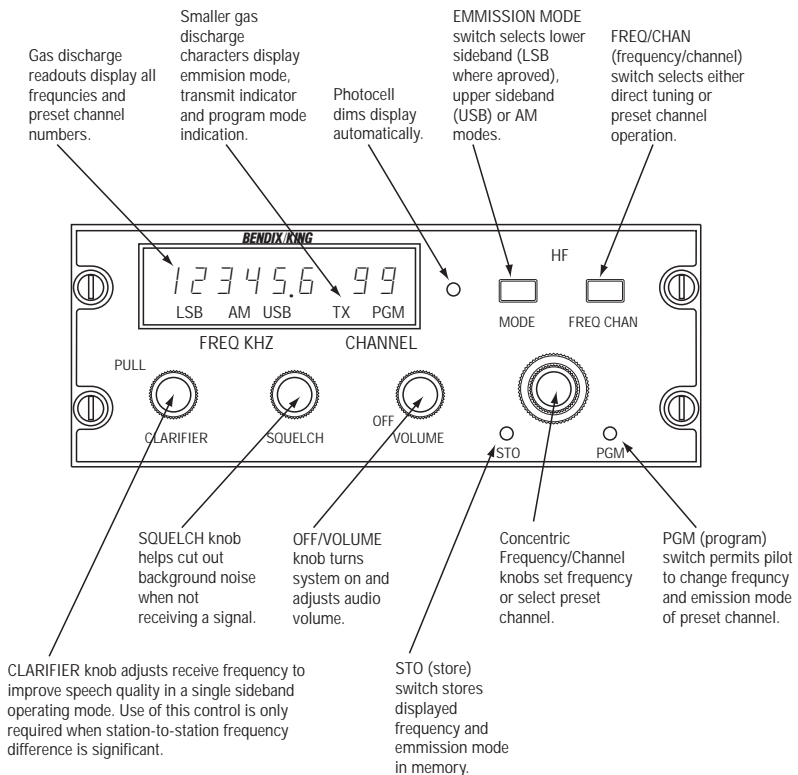

Figure 2-4 KCU 951 Control Display Unit

KHF 950 REMOTE UNITS

KAC 952 POWER AMPLIFIER/ANTENNA COUPLER

The KAC 952 Power Amplifier/Antenna Coupler unit (Figure 2-6) is mounted near the HF antenna to optimize transmission efficiency. The KAC 952 is all solid-state and can be mounted outside the aircraft pressure vessel for operation at any altitude up to 55,000 feet. The power amplifier in the KAC 952 amplifies the signal from the KTR 953 Receiver/Exciter into a 150 watt peak envelope power (PEP) transmitted signal in single sideband operation and 35 watts in AM operation.

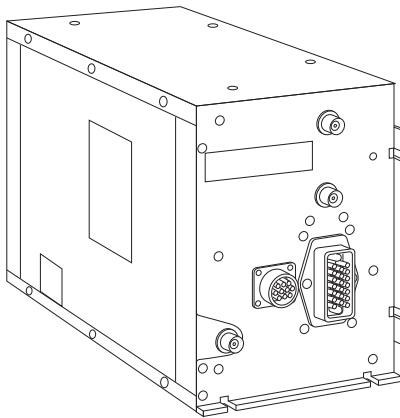

Figure 2-5 KAC 952 Power Amplifier/Antenna Coupler

Because the KHF 950 operates over such a broad frequency range (2.0 to 29.9999 MHz), it is impossible to optimize the actual aircraft HF antenna length for each frequency.

Instead, by changing its electrical impedance, the automatic antenna coupler in the KAC 952 tunes the antenna to each frequency, making the antenna appear to the transmitted signal as though it were the optimum physical length.

KTR 953 RECEIVER/EXITER

The KTR 953 remote unit (Figure 2-6) contains the receiver and the exciter for the KHF 950. The exciter is a transmitter which produces a very low power signal which is fed to the power amplifier in the KAC 952.

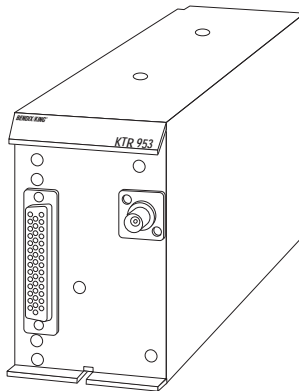

Figure 2-6 KTR 953 Receiver/Exciter

NOTE: Only the KTR 953-01,11,41,53 (KPN 064-1015-01) is compatible with standard SELCAL decoder units (not furnished). The KTR 953-01 and the SELCAL decoder are both necessary to obtain SELCAL operation. See page 19 for additional information on SELCAL.

NOTE: The KHF 950 is designed for continuous duty cycle (transmit) at 150 watts PEP for voice transmission on upper sideband (USB). On all other type transmissions, the unit will operate continuously; however, after an extended period of transmission the power will begin to back down to protect the power amplifier from overheating. The exact time required depends on the ambient temperature. For example, after seven minutes transmission in the AM Mode the power is approximately 1/3 of normal power output. A duty cycle of 3 minutes on and 3 minutes off will insure maximum power output.

ADDITIONAL KHF 950 INSTALLATION OPTIONS

While the standard KHF 950 system requires a wire antenna of only 10 feet, shorter wire antennas as well as “shunt” or “notch” antennas may also be tuned with additional hardware.

Special hardware is also available to allow dual KHF 950 systems (Figure 2-7) to operate from a single antenna and provide a dual receive capability.

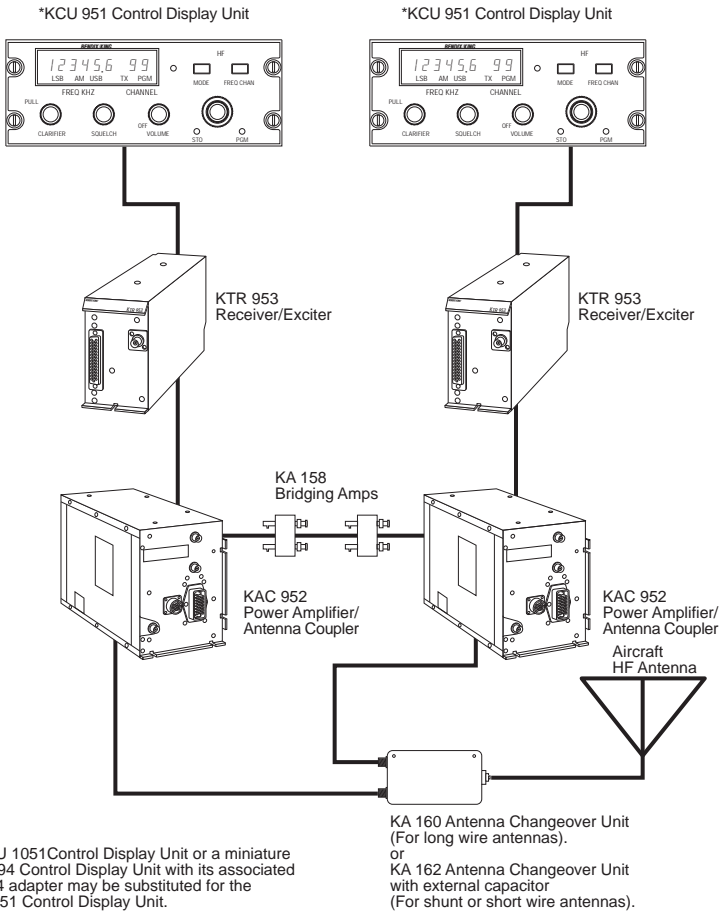
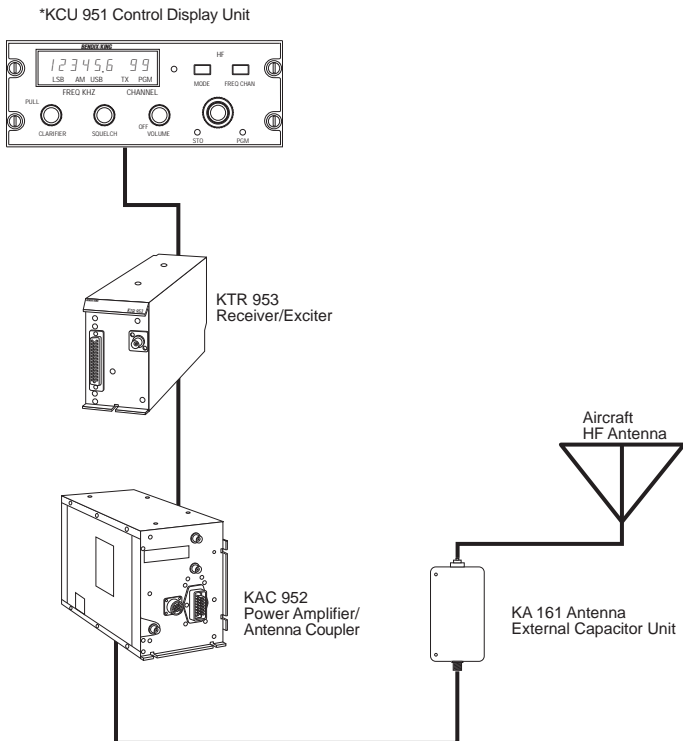

Figure 2-7 Dual KHF 950 System Configuration

SINGLE KHF 950 SYSTEM CONFIGURATION (SHUNT OR SHORT WIRE ANTENNAS)



*A KCU 1051 Control Display Unit or a miniature KFS 594 Control Display Unit with its associated KA 594 adapter may be substituted for the KCU 951 Control Display Unit.

*Figure 2-8 Single KHF 950 System Configuration
(Shunt or Short Wire Antennas)*

KHF 990 REMOTE UNITS

KAC 992 PROBE/ANTENNA COUPLER

The KAC 992 Probe/Antenna Coupler (Figure 2-9) is a combined Whip Antenna and Coupler designed to automatically match the impedance of the antenna to 50 ohms over the full frequency range of 2.0 to 29.999 MHz. The KAC 992 Coupler is hermetically sealed, so may be mounted either totally external or with coupler section mounted internally and the antenna protruding through a clearance hole in the aircraft skin.

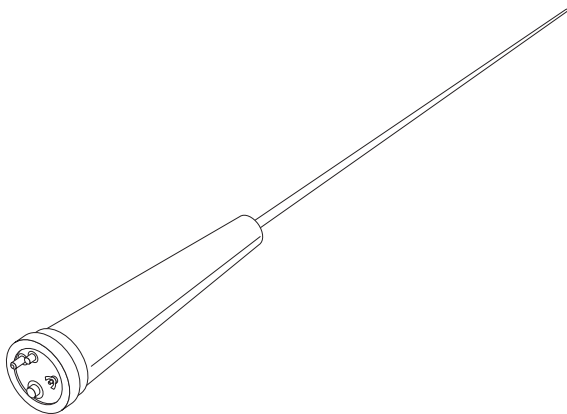

Figure 2-9 KAC 992 Probe/Antenna Coupler

KTR 993 RECEIVER/EXITER/AMPLIFIER

The KTR 993 (Figure 2-10) HF Transceiver contains the receiver/exciter, RF power amplifier, Lowpass filters, and control circuitry necessary for generation of SSB and AME signals. It is capable of 150 watts PEP output on any of 280,000 frequencies from 2 to 29.9999 MHz.

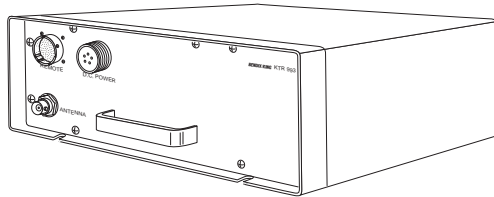
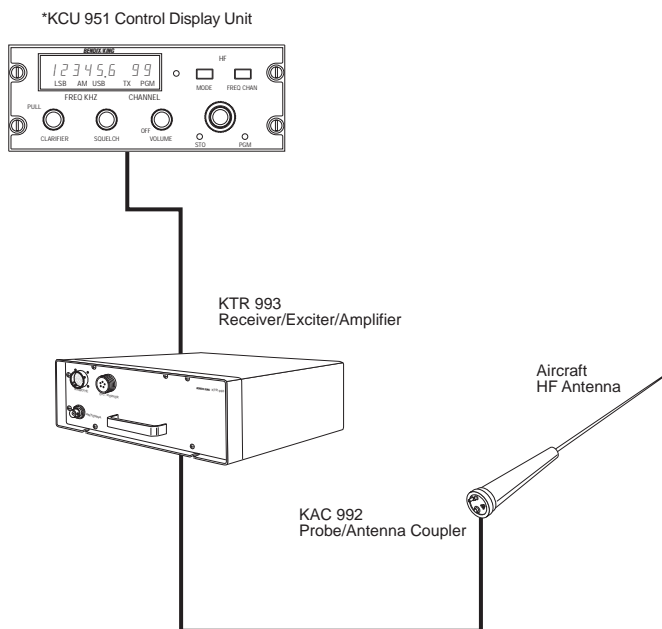

Figure 2-10 KTR 993 Receiver/Exciter/Amplifier

NOTE: The KHF 990 is designed for continuous duty cycle (transmit) at 150 watts PEP for voice transmission on upper sideband (USB). On all other type transmissions, the unit will operate continuously; however, after an extended period of transmission the power will begin to back down to protect the power amplifier from overheating. The exact time required depends on the ambient temperature. For example, after seven minutes transmission in the AM Mode the power is approximately 1/3 of normal power output. A duty cycle of 3 minutes on and 3 minutes off will insure maximum power output.

Description

SINGLE KHF 990 SYSTEM CONFIGURATION



*A KCU 1051 Control Display Unit or a miniature KFS 594 Control Display Unit with its associated KA 594 adapter may be substituted for the KCU 951 Control Display Unit.

Figure 2-11 Single KHF 990 System Configuration

SECTION III OPERATING THE KHF 950/990

KHF 950/990 GENERAL OPERATING INFORMATION **PREFLIGHT INSPECTION**

During preflight walk around inspection, it's important to check the HF antenna for structural integrity. Long wire antennas may be used with the KHF 950, and these can be damaged by ice accumulation in flight or broken by improper aircraft ground handling or fueling operations.

A ground check of the KHF 950/990 is advisable, particularly if it is going to be the primary source of contact with Air Traffic Control during over water flights. (It may be advisable to consider the operational benefit of installing dual KHF 950 radios when HF communications are the primary source of contact with Air Traffic Control. A second unit would provide a backup and a means of monitoring other HF services while the first radio is tuned to an ATC frequency.)

To check for proper antenna tuning, allow the KHF 950/990 to warm up until the display becomes active (up to two minutes), select an authorized frequency and press the microphone key. When using a KCU 1051, "TUNE IN PROGRESS" will be displayed if the channel had not been previously tuned. When tuning stops, the frequency display reappears. If a fault is indicated, refer to the section on Fault Indication in the pilots guide.

NOTE: When using the KCU 951 or the KFS 594, the TX annunciation should flash and the frequency display blank as the antenna coupler tunes the antenna. When the tuning sequence is complete the TX stops flashing and the frequency display reappears. If the TX fails to stop flashing refer to the section on Fault Indication in this pilot's guide.

To check for proper operation of the system, transmit a radio check on an authorized frequency. Make sure you can transmit and receive, using a frequency which is suitable for the time of day.

NOTE: The warm up period is for a crystal oven to heat up which assures an extremely high degree of frequency stability under varying environmental conditions.

CAUTION: When performing a ` radio check on the ground, make certain that all personnel are clear of the HF antenna before transmitting. SERIOUS RF BURNS CAN RESULT FROM DIRECT CONTACT WITH THE ANTENNA OR ANTENNA TERMINAL WHEN THE SYSTEM IS TRANSMITTING.

ANTENNA TUNING

When using a KCU 1051 control display unit, the antenna coupler tune information is stored in non-volatile memory. This means that retunes are required only when new frequencies are entered into the channel non-volatile memory. For semi-duplex channels both the receive and transmit frequency is tuned to provide optimum performance.

When using a KCU 951 or a KFS 594 the antenna coupler retunes the antenna under the following conditions:

1. When the system is first turned on (and warmed up) and the mic key is pressed.
2. When a new channel or frequency is selected and the mic key is pressed. Always initiate a tuning sequence after selecting a new frequency or channel. A tuned antenna improves receiver performance.
3. When an existing channel or frequency is being used while the unit senses an improper match and the mic key is pressed.

The antenna coupler is always utilized when transmitting (regardless of mode) and while receiving in the simplex mode (after mic key is pressed for tuning). The antenna coupler is bypassed during receive when operating in semi-duplex or receive-only channelized operation. The system is then functioning as a receiver connected directly to the HF antenna.

FAULT INDICATION

When using a KCU 1051, if the system detects a fault, a flashing "M" appears in the upper right corner of the display, and a fault message is displayed on the second line. The fault message reads "High VSWR" if there is an antenna problem, otherwise it reads "Fault see MSG pg". If connected, the Remote light also annunciates. The fault messages can be viewed on the message page by pressing the MSG key. If a High VSWR fault occurs, key the microphone to cause the automatic antenna coupler to begin a new tuning cycle to clear the fault.

Using the KCU 951 or KFS 594, if the system detects a fault during transmission or during the tuning of the antenna coupler, the frequency digits on the display begin to flash. Simply key the mic and the automatic antenna coupler begins a new tuning cycle to clear the fault.

TUNING FAULTS

If the antenna coupler is unable to find an acceptable frequency/antenna match, the fault indication continues at the end of the tuning cycle. If repeated antenna tuning cycles fail to clear the fault indication from the display, there is probably an equipment malfunction.

KHF 950/990 CONTROLS-GENERAL

Operating the KHF 950/990 requires that the pilot first determine the correct mode to match the ground station, whether it be upper sideband (USB), lower sideband (LSB), or AM. Correct mode selection is essential for successful contact with a ground station. Most stations use USB mode, but some continue to use AM. Also, the pilot must determine whether simplex, semi-duplex or receive-only frequency operation is required to match the operation of the desired ground station.

THERE ARE SEPARATE OPERATING SECTIONS ON EACH OF THE CONTROL DISPLAY UNITS. READ ONLY THE SECTION WHICH PERTAINS TO THE CONTROL DISPLAY UNIT YOU HAVE INSTALLED WITH YOUR KHF 950/990.

KCU 1051 CONTROL DISPLAY UNIT OPERATION

This section describes the KCU 1051 Control Display Unit controls and display. The ALE database is preloaded as described in Section XII.

KCU 1051 GENERAL OPERATING INFORMATION

KCU 1051 CONTROL DESCRIPTION

The controls on the KCU 1051 CDU are: PUSH/ON control, VOL knob, SQUELCH knob, PUSH CHAR, CURSOR knob, VAR knob, CLR key, ENT key, SCAN key, MSG key,

PUSH ON/VOL

This control (Figure 3-1) turns the system on and off and controls volume. Push the VOL knob to the in position to apply power to the unit or pull the VOL knob to the out position to remove power from the unit. Rotate the VOL knob to control the audio output level.

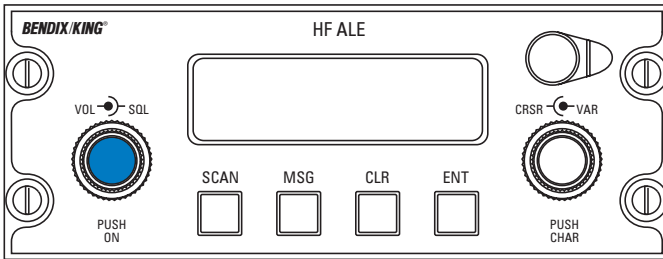

Figure 3-1 Push ON/VOL

SQUELCH (SQL)

Squelch (Figure 3-2) is set by rotating the SQL knob counterclockwise until background noise is heard, and then turning it clockwise until background noise is eliminated or just barely audible. When using ALE, the squelch normally is turned off because ALE turns off the audio until a call is received.

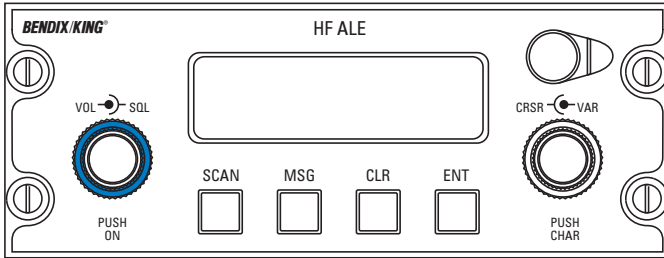

Figure 3-2 Squelch Control

CURSOR (CRSR)

The cursor is moved by rotating the CRSR knob (Figure 3-3). The cursor moves from one field to the next field when in the field cursor mode. The cursor moves from one character to the next character when in the character cursor mode.

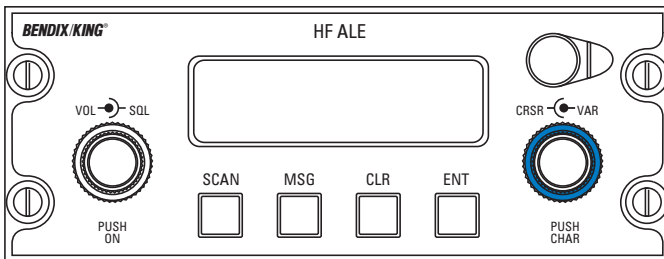

Figure 3-3 Cursor Control

VAR/PUSH CHAR

The VAR knob (Figure 3-4) performs two functions. Rotate the VAR knob to change data under the cursor. Pressing the VAR knob toggles the cursor between field and character modes. In field cursor mode the cursor covers the entire field. In character cursor mode the cursor covers a single digit, or character, within a field.

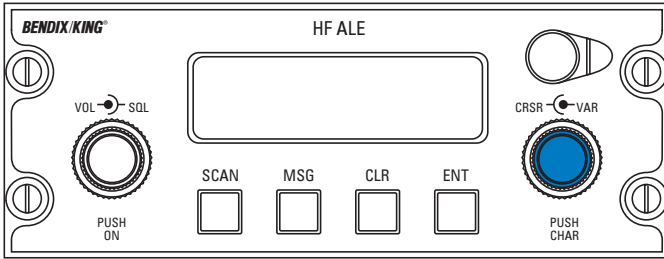

Figure 3-4 Var Control

CLEAR (CLR)

The CLR key (Figure 3-5) cancels changes made to the active field or exits a programming page..

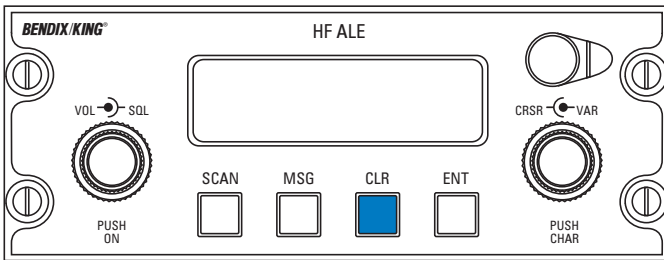

Figure 3-5 CLR key

ENTER (ENT)

The ENT key (Figure 3-6) stores changes made to the active field, or activates the selected mode.

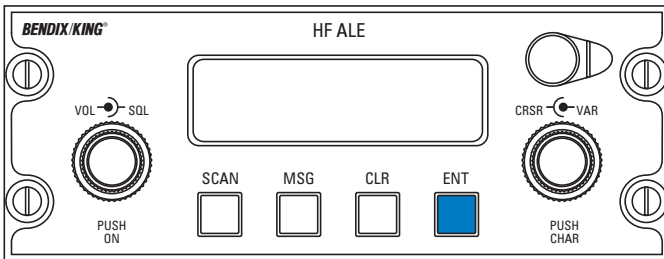

Figure 3-6 ENT key

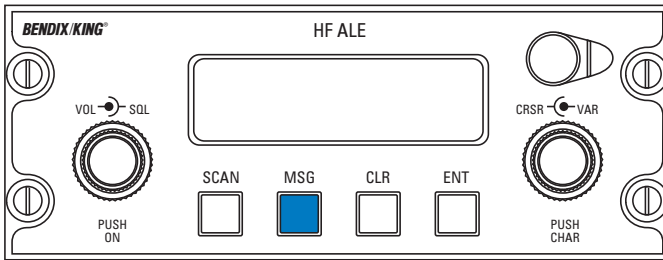

Figure 3-7 MSG Key

MESSAGE (MSG)

The MSG key (Figure 3-7) displays the message page where system messages, and ALE, digital messages (AMDs) can be reviewed.

The MSG key displays the message page where system messages, ALE AMDs, or modem messages can be reviewed.

SCAN

The SCAN key starts and stops scanning and it causes the radio to hang-up from an ALE call. The SCAN key can also be used to abort an initiated call.

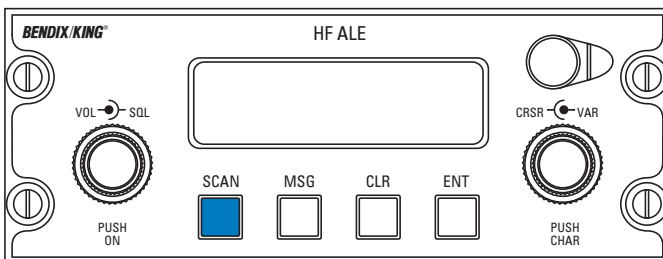

Figure 3-8 Scan Key

KCU 1051 DISPLAY AND CONTROL OPERATION

This section describes the user interface to the HF system.

This is a brief explanation of the operation of the KCU 1051 display and controls used to enter the manual channel and ALE databases (Figure 3-9).

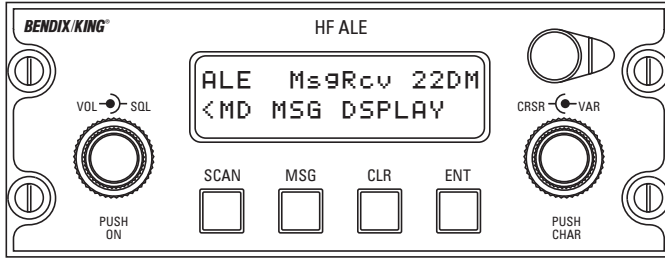

Figure 3-9 KCU 1051 Front Panel Controls And Indicators

DISPLAY

The display has 2 lines of 16 characters. Both upper and lower case letters can be displayed. The use of upper and lower case letters makes some abbreviations easier to read, for example “MSGRCV” could be “MsgRcv”

PAGES

The display is arranged in pages. A page is a presentation of specific data in an organized format. Figure 3-10 shows the page organization. There are four top level pages; ALE, SEND, MAN and SYS. ALE mode is enabled on the ALE and SEND pages. The MAN (manual) page allows the manual database of 100 channels, to be reviewed, entered, and used for receive and transmit. The ALE channels can also be reviewed and used for receive and transmit on the manual page. However, the ALE database can be programmed only in the sub-pages below the SYS (system) page. On the System Page, placing the cursor over the top right field allows selection of subsequent system pages.

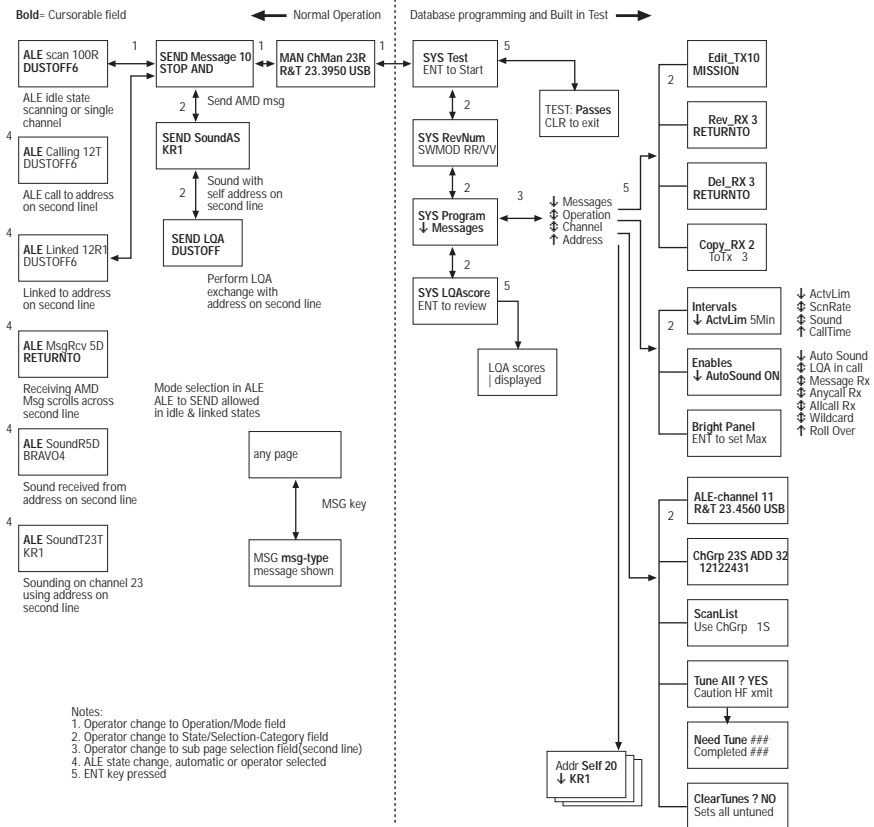

Figure 3-10 Page Organization

DATA STORE AND RECALL WITH THE CLR AND ENT KEYS.

The CLR and ENT keys are used for data entry. The ENT key causes the changes made to the field under the cursor to be stored. The CLR key can be used to restore the original value of the field until the ENT key is pressed. The changes to a field are also stored when the operator moves the cursor to another field.

CLR KEY

1. After data has been entered but before the ENT key is pressed or the cursor is moved from the field:

- A. If the cursor is in the character cursor mode and the field contains ASCII strings, such as an ALE address or AMD message:

The first press of the CLR key clears the data field from the point of the character cursor to the end of the field.

The second press of the CLR key restores the original data.

The third press of the CLR key exits the character cursor mode.

- B. For the field cursor the first press of the CLR key restores the original data.

2. The CLR key is also used to exit from a page and remove the cursor. After satisfying the CLR key actions above, the CLR key returns you to the idle page. The next press of the CLR key removes the cursor, if allowed.

ENT Key

As the operator progresses through the menus the ENT key or the CRSR knob can be used to move the cursor to the next field or item. The ENT key provides a benefit of leading the operator through a list of associated parameters. After the operator changes a field, pressing the ENT key indicates acceptance of the change. The cursor moves to the next field or a parameter is displayed on the bottom line to show a response to this action. For example, on the Operation/Interval page pressing the ENT key stores the change to the current interval and displays the next interval parameter, if there is one. Using the ENT key instead of the CRSR knob prevents the operator from accidentally skipping a field, since the CRSR knob moves the cursor rapidly. Using the operation/interval page as an

example, the sequence can be described as follows:

1. The operation / interval page is displayed.
2. Move the cursor over the interval value field
3. Use the VAR knob to change the interval.
If the data is correct, skip this step
4. Push the ENT key to accept the interval value.
5. The next interval is displayed.
Repeat Steps 3 through 4 until all intervals
have been reviewed or modified.

MICROPHONE KEY OPERATION.

In the Manual mode the microphone key controls the normal talk-listen transitions of push-to-talk operation

In the ALE mode the response to microphone key is dependent on the current ALE state. If ALE is idle (not in the process of sending or receiving a call) then activation of the microphone key initiates a call to the ALE address currently displayed on the screen. The channel(s) used for the ALE call depends on the ALE channel state which can be either scanning or single channel. In the ALE scanning state the call is attempted on the channels selected automatically by LQA criteria until a link is established or all channels on the list have been tried. In the ALE single channel state the call is initiated on the active channel only . If a channel is not tuned, then an automatic tuning sequence occurs the first time a transmit is attempted on the untuned channel.

In the ALE linked state the microphone key controls the normal talk-listen transitions of .microphone key operation. The ALE linked state commences when the audible alert is given, and terminates when link termination occurs and the radio returns to the ALE idle state.

OPERATOR ALERTS

There are three types of operator alerts, audible alert, Message flag, and the Remote Lamp. These alerts are used to inform the operator of messages, states, or faults that require the operators attention. The Audible Alert is a short burst of tones (similar to a ringing telephone) on the audio output. The Message flag is a flashing "M" on the display. The Remote Lamp is a discrete output that can be connected to a remote mounted lamp. The table below shows the conditions that activate these alerts.

Source	Message Flag "M"	Remote Lamp	Audible Alert	ALE Page State
AMD message received	yes	yes	yes	MsgRcv
Sound received	yes	no	no	SoundR
ALE link	no	yes	yes	Linked
Faults	yes	*some	no	

* Remote Lamp not set for VSWR fault

Table 3-1 Operator Alert Indications

The Message flag is reset when the Message page is viewed. The message flag is also reset for AMD messages and Sounds if the ENT, CLR, or SCAN key is pushed while the associated state is displayed on the ALE page. The Remote Lamp discrete is reset on any operator action; microphone key, knob or key

COMMON DISPLAY FORMATS

The top line of the display has the format shown (Figure 3-11) below. It is divided into three fields 1) Operation / Mode, 2) State / Selection-Category, Receive State 3) Message flag.

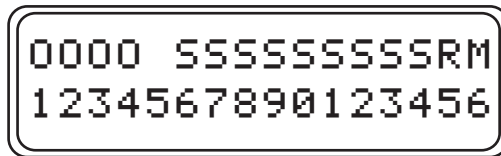

Figure 3-11 Display Format

O000	* Operation / Mode	ALE, SEND, MAN, SYS, MSG.
SSSSSSSS	State /Selection- Category	The format of this field is dependent on the Operation / Mode selected.
R	Receive/Transmit State	R indicates Receive Mode T indicates Transmit Mode D indicates Detecting ALE tone NOTE: When there is no message or untuned flag, this field moves to the message flag location to provide better readability.
M	Message/Untuned flag	A flashing M indicates that there is a message that has not been reviewed by the operator. This could be a system message (fault), or an ALE message. A U indicates that the cur- rent channel is not tuned.

* cursorable field in all top level pages

OPERATION / MODE FIELD

The Operation / Mode field controls which page is displayed. There are four top level pages accessible through the Operation / Mode field: MAN, ALE, SEND, SYS. The MSG page is not selectable in the Operation / Mode field, it is accessed by pushing the MSG key. Changes to the Operation / Mode field are reflected in the rest of the display immediately.

STATE / SELECTION-CATEGORY FIELD

The State / Selection-Category field provides different functions based on the current page. This field is subdivided into smaller fields on most pages. For some pages it displays the system state, for example scanning or single channel. On other pages this field is used to select from a list of available selections.

RECEIVE / TRANSMIT STATE

The receive/transmit state has three states:

- R indicates the radio is in the receive state.
- T indicates the radio is in the transmit state.
- D indicates the radio is receiving ALE tones.

MESSAGE / UNTUNED FLAG

A flashing M is displayed when there is a new message for the operator. To review the message the operator selects the message page by pushing the MSG key. A U is displayed when the current channel is not tuned. An untuned warning message is also displayed on the message page.

SECOND LINE OF DISPLAY

The second line of the display is used as a window into a list of items on most pages. This window can be scrolled up and down a list with the CRSR knob or the next item in the list can be displayed by pushing the ENT key.

Temporary overlays also are displayed on the second line. Some overlays are displayed for a few seconds then the line returns to the original display. Other overlays remain on the display until removed by pushing the CLR key. There are some programs on which that overlays are not displayed. Changes to volume and squelch are temporarily displayed in overlays. Faults are displayed in overlays and on the message page.

LARGE DATA FIELDS

Arrows on the second line indicate that the data within the field is larger than the display.. For items that are longer than 16 characters, left and right arrows are used to indicate that there is more data that can be displayed using the CRSR knob when the cursor is in character mode. The arrows can point up or down for a list of items. The down arrow means this is the top of the list, and the up arrow is used for the bottom of the list. A double arrow that points up and down indicates there are parameters above and below the current one. The ↓↑ symbols are used to represent up and down arrows on the pages below.

MANUAL MODE



Figure 3-12 Manual Mode Displays

CCCCC	* channel type	ChMan, ChITU, ChALE, _ _ _ _ _
####	* channel number	MAN channels 1 through 100 ALE channels 1 through 100 ITU 245 fixed frequency channels channel numbers 401 to 2510 (non consecutive)
R	receiver state	R = Receive T = Transmit D flashing = Detecting ALE tones
M	message flag	Flashing M indicates an unread message. U indicates channel is untuned
TTT	* communication	R&T, Rx, Tx
FF.FFFF	* frequency in MHz	
MOD	* modulation type	

* Cursorable fields

Operation

In manual operation mode four types of channels are available:

- 1 frequency agile
- 100 programmable manual channels
- 100 ALE channels
- 245 fixed ITU channels

FREQUENCY AGILE

The frequency agile channel mode provides the operator with a scratch-pad area to make frequency and modulation changes without modifying stored data. This mode is indicated by five underscores “_ _ _ _ _” in the channel type field and a channel number of zero (0). The frequency agile mode is entered in two ways, it can be selected by the operator or it is entered automatically when changes are made to ITU or ALE channels.

ITU CHANNEL OPERATION

The ITU channels are stored in permanent memory and cannot be changed by the operator. Tunes are not permanently stored for the ITU channels. When an ITU channel is selected it is initially untuned. Pressing the microphone key tunes both the receive and transmit frequency for the current ITU channel. This tune information is saved in RAM until the channel number, channel type or frequency is changed by the operator. To allow the operator to listen on the transmit frequency of the semi-duplex ITU channels, the SCAN key is used as a receive on transmit frequency key. Pressing the SCAN key when an ITU channel is selected changes the receiver to the transmit frequency. The transmit frequency is displayed and the communication field indicates that the transmit frequency is being monitored.

NOTE: This function, listen on transmit frequency, is available only for the ITU channels. Manually changing the communication field to transmit (TX) does not change the receiver to the transmit frequency. Selecting the transmit frequency with the communication field allows the operator to change or view the transmit frequency.

CHANGES TO ALE AND ITU CHANNELS

The stored data for ALE and ITU channels cannot be modified. When the operator modifies the frequency or modulation type of an ALE or ITU channel the channel type reverts to the ‘frequency agile’.

INITIAL MANUAL CHANNEL

The initial channel used when changing from ALE to MAN mode depends on the current ALE state. If the ALE state is linked, then the linked ALE channel is used, otherwise the last channel selected by the operator in manual mode is used.

MANUAL CHANNEL ENTRY

Changes made to the 100 manual channels are stored in nonvolatile memory. The frequency, modulation type, and communication type are programmable. The frequency modulation and communication type are modified with the CRSR and VAR knobs. The communication type field allows simplex or semi-duplex channels to be entered and used. The default state is simplex, shown as R&T, which means that the same frequency is used for both receive and transmit. Changing the communication type to Rx or Tx allows different frequencies to be entered and used for receive and transmit. When the cursor is on the communication type field the operator can view either the receive or transmit frequency. When the cursor is not on the communication type or the frequency field, then the frequency shown corresponds to the current transmit state.

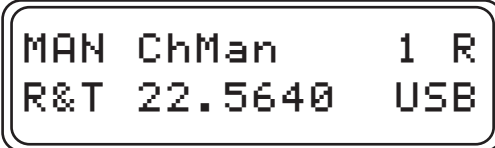

```
MAN ChMan    1 R
R&T 22.5640  USB
```

Figure 3-13 Simplex Channel



```
MAN ChMan   100 R
Rx    6.7550  USB
```

Figure 3-14 Semi Duplex Channel

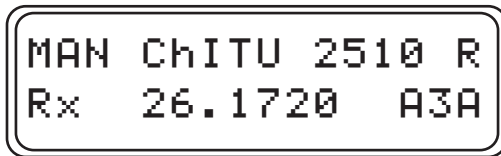

Figure 3-15 Manual ITU Channel

This display indicates that the unit is in receive on ITU channel 2510. Rx is indicated because the receive and transmit frequencies are different.

ALE MODE

The operator can initiate ALE calls and start and stop scanning while in this mode. While in the ALE mode the radio can receive ALE calls, AMD messages and sounds from other ALE radios. ALE mode has the following states :

- CH: Idle not scanning
- Scan Idle scanning
- Linked Linked with single ALE address call type
- NETInk Linked with an ALE network call type
- ALLInk Linked with an ALL call type
- ANYInk Linked with an ANY call type
- WLDInk Linked with a wild card call type
- GRPInk Linked with a Group call type
- MsgRcv Receiving an AMD message
- Calling Performing an ALE call
- SoundR Receiving a sound from an ALE radio.
- SoundT Transmitting a sound
- Polling LQA (Link Quality Analysis) poll in progress

ALE IDLE STATES

The radio has two ALE idle states, scanning and not scanning. The radio is toggled between these two states by pushing the SCAN key. The radio is listening for and will respond to ALE calls in either state. The calling address is selectable on this page. The channel is also selectable when not scanning. The operator initiates a call by pressing the microphone key. If the radio is scanning an auto-call is per-

formed. If the radio is not scanning then a call is performed on the selected channel only.

ALE MODE DISPLAYS

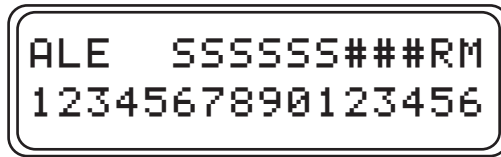

Figure 3- 16 ALE Mode Displays

SSSSSS	state	.
###	* channel number	ALE channels 1 through 100
R	receiver state	R = Receive T = Transmit D flashing = Detecting ALE tones
M	message flag	Flashing M indicates an unread message.
		U indicates that channel is untuned.
line 2	* addr/msg	ALE address or AMD message

* Cursorable fields.

Channel number is cursorable only if not scanning.

ALE IDLE SCANNING



Figure 3-17 ALE IDLE Scanning

ALE IDLE NOT SCANNING



Figure 3-18 ALE Idle

ALE CALL IN PROGRESS TO ADDRESS DISPLAYED ON LINE 2

The Calling state (Figure 3-19) is initiated by pushing the microphone key or on the SEND page. This state continues until a link is established and the state changes to Linked, or until the call completes unsuccessfully and the radio returns to the idle state.

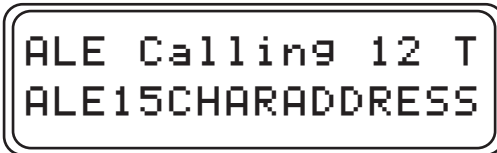

Figure 3-19 ALE Call In Progress To Address Displayed On Line 2

ALE LINKED TO ADDRESS DISPLAYED ON LINE 2

This state indicates that the radio is linked to another ALE radio. The ALE address listed on the second line (Figure 3-20) is the address of the other ALE radio or the ALE net or group. An audible alert is generated and the Remote Lamp discrete is set when the link occurs. The Remote Lamp discrete will be reset on the first activation of the microphone key or any key or knob action. The operator hangs up (unlinks) by pressing the SCAN key. On hang-up the radio returns to the ALE idle state.



```
ALE  Linked  5 R
KR1
```

Figure 3-20 ALE Linked To Address Displayed On Line 2

ALE RECEIVING AMD MESSAGE

This state (Figure 3-21) indicates that an AMD message is being or has been received. The message scrolls across the display as it is being received. The message will remain on the display for 15 seconds or until the operator removes it by pushing a key or initiating another action. An audible alert is generated, the Remote Lamp discrete is set and the message flag (flashing M) will be displayed to inform the operator of the message. The message flag will be removed if a key is pushed while in the MsgRcv state.

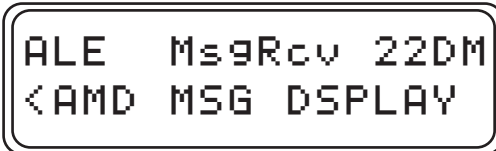

```
ALE  MsgRcv 22DM
<AMD MSG DISPLAY
```

Figure 3-21 AMD Message

ALE SOUND RECEIVED FROM ADDRESS DISPLAYED ON LINE 2

This state (Figure 3-22) is displayed while receiving sounds. The radio will remain in this state for 15 seconds or until the operator cancels it by pushing a key. The message flag (flashing M) is also set by this state. The message flag will be removed if a key is pushed while in the SoundR state. The addresses heard are displayed on the second line.



```
ALE SoundR 32 R
ADDRESSHEARD
```

*Figure 3-22 ALE Sound Received From Address
Displayed On Line 2*

ALE SOUNDING USING ADDRESS DISPLAYED ON LINE 2

This state (Figure 3-23) is active while transmitting sounds. It can be selected automatically by a timed sound or manually when the operator selects sound on the SEND page. This state will remain active until the sound completes, and then the radio will return to the ALE idle state.

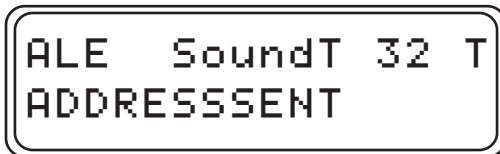

```
ALE SoundT 32 T
ADDRESSSENT
```

Figure 3-23 ALE Sound Using Address Displayed on Line 2

SEND PAGE

The selections available on the SEND page are: Transmit an AMD message, perform a Link Quality Analysis (LQA), or perform a sound. The transmit operation is based on the state of the radio before selecting SEND mode. The following parameters must be setup before entering the SEND page.:

- channel if not scanning
- ALE destination address for any AMD message.

SEND PAGE DISPLAYS

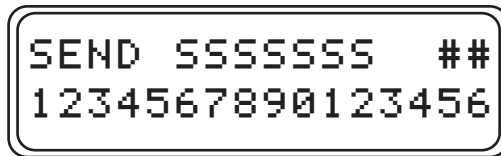

Figure 3-24 Send Page Displays

SSSSSSS	* selection	Message , SoundAs or LQA
##	* message index	Displayed only if 'Message' selected
line 2	* addr/msg	ALE address or AMD message

* Cursorable fields.

SEND MESSAGE PAGE (TRANSMIT AMD MESSAGE)

The cursor can be placed over the message index or the AMD message on line two. With the cursor placed on the AMD message field the VAR knob can be used to select a pre-stored AMD (cursor in field mode) or change the AMD message (cursor in character mode). The transmit starts when the ENT key is pushed, or when microphone key is activated. The Right arrow indicates that there is more data than can fit on the screen. The display reverts to the ALE calling page during the call. The address and channel used to transmit the message depends on the current settings of the ALE page.



*Figure 3-25 Send Message Page
(Transmit AMD Message)*

SEND SOUND AS PAGE (BROADCAST A SOUND)

The cursor can be placed on line two to select the self address to sound as. The sound starts when the ENT key is pushed or when microphone key is activated. The display reverts to the ALE SoundT page while the sound is in progress. The channel or channels sounded depends on the ALE state prior to activating the sound.



*Figure 3-26 Send Sound As Page
(Broadcast A Sound)*

SEND LQA PAGE (PERFORM AN LQA)

The cursor can be placed on line two to select the address to perform a bi-directional LQA with. The LQA starts when the ENT key is pushed or when microphone key is activated. The channel or channels used during the LQA depends on the ALE state prior to activating the LQA.



Figure 3-27 Send LQA Page (Perform an LQA)

Operation

will display the knob or key action on the second line. Pressing CLR twice will exit the keyboard test.

SYSTEM REVNUM

The software revision numbers are displayed on this page. where rr is the release number and vv is the revision number taken directly from the last four digits of the 206 software bill of material number. for engineering releases the release number will be preceded with an 'e' (er/vv).



Figure 3-30 System RevNum

SYSTEM LQA SCORE

This page (Figure 3-31) allow the operator to review the LQA scores for each address in the database. Pressing ENT will display the LQA page.



Figure 3-31 System LQA Score

LQA SCORE PAGE

The LQA score page (Figure 3-32) is used during engineering lab and field tests. The purpose of this page is to present the 100 x 100 LQA data table. The ALE address and the channel number are selected on the top line. The LQA scores are displayed on the second line in the following order SINAD then bit error rate, the composite score is also displayed. The T indicates scores returned for the transmit HF signal and R represents scores measured for the received HF signal. This page is exited with the CLR key.



Figure 3-32 LQA Score Page

AAAAAAAAA	* ALE address to review scores for.
###	* Channel number
T	Transmit signal scores
SS	SINAD score
BB	Bit error rate
R	Received signal scores
CC	Combined score for this channel

* Cursorable fields

SYSTEM PROGRAM



Figure 3-33 System Program

This page provides access to the ALE database. The second line presents a list four sub-page types where the ALE database can be reviewed or modified. The up and/or down arrows on the second line indicate that there is a list of items to choose from. The cursor is placed on the second line by moving the cursor with the CRSR knob. With the cursor on the second line the VAR knob is used to make the desired selection then the ENT key is pressed to enable the selection. The sub-pages return to this page when the CLR key is pushed to exit the page.

Operation

Program	* selection	Program ALE database selection
PPPPPPPPPP	* Sub-page	Messages, Operation, Channel, Address

* Cursorable fields

There are four types of data available for review or modification under the Program ALE database pages. The first three types listed below have sub-pages on which the data can be reviewed or modified. The last type, ALE address, has only one sub page.

I. ALE messages

- A. Edit AMD transmit messages
- B. Review received AMD messages
- C. Delete received AMD messages
- D. Copy a receive AMD message to a transmit message

II. Operational parameters

- A. Set Intervals
- B. Set Enables
- C. Configure brightness for installation.

III. ALE channels

- A. Edit channel data
- B. Edit channel groups
- C. Select channel group to use as the scan list
- D. Tune all untuned ALE channels
- E. Clear all tunes from ALE and manual channels

IV. ALE addresses entry / review of the four address types

- A. Self
- B. Single
- C. Group
- D. Network

PROGRAM MESSAGES



Figure 3-34 Sys Program Messages

The system program page (Figure 3-34) provides access to the message page. When Message is selected on the system program page, pressing the ENT key provides access to the AMD message sub-pages. The sub-pages return to this page when the CLR key is pushed to exit the page. There are four sub-pages below this selection:

- | | |
|---------|--|
| Edit TX | Edit/Review transmit messages. |
| Rev RX | Review messages received. |
| Del RX | Delete received messages. |
| Copy RX | Copy a received message to a transmit message. |

The operator moves between these sub-pages by placing the cursor on the sub-page field and turning the VAR knob to select another sub-page.

EDIT TX (EDIT AMD TRANSMIT MESSAGES)

The transmit messages can be reviewed and edited on this page. The VAR knob is used to select one of the AMD messages for modification or review. To modify the AMD message the cursor is placed on the second line, with the CRSR knob or the ENT key. Depressing the VAR knob will change the field cursor to a character cursor and the message can be entered or modified with the CRSR and VAR knobs. The arrow on the second line indicates that there the message is longer than the display width.



*Figure 3-35 Edit TX
(Edit and Transmit Messages)*

REV RX (REVIEW RECEIVED AMD MESSAGES)

The message index can be changed to review all of the receive messages. Messages longer than 16 characters can be reviewed by placing the cursor on the second line, pressing the VAR knob, and then using the cursor knob to scroll through the message.



*Figure 3-36 Rev RX
(Review Received AMD Messages)*

DEL RX (DELETE AMD RECEIVED MESSAGE)

The message index can be changed to select a single receive message or to "ALL" which will delete all receive messages. Messages longer than 16 characters can be reviewed by placing the cursor on the second line, pressing the VAR knob, and then using the cursor knob to scroll through the message. The message is deleted when the ENT key is pressed.



*Figure 3-37 Del RX
(Delete AMD Received Message)*

DEL RX (DELETE AMD RECEIVED MESSAGE WITH ALL SELECTED)

When “ALL” is selected the second line changes to indicate that pressing the ENT key will delete all receive messages

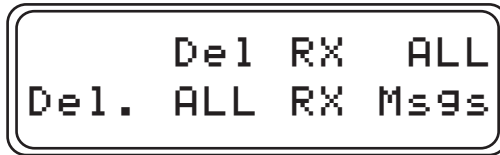

Figure 3-38 Del RX (Delete AMD Received Message with ALL Selected)

COPY RX (COPY A RECEIVED AMD MESSAGE TO A TRANSMIT AMD MESSAGE)

The cursor is automatically placed on the receive message index when this page is displayed. The receive message index and the transmit message index can be changed. The copy function allows the operator to take a received message and place it into the transmit message area where it can be modified and sent to other radios.

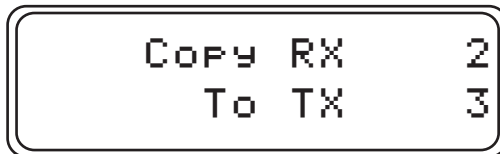

Figure 3-39 Copy RX (copy a received AMD message to a transmit AMD message)

PROGRAM OPERATION

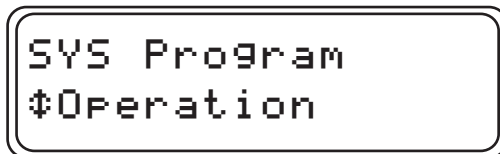

Figure 3-40 SYS Program Operation

The system program page (Figure 3-40) provides access to the operation pages. When ‘Operation’ is selected on the system program page, pressing the ENT key will provide access to the operational

Operation

parameter sub-pages. The sub-pages return to this page when the CLR key is pushed to exit the page. The three sub-pages are:

- Interval Set intervals
- Enables Set Enables
- Bright Adjust display brightness
(performed on installation only)

The operator moves between these sub-pages by placing the operator on the sub-page field and turning the VAR knob to select another sub-page.

INTERVAL

The Interval Page is a Program Operation Sub-Page. The intervals (Figure 3-41) are displayed on the second line. Each time the ENT key is pushed the next interval is displayed, also if the variable knob is turned to the right with the cursor on the interval type field the next interval type is presented. The arrows on the second line indicate that a list of items is available. The down arrow means this is the top of the list, and the up arrow is used for the bottom of the list. The “⤴” points up and down to indicate there are parameters above and below this line. There are four adjustable time intervals: ActvLim, ScanRate, Sound and CallTime (Table 3-2). The units in which each interval is entered are displayed to the right of the interval value.

ITEM	Units	Function
ActvLim	Minutes	The amount of time allowed with no microphone key activity before the system hangs-up. This feature may be turned off.
ScnRate	Hz	The frequency at which the system scans channels, 2 or 5
Sound	Minutes	The interval between automatic sounding sequences.
CallTime	Seconds	Length of scanning call portion of an ALE call.

Table 3-2 Adjustable Time Intervals



Figure 3-41 Interval

IIIIIIII	* Interval type	ActvLim, ScnRate, Sound, CallTime
XX	* Interval	
UUU	unit of measure	

* Cursorable fields

Activity Limit Time-Out Period (ActvLim)

ActvLm stands for activity limit. The activity limit is the amount of inactive time, in minutes, allowed while linked before a radio automatically hangs-up and returns to scan. The inactive timer runs whenever the radio is linked and in receive. The timer is reset each time the microphone key button is released. When the inactive timer reaches the time limit set in ActvLim the radio will hang-up causing both the calling and called radios to return to scan. The activity limit which is specified in minutes ranges from 1 to 60 minutes, it can be disabled by setting the interval to "0 OFF".

Scan Rate (ScnRate)

The scan rate, specified in hertz (Hz), is the rate at which the radio scans through the channels on the scan list. The scan rate can be set to either two channels per second (2 Hz) or five channels per second (5 Hz). Five channels per second is the default scan rate.

Automatic Sounding Interval (Sound)

When sounding is enabled this time interval is the amount of time between automatic sounds. Sounding is a one direction, non-interactive broadcast of a radios self address. Other radios receive the sound and use it to measure the quality of the received signal. The sound interval is specified in minutes, ranges from 1 to 240 (4 hours).

CallTime (CallTime)

This is the amount of time that the 'scanning call' portion of the call wave-form is transmitted. The scanning call can be thought of as the preamble to the call and is used to get the attention of the listening radios. Since a radio that is being called may be anywhere in the scan list cycle, the call time must exceed the time it takes for that radio go completely through its scan list.

The CallTime is specified in seconds and is set for the longest scan

Operation

cycle time of any radio that will be called. The scan cycle time is the length of time a radio takes to go completely through its scan list. The scan cycle time is calculated by dividing the number of channels on the scan list by the scan rate.

Example: 15 channels at 5 Hz scan rate, results in a 3 second scan time ($15 / 5 = 3$).

ENABLES

The Enables Page is a Program Operation Sub-Page. This page works in a similar manner to the interval page. The enables are displayed on the second line (Figure 3-42). Each time the ENT key is pushed the next enable is displayed. The arrows on the second line indicate that a list of items is available. The down arrow means this is the top of the list, and the up arrow is used for the bottom of the list. The double arrow indicates there are parameters above and below this one. The following items can be enabled, set to "ON", or disabled, set to "OFF" on this page.



Figure 3-42 Enables

EEEEEEEEEEEE * Enable type

- Auto Sound Automatic sounding
- LQA in call Exchange LQA information in the ALE call preamble
- Message Rx Allow reception of AMD messages
- AnyCall Rx Allow reception of ALE Anycalls
- AllCall Rx Allow reception of ALE Allcalls
- Wildcard Allow reception of ALE Wildcard calls
- Roll Over Digit rollover for numeric entry

SSS * State ON or OFF

* Cursorable fields

Enable Automatic Sounding (NORMALLY DISABLED) (AutoSound)

When Sounding is enabled, the system will sound at the time interval set in the sound interval. Sounding is a one direction non interactive broadcast of a radios self address. Other radios receive the sound and use it to measure the quality of the received signal.

Enable LQA in Call (NORMALLY ENABLED) (LQA in Call)

When LQA is enabled, Link Quality Analysis data will be exchanged with each call.

Enable Reception of AMD Messages (NORMALLY ENABLED) (Message Rx)

Enabling Message Rx allows an AMD messages to be received and displayed on the screen as it is received.

Enable Reception of Anycalls (NORMALLY ENABLED) (Anycall Rx)

Enabling ANYCALLS allows the radio to respond to Anycalls. Anycalls provide a means of calling and linking with another radio or radios without knowing specific addresses. The receiving radios transmit a response to an AnyCall.

Enable Reception of Allcalls (NORMALLY ENABLED) (AllCall Rx)

Enabling ALLCALLS allows the radio to receive Allcalls. Allcalls do not require a response from the called radio. Messages can be broadcast to multiple stations or a link can be opened to multiple stations without causing the receiving station to broadcast a response.

Enable Reception of Wildcard Calls (NORMALLY ENABLED) (Wildcard)

Enabling WILD CARD allows the radio to respond to calls with the wild card character. Wild card calls provide a means of calling and linking with another radio or radios without knowing the entire addresses. The receiving radios transmit a response to a Wild Card call.

Enable Numeric Digit Roll Over (NORMALLY ENABLED) (Roll Over)

When enabled digit roll over causes numerical entries to 'roll over' from minimum to maximum and maximum to minimum values. When digit roll over is disabled, numerical entries stop changing at the minimum and maximum values. Operation of the frequency field changes depending on the digit rollover state. When direct rollover is enabled, then changes to a frequency digit past nine carries/borrows from the next higher digit. When digit rollover is disabled, each digit is changed independently of the others.

BRIGHTNESS SETTING

The Bright Page is a Program Operation Sub-Page. This page is used during initial installation to configure the display and the panel brightness for the lighting bus maximum voltage. There are three selections:

- Panel Front panel brightness
- Display Display brightness
- Combined One lighting bus, controls both display and panel brightness.

For the combined bus, when the voltage on the lighting bus drops below 1/64 of maximum voltage, the display will go to full brightness.

At installation, the KCU 1051 must be configured for the aircraft lighting bus maximum voltage. This is done by selecting this page, setting the lighting buss for full brightness and pressing the ENT key.

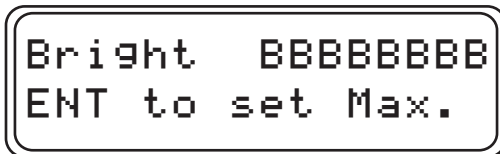

Figure 3-43 Brightness Setting

- BBBBBBBB * bus Bus to initialize Panel, Display, Combined
- line 2 instructions Operator instructions press ENT to set maximum level.

* Cursorable field

PROGRAM CHANNEL

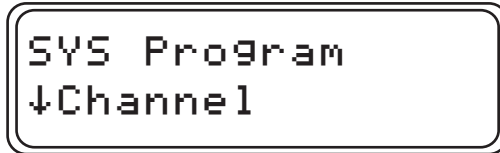

Figure 3-44 Sys Program Channel

The system program page (Figure 3-44) provides access to the ALE channel pages. When 'Channel' is selected on the system program page, pressing the ENT key will provide access to the ALE channel sub-pages. The sub-pages return to this page when the CLR key is pushed to exit the page. There are four sub-pages below this selection:

- ALE-Channel ALE channel data, frequency and modulation.
- ChGrp Channel groupings.
- Scan-List Select the channel group to be used as the scan list.
- Tune-All Tune all untuned ALE channels.
- Clear Tune Clear all ALE chan tunes

The operator moves between these sub-pages by placing the operator on the sub-page field and turning the VAR knob to select another sub-page.

ALE CHANNEL DATA

The ALE Channel Page is a Program Channel Sub-Page. The receive and transmit frequencies and modulation type for ALE channels can be changed on this page. The channel type field (R&T, Rx, Tx, RO, TO) allows simplex, semi-duplex, receive only or transmit only, channels to be entered. There is no transmit frequency entry for a receive only channel, and no receive frequency entry for a transmit only channel.



Figure 3-45 ALE Channel Data

CHANNEL GROUPS (ChGrp)

The Channel Group Page is a Program Channel Sub-Page. This page is used to enter or examine the channel groups (Figure 3-46). A channel group is simply a list of channels. A channel group can be used as a scan list or for restricting addresses to specific channels. There are a total of 23 channel groups available, designated 1 through 23. There is no restriction on how many or which channels may be placed in each channel group.

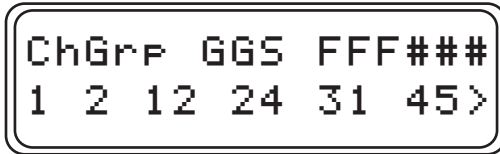

Figure 3-46 Chgrp (Channel Groups)

GG	*Channel group number	1..23
S	Scan list indicator	"S" if scan list, blank otherwise
FFF	* Function	Add or Del
###	* Channel number	1..100
line2	* Channels in channel group	List of channels in this group

*Cursorable fields

To modify the channel group, select either 'Add' (add channels to the group) or 'Del' (delete channels from the group). With the cursor positioned on the channel number, use the variable knob to select the channel to add or delete, then press the ENT key. The channel will be added to or deleted from the channel group and the list of channels on the second line will be shifted so that the new channel appears on the screen. The '<' and '>' signs indicate that the list extends off of the screen. Move the cursor to the second line to review the list. To review the entire list, put the cursor in character mode by pressing the VAR knob and use the CRSR knob to scroll through the list.

The S indicates that the channel group is being used as the current receive scan list.

SCAN-LIST (Scan-List)

The Scan-List Page is a Program Channel Sub-Page. This page is used to select the channel group used for the receive scan list. The S indicates the current scan list. To select a new scan list, change the channel group number and press the ENT key.



Figure 3-47 Scan List

TUNE ALL UNTUNED CHANNELS (Tune-All)

The Tune-All Page is a Program Channel Sub-Page. This page is used to tune all stored ALE channels that are not tuned (Figure 3-48). This operation is most useful after a new ALE database has been entered or downloaded. The cursor must be moved to the YES/NO field, YES selected with the VAR knob and then the ENT key is pressed. The radio will then perform a tune on all ALE channels that are stored but not tuned. The "Caution HF xmit" message will be displayed on the second line to indicate that activation of this mode will cause the HF to transmit.

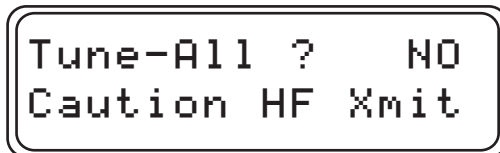

Figure 3-48 Tune All Untuned Channels

Need Tune Completed

After the tuning starts a tuning in progress page (Figure 3-49) will be displayed. While the channels are being tuned the radio will prevent over heating by limiting the duty cycle. The radio will pause between tunes with the length of the pause based on the tune time of the previous channel. The tune in progress page, shown below, will indicate the number of channels that require tuning and the number of channels that have been tuned. Pressing the CLR key will abort this function, between tunes. When all tunes have been completed "Finished" will be displayed.

```
Need Tune ###  
Completed ###
```

Figure 3-49 Need Tune Completed

CLEAR TUNES FROM ALL TUNED CHANNELS (Clear Tunes)

The Clear Tunes Page is a Program Channel Sub-Page. This page is used to mark all stored ALE and Manual channels as untuned. This operation is most useful after a new CDU or Antenna Coupler (KAC 952 or KAC 992) has been added to the system. Since the tunes are stored in the CDU and are valid only for the coupler on which the tunes were performed, if either box changes all channels should be retuned. To clear the tunes (mark all channels as untuned), the cursor must be moved to the YES/NO field, YES selected with the VAR knob and then the ENT key pressed. The radio then sets all Manual and ALE channels that are stored to the not tuned state.

```
Clear Tunes ? NO  
Set all untuned
```

Figure 3-50 Clear Tunes

Marking Untuned

After the ENT key is pressed the marking untuned page (Figure 3-51) is displayed. When all stored channels have been marked untuned, "Finished" is displayed on the second line. "CLR" flashes to indicate that the operator should press the CLR key to exit this page.

```
Marking untuned  
Finished CLR
```

Figure 3-51 Marking Untuned

PROGRAM ADDRESS

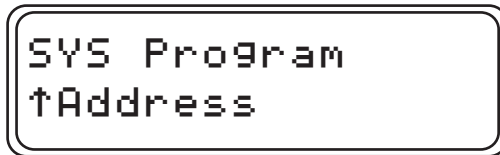

Figure 3-52 SYS Program Address

The system program page provides access to the ALE address page. When 'Address' is selected on the system program page, pressing the ENT key provides access to the ALE address entry page. The sub-page returns to this page when the CLR key is pushed to exit the page. There is only one sub page.

ALE ADDRESS ENTRY PAGE

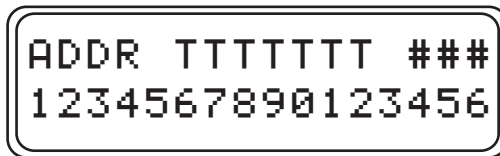

Figure 3-53 ALE Address Entry Page

ADDR ALE address sub page label

TTTTTTTT * Address type SELF, SINGLE, StarNET, GROUP

line 2 * address or parameter

* Cursorable fields

The self address is listed first because an associated self is required for the other address types. There are several parameters that must be entered for each address, such as channel group and the associated self. The number of parameters depends on the address type. After the operator makes an entry and pushes ENT or moves the cursor, the next parameter to be changed is displayed. The address type field requires special handling to prevent accidental changes of address types. Changes to the address type are accepted only if the ENT key is pushed. If the address type is changed and the cursor is moved off of the address type field, the address type will revert back to the original type.

Operation

The address types :

- SELF Address this radio will respond to.
- SINGLE Address for a single ALE station.
- StarNET Star network of addresses that must be programmed into all stations prior to using it.
- GROUP Group of addresses put together after the database is entered.

The self addresses are kept in a separate area of the database from all of the other address types. Because of this changing to or from the self address type causes the address displayed on the second line to change. When the address type is changed from self to any of the other types, the address changes to the first address in the other address area of the selected type. If no address of the specified type is found then the first empty address slot is displayed. Similarly if the address type is changed from any other address type to the self type, the address changes to the first self address in the database.

Changing the address type between SINGLE, StarNET and GROUP does not cause a change to the displayed address. As these types are selected the address displayed is temporarily changed to the selected type. This change is temporary until the ENT key is pushed.

The number and type of parameters varies between the four address types. The section below describes the parameters and the format of the second line for each address type.

All parameters that can appear on the second line are identified and explained here.

- address ALE address

An ALE address can contain up to 15 characters. The address can be thought of as the call sign for an ALE capable radio.

- **ChanGroup**: Channel group

A channel group is a list of ALE channels. The channel group designates which channels an ALE address is valid on. The channel group value can also be set to "ALL" which means that the address is valid on all channels. Normally self addresses are set to ALL. Other address types will have a designated channel group.

- **Slot Time:** Self slot time for responding to network calls.

The slot time is the amount of delay, in TWs.(130.67 msec.), before the radio responds with its self address, when responding to a network call.

- **Self ID:** Self address associated with an address.

This is the self address to use when placing a call.

- **Resp Time:** Response time.

This is the amount of time, in TWs (130.67 msec.), to wait for a reply when placing a call.

- **Slot ##** Network or Group member slots.

There are two parameters on this line, the slot number and the address. The member slots identify which addresses are members of a network or group. There are two special identifiers that appear in the address field, "self-add" and "end-list". The "self-add" identifier means that the self address is in this slot. The "end-list" identifier marks the end of the member list

This section identifies which parameters are used for each address type.

Self

address

ChanGroup:

Slot Time:

Single

address

ChanGroup:

Self ID:

Resp Time:

StarNet

address

ChanGroup:

Self ID:

Resp Time:

Slot##

Group

address

ChanGroup:
Self ID:
Resp Time:
Slot##

SINGLE ADDRESS ENTRY

The pages below show the entry of a SINGLE type of ALE address.

The address is entered on the second line (Figure 3-54) using the CRSR and VAR knob while the cursor is in the character cursor mode.



A rectangular display with a double border showing two lines of text. The first line is "ADDR SINGLE 100". The second line is "↓ALE15CHARADDRESS", with a downward-pointing arrowhead at the beginning.

Figure 3-54 Single Type Of ALE Address

After entering an address and pushing ENT or moving the cursor, the next field displayed is the channel group that this address is active on (Figure 3-55). ALL indicates that this address can be used on all channels. If the selected channel group is also the scan list, than an S will appear after the channel group number



A rectangular display with a double border showing two lines of text. The first line is "ADDR SINGLE 100". The second line is "ⓄChanGroup: 235", with a circled 'O' symbol at the beginning.

Figure 3-55 Channel Group Active On

Self Address

The next field displayed is the self address (Figure 3-56) to use when calling this address. The self address field is both field and character cursorable. The field mode is used to select different self addresses, the character mode allows review of self addresses that are longer than the display field. Since there are multiple parameters associated with a self it must be entered under the SELF selection and cannot be modified here.

```

ADDR SINGLE 100
$Self ID:1ST7CH>

```

Figure 3-56 Self Address Longer Than Display Field

Response Time

The next field is the response time. This is the amount of time in TWs that the unit will wait for a response, before going on the next channel. Default time of 30TW is adequate for most radios.

```

ADDR SINGLE 100
†Resp Time: XXTW

```

Figure 3-57 Response Time

SPECIAL ADDRESS TYPES

There are three additional address types called “allcall”, “anycall”, and “wildcard”. These types are programmable under the SINGLE type. These call types require some ALE expertise for proper utilization.

- | | |
|-----------|---|
| All Call | Allows a message or call to be broadcast to multiple stations without requiring a response from them. |
| Any Call | Allows a call to multiple stations without having to know their entire address. |
| Wild Card | Used to call multiple stations. The called stations will accept the wild card character as a match for the character in it's address that occupies that same position in the address. |

Operation

The following shows the generic address for the special address types ALLCALL, ANYCALL and WILDCARD. In these types of calls the “?” character can be replaced with any character to create a more specific type of call.

Generic	AllCall	@?@
Generic	AllCall	@@?
Wildcard		???

MESSAGE PAGE

When there is a message for the operator to review a flashing M will be displayed on the display and the Remote Lamp discrete will be set. When the MSG key is pressed the flashing M is removed, the Remote Lamp discrete is reset and the message page is displayed. System, and ALE AMD messages can be reviewed on this page. The Operation / Mode field is cursorable on this page to allow exiting of this page. Pressing the CLR or MSG key also exits this page and returns to the last page displayed.

The arrow on line two indicates that there are more messages to review. Once the message is reviewed the message flag on the idle pages is removed. System messages are cleared once they are read. The order in which the message types are displayed is System, ALE_RX , SoundFrom. If there are no new messages then the received ALE messages are displayed to allow past messages to be reviewed.

System messages are mainly faults; for example Figure 3-58 shows an over temperature fault.

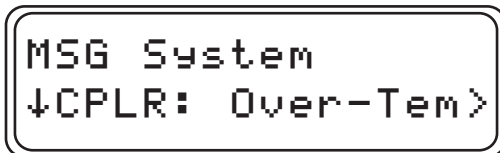

Figure 3-58 OVER TEMPERATURE FAULT

Received ALE messages are available for review under the ALE_RX selection (Figure 3-59). They are shown in order from the newest to the oldest message. The messages can be reviewed by turning the VAR knob with the cursor on the index or the message field.



MSG ALE_RX 01
BEGINNING OF ME>

Figure 3-59 MSG ALE_RX

The SoundFrom selection will display the ALE addresses heard since the last time that sounds were reviewed. The address is removed from this list once it has been reviewed (Figure 3-60).



MSG SoundFrom
↓ ADDRESSSESHEARD

Figure 3-60 SoundFrom

KCU 1051 OPERATIONS SUMMARY

The basic operations for the KDC 1051 are HF SETUP, RECEIVE ALE CALL, ANSWER ALE CALL, PLACE ALE CALL, PERFORM LINK QUALITY ANALYSIS (LQA), SEND DIGITAL MESSAGE (ALE AMD MESSAGE), REVIEW DIGITAL MESSAGE RECEIVED (ALE AMD MESSAGES), and MAN HF operation.

Refer to Figure 3-61 for locations of display segments and front panel controls

1. **HF SETUP.** Push ON/VOL knob to on (in). Set Inter Communications System (ICS) mic selector to HF comm position. Put on ICS HF headset or turn speaker on. Set Cursor over Operations (Ops). field (Figure 3-61) with CRSR knob. Select MAN with VAR knob. Set SQL off. Adjust HF VOL and ICS to a comfortable level.

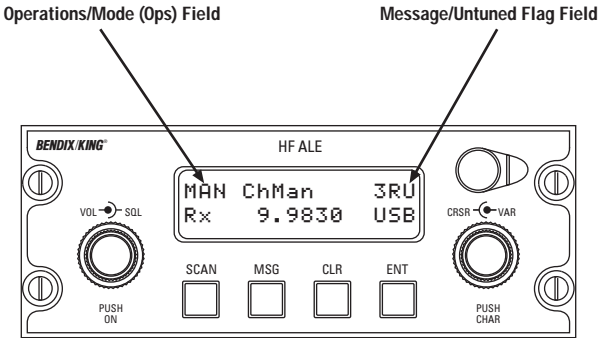

Figure 3-61 KCU 1051 Manual Channel Mode

2. **RECEIVE ALE CALL.** Set Cursor over Ops. field with CRSR knob. Select ALE with VAR knob. Place unit in SCAN with SCAN key if not already scanning. HF is now ready to receive or place ALE calls.

3. **ANSWER ALE CALL.** Wait for Link alert tones to be heard. Display annunciates ALE Linked and address of called radio (Figure 3-62). Begin normal HF communication. When finished, push SCAN key to hang-up.

4. **PLACE ALE CALL.** Set Cursor over address field with CRSR knob. Select address with VAR knob. Momentarily key mic. Wait for linked indication. (Figure 3-62) Begin normal HF communication. When finished, push SCAN key to hang-up.

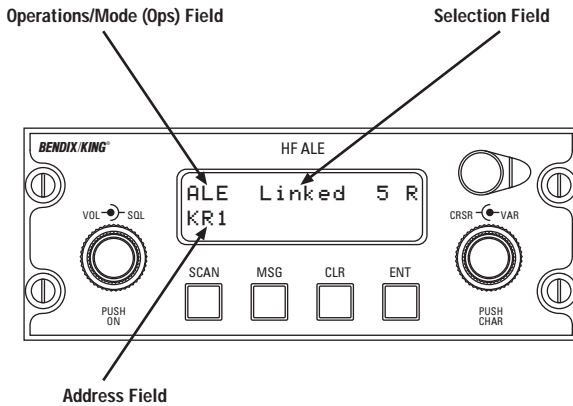

Figure 3-62 Display Annunciating ALE Linked And Address Of Caller

5. **PERFORM LINK QUALITY ANALYSIS (LQA).** Set Cursor over Ops. field (Figure 3-62) with CRSR knob. Select SEND with VAR knob. Select LQA by placing cursor over Selection field with CRSR knob. Select LQA operation with VAR knob. Set Cursor over address field with CRSR knob. Select address with VAR knob. Push ENT key. LQA is performed on all associated channels. HF automatically returns to ALE mode.

6. **SEND DIGITAL MESSAGE (ALE AMD MESSAGE).** Set cursor over address field (Figure 3-62) with CRSR knob. Select address with VAR knob. Set cursor over Ops. field with CRSR knob. Select SEND with VAR knob. Set cursor over Selection field with CRSR knob. Select Message operation with VAR knob. Set cursor over message index or the message on the second line with CRSR knob, and use the VAR knob to select or change the message. Push ENT key. HF sends message and links to selected address.

7. **REVIEW DIGITAL MESSAGES RECEIVED (ALE AMD MESSAGES).** Message scrolls across second line as it is received. To review previous messages; Press MSG key. Select ALE_Rx message type with VAR Knob. Set Cursor over message index or the message on the second line with CRSR knob. Use the VAR knob to review messages. Press VAR knob to view long messages. Push MSG key to return to previous page.

8. **MANUAL HF OPERATION.**

Set Cursor over Ops. field with CRSR knob, select MAN with VAR knob. Select frequency by one of two methods:

Operation

For prestored channels

Set Cursor over channel number with CRSR knob. Select channel with VAR knob.

For new frequency

Set Cursor over frequency with CRSR knob. Push VAR knob (push CHAR), then use the VAR and CRSR knobs to change the frequency. Push ENT when finished.

Begin normal HF communication.

KCU 951 CONTROL DISPLAY UNIT OPERATION

KCU 951 CONTROLS

The controls on the KCU 951 are: OFF/VOLUME knob, SQUELCH knob, CLARIFIER knob, MODE button, FREQ/CHAN button, PGM (program) switch, STO (store) switch and concentric Frequency/Channel control knobs.

OFF/VOLUME

This knob turns the system off and on and controls volume. Clockwise rotation past the first click turns the system on. Further rotation increases audio level. Good operating practice suggests that the system shouldn't be turned on until after starting the engines. It takes about two minutes for the KHF 950/990 to warm up. Until then, no frequencies is displayed.

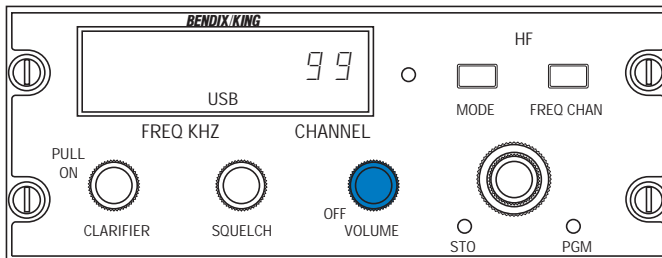

Figure 3-63 Off/Volume

When the KHF 950/990 is first turned on with the KCU 951, and has warmed up the system “wakes up” and display the last frequency transmitted if the FREQ/CHAN button is “out” (direct tuning). If the FREQ/CHAN button is “in” (channelized operation), the system “wakes up” displaying the channel number last used. In either case, all preset channels are stored in nonvolatile memory and can be recalled after the system is turned on.

SQUELCH/OPTIONAL SELCAL

Squelch is set by rotating the knob clockwise until background noise can be heard and then turning it counterclockwise until background noise is eliminated or barely audible.

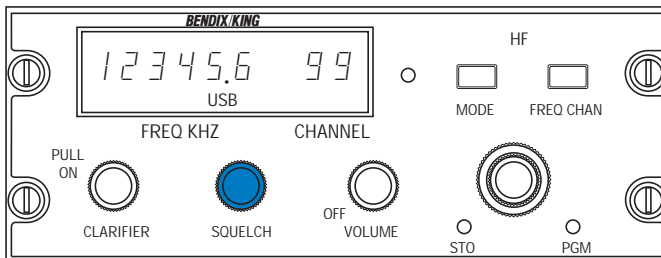

Figure 3-64 Squelch/Optional SELCAL

CAUTION: It is important to know that squelch operation in HF is not as predictable as in conventional VHF. Whereas a VHF receiver normally operates with a non-fading strong signal, an HF receiver many times must operate with a signal subject to considerable fading and which is only marginally strong. **Therefore, it is not unusual for conditions to make it necessary to leave the squelch knob fully clockwise to maintain satisfactory reception.** For this reason, SELCAL (Selective Calling) may be a desirable option to relieve fatigue from background noise on extended flights. SELCAL allows the flight crew to turn the volume level down to eliminate the noise yet still maintain a “SELCAL watch”. When there is a need to contact the aircraft, a discrete coded audio signal is sent which is decoded by a SELCAL decoder on board the aircraft (not furnished as part of the KHF 950 system). The SELCAL decoder then allows a visual signal or aural tone to notify the flight crew of the call. SELCAL is not available for use on the 245 ITU maritime radiotelephone channels.

CAUTION: Only those KHF 950 systems which have the KTR 953-01 Receiver/Exciter (KPN 064-1015-01 are designed to be compatible with the standard SELCAL decoders (not furnished) to obtain SELCAL operation. Due to technical incompatibilities, the single side-

Operation

band suppressed carrier mode of emission is not used to transmit SELCAL signals, therefore ARINC HF ground station transmitters switch to the AM mode when transmitting SELCAL signals. The KTR 953-01 is designed to detect SELCAL signals transmitted in the AM mode even though the mode selector is in a single sideband mode.

CLARIFIER

The CLARIFIER knob is unique to SSB communications and is not used when operating in the AM mode. Because of off frequency ground station transmissions, the audio voice quality from the KHF 950/990 may sound unnatural. The CLARIFIER can help eliminate this unnatural audio quality by slightly shifting the KHF 950/990 receiver generated frequency to match the frequency of the ground station signal.

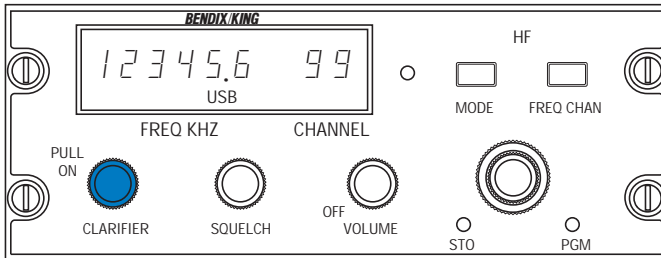

Figure 3-65 Clarifier

To operate the CLARIFIER, pull the knob out and rotate the knob in either direction until the audio quality is optimized. When the knob is pushed in, the CLARIFIER has no effect. When voice quality is good and natural the CLARIFIER knob should remain pushed in.

MODE BUTTON

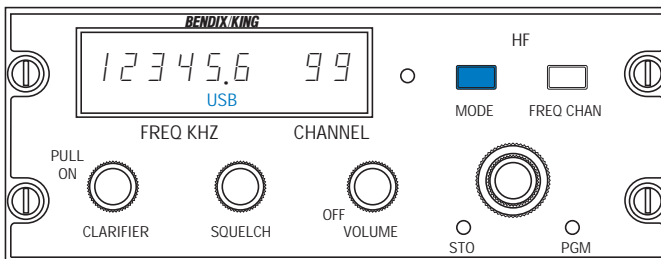

Figure 3-66 Mode Button

The MODE button is used to select transmission and reception mode. Momentary depression of the MODE button cycles the KHF 950/990 from upper sideband (USB) to lower sideband (LSB) to AM. The single sideband reduced carrier (A3A) mode of operation is normally disabled at time of installation. However, if it has been enabled, this mode is annunciated with both “AM” and “USB” simultaneously displayed.

When you store frequencies in channels for channelized operation, you also store the mode by pressing the MODE button until the desired mode is indicated. In preset channel operation the original mode stored with the channel frequency is engaged whenever that channel is first selected. The mode may be changed at any time (the stored mode is not changed, however).

It is vital that you select the same operational mode on the KHF 950/990 that the ground station you wish to contact is using. Most all aircraft HF SSB communications are conducted in the USB Mode. Some ground stations continue to use the AM mode, but those stations are being phased out in favor of the more efficient SSB mode of operation.

FREQ/CHAN BUTTON

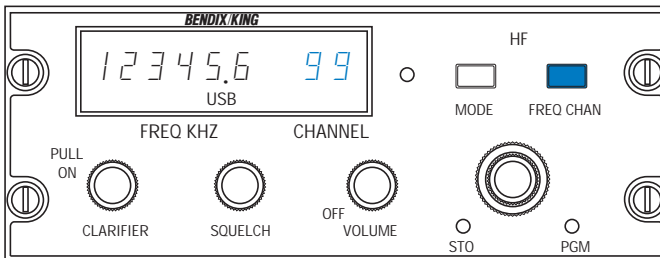

Figure 3-67 FREQ/CHAN Button

The KCU 951 has two methods of frequency selection. First, the pilot may direct tune (FREQ/CHAN button “out”) the system to any of 280,000 available frequencies. Direct tuning is for simplex operation only. Using the second method, channelized operation, (FREQ/CHAN button “in”), the pilot presets the transmit and receive frequencies in up to 99 available channels. These frequencies are electronically stored and are instantly available by their pilot-assigned channel numbers. These preset channels may be used for simplex, semi-duplex, or receive only. Frequencies may be entered in these

Operation

preset channels by the pilot at any time, on the ground or in flight, to increase the convenience of frequency selection when HF use is required.

NOTE: The use of the concentric frequency/channel control knobs, the PGM (Program) switch, and the STO (Store) switch are explained in the following sections.

DIRECT TUNING A FREQUENCY

In direct tune operation, the pilot may select directly any of 280,000 frequencies in the range of 2.0 to 29.9999 MHz. The frequencies progress in 100 Hz steps. Follow these four steps for direct tuning.

1. **Access direct tune operation.** Make sure the **FREQ/CHAN** button is “out”, in the **FREQ** position. Confirm this by seeing that no channel number is annunciated in the frequency display. If the button is “in”, a momentary press unlatches it and engages **FREQ** (direct tune) operation.

2. **Select the desired transmission mode:** **USB**, **LSB** or **AM**, by pressing the mode button.

3. **Enter the frequency.** Because the frequency selected may be made up of as many as six different numbers and 280,000 frequency combinations are possible, each digit in a frequency is selected individually. The large concentric knob on the lower right of the control unit may be rotated in either direction and causes one of the displayed frequency digits to flash. This flashing “cursor” indicates which frequency digit will be changed by twisting the smaller concentric knob. Twist the larger knob until the digit you wish to change flashes and then select the desired number into view by twisting the smaller knob. Only the flashing digit will change, and there is no need to dial up or down to reach a new frequency—simply enter each individual digit.

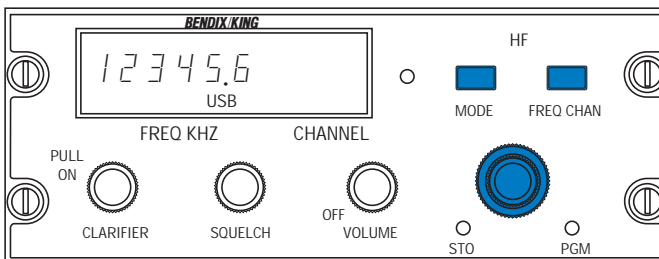

Figure 3-68 Direct Tuning A Frequency

NOTE: Although normally disabled, the KCU 951 also has the capability of being internally enabled by aircraft wiring so that dial-like “borrow/carry” tuning will occur. For example, when so enabled, if two existing frequency digits are 89 with the “cursor” on the 9, a further clockwise rotation of the knob will change the digits to 90 rather than to 80, as is normally accomplished. This feature is desirable if the system is to be used for “search” or “continuous” tuning (100 Hz or greater steps, e.g. amateur radio operation). Working from right to left or left to right, position the flashing “cursor” on each digit with the larger knob and select the new number with the inner smaller knob. Once all digits are changed, twist the larger knob one more click right or left, as appropriate, and the “cursor” will disappear (stow). To recall the flashing “cursor” simply twist the larger knob in either direction until the flashing “cursor” is positioned on the digit to be changed.

4. Tune the antenna coupler: Press the mic button momentarily to initiate antenna tuning. During the tuning process the TX annunciation will flash and the frequency numbers will blank. When the TX stops flashing and the frequency reappears, the antenna tuning cycle is complete and you are ready to transmit on the selected frequency. Direct tuning always provides simplex operation—you transmit and receive on the same frequency.

NOTE: Always key the mic button after selecting a new frequency to initiate antenna tuning. Otherwise you may experience poor reception or miss an important call.

CHANNEL OPERATION AND PROGRAMMING 1

The 99 pilot programmable channels available with the KCU 951 Control Display Unit can be easily programmed by the pilot on the ground or in the air. Each of the 99 channels can be assigned a separate frequency or frequencies (semi-duplex operation) and an operating mode (USB, LSB or AM). This information is stored in non-volatile memory and can then be recalled by the pilot using the selected channel number. Three types of channels can be programmed.

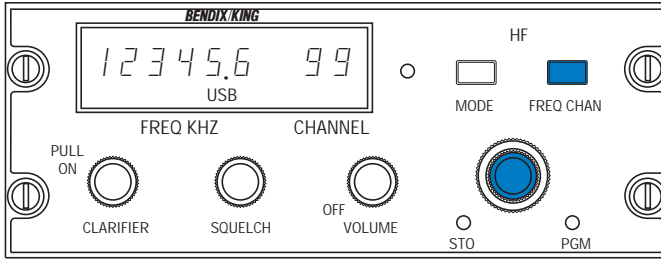

Figure 3-69 Channel Operation And Programming 1

CHANNEL OPERATION AND PROGRAMMING 2

If channel programming is required, it is necessary to activate the program mode once you are in channelized operation. Use a pencil or similar pointed object to push the PGM (program) switch “in”. (This switch is located on the lower right of the KCU 951 Control Display Unit.) The letters “PGM” will appear in the lower part of the display window and the KHF 950/990 will remain in the program mode until the PGM switch is pressed again. (The switch is an alternate-action type: push on, push off.) It is recessed to prevent accidental activation of the program mode.

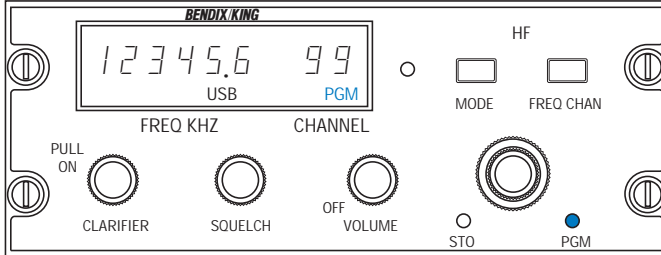

Figure 3-70 Channel Operation And Programming 2

Now you are ready to program. The procedures are only slightly different, depending on the type of channel you are programming.

1. **Semi-duplex.** The pilot programs two different frequencies, one for receive and one for transmit. He also assigns an operating mode (USB, LSB or AM). Semi-duplex is used by maritime radiotelephone network (public correspondence) stations.
2. **Simplex.** The pilot programs the same frequency in receive and transmit, and assigns an operating mode (USB, LSB or AM). (Used by Air Traffic Control, ARINC and others.)

3. **Receive only.** The pilot programs a frequency in receive, but leaves the transmit portion of the preset channel blank. The transmitter is locked out and can't be used when a channel has been programmed for receive only operation. The pilot also assigns an operating mode (USB, LSB or AM). (Used to listen to weather, time, Omega status, frequency standard and geophysical alert broadcasts.)

To gain access to channelized operation of the KHF 950/990, make sure the **FREQ/CHAN** button is "in". If it is not "in", a momentary push will latch in and engage **CHAN** (channelized) operation.

To utilize the existing programmed channels (i.e. no programming is required) simply use the smaller inner concentric Frequency/Channel control knob to select the desired channel number. Then momentarily key the mic to tune the antenna coupler.

If channel programming is required, it is necessary to activate the program mode once you are in channelized operation. Use a pencil or similar pointed object to push the **PGM** (program) switch "in". (This switch is located on the lower right of the **KCU 951 Control Display Unit**.) The letters "PGM" will appear in the lower part of the display window and the **KHF 950/990** will remain in the program mode until the **PGM** switch is pressed again. (The switch is an alternate-action type: push on, push off.) It is recessed to prevent accidental activation of the program mode.

Now you are ready to program. The procedures are only slightly different, depending on the type of channel you are programming.

RECEIVE-ONLY CHANNEL PROGRAMMING

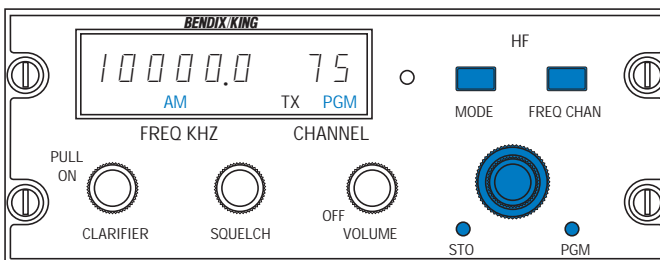

Figure 3-71 Receive Only Channel Programming

With the **FREQ/CHAN** button "in" and **PGM** switch pushed so **PGM** shows in the display window:

Operation

1. Stow the “cursor” if a frequency digit is flashing. The cursor is stowed by twisting the larger concentric knob until no frequency digit is flashing. With the cursor stowed in the program mode, the smaller inner knob is now used to select a channel number to be programmed.
2. Use the smaller inner concentric knob to select the channel number you wish to program. Simply twist the smaller knob until the desired channel number appears on the right side of the display.
3. Select the desired operating mode (USB, LSB or AM) by pushing the MODE button until the appropriate mode appears in the lower part of the display window beneath the frequency.
4. Set the desired frequency by moving the “cursor” into position by means of the larger knob and then using the smaller concentric knob to set the desired number under each “cursor” position. This procedure is identical to direct tuning frequency selection discussed previously.
5. Push the STO (store) switch located just below and to the left of the concentric control knobs with a pencil or similar pointed object. The STO switch stores the information you have just entered into the electronic memory. After you push the STO button, the TX annunciation will flash indicating that the frequency you have just entered is stored in the receive position but nothing is entered in transmit. Since a receive-only frequency is being set, ignore the flashing TX.

Because you are in the program mode, you can move on to other channels and program them by using the smaller inner concentric knob to call up another channel number. After programming a receive-only channel, the “cursor” must be manually stowed before a new channel number can be selected.

6. When you have completed all channel programming, simply push the PGM switch again and the information you have stored is locked into CHANNEL memory.

When a RECEIVE-ONLY programmed channel is activated, the transmitter is locked out and even though you key the mic, no transmission will take place.

SIMPLEX CHANNEL PROGRAMMING

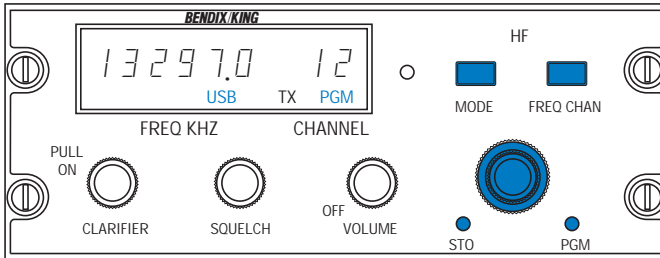

Figure 3-72 Simplex Channel Programming

When you program a simplex frequency in a channel, both the receiver and transmitter will be tuned to the same frequency. Programming a simplex channel is identical to receive-only programming, except the STO switch is pressed twice after a frequency is entered to store the frequency in both receive and transmit positions.

Again, start with the FREQ/CHAN button pressed “in,” the “cursor” stowed, and the PGM switch pressed with a pencil or pointed object and the PGM annunciation showing in the display window.

1. Use the smaller inner concentric knob to select the channel number to be programmed.
2. Set the desired emission mode (USB, LSB or AM) by pressing the MODE button until the desired mode cycles into view on the display.
3. Using the larger knob to position the “cursor” and the smaller inner knob to select the appropriate number, complete the desired frequency entry.
4. Push the STO switch twice. The first press stores the frequency in the receive position and the second press stores the same frequency in the transmit position for simplex operation.

Another channel may be selected for programming at this time by rotating the smaller inner knob. The “cursor” does not have to be manually stowed before selecting a new channel to be programmed, as in receive-only. The “cursor” is automatically stowed when the STO switch is pushed the second time.

5. When all programming is complete, use a pointed object to press the PGM button and remove the system from the program mode.
6. Press the mic key to tune the antenna. After tuning is complete you are ready to transmit.

SEMI-DUPLEX CHANNEL PROGRAMMING

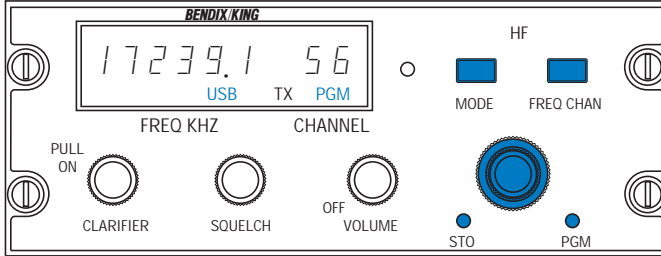

Figure 3-73 Semi-Duplex Channel Programming

Semi-duplex operation uses one frequency for receiving and another for transmitting. The KCU 951 has semi-duplex capability **only** in channelized operation.

Programming semi-duplex channels is much like programming simplex or receive-only channels, except for the final step when frequencies are stored.

Again, begin programming by pressing the **FREQ/CHAN** button “in”, stowing the “cursor” if necessary, and activating the program mode by pressing the **PGM** switch with a pointed object. The **PGM** annunciation will appear in the display.

1. Use the smaller inner concentric knob to select the channel number to be programmed.
2. Use the **MODE** button to select emission mode (**USB**, **LSB** or **AM**). Press the **MODE** button until the desired mode appears.
3. Use the outer larger concentric knob to position the flashing “cursor” on each digit of the **receive** frequency and use the smaller inner knob to select the desired number in each position. Remember, set the receive frequency first.
4. Push the **STO** button once and the receive frequency is entered in electronic memory. The **TX** annunciation will begin to flash in the display window indicating the receive frequency is stored and you are ready to program the transmit frequency. Refer to Figure 3-73.
5. Using the larger knob to control the “cursor” and the inner knob to select the appropriate numbers, set the transmit frequency in the display window.

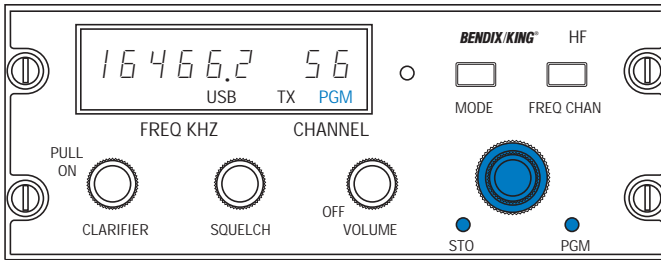

Figure 3-74 Semi-Duplex Channel Programming

6. Press the STO switch again and the transmit frequency is now stored. These steps can be repeated to program other channels at this time, or you can exit the program mode by pressing the PGM switch with a pointed object.

7. Press the mic key to tune the antenna. After tuning is complete you are ready to transmit. Refer to Figure 3-74.

In semi-duplex operation the emission mode you select (USB, LSB or AM) will always control both receive and transmit frequencies. Also, the receive frequency is displayed until the mic is keyed, at which time the transmit frequency is displayed.

KFS 594 CONTROL DISPLAY UNIT OPERATION

KFS 594 CONTROLS

The controls on the KFS 594 are: OFF/VOLUME knob, SQUELCH knob, MODE selector knob, Frequency/Channel control knob and STO (store) switch. The KFS 594 has no knobs or switches dedicated to the clarifier or program functions, but these functions are incorporated in the KFS 594 controls, as will be explained.

OFF/VOLUME

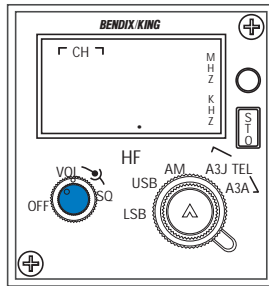

Figure 3-75 OFF/Volume

This smaller inner concentric knob (lower left) turns the system off and on and controls volume. Clockwise rotation past the first click turns the system on. Further rotation increases audio level. Good operating practice suggests that the system shouldn't be turned on while starting the engines. It takes about two minutes for the KHF 950/990 to warm up. Until then, no frequencies or channel numbers will be displayed.

When the KHF 950/990 is first turned on with the KFS 594 and has warmed up, the system will "wake up" and display the last frequency or channel used if the MODE selector knob is in the USB, LSB or AM position. If the MODE selector knob is in the A3J or A3A mode, the last maritime radiotelephone (public correspondence) station channel used will be displayed.

In either case, 19 programmable preset channels and all 245 ITU maritime radiotelephone network channels are stored in a nonvolatile memory and can be recalled after the system is turned on.

SQUELCH/OPTIONAL SELCAL

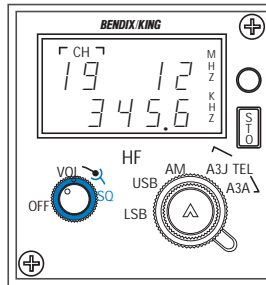

Figure 3-76 Squelch/Optional SELCAL

Squelch is set by rotating the larger outer concentric knob (lower left) clockwise until background noise can be heard and then turning it counterclockwise until background noise is eliminated or just barely audible.

CAUTION: It is important to know that squelch operation in HF is not as predictable as in conventional VHF communications. **It is not unusual for conditions to make it necessary to leave the squelch knob fully clockwise to maintain satisfactory reception.** Otherwise the signal may fade below the threshold you have set on the squelch, and you may miss an important message from a ground station. This is unlike VHF receiver squelch where you are normally dealing with a strong, non-fading signal. For this reason SELCAL or ALE may be a desirable option.

MODE SELECTION

USB MODE A3J MODE

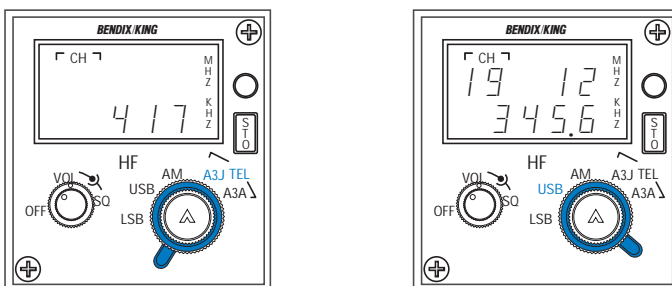

Figure 3-77 Mode Selection

Operation

The KFS 594 MODE selector is the larger outer concentric knob (lower right) which provides access to the USB, LSB and AM modes for either simplex or semi-duplex operation. In addition it has positions marked "A3J" and "A3A" for the two formats of maritime radiotelephone network (public correspondence) station channels. Most of these stations operate in the A3J format. In the A3J and A3A positions the pilot can access all 245 ITU public correspondence station channels which are permanently stored in nonvolatile memory. These channels are assigned numbers such as 417, 822, 1230, 1624 and 2236. (See list of International Channel Designations) Each channel number corresponds to an assigned transmit and receive frequency for semi-duplex operation in USB. For example, when calling station KMI, Point Reyes, California using ITU channel 417, the pilot is receiving on 4407.0 kHz and transmitting on 4112.6 kHz. The transmit and receive frequencies are stored in memory, but it is only the station channel 417 which will appear in the KFS 594 display when you select that channel.

It is possible to operate in USB, LSB and AM modes using either a direct tune operation, or a programmable channel operation in which 19 channels can be programmed by the pilot and stored for recall. While direct tuning a frequency, only simplex operation may be used. However, when utilizing the 19 programmable channels, either simplex or semi-duplex operation may be used. The use of the Frequency/Channel control knob and STO (store) switch are explained in the following sections.

DIRECT TUNING A FREQUENCY

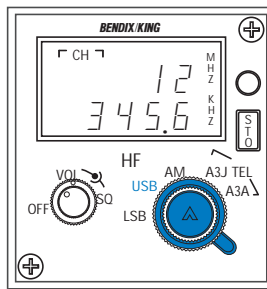

Figure 3-78 Direct Tuning A Frequency

In direct tune operation, the pilot may select directly any of 280,000 frequencies in the range of 2.0 to 29.9999 Mhz. The frequencies progress in 100 Hz intervals. Follow these three steps:

1. **Access direct tune operation.** Set the mode selector to the desired mode (USB, LSB or AM) and check to see that the display is showing a flashing zero in the channel position (upper left) or is blank in that position. If a channel number other than zero is displayed, it will be necessary to move the “cursor” by depressing the Frequency/Channel control knob (lower right). A digit on the display will begin to flash. This flashing “cursor” indicates which digit in the display will be changed by twisting the Frequency/Channel control knob. Each additional time you depress the knob the “cursor” will move one digit. Move the “cursor” until it is on the channel number. Now, rotate the Frequency/Channel control knob until the channel number is set to zero. You are now in direct tune operation.

2. **Change the frequency.** Press the Frequency/Channel control knob to cycle the “cursor” until the first digit in the frequency you wish to change is flashing. (You will notice that the channel number has changed from “0” to blank.) Now rotate this knob until you have selected the desired number. Using the Frequency/Channel control knob in this same manner, change all the digits necessary to display the desired frequency.

NOTE: The first one or two digits (MHz) of the frequency are displayed in the upper right of the display while the last four digits (kHz) of the frequency are displayed at the bottom of the display.

To stow the “cursor”, depress the Frequency/Channel control knob repeatedly until no digit on the display is left flashing, or key the mic momentarily, see Step 3. (Direct tuning always provides simplex operation—you transmit and receive on the same frequency.)

3. **Tune the antenna coupler.** Press the mic button momentarily to initiate antenna tuning. During the tuning process the TX annunciation will flash and the frequency numbers will blank. When the TX stops flashing and the frequency reappears, the antenna tuning cycle is complete and you are ready to transmit on the selected frequency.

NOTE: Always press the mic button after selecting a new frequency to initiate antenna tuning. Otherwise you may experience poor reception or fail to hear a ground station which is calling you.

CHANNEL OPERATION AND PROGRAMMING

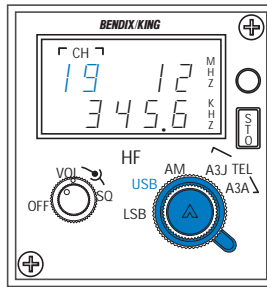

Figure 3-79 Channel Operation And Programming

The 19 pilot programmable channels available with the KFS 594 Control Display Unit can be easily programmed by the pilot on the ground or in the air. Each of the 19 channels can be assigned a separate frequency or frequencies (semi-duplex operation). The operating mode (USB, LSB or AM) of the stored channel is determined by the position of the MODE selector knob at the time the pilot is using the channel.

Two types of channels can be programmed:

1. **Simplex.** The pilot programs the same frequency in receive and transmit.
2. **Semi-duplex.** The pilot programs two different frequencies, one for receive and one for transmit.

To gain access to channelized operation with the KFS 594, make sure that the mode selector knob is in the desired position (USB, LSB or AM) and that a channel number is showing in the display (upper left). If one is not showing (direct tune operation), or if you wish to change the channel, move the “cursor” by pressing the Frequency/Channel control knob until the channel number is flashing. Change the channel number by rotating the Frequency/Channel control knob until the desired channel number appears. The previously programmed receive frequency associated with that channel will appear in the display.

If no reprogramming of channels is required at this time, the KHF 950/990 is made ready for channelized operation on the selected channel number by tuning the antenna (momentarily keying the mic).

If channel programming is required, you are now ready to program

the channel number you have selected. The procedures are only slightly different for simplex and semi-duplex channel programming.

SIMPLEX CHANNEL PROGRAMMING

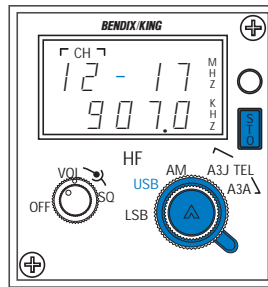

Figure 3-80 Simplex Channel Programming

1. **Change the first frequency digit to enter the program mode.** By pushing the Frequency/Channel control knob move the “cursor” to the first digit in the frequency to be changed. Twist the Frequency/Channel control knob until the desired number has been selected for this frequency digit. As the knob is twisted, a flashing dash will appear to the right of the channel number to signify that you are in the program mode. You will be unable to receive or transmit on the frequency displayed as long as the dash is flashing to indicate you are in the program mode. (It is possible to change the last digit (one tenth kHz) of the frequency without entering the program mode. See clarifier function.)

2. **Select the rest of the desired frequency.** Use the “cursor” by pressing the Frequency/Channel control knob to address each additional digit you want to change. Once the digit is flashing, again twist the knob to select the desired number.

NOTE: You may exit the program mode at any time and return to the previously stored frequency simply by keying the mic.

3. **Store the frequency in the receive portion of memory.** Once you have selected the desired frequency, press the STO button to enter the displayed frequency in the receive portion of memory. The TX light will begin to flash indicating that memory is ready to receive the transmit frequency.

4. **Store the same frequency in the transmit portion of memory.**

Operation

Because this is a simplex channel, simply press the STO button a second time to store the same frequency in the transmit portion of memory.

After the STO button is pressed the second time, the “cursor” will stow and the flashing dash will disappear to indicate the KFS 594 is no longer in the program mode. Additional channels can be programmed by continuing to use the “cursor” and Frequency/Channel control knob in this manner.

5. **Tune the antenna.** Key the mic to tune the antenna. After tuning is completed you are ready to transmit.

SEMI-DUPLEX CHANNEL PROGRAMMING

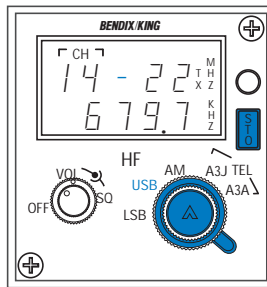

Figure 3-81 Semi-Duplex Channel Programming

Semi-Duplex operation uses one frequency for receiving and another for transmitting. The KFS 594 has semi-duplex capability with all 19 pilot programmable channels. As before, to gain access to channelized operation, make sure that the mode selector is in the desired position (USB, LSB or AM) and that a channel number is showing in the upper left of the display. As previously described, use the Frequency/Channel control knob to select the channel to be programmed. You will note that the first three steps in programming a semi-duplex channel are the same as for programming a simplex channel.

1. **Change the first digit of the receive frequency to enter the program mode.** By pushing the Frequency/Channel control knob move the “cursor” to the first digit in the frequency to be changed. Twist the Frequency/Channel control knob until the desired number has been selected for this frequency digit. As the knob is twisted, a flashing dash will appear to the right of the channel number to signify that you are in the program mode. You will be unable to receive or

transmit on the frequency displayed as long as the dash is flashing to indicate you are in the program mode. (It is possible to change the last digit (one tenth kHz) of the frequency without entering the program mode. See clarifier function.)

2. **Select the rest of the desired frequency.** Use the “cursor” by pressing the Frequency/Channel control knob to address each additional digit you want to change. Once the digit is flashing, again twist the knob to select the desired number.

NOTE: You may exit the program mode at any time and return to the previously stored frequency simply by keying the mic.

3. **Store the receive frequency in memory.** Press the STO button to enter the displayed frequency in the receive portion of memory. The TX light will begin to flash indicating that memory is ready to receive the transmit frequency.

4. **Select the desired transmit frequency.** Use the “cursor” and the Frequency/Channel control knob again to select a new transmit frequency.

5. **Store the transmit frequency in memory.** Press the STO button again to store the transmit frequency. After the STO button is pressed the second time the “cursor” will stop and the TX light will go out. The flashing dash will also disappear to indicate the KFS 594 is no longer in the program mode. Additional channels may be programmed by continuing to use the “cursor” and Frequency/Channel control knob in the same manner.

6. **Press the mic button to tune the antenna.** After tuning is complete you are ready to transmit. Before keying the mic to talk, you may want to press the STO button momentarily. This will allow you to listen momentarily to the transmit frequency to avoid overriding someone else’s transmissions.

CLARIFIER

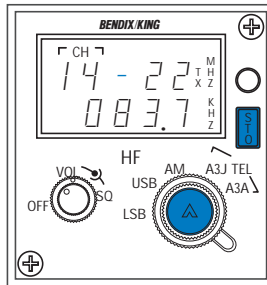

Figure 3-82 Clarifier

A clarifier function is provided by the KFS 594 which can be used to adjust SSB reception in USB or LSB in the channelized mode of operation. The CLARIFIER works whether the channel involved is semi-duplex or simplex. It is not normally used in the AM mode and cannot be used if the mode selector switch is in A3J or A3A position.

The purpose of the CLARIFIER is to help eliminate the unnatural "tinny sound" found at times with SSB audio voice quality as a result of off-frequency ground station transmissions.

To operate the CLARIFIER, unstow the "cursor" by pressing the Frequency/Channel control knob (lower right). Press it until the last digit in the receive frequency is flashing, then rotate this knob to select a new number. If this doesn't improve the quality of the audio you are hearing, try additional changes in the last digit. In effect you are making small changes in the receive frequency. (Radio amateurs call this Receiver Incremental Tuning-RIT.) If you transmit while using the CLARIFIER, however, you will transmit on the originally selected frequency. The dash to the right of the channel number will not flash and you will not enter the program mode. To exit clarifier operation, press the STO button or return the digits to those originally selected.

Remember, long range HF signals received under less than optimum propagation conditions may still vary in quality and volume.

MARITIME RADIOTELEPHONE NETWORK (PUBLIC CORRESPONDENCE) CHANNEL OPERATION

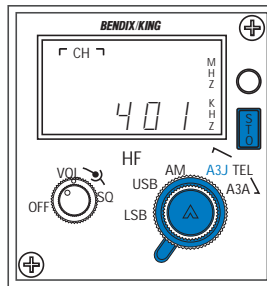

Figure 3-83 Maritime Radiotelephone Network (Public Correspondence) Channel Operation

As explained earlier, all 245 ITU public correspondence channels in the maritime radiotelephone network are programmed permanently in the electronic memory of the KFS 594 Control Display Unit. To operate this mode:

1. **Select the A3J or A3A mode.** Move the MODE selector switch to the A3J or A3A position. Most maritime radiotelephone (public correspondence) stations, including those of the Bell System and Mobile Marine Radio System, work in the A3J format.
2. **Select the desired channel.** An ITU channel number will be displayed in the lower right of the display when you move the MODE selector switch to the A3J or A3A position. If the channel number isn't the one desired, select another by first unstowing the "cursor" (flashing digit) by pressing the Frequency/Channel control knob. Press this knob enough times to move the "cursor" to the first "cursor" position in the ITU channel number to be changed. (This will be 6, 8, 12, 16, etc.) Next twist the Frequency/Channel control knob to select the desired number.

NOTE: There are only two "cursor" positions for the ITU channel number. The "hundreds" position controls the "thousands" position also. For example, if the displayed channel number is 1204 the "cursor" could be moved to the "12" but not to the "1". With the "cursor" on the "12", turning the Frequency/Channel control knob one step counter-clockwise will change the "12" to an "8" while another step in the same direction would change the "8" to a "6". By referring to the Maritime Radiotelephone Network (Public Correspondence) Channel Operation list in table 7-13 you will see that these changes are consistent with the actual channel numbers.

Operation

Change the other two digits in the channel number using the “cursor” and Frequency/Channel control knob for the second “cursor” position in the same manner. The “cursor” may now be stowed by another push of the knob. Neither the receive nor the transmit frequencies in the semi-duplex pairing will be displayed at this time—just the ITU channel number.

3. **Tune the antenna coupler.** Press the mic button momentarily to initiate antenna tuning. During the tuning process the TX annunciation will flash and the channel number will blank. When the TX stops flashing and the channel number reappears, the antenna tuning cycle is complete and you are ready to communicate on the selected ITU channel.

NOTE: Always key the mic after selecting a new frequency to initiate antenna tuning.

4. **Transmit and receive.** Before keying the mic to talk, you may want to press the STO button momentarily. This will allow you to listen on the transmit frequency momentarily to see if another aircraft is calling the same ground station. This way you'll be sure not to override someone else's transmission. Release the STO button when you are done and transmit by keying the mic.

NOTE: British Columbia Telephone operates some public correspondence stations in Canada which require the reception of a 1,000 Hz signal from an aircraft calling the station before it will answer. The KFS 594 is capable of sending this signal by having the pilot first key the mic and then simultaneously press the STO button.

KFS 594 OPERATIONAL NOTES:

1. It is necessary to retune the antenna coupler whenever the MODE selector knob is changed from one mode to another. Pressing the mic button momentarily initiates antenna tuning.
2. Lower Sideband (LSB) operation is normally internally disabled. If the MODE selector knob is moved to the LSB position, a flashing "E" will appear on the upper part of the display. The KHF 950/990 system will operate in the Upper Sideband mode if the MODE selector knob is left in the LSB position. Moving the MODE selector knob to the Upper Sideband (USB) or AM Mode will clear the flashing "E".
3. The A3A Telephone mode (reduced carrier) has been internally disabled and a flashing "E" will appear on the upper part of the display if the MODE selector is moved to this position. Since the preferred mode of operation when utilizing the ITU Maritime Radiotelephone Channels is A3J, make sure the MODE selector knob is in the A3J position when using this service
4. Anytime other than Paragraphs 2 or 3 above that a flashing "E" appears on the display, it is an indication that an inconsistency has been detected in the system and that operator confirmation of the selected mode is required. This confirmation may be easily accomplished by verifying that the desired mode has been selected and then momentarily pressing the STO button.

This Page Intentionally Left Blank

SECTION IV

HF COMMUNICATIONS SERVICES DIRECTORY

SERVICES AVAILABLE ON HF RADIO

HF radio makes available a variety of communication possibilities to the pilot including long range contact with Air Traffic Control agencies, time and weather broadcasts, maritime radiotelephone (public correspondence) service, ARINC operational control services, and others. This portion of the pilot's guide is devoted to advising you of many of the services that are available. It should also serve as a handy reference should any questions arise on how to use a particular service.

CAUTION: *Frequencies and operational procedures relating to the various communications services listed here are subject to change. While the information in this pilot's guide is believed current as of the date of publication, it is the pilot's responsibility to consult current aeronautical publications and appropriate agencies to assure that current frequencies and procedures are being used.*

This Page Intentionally Left Blank

SECTION V

ICAO ENROUTE NETWORKS

ICAO ENROUTE NETWORKS DESCRIPTION OF SERVICES

High frequency radio communications are used by aircraft to maintain contact with Air Traffic Control during long over water flights or flights in remote areas not covered by VHF communications.

HF frequencies are assigned to various areas of the world according to agreements worked out between the International Civil Aviation Organization (ICAO) and the International Telecommunications Union (ITU) and national aviation authorities (such as the FAA in the United States, and the CAA in the United Kingdom, etc.).

These agreements specify a certain family or network of HF frequencies for each area. A network may consist of as many as seven or more frequencies. When you first contact a ground station for ATC communications, you will normally be assigned two or three HF frequencies to use. Then, if you lose contact on the primary HF frequency due to deterioration of HF propagation, you can switch to your secondary or backup frequency and try to reestablish contact.

ARINC, a private not-for-profit company headquartered in Annapolis, Maryland, has been licensed by the FCC to operate these networks in most areas where the United States has been given responsibility by the ICAO.

The ICAO High Frequency Enroute Network Chart which follows shows the general outline of the networks and their associated frequencies.

This Page Intentionally Left Blank

Services

HF RADIOTELEPHONE NETWORKS

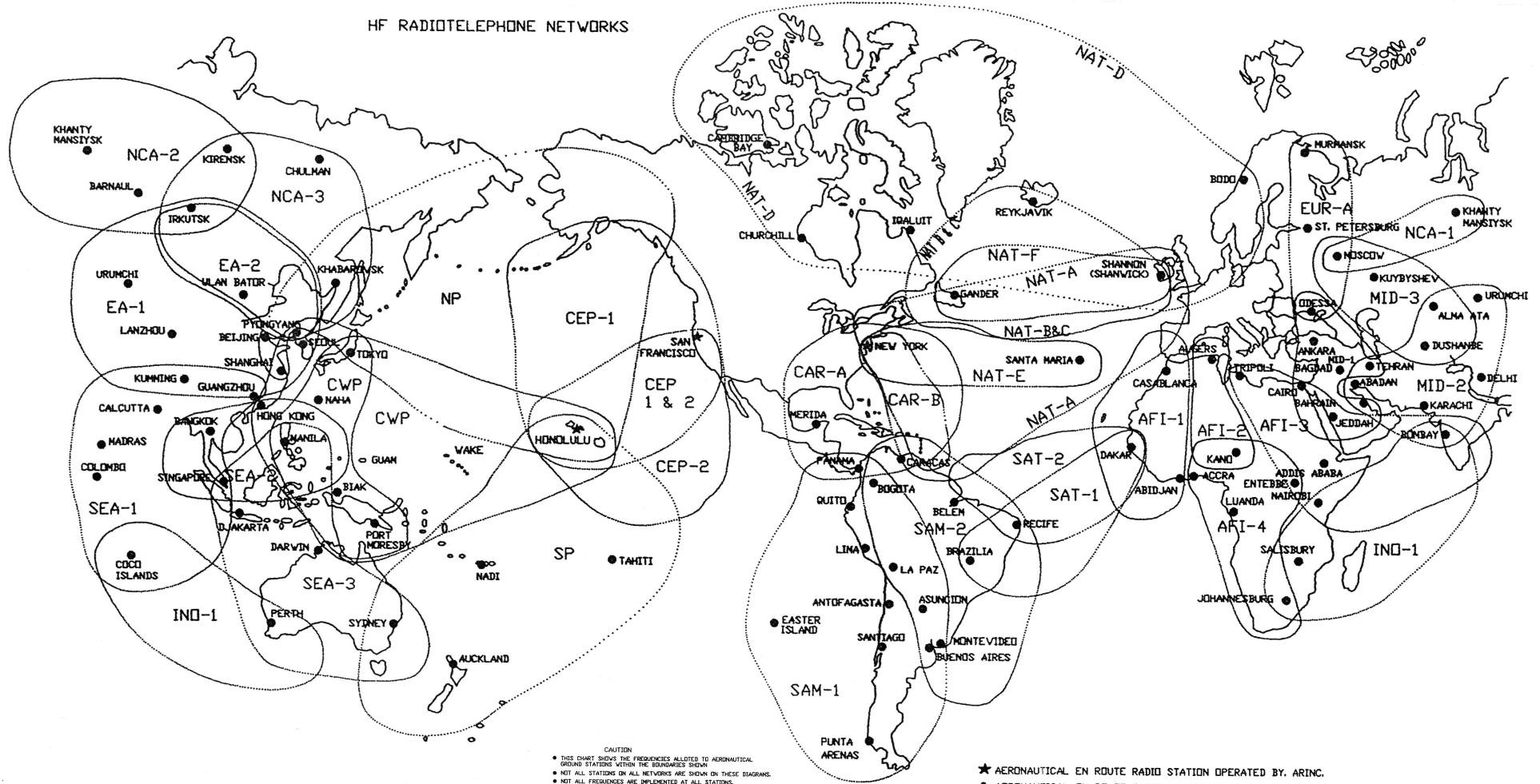

CAUTION
 • THIS CHART SHOWS THE FREQUENCIES ALLOTTED TO AERONAUTICAL GROUND STATIONS WITHIN THE BOUNDARIES SHOWN.
 • NOT ALL STATIONS ON ALL NETWORKS ARE SHOWN IN THESE DIAGRAMS.
 • NOT ALL FREQUENCIES ARE IMPLEMENTED AT ALL STATIONS.
 • LOCAL REGIONAL AIR NAVIGATION PLANS SHOULD BE REFERRED TO FOR ADDITIONAL DETAILS.
 • CURRENT OPERATIONAL DATA MUST BE OBTAINED FROM AERONAUTICAL CHARTS AND NOTICES.

★ AERONAUTICAL EN ROUTE RADIO STATION OPERATED BY ARINC.
 • AERONAUTICAL EN ROUTE RADIO STATION OPERATED BY OTHERS.
 THIS MAP IS NOT SUITABLE FOR NAVIGATIONAL PURPOSES.

ALL FREQUENCIES ARE EXPRESSED IN KILOHERTZ

SEA-1 & 3	SEA-1 & EA-2	EA-1	NCA-1	NCA-2	NCA-3	CWP	CEP-1 & 2	SP	NP	SAT-2	CAR-A	CAR-B	SAM-1	SAM-2	EUR-A	AFI-1 & SAT-1	AFI-2	AFI-3 & MID-2	AFI-4	NAT-A	NAT-B	NAT-C	NAT-D	NAT-E	NAT-F	MID-1	MID-3	INO-1
3470	3485	3016	3019	2851	3004	2998	2869	3467	5667	2854	2887	3455	2944	3479	3479	3419	3467	3467	2878	3016	2899	2872	2971	2962	3476	2992	2944	3476
6556	5649	6571	5646	4678	5664	4666	3413	5643	6655	5565	5550	5520	4669	5526	5661	6535	5652	5658	5493	5598	5616	5649	4675	6628	6622	4669	4669	5634
10066	5655	8897	13315	6592	10039	6532	5547	8867	8915	11291	6577	6586	6549	8855	6598	8861	8894	10018	8903	8906	8864	8879	8891	8825	8831	6631	6631	8879
11396	8942	10042	17958	10096	13303	6562	5574	13261	11330	13315	8918	8846	10024	10096	10084	13357	13273	11300	13294	13306	13291	11336	11279	11309	8951	8951	13306	
13318	11396	17958		17958	17958	8903	6673	17904	13339	17955	11396	11330	11360	13297	10084	13357	13273	11300	13294	13306	13291	11336	11279	11309	8951	8951	13306	
17907	13309	17907				11384	8843		17946		17907	17907	17907	17907	17961	17955	17961	17961	17946	17946	17946	17946	17946	17946	13306	13354	13354	17961
						13300	11282		21925																			
						17904	13288		17946																			
						21985	13354		2932																			
							17904		8951																			
							10048		10048																			
							17904		13273																			

Map reprinted with permission from ARINC

SECTION VI

ARINC

OPERATIONAL CONTROL SERVICES

DESCRIPTION OF SERVICES

ARINC HF SSB Services are handled by Long Distance Operational Control Facilities (LDOCF) and consist of communications between flight crews and designated personnel in their company offices. These communications may utilize either direct voice phone patch techniques or relaying of messages when desired. Public correspondence and personal use is not permitted on these frequencies. Acceptable messages are limited to those of immediate concern to the safe, expeditious, and economic conduct of the flight operations being undertaken.

Acceptable Traffic consists of one of the two following categories:

1. Messages relating to the operation of the aircraft itself

Conduct of the flight.

Performance of the aircraft, including its components.

Information of value to the crew in accomplishing that particular flight.

Information of value to ground personnel concerned with the safe and efficient conduct of the flight.

Information of value to other flights in the same area.

2. Messages relating to aircraft load which require radio handling to insure safety and efficiency

Supplementary information and corrections pertaining to weight, balance and/or passenger counts.

Connections with other transportation.

Essential supplies and services.

Unacceptable Traffic consists of:

Personal messages to or from crew or passengers.

Messages between ground crews when plane is not in flight status.

All other traffic which does not reasonably fall into the Acceptable Traffic category.

NOTE: The HF LDOCFs operate exclusively in the upper sideband (USB) mode. Make sure the KHF 950 is operating in the USB mode when utilizing these services.

The LDOCFs are located at New York, Cedar Rapids, Miami, San Francisco, Honolulu, and Houston. A map depicting the areas served and frequencies of each facility follows to assist flight crews and ground personnel in contacting the appropriate facility. Generally, the higher frequencies are used during the daylight hours and the lower frequencies during hours of darkness. The frequencies in this service may be used from any location, the only limiting factor being the actual propagation of the radio signals.

ARINC OPERATING PROCEDURES

AUTHORIZED CONNECTIONS

A list of personnel authorized by the user to originate and receive calls is located at each ARINC LDOCF and at ARINC headquarters.

AIRCRAFT-TO-GROUND CALLS

Flight crews wishing to place calls to their operational offices using this service will call one of the LDOCFs previously listed. The time of day and distance from the station will determine the most appropriate frequency to be used.

NOTE: Aircraft transiting the U.S. mainland should use another means for contacting their company offices such as the ARINC VHF facilities or UHF airborne telephone. The LDOCF is intended for international communications only; however, this does not preclude its use during an emergency or loss of the aircraft's VHF equipment.

The ARINC ground operator receiving the request for a phone patch will verify that the call is being placed to an authorized office. The operator will refuse to complete the phone patch if he determines the crew is requesting a call to an office not authorized by the crew's company. However, if the crew declares that the call is of an emergency nature, the ground operator may complete it for them.

If the operator determines that the call is to an authorized office, he will then determine if the signal quality is high enough for a successful phone patch. If the signal quality is not adequate, the operator will advise the flight crew of this and they may both try another frequency

or the ground operator may relay the message for the crew, if desired.

If the signal quality is adequate, the operator will advise the aircraft to stand by for the patch. The ARINC operator will then place a call using direct distance “station-to-station” dialing wherever possible.

When the office is reached, the operator will connect his radio equipment to the telephone line and advise the crew to “Go Ahead.”

When the conversation is completed, the crew should advise the ARINC operator, who will then disconnect the phone patch.

GROUND-TO-AIRCRAFT CALLS

Authorized company personnel may call the aircraft by placing a call to the appropriate ARINC facility (using the numbers provided to authorized ARINC users). Long distance calls to the ARINC facilities should be placed on a “station-to-station” basis and must be prepaid. ARINC operators will not accept collect calls.

The company personnel initiating the call must give the following information to the ARINC operator.

- A. Company identification/job title/location.
- B. Authorized telephone number.
- C. Aircraft identification and SELCAL code (if applicable).
- D. Approximate location of the aircraft.

The ARINC operator will request the caller to stand by and will authenticate the call. When the operator is satisfied the call is authorized, he will establish communications with the aircraft and inform the caller the aircraft is standing by.

At the conclusion of the conversation, the company personnel placing the call should advise the ARINC operator who will terminate the telephone/radio connection.

NOTE: This type of telephone/radio connection is “one way” (send or receive) only. Break-ins and interruptions are not possible. In the normal “at rest” condition, the ground caller receives the aircraft transmission. When the ground caller speaks, a voice-operated relay switches the radio channel from receive to send and the aircraft receives the transmission. If the ground caller and aircraft transmit simultaneously, neither will receive the other. Thus, each should indicate the end of a transmission with the words “over” or “go ahead”.

Services

The ground caller should precede each transmission with an “err” or “uhh” to allow the voice operated relay time to complete its switching function.

IMPORTANT: Prior arrangements and service agreements must be established by company personnel desiring to use these ARINC services. To arrange for service or obtain current information contact:

ARINC

2551 Riva Road

Annapolis, Maryland 21403

Telephone (410) 266-4180 Customer Service

(410) 266-4430 Operations

ARINC LONG DISTANCE OPERATIONAL CONTROL FACILITIES (LDOCFs)

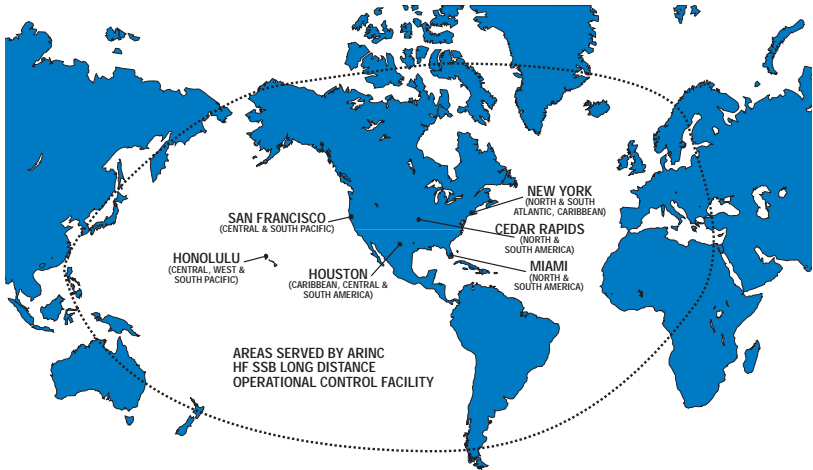

1. The intent of this chart is to show the general areas served via HF from the ARINC HF SSB Long Distance Operational Control Facilities. It does not represent actual coverage to be expected.

2. The frequencies shown are subject to change and must not be relied upon for operational use. Contact the following for current information and arrangements for service.

ARINC
 2551 Riva Road
 Annapolis, Maryland 21403
 Telephone
 (410) 266-4180 Cust. Service
 (410) 266-4430 Operations

FREQUENCIES (KHz)

- 3013
- 3494
- 6637
- 6640
- 8933
- 10033
- 10075
- 11342
- 13330
- 13348
- 17925
- 17940
- 21964

This Page Intentionally Left blank

SECTION VII

ITU MARITIME RADIOTELEPHONE (PUBLIC CORRESPONDENCE) STATIONS

DESCRIPTION OF SERVICES

A worldwide network of public correspondence stations operating in the high frequency band compatible with the Bendix/King KHF 950 make it possible to place personal or operational phone calls in flight. You can be flying thousands of miles from land and reach one of these stations by HF to place your call. These stations link aircraft (and ships at sea) via HF with the regular land line phone system.

Easy access to the maritime radiotelephone network is provided by the pilot programmable and pre-programmed features available depending on whether you have the KCU 1051 Control Display Unit, KCU 951 Control Display Unit, or KFS 594 Control Display Unit.

Access to the radiotelephone network is easy with the KCU 1051 and the KFS 594 because ITU semi-duplex channels assigned to public correspondence stations worldwide are set in the KCU 1051 and KFS 594 permanent memory.

Using KCU 1051, if you want to contact KMI on channel 401, on the manual page, select chITU channel type and select channel 401. The semi-duplex pair of frequencies associated with this channel are pre-programmed in the KCU 1051 memory. Alternatively, the transmit and receive frequencies of the ITU semi-duplex channels can be stored in the 100 user-programmable channels for the KCU 1051. This alternate method could be used to access a public correspondence station that is operating on frequencies other than those programmed into the KCU 1051.

Using KFS 594, if you want to contact KMI on channel 401, just move the MODE selector to the A3J mode position and select channel 401. The semi-duplex pair of frequencies associated with this channel are pre-programmed in the KFS 594 memory. Alternatively, the transmit and receive frequencies of the ITU semi-duplex channels can be stored in the 19 user-programmable channels for the KFS 594. This alternate method could be used to access a public correspondence station that is operating on frequencies other than those programmed into the KFS 594.

The KCU 951 has 99 pilot programmable channels all of which can be set for semi-duplex operation. The public correspondence stations utilize semi-duplex operation. These programmable channels can be set on the ground or in the air by the pilot. For example, coast station KMI in Point Reyes, California operates on 17 semi-duplex channels including ITU channel 401 (aircraft receive on 4357.0 kHz and aircraft transmit on 4065.0 kHz). By preprogramming the transmit and receive frequencies associated with channel 401 into any of the 99 preset channels in the KCU 951, you may later recall this semi-duplex pair of frequencies by selecting the appropriate preset channel number.

AT&T operates three of the four public correspondence stations in the United States utilized for High Seas radiotelephone operation. These are coast stations KMI in Point Reyes, California; station WOO in Manahawkin, New Jersey; and station WOM in Ft. Lauderdale, Florida. The fourth station is station WLO in Mobile, Alabama, which is operated by Mobile Marine Radio, Inc.

The Maritime Radiotelephone Network section of this pilot's guide is in three parts. Part one is devoted to the Bell System's High Seas Service; part two describes the service of station WLO; and part three provides a worldwide listing of public correspondence stations.

AT&T HIGH SEAS RADIOTELEPHONE SERVICE

The AT&T High Seas Network serves commercial shipping and pleasure boat operators as well as aircraft in flight. The service is widely used for personal and operational calling by all of these users. It also broadcasts weather and gives top priority to safety communication.

AT & T COAST STATION COVERAGE MAP

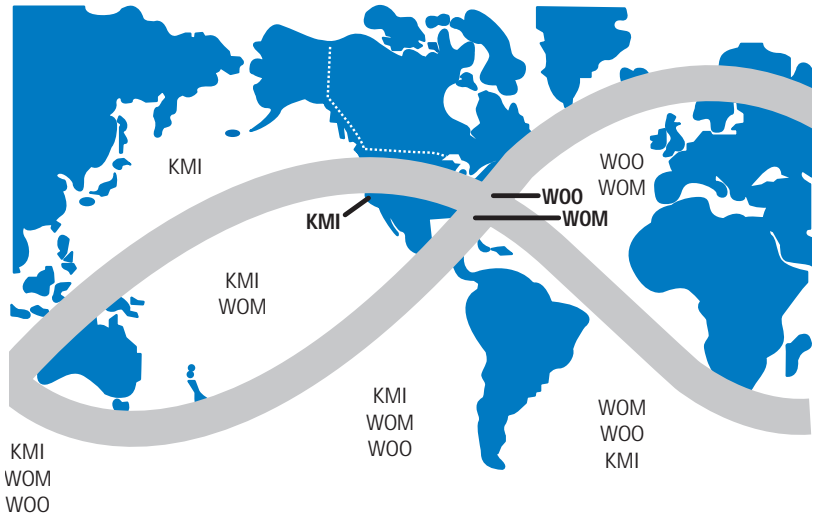

Figure 7-1 AT&T Coast Station Coverage Map

COAST STATION COVERAGE & INFORMATION

The map above indicates the general areas covered by AT&T's three coast stations. A fingertip guide providing other helpful information about AT&T High Seas Service is available by calling 1-800-SEA-CALL.

For General information regarding the High Seas Services, write:

AT&T Product Manager Maritime and Aeronautical
 Room 5170-W028 412 Mt. Kemble Ave.
 Morristown, NJ 07960
 or call (201) 644-7167.

AIRCRAFT REGISTRATION

To register your aircraft for AT&T High Seas Service call 1-800-752-0279, or you may register by placing a High Seas call, passing the billing information to the High Seas traffic operator, and requesting to be registered.

OPERATING PROCEDURES FOR USING THE HIGH SEAS RADIOTELEPHONE NETWORK

NOTE: All communications with public correspondence stations must be done with the KCU 951 Control Display Unit in the upper side-band (USB) mode of operation. The MODE selector of the KFS 594 Control Display Unit must be in the TEL (A3J) position if using a pre-programmed ITU channel, or in USB if using a user-programmed channel. The channel type on the KCU 1051 display must be set for chITU if using a pre-programmed ITU channel, or the modulation type must be USB if using a user-programmed channel.

PLACING AIRCRAFT-TO-GROUND CALLS

When using the KCU 951 Control Display Unit, select a channel you have already programmed, or program the paired receive and transmit frequencies for the channel you want to use. When using the KCU 1051 Control Display Unit or KFS 594 Control Display Unit, simply recall the appropriate ITU channel number from the ITU channels stored in the electronic memory or the user channel number if using a user channel that has been programmed with an ITU semi-duplex frequency. Using the KCU 951 Control Display Unit, the aircraft receive frequency should be monitored. Using the KCU 1051 Control Display Unit or KFS 594 KCU Control Display Unit, both the receive and transmit frequencies may be monitored. Press the SCAN Key on the KCU 1051 to monitor the transmit frequency. Press the STO Key on the KFS 594 to monitor the transmit frequency.

Next, listen; don't call until transmissions in progress have been completed. Calls to a ground station can be placed at any time. In the event that frequencies to a desired station are busy, your call can be placed through another coast station on its assigned channels.

The typical call should begin with the station you are calling and the channel you are calling on. The call should include your aircraft's identification and approximate location.

Example: "...KMI Channel Eight Two Two, KMI Channel Eight Two Two, KMI Channel Eight Two Two, this is aircraft N999XY, off Kodak Island, Alaska, Over."

After you give this call, wait for a response. If you don't hear the shore station within 20 seconds, transmit the same message again on the same channel. If you still don't get a response, switch to another channel in the same band or in a different band. The shore station may not have been able to hear your initial call because of interference or poor propagation. Before completing your call, the High Seas Traffic Operator will ask for your name and the telephone number of the party you wish to reach, and the method of billing; paid, collect, or third party number. Should you need time and charges, advise the operator of this before the call is completed, stand by until the Technical Operator releases the channel.

RECEIVING HIGH SEAS CALLS

You can receive an incoming call only when the KHF 950/990 is TURNED ON and TUNED to the channel of the coast station which is scheduled to broadcast a traffic list.

When your aircraft is called, answer the coast station stating your aircraft identification, location and channel number or frequency on which you are calling. After contact has been established the coast station operator will make any necessary adjustments to provide you with the best possible circuit for your telephone call.

PLACING GROUND-TO-AIRCRAFT CALLS

You may reach the AT&T High Seas Operator by dialing toll free 1-800-SEA-CALL. If calling from outside the United States, ask your local operator for the AT&T High Seas Operator 11362 in Pittsburgh, Pennsylvania. Give the High Seas Operator the aircraft's identification and approximate location, and then follow the operator's instructions.

TELEPHONE SERVICES OFFERING

All High Seas calls are treated as person-to-person and charged at the same rate whether they are directed to individuals or telephone numbers. Conference (multiple) calls can be set up between three or more stations at a special rate. Payments are handled in any of five ways:

1. Paid Call - the calling customer pays all charges.
2. Collect Call - the calling customer indicates that the charges will be billed to the person or station being called.
3. Third Number - the calling customer refers charges to his office

Services

or home number or any other authorized phone number in the U.S.

4. Credit Card Call - the caller indicates that charges will be billed to an AT&T telephone credit card.
5. Name and Address - the caller indicates that the charges will be billed to a name and address.

HIGH SEA RATE STRUCTURE

The High Seas rate for calls handled by any of the three AT&T High Seas stations (WOM, WOO, KMI) is a flat rate for the first three minutes and a flat rate for each additional minute or fraction thereof. There is a three minute minimum on all calls. Call the nearest High Seas Station or the High Seas Product Manager for current rates. The High Seas rate is a total cost and is not dependent on the aircraft location. It applies to any call to any location in the mainland United States, Canada, Mexico, Puerto Rico and the American Virgin Islands. The flat charge will allow you to choose between High Seas Stations without affecting the charge. For all calls to overseas points the charge is the High Seas rate plus the lowest person-to-person overseas rate in effect at the time of the call.

TRAFFIC LIST BROADCAST

The three AT&T Coast Stations regularly broadcast a traffic list indicating those aircraft and ships for which calls are pending.

AT&T HIGH SEAS COAST STATIONS

A FEW VITAL FACTS

- Aircraft and coast stations must transmit and receive on their assigned paired channels.
- "Crossband" operation is strictly forbidden.
- All High Seas Stations continuously monitor the aircraft's transmitting channels.
- Do not wait for a traffic list broadcasting, before making a call. Demand Calling is encouraged.

No calls are accepted on a channel just before it is scheduled to carry a traffic list or weather broadcast. However, when a call is in progress, the broadcast is omitted on the busy channel AT&T HIGH SEAS STATIONS

COAST STATION KMI-CALIFORNIA

Address:

AT&T

Station KMI

P.O. Box 9

Inverness, California 94937

For Technical information call: (800) 538-5936 or (415) 669-1055

Aircraft Coast Station	Aircraft Channel Designation	Receive (kHz)	Transmit (kHz)
KMI Point Reyes, California	401	4357.0	4065.0
	416	4357.0	4065.0
	417	4402.0	4110.0
	804	4405.0	4113.0
	809	8728.0	8204.0
	822	8743.0	8219.0
	1201	8782.0	8285.0
	1202	13,077.0	12,230.0
	1203	13,080.0	12,233.0
	1229	13,083.0	12,236.0
	1602	13,161.0	12,314.0
	1603	17,248.0	16,366.0
	1624	17,311.0	16,429.0
	2214	22,735.0	22,039.0
	2223	22,762.0	22,066.0
	2228	22,777.0	22,081.0
2236	22,801.0	22,105.0	

Table 7-1 Coast Station KMI-California

Channels: 416 and 1203

GMT TRFC WEATHER

0000 X X

0400 X

0800 X

1200

1600

2000 X

Services

COAST STATION WOO - NEW JERSEY

Address:

AT&T

Station WOO

P.O. Box 550, End of Beach Avenue

Manahawkin, New Jersey 08050

For technical information call: (800) 538-5936 or (609) 597-2201

Aircraft Coast Station	Aircraft Channel Designation	Receive (kHz)	Transmit (kHz)
Manhawkin, New Jersey	410	4384.0	4092.0
	411	4387.0	4095.0
	416	4402.0	4110.0
	422	4420.0	4128.0
	808	8740.0	8216.0
	811	8749.0	8225.0
	815	8761.0	8237.0
	826	8794.0	8270.0
	1203	13,083.0	12,236.0
	1210	13,104.0	12,257.0
	1211	13,107.0	12,260.0
	1228	13,158.0	12,311.0
	1605	17,254.0	16,372.0
	1620	17,299.0	16,417.0
	1626	17,317.0	16,435.0
	1631	17,332.0	16,450.0
	2201	22,696.0	22,000.0
2205	22,708.0	22,012.0	
2210	22,723.0	22,027.0	
2236	22,810.0	22,105.0	

Table 7-2 Coast Station WOO - New Jersey

Channels: 411 and 811

GMT TRFC WEATHER

0000 X

0200 X

0400 X

0600 X

0800 X

1000 X

1200 X X

1400 X
 1600 X
 1800 X
 2000 X
 2200 X X

COAST STATION WOM - FLORIDA

Address:
 AT&T
 Station WOM
 1340 N.W. 40th Avenue
 Fort Lauderdale, Florida 33313
 For technical information call: (800) 538-5936 or (305) 587-0910

Aircraft Coast Station	Aircraft Channel Designation	Receive (kHz)	Transmit (kHz)
WOM Fort Lauderdale, Florida	403	4363.0	4071.0
	412	4390.0	4098.0
	417	4405.0	4113.0
	423	4423.0	4131.0
	802	8722.0	8198.0
	805	8731.0	8207.0
	810	8746.0	8222.0
	814	8758.0	8234.0
	825	8791.0	8267.0
	831	8809.0	8295.0
	1206	13,092.0	12,245.0
	1208	13,098.0	12,251.0
	1209	13,101.0	12,254.0
	1215	13,119.0	12,272.0
	1223	13,143.0	12,296.0
	1230	13,164.0	12,317.0
	1601	17,242.0	16,360.0
	1609	17,266.0	16,384.0
	1610	17,269.0	16,387.0
	1611	17,272.0	16,390.0
	1616	17,287.0	16,405.0
	2215	22,738.0	22,042.0
2216	22,741.0	22,045.0	
2222	22,759.0	22,063.0	

Table 7-3 Coast Station WOM - Florida

Services

Channels: 403, 802, 1206, 1601 and 2215

GMT	TRFC	WEATHER
0300	X	
0500	X	
0500	X	
0700	X	
0900	X	
1100	X	
1300	X	X
1500	X	
1700	X	
1900	X	
2100	X	
2300	X	X

MOBILE MARINE RADIO, INC.

Mobile Marine Radio, Inc. operates station WLO in Mobile, Alabama. The services provided by WLO and the procedures for utilizing these services are similar to those of the Bell System's stations previously described.

Mobile Marine Station	ITU Channel	Aircraft/Ship Receive (kHz)	Aircraft/Ship Transmit (kHz)
WLO, Mobile, Alabama	xxx	2572.0	2430.0
	405	4369.0	4060.0
	414	4396.0	4077.0
	419	4351.0	4101.0
	428	4411.0	4119.0
	607	6519.0	6218.0
	824	8788.0	8113.0
	829	8713.0	8264.0
	830	8803.0	8269.0
	836	8806.0	8282.0
	1212	13,110.0	12,263.0
	1225	13,149.0	12,302.0
	1226	13,152.0	12,305.0
	1233	13,173.0	12,326.0
	1235	13,179.0	12,332.0
	1607	17,260.0	16,378.0
	1641	17,362.0	16,480.0
	1643	17,368.0	16,486.0
	1647	17,380.0	16,498.0
	1807	19,773.0	18,798.0
2237	22,804.0	22,108.0	
2242	22,819.0	22,123.0	
2246	22,831.0	22,135.0	
2503	26,151.0	25,076.0	

Table 7-4 Mobile Marine Radio, Inc.

All channels use USB mode (A3J) for KCU 1051 and KFS 594 Control Display Units).

To reach WLO from long distance to place a marine radiotelephone call, dial "0" and ask the operator for the "Mobile Alabama Marine Operator." Or, you may dial direct:
1-800-633-1634 or (334) 666-3555.

For further information write:

Mobile Marine Radio, Inc.

Station WLO

7700 Rinla Avenue

Mobile, Alabama 36619

or call the business office: 1-800-633-1312 or (334) 666-5110.

Services

Traffic Lists

Traffic Lists are broadcast on all available WLO channels every hour on the hour, or shortly after the hour if the channel is busy on the hour.

Aircraft Registration

To pre-register your aircraft with WLO call 1-800-633-1312 and ask for Customer Service. Pre-registration is not a prerequisite for obtaining WLO's services. You may register when you place your first call through WLO by providing the WLO operator with the appropriate information.

Billing Information

For customers calling land destinations via radiotelephone from aircraft, provide the aircraft's identification and a billable telephone number or an AT&T credit card number.

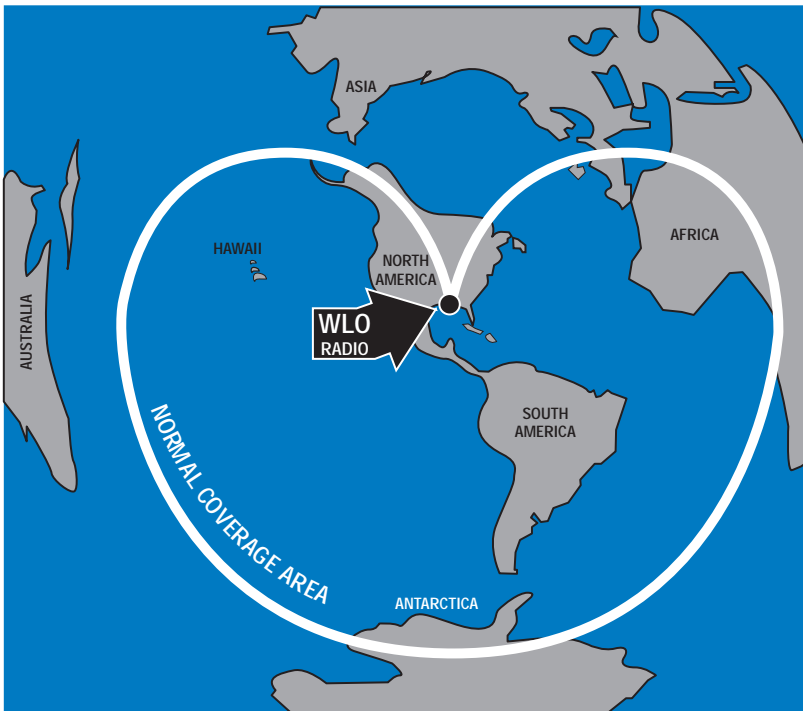

Figure 7-2 Worldwide Listing Coverage Area

For customers sending messages to aircraft, WLO requires name and address, telephone number and other necessary information. WLO accepts charge card payments for messages.

WORLDWIDE LISTING OF PUBLIC CORRESPONDENCE STATIONS

Besides the four domestic stations previously presented, there have been hundreds of maritime radiotelephone (public correspondence) stations authorized for operation around the world. The two listings which follow may help the operator to utilize some of the stations' services. The first listing provides the receive and transmit frequencies for each of the ITU maritime radiotelephone channels. The second listing gives an alphabetical listing by country of each of the maritime radiotelephone stations and the ITU channel numbers assigned to them.

Note: When using the KCU 951 Control Display Unit, it will first be necessary to determine which ITU channel number will be used from the second listing, and then refer to the first listing to obtain the appropriate frequencies for semi-duplex operation. The KCU 951 should be placed in the USB mode. When using the KCU 1051 Control Display Unit, the ITU channel number may be used directly when the channel type is set for chITU. When using the KFS 594 Control Display Unit, the ITU channel number may be used directly with the MODE selector in the A3J position.

Note: The stations and ITU channels provided in the worldwide listings are those which have been authorized for operation. This does not necessarily indicate that each of these stations is presently active or that it is using all ITU channels assigned to it. This listing should be used as a guide only. It is highly recommended that the operator make prior arrangements with these stations before attempting contact to determine language used, rate and billing structure, actual channels used, times in operation and other essential data.

MARITIME RADIOTELEPHONE CHANNEL DESIGNATIONS

Channel (400s)	Aircraft Receive (kHz)	Aircraft Transmit (kHz)
401	4357.0	8195.0
402	4360.0	4068.0
403	4363.0	4071.0
404	4366.0	4074.0
405	4369.0	4077.0
406	4372.0	4080.0
407	4375.0	4083.0
408	4378.0	4086.0
409	4381.0	4089.0
410	4384.0	4092.0
411	4387.0	4095.0
412	4390.0	4098.0
413	4393.0	4101.0
414	4396.0	4104.0
415	4399.0	4107.0
416	4402.0	4110.0
417	4405.0	4113.0
418	4408.0	4116.0
419	4411.0	4119.0
420	4414.0	4122.0
421	4417.0	4125.0
422	4420.0	4128.0
423	4423.0	4131.0
424	4426.0	4134.0
425	4429.0	4137.0
426	4432.0	4140.0
427	4435.0	4143.0
428*	4351.0	4160.0

Table 7-5. Maritime Radiotelephone Channel Designations (400s)

Channel (600s)	Aircraft Receive (kHz)	Aircraft Transmit (kHz)
601	6501.0	6200.0
602	6504.0	6203.0
603	6507.0	6206.0
604	6510.0	6209.0
605	6513.0	6212.0
606	6516.0	6215.0
607	6519.0	6218.0
608	6522.0	6221.0

Table 7-6. Maritime Radiotelephone Channel Designations (600s)

Channel (800s)	Aircraft Receive (kHz)	Aircraft Transmit (kHz)
801	8719.0	8195.0
802	8722.0	8198.0
803	8725.0	8201.0
804	8728.0	8204.0
805	8731.0	8207.0
806	8734.0	8210.0
807	8737.0	8213.0
808	8740.0	8216.0
809	8743.0	8219.0
810	8746.0	8222.0
811	8749.0	8225.0
812	8752.0	8228.0
813	8755.0	8231.0
814	8758.0	8234.0
815	8761.0	8237.0
816	8764.0	8240.0
817	8767.0	8243.0
818	8770.0	8246.0
819	8773.0	8249.0
820	8776.0	8252.0
821	8779.0	8255.0
822	8782.0	8258.0
823	8285.0	8261.0
824	8788.0	8264.0
825	8791.0	8267.0
826	8794.0	8270.0
827	8797.0	8273.0
828	8800.0	8276.0
829	8803.0	8279.0
830	8806.0	8282.0
831	8809.0	8285.0
832	8812.0	8288.0
836*	8713.0	8113.0
837*	8716.0	8128.0

Table 7-7. Maritime Radiotelephone Channel Designations (800s)

Services

*THE AIRCRAFT/SHIP TRANSMIT FREQUENCIES FOR CHANNELS 428, 836 and 837 MAY VARY WORLDWIDE. The frequencies programmed into Bendix/King products are those assigned by the FCC (Federal Communication Commission, U.S.A.) for stations operating under FCC authorization. Contact appropriate authorities for frequencies authorized in other countries.

Channel (1200)	Aircraft Receive (kHz)	Aircraft Transmit (kHz)
1201	13077.0	12230.0
1202	13080.0	12233.0
1203	13083.0	12236.0
1204	13086.0	12239.0
1205	13089.0	12242.0
1206	13092.0	12245.0
1207	13095.0	12248.0
1208	13098.0	12251.0
1209	13101.0	12254.0
1210	13103.0	12257.0
1211	13107.0	12260.0
1212	13110.0	12263.0
1213	13113.0	12266.0
1214	13116.0	12269.0
1215	13119.0	12272.0
1216	13122.0	12275.0
1217	13125.0	12278.0
1218	13128.0	12281.0
1219	13131.0	12284.0
1220	13134.0	12287.0
1221	13137.0	12290.0
1222	13140.0	12293.0
1223	13143.0	12296.0
1224	13146.0	12299.0
1225	13149.0	12302.0
1226	13152.0	12305.0
1227	13155.0	12308.0
1228	13158.0	12311.0
1229	13161.0	12314.0
1230	13164.0	12317.0
1231	13167.0	12320.0
1232	13170.0	12323.0
1233	13173.0	12326.0
1234	13176.0	12329.0
1235	13179.0	12332.0
1236	13282.0	12335.0
1237	13185.0	12338.0
1238	13188.0	12341.0
1239	13191.0	12344.0
1240	13194.0	12347.0
1241	13197.0	12350.0

Table 7-8. Maritime Radiotelephone Channel Designations (1200s)

Channel (1600)	Aircraft Receive (kHz)	Aircraft Transmit (kHz)
1601	17242.0	16360.0
1602	17245.0	16363.0
1603	17248.0	16366.0
1604	17251.0	16369.0
1605	17254.0	16372.0
1606	17257.0	16375.0
1607	17260.0	16378.0
1608	17263.0	16381.0
1609	17266.0	16384.0
1610	17269.0	16387.0
1611	17272.0	16390.0
1612	17275.0	16393.0
1613	17278.0	16396.0
1614	17281.0	16399.0
1615	17284.0	16402.0
1616	17287.0	16405.0
1617	17290.0	16408.0
1618	17293.0	16411.0
1619	17296.0	16414.0
1620	17299.0	16417.0
1621	17302.0	16420.0
1622	17305.0	16423.0
1623	17308.0	16426.0
1624	17311.0	16429.0
1625	17314.0	16432.0
1626	17314.0	16435.0
1627	17320.0	16438.0
1628	17323.0	16441.0
1629	17326.0	16444.0
1630	17329.0	16447.0
1631	17332.0	16450.0
1632	17335.0	16453.0
1633	17338.0	16456.0
1634	17341.0	16459.0
1635	17344.0	16462.0
1636	17347.0	16465.0
1637	17350.0	16468.0
1638	17353.0	16471.0
1639	17356.0	16474.0
1640	17359.0	16477.0
1641	17362.0	16480.0
1642	17365.0	16483.0
1643	17368.0	16486.0
1644	17371.0	16489.0
1645	17374.0	16492.0
1646	17377.0	16495.0
1647	17380.0	16498.0
1648	17383.0	16501.0
1649	17386.0	16504.0
1650	17389.0	16507.0
1651	17392.0	16510.0
1652	17395.0	16513.0
1653	17398.0	16516.0
1654	17401.0	16519.0
1655	17404.0	16522.0
1656	17407.0	16525.0

Table 7-9. Maritime Radiotelephone Channel Designations (1600s)

Services

Channel (1800)	Aircraft Receive (kHz)	Aircraft Transmit (kHz)
1801	19755.0	18780.0
1802	19758.0	18783.0
1803	19761.0	18786.0
1804	19764.0	18789.0
1805	19767.0	18792.0
1806	19770.0	18795.0
1807	19773.0	18798.0
1808	19776.0	18801.0
1809	19779.0	18804.0
1810	19782.0	18807.0
1811	19785.0	18810.0
1812	19788.0	18813.0
1813	19791.0	18816.0
1814	19794.0	18819.0
1815	19797.0	18822.0

Table 7-10. Maritime Radiotelephone Channel Designations (1800s)

Channel (2200)	Aircraft Receive (kHz)	Aircraft Transmit (kHz)
2201	22696.0	22000.0
2202	22699.0	22003.0
2203	22702.0	22006.0
2204	22705.0	22009.0
2205	22708.0	22012.0
2206	22711.0	22015.0
2207	22714.0	22018.0
2208	22717.0	22021.0
2209	22720.0	22024.0
2210	22723.0	22027.0
2211	22726.0	22030.0
2212	22729.0	22033.0
2213	22732.0	22036.0
2214	22735.0	22039.0
2215	22738.0	22042.0
2216	22741.0	22045.0
2217	22744.0	22048.0
2218	22747.0	22051.0
2219	22750.0	22054.0
2220	22753.0	22057.0
2221	22756.0	22060.0
2222	22759.0	22063.0
2223	22762.0	22066.0

2224	22765.0	22069.0
2225	22768.0	22072.0
2226	22771.0	22075.0
2227	22774.0	22078.0
2228	22777.0	22081.0
2229	22780.0	22084.0
2230	22783.0	22087.0
2231	22786.0	22090.0
2232	22789.0	22093.0
2233	22792.0	22096.0
2234	22795.0	22099.0
2235	22798.0	22102.0
2236	22801.0	22105.0
2237	22804.0	22108.0
2238	22807.0	22111.0
2239	22810.0	22114.0
2240	22813.0	22117.0
2241	22816.0	22120.0
2242	22819.0	22123.0
2243	22822.0	22126.0
2244	22825.0	22129.0
2245	22828.0	22132.0
2246	22831.0	22135.0
2247	22834.0	22138.0
2248	22837.0	22141.0
2249	22840.0	22144.0
2250	22843.0	22147.0
2251	22846.0	22150.0
2252	22849.0	22153.0
2253	22852.0	22156.0

Figure 7-11 Maritime Radiotelephone
Channel Designations (2200s)

Channel (2500)	Aircraft Receiver (kHz)	Aircraft Transmit (kHz)
2501	26145.0	25070.0
2502	26148.0	25073.0
2503	26151.0	25076.0
2504	26154.0	25079.0
2505	26157.0	25082.0
2506	26160.0	25085.0
2507	26163.0	25088.0
2508	26166.0	25091.0
2509	26169.0	25094.0
2510	26172.0	25097.0

Figure 7-12 Maritime Radiotelephone
Channel Designations (2500s)

Table 7-13 Maritime RadioTelephone
Public Correspondence Stations

COUNTRY	NAME OF STATION	I.D.	CHANNEL NO.
ALBANIA	DURRES P.T. Radio	ZAD	402,805,1206, 1639,2226
ALGERIA	Alger Radio	7TA	410, 413, 424, 426, 601, 603, 605, 802, 809, 813, 825, 1207, 1215, 1217, 1232, 1629, 1631, 1636, 1641, 2205, 2225, 2227, 2238
ARGENTINA	Bahia Blanca Radio	LPW	406, 421, 601, 818, 821
	Corrientes Radio	LPB	424, 810
	General Pacheco Radio	LPL	413, 421, 426, 603, 606, 802, 814, 821, 1220, 1221, 1601, 1621, 2204, 2221
	Ushuaia Radio	LPC	410, 812, 1230
AUSTRALIA	Adelaide Radio	VIA	401, 419, 424, 603, 817, 1227
	Brisbane Radio	VIB	404, 415, 424, 603, 811, 1229
	Broome Radio	VIO	424, 603
	Carnarvon Radio	VIC	424, 603
	Darwin Radio	VID	415, 424, 603, 811, 815, 1227, 1229
	Esperance Radio	VIE	424, 603
	Hobart Radio	VIH	424, 603
	Melbourne Radio	VIM	404, 424, 603, 811, 1226

	Perth Radio	VIP	404, 424, 603, 811, 1226
	Rockhampton Radio	VIR	424, 603
	Sydney Radio	VIS	405, 417, 424, 603, 802, 829, 1203, 1231, 1602, 1610, 2203, 2223
	Thursday Island Radio	VII	424, 603
	Townsville Radio	VIT	419, 424, 603, 817
AZORES	Miguel Radio	CUG	426, 813, 1207, 1615, 1632, 2207, 2222
BAHRAIN	Bahrain Radio	A9M	413, 806, 1209, 1618
BANGLADESH	Chittagong Radio	S3D	402, 416, 421, 602, 606, 806, 821, 1202, 1221, 1603, 2202
	Khulna Radio	S3E	413, 416, 421
BARBADOS	Barbados Radio	8PO	407, 816, 825, 1213, 1640
BELGIUM	Oostende Radio	OSU	408, 411, 417, 421, 422, 425, 602, 606, 803, 805, 806, 812, 813, 815, 821, 829, 1207, 1213, 1215, 1218, 1219, 1221, 1609, 1613, 1621, 1625, 1627, 1630, 2209, 2214, 2219, 2221, 2225, 2239
BERMUDA	Bermuda Radio	VRT	410, 603, 817, 1220, 1618
BRAZIL	Belem Radio	PPL	404, 405, 419, 819, 821, 822, 830, 1228, 1633

Services

	Fortealeza	PPF	819, 821, 828
	Ilheus Radio	PPI	404, 405, 819, 821, 824
	Itajai Radio	PPC	404, 405, 819, 821, 822
	Juncao Radio	PPJ	404, 409, 419, 819, 821, 824, 828, 1228, 1617
	Manaus Radio	PPM	404, 405, 416, 819, 821, 830
	Natal Radio	PPN	404, 409, 819, 821, 830
	Olinda Radio	PPO	404, 405, 419, 819, 821, 824, 828, 1211, 1606
	Rio Radio	PPR	404, 405, 409, 416, 419, 819, 821, 822, 828, 830, 1214, 1221, 1611, 1613, 1621, 2221, 2238
	Salvador Radio	PPA	404, 409, 416, 819, 821, 822
	Santarem Radio	PPT	404, 409, 819, 821, 824, 1209
	Santos Radio	PPS	404, 409, 416, 819, 821, 824, 1219
	S Luis Radio	PPB	401, 409, 819, 821, 824
	Vitoria Radio	PPV	404, 409, 416, 819, 821, 828
CANADA	Cambridge Bay Coast Guard Radio	VFC	403
	Coppermine Coast Guard Radio	VFU	403
	Coral Harbor	VFU	407

	Frobisher Bay Coast Guard Radio	VFF	407, 603, 812, 1201, 1634
	Goose Bay Coast Guard Radio	VFZ	408
	Halifax Coast Guard Radio	VCS	413, 418, 605, 823, 1213, 1604
	Inuvic Coast Guard Radio	VFA	403
	Killinec Coast Guard Radio	VAW	407
	Resolute Coast Guard Radio	VFR	407,825
	Vancouver Coast Guard Radio	VAI	410, 605, 807, 1207, 1608, 2220
	Vancouver Radio (B.C. Tel.)	CFW	418
CAPE VERDE	Praia de Cabo Verde Radio	D4D	418, 820, 1218, 1623
	S. Vicente de Cabo Verde Radio	D4A	418, 820, 1218, 1623
CHILE	Valparaiso Playa Ancha Radio-maritima	CBV	401, 419, 421, 425, 601,606, 807, 809, 815,821, 1210, 1218, 1221, 1224, 1621, 1631, 1640, 2221, 2225, 2240
COLOMBIA	Barranquilla Radio	HKB	406, 826, 1203, 1615
	Buenaventura Radio	HKC	406, 826, 1203, 1615
COOK ISLANDS	Raratonga Radio	ZKR	401, 821,825
CUBA	Havana Radio	CLA	401, 418
CYPRUS	Cyprus Radio	5BA	406, 414, 421, 426, 603, 606, 807, 818, 820, 821, 829,

Services

			1201, 1208, 1221, 1230, 1603, 1621, 1632, 2212, 2218, 2221
DENMARK	Lyngby Radio	OYZ	401, 403, 409, 415, 418, 420, 421, 424, 426, 603, 605, 606, 801, 808, 811, 813, 818, 821, 823, 825, 827, 829, 1203, 1210, 1211, 1214, 1215, 1217, 1219, 1221, 1223, 1226, 1601, 1603, 1605, 1608, 1614, 1617, 1618, 1621, 1622, 1635, 1641, 2203, 2208, 2211, 2213, 2216, 2218, 2221, 2228, 2234, 2236
DJIBOUTI	Djibouti Radio	J2A	418, 827, 1210
EGYPT	Alexandria Radio	SUY	418, 605, 817, 1216, 1610, 2226
ETHIOPIA	Assab Radio	ETC	403, 605, 805
FIJI	Suva Radio	3DP	406, 810
FRANCE	S. Lys Radio	FFL	404, 405, 416, 419, 817, 825, 828, 830, 1222, 1226, 1229, 1231, 1604, 1619, 1628, 1633, 2204, 2226, 2231, 2235
FRENCH SOUTHERN & ANTARCTIC LANDS	S. Paul et Amsterdam Radio	FJY	411, 825
FINLAND	Hanko Radio	OFI	406, 413, 414, 417, 422
	Helsinki Radio	OHG	406, 413, 414, 417, 422, 802, 804, 805,

			809, 829, 1206, 1209, 1213, 1216, 1224, 1227, 1230, 1606, 1611, 1614, 1615, 1623, 1636, 1638, 2204, 2210, 2214, 2222, 2231
GAMBIA	Banjul Radio	C5G	405,829
GERMANY (FEDERAL REPUBLIC OF)	Norddeich Radio	DAP	401, 824, 1205, 1610, 2217
		DAK	412, 815, 1208, 1624, 2238
		DAH	413, 828, 1212, 1639, 2222
		DAJ	414, 601, 817, 1224, 1616, 2207
		DAI	423, 820, 1218, 1634, 2223
GERMAN (DEMOCRATIC REPUBLIC)	Ruegen Radio	Y5P	405, 407, 410, 419, 802, 809, 826, 831, 1202, 1204, 1206, 1232, 1619, 1629, 1633, 1640, 2220, 2224, 2226, 2230
GHANA	Takoradi Radio	9GA	402, 601, 823, 1202, 1616, 2213
GIBRALTAR	Gibraltar Naval Radio	GYU	401, 404, 602, 807, 1212, 1611, 2212
GREECE	Athinai	SVN	413, 415, 424, 425, 603, 802, 806, 808, 809, 814, 819, 820, 823, 1204, 1207, 1212, 1220, 1232, 1607, 1609, 1625, 1626, 1627, 1629, 1640, 2217, 2219, 2224, 2231, 2235

Services

GUINEA-BISSAU	Bissau Radio	J5M	13, 426, 802, 813, 1203, 1615, 1635
HONG KONG	Cape D'Aguilar Radio (Hong Kong Radio)		411, 417, 606
ICELAND	Hornafjoerdur Radio	TFT	406, 414, 416, 419
	Reykjavik Radio	TFA	406, 414, 416, 419, 601, 603, 805, 807, 809, 831, 1206, 1208, 1215, 1220, 1606, 1615, 1625, 1630, 2225, 2226
	Siglufjoerdur Radio	TFX	406, 414, 416, 419
INDONESIA	Amboina Radio	PKE	408, 826, 1210
	Banjarmasin Radio	PKG	411, 602, 816
	Belawan Radio	PKB	810, 1205
	Bitung Radio	PKM	418, 830, 1209
	Dumai Radio	PKP	401, 816, 1209
	Jakarta Radio	PKI	812, 1210, 1610, 2234
	Kupang Radio 604	PKK	604
	Makassar Radio	PKF	414, 828, 1201
	Palembang Radio	PKC	414, 830
	Sabang Radio	PKA	411, 826
	Semarang Radio	PKR	422, 604, 828
	Sorong Radio	PKY	422, 604, 828
	Surabaya Radio	PKD	408, 826, 1212
Telukbayur Radio	PKP	605	
IRAN	Abadan Radio	EQA	407, 604, 1605
	Abbas Radio	EQI	416, 604, 805, 1616, 2235
	Bushire Radio	EQM	405, 604, 810,

			1629, 2203
	Khark Radio	EQQ	410, 604, 1220
	Khoramshahr Radio	EQK	408, 604, 824, 1625, 2205
	Lavan Radio	EQR	420, 604
	Nowshahr Radio	EQO	420, 604
	Shahpoor Radio	EQN	402, 604, 829, 1231, 2233
ISRAEL	Haifa Radio	4XO	404, 410, 418, 423, 603, 604, 801, 805, 812, 821, 827, 1204, 1207, 1213, 1215, 1221, 1609, 1613, 1617, 1628, 2204, 2207, 2217
ITALY	Genova P.T. Radio	ICB	408, 409, 806, 823, 1205, 1211, 1608, 1614, 2216
	Roma P.T. Radio	IAR	402, 412, 420, 423, 602, 604, 814, 819, 820, 826, 831, 1206, 1209, 1213, 1218, 1230, 1603, 1606, 1616, 1624, 2202, 2211, 2223, 2237
IVORY COAST	Abidjan Peche Radia	TUA	404, 602, 806, 1212
	Abidjan Radio		419, 603, 822, 1205, 1634, 2225
JAMAICA	Kingston Jamaica Radio	6YI	405, 416, 605, 812, 1224
JAPAN	Tokyo Radio	JBO	407, 425, 426, 810, 812, 820, 1207, 1212, 1218, 1604, 1609, 1632, 2227, 2236, 2240

Services

KENYA	Mombasa Radio	5ZF	414,822
KIRIBATI (Republic of)	Tarawa Radio	T3T	411, 814
KOREA (Republuic of)	Seoul Radio	HLS	401, 419, 602, 605, 803, 827, 1213, 1229, 1634, 1637, 2209, 2222
LEBANON	Beyrouth Radio	ODR	426, 828, 1216
MADAGASCAR	Antalaha Radio		402
	Diego-Suarez Radio	5RL	415
	Fort-Dauphin Radio	5RD	406
	Maintirano Radio	5RO	415
	Majunga Radio		415
	Manakara-Sud Radio	5RN	402
	Manajary Radio	5RS	415
	Morondava Radio		406
	Nossi-Be Radio		406
	Tamatave Radio		406,426, 802, 813, 1203, 1207, 1615, 1632, 2207,2222
MADEIRA	Madeira Radio	CUB	413, 426, 802, 813, 1203, 1207, 1615, 1632, 2207, 2222
MARTINIQUE (French Dept.)	Fort de France Radio	FFP	404, 424, 825, 828
MEXICO	Acapulco, Guerrero Radio	XFA	403, 408, 421, 603, 604, 606, 809, 821, 826, 1209, 1221, 1222, 1604, 1614, 1621, 2221, 2225, 2234
	Chetumai, Quintana Roo Radio	XFP	404, 413, 421, 601, 604, 606, 817, 821, 829, 1209, 1221,

			1222, 1604, 1614, 1621, 2221, 2225, 2238
	Ciudad del Carmen Campeche Radio	XFB	404, 413, 421, 606, 809, 821, 826, 1209, 1221, 1222, 1604, 1614, 1621, 2221, 2225, 2234
	Coatzacoalcos, Veracruz Radio	XFF	404, 413, 421, 603, 604, 606, 817, 821, 829, 1221, 1222, 1225, 1604, 1614, 1621, 2221, 2234, 2238
	Cozumel, Quintana Roo Radio	XFC	403, 408, 421, 603, 604, 606, 809, 821, 826, 1209, 1221, 1225, 1604, 1614, 1621, 2221, 2225, 2234
	Ensenada, Baja California Radio	XFE	403, 413, 421, 603, 604, 606, 809, 821, 826, 1209, 1221, 1222, 1604, 1614, 1621, 2221, 2225, 2234
	Guaymas, Sonora Radio	XFY	404, 413, 421, 606, 817, 821, 829, 1209, 1221, 1225, 1604, 1614, 1621, 2221, 2225, 2238
	La Pax, Baja California Radio	XFK	404, 413, 421, 603, 604, 606, 817, 821, 829, 1221, 1222, 1225, 1604, 1621, 2221, 2234, 2238
	Manzanillo, Colima Radio	XFM	404, 413, 421, 601, 603, 606, 817, 821, 829, 1209, 1221, 1222, 1604, 1614, 1621, 2221, 2225, 2234

Services

	Mazatlan, Sinaloa Radio	XFL	403, 408, 601, 604, 606, 809, 821, 826, 1209, 1221, 1225, 1604, 1621, 2221, 2225, 2238
	Progreso, Yucatan Radio	XFN	404, 413, 421, 601, 603, 606, 817, 821, 829, 1221, 1222, 1225, 1614, 1617, 1621, 2221, 2234, 2238
	Salina Cruz, Oaxaca Radio	XFQ	404, 413, 421, 601, 604, 606, 817, 821, 829, 1221, 1222, 1225, 1604, 1621, 2221, 2234, 2238
	Tampico, Tamaulipas Radio	XFS	404, 413, 421, 601, 604, 606, 817, 821, 829, 1221, 1222, 1225, 1604, 1614, 1621, 2221, 2225, 2238
	Veracruz, Veracruz Radio	XFU	404, 413, 421, 601, 604, 606, 817, 821, 829, 1209, 1221, 1222, 1604, 1621, 2221, 2234, 2238
MONACO	Monaco Radio	3AC	403, 413, 421, 602, 804, 809, 821, 1221, 1224, 1607, 1621,
MOROCCO	Casablanca Radio	CNP	828, 1223, 1638
NAURUN	Nauru Radio	C2N	817
NETHERLANDS ANTILLES	Curacao Radio	PJC	408, 803, 1207, 1607

NETHERLANDS	Scheveningen Radio	PCG	405, 407, 410, 419, 421, 602, 606, 805, 806, 821, 826, 1207, 1213, 1219, 1221, 1621, 1623, 1636, 1639, 2205, 2221, 2232
NEW CALEDONIA & Dependencies	Noumea Radio	RJP	404, 805, 1205
NEW ZEALAND	Awarua Radio	ZLB	421
	Wellington Radio	ZLW	408, 421, 601, 807, 1209, 1606, 2213
NORWAY	Rogaland Radio	LGN	401, 403, 407, 409, 415, 418, 420, 421, 424, 425, 426, 603, 605, 606
		LFL	801, 803, 808, 809, 810, 811, 813, 818, 821, 823, 825, 827, 828, 829, 1203, 1204, 1205, 1210, 1211, 1213, 1214, 1217, 1218, 1219, 1221, 1222, 1223, 1225, 1226, 1228, 1231
		LFN	1601, 1603, 1604, 1605, 1607, 1608, 1610, 1613, 1614, 1617, 1618, 1619, 1620, 1621, 1622, 1627, 1629, 1635, 1641, 2202, 2203, 2208, 2211, 2213, 2215, 2216, 2218, 2221, 2228, 2230, 2233, 2234, 2236, 2237, 2239, 2240

Services

PAPUA NEW GUINEA	Port Moresby Radio	P2M	409, 417, 604, 805
	Rabaul Radio	P2R	409, 417, 604, 805, 1225
PHILIPPINES	Bacoor Radio	DZI	409, 605, 817, 1220, 1605
	Bulacan Radio	DZJ	418, 603, 814, 1201, 1605
	Bulacan Radio	DZO	409, 605, 820, 1220, 1605
	Cebu Radio	DYP	825
	Iloilo Radio	DYV	412, 820
	Manila Radio	DZZ	418, 603, 808, 1201, 1605
POLAND	Gdynia Radio	SPF	402, 804, 1209, 1633, 2206
		SPD	406, 824, 1229, 1631, 2232
		SPC	423, 602, 812, 1216, 1607, 1215
		SPG	806, 1231, 2209
		SPR	404, 830, 1227, 1638
		SPO	408, 604, 810, 1220, 1625, 2219
FRENCH POLYNESIA	Mahina Radio	FJA	416, 829, 1605
PORTUGAL	Lisboa Radio	CUL	413, 602, 802, 1203, 1615, 1632, 2207, 2222
PUERTO RICO	Q.P.P.A. Radio	A7S	423, 804, 1229, 1626, 2235

REUNION (French Dept.)	S. Denis Reunion	FFD	404, 418, 819, 824
SAMOA (American)	Pago Pago Radio	KUQ	408, 806, 1232, 1638
SAMOA (Western)	Apia Radio	5WA	603, 820, 1213, 1624, 2219
SAUDI ARABIA	Dammam Radio	HZG	406, 409, 421, 601, 603, 606, 808, 811, 821, 1202, 1221, 1223, 1602, 1609, 1621, 2221, 2222, 2231
SENEGAL	Dakar Radio	6VA	404, 803, 1212, 1629, 2220
SEYCHELLES (Republic of)	Seychelles Radio	S7Q	410, 818, 1215, 1601
S. HELENA	S. Helena Radio	ZHH	414, 807, 1217
SINGAPORE	Singapore Radio	9VG	405, 407, 602, 606, 804, 815, 821, 824, 1216, 1219, 1221, 1613, 1621, 1641, 2212, 2221
SOLOMON ISLANDS	Honiara Radio	VQJ	830
SOUTH AFRICA	Cape Town Radio	ZSC	405, 421, 821, 1209, 1608, 2204
	Durban Radio	ZSD	407, 421, 602, 808, 821, 1221, 1224, 1633, 2206
SPAIN	Pozuelo del Ray Radio	EHY	401, 406, 407, 409, 411, 416, 601, 604, 803, 804, 810, 816, 818, 1201, 1208, 1210, 1225, 1227, 1620, 1630, 1634, 1637, 1639, 2201, 2224, 2226, 2229, 2234

Services

SWEDEN	Goteborg Radio	SAG	401, 403, 409, 418, 420
		SAB	424, 603, 605, 801, 803, 808, 811, 818, 825, 827, 829, 1203, 1210, 1211, 1214, 1215, 1217, 1219, 1223, 1226, 1601, 1603, 1605, 1608, 1614, 1617, 1618, 1622, 1635, 1641, 2203, 2208, 2211, 2213, 2218, 2228, 2230, 2234
	Harnosand Radio	SAH	401, 420, 424
SWITZERLAND	Bern Radio	HEB	408, 424, 822, 824, 831, 1202, 1227, 1230, 1611, 1615, 1631, 2214, 2220, 2232
TOGO	Lome Radio	5VA	403
TURKEY	Antalya Radio	TAM	409, 1620
	Canakkale Radio	TAM	407, 810, 1226
	Iskenderun Radio	TAM	420
	Istanbul Radio	TAN	417, 811, 831, 1218, 1608, 2230
	Izmir Radio	TAN	401, 602, 1618
	Mersin Radio	TAM	803, 1206, 1216, 1611, 2213, 2214
	Samsun Radio	TAN	420, 1606
	Trabzon Radio	TAO	401, 602
	Zonguldak	TAN	411, 1222
TUVALU	Funafuti Island Radio		814, 1207, 1608
UNITED KINGDOM	Portishead Radio	GKT	402, 406, 410, 802, 1201, 1202, 1206,

		GKV	1602, 1606, 2206 426, 822, 826, 1224, 1228, 1230, 1623, 2227, 2229
		GKU	816, 819, 1611, 1615, 1618, 2212, 2220
		GKW	831, 1232, 1632, 1637, 1640
U.S.S.R.	Arkhangelsk Radio		401, 823, 1209, 1626
	Baku Radio		405, 807
	Jdanov, Donetskoj Radio		413, 1641
	Kholmnsk Radio		1626, 2213
	Leningrad Radio		414, 807, 1204, 1605, 2213
	Moskva Radio		1201, 1606, 2207
	Murmansk Radio		402, 824
	Nakhodka, Primorskogo Radio		1613
	Novorossiisk, Krasnodarskogo Radio		405, 815, 1209, 1601, 2231
	Odessa Radio		1205, 1623, 2202, 2218
	Riga Radio		401, 1205, 1630
	Vladivostok Radio		401, 603, 805, 1201, 1607, 2202
UNITED STATES	Mobile, Alabama Radio	WLO	824, 829, 830, 1212, 1225, 1226, 1607, 1632, 1641, 2227, 2231, 2237
	Point Reyes California Radio	KMI	401, 416, 417, 804, 809, 822, 1201,

Services

	Fort Lauderdale, Florida Radio	WOM	1202, 1203, 1229, 1602, 1603, 1624, 2214, 2223, 2228, 2236 403, 412, 417, 423, 802, 805, 810, 814, 825, 831, 1206, 1208, 1209, 1215, 1223, 1230, 1601, 1609, 1610, 1611, 1616, 2215, 2216, 2222
	Manahawkin, New Jersey Radio	WOO	410, 411, 416, 422, 808, 811, 815, 826, 1203, 1210, 1211, 1228, 1605, 1620, 1626, 1631, 2201, 2205, 2210, 2236
VANUATU	Port-Vila Radio	YJM	410,421, 606, 818
VIETNAM	Hai Phong Radio	XVG	403, 421
	VUNG Tau Radio	XVR	413, 415
YEMEN (P.D.R. of)	Aden Radio	XVG	412, 819
YUGOSLAVIA	Rijeka Radio	YUR	408, 419, 602, 605, 810, 830, 1224, 1229, 1611, 1627, 2204, 2206, 2239

SECTION VIII

TIME & FREQUENCY STANDARD

BROADCAST STATIONS

DESCRIPTION OF SERVICES

A worldwide network of high frequency radio stations has been established to broadcast time and frequency signals and other information on HF frequencies. Although this information is broadcast for a wide variety of users, it can be very useful to pilots.

WWV AND WWVH

In the United States, two of these stations are operated by the National Institute of Standard Technology (NIST). These are WWV located at Fort Collins, Colorado, and WWVH located at Kekaha, Kauai, Hawaii. The NIST broadcasts continuous signals from these high frequency radio stations on 2.5, 5.0, 10.0 and 15.0 Mhz. WWV also broadcasts on an additional frequency of 20.0 Mhz. Use the AM receiver mode when listening to these stations.

Frequency Mhz Radiated Power, KW

	WWV	WWVH
2.5	2.5	5.0
5.0	10.0	10.0
10.0	10.0	10.0
15.0	10.0	10.0
20.0	2.5	

All frequencies carry the same program, but because of changes in ionospheric conditions which adversely affect the signals transmission, the KHF 950 will normally not be able to receive the signal on all frequencies at all times in all locations. Except during times of severe magnetic disturbances, however, it should be able to receive the signal on at least one of the broadcast frequencies.

As a general rule, frequencies above 10 MHz provide the best daytime reception while the lower frequencies are best for nighttime reception.

The time and frequency broadcasts are controlled by the primary NIST Frequency Standard in Boulder, Colorado. The frequencies as transmitted are accurate to within one part of 100 billion (1×10^{-11}) at all times

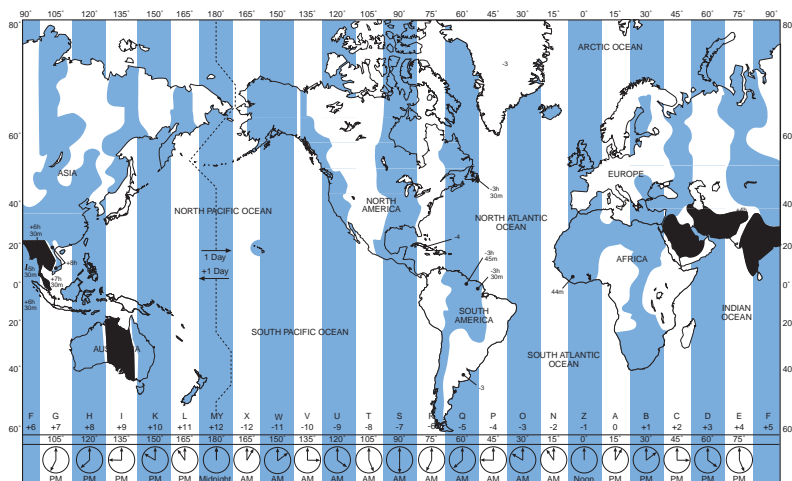

Among the services provided by these stations are:

- Time Announcements
- Geophysical Alerts
- Omega Navigation System Status Reports
- GPS Status Announcement
- Marine Storm Warnings

TIME ANNOUNCEMENTS

Voice announcements are made from WWV and WWVH once every minute. To avoid confusion, a man's voice is used on WWV and a woman's voice on WWVH. The WWVH announcement occurs first - at 15 seconds before the minute - while the WWV announcement occurs at 7.5 seconds before the minute.

The time referred to in the announcements is "Coordinated Universal Time" (UTC). It is coordinated through international agreements by the International Time Bureau (BIH) so that time signals broadcast from the other stations like WWV throughout the world will be in close agreement. The specific hour and minute mentioned is actually the time at the time zone centered around Greenwich, England, and may

be considered generally equivalent to the more well known “Greenwich Mean Time” (GMT).

The most frequent sounds heard on WWV and WWVH are the pulses that mark the seconds of each minute, except for the 29th and 59th seconds pulses which are omitted completely.

GEOPHYSICAL ALERTS ON WWV

WWV broadcasts geophysical alert announcements at 18 minutes past each hour. (A similar recorded message can be heard by calling commercial number (303) 497-3235.) These broadcasts contain information on solar activity which can cause disturbances in the earth’s magnetic field which, in turn, can reduce the effectiveness of HF propagation in the ionosphere. However, this geophysical alert data is in a raw form and must be interpreted by the pilot if he wants to determine what this information means for HF propagation conditions. These broadcasts do not make HF propagation forecasts which predict the best frequencies to use.

However, several values reported on these broadcasts provide useful clues as to whether HF propagation conditions are likely to be good or bad. The following discussion may aid in determining the meaning of the geophysical alert announcement.

The disturbance of the earth’s geomagnetic field is caused by solar particle radiation. The K index measures how disturbed the earth’s geomagnetic field is. It is taken every three hours. Generally speaking, the higher the K index, the poorer HF propagation will be. Possible K index values run from 1 to 9. K values of 5 or 6 indicate you may have difficulty communicating on HF. This is particularly true if you are flying north of 60 degrees North or south of 60 degrees South because geomagnetic disturbances cause HF communications to deteriorate more in polar regions than in middle latitudes or around the equator. Geomagnetic disturbances can even improve the availability of higher frequencies in equatorial latitudes.

If K index values are 7, 8 or 9, HF communications may be impossible in polar regions. If you are flying above 60 degrees North you might try calling a ground station closer to the equator in a region less affected by magnetic disturbances. If you are flying south of 60 degrees South, also call a station toward the equator.

As HF communications deteriorate in polar regions, you are likely to lose the use of the lower frequencies in the window of usable frequencies first. Then the higher frequencies may start to go as well.

During periods of geomagnetic disturbances, the window of usable frequencies is likely to shift rapidly.

As the K index goes up and geomagnetic disturbance increases, HF propagation is deteriorating because the density of electrically charged particles in the ionosphere is being reduced. The fewer of these particles there are, the less effective the ionosphere becomes as a mirror reflecting HF radio waves back toward earth. The lower frequency radio waves start to be absorbed in the ionosphere and the higher frequency ones start to shoot through to outer space.

Another index reported in the geophysical alert announcements is the A index. As mentioned earlier, the K index is measured every 3 hours. Eight successive K values over a 24 hour period are used to derive the A index. The K values are equated to a quasi-logarithmic scale and averaged.

The A index is a measure of how disturbed the geomagnetic field has been over a 24 hour period. A index values vary with each observation station. At Boulder, Colorado, for example, the range of values is 0 to 400. Values from 7 to 15 indicate an unsettled condition. From 15 to 30 indicates an active condition. From 30 to 50 indicates a minor geomagnetic storm. Above 50 indicates a major geomagnetic storm (a condition which occurs very seldom but which can make HF communications impossible.)

The final index included in these geophysical alert broadcasts which you might find useful is the 10 centimeter solar flux. Solar flux is a measure of the level of ultraviolet solar radiation. Solar radiation makes the ionosphere a better mirror for reflecting HF radio waves because it causes ionization or the formation of electrically charged particles which serve to bend HF radio waves back toward earth. So it stands to reason that the more solar radiation there is (that is the higher the value reported for solar flux), the better HF propagation will be. Solar flux levels are also a measure of how well the ionosphere may stand up to geomagnetic disturbances or storms. A high solar flux indicates the ionosphere is hard and will withstand more disturbances than if solar flux is low and the ionosphere is relatively soft.

Solar flux values can run from 65 to over 400. Normal daily levels will be within this range. Generally speaking, the higher this number is, the better HF propagation will be.

So if you listen to the geophysical alert announcements on WWV or call up the commercial number, and you determine the A and K indices and the 10 centimeter solar flux, you will be in a position to know whether you can expect successful HF communications or con-

siderable difficulty getting through. With few exceptions, the higher the solar flux and the lower the A and K index values (level of geomagnetic disturbance), the better HF propagation conditions should be and vice-versa.

See Appendix A for more information on the format of geophysical alert broadcasts and a glossary of related terms. Incidentally, prior to September 30, 1976, radio propagation forecasts useful to an HF user were broadcast on WWV. Some of this information is in geophysical alert announcements, but no forecasts of the actual frequencies you should use is available on a broadcast at this time.

OMEGA NAVIGATION SYSTEM STATUS REPORTS

WWV and WWVH also broadcast status reports on the Omega Navigation System. The Omega System is a very low frequency navigation aid operating in the 10 to 14 kHz frequency band. These broadcasts are in voice from WWV at 16 minutes after the hour and from WWVH at 47 minutes after the hour. Eight Omega stations are in operation around the world. Omega signals are subject to degradation caused by ionospheric disturbances at high latitudes. The Omega announcements on WWV and WWVH are given to provide users with immediate notification of such events and other information on the status of the Omega system.

GLOBAL POSITIONING SYSTEM (GPS) STATUS ANNOUNCEMENT

Since March 1990 the U.S. Coast Guard has sponsored two voice announcements per hour on WWV and WWVH, giving current status information about the GPS satellites and related operations. The 45-s announcements begin at 14 and 15 minutes after each hour on WWV and at 43 and 44 minutes after each hour in WWVH. For further information, contact the Commanding Officer, U.S. Coast Guard Center, 7323 Telegraph Road, Alexandria, VA 22310-3998.

MARINE STORM WARNINGS

Weather information about major storms in the Atlantic and Eastern North Pacific is broadcast on WWV at 8, 9 and 10 minutes past each hour. Similar storm warnings on the Eastern and Central North Pacific are given from WWVH at 48, 49 and 50 minutes after each hour. An additional segment (at 11 minutes after the hour on WWV and at 51 minutes on WWVH) may be used when there are unusually widespread storm conditions.

Services

If there are no warnings in the designated areas, the broadcasts will so indicate.

The ocean areas involved are those for which the U.S. has warning responsibility under international agreement.

The storm warnings are originated by the National Weather Service (NWS) at 0500, 1100, 1700 and 2300 UTC for WWV and 0000, 0600, 1200 and 1800 for WWVH. These broadcasts are updated effective with the next scheduled announcement following the time of issue.

Pilots may find these storm warnings useful even though they are prepared primarily for mariners. An example follows:

North Atlantic weather west of 35 West at 1700 UTC: Hurricane Donna intensifying, 24 North, 60 West, moving northwest, 20 knots, winds 75 knots; storm, 65 North, 35 West, moving east, 10 knots, winds 50 knots, seas 15 feet.

Information regarding these announcements may be obtained from the Director, National Weather Service, Silver Spring, Maryland 20910.

TIME AND FREQUENCY STANDARD SERVICES WORLDWIDE

WWV and WWVH are two of the stations broadcasting time and frequency standard signals around the world. Other stations, all run by government agencies in their respective countries, are listed below along with the frequencies on which they operate.

FREQUENCY (Mhz)	CALL	LOCATION
2.5	WWV	Fort Collins, Colorado, USA
2.5	WWVH	Kekaha, Hawaii, USA
2.5	JJY	Tokyo, JAPAN
2.5	RCH	Tachkenti, USSR
2.5	RAT	Moscow, USSR
3.330	CHU	Ottawa, CANADA
5.0	WWV	Fort Collins, Colorado, USA
5.0	WWVH	Kekaha, Hawaii, USA
5.0	RAT	Moscow, USSR
5.0	BSF	Taipei, TAIWAN
7.335	CHU	Ottawa CANADA
10.0	WWV	Fort Collins, Colorado, USA
10.0	WWVH	Kekaha, Hawaii, USA
10.0	JJY	Tokyo, JAPAN
10.0	RWM	Moscow, USSR
14.670	CHU	Ottawa, CANADA
15.0	WWV	Fort Collins, Colorado, USA
15.0	WWVH	Kekaha, Hawaii, USA
15.0	JJY	Tokyo, JAPAN
15.0	RWM	Moscow, USSR
20.0	WWV	Fort Collins, Colorado, USA

Table 8-2 Time And Frequency Standard Services Worldwide

This Page Intentionally Left Blank

SECTION IX

VOLMETS

VOLMET broadcasts are routine reports of meteorological information for aircraft in flight. These broadcasts are made on VHF as well as HF radio. The VHF reports contain current aerodrome weather reports, with trend information where available. The current observation usually includes temperature, dew point and altimeter setting. The HF reports include the current information as well as aerodrome forecasts.

The ICAO outlines the contents of VOLMET broadcasts, but the broadcasts themselves are made by such government agencies as the FAA in the United States. The sequence in which VOLMETS are broadcast for each aerodrome is published, as are the times of the broadcasts. Consult current aeronautical publications for listings. Each ground station may broadcast information for a variety of aerodromes on each HF frequency it is using for VOLMETS.

For example, the FAA's International Flight Service Station at Islip, Long Island, gathers weather information on a variety of airports in the Northeast and upper Midwest. The current observations and forecasts are taken from teletype and used to prepare the VOLMET broadcast which is made by the FAA in New York currently on four HF frequencies: 3001, 5652, 8868 and 13272 kHz. These automated voice broadcasts include the current weather observation for up to 25 airports plus 16 terminal area forecasts.

ICAO recommends that the aerodrome weather forecasts in VOLMETS have a period of validity of nine hours, and should be issued every three hours to ensure that a forecast reflects the latest opinion of the meteorological office.

SIGMETS are also supposed to be included in VOLMET broadcasts, or the word "NIL SIGMET", which means there is no SIGMET.

Jeppesen publishes a meteorology section available as part of its subscription service which includes the sequence of reports for VOLMETS. For example, from 00 to 05 past the hour, New York broadcasts forecasts for Detroit, Chicago and Cleveland, with hourly reports on these three stations plus Niagara Falls, Milwaukee and Indianapolis. The hourly sequence of reports is listed in chart form. New York broadcasts on a 24 hour basis. Jeppesen also publishes an index on its meteorological section where you may look up the airport you are seeking weather reports for (Windsor Locks, for example) and find which ground station broadcasts the report (New York).

Services

This way you don't have to page through the list of all ground stations searching for a reference to the airport for which you want a forecast.

Other agencies around the world like the FAA also broadcast VOLMETS. These can be very useful when flying over water. The New York station, for example, may be received as you are flying over the North Atlantic and allow you to begin planning your arrival and alternate intentions based on forecast weather for the airports you are planning to use.

ICAO agreements call for changes in the existing frequencies assigned for VOLMET broadcasts, and activating new VOLMET broadcasts in some regions which don't have any at this time. This transition is currently in progress. Therefore, you should check current aeronautical publications and NOTAMs for the most recent information on frequencies and broadcasts in use.

SECTION X EMERGENCY FREQUENCIES

INTERNATIONAL DISTRESS FREQUENCY

The frequency 2182 kHz has been designated as an International Distress Frequency. It is monitored worldwide and should be used only in the case of an actual emergency. If repeated calls on 2182 kHz do not bring a response, the flight crew may wish to try the U.S. Coast Guard on the following channels:

ITU Channel No.	Aircraft Receive (kHz)	Aircraft Transmit (kHz)
424	4428.7	4134.3
601	6506.4	6200.0
816	8765.4	8241.5
1205	13113.2	12342.4
1625	17307.3	16534.4

Table 10-1 U.S.C.G. CHANNELS/FREQUENCIES

If the Coast Guard can't be reached on one of these channels/frequencies, try a maritime radiotelephone (public correspondence) operator channel. The marine operator may be able to connect you to the Coast Guard or to commercial vessels in your area.

It is also possible to obtain emergency assistance from the Air Traffic Control agency you are in contact with via HF ground stations. If you declare an emergency to Air Traffic Control, you can receive special handling similar to services provided on VHF to an aircraft in distress.

The Code of Federal Regulations Title 47 Part 80 state that;

The Frequencies 4125.0 kHz, 6215 kHz, 8291 kHz, 12290 kHz and 16420 kHz may be used by coast and ship stations on a simplex basis for distress and safety communications. The frequency 5167.5 kHz is available to any station for emergency communications in the State of Alaska.

This Page Intentionally Left Blank

SECTION XI SHORTWAVE BROADCASTS

SHORTWAVE BROADCASTS

At various times the flight crew or passengers may find it desirable to monitor a shortwave radio broadcast station from a particular area of the world on the KHF 950/990.

Listed are radio stations from over 75 countries, many of which transmit in English and a few of the other major languages of the world. Some of these stations beam their transmissions in different directions at various times of the day. Also, not all frequencies of a particular station may be transmitting at the same time. The KHF 950/990 should be in the AM mode when receiving these stations.

These stations broadcast a variety of information including news and weather as well as entertainment programs. See appendix C, reference five, for a source of useful information concerning shortwave broadcasts.

Table 11-1. Shortwave Broadcasts For Various Countries

COUNTRY	CITY	FREQUENCIES (KHz)
Afghanistan	Kabul	4775,15195
Albania	Tirana	6200, 7065, 7075, 7080 7120, 7300, 9480, 9500, 9515, 9750, 11965, 11985
Algeria	Algiers	7245
Angola (National Radio Station of Angola)	Luanda	7245, 9660, 11955
Argentina (R.A.E.)	Buenes Aires	9690, 11710
Australia (Radio Australia)	Melbourne	5995, 6005, 6035, 6060, 6080, 9505, 9570, 9580, 9670, 9770, 11705, 11720, 11740, 11790, 11820, 11870, 11880, 15160, 15240, 15310, 15320, 17725, 17755, 17795, 17870, 17890, 21525,

Services

		21570, 21680, 21740
Austria	Vienna	5945, 6155, 9770, 15360, 15410, 15560, 17860, 21575, 21610, 21740
Bagladesh (Radio Bangladesh)	Dacca	11765, 15285, 15375, 15400, 17890, 21670, 21685
Belgium (Radio Bolivia)	La Paz	4895
Brazil (International Service Of Radio Brazil)	Brasilia	15270, 15280, 15290
Bulgaria	Sofia	9700, 9705, 11720, 11735, 11750, 11765, 15135, 15310, 15330, 17825
Burma (Burma Broadcasting Service)	Rangoon	5985, 7185, 9730
Canada (Radio Canada International)	Monteal	5960, 5965, 6045, 6140, 6195, 7155, 7235, 9535, 9555, 9605, 9655, 9715, 9730, 9755, 11735, 11775, 11825, 11845, 11855, 11905, 11915, 11935, 11940, 11945, 15265, 15325, 15355, 17820, 17860, 17865, 17875
Chile	Santiago	9565
China (Mainland) (Radio Peking)	Peking	6810, 6995, 8300, 8425, 9290, 9820, 9860, 9880, 11455, 11500, 11600, 11650, 11685, 11695, 11725, 11845, 12055, 12450, 15060, 15095, 15125, 15230, 15270, 15285, 15315, 15520, 17530, 17635, 17680, 17810, 17855

China (Nationalist)	Taipei	9600, 9685, 9765, 11725, 11745, 11825, 11860, 15225, 17890
Congo	Brazzaville	3232, 4765, 15210
Costa Rica (TIFC)	San Jose	5055, 9645
Cuba (Radio Havana)	Havana	9525, 9770, 11725, 11760, 17750, 17885
Czechoslovakia	Prague	5930, 6055, 7245, 7345, 9540, 9605, 9630, 11855, 11990, 15110, 17705, 17775, 17850, 21700
Dominican Republic (Radio Santo Domingom HISD)	Santo Domingo	5965,9505
Equador	Quito	6095, 6130, 9560, 9635, 9745, 11820, 11900, 11915, 15115, 15380, 17865, 17890, 21480
Egypt	Cairo	6230, 9475, 9805, 15235, 15255 , 17920
Ethiopia	Addis Ababa	5990, 7110, 7165, 9615
Finland (Finnish Broadcasting Company)	Helsinki	6120, 9565, 9585, 11735, 11755, 11910, 15210, 15265, 15270, 21495
France (Radio France International, Corp. Radiophonique)	Paris	7135, 9595, 11745, 11845, 11930, 15200, 15210, 15300, 15360, 15425, 17720, 17795, 17850, 17860, 21580, 21675
Germany (East) (Radio Berlin International)	Berlin	6080, 6115, 7185, 7260, 7300, 9665, 9730, 11720, 11795, 11840, 11890, 11970, 15145, 15165, 15170, 15390, 17700, 21465, 21485, 21540
Germany (West)	Cologne	5960, 6040, 6075, 6085,

Services

(Radio Deutsche Welle)		6100, 6185, 7130, 7150, 7210, 7225, 7285, 9545, 9565, 9650, 9690, 9700, 9735, 9765, 11765, 11785, 11850, 11905, 11945, 11965 15125, 15135, 15150, 15165, 15240 15275, 15410, 17730, 17765, 17780, 17795, 17800, 17875, 21500, 21540, 21600, 21640
Great Britain Broadcasting Corp. —BBC)	London British	5975, 6005, 6050, 6120, 6175, 6180, 6196, 7120, 7130, 7140, 7150, 7180, 7185, 7230, 7325, 9410, 9519, 9570, 9580, 9590, 9650, 9740, 9760, 9915, 11750, 11760, 11775, 11910, 11955, 12090, 12095, 15070, 15105, 15215, 15260, 15280, 15310, 15380, 15400, 15420, 15435, 17705, 17770, 17790, 17830, 17840, 17885, 21470, 21550, 21555, 21660, 21710, 25650
Greece	Athens	6140, 7125, 7205, 9515, 9530, 9640, 9655, 9760, 11730, 11845, 11925, 15160, 15325, 17785, 17840, 21455, 21655
Guam (Radio Guam)	Agana	11730, 11840, 15225, 17855
Hungary	Budapest	6025, 6105, 6110, 7155, 7200, 9585, 9655, 9833, 9835, 11910, 15160, 15220, 15225, 17710, 17785, 21525
India (All India Radio)	New Delhi	7215, 9535, 9715, 9755, 9912, 11620, 11770,

		11810, 11875, 11925, 15110, 15165, 15190, 15205, 15235, 15335, 15387, 17705, 17875, 21695
Indonesia	Djakarta	11790, 15200
Iran	Tehran	9022
Iraq	Baghdad	9745, 11935
Israel	Jerusalem	9009, 9425, 9815, 11655, 15105, 15330, 15485, 17645, 11655, 15105, 15330, 15485, 17645, 17685, 21495, 21625, 25640
Italy (Italian Radio and Television Service)	Rome	5990, 7235, 7275, 9575, 9710, 11800, 11905, 15315, 15330, 17795
Japan (Radio Japan-NHK)	Tokyo	9505, 9585, 9675, 11705, 11815, 11855, 11875, 15135, 15195, 15235, 15270, 15310, 17725, 17755, 17810, 17825, 17855, 17880, 21619, 21640
Jordan (Radio Jordan)	Amman	7155, 9560
Kenya	Nairobi	4805, 7120
Korea (South) (Korean Broadcasting Corp.)	Seoul	7275, 7550, 9525, 9570, 9580, 9640, 9720, 9870, 11860, 11965
Kuwait (Radio Kuwait)	Kuwait	9575, 17850
Liberia (ELWA)	Monrovia	6090
Luxembourg	Luxembourg	6090
Maylaysia	Kuala Lumpur	6175, 9750, 15295

Services

Monaco	Monte Carlo	7105, 7245, 9525, 9640
Mozambique (Radio Mozambique)	Lourenco Marques	3265, 4855, 6005
Nepal (Radio Nepal)	Kathmandu	3424, 5005
Netherlands (Dutch World Broadcasting System)	Hilversum	5055, 6020, 6045, 6165, 7240, 9590, 9715, 9770, 9895, 11720, 11730, 11740, 11930, 15220, 15235, 17700, 17810, 17855, 26140
New Zealand (Radio New Zealand)	Wellington	6105, 11945, 11960, 15280, 17770
Nigeria, (Western Nigeria Broadcasting Service)	Lagos	7255, 11770, 15120, 15185
Norway (Radio Norway)	Oslo	6015, 9590, 9605, 9610, 9645, 11850, 11860, 11870, 11895, 15135, 15170, 15175, 15345, 17755, 17795, 17840, 21655, 21730
Pakistan (Radio Pakistan)	Karachi	11675, 15470, 17640, 17662, 17665, 17830, 21450, 21485, 21545, 21590, 21605, 21655, 21755
Philippines (Far East Broadcasting Company)	Manila	9580, 9590, 11765, 11805, 11855, 11890, 11950, 11955, 15135, 15215, 15280, 15320, 15440, 15450, 17790, 21515
Poland (Polskie Radio Warsaw)	Warsaw	5995, 6095, 6135, 7125, 7145, 7270, 7285, 9525, 9540, 9675, 11815, 11840, 15120

Portugal (Radio Portugal)	Lisbon	6025, 9740, 11935, 15340, 17880
Romania (Radio Bucharest)	Bucharest	5990, 7195, 9570, 9690, 11735, 11790, 11830, 11840, 11940, 15250, 15255, 15335, 15345, 15365, 15380, 17720, 17745, 17805, 17850
Saudi Arabia (Radio Bucharest)	Bucharest	11855
Senegal (Senegalese Broadcasting System)	Dakar	4890, 11895
Sierra Leone (Sierra Leone Broadcasting Service)	Freetown	3316
Singapore (Radio Singapore)	Singapore	5010, 11940
Solomon Islands (Solomons Radio)	Honiara	5015, 9545
Somalia	Mogadiscio	9585
South Africa (Radio Sweden)	Johannesburg	6065, 9630, 9695, 11705, 11905, 15240, 15275, 21615, 21690, 21700
Switzerland (Radio Switzerland)	Bern	6135, 9560, 9725, 11715, 15125, 15130, 15305, 15430, 17730, 17735, 17795, 17830, 17850, 21520, 21545, 21570, 21630, 21695
Taiwan	Taipei	9600, 9685, 9765, 11725, 11745, 11825, 11860, 15225, 17890
Tanzania (Radio Tanzania)	Dar es Salaam	6105, 9750, 15435
Thailand (Radio Thailand)	Bangkoc	9655, 11905

Services

Turkey	Ankara	6185, 7170, 9515, 11955, 15135, 17775
Uganda (Uganda Broadcasting Corp.)	Kampala	6030, 9515, 9730, 15325
United States, (World International Broadcasters, WIBN)	Red Luion, PA	15185, 17720
United States (WYFR—Family Radio Network)	Scituate, MA	11855, 15440, 17785, 17845, 17870, 17875, 21525, 21615
United States (United Nations)	New York, NY	6055, 6135, 9540, 9600, 9605, 9620, 11770, 11830, 11900, 11905, 15120, 15225, 15235, 15250, 15305, 21670
United States (American Forces Radio and Television Service)	Washington DC	6030, 9685, 9700, 11790, 11805, 15330, 15425, 15430, 17765, 21570, 25620
United States (Voice Of America)	Washington DC	3980, 5955, 5995, 6040, 6045, 6060, 6110, 6130, 6170, 6185, 7105, 7110, 7170, 7190, 7195, 7200, 7230, 7235, 7270, 7295, 7325, 9345, 9565, 9640, 9670, 9700, 9730, 9760, 9770, 11710, 11715, 11740, 11745, 11760, 11915, 11925, 11935, 12010, 15140, 15155, 15160, 15185, 15195, 15205, 15215, 15260, 15290, 15330, 15395, 15400, 15445, 17710, 17740, 17785, 17790, 17820, 17870, 17895, 21450, 21610, 25990, 26040, 26095
USSR	Kiev	5950, 5970, 6020, 7125,

(Radio Kiev)		7150, 7175, 7215, 7260, 7320, 9580, 9635, 9800, 11600, 12000, 15100, 15240, 15265, 15780, 16190, 17870,
USSR (Radio Moscow)	Moscow	4860, 5900, 5920, 5940, 5980, 6010, 6020, 6080, 6130, 6150, 6175, 7105, 7115, 7125, 7150, 7165, 7175, 7195, 7200, 7205, 7210, 7260, 7270, 7300, 7330, 7400, 7420, 7440, 7490, 7925, 8125, 9450, 9500, 9560, 9565, 9575, 9580, 9590, 9610, 9620, 9635, 9645, 9655, 9675, 9720, 9635, 9645, 9655, 9675, 9720, 9725, 9745, 9795, 11600, 11630, 11715, 11770, 11820, 11860, 12030, 12050, 12055, 12075, 15140, 15150, 15180, 15260, 15265, 15450, 15455, 15520, 15540, 16190, 17720, 17765
USSR ("Peace and Progress")	Moscow	9675, 9695, 9730, 11720, 11755, 11765, 11785, 11800, 11920, 12075, 15170, 15175, 15205, 15330, 15440, 15460, 17710, 17765
Vatican City	Vatican City	6015, 6190, 7250, 9605, 9615, 9625, 9645, 11705, 11715, 11740, 11745, 11810, 11830, 11845, 15120, 17840, 17900
Yugoslavia (Radio Belgrade)	Belgrade	6100, 7240, 9620, 11735, 15245
Zambia (Radio Zambia)	Lusaka	6100, 6165, 9680, 11800

This Page Intentionally Left Blank

SECTION XII

MANUAL AND ALE PROGRAMMING

To use ALE, the databases in both the receiving and transmitting radios must be setup properly. The following paragraphs describe how the database is entered into the KCU 1051 using the controls and display on the front panel of the KCU 1051.

MANUAL DATABASE PROGRAMMING

The manual database is entered on the manual page (MAN). There are 100 manual channels available for programming. Each channel holds four parameters: receive frequency, transmit frequency, modulation type, and tune information. The frequencies and the modulation type are entered manually. The tune information is stored when a transmit is attempted on an untuned channel. An untuned channel is indicated when a U is displayed in the last character position on the top line of the display.

There are six fields that are cursorable on the manual page;

1. Operation/Mode field Selects different top level pages
ALE, SEND, MAN, SYS.
2. Channel Type ChMan, ChALE, ChITU and _____
3. Channel number 1 through 100
4. Communication type R&T, Rx, Tx (simplex, semi-duplex)
5. Frequency 2.0000 through 29.9999 MHz
6. Modulation type USB, LSB, AM, A3A

MANUAL CHANNEL PROGRAMMING

The operator must enter the frequency and modulation type for each manual channel. Select the manual channel by placing the cursor over the channel number with the cursor control and turning the VAR knob to select the desired channel. After programming of the manual channels is done, the KCU 1051 is ready to use in manual HF mode. The first time a transmit is attempted on an untuned channel, the radio automatically tunes and stores the tune information.

PROGRAMMING FREQUENCY

If the receive and transmit frequency are the same, the communication type is set to R&T. If different receive and transmit frequencies are to be entered, the communication type is set to Rx to enter the receive frequency and Tx to enter the transmit frequency.

1. Select communication type if it is not correct
 - a. Set cursor over communications type field.
 - b. Turn VAR knob to select Rx, Tx, etc.
2. Place cursor over frequency field and push the VAR knob (PUSH CHAR) to put the cursor into character mode.
3. Enter the frequency by moving the character cursor to a digit and turning the VAR knob.
4. Press the ENT key when complete.

PROGRAMMING MODULATION TYPE

Place the cursor over the modulation type field, if it is not already there.

Turn the VAR knob to select the proper modulation type.

Press the ENT key to store the modulation type selection, if a change was made.

ALE DATABASE PROGRAMMING

The ALE database is programmed under the system program page (SYS Program). As a minimum, the following information is needed to setup the ALE database.

1. AMD messages; Any AMD messages to be preprogrammed.
2. Maximum call time: The amount of time this radio must call to insure that any radio it calls has time to go through its scan list at least one time.
3. Frequency and modulation for each ALE channel.
4. Channel groups: The list of channels that this radio scans and the list of channels all other radios scan, if different.
5. Self address; ALE address this radio will respond to.

6. Other addresses: All other addresses that this radio calls
7. Network slot times: If a star net type of call is to be used then the slot times must be calculated for each address in the net.

SYSTEM PROGRAM PAGE

The system program page has “SYS Program” displayed on the top line of the display. All programming sub-pages are accessed from this page. See figure 12-1 for page organization. The bottom line of this page is used to select the type of data to program. The types of data are ; Message : AMD message, Operation : system operational parameters, Channel :ALE channel data, Address :ALE addresses

1. Place the cursor over the operation / mode field and select “SYS” with the VAR knob. The operation / mode field is the first four characters of the top line on the top level pages.
2. Turn the VAR knob until “SYS” is displayed.
3. Move the cursor to the next field on the top line. This field shows one of the following, Test, RevNum, Program, LQA score.
4. Turn the VAR knob until “Program” is displayed.
5. Move the cursor to the bottom line of the system program page. This field allows selection of the four data types, Message, Operation, Channel, Address.

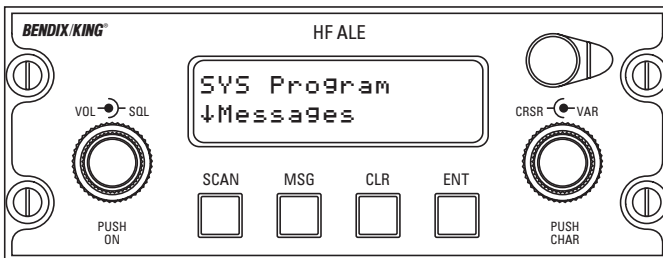

Figure 12-1 SYSTEM PROGRAM PAGE

When the ENT key is pressed on the system program page, a sub-page for the selected data type is displayed. Three of the data types have multiple sub-sub-pages: Messages, Operation, and Channel. The address-sub-page has only one page but multiple parameters for each address that must be set up. To navigate between the sub-pages, the cursor is placed over the first field on the top line of the sub-page and the VAR knob is turned to select a different sub-page.

Services

The table below shows the three data types and the sub-pages beneath each.

Note: To exit a sub-page press the CLR key.

Data Type

Message There are 10 receive and 10 transmit messages of 90 characters each.

Edit_TX Edit transmit messages

Rev_RX Review messages received. Last one received is in slot one.

Del_RX Delete received messages

Copy_RX Copy a received message to a transmit message slot.

Operation System and ALE operational parameters.

Intervals Time intervals and scan rate.

Enables Enable/Disable system and ALE parameters.

Bright Used at installation to configure unit for type of lighting bus.

Channel ALE channel data

ALE-channel Program frequency and modulation type on this page.

ChGrp Channel groups; there are 23 groups.

Scan List Select the channel group to be used as the scan list.

Tune All After programming all ALE channels this page can be used to automatically tune all of the ALE channels.

Clear Tunes Use this page to mark all programmed manual and ALE channels as untuned This is useful when the control head or coupler changes, since the tunes are stored in the control head and are valid only for the coupler on which the tunes were performed.

AMD TRANSMIT MESSAGES

AMD transmit messages can be programmed in two ways. During normal operation an AMD message can be programmed on the SEND page. AMD messages can also be created or edited on the Messages Edit_TX page per the instructions below.

1. From the system program page, select “Messages” on the bottom line.
2. Press the ENT key. One of the message sub-pages is now displayed
3. Select the Edit_TX sub-page.
4. Move the cursor to the message index and select the index of the message to program.
5. Move the cursor to the bottom line, which is the transmit message.
6. Push the VAR knob (PUSH CHAR) to put the cursor into character mode. Use the CLR key to clear old message. Use the CRSR knob to move the character cursor and the VAR knob to change a letter in the cursored field.
7. Press the ENT key when finished.
8. Repeat steps 4 through 7 for each message.

OPERATION PARAMETERS

The following table describes the operation parameters that can be programmed on the operation sub-pages.

Operation

Intervals	Time Intervals and scan rate
ActvLim	Amount of inactive time while linked on an ALE channel, before the radio hangs up and returns to scan. The inactive time is defined as the time since the microphone key was last pressed.
ScnRate	A two or five Hz scan rate is selectable.
Sound	Interval between automatic sounds if sounds are enabled.

CallTime	Amount of time the call is transmitted. This must be set longer than the maximum time it takes for any called radio to go through its scan list.
Enables	Enable/Disable system and ALE parameters.
Auto Sound	Automatic Sounding.
LQA in call	Exchange LQA (Link Quality Analysis).
Message Rx	Display and save received AMD messages.
AnyCall Rx	Respond to a call using the "AnyCall" format.
AllCall Rx	Respond to a call using the "AllCall" format.
Wild Card	Respond to a call using the "Wild Card" format.
Roll Over	<p>Numeric digit rollover. This parameter performs two functions: When enabled and changes are made to one digit of the frequency field, it will barrow/carry from the next higher digit.</p> <p>For other numeric fields, when roll over is enabled, the maximum value will rollover from maximum to minimum or from minimum to maximum.</p>

Programming Operation Parameters

1. From the system program page select "Operation" on the bottom line.
2. Press the ENT key. One of the operation sub-pages is now displayed.
3. Select the Intervals sub-page by moving cursor over to sub page.
4. Move the cursor to the last field on the second line. This is the interval field. The units for the interval are displayed to the right of the interval value.
5. Change the interval if it is not correct.
6. Press the ENT key. This stores any change and displays the

- next interval.
7. Repeat steps 5 and 6 until all intervals are set properly.
 8. Move the cursor to the first field "Interval"
 9. Select "Enables" with VAR knob.
 10. Move the cursor to the last field on the second line. This is the enable field; it shows either "ON" or "OFF". Set to "ON" to enable or "OFF" to disable.
 11. Change the enable if it is not correct.
 12. Press the ENT key. This stores any change and displays the next enable.
 13. Repeat steps 11 and 12 until all enables are set properly.
 14. Press the CLR key to return to the system program page.

ALE CHANNEL DATABASE

The ALE channels, channel groups, and the scan list are programmed on these sub-pages.

1. From the system program page select "Channel" on the bottom line.
2. Press the ENT key. One of the ALE channel sub-pages is now displayed
3. Select the ALE-channel sub-page.

Programming ALE Channels (ALE-Channel Sub-Page)

Select the "ALE channel" page. This is a sub-page to the system, program, channel page. The "ALE channel" page is similar to the manual page (MAN). Set the frequency and modulation type for each channel on this page. See the manual channel programming instructions in MANUAL CHANNEL PROGRAMMING paragraph. When finished with programming the ALE channels, move the cursor over the "ALE channel" field and select the "ChGrp" (channel group) sub-page with VAR knob.

Programming Channel Groups (CHGRP Sub-Page)

Select the "ChGrp" page. This is a sub-page to the system, program,

and channel page. There are 23 channel groups available. Each group can contain from 1 to 100 channels. The contents of a channel group can be reviewed by placing the cursor over the list of channels on the second line and pushing the VAR knob (PUSH CHAR), then use the VAR knob to review the list of channels. Program the channel group as follows:

1. Place the cursor over the channel group index; this is the second cursorable field.
2. Select the channel group to program.
3. Place the cursor over “Add” or “Del” field. Add adds channels to the channel group, Del deletes channels.
4. Move the cursor to the channel number field, this is the last field on the first line.
5. Select the channel to add or delete and press enter. Repeat this until the channel group is programmed properly. When finished programming the channel groups, move the cursor over the ChGrp field and select ScanList.

Programming the Scan List (Scan List Sub-Page)

Select the “Scan List” page. This is a sub-page to the system, program, channel page. The scan list is the list of channels that this radio will scan during ALE scan. One of the channel groups is used as the scan list. The channel group that is currently being used as the scan list is identified by the “S” that appears after the channel group index.

1. Move the cursor over the “ChGrp” field and select “Scan List”.
2. Place the cursor over the channel group index, this is the number field on the second line.
3. Select the channel group to use as the scan list.
4. Press the ENT key.
5. Press the CLR key to return to the system program page.

ALE ADDRESSES

There is only one sub-page under the system program address page. All parameters for an address are programmed on this page. There are several parameters that must be entered for each address, such as channel group and the associated self. The number of parame-

ters depends on the address type. The second lines acts as a window into a list of parameters that must be entered. After the operator makes an entry and presses the ENT key or moves the cursor, the next parameter to be changed is displayed.

CAUTION The address type field requires special handling to prevent accidental changes of address types. Changes to the address type are accepted only if the ENT key is pressed. If the address type is changed and the cursor is moved off of the address type field, the address type will revert back to the original type.

The address types are:

SELF	Address this radio will respond to.
SINGLE	Address for a single ALE station.
StarNET	Star network of addresses that must be programmed into all stations prior to using it.
GROUP	Group of addresses put together after the database is entered.

ALE Address Program Page (ADDR Sub-Page)

All address types are programmed on this page. The database can hold up to 20 self address and 100 other addresses.

1. From the system program page, select "Address" on the bottom line.
2. Press the ENT key. The ALE address sub-page is displayed.

Programming a Self Address

The radio can store up to 20 different self addresses.

1. Place the cursor over the address type field, this is the first cursorable field on the top line of the display.
2. Select "Self"
3. Press the ENT key. The cursor will move over the address index (number in upper right corner of display).
4. Select the index of the self address to modify.
5. Press the ENT key. The cursor will move over the address field

on the second line.

6. Push the VAR knob (PUSH CHAR), to place the cursor into character mode. The CLR key, VAR knob and the CRSR knob can now be used to enter a new address.
7. Press the ENT key. The channel group index is displayed.
8. Select the channel group that has the list of channels that this self address is valid on with the VAR knob. Normally the channel group is set to "ALL" for self addresses.
9. Press the ENT key. The Slot time is displayed.
10. If this self address is used in a Star Network then set the slot time for the beginning of the self address slot.
11. Repeat steps 4 through 10 for additional self addresses

Programming a Single Address

1. Place the cursor over the address type field; this is the first cursorable field on the top line of the display.
2. Select "Single"
3. Press the ENT key. The cursor moves over the address index.
4. Select the index of the address to modify.
5. Press the ENT key. The cursor moves over the address field on the second line.
6. Push the VAR knob (PUSH CHAR), to put the cursor into character mode. The CLR key, VAR knob and the CRSR knob can now be used to enter a new address.
7. Press the ENT key. The channel group index is displayed.
8. Select the channel group that has the list of channels that this address is valid on. This is the list of channels used when placing a call to this address.
9. Press the ENT key. The associated self is displayed.
10. Select the self address to use when calling this address. This is the address that this radio uses to identify itself to another radio.
11. Press the ENT key. The response time is displayed.
12. The response time is programmed in intervals of Triple Word

(TW) which is 130.67 msec. The default response time is 30 and this should be long enough for all units except those that must perform a tune before they transmit a response. Set this time for the maximum time it should take the called radio to respond to an ALE call.

13. Repeat steps 4 through 12 for additional addresses.

Programming a Star Network Address

Note: Performance of this procedure is not a pilot function. This procedure is performed by the local person responsible for setting up the Star Network Addresses at the pilots home base, both initially and if it needs to be repeated. The pilot is directed to identify a need for repeating the setup, and for initiating the process.

This call type requires some ALE expertise for proper utilization. Both the calling and receiving station must be setup properly for Star Network calls to work.

1. Place the cursor over the address index; this is the numeric field on the right corner of the top line.
2. Select the index of the address to change to a Star Network type of address.
3. Move the cursor back one position to cover the address type field, this is the first cursorable field on the top line of the display.
4. Select "StarNET"
5. Press the ENT key. The cursor moves over the address index.
6. Press the ENT key again, the cursor moves over the address field on the second line.
7. Push the VAR knob (PUSH CHAR), to put the cursor into character mode. The CLR key, VAR knob and the CRSR knob can now be used to enter a new network address.
8. Press the ENT key. The channel group index is displayed.
9. Select the channel group that has the list of channels that this address is valid on. This is the list of channels that will be used when placing a call to this Star Network.
10. Press the ENT key. The associated self is displayed.
11. Select the self address that is part of this network..

12. Press the ENT key. The response time is displayed.
13. The response time is programmed in intervals of Triple Word (TW) which is 130.67msec. Set for total Star network call length.
14. Press the ENT key. The network member list will be displayed.
15. This parameter has two cursorable fields, a slot index and an address field.
16. Move the cursor to the address field. There are two special identifiers that appear in this field, "end-list" (end of list) and "self-add" (self address slot).
17. Select the address used in this slot of the Star network.
18. Press the ENT key. The next slot is displayed. Repeat step 19 and 20 until all members of the Star network are entered.
19. Repeat steps 4 through 21 for additional addresses.

Programming a Group Address

1. Place the cursor over the address index; this is the numeric field on the top line.
2. Select the index of the address to change to a group type of address.
3. Move the cursor back one position to cover the address type field, this is the first cursorable field on the top line of the display.
4. Select "GROUP"
5. Press the ENT key. The cursor moves over the address index.
6. Press the ENT key again, the cursor moves over the address field on the second line.
7. Push the VAR knob (PUSH CHAR), to put the cursor into character mode. The CLR key, VAR knob and the CRSR knob can now be used to enter a new group address. This address is not transmitted. It is used as an identifier for the group, to allow selection on the ALE page.
8. Press the ENT key. The channel group index is displayed.
9. Select the channel group that has the list of channels that this address is valid on. This is the list of channels that is used when placing a call to this group.

10. Press the ENT key. The associated self is displayed.
11. Select the self address to use when calling this address. This is the address that this radio uses to identify itself to the other radios when the group call is placed from this radio.
12. Press the ENT key. The response time is displayed.
13. The response time is programmed in intervals of Triple Word (TW) which is 130.67 msec. The default response time is 30 and this should be long enough for all units except those that must perform a tune before they transmit a response. Set this time for the maximum time it should take the called radio to respond to an ALE call.
14. Press the ENT key. The group member list is displayed.
15. This parameter has two cursorable fields, a slot index and an address field.
16. Move the cursor to the address field. This field also has one special identifier, "end-list" that marks the end of the list.
17. Select the address used in this slot of the group.
18. Press the ENT key. The next slot is displayed. Repeat step 17 and 18 until all members of the group are entered.
19. Repeat steps 2 through 17 for additional addresses.

Programming a Special Address Type

There are three additional address types, "AllCall", "AnyCall" and "Wildcard". These types are programmed under the SINGLE type. These call types require some ALE expertise for proper utilization.

Note: The operator must choose the channel that these type of calls are placed on.

All Call

Allows a message or call to be broadcast to multiple stations without requiring a response from them. The generic type of All Call is "@?@". This type of address calls any radio that hears this call and does not have All Calls disabled. Replace the ? with a letter for example @A@. This is a selective All Call and will call any radio with a self address that ends with A.

Any Call Allows a call to multiple stations without having to know their entire address. The generic type of All Call is “@@?”. This type of address calls any radio that hears this call and does not have Any Calls disabled. Replace the ? with a letter for example @@A. This is a selective Any Call and calls any radio with a self address that ends with A.

Wild Card Used to call multiple stations. The called stations accept the wild card character as a match for the character in it's address that occupies that same position in the address. (Example: TR? will call TRA, TRZ, TR9, etc.)

1. Place the cursor over the address index (this is the numeric field on the top line).
2. Select the index of the address to change.
3. Move the cursor back one position to cover the address type field; this is the first cursorable field on the top line of the display.
4. Select “SINGLE”
5. Press the ENT key. The cursor moves over the address index.
6. Press the ENT key again, the cursor moves over the address field on the second line.
7. Push the VAR knob (PUSH CHAR), to put the cursor into character mode. The CLR key, VAR knob and the CRSR knob can now be used to enter a new address.
8. Press the ENT key. The channel group index is displayed. The channel group parameter is not used for this type of address so the channel group index may be ignored.
9. Press the ENT key. The associated self is displayed.
10. Select the self address to use when calling this address. This is the address that this radio uses to identify itself to the other radios when the call is placed from this radio.
11. Press the ENT key to save the self address change. The response time is displayed. The response time parameter is not used for this type of address.
12. Repeat steps 2 through 11 for additional addresses.

SECTION XIII APPENDICES

APPENDIX A: GEOPHYSICAL ALERT BROADCASTS

VOICE MESSAGE FORMATS FOR GEOPHYSICAL ALERTS ON WWV

- A. Solar-terrestrial indices for **(month-day)** follow: (always includes the first two)
1. (X) Solar flux **(value)** and A-Index **(value)**
(X) Repeat, solar flux _____ and A-index _____
 2. () The Boulder K-Index at 1800 UT on **(day)** was **(value)** repeat, **(value)**
() The Boulder K-Index at 0000 UT on _____ was _____ repeat, _____
() The Boulder K-Index at 0600 UT on _____ was _____ repeat, _____
() The Boulder K-Index at 1200 UT on _____ was _____ repeat, _____
- B. Solar-terrestrial conditions for the last 24 hours follow:
(includes any of the following)
1. (X) Solar activity was **(very low) (low) (moderate) (high) (very high)**
 2. (X) Geomagnetic field was **(quiet) (unsettled) (active)**
 3. () A **(minor) (major)** geomagnetic storm **(began at _____ UT) (is in progress) (ended at _____ UT)**
 4. () A major flare occurred at **(day-hour UT) (coordinates)**
 5. () A proton flare occurred at **(day-hour UT) (coordinates)**
 6. () A satellite proton event **(began at _____ UT) (is in progress) (ended at _____ UT)**
 7. () A polar cap absorption event **(began at _____ UT) (is in progress)**

(ended at ____ UT)

- C. The forecast for the next 24 hours follows: (includes any of the following)
 1. (X) Solar activity will be **(very low) (low) (moderate) (high) (very high)**
 2. (X) The geomagnetic field will be **(quiet) (unsettled) (active)**
 3. () A geomagnetic storm is expected **(days-approx. time UT)**
 4. () A proton event is expected **(day-approx. time UT)**
 5. () Stratwarm **(alert - day [s]) (in progress) (ended - days) (brief description of conditions)**

GLOSSARY OF TERMS FOR THE SESC WWV VOICE MESSAGE

- A. 1. **Solar Flux:** Radio flux in flux units ($10^{-22} \text{ Wm}^{-2} \text{ Hz}^{-1}$) at 10 cm (2800 MHz) at local noon (1700 GMT); observed at the Algonquin radio observatory, operated by the Canadian National Research Council, Ottawa.

A-Index: The A-index is derived from eight successive 3-hourly K-indices and gives an indication of how disturbed the geomagnetic field has been over a 24-hour period (in this case, the current GMT day). The A-Index reported is that observed at Fredericksburg, Va. (a mid-latitude station).

- A.2. **K-Index:** The K-value is a quasi-logarithmic index of geomagnetic activity over a 3-hour period ranging from O (very quiet) to 9 (very disturbed). It is obtained by determining the maximum deviation from the quiet day curve of the most disturbed component of the geomagnetic field. The K-Index reported is that observed at the Boulder, Colorado station.

B.1. **Solar Activity**

Very Low: Usually only quiet regions on the solar disk and no more than five of these; fewer than ten class C subflares with out centimetric radio bursts or Sudden Ionospheric Disturbance (SID) observed or expected.

Low: Usually more than five, but less than ten, quiet regions on the solar disk; only class C subflares without centimetric

radio bursts or SID observed or expected.

Moderate: Eruptive regions on the solar disk; fewer than five class M x-ray events with centimetric radio bursts and SID observed or expected.

High: Active regions on the solar disk; several class M x-ray events with centimetric radio bursts and strong SID; and/or one or two importance 2 chromospheric flares or class X x-ray events observed or expected.

Very high: Region capable of producing protons on the sun; one or more chromospheric flares of importance 2 or greater with outstanding centimetric radio bursts (500 flux units or greater), class x-ray bursts and major SID observed or expected.

X-ray events:

Class C-any solar x-ray burst with a peak flux of 1-8 Å of less than 10^{-5} Watts M^{-2}

Class M-a solar x-ray burst with a peak flux at 1-8 Å greater than or equal to 10^{-5} but less than 10^{-4} Watts M^{-2}

Class X-a solar x-ray burst with a peak flux at 1-8 Å greater than or equal to 10^{-4} Watts M^{-2}

B.2. **Geomagnetic Field:**

Quiet: A-Index ≤ 7 ; usually no K-indices > 2

Unsettled: $7 < \text{A-Index} < 15$; usually no K-indices > 3

Active: $15 \leq \text{A-Index} < 30$; a few K-indices of 4

B.3. **Geomagnetic Storm:**

Minor: $30 \leq \text{A-Index} < 50$; K-indices mostly 4 and 5

Major: A-Index ≥ 50 ; solar K-indices of 6 or greater

B.4. **Major Solar Flare:** A flare of optical importance $\geq 2B$ with a centimetric radio burst of 500 flux units or more; or an X x-ray event of duration ≥ 180 min. regardless of optical flare importance.

B.5. **Proton Flare:** Protons by satellite detectors (or polar cap absorption by riometer) have been observed in time association with a chromospheric flare.

- B.6. **Satellite Proton Event:** A proton enhancement detected by earth orbiting satellites with a measure flux of at least 10 protons $\text{cm}^{-2} \text{S}^{-1} \text{ster}^{-1}$ at $\geq 10 \text{ MeV}$.
- B.7. **Polar Cap Absorption:** A proton induced absorption $\geq 2\text{dB}$ during daylight or $\geq .5\text{dB}$ during nighttime as measured by a 30 MHz riometer located within the polar cap.
- B.8. **Stratwarm:** A major disturbance of the winter, polar, middle atmosphere resulting from a breakdown of the polar vortex (a polar nighttime jet stream flowing around the polar cap) into two cells. These disturbances produce strong HF absorption for transpolar transmission paths.

APPENDIX B: SOURCES FOR INFORMATION ABOUT TIME AND FREQUENCY STANDARD SERVICES

Information about the geophysical alerts, marine storm warning, and OMEGA System Status reports that are broadcast on WWV and WWVH are available from the following sources:

Geophysical Alerts:

Space Environment Laboratory
Space Environment Services Center, R43
National Oceanic & Atmospheric Admn.
Boulder, Colo. 80302

Marine Storm Warnings:

Director
National Weather Service
Silver Spring, Md. 20910

Omega System Status Reports:

US Coast Guard HQ
(G-ONSOD/43)
Washington, D.C. 20590

Publications which describe the NIST time and frequency services may be obtained from:

National Institute of Standard Technology 524.06 Boulder, Colo. 80303

You can ask to be placed on the mailing list for:

1. NIST Time & Frequency Bulletin issued monthly.
2. Special bulletins regarding changes in format or operating schedules of NIST services, notices of upcoming events (e.g., leap sec-

onds), etc.issued when appropriate.

3. Technical notes and other publications of the Time & Frequency Dissemination Group issued when published.

Also available is NIST Special Publication 432 (U.S. Government Printing Office number 1979-681-991) which describes in 16 pages the NIST time and frequency dissemination services.

APPENDIX C: ADDITIONAL REFERENCE MATERIAL ON HF RADIO

1. Radio Amateur's Handbook. Published by the American Radio Relay League. 640 pages. Available from: ARRL, 225 Main St., Newington, Connecticut, 06111. This source has long been an authoritative manual for the amateur radio operator. It contains a multitude of information on basic fundamentals and theory of HF radio as well as practical "how to" tips and charts.

2. Radio Communications Handbook Fifth Edition, Volume 2. Published by the Radio Society of Great Britain. Available from: ARRL, 225 Main St., Newington, Connecticut, 06111. A comprehensive textbook on the theory and practice of amateur radio, including all aspects of HF communications.

3. Davies, K., Ionospheric Radio Propagation. US DOC/NIST Monograph 80. Published 1965. 470 pages. Available from: National Technical Information Service, 5285 Port Royal Road, Springfield, Virginia 22161. Order No. P.B. 257342. (Fairly scientific. Assumes a knowledge of physics and electronics).

4. Manley, James A., Capt., Short Term HF Forecasting and Analysis, January 1981, U.S. Air Force, Air Weather Service, Air Force Global Weather Control, Offutt Air Force Base, Nebraska, 68113, AFGW C/TN-81/001.

5. World Radio TV Handbook, edited by Jens M. Frost. Published by Billboard Books. Available from: Billboard Books, P.O. Box 2013, Lakewood, New Jersey, 08701. An excellent reference for anyone interested in shortwave radio listening. It contains detailed information, country by country, on the radio stations of the world including program information and target areas of broadcasts. It also contains instructive information relating to shortwave radio on such subjects as HF broadcast reception conditions and solar activity for the current year.

APPENDIX D: FCC APPLICATION FOR AIRCRAFT RADIO STATION LICENSE

To legally operate an aircraft radio station on aeronautical enroute frequencies (128.825 to 132.000 MHz (VHF) and air-ground high frequencies) the aircraft operator must apply to the FCC for specific authorization. This is done by properly completing Item 9B1 of FCC Form 404 as follows:

- 1) The box in Item 9B1 must be checked and FCC rule numbers 87.293 (a) and (c) must be entered. This covers the VHF aero enroute frequencies 122.825, 122.875, and from 128.825 to 132.000.
- 2) The following rule numbers should also be included if air-ground high frequencies are to be used: 87.295 (b) (c) and 87.299.
- 3) 87.297- (International VHF) Same frequencies as 87.293 (a).
- 4) Item 9B2 must be checked "yes." An agreement with ARINC will cover almost all aeronautical enroute stations in the U.S. and its territories. Some aeronautical enroute stations in Alaska are not licensed to ARINC. None of the aeronautical enroute stations covered by 87.293 (c) (122.825 and 122.875) will be licensed to ARINC.

For further information contact:

ARNIC
Services Department
2551 Riva Road
Annapolis, Maryland 21403
Phone No. (410) 266-4180 Customer Service
(410) 266-4430 Operations

AlliedSignal, Inc.
Commercial Avionics Systems
400 North Rogers Road
Olathe, KS USA 66062-1294
TELEX 669916 KINGRAD • FAX: 913-791-1302
Telephone: 913-768-3000
© 1996 AlliedSignal Inc.

006-18038-0000 Rev. 0 12/96



WARNING

Information subject to the export control laws. This document, which includes any attachments and exhibits hereto, contains information subject to International Traffic in Arms Regulation (ITAR) or Export Administration Regulation (EAR) of 1979, which may not be exported, released or disclosed to foreign nationals inside or outside the U.S. without first obtaining an export license. Violators of ITAR or EAR may be subject to a penalty of 10 years imprisonment and a fine of \$1,000,000 under 22 U.S.C. 2778 of Section 2410 of the Export Administration Act of 1979. Include this notice with any reproduced portion of this document.

COPYRIGHT NOTICE

©1996 AlliedSignal, Inc.

Reproduction of this publication or any portion thereof by any means without the express written permission of AlliedSignal Commercial Avionics Systems is prohibited. For further information contact the Manager, Technical Publications; AlliedSignal Commercial Avionics Systems; 400 North Rogers Road; Olathe, Kansas 66062. Telephone: (913) 782-0400.