



Manpack Transceiver 2110 series Technical Service Manual

No part of this manual may be reproduced, transcribed, translated into any language or transmitted in any form whatsoever without the prior written consent of Codan Limited.

© Copyright 2005, 2008 Codan Limited.

CALM[®] is a registered trademark of Codan Limited. Other brand, product and company names mentioned in this document are trademarks or registered trademarks of their respective holders.

Codan part number 15-02071-EN Issue 2, September 2008

The English version takes precedence over any translated versions.



www.codan.com.au

Head Office

Codan Limited
ABN 77 007 590 605
81 Graves Street
Newton SA 5074
AUSTRALIA
Telephone +61 8 8305 0311
Facsimile +61 8 8305 0411
asiasales@codan.com.au

Codan (UK) Ltd
Unit C4 Endeavour Place
Coxbridge Business Park
Farnham Surrey GU10 5EH
UNITED KINGDOM
Telephone +44 1252 717 272
Facsimile +44 1252 717 337
uksales@codan.com.au

Codan US, Inc.
8430 Kao Circle
Manassas VA 20110
USA
Telephone +1 703 361 2721
Facsimile +1 703 361 3812
ussales@codan.com.au



Index

About this manual

Standards and icons	2
Definitions	3
Acronyms and abbreviations	3
Glossary	6
Circuit reference designations	7
Units	8
Unit multipliers	8
About this issue	9

Compliance

Introduction	12
European R&TTE Directive	13
EMC and safety notices	14
FCC compliance	16
C-tick approval	17
Care and safety information	17

Maintenance

General	19
CMOS devices	20
Circuit boards	21
Transmitter precautions	22
Probe precautions	23

Contact information

Ordering information

Ordering information	27
Component substitution	28

Overview and specifications

Overview	30
Specifications	32
General	32
Receiver	34
Transmitter	35
Antenna tuner	36
Battery chargers	37

3160 Power Amplifier	37
Accessories	38
Pin connections	40
Front panel	40
Bottom panel	44
Battery pack	45
Interface adaptor (2110/2110M only)	46
3160 Power Amplifier	50

Brief description

General information	55
Transmit path	56
Receive path	57
Antenna tuning process	59
Synthesiser operation	59
Control and switching	59

Technical description

Power on	62
Power off	63
Supply voltages	64
Transmit path	67
Front Panel PCB	67
Audio & Control PCB	67
RF/IF & Synthesiser PCB	68
PA & Filter PCB	69
Antenna Tuner PCB	72
Receive path	74
Antenna Tuner PCB	74
Input low-pass filters	74
Broadcast filter and RF amplifier	74
First mixer	74
Post-mixer amplifier	75
45 MHz band-pass filter and amplifier	75
Second mixer	75
Noise limiter	75
455 kHz filter and IF amplifier	76
Automatic gain control	76
Demodulator	77
Audio & Control PCB	77
Front Panel PCB	78

Frequency control	79
Reference oscillator	79
Direct digital synthesis	79
VCO and phase lock loop	80
28 V power supply	80
Microprocessors and control	81
Internal voice encryptor (optional)	84
Internal GPS receiver (optional)	85
Interface adaptor	86
3160 Power Amplifier	87
Overview	87
Supply voltages for the 3160 Power Amplifier	87
Transmit path	87
Microprocessors and control	89
Microprocessor monitoring	90

Channel additions

General	94
Options	94
Programming channels	96
Creating a channel	96
Creating a channel with the TxD option	99
Renaming a channel	101
Editing a channel	103
Copying a channel	105
Deleting a channel	106

Checks and adjustments

Service equipment required	108
Disassembling the transceiver	109
Voltage regulators	111
Low-pass filters	113
Service mode	114
General	114
Accessing Service mode	115
Returning to Normal mode	118
Testing the keypad and display	119
Adjustment locations and test points	120
Aligning the 5 MHz PLL reference	124
Checking the voltage-controlled oscillator	125
Aligning the 45 MHz filter	126
Aligning the 455 kHz IF and noise limiter	127

Adjusting the exciter output level	128
Adjusting carrier re-insertion	129
Adjusting frequency	130
Adjusting mute	131
Adjusting the PA	132
Adjusting the driver bias	132
Adjusting the PA bias	132
Adjusting high output power	133
Adjusting low output power	134
Adjusting balance control	134
Checking intermodulation	135
Checking performance of the receiver at the 50 ohm antenna connector	137
Checking the sensitivity and (signal+noise)/noise ratio	137
Checking the automatic gain control	137
Checking the audio output	138
Checking the selectivity	138
Checking the noise limiter	139
Checking performance of the transmitter at the 50 ohm antenna connector	140
Checking the transmit frequency	140
Checking the automatic level control	140
Checking power output and intermodulation	141
Checking the antenna tuner relays	142
Re-assembling the transceiver	143
Checking the battery charging process	144
Adjusting the 3160 Power Amplifier	148
Disassembling the 3160	148
Adjusting the PA bias	148
Adjusting high output power	149
Re-assembling the 3160	150

Parts lists

Drawings

Figure 1:	The 2110 series Manpack Transceiver	30
Figure 2:	The 3160 Power Amplifier	31
Figure 3:	Front panel of the transceiver (2110 model shown)	40
Figure 4:	Front view of the handset connector	41
Figure 5:	Front view of the 19-way GPIO connector (2110/2110M only)	42
Figure 6:	Front view of the 5-way GPIO connector (2110v only)	43
Figure 7:	Bottom panel of the transceiver unit	44
Figure 8:	Front view of the battery connector on the transceiver unit	44
Figure 9:	Top panel of the battery pack	45
Figure 10:	Front view of the battery connector on the battery pack	45
Figure 11:	Interface adaptor	46
Figure 12:	Front view of the antenna control connector on the interface adaptor	46
Figure 13:	Front view of the 15-way GPIO connector on the interface adaptor	48
Figure 14:	Front view of the 15-way VP-116 connector on the interface adaptor	49
Figure 15:	3160 Power Amplifier	50
Figure 16:	Front view of the 12-way connector on the 3160	50
Figure 17:	2110 amplifier adaptor panel for the 3160	51
Figure 18:	Front view of the 6-way connector on the 2110 amplifier adaptor panel	51
Figure 19:	Representation of compression function by IC202	67
Figure 20:	Position of TPE link on the Audio & Control PCB	94
Figure 21:	Setup for artificial antenna	108
Figure 22:	Setup for test unit	108
Figure 23:	Removing the housing from the chassis	109
Figure 24:	Position of Service mode link on the Audio & Control PCB	115
Figure 25:	RF/IF & Synthesiser PCB	120
Figure 26:	PA & Filter PCB	121
Figure 27:	Audio & Control PCB	122
Figure 28:	Antenna Tuner PCB	123
Figure 29:	Sweep test display	126
Figure 30:	Graph showing adjustment to 90% modulation	129
Figure 31:	Typical front panel of a battery charger	145
Figure 32:	Adjustment locations and test points for the 3160 Power Amplifier	148

This page has been left blank intentionally.

Table 1:	Earth symbols	15
Table 2:	Battery storage times.	17
Table 3:	Resistor and capacitor abbreviations	27
Table 4:	General specifications.	32
Table 5:	Receiver specifications at 50 ohm antenna connector	34
Table 6:	Transmitter specifications at 50 ohm antenna connector	35
Table 7:	Antenna tuner specifications.	36
Table 8:	Battery charger specifications.	37
Table 9:	3160 Power Amplifier specifications	37
Table 10:	Physical specifications of accessories.	38
Table 11:	Pinouts of the handset connector	41
Table 12:	Pinouts of the 19-way GPIO connector (2110/2110M only)	42
Table 13:	Pinouts of the 5-way connector (2110v only).	43
Table 14:	Pinouts of the battery connector on the transceiver unit.	44
Table 15:	Pinouts of the battery connector on the battery pack	45
Table 16:	Pinouts of the antenna control connector on the interface adaptor.	46
Table 17:	Pinouts of the speaker connector on the interface adaptor	47
Table 18:	Pinouts of the 15-way GPIO connector on the interface adaptor	48
Table 19:	Pinouts of the 15-way VP-116 connector on the interface adaptor	49
Table 20:	Pinouts for the 12-way connector on the 3160	50
Table 21:	Pinouts for the 6-way connector on the 2110 amplifier adaptor panel.	51
Table 22:	Supply voltages for the Front Panel PCB	64
Table 23:	Supply voltages for the Audio & Control PCB	64
Table 24:	Supply voltages for the RF/IF & Synthesiser PCB.	65
Table 25:	Supply voltages for the PA & Filter PCB.	65
Table 26:	Supply voltages for the Antenna Tuner PCB	66
Table 27:	Supply voltages for the 3160 Power Amplifier	87
Table 28:	Warning messages for the 3160 Power Amplifier	90
Table 29:	Fault messages for the 3160 Power Amplifier	91
Table 30:	Transmit enable, transmit disable and transmit prohibited options	95
Table 31:	Supply voltages for the Front Panel PCB	111
Table 32:	Supply voltages for the Audio & Control PCB	111
Table 33:	Supply voltages for the RF/IF & Synthesiser PCB.	112
Table 34:	Supply voltages for the PA & Filter PCB.	112
Table 35:	Supply voltages for the Antenna Tuner PCB	113
Table 36:	Pre-defined service channels for Service mode	116
Table 37:	Hot keys on the front panel during Service mode.	117
Table 38:	Power output PEP vs measuring instrument (5/25 W)	141
Table 39:	Typical charging times for Codan battery packs	144

Table 40:	LED indications	145
Table 41:	Power output PEP vs measuring instrument (100/125 W)	150
Table 42:	Parts lists index	151
Table 43:	Drawings index	153

Numerics

- 3160 Power Amplifier
 - adjusting 148
 - ALC 88
 - bias regulator 87
 - disassembling 148
 - fault messages 91
 - high output power
 - adjusting 149
 - input stage 87
 - microprocessor monitoring 90
 - microprocessors and control 89
 - output filter 88
 - output stage 87
 - PA bias
 - adjusting 148
 - re-assembling 150
 - supply voltages 87
 - technical description 87
 - transmit path 87
 - warning messages 90
- 45 MHz filter
 - aligning 126
- 455 kHz IF
 - aligning 127

A

- A/F
 - distortion 35
 - power 35
 - response 35
- accessories
 - specifications 38
- adjustments 107
 - locations and test points 120
- AGC 34, 76
 - checking 137
- ALC 36, 71
 - 3160 Power Amplifier 88
 - checking 140
- alternative charger requirements 147
- amplifier 75
- antenna tuner
 - specifications 36
- Antenna Tuner PCB
 - microprocessors and control 83
 - receive path 74
 - supply voltages 66, 113
 - transmit path 72

- Audio & Control PCB
 - microprocessors and control 81, 87
 - receive path 77
 - supply voltages 64, 111
 - transmit path 67
- audio output
 - checking 138

B

- balance control
 - adjusting 134
- band-pass filter
 - 45 MHz 68, 75
- battery charger
 - specifications 37
- battery discharge regime 147
- bias regulator 70
 - 3160 87
- blocking 34
- brief description 53
 - control and switching 59
 - receive path 57
 - synthesiser operation 59
 - transmit path 56
- broadcast filter 74

C

- capacitor
 - abbreviations 27
- carrier re-insertion
 - adjusting 129
- carrier suppression 35
- channels
 - additions 93
 - capacity 32
 - copying 105
 - creating 96
 - creating with Option TxD 99
 - deleting 106
 - editing 103
 - programming 96
 - renaming 101
- checks 107
- circuit reference designations 7
- clarifier 35
- CMOS devices 20
- compliance 11
 - EMC and safety notices 14
 - battery safety 15
 - earth symbols 15
 - electrical safety 14

- EMC 14
 - radiation safety 14
- European R&TTE Directive 13
 - CE declaration 13
 - product marking and labelling 13
 - protection of the radio spectrum 13
- FCC 16
- components
 - substitution 28
- connectors
 - 2110 amplifier adaptor panel
 - 6-way 51
 - 3160
 - 12-way 50
- battery pack
 - battery 45
- interface adaptor
 - 15-way GPIO 48
 - 15-way VP-116 49
 - antenna control 46
 - speaker 47
- transceiver unit
 - 19-way GPIO 42
 - 5-way 43
 - battery 44
 - handset 41
- contact information 25
- control and switching 59
- cooling 33

D

- DDS 79
- demodulator 77
- desensitisation 34
- discharge regime
 - battery 147
- display
 - testing 119
- distortion
 - A/F 35
- drawings 153
- driver bias
 - adjusting 132
- driver stage 70
- duty cycle 35

E

- EMC and safety notices
 - compliance
 - battery safety 15
 - earth symbols 15
 - electrical safety 14
 - EMC 14
 - radiation safety 14

- emission
 - harmonic 35
 - spurious 35
- European R&TTE Directive
 - compliance 13
 - CE declaration 13
 - product marking and labelling 13
 - protection of the radio spectrum 13
- exciter output
 - adjusting
 - level 128
 - filter 69

F

- FCC compliance 16
- filter
 - 45 MHz 126
 - 45 MHz (band-pass) 68, 75
 - 455 kHz 68, 76
 - broadcast 74
 - exciter output 69
 - low-pass 113
 - low-pass (input) 74
 - output 71
- first mixer
 - receive path 74
 - transmit path 68
- frequency
 - adjusting 130
 - generation 32
 - IF 34
 - range 32
 - reference oscillator 79
 - stability 32
- frequency control 79
- Front Panel PCB
 - microprocessors and control 82
 - receive path 78
 - supply voltages 64, 111
 - transmit path 67

G

- gain control stage 70
- general specifications 32
- GPS receiver
 - technical description 85

H

- harmonic emissions 35
- heatsink 35
- high output power
 - adjusting
 - 3160 149
 - transceiver 133

hot keys
 Service mode 117

I

IF amplifier 76
 image rejection 34
 impedance 32
 input low-pass filters 74
 integrated circuits 20
 interface adaptor
 technical description 86
 intermodulation 34, 36
 checking 135, 141
 distortion 135
 internal voice encryptor
 technical description 84

K

keypad
 testing 119
 Keypad PCB
 microprocessors and control 82

L

local oscillator 79
 low output power
 adjusting 134
 low voltage switch off 32
 low-pass filters 113

M

maintenance 19
 circuit boards
 component replacement 21
 component substitution 21
 de-soldering 21
 excessive heat 21
 integrated circuit replacement 22
 track repair 22
 CMOS devices
 grounding 20
 handling 20
 packaging 20
 switching off 20
 general
 dynamic transistor tests 19
 integrated circuits 20
 spare boards 19
 static transistor tests 19
 precautions
 probe 23
 transmitter 22
 microphone 35, 36

microprocessor monitoring
 3160 90
 microprocessors and control 81
 3160 89
 Antenna Tuner PCB 83
 Audio & Control PCB 81
 Front Panel PCB 82
 Keypad PCB 82
 overview 81
 PA & Filter PCB 82
 RF/IF & Synthesiser PCB 82
 mixer
 first 68
 second 69
 modulator
 transmit 68
 mute
 adjusting 131
 voice 77

N

noise limiter 75
 aligning 127
 checking 139
 Normal mode
 returning to 118

O

operating modes 32
 options
 transmit disable 95
 transmit enable 95
 transmit prohibited 95
 ordering information 27
 output filters
 3160 88
 transceiver 71
 output power 35
 output stage
 3160 87
 transceiver 70
 overview 29, 30

P

PA
 adjusting 132
 balance control 134
 checking intermodulation 135
 driver bias 132
 high output power 133
 low output power 134
 PA bias 132
 PA & Filter PCB
 microprocessors and control 82

- supply voltages 65, 112
 - transmit path 69
 - packaging 20
 - parts lists 151
 - PCB
 - microprocessors and control
 - Audio & Control 81, 87
 - Front Panel 82
 - Keypad 82
 - PA & Filter 82
 - RF/IF & Synthesiser 82
 - receive path
 - Antenna Tuner 74
 - Audio & Control 77
 - Front Panel 78
 - supply voltages
 - Antenna Tuner 66, 113
 - Audio & Control 64, 111
 - Front Panel 64, 111
 - PA & Filter 65, 112
 - RF/IF & Synthesiser 65, 112
 - transmit path
 - 3160 87
 - Antenna Tuner 72
 - Audio & Control 67
 - Front Panel 67
 - PA & Filter 69
 - RF/IF & Synthesiser 68
 - phase lock loop 79
 - pin connections 40
 - 2110 amplifier adaptor panel
 - 6-way connector 51
 - 3160
 - 12-way connector 50
 - battery pack
 - battery connector 45
 - interface adaptor
 - 15-way GPIO connector 48
 - 15-way VP-116 connector 49
 - antenna control connector 46
 - speaker connector 47
 - transceiver unit
 - 19-way GPIO connector 42
 - 5-way connector 43
 - battery connector 44
 - handset connector 41
 - PLL reference 124
 - power
 - A/F 35
 - off 63
 - on 62
 - output 35
 - checking 141
 - reflected 35
 - power supply
 - 28 V 80
 - programming 32
 - options 94
 - protection 35
 - input 34
 - overvoltage 32
 - thermal 35
- ## R
- receive path 74
 - Antenna Tuner PCB 74
 - Audio & Control PCB 77
 - brief description 57
 - first mixer 74
 - Front Panel PCB 78
 - second mixer 75
 - technical description 74
 - receiver
 - checking performance 137
 - AGC 137
 - audio output 138
 - noise limiter 139
 - selectivity 138
 - sensitivity and (signal + noise)/noise ratio 137
 - specifications 34
 - reference oscillator 79
 - frequency 79
 - relative humidity 33
 - resistor
 - abbreviations 27
 - response
 - A/F 35
 - RF amplifier 74
 - RF/IF & Synthesiser PCB
 - microprocessors and control 82
 - supply voltages 65, 112
 - transmit path 68
- ## S
- safety
 - battery 15
 - electrical 14
 - radiation 14
 - second mixer
 - receive path 75
 - transmit path 69
 - selectivity 34
 - checking 138
 - sensitivity 34
 - sensitivity and (signal + noise)/noise ratio
 - checking 137
 - Service mode 114
 - accessing 115
 - channels 116
 - exiting 118
 - hot keys 117

- sideband
 - unwanted 35
- signal
 - input 35
- size 33
- spare boards 19
- specifications 29, 32
 - 3160 37
 - accessories 38
 - antenna tuner 36
 - battery charger 37
 - general 32
 - receiver 34
 - transmitter 35
- spurious
 - emissions 35
 - responses 34
- supply current 32, 35
- supply voltages 32, 64
 - 3160 87
 - Antenna Tuner PCB 66, 113
 - Audio & Control PCB 64, 111
 - Front Panel PCB 64, 111
 - PA & Filter PCB 65, 112
 - RF/IF & Synthesiser PCB 65, 112
- suppression
 - carrier 35
- switch off
 - low voltage 32
- switching
 - transmit/receive 68
- synthesiser operation 59

T

- technical description 61
 - 3160 87
 - frequency control 79
 - GPS receiver 85
 - interface adaptor 86
 - internal voice encryptor 84
 - microprocessors and control 81
 - receive path 74
 - transmit path 67
- temperature 33
- test
 - display 119
 - equipment 108
 - keypad 119
 - points 120
 - unit 108
- TPE link 94
- transceiver
 - disassembly 109
- transistor tests
 - dynamic 19
 - static 19

- transmit
 - disable 95
 - programming 99
 - enable 95
 - frequency
 - checking 140
 - modulator 68
 - prohibited 95
- transmit path 67
 - 3160 87
 - 3160 input stage 87
 - brief description 56
 - first mixer 68
 - second mixer 69
- transceiver
 - Antenna Tuner PCB 72
 - Audio & Control PCB 67
 - Front Panel PCB 67
 - PA & Filter PCB 69
 - RF/IF & Synthesiser PCB 68
 - technical description 67
- transmitter
 - checking performance 140
 - ALC 140
 - intermodulation 141
 - power output 141
 - transmit frequency 140
 - specifications 35
- tuning carrier output 69
- tuning limit 36

U

- unwanted sideband 35

V

- voice encryptor
 - internal 84
- voice mute 77
- voltage regulators 69, 111
- voltage-controlled oscillator
 - checking 125
- voltages
 - supply 32, 64
 - 3160 87
 - Antenna Tuner PCB 66, 113
 - Audio & Control PCB 64, 111
 - Front Panel PCB 64, 111
 - PA & Filter PCB 65, 112
 - RF/IF & Synthesiser PCB 65, 112

W

- weight 33

This page has been left blank intentionally.

About this manual

This Technical Service Manual provides technical descriptions, functional details and drawings for the 2110 series Manpack Transceiver.

This manual assumes that you have a good understanding of electronics and a technical background. There is an index at the beginning of this manual.

This manual contains the following sections:

[About this manual](#)—lists all standards, acronyms, abbreviations and units used in this manual

[Compliance](#)—provides compliance information and safety notices, and information on specific care and safety requirements for your transceiver

[Maintenance](#)—details of maintenance and general cautions and warnings associated with the equipment

[Contact information](#)—directs you to our website, which contains the latest contact details for 24-hour technical support

[Ordering information](#)—explains the details required by Codan to ensure prompt service and delivery

[Overview and specifications](#)—general description and specifications for the transceiver, interface adaptor, and 3160 Power Amplifier

[Brief description](#)—brief technical description of the 2110 series Manpack Transceiver including a general description of the major circuit functions for the control, reception and transmission of signals

[Technical description](#)—detailed technical description of the operation and circuit function of the 2110 series Manpack Transceiver, interface adaptor, GPS receiver, voice encryptor, and 3160 Power Amplifier

[Channel additions](#)—available options and the programming procedures for channel additions

[Checks and adjustments](#)—checks, adjustments and alignments for the transceiver and 3160 Power Amplifier, including a list of the required test equipment

[Parts lists](#)—parts lists for the 2110 series Manpack Transceiver and major accessories

[Drawings](#)—drawings for the 2110 series Manpack Transceiver and major accessories

Standards and icons

The following standards and icons are used in this manual:

This typeface...

Means...

Italics

a cross-reference, or text requiring emphasis

Bold

name of an entry in a list

This icon...

Means...

WARNING

your actions may cause harm to yourself or the equipment

CAUTION

proceed with caution as your actions may lead to loss of data, privacy or signal quality

NOTE

the text provided next to this icon may be of interest to you

□

a step to follow

Definitions

Acronyms and abbreviations

This acronym...	Means...
A/D	analogue to digital
A/F	audio frequency
AC	alternating current
AGC	automatic gain control
ALC	automatic level control
ALE	automatic link establishment, address latch enable
AM	amplitude modulation
ATU	antenna tuner unit
BER	bit error rate
BPF	band-pass filter
BTL	bridge-tied load
CALM	Codan automated link management
CAN	controller area network
CB	citizen band
CMOS	complementary metal oxide semiconductor
codec	coder/decoder
CPLD	complex programmable logic device
CRO	cathode ray oscilloscope
CTS	clear to send
CW	continuous wave, carrier wave
DAC	digital to analogue converter
DC	direct current
DDS	direct digital synthesis
DSB	double sideband
DSP	digital signal processor/processing
EEPROM	electrically erasable programmable read only memory
ESD	electrostatic discharge
etc.	et cetera, and so forth

This acronym...	Means...
ETSI	European Telecommunications Standards Institute
EXT	external
FCC	Federal Communications Commission
FET	field-effect transistor
GPIO	general purpose input/output
GPS	global positioning system
HF	high frequency
ICNIRP	International Commission on Non-Ionizing Radiation Protection
I/P	input
I ² C	inter integrated circuit
IC	integrated circuit
IF	intermediate frequency
IMD	intermodulation distortion
IrDA	Infrared Data Association
LCD	liquid crystal display
LED	light-emitting diode
LO	local oscillator
LPF	low-pass filter
LQA	link quality analysis
LSB	lower sideband
MFLOP	million floating-point operations per second
Modem	modulator-demodulator
NiMh	nickel metal hydride
NPN	NPN transistor type
NSP	NGT system programmer
O/P	output
opamp	operational amplifier
OR	logical OR function
PA	power amplifier
PC	personal computer
PCB	printed circuit board
PD	potential difference

This acronym...	Means...
PEP	peak envelope power
PLL	phase locked loop
PNP	PNP transistor type
p-p	peak to peak
ppm	parts per million
PTC	positive temperature coefficient
PTT	press-to-talk
PWR	power
RAM	random access memory
RC	resistance/capacitance
RC oscillator	resistor/capacitor oscillator
REF OSC	reference oscillator
RF	radio frequency
RMS	root mean square
R&TTE	radio and telecommunications terminal equipment
RTS	request to send
Rx	receive, receiver
RxD	receive data
SCF	suppressed carrier frequency
SCL	serial clock
SDA	serial data
SINAD	(signal+noise+distortion)-to-(noise+distortion) ratio
SLA	sealed lead acid
SSB	single sideband
TCW	tinned copper wire
THD	total harmonic distortion
TPE	transmit program enable
Tx	transmit, transmitter
TxD	transmit data, transmit disabled
TxE	transmit enabled
TxP	transmit prohibited
UART	universal asynchronous receiver/transmitter

This acronym...	Means...
USB	upper sideband
VCO	voltage-controlled oscillator
VSWR	voltage standing wave ratio

Glossary

This term...	Means...
channel	A frequency range over which signals can be transmitted and received.
coder/decoder	A device combining analogue to digital and digital to analogue converters.
digital signal processor	A microprocessor-like device that is designed to provide real-time processing of high-volume digital data streams.
Easitalk	A feature that enables the user to reduce the level of background noise that is present when listening to a channel.
frequency	The number of cycles per second of a radio wave, usually expressed in kilohertz.
front panel	A panel on the transceiver that is used to control the functions of the transceiver. It consists of a display, keypad and connectors.
handset	A hand-held device that consists of a microphone, PTT button, and earphone.
PTT button	Press-to-talk button, located on the left side of the handset. This button enables you to communicate during voice calls, switch mute off, cancel voice calls prior to the point where voice can be transmitted, cancel calls where data is being transmitted, and exit out of editable screens without saving changes.
transceiver unit	The unit in a transceiver that modulates audio signals onto radio frequencies that can be transmitted on air, and demodulates the radio frequencies it receives into audio signals.

Circuit reference designations

Abbreviation	Designation
A	assembly
B	transducer—microphone, loudspeaker etc
C	capacitor
D	diode—small signal and power
E	heating device
F	protection device—fuse etc
G	generator—battery etc
H	signalling/indicating device—lamp, LED, buzzer etc
IC	integrated circuit, thick film hybrid etc
J	jack socket
K	relay, key switch
L	inductor
M	indicating device—meter etc
P	plug
R	resistor
S	switch
T	transformer, common mode choke
TP	test point
U	modem, modulator-demodulator
V	semiconductor (not including small signal and power diodes)
X	terminals
Z	quartz crystal, crystal filter, frequency network

Units

Measurement	Unit	Abbreviation
Attenuation	decibel	dB
Current	ampere	A
Frequency	hertz	Hz
Impedance	ohm	Ω
Length	metre (inch/feet/yard/mile)	m (in/ft/yd/mi)
Mass	gram (pound)	g (lb)
Power	watt	W
Power	decibels relative to 1 mW	dBm
Power ratio	decibel	dB
Temperature	degrees Celsius (degrees Fahrenheit)	$^{\circ}\text{C}$ ($^{\circ}\text{F}$)
Time	hour	h
	second	s
Voltage	volt	V

Unit multipliers

Unit	Name	Multiplier
p	pica	0.000000000001
μ	micro	0.000001
m	milli	0.001
d	deci	0.1
k	kilo	1000
M	mega	1000000

About this issue

This is the second issue of the Manpack Transceiver 2110 series Technical Service Manual.

Associated documents

This manual is one of a series of documents related to the 2110 series Manpack Transceiver. Other associated documents are:

- Manpack Transceiver 2110 series Getting Started Guide (Codan part number 15-04136-EN)
- Manpack Transceiver 2110 series Reference Manual (Codan part number 15-04135-EN)
- Manpack Transceiver 2110M series Getting Started Guide (Codan part number 15-04153-EN)
- Manpack Transceiver 2110M series Reference Manual (Codan part number 15-04152-EN)
- Manpack Transceiver 2110 series Repair Guide (Codan part number 15-04139-EN)
- External Power Amplifier 3160 Installation Handbook (Codan part number 15-04157-EN)
- NGT System Programmer Help (Codan part number 15-04105-EN)
- Declaration of Conformity for the 2110 SSB Transceiver (Codan part number 19-40157)

This page has been left blank intentionally.

This section contains the following topics:

[Introduction \(12\)](#)

[European R&TTE Directive \(13\)](#)

[EMC and safety notices \(14\)](#)

[FCC compliance \(16\)](#)

[C-tick approval \(17\)](#)

[Care and safety information \(17\)](#)

Introduction

This section describes how to ensure the 2110 series Manpack Transceiver complies with the European EMC Directive 89/336/EEC and the European Low Voltage Directive 73/23/EEC as called up in the European R&TTE Directive 1999/5/EC.

The CE Declaration of Conformity and Expert Letter of Opinion for the product are listed on [page 9, *Associated documents*](#). These documents can be made available upon request to Codan or a Codan-authorized supplier.

This section also contains the requirements for FCC compliance and C-tick approval.

European R&TTE Directive

The 2110 series Manpack Transceiver has been tested and complies with the following standards and requirements (articles of the R&TTE Directive):

- Article 3.1b: ETSI EN 301 489-1
- Article 3.1b: ETSI EN 301 489-15
- Article 3.2: Australian type approval according to AZ/NZS 4770:2003
- Article 3.1a: Assessed against ICNIRP and FCC requirements
- Article 3.1a: EN 60950

The 3160 Power Amplifier has been tested and complies with the following standards and requirements (articles of the R&TTE Directive):

- Article 3.1b: ETSI EN301489-1 V1.4.1
- Article 3.1b: ETSI EN301489-15 V1.2.1
- Article 3.1a: EN60950-1

Product marking and labelling

Any equipment supplied by Codan that satisfies these requirements is identified by the CE0191 $\text{\textcircled{C}}$, CE0191 or CE markings on the model label of the product.

Declaration of Conformity and Expert Letter of Opinion

The CE Declaration of Conformity and Expert Letter of Opinion for the product are listed on [page 9, Associated documents](#). These documents can be made available upon request to Codan or a Codan-authorized supplier.

Protection of the radio spectrum

CAUTION Most countries restrict the use of HF radio communications equipment to certain frequency bands and/or require such equipment to be licensed. It is the user's responsibility to check the specific requirements with the appropriate communications authorities. If necessary, contact Codan for more information.

EMC and safety notices

Radiation safety

To ensure optimal transceiver performance and to avoid exposure to excessive electromagnetic fields, the antenna system must be installed according to the instructions provided.

WARNING High RF voltages are present during transmission and tuning. Do not touch the antenna during these activities. RF burns may result.

WARNING Install the grounding system of counterpoise as directed to prevent RF burns from any metal part of the transceiver.

You should not transmit from your transceiver or tune the antenna unless people are beyond the safe working distance of:

- 1.5 m (5 ft) of any part of a mobile antenna
- 0.2 m (8 in) from a long wire, end-fed broadband, broadband dipole, or wire dipole antenna
- 0.6 m (2 ft) from any whip antenna
- 2 m (7 ft) of any part of a fixed antenna in a data installation of up to 125 W output

Safe working distance is based on continuous exposure to CW-type transmissions, as set out in the ICNIRP Exposure Guidelines (1998) for occupational exposure. Safe working distance can be reduced with normal voice communication.

EMC

To ensure compliance with the EMC Directive is maintained, you must:

- Use standard shielded cables supplied from Codan (where applicable).
- Ensure covers for the equipment are fitted correctly.

NOTE If it is necessary to remove the covers at any stage, they must be refitted correctly before using the equipment.

- Cover unused connectors on the transceiver unit with the protective caps supplied to prevent electrostatic discharge passing through your equipment.

Electrical safety

To ensure compliance with the European Low Voltage Directive is maintained, you must deploy and use the 2110 series Manpack Transceiver and antennas in accordance with the instructions in the Getting Started Guide and Reference Manual provided with each transceiver, and the Quick Reference Card supplied with each antenna.

When using equipment that is connected directly to the AC mains these precautions must be followed and checked before applying AC power to the unit:

- Use the standard AC mains cable supplied.
- Ensure the covers for the equipment are fitted correctly.

The 3121 AC Battery Charger and 3123 Fast AC Battery Charger are double insulated and marked with .

CAUTION

If it is necessary for a qualified electronics technician to remove the covers during servicing, they must be refitted correctly before using the charger.

A protective earth connection must be included in the mains wiring to the 3020 Transceiver Supply (see below, *Earth symbols*).

WARNING

The protective cover must always be fitted when the 3121 AC Battery Charger, 3123 Fast AC Battery Charger, or 3020 Transceiver Supply is connected to the AC mains.

Battery safety

Battery cells are electrically live at all times and must be treated with extreme caution. They may supply high short-circuit currents even if they appear to be damaged or inoperable.



Batteries should be used to provide power to the transceiver only, using the supplied connectors.

The batteries will not charge at temperatures higher than 40°C (104°F).

Earth symbols

An antenna earth connection point is provided on the 2110 series Manpack Transceiver and the 3160 Power Amplifier. A protective earth is provided in the AC mains wiring of the 3020 Transceiver Supply. This protective earth needs to be connected at the AC mains supply outlet. The symbols shown in [Table 1](#) identify the earths on the equipment.

Table 1: Earth symbols

Symbol	Meaning
	Antenna earth
	Protective earth

FCC compliance

FCC Part 90 certification

The 2110 series Manpack Transceiver has been tested and certified to FCC Part 90. (FCC identifier code DYY2110).

FCC Part 15 compliance

Any modifications made to the 2110 series Manpack Transceiver, the 3121 AC Battery Charger, the 3123 Fast AC Battery Charger, or battery packs that are not approved by the party responsible for compliance may void your equipment's compliance under Part 15 of the FCC rules.

The 2110 series Manpack Transceiver, the 3121 AC Battery Charger, the 3123 Fast AC Battery Charger, and battery packs have been tested and found to comply with the limits for a Class B device, pursuant to Part 15 of the FCC rules. These limits are designed to provide reasonable protection against harmful interference in a residential installation. This equipment generates, uses and can radiate radio frequency energy and, if not installed and used in accordance with the instructions, may cause harmful interference to radio communications. However, there is no guarantee that interference will not occur in a particular installation. If this equipment does cause harmful interference to radio or television reception, which can be determined by switching the equipment off and on, the user is encouraged to try to correct the interference by one or more of the following measures:

- reorient or relocate the receiving antenna
- increase the separation between the equipment and receiver
- connect the equipment into an outlet on a circuit different from that to which the receiver is connected
- consult the dealer or an experienced radio/TV technician for help

C-tick approval

The 2110 series Manpack Transceiver and 3160 Power Amplifier meet the requirements of the Australian Communications and Media Authority: Radiocommunications (MF and HF equipment—Land Mobile Service) Standard 2003 (AS/NZS 4770).

Care and safety information

Storage of batteries

Codan recommends that batteries are fully charged prior to storage. The length of time that they can be stored before recharging is necessary depends upon the type of battery pack and the average storage temperature.

Table 2: Battery storage times

Type	Storage time @ 20°C (70°F)	Storage time @ 30°C (85°F)
NiMH	12 months	6 months
SLA	15 months	10 months

Disposal of batteries

Batteries should be recycled in accordance with local government regulations and environmental acts.

WARNING Batteries must *not* be burnt or disposed of in landfill due to the risk of personal injury and environmental damage.

Immersion of the transceiver in water

The transceiver unit, battery unit, and 3160 Power Amplifier are designed to be waterproof to IP68. The units can withstand immersion in 1 m (3 ft) of water for up to 1 hour. Prolonged immersion may cause damage to the units.

If the units are immersed in water, drain any water from the front panel speaker and keypad of the transceiver, then wipe and air dry the connectors on all units prior to use or charging the battery pack.

If the units are exposed to salt water, they should be washed with fresh water as soon as possible.

WARNING Do not expose any uncapped connectors on the battery pack to salt water. This will damage the connector.

Deploying antennas

WARNING Do not deploy an antenna at sites with overhead power cables.

WARNING Do not deploy or use any antenna if there is lightning in the area.

General

The removal and substitution of components may damage the components and/or the printed circuit boards. In some cases, it is impossible to remove components without destroying them. Therefore, it is important to carry out as much diagnosis as possible with components in situ.

Spare boards

If spare boards are held in stock, they may be substituted in order to positively localise the fault to one board.

Static transistor tests

Transistor failures are most often due to open-circuit base–emitter or base–collector junctions, or a short circuit between emitter and collector.

These types of faults can often be detected without removing the transistor using the Ω range of a multimeter. The two junctions should both give the appearance of a diode (high resistance with the multimeter leads one way and low resistance when the leads are reversed). Polarity depends on whether a PNP or NPN transistor is being tested. Resistance between collector and emitter should be high with the multimeter leads either way. Before removing a transistor that fails this test, examine the circuit diagram for parallel paths.

Dynamic transistor tests

Some transistor faults can be diagnosed by measuring voltages within the circuit. One of the most significant voltage measurements is the base–emitter voltage. The polarity of this depends on the type of the transistor (PNP or NPN). A base–emitter voltage between 0.5 and 0.9 V should be measured on a forward-biased base–emitter junction.

With its base–emitter junction forward biased, the transistor should conduct. Some indication of satisfactory operation of the transistor is obtained by measuring the voltage drop across its collector or emitter resistor while short circuiting its base to the emitter. The short circuit removes the forward bias, cutting off the transistor so that the voltage across the resistor is reduced considerably.

Integrated circuits

If there appears to be no output from an integrated circuit, before replacing the device, check whether the fault is due to the IC or its load. As a general rule, if changes in input cause absolutely no change in the corresponding output, the IC should be suspected. However, if even a very small change in output can be detected, the load is more likely to be the cause. Depending upon the circuit, further tests should be made by disconnecting resistors, capacitors and the like, to verify this diagnosis before removing the IC.

CMOS devices

A number of CMOS devices are used in the equipment, and most of them have built-in ESD protection. Due to their extremely high open-circuit impedance, they are susceptible to damage from static charges. Care must therefore be used when shipping and handling the devices and when servicing the equipment in which they are installed.

Packaging

Replacement CMOS devices are supplied in special conductive packaging. They should remain in this packaging until required for use.

Switching off

Ensure that power sources are switched off before making connections or disconnections between circuit boards.

Handling

Handle circuit boards by the edges only. Use antistatic bags or trays to store and transport PCBs.

Grounding

Ground any items connected to or touching the tracks of a circuit board as follows:

- Ground test equipment connected to a board through its mains lead.
- Discharge static charges, which may build up on a person, by touching a grounded metal surface with both hands. This should be done before working on, and at frequent intervals while working on circuit boards.
- Wear a suitably grounded conductive wrist strap. This minimises the build up of static on you.

Circuit boards

Excessive heat

Excessive heat may lift tracks from the circuit boards. This causes serious damage. Avoid the use of high-powered soldering irons. A soldering iron rated at a maximum of 60 W, preferably temperature-controlled at approximately 370°C, is sufficient for most tasks. A soldering iron rated at a slightly higher temperature of 425°C may be required for heavier components such as PA transistors. Only apply the soldering iron long enough to de-solder an existing joint or to solder a new one.

De-soldering

When de-soldering a component, use a solder sucker or solder-wick material to remove solder.

CAUTION Do not use sharp metal tools such as screwdrivers or twist drills to remove components as these may damage the printed circuit track and plated-through holes.

Component substitution

Avoid unnecessary component substitution as this may damage the component, the circuit track or adjacent components.

Component replacement

When a component is diagnosed as defective, or the fault cannot be diagnosed in any other way than by substitution, observe the following when replacing components:

- **Leaded components:** Components with axial leads can often be replaced without de-soldering the joints on the boards. The defective component can be removed by clipping its leads close to the component, leaving the leads soldered to the board. These leads should be straightened, so that the leads of the replacement component can be wrapped around and soldered to them. After soldering, the excess lead should be clipped off.
- **SMT components:** The removal or replacement of surface-mount components should only be attempted by a skilled technician experienced in handling surface-mounted components.
- **Solder:** When a component has been de-soldered from the board, ensure the holes are clear of solder before inserting the leads of the replacement component.

CAUTION Never force the leads through the holes as this damages the circuit track, particularly where plated-through holes are used.

- **Orientation:** Before replacing defective diodes, transistors, electrolytic capacitors or integrated circuits, observe any markings that indicate polarity or orientation. It is essential that these types of components are installed correctly. If necessary, consult the manufacturer's data for indications of the polarity of diodes, capacitors and transistors.
- **Heatsinking:** When soldering heat sensitive components to the circuit board, use long-nosed pliers or some other form of heatsinking on the leads of the components.
- **Thermal conduction:** When replacing transistors that are mounted on heatsinks, ensure there is thermal conduction between the heatsink and the component being replaced. This is achieved by cleaning the mounting surfaces, then recoating them with a thermal conduction compound such as Jermyn Thermaflow A30.

Track repair

Broken or burnt sections of printed circuit track may be repaired by bridging the damaged section with tinned copper wire. Clean the area of repair before soldering (see [page 21, De-soldering](#)).

Integrated circuit replacement

It is often possible to de-solder and remove components from the board without damage to the component or the tracks on the board. However, ICs with many connections, mounted on double-sided or multilayer circuit boards with plated-through holes, are almost impossible to remove intact and the operation is likely to damage the circuit boards. To replace these components, their leads must be cut individually until the body of the component can be removed. Individual leads must be de-soldered and removed. The excess solder must be removed before inserting the replacement component (see [page 21, De-soldering](#)).

When replacing SMT components, specialised equipment and techniques are required.

Transmitter precautions

When making measurements of the low-level stages of the exciter, it is advisable to remove the drive to the PA. The supply voltage is applied to the PA at all times when the transceiver is switched on.

CAUTION Caution should be exercised when connecting probes to avoid incorrect readings.

Probe precautions

Observe the following when connecting oscilloscope probes to the equipment:

- When connecting probes to the PA assembly, the earth clip lead should be wound around the body of the probe so that the earth clip just reaches the probe tip. This reduces stray RF pick-up.
- The earth clip should be connected to the ground plane, adjacent to the point of measurement.
- It is not advisable to connect two probes at the same time, particularly when one is earthed to the PA ground plane and the other is earthed to the exciter. This may cause earth loop problems.
- Probes should be connected before power has been applied to the transceiver and the test equipment. The earth connection should be made first and disconnected last.

This page has been left blank intentionally.

Contact information

If the fault diagnosis guidelines do not locate the faulty module or cable, or if further technical assistance is required for any other reason, please see our details on the internet at www.codan.com.au. Click on [↗ Contact](#) at the top of the page, then select your region.

Outside of normal office hours, Codan has Customer Service Engineers on call to provide emergency technical assistance. They will either answer your call immediately or return your call as soon as possible.

If you are connected to a voice mail system when you call, please follow the instructions carefully, that is, leave your name and contact phone number (including the country code), then a brief, clear description of your problem.

This page has been left blank intentionally.

Ordering information

The parts lists for the PCB assemblies contain:

- a circuit reference number
- descriptions, giving the value and type of component
- a manufacturer and manufacturer's part number

NOTE Items having numeric references identifying specific components or subassemblies may be encountered in the parts lists included in this manual. These items, selected from master manufacturing information, identify parts that are either useful for maintenance purposes or related to other items, and may be cross-referenced in the remarks column.

Table 3: Resistor and capacitor abbreviations

Resistors	Capacitors
CC: carbon composition	AS: solid aluminium electrolytic
CF: carbon film	CC: ceramic multilayer chip
MF: metal film	CE: ceramic
MG: metal glaze	EL: wet aluminium electrolytic
MO: metal oxide	M: stacked mica
WW: wire wound	PC: polycarbonate
	PE: polyester
	PP: polypropylene
	PS: polystyrene
	PT: PTFE
	TA: solid tantalum

Ordering information

Orders for replacement parts/modules must include the following information. This ensures that the correct items are supplied, and speeds up delivery times.

- equipment type (e.g. Type 2110 Transceiver)
- part/module location (e.g. Audio & Control PCB, 08-06128)
- full part/module description (e.g. Antenna Tuner PCB)

Component substitution

When replacing general purpose components (resistors, capacitors etc), equivalent parts from other manufacturers may be used provided they have similar tolerances, voltage/power rating and temperature coefficients to the specified part.

Substituting components that do not exactly match those listed in the parts list will not adversely affect the performance of the equipment.

Overview and specifications

This section contains the following topics:

[Overview \(30\)](#)

[Specifications \(32\)](#)

[Pin connections \(40\)](#)

Overview

2110 series Manpack Transceiver

The 2110 series Manpack Transceiver is a self-contained, lightweight, waterproof and rugged communication system.

The handset is a hand-held device with a microphone, PTT button and earphone.

The transceiver unit modulates an audio signal onto a radio frequency that can be transmitted on air, and demodulates the radio frequency it receives into an audio signal.

Figure 1: The 2110 series Manpack Transceiver

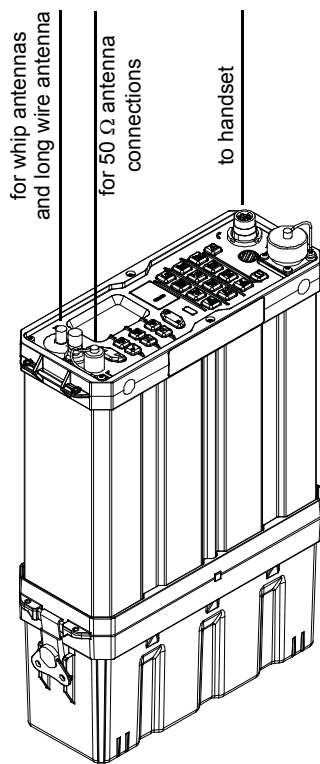

3160 Power Amplifier

The 3160 Power Amplifier is for use in mobile or fixed manpack stations where 125 W of power is required. The 3160 is automatically controlled from the manpack transceiver.

Figure 2: The 3160 Power Amplifier

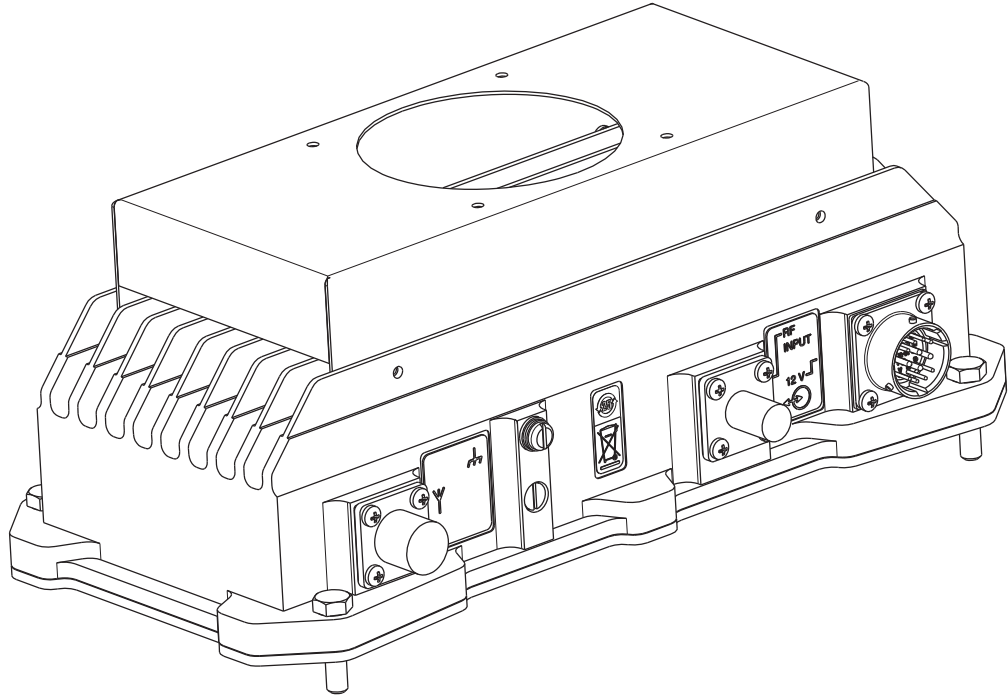

Specifications

The figures listed for specifications are normally exceeded by production equipment. Where relevant, typical values are given in brackets []. All measurements are made at 13.6 V DC, with 50 Ω source and load resistances at 25°C ambient temperature, unless otherwise specified.

General

Table 4: General specifications

Item	Specification
Frequency range	Transmit: 1.6 to 30 MHz Receive: 0.25 to 30 MHz
Channel capacity (single or two-frequency simplex channels)	400 600 channels if MIL-STD-188-141B ALE is installed
Frequency generation	All frequencies generated by PLL and DDS synthesisers with 10 Hz resolution
Operating modes	Single sideband (J3E) USB or LSB or switched USB/LSB (AM H3E optional)
Frequency stability	± 1.5 [1] ppm (–30 to +60°C) (standard) ± 0.5 ppm (–30 to +60°C) (high stability)
Programming	Configuration of transceiver is via the GPIO port using NSP programming software and a PC, or via the front panel by qualified personnel or, where permitted, by the operator
RF input/output impedance	Whip/long wire antenna via internal antenna tuner, or 50 Ω nominal at 50 Ω antenna port
Supply voltage	12 V DC nominal from supplied battery, negative earth Nominal operating range: 10.5 to 15.5 V DC Reverse polarity protected
Overvoltage protection	Shut down at 16 V ± 0.5 V DC nominal for duration of overvoltage
Low voltage switch off	Switch off @ 10 V
Supply current	Transmit: see Table 6 on page 35 Receive: no signal 120 mA nominal (standby mode) no signal 145 mA nominal (operating mode) average speech 1 A for battery life calculations
Useable battery life (Tx:Rx ratio of 1:9)	13 Ah NiMH battery pack: 50 h 8 Ah NiMH battery pack: 30 h 7 Ah SLA battery pack: 15 h

Table 4: General specifications (cont.)

Item	Specification
Cooling	Convection from case
Size	<p>2110 (including battery): 245 mm W × 350 mm D × 92 mm H (9.8 in W × 14.0 in D × 3.7 in H)</p> <p>2110 only: 245 mm W × 250 mm D × 92 mm H (9.8 in W × 10.0 in D × 3.7 in H)</p> <p>For packed sizes of accessories see Table 10 on page 38</p>
Weight	<p>2110 only: 2.5 kg (5.5 lb)</p> <p>13 Ah NiMH battery pack: 2.9 kg (6.4 lb)</p> <p>8 Ah NiMH battery pack: 2.1 kg (4.6 lb)</p> <p>7 Ah SLA battery pack: 3.2 kg (7.1 lb)</p> <p>For weights of accessories see Table 10 on page 38</p>
Environment	<p>Ambient temperature: –30 to 60°C (–22 to 140°F)</p> <p>Relative humidity: 95% non-condensing</p> <p>Derate upper ambient temperature by 1°C (33.8°F) per 330 m (360 yd) above sea level</p> <p>MIL-STD-810F compliance:</p> <p>Method 500.4: Low Pressure (Altitude) Method 506.4: Rain Method 507.4: Humidity Method 508.5: Fungus Method 509.4: Salt Fog Method 510.4: Sand and Dust Method 512.4: Immersion (IP68: immersion for 1 hour at a depth of 1 m (3 ft)) Method 514.5: Vibration Method 516.5: Shock</p>
Finish colour	Dark Grey or CARC 383
Microphone	Standard military handset with microphone, earphone and PTT push-button switch

Receiver

Table 5: Receiver specifications at 50 ohm antenna connector

Item	Specification
Type	Dual conversion, superheterodyne
IF frequencies	45 MHz and 455 kHz
Sensitivity	<p>Frequency: RF amp off: 0.25 to 30 MHz 0.45 [0.28] μV PD -114 [-118] dBm</p> <p>Frequency: RF amp on: 1.6 to 30 MHz 0.22 [0.14] μV PD -120 [-124] dBm</p> <p>For 10 dB SINAD with greater than 50 mW audio output power</p>
Input protection	Will withstand 50 V p-p RF from a 50 Ω source
Selectivity	<p>Greater than 65 [70] dB at -1 kHz and +4 kHz reference SCF USB</p> <p>Maximum pass band level variation: 8 [6] dB @ 300 to 2600 Hz</p> <p>Ripple: 4 [2] dB p-p @ 500 to 2500 Hz</p>
Desensitisation	<p>10 dB SINAD reduced to 7 dB SINAD</p> <p>-1 and +4 kHz (ref SCF) USB 50 [55] dB</p> <p>\pm10 kHz 65 [70] dB</p> <p>\pm50 kHz 80 [85] dB</p>
Blocking	<p>As for Desensitisation</p> <p>For frequencies > \pm50 kHz > 80 dB</p>
Image rejection	Better than 55 [60] dB
Spurious responses	<p>Better than 70 [80] dB</p> <p>No more than 10 self-generated signals > 0.15 μV PD</p>
Intermodulation	<p>To produce a third order intermodulation product equivalent to a wanted signal producing 10 dB SINAD, two unwanted signals, greater than 30 kHz removed from the wanted signal, must have a level greater than 80 [82] dB above the wanted signal</p> <p>Third order intercept (unaffected by AGC): +10 [+13] dBm with RF amp off +0 [+3] dBm with RF amp on</p>
AGC	<p>Less than 6 dB variation in output for input variation between 2.0 [1.0] μV and 100 mV PD (RF amp on)</p> <p>Fast attack, slow release (selectable release time)</p>

Table 5: Receiver specifications at 50 ohm antenna connector (cont.)

Item	Specification
A/F power and A/F distortion	Internal speaker: 0.5 W typical into 8 Ω , 10% THD 0.4 W minimum, 5% THD External speaker on GPIO connector: 1 W typical into 4 Ω , 10% THD 0.75 W minimum, 5% THD
Clarifier	± 10 ppm (nominal) above 5 MHz ± 50 Hz below 5 MHz Clarifier is automatically reset to mid-frequency with channel change
Signal to noise vs input signal	An increase of input level of 40 dB above the sensitivity level increases the signal-to-noise ratio to at least 35 dB

Transmitter

Table 6: Transmitter specifications at 50 ohm antenna connector

Item	Specification
Power output	25 W PEP ± 0.5 dB (high power) 5 W PEP ± 0.5 dB (low power) CW or single tone: approximately 60% of PEP with average PEP control (average control disabled on handset PTT)
Duty cycle	50%: normal speech over full temperature range 50%: multi-tone continuous data mode (5 minutes on maximum) at ambient temperature up to 40°C (104°F) using 50 Ω antenna port
Supply current	Two-tone into 50 Ω : 2.5 to 3.5 A Average speech: 1 A for battery life calculations
Protection	Safe under all load conditions by limiting reflected power to 4 W PEP and limiting PA transistor collector voltage swing Thermal protection against excessive heatsink temperature
A/F response	Overall response of microphone and transmitter rises approximately 6 dB/octave 300 to 2700 Hz Electrical input: -8 [-6] dB 300 to 2600 Hz Ripple: 4 [2] dB p-p 500 to 2500 Hz
Spurious and harmonic emissions	Better than 60 [65] dB below PEP
Carrier suppression	50 [60] dB below PEP
Unwanted sideband	55 [70] dB below PEP (400 Hz) 65 [70] dB below PEP (1 kHz)

Table 6: Transmitter specifications at 50 ohm antenna connector (cont.)

Item	Specification
Intermodulation (Two-tone test)	26 [30] dB below each tone 32 [36] dB below PEP
ALC	A 10 dB increase in signal input above compression threshold produces less than 0.5 dB increase in power output Maximum ALC range greater than 30 dB ALC attack time approximately 1 ms
Microphone	Standard military handset with Dynamic mic insert

Antenna tuner

Table 7: Antenna tuner specifications

Item	Specification
Tuning limit	< 1.5:1 typical SWR All tuning activity performed at 5 W nominal
Antenna types @ antenna stud	Short Whip 1.5 m (5 ft) (nominal): from 3 to 30 MHz Long Whip 3 m (10 ft) (nominal): from 2 to 30 MHz Long Wire 10 m (33 ft): from 1.6 to 30 MHz
Memory capacity	The last 100 frequencies selected
Tuning time (antenna types as in General specifications)	First-time tuning: 2.5 s typical From memory: 50 ms typical
Duty cycle @ antenna stud	10%: normal speech over full temperature range
Protection	Safe under all load conditions

Battery chargers

Table 8: Battery charger specifications

Item	Specification
Input voltage	AC: 90 to 264 V AC DC: 12 to 60 V DC
Charging temperature range	0 to 40°C (0 to 104°F)
Overtemperature shutdown	Charging process shuts down when ambient temperature is >50°C (122°F)

3160 Power Amplifier

Table 9: 3160 Power Amplifier specifications

Item	Specification
Frequency range	Transmit: 1.6 to 30 MHz
Power output	125/100 W PEP reducing with frequency to 95 W PEP at 30 MHz \pm 1 dB (100 W power option is available) CW or single tone: approximately 60% of PEP with average PEP control (average control disabled on handset PTT)
Spurious and harmonic emissions	Better than 60 [65] dB below PEP
Intermodulation (Two-tone test)	100 W: 26 [30] dB below each tone 32 [36] dB below PEP 125 W: 26 [27] dB below each tone 32 [33] dB below PEP
RF input/output impedance	50 Ω nominal
Duty cycle	100%: normal speech over full temperature range 100%: ARQ up to 30°C (86°F) 25%: 16-tone continuous data mode (5 minutes on maximum) at ambient temperature up to 30°C (86°F) 100%: all data modes up to maximum ambient of 45°C (113°F) with Option F
Supply voltage	13.6 V DC nominal, negative earth Nominal operating range: 10.8 to 15 V Reverse polarity protected
Overvoltage protection	Shut down at 16 V \pm 0.5 V DC nominal for duration of overvoltage

Table 9: 3160 Power Amplifier specifications (cont.)

Item	Specification
Supply current	Output power: 100 or 125 W Two-tone or CW: 9 to 17 A Average speech: 8 A for battery life calculations Receive: 65 mA
Protection	Safe under all load conditions by limiting reflected power to 10 W PEP and limiting PA transistor collector voltage swing Thermal protection against excessive heatsink temperature
Environment	Ambient temperature: -30 to +60°C (-22 to 140°F) Relative humidity: 95% Derate upper ambient temperature by 1°C (33.8°F) per 330 m (361 yd) above sea level
Sealing	IP68 (MIL-STD 810F): immersion for 1 hour at a depth of 1 m (3 ft) (Option F not included)
Cooling	Convection or fan (Option F)
Size	286 mm W × 146 mm D × 77 mm H (11.3 in W × 5.7 in D × 3.0 in H)
Weight	2.2 kg (4.9 lb)
Finish colour	CARC 383 (green)

Accessories

Table 10: Physical specifications of accessories

Accessory	Size	Weight
3 m Collapsible Whip Antenna	40 mm W × 40 mm D × 550 mm H (1.6 in W × 1.6 in D × 22.0 in H)	0.4 kg (0.9 lb)
3121 AC Battery Charger	160 mm W × 80 mm D × 30 mm H (6.4 in W × 3.2 in D × 1.2 in H)	0.5 kg (1.1 lb)
3122 DC Battery Charger	160 mm W × 80 mm D × 30 mm H (6.4 in W × 3.2 in D × 1.2 in H)	0.4 kg (0.9 lb)
3160 Power Amplifier	286 mm W × 146 mm D × 77 mm H (11.3 in W × 5.7 in D × 3.0 in H) (includes allowance for connectors)	2.2 kg (4.9 lb)

Table 10: Physical specifications of accessories (cont.)

Accessory	Size	Weight
Backpack External Frame	450 mm W × 30 mm D × 650 mm H (18.0 in W × 1.2 in D × 26.0 in H)	4.3 kg (9.5 lb)
Backpack Internal X Frame	420 mm W × 25 mm D × 650 mm H (16.8 in W × 1.0 in D × 26.0 in H)	3.4 kg (7.5 lb)
Backpack Soft	400 mm W × 20 mm D × 600 mm H (16.0 in W × 0.8 in D × 24.0 in H)	1.4 kg (3.1 lb)
Broadband Dipole Antenna (3 to 30 MHz)	200 mm W × 100 mm D × 200 mm H (8.0 in W × 4.0 in D × 8.0 in H)	3.2 kg (7.1 lb)
Coaxial cable, 15 m (50 ft)		0.6 kg (1.4 lb)
Coaxial cable, 3 m (10 ft)		0.2 kg (0.4 lb)
Counterpoise	105 mm W × 105 mm D × 25 mm H (4.2 in W × 4.2 in D × 1.0 in H)	0.2 kg (0.4 lb)
Earth lead with clip/plug	100 mm W × 25 mm D × 20 mm H (4.0 in W × 1.0 in D × 0.8 in H)	0.1 kg (0.2 lb)
Earth stake	237 mm W × 31 mm dia (head) × 6 mm dia (shaft) (9.5 in H × 1.2 in dia (head) × 0.3 in dia (shaft))	0.1 kg (0.2 lb)
End-fed Broadband Antenna	200 mm W × 70 mm D × 60 mm H (8.0 in W × 2.8 in D × 2.4 in H)	0.7 kg (1.5 lb)
Knock-down Whip Antenna	40 mm W × 40 mm D × 550 mm H (1.6 in W × 1.6 in D × 22.0 in H)	0.4 kg (0.9 lb)
Long Wire Antenna and Adaptor	200 mm W × 70 mm D × 40 mm H (8.0 in W × 2.8 in D × 1.6 in H)	0.5 kg (1.1 lb)
Tape Whip Antenna	50 mm W × 20 mm D × 480 mm H (2.0 in W × 0.8 in D × 19.2 in H)	0.3 kg (0.7 lb)
Wire Dipole Antenna (3 to 30 MHz)	200 mm W × 100 mm D × 200 mm H (8.0 in W × 4.0 in D × 8.0 in H)	2.7 kg (6.0 lb)

Pin connections

Front panel

Figure 3: Front panel of the transceiver (2110 model shown)

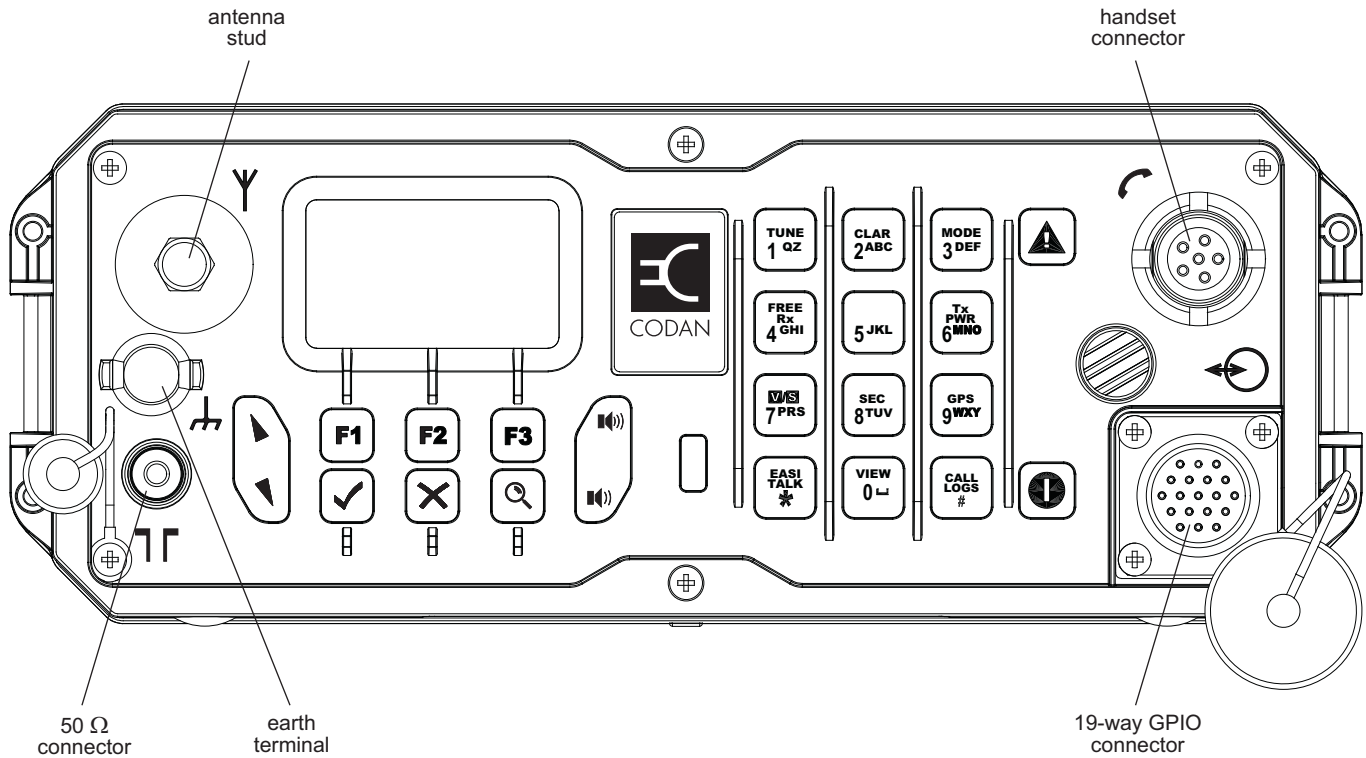

- NOTE** The 2110v Manpack Transceiver uses a 5-way connector in the place of the 19-way GPIO connector (↻).
- NOTE** The 2110M Manpack Transceiver uses **FUNC** and **HOP** hot keys on the **2** and **5** keys respectively.

Antenna connectors

The antenna connectors comprise:

- an antenna stud (Υ)
- a 50 Ω connector (⊓)

The antenna connectors are grounded using the earth terminal (⏏).

Pinouts of the handset connector

Figure 4: Front view of the handset connector

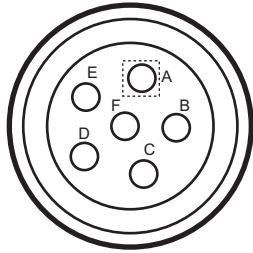

Table 11: Pinouts of the handset connector

Pin no.	Function	Input/output	Signal level
A	Ground		0 V
B	Earphone	Output	10 V p-p maximum (600 Ω)
C	PTT	Input	Active low for PTT
D	Microphone (switched)	Input	15 mV p-p (ALC threshold)
E	Power	Output	+12 V nominal
F	Not used		

Pinouts of the 19-way GPIO connector

Figure 5: Front view of the 19-way GPIO connector (2110/2110M only)

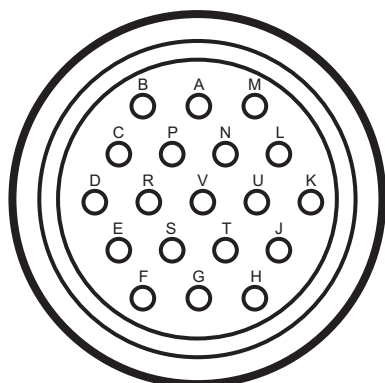

Table 12: Pinouts of the 19-way GPIO connector (2110/2110M only)

Pin no.	Function	Input/output	Signal level
A	Line audio	Input	300 mV p-p (ALC threshold) I/P approx. 50 kΩ bridging
B			
C	Line audio	Output	1 V p-p (20 dB above AGC) 600 Ω load maximum
D	Morse	Input	Active low
E	RS232 Tx data	Output	RS232
F	RS232 Rx data	Input	
G	PTT	Input	Active low
H	Power and signal ground		0 V
J	Speaker (+) audio bridging	Output	1 W into 4 Ω
K	Protected, switched supply from battery	Output	12 V DC nominal 10 to 15 V DC range 1 A maximum
L	Speaker (-) audio paired with J	Output	1 W into 4 Ω
M	Power in for charging battery	Input	15.5 V DC approx. 1 A maximum, current limiting
N	Antenna control	Input	3.3 V logic 5 V tolerant
P		Input/output	3.3 V logic 5 V tolerant

Table 12: Pinouts of the 19-way GPIO connector (2110/2110M only) (cont.)

Pin no.	Function	Input/output	Signal level
R	Scan	Output	Open collector 1 k Ω pull-down
S	RS232 RTS	Output	RS232
T	RS232 CTS	Input	
U	External PA ALC	Input	0 to 5 V DC analogue
V	Quiet	Input	Active low

Pinouts of the 5-way GPIO connector

Figure 6: Front view of the 5-way GPIO connector (2110v only)

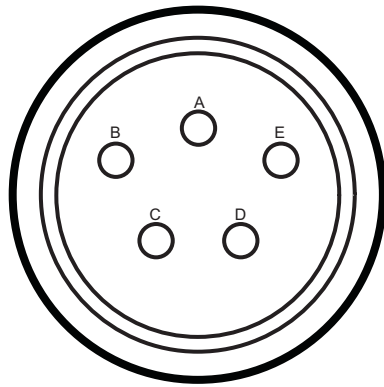
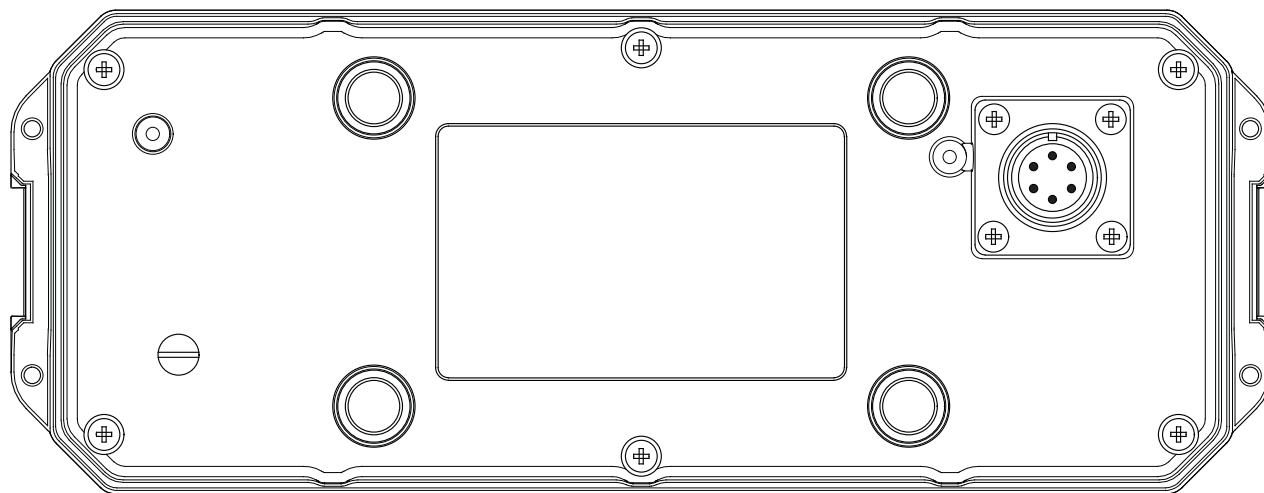

Table 13: Pinouts of the 5-way connector (2110v only)

Pin no.	Function	Input/output	Signal level
A	Power in for charging battery	Input	15.5 V DC approx. 1 A maximum, current limiting
B	RS232 Tx data (for programming)	Output	RS232
C	Morse	Input	Active low
D	Ground		0 V
E	RS232 Rx data (for programming)	Input	RS232

Bottom panel

Figure 7: Bottom panel of the transceiver unit



Pinouts of the battery connector on the transceiver unit

Figure 8: Front view of the battery connector on the transceiver unit

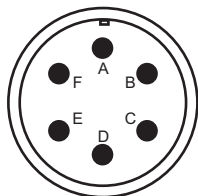
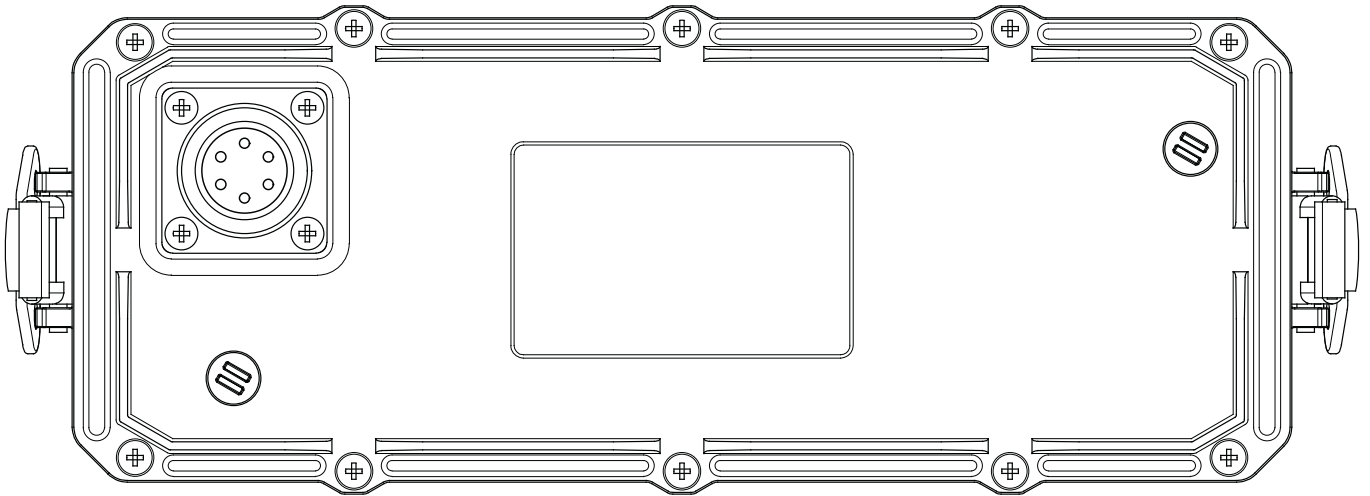

Table 14: Pinouts of the battery connector on the transceiver unit

Pin no.	Function	Input/output	Signal level
A	Ground		0 V
B	Charge out	Output	15.5 V @ 1 A maximum, current limiting
C	Battery+	Input	12 V nominal
D	SMB data, or SDA when external PA is detected	Input/output	3.3 V logic
E	SMB clock, or SCL when external PA is detected	Input/output	3.3 V logic
F	External PA ALC	Input	0 to 5 V DC analogue

Battery pack

Figure 9: Top panel of the battery pack



Pinouts of the battery connector on the battery pack

Figure 10: Front view of the battery connector on the battery pack

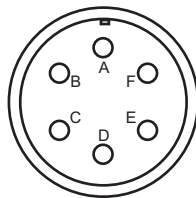
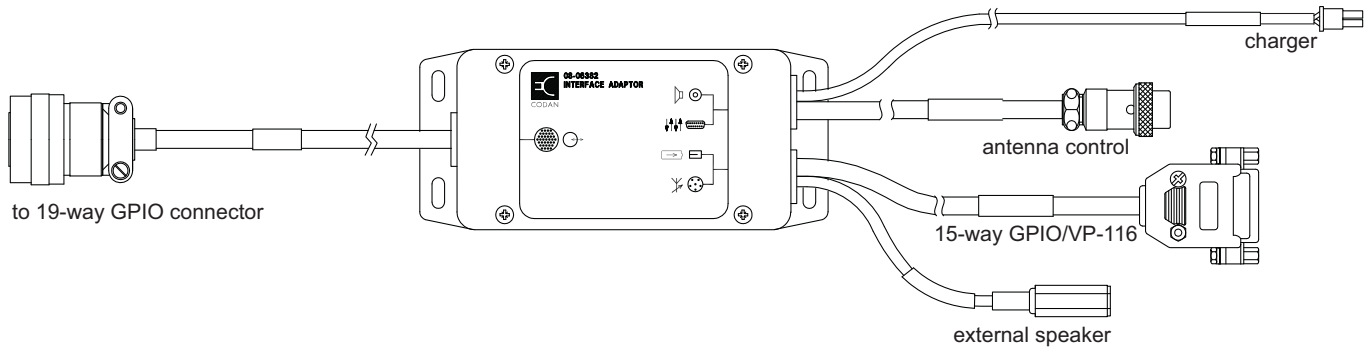

Table 15: Pinouts of the battery connector on the battery pack

Pin no.	Function	Input/output	Signal level
A	Ground		0 V
B	Charge in	Input	15.5 V @ 3 A maximum, current limiting
C	Battery+	Output	12 V nominal
D	SMB data	Input/output	3.3 V logic
E	SMB clock	Input/output	3.3 V logic
F	Spare		

Interface adaptor (2110/2110M only)

Figure 11: Interface adaptor



Pinouts of the antenna control connector on the interface adaptor

The antenna control connector is a flying lead located at the rear of the interface adaptor. The antenna control connector connects to automatic tuning antennas. It supplies power to the antenna and transmits signals to and from the antenna.

Figure 12: Front view of the antenna control connector on the interface adaptor

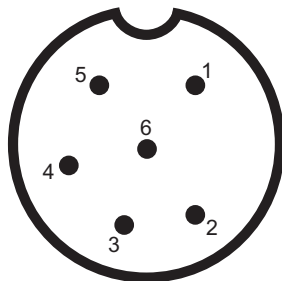

Table 16: Pinouts of the antenna control connector on the interface adaptor

Pin no.	Function	Input/output	Signal level
1	Tune in/out	Input/output	5 V logic, active low
2	Scan	Output	Active low
3	Tuned in	Input	5 V logic
4	A rail protected (2 A maximum)	Output	+13.6 V nominal
5	External ALC input	Input	0 to 5 V analogue
6	Ground		0 V

Pinouts of the speaker connector on the interface adaptor

The speaker should be 4 Ω with a power rating of 5 W.

Table 17: Pinouts of the speaker connector on the interface adaptor

Connection	Function
Tip	Speaker audio output
Sleeve	Ground

Pinouts of the 15-way GPIO connector on the interface adaptor

The GPIO connector is used to interface a variety of third-party products, such as morse keys, GPS units etc.

Figure 13: Front view of the 15-way GPIO connector on the interface adaptor

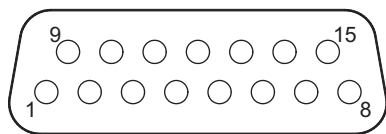

Table 18: Pinouts of the 15-way GPIO connector on the interface adaptor

Pin no.	Function	Input/output	Signal level
1	RTS	Output	RS232
2	RS232 Rx data	Input	RS232
3	RS232 Tx data	Output	RS232
4	Ground		0 V
5	Tx audio ($\geq 10\text{ k}\Omega$ balanced)	Input	300 mV p-p ALC threshold
6	Not connected		
7	Not connected		
8	A rail protected (2 A maximum)	Output	+13.6 V nominal
9	CTS	Input	RS232
10	PTT	Input	5 V logic active low
11	Morse	Input	5 V logic active low
12	Not connected		
13	Quiet (Q) line	Input	5 V logic active high when Fax/Data mode selected 5 V logic active low when all other modes selected
14	System audio unbalanced	Output	1 V p-p (20 dB above AGC) 600 Ω load maximum
15	Tx audio ($\geq 10\text{ k}\Omega$ balanced)	Input	300 mV p-p ALC threshold

Pinouts of the 15-way VP-116 connector on the interface adaptor

The 15-way connector may be used to interface a VP-116 Voice Privacy Unit.

Figure 14: Front view of the 15-way VP-116 connector on the interface adaptor

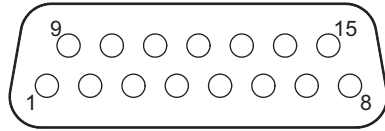
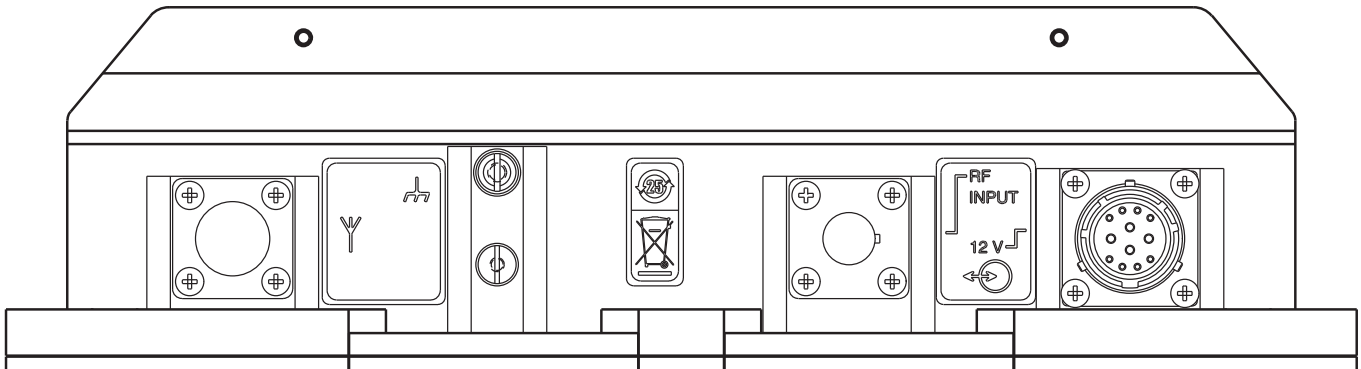

Table 19: Pinouts of the 15-way VP-116 connector on the interface adaptor

Pin no.	Function	Input/output	Signal level
1	A rail protected	Output	+13.6 V nominal
2	A rail protected	Output	+13.6 V nominal
3	Rx audio (encrypted)	Output	Approx. 500 mV p-p (loaded)
4	Rx audio (clear) (600 Ω balanced)	Input	Approx. 500 mV p-p (loaded)
5	Tx audio (encrypted) (600 Ω balanced)	Input	Approx. 500 mV p-p (loaded)
6	Tx audio (clear)	Output	Approx. 500 mV p-p (loaded)
7	Not connected		
8	Private Select		Active low
9	Ground		0 V
10	RS232 Rx data	Input	RS232
11	Rx audio ground		0 V
12	RS232 Tx data	Output	RS232
13	Tx audio ground		0 V
14	PTT	Input	5 V logic active low
15	PTT	Output	Active low

3160 Power Amplifier

Figure 15: 3160 Power Amplifier



Pinouts of the 12-way connector on the 3160

The 12-way connector is used to connect the 12 V DC power supply to the 3160, and provides control and monitoring between the 3160 and the manpack transceiver.

Figure 16: Front view of the 12-way connector on the 3160

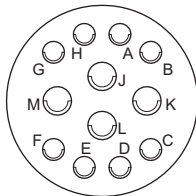

Table 20: Pinouts for the 12-way connector on the 3160

Pin no.	Function	Input/output	Signal level
A	ALC	Output	3.5 V = ALC control
B	Fan (-) switched	Output	0 V
C	DC supply ground (-)	Input	0 V
D	Fan (+)	Output	13.6 V nominal
E	I ² C clock	Input	3.3 V data
F	I ² C data	Input/output	3.3 V data
G	DC supply positive (+)	Input	13.6 V nominal
H	Screen ground	Input	0 V
J	DC supply positive (+)	Input	13.6 V nominal
K	DC supply ground (-)	Input	0 V

Table 20: Pinouts for the 12-way connector on the 3160 (cont.)

Pin no.	Function	Input/output	Signal level
L	DC supply ground (-)	Input	0 V
M	DC supply positive (+)	Input	13.6 V nominal

Pinouts of the 6-way connector on the 2110 amplifier adaptor panel

The 6-way connector is used to connect the 12 V DC power supply to the manpack transceiver.

Figure 17: 2110 amplifier adaptor panel for the 3160

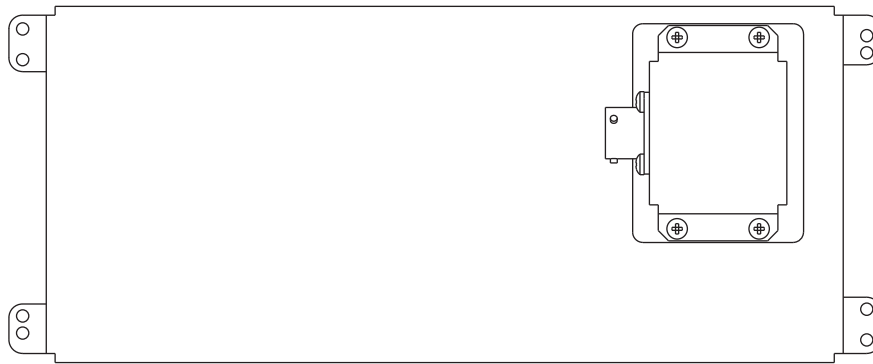

Figure 18: Front view of the 6-way connector on the 2110 amplifier adaptor panel

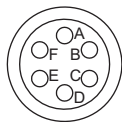

Table 21: Pinouts for the 6-way connector on the 2110 amplifier adaptor panel

Pin no.	Function	Input/output	Signal level
A	Screen ground	Input	0 V
B	DC supply ground (-)	Input	0 V
C	I ² C clock	Input	3.3 V data
D	I ² C data	Input/output	3.3 V data
E	ALC	Output	3.5 V = ALC control
F	DC supply positive (+)	Input	13.6 V nominal

This page has been left blank intentionally.

Brief description

This section contains the following topics:

[General information \(55\)](#)

[Transmit path \(56\)](#)

[Receive path \(57\)](#)

[Antenna tuning process \(59\)](#)

[Synthesiser operation \(59\)](#)

[Control and switching \(59\)](#)

For a detailed description of these functions see [page 61, *Technical description*](#).

This page has been left blank intentionally.

CHANGE REQUEST
 ISSUE 2
 2110 ONLY NOTE
 ADDED
 C/R 30246
 NJA 12-4-06

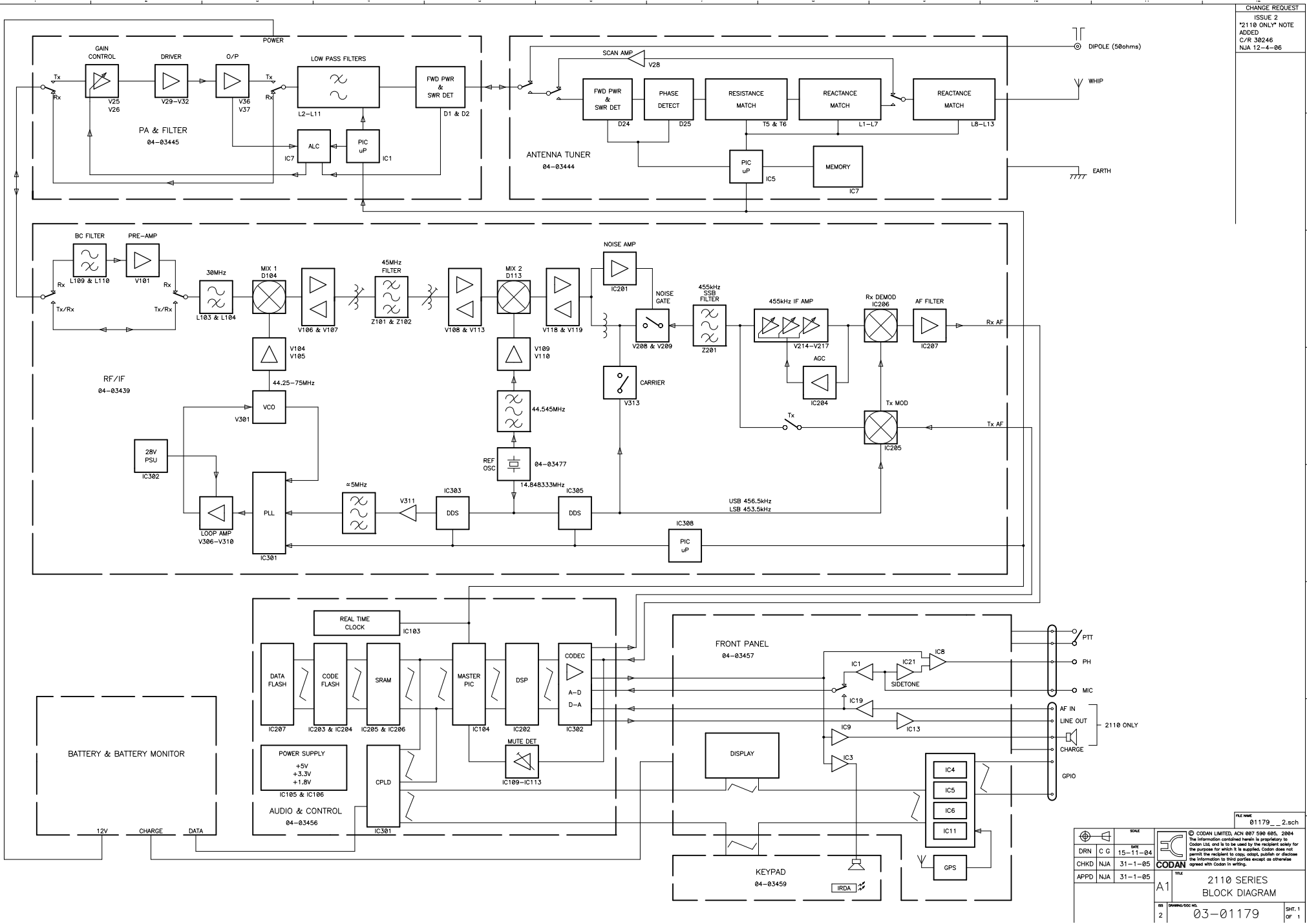

DRN		C G	DATE	15-11-04
CHKD		NJA	31-1-05	
APPD		NJA	31-1-05	
FILE NAME		01179_2.sch		
SCALE				
TITLE		2110 SERIES BLOCK DIAGRAM		
ISS		03-01179		
SHT. 1		OF 1		

General information

NOTE The information in this section should be read in conjunction with the block diagram (Codan part number [03-01179](#)).

The transceiver uses double conversion in both the Receive and Transmit modes. The 455 kHz sideband filter, the 45 MHz BPF, the mixers MIX 1 and MIX 2, and the local oscillators VCO and REF OSC, are common to both modes of operation.

Transmit path

Front Panel PCB

Microphone transmit audio appears at the handset connector, and it is pre-amplified on the Front Panel PCB and passed onto the Audio & Control PCB.

Audio & Control PCB

Pre-amplified audio from the Front Panel PCB passes through the optional encryptor module (where fitted), the codec, and digital signal processor on the Audio & Control PCB. The processing utilises a compression algorithm that converts the audio signal to a relatively constant level. The signal is passed to the RF/IF & Synthesiser PCB.

RF/IF & Synthesiser PCB

The audio is mixed with the local oscillator to produce double sideband. It is filtered by a 2.5 kHz sideband filter centred on 455 kHz so that only the wanted sideband is passed to the second mixer. It is then mixed with the reference oscillator to produce an IF signal centred on 45 MHz.

The transmit signal is filtered by a BPF with a bandwidth of 15 kHz, before being passed to the input of the first mixer.

At the first mixer, the signal mixes with the local oscillator VCO to produce the required channel frequency. The signal is passed to the PA & Filter PCB.

PA & Filter PCB

On the PA & Filter PCB, the signal passes through the first transmit/receive relay to the amplifier. Following amplification, it passes through the second transmit/receive relay to the selected LPF.

The output from the LPF passes via the VSWR DETECTOR circuit to the output connector. From there it is connected by coaxial cable to the Antenna Tuner PCB.

Antenna Tuner PCB

The signal from the PA & Filter PCB is either directly switched to the 50 Ω antenna connector (DIPOLE ANTENNA, J2) or switched via a set of impedance-matching components to the antenna stud (WHIP ANTENNA). Matching components are selected during an iterative tuning process (see [page 59](#), *Antenna tuning process*).

Receive path

Antenna Tuner PCB

The antenna tuner switches the signal received through either the 50 Ω antenna connector (DIPOLE ANTENNA, J2) or the antenna stud (WHIP ANTENNA) to the PA LPF. The signal from the 50 Ω antenna connector is switched directly. The signal from the antenna stud is connected via a set of matching components, selected during the tuning process or via a scanning amplifier.

PA & Filter PCB

The receive signal from the Antenna Tuner PCB passes through a PA LPF to the transmit/receive relays. It is then sent to the Tx/Rx connector on the RF/IF & Synthesiser PCB.

RF/IF & Synthesiser PCB

From the receiver input, the signal passes via a selectable pre-amplifier V101 to the input of the first balanced mixer. Here it mixes with the local oscillator VCO to produce an IF signal centred on 45 MHz.

The 45 MHz signal is filtered using a BPF with a bandwidth of 15 kHz, before being passed to the second balanced mixer. The signal mixes with the third harmonic (44.545 MHz) of the reference oscillator to produce an IF signal centred on 455 kHz.

The output of the second mixer passes through a 2.5 kHz sideband filter so that only the wanted sideband is fed to the high-gain AGC IF amplifier.

The amplified 455 kHz signal is demodulated to produce an audio signal and also to operate an AGC circuit. This circuit controls the gain of the IF amplifier to prevent overloading when strong signals are received. It also maintains constant audio output with changing input levels.

Audio & Control PCB

Analogue receive audio from the RF/IF & Synthesiser PCB passes through the optional encryptor module (where fitted), through the codec and digital signal processor on the Audio & Control PCB. The codec produces separate outputs, which can be either unprocessed (raw) audio, or enhanced (noise-reduced, volume-controlled) audio, which then passes via separate, balanced paths to the Front Panel PCB.

Front Panel PCB

Unprocessed (raw) audio from the Audio & Control PCB is typically passed by the Front Panel PCB to the line output on the 19-way GPIO connector. Enhanced (noise-reduced, volume-controlled) audio is passed to three separate audio amplifiers on the Front Panel PCB, which respectively feed the GPIO external speaker output, the military handset earphone, and the internal speaker. These outputs can be selectively controlled.

Antenna tuning process

Tuning is an iterative process in which selection of impedance-matching components is determined by an on-board microcontroller. A frequency-dependent algorithm decides on a consecutive selection, taking into account the phase and VSWR measurements. The process is repeated until matching is achieved.

Synthesiser operation

The transceiver uses a single loop synthesiser. The synthesiser VCO is used as the first mixer LO, generating an oscillator frequency in 10 Hz steps. In Receive mode, the frequency of the oscillator ranges from 45.25 MHz to 75 MHz. In Transmit mode, the frequency of the oscillator ranges from 46.6 MHz to 75 MHz.

The reference oscillator at 14.848333 MHz is fed through a 44.5 MHz BPF to select the third harmonic to produce the 44.545 MHz second mixer LO. The 14.848333 MHz frequency is also fed to two DDS ICs to produce a variable reference frequency for VCO with 10 Hz resolution.

The second DDS IC produces 456.5 kHz for USB and 453.5 kHz for LSB for the transmit modulator (Tx MOD) and receive demodulator (Rx DEMOD) circuits.

Control and switching

Most functions of the transceiver are controlled by a DSP and microcontrollers. The digital signal processor reads key strokes entered by the user. Update information is sent to the LCD via a dedicated bus.

Information exchange between the DSP on the Audio & Control PCB and the PA & Filter PCB, RF/IF & Synthesiser PCB, and Antenna Tuner PCB is accomplished via four microcontrollers that share a communications bus. Information exchange between the Audio & Control PCB and Front Panel PCB is accomplished via a separate dedicated data bus.

This page has been left blank intentionally.

Technical description

This section contains the following topics:

[Power on \(62\)](#)

[Power off \(63\)](#)

[Supply voltages \(64\)](#)

[Transmit path \(67\)](#)

[Receive path \(74\)](#)

[Frequency control \(79\)](#)

[Microprocessors and control \(81\)](#)

[Internal voice encryptor \(optional\) \(84\)](#)

[Internal GPS receiver \(optional\) \(85\)](#)

[Interface adaptor \(86\)](#)

[3160 Power Amplifier \(87\)](#)

This section should be read in conjunction with [page 153, Drawings](#).

Power on

Drawings [04-03457](#)

If the transceiver is 'off' when the  key on the front panel is pressed, the PWR_ON_REQ line is pulled low.

The PWR_ON_REQ line passes via the flexible flat cable of connector J2 to the Audio & Control PCB on the main chassis.

Drawing [04-03456 \(sheet 1\)](#)

The power on process is initiated by pulling the PWR_ON_REQ line low, which in turn pulls the POWER_ON line low. This action switches on the power relay on the PA & Filter PCB, presenting the A rail to the transceiver. The A rail then switches on the latching relay K101 via capacitor C114, which holds the POWER_ON line low regardless of the state of the PWR_ON_REQ line.

Drawing [04-03445](#)

Pulling the PWR ON line low causes V12 to conduct, which in turn sets relay K12 and connects DC supply to the transceiver. Once K12 is set, V12 stops conducting due to D18, completing the latching function. Transistor V13 is held conducting, holding FET V10 off to ensure the reset coil of K12 is not energised. When the PWR_ON line is released, V13 stops conducting, allowing V10 to conduct and reset K12.

If the DC supply voltage exceeds approximately 16 V, zener diode V16 conducts, causing V15 to conduct and switch off V12, thus preventing K12 from energising. Transistor V9 also conducts, resetting K12 if it was set previously.

If the DC supply voltage drops below approximately 8 V, zener diode V14 stops conducting, causing transistor V13 to switch off, allowing FET V10 to conduct. This resets the power relay K12, switching off the transceiver. The charge stored in C79 ensures that sufficient energy is available to fully reset relay K12.

Diode D19 prevents the circuit from operating if the DC supply is reverse polarised.

The power input circuit is protected from high voltage transients by the voltage-dependent resistor R43 and capacitor C81. Negative voltage transients are clamped by D27 until the power relay K12 is released.

Power off

Drawing [04-03457](#)

If the transceiver is 'on', the PWR_OFF pin (IC6 pin 1) rests at 3.3 V. When the  key on the front panel is held then released, this pin toggles low then high. The transition is detected by quad UART IC6, which forwards a command to the Audio & Control PCB.

Drawing [04-03456 \(sheet 1\)](#)

The power off command is picked up by the DSP IC202, which forwards the command to microcontroller IC104. This processor sets the PWR_OFF pin (IC104 pin 11), which activates the reset coil of the latching relay K101. As this pin goes high only after the  key is released, the POWER_ON line to the PA & Filter PCB is no longer pulled low.

Drawing [04-03445](#)

The PWR_ON line goes high, resetting the power relay K12 as described previously, and switching off the transceiver.

Supply voltages

The supply voltages for the transceiver unit are shown in [Table 22](#) to [Table 25](#).

Drawing [04-03457](#)

Table 22: Supply voltages for the Front Panel PCB

Supply	Description	Source
A	Switched, unregulated battery supply	via Audio & Control PCB
+5 V	+5 V regulated supply	from Audio & Control PCB
+3V3	+3.3 V regulated supply	from Audio & Control PCB
+5V_HC	Not used	IC2
+1V65	+1.65 V quiet for opamp bias	IC1/B
LCD_BIAS	~ -6 V regulated, temperature-compensated supply for LCD bias	IC16, IC17, IC18

Drawings [04-03456 \(sheet 1\)](#), [04-03456 \(sheet 2\)](#) and [04-03456 \(sheet 3\)](#)

Table 23: Supply voltages for the Audio & Control PCB

Supply	Description	Source
A	Switched, unregulated battery supply	via PA & Filter PCB
+10 V	+10 V regulated supply	via PA & Filter PCB
+5 V	+5 V regulated supply	IC105
+3V3	+3.3 V regulated supply	IC106
+1V8	+1.8 V regulated supply	IC106
+1V65	+1.65 V quiet for opamp bias	IC108

Drawing [04-03439 \(sheet 1\)](#)

Table 24: Supply voltages for the RF/IF & Synthesiser PCB

Supply	Description	Source
+5 V	+5 V regulated supply	from Audio & Control PCB
+28 V	+28 V from charge pump supply	IC302
+10 V	+10 V regulated supply	via Audio & Control PCB
+10 VRx	+10 V In Rx	V401, V402, V403
+10 VTx	+10 V In Tx	V501, V502, V503
+3V5	+3.5 V regulated supply	IC208
+3V5 Rx	+3.5 V in Rx	IC308
+3V5 Tx	+3.5 V in Tx	IC308
+3V5 B	+3.5 V LO1 driver	IC208
+3V5 C	+3.5 V LO2 driver	IC208
+3V5 A	+3.5 V DDS supply	IC208

Drawing [04-03445](#)

Table 25: Supply voltages for the PA & Filter PCB

Supply	Description	Source
A	Unregulated battery supply	ext
+10 V	+10 V regulated supply	V2
+5V5	+5.5 V regulated supply	V38
+5 VSW	+5.5 V rail, PTT active	V39
+12 VSW	A rail, PTT active	V8
+10 VSW	+10 V rail, PTT active	V41
+3V3	+3.3 V regulated supply	IC10

Drawing [04-03444](#)

Table 26: Supply voltages for the Antenna Tuner PCB

Supply	Description	Source
A	Unregulated battery supply	via Audio & Control PCB
+3V3	+3.3 V regulated supply	from Audio & Control PCB
+9 V	+9 V regulated supply	IC6

Transmit path

Front Panel PCB

Drawing [04-03457](#)

Microphone transmit audio from the military handset appears at the handset interface connector, and onto J5 pins 1 to 5 via the flexible PCB. This signal passes via K1/D to clamping stage V12, which shorts to ground when no PTT is active to prevent noise pickup. The microphone audio then passes through pre-amplifier stage IC1/D and inverter IC1/C. The resulting, balanced differential signal is routed through analogue multiplexers IC7/D and IC14/C, and passed onto the Audio & Control PCB via J2. A small portion of the microphone transmit audio is fed via IC21 and IC8, back to the earphone, to provide audio sidetone.

Audio & Control PCB

Drawing [04-03456 \(sheet 1\)](#)

The balanced, pre-amplified microphone audio is passed to the Audio & Control PCB via the flexible flat cable and connector J302, into the input channel 2 of Codec IC302. The Codec digitises the audio, which then passes into DSP IC202, via synchronous serial interface 0.

The DSP performs the compression algorithm, which results in relatively constant amplitude audio. [Figure 19](#) shows a pictorial representation of the compression function.

Figure 19: Representation of compression function by IC202

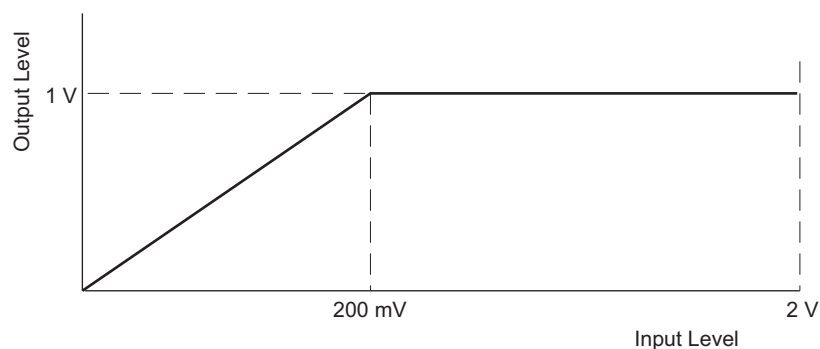

The decay time constant is controlled by firmware and can be varied depending on the type of transmission. For example, for speech, the time constant needs to be short, but for data it needs to be lengthened to improve the BER.

The output of the DSP again passes through the synchronous serial interface, back to the Codec, which converts the signal back to analogue. The resulting differential signal appears at output channel 1. This differential signal passes through IC101, which converts it into a single-ended (unbalanced) signal of approximately 1 V p-p, to drive the RF/IF & Synthesiser PCB.

The output level, which is controlled by firmware, is halved when AM is transmitted or low power is selected.

RF/IF & Synthesiser PCB

Transmit/Receive switching

Drawing [04-03439 \(sheet 1\)](#)

The PTT command from the handset causes V401, V402, and V503 to switch off and V403, V501, and V502 to switch on, thus causing +10 VTx to be active. This switches circuits to the Transmit mode.

Transmit modulator

Drawing [04-03439 \(sheet 1\)](#) and [04-03439 \(sheet 2\)](#)

The audio passes to the Tx Level potentiometer R279 and IC205. R279 is used to set the exciter output level at TP101. The modulator is enabled when +10 VTx is applied via R274 to the bias input pin 5.

The audio is mixed with the local oscillator of 456.5 kHz (453.5 kHz for LSB). The local oscillator is applied to IC205 pins 8 and 10. This produces a DSB output at pin 6. From there it is passed via V220 to the 455 kHz sideband ceramic filter Z201 pin 1.

455 kHz filter and first mixer

Drawings [04-03439 \(sheet 1\)](#) and [04-03439 \(sheet 2\)](#)

(sheet 2) The 455 kHz sideband ceramic filter Z201, with a bandwidth of 2.5 kHz, filters out the unwanted sideband and leaves only the wanted sideband at pin 3. From there it is passed to the noise limiter gate V208.

(sheet 1) The signal is passed on to source followers V118 and V119 with diodes D116 and D118 switched on. The signal is passed from V118 and V119 to MIX 2 (D113) where it is mixed with LO2 via V115, V109 and V110.

45 MHz band-pass filter

Drawing [04-03439 \(sheet 1\)](#)

The 45 MHz signal produced by MIX 2 is amplified by V108 and V113 with D109 and D111 switched on, then it is passed to the 45 MHz BPF.

The 45 MHz IF signal is filtered through a 15 kHz wide BPF consisting of L125, Z102, L124, Z101 and L123. This filter removes unwanted signals produced by the first mixer.

First mixer and exciter output filter

Drawing [04-03439 \(sheet 1\)](#)

The 45 MHz transmit signal is applied to MIX 1 (D104) via amplifier V106 and V107. It is mixed with the output of the local oscillator LO1, LO1_3V5 and amplifiers V104 and V105 to produce the selected channel frequency at the mixer output.

The mixer output passes via a 30 MHz LPF to the transmit exciter output connector J101. From there it is coupled via a coaxial cable to the PA assembly.

Tuning carrier output

Drawings [04-03439 \(sheet 3\)](#), [04-03439 \(sheet 2\)](#) and [04-03439 \(sheet 1\)](#)

When the Tune command is activated, IC308 pin 24 (sheet 3) goes low. This switches V313 off to allow the 456.5 kHz local oscillator carrier (453.5 kHz for LSB) to be passed to V117 (sheet 1) via CAR INJ. V117 inserts carrier to the source followers V118 and V119, and then to the second mixer D113 (sheet 1).

At the same time, IC308 pin 22 (Tx MUTE) goes high and switches on V207 (sheet 2). Thus, IC203/A and IC203/D open the noise gate V208, which stops the inserted carrier from being loaded by the sideband filter Z201.

The carrier at the output of the first mixer D104 (sheet 1) is at the frequency of the selected channel (the SCF). This frequency is used for tuning automatic antennas.

PA & Filter PCB

Voltage regulators

Drawing [04-03445](#)

The +10 V regulator is provided by V2 and associated circuitry, which is a foldback current-limited regulator. Once the current limit of approximately 200 mA is exceeded, the output voltage and current drop, limiting dissipation in the FET V2. The reference voltage for this and other regulators is provided by reference diode IC9.

Voltage clamping to prevent overvoltage under transient conditions is provided by V46 and R139.

The 5V5 supply is provided by V38. +5.5 V is required to ensure sufficient voltage for relay switching under all conditions.

The 3V3 supply is provided by IC10. Diode D26 allows on-board programming of IC1 without links.

Gain control stage

Drawing [04-03445](#)

The RF input is passed through PTT relay K10 to T2, which turns the RF drive into push-pull. This is applied to the variable gain stage V25 and V26. The FETs V27 and V28 are used as variable resistors depending on the ALC voltage applied to the gates.

If there is no power output at the antenna connector, 5 V of ALC voltage is applied to the gates, so that the resistance is low and the gain is at maximum. As the output from the PA increases to the power set point (25 W), the ALC voltage drops, thus increasing the resistance in the FETs and so reducing the gain of V25 and V26 and keeping the Tx output power at the set level (25 W).

Driver stage

Drawing [04-03445](#)

The levelled RF from the gain control stage is passed via T3 to the Class AB push-pull amplifier formed by V29 to V32. L18 and C76 provide a small amount of gain peaking to ensure the overall gain is flat with frequency.

V29 to V32 have collector–base feedback to flatten the gain. R97 balance control varies the gain slightly between each side of the push-pull amplifier, which is used to balance the second harmonic (see [page 134, *Adjusting balance control*](#)).

The bias for the driver stage, provided by V33, V47 and V48, and set by R101 (DR. BIAS), is applied to the centre tap of T3.

Output stage and bias regulator

Drawing [04-03445](#)

The Class B push-pull output stage formed by V36 and V37 is driven from T4 to produce the nominal 25 W PEP.

The bias regulator V34 and V35 provides a voltage to the bases of V36 and V37. The transistors V34 and V35 form a feedback voltage regulator. The output voltage is the base–emitter voltage of V34 and is adjustable by the pre-set potentiometer R105. The transistor V34 is mounted close to the output transistors and provides temperature compensation to the bias network.

The balanced to unbalanced impedance-matching output transformer T5 couples the power amplifier output to the band filters via the PTT relay K9.

Output filters

Drawing [04-03445](#)

The transmit frequency range is 1.6 to 30 MHz. Eight filter bands are available for removal of the harmonics generated by the PA. The filters are operated from IC2 and IC3 and are selected using relays K1 to K8 as required.

The output of the filter circuit passes through the RF bridge formed by T1 and associated components to the output connector.

Automatic level control

Drawing [04-03445](#)

The ALC is controlled by:

- forward power
- reflected power
- collector voltage swing of output stage
- battery voltage
- overtemperature of heatsink
- failure of transmit/receive or filter relays

All the ALC inputs (except relay detection) are applied to V18 to V21. The ORed output is connected via R63 and D21 to the positive input pin of the ALC level comparator IC7/A pin 3. The reference voltage connected to pin 2 is firmware-controlled by the microprocessor IC1.

The microprocessor IC1 and R127 to R131 are used as a 3-bit DAC with an output range of 3.3 V to 1.75 V. The output from R127 is buffered by IC8/A and then divided and filtered by R134, R135 and C110. The output is then buffered again by IC8/D and used as the reference voltage for IC7/A and IC8/C. This allows the microprocessor IC1 to control the PA output if required.

The output voltage of the RF bridge formed by T1 and associated components is rectified by D1 for the forward power and by D2 for the reflected power.

The output of the forward rectifier D1 is applied via R50 to the input of V18. The sum of the resistors between the base of V18 and ground form a resistor divider network. This determines the nominal PEP output level when matched to a 50 Ω load.

For high power, the resistor R124 is shorted out when +3.3 V is applied to the gate of the FET switch V17 and do not contribute to the chain. The nominal high power output, which is measured at low frequency, is set by R56 (SET HI PWR).

For low power, V17 is off, so R124 is added to the divider. R124 (SET LO PWR) sets the power to 5 W PEP.

The output of the forward detector D1 is also applied to V19 via an averaging detector circuit formed by R58, R59 and C85. When the average of the signal exceeds the peak, detector circuit V19 takes control and reduces the output power (this occurs on single tones such as Tune mode, CW (Morse) and in some data transmissions).

When the handset PTT is active, V3 is switched off, which disables the average ALC circuit. In these circumstances, the transceiver produces full PEP on a single tone. This is for measurement reasons only.

The peak output collector swing is rectified by D23 and applied to the transistor V21. V21 conducts and limits the collector peak to 42 V to prevent damage to the output transistors.

The battery voltage is monitored by V42 and associated components. When the supply voltage (**A** rail) drops to approximately 11.5 V, the voltage on C136 falls and causes V25 to conduct. This changes the threshold of the ALC detector. The ALC detector then starts to reduce the output power and since the control is proportional, a further reduction in supply voltage continues to lower the output power.

If the heatsink exceeds 80°C (176°F), the PTC resistor R68 rapidly increases its resistance. This changes the threshold of the ALC detector, which lowers the output power and prevents the heatsink from exceeding 100°C (212°F).

The relay protection circuit is formed by IC7/B and associated components. It simultaneously monitors the output transistor collector swing and forward detector output of D1. If a relay failure results in no signal at the antenna output, the output of IC7/B goes high. This lowers the gain of the input amplifiers V25 and V26, reducing the drive to the output transistors to a safe level.

The ALC controls the output from the summing amplifier IC7/A. This output passes to IC8/C, which inverts the direction of the control signal to drive the variable resistor FETs V27 and V28 in the gain stage (see [page 70, Gain control stage](#)).

Three selections are available for ALC attack/decay filtering, depending upon the application. This filtering is provided by C89, C90, and FET switches V23 and V43.

The ability to quickly drop the gain, and therefore the output power, is provided by controlling the BLANK line and V45. This allows transmitter power to be minimised during antenna tuner relay operations, prolonging relay life.

Antenna Tuner PCB

Drawing [04-03444](#)

The signal from the PA & Filter PCB is connected to connector J1 (RF IN). Depending on the status of relay K1, the signal is connected to either connector J2 (DIPOLE ANTENNA) and then to the 50 Ω antenna connector, or to the antenna stud.

Use of connector J2 is straightforward. Use of the antenna stud (WHIP ANTENNA) is as follows. Relay K2 selects the signal flow via transformers T1 and T2 to the LOAD MATCH circuit. LOAD MATCH consists of transformers T5 and T6, and relays K4, K5 and K6. It is used to match the resistive load, as seen at relay K4 pin 3, to 50 Ω

Further, the signal flows via a combination of inductive and capacitive components, which aim to match the reactive part of the antenna impedance, as seen at relay K4 pin 3. Inductors L1 to L13 are selected by relays K7 to K11 and K15 to K21 respectively. Capacitors C82 to C85 are configured by relays K12 to K14 as series or shunt, and capacitors C87 to C94 are selected by relays K22 and K23 as shunt components.

Matching components are selected during an iterative tuning process. Microcontroller IC5, with shift registers IC1, IC2, IC3 and MOS transistors V1 to V26, change the status of relays. Consecutive steps depend on information stored in EEPROM IC7, the frequency of operation, measurements of forward and reflected voltages, and measurement of phase as provided by the VSWR DETECTOR and PHASE DETECTOR circuits.

EEPROM IC7 stores the status of relays obtained during previous successful tuning operations at a specific frequency. Components T1, part of T3, R21, R22, D24, C95, and C96 form the VSWR DETECTOR circuit, and T2, part of T3, K3, D25, IC4, and associated resistors and capacitors form the PHASE DETECTOR circuit.

During status changes of the relays, the PA & Filter PCB is requested via RF_BLANK line to decrease the output power. When the tuning operation is complete, the voltage regulator IC6 is disabled.

Receive path

Antenna Tuner PCB

Drawing [04-03444](#)

Depending on the antenna selection, the signal from the front panel is present on the Antenna Tuner PCB at connector J2 (DIPOLE ANTENNA), or at the antenna stud.

The signal flow for each case is set by relay K1. Use of connector J2 is straightforward. Use of the antenna stud (WHIP ANTENNA) is as follows. Relay K2 selects the path via the impedance-matching components, as described on [page 72, Antenna Tuner PCB](#), or via the SCAN AMPLIFIER circuit (V28 and associated components).

When the SCAN AMPLIFIER circuit is selected, relays K17 to K23 are configured so that inductors L8 to L13 are bypassed, and capacitors C87 to C94 are disconnected. Biasing of the SCAN AMPLIFIER circuit is enabled by the SCAN AMP ON/OFF line set high.

Input low-pass filters

Drawing [04-03445](#)

The receiver input signal passes through the appropriate sections of the LPF as selected by relays K1 to K8. The signal then passes via the transmit/receive relay K9, signal-clamping diodes D3 to D8, and transmit/receive relay K10 to connector J2.

Broadcast filter and RF amplifier

Drawing [04-03439 \(sheet 1\)](#)

The signal passes through a broadcast filter to reduce any very strong broadcast frequencies below 1.6 MHz, and then passes to the RF amplifier V101. V101 has a nominal gain of 9 dB.

When there are very strong signals present, V101 is not required and may be switched off via the front panel using the Cfg RF Pre-Amp entry in the Control List (administrator access is required). When this occurs, the signal is switched by relay K101 to reduce the signal passing to mixer MIX 1. The signal then passes through a 30 MHz LPF to remove signals above 30 MHz.

First mixer

Drawing [04-03439 \(sheet 1\)](#) and [04-03439 \(sheet 3\)](#)

The balanced mixer D104 (sheet 1) mixes the received signal with the local oscillator LO1, LO1_3V5 (VCO). LO1 is buffered by V304 and V305 (sheet 3) and amplified by V104 and V105 (sheet 1) to produce an IF of 45 MHz. The mixer has a conversion loss of 6 dB.

Post-mixer amplifier

Drawing [04-03439 \(sheet 1\)](#)

The signal from MIX 1 is amplified by V106 and V107 with D105 and D107 switched on.

45 MHz band-pass filter and amplifier

Drawing [04-03439 \(sheet 1\)](#)

The 45 MHz IF signal is filtered through a 15 kHz wide BPF Z101 and Z102, then buffered by V108 and V113 with D110 and D112 switched on. The filter removes the unwanted signals produced by the first mixer.

Second mixer

Drawings [04-03439 \(sheet 1\)](#) and [04-03439 \(sheet 2\)](#)

Mixer D113 is a balanced mixer. The 45 MHz signal is mixed with the third harmonic of the output of the reference oscillator LO2. This operates on 44.545 MHz to produce a second IF centred at 455 kHz.

The mixer has a conversion loss of 6 dB. It is followed by an amplifier V118 and V119 with D115 and D117 switched on.

Noise limiter

Drawings [04-03439 \(sheet 1\)](#) and [04-03439 \(sheet 2\)](#)

The 455 kHz output of V118 and V119 (sheet 1) is applied to the input of the high-gain differential amplifier IC201 pin 13. The balanced outputs at pins 3 and 4 are connected to a tuned auto transformer T201 (455 kHz). The output of T201 passes to the base of the active rectifier V205. Noise bursts produce positive-going pulses at the collector of V205, and via V206, trigger the monostable flip-flop IC203/A/D. The pulse width is determined by C226 and R231 (nominally 250 μ s).

The outputs of IC203/A/D pins 11 and 3 produce complementary pulses that are connected to the FET gates of V208 and V209. These gate out the noise bursts from the 455 kHz signal. With V208 on and V209 off, the IF signal is passed to the sideband filter Z201. When a noise burst is present, V208 is switched off and V209 is switched on, blocking the IF signal for the period of the gate pulse.

The average DC component of the collector current of V205 is used as an automatic gain control to IC201. It is applied via IC202 at TP201. This ensures that only the noise burst signal triggers the flip-flop IC203/A/D. The AGC decay constant is set by the components C220, R227 and R224.

In Transmit mode, IC203 is disabled by V207 (Tx Mute).

455 kHz filter and IF amplifier

Drawing [04-03439 \(sheet 2\)](#)

The IF signal from the noise blanker gate V208 is passed to the 2.5 kHz wide ceramic filter Z201. The filter removes the unwanted sideband, adjacent channels and other unwanted products generated by the second mixer. The wanted sideband, centred at 455 kHz, is passed by the filter to a 3-stage, gain-controlled, IF amplifier comprising V214, V215, V216 and associated components. The IF amplifier is broadly tuned to 455 kHz by the tuned circuits L206 and C236, L207 and C239, and L208 and C243.

When the optional 500 Hz Filter PCB or 3 kHz Filter PCB is installed (Codan part number 08-06044-001 or 08-06044-002 respectively), resistors R241 and R244 are removed. The optional filter is selected when V210 and V212, or V211 and V213, are activated to latch the relays.

Automatic gain control

Drawing [04-03439 \(sheet 2\)](#)

An AGC is applied to a number of stages in the receiver. This is used to increase the dynamic range of the receiver and to maintain an almost constant audio output level for a large variation of input signals.

When the receiver is at maximum gain, the AGC at the output of V225 (AGC test point) is nominally 6.5 V.

The IF signal is rectified by V218 and the resulting DC is amplified by IC204 and V222.

The signal from V218 is passed to the fast-attack circuit comprising V218, R258, C246, C251, and C252. The decay time of this circuit is set by R236 in parallel with R299.

If fast decay AGC is required, the AGC FAST/SLOW control line is held low by the microprocessor. This disables the slow-charge capacitor C251.

The AGC voltage is passed to the IF amplifier. As the signal increases in level, the AGC voltage reduces and hence lowers the gain of the IF amplifier, thus keeping the output level constant.

There is an AGC dump input, which dumps any AGC voltage from a high-level signal on a previously selected channel when the channel is changed. This allows the new channel to have maximum gain. The dump is achieved by pulling the AGC dump and fast/slow control lines low and high respectively for a short period when a channel is changed.

Demodulator

Drawing [04-03439 \(sheet 2\)](#)

The output of the 455 kHz IF amplifier is passed to the input of a double balanced mixer IC206. The IF signal is mixed with the local oscillator applied to pins 8 and 10, to produce an audio output at pin 6. The local oscillator operates at 456.5 kHz for USB operation and 453.5 kHz for LSB.

The audio is then filtered by the LPF comprising IC207 and associated components, before being passed to the Audio & Control PCB.

Audio & Control PCB

Rx audio

Drawings [04-03456 \(sheet 1\)](#), [04-03456 \(sheet 2\)](#) and [04-03456 \(sheet 3\)](#)

The Rx audio from the RF/IF & Synthesiser PCB passes through differential amplifier stage IC102, and into input channel 3 of Codec IC302. The Codec digitises the receive audio, which then passes to DSP IC202 via synchronous serial interface 0.

The DSP performs a variety of functions, including noise reduction (where applicable), volume control, and insertion of tones (for example, key beeps and alarm tones).

The output of the DSP again passes through the synchronous serial interface back to the Codec, which converts the signal back to analogue. The resulting differential signal appears at output channel 2, which passes to the Front Panel PCB via connector J302 and the flexible flat cable.

Voice mute

Drawings [04-03456 \(sheet 1\)](#), [04-03456 \(sheet 2\)](#) and [04-03456 \(sheet 3\)](#)

The unbalanced Rx audio from the RF/IF & Synthesiser PCB is fed to the input of the mute-stage squaring amplifier IC109. The squared audio is then fed to a charge-pump circuit comprising V101 and associated components. This circuit performs a frequency–voltage function that causes the resultant DC voltage to rise as the frequency increases.

IC110 and associated components function as an LPF with a cutoff frequency of approximately 10 Hz. The output from IC110 is a DC voltage, varying at the syllabic rate of the speech received.

IC111 and IC112 form a window comparator. The window width is adjusted by the pre-set MUTE ADJ R163. The divider network R165, R166, and C144 provides the reference voltage for the window comparator. If the output rises or falls below this reference by the amount set by R163, the open drain outputs of IC111 and IC112 discharge C145, thus applying a low to the negative input of comparator IC113. When the output from this comparator goes high, it indicates to microcontroller IC104 that speech has been detected. This signal is forwarded to DSP IC202, which silences or parses the receive audio as appropriate.

Front Panel PCB

Rx audio

Drawing [04-03457](#)

The balanced, processed receive audio from the Audio & Control PCB is passed to the front panel via the flexible flat cable and connector J2. Amplifier stage IC1/A converts this back into an unbalanced (single-ended) signal, which drives the military earphone audio amplifier stage (IC8). The output of IC8 passes via MOSFET V11, which isolates the earphone during startup (eliminating unpleasant thumps), and then to the handset connector via L1.

The output of IC1/A, when enabled by latch IC4 output 5, also drives external speaker amplifier IC9. IC9 is a BTL device, which drives both sides of the loudspeaker. The signals appear at the general purpose interface pins J and L.

A third, identical amplifier stage, IC3 drives the internal loudspeaker via connector P2. This amplifier is switched by latch IC4 output 0.

Frequency control

Reference oscillator

Drawings [04-03439 \(sheet 3\)](#)

The reference oscillator is a temperature-compensated crystal oscillator. It can be supplied in two specifications: 1.5 ppm and 0.5 ppm at a frequency of 14.848333 MHz. It is mounted on a small PCB and is fitted at final assembly.

Drawing [04-03477](#)

The reference oscillator is mounted onto a PCB containing a +3V3 regulated power supply IC and a shunt regulator supplying +2V5 for the frequency-setting potentiometer R2.

Direct digital synthesis

Local oscillator for upper sideband and lower sideband

Drawing [04-03439 \(sheet 3\)](#)

IC305 and IC307/A divide the reference oscillator frequency of 14.848333 MHz down to the required 456.5 kHz for USB and 453.5 kHz for LSB. These frequencies may vary when different optional filters are used.

The frequency information is programmed serially from the on-board microprocessor IC308.

Phase lock loop reference

Drawing [04-03439 \(sheet 3\)](#)

IC303 divides the reference oscillator down to approximately 5 MHz. The signal is buffered by V311 and is then fed as the reference frequency to IC301.

The reference frequency is varied in small step sizes to produce the 10 Hz steps at the output of the phase lock loop.

The frequency information is programmed serially from the microprocessor IC308, based on the channel information.

VCO and phase lock loop

Drawing [04-03439 \(sheet 3\)](#)

The oscillator VCO is a Colpitts type comprising V301 and associated components. The frequency of oscillation is determined by the tuned circuit L303, C301 and the capacitance of the varicaps D301 to D304.

The oscillator output at the tap of the inductor L303 is coupled to the buffer stage made from V304, V305 and associated components. This output is used to drive mixer 1.

Synthesiser IC301 generates a DC control voltage via the phase/frequency detector and control amplifier. This is applied to the varicaps to lock VCO to the nominated frequency.

The VCO input frequency at F IN on IC301 is divided down to approximately 100 kHz and compared with the reference frequency that is also divided down to approximately 100 kHz. Any error between these two signals produces an output from IC301 pin 14 or 15.

The microprocessor IC308 loads serial data into IC301 depending on the channel frequency required. This varies the divide ratio on F IN, causing the VCO frequency to change.

The output pulses from IC301 pin 14 or 15 are applied to the charge pump amplifier comprising V306 to V310. Pin 14 provides a 'go up' pulse, while pin 15 provides a 'go down' pulse. When locked, these pins go high impedance, except for a very narrow pulse that occurs simultaneously at both outputs, thus holding the DC output at a fixed level.

The DC control voltage is filtered by C315, R318, and C314 to remove any reference frequency. The signal is then applied to the varicaps to control the frequency of oscillation.

28 V power supply

Drawing [04-03439 \(sheet 3\)](#)

The charge pump amplifier runs from the 28 V power supply. The 28 V power supply is a voltage tripler circuit comprising IC302/C/E and associated components.

Microprocessors and control

Overview

The transceiver unit is controlled using a 32-bit DSP and four 8-bit microcontrollers. The DSP and master microcontroller are situated on the Audio & Control PCB, and the PA & Filter PCB, Antenna Tuner PCB, and RF/IF & Synthesiser PCB are each controlled by slave microcontrollers. The DSP is responsible for major processing, including speech processing, ALE requirements, keypad scanning and display updates. The master microcontroller provides a bridge between the DSP and the slave microcontrollers, which are used for low-level control of the boards on which they are situated.

Audio & Control PCB

Drawings [04-03456 \(sheet 1\)](#), [04-03456 \(sheet 2\)](#) and [04-03456 \(sheet 3\)](#)

Master microcontroller IC104 provides the interface between DSP IC202 and the slave microcontrollers. The microcontrollers communicate using I²C bus, which is a 2-wire bi-directional serial communications protocol, using the signals SDA (serial data) and SCL (serial clock). IC104 also provides analogue inputs (AN0 to AN4) which are used to measure forward and reflected power from the power amplifier, the transceiver's internal supply rail voltage, and temperature.

Microcontroller IC104 and DSP IC202 communicate using an 8-bit parallel interface. IC202 is a 32-bit, 120 MFLOP, high-performance floating-point DSP. It executes the main transceiver operating code, which is stored in two flash memory devices, IC203 and IC204. A third flash memory device (IC207) stores user-specific transceiver configuration data such as Channel List, Address List, Control List, and the internally used ALE LQA data. IC205 and IC206 are static RAM devices, which provide temporary data storage required by the operating code.

CPLD IC301 provides a number of control functions:

- monitors the status of the POWER_GOOD signal from the power supply to reset and start the system once supply rails have stabilized at startup
- provides a watchdog function, whereby if no transitions are detected on the XF0 signal after a pre-determined time, the system is reset, in case of firmware run-away
- provides the interface between the DSP and the Front Panel PCB components, including the Keypad, LCD, quad UART and output latches described below

Front Panel PCB and Keypad PCB

Drawings [04-03457](#) and [04-03459](#)

The Front Panel PCB is directly controlled by the DSP, via the CPLD.

A quad UART IC6 provides four serial interfaces:

- Channel A provides a serial communications channel to an external handset, via CAN driver IC10.
- Channel B provides the communications with the internal GPS receiver module, which may be fitted to P5 and P6.
- Channel C provides the IrDA interface, through the IrDA transceiver H13, situated on the Keypad PCB.
- Channel D provides the external RS232 interface, via RS232 driver IC11.

This port is used to program code and channels into the transceiver, using NSP software. IC6 interfaces with the DSP via an 8-bit parallel interface.

The buttons on the Keypad PCB connect directly to the CPLD on the Audio & Control PCB, via the Front Panel PCB. The keys are connected in a 3 × 8 matrix; the CPLD generates sequential pulses on the KEYPAD_COL outputs 0 to 2, which are received at the KEYPAD_ROW inputs 0 to 7 when a button is held down.

Two output latches IC4 and IC5 provide additional control functions including:

- switching audio amplifiers IC3 and IC9 on and off
- controlling the audio routing switches IC7 and IC14
- controlling keypad and LCD backlighting via current regulator IC15
- controlling GPIO signals

RF/IF & Synthesiser PCB

Drawing [04-03439 \(sheet 1\)](#)

IC308 is in Sleep mode when no data is present. When data is received from application processor IC104, the RC oscillator starts to run and ‘wakes up’ IC308.

IC308 then programs the phase lock loop and the DDS ICs depending on the channel frequency required. It also controls the transmit/receive switching functions, filter select, AGC time constants, and other ancillary functions.

PA & Filter PCB

Drawing [04-03445](#)

IC1 is in Sleep mode when no data is present. When data is received from application processor IC104, the RC oscillator starts to run and ‘wakes up’ IC1.

IC1 then selects the correct filter for the channel in use, the PTT switching, high/low power switching, ALC time constant, and average ALC on/off. Also, in conjunction with R127 to R131, IC1 forms a DAC that produces the reference ALC voltage. This is used to control the power as required.

Antenna Tuner PCB

Drawing [04-03444](#)

IC5 is in Sleep mode when no data is present. When data is received from application processor IC104, the RC oscillator starts to run and 'wakes up' IC5.

IC5 communicates with EEPROM IC7, configures relays, measures response signals from the VSWR DETECTOR and PHASE DETECTOR circuits, then communicates pass/fail status to application processor IC104.

Internal voice encryptor (optional)

Drawings [04-03456 \(sheet 1\)](#), [04-03456 \(sheet 2\)](#) and [04-03456 \(sheet 3\)](#)

NOTE To operate this option, you must have the hardware fitted and special firmware loaded and enabled in your transceiver.

The Audio & Control PCB may have an internal hardware Encryptor PCB connected to J101. J101 provides power and audio to and from the encryptor, and an asynchronous serial interface (TxD and RxD signals) facilitates communications between the encryptor and microcontroller IC104. Two hardware control signals, –PTT and –WAKE, are also provided.

The special firmware for the transceiver automatically detects the presence of an Encryptor PCB. When the encryptor is enabled, the transceiver routes the transmit and receive audio as appropriate, through the encryptor module.

Internal GPS receiver (optional)

Drawing [04-03457](#)

The Front Panel PCB may have an internal GPS receiver module (Codan part number 08-06149-001) fitted.

The GPS receiver module receives its RF input signal from the GPS antenna, which is mounted on the Keypad PCB, behind the Codan logo on the front panel assembly.

The GPS receiver module processes this RF input signal and determines position, velocity, altitude, time and other information, which is sent to the Front Panel PCB via the GPS_RXD signal.

The GPS receiver module is powered from 3.3 V via the Front Panel PCB. It is periodically shut down to save battery power when fast position updates are not required.

Interface adaptor

Drawing [04-03528](#)

The interface adaptor splits the signals from the 19-way connector on the front panel of the transceiver into the same style of connectors used on the NGT series Transceivers. This enables common accessories to be used.

The interface adaptor also includes an audio power amplifier for an external speaker. This delivers 4 W into 4 Ω .

3160 Power Amplifier

Overview

Drawing [04-03592](#)

The transmit output from the 2110 is connected to the input of the 3160. When the amplifier is enabled and PTT is active, the output from the 2110 is amplified and filtered by the 3160 to a level of 125 W PEP.

The amplifier is internally bypassed in receive.

Supply voltages for the 3160 Power Amplifier

Table 27: Supply voltages for the 3160 Power Amplifier

Supply	Description	Source
A	Unregulated battery supply	ext
+10 V	+10 V regulated supply	IC4
+5 V	+5 V with PTT active	IC3
+3V3	+3.3 V continuous	IC5

Transmit path

Input stage

Drawing [04-03592](#)

The transmit RF power from the 2110 is switched by the PTT relay K9 and is applied to the output transistors V9 and V10 via a 3 dB pad, and a frequency compensation circuit and driver transformer T2.

Output stage and bias regulator

Drawing [04-03592](#)

The Class B push-pull output stage formed by V9 and V10 is driven from T2 to produce the nominal 100 or 125 W PEP.

The bias regulator V11 and V12 provides a voltage to the bases of V9 and V10. The transistors V11 and V12 form a feedback voltage regulator. The output voltage is the base-emitter voltage of V12, and is adjustable by the preset potentiometer R43.

The transistor V12 is mounted close to the output transistor and provides temperature compensation to the bias network.

The balanced to unbalanced impedance-matching output transformer T3 couples the power amplifier output to the band filters.

Output filters

Drawing [04-03592](#)

The transmit frequency range is 1.6 to 30 MHz. Seven LPFs are used to remove the harmonics generated by the PA. The filters are operated from IC1 and V1 to V3 and V5 to V8, and are selected using relays K1 to K3 and K5 to K7 as required.

The output of the filter circuit passes through the RF SWR bridge formed by T1 and associated components to the antenna output.

Automatic level control

Drawing [04-03592](#)

The ALC is controlled by:

- forward power
- reflected power
- average power
- collector voltage swing of output stage
- battery voltage
- overtemperature of heatsink
- failure of transmit/receive or filter relays

All the ALC inputs (except relay detection and overtemperature) are applied to V16 to V19. The ORed output is connected to the 2110 via the control cable and connected to the EXT ALC input on the PA of the 2110 (see drawing [04-03445](#)).

The output voltage of the RF bridge formed by T1 and associated components is rectified by D1 for the forward power, and by D2 for the reflected power.

The cathode of the forward rectifier D1 is applied via R75 to the base of V16. The sum of the resistors between the base of V16 and ground forms a resistor-divider network. This determines the nominal PEP output level when matched to a 50 Ω load.

The nominal high-power output, which is measured at low frequency, is set by SET POWER. V20 switches between 100 W and 125 W.

The cathode of the forward detector D1 is also applied to V17 via an averaging detector circuit formed by R54, R95 and C137. When the average of the signal exceeds the peak detector circuit V16, V17 takes control and reduces the output power (this occurs on single tones such as Tune mode, CW (Morse) and in some data transmissions).

When the handset PTT is active, V14 is switched off, which disables the average ALC circuit. In these circumstances, the transceiver produces full PEP on a single tone. This is for measurement reasons only.

The peak output collector swing is rectified by D12 and applied to the transistor V19. V19 conducts and limits the collector peak to 42 V to prevent damage to the output transistors.

The supply voltage is monitored by V22. When the supply voltage (**A** rail) drops to approximately 12 V, the voltage at the base of V22 falls and causes it to conduct. This changes the threshold of the forward power ALC detector. The ALC detector then starts to reduce the output power and since the control is linear, a further reduction in supply voltage continues to lower the output power.

If the heatsink temperature exceeds 80°C (176°F), the PTC resistor R85 rapidly increases its resistance. This causes the output voltage of IC2/A to increase. This lowers the output power and prevents the heatsink temperature from exceeding 100°C (212°F).

The relay protection circuit is formed by IC2/B and associated components. It simultaneously monitors the output transistor collector swing and forward power detector output. If a relay failure results in no signal at the antenna output, the output of IC2/B goes high. This increases the ALC voltage and thus reduces the drive to the output transistors to a safe level.

Microprocessors and control

Drawing [04-03592](#)

The microprocessor IC1 is connected to the 2110 via an I²C bus. It controls all the switching in the 3160.

The switching is:

- power on via V28
- PTT via V23, V24
- PA bands via V1 to V3, V5 to V8
- average power disable via V14, V15
- 100 or 125 W power select via V20, V21

If the 2110 is removed from the system before the 3160 is powered off, IC6 detects that the 2110 has been removed on the I²C line and signals IC1 to switch off the power relay K10.

Microprocessor monitoring

Drawing [04-03592](#)

The microprocessor IC1 monitors the following parameters during operation:

- forward power
- reflected power
- battery voltage
- input RF power
- ALC voltage
- temperature

If the value of any of these parameters falls outside a specified range, a warning message or a fault message appears on the screen of the transceiver.

Warning messages

The 3160 continues normal operation following a warning message.

Table 28: Warning messages for the 3160 Power Amplifier

Message	Description
PA Warning: Over Temp	The temperature of the 3160 is too hot. Check that the cooling fins are clear of obstructions and are oriented for efficient natural cooling.
PA Warning: Low Bat	The input voltage to the 3160 is too low. Check cable connections and the state of charge of the battery.

Fault messages

There are several faults that disable the PA. The power to the 3160 must be switched off then on again to reset the 3160. These faults are described in the following table.

Table 29: Fault messages for the 3160 Power Amplifier

Message	Description
PA Fault: 4 PA Off	There is input power to the 3160, but there is no output power from the 3160.
PA Fault: 5 PA Off	The ALC voltage in the 3160 is too high. The control cable may be faulty, or you have an earlier 2110 that is not built to drive the 3160.
PA Fault: 6 PA Off	The output power from the 3160 is too high.
PA Fault: 7 PA Off	The data sent to the 3160 has been corrupted.
PA Fault: 8 PA Off	The input power to the 3160 is too high.
PA Fault: 9 PA Off	The 2110 has failed to communicate with the 3160, for example, the PA is removed while the 2110 is powered on and operational.

This page has been left blank intentionally.

Channel additions

This section contains the following topics:

[General \(94\)](#)

[Programming channels \(96\)](#)

General

If you are operating your transceiver in a country that has stringent licensing regulations, you may not be permitted to program channel transmit frequencies. Instead, the preferred option may be option TxD (programming of transmit frequencies is disabled).

If you are permitted to program channel transmit frequencies, you can do this via the 19-way GPIO connector on the front panel using a PC, or via the keypad on the front panel.

Details on how to program channels using a PC can be found in the *NGT System Programmer Help*, which is included with the NSP software.

Options

Options TxD, TxE and TxP are pre-set in the factory. Options TxE and TxD are enabled and disabled by fitting a TPE link (link B) on the Audio & Control PCB (see [Figure 20](#) below). Transceivers are delivered from the factory without the TPE link fitted. Fitting the TPE link in TxE mode disables programming of transmit frequencies. Fitting the TPE link in TxD mode enables programming of transmit frequencies (see [Table 30 on page 95](#)).

Figure 20: Position of TPE link on the Audio & Control PCB

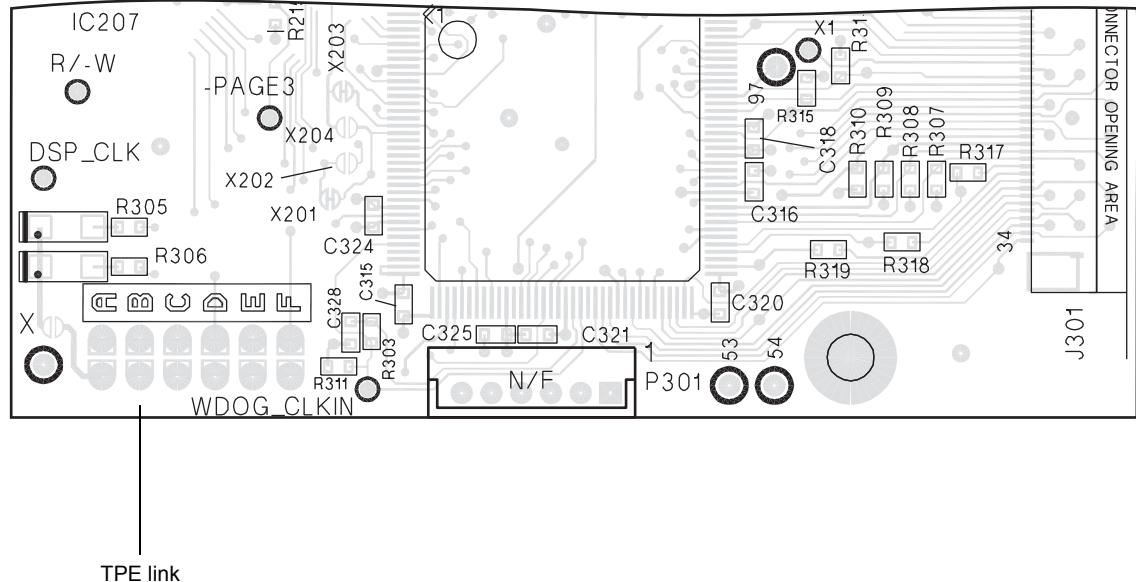

During startup, the status of the TPE link is read by CPLD IC301 and DSP IC202 on the Audio & Control PCB (drawings [04-03456 \(sheet 2\)](#) and [04-03456 \(sheet 3\)](#)).

Table 30: Transmit enable, transmit disable and transmit prohibited options

Status of TPE link	TxD	TxE	TxP
TPE link fitted	Tx & Rx program enabled Normal operation disabled	Tx & Rx program disabled Normal operation enabled	Tx & Rx program disabled Normal operation enabled
TPE link not fitted	Tx & Rx program disabled Normal operation enabled	Tx & Rx program enabled Normal operation enabled	Tx & Rx program disabled Normal operation enabled

Transmit disable option

The TxD option prevents the operator from entering new transmit frequencies while the transceiver is operational.

To enable the operator to enter transmit frequencies, the TPE link must be fitted. While the TPE link is fitted, the normal functions of the transceiver are disabled. To resume normal functions, the TPE link must be removed and the transceiver switched off then on again.

Transmit enable option

When the TxE option is available, and the TPE link is not fitted, the operator can enter new transmit and receive frequencies without disabling the normal functions of the transceiver.

Transmit frequencies between 1.6 to 30 MHz can be programmed in 10 Hz steps. The receive frequency range is 0.25 to 30 MHz.

NOTE Fitting the TPE link disables the programming of new transmit and receive frequencies.

Transmit prohibited option

The TxP option prevents the operator from entering new transmit and receive frequencies. NSP is required to enter new frequencies.

Programming channels

Creating a channel

This section covers creating a channel in a transceiver where receive and transmit frequencies can be entered.

If you are operating the transceiver in a country that has stringent licensing regulations, you may not be permitted to create channels with transmit frequencies.

NOTE

If the TxD option has been installed in the transceiver there are restrictions on the frequencies you can enter. Use [page 99, *Creating a channel with the TxD option.*](#)

If the TxP option has been installed in the transceiver you cannot create channels.

To create a channel:

- Press **X** until the channel screen is displayed.
- If scanning is on, press **SCAN**.

The currently selected channel is displayed. For example:

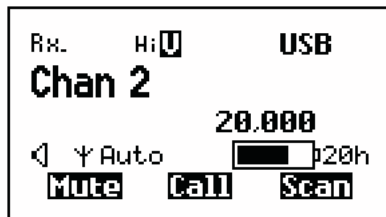

NOTE If the Channel List is empty, **Free Tune** is displayed.

- Hold **Q** to open the List Manager.
- Scroll to **Create entry**, then press **✓**.

The transceiver suggests a name for the new channel based on the name of the channel you were on.

NOTE If the Channel List is empty a name is not displayed. Enter a name for the channel.

- Do one of the following:
 - To use the name displayed, press **✓**.
 - To enter a new name, start typing. When you have entered the name, press **✓**.
 - To edit the name displayed, press **X**. The cursor is placed at the end of the line so you can backspace over characters and/or enter new text. When the name is correct, press **✓**.

NOTE To enter lower-case or numeric characters, press **#** until a lower-case 'a' or the hash symbol (#) is displayed at the bottom right of the screen.

The name must be unique to the Channel List.

Receive Freq? is displayed with the receive frequency of the channel you were on.

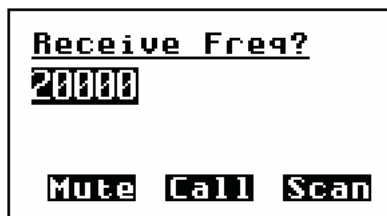

- Do one of the following:
 - To use this frequency, press ✓.
 - To enter a new receive frequency, type the frequency in kilohertz, then press ✓.

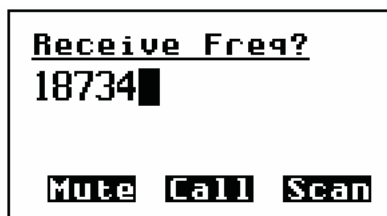

Transmit Freq? is displayed with the receive frequency you entered.

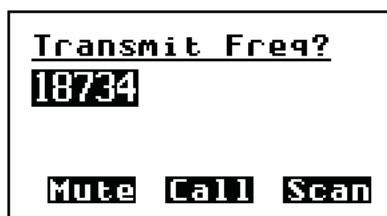

- Do one of the following:
 - To use this frequency, press ✓.
 - To enter a new transmit frequency, type the frequency in kilohertz, then press ✓.
 - To disable the transmit frequency, erase the frequency by pressing ✕ repeatedly, then press ✓ to save the empty setting.



Mode? is displayed.

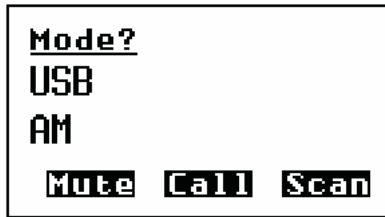

- Scroll to the mode (or one of the modes) you want to use with the channel, then press ✓.

If multiple modes can be added to the channel the transceiver asks you if you want to add another mode. Do one of the following:

- NOTE
- To add another mode press ✓, scroll to the mode you want, then press ✓ again.
 - If you do not want to add another mode, press ✕.

The new channel is created and the List Manager remains open.

If you want to view the channel you have created, press ✕ to close the List Manager.

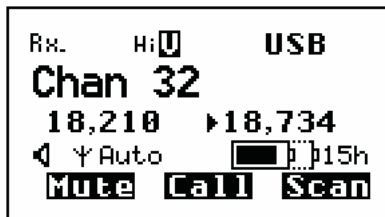

- NOTE
- If you disabled the transmit frequency, dashes are displayed at the bottom left of the channel screen.

Creating a channel with the TxD option

If the TxD option has been installed in the transceiver you cannot create channels with new transmit frequencies unless the TPE link is fitted (see [page 95, Transmit enable option](#) and [Table 30 on page 95](#)). You can, however, create channels with the same transmit frequency as an existing channel, and you can disable transmit frequencies to create receive-only channels.

To create a channel:

- Press **X** until the channel screen is displayed.
- If scanning is on, press **SCAN**.

The currently selected channel is displayed. For example:

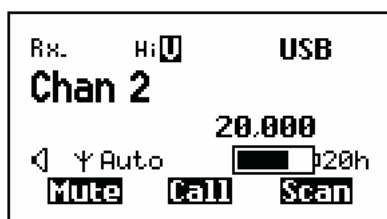

- Do one of the following:
 - To create a transmit channel, scroll to the channel with the transmit frequency you want. The allowed modes for this channel are the only modes that you are able to select for the new channel.
 - To disable the transmit frequency and create a receive-only channel you do not need to scroll to a specific channel. The modes that you are able to select for the new channel are all the modes available in the transceiver.

- Hold **Q** to open the List Manager.
- Scroll to **Create entry**, then press **✓**.

The transceiver suggests a name for the new channel based on the name of the channel you were on.

- Do one of the following:
 - To use the name displayed, press **✓**.
 - To enter a new name, start typing. When you have entered the name, press **✓**.
 - To edit the name displayed, press **X**. The cursor is placed at the end of the line so you can backspace over characters and/or enter new text. When the name is correct, press **✓**.

NOTE To enter lower-case or numeric characters, press **#** until a lower-case 'a' or the hash symbol (#) is displayed at the bottom right of the screen.

The name must be unique to the Channel List.

Receive Freq? is displayed with the receive frequency of the channel you were on.

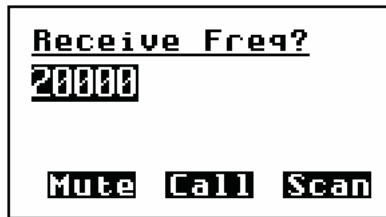

- Do one of the following:
 - To use this frequency, press ✓.
 - To enter a new receive frequency, type the frequency in kilohertz, then press ✓.

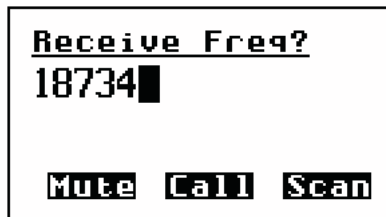

The transceiver asks you if you want to disable the transmit frequency of the new channel.

- Do one of the following:
 - To disable the transmit frequency, press ✓.
 - To create a channel with the same transmit frequency as the channel you were on, press ✕.

Mode? is displayed.

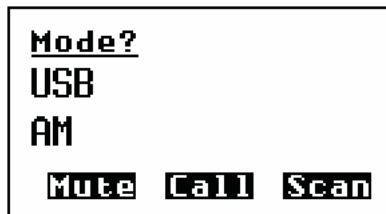

- Scroll to the mode (or one of the modes) you want to use with this channel, then press ✓.

NOTE

If you are creating a transmit channel, the modes from which you can select are the allowed modes for the channel you were on.

If you are creating a receive-only channel, the modes from which you can select are all the modes available in the transceiver.

If multiple modes can be added to the channel the transceiver asks you if you want to add another mode. Do one of the following:

NOTE

- To add another mode press ✓, scroll to the mode you want, then press ✓ again.
- If you do not want to add another mode, press ✕.

The new channel is created and the List Manager remains open.

If you want to view the channel you have created, press **X** to close the List Manager.

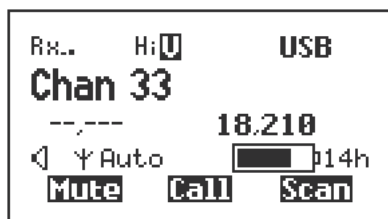

NOTE

If you disabled the transmit frequency, dashes are displayed at the bottom left of the channel screen.

Renaming a channel

When you rename a channel, references to the channel in other lists are not automatically updated; you need to go to the Address, Network and Phone Link Lists and update any references to the channel.

For example, if the channel you renamed is used in a network, go to the channel/mode list for the network, find the reference to the old channel name, then edit it so that the new name is displayed. If you do not update the reference to the channel, the channel is not scanned when scanning is switched on.

To rename a channel:

- Press **X** until the channel screen is displayed.
- If scanning is on, press **SCAN**.
- Scroll to the channel you want to rename. For example:

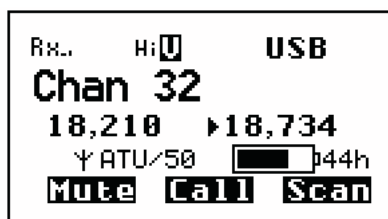

NOTE

Use **▶** or **◀** to scroll to the entry, or use the Find feature.

- Hold* **Q** to open the List Manager.
- Scroll to **Rename entry**, then press **✓**.

The transceiver displays the name of the entry.

- Do one of the following:
 - To enter a new name, start typing.
 - To edit the existing name, press **X** to move the cursor to the end of the name, then edit the name.

NOTE To enter lower-case or numeric characters, press **#** until a lower-case 'a' or the hash symbol (#) is displayed at the bottom right of the screen.

The name must be unique to the Channel List.

- Press **✓**.

The channel is renamed and the List Manager remains open.

If you want to view the channel you have renamed, press **X** to close the List Manager.

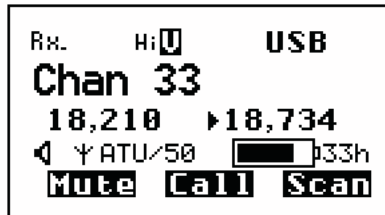

Editing a channel

NOTE If the TxD option has been installed in the transceiver you cannot enable or disable the transmit frequency of a channel by editing the channel. See [page 99, Creating a channel with the TxD option](#) instead.

To edit a channel:

- Press **X** until the channel screen is displayed.
- If scanning is on, press **SCAN**.
- Scroll to the channel you want to edit. For example:

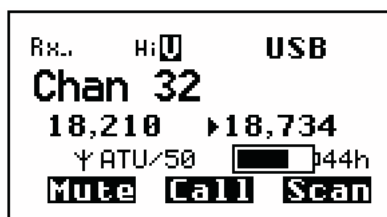

NOTE Use **▲** or **▼** to scroll to the entry, or use the Find feature.

- Press **✓** to display the settings for the channel.
The first setting (**Receive Freq**) is displayed.

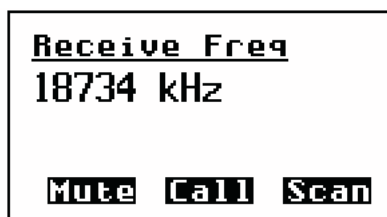

- Scroll to the setting you want to edit, then *hold* **✓**.
The following table explains how to edit each setting.

Name of setting	How to edit the setting
Receive Freq	<p>Do one of the following:</p> <ul style="list-style-type: none"> • To erase the frequency displayed, start typing. Enter the new frequency in kilohertz. • To place the cursor at the end of the line so you can backspace over the text and/or enter new text, press X. Enter the new frequency in kilohertz. <p>When the frequency is correct press ✓.</p>
Transmit Freq	<p>Do one of the following:</p> <ul style="list-style-type: none"> • To erase the frequency displayed, start typing. Enter the new frequency in kilohertz. • To place the cursor at the end of the line so you can backspace over the text and/or enter new text, press X. Enter the new frequency in kilohertz. • To disable transmission on this channel, erase the transmit frequency by pressing X repeatedly. <p>When the frequency is correct (or erased), press ✓.</p>
Mode	<p>Do one of the following:</p> <ul style="list-style-type: none"> • To add a mode, press ✓ to display the first mode, then <i>hold</i> Q to open the List Manager. Scroll to Add item, press ✓, scroll to the mode you want to add to the channel, then press ✓. • To edit a mode, scroll to the mode you want to edit, then <i>hold</i> ✓. Scroll to the mode you want, then press ✓. • To delete a mode, scroll to the mode you want to delete, then <i>hold</i> Q to open the List Manager. Scroll to Delete item, press ✓, then press ✓ to confirm that you want to delete the item. As each channel must have at least one mode you cannot delete the last mode from a channel. <p>The List Manager remains open. If you want to return to the setting, press X to close the List Manager.</p>

Copying a channel

If you want to create a channel that is similar to an existing channel you can copy the existing channel instead of creating a new one. When you copy a channel the transceiver prompts you to enter a name for the copy. The name must be unique to the Channel List.

To copy a channel:

- Press **X** until the channel screen is displayed.
- If scanning is on, press **SCAN**.
- Scroll to the channel you want to copy. For example:

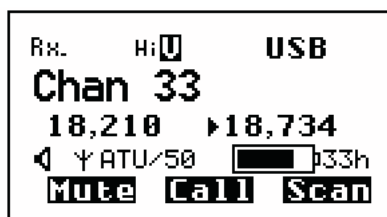

NOTE Use **▲** or **▼** to scroll to the entry, or use the Find feature.

- Hold **Q** to open the List Manager.
- Scroll to **Copy entry**, then press **✓**.

The transceiver suggests a name for the new channel based on the name of the channel you were on.

- Do one of the following:
 - To use the name displayed, press **✓**.
 - To enter a new name, start typing. When you have entered the name, press **✓**.
 - To edit the name displayed, press **X**. The cursor is placed at the end of the line so you can backspace over characters and/or enter new text. When you have entered the name, press **✓**.

NOTE To enter lower-case or numeric characters, press **#** until a lower-case 'a' or the hash symbol (#) is displayed at the bottom right of the screen.

The name must be unique to the Channel List.

A copy of the original channel, with the new name, is created and the List Manager remains open.

If you want to view the channel, press **X** to close the List Manager.

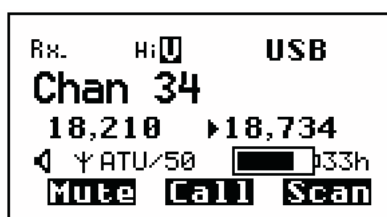

Deleting a channel

To delete a channel:

- Press **X** until the channel screen is displayed.
- If scanning is on, press **SCAN**.
- Scroll to the channel you want to delete. For example:

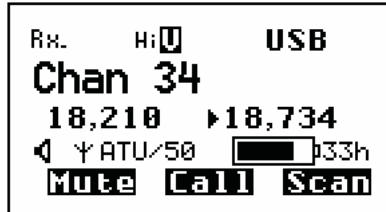

NOTE Use **▶** or **◀** to scroll to the entry, or use the Find feature.

- Hold **Q** to open the List Manager.
- Scroll to **Delete entry**, then press **✓**.

The transceiver asks you to confirm that you want to delete the entry.

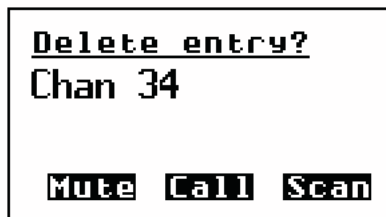

- Press **✓**.

The channel is deleted and the List Manager remains open.

- Press **X** until the channel screen is displayed.

Checks and adjustments

This section contains the following topics:

- Service equipment required (108)
- Disassembling the transceiver (109)
- Voltage regulators (111)
- Low-pass filters (113)
- Service mode (114)
- Testing the keypad and display (119)
- Adjustment locations and test points (120)
- Aligning the 5 MHz PLL reference (124)
- Checking the voltage-controlled oscillator (125)
- Aligning the 45 MHz filter (126)
- Aligning the 455 kHz IF and noise limiter (127)
- Adjusting the exciter output level (128)
- Adjusting carrier re-insertion (129)
- Adjusting frequency (130)
- Adjusting mute (131)
- Adjusting the PA (132)
- Checking performance of the receiver at the 50 ohm antenna connector (137)
- Checking performance of the transmitter at the 50 ohm antenna connector (140)
- Checking the antenna tuner relays (142)
- Re-assembling the transceiver (143)
- Checking the battery charging process (144)
- Adjusting the 3160 Power Amplifier (148)

Service equipment required

The following test equipment is required:

- a 50 MHz oscilloscope, with an external trigger capability
- a 10× oscilloscope probe with an input impedance of 10 MΩ and less than 20 pF
- a 50 Ω RF dummy load
- power meter rated at a minimum of 20 W RMS, or 100 W RMS for the 3160
- an RF signal generator covering the range 400 kHz to 30 MHz, with a calibrated output of –120 to –25 dBm (0.2 μV to 10 mV) from a source impedance of 50 Ω
- a 50 MHz frequency counter with a resolution of 1 Hz
- a regulated DC power supply of 12.0 V ±0.2 V at 7 A peak, or at 25 A peak for the 3160
- a digital multimeter with a 10 MΩ input impedance
- an AC voltmeter with a range of 10 mV to 10 V with dB scale
- an RF spectrum analyser capable of measuring intermodulation
- an artificial antenna assembly comprising: four 220 pF/500 V capacitors (connected in series), and 50 Ω coaxial cable with leads and banana/crocodile clips for connecting capacitors to antenna port/50 Ω dummy load (see [Figure 21](#))
- a two-tone audio generator operating at 700 Hz and 2300 Hz, with balance control and adjustable output 0 to 300 mV RMS (capability provided with the Codan 0208 Test Set)
- a transceiver test unit to Codan drawing 04-03508 (see [Figure 22](#))

Figure 21: Setup for artificial antenna

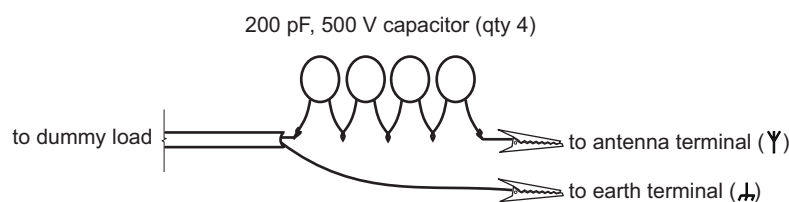
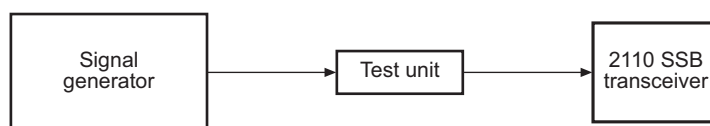

Figure 22: Setup for test unit



Disassembling the transceiver

NOTE Disassembling the transceiver is the reverse of the assembly procedure outlined in drawings [08-06155 \(sheet 2\)](#) and [08-06155 \(sheet 6\)](#).

To disassemble the transceiver:

- Disconnect any cables or antennas attached to the front panel.
- Remove the battery pack from the base of the transceiver.
- Stand the transceiver on its front panel.
- Remove the six screws from the rear panel and ease the panel away from the chassis.
- Remove the rear panel and sealing gasket.
- Disconnect the battery connector.
- Loosen the screw that requires loosening (labelled) about 5 mm, then push the screw back into the hole.
- Stand the transceiver upright.
- Remove the six screws from the front panel.
- Locate the open end of the housing over a block of wood that fits within the housing and is approximately 100 mm high, then push the housing down to expose the chassis.

Figure 23: Removing the housing from the chassis

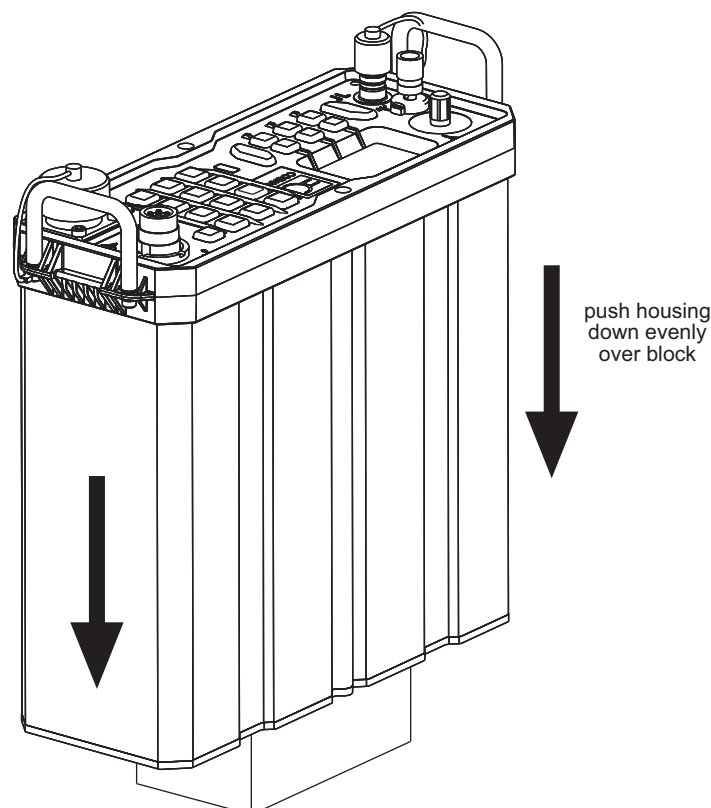

WARNING Do not use the front panel as a handle to pull the chassis out of the housing.

- If you want to access the:
 - Antenna Tuner PCB, remove the ATU screen
 - Audio & Control PCB, remove the CTRL screen
 - RF/IF & Synthesiser PCB, remove the Rx Tx screen
 - PA & Filter PCB, remove the PA screen

NOTE The name of each PCB function is printed on the screen covering the board.

To access the Front Panel PCB and Keypad PCB:

- Undo the screw on the rear of the antenna stud to disconnect the antenna tuner.
- Remove the four screws at the rear of the front panel that hold the chassis to the front panel.
- Remove the screw and four spacers from the Front Panel PCB, then carefully separate the connectors holding the PCBs together.
- Remove the 10 screws from the Keypad PCB, then lift the PCB away from the keymat and front panel.

Voltage regulators

None of the voltage regulators are adjustable. However, the output voltages can be checked.

The supply voltages for the transceiver unit are shown in [Table 31](#) to [Table 35](#).

Drawing [08-06129 \(sheet 1\)](#)

Table 31: Supply voltages for the Front Panel PCB

Supply	Description	Source
A	Switched, unregulated battery supply	via Audio & Control PCB
+5 V	+5 V regulated supply	from Audio & Control PCB
+3V3	+3.3 V regulated supply	from Audio & Control PCB
+5V_HC	Not used	IC2
+1V65	+1.65 V quiet for opamp bias	IC1/B
LCD_BIAS	~ -6 V regulated, temperature-compensated supply for LCD bias	IC16, IC17, IC18

Drawing [08-06128 \(sheet 1\)](#)

Table 32: Supply voltages for the Audio & Control PCB

Supply	Description	Source
A	Switched, unregulated battery supply	via PA & Filter PCB
+10 V	+10 V regulated supply	via PA & Filter PCB
+5 V	+5 V regulated supply	IC105
+3V3	+3.3 V regulated supply	IC106
+1V8	+1.8 V regulated supply	IC106
+1V65	+1.65 V quiet for opamp bias	IC108

Drawing [08-06039](#)

Table 33: Supply voltages for the RF/IF & Synthesiser PCB

Supply	Description	Source
+5 V	+5 V regulated supply	from Audio & Control PCB
+28 V	+28 V from charge-pump supply	IC302
+10 V	+10 V regulated supply	via Audio & Control PCB
+10 VRx	+10 V In Rx	V401, V402, V403
+10 VTx	+10 V In Tx	V501, V502, V503
+3V5	+3.5 V regulated supply	IC208
+3V5 Rx	+3.5 V in Rx	IC308
+3V5 Tx	+3.5 V in Tx	IC308
+3V5 B	+3.5 V LO1 driver	IC208
+3V5 C	+3.5 V LO2 driver	IC208
+3V5 A	+3.5 V DDS supply	IC208

Drawing [08-06064 \(sheet 2\)](#)

Table 34: Supply voltages for the PA & Filter PCB

Supply	Description	Source
A	Unregulated battery supply	ext
+10 V	+10 V regulated supply	V2
+5V5	+5.5 V regulated supply	V38
+5 VSW	+5.5 V rail, PTT active	V39
+12 VSW	A rail, PTT active	V8
+10 VSW	+10 V rail, PTT active	V41
+3V3	+3.3 V regulated supply	IC10

Drawing [08-06063](#)

Table 35: Supply voltages for the Antenna Tuner PCB

Supply	Description	Source
A	Unregulated battery supply	via Audio & Control PCB
+3V3	+3.3 V regulated supply	from Audio & Control PCB
+9 V	+9 V regulated supply	IC6

Low-pass filters

Drawing [08-06039](#)

There is a 30 MHz LPF located on the RF/IF & Synthesiser PCB. It is located between relay K101 and mixer 1.

Alignment of the LPF is not necessary. Coil L104 is pre-aligned to a frequency of 45 MHz.

Service mode

Service mode provides a set of specific channels. These channels enable you to check the performance of the transceiver and when necessary, carry out adjustments to ensure the transceiver meets specifications.

General

The transceiver is provided with a special Service mode to assist you to:

- check VCO1 (this is not adjustable)
- align the 45 MHz BPFs using only an oscilloscope and signal generator
- align the transformer T201 in the noise limiter
- adjust the exciter output level
- adjust carrier reinsertion
- adjust the channel frequency
- adjust mute
- check and adjust the PA
- check the performance of the receiver and the transmitter

NOTE Pre-set adjustments, which are normally factory-set, require attention only if components are replaced that affect their settings.

Accessing Service mode

To put the transceiver into Service mode:

- Switch the transceiver off.
- Access the Audio & Control PCB (see [page 109, Disassembling the transceiver](#)).
- Insert Service mode link (link A) on the Audio & Control PCB (see [08-06128 \(sheet 1\)](#) and [Figure 24](#)).

Figure 24: Position of Service mode link on the Audio & Control PCB

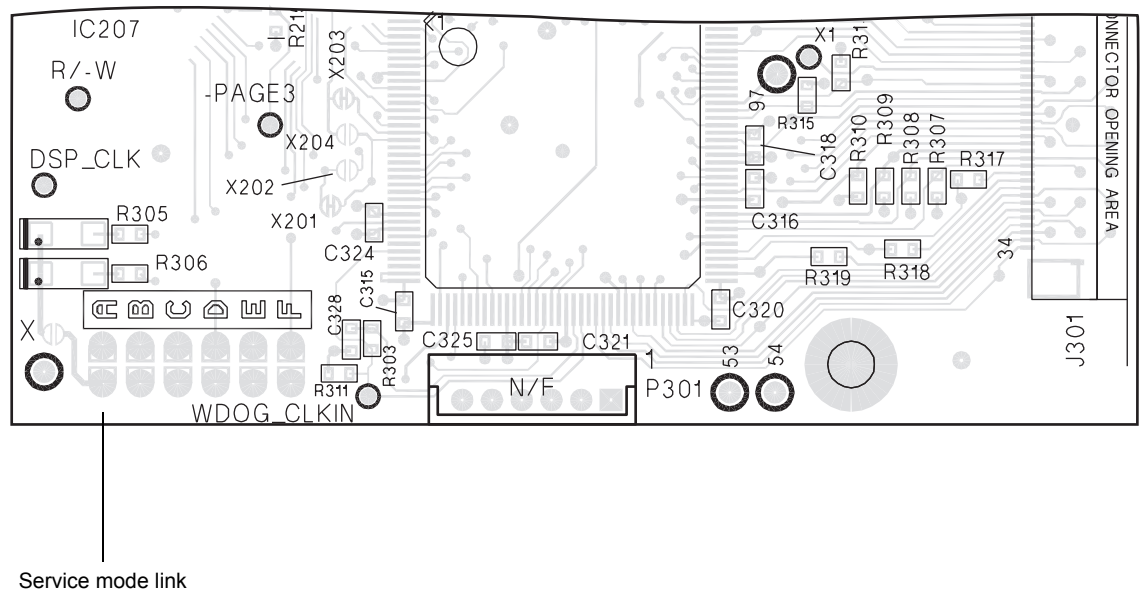

- Switch the transceiver on.
The transceiver is now in Service mode. While in Service mode, normal operation is not possible.

Service channels

The pre-defined service channels for Service mode are shown in [Table 36](#).



Table 36: Pre-defined service channels for Service mode

Channel	Frequency	
1	250 kHz, speaker muted, Tx inhibit	
2	15 MHz, speaker muted, Tx inhibit	
3	30 MHz, speaker muted, Tx inhibit	
The following selections start special test functions		
4	Sweep test the Rx 45 MHz filter	
5	Sweep test the Tx 45 MHz filter	
The following test channels are defined with LSB/USB/AM/IF2 access modes		
7	250 kHz	Receive only
8	1.1 MHz	
9	1.6 MHz	Band 1
10	1.9 MHz	
11	2.2 MHz	
12	2.3 MHz	Band 2
13	2.8 MHz	
14	3.2 MHz	
15	3.3 MHz	Band 3
16	4.1 MHz	
17	4.6 MHz	
18	4.7 MHz	Band 4
19	5.3 MHz	
20	6.7 MHz	
21	6.8 MHz	Band 5
22	8.3 MHz	
23	9.7 MHz	
24	9.8 MHz	Band 6
25	11.9 MHz	
26	14.0 MHz	
27	14.1 MHz	Band 7
28	17.1 MHz	
30	20.1 MHz	
32	20.2 MHz	Band 8
33	25.1 MHz	
34	29.9 MHz	
29	27.2 MHz	CB test frequency
31	19.999 MHz	

Service mode hot keys

When the transceiver is in Service mode, pre-defined Service mode hot keys replace the normal key definitions on the front panel, as shown in [Table 37](#).

Table 37: Hot keys on the front panel during Service mode

Key(s)	Hot key function
MUTE	Mute ON/OFF
1	Switch transceiver ON/OFF
PTT	Transmit
	Normal volume control operation
	Select a test
1 + 9	Set display contrast
1 + 0	Set display brightness
1 + #	Keypad and display test
1	Automatic gain control SLOW/FAST (Default = SLOW)
2	Select next mode USB/LSB/AM/IF2 (Default = USB)
3	Tune carrier ON/OFF (Default = OFF)
4	Talk power ON/OFF (Default = OFF)
5	Receive pre-amplifier ON/OFF (Default = ON)
6	PA average power limiter ON/OFF (Default = OFF)
7	PA power HIGH/LOW (Default = HIGH)
8	PA ALC response SLOW/FAST (Default = FAST)
9	Select internal antenna tuning mode (Default = 50 Ω) 50 Ω/WHIP BYPASS/WHIP SCAN MODE/WHIP TUNE MODE (applies to service PTT on/off)
0	Activates the whip antenna connector (antenna stud) Scan amplifier ON/OFF (Default = OFF)

Returning to Normal mode

To return the transceiver to Normal mode:

- Switch the transceiver off.
- Remove Service mode link (link A) on the Audio & Control PCB (see drawing [08-06128 \(sheet 1\)](#) and [Figure 24 on page 115](#)).
- If required at this stage, re-assemble the transceiver (see [page 143, *Re-assembling the transceiver*](#)).
- Switch the transceiver on.

The transceiver is now in Normal mode and normal operation can resume.

Testing the keypad and display

NOTE The transceiver does not have to be in Service mode to perform this test.

To enter the keypad and display test mode:

- Hold down **Ⓜ** and press **#**.

The display prompts you to press a key. This message is displayed for approximately one second, then the front panel test screen flashes at 2 Hz to ensure all pixels are functional.

- Press each key on the keypad one at a time, except the **X** key.

As each key is pressed, it is displayed for one second.

To exit from the keypad and display test mode:

- Press **X**.

Adjustment locations and test points

To view the adjustment locations and test points for the... See...

RF/IF & Synthesiser PCB

[Figure 25 on page 120](#)

PA & Filter PCB

[Figure 26 on page 121](#)

Audio & Control PCB

[Figure 27 on page 122](#)

Antenna Tuner PCB

[Figure 28 on page 123](#)

Figure 25: RF/IF & Synthesiser PCB

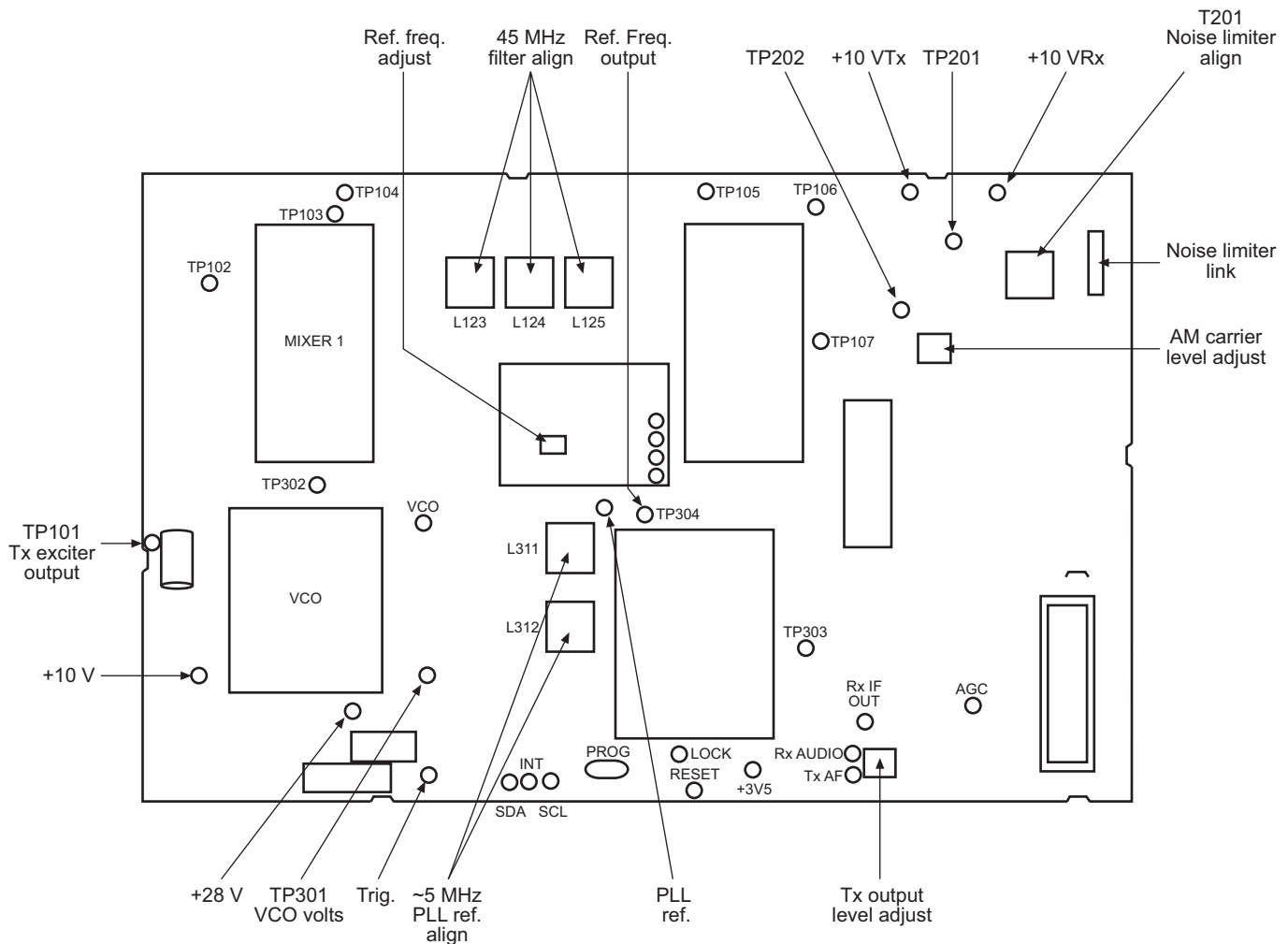

Figure 26: PA & Filter PCB

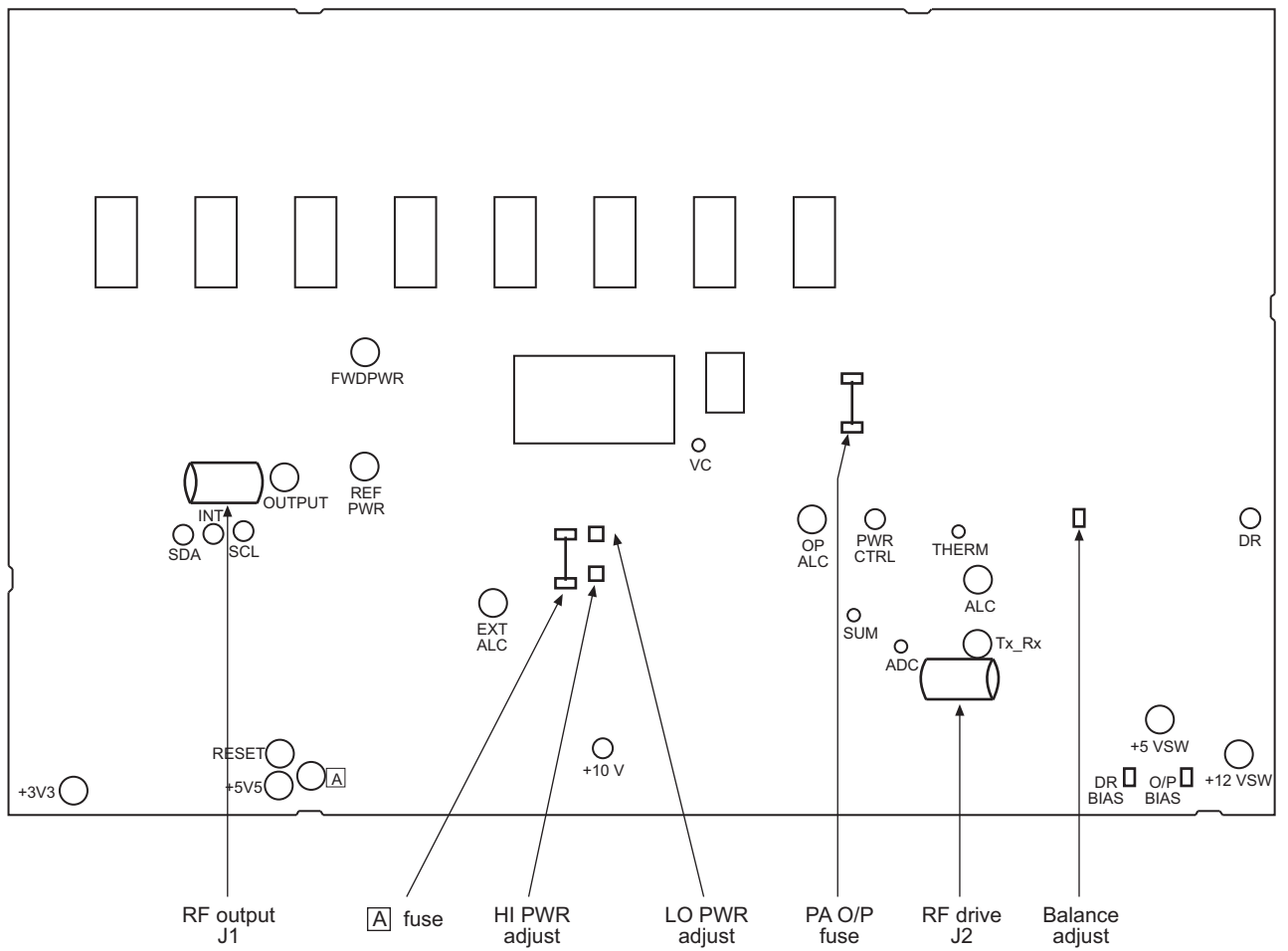

Figure 27: Audio & Control PCB

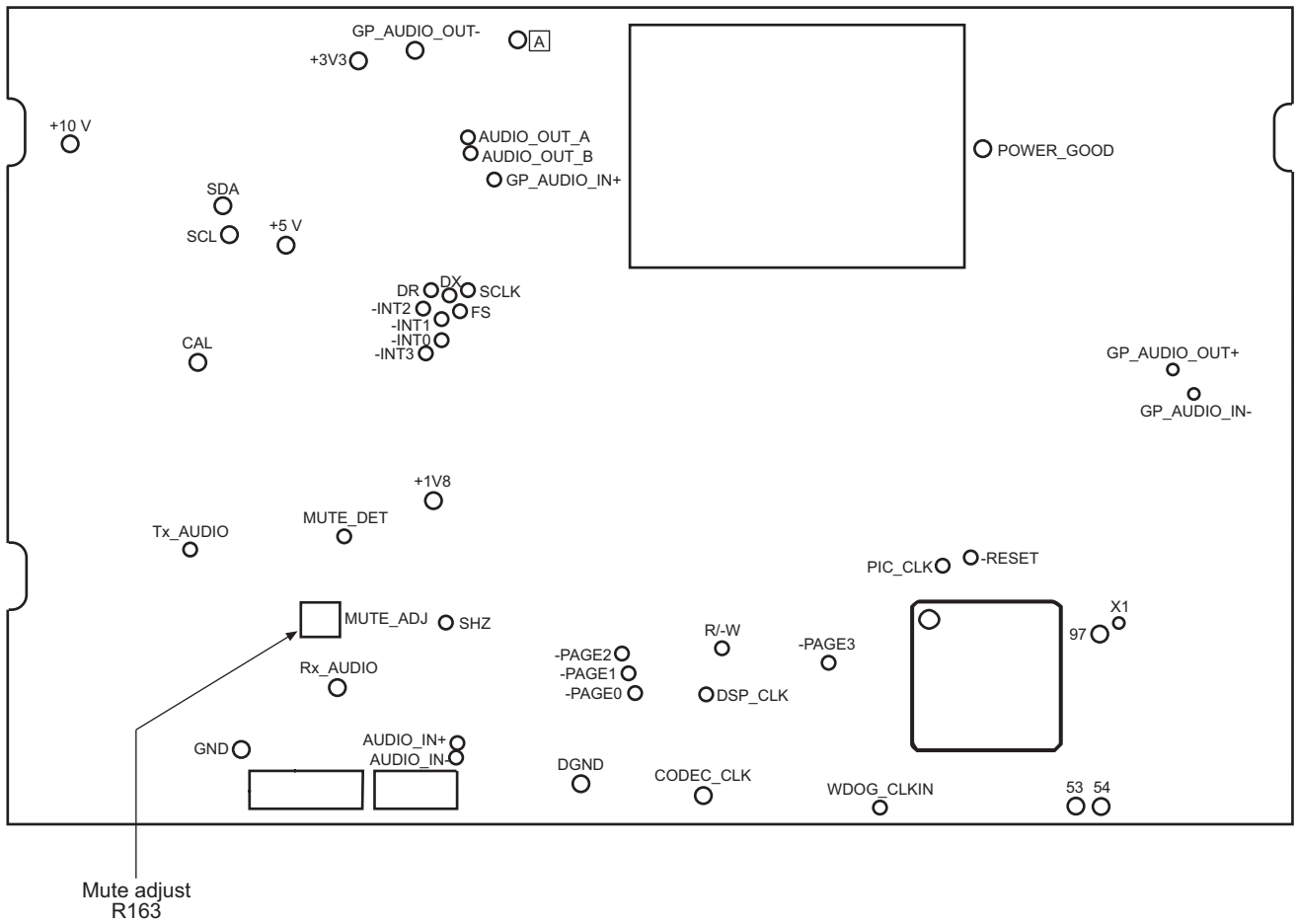
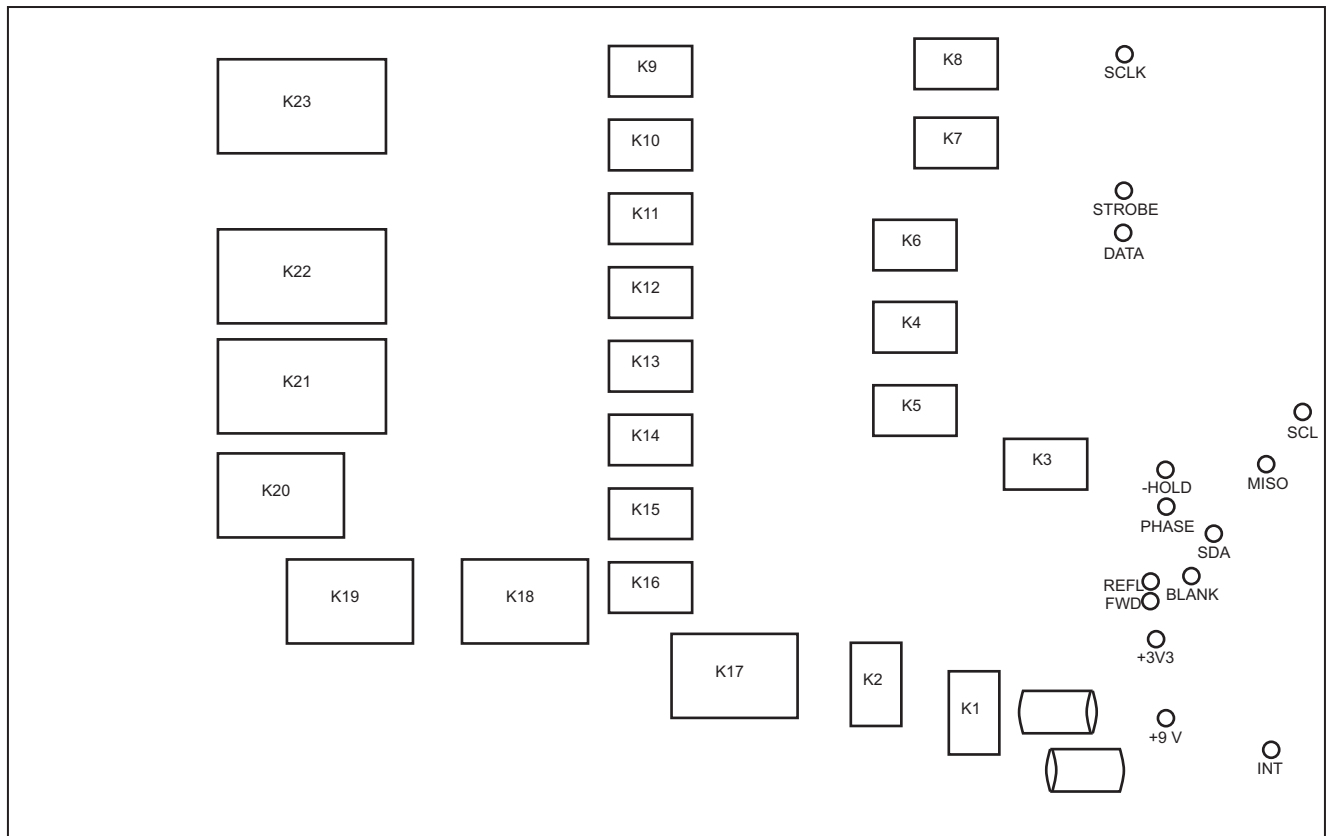

Figure 28: Antenna Tuner PCB



Aligning the 5 MHz PLL reference

Drawing [08-06039](#)

NOTE The transceiver does not have to be in Service mode to perform this alignment.

There are two inductors, L311 and L312, on the RF/IF & Synthesiser PCB.

To align the 5 MHz PLL reference:

- Connect a 10× probe on channel 1 of an oscilloscope to PLL Ref on the RF/IF & Synthesiser PCB.
- Set the channel 1 input to AC at 500 mV per division (50 mV per division with 10× probe).
- Set the timebase of the oscilloscope to 2 ms per division.
- Adjust L311 and L312 for a maximum that should be 2 V p-p ± 0.25 V.

Checking the voltage-controlled oscillator

Drawing [08-06039](#)

NOTE The transceiver must be in Service mode to perform this check (see [page 115, Accessing Service mode](#)).

VCO1 is located on the RF/IF & Synthesiser PCB. There is no adjustment available for VCO, but it can be checked to ensure it is operating correctly.

To check the operation of VCO:

- Place a screening can over VCO and mixer 1 (see [Figure 25 on page 120](#)).
- Select test channel 1.
- Connect a DC voltmeter to TP301 and check that the voltage is between 1.5 V and 3.5 V. The frequency at VCO test point should be approximately 45.25 MHz.
- Select test channel 2.
- Check that the voltage at TP301 is between 7 V and 10.5 V. The frequency at VCO test point should be approximately 60 MHz.
- Select test channel 3.
- Check that the voltage at TP301 is between 13 V and 20 V. The frequency at VCO test point should be approximately 75 MHz.

Aligning the 45 MHz filter

Drawing [08-06039](#)

NOTE The transceiver must be in Service mode to perform this alignment (see [page 115, Accessing Service mode](#)).

To align the 45 MHz filter:

- Connect a signal generator to the receiver input of the transceiver. Set the signal generator to 8.4 MHz at -40 dBm.
- Connect a $10\times$ probe on channel 1 of an oscilloscope to TP202 on the RF/IF & Synthesiser PCB (see [Figure 25 on page 120](#)).
- Set the channel 1 input to AC at 200 mV per division (20 mV per division with $10\times$ probe).
- Set the timebase of the oscilloscope to 5 ms per division.
- Connect the TRIG test point on the RF/IF & Synthesiser PCB to the external trigger of the oscilloscope.
- Set the oscilloscope for an external positive trigger and adjust for lock.
- Set the transceiver to channel 4 to initiate the sweep test.
- Adjust the centre of the peaks to be in the centre of the CRO.
- Adjust 45 MHz filter inductors (L123, L124 and L125) for a flat response as shown in [Figure 29](#).
- Repeat the last two steps in this process.

Figure 29: Sweep test display

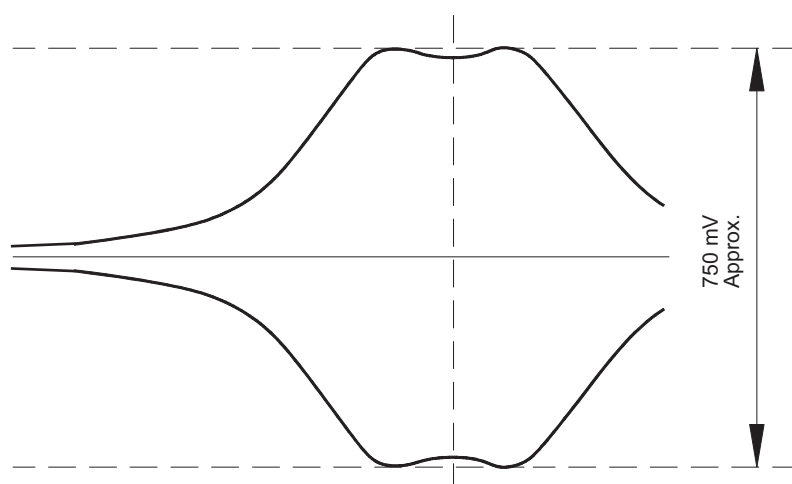

- Select any other channel to stop the sweep test.

Aligning the 455 kHz IF and noise limiter

Drawing [08-06039](#)

NOTE The transceiver does not have to be in Service mode to make this alignment.

There is a tuned transformer T201 in the 455 kHz IF circuit located on the RF/IF & Synthesiser PCB (see [Figure 25 on page 120](#)). T201 is located at the output of the noise limiter 455 kHz amplifier.

To align the transformer in the 455 kHz IF circuit on the RF/IF & Synthesiser PCB:

- Select any normal receive channel.
- Connect a signal generator to the receiver input.
- Set the signal generator to 1 kHz above the channel frequency selected (or 1 kHz below for LSB) at an output of approximately -100 dBm.
- Measure the DC voltage at TP201 and adjust T201 for a minimum voltage (between 1.5 and 3 V).

Adjusting the exciter output level

Drawing [08-06039](#)

NOTE The transceiver must be in Service mode to make this adjustment (see [page 115, Accessing Service mode](#)).

To adjust the exciter output level:

- Unplug the coaxial cable at J101 on the RF/IF & Synthesiser PCB.
- Connect a 47 Ω resistor from the Tx exciter output test point (TP101) to ground on the RF/IF & Synthesiser PCB (see [Figure 25 on page 120](#)).
- Connect an oscilloscope to the Tx exciter output test point.
- Connect a signal generator to provide two-tone audio (700 Hz and 2300 Hz) via the test unit to the audio input on the GPIO connector (see [Figure 22 on page 108](#)).
- Select test channel 26 with USB mode, or a mid-band frequency of approximately 14 MHz.
- Select PTT (Transmit mode) and adjust the level of the two tones for microphone compression.
- Adjust the Y sensitivity of the oscilloscope for on-screen display, and adjust the trigger for a stationary waveform.
- Adjust the two-tone balance control for good crossover display.
- Adjust the Tx output level control (R279) for a level of 180 mV p-p on the oscilloscope.

Adjusting carrier re-insertion

Drawing [08-06039](#)

NOTE The exciter output level must be set before this adjustment is made (see [page 128, Adjusting the exciter output level](#)).

NOTE The transceiver must be in Service mode to make this adjustment (see [page 115, Accessing Service mode](#)).

To adjust carrier re-insertion:

- Select test channel 16 and the AM mode (press **2**).
- Unplug the coaxial cable between the PA & Filter PCB and the RF/IF & Synthesiser PCB.
- Connect an oscilloscope with a 50 Ω termination to the Tx exciter output test point (TP101) on the RF/IF & Synthesiser PCB (see [Figure 25 on page 120](#)).
- Using the transceiver test unit, apply an audio signal of 1 kHz to the audio input on the GPIO connector.
- Select PTT (Transmit mode).
- Adjust the AM carrier control (R154, near the SSB filter Z201) for 100% modulation.
- Rotate R154 clockwise to set it to approximately 90% modulation (see [Figure 30](#)).

Figure 30: Graph showing adjustment to 90% modulation

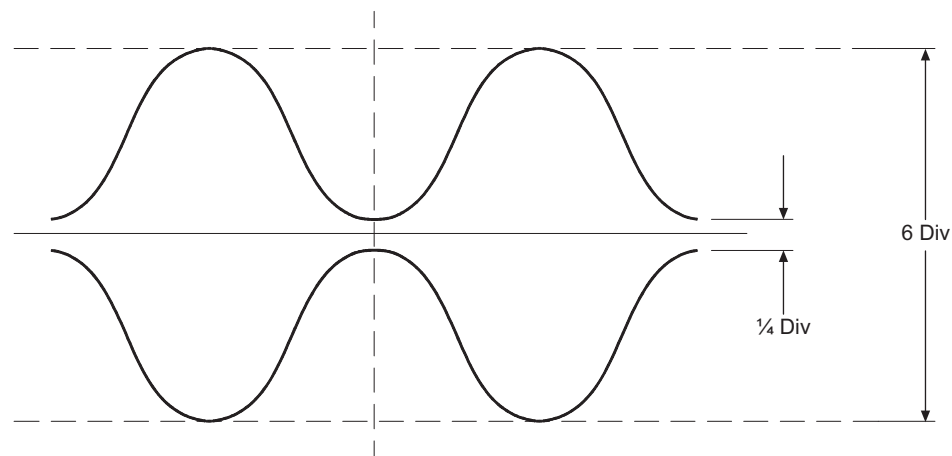

Adjusting frequency

Drawings [08-06039](#) and [08-06163](#)

NOTE The transceiver must be in Service mode to make this adjustment (see [page 115, Accessing Service mode](#)).

All the channels are synthesised and locked to the 14.848333 MHz reference crystal oscillator Z1.

To adjust the frequency:

NOTE Wait for at least one minute after switching the transceiver on before adjusting the frequency.

- Select test channel 34 (29.9 MHz).
- Connect a frequency counter to the Tx exciter output J101 (see [Figure 25 on page 120](#)).
- Hold down 3* on the front panel.
- Adjust the reference frequency using trimpot R2 on the REF OSC PCB (drawing [08-06163](#)) for an exciter output frequency of 29.9 MHz \pm 3 Hz.

Adjusting mute

Drawing [08-06128 \(sheet 1\)](#)

NOTE The transceiver must be in Normal mode to make this adjustment.

The mute control should be adjusted so that it is sensitive enough to operate on the weakest signal possible without false triggering on noise pulses.

To adjust the mute:

- Connect the transceiver to an antenna (a short length of wire will do).
- Select an unoccupied channel.
- Press **V/S** until **V** is displayed, then press **MUTE** until **V** is highlighted.
- Turn the pre-set potentiometer MUTE ADJ (R163) on the Audio & Control PCB in the transceiver unit fully clockwise (see [Figure 27 on page 122](#)).
- Slowly turn the potentiometer counterclockwise until you hear receiver noise in the loudspeaker (this is the mute threshold).
- Turn the potentiometer back a quarter turn in a clockwise direction.

The sensitivity may be varied from this setting to suit individual requirements. Turning the potentiometer counterclockwise increases sensitivity.

Adjusting the PA

Adjusting the driver bias

Drawing [08-06064 \(sheet 2\)](#) and [08-06039](#)

NOTE The transceiver does not have to be in Service mode to make this adjustment.

To adjust the driver bias:

- Switch off the transceiver.
- Disconnect the exciter output from the PA by removing the RF drive between connector J2 (Tx coaxial) on the PA & Filter PCB and connector J101 on the RF/IF & Synthesiser PCB (see [Figure 25 on page 120](#)).
- Set a multimeter to DC low voltage range and connect it between the +12VSW and DR test points.

WARNING Do not short the multimeter leads to the chassis.

- Switch on the transceiver.
- Select any transmit channel and *hold down* PTT for at least 30 seconds.
- Check that the voltage measures 160 mV \pm 10 mV.

If the current is out of the specified limit stated above, change it by adjusting DR BIAS (R101) (see [Figure 26 on page 121](#)).

- Release PTT on the handset.
- Switch off the transceiver, disconnect the multimeter, then reconnect the RF drive to connector J2.

Adjusting the PA bias

Drawing [08-06064 \(sheet 2\)](#) and [08-06039](#)

NOTE The transceiver does not have to be in Service mode to make this adjustment.

To adjust the bias of the PA output transistors:

- Switch off the transceiver.
- Disconnect the exciter output from the PA by removing the RF drive between connector J2 (Tx coaxial) on the PA & Filter PCB and connector J101 on the RF/IF & Synthesiser PCB (see [Figure 25 on page 120](#)).
- De-solder the fuse F1/F2 next to the output transistors (DC supply to the output transistors V36 and V37) (see [Figure 26 on page 121](#)).

- Set a multimeter to DC 1 A range and connect it in place of the removed fuse (positive nearest to transistors).
- Switch on the transceiver.
- Select any transmit channel and *hold down* PTT for at least 30 seconds.
- Check that the output current measures 200 mA \pm 20 mA.

If the current is out of the specified limit stated above, change it by adjusting the pre-set potentiometer O/P BIAS (R105) (see [Figure 26 on page 121](#)).

- Release PTT on the handset.
- Switch off the transceiver, then resolder the fuse F1/F2.

If the fuse is broken, replace it with one strand (0.2 mm TCW) taken from a piece of 7×0.2 mm cable. Extend the centre of the wire down from the two stakes to form a V, ensuring it does not touch the PCB. Solder the wire to the two stakes, making sure the solder does not run down the strand of wire (see [Figure 26 on page 121](#), PA O/P Fuse).

Adjusting high output power

Drawing [08-06064 \(sheet 2\)](#)

NOTE The transceiver does not have to be in Service mode to make this adjustment.

NOTE The output power is factory-set, so it is not likely to be outside the specified limits. Check that there are no faults with the transmitter circuits before attempting to adjust the power output.

To adjust the high output power:

- Select any test channel frequency between 4 and 6 MHz (for example, test channel 16).
- Connect an average or PEP power meter with a 50 Ω dummy load to the antenna connector (1F) and ensure that this antenna port is selected in the Cfg Auto Tune Mode entry in the Control List (see the *Manpack Transceiver 2110 series Reference Manual*).
- Connect an oscilloscope via a 47 k Ω resistor to the antenna connector.
- Set the oscilloscope timebase to 500 μ s per division and the trigger to Auto.
- Connect a signal generator to provide two-tone audio (700 Hz and 2300 Hz) via the test unit to the audio input on the GPIO connector.
- Hold down* PTT and adjust the two-tone level for compression.
- Adjust the Y sensitivity of the oscilloscope for on-screen display and adjust the trigger for a stationary waveform.
- Adjust the two-tone balance control for good crossover display.
- Adjust HI PWR (R56) (see [Figure 26 on page 121](#)) for 25 W PEP.

The indicated PEP level with two-tone modulation depends on the type of measuring instrument, as shown in [Table 38 on page 141](#).

- Release PTT on the handset.
- Check that the two-tone waveform is clean and undistorted.
If it is not clean and undistorted, further analysis is required.

Adjusting low output power

Drawing [08-06064 \(sheet 2\)](#)

NOTE Before adjusting the low output power, set the high output power (see [page 133, Adjusting high output power](#)).

NOTE The transceiver must be in Service mode to make this adjustment (see [page 115, Accessing Service mode](#)).

To adjust the low output power:

- Select any test channel frequency between 4 and 6 MHz (for example, test channel 16).
- Press **7** on the front panel to select low power.
- Proceed as for [page 133, Adjusting high output power](#).
- Adjust LO PWR (R124) for 5 W PEP (see [Figure 26 on page 121](#) and [Table 38 on page 141](#)).
- Check that the two-tone waveform is clean and undistorted.
If it is not clean and undistorted, further analysis is required.

Adjusting balance control

Drawing [08-06064 \(sheet 2\)](#)

NOTE The transceiver must be in Service mode to make this adjustment (see [page 115, Accessing Service mode](#)).

To adjust the balance control:

- Connect setup as per the output power adjustment (see [page 133, Adjusting high output power](#)), connecting a spectrum analyser in place of the oscilloscope.
- Select test channel 18 (4.7 MHz).
- Connect the signal generator to provide single-tone audio via the test unit to the audio input on the GPIO connector.
- Set up the spectrum analyser as follows:

Centre frequency	9.4 MHz
Frequency span	20 kHz (2 kHz per division)
Vertical level	10 dB per division
Sensitivity	Depends on the signal level applied to the analyser and requires adjustment when transmitting

- Hold down* PTT, then adjust the level of the single tone for compression.
- Adjust the sensitivity control on the spectrum analyser to set the tone at the top of the screen.
- Adjust the balance control (R273) for a minimum on 9.4 MHz.
- Check that the level of the 2nd harmonic (9.4 MHz) is more than 60 dB below the carrier level.
- Release PTT.

Checking intermodulation

Drawing [08-06064 \(sheet 2\)](#)

NOTE The transceiver must be in Service mode to perform this check (see [page 115, Accessing Service mode](#)).

The test channels 9 to 34 can be used to check for IMD. To facilitate checking each band, there is a test channel allocated near the top, centre and bottom of each band.

To check the IMD:

- Connect setup as per the balance control adjustment (see [page 134, Adjusting balance control](#)).
- Connect a signal generator to provide two-tone audio (700 Hz and 2300 Hz) via the test unit to the audio input on the GPIO connector.
- Set up the spectrum analyser as follows:

Centre frequency	Set to frequency of selected test channel
Frequency span	20 kHz (2 kHz per division)
Vertical level	10 dB per division
Video bandwidth	300 Hz
Sensitivity	Depends on the signal level applied to the analyser and requires adjustment when transmitting

- Select PTT (Transmit mode) and adjust the level of the two tones for compression.
- Adjust the two tones displayed on the spectrum analyser for equal amplitude by adjusting the balance control on the two-tone signal generator.

- Adjust the sensitivity control on the spectrum analyser to set the two tones at the top of the screen.
- Measure the IMD levels relative to each tone.
Add 6 dB to the reading if referenced to PEP (see [Table 6 on page 35](#) for limits).
If IMD is outside of the specified limits, further analysis is required.
- Check the IMD on the remaining frequencies (see [Table 36 on page 116](#)). The centre frequency of the spectrum analyser must be set to the channel frequency selected.

NOTE To check for spurious and harmonic components during the IMD checks, adjust the frequency span of the spectrum analyser.

Checking performance of the receiver at the 50 ohm antenna connector

NOTE The transceiver does not have to be in Service mode to perform any of these adjustments.

Checking the sensitivity and (signal+noise)/noise ratio

To check the sensitivity and (S+N)/N ratio:

- Connect an AC voltmeter across the audio output (loudspeaker).
- Check that the Cfg RF Pre-Amp entry in the Control List is set to On (see the *Manpack Transceiver 2110 series Reference Manual*).
- Connect the signal generator to the 50 Ω antenna connector (1F) and check that this antenna port is selected in the Cfg Auto Tune Mode entry in the Control List (see the *Manpack Transceiver 2110 series Reference Manual*).
- Set the frequency of the signal generator 1 kHz above the suppressed carrier frequency of the selected channel.
- Set the generator output level to -120 dBm (0.2 μ V PD).
- Adjust the volume control for a suitable, near full-scale dB reading on the AC voltmeter. Record the reading.
- Switch off or adjust the output of the signal generator to a frequency outside the receiver pass-band. Check that the audio output drops by at least 10 dB.
- Repeat the above with the RF gain off and the output of the signal generator set to -114 dBm (0.45 μ V PD). Check that the audio output drops by at least 10 dB.

If the audio output does not drop by at least 10 dB, further analysis is required.

Checking the automatic gain control

To check the AGC:

- Set up the equipment as described on [page 137, *Checking the sensitivity and \(signal+noise\)/noise ratio*](#), but set the output of the signal generator to -13 dBm (50 mV PD).
- Check that the Cfg RF Pre-Amp entry in the Control List is set to On (see the *Manpack Transceiver 2110 series Reference Manual*).
- Adjust the volume control for a suitable, near full-scale dB reading on the AC voltmeter. Record the reading.
- Reduce the output of the signal generator until the receiver output drops by 6 dB.

The signal generator level should be less than -100 dBm (2 μ V PD).

If the signal generator level is not less than -100 dBm (2 μ V PD), further analysis is required.

Checking the audio output

To check the audio output:

- Set up the equipment as described on [page 137, *Checking the sensitivity and \(signal+noise\)/noise ratio*](#), with an input signal of -67 dBm (100 μ V PD).
- Connect an oscilloscope in parallel to the AC voltmeter across each audio output (loudspeaker), pin J then pin L, on the 19-way GPIO connector on the front panel of the transceiver.

NOTE Check that the Cfg Speaker External entry in the Control List is set to Enabled.

- Increase the audio level by adjusting the volume control and check that the audio output exceeds 1.2 V p-p (displayed on the oscilloscope).

If the audio output does not exceed 1.2 V p-p, further analysis is required.

- Check for sound from the internal speaker.

NOTE Check that the Cfg Speaker Internal entry in the Control List is set to Enabled.

- Check for sound from the handset earphone.

Checking the selectivity

To check the selectivity (USB operation):

- Set up the equipment as described on [page 137, *Checking the sensitivity and \(signal+noise\)/noise ratio*](#).
- Set the output of the signal generator to -120 dBm (0.20 μ V PD).
- Measure and record the reference level of the audio output using the AC voltmeter.
- Monitor the signal generator using a frequency counter. Adjust the frequency to -1 kHz and then to $+4$ kHz from the SCF (USB operation).
- Increase the output of the signal generator to -60 dBm (0.22 mV) and check that the audio output is less than the reference level.
- Repeat at $+4$ kHz from the SCF (USB operation) and check that the audio output is less than the reference level.

If the audio output is not less than the reference level at both frequencies, further analysis is required.

Checking the noise limiter

To check the operation of the noise limiter:

- Connect the signal generator to the 50 Ω antenna connector (1F) via a T-piece and check that this antenna port is selected in the Cfg Auto Tune Mode entry in the Control List (see the *Manpack Transceiver 2110 series Reference Manual*).
- Set the frequency of the signal generator 1 kHz above the SCF of the selected channel (1 kHz below for LSB).
- Set the output of the signal generator to -115 dBm (0.4 μ V PD).
- Connect the output of a square-wave generator to the other input on the T-piece via a 100 pF capacitor (a BNC to 2-terminal adaptor may be useful).
- Set the frequency of the square-wave generator to 100 Hz and the output to 5 V p-p.

When the noise limiter is on, the signal produced by the signal generator should be clearly heard over the interfering signal from the square-wave generator.

If the signal produced by the signal generator is not clearly heard over the interfering signal from the square-wave generator, further analysis is required.

- Switch the noise limiter off by shorting OFF/ON on the 4-pin plug of the noise limiter on the RF/IF & Synthesiser PCB (see drawing [08-06039](#) and [Figure 25 on page 120](#)).

The noise from the square-wave generator should obliterate the wanted signal produced by the signal generator, thereby verifying that the noise limiter is functioning correctly.

Checking performance of the transmitter at the 50 ohm antenna connector

NOTE The transceiver must be in Service mode to perform these checks (see [page 115, Accessing Service mode](#)).

NOTE Check that the 50 Ω antenna port is selected in the Cfg Auto Tune Mode entry in the Control List (see the *Manpack Transceiver 2110 series Reference Manual*).

Checking the transmit frequency

Check the transmit frequency (see [page 130, Adjusting frequency](#)).

Checking the automatic level control

To check the operation of the ALC:

- Connect a signal generator to provide two-tone audio (700 Hz and 2300 Hz) via the test unit to the audio input on the GPIO connector.
- Select PTT (Transmit mode) and increase the audio output slowly until the moment when the output power stops increasing.

This point is the ALC threshold.

- Record the PEP output and increase the audio input by 10 dB.

The increase in output should be less than 0.5 dB above the ALC threshold.

If the increase in output is greater than 0.5 dB above the ALC threshold, further analysis is required.

Checking power output and intermodulation

NOTE The indicated PEP level with two-tone modulation depends upon the type of measuring instrument used, as shown in [Table 38](#).

Table 38: Power output PEP vs measuring instrument (5/25 W)

Power output PEP	5 W	25 W
Peak reading meter	5 W	25 W
RMS reading meter	2.5 W	12.5 W
Average reading meter	2 W	10 W
Oscilloscope	45 V p-p	100 V p-p

To check the power output and modulation:

- Connect a signal generator to provide two-tone audio (700 Hz and 2300 Hz) via the test unit to the audio input on the GPIO connector.
- Check that the power output is 25 W PEP at 1.6 MHz to 30 MHz.
- Use a spectrum analyser to check that the IMD is better than -32 dB below PEP (-26 dB below each tone) (see [page 135, Checking intermodulation](#)).

Checking the antenna tuner relays

Drawing [04-03444](#) and [08-06063](#)

NOTE The transceiver must be in Service mode to perform this check (see [page 115, Accessing Service mode](#))

Relay tests are grouped after service test 34. Relays may be tested individually, for example **ATU SET 1**, **ATU RESET 1**, through to **ATU SET 23**, **ATU RESET 23**, or as a group with **SERVICE 81**.

Each relay may be SET or RESET individually. Definition of the SET condition for each relay is provided on drawing [04-03444](#), and relay numbers are shown on [Figure 28 on page 123](#).

To check an individual relay:

- Select **ATU SET 7** to test relay K7.
If the relay is operating correctly you will hear a click.
- Select **ATU RESET 7** to test relay K7.
If the relay is operating correctly you will hear a click.

To check the relays as a group:

- Select test **SERVICE 81**.

Each individual relay is set and reset four times. The relays are selected in ascending order, that is K1, K2, through to K23.

NOTE The clicks from K1 to K16 are quiet due to the small size of the relay.

Re-assembling the transceiver

When re-assembling the transceiver you must:

- check that gaskets are not damaged and that they retain waterproof integrity
- use original screws or genuine replacements

To re-assemble the Front Panel PCB onto the front panel and onto the chassis:

- Insert the keymat and Keypad PCB into the front panel, then re-insert the 10 screws into the Keypad PCB.
- Carefully align the connector pins on the Keypad PCB with the sockets on the Front Panel PCB, then gently push the PCBs together.
- Re-insert the screw and four spacers on the Front Panel PCB.
- Place the front panel assembly against the chassis, then re-insert the four screws that hold the chassis to the front panel, into the rear of the front panel.
- Tighten the screw on the rear of the antenna stud to reconnect the antenna tuner.

To re-assemble the transceiver:

- Replace any screen covers that have been removed from the PCBs.
- Stand the housing on its bottom end, then slide the transceiver chassis into the housing.

WARNING Ensure that the transceiver slides in parallel to the housing.

CAUTION Apply firm pressure to the front panel to ensure that the o-ring is in contact with the housing.

- Re-insert the six screws into the front panel.
- Stand the transceiver on its front panel.
- Tighten the screw that required loosening (labelled).
- Check the integrity of the sealing gasket, and replace with a new gasket if necessary.
- Reconnect the battery connector.
- Push the rear panel onto the chassis, then re-insert the six screws.
- Connect the battery pack to the base of the transceiver.

Checking the battery charging process

You may use any of the following chargers to charge the battery:

- a 3121 AC Battery Charger (1 A), which uses a universal AC mains input of 90 to 264 V AC
- a 3122 DC Battery Charger (1 A), which may be powered from any 12 to 60 V DC source (for example, from a 12 V DC outlet in a vehicle, or from a 24 V vehicle battery)
- a 3123 Fast AC Battery Charger (3 A), which uses a universal AC mains input of 90 to 264 V AC
- a solar battery charger and lead (1 A, in full sunlight)
- a hand-powered battery charger (1 A at 60 rpm)

The Codan 3121 AC Battery Charger and 3122 DC Battery Charger are specially designed for low-noise operation, so receiver performance remains optimal while charging the battery pack via the front panel.

NOTE The 3123 Fast AC Battery Charger connects directly to the battery pack for charging. You cannot use this charger through the 19-way or 5-way connector on the front panel of the transceiver.

CAUTION Charging is recommended between 0 and 40°C (104°F). The battery will not commence charging if the temperature is at or above 40°C (104°F). If charging is already in progress, and the temperature rises to 50°C (122°F), charging is stopped automatically.

CAUTION To prevent damage to the battery, Codan recommends the use of the Codan battery chargers to charge the battery pack.

Table 39: Typical charging times for Codan battery packs

Charger type	Rating (A)	Charging time (h)	
		7 Ah and 8 Ah	13 Ah
3121	1	10	16
3122	1		
Solar battery charger	1 (in full sun)		
Hand-powered battery charger	1 (@ 60 rpm)		
3123	3	3	5

Figure 31: Typical front panel of a battery charger

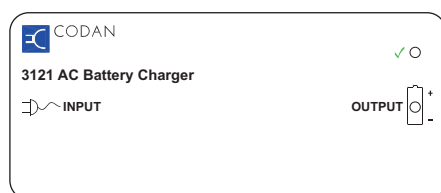







Table 40: LED indications

Charger type	LED	Status	Meaning
3121 3122	✓	Green, solid	The charger has an appropriate power supply connected.
		Off	The charger does not have an appropriate power supply connected.
	OUTPUT	Orange, solid	The charger is charging the battery pack.
		Off	The charger has finished charging the battery pack.
3123	✓	Green, solid	The charger has an appropriate power supply connected.
		Off	The charger does not have an appropriate power supply connected, or is not functioning correctly.
	OUTPUT	Yellow, solid 	The charger is charging the battery pack.
		Yellow, slow flash 	The charger has finished charging the battery pack.
		Yellow/red, alternating flash 	The battery pack has an overtemperature condition.
		Red, double flash then long pause 	The battery pack has a faulty fuse.
		Red, rapid flash 	The battery pack is unserviceable and cannot be charged.

Charging a battery

WARNING The battery pack should be charged with the connector facing upward and the vents clear of obstructions so that any gas created during the charging process is released.

CAUTION Provide clear notification that charging is underway. Ensure there is adequate ventilation around the battery during charging.

NOTE If the voltage of the battery is below 10 V, the **OUTPUT LED** on the charger flashes orange for a period of time before charging commences. The ✓ LED may also flash during this period.

To charge a battery:

Do one of the following:

- For 2110 and 2110M Manpack Transceivers with the battery attached to the transceiver, use cable 08-06215-001 to connect the output of the 3121, 3122, solar or hand-powered battery charger to the 19-way connector on the front panel of the transceiver.
- For 2110v Manpack Transceivers with the battery attached to the transceiver, use cable 08-06738-001 to connect the output of the 3121, 3122, solar or hand-powered battery charger to the 5-way connector on the front panel of the transceiver.

NOTE The 3123 Fast AC Battery Charger cannot be used to charge a battery pack via the front panel of the transceiver.

- If the battery is detached from the transceiver, use cable 08-06214-001 to connect the output of any of the Codan battery chargers to the 6-way connector on the top of the battery pack.

Connect the charger to an appropriate power source.

NOTE If you are using a solar battery charger, ensure that the panel is oriented at right angles to the rays of the sun.

NOTE If you are using a hand-powered battery charger, strap it to a tree, or attach it to the stand provided.

If the transceiver is operational during charging, the battery status indicator on the front panel screen shows that the battery pack is charging. When charging is complete, the battery status indicator is full.

NOTE It takes approximately 16 seconds following appropriate connections for the 3121, 3122, solar and hand-powered battery chargers to commence charging the battery pack.

Requirements for alternative chargers

The Codan battery packs may be charged using alternative supplies, for example, third-party solar panels or hand-powered battery chargers. In this situation, the voltage level must not exceed 15.5 V and the current must be within 1 to 3 A. These chargers must be connected between pin B (charge in) and pin A (ground) of the connector on the battery pack.

Notes on charging batteries

A battery requires 3 to 5 discharge/recharge cycles when new before it reaches its full capacity. In order to increase the battery service life, it is recommended that the battery *is not* fully discharged during each cycle. Full discharge should only be carried out periodically as follows:

Type Full discharge

NiMH Two full discharge/recharge cycles every 20 charge cycles

SLA One full discharge/recharge cycle every 20 charge cycles

For the periodic full-discharge cycle, run the battery down to zero capacity using the transceiver. The transceiver switches off automatically when the battery is fully discharged.

WARNING If you are using alternative means to discharge the battery, the battery voltage must not go below 10 V.

WARNING An SLA battery must be charged immediately after discharge to prevent damage to the battery.

The Codan battery packs have in-built monitoring, which is reported in the Battery entry in the Control List. You should view the Battery Cycle setting for the number of times the battery has received input current (that is, has been charged).

NOTE You must log in as administrator to see the Control List.

Adjusting the 3160 Power Amplifier

Disassembling the 3160

To disassemble the 3160:

- Lay the 3160 on a flat surface with the heatsink facing down.
- Remove the 10 M3 × 8 taptite countersunk pozi screws from the lid.
- Remove the lid and o-ring, then set aside.

Figure 32: Adjustment locations and test points for the 3160 Power Amplifier

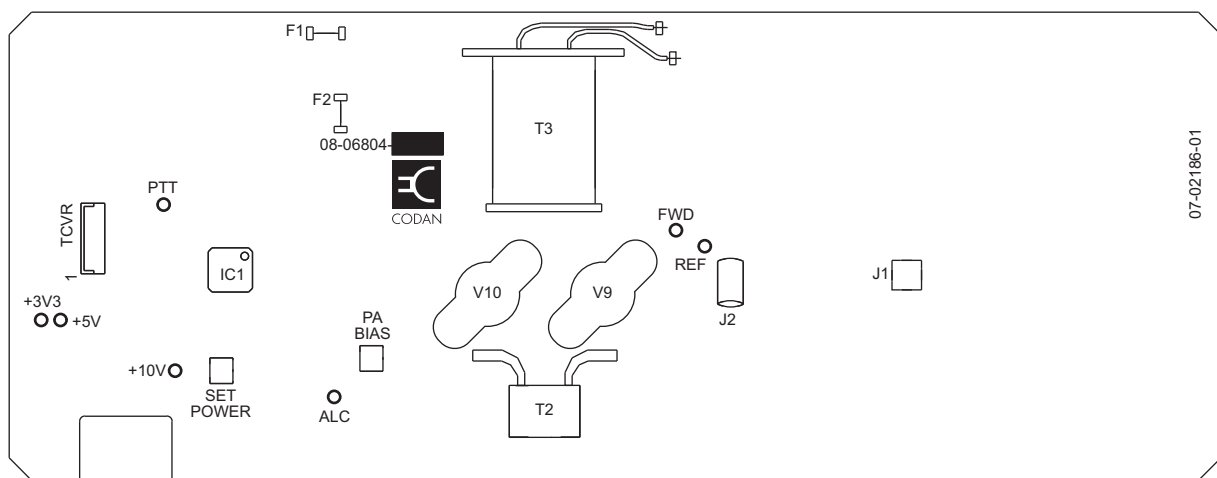

Adjusting the PA bias

Drawing 08-06804

NOTE The transceiver does not have to be in Service mode to make this adjustment.

NOTE This adjustment assumes that the transceiver is adjusted correctly (see [page 132, Adjusting the PA bias](#)).

To adjust the bias of the PA output transistors:

- Switch off the transceiver.
- Disconnect the coax cable from the **RF INPUT** connector on the 3160.
- De-solder fuse F1.

NOTE F1 protects the DC supply to output transistors V9 and V10.

- Set a multimeter to DC 1 A range, then connect it in place of the removed fuse.
- Switch on the transceiver.

- Select any transmit channel, then *hold down* PTT.
- Check that the output current measures 400 mA \pm 20 mA.
If the current is out of the specified limit stated above, change it by adjusting the pre-set potentiometer PA BIAS (R43).
- Switch off the transceiver, then resolder the fuse F1.
- If the fuse is broken, replace it with two strands (0.2 mm TCW) taken from a piece of 7 \times 0.2 mm cable. Extend the centre of the wire down from the two stakes to form a V, ensuring it does not touch the PCB. Solder the wire to the two stakes, making sure the solder does not run down the strands of wire.

Adjusting high output power

Drawing 08-06804

- NOTE The transceiver must be in Service mode to make this adjustment (see [page 115, Accessing Service mode](#)).
- NOTE The output power is factory-set, so it is not likely to be outside the specified limits. Check that there are no faults with the transmitter circuits before attempting to adjust the power output.
- NOTE This adjustment assumes that the transceiver is adjusted correctly (see [page 133, Adjusting high output power](#)).

To adjust the output power:

- Select any test channel frequency between 4 and 6 MHz (for example, test channel 16).
- Connect an average or PEP power meter with a 50 Ω dummy load to the antenna connector.
- Connect an oscilloscope via a 47 k Ω resistor to the antenna connector.
- Set the oscilloscope timebase to 500 μ s per division and the trigger to Auto.
- Connect a signal generator to provide two-tone audio (700 Hz and 2300 Hz) via the test unit to the audio input on the GPIO connector.
- Hold down* PTT and adjust the two-tone level for compression.
- Adjust the Y sensitivity of the oscilloscope for on-screen display and adjust the trigger for a stationary waveform.
- Adjust the two-tone balance control for good crossover display.
- Adjust SET POWER for 125 W PEP.

The indicated PEP level with two-tone modulation depends on the type of measuring instrument, as shown in [Table 41](#).

Table 41: Power output PEP vs measuring instrument (100/125 W)

Power output PEP	100 W	125 W
Peak reading meter	100 W	125 W
RMS reading meter	50 W	62.5 W
Average reading meter (e.g. Bird Model 43)	40.5 W	50.6 W
Oscilloscope	200 V p-p	224 V p-p

- Check that the two-tone waveform is clean and undistorted.
If it is not clean and undistorted, further analysis is required.

Re-assembling the 3160

To re-assemble the 3160:

- Apply Molykote[®] 111 Valve and O-ring lubricant to the o-ring (30-29011-505), then place the o-ring into the groove in the housing of the 3160.
- Place the lid over the housing, taking care not to pinch the o-ring.
- Insert the 10 M3 × 8 taptite countersunk pozi screws into the lid, then tighten to 1.1 Nm using a torque screwdriver.

Table 42: Parts lists index

Title	Assembly number
Transceiver unit Assembly	08-06155-000
	08-06155-001
	08-06155-002
Front Panel	08-06129-001
Keypad	08-06140-001
Audio & Control	08-06128-001
RF/IF & Synthesiser	08-06039-001
Reference Oscillator	08-06163-000
	08-06163-001
	08-06163-002
PA & Filter	08-06064-001
Antenna Tuner	08-06063-001
Second IF Filter Option	08-06044-000
	08-06044-001
	08-06044-002
GPS Receiver Option	08-06149-001
Voice Encryptor Option	08-06001-001
Interface Adaptor	08-06382-001
VP-116 to 2110 Interface	08-06421-001
3160 Power Amplifier	08-06804-001

This page has been left blank intentionally.

08-06155-000 - 2110 SSB Tcwr Final Assembly

BOM Revision
Date Valid On

12 -- Production
17.06.2008

Ref	Description	Manufacturer	Manufacturer's P/N	Codan P/N	Qty
	Interconnection Diagram 2110			04-03515	1
	Build Std & Mod Status, 2110			01-01665	1
	2110 Customising Reference			11-90395	1
	Packing 2110			11-90412	1
	PAP, CMR			10-50074	1
	Final Assembly, 2 2110			11-90408	1
	Seal Verification, Lo Pressure 2110			11-90399	1
	Customising, 3 2110			11-90410	1
	Final Auto Test,2 2110			11-90409	1
*	2110 SSB Tcwr Final Assembly			08-06155	1
3	Screen, ATU	Metalcraft	05-07375	05-07375	1
4	Screen, PA	Metalcraft	05-07376	05-07376	1
5	Screen, RF-IF	Metalcraft	05-07377	05-07377	1
6	Screen, UPROC	Metalcraft	05-07378	05-07378	1
7	Internal Chassis	Metalcraft	05-07379	05-07379	1
8	Slider, Heatsink	Metalcraft	05-07392	05-07392	1
10	Gasket, Main	Ind Gaskets	06-02210	06-02210	1
13	Bumper, Self Adhesive	Richco	RBS-2	06-02233	4
14	Washer, Cup, Nylon M3	Micro Plastics	16CW004040	06-02234	6
15	Label, Septum Clamping Screw Location	Entech	06-02248	06-02248	1
17	RF/IF & Synthesiser PCB	Codan	08-06039-001	08-06039-001	1
18	Antenna Tuner PCB	Codan	08-06063-001	08-06063-001	1
19	PA & Filter PCB	Codan	08-06064-001	08-06064-001	1
21	Front Panel PCB	Codan	08-06129-001	08-06129-001	1
22	Cable, Ribbon 16way 75mm	Auto Assemblies	08-06153-001	08-06153-001	1
23	Cable, Ribbon 16way 220mm	Auto Assemblies	08-06153-002	08-06153-002	1
24	Cable, Ribbon 10way 145mm	Auto Assemblies	08-06154-001	08-06154-001	1
25	Cable, Coax RF/IF to PA	Auto Assemblies	08-06156-001	08-06156-001	1
26	Cable, Coax PA to ATU	Auto Assemblies	08-06157-001	08-06157-001	1
27	Cable, Coax ATU to FP	Auto Assemblies	08-06158-001	08-06158-001	1
30	Loom, Power & Control	Auto Assemblies	08-06164-001	08-06164-001	1
31	Loom, Battery Connector	Auto Assemblies	08-06165-001	08-06165-001	1
32	O-Ring, 21,6 ID x 2,4d NitrileBlack	James Walker	72-0216-24 N70	30-29011-508	1
33	Washer, 3,05 x 5,84 x 0,89 MS Fe/Zn12 Bk	PSM	WSM3X6-BZ12	31-23001-007	5
34	Spacer, Threaded Hex/Stud M6x16	PSM Fasteners	SPA-02-B-M3-16	30-37007-010	4
36	Spacer, Threaded Hex/Stud M3x19	PSM Fasteners	SPA-02-B-M3-19MM	30-37007-015	1
37	Spacer, Threaded Hex/Stud M3x23	PSM Fasteners	SPA-02-B-M3-23MM	30-37007-016	3
38	Screw, M3x6 304 SS Pan Pozi	*	31-23006-580	31-23006-580	24
39	Screw, Breather M3x6 Nylon Black slotted	Brownell	BL/D 9301	31-23006-920	1
40	Screw, M3x20 MS to AS1789 Fe/Zn12 Bk Skt	RGA Fasteners	HKCMX20-BTZ-12	31-23020-907	12
41	Screw, M3x8 MS to AS1789 Fe/Zn12 Bk Skt	RGA Fasteners	HKCM3X8-BTZ-12	31-23008-907	4
42	Screw, M3x80 MS Zn PI Pan Pozi	James Glen	MS ZN PLATE	31-23080-801	1
43	Cap, with cord, Black 14 shell	VGL	62IN-812-14-624-609	60-90905	1
44	Cap, with cord, BNC Black	VGL	A31-6-01-RFX-NC	60-90906	1
46	Cable, 34way 0,5mm Ptchx100mm long	TennRich	TFCDC34	67-50340-100	2
47	Compound, Heat Transfer 70g Electrolube	Electrolube	HTC35SL	71-31000-006	0.01
48	Label, Serial/Barcode	Codan	06-02068	06-02068	1
50	Silica Gel, 10g Sachet	Dri-Pax	S153070	30-38000-005	1
51	Tape, Urethane foam double sided	3M	4032 12,7MMX65.8MX0,8MM	30-39308-005	10
52	Plug, 4mm dia Banana Panel Mnt	Trewin	P445M-CODAN	60-00010-000	2
53	Socket, 4mm dia Banana Panel	Trewin	S438-CODAN	60-00013-001	2

08-06155-000 - 2110 SSB Tcwr Final Assembly

BOM Revision
Date Valid On

12 -- Production
17.06.2008

Ref	Description	Manufacturer	Manufacturer's P/N	Codan P/N	Qty
54	Tie, Cable 2,5mm W x 115mm Long	Richco	WIT 18 R	30-39100-004	3
55	Label, Rear CMR	Entech	06-02180	06-02180	1
57	Screw, M3x6 304 SS Skt Cap	*	31-23006-980	31-23006-980	5
58	Screw, M3x10 MS to AS1789 Fe/Zn12 Bk Skt	RGA Fasteners	HKCM3X10-BTZ-12	31-23010-901	4
59	Label, Serial/Barcode	Codan	06-02370	06-02370	1
60	Screw, M3x6 MS to AS1789 Fe/Zn12 Bk Skt	RGA Fasteners	HKCM3X6-BTZ-12	31-23006-901	3
61	Gasket, I/O Connector	Industrial Gaskets	06-02309	06-02309	1
64	Screw, M3x8 304 SS Pan Pozi	RGA Fasteners	31-23008-580	31-23008-580	2
65	Label, WEEE 10x15mm White	Entech	06-02352-001	06-02352-001	1
66	Clip, 'P' 5,6mm Speed Clamp	Richco	RSC-3-01	30-05210-011	1

08-06155-001 - 2110 SSB Tcwr Unit (1,5ppm)

BOM Revision
Date Valid On

13 -- Production
17.06.2008

Ref	Description	Manufacturer	Manufacturer's P/N	Codan P/N	Qty
	NSP Profile 2110			15-10538	1
	Interconnection Diagram 2110			04-03515	1
	Build Std & Mod Status, 2110			01-01665	1
	2110 Customising Reference			11-90395	1
	Final Assembly, 2 2110			11-90408	1
	Final Auto Test,2 2110			11-90409	1
	Customising, 3 2110			11-90410	1
	Seal Verification, Lo Pressure 2110			11-90399	1
	Packing 2110			11-90412	1
	PAP, CMR			10-50074	1
*	2110 SSB Tcwr Final Assembly			08-06155	1
1	Housing, Rear, 2110, Black	Metalcraft	05-07371-001	05-07371-001	1
2	Housing Body 2110 Black	Timminco	05-07372-001	05-07372-001	1
3	Screen, ATU	Metalcraft	05-07375	05-07375	1
4	Screen, PA	Metalcraft	05-07376	05-07376	1
5	Screen, RF-IF	Metalcraft	05-07377	05-07377	1
6	Screen, UPROC	Metalcraft	05-07378	05-07378	1
7	Internal Chassis	Metalcraft	05-07379	05-07379	1
8	Slider, Heatsink	Metalcraft	05-07392	05-07392	1
10	Gasket, Main	Ind Gaskets	06-02210	06-02210	1
12	Label, Ident	Entech	06-02216	06-02216	1
13	Bumper, Self Adhesive	Richco	RBS-2	06-02233	4
14	Washer, Cup, Nylon M3	Micro Plastics	16CW004040	06-02234	6
15	Label, Septum Clamping Screw Location	Entech	06-02248	06-02248	1
17	RF/IF & Synthesiser PCB	Codan	08-06039-001	08-06039-001	1
18	Antenna Tuner PCB	Codan	08-06063-001	08-06063-001	1
19	PA & Filter PCB	Codan	08-06064-001	08-06064-001	1
20	Audio & Control PCB	Codan	08-06128-001	08-06128-001	1
21	Front Panel PCB	Codan	08-06129-001	08-06129-001	1
22	Cable, Ribbon 16way 75mm	Auto Assemblies	08-06153-001	08-06153-001	1
23	Cable, Ribbon 16way 220mm	Auto Assemblies	08-06153-002	08-06153-002	1
24	Cable, Ribbon 10way 145mm	Auto Assemblies	08-06154-001	08-06154-001	1
25	Cable, Coax RF/IF to PA	Auto Assemblies	08-06156-001	08-06156-001	1
26	Cable, Coax PA to ATU	Auto Assemblies	08-06157-001	08-06157-001	1
27	Cable, Coax ATU to FP	Auto Assemblies	08-06158-001	08-06158-001	1
28	Front Panel Sub Assy 2110/v, Black	Codan	08-06140-001	08-06140-001	1
29	Ref Osc 14,8483MHz 1,5ppm PCB	Codan	08-06163-001	08-06163-001	1
30	Loom, Power & Control	Auto Assemblies	08-06164-001	08-06164-001	1
31	Loom, Battery Connector	Auto Assemblies	08-06165-001	08-06165-001	1
32	O-Ring, 21,6 ID x 2,4d NitrileBlack	James Walker	72-0216-24 N70	30-29011-508	1
33	Washer, 3,05 x 5,84 x 0,89 MS Fe/Zn12 Bk	PSM	WSM3X6-BZ12	31-23001-007	5
34	Spacer, Threaded Hex/Stud M6x16	PSM Fasteners	SPA-02-B-M3-16	30-37007-010	4
36	Spacer, Threaded Hex/Stud M3x19	PSM Fasteners	SPA-02-B-M3-19MM	30-37007-015	1
37	Spacer, Threaded Hex/Stud M3x23	PSM Fasteners	SPA-02-B-M3-23MM	30-37007-016	3
38	Screw, M3x6 304 SS Pan Pozi	*	31-23006-580	31-23006-580	24
39	Screw, Breather M3x6 Nylon Black slotted	Brownell	BL/D 9301	31-23006-920	1
40	Screw, M3x20 MS to AS1789 Fe/Zn12 Bk Skt	RGA Fasteners	HKCMX20-BTZ-12	31-23020-907	12
41	Screw, M3x8 MS to AS1789 Fe/Zn12 Bk Skt	RGA Fasteners	HKCM3X8-BTZ-12	31-23008-907	4
42	Screw, M3x80 MS Zn PI Pan Pozi	James Glen	MS ZN PLATE	31-23080-801	1
43	Cap, with cord, Black 14 shell	VGL	62IN-812-14-624-609	60-90905	1
44	Cap, with cord, BNC Black	VGL	A31-6-01-RFX-NC	60-90906	1
46	Cable, 34way 0,5mm Ptchx100mm long	TennRich	TFCDC34	67-50340-100	2

08-06155-001 - 2110 SSB Tcwr Unit (1,5ppm)

BOM Revision
Date Valid On

13 -- Production
17.06.2008

Ref	Description	Manufacturer	Manufacturer's P/N	Codan P/N	Qty
47	Compound, Heat Transfer 70g Electrolube	Electrolube	HTC35SL	71-31000-006	0.01
48	Label, Serial/Barcode	Codan	06-02068	06-02068	1
50	Silica Gel, 10g Sachet	Dri-Pax	S153070	30-38000-005	1
51	Tape, Urethane foam double sided	3M	4032 12,7MMX65.8MX0,8MM	30-39308-005	10
52	Plug, 4mm dia Banana Panel Mnt	Trewin	P445M-CODAN	60-00010-000	2
53	Socket, 4mm dia Banana Panel	Trewin	S438-CODAN	60-00013-001	2
54	Tie, Cable 2,5mm W x 115mm Long	Richco	WIT 18 R	30-39100-004	3
55	Label, Rear CMR	Entech	06-02180	06-02180	1
56	Handle, 2110, Black	Metalcraft	05-07439-001	05-07439-001	2
57	Screw, M3x6 304 SS Skt Cap	*	31-23006-980	31-23006-980	5
58	Screw, M3x10 MS to AS1789 Fe/Zn12 Bk Skt	RGA Fasteners	HKCM3X10-BTZ-12	31-23010-901	4
59	Label, Serial/Barcode	Codan	06-02370	06-02370	1
60	Screw, M3x6 MS to AS1789 Fe/Zn12 Bk Skt	RGA Fasteners	HKCM3X6-BTZ-12	31-23006-901	3
61	Gasket, I/O Connector	Industrial Gaskets	06-02309	06-02309	1
62	Label, Codan 21x30	Entech	06-02181	06-02181	1
63	Flexible PCB, MIL Connect	Braemac	08-06139-001	08-06139-001	1
64	Screw, M3x8 304 SS Pan Pozi	RGA Fasteners	31-23008-580	31-23008-580	2
65	Label, WEEE 10x15mm White	Entech	06-02352-001	06-02352-001	1
66	Clip, 'P' 5,6mm Speed Clamp	Richco	RSC-3-01	30-05210-011	1
H1	LED, White 5mm 22000-31000mcd @ 20mA	Nichia	NSPW500CS-b1/b2-V	65-61110-701	1

08-06155-002 - 2110 SSB Tcwr Unit (0,5ppm)

BOM Revision
Date Valid On

13 -- Production
17.06.2008

Ref	Description	Manufacturer	Manufacturer's P/N	Codan P/N	Qty
	NSP Profile 2110			15-10538	1
	Interconnection Diagram 2110			04-03515	1
	Build Std & Mod Status, 2110			01-01665	1
	2110 Customising Reference			11-90395	1
	Final Assembly, 2 2110			11-90408	1
	Final Auto Test,2 2110			11-90409	1
	Customising, 3 2110			11-90410	1
	Seal Verification, Lo Pressure 2110			11-90399	1
	Packing 2110			11-90412	1
	PAP, CMR			10-50074	1
*	2110 SSB Tcwr Final Assembly			08-06155	1
1	Housing, Rear, 2110, Black	Metalcraft	05-07371-001	05-07371-001	1
2	Housing Body 2110 Black	Timminco	05-07372-001	05-07372-001	1
3	Screen, ATU	Metalcraft	05-07375	05-07375	1
4	Screen, PA	Metalcraft	05-07376	05-07376	1
5	Screen, RF-IF	Metalcraft	05-07377	05-07377	1
6	Screen, UPROC	Metalcraft	05-07378	05-07378	1
7	Internal Chassis	Metalcraft	05-07379	05-07379	1
8	Slider, Heatsink	Metalcraft	05-07392	05-07392	1
10	Gasket, Main	Ind Gaskets	06-02210	06-02210	1
12	Label, Ident	Entech	06-02216	06-02216	1
13	Bumper, Self Adhesive	Richco	RBS-2	06-02233	4
14	Washer, Cup, Nylon M3	Micro Plastics	16CW004040	06-02234	6
15	Label, Septum Clamping Screw Location	Entech	06-02248	06-02248	1
17	RF/IF & Synthesiser PCB	Codan	08-06039-001	08-06039-001	1
18	Antenna Tuner PCB	Codan	08-06063-001	08-06063-001	1
19	PA & Filter PCB	Codan	08-06064-001	08-06064-001	1
20	Audio & Control PCB	Codan	08-06128-001	08-06128-001	1
21	Front Panel PCB	Codan	08-06129-001	08-06129-001	1
22	Cable, Ribbon 16way 75mm	Auto Assemblies	08-06153-001	08-06153-001	1
23	Cable, Ribbon 16way 220mm	Auto Assemblies	08-06153-002	08-06153-002	1
24	Cable, Ribbon 10way 145mm	Auto Assemblies	08-06154-001	08-06154-001	1
25	Cable, Coax RF/IF to PA	Auto Assemblies	08-06156-001	08-06156-001	1
26	Cable, Coax PA to ATU	Auto Assemblies	08-06157-001	08-06157-001	1
27	Cable, Coax ATU to FP	Auto Assemblies	08-06158-001	08-06158-001	1
28	Front Panel Sub Assy 2110/v, Black	Codan	08-06140-001	08-06140-001	1
29	Ref Osc 14,8483MHz 0,5ppm PCB	Codan	08-06163-002	08-06163-002	1
30	Loom, Power & Control	Auto Assemblies	08-06164-001	08-06164-001	1
31	Loom, Battery Connector	Auto Assemblies	08-06165-001	08-06165-001	1
32	O-Ring, 21,6 ID x 2,4d NitrileBlack	James Walker	72-0216-24 N70	30-29011-508	1
33	Washer, 3,05 x 5,84 x 0,89 MS Fe/Zn12 Bk	PSM	WSM3X6-BZ12	31-23001-007	5
34	Spacer, Threaded Hex/Stud M6x16	PSM Fasteners	SPA-02-B-M3-16	30-37007-010	4
36	Spacer, Threaded Hex/Stud M3x19	PSM Fasteners	SPA-02-B-M3-19MM	30-37007-015	1
37	Spacer, Threaded Hex/Stud M3x23	PSM Fasteners	SPA-02-B-M3-23MM	30-37007-016	3
38	Screw, M3x6 304 SS Pan Pozi	*	31-23006-580	31-23006-580	24
39	Screw, Breather M3x6 Nylon Black slotted	Brownell	BL/D 9301	31-23006-920	1
40	Screw, M3x20 MS to AS1789 Fe/Zn12 Bk Skt	RGA Fasteners	HKCMX20-BTZ-12	31-23020-907	12
41	Screw, M3x8 MS to AS1789 Fe/Zn12 Bk Skt	RGA Fasteners	HKCM3X8-BTZ-12	31-23008-907	4
42	Screw, M3x80 MS Zn PI Pan Pozi	James Glen	MS ZN PLATE	31-23080-801	1
43	Cap, with cord, Black 14 shell	VGL	62IN-812-14-624-609	60-90905	1
44	Cap, with cord, BNC Black	VGL	A31-6-01-RFX-NC	60-90906	1
46	Cable, 34way 0,5mm Ptchx100mm long	TennRich	TFCDC34	67-50340-100	2

08-06155-002 - 2110 SSB Tcwr Unit (0,5ppm)

BOM Revision
Date Valid On

13 -- Production
17.06.2008

Ref	Description	Manufacturer	Manufacturer's P/N	Codan P/N	Qty
47	Compound, Heat Transfer 70g Electrolube	Electrolube	HTC35SL	71-31000-006	0.01
48	Label, Serial/Barcode	Codan	06-02068	06-02068	1
50	Silica Gel, 10g Sachet	Dri-Pax	S153070	30-38000-005	1
51	Tape, Urethane foam double sided	3M	4032 12,7MMX65.8MX0,8MM	30-39308-005	10
52	Plug, 4mm dia Banana Panel Mnt	Trewin	P445M-CODAN	60-00010-000	2
53	Socket, 4mm dia Banana Panel	Trewin	S438-CODAN	60-00013-001	2
54	Tie, Cable 2,5mm W x 115mm Long	Richco	WIT 18 R	30-39100-004	3
55	Label, Rear CMR	Entech	06-02180	06-02180	1
56	Handle, 2110, Black	Metalcraft	05-07439-001	05-07439-001	2
57	Screw, M3x6 304 SS Skt Cap	*	31-23006-980	31-23006-980	5
58	Screw, M3x10 MS to AS1789 Fe/Zn12 Bk Skt	RGA Fasteners	HKCM3X10-BTZ-12	31-23010-901	4
59	Label, Serial/Barcode	Codan	06-02370	06-02370	1
60	Screw, M3x6 MS to AS1789 Fe/Zn12 Bk Skt	RGA Fasteners	HKCM3X6-BTZ-12	31-23006-901	3
61	Gasket, I/O Connector	Industrial Gaskets	06-02309	06-02309	1
62	Label, Codan 21x30	Entech	06-02181	06-02181	1
63	Flexible PCB, MIL Connect	Braemac	08-06139-001	08-06139-001	1
64	Screw, M3x8 304 SS Pan Pozi	RGA Fasteners	31-23008-580	31-23008-580	2
65	Label, WEEE 10x15mm White	Entech	06-02352-001	06-02352-001	1
66	Clip, 'P' 5,6mm Speed Clamp	Richco	RSC-3-01	30-05210-011	1
H1	LED, White 5mm 22000-31000mcd @ 20mA	Nichia	NSPW500CS-b1/b2-V	65-61110-701	1

08-06129-001 - Front Panel PCB

BOM Revision
Date Valid On

07 -- Production
17.06.2008

Ref	Description	Manufacturer	Manufacturer's P/N	Codan P/N	Qty
	MRS, Front Panel, 2110			01-01378	1
	Front Panel			04-03457	1
	Front Panel PCB			08-06129	1
	Front Panel PCB			11-06166	1
	TP, Front Panel, Test Setup 2110			10-01058	1
1	PCB, Front Panel	IMP	07-02029-04	07-02029-04	1
2	Label, Serial/Barcode	Codan	06-02068	06-02068	1
4	LCD Mount, Lower	Metalcraft	05-07444	05-07444	1
5	LCD Mount, Upper	Metalcraft	05-07443	05-07443	1
6	Backlight Module, LCD 60x33 No LED	Lumitex/Poly Optical		65-61190-001	1
C1	1u 10% 10V X7R 0805 NiSn	Phycomp	2222-240-15663	46-61000-281	1
C2	100n 10% 50V X7R 0805 Nisn	Philips	08052R104K9BB	46-51000-282	1
C3	1n 5% 25V NPO 0603 NiSn	AVX	06033A102JAT2A	46-31000-083	1
C4	1n 5% 25V NPO 0603 NiSn	AVX	06033A102JAT2A	46-31000-083	1
C5	100n 10% 16V X7R 0603 NiSn	Vitramon	VJ0603Y104KXJT	46-51000-283	1
C6	100n 10% 16V X7R 0603 NiSn	Vitramon	VJ0603Y104KXJT	46-51000-283	1
C7	1u 10% 10V X7R 0805 NiSn	Phycomp	2222-240-15663	46-61000-281	1
C8	100p 5% 50V NPO 0603 NiSn	Philips	0603CG101J9B200	46-21000-083	1
C9	100p 5% 50V NPO 0603 NiSn	Philips	0603CG101J9B200	46-21000-083	1
C10	33n 10% 25V X7R 0603 NiSn	Vitramon	VJ0603Y333KXXT	46-43300-282	1
C11	100n 10% 16V X7R 0603 NiSn	Vitramon	VJ0603Y104KXJT	46-51000-283	1
C12	560p 5% 50V NPO 0603 NiSn	Philips	0603CG561J9BB00	46-25600-080	1
C13	33n 10% 25V X7R 0603 NiSn	Vitramon	VJ0603Y333KXXT	46-43300-282	1
C14	33n 10% 25V X7R 0603 NiSn	Vitramon	VJ0603Y333KXXT	46-43300-282	1
C15	22p 5% 100V NPO 0603 NiSn	Philips	0603CG220J0B200	46-12200-083	1
C16	22p 5% 100V NPO 0603 NiSn	Philips	0603CG220J0B200	46-12200-083	1
C17	33n 10% 25V X7R 0603 NiSn	Vitramon	VJ0603Y333KXXT	46-43300-282	1
C18	33n 10% 25V X7R 0603 NiSn	Vitramon	VJ0603Y333KXXT	46-43300-282	1
C19	33n 10% 25V X7R 0603 NiSn	Vitramon	VJ0603Y333KXXT	46-43300-282	1
C20	33n 10% 25V X7R 0603 NiSn	Vitramon	VJ0603Y333KXXT	46-43300-282	1
C21	33n 10% 25V X7R 0603 NiSn	Vitramon	VJ0603Y333KXXT	46-43300-282	1
C22	100n 10% 16V X7R 0603 NiSn	Vitramon	VJ0603Y104KXJT	46-51000-283	1
C23	33n 10% 25V X7R 0603 NiSn	Vitramon	VJ0603Y333KXXT	46-43300-282	1
C24	47p 5% 50V NPO 0603 NiSn	Philips	0603CG470J9B200	46-14700-083	1
C25	100n 10% 16V X7R 0603 NiSn	Vitramon	VJ0603Y104KXJT	46-51000-283	1
C26	100n 10% 16V X7R 0603 NiSn	Vitramon	VJ0603Y104KXJT	46-51000-283	1
C27	100n 10% 16V X7R 0603 NiSn	Vitramon	VJ0603Y104KXJT	46-51000-283	1
C28	100n 10% 16V X7R 0603 NiSn	Vitramon	VJ0603Y104KXJT	46-51000-283	1
C29	100n 10% 16V X7R 0603 NiSn	Vitramon	VJ0603Y104KXJT	46-51000-283	1
C30	1u 10% 16V X7R 1206 NiSn	Philips	12062R105K7BB00	46-61000-280	1
C31	100n 10% 50V X7R 0805 Nisn	Philips	08052R104K9BB	46-51000-282	1
C32	22u 20% 16V 5846 TA Cap	NEC	NRT226M16R	47-12201-620	1
C33	33n 10% 25V X7R 0603 NiSn	Vitramon	VJ0603Y333KXXT	46-43300-282	1
C34	33n 10% 25V X7R 0603 NiSn	Vitramon	VJ0603Y333KXXT	46-43300-282	1
C35	33n 10% 25V X7R 0603 NiSn	Vitramon	VJ0603Y333KXXT	46-43300-282	1
C36	1p 0,25p 50V NPO 0603 NiSn	Philips	0603CG109C9BB00	46-01000-084	1
C37	100n 10% 16V X7R 0603 NiSn	Vitramon	VJ0603Y104KXJT	46-51000-283	1
C38	100n 10% 16V X7R 0603 NiSn	Vitramon	VJ0603Y104KXJT	46-51000-283	1
C39	100n 10% 16V X7R 0603 NiSn	Vitramon	VJ0603Y104KXJT	46-51000-283	1
C40	100n 10% 16V X7R 0603 NiSn	Vitramon	VJ0603Y104KXJT	46-51000-283	1
C41	100n 10% 16V X7R 0603 NiSn	Vitramon	VJ0603Y104KXJT	46-51000-283	1
C42	33n 10% 25V X7R 0603 NiSn	Vitramon	VJ0603Y333KXXT	46-43300-282	1
C43	33n 10% 25V X7R 0603 NiSn	Vitramon	VJ0603Y333KXXT	46-43300-282	1
C44	1n 5% 25V NPO 0603 NiSn	AVX	06033A102JAT2A	46-31000-083	1
C45	1n 5% 25V NPO 0603 NiSn	AVX	06033A102JAT2A	46-31000-083	1
C46	1n 5% 25V NPO 0603 NiSn	AVX	06033A102JAT2A	46-31000-083	1
C47	33n 10% 50V X7R 0805 NiSn	Philips	08052R333K9BB00	46-43300-281	1

08-06129-001 - Front Panel PCB

BOM Revision
Date Valid On

07 -- Production
17.06.2008

Ref	Description	Manufacturer	Manufacturer's P/N	Codan P/N	Qty
C48	390p 5% 50V NPO 0603 NiSn	Phycomp	0603CG391J9B200	46-23900-083	1
C49	390p 5% 50V NPO 0603 NiSn	Phycomp	0603CG391J9B200	46-23900-083	1
C50	390p 5% 50V NPO 0603 NiSn	Phycomp	0603CG391J9B200	46-23900-083	1
C51	390p 5% 50V NPO 0603 NiSn	Phycomp	0603CG391J9B200	46-23900-083	1
C52	1n 5% 25V NPO 0603 NiSn	AVX	06033A102JAT2A	46-31000-083	1
C53	1n 5% 25V NPO 0603 NiSn	AVX	06033A102JAT2A	46-31000-083	1
C54	1n 5% 25V NPO 0603 NiSn	AVX	06033A102JAT2A	46-31000-083	1
C55	1n 5% 25V NPO 0603 NiSn	AVX	06033A102JAT2A	46-31000-083	1
C56	1n 5% 25V NPO 0603 NiSn	AVX	06033A102JAT2A	46-31000-083	1
C57	1n 5% 25V NPO 0603 NiSn	AVX	06033A102JAT2A	46-31000-083	1
C58	1n 5% 25V NPO 0603 NiSn	AVX	06033A102JAT2A	46-31000-083	1
C59	33n 10% 25V X7R 0603 NiSn	Vitramon	VJ0603Y333KXXT	46-43300-282	1
C60	1n 5% 25V NPO 0603 NiSn	AVX	06033A102JAT2A	46-31000-083	1
C69	33n 10% 25V X7R 0603 NiSn	Vitramon	VJ0603Y333KXXT	46-43300-282	1
C70	100n 10% 16V X7R 0603 NiSn	Vitramon	VJ0603Y104KXJT	46-51000-283	1
C71	1n 5% 25V NPO 0603 NiSn	AVX	06033A102JAT2A	46-31000-083	1
C72	100n 10% 16V X7R 0603 NiSn	Vitramon	VJ0603Y104KXJT	46-51000-283	1
C73	100n 10% 16V X7R 0603 NiSn	Vitramon	VJ0603Y104KXJT	46-51000-283	1
C74	33n 10% 25V X7R 0603 NiSn	Vitramon	VJ0603Y333KXXT	46-43300-282	1
C75	1n 5% 25V NPO 0603 NiSn	AVX	06033A102JAT2A	46-31000-083	1
C77	1u 10% 10V X7R 0805 NiSn	Phycomp	2222-240-15663	46-61000-281	1
C78	1n 5% 25V NPO 0603 NiSn	AVX	06033A102JAT2A	46-31000-083	1
C79	1n 5% 25V NPO 0603 NiSn	AVX	06033A102JAT2A	46-31000-083	1
C80	33n 10% 25V X7R 0603 NiSn	Vitramon	VJ0603Y333KXXT	46-43300-282	1
C82	100n 10% 16V X7R 0603 NiSn	Vitramon	VJ0603Y104KXJT	46-51000-283	1
C83	33n 10% 25V X7R 0603 NiSn	Vitramon	VJ0603Y333KXXT	46-43300-282	1
C84	100n 10% 16V X7R 0603 NiSn	Vitramon	VJ0603Y104KXJT	46-51000-283	1
C85	100n 10% 16V X7R 0603 NiSn	Vitramon	VJ0603Y104KXJT	46-51000-283	1
C86	2,2u 20% 20V 3528 TA Cap	AVX	TAJB225M020R	47-02202-000	1
C87	2,2u 20% 20V 3528 TA Cap	AVX	TAJB225M020R	47-02202-000	1
C88	2,2u 20% 20V 3528 TA Cap	AVX	TAJB225M020R	47-02202-000	1
C89	2,2u 20% 20V 3528 TA Cap	AVX	TAJB225M020R	47-02202-000	1
C90	100n 10% 16V X7R 0603 NiSn	Vitramon	VJ0603Y104KXJT	46-51000-283	1
C91	100n 10% 16V X7R 0603 NiSn	Vitramon	VJ0603Y104KXJT	46-51000-283	1
C92	100n 10% 16V X7R 0603 NiSn	Vitramon	VJ0603Y104KXJT	46-51000-283	1
C93	100n 10% 16V X7R 0603 NiSn	Vitramon	VJ0603Y104KXJT	46-51000-283	1
C94	100n 10% 16V X7R 0603 NiSn	Vitramon	VJ0603Y104KXJT	46-51000-283	1
C95	33n 10% 25V X7R 0603 NiSn	Vitramon	VJ0603Y333KXXT	46-43300-282	1
C96	100n 10% 16V X7R 0603 NiSn	Vitramon	VJ0603Y104KXJT	46-51000-283	1
C97	2,2u 20% 20V 3528 TA Cap	AVX	TAJB225M020R	47-02202-000	1
C98	100n 10% 16V X7R 0603 NiSn	Vitramon	VJ0603Y104KXJT	46-51000-283	1
C99	100n 10% 16V X7R 0603 NiSn	Vitramon	VJ0603Y104KXJT	46-51000-283	1
C100	100n 10% 16V X7R 0603 NiSn	Vitramon	VJ0603Y104KXJT	46-51000-283	1
C101	10n 5% 50V PPS 1206 NiSn	Panasonic	ECHU1H103JB5	46-41000-900	1
C102	10n 5% 50V PPS 1206 NiSn	Panasonic	ECHU1H103JB5	46-41000-900	1
C103	10n 5% 50V PPS 1206 NiSn	Panasonic	ECHU1H103JB5	46-41000-900	1
C104	10n 5% 50V PPS 1206 NiSn	Panasonic	ECHU1H103JB5	46-41000-900	1
C105	270p 5% 50V NPO 0805 NiSn	Philips	0805CG271J9B200	46-22700-081	1
C106	2,2u 20% 20V 3528 TA Cap	AVX	TAJB225M020R	47-02202-000	1
C107	10n 5% 50V PPS 1206 NiSn	Panasonic	ECHU1H103JB5	46-41000-900	1
C108	10n 5% 50V PPS 1206 NiSn	Panasonic	ECHU1H103JB5	46-41000-900	1
C109	1n 5% 25V NPO 0603 NiSn	AVX	06033A102JAT2A	46-31000-083	1
C110	1n 5% 25V NPO 0603 NiSn	AVX	06033A102JAT2A	46-31000-083	1
C111	1n 5% 25V NPO 0603 NiSn	AVX	06033A102JAT2A	46-31000-083	1
C112	1n 5% 25V NPO 0603 NiSn	AVX	06033A102JAT2A	46-31000-083	1
C113	1n 5% 25V NPO 0603 NiSn	AVX	06033A102JAT2A	46-31000-083	1
C114	1n 5% 25V NPO 0603 NiSn	AVX	06033A102JAT2A	46-31000-083	1
C115	1n 5% 25V NPO 0603 NiSn	AVX	06033A102JAT2A	46-31000-083	1

08-06129-001 - Front Panel PCB

BOM Revision
Date Valid On

07 -- Production
17.06.2008

Ref	Description	Manufacturer	Manufacturer's P/N	Codan P/N	Qty
C116	1n 5% 25V NPO 0603 NiSn	AVX	06033A102JAT2A	46-31000-083	1
C117	1n 5% 25V NPO 0603 NiSn	AVX	06033A102JAT2A	46-31000-083	1
C118	1n 5% 25V NPO 0603 NiSn	AVX	06033A102JAT2A	46-31000-083	1
C119	100n 10% 50V X7R 0805 Nisn	Philips	08052R104K9BB	46-51000-282	1
C120	1n 5% 25V NPO 0603 NiSn	AVX	06033A102JAT2A	46-31000-083	1
C121	100n 10% 50V X7R 0805 Nisn	Philips	08052R104K9BB	46-51000-282	1
C122	47p 5% 50V NPO 0603 NiSn	Philips	0603CG470J9B200	46-14700-083	1
C123	47p 5% 50V NPO 0603 NiSn	Philips	0603CG470J9B200	46-14700-083	1
C124	47p 5% 50V NPO 0603 NiSn	Philips	0603CG470J9B200	46-14700-083	1
C125	Not Fitted	Codan	**00000-001	99-00000-001	1
C126	Not Fitted	Codan	**00000-001	99-00000-001	1
C127	Not Fitted	Codan	**00000-001	99-00000-001	1
C128	Not Fitted	Codan	**00000-001	99-00000-001	1
C129	Not Fitted	Codan	**00000-001	99-00000-001	1
C130	Not Fitted	Codan	**00000-001	99-00000-001	1
C131	Not Fitted	Codan	**00000-001	99-00000-001	1
C132	Not Fitted	Codan	**00000-001	99-00000-001	1
C133	47p 5% 50V NPO 0603 NiSn	Philips	0603CG470J9B200	46-14700-083	1
C134	47p 5% 50V NPO 0603 NiSn	Philips	0603CG470J9B200	46-14700-083	1
C135	47p 5% 50V NPO 0603 NiSn	Philips	0603CG470J9B200	46-14700-083	1
C137	560p 5% 50V NPO 0603 NiSn	Philips	0603CG561J9BB00	46-25600-080	1
D1	Diode, Si High speed 75V SOT23	Philips	BAS16	BAS16	1
D2	Diode, Si High speed 75V SOT23	Philips	BAS16	BAS16	1
D3	Diode, Si High speed 75V SOT23	Philips	BAS16	BAS16	1
D4	Diode, Si High speed 75V SOT23	Philips	BAS16	BAS16	1
D5	Diode, Schottky SOT23	Philips	BAT54	BAT54	1
D6	Diode, Si High speed 75V SOT23	Philips	BAS16	BAS16	1
D7	Diode, Schottky SOT23	Philips	BAT54	BAT54	1
D8	Diode, Schottky SOT23	Philips	BAT54	BAT54	1
D9	Diode, Schottky SOT23	Philips	BAT54	BAT54	1
D10	TVS, Bidirec 15V wkg SMB	SGS Thomson	SMBJ15CA-TR	SMBJ15CA-TR	1
D11	TVS, Bidirec 15V wkg SMB	SGS Thomson	SMBJ15CA-TR	SMBJ15CA-TR	1
D12	TVS, Bidirec 15V wkg SMB	SGS Thomson	SMBJ15CA-TR	SMBJ15CA-TR	1
D13	TVS, Bidirec 15V wkg SMB	SGS Thomson	SMBJ15CA-TR	SMBJ15CA-TR	1
D14	Diode, Schottky SOT23	Philips	BAT54	BAT54	1
D15	Diode, Si High speed 75V SOT23	Philips	BAS16	BAS16	1
D16	Diode, Si High speed 75V SOT23	Philips	BAS16	BAS16	1
D17	TVS, Bidirec 8,5V wkg SMB	SGS Thomson	SMBJ8,5CA-TR	SMBJ8,5CA-TR	1
H2	Display, 128x64 dot LCD 3,3V	Powertip	PE12864ARF-001-HC1	65-65000	1
IC1	Amp, Op Quad Rail-Rail I/O LowV TSSOP14	Texas Instruments	OPA4364AIPWT	XA-04364-700	1
IC2	Not Fitted	Codan	**00000-001	99-00000-001	1
IC3	Amp, Audio Power BTL 2W/4Ohm MSOP8	Texas Instruments	TPA0211DGN	TPA0211DGN	1
IC4	Latch, Octal T/State TSSOP20	ST Microelectronics	74LCX573TTR	YX-74573-700	1
IC5	Latch, Octal T/State TSSOP20	ST Microelectronics	74LCX573TTR	YX-74573-700	1
IC6	UART, Quad 64b FIFO 3-5V w/IrDA TQFP64	Exar	ST16C654IQ64	YK-16654-910	1
IC7	MUX, Analog, Dual DPDT 2-11V QFN16	Maxim	MAX4694EGE	YN-04694-800	1
IC8	Amp, Rail to Rail I/O SOT23-5	National Semiconduct	LMC7101BIM5X	XA-07101-700	1
IC9	Amp, Audio Power BTL 2W/4Ohm MSOP8	Texas Instruments	TPA0211DGN	TPA0211DGN	1
IC10	Tcvr, CAN bus 3,3v 1Mbps w/stby SOIC8	Texas Instruments	SN65HVD233D	YI-65233-700	1

08-06129-001 - Front Panel PCB

BOM Revision
Date Valid On

07 -- Production
17.06.2008

Ref	Description	Manufacturer	Manufacturer's P/N	Codan P/N	Qty
IC11	Tcvr, RS232 Dual 3-5V w/shutdown SSOP20	Sipex	SP3222EEA-L/TR	YI-03222-710	1
IC12	Comparator, Rail-Rail I/O LP SOT23-5	National Semiconduct	LMC7221AIM5	XD-07221-700	1
IC13	Amp, Rail to Rail I/O SOT23-5	National Semiconduct	LMC7101BIM5X	XA-07101-700	1
IC14	MUX, Analog, Dual DPDT 2-11V QFN16	Maxim	MAX4694EGE	YN-04694-800	1
IC15	Amp, Op Rail-Rail I/O Dual SOIC8	National Semiconduct	LMC6482IM	XA-06482-700	1
IC16	Pot, 50k Digital 32-Tap uMAX8	Maxim	MAX5160LEUA-T	YN-05160-700	1
IC17	Amp, Rail to Rail I/O SOT23-5	National Semiconduct	LMC7101BIM5X	XA-07101-700	1
IC18	Conv, Charge Pump Dbl/Inv 20mA uMAX8	Maxim	MAX865EUA-T	XB-00865-700	1
IC19	Amp, Op Rail-Rail I/O Dual SOIC8	National Semiconduct	LMC6482IM	XA-06482-700	1
IC20	MOSFET, High Side Switch 1,4A cont SOIC8	IR	IPS511G-TR	IPS511G	1
IC21	Amp, Rail to Rail I/O SOT23-5	National Semiconduct	LMC7101BIM5X	XA-07101-700	1
J1	Socket, 34way FPC ZIF 0,5mm Pitch SMD	Oupiin	2345-34TD2	60-00343-002	1
J2	Socket, 34way FPC ZIF 0,5mm Pitch SMD	Oupiin	2345-34TD2	60-00343-002	1
J3	Socket, 34way FPC ZIF 0,5mm Pitch SMD	Oupiin	2345-34TD2	60-00343-002	1
J4	Socket, 34way FPC ZIF 0,5mm Pitch SMD	Oupiin	2345-34TD2	60-00343-002	1
J5	Socket, 34way FPC ZIF 0,5mm Pitch SMD	Oupiin	2345-34TD2	60-00343-002	1
J6	Socket, 20way 2row SMD 2mm	Samtec	TLE-110-01-G-DV-A-P-TR	60-00203-001	1
J7	Not Fitted	Codan	**00000-001	99-00000-001	1
K1	Relay, 2C 9V Ltch SMD 2x579 Ohm	Matsushita	TQ2SL-L2-9V	64-21225-258	1
L1	Ind, 100uH 10% 4532	Taiyo Yuden	LEM 4532T101K	43-82100-134	1
L2	Ind, Common Mode 1.5A	Taiyo Yuden	CM05RA06	43-80000	1
L3	Choke, Common Mode (Data) SMD	Taiyo Yuden	CM04RC04	43-82470-000	1
L4	Choke, Common Mode (Data) SMD	Taiyo Yuden	CM04RC04	43-82470-000	1
L5	Ind, 100uH 10% 4532	Taiyo Yuden	LEM 4532T101K	43-82100-134	1
L6	Ind, 100uH 10% 4532	Taiyo Yuden	LEM 4532T101K	43-82100-134	1
L7	Choke, EMI/EMC 0A DC >1MHz 4516	Taiyo Yuden	FB-MJ4516HS111-T	43-90003	1
L8	Choke, EMI/EMC 0A DC >1MHz 4516	Taiyo Yuden	FB-MJ4516HS111-T	43-90003	1
P2	Header (P) 4way 2mm Latch Fixed	AMP	173981-4	60-00040-352	1
P3	Header (P) 4way 2mm Latch Fixed	AMP	173981-4	60-00040-352	1
P5	Header (P) 10way 1row 2mm SMD	Samtec	TMM110-01T-S-SM-P-TR	60-00100-005	1
P6	Header (P) 10way 1row 2mm SMD	Samtec	TMM110-01T-S-SM-P-TR	60-00100-005	1
R1	100k Ohm 5% 0,06W 0603	Philips	2322 702 60104	40-51000-121	1
R2	100k Ohm 5% 0,06W 0603	Philips	2322 702 60104	40-51000-121	1
R3	100k Ohm 5% 0,06W 0603	Philips	2322 702 60104	40-51000-121	1
R4	10k Ohm 5% 0,06W 0603	Philips	2322 702 60103	40-41000-121	1
R5	10k Ohm 5% 0,06W 0603	Philips	2322 702 60103	40-41000-121	1
R6	6,8k Ohm 5% 0,06W 0603	Philips	2322 702 60682	40-36800-121	1
R7	33k Ohm 5% 0,06W 0603	Philips	2322 702 60333	40-43300-121	1
R8	10k Ohm 5% 0,06W 0603	Philips	2322 702 60103	40-41000-121	1
R9	10k Ohm 5% 0,06W 0603	Philips	2322 702 60103	40-41000-121	1
R10	33k Ohm 5% 0,06W 0603	Philips	2322 702 60333	40-43300-121	1

08-06129-001 - Front Panel PCB

BOM Revision
Date Valid On

07 -- Production
17.06.2008

Ref	Description	Manufacturer	Manufacturer's P/N	Codan P/N	Qty
R11	22k Ohm 5% 0,06W 0603	Philips	2322 702 60223	40-42200-121	1
R12	22k Ohm 5% 0,06W 0603	Philips	2322 702 60223	40-42200-121	1
R13	22k Ohm 5% 0,06W 0603	Philips	2322 702 60223	40-42200-121	1
R14	22k Ohm 5% 0,06W 0603	Philips	2322 702 60223	40-42200-121	1
R15	10k Ohm 5% 0,06W 0603	Philips	2322 702 60103	40-41000-121	1
R16	10k Ohm 5% 0,06W 0603	Philips	2322 702 60103	40-41000-121	1
R17	100k Ohm 5% 0,06W 0603	Philips	2322 702 60104	40-51000-121	1
R18	10k Ohm 5% 0,06W 0603	Philips	2322 702 60103	40-41000-121	1
R19	330k Ohm 5% 0,06W 0603	Phycomp	2322 702 60334	40-53300-121	1
R20	100k Ohm 5% 0,06W 0603	Philips	2322 702 60104	40-51000-121	1
R21	10k Ohm 5% 0,06W 0603	Philips	2322 702 60103	40-41000-121	1
R22	100k Ohm 5% 0,06W 0603	Philips	2322 702 60104	40-51000-121	1
R23	33k Ohm 5% 0,06W 0603	Philips	2322 702 60333	40-43300-121	1
R24	47k Ohm 5% 0,06W 0603	Philips	2322 702 60473	40-44700-121	1
R25	68k Ohm 5% 0,06W 0603	Philips	2322 702 60683	40-46800-121	1
R26	270k Ohm 5% 0,06W 0603	Philips	2322 702 60274	40-52700-121	1
R27	100k Ohm 5% 0,06W 0603	Philips	2322 702 60104	40-51000-121	1
R28	100k Ohm 5% 0,06W 0603	Philips	2322 702 60104	40-51000-121	1
R29	100k Ohm 5% 0,06W 0603	Philips	2322 702 60104	40-51000-121	1
R30	100 Ohm 5% 0,06W 0603	Philips	2322 702 60101	40-21000-121	1
R31	100k Ohm 5% 0,06W 0603	Philips	2322 702 60104	40-51000-121	1
R32	33k Ohm 5% 0,06W 0603	Philips	2322 702 60333	40-43300-121	1
R33	33k Ohm 5% 0,06W 0603	Philips	2322 702 60333	40-43300-121	1
R34	33k Ohm 5% 0,06W 0603	Philips	2322 702 60333	40-43300-121	1
R35	33k Ohm 5% 0,06W 0603	Philips	2322 702 60333	40-43300-121	1
R36	33k Ohm 5% 0,06W 0603	Philips	2322 702 60333	40-43300-121	1
R37	33k Ohm 5% 0,06W 0603	Philips	2322 702 60333	40-43300-121	1
R38	33k Ohm 5% 0,06W 0603	Philips	2322 702 60333	40-43300-121	1
R39	33k Ohm 5% 0,06W 0603	Philips	2322 702 60333	40-43300-121	1
R40	330 Ohm 5% 0,06W 0603	Philips	2322 702 60331	40-23300-121	1
R41	330 Ohm 5% 0,06W 0603	Philips	2322 702 60331	40-23300-121	1
R42	330 Ohm 5% 0,06W 0603	Philips	2322 702 60331	40-23300-121	1
R43	330 Ohm 5% 0,06W 0603	Philips	2322 702 60331	40-23300-121	1
R44	100 Ohm 5% 0,06W 0603	Philips	2322 702 60101	40-21000-121	1
R45	100 Ohm 5% 0,06W 0603	Philips	2322 702 60101	40-21000-121	1
R46	33k Ohm 5% 0,06W 0603	Philips	2322 702 60333	40-43300-121	1
R47	1k Ohm 5% 0,06W 0603	Philips	2322 702 60102	40-31000-121	1
R48	2,2M Ohm 5% 0,06W 0603	Philips	2322 702 60225	40-62200-121	1
R49	220k Ohm 5% 0,06W 0603	Philips	2322 702 60224	40-52200-121	1
R50	100k Ohm 5% 0,06W 0603	Philips	2322 702 60104	40-51000-121	1
R51	220k Ohm 5% 0,06W 0603	Philips	2322 702 60224	40-52200-121	1
R52	1k Ohm 5% 0,06W 0603	Philips	2322 702 60102	40-31000-121	1
R53	1k Ohm 5% 0,06W 0603	Philips	2322 702 60102	40-31000-121	1
R54	100k Ohm 5% 0,06W 0603	Philips	2322 702 60104	40-51000-121	1
R55	0,1 Ohm nom 1,6A@20°C 16Vwkg SMD	Raychem	SMDH160	41-10010-000	1
R56	10k Ohm 5% 0,06W 0603	Philips	2322 702 60103	40-41000-121	1
R57	270 Ohm 5% 0,06W 0603	Philips	2322 702 60271	40-22700-121	1
R58	10k Ohm 5% 0,06W 0603	Philips	2322 702 60103	40-41000-121	1
R59	10k Ohm 5% 0,06W 0603	Philips	2322 702 60103	40-41000-121	1
R60	10k Ohm 5% 0,06W 0603	Philips	2322 702 60103	40-41000-121	1
R61	10k Ohm 5% 0,06W 0603	Philips	2322 702 60103	40-41000-121	1
R62	100 Ohm 5% 0,06W 0603	Philips	2322 702 60101	40-21000-121	1
R63	10k Ohm 5% 0,06W 0603	Philips	2322 702 60103	40-41000-121	1
R64	100 Ohm 5% 0,06W 0603	Philips	2322 702 60101	40-21000-121	1
R65	10k Ohm 5% 0,06W 0603	Philips	2322 702 60103	40-41000-121	1
R66	100 Ohm 5% 0,06W 0603	Philips	2322 702 60101	40-21000-121	1
R67	10k Ohm 5% 0,06W 0603	Philips	2322 702 60103	40-41000-121	1
R68	1k Ohm 5% 0,06W 0603	Philips	2322 702 60102	40-31000-121	1

08-06129-001 - Front Panel PCB

BOM Revision
Date Valid On

07 -- Production
17.06.2008

Ref	Description	Manufacturer	Manufacturer's P/N	Codan P/N	Qty
R69	22k Ohm 5% 0,06W 0603	Philips	2322 702 60223	40-42200-121	1
R71	22k Ohm 5% 0,06W 0603	Philips	2322 702 60223	40-42200-121	1
R72	22k Ohm 5% 0,06W 0603	Philips	2322 702 60223	40-42200-121	1
R73	10k Ohm 5% 0,06W 0603	Philips	2322 702 60103	40-41000-121	1
R74	10k Ohm 5% 0,06W 0603	Philips	2322 702 60103	40-41000-121	1
R75	15 Ohm 5% 0,05W 0603	Philips	2322-702-60159	40-11500-121	1
R76	100 Ohm 5% 0,06W 0603	Philips	2322 702 60101	40-21000-121	1
R77	100 Ohm 5% 0,06W 0603	Philips	2322 702 60101	40-21000-121	1
R78	100 Ohm 5% 0,06W 0603	Philips	2322 702 60101	40-21000-121	1
R79	15 Ohm 5% 0,05W 0603	Philips	2322-702-60159	40-11500-121	1
R80	330k Ohm 5% 0,06W 0603	Phycomp	2322 702 60334	40-53300-121	1
R81	10k Ohm 5% 0,06W 0603	Philips	2322 702 60103	40-41000-121	1
R82	33k Ohm 5% 0,06W 0603	Philips	2322 702 60333	40-43300-121	1
R83	33k Ohm 5% 0,06W 0603	Philips	2322 702 60333	40-43300-121	1
R84	33k Ohm 5% 0,06W 0603	Philips	2322 702 60333	40-43300-121	1
R85	33k Ohm 5% 0,06W 0603	Philips	2322 702 60333	40-43300-121	1
R86	33k Ohm 5% 0,06W 0603	Philips	2322 702 60333	40-43300-121	1
R87	10k Ohm 5% 0,06W 0603	Philips	2322 702 60103	40-41000-121	1
R88	100k Ohm 5% 0,06W 0603	Philips	2322 702 60104	40-51000-121	1
R89	10k Ohm 5% 0,06W 0603	Philips	2322 702 60103	40-41000-121	1
R90	1M Ohm 5% 0,06W 0603	Philips	2322 702 60105	40-61000-121	1
R91	1k Ohm 5% 0,06W 0603	Philips	2322 702 60102	40-31000-121	1
R92	10k Ohm 5% 0,06W 0603	Philips	2322 702 60103	40-41000-121	1
R93	1k Ohm 5% 0,06W 0603	Philips	2322 702 60102	40-31000-121	1
R94	10k Ohm 5% 0,06W 0603	Philips	2322 702 60103	40-41000-121	1
R95	22k Ohm 5% 0,06W 0603	Philips	2322 702 60223	40-42200-121	1
R96	47k Ohm 5% 0,06W 0603	Philips	2322 702 60473	40-44700-121	1
R97	1k Ohm 5% 0,06W 0603	Philips	2322 702 60102	40-31000-121	1
R98	1k Ohm 5% 0,06W 0603	Philips	2322 702 60102	40-31000-121	1
R99	10k Ohm 5% 0,06W 0603	Philips	2322 702 60103	40-41000-121	1
R100	10k Ohm 5% 0,06W 0603	Philips	2322 702 60103	40-41000-121	1
R101	1k Ohm 5% 0,06W 0603	Philips	2322 702 60102	40-31000-121	1
R102	1k Ohm 5% 0,06W 0603	Philips	2322 702 60102	40-31000-121	1
R103	10 Ohm 5% 0,06W 0603	Philips	2322 702 60109	40-11000-121	1
R104	6,8k Ohm 5% 0,06W 0603	Philips	2322 702 60682	40-36800-121	1
R105	3,3k Ohm 5% 0,06W 0603	Philips	2322 702 60332	40-33300-121	1
R106	3,3k Ohm 5% 0,06W 0603	Philips	2322 702 60332	40-33300-121	1
R107	18k Ohm 1% 0,06W 0603	Philips	2322 704 61803	40-41800-125	1
R108	18k Ohm 1% 0,06W 0603	Philips	2322 704 61803	40-41800-125	1
R109	18k Ohm 1% 0,06W 0603	Philips	2322 704 61803	40-41800-125	1
R110	18k Ohm 1% 0,06W 0603	Philips	2322 704 61803	40-41800-125	1
R111	4,7k Ohm 5% 0,06W 0603	Philips	2322 702 60472	40-34700-121	1
R112	10k Ohm 5% 0,06W 0603	Philips	2322 702 60103	40-41000-121	1
R113	470k Ohm 5% 0,06W 0603	Phycomp	2322 702 60474	40-54700-121	1
R114	10k Ohm 5% 0,06W 0603	Philips	2322 702 60103	40-41000-121	1
R115	10k Ohm 5% 0,06W 0603	Philips	2322 702 60103	40-41000-121	1
R116	330k Ohm 5% 0,06W 0603	Phycomp	2322 702 60334	40-53300-121	1
R117	33k Ohm 5% 0,06W 0603	Philips	2322 702 60333	40-43300-121	1
R118	330 Ohm 5% 0,06W 0603	Philips	2322 702 60331	40-23300-121	1
R119	100 Ohm 5% 0,06W 0603	Philips	2322 702 60101	40-21000-121	1
R120	100 Ohm 5% 0,06W 0603	Philips	2322 702 60101	40-21000-121	1
R121	470k Ohm 5% 0,06W 0603	Phycomp	2322 702 60474	40-54700-121	1
R122	10k Ohm 5% 0,06W 0603	Philips	2322 702 60103	40-41000-121	1
R123	10k Ohm 5% 0,06W 0603	Philips	2322 702 60103	40-41000-121	1
R124	150k Ohm 5% 0,06W 0603	Philips	2322 702 60154	40-51500-121	1
V1	Transistor, NPN Si SOT23	Philips	BC847	BC847	1
V2	Transistor, NPN Si SOT23	Philips	BC847	BC847	1
V3	Transistor, NPN Si SOT23	Philips	BC847	BC847	1

08-06129-001 - Front Panel PCB

BOM Revision
Date Valid On

07 -- Production
17.06.2008

Ref	Description	Manufacturer	Manufacturer's P/N	Codan P/N	Qty
V4	Transistor, NPN Si SOT23	Philips	BC847	BC847	1
V5	MOSFET, N Chan Enhance SOT23	Philips	BST82	BST82	1
V6	Transistor, NPN Si SOT23	Philips	BC847	BC847	1
V7	Transistor, NPN Si SOT23	Philips	BC847	BC847	1
V8	Transistor, NPN Si SOT23	Philips	BC847	BC847	1
V9	Transistor, NPN Si SOT23	Philips	BC847	BC847	1
V10	Transistor, NPN Si SOT23	Philips	BC847	BC847	1
V11	MOSFET, N Chan Enhance SOT23	Philips	BST82	BST82	1
V12	MOSFET, N Channel Enhanced SOT23	Fairchild	BSS138	BSS138	1
V13	MOSFET, N Channel Enhanced SOT23	Fairchild	BSS138	BSS138	1
Z1	Crystal, 3686,4 kHz uP Grade SMD	HY-Q	M/P QC49/SMD EBO1C	65-90101	1

08-06140-001 - Front Panel Sub Assy 2110/v, Black

BOM Revision
Date Valid On

07 -- Production
17.06.2008

Ref	Description	Manufacturer	Manufacturer's P/N	Codan P/N	Qty
	Front Panel Sub Assembly			08-06140	1
	Keypad, 2110			04-03459	1
	Front Panel Assembly			11-06209	1
	Sealing Test 2110			11-90411	1
1	PCB, Keypad 2110		07-02032-03	07-02032-03	1
2	Label, Serial/Barcode	Codan	06-02068	06-02068	1
3	Fastener, PCB M3	PEM	KFS2-M3	33-53004-001	2
4	Earth Tang	Metalcraft	05-07380	05-07380	4
5	Rivet, Pop Al Dome 2,4dx2,4mm	Tucker	TAP/D/33/BS	33-23124-024	5
7	Flexible PCB, Audio	Braemac	08-06146-001	08-06146-001	1
8	Speaker Assembly	Axiam Plastics	08-06197-001	08-06197-001	1
10	O-Ring, 15,1 ID x 1,6d nitrile	James Walker	72-0151-16 PB80	30-29011-506	1
11	O-Ring, 7,1 ID x 1,6d nitrile	James Walker	72-0071-16 PB80	30-29011-507	1
12	Spacer, Threaded Hex/Stud M3x8x5	PSM Fasteners	SPA-02-B-M3-8-5MMMALE	30-37007-017	5
14	Screw, M3x6 304 SS Pan Pozi	*	31-23006-580	31-23006-580	13
15	Socket, BNC Panel Water Proof Black	Srinar	V20-31-4238	60-12301	1
16	Compound, 100g Tube	Dow Corning	Molykote 111	71-31000-002	0.01
17	Grease, Contact	Electrotube	CG53A35SL	71-40004	0.01
18	Strip, Earth	Metalcraft	05-07457	05-07457	1
19	Gasket, Main	Ind Gaskets	06-02210	06-02210	1
20	Terminal, Panel, Thumb Screw Black M5	Gallard Trewin	05-07433	05-07433	1
21	Faceplate, 2110, Black	Axizm Plastics	06-02169-001	06-02169-001	1
22	Keymat, Numeric Front Panel	KEYFLEX	06-02170	06-02170	1
23	Keymat, Control Front Panel	KEYFLEX	06-02171	06-02171	1
25	Loom, Speaker	Auto Assemblies	08-06278-001	08-06278-001	1
29	Earth Tang, Connector	Metalcraft	05-07478	05-07478	1
C1	100n 10% 16V X7R 0603 NiSn	Vitramon	VJ0603Y104KXJT	46-51000-283	1
C2	10u 20% 10V X7R 1210 NiSn	Taiyo Yuden	LMK325BJ106MN	46-71000-280	1
H1	LED, White PLCC 180-355mCd Diffused	Osram	LW T673-S1T1-3C5D	65-61110-700	1
H2	LED, White PLCC 180-355mCd Diffused	Osram	LW T673-S1T1-3C5D	65-61110-700	1
H3	LED, White PLCC 180-355mCd Diffused	Osram	LW T673-S1T1-3C5D	65-61110-700	1
H4	LED, White PLCC 180-355mCd Diffused	Osram	LW T673-S1T1-3C5D	65-61110-700	1
H5	LED, White PLCC 180-355mCd Diffused	Osram	LW T673-S1T1-3C5D	65-61110-700	1
H6	LED, White PLCC 180-355mCd Diffused	Osram	LW T673-S1T1-3C5D	65-61110-700	1
H7	LED, White PLCC 180-355mCd Diffused	Osram	LW T673-S1T1-3C5D	65-61110-700	1
H8	LED, White PLCC 180-355mCd Diffused	Osram	LW T673-S1T1-3C5D	65-61110-700	1
H9	LED, White PLCC 180-355mCd Diffused	Osram	LW T673-S1T1-3C5D	65-61110-700	1
H10	LED, White PLCC 180-355mCd Diffused	Osram	LW T673-S1T1-3C5D	65-61110-700	1
H11	LED, White PLCC 180-355mCd Diffused	Osram	LW T673-S1T1-3C5D	65-61110-700	1
H12	LED, White PLCC 180-355mCd Diffused	Osram	LW T673-S1T1-3C5D	65-61110-700	1
H13	Tcvr, IrDA 115k2 bps Top-look SMD	Zilog	ZHX1820TV115THTR	Y1-01820-700	1
P1	Header (P) 20way 2row SMD 2mm Fixed	Samtec	TW-10-06-G-D-300-SM-A	60-00200-002	1
R1	10 Ohm 5% 0,06W 0603	Philips	2322 702 60109	40-11000-121	1
R2	10 Ohm 5% 0,06W 0603	Philips	2322 702 60109	40-11000-121	1
R3	10 Ohm 5% 0,06W 0603	Philips	2322 702 60109	40-11000-121	1
R4	10 Ohm 5% 0,06W 0603	Philips	2322 702 60109	40-11000-121	1
R5	10 Ohm 5% 0,06W 0603	Philips	2322 702 60109	40-11000-121	1
R6	10 Ohm 5% 0,06W 0603	Philips	2322 702 60109	40-11000-121	1
R7	10 Ohm 5% 0,06W 0603	Philips	2322 702 60109	40-11000-121	1

08-06128-001 - Audio & Control PCB

BOM Revision
Date Valid On

07 -- Production
17.06.2008

Ref	Description	Manufacturer	Manufacturer's P/N	Codan P/N	Qty
	TP, Audio & Control, Test Setup 2110			10-01059	1
	Audio & Control PCB			08-06128	1
	Audio & Control			04-03456	1
	Audio & Control PCB			11-06165	1
	S/W mstr assy for 90-20627-201 ver 4.91			90-30627-201	1
	S/W mstr assy for 90-20627-001 ver 4.91			90-30627-001	1
	MRS, Audio & Control, 2110			01-01377	1
1	PCB, Audio & Control		07-02028-03	07-02028-03	1
2	Label, Serial/Barcode	Codan	06-02068	06-02068	1
3	Tape, EPDM Rubber foam 12mmx3mm	Beirsdorf	TESA 61102	30-39301-002	25
4	Sleeve, Sil Rubber 6x0,5 Any Col	Jones Stroud	71-80605-199	71-80605-199	0.01
5	Screen, Aud&Cntrl, 30x42x8	Metalcraft	05-07408	05-07408	1
6	Label, 28 pin DIL 0.6 IC	Copyhouse	06-01331	06-01331	2
C101	100p 5% 50V NPO 0603 NiSn	Philips	0603CG101J9B200	46-21000-083	1
C102	100p 5% 50V NPO 0603 NiSn	Philips	0603CG101J9B200	46-21000-083	1
C103	100p 5% 50V NPO 0603 NiSn	Philips	0603CG101J9B200	46-21000-083	1
C104	100p 5% 50V NPO 0603 NiSn	Philips	0603CG101J9B200	46-21000-083	1
C105	100p 5% 50V NPO 0603 NiSn	Philips	0603CG101J9B200	46-21000-083	1
C106	100p 5% 50V NPO 0603 NiSn	Philips	0603CG101J9B200	46-21000-083	1
C107	100p 5% 50V NPO 0603 NiSn	Philips	0603CG101J9B200	46-21000-083	1
C108	100p 5% 50V NPO 0603 NiSn	Philips	0603CG101J9B200	46-21000-083	1
C109	100p 5% 50V NPO 0603 NiSn	Philips	0603CG101J9B200	46-21000-083	1
C110	33n 10% 25V X7R 0603 NiSn	Vitramon	VJ0603Y333KXXT	46-43300-282	1
C111	100n 10% 16V X7R 0603 NiSn	Vitramon	VJ0603Y104KXJT	46-51000-283	1
C112	100n 10% 16V X7R 0603 NiSn	Vitramon	VJ0603Y104KXJT	46-51000-283	1
C113	33n 10% 25V X7R 0603 NiSn	Vitramon	VJ0603Y333KXXT	46-43300-282	1
C114	100u 25V 105°C SMD EL Cap Low ESR	Nippon Chemicon	MVY25VC100MF80	48-21002-502	1
C115	1n 5% 25V NPO 0603 NiSn	AVX	06033A102JAT2A	46-31000-083	1
C116	33n 10% 25V X7R 0603 NiSn	Vitramon	VJ0603Y333KXXT	46-43300-282	1
C117	100n 10% 16V X7R 0603 NiSn	Vitramon	VJ0603Y104KXJT	46-51000-283	1
C118	10n 5% 50V X7R 0603 NiSn	Philips	06032R103J9BB00	46-41000-080	1
C119	10u 20% 10V X7R 1210 NiSn	Taiyo Yuden	LMK325BJ106MN	46-71000-280	1
C120	10u 20% 10V X7R 1210 NiSn	Taiyo Yuden	LMK325BJ106MN	46-71000-280	1
C121	100u 20% 16V 7343H TA Cap Low ESR	AVX	TPSE107M016R0100	47-21001-600	1
C122	10u 20% 10V X7R 1210 NiSn	Taiyo Yuden	LMK325BJ106MN	46-71000-280	1
C123	220p 5% 50V NPO 0603 NiSn	Philips	0603CG221C9BB00	46-22200-083	1
C124	100n 10% 16V X7R 0603 NiSn	Vitramon	VJ0603Y104KXJT	46-51000-283	1
C125	1n 5% 25V NPO 0603 NiSn	AVX	06033A102JAT2A	46-31000-083	1
C126	1u 10% 10V X7R 0805 NiSn	Phycomp	2222-240-15663	46-61000-281	1
C127	100n 10% 16V X7R 0603 NiSn	Vitramon	VJ0603Y104KXJT	46-51000-283	1
C128	330p 5% 50V NPO 0603 NiSn	Phycomp	0603CG331J9B200	46-23300-083	1
C129	10u 20% 10V X7R 1210 NiSn	Taiyo Yuden	LMK325BJ106MN	46-71000-280	1
C130	100n 10% 16V X7R 0603 NiSn	Vitramon	VJ0603Y104KXJT	46-51000-283	1
C131	100n 10% 16V X7R 0603 NiSn	Vitramon	VJ0603Y104KXJT	46-51000-283	1
C132	100n 10% 16V X7R 0603 NiSn	Vitramon	VJ0603Y104KXJT	46-51000-283	1
C133	100n 10% 16V X7R 0603 NiSn	Vitramon	VJ0603Y104KXJT	46-51000-283	1
C134	1u 10% 10V X7R 0805 NiSn	Phycomp	2222-240-15663	46-61000-281	1
C135	10u 20% 10V X7R 1210 NiSn	Taiyo Yuden	LMK325BJ106MN	46-71000-280	1
C136	1u 10% 10V X7R 0805 NiSn	Phycomp	2222-240-15663	46-61000-281	1
C137	100n 10% 16V X7R 0603 NiSn	Vitramon	VJ0603Y104KXJT	46-51000-283	1
C138	820p 5% 50V NPO 0805 NiSn	Philips	0805CG821J9B200	46-28200-081	1
C139	33n 10% 25V X7R 0603 NiSn	Vitramon	VJ0603Y333KXXT	46-43300-282	1
C140	100n 10% 16V X7R 0603 NiSn	Vitramon	VJ0603Y104KXJT	46-51000-283	1
C141	1n 5% 25V NPO 0603 NiSn	AVX	06033A102JAT2A	46-31000-083	1
C142	3,3n 10% 100V X7R 0603 NiSn	Vishay	VJ0603Y332KXBAC	46-33300-282	1
C143	33n 10% 25V X7R 0603 NiSn	Vitramon	VJ0603Y333KXXT	46-43300-282	1

08-06128-001 - Audio & Control PCB

BOM Revision
Date Valid On

07 -- Production
17.06.2008

Ref	Description	Manufacturer	Manufacturer's P/N	Codan P/N	Qty
C144	1u 10% 10V X7R 0805 NiSn	Phycomp	2222-240-15663	46-61000-281	1
C145	1u 10% 10V X7R 0805 NiSn	Phycomp	2222-240-15663	46-61000-281	1
C146	Not Fitted	Codan	**--00000-001	99-00000-001	1
C147	10u 20% 10V X7R 1210 NiSn	Taiyo Yuden	LMK325BJ106MN	46-71000-280	1
C148	100n 10% 16V X7R 0603 NiSn	Vitramon	VJ0603Y104KXJT	46-51000-283	1
C149	100n 10% 16V X7R 0603 NiSn	Vitramon	VJ0603Y104KXJT	46-51000-283	1
C150	1n 5% 25V NPO 0603 NiSn	AVX	06033A102JAT2A	46-31000-083	1
C151	100n 10% 16V X7R 0603 NiSn	Vitramon	VJ0603Y104KXJT	46-51000-283	1
C152	100n 10% 16V X7R 0603 NiSn	Vitramon	VJ0603Y104KXJT	46-51000-283	1
C153	100n 10% 16V X7R 0603 NiSn	Vitramon	VJ0603Y104KXJT	46-51000-283	1
C154	100n 10% 16V X7R 0603 NiSn	Vitramon	VJ0603Y104KXJT	46-51000-283	1
C155	100n 10% 16V X7R 0603 NiSn	Vitramon	VJ0603Y104KXJT	46-51000-283	1
C156	100n 10% 16V X7R 0603 NiSn	Vitramon	VJ0603Y104KXJT	46-51000-283	1
C157	1n 5% 25V NPO 0603 NiSn	AVX	06033A102JAT2A	46-31000-083	1
C158	100n 10% 16V X7R 0603 NiSn	Vitramon	VJ0603Y104KXJT	46-51000-283	1
C159	10n 5% 50V X7R 0603 NiSn	Philips	06032R103J9BB00	46-41000-080	1
C160	10n 5% 50V X7R 0603 NiSn	Philips	06032R103J9BB00	46-41000-080	1
C161	100n 10% 16V X7R 0603 NiSn	Vitramon	VJ0603Y104KXJT	46-51000-283	1
C162	100n 10% 16V X7R 0603 NiSn	Vitramon	VJ0603Y104KXJT	46-51000-283	1
C163	1n 5% 25V NPO 0603 NiSn	AVX	06033A102JAT2A	46-31000-083	1
C201	15p 5% 50V NPO 0603 NiSn	Philips	0603CG150C9BB00	46-11500-083	1
C202	15p 5% 50V NPO 0603 NiSn	Philips	0603CG150C9BB00	46-11500-083	1
C203	10n 10% 100V X7R 0805 NiSn	Philips	08052R103K0B200	46-41000-281	1
C204	100n 10% 50V X7R 0805 NiSn	Philips	08052R104K9BB	46-51000-282	1
C205	100n 10% 16V X7R 0603 NiSn	Vitramon	VJ0603Y104KXJT	46-51000-283	1
C206	100n 10% 16V X7R 0603 NiSn	Vitramon	VJ0603Y104KXJT	46-51000-283	1
C207	100n 10% 16V X7R 0603 NiSn	Vitramon	VJ0603Y104KXJT	46-51000-283	1
C208	100n 10% 16V X7R 0603 NiSn	Vitramon	VJ0603Y104KXJT	46-51000-283	1
C209	100n 10% 16V X7R 0603 NiSn	Vitramon	VJ0603Y104KXJT	46-51000-283	1
C210	100n 10% 16V X7R 0603 NiSn	Vitramon	VJ0603Y104KXJT	46-51000-283	1
C211	100n 10% 16V X7R 0603 NiSn	Vitramon	VJ0603Y104KXJT	46-51000-283	1
C212	100n 10% 16V X7R 0603 NiSn	Vitramon	VJ0603Y104KXJT	46-51000-283	1
C213	100n 10% 16V X7R 0603 NiSn	Vitramon	VJ0603Y104KXJT	46-51000-283	1
C214	100n 10% 16V X7R 0603 NiSn	Vitramon	VJ0603Y104KXJT	46-51000-283	1
C215	100n 10% 16V X7R 0603 NiSn	Vitramon	VJ0603Y104KXJT	46-51000-283	1
C216	100n 10% 16V X7R 0603 NiSn	Vitramon	VJ0603Y104KXJT	46-51000-283	1
C217	100n 10% 16V X7R 0603 NiSn	Vitramon	VJ0603Y104KXJT	46-51000-283	1
C218	100n 10% 16V X7R 0603 NiSn	Vitramon	VJ0603Y104KXJT	46-51000-283	1
C219	100n 10% 16V X7R 0603 NiSn	Vitramon	VJ0603Y104KXJT	46-51000-283	1
C220	100n 10% 16V X7R 0603 NiSn	Vitramon	VJ0603Y104KXJT	46-51000-283	1
C222	100n 10% 16V X7R 0603 NiSn	Vitramon	VJ0603Y104KXJT	46-51000-283	1
C223	100n 10% 16V X7R 0603 NiSn	Vitramon	VJ0603Y104KXJT	46-51000-283	1
C225	100n 10% 16V X7R 0603 NiSn	Vitramon	VJ0603Y104KXJT	46-51000-283	1
C301	10u 20% 20V 3528 TA Cap	AVX	TAJB106M020R	47-11002-000	1
C302	100n 10% 16V X7R 0603 NiSn	Vitramon	VJ0603Y104KXJT	46-51000-283	1
C303	100n 10% 16V X7R 0603 NiSn	Vitramon	VJ0603Y104KXJT	46-51000-283	1
C304	100n 10% 16V X7R 0603 NiSn	Vitramon	VJ0603Y104KXJT	46-51000-283	1
C305	100n 10% 16V X7R 0603 NiSn	Vitramon	VJ0603Y104KXJT	46-51000-283	1
C306	100n 10% 16V X7R 0603 NiSn	Vitramon	VJ0603Y104KXJT	46-51000-283	1
C307	100n 10% 16V X7R 0603 NiSn	Vitramon	VJ0603Y104KXJT	46-51000-283	1
C308	100n 10% 16V X7R 0603 NiSn	Vitramon	VJ0603Y104KXJT	46-51000-283	1
C309	100n 10% 16V X7R 0603 NiSn	Vitramon	VJ0603Y104KXJT	46-51000-283	1
C310	100n 10% 16V X7R 0603 NiSn	Vitramon	VJ0603Y104KXJT	46-51000-283	1
C311	10n 5% 50V X7R 0603 NiSn	Philips	06032R103J9BB00	46-41000-080	1
C312	1u 10% 10V X7R 0805 NiSn	Phycomp	2222-240-15663	46-61000-281	1
C313	100n 10% 16V X7R 0603 NiSn	Vitramon	VJ0603Y104KXJT	46-51000-283	1
C314	10n 5% 50V X7R 0603 NiSn	Philips	06032R103J9BB00	46-41000-080	1
C315	100n 10% 16V X7R 0603 NiSn	Vitramon	VJ0603Y104KXJT	46-51000-283	1

08-06128-001 - Audio & Control PCB

BOM Revision
Date Valid On

07 -- Production
17.06.2008

Ref	Description	Manufacturer	Manufacturer's P/N	Codan P/N	Qty
C316	100n 10% 16V X7R 0603 NiSn	Vitramon	VJ0603Y104KXJT	46-51000-283	1
C317	100n 10% 16V X7R 0603 NiSn	Vitramon	VJ0603Y104KXJT	46-51000-283	1
C318	100n 10% 16V X7R 0603 NiSn	Vitramon	VJ0603Y104KXJT	46-51000-283	1
C319	100n 10% 16V X7R 0603 NiSn	Vitramon	VJ0603Y104KXJT	46-51000-283	1
C320	100n 10% 16V X7R 0603 NiSn	Vitramon	VJ0603Y104KXJT	46-51000-283	1
C321	100n 10% 16V X7R 0603 NiSn	Vitramon	VJ0603Y104KXJT	46-51000-283	1
C322	100n 10% 16V X7R 0603 NiSn	Vitramon	VJ0603Y104KXJT	46-51000-283	1
C323	100n 10% 16V X7R 0603 NiSn	Vitramon	VJ0603Y104KXJT	46-51000-283	1
C324	100n 10% 16V X7R 0603 NiSn	Vitramon	VJ0603Y104KXJT	46-51000-283	1
C325	100n 10% 16V X7R 0603 NiSn	Vitramon	VJ0603Y104KXJT	46-51000-283	1
C326	100n 10% 16V X7R 0603 NiSn	Vitramon	VJ0603Y104KXJT	46-51000-283	1
C327	100n 10% 16V X7R 0603 NiSn	Vitramon	VJ0603Y104KXJT	46-51000-283	1
C328	100n 10% 16V X7R 0603 NiSn	Vitramon	VJ0603Y104KXJT	46-51000-283	1
C329	100n 10% 16V X7R 0603 NiSn	Vitramon	VJ0603Y104KXJT	46-51000-283	1
C330	100n 10% 16V X7R 0603 NiSn	Vitramon	VJ0603Y104KXJT	46-51000-283	1
C331	33n 10% 25V X7R 0603 NiSn	Vitramon	VJ0603Y333KXJT	46-43300-282	1
C332	100n 10% 16V X7R 0603 NiSn	Vitramon	VJ0603Y104KXJT	46-51000-283	1
D101	Diode, Si High speed 75V SOT23	Philips	BAS16	BAS16	1
D102	Diode, Schottky 40V 1A SMA	Taiwan Semiconductor	SS14	MBRA140T3	1
D103	Diode, Si High speed 75V SOT23	Philips	BAS16	BAS16	1
D104	Diode, Si High speed 75V SOT23	Philips	BAS16	BAS16	1
D105	Diode, Schottky 40V 1A SMA	Taiwan Semiconductor	SS14	MBRA140T3	1
D106	Diode, Si High speed 75V SOT23	Philips	BAS16	BAS16	1
D107	Diode, Si High speed 75V SOT23	Philips	BAS16	BAS16	1
D108	Diode, Si High speed 75V SOT23	Philips	BAS16	BAS16	1
D109	Diode, Schottky 40V 1A SMA	Taiwan Semiconductor	SS14	MBRA140T3	1
D110	Diode, Si High speed 75V SOT23	Philips	BAS16	BAS16	1
D111	Diode, Si High speed 75V SOT23	Philips	BAS16	BAS16	1
D301	Diode, Switching Dual SOT23	Philips	BAS31	BAS31	1
D302	Diode, Switching Dual SOT23	Philips	BAS31	BAS31	1
G101	Cell, Lithium 3V, 35mAh PCB Mtg	National Semiconduct	BR1225-1VB	65-71000-002	1
H301	LED, Red Ultra High 1206	Apex Science	RY-SP350UDR	65-61110-219	1
H302	LED, Red Ultra High 1206	Apex Science	RY-SP350UDR	65-61110-219	1
IC101	Amp, Op Rail to Rail I/O SOT23-6	National Semiconduct	LMV711M6	XA-00711-700	1
IC102	Amp, Op Rail to Rail I/O SOT23-6	National Semiconduct	LMV711M6	XA-00711-700	1
IC103	Clock/Calendar/RAM IIC Bus SOIC8	SGS Thomson	MK41T56S00TR	YK-04156-700	1
IC104	Micro prgmd, Audio & Ctrl	Codan	90-20628-001	90-20628-001	1
IC105	Conv, Boost +5V 1,5A Switch QFN10	Texas Instruments	TPS61027DRC	XB-61027-800	1
IC106	Reg, Dual Step-Down 1,4A 1,1MHz TSSOP16	Linear Tech	LT1940EFE	XB-01940-700	1
IC107	Amp, Op Rail to Rail I/O SOT23-6	National Semiconduct	LMV711M6	XA-00711-700	1
IC108	Amp, Op Rail to Rail I/O SOT23-6	National Semiconduct	LMV711M6	XA-00711-700	1
IC109	Comparator, Rail-Rail I/O LP SOT23-5	National Semiconduct	LMC7221AIM5	XD-07221-700	1
IC110	Amp, Rail to Rail I/O SOT23-5	National Semiconduct	LMC7101BIM5X	XA-07101-700	1
IC111	Comparator, Rail-Rail I/O LP SOT23-5	National Semiconduct	LMC7221AIM5	XD-07221-700	1

08-06128-001 - Audio & Control PCB

BOM Revision
Date Valid On

07 -- Production
17.06.2008

Ref	Description	Manufacturer	Manufacturer's P/N	Codan P/N	Qty
IC112	Comparator, Rail-Rail I/O LP SOT23-5	National Semiconduct	LMC7221AIM5	XD-07221-700	1
IC113	Comparator, Rail-Rail I/O LP SOT23-5	National Semiconduct	LMC7221AIM5	XD-07221-700	1
IC201	Serial Number, 48 bit SOT223	Dallas	DS2401Z	YM-02401-700	1
IC202	DSP, 32 Bit Filtnng Point 60MIPS LQFP144	Texas Instruments	TMS320VC33PGE120	YP-32033-900	1
IC203	Flash, 1Mx16 Bit 3V 70ns TSOP48	STMicroelectronic s	M29W160DB70N1T	YM-29160-700	1
IC204	Flash, 1Mx16 Bit 3V 70ns TSOP48	STMicroelectronic s	M29W160DB70N1T	YM-29160-700	1
IC205	RAM, CMOS 512kx16Bit 55ns 3V TSOP2-44	Samsung	K6X8016T3B-UF55T	YM-16512-710	1
IC206	RAM, CMOS 512kx16Bit 55ns 3V TSOP2-44	Samsung	K6X8016T3B-UF55T	YM-16512-710	1
IC207	Flash 1Mx8bit/512k x16bit 3V 70ns TSOP48	AMD	AM29LV800BB-70EI	YM-29800-710	1
IC301	CPLD prgmd, Audio & Ctrl	Memec	90-20629-001	90-20629-001	1
IC302	Codec, Dual 16 Bit 26KSPS Low Pwr TQFP48	Texas Instruments	TLV320AIC24I	YN-32024-910	1
IC303	Buffer, Dual Bus T/State VSSOP8	Texas Instruments	SN74LVC2G125DCUT	YX-74125-700	1
J101	Socket, 16way 1row ZIF 1mm Pitch SMD	Global Shine	GS008-16-G-1	60-00163-004	1
J102	Header (P) 4way 2mm Latch Fixed	AMP	173981-4	60-00040-352	1
J301	Socket, 34way FPC ZIF 0,5mm Pitch SMD	Oupiin	2345-34TD2	60-00343-002	1
J302	Socket, 34way FPC ZIF 0,5mm Pitch SMD	Oupiin	2345-34TD2	60-00343-002	1
K101	Relay, 2C 9V Ltch SMD 2x579 Ohm	Matsushita	TQ2SL-L2-9V	64-21225-258	1
L101	Ind, Common Mode 1.5A	Taiyo Yuden	CM05RA06	43-80000	1
L102	Ind, Common Mode 1.5A	Taiyo Yuden	CM05RA06	43-80000	1
L103	Ind, 4,7uH 20% 1,1A 1812 Shielded	Coilcraft	1812PS-472MC	43-80470-004	1
L104	Ind, 4,7uH 20% 1,1A 1812 Shielded	Coilcraft	1812PS-472MC	43-80470-004	1
L105	Ind, Common Mode 1.5A	Taiyo Yuden	CM05RA06	43-80000	1
L106	Choke, EMI/EMC 0A DC >1MHz 4516	Taiyo Yuden	FB-MJ4516HS111-T	43-90003	1
L107	Choke, EMI/EMC 0A DC >1MHz 4516	Taiyo Yuden	FB-MJ4516HS111-T	43-90003	1
L108	Choke, EMI/EMC 0A DC >1MHz 4516	Taiyo Yuden	FB-MJ4516HS111-T	43-90003	1
L109	Choke, EMI/EMC 0A DC >1MHz 4516	Taiyo Yuden	FB-MJ4516HS111-T	43-90003	1
L110	Choke, EMI/EMC 0A DC >1MHz 4516	Taiyo Yuden	FB-MJ4516HS111-T	43-90003	1
L111	Choke, EMI/EMC 0A DC >1MHz 4516	Taiyo Yuden	FB-MJ4516HS111-T	43-90003	1
L112	Choke, EMI/EMC 0A DC >1MHz 4516	Taiyo Yuden	FB-MJ4516HS111-T	43-90003	1
L113	Choke, EMI/EMC 0A DC >1MHz 4516	Taiyo Yuden	FB-MJ4516HS111-T	43-90003	1
L114	Choke, EMI/EMC 0A DC >1MHz 4516	Taiyo Yuden	FB-MJ4516HS111-T	43-90003	1
L115	Choke, EMI/EMC 0A DC >1MHz 4516	Taiyo Yuden	FB-MJ4516HS111-T	43-90003	1
L116	Choke, EMI/EMC 0A DC >1MHz 4516	Taiyo Yuden	FB-MJ4516HS111-T	43-90003	1

08-06128-001 - Audio & Control PCB

BOM Revision
Date Valid On

07 -- Production
17.06.2008

Ref	Description	Manufacturer	Manufacturer's P/N	Codan P/N	Qty
L117	Choke, EMI/EMC 0A DC >1MHz 4516	Taiyo Yuden	FB-MJ4516HS111-T	43-90003	1
L118	Choke, EMI/EMC 0A DC >1MHz 4516	Taiyo Yuden	FB-MJ4516HS111-T	43-90003	1
L119	Choke, EMI/EMC 0A DC >1MHz 4516	Taiyo Yuden	FB-MJ4516HS111-T	43-90003	1
L120	Ind, 4,7uH 20% 1,1A 1812 Shielded	Coilcraft	1812PS-472MC	43-80470-004	1
L301	Ind, 100uH 10% 4532	Taiyo Yuden	LEM 4532T101K	43-82100-134	1
L302	Choke, EMI/EMC 0A DC >1MHz 4516	Taiyo Yuden	FB-MJ4516HS111-T	43-90003	1
P101	Header (P) 16way 2row Boxed SMD 2,54mm	Neltron	2316SMD-16G	60-00160-003	1
P102	Header (P) 10way 2row Boxed SMD 2,54mm	Neltron	2316SM-10G	60-00100-004	1
P103	Header (P) 16way 2row Boxed SMD 2,54mm	Neltron	2316SMD-16G	60-00160-003	1
P105	Not Fitted	Codan	**00000-001	99-00000-001	1
P201	Not Fitted	Codan	**00000-001	99-00000-001	1
P202	Header (P) 8way 2mm Latch Fixed	AMP	292161-8	60-00080-001	1
P301	Not Fitted	Codan	**00000-001	99-00000-001	1
R101	33 Ohm 5% 0,06W 0603	Philips	2322 702 60339	40-13300-121	1
R102	1k Ohm 5% 0,06W 0603	Philips	2322 702 60102	40-31000-121	1
R103	33 Ohm 5% 0,06W 0603	Philips	2322 702 60339	40-13300-121	1
R104	1k Ohm 5% 0,06W 0603	Philips	2322 702 60102	40-31000-121	1
R105	1k Ohm 5% 0,06W 0603	Philips	2322 702 60102	40-31000-121	1
R106	1k Ohm 5% 0,06W 0603	Philips	2322 702 60102	40-31000-121	1
R107	1M Ohm 5% 0,06W 0603	Philips	2322 702 60105	40-61000-121	1
R108	33 Ohm 5% 0,06W 0603	Philips	2322 702 60339	40-13300-121	1
R109	1k Ohm 5% 0,06W 0603	Philips	2322 702 60102	40-31000-121	1
R110	33 Ohm 5% 0,06W 0603	Philips	2322 702 60339	40-13300-121	1
R111	1k Ohm 5% 0,06W 0603	Philips	2322 702 60102	40-31000-121	1
R112	33 Ohm 5% 0,06W 0603	Philips	2322 702 60339	40-13300-121	1
R113	1k Ohm 5% 0,06W 0603	Philips	2322 702 60102	40-31000-121	1
R114	33 Ohm 5% 0,06W 0603	Philips	2322 702 60339	40-13300-121	1
R115	1k Ohm 5% 0,06W 0603	Philips	2322 702 60102	40-31000-121	1
R116	10k Ohm 5% 0,06W 0603	Philips	2322 702 60103	40-41000-121	1
R117	10k Ohm 5% 0,06W 0603	Philips	2322 702 60103	40-41000-121	1
R118	22k Ohm 5% 0,06W 0603	Philips	2322 702 60223	40-42200-121	1
R119	22k Ohm 5% 0,06W 0603	Philips	2322 702 60223	40-42200-121	1
R120	1k Ohm 5% 0,06W 0603	Philips	2322 702 60102	40-31000-121	1
R121	100k Ohm 5% 0,06W 0603	Philips	2322 702 60104	40-51000-121	1
R122	100k Ohm 5% 0,06W 0603	Philips	2322 702 60104	40-51000-121	1
R123	10k Ohm 5% 0,06W 0603	Philips	2322 702 60103	40-41000-121	1
R124	10k Ohm 5% 0,06W 0603	Philips	2322 702 60103	40-41000-121	1
R127	10 Ohm 5% 0,06W 0603	Philips	2322 702 60109	40-11000-121	1
R128	10k Ohm 5% 0,06W 0603	Philips	2322 702 60103	40-41000-121	1
R129	10k Ohm 5% 0,06W 0603	Philips	2322 702 60103	40-41000-121	1
R130	560 Ohm 5% 0,06W 0603	Philips	2322 702 60561	40-25600-121	1
R131	22k Ohm 5% 0,06W 0603	Philips	2322 702 60223	40-42200-121	1
R132	22k Ohm 5% 0,06W 0603	Philips	2322 702 60223	40-42200-121	1
R133	15k Ohm 5% 0,06W 0603	Philips	2322 702 60153	40-41500-121	1
R134	10k Ohm 5% 0,06W 0603	Philips	2322 702 60103	40-41000-121	1
R135	33k Ohm 5% 0,06W 0603	Philips	2322 702 60333	40-43300-121	1
R136	33k Ohm 5% 0,06W 0603	Philips	2322 702 60333	40-43300-121	1
R137	100k Ohm 5% 0,06W 0603	Philips	2322 702 60104	40-51000-121	1
R138	10k Ohm 5% 0,06W 0603	Philips	2322 702 60103	40-41000-121	1
R139	33k Ohm 5% 0,06W 0603	Philips	2322 702 60333	40-43300-121	1
R140	10k Ohm 5% 0,06W 0603	Philips	2322 702 60103	40-41000-121	1

08-06128-001 - Audio & Control PCB

BOM Revision
Date Valid On

07 -- Production
17.06.2008

Ref	Description	Manufacturer	Manufacturer's P/N	Codan P/N	Qty
R141	33k Ohm 5% 0,06W 0603	Philips	2322 702 60333	40-43300-121	1
R142	33k Ohm 5% 0,06W 0603	Philips	2322 702 60333	40-43300-121	1
R143	33k Ohm 5% 0,06W 0603	Philips	2322 702 60333	40-43300-121	1
R144	3,3k Ohm 5% 0,06W 0603	Philips	2322 702 60332	40-33300-121	1
R145	3,3k Ohm 5% 0,06W 0603	Philips	2322 702 60332	40-33300-121	1
R146	10k Ohm 5% 0,06W 0603	Philips	2322 702 60103	40-41000-121	1
R147	10k Ohm 5% 0,06W 0603	Philips	2322 702 60103	40-41000-121	1
R148	47k Ohm 1% 0,06W 0603	Philips	2322 704 64703	40-44700-125	1
R149	10k Ohm 1% 0,06W 0603	Phycomp	2322 704 61003	40-41000-125	1
R150	6,8k Ohm 5% 0,06W 0603	Philips	2322 702 60682	40-36800-121	1
R151	6,8k Ohm 5% 0,06W 0603	Philips	2322 702 60682	40-36800-121	1
R152	10k Ohm 5% 0,06W 0603	Philips	2322 702 60103	40-41000-121	1
R153	10k Ohm 5% 0,06W 0603	Philips	2322 702 60103	40-41000-121	1
R154	2,2k Ohm 5% 0,06W 0603	Philips	2322 702 60222	40-32200-121	1
R155	47k Ohm 5% 0,06W 0603	Philips	2322 702 60473	40-44700-121	1
R156	47k Ohm 5% 0,06W 0603	Philips	2322 702 60473	40-44700-121	1
R157	47k Ohm 5% 0,06W 0603	Philips	2322 702 60473	40-44700-121	1
R158	10k Ohm 5% 0,06W 0603	Philips	2322 702 60103	40-41000-121	1
R159	10k Ohm 5% 0,06W 0603	Philips	2322 702 60103	40-41000-121	1
R160	680k Ohm 1% 0,06W 0603	Philips	2322 704 66804	40-56800-125	1
R161	680k Ohm 1% 0,06W 0603	Philips	2322 704 66804	40-56800-125	1
R162	680k Ohm 1% 0,06W 0603	Philips	2322 704 66804	40-56800-125	1
R163	Pot,10k Lin MG Trim SMD	Bourns	3314 J-1-103	42-41004-000	1
R164	10k Ohm 5% 0,06W 0603	Philips	2322 702 60103	40-41000-121	1
R165	1M Ohm 5% 0,06W 0603	Philips	2322 702 60105	40-61000-121	1
R166	1M Ohm 5% 0,06W 0603	Philips	2322 702 60105	40-61000-121	1
R167	100k Ohm 5% 0,06W 0603	Philips	2322 702 60104	40-51000-121	1
R168	220k Ohm 5% 0,06W 0603	Philips	2322 702 60224	40-52200-121	1
R169	22k Ohm 5% 0,06W 0603	Philips	2322 702 60223	40-42200-121	1
R170	100k Ohm 5% 0,06W 0603	Philips	2322 702 60104	40-51000-121	1
R171	22k Ohm 5% 0,06W 0603	Philips	2322 702 60223	40-42200-121	1
R172	Temp Sensor 10mV/degree C SOT23	National Semiconduct	LM50CIM3X	LM50CIM3X	1
R173	220k Ohm 5% 0,06W 0603	Philips	2322 702 60224	40-52200-121	1
R174	100k Ohm 5% 0,06W 0603	Philips	2322 702 60104	40-51000-121	1
R175	10 Ohm 5% 0,06W 0603	Philips	2322 702 60109	40-11000-121	1
R201	4,7k Ohm 5% 0,06W 0603	Philips	2322 702 60472	40-34700-121	1
R202	10k Ohm 5% 0,06W 0603	Philips	2322 702 60103	40-41000-121	1
R203	10 Ohm 5% 0,06W 0603	Philips	2322 702 60109	40-11000-121	1
R204	33k Ohm 5% 0,06W 0603	Philips	2322 702 60333	40-43300-121	1
R205	33k Ohm 5% 0,06W 0603	Philips	2322 702 60333	40-43300-121	1
R206	33k Ohm 5% 0,06W 0603	Philips	2322 702 60333	40-43300-121	1
R207	220 Ohm 5% 0,06W 0603	Philips	2322 702 60221	40-22200-121	1
R208	10 Ohm 5% 0,06W 0603	Philips	2322 702 60109	40-11000-121	1
R209	33k Ohm 5% 0,06W 0603	Philips	2322 702 60333	40-43300-121	1
R210	33k Ohm 5% 0,06W 0603	Philips	2322 702 60333	40-43300-121	1
R211	4,7k Ohm 5% 0,06W 0603	Philips	2322 702 60472	40-34700-121	1
R212	4,7k Ohm 5% 0,06W 0603	Philips	2322 702 60472	40-34700-121	1
R213	33k Ohm 5% 0,06W 0603	Philips	2322 702 60333	40-43300-121	1
R214	10k Ohm 5% 0,06W 0603	Philips	2322 702 60103	40-41000-121	1
R215	33k Ohm 5% 0,06W 0603	Philips	2322 702 60333	40-43300-121	1
R216	33k Ohm 5% 0,06W 0603	Philips	2322 702 60333	40-43300-121	1
R301	10k Ohm 5% 0,06W 0603	Philips	2322 702 60103	40-41000-121	1
R302	10k Ohm 5% 0,06W 0603	Philips	2322 702 60103	40-41000-121	1
R303	470k Ohm 5% 0,06W 0603	Phycomp	2322 702 60474	40-54700-121	1
R305	470 Ohm 5% 0,06W 0603	Philips	2322 702 60471	40-24700-121	1
R306	470 Ohm 5% 0,06W 0603	Philips	2322 702 60471	40-24700-121	1
R307	33k Ohm 5% 0,06W 0603	Philips	2322 702 60333	40-43300-121	1

08-06128-001 - Audio & Control PCB

BOM Revision
Date Valid On

07 -- Production
17.06.2008

Ref	Description	Manufacturer	Manufacturer's P/N	Codan P/N	Qty
R308	33k Ohm 5% 0,06W 0603	Philips	2322 702 60333	40-43300-121	1
R309	33k Ohm 5% 0,06W 0603	Philips	2322 702 60333	40-43300-121	1
R310	33k Ohm 5% 0,06W 0603	Philips	2322 702 60333	40-43300-121	1
R311	1M Ohm 5% 0,06W 0603	Philips	2322 702 60105	40-61000-121	1
R312	4,7k Ohm 5% 0,06W 0603	Philips	2322 702 60472	40-34700-121	1
R313	4,7k Ohm 5% 0,06W 0603	Philips	2322 702 60472	40-34700-121	1
R314	4,7k Ohm 5% 0,06W 0603	Philips	2322 702 60472	40-34700-121	1
R315	4,7k Ohm 5% 0,06W 0603	Philips	2322 702 60472	40-34700-121	1
R316	1k Ohm 5% 0,06W 0603	Philips	2322 702 60102	40-31000-121	1
R317	47 Ohm 5% 0,06W 0603	Philips	2322 702 60479	40-14700-121	1
R318	47 Ohm 5% 0,06W 0603	Philips	2322 702 60479	40-14700-121	1
R319	47 Ohm 5% 0,06W 0603	Philips	2322 702 60479	40-14700-121	1
R320	33 Ohm 5% 0,06W 0603	Philips	2322 702 60339	40-13300-121	1
R321	33 Ohm 5% 0,06W 0603	Philips	2322 702 60339	40-13300-121	1
V101	Transistor, PNP Si SOT23	Philips	BC857	BC857	1
V102	Transistor, NPN Si SOT23	Philips	BC847	BC848	1
V103	MOSFET, N Channel Enhanced SOT23	Fairchild	BSS138	BSS138	1
V104	MOSFET, N Chan Enhance SOT23	Philips	BST82	BST82	1
V105	MOSFET, P 20V 3,9A 0,6W 27mOhmTSOP6	Vishay	SI349BDV-T1-E3	SI3493DV	1
Z101	Crystal, 32,768kHz 12pF	HY-Q	TC38	65-90057-000	1
Z201	Crystal, 11059,2 kHz uP Grade SMD	HY-Q	M/P QC49/SMD EB01C	65-90094	1

08-06039-001 - RF/IF & Synthesiser PCB

BOM Revision
Date Valid On

06 -- Production
17.06.2008

Ref	Description	Manufacturer	Manufacturer's P/N	Codan P/N	Qty
	MRS, RF/IF & Synthesiser, 2110			01-01376	1
	RF/IF & Synthesiser			04-03439	1
	RF/IF & Synthesiser PCB			08-06039	1
	RF/IF & Synthesiser PCB			11-06162	1
	TP, RF/IF PCB			10-01002	1
1	PCB, RF/IF & Synthesiser		07-02012-04	07-02012-04	1
2	Screen, VCO	Metalcraft	05-07079	05-07079	1
3	Screen, DDS	Metalcraft	05-07080	05-07080	1
4	Shield, Mixer	Metalcraft	05-07343	05-07343	2
5	Label, Serial/Barcode	Codan	06-02068	06-02068	1
6	Not Fitted	Codan	**--00000-001	99-00000-001	1
7	Jumper (S) 2way Open Top	Molex	15-38-1024	60-90410-001	1
C101	100n 10% 50V X7R 0805 NiSn	Philips	08052R104K9BB	46-51000-282	1
C102	150p 5% 50V NPO 0603 NiSn	Philips	0603CG151J9B200	46-21500-083	1
C103	33n 10% 25V X7R 0603 NiSn	Vitramon	VJ0603Y333KXXT	46-43300-282	1
C104	100n 10% 16V X7R 0603 NiSn	Vitramon	VJ0603Y104KXJT	46-51000-283	1
C105	3,3n 10% 100V X7R 0603 NiSn	Vishay	VJ0603Y332KXBAC	46-33300-282	1
C106	10n 5% 50V X7R 0603 NiSn	Philips	06032R103J9BB00	46-41000-080	1
C107	100n 10% 50V X7R 0805 NiSn	Philips	08052R104K9BB	46-51000-282	1
C109	33n 10% 50V X7R 0805 NiSn	Philips	08052R333K9BB00	46-43300-281	1
C110	33n 10% 50V X7R 0805 NiSn	Philips	08052R333K9BB00	46-43300-281	1
C111	33n 10% 50V X7R 0805 NiSn	Philips	08052R333K9BB00	46-43300-281	1
C112	3,3p 0,25p 50V NPO 0603 NiSn	Philips	0603CG339C9BB00	46-03300-082	1
C113	12p 5% 50V NPO 0805 NiSn	Philips	0805CG120J9B200	46-11200-081	1
C114	56p 5% 50V NPO 0805 NiSn	Philips	0805CG560J9B200	46-15600-081	1
C115	56p 5% 50V NPO 0805 NiSn	Philips	0805CG560J9B200	46-15600-081	1
C116	120p 5% 50V NPO 0603 NiSn	Philips	0603CG121J9B200	46-21200-083	1
C117	47p 5% 50V NPO 0603 NiSn	Philips	0603CG470J9B200	46-14700-083	1
C118	68p 5% 50V NPO 0805 NiSn	Philips	0805CG680J9B200	46-16800-081	1
C119	3,3n 10% 100V X7R 0603 NiSn	Vishay	VJ0603Y332KXBAC	46-33300-282	1
C120	10n 5% 50V X7R 0603 NiSn	Philips	06032R103J9BB00	46-41000-080	1
C121	10n 5% 50V X7R 0603 NiSn	Philips	06032R103J9BB00	46-41000-080	1
C122	3,3n 10% 100V X7R 0603 NiSn	Vishay	VJ0603Y332KXBAC	46-33300-282	1
C124	68p 5% 50V NPO 0805 NiSn	Philips	0805CG680J9B200	46-16800-081	1
C125	56p 5% 50V NPO 0805 NiSn	Philips	0805CG560J9B200	46-15600-081	1
C126	27p 5% 50V NPO 0805 NiSn	Philips	0805CG270J9B200	46-12700-080	1
C127	3,3n 10% 100V X7R 0603 NiSn	Vishay	VJ0603Y332KXBAC	46-33300-282	1
C128	3,3n 10% 100V X7R 0603 NiSn	Vishay	VJ0603Y332KXBAC	46-33300-282	1
C129	10n 5% 50V X7R 0603 NiSn	Philips	06032R103J9BB00	46-41000-080	1
C130	3,3n 10% 100V X7R 0603 NiSn	Vishay	VJ0603Y332KXBAC	46-33300-282	1
C131	12p 5% 50V NPO 0805 NiSn	Philips	0805CG120J9B200	46-11200-081	1
C132	18p 5% 50V NPO 0603 NiSn	Philips	0603CG180C9BB00	46-11800-083	1
C133	10p 5% 50V NPO 0603 NiSn	Philips	0603CG100J9B200	46-11000-083	1
C134	3,3n 10% 100V X7R 0603 NiSn	Vishay	VJ0603Y332KXBAC	46-33300-282	1
C135	3,3n 10% 100V X7R 0603 NiSn	Vishay	VJ0603Y332KXBAC	46-33300-282	1
C136	3,3n 10% 100V X7R 0603 NiSn	Vishay	VJ0603Y332KXBAC	46-33300-282	1
C137	3,3n 10% 100V X7R 0603 NiSn	Vishay	VJ0603Y332KXBAC	46-33300-282	1
C138	3,3n 10% 100V X7R 0603 NiSn	Vishay	VJ0603Y332KXBAC	46-33300-282	1
C139	3,3n 10% 100V X7R 0603 NiSn	Vishay	VJ0603Y332KXBAC	46-33300-282	1
C140	15p 5% 50V NPO 0603 NiSn	Philips	0603CG150C9BB00	46-11500-083	1
C141	10p 5% 50V NPO 0603 NiSn	Philips	0603CG100J9B200	46-11000-083	1
C142	3,3n 10% 100V X7R 0603 NiSn	Vishay	VJ0603Y332KXBAC	46-33300-282	1
C143	3,3n 10% 100V X7R 0603 NiSn	Vishay	VJ0603Y332KXBAC	46-33300-282	1
C144	4,7p 0,25p 50V NPO 0603 NiSn	Philips	0603CG479C9B200	46-04700-084	1
C145	3,3n 10% 100V X7R 0603 NiSn	Vishay	VJ0603Y332KXBAC	46-33300-282	1
C146	3,3n 10% 100V X7R 0603 NiSn	Vishay	VJ0603Y332KXBAC	46-33300-282	1
C147	3,3n 10% 100V X7R 0603 NiSn	Vishay	VJ0603Y332KXBAC	46-33300-282	1
C148	6,8n 10% 100V X7R 0805 NiSn	Philips	08052R682K0B200	46-36800-281	1

08-06039-001 - RF/IF & Synthesiser PCB

BOM Revision
Date Valid On

06 -- Production
17.06.2008

Ref	Description	Manufacturer	Manufacturer's P/N	Codan P/N	Qty
C149	1,8n 5% 50V NPO 0805 NiSn	Phycomp	0805CG182J9B200	46-31800-080	1
C150	27p 5% 50V NPO 0805 NiSn	Philips	0805CG270J9B200	46-12700-080	1
C151	39p 5% 100V NPO 0603 NiSn	Philips	0603CG390J0B200	46-13900-083	1
C152	68p 5% 50V NPO 0805 NiSn	Philips	0805CG680J9B200	46-16800-081	1
C153	33p 5% 50V NPO 0603 NiSn	Phycomp	0603CG330J9B200	46-13300-083	1
C154	1,8n 5% 50V NPO 0805 NiSn	Phycomp	0805CG182J9B200	46-31800-080	1
C155	10n 5% 50V X7R 0603 NiSn	Philips	06032R103J9BB00	46-41000-080	1
C156	3,3n 10% 100V X7R 0603 NiSn	Vishay	VJ0603Y332KXBAC	46-33300-282	1
C158	680p 5% 50V NPO 0805 NiSn	Philips	0805CG681J9B200	46-26800-081	1
C159	3,3p 0,25p 50V NPO 0603 NiSn	Philips	0603CG339C9BB00	46-03300-082	1
C160	10p 5% 50V NPO 0603 NiSn	Philips	0603CG100J9B200	46-11000-083	1
C161	18p 5% 50V NPO 0603 NiSn	Philips	0603CG180C9BB00	46-11800-083	1
C162	3,3n 10% 100V X7R 0603 NiSn	Vishay	VJ0603Y332KXBAC	46-33300-282	1
C163	1n 5% 25V NPO 0603 NiSn	AVX	06033A102JAT2A	46-31000-083	1
C164	1n 5% 25V NPO 0603 NiSn	AVX	06033A102JAT2A	46-31000-083	1
C165	27p 5% 50V NPO 0603 NiSn	Phycomp	0603CG270J9B200	46-12700-083	1
C166	27p 5% 50V NPO 0603 NiSn	Phycomp	0603CG270J9B200	46-12700-083	1
C167	12p 5% 50V NPO 0603 NiSn	Phycomp	0603CG120J9B200	46-11200-083	1
C168	12p 5% 50V NPO 0603 NiSn	Phycomp	0603CG120J9B200	46-11200-083	1
C169	33n 10% 25V X7R 0603 NiSn	Vitramon	VJ0603Y333KXXT	46-43300-282	1
C170	47p 5% 50V NPO 0603 NiSn	Philips	0603CG470J9B200	46-14700-083	1
C171	56p 5% 50V NPO 0805 NiSn	Philips	0805CG560J9B200	46-15600-081	1
C172	330p 5% 50V NPO 0603 NiSn	Phycomp	0603CG331J9B200	46-23300-083	1
C173	100n 10% 16V X7R 0603 NiSn	Vitramon	VJ0603Y104KXJT	46-51000-283	1
C174	220p 5% 50V NPO 0603 NiSn	Philips	0603CG221C9BB00	46-22200-083	1
C175	33n 10% 25V X7R 0603 NiSn	Vitramon	VJ0603Y333KXXT	46-43300-282	1
C176	33n 10% 25V X7R 0603 NiSn	Vitramon	VJ0603Y333KXXT	46-43300-282	1
C177	33n 10% 25V X7R 0603 NiSn	Vitramon	VJ0603Y333KXXT	46-43300-282	1
C178	33n 10% 25V X7R 0603 NiSn	Vitramon	VJ0603Y333KXXT	46-43300-282	1
C179	100n 10% 16V X7R 0603 NiSn	Vitramon	VJ0603Y104KXJT	46-51000-283	1
C180	120p 5% 50V NPO 0603 NiSn	Philips	0603CG121J9B200	46-21200-083	1
C181	3,3n 10% 100V X7R 0603 NiSn	Vishay	VJ0603Y332KXBAC	46-33300-282	1
C182	100n 10% 16V X7R 0603 NiSn	Vitramon	VJ0603Y104KXJT	46-51000-283	1
C203	100p 5% 50V NPO 0603 NiSn	Philips	0603CG101J9B200	46-21000-083	1
C204	10u 20% 10V X7R 1210 NiSn	Taiyo Yuden	LMK325BJ106MN	46-71000-280	1
C212	1n 5% 25V NPO 0603 NiSn	AVX	06033A102JAT2A	46-31000-083	1
C213	1u 10% 16V X7R 1206 NiSn	Philips	12062R105K7BB00	46-61000-280	1
C214	10u 20% 25V 6032 TA Cap	AVX	TAJC106M025R	47-11002-520	1
C215	1n 5% 25V NPO 0603 NiSn	AVX	06033A102JAT2A	46-31000-083	1
C216	33n 10% 25V X7R 0603 NiSn	Vitramon	VJ0603Y333KXXT	46-43300-282	1
C217	820p 5% 50V NPO 0805 NiSn	Philips	0805CG821J9B200	46-28200-081	1
C218	820p 5% 50V NPO 0805 NiSn	Philips	0805CG821J9B200	46-28200-081	1
C219	33n 10% 25V X7R 0603 NiSn	Vitramon	VJ0603Y333KXXT	46-43300-282	1
C220	22n 10% 25V X7R 0603 NiSn	AVX	06033C223KAT2A	46-42200-281	1
C222	3,3n 10% 100V X7R 0603 NiSn	Vishay	VJ0603Y332KXBAC	46-33300-282	1
C223	100p 5% 50V NPO 0603 NiSn	Philips	0603CG101J9B200	46-21000-083	1
C224	10u 20% 10V X7R 1210 NiSn	Taiyo Yuden	LMK325BJ106MN	46-71000-280	1
C225	33n 10% 25V X7R 0603 NiSn	Vitramon	VJ0603Y333KXXT	46-43300-282	1
C226	3,3n 10% 100V X7R 0603 NiSn	Vishay	VJ0603Y332KXBAC	46-33300-282	1
C228	33n 10% 25V X7R 0603 NiSn	Vitramon	VJ0603Y333KXXT	46-43300-282	1
C229	33n 10% 25V X7R 0603 NiSn	Vitramon	VJ0603Y333KXXT	46-43300-282	1
C230	100p 5% 50V NPO 0603 NiSn	Philips	0603CG101J9B200	46-21000-083	1
C231	33n 10% 25V X7R 0603 NiSn	Vitramon	VJ0603Y333KXXT	46-43300-282	1
C232	1u 20% 35V 3528 TA Cap	AVX	TAJB105M035R	47-01003-520	1
C233	10n 5% 50V X7R 0603 NiSn	Philips	06032R103J9BB00	46-41000-080	1
C234	1n 5% 25V NPO 0603 NiSn	AVX	06033A102JAT2A	46-31000-083	1
C235	3,3n 10% 100V X7R 0603 NiSn	Vishay	VJ0603Y332KXBAC	46-33300-282	1
C236	100p 5% 50V NPO 0603 NiSn	Philips	0603CG101J9B200	46-21000-083	1

08-06039-001 - RF/IF & Synthesiser PCB

BOM Revision
Date Valid On

06 -- Production
17.06.2008

Ref	Description	Manufacturer	Manufacturer's P/N	Codan P/N	Qty
C237	33n 10% 25V X7R 0603 NiSn	Vitramon	VJ0603Y333KXXT	46-43300-282	1
C238	1n 5% 25V NPO 0603 NiSn	AVX	06033A102JAT2A	46-31000-083	1
C239	100p 5% 50V NPO 0603 NiSn	Philips	0603CG101J9B200	46-21000-083	1
C240	33n 10% 25V X7R 0603 NiSn	Vitramon	VJ0603Y333KXXT	46-43300-282	1
C241	1n 5% 25V NPO 0603 NiSn	AVX	06033A102JAT2A	46-31000-083	1
C242	100n 10% 16V X7R 0603 NiSn	Vitramon	VJ0603Y104KXJT	46-51000-283	1
C243	100p 5% 50V NPO 0603 NiSn	Philips	0603CG101J9B200	46-21000-083	1
C244	33n 10% 25V X7R 0603 NiSn	Vitramon	VJ0603Y333KXXT	46-43300-282	1
C245	3,3n 10% 100V X7R 0603 NiSn	Vishay	VJ0603Y332KXBAC	46-33300-282	1
C246	2,2u 10% 16V X7R 0805 NiSn	Kemet	C0805C225K4RAC	46-62200-281	1
C247	3,3n 10% 100V X7R 0603 NiSn	Vishay	VJ0603Y332KXBAC	46-33300-282	1
C248	1u 20% 35V 3528 TA Cap	AVX	TAJB105M035R	47-01003-520	1
C249	120p 5% 50V NPO 0603 NiSn	Philips	0603CG121J9B200	46-21200-083	1
C251	22u 20% 16V X5R 1210 NiSn	Kemet	C1210C226M4PAC7800	46-72200-280	1
C252	2,2u 10% 16V X7R 0805 NiSn	Kemet	C0805C225K4RAC	46-62200-281	1
C253	100p 5% 50V NPO 0603 NiSn	Philips	0603CG101J9B200	46-21000-083	1
C254	10u 20% 25V 6032 TA Cap	AVX	TAJC106M025R	47-11002-520	1
C255	33n 10% 25V X7R 0603 NiSn	Vitramon	VJ0603Y333KXXT	46-43300-282	1
C256	100n 10% 16V X7R 0603 NiSn	Vitramon	VJ0603Y104KXJT	46-51000-283	1
C257	10u 20% 25V 6032 TA Cap	AVX	TAJC106M025R	47-11002-520	1
C258	33n 10% 25V X7R 0603 NiSn	Vitramon	VJ0603Y333KXXT	46-43300-282	1
C259	33n 10% 25V X7R 0603 NiSn	Vitramon	VJ0603Y333KXXT	46-43300-282	1
C260	10u 20% 25V 6032 TA Cap	AVX	TAJC106M025R	47-11002-520	1
C261	33n 10% 100V X7R 1206 NiSn	Philips	12062R333K0BB-	46-43300-280	1
C262	100n 10% 16V X7R 0603 NiSn	Vitramon	VJ0603Y104KXJT	46-51000-283	1
C263	4,7n 5% 25V NPO 0805 NiSn	Phycomp	0805CG472J8BB00	46-34700-081	1
C264	470p 5% 50V NPO 0805 NiSn	Philips	0805CG471J9B200	46-24700-081	1
C265	100p 5% 50V NPO 0603 NiSn	Philips	0603CG101J9B200	46-21000-083	1
C266	100p 5% 50V NPO 0603 NiSn	Philips	0603CG101J9B200	46-21000-083	1
C267	100p 5% 50V NPO 0603 NiSn	Philips	0603CG101J9B200	46-21000-083	1
C268	100p 5% 50V NPO 0603 NiSn	Philips	0603CG101J9B200	46-21000-083	1
C269	1n 5% 25V NPO 0603 NiSn	AVX	06033A102JAT2A	46-31000-083	1
C270	33n 10% 25V X7R 0603 NiSn	Vitramon	VJ0603Y333KXXT	46-43300-282	1
C271	33n 10% 25V X7R 0603 NiSn	Vitramon	VJ0603Y333KXXT	46-43300-282	1
C272	3,3n 10% 100V X7R 0603 NiSn	Vishay	VJ0603Y332KXBAC	46-33300-282	1
C273	33n 10% 25V X7R 0603 NiSn	Vitramon	VJ0603Y333KXXT	46-43300-282	1
C274	1u 10% 10V X7R 0805 NiSn	Phycomp	2222-240-15663	46-61000-281	1
C275	Not Fitted	Codan	**--00000-001	99-00000-001	1
C276	1u 10% 16V X7R 1206 NiSn	Philips	12062R105K7BB00	46-61000-280	1
C277	100n 10% 16V X7R 0603 NiSn	Vitramon	VJ0603Y104KXJT	46-51000-283	1
C278	10p 5% 50V NPO 0603 NiSn	Philips	0603CG100J9B200	46-11000-083	1
C279	33n 10% 25V X7R 0603 NiSn	Vitramon	VJ0603Y333KXXT	46-43300-282	1
C280	3,3n 10% 100V X7R 0603 NiSn	Vishay	VJ0603Y332KXBAC	46-33300-282	1
C281	100p 5% 50V NPO 0603 NiSn	Philips	0603CG101J9B200	46-21000-083	1
C282	10n 5% 50V X7R 0603 NiSn	Philips	06032R103J9BB00	46-41000-080	1
C301	100p 5% 500V NPO 1206 <300		46-21000-088 selected for ESR 10-01095	46-21000-0820	1
C302	1n 5% 50V NPO 0805 NiSn	Philips	0805CG102J9BB-	46-31000-082	1
C303	1p 0,25p 50V NPO 0603 NiSn	Philips	0603CG109C9BB00	46-01000-084	1
C304	4,7p 0,25p 50V NPO 0603 NiSn	Philips	0603CG479C9B200	46-04700-084	1
C305	100n 10% 16V X7R 0603 NiSn	Vitramon	VJ0603Y104KXJT	46-51000-283	1
C306	10u 20% 25V 6032 TA Cap	AVX	TAJC106M025R	47-11002-520	1
C308	100n 10% 16V X7R 0603 NiSn	Vitramon	VJ0603Y104KXJT	46-51000-283	1
C309	100n 10% 16V X7R 0603 NiSn	Vitramon	VJ0603Y104KXJT	46-51000-283	1
C310	3,3n 10% 100V X7R 0603 NiSn	Vishay	VJ0603Y332KXBAC	46-33300-282	1
C311	3,3n 10% 100V X7R 0603 NiSn	Vishay	VJ0603Y332KXBAC	46-33300-282	1
C312	3,3n 10% 100V X7R 0603 NiSn	Vishay	VJ0603Y332KXBAC	46-33300-282	1
C313	100n 10% 16V X7R 0603 NiSn	Vitramon	VJ0603Y104KXJT	46-51000-283	1

08-06039-001 - RF/IF & Synthesiser PCB

BOM Revision
Date Valid On

06 -- Production
17.06.2008

Ref	Description	Manufacturer	Manufacturer's P/N	Codan P/N	Qty
C314	1u 10% 63V PE Cap	Philips	2222 370 11105	46-61000-521	1
C315	100n 5% 50V PPS 1812 NiSn	Panasonic	ECHU1H104JB9	46-51000-900	1
C316	100n 10% 50V X7R 0805 Nisn	Philips	08052R104K9BB	46-51000-282	1
C317	1u 20% 35V 3528 TA Cap	AVX	TAJB105M035R	47-01003-520	1
C318	33p 5% 50V NPO 0603 NiSn	Phycomp	0603CG330J9B200	46-13300-083	1
C319	100n 10% 50V X7R 0805 Nisn	Philips	08052R104K9BB	46-51000-282	1
C320	100n 10% 50V X7R 0805 Nisn	Philips	08052R104K9BB	46-51000-282	1
C321	33n 10% 25V X7R 0603 NiSn	Vitramon	VJ0603Y333KXXT	46-43300-282	1
C322	33p 5% 50V NPO 0603 NiSn	Phycomp	0603CG330J9B200	46-13300-083	1
C325	100n 10% 16V X7R 0603 NiSn	Vitramon	VJ0603Y104KXJT	46-51000-283	1
C326	3,3n 10% 100V X7R 0603 NiSn	Vishay	VJ0603Y332KXBAC	46-33300-282	1
C327	3,3n 10% 100V X7R 0603 NiSn	Vishay	VJ0603Y332KXBAC	46-33300-282	1
C328	1n 5% 50V NPO 1206 NiSn	Philips	1206CG102J9BB-	46-31000-081	1
C329	100n 10% 50V X7R 0805 Nisn	Philips	08052R104K9BB	46-51000-282	1
C330	100n 10% 50V X7R 0805 Nisn	Philips	08052R104K9BB	46-51000-282	1
C331	100n 10% 50V X7R 0805 Nisn	Philips	08052R104K9BB	46-51000-282	1
C332	100n 10% 50V X7R 0805 Nisn	Philips	08052R104K9BB	46-51000-282	1
C333	100n 10% 50V X7R 0805 Nisn	Philips	08052R104K9BB	46-51000-282	1
C334	100n 10% 50V X7R 0805 Nisn	Philips	08052R104K9BB	46-51000-282	1
C336	33n 10% 25V X7R 0603 NiSn	Vitramon	VJ0603Y333KXXT	46-43300-282	1
C337	1n 5% 50V NPO 0805 NiSn	Philips	0805CG102J9BB-	46-31000-082	1
C338	15p 5% 50V NPO 0603 NiSn	Philips	0603CG150C9BB00	46-11500-083	1
C339	1n 5% 50V NPO 0805 NiSn	Philips	0805CG102J9BB-	46-31000-082	1
C340	33n 10% 25V X7R 0603 NiSn	Vitramon	VJ0603Y333KXXT	46-43300-282	1
C341	1n 5% 25V NPO 0603 NiSn	AVX	06033A102JAT2A	46-31000-083	1
C342	220p 5% 50V NPO 0603 NiSn	Philips	0603CG221C9BB00	46-22200-083	1
C343	390p 5% 50V NPO 0603 NiSn	Phycomp	0603CG391J9B200	46-23900-083	1
C344	10n 10% 100V X7R 0805 NiSn	Philips	08052R103K0B200	46-41000-281	1
C346	1u 10% 10V X7R 0805 NiSn	Phycomp	2222-240-15663	46-61000-281	1
C347	33n 10% 25V X7R 0603 NiSn	Vitramon	VJ0603Y333KXXT	46-43300-282	1
C348	10n 5% 50V X7R 0603 NiSn	Philips	06032R103J9BB00	46-41000-080	1
C349	33n 10% 50V X7R 0805 NiSn	Philips	08052R333K9BB00	46-43300-281	1
C350	100n 10% 16V X7R 0603 NiSn	Vitramon	VJ0603Y104KXJT	46-51000-283	1
C351	100n 10% 16V X7R 0603 NiSn	Vitramon	VJ0603Y104KXJT	46-51000-283	1
C359	33n 10% 50V X7R 0805 NiSn	Philips	08052R333K9BB00	46-43300-281	1
C360	10n 5% 50V X7R 0603 NiSn	Philips	06032R103J9BB00	46-41000-080	1
C361	33n 10% 25V X7R 0603 NiSn	Vitramon	VJ0603Y333KXXT	46-43300-282	1
C362	10n 10% 100V X7R 0805 NiSn	Philips	08052R103K0B200	46-41000-281	1
C363	33n 10% 25V X7R 0603 NiSn	Vitramon	VJ0603Y333KXXT	46-43300-282	1
C364	330p 5% 50V NPO 0603 NiSn	Phycomp	0603CG331J9B200	46-23300-083	1
C365	1n 5% 25V NPO 0603 NiSn	AVX	06033A102JAT2A	46-31000-083	1
C366	220p 5% 50V NPO 0603 NiSn	Philips	0603CG221C9BB00	46-22200-083	1
C370	33n 10% 25V X7R 0603 NiSn	Vitramon	VJ0603Y333KXXT	46-43300-282	1
C372	47p 5% 50V NPO 0603 NiSn	Philips	0603CG470J9B200	46-14700-083	1
C373	10u 20% 25V 6032 TA Cap	AVX	TAJC106M025R	47-11002-520	1
C374	33n 10% 25V X7R 0603 NiSn	Vitramon	VJ0603Y333KXXT	46-43300-282	1
C375	33n 10% 25V X7R 0603 NiSn	Vitramon	VJ0603Y333KXXT	46-43300-282	1
C376	22p 5% 100V NPO 0603 NiSn	Philips	0603CG220J0B200	46-12200-083	1
C377	3,3n 10% 100V X7R 0603 NiSn	Vishay	VJ0603Y332KXBAC	46-33300-282	1
C378	33n 10% 25V X7R 0603 NiSn	Vitramon	VJ0603Y333KXXT	46-43300-282	1
C380	330p 5% 50V NPO 0603 NiSn	Phycomp	0603CG331J9B200	46-23300-083	1
C381	3,3n 10% 100V X7R 0603 NiSn	Vishay	VJ0603Y332KXBAC	46-33300-282	1
C382	33n 10% 25V X7R 0603 NiSn	Vitramon	VJ0603Y333KXXT	46-43300-282	1
D101	Diode, Si High speed 75V SOT23	Philips	BAS16	BAS16	1
D104	Diode, Schottky X-over Quad SOT-143	Agilent	HSMS-2829-TR1	HSMS-2829	1
D105	Diode,PIN 150V 1ohm@10mA 700nsTrr SC79	Infineon	BAR67-02V	BAR67-02V	1

08-06039-001 - RF/IF & Synthesiser PCB

BOM Revision
Date Valid On

06 -- Production
17.06.2008

Ref	Description	Manufacturer	Manufacturer's P/N	Codan P/N	Qty
D106	Diode,PIN 150V 1ohm@10mA 700nsTrr SC79	Infineon	BAR67-02V	BAR67-02V	1
D107	Diode,PIN 150V 1ohm@10mA 700nsTrr SC79	Infineon	BAR67-02V	BAR67-02V	1
D108	Diode,PIN 150V 1ohm@10mA 700nsTrr SC79	Infineon	BAR67-02V	BAR67-02V	1
D109	Diode,PIN 150V 1ohm@10mA 700nsTrr SC79	Infineon	BAR67-02V	BAR67-02V	1
D110	Diode,PIN 150V 1ohm@10mA 700nsTrr SC79	Infineon	BAR67-02V	BAR67-02V	1
D111	Diode,PIN 150V 1ohm@10mA 700nsTrr SC79	Infineon	BAR67-02V	BAR67-02V	1
D112	Diode,PIN 150V 1ohm@10mA 700nsTrr SC79	Infineon	BAR67-02V	BAR67-02V	1
D113	Diode, Schottky X-over Quad SOT-143	Agilent	HSMS-2829-TR1	HSMS-2829	1
D114	Diode, Si High speed 75V SOT23	Philips	BAS16	BAS16	1
D115	Diode,PIN 150V 2ohm@10mA 1500nTrr SOD323	Infineon	BAR64-03W	BAR64-03W	1
D116	Diode,PIN 150V 2ohm@10mA 1500nTrr SOD323	Infineon	BAR64-03W	BAR64-03W	1
D117	Diode,PIN 150V 2ohm@10mA 1500nTrr SOD323	Infineon	BAR64-03W	BAR64-03W	1
D118	Diode,PIN 150V 2ohm@10mA 1500nTrr SOD323	Infineon	BAR64-03W	BAR64-03W	1
D201	Diode, Si High speed 75V SOT23	Philips	BAS16	BAS16	1
D208	Diode, Schottky 70V 70mA SOT23	Siemens	BAS70	BAS70	1
D209	Diode,PIN 150V 2ohm@10mA 1500nTrr SOD323	Infineon	BAR64-03W	BAR64-03W	1
D301	Diode, Tuner Si SOD323	Siemens	BB639-E6327	BB639	1
D302	Diode, Tuner Si SOD323	Siemens	BB639-E6327	BB639	1
D303	Diode, Tuner Si SOD323	Siemens	BB639-E6327	BB639	1
D304	Diode, Tuner Si SOD323	Siemens	BB639-E6327	BB639	1
D305	Diode, Schottky 70V 70mA SOT23	Siemens	BAS70	BAS70	1
D308	Diode, Si High speed 75V SOT23	Philips	BAS16	BAS16	1
D309	Diode, Si High speed 75V SOT23	Philips	BAS16	BAS16	1
D310	Diode, Si High speed 75V SOT23	Philips	BAS16	BAS16	1
D312	Diode, Si High speed 75V SOT23	Philips	BAS16	BAS16	1
IC201	Array, Transistor SOIC14	Intersil	CA3054M96	XT-03054-700	1
IC202	Amp, Rail to Rail I/O SOT23-5	National Semiconduct	LMC7101BIM5X	XA-07101-700	1
IC203	Gate, NAND 2 Input Quad SOIC14	Philips	HEF4011BTD	YG-40011-700	1
IC204	Amp, Rail to Rail I/O SOT23-5	National Semiconduct	LMC7101BIM5X	XA-07101-700	1
IC205	Modulator, Balanced SOIC14	Motorola	MC1496D	XA-01496-700	1
IC206	Modulator, Balanced SOIC14	Motorola	MC1496D	XA-01496-700	1
IC207	Amp, Rail to Rail I/O SOT23-5	National Semiconduct	LMC7101BIM5X	XA-07101-700	1
IC208	Reg,Voltage +Adj 150mA LDO LoPwr SOT23-5	Texas Instruments	TPS76301 DBVT (250)	XB-76301-700	1
IC209	Comparator, Dual O/C Output SOIC8	National Semiconduct	LM393M	XD-00393-700	1
IC301	Synthesiser, Freq SOIC16	Motorola	MC145170D2	MC145170D1	1
IC302	Buffer, Hex Inverting Schmitt SOIC14	Philips	HEF40106BT	YG-40106-700	1
IC303	Direct Digital Synthesiser TSSOP16	Analog Devices	AD9832BRU	YL-09832-700	1
IC305	Direct Digital Synthesiser TSSOP16	Analog Devices	AD9832BRU	YL-09832-700	1
IC306	Inverter, Single Unbuffered SOT23-5	SGS Thomson	74V1GU04S	YZ-74004-700	1
IC307	Flip Flop, D Dual SOIC14	Motorola	MC74HC74AD	YH-74074-700	1

08-06039-001 - RF/IF & Synthesiser PCB

BOM Revision
Date Valid On

06 -- Production
17.06.2008

Ref	Description	Manufacturer	Manufacturer's P/N	Codan P/N	Qty
IC308	Micro prgmd, RF/IF & Synth	Codan	90-20632-001	90-20632-001	1
J101	Socket, Coax Mini Low Prof Fixed	Taiko Denki	TMP-J02X-A1	60-19390-002	1
K101	Relay, 2C 9V Ltch SMD 2x579 Ohm	Matsushita	TQ2SL-L2-9V	64-21225-258	1
L101	Ind, 100uH 10% 4532	Taiyo Yuden	LEM 4532T101K	43-82100-134	1
L102	Ind, 100uH 10% 4532	Taiyo Yuden	LEM 4532T101K	43-82100-134	1
L103	Ind, 220nH 20% 4532	Taiyo Yuden	LEM4532TR22M	43-80022-000	1
L104	Ind	Koilkraft	44-70490	44-70490	1
L105	Ind, 330nH 20% 4532	Taiyo Yuden	LEM4532TR33M	43-80033-000	1
L106	Ind, Common Mode 1.5A	Taiyo Yuden	CM05RA06	43-80000	1
L107	Ind, 120nH 5% 3028	Coilcraft	1008CS-121XJBB	43-80012-000	1
L108	Ind, Common Mode 1.5A	Taiyo Yuden	CM05RA06	43-80000	1
L109	Ind, 4,7uH 10% 4532	Taiyo Yuden	LEM4532T4R7K	43-80470-000	1
L110	Ind, 10uH 10% 4532	Taiyo Yuden	LEM 4532T100K	43-81100-000	1
L111	Ind, 180nH 20% 3225	TOKO	380NB-R18M	43-80018-000	1
L113	Ind, 330nH 20% 4532	Taiyo Yuden	LEM4532TR33M	43-80033-000	1
L114	Ind, 470nH 20% 4532	Taiyo Yuden	LEM4532TR47M	43-80047-001	1
L117	Choke, EMI/EMC 0A DC >10MHz 0805	Taiyo Yuden	BK 2125 HS 330-T	43-90004	1
L118	Ind, 10uH 5% 3225	TDK	NL322522T-100J	43-81100-003	1
L119	Choke, EMI/EMC 0A DC >10MHz 0805	Taiyo Yuden	BK 2125 HS 330-T	43-90004	1
L120	Ind, 10uH 5% 3225	TDK	NL322522T-100J	43-81100-003	1
L121	Ind, 10uH 5% 3225	TDK	NL322522T-100J	43-81100-003	1
L122	Ind, 10uH 5% 3225	TDK	NL322522T-100J	43-81100-003	1
L123	Inductor, 45MHz Roofing Filter	Sumida	44-70509	44-70509	1
L124	Ind, 45MHz roofing filter	Sumida	Type:S-7GC Spec No:0236 T250	44-70452	1
L125	Inductor, 45MHz Roofing Filter	Sumida	44-70509	44-70509	1
L126	Ind, 10uH 5% 3225	TDK	NL322522T-100J	43-81100-003	1
L127	Choke, EMI/EMC 0A DC >10MHz 0805	Taiyo Yuden	BK 2125 HS 330-T	43-90004	1
L128	Choke, EMI/EMC 0A DC >10MHz 0805	Taiyo Yuden	BK 2125 HS 330-T	43-90004	1
L130	Ind, 10uH 5% 3225	TDK	NL322522T-100J	43-81100-003	1
L131	Ind, 10uH 5% 3225	TDK	NL322522T-100J	43-81100-003	1
L132	Ind, 10uH 5% 3225	TDK	NL322522T-100J	43-81100-003	1
L134	Ind, 470nH 20% 4532	Taiyo Yuden	LEM4532TR47M	43-80047-001	1
L135	Ind, 270nH 20% 3225	TOKO	380NB-R27M	43-80027-000	1
L137	Ind, 180nH 20% 3225	TOKO	380NB-R18M	43-80018-000	1
L138	Ind, 220nH 20% 3225	TOKO	380NB-R22M	43-80022-001	1
L139	Ind, 220nH 20% 3225	TOKO	380NB-R22M	43-80022-001	1
L140	Ind, 10uH 10% 4532	Taiyo Yuden	LEM 4532T100K	43-81100-000	1
L141	Ind, Common Mode 1.5A	Taiyo Yuden	CM05RA06	43-80000	1
L142	Ind, 1,8uH 10% 4532	Vishay	IMC-1812 1,8UH 10%	43-80180-000	1
L143	Ind, 470nH 20% 4532	Taiyo Yuden	LEM4532TR47M	43-80047-001	1
L144	Ind, 330nH 20% 4532	Taiyo Yuden	LEM4532TR33M	43-80033-000	1
L145	Ind, 1mH Shielded 3225	TDK	NLFC322522T-102K	43-83100-002	1
L146	Ind, 2,2uH 10% 3225	TOKO	380LB-2R2K	43-80220-001	1
L147	Ind, 1mH Shielded 3225	TDK	NLFC322522T-102K	43-83100-002	1
L148	Choke, EMI/EMC 0A DC >10MHz 0805	Taiyo Yuden	BK 2125 HS 330-T	43-90004	1
L149	Choke, EMI/EMC 0A DC >10MHz 0805	Taiyo Yuden	BK 2125 HS 330-T	43-90004	1
L150	Ind, 1mH Shielded 3225	TDK	NLFC322522T-102K	43-83100-002	1
L205	Ind, 1mH Shielded 3225	TDK	NLFC322522T-102K	43-83100-002	1
L206	Ind, 1mH Shielded 3225	TDK	NLFC322522T-102K	43-83100-002	1
L207	Ind, 1mH Shielded 3225	TDK	NLFC322522T-102K	43-83100-002	1
L208	Ind, 1mH Shielded 3225	TDK	NLFC322522T-102K	43-83100-002	1

08-06039-001 - RF/IF & Synthesiser PCB

BOM Revision
Date Valid On

06 -- Production
17.06.2008

Ref	Description	Manufacturer	Manufacturer's P/N	Codan P/N	Qty
L209	Ind, 1mH Shielded 3225	TDK	NLFC322522T-102K	43-83100-002	1
L210	Choke, EMI/EMC 0A DC >1MHz 4516	Taiyo Yuden	FB-MJ4516HS111-T	43-90003	1
L212	Choke, EMI/EMC 0A DC >1MHz 4516	Taiyo Yuden	FB-MJ4516HS111-T	43-90003	1
L213	Ind, 1mH Shielded 3225	TDK	NLFC322522T-102K	43-83100-002	1
L214	Choke, EMI/EMC 0A DC >1MHz 4516	Taiyo Yuden	FB-MJ4516HS111-T	43-90003	1
L215	Choke, EMI/EMC 0A DC >1MHz 4516	Taiyo Yuden	FB-MJ4516HS111-T	43-90003	1
L301	Ind, 10uH 10% 4532	Taiyo Yuden	LEM 4532T100K	43-81100-000	1
L302	Ind, Common Mode 1.5A	Taiyo Yuden	CM05RA06	43-80000	1
L303	Ind, VCO	Protran	44-70488	44-70488	1
L304	Ind, 10uH 10% 4532	Taiyo Yuden	LEM 4532T100K	43-81100-000	1
L306	Ind, 10uH 10% 4532	Taiyo Yuden	LEM 4532T100K	43-81100-000	1
L307	Ind, 10uH 10% 4532	Taiyo Yuden	LEM 4532T100K	43-81100-000	1
L308	Ind, 1uH 10% 3028	Coilcraft	1008CS-102XKBC	43-80100-000	1
L309	Ind, 100uH 10% 4532	Taiyo Yuden	LEM 4532T101K	43-82100-134	1
L310	Ind, 100uH 10% 4532	Taiyo Yuden	LEM 4532T101K	43-82100-134	1
L311	Ind	Koilkraft	44-70492	44-70492	1
L312	Ind	Koilkraft	44-70492	44-70492	1
L313	Ind, 4,7uH 10% 4532	Taiyo Yuden	LEM4532T4R7K	43-80470-000	1
L314	Choke, EMI/EMC 0A DC >1MHz 4516	Taiyo Yuden	FB-MJ4516HS111-T	43-90003	1
L315	Ind, 10uH 10% 4532	Taiyo Yuden	LEM 4532T100K	43-81100-000	1
L316	Ind, 3,3uH 10% 3225	TOKO	380LB-3R3K	43-80330-000	1
L318	Ind, 47uH 5% 3225	TDK	NL322522T-470J	43-81470-001	1
P201	Header (P) 4way 1row	Molex	22-03-2041	60-00041-100	1
P202	Header (P) 16way 2row Boxed SMD 2,54mm	Neltron	2316SMD-16G	60-00160-003	1
P301	Not Fitted	Codan	** -00000-001	99-00000-001	1
P302	Not Fitted	Codan	** -00000-001	99-00000-001	1
P303	Header (P) 4way 1row	Molex	22-03-2041	60-00041-100	1
P304	Header (P) 4way 1row	Molex	22-03-2041	60-00041-100	1
R101	150 Ohm 5% 0,06W 0603	Philips	2322 702 60151	40-21500-121	1
R102	3,3k Ohm 5% 0,06W 0603	Philips	2322 702 60332	40-33300-121	1
R103	3,9k Ohm 5% 0,06W 0603	Philips	2322 702 60392	40-33900-121	1
R105	33 Ohm 5% 0,06W 0603	Philips	2322 702 60339	40-13300-121	1
R106	47 Ohm 5% 0,06W 0603	Philips	2322 702 60479	40-14700-121	1
R107	560 Ohm 5% 0,06W 0603	Philips	2322 702 60561	40-25600-121	1
R108	22 Ohm 5% 0,06W 0603	Philips	2322 702 60229	40-12200-121	1
R109	2,2k Ohm 5% 0,06W 0603	Philips	2322 702 60222	40-32200-121	1
R110	470 Ohm 5% 0,06W 0603	Philips	2322 702 60471	40-24700-121	1
R111	22 Ohm 5% 0,06W 0603	Philips	2322 702 60229	40-12200-121	1
R112	560 Ohm 5% 0,06W 0603	Philips	2322 702 60561	40-25600-121	1
R113	47 Ohm 5% 0,06W 0603	Philips	2322 702 60479	40-14700-121	1
R114	56 Ohm 5% 0,06W 0603	Philips	2322 702 60569	40-15600-121	1
R115	100k Ohm 5% 0,06W 0603	Philips	2322 702 60104	40-51000-121	1
R116	10k Ohm 5% 0,06W 0603	Philips	2322 702 60103	40-41000-121	1
R117	10k Ohm 5% 0,06W 0603	Philips	2322 702 60103	40-41000-121	1
R118	8,2k Ohm 5% 0,06W 0603	Phycomp	2322 702 60822	40-38200-121	1
R119	5,6k Ohm 5% 0,06W 0603	Philips	2322 702 60562	40-35600-121	1
R120	10k Ohm 5% 0,06W 0603	Philips	2322 702 60103	40-41000-121	1
R121	100k Ohm 5% 0,06W 0603	Philips	2322 702 60104	40-51000-121	1
R122	56 Ohm 5% 0,06W 0603	Philips	2322 702 60569	40-15600-121	1
R123	47 Ohm 5% 0,06W 0603	Philips	2322 702 60479	40-14700-121	1
R124	820 Ohm 5% 0,06W 0603	Phycomp	2322 702 60821	40-28200-121	1
R125	22 Ohm 5% 0,06W 0603	Philips	2322 702 60229	40-12200-121	1

08-06039-001 - RF/IF & Synthesiser PCB

BOM Revision
Date Valid On

06 -- Production
17.06.2008

Ref	Description	Manufacturer	Manufacturer's P/N	Codan P/N	Qty
R126	220 Ohm 5% 0,06W 0603	Philips	2322 702 60221	40-22200-121	1
R128	22 Ohm 5% 0,06W 0603	Philips	2322 702 60229	40-12200-121	1
R129	820 Ohm 5% 0,06W 0603	Phycomp	2322 702 60821	40-28200-121	1
R130	47 Ohm 5% 0,06W 0603	Philips	2322 702 60479	40-14700-121	1
R131	47 Ohm 5% 0,06W 0603	Philips	2322 702 60479	40-14700-121	1
R132	560 Ohm 5% 0,06W 0603	Philips	2322 702 60561	40-25600-121	1
R133	470k Ohm 5% 0,06W 0603	Phycomp	2322 702 60474	40-54700-121	1
R134	220 Ohm 5% 0,1W 0805	Philips	2322 730 61221	40-22200-111	1
R135	470k Ohm 5% 0,06W 0603	Phycomp	2322 702 60474	40-54700-121	1
R136	220 Ohm 5% 0,1W 0805	Philips	2322 730 61221	40-22200-111	1
R137	470k Ohm 5% 0,06W 0603	Phycomp	2322 702 60474	40-54700-121	1
R138	270 Ohm 5% 0,1W 0805	Philips	2322 730 61271	40-22700-111	1
R139	33 Ohm 5% 0,06W 0603	Philips	2322 702 60339	40-13300-121	1
R140	560 Ohm 5% 0,06W 0603	Philips	2322 702 60561	40-25600-121	1
R141	470 Ohm 5% 0,06W 0603	Philips	2322 702 60471	40-24700-121	1
R142	3,3k Ohm 5% 0,06W 0603	Philips	2322 702 60332	40-33300-121	1
R143	3,3k Ohm 5% 0,06W 0603	Philips	2322 702 60332	40-33300-121	1
R144	100k Ohm 5% 0,06W 0603	Philips	2322 702 60104	40-51000-121	1
R145	100k Ohm 5% 0,06W 0603	Philips	2322 702 60104	40-51000-121	1
R146	10k Ohm 5% 0,06W 0603	Philips	2322 702 60103	40-41000-121	1
R147	100 Ohm 5% 0,06W 0603	Philips	2322 702 60101	40-21000-121	1
R148	100 Ohm 5% 0,06W 0603	Philips	2322 702 60101	40-21000-121	1
R149	680 Ohm 5% 0,06W 0603	Philips	2322 702 60681	40-26800-121	1
R150	4,7k Ohm 5% 0,06W 0603	Philips	2322 702 60472	40-34700-121	1
R151	100 Ohm 5% 0,06W 0603	Philips	2322 702 60101	40-21000-121	1
R152	100k Ohm 5% 0,06W 0603	Philips	2322 702 60104	40-51000-121	1
R153	15k Ohm 5% 0,06W 0603	Philips	2322 702 60153	40-41500-121	1
R154	Pot,5k Lin MG Trim SMD	Bourns	3314 J-1-502	42-35004-000	1
R155	8,2k Ohm 5% 0,06W 0603	Phycomp	2322 702 60822	40-38200-121	1
R156	8,2k Ohm 5% 0,06W 0603	Phycomp	2322 702 60822	40-38200-121	1
R200	470k Ohm 5% 0,06W 0603	Phycomp	2322 702 60474	40-54700-121	1
R201	100k Ohm 5% 0,06W 0603	Philips	2322 702 60104	40-51000-121	1
R202	10M Ohm 5% 0,06W 0603	Jageo	RC0603JR-07 10ML	40-71000-121	1
R203	100k Ohm 5% 0,06W 0603	Philips	2322 702 60104	40-51000-121	1
R204	1 Ohm 5% 0,06W 0603	Phycomp	2322 702 60108	40-01000-121	1
R205	100k Ohm 1% 0,1W 0805	Philips	2322 734 61004	40-51000-115	1
R206	10k Ohm 5% 0,06W 0603	Philips	2322 702 60103	40-41000-121	1
R207	1k Ohm 5% 0,06W 0603	Philips	2322 702 60102	40-31000-121	1
R208	100k Ohm 5% 0,06W 0603	Philips	2322 702 60104	40-51000-121	1
R209	100k Ohm 1% 0,1W 0805	Philips	2322 734 61004	40-51000-115	1
R210	33k Ohm 5% 0,06W 0603	Philips	2322 702 60333	40-43300-121	1
R211	5,6k Ohm 5% 0,06W 0603	Philips	2322 702 60562	40-35600-121	1
R212	4,7k Ohm 5% 0,06W 0603	Philips	2322 702 60472	40-34700-121	1
R213	3,3k Ohm 5% 0,06W 0603	Philips	2322 702 60332	40-33300-121	1
R214	3,3k Ohm 5% 0,06W 0603	Philips	2322 702 60332	40-33300-121	1
R215	3,3k Ohm 5% 0,06W 0603	Philips	2322 702 60332	40-33300-121	1
R216	3,3k Ohm 5% 0,06W 0603	Philips	2322 702 60332	40-33300-121	1
R217	3,3k Ohm 5% 0,06W 0603	Philips	2322 702 60332	40-33300-121	1
R218	3,3k Ohm 5% 0,06W 0603	Philips	2322 702 60332	40-33300-121	1
R219	22k Ohm 5% 0,06W 0603	Philips	2322 702 60223	40-42200-121	1
R220	3,3k Ohm 5% 0,06W 0603	Philips	2322 702 60332	40-33300-121	1
R221	1k Ohm 5% 0,06W 0603	Philips	2322 702 60102	40-31000-121	1
R223	100k Ohm 5% 0,06W 0603	Philips	2322 702 60104	40-51000-121	1
R224	15k Ohm 5% 0,06W 0603	Philips	2322 702 60153	40-41500-121	1
R225	100k Ohm 1% 0,1W 0805	Philips	2322 734 61004	40-51000-115	1
R226	100 Ohm 5% 0,06W 0603	Philips	2322 702 60101	40-21000-121	1
R227	33k Ohm 5% 0,06W 0603	Philips	2322 702 60333	40-43300-121	1
R228	100 Ohm 5% 0,06W 0603	Philips	2322 702 60101	40-21000-121	1

08-06039-001 - RF/IF & Synthesiser PCB

BOM Revision
Date Valid On

06 -- Production
17.06.2008

Ref	Description	Manufacturer	Manufacturer's P/N	Codan P/N	Qty
R229	47k Ohm 5% 0,06W 0603	Philips	2322 702 60473	40-44700-121	1
R230	47k Ohm 5% 0,06W 0603	Philips	2322 702 60473	40-44700-121	1
R231	120k Ohm 5% 0,06W 0603	Philips	2322 702 60124	40-51200-121	1
R232	82k Ohm 5% 0,06W 0603	Philips	2322 702 60823	40-48200-121	1
R233	22k Ohm 5% 0,06W 0603	Philips	2322 702 60223	40-42200-121	1
R234	20k Ohm 1% 0,06W 0603	Phycomp	2322 704 62003	40-42000-125	1
R235	1k Ohm 5% 0,06W 0603	Philips	2322 702 60102	40-31000-121	1
R236	1M Ohm 5% 0,06W 0603	Philips	2322 702 60105	40-61000-121	1
R237	68k Ohm 5% 0,06W 0603	Philips	2322 702 60683	40-46800-121	1
R238	1M Ohm 5% 0,06W 0603	Philips	2322 702 60105	40-61000-121	1
R239	100k Ohm 5% 0,06W 0603	Philips	2322 702 60104	40-51000-121	1
R240	100k Ohm 5% 0,06W 0603	Philips	2322 702 60104	40-51000-121	1
R241	0 Ohm Jumper 0603	Philips	2322 702 96001	40-00001-121	1
R242	15k Ohm 5% 0,06W 0603	Philips	2322 702 60153	40-41500-121	1
R243	15k Ohm 5% 0,06W 0603	Philips	2322 702 60153	40-41500-121	1
R244	0 Ohm Jumper 0603	Philips	2322 702 96001	40-00001-121	1
R245	100 Ohm 5% 0,06W 0603	Philips	2322 702 60101	40-21000-121	1
R246	2,2k Ohm 5% 0,06W 0603	Philips	2322 702 60222	40-32200-121	1
R247	1M Ohm 5% 0,06W 0603	Philips	2322 702 60105	40-61000-121	1
R248	470 Ohm 5% 0,06W 0603	Philips	2322 702 60471	40-24700-121	1
R249	4,7k Ohm 5% 0,06W 0603	Philips	2322 702 60472	40-34700-121	1
R250	470 Ohm 5% 0,06W 0603	Philips	2322 702 60471	40-24700-121	1
R251	4,7k Ohm 5% 0,06W 0603	Philips	2322 702 60472	40-34700-121	1
R252	470 Ohm 5% 0,06W 0603	Philips	2322 702 60471	40-24700-121	1
R253	15k Ohm 5% 0,06W 0603	Philips	2322 702 60153	40-41500-121	1
R254	10k Ohm 5% 0,06W 0603	Philips	2322 702 60103	40-41000-121	1
R255	150 Ohm 5% 0,06W 0603	Philips	2322 702 60151	40-21500-121	1
R256	560 Ohm 5% 0,06W 0603	Philips	2322 702 60561	40-25600-121	1
R257	10 Ohm 5% 0,06W 0603	Philips	2322 702 60109	40-11000-121	1
R258	470 Ohm 5% 0,06W 0603	Philips	2322 702 60471	40-24700-121	1
R259	100 Ohm 5% 0,06W 0603	Philips	2322 702 60101	40-21000-121	1
R260	220 Ohm 5% 0,06W 0603	Philips	2322 702 60221	40-22200-121	1
R261	150k Ohm 1% 0,06W 0603	Phycomp	2322 704 61504	40-51500-125	1
R262	100 Ohm 5% 0,06W 0603	Philips	2322 702 60101	40-21000-121	1
R263	100k Ohm 1% 0,06W 0603	Phycomp	2322 704 61004	40-51000-125	1
R264	2,7k Ohm 1% 0,06W 0603	Phycomp	2322 704 62702	40-32700-125	1
R265	470 Ohm 1% 0,1W 0805	Philips	2322 734 64701	40-24700-115	1
R266	10k Ohm 5% 0,06W 0603	Philips	2322 702 60103	40-41000-121	1
R267	1M Ohm 5% 0,06W 0603	Philips	2322 702 60105	40-61000-121	1
R268	560k Ohm 5% 0,1W 0805	Philips	2322 730 61564	40-55600-111	1
R269	680 Ohm 1% 0,06W 0603	Philips	2322 704 66801	40-26800-125	1
R270	33k Ohm 1% 0,1W 0805	Philips	2322 734 63303	40-43300-115	1
R271	30k Ohm 1% 0,1W 0805	Philips	2322 734 63003	40-43000-115	1
R272	680 Ohm 10% NTC Thermistor	Philips	2322 640 63681	41-02684-642	1
R273	470 Ohm 5% 0,06W 0603	Philips	2322 702 60471	40-24700-121	1
R274	820 Ohm 5% 0,06W 0603	Phycomp	2322 702 60821	40-28200-121	1
R275	10k Ohm 5% 0,06W 0603	Philips	2322 702 60103	40-41000-121	1
R276	8,2k Ohm 5% 0,06W 0603	Phycomp	2322 702 60822	40-38200-121	1
R277	3,3k Ohm 5% 0,06W 0603	Philips	2322 702 60332	40-33300-121	1
R278	1M Ohm 5% 0,06W 0603	Philips	2322 702 60105	40-61000-121	1
R279	Pot,10k Lin MG Trim SMD	Bourns	3314 J-1-103	42-41004-000	1
R280	2,2k Ohm 5% 0,06W 0603	Philips	2322 702 60222	40-32200-121	1
R281	1,2k Ohm 5% 0,06W 0603	Philips	2322 702 60122	40-31200-121	1
R282	4,7k Ohm 5% 0,06W 0603	Philips	2322 702 60472	40-34700-121	1
R283	1k Ohm 5% 0,06W 0603	Philips	2322 702 60102	40-31000-121	1
R284	1,8k Ohm 5% 0,06W 0603	Philips	2322 702 60182	40-31800-121	1
R285	100 Ohm 5% 0,06W 0603	Philips	2322 702 60101	40-21000-121	1
R286	100k Ohm 5% 0,06W 0603	Philips	2322 702 60104	40-51000-121	1

08-06039-001 - RF/IF & Synthesiser PCB

BOM Revision
Date Valid On

06 -- Production
17.06.2008

Ref	Description	Manufacturer	Manufacturer's P/N	Codan P/N	Qty
R287	20k Ohm 1% 0,06W 0603	Phycomp	2322 704 62003	40-42000-125	1
R288	43k Ohm 1% 0,1W 0805	Philips	2322 734 64303	40-44300-115	1
R289	100k Ohm 5% 0,06W 0603	Philips	2322 702 60104	40-51000-121	1
R290	100 Ohm 5% 0,06W 0603	Philips	2322 702 60101	40-21000-121	1
R291	100 Ohm 5% 0,06W 0603	Philips	2322 702 60101	40-21000-121	1
R292	100 Ohm 5% 0,06W 0603	Philips	2322 702 60101	40-21000-121	1
R293	100 Ohm 5% 0,06W 0603	Philips	2322 702 60101	40-21000-121	1
R294	15k Ohm 5% 0,06W 0603	Philips	2322 702 60153	40-41500-121	1
R295	15k Ohm 5% 0,06W 0603	Philips	2322 702 60153	40-41500-121	1
R296	100k Ohm 5% 0,06W 0603	Philips	2322 702 60104	40-51000-121	1
R297	10k Ohm 5% 0,06W 0603	Philips	2322 702 60103	40-41000-121	1
R298	10k Ohm 5% 0,06W 0603	Philips	2322 702 60103	40-41000-121	1
R299	470k Ohm 1% 0,1W 0805	Philips	2322 734 64704	40-54700-115	1
R301	220 Ohm 5% 0,06W 0603	Philips	2322 702 60221	40-22200-121	1
R302	1M Ohm 5% 0,06W 0603	Philips	2322 702 60105	40-61000-121	1
R303	470 Ohm 5% 0,06W 0603	Philips	2322 702 60471	40-24700-121	1
R304	100 Ohm 5% 0,06W 0603	Philips	2322 702 60101	40-21000-121	1
R306	10k Ohm 5% 0,06W 0603	Philips	2322 702 60103	40-41000-121	1
R308	22 Ohm 5% 0,06W 0603	Philips	2322 702 60229	40-12200-121	1
R309	1k Ohm 5% 0,06W 0603	Philips	2322 702 60102	40-31000-121	1
R310	390 Ohm 5% 0,06W 0603	Philips	2322-702-60391	40-23900-121	1
R311	1k Ohm 5% 0,06W 0603	Philips	2322 702 60102	40-31000-121	1
R312	10 Ohm 5% 0,06W 0603	Philips	2322 702 60109	40-11000-121	1
R313	120 Ohm 5% 0,06W 0603	Philips	2322 702 60121	40-21200-121	1
R314	330 Ohm 5% 0,06W 0603	Philips	2322 702 60331	40-23300-121	1
R315	3,3k Ohm 5% 0,06W 0603	Philips	2322 702 60332	40-33300-121	1
R316	330 Ohm 5% 0,06W 0603	Philips	2322 702 60331	40-23300-121	1
R317	330 Ohm 5% 0,06W 0603	Philips	2322 702 60331	40-23300-121	1
R318	470 Ohm 5% 0,06W 0603	Philips	2322 702 60471	40-24700-121	1
R319	390 Ohm 5% 0,06W 0603	Philips	2322-702-60391	40-23900-121	1
R320	390 Ohm 5% 0,06W 0603	Philips	2322-702-60391	40-23900-121	1
R321	100 Ohm 5% 0,06W 0603	Philips	2322 702 60101	40-21000-121	1
R322	1,8k Ohm 5% 0,06W 0603	Philips	2322 702 60182	40-31800-121	1
R323	3,9k Ohm 5% 0,06W 0603	Philips	2322 702 60392	40-33900-121	1
R324	4,7k Ohm 5% 0,06W 0603	Philips	2322 702 60472	40-34700-121	1
R325	3,9k Ohm 5% 0,06W 0603	Philips	2322 702 60392	40-33900-121	1
R326	100 Ohm 5% 0,06W 0603	Philips	2322 702 60101	40-21000-121	1
R327	2,2k Ohm 5% 0,06W 0603	Philips	2322 702 60222	40-32200-121	1
R328	3,3k Ohm 5% 0,06W 0603	Philips	2322 702 60332	40-33300-121	1
R329	4,7k Ohm 5% 0,06W 0603	Philips	2322 702 60472	40-34700-121	1
R330	1M Ohm 5% 0,06W 0603	Philips	2322 702 60105	40-61000-121	1
R331	47k Ohm 5% 0,06W 0603	Philips	2322 702 60473	40-44700-121	1
R332	10 Ohm 5% 0,06W 0603	Philips	2322 702 60109	40-11000-121	1
R334	100 Ohm 5% 0,06W 0603	Philips	2322 702 60101	40-21000-121	1
R335	1k Ohm 5% 0,06W 0603	Philips	2322 702 60102	40-31000-121	1
R336	10k Ohm 5% 0,06W 0603	Philips	2322 702 60103	40-41000-121	1
R337	100k Ohm 5% 0,06W 0603	Philips	2322 702 60104	40-51000-121	1
R338	10k Ohm 5% 0,06W 0603	Philips	2322 702 60103	40-41000-121	1
R339	10k Ohm 5% 0,06W 0603	Philips	2322 702 60103	40-41000-121	1
R340	270 Ohm 5% 0,1W 0805	Philips	2322 730 61271	40-22700-111	1
R341	4,7k Ohm 5% 0,06W 0603	Philips	2322 702 60472	40-34700-121	1
R342	8,2k Ohm 5% 0,06W 0603	Phycomp	2322 702 60822	40-38200-121	1
R343	22 Ohm 5% 0,06W 0603	Philips	2322 702 60229	40-12200-121	1
R344	390 Ohm 5% 0,06W 0603	Philips	2322-702-60391	40-23900-121	1
R345	22 Ohm 5% 0,06W 0603	Philips	2322 702 60229	40-12200-121	1
R346	4,7k Ohm 5% 0,1W 0805	Philips	2322 730 61472	40-34700-111	1
R347	22 Ohm 5% 0,1W 0805	Philips	2322 730 61229	40-12200-111	1
R348	1k Ohm 5% 0,06W 0603	Philips	2322 702 60102	40-31000-121	1

08-06039-001 - RF/IF & Synthesiser PCB

BOM Revision
Date Valid On

06 -- Production
17.06.2008

Ref	Description	Manufacturer	Manufacturer's P/N	Codan P/N	Qty
R350	150 Ohm 5% 0,06W 0603	Philips	2322 702 60151	40-21500-121	1
R355	22 Ohm 5% 0,1W 0805	Philips	2322 730 61229	40-12200-111	1
R356	22 Ohm 5% 0,06W 0603	Philips	2322 702 60229	40-12200-121	1
R357	5,6k Ohm 5% 0,1W 0805	Philips	2322 730 61562	40-35600-111	1
R358	390 Ohm 5% 0,06W 0603	Philips	2322-702-60391	40-23900-121	1
R359	1k Ohm 5% 0,06W 0603	Philips	2322 702 60102	40-31000-121	1
R360	1k Ohm 5% 0,06W 0603	Philips	2322 702 60102	40-31000-121	1
R361	1k Ohm 5% 0,06W 0603	Philips	2322 702 60102	40-31000-121	1
R362	1k Ohm 5% 0,06W 0603	Philips	2322 702 60102	40-31000-121	1
R363	1k Ohm 5% 0,06W 0603	Philips	2322 702 60102	40-31000-121	1
R364	1M Ohm 5% 0,06W 0603	Philips	2322 702 60105	40-61000-121	1
R365	6,8k Ohm 5% 0,06W 0603	Philips	2322 702 60682	40-36800-121	1
R366	6,8k Ohm 5% 0,06W 0603	Philips	2322 702 60682	40-36800-121	1
R367	5,6k Ohm 5% 0,06W 0603	Philips	2322 702 60562	40-35600-121	1
R368	470 Ohm 5% 0,06W 0603	Philips	2322 702 60471	40-24700-121	1
R369	470 Ohm 5% 0,06W 0603	Philips	2322 702 60471	40-24700-121	1
R370	10k Ohm 5% 0,06W 0603	Philips	2322 702 60103	40-41000-121	1
R371	10k Ohm 5% 0,06W 0603	Philips	2322 702 60103	40-41000-121	1
R372	390 Ohm 5% 0,06W 0603	Philips	2322-702-60391	40-23900-121	1
R373	2,2k Ohm 5% 0,06W 0603	Philips	2322 702 60222	40-32200-121	1
R374	10k Ohm 5% 0,06W 0603	Philips	2322 702 60103	40-41000-121	1
R376	10k Ohm 5% 0,06W 0603	Philips	2322 702 60103	40-41000-121	1
R402	100k Ohm 5% 0,06W 0603	Philips	2322 702 60104	40-51000-121	1
R403	470 Ohm 5% 0,06W 0603	Philips	2322 702 60471	40-24700-121	1
R502	100k Ohm 5% 0,06W 0603	Philips	2322 702 60104	40-51000-121	1
R503	470 Ohm 5% 0,06W 0603	Philips	2322 702 60471	40-24700-121	1
T101	Txfr, RF Amp	Protran	44-80263	44-80263	1
T102	Txfr, Rcvr I/P	Codan	44-80204	44-80204	1
T103	Transformer, Mixer Drive	Protran	44-80313	44-80313	1
T104	Balun	Protran	44-80262	44-80262	1
T105	Txfr, Rcvr I/P	Codan	44-80204	44-80204	1
T106	Transformer, Mixer Drive	Protran	44-80313	44-80313	1
T107	Balun	Protran	44-80262	44-80262	1
T201	Ind, Buffer Output	Koilkraft	44-70487	44-70487	1
V101	Transistor, NPN Si SOT23	Philips	BFR92A	BFR92A	1
V102	MOSFET, N Channel Enhanced SOT23	Fairchild	BSS138	BSS138	1
V103	MOSFET, N Channel Enhanced SOT23	Fairchild	BSS138	BSS138	1
V104	Transistor, PNP Si SOT23	Philips	BFT92	BFT92	1
V105	Transistor, PNP Si SOT23	Philips	BFT92	BFT92	1
V106	JFET, N Channel SOT23	Philips	PMBFJ309-215	PMBFJ309	1
V107	JFET, N Channel SOT23	Philips	PMBFJ309-215	PMBFJ309	1
V108	JFET, N Channel SOT23	Philips	PMBFJ309-215	PMBFJ309	1
V109	Transistor, PNP Si SOT23	Philips	BFT92	BFT92	1
V110	Transistor, PNP Si SOT23	Philips	BFT92	BFT92	1
V111	Transistor, PNP Si SOT23	Philips	BC857	BC857	1
V112	MOSFET, N Channel Enhanced SOT23	Fairchild	BSS138	BSS138	1
V113	JFET, N Channel SOT23	Philips	PMBFJ309-215	PMBFJ309	1
V114	MOSFET, N Channel Enhanced SOT23	Fairchild	BSS138	BSS138	1
V115	Transistor, NPN Si SOT23	Philips	BFR92A	BFR92A	1
V116	MOSFET, N Channel Enhanced SOT23	Fairchild	BSS138	BSS138	1
V117	Transistor, NPN Si SOT23	Philips	BC847	BC847	1
V118	JFET, N Channel SOT23	Philips	PMBFJ309-215	PMBFJ309	1
V119	JFET, N Channel SOT23	Philips	PMBFJ309-215	PMBFJ309	1
V203	MOSFET, N Channel Enhanced SOT23	Fairchild	BSS138	BSS138	1
V204	MOSFET, P Channel Enhanced SOT23	Philips	BSH201	BSH201	1
V205	Transistor, PNP Si SOT23	Philips	BC857	BC857	1
V206	Transistor, NPN Si SOT23	Philips	BC847	BC847	1
V207	MOSFET, N Channel Enhanced SOT23	Fairchild	BSS138	BSS138	1

08-06039-001 - RF/IF & Synthesiser PCB

BOM Revision
Date Valid On

06 -- Production
17.06.2008

Ref	Description	Manufacturer	Manufacturer's P/N	Codan P/N	Qty
V208	MOSFET, N Chan Enhance SOT143	Philips	BSS83	BSS83	1
V209	MOSFET, N Chan Enhance SOT143	Philips	BSS83	BSS83	1
V210	MOSFET, N Channel Enhanced SOT23	Fairchild	BSS138	BSS138	1
V211	MOSFET, N Channel Enhanced SOT23	Fairchild	BSS138	BSS138	1
V212	MOSFET, N Channel Enhanced SOT23	Fairchild	BSS138	BSS138	1
V213	MOSFET, N Channel Enhanced SOT23	Fairchild	BSS138	BSS138	1
V214	JFET, N Channel SOT23	Philips	BF545B	BF545B	1
V215	JFET, N Channel SOT23	Philips	BF545B	BF545B	1
V216	JFET, N Channel SOT23	Philips	BF545B	BF545B	1
V217	Transistor, PNP Si SOT23	Philips	BF550.215	BF550	1
V218	Transistor, NPN Si SOT23	Philips	BC847	BC847	1
V219	MOSFET, N Channel Dual 20V 0,5A SOT363	Vishay	SI1902DL	SI1902DL	1
V220	Transistor, NPN Si SOT23	Philips	BFR92A	BFR92A	1
V221	Transistor, NPN Si SOT23	Philips	BC847	BC847	1
V222	Transistor, NPN Si SOT23	Philips	BC847	BC847	1
V223	Transistor, NPN Si SOT23	Philips	BC850C	BC850C	1
V224	Transistor, NPN Si SOT23	Philips	BC850C	BC850C	1
V225	Transistor, NPN Si SOT23	Philips	BC850C	BC850C	1
V226	MOSFET, N Channel Dual 20V 0,5A SOT363	Vishay	SI1902DL	SI1902DL	1
V301	JFET, N Channel SOT23	Philips	BF556B	BF556B	1
V302	Transistor, NPN Si SOT23	Philips	BC847	BC847	1
V303	Transistor, PNP Si SOT23	Philips	BFT92	BFT92	1
V304	Transistor, NPN Si SOT23	Philips	BFR92A	BFR92A	1
V305	Transistor, NPN Si SOT23	Philips	BFR92A	BFR92A	1
V306	Transistor, PNP Si SOT23	Philips	BC857	BC857	1
V307	Transistor, NPN Si SOT23	Philips	BC847	BC847	1
V308	Transistor, PNP Si SOT23	Philips	BFT92	BFT92	1
V309	Transistor, NPN Si SOT23	Philips	BC847	BC847	1
V310	Transistor, NPN Si SOT23	Philips	BC847	BC847	1
V311	Transistor, NPN Si SOT23	Philips	BC847	BC847	1
V313	Transistor, NPN Si SOT23	Philips	BC847	BC847	1
V314	Transistor, PNP Si SOT23	Philips	BC857	BC857	1
V401	MOSFET, N Channel Enhanced SOT23	Fairchild	BSS138	BSS138	1
V402	MOSFET, P Channel Enhanced SOT23	Philips	BSH201	BSH201	1
V403	MOSFET, N Channel Enhanced SOT23	Fairchild	BSS138	BSS138	1
V501	MOSFET, N Channel Enhanced SOT23	Fairchild	BSS138	BSS138	1
V502	MOSFET, P Channel Enhanced SOT23	Philips	BSH201	BSH201	1
V503	MOSFET, N Channel Enhanced SOT23	Fairchild	BSS138	BSS138	1
Z101	Filter, 45- MHz 4Pole 15 kHz BW	UNIDEN	UMF-7344	65-91115-000	1
Z102	Filter, 45- MHz 4Pole 15 kHz BW	UNIDEN	UMF-7344	65-91115-000	1
Z201	Filter, 455kHz 2,4kHz min.	Murata	CFJ455K5	65-91124	1

08-06163-000 - Ref Oscillator PCB Com Parts

BOM Revision
Date Valid On

01 -- Production
17.06.2008

Ref	Description	Manufacturer	Manufacturer's P/N	Codan P/N	Qty
	Ref Osc 14,8483MHz 1,5ppm PCB			08-06163	1
	Ref Oscillator 14,8483MHz			04-03477	1
1	PCB, Reference Oscillator	IMP	07-02052-01	07-02052-01	1
C1	10u 20% 25V 6032 TA Cap	AVX	TAJC106M025R	47-11002-520	1
C2	33n 10% 25V X7R 0603 NiSn	Vitramon	VJ0603Y333KXXT	46-43300-282	1
H1	LED, Green Ultra Pure 1206	Apex Science	RY-SP350UYG24-5M	65-61110-510	1
IC1	Reg. Voltage +3,3V 150mA LDO SOT23-5	Texas Instruments	TPS76333DBVT	XB-76333-700	1
IC2	Diode, Ref 2,5V 0,5% SOT23	National Semiconduct	LM4040CIM3-2.5	XB-04040-700	1
R1	2,7k Ohm 5% 0,06W 0603	Philips	2322 702 60272	40-32700-121	1
R2	Pot,10k Lin MG Trim SMD	Bourns	3314 J-1-103	42-41004-000	1
R3	15k Ohm 5% 0,06W 0603	Philips	2322 702 60153	40-41500-121	1
R4	5,6k Ohm 5% 0,06W 0603	Philips	2322 702 60562	40-35600-121	1
R5	5,6k Ohm 5% 0,06W 0603	Philips	2322 702 60562	40-35600-121	1

08-06163-001 - Ref Osc 14,8483MHz 1,5ppm PCB

BOM Revision
Date Valid On

01 -- Production
 17.06.2008

Ref	Description	Manufacturer	Manufacturer's P/N	Codan P/N	Qty
	Ref Osc 14,8483MHz 1,5ppm PCB			08-06163	1
	Ref Oscillator 14,8483MHz			04-03477	1
1	PCB, Reference Oscillator	IMP	07-02052-01	07-02052-01	1
C1	10u 20% 25V 6032 TA Cap	AVX	TAJC106M025R	47-11002-520	1
C2	33n 10% 25V X7R 0603 NiSn	Vitramon	VJ0603Y333KXXT	46-43300-282	1
H1	LED, Green Ultra Pure 1206	Apex Science	RY-SP350UYG24-5M	65-61110-510	1
IC1	Reg. Voltage +3,3V 150mA LDO SOT23-5	Texas Instruments	TPS76333DBVT	XB-76333-700	1
IC2	Diode, Ref 2,5V 0,5% SOT23	National Semiconduct	LM4040CIM3-2.5	XB-04040-700	1
R1	2,7k Ohm 5% 0,06W 0603	Philips	2322 702 60272	40-32700-121	1
R2	Pot,10k Lin MG Trim SMD	Bourns	3314 J-1-103	42-41004-000	1
R3	15k Ohm 5% 0,06W 0603	Philips	2322 702 60153	40-41500-121	1
R4	5,6k Ohm 5% 0,06W 0603	Philips	2322 702 60562	40-35600-121	1
R5	5,6k Ohm 5% 0,06W 0603	Philips	2322 702 60562	40-35600-121	1
Z1	Osc, TCXO 14,848333MHz 1,5ppm	C-MAC	14.848333MHZ CFPT9058CU1A	78-15033	1

08-06163-002 - Ref Osc 14,8483MHz 0,5ppm PCB

BOM Revision
Date Valid On

01 -- Production
 17.06.2008

Ref	Description	Manufacturer	Manufacturer's P/N	Codan P/N	Qty
	Ref Osc 14,8483MHz 1,5ppm PCB			08-06163	1
	Ref Oscillator 14,8483MHz			04-03477	1
1	PCB, Reference Oscillator	IMP	07-02052-01	07-02052-01	1
C1	10u 20% 25V 6032 TA Cap	AVX	TAJC106M025R	47-11002-520	1
C2	33n 10% 25V X7R 0603 NiSn	Vitramon	VJ0603Y333KXXT	46-43300-282	1
H1	LED, Green Ultra Pure 1206	Apex Science	RY-SP350UYG24-5M	65-61110-510	1
IC1	Reg. Voltage +3,3V 150mA LDO SOT23-5	Texas Instruments	TPS76333DBVT	XB-76333-700	1
IC2	Diode, Ref 2,5V 0,5% SOT23	National Semiconduct	LM4040CIM3-2.5	XB-04040-700	1
R1	2,7k Ohm 5% 0,06W 0603	Philips	2322 702 60272	40-32700-121	1
R2	Pot,10k Lin MG Trim SMD	Bourns	3314 J-1-103	42-41004-000	1
R3	15k Ohm 5% 0,06W 0603	Philips	2322 702 60153	40-41500-121	1
R4	5,6k Ohm 5% 0,06W 0603	Philips	2322 702 60562	40-35600-121	1
R5	5,6k Ohm 5% 0,06W 0603	Philips	2322 702 60562	40-35600-121	1
Z1	Osc, TCXO 14,848333MHz 0,5ppm	C-MAC	14.848333MHZ CFPT9058EU1A	78-15032	1

08-06064-001 - PA & Filter PCB

BOM Revision
Date Valid On

06 -- Production
28.08.2008

Ref	Description	Manufacturer	Manufacturer's P/N	Codan P/N	Qty
	MRS, PA & Filter, 2110			01-01375	1
	MTS, PA & Filter, 2110			01-01383	1
	TP, PA & Filter			10-00956	1
	PA & Filter PCB			08-06064	1
	PA & Filter			04-03445	1
	PA & Filter PCB			11-06163	1
1	PCB, PA & Filter		07-02019-04	07-02019-04	1
2	Heatsink	Metalcraft	05-07374	05-07374	1
3	Label, Serial/Barcode	Codan	06-02068	06-02068	1
4	Screw, M3x8 304 SS Pan Pozi	RGA Fasteners	31-23008-580	31-23008-580	6
5	Lug, Solder 3,5mm	Cliford W Ltd	G410 CODE 330	61-30200-025	2
6	Stake, Terminal	Autosplice	7-22461-5	61-40300-004	4
7	Heat, Transfer Compound	Gensil	GENSIL 13 45gm Tube	71-31000-004	0.01
8	Tubing, Heatshrink 4,8x0,2 Bk	3M	FP-301 3/16" Black	71-80502-400	0.01
C1	3,3n 10% 100V X7R 0603 NiSn	Vishay	VJ0603Y332KXBAC	46-33300-282	1
C2	100n 10% 16V X7R 0603 NiSn	Vitramon	VJ0603Y104KXJT	46-51000-283	1
C3	180p 5% 500V NPO 1206 <1000		46-21800-088 selescted for 10-01095	46-21800-082	1
C4	39p 5% 500V NPO 1206 <1000	Obsolete	46-13900-088 selected for ESR 10-01095	46-13900-082	1
C7	220p 5% 50V NPO 0603 NiSn	Philips	0603CG221C9BB00	46-22200-083	1
C8	56p 5% 500V NPO 1206 <1000	Obsolete	46-15600-088 selected for ESR 10-01095	46-15600-082	1
C9	100p 5% 500V NPO 1206 <1000	Obsolete	46-21000-088 selected for ESR 10-01095	46-21000-082	1
C10	10p 5% 500V NPO 1206 <1000	Obsolete	46-11000-088 selected for ESR 10-01095	46-11000-082	1
C11	56p 5% 500V NPO 1206 <1000	Obsolete	46-15600-088 selected for ESR 10-01095	46-15600-082	1
C12	100p 5% 500V NPO 1206 <1000	Obsolete	46-21000-088 selected for ESR 10-01095	46-21000-082	1
C13	27p 5% 500V NPO 1206 <1000	Obsolete	46-12700-088 selected for ESR 10-01095	46-12700-082	1
C14	15p 5% 500V NPO 1206 <1000	Obsolete	46-11500-088 selected for ESR 10-01095	46-11500-082	1
C15	68p 5% 500V NPO 1206 <1000	Obsolete	46-16800-088 selected for ESR 10-01095	46-16800-082	1
C16	82p 5% 500V NPO 1206 <1000	Obsolete	46-18200-088 selected for ESR 10-01095	46-18200-082	1
C17	100p 5% 500V NPO 1206 <1000	Obsolete	46-21000-088 selected for ESR 10-01095	46-21000-082	1
C18	56p 5% 500V NPO 1206 <1000	Obsolete	46-15600-088 selected for ESR 10-01095	46-15600-082	1
C19	68p 5% 500V NPO 1206 <1000	Obsolete	46-16800-088 selected for ESR 10-01095	46-16800-082	1
C20	120p 5% 500V NPO 1206 <400		46-21200-088 selected for ESR 10-01095	46-21200-0820	1
C21	15p 5% 500V NPO 1206 <1000	Obsolete	46-11500-088 selected for ESR 10-01095	46-11500-082	1
C22	180p 5% 500V NPO 1206 <1000		46-21800-088 selescted for 10-01095	46-21800-082	1
C23	56p 5% 500V NPO 1206 <1000	Obsolete	46-15600-088 selected for ESR 10-01095	46-15600-082	1
C24	120p 5% 500V NPO 1206 <1000	Obsolete	46-21200-088 selected for ESR 10-01095	46-21200-082	1
C25	100p 5% 500V NPO 1206 <1000	Obsolete	46-21000-088 selected for ESR 10-01095	46-21000-082	1

08-06064-001 - PA & Filter PCB

BOM Revision
Date Valid On

06 -- Production
28.08.2008

Ref	Description	Manufacturer	Manufacturer's P/N	Codan P/N	Qty
C26	56p 5% 500V NPO 1206 <1000	Obsolete	46-15600-088 selected for ESR 10-01095	46-15600-082	1
C27	33p 5% 500V NPO 1206 <1000	Obsolete	46-13300-088 selected for ESR 10-01095	46-13300-082	1
C28	220p 5% 500V NPO 1206 <1000	Obsolete	46-22200-088 selected for ESR 10-01095	46-22200-082	1
C29	120p 5% 500V NPO 1206 <1000	Obsolete	46-21200-088 selected for ESR 10-01095	46-21200-082	1
C30	180p 5% 500V NPO 1206 <1000		46-21800-088 selected for 10-01095	46-21800-082	1
C31	220p 5% 500V NPO 1206 <1000	Obsolete	46-22200-088 selected for ESR 10-01095	46-22200-082	1
C32	27p 5% 500V NPO 1206 <1000	Obsolete	46-12700-088 selected for ESR 10-01095	46-12700-082	1
C33	68p 5% 500V NPO 1206 <1000	Obsolete	46-16800-088 selected for ESR 10-01095	46-16800-082	1
C34	270p 5% 500V NPO 1206 <1000	Obsolete	46-22700-088 selected for ESR 10-01095	46-22700-082	1
C35	180p 5% 500V NPO 1206 <1000		46-21800-088 selected for 10-01095	46-21800-082	1
C36	220p 5% 500V NPO 1206 <1000	Obsolete	46-22200-088 selected for ESR 10-01095	46-22200-082	1
C37	330p 5% 500V NPO 1206 <1000	Obsolete	46-23300-088 selected for ESR 10-01095	46-23300-082	1
C38	18p 5% 500V NPO 1206 <1000		46-11800-088 selected for ESR 10-01095	46-11800-082	1
C39	120p 5% 500V NPO 1206 <1000	Obsolete	46-21200-088 selected for ESR 10-01095	46-21200-082	1
C40	390p 5% 500V NPO 1206 <1000	Obsolete	46-23900-088 selected for ESR 10-01095	46-23900-082	1
C41	220p 5% 500V NPO 1206 <1000	Obsolete	46-22200-088 selected for ESR 10-01095	46-22200-082	1
C42	330p 5% 500V NPO 1206 <1000	Obsolete	46-23300-088 selected for ESR 10-01095	46-23300-082	1
C43	46-24700-088 selected to 10-01095 <1000	Philips	1210CG471GBB-	46-24700-082	1
C44	10p 5% 500V NPO 1206 <1000	Obsolete	46-11000-088 selected for ESR 10-01095	46-11000-082	1
C45	180p 5% 500V NPO 1206 <1000		46-21800-088 selected for 10-01095	46-21800-082	1
C46	46-24700-088 selected to 10-01095 <1000	Philips	1210CG471GBB-	46-24700-082	1
C47	390p 5% 500V NPO 1206 <1000	Obsolete	46-23900-088 selected for ESR 10-01095	46-23900-082	1
C48	330p 5% 500V NPO 1206 <1000	Obsolete	46-23300-088 selected for ESR 10-01095	46-23300-082	1
C49	46-24700-088 selected to 10-01095 <1000	Philips	1210CG471GBB-	46-24700-082	1
C50	56p 5% 500V NPO 1206 <1000	Obsolete	46-15600-088 selected for ESR 10-01095	46-15600-082	1
C51	46-24700-088 selected to 10-01095 <1000	Philips	1210CG471GBB-	46-24700-082	1
C52	180p 5% 500V NPO 1206 <1000		46-21800-088 selected for 10-01095	46-21800-082	1
C53	46-24700-088 selected to 10-01095 <1000	Philips	1210CG471GBB-	46-24700-082	1
C54	46-24700-088 selected to 10-01095 <1000	Philips	1210CG471GBB-	46-24700-082	1

08-06064-001 - PA & Filter PCB

BOM Revision
Date Valid On

06 -- Production
28.08.2008

Ref	Description	Manufacturer	Manufacturer's P/N	Codan P/N	Qty
C55	330p 5% 500V NPO 1206 <1000	Obsolete	46-23300-088 selected for ESR 10-01095	46-23300-082	1
C56	46-24700-088 selected to 10-01095 <1000	Philips	1210CG471GBB-	46-24700-082	1
C57	46-24700-088 selected to 10-01095 <1000	Philips	1210CG471GBB-	46-24700-082	1
C58	390p 5% 500V NPO 1206 <1000	Obsolete	46-23900-088 selected for ESR 10-01095	46-23900-082	1
C59	33n 10% 25V X7R 0603 NiSn	Vitramon	VJ0603Y333KXXT	46-43300-282	1
C60	100n 10% 16V X7R 0603 NiSn	Vitramon	VJ0603Y104KXJT	46-51000-283	1
C61	100n 10% 16V X7R 0603 NiSn	Vitramon	VJ0603Y104KXJT	46-51000-283	1
C62	33n 10% 25V X7R 0603 NiSn	Vitramon	VJ0603Y333KXXT	46-43300-282	1
C63	22p 5% 100V NPO 0603 NiSn	Philips	0603CG220J0B200	46-12200-083	1
C64	33n 10% 25V X7R 0603 NiSn	Vitramon	VJ0603Y333KXXT	46-43300-282	1
C65	33n 10% 25V X7R 0603 NiSn	Vitramon	VJ0603Y333KXXT	46-43300-282	1
C66	100p 5% 50V NPO 0603 NiSn	Philips	0603CG101J9B200	46-21000-083	1
C67	100p 5% 50V NPO 0603 NiSn	Philips	0603CG101J9B200	46-21000-083	1
C68	100p 5% 50V NPO 0603 NiSn	Philips	0603CG101J9B200	46-21000-083	1
C69	10n 5% 50V X7R 0603 NiSn	Philips	06032R103J9BB00	46-41000-080	1
C70	100p 5% 50V NPO 0603 NiSn	Philips	0603CG101J9B200	46-21000-083	1
C71	10u 20% 25V 6032 TA Cap	AVX	TAJC106M025R	47-11002-520	1
C74	33n 10% 25V X7R 0603 NiSn	Vitramon	VJ0603Y333KXXT	46-43300-282	1
C75	33n 10% 25V X7R 0603 NiSn	Vitramon	VJ0603Y333KXXT	46-43300-282	1
C76	15p 5% 50V NPO 0603 NiSn	Philips	0603CG150C9BB00	46-11500-083	1
C77	10u 20% 25V 6032 TA Cap	AVX	TAJC106M025R	47-11002-520	1
C78	33n 10% 25V X7R 0603 NiSn	Vitramon	VJ0603Y333KXXT	46-43300-282	1
C79	100u 25V 105°C SMD EL Cap Low ESR	Nippon Chemicon	MVY25VC100MF80	48-21002-502	1
C80	33n 10% 25V X7R 0603 NiSn	Vitramon	VJ0603Y333KXXT	46-43300-282	1
C81	470n 10% 63V PE Cap	Philips	2222 370 18474	46-54700-521	1
C82	100n 10% 16V X7R 0603 NiSn	Vitramon	VJ0603Y104KXJT	46-51000-283	1
C83	100p 5% 50V NPO 0603 NiSn	Philips	0603CG101J9B200	46-21000-083	1
C84	1u 10% 16V X7R 1206 NiSn	Philips	12062R105K7BB00	46-61000-280	1
C85	1u 10% 16V X7R 1206 NiSn	Philips	12062R105K7BB00	46-61000-280	1
C86	100p 5% 50V NPO 0603 NiSn	Philips	0603CG101J9B200	46-21000-083	1
C87	33n 10% 25V X7R 0603 NiSn	Vitramon	VJ0603Y333KXXT	46-43300-282	1
C88	33n 10% 25V X7R 0603 NiSn	Vitramon	VJ0603Y333KXXT	46-43300-282	1
C89	1u 10% 16V X7R 1206 NiSn	Philips	12062R105K7BB00	46-61000-280	1
C90	10u 20% 25V 6032 TA Cap	AVX	TAJC106M025R	47-11002-520	1
C91	100p 5% 50V NPO 0603 NiSn	Philips	0603CG101J9B200	46-21000-083	1
C92	33n 10% 25V X7R 0603 NiSn	Vitramon	VJ0603Y333KXXT	46-43300-282	1
C93	Not Fitted	Codan	**00000-001	99-00000-001	1
C94	33n 10% 25V X7R 0603 NiSn	Vitramon	VJ0603Y333KXXT	46-43300-282	1
C95	100n 10% 16V X7R 0603 NiSn	Vitramon	VJ0603Y104KXJT	46-51000-283	1
C96	100n 10% 50V X7R 0805 Nisn	Philips	08052R104K9BB	46-51000-282	1
C97	100n 10% 50V X7R 0805 Nisn	Philips	08052R104K9BB	46-51000-282	1
C98	33n 10% 25V X7R 0603 NiSn	Vitramon	VJ0603Y333KXXT	46-43300-282	1
C99	33n 10% 25V X7R 0603 NiSn	Vitramon	VJ0603Y333KXXT	46-43300-282	1
C100	100p 5% 50V NPO 0603 NiSn	Philips	0603CG101J9B200	46-21000-083	1
C101	33n 10% 25V X7R 0603 NiSn	Vitramon	VJ0603Y333KXXT	46-43300-282	1
C102	1u 20% 16V 3216 TA Cap	AVX	TAJA105M016R	47-01001-600	1
C103	100n 10% 50V X7R 0805 Nisn	Philips	08052R104K9BB	46-51000-282	1
C104	100n 10% 50V X7R 0805 Nisn	Philips	08052R104K9BB	46-51000-282	1
C105	100n 10% 50V X7R 1206 NiSn	Philips	12062R104K9BB-	46-51000-281	1
C106	330p 5% 500V NPO 1206 <1000	Obsolete	46-23300-088 selected for ESR 10-01095	46-23300-082	1
C107	100n 10% 50V X7R 1206 NiSn	Philips	12062R104K9BB-	46-51000-281	1
C108	47p 5% 50V NPO 0603 NiSn	Philips	0603CG470J9B200	46-14700-083	1

08-06064-001 - PA & Filter PCB

BOM Revision
Date Valid On

06 -- Production
28.08.2008

Ref	Description	Manufacturer	Manufacturer's P/N	Codan P/N	Qty
C109	82p 5% 50V NPO 1206 <1000	Obsolete	46-18200-088 selected for ESR 10-01095	46-18200-082	1
C110	10n 5% 50V X7R 0603 NiSn	Philips	06032R103J9BB00	46-41000-080	1
C111	33n 10% 25V X7R 0603 NiSn	Vitramon	VJ0603Y333KXXT	46-43300-282	1
C112	100n 10% 50V X7R 1206 NiSn	Philips	12062R104K9BB-	46-51000-281	1
C113	Not Fitted	Codan	**00000-001	99-00000-001	1
C114	10n 5% 50V X7R 0603 NiSn	Philips	06032R103J9BB00	46-41000-080	1
C115	33n 10% 25V X7R 0603 NiSn	Vitramon	VJ0603Y333KXXT	46-43300-282	1
C116	10n 5% 50V X7R 0603 NiSn	Philips	06032R103J9BB00	46-41000-080	1
C117	10n 5% 50V X7R 0603 NiSn	Philips	06032R103J9BB00	46-41000-080	1
C118	10n 5% 50V X7R 0603 NiSn	Philips	06032R103J9BB00	46-41000-080	1
C119	10n 5% 50V X7R 0603 NiSn	Philips	06032R103J9BB00	46-41000-080	1
C120	10n 5% 50V X7R 0603 NiSn	Philips	06032R103J9BB00	46-41000-080	1
C121	10n 5% 50V X7R 0603 NiSn	Philips	06032R103J9BB00	46-41000-080	1
C122	10n 5% 50V X7R 0603 NiSn	Philips	06032R103J9BB00	46-41000-080	1
C123	10n 5% 50V X7R 0603 NiSn	Philips	06032R103J9BB00	46-41000-080	1
C124	10n 5% 50V X7R 0603 NiSn	Philips	06032R103J9BB00	46-41000-080	1
C125	10n 5% 50V X7R 0603 NiSn	Philips	06032R103J9BB00	46-41000-080	1
C127	33n 10% 25V X7R 0603 NiSn	Vitramon	VJ0603Y333KXXT	46-43300-282	1
C128	100p 5% 50V NPO 0603 NiSn	Philips	0603CG101J9B200	46-21000-083	1
C129	Not Fitted	Codan	**00000-001	99-00000-001	1
C130	Not Fitted	Codan	**00000-001	99-00000-001	1
C131	1u 10% 16V X7R 1206 NiSn	Philips	12062R105K7BB00	46-61000-280	1
C132	10u 20% 10V X7R 1210 NiSn	Taiyo Yuden	LMK325BJ106MN	46-71000-280	1
C133	220p 5% 50V NPO 0603 NiSn	Philips	0603CG221C9BB00	46-22200-083	1
C134	33n 10% 25V X7R 0603 NiSn	Vitramon	VJ0603Y333KXXT	46-43300-282	1
C135	100n 10% 50V X7R 1206 NiSn	Philips	12062R104K9BB-	46-51000-281	1
C136	1u 10% 16V X7R 1206 NiSn	Philips	12062R105K7BB00	46-61000-280	1
C137	47p 5% 50V NPO 0603 NiSn	Philips	0603CG470J9B200	46-14700-083	1
D1	Diode, Schottky 70V 70mA SOT23	Siemens	BAS70	BAS70	1
D2	Diode, Schottky 70V 70mA SOT23	Siemens	BAS70	BAS70	1
D3	Diode, Si High speed 75V SOD80C	Philips	BAS32L/S	BAS32L/S	1
D4	Diode, Si High speed 75V SOD80C	Philips	BAS32L/S	BAS32L/S	1
D5	Diode, Si High speed 75V SOD80C	Philips	BAS32L/S	BAS32L/S	1
D6	Diode, Si High speed 75V SOD80C	Philips	BAS32L/S	BAS32L/S	1
D7	Diode, Si High speed 75V SOD80C	Philips	BAS32L/S	BAS32L/S	1
D8	Diode, Si High speed 75V SOD80C	Philips	BAS32L/S	BAS32L/S	1
D13	Diode, Schottky 70V 70mA SOT23	Siemens	BAS70	BAS70	1
D14	Diode, Si High speed 75V SOT23	Philips	BAS16	BAS16	1
D15	Diode, Si High speed 75V SOT23	Philips	BAS16	BAS16	1
D16	Diode, Si High speed 75V SOT23	Philips	BAS16	BAS16	1
D17	Diode, Si High speed 75V SOT23	Philips	BAS16	BAS16	1
D19	Diode, Si High speed 75V SOT23	Philips	BAS16	BAS16	1
D20	Diode, Si High speed 75V SOT23	Philips	BAS16	BAS16	1
D21	Diode, Schottky 70V 70mA SOT23	Siemens	BAS70	BAS70	1
D23	Diode, Schottky 70V 70mA SOT23	Siemens	BAS70	BAS70	1
D24	Diode, Si High speed 75V SOT23	Philips	BAS16	BAS16	1
D25	Diode, Schottky 70V 70mA SOT23	Siemens	BAS70	BAS70	1
D26	Diode, Si High speed 75V SOT23	Philips	BAS16	BAS16	1
D27	Diode, Schottky 40V 3A SMC	Motorola	MBRS340T3	MBRS340T3	1
H1	LED, Green PLCC SMD Non Diffused	Siemens	LGT670-L	65-61110-507	1
IC1	Micro prgmd, Power Amp	Codan	90-20631-001	90-20631-001	1
IC2	Decoder/MUX, 1 of 8, SOIC16	Motorola	MC74ACT138D	YQ-74138-700	1
IC3	Decoder/MUX, 1 of 8, SOIC16	Motorola	MC74ACT138D	YQ-74138-700	1
IC4	Decoder/MUX, 1 of 8, SOIC16	Motorola	MC74ACT138D	YQ-74138-700	1
IC5	Amp, Op Rail-Rail I/O Quad SOIC14	ST Microelectronics	TS914IDT	XA-00914-700	1

08-06064-001 - PA & Filter PCB

BOM Revision
Date Valid On

06 -- Production
28.08.2008

Ref	Description	Manufacturer	Manufacturer's P/N	Codan P/N	Qty
IC7	Amp, Oper Dual CMOS SOIC8	National Semiconduct	LMC662CM	XA-00662-700	1
IC8	Amp, Operational Quad SOIC14	National Semiconduct	LM324M	XA-00324-700	1
IC9	Diode, Ref 2,5V 0,5% SOT23	National Semiconduct	LM4040CIM3-2.5	XB-04040-700	1
IC10	Reg, Voltage +3,3V 150mA LDO SOT23-5	Texas Instruments	TPS76333DBVT	XB-76333-700	1
J1	Socket, Coax Mini Low Prof Fixed	Taiko Denki	TMP-J02X-A1	60-19390-002	1
J2	Socket, Coax Mini Low Prof Fixed	Taiko Denki	TMP-J02X-A1	60-19390-002	1
K1	Relay, 2C Bif 5V Latch SMD 250 Ohm	Matsushita	TX2SL-L-5V	64-21223-225	1
K2	Relay, 2C Bif 5V Latch SMD 250 Ohm	Matsushita	TX2SL-L-5V	64-21223-225	1
K3	Relay, 2C Bif 5V Latch SMD 250 Ohm	Matsushita	TX2SL-L-5V	64-21223-225	1
K4	Relay, 2C Bif 5V Latch SMD 250 Ohm	Matsushita	TX2SL-L-5V	64-21223-225	1
K5	Relay, 2C Bif 5V Latch SMD 250 Ohm	Matsushita	TX2SL-L-5V	64-21223-225	1
K6	Relay, 2C Bif 5V Latch SMD 250 Ohm	Matsushita	TX2SL-L-5V	64-21223-225	1
K7	Relay, 2C Bif 5V Latch SMD 250 Ohm	Matsushita	TX2SL-L-5V	64-21223-225	1
K8	Relay, 2C Bif 5V Latch SMD 250 Ohm	Matsushita	TX2SL-L-5V	64-21223-225	1
K9	Relay, 2C Bif 5V Latch SMD 250 Ohm	Matsushita	TX2SL-L-5V	64-21223-225	1
K10	Relay, 2C Bif 5V Latch SMD 250 Ohm	Matsushita	TX2SL-L-5V	64-21223-225	1
K12	Relay, 2M 9V 5A Latch 2x270 Ohm	Matsushita	DSP2A-L2-DC9V	64-31205-227	1
L1	Ind, 1mH 10% 1812	Coilcraft	1812LS-105XKBC	43-83100-000	1
L2	Inductor, 183nH	Protran	44-70538	44-70538	1
L3	Inductor, 233nH	Protran	44-70539	44-70539	1
L4	Inductor, 290nH	Protran	44-70540	44-70540	1
L5	Inductor, 350nH	Protran	44-70541	44-70541	1
L6	Inductor, 560nH	Protran	44-70542	44-70542	1
L7	Inductor, 720nH	Protran	44-70543	44-70543	1
L8	Inductor, 1030nH	Protran	44-70544	44-70544	1
L9	Inductor, 1530nH	Protran	44-70545	44-70545	1
L10	Inductor, 2275nH	Protran	44-70546	44-70546	1
L11	Inductor, 3193nH	Protran	44-70547	44-70547	1
L12	Choke, EMI/EMC 0A DC >1MHz 4516	Taiyo Yuden	FB-MJ4516HS111-T	43-90003	1
L14	Choke, EMI/EMC 0A DC >1MHz 4516	Taiyo Yuden	FB-MJ4516HS111-T	43-90003	1
L15	Choke, EMI/EMC 0A DC >1MHz 4516	Taiyo Yuden	FB-MJ4516HS111-T	43-90003	1
L16	Choke, EMI/EMC 0A DC >10MHz 0805	Taiyo Yuden	BK 2125 HS 330-T	43-90004	1
L17	Ind, 1uH 10% 3225	TOKO	380LB-1R0K	43-80100-001	1
L18	Ind, 1uH 10% 3225	TOKO	380LB-1R0K	43-80100-001	1
L19	Choke, EMI/EMC 0A DC >1MHz 4516	Taiyo Yuden	FB-MJ4516HS111-T	43-90003	1
L20	Choke, EMI/EMC 0A DC >1MHz 4516	Taiyo Yuden	FB-MJ4516HS111-T	43-90003	1
L21	Ind, 1uH 10% 3225	TOKO	380LB-1R0K	43-80100-001	1
L22	Ind, 1uH 10% 3225	TOKO	380LB-1R0K	43-80100-001	1
L23	Inductor, 350nH	Protran	44-70541	44-70541	1
L24	Ind, 270nH 20% 3225	TOKO	380NB-R27M	43-80027-000	1
L25	Ind, 270nH 20% 3225	TOKO	380NB-R27M	43-80027-000	1
P1	Not Fitted	Codan	**00000-001	99-00000-001	1
P2	Header (P) 16way 2row Boxed SMD 2,54mm	Neltron	2316SMD-16G	60-00160-003	1
P3	QC Tab 6,3mm PCB 1,5mm PCB Hole SnPlated	Stocko	F/RM-0118	61-00800-006	1
P4	QC Tab 6,3mm PCB 1,5mm PCB Hole SnPlated	Stocko	F/RM-0118	61-00800-006	1

08-06064-001 - PA & Filter PCB

BOM Revision
Date Valid On

06 -- Production
28.08.2008

Ref	Description	Manufacturer	Manufacturer's P/N	Codan P/N	Qty
P5	Header (P) 2way 2mm Latch Fixed	Tyco Electronics/AMP	292161-2	60-00020-008	1
R1	33k Ohm 5% 0,1W 0805	Philips	2322 730 61333	40-43300-111	1
R2	33k Ohm 5% 0,1W 0805	Philips	2322 730 61333	40-43300-111	1
R3	33k Ohm 5% 0,1W 0805	Philips	2322 730 61333	40-43300-111	1
R4	180 Ohm 5% 1,0W 2512	Phycomp	2322 762 60181	40-21800-141	1
R5	180 Ohm 5% 1,0W 2512	Phycomp	2322 762 60181	40-21800-141	1
R6	390k Ohm 5% 0,06W 0603	Phycomp	2322 702 60394	40-53900-121	1
R7	4,7k Ohm 5% 0,06W 0603	Philips	2322 702 60472	40-34700-121	1
R8	10k Ohm 5% 0,06W 0603	Philips	2322 702 60103	40-41000-121	1
R9	390k Ohm 5% 0,06W 0603	Phycomp	2322 702 60394	40-53900-121	1
R10	100 Ohm 5% 0,06W 0603	Philips	2322 702 60101	40-21000-121	1
R11	100 Ohm 5% 0,06W 0603	Philips	2322 702 60101	40-21000-121	1
R12	470 Ohm 5% 0,06W 0603	Philips	2322 702 60471	40-24700-121	1
R13	10k Ohm 5% 0,06W 0603	Philips	2322 702 60103	40-41000-121	1
R14	10k Ohm 5% 0,06W 0603	Philips	2322 702 60103	40-41000-121	1
R16	100k Ohm 5% 0,06W 0603	Philips	2322 702 60104	40-51000-121	1
R17	270k Ohm 1% 0,06W 0603	Phycomp	2322 704 62704	40-52700-125	1
R18	47k Ohm 1% 0,06W 0603	Philips	2322 704 64703	40-44700-125	1
R19	390k Ohm 5% 0,06W 0603	Phycomp	2322 702 60394	40-53900-121	1
R20	1k Ohm 5% 0,06W 0603	Philips	2322 702 60102	40-31000-121	1
R21	1 Ohm 5% 0,06W 0603	Phycomp	2322 702 60108	40-01000-121	1
R22	1 Ohm 5% 0,06W 0603	Phycomp	2322 702 60108	40-01000-121	1
R23	3,3k Ohm 5% 0,06W 0603	Philips	2322 702 60332	40-33300-121	1
R24	390k Ohm 5% 0,06W 0603	Phycomp	2322 702 60394	40-53900-121	1
R25	2,2k Ohm 5% 0,06W 0603	Philips	2322 702 60222	40-32200-121	1
R26	390k Ohm 1% 0,06W 0603	Phycomp	2322 704 63904	40-53900-125	1
R27	130k Ohm 1% 0,06W 0603	Phycomp	2322 704 61304	40-51300-125	1
R28	270k Ohm 5% 0,06W 0603	Philips	2322 702 60274	40-52700-121	1
R29	100k Ohm 5% 0,06W 0603	Philips	2322 702 60104	40-51000-121	1
R30	100k Ohm 5% 0,06W 0603	Philips	2322 702 60104	40-51000-121	1
R31	100k Ohm 5% 0,06W 0603	Philips	2322 702 60104	40-51000-121	1
R32	220k Ohm 5% 0,06W 0603	Philips	2322 702 60224	40-52200-121	1
R33	220k Ohm 5% 0,06W 0603	Philips	2322 702 60224	40-52200-121	1
R34	100k Ohm 1% 0,06W 0603	Phycomp	2322 704 61004	40-51000-125	1
R35	120k Ohm 1% 0,06W 0603	Phycomp	2322 704 61204	40-51200-125	1
R36	10k Ohm 5% 0,06W 0603	Philips	2322 702 60103	40-41000-121	1
R37	10k Ohm 5% 0,06W 0603	Philips	2322 702 60103	40-41000-121	1
R38	2,2 Ohm 5% 1,0W 2512	Phycomp	2322 762 60228	40-02200-141	1
R39	47k Ohm 5% 0,06W 0603	Philips	2322 702 60473	40-44700-121	1
R40	390k Ohm 5% 0,06W 0603	Phycomp	2322 702 60394	40-53900-121	1
R41	470k Ohm 5% 0,06W 0603	Phycomp	2322 702 60474	40-54700-121	1
R42	4,7k Ohm 5% 0,06W 0603	Philips	2322 702 60472	40-34700-121	1
R43	Res, Voltage Dependent	Philips	2322-592-52506	41-22506-592	1
R44	100k Ohm 5% 0,06W 0603	Philips	2322 702 60104	40-51000-121	1
R45	120k Ohm 5% 0,06W 0603	Philips	2322 702 60124	40-51200-121	1
R46	39k Ohm 1% 0,06W 0603	Philips	2322 704 63903	40-43900-125	1
R47	5,6k Ohm 5% 0,06W 0603	Philips	2322 702 60562	40-35600-121	1
R48	36k Ohm 1% 0,06W 0603	Phycomp	2322 704 63603	40-43600-125	1
R49	36k Ohm 1% 0,06W 0603	Phycomp	2322 704 63603	40-43600-125	1
R50	33k Ohm 5% 0,06W 0603	Philips	2322 702 60333	40-43300-121	1
R51	100k Ohm 5% 0,06W 0603	Philips	2322 702 60104	40-51000-121	1
R52	560k Ohm 5% 0,06W 0603	Phycomp	2322 702 60564	40-55600-121	1
R53	33k Ohm 5% 0,06W 0603	Philips	2322 702 60333	40-43300-121	1
R54	390k Ohm 5% 0,06W 0603	Phycomp	2322 702 60394	40-53900-121	1
R55	6,8k Ohm 5% 0,06W 0603	Philips	2322 702 60682	40-36800-121	1
R56	Pot,10k Lin MG Trim SMD	Bourns	3314 J-1-103	42-41004-000	1
R57	Not Fitted	Codan	**--00000-001	99-00000-001	1

08-06064-001 - PA & Filter PCB

BOM Revision
Date Valid On

06 -- Production
28.08.2008

Ref	Description	Manufacturer	Manufacturer's P/N	Codan P/N	Qty
R58	82k Ohm 5% 0,06W 0603	Philips	2322 702 60823	40-48200-121	1
R59	1,8k Ohm 5% 0,06W 0603	Philips	2322 702 60182	40-31800-121	1
R60	56k Ohm 5% 0,06W 0603	Philips	2322 702 60563	40-45600-121	1
R61	22k Ohm 1% 0,06W 0603	Philips	2322 704 62203	40-42200-125	1
R62	47k Ohm 5% 0,06W 0603	Philips	2322 702 60473	40-44700-121	1
R63	1k Ohm 5% 0,06W 0603	Philips	2322 702 60102	40-31000-121	1
R64	120k Ohm 5% 0,06W 0603	Philips	2322 702 60124	40-51200-121	1
R65	22k Ohm 5% 0,06W 0603	Philips	2322 702 60223	40-42200-121	1
R66	470k Ohm 5% 0,06W 0603	Phycomp	2322 702 60474	40-54700-121	1
R67	1k Ohm 5% 0,06W 0603	Philips	2322 702 60102	40-31000-121	1
R68	50 Ohm 80°C PTC Thermistor	Philips	2322-660-91008	41-11500-660	1
R69	10k Ohm 5% 0,06W 0603	Philips	2322 702 60103	40-41000-121	1
R70	82k Ohm 5% 0,06W 0603	Philips	2322 702 60823	40-48200-121	1
R71	4,7k Ohm 5% 0,06W 0603	Philips	2322 702 60472	40-34700-121	1
R72	22 Ohm 5% 0,06W 0603	Philips	2322 702 60229	40-12200-121	1
R73	10k Ohm 5% 0,06W 0603	Philips	2322 702 60103	40-41000-121	1
R74	82 Ohm 5% 0,06W 0603	Philips	2322 702 60829	40-18200-121	1
R75	100k Ohm 5% 0,06W 0603	Philips	2322 702 60104	40-51000-121	1
R76	100k Ohm 5% 0,06W 0603	Philips	2322 702 60104	40-51000-121	1
R77	3,9k Ohm 5% 0,06W 0603	Philips	2322 702 60392	40-33900-121	1
R78	4,7k Ohm 5% 0,06W 0603	Philips	2322 702 60472	40-34700-121	1
R79	10k Ohm 5% 0,06W 0603	Philips	2322 702 60103	40-41000-121	1
R80	10k Ohm 5% 0,06W 0603	Philips	2322 702 60103	40-41000-121	1
R81	220 Ohm 5% 0,06W 0603	Philips	2322 702 60221	40-22200-121	1
R82	470 Ohm 5% 0,06W 0603	Philips	2322 702 60471	40-24700-121	1
R83	470 Ohm 5% 0,06W 0603	Philips	2322 702 60471	40-24700-121	1
R84	4,7 Ohm 5% 0,06W 0603	Phycomp	2322 702 60478	40-04700-121	1
R85	4,7 Ohm 5% 0,06W 0603	Phycomp	2322 702 60478	40-04700-121	1
R86	47k Ohm 5% 0,06W 0603	Philips	2322 702 60473	40-44700-121	1
R87	47 Ohm 5% 0,06W 0603	Philips	2322 702 60479	40-14700-121	1
R88	10 Ohm 5% 0,06W 0603	Philips	2322 702 60109	40-11000-121	1
R89	3,3k Ohm 5% 0,06W 0603	Philips	2322 702 60332	40-33300-121	1
R90	82 Ohm 5% 0,06W 0603	Philips	2322 702 60829	40-18200-121	1
R91	3,3k Ohm 5% 0,06W 0603	Philips	2322 702 60332	40-33300-121	1
R92	4,7 Ohm 5% 0,06W 0603	Phycomp	2322 702 60478	40-04700-121	1
R93	4,7 Ohm 5% 0,06W 0603	Phycomp	2322 702 60478	40-04700-121	1
R94	100 Ohm 5% 0,06W 0603	Philips	2322 702 60101	40-21000-121	1
R95	100 Ohm 5% 0,06W 0603	Philips	2322 702 60101	40-21000-121	1
R96	470 Ohm 5% 0,06W 0603	Philips	2322 702 60471	40-24700-121	1
R97	Pot,100 Lin MG Trim SMD	Bourns	3314 J-1-101	42-21004-000	1
R99	10 Ohm 5% 0,06W 0603	Philips	2322 702 60109	40-11000-121	1
R100	1,8k Ohm 5% 0,06W 0603	Philips	2322 702 60182	40-31800-121	1
R101	Pot,1k Lin MG Trim SMD	Bourns	3314 J-1-102	42-31004-000	1
R102	100 Ohm 5% 0,06W 0603	Philips	2322 702 60101	40-21000-121	1
R103	3,3k Ohm 5% 0,06W 0603	Philips	2322 702 60332	40-33300-121	1
R104	3,9k Ohm 5% 0,06W 0603	Philips	2322 702 60392	40-33900-121	1
R105	Pot,1k Lin MG Trim SMD	Bourns	3314 J-1-102	42-31004-000	1
R106	1,5k Ohm 5% 0,06W 0603	Philips	2322 702 60152	40-31500-121	1
R107	150 Ohm 5% 0,06W 0603	Philips	2322 702 60151	40-21500-121	1
R108	1k Ohm 5% 0,06W 0603	Philips	2322 702 60102	40-31000-121	1
R109	47 Ohm 5% 0,06W 0603	Philips	2322 702 60479	40-14700-121	1
R110	100 Ohm 5% 0,06W 0603	Philips	2322 702 60101	40-21000-121	1
R111	100 Ohm 5% 1,0W 2512	Phycomp	2322 762 60101	40-21000-141	1
R112	150 Ohm 5% 1,0W 2512	Phycomp	2322 762 60151	40-21500-141	1
R113	150 Ohm 5% 1,0W 2512	Phycomp	2322 762 60151	40-21500-141	1
R114	2,2 Ohm 5% 1,0W 2512	Phycomp	2322 762 60228	40-02200-141	1
R115	470 Ohm 5% 0,06W 0603	Philips	2322 702 60471	40-24700-121	1
R116	180k Ohm 5% 0,1W 0805	Philips	2322 730 61184	40-51800-111	1

08-06064-001 - PA & Filter PCB

BOM Revision
Date Valid On

06 -- Production
28.08.2008

Ref	Description	Manufacturer	Manufacturer's P/N	Codan P/N	Qty
R117	390k Ohm 5% 0,06W 0603	Phycomp	2322 702 60394	40-53900-121	1
R118	390k Ohm 5% 0,06W 0603	Phycomp	2322 702 60394	40-53900-121	1
R119	22k Ohm 5% 0,06W 0603	Philips	2322 702 60223	40-42200-121	1
R120	100 Ohm 5% 1,0W 2512	Phycomp	2322 762 60101	40-21000-141	1
R121	100 Ohm 5% 1,0W 2512	Phycomp	2322 762 60101	40-21000-141	1
R122	220k Ohm 5% 0,06W 0603	Philips	2322 702 60224	40-52200-121	1
R123	4,7k Ohm 5% 0,06W 0603	Philips	2322 702 60472	40-34700-121	1
R124	Pot,100k Lin MG Trim SMD	Bourns	3314 J-1-104	42-51060-001	1
R125	220 Ohm 5% 0,06W 0603	Philips	2322 702 60221	40-22200-121	1
R126	2,2k Ohm 5% 0,06W 0603	Philips	2322 702 60222	40-32200-121	1
R127	10k Ohm 5% 0,06W 0603	Philips	2322 702 60103	40-41000-121	1
R128	20k Ohm 1% 0,06W 0603	Phycomp	2322 704 62003	40-42000-125	1
R129	10k Ohm 5% 0,06W 0603	Philips	2322 702 60103	40-41000-121	1
R130	24k Ohm 1% 0,06W 0603	Phycomp	2322 704 62403	40-42400-125	1
R131	47k Ohm 5% 0,06W 0603	Philips	2322 702 60473	40-44700-121	1
R132	220k Ohm 5% 0,06W 0603	Philips	2322 702 60224	40-52200-121	1
R133	82k Ohm 5% 0,06W 0603	Philips	2322 702 60823	40-48200-121	1
R134	39k Ohm 1% 0,06W 0603	Philips	2322 704 63903	40-43900-125	1
R135	150k Ohm 5% 0,06W 0603	Philips	2322 702 60154	40-51500-121	1
R136	47k Ohm 5% 0,06W 0603	Philips	2322 702 60473	40-44700-121	1
R137	10k Ohm 5% 0,06W 0603	Philips	2322 702 60103	40-41000-121	1
R138	10k Ohm 5% 0,06W 0603	Philips	2322 702 60103	40-41000-121	1
R139	1 Ohm 2% 0,125W 1206	Philips	2322 712 83108	40-01000-102	1
R140	1 Ohm 5% 0,06W 0603	Phycomp	2322 702 60108	40-01000-121	1
R141	33k Ohm 5% 0,06W 0603	Philips	2322 702 60333	40-43300-121	1
R142	2,2k Ohm 5% 0,06W 0603	Philips	2322 702 60222	40-32200-121	1
R143	18k Ohm 1% 0,06W 0603	Philips	2322 704 61803	40-41800-125	1
R144	2,7k Ohm 5% 0,06W 0603	Philips	2322 702 60272	40-32700-121	1
R145	100k Ohm 5% 0,06W 0603	Philips	2322 702 60104	40-51000-121	1
R146	100k Ohm 5% 0,06W 0603	Philips	2322 702 60104	40-51000-121	1
R147	10k Ohm 5% 0,06W 0603	Philips	2322 702 60103	40-41000-121	1
R148	1k Ohm 5% 0,06W 0603	Philips	2322 702 60102	40-31000-121	1
R149	47k Ohm 5% 0,06W 0603	Philips	2322 702 60473	40-44700-121	1
R150	68k Ohm 5% 0,06W 0603	Philips	2322 702 60683	40-46800-121	1
R151	1k Ohm 5% 0,06W 0603	Philips	2322 702 60102	40-31000-121	1
R152	180k Ohm 5% 0,06W 0603	Philips	2322 702 60184	40-51800-121	1
R153	10M Ohm 1% 0,1W 0805	Philips	2322 734 61006	40-71000-115	1
R154	47 Ohm 5% 0,125W 1206	Philips	2322 711 61479	40-14700-101	1
R192	4,7 Ohm 5% 0,06W 0603	Phycomp	2322 702 60478	40-04700-121	1
R193	4,7 Ohm 5% 0,06W 0603	Phycomp	2322 702 60478	40-04700-121	1
R194	100 Ohm 5% 0,06W 0603	Philips	2322 702 60101	40-21000-121	1
R195	100 Ohm 5% 0,06W 0603	Philips	2322 702 60101	40-21000-121	1
T1	Txfr, RF or	Fetronics	44-80021	44-80021	1
T2	Transformer, Input	Protran	44-80312	44-80312	1
T3	Transformer, Pre-Driver	Protran	44-80304	44-80304	1
T4	Transformer, Driver	Protran	44-80305	44-80305	1
T5	Transformer, O/P	Protran	44-80306	44-80306	1
V1	Transistor, PNP Si TO252	Motorola	MJD32C	MJD32C	1
V2	MOSFET, P 30V 5A 3W 65mOhm SOT223	Fairchild	NDT452AP	NDT452AP	1
V3	MOSFET, N Chan Enhance SOT23	Philips	BST82	BST82	1
V4	Transistor, NPN Si SOT23	Philips	BC847	BC847	1
V5	Transistor, NPN Si SOT23	Philips	BC847	BC847	1
V6	Transistor, NPN Si SOT23	Philips	BC847	BC847	1
V7	Transistor, PNP Si SOT23	Philips	BC857	BC857	1
V8	MOSFET, P 30V 5A 3W 65mOhm SOT223	Fairchild	NDT452AP	NDT452AP	1
V9	Transistor, NPN Si SOT23	Philips	BC847	BC847	1

08-06064-001 - PA & Filter PCB

BOM Revision
Date Valid On

06 -- Production
28.08.2008

Ref	Description	Manufacturer	Manufacturer's P/N	Codan P/N	Qty
V10	MOSFET, N Chan Enhance SOT23	Philips	BST82	BST82	1
V11	Diode, Zener 15V 5% 0,2W SOT23	Philips	BZX84-C15	BZX84C15	1
V12	Trnstor, Darl. PNP 30V 1,2A 0,35W SOT23	Fairchild	BCV26	BCV26	1
V13	Transistor, NPN Si SOT23	Philips	BC847	BC847	1
V14	Diode, Zener 6,8V 5% 0,2W SOT23	Philips	BZX84C6V8	BZX84C6V8	1
V15	Transistor, PNP Si SOT23	Philips	BC857	BC857	1
V16	Diode, Zener 15V 5% 0,2W SOT23	Philips	BZX84-C15	BZX84C15	1
V17	MOSFET, N Channel Enhanced SOT23	Fairchild	BSS138	BSS138	1
V18	Transistor, NPN Si SOT23	Philips	BC847	BC847	1
V19	Transistor, NPN Si SOT23	Philips	BC847	BC847	1
V20	Transistor, NPN Si SOT23	Philips	BC847	BC847	1
V21	Transistor, NPN Si SOT23	Philips	BC847	BC847	1
V22	Transistor, NPN Si SOT23	Philips	BC847	BC847	1
V23	MOSFET, N Chan Enhance SOT23	Philips	BST82	BST82	1
V24	Transistor, NPN Si SOT23	Philips	BC847	BC847	1
V25	Transistor, NPN Si 18V 0,15A 4GHz SOT89	Philips	BFQ18A	BFQ18A	1
V26	Transistor, NPN Si 18V 0,15A 4GHz SOT89	Philips	BFQ18A	BFQ18A	1
V27	JFET, N Channel SOT23	Philips	PMBFJ309-215	PMBFJ309	1
V28	JFET, N Channel SOT23	Philips	PMBFJ309-215	PMBFJ309	1
V29	Transistor, NPN Si SOT89	Philips	BFQ17	BFQ17	1
V30	Transistor, NPN Si SOT89	Philips	BFQ17	BFQ17	1
V31	Transistor, NPN Si SOT89	Philips	BFQ17	BFQ17	1
V32	Transistor, NPN Si SOT89	Philips	BFQ17	BFQ17	1
V33	Transistor, PNP Si SOT23	Philips	BC857	BC857	1
V34	Transistor, NPN Si SOT23	Philips	BC847	BC847	1
V35	Transistor, Darl. NPN 100V 2A 20W TO-252	STMicroelectronic	MJD112T4	MJD112T4	1
V36	Transistor, RF Power HF	Microsemi	MS1253-CDN	MS1253-CDN	1
V37	Transistor, RF Power HF	Microsemi	MS1253-CDN	MS1253-CDN	1
V38	Transistor, NPN Si SOT23	Philips	BC847	BC847	1
V39	MOSFET, P Channel Enhanced SOT23	Philips	BSH201	BSH201	1
V40	MOSFET, N Chan Enhance SOT23	Philips	BST82	BST82	1
V41	MOSFET, P Channel Enhanced SOT23	Philips	BSH201	BSH201	1
V42	Diode, Zener 6,8V 5% 0,2W SOT23	Philips	BZX84C6V8	BZX84C6V8	1
V43	MOSFET, N Chan Enhance SOT23	Philips	BST82	BST82	1
V44	Transistor, NPN Si SOT23	Philips	BC847	BC847	1
V45	MOSFET, N Channel Enhanced SOT23	Fairchild	BSS138	BSS138	1
V46	Transistor, PNP Si SOT89	Philips	BC869	BC869	1
V47	Transistor, NPN Si SOT23	Philips	BC847	BC847	1
V48	Transistor, NPN Si SOT23	Philips	BC847	BC847	1
V49	MOSFET, N Chan Enhance SOT23	Philips	BST82	BST82	1

08-06063-001 - Antenna Tuner PCB

BOM Revision
Date Valid On

03 -- Production
17.06.2008

Ref	Description	Manufacturer	Manufacturer's P/N	Codan P/N	Qty
	Antenna Tuner			04-03444	1
	Antenna Tuner PCB			08-06063	1
	Antenna Tuner PCB			11-06155	1
	MRS, Antenna Tuner, 2110			01-01374	1
	TP, Antenna Tuner PCB			10-01003	1
1	PCB, Antenna Tuner		07-02018-03	07-02018-03	1
2	Label, Serial/Barcode	Codan	06-02068	06-02068	1
3	Screw, M6x25 Nylon Pan Slotted	Micro Plastics	50M060100N025	31-26025-820	5
4	Nut, M6 Nylon	Micro Plastics	04M060100HN	31-26000-020	5
5	Washer, M8 Nylon	Micro Plastics	16M08018200	32-00801-090	3
6	Washer, 14,2x6,7x0,76 Nylon	Micro Plastics	17W05601	32-90601-990	2
7	Wire, Eq rd V75 Thick 10/0,25	Hartland	66-02102-502	66-02102-502	0.01
8	Lug, Solder 3,5mm	Cliford W Ltd	G410 CODE 330	61-30200-025	1
9	Adhesive, Jet Melt 177'-196'C	3M	3748-TC-Q	71-30002	0.01
10	Loctite, 20g Bottles	Loctite	401	71-32000-003	0.01
C1	10n 5% 50V X7R 0603 NiSn	Philips	06032R103J9BB00	46-41000-080	1
C2	100n 10% 16V X7R 0603 NiSn	Vitramon	VJ0603Y104KXJT	46-51000-283	1
C3	10n 5% 50V X7R 0603 NiSn	Philips	06032R103J9BB00	46-41000-080	1
C4	100n 10% 16V X7R 0603 NiSn	Vitramon	VJ0603Y104KXJT	46-51000-283	1
C5	10n 5% 50V X7R 0603 NiSn	Philips	06032R103J9BB00	46-41000-080	1
C6	100n 10% 16V X7R 0603 NiSn	Vitramon	VJ0603Y104KXJT	46-51000-283	1
C7	10n 5% 50V X7R 0603 NiSn	Philips	06032R103J9BB00	46-41000-080	1
C8	10n 5% 50V X7R 0603 NiSn	Philips	06032R103J9BB00	46-41000-080	1
C9	10n 5% 50V X7R 0603 NiSn	Philips	06032R103J9BB00	46-41000-080	1
C10	10n 5% 50V X7R 0603 NiSn	Philips	06032R103J9BB00	46-41000-080	1
C11	10n 5% 50V X7R 0603 NiSn	Philips	06032R103J9BB00	46-41000-080	1
C12	10n 5% 50V X7R 0603 NiSn	Philips	06032R103J9BB00	46-41000-080	1
C13	10n 5% 50V X7R 0603 NiSn	Philips	06032R103J9BB00	46-41000-080	1
C14	10n 5% 50V X7R 0603 NiSn	Philips	06032R103J9BB00	46-41000-080	1
C15	10n 5% 50V X7R 0603 NiSn	Philips	06032R103J9BB00	46-41000-080	1
C16	10n 5% 50V X7R 0603 NiSn	Philips	06032R103J9BB00	46-41000-080	1
C17	10n 5% 50V X7R 0603 NiSn	Philips	06032R103J9BB00	46-41000-080	1
C18	10n 5% 50V X7R 0603 NiSn	Philips	06032R103J9BB00	46-41000-080	1
C19	10n 5% 50V X7R 0603 NiSn	Philips	06032R103J9BB00	46-41000-080	1
C20	10n 5% 50V X7R 0603 NiSn	Philips	06032R103J9BB00	46-41000-080	1
C21	10n 5% 50V X7R 0603 NiSn	Philips	06032R103J9BB00	46-41000-080	1
C22	10n 5% 50V X7R 0603 NiSn	Philips	06032R103J9BB00	46-41000-080	1
C23	10n 5% 50V X7R 0603 NiSn	Philips	06032R103J9BB00	46-41000-080	1
C24	10n 5% 50V X7R 0603 NiSn	Philips	06032R103J9BB00	46-41000-080	1
C25	10n 5% 50V X7R 0603 NiSn	Philips	06032R103J9BB00	46-41000-080	1
C26	10n 5% 50V X7R 0603 NiSn	Philips	06032R103J9BB00	46-41000-080	1
C27	10n 5% 50V X7R 0603 NiSn	Philips	06032R103J9BB00	46-41000-080	1
C28	10n 5% 50V X7R 0603 NiSn	Philips	06032R103J9BB00	46-41000-080	1
C29	10n 5% 50V X7R 0603 NiSn	Philips	06032R103J9BB00	46-41000-080	1
C30	10n 5% 50V X7R 0603 NiSn	Philips	06032R103J9BB00	46-41000-080	1
C31	10n 5% 50V X7R 0603 NiSn	Philips	06032R103J9BB00	46-41000-080	1
C32	10n 5% 50V X7R 0603 NiSn	Philips	06032R103J9BB00	46-41000-080	1
C33	10n 5% 50V X7R 0603 NiSn	Philips	06032R103J9BB00	46-41000-080	1
C34	10n 5% 50V X7R 0603 NiSn	Philips	06032R103J9BB00	46-41000-080	1
C35	10n 5% 50V X7R 0603 NiSn	Philips	06032R103J9BB00	46-41000-080	1
C36	10n 5% 50V X7R 0603 NiSn	Philips	06032R103J9BB00	46-41000-080	1
C37	10n 5% 50V X7R 0603 NiSn	Philips	06032R103J9BB00	46-41000-080	1
C38	10n 5% 50V X7R 0603 NiSn	Philips	06032R103J9BB00	46-41000-080	1
C39	10n 5% 50V X7R 0603 NiSn	Philips	06032R103J9BB00	46-41000-080	1
C40	100p 5% 50V NPO 0603 NiSn	Philips	0603CG101J9B200	46-21000-083	1
C41	100p 5% 50V NPO 0603 NiSn	Philips	0603CG101J9B200	46-21000-083	1
C42	10n 5% 50V X7R 0603 NiSn	Philips	06032R103J9BB00	46-41000-080	1
C43	10n 5% 50V X7R 0603 NiSn	Philips	06032R103J9BB00	46-41000-080	1

08-06063-001 - Antenna Tuner PCB

BOM Revision
Date Valid On

03 -- Production
17.06.2008

Ref	Description	Manufacturer	Manufacturer's P/N	Codan P/N	Qty
C44	10n 5% 50V X7R 0603 NiSn	Philips	06032R103J9BB00	46-41000-080	1
C45	10n 5% 50V X7R 0603 NiSn	Philips	06032R103J9BB00	46-41000-080	1
C46	100p 5% 50V NPO 0603 NiSn	Philips	0603CG101J9B200	46-21000-083	1
C47	100p 5% 50V NPO 0603 NiSn	Philips	0603CG101J9B200	46-21000-083	1
C48	10n 5% 50V X7R 0603 NiSn	Philips	06032R103J9BB00	46-41000-080	1
C49	10n 5% 50V X7R 0603 NiSn	Philips	06032R103J9BB00	46-41000-080	1
C50	100p 5% 50V NPO 0603 NiSn	Philips	0603CG101J9B200	46-21000-083	1
C51	100p 5% 50V NPO 0603 NiSn	Philips	0603CG101J9B200	46-21000-083	1
C52	10n 5% 50V X7R 0603 NiSn	Philips	06032R103J9BB00	46-41000-080	1
C53	10n 5% 50V X7R 0603 NiSn	Philips	06032R103J9BB00	46-41000-080	1
C54	100p 5% 50V NPO 0603 NiSn	Philips	0603CG101J9B200	46-21000-083	1
C55	100p 5% 50V NPO 0603 NiSn	Philips	0603CG101J9B200	46-21000-083	1
C56	10n 5% 50V X7R 0603 NiSn	Philips	06032R103J9BB00	46-41000-080	1
C57	10n 5% 50V X7R 0603 NiSn	Philips	06032R103J9BB00	46-41000-080	1
C58	100p 5% 50V NPO 0603 NiSn	Philips	0603CG101J9B200	46-21000-083	1
C59	100p 5% 50V NPO 0603 NiSn	Philips	0603CG101J9B200	46-21000-083	1
C60	10n 5% 50V X7R 0603 NiSn	Philips	06032R103J9BB00	46-41000-080	1
C61	10n 5% 50V X7R 0603 NiSn	Philips	06032R103J9BB00	46-41000-080	1
C62	100p 5% 50V NPO 0603 NiSn	Philips	0603CG101J9B200	46-21000-083	1
C63	100p 5% 50V NPO 0603 NiSn	Philips	0603CG101J9B200	46-21000-083	1
C64	10n 5% 50V X7R 0603 NiSn	Philips	06032R103J9BB00	46-41000-080	1
C65	10n 5% 50V X7R 0603 NiSn	Philips	06032R103J9BB00	46-41000-080	1
C66	100p 5% 50V NPO 0603 NiSn	Philips	0603CG101J9B200	46-21000-083	1
C67	100p 5% 50V NPO 0603 NiSn	Philips	0603CG101J9B200	46-21000-083	1
C68	10n 5% 50V X7R 0603 NiSn	Philips	06032R103J9BB00	46-41000-080	1
C69	10n 5% 50V X7R 0603 NiSn	Philips	06032R103J9BB00	46-41000-080	1
C70	100p 5% 50V NPO 0603 NiSn	Philips	0603CG101J9B200	46-21000-083	1
C71	100p 5% 50V NPO 0603 NiSn	Philips	0603CG101J9B200	46-21000-083	1
C72	10n 5% 50V X7R 0603 NiSn	Philips	06032R103J9BB00	46-41000-080	1
C73	10n 5% 50V X7R 0603 NiSn	Philips	06032R103J9BB00	46-41000-080	1
C74	100n 10% 50V X7R 0805 Nisn	Philips	08052R104K9BB	46-51000-282	1
C75	100n 10% 50V X7R 0805 Nisn	Philips	08052R104K9BB	46-51000-282	1
C76	100n 10% 50V X7R 0805 Nisn	Philips	08052R104K9BB	46-51000-282	1
C77	10n 5% 50V X7R 0603 NiSn	Philips	06032R103J9BB00	46-41000-080	1
C78	10n 5% 50V X7R 0603 NiSn	Philips	06032R103J9BB00	46-41000-080	1
C79	10n 5% 50V X7R 0603 NiSn	Philips	06032R103J9BB00	46-41000-080	1
C80	100n 10% 50V X7R 0805 Nisn	Philips	08052R104K9BB	46-51000-282	1
C81	100n 10% 50V X7R 0805 Nisn	Philips	08052R104K9BB	46-51000-282	1
C82	15p 5% 500V NPO 1206 <300		46-11500-088 selected for ESR 10-01095	46-11500-0820	1
C83	15p 5% 500V NPO 1206 <300		46-11500-088 selected for ESR 10-01095	46-11500-0820	1
C84	27p 5% 500V NPO 1206 <300		46-12700-088 selected for ESR 10-01095	46-12700-0820	1
C85	27p 5% 500V NPO 1206 <300		46-12700-088 selected for ESR 10-01095	46-12700-0820	1
C86	100n 10% 50V X7R 0805 Nisn	Philips	08052R104K9BB	46-51000-282	1
C87	56p 5% 500V NPO 1206 <300		46-15600-088 selected for ESR 10-01095	46-15600-0820	1
C88	56p 5% 500V NPO 1206 <300		46-15600-088 selected for ESR 10-01095	46-15600-0820	1
C89	56p 5% 500V NPO 1206 <300		46-15600-088 selected for ESR 10-01095	46-15600-0820	1
C90	56p 5% 500V NPO 1206 <300		46-15600-088 selected for ESR 10-01095	46-15600-0820	1
C91	100p 5% 500V NPO 1206 <300		46-21000-088 selected for ESR 10-01095	46-21000-0820	1

08-06063-001 - Antenna Tuner PCB

BOM Revision
Date Valid On

03 -- Production
17.06.2008

Ref	Description	Manufacturer	Manufacturer's P/N	Codan P/N	Qty
C92	100p 5% 500V NPO 1206 <300		46-21000-088 selected for ESR 10-01095	46-21000-0820	1
C93	100p 5% 500V NPO 1206 <300		46-21000-088 selected for ESR 10-01095	46-21000-0820	1
C94	100p 5% 500V NPO 1206 <300		46-21000-088 selected for ESR 10-01095	46-21000-0820	1
C95	3,3n 10% 100V X7R 0603 NiSn	Vishay	VJ0603Y332KXBAC	46-33300-282	1
C96	3,3n 10% 100V X7R 0603 NiSn	Vishay	VJ0603Y332KXBAC	46-33300-282	1
C97	470p 5% 50V NPO 0805 NiSn	Philips	0805CG471J9B200	46-24700-081	1
C98	100n 10% 16V X7R 0603 NiSn	Vitramon	VJ0603Y104KXJT	46-51000-283	1
C99	6,8n 10% 100V X7R 0805 NiSn	Philips	08052R682K0B200	46-36800-281	1
C100	10n 5% 50V X7R 0603 NiSn	Philips	06032R103J9BB00	46-41000-080	1
C101	10n 5% 50V X7R 0603 NiSn	Philips	06032R103J9BB00	46-41000-080	1
C102	100n 10% 16V X7R 0603 NiSn	Vitramon	VJ0603Y104KXJT	46-51000-283	1
C103	100n 10% 16V X7R 0603 NiSn	Vitramon	VJ0603Y104KXJT	46-51000-283	1
C104	10n 5% 50V X7R 0603 NiSn	Philips	06032R103J9BB00	46-41000-080	1
C105	100p 5% 50V NPO 0603 NiSn	Philips	0603CG101J9B200	46-21000-083	1
C106	100p 5% 50V NPO 0603 NiSn	Philips	0603CG101J9B200	46-21000-083	1
C107	100n 10% 16V X7R 0603 NiSn	Vitramon	VJ0603Y104KXJT	46-51000-283	1
C108	100n 10% 16V X7R 0603 NiSn	Vitramon	VJ0603Y104KXJT	46-51000-283	1
C109	100n 10% 16V X7R 0603 NiSn	Vitramon	VJ0603Y104KXJT	46-51000-283	1
C110	100n 10% 16V X7R 0603 NiSn	Vitramon	VJ0603Y104KXJT	46-51000-283	1
C111	1u 10% 16V X7R 1206 NiSn	Philips	12062R105K7BB00	46-61000-280	1
C112	1n 5% 25V NPO 0603 NiSn	AVX	06033A102JAT2A	46-31000-083	1
C113	100n 10% 16V X7R 0603 NiSn	Vitramon	VJ0603Y104KXJT	46-51000-283	1
C114	2,2u 20% 20V 3528 TA Cap	AVX	TAJB225M020R	47-02202-000	1
C115	100n 10% 50V X7R 0805 Nisn	Philips	08052R104K9BB	46-51000-282	1
C116	10n 5% 50V X7R 0603 NiSn	Philips	06032R103J9BB00	46-41000-080	1
C117	100n 10% 16V X7R 0603 NiSn	Vitramon	VJ0603Y104KXJT	46-51000-283	1
C118	10u 20% 20V 3528 TA Cap	AVX	TAJB106M020R	47-11002-000	1
C119	10n 5% 50V X7R 0603 NiSn	Philips	06032R103J9BB00	46-41000-080	1
C120	100p 5% 50V NPO 0603 NiSn	Philips	0603CG101J9B200	46-21000-083	1
C121	100p 5% 50V NPO 0603 NiSn	Philips	0603CG101J9B200	46-21000-083	1
C122	100p 5% 50V NPO 0603 NiSn	Philips	0603CG101J9B200	46-21000-083	1
C123	Not Fitted	Codan	**00000-001	99-00000-001	1
C124	Not Fitted	Codan	**00000-001	99-00000-001	1
C125	Not Fitted	Codan	**00000-001	99-00000-001	1
C126	Not Fitted	Codan	**00000-001	99-00000-001	1
D1	Diode, Switching Dual SOT143	Philips	BAS28	BAS28	1
D2	Diode, Switching Dual SOT143	Philips	BAS28	BAS28	1
D3	Diode, Switching Dual SOT143	Philips	BAS28	BAS28	1
D4	Diode, Switching Dual SOT143	Philips	BAS28	BAS28	1
D5	Diode, Switching Dual SOT143	Philips	BAS28	BAS28	1
D6	Diode, Switching Dual SOT143	Philips	BAS28	BAS28	1
D7	Diode, Switching Dual SOT143	Philips	BAS28	BAS28	1
D8	Diode, Switching Dual SOT143	Philips	BAS28	BAS28	1
D9	Diode, Switching Dual SOT143	Philips	BAS28	BAS28	1
D10	Diode, Switching Dual SOT143	Philips	BAS28	BAS28	1
D11	Diode, Switching Dual SOT143	Philips	BAS28	BAS28	1
D12	Diode, Switching Dual SOT143	Philips	BAS28	BAS28	1
D13	Diode, Switching Dual SOT143	Philips	BAS28	BAS28	1
D14	Diode, Switching Dual SOT143	Philips	BAS28	BAS28	1
D15	Diode, Switching Dual SOT143	Philips	BAS28	BAS28	1
D16	Diode, Switching Dual SOT143	Philips	BAS28	BAS28	1
D17	Diode, Switching Dual SOT143	Philips	BAS28	BAS28	1
D18	Diode, Switching Dual SOT143	Philips	BAS28	BAS28	1
D19	Diode, Switching Dual SOT143	Philips	BAS28	BAS28	1
D20	Diode, Switching Dual SOT143	Philips	BAS28	BAS28	1

08-06063-001 - Antenna Tuner PCB

BOM Revision
Date Valid On

03 -- Production
17.06.2008

Ref	Description	Manufacturer	Manufacturer's P/N	Codan P/N	Qty
D21	Diode, Switching Dual SOT143	Philips	BAS28	BAS28	1
D22	Diode, Switching Dual SOT143	Philips	BAS28	BAS28	1
D23	Diode, Switching Dual SOT143	Philips	BAS28	BAS28	1
D24	Diode, Schottky Dual 70V sep SOT143B	Philips	BAS70-07	BAS70-07	1
D25	Diode, Schottky Dual 70V sep SOT143B	Philips	BAS70-07	BAS70-07	1
D26	Diode, Switching Dual SOT143	Philips	BAS28	BAS28	1
D27	Diode, Schottky Dual 70V sep SOT143B	Philips	BAS70-07	BAS70-07	1
D28	Diode, Schottky Dual 70V sep SOT143B	Philips	BAS70-07	BAS70-07	1
D29	Diode, Si High speed 75V SOD80C	Philips	BAS32L/S	BAS32L/S	1
D30	Diode, Si High speed 75V SOD80C	Philips	BAS32L/S	BAS32L/S	1
IC1	Register, Shift & Store 8 Bit SOIC16	Philips	PC74HC4094T	YH-40094-700	1
IC2	Register, Shift & Store 8 Bit SOIC16	Philips	PC74HC4094T	YH-40094-700	1
IC3	Register, Shift & Store 8 Bit SOIC16	Philips	PC74HC4094T	YH-40094-700	1
IC4	Amp, Rail to Rail I/O Low Offset SOT23-5	National Semiconduct	LMC7101AIM5	XA-07101-701	1
IC5	Micro prgmd, Antenna Tuner	Codan	90-20630-001	90-20630-001	1
IC6	Reg, Voltage +9V 1A PPAK	STMicroelectronics	LF90CPT	XB-00090-700	1
IC7	EEPROM, CMOS 16k x 8 SPI Bus SOIC8	STMicroelectronics	M95128-WMN6T	YM-95128-700	1
J1	Socket, Coax Mini Low Prof Fixed	Taiko Denki	TMP-J02X-A1	60-19390-002	1
J2	Socket, Coax Mini Low Prof Fixed	Taiko Denki	TMP-J02X-A1	60-19390-002	1
K1	Relay, 2C Bif 9V Latch SMD 810 Ohm	Axicom (Tyco)	IM45GR (6-1462037-4)	64-21223-281	1
K2	Relay, 2C Bif 9V Latch SMD 810 Ohm	Axicom (Tyco)	IM45GR (6-1462037-4)	64-21223-281	1
K3	Relay, 2C Bif 9V Latch SMD 810 Ohm	Axicom (Tyco)	IM45GR (6-1462037-4)	64-21223-281	1
K4	Relay, 2C Bif 9V Latch SMD 810 Ohm	Axicom (Tyco)	IM45GR (6-1462037-4)	64-21223-281	1
K5	Relay, 2C Bif 9V Latch SMD 810 Ohm	Axicom (Tyco)	IM45GR (6-1462037-4)	64-21223-281	1
K6	Relay, 2C Bif 9V Latch SMD 810 Ohm	Axicom (Tyco)	IM45GR (6-1462037-4)	64-21223-281	1
K7	Relay, 2C Bif 9V Latch SMD 810 Ohm	Axicom (Tyco)	IM45GR (6-1462037-4)	64-21223-281	1
K8	Relay, 2C Bif 9V Latch SMD 810 Ohm	Axicom (Tyco)	IM45GR (6-1462037-4)	64-21223-281	1
K9	Relay, 2C Bif 9V Latch SMD 810 Ohm	Axicom (Tyco)	IM45GR (6-1462037-4)	64-21223-281	1
K10	Relay, 2C Bif 9V Latch SMD 810 Ohm	Axicom (Tyco)	IM45GR (6-1462037-4)	64-21223-281	1
K11	Relay, 2C Bif 9V Latch SMD 810 Ohm	Axicom (Tyco)	IM45GR (6-1462037-4)	64-21223-281	1
K12	Relay, 2C Bif 9V Latch SMD 810 Ohm	Axicom (Tyco)	IM45GR (6-1462037-4)	64-21223-281	1
K13	Relay, 2C Bif 9V Latch SMD 810 Ohm	Axicom (Tyco)	IM45GR (6-1462037-4)	64-21223-281	1
K14	Relay, 2C Bif 9V Latch SMD 810 Ohm	Axicom (Tyco)	IM45GR (6-1462037-4)	64-21223-281	1
K15	Relay, 2C Bif 9V Latch SMD 810 Ohm	Axicom (Tyco)	IM45GR (6-1462037-4)	64-21223-281	1
K16	Relay, 2C Bif 9V Latch SMD 810 Ohm	Axicom (Tyco)	IM45GR (6-1462037-4)	64-21223-281	1
K17	Relay, 1C Bif 9V Latch 1x450 Ohm	Matsushita	DS1E-ML-DC9V	64-21123-245	1
K18	Relay, 1C Bif 9V Latch 1x450 Ohm	Matsushita	DS1E-ML-DC9V	64-21123-245	1
K19	Relay, 1C Bif 9V Latch 1x450 Ohm	Matsushita	DS1E-ML-DC9V	64-21123-245	1
K20	Relay, 1C Bif 9V Latch 1x450 Ohm	Matsushita	DS1E-ML-DC9V	64-21123-245	1
K21	Relay, 2M 9V 5A Latch 2x270 Ohm	Matsushita	DSP2A-L2-DC9V	64-31205-227	1
K22	Relay, 2M 9V 5A Latch 2x270 Ohm	Matsushita	DSP2A-L2-DC9V	64-31205-227	1
K23	Relay, 2M 9V 5A Latch 2x270 Ohm	Matsushita	DSP2A-L2-DC9V	64-31205-227	1
L1	Inductor, 125nH	Protran	44-70548	44-70548	1
L2	Inductor, 208nH	Protran	44-70549	44-70549	1
L3	Inductor, 347nH	Protran	44-70550	44-70550	1
L4	Inductor, 578nH	Protran	44-70551	44-70551	1
L5	Inductor, 963nH	Protran	44-70552	44-70552	1
L6	Inductor, 1,65uH	Protran	44-70553	44-70553	1
L7	Inductor, 2,89uH	Protran	44-70554	44-70554	1
L8	Inductor, 5,07uH	Protran	44-70555	44-70555	1
L9	Inductor, 8,89uH	Protran	44-70556	44-70556	1

08-06063-001 - Antenna Tuner PCB

BOM Revision
Date Valid On

03 -- Production
17.06.2008

Ref	Description	Manufacturer	Manufacturer's P/N	Codan P/N	Qty
L10	Inductor, 15,6uH	Protran	44-70557	44-70557	1
L11	Inductor, 27,4uH	Protran	44-70558	44-70558	1
L12	Inductor, 24,0uH	Protran	44-70559	44-70559	1
L13	Inductor, 24,0uH	Protran	44-70559	44-70559	1
L14	Ind, 100uH 10% 4532	Taiyo Yuden	LEM 4532T101K	43-82100-134	1
L15	Choke, EMI/EMC 0A DC >10MHz 0805	Taiyo Yuden	BK 2125 HS 330-T	43-90004	1
L16	Choke, EMI/EMC 0A DC >10MHz 0805	Taiyo Yuden	BK 2125 HS 330-T	43-90004	1
P1	Header (P) 10way 2row Boxed SMD 2,54mm	Neltron	2316SM-10G	60-00100-004	1
P2	Not Fitted	Codan	**-00000-001	99-00000-001	1
P3	Header (P) 10way 2row	JAE	PS-10PE-D4T1-PN1	60-00100-260	1
R1	100k Ohm 5% 0,06W 0603	Philips	2322 702 60104	40-51000-121	1
R2	33k Ohm 5% 0,06W 0603	Philips	2322 702 60333	40-43300-121	1
R3	1,5k Ohm 5% 0,06W 0603	Philips	2322 702 60152	40-31500-121	1
R4	1,5k Ohm 5% 0,06W 0603	Philips	2322 702 60152	40-31500-121	1
R5	1,5k Ohm 5% 0,06W 0603	Philips	2322 702 60152	40-31500-121	1
R6	1,5k Ohm 5% 0,06W 0603	Philips	2322 702 60152	40-31500-121	1
R7	1,5k Ohm 5% 0,06W 0603	Philips	2322 702 60152	40-31500-121	1
R8	1,5k Ohm 5% 0,06W 0603	Philips	2322 702 60152	40-31500-121	1
R9	100k Ohm 5% 0,06W 0603	Philips	2322 702 60104	40-51000-121	1
R10	33k Ohm 5% 0,06W 0603	Philips	2322 702 60333	40-43300-121	1
R11	100k Ohm 5% 0,06W 0603	Philips	2322 702 60104	40-51000-121	1
R12	33k Ohm 5% 0,06W 0603	Philips	2322 702 60333	40-43300-121	1
R13	47k Ohm 5% 0,06W 0603	Philips	2322 702 60473	40-44700-121	1
R14	15k Ohm 5% 0,06W 0603	Philips	2322 702 60153	40-41500-121	1
R15	680 Ohm 5% 0,06W 0603	Philips	2322 702 60681	40-26800-121	1
R16	1k Ohm 5% 0,06W 0603	Philips	2322 702 60102	40-31000-121	1
R17	220k Ohm 5% 0,1W 0805	Philips	2322 730 61224	40-52200-111	1
R18	220k Ohm 5% 0,1W 0805	Philips	2322 730 61224	40-52200-111	1
R19	220k Ohm 5% 0,1W 0805	Philips	2322 730 61224	40-52200-111	1
R20	220k Ohm 5% 0,1W 0805	Philips	2322 730 61224	40-52200-111	1
R21	100 Ohm 5% 1,0W 2512	Phycomp	2322 762 60101	40-21000-141	1
R22	100 Ohm 5% 1,0W 2512	Phycomp	2322 762 60101	40-21000-141	1
R23	1,5k Ohm 1% 0,1W 0805	Philips	2322 734 61502	40-31500-115	1
R24	1,5k Ohm 1% 0,1W 0805	Philips	2322 734 61502	40-31500-115	1
R25	100 Ohm 5% 0,06W 0603	Philips	2322 702 60101	40-21000-121	1
R26	1k Ohm 5% 0,06W 0603	Philips	2322 702 60102	40-31000-121	1
R27	15k Ohm 5% 0,06W 0603	Philips	2322 702 60153	40-41500-121	1
R28	10k Ohm 5% 0,06W 0603	Philips	2322 702 60103	40-41000-121	1
R29	15k Ohm 5% 0,06W 0603	Philips	2322 702 60153	40-41500-121	1
R30	10k Ohm 5% 0,06W 0603	Philips	2322 702 60103	40-41000-121	1
R31	10k Ohm 5% 0,06W 0603	Philips	2322 702 60103	40-41000-121	1
R32	10k Ohm 5% 0,06W 0603	Philips	2322 702 60103	40-41000-121	1
R33	33k Ohm 5% 0,06W 0603	Philips	2322 702 60333	40-43300-121	1
R34	33k Ohm 5% 0,06W 0603	Philips	2322 702 60333	40-43300-121	1
R35	10 Ohm 5% 0,06W 0603	Philips	2322 702 60109	40-11000-121	1
R36	4,7k Ohm 5% 0,06W 0603	Philips	2322 702 60472	40-34700-121	1
R37	4,7k Ohm 5% 0,06W 0603	Philips	2322 702 60472	40-34700-121	1
R38	4,7k Ohm 5% 0,06W 0603	Philips	2322 702 60472	40-34700-121	1
R39	4,7k Ohm 5% 0,06W 0603	Philips	2322 702 60472	40-34700-121	1
R40	4,7k Ohm 5% 0,06W 0603	Philips	2322 702 60472	40-34700-121	1
R41	4,7k Ohm 5% 0,06W 0603	Philips	2322 702 60472	40-34700-121	1
R42	10k Ohm 5% 0,06W 0603	Philips	2322 702 60103	40-41000-121	1
R43	33k Ohm 5% 0,06W 0603	Philips	2322 702 60333	40-43300-121	1
R44	33k Ohm 5% 0,06W 0603	Philips	2322 702 60333	40-43300-121	1
R45	33k Ohm 5% 0,06W 0603	Philips	2322 702 60333	40-43300-121	1

08-06063-001 - Antenna Tuner PCB

BOM Revision
Date Valid On

03 -- Production
17.06.2008

Ref	Description	Manufacturer	Manufacturer's P/N	Codan P/N	Qty
R46	1k Ohm 5% 0,06W 0603	Philips	2322 702 60102	40-31000-121	1
R47	1k Ohm 5% 0,06W 0603	Philips	2322 702 60102	40-31000-121	1
R48	100 Ohm 5% 0,06W 0603	Philips	2322 702 60101	40-21000-121	1
R49	100 Ohm 5% 0,06W 0603	Philips	2322 702 60101	40-21000-121	1
R50	100 Ohm 5% 0,06W 0603	Philips	2322 702 60101	40-21000-121	1
R51	Not Fitted	Codan	**-00000-001	99-00000-001	1
R52	33k Ohm 5% 0,06W 0603	Philips	2322 702 60333	40-43300-121	1
T1	Txfr, RF or	Fetronics	44-80021	44-80021	1
T2	Transformer, Phase Detector	Protran	44-80307	44-80307	1
T3	Transformer, Phase Detector	Protran	44-80308	44-80308	1
T4	Transformer, Matching	Protran	44-80311	44-80311	1
T5	Transformer, Matching	Protran	44-80309	44-80309	1
T6	Transformer, Matching	Protran	44-80310	44-80310	1
V1	MOSFET, N Channel Dual 20V 0,5A SOT363	Vishay	SI1902DL	SI1902DL	1
V2	MOSFET, P+N Channel 30V 0,4A SOT363	Vishay	SI1539DL	SI1539DL	1
V3	MOSFET, P+N Channel 30V 0,4A SOT363	Vishay	SI1539DL	SI1539DL	1
V4	MOSFET, N Channel Dual 20V 0,5A SOT363	Vishay	SI1902DL	SI1902DL	1
V5	MOSFET, N Channel Dual 20V 0,5A SOT363	Vishay	SI1902DL	SI1902DL	1
V6	MOSFET, N Channel Dual 20V 0,5A SOT363	Vishay	SI1902DL	SI1902DL	1
V7	MOSFET, N Channel Dual 20V 0,5A SOT363	Vishay	SI1902DL	SI1902DL	1
V8	MOSFET, N Channel Dual 20V 0,5A SOT363	Vishay	SI1902DL	SI1902DL	1
V9	MOSFET, N Channel Dual 20V 0,5A SOT363	Vishay	SI1902DL	SI1902DL	1
V10	MOSFET, N Channel Dual 20V 0,5A SOT363	Vishay	SI1902DL	SI1902DL	1
V11	MOSFET, N Channel Dual 20V 0,5A SOT363	Vishay	SI1902DL	SI1902DL	1
V12	MOSFET, N Channel Dual 20V 0,5A SOT363	Vishay	SI1902DL	SI1902DL	1
V13	MOSFET, N Channel Dual 20V 0,5A SOT363	Vishay	SI1902DL	SI1902DL	1
V14	MOSFET, N Channel Dual 20V 0,5A SOT363	Vishay	SI1902DL	SI1902DL	1
V15	MOSFET, N Channel Dual 20V 0,5A SOT363	Vishay	SI1902DL	SI1902DL	1
V16	MOSFET, N Channel Dual 20V 0,5A SOT363	Vishay	SI1902DL	SI1902DL	1
V17	MOSFET, N Channel Dual 20V 0,5A SOT363	Vishay	SI1902DL	SI1902DL	1
V18	MOSFET, N Channel Dual 20V 0,5A SOT363	Vishay	SI1902DL	SI1902DL	1
V19	MOSFET, N Channel Dual 20V 0,5A SOT363	Vishay	SI1902DL	SI1902DL	1
V20	MOSFET, N Channel Dual 20V 0,5A SOT363	Vishay	SI1902DL	SI1902DL	1
V21	MOSFET, N Channel Dual 20V 0,5A SOT363	Vishay	SI1902DL	SI1902DL	1
V22	MOSFET, N Channel Dual 20V 0,5A SOT363	Vishay	SI1902DL	SI1902DL	1

08-06063-001 - Antenna Tuner PCB

BOM Revision
Date Valid On

03 -- Production
17.06.2008

Ref	Description	Manufacturer	Manufacturer's P/N	Codan P/N	Qty
V23	MOSFET, N Channel Dual 20V 0,5A SOT363	Vishay	SI1902DL	SI1902DL	1
V24	MOSFET, N Channel Dual 20V 0,5A SOT363	Vishay	SI1902DL	SI1902DL	1
V25	MOSFET, N Channel Dual 20V 0,5A SOT363	Vishay	SI1902DL	SI1902DL	1
V26	MOSFET, N Channel Dual 20V 0,5A SOT363	Vishay	SI1902DL	SI1902DL	1
V27	MOSFET, P+N Channel 30V 0,4A SOT363	Vishay	SI1539DL	SI1539DL	1
V28	JFET, N Channel SOT23	Philips	BF512	BF512	1

08-06044-000 - Filter, 500Hz or 3KHz PCB CP

BOM Revision
Date Valid On

01 -- Production
17.06.2008

Ref	Description	Manufacturer	Manufacturer's P/N	Codan P/N	Qty
	Filter, 500Hz/3KHz PCB			08-06044	1
	Filter, 500Hz or 3KHz			04-03442	1
1	PCB, Filter 500Hz or 3KHz	IMP	07-02016-01	07-02016-01	1
C1	27p 5% 50V NPO 0805 NiSn	Philips	0805CG270J9B200	46-12700-080	1
C2	27p 5% 50V NPO 0805 NiSn	Philips	0805CG270J9B200	46-12700-080	1
C4	33n 10% 50V X7R 0805 NiSn	Philips	08052R333K9BB00	46-43300-281	1
C5	33n 10% 50V X7R 0805 NiSn	Philips	08052R333K9BB00	46-43300-281	1
C7	33n 10% 50V X7R 0805 NiSn	Philips	08052R333K9BB00	46-43300-281	1
C8	33n 10% 50V X7R 0805 NiSn	Philips	08052R333K9BB00	46-43300-281	1
C9	33n 10% 50V X7R 0805 NiSn	Philips	08052R333K9BB00	46-43300-281	1
C10	33n 10% 50V X7R 0805 NiSn	Philips	08052R333K9BB00	46-43300-281	1
K1	Relay, 2C 9V Ltch SMD 2x579 Ohm	Matsushita	TQ2SL-L2-9V	64-21225-258	1
K2	Relay, 2C 9V Ltch SMD 2x579 Ohm	Matsushita	TQ2SL-L2-9V	64-21225-258	1
L1	Choke, EMI/EMC 0A DC >10MHz 0805	Taiyo Yuden	BK 2125 HS 330-T	43-90004	1
P1	Header (P) 4way 1row	Molex	22-03-2041	60-00041-100	1
P2	Header (P) 4way 1row	Molex	22-03-2041	60-00041-100	1
P3	Header (P) 4way 1row	Molex	22-03-2041	60-00041-100	1
P4	Header (P) 4way 1row	Molex	22-03-2041	60-00041-100	1
P5	Header (P) 2way 1row	Molex	22-03-2021	60-00021-100	1
R1	1,8k Ohm 5% 0,1W 0805	Philips	2322 730 61182	40-31800-111	1
R2	3,3k Ohm 5% 0,1W 0805	Philips	2322 730 61332	40-33300-111	1
R3	1k Ohm 5% 0,1W 0805	Philips	2322-730-61102	40-31000-111	1

08-06044-001 - Filter, 500Hz PCB

BOM Revision
Date Valid On

01 -- Production
17.06.2008

Ref	Description	Manufacturer	Manufacturer's P/N	Codan P/N	Qty
	Filter, 500Hz/3KHz PCB			08-06044	1
	Filter, 500Hz or 3KHz			04-03442	1
*	Filter, 500Hz/3KHz PCB			08-06044	1
1	PCB, Filter 500Hz or 3KHz	IMP	07-02016-01	07-02016-01	1
C1	27p 5% 50V NPO 0805 NiSn	Philips	0805CG270J9B200	46-12700-080	1
C2	27p 5% 50V NPO 0805 NiSn	Philips	0805CG270J9B200	46-12700-080	1
C4	33n 10% 50V X7R 0805 NiSn	Philips	08052R333K9BB00	46-43300-281	1
C5	33n 10% 50V X7R 0805 NiSn	Philips	08052R333K9BB00	46-43300-281	1
C7	33n 10% 50V X7R 0805 NiSn	Philips	08052R333K9BB00	46-43300-281	1
C8	33n 10% 50V X7R 0805 NiSn	Philips	08052R333K9BB00	46-43300-281	1
C9	33n 10% 50V X7R 0805 NiSn	Philips	08052R333K9BB00	46-43300-281	1
C10	33n 10% 50V X7R 0805 NiSn	Philips	08052R333K9BB00	46-43300-281	1
K1	Relay, 2C 9V Ltch SMD 2x579 Ohm	Matsushita	TQ2SL-L2-9V	64-21225-258	1
K2	Relay, 2C 9V Ltch SMD 2x579 Ohm	Matsushita	TQ2SL-L2-9V	64-21225-258	1
L1	Choke, EMI/EMC 0A DC >10MHz 0805	Taiyo Yuden	BK 2125 HS 330-T	43-90004	1
P1	Header (P) 4way 1row	Molex	22-03-2041	60-00041-100	1
P2	Header (P) 4way 1row	Molex	22-03-2041	60-00041-100	1
P3	Header (P) 4way 1row	Molex	22-03-2041	60-00041-100	1
P4	Header (P) 4way 1row	Molex	22-03-2041	60-00041-100	1
P5	Header (P) 2way 1row	Molex	22-03-2021	60-00021-100	1
R1	1,8k Ohm 5% 0,1W 0805	Philips	2322 730 61182	40-31800-111	1
R2	3,3k Ohm 5% 0,1W 0805	Philips	2322 730 61332	40-33300-111	1
R3	1k Ohm 5% 0,1W 0805	Philips	2322-730-61102	40-31000-111	1
Z1	Filter, 455 kHz 500 Hz BW	Rockwell	526-8693-010	65-91118	1

08-06044-002 - Filter, 2,7KHz PCB

BOM Revision
Date Valid On

01 -- Production
17.06.2008

Ref	Description	Manufacturer	Manufacturer's P/N	Codan P/N	Qty
	Filter, 455kHz 2,7kHz BW	Rockwell	526-8759-010	65-91123	1
	Filter, 500Hz/3KHz PCB			08-06044	1
	Filter, 500Hz or 3KHz			04-03442	1
*	Filter, 500Hz/3KHz PCB			08-06044	1
1	PCB, Filter 500Hz or 3KHz	IMP	07-02016-01	07-02016-01	1
C1	27p 5% 50V NPO 0805 NiSn	Philips	0805CG270J9B200	46-12700-080	1
C2	27p 5% 50V NPO 0805 NiSn	Philips	0805CG270J9B200	46-12700-080	1
C4	33n 10% 50V X7R 0805 NiSn	Philips	08052R333K9BB00	46-43300-281	1
C5	33n 10% 50V X7R 0805 NiSn	Philips	08052R333K9BB00	46-43300-281	1
C7	33n 10% 50V X7R 0805 NiSn	Philips	08052R333K9BB00	46-43300-281	1
C8	33n 10% 50V X7R 0805 NiSn	Philips	08052R333K9BB00	46-43300-281	1
C9	33n 10% 50V X7R 0805 NiSn	Philips	08052R333K9BB00	46-43300-281	1
C10	33n 10% 50V X7R 0805 NiSn	Philips	08052R333K9BB00	46-43300-281	1
K1	Relay, 2C 9V Ltch SMD 2x579 Ohm	Matsushita	TQ2SL-L2-9V	64-21225-258	1
K2	Relay, 2C 9V Ltch SMD 2x579 Ohm	Matsushita	TQ2SL-L2-9V	64-21225-258	1
L1	Choke, EMI/EMC 0A DC >10MHz 0805	Taiyo Yuden	BK 2125 HS 330-T	43-90004	1
P1	Header (P) 4way 1row	Molex	22-03-2041	60-00041-100	1
P2	Header (P) 4way 1row	Molex	22-03-2041	60-00041-100	1
P3	Header (P) 4way 1row	Molex	22-03-2041	60-00041-100	1
P4	Header (P) 4way 1row	Molex	22-03-2041	60-00041-100	1
P5	Header (P) 2way 1row	Molex	22-03-2021	60-00021-100	1
R1	1,8k Ohm 5% 0,1W 0805	Philips	2322 730 61182	40-31800-111	1
R2	3,3k Ohm 5% 0,1W 0805	Philips	2322 730 61332	40-33300-111	1
R3	1k Ohm 5% 0,1W 0805	Philips	2322-730-61102	40-31000-111	1

08-06149-001 - GPS Receiver PCB

BOM Revision
Date Valid On

02 -- Production
17.06.2008

Ref	Description	Manufacturer	Manufacturer's P/N	Codan P/N	Qty
	GPS Receiver			04-03488	1
	GPS Receiver PCB			08-06149	1
1	PCB, GPS Receiver	IMP	07-02039-01	07-02039-01	1
A1	GPS Rcvr Module, u-blox TIM-4H	u-blox	TIM-4H-0-000-0	78-07006	1
P1	Plug, Coax Ultra Mini 6GHz SMD	Hirose	U.FL-R-SMT(01)	60-19003	1
P2	Not Fitted	Codan	**00000-001	99-00000-001	1

08-06001-001 - NGT Voice Encryptor PCB

BOM Revision
Date Valid On

06 -- Production
17.06.2008

Ref	Description	Manufacturer	Manufacturer's P/N	Codan P/N	Qty
	PTP, CES Scrambler			10-50059	1
	NGT Voice Encryptor			04-03431	1
	NGT Voice Encryptor PCB			08-06001	1
1	PCB, NGT Voice Encryptor	Codan	07-02000-04	07-02000-04	1
2	Label, Serial/Barcode	Codan	06-02068	06-02068	1
3	Socket, 32PLCC IC SMD	Method	213-032-602	60-00323-000	1
4	Socket, 44PLCC IC, Surface mount	Method	213-044-602	60-00443-610	1
5	Cable, 16way FPC 1mm Ptchx45mmLg	TennRich	TFCAC16.35	67-50160-045	1
C1	100n 10% 16V X7R 0603 NiSn	Vitramon	VJ0603Y104KXJT	46-51000-283	1
C2	100n 10% 16V X7R 0603 NiSn	Vitramon	VJ0603Y104KXJT	46-51000-283	1
C3	100n 10% 16V X7R 0603 NiSn	Vitramon	VJ0603Y104KXJT	46-51000-283	1
C4	100n 10% 16V X7R 0603 NiSn	Vitramon	VJ0603Y104KXJT	46-51000-283	1
C5	100n 10% 16V X7R 0603 NiSn	Vitramon	VJ0603Y104KXJT	46-51000-283	1
C6	100n 10% 16V X7R 0603 NiSn	Vitramon	VJ0603Y104KXJT	46-51000-283	1
C7	100n 10% 16V X7R 0603 NiSn	Vitramon	VJ0603Y104KXJT	46-51000-283	1
C8	100n 10% 16V X7R 0603 NiSn	Vitramon	VJ0603Y104KXJT	46-51000-283	1
C9	100n 10% 16V X7R 0603 NiSn	Vitramon	VJ0603Y104KXJT	46-51000-283	1
C10	100n 10% 16V X7R 0603 NiSn	Vitramon	VJ0603Y104KXJT	46-51000-283	1
C11	100n 10% 16V X7R 0603 NiSn	Vitramon	VJ0603Y104KXJT	46-51000-283	1
C12	100n 10% 16V X7R 0603 NiSn	Vitramon	VJ0603Y104KXJT	46-51000-283	1
C13	100n 10% 16V X7R 0603 NiSn	Vitramon	VJ0603Y104KXJT	46-51000-283	1
C14	100n 10% 16V X7R 0603 NiSn	Vitramon	VJ0603Y104KXJT	46-51000-283	1
C15	10u 20% 20V 3528 TA Cap	AVX	TAJB106M020R	47-11002-000	1
C16	10u 20% 20V 3528 TA Cap	AVX	TAJB106M020R	47-11002-000	1
C17	10u 20% 20V 3528 TA Cap	AVX	TAJB106M020R	47-11002-000	1
C18	10u 20% 20V 3528 TA Cap	AVX	TAJB106M020R	47-11002-000	1
C19	22p 5% 100V NPO 0603 NiSn	Philips	0603CG220J0B200	46-12200-083	1
C20	22p 5% 100V NPO 0603 NiSn	Philips	0603CG220J0B200	46-12200-083	1
C21	100n 10% 16V X7R 0603 NiSn	Vitramon	VJ0603Y104KXJT	46-51000-283	1
C22	100n 10% 16V X7R 0603 NiSn	Vitramon	VJ0603Y104KXJT	46-51000-283	1
C23	100n 10% 16V X7R 0603 NiSn	Vitramon	VJ0603Y104KXJT	46-51000-283	1
C24	100n 10% 16V X7R 0603 NiSn	Vitramon	VJ0603Y104KXJT	46-51000-283	1
C25	100n 10% 16V X7R 0603 NiSn	Vitramon	VJ0603Y104KXJT	46-51000-283	1
C27	100n 10% 16V X7R 0603 NiSn	Vitramon	VJ0603Y104KXJT	46-51000-283	1
C28	1u 20% 16V 3216 TA Cap	AVX	TAJA105M016R	47-01001-600	1
C29	330p 5% 50V NPO 0603 NiSn	Phycomp	0603CG331J9B200	46-23300-083	1
C30	100n 10% 16V X7R 0603 NiSn	Vitramon	VJ0603Y104KXJT	46-51000-283	1
C31	1u 20% 16V 3216 TA Cap	AVX	TAJA105M016R	47-01001-600	1
C32	330p 5% 50V NPO 0603 NiSn	Phycomp	0603CG331J9B200	46-23300-083	1
C33	100n 10% 16V X7R 0603 NiSn	Vitramon	VJ0603Y104KXJT	46-51000-283	1
C34	100n 10% 16V X7R 0603 NiSn	Vitramon	VJ0603Y104KXJT	46-51000-283	1
C35	100n 10% 16V X7R 0603 NiSn	Vitramon	VJ0603Y104KXJT	46-51000-283	1
C36	100n 10% 16V X7R 0603 NiSn	Vitramon	VJ0603Y104KXJT	46-51000-283	1
C37	100n 10% 16V X7R 0603 NiSn	Vitramon	VJ0603Y104KXJT	46-51000-283	1
C38	1u 10% 16V X7R 1206 NiSn	Philips	12062R105K7BB00	46-61000-280	1
C39	1u 10% 16V X7R 1206 NiSn	Philips	12062R105K7BB00	46-61000-280	1
C40	1u 10% 16V X7R 1206 NiSn	Philips	12062R105K7BB00	46-61000-280	1
C41	1u 10% 16V X7R 1206 NiSn	Philips	12062R105K7BB00	46-61000-280	1
C42	1u 10% 16V X7R 1206 NiSn	Philips	12062R105K7BB00	46-61000-280	1
C43	1u 10% 16V X7R 1206 NiSn	Philips	12062R105K7BB00	46-61000-280	1
C44	1u 20% 16V 3216 TA Cap	AVX	TAJA105M016R	47-01001-600	1
C74	100n 10% 16V X7R 0603 NiSn	Vitramon	VJ0603Y104KXJT	46-51000-283	1
D1	Diode, Si 70V Dual SOT23	Philips	BAV99	BAV99	1
D3	Diode, Si High speed 75V SOT23	Philips	BAS16	BAS16	1
J4	Not Fitted	Codan	**--00000-001	99-00000-001	1
J6	Socket, 16way 1row 90deg ZIF 1mmPitchSMD	AMP	1-487951-6	60-00163-003	1

08-06001-001 - NGT Voice Encryptor PCB

BOM Revision
Date Valid On

06 -- Production
17.06.2008

Ref	Description	Manufacturer	Manufacturer's P/N	Codan P/N	Qty
L1	Choke, EMI/EMC 0A DC >1MHz 4516	Taiyo Yuden	FB-MJ4516HS111-T	43-90003	1
R1	4,7k Ohm 5% 0,06W 0603	Philips	2322 702 60472	40-34700-121	1
R2	4,7k Ohm 5% 0,06W 0603	Philips	2322 702 60472	40-34700-121	1
R3	220 Ohm 5% 0,06W 0603	Philips	2322 702 60221	40-22200-121	1
R4	270 Ohm 5% 0,06W 0603	Philips	2322 702 60271	40-22700-121	1
R5	10k Ohm 5% 0,06W 0603	Philips	2322 702 60103	40-41000-121	1
R6	18k Ohm 1% 0,06W 0603	Philips	2322 704 61803	40-41800-125	1
R7	1k Ohm 5% 0,06W 0603	Philips	2322 702 60102	40-31000-121	1
R8	10k Ohm 5% 0,06W 0603	Philips	2322 702 60103	40-41000-121	1
R9	100 Ohm 5% 0,06W 0603	Philips	2322 702 60101	40-21000-121	1
R10	10k Ohm 5% 0,06W 0603	Philips	2322 702 60103	40-41000-121	1
R11	10k Ohm 5% 0,06W 0603	Philips	2322 702 60103	40-41000-121	1
R12	10k Ohm 5% 0,06W 0603	Philips	2322 702 60103	40-41000-121	1
R13	10k Ohm 5% 0,06W 0603	Philips	2322 702 60103	40-41000-121	1
R16	100 Ohm 5% 0,06W 0603	Philips	2322 702 60101	40-21000-121	1
R19	100 Ohm 5% 0,06W 0603	Philips	2322 702 60101	40-21000-121	1
R25	33k Ohm 5% 0,06W 0603	Philips	2322 702 60333	40-43300-121	1
R26	47k Ohm 5% 0,06W 0603	Philips	2322 702 60473	40-44700-121	1
R27	47k Ohm 5% 0,06W 0603	Philips	2322 702 60473	40-44700-121	1
R28	33k Ohm 5% 0,06W 0603	Philips	2322 702 60333	40-43300-121	1
R77	6,8k Ohm 5% 0,06W 0603	Philips	2322 702 60682	40-36800-121	1
R95	6,8k Ohm 5% 0,06W 0603	Philips	2322 702 60682	40-36800-121	1
RN5	10k Ohm 5% 0,063W 1206 Sep x4Res	AVX	CRC3A4E103JT	40-84101-423	1
RN6	10k Ohm 5% 0,063W 1206 Sep x4Res	AVX	CRC3A4E103JT	40-84101-423	1
U1	DSP, 16-Bit Fixed-point 100MIPS TQFP144	Texas Instruments	TMS320VC5402PGE100	YP-32054-900	1
U2	Buffer, Octal Bus T/State SOIC20	FSC	74LCX541WMX-NL	YX-74541-700	1
U3	Tcvr, Octal Bus SOIC20	STMicroelectronics	74LCX245M	YX-74245-700	1
U4	Decode/MUX 2 to 4 Line SOIC16	STMicroelectronics	M74HCT139M1R	YV-74139-700	1
U5	EPROM prgmd, Voice Encryptor	CES Communications	90-20614-001	90-20614-001	1
U6	Flip Flop, D Dual SOIC14	STMicroelectronics	74LCX74M	YX-74074-700	1
U7	Reg, Voltage +3,3V 150mA LDO SOT23-5	Texas Instruments	TPS76333DBVT	XB-76333-700	1
U8	Reg, Voltage +1,8V 150mA LDO SOT23-5	Texas Instruments	TPS76318DBVT	XB-76318-700	1
U9	Buffer, Octal Bus T/State SOIC20	FSC	74LCX541WMX-NL	YX-74541-700	1
U11	Monitor, Micro 4,35V SOT23	Dallas	DS1811R-10	XD-01811-700	1
U12	Micro prgmd, Voice Encryptor	CES Communications	90-20615-001	90-20615-001	1
U13	Amp, Op Rail-Rail I/O Dual SOIC8	National Semiconductor	LMC6482IM	XA-06482-700	1
U14	Counter, BCD Dual SOIC16	STMicroelectronics	M74HC390M1R	YH-74390-700	1
U15	EEPROM, CMOS 2k x 8bit IIC Bus SOIC8	Catalyst	CAT24C16W	YM-02416-700	1
U18	Codec/Filter, Mu/A-Law Serial SOIC20	Motorola	MC14LC5480DW	YN-45480-700	1
U19	Codec/Filter, Mu/A-Law Serial SOIC20	Motorola	MC14LC5480DW	YN-45480-700	1
U30	Gate, OR 2 Input Single SOT23-5	Fairchild	NC7S32M5X	YH-74032-700	1

08-06001-001 - NGT Voice Encryptor PCB

BOM Revision
Date Valid On

06 -- Production
17.06.2008

Ref	Description	Manufacturer	Manufacturer's P/N	Codan P/N	Qty
X1	Crystal, 20 MHz Fundamental QC49/SMD	Saronix	49SMLB200	65-90115	1

08-06382-001 - Interface Adaptor

BOM Revision
Date Valid On

03 -- Production
17.06.2008

Ref	Description	Manufacturer	Manufacturer's P/N	Codan P/N	Qty
	Label, VP-116 Interface	Codan	06-02375	06-02375	2
	Fitting Instructions	Codan	15-00140-001	15-00140-001	1
	Interface Adaptor			08-06382	1
	Interface, Adaptor 2110			04-03528	1
1	PCB, Interface Adaptor		07-02099-03	07-02099-03	1
2	Box, Interface Adaptor	Metalcraft	05-07495	05-07495	1
3	Escutcheon, Interface Adaptor	Entech	06-02351	06-02351	1
4	Cable, 6way & 2way I/F O/P	Electronic Synergies	08-06398-001	08-06398-001	1
5	Cable, 15way & 2way I/F O/P	Electronic Synergies	08-06399-001	08-06399-001	1
6	Cable, 19way Interface I/P	Electronic Synergies	08-06400-001	08-06400-001	1
7	Nut, M3 MS Zn Pl Hex	Spec 01-00201	31-23000-001	31-23000-001	4
8	Screw, M3x12 304 SS Bk Csk Pozi	Spec 01-00205	31-23012-782	31-23012-782	4
9	Label, Serial/Barcode	Codan	06-02068	06-02068	1
10	Standoff, PCB 3,6x4	PEM	KFE-3,6-4ET	33-53604-040	4
C1	22u 20% 16V X5R 1210 NiSn	Kemet	C1210C226M4PAC7800	46-72200-280	1
C2	1u 20% 35V 3528 TA Cap	AVX	TAJB105M035R	47-01003-520	1
C3	100u 25V 105°C SMD EL Cap Low ESR	Nippon Chemicon	MVY25VC100MF80	48-21002-502	1
C4	470u 16V Ax EL Cap	Jamicon	SKR470T1CG18	48-24701-651	1
C5	1000u 16V Ax EL Cap	Jamicon	SKR102T1CJ21	48-31001-651	1
C6	33n 10% 25V X7R 0603 NiSn	Vitramon	VJ0603Y333KXXT	46-43300-282	1
C7	100p 5% 50V NPO 0603 NiSn	Philips	0603CG101J9B200	46-21000-083	1
C8	33n 10% 25V X7R 0603 NiSn	Vitramon	VJ0603Y333KXXT	46-43300-282	1
C9	1n 5% 25V NPO 0603 NiSn	AVX	06033A102JAT2A	46-31000-083	1
C10	33n 10% 25V X7R 0603 NiSn	Vitramon	VJ0603Y333KXXT	46-43300-282	1
C11	33n 10% 25V X7R 0603 NiSn	Vitramon	VJ0603Y333KXXT	46-43300-282	1
C12	33n 10% 25V X7R 0603 NiSn	Vitramon	VJ0603Y333KXXT	46-43300-282	1
C13	100u 25V 105°C SMD EL Cap Low ESR	Nippon Chemicon	MVY25VC100MF80	48-21002-502	1
C14	33n 10% 25V X7R 0603 NiSn	Vitramon	VJ0603Y333KXXT	46-43300-282	1
C15	1u 20% 35V 3528 TA Cap	AVX	TAJB105M035R	47-01003-520	1
D1	Diode, Si High speed 75V SOT23	Philips	BAS16	BAS16	1
D2	Diode, Si High speed 75V SOT23	Philips	BAS16	BAS16	1
IC1	Amp, Audio Power 2x11w SIL9P	Philips	TDA1519C	TDA1519C	1
K1	Relay, 2C 12V 2A SMD 1028 Ohm	Matsushita	TQ2SL-12V	64-21225-310	1
L1	Choke, EMI/EMC 0A DC >1MHz 4516	Taiyo Yuden	FB-MJ4516HS111-T	43-90003	1
L2	Choke, EMI/EMC 0A DC >1MHz 4516	Taiyo Yuden	FB-MJ4516HS111-T	43-90003	1
P1	Header (P) 15way 2mm Latch Fixed	Chyao Shunn	JS-1125-15	60-00150-005	1
P2	Header (P) 4way 2mm Latch Fixed	AMP	173981-4	60-00040-352	1
P3	Header (P) 15way 2mm Latch Fixed	Chyao Shunn	JS-1125-15	60-00150-005	1
P4	Header (P) 15way 2mm Latch Fixed	Chyao Shunn	JS-1125-15	60-00150-005	1
P5	Header (P) 2way 1row Latch	JAE	IL-2P-S3EN2	60-00020-260	1
P6	Header (P) 2way 1row Latch	JAE	IL-2P-S3EN2	60-00020-260	1
P7	Header (P) 6way 2mm Latch Fixed	AMP	173981-6	60-00060-350	1
R1	82k Ohm 5% 0,06W 0603	Philips	2322 702 60823	40-48200-121	1
R2	4,7k Ohm 5% 0,06W 0603	Philips	2322 702 60472	40-34700-121	1
R3	10k Ohm 5% 0,06W 0603	Philips	2322 702 60103	40-41000-121	1
R4	4,7k Ohm 5% 0,06W 0603	Philips	2322 702 60472	40-34700-121	1
R5	10k Ohm 5% 0,06W 0603	Philips	2322 702 60103	40-41000-121	1
R6	220 Ohm 5% 0,06W 0603	Philips	2322 702 60221	40-22200-121	1
R7	10 Ohm 5% 0,06W 0603	Philips	2322 702 60109	40-11000-121	1
T1	Txfr, Line Isolation 600 Ohm CT SMD	Premier Magnetics	PM-MC27	43-30006	1

08-06382-001 - Interface Adaptor

BOM Revision
Date Valid On

03 -- Production
17.06.2008

Ref	Description	Manufacturer	Manufacturer's P/N	Codan P/N	Qty
T2	Txfr, Line Isolation 600 Ohm CT SMD	Premier Magnetics	PM-MC27	43-30006	1
V1	MOSFET, N Channel Enhanced SOT23	Fairchild	BSS138	BSS138	1
V2	MOSFET, N Channel Enhanced SOT23	Fairchild	BSS138	BSS138	1
V3	Transistor, NPN Si 100V 1A D-Pak	Fairchild	MJD31C	MJD31C	1

08-06421-001 - VP116-2110 Interface

BOM Revision
Date Valid On

01 -- Production
17.06.2008

Ref	Description	Manufacturer	Manufacturer's P/N	Codan P/N	Qty
	VP116-2110 Interface PCB			08-06421	1
	VP116-2110 Interface			04-03531	1
1	PCB, VP116-2110 Interface	Codan	07-02102-01	07-02102-01	1
2	Cable,VP116 Interface 2110 Side		08-06720-001	08-06720-001	1
3	Cable,VP116 Interface VP116 Side		08-06719-001	08-06719-001	1
4	Enclosure, VP116 - 2110 Interface		05-07704	05-07704	1
5	Escutcheon, VP116 - 2110 Interface		06-02458	06-02458	1
6	Tie, Cable 2,5mm W x 115mm Long	Richco	WIT 18 R	30-39100-004	2
C1	33n 10% 25V X7R 0603 NiSn	Vitramon	VJ0603Y333KXXT	46-43300-282	1
C2	33n 10% 25V X7R 0603 NiSn	Vitramon	VJ0603Y333KXXT	46-43300-282	1
C3	33n 10% 25V X7R 0603 NiSn	Vitramon	VJ0603Y333KXXT	46-43300-282	1
C4	33n 10% 25V X7R 0603 NiSn	Vitramon	VJ0603Y333KXXT	46-43300-282	1
D1	Diode, Si High speed 75V SOT23	Philips	BAS16	BAS16	1
K1	Relay, 2C 12V 2A SMD 1028 Ohm	Matsushita	TQ2SL-12V	64-21225-310	1
L1	Choke, EMI/EMC 0A DC >1MHz 4516	Taiyo Yuden	FB-MJ4516HS111-T	43-90003	1
P1	Header (P) 8way 2mm Latch Fixed	AMP	292161-8	60-00080-001	1
P2	Header (P) 4way 2mm Latch Fixed	AMP	173981-4	60-00040-352	1
P3	Header (P) 10way 2mm Latch Fixed	AMP	1-173981-0	60-00100-351	1
P4	Header (P) 6way 2mm Latch Fixed	AMP	173981-6	60-00060-350	1
R1	4,7k Ohm 5% 0,06W 0603	Philips	2322 702 60472	40-34700-121	1
R2	10k Ohm 5% 0,06W 0603	Philips	2322 702 60103	40-41000-121	1
T1	Txfr, Line Isolation 600 Ohm CT SMD	Premier Magnetics	PM-MC27	43-30006	1
V1	MOSFET, N Channel Enhanced SOT23	Fairchild	BSS138	BSS138	1
V2	MOSFET, N Channel Enhanced SOT23	Fairchild	BSS138	BSS138	1

08-06804-001 - 3160 Power Amplifier 125W

BOM Revision
Date Valid On

02 -- Production
28.08.2008

Ref	Description	Manufacturer	Manufacturer's P/N	Codan P/N	Qty
	3160 Power Amplifier 125W			08-06804	1
	3160 Power Amplifier 125W			04-03592	1
	PTP, 3160 Manpack PA Test Procedure			10-01097	1
	S/w Mstr Assy for 90-20663-001 ver 1.00			90-30663-001	1
	CMR Power Amplifier 3160			11-06256	1
1	PCB, 3160 Power Amplifier 125W		07-02186-02	07-02186-02	1
2	Housing, 3160 Power Amplifier		05-07771	05-07771	1
3	Lid, 3160 Power Amplifier		05-07772	05-07772	1
4	Label, 32 pin PLCC	Codan	06-01674	06-01674	1
5	Label, WEEE 10x15mm White	Entech	06-02352-001	06-02352-001	1
6	Label, Serial/Barcode	Codan	06-02370	06-02370	1
7	Label, Serial No. 3160		06-02530	06-02530	1
8	Label, Output / GND 3160		06-02531	06-02531	1
9	Label, Input / Control 3160		06-02532	06-02532	1
10	Cable, RF Output 3160		08-06813-001	08-06813-001	1
11	Cable, RF Input 3160			08-06814-001	1
12	Loom, Control/Power 3160		08-06812-001	08-06812-001	1
13	O-Ring EPDM 221,92IDx2,26mm dia	James Walker	JW50-174 EP18/H/75	30-29011-505	1
14	Washer, Mica (1kV) TO-220	Philips	56359B	30-45002-002	1
15	Screw, M3x8 TAPTITE 2 P/Pozi	Ajax Fasteners	31-03008-580	31-03008-580	25
16	Screw, M3x8 304 SS Bk Csk Pozi	Spec 01-00205	31-23008-782	31-23008-782	10
17	Screw, M4x12 TAPTITE 2Pan Slot	Ajax Fasteners	31-04012-880	31-04012-880	1
18	Screw, Breather M3x6 Nylon Black slotted	Brownell	BL/D 9301	31-23006-920	1
19	Washer, M4 304 SS Normal	*	31-24001-080	31-24001-080	2
20	Socket, UHF Flange Fixed	Marushin	MR-589	60-11360-589	1
21	Socket, BNC Large Flange Mount	Huber+Suhner	23_BNC-50-0-2/133_N	60-12305	1
22	Gasket, Connector MS 14 Shell	Amphenol	62IN-760-14	60-90710	1
23	Gasket, Connector 10 Shell	VGL	62IN-760-10	60-90711	2
24	Lug, Solder 3,5mm	Cliford W Ltd	G410 CODE 330	61-30200-025	6
25	Compound, 100g Tube	Dow Corning	Molykote 111	71-31000-002	1
26	Heat, Transfer Compound	Gensil	GENSIL 13 45gm Tube	71-31000-004	1
27	Stake, Terminal	Autosplice	7-22461-5	61-40300-004	6
28	Tubing, Heatshrink 4,8x0,2 Bk	3M	FP-301 3/16" Black	71-80502-400	10
29	Not Fitted	Codan	**-00000-001	99-00000-001	1
30	Loctite 5140, Adhesive/Sealant, Clear RTV	Loctite	5140 300ml tube	71-30001	0.01
31	Adhesive, Jet Melt 177'-196'C	3M	3748-TC-Q	71-30002	0.01
B1	Temp Sensor 10mV/degree C SOT23	National Semiconduct	LM50CIM3X	LM50CIM3X	1
C1	3,3n 10% 100V X7R 0603 NiSn	Vishay	VJ0603Y332KXBAC	46-33300-282	1
C2	120p 5% 500V NPO 1206 <1000		46-21200-088 selected for ESR 10-01095	46-21200-0821	1
C3	120p 5% 500V NPO 1206 <1000		46-21200-088 selected for ESR 10-01095	46-21200-0821	1
C4	39p 5% 500V NPO 1206 <1000		46-13900-088 selected for ESR 10-01095	46-13900-0821	1
C5	120p 5% 500V NPO 1206 <1000		46-21200-088 selected for ESR 10-01095	46-21200-0821	1
C6	220p 5% 500V NPO 1206 <1000		46-22200-088 selected for ESR 10-01095	46-22200-0821	1
C8	56p 5% 500V NPO 1206 <1000		46-15600-088 selected for ESR 10-01095	46-15600-0821	1
C9	Not Fitted	Codan	**-00000-001	99-00000-001	1
C10	33p 5% 500V NPO 1206 <1000		46-13300-088 selected for ESR 10-01095	46-13300-0821	1
C11	22p 5% 500V NPO 1206 <1000		46-12200-088 selected for ESR 10-01095	46-12200-0821	1

08-06804-001 - 3160 Power Amplifier 125W

BOM Revision
Date Valid On

02 -- Production
28.08.2008

Ref	Description	Manufacturer	Manufacturer's P/N	Codan P/N	Qty
C12	Not Fitted	Codan	**-00000-001	99-00000-001	1
C13	27p 5% 500V NPO 1206 <1000		46-12700-088 selected for ESR 10-01095	46-12700-0821	1
C14	33p 5% 500V NPO 1206 <1000		46-13300-088 selected for ESR 10-01095	46-13300-0821	1
C15	47p 5% 500V NPO 1206 <1000		46-14700-088 selected for ESR 10-01095	46-14700-0821	1
C16	47p 5% 500V NPO 1206 <1000		46-14700-088 selected for ESR 10-01095	46-14700-0821	1
C17	27p 5% 500V NPO 1206 <1000		46-12700-088 selected for ESR 10-01095	46-12700-0821	1
C18	33p 5% 500V NPO 1206 <1000		46-13300-088 selected for ESR 10-01095	46-13300-0821	1
C19	22p 5% 500V NPO 1206 <1000		46-12200-088 selected for ESR 10-01095	46-12200-0821	1
C20	56p 5% 500V NPO 1206 <1000		46-15600-088 selected for ESR 10-01095	46-15600-0821	1
C21	27p 5% 500V NPO 1206 <1000		46-12700-088 selected for ESR 10-01095	46-12700-0821	1
C22	18p 5% 500V NPO 1206 <1000		46-11800-088 selected for ESR 10-01095	46-11800-0821	1
C23	56p 5% 500V NPO 1206 <1000		46-15600-088 selected for ESR 10-01095	46-15600-0821	1
C24	Not Fitted	Codan	**-00000-001	99-00000-001	1
C25	47p 5% 500V NPO 1206 <1000		46-14700-088 selected for ESR 10-01095	46-14700-0821	1
C26	33p 5% 500V NPO 1206 <1000		46-13300-088 selected for ESR 10-01095	46-13300-0821	1
C27	39p 5% 500V NPO 1206 <1000		46-13900-088 selected for ESR 10-01095	46-13900-0821	1
C28	68p 5% 500V NPO 1206 <1000		46-16800-088 selected for ESR 10-01095	46-16800-0821	1
C29	39p 5% 500V NPO 1206 <1000		46-13900-088 selected for ESR 10-01095	46-13900-0821	1
C30	22p 5% 500V NPO 1206 <1000		46-12200-088 selected for ESR 10-01095	46-12200-0821	1
C31	68p 5% 500V NPO 1206 <1000		46-16800-088 selected for ESR 10-01095	46-16800-0821	1
C32	68p 5% 500V NPO 1206 <1000		46-16800-088 selected for ESR 10-01095	46-16800-0821	1
C33	56p 5% 500V NPO 1206 <1000		46-15600-088 selected for ESR 10-01095	46-15600-0821	1
C34	27p 5% 500V NPO 1206 <1000		46-12700-088 selected for ESR 10-01095	46-12700-0821	1
C35	Not Fitted	Codan	**-00000-001	99-00000-001	1
C36	150p 5% 500V NPO 1206 <1000		46-21500-088 selected for ESR 10-01095	46-21500-0821	1
C37	150p 5% 500V NPO 1206 <1000		46-21500-088 selected for ESR 10-01095	46-21500-0821	1
C38	22p 5% 500V NPO 1206 <1000		46-12200-088 selected for ESR 10-01095	46-12200-0821	1
C39	39p 5% 500V NPO 1206 <1000		46-13900-088 selected for ESR 10-01095	46-13900-0821	1
C40	47p 5% 500V NPO 1206 <1000		46-14700-088 selected for ESR 10-01095	46-14700-0821	1
C41	27p 5% 500V NPO 1206 <1000		46-12700-088 selected for ESR 10-01095	46-12700-0821	1

08-06804-001 - 3160 Power Amplifier 125W

BOM Revision
Date Valid On

02 -- Production
28.08.2008

Ref	Description	Manufacturer	Manufacturer's P/N	Codan P/N	Qty
C42	82p 5% 500V NPO 1206 <1000		46-18200-088 selected for ESR 10-01095	46-18200-0821	1
C43	82p 5% 500V NPO 1206 <1000		46-18200-088 selected for ESR 10-01095	46-18200-0821	1
C44	Not Fitted	Codan	**-00000-001	99-00000-001	1
C45	Not Fitted	Codan	**-00000-001	99-00000-001	1
C46	47p 5% 500V NPO 1206 <1000		46-14700-088 selected for ESR 10-01095	46-14700-0821	1
C50	180p 5% 500V NPO 1206 <1000		46-21800-088 selected for ESR 10-01095	46-21800-0821	1
C51	180p 5% 500V NPO 1206 <1000		46-21800-088 selected for ESR 10-01095	46-21800-0821	1
C52	180p 5% 500V NPO 1206 <1000		46-21800-088 selected for ESR 10-01095	46-21800-0821	1
C56	150p 5% 500V NPO 1206 <1000		46-21500-088 selected for ESR 10-01095	46-21500-0821	1
C57	150p 5% 500V NPO 1206 <1000		46-21500-088 selected for ESR 10-01095	46-21500-0821	1
C58	150p 5% 500V NPO 1206 <1000		46-21500-088 selected for ESR 10-01095	46-21500-0821	1
C59	150p 5% 500V NPO 1206 <1000		46-21500-088 selected for ESR 10-01095	46-21500-0821	1
C60	120p 5% 500V NPO 1206 <1000		46-21200-088 selected for ESR 10-01095	46-21200-0821	1
C61	39p 5% 500V NPO 1206 <1000		46-13900-088 selected for ESR 10-01095	46-13900-0821	1
C62	Not Fitted	Codan	**-00000-001	99-00000-001	1
C63	180p 5% 500V NPO 1206 <1000		46-21800-088 selected for ESR 10-01095	46-21800-0821	1
C64	150p 5% 500V NPO 1206 <1000		46-21500-088 selected for ESR 10-01095	46-21500-0821	1
C65	Not Fitted	Codan	**-00000-001	99-00000-001	1
C66	Not Fitted	Codan	**-00000-001	99-00000-001	1
C67	150p 5% 500V NPO 1206 <1000		46-21500-088 selected for ESR 10-01095	46-21500-0821	1
C68	150p 5% 500V NPO 1206 <1000		46-21500-088 selected for ESR 10-01095	46-21500-0821	1
C69	150p 5% 500V NPO 1206 <1000		46-21500-088 selected for ESR 10-01095	46-21500-0821	1
C70	180p 5% 500V NPO 1206 <1000		46-21800-088 selected for ESR 10-01095	46-21800-0821	1
C71	180p 5% 500V NPO 1206 <1000		46-21800-088 selected for ESR 10-01095	46-21800-0821	1
C72	68p 5% 500V NPO 1206 <1000		46-16800-088 selected for ESR 10-01095	46-16800-0821	1
C73	68p 5% 500V NPO 1206 <1000		46-16800-088 selected for ESR 10-01095	46-16800-0821	1
C74	220p 5% 500V NPO 1206 <1000		46-22200-088 selected for ESR 10-01095	46-22200-0821	1
C75	220p 5% 500V NPO 1206 <1000		46-22200-088 selected for ESR 10-01095	46-22200-0821	1
C76	33p 5% 500V NPO 1206 <1000		46-13300-088 selected for ESR 10-01095	46-13300-0821	1
C77	Not Fitted	Codan	**-00000-001	99-00000-001	1
C78	220p 5% 500V NPO 1206 <1000		46-22200-088 selected for ESR 10-01095	46-22200-0821	1
C79	Not Fitted	Codan	**-00000-001	99-00000-001	1

08-06804-001 - 3160 Power Amplifier 125W

BOM Revision
Date Valid On

02 -- Production
28.08.2008

Ref	Description	Manufacturer	Manufacturer's P/N	Codan P/N	Qty
C80	220p 5% 500V NPO 1206 <1000		46-22200-088 selected for ESR 10-01095	46-22200-0821	1
C81	180p 5% 500V NPO 1206 <1000		46-21800-088 selected for ESR 10-01095	46-21800-0821	1
C82	330p 5% 500V NPO 1206 <1000		46-23300-088 selected for ESR 10-01095	46-23300-0821	1
C83	270p 5% 500V NPO 1206 <1000		46-22700-088 selected for ESR 10-01095	46-22700-0821	1
C84	180p 5% 500V NPO 1206 <1000		46-21800-088 selected for ESR 10-01095	46-21800-0821	1
C85	330p 5% 500V NPO 1206 <1000		46-23300-088 selected for ESR 10-01095	46-23300-0821	1
C86	330p 5% 500V NPO 1206 <1000		46-23300-088 selected for ESR 10-01095	46-23300-0821	1
C87	82p 5% 500V NPO 1206 <1000		46-18200-088 selected for ESR 10-01095	46-18200-0821	1
C88	100p 5% 500V NPO 1206 <1000		46-21000-088 selected for ESR 10-01095	46-21000-0821	1
C89	470p 5% 500V NPO 1206 <1000		46-24700-088 selected for ESR 10-01095	46-24700-0821	1
C90	470p 5% 500V NPO 1206 <1000		46-24700-088 selected for ESR 10-01095	46-24700-0821	1
C91	390p 5% 500V NPO 1206 <1000		46-23900-088 selected for ESR 10-01095	46-23900-0821	1
C92	Not Fitted	Codan	**-00000-001	99-00000-001	1
C93	330p 5% 500V NPO 1206 <1000		46-23300-088 selected for ESR 10-01095	46-23300-0821	1
C94	330p 5% 500V NPO 1206 <1000		46-23300-088 selected for ESR 10-01095	46-23300-0821	1
C95	390p 5% 500V NPO 1206 <1000		46-23900-088 selected for ESR 10-01095	46-23900-0821	1
C96	220p 5% 500V NPO 1206 <1000		46-22200-088 selected for ESR 10-01095	46-22200-0821	1
C97	120p 5% 500V NPO 1206 <1000		46-21200-088 selected for ESR 10-01095	46-21200-0821	1
C98	33n 10% 25V X7R 0603 NiSn	Vitramon	VJ0603Y333KXXT	46-43300-282	1
C99	33n 10% 25V X7R 0603 NiSn	Vitramon	VJ0603Y333KXXT	46-43300-282	1
C100	33n 10% 25V X7R 0603 NiSn	Vitramon	VJ0603Y333KXXT	46-43300-282	1
C102	33n 10% 25V X7R 0603 NiSn	Vitramon	VJ0603Y333KXXT	46-43300-282	1
C103	33n 10% 25V X7R 0603 NiSn	Vitramon	VJ0603Y333KXXT	46-43300-282	1
C104	33n 10% 25V X7R 0603 NiSn	Vitramon	VJ0603Y333KXXT	46-43300-282	1
C105	33n 10% 25V X7R 0603 NiSn	Vitramon	VJ0603Y333KXXT	46-43300-282	1
C106	22p 5% 500V NPO 1206 <1000		46-12200-088 selected for ESR 10-01095	46-12200-0821	1
C107	100p 5% 500V NPO 1206 <1000		46-21000-088 selected for ESR 10-01095	46-21000-0821	1
C108	330p 5% 50V NPO 0805 NiSn	Philips	0805CG331J9B200	46-23300-081	1
C109	470p 5% 500V NPO 1206 <1000		46-24700-088 selected for ESR 10-01095	46-24700-0821	1
C110	470p 5% 500V NPO 1206 <1000		46-24700-088 selected for ESR 10-01095	46-24700-0821	1
C111	470p 5% 500V NPO 1206 <1000		46-24700-088 selected for ESR 10-01095	46-24700-0821	1
C112	100n 10% 50V X7R 0805 Nisn	Philips	08052R104K9BB	46-51000-282	1
C113	100n 10% 50V X7R 0805 Nisn	Philips	08052R104K9BB	46-51000-282	1
C114	Not Fitted	Codan	**-00000-001	99-00000-001	1
C115	100n 10% 50V X7R 0805 Nisn	Philips	08052R104K9BB	46-51000-282	1
C116	100u 25V Ax EL Cap	Elna	RB	48-21002-551	1

08-06804-001 - 3160 Power Amplifier 125W

BOM Revision
Date Valid On

02 -- Production
28.08.2008

Ref	Description	Manufacturer	Manufacturer's P/N	Codan P/N	Qty
C117	Not Fitted	Codan	**--00000-001	99-00000-001	1
C118	47p 5% 50V NPO 0603 NiSn	Philips	0603CG470J9B200	46-14700-083	1
C119	33n 10% 25V X7R 0603 NiSn	Vitramon	VJ0603Y333KXXT	46-43300-282	1
C120	33n 10% 25V X7R 0603 NiSn	Vitramon	VJ0603Y333KXXT	46-43300-282	1
C121	100n 10% 16V X7R 0603 NiSn	Vitramon	VJ0603Y104KXJT	46-51000-283	1
C122	10u 20% 10V X7R 1210 NiSn	Taiyo Yuden	LMK325BJ106MN	46-71000-280	1
C123	1u 20% 10V X7R 0603 NiSn	Kemet	C0603C105M8PAC7867	46-61000-283	1
C124	100n 10% 16V X7R 0603 NiSn	Vitramon	VJ0603Y104KXJT	46-51000-283	1
C125	100n 10% 16V X7R 0603 NiSn	Vitramon	VJ0603Y104KXJT	46-51000-283	1
C126	100n 10% 16V X7R 0603 NiSn	Vitramon	VJ0603Y104KXJT	46-51000-283	1
C127	10n 10% 50V X7R 0603 NiSn	Phycomp	06032R103K9B20D	46-41000-282	1
C128	10n 10% 50V X7R 0603 NiSn	Phycomp	06032R103K9B20D	46-41000-282	1
C129	100n 10% 16V X7R 0603 NiSn	Vitramon	VJ0603Y104KXJT	46-51000-283	1
C130	100n 10% 16V X7R 0603 NiSn	Vitramon	VJ0603Y104KXJT	46-51000-283	1
C131	33n 10% 25V X7R 0603 NiSn	Vitramon	VJ0603Y333KXXT	46-43300-282	1
C133	100p 5% 50V NPO 0603 NiSn	Philips	0603CG101J9B200	46-21000-083	1
C134	100p 5% 50V NPO 0603 NiSn	Philips	0603CG101J9B200	46-21000-083	1
C135	100n 10% 16V X7R 0603 NiSn	Vitramon	VJ0603Y104KXJT	46-51000-283	1
C136	33n 10% 25V X7R 0603 NiSn	Vitramon	VJ0603Y333KXXT	46-43300-282	1
C137	1u 20% 10V X7R 0603 NiSn	Kemet	C0603C105M8PAC7867	46-61000-283	1
C138	1u 20% 10V X7R 0603 NiSn	Kemet	C0603C105M8PAC7867	46-61000-283	1
C139	1u 20% 10V X7R 0603 NiSn	Kemet	C0603C105M8PAC7867	46-61000-283	1
C140	33n 10% 25V X7R 0603 NiSn	Vitramon	VJ0603Y333KXXT	46-43300-282	1
C141	1n 5% 25V NPO 0603 NiSn	AVX	06033A102JAT2A	46-31000-083	1
C142	33n 10% 25V X7R 0603 NiSn	Vitramon	VJ0603Y333KXXT	46-43300-282	1
C143	1u 20% 35V 3528 TA Cap	AVX	TAJB105M035R	47-01003-520	1
C144	1u 20% 10V X7R 0603 NiSn	Kemet	C0603C105M8PAC7867	46-61000-283	1
C145	1u 20% 35V 3528 TA Cap	AVX	TAJB105M035R	47-01003-520	1
C146	10u 20% 25V 6032 TA Cap	AVX	TAJC106M025R	47-11002-520	1
C147	10u 20% 25V 6032 TA Cap	AVX	TAJC106M025R	47-11002-520	1
C148	470n 10% 63V PE Cap	Philips	2222 370 18474	46-54700-521	1
C149	100n 10% 50V X7R 0805 Nisn	Philips	08052R104K9BB	46-51000-282	1
C150	100n 10% 50V X7R 0805 Nisn	Philips	08052R104K9BB	46-51000-282	1
C151	10u 20% 10V X7R 1210 NiSn	Taiyo Yuden	LMK325BJ106MN	46-71000-280	1
C152	10u 20% 10V X7R 1210 NiSn	Taiyo Yuden	LMK325BJ106MN	46-71000-280	1
C153	33n 10% 25V X7R 0603 NiSn	Vitramon	VJ0603Y333KXXT	46-43300-282	1
C154	33n 10% 25V X7R 0603 NiSn	Vitramon	VJ0603Y333KXXT	46-43300-282	1
C155	1n 5% 25V NPO 0603 NiSn	AVX	06033A102JAT2A	46-31000-083	1
C156	100n 10% 16V X7R 0603 NiSn	Vitramon	VJ0603Y104KXJT	46-51000-283	1
C157	Not Fitted	Codan	**--00000-001	99-00000-001	1
C158	Not Fitted	Codan	**--00000-001	99-00000-001	1
C159	220p 5% 50V NPO 0603 NiSn	Philips	0603CG221C9BB00	46-22200-083	1
C160	220p 5% 50V NPO 0603 NiSn	Philips	0603CG221C9BB00	46-22200-083	1
C161	100n 10% 50V X7R 1206 NiSn	Philips	12062R104K9BB-	46-51000-281	1
C162	100n 10% 50V X7R 1206 NiSn	Philips	12062R104K9BB-	46-51000-281	1
C163	100n 10% 50V X7R 1206 NiSn	Philips	12062R104K9BB-	46-51000-281	1
C164	100n 10% 50V X7R 1206 NiSn	Philips	12062R104K9BB-	46-51000-281	1
C165	Not Fitted	Codan	**--00000-001	99-00000-001	1
C166	33n 10% 25V X7R 0603 NiSn	Vitramon	VJ0603Y333KXXT	46-43300-282	1
C167	1n 5% 25V NPO 0603 NiSn	AVX	06033A102JAT2A	46-31000-083	1
C168	100n 10% 16V X7R 0603 NiSn	Vitramon	VJ0603Y104KXJT	46-51000-283	1
C169	100n 10% 16V X7R 0603 NiSn	Vitramon	VJ0603Y104KXJT	46-51000-283	1
C170	Not Fitted	Codan	**--00000-001	99-00000-001	1
C171	Not Fitted	Codan	**--00000-001	99-00000-001	1
C172	1n 5% 50V NPO 0805 NiSn	Philips	0805CG102J9BB-	46-31000-082	1
C173	3,3n 10% 100V X7R 0805 NiSn	Philips	08052R332K0B200	46-33300-281	1
C174	33p 5% 500V NPO 1206 <1000		46-13300-088 selected for ESR 10-01095	46-13300-0821	1

08-06804-001 - 3160 Power Amplifier 125W

BOM Revision
Date Valid On

02 -- Production
28.08.2008

Ref	Description	Manufacturer	Manufacturer's P/N	Codan P/N	Qty
C175	33n 10% 25V X7R 0603 NiSn	Vitramon	VJ0603Y333KXXT	46-43300-282	1
D1	Diode, Schottky 70V 70mA SOT23	Siemens	BAS70	BAS70	1
D2	Diode, Schottky 70V 70mA SOT23	Siemens	BAS70	BAS70	1
D3	Diode, Si High speed 75V SOT23	Philips	BAS16	BAS16	1
D4	Diode, Si High speed 75V SOT23	Philips	BAS16	BAS16	1
D5	Diode, Si High speed 75V SOT23	Philips	BAS16	BAS16	1
D6	Diode, Si High speed 75V SOT23	Philips	BAS16	BAS16	1
D7	Diode, Si High speed 75V SOT23	Philips	BAS16	BAS16	1
D8	Diode, Si High speed 75V SOT23	Philips	BAS16	BAS16	1
D9	Diode, Si High speed 75V SOT23	Philips	BAS16	BAS16	1
D10	Diode, Si High speed 75V SOT23	Philips	BAS16	BAS16	1
D11	Not Fitted	Codan	**-00000-001	99-00000-001	1
D12	Diode, Schottky 70V 70mA SOT23	Siemens	BAS70	BAS70	1
D13	Not Fitted	Codan	**-00000-001	99-00000-001	1
D14	Not Fitted	Codan	**-00000-001	99-00000-001	1
D15	Diode, Schottky 70V 70mA SOT23	Siemens	BAS70	BAS70	1
D16	Diode, Schottky 70V 70mA SOT23	Siemens	BAS70	BAS70	1
D17	Diode, Si High speed 75V SOT23	Philips	BAS16	BAS16	1
D18	Diode, Si High speed 75V SOT23	Philips	BAS16	BAS16	1
D19	Diode, Si High speed 75V SOT23	Philips	BAS16	BAS16	1
D20	Diode, 400V 1A SMA	On Semiconductor	MRA4004T3	MRA4004T3	1
D21	Diode, Si High speed 75V SOT23	Philips	BAS16	BAS16	1
D22	Diode, Si High speed 75V SOT23	Philips	BAS16	BAS16	1
D23	Diode, Si High speed 75V SOT23	Philips	BAS16	BAS16	1
D24	Diode, Si High speed 75V SOT23	Philips	BAS16	BAS16	1
IC1	MCU, 8 Bit 32k Flash 8MHz TQFP44	Atmel	ATMEGA32L-8AI	YP-00032-910	1
IC2	Amp, Oper Dual CMOS SOIC8	National Semiconduct	LMC662CM	XA-00662-700	1
IC3	Reg, Voltage +5V 0,1A SOIC8	National Semiconduct	LM78L05ACM	XB-07805-700	1
IC4	Reg, Voltage +10V LVD 1A SOT223	National Semiconductor	LM2940IPM-10	XB-02940-704	1
IC5	Reg, Voltage +3,3V 50mA LDO 60V in SOIC8	National Semiconduct	LM2936HVBMA-3,3NOPB	XB-02936-700	1
IC6	Amp, Rail to Rail I/O Low Offset SOT23-5	National Semiconduct	LMC7101AIM5	XA-07101-701	1
J1	Socket, MCX Straight PCB	Chin Nan	27-05-TGN	60-19300	1
J2	Socket, Coax Mini Low Prof Fixed	Taiko Denki	TMP-J02X-A1	60-19390-002	1
K1	Relay, 2C 12V 2A SMD 1028 Ohm	Matsushita	TQ2SL-12V	64-21225-310	1
K2	Relay, 2C 12V 2A SMD 1028 Ohm	Matsushita	TQ2SL-12V	64-21225-310	1
K3	Relay, 2C 12V 2A SMD 1028 Ohm	Matsushita	TQ2SL-12V	64-21225-310	1
K5	Relay, 2C 12V 2A SMD 1028 Ohm	Matsushita	TQ2SL-12V	64-21225-310	1
K6	Relay, 2C 12V 2A SMD 1028 Ohm	Matsushita	TQ2SL-12V	64-21225-310	1
K7	Relay, 2C 12V 2A SMD 1028 Ohm	Matsushita	TQ2SL-12V	64-21225-310	1
K8	Relay, 2C 12V 2A SMD 1028 Ohm	Matsushita	TQ2SL-12V	64-21225-310	1
K9	Relay, 2C 12V 2A SMD 1028 Ohm	Matsushita	TQ2SL-12V	64-21225-310	1
K10	Relay, 1C 12V 16A 340 Ohm	Tyco	RTH34012	64-31125-234	1
L1	Ind, 1mH 10% 1812	Coilcraft	1812LS-105XKBC	43-83100-000	1
L2	Inductor, 115nH		44-70574	44-70574	1
L3	Inductor, 170nH		44-70575	44-70575	1
L4	Inductor, 280nH		44-70576	44-70576	1
L5	Inductor, 380nH		44-70577	44-70577	1
L6	Ind, 620nH vi/vi/wh	Fetronics	44-70393	44-70393	1
L7	Ind, 530nH bl/bl/bl/bn	Fetronics	44-70478	44-70478	1
L8	Ind, 1,0uH sl/sl/or	Fetronics	44-70368	44-70368	1
L9	Ind, 1,5uH sl/sl/vi	Codan	44-70370	44-70370	1

08-06804-001 - 3160 Power Amplifier 125W

BOM Revision
Date Valid On

02 -- Production
28.08.2008

Ref	Description	Manufacturer	Manufacturer's P/N	Codan P/N	Qty
L10	Ind, 2,1uH vi/gn/bn/rd	Fetronics	44-70512	44-70512	1
L11	Inductor, 3,2uH		44-70578	44-70578	1
L12	Inductor, 720nH	Protran	44-70543	44-70543	1
L13	Choke, EMI/EMC 0A DC >1MHz 4516	Taiyo Yuden	FB-MJ4516HS111-T	43-90003	1
L14	Ind, PA DC feed or/wh/or	Fetronics	44-70457	44-70457	1
L15	Not Fitted	Codan	**00000-001	99-00000-001	1
L16	Ind, 100uH 5% 3225	TOKO	LLM3225-101_J	43-82100-006	1
L17	Ind, 100uH 5% 3225	TOKO	LLM3225-101_J	43-82100-006	1
L18	Ind, 100uH 5% 3225	TOKO	LLM3225-101_J	43-82100-006	1
L19	Ind, 2,2uH 10% 3225	TOKO	380LB-2R2K	43-80220-001	1
L20	Ind, 2,2uH 10% 3225	TOKO	380LB-2R2K	43-80220-001	1
L21	Ind, 2,2uH 10% 3225	TOKO	380LB-2R2K	43-80220-001	1
L22	Ind, 10uH 10% 4532	Taiyo Yuden	LEM 4532T100K	43-81100-000	1
L23	Ind, 10uH 10% 4532	Taiyo Yuden	LEM 4532T100K	43-81100-000	1
L24	Ind, 2,2uH 10% 3225	TOKO	380LB-2R2K	43-80220-001	1
L25	Ind, 2,2uH 10% 3225	TOKO	380LB-2R2K	43-80220-001	1
L26	Inductor, 290nH	Protran	44-70540	44-70540	1
P1	Not Fitted	Codan	**00000-001	99-00000-001	1
P2	Not Fitted	Codan	**00000-001	99-00000-001	1
P3	Header (P) 6way 2mm Latch Fixed	AMP	173981-6	60-00060-350	1
P4	Header (P) 6way 2row Boxed Pol. 2,54 PCB	Neltron	2316S-06G	60-00060-005	1
R1	33k Ohm 5% 0,1W 0805	Philips	2322 730 61333	40-43300-111	1
R2	33k Ohm 5% 0,1W 0805	Philips	2322 730 61333	40-43300-111	1
R3	33k Ohm 5% 0,1W 0805	Philips	2322 730 61333	40-43300-111	1
R4	100 Ohm 2% 1,0W 2512 MELF	Vishay	SMM0207 100 100R2%BP	40-21000-135	1
R5	100 Ohm 2% 1,0W 2512 MELF	Vishay	SMM0207 100 100R2%BP	40-21000-135	1
R6	100k Ohm 5% 0,06W 0603	Philips	2322 702 60104	40-51000-121	1
R7	100k Ohm 5% 0,06W 0603	Philips	2322 702 60104	40-51000-121	1
R8	100k Ohm 5% 0,06W 0603	Philips	2322 702 60104	40-51000-121	1
R10	100k Ohm 5% 0,06W 0603	Philips	2322 702 60104	40-51000-121	1
R11	100k Ohm 5% 0,06W 0603	Philips	2322 702 60104	40-51000-121	1
R12	100k Ohm 5% 0,06W 0603	Philips	2322 702 60104	40-51000-121	1
R13	100k Ohm 5% 0,06W 0603	Philips	2322 702 60104	40-51000-121	1
R14	150 Ohm 5% 1,0W 2512	Phycomp	2322 762 60151	40-21500-141	1
R15	180 Ohm 5% 1,0W 2512	Phycomp	2322 762 60181	40-21800-141	1
R16	220k Ohm 5% 0,06W 0603	Philips	2322 702 60224	40-52200-121	1
R17	330 Ohm 5% 1,0W 2512	Phycomp	2322 762 60331	40-23300-141	1
R18	180 Ohm 5% 1,0W 2512	Phycomp	2322 762 60181	40-21800-141	1
R19	180 Ohm 5% 1,0W 2512	Phycomp	2322 762 60181	40-21800-141	1
R20	47 Ohm 5% 1,0W 2512	Phycomp	2322 762 60479	40-14700-141	1
R21	47 Ohm 5% 1,0W 2512	Phycomp	2322 762 60479	40-14700-141	1
R22	180 Ohm 5% 1,0W 2512	Phycomp	2322 762 60181	40-21800-141	1
R23	4,7 Ohm 5% 1,0W 2512 MELF	IRC	CHP1-100-4R70-J-7	40-04700-135	1
R24	4,7 Ohm 5% 1,0W 2512 MELF	IRC	CHP1-100-4R70-J-7	40-04700-135	1
R25	4,7 Ohm 5% 1,0W 2512 MELF	IRC	CHP1-100-4R70-J-7	40-04700-135	1
R26	4,7 Ohm 5% 1,0W 2512 MELF	IRC	CHP1-100-4R70-J-7	40-04700-135	1
R27	4,7 Ohm 5% 1,0W 2512 MELF	IRC	CHP1-100-4R70-J-7	40-04700-135	1
R28	4,7 Ohm 5% 1,0W 2512 MELF	IRC	CHP1-100-4R70-J-7	40-04700-135	1
R29	4,7 Ohm 5% 1,0W 2512 MELF	IRC	CHP1-100-4R70-J-7	40-04700-135	1
R30	4,7 Ohm 5% 1,0W 2512 MELF	IRC	CHP1-100-4R70-J-7	40-04700-135	1
R31	2,2 Ohm 5% 1,0W 2512	Phycomp	2322 762 60228	40-02200-141	1
R32	2,2 Ohm 5% 1,0W 2512	Phycomp	2322 762 60228	40-02200-141	1
R33	2,2 Ohm 5% 1,0W 2512	Phycomp	2322 762 60228	40-02200-141	1
R34	2,2 Ohm 5% 1,0W 2512	Phycomp	2322 762 60228	40-02200-141	1

08-06804-001 - 3160 Power Amplifier 125W

BOM Revision
Date Valid On

02 -- Production
28.08.2008

Ref	Description	Manufacturer	Manufacturer's P/N	Codan P/N	Qty
R35	Not Fitted	Codan	**-00000-001	99-00000-001	1
R36	470 Ohm 5% 0,06W 0603	Philips	2322 702 60471	40-24700-121	1
R37	180k Ohm 5% 0,06W 0603	Philips	2322 702 60184	40-51800-121	1
R38	1M Ohm 1% 0,06W 0603	Yageo	RC0603FR-071ML	40-61000-125	1
R39	820 Ohm 5% 0,06W 0603	Phycomp	2322 702 60821	40-28200-121	1
R40	1k Ohm 5% 0,06W 0603	Philips	2322 702 60102	40-31000-121	1
R41	100 Ohm 5% 0,06W 0603	Philips	2322 702 60101	40-21000-121	1
R42	820 Ohm 5% 0,06W 0603	Phycomp	2322 702 60821	40-28200-121	1
R43	Pot,1k Lin MG Trim SMD	Bourns	3314 J-1-102	42-31004-000	1
R44	Not Fitted	Codan	**-00000-001	99-00000-001	1
R45	Not Fitted	Codan	**-00000-001	99-00000-001	1
R46	Not Fitted	Codan	**-00000-001	99-00000-001	1
R47	Not Fitted	Codan	**-00000-001	99-00000-001	1
R48	47 Ohm 5% 0,06W 0603	Philips	2322 702 60479	40-14700-121	1
R49	15 Ohm 5% 0,05W 0603	Philips	2322-702-60159	40-11500-121	1
R50	10 Ohm 5% 0,06W 0603	Philips	2322 702 60109	40-11000-121	1
R51	1k Ohm 5% 0,06W 0603	Philips	2322 702 60102	40-31000-121	1
R52	10k Ohm 5% 0,06W 0603	Philips	2322 702 60103	40-41000-121	1
R53	33k Ohm 5% 0,06W 0603	Philips	2322 702 60333	40-43300-121	1
R54	270k Ohm 5% 0,06W 0603	Philips	2322 702 60274	40-52700-121	1
R55	10k Ohm 5% 0,06W 0603	Philips	2322 702 60103	40-41000-121	1
R56	5,6k Ohm 5% 0,06W 0603	Philips	2322 702 60562	40-35600-121	1
R57	33k Ohm 5% 0,06W 0603	Philips	2322 702 60333	40-43300-121	1
R58	12k Ohm 5% 0,1W 0805	Philips	2322 730 61123	40-41200-111	1
R59	10k Ohm 5% 0,06W 0603	Philips	2322 702 60103	40-41000-121	1
R60	10k Ohm 5% 0,06W 0603	Philips	2322 702 60103	40-41000-121	1
R61	10k Ohm 1% 0,06W 0603	Phycomp	2322 704 61003	40-41000-125	1
R62	2,2k Ohm 1% 0,06W 0603	Philips	2322 704 62202	40-32200-125	1
R63	1k Ohm 5% 0,06W 0603	Philips	2322 702 60102	40-31000-121	1
R64	4,7k Ohm 5% 0,06W 0603	Philips	2322 702 60472	40-34700-121	1
R65	4,7k Ohm 5% 0,06W 0603	Philips	2322 702 60472	40-34700-121	1
R66	4,7k Ohm 5% 0,06W 0603	Philips	2322 702 60472	40-34700-121	1
R67	4,7k Ohm 5% 0,06W 0603	Philips	2322 702 60472	40-34700-121	1
R68	33k Ohm 5% 0,06W 0603	Philips	2322 702 60333	40-43300-121	1
R69	10k Ohm 5% 0,06W 0603	Philips	2322 702 60103	40-41000-121	1
R70	10k Ohm 5% 0,06W 0603	Philips	2322 702 60103	40-41000-121	1
R71	10k Ohm 5% 0,06W 0603	Philips	2322 702 60103	40-41000-121	1
R72	2,7k Ohm 5% 0,06W 0603	Philips	2322 702 60272	40-32700-121	1
R73	10k Ohm 5% 0,06W 0603	Philips	2322 702 60103	40-41000-121	1
R74	100k Ohm 5% 0,06W 0603	Philips	2322 702 60104	40-51000-121	1
R75	33k Ohm 5% 0,06W 0603	Philips	2322 702 60333	40-43300-121	1
R76	6,8k Ohm 5% 0,06W 0603	Philips	2322 702 60682	40-36800-121	1
R77	82k Ohm 5% 0,06W 0603	Philips	2322 702 60823	40-48200-121	1
R78	33k Ohm 5% 0,06W 0603	Philips	2322 702 60333	40-43300-121	1
R79	10k Ohm 1% 0,06W 0603	Phycomp	2322 704 61003	40-41000-125	1
R80	10k Ohm 1% 0,06W 0603	Phycomp	2322 704 61003	40-41000-125	1
R81	100k Ohm 5% 0,06W 0603	Philips	2322 702 60104	40-51000-121	1
R82	560k Ohm 5% 0,06W 0603	Phycomp	2322 702 60564	40-55600-121	1
R83	390 Ohm 5% 0,06W 0603	Philips	2322-702-60391	40-23900-121	1
R84	560k Ohm 5% 0,06W 0603	Phycomp	2322 702 60564	40-55600-121	1
R85	50 Ohm 80°C PTC Thermistor	Philips	2322-660-91008	41-11500-660	1
R86	5,6k Ohm 5% 0,06W 0603	Philips	2322 702 60562	40-35600-121	1
R87	47k Ohm 5% 0,06W 0603	Philips	2322 702 60473	40-44700-121	1
R88	1k Ohm 5% 0,06W 0603	Philips	2322 702 60102	40-31000-121	1
R89	10k Ohm 5% 0,06W 0603	Philips	2322 702 60103	40-41000-121	1
R90	22k Ohm 5% 0,06W 0603	Philips	2322 702 60223	40-42200-121	1
R91	Pot,10k Lin MG Trim SMD	Bourns	3314 J-1-103	42-41004-000	1
R92	1,5k Ohm 5% 0,06W 0603	Philips	2322 702 60152	40-31500-121	1

08-06804-001 - 3160 Power Amplifier 125W

BOM Revision
Date Valid On

02 -- Production
28.08.2008

Ref	Description	Manufacturer	Manufacturer's P/N	Codan P/N	Qty
R93	33k Ohm 5% 0,06W 0603	Philips	2322 702 60333	40-43300-121	1
R94	10k Ohm 5% 0,06W 0603	Philips	2322 702 60103	40-41000-121	1
R95	1,8k Ohm 5% 0,06W 0603	Philips	2322 702 60182	40-31800-121	1
R96	100k Ohm 5% 0,06W 0603	Philips	2322 702 60104	40-51000-121	1
R97	220 Ohm 5% 0,06W 0603	Philips	2322 702 60221	40-22200-121	1
R98	10k Ohm 5% 0,06W 0603	Philips	2322 702 60103	40-41000-121	1
R99	18k Ohm 5% 0,06W 0603	Yageo	RC0603JR-07 18KL	40-41800-121	1
R100	330 Ohm 5% 0,06W 0603	Philips	2322 702 60331	40-23300-121	1
R101	10 Ohm 5% 0,06W 0603	Philips	2322 702 60109	40-11000-121	1
R102	4,7k Ohm 5% 0,06W 0603	Philips	2322 702 60472	40-34700-121	1
R103	4,7k Ohm 5% 0,06W 0603	Philips	2322 702 60472	40-34700-121	1
R104	Res, Voltage Dependent	Philips	2322-592-52506	41-22506-592	1
R105	100 Ohm 5% 0,06W 0603	Philips	2322 702 60101	40-21000-121	1
R106	10k Ohm 5% 0,06W 0603	Philips	2322 702 60103	40-41000-121	1
R107	4,7k Ohm 5% 0,06W 0603	Philips	2322 702 60472	40-34700-121	1
R108	100k Ohm 5% 0,06W 0603	Philips	2322 702 60104	40-51000-121	1
R109	470 Ohm 5% 0,06W 0603	Philips	2322 702 60471	40-24700-121	1
R110	470 Ohm 5% 0,06W 0603	Philips	2322 702 60471	40-24700-121	1
R111	47 Ohm 5% 0,06W 0603	Philips	2322 702 60479	40-14700-121	1
R112	47 Ohm 5% 0,06W 0603	Philips	2322 702 60479	40-14700-121	1
R113	180 Ohm 5% 1,0W 2512	Phycomp	2322 762 60181	40-21800-141	1
R114	47 Ohm 5% 1,0W 2512	Phycomp	2322 762 60479	40-14700-141	1
R115	220k Ohm 5% 0,06W 0603	Philips	2322 702 60224	40-52200-121	1
R116	560 Ohm 5% 0,06W 0603	Philips	2322 702 60561	40-25600-121	1
R117	1 Ohm 5% 0,06W 0603	Phycomp	2322 702 60108	40-01000-121	1
R118	2,7 Ohm 5% 0,1W 0805	Yageo	RC0805JR-07 2R7L	40-02700-111	1
R119	100k Ohm 5% 0,06W 0603	Philips	2322 702 60104	40-51000-121	1
R120	1M Ohm 5% 0,06W 0603	Philips	2322 702 60105	40-61000-121	1
R121	10k Ohm 5% 0,06W 0603	Philips	2322 702 60103	40-41000-121	1
R122	4,7k Ohm 5% 0,06W 0603	Philips	2322 702 60472	40-34700-121	1
R123	100k Ohm 5% 0,06W 0603	Philips	2322 702 60104	40-51000-121	1
R124	100k Ohm 5% 0,06W 0603	Philips	2322 702 60104	40-51000-121	1
R126	180 Ohm 5% 1,0W 2512	Phycomp	2322 762 60181	40-21800-141	1
R127	12 Ohm 5% 1,0W 2512 MELF	IRC	CHP1-100-12R0-J-7	40-11200-135	1
R128	12 Ohm 5% 1,0W 2512 MELF	IRC	CHP1-100-12R0-J-7	40-11200-135	1
R129	270 Ohm 5% 1,0W 2512	Phycomp	2322 762 60271	40-22700-141	1
R130	47 Ohm 5% 1,0W 2512	Phycomp	2322 762 60479	40-14700-141	1
R132	33k Ohm 5% 0,06W 0603	Philips	2322 702 60333	40-43300-121	1
T1	Txfr, RF or	Fetronics	44-80021	44-80021	1
T2	Transformer, 125W Amp in	Protran	44-80327	44-80327	1
T3	Transformer, Output 3160		44-80329	44-80329	1
V1	MOSFET, N Channel Enhanced SOT23	Fairchild	BSS138	BSS138	1
V2	MOSFET, N Channel Enhanced SOT23	Fairchild	BSS138	BSS138	1
V3	MOSFET, N Channel Enhanced SOT23	Fairchild	BSS138	BSS138	1
V5	MOSFET, N Channel Enhanced SOT23	Fairchild	BSS138	BSS138	1
V6	MOSFET, N Channel Enhanced SOT23	Fairchild	BSS138	BSS138	1
V7	MOSFET, N Channel Enhanced SOT23	Fairchild	BSS138	BSS138	1
V8	MOSFET, N Channel Enhanced SOT23	Fairchild	BSS138	BSS138	1
V9	Transistor, RF Power HF	Microsemi	MS1253-CDN	MS1253-CDN	1
V10	Transistor, RF Power HF	Microsemi	MS1253-CDN	MS1253-CDN	1
V11	Transistor, Darlington NPN Si	Philips	BD675	BD675	1
V12	Transistor, NPN Si SOT23	Philips	BC847	BC847	1
V13	Not Fitted	Codan	**00000-001	99-00000-001	1
V14	Transistor, NPN Si SOT23	Philips	BC847	BC847	1
V15	MOSFET, N Chan Enhance SOT23	Philips	BST82	BST82	1
V16	Transistor, NPN Si SOT23	Philips	BC847	BC847	1
V17	Transistor, NPN Si SOT23	Philips	BC847	BC847	1
V18	Transistor, NPN Si SOT23	Philips	BC847	BC847	1

08-06804-001 - 3160 Power Amplifier 125W

BOM Revision
Date Valid On

02 -- Production
 28.08.2008

Ref	Description	Manufacturer	Manufacturer's P/N	Codan P/N	Qty
V19	Transistor, NPN Si SOT23	Philips	BC847	BC847	1
V20	MOSFET, N Channel Enhanced SOT23	Fairchild	BSS138	BSS138	1
V21	Transistor, NPN Si SOT23	Philips	BC847	BC847	1
V22	Transistor, PNP Si SOT23	Philips	BC857	BC857	1
V23	Transistor, NPN Si SOT23	Philips	BC847	BC847	1
V24	Transistor, PNP Si SOT23	Philips	BC856	BC856	1
V25	Transistor, PNP Si SOT23	Philips	BC856	BC856	1
V26	Transistor, PNP Si SOT23	Philips	BC856	BC856	1
V27	Diode, Zener 15V 5% 0,2W SOT23	Philips	BZX84-C15	BZX84C15	1
V28	MOSFET, N Channel Enhanced SOT23	Fairchild	BSS138	BSS138	1
V29	NPN Si SOT23	Infineon	BC817K-25E6327	BC817	1
V30	MOSFET, N Channel Enhanced SOT23	Fairchild	BSS138	BSS138	1
V31	MOSFET, N Channel Enhanced SOT23	Fairchild	BSS138	BSS138	1
X2	Rivet, Tinned Brass Chobert 4,0dx9,5	Avdel	01143-00516	33-40340-095	1
X3	Rivet, Tinned Brass Chobert 4,0dx9,5	Avdel	01143-00516	33-40340-095	1

The drawings in this section consist of the mechanical and electrical diagrams required to maintain the 2110 series Manpack Transceiver.

Table 43: Drawings index

Title	Drawing	Drawing number
Transceiver unit Assembly	Final assembly	08-06155 (sheet 2) 08-06155 (sheet 6)
Interconnection Diagram	Circuit diagram	04-03515
Front Panel PCB	Circuit diagram	04-03457
	PCB assembly	08-06129 (sheet 1)
Keypad PCB	Circuit diagram	04-03459
Front panel Assembly	PCB assembly	08-06140 (sheet 1) 08-06140 (sheet 2) 08-06140 (sheet 3)
Audio & Control	Circuit diagram	04-03456 (sheet 1) 04-03456 (sheet 2) 04-03456 (sheet 3)
	PCB assembly	08-06128 (sheet 1)
RF/IF & Synthesiser	Circuit diagram	04-03439 (sheet 1) 04-03439 (sheet 2) 04-03439 (sheet 3)
	PCB assembly	08-06039
Reference Oscillator	Circuit diagram	04-03477
	PCB assembly	08-06163
PA & Filter	Circuit diagram	04-03445
	PCB assembly	08-06064 (sheet 2)
	PCB assembly	08-06064 (sheet 3)
Antenna tuner	Circuit diagram	04-03444
	PCB assembly	08-06063
Second IF Filter Option	Circuit diagram	04-03442
	PCB assembly	08-06044

Table 43: Drawings index (cont.)

Title	Drawing	Drawing number
GPS Receiver Option	Circuit diagram	04-03488
	PCB assembly	08-06149
	Fitting instructions	15-10525-001
Voice Encryptor Option	Fitting instructions	15-10531-001
500 Hz Filter Option	Fitting instructions	15-10530-001
3 kHz Filter Option	Fitting instructions	15-10529-001
Transceiver test unit	Circuit diagram	04-03508
Battery Pack	Circuit diagram	CMR-SBP Main PCB Circuit
	PCB assembly	CMR-SBP Main PCB Designations
Interface Adaptor	Circuit diagram	04-03528
	PCB assembly	08-06382 (sheet 1)
VP-116 to 2110 Interface	Circuit diagram	04-03531
	PCB assembly	08-06421 (sheet 1)
3160 Power Amplifier	Circuit diagram	04-03592
	PCB assembly	08-06804 (sheet 2)
		08-06804 (sheet 3)

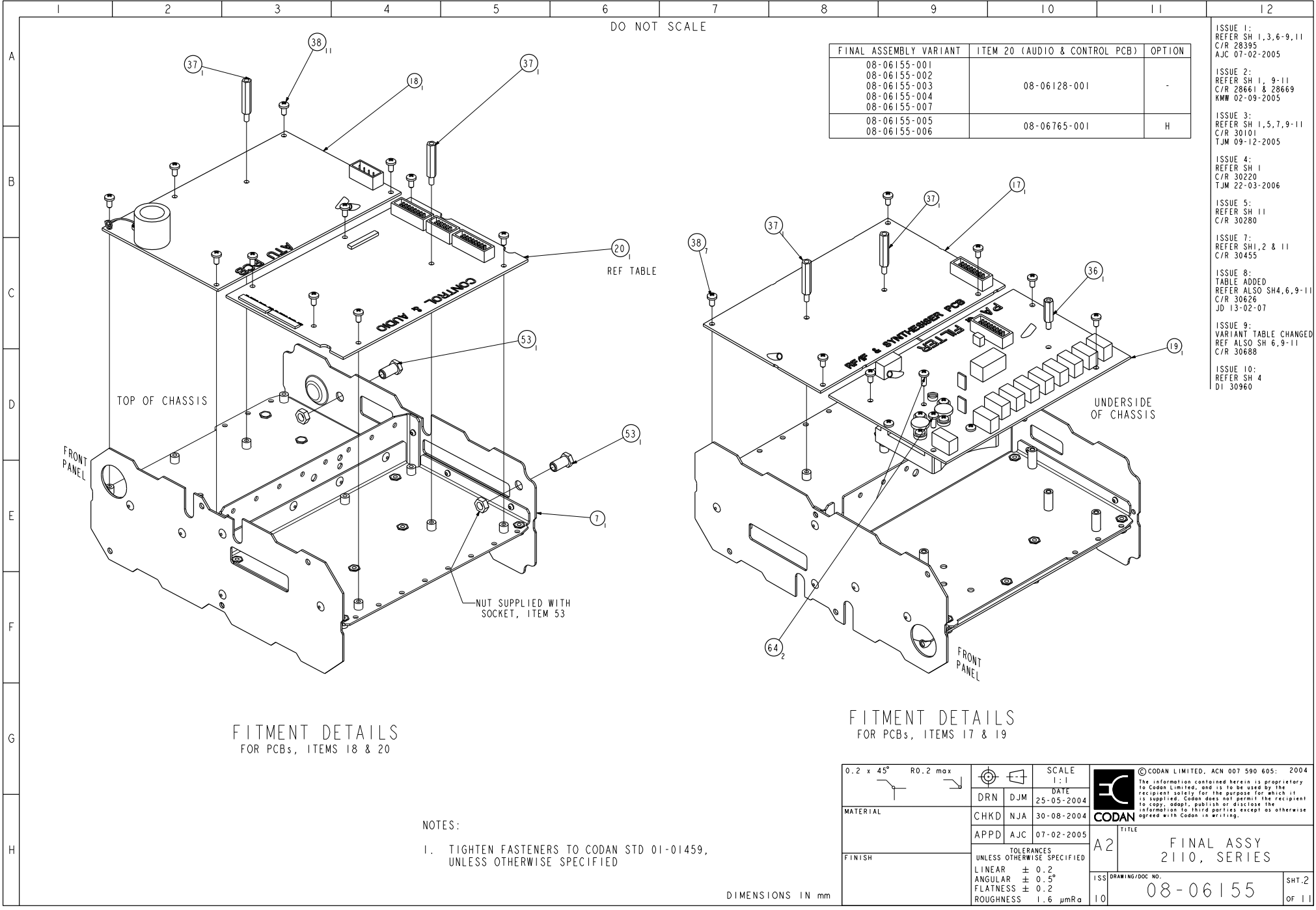

DO NOT SCALE

FINAL ASSEMBLY VARIANT	ITEM 20 (AUDIO & CONTROL PCB)	OPTION
08-06155-001		
08-06155-002		
08-06155-003	08-06128-001	-
08-06155-004		
08-06155-007		
08-06155-005	08-06765-001	H
08-06155-006		

ISSUE 1:
REFER SH 1,3,6,9,11
C/R 28395
AJC 07-02-2005

ISSUE 2:
REFER SH 1, 9-11
C/R 28661 & 28669
KMW 02-09-2005

ISSUE 3:
REFER SH 1,5,7,9-11
C/R 30101
TJM 09-12-2005

ISSUE 4:
REFER SH 1
C/R 30220
TJM 22-03-2006

ISSUE 5:
REFER SH 11
C/R 30280

ISSUE 7:
REFER SH 1,2 & 11
C/R 30455

ISSUE 8:
TABLE ADDED
REFER ALSO SH4,6,9-11
C/R 30626
JD 13-02-07

ISSUE 9:
VARIANT TABLE CHANGED
REF ALSO SH 6,9-11
C/R 30688

ISSUE 10:
REFER SH 4
DI 30960

FITMENT DETAILS
FOR PCBs, ITEMS 18 & 20

FITMENT DETAILS
FOR PCBs, ITEMS 17 & 19

- NOTES:
- TIGHTEN FASTENERS TO CODAN STD 01-01459, UNLESS OTHERWISE SPECIFIED

DIMENSIONS IN mm

0.2 x 45°	RO.2 max	SCALE 1:1	©CODAN LIMITED, ACN 007 590 605: 2004 The information contained herein is proprietary to Codan Limited, and is to be used by the recipient solely for the purpose for which it is supplied. Codan does not permit the recipient to copy, adapt, publish or disclose the information to third parties except as otherwise agreed with Codan in writing.
		DATE 25-05-2004	
MATERIAL	CHKD NJA	30-08-2004	TITLE FINAL ASSY 2110, SERIES
	APPD AJC	07-02-2005	
FINISH	TOLERANCES UNLESS OTHERWISE SPECIFIED LINEAR ± 0.2 ANGULAR ± 0.5° FLATNESS ± 0.2 ROUGHNESS 1.6 µmRa		ISS DRAWING/DOC NO. 08-06155
			SHT.2 OF 11

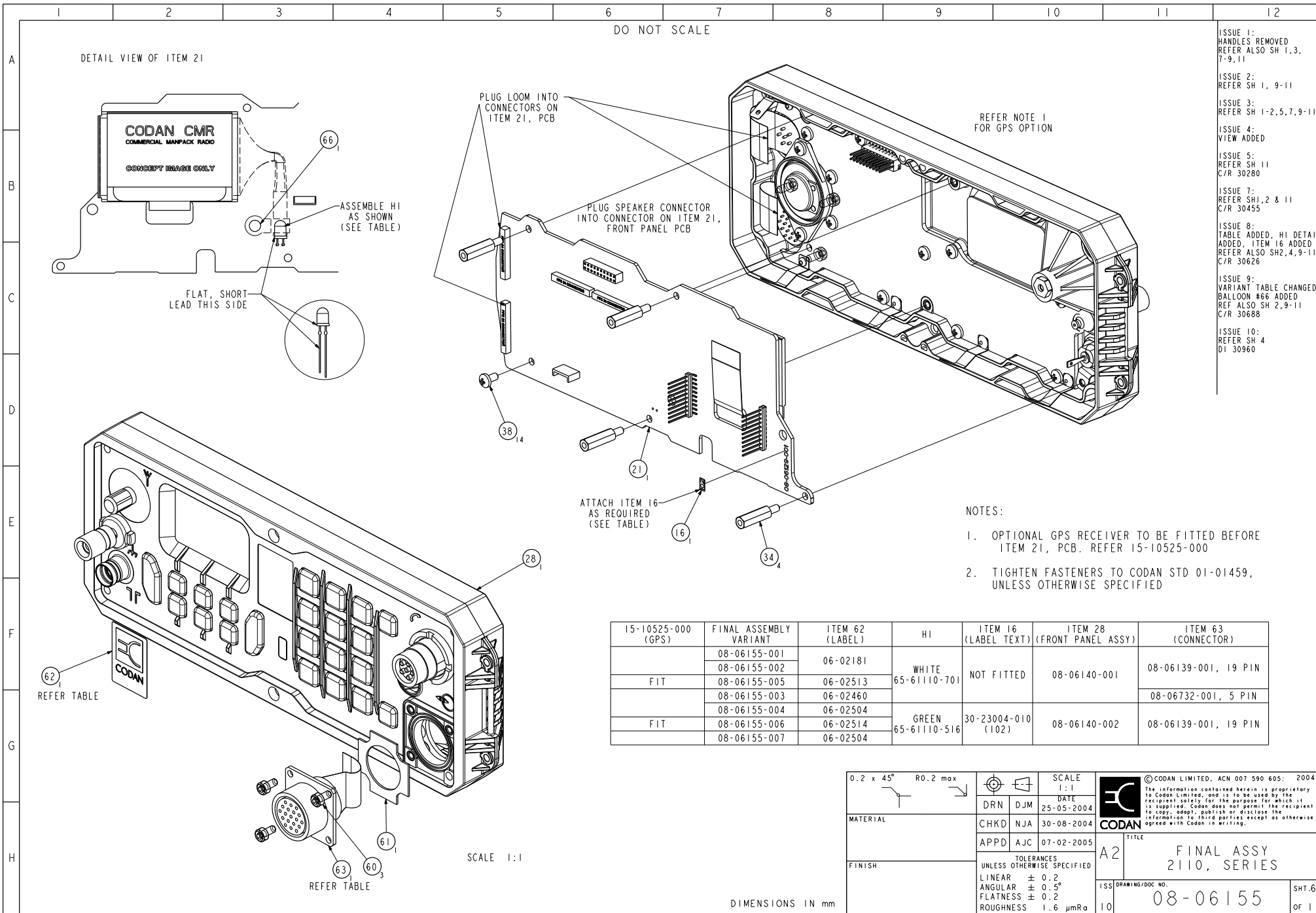

DO NOT SCALE

ISSUE 1:
HANDLES REMOVED
REFER ALSO SH 1,3,
7-9,11

ISSUE 2:
REFER SH 1, 9-11

ISSUE 3:
REFER SH 1-2,5,7,9-11

ISSUE 4:
VIEW ADDED

ISSUE 5:
REFER SH 11
C/R 30280

ISSUE 7:
REFER SH 1,2 & 11
C/R 30455

ISSUE 8:
TABLE ADDED, HI DETAIL
ADDED, ITEM 16 ADDED
REFER ALSO SH 2,4,9-11
C/R 30626

ISSUE 9:
VARIANT TABLE CHANGED,
BALLOON #66 ADDED
REF ALSO SH 2.9-11
C/R 30688

ISSUE 10:
REFER SH 4
D1 30960

REFER NOTE 1
FOR GPS OPTION

NOTES:

- OPTIONAL GPS RECEIVER TO BE FITTED BEFORE ITEM 21, PCB. REFER 15-10525-000
- TIGHTEN FASTENERS TO CODAN STD 01-01459, UNLESS OTHERWISE SPECIFIED

15-10525-000 (GPS)	FINAL ASSEMBLY VARIANT	ITEM 62 (LABEL)	HI	ITEM 16 (LABEL TEXT)	ITEM 28 (FRONT PANEL ASSY)	ITEM 63 (CONNECTOR)
FIT	08-06155-001	06-02181	65-61110-701	WHITE	NOT FITTED	08-06140-001
	08-06155-002	06-02513				
	08-06155-005	06-02460				08-06732-001, 5 PIN
	08-06155-004	06-02504				
FIT	08-06155-006	06-02514	65-61110-516	GREEN	30-23004-010 (102)	08-06140-002
	08-06155-007	06-02504				

0.2 x 45° R0.2 max	SCALE 1:1	<p>©CODAN LIMITED, ACN 007 590 605: 2004 The information contained herein is proprietary to Codan Limited, and is to be used by the recipient solely for the purpose for which it is supplied. Codan does not permit the recipient to copy, adapt, publish or disclose the information to third parties except as otherwise agreed with Codan in writing.</p>
	DATE 25-05-2004	
MATERIAL	CHKD NJA 30-08-2004	<p>TITLE</p> <p>A2 FINAL ASSY 2110, SERIES</p>
	APPD AJC 07-02-2005	
FINISH	TOLERANCES UNLESS OTHERWISE SPECIFIED	<p>ISS DRAWING/DOC NO.</p> <p>10 08-06155</p>
	LINEAR ± 0.2 ANGULAR ± 0.5° FLATNESS ± 0.2 ROUGHNESS 1.6 µmRa	
		SHT.6 OF 11

SCALE 1:1

DIMENSIONS IN mm

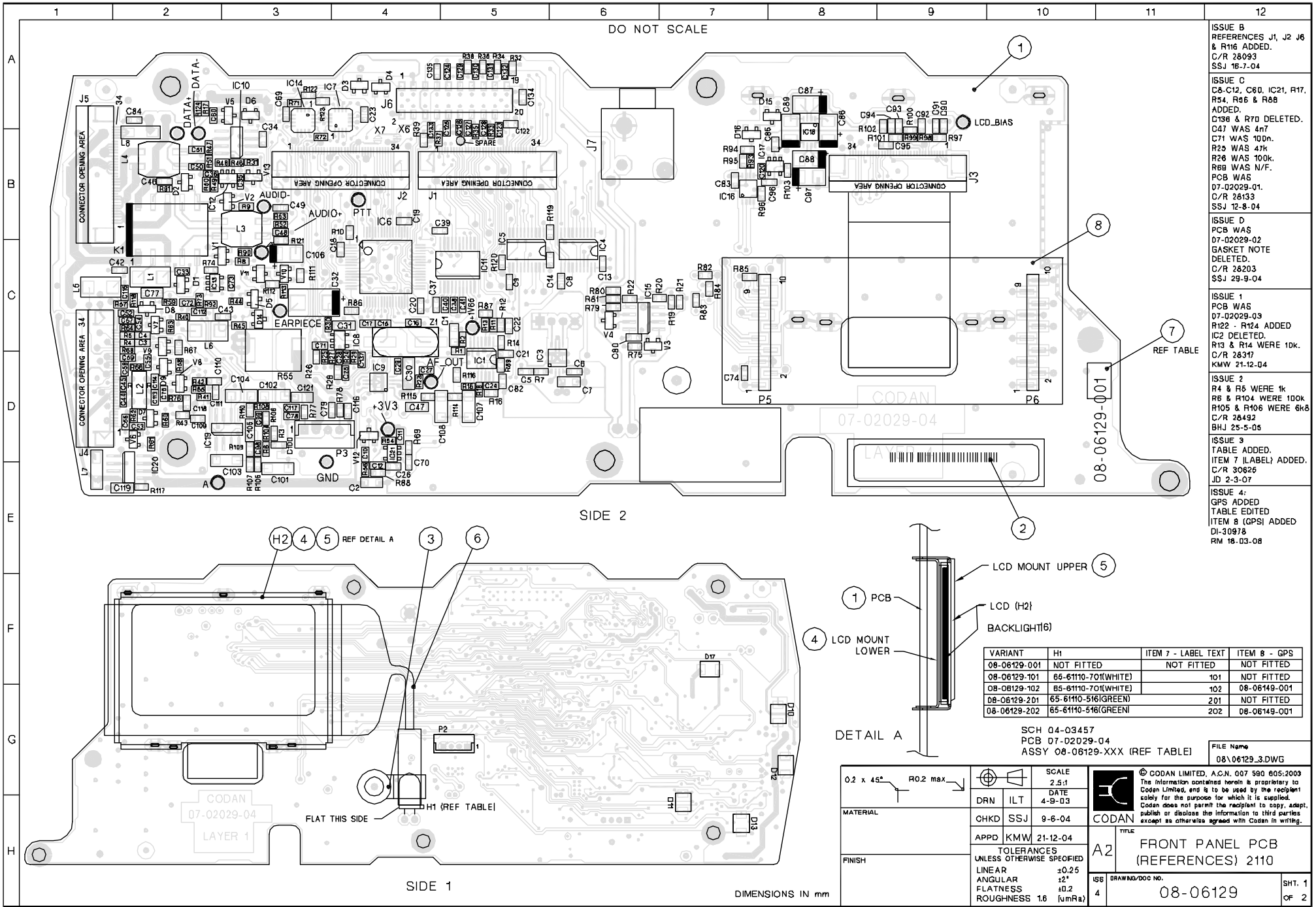

DO NOT SCALE

SIDE 2

SIDE 1

DIMENSIONS IN mm

ISSUE B
REFERENCES J1, J2 J6
& R116 ADDED.
C/R 28093
SSJ 16-7-04

ISSUE C
C6-C12, C60, IC21, R17,
R54, R66 & R88
ADDED.
C136 & R70 DELETED.
C47 WAS 4n7
C71 WAS 100n.
R25 WAS 47k
R26 WAS 100k.
R69 WAS N/F.
PCB WAS
07-02029-01.
C/R 28133
SSJ 12-8-04

ISSUE D
PCB WAS
07-02029-02
GASKET NOTE
DELETED.
C/R 28203
SSJ 29-9-04

ISSUE 1
PCB WAS
07-02029-03
R122 - R124 ADDED
IC2 DELETED.
R13 & R14 WERE 10k.
C/R 28317
KMW 21-12-04

ISSUE 2
R4 & R5 WERE 1k
R6 & R104 WERE 100k
R105 & R106 WERE 6k8
C/R 28492
BHJ 25-5-05

ISSUE 3
TABLE ADDED.
ITEM 7 (LABEL) ADDED.
C/R 30626
JD 2-3-07

ISSUE 4:
GPS ADDED
TABLE EDITED
ITEM 8 (GPS) ADDED
DI-30978
RM 18-03-08

08-06129-001

VARIANT	H1	ITEM 7 - LABEL TEXT	ITEM 8 - GPS
08-06129-001	NOT FITTED	NOT FITTED	NOT FITTED
08-06129-101	65-61110-70(WHITE)	101	NOT FITTED
08-06129-102	65-61110-70(WHITE)	102	08-06149-001
08-06129-201	65-61110-516(GREEN)	201	NOT FITTED
08-06129-202	65-61110-516(GREEN)	202	08-06149-001

SCH 04-03457
PCB 07-02029-04
ASSY 08-06129-XXX (REF TABLE)

FILE Name
08\06129_3.DWG

MATERIAL	DRN	ILT	SCALE	<p>© CODAN LIMITED, A.C.N. 007 580 805/2003 The information contained herein is proprietary to Codan Limited, and is to be used by the recipient solely for the purpose for which it is supplied. Codan does not warrant the recipient to copy, adapt, publish or disclose the information to third parties except as otherwise agreed with Codan in writing.</p>
	CHKD	SSJ	DATE	
FINISH	APPD	KMW	DATE	<p>TITLE</p> <p>FRONT PANEL PCB (REFERENCES) 2110</p>
	TOLERANCES UNLESS OTHERWISE SPECIFIED		DATE	
LINEAR			±0.25	<p>ISS</p> <p>DRAWING/DOC NO.</p> <p>08-06129</p>
ANGULAR			12°	
FLATNESS			±0.2	
ROUGHNESS		1.6	(µmRa)	<p>SHT. 1 OF 2</p>

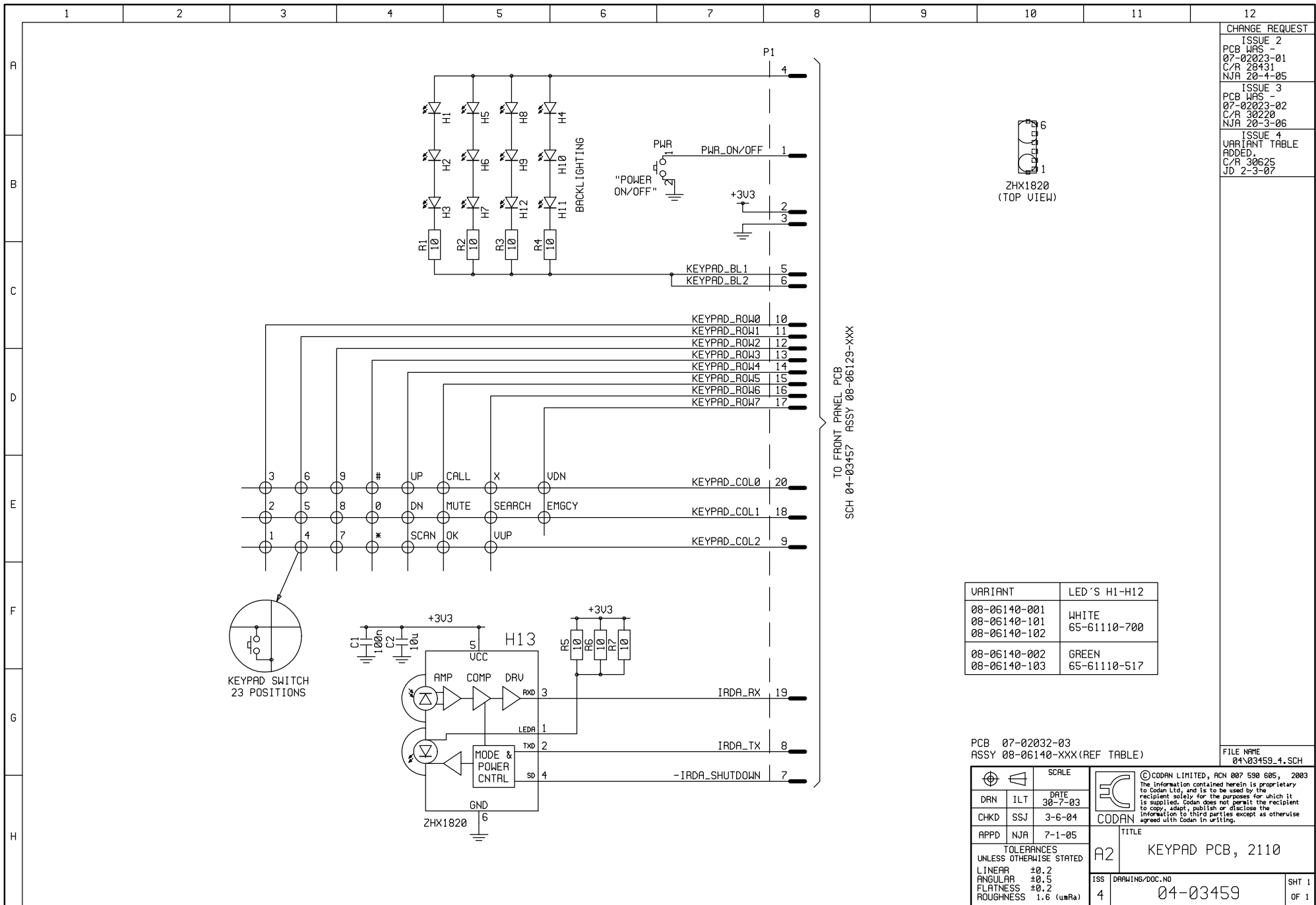

CHANGE REQUEST
 ISSUE 2
 PCB WAS -
 07-02023-01
 C/R 28431
 NJA 20-4-05
 ISSUE 3
 PCB WAS -
 07-02023-02
 C/R 30220
 NJA 20-3-06
 ISSUE 4
 VARIANT TABLE
 ADDED.
 C/R 30625
 JD 2-3-07

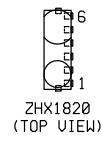

TO FRONT PANEL PCB
 SCH 04-03457 ASSY 08-06129-XXX

VARIANT	LED'S H1-H12
08-06140-001	WHITE
08-06140-101	65-61110-700
08-06140-102	
08-06140-002	GREEN
08-06140-103	65-61110-517

PCB 07-02032-03
 ASSY 08-06140-XXX (REF TABLE)

FILE NAME
 04\03459_4.SCH

DRN	ILT	SCALE	DATE	<p>© CODAN LIMITED, ACN 007 590 605, 2003 The information contained herein is proprietary to Codan Ltd, and is to be used by the recipient solely for the purposes for which it is supplied. Codan does not permit the recipient to copy, adapt, publish or disclose the information to third parties except as otherwise agreed with Codan in writing.</p>
CHKD	SSJ	3-6-04	30-7-03	
APPD	NJA	7-1-05		
TOLERANCES UNLESS OTHERWISE STATED				
LINEAR			±0.2	TITLE KEYPAD PCB, 2110
ANGULAR			±0.5	
FLATNESS			±0.2	
ROUGHNESS			1.6 (umRa)	
ISS DRAWING/DOC.NO				SHT 1
4				04-03459
				OF 1

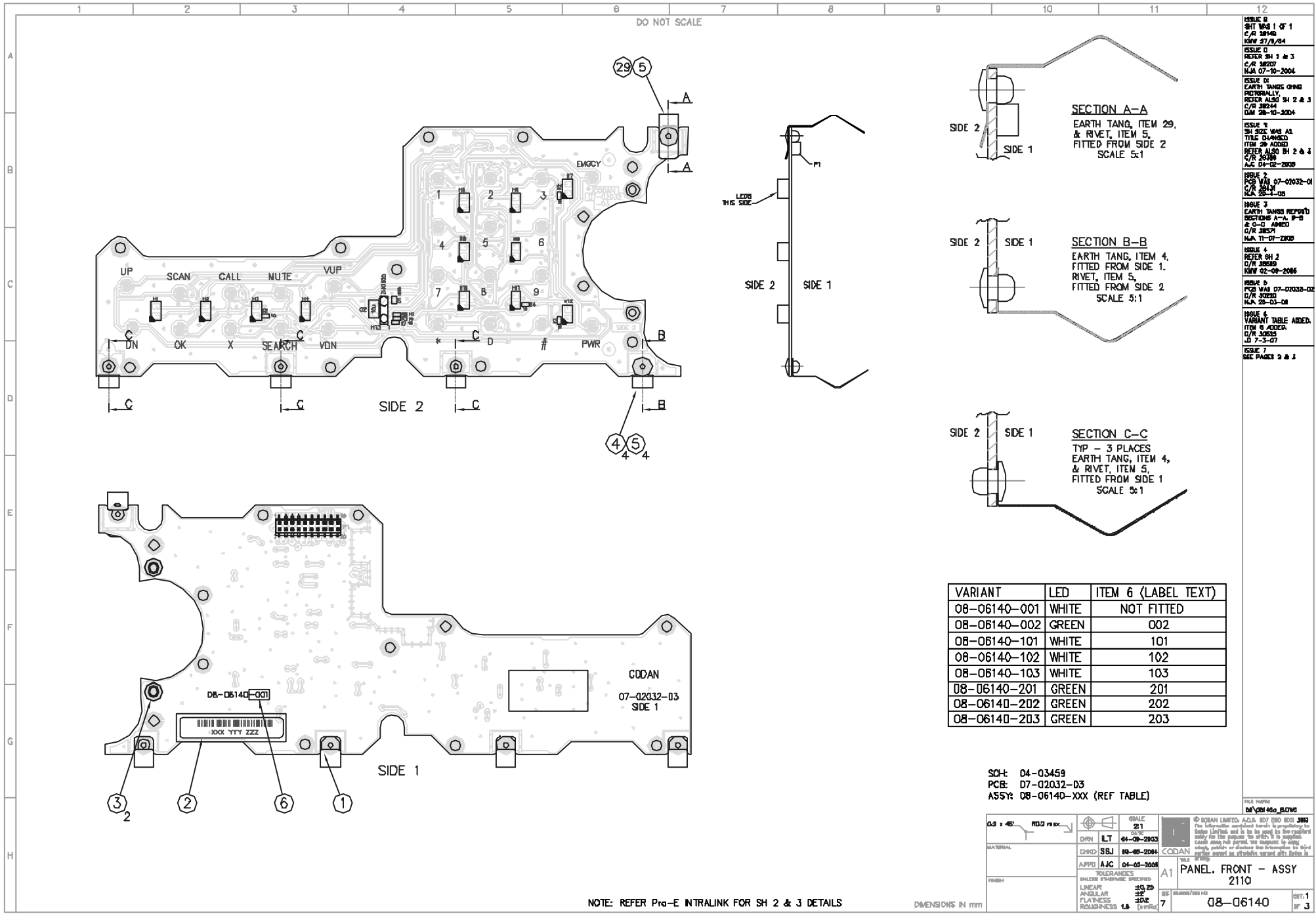

DO NOT SCALE

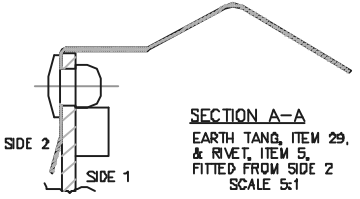

SECTION A-A
EARTH TANG, ITEM 29,
& RIVET, ITEM 5,
FITTED FROM SIDE 2
SCALE 5:1

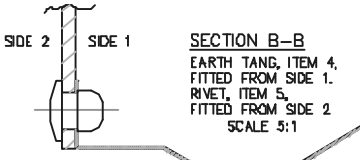

SECTION B-B
EARTH TANG, ITEM 4,
FITTED FROM SIDE 2
SCALE 5:1

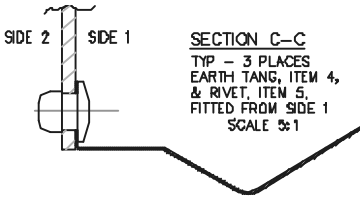

SECTION C-C
TYP - 3 PLACES
EARTH TANG, ITEM 4,
& RIVET, ITEM 5,
FITTED FROM SIDE 1
SCALE 5:1

VARIANT	LED	ITEM 6 (LABEL TEXT)
08-06140-001	WHITE	NOT FITTED
08-06140-002	GREEN	002
08-06140-101	WHITE	101
08-06140-102	WHITE	102
08-06140-103	WHITE	103
08-06140-201	GREEN	201
08-06140-202	GREEN	202
08-06140-203	GREEN	203

SO-L: 04-03459
PCB: 07-02032-03
ASSY: 08-06140-XXX (REF TABLE)

NOTE: REFER PRO-E INTRALINK FOR SH 2 & 3 DETAILS

DIMENSIONS IN mm

DATE: 04-03-2011	SCALE: 2:1	DRN: ILT	DATE: 04-03-2011	FILE: 08-06140_01.dwg
CHKD: SBJ	04-03-2011	APPR: AJC	04-03-2011	
TOLERANCES UNLESS OTHERWISE SPECIFIED				© ROYAN LIMITED, A.S. 807 BLD BLD 2003 This information is confidential and its disclosure to third parties is prohibited. It is intended for use only for the purpose for which it is supplied. It is not to be used for any other purpose without the prior written consent of Royan Limited.
FINISH: LINEAR ±0.05mm SPECIFIED				
LINEAR: ±0.20				
ANGULAR: ±30°				
FLATNESS: ±0.05				PANEL. FRONT - ASSY 2110 08-06140
ROUGHNESS: 1.6 (V=Ra)				
SHEET: 7				SHT. 1 OF 3

DO NOT SCALE

VARIANT	ITEM 9	ITEM 13	ITEM 21	ITEM 24	ITEM 26	WHERE USED
08-06140-001 BLACK	-	-	06-02169-001	-	-	2110/V
08-06140-002 GREEN	-	-	06-02169-002	-	-	2110M
08-06140-101 BLACK	06-02309	31-23006-901	06-02169-001	08-06139-001	06-02181	2110
08-06140-102 BLACK	06-02309	31-23006-901	06-02169-001	08-06732-001	06-02460	2110V
08-06140-103 BLACK	06-02309	31-23006-901	06-02169-001	08-06139-001	06-02181	2110 WITH GPS
08-06140-201 GREEN	06-02309	31-23006-901	06-02169-002	08-06139-001	06-02504	2110 GREEN
08-06140-202 GREEN	06-02309	31-23006-901	06-02169-002	08-06139-001	06-02504	2110 GREEN WITH GPS
08-06140-203 GREEN	06-02309	31-23006-901	06-02169-002	08-06139-001	06-02514	2110M GREEN WITH GPS

ISSUE 1:
WASHER REMOVED FROM ITEM 20. SOME GREASE NOTES REMOVED. REFER ALSO SH 1 & 3 C/R 28396 AJC 04-02-2006

ISSUE 2:
REFER SHEET 1

ISSUE 3:
REFER SH 1

ISSUE 4:
ITEM 2 WERE PAN POZI SCREWS. REFER ALSO SH 1 C/R 28669 KMW 02-09-2006

ISSUE 5:
CONNECTOR REMOVED. REFER ALSO SH 1 C/R 30220 NJA 22-03-2006

ISSUE 6:
ITEM 9, 13, 24, 26, & VARIANT TABLE ADDED. REFER ALSO SH 1 C/R 30626 JD 09-02-2007

ISSUE 7:
TABLE EDITED DB-06140-201 DB-06140-202 DB-06140-203 ADDED. REFER TO SHEET 1 & 3 D1-30978

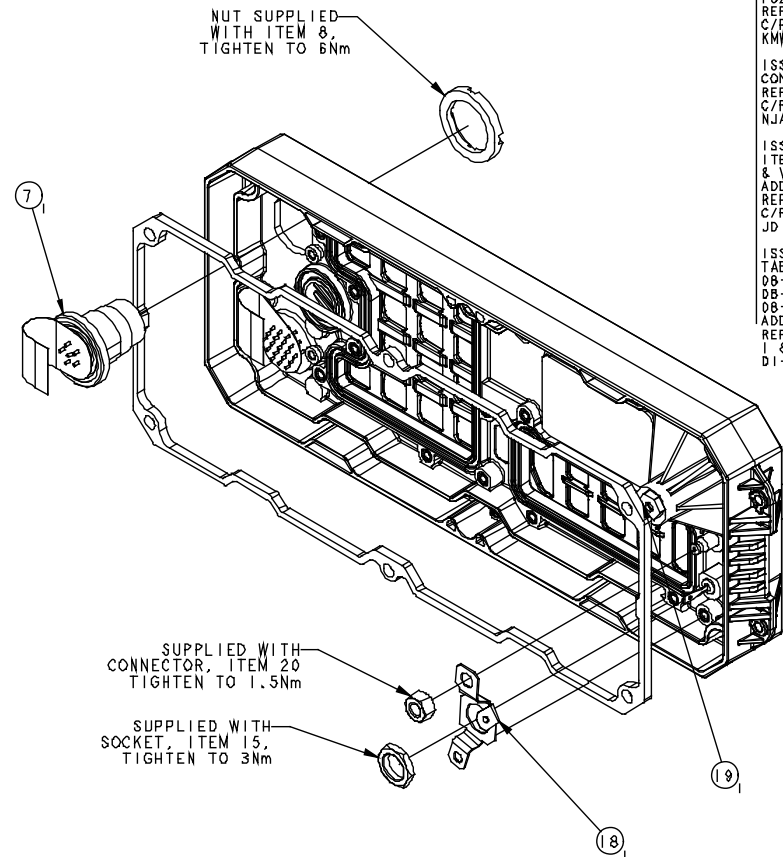
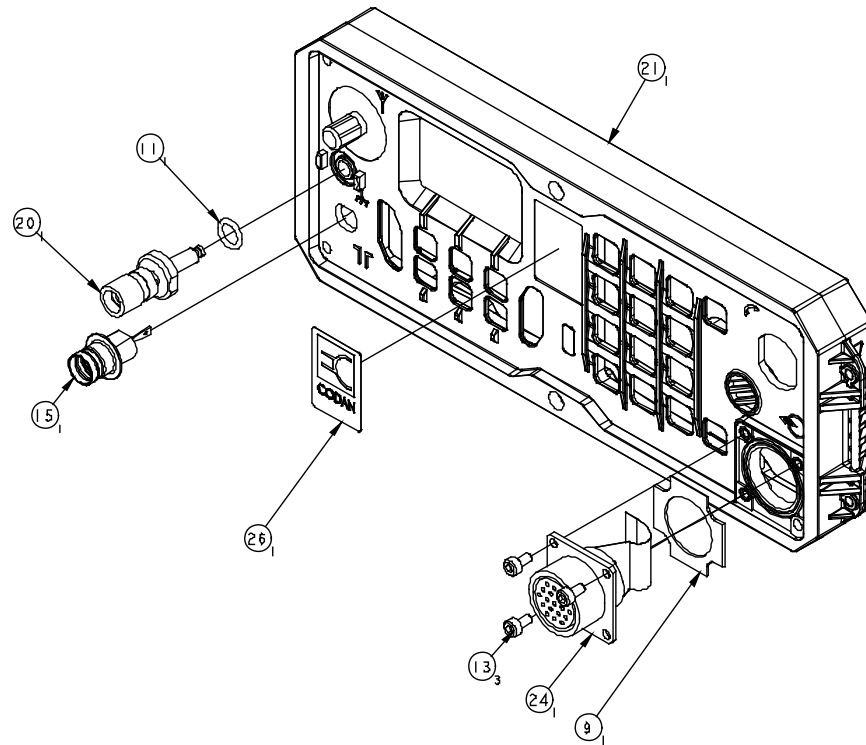

NOTES:

- ASSEMBLED CONNECTORS TO BE WATER TIGHT TO IMMERSION DEPTH OF 1m FOR 1 HOUR AS PER MIL-STD-810F METHOD 512.4 PROCEDURE 1
- ASSEMBLE FASTENERS IN ACCORDANCE WITH CODAN SPEC 01-01459 UNLESS SPECIFIED OTHERWISE

$0.2 \times 45^\circ$ RD.2 max 	SCALE 1:1		©CODAN LIMITED. ACH 007 090 005: 2004 The information contained herein is proprietary to Codan Limited, and is to be used by the recipient solely for the purpose for which it is supplied. Codan does not warrant the recipient to copy, amend, publish or disclose the information to third parties except as otherwise agreed with Codan in writing.
	DRN DJM	DATE 10-03-2004	
MATERIAL SCALE 9:1D	CHKD NJA	12-08-2004	ISS DRAWING/DOC NO 7 08-06140
FINISH	APPD		
TOLERANCES UNLESS OTHERWISE SPECIFIED			
LINEAR ± 0.2			
ANGULAR $\pm 0.5^\circ$			
FLATNESS ± 0.2			
ROUGHNESS 1.6 μmRa			

DIMENSIONS IN mm

DO NOT SCALE

ISSUE 1:
HANDLES REMOVED,
SOME GREASE NOTES
REMOVED,
REFER ALSO SH 1&2

ISSUE 2:
REFER SH 1

ISSUE 3
PICTORIAL CHANGE
TO PCB, ITEM 1
REFER ALSO SH 1

ISSUE 4:
REFER SH 1 & 2

ISSUE 5
REFER SH 1 & 2

ISSUE 6,
REFER SH 1 & 2

ISSUE 7:
TABLE ADDED
GPS ADDED
(ITEM 30)
REFER TO SHEET
1&2
D1-30978

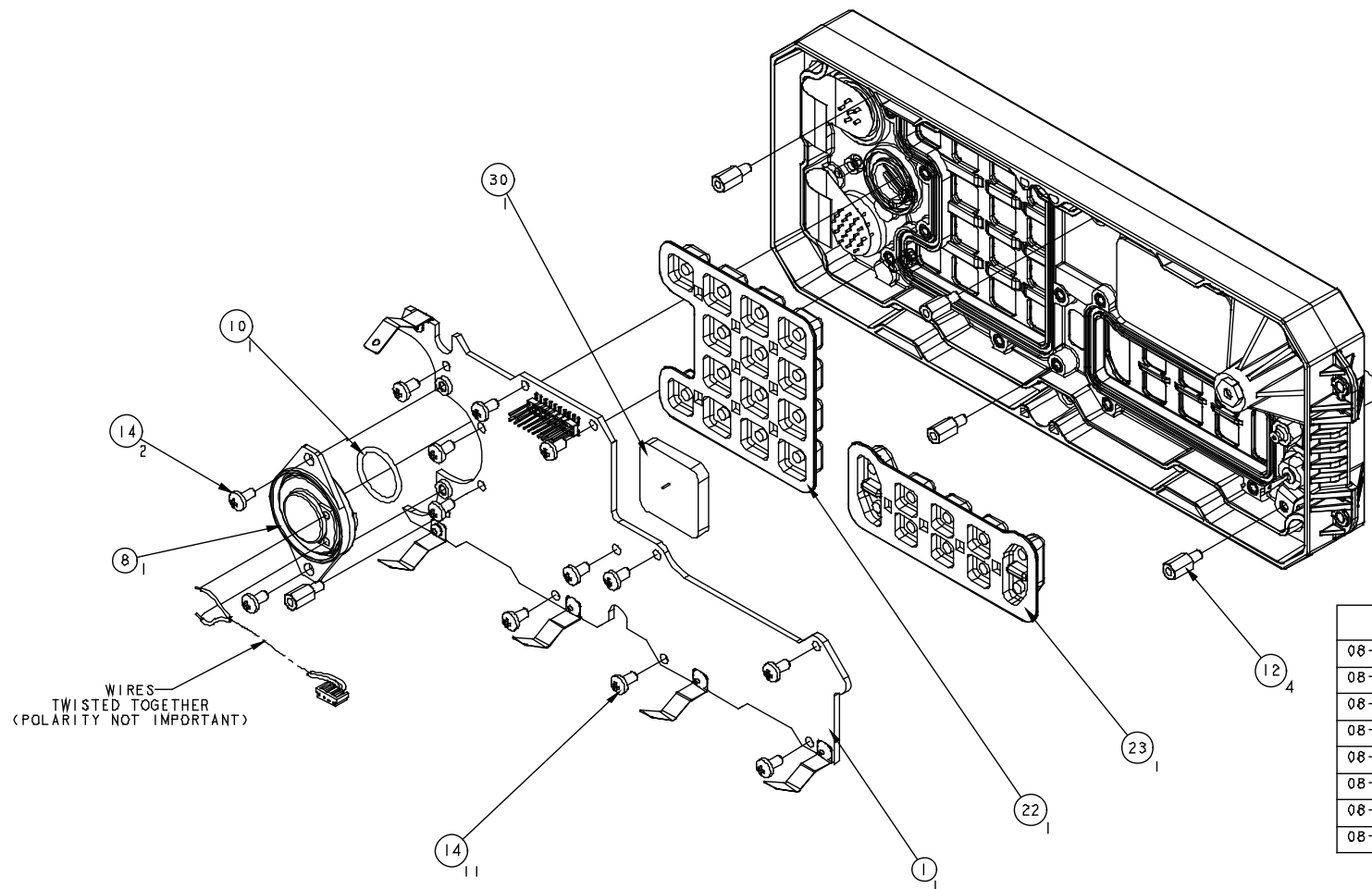

VARIANT	GPS ANTENNA (ITEM 30)
08-06140-001	NOT FITTED
08-06140-002	NOT FITTED
08-06140-101	NOT FITTED
08-06140-102	NOT FITTED
08-06140-103	08-06190-001
08-06140-201	NOT FITTED
08-06140-202	08-06190-001
08-06140-203	08-06190-001

0.2 x 45° RD.2 max		SCALE 1:1	<p>©CODAN LIMITED, ACH 007 090 000: 2004 The information contained herein is proprietary to Codan Limited, and is to be used by the recipient solely for the purpose for which it is supplied. Codan does not warrant the recipient to copy, amend, publish or disclose the information to third parties except as otherwise agreed with Codan in writing.</p>
MATERIAL	CHKD NJA	DATE 10-03-2004	
FINISH	APPD	TOLERANCES UNLESS OTHERWISE SPECIFIED LINEAR ± 0.2 ANGULAR ± 0.5° FLATNESS ± 0.2 ROUGHNESS 1.6 µmRa	<p>TITLE A2 PANEL, FRONT - ASSY 2110, SERIES</p> <p>ISS DRAWING/DOC NO 7 08-06140</p>

DIMENSIONS IN mm

SHT.3
OF 3

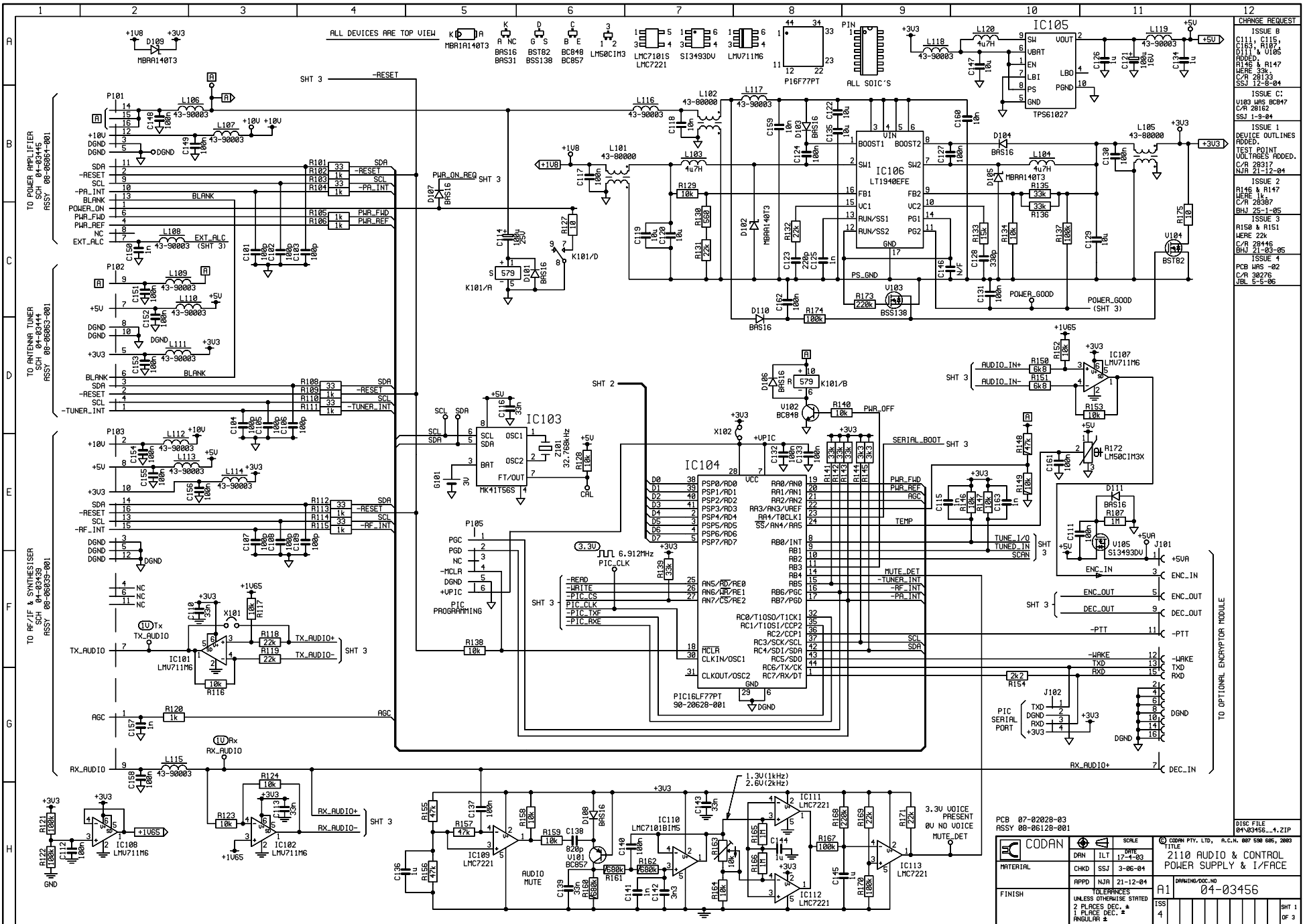

CHANGE REQUEST

ISSUE B
 C111, C115
 C163, R107,
 D11 & U105
 ADDED.
 HERE IN R4
 C/R 28133
 SSJ 12-8-04

ISSUE C:
 U103 WRS BC847
 C/R 28182
 SSJ 1-9-04

ISSUE 1
 DEVICE OUTLINES
 ADDED.
 TEST POINT
 VOLTAGES ADDED.
 C/R 28317
 NJR 21-12-04

ISSUE 2
 R146 & R147
 WERE 1K
 C/R 28367
 BHJ 25-1-05

ISSUE 3
 R150 & R151
 WERE 22K
 C/R 28446
 BHJ 21-03-05

ISSUE 4
 PCB WRS -02
 C/R 28276
 JBL 5-5-06

PCB 07-02028-03 ASSY 08-06128-001		DSC FILE 04-03456_4.ZIP	
CODAN		SCALE	
MATERIAL	DRN ILT 17-4-03	TITLE 2110 AUDIO & CONTROL POWER SUPPLY & I/FACE	
FINISH	CHD SSJ 3-06-04	DRAWING/DOC NO 04-03456	
	APPD NJR 21-12-04	1 UNLESS OTHERWISE STATED	
		2 PLACES DEC. *	
		1 PLACE DEC. *	
		ANGULAR ±	
ISS	4	SHT 1	OF 3

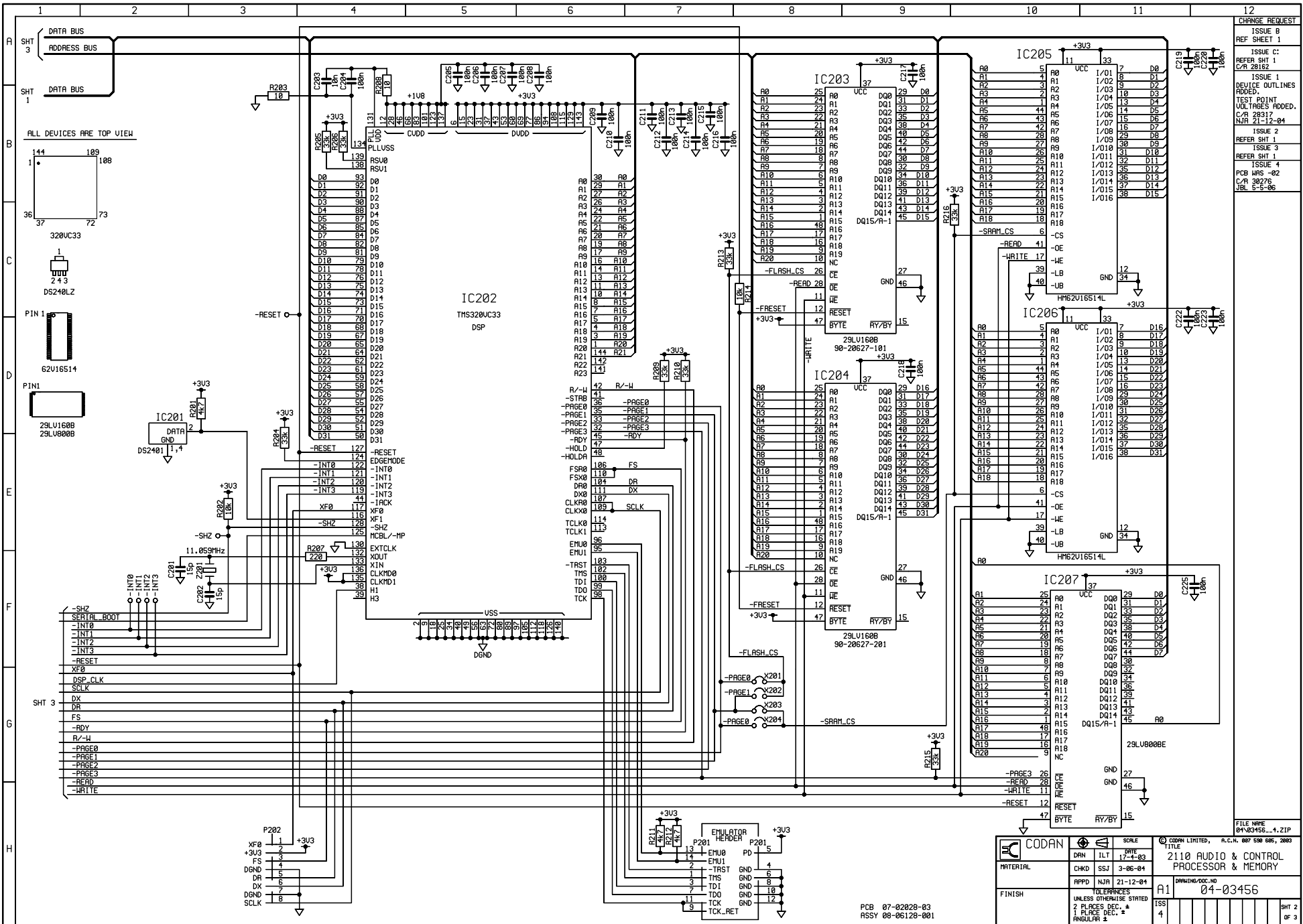

CHANGE REQUEST	
ISSUE B	REF SHEET 1
ISSUE C:	ISSUE 1
REFER SHT 1	C/R 28162
ISSUE 1	ISSUE 1
DEVICE OUTLINES	ADDED.
TEST POINT	VOL TAGS ADDED.
C/R 2817	NJA 21-12-04
ISSUE 2	REFER SHT 1
ISSUE 3	REFER SHT 1
ISSUE 4	PCB MRS -02
C/R 28276	UB 5-5-92

CODAN		SCALE		CODAN LIMITED, A.C.N. 007 530 085, 2003	
DRAWN	ILT	DATE	17-4-83	2110 AUDIO & CONTROL PROCESSOR & MEMORY	
CHECKED	SSJ	3-06-04		DRAWING/DOC NO	
APPD	NJA	21-12-04		04-03456	
FINISH		TOLERANCES		UNLESS OTHERWISE STATED	
		2 PLACES DEC. *		1 PLACE DEC. *	
		ANGULAR 2		1SS	
				SHT 2 OF 3	

PCB 07-02028-03
ASSY 08-06128-001

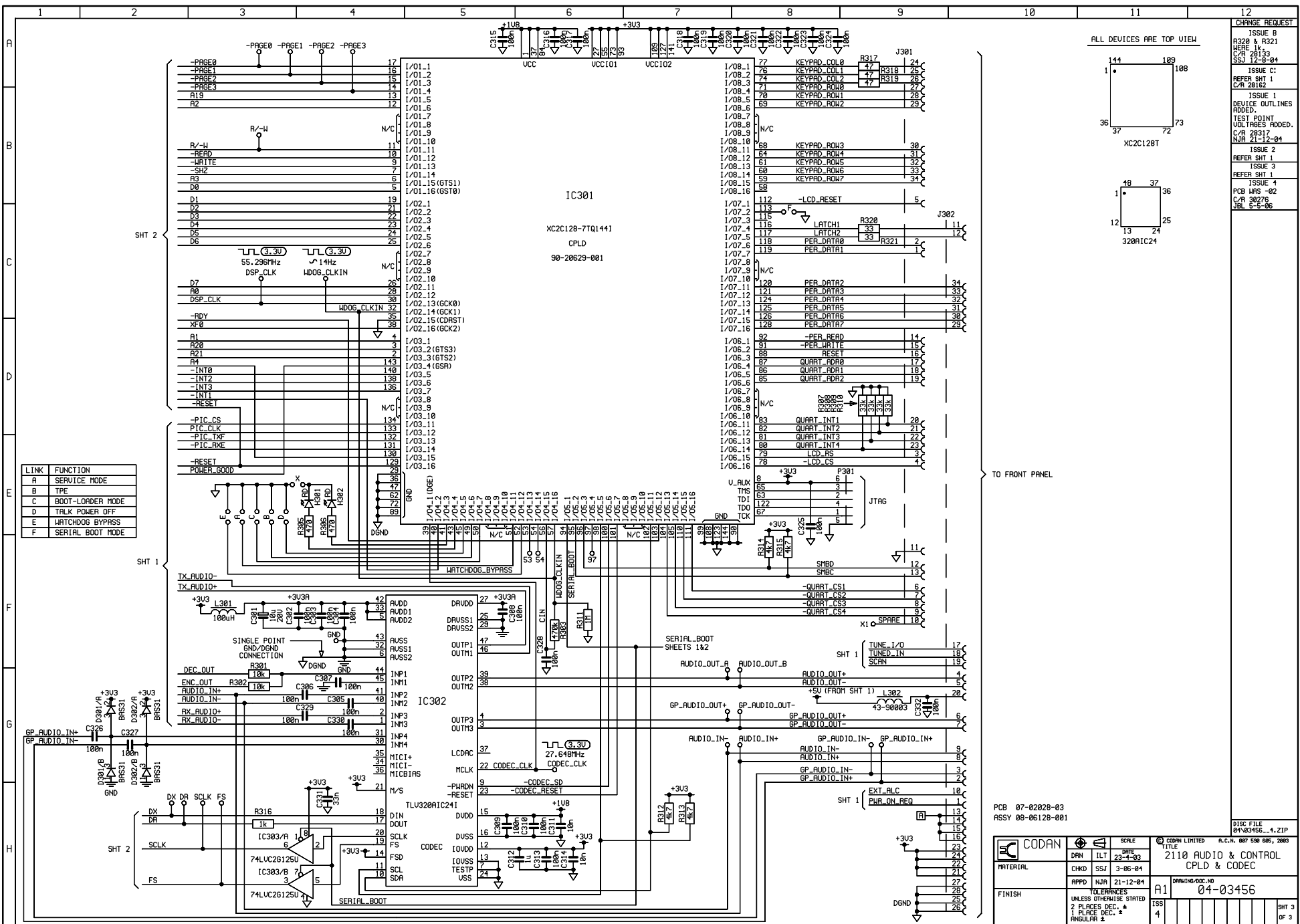

LINK	FUNCTION
A	SERVICE MODE
B	TPE
C	BOOT-LOADER MODE
D	TALK POWER OFF
E	WATCHDOG BYPASS
F	SERIAL_BOOT MODE

ALL DEVICES ARE TOP VIEW

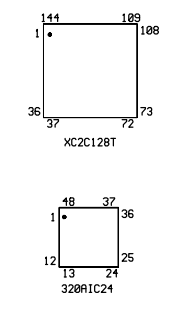

CHANGE REQUEST
 ISSUE B
 R320 & R321
 HERE IN
 C/R 28133
 S/CJ 12-B-04
 ISSUE C:
 REFER SHT 1
 C/R 28152
 ISSUE 1
 DEVICE OUTLINES
 ADDED.
 TEST POINT
 VOLTAGES ADDED.
 C/R 28317
 N/A 21-12-04
 ISSUE 2
 REFER SHT 1
 ISSUE 3
 REFER SHT 1
 ISSUE 4
 PCB MRS -02
 C/R 30276
 JBL 5-5-06

TO FRONT PANEL

PCB 07-02028-03
 ASSY 08-06128-001

DISC FILE 04-03456-4.21P

CODAN	SCALE	23+4-03	2110 AUDIO & CONTROL CPLD & CODEC
	DATE	23+4-03	
MATERIAL	CHKD	SSJ	3-06-04
FINISH	APPD	NJA	21-12-04
	UNLESS OTHERWISE STATED 2 PLACES DEC. * 1 PLACE DEC. * ANGULAR ±		
ISS		4	
SHT 3			
OF 3			

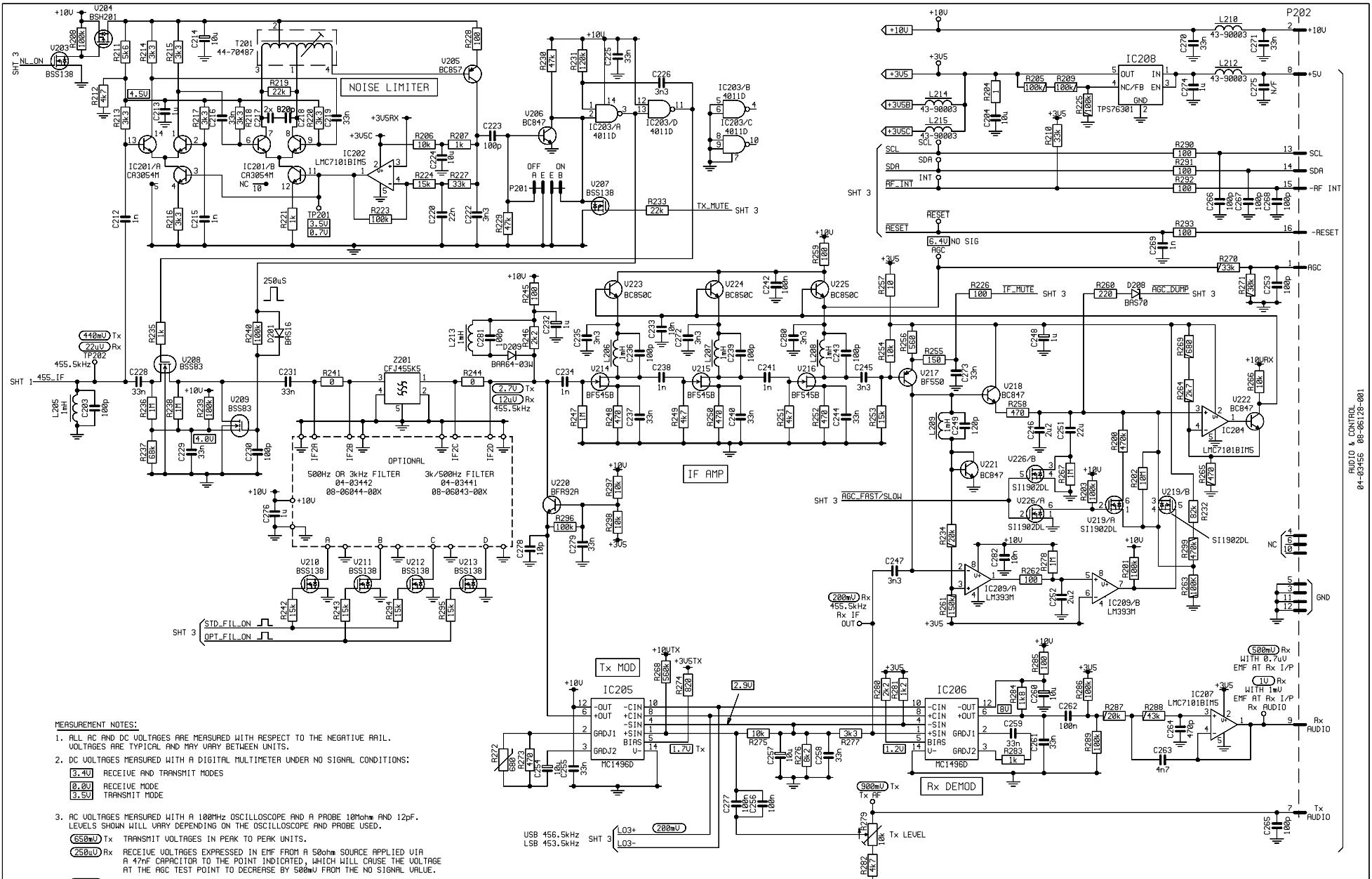

AUDIO & CONTROL
04-03456 08-06108-001

MEASUREMENT NOTES:

- ALL AC AND DC VOLTAGES ARE MEASURED WITH RESPECT TO THE NEGATIVE RAIL. VOLTAGES ARE TYPICAL AND MAY VARY BETWEEN UNITS.
- DC VOLTAGES MEASURED WITH A DIGITAL MULTIMETER UNDER NO SIGNAL CONDITIONS:
 - (3.4V) RECEIVE AND TRANSMIT MODES
 - (0.0V) RECEIVE MODE
 - (3.5V) TRANSMIT MODE
- AC VOLTAGES MEASURED WITH A 100MHz OSCILLOSCOPE AND A PROBE 10Mohm AND 12pF. LEVELS SHOWN WILL VARY DEPENDING ON THE OSCILLOSCOPE AND PROBE USED.
 - (650mV) Tx TRANSMIT VOLTAGES IN PEAK TO PEAK UNITS.
 - (250uV) Rx RECEIVE VOLTAGES EXPRESSED IN EMF FROM A 500mV SOURCE APPLIED VIA A 47nF CAPACITOR TO THE POINT INDICATED, WHICH WILL CAUSE THE VOLTAGE AT THE AGC TEST POINT TO DECREASE BY 500mV FROM THE NO SIGNAL VALUE.
 - (140mV) VOLTAGES IN PEAK TO PEAK UNITS IN RECEIVE AND TRANSMIT MODES.

PCB 07-02012-04
ASSY 08-06039-001

		SCALE	© CODAN PTY. LTD., A.C.N. 007 590 695, 2002
DRAWN	C.G.	DATE	TITLE
CHKD	SJC	6-12-02	RF/IF & SYNTHESISER
APPD	NJR	21-12-04	
FINISH		TOLERANCES	DRAWING/DOC. NO.
		UNLESS OTHERWISE STATED	A1 04-03439
		2 PLACES DEC. *	ISS
		1 PLACE DEC. *	3
		ANGULAR #	

ISSUE CHANGE	ISSUE 1
R236 MS 5Z 10L	C236 MS 47p
R274 MS 5K 5K 5K	C237 MS 100n
R274 MS 5K 5K 5K	C238 MS 100n
REFER SHT 1	C239 MS 100n
FOR 208 18S -01	C240 MS 100n
08-06108-001	C241 MS 100n
08-06108-001	C242 MS 100n
08-06108-001	C243 MS 100n
08-06108-001	C244 MS 100n
08-06108-001	C245 MS 100n
08-06108-001	C246 MS 100n
08-06108-001	C247 MS 100n
08-06108-001	C248 MS 100n
08-06108-001	C249 MS 100n
08-06108-001	C250 MS 100n
08-06108-001	C251 MS 100n
08-06108-001	C252 MS 100n
08-06108-001	C253 MS 100n
08-06108-001	C254 MS 100n
08-06108-001	C255 MS 100n
08-06108-001	C256 MS 100n
08-06108-001	C257 MS 100n
08-06108-001	C258 MS 100n
08-06108-001	C259 MS 100n
08-06108-001	C260 MS 100n
08-06108-001	C261 MS 100n
08-06108-001	C262 MS 100n
08-06108-001	C263 MS 100n
08-06108-001	C264 MS 100n
08-06108-001	C265 MS 100n
08-06108-001	C266 MS 100n
08-06108-001	C267 MS 100n
08-06108-001	C268 MS 100n
08-06108-001	C269 MS 100n
08-06108-001	C270 MS 100n
08-06108-001	C271 MS 100n
08-06108-001	C272 MS 100n
08-06108-001	C273 MS 100n
08-06108-001	C274 MS 100n
08-06108-001	C275 MS 100n
08-06108-001	C276 MS 100n
08-06108-001	C277 MS 100n
08-06108-001	C278 MS 100n
08-06108-001	C279 MS 100n
08-06108-001	C280 MS 100n
08-06108-001	C281 MS 100n
08-06108-001	C282 MS 100n
08-06108-001	C283 MS 100n
08-06108-001	C284 MS 100n
08-06108-001	C285 MS 100n
08-06108-001	C286 MS 100n
08-06108-001	C287 MS 100n
08-06108-001	C288 MS 100n
08-06108-001	C289 MS 100n
08-06108-001	C290 MS 100n
08-06108-001	C291 MS 100n
08-06108-001	C292 MS 100n
08-06108-001	C293 MS 100n
08-06108-001	C294 MS 100n
08-06108-001	C295 MS 100n
08-06108-001	C296 MS 100n
08-06108-001	C297 MS 100n
08-06108-001	C298 MS 100n
08-06108-001	C299 MS 100n
08-06108-001	C300 MS 100n
08-06108-001	C301 MS 100n
08-06108-001	C302 MS 100n
08-06108-001	C303 MS 100n
08-06108-001	C304 MS 100n
08-06108-001	C305 MS 100n
08-06108-001	C306 MS 100n
08-06108-001	C307 MS 100n
08-06108-001	C308 MS 100n
08-06108-001	C309 MS 100n
08-06108-001	C310 MS 100n
08-06108-001	C311 MS 100n
08-06108-001	C312 MS 100n
08-06108-001	C313 MS 100n
08-06108-001	C314 MS 100n
08-06108-001	C315 MS 100n
08-06108-001	C316 MS 100n
08-06108-001	C317 MS 100n
08-06108-001	C318 MS 100n
08-06108-001	C319 MS 100n
08-06108-001	C320 MS 100n
08-06108-001	C321 MS 100n
08-06108-001	C322 MS 100n
08-06108-001	C323 MS 100n
08-06108-001	C324 MS 100n
08-06108-001	C325 MS 100n
08-06108-001	C326 MS 100n
08-06108-001	C327 MS 100n
08-06108-001	C328 MS 100n
08-06108-001	C329 MS 100n
08-06108-001	C330 MS 100n
08-06108-001	C331 MS 100n
08-06108-001	C332 MS 100n
08-06108-001	C333 MS 100n
08-06108-001	C334 MS 100n
08-06108-001	C335 MS 100n
08-06108-001	C336 MS 100n
08-06108-001	C337 MS 100n
08-06108-001	C338 MS 100n
08-06108-001	C339 MS 100n
08-06108-001	C340 MS 100n
08-06108-001	C341 MS 100n
08-06108-001	C342 MS 100n
08-06108-001	C343 MS 100n
08-06108-001	C344 MS 100n
08-06108-001	C345 MS 100n
08-06108-001	C346 MS 100n
08-06108-001	C347 MS 100n
08-06108-001	C348 MS 100n
08-06108-001	C349 MS 100n
08-06108-001	C350 MS 100n
08-06108-001	C351 MS 100n
08-06108-001	C352 MS 100n
08-06108-001	C353 MS 100n
08-06108-001	C354 MS 100n
08-06108-001	C355 MS 100n
08-06108-001	C356 MS 100n
08-06108-001	C357 MS 100n
08-06108-001	C358 MS 100n
08-06108-001	C359 MS 100n
08-06108-001	C360 MS 100n
08-06108-001	C361 MS 100n
08-06108-001	C362 MS 100n
08-06108-001	C363 MS 100n
08-06108-001	C364 MS 100n
08-06108-001	C365 MS 100n
08-06108-001	C366 MS 100n
08-06108-001	C367 MS 100n
08-06108-001	C368 MS 100n
08-06108-001	C369 MS 100n
08-06108-001	C370 MS 100n
08-06108-001	C371 MS 100n
08-06108-001	C372 MS 100n
08-06108-001	C373 MS 100n
08-06108-001	C374 MS 100n
08-06108-001	C375 MS 100n
08-06108-001	C376 MS 100n
08-06108-001	C377 MS 100n
08-06108-001	C378 MS 100n
08-06108-001	C379 MS 100n
08-06108-001	C380 MS 100n
08-06108-001	C381 MS 100n
08-06108-001	C382 MS 100n
08-06108-001	C383 MS 100n
08-06108-001	C384 MS 100n
08-06108-001	C385 MS 100n
08-06108-001	C386 MS 100n
08-06108-001	C387 MS 100n
08-06108-001	C388 MS 100n
08-06108-001	C389 MS 100n
08-06108-001	C390 MS 100n
08-06108-001	C391 MS 100n
08-06108-001	C392 MS 100n
08-06108-001	C393 MS 100n
08-06108-001	C394 MS 100n
08-06108-001	C395 MS 100n
08-06108-001	C396 MS 100n
08-06108-001	C397 MS 100n
08-06108-001	C398 MS 100n
08-06108-001	C399 MS 100n
08-06108-001	C400 MS 100n
08-06108-001	C401 MS 100n
08-06108-001	C402 MS 100n
08-06108-001	C403 MS 100n
08-06108-001	C404 MS 100n
08-06108-001	C405 MS 100n
08-06108-001	C406 MS 100n
08-06108-001	C407 MS 100n
08-06108-001	C408 MS 100n
08-06108-001	C409 MS 100n
08-06108-001	C410 MS 100n
08-06108-001	C411 MS 100n
08-06108-001	C412 MS 100n
08-06108-001	C413 MS 100n
08-06108-001	C414 MS 100n
08-06108-001	C415 MS 100n
08-06108-001	C416 MS 100n
08-06108-001	C417 MS 100n
08-06108-001	C418 MS 100n
08-06108-001	C419 MS 100n
08-06108-001	C420 MS 100n
08-06108-001	C421 MS 100n
08-06108-001	C422 MS 100n
08-06108-001	C423 MS 100n
08-06108-001	C424 MS 100n
08-06108-001	C425 MS 100n
08-06108-001	C426 MS 100n
08-06108-001	C427 MS 100n
08-06108-001	C428 MS 100n
08-06108-001	C429 MS 100n
08-06108-001	C430 MS 100n
08-06108-001	C431 MS 100n
08-06108-001	C432 MS 100n
08-06108-001	C433 MS 100n
08-06108-001	C434 MS 100n
08-06108-001	C435 MS 100n
08-06108-001	C436 MS 100n
08-06108-001	C437 MS 100n
08-06108-001	C438 MS 100n
08-06108-001	C439 MS 100n
08-06108-001	C440 MS 100n
08-06108-001	C441 MS 100n
08-06108-001	C442 MS 100n
08-06108-001	C443 MS 100n
08-06108-001	C444 MS 100n
08-06108-001	C445 MS 100n
08-06108-001	C446 MS 100n
08-06108-001	C447 MS 100n
08-06108-001	C448 MS 100n
08-06108-001	C449 MS 100n
08-06108-001	C450 MS 100n
08-06108-001	C451 MS 100n
08-06108-001	C452 MS 100n
08-06108-001	C453 MS 100n
08-06108-001	C454 MS 100n
08-06108-001	C455 MS 100n
08-06108-001	C456 MS 100n
08-06108-001	C457 MS 100n
08-06108-001	C458 MS 100n
08-06108-001	C459 MS 100n
08-06108-001	C460 MS 100n
08-06108-001	C461 MS 100n
08-06108-001	C462 MS 100n
08-06108-001	C463 MS 100n
08-06108-001	C464 MS 100n
08-06108-001	C465 MS 100n
08-06108-001	C466 MS 100n
08-06108-001	C467 MS 100n
08-06108-001	C468 MS 100n
08-06108-001	C469 MS 100n
08-06108-001	C470 MS 100n
08-06108-001	C471 MS 100n
08-06108-001	C472 MS 100n
08-06108-001	C473 MS 100n
08-06108-001	C474 MS 100n
08-06108-001	C475 MS 100n
08-06108-001	C476 MS 100n
08-06108-001	C477 MS 100n
08-06108-001	C478 MS 100n
08-06108-001	C479 MS 100n
08-06108-001	C480 MS 100n
08-06108-001	C481 MS 100n
08-06108-001	C482 MS 100n
08-06108-001	C483 MS 100n
08-06108-001	C484 MS 100n
08-06108-001	C485 MS 100n
08-06108-001	C486 MS 100n
08-06108-001	C487 MS 100n
08-06108-001	C488 MS 100n
08-06108-001	C489 MS 100n
08-06108-001	C490 MS 100n
08-06108-001	C491 MS 100n
08-06108-001	C492 MS 100n
08-06108-001	C493 MS 100n
08-06108-001	C494 MS 100n
08-06108-001	C495 MS 100n
08-06108-001	C496 MS 100n
08-06108-001	C497 MS 100n
08-06108-001	C498 MS 100n
08-06108-001	C499 MS 100n
08-06108-001	C500 MS 100n

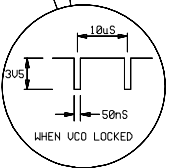
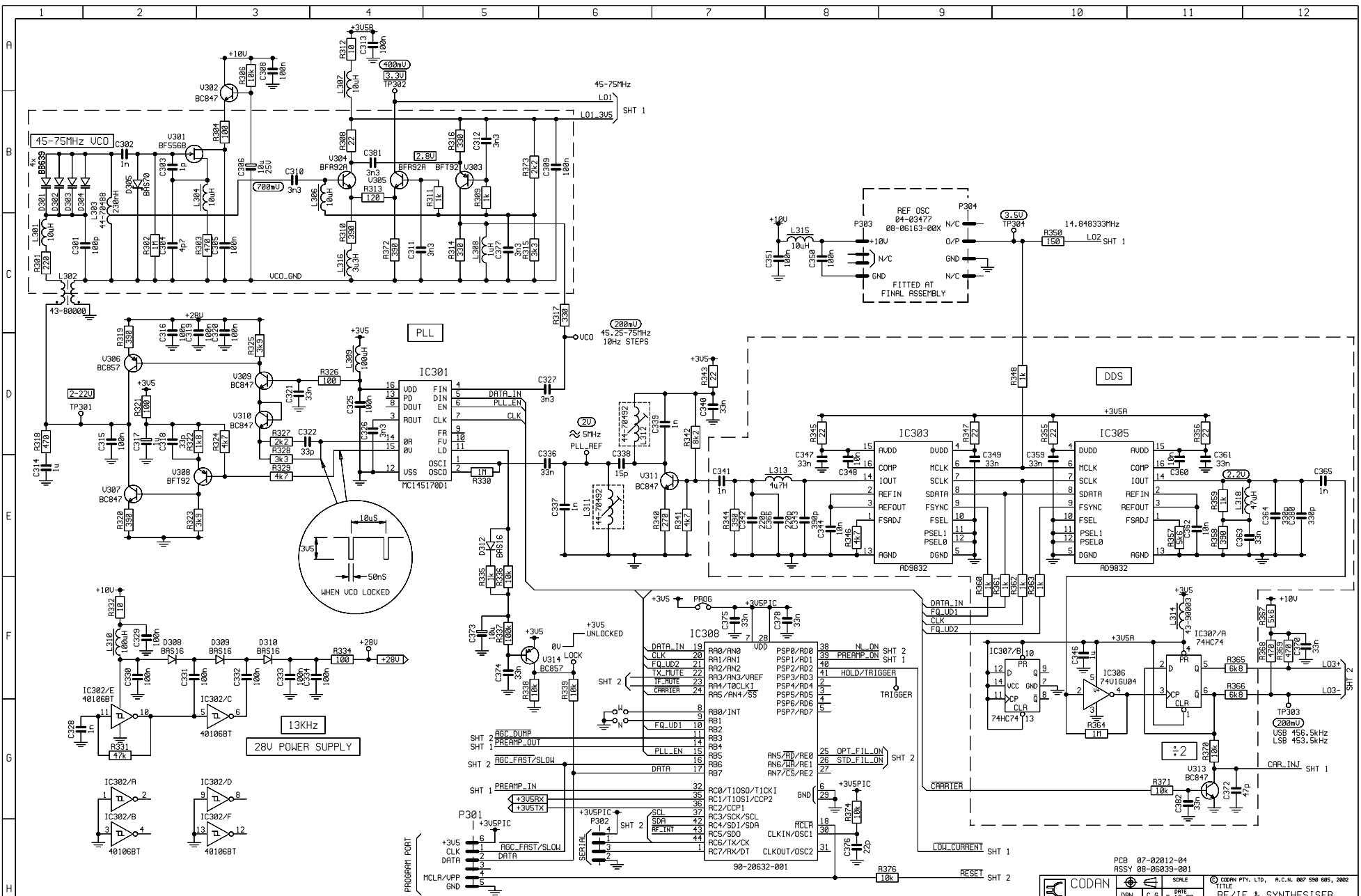

PCB 07-02012-04 ASSY 08-06039-001		SCALE DATE 5-12-02	TITLE RF/IF & SYNTHESISER
CODAN		DRN CHKD APPD	ISS
MATERIAL		NGR SVC NJR	21-12-04
FINISH		TOLERANCES UNLESS OTHERWISE STATED 2 PLACES DEC. * 1 PLACE DEC. * ANGULAR *	
DRAWING/DOC. NO. 04-03439		A1	
ISS		3	
SHT		3	
OF		3	

ISSUE CHANGE	ISSUE NO.	DATE	BY
ISSUE 01	142	12-02-02	SS
ISSUE 02	143	12-02-02	SS
ISSUE 03	144	12-02-02	SS
ISSUE 04	145	12-02-02	SS
ISSUE 05	146	12-02-02	SS
ISSUE 06	147	12-02-02	SS
ISSUE 07	148	12-02-02	SS
ISSUE 08	149	12-02-02	SS
ISSUE 09	150	12-02-02	SS
ISSUE 10	151	12-02-02	SS
ISSUE 11	152	12-02-02	SS
ISSUE 12	153	12-02-02	SS
ISSUE 13	154	12-02-02	SS
ISSUE 14	155	12-02-02	SS
ISSUE 15	156	12-02-02	SS
ISSUE 16	157	12-02-02	SS
ISSUE 17	158	12-02-02	SS
ISSUE 18	159	12-02-02	SS
ISSUE 19	160	12-02-02	SS
ISSUE 20	161	12-02-02	SS

ISSUE 01: 142, 12-02-02, SS

ISSUE 02: 143, 12-02-02, SS

ISSUE 03: 144, 12-02-02, SS

ISSUE 04: 145, 12-02-02, SS

ISSUE 05: 146, 12-02-02, SS

ISSUE 06: 147, 12-02-02, SS

ISSUE 07: 148, 12-02-02, SS

ISSUE 08: 149, 12-02-02, SS

ISSUE 09: 150, 12-02-02, SS

ISSUE 10: 151, 12-02-02, SS

ISSUE 11: 152, 12-02-02, SS

ISSUE 12: 153, 12-02-02, SS

ISSUE 13: 154, 12-02-02, SS

ISSUE 14: 155, 12-02-02, SS

ISSUE 15: 156, 12-02-02, SS

ISSUE 16: 157, 12-02-02, SS

ISSUE 17: 158, 12-02-02, SS

ISSUE 18: 159, 12-02-02, SS

ISSUE 19: 160, 12-02-02, SS

ISSUE 20: 161, 12-02-02, SS

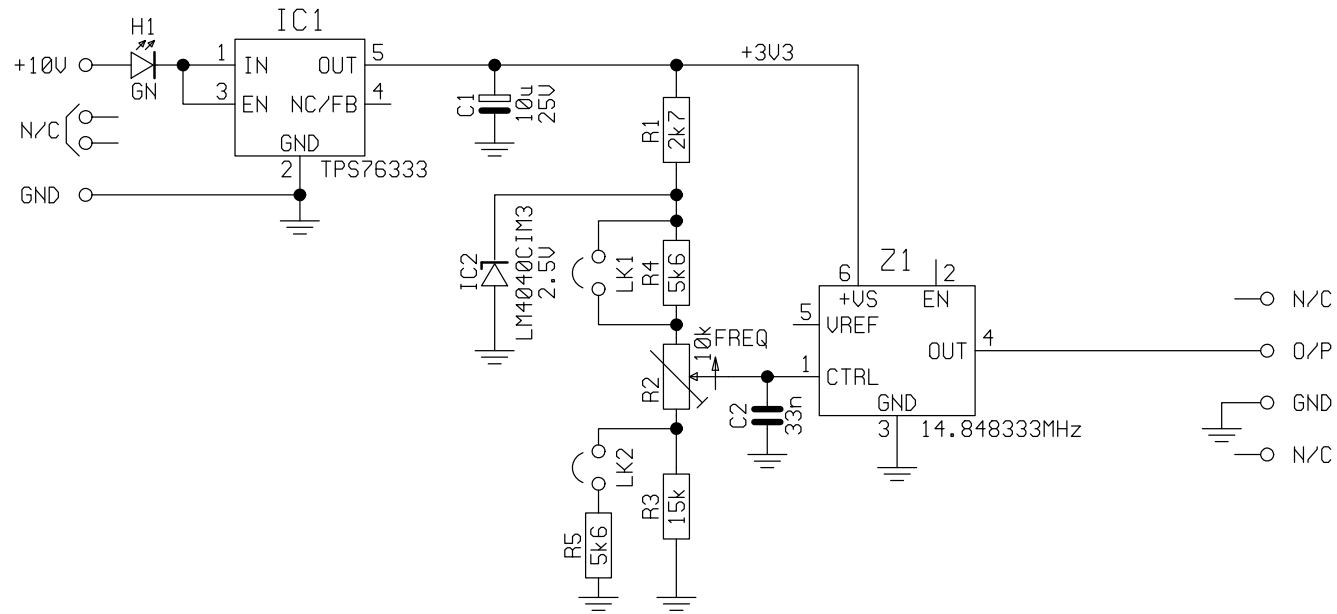

PCB : 07-02052-01
 ASSY: REFER TABLE

FILE NAME
 04\03477_1.ZIP

	ASSEMBLY	Z1
1.5ppm	08-06163-001	CFPT-9058-CU-1A 78-15033
0.5ppm	08-06163-002	CFPT-9058-EU-1A 78-15032

<p>© CODAN LIMITED, ACN 007 590 605, 2003 The information contained herein is proprietary to Codan Ltd, and is to be used by the recipient solely for the purposes for which it is supplied. Codan does not permit the recipient to copy, adapt, publish or disclose the information to third parties except as otherwise agreed with Codan in writing.</p>	
DRN C G CHKD GJC APPD NJA	SCALE DATE 10-12-03 10-6-04 31-1-05
TOLERANCES UNLESS OTHERWISE STATED LINEAR ±0.2 ANGULAR ±0.5 FLATNESS ±0.2 ROUGHNESS 1.6 (µmRa)	
TITLE REF OSC 14.8483MHz 1.5ppm/0.5ppm	
ISS 1	DRAWING/DOC.NO 04-03477
SHT 1 OF 1	

DO NOT SCALE

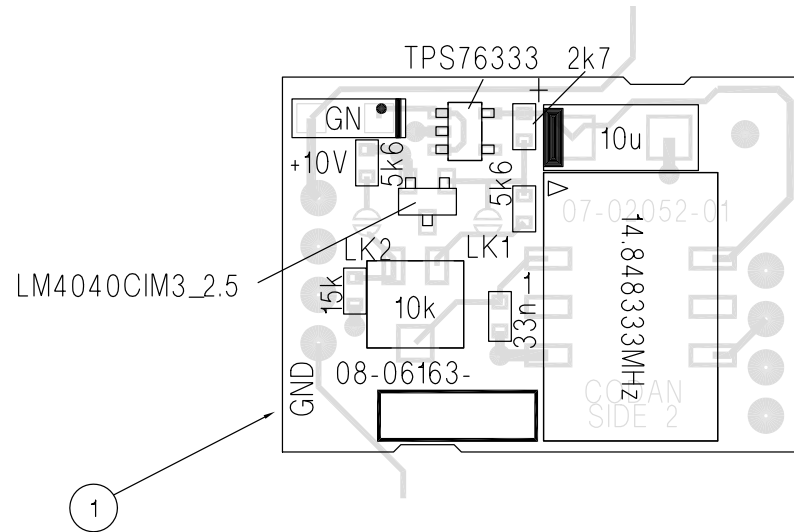

COMPONENT VALUES

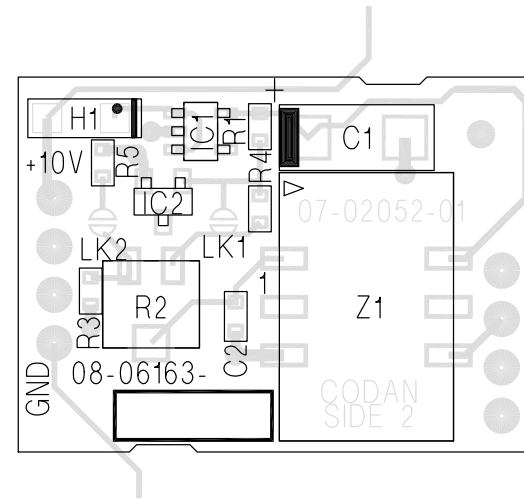

COMPONENT REFERENCES

1

DIMENSIONS IN mm

SCH : 04-03477
PCB : 07-02052-01

	ASSEMBLY	Z1
1.5ppm	08-06163-001	CFPT-9058-CU-1A
0.5ppm	08-06163-002	CFPT-9058-EU-1A

FILE Name
08\06163_1.DWG

	SCALE 4:1
DRN C G	DATE 7-1-04
CHKD GJC	10-6-04
APPD KMW	31-1-05

© CODAN LIMITED, A.C.N. 007 590 605:2004
The information contained herein is proprietary to Codan Limited, and is to be used by the recipient solely for the purpose for which it is supplied. Codan does not permit the recipient to copy, adapt, publish or disclose the information to third parties except as otherwise agreed with Codan in writing.

TOLERANCES
UNLESS OTHERWISE SPECIFIED
LINEAR
ANGULAR
FLATNESS
ROUGHNESS (umRa)

A3	TITLE REF OSC - 14.8483MHz 1.5ppm/0.5ppm
	ISS DRAWING/DOC. NO. 1 08-06163
	SHT. 1 OF 1

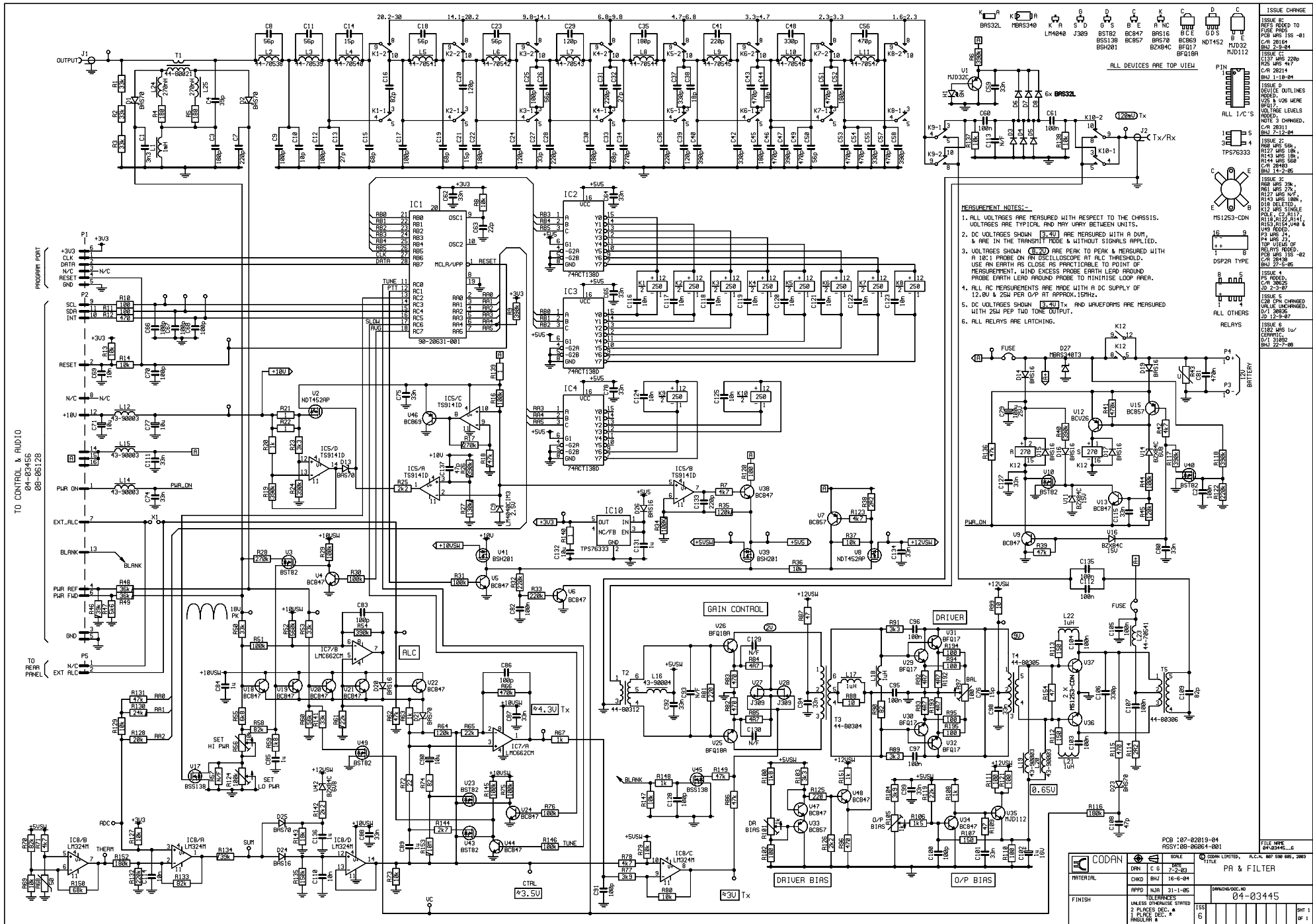

MEASUREMENT NOTES:-

1. ALL VOLTAGES ARE MEASURED WITH RESPECT TO THE CHASSIS. VOLTAGES ARE TYPICAL AND MAY VARY BETWEEN UNITS.
2. DC VOLTAGES SHOWN [3.40] ARE MEASURED WITH A DUM, & ARE IN THE TRANSPARENT MODE & WITHOUT SIGNALS APPLIED.
3. VOLTAGES SHOWN [8.70] ARE PEAK TO PEAK & MEASURED WITH A 10:1 PROBE ON AN OSCILLOSCOPE AT PLC THRESHOLD. USE AN EARTH AS CLOSE AS PRACTICABLE TO POINT OF MEASUREMENT. AVOID EXCESS PROBE EARTH LEAD AROUND PROBE EARTH LEAD AROUND PROBE TO MINIMISE LOOP AREA.
4. ALL AC MEASUREMENTS ARE MADE WITH A DC SUPPLY OF 12.0V & 25M PER O/P AT APPROX. 157Hz.
5. DC VOLTAGES SHOWN [3.20] AND WAVEFORMS ARE MEASURED WITH 25M PER 140 TONE OUTPUT.
6. ALL RELAYS ARE LATCHING.

CODAN		SCALE	DATE	FILE NO.
MATERIAL	DRN C E	BY	2-2-85	PA & FILTER
FINISH	CHKD BHJ	14-8-84		
	APPD NJM	21-1-85	DRNG/DOC NO	04-03445
	UNLESS OTHERWISE STATED			
	2 PLACES DEC. *			
	IN MILLIM. #			
ISS	6			
				DR 1
				DF 1

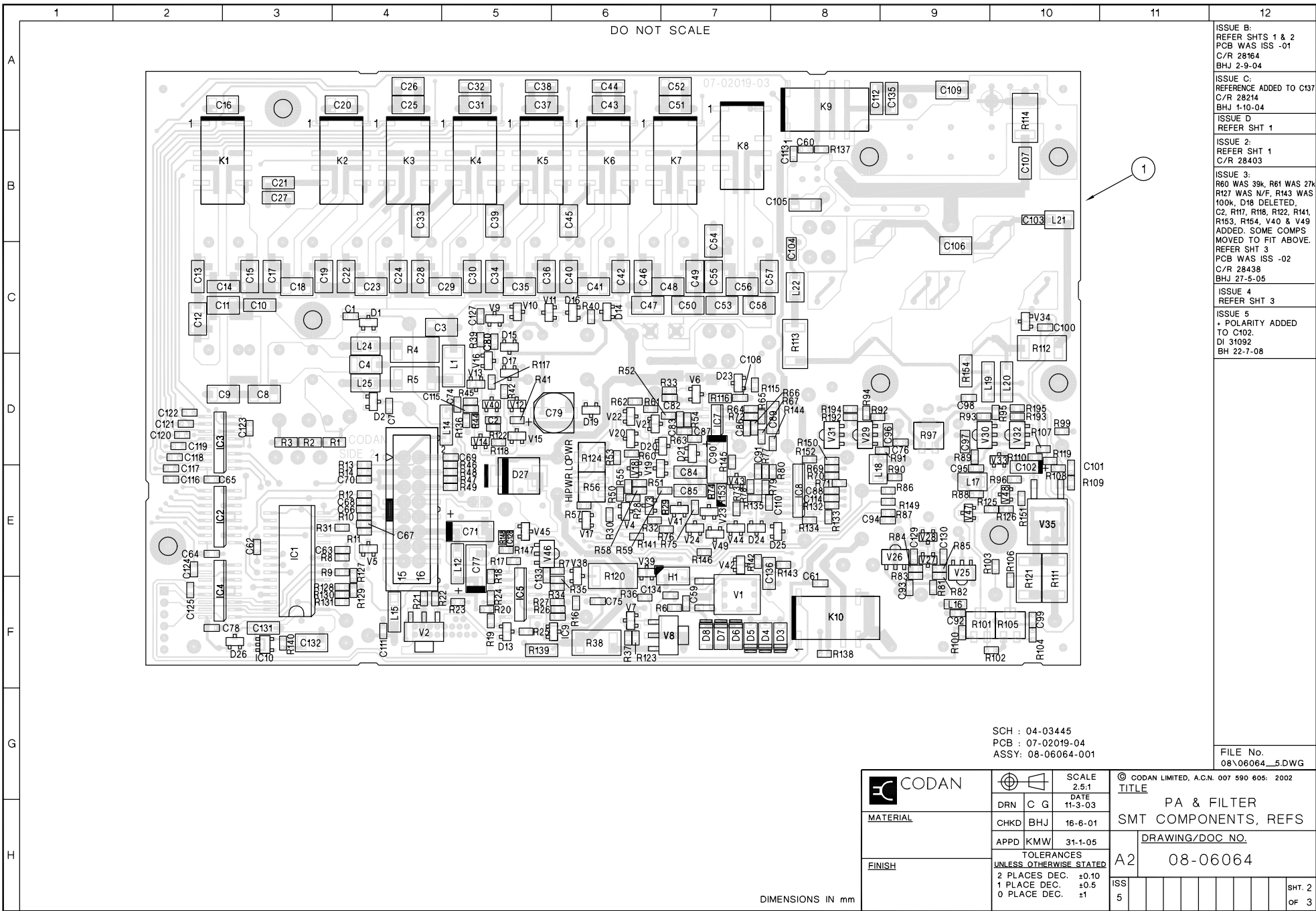

ISSUE B:
REFER SHTS 1 & 2
PCB WAS ISS -01
C/R 28164
BHJ 2-9-04

ISSUE C:
REFERENCE ADDED TO C137
C/R 28214
BHJ 1-10-04

ISSUE D:
REFER SHT 1

ISSUE 2:
REFER SHT 1
C/R 28403

ISSUE 3:
R60 WAS 39K; R61 WAS 27K
R127 WAS 3N/F; R143 WAS
100K; D18 DELETED,
C2, R117, R118, R122, R141,
R153, R154, V40 & V49
ADDED. SOME COMPS
MOVED TO FIT ABOVE.
REFER SHT 3
PCB WAS ISS -02
C/R 28438
BHJ 27-5-05

ISSUE 4:
REFER SHT 3

ISSUE 5:
+ POLARITY ADDED
TO C102,
DI 31092
BH 22-7-08

SCH : 04-03445
PCB : 07-02019-04
ASSY: 08-06064-001

FILE No.
08\06064_5.DWG

	SCALE 2.5:1		© CODAN LIMITED, A.C.N. 007 590 605. 2002 TITLE	
	MATERIAL	DRN C G 11-3-03	PA & FILTER SMT COMPONENTS, REFS	
FINISH	CHKD BHJ 16-6-01	APPD KMW 31-1-05		
	TOLERANCES UNLESS OTHERWISE STATED 2 PLACE DEC. ±0.10 1 PLACE DEC. ±0.5 0 PLACE DEC. ±1		DRAWING/DOC NO. A2 08-06064	
DIMENSIONS IN mm				ISS 5
				SHT. 2 OF 3

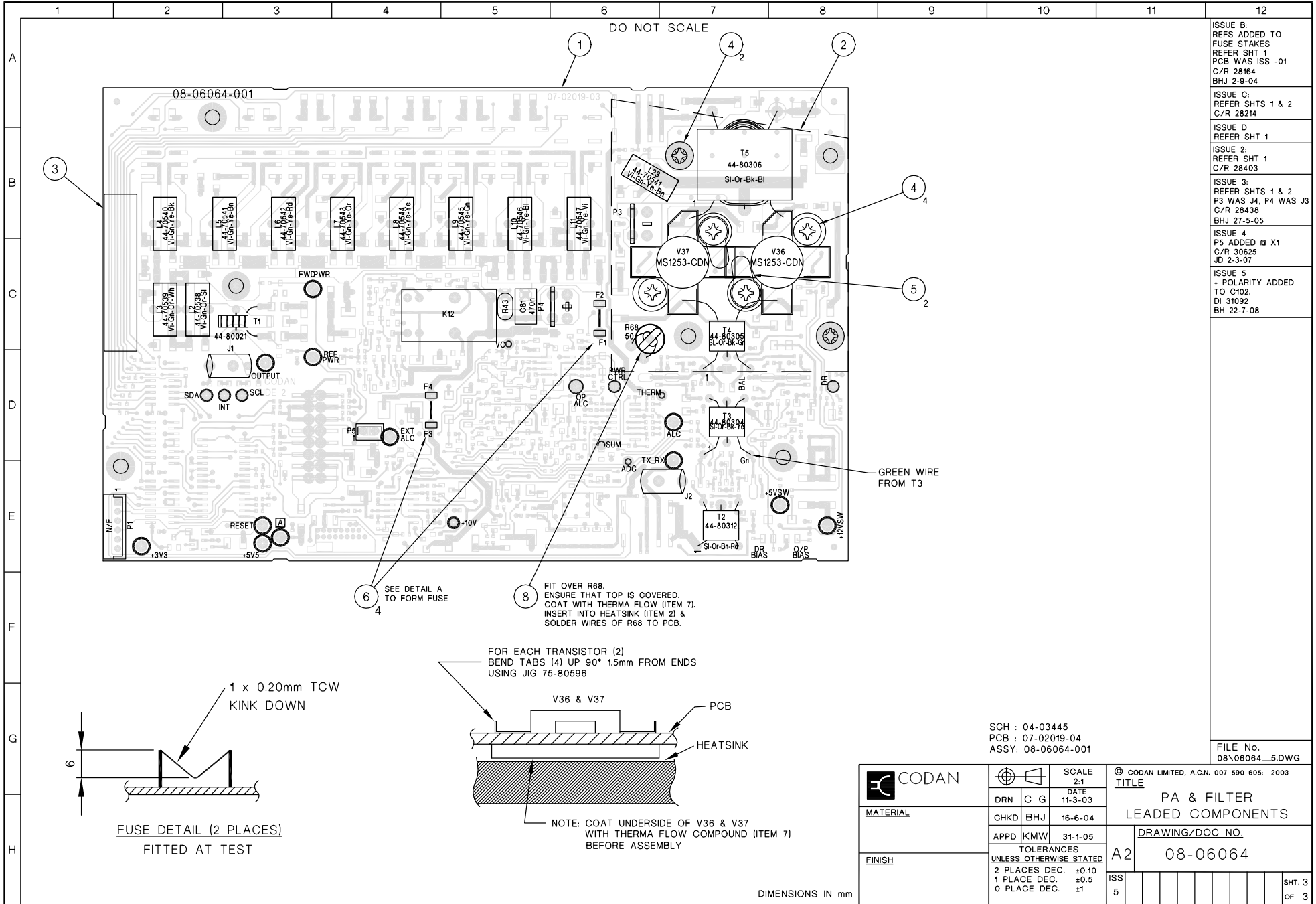

ISSUE B:
REFS ADDED TO FUSE STAKES
REFER SHT 1
PCB WAS ISS -01
C/R 28164
BHJ 2-9-04

ISSUE C:
REFER SHTS 1 & 2
C/R 28214

ISSUE D
REFER SHT 1

ISSUE 2:
REFER SHT 1
C/R 28403

ISSUE 3:
REFER SHTS 1 & 2
P3 WAS J4, P4 WAS J3
C/R 28438
BHJ 27-5-05

ISSUE 4
P5 ADDED X1
C/R 30625
JD 2-3-07

ISSUE 5
+ POLARITY ADDED
TO C102
DI 31092
BH 22-7-08

FILE No.
08-06064_5.DWG

SCH : 04-03445
PCB : 07-02019-04
ASSY: 08-06064-001

	SCALE 2:1		© CODAN LIMITED, A.C.N. 007 590 605: 2003 TITLE PA & FILTER LEADED COMPONENTS
	DRN C G	DATE 11-3-03	
MATERIAL	CHKD BHJ	16-6-04	DRAWING/DOC NO. 08-06064
FINISH	APPD KMW	31-1-05	
TOLERANCES UNLESS OTHERWISE STATED			ISS 5
2 PLACES DEC. ±0.10			
1 PLACE DEC. ±0.5			
0 PLACE DEC. ±1			SHT. 3 OF 3

DIMENSIONS IN mm

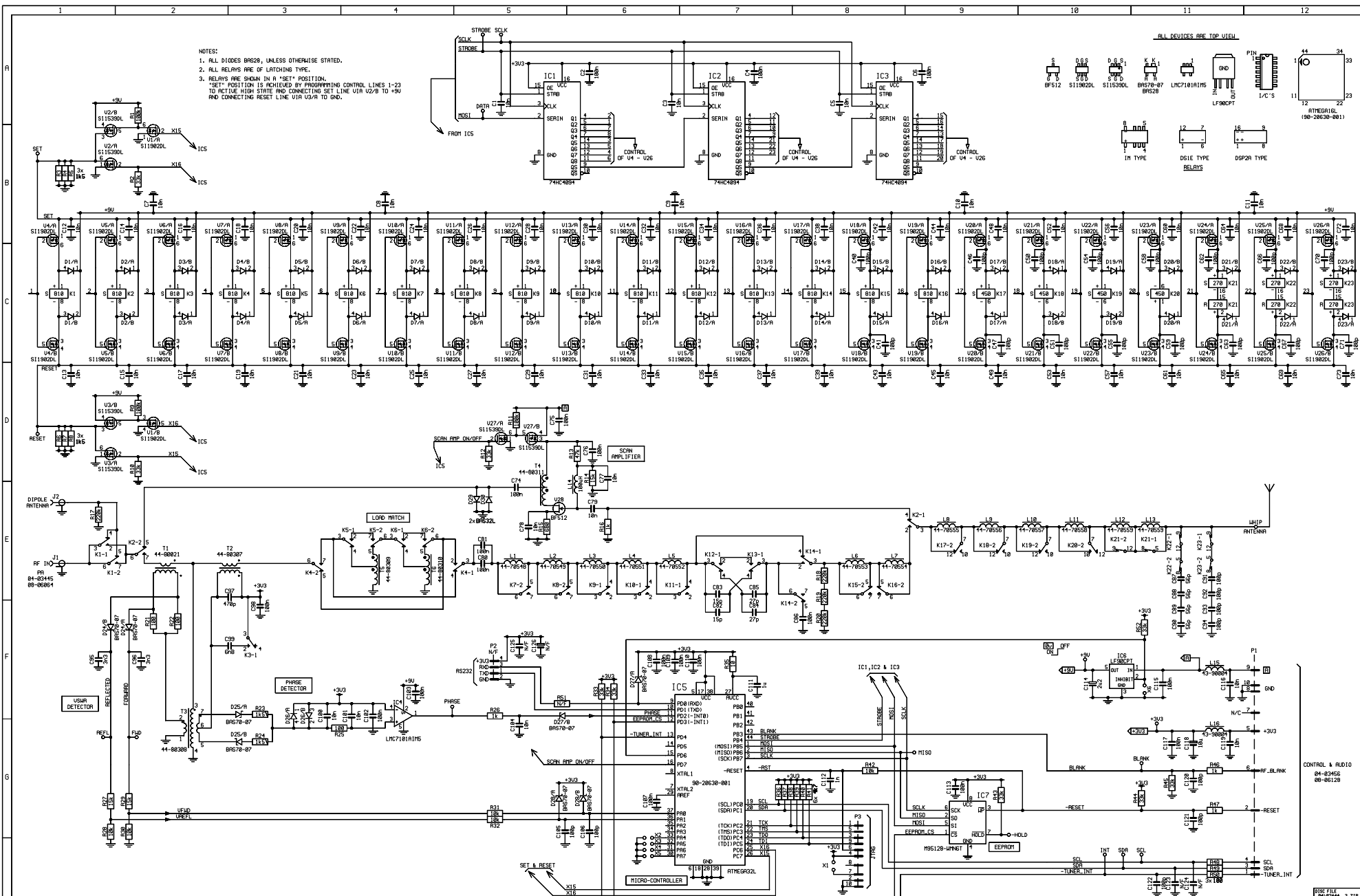

NOTES:
 1. ALL DIODES BR528, UNLESS OTHERWISE STATED.
 2. ALL RELAYS ARE OF LATCHING TYPE.
 3. RELAYS ARE SHOWN IN A "RESET" POSITION.
 "SET" POSITION IS ACHIEVED BY PROGRAMMING CONTROL LINES 1-23 TO ACTIVE HIGH STATE AND CONNECTING SET LINE VIA U2/B TO +3V AND CONNECTING RESET LINE VIA U3/A TO GND.

ALL DEVICES ARE TOP VIEW

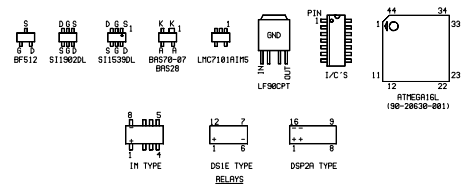

IN TYPE
 DSIE TYPE
 DSP2H TYPE



PCB : 07-03010-03
 ASSY: 00-00630-001

CODAN		ANTENNA TUNER	
DATE	REV	DATE	REV
04-12-04	1	04-12-04	1
DESIGNED BY	APPROVED BY	DATE	REV
		04-12-04	1

ISSUE CHANGE	DATE	BY
1	04-12-04	00-00630-001

DO NOT SCALE

ISSUE 2:
PCB WAS ISS -02
C/R 30247
AML 12-4-06

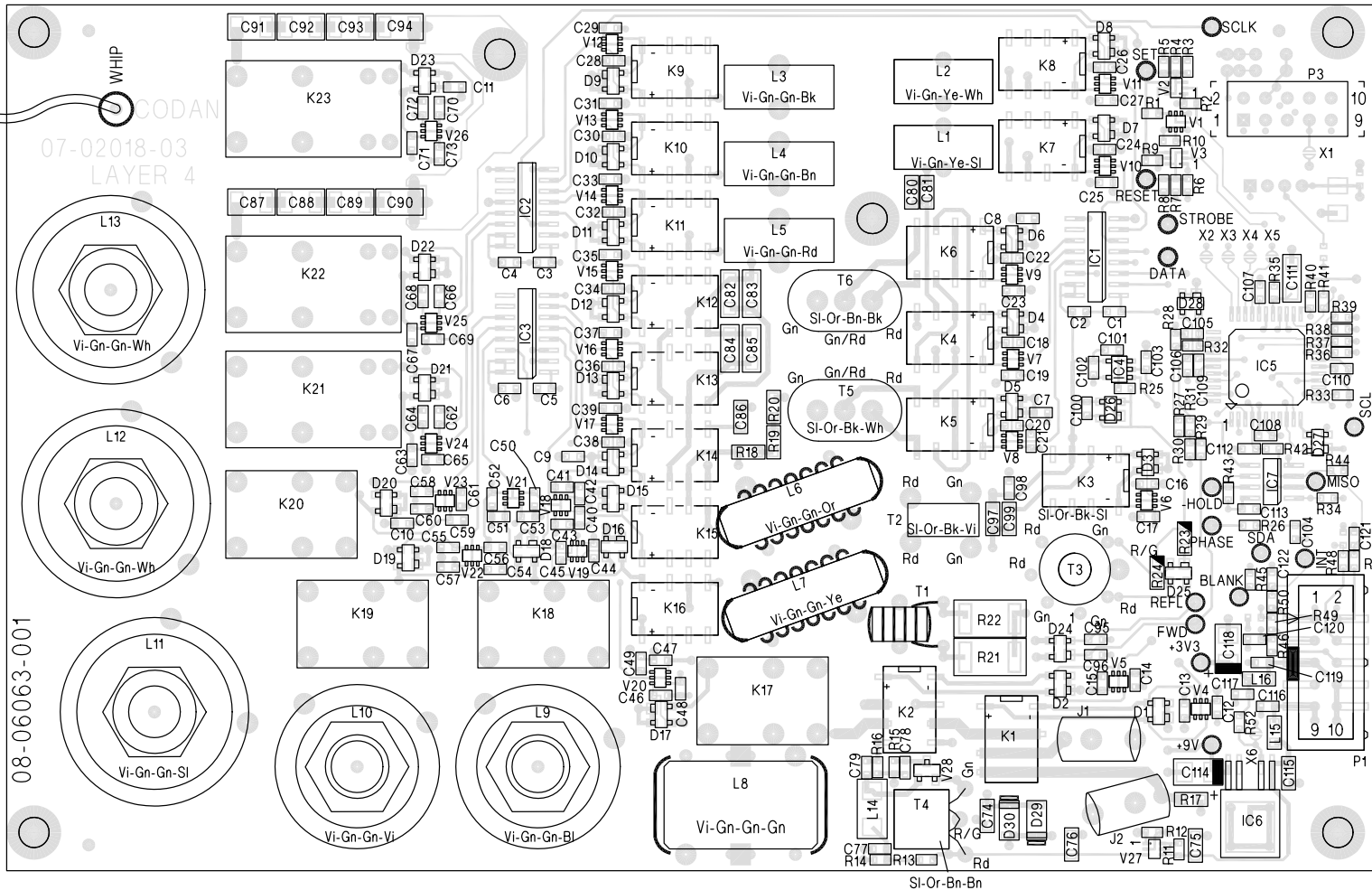

WHIP
CODAN
07-02018-03
LAYER 4

08-06063-001

TSM

FILE Name
08\06063_2.DWG

COMPONENT REFERENCES

SCH : 04-03444
PCB : 07-02018-03
ASSY: 08-06063-001

DIMENSIONS IN mm

	SCALE	2:1
DRN	C G	DATE
CHKD	J D	16-6-04
APPD	KMW	15-12-04
TOLERANCES UNLESS OTHERWISE SPECIFIED		
LINEAR		
ANGULAR		
FLATNESS		
ROUGHNESS (umRa)		

	© CODAN LIMITED, A.C.N. 007 590 605:2003 The information contained herein is proprietary to Codan Limited, and is to be used by the recipient solely for the purpose for which it is supplied. Codan does not permit the recipient to copy, adapt, publish or disclose the information to third parties except as otherwise agreed with Codan in writing.	
	TITLE	A3 ANTENNA TUNER PCB
ISS	DRAWING/DOC NO.	08-06063
SHT.	1	OF 1

RF/IF
(04-03439)

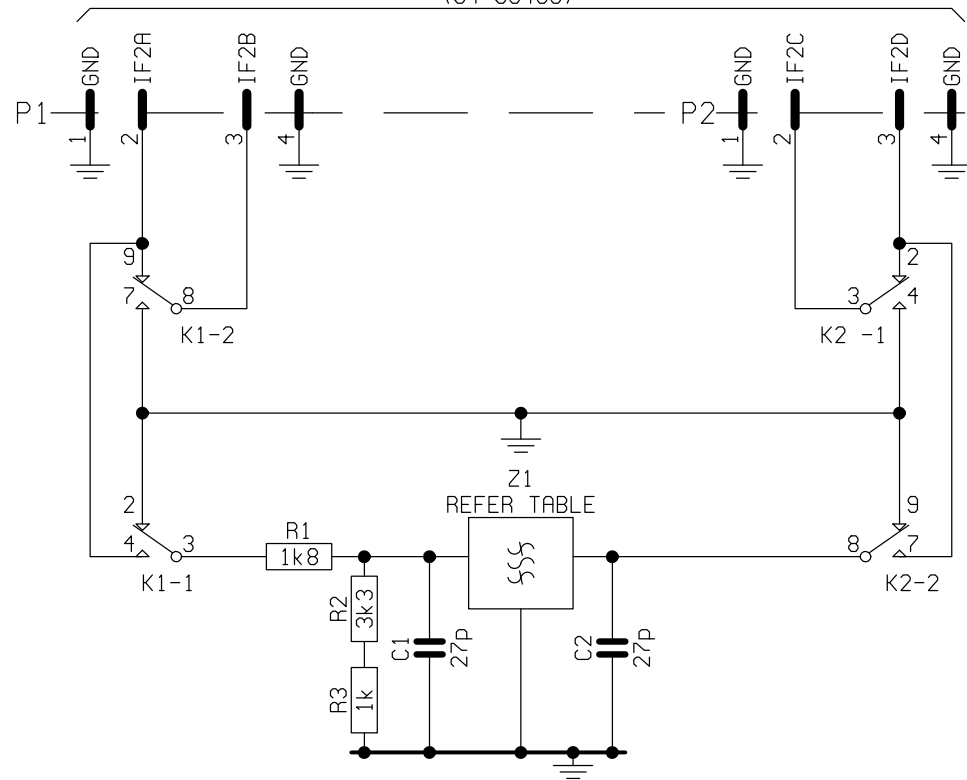

DEVICES ARE SHOWN TOP VIEW

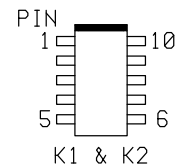

ASSEMBLY	Z1		Fc
	MANUF PART No	CODAN PART No	
08-06044-001	526-8693-010	65-91118	500Hz
08-06044-002	526-8759-010	65-91123	2700Hz
08-06044-003	526-8711-020	65-91125	3000Hz

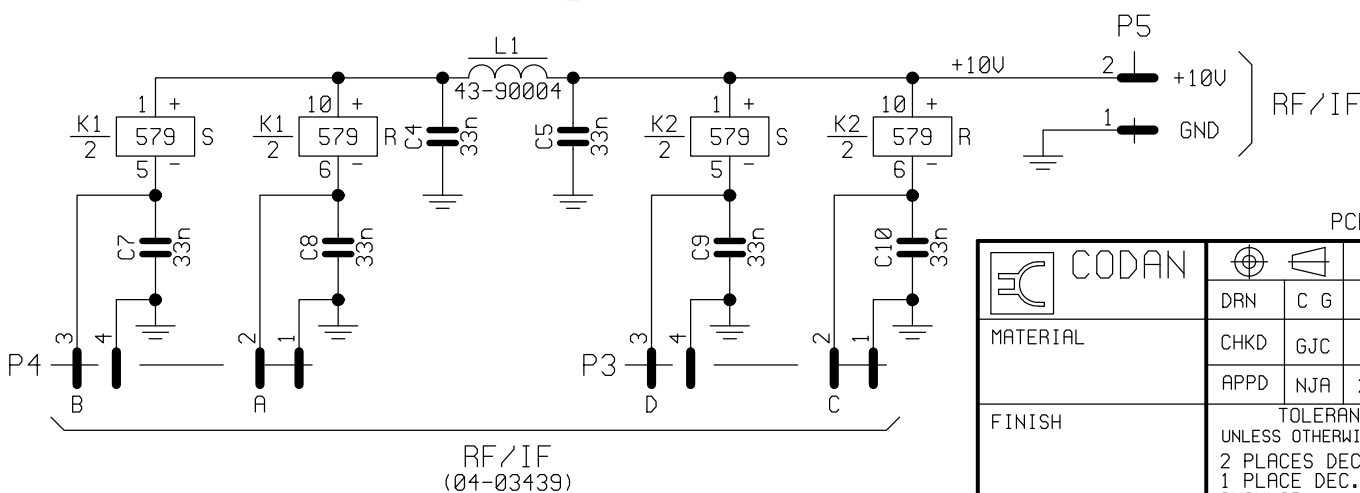

RF/IF
(04-03439)

ISSUE CHANGE

ISSUE 1:
LETTERS A,B,C & D
ADDED TO P3 & P4
PINS
C/R 28336
GCohen 21-12-04

ISSUE 2:
VARIANT TABLE
MODIFIED. VAR
-003 ADDED.
TITLE CHANGED.
C/R 28690
GB 05-10-05

FILE NAME
04\03442...2.ZIP

PCB : 07-02016-01

		SCALE	© CODAN LIMITED, A.C.N. 007 590 605, 2002	
	DRN	C G	DATE	TITLE
MATERIAL	CHKD	GJC	28-9-04	FILTER, SWITCH
FINISH	APPD	NJA	21-12-04	DRAWING/DOC.NO
	TOLERANCES UNLESS OTHERWISE STATED			A3
2 PLACES DEC. ±			ISS	SHT 1
1 PLACE DEC. ±				
ANGULAR ±			2	OF 1

DO NOT SCALE

ISSUE 2:
 ASSY VARIANT TABLE
 MODIFIED. -003 VARIANT
 ADDED. TITLE CHANGED
 C/R 28690
 GB 05-10-05

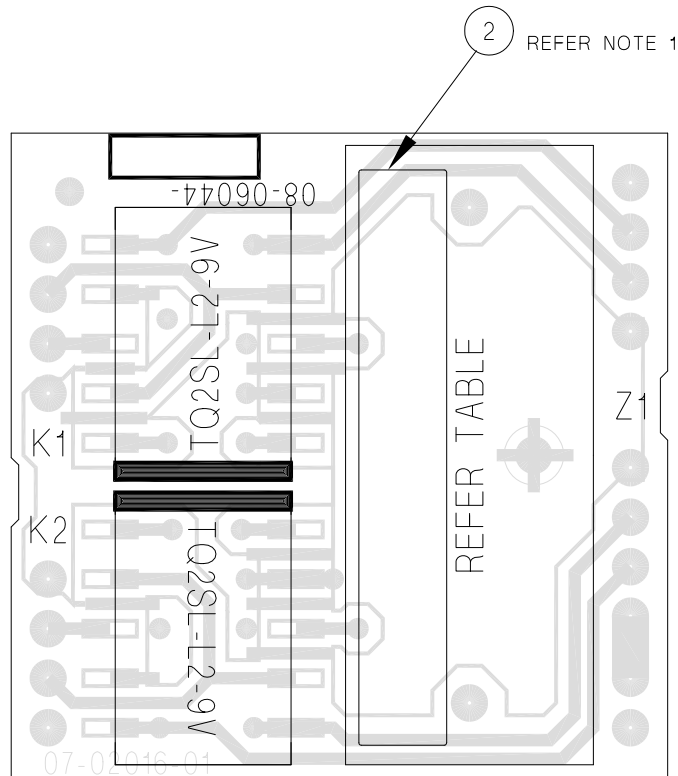

TOP (SIDE 2) COMPONENTS
 SURFACE MOUNT & LEADED
 VALUES & REFERENCES

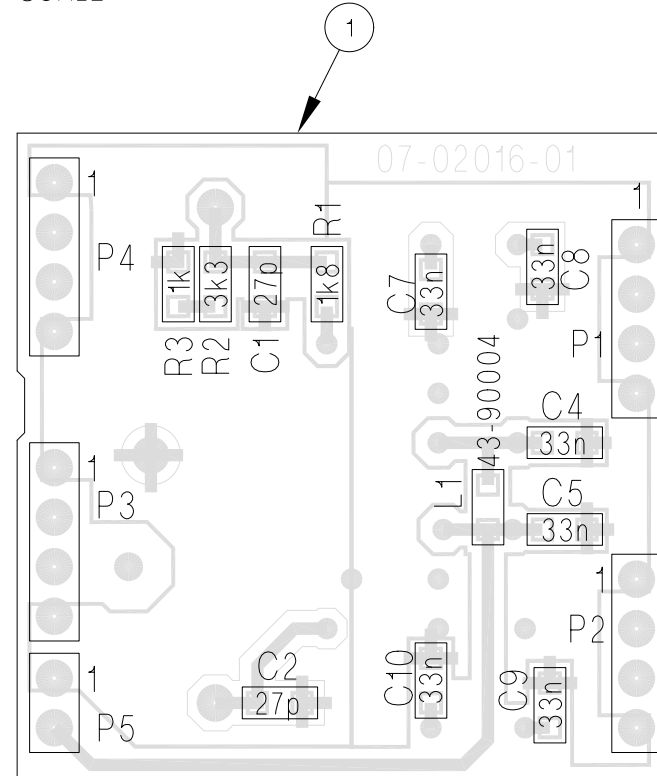

BOTTOM (SIDE 1) COMPONENTS
 SURFACE MOUNT & LEADED
 VALUES & REFERENCES

NOTES:

1. PLACE LABEL (ITEM 2) ON TOP OF Z1.

SCH : 04-03442
 PCB : 07-02016-01

ASSEMBLY	Z1		Fc
	MANUF PART No.	CODAN PART No.	
08-06044-001	526-8693-010	65-91118	500Hz
08-06044-002	526-8759-010	65-91123	2700Hz
08-06044-003	526-8711-020	65-91125	3000Hz

DIMENSIONS IN mm

FILE Name
 08\06044_2.DWG

		SCALE 4:1		© CODAN LIMITED, A.C.N. 007 590 605:2004 The information contained herein is proprietary to Codan Limited, and is to be used by the recipient solely for the purpose for which it is supplied. Codan does not permit the recipient to copy, adapt, publish or disclose the information to third parties except as otherwise agreed with Codan in writing.
DRN	C G	DATE 10-3-04		
CHKD	GJC	28-9-04	CODAN	TITLE FILTER, SWITCH
APPD	KMW	31-1-05		
TOLERANCES UNLESS OTHERWISE SPECIFIED			A3	ISS 2
LINEAR		±0.25		
ANGULAR		±2°		
FLATNESS ROUGHNESS		(µmRa)		
DRAWING/DOC NO. 08-06044			SHT. 1 OF 1	

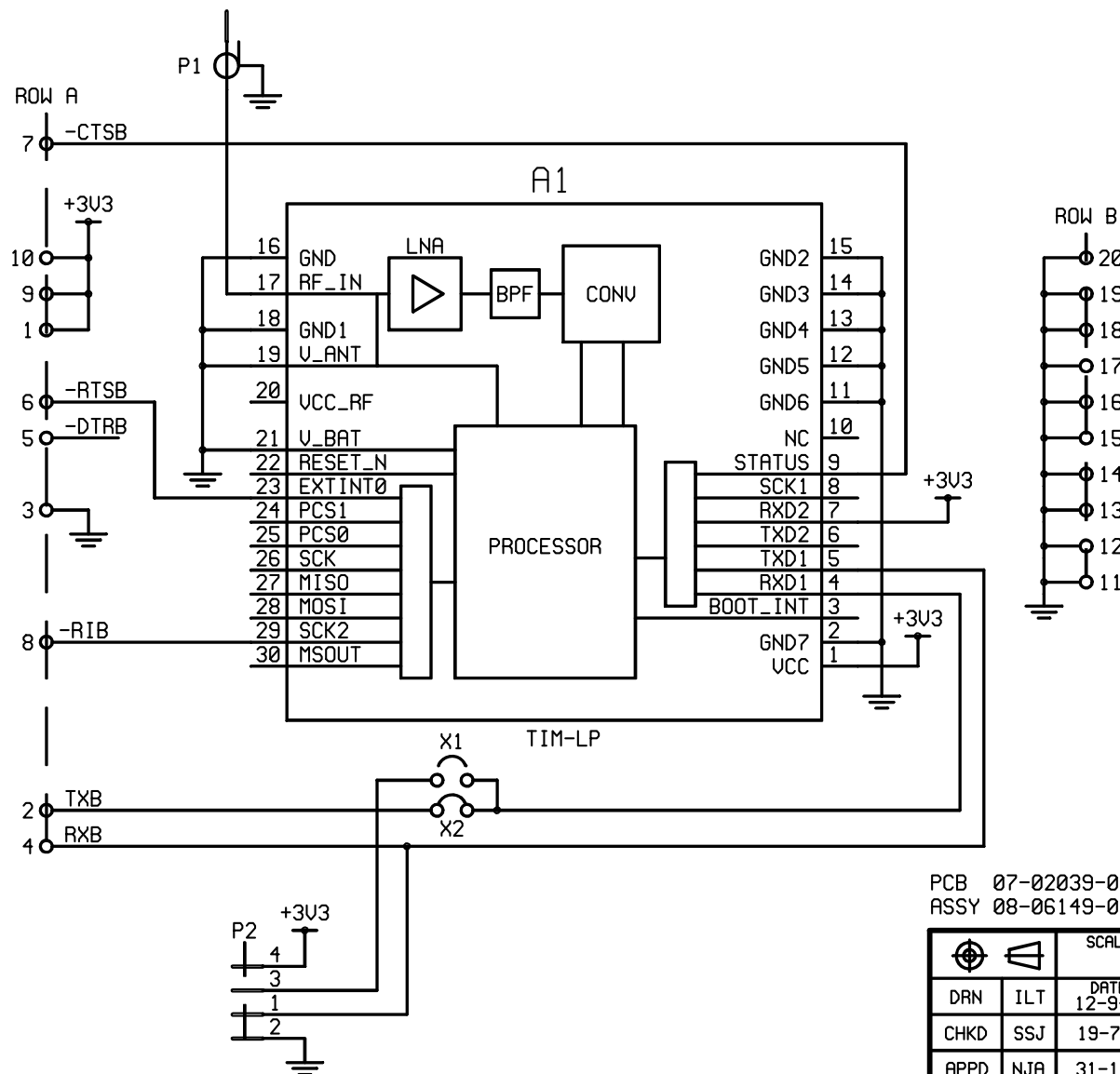

PCB 07-02039-01
 ASSY 08-06149-001

FILE NAME
 04\03488_1.SCH

SCALE			© CODAN LIMITED, ACN 007 590 605, 2003 The information contained herein is proprietary to Codan Ltd, and is to be used by the recipient solely for the purposes for which it is supplied. Codan does not permit the recipient to copy, adapt, publish or disclose the information to third parties except as otherwise agreed with Codan in writing.	
DRN	ILT		DATE	12-9-03
CHKD	SSJ	19-7-04		
APPD	NJA	31-1-05		
TOLERANCES UNLESS OTHERWISE STATED LINEAR ±0.2 ANGULAR ±0.5 FLATNESS ±0.2 ROUGHNESS 1.6 (umRa)			TITLE GPS RECEIVER	
ISS	DRAWING/DOC. NO		SHT 1	
1	04-03488		OF 1	

DO NOT SCALE

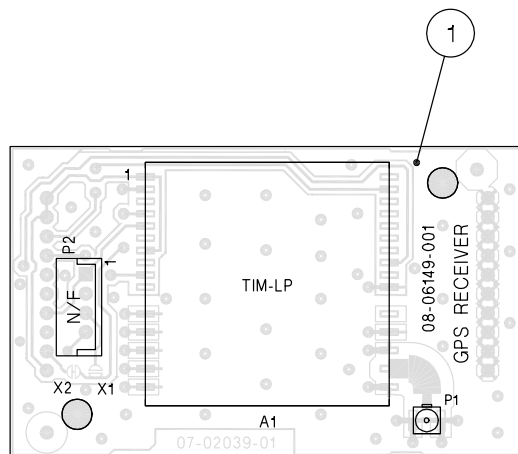

SCH 04-03488
 PCB 07-02039-01
 ASSY 08-06149-001

DIMENSIONS IN mm
 FILE Name 08\06149_1.DWG

			SCALE 2:1	© CODAN LIMITED, A.C.N. 007 590 605: 2004 The information contained herein is proprietary to Codan Limited, and is to be used by the recipient solely for the purpose for which it is supplied. Codan does not permit the recipient to copy, adapt, publish or disclose the information to third parties except as otherwise agreed with Codan in writing.
	DRN	ILT	DATE 22-3-04	
MATERIAL	CHKD	SSJ	19-7-04	TITLE CMR GPS RECEIVER PCB
FINISH	APPD	KMW	31-1-05	
	TOLERANCES UNLESS OTHERWISE SPECIFIED			A 4 ISS DRAWING/DOC NO. 1 08-06149
	LINEAR ±0.25			
	ANGULAR ±2°			
FLATNESS ±0.2				
ROUGHNESS 1.6 (umRa)			SHT. 1 OF 1	

DO NOT SCALE

POSITION GPS ANTENNA, ITEM 2,
AGAINST PCB FACES INDICATED
& SOLDER IN POSITION, REFER DETAIL

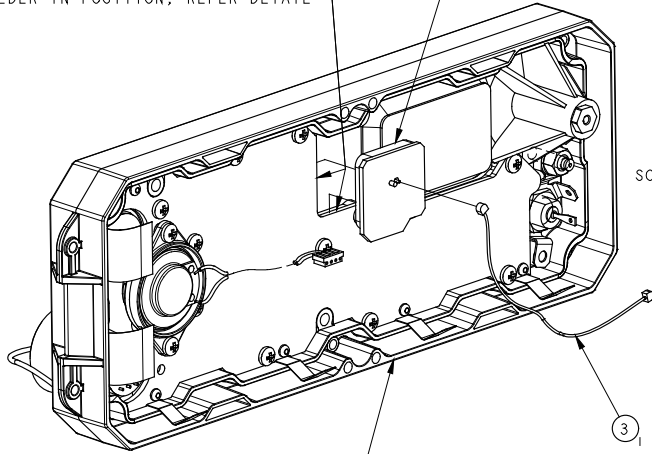

PANEL, FRONT
08-06161

STEP 1

SOLDER ALONG FULL LENGTH
OF SIDES AS INDICATED

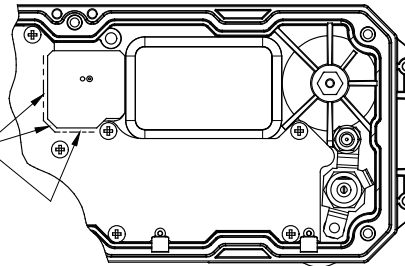

SOLDER DETAIL
GPS ANTENNA, ITEM 2

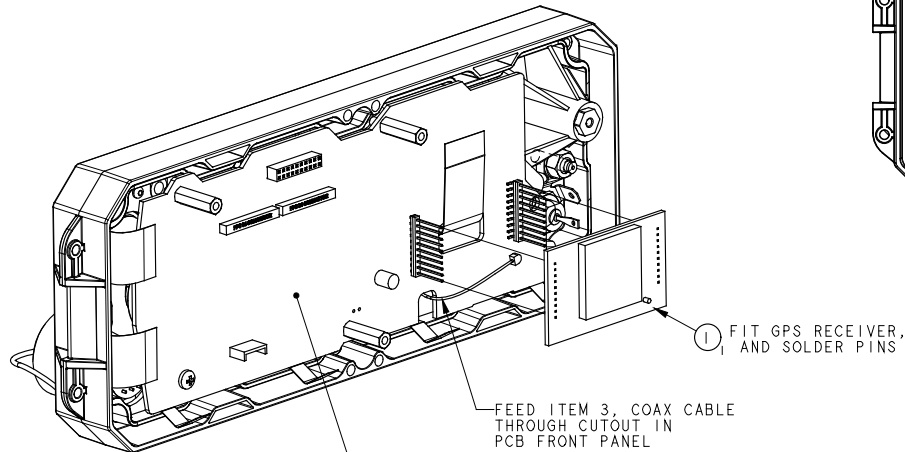

1 FIT GPS RECEIVER,
AND SOLDER PINS

FEED ITEM 3, COAX CABLE
THROUGH CUTOUT IN
PCB FRONT PANEL

ASSEMBLE PCB, FRONT PANEL
REFER FINAL SSEMBLY,
08-06155

STEP 2

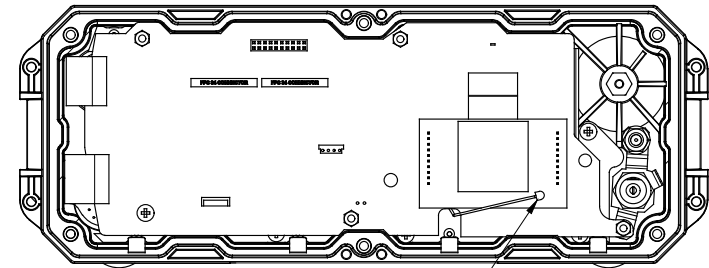

STEP 3

ATTACH ITEM 3, COAX CABLE
TO PLUG ON ITEM 1, GPS PCB

NOTES:

1. REFER ALSO 2110 FINAL ASSEMBLY, 08-06155

0.2 x 45°	R0.2 max			SCALE 1:1	<p>©CODAN LIMITED, ACN 007 590 605: 2004 The information contained herein is proprietary to Codan Limited, and is to be used by the recipient solely for the purpose for which it is supplied. Codan does not permit the recipient to copy, adapt, publish or disclose the information to third parties except as otherwise agreed with Codan in writing.</p>		
DRN	GS	10-08-2004	DATE	A2			
MATERIAL	CHKD	SSJ	01-09-2004	APPD	AJC	03-02-2005	TITLE OPT GPS Rcvr, 2110 (INT FIT)
FINISH	TOLERANCES UNLESS OTHERWISE SPECIFIED			ISS		DRAWING/DOC No.	SHT.1 OF 1
	LINEAR	± 0.2		115-10525-001			
	ANGULAR	± 0.5°					
	FLATNESS	± 0.2					
	ROUGHNESS	1.6 µmRa					

DIMENSIONS IN mm

1 2 3 4 5 6 7 8 9 10 11 12

DO NOT SCALE

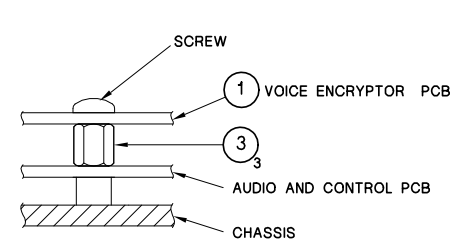

TYP MOUNTING DETAIL A
3 PLACES

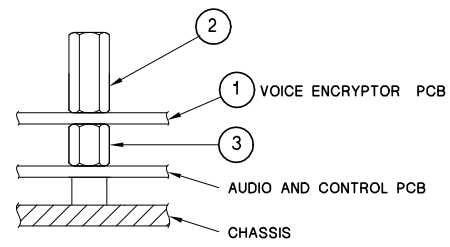

MOUNTING DETAIL B
1 PLACE

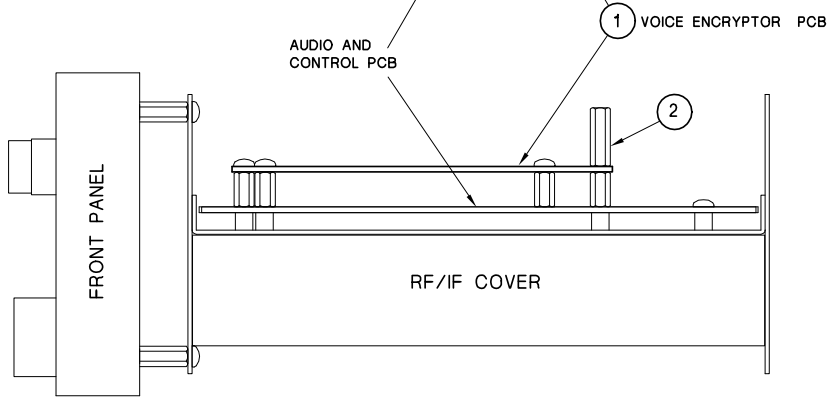
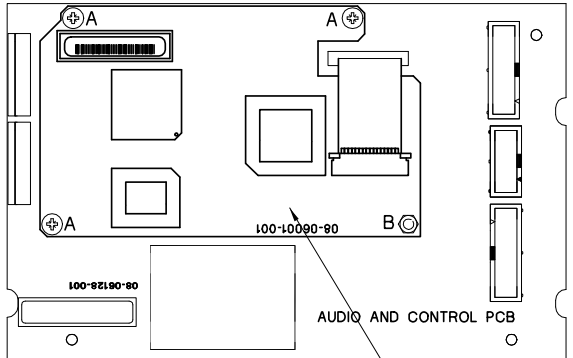

NOTES:

1. REMOVE AND KEEP 4 MACHINE SCREWS HOLDING THE AUDIO AND CONTROL PCB IN PLACE, REPLACE WITH 4 x STUDED SPACERS (ITEM 3).
2. LOCATE ENCRYPTOR BOARD ONTO AUDIO AND CONTROL BOARD. INSERT AND LATCH ENCRYPTOR INTERCONNECT CABLE.
3. SECURE ENCRYPTOR BOARD WITH 3 x MACHINE SCREWS.
4. SECURE ENCRYPTOR PCB WITH 1 x 12mm SPACER (ITEM 2).

ITEM	DESCRIPTION	P/No	QTY
1	VOICE ENCRYPTOR PCB	08-06001-001	1
2	SPACER, THREADED HEX WITH STUD	30-37007-007	1
3	SPACER, THREADED HEX WITH STUD	30-37007-011	4

FILE No.
15\ 10531_1.DWG

	SCALE 1:1 DRN ILT DATE 20-10-04 CHKD SSJ 17-11-04	© CODAN LIMITED, A.C.N. 007 590 605: 2001 TITLE 2110 VOICE ENCRYPTOR INSTALLATION DETAIL
	APPD KMW 31-1-05 TOLERANCES UNLESS OTHERWISE STATED 2 PLACES DEC. ±0.10 1 PLACE DEC. ±0.5 0 PLACE DEC. ±1	DRAWING/DOC NO. A2 15-10531-001
DIMENSIONS IN mm		SHT. 1 OF 1

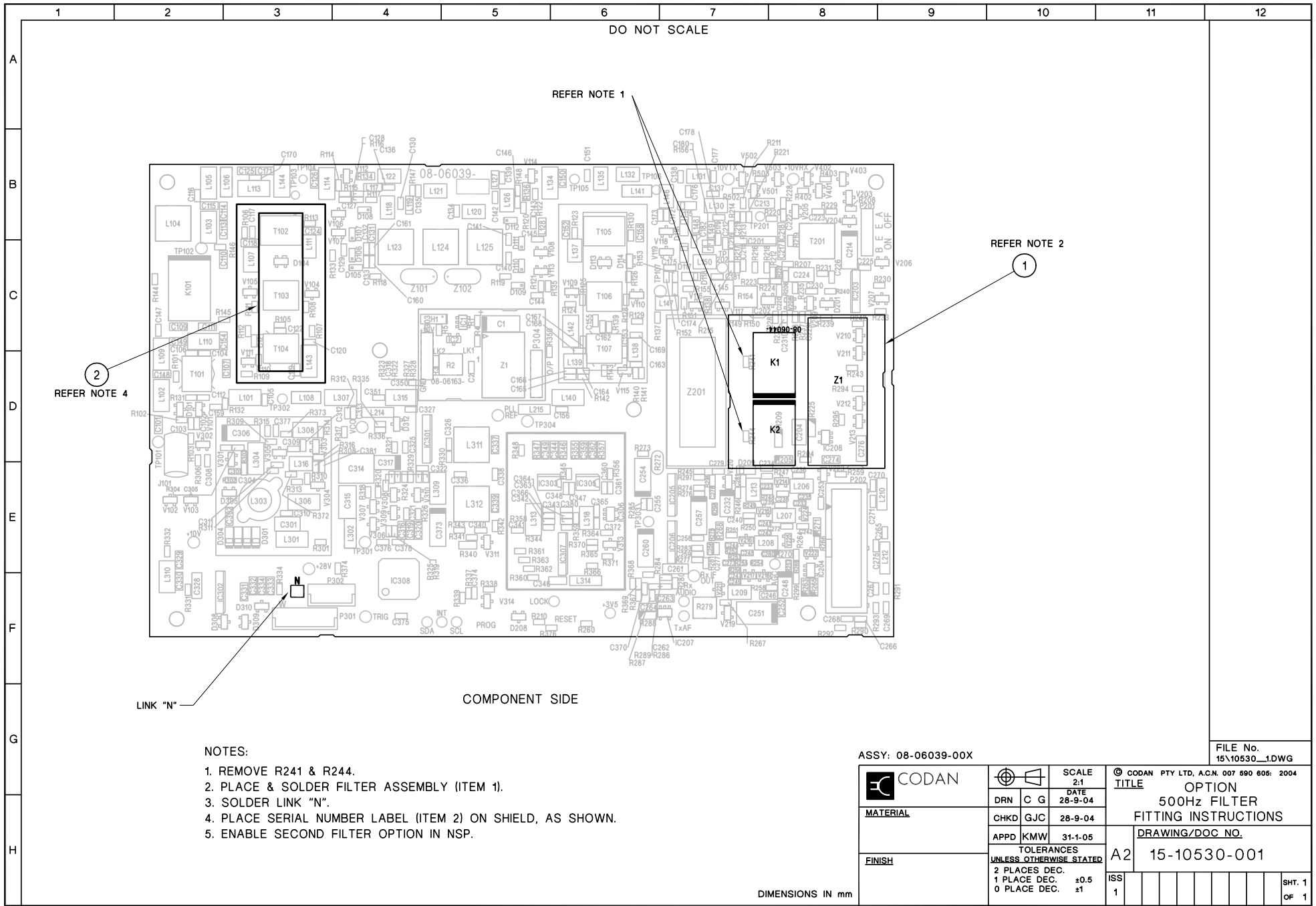

NOTES:

1. REMOVE R241 & R244.
2. PLACE & SOLDER FILTER ASSEMBLY (ITEM 1).
3. SOLDER LINK "N".
4. PLACE SERIAL NUMBER LABEL (ITEM 2) ON SHIELD, AS SHOWN.
5. ENABLE SECOND FILTER OPTION IN NSP.

ASSY: 08-06039-00X

FILE No.
15\10530_1.DWG

		SCALE 2:1	© CODAN PTY LTD, A.C.N. 007 590 605: 2004	
	DRN C G	DATE 28-9-04	TITLE OPTION 500Hz FILTER	
MATERIAL		CHKD GJC	DATE 28-9-04	FITTING INSTRUCTIONS
FINISH		APPD KMW	DATE 31-1-05	DRAWING/DOC NO.
TOLERANCES UNLESS OTHERWISE STATED			A2	15-10530-001
2 PLACES DEC.			ISS	SHT. 1 OF 1
1 PLACE DEC. ±0.5				
0 PLACE DEC. ±1				

DIMENSIONS IN mm

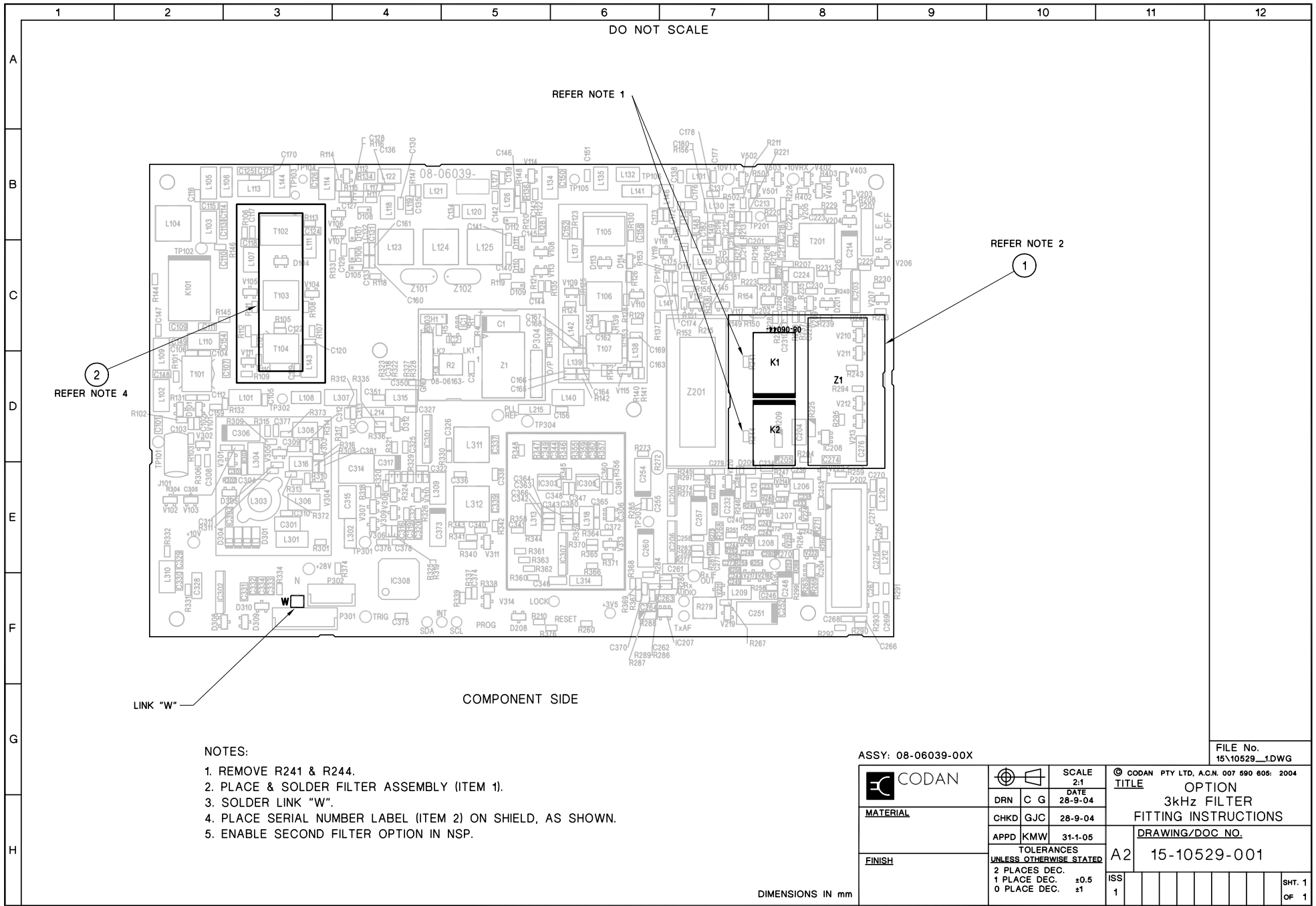

DO NOT SCALE

REFER NOTE 1

REFER NOTE 2

REFER NOTE 4

LINK "W"

COMPONENT SIDE

- NOTES:
1. REMOVE R241 & R244.
 2. PLACE & SOLDER FILTER ASSEMBLY (ITEM 1).
 3. SOLDER LINK "W".
 4. PLACE SERIAL NUMBER LABEL (ITEM 2) ON SHIELD, AS SHOWN.
 5. ENABLE SECOND FILTER OPTION IN NSP.

ASSY: 08-06039-00X

FILE No.
15\10529_1.DWG

			SCALE 2:1	© CODAN PTY LTD, A.C.N. 007 590 605: 2004 TITLE OPTION 3kHz FILTER FITTING INSTRUCTIONS	
	DRN	C G	DATE 28-9-04		
MATERIAL		CHKD	GJC	28-9-04	DRAWING/DOC NO.
FINISH		APPD	KMW	31-1-05	
TOLERANCES UNLESS OTHERWISE STATED				A2	15-10529-001
2 PLACES DEC. ±0.5 1 PLACE DEC. ±0.5 0 PLACE DEC. ±1					
DIMENSIONS IN mm					ISS
					1
					SHT. 1 OF 1

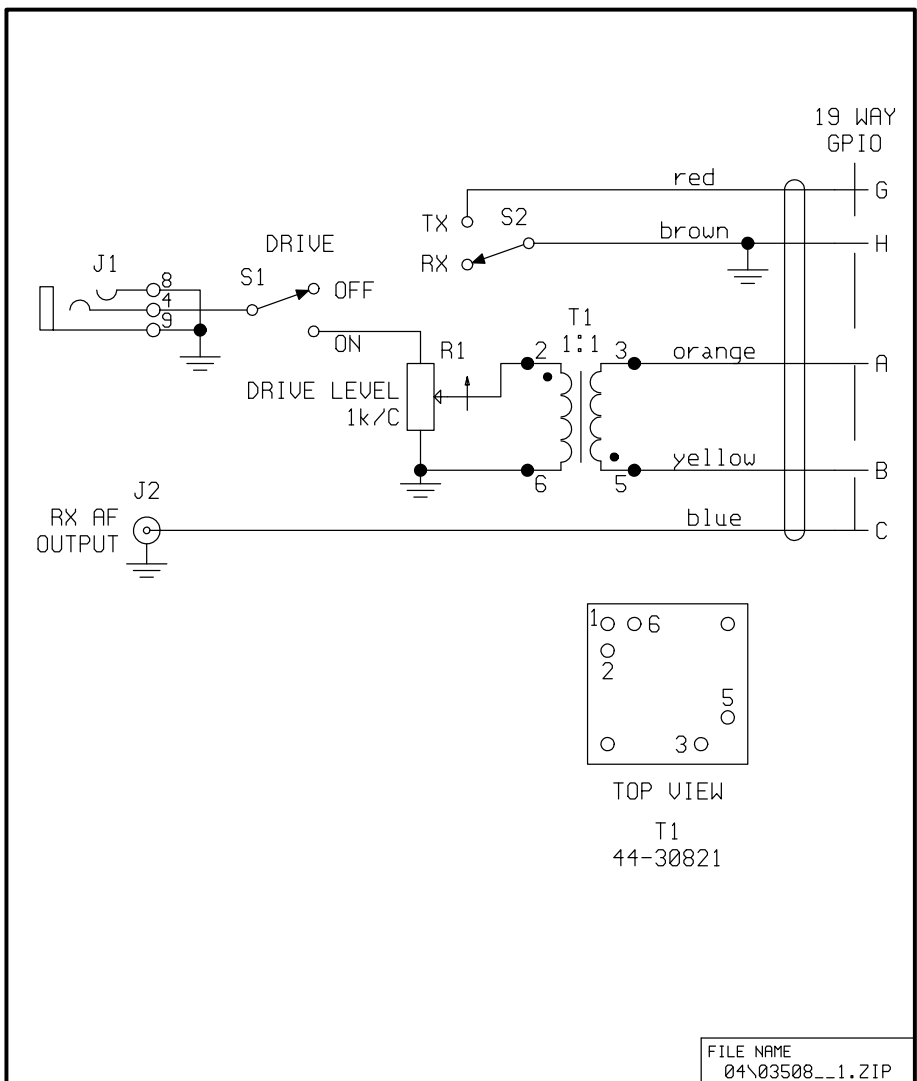

FILE NAME
04\03508__1.ZIP

		SCALE	<p>© CODAN LIMITED, ACN 007 590 605, 2004</p> <p>The information contained herein is proprietary to Codan Ltd, and is to be used by the recipient solely for the purpose for which it is supplied. Codan does not permit the recipient to copy, adapt, publish or disclose the information to third parties except as otherwise agreed with Codan in writing.</p>
DRN	DOW	DATE	
CHKD	GC	28-09-04	
APPD	NJA	29-09-04	
<p>TOLERANCES UNLESS OTHERWISE STATED</p> <p>LINEAR ±0.2</p> <p>ANGULAR ±0.5</p> <p>FLATNESS ±0.2</p> <p>ROUGHNESS 1.6 (umRa)</p>			<p>CODAN</p> <p>TITLE</p> <p>A4 TRANSCEIVER TEST UNIT</p>
ISS	DRAWING/DOC. NO		SHT 1
1	04-03508		OF 1

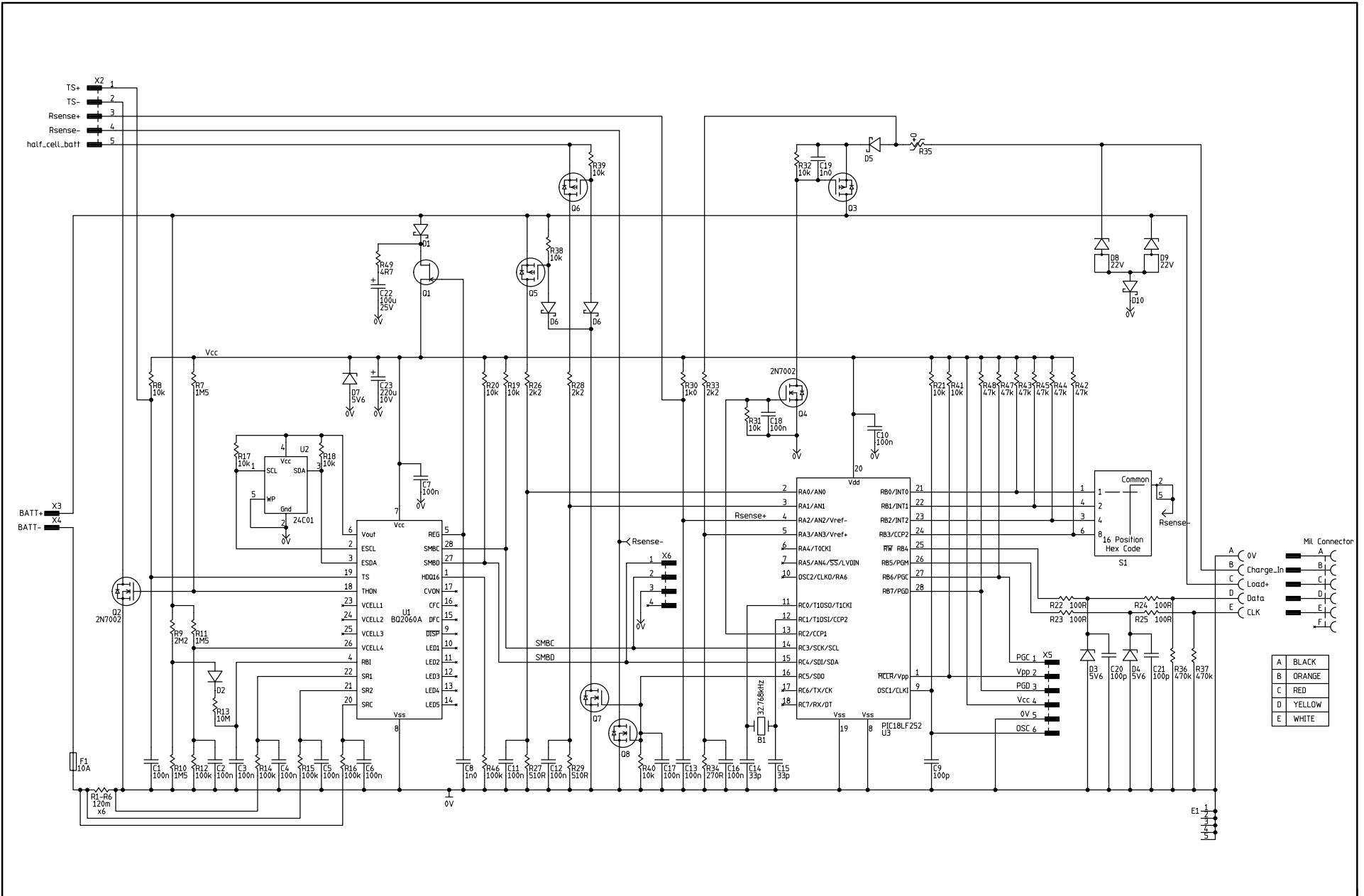

© SETEC PTY LTD 2003

SETEC PTY. LTD.				
TITLE: CMR-SBP Main PCB				
DRAWN: DSR	DATE: 29-June-2004	REV: 5	SHEET: 1 of 1	SIZE: A3

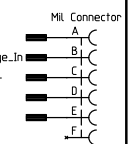

A	BLACK
B	ORANGE
C	RED
D	YELLOW
E	WHITE

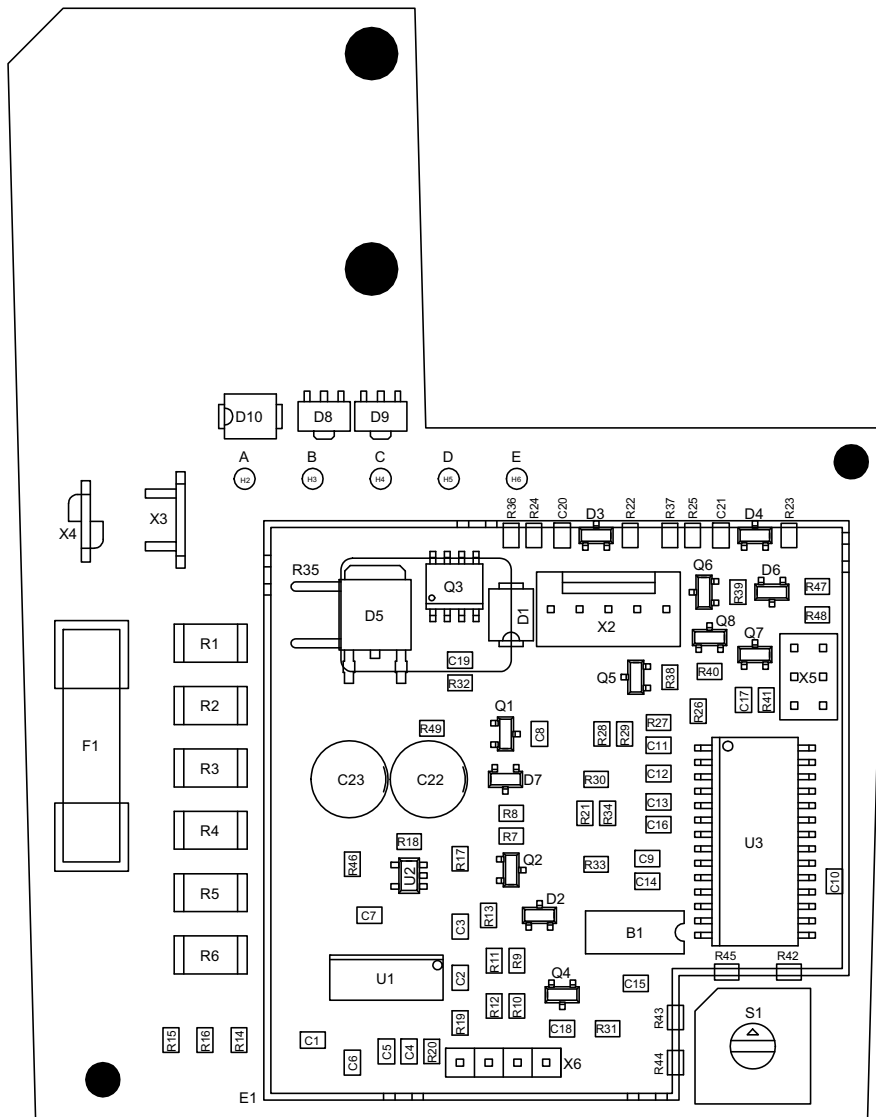

(C) SETEC PTY LTD 2004

SETEC PTY. LTD.		
BOARD:	CMR-SBP PCB MAIN	PART NO: 5321 REV: 5
DESCRIPTION:	REFERENCE DESIGNATORS, TOP SIDE	DATE: 01 Jul 2004

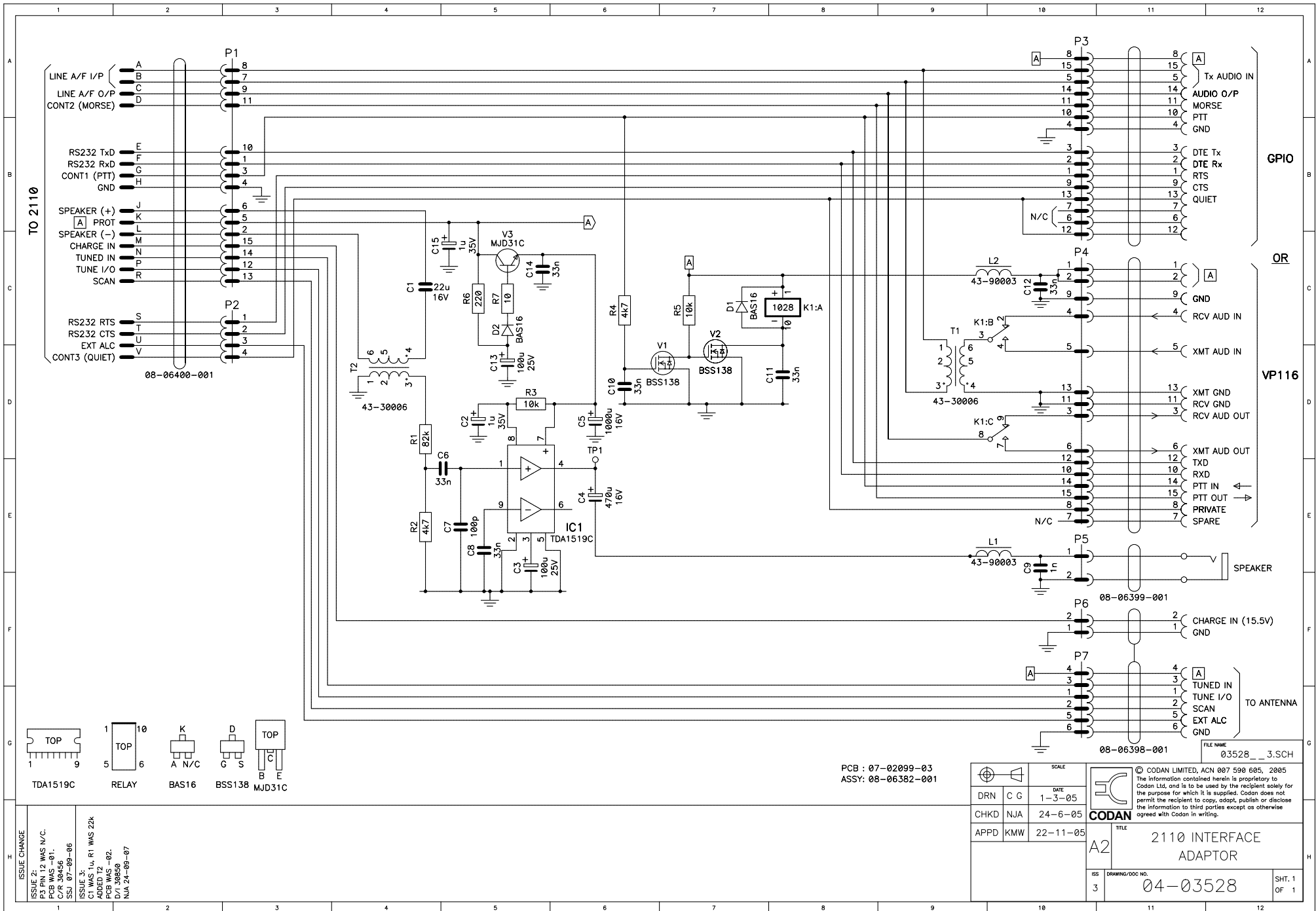

PCB : 07-02099-03
 ASSY: 08-06382-001

DRN	C G	DATE	1-3-05
CHKD	NJA	DATE	24-6-05
APPD	KMW	DATE	22-11-05

SCALE: 1-3-05

CODAN

TITLE: 2110 INTERFACE ADAPTOR

ISS: 3 DRAWING/DOC NO. 04-03528

FILE NAME: 08-06398-001_3.SCH

SHT. 1 OF 1

ISSUE CHANGE

ISSUE 2:
 P3 PIN 12 WAS N/C.
 PCB WAS 01.
 SSA 07-09-06

ISSUE 3:
 C1 WAS 1u. R1 WAS 22k
 ADDED T2
 PCB WAS -02.
 D/1.36850
 NJA 24-09-07

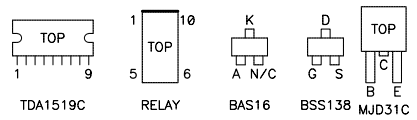

TO 2110

GPIO

OR

VP116

TO ANTENNA

TO 2110

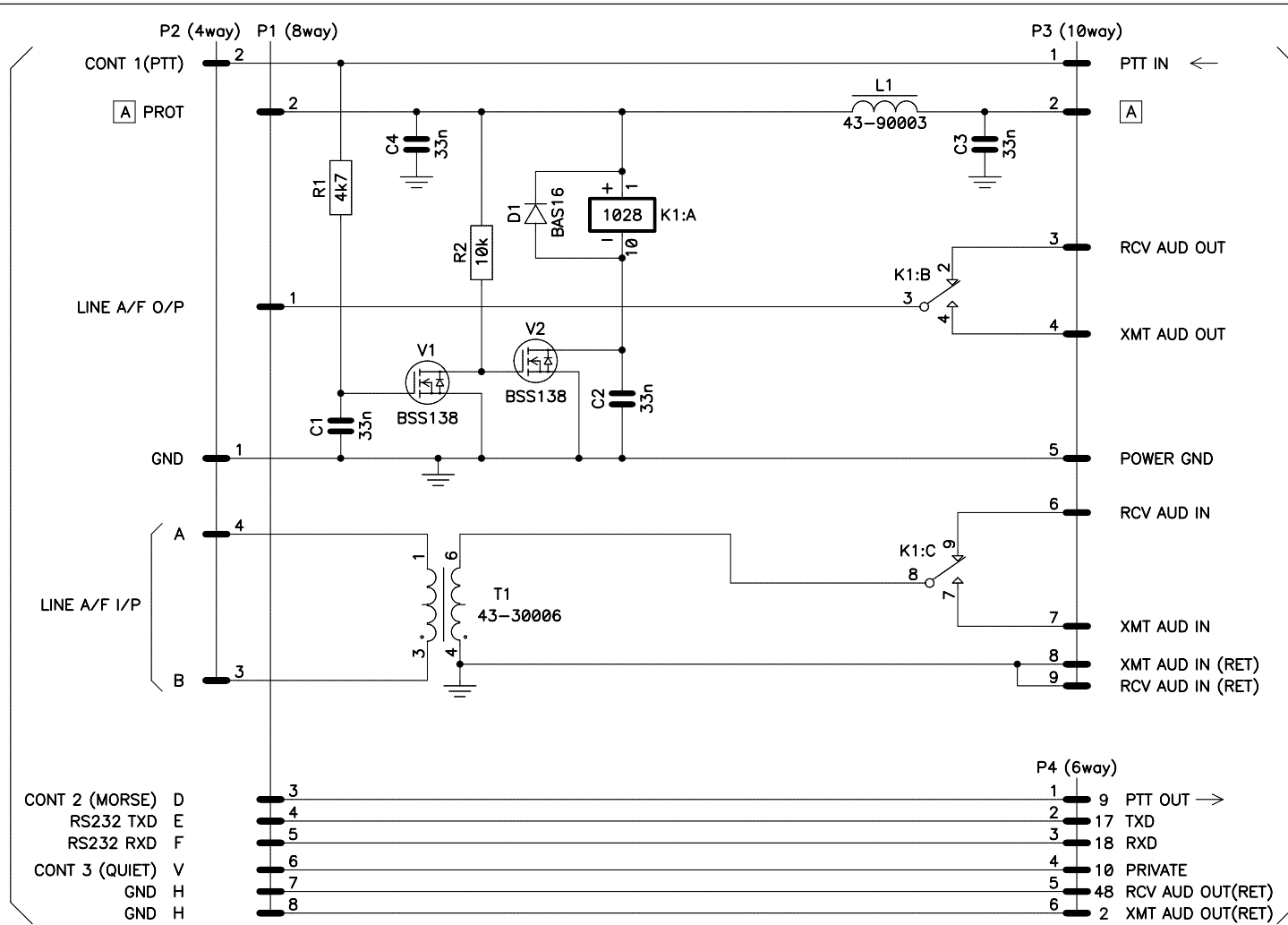

VP116

CONT 2 (MORSE) D
 RS232 TXD E
 RS232 RXD F
 CONT 3 (QUIET) V
 GND H
 GND H

FILE NAME
 03531_1.SCH

TOP VIEW

 BSS138

PCB 07-02102-01
 ASSY 08-06421-001

DRN		ILT	DATE	<p>© CODAN LIMITED, ACN 007 590 605, 2005 The information contained herein is proprietary to Codan Ltd, and is to be used by the recipient solely for the purpose for which it is supplied. Codan does not permit the recipient to copy, adapt, publish or disclose the information to third parties except as otherwise agreed with Codan in writing.</p>
CHKD		PM	5-05-05	
APPD		NJA	21-02-06	
			09-01-07	TITLE A3 VP116 - 2110 INTERFACE
ISS	DRAWING/DOC NO.		SHT. 1	
1	04-03531		OF 1	

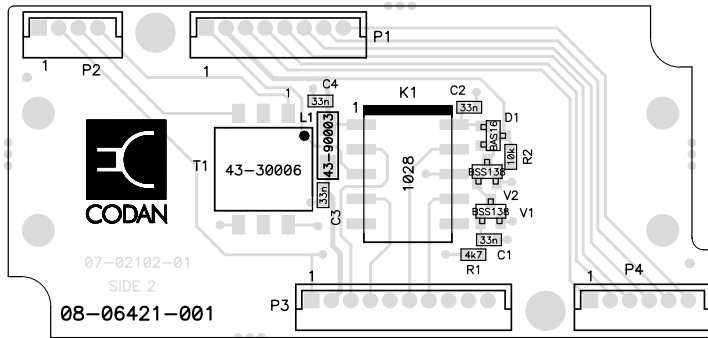

FILE NAME
02102_1.pcb

		SCALE 2:1		© CODAN LTD. ACN 007 590 605; 2005 The information contained herein is proprietary to Codan Limited, and is to be used by the recipient solely for the purpose for which it is supplied. Codan does not permit the recipient to copy, adapt, publish or disclose the information to third parties except as otherwise agreed with Codan in writing.	
DRN	ILT	DATE 6-12-05			
CHKD	PM	29-3-06		TITLE	
APPD	HB	09-01-07		A4	VP116 - 2110
TOLERANCES UNLESS OTHERWISE STATED LINEAR ANGULAR			ISS 1	DRAWING/DOC NO. 08-06421	
				SHT 1 OF 2	

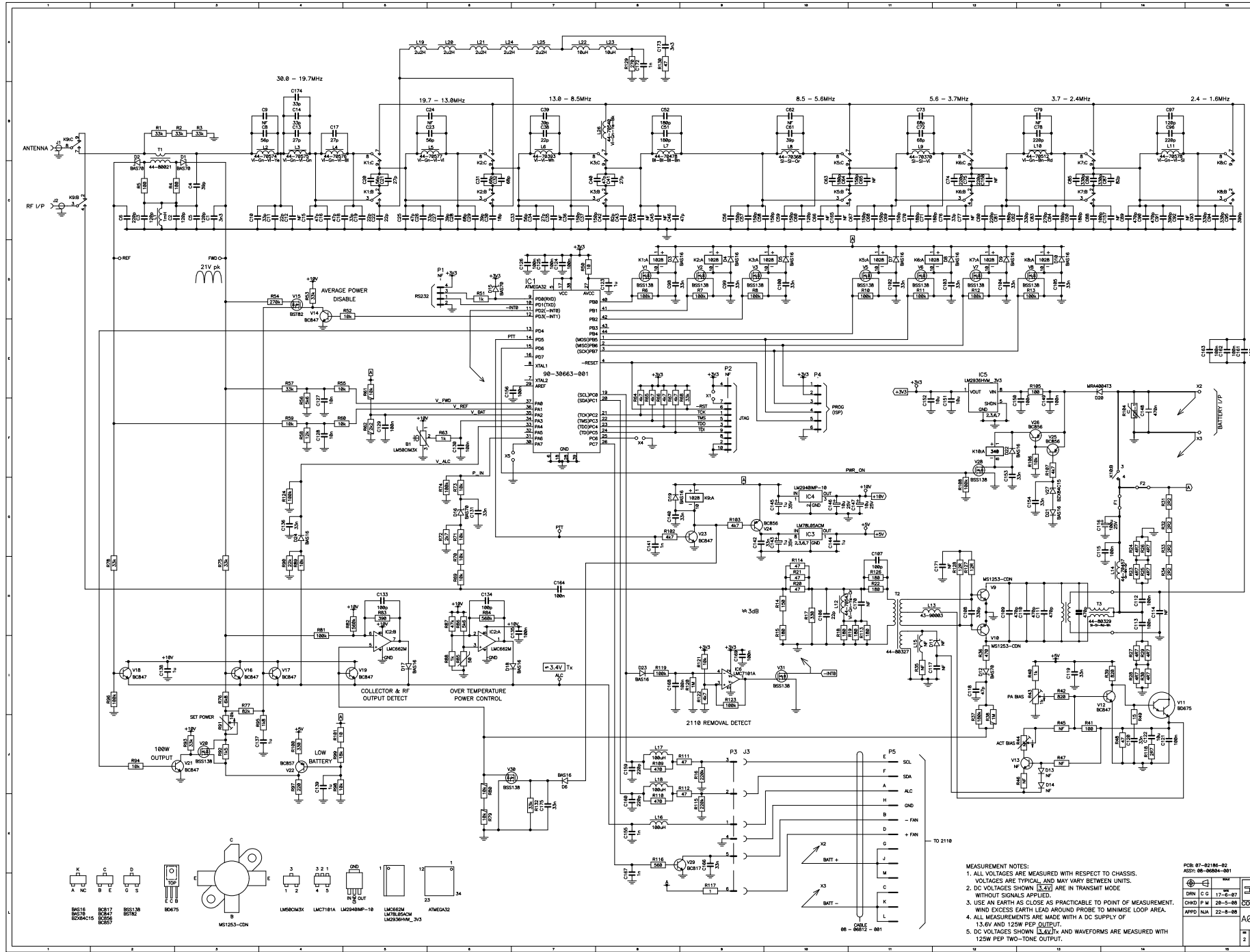

ISSUE 2:
 C127,128 were 100nF
 R97 was 330R
 R99 was 10k
 R100 was 100R
 R101 was 1k2
 R118 was 2R2
 T3 was 44-80277
 C171 was 100nF
 Title re "125W" removed
 DI 31124
 P.M. 21-8-08

- MEASUREMENT NOTES:
1. ALL VOLTAGES ARE MEASURED WITH RESPECT TO CHASSIS. VOLTAGES ARE TYPICAL, AND MAY VARY BETWEEN UNITS.
 2. DC VOLTAGES SHOWN IN SET ARE IN TRANSMIT MODE WITHOUT SIGNALS APPLIED.
 3. USE AN EARTH AS CLOSE AS PRACTICABLE TO POINT OF MEASUREMENT. WIND EXCESS EARTH LEAD AROUND PROBE TO MINIMIZE LOOP AREA.
 4. ALL MEASUREMENTS ARE MADE WITH A DC SUPPLY OF 13.6V AND 125W PEP OUTPUT.
 5. DC VOLTAGES SHOWN IN SIGNAL AND WAVEFORMS ARE MEASURED WITH 125W PEP TWO-TONE OUTPUT.

PCB: 87-02186-02
 ASSY: 08-00004-001

DRN	C C	17-0-07
CHD	P M	28-5-08
APPD	N A	22-8-08

© CODAN LIMITED, NOV 897 008 846, 1988
 This document is the property of CODAN Limited. It is to be used only for the purposes for which it is issued. It is not to be reproduced, stored in a retrieval system, or transmitted in any form or by any means, electronic, mechanical, photocopying, recording, or by any information storage and retrieval system, without the prior written permission of CODAN Limited.

3168 POWER AMPLIFIER

04-03592

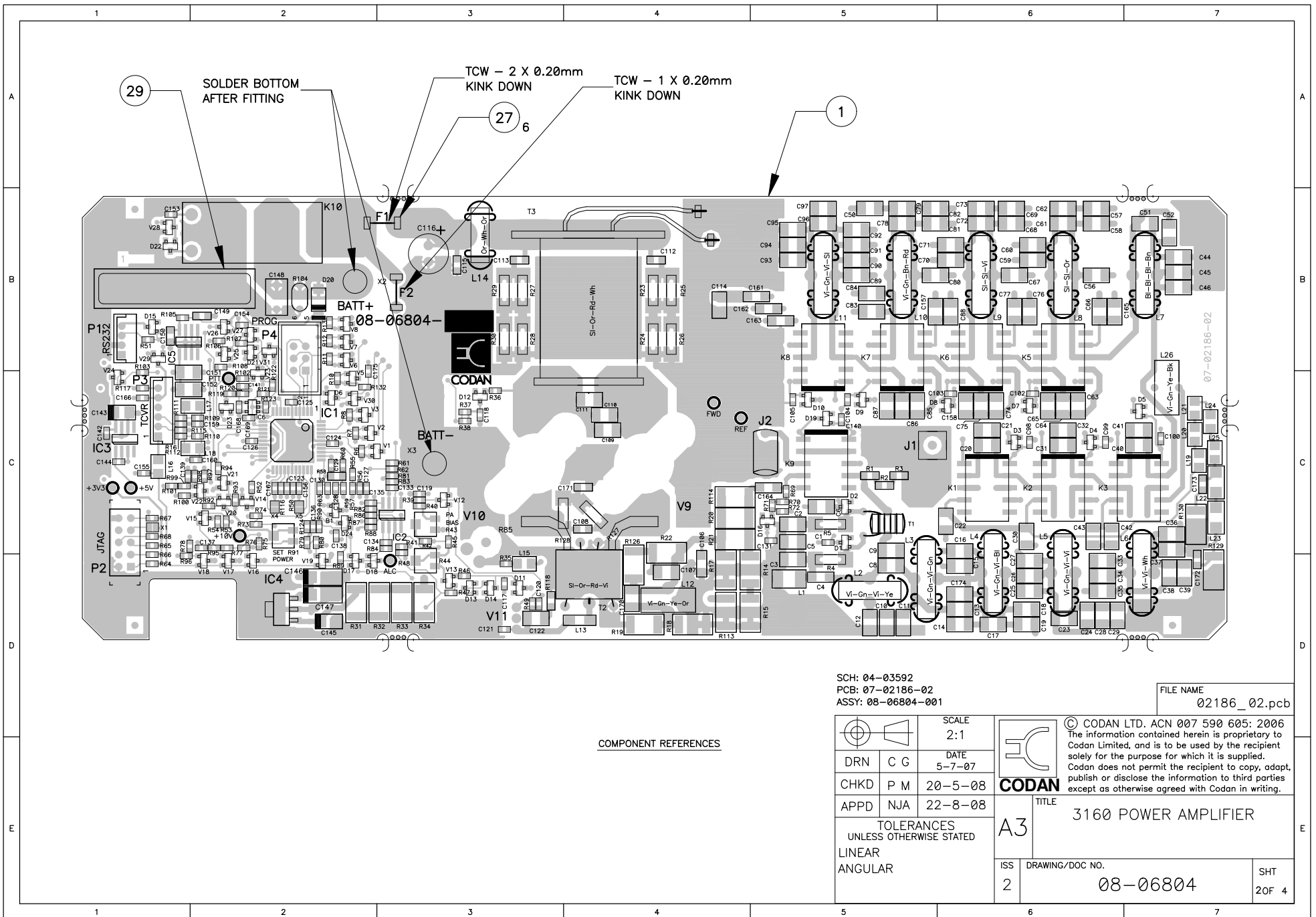

COMPONENT REFERENCES

SCH: 04-03592
 PCB: 07-02186-02
 ASSY: 08-06804-001

FILE NAME
 02186_02.pcb

		SCALE 2:1
		DATE 5-7-07
		20-5-08
TOLERANCES UNLESS OTHERWISE STATED		A3
LINEAR		
ANGULAR		

	© CODAN LTD. ACN 007 590 605: 2006 The information contained herein is proprietary to Codan Limited, and is to be used by the recipient solely for the purpose for which it is supplied. Codan does not permit the recipient to copy, adapt, publish or disclose the information to third parties except as otherwise agreed with Codan in writing.	
	TITLE 3160 POWER AMPLIFIER	
ISS 2	DRAWING/DOC NO. 08-06804	SHT 2 OF 4

