



NGT Transceiver System Technical Service Manual

No part of this manual may be reproduced, transcribed, translated into any language or transmitted in any form whatsoever without the prior written consent of Codan Limited.

© Copyright 1999, 2002, 2003, 2006 Codan Limited

NGT[®], *Easitalk*[®] and CALM[®] are registered trademarks of Codan Limited. Other brand, product and company names mentioned in this document are trademarks or registered trademarks of their respective holders.

Codan part number 15-02063-EN Issue 5, October 2006

The English version takes precedence over any translated versions.



CODAN

www.codan.com.au

Head Office

Codan Limited
ABN 77 007 590 605
81 Graves Street
Newton SA 5074
AUSTRALIA
Telephone +61 8 8305 0311
Facsimile +61 8 8305 0411
asiatech.support@codan.com.au

Codan (UK) Ltd
Gostrey House
Union Road
Farnham Surrey GU9 7PT
UNITED KINGDOM
Telephone +44 1252 717 272
Facsimile +44 1252 717 337
uktech.support@codan.com.au

Codan US, Inc.
8430 Kao Circle
Manassas VA 20110
USA
Telephone +1 703 361 2721
Facsimile +1 703 361 3812
ustech.support@codan.com.au

Index

About this manual

Standards and icons	4
Definitions	5
Acronyms and abbreviations	5
Glossary	11
Circuit reference designations	13
Units	14
Unit multipliers	15
About this issue	16

Compliance

Introduction	18
European Radio and Telecommunications Terminal Equipment Directive	19
Electromagnetic compatibility and safety notices	21
FCC compliance	23
IC certification	24
C-tick approval	24

Maintenance

General	25
CMOS devices	26
Circuit boards	26
Transmitter precautions	28
Probe precautions	28

Contact information

Ordering information

Ordering information	31
Component substitution	32

NGT—Index

NGT—Overview and specifications

Overview	34
Specifications	36
General	36
Receiver	38
Transmitter	39

Pin connections	41
RF unit	41
Junction box (used with 2010 RF Units only)	49
Desk console	53
NGT—Brief description (2010)	
General information	57
Transmit path	59
Handset transmit path	59
Junction box transmit path	59
RF unit transmit path	59
Receive path	60
RF unit receive path	60
Junction box receive path	60
Synthesiser operation	61
Control and switching	61
NGT—Brief description (2011/2012)	
General information	65
Transmit path	66
Handset transmit path	66
RF unit transmit path	66
Receive path	67
RF unit receive path	67
Synthesiser operation	68
Control and switching	68
NGT—Technical description (2010)	
Power on	70
Power off	71
Supply voltages	72
Handset	72
Junction box	72
RF unit	73
Transmit path	75
Handset microphone amplifier transmit path	75
Junction box transmit path	75
Codan Interconnect Bus transmit path	77
RF unit—Audio Interface PCB transmit path	77
RF unit—Application Processor PCB transmit path	78
RF unit—RF/IF PCB transmit path	79
RF unit—PA PCB transmit path	81

Receive path	87
Input low-pass filters	87
Broadcast filter and RF amplifier	87
First mixer	87
45 MHz band-pass filter and amplifier	87
Second mixer	88
Noise limiter	88
455 kHz filter and IF amplifier	89
Automatic gain control	90
Demodulator	91
RF unit—Audio Interface PCB receive path	91
Codan Interconnect Bus receive path	92
Junction box receive path	92
Frequency control	93
Reference oscillator	93
Oven controller	93
Direct digital synthesis	94
VCO and phase lock loop	95
26 V power supply	95
Microprocessors and control	96
Handset microprocessor and control	96
Junction box microprocessor and control	97
RF unit microprocessors and control	98
Desk console	100
Internal voice encryptor	101
Second IF filter option	102

NGT—Technical description (2011/2012)

Power on	104
Power off	105
Supply voltages	106
Handset	106
RF unit	106
Transmit path	109
Handset microphone amplifier transmit path	109
RF unit—Audio & Interconnect PCB (2011)/Audio Interconnect & Data I/O PCB (2012) transmit path	109
RF unit—Application Processor Handset I/F 3 V PCB (2011)/Application Processor Handset & Data I/F PCB (2012) transmit path	110
RF unit—RF/IF PCB transmit path	110
RF unit—PA PCB transmit path	113
Receive path	116

Input low-pass filters	116
Broadcast filter and RF amplifier	116
First mixer	116
45 MHz band-pass filter and amplifier	116
Second mixer	117
Noise limiter	117
455 kHz filter and IF amplifier	117
Automatic gain control	118
Demodulator	119
RF unit—Audio & Interconnect PCB (2011)/Audio Interconnect & Data I/O PCB (2012) receive path	119
Frequency control	121
Reference oscillator	121
Oven controller	121
Direct digital synthesis	121
VCO and phase lock loop	122
26 V power supply	123
Microprocessors and control	124
Handset microprocessor and control	124
RF unit—microprocessors and control	125
Internal voice encryptor	128

NGT—Channel additions

General	130
Options	130
Programming channels	134
Creating a channel	134
Creating a channel with the TxD option	137
Renaming a channel	139
Copying a channel	141
Editing a channel	142
Deleting a channel	144

NGT—Checks and adjustments

Test equipment required	146
Voltage regulators	147
Handset voltages	147
Junction box voltages	147
RF unit voltages	148
Crystal oven	152
Low-pass filters	152
Service mode	153

General	153
Accessing Service mode	154
Returning to Normal mode	158
Testing the keypad and display	159
Adjustment locations and test points	160
Checking the voltage-controlled oscillator	166
Aligning the 45 MHz filters	167
Aligning the Rx filter	167
Aligning the Tx filter	168
Aligning the 455 kHz IF and noise limiter	169
Adjusting the exciter output level	170
Adjusting carrier re-insertion	171
Adjusting the exciter output spurious balance	172
Adjusting frequency	173
Adjusting mute	175
Adjusting the PA	176
Adjusting the driver bias	176
Adjusting high output power	180
Adjusting low output power	182
Adjusting the bias gain	182
Adjusting the active bias	184
Adjusting balance control	185
Checking intermodulation	187
Adjusting the PA gain	189
Checking performance of the receiver	190
Checking the sensitivity and (signal+noise)/noise ratio	190
Checking the AGC	191
Checking the audio output	191
Checking the selectivity	192
Checking the noise limiter	193
Checking performance of the transmitter	194
Checking the transmit frequency	194
Checking the ALC	194
Checking power output and intermodulation	195

NGT—Parts lists

NGT—Drawings

High power—Index

High power—Overview and specifications

Overview	208
Specifications	209
Power amplifier specifications (3061/3062)	209
Power amplifier specifications (TW500/TW1000)	210
Pin connections	211
Power amplifier (3061/3062)	211
HPAC module (used with vendor equipment only)	215
ALC adaptor module (used with vendor equipment only)	217

High power—Brief description

General information	221
Power amplifier (3061/3062)	222
HPAC and ALC adaptor modules with vendor equipment	223

High power—Technical description

LED indications on the NGT	226
3061/3062 power amplifiers	227
Supply voltages	227
Transmit path	228
External high-power systems	231
Supply voltages	231
Transmit path	232

High power—Fault finding and adjustments

General information	236
Fault finding the power amplifiers (3061/3062)	237
Adjusting the power amplifiers (3061/3062)	239
Replacing output transistors	239
Adjusting the amplifier bias	239
Adjusting the bar graph meter	240
Adjusting the amplifier output power	240
Adjusting the ALC bridge	241
Adjusting the power supply frequency	241
Adjusting the power supply operating area	242
Adjusting the input attenuator	242
Adjusting the external high-power amplifier	243

High power—Parts lists

High power—Drawings

NRI—Index

NRI—Overview and specifications

Overview	250
Components in a remote control NGT system.....	250
Specifications	252
General.....	252
Environmental	252
Physical	252
2-wire land line	252
Control points	253
Pin connections.....	254

NRI—Brief description

General information	261
NGT remote interface.....	261
Remote control junction box	262

NRI—Technical description

NRI User Connect PCB	264
NRI Microcontroller PCB	265
NRI Vocoder PCB	267

NRI—Fault finding

PCB and unit replacement	270
PCBs and units available as replacements.....	270
Upgrading the NRI firmware	271
Error messages	272
LED indicators	273
Dismantling the NRI.....	275
Test procedures.....	277

NRI—Parts lists

NRI—Drawings

3012—Index

3012—Overview and specifications

Overview	292
Channel selection.....	292
Types of data transmission	293
Transmission protocol	293
Indicators	294

Specifications	295
General	295
System requirements	296
Environmental	296
Physical	296
Pin connections	297
3012—Brief description	
General information	301
DSP modem	301
Transceiver interface	301
Terminal interface	301
3012—Technical description	
DSP Modem PCB	304
Digital signal processor and CoDec	304
Memory	304
Logic and interfacing	304
Throughput indicator	305
Power supply	305
User Connector PCB	306
Transceiver interface	306
Serial ports	306
3012—Fault finding	
Adjustments and routine maintenance	308
Basic fault finding	309
Advanced fault finding	310
What you need	310
Dismantling the data modem	310
Fault finding the power supply in the data modem	312
Testing the HF subsystem	313
3012—Parts lists	
3012—Drawings	
8571—Index	
8571—Overview and specifications	
Overview	320
Specifications	322
General	322
Environmental	322

Physical	323
Pin connections	324

8571—Brief description

General information	333
Receive audio path	333
Transmit audio path	334
Microprocessor control and signalling	334
Automatic line equalisation	334

8571—Technical description

Backplane and power supply	336
Receive audio path	337
Receive audio from transceiver	337
300 Hz notch filter and audio compressor	337
Receive audio bus and audio gate	338
Line driver and hybrid	338
2-wire interface	338
4-wire interface	339
Transmit audio path	340
2-wire or 4-wire interface	340
Hybrid	340
Gain and equalisation stage	340
Low-pass filter, audio gate and transmit audio bus	341
300 Hz notch filter	342
Transmit audio to split-site interface controller and transceiver	342
Signalling and microprocessor	343
Microcontroller bus	343
Internal I ² C bus	343
300 Hz control tone—generation and detection	344
Signalling modem	345
Signalling format	346
Transceiver control logic	346
RS232 port	346
Automatic equalisation	348
Multi-line capability	350

8571—Fault finding

Dismantling the NGT Split-site Remote Interface 8571	352
Fault finding	353
Voltage measurements	353
No signalling	354
No reception, with signalling	356
No reception, without signalling	357
No transmission, with signalling	359

8571—Parts lists

8571—Drawings

Figure 1:	Relationship of the 2010 RF Unit, 2030 Junction Box, and 2020 Handset	34
Figure 2:	Relationship of the 2011/2012 RF Unit and 2020 Handset	35
Figure 3:	Rear panel of the 2010 RF Unit	41
Figure 4:	Rear panel of the 2011 RF Unit	41
Figure 5:	Rear panel of the 2012 RF Unit	41
Figure 6:	Front view of the CIB connector on the RF unit (2010 only).	42
Figure 7:	Front view of the antenna control connector on the RF unit	43
Figure 8:	Front view of the fan connector on the RF unit	44
Figure 9:	Front view of the 10-way connector on the RF unit (2011/2012 only)	45
Figure 10:	Front view of the 4-way connector on the RF unit (2011/2012 only)	46
Figure 11:	Front view of the 6-way connector on the RF unit (2011/2012 only)	46
Figure 12:	Front view of the handset and speaker connector attached to the RF unit (2011/2012 only).	47
Figure 13:	Front view of the 15-way GPIO connector on the RF unit (2012 only).	48
Figure 14:	Connector panel of the junction box.	49
Figure 15:	Front view of the handset connector on the junction box.	49
Figure 16:	Front view of a CIB connector on the junction box	50
Figure 17:	Front view of the 9-way serial data connector on the junction box	51
Figure 18:	Front view of the 15-way GPIO connector on the junction box.	52
Figure 19:	Representation of the waveform as measured at TP2.	76
Figure 20:	Representation of compression function by IC5.	78
Figure 21:	Representation of compression function by IC7.	110
Figure 22:	Position of TPE link on the Microprocessor PCB in the junction box	131
Figure 23:	Position of TPE link on the Application Processor Handset I/F 3 V PCB in the 2011.	131
Figure 24:	Position of TPE link on the Application Processor Handset & Data I/F PCB in the 2012.	132
Figure 25:	Position of link 11 on the Microprocessor PCB in the junction box	154
Figure 26:	Position of link A on the Application Processor Handset I/F 3 V PCB in the 2011.	155
Figure 27:	Position of link A on the Application Processor Handset & Data I/F PCB in the 2012.	155
Figure 28:	RF/IF PCB in the RF unit (08-05261)	160
Figure 29:	RF/IF PCB in the RF unit (08-05889)	161
Figure 30:	PA PCB in the RF unit (08-05415 or 08-05511)	161
Figure 31:	PA PCB in the RF unit (08-05869).	162
Figure 32:	PA PCB in the RF unit (08-06461).	162
Figure 33:	Filter and Control PCB in the RF unit (08-05416).	163
Figure 34:	Filter and Control PCB in the RF unit (08-05910).	163
Figure 35:	Audio Interface PCB in the RF unit (08-05266, 2010 only).	164

Figure 36:	Audio & Interconnect PCB in the RF unit (08-05988, 2011 only)	164
Figure 37:	Audio Interconnect & Data I/O PCB in the RF unit (08-06261, 2012 only).	165
Figure 38:	Receive sweep test display.	167
Figure 39:	Transmit sweep test display.	168
Figure 40:	Setup for test unit with a 2010/2012 RF Unit	170
Figure 41:	Setup for test unit and NGT test handset with a 2011 RF Unit	170
Figure 42:	Graph showing adjustment to 90% modulation.	171
Figure 43:	Setup for adjusting the bias gain	183
Figure 44:	Setup for checking intermodulation distortion	187
Figure 45:	Basic layout of a 3061/3062 high-power system.	208
Figure 46:	Basic layout of an HPAC module and an ALC adaptor module with vendor equipment.	208
Figure 47:	Typical rear panel of a power amplifier.	211
Figure 48:	Front view of the ATU connector on the power amplifier	212
Figure 49:	Front view of the TCVR connector on the power amplifier	213
Figure 50:	Front view of the DC supply connector on the power amplifier	214
Figure 51:	Front view of the IEC mains connector (10 A) on the power supply	214
Figure 52:	Front view of the IEC mains connector (15 A) on the power supply	214
Figure 53:	Rear panel of the HPAC	215
Figure 54:	Front view of the ATU connector on the HPAC	215
Figure 55:	Front view of the Power Amp connector on the HPAC	216
Figure 56:	Front view of the TCVR connector on the HPAC.	217
Figure 57:	ALC adaptor.	217
Figure 58:	Front view of the 3-way connector on the ALC adaptor	218
Figure 59:	Basic layout of the remote control NGT system	250
Figure 60:	Rear panel of the NRI	254
Figure 61:	Front view of the Modem connector on the NRI.	254
Figure 62:	Front view of the Test connector on the NRI	255
Figure 63:	Front view of a CIB connector on the NRI	256
Figure 64:	Front view of a DC power supply connector on the NRI	257
Figure 65:	Exploded view of the NRI	275
Figure 66:	Power supply fault diagnosis chart	277
Figure 67:	NRI fault diagnosis chart	279
Figure 68a:	NGT remote interface User Connect PCB fault diagnosis chart	284
Figure 68b:	NGT remote interface User Connect PCB fault diagnosis chart continued	285
Figure 69:	Basic layout of a 3012 data system	292
Figure 70:	Rear panel of the 3012.	297
Figure 71:	Front view of the Terminal connector on the 3012	297
Figure 72:	Front view of the Transceiver connector on the 3012	298
Figure 73:	Exploded view of the 3012	311
Figure 74:	Basic layout for a split-site remote control NGT system.	320
Figure 75:	Rear panel of the 8571	324

Figure 76:	Front view of the Tcvr Control connector on the 8571	324
Figure 77:	Front view of the Tcvr Audio connector on the 8571.....	325
Figure 78:	Front view of the DC Supply connector on the 8571	326
Figure 79:	Front view of the Option 2-wire connector on the 8571.....	327
Figure 80:	Front view of the Option 4-wire connector on the 8571.....	328
Figure 81:	Front view of the 15-way GPIO connector on the split-site interface controller.....	329
Figure 82:	Location of switch S1	348

This page has been left blank intentionally.

Table 1:	Earth symbols	22
Table 2:	Resistor and capacitor abbreviations	31
Table 3:	General specifications	36
Table 4:	Receiver specifications	38
Table 5:	Transmitter specifications	39
Table 6:	Pinouts of the CIB connector on the RF unit (2010 only)	42
Table 7:	Pinouts of the antenna control connector on the RF unit	43
Table 8:	Pinouts of the DC supply connector on the RF unit	43
Table 9:	Pinouts of the fan connector on the RF unit	44
Table 10:	Pinouts of the 10-way connector on the RF unit (2011/2012 only)	45
Table 11:	Pinouts of the 4-way connector on the RF unit (2011/2012 only)	46
Table 12:	Pinouts of the 6-way connector on the RF unit (2011/2012 only)	46
Table 13:	Pinouts of the 15-way GPIO connector on the RF unit (2012 only)	48
Table 14:	Pinouts of the handset connector on the junction box	49
Table 15:	Pinouts of the CIB connectors on the junction box	50
Table 16:	Pinouts of the speaker connector on the junction box	50
Table 17:	Pinouts of the 9-way serial data connector on the junction box	51
Table 18:	Pinouts of the 15-way GPIO connector on the junction box	52
Table 19:	Pinouts of the headphone jack on the desk console	53
Table 20:	Supply voltages for the Handset PCB in the handset	72
Table 21:	Supply voltages for the Audio PCB in the junction box (04-03201 or 04-03423)	72
Table 22:	Supply voltages for the Microprocessor PCB in the junction box	72
Table 23:	Supply voltages for the Audio Interface PCB in the RF unit	73
Table 24:	Supply voltages for the Application Processor PCB in the RF unit	73
Table 25:	Supply voltages for the RF/IF PCB in the RF unit (04-03106)	73
Table 26:	Supply voltages for the RF/IF PCB in the RF unit (04-03378)	74
Table 27:	Supply voltages for the PA PCB and Filter and Control PCB in the RF unit (04-03169 or 04-03369 or 04-03542)	74
Table 28:	Supply voltages for the Handset PCB in the handset	106
Table 29:	Supply voltages for the Audio & Interconnect PCB in the RF unit (2011 only)	106
Table 30:	Supply voltages for the Audio Interconnect & Data I/O PCB in the RF unit (2012 only)	107
Table 31:	Supply voltages for the Application Processor Handset I/F 3 V PCB in the RF unit (2011 only)	107
Table 32:	Supply voltages for the Application Processor Handset & Data I/F PCB in the RF unit (2012 only)	107
Table 33:	Supply voltages for the RF/IF PCB in the RF unit	108
Table 34:	Supply voltages for the PA PCB and Filter and Control PCB in the RF unit (04-03369 or 04-03542)	108

Table 35:	Transmit disable, transmit enable and transmit prohibited options	130
Table 36:	Supply voltages for the Handset PCB in the handset	147
Table 37:	Supply voltages for the Audio PCB in the junction box	147
Table 38:	Supply voltages for the Microprocessor PCB in the junction box	147
Table 39:	Supply voltages for the Audio Interface PCB in the RF unit (2010 only)	148
Table 40:	Supply voltages for the Audio & Interconnect PCB in the RF unit (2011 only) . .	148
Table 41:	Supply voltages for the Audio Interconnect & Data I/O PCB in the RF unit (2012 only)	149
Table 42:	Supply voltages for the Application Processor PCB in the RF unit (2010 only) . .	149
Table 43:	Supply voltages for the Application Processor Handset I/F 3 V PCB in the RF unit (2011 only)	149
Table 44:	Supply voltages for the Application Processor Handset & Data I/F PCB in the RF unit (2012 only)	150
Table 45:	Supply voltages for the RF/IF PCB in the RF unit (08-05261)	150
Table 46:	Supply voltages for the RF/IF PCB in the RF unit (08-05889)	151
Table 47:	Supply voltages for the PA PCB and Filter and Control PCB in the RF unit	151
Table 48:	Pre-defined service channels for Service mode	156
Table 49:	Hot keys on the handset during Service mode	157
Table 50:	Power output PEP vs measuring instrument (12/100/125 W)	181
Table 51:	Power output PEP vs measuring instrument (12/100/125 W)	195
Table 52:	NGT parts lists index	197
Table 53:	NGT—list of drawings	201
Table 54:	Power amplifier specifications (3061/3062)	209
Table 55:	Pinouts of the ATU connector on the power amplifier	212
Table 56:	Pinouts of the TCVR connector on the power amplifier	213
Table 57:	Pinouts of the ATU connector on the HPAC	215
Table 58:	Pinouts of the Power Amp connector on the HPAC	216
Table 59:	Pinouts of the TCVR connector on the HPAC	217
Table 60:	Pinouts of the 3-way connector on the ALC adaptor	218
Table 61:	Status of LED and its meaning	226
Table 62:	Supply voltages for the Control PCB in the power amplifier	227
Table 63:	Supply voltages for the Power Amplifier PCB in the power amplifier	227
Table 64:	Supply voltages for the Power Supply PCB in the power amplifier	227
Table 65:	Supply voltages for the High-power PA & Antenna Control PCB in the HPAC	231
Table 66:	Supply voltages for the High-power ALC Adaptor PCB in the ALC adaptor module	231
Table 67:	Position of digi switch S1	232
Table 68:	Meaning of LED indicators on the front panel of the power amplifier	237
Table 69:	Meaning of internal LED indicators on the Control PCB	238
Table 70:	Power output PEP vs measuring instrument (500 W/1 kW)	240
Table 71:	High power parts lists index	245
Table 72:	High power—list of drawings	247

Table 73:	Pinouts of the Modem connector on the NRI	254
Table 74:	Pinouts of the Test connector on the NRI	255
Table 75:	Pinouts of a CIB connector on the NRI	256
Table 76:	Pinouts of a DC power supply connector on the NRI	257
Table 77:	Replacement PCBs and units for the NRI	270
Table 78:	Error messages	272
Table 79:	Description of LEDs	273
Table 80:	Test points on the NRI Microcontroller PCB	280
Table 81:	Test points on the NRI Vocoder PCB	282
Table 82:	NRI parts lists index	287
Table 83:	NRI—list of drawings	289
Table 84:	Pinouts for the Terminal connector on the 3012	297
Table 85:	Pinouts for the Transceiver connector on the 3012	298
Table 86:	Replacement PCBs and units for the 3012	308
Table 87:	Basic fault finding for the 3012	309
Table 88:	3012 parts lists index	315
Table 89:	3012—list of drawings	317
Table 90:	Pinouts of the Tcwr Control connector on the 8571	324
Table 91:	Pinouts of the Tcwr Audio connector on the 8571	325
Table 92:	Pinouts of the DC Supply connector on the 8571	326
Table 93:	Pinouts of the Option 2-wire connector on the 8571 (15-10509-001)	327
Table 94:	Pinouts of the Option 4-wire connector on the 8571 (15-10510-001)	328
Table 95:	Pinouts of the 15-way GPIO connector on the split-site interface controller	329
Table 96:	Supply voltages for the Backplane PCB	353
Table 97:	Supply voltages for the Microprocessor & TCVR Interface PCB	353
Table 98:	Supply voltages for the Dual Line Equaliser PCB	354
Table 99:	8571 parts lists index	361
Table 100:	8571—list of drawings	363

This page has been left blank intentionally.

Numerics

3012

- brief description 299
- dismantling 310
- drawings 317
- fault finding 307
- LED indicators 294
- overview 291, 292
- parts lists 315
- pin connections 297
- power supply 305
- specifications 291, 295
- technical description 303

8571

- brief description 331
- dismantling 352
- drawings 363
- fault finding 351
- overview 319, 320
- parts lists 361
- pin connections 324
- power supply 336
- receive path 337
- specifications 319, 322
- technical description 335
- transmit path 340

A

- adjustments
 - high power 235
 - NGT 145
- Application Processor Handset & Data I/F PCB
 - microprocessors and control 126
 - supply voltages 107, 150
 - transmit path 110
- Application Processor Handset I/F 3 V PCB
 - microprocessors and control 126
 - supply voltages 107, 149
 - transmit path 110
- Application Processor PCB
 - microprocessors and control 98
 - supply voltages 73, 149
 - transmit path 78
- Audio & Interconnect PCB
 - microprocessors and control 127
 - receive path 119
 - supply voltages 106, 148
 - transmit path 109
- Audio Interconnect & Data I/O PCB
 - microprocessors and control 127
 - receive path 119

- supply voltages 107, 149
- transmit path 109

Audio Interface PCB

- microprocessors and control 99
- receive path 91
- supply voltages 73, 148
- transmit path 77

Audio PCB

- supply voltages 72, 147

B

Backplane PCB

- supply voltages 353

balance control

- adjusting 185

bias

- active
 - adjusting 184
- gain
 - adjusting 182

brief description

- 3012 299
- 8571 331
- high power 219
- NGT
 - 2010 55
 - 2011/2012 63
- NRI 259

C

capacitor

- abbreviations 31

channel additions

- NGT 129

checks

- NGT 145

circuit reference designations 13

CMOS devices 26

compliance 17

- electromagnetic compatibility and safety notices 21
 - earth symbols 22
 - electrical safety 22
 - electromagnetic compatibility 21
- R&TTE Directive 19
 - declarations of conformity 19
 - product marking and labelling 19
 - protection of the radio spectrum 20

components

- substitution 32

contact information 29

C-tick 24

D

- dismantling
 - 3012 310
 - 8571 352
 - NRI 275
- drawings
 - 3012 317
 - 8571 363
 - high power 247
 - NGT 201
 - NRI 289
- driver bias
 - adjusting 176
- DSP Modem PCB 304
 - testing 313
- Dual Line Equaliser PCB
 - supply voltages 354

E

- electromagnetic compatibility and safety notices
 - compliance
 - earth symbols 22
 - electrical safety 22
 - electromagnetic compatibility 21

F

- fault finding
 - 3012 307
 - 8571 351
 - high power 235
 - NRI 269
- filter
 - second IF 102
- Filter and Control PCB
 - microprocessors and control 100, 127
 - supply voltages 74, 108, 151

H

- Handset PCB
 - supply voltages 72, 106, 147
- high output power
 - adjusting 180
- high power
 - adjustments 235
 - brief description 219
 - drawings 247
 - fault finding 235
 - overview 207, 208
 - parts lists 245
 - pin connections 211
 - specifications 207, 209
 - technical description 225

I

- integrated circuits 25
- intermodulation
 - checking 187, 195
 - distortion 187

L

- LED indicators
 - 3012 294
 - NRI 273
- low output power
 - adjusting 182

M

- maintenance 25
 - circuit boards
 - component replacement 27
 - component substitution 27
 - excessive heat 26
 - integrated circuit replacement 28
 - unsoldering 27
 - CMOS devices
 - grounding 26
 - handling 26
 - packaging 26
 - switching off 26
 - general
 - dynamic transistor tests 25
 - integrated circuits 25
 - spare boards 25
 - static transistor tests 25
 - precautions
 - probe 28
 - transmitter 28
- Microprocessor & TCVR Interface PCB
 - supply voltages 353
- Microprocessor PCB
 - supply voltages 72, 147

N

- NGT
 - brief description
 - 2010 55
 - 2011/2012 63
 - channel additions 129
 - checks and adjustments 145
 - drawings 201
 - overview 33, 34
 - parts lists 197
 - pin connections 41
 - specifications 33, 36
 - technical description
 - 2010 69
 - 2011/2012 103

NRI 249
 brief description 259
 dismantling 275
 drawings 289
 fault finding 269
 LED indicators 273
 overview 250
 parts lists 287
 pin connections 254
 specifications 249, 252
 technical description 263
 test procedures 277
 upgrading firmware 271
 NRI Microcontroller PCB
 technical description 265
 testing 280
 NRI User Connect PCB
 technical description 264
 testing 283
 NRI Vocoder PCB
 technical description 267
 testing 281

O

ordering information 31
 overview 249
 3012 291, 292
 8571 319, 320
 high power 207, 208
 NGT 33, 34
 NRI 249, 250

P

PA
 adjusting
 active bias 184
 balance control 185
 bias gain 182
 checking intermodulation 187
 driver bias 176
 high output power 180
 low output power 182
 PA gain 189
 PA PCB
 supply voltages 74, 108, 151
 transmit path 81, 113
 packaging 26
 parts lists
 3012 315
 8571 361
 high power 245
 NGT 197
 NRI 287

PCB

microprocessors and control
 Application Processor 98
 Application Processor Handset & Data I/F 126
 Application Processor Handset I/F 3 V 126
 Audio & Interconnect 127
 Audio Interconnect & Data I/O 127
 Audio Interface 99
 Filter and Control 100, 127
 RF/IF 99, 127
 receive path
 Audio & Interconnect 119
 Audio Interconnect & Data I/O 119
 Audio Interface 91
 supply voltages
 Application Processor 73, 149
 Application Processor Handset & Data I/F 107, 150
 Application Processor Handset I/F 3 V 107, 149
 Audio 72, 147
 Audio & Interconnect 106, 148
 Audio Interconnect & Data I/O 107, 149
 Audio Interface 73, 148
 Backplane 353
 Dual Line Equaliser 354
 Filter and Control 74, 108, 151
 Handset 72, 106, 147
 Microprocessor 72, 147
 Microprocessor & TCVR Interface 353
 PA 74, 108, 151
 RF/IF 73, 74, 108, 150, 151
 transmit path
 Application Processor 78
 Application Processor Handset & Data I/F 110
 Application Processor Handset I/F 3 V 110
 Audio & Interconnect 109
 Audio Interconnect & Data I/O 109
 Audio Interface 77
 PA 81, 113
 RF/IF 79, 110
 pin connections
 3012 297
 8571 324
 high power 211
 NGT 41
 NRI 254
 power
 output
 checking 195
 power supply
 3012 305
 8571 336

R

- R&TTE Directive
 - compliance 19
 - declarations of conformity 19
 - product marking and labelling 19
 - protection of the radio spectrum 20
- receive path
 - 8571 337
 - NGT
 - 2010 87
 - 2011/2012 116
- resistor
 - abbreviations 31
- RF/IF PCB
 - microprocessors and control 99, 127
 - supply voltages 73, 74, 108, 150, 151
 - transmit path 79, 110

S

- safety
 - radiation 21
- second IF filter 102
- serial ports
 - 3012 306
- size
 - 3012 296
 - 8571 323
 - high power 210
 - NGT 37
 - NRI 252
- spare boards 25
- specifications
 - 3012 291, 295
 - 8571 319, 322
 - high power 207, 209
 - NGT 33, 36
 - NRI 249, 252

T

- technical description
 - 3012 303
 - 8571 335
 - high power 225
 - NGT
 - 2010 69
 - 2011/2012 103
 - NRI 263
- test
 - unit 146
- transistor tests
 - dynamic 25
 - static 25

- transmit path
 - 8571 340
 - high power 228
 - NGT
 - 2010 75
 - 2011/2012 109
- transmitter
 - checking performance
 - intermodulation 195
 - power output 195

U

- User Connector PCB
 - technical description 306
 - testing 312

W

- weight
 - 3012 296
 - 8571 323
 - high power 210
 - NGT 37
 - NRI 252

About this manual

This Technical Service Manual provides technical descriptions, functional details and drawings for the following equipment:

- NGT Transceivers that use the 2010 RF Unit with 2030 Junction Box and 2020 Handset
- NGT Transceivers that use the 2011/2012 RF Unit with 2020 Handset
- 500 W Power Amplifier 3061 and 1 kW Power Amplifier 3062
- High-power PA and Antenna Controller (HPAC) module and ALC adaptor module used with external high-power vendor equipment
- NGT Remote Interface 3030 (NRI)
- HF Data Modem 3012
- NGT Split-site Remote Interface 8571

This manual assumes that you have a good understanding of electronics and a technical background.

This manual contains the following sections:

Volume 1

[About this manual](#)—lists all standards, acronyms, abbreviations and units used in this manual

[Compliance](#)—compliance information and safety notices

[Maintenance](#)—details of maintenance and general cautions and warnings associated with the equipment

[Contact information](#)—provides information on accessing Codan's website to obtain current contact phone numbers and email addresses for 24-hour technical support

[Ordering information](#)—explains the details required by Codan to ensure prompt service and delivery

NGT Transceivers

[NGT—Overview and specifications](#)—general description of the transceivers and their specifications

[NGT—Brief description \(2010\)](#)—brief technical description of the 2010 RF Unit with 2030 Junction Box and 2020 Handset, including a general description of the major circuit functions for the control, reception and transmission of signals

[NGT—Brief description \(2011/2012\)](#)—brief technical description of the 2011/2012 RF Unit with 2020 Handset, including a general description of the major circuit functions for the control, reception and transmission of signals

[NGT—Technical description \(2010\)](#)—detailed technical description of the operation and circuit function of the 2010 RF Unit with 2030 Junction Box and 2020 Handset

[NGT—Technical description \(2011/2012\)](#)—detailed technical description of the operation and circuit function of the 2011/2012 RF Unit with 2020 Handset

[NGT—Channel additions](#)—available options and the programming procedures for channel additions

[NGT—Checks and adjustments](#)—checks, adjustments and alignments to the transceiver including a list of the required test equipment

Volume 2

NGT Transceivers

[NGT—Parts lists](#)

[NGT—Drawings](#)

Volume 3

500 W Power Amplifier 3061, 1 kW Power Amplifier 3062, and High-power PA and Antenna Controller (HPAC) module and ALC adaptor module used with external high-power vendor equipment

[High power—Overview and specifications](#)—general description of the 500 W and 1 kW power amplifiers and supplies, the modules used with vendor equipment, and their specifications

[High power—Brief description](#)—brief technical description of the 500 W and 1 kW power amplifiers including a general description of the major circuit functions for the control and transmission of signals

[High power—Technical description](#)—detailed technical description of the operation and circuit function of the 500 W and 1 kW power amplifiers

[High power—Fault finding and adjustments](#)—general fault finding through LED diagnosis and adjustments to the power amplifiers

[High power—Parts lists](#)

[High power—Drawings](#)

NGT Remote Interface 3030 (NRI)

[NRI—Overview and specifications](#)—general description of the NRI and its specifications

[NRI—Brief description](#)—brief technical description of the NRI and associated equipment

[NRI—Technical description](#)—detailed technical description of the operation and circuit function of the NRI

[NRI—Fault finding](#)—general fault finding and test procedures for diagnosing the NRI

[NRI—Parts lists](#)

[NRI—Drawings](#)

HF Data Modem 3012

[3012—Overview and specifications](#)—general description of the 3012 and its specifications

[3012—Brief description](#)—brief technical description of the 3012

[3012—Technical description](#)—detailed technical description of the operation and circuit function of the 3012

[3012—Fault finding](#)—fault finding procedures for diagnosing the 3012

[3012—Parts lists](#)

[3012—Drawings](#)

NGT Split-site Remote Interface 8571

[8571—Overview and specifications](#)—general description of the 8571 and its specifications

[8571—Brief description](#)—brief technical description of the 8571 including a general description of the major circuit functions for the control, reception and transmission of signals

[8571—Technical description](#)—detailed technical description of the operation and circuit function of the 8571

[8571—Fault finding](#)—fault finding procedures for diagnosing an 8571 system

[8571—Parts lists](#)

[8571—Drawings](#)

A master index can be found at the beginning of this manual. An index for each section can be found at the beginning of the corresponding section.

Standards and icons

The following standards and icons are used in this manual:

This typeface	Means...
<i>Italics</i>	a cross-reference, text requiring emphasis or a variable in a system message
Bold	name of a connector, LED, label, rail, or setting
Courier	an error message displayed on the handset

This icon	Means...
WARNING	your actions may cause harm to yourself or the equipment
CAUTION	proceed with caution as your actions may lead to loss of data, privacy or signal quality
NOTE	the text provided next to this icon may be of interest to you
ALTERNATIVE TEXT	select the segment of text to read carefully—multiple circuit/assembly numbers exist for this type of board
☐	a step to follow

Definitions

Acronyms and abbreviations

Acronym	Means...
A/F	audio frequency
AC	alternating current
ACE	asynchronous communications element
ADC	analog to digital converter
AGC	automatic gain control
ALC	automatic level control
ALE	automatic link establishment, address latch enable
AM	amplitude modulation
AND	logical AND function
ARQ	automatic repeat request
ASCII	American standard code for information interchange
AT	attention
ATU	antenna tuner unit
BCD	binary-coded decimal
B-E	base to emitter
BER	bit error rate
BPF	band-pass filter
BW	bandwidth
CALM	Codan automated link management
CAN	controller area network
CB	citizen band
CD	carrier detect, compact disc
CIB	Codan interconnect bus
CICS	computer interface command set
CMOS	complementary metal oxide semiconductor
CoDec	coder/decoder
CPLD	complex programmable logic device
CPU	central processing unit

Acronym	Means...
CRO	cathode-ray oscilloscope
CSK	consumable spares kit
CTS	clear to send
CW	continuous wave, carrier wave
DAC	digital to analog converter
DC	direct current
DDS	direct digital synthesis
DSB	double sideband
DSP	digital signal processor/processing
DSR	data set ready
DTE	data terminal equipment
DTR	data terminal ready
DUART	dual universal asynchronous receiver/transmitter
e.g.	exempli gratia, for example
EEPROM	electrically erasable programmable read only memory
EMF	electromotive force
Emgcy	emergency
EPLD	electronically programmable logic device
EPROM	erasable programmable read only memory
ES	emergency selcall
ESN	electronic serial number
ESR	equivalent series resistance
etc.	et cetera, and so forth
ETSI	European Telecommunications Standards Institute
EXT	external
FCC	Federal Communications Commission
FET	field-effect transistor
FIFO	first-in first-out
FSK	frequency shift keying
FWD-PWR	forward power
GND	ground
GP	general purpose

Acronym	Means...
GPIO	general purpose input/output
GPS	global positioning system
HF	high frequency
HPAC	high-power PA and antenna controller
HPF	high-pass filter
i.e.	id est, that is
I/O	input/output
I/P	input
I ² C	inter integrated circuit
IC	integrated circuit; Industry Canada
ICNIRP	International Commission on Non-Ionizing Radiation Protection
ID	identification
IF	intermediate frequency
IMD	intermodulation distortion
imp	impedance
IrDA	Infrared Data Association
ITU	International Telecommunication Union
JB	junction box
LCD	liquid crystal display
LED	light-emitting diode
LO	local oscillator
LPF	low-pass filter
LSB	lower sideband
M	morse
MIC	microphone
Modem	modulator-demodulator
N/C	not connected
NAND	inverted AND logic
NC	normally closed
NL	noise limiter
NO	normally open
NOR	inverted OR logic

Acronym	Means...
NPN	NPN transistor type
NRI	NGT remote interface
NSP	NGT system programmer
NTC	negative temperature coefficient
O/C	open circuit
O/P	output
OC	open collector (active low)
opamp	operational amplifier
OR	logical OR function
P	peak
PA	power amplifier
PC	personal computer
PCB	printed circuit board
PD	potential difference
PEP	peak envelope power
PIUT	paper insulated unit twin
PLCC	plastic J-leaded chip carrier
PLL	phase locked loop
PNP	PNP transistor type
p-p	peak to peak
ppm	parts per million
PSEN	program select enable
PSU	power supply unit
PTC	positive temperature coefficient
PTFE	polytetra fluoro ethylene
PTT	press-to-talk
PWM	pulse width modulation
PWR	power
Q	quality factor
QPSK	quadrature phase shift keying
R&TTE	radio and telecommunications terminal equipment
RAM	random access memory

Acronym	Means...
RC	resistor/capacitor; resistance/capacitance
RCJB	remote control junction box
REF OSC	reference oscillator
REF-PWR	reference power
RF	radio frequency
RFDS	Royal Flying Doctor Service
RFU	RF unit
RMS	root mean square
ROM	read only memory
RSK	recommended spares kit
RTS	request to send
Rx	receive, receiver
Rx DEMOD	receive demodulator
RxD	receive data
SBY	standby
SCF	suppressed carrier frequency
SCL	synchronous clock
SDA	synchronous data
SINAD	(signal+noise+distortion)-to-(noise+distortion) ratio
SOT	select on test
SRAM	static random access memory
SSB	single sideband
sync	synchronised
tcvr	transceiver
TCW	tinned copper wire
TDM	time division multiplex
THD	total harmonic distortion
TPE	transmit program enable
TSOP	thin small outline package
TTL	transistor to transistor logic
Tx	transmit, transmitter
Tx MOD	transmit modulator

Acronym	Means...
TxD	transmit data, transmit disabled
TxE	transmit enabled
TxP	transmit prohibited
UART	universal asynchronous receiver/transmitter
UHF	ultra high frequency
USB	upper sideband
VCO	voltage-controlled oscillator
VDR	voltage-dependant resistor
VHF	very high frequency
Vocoder	voice coder
VSWR	voltage standing wave ratio

Glossary

Term	Means...
ACE	A peripheral semiconductor device used to provide additional serial interfaces to a microcontroller or digital signal processor.
AT commands	A set of commands commonly used to operate many types of modems.
CAN protocol	A communication method that has good error-detection capabilities and performs well in high-noise environments.
channel	Frequencies programmed in the transceiver to transmit and receive signals on air.
CHIRP	A robust signalling protocol used by the HF Data Modem 3012 during link establishment.
coder/decoder	A device combining an ADC and a DAC.
control site	The site where the user or equipment that controls the system is located.
data terminal equipment	An RS232-related term indicating a PC or terminal.
digital signal processor	A microprocessor-like device that is designed to process high-volume digital data streams quickly.
Easitalk	A feature that enables the user to reduce the level of background noise that is present when listening to a channel.
effective throughput	The average data transfer rate taking into account the effects of data compression. For example, if system throughput is 1 000 bps and data compression reduces data size by 50%, the effective throughput is 2 000 bps.
first-in first-out	A buffer used in serial communications devices to reduce CPU overheads.
fixed base station	A transceiver that is permanently installed and cannot be moved without significant effort.
frequency	The number of cycles per second of a radio wave, usually expressed in kilohertz.
frequency offset	The difference between the frequencies being used by a sending and a receiving modem station. The variation is due to changes in temperature, variations in power supply voltage or the aging of components.
handset	A hand-held device that is used to control the functions of a transceiver. It consists of a microphone, PTT button, display and keypad.

Term	Means...
junction box	The unit in a transceiver to which a handset, 2010 RF Unit, speaker and related devices are connected. The junction box receives the instructions that a user enters through the handset and sends these instruction to the relevant devices.
Master Bus mode	A CIB operating mode in which a CIB device, e.g. a 2010 RF Unit, supplies power and TDM audio synchronisation pulses to the bus.
NGT remote interface	A device that converts CIB audio, control and status signals to and from RS232 data to enable interfacing with a line modem.
PTT button	The press-to-talk button, located on the left side of the handset. This button enables you to communicate during voice calls, switch mute off, cancel voice calls prior to the point where voice can be transmitted, cancel calls where data is being transmitted, and exit out of editable screens without saving changes.
remote control junction box	A device that is used in a remote control system to interface with other equipment including a modem or a radio/telephone interconnect unit.
remote control NGT system	A fixed base station that consists of a control site and transceiver site. The control and transceiver sites communicate via a modem at each site. This enables the transceiver site to be located in an electrically quiet area for more reliable transmission with less noise interference.
RF unit	The unit in a transceiver that modulates audio signals onto radio frequencies that can be transmitted on air, and that demodulates the radio frequencies it receives into audio signals.
signalling rate	The rate at which data is transmitted (this remains constant at 2400 bps).
Slave Bus mode	A CIB operating mode in which a CIB device, e.g. a junction box, sources its power supply and TDM audio synchronisation pulses from the bus.
throughput	The average data transfer rate between stations (this varies with different channel conditions).
transceiver	The unit that modulates audio signals onto radio frequencies that may be transmitted on air, and that demodulates the radio frequencies it receives into audio signals. A transceiver comprises an RF unit, handset, speaker, and appropriate connecting cables. Transceivers that use a 2010 RF Unit also include a 2030 Junction Box.
transceiver site	The location of the RF unit in a remote control NGT system. This site is selected for its low electrical noise and good HF propagation.
transmission protocol	The method used by a modem to transmit and receive information.

Circuit reference designations

Abbreviation	Designation
A	assembly
B	transducer—microphone, loudspeaker etc
C	capacitor
D	diode—small signal and power
E	heating device
F	protection device—fuse etc
G	generator—battery etc
H	signalling/indicating device—lamp, LED, buzzer etc
IC	integrated circuit, thick film hybrid etc
J	jack socket
K	relay, key switch
L	inductor
M	indicating device—meter etc
P	plug
R	resistor
S	switch
T	transformer, common mode choke
TP	test point
U	modem, modulator-demodulator
V	semiconductor (not including small signal and power diodes)
X	terminals
Z	quartz crystal, crystal filter, frequency network

Units

Measurement	Unit	Abbreviation
Attenuation	decibel	dB
Current	ampere	A
Data rate	bits per second	bps
Frequency	hertz	Hz
Impedance	ohm	Ω
Length	metre (feet/inch)	m (ft/in)
Mass	gram	g
Noise temperature	kelvin	K
Power	watt	W
Power	decibels relative to 1 mW	dBm
Power ratio	decibel	dB
Pressure	pascal	Pa
Rate of data transfer	baud	baud
Temperature	degrees Celsius (Fahrenheit)	$^{\circ}\text{C}$ ($^{\circ}\text{F}$)
Time	hour	h
Time	second	s
Voltage	volt	V
Weight	gram (pound)	g (lb)

Unit multipliers

Unit	Name	Multiplier
n	nano	0.000000001
μ	micro	0.000001
m	milli	0.001
d	deci	0.1
k	kilo	1000
M	mega	1000000
G	giga	1000000000

About this issue

This is the fifth issue of the NGT Transceiver System Technical Service Manual.

Information is included on the 2012 RF Unit, which does not use a 2030 Junction Box, but provides data capability through a 15-way connector on a flying lead from the RF unit.

The 2011/2012 RF Unit is now manufactured with a 6-way connector, replacing the 4-way connector.

Reference to NGT Transceivers is now made according to the type number of the RF unit, that is, 2010, 2011, and 2012.

Technical information for the HF Data Modem 3012 is included to update for component obsolescence.

NOTE In the event of discrepancies between the English version of this document and a translated version, the English version takes precedence.

Associated documents

This manual is one of a series of publications related to the NGT series Transceiver. Other associated publications are:

- NGT Transceiver Getting Started Guide (Codan part number 15-04127-EN)
- NGT Transceiver Reference Manual (Codan part number 15-04126-EN)
- NGT *ASR* Transceiver Getting Started Guide (Codan part number 15-04137-EN)
- NGT *ASR* Transceiver Reference Manual (Codan part number 15-04138-EN)
- NGT *SRx* Transceiver Getting Started Guide (Codan part number 15-04140-EN)
- NGT *SRx* Transceiver Reference Manual (Codan part number 15-04141-EN)
- NGT *CR* Transceiver Getting Started Guide (Codan part number 15-04144-CH, Chinese version)
- NGT *CR* Transceiver Reference Manual (Codan part number 15-04145-EN)
- NGT System Programmer Help (Codan part number 15-04105-EN)
- NGT Transceiver System Repair Guide (Codan part number 15-04143-EN)
- Antenna Matrix (Codan part number 12-50133)
- HF Data Modem 3012 Reference Manual (Codan part number 15-04104-EN)
- Remote Control NGT Systems Reference Manual (Codan part number 15-04102-EN)
- Split-site Remote Control NGT Systems Reference Manual (Codan part number 15-04125-EN)
- Aide du Service Technique du système des émetteurs-récepteurs NGT (Codan part number 15-02063-FR) on the enclosed CD

This section contains the following topics:

[Introduction \(18\)](#)

[European Radio and Telecommunications Terminal Equipment Directive \(19\)](#)

[Electromagnetic compatibility and safety notices \(21\)](#)

[FCC compliance \(23\)](#)

[IC certification \(24\)](#)

[C-tick approval \(24\)](#)

Introduction

This section describes how to ensure that the NGT series Transceiver, the 3061/3062 Power Amplifier, the NRI and 3012 HF Data Modem comply with the European Electromagnetic Compatibility Directive 89/336/EEC and the European Low Voltage Directive 73/23/EEC as called up in the European R&TTE Directive 1999/5/EC.

This section also contains the requirements for FCC compliance, IC certification and C-tick, as indicated on the product label of the equipment.

European Radio and Telecommunications Terminal Equipment Directive

The NGT series Transceivers have been tested and comply with the following standards and requirements (articles of the R&TTE Directive):

- Article 3.1b: ETSI EN 301 489-1
- Article 3.1b: ETSI EN 301 489-15
- Article 3.2: Australian type approval according to AZ/NZS 4770:2003 or ECR 209
- Article 3.1a: assessed against ICNIRP and FCC requirements
- Article 3.1a: EN 60950

The 3061/3062 Power Amplifiers have been tested and comply with the following standards and requirements (articles of the R&TTE Directive):

- Article 3.1b: ETSI EN 301 489-1
- Article 3.1b: ETSI EN 301 489-15
- Article 3.2: Australian type approval according to AZ/NZS 4770
- Article 3.1a: assessed against ICNIRP
- Article 3.1a: EN 60950
- Article 3.1a: EN 50392

The NGT Remote Interface 3030 and HF Data Modem 3012 have been tested and comply with the following standards and requirements (articles of the R&TTE Directive):

- Article 3.1b: ETSI EN 301 489-1
- Article 3.1b: ETSI EN 301 489-15
- Article 3.1b: EN 55022 (CISPR 22)
- Article 3.1b: 47CFR15
- Article 3.1a: EN 60950

Product marking and labelling

Any equipment supplied by Codan that satisfies these requirements is identified by the **CE0191** Ⓞ, **CE0191**, or **CE** markings on the model label of the product.

Declarations of Conformity

The CE Declarations of Conformity for this product range available upon request to Codan or a Codan-authorized supplier.

Protection of the radio spectrum

CAUTION

Most countries restrict the use of HF radio communications equipment to certain frequency bands and/or require such equipment to be licensed. It is the user's responsibility to check the specific requirements with the appropriate communications authorities. If necessary, contact Codan for more information.

Electromagnetic compatibility and safety notices

Radiation safety

To ensure optimal transceiver performance and to avoid exposure to excessive electromagnetic fields, the antenna system must be installed according to the instructions provided.

WARNING High voltages exist on the antenna during transmission and tuning. Do not touch the antenna during these activities. RF burns may result.

WARNING Install the grounding system or counterpoise as directed to prevent RF burns from any metal part of the transceiver.

You should not transmit from your transceiver or tune the antenna unless people are beyond the safe working distance of:

- 1.5 m (5 ft) of any part of a mobile antenna
- WARNING** • 2 m (7 ft) of any part of a fixed antenna in a data installation of up to 125 W output
- 5 m (17 ft) of any part of a fixed antenna in a data installation of up to 1 kW output

Safe working distance is based on continuous exposure to CW-type transmissions, as set out in the ICNIRP Exposure Guidelines (1998) for occupational exposure. Safe working distance can be reduced with normal voice communication.

Electromagnetic compatibility

To ensure that compliance with the EMC Directive is maintained, you must:

- Use standard shielded cables supplied from Codan (where applicable).
- Ensure the covers for the equipment are fitted correctly.

CAUTION If it is necessary to remove the covers at any stage, they must be refitted correctly before using the equipment.

- Cover unused connectors on the junction box (if fitted) and RF unit with the protective caps supplied to prevent electrostatic discharge passing through your NGT equipment.

Electrical safety

To ensure compliance with the European Low Voltage Directive is maintained, you must install and use the NGT series Transceiver in accordance with the instructions in the relevant *NGT Transceiver Getting Started Guide* and *NGT Transceiver Reference Manual*.

When using equipment that is connected directly to the AC mains, these precautions must be followed and checked before applying AC power to the unit:

- Use the standard AC mains cable supplied.
- Ensure the covers for the equipment are fitted correctly.

CAUTION If it is necessary for a qualified electronics technician to remove the covers during servicing, they must be refitted correctly before using the equipment.



WARNING A protective earth connection must be included in the mains wiring to the 3020 Transceiver Supply (see below, *Earth symbols*).

The protective cover must always be fitted when the 3020 Transceiver Supply is connected to the AC mains.

Earth symbols

Chassis earth connection points are provided on the NGT series Transceiver and 3020 Transceiver Supply. A protective earth is provided in the AC mains wiring of the 3020 Transceiver Supply. This protective earth must be connected at the AC mains supply outlet. The symbols shown in [Table 1](#) are used to identify the earths on the equipment.

Table 1: Earth symbols

Symbol	Meaning
	Chassis earth
	Protective earth

FCC compliance

FCC Part 90 certification

The 2010 RF Unit with 2030 Junction Box and 2020 Handset complies with FCC standards (FCC identifier code DYYNGT-3).

The 2011/2012 RF Unit with 2020 Handset complies with FCC standards (FCC identifier code DYYNGT-11).

FCC Part 15 compliance

Any modifications made to the NGT series Transceiver (2010 RF Unit with 2030 Junction Box and 2020 Handset, or 2011/2012 RF Unit with 2020 Handset) and 3020 Transceiver Supply that are not approved by the party responsible for compliance may void your equipment's compliance under Part 15 of the FCC rules.

The NGT series Transceiver (2010 RF Unit with 2030 Junction Box and 2020 Handset, or 2011/2012 RF Unit with 2020 Handset) and 3020 Transceiver Supply have been tested and found to comply with the limits for a Class B device, pursuant to Part 15 of the FCC rules. These limits are designed to provide reasonable protection against harmful interference in a residential installation. This equipment generates, uses and can radiate radio frequency energy and, if not installed and used in accordance with the instructions, may cause harmful interference to radio communications. However, there is no guarantee that interference will not occur in a particular installation. If this equipment does cause harmful interference to radio or television reception, which can be determined by switching the equipment off and on, the user is encouraged to try to correct the interference by one or more of the following measures:

- reorient or relocate the receiving antenna
- increase the separation between the equipment and receiver
- connect the equipment into an outlet on a circuit different from that to which the receiver is connected
- consult the dealer or an experienced radio/TV technician for help

IC certification

Product markings and labelling

The 2011/2012 RF Unit with 2020 Handset is certified to IC standards (IC identifier 1029A-NGT-3).

C-tick approval

The 2012 RF Unit with 2020 Handset meets the requirements of the Australian Communications Authority Radiocommunications (MF and HF Radiotelephone equipment—Land Mobile Services) Standard 2003 (AS/NZS 4770).

The NRI complies with C-tick specifications for the following:

- electromagnetic emission
- electromagnetic immunity

To comply with electromagnetic emission requirements, all cables to and from the NRI carry adequately filtered signals so that the performance of the RF unit receiver is unaffected.

To comply with electromagnetic immunity requirements, emissions from other external pieces of equipment do not affect the operation of the NRI.

General

The removal and substitution of components may damage the components and/or the printed circuit boards. In some cases, it is impossible to remove components without destroying them. Therefore, it is important to carry out as much diagnosis as possible with components in situ.

Spare boards

If spare boards are held in stock, they may be substituted in order to positively localise the fault to one board.

Static transistor tests

Transistor failures are most often due to open circuit base–emitter or base–collector junctions, or a short circuit between emitter and collector.

These types of faults can often be detected without removing the transistor using the Ω range of a multimeter. The two junctions should both give the appearance of a diode (high resistance with the multimeter leads one way and low resistance when the leads are reversed). Polarity depends on whether a PNP or NPN transistor is being tested. Resistance between collector and emitter should be high with the multimeter leads either way. The circuit diagram should be examined for parallel paths before a transistor failing this test is removed.

Dynamic transistor tests

Some transistor faults can be diagnosed by measuring voltages within the circuit. One of the most significant voltage measurements is the base–emitter voltage. The polarity of this will depend on the type of the transistor (PNP or NPN). A base–emitter voltage between 0.5 and 0.9 V should be measured on a forward-biased base–emitter junction.

With its base–emitter junction forward biased, the transistor should conduct. Some indication of satisfactory operation of the transistor is obtained by measuring the voltage drop across its collector or emitter resistor while short circuiting its base to the emitter. The short circuit will remove the forward bias, cutting off the transistor so that the voltage across the resistor is considerably reduced.

Integrated circuits

If there appears to be no output from a particular pin on an integrated circuit, before replacing the device, it should be ascertained whether the fault is due to the IC or its load. As a general rule, if changes in input cause absolutely no change in the corresponding output, the IC should be suspected. However, if even a very small change in output can be detected, the load is more likely to be the cause. Depending upon the circuit, further tests should be made by disconnecting the circuit that follows the IC.

CMOS devices

A number of CMOS devices are used in the transceiver and most of them have built-in protection. However, their extremely high open-circuit impedance makes them susceptible to damage from static charges. Care must therefore be used when shipping and handling the devices and when servicing the equipment in which they are installed.

Packaging

Replacement CMOS devices are supplied in special conductive packaging. They should remain in this packaging until required for use.

Switching off

Ensure that power supplies are switched off before making connections or disconnections between circuit boards.

Handling

Handle circuit boards and conductive parts as little as possible.

Grounding

Anything connected to or touching the circuit board tracks should be grounded as follows:

- Ground test equipment connected to a board through its mains lead.
- Discharge static charges, which may build up on a person, by touching a grounded metal surface with both hands. This should be done before working on, and at frequent intervals while working on circuit boards.
- Wear a suitably grounded conductive wrist strap. This will minimise the build up of static on you.

Circuit boards

Excessive heat

Excessive heat may lift the track from the circuit boards. This will cause serious damage. Avoid the use of high-powered soldering irons. A soldering iron rated at a maximum of 60 W, preferably temperature-controlled at approximately 370°C (700°F), is sufficient for most tasks. A soldering iron rated at a slightly higher temperature of 425°C (800°F) may be required for heavier components such as PA transistors. Only apply the soldering iron long enough to unsolder an existing joint or to solder a new one.

Unsoldering

When unsoldering a component, use a solder sucker or solder wick to remove solder.

CAUTION Do not use sharp metal tools such as screwdrivers or twist drills to remove components as these may damage the printed circuit track and plated thru-holes.

Component substitution

Avoid unnecessary component substitution as this may damage the component, the circuit track or adjacent components.

Component replacement

When a component is diagnosed as defective, or the fault cannot be diagnosed in any other way than by substitution, observe the following when replacing components:

- **Surface-mount components:** The removal or replacement of surface-mount components should only be attempted by a skilled technician experienced in handling surface-mount components, using special tools for desoldering.
- **Remove solder:** When a component has been unsoldered from the board, ensure the holes are clear of solder before inserting the leads of the replacement component.

CAUTION Never force the leads through the holes as this will damage the circuit track, particularly where plated thru-holes are used.

- **Observe orientation:** Before replacing defective diodes, transistors, electrolytic capacitors or integrated circuits, observe any markings that indicate polarity or orientation. It is essential that these types of components are installed correctly. If necessary, consult the manufacturer's data for indications of the polarity of diodes, capacitors and transistors.
- **Heatsinking:** When soldering heat-sensitive components to the circuit board, where possible use long-nosed pliers or some other form of heatsinking on the leads of the components.
- **Thermal conduction:** When replacing transistors that are mounted on heatsinks, ensure there is thermal conduction between the heatsink and the component being replaced. This can be achieved by cleaning the mounting surfaces then re-coating them with a thermal conduction compound such as Jermyn Thermaflow A30.

Integrated circuit replacement

It is often possible to unsolder and remove components from the board without damage to the component or the tracks on the board. However, ICs with many connections, mounted on double-sided or multilayer circuit boards with plated thru-holes, are almost impossible to remove intact and the operation is likely to damage the circuit boards. To replace these components, their leads must be cut individually until the body of the component can be removed. Individual leads must be unsoldered and removed. The excess solder must be removed before inserting the replacement component (see [page 27, *Unsoldering*](#)).

Transmitter precautions

When making measurements of the low-level stages of the exciter, it is advisable to remove the drive to the PA PCB. The supply voltage is applied to the PA at all times when the transceiver is switched on.

CAUTION Caution should be exercised when connecting probes to avoid incorrect readings.

Probe precautions

Observe the following when connecting oscilloscope probes to the transceiver:

- When connecting probes to the PA assembly, the earth clip lead should be wound around the body of the probe so that the earth clip just reaches the probe tip. This reduces stray RF pick-up.
 - The earth clip should be connected to the ground plane, adjacent to the point of measurement.
- CAUTION**
- It is not advisable to connect two probes at the same time, particularly when one is earthed to the PA ground plane and the other is earthed to the exciter. This may cause earth loop problems.
 - Probes should be connected after power has been applied to the transceiver and the test equipment. The earth connection should be made first and disconnected last.

Contact information

If the fault diagnosis guidelines do not locate the faulty module or cable, or if further technical assistance is required for any other reason, please see our details on the internet at www.codan.com.au. In the HF Radio Communications section, click on Product Support.

Outside of normal office hours, Codan has Customer Service Engineers on call to provide emergency technical assistance. They will either answer your call immediately or return your call as soon as possible.

If you are connected to a voice mail system when you call, please follow the instructions carefully, that is, leave your name and contact phone number (including the country code), then a brief, clear description of your problem.

This page has been left blank intentionally.

The parts lists for the PCB assemblies contain:

- a circuit reference number
- descriptions, giving the value and type of component
- a manufacturer and manufacturer's part number

NOTE Items having numeric references identifying specific components or subassemblies may be encountered in the parts lists included in this manual. These items, selected from master manufacturing information, identify parts that are either useful for maintenance purposes or related to other items, and may be cross-referenced in the remarks column.

Table 2: Resistor and capacitor abbreviations

Resistors	Capacitors
CC: carbon composition	AS: solid aluminium electrolytic
CF: carbon film	CC: ceramic multilayer chip
MF: metal film	CE: ceramic
MG: metal glaze	EL: wet aluminium electrolytic
MO: metal oxide	M: stacked mica
WW: wire wound	PC: polycarbonate
	PE: polyester
	PP: polypropylene
	PS: polystyrene
	PT: PTFE
	TA: solid tantalum

Ordering information

Orders for replacement parts/modules must include the following information. This ensures that the correct items are supplied, and speeds up delivery times.

- equipment type (e.g. Type 2020 Handset)
- part/module location (e.g. SR Handset assembly, 08-05629-001)
- full part/module description (e.g. Handset power/Emergency key PCB)

Component substitution

When replacing general purpose components (resistors, capacitors etc), equivalent parts from other manufacturers may be used provided they have similar tolerances, voltage/power rating and temperature coefficients to the specified part.

Substituting components that do not exactly match those listed in the parts list will not adversely affect the performance of the equipment.

Numerics

- 10-way connector
 - pinouts 45
- 4/6-way connector
 - pinouts 46
- 45 MHz filter
 - aligning the Rx filter 167
 - aligning the Tx filter 168
- 455 kHz IF
 - aligning 169

A

- A/F
 - distortion 39
 - power 39
 - response 39, 40
- adjustments 145
 - locations and test points 160
- AGC 38, 90, 118
 - checking 191
- ALC 40, 84, 114
 - checking 194
- amplifier 87, 116
- antenna control connector
 - pinouts 43
- Application Processor Handset & Data I/F PCB 126
 - supply voltages 107, 150
 - transmit path 110
- Application Processor Handset I/F 3 V PCB 126
 - supply voltages 107, 149
 - transmit path 110
- Application Processor PCB 98
 - supply voltages 73, 149
 - transmit path 78
- Audio & Interconnect PCB 127
 - receive path 119
 - supply voltages 106, 148
 - transmit path 109
- audio generation 91
- Audio Interconnect & Data I/O PCB 127
 - receive path 119
 - supply voltages 107, 149
 - transmit path 109
- Audio Interface PCB 99
 - receive path 91
 - supply voltages 73, 148
 - transmit path 77
- audio output
 - checking 191

- Audio PCB
 - receive path 92
 - supply voltages 72, 147
 - transmit path 75

B

- balance control
 - adjusting 185
- band-pass filter
 - 45 MHz 80, 87, 111, 116
- bias
 - active
 - adjusting 184
 - gain
 - adjusting 182
 - generator 83
 - regulator 83, 114
 - voltage 83
- blocking 38
- brief description
 - 2010 55
 - control and switching 61
 - receive path 60
 - synthesiser operation 61
 - transmit path 59
 - 2011/2012 63
 - control and switching 68
 - receive path 67
 - synthesiser operation 68
 - transmit path 66
- broadcast filter 87, 116

C

- CAN
 - driver 98
- carrier re-insertion
 - adjusting 171
- carrier suppression 40
- channels
 - additions 129
 - capacity 36
 - copying 141
 - creating 134
 - creating with Option TxD 137
 - deleting 144
 - editing 142
 - programming 134
 - renaming 139
- checks 145
- CIB
 - receive path 92
 - transmit path 77

CIB connector
 pinouts 42, 50
 clarifier 39
 connectors
 desk console
 headphone 53
 junction box
 CIB 50
 GPIO 52
 handset 49
 serial data 51
 speaker 50
 RF unit
 10-way 45
 4/6-way 46
 antenna control 43
 CIB 42
 DC supply 43
 fan 44
 GPIO 48
 handset and speaker 47
 RF 43
 control and switching
 2010 61
 2011/2012 68
 cooling 37
 crystal oven 93, 152

D

data bus
 handset 97, 125
 DC supply connector
 pinouts 43
 DDS 94, 121
 demodulator 91, 119
 desensitisation 38
 desk console 100
 headphone connector 53
 display 96, 124
 testing 159
 distortion
 A/F 39
 drawings 201
 driver bias
 adjusting 176
 driver stage 82, 113
 duty cycle 39

E

emission
 harmonic 40
 spurious 40

exciter output
 adjusting
 level 170
 spurious balance 172
 filter 80, 112

F

fan connector
 pinouts 44
 filter
 45 MHz (band-pass) 80, 87, 111, 116
 455 kHz 79, 89, 111, 117
 broadcast 87, 116
 exciter output 80, 112
 input (low-pass) 87, 116
 low-pass 152
 output 83, 114
 Rx 167
 second IF 102
 Tx 168
 Filter and Control PCB 100, 127
 supply voltages 74, 108, 151
 first mixer
 receive path 87, 116
 transmit path 79, 111
 frequency
 adjusting 173
 generation 36
 IF 38
 range 36
 reference oscillator 94, 121
 stability 36
 frequency control
 2010 93
 2011/2012 121

G

gain control stage 81, 113
 general specifications 36
 GPIO connector
 pinouts 48, 52

H

handset
 control 96, 124
 data bus 97, 125
 microphone amplifier transmit path 75, 109
 microprocessor 96, 124
 size 37
 weight 37
 handset and speaker connector
 pinouts 47
 handset connector
 pinouts 49

handset data 97, 125
 Handset PCB
 supply voltages 72, 106, 147
 handset transmit path 59, 66
 harmonic emissions 40
 headphone connector
 pinouts 53
 heatsink 39
 high output power
 adjusting 180
 hot keys
 Service mode 157

I

IF amplifier 89, 117
 image rejection 38
 impedance 36
 input low-pass filters 87, 116
 intermodulation 38, 40
 checking 187, 195
 distortion 187
 inband 39
 internal voice encryptor 101, 128

J

junction box
 connectors
 CIB 50
 GPIO 52
 handset 49
 serial data 51
 speaker 50
 control 97
 EEPROM 98
 microprocessor 97
 receive path 60, 92
 size 37
 transmit path 59, 75
 weight 37

K

keypad 96, 124
 testing 159

L

local oscillator 94, 121
 low output power
 adjusting 182
 low-pass filter 152

M

microphone 40, 75, 109
 Microprocessor PCB
 supply voltages 72, 147
 transmit path 75
 microprocessors and control
 2010 96
 2011/2012 124
 mixer
 first 79, 111
 second 80, 112
 modulator
 transmit 79, 111
 mute
 adjusting 175
 voice 91, 120

N

NGT test handset 146
 noise limiter 88, 117
 aligning 169
 checking 193
 Normal mode
 returning to 158

O

operating modes 36
 options
 transmit disable 132
 transmit enable 132
 transmit prohibited 133
 output
 filters 83, 114
 power 39
 stage 83, 114
 oven controller 93, 121
 oven warm up time 36
 overview 33, 34

P

PA
 adjusting 176
 active bias 184
 balance control 185
 bias gain 182
 checking intermodulation 187
 driver bias 176
 high output power 180
 low output power 182
 PA bias 178
 PA gain 189
 PA PCB
 supply voltages 74, 108, 151
 transmit path 81, 113

- parts lists 197
- phase lock loop 94, 122
- pin connections 41
 - desk console
 - headphone connector 53
 - junction box
 - CIB connectors 50
 - GPIO connector 52
 - handset connector 49
 - serial data connector 51
 - speaker connector 50
- RF unit
 - 10-way connector 45
 - 4/6-way connector 46
 - antenna control connector 43
 - CIB connector 42
 - DC supply connector 43
 - fan connector 44
 - GPIO connector 48
 - handset and speaker connector 47
- power
 - A/F 39
 - off 71, 105
 - on 70, 96, 104, 124
 - output 39
 - checking 195
 - reflected 39
 - standby 96, 124
- power supply
 - 26 V 95, 123
- pre-driver stage 82, 113
- programming 36
 - options 130
 - RS232 port 97, 125
- protection 39
 - input 38
 - overvoltage 37
 - thermal 39

R

- real time clock 126
- receive path
 - brief description
 - 2010 60
 - 2011/2012 67
 - CIB 92
 - first mixer 87, 116
 - junction box 60, 92
 - RF unit
 - 2010 60
 - 2011/2012 67
 - second mixer 88, 117
 - technical description
 - 2010 87
 - 2011/2012 116

- receiver
 - checking performance 190
 - AGC 191
 - audio output 191
 - noise limiter 193
 - selectivity 192
 - sensitivity and (signal + noise)/noise ratio 190
 - specifications 38
- reference oscillator 93, 121
 - frequency 94, 121
- relative humidity 37
- response
 - A/F 39, 40
- RF amplifier 87, 116
- RF connector 43
- RF unit
 - connectors
 - 10-way 45
 - 4/6-way 46
 - antenna control 43
 - CIB 42
 - DC supply 43
 - fan 44
 - GPIO 48
 - handset and speaker 47
 - RF 43
 - control 98, 125
 - PCBs
 - Application Processor 98
 - Application Processor Handset & Data I/F 126
 - Application Processor Handset I/F 3 V 126
 - Audio & Interconnect 127
 - Audio Interconnect & Data I/O 127
 - Audio Interface 99
 - Filter and Control 100, 127
 - RF/IF 99, 127
 - receive path
 - 2010 60
 - 2011/2012 67
 - Audio & Interconnect PCB 119
 - Audio Interconnect & Data I/O PCB 119
 - Audio Interface PCB 91
 - size 37
 - transmit path
 - 2010 59
 - 2011/2012 66
 - Application Processor Handset & Data I/F PCB 110
 - Application Processor Handset I/F 3 V PCB 110
 - Application Processor PCB 78
 - Audio & Interconnect PCB 109
 - Audio Interconnect & Data I/O PCB 109
 - Audio Interface PCB 77
 - PA PCB 81, 113
 - RF/IF PCB 79, 110
- weight 37

RF/IF PCB 99, 127
 supply voltages 73, 74, 108, 150, 151
 transmit path 79, 110

RS232 programming port 97, 125

Rx filter
 aligning 167

S

second IF filter 102

second mixer
 receive path 88, 117
 transmit path 80, 112

selectivity 38
 checking 192

sensitivity 38

sensitivity and (signal + noise)/noise ratio
 checking 190

serial data connector
 pinouts 51

Service mode 153
 accessing 154
 channels 156
 exiting 158
 hot keys 157

sideband
 unwanted 40

signal
 input 39

size
 handset 37
 junction box 37
 RF unit 37

speaker connector
 pinouts 50

specifications 33, 36
 general 36
 receiver 38
 transmitter 39

spurious
 emissions 40
 responses 38

standby power 96, 124

supply current 37, 39

supply voltages 36, 72, 106
 Application Processor Handset & Data I/F PCB 107, 150
 Application Processor Handset I/F 3 V PCB 107, 149
 Application Processor PCB 73, 149
 Audio & Interconnect PCB 106, 148
 Audio Interconnect & Data I/O PCB 107, 149
 Audio Interface PCB 73, 148
 Audio PCB 72, 147
 Filter and Control PCB 74, 108, 151
 Handset PCB 72, 106, 147
 Microprocessor PCB 72, 147
 PA PCB 74, 108, 151
 RF/IF PCB 73, 74, 108, 150, 151

suppression
 carrier 40
 switching 36
 transmit/receive 79, 110
 synthesiser operation
 2010 61
 2011/2012 68

T

TDM audio
 channels 76
 generation 91
 reconstruction 92
 technical description
 2010 69
 frequency control 93
 microprocessors and control 96
 receive path 87
 transmit path 75
 2011/2012 103
 frequency control 121
 microprocessors and control 124
 receive path 116
 transmit path 109

temperature 37

test
 display 159
 equipment 146
 keypad 159
 points 160
 unit 146

tone generation 98

TPE link 132

transmit
 disable 132
 programming 137
 enable 132
 frequency
 checking 194
 modulator 79, 111
 prohibited 133

transmit path
 brief description
 2010 59
 2011/2012 66
 CIB 77
 first mixer 79, 111
 handset 59, 66
 junction box 59, 75
 RF unit
 2010 59
 2011/2012 66
 second mixer 80, 112
 technical description
 2010 75
 2011/2012 109

transmitter

- checking performance 194
 - ALC 194
 - intermodulation 195
 - power output 195
 - transmit frequency 194
- specifications 39

tuning 80, 112

Tx filter

- aligning 168

U

UART 97, 126

unwanted sideband 40

V

VCO 122

voice encryptor

- internal 101, 128

voice mute 91, 120

voltage controlled oscillator

- checking 166

voltage regulators 147

voltages

- handset 72, 106, 147
- junction box 72, 147
- RF unit 73, 74, 106, 107, 108, 148, 149, 150, 151
- supply 36, 72, 106

W

weight

- handset 37
- junction box 37
- RF unit 37

This section contains the following topics:

[Overview \(34\)](#)

[Specifications \(36\)](#)

[Pin connections \(41\)](#)

Overview

The NGT is a transceiver that can be installed in a vehicle or used as a base station. The minimum NGT system comprises:

- any one of:
 - a 2010 RF Unit with 2030 Junction Box, or
 - a 2011 RF Unit, or
 - a 2012 RF Unit
- a 2020 Handset

The handset is a hand-held device with a microphone, PTT button, display and keypad. A desk console unit for the handset is available for use in base stations.

The junction box is a unit to which the handset, 2010 RF Unit, speaker and related units are connected in a complex system. In transceivers that use the 2011/2012 RF Unit, the handset and speaker are connected to the RF unit via the handset and speaker connector and 10-way connector.

The RF unit modulates audio signals received from the handset onto radio frequencies and transmits these frequencies. It also demodulates received radio frequencies into audio signals.

The 2010 RF Unit and 2030 Junction Box are connected together using a versatile and flexible bus system called the Codan interconnect bus (CIB). Transceivers that use the 2011 RF Unit do not have system connection capabilities. Transceivers that use the 2012 RF Unit have limited system connection capabilities.

Figure 1: Relationship of the 2010 RF Unit, 2030 Junction Box, and 2020 Handset

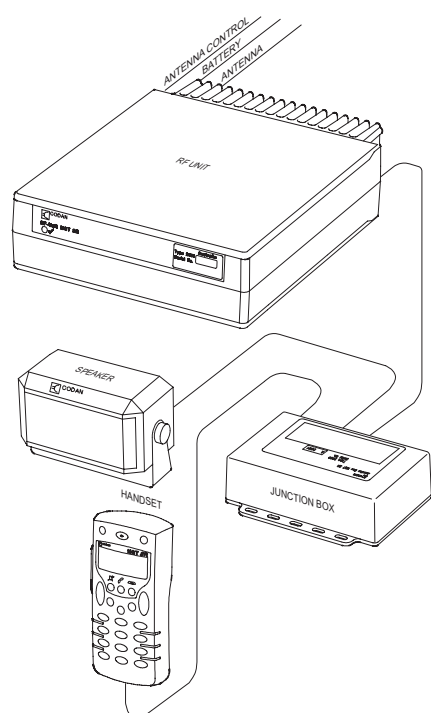

Figure 2: Relationship of the 2011/2012 RF Unit and 2020 Handset

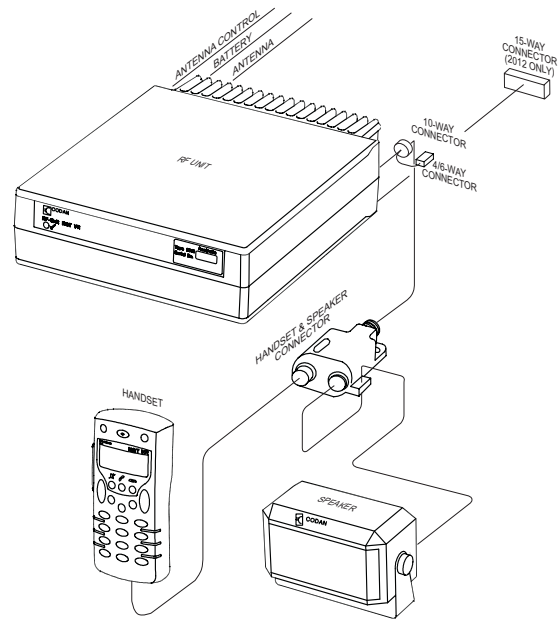

Table 1: General specifications (cont.)

Item	Specification
Overvoltage protection	Shut down at 16 V DC nominal for duration of overvoltage
Supply current	Transmit: see Table 3 on page 39 Receive: 2010 RF Unit: no signal 1 A 2011/2012 RF Unit: no signal < 0.70 A
Environment	Ambient temperature: –30 to +60°C (–22 to 140°F) Relative humidity: 95% Derate upper ambient temperature by 1°C (33.8°F) per 330 m (360 yd) above sea level
Cooling	Convection or fan (Option F)
Size	2010/2011/2012 RF Unit: 210 mm W × 270 mm D × 65 mm H (8.4 in W × 10.8 in D × 2.6 in H) 2020 Handset: 65 mm W × 35 mm D × 130 mm H (2.6 in W × 1.4 in D × 5.2 in H) 2030 Junction Box: 135 mm W × 106 mm D × 38 mm H (5.4 in W × 4.3 in D × 1.5 in H) Handset and speaker connector: 42 mm W × 55 mm D × 22 mm H 1.7 in W × 2.2 in D × 0.9 in H)
Weight	2010/2011/2012 RF Unit: 3.3 kg (7.3 lb) 2020 Handset: 0.3 kg (0.7 lb) 2030 Junction Box: 0.4 kg (0.9 lb)
Finish colour	Dark Grey

Receiver

Table 2: Receiver specifications

Item	Specification
Type	Dual conversion, superheterodyne
IF frequencies	45 MHz and 455 kHz
Sensitivity	Frequency: RF amp off: 0.25 to 30 MHz 1.5 [1.25] μ V PD -103 [-105] dBm Frequency: RF amp on: 1.6 to 30 MHz 0.2 [0.12] μ V PD -121 [-125] dBm For 10 dB SINAD with greater than 50 mW audio output
Input protection	Will withstand 50 V p-p RF from a 50 W source
Selectivity	Greater than 65 [70] dB at -1 kHz and +4 kHz reference SCF USB Pass Band: -8 [-6] dB 300 to 2800 Hz Ripple: 4 [2] dB p-p 500 to 2700 Hz
Desensitisation	10 dB SINAD reduced to 7 dB SINAD -1 and +4 kHz (ref SCF) 60 [65] dB \pm 10 kHz 75 [80] dB \pm 50 kHz 90 [95] dB
Blocking	As for Desensitisation For frequencies > \pm 50 kHz > 95 dB
Image rejection	Better than 65 [70] dB
Spurious responses	Better than 70 [90] dB Self-generated signals > 0.15 mV PD: 4.999, 29.49 MHz
Intermodulation	To produce a third order intermodulation product equivalent to a wanted signal producing 10 dB SINAD, two unwanted signals greater than 30 kHz removed from the wanted signal must have a level greater than 90 [92] dB above the wanted signal Third order intercept (unaffected by AGC): +30 [+33] dBm with RF amp off +10 [+13] dBm with RF amp on
AGC	Less than 6 dB variation in output for input variation between 2.0 [1.0] μ V and 100 mV PD (RF amp on) Fast attack, slow release (selectable release time)

Table 2: Receiver specifications (cont.)

Item	Specification
A/F response @ GPIO connector	Typical: -6 dB 300 to 2800 Hz
A/F response @ loudspeaker	Typical: -6 dB 300 to 2500 Hz
A/F power and A/F distortion	2.4 W into 8 Ω , 5% THD 4 W into 4 Ω , 5% THD 6 W into 2 Ω , 5% THD
Clarifier	± 10 ppm (nominal) ± 50 Hz below 5 MHz, increasing to ± 300 Hz at 30 MHz Clarifier is automatically reset to mid-frequency with channel change
Inband IMD	Better than 25 dB IMD with two 100 mV PD RF inputs
Signal to noise vs input signal	An increase of input level of 40 dB above the sensitivity level increases the signal to noise ratio to at least 40 dB

Transmitter

Table 3: Transmitter specifications

Item	Specification
Power output for AUST & FCC	100 W PEP ± 0.5 dB, 27 MHz CB 10 W PEP (Aust only)
Power output	125 W PEP reducing with frequency to 100 W PEP at 30 MHz ± 1 dB CW or single tone: approximately 60% of PEP with average PEP control (average control disabled on handset PTT)
Duty cycle	100%: normal speech over full temperature range 100%: ARQ up to 30°C (86°F) 25%: 16-tone continuous data mode (5 minutes on maximum) at ambient temperature up to 30°C (86°F) 100%: all modes up to maximum ambient of 45°C (113°F) with Option F
Supply current	Output power: 100 W or 125 W Two-tone or CW: 9 to 17 A Average speech: 8 A for battery life calculations
Protection	Safe under all load conditions by limiting reflected power to 10 W PEP and limiting PA transistor collector voltage swing Thermal protection against excessive heatsink temperature

Pin connections

RF unit

Figure 3: Rear panel of the 2010 RF Unit

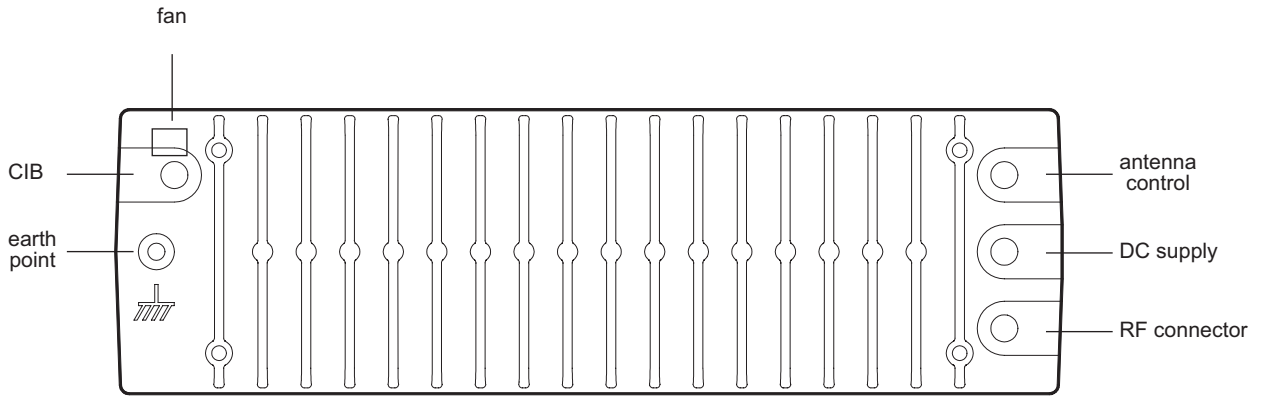

Figure 4: Rear panel of the 2011 RF Unit

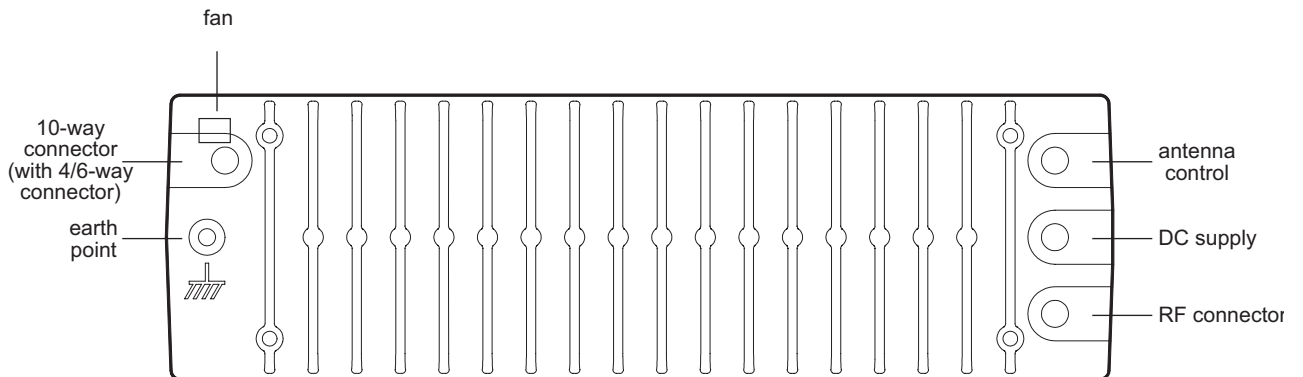
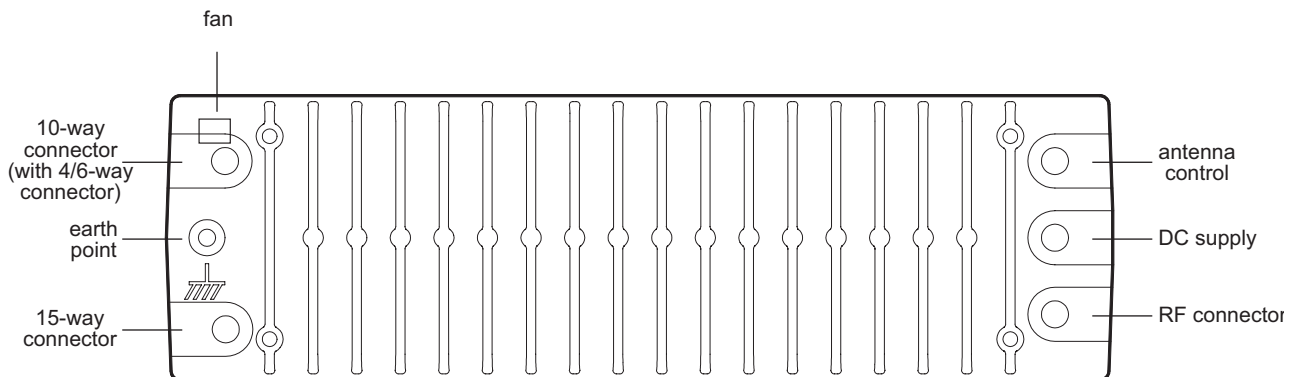

Figure 5: Rear panel of the 2012 RF Unit



Pinouts of the CIB connector on the RF unit (2010 only)

Figure 6: Front view of the CIB connector on the RF unit (2010 only)

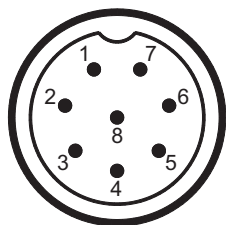

Table 4: Pinouts of the CIB connector on the RF unit (2010 only)

Pin no.	Function	Input/output	Signal level
1	Ground		0 V
2	System data	Input/output	1 to 5 V logic
3	System data	Input/output	1 to 5 V logic
4	Power on	Input	Momentary 0 V = PWR ON
5	+6 V standby	Output	+6 V
6	System audio	Input/output	5 to 10 V sync and TDM
7	System audio	Input/output	0 to 5 V sync and TDM
8	A rail protected (2 A)	Output	+13.6 V nominal

Pinouts of the antenna control connector on the RF unit

Figure 7: Front view of the antenna control connector on the RF unit

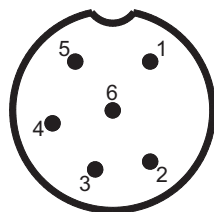

Table 5: Pinouts of the antenna control connector on the RF unit

Pin no.	Function	Input/output	Signal level
1	Tune in/out	Input/output	5 V logic, active low
2	Scan	Output	Active low (open collector)
3	Tuned in	Input	5 V logic
4	A rail protected (1 to 2 A) nominal	Output	+13.6 V nominal
5	External ALC input	Input	Control at 3.6 V
6	Ground		0 V

Pinouts of the DC supply connector on the RF unit

Table 6: Pinouts of the DC supply connector on the RF unit

Pin no.	Function
1	+12 V nominal (10.8 to 16 V DC)
2	Ground

RF connector

The RF connector is a flying lead located on the right side of the rear panel. It is used to connect to an antenna.

Pinouts of the fan connector on the RF unit

Figure 8: Front view of the fan connector on the RF unit



Table 7: Pinouts of the fan connector on the RF unit

Pin no.	Function
-	0 V
+	+13.6 V nominal (when fan is activated)

Pinouts of the 10-way connector on the RF unit (2011/2012 only)

Figure 9: Front view of the 10-way connector on the RF unit (2011/2012 only)

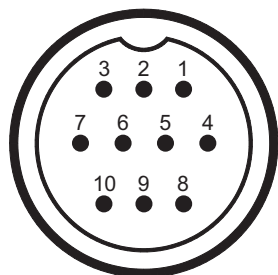

Table 8: Pinouts of the 10-way connector on the RF unit (2011/2012 only)

Pin no.	Function	Input/output	Signal level
1	Speaker audio +	Output	Approx. 12 V p-p at onset of clipping
2	Speaker audio –	Output	0 V
3	Microphone audio +	Input	Nominally 500 mV p-p to ground with normal speech
4	Microphone audio –	Input	Nominally 500 mV p-p to ground with normal speech
5	Handset data +	Input/output	1 to 5 V logic
6	Handset data –	Input/output	1 to 5 V logic
7	Power on	Input	Momentary 0 V = PWR ON
8	Standby power for handset	Output	+5 V standby power, or +9 V handset power
9	A rail protected (1 A nominal)	Output	+13.6 V nominal
10	Ground		0 V

Pinouts of the 4-way connector on the RF unit (2011/2012 only)

Figure 10: Front view of the 4-way connector on the RF unit (2011/2012 only)

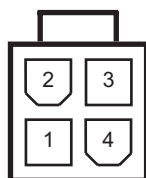

Table 9: Pinouts of the 4-way connector on the RF unit (2011/2012 only)

Pin no.	Function	Input/output	Signal level
1	A rail protected (2 A)	Output	+13.6 V nominal
2	Ground		0 V
3	RS232 Transmit data	Output	RS232
4	RS233 Receive data	Input	RS232

Pinouts of the 6-way connector on the RF unit (2011/2012 only)

Figure 11: Front view of the 6-way connector on the RF unit (2011/2012 only)

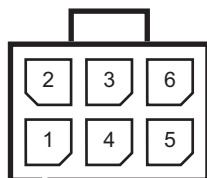
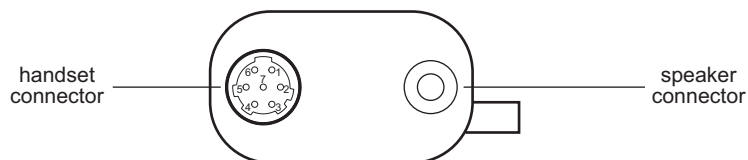

Table 10: Pinouts of the 6-way connector on the RF unit (2011/2012 only)

Pin no.	Function	Input/output	Signal level
1	A rail protected (2 A)	Output	+13.6 V nominal
2	Ground		0 V
3	RS232 Transmit data A	Output	RS232
4	RS233 Receive data A	Input	RS232
5	RS232 Transmit data B	Output	RS232
6	RS233 Receive data B	Input	RS232

Pinouts of the handset and speaker connector attached to the RF unit (2011/2012 only)

Figure 12: Front view of the handset and speaker connector attached to the RF unit (2011/2012 only)



For details on the pinouts of the handset connector see [Table 12 on page 49](#). For details on the pinouts of the speaker connector see [Table 14 on page 50](#).

Pinouts of the 15-way GPIO connector on the RF unit (2012 only)

Figure 13: Front view of the 15-way GPIO connector on the RF unit (2012 only)

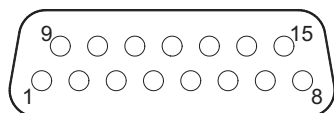

Table 11: Pinouts of the 15-way GPIO connector on the RF unit (2012 only)

Pin no.	Function	Input/output	Signal level
1	RTS	Output	RS232
2	RS232 Receive data	Input	RS232
3	RS232 Transmit data	Output	RS232
4	Ground		0 V
5	Tx audio (10 k Ω balanced)	Input	300 mV p-p ALC threshold
6	External alarm relay contact (NO or NC depending on jumper P10)		Contacts rated 50 V, 1 A
7	External alarm relay common, or 600 Ω balanced audio	Output	Contacts rated at 5 V, 1 A, or 600 Ω audio output
8	A rail protected	Output	+13.6 V nominal
9	CTS	Input	RS232
10	PTT	Input	5 V TTL logic active low
11	Morse	Input	5 V TTL logic active low
12	Busy	Output	5 V TTL logic
13	Quiet (Q) line	Input	5 V TTL logic active high when Fax/Data mode selected 5 V TTL logic active low when all other modes selected
14	System audio unbalanced, or 600 Ω balanced audio	Output	100 Ω audio output 1 V p-p, or 600 Ω balanced audio output
15	Tx audio (10 k Ω balanced)	Input	300 mV p-p ALC threshold

NOTE The 600 Ω output option is selected by internal links (pins 7 and 14).

Junction box (used with 2010 RF Units only)

Figure 14: Connector panel of the junction box

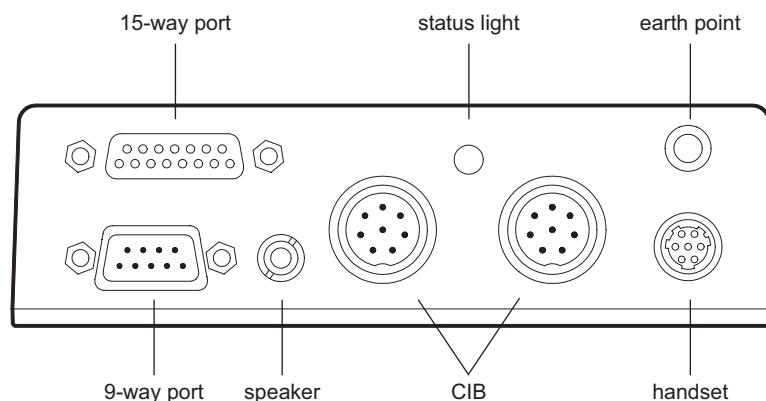

Pinouts of the handset connector on the junction box

Figure 15: Front view of the handset connector on the junction box

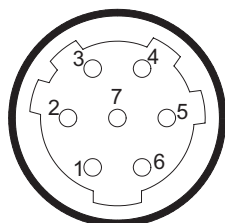

Table 12: Pinouts of the handset connector on the junction box

Pin no.	Function	Input/output	Signal level
1	Standby power for handset	Output	+5 V standby power, or +9 V handset power
2	Handset data	Input/output	1 to 5 V logic
3	Handset data	Input/output	1 to 5 V logic
4	Ground		0 V
5	Microphone audio	Input	Nominally 500 mV p-p to ground with normal speech
6	Microphone audio	Input	Nominally 500 mV p-p to ground with normal speech
7	Power on	Input	Momentary 0 V = PWR ON

Pinouts of the CIB connectors on the junction box

Figure 16: Front view of a CIB connector on the junction box

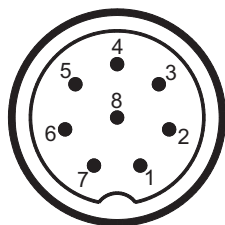

Table 13: Pinouts of the CIB connectors on the junction box

Pin no.	Function	Input/output	Signal level
1	Ground		0 V
2	System data	Input/output	1 to 5 V logic
3	System data	Input/output	1 to 5 V logic
4	Power on	Input	Momentary 0 V = PWR ON
5	+6 V standby	Output	+6 V
6	System audio +	Input/output	5 to 10 V sync and TDM
7	System audio –	Input/output	0 to 5 V sync and TDM
8	A rail protected (2 A)	Output	+13.6 V nominal

Pinouts of the speaker connector on the junction box

The speaker should be 4 Ω with a power rating of 5 W.

Table 14: Pinouts of the speaker connector on the junction box

Connection	Function
Tip	Speaker audio output
Sleeve	Ground

Pinouts of the 9-way serial data connector on the junction box

Figure 17: Front view of the 9-way serial data connector on the junction box

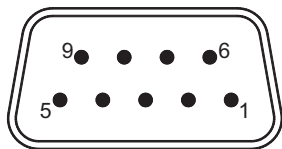

Table 15: Pinouts of the 9-way serial data connector on the junction box

Pin no.	Function	Input/output	Signal level
1	N/C		
2	RS232 Receive data	Input	RS232
3	RS232 Transmit data	Output	RS232
4	DTR	Output	RS232
5	Ground		0 V
6	DSR	Input	RS232
7	RTS	Output	RS232
8	CTS	Input	RS232
9	N/C		

Pinouts of the 15-way GPIO connector on the junction box

Figure 18: Front view of the 15-way GPIO connector on the junction box

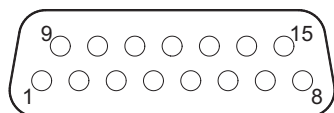

Table 16: Pinouts of the 15-way GPIO connector on the junction box

Pin no.	Function	Input/output	Signal level
1	RTS	Output	RS232
2	RS232 Receive data	Input	RS232
3	RS232 Transmit data	Output	RS232
4	Ground		0 V
5	Tx audio (50 kΩ balanced)	Input	300 mV p-p ALC threshold
6	External alarm relay		Contacts rated 50 V, 1 A
7	External alarm relay		Closed for alarm
8	A rail	Output	+13.6 V nominal
9	CTS	Input	RS232
10	PTT	Input	5 V TTL logic active low
11	Morse	Input	5 V TTL logic active low
12	Spare	Input/output	5 V TTL logic
13	Spare	Input/output	5 V TTL logic
14	System audio	Output	1 V p-p (maximum load 1 kΩ)
15	Tx audio (50 kΩ balanced)	Input	300 mV p-p ALC threshold

NOTE Pins 6, 7 and 9 may be linked internally to select normally open or closed. The pins can be configured to switch to ground or the **A** rail.

Desk console

Pinouts of the headphone jack on the desk console

Table 17: Pinouts of the headphone jack on the desk console

Connection	Function	Input/output
Ring	Audio	Output
Tip	Audio	Output
Sleeve	Ground	

This page has been left blank intentionally.

NGT—Brief description (2010)

This section contains the following topics:

[General information \(57\)](#)

[Transmit path \(59\)](#)

[Receive path \(60\)](#)

[Synthesiser operation \(61\)](#)

[Control and switching \(61\)](#)

For a detailed description of these functions see [page 69, NGT—Technical description \(2010\)](#).

This page has been left blank intentionally.

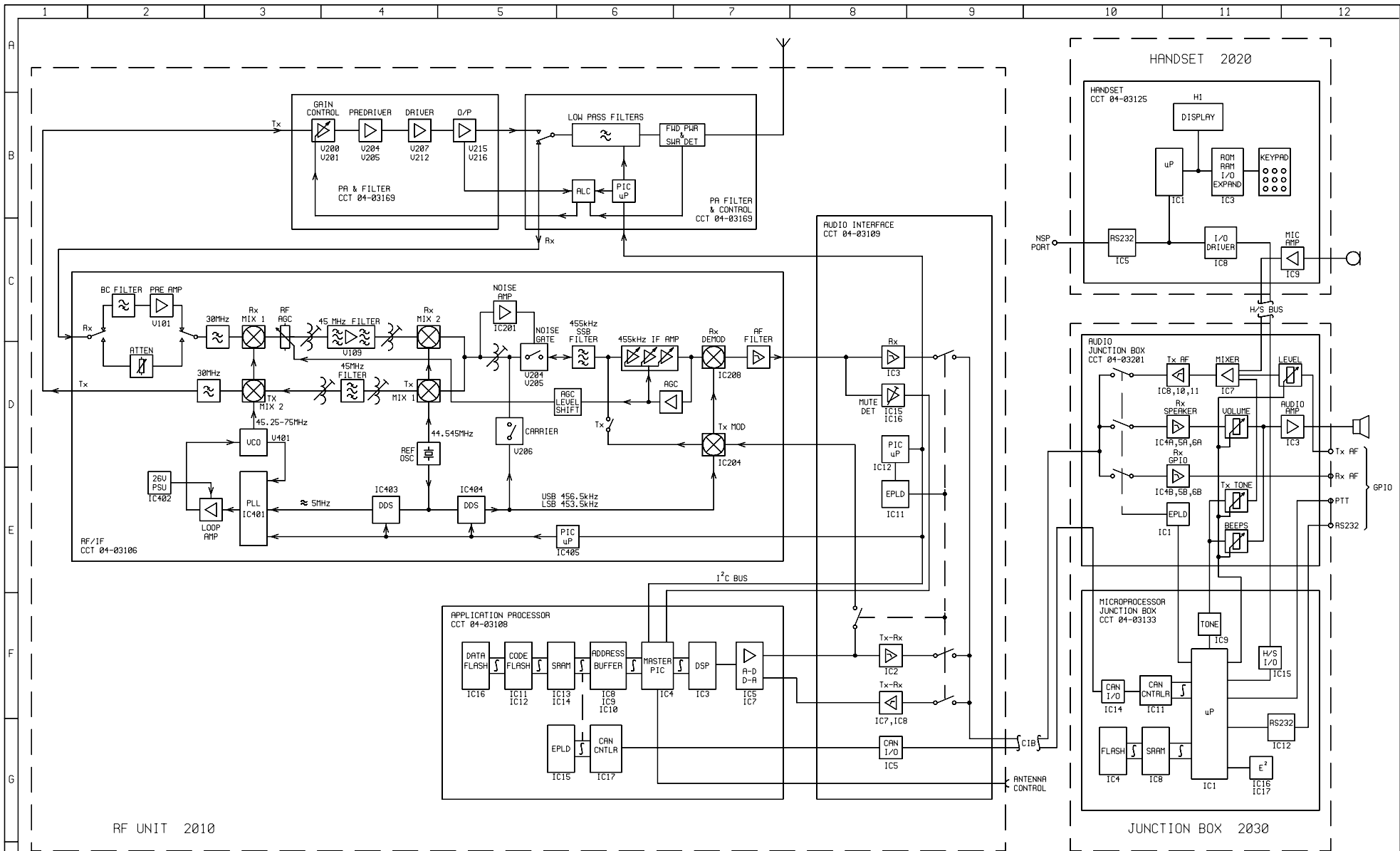

RF UNIT 2010

JUNCTION BOX 2030

CHANGE REQUEST
 ISSUE 2
 TX MIX 2 &
 TX MIX 1
 TRANSPOSED.
 H/S BUS ADDED.
 C/R 26227
 SW 2-9-99

CODAN		SCALE	CODAN PTY. LTD., A.C.N. 007 590 605, 1999	
DRAWN	ILT	DATE	TITLE	
CHKD	NJA	8-7-99	NGT BLOCK DIAGRAM	
APPD	NJA	8-7-99	DRAWING/DOC. NO	
FINISH		TOLERANCES	A1	03-01032
		UNLESS OTHERWISE STATED	ISS	
		2 PLACE DEC. *	2	
		1 PLACE DEC. *		
		ANGULAR *		
			BHT	1 OF 1

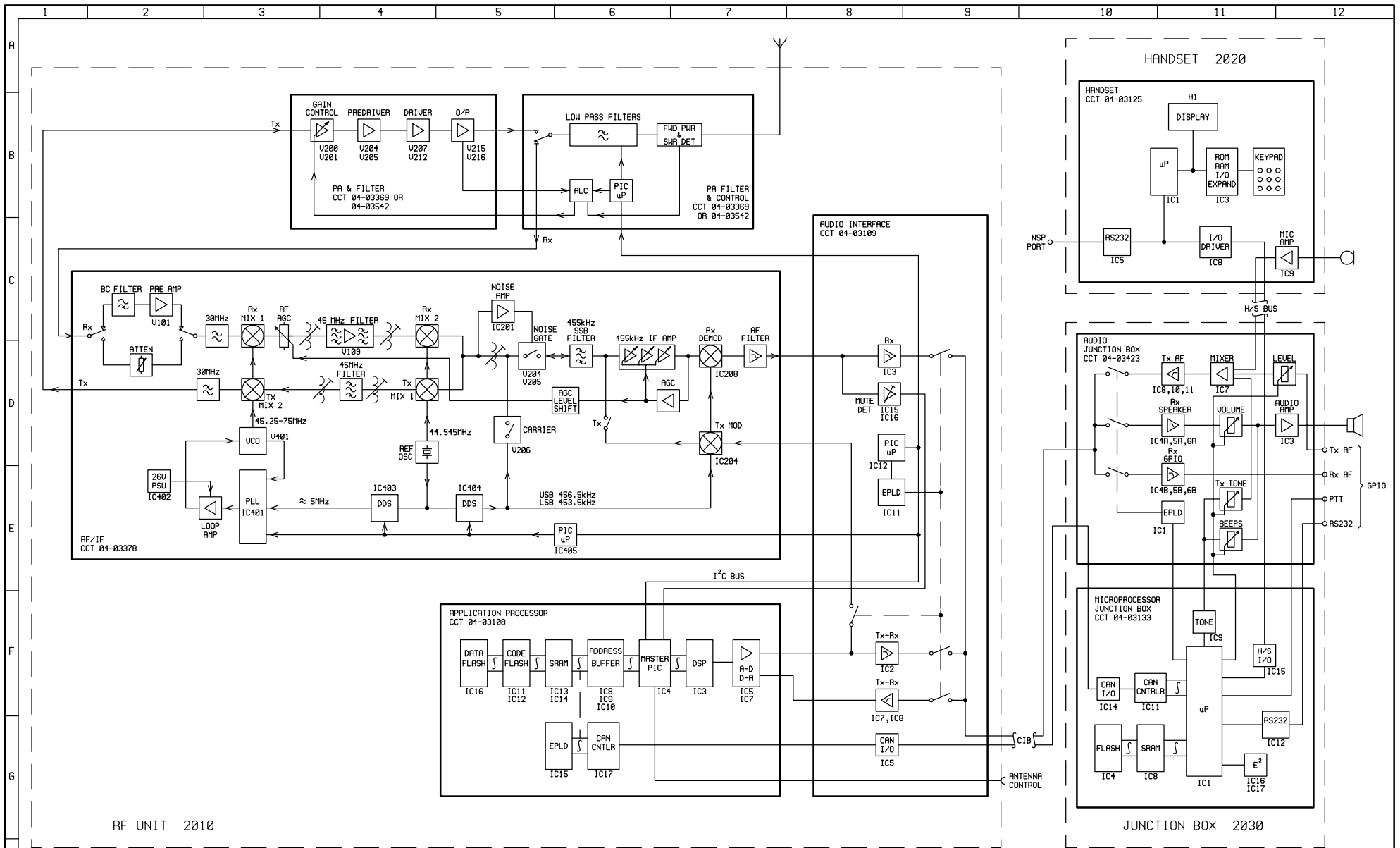

RF UNIT 2010

JUNCTION BOX 2030

CHANGE REQUEST
 ISSUE 2
 TX MIX 1 & TRANSDUCER
 H/S BUS ADDED.
 C/A 26227
 N/A 2-8-99
 ISSUE 3
 TUNING NOS
 UPDATED.
 17-12-02 JD
 ISSUE 4:
 ALT PA & FILTER
 ADDED.
 04-03542
 04-03369
 04-03542

CODAN		SCALE	DATE	CODAN PVT. LTD. A.C.N. 007 590 686, 1999	
DRAWN	ILT	15-6-99	TITLE NGT		
MATERIAL	CHKD	NJA	BLOCK DIAGRAM		
APPD	NJA	8-7-99	DRAWING/DOC. NO		
FINISH			A1 03-01032		
UNLESS OTHERWISE STATED			ISS		
2 PLACES DEC. #			4		
1 PLACE DEC. *			SHT 1		
ANGULAR #			OF 1		

General information

The information in this section should be read in conjunction with the appropriate issue of the block diagram for the NGT series Transceiver. See below to determine which issue of the block diagram you should be viewing.

For transceivers with:

Codan part number of PCB assembly	See...
Audio PCB (2030 Junction Box) 04-03201 08-05470 Application Processor PCB (2010 RF Unit) 04-03108 08-05265 RF/IF PCB (2010 RF Unit) 04-03106 08-05261 04-03095 08-05235 PA PCB (2010 RF Unit) 04-03169 08-05415 08-05416 08-05511	03-01032 Issue 2
Audio PCB (2030 Junction Box) 04-03423 08-05986 RF/IF PCB (2010 RF Unit) 04-03378 08-05889 04-03410 04-03414 08-05963 08-05962 08-05973 PA PCB (2010 RF Unit) 04-03369 or 04-03542 08-05869 or 08-06461 08-05910	03-01032 Issue 4

The transceiver uses double conversion in both the Receive and Transmit modes. Only the 455 kHz sideband filter and the local oscillators VCO and REF OSC are common to both modes of operation.

The signal routing is determined by switching and control voltages according to the selected mode.

Transmit path

Handset transmit path

The microphone audio is amplified in the handset and passed to the junction box via the handset bus.

Junction box transmit path

The audio from the handset is amplified and gated to produce TDM channel audio on the Audio PCB in the junction box. There are eight time slots for the TDM, comprising one synchronisation channel and seven audio channels.

The audio is passed to the RF unit via the CIB.

RF unit transmit path

Audio Interface PCB

The audio from the junction box connects to the Audio Interface PCB. This PCB decodes the TDM audio to normal audio.

Application Processor PCB

The transmit audio is passed to the Application Processor PCB for compression, which converts the signal to a fixed level before passing to the RF/IF PCB.

RF/IF PCB

The audio is mixed with the local oscillator to produce double sideband. It is then filtered by a 2.5 kHz sideband filter centred on 455 kHz, so that only the wanted sideband is passed to the first mixer. It is then mixed with the reference oscillator to produce an IF signal centred on 45 MHz.

The transmit signal is filtered by a BPF with a bandwidth of 15 kHz, before being passed to the input of the second mixer.

At the second mixer, the signal mixes with the local oscillator VCO to produce the required channel frequency. The signal is passed to the PA PCB.

PA PCB

On the PA PCB, the signal is amplified then passed through the transmit/receive relay to the selected LPF.

The output from the LPF is passed via the VSWR detector to the RF output connector. From there it is connected by coaxial cable to the antenna.

Receive path

RF unit receive path

PA PCB

The receive signal from the antenna passes through a PA LPF to the transmit/receive relay. It is then passed to the receiver input on the RF/IF PCB.

RF/IF PCB

From the receiver input, the signal passes to the input of the first balanced mixer. Here it mixes with the local oscillator VCO to produce an IF signal centred on 45 MHz.

The 45 MHz signal is filtered using a BPF with a bandwidth of 15 kHz, before being passed to the second balanced mixer. The signal mixes with 44.545 MHz to produce an IF signal centred on 455 kHz.

The output from the second mixer passes through a 2.5 kHz sideband filter so that only the wanted sideband is fed to the high-gain AGC IF amplifier.

The amplified 455 kHz signal is demodulated to produce an audio signal and also to operate an AGC circuit. This circuit controls the gain of the IF amplifier to prevent overloading when strong signals are received. It also maintains constant audio output with changing input signals.

Audio Interface PCB

The audio is passed to the Audio Interface PCB where it divides into two paths. One path is the unprocessed (raw) audio on one TDM channel. The other path is passed to the Application Processor PCB where the audio is enhanced (noise-reduced). This audio is then passed back to the Audio Interface PCB and becomes another TDM audio channel.

The audio is then passed to the junction box via the CIB.

Junction box receive path

The audio from the RF unit is decoded and either raw audio or noise-reduced audio (as selected by the user) is passed to the speaker.

Synthesiser operation

The transceiver uses a single-loop synthesiser. The synthesiser VCO is used as the first mixer LO, generating an oscillator frequency in 10 Hz steps. In Receive mode, the frequency of the oscillator ranges from 45.25 MHz to 75 MHz. In Transmit mode, the frequency of the oscillator ranges from 46.6 MHz to 75 MHz.

ALTERNATIVE TEXT

The reference oscillator (REF OSC) at 44.545 MHz is used as the second mixer LO. This frequency is also fed to two DDS ICs to produce a variable reference frequency for VCO with 10 Hz resolution.

The second DDS IC produces 456.5 kHz (USB) and 453.5 kHz (LSB) for the Tx MOD and Rx DEMOD circuits.

ALTERNATIVE TEXT

The reference oscillator at 14.848333 MHz is fed through a 44.5 MHz BPF to select the 3rd harmonic to produce the 44.545 MHz second mixer LO. The 14.848333 MHz frequency is also fed to two DDS ICs to produce a variable reference frequency for VCO with 10 Hz resolution.

The second DDS IC produces 456.5 kHz (USB) and 453.5 kHz (LSB) for the Tx MOD and Rx DEMOD circuits.

Control and switching

Most functions of the transceiver are controlled by microprocessors.

A microprocessor in the handset reads the key strokes entered by the user. The keyed data is then passed to the junction box via the handset bus. The junction box sends data to the handset to update the display.

A microprocessor in the junction box transmits commands and data onto the CIB using the CAN protocol. The data rate on the bus is 125 kbps.

The RF unit receives the data, decodes it and then carries out the required function.

The RF unit contains five microprocessors located on four PCBs. Incoming data first goes to the main application microprocessor. This microprocessor then commands lower level microprocessors to carry out the required function.

This page has been left blank intentionally.

NGT—Brief description (2011/2012)

This section contains the following topics:

[General information \(65\)](#)

[Transmit path \(66\)](#)

[Receive path \(67\)](#)

[Synthesiser operation \(68\)](#)

[Control and switching \(68\)](#)

This page has been left blank intentionally.

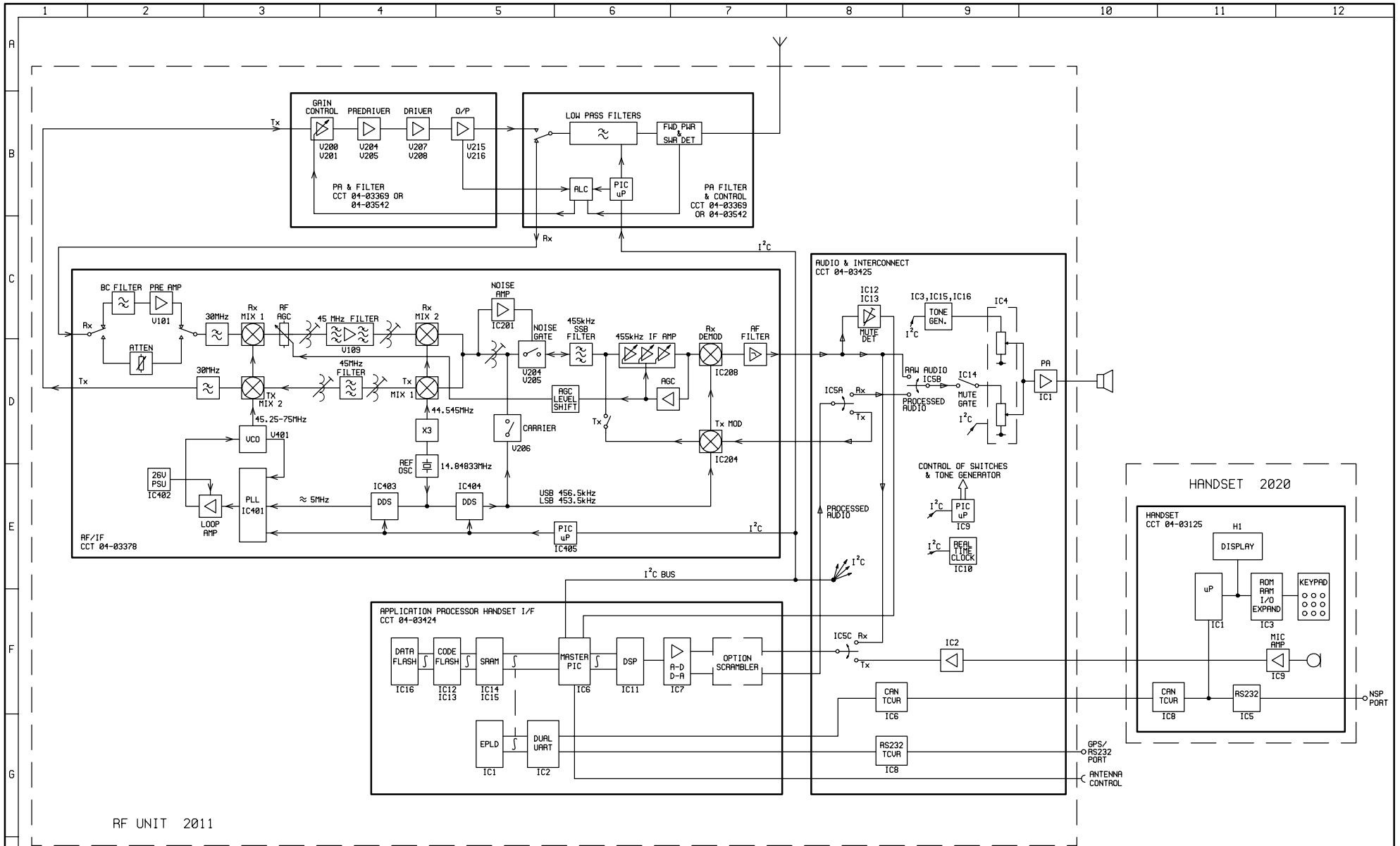

RF UNIT 2011

CHANGE REQUEST
 ISSUE 2: FILTER
 SCH. NO: 04-03542
 REV: 04/05/05
 BY: 28-11-05

CODAN		SCALE	© CODAN LIMITED, A.C.N. 007 590 686, 2003
DRAWN	ILL	DATE	TITLE
CHKD	JD	11-2-03	NGT 2011
APPD	NJA	21-2-03	BLOCK DIAGRAM
FINISH		TOLERANCES	A1 DRAWING/DOC. NO
		UNLESS OTHERWISE STATED	03-01126
		2 PLACES DEC. *	ISS
		1 PLACE DEC. *	2
		ANGULAR *	SHT 1
			OF 1

DISC FILE
 04-01126-2.ZIP

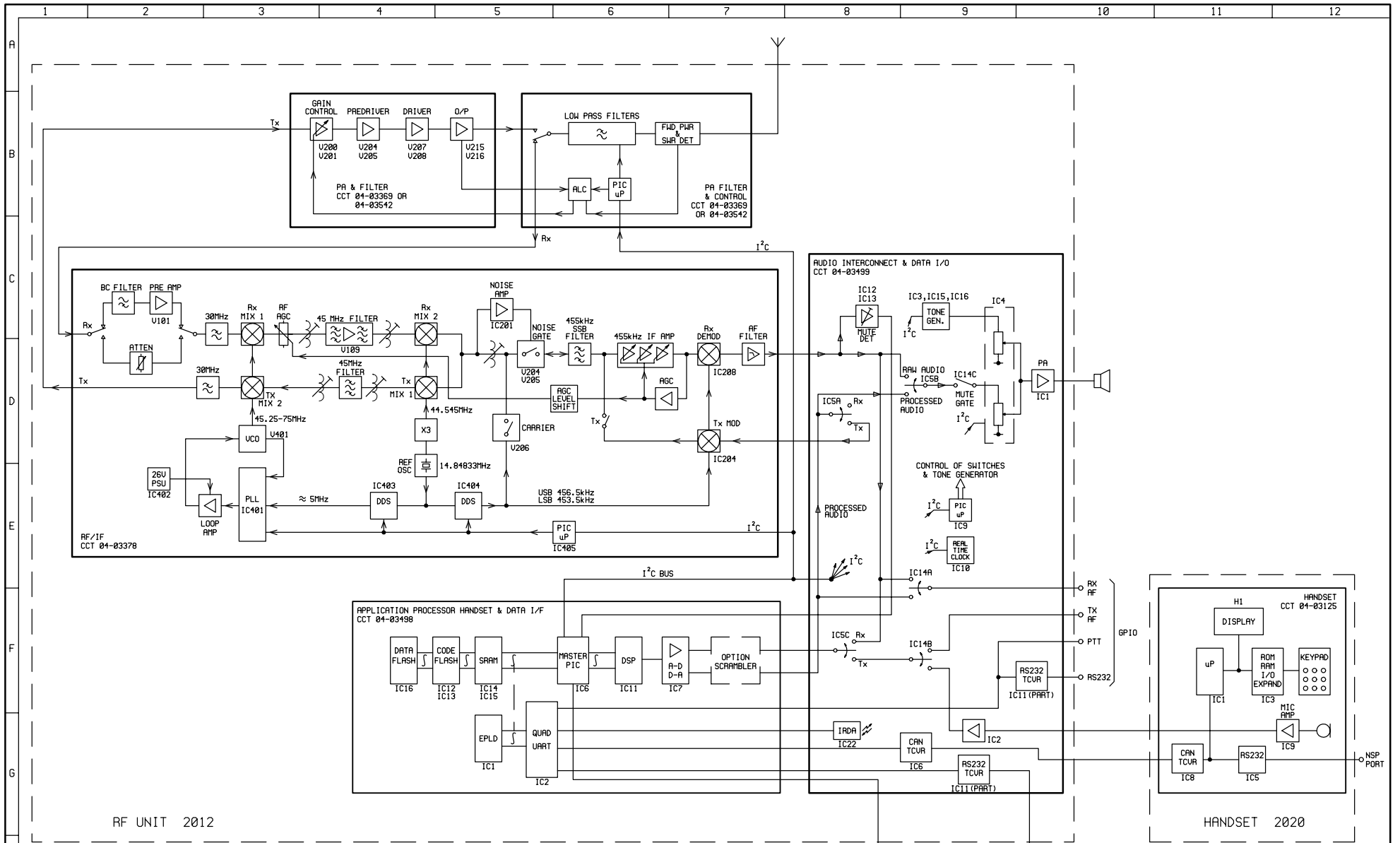

RF UNIT 2012

ISSUE CHANGE
 ISSUE 2:
 1. PA & FILTER
 2. PA & FILTER
 3. PA & FILTER
 4. PA & FILTER
 5. PA & FILTER

CODAN		SCALE	DATE	DISC FILE	
DRN	C G	7-6-05	A.C.N. 907 550 005, 2005		83-01190...2.ZIP
MATERIAL	CHKD	NJA	9-6-05	TITLE	
FINISH	APPD	NJA	9-6-05	NGT 2012	
TOLERANCES			DRAWING/DOC. NO.		
UNLESS OTHERWISE STATED			03-01190		
2 PLACES DEC. ±			ISS		
1 PLACE DEC. ±			2		
ANGULAR 5			SHT 1		
			OF 1		

General information

NOTE The information in this section should be read in conjunction with the appropriate block diagram for the RF unit. See below to determine which block diagram you should be viewing.

For RF unit type...	See...
2011	03-01126
2012	03-01190

The transceiver uses double conversion in both the Receive and Transmit modes. Only the 455 kHz sideband filter and the local oscillators VCO and REF OSC are common to both modes of operation.

The signal routing is determined by switching and control voltages according to the selected mode.

Transmit path

Handset transmit path

The microphone audio is amplified in the handset and passed to the RF unit via the handset and speaker connection cable.

RF unit transmit path

Audio & Interconnect PCB (2011)/Audio Interconnect & Data I/O PCB (2012)

The audio from the microphone is buffered on the Audio & Interconnect PCB (2011)/Audio Interconnect & Data I/O PCB (2012), then passed to the Application Processor Handset I/F 3 V PCB (2011)/Application Processor Handset & Data I/F PCB (2012) for compression to convert the signal to a fixed level. This signal is then returned to the Audio & Interconnect PCB (2011)/Audio Interconnect & Data I/O PCB (2012) where it is forwarded to the RF/IF PCB.

RF/IF PCB

The audio is mixed with the local oscillator to produce double sideband. It is then filtered by a 2.5 kHz sideband filter centred on 455 kHz, so that only the wanted sideband is passed to the first mixer. It is then mixed with the reference oscillator to produce an IF signal centred on 45 MHz.

The transmit signal is filtered by a BPF with a bandwidth of 15 kHz, before being passed to the input of the second mixer.

At the second mixer, the signal mixes with the local oscillator VCO to produce the required channel frequency. The signal is passed to the PA PCB.

PA PCB

On the PA PCB, the signal is amplified then passed through the transmit/receive relay to the selected LPF.

The output from the LPF is passed via the VSWR detector to the RF output connector. From there it is connected by coaxial cable to the antenna.

Receive path

RF unit receive path

PA PCB

The receive signal from the antenna passes through a PA LPF to the transmit/receive relay. It is then passed to the receiver input on the RF/IF PCB.

RF/IF PCB

From the receiver input, the signal passes via a selectable pre-amplifier to the input of the first balanced mixer. Here it mixes with the local oscillator VCO to produce an IF signal centred on 45 MHz.

The 45 MHz signal is filtered using a BPF with a bandwidth of 15 kHz, before being passed to the second balanced mixer. The signal mixes with 44.545 MHz to produce an IF signal centred on 455 kHz.

The output from the second mixer passes through a 2.5 kHz sideband filter so that only the wanted sideband is fed to the high-gain AGC IF amplifier.

The amplified 455 kHz signal is demodulated to produce an audio signal and also to operate an AGC circuit. This circuit controls the gain of the IF amplifier to prevent overloading when strong signals are received. It also maintains constant audio output with changing input levels.

Audio & Interconnect PCB (2011)/Audio Interconnect & Data I/O PCB (2012)

The audio is passed to the Audio & Interconnect PCB (2011)/Audio Interconnect & Data I/O PCB (2012) where it divides into two paths. One path is the unprocessed (raw) audio. The other path is passed to the Application Processor Handset I/F 3 V PCB (2011)/Application Processor Handset & Data I/F PCB (2012) where the audio is enhanced (noise-reduced) before returning to the Audio & Interconnect PCB (2011)/Audio Interconnect & Data I/O PCB (2012). The required audio path is switch-selected and passed to the audio amplifier, then to the speaker via the handset and speaker connection cable.

Synthesiser operation

The transceiver uses a single-loop synthesiser. The synthesiser VCO is used as the first mixer LO, generating an oscillator frequency in 10 Hz steps. In Receive mode, the frequency of the oscillator ranges from 45.25 MHz to 75 MHz. In Transmit mode, the frequency of the oscillator ranges from 46.6 MHz to 75 MHz.

The reference oscillator at 14.848333 MHz is fed through a 44.5 MHz BPF to select the 3rd harmonic to produce the 44.545 MHz second mixer LO. The 14.848333 MHz frequency is also fed to two DDS ICs to produce a variable reference frequency for VCO with 10 Hz resolution.

The second DDS IC produces 456.5 kHz (USB) and 453.5 kHz (LSB) for the Tx MOD and Rx DEMOD circuits.

Control and switching

Most functions of the transceiver are controlled by microprocessors.

A microprocessor in the handset reads the key strokes entered by the user. The keyed data is then passed to the RF unit via the differential handset bus. The RF unit sends data to the handset to update the display over the same bus.

The RF unit contains five microprocessors located on four PCBs. Incoming data first goes to the main application microprocessor. This microprocessor then commands lower level microprocessors to carry out the required function.

This section contains the following topics:

[Power on \(70\)](#)

[Power off \(71\)](#)

[Supply voltages \(72\)](#)

[Transmit path \(75\)](#)

[Receive path \(87\)](#)

[Frequency control \(93\)](#)

[Microprocessors and control \(96\)](#)

[Internal voice encryptor \(101\)](#)

[Second IF filter option \(102\)](#)

This section should be read in conjunction with [page 201, *NGT—Drawings*](#).

Power on

Drawing [04-03125](#) and [04-03201](#), or

Drawing [04-03125](#) and [04-03423](#)

If the transceiver is off when the **Ⓢ** key is pressed, the +5.4 V standby voltage is applied to gate V9 resulting in the drain going low.

The PWR ON line passes via the handset bus, junction box and CIB to the Audio Interface PCB in the RF unit.

Drawing [04-03109](#)

PWR ON from the CIB switches V2 on and energises the latching relay coil K1. This closes contacts K1/C and K1/D resulting in the PWR ON line to the PA PCB being grounded.

ALTERNATIVE TEXT Drawing [04-03169](#)

The PWR ON line goes to the power relay coil K200. If the polarity of the DC supply is correct and below 16 V, V218 conducts and relay K200 energises, thus closing contacts of K200 and connecting the DC supply to the transceiver.

If the DC supply voltage exceeds 16 V, zener diode D203 conducts, causing V217 to also conduct and switch off V218, thus preventing K200 from energising.

Diode D205 prevents relay K200 from operating if the DC supply is reverse polarised.

The power input circuit is protected from high voltage transients by the voltage-dependent resistor R261.

ALTERNATIVE TEXT Drawing [04-03369](#), or
Drawing [04-03542](#)

The PWR ON line goes to the power relay coil K200. If the polarity of the DC supply is correct and below 16 V, V216 conducts and relay K200 energises, thus closing contacts of K200 and connecting the DC supply to the transceiver.

If the DC supply voltage exceeds 16 V, zener diode D203 conducts, causing V215 to also conduct and switch off V216, thus preventing K200 from energising.

Diode D205 prevents relay K200 from operating if the DC supply is reverse polarised.

The power input circuit is protected from high voltage transients by the voltage-dependent resistor R261.

Power off

Drawing [04-03125](#)

If the transceiver is on when the  key is pressed, IC3 pin 15 goes high. This causes data to be sent via the handset bus and CIB to the RF unit.

Drawing [04-03109](#)

The CIB data is decoded and the microprocessor IC12 pin 17 goes high. This causes V6 to conduct and energise the coil K1-OFF, thus opening the contacts K1/C and K1/D.

Drawing [04-03169](#), or

ALTERNATIVE TEXT Drawing [04-03369](#), or

Drawing [04-03542](#)

The PWR ON line goes high, de-energising the power relay coil K200 and thus switching off the transceiver.

Supply voltages

Handset

The supply voltages for the handset are shown in [Table 18](#).

Drawing [04-03125](#)

Table 18: Supply voltages for the Handset PCB in the handset

Supply	Description	Source
Standby	+5.4 V when transceiver is off	ext from junction box
Handset power	+9.2 V when transceiver is on	ext from junction box
+5 V	+5 V regulated supply	IC10
−9 V	−9 V for IC7	IC5

Junction box

The supply voltages for the junction box are shown in [Table 19](#) and [Table 20](#).

ALTERNATIVE TEXT Drawing [04-03201](#), or
Drawing [04-03423](#)

Table 19: Supply voltages for the Audio PCB in the junction box (04-03201 or 04-03423)

Supply	Description	Source
A (protected)	Unregulated battery supply	ext from RF unit
+10 V	+10 V regulated supply	IC12
+5 V	+5 V regulated supply	IC13
+5 VQ	+5 V quiet for opamp bias	IC13 (filtered)

Drawing [04-03133](#)

Table 20: Supply voltages for the Microprocessor PCB in the junction box

Supply	Description	Source
+5 V	+5 V digital supply	IC13
A (protected)	Unregulated battery supply	from RF unit

RF unit

The supply voltages for the RF unit are shown in [Table 21](#) to [Table 25](#).

Drawing [04-03109](#)

Table 21: Supply voltages for the Audio Interface PCB in the RF unit

Supply	Description	Source
A	Unregulated battery supply	via Filter and Control PCB
A (protected)	2 A current-limited battery	IC14
+10 V	+10 V regulated supply	IC9
+5 V	+5 V regulated supply	IC10
+5 VQ	+5 V quiet for opamp bias	IC10 (filtered)
+6 VSBY	+6.2 V standby for CIB	IC4, D9, D10

Drawing [04-03108 \(sheet 1\)](#)

Table 22: Supply voltages for the Application Processor PCB in the RF unit

Supply	Description	Source
+5 V	+5 V switchmode supply	IC6
VREF	+2.5 V reference voltage	IC5

ALTERNATIVE TEXT Drawing [04-03106 \(sheet 1\)](#)

Table 23: Supply voltages for the RF/IF PCB in the RF unit (04-03106)

Supply	Description	Source
A	Unregulated battery supply	via Audio Interface PCB
+5 V	+5 V regulated supply	IC210
+26 V	+26 V from charge pump supply	IC402
+10 V	+10 V regulated supply	via Audio Interface PCB
+10 VRx	+10 V In Rx	V419, V420
+10 VTx	+10 V In Tx	V421, V422

ALTERNATIVE TEXT Drawing [04-03378 \(sheet 1\)](#)

NOTE If the PCB issue status is -06 or earlier, see drawing [04-03378 \(sheet 1\)](#).

Table 24: Supply voltages for the RF/IF PCB in the RF unit (04-03378)

Supply	Description	Source
A	Unregulated battery supply	via Audio Interface PCB
+5 V	+5 V regulated supply	IC210
+26 V	+26 V from charge pump supply	IC402
+10 V	+10 V regulated supply	via Audio Interface PCB
+10 VRx	+10 V In Rx	V415, V416
+10 VTx	+10 V In Tx	V417, V418

ALTERNATIVE TEXT Drawing [04-03169](#), or
 Drawing [04-03369](#), or
 Drawing [04-03542](#)

Table 25: Supply voltages for the PA PCB and Filter and Control PCB in the RF unit (04-03169 or 04-03369 or 04-03542)

Supply	Description	Source
A	Unregulated battery supply	ext
+10 VA	+10 V regulated supply	IC1
+5 VA	+5 V regulated supply	IC4
+5 V	+5 V regulated supply	IC200

Transmit path

Handset microphone amplifier transmit path

Drawing [04-03125](#)

The handset has an electret microphone. When PTT is not pressed, the microphone audio is clamped by V5.

When PTT is pressed, V5 is turned off, allowing audio from the microphone to be passed to the amplifier IC9/B. The output of IC9/B is split into two paths, one going to the handset audio bus, the other passing through the inverter IC9/A before going to the handset audio bus. In this way, push-pull balanced audio is provided to the junction box via the handset bus.

Junction box transmit path

ALTERNATIVE TEXT Drawing [04-03201](#), or
Drawing [04-03423](#)

The junction box has four transmit audio inputs. These four inputs are mixed together at the input of IC7/A as described below:

- **Tx Audio Input 1:** When PTT is pressed on the handset, the handset audio on P7, pins 6 and 7, is passed to IC11/A. IC11/A converts the balanced audio to single-ended audio that is then passed to IC7/A.
- **Tx Audio Input 2:** When PTT is pressed on the desk console, the desk console audio is mixed via R57 at the input of IC7/A.
- **Tx Audio Input 3:** The audio input of the GPIO port is on pins 5 and 15 of J108. When the GPIO PTT is active, the balanced audio is passed via T1 before passing to the volume control IC2/C. IC2/C is activated to a preset level, controlled by firmware. The audio is then mixed via R58 at the input of IC7/A.
- **Tx Audio Input 4:** A tone used for Morse is generated by IC9 on the Microprocessor PCB in the junction box (drawing [04-03133](#)). The tone is passed to the tone volume control IC2/B before mixing via R56 at the input of IC7/A.

The output of IC7/A goes to IC11/B and then to IC10/A. These two ICs form a 3-pole low-pass anti-aliasing filter with a nominal 3 kHz cutoff frequency.

The output of IC10/A passes to IC10/B. IC10/B acts as a peak limiter due to H2 and H3 in the feedback path. The normal level for the audio is 1 V p-p. Where the audio level is much higher than this (such as when someone shouts into the microphone), IC10/B limits the output of IC10/A to approximately 4 V p-p. This protects the synchronisation pulse generated in the RF unit from becoming corrupted by large audio levels.

The output of IC10/B is split into two paths, one going to the TDM gate IC9/B, the other passing through the inverter IC8/B before going to the TDM gate IC9/A. This produces push-pull balanced audio.

Time division multiplex audio channels

ALTERNATIVE TEXT

Drawing [04-03201](#), or
 Drawing [04-03423](#)

The system audio uses TDM to produce seven channels of audio and one synchronisation pulse to reference the channel timing.

The audio is sampled at a rate of 12.5 kHz by the TDM gates IC9/A and IC9/B. IC9/A and IC9/B are driven by IC1.

The position of the audio channel varies depending on the requirements of the system. Its position can be determined by attaching an oscilloscope at TP2.

Figure 19: Representation of the waveform as measured at TP2

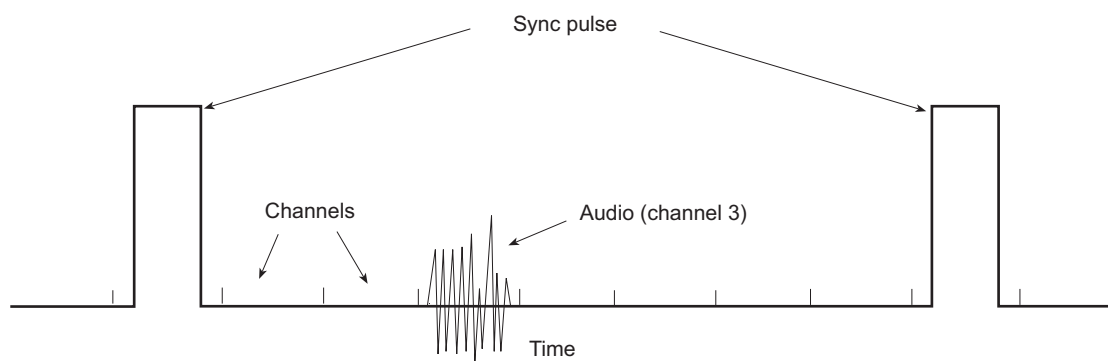

IC11 on the Audio Interface PCB in the RF unit (drawing [04-03109](#)), drives V3 and IC6/A to generate the synchronisation pulse.

The TDM audio from TDM gates IC9/A and IC9/B is passed to the RF unit via SYS AUDIO+/- on the CIB.

Codan Interconnect Bus transmit path

The CIB is an 8-wire bus that connects all the units in the system together:

- **SYS AUDIO+/-:** The audio is TDM balanced, as described in the previous section.
- **SYS DATA+/-:** The data uses CAN protocol. This protocol has good error-detection capabilities and performs well in high-noise environments. The data rate on the CIB is 125 kbps.
- **STBY:** Standby power is a 100 mA, 6 V DC continuous supply. This is used to backlight the **Ⓢ** key at night.
- **A PROTECTED:** The Protected **A** rail is an unregulated battery supply that is used to supply power to all the units in the transceiver system. The maximum current that this can supply is 2 A. If very long runs of the CIB cabling are required, an external supply may be connected to the junction box to supply power locally.
- **PWR ON:** The power on line is used to switch on the transceiver when the line is grounded (see [page 70, Power on](#)).
- **GND:** Ground is the supply return wire and is connected to the negative terminal of the battery.

RF unit—Audio Interface PCB transmit path

Drawing [04-03109](#)

The Transmit TDM SYS audio from the CIB goes to IC7/B. IC7/B then converts the push-pull audio to single-ended audio so that the correct audio channel is sampled by IC6/D.

C21 is the hold capacitor, and IC7/A, IC8/A and IC8/B form a 5-pole Chebyshev reconstruction filter with a nominal cutoff frequency of 3 kHz. The filtered audio then goes to the Application Processor PCB via ADC AUX IN.

RF unit—Application Processor PCB transmit path

Drawing [04-03108 \(sheet 1\)](#)

The transmit audio goes to IC5 pin 28. This audio interface device contains an ADC and a DAC.

The analog transmit audio is sampled and converted by IC5 into digital format. A compression function is applied to the digital audio as shown in [Figure 20](#) below.

Figure 20: Representation of compression function by IC5

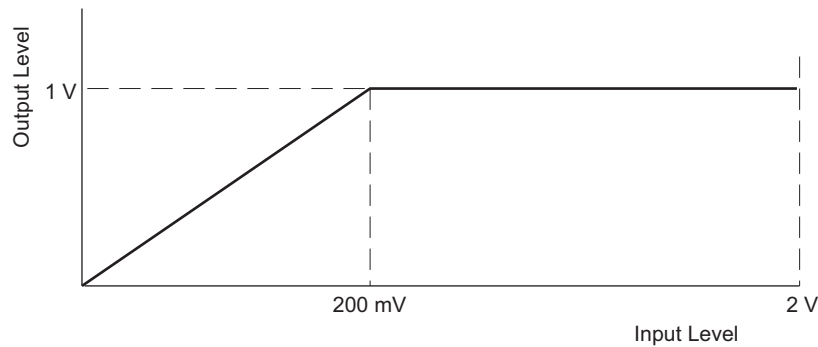

The decay time constant is controlled by firmware and can be varied depending on the type of transmission. For example, for speech, the time constant needs to be short, but for data it needs to be lengthened to improve the BER.

The DAC outputs of IC5 pins 3 and 4 are summed together in IC7/A to produce an output of 1 V p-p. This output then goes via the Audio Interface PCB to the RF/IF PCB.

The output level, which is controlled by firmware, is halved when AM is transmitted or low power is selected.

RF unit—RF/IF PCB transmit path

Transmit/Receive switching

ALTERNATIVE TEXT Drawing [04-03106 \(sheet 3\)](#)

The PTT command from the handset via the CIB causes IC405 to drive pins 12 and 13 (Rx Switch and Tx Switch). This switches off V419 and V420 and switches on V421 and V422, thus causing +10 V_{Tx} to be active. This switches all circuits to the Transmit mode.

ALTERNATIVE TEXT Drawing [04-03378 \(sheet 3\)](#)

NOTE If the PCB issue status is -06 or earlier, see drawing [04-03378 \(sheet 3\)](#).

The PTT command from the handset via the CIB causes IC408 to drive pins 12 and 13 (Rx Switch and Tx Switch). This switches off V415 and V416 and switches on V417 and V418, thus causing +10 V_{Tx} to be active. This switches all circuits to the Transmit mode.

Transmit modulator

ALTERNATIVE TEXT Drawing [04-03106 \(sheet 2\)](#), or
Drawing [04-03378 \(sheet 2\)](#)

NOTE If the PCB issue status is -06 or earlier, see drawing [04-03378 \(sheet 2\)](#).

The audio goes to the Tx Level potentiometer R256 to set the exciter output level at J2 to 650 mV p-p. It is passed to the input of the balanced modulator IC204 pin 1. The modulator is enabled when +10 V_{Tx} is applied via R254 to the bias input pin 5.

The audio is mixed with the local oscillator of 456.5 kHz (453.5 kHz for LSB). The local oscillator is applied to IC204 pins 8 and 10. This produces a DSB output at pin 6. From there it is passed via D205 to the 455 kHz sideband ceramic filter Z201 pin 1.

455 kHz filter and first mixer

ALTERNATIVE TEXT Drawings [04-03106 \(sheet 1\)](#) and [04-03106 \(sheet 2\)](#), or
Drawings [04-03378 \(sheet 1\)](#) and [04-03378 \(sheet 2\)](#)

NOTE If the PCB issue status is -06 or earlier, see drawings [04-03378 \(sheet 1\)](#) and [04-03378 \(sheet 2\)](#).

(sheet 2) The 455 kHz sideband ceramic filter Z201, with a bandwidth of 2.5 kHz, filters out the unwanted sideband and leaves only the wanted sideband at pin 3. From there it is passed via the noise limiter gate V204 to a tuned auto transformer T202.

(sheet 1) The signal is passed from T202 via a resistor-matching attenuator network R144, R145 and R146 to the input of the first balanced amplifier/mixer IC103 pins 12 and 13. IC103 is enabled by applying +10 V_{Tx}. This applies DC via R142 to pin 4, and bias current via R143 to pin 11. The filtered +10 V rail is applied to the mixer output, pins 3 and 14, via the centre tap of the output transformer T108.

The 455 kHz transmit signal is mixed with 44.545 MHz (LO2), which is applied to IC103 pin 5 to produce a second IF output signal at pins 3 and 14 centred on 45 MHz. The gain of the mixer/amplifier is approximately 20 dB.

45 MHz band-pass filter

ALTERNATIVE TEXT Drawing [04-03106 \(sheet 1\)](#), or
Drawing [04-03378 \(sheet 1\)](#)

NOTE If the PCB issue status is -06 or earlier, see drawing [04-03378 \(sheet 1\)](#).

The 45 MHz IF signal is filtered through a 15 kHz-wide BPF consisting of T108, Z104, L117, Z103 and T107. This filter removes unwanted signals produced by the first mixer. The filtered output goes to the balanced input of the second mixer IC102 pins 12 and 13. R138 is between T107 and IC102 and is used as a fine balance adjustment for the mixer to remove unwanted spurious signals.

Second mixer and exciter output filter

ALTERNATIVE TEXT Drawing [04-03106 \(sheet 1\)](#), or
Drawing [04-03378 \(sheet 1\)](#)

NOTE If the PCB issue status is -06 or earlier, see drawing [04-03378 \(sheet 1\)](#).

The second mixer IC102 is enabled by applying +10 VTx. This applies DC via R133 to pin 4, and bias current via R134 to pin 11. The filtered +10 V rail is applied via L116 and the transformer T106 to the mixer output from pins 3 and 14.

The 45 MHz transmit signal is applied to IC102 pins 12 and 13. It is mixed with the output of the local oscillator LO1+, LO1– (applied to IC102 pins 5 and 7) to produce the selected channel frequency at the mixer output pins 3 and 14. The gain of the mixer/amplifier is approximately 20 dB.

The mixer output goes via a 30 MHz LPF to the transmit exciter output connector J2. From there it is coupled via a coaxial cable to the PA assembly.

Tuning

ALTERNATIVE TEXT Drawings [04-03106 \(sheet 3\)](#), [04-03106 \(sheet 2\)](#) and [04-03106 \(sheet 1\)](#)

When the Tune command is activated, IC405 pin 7 (sheet 3) goes low. This switches off V416 to allow the 456.5 kHz local oscillator carrier (453.5 kHz for LSB) to be passed to V206 (sheet 2) via CAR INJ. V206 inserts carrier to the input transformer T202 of the first Tx mixer IC103 (sheet 1).

At the same time, IC405 pin 5 (Tx MUTE) goes high and switches on V203 (sheet 2). Thus, IC202/C and IC202/B open the noise gate V204, which stops the inserted carrier from being loaded by the sideband filter Z201.

The carrier at the output of the second mixer IC102 (sheet 1) is at the frequency of the selected channel (the SCF). This frequency is used for tuning automatic antennas.

ALTERNATIVE TEXT Drawings [04-03378 \(sheet 3\)](#), [04-03378 \(sheet 2\)](#) and [04-03378 \(sheet 1\)](#)

NOTE If the PCB issue status is -06 or earlier, see drawings [04-03378 \(sheet 3\)](#), [04-03378 \(sheet 2\)](#) and [04-03378 \(sheet 1\)](#).

When the Tune command is activated, IC408 pin 7 (sheet 3) goes low. This switches off V413 to allow the 456.5 kHz local oscillator carrier (453.5 kHz for LSB) to be passed to V206 (sheet 2) via CAR INJ. V206 inserts carrier to the input transformer T202 of the first Tx mixer IC103 (sheet 1).

At the same time, IC408 pin 5 (Tx MUTE) goes high and switches on V203 (sheet 2). Thus, IC202/C and IC202/B open the noise gate V204, which stops the inserted carrier from being loaded by the sideband filter Z201.

The carrier at the output of the second mixer IC102 (sheet 1) is at the frequency of the selected channel (the SCF). This frequency is used for tuning automatic antennas.

RF unit—PA PCB transmit path

Gain control stage

ALTERNATIVE TEXT Drawing [04-03169](#)

The RF input is passed to T200, which turns the RF drive into push-pull. This is applied to the variable gain stage V200 and V201. The FETs V202 and V203 are used as variable resistors depending on the ALC voltage applied to the gates.

If there is no power output at the antenna connector, 5 V of ALC voltage is applied to the gates, so that the resistance is low and the gain is at maximum. As the output from the PA increases to the power set point (100 W or 125 W), the ALC voltage drops, thus increasing the resistance in the FETs, and so reducing the gain of V200 and V201, and keeping the Tx output power at the set level (100 W or 125 W).

The overall gain of the PA is set to a constant value by R205 (PA GAIN).

ALTERNATIVE TEXT Drawing [04-03369](#), or
Drawing [04-03542](#)

The RF input is passed to T200, which turns the RF drive into push-pull. This is applied to the variable gain stage V200 and V201. The FETs V202 and V203 are used as variable resistors depending on the ALC voltage applied to the gates.

If there is no power output at the antenna connector, 5 V of ALC voltage is applied to the gates, so that the resistance is low and the gain is at maximum. As the output from the PA increases to the power set point (100 W or 125 W), the ALC voltage drops, thus increasing the resistance in the FETs, and so reducing the gain of V200 and V201, and keeping the Tx output power at the set level (100 W or 125 W). V16 and V17 switch between 100 W and 125 W. When V17 is on, the output power is 100 W. When V17 is off, the output power is 125 W.

The overall gain of the PA is set to a constant value by R205 (PA GAIN).

Pre-driver stage

ALTERNATIVE TEXT Drawing [04-03169](#)

The levelled RF from the gain control stage is passed via T201 to the Class A push-pull amplifier formed by V204 and V205. L202 and C207 provide a small amount of high frequency gain peaking to ensure the overall gain is flat with frequency.

ALTERNATIVE TEXT Drawing [04-03369](#), or
Drawing [04-03542](#)

The levelled RF from the gain control stage is passed via T201 to the Class A push-pull amplifier formed by V204 and V205. L202 and C207 provide a small amount of gain peaking to ensure the overall gain is flat with frequency.

Driver stage

ALTERNATIVE TEXT Drawing [04-03169](#)

The signal from the pre-driver stage goes via T202 to the driver stage. The driver is a Class B push-pull amplifier that provides a voltage drive to the output stage.

Each side of the amplifier has three transistors in parallel (V207, V208 and V209, and V210, V211 and V212). These transistors have resistors on their emitters to force them to share the load.

The bias for the driver stage, provided by the emitter follower V206 and set by R222 (DR. BIAS), is applied to the centre tap of T202.

ALTERNATIVE TEXT Drawing [04-03369](#)

The signal from the pre-driver stage goes via T202 to the driver stage. The driver is a Class B push-pull amplifier that provides a current drive to the output stage.

V207 and V208 have collector to base feedback to flatten the gain. R273 balance control varies the gain slightly in V208, which is used to balance the second harmonic (see [page 185, *Adjusting balance control*](#)).

The bias for the driver stage, provided by V214 and V206, and set by R222 (DR. BIAS), is applied to the centre tap of T202.

ALTERNATIVE TEXT Drawing [04-03542](#)

The signal from the pre-driver stage goes via T202 to the driver stage. The driver is a Class B push-pull amplifier that provides a current drive to the output stage.

V207 and V208 have drain to gate feedback to allow balance adjustment to the second harmonic (see [page 185, *Adjusting balance control*](#)).

The bias for the driver FET is provided to each gate individually via R222 (DR BIAS 1) and R235 (DR BIAS 2) from the temperature-compensated reference IC201/A.

Output stage and bias generator

ALTERNATIVE TEXT Drawing [04-03169](#)

The Class B push-pull output stage formed by V215 and V216 is driven from T203 to produce the nominal 100 W or 125 W PEP.

The bias voltage applied to each gate of V215 and V216 via R250 and R251 varies in level depending on the output level.

The drive waveform from the halfwave rectifier D200 is applied to the squaring (x^2) function circuit comprising IC202/B, V213 and V214. The output of this circuit is then amplified by IC202/A.

The static point of the bias is set by R240 (PA. BIAS) and the amount of waveform bias is set by R244 (GAIN). The bias voltage is then passed to the gates of the output stage. When the matched pair of output FETs is not perfect, the balance potentiometer R253 is used to trim the bias voltage so that equal current is drawn by each output FET.

The balanced to unbalanced impedance-matching output transformer T204 couples the power amplifier output to the band filters via J2 and the PTT relay K8.

Output stage and bias regulator

ALTERNATIVE TEXT Drawing [04-03369](#), or
Drawing [04-03542](#)

The Class B push-pull output stage formed by V211 and V212 is driven from T203 to produce the nominal 100 W or 125 W PEP.

The bias regulator V209 and V213 provides a voltage to the bases of V211 and V212. The transistors V209 and V213 form a feedback voltage regulator. The output voltage is the base-emitter voltage of V209 and is adjustable by the preset potentiometer R239. The transistor V209 is mounted close to the output transistor and provides temperature compensation to the bias network.

The transistor V210 modifies the output bias voltage slightly depending on the level of signal detected by D208. The amount of control voltage is varied by R241 and is adjusted to minimise high order intermodulation products.

The balanced to unbalanced impedance-matching output transformer T204 couples the power amplifier output to the band filters via J2 and the PTT relay K8.

Output filters

ALTERNATIVE TEXT Drawing [04-03169](#), or
Drawing [04-03369](#), or
Drawing [04-03542](#)

The transmit frequency range is 1.6 to 30 MHz. Seven LPFs are used to remove the harmonics generated by the PA. The filters are operated from IC2 and IC3 and are selected using relays K1 to K7 as required.

The output of the filter circuit passes through the RF bridge formed by T1 and associated components to the antenna output.

Automatic level control

The ALC is controlled by:

- forward power
- reflected power
- drain voltage swing of output stage
- battery voltage
- overtemperature of heatsink
- failure of transmit/receive or filter relays

ALTERNATIVE TEXT Drawing [04-03169](#)

All the ALC inputs (except relay detection) are applied to V7 to V10. The ORed output is connected via R50 and D14 to the positive input pin of the ALC level comparator IC5/A pin 3. The reference voltage connected to pin 2 is firmware controlled by the microprocessor IC2.

The microprocessor IC2 and R19 are used as a 5-bit DAC with an output range of 5 to 2.5 V. The output from R19 pin 1 is buffered by IC6/B and then divided and filtered by R55, R56 and C151. The output is then buffered again by IC6/A and used as the reference voltage for IC5/A and IC201/B. This allows the microprocessor IC2 to reduce the PA output at the higher operating frequencies and ensures that the intermodulation distortion remains within specified limits.

The output voltage of the RF bridge formed by T1 and associated components is rectified by D1 for the forward power and by D2 for the reflected power.

The output of the forward rectifier D1 is applied via R37 to the input of V7. The sum of the resistors between the base of V7 and ground form a resistor divider network. This determines the nominal PEP output level when matched to a 50 Ω load.

For high power, the resistors R34 and R35 are shorted out when +5 V is applied to the gate of the FET switch V6 and do not contribute to the chain. The nominal high-power output, which is measured at low frequency, is set by R32 (SET HI PWR).

For low power, V6 is off, so R34 and R35 are added to the divider. R35 (LOW PWR) sets the power to 12 W PEP.

The output of the forward detector D1 is also applied to V8 via an averaging detector circuit formed by R40, R43 and C147. When the average of the signal exceeds the peak detector circuit V7, V8 takes control and reduces the output power (this occurs on single tones such as Tune mode, CW (Morse) and in some data transmissions).

When the handset PTT is active, V11 is switched off, which disables the average ALC circuit. In these circumstances, the transceiver produces full PEP on a single tone. This is for measurement reasons only.

The peak output drain swing is rectified by D202 and applied to the transistor V10. V10 conducts and limits the drain peak to 34 V to prevent damage to the output FETs.

The battery voltage is monitored by V5. When the supply voltage (**A** rail) drops to approximately 12 V, the voltage at the base of V5 falls and causes V5 to conduct. This changes the threshold of the forward power ALC detector. The ALC detector then starts to reduce the output power and since the control is linear, a further reduction in supply voltage continues to lower the output power.

If the heatsink temperature exceeds 80°C (176°F), the PTC resistor R262 rapidly increases its resistance. This causes V13 to conduct and thus reduces the reference voltage (R19 pin 1). This lowers the output power and prevents the heatsink temperature from exceeding 100°C (212°F).

The relay protection circuit is formed by IC5/B and associated components. It simultaneously monitors the output FET, drain swing of the output FET and forward detector output of D1. If a relay failure results in no signal at the antenna output, the output of IC5/B goes high. This lowers the gain of the input amplifiers V200 and V201 and thus reduces the drive to the output FETs to a safe level.

The ALCs control the output from the summing amplifier IC5/A. This output passes to IC201/B, which inverts the direction of the control signal to drive the variable resistor FETs V202 and V203 in the gain stage (see [page 81, Gain control stage](#)).

ALTERNATIVE TEXT

Drawing [04-03369](#), or
Drawing [04-03542](#)

All the ALC inputs (except relay detection) are applied to V7 to V10. The ORed output is connected via R50 and D14 to the positive input pin of the ALC level comparator IC5/A pin 3. The reference voltage connected to pin 2 is firmware controlled by the microprocessor IC2.

The microprocessor IC2 and R19 are used as a 5-bit DAC with an output range of 5 to 2.5 V. The output from R19 is buffered by IC6/B and then divided and filtered by R55, R56 and C151. The output is then buffered again by IC6/A and used as the reference voltage for IC5/A and IC201/B. This allows the microprocessor IC2 to reduce the PA output at the higher operating frequencies and ensures that the intermodulation distortion remains within specified limits.

The output voltage of the RF bridge formed by T1 and associated components is rectified by D1 for the forward power and by D2 for the reflected power.

The output of the forward rectifier D1 is applied via R37 to the input of V7. The sum of the resistors between the base of V7 and ground form a resistor divider network. This determines the nominal PEP output level when matched to a 50 Ω load.

For high power, the resistors R34 and R35 are shorted out when +5 V is applied to the gate of the FET switch V6 and do not contribute to the chain. The nominal high-power output, which is measured at low frequency, is set by R32 (SET HI PWR). V17 switches between 100 W and 125 W.

NOTE Fitting link X2 toggles the power setting from 125 to 100 W or from 100 to 125 W.

For low power, V6 is off, so R34 and R35 are added to the divider. R35 (LOW PWR) sets the power to 12 W PEP.

The output of the forward detector D1 is also applied to V8 via an averaging detector circuit formed by R40, R43 and C147. When the average of the signal exceeds the peak detector circuit V7, V8 takes control and reduces the output power (this occurs on single tones such as Tune mode, CW (Morse) and in some data transmissions).

When the handset PTT is active, V11 is switched off, which disables the average ALC circuit. In these circumstances, the transceiver produces full PEP on a single tone. This is for measurement reasons only.

The peak output collector swing is rectified by D202 and applied to the transistor V10. V10 conducts and limits the collector peak to 42 V to prevent damage to the output transistors.

The battery voltage is monitored by V5. When the supply voltage (**A** rail) drops to approximately 12 V, the voltage at the base of V5 falls and causes V5 to conduct. This changes the threshold of the forward power ALC detector. The ALC detector then starts to reduce the output power and since the control is linear, a further reduction in supply voltage continues to lower the output power.

If the heatsink temperature exceeds 80°C (176°F), the PTC resistor R262 rapidly increases its resistance. This causes V13 to conduct and thus reduces the reference voltage R19. This lowers the output power and prevents the heatsink temperature from exceeding 100°C (212°F).

The relay protection circuit is formed by IC5/B and associated components. It simultaneously monitors the output transistor collector swing and forward detector output of D1. If a relay failure results in no signal at the antenna output, the output of IC5/B goes high. This lowers the gain of the input amplifiers V200 and V201 and thus reduces the drive to the output transistors to a safe level.

The ALCs control the output from the summing amplifier IC5/A. This output passes to IC201/B, which inverts the direction of the control signal to drive the variable resistor FETs V202 and V203 in the gain stage (see [page 81](#), *Gain control stage*).

Receive path

Input low-pass filters

ALTERNATIVE TEXT Drawing [04-03169](#), or
Drawing [04-03369](#), or
Drawing [04-03542](#)

The receiver input signal goes through one of seven relay-selected LPFs K1 to K7. The signal then goes via the transmit/receive relay K8 and signal-clamping diodes D3 to D9 to connector J1.

Broadcast filter and RF amplifier

ALTERNATIVE TEXT Drawing [04-03106 \(sheet 1\)](#), or
Drawing [04-03378 \(sheet 1\)](#)

NOTE If the PCB issue status is -06 or earlier, see drawing [04-03378 \(sheet 1\)](#).

The signal goes through a broadcast filter to reduce any very strong broadcast frequencies below 1.6 MHz, and then goes to the RF amplifier V101. V101 has a nominal gain of 9 dB.

When there are very strong signals present, V101 is not required and may be switched off via the handset using the Cfg RF Pre-Amp entry in the Control List. When this occurs, a 10 dB attenuator pad is switched by relay K101 to reduce the signal going to mixer RxMIX1. The signal then passes through a 30 MHz LPF to remove signals above 30 MHz.

First mixer

ALTERNATIVE TEXT Drawing [04-03106 \(sheet 1\)](#), or
Drawing [04-03378 \(sheet 1\)](#)

NOTE If the PCB issue status is -06 or earlier, see drawing [04-03378 \(sheet 1\)](#).

The balanced mixer, formed by V103, V104, V105 and V106, mixes the received signal with the local oscillator LO1+, LO1– (VCO). LO1 is buffered by V107 and V108 to produce an IF of 45 MHz. The mixer has a conversion gain of 4 dB.

45 MHz band-pass filter and amplifier

ALTERNATIVE TEXT Drawing [04-03106 \(sheet 1\)](#), or
Drawing [04-03378 \(sheet 1\)](#)

NOTE If the PCB issue status is -06 or earlier, see drawing [04-03378 \(sheet 1\)](#).

The 45 MHz IF signal is filtered through a 15 kHz-wide BPF Z101 and then amplified by V109. It is filtered again by Z102. This removes the unwanted signals produced by the first mixer.

Second mixer

ALTERNATIVE TEXT Drawings [04-03106 \(sheet 1\)](#) and [04-03106 \(sheet 2\)](#), or Drawings [04-03378 \(sheet 1\)](#) and [04-03378 \(sheet 2\)](#)

NOTE If the PCB issue status is -06 or earlier, see drawings [04-03378 \(sheet 1\)](#) and [04-03378 \(sheet 2\)](#).

Mixer IC101 is a combined amplifier/balanced mixer. The 45 MHz signal is mixed with the local oscillator LO2 (44.545 MHz) applied to pin 5. The mixing produces a second IF centred at 455 kHz.

DC to the mixer output is provided by the +10 V rail, which is connected to the centre tap of the 455 kHz output transformer T202 (sheet 2). In Receive mode, the +10 VRx rail provides DC via R132 to IC101 pin 4, and bias via R131 to IC101 pin 11.

Noise limiter

ALTERNATIVE TEXT Drawings [04-03106 \(sheet 1\)](#) and [04-03106 \(sheet 2\)](#)

The 455 kHz output of IC101 pins 3 and 14 (sheet 1) is applied to the balanced input of the high-gain amplifier IC201 pins 4 and 6. The balanced outputs at pins 1 and 8 are connected to a tuned auto transformer T201 (455 kHz). The output of T201 goes to the base of the active rectifier V201. Noise bursts produce positive-going pulses at the collector of V201, and via V202, trigger the monostable flip-flop IC202/B/C. The pulse width is determined by C210, R210 and R211 (nominally 250 µs).

The outputs of IC202/B/D pins 11 and 4 produce complementary pulses that are connected to the FET gates of V204 and V205. These gate out the noise bursts from the 455 kHz signal. With V204 on and V205 off, the IF signal is passed to the sideband filter Z201. When a noise burst is present, V204 is switched off and V205 is switched on, blocking the IF signal for the period of the gate pulse.

The average DC component of the collector current of V201 is used as an automatic gain control to IC201. It is applied via R206 to pin 5. This ensures that only the noise burst signal triggers the flip-flop IC202/B/C. The AGC decay constant is set by the components C206 and R205.

In Transmit mode, IC202 is disabled (see [page 80, Tuning](#)).

ALTERNATIVE TEXT Drawings [04-03378 \(sheet 1\)](#) and [04-03378 \(sheet 2\)](#)

NOTE If the PCB issue status is -06 or earlier, see drawings [04-03378 \(sheet 1\)](#) and [04-03378 \(sheet 2\)](#).

The 455 kHz output of IC101 pins 3 and 14 (sheet 1) is applied to the balanced input of the high-gain differential amplifier IC201 pins 2 and 13. The balanced outputs at pins 7 and 8 are connected to a tuned auto transformer T201 (455 kHz). The output of T201 goes to the base of the active rectifier V201. Noise bursts produce positive-going pulses at the collector of V201, and via V202, trigger the monostable flip-flop IC202/B/C. The pulse width is determined by C210, R210 and R211 (nominally 250 µs).

The outputs of IC202/B/D pins 11 and 4 produce complementary pulses that are connected to the FET gates of V204 and V205. These gate out the noise bursts from the 455 kHz signal. With V204 on and V205 off, the IF signal is passed to the sideband filter Z201. When a noise burst is present, V204 is switched off and V205 is switched on, blocking the IF signal for the period of the gate pulse.

The average DC component of the collector current of V201 is used as an automatic gain control to IC201. It is applied via R206 and IC211 to pins 6 and 11. This ensures that only the noise burst signal triggers the flip-flop IC202/B/C. The AGC decay constant is set by the components C206 and R204.

In Transmit mode, IC202 is disabled (see [page 80, Tuning](#)).

455 kHz filter and IF amplifier

ALTERNATIVE TEXT Drawing [04-03106 \(sheet 2\)](#)

The IF signal from the noise blanker gate V204 is passed to the 2.5 kHz-wide ceramic filter Z201. The filter removes the unwanted sideband, adjacent channels and other unwanted products generated by the second mixer. The wanted sideband, centred at 455 kHz, is passed by the filter to a 3-stage gain-controlled IF amplifier comprising V210, V211, V212 and associated components. The IF amplifier is broadly tuned to 455 kHz by the tuned circuits L201 and C229, L202 and C232, and L203 and C236.

When the optional filter Z202 is installed, relays K201 and K202 are fitted and links LK201 and LK202 are cut. The optional filter is selected when V207 is activated to energise the relays.

ALTERNATIVE TEXT Drawing [04-03378 \(sheet 2\)](#)

NOTE If the PCB issue status is -06 or earlier, see drawing [04-03378 \(sheet 2\)](#).

The IF signal from the noise blanker gate V204 is passed to the 2.5 kHz-wide ceramic filter Z201. The filter removes the unwanted sideband, adjacent channels and other unwanted products generated by the second mixer. The wanted sideband, centred at 455 kHz, is passed by the filter to a 3-stage gain-controlled IF amplifier comprising V210, V211, V212 and associated components. The IF amplifier is broadly tuned to 455 kHz by the tuned circuits L201 and C229, L202 and C232, and L203 and C236.

When the optional 500 Hz filter is installed, the 500 Hz Filter PCB (Codan part number 08-05890-001) is added and R222 and R223 are removed. The optional filter is selected when V207 is activated.

Automatic gain control

ALTERNATIVE TEXT Drawing [04-03106 \(sheet 2\)](#), or
Drawing [04-03378 \(sheet 2\)](#)

NOTE If the PCB issue status is -06 or earlier, see drawing [04-03378 \(sheet 2\)](#).

An AGC is applied to a number of stages in the receiver. This is used to increase the dynamic range of the receiver and to maintain an almost constant audio output level for a large variation of input signals.

When the receiver is at maximum gain, the AGC at the output of IC205/A is nominally 6.4 V. This voltage is set by the voltage reference IC206 and associated components.

The IF signal is rectified by V214 and the resulting DC is amplified by IC205/B. The signal is then passed to various timing circuits.

The signal is passed through D207 to the fast attack circuit (2 ms) comprising V215, R274 and C253. The signal also charges the slow decay circuit comprising IC207/D, R279 and C254. The outputs from these two circuits are summed together at the emitter junction of V216 and IC207/A, then passed to the amplifier IC205/A.

The decay characteristic of the AGC circuit can be fast, slow or hold. Fast decay time is set by C253 and R280. Slow decay time is set by C254 and R283 (1 s). Hold decay timing is set by the discharge constant of C254, R285 and delay circuit C256 and R284. The hold circuit holds the AGC voltage constant for a short period after the signal reduces, which can improve the readability of the signal.

If fast decay AGC is required the AGC FAST/SLOW control line is held high by the microprocessor. This disables the slow charge capacitor C254.

If slow decay AGC is required the AGC FAST/SLOW control line is held low and the HOLD/TRIGGER line is held high.

If hold decay AGC is required both the AGC FAST/SLOW and the HOLD/TRIGGER control lines are held low.

Note that the ‘trigger’ part of the HOLD/TRIGGER control line name is not related to the AGC circuit at all. This multifunction HOLD/TRIGGER line is used by a built-in test function during adjustment procedures.

The AGC voltage is passed to the IF amplifier. As the signal increases in level, the AGC voltage reduces and hence lowers the gain of the IF amplifier, thus keeping the output level constant.

If the signal level is very large, the anti-log and bias circuit comprising IC203 and associated components operates. When operating, this circuit causes RF AGC voltage to reduce, which in turn causes D104 (drawing [04-03106 \(sheet 1\)](#) or [04-03378 \(sheet 1\)](#)) to conduct. This reduces signal levels at mixer RxMIX1 and helps to keep the level constant at the 455 kHz IF output.

There is an AGC DUMP input to dump any AGC voltage from a high-level signal on a previously selected channel when the channel is changed. This allows the new channel to have maximum gain. The dump is achieved by pulling the AGC DUMP control line low and the AGC FAST/SLOW control line high for a short period when a channel is changed.

Demodulator

ALTERNATIVE TEXT Drawing [04-03106 \(sheet 2\)](#), or
Drawing [04-03378 \(sheet 2\)](#)

NOTE If the PCB issue status is -06 or earlier, see drawing [04-03378 \(sheet 2\)](#).

The output of the 455 kHz IF amplifier is passed to the input of a double balanced mixer IC208. The IF signal is mixed with the local oscillator that is applied to pins 8 and 10 to produce an audio output at pin 6. The local oscillator operates at 456.5 kHz for USB operation and 453.5 kHz for LSB.

The audio is then filtered by the LPF comprising IC209 and associated components, before being passed to the Audio Interface PCB.

RF unit—Audio Interface PCB receive path

Voice mute

Drawing [04-03109](#)

The audio from the RF/IF PCB is fed to the input of the mute stage squaring amplifier IC15/A. The squared audio is then fed to a charge pump circuit comprising V10 and associated components. This circuit performs a frequency to voltage function that causes the resultant DC voltage to rise as the frequency increases.

IC16/A and associated components function as an LPF with a cutoff frequency of approximately 10 Hz. The output from IC16/A is a DC voltage, varying at the syllabic rate of the speech received.

IC15/C and IC15/D form a window comparator. The window width is adjusted by the preset MUTE ADJ R85. The divider network R87, R88 and C64 provides the reference voltage for the window comparator. If the output rises or falls below this reference by the amount set by R85, the open collector outputs of IC15/C and IC15/D discharge C65, thus applying a low to the negative input of comparator IC15/B. When the output from this comparator goes high, it indicates to several microprocessors that speech has been detected. The microprocessors then signal the junction box (via the CIB) to switch the audio path on by enabling volume control IC2/E (drawing [04-03201](#) or [04-03423](#)).

Time division multiplex audio generation

Drawing [04-03109](#)

The raw receive audio passes through an LPF comprising IC3/B and IC3/A. It is then sampled by IC1/A and IC1/D at a rate of 12.5 kHz, which produces the TDM audio for the CIB.

The raw CIB audio is also passed via IC7 and IC8 to the Application Processor PCB where the DSP enhances the received audio. This audio enhancement is a proprietary function called *Easitalk*[®].

The output from the DSP (DAC-OUT) is filtered by IC2/B and IC2/A. It is then sampled by IC1/B and IC1/C and becomes another audio channel on the CIB. The user can select either raw audio or this enhanced audio via the handset. The channel switching is performed in the junction box.

Codan Interconnect Bus receive path

The CIB is an 8-wire bus that connects all the units in the system together:

- **SYS AUDIO+/-:** The audio is TDM balanced (see [page 91, Time division multiplex audio generation](#)).
- **SYS DATA+/-:** The data uses CAN protocol. This protocol has good error-detection capabilities and performs well in high-noise environments. The data rate on the CIB is 125 kbps.
- **STBY:** Standby power is a 100 mA, 6 V DC continuous supply. This is used to backlight the  key at night.
- **A PROTECTED:** The Protected A rail is an unregulated battery supply that is used to supply power to all the units in the transceiver system. The maximum current that this can supply is 2 A. If very long runs of the CIB cabling are required, an external supply may be connected to the junction box to supply power locally.
- **PWR ON:** The power on line is used to switch the transceiver on when the line is grounded (see [page 70, Power on](#)).
- **GND:** Ground is the supply return wire and is connected to the negative terminal of the battery.

Junction box receive path

Time division multiplex audio reconstruction and audio amplifier

Drawing [04-03201](#), or
Drawing [04-03423](#)

The push-pull system audio is converted to single-ended audio by IC8/A. The synchronisation pulse is detected by V1 and fed to IC1 to synchronise the audio channels. IC9/D and IC9/C sample the audio channels depending on requirements. Each audio path has a 5-pole Chebyshev reconstruction filter comprising IC4, IC5 and IC6, with a nominal cutoff frequency of 3 kHz.

One audio path goes via the volume control IC2/E and IC7/B, which is microprocessor controlled from the speaker volume keys on the handset. This signal then goes to the audio power amplifier IC3, which drives the loudspeaker.

The other audio path goes to the GPIO port for auxiliary equipment.

Frequency control

Reference oscillator

ALTERNATIVE TEXT Drawing [04-03106 \(sheet 3\)](#)

The reference oscillator is a Butler zero phase-shift type, and is formed by V412, V413 and associated components. There are two outputs from the reference oscillator, one via V414, which is the local oscillator signal (LO2) for IC101 and IC103, the other via V415 to the two DDS ICs IC403 and IC404.

ALTERNATIVE TEXT Drawings [04-03410](#) and [04-03378 \(sheet 3\)](#)

NOTE If the PCB issue status is -06 or earlier, see drawing [04-03378 \(sheet 3\)](#).

The reference oscillator is formed by the unbuffered inverter logic gate IC1 and Z1. The output from IC1 is amplified by IC2 to ensure there is a square wave output. The 14.848333 MHz square wave output is then connected to the DDS ICs IC403 and IC405 via the buffer IC404.

The 14.848333 MHz square wave output is also fed to the 44.5 MHz BPF where the third harmonic is selected and then buffered by V412 to produce the 44.545 MHz local oscillator signal (LO2) for IC101 and IC103.

Oven controller

ALTERNATIVE TEXT Drawing [04-03095](#)

The crystal Z401 is in an oven that runs at approximately 70°C (158°F). The NTC resistor R4 measures the temperature of the crystal and causes the opamp comparator IC1 to vary the current in the heating element V2 to maintain the temperature within ±1°C (33.8°F).

The peak current of the oven is limited to 400 mA.

ALTERNATIVE TEXT Drawing [04-03414](#)

The crystal Z1 is in an oven that runs at approximately 70°C (158°F). The NTC resistor R3 measures the temperature of the crystal and causes the opamp comparator IC1 to vary the current in the heating element V2 to maintain the temperature within ±1°C (33.8°F).

The peak current of the oven is limited to 400 mA.

Direct digital synthesis

Local oscillator for upper sideband and lower sideband

ALTERNATIVE TEXT Drawing [04-03106 \(sheet 3\)](#)

IC404 divides the reference oscillator frequency of 44.545 MHz down to the required 456.5 kHz for USB and 453.5 kHz for LSB. These frequencies may vary when different optional filters are used.

The frequency information is programmed serially from the on-board microprocessor IC405.

ALTERNATIVE TEXT Drawing [04-03378 \(sheet 3\)](#)

NOTE If the PCB issue status is -06 or earlier, see drawing [04-03378 \(sheet 3\)](#).

IC405 and IC407 divide the reference oscillator frequency of 14.848333 MHz down to the required 456.5 kHz for USB and 453.5 kHz for LSB. These frequencies may vary when different optional filters are used.

The frequency information is programmed serially from the on-board microprocessor IC408.

Phase lock loop reference

ALTERNATIVE TEXT Drawing [04-03106 \(sheet 3\)](#)

IC403 divides the reference oscillator down to approximately 5 MHz. The signal is buffered by V411 and is then fed as the reference frequency to IC401.

The reference frequency is varied in small step sizes to produce the 10 Hz steps at the output of the phase lock loop.

The frequency information is programmed serially from the microprocessor IC405, based on the channel information.

ALTERNATIVE TEXT Drawing [04-03378 \(sheet 3\)](#)

NOTE If the PCB issue status is -06 or earlier, see drawing [04-03378 \(sheet 3\)](#).

IC403 divides the reference oscillator down to approximately 5 MHz. The signal is buffered by V411 and is then fed as the reference frequency to IC401.

The reference frequency is varied in small step sizes to produce the 10 Hz steps at the output of the phase lock loop.

The frequency information is programmed serially from the microprocessor IC408, based on the channel information.

VCO and phase lock loop

ALTERNATIVE TEXT Drawing [04-03106 \(sheet 3\)](#), or
Drawing [04-03378 \(sheet 3\)](#)

NOTE If the PCB issue status is -06 or earlier, see drawing [04-03378 \(sheet 3\)](#).

The oscillator VCO is a Colpitts type comprising V401 and associated components. The frequency of oscillation is determined by the tuned circuit L403, C401 and the capacitance of the varicaps D401 to D404.

The oscillator output at the tap of the inductor L403 is coupled to the buffer stage made from V402, V403 and associated components. This output is used to drive mixers RxMIX1 and TxMIX2.

Synthesiser IC401 generates a DC control voltage via the phase/frequency detector and control amplifier. This is applied to the varicaps to lock VCO to the nominated frequency.

The VCO input frequency at F IN (pin 4) on IC401 is divided down to approximately 100 kHz and compared with the reference frequency that is also divided down to approximately 100 kHz. Any error between these two signals produces an output from IC401 pin 14 or 15.

The microprocessor IC405 (04-03106) or IC408 (04-03378) loads serial data into IC401 depending on the channel frequency required. This varies the divide ratio on F IN, causing the VCO frequency to change.

The output pulses from IC401 pin 14 or 15 are applied to the charge pump amplifier comprising V406 to V410. Pin 14 provides a 'go up' pulse, while pin 15 provides a 'go down' pulse. When locked, these pins go high impedance except for a very narrow pulse that occurs simultaneously at both outputs, thus holding the DC output at a fixed level.

The DC control voltage is filtered by C419, R422 and C418 to remove any reference frequency. The signal is then applied to the varicaps to control the frequency of oscillation.

26 V power supply

ALTERNATIVE TEXT Drawing [04-03106 \(sheet 3\)](#), or
Drawing [04-03378 \(sheet 3\)](#)

NOTE If the PCB issue status is -06 or earlier, see drawing [04-03378 \(sheet 3\)](#).

The charge pump amplifier runs from the 26 V power supply. The 26 V power supply is a voltage tripler circuit comprising IC402 and associated components.

Microprocessors and control

Handset microprocessor and control

Standby and power on

Drawing [04-03125](#)

When the transceiver is switched off, the standby indicator LED behind the **Ⓢ** key is illuminated. When the **Ⓢ** key is pressed, V9 is switched on. This causes the main power relay K200 (drawing [04-03169](#) or [04-03369](#) or [04-03542](#)) in the RF unit to be switched on (via the CIB) and power is supplied to the entire system.

Microprocessor

Drawing [04-03125](#)

The handset has an 8-bit microprocessor IC1. In conjunction with IC3, which contains the program memory and an I/O expander with internal logic circuits, IC1 controls all the functions in the handset.

The reset device IC2 resets microprocessor IC1 if the 5 V supply drops below approximately 4.7 V.

Keypad

Drawing [04-03125](#)

The row lines (ROW 0 to ROW 2) are held low. When any button on the keypad is pressed, a low is detected by microprocessor IC1. This causes IC1 to scan the keypad to identify which button has been pressed, and then perform the function for that button.

The keypad is backlit by LEDs. The brightness of the LEDs is controlled by switching V1 and V2 as required.

Display

Drawing [04-03125](#)

The LCD H1 consists of a 98×32 dot matrix with LED backlighting. Data from the microprocessor IC1 is sent via the 8-bit data lines to the display where the in-built decoder and driver display the information required.

When the user selects to adjust the contrast of the LCD via the appropriate menu in the handset, the microprocessor IC1 varies the output of the electronic voltage divider IC6. IC6 feeds the temperature-compensated driver IC7/A. IC7/A has an output of approximately -1 to -3 V, which is used to set the negative (VEE) level to the LCD to achieve the required contrast.

The backlighting of the LCD is achieved by a bank of LEDs mounted at the back of the display. The intensity of the backlighting is switched from bright to medium to dark (off) by switching V3, V4, R36, and R37.

RS232 programming port

Drawing [04-03125](#)

IC5 is a complete RS232 driver/receiver with in-built negative voltage generator.

Microprocessor IC1 receives data from IC5 and then re-transmits the data onto the handset bus. Data received from the handset bus is transmitted by IC5.

Handset data bus

Drawing [04-03125](#)

The data bus is a push-pull balanced system and is driven from the CAN driver IC8, which is controlled by the microprocessor. The data bus connects to the junction box. The data rate is approximately 125 kbps.

Junction box microprocessor and control

Handset data

Drawing [04-03133](#)

Data from the handset is fed via the Audio PCB in the junction box to IC15. IC15 changes the push-pull balanced data to single-ended data, which is read by microprocessor IC1.

Microprocessor

Drawing [04-03133](#)

Microprocessor IC1 has a 16-bit data bus that connects to SRAM IC8 and flash memory IC4, which contains the firmware. The reset device IC2 resets the microprocessor if the 5 V supply drops below approximately 4.7 V.

UART and dual RS232

Drawing [04-03133](#)

UART IC10 is connected to microprocessor IC1 via an 8-bit data bus. The output of the UART is used to control the dual RS232 IC12, the outputs of which go to the serial port and the GPIO port.

The UART is also used to drive the diagnostic LEDs H1 to H4, and read the links LK1 to LK4.

EEPROM

Drawing [04-03133](#)

IC16 is a serial flash ROM memory. It contains all the user settings for the system and is read by microprocessor IC1 as required.

Tone generation

Drawing [04-03133](#)

Tone generator IC9 generates tones by dividing the clock output from IC11, which is nominally 4 MHz, by various factors as programmed by the data inputs from the microprocessor. IC11 also varies its output frequency of 4 MHz to extend the range of tones. This provides the audible signals required for key beeps and warning signals at the loudspeaker.

CAN driver

Drawing [04-03133](#)

CAN bus controller IC11 decodes the CAN protocol and passes data to and from microprocessor IC1.

IC11 is connected to the push-pull balanced driver for the CIB IC14, which transfers data to the RF unit. The data rate is 125 kbps.

RF unit microprocessors and control

Overview

The RF unit has five microprocessors, two of which are on the Application Processor PCB. The first of these microprocessors is the DSP processor IC3, which performs speech processing, ALE requirements and high-level control. The other processor is an Application Processor IC4, which controls three slave processors on the other PCBs. The slave processors are used for low-level control for the PCB on which they are located.

Application Processor PCB

Drawings [04-03108 \(sheet 1\)](#) and [04-03108 \(sheet 2\)](#)

CIB data from the junction box is fed via the push-pull balanced driver IC5 (drawing [04-03109](#)) on the Audio Interface PCB to the CAN controller IC17 (sheet 2) on the Application Processor PCB, where data is decoded for the Application Processor IC4 (sheet 1). The Application Processor then issues commands to the other microprocessors.

IC3 is a 32-bit DSP processor. IC8, IC9 and IC10 are address bus buffers. IC11 and IC12 (sheet 2) are flash memory devices that hold the main operating code. IC13 and IC14 are SRAM devices.

IC15 is an EPLD used for address decoding and controlling the CAN controller IC17.

IC16 is another flash memory device that contains all the channel information as well as the ALE link quality statistics.

The audio interface device IC5 (sheet 1) receives audio on pin 28, then converts this to 14-bit data. The 14-bit data is processed in IC3 and then converted back to audio and output through IC7/A. The audio is then fed to the Audio Interface PCB.

The reset device IC2 resets the microprocessor if the 5 V supply drops below approximately 4.7 V.

Audio Interface PCB

Drawing [04-03109](#)

IC12 is in Sleep mode when no data is present. When data is received from Application Processor IC4, the RC oscillator starts to run and ‘wakes up’ IC12.

IC12 then controls the power off, and drives the diagnostic LED H1. It also controls the EPLD IC11, which samples the CIB audio TDM channels and generates the synchronisation pulse.

RF/IF PCB

ALTERNATIVE TEXT Drawing [04-03106 \(sheet 3\)](#), or
Drawing [04-03378 \(sheet 3\)](#)

NOTE If the PCB issue status is -06 or earlier, see drawing [04-03378 \(sheet 3\)](#).

IC405 (04-03106) or IC408 (04-03378) is in Sleep mode when no data is present. When data is received from Application Processor IC4, the RC oscillator starts to run and ‘wakes up’ IC405/IC408.

IC405/IC408 then programs the phase lock loop and the DDS ICs depending on the channel frequency required. It also controls the transmit/receive switching functions, filter select, AGC time constants and other ancillary functions.

Filter and Control PCB

ALTERNATIVE TEXT Drawing [04-03169](#), or
Drawing [04-03369](#), or
Drawing [04-03542](#)

IC2 is in Sleep mode when no data is present. When data is received from Application Processor IC4, the RC oscillator starts to run and ‘wakes up’ IC2.

IC2 then selects the correct filter for the channel in use, the PTT switching, high/low power switching, fast/slow ALC time constant, average ALC on/off and fan control. Also, in conjunction with R19, IC2 forms a DAC that produces the reference ALC voltage. This is used to control the power versus frequency output level.

Desk console

Drawing [04-03110](#)

The desk console sends data via a 10-way ribbon cable to the junction box to provide four programmed functions, F1 to F4 and PTT.

When the PTT button on the console is pressed, the goose-neck microphone (B1) becomes active. The audio is amplified by IC2A and then passed to the junction box. V4 provides debouncing for the PTT function.

IC1 reads the data sent from the function keys, F1 to F4 and PTT. The I²C output from IC1 is passed to the junction box to perform the function required.

NOTE When headphones are connected to the desk console, the internal speaker is disconnected.

Internal voice encryptor

Voice encryption is possible with the NGT when a plug-in Encryptor PCB is fitted via P8 to the Application Processor PCB. The microprocessor on the Application Processor PCB detects that the Encryptor PCB is present at power up and enables the control firmware.

The encryptor is controlled by the TxD, RxD and SILENCE lines. The WAKE line is used to reduce the current drain when the encryptor is not in use.

When encryption is enabled, encrypted receive audio is fed via DEC_IN to the Encryptor PCB. The de-crypted audio comes out of DEC_OUT. This signal is fed into the system audio.

In Transmit mode, the microphone audio is fed into ENC_IN on the Encryptor PCB where it is encrypted then fed through ENC_OUT to the DSP audio compressor, and then to the transmitter.

When the encryptor is not enabled, all audio bypasses the Encryptor PCB.

Second IF filter option

Drawing [04-03379](#) and [04-03378 \(sheet 2\)](#)

NOTE If the PCB issue status is -06 or earlier, see drawing [04-03378 \(sheet 2\)](#).

The second filter is fitted on a small daughter PCB ([08-05890](#)), which is fitted to the main RF/IF PCB. When the filter is required, the relays K-1 and K-2 are switched by the microprocessor IC408 and V207 to change the signal path to the second filter Z1.

The second filter may be either 500 Hz wide for CW and data applications ([15-10506-001](#)) or it can be 2700 Hz wide for high-speed data applications ([15-10514-001](#)).

The N (500 Hz) and W (2700 Hz) link on IC408 tell the processor which filter is fitted so the synthesiser frequency is set correctly for the filter in use.

This section contains the following topics:

[Power on \(104\)](#)

[Power off \(105\)](#)

[Supply voltages \(106\)](#)

[Transmit path \(109\)](#)

[Receive path \(116\)](#)

[Frequency control \(121\)](#)

[Microprocessors and control \(124\)](#)

[Internal voice encryptor \(128\)](#)

This section should be read in conjunction with [page 201, NGT—Drawings](#).

Power on

Drawings [04-03125](#)

If the transceiver is off when the **Ⓢ** key is pressed, the +5.4 V standby voltage is applied to gate V9 resulting in the drain going low.

The PWR ON line passes via the handset cable to the Audio & Interconnect PCB (2011)/Audio Interconnect & Data I/O PCB (2012) in the RF unit.

2011: Drawing [04-03425](#)

2012: Drawing [04-03499 \(sheet 1\)](#) and [04-03499 \(sheet 2\)](#)

Control for the power relay on the PA PCB, which in turn controls the transceiver power, is via latching relay K1. This relay is activated by pressing the **Ⓢ** key on the handset, which grounds the PWR ON line in the handset, setting relay K1 via transistor V1.

Drawing [04-03369](#), or

Drawing [04-03542](#)

The PWR ON line goes to the power relay coil K200. If the polarity of the DC supply is correct and below 16 V, V216 conducts and relay K200 energises, thus closing contacts of K200 and connecting the DC supply to the transceiver.

If the DC supply voltage exceeds 16 V, zener diode D203 conducts, causing V215 to also conduct and switch off V216, thus preventing K200 from energising.

Diode D205 prevents relay K200 from operating if the DC supply is reverse polarised.

The power input circuit is protected from high voltage transients by the voltage-dependent resistor R261.

Power off

Drawing [04-03125](#)

If the transceiver is on when the **Ⓞ** key is pressed, IC3 pin 15 goes high. This causes data to be sent via the handset bus to the RF unit.

2011: Drawing [04-03425](#)

2012: Drawing [04-03499 \(sheet 1\)](#) and [04-03499 \(sheet 2\)](#)

Power is switched off when the microprocessor is instructed from the Application Processor Handset I/F 3 V PCB (2011)/Application Processor Handset & Data I/F PCB (2012) to drive V5, resetting relay K1.

Drawing [04-03369](#), or

Drawing [04-03542](#)

The PWR ON line goes high, de-energising the power relay coil K200 and thus switching off the transceiver.

Supply voltages

Handset

The supply voltages for the handset are shown in [Table 26](#).

Drawing [04-03125](#)

Table 26: Supply voltages for the Handset PCB in the handset

Supply	Description	Source
Standby	+5.4 V when transceiver is off	ext
Handset power	+9.2 V when transceiver is on	ext
+5 V	+5 V regulated supply	IC10
−9 V	−9 V for IC7	IC5

RF unit

The supply voltages for the RF unit are shown in [Table 27](#) to [Table 32](#).

Drawing [04-03425](#)

Table 27: Supply voltages for the Audio & Interconnect PCB in the RF unit (2011 only)

Supply	Description	Source
A	Unregulated battery supply	via Filter and Control PCB
A (protected)	2 A current-limited battery	F1
+10 V	+10 V regulated supply	via Filter and Control PCB
+5 V	+5 V regulated supply	IC7
+2.5 VQ	+2.5 V quiet for opamp bias	IC7 (filtered)
+5 VQ	+5 V quiet for opamp bias	IC7 (filtered)
+5 VSBY	+5.4 V standby for handset	D3, D4

Drawings [04-03499 \(sheet 1\)](#)

Table 28: Supply voltages for the Audio Interconnect & Data I/O PCB in the RF unit (2012 only)

Supply	Description	Source
A	Unregulated battery supply	via Filter and Control PCB
A (protected)	2 A current-limited battery	F1
+10 V	+10 V regulated supply	via Filter and Control PCB
+5 V	+5 V regulated supply	IC7
+2.5 VQ	+2.5 V quiet for opamp bias	IC7 (filtered)
+5 VQ	+5 V quiet for opamp bias	IC7 (filtered)
+5 VSBY	+5.4 V standby for handset	D3, D4

Drawings [04-03424 \(sheet 1\)](#)

Table 29: Supply voltages for the Application Processor Handset I/F 3 V PCB in the RF unit (2011 only)

Supply	Description	Source
+1V8	+1.8 V DSP core supply	IC4
+3V3	+3.3 V switchmode supply	IC5
+5 V	+5 V regulated supply	IC3

Drawings [04-03498 \(sheet 1\)](#)

Table 30: Supply voltages for the Application Processor Handset & Data I/F PCB in the RF unit (2012 only)

Supply	Description	Source
+1V8	+1.8 V DSP core supply	IC4
+3V3	+3.3 V switchmode supply	IC5
+5 V	+5 V regulated supply	IC3

Drawing [04-03378 \(sheet 1\)](#)

NOTE If the PCB issue status is -06 or earlier, see drawing [04-03378 \(sheet 1\)](#).

Table 31: Supply voltages for the RF/IF PCB in the RF unit

Supply	Description	Source
A	Unregulated battery supply	via Audio & Interconnect PCB (2011)/Audio Interconnect & Data I/O PCB (2012)
+5 V	+5 V regulated supply	IC210
+26 V	+26 V from charge pump supply	IC402
+10 V	+10 V regulated supply	via Audio & Interconnect PCB (2011)/Audio Interconnect & Data I/O PCB (2012)
+10 VRx	+10 V In Rx	V415, V416
+10 VTx	+10 V In Tx	V417, V418

ALTERNATIVE TEXT

Drawing [04-03369](#), or
Drawing [04-03542](#)

Table 32: Supply voltages for the PA PCB and Filter and Control PCB in the RF unit (04-03369 or 04-03542)

Supply	Description	Source
A	Unregulated battery supply	ext
+10 VA	+10 V regulated supply	IC1
+5 VA	+5 V regulated supply	IC4
+5 V	+5 V regulated supply	IC200

Transmit path

Handset microphone amplifier transmit path

Drawing [04-03125](#)

The handset has an electret microphone. When PTT is not pressed, the microphone audio is clamped by V5.

When PTT is pressed, V5 is turned off, allowing audio from the microphone to be passed to the amplifier IC9/B. The output of IC9/B is split into two paths, one going to the handset audio bus, the other passing through the inverter IC9/A before going to the handset audio bus. In this way, push-pull balanced audio is provided to the handset bus.

RF unit—Audio & Interconnect PCB (2011)/Audio Interconnect & Data I/O PCB (2012) transmit path

2011: Drawing [04-03425](#)

2012: Drawing [04-03499 \(sheet 1\)](#) and [04-03499 \(sheet 2\)](#)

Tx audio

The balanced microphone audio from the handset is filtered in L2, then converted to a single-ended signal in IC2/A. It then passes via the Application Processor Handset I/F 3 V PCB (2011)/Application Processor Handset & Data I/F PCB (2012), which provides the microphone compression, through the analog switch IC5 to the RF/IF PCB Tx audio path.

RF unit—Application Processor Handset I/F 3 V PCB (2011)/Application Processor Handset & Data I/F PCB (2012) transmit path

2011: Drawing [04-03424 \(sheet 1\)](#)

2012: Drawing [04-03498 \(sheet 1\)](#) and [04-03498 \(sheet 2\)](#)

The transmit audio goes to IC7 pin 2. This audio interface device contains an ADC and a DAC.

The analog transmit audio is sampled and converted by IC7 into digital format. A compression function is applied to the digital audio as shown in [Figure 21](#) below.

Figure 21: Representation of compression function by IC7

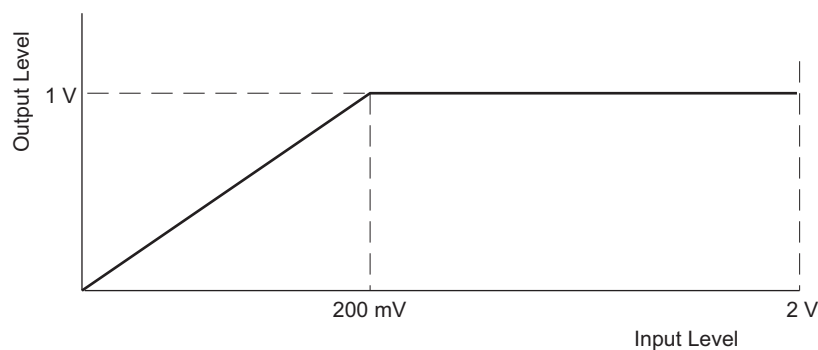

The decay time constant is controlled by firmware and can be varied depending on the type of transmission. For example, for speech, the time constant needs to be short, but for data it needs to be lengthened to improve the BER.

The DAC outputs of IC7 pins 8 and 9 are summed together in IC8/A to produce an output of 1 V p-p. This output then goes via the Audio & Interconnect PCB (2011)/Audio Interconnect & Data I/O PCB (2012) to the RF/IF PCB.

The output level, which is controlled by firmware, is halved when AM is transmitted or low power is selected.

RF unit—RF/IF PCB transmit path

Transmit/Receive switching

Drawing [04-03378 \(sheet 3\)](#)

NOTE If the PCB issue status is -06 or earlier, see drawing [04-03378 \(sheet 3\)](#).

The PTT command from the handset causes IC408 to drive pins 12 and 13 (Rx Switch and Tx Switch). This switches off V415 and V416 and switches on V417 and V418, thus causing +10 V_{Tx} to be active. This switches all circuits to the Transmit mode.

Transmit modulator

Drawing [04-03378 \(sheet 2\)](#)

NOTE If the PCB issue status is -06 or earlier, see drawing [04-03378 \(sheet 2\)](#).

The audio goes to the Tx Level potentiometer R256 to set the exciter output level at J2 to 650 mV p-p. It is passed to the input of the balanced modulator IC204 pin 1. The modulator is enabled when +10 V_{Tx} is applied via R254 to the bias input pin 5.

The audio is mixed with the local oscillator of 456.5 kHz (453.5 kHz for LSB). The local oscillator is applied to IC204 pins 8 and 10. This produces a DSB output at pin 6. From there it is passed via D205 to the 455 kHz sideband ceramic filter Z201 pin 1.

455 kHz filter and first mixer

Drawings [04-03378 \(sheet 1\)](#) and [04-03378 \(sheet 2\)](#)

NOTE If the PCB issue status is -06 or earlier, see drawings [04-03378 \(sheet 1\)](#) and [04-03378 \(sheet 2\)](#).

(sheet 2) The 455 kHz sideband ceramic filter Z201, with a bandwidth of 2.5 kHz, filters out the unwanted sideband and leaves only the wanted sideband at pin 3. From there it is passed via the noise limiter gate V204 to a tuned auto transformer T202.

(sheet 1) The signal is passed from T202 via a resistor-matching attenuator network R144, R145 and R146 to the input of the first balanced amplifier/mixer IC103 pins 12 and 13. IC103 is enabled by applying +10 V_{Tx}. This applies DC via R142 to pin 4, and bias current via R143 to pin 11. The filtered +10 V rail is applied to the mixer output, pins 3 and 14, via the centre tap of the output transformer T108.

The 455 kHz transmit signal is mixed with 44.545 MHz (LO2), which is applied to IC103 pin 5 to produce a second IF output signal at pins 3 and 14 centred on 45 MHz. The gain of the mixer/amplifier is approximately 20 dB.

45 MHz band-pass filter

Drawing [04-03378 \(sheet 1\)](#)

NOTE If the PCB issue status is -06 or earlier, see drawing [04-03378 \(sheet 1\)](#).

The 45 MHz IF signal is filtered through a 15 kHz-wide BPF consisting of T108, Z104, L117, Z103 and T107. This filter removes unwanted signals produced by the first mixer. The filtered output goes to the balanced input of the second mixer IC102 pins 12 and 13. R138 is between T107 and IC102 and is used as a fine balance adjustment for the mixer to remove unwanted spurious signals.

Second mixer and exciter output filter

Drawing [04-03378 \(sheet 1\)](#)

NOTE If the PCB issue status is -06 or earlier, see drawing [04-03378 \(sheet 1\)](#).

The second mixer IC102 is enabled by applying +10 VTx. This applies DC via R133 to pin 4, and bias current via R134 to pin 11. The filtered +10 V rail is applied via L116 and the transformer T106 to the mixer output from pins 3 and 14.

The 45 MHz transmit signal is applied to IC102 pins 12 and 13. It is mixed with the output of the local oscillator LO1+, LO1– (applied to IC102 pins 5 and 7) to produce the selected channel frequency at the mixer output pins 3 and 14. The gain of the mixer/amplifier is approximately 20 dB.

The mixer output goes via a 30 MHz LPF to the transmit exciter output connector J2. From there it is coupled via a coaxial cable to the PA assembly.

Tuning

Drawings [04-03378 \(sheet 3\)](#), [04-03378 \(sheet 2\)](#) and [04-03378 \(sheet 1\)](#)

NOTE If the PCB issue status is -06 or earlier, see drawings [04-03378 \(sheet 3\)](#), [04-03378 \(sheet 2\)](#) and [04-03378 \(sheet 1\)](#).

When the Tune command is activated, IC408 pin 7 (sheet 3) goes low. This switches off V413 to allow the 456.5 kHz local oscillator carrier (453.5 kHz for LSB) to be passed to V206 (sheet 2) via CAR INJ. V206 inserts carrier to the input transformer T202 of the first Tx mixer IC103 (sheet 1).

At the same time, IC408 pin 5 (Tx MUTE) goes high and switches on V203 (sheet 2). Thus, IC202/C and IC202/B open the noise gate V204, which stops the inserted carrier from being loaded by the sideband filter Z201.

The carrier at the output of the second mixer IC102 (sheet 1) is at the frequency of the selected channel (the SCF). This frequency is used for tuning automatic antennas.

RF unit—PA PCB transmit path

Gain control stage

Drawing [04-03369](#), or
Drawing [04-03542](#)

The RF input is passed to T200, which turns the RF drive into push-pull. This is applied to the variable gain stage V200 and V201. The FETs V202 and V203 are used as variable resistors depending on the ALC voltage applied to the gates.

If there is no power output at the antenna connector, 5 V of ALC voltage is applied to the gates, so that the resistance is low and the gain is at maximum. As the output from the PA increases to the power set point (100 W or 125 W), the ALC voltage drops, thus increasing the resistance in the FETs and so reducing the gain of V200 and V201 and keeping the Tx output power at the set level (100 W or 125 W). V16 and V17 switch between 100 W and 125 W. When V17 is on, the output power is 100 W. When V17 is off, the output power is 125 W.

The overall gain of the PA is set to a constant value by R205 (PA GAIN).

Pre-driver stage

Drawing [04-03369](#), or
Drawing [04-03542](#)

The levelled RF from the gain control stage is passed via T201 to the Class A push-pull amplifier formed by V204 and V205. L202 and C207 provide a small amount of gain peaking to ensure the overall gain is flat with frequency.

Driver stage

ALTERNATIVE TEXT Drawing [04-03369](#)

The signal from the pre-driver stage goes via T202 to the driver stage. The driver is a Class B push-pull amplifier that provides a current drive to the output stage.

V207 and V208 have collector to base feedback to flatten the gain. R273 balance control varies the gain slightly in V208, which is used to balance the second harmonic (see [page 185, Adjusting balance control](#)).

The bias for the driver stage, provided by V214 and V206, and set by R222 (DR. BIAS), is applied to the centre tap of T202.

ALTERNATIVE TEXT Drawing [04-03542](#)

The signal from the pre-driver stage goes via T202 to the driver stage. The driver is a Class B push-pull amplifier that provides a current drive to the output stage.

V207 and V208 have drain to gate feedback to allow balance adjustment to the second harmonic (see [page 185, Adjusting balance control](#)).

The bias for the driver FET is provided to each gate individually via R222 (DR BIAS 1) and R235 (DR BIAS 2) from the temperature-compensated reference IC201/A.

Output stage and bias regulator

Drawing [04-03369](#), or

Drawing [04-03542](#)

The Class B push-pull output stage formed by V211 and V212 is driven from T203 to produce the nominal 100 W or 125 W PEP.

The bias regulator V209 and V213 provides a voltage to the bases of V211 and V212. The transistors V209 and V213 form a feedback voltage regulator. The output voltage is the base-emitter voltage of V209 and is adjustable by the preset potentiometer R239. The transistor V209 is mounted close to the output transistor and provides temperature compensation to the bias network.

The transistor V210 modifies the output bias voltage slightly depending on the level of signal detected by D208. The amount of control voltage is varied by R241 and is adjusted to minimise high-order intermodulation products.

The balanced to unbalanced impedance-matching output transformer T204 couples the power amplifier output to the band filters via J2 and the PTT relay K8.

Output filters

Drawing [04-03369](#), or

Drawing [04-03542](#)

The transmit frequency range is 1.6 to 30 MHz. Seven LPFs are used to remove the harmonics generated by the PA. The filters are operated from IC2 and IC3 and are selected using relays K1 to K7 as required.

The output of the filter circuit passes through the RF bridge formed by T1 and associated components to the antenna output.

Automatic level control

The ALC is controlled by:

- forward power
- reflected power
- drain voltage swing of output stage
- battery voltage
- overtemperature of heatsink
- failure of transmit/receive or filter relays

Drawing [04-03369](#), or

Drawing [04-03542](#)

All the ALC inputs (except relay detection) are applied to V7 to V10. The ORed output is connected via R50 and D14 to the positive input pin of the ALC level comparator IC5/A pin 3. The reference voltage connected to pin 2 is firmware controlled by the microprocessor IC2.

The microprocessor IC2 and R19 are used as a 5-bit DAC with an output range of 5 to 2.5 V. The output from R19 is buffered by IC6/B and then divided and filtered by R55, R56 and C151. The output is then buffered again by IC6/A and used as the reference voltage for IC5/A and IC201/B. This allows the microprocessor IC2 to reduce the PA output at the higher operating frequencies and ensures that the intermodulation distortion remains within specified limits.

The output voltage of the RF bridge formed by T1 and associated components is rectified by D1 for the forward power and by D2 for the reflected power.

The output of the forward rectifier D1 is applied via R37 to the input of V7. The sum of the resistors between the base of V7 and ground form a resistor divider network. This determines the nominal PEP output level when matched to a 50 Ω load.

For high power, the resistors R34 and R35 are shorted out when +5 V is applied to the gate of the FET switch V6 and do not contribute to the chain. The nominal high-power output, which is measured at low frequency, is set by R32 (SET HI PWR). V17 switches between 100 W and 125 W.

For low power, V6 is off, so R34 and R35 are added to the divider. R35 (LOW PWR) sets the power to 12 W PEP.

The output of the forward detector D1 is also applied to V8 via an averaging detector circuit formed by R40, R43 and C147. When the average of the signal exceeds the peak detector circuit V7, V8 takes control and reduces the output power (this occurs on single tones such as Tune mode, CW (Morse) and in some data transmissions).

When the handset PTT is active, V11 is switched off, which disables the average ALC circuit. In these circumstances, the transceiver produces full PEP on a single tone. This is for measurement reasons only.

The peak output collector swing is rectified by D202 and applied to the transistor V10. V10 conducts and limits the collector peak to 42 V to prevent damage to the output transistors.

The battery voltage is monitored by V5. When the supply voltage (**A** rail) drops to approximately 12 V, the voltage at the base of V5 falls and causes V5 to conduct. This changes the threshold of the forward power ALC detector. The ALC detector then starts to reduce the output power and since the control is linear, a further reduction in supply voltage continues to lower the output power.

If the heatsink temperature exceeds 80°C (176°F), the PTC resistor R262 rapidly increases its resistance. This causes V13 to conduct and thus reduces the reference voltage R19. This lowers the output power and prevents the heatsink temperature from exceeding 100°C (212°F).

The relay protection circuit is formed by IC5/B and associated components. It simultaneously monitors the output transistor collector swing and forward detector output of D1. If a relay failure results in no signal at the antenna output, the output of IC5/B goes high. This lowers the gain of the input amplifiers V200 and V201 and thus reduces the drive to the output transistors to a safe level.

The ALCs control the output from the summing amplifier IC5/A. This output passes to IC201/B, which inverts the direction of the control signal to drive the variable resistor FETs V202 and V203 in the gain stage (see [page 113, Gain control stage](#)).

Receive path

Input low-pass filters

Drawing [04-03369](#), or
Drawing [04-03542](#)

The receiver input signal goes through one of seven relay-selected LPFs K1 to K7. The signal then goes via the transmit/receive relay K8 and signal-clamping diodes D3 to D9 to connector J1.

Broadcast filter and RF amplifier

Drawing [04-03378 \(sheet 1\)](#)

NOTE If the PCB issue status is -06 or earlier, see drawing [04-03378 \(sheet 1\)](#).

The signal goes through a broadcast filter to reduce any very strong broadcast frequencies below 1.6 MHz, and then goes to the RF amplifier V101. V101 has a nominal gain of 9 dB.

When there are very strong signals present, V101 is not required and may be switched off via the handset using the Cfg RF Pre-Amp entry in the Control List. When this occurs, a 10 dB attenuator pad is switched by relay K101 to reduce the signal going to mixer RxMIX1. The signal then passes through a 30 MHz LPF to remove signals above 30 MHz.

First mixer

Drawing [04-03378 \(sheet 1\)](#)

NOTE If the PCB issue status is -06 or earlier, see drawing [04-03378 \(sheet 1\)](#).

The balanced mixer, formed by V103, V104, V105 and V106, mixes the received signal with the local oscillator LO1+, LO1– (VCO). LO1 is buffered by V107 and V108 to produce an IF of 45 MHz. The mixer has a conversion gain of 4 dB.

45 MHz band-pass filter and amplifier

Drawing [04-03378 \(sheet 1\)](#)

NOTE If the PCB issue status is -06 or earlier, see drawing [04-03378 \(sheet 1\)](#).

The 45 MHz IF signal is filtered through a 15 kHz-wide BPF Z101 and then amplified by V109. It is filtered again by Z102. This removes the unwanted signals produced by the first mixer.

Second mixer

Drawings [04-03378 \(sheet 1\)](#) and [04-03378 \(sheet 2\)](#)

NOTE If the PCB issue status is -06 or earlier, see drawings [04-03378 \(sheet 1\)](#) and [04-03378 \(sheet 2\)](#).

Mixer IC101 is a combined amplifier/balanced mixer. The 45 MHz signal is mixed with the local oscillator LO2 (44.545 MHz) applied to pin 5. The mixing produces a second IF centred at 455 kHz.

DC to the mixer output is provided by the +10 V rail, which is connected to the centre tap of the 455 kHz output transformer T202 (sheet 2). In Receive mode, the +10 VRx rail provides DC via R132 to IC101 pin 4, and bias via R131 to IC101 pin 11.

Noise limiter

Drawings [04-03378 \(sheet 1\)](#) and [04-03378 \(sheet 2\)](#)

NOTE If the PCB issue status is -06 or earlier, see drawings [04-03378 \(sheet 1\)](#) and [04-03378 \(sheet 2\)](#).

The 455 kHz output of IC101 pins 3 and 14 (sheet 1) is applied to the balanced input of the high-gain differential amplifier IC201 pins 2 and 13. The balanced outputs at pins 7 and 8 are connected to a tuned auto transformer T201 (455 kHz). The output of T201 goes to the base of the active rectifier V201. Noise bursts produce positive-going pulses at the collector of V201, and via V202, trigger the monostable flip-flop IC202/B/C. The pulse width is determined by C210, R210 and R211 (nominally 250 µs).

The outputs of IC202/B/D pins 11 and 4 produce complementary pulses that are connected to the FET gates of V204 and V205. These gate out the noise bursts from the 455 kHz signal. With V204 on and V205 off, the IF signal is passed to the sideband filter Z201. When a noise burst is present, V204 is switched off and V205 is switched on, blocking the IF signal for the period of the gate pulse.

The average DC component of the collector current of V201 is used as an automatic gain control to IC201. It is applied via R206 and IC211 to pins 6 and 11. This ensures that only the noise burst signal triggers the flip-flop IC202/B/C. The AGC decay constant is set by the components C206 and R204.

In Transmit mode, IC202 is disabled (see [page 112, Tuning](#)).

455 kHz filter and IF amplifier

Drawing [04-03378 \(sheet 2\)](#)

NOTE If the PCB issue status is -06 or earlier, see drawing [04-03378 \(sheet 2\)](#).

The IF signal from the noise blanker gate V204 is passed to the 2.5 kHz-wide ceramic filter Z201. The filter removes the unwanted sideband, adjacent channels and other unwanted products generated by the second mixer. The wanted sideband, centred at 455 kHz, is passed by the filter to a 3-stage gain-controlled IF amplifier comprising V210, V211, V212 and associated components. The IF amplifier is broadly tuned to 455 kHz by the tuned circuits L201 and C229, L202 and C232, and L203 and C236.

When the optional 500 Hz filter is installed, the 500 Hz Filter PCB (Codan part number 08-05890-001) is added and R222 and R223 are removed. The optional filter is selected when V207 is activated.

Automatic gain control

Drawing [04-03378 \(sheet 2\)](#)

NOTE If the PCB issue status is -06 or earlier, see drawing [04-03378 \(sheet 2\)](#).

An AGC is applied to a number of stages in the receiver. This is used to increase the dynamic range of the receiver and to maintain an almost constant audio output level for a large variation of input signals.

When the receiver is at maximum gain, the AGC at the output of IC205/A is nominally 6.4 V. This voltage is set by the voltage reference IC206 and associated components.

The IF signal is rectified by V214 and the resulting DC is amplified by IC205/B. The signal is then passed to various timing circuits.

The signal is passed through D207 to the fast attack circuit (2 ms) comprising V215, R274 and C253. The signal also charges the slow decay circuit comprising IC207/D, R279 and C254. The outputs from these two circuits are summed together at the emitter junction of V216 and IC207/A, then passed to the amplifier IC205/A.

The decay characteristic of the AGC circuit can be fast, slow or hold. Fast decay time is set by C253 and R280. Slow decay time is set by C254 and R283 (1 s). Hold decay timing is set by the discharge constant of C254, R285 and delay circuit C256 and R284. The hold circuit holds the AGC voltage constant for a short period after the signal reduces, which can improve the readability of the signal.

If fast decay AGC is required the AGC FAST/SLOW control line is held high by the microprocessor. This disables the slow charge capacitor C254.

If slow decay AGC is required the AGC FAST/SLOW control line is held low and the HOLD/TRIGGER line is held high.

If hold decay AGC is required both the AGC FAST/SLOW and the HOLD/TRIGGER control lines are held low.

Note that the ‘trigger’ part of the HOLD/TRIGGER control line name is not related to the AGC circuit at all. This multifunction HOLD/TRIGGER line is used by a built-in test function during adjustment procedures.

The AGC voltage is passed to the IF amplifier. As the signal increases in level, the AGC voltage reduces and hence lowers the gain of the IF amplifier, thus keeping the output level constant.

If the signal level is very large, the anti-log and bias circuit comprising IC203 and associated components operates. When operating, this circuit causes RF AGC voltage to reduce, which in turn causes D104 (drawing [04-03106 \(sheet 1\)](#) or [04-03378 \(sheet 1\)](#)) to conduct. This reduces signal levels at mixer RxMIX1 and helps to keep the level constant at the 455 kHz IF output.

There is an AGC DUMP input to dump any AGC voltage from a high-level signal on a previously selected channel when the channel is changed. This allows the new channel to have maximum gain. The dump is achieved by pulling the AGC DUMP control line low and the AGC FAST/SLOW control line high for a short period when a channel is changed.

Demodulator

Drawing [04-03378 \(sheet 2\)](#)

NOTE If the PCB issue status is -06 or earlier, see drawing [04-03378 \(sheet 2\)](#).

The output of the 455 kHz IF amplifier is passed to the input of a double balanced mixer IC208. The IF signal is mixed with the local oscillator that is applied to pins 8 and 10 to produce an audio output at pin 6. The local oscillator operates at 456.5 kHz for USB operation and 453.5 kHz for LSB.

The audio is then filtered by the LPF comprising IC209 and associated components, before being passed to the Audio & Interconnect PCB (2011)/Audio Interconnect & Data I/O PCB (2012).

RF unit—Audio & Interconnect PCB (2011)/Audio Interconnect & Data I/O PCB (2012) receive path

Rx audio

2011: Drawing [04-03425](#)

2012: Drawings [04-03499 \(sheet 1\)](#) and [04-03499 \(sheet 2\)](#)

The Rx audio from the RF/IF PCB passes through the analog switches IC5 and IC14 to the volume control IC4/C and buffer amplifier U2/B, then to the audio amplifier IC1 for delivery to the loudspeaker via the Handset LS Audio connections. A sample of the Rx audio is also sent to the voice mute circuitry (see [page 120, Voice mute](#)).

The volume setting is controlled using the 2-wire serial communications from the Application Processor Handset I/F 3 V PCB (2011)/Application Processor Handset & Data I/F PCB (2012).

Tone generation

2011: Drawing [04-03425](#)

2012: Drawings [04-03499 \(sheet 1\)](#) and [04-03499 \(sheet 2\)](#)

Tones for the audible signals required for key beeps and warning signals at the loudspeaker are added to the Rx audio before the audio amplifier via volume control IC4/B. These tones are generated in IC3, which divides the 4 MHz/2 MHz oscillator provided by Z1, IC16 and IC15, according to the division ratio assigned by the Application Processor Handset I/F 3 V PCB (2011)/Application Processor Handset & Data I/F PCB (2012).

The volume of the tones is controlled from the Application Processor Handset I/F 3 V PCB (2011)/Application Processor Handset & Data I/F PCB (2012), based on the Rx audio volume, to give a constant relative level between the two signals.

Voice mute

2011: Drawing [04-03425](#)

2012: Drawing [04-03499 \(sheet 1\)](#) and [04-03499 \(sheet 2\)](#)

The audio from the RF/IF PCB is fed to the input of the mute stage squaring amplifier IC12/A. The squared audio is then fed to a charge pump circuit comprising V9 and associated components. This circuit performs a frequency to voltage function that causes the resultant DC voltage to rise as the frequency increases.

IC13/A and associated components function as an LPF with a cutoff frequency of approximately 10 Hz. The output from IC13/A is a DC voltage, varying at the syllabic rate of the speech received.

IC12/C and IC12/D form a window comparator. The window width is adjusted by the preset MUTE ADJ R85. The divider network R87, R88 and C64 provides the reference voltage for the window comparator. If the output rises or falls below this reference by the amount set by R85, the open collector outputs of IC12/C and IC12/D discharge C65, thus applying a low to the negative input of comparator IC12/B. When the output from this comparator goes high, it indicates to the Application Processor Handset I/F 3 V PCB (2011)/Application Processor Handset & Data I/F PCB (2012) that speech has been detected. This PCB then instructs the switch IC14/A to close, enabling the audio path.

Frequency control

Reference oscillator

Drawings [04-03410](#) and [04-03378 \(sheet 3\)](#)

NOTE If the PCB issue status is -06 or earlier, see drawing [04-03378 \(sheet 3\)](#).

The reference oscillator is formed by the unbuffered inverter logic gate IC1 and Z1. The output from IC1 is amplified by IC2 to ensure there is a square wave output. The 14.848333 MHz square wave output is then connected to the DDS ICs IC403 and IC405 via the buffer IC404.

The 14.848333 MHz square wave output is also fed to the 44.5 MHz BPF where the third harmonic is selected and then buffered by V412 to produce the 44.545 MHz local oscillator signal (LO2) for IC101 and IC103.

Oven controller

Drawing [04-03414](#)

The crystal Z1 is in an oven that runs at approximately 70°C (158°F). The NTC resistor R3 measures the temperature of the crystal and causes the opamp comparator IC1 to vary the current in the heating element V2 to maintain the temperature within ±1°C (33.8°F).

The peak current of the oven is limited to 400 mA.

Direct digital synthesis

Local oscillator for upper sideband and lower sideband

Drawing [04-03378 \(sheet 3\)](#)

NOTE If the PCB issue status is -06 or earlier, see drawing [04-03378 \(sheet 3\)](#).

IC405 and IC407 divide the reference oscillator frequency of 14.848333 MHz down to the required 456.5 kHz for USB and 453.5 kHz for LSB. These frequencies may vary when different optional filters are used.

The frequency information is programmed serially from the on-board microprocessor IC408.

Phase lock loop reference

Drawing [04-03378 \(sheet 3\)](#)

NOTE If the PCB issue status is -06 or earlier, see drawing [04-03378 \(sheet 3\)](#).

IC403 divides the reference oscillator down to approximately 5 MHz. The signal is buffered by V411 and is then fed as the reference frequency to IC401.

The reference frequency is varied in small step sizes to produce the 10 Hz steps at the output of the phase lock loop.

The frequency information is programmed serially from the microprocessor IC408, based on the channel information.

VCO and phase lock loop

Drawing [04-03378 \(sheet 3\)](#)

NOTE If the PCB issue status is -06 or earlier, see drawing [04-03378 \(sheet 3\)](#).

The oscillator VCO is a Colpitts type comprising V401 and associated components. The frequency of oscillation is determined by the tuned circuit L403, C401 and the capacitance of the varicaps D401 to D404.

The oscillator output at the tap of the inductor L403 is coupled to the buffer stage made from V402, V403 and associated components. This output is used to drive mixers RxMIX1 and TxMIX2.

Synthesiser IC401 generates a DC control voltage via the phase/frequency detector and control amplifier. This is applied to the varicaps to lock VCO to the nominated frequency.

The VCO input frequency at F IN (pin 4) on IC401 is divided down to approximately 100 kHz and compared with the reference frequency that is also divided down to approximately 100 kHz. Any error between these two signals will produce an output from IC401 pin 14 or 15.

The microprocessor IC408 loads serial data into IC401 depending on the channel frequency required. This varies the divide ratio on F IN, causing the VCO frequency to change.

The output pulses from IC401 pin 14 or 15 are applied to the charge pump amplifier comprising V406 to V410. Pin 14 provides a 'go up' pulse, while pin 15 provides a 'go down' pulse. When locked, these pins go high impedance except for a very narrow pulse that occurs simultaneously at both outputs, thus holding the DC output at a fixed level.

The DC control voltage is filtered by C419, R422 and C418 to remove any reference frequency. The signal is then applied to the varicaps to control the frequency of oscillation.

26 V power supply

Drawing [04-03378 \(sheet 3\)](#)

NOTE If the PCB issue status is -06 or earlier, see drawing [04-03378 \(sheet 3\)](#).

The charge pump amplifier runs from the 26 V power supply. The 26 V power supply is a voltage tripler circuit comprising IC402 and associated components.

Microprocessors and control

Handset microprocessor and control

Standby and power on

Drawing [04-03125](#)

When the transceiver is switched off, the standby indicator LED behind the **Ⓢ** key is illuminated. When the **Ⓢ** key is pressed, V9 is switched on. This causes the main power relay K200 (drawing [04-03369](#)) in the RF unit to be switched on and power is supplied to the entire system.

Microprocessor

Drawing [04-03125](#)

The handset has an 8-bit microprocessor IC1. In conjunction with IC3, which contains the program memory and an I/O expander with internal logic circuits, IC1 controls all the functions in the handset.

The reset device IC2 resets microprocessor IC1 if the 5 V supply drops below approximately 4.7 V.

Keypad

Drawing [04-03125](#)

The row lines (ROW 0 to ROW 2) are held low. When any button on the keypad is pressed, a low is detected by microprocessor IC1. This causes IC1 to scan the keypad to identify which button has been pressed, and then perform the function for that button.

The keypad is backlit by LEDs. The brightness of the LEDs is controlled by switching V1 and V2 as required.

Display

Drawing [04-03125](#)

The LCD H1 consists of a 98×32 dot matrix with LED backlighting. Data from the microprocessor IC1 is sent via the 8-bit data lines to the display where the in-built decoder and driver display the information required.

When the user selects to adjust the contrast of the LCD via the appropriate menu in the handset, the microprocessor IC1 varies the output of the electronic voltage divider IC6. IC6 feeds the temperature-compensated driver IC7/A. IC7/A has an output of approximately -1 to -3 V, which is used to set the negative (VEE) level to the LCD to achieve the required contrast.

The backlighting of the LCD is achieved by a bank of LEDs mounted at the back of the display. The intensity of the backlighting is switched from bright to medium to dark (off) by switching V3, V4, R36, and R37.

RS232 programming port

Drawing [04-03125](#)

IC5 is a complete RS232 driver/receiver with in-built negative voltage generator.

Microprocessor IC1 receives data from IC5 and then re-transmits the data onto the handset bus. Data received from the handset bus is transmitted by IC5.

Handset data bus

Drawing [04-03125](#)

The data bus is a push-pull balanced system and is driven from the driver IC8, which is controlled by the microprocessor. The data bus connects to the RF unit.

RF unit—microprocessors and control

Overview

The RF unit has five microprocessors, two of which are on the Application Processor Handset I/F 3 V PCB. The first of these microprocessors is the Digital Signal Processor IC11, which performs speech processing, ALE requirements and high-level control including operation of the user interface. The other processor is an 8-bit microcontroller IC6, which controls three slave processors on the other PCBs. The slave processors are used for low-level control for the PCB on which they are located.

Handset data

2011: Drawing [04-03425](#)

2012: Drawings [04-03499 \(sheet 1\)](#) and [04-03499 \(sheet 2\)](#)

Data from the handset is fed to IC6 on the Audio & Interconnect PCB (2011)/Audio Interconnect & Data I/O PCB (2012) in the RF unit. This interfaces the push-pull balanced data to single-ended data, which is required by the Application Processor Handset I/F 3 V PCB (2011)/Application Processor Handset & Data I/F PCB (2012).

RS232

2011: Drawing [04-03425](#)

2012: Drawings [04-03499 \(sheet 1\)](#) and [04-03499 \(sheet 2\)](#)

IC8 (04-03425) or IC11 (04-03499) provides the interface between the serial port RS232 and the logic levels required by the Application Processor Handset I/F 3 V PCB (2011)/Application Processor Handset & Data I/F PCB (2012) serial communications port TXB and RXB.

Real time clock

2011: Drawing [04-03425](#)

2012: Drawings [04-03499 \(sheet 1\)](#) and [04-03499 \(sheet 2\)](#)

The transceiver has real time clock capabilities provided by IC10, which is a battery-backed device to ensure time information is retained during power loss.

Application Processor Handset I/F 3 V PCB (2011)/Application Processor Handset & Data I/F PCB (2012)

2011: Drawings [04-03424 \(sheet 1\)](#) and [04-03424 \(sheet 2\)](#)

2012: Drawings [04-03498 \(sheet 1\)](#) and [04-03498 \(sheet 2\)](#)

Handset data is fed via the push-pull balanced driver IC6 (drawing [04-03425](#) or drawing [04-03499 \(sheet 1\)](#) and [04-03499 \(sheet 2\)](#)) on the Audio & Interconnect PCB (2011)/Audio Interconnect & Data I/O PCB (2012) to channel A of the DUART IC2 (sheet 1) on the Application Processor Handset I/F 3 V PCB (2011)/Application Processor Handset & Data I/F PCB (2012), where data is decoded for the DSP IC11 (sheet 2).

IC11 is a 32-bit floating point DSP. IC12 and IC13 (sheet 2) are flash memory devices that hold the main operating code. IC14 and IC15 are SRAM devices.

IC1 is a CPLD used for address decoding, interfacing between various devices and controlling bus cycle times.

IC16 is another flash memory device that contains all the channel information as well as the ALE link quality statistics, and user-programmed information such as Address List, Phone Link List and Control List settings.

Transmit and receive audio is digitally processed by the DSP via the CoDec (analog/digital audio interface device) IC7. IC7 converts analog audio signals into 16-bit digital format suitable for the DSP, and converts these digital signals back to analog format.

Supervisory (Reset) devices IC10 and IC17 monitor the onboard +5 V, +3.3 V and 1.8 V supplies and reset the system if any of these supplies fall outside the specification.

Audio & Interconnect PCB (2011)/Audio Interconnect & Data I/O PCB (2012)

2011: Drawing [04-03425](#)

2012: Drawings [04-03499 \(sheet 1\)](#) and [04-03499 \(sheet 2\)](#)

Under instruction from the Application Processor Handset I/F 3 V PCB (2011)/Application Processor Handset & Data I/F PCB (2012), the microprocessor IC9 controls the audio routing via the analog switches, the RF unit diagnostic LED H1, and the power off control. It also provides status information about the integrity of the protected **A** rail voltage back to the Application Processor Handset I/F 3 V PCB (2011)/Application Processor Handset & Data I/F PCB (2012).

The microprocessor is in Sleep mode when no data is present. When data is received from the Application Processor Handset I/F 3 V PCB (2011)/Application Processor Handset & Data I/F PCB (2012) over the 2-wire serial communications, the RC oscillator starts to run and 'wakes up' IC9.

IrDA (2012 only)

Drawings [04-03499 \(sheet 1\)](#) and [04-03499 \(sheet 2\)](#)

IC22 is an IrDA transceiver that passes data to the application processor UART IC2.

RF/IF PCB

Drawing [04-03378 \(sheet 3\)](#)

NOTE If the PCB issue status is -06 or earlier, see drawing [04-03378 \(sheet 3\)](#).

IC408 is in Sleep mode when no data is present. When data is received from Application Processor IC4, the RC oscillator starts to run and 'wakes up' IC408.

IC408 then programs the phase lock loop and the DDS ICs depending on the channel frequency required. It also controls the transmit/receive switching functions, filter select, AGC time constants and other ancillary functions.

Filter and Control PCB

Drawing [04-03369](#), or

Drawing [04-03542](#)

IC2 is in Sleep mode when no data is present. When data is received from Application Processor IC4, the RC oscillator starts to run and 'wakes up' IC2.

IC2 then selects the correct filter for the channel in use, the PTT switching, high/low power switching, fast/slow ALC time constant, average ALC on/off and fan control. Also, in conjunction with R19, IC2 forms a DAC that produces the reference ALC voltage. This is used to control the power versus frequency output level.

Internal voice encryptor

Voice encryption is possible with the NGT when a plug-in Encryptor PCB is fitted via P8 to the Application Processor Handset I/F 3 V PCB (2011)/Application Processor Handset & Data I/F PCB (2012). The microprocessor on this PCB detects that the Encryptor PCB is present at power up and enables the control firmware.

The encryptor is controlled by the TxD, RxD and SILENCE lines. The WAKE line is used to reduce the current drain when the encryptor is not in use.

When encryption is enabled, encrypted receive audio is fed via DEC_IN to the Encryptor PCB. The de-crypted audio comes out of DEC_OUT. This signal is fed into the system audio.

In Transmit mode, the microphone audio is fed into ENC_IN on the Encryptor PCB where it is encrypted then fed through ENC_OUT to the DSP audio compressor, and then to the transmitter.

When the encryptor is not enabled, all audio bypasses the Encryptor PCB.

NGT—Channel additions

This section contains the following topics:

[General \(130\)](#)

[Programming channels \(134\)](#)

General

If you are operating your transceiver in a country that has stringent licensing regulations, you may not be permitted to program channel transmit frequencies. Instead, the preferred option may be option TxD (programming of transmit frequencies is disabled).

If you are permitted to program channel transmit frequencies, you can do this via the RS232 socket of the handset using a PC, or via the keypad on the handset.

Details on how to program channels using a PC can be found in the *NGT System Programmer Help*.

Options

Options TxD, TxE and TxP are preset in the factory. Options TxE and TxD are enabled and disabled by fitting a TPE link on:

- Lk 6 on the Microprocessor PCB inside the junction box (see [Figure 22 on page 131](#)), or
- Link B on the Application Processor Handset I/F 3 V PCB inside the 2011 (see [Figure 23 on page 131](#)), or
- Link B on the Application Processor Handset & Data I/F PCB inside the 2012 (see [Figure 24 on page 132](#))

The transceivers are delivered from the factory without the TPE link fitted. Fitting the TPE link in TxE mode disables programming of transmit frequencies. Fitting the TPE link in TxD mode enables programming of transmit frequencies (see [Table 33](#)).

Table 33: Transmit disable, transmit enable and transmit prohibited options

Status of TPE link	TxD	TxE	TxP
TPE link fitted	Tx & Rx program enabled Normal operation disabled	Tx & Rx program disabled Normal operation enabled	Tx & Rx program disabled Normal operation enabled
TPE link not fitted	Tx & Rx program disabled Normal operation enabled	Tx & Rx program enabled Normal operation enabled	Tx & Rx program disabled Normal operation enabled

Figure 22: Position of TPE link on the Microprocessor PCB in the junction box

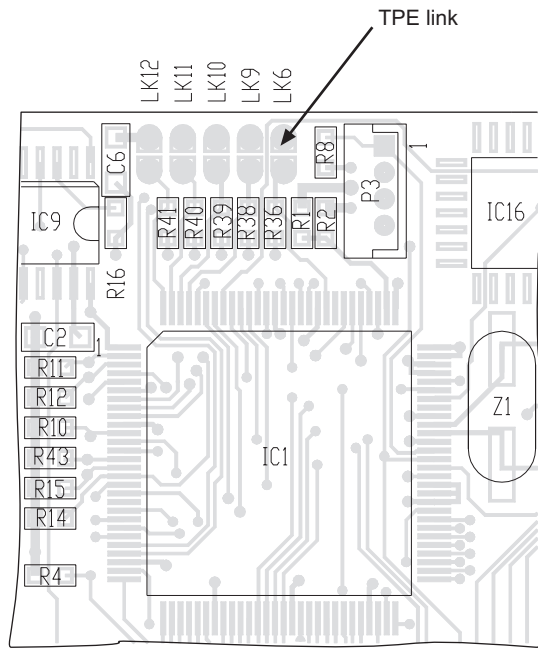

Figure 23: Position of TPE link on the Application Processor Handset I/F 3 V PCB in the 2011

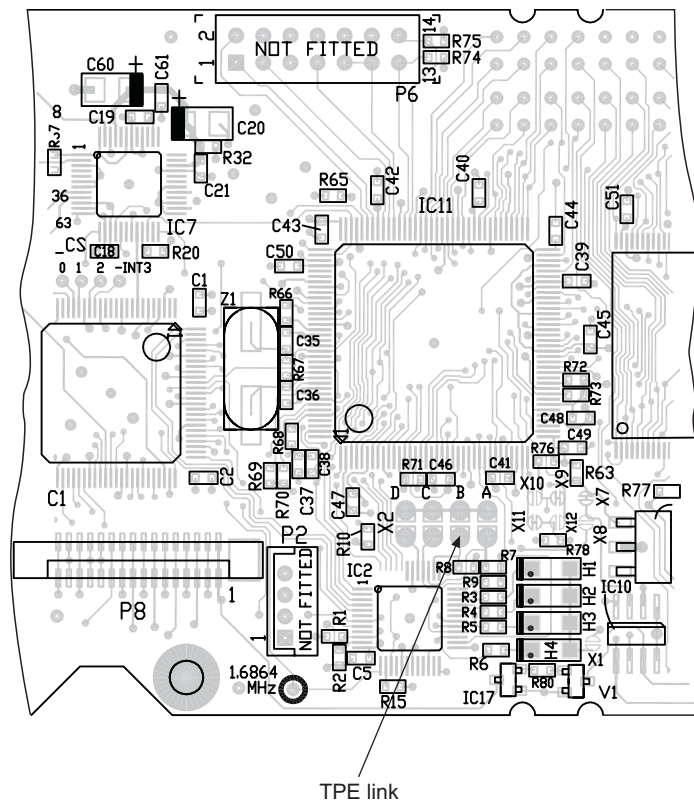
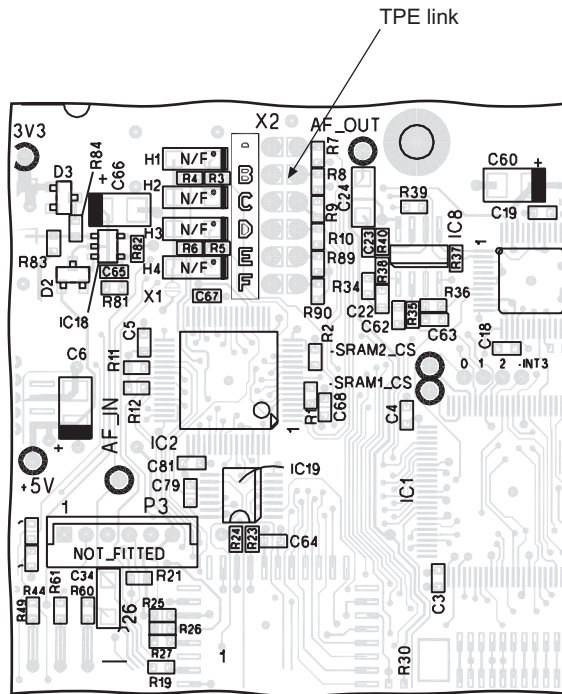

Figure 24: Position of TPE link on the Application Processor Handset & Data I/F PCB in the 2012



During startup, the status of the TPE link is read by:

- the microprocessor IC1 on the Microprocessor PCB in the junction box (drawing [04-03133](#)), or
- the microprocessor IC11 on the Application Processor Handset I/F 3 V PCB in the 2011 (drawing [04-03424 \(sheet 2\)](#))
- the microprocessor IC11 on the Application Processor Handset & Data I/F PCB in the 2012 (drawing [04-03498 \(sheet 2\)](#))

Transmit disable option

The TxD option prevents the user from entering new transmit frequencies while the transceiver is operational.

To enable the user to enter transmit frequencies, the TPE link must be fitted. While the TPE link is fitted, the normal functions of the transceiver are disabled. To resume normal functions, the TPE link must be removed and the transceiver switched off then on again.

Transmit enable option

With the TxE option without the TPE link fitted, the user can enter new transmit and receive frequencies without disabling the normal functions of the transceiver.

Transmit frequencies between 1.6 to 30 MHz can be programmed in 10 Hz steps. The receive frequency range is 0.25 to 30 MHz.

NOTE Fitting the TPE link disables the programming of new transmit and receive frequencies.

Transmit prohibited option

The TxP option prevents the user from entering new transmit and receive frequencies. NSP is required to enter new frequencies.

Programming channels

Creating a channel

This section covers creating a channel in a transceiver in which receive and transmit frequencies can be entered.

If you are operating the transceiver in a country that has stringent licensing regulations, you may not be permitted to create channels with transmit frequencies.

NOTE If the TxD option has been installed in the transceiver there are restrictions on the frequencies you can enter. Use [page 137, *Creating a channel with the TxD option.*](#)

If the TxP option has been installed in the transceiver you cannot create channels.

To create a channel:

- Press **X** until **Main Menu** is displayed.
- Select **Channel**.

The currently selected channel is displayed. For example:

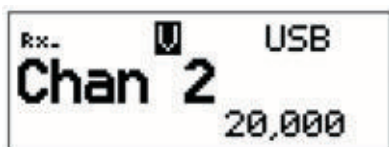

NOTE If the Channel List is empty, Free Tune is displayed.

- Hold **Q** to open the List Manager.
- Select **Create entry**.



The transceiver suggests a name for the new channel based on the name of the channel you were on.



NOTE If the Channel List is empty a name is not displayed. Enter a name for the channel.

- Do one of the following:
 - To use the name displayed, press ✓.
 - To enter a new name, start typing. When you have entered the name, press ✓.
 - To edit the name displayed, press ✕. The cursor is placed at the end of the line so you can backspace over characters and/or enter new text. When the name is correct, press ✓.

NOTE To enter lower-case or numeric characters, press the # key until a lower-case **a** or the hash symbol **#** is displayed at the bottom right of the screen.

The name must be unique to the Channel List.

The Receive Freq setting is displayed with the receive frequency of the channel you were on.



- Do one of the following:
 - to use this frequency, press ✓
 - to enter a new receive frequency, type the frequency in kilohertz, then press ✓



The Transmit Freq setting is displayed with the receive frequency you entered.

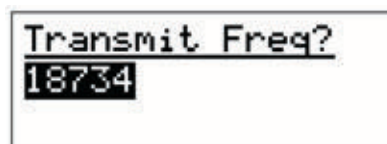

- Do one of the following:
 - to use this frequency, press ✓
 - to enter a new transmit frequency, type the frequency in kilohertz, then press ✓
 - to disable the transmit frequency, erase the frequency by pressing ✕ repeatedly, then press ✓ to save the empty setting

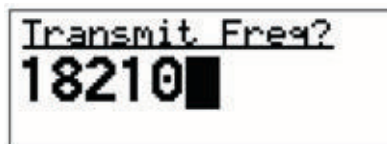

The Mode setting is displayed.



- Scroll to the mode (or one of the modes) you want to use with the channel.
- Press ✓ to save the mode.

If multiple modes can be added to the channel the transceiver asks you if you want to add another mode. Do one of the following:

NOTE

- to add another mode, press ✓, scroll to the mode you want to add, then press ✓ again
- if you do not want to add another mode, press ✕

The new channel is created and the List Manager remains open.

If you want to view the channel you have created, close the List Manager by pressing ✕.



NOTE

If you disabled the transmit frequency, dashes are displayed at the bottom left of the channel screen.

- Press ✕ until **Main Menu** is displayed.

Creating a channel with the TxD option

If the TxD option has been installed in the transceiver you cannot create channels with new transmit frequencies unless the TPE link is fitted (see [page 132, Transmit enable option](#) and [Table 33 on page 130](#)). You can, however, create channels with the same transmit frequency as an existing channel, and you can disable transmit frequencies to create receive-only channels.

To create a channel:

- Press **X** until **Main Menu** is displayed.
- Select **Channel**.

The currently selected channel is displayed. For example:



- Do one of the following:
 - To create a transmit channel, scroll to the channel with the transmit frequency you want. The allowed modes for this channel are the only modes you will be able to select for the new channel.
 - To disable the transmit frequency and create a receive-only channel you do not need to scroll to a specific channel. The modes you will be able to select for the new channel are all the modes available in the transceiver.
- Hold **Q** to open the List Manager.
- Select **Create entry**.



The transceiver suggests a name for the new channel based on the name of the channel you were on.



- Do one of the following:
 - To use the name displayed, press **✓**.
 - To enter a new name, start typing. When you have entered the name, press **✓**.
 - To edit the name displayed, press **X**. The cursor is placed at the end of the line so you can backspace over characters and/or enter new text. When the name is correct, press **✓**.

NOTE To enter lower-case or numeric characters, press the # key until a lower-case **a** or the hash symbol **#** is displayed at the bottom right of the screen.

The name must be unique to the Channel List.

The Receive Freq setting is displayed with the receive frequency of the channel you were on.

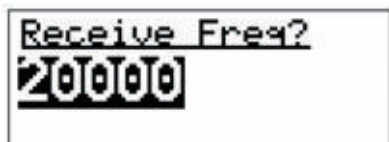

- Do one of the following:
 - to use this frequency, press ✓
 - to enter a new receive frequency, type the frequency in kilohertz, then press ✓



The transceiver asks you if you want to disable the transmit frequency of the new channel.

- Do one of the following:
 - to disable the transmit frequency, press ✓
 - to create a channel with the same transmit frequency as the channel you were on, press ✕

The Mode setting is displayed.

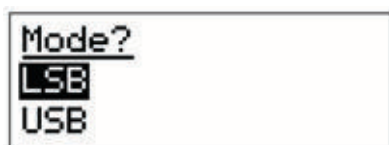

- Scroll to the mode (or one of the modes) you want to use with this channel.

NOTE If you are creating a transmit channel, the modes from which you can select are the allowed modes for the channel you were on.

If you are creating a receive-only channel, the modes from which you can select are all the modes available in the transceiver.

- Press ✓ to save the mode.

If multiple modes can be added to the channel the transceiver asks you if you want to add another mode. Do one of the following:

- NOTE**
 - to add another mode press ✓, scroll to the mode you want to add, then press ✓ again
 - if you do not want to add another mode, press ✕

The new channel is created and the List Manager remains open.

If you want to view the channel you have created, close the List Manager by pressing **X**.

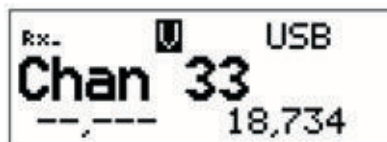

NOTE If you disabled the transmit frequency, dashes are displayed at the bottom left of the channel screen.

- Press **X** until **Main Menu** is displayed.

Renaming a channel

When you rename a channel, references to the channel in other lists are not automatically updated; you need to go to the Address, Network and Phone Link Lists and update any references to the channel.

For example, if the channel you renamed is used in a network, go to the channel/mode list for the network, find the reference to the old channel name, then edit it so that the new name is displayed. If you do not update the reference to the channel, the channel is not scanned when scanning is switched on.

To rename a channel:

- Press **X** until **Main Menu** is displayed.
- Select **Channel**.
- Go to the entry you want to rename. For example:

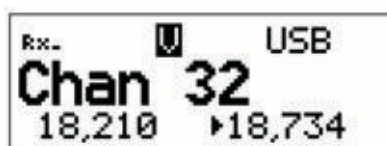

NOTE Use **▶** or **◀** to scroll to the entry, or use the Find feature.

- Hold* **Q** to open the List Manager.

- Select **Rename entry**.



The transceiver displays the name of the entry.



- Do one of the following:
 - to enter a new name, start typing
 - to edit the existing name, press **X** to move the cursor to the end of the name, then edit the name

NOTE To enter lower-case or numeric characters, press **#** until a lower-case **a** or the hash symbol **#** is displayed at the bottom right of the screen.

The name must be unique to the Channel List.

- Press **✓**.

The channel is renamed and the List Manager remains open.

If you want to view the channel you have renamed, close the List Manager by pressing **X**.

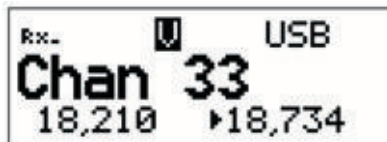

- Press **X** until **Main Menu** is displayed.

Copying a channel

If you want to create a channel that is similar to an existing channel you can copy the existing channel instead of creating a new one. When you copy a channel the transceiver prompts you to enter a name for the copy. The name must be unique to the Channel List.

To copy a channel:

- Press **X** until **Main Menu** is displayed.
- Select **Channel**.
- Go to the entry you want to copy. For example:

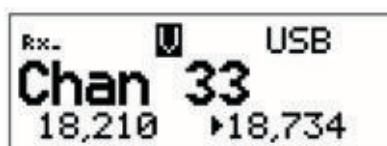

NOTE Use **▶** or **◀** to scroll to the entry, or use the Find feature.

- Hold **Q** to open the List Manager.
- Select **Copy entry**.



The transceiver suggests a name for the new channel based on the name of the channel you were on.

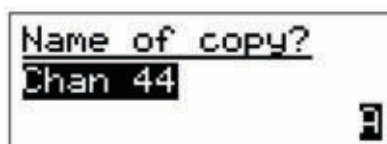

- Do one of the following:
 - To use the name displayed, press **✓**.
 - To enter a new name, start typing. When you have entered the name, press **✓**.
 - To edit the name displayed, press **X**. The cursor is placed at the end of the line so you can backspace over characters and/or enter new text. When you have entered the name, press **✓**.

NOTE To enter lower-case or numeric characters, press **#** until a lower-case **a** or the hash symbol **#** is displayed at the bottom right of the screen.

The name must be unique to the Channel List.

A copy of the original channel, with the new name, is created and the List Manager remains open.

If you want to view the channel, close the List Manager by pressing **X**.



- Press **X** until **Main Menu** is displayed.

Editing a channel

NOTE If the TxD option has been installed in the transceiver you cannot enable or disable the transmit frequency of a channel by editing the channel. See [page 137, *Creating a channel with the TxD option*](#) instead.

To edit a channel:

- Press **X** until **Main Menu** is displayed.
- Select **Channel**.
- Go to the entry you want to edit. For example:

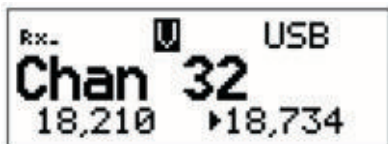

NOTE Use **▶** or **◀** to scroll to the entry, or use the Find feature.

- Press **✓** to display the settings for the entry.
The first setting (Receive Freq) is displayed.



- Scroll to the setting you want to edit, then *hold* **✓**.
The following table explains how to edit each setting.

Name of setting	How to edit the setting
Receive Freq	<p>Do one of the following:</p> <ul style="list-style-type: none"> To erase the frequency displayed, start typing. Enter the new frequency in kilohertz. To place the cursor at the end of the line so you can backspace over the text and/or enter new text, press X. Enter the new frequency in kilohertz. <p>When the frequency is correct, press ✓.</p>
Transmit Freq	<p>Do one of the following:</p> <ul style="list-style-type: none"> To erase the frequency displayed, start typing. Enter the new frequency in kilohertz. To place the cursor at the end of the line so you can backspace over the text and/or enter new text, press X. Enter the new frequency in kilohertz. To disable transmission on this channel, erase the transmit frequency by pressing X repeatedly. <p>When the frequency is correct (or erased), press ✓.</p>
Mode	<p>Do one of the following:</p> <ul style="list-style-type: none"> To add a mode, press ✓ to display the first mode, then <i>hold</i> Q to open the List Manager. Select Add item, then select the mode you want to add to the channel. To edit a mode, scroll to the mode you want to edit, then <i>hold</i> ✓. Select the mode you want. To delete a mode, scroll to the mode you want to delete, then <i>hold</i> Q to open the List Manager. Select Delete item, then press ✓ to confirm that you want to delete the item. <p>As each channel must have at least one mode you cannot delete the last mode from a channel.</p> <p>The List Manager remains open. If you want to return to the setting, close the List Manager by pressing X.</p>

- When you have edited the settings, press **X** until you return to the channel screen.
- Press **X** until **Main Menu** is displayed.

Deleting a channel

To delete a channel:

- Press **X** until **Main Menu** is displayed.
- Select **Channel**.
- Go to the entry you want to delete. For example:

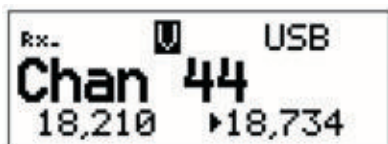

NOTE Use **▶** or **◀** to scroll to the entry, or use the Find feature.

- Hold **Q** to open the List Manager.
- Select **Delete entry**.

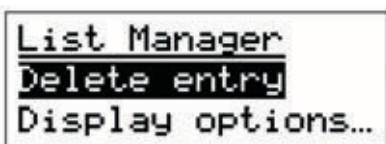

The transceiver asks you to confirm that you want to delete the entry.

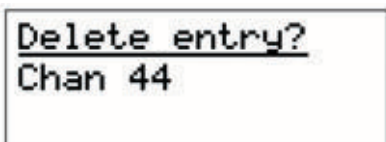

- Press **✓**.
The channel is deleted and the List Manager remains open.
- Press **X** until **Main Menu** is displayed.

This section contains the following topics:

- Test equipment required (146)
- Voltage regulators (147)
- Crystal oven (152)
- Low-pass filters (152)
- Service mode (153)
- Testing the keypad and display (159)
- Adjustment locations and test points (160)
- Checking the voltage-controlled oscillator (166)
- Aligning the 45 MHz filters (167)
- Aligning the 455 kHz IF and noise limiter (169)
- Adjusting the exciter output level (170)
- Adjusting carrier re-insertion (171)
- Adjusting the exciter output spurious balance (172)
- Adjusting frequency (173)
- Adjusting mute (175)
- Adjusting the PA (176)
- Checking performance of the receiver (190)
- Checking performance of the transmitter (194)

Test equipment required

The following test equipment is required:

- a 50 MHz oscilloscope with an external trigger capability
- a 10× oscilloscope probe with an input impedance of 10 MΩ and less than 20 pF
- a 50 Ω RF dummy load and power meter rated at a minimum of 100 W RMS (rated to 1 kW PEP (500 W CW) for high-power amplifier adjustments)
- an RF signal generator covering the range 400 kHz to 30 MHz, with a calibrated output of -130 dBm to 0 dBm from a source impedance of 50 Ω
- a 50 MHz frequency counter with a resolution of 1 Hz
- a regulated power supply of 13.6 V ±0.2 V at 20 A peak
- two-tone audio generator operating at 700 Hz and 2300 Hz, with balance control and adjustable output 0 to 100 mV RMS
- a digital multimeter with a 10 MΩ input impedance
- an AC voltmeter with a range of 10 mV to 10 V
- transceiver test unit to Codan drawing [04-03272](#) (the microphone isolating transformer should be fitted with a μ-metal screen to prevent the 50 Hz mains from being picked up)
- an RF spectrum analyser capable of measuring intermodulation
- NGT test handset for use with 2011 RF Units during tests that require a GPIO connector

Voltage regulators

None of the voltage regulators are adjustable. However, the output voltages can be checked.

Handset voltages

The supply voltages for the handset are shown in [Table 34](#).

Drawing [08-05300](#)

Table 34: Supply voltages for the Handset PCB in the handset

Supply	Description	Source
Standby	+5.4 V when transceiver is off	ext
Handset power	+9.2 V when transceiver is on	ext
+5 V	+5 V regulated supply	IC10
−9 V	−9 V for IC7	IC5

Junction box voltages

The supply voltages for the junction box are shown in [Table 35](#) and [Table 36](#).

Drawing [08-05470](#) or [08-05986 \(sheet 1\)](#)

Table 35: Supply voltages for the Audio PCB in the junction box

Supply	Description	Source
A (protected)	Unregulated battery supply	ext from RF unit
+10 V	+10 V regulated supply	IC12
+5 V	+5 V regulated supply	IC13
+5 VQ	+5 V quiet for opamp bias	IC13 (filtered)

Drawing [08-05317](#)

Table 36: Supply voltages for the Microprocessor PCB in the junction box

Supply	Description	Source
+5 V	+5 V digital supply	IC13
A (protected)	Unregulated battery supply	from RF unit

RF unit voltages

The supply voltages for the RF unit are shown in [Table 37](#) to [Table 45](#).

Drawing [08-05266](#)

Table 37: Supply voltages for the Audio Interface PCB in the RF unit (2010 only)

Supply	Description	Source
A	Unregulated battery supply	via Filter and Control PCB
A (protected)	2 A current-limited battery	IC14
+10 V	+10 V regulated supply	IC9
+5 V	+5 V regulated supply	IC10
+5 VQ	+5 V quiet for opamp bias	IC10 (filtered)
+6 VSBY	+6.2 V standby for CIB	IC4, D9, D10

Drawing [08-05988 \(sheet 1\)](#)

Table 38: Supply voltages for the Audio & Interconnect PCB in the RF unit (2011 only)

Supply	Description	Source
A	Unregulated battery supply	via Filter and Control PCB
A (protected)	2 A current-limited battery	F1
+10 V	+10 V regulated supply	via Filter and Control PCB
+5 V	+5 V regulated supply	IC7
+2.5 VQ	+2.5 V quiet for opamp bias	IC7 (filtered)
+5 VQ	+5 V quiet for opamp bias	IC7 (filtered)
+5 VSBY	+5.4 V standby for handset	D3, D4

Drawing [08-06261 \(sheet 1\)](#) and [08-06261 \(sheet 2\)](#)

Table 39: Supply voltages for the Audio Interconnect & Data I/O PCB in the RF unit (2012 only)

Supply	Description	Source
A	Unregulated battery supply	via Filter and Control PCB
A (protected)	2 A current-limited battery	F1
+10 V	+10 V regulated supply	via Filter and Control PCB
+5 V	+5 V regulated supply	IC7
+2.5 VQ	+2.5 V quiet for opamp bias	IC7 (filtered)
+5 VQ	+5 V quiet for opamp bias	IC7 (filtered)
+5 VSBY	+5.4 V standby for handset	D3, D4

Drawing [08-05265](#)

Table 40: Supply voltages for the Application Processor PCB in the RF unit (2010 only)

Supply	Description	Source
+5 V	+5 V switchmode supply	IC6
VREF	+2.5 V reference voltage	IC5

Drawing [08-05987](#)

Table 41: Supply voltages for the Application Processor Handset I/F 3 V PCB in the RF unit (2011 only)

Supply	Description	Source
+1V8	+1.8 V DSP core supply	IC4
+3V3	+3.3 V switchmode supply	IC5
+5 V	+5 V regulated supply	IC3

Drawing [08-06260](#)

Table 42: Supply voltages for the Application Processor Handset & Data I/F PCB in the RF unit (2012 only)

Supply	Description	Source
+1V8	+1.8 V DSP core supply	IC4
+3V3	+3.3 V switchmode supply	IC5
+5 V	+5 V regulated supply	IC3

ALTERNATIVE TEXT Drawing [08-05261 \(sheet 1\)](#)

Table 43: Supply voltages for the RF/IF PCB in the RF unit (08-05261)

Supply	Description	Source
A	Unregulated battery supply	via Audio Interface PCB
+5 V	+5 V regulated supply	IC210
+26 V	+26 V from charge pump supply	IC402
+10 V	+10 V regulated supply	via Audio Interface PCB
+10 VRx	+10 V In Rx	V419, V420
+10 VTx	+10 V In Tx	V421, V422

ALTERNATIVE TEXT Drawing [08-05889 \(sheet 1\)](#)

NOTE If the PCB issue status is -06 or earlier, see drawing [08-05889 \(sheet 1\)](#).

Table 44: Supply voltages for the RF/IF PCB in the RF unit (08-05889)

Supply	Description	Source
A	Unregulated battery supply	via Audio Interface PCB (2010), or Audio & Interconnect PCB (2011), or Audio Interconnect & Data I/O PCB (2012)
+5 V	+5 V regulated supply	IC210
+26 V	+26 V from charge pump supply	IC402
+10 V	+10 V regulated supply	via Audio Interface PCB (2010), or Audio & Interconnect PCB (2011), or Audio Interconnect & Data I/O PCB (2012)
+10 VRx	+10 V In Rx	V415, V416
+10 VTx	+10 V In Tx	V417, V418

ALTERNATIVE TEXT Drawing [08-05415](#) or [08-05511 \(sheet 1\)](#) and drawing [08-05416](#), or Drawings [08-05869 \(sheet 2\)](#) and [08-05910 \(sheet 1\)](#), or Drawings [08-06461 \(sheet 2\)](#) and [08-05910 \(sheet 1\)](#)

NOTE If the PCB issue status is -04 or earlier, see drawing [08-05910 \(sheet 1\)](#).

Table 45: Supply voltages for the PA PCB and Filter and Control PCB in the RF unit

Supply	Description	Source
A	Unregulated battery supply	external battery or power supply
+10 VA	+10 V regulated supply	IC1
+5 VA	+5 V regulated supply	IC4
+5 V	+5 V regulated supply	IC200

Crystal oven

ALTERNATIVE TEXT Drawings [08-05235](#), [04-03095](#) and [08-05261 \(sheet 1\)](#)

The crystal oven (drawings [08-05235](#) and [04-03095](#)) on the RF/IF PCB (drawing [08-05261 \(sheet 1\)](#)) is attached to the reference crystal Z1.

The oven should be checked after a warm-up period of five minutes.

The operating temperature of the oven should be $70^{\circ}\text{C} \pm 5^{\circ}\text{C}$ ($158^{\circ}\text{F} \pm 41^{\circ}\text{F}$).

ALTERNATIVE TEXT Drawings [08-05963](#), [04-03410](#) and [08-05889 \(sheet 1\)](#)

NOTE If the PCB issue status is -06 or earlier, see drawing [08-05889 \(sheet 1\)](#).

The Crystal Oven Assembly (drawing [08-05963](#)) is used on the RF/IF PCB (drawing [08-05889 \(sheet 1\)](#)) and contains the reference crystal Z1.

The oven should be checked after a warm-up period of five minutes.

The operating temperature of the oven should be $70^{\circ}\text{C} \pm 5^{\circ}\text{C}$ ($158^{\circ}\text{F} \pm 41^{\circ}\text{F}$).

Low-pass filters

ALTERNATIVE TEXT Drawing [08-05261 \(sheet 2\)](#) or [08-05889 \(sheet 2\)](#)

NOTE If the PCB issue status is -06 or earlier, see drawing [08-05889 \(sheet 2\)](#).

There are two 30 MHz LPFs. Both are located on the RF/IF PCB in the RF unit. One is located in the receiver input and the other is located in the exciter output.

Alignment of the LPFs is not necessary. Each coil (L106 and L114) is pre-aligned to a frequency of 45 MHz.

Service mode

Service mode provides a set of specific channels. These channels enable you to check the performance of the transceiver and when necessary, carry out adjustments to ensure the transceiver meets specifications.

General

The transceiver is provided with a special Service mode to assist you to:

- check VCO1 (this is not adjustable)
- align the 45 MHz BPFs using only an oscilloscope and signal generator
- align the transformers T201 and T202 in the 455 kHz IF
- adjust the exciter output level
- adjust carrier re-insertion
- adjust the exciter output spurious balance
- adjust the channel frequency
- adjust mute
- check and adjust the PA
- check the performance of the receiver and the transmitter

NOTE Preset adjustments, which are normally factory-set, require attention only if components are replaced that affect their settings.

Accessing Service mode

To put the transceiver into Service mode:

- Switch off the transceiver.
- Access the appropriate PCB.
- Insert:
 - link 11 on the Microprocessor PCB in the junction box (see drawing [08-05317](#) and [Figure 25](#)), or
 - link A on the Application Processor Handset I/F 3 V PCB in the 2011 (see drawing [08-05987](#) and [Figure 26 on page 155](#))
 - link A on the Application Processor Handset & Data I/F PCB in the 2012 (see drawing [08-06260](#) and [Figure 27 on page 155](#))

Figure 25: Position of link 11 on the Microprocessor PCB in the junction box

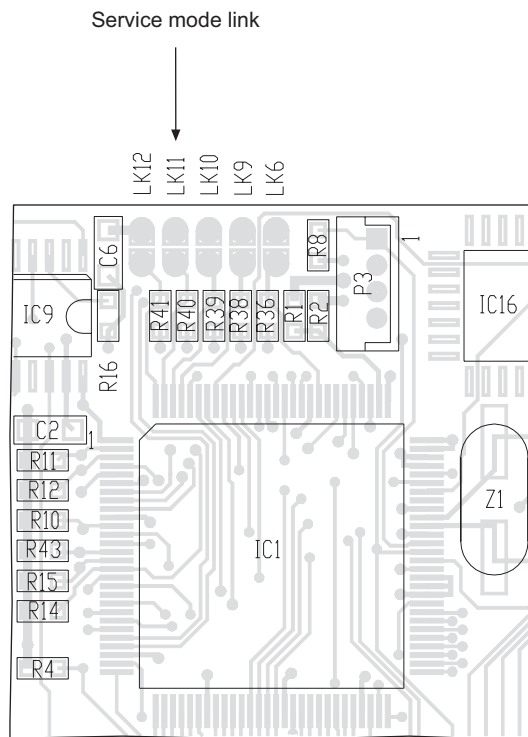

Figure 26: Position of link A on the Application Processor Handset I/F 3 V PCB in the 2011

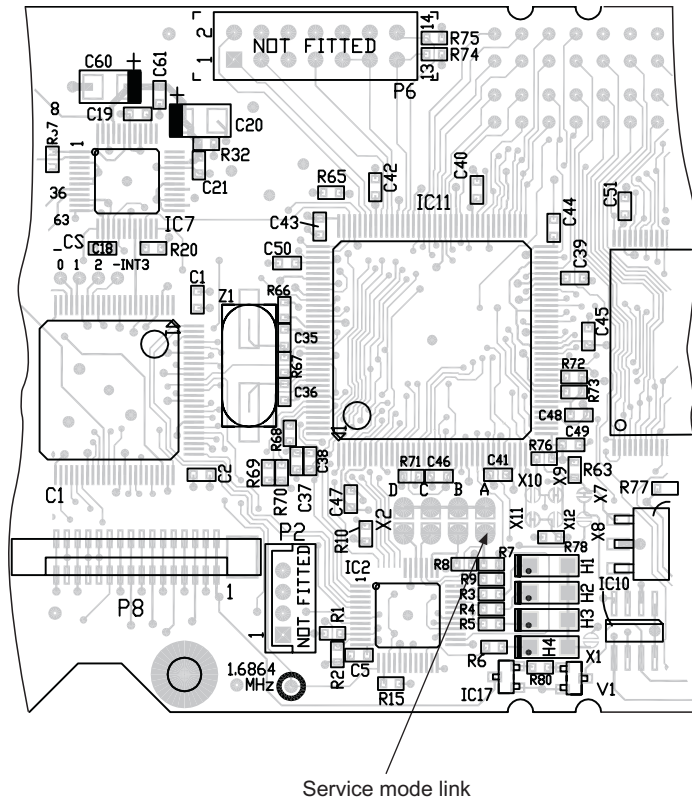
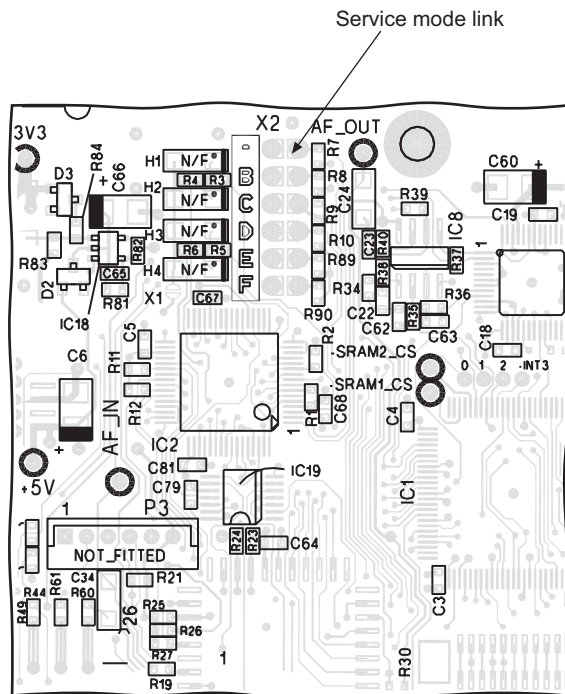

Figure 27: Position of link A on the Application Processor Handset & Data I/F PCB in the 2012



- Switch on the transceiver.

The transceiver is now in Service mode. While in Service mode, normal operation is not possible.

Service channels

The pre-defined service channels for Service mode are shown in [Table 46](#).



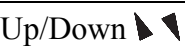



Table 46: Pre-defined service channels for Service mode

Channel	Frequency	
1	250 kHz, speaker muted, Tx inhibit	
2	15 MHz, speaker muted, Tx inhibit	
3	30 MHz, speaker muted, Tx inhibit	
The following selections start special test functions		
4	Sweep test the Rx 45 MHz filter	
5	Sweep test the Tx 45 MHz filter	
The following channels are defined with LSB/USB/AM/IF2 access modes		
7	250 kHz	Receive only
8	1.1 MHz	
9	1.6 MHz	Band 1
10	1.9 MHz	
11	2.3 MHz	
12	2.5 MHz	Band 2
13	3.1 MHz	
14	3.6 MHz	
15	3.8 MHz	Band 3
16	4.6 MHz	
17	5.5 MHz	
18	5.7 MHz	Band 4
19	7.1 MHz	
20	8.4 MHz	
21	8.6 MHz	Band 5
22	10.6 MHz	
23	12.9 MHz	
24	13.1 MHz	Band 6
25	16.1 MHz	
26	19.6 MHz	
27	19.8 MHz	Band 7
28	24.9 MHz	
29	27.2 MHz	
30	29.9 MHz	
31	19.999 MHz	

Service mode hot keys

When the transceiver is in Service mode, pre-defined Service mode hot keys replace the normal key definitions on the handset.

Table 47: Hot keys on the handset during Service mode

Key(s)	Hot key function
MUTE	Set Mute ON/OFF
Power 	Switch transceiver ON/OFF
PTT	Transmit
Volume 	Change volume
Up/Down 	Change channel
 + 9	Set display contrast
 + 0	Set display brightness
 + #	Test keypad and display
1	Set AGC SLOW/FAST/HOLD (Default = SLOW)
2	Select next mode USB/LSB/AM/IF2 (Default = USB)
3	Set tune carrier ON/OFF (Default = OFF)
4	Set talk power ON/OFF (Default = OFF)
5	Set receive preamplifier ON/OFF (Default = ON)
6	Set PA average power limiter ON/OFF (Default = OFF)
7	Set PA power HIGH/LOW (Default = HIGH)
8	Set PA ALC response SLOW/FAST (Default = FAST)

Returning to Normal mode

To return the transceiver to Normal mode:

- Switch off the transceiver.
- Remove:
 - link 11 on the Microprocessor PCB in the junction box (see drawing [08-05317](#) and [Figure 25 on page 154](#)), or
 - link A on the Application Processor Handset I/F 3 V PCB in the 2011 (see drawing [08-05987](#) and [Figure 26 on page 155](#))
 - link A on the Application Processor Handset & Data I/F PCB in the 2012 (see drawing [08-06260](#) and [Figure 27 on page 155](#))
- Switch on the transceiver.

The transceiver is now in Normal mode and normal operation can resume.

Testing the keypad and display

NOTE The transceiver does not have to be in Service mode to perform this test.

To enter the keypad and display test mode:

- Hold down* **Ⓜ** and press **#**.

The display prompts you to press a key. This message is displayed for approximately one second, then the handset screen flashes at 2 Hz to ensure all pixels are functional.

- Press each key on the keypad one at a time, except **X**.

As each key is pressed, it is displayed on the handset screen for one second.

To exit from the keypad and display test mode:

- Press **X**.

Adjustment locations and test points

To view the adjustment locations and test points for the...	See...
RF/IF PCB in the RF unit (08-05261)	Figure 28 on page 160
RF/IF PCB in the RF unit (08-05889)	Figure 29 on page 161
PA PCB in the RF unit (08-05415 or 08-05511)	Figure 30 on page 161
PA PCB in the RF unit (08-05869)	Figure 31 on page 162
PA PCB in the RF unit (08-06461)	Figure 32 on page 162
Filter and Control PCB in the RF unit (08-05416)	Figure 33 on page 163
Filter and Control PCB in the RF unit (08-05910)	Figure 34 on page 163
Audio Interface PCB in the RF unit (08-05266, 2010 only)	Figure 35 on page 164
Audio & Interconnect PCB in the RF unit (08-05988, 2011 only)	Figure 36 on page 164
Audio Interconnect & Data I/O PCB in the RF unit (08-06261, 2012 only)	Figure 37 on page 165

Figure 28: RF/IF PCB in the RF unit (08-05261)

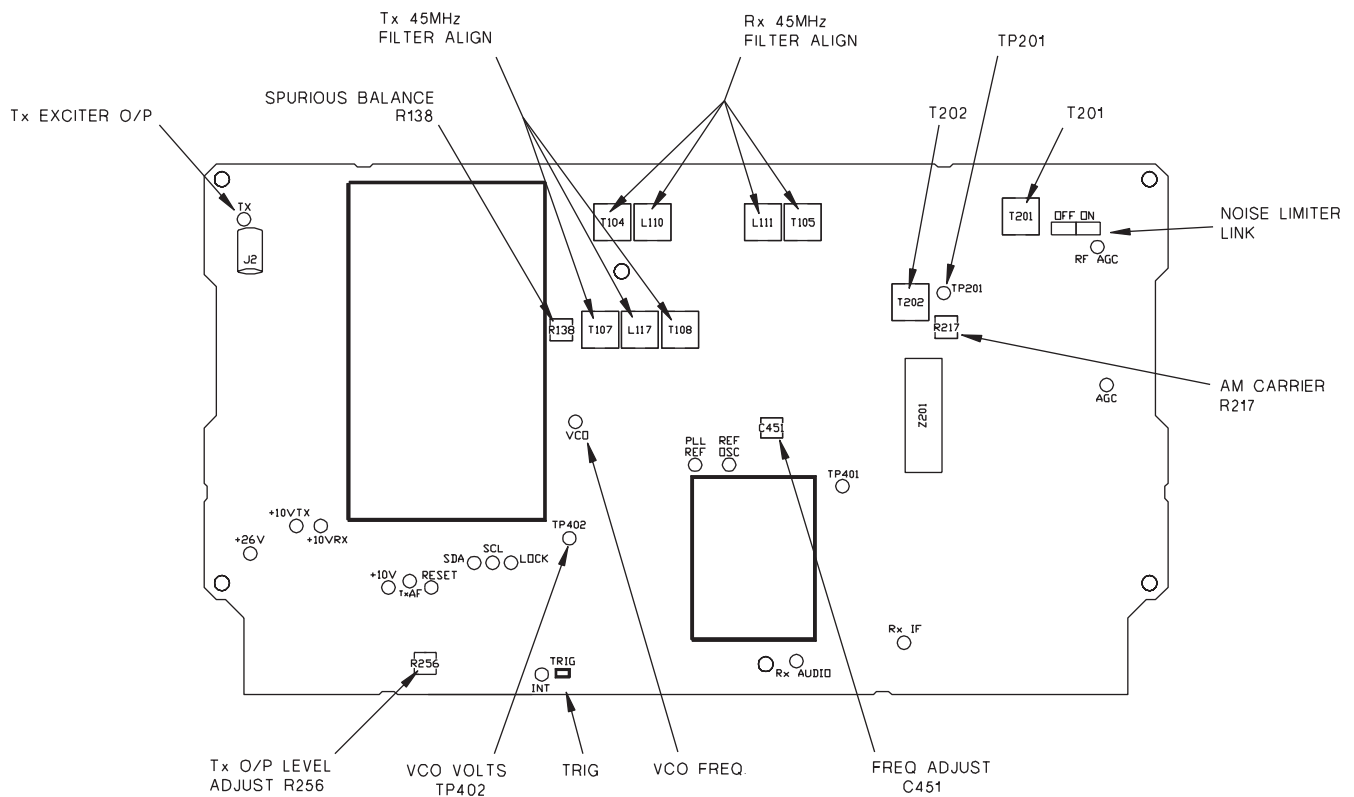

Figure 29: RF/IF PCB in the RF unit (08-05889)

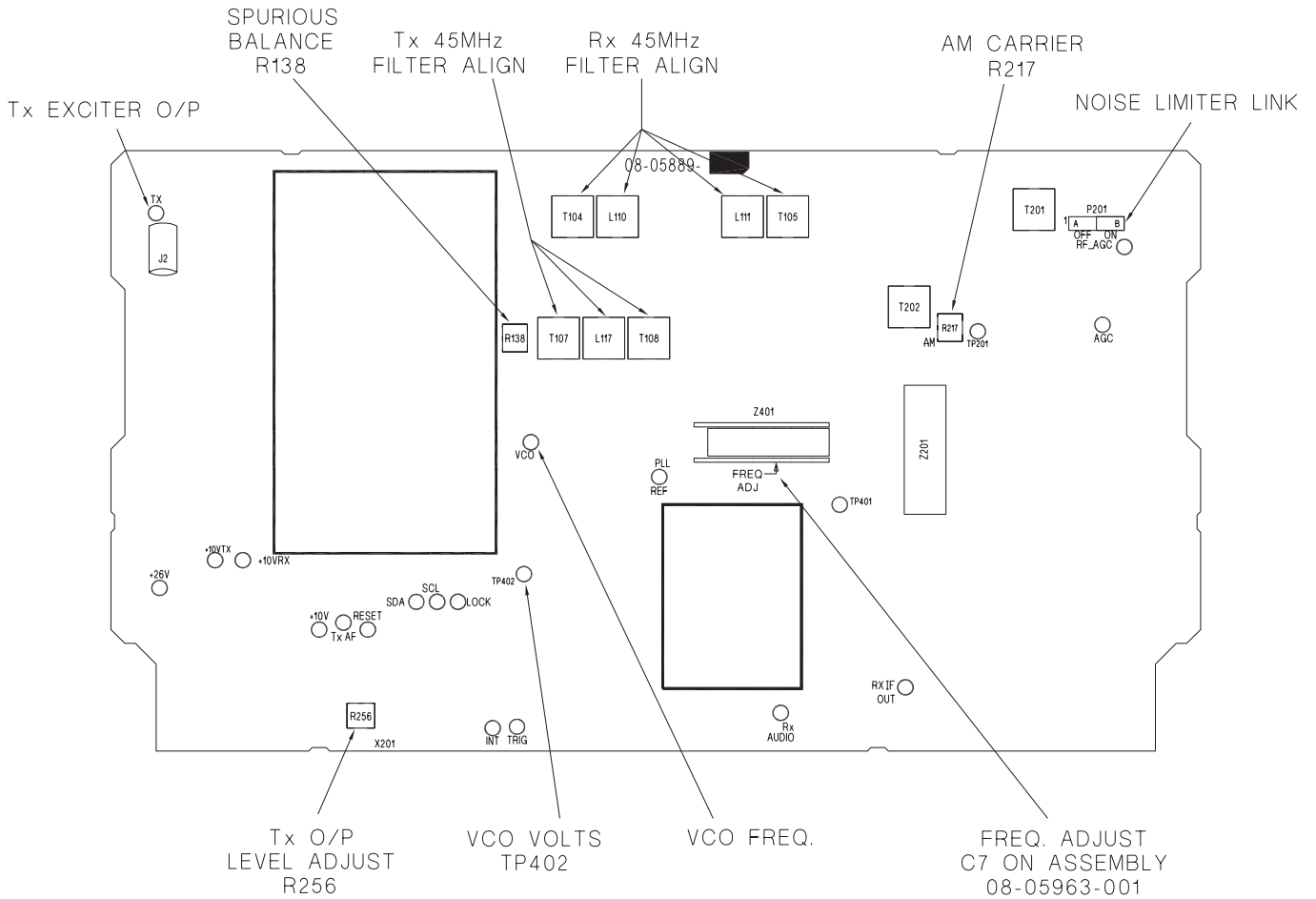

Figure 30: PA PCB in the RF unit (08-05415 or 08-05511)

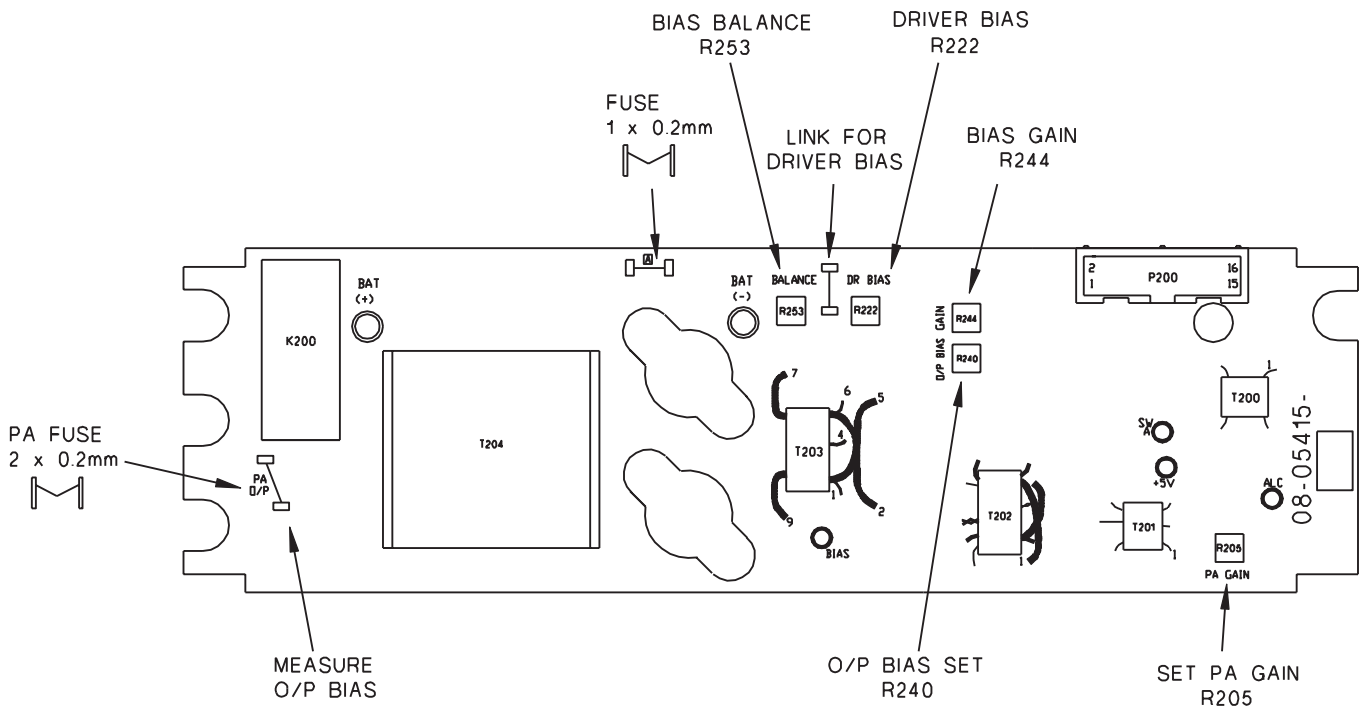

Figure 31: PA PCB in the RF unit (08-05869)

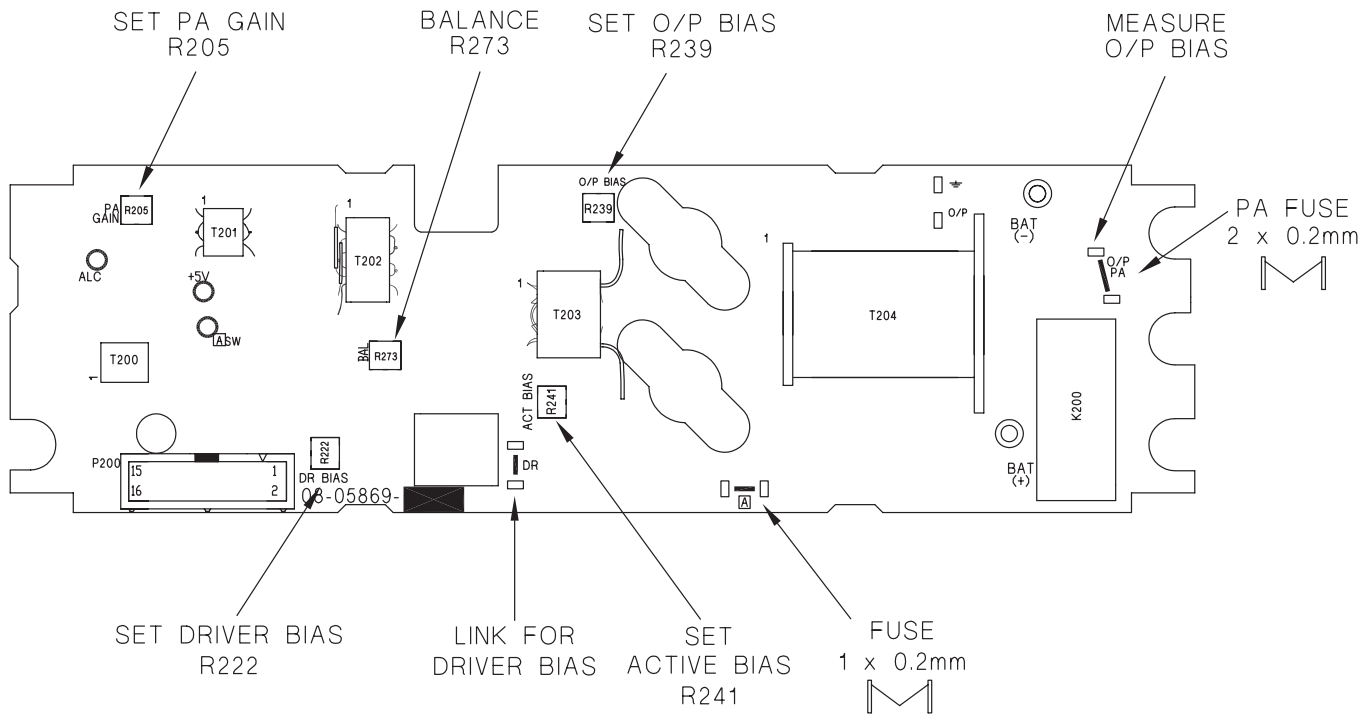

Figure 32: PA PCB in the RF unit (08-06461)

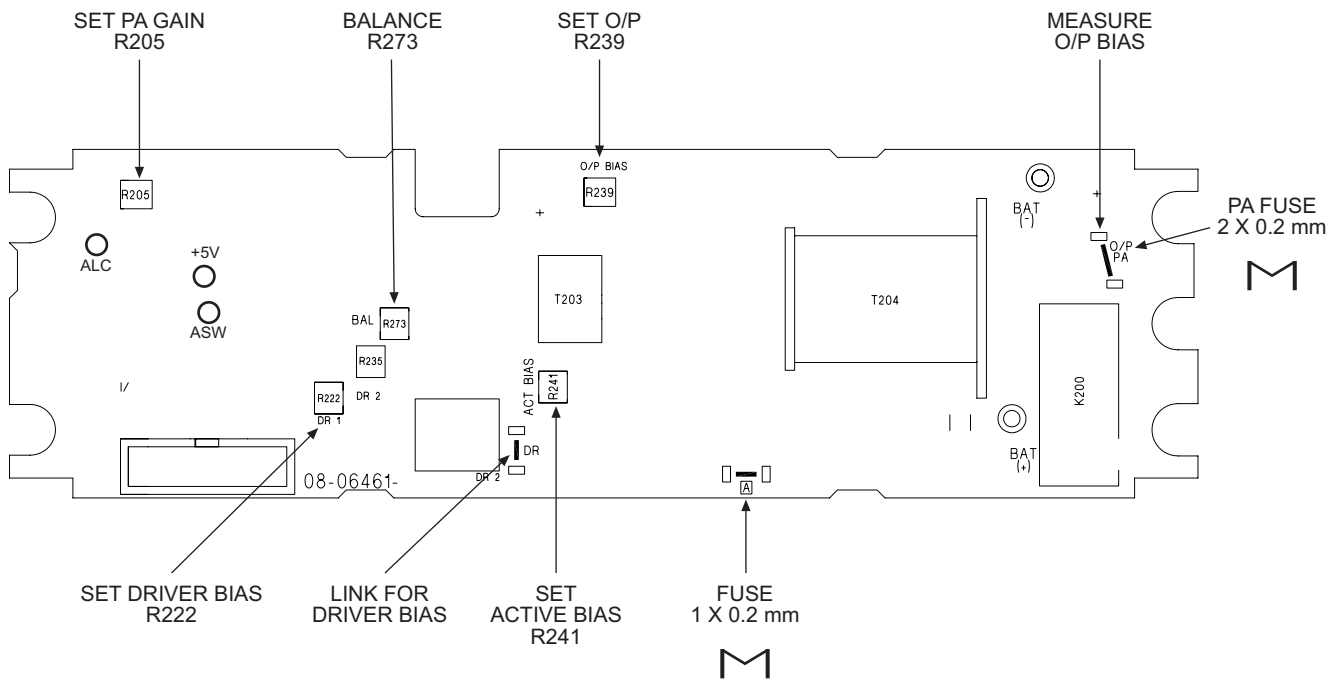

Figure 33: Filter and Control PCB in the RF unit (08-05416)

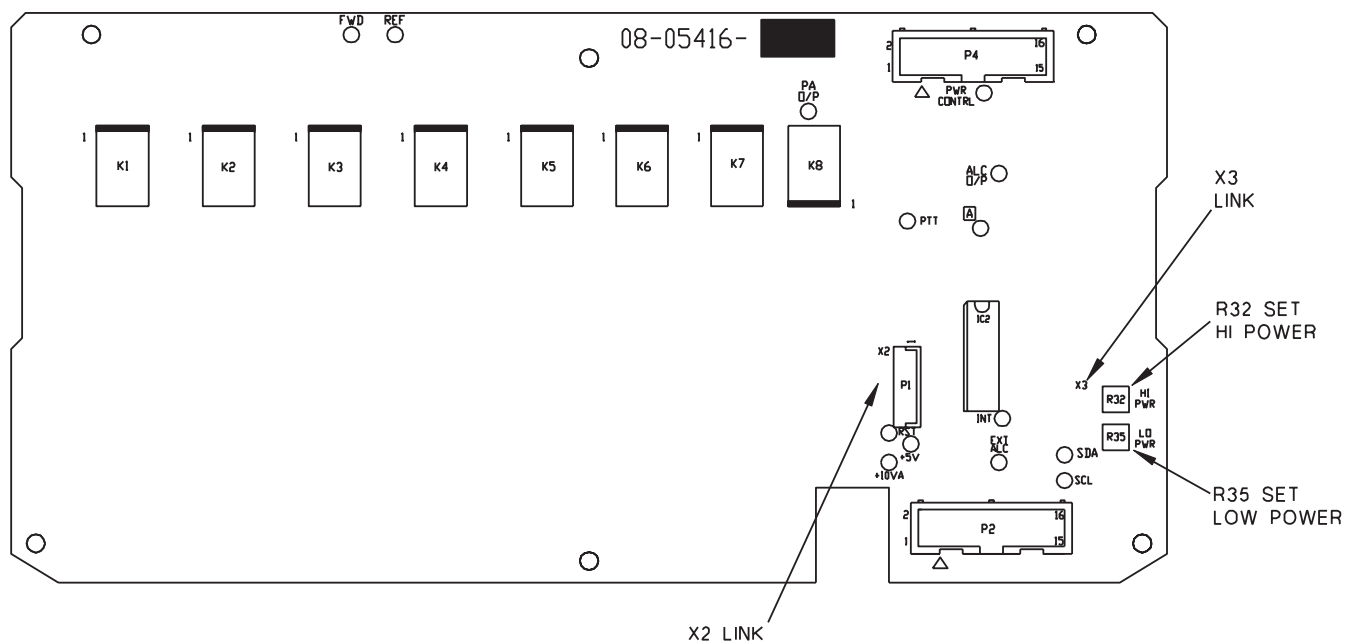

Figure 34: Filter and Control PCB in the RF unit (08-05910)

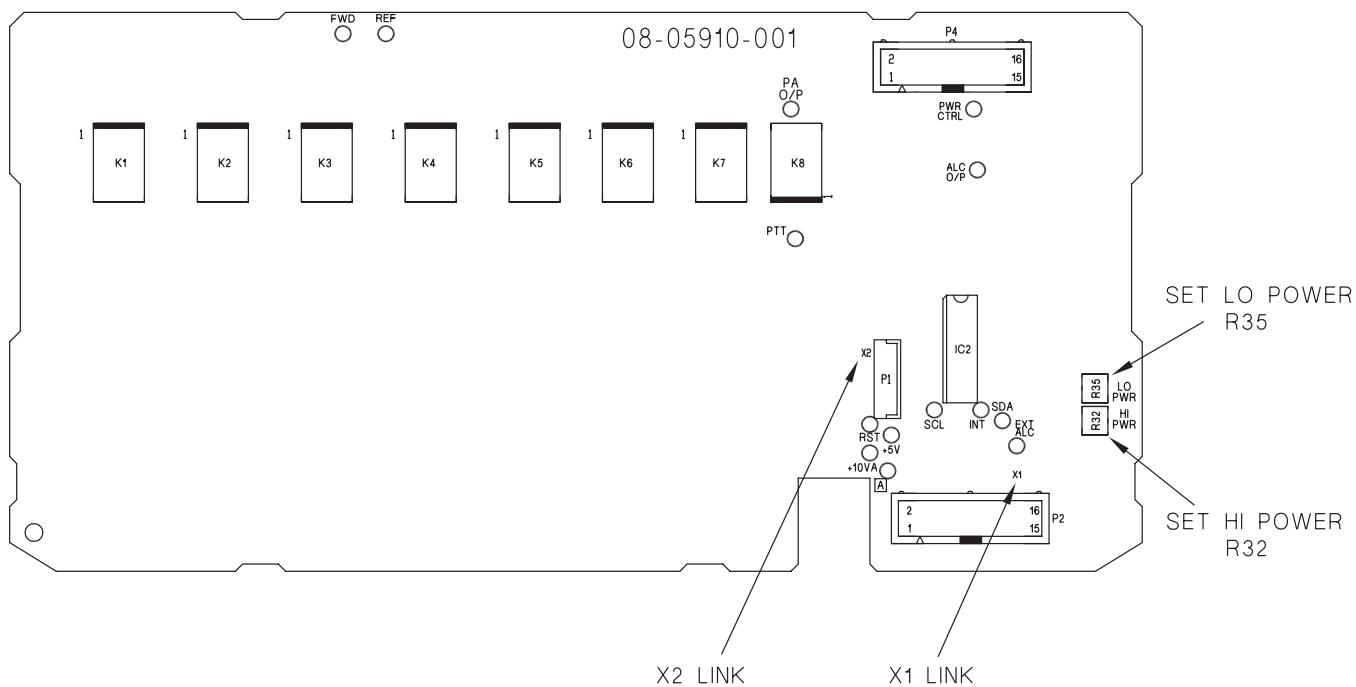

Figure 35: Audio Interface PCB in the RF unit (08-05266, 2010 only)

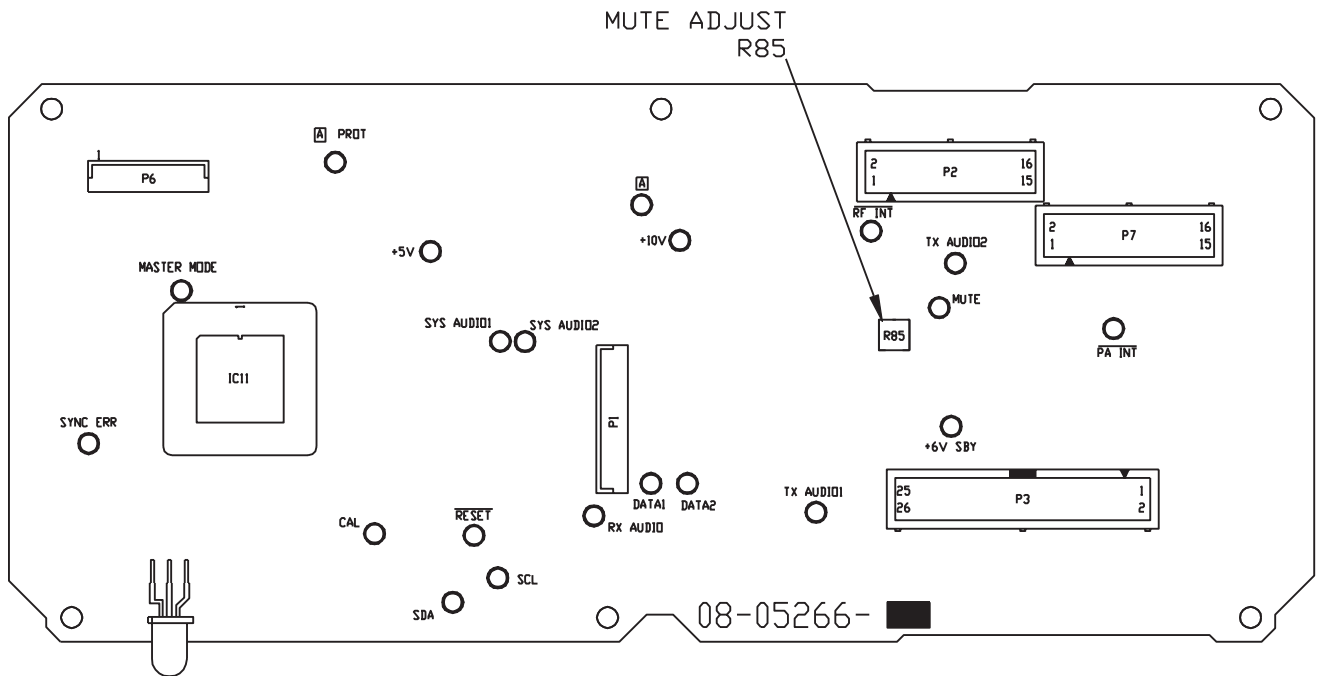

Figure 36: Audio & Interconnect PCB in the RF unit (08-05988, 2011 only)

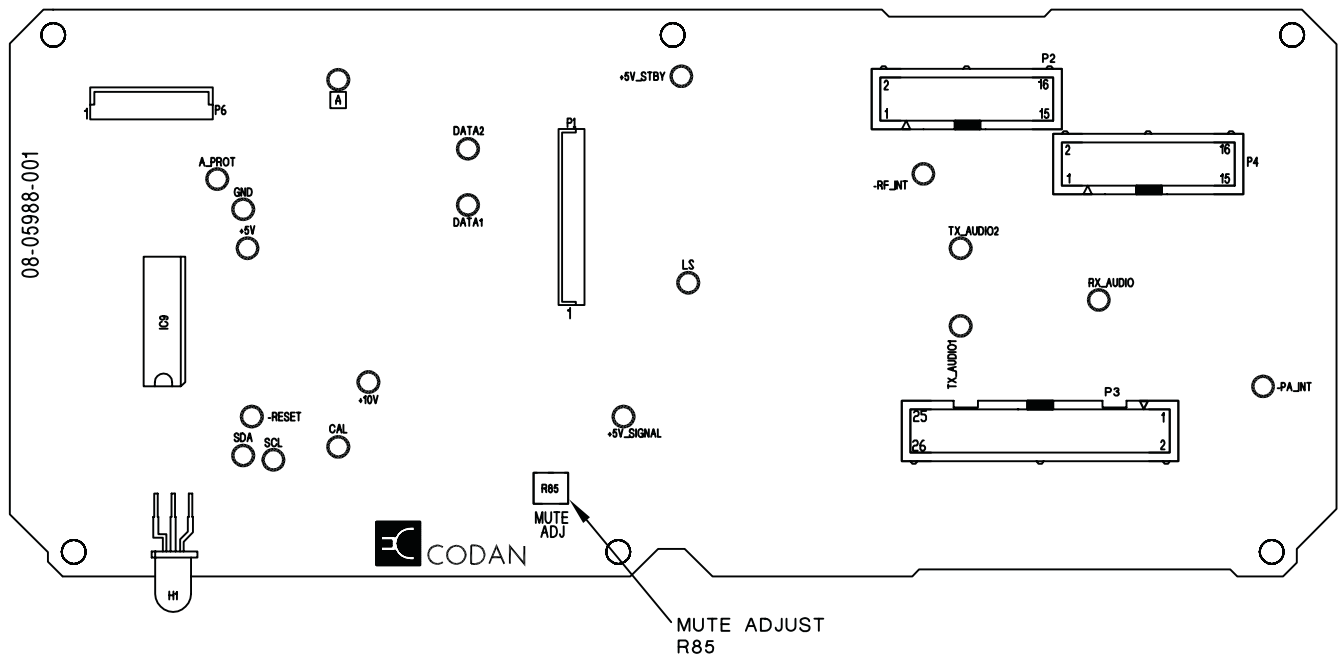
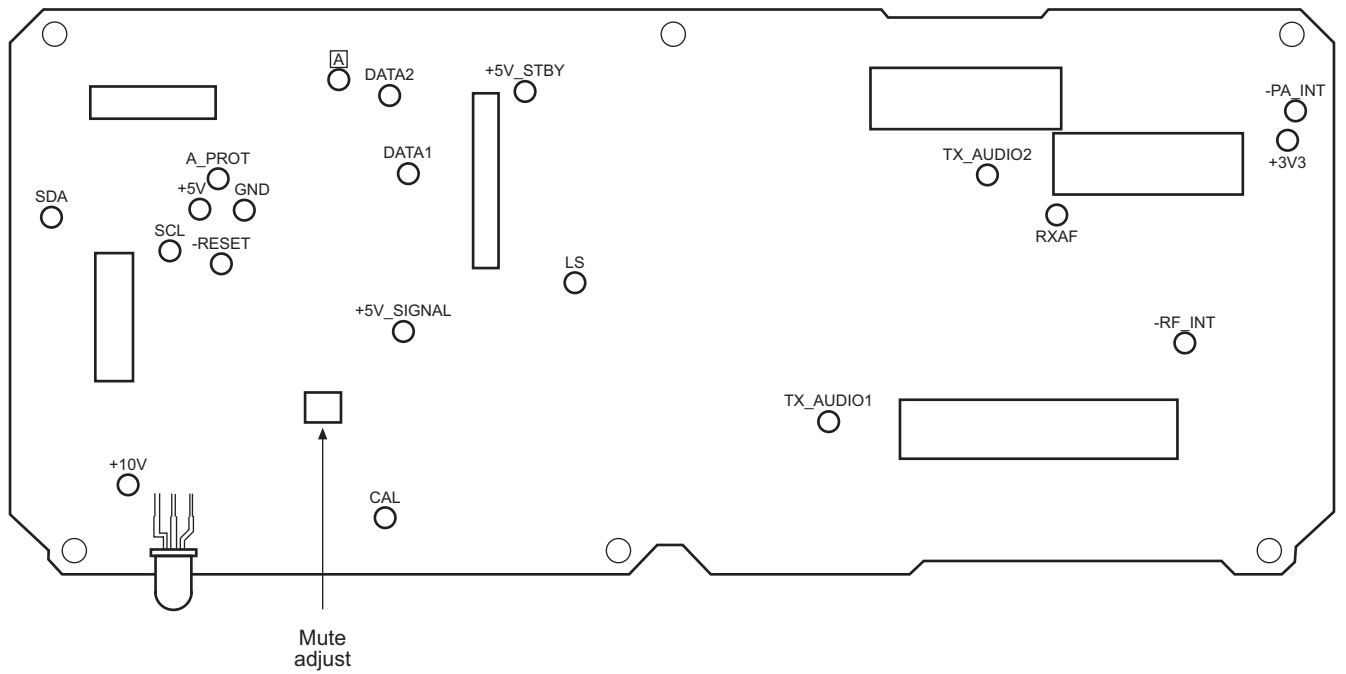

Figure 37: Audio Interconnect & Data I/O PCB in the RF unit (08-06261, 2012 only)



Checking the voltage-controlled oscillator

ALTERNATIVE TEXT Drawing [08-05261 \(sheet 2\)](#) or [08-05889 \(sheet 2\)](#)

NOTE If the PCB issue status is -06 or earlier, see drawing [08-05889 \(sheet 2\)](#).

NOTE The transceiver must be in Service mode to perform this check (see [page 154, Accessing Service mode](#)).

VCO1 is located on the RF/IF PCB in the RF unit. There is no adjustment available for VCO, but it can be checked to ensure it is operating correctly.

To check the operation of VCO:

- Ensure a screening can is over VCO and RxMIX1.
- Select test channel 1.
- Connect a DC voltmeter to TP402 and check that the voltage is between 2 V and 4 V.

The frequency at VCO test point should be approximately 45.25 MHz.

- Select test channel 2.
- Check that the voltage at TP402 is between 9 V and 11.5 V.

The frequency at VCO test point should be approximately 60 MHz.

- Select test channel 3.
- Check that the voltage at TP402 is between 19 V and 25 V.

The frequency at VCO test point should be approximately 75 MHz.

Aligning the 45 MHz filters

Aligning the Rx filter

ALTERNATIVE TEXT Drawing [08-05261 \(sheet 2\)](#) or [08-05889 \(sheet 2\)](#)

NOTE If the PCB issue status is -06 or earlier, see drawing [08-05889 \(sheet 2\)](#).

NOTE The transceiver must be in Service mode to perform this check (see [page 154, Accessing Service mode](#)).

To align the 45 MHz Rx filter:

- Connect a signal generator to the receiver input of the transceiver.
- Set the signal generator to 8.4 MHz at -40 dBm (2 mV).
- Connect a $10\times$ probe on channel 1 of an oscilloscope to TP201 on the RF/IF PCB.
- Set the channel 1 input to AC at 20 mV per division (200 mV per division with $10\times$ probe).
- Set the timebase of the oscilloscope to 5 ms per division.
- Connect the TRIG test point on the RF/IF PCB to the external trigger of the oscilloscope.
- Set the oscilloscope for an external positive trigger and adjust for lock.
- Set the transceiver to channel 4 to initiate the receive sweep test.
- Adjust the trace to the centre position.
- Adjust T104, L110, L111 and T105 for a flat response as shown in [Figure 38](#).

NOTE With 08-05889, spikes on the waveform are normal.

Figure 38: Receive sweep test display

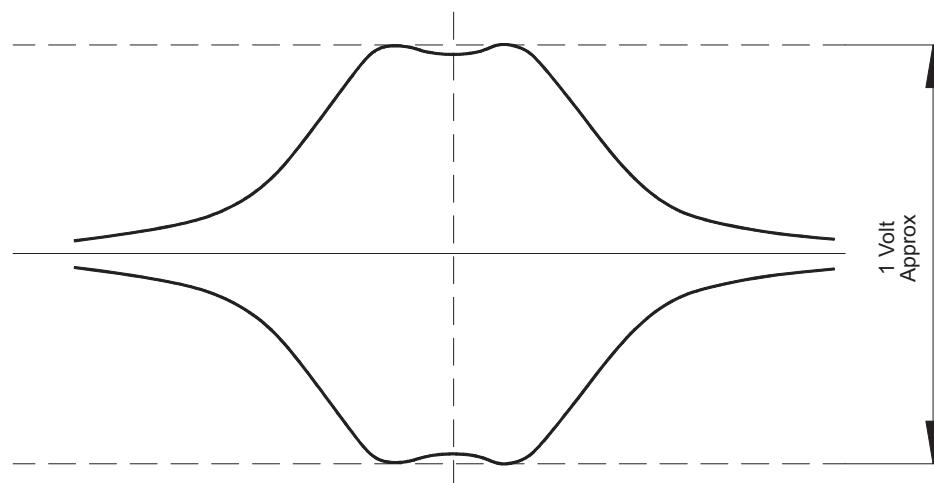

- Select any other channel to stop the sweep test.

Aligning the Tx filter

ALTERNATIVE TEXT Drawing [08-05261 \(sheet 2\)](#) or [08-05889 \(sheet 2\)](#)

NOTE If the PCB issue status is -06 or earlier, see drawing [08-05889 \(sheet 2\)](#).

NOTE The transceiver must be in Service mode to perform this check (see [page 154, Accessing Service mode](#)).

To align the 45 MHz Tx filter:

- Connect the Tx exciter output on the RF/IF PCB in the RF unit to channel 1 of an oscilloscope terminated with 50 Ω .
- Set the channel 1 input to AC at 100 mV per division.
- Set the timebase of the oscilloscope to 5 ms per division.
- Connect the TRIG test point on the RF/IF PCB to the external trigger of the oscilloscope.
- Set the oscilloscope for an external positive trigger and adjust for lock.
- Set the transceiver to channel 5 to initiate the transmit sweep test.
- Adjust the trace to the centre position.
- Adjust T107, L117 and T108 for a flat response as shown in [Figure 39](#).

NOTE The amplitude depends on the setting of the preset carrier level potentiometer R217.

Figure 39: Transmit sweep test display

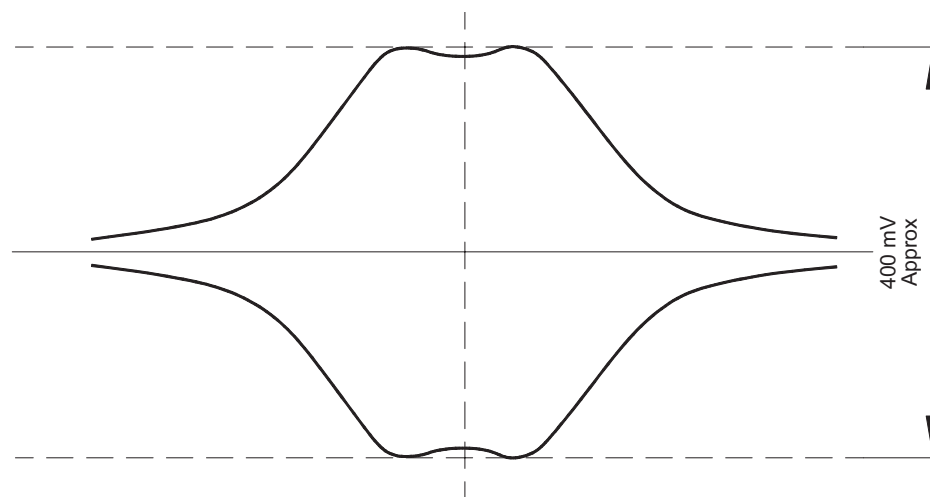

- Select any other channel to stop the sweep test.

Aligning the 455 kHz IF and noise limiter

ALTERNATIVE TEXT Drawing [08-05261 \(sheet 2\)](#) or [08-05889 \(sheet 2\)](#)

NOTE If the PCB issue status is -06 or earlier, see drawing [08-05889 \(sheet 2\)](#).

NOTE The transceiver must be in Service mode to perform this check (see [page 154, Accessing Service mode](#)).

There are two tuned transformers in the 455 kHz IF circuit located on the RF/IF PCB in the RF unit. T202 is located in the IF path to the sideband filter. T201 is located at the output of the noise limiter 455 kHz amplifier.

To align the transformers in the 455 kHz IF circuit on the RF/IF PCB:

- Select any normal receive channel.
- Connect a signal generator to the receiver input.
- Set the signal generator to 1 kHz above the channel frequency selected (or 1 kHz below for LSB) at an output of approximately -30 dBm (10 mV).
- Fit a link across ON to disable the noise limiter gate (see [Figure 28 on page 160](#) or [Figure 29 on page 161](#)).
- Connect an oscilloscope to TP201 using a $10\times$ probe.
- Set the input to 50 mV per division (0.5 V per division with the $10\times$ probe).
- Set the timebase of the oscilloscope to 50 μ s per division.
- Set the oscilloscope for an auto trigger.
- Adjust T202 for maximum amplitude.

Only a small change in amplitude is seen due to the low Q of the tuned circuit.

- Remove the $10\times$ probe from TP201.
- Connect a $1\times$ probe to position A (part of the noise limiter links) (see [Figure 28 on page 160](#) and drawing [04-03106 \(sheet 1\)](#) or [Figure 29 on page 161](#) and drawing [04-03378 \(sheet 1\)](#)).
- Set the oscilloscope to a sensitivity of 10 mV per division.
- Adjust T201 for maximum amplitude.
- Remove the link across ON and return it to its parking position (centre).

Adjusting the exciter output level

ALTERNATIVE TEXT Drawing [08-05261 \(sheet 2\)](#) or [08-05889 \(sheet 2\)](#)

NOTE If the PCB issue status is -06 or earlier, see drawing [08-05889 \(sheet 2\)](#).

NOTE The transceiver must be in Service mode to perform this check (see [page 154, Accessing Service mode](#)).

To adjust the exciter output level:

- Unplug the coaxial cable between the PA PCB and RF/IF PCB in the RF unit.
- Connect a 47 Ω resistor from the Tx test point to ground on the RF/IF PCB.
- Connect an oscilloscope to the Tx test point.
- Connect a signal generator to provide two-tone audio (700 Hz and 2300 Hz) via the test unit to:
 - the audio input on the 15-way GPIO connector on the junction box or 2012 RF Unit (see [Figure 40](#)), or
 - the 2011 RF Unit via the NGT test handset (see [Figure 41](#))

Figure 40: Setup for test unit with a 2010/2012 RF Unit

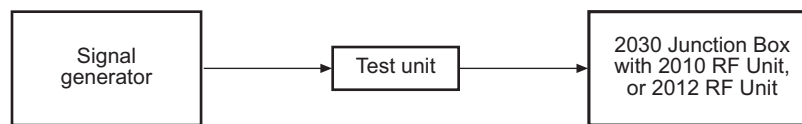
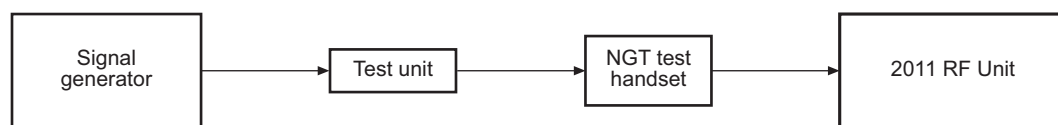

Figure 41: Setup for test unit and NGT test handset with a 2011 RF Unit



- Select test channel 16 with USB mode.
- Hold down* PTT, then adjust the level of the two tones for compression.
- Adjust the Y sensitivity of the oscilloscope for on-screen display, and adjust the trigger for a stationary waveform.
- Adjust the two-tone balance control for good crossover display.
- Adjust the Tx level control (R256, near the ribbon cable) for a level of 650 mV p-p on the oscilloscope (see [Figure 28 on page 160](#) or [Figure 29 on page 161](#)).
- Release PTT.

Adjusting carrier re-insertion

ALTERNATIVE TEXT Drawing [08-05261 \(sheet 2\)](#) or [08-05889 \(sheet 2\)](#)

- NOTE** If the PCB issue status is -06 or earlier, see drawing [08-05889 \(sheet 2\)](#).
- NOTE** The exciter output level must be set before this adjustment is made (see [page 170, Adjusting the exciter output level](#)).
- NOTE** The transceiver must be in Service mode to perform this check (see [page 154, Accessing Service mode](#)).

To adjust carrier re-insertion:

- Select test channel 16 with AM mode.
- Unplug the coaxial cable between the PA PCB and the RF/IF PCB in the RF unit.
- Connect an oscilloscope with a 50 Ω termination to the Tx test point on the RF/IF PCB.
- Using the transceiver test unit, apply an audio signal of 1 kHz at a level of 300 mV p-p to:
 - the audio input on the 15-way GPIO connector on the junction box or 2012 RF Unit (see [Figure 40 on page 170](#)), or
 - the 2011 RF Unit via the NGT test handset (see [Figure 41 on page 170](#))
- Hold down PTT.
- Adjust R217 (near the SSB filter Z201) for 100% modulation.
- Rotate R217 clockwise to set it to approximately 90% modulation (see [Figure 42](#)).

Figure 42: Graph showing adjustment to 90% modulation

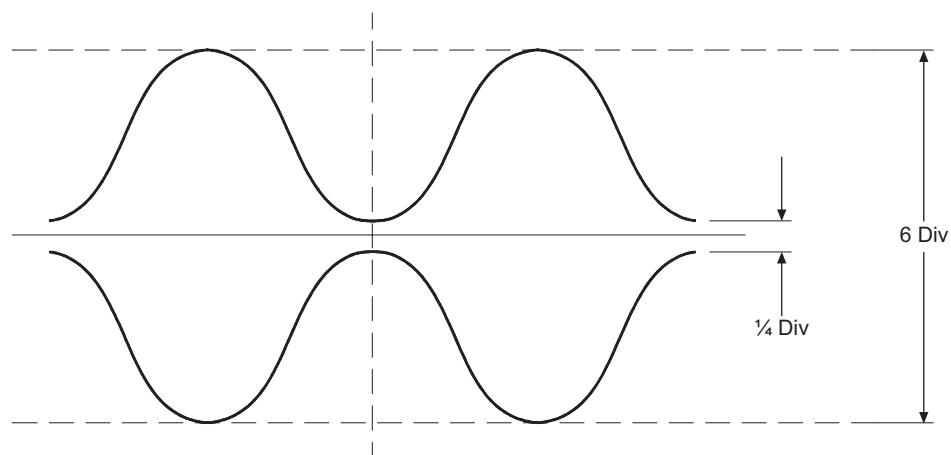

- Release PTT.

Adjusting the exciter output spurious balance

ALTERNATIVE TEXT Drawing [08-05261 \(sheet 2\)](#) or [08-05889 \(sheet 2\)](#)

NOTE If the PCB issue status is -06 or earlier, see drawing [08-05889 \(sheet 2\)](#).

NOTE The transceiver must be in Service mode to perform this check (see [page 154, Accessing Service mode](#)).

Adjustment of the exciter output spurious balance may be necessary only if the mixer IC102 on the RF/IF PCB in the RF unit has been replaced.

To perform the adjustment:

- Select test channel 28.
- Unplug the coaxial cable between the PA PCB and the RF/IF PCB in the RF unit.
- Connect a spectrum analyser to the Tx test point on the RF/IF PCB.
- Set up the spectrum analyser as follows:

Centre frequency	24.9 MHz
Frequency span	20 kHz
Vertical level	10 dB per division
Trigger	Continuous sweep
Video bandwidth	1 kHz

- Using the transceiver test unit, apply an audio signal of 1 kHz at a level of 300 mV p-p to:
 - the audio input on the 15-way GPIO connector on the junction box or 2012 RF Unit (see [Figure 40 on page 170](#)), or
 - the 2011 RF Unit via the NGT test handset (see [Figure 41 on page 170](#))
- Hold down* PTT.
- Adjust the 24.9 MHz signal displayed on the spectrum analyser to the top of the screen.
- Reset the spectrum analyser centre frequency to 20.1 MHz.
- Adjust R138 for a minimum 20.1 MHz signal.

The unwanted 20.1 MHz product should be greater than 60 dB below the 24.9 MHz signal.
- Release PTT.

Adjusting frequency

ALTERNATIVE TEXT Drawing [08-05261 \(sheet 2\)](#)

NOTE The transceiver must be in Service mode to make this adjustment (see [page 154, Accessing Service mode](#)).

All the channels are synthesised and locked to the 44.545 MHz reference crystal oscillator Z401.

To adjust the frequency:

NOTE Wait for at least five minutes after switching on the transceiver before adjusting the frequency.

- Select test channel 30.
- Remove the coaxial connector from J2 on the RF/IF PCB in the RF unit.
This disconnects the exciter output to the PA.
- Connect a frequency counter to the exciter output J2 – Tx.
- Hold down 3* to switch on the tune carrier.
- Adjust trimmer C451 (drawing [08-05235](#)) to a frequency of 29.9 MHz \pm 3 Hz.

ALTERNATIVE TEXT Drawing [08-05889 \(sheet 2\)](#)

NOTE If the PCB issue status is -06 or earlier, see drawing [08-05889 \(sheet 2\)](#).

NOTE The transceiver must be in Service mode to perform this check (see [page 154, Accessing Service mode](#)).

All the channels are synthesised and locked to the 14.848333 MHz reference crystal oscillator Z1.

To adjust the frequency:

NOTE Wait for at least five minutes after switching the transceiver on before adjusting the frequency.

- Select test channel 30.
- Remove the coaxial connector from J2 on the RF/IF PCB in the RF unit.
This disconnects the exciter output to the PA.
- Connect a frequency counter to the exciter output J2 – Tx.
- Hold down 3* to switch on the tune carrier.
- Adjust trimmer C7 (drawing [08-05963](#)) to a frequency of 29.9 MHz \pm 3 Hz.

Links X1 and X2 on the oscillator PCB (drawing [08-05963](#)) may be joined to lower the frequency if the trimmer does not have enough range.

NOTE

Approximate link settings are:

- X1: 200 Hz
- X2: 400 Hz
- X1 + X2: 600 Hz

Adjusting mute

2010: Drawing [08-05266](#)

ALTERNATIVE TEXT 2011: Drawing [08-05988 \(sheet 1\)](#)

2012: Drawing [08-06261 \(sheet 1\)](#)

NOTE The transceiver does not have to be in Service mode to make this adjustment.

The mute control should be adjusted so that it is sensitive enough to operate on the weakest signal possible without false triggering on noise pulses.

To adjust the mute:

- Connect the transceiver to an antenna (a short length of wire will do).
- Select an unoccupied channel.
- Press **MUTE** and **V/S** until a highlighted V is displayed on the handset screen.
Voice mute is enabled.
- Turn the preset potentiometer MUTE ADJ (R85) on the Audio Interface PCB (2010)/Audio & Interconnect PCB (2011)/Audio Interconnect & Data I/O PCB (2012) in the RF unit fully clockwise.
- Slowly turn the potentiometer counterclockwise until you hear receiver noise in the loudspeaker (this is the mute threshold).
- Turn the potentiometer back in a clockwise direction a quarter turn.

The sensitivity may be varied from this setting to suit individual requirements. Turning the potentiometer counterclockwise increases sensitivity.

Adjusting the PA

Adjusting the driver bias

ALTERNATIVE TEXT Drawing [08-05415](#) or [08-05511 \(sheet 1\)](#)

NOTE The transceiver must be in Service mode to make this adjustment (see [page 154, Accessing Service mode](#)).

To adjust the driver bias:

- Ensure the transceiver is switched off and the DC supply is disconnected.
- Disconnect the exciter output from the PA by removing the connector from J2 (Tx coaxial) on the RF/IF PCB in the RF unit (drawing [08-05261 \(sheet 1\)](#) or [08-05889 \(sheet 1\)](#)).
- Unsolder the link next to the DR (driver) BIAS control (DC supply to the driver transistors V207 to V212) (see [Figure 30 on page 161](#)).
- Set a multimeter to DC 10 mA range and connect it in place of the removed link.
- Connect the DC supply, then switch on the transceiver.
- Select any transmit channel, then *hold down* PTT.
- Check that the driver current measures $4\text{ mA} \pm 1\text{ mA}$.
- If the current is out of the specified limit stated above, change it by adjusting DR BIAS (R222) (see [Figure 30 on page 161](#)).
- Release PTT.
- Switch off the transceiver, disconnect the multimeter, then replace the link with a length of tinned copper wire.

ALTERNATIVE TEXT Drawing [08-05869 \(sheet 2\)](#)

NOTE The transceiver must be in Service mode to make this adjustment (see [page 154, Accessing Service mode](#)).

To adjust the driver bias:

- Ensure the transceiver is switched off and the DC supply is disconnected.
- Disconnect the exciter output from the PA by removing the connector from J2 (Tx coaxial) on the RF/IF PCB in the RF unit (drawing [08-05261 \(sheet 1\)](#) or [08-05889 \(sheet 1\)](#)).
- Unsolder the link labelled DR (DC supply to the driver transistors V207 and V208) (see [Figure 31 on page 162](#)).
- Set a multimeter to DC 20 mA range and connect it in place of the removed link.
- Connect the DC supply, then switch on the transceiver.
- Select any transmit channel, then *hold down* PTT.
- Check that the driver current measures 13 mA \pm 2 mA.
- If the current is out of the specified limit stated above, change it by adjusting DR BIAS (R222) (see [Figure 31 on page 162](#)).
- Release PTT.
- Switch off the transceiver, disconnect the multimeter, then replace the link with a length of tinned copper wire.

ALTERNATIVE TEXT Drawing [08-06461 \(sheet 2\)](#)

NOTE The transceiver must be in Service mode to make this adjustment (see [page 154, Accessing Service mode](#)).

To adjust the driver bias:

- Ensure the transceiver is switched off and the DC supply is disconnected.
- Disconnect the exciter output from the PA by removing the connector from J2 (Tx coaxial) on the RF/IF PCB in the RF unit (drawing [08-05889 \(sheet 1\)](#)).
- Unsolder the link labelled DR (DC supply to the driver FETs V207 and V208) (see [Figure 32 on page 162](#)).
- Set a multimeter to DC 200 mA range and connect it in place of the removed link.
- Connect the DC supply, then switch on the transceiver.
- Select any transmit channel, then *hold down* PTT.
- Check that the driver current measures 40 mA \pm 2 mA.

- If the current is out of the specified limit stated above, adjust any of the following:
 - R222 (DR BIAS 1) and R235 (DR BIAS 2) fully counterclockwise (see [Figure 32 on page 162](#))
 - R222 (DR BIAS 1) until the current measures 20 mA \pm 2 mA
 - R235 (DR BIAS 2) until the current measures 40 mA \pm 2 mA
- Release PTT.
- Switch off the transceiver, disconnect the multimeter, then replace the link with a length of tinned copper wire.

Adjusting the PA bias

ALTERNATIVE TEXT Drawing [08-05415](#) or [08-05511 \(sheet 1\)](#)

NOTE The transceiver must be in Service mode to make this adjustment (see [page 154, Accessing Service mode](#)).

To adjust the bias of the PA output FETs:

- Ensure the transceiver is switched off and the DC supply is disconnected.
- Disconnect the exciter output from the PA by removing the connector from J2 (Tx coaxial) on the RF/IF PCB in the RF unit (drawing [08-05261 \(sheet 1\)](#) or [08-05889 \(sheet 1\)](#)).
- Unsolder the fuse PA O/P (F201) next to the power relay (DC supply to the output FETs V215 and V216) (see [Figure 30 on page 161](#)).
- Set a multimeter to DC 10 A range and connect it in place of the removed fuse (positive near to relay).
- Connect the DC supply, then switch on the transceiver.
- Select any transmit channel, then *hold down* PTT.
- Check that the output FET current measures 4 A \pm 100 mA.

If the current is out of the specified limit stated above, change it by adjusting the preset potentiometer PA BIAS (R240) (see [Figure 30 on page 161](#)).

- Release PTT.
- Switch off the transceiver, disconnect the DC supply, then resolder the fuse PA O/P.

If the fuse is broken, replace it with two strands (2×0.2 mm TCW) taken from a piece of 7×0.2 mm cable. Extend the centre of the wire down from the two stakes to form a V, ensuring it does not touch the PCB. Solder the wire to the two stakes, making sure the solder does not run down the strand of wire (see [Figure 30 on page 161](#), PA Fuse).

ALTERNATIVE TEXT Drawing [08-05869 \(sheet 2\)](#) or [08-06461 \(sheet 2\)](#)

NOTE The transceiver must be in Service mode to make this adjustment (see [page 154, Accessing Service mode](#)).

To adjust the bias of the PA output transistors:

- Ensure the transceiver is switched off and the DC supply is disconnected.
- Disconnect the exciter output from the PA by removing the connector from J2 (Tx coaxial) on the RF/IF PCB in the RF unit (drawing [08-05261 \(sheet 1\)](#) or [08-05889 \(sheet 1\)](#)).
- Unsolder the fuse PA O/P (F201) next to the power relay (DC supply to the output transistors V211 and V212) (see [Figure 31 on page 162](#) or [Figure 32 on page 162](#)).
- Set a multimeter to DC 1 A range and connect it in place of the removed fuse (positive near to relay).
- Connect the DC supply, then switch on the transceiver.
- Select any transmit channel, then *hold down* PTT.
- Check that the output current measures:
 - 400 mA \pm 50 mA for 08-05869, or
 - 400 mA \pm 20 mA for 08-06461

If the current is out of the specified limit stated above, change it by adjusting the preset potentiometer PA BIAS (R239) (see [Figure 31 on page 162](#) or [Figure 32 on page 162](#)).

- Release PTT.
- Switch off the transceiver, disconnect the DC supply, then resolder the fuse PA O/P.

If the fuse is broken, replace it with two strands (2×0.2 mm TCW) taken from a piece of 7×0.2 mm cable. Extend the centre of the wire down from the two stakes to form a V, ensuring it does not touch the PCB. Solder the wire to the two stakes, making sure the solder does not run down the strand of wire (see [Figure 31 on page 162](#) or [Figure 32 on page 162](#), PA Fuse).

Adjusting high output power

ALTERNATIVE TEXT Drawing [08-05416](#)

NOTE The transceiver does not have to be in Service mode to make this adjustment.

NOTE The output power is factory-set, so it is not likely to be outside the specified limits. Check that there are no faults with the transmitter circuits before attempting to adjust the output power.

Before adjusting the output power, you must check the state of links X2 and X3 on the Filter and Control PCB in the RF unit:

- X2 and X3 both open—required when setting the output power to 100 W PEP (this complies with the licensing regulations in Australia)
- X2 and X3 joined—required when setting the output power to 125 W PEP at low frequency, reducing to 100 W PEP at 30 MHz

To adjust the high output power:

- Select any channel frequency between 4 and 6 MHz.
- Connect an average or PEP power meter with a 50 Ω dummy load to the RF connector (⌚).
- Connect an oscilloscope via a 47 k Ω resistor to the antenna connector.
- Set the oscilloscope timebase to 500 μ s per division and the trigger to auto.
- Connect a signal generator to provide two-tone audio (700 Hz and 2300 Hz) via the test unit to:
 - the audio input on the 15-way GPIO connector on the junction box or 2012 RF Unit (see [Figure 40 on page 170](#)), or
 - the 2011 RF Unit via the NGT test handset (see [Figure 41 on page 170](#))
- Hold down* PTT, then adjust the two-tone level for compression.
- Adjust the Y sensitivity of the oscilloscope for on-screen display and adjust the trigger for a stationary waveform.
- Adjust the two-tone balance control for good crossover display.
- Adjust HI PWR (R32) (see [Figure 33 on page 163](#)) for the required output:
 - for 100 W PEP, X2 and X3 both open
 - for 125 W PEP, X2 and X3 joined

The indicated PEP level with two-tone modulation depends on the type of measuring instrument, as shown in [Table 48](#).

Table 48: Power output PEP vs measuring instrument (12/100/125 W)

Power Output PEP	12 W	100 W	125 W
Peak reading meter	12 W	100 W	125 W
RMS reading meter	6 W	50 W	62.5 W
Average reading meter (e.g. Bird Model 43)	5 W	40.5 W	50.6 W
Oscilloscope	69 V p-p	200 V p-p	224 V p-p

- Release PTT.
- Check that the two-tone waveform is clean and undistorted.
If it is not clean and undistorted, further analysis is required.

ALTERNATIVE TEXT Drawing [08-05910 \(sheet 1\)](#)

NOTE If the PCB issue status is -04 or earlier, see drawing [08-05910 \(sheet 1\)](#).

NOTE The transceiver does not have to be in Service mode to make this adjustment.

NOTE The output power is factory-set, so it is not likely to be outside the specified limits. Check that there are no faults with the transmitter circuits before attempting to adjust the output power.

To adjust the high output power:

- Select any channel frequency between 4 and 6 MHz.
- Connect an average or PEP power meter with a 50 Ω dummy load to the RF connector (Y).
- Connect an oscilloscope via a 47 k Ω resistor to the antenna connector.
- Set the oscilloscope timebase to 500 μ s per division and the trigger to auto.
- Connect a signal generator to provide two-tone audio (700 Hz and 2300 Hz) via the test unit to:
 - the audio input on the 15-way GPIO connector on the junction box or 2012 RF Unit (see [Figure 40 on page 170](#)), or
 - the 2011 RF Unit via the NGT test handset (see [Figure 41 on page 170](#))
- Hold down* PTT, then adjust the two-tone level for compression.
- Adjust the Y sensitivity of the oscilloscope for on-screen display and adjust the trigger for a stationary waveform.
- Adjust the two-tone balance control for good crossover display.
- Adjust HI PWR (R32) (see [Figure 34 on page 163](#)) for the required output.

The indicated PEP level with two-tone modulation depends on the type of measuring instrument, as shown in [Table 48 on page 181](#).

- Release PTT.
- Check that the two-tone waveform is clean and undistorted.
If it is not clean and undistorted, further analysis is required.

Adjusting low output power

ALTERNATIVE TEXT Drawing [08-05416](#) or [08-05910 \(sheet 1\)](#)

NOTE If the PCB issue status is -04 or earlier, see drawing [08-05910 \(sheet 1\)](#).

NOTE Before adjusting the low output power, set the high output power (see [page 180, Adjusting high output power](#)).

NOTE The transceiver must be in Service mode to make this adjustment (see [page 154, Accessing Service mode](#)).

To adjust the low output power:

- Select any test channel frequency between 4 and 6 MHz (for example, test channel 16).
- Press **7** to select low power.
- Proceed as for [page 180, Adjusting high output power](#).
- Adjust LO PWR (R35) for 12 W PEP (5 W on an average reading meter) (see [Figure 33 on page 163](#) or [Figure 34 on page 163](#) and [Table 48 on page 181](#)).
- Check that the two-tone waveform is clean and undistorted.
If it is not clean and undistorted, further analysis is required.

Adjusting the bias gain

ALTERNATIVE TEXT Drawing [08-05415](#) or [08-05511 \(sheet 1\)](#)

NOTE The bias gain must be set before any intermodulation tests are performed.

NOTE The transceiver must be in Service mode to make this adjustment (see [page 154, Accessing Service mode](#)).

To adjust the bias gain:

- Connect a 50 Ω dummy load to the RF connector (Υ) (see [Figure 43](#)).
- Connect a spectrum analyser via a 47 k Ω resistor to the RF connector (see [Figure 43](#)).

This provides a low-level output for the spectrum analyser.

Figure 43: Setup for adjusting the bias gain

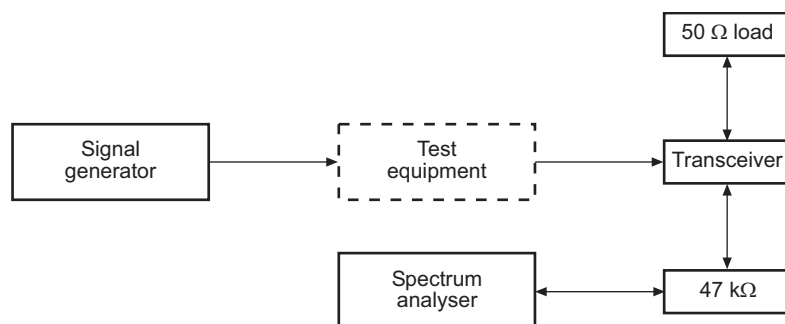

- Select test channel 28.
- Connect the signal generator to provide two-tone audio (700 Hz and 2300 Hz) via the test unit to:
 - the audio input on the 15-way GPIO connector on the junction box or 2012 RF Unit (see [Figure 40 on page 170](#)), or
 - the 2011 RF Unit via the NGT test handset (see [Figure 41 on page 170](#))
- Set up the spectrum analyser as follows:

Centre frequency	24.9 MHz
Frequency span	20 kHz (2 kHz per division)
Vertical level	10 dB per division
Video bandwidth	300 Hz
Sensitivity	Depends on the signal level applied to the spectrum analyser and requires adjustment when transmitting
- Hold down* PTT, then adjust the level of the two tones for compression.
- Adjust the two tones displayed on the spectrum analyser for equal amplitude by adjusting the balance control on the two-tone signal generator.
- Adjust the sensitivity control on the spectrum analyser to set the two tones at the top of the screen.
- Adjust the GAIN potentiometer (R244) for a minimum intermodulation distortion level (see [Figure 30 on page 161](#)).
- Measure the intermodulation distortion levels relative to each tone.

Add 6 dB to the reading if referenced to PEP (see [page 39, Transmitter specifications](#) for limits).
- Release PTT.

Adjusting the active bias

ALTERNATIVE TEXT Drawing [08-05869 \(sheet 2\)](#) or [08-06461 \(sheet 2\)](#)

- NOTE** The active bias must be set before any intermodulation tests are performed.
- NOTE** The transceiver must be in Service mode to make this adjustment (see [page 154, Accessing Service mode](#)).

To adjust the active bias:

- Connect a 50 Ω dummy load to the RF connector (Υ) (see [Figure 43 on page 183](#)).
 - Connect a spectrum analyser via a 47 k Ω resistor to the RF connector (see [Figure 43](#)).
- This provides a low-level output for the spectrum analyser.
- Select test channel 16.
 - Connect the signal generator to provide two-tone audio (700 Hz and 2300 Hz) via the test unit to:
 - the audio input on the 15-way GPIO connector on the junction box or 2012 RF Unit (see [Figure 40 on page 170](#)), or
 - the 2011 RF Unit via the NGT test handset (see [Figure 41 on page 170](#))
 - Set up the spectrum analyser as follows:

Centre frequency	4.6 MHz
Frequency span	20 kHz (2 kHz per division)
Vertical level	10 dB per division
Video bandwidth	300 Hz
Sensitivity	Depends on the signal level applied to the spectrum analyser and requires adjustment when transmitting
 - Hold down* PTT, then adjust the level of the two tones for compression.
 - Adjust the two tones displayed on the spectrum analyser for equal amplitude by adjusting the balance control on the two-tone signal generator.
 - Adjust the sensitivity control on the spectrum analyser to set the two tones at the top of the screen.
 - Adjust the ACT BIAS potentiometer (R241) for a minimum high order (> 9th) intermodulation distortion level (see [Figure 31 on page 162](#) or [Figure 32 on page 162](#)).
 - Measure the intermodulation distortion levels relative to each tone.

Add 6 dB to the reading if referenced to PEP (see [page 39, Transmitter specifications](#) for limits).
 - Release PTT.

Adjusting balance control

ALTERNATIVE TEXT Drawing [08-05415](#) or [08-05511](#) (sheet 1)

NOTE The transceiver must be in Service mode to make this adjustment (see [page 154, *Accessing Service mode*](#)).

To adjust the balance control:

- Connect setup as per the bias gain adjustment (see [page 182, *Adjusting the bias gain*](#)).
- Select test channel 21.
- Connect the signal generator to provide single-tone audio (1 kHz) via the test unit to:
 - the audio input on the 15-way GPIO connector on the junction box or 2012 RF Unit (see [Figure 40 on page 170](#)), or
 - the 2011 RF Unit via the NGT test handset (see [Figure 41 on page 170](#))
- Set up the spectrum analyser as follows:

Centre frequency	10 MHz
Frequency span	20 MHz (2 MHz per division)
Vertical level	10 dB per division
Sensitivity	Depends on the signal level applied to the spectrum analyser and requires adjustment when transmitting
- Hold down* PTT, then adjust the single-tone level for compression.
- Adjust the sensitivity control on the spectrum analyser to set the tone at the top of the screen.
- Adjust the balance control (R253) for a minimum on 17.2 MHz.
- Check that the level of the 2nd harmonic (17.2 MHz) is below 60 dB.
- Release PTT.

ALTERNATIVE TEXT Drawing [08-05869 \(sheet 2\)](#) or [08-06461 \(sheet 2\)](#)

NOTE The transceiver must be in Service mode to make this adjustment (see [page 154, Accessing Service mode](#)).

To adjust the balance control:

- Connect setup as per the bias gain adjustment (see [page 182, Adjusting the bias gain](#)).
- Select test channel 18.
- Connect the signal generator to provide single-tone audio (1 kHz) via the test unit to:
 - the audio input on the 15-way GPIO connector on the junction box or 2012 RF Unit (see [Figure 40 on page 170](#)), or
 - the 2011 RF Unit via the NGT test handset (see [Figure 41 on page 170](#))
- Set up the spectrum analyser as follows:

Centre frequency	11.4 MHz
Frequency span	20 kHz (2 kHz per division)
Vertical level	10 dB per division
Sensitivity	Depends on the signal level applied to the spectrum analyser and requires adjustment when transmitting

- Hold down* PTT, then adjust the single-tone level for compression.
- Adjust the balance control (R273) for a minimum on 11.4 MHz.
- Check that the level of the 2nd harmonic (11.4 MHz) is below 60 dB.
- Release PTT.

Checking intermodulation

ALTERNATIVE TEXT Drawing [08-05416](#) or [08-05910 \(sheet 1\)](#)

- NOTE** If the PCB issue status is -04 or earlier, see drawing [08-05910 \(sheet 1\)](#).
- NOTE** The bias gain or active bias must be set before any intermodulation tests are performed (see [page 182, Adjusting the bias gain](#) or [page 184, Adjusting the active bias](#)).
- NOTE** The transceiver must be in Service mode to perform this check (see [page 154, Accessing Service mode](#)).

The test channels 9 to 30 can be used to check for IMD. To facilitate checking each band, there is a test channel allocated near the bottom, top and centre of each band.

To check the IMD:

- Connect a 50 Ω dummy load to the RF connector (Y).
- Connect a spectrum analyser via a 47 k Ω resistor to the RF connector (see [Figure 44](#)).

This provides a low-level output for the spectrum analyser.

Figure 44: Setup for checking intermodulation distortion

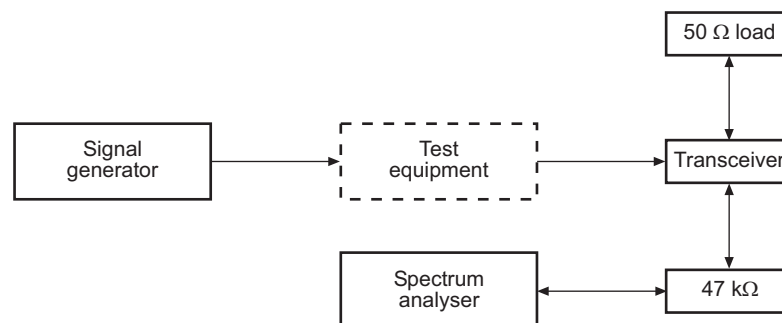

- Connect a signal generator to provide two-tone audio (700 Hz and 2300 Hz) via the test unit to:
 - the audio input on the 15-way GPIO connector on the junction box or 2012 RF Unit (see [Figure 40 on page 170](#)), or
 - the 2011 RF Unit via the NGT test handset (see [Figure 41 on page 170](#))

- Set up the spectrum analyser as follows:

Centre frequency	Set to frequency of selected test channel
Frequency span	20 kHz (2 kHz per division)
Vertical level	10 dB per division
Video bandwidth	300 Hz
Sensitivity	Depends on the signal level applied to the spectrum analyser and requires adjustment when transmitting

- Hold down* PTT, then adjust the level of the two tones for compression.
- Adjust the two tones displayed on the spectrum analyser for equal amplitude by adjusting the balance control on the two-tone signal generator.
- Adjust the sensitivity control on the spectrum analyser to set the two tones at the top of the screen.
- Measure the IMD levels relative to each tone.
 Add 6 dB to the reading if referenced to PEP (see [page 39, Transmitter specifications](#) for limits).
 If IMD is outside of the specified limits, further analysis is required.
- Release PTT.
- Check the IMD on the remaining frequencies (see [Table 46 on page 156](#)).

NOTE The centre frequency of the spectrum analyser must be set to the channel frequency selected.

NOTE To check for spurious and harmonic components during the IMD checks, adjust the frequency span of the spectrum analyser.

Adjusting the PA gain

ALTERNATIVE TEXT Drawing [08-05261 \(sheet 1\)](#) or [08-05889 \(sheet 1\)](#) and drawing [08-05415](#) or [08-05511 \(sheet 1\)](#), or
Drawing [08-05869 \(sheet 2\)](#), or
Drawing [08-06461 \(sheet 2\)](#)

NOTE If the PCB issue status is -06 or earlier, see drawing [08-05889 \(sheet 1\)](#).

NOTE The transceiver must be in Service mode to perform this check (see [page 154, Accessing Service mode](#)).

To adjust the PA gain:

- Select any test channel frequency between 4 and 6 MHz (for example, test channel 16).
- Connect an oscilloscope to the Tx test point (exciter output) on the RF/IF PCB in the RF unit (use connector J2 body as earth) (see [Figure 28 on page 160](#) or [Figure 29 on page 161](#)).
- Using a single-tone audio (1 kHz), adjust the audio input level until the exciter output level is 225 mV p-p.
- Adjust the PA GAIN control (R205) on the PA PCB to give a 45 W output (see [Figure 30 on page 161](#) or [Figure 31 on page 162](#) or [Figure 32 on page 162](#)).

Checking performance of the receiver

NOTE The transceiver does not have to be in Service mode to perform any of the checks in this section.

Checking the sensitivity and (signal+noise)/noise ratio

To check the sensitivity and (S+N)/N ratio:

- Connect an AC voltmeter across the audio output (loudspeaker).
- Press **5** to select RF Gain On.
- Connect the signal generator to the RF connector (γ).
- Select any channel.
- Set the frequency of the signal generator 1 kHz above the suppressed carrier frequency of the selected channel (1 kHz below for LSB).
- Set the signal generator output level to -121 dBm (0.2 mV PD).
- Adjust the volume control for a suitable, near full-scale dB reading on the AC voltmeter.
- Record the reading.
- Switch off or adjust the output of the signal generator to a frequency outside the receiver pass-band.
- Check that the audio output drops by at least 10 dB.
- Repeat the above with the RF gain off and the output of the signal generator set to -103 dBm (1.5 mV PD).
- Check that the audio output drops by at least 10 dB.

If the audio output does not drop by at least 10 dB, further analysis is required.

Checking the AGC

To check the AGC:

- Set up the equipment as described on [page 190, *Checking the sensitivity and \(signal+noise\)/noise ratio*](#), but set the output of the signal generator to -13 dBm (50 mV PD).
- Press **5** to select RF Gain On.
- Adjust the volume control for a suitable, near full-scale dB reading on the AC voltmeter.
- Record the reading.
- Reduce the output of the signal generator until the receiver output drops by 6 dB.

The signal generator level should be less than -99 dBm (2.5 μ V PD).

If the signal generator level is greater than -99 dBm (2.5 μ V PD), further analysis is required.

Checking the audio output

To check the audio output:

- Set up the equipment as described on [page 190, *Checking the sensitivity and \(signal+noise\)/noise ratio*](#), with a signal generator output level of -67 dBm (100 mV PD).
- Connect an oscilloscope in parallel to the AC voltmeter across the audio output (loudspeaker).

For this test, it is advisable to replace the loudspeaker with an 8 Ω , 5 W resistor.

- Increase the audio level by adjusting the volume control and check that the audio output exceeds 12 V p-p at the onset of clipping (displayed on the oscilloscope).

If the audio output does not exceed 12 V p-p at the onset of clipping, further analysis is required.

Checking the selectivity

To check the selectivity (USB operation):

- Set up the equipment as described on [page 190](#), *Checking the sensitivity and (signal+noise)/noise ratio*.
- Set the output of the signal generator to -121 dBm (0.20 μ V PD).
- Measure and record the reference level of the audio output using the AC voltmeter.
- Monitor the signal generator using a frequency counter.
- Adjust the frequency to -1 kHz and then to $+4$ kHz from the SCF (USB operation).
- Increase the output of the signal generator to -55 dBm (0.4 mV) and check that the audio output is less than the reference level.
- Repeat at $+4$ kHz from the SCF (USB operation) and check that the audio output is less than the reference level.

If the audio output is not less than the reference level at both frequencies, further analysis is required.

Checking the noise limiter

To check the operation of the noise limiter:

- Connect the signal generator to the RF connector (Υ) via a T-piece.
- Set the frequency of the signal generator 1 kHz above the SCF of the selected channel (1 kHz below for LSB).
- Set the output of the signal generator to -115 dBm (0.4 μ V PD).
- Connect the output of a square-wave generator to the other input on the T-piece via a 100 pF capacitor (a BNC to 2-terminal adaptor may be useful).
- Set the frequency of the square-wave generator to 100 Hz and the output to 5 V p-p.

When the noise limiter is on, the signal produced by the signal generator should be heard clearly over the interfering signal from the square-wave generator.

If the signal produced by the signal generator is not heard clearly over the interfering signal from the square-wave generator, further analysis is required.

- Switch the noise limiter off by shorting OFF/ON on the 4-pin plug of the noise limiter located on the RF/IF PCB in the RF unit (drawing [08-05261 \(sheet 1\)](#) and [Figure 28 on page 160](#), or drawing [08-05889 \(sheet 1\)](#) and [Figure 29 on page 161](#)).

The noise from the square-wave generator should obliterate the wanted signal produced by the signal generator, thereby verifying that the noise limiter is functioning correctly.

Checking performance of the transmitter

NOTE The transceiver must be in Service mode to perform these checks (see [page 154, *Accessing Service mode*](#)).

Checking the transmit frequency

The transmit frequency is checked using the same method as frequency adjustment (see [page 173, *Adjusting frequency*](#)).

Checking the ALC

To check the ALC:

- Connect a signal generator to provide two-tone audio (700 Hz and 2300 Hz) via the test unit to:
 - the audio input on the 15-way GPIO connector on the junction box or 2012 RF Unit (see [Figure 40 on page 170](#)), or
 - the 2011 RF Unit via the NGT test handset (see [Figure 41 on page 170](#))
- Hold down* PTT, then increase the audio output slowly until the moment when the output power stops increasing.

This point is the ALC threshold.
- Record the PEP output and increase the audio input by 10 dB.

The increase in output should be less than 0.5 dB above the ALC threshold.

If the increase in output is greater than 0.5 dB above the ALC threshold, further analysis is required.
- Release PTT.

Checking power output and intermodulation

NOTE The indicated PEP level with two-tone modulation depends upon the type of measuring instrument used, as shown in [Table 49](#).

Table 49: Power output PEP vs measuring instrument (12/100/125 W)

Power output PEP	12 W	100 W	125 W
Peak reading meter	12 W	100 W	125 W
RMS reading meter	6 W	50 W	62.5 W
Average reading meter	5 W	40.5 W	50.6 W
Oscilloscope	69 V p-p	200 V p-p	224 V p-p

To check the power output and intermodulation:

- Connect a signal generator to provide two-tone audio (700 Hz and 2300 Hz) via the test unit to:
 - the audio input on the 15-way GPIO connector on the junction box or 2012 RF Unit (see [Figure 40 on page 170](#)), or
 - the 2011 RF Unit via the NGT test handset (see [Figure 41 on page 170](#))
- Hold down* PTT.
- Do one of the following:
 - If links X2 and X3 on the Filter and Control PCB in the RF unit (drawing [08-05416](#)) are open, check that the power output is 100 W PEP at 1.6 MHz to 30 MHz.
 - If links X2 and X3 on the Filter and Control PCB in the RF unit (drawing [08-05416](#)) are closed, check that the power output is 125 W PEP at 1.6 MHz to 100 W PEP at 30 MHz.
- Use a spectrum analyser to check that the IMD is better than –32 dB below PEP (–26 dB below each tone) (see [page 187, Checking intermodulation](#)).
- Release PTT.

This page has been left blank intentionally.

Table 50: NGT parts lists index

Title	Assembly number
Handset Assembly	08-05513-001
Junction box Assembly	08-05514-001
RF unit Assembly	
2010	08-05628-003 08-05628-001 08-05628-002 08-05628-007
2011	08-05628-005 08-05628-004
2012	08-05628-009
Handset	08-05300-001
Handset key-matrix	08-05522-001
Handset PTT button	08-05523-001
Handset power/emergency	08-05524-001
Junction box	
Audio	08-05470-001 08-05986-001
Microprocessor	08-05317-001

Table 50: NGT parts lists index (cont.)

Title	Assembly number
RF Unit 2010 Audio Interface Application Processor RF/IF Crystal Oven Power Amplifier Filter & Control PA Assembly complete with heatsink	08-05266-001 08-05265-001 08-05261-001 or 08-05889-001 08-05235-002 and or 08-05963-001 and 08-05962-001 and 08-05973-001 08-05415-001 or 08-05869-001 or 08-06461-001 08-05416-001 or 08-05910-001 08-05511-001
RF Unit 2011 Audio & Interconnect Application Processor Handset I/F 3 V RF/IF Crystal Oven Power Amplifier Filter & Control	08-05988-001 08-05987-001 08-05889-001 08-05963-001 08-05962-001 08-05973-001 08-05869-001 or 08-06461-001 08-05910-001

Table 50: NGT parts lists index (cont.)

Title	Assembly number
RF Unit 2012 Audio Interconnect & Data I/O Application Processor Handset & Data I/F RF/IF Crystal Oven Power Amplifier Filter & Control	 08-06261-001 08-06260-001 08-05889-001 08-05963-001 08-05962-001 08-05973-001 08-05869-001 or 08-06461-001 08-05910-001
Second Filter Option 500 Hz 2700 Hz	 08-05890-001 08-05890-002
Desk console (15-10471)	08-05267-001
Desk console (15-00766)	08-06320-001

This page has been left blank intentionally.

08-05513-001 - Handset Assy

BOM Revision
Date Valid On

07 -- Production
27.09.2006

Ref	Description	Manufacturer	Manufacturer's P/N	Codan P/N	Qty
	Build Standard, 2020			01-01251	1
	Assy Procedure for 08-05513			11-05513	1
*	Tcwr Handset			08-05513	1
1	Numeric Keypad, NGT	Tatt Shing	06-02104	06-02104	1
2	NGT Handset Upper & Lower	Inztep	06-02138	06-02138	1
4	Label, Serial/Barcode	Codan	06-02068	06-02068	1
5	Handset PCB	Codan	08-05300-001	08-05300-001	1
6	Handset Key-matrix PCB	Codan	08-05522-001	08-05522-001	1
7	Handset PTT Button PCB	Codan	08-05523-001	08-05523-001	1
8	Handset Power/Emerg Key PCB	Codan	08-05524-001	08-05524-001	1
9	Cable, Handset curly cord	Key	08-05592-001	08-05592-001	1
10	Screw, 2,5x16 PT S/S Pan Pozi	PSM Fasteners	WN1412-KB25x16-STST	31-02516-580	5
11	Power/Emerg Keypad, NGT	Tatt Shing	06-02105	06-02105	1

08-05514-001 - Junction Box Assy

BOM Revision
Date Valid On

06 -- Production
27.09.2006

Ref	Description	Manufacturer	Manufacturer's P/N	Codan P/N	Qty
	Build Standard, 2030			01-01250	1
*	Tcwr Junction Box			08-05514	1
1	Junction Box	Diometrics	05-07066	05-07066	1
2	Junction Box, Base Plate	Diometrics	05-07067	05-07067	1
3	Label, Serial/Barcode	Codan	06-02068	06-02068	1
4	MicroP PCB	Codan	08-05317-001	08-05317-001	1
5	Audio PCB	Codan	08-05986-001	08-05986-001	1
6	Loom, CIB	Auto Assemblies	08-05517-001	08-05517-001	2
7	Loom, Handset	Auto Assemblies	08-05518-001	08-05518-001	1
8	Loom, Serial	Auto Assemblies	08-05519-001	08-05519-001	1
9	Loom, GPIO	Auto Assemblies	08-05520-001	08-05520-001	1
10	Speaker Filter PCB	Codan	08-05724-001	08-05724-001	1
11	Bush, Transistor TO-220	Motorola	B51547F019	30-03801-001	1
12	Washer, Mica (1kV) TO-220	Philips	56359B	30-45002-002	1
13	Screw, M3x6 TAPTITE 2 P/Pozi	Ajax Fasteners	304 Stainless	31-03006-580	8
17	Washer, Insulating Stepped	Micro Plastics	12SWS1014 Black	32-90000-002	1
18	Screw lock assy, 'D' 5,0mm Stud	ACD	1-024	60-91563-001	4
19	Screw, M3x8 TAPTITE 2 P/Pozi	Ajax Fasteners	31-03008-580	31-03008-580	1
20	Heat, Transfer Compound	Gensil	GENSIL 13 45gm Tube	71-31000-004	0.01

08-05628-003 - RF Unit, NGT AR

BOM Revision
Date Valid On

14 -- Production
27.09.2006

Ref	Description	Manufacturer	Manufacturer's P/N	Codan P/N	Qty
	Opt AR	Codan	15-10487	15-10487	0.01
	Customising Reference Booklet			11-90350	1
	Build Standard, 2010			01-01252	1
*	RF Unit, NGT			08-05628	1
*	RF Unit, NGT			08-05628	1
1	Chassis	Diometrics	05-07057	05-07057	1
2	Cover & Gasket Assembly	Diometrics	08-06150-001	08-06150-001	2
3	Screen, Audio I/F	Metalcraft	05-07102	05-07102	1
4	Screen, Application Processor	Metalcraft	05-07103	05-07103	1
5	Screen, Rx/Exciter	Metalcraft	05-07104	05-07104	1
6	Card, Voltage Warning	Aust Printing	06-00380	06-00380	1
8	Label, Serial/Barcode	Codan	06-02068	06-02068	1
12	PA c/w Heatsink PCB	Codan	08-06461-001	08-06461-001	1
13	RF/I/F PCB	Codan	08-05889-001	08-05889-001	1
14	Filter & Control PCB	Codan	08-05910-001	08-05910-001	1
15	Screw, M3x8 TAPTITE 2 P/Pozi	Ajax Fasteners	31-03008-580	31-03008-580	26
16	Screw, M3x8 TAPTITE 2 Csk Pozi	Ajax Fasteners	304SS Bk to 01-00205	31-03008-782	4
17	Screw, M3x10 TAPTITE 2 P/Pozi	Ajax Fasteners	31-03010-582	31-03010-582	14
18	Washer, M3 304 SS Spring	W.J.Smith	31-23001-580	31-23001-580	8
26	Label, WEEE 10x20mm Black	Entech	06-02352-005	06-02352-005	1
101	Escutcheon, 2010 RF-Unit AR	Entech	06-01929-003	06-01929-003	1
102	Label, Serial No. 2010	x	06-01959	06-01959	1
103	Application Processor PCB	Codan	08-05265-001	08-05265-001	1
104	Audio I/F PCB	Codan	08-05266-001	08-05266-001	1
105	Cable, CIB	Intertech	08-05483-001	08-05483-001	1
106	Grommet, Blanking,NGT Heatsink	Electronic Synergies	06-02294	06-02294	1

08-05628-001 - RF Unit, NGT SR

BOM Revision
Date Valid On

14 -- Production
27.09.2006

Ref	Description	Manufacturer	Manufacturer's P/N	Codan P/N	Qty
	Opt SR	Codan	15-10489	15-10489	0.01
	Customising Reference Booklet			11-90350	1
	Build Standard, 2010			01-01252	1
*	RF Unit, NGT			08-05628	1
*	RF Unit, NGT			08-05628	1
1	Chassis	Diometrics	05-07057	05-07057	1
2	Cover & Gasket Assembly	Diometrics	08-06150-001	08-06150-001	2
3	Screen, Audio I/F	Metalcraft	05-07102	05-07102	1
4	Screen, Application Processor	Metalcraft	05-07103	05-07103	1
5	Screen, Rx/Exciter	Metalcraft	05-07104	05-07104	1
6	Card, Voltage Warning	Aust Printing	06-00380	06-00380	1
8	Label, Serial/Barcode	Codan	06-02068	06-02068	1
12	PA c/w Heatsink PCB	Codan	08-06461-001	08-06461-001	1
13	RF/I/F PCB	Codan	08-05889-001	08-05889-001	1
14	Filter & Control PCB	Codan	08-05910-001	08-05910-001	1
15	Screw, M3x8 TAPTITE 2 P/Pozi	Ajax Fasteners	31-03008-580	31-03008-580	26
16	Screw, M3x8 TAPTITE 2 Csk Pozi	Ajax Fasteners	304SS Bk to 01-00205	31-03008-782	4
17	Screw, M3x10 TAPTITE 2 P/Pozi	Ajax Fasteners	31-03010-582	31-03010-582	14
18	Washer, M3 304 SS Spring	W.J.Smith	31-23001-580	31-23001-580	8
26	Label, WEEE 10x20mm Black	Entech	06-02352-005	06-02352-005	1
101	Escutcheon, 2010 RF-Unit SR	Entech	06-01929-001	06-01929-001	1
102	Label, Serial No. 2010	x	06-01959	06-01959	1
103	Application Processor PCB	Codan	08-05265-001	08-05265-001	1
104	Audio I/F PCB	Codan	08-05266-001	08-05266-001	1
105	Cable, CIB	Intertech	08-05483-001	08-05483-001	1
106	Grommet, Blanking,NGT Heatsink	Electronic Synergies	06-02294	06-02294	1

08-05628-002 - RF Unit, NGT VR 2010

BOM Revision
Date Valid On

14 -- Production
27.09.2006

Ref	Description	Manufacturer	Manufacturer's P/N	Codan P/N	Qty
	Opt VR	Codan	15-10490	15-10490	1
	Customising Reference Booklet			11-90350	1
	Build Standard, 2010			01-01252	1
*	RF Unit, NGT			08-05628	1
*	RF Unit, NGT			08-05628	1
1	Chassis	Diometrics	05-07057	05-07057	1
2	Cover & Gasket Assembly	Diometrics	08-06150-001	08-06150-001	2
3	Screen, Audio I/F	Metalcraft	05-07102	05-07102	1
4	Screen, Application Processor	Metalcraft	05-07103	05-07103	1
5	Screen, Rx/Exciter	Metalcraft	05-07104	05-07104	1
6	Card, Voltage Warning	Aust Printing	06-00380	06-00380	1
8	Label, Serial/Barcode	Codan	06-02068	06-02068	1
12	PA c/w Heatsink PCB	Codan	08-06461-001	08-06461-001	1
13	RF/I/F PCB	Codan	08-05889-001	08-05889-001	1
14	Filter & Control PCB	Codan	08-05910-001	08-05910-001	1
15	Screw, M3x8 TAPTITE 2 P/Pozi	Ajax Fasteners	31-03008-580	31-03008-580	26
16	Screw, M3x8 TAPTITE 2 Csk Pozi	Ajax Fasteners	304SS Bk to 01-00205	31-03008-782	4
17	Screw, M3x10 TAPTITE 2 P/Pozi	Ajax Fasteners	31-03010-582	31-03010-582	14
18	Washer, M3 304 SS Spring	W.J.Smith	31-23001-580	31-23001-580	8
26	Label, WEEE 10x20mm Black	Entech	06-02352-005	06-02352-005	1
101	Escutcheon, 2010 RF-Unit VR	Entech	06-01929-002	06-01929-002	1
102	Label, Serial No. 2010	x	06-01959	06-01959	1
103	Application Processor PCB	Codan	08-05265-001	08-05265-001	1
104	Audio I/F PCB	Codan	08-05266-001	08-05266-001	1
105	Cable, CIB	Intertech	08-05483-001	08-05483-001	1
106	Grommet, Blanking,NGT Heatsink	Electronic Synergies	06-02294	06-02294	1

08-05628-007 - RF Unit, NGT ASR

BOM Revision
Date Valid On

08 -- Production
28.09.2006

Ref	Description	Manufacturer	Manufacturer's P/N	Codan P/N	Qty
	Opt ASR	Codan	15-10517	15-10517	1
	Customising Reference Booklet			11-90350	1
	Build Standard, 2010			01-01252	1
*	RF Unit, NGT			08-05628	1
*	RF Unit, NGT			08-05628	1
1	Chassis	Diometrics	05-07057	05-07057	1
2	Cover & Gasket Assembly	Diometrics	08-06150-001	08-06150-001	2
3	Screen, Audio I/F	Metalcraft	05-07102	05-07102	1
4	Screen, Application Processor	Metalcraft	05-07103	05-07103	1
5	Screen, Rx/Exciter	Metalcraft	05-07104	05-07104	1
6	Card, Voltage Warning	Aust Printing	06-00380	06-00380	1
8	Label, Serial/Barcode	Codan	06-02068	06-02068	1
12	PA c/w Heatsink PCB	Codan	08-06461-001	08-06461-001	1
13	RF/I/F PCB	Codan	08-05889-001	08-05889-001	1
14	Filter & Control PCB	Codan	08-05910-001	08-05910-001	1
15	Screw, M3x8 TAPTITE 2 P/Pozi	Ajax Fasteners	31-03008-580	31-03008-580	26
16	Screw, M3x8 TAPTITE 2 Csk Pozi	Ajax Fasteners	304SS Bk to 01-00205	31-03008-782	4
17	Screw, M3x10 TAPTITE 2 P/Pozi	Ajax Fasteners	31-03010-582	31-03010-582	14
18	Washer, M3 304 SS Spring	W.J.Smith	31-23001-580	31-23001-580	8
26	Label, WEEE 10x20mm Black	Entech	06-02352-005	06-02352-005	1
101	Escutcheon, 2010 RF-Unit ASR	Entech	06-01929-004	06-01929-004	1
102	Label, Serial No. 2010	x	06-01959	06-01959	1
103	Application Processor PCB	Codan	08-05265-001	08-05265-001	1
104	Audio I/F PCB	Codan	08-05266-001	08-05266-001	1
105	Cable, CIB	Intertech	08-05483-001	08-05483-001	1
106	Grommet, Blanking,NGT Heatsink	Electronic Synergies	06-02294	06-02294	1

08-05628-005 - RF Unit, NGT AR Voice

BOM Revision
Date Valid On

08 -- Production
28.09.2006

Ref	Description	Manufacturer	Manufacturer's P/N	Codan P/N	Qty
	Opt AR Voice	Codan	15-10516	15-10516	0.01
	Customising Reference Booklet			11-90350	1
	Customising Reference Booklet			11-90350	1
	Build Standard, 2010			01-01252	1
*	RF Unit, NGT			08-05628	1
*	RF Unit, NGT			08-05628	1
1	Chassis	Diometrics	05-07057	05-07057	1
2	Cover & Gasket Assembly	Diometrics	08-06150-001	08-06150-001	2
3	Screen, Audio I/F	Metalcraft	05-07102	05-07102	1
4	Screen, Application Processor	Metalcraft	05-07103	05-07103	1
5	Screen, Rx/Exciter	Metalcraft	05-07104	05-07104	1
6	Card, Voltage Warning	Aust Printing	06-00380	06-00380	1
8	Label, Serial/Barcode	Codan	06-02068	06-02068	1
12	PA c/w Heatsink PCB	Codan	08-06461-001	08-06461-001	1
13	RF/I/F PCB	Codan	08-05889-001	08-05889-001	1
14	Filter & Control PCB	Codan	08-05910-001	08-05910-001	1
15	Screw, M3x8 TAPTITE 2 P/Pozi	Ajax Fasteners	31-03008-580	31-03008-580	26
16	Screw, M3x8 TAPTITE 2 Csk Pozi	Ajax Fasteners	304SS Bk to 01-00205	31-03008-782	4
17	Screw, M3x10 TAPTITE 2 P/Pozi	Ajax Fasteners	31-03010-582	31-03010-582	14
18	Washer, M3 304 SS Spring	W.J.Smith	31-23001-580	31-23001-580	8
26	Label, WEEE 10x20mm Black	Entech	06-02352-005	06-02352-005	1
101	Escutcheon, 2011 RF Unit AR Voice	Price Screen Process	06-02136-002	06-02136-002	1
102	Label, Serial No. 2010	x	06-01959	06-01959	1
103	Appn Proc PCB,3V (Handset I/F)	Codan	08-05987-001	08-05987-001	1
104	Audio & Interconnect PCB	Codan	08-05988-001	08-05988-001	1
105	Cable, Control	Electronic Synergies	08-06021-001	08-06021-001	1
106	Grommet, Blanking,NGT Heatsink	Electronic Synergies	06-02294	06-02294	1

08-05628-004 - RF Unit, NGT VR 2011

BOM Revision
Date Valid On

08 -- Production
27.09.2006

Ref	Description	Manufacturer	Manufacturer's P/N	Codan P/N	Qty
	Opt VR Mobile	Codan	15-10515	15-10515	0.01
	Customising Reference Booklet			11-90350	1
	Customising Reference Booklet			11-90350	1
	Build Standard, 2010			01-01252	1
*	RF Unit, NGT			08-05628	1
*	RF Unit, NGT			08-05628	1
1	Chassis	Diometrics	05-07057	05-07057	1
2	Cover & Gasket Assembly	Diometrics	08-06150-001	08-06150-001	2
3	Screen, Audio I/F	Metalcraft	05-07102	05-07102	1
4	Screen, Application Processor	Metalcraft	05-07103	05-07103	1
5	Screen, Rx/Exciter	Metalcraft	05-07104	05-07104	1
6	Card, Voltage Warning	Aust Printing	06-00380	06-00380	1
8	Label, Serial/Barcode	Codan	06-02068	06-02068	1
12	PA c/w Heatsink PCB	Codan	08-06461-001	08-06461-001	1
13	RF/I/F PCB	Codan	08-05889-001	08-05889-001	1
14	Filter & Control PCB	Codan	08-05910-001	08-05910-001	1
15	Screw, M3x8 TAPTITE 2 P/Pozi	Ajax Fasteners	31-03008-580	31-03008-580	26
16	Screw, M3x8 TAPTITE 2 Csk Pozi	Ajax Fasteners	304SS Bk to 01-00205	31-03008-782	4
17	Screw, M3x10 TAPTITE 2 P/Pozi	Ajax Fasteners	31-03010-582	31-03010-582	14
18	Washer, M3 304 SS Spring	W.J.Smith	31-23001-580	31-23001-580	8
26	Label, WEEE 10x20mm Black	Entech	06-02352-005	06-02352-005	1
101	Escutcheon,2011 RF Unit Mobile	Price Screen Process	06-02136-001	06-02136-001	1
102	Label, Serial No. 2010	x	06-01959	06-01959	1
103	Appn Proc PCB,3V (Handset I/F)	Codan	08-05987-001	08-05987-001	1
104	Audio & Interconnect PCB	Codan	08-05988-001	08-05988-001	1
105	Cable, Control	Electronic Synergies	08-06021-001	08-06021-001	1
106	Grommet, Blanking,NGT Heatsink	Electronic Synergies	06-02294	06-02294	1

08-05628-009 - RF Unit, NGT SRx

BOM Revision
Date Valid On

05 -- Production
28.09.2006

Ref	Description	Manufacturer	Manufacturer's P/N	Codan P/N	Qty
	Appn Proc PCB, Handset & Data I/F	Codan	08-06260-001	08-06260-001	1
	Label, Serial No. 2010	x	06-01959	06-01959	1
	Escutcheon, 2012 RF Unit SRx	Price Screen Process	06-01929-006	06-01929-006	1
	Opt SRx	Codan	15-10533	15-10533	0.01
	Audio Interconnect & Data I/O PCB	Codan	08-06261-001	08-06261-001	1
	Cable, Control	Electronic Synergies	08-06021-001	08-06021-001	1
	Cable, GPIO	Electronic Synergies	08-06279-001	08-06279-001	1
	Customising Reference Booklet			11-90350	1
	Build Standard, 2010			01-01252	1
*	RF Unit, NGT			08-05628	1
*	RF Unit, NGT			08-05628	1
1	Chassis	Diometrics	05-07057	05-07057	1
2	Cover & Gasket Assembly	Diometrics	08-06150-001	08-06150-001	2
3	Screen, Audio I/F	Metalcraft	05-07102	05-07102	1
4	Screen, Application Processor	Metalcraft	05-07103	05-07103	1
5	Screen, Rx/Exciter	Metalcraft	05-07104	05-07104	1
6	Card, Voltage Warning	Aust Printing	06-00380	06-00380	1
8	Label, Serial/Barcode	Codan	06-02068	06-02068	1
12	PA c/w Heatsink PCB	Codan	08-06461-001	08-06461-001	1
13	RF/IF PCB	Codan	08-05889-001	08-05889-001	1
14	Filter & Control PCB	Codan	08-05910-001	08-05910-001	1
15	Screw, M3x8 TAPTITE 2 P/Pozi	Ajax Fasteners	31-03008-580	31-03008-580	26
16	Screw, M3x8 TAPTITE 2 Csk Pozi	Ajax Fasteners	304SS Bk to 01-00205	31-03008-782	4
17	Screw, M3x10 TAPTITE 2 P/Pozi	Ajax Fasteners	31-03010-582	31-03010-582	14
18	Washer, M3 304 SS Spring	W.J.Smith	31-23001-580	31-23001-580	8
26	Label, WEEE 10x20mm Black	Entech	06-02352-005	06-02352-005	1

08-05300-001 - Handset PCB

BOM Revision
Date Valid On

09 -- Production
27.09.2006

Ref	Description	Manufacturer	Manufacturer's P/N	Codan P/N	Qty
	Handset PCB			11-06080	1
	Handset, PCB			08-05300	1
	Handset			04-03125	1
	Build Standard, 2020			01-01251	1
1	PCB, Handset	IMP	07-01761-05	07-01761-05	1
2	Header (P) 20way 2row thin insul	Berg	67997-120	60-00200-262	1
3	Label, Serial/Barcode	Codan	06-02068	06-02068	1
C1	15p 5% 50V NPO 1206 NiSn	Philips	1206CG150J9BB-	46-11500-080	1
C2	15p 5% 50V NPO 1206 NiSn	Philips	1206CG150J9BB-	46-11500-080	1
C3	33n 10% 100V X7R 1206 NiSn	Philips	12062R333K0BB-	46-43300-280	1
C4	1u 20% 35V 3528 TA Cap	AVX	TAJB105M035R	47-01003-520	1
C5	3,3n 10% 100V X7R 1206 NiSn	Philips	12062R332K0BB-	46-33300-280	1
C6	1u 20% 35V 3528 TA Cap	AVX	TAJB105M035R	47-01003-520	1
C7	10u 20% 25V 6032 TA Cap	AVX	TAJC106M025R	47-11002-520	1
C8	10u 20% 25V 6032 TA Cap	AVX	TAJC106M025R	47-11002-520	1
C9	1n 5% 50V NPO 1206 NiSn	Philips	1206CG102J9BB-	46-31000-081	1
C10	1n 5% 50V NPO 1206 NiSn	Philips	1206CG102J9BB-	46-31000-081	1
C11	1n 5% 50V NPO 1206 NiSn	Philips	1206CG102J9BB-	46-31000-081	1
C12	1u 20% 35V 3528 TA Cap	AVX	TAJB105M035R	47-01003-520	1
C13	1u 20% 35V 3528 TA Cap	AVX	TAJB105M035R	47-01003-520	1
C14	100p 5% 50V NPO 1206 NiSn	Philips	1206CG101J9BB-	46-21000-080	1
C15	22n 10% 100V X7R 1206 NiSn	Philips	12062R223K0BB-	46-42200-280	1
C16	22n 10% 100V X7R 1206 NiSn	Philips	12062R223K0BB-	46-42200-280	1
C17	1u 20% 35V 3528 TA Cap	AVX	TAJB105M035R	47-01003-520	1
C18	1n 5% 50V NPO 1206 NiSn	Philips	1206CG102J9BB-	46-31000-081	1
C19	100p 5% 50V NPO 1206 NiSn	Philips	1206CG101J9BB-	46-21000-080	1
C20	10u 20% 25V 6032 TA Cap	AVX	TAJC106M025R	47-11002-520	1
C21	1u 20% 35V 3528 TA Cap	AVX	TAJB105M035R	47-01003-520	1
C22	470p 5% 50V NPO 1206 NiSn	Philips	1206CG471J9BB-	46-24700-080	1
C23	470p 5% 50V NPO 1206 NiSn	Philips	1206CG471J9BB-	46-24700-080	1
C24	3,3n 10% 100V X7R 1206 NiSn	Philips	12062R332K0BB-	46-33300-280	1
C25	3,3n 10% 100V X7R 1206 NiSn	Philips	12062R332K0BB-	46-33300-280	1

08-05300-001 - Handset PCB

BOM Revision
Date Valid On

09 -- Production
27.09.2006

Ref	Description	Manufacturer	Manufacturer's P/N	Codan P/N	Qty
C26	1u 20% 35V 3528 TA Cap	AVX	TAJB105M035R	47-01003-520	1
C27	33n 10% 100V X7R 1206 NiSn	Philips	12062R333K0BB-	46-43300-280	1
C28	33n 10% 100V X7R 1206 NiSn	Philips	12062R333K0BB-	46-43300-280	1
C29	1u 20% 35V 3528 TA Cap	AVX	TAJB105M035R	47-01003-520	1
C30	220p 5% 50V NPO 0805 NiSn	Philips	0805CG221J9BB	46-22200-081	1
C31	33n 10% 100V X7R 1206 NiSn	Philips	12062R333K0BB-	46-43300-280	1
D1	Diode, Si High speed 75V SOT23	Philips	BAS16	BAS16	1
D2	Diode, Si High speed 75V SOT23	Philips	BAS16	BAS16	1
D3	Diode, Si High speed 75V SOT23	Philips	BAS16	BAS16	1
D4	Diode, Si High speed 75V SOT23	Philips	BAS16	BAS16	1
H1	Display, 98x32 dot LCD back- lit	Powertip	PG9832LRS-ANN-H-Y1	65-63000	1
IC1	MCU, 8 Bit CMOS 30MHz 8Kb 32I/O PLCC44	Atmel	TS80C32X2-MCB-R	YP-08032-900	1
IC2	Monitor, Micro SOIC8	Dallas	DS1232LPS-2	XD-01232-700	1
IC3	PSD prgmd, Handset	Codan	90-20597-001	90-20597-001	1
IC4	Buffer, Hex Inverting Schmitt SOIC14	Motorola	MC74HC14D	YH-74014-700	1
IC5	Tcwr, RS232 DUAL +12V SOIC16	Maxim	MAX231CWE	YI-00231-700	1
IC6	Pot, 1k Digital SOIC8	Xicor	X9313ZS	YN-09313-700	1
IC7	Amp, Operational Dual SOIC8	National Semiconduct	LM358M	XA-00358-700	1
IC8	Tcwr, CAN bus SOIC8	Philips	PCA82C250T	YI-82250-700	1
IC9	Amp, Operational Dual SOIC8	National Semiconduct	LM358M	XA-00358-700	1
IC10	Reg, Voltage +5V 0,1A SOIC8	National Semiconduct	LM78L05ACM	XB-07805-700	1
J1	Socket, Jack 3,5 dia stereo PCB	Marushin	MJ-156L	60-00013-373	1
L1	Choke, Common Mode (Data) SMD	Taiyo Yuden	CM04RC04	43-82470-000	1
L2	Choke, Common Mode (Data) SMD	Taiyo Yuden	CM04RC04	43-82470-000	1
L3	Choke, EMI/EMC 0A DC >1MHz 4516	Taiyo Yuden	FCFBMJ 4516 HS 110- T	43-90003	1
L4	Choke, EMI/EMC 0A DC >1MHz 4516	Taiyo Yuden	FCFBMJ 4516 HS 110- T	43-90003	1
P1	Header (P) 4way 1row 2mm Fixed	Samtec	TW-04-09-L-S-120-150	60-00040-000	1
P2	Header (P) 5way 1row 2mm Fixed	Samtec	TW-05-09-L-S-120-150	60-00050-000	1
P3	Header (P) 5way 1row 2mm Fixed	Samtec	TW-05-09-L-S-120-150	60-00050-000	1

08-05300-001 - Handset PCB

BOM Revision
Date Valid On

09 -- Production
27.09.2006

Ref	Description	Manufacturer	Manufacturer's P/N	Codan P/N	Qty
P4	Header (P) 4way 1row 2mm Fixed	Samtec	TW-04-09-L-S-120-150	60-00040-000	1
P5	Header (P) 4way 1row 2mm Fixed	Samtec	TW-04-09-L-S-120-150	60-00040-000	1
P6	Header (P) 4way 2mm Latch Fixed	AMP	173981-4	60-00040-352	1
P7	Header (P) 4way 1row 2mm Fixed	Samtec	TW-04-09-L-S-120-150	60-00040-000	1
P8	Header (P) 8way 2mm Latch Fixed	AMP	292161-8	60-00080-001	1
R1	22k Ohm 5% 0,125W 1206	Philips	2322 711 61223	40-42200-101	1
R2	22k Ohm 5% 0,125W 1206	Philips	2322 711 61223	40-42200-101	1
R3	22k Ohm 5% 0,125W 1206	Philips	2322 711 61223	40-42200-101	1
R4	22k Ohm 5% 0,125W 1206	Philips	2322 711 61223	40-42200-101	1
R5	22k Ohm 5% 0,125W 1206	Philips	2322 711 61223	40-42200-101	1
R6	22k Ohm 5% 0,125W 1206	Philips	2322 711 61223	40-42200-101	1
R7	22k Ohm 5% 0,125W 1206	Philips	2322 711 61223	40-42200-101	1
R8	22k Ohm 5% 0,125W 1206	Philips	2322 711 61223	40-42200-101	1
R9	22k Ohm 5% 0,125W 1206	Philips	2322 711 61223	40-42200-101	1
R10	56 Ohm 5% 0,125W 1206	Philips	2322 711 61569	40-15600-101	1
R11	56 Ohm 5% 0,125W 1206	Philips	2322 711 61569	40-15600-101	1
R12	150 Ohm 1% 0,1W 0805	Philips	2322 734 61501	40-21500-115	1
R13	56 Ohm 5% 0,125W 1206	Philips	2322 711 61569	40-15600-101	1
R14	680 Ohm 5% 0,125W 1206	Philips	2322 711 61681	40-26800-101	1
R15	2,2k Ohm 1% 0,1W 0805	Philips	2322 734 62202	40-32200-115	1
R16	10k Ohm 5% 0,125W 1206	Philips	2322 711 61103	40-41000-101	1
R17	12k Ohm 5% 0,125W 1206	Philips	2322 711 61123	40-41200-101	1
R18	100k Ohm 5% 0,125W 1206	Philips	2322 711 61104	40-51000-101	1
R19	100 Ohm 5% 0,1W 0805	Philips	2322 730 61101	40-21000-111	1
R20	100 Ohm 5% 0,1W 0805	Philips	2322 730 61101	40-21000-111	1
R21	100k Ohm 5% 0,125W 1206	Philips	2322 711 61104	40-51000-101	1
R22	6,8k Ohm 5% 0,125W 1206	Philips	2322 711 61682	40-36800-101	1
R23	27k Ohm 5% 0,125W 1206	Philips	2322 711 61273	40-42700-101	1
R24	10k Ohm 5% 0,125W 1206	Philips	2322 711 61103	40-41000-101	1

08-05300-001 - Handset PCB

BOM Revision
Date Valid On

09 -- Production
27.09.2006

Ref	Description	Manufacturer	Manufacturer's P/N	Codan P/N	Qty
R25	22k Ohm 5% 0,125W 1206	Philips	2322 711 61223	40-42200-101	1
R26	1k Ohm 5% 0,125W 1206	Philips	2322 711 61102	40-31000-101	1
R27	2,2k Ohm 5% 0,1W 0805	Philips	2322 730 61222	40-32200-111	1
R28	4,7k Ohm 5% 0,06W 0603	Philips	2322 702 60472	40-34700-121	1
R29	10k Ohm 5% 0,125W 1206	Philips	2322 711 61103	40-41000-101	1
R30	22k Ohm 5% 0,125W 1206	Philips	2322 711 61223	40-42200-101	1
R31	4,7k Ohm 5% 0,06W 0603	Philips	2322 702 60472	40-34700-121	1
R32	100 Ohm 5% 0,1W 0805	Philips	2322 730 61101	40-21000-111	1
R33	47k Ohm 5% 0,125W 1206	Philips	2322 711 61473	40-44700-101	1
R34	47k Ohm 5% 0,125W 1206	Philips	2322 711 61473	40-44700-101	1
R35	47k Ohm 5% 0,125W 1206	Philips	2322 711 61473	40-44700-101	1
R36	12 Ohm 5% 0,125W 1206	Philips	2322 711 61129	40-11200-101	1
R37	68 Ohm 5% 0,125W 1206	Philips	2322 711 61689	40-16800-101	1
R38	100k Ohm 5% 0,125W 1206	Philips	2322 711 61104	40-51000-101	1
R39	2,2k Ohm 5% 0,1W 0805	Philips	2322 730 61222	40-32200-111	1
R40	2,2k Ohm 5% 0,1W 0805	Philips	2322 730 61222	40-32200-111	1
R41	39 Ohm 5% 0,125W 1206	Philips	2322 711 61399	40-13900-101	1
R42	39 Ohm 5% 0,125W 1206	Philips	2322 711 61399	40-13900-101	1
R43	47k Ohm 5% 0,125W 1206	Philips	2322 711 61473	40-44700-101	1
R44	47k Ohm 5% 0,125W 1206	Philips	2322 711 61473	40-44700-101	1
R45	1k Ohm 5% 0,125W 1206	Philips	2322 711 61102	40-31000-101	1
R46	1k Ohm 5% 0,125W 1206	Philips	2322 711 61102	40-31000-101	1
R47	4,7k Ohm 5% 0,06W 0603	Philips	2322 702 60472	40-34700-121	1
R48	10k Ohm 5% 0,125W 1206	Philips	2322 711 61103	40-41000-101	1
R49	10k Ohm 5% 0,125W 1206	Philips	2322 711 61103	40-41000-101	1
R50	10k Ohm 5% 0,125W 1206	Philips	2322 711 61103	40-41000-101	1
R51	10k Ohm 1% 0,1W 0805	Philips	2322 734 61003	40-41000-115	1
R52	100k Ohm 1% 0,1W 0805	Philips	2311 734 61004	40-51000-115	1
R53	4,7k Ohm 5% 0,06W 0603	Philips	2322 702 60472	40-34700-121	1

08-05300-001 - Handset PCB

BOM Revision
Date Valid On

09 -- Production
27.09.2006

Ref	Description	Manufacturer	Manufacturer's P/N	Codan P/N	Qty
R54	100k Ohm 1% 0,1W 0805	Philips	2311 734 61004	40-51000-115	1
R55	220 Ohm 1% 0,1W 0805	Philips	2322 734 62201	40-22200-115	1
V1	MOSFET, N Chan Enhance SOT23	Philips	BST82	BST82	1
V2	MOSFET, N Chan Enhance SOT23	Philips	BST82	BST82	1
V3	MOSFET, N Chan Enhance SOT23	Philips	BST82	BST82	1
V4	MOSFET, N Chan Enhance SOT23	Philips	BST82	BST82	1
V5	MOSFET, N Chan Enhance SOT23	Philips	BST82	BST82	1
V6	Transistor, PNP Si SOT89	Philips	BC869	BC869	1
V7	Transistor, NPN Si SOT23	Philips	BC848	BC848	1
V8	Diode, Zener 6,8V 5% 0,2W SOT23	Philips	BZX84C6V8	BZX84C6V8	1
V9	MOSFET, N Chan Enhance SOT23	Philips	BST82	BST82	1
Z1	Crystal, 14745,6 kHz uP Grade	HY-Q	QC49/SMD 14745,6KHZ	65-90104	1

08-05522-001 - Handset Key-matrix PCB

BOM Revision
Date Valid On

03 -- Production
27.09.2006

Ref	Description	Manufacturer	Manufacturer's P/N	Codan P/N	Qty
	Handset			04-03125	1
	Handset Key-matrix PCB			08-05522	1
	Key Pad PCB Assembly			11-06076	1
1	PCB, Keypad	IMP	07-01784-04	07-01784-04	1
H101	LED, Green PLCC SMD Non Diffused	Siemens	LGT670-L	65-61110-507	1
H102	LED, Green PLCC SMD Non Diffused	Siemens	LGT670-L	65-61110-507	1
H103	LED, Green PLCC SMD Non Diffused	Siemens	LGT670-L	65-61110-507	1
H104	LED, Green PLCC SMD Non Diffused	Siemens	LGT670-L	65-61110-507	1
H105	LED, Green PLCC SMD Non Diffused	Siemens	LGT670-L	65-61110-507	1
H106	LED, Green PLCC SMD Non Diffused	Siemens	LGT670-L	65-61110-507	1
H107	LED, Green PLCC SMD Non Diffused	Siemens	LGT670-L	65-61110-507	1
H108	LED, Green PLCC SMD Non Diffused	Siemens	LGT670-L	65-61110-507	1
J2	Socket, 5way 1row 2mm Fixed	Samtec	SMM-105-01-S-S	60-00053-000	1
J3	Socket, 5way 1row 2mm Fixed	Samtec	SMM-105-01-S-S	60-00053-000	1
J4	Socket, 4way 1row 2mm Fixed	Samtec	SMM-104-01-S-S	60-00043-000	1
J5	Socket, 4way 1row 2mm Fixed	Samtec	SMM-104-01-S-S	60-00043-000	1

08-05523-001 - Handset PTT Button PCB

BOM Revision
Date Valid On

04 -- Production
27.09.2006

Ref	Description	Manufacturer	Manufacturer's P/N	Codan P/N	Qty
	Handset			04-03125	1
	H/S PTT button PCB			11-06077	1
*	Handset PTT Button PCB			08-05523	1
1	PCB, PTT Switch	IMP	07-01795-05	07-01795-05	1
2	Button, Push to talk (PTT)	Keyflex	06-01961	06-01961	1
3	Loom, PTT Button	Auto Assemblies	08-05758-001	08-05758-001	1

08-05524-001 - Handset Power/Emgcy Key PCB

BOM Revision
Date Valid On

05 -- Production
 27.09.2006

Ref	Description	Manufacturer	Manufacturer's P/N	Codan P/N	Qty
	Handset Pwr/Emgcy Key PCB			11-06070	1
	Handset Power/Emgcy Key PCB			08-05524	1
	Handset			04-03125	1
1	PCB, Pwr/Emgcy Keypad	Codan	07-01796-06	07-01796-06	1
B201	Insert, Mic electret	Hosiden	KUC2123-030232	65-31510	1
H201	LED, Green PLCC SMD Non Diffused	Siemens	LGT670-L	65-61110-507	1
H202	LED, Red PLCC SMD Non Diffused	Siemens	LST670-L	65-61110-216	1
J1	Socket, 4way 1row 2mm Fixed	Samtec	SMM-104-01-S-S	60-00043-000	1
J7	Socket, 4way 1row 2mm Fixed	Samtec	SMM-104-01-S-S	60-00043-000	1

08-05470-001 - Audio PCB

BOM Revision
Date Valid On

07 -- Production
27.09.2006

Ref	Description	Manufacturer	Manufacturer's P/N	Codan P/N	Qty
	Header (P) 3way 1row	Molex	22-03-2031	60-00031-100	1
	PTP, 2030, Audio PCB			10-50043	1
	Audio PCB			11-06074	1
	Audio			04-03201	1
	Audio PCB			08-05470	1
	Build Standard, 2030			01-01250	1
1	PCB, Audio	IMP	07-01825-07	07-01825-07	1
2	Label, Serial/Barcode	Codan	06-02068	06-02068	1
3	Jumper (S) 2way Open Top	Molex	15-38-1024	60-90410-001	2
C1	33n 10% 100V X7R 1206 NiSn	Philips	12062R333K0BB-	46-43300-280	1
C2	33n 10% 100V X7R 1206 NiSn	Philips	12062R333K0BB-	46-43300-280	1
C3	3,3n 10% 100V X7R 1206 NiSn	Philips	12062R332K0BB-	46-33300-280	1
C4	100p 5% 50V NPO 1206 NiSn	Philips	1206CG101J9BB-	46-21000-080	1
C5	100p 5% 50V NPO 1206 NiSn	Philips	1206CG101J9BB-	46-21000-080	1
C6	100p 5% 50V NPO 1206 NiSn	Philips	1206CG101J9BB-	46-21000-080	1
C7	100p 5% 50V NPO 1206 NiSn	Philips	1206CG101J9BB-	46-21000-080	1
C8	100n 10% 50V X7R 1206 NiSn	Philips	12062R104K9BB-	46-51000-281	1
C9	10u 20% 25V 6032 TA Cap	AVX	TAJC106M025R	47-11002-520	1
C10	1000u 16V Ax EL Cap	Jamicon	SKR102T1CJ21	48-31001-651	1
C11	33n 10% 100V X7R 1206 NiSn	Philips	12062R333K0BB-	46-43300-280	1
C12	3,3n 10% 100V X7R 1206 NiSn	Philips	12062R332K0BB-	46-33300-280	1
C13	33n 10% 100V X7R 1206 NiSn	Philips	12062R333K0BB-	46-43300-280	1
C14	100n 10% 50V X7R 1206 NiSn	Philips	12062R104K9BB-	46-51000-281	1
C15	100u 25V Ax EL Cap	Elna	RB	48-21002-551	1
C16	470u 16V Ax EL Cap	Jamicon	SKR470T1CG18	48-24701-651	1
C17	2,2n 5% 50V NPO 1206 NiSn	Philips	1206CG222J9BB-	46-32200-081	1
C18	33n 10% 100V X7R 1206 NiSn	Philips	12062R333K0BB-	46-43300-280	1
C19	2,2n 5% 50V NPO 1206 NiSn	Philips	1206CG222J9BB-	46-32200-081	1
C20	3,9n 5% 50V NPO 1206 NiSn	Philips	1206CG392J9BB0C	46-33900-080	1
C21	330p 5% 50V NPO 1206 NiSn	Philips	1206CG331J9BB-	46-23300-080	1
C22	33n 10% 100V X7R 1206 NiSn	Philips	12062R333K0BB-	46-43300-280	1
C23	4,7n 5% 50V NPO 1206 NiSn	Philips	1206CG472J9BB0C	46-34700-080	1
C24	4,7n 5% 50V NPO 1206 NiSn	Philips	1206CG472J9BB0C	46-34700-080	1

08-05470-001 - Audio PCB

BOM Revision
Date Valid On

07 -- Production
27.09.2006

Ref	Description	Manufacturer	Manufacturer's P/N	Codan P/N	Qty
C25	220p 5% 50V NPO 1206 NiSn	Philips	1206CG221J9BB-	46-22200-080	1
C26	33n 10% 100V X7R 1206 NiSn	Philips	12062R333K0BB-	46-43300-280	1
C27	33n 10% 100V X7R 1206 NiSn	Philips	12062R333K0BB-	46-43300-280	1
C28	33n 10% 100V X7R 1206 NiSn	Philips	12062R333K0BB-	46-43300-280	1
C29	2,2n 5% 50V NPO 1206 NiSn	Philips	1206CG222J9BB-	46-32200-081	1
C30	2,2n 5% 50V NPO 1206 NiSn	Philips	1206CG222J9BB-	46-32200-081	1
C31	3,9n 5% 50V NPO 1206 NiSn	Philips	1206CG392J9BB0C	46-33900-080	1
C32	330p 5% 50V NPO 1206 NiSn	Philips	1206CG331J9BB-	46-23300-080	1
C33	4,7n 5% 50V NPO 1206 NiSn	Philips	1206CG472J9BB0C	46-34700-080	1
C34	4,7n 5% 50V NPO 1206 NiSn	Philips	1206CG472J9BB0C	46-34700-080	1
C35	220p 5% 50V NPO 1206 NiSn	Philips	1206CG221J9BB-	46-22200-080	1
C36	1u 20% 35V 3528 TA Cap	AVX	TAJB105M035R	47-01003-520	1
C37	470p 5% 50V NPO 1206 NiSn	Philips	1206CG471J9BB-	46-24700-080	1
C38	470p 5% 50V NPO 1206 NiSn	Philips	1206CG471J9BB-	46-24700-080	1
C39	33n 10% 100V X7R 1206 NiSn	Philips	12062R333K0BB-	46-43300-280	1
C40	33n 10% 100V X7R 1206 NiSn	Philips	12062R333K0BB-	46-43300-280	1
C41	3,3n 10% 100V X7R 1206 NiSn	Philips	12062R332K0BB-	46-33300-280	1
C42	3,3n 10% 100V X7R 1206 NiSn	Philips	12062R332K0BB-	46-33300-280	1
C43	33n 10% 100V X7R 1206 NiSn	Philips	12062R333K0BB-	46-43300-280	1
C44	33n 10% 100V X7R 1206 NiSn	Philips	12062R333K0BB-	46-43300-280	1
C45	33n 10% 100V X7R 1206 NiSn	Philips	12062R333K0BB-	46-43300-280	1
C46	3,3n 10% 100V X7R 1206 NiSn	Philips	12062R332K0BB-	46-33300-280	1
C47	3,3n 10% 100V X7R 1206 NiSn	Philips	12062R332K0BB-	46-33300-280	1
C48	470p 5% 50V NPO 1206 NiSn	Philips	1206CG471J9BB-	46-24700-080	1
C49	470p 5% 50V NPO 1206 NiSn	Philips	1206CG471J9BB-	46-24700-080	1
C50	470p 5% 50V NPO 1206 NiSn	Philips	1206CG471J9BB-	46-24700-080	1
C51	470p 5% 50V NPO 1206 NiSn	Philips	1206CG471J9BB-	46-24700-080	1
C52	10u 20% 25V 6032 TA Cap	AVX	TAJC106M025R	47-11002-520	1
C53	10u 20% 25V 6032 TA Cap	AVX	TAJC106M025R	47-11002-520	1

08-05470-001 - Audio PCB

BOM Revision
Date Valid On

07 -- Production
27.09.2006

Ref	Description	Manufacturer	Manufacturer's P/N	Codan P/N	Qty
C54	10u 20% 25V 6032 TA Cap	AVX	TAJC106M025R	47-11002-520	1
C55	470u 16V Ax EL Cap	Jamicon	SKR470T1CG18	48-24701-651	1
C56	100n 10% 50V X7R 1206 NiSn	Philips	12062R104K9BB-	46-51000-281	1
C57	100n 10% 50V X7R 1206 NiSn	Philips	12062R104K9BB-	46-51000-281	1
C58	100n 10% 50V X7R 1206 NiSn	Philips	12062R104K9BB-	46-51000-281	1
C59	100n 10% 50V X7R 1206 NiSn	Philips	12062R104K9BB-	46-51000-281	1
C60	100n 10% 50V X7R 1206 NiSn	Philips	12062R104K9BB-	46-51000-281	1
C61	3,3n 10% 100V X7R 1206 NiSn	Philips	12062R332K0BB-	46-33300-280	1
C62	3,3n 10% 100V X7R 1206 NiSn	Philips	12062R332K0BB-	46-33300-280	1
C63	3,3n 10% 100V X7R 1206 NiSn	Philips	12062R332K0BB-	46-33300-280	1
C64	3,3n 10% 100V X7R 1206 NiSn	Philips	12062R332K0BB-	46-33300-280	1
C65	3,3n 10% 100V X7R 1206 NiSn	Philips	12062R332K0BB-	46-33300-280	1
C66	3,3n 10% 100V X7R 1206 NiSn	Philips	12062R332K0BB-	46-33300-280	1
C67	3,3n 10% 100V X7R 1206 NiSn	Philips	12062R332K0BB-	46-33300-280	1
C68	3,3n 10% 100V X7R 1206 NiSn	Philips	12062R332K0BB-	46-33300-280	1
C69	3,3n 10% 100V X7R 1206 NiSn	Philips	12062R332K0BB-	46-33300-280	1
C70	3,3n 10% 100V X7R 1206 NiSn	Philips	12062R332K0BB-	46-33300-280	1
C71	3,3n 10% 100V X7R 1206 NiSn	Philips	12062R332K0BB-	46-33300-280	1
C72	3,3n 10% 100V X7R 1206 NiSn	Philips	12062R332K0BB-	46-33300-280	1
C73	3,3n 10% 100V X7R 1206 NiSn	Philips	12062R332K0BB-	46-33300-280	1
C74	3,3n 10% 100V X7R 1206 NiSn	Philips	12062R332K0BB-	46-33300-280	1
C75	220p 5% 50V NPO 1206 NiSn	Philips	1206CG221J9BB-	46-22200-080	1
C76	220p 5% 50V NPO 1206 NiSn	Philips	1206CG221J9BB-	46-22200-080	1
C77	22p 5% 50V NPO 1206 NiSn	Philips	1206CG220J9BB-	46-12200-080	1
C78	22p 5% 50V NPO 1206 NiSn	Philips	1206CG220J9BB-	46-12200-080	1
C79	100p 5% 50V NPO 1206 NiSn	Philips	1206CG101J9BB-	46-21000-080	1
D1	Diode, Si High speed 75V SOT23	Philips	BAS16	BAS16	1
D2	Diode, Si High speed 75V SOT23	Philips	BAS16	BAS16	1
D3	Diode, Si 400V 1A	Fairchild	1N4004	1N4004	1

08-05470-001 - Audio PCB

BOM Revision
Date Valid On

07 -- Production
27.09.2006

Ref	Description	Manufacturer	Manufacturer's P/N	Codan P/N	Qty
H1	LED, Tricolour T-1 3/4 Diffused	Liteon	LTL-52RG	65-61110-901	1
H2	LED, Green PLCC SMD Non Diffused	Siemens	LGT670-L	65-61110-507	1
H3	LED, Green PLCC SMD Non Diffused	Siemens	LGT670-L	65-61110-507	1
IC1	EPLD prgmd, JB Audio	Codan	90-20587-001	90-20587-001	1
IC2	Pot, 50k Digital Quad SOIC20	Xicor	X9241US	YN-09241-701	1
IC3	Amp, Power 12W IC	Philips	TDA1020	TDA1020	1
IC4	Amp, Op Dual Fast SOIC8	Texas Instruments	TLE2082CD	XA-02082-700	1
IC5	Amp, Op Dual Fast SOIC8	Texas Instruments	TLE2082CD	XA-02082-700	1
IC6	Amp, Op Dual Fast SOIC8	Texas Instruments	TLE2082CD	XA-02082-700	1
IC7	Amp, Op Dual Fast SOIC8	Texas Instruments	TLE2082CD	XA-02082-700	1
IC8	Amp, Op Dual Fast SOIC8	Texas Instruments	TLE2082CD	XA-02082-700	1
IC9	Switch, Analog Quad Fast SOIC16	Harris	DG445DY	YI-00445-700	1
IC10	Amp, Op Dual Fast SOIC8	Texas Instruments	TLE2082CD	XA-02082-700	1
IC11	Amp, Op Dual Fast SOIC8	Texas Instruments	TLE2082CD	XA-02082-700	1
IC12	Reg, Voltage +10V IC	National Semiconduct	LM2940T-10	XB-02940-402	1
IC13	Reg, Voltage +5V 0,1A SOIC8	National Semiconduct	LM78L05ACM	XB-07805-700	1
K1	Relay, 2C 12V 2A SMD 1028 Ohm	Matsushita	TQ2SL-12V	64-21225-310	1
L1	Choke, EMI/EMC 0A DC >1MHz 4516	Taiyo Yuden	FCFBMJ 4516 HS 110- T	43-90003	1
L2	Choke, EMI/EMC 0A DC >1MHz 4516	Taiyo Yuden	FCFBMJ 4516 HS 110- T	43-90003	1
L3	Choke, EMI/EMC 0A DC >1MHz 4516	Taiyo Yuden	FCFBMJ 4516 HS 110- T	43-90003	1
L4	Choke, EMI/EMC 0A DC >1MHz 4516	Taiyo Yuden	FCFBMJ 4516 HS 110- T	43-90003	1
L5	Choke, Common Mode (Data) SMD	Taiyo Yuden	CM04RC04	43-82470-000	1
L6	Choke, Common Mode (Data) SMD	Taiyo Yuden	CM04RC04	43-82470-000	1
L7	Choke, Common Mode (Data) SMD	Taiyo Yuden	CM04RC04	43-82470-000	1
L8	Choke, Common Mode (Data) SMD	Taiyo Yuden	CM04RC04	43-82470-000	1
L9	Choke, EMI/EMC 0A DC >1MHz 4516	Taiyo Yuden	FCFBMJ 4516 HS 110- T	43-90003	1
L10	Ind, Common Mode 5.5A	Taiyo Yuden	CMO8RA20	43-80001	1
P1	Header (P) 34way 2row Boxed Fix	Thomas & Betts	609-3427	60-00340-001	1
P2	Header (P) 10way 2mm Latch Fixed	AMP	1-173981-0	60-00100-351	1
P3	Header (P) 10way 2mm Latch Fixed	AMP	1-173981-0	60-00100-351	1
P5	Header (P) 10way 2row thin insul	Berg	67997-410H	60-00100-002	1

08-05470-001 - Audio PCB

BOM Revision
Date Valid On

07 -- Production
27.09.2006

Ref	Description	Manufacturer	Manufacturer's P/N	Codan P/N	Qty
P6	Header (P) 4way 2mm Latch Fixed	AMP	173981-4	60-00040-352	1
P7	Header (P) 8way 2mm Latch Fixed	AMP	292161-8	60-00080-001	1
P8	Header (P) 3way 1row	Molex	22-03-2031	60-00031-100	1
P9	Header (P) 16way 2row thin insul	Berg	67997-416H	60-00160-001	1
P10	Header (P) 10way 2row thin insul	Berg	67997-410H	60-00100-002	1
R1	4,7k Ohm 5% 0,125W 1206	Philips	2322 711 61472	40-34700-101	1
R2	2,2k Ohm 5% 0,125W 1206	Philips	2322 711 61222	40-32200-101	1
R3	1k Ohm 5% 0,125W 1206	Philips	2322 711 61102	40-31000-101	1
R4	1k Ohm 5% 0,125W 1206	Philips	2322 711 61102	40-31000-101	1
R5	1k Ohm 5% 0,125W 1206	Philips	2322 711 61102	40-31000-101	1
R6	1k Ohm 5% 0,125W 1206	Philips	2322 711 61102	40-31000-101	1
R7	2,2k Ohm 5% 0,125W 1206	Philips	2322 711 61222	40-32200-101	1
R8	100 Ohm 5% 0,125W 1206	Philips	2322 711 61101	40-21000-101	1
R9	2,2k Ohm 5% 0,125W 1206	Philips	2322 711 61222	40-32200-101	1
R10	270 Ohm 5% 0,125W 1206	Philips	2322 711 61271	40-22700-101	1
R11	2,2k Ohm 5% 0,125W 1206	Philips	2322 711 61222	40-32200-101	1
R12	2,2k Ohm 5% 0,125W 1206	Philips	2322 711 61222	40-32200-101	1
R13	2,2k Ohm 5% 0,125W 1206	Philips	2322 711 61222	40-32200-101	1
R14	100 Ohm 5% 0,125W 1206	Philips	2322 711 61101	40-21000-101	1
R15	100 Ohm 5% 0,125W 1206	Philips	2322 711 61101	40-21000-101	1
R16	100 Ohm 5% 0,125W 1206	Philips	2322 711 61101	40-21000-101	1
R17	1k Ohm 5% 0,125W 1206	Philips	2322 711 61102	40-31000-101	1
R18	100 Ohm 5% 0,125W 1206	Philips	2322 711 61101	40-21000-101	1
R19	330k Ohm 2% 0,125W 1206	Philips	2322-711-41334	40-53300-102	1
R20	47k Ohm 5% 0,125W 1206	Philips	2322 711 61473	40-44700-101	1
R21	3,3 Ohm 5% 0,125W 1206	Philips	2322 711 61338	40-03300-101	1
R22	4,7k Ohm 5% 0,125W 1206	Philips	2322 711 61472	40-34700-101	1
R23	51k Ohm 5% 0,1W 0805	Philips	2322 730 61513	40-45100-111	1
R25	51k Ohm 5% 0,1W 0805	Philips	2322 730 61513	40-45100-111	1

08-05470-001 - Audio PCB

BOM Revision
Date Valid On

07 -- Production
 27.09.2006

Ref	Description	Manufacturer	Manufacturer's P/N	Codan P/N	Qty
R27	51k Ohm 5% 0,1W 0805	Philips	2322 730 61513	40-45100-111	1
R29	33k Ohm 5% 0,1W 0805	Philips	2322 730 61333	40-43300-111	1
R30	33k Ohm 5% 0,1W 0805	Philips	2322 730 61333	40-43300-111	1
R31	18k Ohm 5% 0,125W 1206	Philips	2322 711 61183	40-41800-101	1
R32	1,5k Ohm 5% 0,125W 1206	Philips	2322 711 61152	40-31500-101	1
R33	1,5k Ohm 5% 0,125W 1206	Philips	2322 711 61152	40-31500-101	1
R34	47k Ohm 5% 0,125W 1206	Philips	2322 711 61473	40-44700-101	1
R35	4,7k Ohm 5% 0,125W 1206	Philips	2322 711 61472	40-34700-101	1
R36	10k Ohm 5% 0,125W 1206	Philips	2322 711 61103	40-41000-101	1
R37	22k Ohm 5% 0,125W 1206	Philips	2322 711 61223	40-42200-101	1
R38	22k Ohm 5% 0,125W 1206	Philips	2322 711 61223	40-42200-101	1
R39	10k Ohm 5% 0,125W 1206	Philips	2322 711 61103	40-41000-101	1
R40	51k Ohm 5% 0,1W 0805	Philips	2322 730 61513	40-45100-111	1
R42	51k Ohm 5% 0,1W 0805	Philips	2322 730 61513	40-45100-111	1
R44	51k Ohm 5% 0,1W 0805	Philips	2322 730 61513	40-45100-111	1
R46	33k Ohm 5% 0,1W 0805	Philips	2322 730 61333	40-43300-111	1
R47	33k Ohm 5% 0,1W 0805	Philips	2322 730 61333	40-43300-111	1
R48	22k Ohm 5% 0,125W 1206	Philips	2322 711 61223	40-42200-101	1
R49	22k Ohm 5% 0,125W 1206	Philips	2322 711 61223	40-42200-101	1
R50	22k Ohm 5% 0,125W 1206	Philips	2322 711 61223	40-42200-101	1
R51	22k Ohm 5% 0,125W 1206	Philips	2322 711 61223	40-42200-101	1
R52	10k Ohm 5% 0,125W 1206	Philips	2322 711 61103	40-41000-101	1
R53	18k Ohm 5% 0,125W 1206	Philips	2322 711 61183	40-41800-101	1
R54	1,8k Ohm 5% 0,125W 1206	Philips	2322 711 61182	40-31800-101	1
R55	47k Ohm 5% 0,125W 1206	Philips	2322 711 61473	40-44700-101	1
R56	10k Ohm 5% 0,125W 1206	Philips	2322 711 61103	40-41000-101	1
R57	47k Ohm 5% 0,125W 1206	Philips	2322 711 61473	40-44700-101	1
R58	47k Ohm 5% 0,125W 1206	Philips	2322 711 61473	40-44700-101	1
R59	47k Ohm 5% 0,125W 1206	Philips	2322 711 61473	40-44700-101	1

08-05470-001 - Audio PCB

BOM Revision
Date Valid On

07 -- Production
27.09.2006

Ref	Description	Manufacturer	Manufacturer's P/N	Codan P/N	Qty
R60	22k Ohm 5% 0,125W 1206	Philips	2322 711 61223	40-42200-101	1
R61	47k Ohm 5% 0,125W 1206	Philips	2322 711 61473	40-44700-101	1
R62	47k Ohm 5% 0,125W 1206	Philips	2322 711 61473	40-44700-101	1
R63	22k Ohm 5% 0,125W 1206	Philips	2322 711 61223	40-42200-101	1
R64	100 Ohm 5% 0,125W 1206	Philips	2322 711 61101	40-21000-101	1
R65	33k Ohm 5% 0,1W 0805	Philips	2322 730 61333	40-43300-111	1
R66	33k Ohm 5% 0,1W 0805	Philips	2322 730 61333	40-43300-111	1
R67	33k Ohm 5% 0,1W 0805	Philips	2322 730 61333	40-43300-111	1
R68	1k Ohm 5% 0,125W 1206	Philips	2322 711 61102	40-31000-101	1
R69	1k Ohm 5% 0,125W 1206	Philips	2322 711 61102	40-31000-101	1
R70	1k Ohm 5% 0,125W 1206	Philips	2322 711 61102	40-31000-101	1
R71	1k Ohm 5% 0,125W 1206	Philips	2322 711 61102	40-31000-101	1
R72	100 Ohm 5% 0,125W 1206	Philips	2322 711 61101	40-21000-101	1
R73	100 Ohm 5% 0,125W 1206	Philips	2322 711 61101	40-21000-101	1
R74	100 Ohm 5% 0,125W 1206	Philips	2322 711 61101	40-21000-101	1
R75	100 Ohm 5% 0,125W 1206	Philips	2322 711 61101	40-21000-101	1
R76	100 Ohm 5% 0,125W 1206	Philips	2322 711 61101	40-21000-101	1
R77	100 Ohm 5% 0,125W 1206	Philips	2322 711 61101	40-21000-101	1
R78	100 Ohm 5% 0,125W 1206	Philips	2322 711 61101	40-21000-101	1
R79	100 Ohm 5% 0,125W 1206	Philips	2322 711 61101	40-21000-101	1
R80	100 Ohm 5% 0,125W 1206	Philips	2322 711 61101	40-21000-101	1
R81	100 Ohm 5% 0,125W 1206	Philips	2322 711 61101	40-21000-101	1
R82	33k Ohm 5% 0,1W 0805	Philips	2322 730 61333	40-43300-111	1
R83	1M Ohm 5% 0,1W 0805	Philips	2322 730 61105	40-61000-111	1
R84	1k Ohm 5% 0,125W 1206	Philips	2322 711 61102	40-31000-101	1
R85	1M Ohm 5% 0,1W 0805	Philips	2322 730 61105	40-61000-111	1
R86	1M Ohm 5% 0,1W 0805	Philips	2322 730 61105	40-61000-111	1
T1	Txfr, Line isolation SMD	Etal	P2781	43-30002	1
V1	Transistor, NPN Si SOT23	Philips	BFR92A	BFR92A	1

08-05470-001 - Audio PCB

BOM Revision
Date Valid On

07 -- Production
27.09.2006

Ref	Description	Manufacturer	Manufacturer's P/N	Codan P/N	Qty
V2	Transistor, PNP Si SOT23	Philips	BC858	BC858	1
V3	Transistor, PNP Si SOT23	Philips	BC858	BC858	1
V4	Transistor, NPN Si SOT23	Philips	BC848	BC848	1
V5	Transistor, NPN Si SOT23	Philips	BC848	BC848	1
Z1	Crystal, 16000 kHz uP Grade	HY-Q	QC49/SMD	65-90103	1

08-05986-001 - Audio PCB

BOM Revision
Date Valid On

05 -- Production
28.09.2006

Ref	Description	Manufacturer	Manufacturer's P/N	Codan P/N	Qty
	Audio PCB			08-05986	1
	Audio, Junction Box			04-03423	1
	Spec, Audio (JB) PCB Board Level			01-01051	1
	NGT JBox Audio PCB			11-06093	1
1	PCB, Audio	Codan	07-01992-02	07-01992-02	1
2	Label, Serial/Barcode	Codan	06-02068	06-02068	1
3	Jumper (S) 2way Open Top	Molex	15-38-1024	60-90410-001	2
C1	33n 10% 50V X7R 0805 NiSn	Philips	08052R333K9BB00	46-43300-281	1
C2	33n 10% 50V X7R 0805 NiSn	Philips	08052R333K9BB00	46-43300-281	1
C3	3,3n 10% 100V X7R 0603 NiSn	Vishay	VJ0603Y332KXBAC	46-33300-282	1
C4	100p 5% 50V NPO 0603 NiSn	Philips	0603CG101J9B200	46-21000-083	1
C5	100p 5% 50V NPO 0603 NiSn	Philips	0603CG101J9B200	46-21000-083	1
C6	100p 5% 50V NPO 0603 NiSn	Philips	0603CG101J9B200	46-21000-083	1
C7	100p 5% 50V NPO 0603 NiSn	Philips	0603CG101J9B200	46-21000-083	1
C8	100n 10% 50V X7R 0805 Nisn	Philips	08052R104K9BB	46-51000-282	1
C9	Not Fitted	Codan	**-.00000-001	99-00000-001	1
C10	1000u 16V Ax EL Cap	Jamicon	SKR102T1CJ21	48-31001-651	1
C11	33n 10% 50V X7R 0805 NiSn	Philips	08052R333K9BB00	46-43300-281	1
C12	33n 10% 50V X7R 0805 NiSn	Philips	08052R333K9BB00	46-43300-281	1
C15	100u 25V 105°C SMD EL Cap Low ESR	Nippon Chemicon	MVY25VC100MF80	48-21002-502	1
C16	470u 16V Ax EL Cap	Jamicon	SKR470T1CG18	48-24701-651	1
C17	2,2n 5% 50V NPO 1206 NiSn	Philips	1206CG222J9BB-	46-32200-081	1
C18	33n 10% 50V X7R 0805 NiSn	Philips	08052R333K9BB00	46-43300-281	1
C19	2,2n 5% 50V NPO 1206 NiSn	Philips	1206CG222J9BB-	46-32200-081	1
C20	3,9n 5% 50V NPO 1206 NiSn	Philips	1206CG392J9BB0C	46-33900-080	1
C21	330p 5% 50V NPO 0603 NiSn	Phycomp	0603CG331J9B200	46-23300-083	1
C22	33n 10% 50V X7R 0805 NiSn	Philips	08052R333K9BB00	46-43300-281	1
C23	4,7n 5% 25V NPO 0805 NiSn	Phycomp	0805CG472J8BB00	46-34700-081	1
C24	4,7n 5% 25V NPO 0805 NiSn	Phycomp	0805CG472J8BB00	46-34700-081	1
C25	220p 5% 50V NPO 0603 NiSn	Philips	0603CG221C9BB00	46-22200-083	1
C26	33n 10% 50V X7R 0805 NiSn	Philips	08052R333K9BB00	46-43300-281	1
C27	33n 10% 50V X7R 0805 NiSn	Philips	08052R333K9BB00	46-43300-281	1

08-05986-001 - Audio PCB

BOM Revision
Date Valid On

05 -- Production
28.09.2006

Ref	Description	Manufacturer	Manufacturer's P/N	Codan P/N	Qty
C28	33n 10% 50V X7R 0805 NiSn	Philips	08052R333K9BB00	46-43300-281	1
C29	2,2n 5% 50V NPO 1206 NiSn	Philips	1206CG222J9BB-	46-32200-081	1
C30	2,2n 5% 50V NPO 1206 NiSn	Philips	1206CG222J9BB-	46-32200-081	1
C31	3,9n 5% 50V NPO 1206 NiSn	Philips	1206CG392J9BB0C	46-33900-080	1
C32	330p 5% 50V NPO 0603 NiSn	Phycomp	0603CG331J9B200	46-23300-083	1
C33	4,7n 5% 25V NPO 0805 NiSn	Phycomp	0805CG472J8BB00	46-34700-081	1
C34	4,7n 5% 25V NPO 0805 NiSn	Phycomp	0805CG472J8BB00	46-34700-081	1
C35	220p 5% 50V NPO 0603 NiSn	Philips	0603CG221C9BB00	46-22200-083	1
C36	10u 20% 25V 6032 TA Cap	AVX	TAJC106M025R	47-11002-520	1
C37	470p 5% 50V NPO 0805 NiSn	Philips	0805CG471J9B200	46-24700-081	1
C38	470p 5% 50V NPO 0805 NiSn	Philips	0805CG471J9B200	46-24700-081	1
C39	33n 10% 50V X7R 0805 NiSn	Philips	08052R333K9BB00	46-43300-281	1
C40	33n 10% 50V X7R 0805 NiSn	Philips	08052R333K9BB00	46-43300-281	1
C41	3,3n 10% 100V X7R 0603 NiSn	Vishay	VJ0603Y332KXBAC	46-33300-282	1
C42	3,3n 10% 100V X7R 0603 NiSn	Vishay	VJ0603Y332KXBAC	46-33300-282	1
C43	33n 10% 50V X7R 0805 NiSn	Philips	08052R333K9BB00	46-43300-281	1
C44	33n 10% 50V X7R 0805 NiSn	Philips	08052R333K9BB00	46-43300-281	1
C45	33n 10% 50V X7R 0805 NiSn	Philips	08052R333K9BB00	46-43300-281	1
C46	3,3n 10% 100V X7R 0603 NiSn	Vishay	VJ0603Y332KXBAC	46-33300-282	1
C47	3,3n 10% 100V X7R 0603 NiSn	Vishay	VJ0603Y332KXBAC	46-33300-282	1
C48	470p 5% 50V NPO 0805 NiSn	Philips	0805CG471J9B200	46-24700-081	1
C49	470p 5% 50V NPO 0805 NiSn	Philips	0805CG471J9B200	46-24700-081	1
C50	470p 5% 50V NPO 0805 NiSn	Philips	0805CG471J9B200	46-24700-081	1
C51	470p 5% 50V NPO 0805 NiSn	Philips	0805CG471J9B200	46-24700-081	1
C52	10u 20% 25V 6032 TA Cap	AVX	TAJC106M025R	47-11002-520	1
C53	10u 20% 25V 6032 TA Cap	AVX	TAJC106M025R	47-11002-520	1
C54	10u 20% 25V 6032 TA Cap	AVX	TAJC106M025R	47-11002-520	1
C55	470u 16V Ax EL Cap	Jamicon	SKR470T1CG18	48-24701-651	1
C56	100n 10% 50V X7R 0805 Nisn	Philips	08052R104K9BB	46-51000-282	1

08-05986-001 - Audio PCB

BOM Revision
Date Valid On

05 -- Production
28.09.2006

Ref	Description	Manufacturer	Manufacturer's P/N	Codan P/N	Qty
C57	100n 10% 50V X7R 0805 NiSn	Philips	08052R104K9BB	46-51000-282	1
C58	100n 10% 50V X7R 0805 NiSn	Philips	08052R104K9BB	46-51000-282	1
C59	100n 10% 50V X7R 0805 NiSn	Philips	08052R104K9BB	46-51000-282	1
C60	100n 10% 50V X7R 0805 NiSn	Philips	08052R104K9BB	46-51000-282	1
C61	3,3n 10% 100V X7R 0603 NiSn	Vishay	VJ0603Y332KXBAC	46-33300-282	1
C62	3,3n 10% 100V X7R 0603 NiSn	Vishay	VJ0603Y332KXBAC	46-33300-282	1
C63	3,3n 10% 100V X7R 0603 NiSn	Vishay	VJ0603Y332KXBAC	46-33300-282	1
C64	3,3n 10% 100V X7R 0603 NiSn	Vishay	VJ0603Y332KXBAC	46-33300-282	1
C65	3,3n 10% 100V X7R 0603 NiSn	Vishay	VJ0603Y332KXBAC	46-33300-282	1
C66	3,3n 10% 100V X7R 0603 NiSn	Vishay	VJ0603Y332KXBAC	46-33300-282	1
C67	3,3n 10% 100V X7R 0603 NiSn	Vishay	VJ0603Y332KXBAC	46-33300-282	1
C68	3,3n 10% 100V X7R 0603 NiSn	Vishay	VJ0603Y332KXBAC	46-33300-282	1
C69	3,3n 10% 100V X7R 0603 NiSn	Vishay	VJ0603Y332KXBAC	46-33300-282	1
C70	3,3n 10% 100V X7R 0603 NiSn	Vishay	VJ0603Y332KXBAC	46-33300-282	1
C71	3,3n 10% 100V X7R 0603 NiSn	Vishay	VJ0603Y332KXBAC	46-33300-282	1
C72	3,3n 10% 100V X7R 0603 NiSn	Vishay	VJ0603Y332KXBAC	46-33300-282	1
C73	3,3n 10% 100V X7R 0603 NiSn	Vishay	VJ0603Y332KXBAC	46-33300-282	1
C74	3,3n 10% 100V X7R 0603 NiSn	Vishay	VJ0603Y332KXBAC	46-33300-282	1
C75	220p 5% 50V NPO 0603 NiSn	Philips	0603CG221C9BB00	46-22200-083	1
C76	220p 5% 50V NPO 0603 NiSn	Philips	0603CG221C9BB00	46-22200-083	1
C77	22p 5% 100V NPO 0603 NiSn	Philips	0603CG220J0B200	46-12200-083	1
C78	22p 5% 100V NPO 0603 NiSn	Philips	0603CG220J0B200	46-12200-083	1
C79	100p 5% 50V NPO 0603 NiSn	Philips	0603CG101J9B200	46-21000-083	1
C80	1u 10% 16V X7R 1206 NiSn	Philips	12062R105K7BB00	46-61000-280	1
C81	10u 20% 25V 6032 TA Cap	AVX	TAJC106M025R	47-11002-520	1
D1	Diode, Si High speed 75V SOT23	Philips	BAS16	BAS16	1
D2	Diode, Si High speed 75V SOT23	Philips	BAS16	BAS16	1
D3	Diode, 400V 1A SMA	On Semiconductor	MRA4004T3	MRA4004T3	1
H1	LED, Tricolour T-1 3/4 Diffused	Liteon	LTL-52RG	65-61110-901	1

08-05986-001 - Audio PCB

BOM Revision
Date Valid On

05 -- Production
28.09.2006

Ref	Description	Manufacturer	Manufacturer's P/N	Codan P/N	Qty
H2	LED, Green PLCC SMD Non Diffused	Siemens	LGT670-L	65-61110-507	1
H3	LED, Green PLCC SMD Non Diffused	Siemens	LGT670-L	65-61110-507	1
IC1	EPLD prgmd, JB Audio 3V	Codan	90-20622-001	90-20622-001	1
IC2	Pot, 50k Digital Quad SOIC20	Xicor	X9241US	YN-09241-701	1
IC3	Amp, Audio Power 2x11w SIL9P	Philips	TDA1519C	TDA1519C	1
IC4	Amp, Operational Dual SOIC8	Texas Instruments	TL082CD	XA-00082-700	1
IC5	Amp, Operational Dual SOIC8	Texas Instruments	TL082CD	XA-00082-700	1
IC6	Amp, Op Dual Fast SOIC8	Texas Instruments	TLE2082CD	XA-02082-700	1
IC7	Amp, Operational Dual SOIC8	Texas Instruments	TL082CD	XA-00082-700	1
IC8	Amp, Op Dual Fast SOIC8	Texas Instruments	TLE2082CD	XA-02082-700	1
IC9	Switch, Analog Quad Fast SOIC16	Harris	DG445DY	YI-00445-700	1
IC10	Amp, Op Dual Fast SOIC8	Texas Instruments	TLE2082CD	XA-02082-700	1
IC11	Amp, Operational Dual SOIC8	Texas Instruments	TL082CD	XA-00082-700	1
IC12	Reg, Voltage +10V IC	National Semiconduct	LM2940T-10	XB-02940-402	1
IC13	Reg, Voltage +5V 0,1A SOIC8	National Semiconduct	LM78L05ACM	XB-07805-700	1
IC14	Reg, Voltage +3,3V 150mA LDO SOT23-5	Texas Instruments	TPS76333DBVT	XB-76333-700	1
K1	Relay, 2C 12V 2A SMD 1028 Ohm	Matsushita	TQ2SL-12V	64-21225-310	1
L1	Choke, EMI/EMC 0A DC >1MHz 4516	Taiyo Yuden	FCFBMJ 4516 HS 110-T	43-90003	1
L2	Choke, EMI/EMC 0A DC >1MHz 4516	Taiyo Yuden	FCFBMJ 4516 HS 110-T	43-90003	1
L3	Choke, EMI/EMC 0A DC >1MHz 4516	Taiyo Yuden	FCFBMJ 4516 HS 110-T	43-90003	1
L4	Choke, EMI/EMC 0A DC >1MHz 4516	Taiyo Yuden	FCFBMJ 4516 HS 110-T	43-90003	1
L5	Choke, Common Mode (Data) SMD	Taiyo Yuden	CM04RC04	43-82470-000	1
L6	Choke, Common Mode (Data) SMD	Taiyo Yuden	CM04RC04	43-82470-000	1
L7	Choke, Common Mode (Data) SMD	Taiyo Yuden	CM04RC04	43-82470-000	1
L8	Choke, Common Mode (Data) SMD	Taiyo Yuden	CM04RC04	43-82470-000	1
L9	Choke, EMI/EMC 0A DC >1MHz 4516	Taiyo Yuden	FCFBMJ 4516 HS 110-T	43-90003	1
L10	Ind, Common Mode 5.5A	Taiyo Yuden	CMO8RA20	43-80001	1
P1	Header (P) 34way 2row Boxed Fix	Thomas & Betts	609-3427	60-00340-001	1
P2	Header (P) 10way 2mm Latch Fixed	AMP	1-173981-0	60-00100-351	1
P3	Header (P) 10way 2mm Latch Fixed	AMP	1-173981-0	60-00100-351	1
P4	Not Fitted	Codan	** -00000-001	99-00000-001	1

08-05986-001 - Audio PCB

BOM Revision
Date Valid On

05 -- Production
28.09.2006

Ref	Description	Manufacturer	Manufacturer's P/N	Codan P/N	Qty
P5	Header (P) 10way 2row thin insul	Berg	67997-410H	60-00100-002	1
P6	Header (P) 4way 2mm Latch Fixed	AMP	173981-4	60-00040-352	1
P7	Header (P) 8way 2mm Latch Fixed	AMP	292161-8	60-00080-001	1
P8	Header (P) 3way 1row	Molex	22-03-2031	60-00031-100	1
P9	Header (P) 3way 1row	Molex	22-03-2031	60-00031-100	1
P10	Header (P) 16way 2row Boxed SMD 2,54mm	Neltron	2316SMD-16G	60-00160-003	1
P11	Header (P) 10way 2row thin insul	Berg	67997-410H	60-00100-002	1
R1	4,7k Ohm 5% 0,06W 0603	Philips	2322 702 60472	40-34700-121	1
R2	2,2k Ohm 5% 0,06W 0603	Philips	2322 702 60222	40-32200-121	1
R7	2,2k Ohm 5% 0,06W 0603	Philips	2322 702 60222	40-32200-121	1
R8	33 Ohm 5% 0,06W 0603	Philips	2322 702 60339	40-13300-121	1
R9	2,2k Ohm 5% 0,06W 0603	Philips	2322 702 60222	40-32200-121	1
R10	270 Ohm 5% 0,06W 0603	Philips	2322 702 60271	40-22700-121	1
R11	2,2k Ohm 5% 0,06W 0603	Philips	2322 702 60222	40-32200-121	1
R12	2,2k Ohm 5% 0,06W 0603	Philips	2322 702 60222	40-32200-121	1
R13	2,2k Ohm 5% 0,06W 0603	Philips	2322 702 60222	40-32200-121	1
R14	100 Ohm 5% 0,06W 0603	Philips	2322 702 60101	40-21000-121	1
R15	100 Ohm 5% 0,06W 0603	Philips	2322 702 60101	40-21000-121	1
R16	100 Ohm 5% 0,06W 0603	Philips	2322 702 60101	40-21000-121	1
R17	1k Ohm 5% 0,06W 0603	Philips	2322 702 60102	40-31000-121	1
R18	100 Ohm 5% 0,06W 0603	Philips	2322 702 60101	40-21000-121	1
R19	10k Ohm 5% 0,06W 0603	Philips	2322 702 60103	40-41000-121	1
R20	18k Ohm 1% 0,06W 0603	Philips	2322 704 61803	40-41800-125	1
R21	33 Ohm 5% 0,06W 0603	Philips	2322 702 60339	40-13300-121	1
R22	4,7k Ohm 5% 0,06W 0603	Philips	2322 702 60472	40-34700-121	1
R23	51k Ohm 5% 0,1W 0805	Philips	2322 730 61513	40-45100-111	1
R24	33 Ohm 5% 0,06W 0603	Philips	2322 702 60339	40-13300-121	1
R25	51k Ohm 5% 0,1W 0805	Philips	2322 730 61513	40-45100-111	1
R27	51k Ohm 5% 0,1W 0805	Philips	2322 730 61513	40-45100-111	1
R28	100 Ohm 5% 0,06W 0603	Philips	2322 702 60101	40-21000-121	1

08-05986-001 - Audio PCB

BOM Revision
Date Valid On

05 -- Production
28.09.2006

Ref	Description	Manufacturer	Manufacturer's P/N	Codan P/N	Qty
R29	33k Ohm 5% 0,06W 0603	Philips	2322 702 60333	40-43300-121	1
R30	33k Ohm 5% 0,06W 0603	Philips	2322 702 60333	40-43300-121	1
R31	18k Ohm 1% 0,06W 0603	Philips	2322 704 61803	40-41800-125	1
R32	1,5k Ohm 5% 0,06W 0603	Philips	2322 702 60152	40-31500-121	1
R33	1,5k Ohm 5% 0,06W 0603	Philips	2322 702 60152	40-31500-121	1
R34	18k Ohm 1% 0,06W 0603	Philips	2322 704 61803	40-41800-125	1
R35	4,7k Ohm 5% 0,06W 0603	Philips	2322 702 60472	40-34700-121	1
R36	10k Ohm 5% 0,06W 0603	Philips	2322 702 60103	40-41000-121	1
R37	22k Ohm 5% 0,06W 0603	Philips	2322 702 60223	40-42200-121	1
R38	22k Ohm 5% 0,06W 0603	Philips	2322 702 60223	40-42200-121	1
R39	10k Ohm 5% 0,06W 0603	Philips	2322 702 60103	40-41000-121	1
R40	51k Ohm 5% 0,1W 0805	Philips	2322 730 61513	40-45100-111	1
R42	51k Ohm 5% 0,1W 0805	Philips	2322 730 61513	40-45100-111	1
R44	51k Ohm 5% 0,1W 0805	Philips	2322 730 61513	40-45100-111	1
R46	33k Ohm 5% 0,06W 0603	Philips	2322 702 60333	40-43300-121	1
R47	33k Ohm 5% 0,06W 0603	Philips	2322 702 60333	40-43300-121	1
R48	22k Ohm 5% 0,06W 0603	Philips	2322 702 60223	40-42200-121	1
R49	22k Ohm 5% 0,06W 0603	Philips	2322 702 60223	40-42200-121	1
R50	22k Ohm 5% 0,06W 0603	Philips	2322 702 60223	40-42200-121	1
R51	22k Ohm 5% 0,06W 0603	Philips	2322 702 60223	40-42200-121	1
R52	10k Ohm 5% 0,06W 0603	Philips	2322 702 60103	40-41000-121	1
R53	18k Ohm 1% 0,06W 0603	Philips	2322 704 61803	40-41800-125	1
R54	1,8k Ohm 5% 0,06W 0603	Philips	2322 702 60182	40-31800-121	1
R55	47k Ohm 5% 0,06W 0603	Philips	2322 702 60473	40-44700-121	1
R56	10k Ohm 1% 0,06W 0603	Phycomp	2322 704 61003	40-41000-125	1
R57	47k Ohm 5% 0,06W 0603	Philips	2322 702 60473	40-44700-121	1
R58	47k Ohm 5% 0,06W 0603	Philips	2322 702 60473	40-44700-121	1
R59	47k Ohm 5% 0,06W 0603	Philips	2322 702 60473	40-44700-121	1
R60	22k Ohm 5% 0,06W 0603	Philips	2322 702 60223	40-42200-121	1

08-05986-001 - Audio PCB

BOM Revision
Date Valid On

05 -- Production
28.09.2006

Ref	Description	Manufacturer	Manufacturer's P/N	Codan P/N	Qty
R61	47k Ohm 5% 0,06W 0603	Philips	2322 702 60473	40-44700-121	1
R62	47k Ohm 5% 0,06W 0603	Philips	2322 702 60473	40-44700-121	1
R63	22k Ohm 5% 0,06W 0603	Philips	2322 702 60223	40-42200-121	1
R65	33k Ohm 5% 0,06W 0603	Philips	2322 702 60333	40-43300-121	1
R66	33k Ohm 5% 0,06W 0603	Philips	2322 702 60333	40-43300-121	1
R67	33k Ohm 5% 0,06W 0603	Philips	2322 702 60333	40-43300-121	1
R68	1k Ohm 5% 0,06W 0603	Philips	2322 702 60102	40-31000-121	1
R69	1k Ohm 5% 0,06W 0603	Philips	2322 702 60102	40-31000-121	1
R70	1k Ohm 5% 0,06W 0603	Philips	2322 702 60102	40-31000-121	1
R71	1k Ohm 5% 0,06W 0603	Philips	2322 702 60102	40-31000-121	1
R72	100 Ohm 5% 0,06W 0603	Philips	2322 702 60101	40-21000-121	1
R73	100 Ohm 5% 0,06W 0603	Philips	2322 702 60101	40-21000-121	1
R74	100 Ohm 5% 0,06W 0603	Philips	2322 702 60101	40-21000-121	1
R75	100 Ohm 5% 0,06W 0603	Philips	2322 702 60101	40-21000-121	1
R76	100 Ohm 5% 0,06W 0603	Philips	2322 702 60101	40-21000-121	1
R77	100 Ohm 5% 0,06W 0603	Philips	2322 702 60101	40-21000-121	1
R78	100 Ohm 5% 0,06W 0603	Philips	2322 702 60101	40-21000-121	1
R79	100 Ohm 5% 0,06W 0603	Philips	2322 702 60101	40-21000-121	1
R80	100 Ohm 5% 0,06W 0603	Philips	2322 702 60101	40-21000-121	1
R81	100 Ohm 5% 0,06W 0603	Philips	2322 702 60101	40-21000-121	1
R82	33k Ohm 5% 0,06W 0603	Philips	2322 702 60333	40-43300-121	1
R83	1M Ohm 5% 0,06W 0603	Philips	2322 702 60105	40-61000-121	1
R84	1k Ohm 5% 0,06W 0603	Philips	2322 702 60102	40-31000-121	1
R85	1M Ohm 5% 0,06W 0603	Philips	2322 702 60105	40-61000-121	1
R86	1M Ohm 5% 0,06W 0603	Philips	2322 702 60105	40-61000-121	1
T1	Txfr, Line isolation SMD	Etal	P2781	43-30002	1
V1	Transistor, NPN Si SOT23	Philips	BFR92A	BFR92A	1
V2	Transistor, PNP Si SOT23	Philips	BC858	BC858	1
V3	Transistor, PNP Si SOT23	Philips	BC858	BC858	1

08-05986-001 - Audio PCB

BOM Revision
Date Valid On

05 -- Production
28.09.2006

Ref	Description	Manufacturer	Manufacturer's P/N	Codan P/N	Qty
V4	Transistor, NPN Si SOT23	Philips	BC848	BC848	1
V5	Transistor, NPN Si SOT23	Philips	BC848	BC848	1
Z1	Crystal, 16000 kHz uP Grade	HY-Q	QC49/SMD	65-90103	1

08-05317-001 - MicroP PCB

BOM Revision
Date Valid On

15 -- Production
27.09.2006

Ref	Description	Manufacturer	Manufacturer's P/N	Codan P/N	Qty
	Build Standard, 2030			01-01250	1
	Microprocessor PCB			08-05317	1
	MicroP			04-03133	1
	Micro Processor PCB			11-06075	1
1	PCB, MicroP	IMP	07-01767-09	07-01767-09	1
2	Cable, Ribbon, Micro - Audio	Auto Assemblies	08-05625-001	08-05625-001	1
3	Label, Serial/Barcode	Codan	06-02068	06-02068	1
4	Header (P) 10way 2row thin insul	Berg	67997-410H	60-00100-002	1
C1	10p 5% 50V NPO 0805 NiSn	Philips	0805CG100J9B200	46-11000-081	1
C2	33n 10% 50V X7R 0805 NiSn	Philips	08052R333K9BB00	46-43300-281	1
C3	10p 5% 50V NPO 0805 NiSn	Philips	0805CG100J9B200	46-11000-081	1
C4	33n 10% 50V X7R 0805 NiSn	Philips	08052R333K9BB00	46-43300-281	1
C5	33n 10% 50V X7R 0805 NiSn	Philips	08052R333K9BB00	46-43300-281	1
C6	33n 10% 50V X7R 0805 NiSn	Philips	08052R333K9BB00	46-43300-281	1
C7	100n 10% 50V X7R 0805 Nisn	Philips	08052R104K9BB	46-51000-282	1
C8	27p 5% 50V NPO 0805 NiSn	Philips	0805CG270J9B200	46-12700-080	1
C9	27p 5% 50V NPO 0805 NiSn	Philips	0805CG270J9B200	46-12700-080	1
C10	33n 10% 50V X7R 0805 NiSn	Philips	08052R333K9BB00	46-43300-281	1
C11	33n 10% 50V X7R 0805 NiSn	Philips	08052R333K9BB00	46-43300-281	1
C12	100n 10% 50V X7R 0805 Nisn	Philips	08052R104K9BB	46-51000-282	1
C13	100n 10% 50V X7R 0805 Nisn	Philips	08052R104K9BB	46-51000-282	1
C14	100n 10% 50V X7R 0805 Nisn	Philips	08052R104K9BB	46-51000-282	1
C15	33n 10% 50V X7R 0805 NiSn	Philips	08052R333K9BB00	46-43300-281	1
C16	100n 10% 50V X7R 0805 Nisn	Philips	08052R104K9BB	46-51000-282	1
C17	1u 10% 16V X7R 1206 NiSn	Philips	12062R105K7BB00	46-61000-280	1
C18	1u 10% 16V X7R 1206 NiSn	Philips	12062R105K7BB00	46-61000-280	1
C19	33n 10% 50V X7R 0805 NiSn	Philips	08052R333K9BB00	46-43300-281	1
C20	33n 10% 50V X7R 0805 NiSn	Philips	08052R333K9BB00	46-43300-281	1
C21	33n 10% 50V X7R 0805 NiSn	Philips	08052R333K9BB00	46-43300-281	1
C22	33n 10% 50V X7R 0805 NiSn	Philips	08052R333K9BB00	46-43300-281	1
C23	33n 10% 50V X7R 0805 NiSn	Philips	08052R333K9BB00	46-43300-281	1
C24	33n 10% 50V X7R 0805 NiSn	Philips	08052R333K9BB00	46-43300-281	1

08-05317-001 - MicroP PCB

BOM Revision
Date Valid On

15 -- Production
27.09.2006

Ref	Description	Manufacturer	Manufacturer's P/N	Codan P/N	Qty
C25	33n 10% 50V X7R 0805 NiSn	Philips	08052R333K9BB00	46-43300-281	1
C26	1u 10% 16V X7R 1206 NiSn	Philips	12062R105K7BB00	46-61000-280	1
D1	Diode, Si High speed 75V SOT23	Philips	BAS16	BAS16	1
D3	Diode, Si High speed 75V SOT23	Philips	BAS16	BAS16	1
D4	Diode, Si High speed 75V SOT23	Philips	BAS16	BAS16	1
H1	Not Fitted	Codan	**_00000-001	99-00000-001	1
H2	Not Fitted	Codan	**_00000-001	99-00000-001	1
H3	Not Fitted	Codan	**_00000-001	99-00000-001	1
H4	Not Fitted	Codan	**_00000-001	99-00000-001	1
IC1	MicroC, 16 Bit CMOS QFP20112	Hitachi	HD6413003TF16	YP-83003-700	1
IC2	Monitor, Micro SOIC8	Dallas	DS1232LPS-2	XD-01232-700	1
IC3	Serial Number, 48 bit SOT223	Dallas	DS2401Z	YM-02401-700	1
IC4	FLASH prgmd, Junction Box	Braemac	90-20596-001	90-20596-001	1
IC5	Gate, AND 2 Input Quad SOIC14	Motorola	MC74HC08AD	YH-74008-700	1
IC7	Buffer, Hex inverting schmitt SOIC14	Motorola	MC74AC14D	YS-74014-700	1
IC8	SRAM, CMOS 256k x 16 Bit 20ns SOJ44	Alliance	AS7C4098-20JC	YM-74098-700	1
IC9	DTMF Tone Generator SOIC8	Philips	PCD3312CT-118	XE-03312-700	1
IC10	DUART, CMOS PLCC44	Philips	SC26C92C1A	YK-02692-900	1
IC11	Cntrl, CAN bus 2,0B SOIC28	Philips	SJA1000T/N1	YL-81000-700	1
IC12	Tcvr, RS232 6Tx / 10Rx ESD PROT TSSOP38	Maxim	MAX3209ECUU	YI-03209-700	1
IC13	Reg, Voltage +5V 1A TO263_3	National Semiconduct	LM7805S	XB-07805-701	1
IC14	Tcvr, CAN bus SOIC8	Philips	PCA82C250T	YI-82250-700	1
IC15	Tcvr, CAN bus SOIC8	Philips	PCA82C250T	YI-82250-700	1
IC16	FLASH, Serial 512k x 8 Bit 3V SOIC8	Atmel	AT45DB041B-SC	YM-45041-700	1
P1	Not Fitted	Codan	**_00000-001	99-00000-001	1
P3	Not Fitted	Codan	**_00000-001	99-00000-001	1
R1	18k Ohm 5% 0,1W 0805	Philips	2322 730 61183	40-41800-111	1
R2	10k Ohm 5% 0,1W 0805	Philips	2322-730-61103	40-41000-111	1
R3	33k Ohm 5% 0,1W 0805	Philips	2322 730 61333	40-43300-111	1
R4	33k Ohm 5% 0,1W 0805	Philips	2322 730 61333	40-43300-111	1
R6	33k Ohm 5% 0,1W 0805	Philips	2322 730 61333	40-43300-111	1
R7	4,7k Ohm 5% 0,1W 0805	Philips	2322 730 61472	40-34700-111	1

08-05317-001 - MicroP PCB

BOM Revision
Date Valid On

15 -- Production
27.09.2006

Ref	Description	Manufacturer	Manufacturer's P/N	Codan P/N	Qty
R8	33k Ohm 5% 0,1W 0805	Philips	2322 730 61333	40-43300-111	1
R9	33k Ohm 5% 0,1W 0805	Philips	2322 730 61333	40-43300-111	1
R10	4,7k Ohm 5% 0,1W 0805	Philips	2322 730 61472	40-34700-111	1
R11	4,7k Ohm 5% 0,1W 0805	Philips	2322 730 61472	40-34700-111	1
R12	4,7k Ohm 5% 0,1W 0805	Philips	2322 730 61472	40-34700-111	1
R13	33k Ohm 5% 0,1W 0805	Philips	2322 730 61333	40-43300-111	1
R14	33k Ohm 5% 0,1W 0805	Philips	2322 730 61333	40-43300-111	1
R15	33k Ohm 5% 0,1W 0805	Philips	2322 730 61333	40-43300-111	1
R16	100 Ohm 5% 0,1W 0805	Philips	2322 730 61101	40-21000-111	1
R17	33k Ohm 5% 0,1W 0805	Philips	2322 730 61333	40-43300-111	1
R18	33k Ohm 5% 0,1W 0805	Philips	2322 730 61333	40-43300-111	1
R19	33k Ohm 5% 0,1W 0805	Philips	2322 730 61333	40-43300-111	1
R20	33k Ohm 5% 0,1W 0805	Philips	2322 730 61333	40-43300-111	1
R21	1k Ohm 5% 0,1W 0805	Philips	2322-730-61102	40-31000-111	1
R22	1k Ohm 5% 0,1W 0805	Philips	2322-730-61102	40-31000-111	1
R23	1k Ohm 5% 0,1W 0805	Philips	2322-730-61102	40-31000-111	1
R24	1k Ohm 5% 0,1W 0805	Philips	2322-730-61102	40-31000-111	1
R25	1k Ohm 5% 0,1W 0805	Philips	2322-730-61102	40-31000-111	1
R26	2,2k Ohm 5% 0,1W 0805	Philips	2322 730 61222	40-32200-111	1
R27	1k Ohm 5% 0,1W 0805	Philips	2322-730-61102	40-31000-111	1
R28	470 Ohm 5% 0,1W 0805	Philips	2322 730 61471	40-24700-111	1
R29	2,2k Ohm 5% 0,1W 0805	Philips	2322 730 61222	40-32200-111	1
R30	100 Ohm 5% 0,1W 0805	Philips	2322 730 61101	40-21000-111	1
R31	2,2k Ohm 5% 0,1W 0805	Philips	2322 730 61222	40-32200-111	1
R33	10k Ohm 5% 0,1W 0805	Philips	2322-730-61103	40-41000-111	1
R34	2,2k Ohm 5% 0,1W 0805	Philips	2322 730 61222	40-32200-111	1
R35	100 Ohm 5% 0,1W 0805	Philips	2322 730 61101	40-21000-111	1
R36	33k Ohm 5% 0,1W 0805	Philips	2322 730 61333	40-43300-111	1
R37	33k Ohm 5% 0,1W 0805	Philips	2322 730 61333	40-43300-111	1

08-05317-001 - MicroP PCB

BOM Revision
Date Valid On

15 -- Production
27.09.2006

Ref	Description	Manufacturer	Manufacturer's P/N	Codan P/N	Qty
R38	33k Ohm 5% 0,1W 0805	Philips	2322 730 61333	40-43300-111	1
R39	33k Ohm 5% 0,1W 0805	Philips	2322 730 61333	40-43300-111	1
R40	33k Ohm 5% 0,1W 0805	Philips	2322 730 61333	40-43300-111	1
R41	33k Ohm 5% 0,1W 0805	Philips	2322 730 61333	40-43300-111	1
R42	33k Ohm 5% 0,1W 0805	Philips	2322 730 61333	40-43300-111	1
R43	100 Ohm 5% 0,1W 0805	Philips	2322 730 61101	40-21000-111	1
R44	33k Ohm 5% 0,1W 0805	Philips	2322 730 61333	40-43300-111	1
R45	10k Ohm 5% 0,1W 0805	Philips	2322-730-61103	40-41000-111	1
R46	10k Ohm 5% 0,1W 0805	Philips	2322-730-61103	40-41000-111	1
R47	10k Ohm 5% 0,1W 0805	Philips	2322-730-61103	40-41000-111	1
R48	10k Ohm 5% 0,1W 0805	Philips	2322-730-61103	40-41000-111	1
R49	10k Ohm 5% 0,1W 0805	Philips	2322-730-61103	40-41000-111	1
R50	10k Ohm 5% 0,1W 0805	Philips	2322-730-61103	40-41000-111	1
R51	33k Ohm 5% 0,1W 0805	Philips	2322 730 61333	40-43300-111	1
R52	100 Ohm 5% 0,1W 0805	Philips	2322 730 61101	40-21000-111	1
V1	Transistor, NPN Si SOT23	Philips	BC848	BC848	1
V2	Diode, Zener 3,3V 5% 0,2W SOT23	Philips	BZX84-C3V3	BZX84C3V3	1
V3	Transistor, NPN Si SOT23	Philips	BC848	BC848	1
V4	Diode, Zener 12V 5% 0,2W SOT23	Philips	BZX84-C12	BZX84C12	1
Z1	Crystal, 16000 kHz uP Grade	HY-Q	QC49/SMD	65-90103	1
Z2	Crystal, 3686,4 kHz uP Grade	HY-Q	M/P QC49/SMD EBO1C	65-90101	1

08-05266-001 - Audio I/F PCB

BOM Revision
Date Valid On

13 -- Production
27.09.2006

Ref	Description	Manufacturer	Manufacturer's P/N	Codan P/N	Qty
	Audio I/F PCB			11-06072	1
	PTP, RF Unit Audio PCB			10-50033	1
	Audio Interface PCB			08-05266	1
	Audio I/F			04-03109	1
	Build Standard, 2010			01-01252	1
	Sleeve, Sil Rubber 6x0,5 Any Col	Jones Stroud	71-80605-199	71-80605-199	0.01
1	PCB, Audio I/F	Entech	07-01742-06	07-01742-06	1
2	Label, Serial/Barcode	Codan	06-02068	06-02068	1
3	Tape, EPDM Rubber foam 12mmx3mm	Beirsdorf	TESA 61102	30-39301-002	15
C1	470p 5% 50V NPO 1206 NiSn	Philips	1206CG471J9BB-	46-24700-080	1
C2	33n 10% 100V X7R 1206 NiSn	Philips	12062R333K0BB-	46-43300-280	1
C3	33n 10% 100V X7R 1206 NiSn	Philips	12062R333K0BB-	46-43300-280	1
C4	1n 5% 50V NPO 1206 NiSn	Philips	1206CG102J9BB-	46-31000-081	1
C5	3,3n 10% 100V X7R 1206 NiSn	Philips	12062R332K0BB-	46-33300-280	1
C6	33n 10% 100V X7R 1206 NiSn	Philips	12062R333K0BB-	46-43300-280	1
C7	100p 5% 50V NPO 1206 NiSn	Philips	1206CG101J9BB-	46-21000-080	1
C8	100p 5% 50V NPO 1206 NiSn	Philips	1206CG101J9BB-	46-21000-080	1
C9	100p 5% 50V NPO 1206 NiSn	Philips	1206CG101J9BB-	46-21000-080	1
C10	100p 5% 50V NPO 1206 NiSn	Philips	1206CG101J9BB-	46-21000-080	1
C11	33n 10% 100V X7R 1206 NiSn	Philips	12062R333K0BB-	46-43300-280	1
C12	1n 5% 50V NPO 1206 NiSn	Philips	1206CG102J9BB-	46-31000-081	1
C13	1n 5% 50V NPO 1206 NiSn	Philips	1206CG102J9BB-	46-31000-081	1
C14	100n 10% 50V X7R 1206 NiSn	Philips	12062R104K9BB-	46-51000-281	1
C15	22u 20% 16V 5846 TA Cap	NEC	NRT226M16R	47-12201-620	1
C16	10u 20% 25V 6032 TA Cap	AVX	TAJC106M025R	47-11002-520	1
C17	470p 5% 50V NPO 1206 NiSn	Philips	1206CG471J9BB-	46-24700-080	1
C18	470p 5% 50V NPO 1206 NiSn	Philips	1206CG471J9BB-	46-24700-080	1
C19	100n 10% 50V X7R 1206 NiSn	Philips	12062R104K9BB-	46-51000-281	1
C20	470p 5% 50V NPO 1206 NiSn	Philips	1206CG471J9BB-	46-24700-080	1
C21	2,2n 5% 50V NPO 1206 NiSn	Philips	1206CG222J9BB-	46-32200-081	1
C22	2,2n 5% 50V NPO 1206 NiSn	Philips	1206CG222J9BB-	46-32200-081	1
C23	3,9n 5% 50V NPO 1206 NiSn	Philips	1206CG392J9BB0C	46-33900-080	1

08-05266-001 - Audio I/F PCB

BOM Revision
Date Valid On

13 -- Production
27.09.2006

Ref	Description	Manufacturer	Manufacturer's P/N	Codan P/N	Qty
C24	330p 5% 50V NPO 1206 NiSn	Philips	1206CG331J9BB-	46-23300-080	1
C25	4,7n 5% 50V NPO 1206 NiSn	Philips	1206CG472J9BB0C	46-34700-080	1
C26	4,7n 5% 50V NPO 1206 NiSn	Philips	1206CG472J9BB0C	46-34700-080	1
C27	220p 5% 50V NPO 1206 NiSn	Philips	1206CG221J9BB-	46-22200-080	1
C28	1u 20% 35V 3528 TA Cap	AVX	TAJB105M035R	47-01003-520	1
C29	10u 20% 25V 6032 TA Cap	AVX	TAJC106M025R	47-11002-520	1
C30	10u 20% 25V 6032 TA Cap	AVX	TAJC106M025R	47-11002-520	1
C31	10u 20% 25V 6032 TA Cap	AVX	TAJC106M025R	47-11002-520	1
C32	100n 10% 50V X7R 1206 NiSn	Philips	12062R104K9BB-	46-51000-281	1
C33	10u 20% 25V 6032 TA Cap	AVX	TAJC106M025R	47-11002-520	1
C34	10u 20% 25V 6032 TA Cap	AVX	TAJC106M025R	47-11002-520	1
C35	1u 20% 35V 3528 TA Cap	AVX	TAJB105M035R	47-01003-520	1
C36	1u 20% 35V 3528 TA Cap	AVX	TAJB105M035R	47-01003-520	1
C37	33n 10% 100V X7R 1206 NiSn	Philips	12062R333K0BB-	46-43300-280	1
C38	100u 25V Ax EL Cap	Elna	RB	48-21002-551	1
C39	33n 10% 100V X7R 1206 NiSn	Philips	12062R333K0BB-	46-43300-280	1
C40	33n 10% 100V X7R 1206 NiSn	Philips	12062R333K0BB-	46-43300-280	1
C41	33n 10% 100V X7R 1206 NiSn	Philips	12062R333K0BB-	46-43300-280	1
C42	33n 10% 100V X7R 1206 NiSn	Philips	12062R333K0BB-	46-43300-280	1
C43	22p 5% 50V NPO 1206 NiSn	Philips	1206CG220J9BB-	46-12200-080	1
C44	33n 10% 100V X7R 1206 NiSn	Philips	12062R333K0BB-	46-43300-280	1
C45	33n 10% 100V X7R 1206 NiSn	Philips	12062R333K0BB-	46-43300-280	1
C46	1n 5% 50V NPO 1206 NiSn	Philips	1206CG102J9BB-	46-31000-081	1
C47	220p 5% 50V NPO 1206 NiSn	Philips	1206CG221J9BB-	46-22200-080	1
C48	220p 5% 50V NPO 1206 NiSn	Philips	1206CG221J9BB-	46-22200-080	1
C49	10u 20% 25V 6032 TA Cap	AVX	TAJC106M025R	47-11002-520	1
C50	33n 10% 100V X7R 1206 NiSn	Philips	12062R333K0BB-	46-43300-280	1
C51	1n 5% 50V NPO 1206 NiSn	Philips	1206CG102J9BB-	46-31000-081	1
C52	33n 10% 100V X7R 1206 NiSn	Philips	12062R333K0BB-	46-43300-280	1

08-05266-001 - Audio I/F PCB

BOM Revision
Date Valid On

13 -- Production
27.09.2006

Ref	Description	Manufacturer	Manufacturer's P/N	Codan P/N	Qty
C53	33n 10% 100V X7R 1206 NiSn	Philips	12062R333K0BB-	46-43300-280	1
C54	33n 10% 100V X7R 1206 NiSn	Philips	12062R333K0BB-	46-43300-280	1
C55	33n 10% 100V X7R 1206 NiSn	Philips	12062R333K0BB-	46-43300-280	1
C56	100n 10% 50V X7R 1206 NiSn	Philips	12062R104K9BB-	46-51000-281	1
C57	1u 20% 35V 3528 TA Cap	AVX	TAJB105M035R	47-01003-520	1
C58	470p 5% 50V NPO 1206 NiSn	Philips	1206CG471J9BB-	46-24700-080	1
C59	33n 10% 100V X7R 1206 NiSn	Philips	12062R333K0BB-	46-43300-280	1
C60	100n 10% 50V X7R 1206 NiSn	Philips	12062R104K9BB-	46-51000-281	1
C61	33n 10% 100V X7R 1206 NiSn	Philips	12062R333K0BB-	46-43300-280	1
C62	3,3n 10% 100V X7R 1206 NiSn	Philips	12062R332K0BB-	46-33300-280	1
C63	1n 5% 50V NPO 1206 NiSn	Philips	1206CG102J9BB-	46-31000-081	1
C64	10u 20% 25V 6032 TA Cap	AVX	TAJC106M025R	47-11002-520	1
C65	1u 20% 35V 3528 TA Cap	AVX	TAJB105M035R	47-01003-520	1
C66	1n 5% 50V NPO 1206 NiSn	Philips	1206CG102J9BB-	46-31000-081	1
C67	1n 5% 50V NPO 1206 NiSn	Philips	1206CG102J9BB-	46-31000-081	1
C68	100p 5% 50V NPO 1206 NiSn	Philips	1206CG101J9BB-	46-21000-080	1
C69	100p 5% 50V NPO 1206 NiSn	Philips	1206CG101J9BB-	46-21000-080	1
C70	100p 5% 50V NPO 1206 NiSn	Philips	1206CG101J9BB-	46-21000-080	1
C71	100p 5% 50V NPO 1206 NiSn	Philips	1206CG101J9BB-	46-21000-080	1
C72	33n 10% 100V X7R 1206 NiSn	Philips	12062R333K0BB-	46-43300-280	1
C73	220p 5% 50V NPO 1206 NiSn	Philips	1206CG221J9BB-	46-22200-080	1
C74	220p 5% 50V NPO 1206 NiSn	Philips	1206CG221J9BB-	46-22200-080	1
C75	1u 20% 35V 3528 TA Cap	AVX	TAJB105M035R	47-01003-520	1
C76	220p 5% 50V NPO 1206 NiSn	Philips	1206CG221J9BB-	46-22200-080	1
C77	1n 5% 50V NPO 1206 NiSn	Philips	1206CG102J9BB-	46-31000-081	1
C78	1n 5% 50V NPO 1206 NiSn	Philips	1206CG102J9BB-	46-31000-081	1
D1	Diode, Si High speed 75V SOT23	Philips	BAS16	BAS16	1
D2	Diode, Si High speed 75V SOT23	Philips	BAS16	BAS16	1
D3	Diode, Si High speed 75V SOT23	Philips	BAS16	BAS16	1

08-05266-001 - Audio I/F PCB

BOM Revision
Date Valid On

13 -- Production
27.09.2006

Ref	Description	Manufacturer	Manufacturer's P/N	Codan P/N	Qty
D4	Diode, Si High speed 75V SOT23	Philips	BAS16	BAS16	1
D5	Diode, Schottky SOT23	Philips	BAT54	BAT54	1
D6	Diode, Schottky SOT23	Philips	BAT54	BAT54	1
D7	Diode, Si High speed 75V SOT23	Philips	BAS16	BAS16	1
D8	Diode, Schottky SOT23	Philips	BAT54	BAT54	1
D9	Diode, Si High speed 75V SOT23	Philips	BAS16	BAS16	1
D10	Diode, Si High speed 75V SOT23	Philips	BAS16	BAS16	1
G1	Cell, Lithium 3V, 35mAh PCB Mtg	National Semiconduct	BR1225-1VD	65-71000-002	1
H1	LED, Tricolour T-1 3/4 Diffused	Liteon	LTL-52RG	65-61110-901	1
IC1	Switch, Analog Quad Fast SOIC16	Harris	DG445DY	YI-00445-700	1
IC2	Amp, Op Dual Fast SOIC8	Texas Instruments	TLE2082CD	XA-02082-700	1
IC3	Amp, Op Dual Fast SOIC8	Texas Instruments	TLE2082CD	XA-02082-700	1
IC4	Reg, Voltage +5V 0,1A SOIC8	National Semiconduct	LM78L05ACM	XB-07805-700	1
IC5	Tcvt, CAN bus SOIC8	Philips	PCA82C250T	YI-82250-700	1
IC6	Switch, Analog Quad Fast SOIC16	Harris	DG445DY	YI-00445-700	1
IC7	Amp, Op Dual Fast SOIC8	Texas Instruments	TLE2082CD	XA-02082-700	1
IC8	Amp, Op Dual Fast SOIC8	Texas Instruments	TLE2082CD	XA-02082-700	1
IC9	Reg, Voltage +10V LVD 1A TO263_3	National Semiconduct	LM2940S-10	XB-02940-700	1
IC10	Reg, Voltage +5V 1A TO263_3	National Semiconduct	LM7805S	XB-07805-701	1
IC11	EPLD prgmd, RFU Audio	Codan	90-20588-001	90-20588-001	1
IC12	Micro prgmd, RFU Audio I/O	Codan	90-20591-001	90-20591-001	1
IC13	Clock/Calendar/RAM IIC Bus SOIC8	SGS Thomson	MK41T56S00TR	YK-04156-700	1
IC14	MOSFET, high side switch 4A SOT426	Philips	BUK207-50Y	BUK207-50Y	1
IC15	Comparator, Quad O/C Output SOIC14	National Semiconduct	LM339M	XD-00339-700	1
IC16	Amp, Operational Dual SOIC8	National Semiconduct	LM358M	XA-00358-700	1
K1	Relay, 2C 9V Ltch SMD 2x579 Ohm	Matsushita	TQ2SL-L2-9V	64-21225-258	1
L1	Choke, Common Mode (Data) SMD	Taiyo Yuden	CM04RC04	43-82470-000	1
L2	Choke, EMI/EMC 0A DC >1MHz 4516	Taiyo Yuden	FCFBMJ 4516 HS 110- T	43-90003	1
L3	Choke, Common Mode (Data) SMD	Taiyo Yuden	CM04RC04	43-82470-000	1
L4	Choke, EMI/EMC 0A DC >1MHz 4516	Taiyo Yuden	FCFBMJ 4516 HS 110- T	43-90003	1

08-05266-001 - Audio I/F PCB

BOM Revision
Date Valid On

13 -- Production
27.09.2006

Ref	Description	Manufacturer	Manufacturer's P/N	Codan P/N	Qty
L5	Ind, Common Mode 5.5A	Taiyo Yuden	CMO8RA20	43-80001	1
L6	Ind, 10uH 10% 4532	Taiyo Yuden	LEM 4532T100K	43-81100-000	1
L7	Choke, EMI/EMC 0A DC >1MHz 4516	Taiyo Yuden	FCFBMJ 4516 HS 110-T	43-90003	1
L8	Ind, 100uH 10% 4532	Taiyo Yuden	LEM 4532T101K	43-82100-134	1
L9	Ind, 100uH 10% 4532	Taiyo Yuden	LEM 4532T101K	43-82100-134	1
L10	Ind, 10uH 10% 4532	Taiyo Yuden	LEM 4532T100K	43-81100-000	1
L11	Ind, 10uH 10% 4532	Taiyo Yuden	LEM 4532T100K	43-81100-000	1
L12	Choke, EMI/EMC 0A DC >1MHz 4516	Taiyo Yuden	FCFBMJ 4516 HS 110-T	43-90003	1
L13	Ind, 100uH 10% 4532	Taiyo Yuden	LEM 4532T101K	43-82100-134	1
L14	Ind, 100uH 10% 4532	Taiyo Yuden	LEM 4532T101K	43-82100-134	1
L15	Choke, EMI/EMC 0A DC >1MHz 4516	Taiyo Yuden	FCFBMJ 4516 HS 110-T	43-90003	1
L16	Ind, 100uH 10% 4532	Taiyo Yuden	LEM 4532T101K	43-82100-134	1
L17	Choke, EMI/EMC 0A DC >1MHz 4516	Taiyo Yuden	FCFBMJ 4516 HS 110-T	43-90003	1
L18	Choke, EMI/EMC 0A DC >1MHz 4516	Taiyo Yuden	FCFBMJ 4516 HS 110-T	43-90003	1
P1	Header (P) 10way 2mm Latch Fixed	AMP	1-173981-0	60-00100-351	1
P2	Header (P) 16way 2row Boxed	Thomas & Betts	609-1627	60-00160-000	1
P3	Header (P) 26way 2row Boxed Fix	Thomas & Betts	609-2627	60-00260-000	1
P4	Not Fitted	Codan	**_00000-001	99-00000-001	1
P5	Not Fitted	Codan	**_00000-001	99-00000-001	1
P6	Header (P) 8way 2mm Latch Fixed	AMP	292161-8	60-00080-001	1
P7	Header (P) 16way 2row Boxed	Thomas & Betts	609-1627	60-00160-000	1
R1	22k Ohm 5% 0,125W 1206	Philips	2322 711 61223	40-42200-101	1
R2	22k Ohm 5% 0,125W 1206	Philips	2322 711 61223	40-42200-101	1
R3	22k Ohm 5% 0,125W 1206	Philips	2322 711 61223	40-42200-101	1
R4	22k Ohm 5% 0,125W 1206	Philips	2322 711 61223	40-42200-101	1
R5	22k Ohm 5% 0,125W 1206	Philips	2322 711 61223	40-42200-101	1
R6	22k Ohm 5% 0,125W 1206	Philips	2322 711 61223	40-42200-101	1
R7	22k Ohm 5% 0,125W 1206	Philips	2322 711 61223	40-42200-101	1
R8	22k Ohm 5% 0,125W 1206	Philips	2322 711 61223	40-42200-101	1
R9	100k Ohm 5% 0,125W 1206	Philips	2322 711 61104	40-51000-101	1
R10	10k Ohm 5% 0,125W 1206	Philips	2322 711 61103	40-41000-101	1
R11	100 Ohm 5% 0,125W 1206	Philips	2322 711 61101	40-21000-101	1
R12	100 Ohm 5% 0,125W 1206	Philips	2322 711 61101	40-21000-101	1
R13	100 Ohm 5% 0,125W 1206	Philips	2322 711 61101	40-21000-101	1

08-05266-001 - Audio I/F PCB

BOM Revision
Date Valid On

13 -- Production
27.09.2006

Ref	Description	Manufacturer	Manufacturer's P/N	Codan P/N	Qty
R14	100 Ohm 5% 0,125W 1206	Philips	2322 711 61101	40-21000-101	1
R15	100 Ohm 5% 0,125W 1206	Philips	2322 711 61101	40-21000-101	1
R16	100 Ohm 5% 0,125W 1206	Philips	2322 711 61101	40-21000-101	1
R17	100 Ohm 5% 0,125W 1206	Philips	2322 711 61101	40-21000-101	1
R18	0 Ohm Jumper 1206	Philips	2322 711 90001	40-00001-101	1
R19	0 Ohm Jumper 1206	Philips	2322 711 90001	40-00001-101	1
R20	2,2k Ohm 5% 0,125W 1206	Philips	2322 711 61222	40-32200-101	1
R21	2,2k Ohm 5% 0,125W 1206	Philips	2322 711 61222	40-32200-101	1
R22	100 Ohm 5% 0,125W 1206	Philips	2322 711 61101	40-21000-101	1
R23	4,7k Ohm 5% 0,125W 1206	Philips	2322 711 61472	40-34700-101	1
R24	2,2k Ohm 5% 0,125W 1206	Philips	2322 711 61222	40-32200-101	1
R25	4,7k Ohm 5% 0,125W 1206	Philips	2322 711 61472	40-34700-101	1
R26	22k Ohm 5% 0,125W 1206	Philips	2322 711 61223	40-42200-101	1
R27	22k Ohm 5% 0,125W 1206	Philips	2322 711 61223	40-42200-101	1
R28	10k Ohm 5% 0,125W 1206	Philips	2322 711 61103	40-41000-101	1
R29	10k Ohm 5% 0,125W 1206	Philips	2322 711 61103	40-41000-101	1
R30	33k Ohm 5% 0,125W 1206	Philips	2322 711 61333	40-43300-101	1
R31	18k Ohm 5% 0,125W 1206	Philips	2322 711 61183	40-41800-101	1
R32	33k Ohm 5% 0,125W 1206	Philips	2322 711 61333	40-43300-101	1
R33	18k Ohm 5% 0,125W 1206	Philips	2322 711 61183	40-41800-101	1
R34	33k Ohm 5% 0,125W 1206	Philips	2322 711 61333	40-43300-101	1
R35	18k Ohm 5% 0,125W 1206	Philips	2322 711 61183	40-41800-101	1
R36	33k Ohm 5% 0,125W 1206	Philips	2322 711 61333	40-43300-101	1
R37	33k Ohm 5% 0,125W 1206	Philips	2322 711 61333	40-43300-101	1
R38	100 Ohm 5% 0,125W 1206	Philips	2322 711 61101	40-21000-101	1
R39	1k Ohm 5% 0,125W 1206	Philips	2322 711 61102	40-31000-101	1
R40	1k Ohm 5% 0,125W 1206	Philips	2322 711 61102	40-31000-101	1
R41	1k Ohm 5% 0,125W 1206	Philips	2322 711 61102	40-31000-101	1
R42	10 Ohm 5% 0,125W 1206	Philips	2322 711 61109	40-11000-101	1
R43	10 Ohm 5% 0,125W 1206	Philips	2322 711 61109	40-11000-101	1

08-05266-001 - Audio I/F PCB

BOM Revision
Date Valid On

13 -- Production
27.09.2006

Ref	Description	Manufacturer	Manufacturer's P/N	Codan P/N	Qty
R44	10k Ohm 5% 0,125W 1206	Philips	2322 711 61103	40-41000-101	1
R45	2,2k Ohm 5% 0,125W 1206	Philips	2322 711 61222	40-32200-101	1
R46	10 Ohm 5% 0,125W 1206	Philips	2322 711 61109	40-11000-101	1
R47	47 Ohm 5% 0,125W 1206	Philips	2322 711 61479	40-14700-101	1
R48	1k Ohm 5% 0,125W 1206	Philips	2322 711 61102	40-31000-101	1
R49	1k Ohm 5% 0,125W 1206	Philips	2322 711 61102	40-31000-101	1
R50	1k Ohm 5% 0,125W 1206	Philips	2322 711 61102	40-31000-101	1
R51	1k Ohm 5% 0,125W 1206	Philips	2322 711 61102	40-31000-101	1
R52	10k Ohm 5% 0,125W 1206	Philips	2322 711 61103	40-41000-101	1
R53	5,6k Ohm 5% 0,125W 1206	Philips	2322 711 61562	40-35600-101	1
R54	10k Ohm 5% 0,125W 1206	Philips	2322 711 61103	40-41000-101	1
R55	10k Ohm 5% 0,125W 1206	Philips	2322 711 61103	40-41000-101	1
R56	10k Ohm 5% 0,125W 1206	Philips	2322 711 61103	40-41000-101	1
R57	10k Ohm 5% 0,125W 1206	Philips	2322 711 61103	40-41000-101	1
R58	100 Ohm 5% 0,125W 1206	Philips	2322 711 61101	40-21000-101	1
R59	270 Ohm 5% 0,125W 1206	Philips	2322 711 61271	40-22700-101	1
R60	10k Ohm 5% 0,125W 1206	Philips	2322 711 61103	40-41000-101	1
R61	4,7k Ohm 5% 0,125W 1206	Philips	2322 711 61472	40-34700-101	1
R62	3,3k Ohm 5% 0,125W 1206	Philips	2322 711 61332	40-33300-101	1
R63	3,3k Ohm 5% 0,125W 1206	Philips	2322 711 61332	40-33300-101	1
R64	470 Ohm 5% 0,125W 1206	Philips	2322 711 61471	40-24700-101	1
R65	470 Ohm 5% 0,125W 1206	Philips	2322 711 61471	40-24700-101	1
R66	47 Ohm 5% 0,125W 1206	Philips	2322 711 61479	40-14700-101	1
R67	47 Ohm 5% 0,125W 1206	Philips	2322 711 61479	40-14700-101	1
R68	1k Ohm 5% 0,125W 1206	Philips	2322 711 61102	40-31000-101	1
R69	1k Ohm 5% 0,125W 1206	Philips	2322 711 61102	40-31000-101	1
R70	1k Ohm 5% 0,125W 1206	Philips	2322 711 61102	40-31000-101	1
R71	10k Ohm 5% 0,125W 1206	Philips	2322 711 61103	40-41000-101	1
R72	10k Ohm 5% 0,125W 1206	Philips	2322 711 61103	40-41000-101	1

08-05266-001 - Audio I/F PCB

BOM Revision
Date Valid On

13 -- Production
 27.09.2006

Ref	Description	Manufacturer	Manufacturer's P/N	Codan P/N	Qty
R73	10k Ohm 5% 0,125W 1206	Philips	2322 711 61103	40-41000-101	1
R74	10k Ohm 5% 0,125W 1206	Philips	2322 711 61103	40-41000-101	1
R75	10k Ohm 5% 0,125W 1206	Philips	2322 711 61103	40-41000-101	1
R76	10k Ohm 5% 0,125W 1206	Philips	2322 711 61103	40-41000-101	1
R77	100k Ohm 5% 0,125W 1206	Philips	2322 711 61104	40-51000-101	1
R78	47k Ohm 5% 0,125W 1206	Philips	2322 711 61473	40-44700-101	1
R79	47k Ohm 5% 0,125W 1206	Philips	2322 711 61473	40-44700-101	1
R80	10k Ohm 5% 0,125W 1206	Philips	2322 711 61103	40-41000-101	1
R81	10k Ohm 5% 0,125W 1206	Philips	2322 711 61103	40-41000-101	1
R82	680k Ohm 5% 0,125W 1206	Philips	2322 711 61684	40-56800-101	1
R83	680k Ohm 5% 0,125W 1206	Philips	2322 711 61684	40-56800-101	1
R84	680k Ohm 5% 0,125W 1206	Philips	2322 711 61684	40-56800-101	1
R85	Pot,10k Lin MG Trim SMD	Bourns	3314 J-1-103	42-41004-000	1
R86	10k Ohm 5% 0,125W 1206	Philips	2322 711 61103	40-41000-101	1
R87	100k Ohm 5% 0,125W 1206	Philips	2322 711 61104	40-51000-101	1
R88	100k Ohm 5% 0,125W 1206	Philips	2322 711 61104	40-51000-101	1
R89	100k Ohm 5% 0,125W 1206	Philips	2322 711 61104	40-51000-101	1
R90	1M Ohm 5% 0,125W 1206	Philips	2322 711 61105	40-61000-101	1
R91	100k Ohm 5% 0,125W 1206	Philips	2322 711 61104	40-51000-101	1
R92	68k Ohm 5% 0,125W 1206	Philips	2322 711 61683	40-46800-101	1
R93	22k Ohm 5% 0,125W 1206	Philips	2322 711 61223	40-42200-101	1
R94	100 Ohm 5% 0,125W 1206	Philips	2322 711 61101	40-21000-101	1
R95	100 Ohm 5% 0,125W 1206	Philips	2322 711 61101	40-21000-101	1
R96	100 Ohm 5% 0,125W 1206	Philips	2322 711 61101	40-21000-101	1
R97	100 Ohm 5% 0,125W 1206	Philips	2322 711 61101	40-21000-101	1
R98	1k Ohm 5% 0,125W 1206	Philips	2322 711 61102	40-31000-101	1
R99	1k Ohm 5% 0,125W 1206	Philips	2322 711 61102	40-31000-101	1
R100	10k Ohm 5% 0,125W 1206	Philips	2322 711 61103	40-41000-101	1
R101	10k Ohm 5% 0,125W 1206	Philips	2322 711 61103	40-41000-101	1

08-05266-001 - Audio I/F PCB

BOM Revision
Date Valid On

13 -- Production
27.09.2006

Ref	Description	Manufacturer	Manufacturer's P/N	Codan P/N	Qty
R102	10k Ohm 5% 0,125W 1206	Philips	2322 711 61103	40-41000-101	1
V1	Transistor, NPN Si SOT23	Philips	BFR92A	BFR92A	1
V2	Transistor, PNP Si SOT23	Philips	BC858	BC858	1
V3	MOSFET, N Chan Enhance SOT23	Philips	BST82	BST82	1
V4	Transistor, PNP Si SOT23	Philips	BC858	BC858	1
V5	Transistor, PNP Si SOT23	Philips	BC858	BC858	1
V6	Transistor, NPN Si SOT23	Philips	BC848	BC848	1
V7	Diode, Zener 6,8V 5% 0,2W SOT23	Philips	BZX84C6V8	BZX84C6V8	1
V8	Transistor, NPN Si SOT23	Philips	BC848	BC848	1
V9	Transistor, NPN Si SOT23	Philips	BC848	BC848	1
V10	Transistor, PNP Si SOT23	Philips	BC858	BC858	1
Z1	Osc, Xtal TTL 16,000 MHz	HY-Q	MIN80AS-T100PPM	65-91406-000	1
Z2	Crystal, 32,768kHz 12pF	HY-Q	TC38	65-90057-000	1

08-05265-001 - Application Processor PCB

BOM Revision
Date Valid On

15 -- Production
27.09.2006

Ref	Description	Manufacturer	Manufacturer's P/N	Codan P/N	Qty
	Application Processor PCB			11-06073	1
	PTP, RF Unit uProc PCB			10-50032	1
	Build Standard, 2010			01-01252	1
	Application Processor			04-03108	1
	Application Processor PCB			08-05265	1
1	PCB, Application Processor	Entech	07-01741-06	07-01741-06	1
2	Label, Serial/Barcode	Codan	06-02068	06-02068	1
3	Cable, Ribbon, Audio - DSP	Auto Assemblies	08-05490-001	08-05490-001	1
C1	33n 10% 25V X7R 0603 NiSn	Vitramon	VJ0603Y333KXXT	46-43300-282	1
C2	33n 10% 25V X7R 0603 NiSn	Vitramon	VJ0603Y333KXXT	46-43300-282	1
C3	33n 10% 25V X7R 0603 NiSn	Vitramon	VJ0603Y333KXXT	46-43300-282	1
C4	33n 10% 25V X7R 0603 NiSn	Vitramon	VJ0603Y333KXXT	46-43300-282	1
C5	33n 10% 25V X7R 0603 NiSn	Vitramon	VJ0603Y333KXXT	46-43300-282	1
C6	33n 10% 25V X7R 0603 NiSn	Vitramon	VJ0603Y333KXXT	46-43300-282	1
C7	100u 25V 105°C SMD EL Cap Low ESR	Nippon Chemicon	MVY25VC100MF80	48-21002-502	1
C8	100u 25V 105°C SMD EL Cap Low ESR	Nippon Chemicon	MVY25VC100MF80	48-21002-502	1
C9	33n 10% 25V X7R 0603 NiSn	Vitramon	VJ0603Y333KXXT	46-43300-282	1
C10	100u 25V 105°C SMD EL Cap Low ESR	Nippon Chemicon	MVY25VC100MF80	48-21002-502	1
C11	10u 20% 25V 6032 TA Cap	AVX	TAJC106M025R	47-11002-520	1
C12	100n 10% 16V X7R 0603 NiSn	Vitramon	VJ0603Y104KXJT	46-51000-283	1
C13	33n 10% 25V X7R 0603 NiSn	Vitramon	VJ0603Y333KXXT	46-43300-282	1
C14	1u 20% 35V 3528 TA Cap	AVX	TAJB105M035R	47-01003-520	1
C15	33n 10% 25V X7R 0603 NiSn	Vitramon	VJ0603Y333KXXT	46-43300-282	1
C16	10u 20% 25V 6032 TA Cap	AVX	TAJC106M025R	47-11002-520	1
C17	1u 20% 35V 3528 TA Cap	AVX	TAJB105M035R	47-01003-520	1
C18	22p 5% 100V NPO 0603 NiSn	Philips	0603CG220J0B200	46-12200-083	1
C19	22p 5% 100V NPO 0603 NiSn	Philips	0603CG220J0B200	46-12200-083	1
C20	1u 20% 35V 3528 TA Cap	AVX	TAJB105M035R	47-01003-520	1
C21	3,3n 10% 100V X7R 0603 NiSn	Vishay	VJ0603Y332KXBAC	46-33300-282	1
C22	3,3n 10% 100V X7R 0603 NiSn	Vishay	VJ0603Y332KXBAC	46-33300-282	1
C23	100n 10% 16V X7R 0603 NiSn	Vitramon	VJ0603Y104KXJT	46-51000-283	1
C24	33n 10% 25V X7R 0603 NiSn	Vitramon	VJ0603Y333KXXT	46-43300-282	1
C25	33n 10% 25V X7R 0603 NiSn	Vitramon	VJ0603Y333KXXT	46-43300-282	1

08-05265-001 - Application Processor PCB

BOM Revision
Date Valid On

15 -- Production
27.09.2006

Ref	Description	Manufacturer	Manufacturer's P/N	Codan P/N	Qty
C26	33n 10% 25V X7R 0603 NiSn	Vitramon	VJ0603Y333KXXT	46-43300-282	1
C27	33n 10% 25V X7R 0603 NiSn	Vitramon	VJ0603Y333KXXT	46-43300-282	1
C28	33n 10% 25V X7R 0603 NiSn	Vitramon	VJ0603Y333KXXT	46-43300-282	1
C29	33n 10% 25V X7R 0603 NiSn	Vitramon	VJ0603Y333KXXT	46-43300-282	1
C30	22p 5% 100V NPO 0603 NiSn	Philips	0603CG220J0B200	46-12200-083	1
C31	22p 5% 100V NPO 0603 NiSn	Philips	0603CG220J0B200	46-12200-083	1
C32	33n 10% 25V X7R 0603 NiSn	Vitramon	VJ0603Y333KXXT	46-43300-282	1
C33	3,3n 10% 100V X7R 0603 NiSn	Vishay	VJ0603Y332KXBAC	46-33300-282	1
C34	100p 5% 50V NPO 0603 NiSn	Philips	0603CG101J9B200	46-21000-083	1
C35	100p 5% 50V NPO 0603 NiSn	Philips	0603CG101J9B200	46-21000-083	1
C36	Not Fitted	Codan	**_00000-001	99-00000-001	1
C37	Not Fitted	Codan	**_00000-001	99-00000-001	1
C38	Not Fitted	Codan	**_00000-001	99-00000-001	1
C39	Not Fitted	Codan	**_00000-001	99-00000-001	1
C40	Not Fitted	Codan	**_00000-001	99-00000-001	1
C41	Not Fitted	Codan	**_00000-001	99-00000-001	1
C42	Not Fitted	Codan	**_00000-001	99-00000-001	1
C43	Not Fitted	Codan	**_00000-001	99-00000-001	1
C44	Not Fitted	Codan	**_00000-001	99-00000-001	1
C45	Not Fitted	Codan	**_00000-001	99-00000-001	1
C46	100p 5% 50V NPO 0603 NiSn	Philips	0603CG101J9B200	46-21000-083	1
C47	3,3n 10% 100V X7R 0603 NiSn	Vishay	VJ0603Y332KXBAC	46-33300-282	1
C48	Not Fitted	Codan	**_00000-001	99-00000-001	1
C49	Not Fitted	Codan	**_00000-001	99-00000-001	1
C50	100p 5% 50V NPO 0603 NiSn	Philips	0603CG101J9B200	46-21000-083	1
C51	100p 5% 50V NPO 0603 NiSn	Philips	0603CG101J9B200	46-21000-083	1
C52	100p 5% 50V NPO 0603 NiSn	Philips	0603CG101J9B200	46-21000-083	1
C53	Not Fitted	Codan	**_00000-001	99-00000-001	1
C54	100n 10% 16V X7R 0603 NiSn	Vitramon	VJ0603Y104KXJT	46-51000-283	1
D1	Diode, Schottky 40V 3A SMC	Motorola	MBRS340T3	MBRS340T3	1
H1	Not Fitted	Codan	**_00000-001	99-00000-001	1
H2	Not Fitted	Codan	**_00000-001	99-00000-001	1
IC1	Serial Number, 48 bit SOT223	Dallas	DS2401Z	YM-02401-700	1
IC2	Monitor, Micro SOIC8	Dallas	DS1232LPS-2	XD-01232-700	1
IC3	Digital Signal Processor QFP144	Texas Instruments	TMS320C32PCM40	YP-32032-700	1
IC4	Micro prgmd, RFU Master I/O	MEMEC	90-20590-001	90-20590-001	1

08-05265-001 - Application Processor PCB

BOM Revision
Date Valid On

15 -- Production
27.09.2006

Ref	Description	Manufacturer	Manufacturer's P/N	Codan P/N	Qty
IC5	Voice-Band ADC & DAC 14BIT PLCC28	Texas Instruments	TLC320AC01CFN	YN-32001-900	1
IC6	Reg, Voltage +5V 1A Switch	National Semiconduct	LM2575T-5.0	XB-02575-400	1
IC7	Amp, Oper Dual CMOS SOIC8	National Semiconduct	LMC662CM	XA-00662-700	1
IC11	FLASH prgmd, RF-Unit D0- D15	Braemac	90-20595-101	90-20595-101	1
IC12	FLASH prgmd, RF-Unit D16-31	Braemac	90-20595-201	90-20595-201	1
IC13	SRAM, CMOS 256k x 16 Bit 20ns SOJ44	Alliance	AS7C4098-20JC	YM-74098-700	1
IC14	SRAM, CMOS 256k x 16 Bit 20ns SOJ44	Alliance	AS7C4098-20JC	YM-74098-700	1
IC15	EPLD prgmd, RFU Address Decoder	Codan	90-20589-001	90-20589-001	1
IC16	FLASH, 512k x 8 Bit 75ns PLCC32	AMD	AM29F040B-75JC	YM-29040-900	1
IC17	Cntrl, CAN bus 2,0B SOIC28	Philips	SJA1000T/N1	YL-81000-700	1
L1	Ind, 680uH Switched Supply	Coilcraft	DS5022P-684	43-82680-000	1
L2	Ind, 10uH 10% 4532	Taiyo Yuden	LEM 4532T100K	43-81100-000	1
L3	Choke, EMI/EMC 0A DC >1MHz 4516	Taiyo Yuden	FCFBMJ 4516 HS 110- T	43-90003	1
L4	Choke, EMI/EMC 0A DC >1MHz 4516	Taiyo Yuden	FCFBMJ 4516 HS 110- T	43-90003	1
P1	Not Fitted	Codan	**_00000-001	99-00000-001	1
P2	Not Fitted	Codan	**_00000-001	99-00000-001	1
P3	Not Fitted	Codan	**_00000-001	99-00000-001	1
P4	Not Fitted	Codan	**_00000-001	99-00000-001	1
P5	Header (P) 26way 2row Boxed SMD	Neltron	2316SMD-26G-CAP-TR	60-00260-002	1
P6	Not Fitted	Codan	**_00000-001	99-00000-001	1
P7	Not Fitted	Codan	**_00000-001	99-00000-001	1
P8	Socket, 16way 1row ZIF 1mm Pitch SMD	Global Shine	GS008-16-G-1	60-00163-004	1
R1	10k Ohm 5% 0,06W 0603	Philips	2322 702 60103	40-41000-121	1
R2	10k Ohm 5% 0,06W 0603	Philips	2322 702 60103	40-41000-121	1
R3	10k Ohm 5% 0,06W 0603	Philips	2322 702 60103	40-41000-121	1
R4	2,7k Ohm 5% 0,06W 0603	Philips	2322 702 60272	40-32700-121	1
R5	10k Ohm 5% 0,06W 0603	Philips	2322 702 60103	40-41000-121	1
R6	10k Ohm 5% 0,06W 0603	Philips	2322 702 60103	40-41000-121	1
R7	10k Ohm 5% 0,06W 0603	Philips	2322 702 60103	40-41000-121	1
R8	22k Ohm 5% 0,06W 0603	Philips	2322 702 60223	40-42200-121	1
R9	22k Ohm 5% 0,06W 0603	Philips	2322 702 60223	40-42200-121	1
R10	22k Ohm 5% 0,06W 0603	Philips	2322 702 60223	40-42200-121	1
R11	22k Ohm 5% 0,06W 0603	Philips	2322 702 60223	40-42200-121	1

08-05265-001 - Application Processor PCB

BOM Revision
Date Valid On

15 -- Production
27.09.2006

Ref	Description	Manufacturer	Manufacturer's P/N	Codan P/N	Qty
R12	10k Ohm 5% 0,06W 0603	Philips	2322 702 60103	40-41000-121	1
R13	10k Ohm 5% 0,06W 0603	Philips	2322 702 60103	40-41000-121	1
R14	10k Ohm 5% 0,06W 0603	Philips	2322 702 60103	40-41000-121	1
R15	10k Ohm 5% 0,06W 0603	Philips	2322 702 60103	40-41000-121	1
R16	33k Ohm 5% 0,06W 0603	Philips	2322 702 60333	40-43300-121	1
R17	33k Ohm 5% 0,06W 0603	Philips	2322 702 60333	40-43300-121	1
R18	10k Ohm 5% 0,06W 0603	Philips	2322 702 60103	40-41000-121	1
R19	Not Fitted	Codan	** -00000-001	99-00000-001	1
R20	Not Fitted	Codan	** -00000-001	99-00000-001	1
R21	22k Ohm 5% 0,06W 0603	Philips	2322 702 60223	40-42200-121	1
R22	33 Ohm 5% 0,06W 0603	Philips	2322 702 60339	40-13300-121	1
R23	33 Ohm 5% 0,06W 0603	Philips	2322 702 60339	40-13300-121	1
R24	120 Ohm 5% 0,06W 0603	Philips	2322 702 60121	40-21200-121	1
R25	10k Ohm 5% 0,06W 0603	Philips	2322 702 60103	40-41000-121	1
R26	4,7k Ohm 5% 0,06W 0603	Philips	2322 702 60472	40-34700-121	1
R27	4,7k Ohm 5% 0,06W 0603	Philips	2322 702 60472	40-34700-121	1
R28	120 Ohm 5% 0,06W 0603	Philips	2322 702 60121	40-21200-121	1
R29	120 Ohm 5% 0,06W 0603	Philips	2322 702 60121	40-21200-121	1
R30	120 Ohm 5% 0,06W 0603	Philips	2322 702 60121	40-21200-121	1
R31	120 Ohm 5% 0,06W 0603	Philips	2322 702 60121	40-21200-121	1
R32	10k Ohm 5% 0,06W 0603	Philips	2322 702 60103	40-41000-121	1
R33	10k Ohm 5% 0,06W 0603	Philips	2322 702 60103	40-41000-121	1
R34	120 Ohm 5% 0,06W 0603	Philips	2322 702 60121	40-21200-121	1
R35	120 Ohm 5% 0,06W 0603	Philips	2322 702 60121	40-21200-121	1
R36	120 Ohm 5% 0,06W 0603	Philips	2322 702 60121	40-21200-121	1
R37	120 Ohm 5% 0,06W 0603	Philips	2322 702 60121	40-21200-121	1
R38	120 Ohm 5% 0,06W 0603	Philips	2322 702 60121	40-21200-121	1
R39	33 Ohm 5% 0,06W 0603	Philips	2322 702 60339	40-13300-121	1
R40	33 Ohm 5% 0,06W 0603	Philips	2322 702 60339	40-13300-121	1
R41	33 Ohm 5% 0,06W 0603	Philips	2322 702 60339	40-13300-121	1

08-05265-001 - Application Processor PCB

BOM Revision
Date Valid On

15 -- Production
27.09.2006

Ref	Description	Manufacturer	Manufacturer's P/N	Codan P/N	Qty
R43	120 Ohm 5% 0,06W 0603	Philips	2322 702 60121	40-21200-121	1
R44	120 Ohm 5% 0,06W 0603	Philips	2322 702 60121	40-21200-121	1
R45	1k Ohm 5% 0,06W 0603	Philips	2322 702 60102	40-31000-121	1
R46	10 Ohm 5% 0,06W 0603	Philips	2322 702 60109	40-11000-121	1
R47	47k Ohm 5% 0,06W 0603	Philips	2322 702 60473	40-44700-121	1
R48	10k Ohm 5% 0,06W 0603	Philips	2322 702 60103	40-41000-121	1
R49	10k Ohm 5% 0,06W 0603	Philips	2322 702 60103	40-41000-121	1
R50	10k Ohm 5% 0,06W 0603	Philips	2322 702 60103	40-41000-121	1
R51	47k Ohm 5% 0,06W 0603	Philips	2322 702 60473	40-44700-121	1
R53	33k Ohm 5% 0,06W 0603	Philips	2322 702 60333	40-43300-121	1
R54	33k Ohm 5% 0,06W 0603	Philips	2322 702 60333	40-43300-121	1
R55	33k Ohm 5% 0,06W 0603	Philips	2322 702 60333	40-43300-121	1
R56	33k Ohm 5% 0,06W 0603	Philips	2322 702 60333	40-43300-121	1
R57	470 Ohm 5% 0,06W 0603	Philips	2322 702 60471	40-24700-121	1
R58	470 Ohm 5% 0,06W 0603	Philips	2322 702 60471	40-24700-121	1
R59	33 Ohm 5% 0,06W 0603	Philips	2322 702 60339	40-13300-121	1
R60	10k Ohm 5% 0,06W 0603	Philips	2322 702 60103	40-41000-121	1
R61	33k Ohm 5% 0,06W 0603	Philips	2322 702 60333	40-43300-121	1
R62	1k Ohm 5% 0,06W 0603	Philips	2322 702 60102	40-31000-121	1
R63	33k Ohm 5% 0,06W 0603	Philips	2322 702 60333	40-43300-121	1
R64	33k Ohm 5% 0,06W 0603	Philips	2322 702 60333	40-43300-121	1
R65	1k Ohm 5% 0,06W 0603	Philips	2322 702 60102	40-31000-121	1
R66	1k Ohm 5% 0,06W 0603	Philips	2322 702 60102	40-31000-121	1
R67	1k Ohm 5% 0,06W 0603	Philips	2322 702 60102	40-31000-121	1
R68	1k Ohm 5% 0,06W 0603	Philips	2322 702 60102	40-31000-121	1
R69	10k Ohm 5% 0,06W 0603	Philips	2322 702 60103	40-41000-121	1
R70	33k Ohm 5% 0,06W 0603	Philips	2322 702 60333	40-43300-121	1
R71	33k Ohm 5% 0,06W 0603	Philips	2322 702 60333	40-43300-121	1
R72	33k Ohm 5% 0,06W 0603	Philips	2322 702 60333	40-43300-121	1

08-05265-001 - Application Processor PCB

BOM Revision
Date Valid On

15 -- Production
27.09.2006

Ref	Description	Manufacturer	Manufacturer's P/N	Codan P/N	Qty
R73	33k Ohm 5% 0,06W 0603	Philips	2322 702 60333	40-43300-121	1
R74	10k Ohm 5% 0,06W 0603	Philips	2322 702 60103	40-41000-121	1
R75	10k Ohm 5% 0,06W 0603	Philips	2322 702 60103	40-41000-121	1
R76	10k Ohm 5% 0,06W 0603	Philips	2322 702 60103	40-41000-121	1
Z1	Osc, Xtal TTL 41,472 MHz	HY-Q	MIN80AS-T100PPM 41,472MHZ	65-91407-000	1
Z2	Crystal, 16000 kHz uP Grade	HY-Q	QC49/SMD	65-90103	1

08-05261-001 - RF/IF PCB

BOM Revision
Date Valid On

12 -- Production
27.09.2006

Ref	Description	Manufacturer	Manufacturer's P/N	Codan P/N	Qty
	RF/IF PCB			08-05261	1
	RF/IF			04-03106	1
	TP, NGT Rcvr/Exciter			10-00815	1
	RF/IF PCB			11-06071	1
	Build Standard, 2010			01-01252	1
1	PCB, RF/IF	Morris Productions	07-01740-07	07-01740-07	1
2	Screen, VCO1 & Mixer	Metalcraft	05-06518	05-06518	1
3	Screen, VCO	Metalcraft	05-07079	05-07079	1
4	Screen, DDS	Metalcraft	05-07080	05-07080	1
5	Oven, Hi-Stab for HC18 Xtal	Codan	08-05235-002	08-05235-002	1
6	Jumper (S) 2way Open Top	Molex	15-38-1024	60-90410-001	1
8	Label, Serial/Barcode	Codan	06-02068	06-02068	1
9	Filter, 45- MHz 4Pole 15 kHz BW	KDK	45M15B	65-91115-000	2
10	Cable, Ribbon, Audio - RF	Auto Assemblies	08-05489-001	08-05489-001	1
C101	33n 10% 100V X7R 1206 NiSn	Philips	12062R333K0BB-	46-43300-280	1
C102	100n 10% 50V X7R 1206 NiSn	Philips	12062R104K9BB-	46-51000-281	1
C103	33n 10% 100V X7R 1206 NiSn	Philips	12062R333K0BB-	46-43300-280	1
C104	3,3n 10% 100V X7R 1206 NiSn	Philips	12062R332K0BB-	46-33300-280	1
C105	820p 5% 50V NPO 1206 NiSn	Philips	1206CG821J9BB-	46-28200-080	1
C106	820p 5% 50V NPO 1206 NiSn	Philips	1206CG821J9BB-	46-28200-080	1
C107	3,3n 10% 100V X7R 1206 NiSn	Philips	12062R332K0BB-	46-33300-280	1
C108	3,3n 10% 100V X7R 1206 NiSn	Philips	12062R332K0BB-	46-33300-280	1
C109	820p 5% 50V NPO 1206 NiSn	Philips	1206CG821J9BB-	46-28200-080	1
C110	820p 5% 50V NPO 1206 NiSn	Philips	1206CG821J9BB-	46-28200-080	1
C111	10n 10% 100V X7R 1206 NiSn	Philips	12062R103K0BB-	46-41000-280	1
C112	150p 5% 50V NPO 0805 NiSn	Philips	0805CG151J9BB-	46-21500-081	1
C113	33n 10% 100V X7R 1206 NiSn	Philips	12062R333K0BB-	46-43300-280	1
C114	100n 10% 50V X7R 1206 NiSn	Philips	12062R104K9BB-	46-51000-281	1
C115	3,3n 10% 100V X7R 1206 NiSn	Philips	12062R332K0BB-	46-33300-280	1
C116	33n 10% 100V X7R 1206 NiSn	Philips	12062R333K0BB-	46-43300-280	1
C117	33n 10% 100V X7R 1206 NiSn	Philips	12062R333K0BB-	46-43300-280	1
C118	1n 5% 50V NPO 1206 NiSn	Philips	1206CG102J9BB-	46-31000-081	1
C119	1n 5% 50V NPO 1206 NiSn	Philips	1206CG102J9BB-	46-31000-081	1
C120	22p 5% 50V NPO 1206 NiSn	Philips	1206CG220J9BB-	46-12200-080	1
C121	100p 5% 50V NPO 1206 NiSn	Philips	1206CG101J9BB-	46-21000-080	1

08-05261-001 - RF/IF PCB

BOM Revision
Date Valid On

12 -- Production
27.09.2006

Ref	Description	Manufacturer	Manufacturer's P/N	Codan P/N	Qty
C122	150p 5% 50V NPO 0805 NiSn	Philips	0805CG151J9BB-	46-21500-081	1
C123	150p 5% 50V NPO 0805 NiSn	Philips	0805CG151J9BB-	46-21500-081	1
C124	33n 10% 100V X7R 1206 NiSn	Philips	12062R333K0BB-	46-43300-280	1
C125	Not Fitted	Codan	** -00000-001	99-00000-001	1
C126	Not Fitted	Codan	** -00000-001	99-00000-001	1
C127	3,3n 10% 100V X7R 1206 NiSn	Philips	12062R332K0BB-	46-33300-280	1
C128	10p 5% 50V NPO 1206 NiSn	Philips	1206CG100J9BB-	46-11000-080	1
C129	3,3n 10% 100V X7R 1206 NiSn	Philips	12062R332K0BB-	46-33300-280	1
C130	10p 5% 50V NPO 1206 NiSn	Philips	1206CG100J9BB-	46-11000-080	1
C131	1n 5% 50V NPO 1206 NiSn	Philips	1206CG102J9BB-	46-31000-081	1
C132	3,3n 10% 100V X7R 1206 NiSn	Philips	12062R332K0BB-	46-33300-280	1
C133	3,3n 10% 100V X7R 1206 NiSn	Philips	12062R332K0BB-	46-33300-280	1
C134	3,3n 10% 100V X7R 1206 NiSn	Philips	12062R332K0BB-	46-33300-280	1
C135	3,3n 10% 100V X7R 1206 NiSn	Philips	12062R332K0BB-	46-33300-280	1
C136	3,3n 10% 100V X7R 1206 NiSn	Philips	12062R332K0BB-	46-33300-280	1
C137	3,3n 10% 100V X7R 1206 NiSn	Philips	12062R332K0BB-	46-33300-280	1
C138	33n 10% 100V X7R 1206 NiSn	Philips	12062R333K0BB-	46-43300-280	1
C139	47p 5% 50V NPO 1206 NiSn	Philips	1206CG470J9BB-	46-14700-081	1
C140	47p 5% 50V NPO 1206 NiSn	Philips	1206CG470J9BB-	46-14700-081	1
C141	3,3n 10% 100V X7R 1206 NiSn	Philips	12062R332K0BB-	46-33300-280	1
C142	Not Fitted	Codan	** -00000-001	99-00000-001	1
C143	3,3n 10% 100V X7R 1206 NiSn	Philips	12062R332K0BB-	46-33300-280	1
C144	3,3n 10% 100V X7R 1206 NiSn	Philips	12062R332K0BB-	46-33300-280	1
C145	33n 10% 100V X7R 1206 NiSn	Philips	12062R333K0BB-	46-43300-280	1
C146	820p 5% 50V NPO 1206 NiSn	Philips	1206CG821J9BB-	46-28200-080	1
C147	820p 5% 50V NPO 1206 NiSn	Philips	1206CG821J9BB-	46-28200-080	1
C148	100p 5% 50V NPO 1206 NiSn	Philips	1206CG101J9BB-	46-21000-080	1
C149	68p 5% 50V NPO 1206 NiSn	Philips	1206CG680J9BB-	46-16800-080	1
C150	68p 5% 50V NPO 1206 NiSn	Philips	1206CG680J9BB-	46-16800-080	1
C151	82p 5% 50V NPO 1206 NiSn	Philips	1206CG820J9BB-	46-18200-080	1

08-05261-001 - RF/IF PCB

BOM Revision
Date Valid On

12 -- Production
27.09.2006

Ref	Description	Manufacturer	Manufacturer's P/N	Codan P/N	Qty
C152	82p 5% 50V NPO 1206 NiSn	Philips	1206CG820J9BB-	46-18200-080	1
C153	33n 10% 100V X7R 1206 NiSn	Philips	12062R333K0BB-	46-43300-280	1
C154	3,3n 10% 100V X7R 1206 NiSn	Philips	12062R332K0BB-	46-33300-280	1
C155	3,3n 10% 100V X7R 1206 NiSn	Philips	12062R332K0BB-	46-33300-280	1
C156	3,3n 10% 100V X7R 1206 NiSn	Philips	12062R332K0BB-	46-33300-280	1
C157	3,3n 10% 100V X7R 1206 NiSn	Philips	12062R332K0BB-	46-33300-280	1
C158	3,3n 10% 100V X7R 1206 NiSn	Philips	12062R332K0BB-	46-33300-280	1
C159	3,3n 10% 100V X7R 1206 NiSn	Philips	12062R332K0BB-	46-33300-280	1
C160	3,3n 10% 100V X7R 1206 NiSn	Philips	12062R332K0BB-	46-33300-280	1
C161	3,3n 10% 100V X7R 1206 NiSn	Philips	12062R332K0BB-	46-33300-280	1
C162	33n 10% 100V X7R 1206 NiSn	Philips	12062R333K0BB-	46-43300-280	1
C163	3,3n 10% 100V X7R 1206 NiSn	Philips	12062R332K0BB-	46-33300-280	1
C164	3,3n 10% 100V X7R 1206 NiSn	Philips	12062R332K0BB-	46-33300-280	1
C165	33n 10% 100V X7R 1206 NiSn	Philips	12062R333K0BB-	46-43300-280	1
C166	33n 10% 100V X7R 1206 NiSn	Philips	12062R333K0BB-	46-43300-280	1
C167	Not Fitted	Codan	** -00000-001	99-00000-001	1
C201	1n 5% 50V NPO 1206 NiSn	Philips	1206CG102J9BB-	46-31000-081	1
C202	1n 5% 50V NPO 1206 NiSn	Philips	1206CG102J9BB-	46-31000-081	1
C203	10u 20% 25V 6032 TA Cap	AVX	TAJC106M025R	47-11002-520	1
C204	820p 5% 50V NPO 1206 NiSn	Philips	1206CG821J9BB-	46-28200-080	1
C205	820p 5% 50V NPO 1206 NiSn	Philips	1206CG821J9BB-	46-28200-080	1
C206	1u 20% 35V 3528 TA Cap	AVX	TAJB105M035R	47-01003-520	1
C207	3,3n 10% 100V X7R 1206 NiSn	Philips	12062R332K0BB-	46-33300-280	1
C208	100p 5% 50V NPO 1206 NiSn	Philips	1206CG101J9BB-	46-21000-080	1
C209	33n 10% 100V X7R 1206 NiSn	Philips	12062R333K0BB-	46-43300-280	1
C210	3,3n 10% 100V X7R 1206 NiSn	Philips	12062R332K0BB-	46-33300-280	1
C211	3,3n 10% 100V X7R 1206 NiSn	Philips	12062R332K0BB-	46-33300-280	1
C212	3,3n 10% 100V X7R 1206 NiSn	Philips	12062R332K0BB-	46-33300-280	1
C213	33n 10% 100V X7R 1206 NiSn	Philips	12062R333K0BB-	46-43300-280	1

08-05261-001 - RF/IF PCB

BOM Revision
Date Valid On

12 -- Production
27.09.2006

Ref	Description	Manufacturer	Manufacturer's P/N	Codan P/N	Qty
C214	33n 10% 100V X7R 1206 NiSn	Philips	12062R333K0BB-	46-43300-280	1
C215	33n 10% 100V X7R 1206 NiSn	Philips	12062R333K0BB-	46-43300-280	1
C216	Not Fitted	Codan	** -00000-001	99-00000-001	1
C217	Not Fitted	Codan	** -00000-001	99-00000-001	1
C218	27p 5% 50V NPO 1206 NiSn	Philips	1206CG270J9BB-	46-12700-081	1
C219	27p 5% 50V NPO 1206 NiSn	Philips	1206CG270J9BB-	46-12700-081	1
C220	33n 10% 100V X7R 1206 NiSn	Philips	12062R333K0BB-	46-43300-280	1
C221	1n 5% 50V NPO 1206 NiSn	Philips	1206CG102J9BB-	46-31000-081	1
C222	1u 20% 35V 3528 TA Cap	AVX	TAJB105M035R	47-01003-520	1
C223	33n 10% 100V X7R 1206 NiSn	Philips	12062R333K0BB-	46-43300-280	1
C224	1n 5% 50V NPO 1206 NiSn	Philips	1206CG102J9BB-	46-31000-081	1
C225	33n 10% 100V X7R 1206 NiSn	Philips	12062R333K0BB-	46-43300-280	1
C226	33n 10% 100V X7R 1206 NiSn	Philips	12062R333K0BB-	46-43300-280	1
C227	33n 10% 100V X7R 1206 NiSn	Philips	12062R333K0BB-	46-43300-280	1
C228	1u 20% 35V 3528 TA Cap	AVX	TAJB105M035R	47-01003-520	1
C229	100p 5% 50V NPO 1206 NiSn	Philips	1206CG101J9BB-	46-21000-080	1
C230	33n 10% 100V X7R 1206 NiSn	Philips	12062R333K0BB-	46-43300-280	1
C231	1n 5% 50V NPO 1206 NiSn	Philips	1206CG102J9BB-	46-31000-081	1
C232	100p 5% 50V NPO 1206 NiSn	Philips	1206CG101J9BB-	46-21000-080	1
C233	33n 10% 100V X7R 1206 NiSn	Philips	12062R333K0BB-	46-43300-280	1
C234	1n 5% 50V NPO 1206 NiSn	Philips	1206CG102J9BB-	46-31000-081	1
C235	1n 5% 50V NPO 1206 NiSn	Philips	1206CG102J9BB-	46-31000-081	1
C236	100p 5% 50V NPO 1206 NiSn	Philips	1206CG101J9BB-	46-21000-080	1
C237	33n 10% 100V X7R 1206 NiSn	Philips	12062R333K0BB-	46-43300-280	1
C238	3,3n 10% 100V X7R 1206 NiSn	Philips	12062R332K0BB-	46-33300-280	1
C239	1u 20% 35V 3528 TA Cap	AVX	TAJB105M035R	47-01003-520	1
C240	100p 5% 50V NPO 1206 NiSn	Philips	1206CG101J9BB-	46-21000-080	1
C241	10u 20% 25V 6032 TA Cap	AVX	TAJC106M025R	47-11002-520	1
C242	33n 10% 100V X7R 1206 NiSn	Philips	12062R333K0BB-	46-43300-280	1
C243	1u 20% 35V 3528 TA Cap	AVX	TAJB105M035R	47-01003-520	1

08-05261-001 - RF/IF PCB

BOM Revision
Date Valid On

12 -- Production
27.09.2006

Ref	Description	Manufacturer	Manufacturer's P/N	Codan P/N	Qty
C244	10u 20% 25V 6032 TA Cap	AVX	TAJC106M025R	47-11002-520	1
C245	33n 10% 100V X7R 1206 NiSn	Philips	12062R333K0BB-	46-43300-280	1
C246	3,3n 10% 100V X7R 1206 NiSn	Philips	12062R332K0BB-	46-33300-280	1
C247	3,3n 10% 100V X7R 1206 NiSn	Philips	12062R332K0BB-	46-33300-280	1
C248	10n 10% 100V X7R 1206 NiSn	Philips	12062R103K0BB-	46-41000-280	1
C249	10n 10% 100V X7R 1206 NiSn	Philips	12062R103K0BB-	46-41000-280	1
C250	10p 5% 50V NPO 1206 NiSn	Philips	1206CG100J9BB-	46-11000-080	1
C251	33n 10% 100V X7R 1206 NiSn	Philips	12062R333K0BB-	46-43300-280	1
C252	33n 10% 100V X7R 1206 NiSn	Philips	12062R333K0BB-	46-43300-280	1
C253	1u 20% 35V 3528 TA Cap	AVX	TAJB105M035R	47-01003-520	1
C254	10u 20% 25V 6032 TA Cap	AVX	TAJC106M025R	47-11002-520	1
C255	33n 10% 100V X7R 1206 NiSn	Philips	12062R333K0BB-	46-43300-280	1
C256	10u 20% 25V 6032 TA Cap	AVX	TAJC106M025R	47-11002-520	1
C257	10u 20% 25V 6032 TA Cap	AVX	TAJC106M025R	47-11002-520	1
C258	33n 10% 100V X7R 1206 NiSn	Philips	12062R333K0BB-	46-43300-280	1
C259	33n 10% 50V X7R 0805 NiSn	Philips	08052R333K9BB00	46-43300-281	1
C260	100n 10% 50V X7R 1206 NiSn	Philips	12062R104K9BB-	46-51000-281	1
C261	3,3n 10% 100V X7R 1206 NiSn	Philips	12062R332K0BB-	46-33300-280	1
C262	3,3n 10% 100V X7R 1206 NiSn	Philips	12062R332K0BB-	46-33300-280	1
C263	1u 20% 35V 3528 TA Cap	AVX	TAJB105M035R	47-01003-520	1
C265	Not Fitted	Codan	** -00000-001	99-00000-001	1
C266	33n 10% 100V X7R 1206 NiSn	Philips	12062R333K0BB-	46-43300-280	1
C267	Not Fitted	Codan	** -00000-001	99-00000-001	1
C268	Not Fitted	Codan	** -00000-001	99-00000-001	1
C269	Not Fitted	Codan	** -00000-001	99-00000-001	1
C270	Not Fitted	Codan	** -00000-001	99-00000-001	1
C271	1n 5% 50V NPO 1206 NiSn	Philips	1206CG102J9BB-	46-31000-081	1
C272	33n 10% 100V X7R 1206 NiSn	Philips	12062R333K0BB-	46-43300-280	1
C273	33n 10% 100V X7R 1206 NiSn	Philips	12062R333K0BB-	46-43300-280	1
C274	10u 20% 25V 6032 TA Cap	AVX	TAJC106M025R	47-11002-520	1
C275	33n 10% 100V X7R 1206 NiSn	Philips	12062R333K0BB-	46-43300-280	1

08-05261-001 - RF/IF PCB

BOM Revision
Date Valid On

12 -- Production
27.09.2006

Ref	Description	Manufacturer	Manufacturer's P/N	Codan P/N	Qty
C276	1u 20% 35V 3528 TA Cap	AVX	TAJB105M035R	47-01003-520	1
C277	47p 5% 50V NPO 1206 NiSn	Philips	1206CG470J9BB-	46-14700-081	1
C401	100p 5% 50V NPO 1206 NiSn	Philips	1206CG101J9BB-	46-21000-080	1
C402	1n 5% 50V NPO 1206 NiSn	Philips	1206CG102J9BB-	46-31000-081	1
C403	1p 0,25p 50V NPO 1206 NiSn	Philips	1206CG109C9BB-	46-01000-080	1
C404	4,7p 0,25p 50V NPO 1206 NiSn	Philips	1206CG479C9BB-	46-04700-080	1
C405	3,3n 10% 100V X7R 1206 NiSn	Philips	12062R332K0BB-	46-33300-280	1
C406	1p 0,25p 50V NPO 1206 NiSn	Philips	1206CG109C9BB-	46-01000-080	1
C407	3,3n 10% 100V X7R 1206 NiSn	Philips	12062R332K0BB-	46-33300-280	1
C408	3,3n 10% 100V X7R 1206 NiSn	Philips	12062R332K0BB-	46-33300-280	1
C409	3,3n 10% 100V X7R 1206 NiSn	Philips	12062R332K0BB-	46-33300-280	1
C410	10u 20% 25V 6032 TA Cap	AVX	TAJC106M025R	47-11002-520	1
C411	10u 20% 25V 6032 TA Cap	AVX	TAJC106M025R	47-11002-520	1
C412	3,3n 10% 100V X7R 1206 NiSn	Philips	12062R332K0BB-	46-33300-280	1
C413	10u 20% 25V 6032 TA Cap	AVX	TAJC106M025R	47-11002-520	1
C414	3,3n 10% 100V X7R 1206 NiSn	Philips	12062R332K0BB-	46-33300-280	1
C415	3,3n 10% 100V X7R 1206 NiSn	Philips	12062R332K0BB-	46-33300-280	1
C416	3,3n 10% 100V X7R 1206 NiSn	Philips	12062R332K0BB-	46-33300-280	1
C417	10u 20% 35V 7343 TA Cap	AVX	TAJD106M035R	47-11003-521	1
C418	1u 10% 63V PE Cap	Philips	2222 370 11105	46-61000-521	1
C419	100n 10% 50V X7R 1206 NiSn	Philips	12062R104K9BB-	46-51000-281	1
C420	1u 20% 35V 3528 TA Cap	AVX	TAJB105M035R	47-01003-520	1
C421	15p 5% 50V NPO 1206 NiSn	Philips	1206CG150J9BB-	46-11500-080	1
C422	33n 10% 100V X7R 1206 NiSn	Philips	12062R333K0BB-	46-43300-280	1
C423	3,3n 10% 100V X7R 1206 NiSn	Philips	12062R332K0BB-	46-33300-280	1
C424	33n 10% 100V X7R 1206 NiSn	Philips	12062R333K0BB-	46-43300-280	1
C425	15p 5% 50V NPO 1206 NiSn	Philips	1206CG150J9BB-	46-11500-080	1
C426	1u 20% 35V 3528 TA Cap	AVX	TAJB105M035R	47-01003-520	1
C427	3,3n 10% 100V X7R 1206 NiSn	Philips	12062R332K0BB-	46-33300-280	1

08-05261-001 - RF/IF PCB

BOM Revision
Date Valid On

12 -- Production
27.09.2006

Ref	Description	Manufacturer	Manufacturer's P/N	Codan P/N	Qty
C428	3,3n 10% 100V X7R 1206 NiSn	Philips	12062R332K0BB-	46-33300-280	1
C429	3,3n 10% 100V X7R 1206 NiSn	Philips	12062R332K0BB-	46-33300-280	1
C430	3,3n 10% 100V X7R 1206 NiSn	Philips	12062R332K0BB-	46-33300-280	1
C431	3,3n 10% 100V X7R 1206 NiSn	Philips	12062R332K0BB-	46-33300-280	1
C432	33n 10% 100V X7R 1206 NiSn	Philips	12062R333K0BB-	46-43300-280	1
C433	33n 10% 100V X7R 1206 NiSn	Philips	12062R333K0BB-	46-43300-280	1
C434	100p 5% 50V NPO 1206 NiSn	Philips	1206CG101J9BB-	46-21000-080	1
C435	1n 5% 50V NPO 1206 NiSn	Philips	1206CG102J9BB-	46-31000-081	1
C436	10u 20% 35V 7343 TA Cap	AVX	TAJD106M035R	47-11003-521	1
C437	3,3n 10% 100V X7R 1206 NiSn	Philips	12062R332K0BB-	46-33300-280	1
C438	10u 20% 35V 7343 TA Cap	AVX	TAJD106M035R	47-11003-521	1
C439	10u 20% 35V 7343 TA Cap	AVX	TAJD106M035R	47-11003-521	1
C440	10u 20% 35V 7343 TA Cap	AVX	TAJD106M035R	47-11003-521	1
C441	10u 20% 35V 7343 TA Cap	AVX	TAJD106M035R	47-11003-521	1
C442	10u 20% 35V 7343 TA Cap	AVX	TAJD106M035R	47-11003-521	1
C443	3,3n 10% 100V X7R 1206 NiSn	Philips	12062R332K0BB-	46-33300-280	1
C444	3,3n 10% 100V X7R 1206 NiSn	Philips	12062R332K0BB-	46-33300-280	1
C445	3,3n 10% 100V X7R 1206 NiSn	Philips	12062R332K0BB-	46-33300-280	1
C446	10u 20% 25V 6032 TA Cap	AVX	TAJC106M025R	47-11002-520	1
C447	3,3n 10% 100V X7R 1206 NiSn	Philips	12062R332K0BB-	46-33300-280	1
C448	68p 2% 100V N750 CE Cap	Philips	2222 680 58689	46-16800-013	1
C449	33p 2% 100V NPO CE Cap	Philips	2222 680 10339	46-13300-011	1
C450	3,3n 10% 100V X7R 1206 NiSn	Philips	12062R332K0BB-	46-33300-280	1
C451	4,5-20p Ceramic Trim Cap SMD	Voltronics	JZ200	49-51200	1
C452	27p 5% 50V NPO 1206 NiSn	Philips	1206CG270J9BB-	46-12700-081	1
C453	SOT 5% 50V NPO 1206 NiSn	Philips	1206CG	46-00000-080	1
C454	33n 10% 100V X7R 1206 NiSn	Philips	12062R333K0BB-	46-43300-280	1
C455	3,3n 10% 100V X7R 1206 NiSn	Philips	12062R332K0BB-	46-33300-280	1
C456	33p 5% 50V NPO 1206 NiSn	Philips	1206CG330J9BB-	46-13300-080	1

08-05261-001 - RF/IF PCB

BOM Revision
Date Valid On

12 -- Production
27.09.2006

Ref	Description	Manufacturer	Manufacturer's P/N	Codan P/N	Qty
C457	3,3n 10% 100V X7R 1206 NiSn	Philips	12062R332K0BB-	46-33300-280	1
C458	3,3n 10% 100V X7R 1206 NiSn	Philips	12062R332K0BB-	46-33300-280	1
C459	39p 5% 50V NPO 1206 NiSn	Philips	1206CG390J9BB-	46-13900-080	1
C460	3,3n 10% 100V X7R 1206 NiSn	Philips	12062R332K0BB-	46-33300-280	1
C461	33p 5% 50V NPO 1206 NiSn	Philips	1206CG330J9BB-	46-13300-080	1
C462	3,3n 10% 100V X7R 1206 NiSn	Philips	12062R332K0BB-	46-33300-280	1
C463	330p 5% 50V NPO 1206 NiSn	Philips	1206CG331J9BB-	46-23300-080	1
C464	33n 10% 100V X7R 1206 NiSn	Philips	12062R333K0BB-	46-43300-280	1
C465	33n 10% 100V X7R 1206 NiSn	Philips	12062R333K0BB-	46-43300-280	1
C466	33n 10% 100V X7R 1206 NiSn	Philips	12062R333K0BB-	46-43300-280	1
C467	33n 10% 100V X7R 1206 NiSn	Philips	12062R333K0BB-	46-43300-280	1
C468	1n 5% 50V NPO 1206 NiSn	Philips	1206CG102J9BB-	46-31000-081	1
C469	1n 5% 50V NPO 1206 NiSn	Philips	1206CG102J9BB-	46-31000-081	1
C470	33n 10% 50V X7R 0805 NiSn	Philips	08052R333K9BB00	46-43300-281	1
C471	47p 5% 50V NPO 1206 NiSn	Philips	1206CG470J9BB-	46-14700-081	1
C472	150p 5% 50V NPO 0805 NiSn	Philips	0805CG151J9BB-	46-21500-081	1
C473	150p 5% 50V NPO 0805 NiSn	Philips	0805CG151J9BB-	46-21500-081	1
C474	150p 5% 50V NPO 0805 NiSn	Philips	0805CG151J9BB-	46-21500-081	1
C475	150p 5% 50V NPO 0805 NiSn	Philips	0805CG151J9BB-	46-21500-081	1
C476	33n 10% 100V X7R 1206 NiSn	Philips	12062R333K0BB-	46-43300-280	1
C477	22p 5% 50V NPO 1206 NiSn	Philips	1206CG220J9BB-	46-12200-080	1
C478	10u 20% 25V 6032 TA Cap	AVX	TAJC106M025R	47-11002-520	1
D101	Diode, Band Switch Si SOD80	Philips	BA423L	BA423L	1
D102	Diode, Si High speed 75V SOT23	Philips	BAS16	BAS16	1
D103	Diode, Si High speed 75V SOT23	Philips	BAS16	BAS16	1
D104	Diode, Pin atten, dual com K SOT23	HP	HSMP-3814	HSMP-3814	1
D201	Diode, Si High speed 75V SOT23	Philips	BAS16	BAS16	1
D204	Diode, Si High speed 75V SOT23	Philips	BAS16	BAS16	1
D205	Diode, Si High speed 75V SOT23	Philips	BAS16	BAS16	1

08-05261-001 - RF/IF PCB

BOM Revision
Date Valid On

12 -- Production
27.09.2006

Ref	Description	Manufacturer	Manufacturer's P/N	Codan P/N	Qty
D206	Diode, Schottky 70V 70mA SOT23	Siemens	BAS70	BAS70	1
D207	Diode, Si High speed 75V SOT23	Philips	BAS16	BAS16	1
D208	Diode, Si High speed 75V SOT23	Philips	BAS16	BAS16	1
D209	Diode, Si High speed 75V SOT23	Philips	BAS16	BAS16	1
D210	Diode, Si High speed 75V SOT23	Philips	BAS16	BAS16	1
D212	Diode, Si High speed 75V SOT23	Philips	BAS16	BAS16	1
D401	Diode, Tuner Si SOD323	Siemens	BB639-E6327	BB639	1
D402	Diode, Tuner Si SOD323	Siemens	BB639-E6327	BB639	1
D403	Diode, Tuner Si SOD323	Siemens	BB639-E6327	BB639	1
D404	Diode, Tuner Si SOD323	Siemens	BB639-E6327	BB639	1
D405	Diode, Schottky 70V 70mA SOT23	Siemens	BAS70	BAS70	1
D406	Diode, Si High speed 75V SOT23	Philips	BAS16	BAS16	1
D407	Diode, Si High speed 75V SOT23	Philips	BAS16	BAS16	1
D408	Diode, Si High speed 75V SOT23	Philips	BAS16	BAS16	1
D409	Diode, Si High speed 75V SOT23	Philips	BAS16	BAS16	1
D410	Diode, Si High speed 75V SOT23	Philips	BAS16	BAS16	1
IC101	Mixer, High level IC	Philips	23-30012	23-30012	1
IC102	Mixer, High level IC	Philips	23-30012	23-30012	1
IC103	Mixer, High level IC	Philips	23-30012	23-30012	1
IC201	Amp, RF/AGC SOIC8	Motorola	MC1350D	XA-01350-700	1
IC202	Gate, NAND 2 Input Quad SOIC14	Philips	HEF4011BTD	YG-40011-700	1
IC203	Array, Transistor SOIC14	Motorola	MC3346D	XT-03346-700	1
IC204	Modulator, Balanced SOIC14	Motorola	MC1496D	XA-01496-700	1
IC205	Amp, Operational Dual SOIC8	National Semiconduct	LM358M	XA-00358-700	1
IC206	Diode, Ref 2,5V 2% SOIC8	National Semiconduct	LM336M-2,5	XB-00336-700	1
IC207	Array, Transistor SOIC14	Motorola	MC3346D	XT-03346-700	1
IC208	Modulator, Balanced SOIC14	Motorola	MC1496D	XA-01496-700	1
IC209	Amp, Operational Dual SOIC8	National Semiconduct	LM358M	XA-00358-700	1
IC210	Reg, Voltage +5V 1A TO263_3	National Semiconduct	LM7805S	XB-07805-701	1
IC401	Synthesiser, Freq SOIC16	Motorola	MC145170D2	MC145170D1	1

08-05261-001 - RF/IF PCB

BOM Revision
Date Valid On

12 -- Production
27.09.2006

Ref	Description	Manufacturer	Manufacturer's P/N	Codan P/N	Qty
IC402	Buffer, Hex Inverting Schmitt SOIC14	Philips	HEF40106BT	YG-40106-700	1
IC403	Direct digital synthesiser SSOP28	Analog Devices	AD9850BRS	YL-09850-700	1
IC404	Direct digital synthesiser SSOP28	Analog Devices	AD9850BRS	YL-09850-700	1
IC405	Micro prgmd, RFU RF/IF I/O	Codan	90-20592-001	90-20592-001	1
J1	Socket, Coax Mini Low Prof Fixed	Taiko Denki	TMP-J02X-A1	60-19390-002	1
J2	Socket, Coax Mini Low Prof Fixed	Taiko Denki	TMP-J02X-A1	60-19390-002	1
K101	Relay, 2C 12V 2A SMD 1028 Ohm	Matsushita	TQ2SL-12V	64-21225-310	1
K201	Not Fitted	Codan	**-00000-001	99-00000-001	1
K202	Not Fitted	Codan	**-00000-001	99-00000-001	1
L101	Ind, 4,7uH 10% 4532	Taiyo Yuden	LEM4532T4R7K	43-80470-000	1
L102	Ind, 10uH 10% 3225	TOKO	380KB-100K	43-81100-001	1
L103	Ind, 100uH 10% 4532	Taiyo Yuden	LEM 4532T101K	43-82100-134	1
L104	Ind, 100uH 10% 4532	Taiyo Yuden	LEM 4532T101K	43-82100-134	1
L105	Ind, 220nH 20% 4532	Taiyo Yuden	LEM4532TR22M	43-80022-000	1
L106	Ind	Koilkraft	44-70490	44-70490	1
L107	Ind, 470nH 20% 4532	Taiyo Yuden	LEM4532TR47M	43-80047-001	1
L108	Ind, 220nH 20% 4532	Taiyo Yuden	LEM4532TR22M	43-80022-000	1
L109	Ind, 4,7uH 10% 4532	Taiyo Yuden	LEM4532T4R7K	43-80470-000	1
L110	Ind, 45MHz roofing filter	Codan	44-70452	44-70452	1
L111	Ind, 45MHz roofing filter	Codan	44-70452	44-70452	1
L112	Ind, 4,7uH 10% 4532	Taiyo Yuden	LEM4532T4R7K	43-80470-000	1
L113	Ind, 330nH 20% 4532	Taiyo Yuden	LEM4532TR33M	43-80033-000	1
L114	Ind	Koilkraft	44-70490	44-70490	1
L115	Ind, 390nH 20% 4532	Taiyo Yuden	LEM4532TR39M	43-80039-001	1
L116	Ind, 100uH 10% 4532	Taiyo Yuden	LEM 4532T101K	43-82100-134	1
L117	Ind, 45MHz roofing filter	Codan	44-70452	44-70452	1
L118	Ind, 4,7uH 10% 4532	Taiyo Yuden	LEM4532T4R7K	43-80470-000	1
L119	Ind, 100nH 20% 3225	TOKO	380NB-R10M	43-80010-000	1
L201	Ind, 1mH 10% 1812	Coilcraft	1812LS-105XKBC	43-83100-000	1
L202	Ind, 1mH 10% 1812	Coilcraft	1812LS-105XKBC	43-83100-000	1
L203	Ind, 1mH 10% 1812	Coilcraft	1812LS-105XKBC	43-83100-000	1
L204	Ind, 1mH 10% 1812	Coilcraft	1812LS-105XKBC	43-83100-000	1
L205	Choke, EMI/EMC 0A DC >1MHz 4516	Taiyo Yuden	FCFBMJ 4516 HS 110-T	43-90003	1
L206	Choke, EMI/EMC 0A DC >1MHz 4516	Taiyo Yuden	FCFBMJ 4516 HS 110-T	43-90003	1
L207	Choke, EMI/EMC 0A DC >1MHz 4516	Taiyo Yuden	FCFBMJ 4516 HS 110-T	43-90003	1
L401	Ind, 10uH 10% 3225	TOKO	380KB-100K	43-81100-001	1
L402	Ind, Common Mode 1.5A	Taiyo Yuden	CM05RA06	43-80000	1
L403	Ind, VCO	Protran	44-70488	44-70488	1
L404	Ind, 10uH 10% 3225	TOKO	380KB-100K	43-81100-001	1
L405	Ind, Common Mode 1.5A	Taiyo Yuden	CM05RA06	43-80000	1
L406	Ind, Common Mode 1.5A	Taiyo Yuden	CM05RA06	43-80000	1
L407	Ind, 100uH 10% 4532	Taiyo Yuden	LEM 4532T101K	43-82100-134	1
L408	Ind, 10uH 10% 3225	TOKO	380KB-100K	43-81100-001	1
L409	Ind	Koilkraft	44-70492	44-70492	1
L410	Ind, 100uH 10% 4532	Taiyo Yuden	LEM 4532T101K	43-82100-134	1
L411	Ind, 120nH 5% 3028	Coilcraft	1008CS-121XJBB	43-80012-000	1
L412	Ind, 330nH 10% 3028	Coilcraft	1008CS-331XKBC	43-80033-001	1
L413	Ind, 330nH 20% 4532	Taiyo Yuden	LEM4532TR33M	43-80033-000	1

08-05261-001 - RF/IF PCB

BOM Revision
Date Valid On

12 -- Production
27.09.2006

Ref	Description	Manufacturer	Manufacturer's P/N	Codan P/N	Qty
P1	Header (P) 16way 2row Boxed	Thomas & Betts	609-1627	60-00160-000	1
P201	Header (P) 4way 1row	Molex	22-03-2041	60-00041-100	1
P401	Not Fitted	Codan	** -00000-001	99-00000-001	1
R101	4,7k Ohm 5% 0,125W 1206	Philips	2322 711 61472	40-34700-101	1
R102	4,7k Ohm 5% 0,125W 1206	Philips	2322 711 61472	40-34700-101	1
R103	3,3k Ohm 5% 0,125W 1206	Philips	2322 711 61332	40-33300-101	1
R104	8,2k Ohm 5% 0,125W 1206	Philips	2322 711 61822	40-38200-101	1
R105	100 Ohm 5% 0,125W 1206	Philips	2322 711 61101	40-21000-101	1
R106	68 Ohm 5% 0,125W 1206	Philips	2322 711 61689	40-16800-101	1
R107	100 Ohm 5% 0,125W 1206	Philips	2322 711 61101	40-21000-101	1
R108	220 Ohm 5% 0,125W 1206	Philips	2322 711 61221	40-22200-101	1
R109	10k Ohm 5% 0,125W 1206	Philips	2322 711 61103	40-41000-101	1
R110	100 Ohm 5% 0,125W 1206	Philips	2322 711 61101	40-21000-101	1
R111	150 Ohm 5% 0,125W 1206	Philips	2322 711 61151	40-21500-101	1
R112	150 Ohm 5% 0,125W 1206	Philips	2322 711 61151	40-21500-101	1
R113	220 Ohm 5% 0,125W 1206	Philips	2322 711 61221	40-22200-101	1
R114	22 Ohm 5% 0,125W 1206	Philips	2322 711 61229	40-12200-101	1
R115	22 Ohm 5% 0,125W 1206	Philips	2322 711 61229	40-12200-101	1
R116	1k Ohm 5% 0,125W 1206	Philips	2322 711 61102	40-31000-101	1
R117	220 Ohm 5% 0,125W 1206	Philips	2322 711 61221	40-22200-101	1
R118	68k Ohm 5% 0,125W 1206	Philips	2322 711 61683	40-46800-101	1
R119	82k Ohm 5% 0,125W 1206	Philips	2322 711 61823	40-48200-101	1
R120	82k Ohm 5% 0,125W 1206	Philips	2322 711 61823	40-48200-101	1
R121	3,9k Ohm 5% 0,125W 1206	Philips	2322 711 61392	40-33900-101	1
R122	100 Ohm 5% 0,125W 1206	Philips	2322 711 61101	40-21000-101	1
R123	100 Ohm 5% 0,125W 1206	Philips	2322 711 61101	40-21000-101	1
R124	82k Ohm 5% 0,125W 1206	Philips	2322 711 61823	40-48200-101	1
R125	330 Ohm 5% 0,125W 1206	Philips	2322 711 61331	40-23300-101	1
R126	150 Ohm 5% 0,125W 1206	Philips	2322 711 61151	40-21500-101	1
R127	3,9k Ohm 5% 0,125W 1206	Philips	2322 711 61392	40-33900-101	1

08-05261-001 - RF/IF PCB

BOM Revision
Date Valid On

12 -- Production
27.09.2006

Ref	Description	Manufacturer	Manufacturer's P/N	Codan P/N	Qty
R128	10k Ohm 5% 0,125W 1206	Philips	2322 711 61103	40-41000-101	1
R129	100 Ohm 5% 0,125W 1206	Philips	2322 711 61101	40-21000-101	1
R130	100 Ohm 5% 0,125W 1206	Philips	2322 711 61101	40-21000-101	1
R131	270 Ohm 5% 0,125W 1206	Philips	2322 711 61271	40-22700-101	1
R132	220 Ohm 5% 0,125W 1206	Philips	2322 711 61221	40-22200-101	1
R133	180 Ohm 5% 0,125W 1206	Philips	2322 711 61181	40-21800-101	1
R134	150 Ohm 5% 0,125W 1206	Philips	2322 711 61151	40-21500-101	1
R135	180 Ohm 5% 0,125W 1206	Philips	2322 711 61181	40-21800-101	1
R136	180 Ohm 5% 0,125W 1206	Philips	2322 711 61181	40-21800-101	1
R137	10k Ohm 5% 0,125W 1206	Philips	2322 711 61103	40-41000-101	1
R138	Pot,100k Lin MG Trim SMD	Bourns	3314 J-1-104	42-51060-001	1
R139	10k Ohm 5% 0,125W 1206	Philips	2322 711 61103	40-41000-101	1
R140	10 Ohm 5% 0,06W 0603	Philips	2322 702 60109	40-11000-121	1
R141	1k Ohm 5% 0,125W 1206	Philips	2322 711 61102	40-31000-101	1
R142	220 Ohm 5% 0,125W 1206	Philips	2322 711 61221	40-22200-101	1
R143	270 Ohm 5% 0,125W 1206	Philips	2322 711 61271	40-22700-101	1
R144	470 Ohm 5% 0,125W 1206	Philips	2322 711 61471	40-24700-101	1
R145	470 Ohm 5% 0,125W 1206	Philips	2322 711 61471	40-24700-101	1
R146	470 Ohm 5% 0,125W 1206	Philips	2322 711 61471	40-24700-101	1
R201	47 Ohm 5% 0,125W 1206	Philips	2322 711 61479	40-14700-101	1
R202	47 Ohm 5% 0,125W 1206	Philips	2322 711 61479	40-14700-101	1
R203	22k Ohm 5% 0,125W 1206	Philips	2322 711 61223	40-42200-101	1
R204	10k Ohm 5% 0,125W 1206	Philips	2322 711 61103	40-41000-101	1
R205	100k Ohm 5% 0,125W 1206	Philips	2322 711 61104	40-51000-101	1
R206	1k Ohm 5% 0,125W 1206	Philips	2322 711 61102	40-31000-101	1
R207	100 Ohm 5% 0,125W 1206	Philips	2322 711 61101	40-21000-101	1
R208	10k Ohm 5% 0,125W 1206	Philips	2322 711 61103	40-41000-101	1
R209	47k Ohm 5% 0,125W 1206	Philips	2322 711 61473	40-44700-101	1
R210	22k Ohm 5% 0,125W 1206	Philips	2322 711 61223	40-42200-101	1

08-05261-001 - RF/IF PCB

BOM Revision
Date Valid On

12 -- Production
27.09.2006

Ref	Description	Manufacturer	Manufacturer's P/N	Codan P/N	Qty
R211	100k Ohm 5% 0,125W 1206	Philips	2322 711 61104	40-51000-101	1
R212	22k Ohm 5% 0,125W 1206	Philips	2322 711 61223	40-42200-101	1
R213	10k Ohm 5% 0,125W 1206	Philips	2322 711 61103	40-41000-101	1
R214	1k Ohm 5% 0,125W 1206	Philips	2322 711 61102	40-31000-101	1
R215	1k Ohm 5% 0,125W 1206	Philips	2322 711 61102	40-31000-101	1
R216	10 Ohm 5% 0,06W 0603	Philips	2322 702 60109	40-11000-121	1
R217	Pot,10k Lin MG Trim SMD	Bourns	3314 J-1-103	42-41004-000	1
R218	1k Ohm 5% 0,125W 1206	Philips	2322 711 61102	40-31000-101	1
R219	1M Ohm 5% 0,125W 1206	Philips	2322 711 61105	40-61000-101	1
R220	68k Ohm 5% 0,125W 1206	Philips	2322 711 61683	40-46800-101	1
R221	100k Ohm 5% 0,125W 1206	Philips	2322 711 61104	40-51000-101	1
R222	0 Ohm Jumper 1206	Philips	2322 711 90001	40-00001-101	1
R223	Not Fitted	Codan	** -00000-001	99-00000-001	1
R224	Not Fitted	Codan	** -00000-001	99-00000-001	1
R225	1,8k Ohm 5% 0,125W 1206	Philips	2322 711 61182	40-31800-101	1
R226	3,3k Ohm 5% 0,125W 1206	Philips	2322 711 61332	40-33300-101	1
R227	1k Ohm 5% 0,125W 1206	Philips	2322 711 61102	40-31000-101	1
R228	4,7k Ohm 5% 0,125W 1206	Philips	2322 711 61472	40-34700-101	1
R229	2,2k Ohm 5% 0,125W 1206	Philips	2322 711 61222	40-32200-101	1
R230	100 Ohm 5% 0,125W 1206	Philips	2322 711 61101	40-21000-101	1
R231	10k Ohm 5% 0,125W 1206	Philips	2322 711 61103	40-41000-101	1
R232	100 Ohm 5% 0,125W 1206	Philips	2322 711 61101	40-21000-101	1
R233	6,8k Ohm 5% 0,125W 1206	Philips	2322 711 61682	40-36800-101	1
R234	10k Ohm 5% 0,125W 1206	Philips	2322 711 61103	40-41000-101	1
R235	47k Ohm 5% 0,125W 1206	Philips	2322 711 61473	40-44700-101	1
R236	5,6k Ohm 5% 0,125W 1206	Philips	2322 711 61562	40-35600-101	1
R237	2,2k Ohm 5% 0,125W 1206	Philips	2322 711 61222	40-32200-101	1
R238	150 Ohm 5% 0,125W 1206	Philips	2322 711 61151	40-21500-101	1
R239	22k Ohm 5% 0,125W 1206	Philips	2322 711 61223	40-42200-101	1
R240	2,2k Ohm 5% 0,125W 1206	Philips	2322 711 61222	40-32200-101	1

08-05261-001 - RF/IF PCB

BOM Revision
Date Valid On

12 -- Production
27.09.2006

Ref	Description	Manufacturer	Manufacturer's P/N	Codan P/N	Qty
R241	1M Ohm 5% 0,125W 1206	Philips	2322 711 61105	40-61000-101	1
R242	220 Ohm 5% 0,125W 1206	Philips	2322 711 61221	40-22200-101	1
R243	3,3k Ohm 5% 0,125W 1206	Philips	2322 711 61332	40-33300-101	1
R244	220 Ohm 5% 0,125W 1206	Philips	2322 711 61221	40-22200-101	1
R245	3,3k Ohm 5% 0,125W 1206	Philips	2322 711 61332	40-33300-101	1
R246	220 Ohm 5% 0,125W 1206	Philips	2322 711 61221	40-22200-101	1
R247	33k Ohm 5% 0,125W 1206	Philips	2322 711 61333	40-43300-101	1
R248	6,8k Ohm 5% 0,125W 1206	Philips	2322 711 61682	40-36800-101	1
R249	100 Ohm 5% 0,125W 1206	Philips	2322 711 61101	40-21000-101	1
R250	330 Ohm 5% 0,125W 1206	Philips	2322 711 61331	40-23300-101	1
R252	680 Ohm 10% NTC Thermistor	Philips	2322 640 63681	41-02684-642	1
R253	470 Ohm 5% 0,125W 1206	Philips	2322 711 61471	40-24700-101	1
R254	5,6k Ohm 5% 0,125W 1206	Philips	2322 711 61562	40-35600-101	1
R255	10k Ohm 5% 0,125W 1206	Philips	2322 711 61103	40-41000-101	1
R256	Pot,10k Lin MG Trim SMD	Bourns	3314 J-1-103	42-41004-000	1
R257	10k Ohm 5% 0,125W 1206	Philips	2322 711 61103	40-41000-101	1
R258	8,2k Ohm 5% 0,125W 1206	Philips	2322 711 61822	40-38200-101	1
R259	3,3k Ohm 5% 0,125W 1206	Philips	2322 711 61332	40-33300-101	1
R260	10 Ohm 5% 0,06W 0603	Philips	2322 702 60109	40-11000-121	1
R261	1k Ohm 5% 0,125W 1206	Philips	2322 711 61102	40-31000-101	1
R262	1k Ohm 5% 0,125W 1206	Philips	2322 711 61102	40-31000-101	1
R263	10k Ohm 5% 0,125W 1206	Philips	2322 711 61103	40-41000-101	1
R264	82k Ohm 5% 0,125W 1206	Philips	2322 711 61823	40-48200-101	1
R265	0 Ohm Jumper 1206	Philips	2322 711 90001	40-00001-101	1
R266	100k Ohm 5% 0,125W 1206	Philips	2322 711 61104	40-51000-101	1
R267	10k Ohm 5% 0,125W 1206	Philips	2322 711 61103	40-41000-101	1
R268	100k Ohm 5% 0,125W 1206	Philips	2322 711 61104	40-51000-101	1
R269	100k Ohm 5% 0,125W 1206	Philips	2322 711 61104	40-51000-101	1
R270	4,7k Ohm 5% 0,125W 1206	Philips	2322 711 61472	40-34700-101	1

08-05261-001 - RF/IF PCB

BOM Revision
Date Valid On

12 -- Production
27.09.2006

Ref	Description	Manufacturer	Manufacturer's P/N	Codan P/N	Qty
R271	3,3k Ohm 5% 0,125W 1206	Philips	2322 711 61332	40-33300-101	1
R272	22k Ohm 5% 0,125W 1206	Philips	2322 711 61223	40-42200-101	1
R273	18k Ohm 5% 0,125W 1206	Philips	2322 711 61183	40-41800-101	1
R274	18k Ohm 5% 0,125W 1206	Philips	2322 711 61183	40-41800-101	1
R275	0 Ohm Jumper 1206	Philips	2322 711 90001	40-00001-101	1
R276	100 Ohm 5% 0,125W 1206	Philips	2322 711 61101	40-21000-101	1
R277	1k Ohm 5% 0,125W 1206	Philips	2322 711 61102	40-31000-101	1
R278	0 Ohm Jumper 1206	Philips	2322 711 90001	40-00001-101	1
R279	10k Ohm 5% 0,125W 1206	Philips	2322 711 61103	40-41000-101	1
R280	220k Ohm 5% 0,125W 1206	Philips	2322 711 61224	40-52200-101	1
R281	22k Ohm 5% 0,125W 1206	Philips	2322 711 61223	40-42200-101	1
R282	100k Ohm 5% 0,125W 1206	Philips	2322 711 61104	40-51000-101	1
R283	1M Ohm 5% 0,125W 1206	Philips	2322 711 61105	40-61000-101	1
R284	100k Ohm 5% 0,125W 1206	Philips	2322 711 61104	40-51000-101	1
R285	47k Ohm 5% 0,125W 1206	Philips	2322 711 61473	40-44700-101	1
R286	1M Ohm 5% 0,125W 1206	Philips	2322 711 61105	40-61000-101	1
R287	10k Ohm 5% 0,125W 1206	Philips	2322 711 61103	40-41000-101	1
R288	100k Ohm 5% 0,125W 1206	Philips	2322 711 61104	40-51000-101	1
R289	8,2k Ohm 5% 0,125W 1206	Philips	2322 711 61822	40-38200-101	1
R290	18k Ohm 5% 0,125W 1206	Philips	2322 711 61183	40-41800-101	1
R291	1,2k Ohm 5% 0,125W 1206	Philips	2322 711 61122	40-31200-101	1
R292	1,8k Ohm 5% 0,125W 1206	Philips	2322 711 61182	40-31800-101	1
R293	100 Ohm 5% 0,125W 1206	Philips	2322 711 61101	40-21000-101	1
R294	18k Ohm 5% 0,125W 1206	Philips	2322 711 61183	40-41800-101	1
R295	100k Ohm 5% 0,125W 1206	Philips	2322 711 61104	40-51000-101	1
R296	10k Ohm 5% 0,125W 1206	Philips	2322 711 61103	40-41000-101	1
R297	10k Ohm 5% 0,125W 1206	Philips	2322 711 61103	40-41000-101	1
R298	4,7k Ohm 5% 0,125W 1206	Philips	2322 711 61472	40-34700-101	1
R299	100 Ohm 5% 0,125W 1206	Philips	2322 711 61101	40-21000-101	1
R300	100 Ohm 5% 0,125W 1206	Philips	2322 711 61101	40-21000-101	1

08-05261-001 - RF/IF PCB

BOM Revision
Date Valid On

12 -- Production
27.09.2006

Ref	Description	Manufacturer	Manufacturer's P/N	Codan P/N	Qty
R301	100 Ohm 5% 0,125W 1206	Philips	2322 711 61101	40-21000-101	1
R302	100 Ohm 5% 0,125W 1206	Philips	2322 711 61101	40-21000-101	1
R303	10k Ohm 5% 0,125W 1206	Philips	2322 711 61103	40-41000-101	1
R304	1M Ohm 5% 0,125W 1206	Philips	2322 711 61105	40-61000-101	1
R305	2,2k Ohm 5% 0,125W 1206	Philips	2322 711 61222	40-32200-101	1
R401	220 Ohm 5% 0,125W 1206	Philips	2322 711 61221	40-22200-101	1
R402	1M Ohm 5% 0,125W 1206	Philips	2322 711 61105	40-61000-101	1
R403	22k Ohm 5% 0,125W 1206	Philips	2322 711 61223	40-42200-101	1
R404	470 Ohm 5% 0,125W 1206	Philips	2322 711 61471	40-24700-101	1
R405	100 Ohm 5% 0,125W 1206	Philips	2322 711 61101	40-21000-101	1
R406	22k Ohm 5% 0,125W 1206	Philips	2322 711 61223	40-42200-101	1
R407	470 Ohm 5% 0,125W 1206	Philips	2322 711 61471	40-24700-101	1
R408	2,2k Ohm 5% 0,125W 1206	Philips	2322 711 61222	40-32200-101	1
R409	100 Ohm 5% 0,125W 1206	Philips	2322 711 61101	40-21000-101	1
R410	100 Ohm 5% 0,125W 1206	Philips	2322 711 61101	40-21000-101	1
R411	10 Ohm 5% 0,06W 0603	Philips	2322 702 60109	40-11000-121	1
R412	470 Ohm 5% 0,125W 1206	Philips	2322 711 61471	40-24700-101	1
R413	10 Ohm 5% 0,06W 0603	Philips	2322 702 60109	40-11000-121	1
R414	10k Ohm 5% 0,125W 1206	Philips	2322 711 61103	40-41000-101	1
R415	10 Ohm 5% 0,06W 0603	Philips	2322 702 60109	40-11000-121	1
R416	10 Ohm 5% 0,06W 0603	Philips	2322 702 60109	40-11000-121	1
R417	330 Ohm 5% 0,125W 1206	Philips	2322 711 61331	40-23300-101	1
R418	100 Ohm 5% 0,125W 1206	Philips	2322 711 61101	40-21000-101	1
R419	470 Ohm 5% 0,125W 1206	Philips	2322 711 61471	40-24700-101	1
R420	1,8k Ohm 5% 0,125W 1206	Philips	2322 711 61182	40-31800-101	1
R421	2,2k Ohm 5% 0,125W 1206	Philips	2322 711 61222	40-32200-101	1
R422	470 Ohm 5% 0,125W 1206	Philips	2322 711 61471	40-24700-101	1
R423	390 Ohm 5% 0,125W 1206	Philips	2322 711 61391	40-23900-101	1
R424	390 Ohm 5% 0,125W 1206	Philips	2322 711 61391	40-23900-101	1

08-05261-001 - RF/IF PCB

BOM Revision
Date Valid On

12 -- Production
27.09.2006

Ref	Description	Manufacturer	Manufacturer's P/N	Codan P/N	Qty
R425	100 Ohm 5% 0,125W 1206	Philips	2322 711 61101	40-21000-101	1
R426	3,9k Ohm 5% 0,125W 1206	Philips	2322 711 61392	40-33900-101	1
R427	3,9k Ohm 5% 0,125W 1206	Philips	2322 711 61392	40-33900-101	1
R428	5,6k Ohm 5% 0,125W 1206	Philips	2322 711 61562	40-35600-101	1
R429	3,9k Ohm 5% 0,125W 1206	Philips	2322 711 61392	40-33900-101	1
R430	100 Ohm 5% 0,125W 1206	Philips	2322 711 61101	40-21000-101	1
R431	4,7k Ohm 5% 0,125W 1206	Philips	2322 711 61472	40-34700-101	1
R432	6,8k Ohm 5% 0,125W 1206	Philips	2322 711 61682	40-36800-101	1
R433	4,7k Ohm 5% 0,125W 1206	Philips	2322 711 61472	40-34700-101	1
R434	1M Ohm 5% 0,125W 1206	Philips	2322 711 61105	40-61000-101	1
R435	10k Ohm 5% 0,125W 1206	Philips	2322 711 61103	40-41000-101	1
R436	330 Ohm 5% 0,125W 1206	Philips	2322 711 61331	40-23300-101	1
R437	1k Ohm 5% 0,125W 1206	Philips	2322 711 61102	40-31000-101	1
R438	100 Ohm 5% 0,125W 1206	Philips	2322 711 61101	40-21000-101	1
R439	1,8k Ohm 5% 0,125W 1206	Philips	2322 711 61182	40-31800-101	1
R440	47 Ohm 5% 0,125W 1206	Philips	2322 711 61479	40-14700-101	1
R441	10 Ohm 5% 0,06W 0603	Philips	2322 702 60109	40-11000-121	1
R442	100k Ohm 5% 0,125W 1206	Philips	2322 711 61104	40-51000-101	1
R443	100 Ohm 5% 0,125W 1206	Philips	2322 711 61101	40-21000-101	1
R444	2,2k Ohm 5% 0,125W 1206	Philips	2322 711 61222	40-32200-101	1
R445	2,2k Ohm 5% 0,125W 1206	Philips	2322 711 61222	40-32200-101	1
R446	1k Ohm 5% 0,125W 1206	Philips	2322 711 61102	40-31000-101	1
R447	22 Ohm 5% 0,125W 1206	Philips	2322 711 61229	40-12200-101	1
R448	1k Ohm 5% 0,125W 1206	Philips	2322 711 61102	40-31000-101	1
R449	10 Ohm 5% 0,06W 0603	Philips	2322 702 60109	40-11000-121	1
R450	330 Ohm 5% 0,125W 1206	Philips	2322 711 61331	40-23300-101	1
R451	1k Ohm 5% 0,125W 1206	Philips	2322 711 61102	40-31000-101	1
R452	1k Ohm 5% 0,125W 1206	Philips	2322 711 61102	40-31000-101	1
R453	100 Ohm 5% 0,125W 1206	Philips	2322 711 61101	40-21000-101	1

08-05261-001 - RF/IF PCB

BOM Revision
Date Valid On

12 -- Production
27.09.2006

Ref	Description	Manufacturer	Manufacturer's P/N	Codan P/N	Qty
R454	1k Ohm 5% 0,125W 1206	Philips	2322 711 61102	40-31000-101	1
R455	10 Ohm 5% 0,06W 0603	Philips	2322 702 60109	40-11000-121	1
R456	2,2k Ohm 5% 0,125W 1206	Philips	2322 711 61222	40-32200-101	1
R457	100 Ohm 5% 0,125W 1206	Philips	2322 711 61101	40-21000-101	1
R458	2,2k Ohm 5% 0,125W 1206	Philips	2322 711 61222	40-32200-101	1
R459	10 Ohm 5% 0,06W 0603	Philips	2322 702 60109	40-11000-121	1
R460	330 Ohm 5% 0,125W 1206	Philips	2322 711 61331	40-23300-101	1
R461	18k Ohm 5% 0,125W 1206	Philips	2322 711 61183	40-41800-101	1
R462	4,7k Ohm 5% 0,125W 1206	Philips	2322 711 61472	40-34700-101	1
R463	1k Ohm 5% 0,125W 1206	Philips	2322 711 61102	40-31000-101	1
R464	470 Ohm 5% 0,125W 1206	Philips	2322 711 61471	40-24700-101	1
R465	22 Ohm 5% 0,125W 1206	Philips	2322 711 61229	40-12200-101	1
R466	22 Ohm 5% 0,125W 1206	Philips	2322 711 61229	40-12200-101	1
R467	3,9k Ohm 5% 0,125W 1206	Philips	2322 711 61392	40-33900-101	1
R468	22 Ohm 5% 0,125W 1206	Philips	2322 711 61229	40-12200-101	1
R469	10k Ohm 5% 0,125W 1206	Philips	2322 711 61103	40-41000-101	1
R470	22 Ohm 5% 0,125W 1206	Philips	2322 711 61229	40-12200-101	1
R471	22 Ohm 5% 0,125W 1206	Philips	2322 711 61229	40-12200-101	1
R472	10k Ohm 5% 0,125W 1206	Philips	2322 711 61103	40-41000-101	1
R473	22k Ohm 5% 0,125W 1206	Philips	2322 711 61223	40-42200-101	1
R474	470 Ohm 5% 0,125W 1206	Philips	2322 711 61471	40-24700-101	1
R475	470 Ohm 5% 0,125W 1206	Philips	2322 711 61471	40-24700-101	1
R476	100 Ohm 5% 0,125W 1206	Philips	2322 711 61101	40-21000-101	1
R477	470 Ohm 5% 0,1W 0805	Philips	2322 730 61471	40-24700-111	1
R478	470 Ohm 5% 0,1W 0805	Philips	2322 730 61471	40-24700-111	1
R479	10k Ohm 5% 0,125W 1206	Philips	2322 711 61103	40-41000-101	1
R480	10k Ohm 5% 0,1W 0805	Philips	2322-730-61103	40-41000-111	1
R481	10k Ohm 5% 0,125W 1206	Philips	2322 711 61103	40-41000-101	1
R482	10k Ohm 5% 0,1W 0805	Philips	2322-730-61103	40-41000-111	1

08-05261-001 - RF/IF PCB

BOM Revision
Date Valid On

12 -- Production
27.09.2006

Ref	Description	Manufacturer	Manufacturer's P/N	Codan P/N	Qty
R483	10 Ohm 5% 0,06W 0603	Philips	2322 702 60109	40-11000-121	1
R484	10 Ohm 5% 0,06W 0603	Philips	2322 702 60109	40-11000-121	1
R485	10 Ohm 5% 0,06W 0603	Philips	2322 702 60109	40-11000-121	1
R486	10 Ohm 5% 0,06W 0603	Philips	2322 702 60109	40-11000-121	1
R487	10k Ohm 5% 0,125W 1206	Philips	2322 711 61103	40-41000-101	1
R488	10k Ohm 5% 0,125W 1206	Philips	2322 711 61103	40-41000-101	1
R489	5,6k Ohm 5% 0,125W 1206	Philips	2322 711 61562	40-35600-101	1
R490	10k Ohm 5% 0,125W 1206	Philips	2322 711 61103	40-41000-101	1
R491	47k Ohm 5% 0,125W 1206	Philips	2322 711 61473	40-44700-101	1
R492	10k Ohm 5% 0,125W 1206	Philips	2322 711 61103	40-41000-101	1
R493	47k Ohm 5% 0,125W 1206	Philips	2322 711 61473	40-44700-101	1
R494	10k Ohm 5% 0,125W 1206	Philips	2322 711 61103	40-41000-101	1
R495	3,3k Ohm 5% 0,125W 1206	Philips	2322 711 61332	40-33300-101	1
R496	47k Ohm 5% 0,125W 1206	Philips	2322 711 61473	40-44700-101	1
R497	10k Ohm 5% 0,125W 1206	Philips	2322 711 61103	40-41000-101	1
R498	3,3k Ohm 5% 0,125W 1206	Philips	2322 711 61332	40-33300-101	1
R499	10k Ohm 5% 0,125W 1206	Philips	2322 711 61103	40-41000-101	1
R500	1k Ohm 5% 0,125W 1206	Philips	2322 711 61102	40-31000-101	1
R501	100k Ohm 5% 0,125W 1206	Philips	2322 711 61104	40-51000-101	1
T101	Txfr, RF Amp	Protran	44-80263	44-80263	1
T102	Txfr, Rx I/P	Protran	44-80261	44-80261	1
T103	Ind, Mixer 1 L.O. Buffer	Sumida	44-70491	44-70491	1
T104	45MHz Roofing Filter Txfr	Sumida	44-70493	44-70493	1
T105	Txfr, Mixer 2 Input	Koilkraft	44-70486	44-70486	1
T106	Txfr, Exciter O/P	Protran	44-80260	44-80260	1
T107	Txfr, 45MHz roofing filtr	Codan	44-70451	44-70451	1
T108	Txfr, 45MHz roofing filtr	Codan	44-70451	44-70451	1
T201	Ind, Buffer Output	Koilkraft	44-70487	44-70487	1
T202	Ind, Buffer Output	Koilkraft	44-70487	44-70487	1
T401	Balun	Protran	44-80262	44-80262	1
T402	Ind, Mixer 1 L.O. Buffer	Sumida	44-70491	44-70491	1
V101	Transistor, NPN Si SOT89	Philips	BFQ17	BFQ17	1
V102	Transistor, NPN Si SOT23	Philips	BC848	BC848	1
V103	JFET, Selected J310 01-01031	Avnet	PST00-3289	PST00-3289	1
V104	JFET, Selected J310 01-01031	Avnet	PST00-3289	PST00-3289	1

08-05261-001 - RF/IF PCB

BOM Revision
Date Valid On

12 -- Production
27.09.2006

Ref	Description	Manufacturer	Manufacturer's P/N	Codan P/N	Qty
V105	JFET, Selected J310 01-01031	Avnet	PST00-3289	PST00-3289	1
V106	JFET, Selected J310 01-01031	Avnet	PST00-3289	PST00-3289	1
V107	Transistor, PNP Si SOT23	Philips	BFT92	BFT92	1
V108	Transistor, PNP Si SOT23	Philips	BFT92	BFT92	1
V109	MOSFET,N Chan Dual Gate SOT143	Philips	BF991	BF991	1
V201	Transistor, PNP Si SOT23	Philips	BC858	BC858	1
V202	Transistor, NPN Si SOT23	Philips	BC848	BC848	1
V203	Transistor, NPN Si SOT23	Philips	BC848	BC848	1
V204	MOSFET, N Chan Enhance SOT143	Philips	BSS83	BSS83	1
V205	MOSFET, N Chan Enhance SOT143	Philips	BSS83	BSS83	1
V206	Transistor, NPN Si SOT23	Philips	BC848	BC848	1
V207	Transistor, NPN Si SOT23	Philips	BC848	BC848	1
V208	Transistor, PNP Si SOT23	Philips	BC858	BC858	1
V209	Transistor, PNP Si SOT23	Philips	BC858	BC858	1
V210	JFET, N Channel SOT23	Philips	BF545B	BF545B	1
V211	JFET, N Channel SOT23	Philips	BF545B	BF545B	1
V212	JFET, N Channel SOT23	Philips	BF545B	BF545B	1
V213	Transistor, PNP Si SOT23	Philips	BFT92	BFT92	1
V214	Transistor, NPN Si SOT23	Philips	BC848	BC848	1
V215	Transistor, NPN Si SOT23	Philips	BC848	BC848	1
V216	Transistor, NPN Si SOT23	Philips	BC848	BC848	1
V217	Transistor, NPN Si SOT23	Philips	BC848	BC848	1
V218	Diode, Zener 6,8V 5% 0,2W SOT23	Philips	BZX84C6V8	BZX84C6V8	1
V219	Transistor, NPN Si SOT23	Philips	BC848	BC848	1
V220	Transistor, NPN Si SOT23	Philips	BC848	BC848	1
V401	JFET, N Channel SOT23	Philips	BF556B	BF556B	1
V402	Transistor, NPN Si SOT23	Philips	BFR92A	BFR92A	1
V403	Transistor, NPN Si SOT23	Philips	BFR92A	BFR92A	1
V404	Transistor, NPN Si SOT23	Philips	BC846	BC846	1

08-05261-001 - RF/IF PCB

BOM Revision
Date Valid On

12 -- Production
27.09.2006

Ref	Description	Manufacturer	Manufacturer's P/N	Codan P/N	Qty
V405	Transistor, NPN Si SOT23	Philips	BFR92A	BFR92A	1
V406	Transistor, PNP Si SOT23	Philips	BC856	BC856	1
V407	Transistor, NPN Si SOT23	Philips	BC846	BC846	1
V408	Transistor, PNP Si SOT23	Philips	BFT92	BFT92	1
V409	Transistor, NPN Si SOT23	Philips	BC846	BC846	1
V410	Transistor, NPN Si SOT23	Philips	BC846	BC846	1
V411	Transistor, PNP Si SOT23	Philips	BC858	BC858	1
V412	Transistor, PNP Si SOT23	Philips	BFT92	BFT92	1
V413	Transistor, PNP Si SOT23	Philips	BFT92	BFT92	1
V414	Transistor, NPN Si SOT23	Philips	BFR92A	BFR92A	1
V415	Transistor, NPN Si SOT23	Philips	BFR92A	BFR92A	1
V416	Transistor, NPN Si SOT23	Philips	BC848	BC848	1
V417	Transistor, PNP Si SOT23	Philips	BC858	BC858	1
V418	Transistor, PNP Si SOT23	Philips	BC858	BC858	1
V419	Transistor, NPN Si SOT23	Philips	BC848	BC848	1
V420	Transistor, PNP Si SOT89	Philips	BC869	BC869	1
V421	Transistor, NPN Si SOT23	Philips	BC848	BC848	1
V422	Transistor, PNP Si SOT89	Philips	BC869	BC869	1
Z101	Composite Item	Codan	**_00000-003	99-00000-003	1
Z102	Composite Item	Codan	**_00000-003	99-00000-003	1
Z103	Composite Item	Codan	**_00000-003	99-00000-003	1
Z104	Composite Item	Codan	**_00000-003	99-00000-003	1
Z201	Filter, 455 kHz 2,4 kHz BW	Murata	CFJ455K14	65-91116-000	1

08-05889-001 - RF/IF PCB

BOM Revision
Date Valid On

18 -- Production
28.09.2006

Ref	Description	Manufacturer	Manufacturer's P/N	Codan P/N	Qty
	Filter, 45- MHz 4Pole 15 kHz BW	KDK	45M15B	65-91115-000	2
	Build Standard, 2010			01-01252	1
	RF/IF PCB			08-05889	1
	RF/IF			04-03378	1
	TP, NGT RF/IF PCB			10-00899	1
1	PCB, IF/RF		07-01961-07	07-01961-07	1
2	Screen, VCO1 & Mixer	Metalcraft	05-06518	05-06518	1
3	Screen, VCO	Metalcraft	05-07079	05-07079	1
4	Screen, DDS	Metalcraft	05-07080	05-07080	1
5	Insulator, Oven	RMAX	06-02045	06-02045	1
6	Jumper (S) 2way Open Top	Molex	15-38-1024	60-90410-001	1
7	Label, Serial/Barcode	Codan	06-02068	06-02068	1
8	Crystal Oven Assembly	Codan	08-05963-001	08-05963-001	1
9	Cable, Ribbon, Audio - RF	Auto Assemblies	08-05489-001	08-05489-001	1
10	Cable, Rx coax	Auto Assemblies	08-05491-001	08-05491-001	1
11	Cable, Tx coax	Auto Assemblies	08-05492-001	08-05492-001	1
C101	33n 10% 50V X7R 0805 NiSn	Philips	08052R333K9BB00	46-43300-281	1
C102	100n 10% 50V X7R 0805 Nisn	Philips	08052R104K9BB	46-51000-282	1
C103	33n 10% 50V X7R 0805 NiSn	Philips	08052R333K9BB00	46-43300-281	1
C104	3,3n 10% 100V X7R 0805 NiSn	Philips	08052R332K0B200	46-33300-281	1
C105	820p 5% 50V NPO 0805 NiSn	Philips	0805CG821J9B200	46-28200-081	1
C106	820p 5% 50V NPO 0805 NiSn	Philips	0805CG821J9B200	46-28200-081	1
C107	3,3n 10% 100V X7R 0805 NiSn	Philips	08052R332K0B200	46-33300-281	1
C108	3,3n 10% 100V X7R 0805 NiSn	Philips	08052R332K0B200	46-33300-281	1
C109	820p 5% 50V NPO 0805 NiSn	Philips	0805CG821J9B200	46-28200-081	1
C110	820p 5% 50V NPO 0805 NiSn	Philips	0805CG821J9B200	46-28200-081	1
C111	10n 10% 100V X7R 0805 NiSn	Philips	08052R103K0B200	46-41000-281	1
C112	150p 5% 50V NPO 0805 NiSn	Philips	0805CG151J9BB-	46-21500-081	1
C113	33n 10% 50V X7R 0805 NiSn	Philips	08052R333K9BB00	46-43300-281	1
C114	100n 10% 50V X7R 0805 Nisn	Philips	08052R104K9BB	46-51000-282	1
C115	3,3n 10% 100V X7R 0805 NiSn	Philips	08052R332K0B200	46-33300-281	1
C116	33n 10% 50V X7R 0805 NiSn	Philips	08052R333K9BB00	46-43300-281	1
C117	33n 10% 50V X7R 0805 NiSn	Philips	08052R333K9BB00	46-43300-281	1
C118	1n 5% 50V NPO 0805 NiSn	Philips	0805CG102J9BB-	46-31000-082	1
C119	1n 5% 50V NPO 0805 NiSn	Philips	0805CG102J9BB-	46-31000-082	1
C120	22p 5% 50V NPO 0805 NiSn	Philips	0805CG220J9B200	46-12200-081	1

08-05889-001 - RF/IF PCB

BOM Revision
Date Valid On

18 -- Production
28.09.2006

Ref	Description	Manufacturer	Manufacturer's P/N	Codan P/N	Qty
C121	100p 5% 50V NPO 0805 NiSn	Philips	0805CG101J9B200	46-21000-081	1
C122	150p 5% 50V NPO 0805 NiSn	Philips	0805CG151J9BB-	46-21500-081	1
C123	150p 5% 50V NPO 0805 NiSn	Philips	0805CG151J9BB-	46-21500-081	1
C124	33n 10% 50V X7R 0805 NiSn	Philips	08052R333K9BB00	46-43300-281	1
C125	Not Fitted	Codan	** -00000-001	99-00000-001	1
C126	Not Fitted	Codan	** -00000-001	99-00000-001	1
C127	3,3n 10% 100V X7R 0805 NiSn	Philips	08052R332K0B200	46-33300-281	1
C128	10p 5% 50V NPO 0805 NiSn	Philips	0805CG100J9B200	46-11000-081	1
C129	3,3n 10% 100V X7R 0805 NiSn	Philips	08052R332K0B200	46-33300-281	1
C130	10p 5% 50V NPO 0805 NiSn	Philips	0805CG100J9B200	46-11000-081	1
C131	1n 5% 50V NPO 0805 NiSn	Philips	0805CG102J9BB-	46-31000-082	1
C132	3,3n 10% 100V X7R 0805 NiSn	Philips	08052R332K0B200	46-33300-281	1
C133	3,3n 10% 100V X7R 0805 NiSn	Philips	08052R332K0B200	46-33300-281	1
C134	3,3n 10% 100V X7R 0805 NiSn	Philips	08052R332K0B200	46-33300-281	1
C135	3,3n 10% 100V X7R 0805 NiSn	Philips	08052R332K0B200	46-33300-281	1
C136	3,3n 10% 100V X7R 0805 NiSn	Philips	08052R332K0B200	46-33300-281	1
C137	3,3n 10% 100V X7R 0805 NiSn	Philips	08052R332K0B200	46-33300-281	1
C138	33n 10% 50V X7R 0805 NiSn	Philips	08052R333K9BB00	46-43300-281	1
C139	47p 5% 50V NPO 0805 NiSn	Philips	0805CG470J9B200	46-14700-080	1
C140	47p 5% 50V NPO 0805 NiSn	Philips	0805CG470J9B200	46-14700-080	1
C141	3,3n 10% 100V X7R 0805 NiSn	Philips	08052R332K0B200	46-33300-281	1
C142	Not Fitted	Codan	** -00000-001	99-00000-001	1
C143	3,3n 10% 100V X7R 0805 NiSn	Philips	08052R332K0B200	46-33300-281	1
C144	3,3n 10% 100V X7R 0805 NiSn	Philips	08052R332K0B200	46-33300-281	1
C145	33n 10% 50V X7R 0805 NiSn	Philips	08052R333K9BB00	46-43300-281	1
C146	820p 5% 50V NPO 0805 NiSn	Philips	0805CG821J9B200	46-28200-081	1
C147	820p 5% 50V NPO 0805 NiSn	Philips	0805CG821J9B200	46-28200-081	1
C148	100p 5% 50V NPO 0805 NiSn	Philips	0805CG101J9B200	46-21000-081	1
C149	68p 5% 50V NPO 0805 NiSn	Philips	0805CG680J9B200	46-16800-081	1
C150	68p 5% 50V NPO 0805 NiSn	Philips	0805CG680J9B200	46-16800-081	1

08-05889-001 - RF/IF PCB

BOM Revision
Date Valid On

18 -- Production
28.09.2006

Ref	Description	Manufacturer	Manufacturer's P/N	Codan P/N	Qty
C151	82p 5% 50V NPO 0805 NiSn	Philips	0805CG820J9B200	46-18200-081	1
C152	82p 5% 50V NPO 0805 NiSn	Philips	0805CG820J9B200	46-18200-081	1
C153	33n 10% 50V X7R 0805 NiSn	Philips	08052R333K9BB00	46-43300-281	1
C154	3,3n 10% 100V X7R 0805 NiSn	Philips	08052R332K0B200	46-33300-281	1
C155	3,3n 10% 100V X7R 0805 NiSn	Philips	08052R332K0B200	46-33300-281	1
C156	3,3n 10% 100V X7R 0805 NiSn	Philips	08052R332K0B200	46-33300-281	1
C157	3,3n 10% 100V X7R 0805 NiSn	Philips	08052R332K0B200	46-33300-281	1
C158	3,3n 10% 100V X7R 0805 NiSn	Philips	08052R332K0B200	46-33300-281	1
C159	3,3n 10% 100V X7R 0805 NiSn	Philips	08052R332K0B200	46-33300-281	1
C160	3,3n 10% 100V X7R 0805 NiSn	Philips	08052R332K0B200	46-33300-281	1
C161	3,3n 10% 100V X7R 0805 NiSn	Philips	08052R332K0B200	46-33300-281	1
C162	33n 10% 50V X7R 0805 NiSn	Philips	08052R333K9BB00	46-43300-281	1
C163	3,3n 10% 100V X7R 0805 NiSn	Philips	08052R332K0B200	46-33300-281	1
C164	3,3n 10% 100V X7R 0805 NiSn	Philips	08052R332K0B200	46-33300-281	1
C165	33n 10% 50V X7R 0805 NiSn	Philips	08052R333K9BB00	46-43300-281	1
C166	33n 10% 50V X7R 0805 NiSn	Philips	08052R333K9BB00	46-43300-281	1
C167	Not Fitted	Codan	** -00000-001	99-00000-001	1
C201	1n 5% 50V NPO 0805 NiSn	Philips	0805CG102J9BB-	46-31000-082	1
C202	1n 5% 50V NPO 0805 NiSn	Philips	0805CG102J9BB-	46-31000-082	1
C203	10u 20% 25V 6032 TA Cap	AVX	TAJC106M025R	47-11002-520	1
C204	820p 5% 50V NPO 0805 NiSn	Philips	0805CG821J9B200	46-28200-081	1
C205	820p 5% 50V NPO 0805 NiSn	Philips	0805CG821J9B200	46-28200-081	1
C206	22n 10% 100V X7R 1206 NiSn	Philips	12062R223K0BB-	46-42200-280	1
C207	3,3n 10% 100V X7R 0805 NiSn	Philips	08052R332K0B200	46-33300-281	1
C208	100p 5% 50V NPO 0805 NiSn	Philips	0805CG101J9B200	46-21000-081	1
C209	10u 20% 10V X7R 1210 NiSn	Taiyo Yuden	LMK325BJ106MN	46-71000-280	1
C210	3,3n 10% 100V X7R 0805 NiSn	Philips	08052R332K0B200	46-33300-281	1
C211	3,3n 10% 100V X7R 0805 NiSn	Philips	08052R332K0B200	46-33300-281	1
C212	3,3n 10% 100V X7R 0805 NiSn	Philips	08052R332K0B200	46-33300-281	1

08-05889-001 - RF/IF PCB

BOM Revision
Date Valid On

18 -- Production
28.09.2006

Ref	Description	Manufacturer	Manufacturer's P/N	Codan P/N	Qty
C213	33n 10% 50V X7R 0805 NiSn	Philips	08052R333K9BB00	46-43300-281	1
C214	33n 10% 50V X7R 0805 NiSn	Philips	08052R333K9BB00	46-43300-281	1
C215	33n 10% 50V X7R 0805 NiSn	Philips	08052R333K9BB00	46-43300-281	1
C216	1u 10% 10V X7R 0805 NiSn	Phycomp	2222-240-15663	46-61000-281	1
C217	33n 10% 50V X7R 0805 NiSn	Philips	08052R333K9BB00	46-43300-281	1
C218	33n 10% 50V X7R 0805 NiSn	Philips	08052R333K9BB00	46-43300-281	1
C219	10p 5% 50V NPO 0805 NiSn	Philips	0805CG100J9B200	46-11000-081	1
C222	1u 20% 35V 3528 TA Cap	AVX	TAJB105M035R	47-01003-520	1
C223	33n 10% 50V X7R 0805 NiSn	Philips	08052R333K9BB00	46-43300-281	1
C224	1n 5% 50V NPO 0805 NiSn	Philips	0805CG102J9BB-	46-31000-082	1
C225	33n 10% 50V X7R 0805 NiSn	Philips	08052R333K9BB00	46-43300-281	1
C226	33n 10% 50V X7R 0805 NiSn	Philips	08052R333K9BB00	46-43300-281	1
C227	33n 10% 50V X7R 0805 NiSn	Philips	08052R333K9BB00	46-43300-281	1
C228	1u 20% 35V 3528 TA Cap	AVX	TAJB105M035R	47-01003-520	1
C229	100p 5% 50V NPO 0805 NiSn	Philips	0805CG101J9B200	46-21000-081	1
C230	33n 10% 50V X7R 0805 NiSn	Philips	08052R333K9BB00	46-43300-281	1
C231	1n 5% 50V NPO 0805 NiSn	Philips	0805CG102J9BB-	46-31000-082	1
C232	100p 5% 50V NPO 0805 NiSn	Philips	0805CG101J9B200	46-21000-081	1
C233	33n 10% 50V X7R 0805 NiSn	Philips	08052R333K9BB00	46-43300-281	1
C234	1n 5% 50V NPO 0805 NiSn	Philips	0805CG102J9BB-	46-31000-082	1
C235	1n 5% 50V NPO 0805 NiSn	Philips	0805CG102J9BB-	46-31000-082	1
C236	100p 5% 50V NPO 0805 NiSn	Philips	0805CG101J9B200	46-21000-081	1
C237	33n 10% 50V X7R 0805 NiSn	Philips	08052R333K9BB00	46-43300-281	1
C238	3,3n 10% 100V X7R 0805 NiSn	Philips	08052R332K0B200	46-33300-281	1
C239	1u 20% 35V 3528 TA Cap	AVX	TAJB105M035R	47-01003-520	1
C240	100p 5% 50V NPO 0805 NiSn	Philips	0805CG101J9B200	46-21000-081	1
C241	10u 20% 25V 6032 TA Cap	AVX	TAJC106M025R	47-11002-520	1
C242	33n 10% 50V X7R 0805 NiSn	Philips	08052R333K9BB00	46-43300-281	1
C243	1u 20% 35V 3528 TA Cap	AVX	TAJB105M035R	47-01003-520	1

08-05889-001 - RF/IF PCB

BOM Revision
Date Valid On

18 -- Production
28.09.2006

Ref	Description	Manufacturer	Manufacturer's P/N	Codan P/N	Qty
C244	10u 20% 25V 6032 TA Cap	AVX	TAJC106M025R	47-11002-520	1
C245	33n 10% 50V X7R 0805 NiSn	Philips	08052R333K9BB00	46-43300-281	1
C246	3,3n 10% 100V X7R 0805 NiSn	Philips	08052R332K0B200	46-33300-281	1
C247	3,3n 10% 100V X7R 0805 NiSn	Philips	08052R332K0B200	46-33300-281	1
C248	10n 10% 100V X7R 0805 NiSn	Philips	08052R103K0B200	46-41000-281	1
C249	10n 10% 100V X7R 0805 NiSn	Philips	08052R103K0B200	46-41000-281	1
C250	10p 5% 50V NPO 0805 NiSn	Philips	0805CG100J9B200	46-11000-081	1
C251	33n 10% 50V X7R 0805 NiSn	Philips	08052R333K9BB00	46-43300-281	1
C252	3,3n 10% 100V X7R 0805 NiSn	Philips	08052R332K0B200	46-33300-281	1
C253	1u 20% 35V 3528 TA Cap	AVX	TAJB105M035R	47-01003-520	1
C254	10u 10% 25V X5R 1210 NiSn	Kemet	C1210C106K3PAC	46-71000-281	1
C255	33n 10% 50V X7R 0805 NiSn	Philips	08052R333K9BB00	46-43300-281	1
C256	2,2u 10% 16V X7R 0805 NiSn	Kemet	C0805C225K4RAC	46-62200-281	1
C257	10u 20% 25V 6032 TA Cap	AVX	TAJC106M025R	47-11002-520	1
C258	33n 10% 50V X7R 0805 NiSn	Philips	08052R333K9BB00	46-43300-281	1
C259	33n 10% 50V X7R 0805 NiSn	Philips	08052R333K9BB00	46-43300-281	1
C260	100n 10% 50V X7R 0805 Nisn	Philips	08052R104K9BB	46-51000-282	1
C261	3,3n 10% 100V X7R 0805 NiSn	Philips	08052R332K0B200	46-33300-281	1
C262	3,3n 10% 100V X7R 0805 NiSn	Philips	08052R332K0B200	46-33300-281	1
C263	1u 20% 35V 3528 TA Cap	AVX	TAJB105M035R	47-01003-520	1
C266	33n 10% 50V X7R 0805 NiSn	Philips	08052R333K9BB00	46-43300-281	1
C271	1n 5% 50V NPO 0805 NiSn	Philips	0805CG102J9BB-	46-31000-082	1
C272	33n 10% 50V X7R 0805 NiSn	Philips	08052R333K9BB00	46-43300-281	1
C273	33n 10% 50V X7R 0805 NiSn	Philips	08052R333K9BB00	46-43300-281	1
C274	10u 20% 25V 6032 TA Cap	AVX	TAJC106M025R	47-11002-520	1
C275	33n 10% 50V X7R 0805 NiSn	Philips	08052R333K9BB00	46-43300-281	1
C276	1u 20% 35V 3528 TA Cap	AVX	TAJB105M035R	47-01003-520	1
C278	1u 20% 35V 3528 TA Cap	AVX	TAJB105M035R	47-01003-520	1
C279	1u 20% 35V 3528 TA Cap	AVX	TAJB105M035R	47-01003-520	1

08-05889-001 - RF/IF PCB

BOM Revision
Date Valid On

18 -- Production
28.09.2006

Ref	Description	Manufacturer	Manufacturer's P/N	Codan P/N	Qty
C282	33n 10% 50V X7R 0805 NiSn	Philips	08052R333K9BB00	46-43300-281	1
C401	100p 5% 500V NPO 1210 NiSn	Philips	1210CG101GBB-	46-21000-082	1
C402	1n 5% 50V NPO 0805 NiSn	Philips	0805CG102J9BB-	46-31000-082	1
C403	1p 0,25p 50V NPO 0805 NiSn	Philips	0805CG109C9BB-	46-01000-082	1
C404	4,7p 0,25p 50V NPO 0805 NiSn	Philips	0805CG479C9BB-	46-04700-081	1
C405	3,3n 10% 100V X7R 0805 NiSn	Philips	08052R332K0B200	46-33300-281	1
C406	1p 0,25p 50V NPO 0805 NiSn	Philips	0805CG109C9BB-	46-01000-082	1
C407	3,3n 10% 100V X7R 0805 NiSn	Philips	08052R332K0B200	46-33300-281	1
C408	3,3n 10% 100V X7R 0805 NiSn	Philips	08052R332K0B200	46-33300-281	1
C409	3,3n 10% 100V X7R 0805 NiSn	Philips	08052R332K0B200	46-33300-281	1
C410	10u 20% 25V 6032 TA Cap	AVX	TAJC106M025R	47-11002-520	1
C411	10u 20% 25V 6032 TA Cap	AVX	TAJC106M025R	47-11002-520	1
C412	3,3n 10% 100V X7R 0805 NiSn	Philips	08052R332K0B200	46-33300-281	1
C413	10u 20% 25V 6032 TA Cap	AVX	TAJC106M025R	47-11002-520	1
C414	3,3n 10% 100V X7R 0805 NiSn	Philips	08052R332K0B200	46-33300-281	1
C415	3,3n 10% 100V X7R 0805 NiSn	Philips	08052R332K0B200	46-33300-281	1
C416	3,3n 10% 100V X7R 0805 NiSn	Philips	08052R332K0B200	46-33300-281	1
C417	10u 20% 35V 7343 TA Cap	AVX	TAJD106M035R	47-11003-521	1
C418	1u 10% 63V PE Cap	Philips	2222 370 11105	46-61000-521	1
C419	100n 10% 50V X7R 0805 Nisn	Philips	08052R104K9BB	46-51000-282	1
C420	1u 20% 35V 3528 TA Cap	AVX	TAJB105M035R	47-01003-520	1
C421	15p 5% 50V NPO 0805 NiSn	Philips	0805CG150J9B200	46-11500-081	1
C422	33n 10% 50V X7R 0805 NiSn	Philips	08052R333K9BB00	46-43300-281	1
C423	3,3n 10% 100V X7R 0805 NiSn	Philips	08052R332K0B200	46-33300-281	1
C424	33n 10% 50V X7R 0805 NiSn	Philips	08052R333K9BB00	46-43300-281	1
C425	15p 5% 50V NPO 0805 NiSn	Philips	0805CG150J9B200	46-11500-081	1
C426	1u 20% 35V 3528 TA Cap	AVX	TAJB105M035R	47-01003-520	1
C427	3,3n 10% 100V X7R 0805 NiSn	Philips	08052R332K0B200	46-33300-281	1
C428	3,3n 10% 100V X7R 0805 NiSn	Philips	08052R332K0B200	46-33300-281	1

08-05889-001 - RF/IF PCB

BOM Revision
Date Valid On

18 -- Production
28.09.2006

Ref	Description	Manufacturer	Manufacturer's P/N	Codan P/N	Qty
C429	3,3n 10% 100V X7R 0805 NiSn	Philips	08052R332K0B200	46-33300-281	1
C430	3,3n 10% 100V X7R 0805 NiSn	Philips	08052R332K0B200	46-33300-281	1
C431	3,3n 10% 100V X7R 0805 NiSn	Philips	08052R332K0B200	46-33300-281	1
C432	1n 5% 50V NPO 0805 NiSn	Philips	0805CG102J9BB-	46-31000-082	1
C433	22p 5% 50V NPO 0805 NiSn	Philips	0805CG220J9B200	46-12200-081	1
C434	1n 5% 50V NPO 0805 NiSn	Philips	0805CG102J9BB-	46-31000-082	1
C435	33n 10% 50V X7R 0805 NiSn	Philips	08052R333K9BB00	46-43300-281	1
C436	10u 20% 35V 7343 TA Cap	AVX	TAJD106M035R	47-11003-521	1
C437	3,3n 10% 100V X7R 0805 NiSn	Philips	08052R332K0B200	46-33300-281	1
C438	10u 20% 35V 7343 TA Cap	AVX	TAJD106M035R	47-11003-521	1
C439	10u 20% 35V 7343 TA Cap	AVX	TAJD106M035R	47-11003-521	1
C440	10u 20% 35V 7343 TA Cap	AVX	TAJD106M035R	47-11003-521	1
C441	10u 20% 35V 7343 TA Cap	AVX	TAJD106M035R	47-11003-521	1
C442	10u 20% 35V 7343 TA Cap	AVX	TAJD106M035R	47-11003-521	1
C443	10n 10% 100V X7R 0805 NiSn	Philips	08052R103K0B200	46-41000-281	1
C444	180p 5% 50V NPO 0805 NiSn	Philips	0805CG181J9B200	46-21800-081	1
C445	220p 5% 50V NPO 0805 NiSn	Philips	0805CG221J9BB	46-22200-081	1
C446	10n 10% 100V X7R 0805 NiSn	Philips	08052R103K0B200	46-41000-281	1
C447	33n 10% 50V X7R 0805 NiSn	Philips	08052R333K9BB00	46-43300-281	1
C448	10n 10% 100V X7R 0805 NiSn	Philips	08052R103K0B200	46-41000-281	1
C449	33n 10% 50V X7R 0805 NiSn	Philips	08052R333K9BB00	46-43300-281	1
C450	33n 10% 50V X7R 0805 NiSn	Philips	08052R333K9BB00	46-43300-281	1
C451	33n 10% 50V X7R 0805 NiSn	Philips	08052R333K9BB00	46-43300-281	1
C452	15p 5% 50V NPO 0805 NiSn	Philips	0805CG150J9B200	46-11500-081	1
C453	330p 5% 50V NPO 0805 NiSn	Philips	0805CG331J9B200	46-23300-081	1
C454	330p 5% 50V NPO 0805 NiSn	Philips	0805CG331J9B200	46-23300-081	1
C455	12p 5% 50V NPO 0805 NiSn	Philips	0805CG120J9B200	46-11200-081	1
C456	5,6p 0,25p 50V NPO 0805 NiSn	Philips	0805CG569C9B200	46-05600-081	1
C457	3,3n 10% 100V X7R 0805 NiSn	Philips	08052R332K0B200	46-33300-281	1

08-05889-001 - RF/IF PCB

BOM Revision
Date Valid On

18 -- Production
28.09.2006

Ref	Description	Manufacturer	Manufacturer's P/N	Codan P/N	Qty
C458	3,3n 10% 100V X7R 0805 NiSn	Philips	08052R332K0B200	46-33300-281	1
C459	33n 10% 50V X7R 0805 NiSn	Philips	08052R333K9BB00	46-43300-281	1
C460	10n 10% 100V X7R 0805 NiSn	Philips	08052R103K0B200	46-41000-281	1
C461	33n 10% 50V X7R 0805 NiSn	Philips	08052R333K9BB00	46-43300-281	1
C462	10n 10% 100V X7R 0805 NiSn	Philips	08052R103K0B200	46-41000-281	1
C463	1n 5% 50V NPO 0805 NiSn	Philips	0805CG102J9BB-	46-31000-082	1
C464	1,8n 5% 50V NPO 0805 NiSn	Phycomp	0805CG182J9B200	46-31800-080	1
C465	1n 5% 50V NPO 0805 NiSn	Philips	0805CG102J9BB-	46-31000-082	1
C466	150p 5% 50V NPO 0805 NiSn	Philips	0805CG151J9BB-	46-21500-081	1
C467	150p 5% 50V NPO 0805 NiSn	Philips	0805CG151J9BB-	46-21500-081	1
C468	150p 5% 50V NPO 0805 NiSn	Philips	0805CG151J9BB-	46-21500-081	1
C469	150p 5% 50V NPO 0805 NiSn	Philips	0805CG151J9BB-	46-21500-081	1
C470	33n 10% 50V X7R 0805 NiSn	Philips	08052R333K9BB00	46-43300-281	1
C471	47p 5% 50V NPO 0805 NiSn	Philips	0805CG470J9B200	46-14700-080	1
C472	33n 10% 50V X7R 0805 NiSn	Philips	08052R333K9BB00	46-43300-281	1
C473	10u 20% 25V 6032 TA Cap	AVX	TAJC106M025R	47-11002-520	1
C474	33n 10% 50V X7R 0805 NiSn	Philips	08052R333K9BB00	46-43300-281	1
C475	22p 5% 50V NPO 0805 NiSn	Philips	0805CG220J9B200	46-12200-081	1
C476	1n 5% 50V NPO 0805 NiSn	Philips	0805CG102J9BB-	46-31000-082	1
D101	Diode,PIN 150V 1ohm@10mA 700nsTrr SC79	Infineon	BAR67-02V	BAR67-02V	1
D102	Diode, Si High speed 75V SOT23	Philips	BAS16	BAS16	1
D103	Diode, Si High speed 75V SOT23	Philips	BAS16	BAS16	1
D104	Diode, Pin atten, dual com K SOT23	HP	HSMP-3814	HSMP-3814	1
D201	Diode, Si High speed 75V SOT23	Philips	BAS16	BAS16	1
D205	Diode, Si High speed 75V SOT23	Philips	BAS16	BAS16	1
D206	Diode, Schottky 70V 70mA SOT23	Siemens	BAS70	BAS70	1
D207	Diode, Si High speed 75V SOT23	Philips	BAS16	BAS16	1
D210	Diode, Si High speed 75V SOT23	Philips	BAS16	BAS16	1

08-05889-001 - RF/IF PCB

BOM Revision
Date Valid On

18 -- Production
28.09.2006

Ref	Description	Manufacturer	Manufacturer's P/N	Codan P/N	Qty
D212	Diode, Si High speed 75V SOT23	Philips	BAS16	BAS16	1
D213	Diode, Si High speed 75V SOT23	Philips	BAS16	BAS16	1
D401	Diode, Tuner Si SOD323	Siemens	BB639-E6327	BB639	1
D402	Diode, Tuner Si SOD323	Siemens	BB639-E6327	BB639	1
D403	Diode, Tuner Si SOD323	Siemens	BB639-E6327	BB639	1
D404	Diode, Tuner Si SOD323	Siemens	BB639-E6327	BB639	1
D405	Diode, Schottky 70V 70mA SOT23	Siemens	BAS70	BAS70	1
D406	Diode, Si High speed 75V SOT23	Philips	BAS16	BAS16	1
D407	Diode, Si High speed 75V SOT23	Philips	BAS16	BAS16	1
D408	Diode, Si High speed 75V SOT23	Philips	BAS16	BAS16	1
D409	Diode, Si High speed 75V SOT23	Philips	BAS16	BAS16	1
D410	Diode, Si High speed 75V SOT23	Philips	BAS16	BAS16	1
IC101	Mixer, High level IC	Philips	23-30012	23-30012	1
IC102	Mixer, High level IC	Philips	23-30012	23-30012	1
IC103	Mixer, High level IC	Philips	23-30012	23-30012	1
IC201	Array, Transistor SOIC14	Intersil	CA3054M96	XT-03054-700	1
IC202	Gate, NAND 2 Input Quad SOIC14	Philips	HEF4011BTD	YG-40011-700	1
IC203	Array, Transistor SOIC14	Motorola	MC3346D	XT-03346-700	1
IC204	Modulator, Balanced SOIC14	Motorola	MC1496D	XA-01496-700	1
IC205	Amp, Operational Dual SOIC8	National Semiconduct	LM358M	XA-00358-700	1
IC206	Diode, Ref 2,5V 2% SOIC8	National Semiconduct	LM336M-2,5	XB-00336-700	1
IC207	Array, Transistor SOIC14	Motorola	MC3346D	XT-03346-700	1
IC208	Modulator, Balanced SOIC14	Motorola	MC1496D	XA-01496-700	1
IC209	Amp, Operational Dual SOIC8	National Semiconduct	LM358M	XA-00358-700	1
IC210	Reg, Voltage +5V 1A TO263_3	National Semiconduct	LM7805S	XB-07805-701	1
IC211	Amp, Rail to Rail I/O SOT23-5	National Semiconduct	LMC7101BIM5X	XA-07101-700	1
IC212	Amp, Rail to Rail I/O SOT23-5	National Semiconduct	LMC7101BIM5X	XA-07101-700	1
IC213	Comparator, Dual O/C Output SOIC8	National Semiconduct	LM393M	XD-00393-700	1
IC401	Synthesiser, Freq SOIC16	Motorola	MC145170D2	MC145170D1	1
IC402	Buffer, Hex Inverting Schmitt SOIC14	Philips	HEF40106BT	YG-40106-700	1

08-05889-001 - RF/IF PCB

BOM Revision
Date Valid On

18 -- Production
28.09.2006

Ref	Description	Manufacturer	Manufacturer's P/N	Codan P/N	Qty
IC403	Direct Digital Synthesiser TSSOP16	Analog Devices	AD9832BRU	YL-09832-700	1
IC404	Inverter, Single Unbuffered SOT23-5	SGS Thomson	74V1GU04S	YZ-74004-700	1
IC405	Direct Digital Synthesiser TSSOP16	Analog Devices	AD9832BRU	YL-09832-700	1
IC406	Inverter, Single Unbuffered SOT23-5	SGS Thomson	74V1GU04S	YZ-74004-700	1
IC407	Flip Flop, D Dual SOIC14	Motorola	MC74HC74AD	YH-74074-700	1
IC408	Micro prgmd, RFU RF/IF I/O		90-20651-001	90-20651-001	1
J1	Socket, Coax Mini Low Prof Fixed	Taiko Denki	TMP-J02X-A1	60-19390-002	1
J2	Socket, Coax Mini Low Prof Fixed	Taiko Denki	TMP-J02X-A1	60-19390-002	1
K101	Relay, 2C 12V 2A SMD 1028 Ohm	Matsushita	TQ2SL-12V	64-21225-310	1
L101	Ind, 4,7uH 10% 4532	Taiyo Yuden	LEM4532T4R7K	43-80470-000	1
L102	Ind, 10uH 10% 3225	TOKO	380KB-100K	43-81100-001	1
L103	Ind, 100uH 10% 4532	Taiyo Yuden	LEM 4532T101K	43-82100-134	1
L104	Ind, 100uH 10% 4532	Taiyo Yuden	LEM 4532T101K	43-82100-134	1
L105	Ind, 220nH 20% 4532	Taiyo Yuden	LEM4532TR22M	43-80022-000	1
L106	Ind	Koilkraft	44-70490	44-70490	1
L107	Ind, 470nH 20% 4532	Taiyo Yuden	LEM4532TR47M	43-80047-001	1
L108	Ind, 220nH 20% 4532	Taiyo Yuden	LEM4532TR22M	43-80022-000	1
L109	Ind, 4,7uH 10% 4532	Taiyo Yuden	LEM4532T4R7K	43-80470-000	1
L110	Ind, 45MHz roofing filter	Codan	44-70452	44-70452	1
L111	Ind, 45MHz roofing filter	Codan	44-70452	44-70452	1
L112	Ind, 4,7uH 10% 4532	Taiyo Yuden	LEM4532T4R7K	43-80470-000	1
L113	Ind, 330nH 20% 4532	Taiyo Yuden	LEM4532TR33M	43-80033-000	1
L114	Ind	Koilkraft	44-70490	44-70490	1
L115	Ind, 390nH 20% 4532	Taiyo Yuden	LEM4532TR39M	43-80039-001	1
L116	Ind, 100uH 10% 4532	Taiyo Yuden	LEM 4532T101K	43-82100-134	1
L117	Ind, 45MHz roofing filter	Codan	44-70452	44-70452	1
L118	Ind, 4,7uH 10% 4532	Taiyo Yuden	LEM4532T4R7K	43-80470-000	1
L119	Ind, 100nH 20% 3225	TOKO	380NB-R10M	43-80010-000	1
L201	Ind, 1mH 10% 1812	Coilcraft	1812LS-105XKBC	43-83100-000	1
L202	Ind, 1mH 10% 1812	Coilcraft	1812LS-105XKBC	43-83100-000	1
L203	Ind, 1mH 10% 1812	Coilcraft	1812LS-105XKBC	43-83100-000	1
L204	Ind, 1mH 10% 1812	Coilcraft	1812LS-105XKBC	43-83100-000	1
L205	Choke, EMI/EMC 0A DC >1MHz 4516	Taiyo Yuden	FCFBMJ 4516 HS 110-T	43-90003	1
L206	Choke, EMI/EMC 0A DC >1MHz 4516	Taiyo Yuden	FCFBMJ 4516 HS 110-T	43-90003	1
L207	Choke, EMI/EMC 0A DC >1MHz 4516	Taiyo Yuden	FCFBMJ 4516 HS 110-T	43-90003	1
L401	Ind, 10uH 10% 3225	TOKO	380KB-100K	43-81100-001	1
L402	Ind, Common Mode 1.5A	Taiyo Yuden	CM05RA06	43-80000	1
L403	Ind, VCO	Protran	44-70488	44-70488	1
L404	Ind, 10uH 10% 3225	TOKO	380KB-100K	43-81100-001	1
L405	Ind, Common Mode 1.5A	Taiyo Yuden	CM05RA06	43-80000	1
L406	Ind, Common Mode 1.5A	Taiyo Yuden	CM05RA06	43-80000	1
L407	Ind, 100uH 10% 4532	Taiyo Yuden	LEM 4532T101K	43-82100-134	1
L409	Ind	Koilkraft	44-70492	44-70492	1
L410	Ind	Koilkraft	44-70492	44-70492	1
L411	Ind, 100uH 10% 4532	Taiyo Yuden	LEM 4532T101K	43-82100-134	1
L412	Ind, 10uH 5% 3225	TDK	NL322522T-100J	43-81100-003	1

08-05889-001 - RF/IF PCB

BOM Revision
Date Valid On

18 -- Production
28.09.2006

Ref	Description	Manufacturer	Manufacturer's P/N	Codan P/N	Qty
L413	Choke, EMI/EMC 0A DC >1MHz 4516	Taiyo Yuden	FCFBMJ 4516 HS 110-T	43-90003	1
L414	Ind, 680nH 5% 3225	TDK	NL322522T-R68J	43-80068-001	1
L415	Ind, 180nH 5% 3225	TDK	NL322522T-R18J	43-80018-001	1
L416	Ind, 680nH 5% 3225	TDK	NL322522T-R68J	43-80068-001	1
L417	Ind, 47uH 5% 3225	TDK	NL322522T-470J	43-81470-001	1
P1	Header (P) 16way 2row Boxed	Thomas & Betts	609-1627	60-00160-000	1
P201	Header (P) 4way 1row	Molex	22-03-2041	60-00041-100	1
R101	4,7k Ohm 5% 0,1W 0805	Philips	2322 730 61472	40-34700-111	1
R102	4,7k Ohm 5% 0,1W 0805	Philips	2322 730 61472	40-34700-111	1
R103	3,3k Ohm 5% 0,1W 0805	Philips	2322 730 61332	40-33300-111	1
R104	8,2k Ohm 5% 0,1W 0805	Philips	2322 730 61822	40-38200-111	1
R105	100 Ohm 5% 0,1W 0805	Philips	2322 730 61101	40-21000-111	1
R106	68 Ohm 5% 0,1W 0805	Philips	2322 730 61689	40-16800-111	1
R107	100 Ohm 5% 0,1W 0805	Philips	2322 730 61101	40-21000-111	1
R108	220 Ohm 5% 0,1W 0805	Philips	2322 730 61221	40-22200-111	1
R109	10k Ohm 5% 0,1W 0805	Philips	2322-730-61103	40-41000-111	1
R110	100 Ohm 5% 0,1W 0805	Philips	2322 730 61101	40-21000-111	1
R111	150 Ohm 5% 0,1W 0805	Philips	2322 730 61151	40-21500-111	1
R112	150 Ohm 5% 0,1W 0805	Philips	2322 730 61151	40-21500-111	1
R113	180 Ohm 5% 0,1W 0805	Philips	2322 730 61181	40-21800-111	1
R114	22 Ohm 5% 0,1W 0805	Philips	2322 730 61229	40-12200-111	1
R115	22 Ohm 5% 0,1W 0805	Philips	2322 730 61229	40-12200-111	1
R116	1k Ohm 5% 0,1W 0805	Philips	2322-730-61102	40-31000-111	1
R117	220 Ohm 5% 0,1W 0805	Philips	2322 730 61221	40-22200-111	1
R118	68k Ohm 5% 0,1W 0805	Philips	2322 730 61683	40-46800-111	1
R119	82k Ohm 5% 0,1W 0805	Philips	2322 730 61823	40-48200-111	1
R120	82k Ohm 5% 0,1W 0805	Philips	2322 730 61823	40-48200-111	1
R121	3,9k Ohm 5% 0,1W 0805	Philips	2322 730 61392	40-33900-111	1
R122	100 Ohm 5% 0,1W 0805	Philips	2322 730 61101	40-21000-111	1
R123	100 Ohm 5% 0,1W 0805	Philips	2322 730 61101	40-21000-111	1
R124	82k Ohm 5% 0,1W 0805	Philips	2322 730 61823	40-48200-111	1

08-05889-001 - RF/IF PCB

BOM Revision
Date Valid On

18 -- Production
28.09.2006

Ref	Description	Manufacturer	Manufacturer's P/N	Codan P/N	Qty
R125	330 Ohm 5% 0,1W 0805	Philips	2322 730 61331	40-23300-111	1
R126	150 Ohm 5% 0,1W 0805	Philips	2322 730 61151	40-21500-111	1
R127	3,9k Ohm 5% 0,1W 0805	Philips	2322 730 61392	40-33900-111	1
R128	10k Ohm 5% 0,1W 0805	Philips	2322-730-61103	40-41000-111	1
R129	100 Ohm 5% 0,1W 0805	Philips	2322 730 61101	40-21000-111	1
R130	100 Ohm 5% 0,1W 0805	Philips	2322 730 61101	40-21000-111	1
R131	270 Ohm 5% 0,1W 0805	Philips	2322 730 61271	40-22700-111	1
R132	220 Ohm 5% 0,1W 0805	Philips	2322 730 61221	40-22200-111	1
R133	180 Ohm 5% 0,1W 0805	Philips	2322 730 61181	40-21800-111	1
R134	150 Ohm 5% 0,1W 0805	Philips	2322 730 61151	40-21500-111	1
R135	180 Ohm 5% 0,1W 0805	Philips	2322 730 61181	40-21800-111	1
R136	180 Ohm 5% 0,1W 0805	Philips	2322 730 61181	40-21800-111	1
R137	10k Ohm 5% 0,1W 0805	Philips	2322-730-61103	40-41000-111	1
R138	Pot,100k Lin MG Trim SMD	Bourns	3314 J-1-104	42-51060-001	1
R139	10k Ohm 5% 0,1W 0805	Philips	2322-730-61103	40-41000-111	1
R140	10 Ohm 5% 0,06W 0603	Philips	2322 702 60109	40-11000-121	1
R141	1k Ohm 5% 0,1W 0805	Philips	2322-730-61102	40-31000-111	1
R142	220 Ohm 5% 0,1W 0805	Philips	2322 730 61221	40-22200-111	1
R143	270 Ohm 5% 0,1W 0805	Philips	2322 730 61271	40-22700-111	1
R144	470 Ohm 5% 0,1W 0805	Philips	2322 730 61471	40-24700-111	1
R145	470 Ohm 5% 0,1W 0805	Philips	2322 730 61471	40-24700-111	1
R146	470 Ohm 5% 0,1W 0805	Philips	2322 730 61471	40-24700-111	1
R201	5,6k Ohm 5% 0,1W 0805	Philips	2322 730 61562	40-35600-111	1
R202	3,9k Ohm 5% 0,1W 0805	Philips	2322 730 61392	40-33900-111	1
R203	22k Ohm 5% 0,1W 0805	Philips	2322 730 61223	40-42200-111	1
R204	15k Ohm 5% 0,1W 0805	Philips	2322 730 61153	40-41500-111	1
R205	100k Ohm 5% 0,1W 0805	Philips	2322 730 61104	40-51000-111	1
R206	33k Ohm 5% 0,1W 0805	Philips	2322 730 61333	40-43300-111	1
R207	100 Ohm 5% 0,1W 0805	Philips	2322 730 61101	40-21000-111	1

08-05889-001 - RF/IF PCB

BOM Revision
Date Valid On

18 -- Production
28.09.2006

Ref	Description	Manufacturer	Manufacturer's P/N	Codan P/N	Qty
R208	47k Ohm 5% 0,1W 0805	Philips	2322 730 61473	40-44700-111	1
R209	47k Ohm 5% 0,1W 0805	Philips	2322 730 61473	40-44700-111	1
R210	22k Ohm 5% 0,1W 0805	Philips	2322 730 61223	40-42200-111	1
R211	100k Ohm 5% 0,1W 0805	Philips	2322 730 61104	40-51000-111	1
R212	22k Ohm 5% 0,1W 0805	Philips	2322 730 61223	40-42200-111	1
R213	10k Ohm 5% 0,1W 0805	Philips	2322-730-61103	40-41000-111	1
R214	100k Ohm 5% 0,1W 0805	Philips	2322 730 61104	40-51000-111	1
R215	1k Ohm 5% 0,1W 0805	Philips	2322-730-61102	40-31000-111	1
R216	10 Ohm 5% 0,06W 0603	Philips	2322 702 60109	40-11000-121	1
R217	Pot,10k Lin MG Trim SMD	Bourns	3314 J-1-103	42-41004-000	1
R218	1k Ohm 5% 0,1W 0805	Philips	2322-730-61102	40-31000-111	1
R219	1M Ohm 5% 0,1W 0805	Philips	2322 730 61105	40-61000-111	1
R220	68k Ohm 5% 0,1W 0805	Philips	2322 730 61683	40-46800-111	1
R221	100k Ohm 5% 0,1W 0805	Philips	2322 730 61104	40-51000-111	1
R222	0 Ohm Jumper 0805	Philips	2322 730 91002	40-00001-111	1
R223	0 Ohm Jumper 0805	Philips	2322 730 91002	40-00001-111	1
R224	3,3k Ohm 5% 0,1W 0805	Philips	2322 730 61332	40-33300-111	1
R225	3,3k Ohm 5% 0,1W 0805	Philips	2322 730 61332	40-33300-111	1
R226	3,3k Ohm 5% 0,1W 0805	Philips	2322 730 61332	40-33300-111	1
R227	3,3k Ohm 5% 0,1W 0805	Philips	2322 730 61332	40-33300-111	1
R228	4,7k Ohm 5% 0,1W 0805	Philips	2322 730 61472	40-34700-111	1
R229	2,2k Ohm 5% 0,1W 0805	Philips	2322 730 61222	40-32200-111	1
R230	100 Ohm 5% 0,1W 0805	Philips	2322 730 61101	40-21000-111	1
R231	10k Ohm 5% 0,1W 0805	Philips	2322-730-61103	40-41000-111	1
R232	100 Ohm 5% 0,1W 0805	Philips	2322 730 61101	40-21000-111	1
R233	6,8k Ohm 5% 0,1W 0805	Philips	2322 730 61682	40-36800-111	1
R234	10k Ohm 5% 0,1W 0805	Philips	2322-730-61103	40-41000-111	1
R235	47k Ohm 5% 0,1W 0805	Philips	2322 730 61473	40-44700-111	1
R236	5,6k Ohm 5% 0,1W 0805	Philips	2322 730 61562	40-35600-111	1
R237	2,2k Ohm 5% 0,1W 0805	Philips	2322 730 61222	40-32200-111	1

08-05889-001 - RF/IF PCB

BOM Revision
Date Valid On

18 -- Production
28.09.2006

Ref	Description	Manufacturer	Manufacturer's P/N	Codan P/N	Qty
R238	150 Ohm 5% 0,1W 0805	Philips	2322 730 61151	40-21500-111	1
R239	22k Ohm 5% 0,1W 0805	Philips	2322 730 61223	40-42200-111	1
R240	2,2k Ohm 5% 0,1W 0805	Philips	2322 730 61222	40-32200-111	1
R241	1M Ohm 5% 0,1W 0805	Philips	2322 730 61105	40-61000-111	1
R242	220 Ohm 5% 0,1W 0805	Philips	2322 730 61221	40-22200-111	1
R243	3,3k Ohm 5% 0,1W 0805	Philips	2322 730 61332	40-33300-111	1
R244	220 Ohm 5% 0,1W 0805	Philips	2322 730 61221	40-22200-111	1
R245	3,3k Ohm 5% 0,1W 0805	Philips	2322 730 61332	40-33300-111	1
R246	220 Ohm 5% 0,1W 0805	Philips	2322 730 61221	40-22200-111	1
R247	33k Ohm 5% 0,1W 0805	Philips	2322 730 61333	40-43300-111	1
R248	6,8k Ohm 5% 0,1W 0805	Philips	2322 730 61682	40-36800-111	1
R249	100 Ohm 5% 0,1W 0805	Philips	2322 730 61101	40-21000-111	1
R250	330 Ohm 5% 0,1W 0805	Philips	2322 730 61331	40-23300-111	1
R252	680 Ohm 10% NTC Thermistor	Philips	2322 640 63681	41-02684-642	1
R253	470 Ohm 5% 0,1W 0805	Philips	2322 730 61471	40-24700-111	1
R254	5,6k Ohm 5% 0,1W 0805	Philips	2322 730 61562	40-35600-111	1
R255	4,7k Ohm 5% 0,1W 0805	Philips	2322 730 61472	40-34700-111	1
R256	Pot,10k Lin MG Trim SMD	Bourns	3314 J-1-103	42-41004-000	1
R257	10k Ohm 5% 0,1W 0805	Philips	2322-730-61103	40-41000-111	1
R258	8,2k Ohm 5% 0,1W 0805	Philips	2322 730 61822	40-38200-111	1
R259	3,3k Ohm 5% 0,1W 0805	Philips	2322 730 61332	40-33300-111	1
R260	10 Ohm 5% 0,06W 0603	Philips	2322 702 60109	40-11000-121	1
R261	1k Ohm 5% 0,1W 0805	Philips	2322-730-61102	40-31000-111	1
R262	1k Ohm 5% 0,1W 0805	Philips	2322-730-61102	40-31000-111	1
R263	10k Ohm 5% 0,1W 0805	Philips	2322-730-61103	40-41000-111	1
R264	82k Ohm 5% 0,1W 0805	Philips	2322 730 61823	40-48200-111	1
R265	10 Ohm 5% 0,1W 0805	Philips	2322 730 61109	40-11000-111	1
R266	100k Ohm 5% 0,1W 0805	Philips	2322 730 61104	40-51000-111	1
R267	10k Ohm 5% 0,1W 0805	Philips	2322-730-61103	40-41000-111	1

08-05889-001 - RF/IF PCB

BOM Revision
Date Valid On

18 -- Production
28.09.2006

Ref	Description	Manufacturer	Manufacturer's P/N	Codan P/N	Qty
R268	100k Ohm 5% 0,1W 0805	Philips	2322 730 61104	40-51000-111	1
R269	100k Ohm 5% 0,1W 0805	Philips	2322 730 61104	40-51000-111	1
R270	4,7k Ohm 5% 0,1W 0805	Philips	2322 730 61472	40-34700-111	1
R271	3,3k Ohm 5% 0,1W 0805	Philips	2322 730 61332	40-33300-111	1
R272	22k Ohm 5% 0,1W 0805	Philips	2322 730 61223	40-42200-111	1
R273	18k Ohm 5% 0,1W 0805	Philips	2322 730 61183	40-41800-111	1
R274	47k Ohm 5% 0,1W 0805	Philips	2322 730 61473	40-44700-111	1
R275	0 Ohm Jumper 0805	Philips	2322 730 91002	40-00001-111	1
R276	100 Ohm 5% 0,1W 0805	Philips	2322 730 61101	40-21000-111	1
R277	1k Ohm 5% 0,1W 0805	Philips	2322-730-61102	40-31000-111	1
R278	0 Ohm Jumper 0805	Philips	2322 730 91002	40-00001-111	1
R279	10k Ohm 5% 0,1W 0805	Philips	2322-730-61103	40-41000-111	1
R280	560k Ohm 5% 0,1W 0805	Philips	2322 730 61564	40-55600-111	1
R281	22k Ohm 5% 0,1W 0805	Philips	2322 730 61223	40-42200-111	1
R282	100 Ohm 5% 0,1W 0805	Philips	2322 730 61101	40-21000-111	1
R283	1M Ohm 5% 0,1W 0805	Philips	2322 730 61105	40-61000-111	1
R284	1,5M Ohm 5% 0,1W 0805	Yageo	RC0805JR-071M5L	40-61500-111	1
R285	180k Ohm 5% 0,1W 0805	Philips	2322 730 61184	40-51800-111	1
R286	10M Ohm 1% 0,1W 0805	Philips	2322 734 61006	40-71000-115	1
R287	10k Ohm 5% 0,1W 0805	Philips	2322-730-61103	40-41000-111	1
R289	8,2k Ohm 5% 0,1W 0805	Philips	2322 730 61822	40-38200-111	1
R290	18k Ohm 5% 0,1W 0805	Philips	2322 730 61183	40-41800-111	1
R291	1,2k Ohm 5% 0,1W 0805	Philips	2322 730 61122	40-31200-111	1
R292	1,8k Ohm 5% 0,1W 0805	Philips	2322 730 61182	40-31800-111	1
R293	100 Ohm 5% 0,1W 0805	Philips	2322 730 61101	40-21000-111	1
R294	18k Ohm 5% 0,1W 0805	Philips	2322 730 61183	40-41800-111	1
R295	100k Ohm 5% 0,1W 0805	Philips	2322 730 61104	40-51000-111	1
R296	10k Ohm 5% 0,1W 0805	Philips	2322-730-61103	40-41000-111	1
R297	10k Ohm 5% 0,1W 0805	Philips	2322-730-61103	40-41000-111	1
R298	4,7k Ohm 5% 0,1W 0805	Philips	2322 730 61472	40-34700-111	1

08-05889-001 - RF/IF PCB

BOM Revision
Date Valid On

18 -- Production
28.09.2006

Ref	Description	Manufacturer	Manufacturer's P/N	Codan P/N	Qty
R299	100 Ohm 5% 0,1W 0805	Philips	2322 730 61101	40-21000-111	1
R300	100 Ohm 5% 0,1W 0805	Philips	2322 730 61101	40-21000-111	1
R301	100 Ohm 5% 0,1W 0805	Philips	2322 730 61101	40-21000-111	1
R302	100 Ohm 5% 0,1W 0805	Philips	2322 730 61101	40-21000-111	1
R303	10k Ohm 5% 0,1W 0805	Philips	2322-730-61103	40-41000-111	1
R304	1M Ohm 5% 0,1W 0805	Philips	2322 730 61105	40-61000-111	1
R305	2,2k Ohm 5% 0,1W 0805	Philips	2322 730 61222	40-32200-111	1
R306	3,3k Ohm 5% 0,1W 0805	Philips	2322 730 61332	40-33300-111	1
R307	1k Ohm 5% 0,1W 0805	Philips	2322-730-61102	40-31000-111	1
R308	3,3k Ohm 5% 0,1W 0805	Philips	2322 730 61332	40-33300-111	1
R309	10k Ohm 5% 0,1W 0805	Philips	2322-730-61103	40-41000-111	1
R310	3,3k Ohm 5% 0,1W 0805	Philips	2322 730 61332	40-33300-111	1
R311	1k Ohm 5% 0,1W 0805	Philips	2322-730-61102	40-31000-111	1
R312	3,3k Ohm 5% 0,1W 0805	Philips	2322 730 61332	40-33300-111	1
R313	560k Ohm 5% 0,1W 0805	Philips	2322 730 61564	40-55600-111	1
R314	100k Ohm 5% 0,1W 0805	Philips	2322 730 61104	40-51000-111	1
R401	220 Ohm 5% 0,1W 0805	Philips	2322 730 61221	40-22200-111	1
R402	1M Ohm 5% 0,1W 0805	Philips	2322 730 61105	40-61000-111	1
R403	22k Ohm 5% 0,1W 0805	Philips	2322 730 61223	40-42200-111	1
R404	470 Ohm 5% 0,1W 0805	Philips	2322 730 61471	40-24700-111	1
R405	100 Ohm 5% 0,1W 0805	Philips	2322 730 61101	40-21000-111	1
R406	22k Ohm 5% 0,1W 0805	Philips	2322 730 61223	40-42200-111	1
R407	470 Ohm 5% 0,1W 0805	Philips	2322 730 61471	40-24700-111	1
R408	2,2k Ohm 5% 0,1W 0805	Philips	2322 730 61222	40-32200-111	1
R409	100 Ohm 5% 0,1W 0805	Philips	2322 730 61101	40-21000-111	1
R410	100 Ohm 5% 0,1W 0805	Philips	2322 730 61101	40-21000-111	1
R411	10 Ohm 5% 0,06W 0603	Philips	2322 702 60109	40-11000-121	1
R412	470 Ohm 5% 0,1W 0805	Philips	2322 730 61471	40-24700-111	1
R413	10 Ohm 5% 0,06W 0603	Philips	2322 702 60109	40-11000-121	1

08-05889-001 - RF/IF PCB

BOM Revision
Date Valid On

18 -- Production
28.09.2006

Ref	Description	Manufacturer	Manufacturer's P/N	Codan P/N	Qty
R414	10k Ohm 5% 0,1W 0805	Philips	2322-730-61103	40-41000-111	1
R415	10 Ohm 5% 0,06W 0603	Philips	2322 702 60109	40-11000-121	1
R416	10 Ohm 5% 0,06W 0603	Philips	2322 702 60109	40-11000-121	1
R417	330 Ohm 5% 0,1W 0805	Philips	2322 730 61331	40-23300-111	1
R418	100 Ohm 5% 0,1W 0805	Philips	2322 730 61101	40-21000-111	1
R419	470 Ohm 5% 0,1W 0805	Philips	2322 730 61471	40-24700-111	1
R420	820 Ohm 5% 0,1W 0805	Philips	2322 730 61821	40-28200-111	1
R421	1k Ohm 5% 0,1W 0805	Philips	2322-730-61102	40-31000-111	1
R422	470 Ohm 5% 0,1W 0805	Philips	2322 730 61471	40-24700-111	1
R423	390 Ohm 5% 0,1W 0805	Philips	2322 730 61391	40-23900-111	1
R424	390 Ohm 5% 0,1W 0805	Philips	2322 730 61391	40-23900-111	1
R425	100 Ohm 5% 0,1W 0805	Philips	2322 730 61101	40-21000-111	1
R426	3,9k Ohm 5% 0,1W 0805	Philips	2322 730 61392	40-33900-111	1
R427	3,9k Ohm 5% 0,1W 0805	Philips	2322 730 61392	40-33900-111	1
R428	5,6k Ohm 5% 0,1W 0805	Philips	2322 730 61562	40-35600-111	1
R429	3,9k Ohm 5% 0,1W 0805	Philips	2322 730 61392	40-33900-111	1
R430	100 Ohm 5% 0,1W 0805	Philips	2322 730 61101	40-21000-111	1
R431	4,7k Ohm 5% 0,1W 0805	Philips	2322 730 61472	40-34700-111	1
R432	6,8k Ohm 5% 0,1W 0805	Philips	2322 730 61682	40-36800-111	1
R433	4,7k Ohm 5% 0,1W 0805	Philips	2322 730 61472	40-34700-111	1
R434	1M Ohm 5% 0,1W 0805	Philips	2322 730 61105	40-61000-111	1
R435	10k Ohm 5% 0,1W 0805	Philips	2322-730-61103	40-41000-111	1
R436	330 Ohm 5% 0,1W 0805	Philips	2322 730 61331	40-23300-111	1
R437	220 Ohm 5% 0,1W 0805	Philips	2322 730 61221	40-22200-111	1
R438	4,7k Ohm 5% 0,1W 0805	Philips	2322 730 61472	40-34700-111	1
R439	18k Ohm 5% 0,1W 0805	Philips	2322 730 61183	40-41800-111	1
R440	100 Ohm 5% 0,1W 0805	Philips	2322 730 61101	40-21000-111	1
R441	10 Ohm 5% 0,06W 0603	Philips	2322 702 60109	40-11000-121	1
R442	100k Ohm 5% 0,1W 0805	Philips	2322 730 61104	40-51000-111	1

08-05889-001 - RF/IF PCB

BOM Revision
Date Valid On

18 -- Production
28.09.2006

Ref	Description	Manufacturer	Manufacturer's P/N	Codan P/N	Qty
R443	100 Ohm 5% 0,1W 0805	Philips	2322 730 61101	40-21000-111	1
R444	330 Ohm 5% 0,1W 0805	Philips	2322 730 61331	40-23300-111	1
R445	22 Ohm 5% 0,1W 0805	Philips	2322 730 61229	40-12200-111	1
R446	3,9k Ohm 5% 0,1W 0805	Philips	2322 730 61392	40-33900-111	1
R447	22 Ohm 5% 0,1W 0805	Philips	2322 730 61229	40-12200-111	1
R448	Not Fitted	Codan	**00000-001	99-00000-001	1
R449	56 Ohm 5% 0,1W 0805	Philips	2322 730 61569	40-15600-111	1
R450	4,7k Ohm 5% 0,1W 0805	Philips	2322 730 61472	40-34700-111	1
R451	10k Ohm 5% 0,1W 0805	Philips	2322-730-61103	40-41000-111	1
R452	100 Ohm 5% 0,1W 0805	Philips	2322 730 61101	40-21000-111	1
R453	1k Ohm 5% 0,1W 0805	Philips	2322-730-61102	40-31000-111	1
R454	22 Ohm 5% 0,1W 0805	Philips	2322 730 61229	40-12200-111	1
R455	22 Ohm 5% 0,1W 0805	Philips	2322 730 61229	40-12200-111	1
R456	3,9k Ohm 5% 0,1W 0805	Philips	2322 730 61392	40-33900-111	1
R458	330 Ohm 5% 0,1W 0805	Philips	2322 730 61331	40-23300-111	1
R459	10 Ohm 5% 0,06W 0603	Philips	2322 702 60109	40-11000-121	1
R460	10 Ohm 5% 0,06W 0603	Philips	2322 702 60109	40-11000-121	1
R461	10 Ohm 5% 0,06W 0603	Philips	2322 702 60109	40-11000-121	1
R462	10 Ohm 5% 0,06W 0603	Philips	2322 702 60109	40-11000-121	1
R463	1M Ohm 5% 0,1W 0805	Philips	2322 730 61105	40-61000-111	1
R464	10k Ohm 5% 0,1W 0805	Philips	2322-730-61103	40-41000-111	1
R465	470 Ohm 5% 0,1W 0805	Philips	2322 730 61471	40-24700-111	1
R466	100 Ohm 5% 0,1W 0805	Philips	2322 730 61101	40-21000-111	1
R467	470 Ohm 5% 0,1W 0805	Philips	2322 730 61471	40-24700-111	1
R468	10k Ohm 5% 0,1W 0805	Philips	2322-730-61103	40-41000-111	1
R469	10k Ohm 5% 0,1W 0805	Philips	2322-730-61103	40-41000-111	1
R470	10k Ohm 5% 0,1W 0805	Philips	2322-730-61103	40-41000-111	1
R471	100k Ohm 5% 0,1W 0805	Philips	2322 730 61104	40-51000-111	1
R472	10k Ohm 5% 0,1W 0805	Philips	2322-730-61103	40-41000-111	1

08-05889-001 - RF/IF PCB

BOM Revision
Date Valid On

18 -- Production
28.09.2006

Ref	Description	Manufacturer	Manufacturer's P/N	Codan P/N	Qty
R473	10k Ohm 5% 0,1W 0805	Philips	2322-730-61103	40-41000-111	1
R474	5,6k Ohm 5% 0,1W 0805	Philips	2322 730 61562	40-35600-111	1
R475	3,3k Ohm 5% 0,1W 0805	Philips	2322 730 61332	40-33300-111	1
R476	10k Ohm 5% 0,1W 0805	Philips	2322-730-61103	40-41000-111	1
R477	47k Ohm 5% 0,1W 0805	Philips	2322 730 61473	40-44700-111	1
R478	10k Ohm 5% 0,1W 0805	Philips	2322-730-61103	40-41000-111	1
R479	3,3k Ohm 5% 0,1W 0805	Philips	2322 730 61332	40-33300-111	1
R480	10k Ohm 5% 0,1W 0805	Philips	2322-730-61103	40-41000-111	1
R481	47k Ohm 5% 0,1W 0805	Philips	2322 730 61473	40-44700-111	1
R482	1k Ohm 5% 0,1W 0805	Philips	2322-730-61102	40-31000-111	1
R483	1k Ohm 5% 0,1W 0805	Philips	2322-730-61102	40-31000-111	1
R484	10k Ohm 5% 0,1W 0805	Philips	2322-730-61103	40-41000-111	1
T101	Txfr, RF Amp	Protran	44-80263	44-80263	1
T102	Txfr, Rx I/P	Protran	44-80261	44-80261	1
T103	Ind, Mixer 1 L.O. Buffer	Sumida	44-70491	44-70491	1
T104	45MHz Roofing Filter Txfr	Sumida	44-70493	44-70493	1
T105	Txfr, Mixer 2 Input	KoilKraft	44-70486	44-70486	1
T106	Txfr, Exciter O/P	Protran	44-80260	44-80260	1
T107	Txfr, 45MHz roofing filtr	Codan	44-70451	44-70451	1
T108	Txfr, 45MHz roofing filtr	Codan	44-70451	44-70451	1
T201	Ind, Buffer Output	KoilKraft	44-70487	44-70487	1
T202	Ind, Buffer Output	KoilKraft	44-70487	44-70487	1
T401	Balun	Protran	44-80262	44-80262	1
V101	Transistor, NPN Si 18V 0,15A 4GHz SOT89	Philips	BFQ18A	BFQ18A	1
V102	Transistor, NPN Si SOT23	Philips	BC848	BC848	1
V103	JFET, Selected J310 01-01031	Avnet	PST00-3289	PST00-3289	1
V104	JFET, Selected J310 01-01031	Avnet	PST00-3289	PST00-3289	1
V105	JFET, Selected J310 01-01031	Avnet	PST00-3289	PST00-3289	1
V106	JFET, Selected J310 01-01031	Avnet	PST00-3289	PST00-3289	1
V107	Transistor, PNP Si SOT23	Philips	BFT92	BFT92	1
V108	Transistor, PNP Si SOT23	Philips	BFT92	BFT92	1
V109	MOSFET,N Chan Dual Gate SOT143	Philips	BF991	BF991	1
V201	Transistor, PNP Si SOT23	Philips	BC858	BC858	1
V202	Transistor, NPN Si SOT23	Philips	BC848	BC848	1

08-05889-001 - RF/IF PCB

BOM Revision
Date Valid On

18 -- Production
28.09.2006

Ref	Description	Manufacturer	Manufacturer's P/N	Codan P/N	Qty
V203	Transistor, NPN Si SOT23	Philips	BC848	BC848	1
V204	MOSFET, N Chan Enhance SOT143	Philips	BSS83	BSS83	1
V205	MOSFET, N Chan Enhance SOT143	Philips	BSS83	BSS83	1
V206	Transistor, NPN Si SOT23	Philips	BC848	BC848	1
V207	Transistor, NPN Si SOT23	Philips	BC848	BC848	1
V208	Transistor, PNP Si SOT23	Philips	BC858	BC858	1
V209	Transistor, PNP Si SOT23	Philips	BC858	BC858	1
V210	JFET, N Channel SOT23	Philips	BF545B	BF545B	1
V211	JFET, N Channel SOT23	Philips	BF545B	BF545B	1
V212	JFET, N Channel SOT23	Philips	BF545B	BF545B	1
V213	Transistor, PNP Si SOT23	Philips	BFT92	BFT92	1
V214	Transistor, NPN Si SOT23	Philips	BC848	BC848	1
V215	Transistor, NPN Si SOT23	Philips	BC848	BC848	1
V216	MOSFET, N Channel Dual 20V 0,5A SOT363	Vishay	SI1902DL	SI1902DL	1
V220	Transistor, NPN Si SOT23	Philips	BC848	BC848	1
V221	Diode, Zener 3,3V 5% 0,2W SOT23	Philips	BZX84-C3V3	BZX84C3V3	1
V401	JFET, N Channel SOT23	Philips	BF556B	BF556B	1
V402	Transistor, NPN Si SOT23	Philips	BFR92A	BFR92A	1
V403	Transistor, NPN Si SOT23	Philips	BFR92A	BFR92A	1
V404	Transistor, NPN Si SOT23	Philips	BC846	BC846	1
V405	Transistor, NPN Si SOT23	Philips	BFR92A	BFR92A	1
V406	Transistor, PNP Si SOT23	Philips	BC856	BC856	1
V407	Transistor, NPN Si SOT23	Philips	BC846	BC846	1
V408	Transistor, PNP Si SOT23	Philips	BFT92	BFT92	1
V409	Transistor, NPN Si SOT23	Philips	BC846	BC846	1
V410	Transistor, NPN Si SOT23	Philips	BC846	BC846	1
V411	Transistor, NPN Si SOT23	Philips	BFR92A	BFR92A	1
V412	Transistor, NPN Si SOT23	Philips	BFR92A	BFR92A	1
V413	Transistor, NPN Si SOT23	Philips	BC848	BC848	1

08-05889-001 - RF/IF PCB

BOM Revision
Date Valid On

18 -- Production
 28.09.2006

Ref	Description	Manufacturer	Manufacturer's P/N	Codan P/N	Qty
V414	Transistor, PNP Si SOT23	Philips	BC858	BC858	1
V415	Transistor, PNP Si SOT89	Philips	BC869	BC869	1
V416	Transistor, NPN Si SOT23	Philips	BC848	BC848	1
V417	Transistor, PNP Si SOT89	Philips	BC869	BC869	1
V418	Transistor, NPN Si SOT23	Philips	BC848	BC848	1
Z101	Composite Item	Codan	**_00000-003	99-00000-003	1
Z102	Composite Item	Codan	**_00000-003	99-00000-003	1
Z103	Composite Item	Codan	**_00000-003	99-00000-003	1
Z104	Composite Item	Codan	**_00000-003	99-00000-003	1
Z201	Filter, 455kHz 2,4kHz min.	Murata	CFJ455K5	65-91124	1

08-05235-002 - Oven, Hi-Stab for HC18 Xtal

BOM Revision
Date Valid On

04 -- Production
27.09.2006

Ref	Description	Manufacturer	Manufacturer's P/N	Codan P/N	Qty
	Oven, Hi-Stab for HC18 Xtal			08-05235	1
	Oven, Crystal			04-03095	1
	H/Stab. Crystal Oven			11-05235	1
1	PCB, Oven, Crystal	Codan	07-01732-04	07-01732-04	1
2	Heatsink, Oven	Metalcraft	05-06936	05-06936	1
3	Tape, Masking 13mm 33m	Permacel	P-221 (Paint Mask)	30-39306-006	1
C1	33n 10% 100V X7R 1206 NiSn	Philips	12062R333K0BB-	46-43300-280	1
C2	10u 20% 25V 6032 TA Cap	AVX	TAJC106M025R	47-11002-520	1
IC1	Amp, Operational Dual SOIC8	National Semiconduct	LM358M	XA-00358-700	1
R1	820 Ohm 5% 0,125W 1206	Philips	2322 711 61821	40-28200-101	1
R2	2,2k Ohm 5% 0,125W 1206	Philips	2322 711 61222	40-32200-101	1
R3	4,7k Ohm 5% 0,06W 0603	Philips	2322 702 60472	40-34700-121	1
R4	30k Ohm 5% NTC Thermistor	Philips	2322 633 53303	41-04303-000	1
R5	100 Ohm 5% 0,125W 1206	Philips	2322 711 61101	40-21000-101	1
R6	270 Ohm 5% 0,125W 1206	Philips	2322 711 61271	40-22700-101	1
R7	150 Ohm 5% 0,125W 1206	Philips	2322 711 61151	40-21500-101	1
R8	100k Ohm 5% 0,06W 0603	Philips	2322 702 60104	40-51000-121	1
R9	100k Ohm 5% 0,06W 0603	Philips	2322 702 60104	40-51000-121	1
R10	1M Ohm 5% 0,125W 1206	Philips	2322 711 61105	40-61000-101	1
R11	4,7k Ohm 5% 0,06W 0603	Philips	2322 702 60472	40-34700-121	1
R12	4,7k Ohm 5% 0,06W 0603	Philips	2322 702 60472	40-34700-121	1
R13	3,3 Ohm 5% 0,125W 1206	Philips	2322 711 61338	40-03300-101	1
R14	3,3 Ohm 5% 0,125W 1206	Philips	2322 711 61338	40-03300-101	1
V1	Diode, Zener 6,8V 5% 0,2W SOT23	Philips	BZX84C6V8	BZX84C6V8	1
V2	MOSFET, Power N Channel	Motorola	MTD3055EL1	MTD3055EL1	1
V3	Transistor, NPN Si SOT23	Philips	BC848	BC848	1
Z401	Crystal, 44545 kHz series	HY-Q	TW07S QC49	65-90102	1

08-05963-001 - Crystal Oven Assembly

BOM Revision
Date Valid On

02 -- Production
28.09.2006

Ref	Description	Manufacturer	Manufacturer's P/N	Codan P/N	Qty
	Compound, Heat Transfer 70g Electrolube	Electrolube	HTC35SL	71-31000-006	0.01
*	Crystal Oven Assembly			08-05963	1
1	Heatsink, Shell, Bottom	Metalcraft	05-07188	05-07188	1
2	Heatsink, Shell, Spacer	Metalcraft	05-07189	05-07189	1
3	Heatsink, Shell, Top	Metalcraft	05-07190	05-07190	1
4	Fundamental Xtal Osc PCB	Codan	08-05962-001	08-05962-001	1
5	Controller, Crystal Oven PCB	Codan	08-05973-001	08-05973-001	1
V2	MOSFET, Power N Channel	Motorola	MTD3055EL1	MTD3055EL1	1
Z1	Crystal, 14848,33 kHz Fundamental QC49	HY-Q	TW07C QC49 14848.33K	65-90111	1

08-05962-001 - Fundamental Xtal Osc PCB

BOM Revision
Date Valid On

06 -- Production
28.09.2006

Ref	Description	Manufacturer	Manufacturer's P/N	Codan P/N	Qty
	Fundamental Xtal Osc PCB			08-05962	1
	Fundamental Xtal Oscillator			04-03410	1
1	PCB, Fundamental Xtal Osc	IMP	07-01980-03	07-01980-03	1
C1	1u 20% 35V 3528 TA Cap	AVX	TAJB105M035R	47-01003-520	1
C2	33n 10% 50V X7R 0805 NiSn	Philips	08052R333K9BB00	46-43300-281	1
C3	1u 20% 35V 3528 TA Cap	AVX	TAJB105M035R	47-01003-520	1
C4	22p 5% 50V NPO 0805 NiSn	Philips	0805CG220J9B200	46-12200-081	1
C5	47p 5% 50V NPO 0805 NiSn	Philips	0805CG470J9B200	46-14700-080	1
C6	15p 5% 50V NPO 0603 NiSn	Philips	0603CG150C9BB00	46-11500-083	1
C7	2 - 10p Ceramic Trim Cap SMD	Voltronics	JZ100	49-51100	1
C8	4,7p 0,25p 50V NPO 0603 NiSn	Philips	0603CG479C9B200	46-04700-084	1
C9	2,2p 0,25p 50V NPO 0603 NiSn	AVX	06035A2R2CAT2A	46-02200-082	1
C10	4,7p 0,25p 50V NPO 0603 NiSn	Philips	0603CG479C9B200	46-04700-084	1
C11	8,2p 0,25p 50V NPO 0603 NiSn	Philips	0603CG829C9BB00	46-08200-082	1
IC1	Inverter, Single Unbuffered SOT23-5	SGS Thomson	74V1GU04S	YZ-74004-700	1
IC2	Inverter, Single Unbuffered SOT23-5	SGS Thomson	74V1GU04S	YZ-74004-700	1
IC3	Reg, Voltage +5V 0,1A SOIC8	National Semiconduct	LM78L05ACM	XB-07805-700	1
R1	1M Ohm 5% 0,06W 0603	Philips	2322 702 60105	40-61000-121	1
R2	3,3k Ohm 5% 0,1W 0805	Philips	2322 730 61332	40-33300-111	1

08-05973-001 - Controller, Crystal Oven PCB

BOM Revision
Date Valid On

03 -- Production
28.09.2006

Ref	Description	Manufacturer	Manufacturer's P/N	Codan P/N	Qty
	Controller, Crystal Oven			08-05973	1
	Controller, Crystal Oven			04-03414	1
1	PCB, Controller Crystal Oven	IMP	07-01905-02	07-01905-02	1
C1	10u 20% 25V 6032 TA Cap	AVX	TAJC106M025R	47-11002-520	1
C2	1n 5% 50V NPO 0805 NiSn	Philips	0805CG102J9BB-	46-31000-082	1
IC1	Amp, Rail to Rail I/O SOT23-5	National Semiconduct	LMC7101BIM5X	XA-07101-700	1
R1	56k Ohm 5% 0,1W 0805	Philips	2322 730 61563	40-45600-111	1
R2	330k Ohm 5% 0,1W 0805	Philips	2322 730 61334	40-53300-111	1
R3	30k Ohm 5% NTC Thermistor	Philips	2322 633 53303	41-04303-000	1
R4	51k Ohm 1% 0,1W 0805	Philips	2322 734 65103	40-45100-115	1
R5	820k Ohm 5% 0,1W 0805	Philips	2322 730 61824	40-58200-111	1
R6	5,6k Ohm 1% 0,1W 0805	Philips	2322 734 65602	40-35600-115	1
R7	2,2M Ohm 5% 0,1W 0805	Philips	2322 730 61225	40-62200-111	1
R8	4,7k Ohm 5% 0,1W 0805	Philips	2322 730 61472	40-34700-111	1
R9	3,3 Ohm 5% 0,125W 1206	Philips	2322 711 61338	40-03300-101	1
R10	3,3 Ohm 5% 0,125W 1206	Philips	2322 711 61338	40-03300-101	1
V1	Transistor, NPN Si SOT23	Philips	BC848	BC848	1

08-05415-001 - PA PCB

BOM Revision
Date Valid On

03 -- Production
27.09.2006

Ref	Description	Manufacturer	Manufacturer's P/N	Codan P/N	Qty
	PA PCB			08-05415	1
1	Spacer, Swaged	Routley & W		05-05569	2
2	PCB, PA	IMP	07-01799-03	07-01799-03	1
3	Stake, Terminal	Autosplice	7-22461-5	61-40300-004	6
C200	1u 20% 35V 3528 TA Cap	AVX	TAJB105M035R	47-01003-520	1
C201	1u 20% 35V 3528 TA Cap	AVX	TAJB105M035R	47-01003-520	1
C202	100u 25V Ax EL Cap	Elna	RB	48-21002-551	1
C203	33n 10% 100V X7R 1206 NiSn	Philips	12062R333K0BB-	46-43300-280	1
C204	22p 5% 50V NPO 1206 NiSn	Philips	1206CG220J9BB-	46-12200-080	1
C205	33n 10% 100V X7R 1206 NiSn	Philips	12062R333K0BB-	46-43300-280	1
C206	33n 10% 100V X7R 1206 NiSn	Philips	12062R333K0BB-	46-43300-280	1
C207	15p 5% 500V NPO 1206 NiSn	Philips	1206CG150GBB-	46-11500-082	1
C208	100u 25V Ax EL Cap	Elna	RB	48-21002-551	1
C209	33n 10% 100V X7R 1206 NiSn	Philips	12062R333K0BB-	46-43300-280	1
C210	33n 10% 100V X7R 1206 NiSn	Philips	12062R333K0BB-	46-43300-280	1
C211	33n 10% 100V X7R 1206 NiSn	Philips	12062R333K0BB-	46-43300-280	1
C212	33n 10% 100V X7R 1206 NiSn	Philips	12062R333K0BB-	46-43300-280	1
C213	1n 5% 50V NPO 1206 NiSn	Philips	1206CG102J9BB-	46-31000-081	1
C214	100u 25V Ax EL Cap	Elna	RB	48-21002-551	1
C215	33n 10% 100V X7R 1206 NiSn	Philips	12062R333K0BB-	46-43300-280	1
C216	33n 10% 100V X7R 1206 NiSn	Philips	12062R333K0BB-	46-43300-280	1
C217	22p 5% 50V NPO 1206 NiSn	Philips	1206CG220J9BB-	46-12200-080	1
C218	22p 5% 50V NPO 1206 NiSn	Philips	1206CG220J9BB-	46-12200-080	1
C219	100p 5% 50V NPO 1206 NiSn	Philips	1206CG101J9BB-	46-21000-080	1
C220	10n 10% 100V X7R 1206 NiSn	Philips	12062R103K0BB-	46-41000-280	1
C221	10n 10% 100V X7R 1206 NiSn	Philips	12062R103K0BB-	46-41000-280	1
C222	100p 5% 50V NPO 1206 NiSn	Philips	1206CG101J9BB-	46-21000-080	1
C223	330p 5% 500V NPO 1210 NiSn	Philips	1210CG311GBB-	46-23300-082	1
C224	330p 5% 500V NPO 1210 NiSn	Philips	1210CG311GBB-	46-23300-082	1
C225	330p 5% 500V NPO 1210 NiSn	Philips	1210CG311GBB-	46-23300-082	1
C226	47p 5% 50V NPO 1206 NiSn	Philips	1206CG470J9BB-	46-14700-081	1

08-05415-001 - PA PCB

BOM Revision
Date Valid On

03 -- Production
27.09.2006

Ref	Description	Manufacturer	Manufacturer's P/N	Codan P/N	Qty
C227	33n 10% 100V X7R 1206 NiSn	Philips	12062R333K0BB-	46-43300-280	1
C228	100u 25V Ax EL Cap	Elna	RB	48-21002-551	1
C229	33n 10% 100V X7R 1206 NiSn	Philips	12062R333K0BB-	46-43300-280	1
C230	100n 10% 50V X7R 1206 NiSn	Philips	12062R104K9BB-	46-51000-281	1
C231	470n 10% 63V PE Cap	Philips	2222 370 18474	46-54700-521	1
C232	33n 10% 100V X7R 1206 NiSn	Philips	12062R333K0BB-	46-43300-280	1
C233	100p 5% 50V NPO 1206 NiSn	Philips	1206CG101J9BB-	46-21000-080	1
D200	Diode, Schottky 70V 70mA SOT23	Siemens	BAS70	BAS70	1
D201	Diode, Schottky SOT23	Philips	BAT54	BAT54	1
D202	Diode, Schottky 70V 70mA SOT23	Siemens	BAS70	BAS70	1
D203	Diode, Zener 15V 5% 0,2W SOT23	Philips	BZX84-C15	BZX84C15	1
D204	Diode, Si High speed 75V SOT23	Philips	BAS16	BAS16	1
D205	Diode, Si 400V 1A	Fairchild	1N4004	1N4004	1
IC200	Reg, Voltage +5V 0,1A SOIC8	National Semiconduct	LM78L05ACM	XB-07805-700	1
IC201	Amp, Operational Dual SOIC8	National Semiconduct	LM358M	XA-00358-700	1
IC202	Amp, Oper Dual CMOS SOIC8	National Semiconduct	LMC662CM	XA-00662-700	1
J200	Socket, Coax Mini Low Prof Fixed	Taiko Denki	TMP-J02X-A1	60-19390-002	1
K200	Relay, 1C 12V 16A 340 Ohm	Eberle	042901 62 0100	64-31125-234	1
L202	Ind, 1uH 10% 3028	Coilcraft	1008CS-102XKBC	43-80100-000	1
L205	Ind, PA DC feed or/wh/or	Fetronics	44-70457	44-70457	1
P200	Header (P) 16way 2row Boxed	Thomas & Betts	609-1627	60-00160-000	1
R200	47 Ohm 5% 0,125W 1206	Philips	2322 711 61479	40-14700-101	1
R201	47 Ohm 5% 0,125W 1206	Philips	2322 711 61479	40-14700-101	1
R202	56 Ohm 5% 0,125W 1206	Philips	2322 711 61569	40-15600-101	1
R203	330 Ohm 5% 0,125W 1206	Philips	2322 711 61331	40-23300-101	1
R204	330 Ohm 5% 0,125W 1206	Philips	2322 711 61331	40-23300-101	1
R205	Pot,100 Lin MG Trim SMD	Bourns	3314 J-1-101	42-21004-000	1
R206	27 Ohm 5% 0,125W 1206	Philips	2322 711 61279	40-12700-101	1
R207	10 Ohm 5% 0,125W 1206	Philips	2322 711 61109	40-11000-101	1
R208	47k Ohm 5% 0,125W 1206	Philips	2322 711 61473	40-44700-101	1

08-05415-001 - PA PCB

BOM Revision
Date Valid On

03 -- Production
27.09.2006

Ref	Description	Manufacturer	Manufacturer's P/N	Codan P/N	Qty
R209	3,9k Ohm 5% 0,125W 1206	Philips	2322 711 61392	40-33900-101	1
R210	10k Ohm 5% 0,125W 1206	Philips	2322 711 61103	40-41000-101	1
R211	4,7k Ohm 5% 0,125W 1206	Philips	2322 711 61472	40-34700-101	1
R212	10k Ohm 5% 0,125W 1206	Philips	2322 711 61103	40-41000-101	1
R213	680 Ohm 5% 0,125W 1206	Philips	2322 711 61681	40-26800-101	1
R214	680 Ohm 5% 0,125W 1206	Philips	2322 711 61681	40-26800-101	1
R215	470 Ohm 5% 0,125W 1206	Philips	2322 711 61471	40-24700-101	1
R216	4,7 Ohm 5% 0,125W 1206	Philips	2322 711 61478	40-04700-101	1
R217	22 Ohm 5% 0,125W 1206	Philips	2322 711 61229	40-12200-101	1
R218	4,7 Ohm 5% 0,125W 1206	Philips	2322 711 61478	40-04700-101	1
R219	22 Ohm 5% 0,125W 1206	Philips	2322 711 61229	40-12200-101	1
R220	4,7k Ohm 5% 0,125W 1206	Philips	2322 711 61472	40-34700-101	1
R221	180 Ohm 5% 0,125W 1206	Philips	2322 711 61181	40-21800-101	1
R222	Pot,1k Lin MG Trim SMD	Bourns	3314 J-1-102	42-31004-000	1
R223	10 Ohm 5% 0,125W 1206	Philips	2322 711 61109	40-11000-101	1
R224	1k Ohm 5% 0,125W 1206	Philips	2322 711 61102	40-31000-101	1
R225	22 Ohm 5% 0,125W 1206	Philips	2322 711 61229	40-12200-101	1
R226	15 Ohm 5% 0,125W 1206	Philips	2322 711 61159	40-11500-101	1
R227	15 Ohm 5% 0,125W 1206	Philips	2322 711 61159	40-11500-101	1
R228	15 Ohm 5% 0,125W 1206	Philips	2322 711 61159	40-11500-101	1
R229	15 Ohm 5% 0,125W 1206	Philips	2322 711 61159	40-11500-101	1
R230	15 Ohm 5% 0,125W 1206	Philips	2322 711 61159	40-11500-101	1
R231	15 Ohm 5% 0,125W 1206	Philips	2322 711 61159	40-11500-101	1
R232	22 Ohm 5% 0,125W 1206	Philips	2322 711 61229	40-12200-101	1
R233	2,2k Ohm 5% 0,125W 1206	Philips	2322 711 61222	40-32200-101	1
R234	100k Ohm 5% 0,125W 1206	Philips	2322 711 61104	40-51000-101	1
R235	1k Ohm 5% 0,125W 1206	Philips	2322 711 61102	40-31000-101	1
R236	270k Ohm 5% 0,125W 1206	Philips	2322 711 61274	40-52700-101	1
R237	1k Ohm 5% 0,125W 1206	Philips	2322 711 61102	40-31000-101	1

08-05415-001 - PA PCB

BOM Revision
Date Valid On

03 -- Production
27.09.2006

Ref	Description	Manufacturer	Manufacturer's P/N	Codan P/N	Qty
R238	4,7k Ohm 5% 0,125W 1206	Philips	2322 711 61472	40-34700-101	1
R239	5,6k Ohm 5% 0,125W 1206	Philips	2322 711 61562	40-35600-101	1
R240	Pot,10k Lin MG Trim SMD	Bourns	3314 J-1-103	42-41004-000	1
R241	5,6k Ohm 5% 0,125W 1206	Philips	2322 711 61562	40-35600-101	1
R242	100 Ohm 5% 0,125W 1206	Philips	2322 711 61101	40-21000-101	1
R243	39k Ohm 2% 0,125W 1206	Philips	2322-711-41393	40-43900-102	1
R244	Pot,100k Lin MG Trim SMD	Bourns	3314 J-1-104	42-51060-001	1
R245	27k Ohm 5% 0,125W 1206	Philips	2322 711 61273	40-42700-101	1
R246	47 Ohm 5% 0,125W 1206	Philips	2322 711 61479	40-14700-101	1
R247	47 Ohm 5% 0,125W 1206	Philips	2322 711 61479	40-14700-101	1
R248	47 Ohm 5% 0,125W 1206	Philips	2322 711 61479	40-14700-101	1
R249	47 Ohm 5% 0,125W 1206	Philips	2322 711 61479	40-14700-101	1
R250	330 Ohm 5% 0,125W 1206	Philips	2322 711 61331	40-23300-101	1
R251	330 Ohm 5% 0,125W 1206	Philips	2322 711 61331	40-23300-101	1
R252	4,7k Ohm 5% 0,125W 1206	Philips	2322 711 61472	40-34700-101	1
R253	Pot,10k Lin MG Trim SMD	Bourns	3314 J-1-103	42-41004-000	1
R254	4,7k Ohm 5% 0,125W 1206	Philips	2322 711 61472	40-34700-101	1
R255	470 Ohm 5% 0,125W 1206	Philips	2322 711 61471	40-24700-101	1
R256	270k Ohm 2% 0,125W 1206	Philips	2322 711 41274	40-52700-102	1
R257	270k Ohm 2% 0,125W 1206	Philips	2322 711 41274	40-52700-102	1
R258	4,7k Ohm 5% 0,125W 1206	Philips	2322 711 61472	40-34700-101	1
R259	4,7 Ohm 5% 0,125W 1206	Philips	2322 711 61478	40-04700-101	1
R260	10k Ohm 5% 0,125W 1206	Philips	2322 711 61103	40-41000-101	1
R261	Res, Voltage Dependent	Philips	2322-592-52506	41-22506-592	1
R263	2,7k Ohm 5% 0,125W 1206	Philips	2322 711 61272	40-32700-101	1
R264	22k Ohm 5% 0,125W 1206	Philips	2322 711 61223	40-42200-101	1
T200	Input Txfr	Protran	44-80270	44-80270	1
T201	Pre-Driver I/P Txfr	Protran	44-80271	44-80271	1
T202	Pre-Driver O/P Txfr	Protran	44-80272	44-80272	1
T203	Driver O/P Txfr	Protran	44-80273	44-80273	1
T204	Output Txfr	Codan	44-80274	44-80274	1
V200	Transistor, NPN Si SOT89	Philips	BFQ17	BFQ17	1

08-05415-001 - PA PCB

BOM Revision
Date Valid On

03 -- Production
 27.09.2006

Ref	Description	Manufacturer	Manufacturer's P/N	Codan P/N	Qty
V201	Transistor, NPN Si SOT89	Philips	BFQ17	BFQ17	1
V202	JFET, N Channel SOT23	Motorola	MMBFJ310LT1	MMBFJ310LT1	1
V203	JFET, N Channel SOT23	Motorola	MMBFJ310LT1	MMBFJ310LT1	1
V204	Transistor, NPN Si SOT89	Philips	BFQ17	BFQ17	1
V205	Transistor, NPN Si SOT89	Philips	BFQ17	BFQ17	1
V206	Transistor, PNP Si SOT89	Philips	BC869	BC869	1
V207	Transistor, NPN Si SOT89	Philips	BFQ17	BFQ17	1
V208	Transistor, NPN Si SOT89	Philips	BFQ17	BFQ17	1
V209	Transistor, NPN Si SOT89	Philips	BFQ17	BFQ17	1
V210	Transistor, NPN Si SOT89	Philips	BFQ17	BFQ17	1
V211	Transistor, NPN Si SOT89	Philips	BFQ17	BFQ17	1
V212	Transistor, NPN Si SOT89	Philips	BFQ17	BFQ17	1
V213	Transistor, PNP Curr Mirror SOT143	Philips	BCV62B	BCV62B	1
V214	Transistor, NPN Curr Mirror SOT143	Philips	BCV61B	BCV61B	1
V217	Transistor, PNP Si SOT23	Philips	BC856	BC856	1
V218	Transistor, PNP Si SOT23	Philips	BC856	BC856	1
V219	Transistor, PNP Si SOT89	Philips	BC869	BC869	1
V220	Transistor, NPN Si SOT23	Philips	BC848	BC848	1

08-05869-001 - PA Assy c/w Heatsink

BOM Revision
Date Valid On

10 -- Production
28.09.2006

Ref	Description	Manufacturer	Manufacturer's P/N	Codan P/N	Qty
	Build Standard, 2010			01-01252	1
	Assy Proc, NGT PA			11-06068	1
	Heat, Transfer Compound	Gensil	GENSIL 13 45gm Tube	71-31000-004	0.01
	PA Assy c/w Heatsink			08-05869	1
	PA Filter & Control			04-03369	1
	Matching Proc for 23-20011			10-00895	1
1	PCB, Power Amplifier	IMP	07-01948-03	07-01948-03	1
2	Rivet, Tinned Brass Chobert 4,0dx9,5	Avdel	01143-00516	33-40340-095	2
3	Stake, Terminal	Autosplice	7-22461-5	61-40300-004	8
4	Heatsink, RF Unit	Diometrics	05-07243	05-07243	1
5	Label, Serial/Barcode	Codan	06-02068	06-02068	1
7	Cable, Ant control	Intertech	08-05486-001	08-05486-001	1
8	Cable, PA O/P Coax	COMOSS	08-05964-001	08-05964-001	1
9	Cable, Battery	Cablex	08-05969-001	08-05969-001	1
11	Screw, M3x8 TAPTITE 2 P/Pozi	Ajax Fasteners	31-03008-580	31-03008-580	13
12	Lug, Solder 3,5mm	Cliford W Ltd	G410 CODE 330	61-30200-025	4
13	Washer, Mica (1kV) TO-220	Philips	56359B	30-45002-002	3
14	Bush, Transistor TO-220	Motorola	B51547F019	30-03801-001	2
15	Tubing, Heatshrink 4,8x0,2 Bk	3M	FP-301 3/16" Black	71-80502-400	0.01
17	Screw, M3x10 TAPTITE 2 P/Pozi	Ajax Fasteners	31-03010-582	31-03010-582	1
C200	1u 20% 35V 3528 TA Cap	AVX	TAJB105M035R	47-01003-520	1
C201	1u 20% 35V 3528 TA Cap	AVX	TAJB105M035R	47-01003-520	1
C202	100u 25V Ax EL Cap	Elna	RB	48-21002-551	1
C203	33n 10% 50V X7R 0805 NiSn	Philips	08052R333K9BB00	46-43300-281	1
C204	22p 5% 50V NPO 0805 NiSn	Philips	0805CG220J9B200	46-12200-081	1
C205	33n 10% 50V X7R 0805 NiSn	Philips	08052R333K9BB00	46-43300-281	1
C206	33n 10% 50V X7R 0805 NiSn	Philips	08052R333K9BB00	46-43300-281	1
C207	39p 5% 50V NPO 0805 NiSn	Philips	0805CG390J9B200	46-13900-081	1
C208	100u 25V Ax EL Cap	Elna	RB	48-21002-551	1
C209	33n 10% 50V X7R 0805 NiSn	Philips	08052R333K9BB00	46-43300-281	1
C210	33n 10% 50V X7R 0805 NiSn	Philips	08052R333K9BB00	46-43300-281	1
C211	33n 10% 50V X7R 0805 NiSn	Philips	08052R333K9BB00	46-43300-281	1
C212	100n 10% 50V X7R 0805 Nisn	Philips	08052R104K9BB	46-51000-282	1
C213	100n 10% 50V X7R 0805 Nisn	Philips	08052R104K9BB	46-51000-282	1
C214	100n 10% 50V X7R 0805 Nisn	Philips	08052R104K9BB	46-51000-282	1
C215	100n 10% 50V X7R 0805 Nisn	Philips	08052R104K9BB	46-51000-282	1

08-05869-001 - PA Assy c/w Heatsink

BOM Revision
Date Valid On

10 -- Production
28.09.2006

Ref	Description	Manufacturer	Manufacturer's P/N	Codan P/N	Qty
C216	100n 10% 50V X7R 0805 Nisn	Philips	08052R104K9BB	46-51000-282	1
C217	330p 5% 50V NPO 0805 NiSn	Philips	0805CG331J9B200	46-23300-081	1
C218	22p 5% 50V NPO 0805 NiSn	Philips	0805CG220J9B200	46-12200-081	1
C219	1n 5% 50V NPO 0805 NiSn	Philips	0805CG102J9BB-	46-31000-082	1
C220	33n 10% 50V X7R 0805 NiSn	Philips	08052R333K9BB00	46-43300-281	1
C221	470p 5% 500V NPO 1210 NiSn	Philips	1210CG471GBB-	46-24700-082	1
C222	470p 5% 500V NPO 1210 NiSn	Philips	1210CG471GBB-	46-24700-082	1
C223	470p 5% 500V NPO 1210 NiSn	Philips	1210CG471GBB-	46-24700-082	1
C225	100n 10% 50V X7R 0805 Nisn	Philips	08052R104K9BB	46-51000-282	1
C226	47p 5% 50V NPO 0805 NiSn	Philips	0805CG470J9B200	46-14700-080	1
C227	10u 20% 25V 6032 TA Cap	AVX	TAJC106M025R	47-11002-520	1
C228	100n 10% 50V X7R 0805 Nisn	Philips	08052R104K9BB	46-51000-282	1
C229	33n 10% 50V X7R 0805 NiSn	Philips	08052R333K9BB00	46-43300-281	1
C230	100n 10% 50V X7R 0805 Nisn	Philips	08052R104K9BB	46-51000-282	1
C231	470n 10% 63V PE Cap	Philips	2222 370 18474	46-54700-521	1
C232	33n 10% 50V X7R 0805 NiSn	Philips	08052R333K9BB00	46-43300-281	1
C233	100p 5% 50V NPO 0805 NiSn	Philips	0805CG101J9B200	46-21000-081	1
C234	100n 10% 50V X7R 0805 Nisn	Philips	08052R104K9BB	46-51000-282	1
C235	22p 5% 500V NPO 1206 NiSn	Philips	1206CG220GBB-	46-12200-082	1
C236	100n 10% 50V X7R 0805 Nisn	Philips	08052R104K9BB	46-51000-282	1
C237	100u 25V Ax EL Cap	Elna	RB	48-21002-551	1
C238	33n 10% 50V X7R 0805 NiSn	Philips	08052R333K9BB00	46-43300-281	1
C239	33n 10% 50V X7R 0805 NiSn	Philips	08052R333K9BB00	46-43300-281	1
D202	Diode, Schottky 70V 70mA SOT23	Siemens	BAS70	BAS70	1
D203	Diode, Zener 15V 5% 0,2W SOT23	Philips	BZX84-C15	BZX84C15	1
D204	Diode, Si High speed 75V SOT23	Philips	BAS16	BAS16	1
D205	Diode, 400V 1A SMA	On Semiconductor	MRA4004T3	MRA4004T3	1
D206	Diode, Si High speed 75V SOT23	Philips	BAS16	BAS16	1
D207	Diode, Si High speed 75V SOT23	Philips	BAS16	BAS16	1

08-05869-001 - PA Assy c/w Heatsink

BOM Revision
Date Valid On

10 -- Production
28.09.2006

Ref	Description	Manufacturer	Manufacturer's P/N	Codan P/N	Qty
D208	Diode, Schottky 70V 70mA SOT23	Siemens	BAS70	BAS70	1
IC200	Reg, Voltage +5V 0,1A SOIC8	National Semiconduct	LM78L05ACM	XB-07805-700	1
IC201	Amp, Operational Dual SOIC8	National Semiconduct	LM358M	XA-00358-700	1
J200	Socket, Coax Mini Low Prof Fixed	Taiko Denki	TMP-J02X-A1	60-19390-002	1
K200	Relay, 1C 12V 16A 340 Ohm	Eberle	042901 62 0100	64-31125-234	1
L200	Choke, EMI/EMC 0A DC >10MHz 0805	Taiyo Yuden	BK 2125 HS 330-T	43-90004	1
L201	Choke, EMI/EMC 0A DC >10MHz 0805	Taiyo Yuden	BK 2125 HS 330-T	43-90004	1
L202	Ind, 1uH 10% 3225	TOKO	380LB-1R0K	43-80100-001	1
L203	Ind, 100nH 20% 3225	TOKO	380NB-R10M	43-80010-000	1
L204	Choke, EMI/EMC 0A DC >10MHz 0805	Taiyo Yuden	BK 2125 HS 330-T	43-90004	1
L205	Choke, EMI/EMC 0A DC >1MHz 4516	Taiyo Yuden	FCFBMJ 4516 HS 110-T	43-90003	1
L206	Choke, EMI/EMC 0A DC >1MHz 4516	Taiyo Yuden	FCFBMJ 4516 HS 110-T	43-90003	1
L207	Ind, PA DC feed or/wh/or	Fetronics	44-70457	44-70457	1
L208	Choke, EMI/EMC 0A DC >10MHz 0805	Taiyo Yuden	BK 2125 HS 330-T	43-90004	1
P200	Header (P) 16way 2row Boxed SMD 2,54mm	Neltron	2316SMD-16G	60-00160-003	1
R200	47 Ohm 5% 0,1W 0805	Philips	2322 730 61479	40-14700-111	1
R201	47 Ohm 5% 0,1W 0805	Philips	2322 730 61479	40-14700-111	1
R202	56 Ohm 5% 0,1W 0805	Philips	2322 730 61569	40-15600-111	1
R203	330 Ohm 5% 0,1W 0805	Philips	2322 730 61331	40-23300-111	1
R204	330 Ohm 5% 0,1W 0805	Philips	2322 730 61331	40-23300-111	1
R205	Pot,100 Lin MG Trim SMD	Bourns	3314 J-1-101	42-21004-000	1
R206	27 Ohm 5% 0,1W 0805	Philips	2322 730 61279	40-12700-111	1
R207	10 Ohm 5% 0,1W 0805	Philips	2322 730 61109	40-11000-111	1
R208	47k Ohm 5% 0,1W 0805	Philips	2322 730 61473	40-44700-111	1
R209	3,9k Ohm 5% 0,1W 0805	Philips	2322 730 61392	40-33900-111	1
R210	10k Ohm 5% 0,1W 0805	Philips	2322-730-61103	40-41000-111	1
R211	4,7k Ohm 5% 0,1W 0805	Philips	2322 730 61472	40-34700-111	1
R212	10k Ohm 5% 0,1W 0805	Philips	2322-730-61103	40-41000-111	1
R213	680 Ohm 5% 0,1W 0805	Philips	2322 730 61681	40-26800-111	1
R214	680 Ohm 5% 0,1W 0805	Philips	2322 730 61681	40-26800-111	1

08-05869-001 - PA Assy c/w Heatsink

BOM Revision
Date Valid On

10 -- Production
28.09.2006

Ref	Description	Manufacturer	Manufacturer's P/N	Codan P/N	Qty
R215	470 Ohm 5% 0,1W 0805	Philips	2322 730 61471	40-24700-111	1
R216	4,7 Ohm 5% 0,1W 0805	Phycomp	2322 730 61478	40-04700-111	1
R217	22 Ohm 5% 0,1W 0805	Philips	2322 730 61229	40-12200-111	1
R218	4,7 Ohm 5% 0,1W 0805	Phycomp	2322 730 61478	40-04700-111	1
R219	22 Ohm 5% 0,1W 0805	Philips	2322 730 61229	40-12200-111	1
R220	4,7k Ohm 5% 0,1W 0805	Philips	2322 730 61472	40-34700-111	1
R222	Pot,1k Lin MG Trim SMD	Bourns	3314 J-1-102	42-31004-000	1
R224	2,2k Ohm 5% 0,1W 0805	Philips	2322 730 61222	40-32200-111	1
R225	3,9k Ohm 5% 0,1W 0805	Philips	2322 730 61392	40-33900-111	1
R226	56 Ohm 5% 0,1W 0805	Philips	2322 730 61569	40-15600-111	1
R227	220 Ohm 5% 0,1W 0805	Philips	2322 730 61221	40-22200-111	1
R228	100 Ohm 5% 0,1W 0805	Philips	2322 730 61101	40-21000-111	1
R229	150 Ohm 5% 0,125W 1206	Philips	2322 711 61151	40-21500-101	1
R230	120 Ohm 5% 0,125W 1206	Philips	2322 711 61121	40-21200-101	1
R231	1,0 Ohm 1% 0,1W 0805	Phycomp	2322 734 61008	40-01000-115	1
R232	1,0 Ohm 1% 0,1W 0805	Phycomp	2322 734 61008	40-01000-115	1
R233	1,0 Ohm 1% 0,1W 0805	Phycomp	2322 734 61008	40-01000-115	1
R234	1,0 Ohm 1% 0,1W 0805	Phycomp	2322 734 61008	40-01000-115	1
R235	120 Ohm 5% 0,125W 1206	Philips	2322 711 61121	40-21200-101	1
R236	120 Ohm 5% 0,125W 1206	Philips	2322 711 61121	40-21200-101	1
R238	1k Ohm 5% 0,1W 0805	Philips	2322-730-61102	40-31000-111	1
R239	Pot,1k Lin MG Trim SMD	Bourns	3314 J-1-102	42-31004-000	1
R240	820 Ohm 5% 0,1W 0805	Philips	2322 730 61821	40-28200-111	1
R241	Pot,10k Lin MG Trim SMD	Bourns	3314 J-1-103	42-41004-000	1
R243	330 Ohm 5% 0,1W 0805	Philips	2322 730 61331	40-23300-111	1
R244	100 Ohm 5% 0,1W 0805	Philips	2322 730 61101	40-21000-111	1
R245	10k Ohm 5% 0,1W 0805	Philips	2322-730-61103	40-41000-111	1
R246	820 Ohm 5% 0,1W 0805	Philips	2322 730 61821	40-28200-111	1
R247	15 Ohm 5% 0,1W 0805	Philips	2322 730 61159	40-11500-111	1

08-05869-001 - PA Assy c/w Heatsink

BOM Revision
Date Valid On

10 -- Production
28.09.2006

Ref	Description	Manufacturer	Manufacturer's P/N	Codan P/N	Qty
R248	47 Ohm 5% 0,1W 0805	Philips	2322 730 61479	40-14700-111	1
R249	2,2 Ohm 5% 1,0W 2512 MELF	IRC	CHP1-100-2R20-J-7	40-02200-135	1
R250	2,2 Ohm 5% 1,0W 2512 MELF	IRC	CHP1-100-2R20-J-7	40-02200-135	1
R251	2,2 Ohm 5% 1,0W 2512 MELF	IRC	CHP1-100-2R20-J-7	40-02200-135	1
R252	2,2 Ohm 5% 1,0W 2512 MELF	IRC	CHP1-100-2R20-J-7	40-02200-135	1
R253	470 Ohm 5% 0,1W 0805	Philips	2322 730 61471	40-24700-111	1
R254	4,7 Ohm 5% 1,0W 2512 MELF	IRC	CHP1-100-4R70-J-7	40-04700-135	1
R255	470 Ohm 5% 0,1W 0805	Philips	2322 730 61471	40-24700-111	1
R256	180k Ohm 1% 0,1W 0805	Philips	2322 734 61804	40-51800-115	1
R258	4,7k Ohm 5% 0,1W 0805	Philips	2322 730 61472	40-34700-111	1
R259	4,7 Ohm 5% 0,1W 0805	Phycomp	2322 730 61478	40-04700-111	1
R260	10k Ohm 5% 0,1W 0805	Philips	2322-730-61103	40-41000-111	1
R261	Res, Voltage Dependent	Philips	2322-592-52506	41-22506-592	1
R262	50 Ohm 80°C PTC Thermistor	Philips	2322-660-91008	41-11500-660	1
R263	4,7 Ohm 5% 1,0W 2512 MELF	IRC	CHP1-100-4R70-J-7	40-04700-135	1
R264	4,7 Ohm 5% 1,0W 2512 MELF	IRC	CHP1-100-4R70-J-7	40-04700-135	1
R265	4,7 Ohm 5% 1,0W 2512 MELF	IRC	CHP1-100-4R70-J-7	40-04700-135	1
R266	4,7 Ohm 5% 1,0W 2512 MELF	IRC	CHP1-100-4R70-J-7	40-04700-135	1
R267	4,7 Ohm 5% 1,0W 2512 MELF	IRC	CHP1-100-4R70-J-7	40-04700-135	1
R268	4,7 Ohm 5% 1,0W 2512 MELF	IRC	CHP1-100-4R70-J-7	40-04700-135	1
R269	4,7 Ohm 5% 1,0W 2512 MELF	IRC	CHP1-100-4R70-J-7	40-04700-135	1
R270	47 Ohm 5% 0,1W 0805	Philips	2322 730 61479	40-14700-111	1
R271	68 Ohm 5% 0,1W 0805	Philips	2322 730 61689	40-16800-111	1
R272	100 Ohm 5% 0,125W 1206	Philips	2322 711 61101	40-21000-101	1
R273	Pot,100 Lin MG Trim SMD	Bourns	3314 J-1-101	42-21004-000	1
R274	220 Ohm 5% 0,1W 0805	Philips	2322 730 61221	40-22200-111	1
R275	2,2k Ohm 5% 0,1W 0805	Philips	2322 730 61222	40-32200-111	1
R276	Not Fitted	Codan	**_00000-001	99-00000-001	1
T200	Transformer, Input	Protran	44-80283	44-80283	1
T201	Transformer, Pre-driver I/P	Protran	44-80284	44-80284	1
T202	Pre-Driver Transformer	Protran	44-80278	44-80278	1
T203	Driver Transformer	Protran	44-80279	44-80279	1

08-05869-001 - PA Assy c/w Heatsink

BOM Revision
Date Valid On

10 -- Production
28.09.2006

Ref	Description	Manufacturer	Manufacturer's P/N	Codan P/N	Qty
T204	Output Transformer	Protran	44-80277	44-80277	1
V200	Transistor, NPN Si 18V 0,15A 4GHz SOT89	Philips	BFQ18A	BFQ18A	1
V201	Transistor, NPN Si 18V 0,15A 4GHz SOT89	Philips	BFQ18A	BFQ18A	1
V202	JFET, N Channel SOT23	Philips	PMBFJ309-215	PMBFJ309	1
V203	JFET, N Channel SOT23	Philips	PMBFJ309-215	PMBFJ309	1
V204	Transistor, NPN Si 40V 100mA 1,2W SOT89	Philips	PXT3904	PXT3904	1
V205	Transistor, NPN Si 40V 100mA 1,2W SOT89	Philips	PXT3904	PXT3904	1
V206	Transistor, NPN Si SOT23	Philips	BC847	BC847	1
V207	Transistor, NPN Si	Mitsubishi	2SC1971	2SC1971	1
V208	Transistor, NPN Si	Mitsubishi	2SC1971	2SC1971	1
V209	Transistor, NPN Si SOT23	Philips	BC847	BC847	1
V210	Transistor, NPN Si SOT23	Philips	BC847	BC847	1
V211	Transistor, RF Power HF	Microsemi	MS1253-CDN	MS1253-CDN	1
V212	Transistor, RF Power HF	Microsemi	MS1253-CDN	MS1253-CDN	1
V213	Transistor, Darlington NPN Si	Philips	BD675	BD675	1
V214	MOSFET, N Channel Enhance SOT223	Philips	BSP126	BSP126	1
V215	Transistor, PNP Si SOT23	Philips	BC856	BC856	1
V216	Transistor, PNP Si SOT23	Philips	BC856	BC856	1
V217	Transistor, PNP Si SOT89	Philips	BC869	BC869	1

08-06461-001 - PA c/w Heatsink PCB

BOM Revision
Date Valid On

03 -- Production
28.09.2006

Ref	Description	Manufacturer	Manufacturer's P/N	Codan P/N	Qty
	Heat, Transfer Compound	Gensil	GENSIL 13 45gm Tube	71-31000-004	0.01
	TP, NGT FET Driver Bipolar PA			10-01060	1
	PA Filter & Control			04-03542	1
	Spec, Test RD06HVF1			01-01698	1
	PA c/w Heatsink PCB			08-06461	1
	Assy Proc, NGT PA			11-06068	1
1	PCB, Power Amplifier	Codan	07-02111-01	07-02111-01	1
2	Rivet, Tinned Brass Chobert 4,0dx9,5	Avdel	01143-00516	33-40340-095	2
3	Stake, Terminal	Autosplice	7-22461-5	61-40300-004	8
4	Heatsink, RF Unit	Diometrics	05-07243	05-07243	1
5	Label, Serial/Barcode	Codan	06-02068	06-02068	1
7	Cable, Ant control	Intertech	08-05486-001	08-05486-001	1
8	Cable, PA O/P Coax	COMOSS	08-05964-001	08-05964-001	1
9	Cable, Battery	Cablex	08-05969-001	08-05969-001	1
11	Screw, M3x8 TAPTITE 2 P/Pozi	Ajax Fasteners	31-03008-580	31-03008-580	13
12	Lug, Solder 3,5mm	Cliford W Ltd	G410 CODE 330	61-30200-025	4
13	Washer, Mica (1kV) TO-220	Philips	56359B	30-45002-002	3
14	Bush, Transistor TO-220	Motorola	B51547F019	30-03801-001	2
15	Tubing, Heatshrink 4,8x0,2 Bk	3M	FP-301 3/16" Black	71-80502-400	0.01
17	Screw, M3x10 TAPTITE 2 P/Pozi	Ajax Fasteners	31-03010-582	31-03010-582	1
C200	1u 20% 35V 3528 TA Cap	AVX	TAJB105M035R	47-01003-520	1
C201	1u 20% 35V 3528 TA Cap	AVX	TAJB105M035R	47-01003-520	1
C202	100u 25V Ax EL Cap	Elna	RB	48-21002-551	1
C203	33n 10% 50V X7R 0805 NiSn	Philips	08052R333K9BB00	46-43300-281	1
C204	22p 5% 50V NPO 0805 NiSn	Philips	0805CG220J9B200	46-12200-081	1
C205	33n 10% 50V X7R 0805 NiSn	Philips	08052R333K9BB00	46-43300-281	1
C206	33n 10% 50V X7R 0805 NiSn	Philips	08052R333K9BB00	46-43300-281	1
C207	82p 5% 50V NPO 0805 NiSn	Philips	0805CG820J9B200	46-18200-081	1
C208	100u 25V Ax EL Cap	Elna	RB	48-21002-551	1
C209	33n 10% 50V X7R 0805 NiSn	Philips	08052R333K9BB00	46-43300-281	1
C210	33n 10% 50V X7R 0805 NiSn	Philips	08052R333K9BB00	46-43300-281	1
C211	33n 10% 50V X7R 0805 NiSn	Philips	08052R333K9BB00	46-43300-281	1
C212	100n 10% 50V X7R 0805 Nisn	Philips	08052R104K9BB	46-51000-282	1
C213	1n 5% 50V NPO 0805 NiSn	Philips	0805CG102J9BB-	46-31000-082	1
C214	100n 10% 50V X7R 0805 Nisn	Philips	08052R104K9BB	46-51000-282	1

08-06461-001 - PA c/w Heatsink PCB

BOM Revision
Date Valid On

03 -- Production
28.09.2006

Ref	Description	Manufacturer	Manufacturer's P/N	Codan P/N	Qty
C215	100n 10% 50V X7R 0805 Nisn	Philips	08052R104K9BB	46-51000-282	1
C216	1n 5% 50V NPO 0805 NiSn	Philips	0805CG102J9BB-	46-31000-082	1
C217	330p 5% 50V NPO 0805 NiSn	Philips	0805CG331J9B200	46-23300-081	1
C218	22p 5% 50V NPO 0805 NiSn	Philips	0805CG220J9B200	46-12200-081	1
C219	1n 5% 50V NPO 0805 NiSn	Philips	0805CG102J9BB-	46-31000-082	1
C220	33n 10% 50V X7R 0805 NiSn	Philips	08052R333K9BB00	46-43300-281	1
C221	470p 5% 500V NPO 1210 NiSn	Philips	1210CG471GBB-	46-24700-082	1
C222	470p 5% 500V NPO 1210 NiSn	Philips	1210CG471GBB-	46-24700-082	1
C223	470p 5% 500V NPO 1210 NiSn	Philips	1210CG471GBB-	46-24700-082	1
C225	100n 10% 50V X7R 0805 Nisn	Philips	08052R104K9BB	46-51000-282	1
C226	47p 5% 50V NPO 0805 NiSn	Philips	0805CG470J9B200	46-14700-080	1
C227	10u 20% 25V 6032 TA Cap	AVX	TAJC106M025R	47-11002-520	1
C228	100n 10% 50V X7R 0805 Nisn	Philips	08052R104K9BB	46-51000-282	1
C229	33n 10% 50V X7R 0805 NiSn	Philips	08052R333K9BB00	46-43300-281	1
C230	100n 10% 50V X7R 0805 Nisn	Philips	08052R104K9BB	46-51000-282	1
C231	470n 10% 63V PE Cap	Philips	2222 370 18474	46-54700-521	1
C232	33n 10% 50V X7R 0805 NiSn	Philips	08052R333K9BB00	46-43300-281	1
C233	100p 5% 50V NPO 0805 NiSn	Philips	0805CG101J9B200	46-21000-081	1
C234	100n 10% 50V X7R 0805 Nisn	Philips	08052R104K9BB	46-51000-282	1
C235	22p 5% 500V NPO 1206 NiSn	Philips	1206CG220GBB-	46-12200-082	1
C236	100n 10% 50V X7R 0805 Nisn	Philips	08052R104K9BB	46-51000-282	1
C237	100u 25V Ax EL Cap	Elna	RB	48-21002-551	1
C239	33n 10% 50V X7R 0805 NiSn	Philips	08052R333K9BB00	46-43300-281	1
D202	Diode, Schottky 70V 70mA SOT23	Siemens	BAS70	BAS70	1
D203	Diode, Zener 15V 5% 0,2W SOT23	Philips	BZX84-C15	BZX84C15	1
D204	Diode, Si High speed 75V SOT23	Philips	BAS16	BAS16	1
D205	Diode, 400V 1A SMA	On Semiconductor	MRA4004T3	MRA4004T3	1
D206	Diode, Si High speed 75V SOT23	Philips	BAS16	BAS16	1
D207	Diode, Si High speed 75V SOT23	Philips	BAS16	BAS16	1

08-06461-001 - PA c/w Heatsink PCB

BOM Revision
Date Valid On

03 -- Production
28.09.2006

Ref	Description	Manufacturer	Manufacturer's P/N	Codan P/N	Qty
D208	Diode, Schottky 70V 70mA SOT23	Siemens	BAS70	BAS70	1
D209	Diode, Si High speed 75V SOT23	Philips	BAS16	BAS16	1
IC200	Reg, Voltage +5V 0,1A SOIC8	National Semiconduct	LM78L05ACM	XB-07805-700	1
IC201	Amp, Operational Dual SOIC8	National Semiconduct	LM358M	XA-00358-700	1
J200	Socket, Coax Mini Low Prof Fixed	Taiko Denki	TMP-J02X-A1	60-19390-002	1
K200	Relay, 1C 12V 16A 340 Ohm	Eberle	042901 62 0100	64-31125-234	1
L200	Choke, EMI/EMC 0A DC >10MHz 0805	Taiyo Yuden	BK 2125 HS 330-T	43-90004	1
L201	Choke, EMI/EMC 0A DC >10MHz 0805	Taiyo Yuden	BK 2125 HS 330-T	43-90004	1
L202	Ind, 1,8uH 5% 2520	Vishay	IMC1008-1800NH-5	43-80180-001	1
L203	Ind, 100nH 20% 3225	TOKO	380NB-R10M	43-80010-000	1
L204	Ind, 2,2uH 10% 3225	TOKO	380LB-2R2K	43-80220-001	1
L205	Choke, EMI/EMC 0A DC >1MHz 4516	Taiyo Yuden	FCFBMJ 4516 HS 110-T	43-90003	1
L206	Choke, EMI/EMC 0A DC >1MHz 4516	Taiyo Yuden	FCFBMJ 4516 HS 110-T	43-90003	1
L207	Ind, PA DC feed or/wh/or	Fetronics	44-70457	44-70457	1
P200	Header (P) 16way 2row Boxed SMD 2,54mm	Neltron	2316SMD-16G	60-00160-003	1
R200	47 Ohm 5% 0,1W 0805	Philips	2322 730 61479	40-14700-111	1
R201	47 Ohm 5% 0,1W 0805	Philips	2322 730 61479	40-14700-111	1
R202	56 Ohm 5% 0,1W 0805	Philips	2322 730 61569	40-15600-111	1
R203	330 Ohm 5% 0,1W 0805	Philips	2322 730 61331	40-23300-111	1
R204	330 Ohm 5% 0,1W 0805	Philips	2322 730 61331	40-23300-111	1
R205	Pot,100 Lin MG Trim SMD	Bourns	3314 J-1-101	42-21004-000	1
R206	27 Ohm 5% 0,1W 0805	Philips	2322 730 61279	40-12700-111	1
R207	10 Ohm 5% 0,1W 0805	Philips	2322 730 61109	40-11000-111	1
R208	47k Ohm 5% 0,1W 0805	Philips	2322 730 61473	40-44700-111	1
R209	3,9k Ohm 5% 0,1W 0805	Philips	2322 730 61392	40-33900-111	1
R210	10k Ohm 5% 0,1W 0805	Philips	2322-730-61103	40-41000-111	1
R211	4,7k Ohm 5% 0,1W 0805	Philips	2322 730 61472	40-34700-111	1
R212	10k Ohm 5% 0,1W 0805	Philips	2322-730-61103	40-41000-111	1
R213	680 Ohm 5% 0,1W 0805	Philips	2322 730 61681	40-26800-111	1
R214	680 Ohm 5% 0,1W 0805	Philips	2322 730 61681	40-26800-111	1
R215	390 Ohm 5% 0,1W 0805	Philips	2322 730 61391	40-23900-111	1

08-06461-001 - PA c/w Heatsink PCB

BOM Revision
Date Valid On

03 -- Production
28.09.2006

Ref	Description	Manufacturer	Manufacturer's P/N	Codan P/N	Qty
R216	4,7 Ohm 5% 0,1W 0805	Phycomp	2322 730 61478	40-04700-111	1
R217	22 Ohm 5% 0,1W 0805	Philips	2322 730 61229	40-12200-111	1
R218	4,7 Ohm 5% 0,1W 0805	Phycomp	2322 730 61478	40-04700-111	1
R219	22 Ohm 5% 0,1W 0805	Philips	2322 730 61229	40-12200-111	1
R220	4,7k Ohm 5% 0,1W 0805	Philips	2322 730 61472	40-34700-111	1
R222	Pot,1k Lin MG Trim SMD	Bourns	3314 J-1-102	42-31004-000	1
R224	560 Ohm 5% 0,1W 0805	Philips	2322 730 61561	40-25600-111	1
R225	3,3k Ohm 5% 0,1W 0805	Philips	2322 730 61332	40-33300-111	1
R226	560 Ohm 5% 0,1W 0805	Philips	2322 730 61561	40-25600-111	1
R227	3,9k Ohm 5% 0,1W 0805	Philips	2322 730 61392	40-33900-111	1
R228	1k Ohm 5% 0,1W 0805	Philips	2322-730-61102	40-31000-111	1
R229	12k Ohm 5% 0,1W 0805	Philips	2322 730 61123	40-41200-111	1
R230	100 Ohm 5% 0,1W 0805	Philips	2322 730 61101	40-21000-111	1
R231	470 Ohm 5% 0,1W 0805	Philips	2322 730 61471	40-24700-111	1
R232	1,0 Ohm 1% 0,1W 0805	Phycomp	2322 734 61008	40-01000-115	1
R233	470 Ohm 5% 0,1W 0805	Philips	2322 730 61471	40-24700-111	1
R234	1,0 Ohm 1% 0,1W 0805	Phycomp	2322 734 61008	40-01000-115	1
R235	Pot,1k Lin MG Trim SMD	Bourns	3314 J-1-102	42-31004-000	1
R236	4,7k Ohm 5% 0,1W 0805	Philips	2322 730 61472	40-34700-111	1
R238	1k Ohm 5% 0,1W 0805	Philips	2322-730-61102	40-31000-111	1
R239	Pot,1k Lin MG Trim SMD	Bourns	3314 J-1-102	42-31004-000	1
R240	820 Ohm 5% 0,1W 0805	Philips	2322 730 61821	40-28200-111	1
R241	Pot,10k Lin MG Trim SMD	Bourns	3314 J-1-103	42-41004-000	1
R243	330 Ohm 5% 0,1W 0805	Philips	2322 730 61331	40-23300-111	1
R244	100 Ohm 5% 0,1W 0805	Philips	2322 730 61101	40-21000-111	1
R245	10k Ohm 5% 0,1W 0805	Philips	2322-730-61103	40-41000-111	1
R246	820 Ohm 5% 0,1W 0805	Philips	2322 730 61821	40-28200-111	1
R247	15 Ohm 5% 0,1W 0805	Philips	2322 730 61159	40-11500-111	1
R248	47 Ohm 5% 0,1W 0805	Philips	2322 730 61479	40-14700-111	1

08-06461-001 - PA c/w Heatsink PCB

BOM Revision
Date Valid On

03 -- Production
28.09.2006

Ref	Description	Manufacturer	Manufacturer's P/N	Codan P/N	Qty
R249	2,2 Ohm 5% 1,0W 2512 MELF	IRC	CHP1-100-2R20-J-7	40-02200-135	1
R250	2,2 Ohm 5% 1,0W 2512 MELF	IRC	CHP1-100-2R20-J-7	40-02200-135	1
R251	2,2 Ohm 5% 1,0W 2512 MELF	IRC	CHP1-100-2R20-J-7	40-02200-135	1
R252	2,2 Ohm 5% 1,0W 2512 MELF	IRC	CHP1-100-2R20-J-7	40-02200-135	1
R253	1k Ohm 5% 0,1W 0805	Philips	2322-730-61102	40-31000-111	1
R254	4,7 Ohm 5% 1,0W 2512 MELF	IRC	CHP1-100-4R70-J-7	40-04700-135	1
R255	470 Ohm 5% 0,1W 0805	Philips	2322 730 61471	40-24700-111	1
R256	180k Ohm 1% 0,1W 0805	Philips	2322 734 61804	40-51800-115	1
R258	4,7k Ohm 5% 0,1W 0805	Philips	2322 730 61472	40-34700-111	1
R259	3,3 Ohm 5% 0,1W 0805	Philips	2322 730 61338	40-03300-111	1
R260	10k Ohm 5% 0,1W 0805	Philips	2322-730-61103	40-41000-111	1
R261	Res, Voltage Dependent	Philips	2322-592-52506	41-22506-592	1
R262	50 Ohm 80°C PTC Thermistor	Philips	2322-660-91008	41-11500-660	1
R263	4,7 Ohm 5% 1,0W 2512 MELF	IRC	CHP1-100-4R70-J-7	40-04700-135	1
R264	4,7 Ohm 5% 1,0W 2512 MELF	IRC	CHP1-100-4R70-J-7	40-04700-135	1
R265	4,7 Ohm 5% 1,0W 2512 MELF	IRC	CHP1-100-4R70-J-7	40-04700-135	1
R266	4,7 Ohm 5% 1,0W 2512 MELF	IRC	CHP1-100-4R70-J-7	40-04700-135	1
R267	4,7 Ohm 5% 1,0W 2512 MELF	IRC	CHP1-100-4R70-J-7	40-04700-135	1
R268	4,7 Ohm 5% 1,0W 2512 MELF	IRC	CHP1-100-4R70-J-7	40-04700-135	1
R269	4,7 Ohm 5% 1,0W 2512 MELF	IRC	CHP1-100-4R70-J-7	40-04700-135	1
R270	220 Ohm 5% 0,1W 0805	Philips	2322 730 61221	40-22200-111	1
R271	100 Ohm 5% 0,1W 0805	Philips	2322 730 61101	40-21000-111	1
R272	560 Ohm 5% 0,1W 0805	Philips	2322 730 61561	40-25600-111	1
R273	Pot,10k Lin MG Trim SMD	Bourns	3314 J-1-103	42-41004-000	1
R274	100 Ohm 5% 0,1W 0805	Philips	2322 730 61101	40-21000-111	1
R275	100 Ohm 5% 0,1W 0805	Philips	2322 730 61101	40-21000-111	1
R276	Not Fitted	Codan	**_00000-001	99-00000-001	1
R277	3,3 Ohm 5% 0,1W 0805	Philips	2322 730 61338	40-03300-111	1
R278	Not Fitted	Codan	**_00000-001	99-00000-001	1
R279	Not Fitted	Codan	**_00000-001	99-00000-001	1
R280	100 Ohm 5% 0,1W 0805	Philips	2322 730 61101	40-21000-111	1

08-06461-001 - PA c/w Heatsink PCB

BOM Revision
Date Valid On

03 -- Production
28.09.2006

Ref	Description	Manufacturer	Manufacturer's P/N	Codan P/N	Qty
R281	1k Ohm 5% 0,1W 0805	Philips	2322-730-61102	40-31000-111	1
R282	Not Fitted	Codan	**-00000-001	99-00000-001	1
T200	Transformer, Input	Protran	44-80283	44-80283	1
T201	Transformer, Pre-driver I/P	Protran	44-80284	44-80284	1
T202	Transformer, Pre-Driver	Codan	44-80318	44-80318	1
T203	Driver Transformer	Protran	44-80279	44-80279	1
T204	Output Transformer	Protran	44-80277	44-80277	1
V200	Transistor, NPN Si 18V 0,15A 4GHz SOT89	Philips	BFQ18A	BFQ18A	1
V201	Transistor, NPN Si 18V 0,15A 4GHz SOT89	Philips	BFQ18A	BFQ18A	1
V202	JFET, N Channel SOT23	Philips	PMBFJ309-215	PMBFJ309	1
V203	JFET, N Channel SOT23	Philips	PMBFJ309-215	PMBFJ309	1
V204	Transistor, NPN Si 40V 600mA 1,1W SOT89	Philips	PXT4401	PXT4401	1
V205	Transistor, NPN Si 40V 600mA 1,1W SOT89	Philips	PXT4401	PXT4401	1
V207	FET, RF Power, 6W	Mitsubishi	RD06HVF1-101	RD06HVF1	1
V208	FET, RF Power, 6W	Mitsubishi	RD06HVF1-101	RD06HVF1	1
V209	Transistor, NPN Si SOT23	Philips	BC847	BC847	1
V210	Transistor, NPN Si SOT23	Philips	BC847	BC847	1
V211	Transistor, RF Power HF	Microsemi	MS1253-CDN	MS1253-CDN	1
V212	Transistor, RF Power HF	Microsemi	MS1253-CDN	MS1253-CDN	1
V213	Transistor, Darlington NPN Si	Philips	BD675	BD675	1
V215	Transistor, PNP Si SOT23	Philips	BC856	BC856	1
V216	Transistor, PNP Si SOT23	Philips	BC856	BC856	1
V217	Transistor, PNP Si SOT89	Philips	BC869	BC869	1

08-05416-001 - Filter & Control PCB

BOM Revision
Date Valid On

11 -- Production
27.09.2006

Ref	Description	Manufacturer	Manufacturer's P/N	Codan P/N	Qty
	X3 PA Assembly Proc (Interim)			11-06034	1
	TP, NGT PA Alignment			10-00816	1
	PA & Filter			04-03169	1
	Build Standard, 2010			01-01252	1
	Filter & Control PCB			08-05416	1
1	PCB, Filter & Control	Codan	07-01800-07	07-01800-07	1
2	Label, Serial/Barcode	Codan	06-02068	06-02068	1
3	Cable, Coax	Intertech	08-05484-001	08-05484-001	1
5	Cable, Ribbon, PA - Filter	Auto Assemblies	08-05487-001	08-05487-001	1
6	Cable, Ribbon, Filter - Audio	Auto Assemblies	08-05488-001	08-05488-001	1
B1	Temp Sensor 10mV/degree C SOT23	National Semiconduct	LM50CIM3X	LM50CIM3X	1
C1	3,3n 10% 100V X7R 1206 NiSn	Philips	12062R332K0BB-	46-33300-280	1
C2	120p 5% 500V NPO 1210 NiSn	Philips	1210CG121GBB-	46-21200-082	1
C3	120p 5% 500V NPO 1210 NiSn	Philips	1210CG121GBB-	46-21200-082	1
C4	39p 5% 500V NPO 1206 NiSn	Philips	1206CG390GBB-	46-13900-082	1
C5	120p 5% 500V NPO 1210 NiSn	Philips	1210CG121GBB-	46-21200-082	1
C6	120p 5% 500V NPO 1210 NiSn	Philips	1210CG121GBB-	46-21200-082	1
C7	120p 5% 500V NPO 1210 NiSn	Philips	1210CG121GBB-	46-21200-082	1
C8	330p 5% 500V NPO 1210 NiSn	Philips	1210CG311GBB-	46-23300-082	1
C9	220p 5% 500V NPO 1210 NiSn	Philips	1210CG221GBB-	46-22200-082	1
C10	150p 5% 500V NPO 1210 NiSn	Philips	1210CG151GBB-	46-21500-082	1
C11	470p 5% 500V NPO 1210 NiSn	Philips	1210CG471GBB-	46-24700-082	1
C12	470p 5% 500V NPO 1210 NiSn	Philips	1210CG471GBB-	46-24700-082	1
C13	390p 5% 500V NPO 1210 NiSn	Philips	1210CG391GBB-	46-23900-082	1
C14	330p 5% 500V NPO 1210 NiSn	Philips	1210CG311GBB-	46-23300-082	1
C15	330p 5% 500V NPO 1210 NiSn	Philips	1210CG311GBB-	46-23300-082	1
C16	330p 5% 500V NPO 1210 NiSn	Philips	1210CG311GBB-	46-23300-082	1
C17	470p 5% 500V NPO 1210 NiSn	Philips	1210CG471GBB-	46-24700-082	1
C18	470p 5% 500V NPO 1210 NiSn	Philips	1210CG471GBB-	46-24700-082	1
C19	390p 5% 500V NPO 1210 NiSn	Philips	1210CG391GBB-	46-23900-082	1
C20	220p 5% 500V NPO 1210 NiSn	Philips	1210CG221GBB-	46-22200-082	1
C21	180p 5% 500V NPO 1210 NiSn	Philips	1210CG181GBB-	46-21800-082	1
C22	470p 5% 500V NPO 1210 NiSn	Philips	1210CG471GBB-	46-24700-082	1

08-05416-001 - Filter & Control PCB

BOM Revision
Date Valid On

11 -- Production
27.09.2006

Ref	Description	Manufacturer	Manufacturer's P/N	Codan P/N	Qty
C23	470p 5% 500V NPO 1210 NiSn	Philips	1210CG471GBB-	46-24700-082	1
C24	220p 5% 500V NPO 1210 NiSn	Philips	1210CG221GBB-	46-22200-082	1
C25	180p 5% 500V NPO 1210 NiSn	Philips	1210CG181GBB-	46-21800-082	1
C26	47p 5% 500V NPO 1206 NiSn	Philips	1206CG470JDB2	46-14700-082	1
C27	47p 5% 500V NPO 1206 NiSn	Philips	1206CG470JDB2	46-14700-082	1
C28	330p 5% 500V NPO 1210 NiSn	Philips	1210CG311GBB-	46-23300-082	1
C29	330p 5% 500V NPO 1210 NiSn	Philips	1210CG311GBB-	46-23300-082	1
C30	270p 5% 500V NPO 1210 NiSn	Philips	1210CG271GBB-	46-22700-082	1
C31	220p 5% 500V NPO 1210 NiSn	Philips	1210CG221GBB-	46-22200-082	1
C32	220p 5% 500V NPO 1210 NiSn	Philips	1210CG221GBB-	46-22200-082	1
C33	220p 5% 500V NPO 1210 NiSn	Philips	1210CG221GBB-	46-22200-082	1
C34	330p 5% 500V NPO 1210 NiSn	Philips	1210CG311GBB-	46-23300-082	1
C35	330p 5% 500V NPO 1210 NiSn	Philips	1210CG311GBB-	46-23300-082	1
C36	270p 5% 500V NPO 1210 NiSn	Philips	1210CG271GBB-	46-22700-082	1
C37	33p 5% 500V NPO 1206 NiSn	Philips	1206CG330GBB-	46-13300-082	1
C38	220p 5% 500V NPO 1210 NiSn	Philips	1210CG221GBB-	46-22200-082	1
C39	330p 5% 500V NPO 1210 NiSn	Philips	1210CG311GBB-	46-23300-082	1
C40	330p 5% 500V NPO 1210 NiSn	Philips	1210CG311GBB-	46-23300-082	1
C41	150p 5% 500V NPO 1210 NiSn	Philips	1210CG151GBB-	46-21500-082	1
C42	33p 5% 500V NPO 1206 NiSn	Philips	1206CG330GBB-	46-13300-082	1
C43	39p 5% 500V NPO 1206 NiSn	Philips	1206CG390GBB-	46-13900-082	1
C44	220p 5% 500V NPO 1210 NiSn	Philips	1210CG221GBB-	46-22200-082	1
C45	220p 5% 500V NPO 1210 NiSn	Philips	1210CG221GBB-	46-22200-082	1
C46	120p 5% 500V NPO 1210 NiSn	Philips	1210CG121GBB-	46-21200-082	1
C47	120p 5% 500V NPO 1210 NiSn	Philips	1210CG121GBB-	46-21200-082	1
C48	120p 5% 500V NPO 1210 NiSn	Philips	1210CG121GBB-	46-21200-082	1
C49	150p 5% 500V NPO 1210 NiSn	Philips	1210CG151GBB-	46-21500-082	1
C50	220p 5% 500V NPO 1210 NiSn	Philips	1210CG221GBB-	46-22200-082	1
C51	220p 5% 500V NPO 1210 NiSn	Philips	1210CG221GBB-	46-22200-082	1

08-05416-001 - Filter & Control PCB

BOM Revision
Date Valid On

11 -- Production
27.09.2006

Ref	Description	Manufacturer	Manufacturer's P/N	Codan P/N	Qty
C52	220p 5% 500V NPO 1210 NiSn	Philips	1210CG221GBB-	46-22200-082	1
C53	100p 5% 500V NPO 1210 NiSn	Philips	1210CG101GBB-	46-21000-082	1
C54	270p 5% 500V NPO 1210 NiSn	Philips	1210CG271GBB-	46-22700-082	1
C55	270p 5% 500V NPO 1210 NiSn	Philips	1210CG271GBB-	46-22700-082	1
C56	120p 5% 500V NPO 1210 NiSn	Philips	1210CG121GBB-	46-21200-082	1
C57	39p 5% 500V NPO 1206 NiSn	Philips	1206CG390GBB-	46-13900-082	1
C58	120p 5% 500V NPO 1210 NiSn	Philips	1210CG121GBB-	46-21200-082	1
C59	120p 5% 500V NPO 1210 NiSn	Philips	1210CG121GBB-	46-21200-082	1
C60	120p 5% 500V NPO 1210 NiSn	Philips	1210CG121GBB-	46-21200-082	1
C61	82p 5% 500V NPO 1210 NiSn	Philips	1210CG820GBB-	46-18200-082	1
C62	82p 5% 500V NPO 1210 NiSn	Philips	1210CG820GBB-	46-18200-082	1
C63	100p 5% 500V NPO 1210 NiSn	Philips	1210CG101GBB-	46-21000-082	1
C64	150p 5% 500V NPO 1210 NiSn	Philips	1210CG151GBB-	46-21500-082	1
C65	120p 5% 500V NPO 1210 NiSn	Philips	1210CG121GBB-	46-21200-082	1
C66	120p 5% 500V NPO 1210 NiSn	Philips	1210CG121GBB-	46-21200-082	1
C67	100p 5% 500V NPO 1210 NiSn	Philips	1210CG101GBB-	46-21000-082	1
C68	100p 5% 500V NPO 1210 NiSn	Philips	1210CG101GBB-	46-21000-082	1
C69	100p 5% 500V NPO 1210 NiSn	Philips	1210CG101GBB-	46-21000-082	1
C70	39p 5% 500V NPO 1206 NiSn	Philips	1206CG390GBB-	46-13900-082	1
C71	39p 5% 500V NPO 1206 NiSn	Philips	1206CG390GBB-	46-13900-082	1
C72	27p 5% 500V NPO 1206 NiSn	Philips	1206CG270GBB-	46-12700-082	1
C73	33p 5% 500V NPO 1206 NiSn	Philips	1206CG330GBB-	46-13300-082	1
C74	82p 5% 500V NPO 1210 NiSn	Philips	1210CG820GBB-	46-18200-082	1
C75	82p 5% 500V NPO 1210 NiSn	Philips	1210CG820GBB-	46-18200-082	1
C76	82p 5% 500V NPO 1210 NiSn	Philips	1210CG820GBB-	46-18200-082	1
C77	56p 5% 500V NPO 1210 NiSn	Philips	1210CG560GBB-	46-15600-082	1
C78	56p 5% 500V NPO 1210 NiSn	Philips	1210CG560GBB-	46-15600-082	1
C79	47p 5% 500V NPO 1206 NiSn	Philips	1206CG470JDB2	46-14700-082	1
C80	82p 5% 500V NPO 1210 NiSn	Philips	1210CG820GBB-	46-18200-082	1

08-05416-001 - Filter & Control PCB

BOM Revision
Date Valid On

11 -- Production
27.09.2006

Ref	Description	Manufacturer	Manufacturer's P/N	Codan P/N	Qty
C81	68p 5% 500V NPO 1210 NiSn	Philips	1210CG680GBB-	46-16800-082	1
C82	68p 5% 500V NPO 1210 NiSn	Philips	1210CG680GBB-	46-16800-082	1
C83	22p 5% 500V NPO 1206 NiSn	Philips	1206CG220GBB-	46-12200-082	1
C84	68p 5% 500V NPO 1210 NiSn	Philips	1210CG680GBB-	46-16800-082	1
C85	68p 5% 500V NPO 1210 NiSn	Philips	1210CG680GBB-	46-16800-082	1
C86	22p 5% 500V NPO 1206 NiSn	Philips	1206CG220GBB-	46-12200-082	1
C87	27p 5% 500V NPO 1206 NiSn	Philips	1206CG270GBB-	46-12700-082	1
C88	33p 5% 500V NPO 1206 NiSn	Philips	1206CG330GBB-	46-13300-082	1
C89	47p 5% 500V NPO 1206 NiSn	Philips	1206CG470JDB2	46-14700-082	1
C90	39p 5% 500V NPO 1206 NiSn	Philips	1206CG390GBB-	46-13900-082	1
C91	39p 5% 500V NPO 1206 NiSn	Philips	1206CG390GBB-	46-13900-082	1
C92	39p 5% 500V NPO 1206 NiSn	Philips	1206CG390GBB-	46-13900-082	1
C93	47p 5% 500V NPO 1206 NiSn	Philips	1206CG470JDB2	46-14700-082	1
C94	39p 5% 500V NPO 1206 NiSn	Philips	1206CG390GBB-	46-13900-082	1
C95	39p 5% 500V NPO 1206 NiSn	Philips	1206CG390GBB-	46-13900-082	1
C96	47p 5% 500V NPO 1206 NiSn	Philips	1206CG470JDB2	46-14700-082	1
C97	47p 5% 500V NPO 1206 NiSn	Philips	1206CG470JDB2	46-14700-082	1
C98	47p 5% 500V NPO 1206 NiSn	Philips	1206CG470JDB2	46-14700-082	1
C99	39p 5% 500V NPO 1206 NiSn	Philips	1206CG390GBB-	46-13900-082	1
C100	15p 5% 500V NPO 1206 NiSn	Philips	1206CG150GBB-	46-11500-082	1
C101	68p 5% 500V NPO 1210 NiSn	Philips	1210CG680GBB-	46-16800-082	1
C102	56p 5% 500V NPO 1210 NiSn	Philips	1210CG560GBB-	46-15600-082	1
C103	10p 5% 500V NPO 1206 NiSn	Philips	1206CG100GBB-	46-11000-082	1
C104	10p 5% 500V NPO 1206 NiSn	Philips	1206CG100GBB-	46-11000-082	1
C105	27p 5% 500V NPO 1206 NiSn	Philips	1206CG270GBB-	46-12700-082	1
C106	39p 5% 500V NPO 1206 NiSn	Philips	1206CG390GBB-	46-13900-082	1
C107	39p 5% 500V NPO 1206 NiSn	Philips	1206CG390GBB-	46-13900-082	1
C108	22p 5% 500V NPO 1206 NiSn	Philips	1206CG220GBB-	46-12200-082	1
C109	22p 5% 500V NPO 1206 NiSn	Philips	1206CG220GBB-	46-12200-082	1

08-05416-001 - Filter & Control PCB

BOM Revision
Date Valid On

11 -- Production
27.09.2006

Ref	Description	Manufacturer	Manufacturer's P/N	Codan P/N	Qty
C110	22p 5% 500V NPO 1206 NiSn	Philips	1206CG220GBB-	46-12200-082	1
C111	39p 5% 500V NPO 1206 NiSn	Philips	1206CG390GBB-	46-13900-082	1
C112	39p 5% 500V NPO 1206 NiSn	Philips	1206CG390GBB-	46-13900-082	1
C113	22p 5% 500V NPO 1206 NiSn	Philips	1206CG220GBB-	46-12200-082	1
C114	27p 5% 500V NPO 1206 NiSn	Philips	1206CG270GBB-	46-12700-082	1
C115	18p 5% 500V NPO 1206 NiSn	Philips	1206CG180GBB-	46-11800-082	1
C116	100n 10% 50V X7R 1206 NiSn	Philips	12062R104K9BB-	46-51000-281	1
C117	100n 10% 50V X7R 1206 NiSn	Philips	12062R104K9BB-	46-51000-281	1
C118	100n 10% 50V X7R 1206 NiSn	Philips	12062R104K9BB-	46-51000-281	1
C119	33n 10% 100V X7R 1206 NiSn	Philips	12062R333K0BB-	46-43300-280	1
C120	33n 10% 100V X7R 1206 NiSn	Philips	12062R333K0BB-	46-43300-280	1
C121	100p 5% 50V NPO 1206 NiSn	Philips	1206CG101J9BB-	46-21000-080	1
C122	100p 5% 50V NPO 1206 NiSn	Philips	1206CG101J9BB-	46-21000-080	1
C123	100p 5% 50V NPO 1206 NiSn	Philips	1206CG101J9BB-	46-21000-080	1
C124	100p 5% 50V NPO 1206 NiSn	Philips	1206CG101J9BB-	46-21000-080	1
C125	33n 10% 100V X7R 1206 NiSn	Philips	12062R333K0BB-	46-43300-280	1
C126	33n 10% 100V X7R 1206 NiSn	Philips	12062R333K0BB-	46-43300-280	1
C127	33n 10% 100V X7R 1206 NiSn	Philips	12062R333K0BB-	46-43300-280	1
C129	10u 20% 25V 6032 TA Cap	AVX	TAJC106M025R	47-11002-520	1
C130	10u 20% 25V 6032 TA Cap	AVX	TAJC106M025R	47-11002-520	1
C131	10u 20% 25V 6032 TA Cap	AVX	TAJC106M025R	47-11002-520	1
C132	1u 20% 35V 3528 TA Cap	AVX	TAJB105M035R	47-01003-520	1
C133	33n 10% 100V X7R 1206 NiSn	Philips	12062R333K0BB-	46-43300-280	1
C134	22p 5% 50V NPO 1206 NiSn	Philips	1206CG220J9BB-	46-12200-080	1
C135	33n 10% 100V X7R 1206 NiSn	Philips	12062R333K0BB-	46-43300-280	1
C136	33n 10% 100V X7R 1206 NiSn	Philips	12062R333K0BB-	46-43300-280	1
C137	33n 10% 100V X7R 1206 NiSn	Philips	12062R333K0BB-	46-43300-280	1
C138	33n 10% 100V X7R 1206 NiSn	Philips	12062R333K0BB-	46-43300-280	1
C139	33n 10% 100V X7R 1206 NiSn	Philips	12062R333K0BB-	46-43300-280	1

08-05416-001 - Filter & Control PCB

BOM Revision
Date Valid On

11 -- Production
27.09.2006

Ref	Description	Manufacturer	Manufacturer's P/N	Codan P/N	Qty
C140	33n 10% 100V X7R 1206 NiSn	Philips	12062R333K0BB-	46-43300-280	1
C141	33n 10% 100V X7R 1206 NiSn	Philips	12062R333K0BB-	46-43300-280	1
C142	33n 10% 100V X7R 1206 NiSn	Philips	12062R333K0BB-	46-43300-280	1
C143	33n 10% 100V X7R 1206 NiSn	Philips	12062R333K0BB-	46-43300-280	1
C144	1u 20% 35V 3528 TA Cap	AVX	TAJB105M035R	47-01003-520	1
C145	1u 20% 35V 3528 TA Cap	AVX	TAJB105M035R	47-01003-520	1
C146	1u 20% 35V 3528 TA Cap	AVX	TAJB105M035R	47-01003-520	1
C147	1u 20% 35V 3528 TA Cap	AVX	TAJB105M035R	47-01003-520	1
C148	100p 5% 50V NPO 1206 NiSn	Philips	1206CG101J9BB-	46-21000-080	1
C149	1u 20% 35V 3528 TA Cap	AVX	TAJB105M035R	47-01003-520	1
C150	1u 20% 35V 3528 TA Cap	AVX	TAJB105M035R	47-01003-520	1
C151	10u 20% 25V 6032 TA Cap	AVX	TAJC106M025R	47-11002-520	1
C153	33n 10% 100V X7R 1206 NiSn	Philips	12062R333K0BB-	46-43300-280	1
C154	1u 20% 35V 3528 TA Cap	AVX	TAJB105M035R	47-01003-520	1
C155	10u 20% 25V 6032 TA Cap	AVX	TAJC106M025R	47-11002-520	1
C156	33n 10% 100V X7R 1206 NiSn	Philips	12062R333K0BB-	46-43300-280	1
C157	100p 5% 50V NPO 1206 NiSn	Philips	1206CG101J9BB-	46-21000-080	1
C158	33p 5% 500V NPO 1206 NiSn	Philips	1206CG330GBB-	46-13300-082	1
D1	Diode, Schottky 70V 70mA SOT23	Siemens	BAS70	BAS70	1
D2	Diode, Schottky 70V 70mA SOT23	Siemens	BAS70	BAS70	1
D3	Diode, Si fast low cap high cond	Codan	23-10001	23-10001	1
D4	Diode, Si fast low cap high cond	Codan	23-10001	23-10001	1
D5	Diode, Si fast low cap high cond	Codan	23-10001	23-10001	1
D6	Diode, Si fast low cap high cond	Codan	23-10001	23-10001	1
D7	Diode, Si fast low cap high cond	Codan	23-10001	23-10001	1
D8	Diode, Si fast low cap high cond	Codan	23-10001	23-10001	1
D9	Diode, Band Switch Si SOD80	Philips	BA423L	BA423L	1
D10	LED, Green PLCC SMD Non Diffused	Siemens	LGT670-L	65-61110-507	1
D11	Diode, Si High speed 75V SOT23	Philips	BAS16	BAS16	1

08-05416-001 - Filter & Control PCB

BOM Revision
Date Valid On

11 -- Production
27.09.2006

Ref	Description	Manufacturer	Manufacturer's P/N	Codan P/N	Qty
D12	Diode, Si High speed 75V SOT23	Philips	BAS16	BAS16	1
D14	Diode, Schottky 70V 70mA SOT23	Siemens	BAS70	BAS70	1
IC1	Reg, Voltage +10V IC	National Semiconduct	LM2940T-10	XB-02940-402	1
IC2	Micro prgmd, RFU Filter I/O	Codan	90-20593-001	90-20593-001	1
IC3	Array, Transistor SOIC14	Motorola	MC1413D	XT-01413-700	1
IC4	Reg, Voltage +5V 0,1A SOIC8	National Semiconduct	LM78L05ACM	XB-07805-700	1
IC5	Amp, Oper Dual CMOS SOIC8	National Semiconduct	LMC662CM	XA-00662-700	1
IC6	Amp, Operational Dual SOIC8	National Semiconduct	LM358M	XA-00358-700	1
J1	Socket, Coax Mini Low Prof Fixed	Taiko Denki	TMP-J02X-A1	60-19390-002	1
J2	Socket, MCX Straight PCB	Chin Nan	27-05-TGN	60-19300	1
J3	Terminal Block 2 way PCB	Phoenix Mecano	AK300/2-5,0-GREY	61-10200-202	1
K1	Relay, 2C 12V 2A SMD 1028 Ohm	Matsushita	TQ2SL-12V	64-21225-310	1
K2	Relay, 2C 12V 2A SMD 1028 Ohm	Matsushita	TQ2SL-12V	64-21225-310	1
K3	Relay, 2C 12V 2A SMD 1028 Ohm	Matsushita	TQ2SL-12V	64-21225-310	1
K4	Relay, 2C 12V 2A SMD 1028 Ohm	Matsushita	TQ2SL-12V	64-21225-310	1
K5	Relay, 2C 12V 2A SMD 1028 Ohm	Matsushita	TQ2SL-12V	64-21225-310	1
K6	Relay, 2C 12V 2A SMD 1028 Ohm	Matsushita	TQ2SL-12V	64-21225-310	1
K7	Relay, 2C 12V 2A SMD 1028 Ohm	Matsushita	TQ2SL-12V	64-21225-310	1
K8	Relay, 2C 12V 2A SMD 1028 Ohm	Matsushita	TQ2SL-12V	64-21225-310	1
L2	Ind, 1mH 10% 1812	Coilcraft	1812LS-105XKBC	43-83100-000	1
L3	Ind, 3u36 vi/gn/bk/ye	Fetronics	44-70504	44-70504	1
L4	Ind, 2u28 bl/bl/bl/bk	Fetronics	44-70476	44-70476	1
L5	Ind, 2u89 vi/gn/bk/or	Fetronics	44-70503	44-70503	1
L6	Ind, 2u28 bl/bl/bl/bk	Fetronics	44-70476	44-70476	1
L7	Ind, 1,6uH gn/bk/gn	Fetronics	44-70465	44-70465	1
L8	Ind, 1,8uH gn/sl/gn	Fetronics	44-70466	44-70466	1
L9	Ind, 1u21 vi/gn/bk/rd	Fetronics	44-70502	44-70502	1
L10	Ind, 1,2uH sl/sl/sl	Fetronics	44-70369	44-70369	1
L11	Ind, 1,6uH gn/bk/gn	Fetronics	44-70465	44-70465	1
L12	Ind, 1,0uH sl/sl/or	Fetronics	44-70368	44-70368	1
L13	Ind, 712nH bn/sl/bn	Fetronics	44-70467	44-70467	1
L14	Ind, 837nH bl/bl/bl/gn	Fetronics	44-70477	44-70477	1
L15	Ind, 620nH vi/vi/wh	Fetronics	44-70393	44-70393	1
L16	Ind, 499nH vi/gn/bk/bn	Fetronics	44-70501	44-70501	1
L17	Ind, 530nH bl/bl/bl/bn	Fetronics	44-70478	44-70478	1
L18	Ind, 422nH bl/bl/bl/or	Fetronics	44-70479	44-70479	1
L19	Ind, 291nH vi/gn/bk/bk	Fetronics	44-70500	44-70500	1
L20	Ind, 422nH bl/bl/bl/or	Fetronics	44-70479	44-70479	1
L21	Ind, 80nH vi/gn/bk/bl	Fetronics	44-70506	44-70506	1
L22	Ind, 225nH bn/bl	Fetronics	44-70470	44-70470	1
L23	Ind, 225nH bn/bl	Fetronics	44-70470	44-70470	1

08-05416-001 - Filter & Control PCB

BOM Revision
Date Valid On

11 -- Production
27.09.2006

Ref	Description	Manufacturer	Manufacturer's P/N	Codan P/N	Qty
L24	Ind, 267nH vi/ye/wh/wh	Fetronics	44-70499	44-70499	1
L25	Ind, Common Mode 1.5A	Taiyo Yuden	CM05RA06	43-80000	1
L26	Choke, EMI/EMC 0A DC >1MHz 4516	Taiyo Yuden	FCFBMJ 4516 HS 110-T	43-90003	1
L27	Choke, EMI/EMC 0A DC >1MHz 4516	Taiyo Yuden	FCFBMJ 4516 HS 110-T	43-90003	1
L28	Choke, EMI/EMC 0A DC >1MHz 4516	Taiyo Yuden	FCFBMJ 4516 HS 110-T	43-90003	1
L29	Choke, EMI/EMC 0A DC >1MHz 4516	Taiyo Yuden	FCFBMJ 4516 HS 110-T	43-90003	1
P1	Not Fitted	Codan	**-.00000-001	99-00000-001	1
P2	Header (P) 16way 2row Boxed	Thomas & Betts	609-1627	60-00160-000	1
P3	Header (P) 2way 1row Latch	JAE	IL-2P-S3EN2	60-00020-260	1
P4	Header (P) 16way 2row Boxed	Thomas & Betts	609-1627	60-00160-000	1
R1	33k Ohm 5% 0,125W 1206	Philips	2322 711 61333	40-43300-101	1
R2	33k Ohm 5% 0,125W 1206	Philips	2322 711 61333	40-43300-101	1
R3	33k Ohm 5% 0,125W 1206	Philips	2322 711 61333	40-43300-101	1
R4	100 Ohm 5% 0,33W CF Res	Philips	2322 211 13101	40-21000-020	1
R5	100 Ohm 5% 0,33W CF Res	Philips	2322 211 13101	40-21000-020	1
R6	10k Ohm 5% 0,125W 1206	Philips	2322 711 61103	40-41000-101	1
R7	4,7k Ohm 5% 0,125W 1206	Philips	2322 711 61472	40-34700-101	1
R8	10k Ohm 5% 0,125W 1206	Philips	2322 711 61103	40-41000-101	1
R9	100k Ohm 5% 0,125W 1206	Philips	2322 711 61104	40-51000-101	1
R10	4,7k Ohm 5% 0,125W 1206	Philips	2322 711 61472	40-34700-101	1
R11	100k Ohm 5% 0,125W 1206	Philips	2322 711 61104	40-51000-101	1
R12	10k Ohm 5% 0,125W 1206	Philips	2322 711 61103	40-41000-101	1
R13	22k Ohm 5% 0,125W 1206	Philips	2322 711 61223	40-42200-101	1
R14	100 Ohm 5% 0,125W 1206	Philips	2322 711 61101	40-21000-101	1
R15	100 Ohm 5% 0,125W 1206	Philips	2322 711 61101	40-21000-101	1
R16	100 Ohm 5% 0,125W 1206	Philips	2322 711 61101	40-21000-101	1
R17	100 Ohm 5% 0,125W 1206	Philips	2322 711 61101	40-21000-101	1
R18	1k Ohm 5% 0,125W 1206	Philips	2322 711 61102	40-31000-101	1
R19	10k Ohm 2% 0,125W SIL R/2R 8Bit	Bourns	4610X-R2R-103	40-84109-002	1
R20	3,3k Ohm 5% 0,125W 1206	Philips	2322 711 61332	40-33300-101	1
R21	10k Ohm 5% 0,125W 1206	Philips	2322 711 61103	40-41000-101	1

08-05416-001 - Filter & Control PCB

BOM Revision
Date Valid On

11 -- Production
27.09.2006

Ref	Description	Manufacturer	Manufacturer's P/N	Codan P/N	Qty
R22	1k Ohm 5% 0,125W 1206	Philips	2322 711 61102	40-31000-101	1
R23	100 Ohm 5% 0,125W 1206	Philips	2322 711 61101	40-21000-101	1
R26	4,7k Ohm 5% 0,125W 1206	Philips	2322 711 61472	40-34700-101	1
R27	1k Ohm 5% 0,125W 1206	Philips	2322 711 61102	40-31000-101	1
R28	18k Ohm 5% 0,125W 1206	Philips	2322 711 61183	40-41800-101	1
R29	10k Ohm 5% 0,125W 1206	Philips	2322 711 61103	40-41000-101	1
R30	100 Ohm 5% 0,125W 1206	Philips	2322 711 61101	40-21000-101	1
R32	Pot,10k Lin MG Trim SMD	Bourns	3314 J-1-103	42-41004-000	1
R33	1k Ohm 5% 0,125W 1206	Philips	2322 711 61102	40-31000-101	1
R34	33k Ohm 5% 0,125W 1206	Philips	2322 711 61333	40-43300-101	1
R35	Pot,100k Lin MG Trim SMD	Bourns	3314 J-1-104	42-51060-001	1
R36	220 Ohm 5% 0,125W 1206	Philips	2322 711 61221	40-22200-101	1
R37	33k Ohm 5% 0,125W 1206	Philips	2322 711 61333	40-43300-101	1
R38	6,8k Ohm 5% 0,125W 1206	Philips	2322 711 61682	40-36800-101	1
R39	82k Ohm 5% 0,125W 1206	Philips	2322 711 61823	40-48200-101	1
R40	270k Ohm 5% 0,125W 1206	Philips	2322 711 61274	40-52700-101	1
R41	33k Ohm 5% 0,125W 1206	Philips	2322 711 61333	40-43300-101	1
R42	10k Ohm 5% 0,125W 1206	Philips	2322 711 61103	40-41000-101	1
R43	1,8k Ohm 5% 0,125W 1206	Philips	2322 711 61182	40-31800-101	1
R44	33k Ohm 5% 0,125W 1206	Philips	2322 711 61333	40-43300-101	1
R45	100k Ohm 5% 0,125W 1206	Philips	2322 711 61104	40-51000-101	1
R46	18k Ohm 2% 0,125W 1206	Philips	2322 711 41183	40-41800-102	1
R47	100k Ohm 5% 0,125W 1206	Philips	2322 711 61104	40-51000-101	1
R48	560k Ohm 5% 0,125w 1206	Philips	2322 711 61564	40-55600-101	1
R49	390k Ohm 5% 0,125W 1206	Philips	2322 711 61394	40-53900-101	1
R50	1k Ohm 5% 0,125W 1206	Philips	2322 711 61102	40-31000-101	1
R51	68k Ohm 5% 0,125W 1206	Philips	2322 711 61683	40-46800-101	1
R52	2,7k Ohm 5% 0,125W 1206	Philips	2322 711 61272	40-32700-101	1
R53	3,3k Ohm 5% 0,125W 1206	Philips	2322 711 61332	40-33300-101	1

08-05416-001 - Filter & Control PCB

BOM Revision
Date Valid On

11 -- Production
27.09.2006

Ref	Description	Manufacturer	Manufacturer's P/N	Codan P/N	Qty
R54	4,7k Ohm 5% 0,125W 1206	Philips	2322 711 61472	40-34700-101	1
R55	3,9k Ohm 5% 0,125W 1206	Philips	2322 711 61392	40-33900-101	1
R56	10k Ohm 5% 0,125W 1206	Philips	2322 711 61103	40-41000-101	1
R57	10k Ohm 5% 0,125W 1206	Philips	2322 711 61103	40-41000-101	1
R58	100 Ohm 5% 0,125W 1206	Philips	2322 711 61101	40-21000-101	1
R59	120k Ohm 5% 0,125W 1206	Philips	2322 711 61124	40-51200-101	1
R60	22k Ohm 5% 0,125W 1206	Philips	2322 711 61223	40-42200-101	1
R61	82 Ohm 5% 0,125W 1206	Philips	2322 711 61829	40-18200-101	1
R62	33k Ohm 5% 0,125W 1206	Philips	2322 711 61333	40-43300-101	1
R63	10k Ohm 5% 0,125W 1206	Philips	2322 711 61103	40-41000-101	1
R64	470k Ohm 5% 0,125W 1206	Philips	2322 711 61474	40-54700-101	1
R65	1k Ohm 5% 0,125W 1206	Philips	2322 711 61102	40-31000-101	1
R66	1k Ohm 5% 0,125W 1206	Philips	2322 711 61102	40-31000-101	1
R67	39k Ohm 2% 0,125W 1206	Philips	2322-711-41393	40-43900-102	1
R68	5,6k Ohm 2% 0,125W 1206	Philips	2322-711-41562	40-35600-102	1
R69	1 Ohm 2% 0,125W 1206	Philips	2322 712 83108	40-01000-102	1
R70	10k Ohm 5% 0,125W 1206	Philips	2322 711 61103	40-41000-101	1
R71	1k Ohm 5% 0,125W 1206	Philips	2322 711 61102	40-31000-101	1
R72	47k Ohm 5% 0,125W 1206	Philips	2322 711 61473	40-44700-101	1
T1	Txfr, RF or	Fetronics	44-80021	44-80021	1
V1	Transistor, NPN Si SOT23	Philips	BC848	BC848	1
V2	Transistor, PNP Si TO252	Motorola	MJD32C	MJD32C	1
V3	Transistor, NPN Si SOT23	Philips	BCX20	BCX20	1
V4	Transistor, NPN Si SOT23	Philips	BC848	BC848	1
V5	Transistor, PNP Si SOT23	Philips	BC858	BC858	1
V6	MOSFET, N Chan Enhance SOT23	Philips	BST82	BST82	1
V7	Transistor, NPN Si SOT23	Philips	BC848	BC848	1
V8	Transistor, NPN Si SOT23	Philips	BC848	BC848	1
V9	Transistor, NPN Si SOT23	Philips	BC848	BC848	1

08-05416-001 - Filter & Control PCB

BOM Revision
Date Valid On

11 -- Production
27.09.2006

Ref	Description	Manufacturer	Manufacturer's P/N	Codan P/N	Qty
V10	Transistor, NPN Si SOT23	Philips	BC848	BC848	1
V11	MOSFET, N Chan Enhance SOT23	Philips	BST82	BST82	1
V12	Transistor, NPN Si SOT23	Philips	BC848	BC848	1
V13	Transistor, NPN Si SOT23	Philips	BC848	BC848	1
V14	MOSFET, N Chan Enhance SOT23	Philips	BST82	BST82	1
V15	Transistor, NPN Si SOT23	Philips	BC848	BC848	1
V16	Transistor, NPN Si SOT23	Philips	BC848	BC848	1

08-05910-001 - Filter & Control PCB

BOM Revision
Date Valid On

09 -- Production
28.09.2006

Ref	Description	Manufacturer	Manufacturer's P/N	Codan P/N	Qty
	PA Filter & Control			04-03542	1
	Build Standard, 2010			01-01252	1
	PCB, Filter & Control			08-05910	1
	Assy Proc, NGT Filter			11-06069	1
1	PCB, Filter Control		07-01967-05	07-01967-05	1
2	Label, Serial/Barcode	Codan	06-02068	06-02068	1
3	Cable, Coax	Intertech	08-05484-001	08-05484-001	1
4	Cable, Ribbon, PA - Filter	Auto Assemblies	08-05487-001	08-05487-001	1
5	Cable, Ribbon, Filter - Audio	Auto Assemblies	08-05488-001	08-05488-001	1
B1	Temp Sensor 10mV/degree C SOT23	National Semiconduct	LM50CIM3X	LM50CIM3X	1
C1	3,3n 10% 100V X7R 0805 NiSn	Philips	08052R332K0B200	46-33300-281	1
C2	120p 5% 500V NPO 1210 NiSn	Philips	1210CG121GBB-	46-21200-082	1
C3	120p 5% 500V NPO 1210 NiSn	Philips	1210CG121GBB-	46-21200-082	1
C4	39p 5% 500V NPO 1206 NiSn	Philips	1206CG390GBB-	46-13900-082	1
C5	120p 5% 500V NPO 1210 NiSn	Philips	1210CG121GBB-	46-21200-082	1
C6	120p 5% 500V NPO 1210 NiSn	Philips	1210CG121GBB-	46-21200-082	1
C7	120p 5% 500V NPO 1210 NiSn	Philips	1210CG121GBB-	46-21200-082	1
C8	100p 5% 500V NPO 1210 NiSn	Philips	1210CG101GBB-	46-21000-082	1
C9	100p 5% 500V NPO 1210 NiSn	Philips	1210CG101GBB-	46-21000-082	1
C10	270p 5% 500V NPO 1210 NiSn	Philips	1210CG271GBB-	46-22700-082	1
C11	330p 5% 500V NPO 1210 NiSn	Philips	1210CG311GBB-	46-23300-082	1
C12	330p 5% 500V NPO 1210 NiSn	Philips	1210CG311GBB-	46-23300-082	1
C13	330p 5% 500V NPO 1210 NiSn	Philips	1210CG311GBB-	46-23300-082	1
C14	470p 5% 500V NPO 1210 NiSn	Philips	1210CG471GBB-	46-24700-082	1
C15	390p 5% 500V NPO 1210 NiSn	Philips	1210CG391GBB-	46-23900-082	1
C16	330p 5% 500V NPO 1210 NiSn	Philips	1210CG311GBB-	46-23300-082	1
C17	470p 5% 500V NPO 1210 NiSn	Philips	1210CG471GBB-	46-24700-082	1
C18	390p 5% 500V NPO 1210 NiSn	Philips	1210CG391GBB-	46-23900-082	1
C19	390p 5% 500V NPO 1210 NiSn	Philips	1210CG391GBB-	46-23900-082	1
C21	150p 5% 500V NPO 1210 NiSn	Philips	1210CG151GBB-	46-21500-082	1
C22	330p 5% 500V NPO 1210 NiSn	Philips	1210CG311GBB-	46-23300-082	1
C23	390p 5% 500V NPO 1210 NiSn	Philips	1210CG391GBB-	46-23900-082	1
C24	68p 5% 500V NPO 1210 NiSn	Philips	1210CG680GBB-	46-16800-082	1

08-05910-001 - Filter & Control PCB

BOM Revision
Date Valid On

09 -- Production
28.09.2006

Ref	Description	Manufacturer	Manufacturer's P/N	Codan P/N	Qty
C25	56p 5% 500V NPO 1210 NiSn	Philips	1210CG560GBB-	46-15600-082	1
C26	180p 5% 500V NPO 1210 NiSn	Philips	1210CG181GBB-	46-21800-082	1
C27	180p 5% 500V NPO 1210 NiSn	Philips	1210CG181GBB-	46-21800-082	1
C28	220p 5% 500V NPO 1210 NiSn	Philips	1210CG221GBB-	46-22200-082	1
C29	220p 5% 500V NPO 1210 NiSn	Philips	1210CG221GBB-	46-22200-082	1
C30	270p 5% 500V NPO 1210 NiSn	Philips	1210CG271GBB-	46-22700-082	1
C31	270p 5% 500V NPO 1210 NiSn	Philips	1210CG271GBB-	46-22700-082	1
C32	270p 5% 500V NPO 1210 NiSn	Philips	1210CG271GBB-	46-22700-082	1
C33	270p 5% 500V NPO 1210 NiSn	Philips	1210CG271GBB-	46-22700-082	1
C34	330p 5% 500V NPO 1210 NiSn	Philips	1210CG311GBB-	46-23300-082	1
C35	270p 5% 500V NPO 1210 NiSn	Philips	1210CG271GBB-	46-22700-082	1
C36	270p 5% 500V NPO 1210 NiSn	Philips	1210CG271GBB-	46-22700-082	1
C37	47p 5% 500V NPO 1206 NiSn	Philips	1206CG470JDB2	46-14700-082	1
C38	56p 5% 500V NPO 1210 NiSn	Philips	1210CG560GBB-	46-15600-082	1
C39	220p 5% 500V NPO 1210 NiSn	Philips	1210CG221GBB-	46-22200-082	1
C40	270p 5% 500V NPO 1210 NiSn	Philips	1210CG271GBB-	46-22700-082	1
C41	47p 5% 500V NPO 1206 NiSn	Philips	1206CG470JDB2	46-14700-082	1
C42	120p 5% 500V NPO 1210 NiSn	Philips	1210CG121GBB-	46-21200-082	1
C43	100p 5% 500V NPO 1210 NiSn	Philips	1210CG101GBB-	46-21000-082	1
C44	150p 5% 500V NPO 1210 NiSn	Philips	1210CG151GBB-	46-21500-082	1
C45	150p 5% 500V NPO 1210 NiSn	Philips	1210CG151GBB-	46-21500-082	1
C46	180p 5% 500V NPO 1210 NiSn	Philips	1210CG181GBB-	46-21800-082	1
C47	180p 5% 500V NPO 1210 NiSn	Philips	1210CG181GBB-	46-21800-082	1
C48	180p 5% 500V NPO 1210 NiSn	Philips	1210CG181GBB-	46-21800-082	1
C49	150p 5% 500V NPO 1210 NiSn	Philips	1210CG151GBB-	46-21500-082	1
C50	150p 5% 500V NPO 1210 NiSn	Philips	1210CG151GBB-	46-21500-082	1
C51	180p 5% 500V NPO 1210 NiSn	Philips	1210CG181GBB-	46-21800-082	1
C52	220p 5% 500V NPO 1210 NiSn	Philips	1210CG221GBB-	46-22200-082	1
C53	68p 5% 500V NPO 1210 NiSn	Philips	1210CG680GBB-	46-16800-082	1

08-05910-001 - Filter & Control PCB

BOM Revision
Date Valid On

09 -- Production
28.09.2006

Ref	Description	Manufacturer	Manufacturer's P/N	Codan P/N	Qty
C54	150p 5% 500V NPO 1210 NiSn	Philips	1210CG151GBB-	46-21500-082	1
C55	150p 5% 500V NPO 1210 NiSn	Philips	1210CG151GBB-	46-21500-082	1
C56	33p 5% 500V NPO 1206 NiSn	Philips	1206CG330GBB-	46-13300-082	1
C57	82p 5% 500V NPO 1210 NiSn	Philips	1210CG820GBB-	46-18200-082	1
C58	100p 5% 500V NPO 1210 NiSn	Philips	1210CG101GBB-	46-21000-082	1
C59	100p 5% 500V NPO 1210 NiSn	Philips	1210CG101GBB-	46-21000-082	1
C60	100p 5% 500V NPO 1210 NiSn	Philips	1210CG101GBB-	46-21000-082	1
C61	120p 5% 500V NPO 1210 NiSn	Philips	1210CG121GBB-	46-21200-082	1
C62	120p 5% 500V NPO 1210 NiSn	Philips	1210CG121GBB-	46-21200-082	1
C63	120p 5% 500V NPO 1210 NiSn	Philips	1210CG121GBB-	46-21200-082	1
C64	150p 5% 500V NPO 1210 NiSn	Philips	1210CG151GBB-	46-21500-082	1
C65	120p 5% 500V NPO 1210 NiSn	Philips	1210CG121GBB-	46-21200-082	1
C66	100p 5% 500V NPO 1210 NiSn	Philips	1210CG101GBB-	46-21000-082	1
C67	22p 5% 500V NPO 1206 NiSn	Philips	1206CG220GBB-	46-12200-082	1
C68	120p 5% 500V NPO 1210 NiSn	Philips	1210CG121GBB-	46-21200-082	1
C69	120p 5% 500V NPO 1210 NiSn	Philips	1210CG121GBB-	46-21200-082	1
C70	56p 5% 500V NPO 1210 NiSn	Philips	1210CG560GBB-	46-15600-082	1
C71	47p 5% 500V NPO 1206 NiSn	Philips	1206CG470JDB2	46-14700-082	1
C72	27p 5% 500V NPO 1206 NiSn	Philips	1206CG270GBB-	46-12700-082	1
C73	33p 5% 500V NPO 1206 NiSn	Philips	1206CG330GBB-	46-13300-082	1
C74	82p 5% 500V NPO 1210 NiSn	Philips	1210CG820GBB-	46-18200-082	1
C75	82p 5% 500V NPO 1210 NiSn	Philips	1210CG820GBB-	46-18200-082	1
C76	82p 5% 500V NPO 1210 NiSn	Philips	1210CG820GBB-	46-18200-082	1
C77	56p 5% 500V NPO 1210 NiSn	Philips	1210CG560GBB-	46-15600-082	1
C78	56p 5% 500V NPO 1210 NiSn	Philips	1210CG560GBB-	46-15600-082	1
C79	47p 5% 500V NPO 1206 NiSn	Philips	1206CG470JDB2	46-14700-082	1
C80	82p 5% 500V NPO 1210 NiSn	Philips	1210CG820GBB-	46-18200-082	1
C81	68p 5% 500V NPO 1210 NiSn	Philips	1210CG680GBB-	46-16800-082	1
C82	68p 5% 500V NPO 1210 NiSn	Philips	1210CG680GBB-	46-16800-082	1

08-05910-001 - Filter & Control PCB

BOM Revision
Date Valid On

09 -- Production
28.09.2006

Ref	Description	Manufacturer	Manufacturer's P/N	Codan P/N	Qty
C83	22p 5% 500V NPO 1206 NiSn	Philips	1206CG220GBB-	46-12200-082	1
C84	22p 5% 500V NPO 1206 NiSn	Philips	1206CG220GBB-	46-12200-082	1
C85	22p 5% 500V NPO 1206 NiSn	Philips	1206CG220GBB-	46-12200-082	1
C86	10p 5% 500V NPO 1206 NiSn	Philips	1206CG100GBB-	46-11000-082	1
C87	15p 5% 500V NPO 1206 NiSn	Philips	1206CG150GBB-	46-11500-082	1
C88	68p 5% 500V NPO 1210 NiSn	Philips	1210CG680GBB-	46-16800-082	1
C89	33p 5% 500V NPO 1206 NiSn	Philips	1206CG330GBB-	46-13300-082	1
C90	33p 5% 500V NPO 1206 NiSn	Philips	1206CG330GBB-	46-13300-082	1
C91	33p 5% 500V NPO 1206 NiSn	Philips	1206CG330GBB-	46-13300-082	1
C92	33p 5% 500V NPO 1206 NiSn	Philips	1206CG330GBB-	46-13300-082	1
C93	47p 5% 500V NPO 1206 NiSn	Philips	1206CG470JDB2	46-14700-082	1
C94	47p 5% 500V NPO 1206 NiSn	Philips	1206CG470JDB2	46-14700-082	1
C95	56p 5% 500V NPO 1210 NiSn	Philips	1210CG560GBB-	46-15600-082	1
C96	39p 5% 500V NPO 1206 NiSn	Philips	1206CG390GBB-	46-13900-082	1
C97	39p 5% 500V NPO 1206 NiSn	Philips	1206CG390GBB-	46-13900-082	1
C98	39p 5% 500V NPO 1206 NiSn	Philips	1206CG390GBB-	46-13900-082	1
C99	39p 5% 500V NPO 1206 NiSn	Philips	1206CG390GBB-	46-13900-082	1
C100	18p 5% 500V NPO 1206 NiSn	Philips	1206CG180GBB-	46-11800-082	1
C101	68p 5% 500V NPO 1210 NiSn	Philips	1210CG680GBB-	46-16800-082	1
C102	68p 5% 500V NPO 1210 NiSn	Philips	1210CG680GBB-	46-16800-082	1
C103	18p 5% 500V NPO 1206 NiSn	Philips	1206CG180GBB-	46-11800-082	1
C104	22p 5% 500V NPO 1206 NiSn	Philips	1206CG220GBB-	46-12200-082	1
C105	27p 5% 500V NPO 1206 NiSn	Philips	1206CG270GBB-	46-12700-082	1
C106	27p 5% 500V NPO 1206 NiSn	Philips	1206CG270GBB-	46-12700-082	1
C107	33p 5% 500V NPO 1206 NiSn	Philips	1206CG330GBB-	46-13300-082	1
C108	33p 5% 500V NPO 1206 NiSn	Philips	1206CG330GBB-	46-13300-082	1
C109	33p 5% 500V NPO 1206 NiSn	Philips	1206CG330GBB-	46-13300-082	1
C110	27p 5% 500V NPO 1206 NiSn	Philips	1206CG270GBB-	46-12700-082	1
C111	33p 5% 500V NPO 1206 NiSn	Philips	1206CG330GBB-	46-13300-082	1

08-05910-001 - Filter & Control PCB

BOM Revision
Date Valid On

09 -- Production
28.09.2006

Ref	Description	Manufacturer	Manufacturer's P/N	Codan P/N	Qty
C112	33p 5% 500V NPO 1206 NiSn	Philips	1206CG330GGB-	46-13300-082	1
C113	33p 5% 500V NPO 1206 NiSn	Philips	1206CG330GGB-	46-13300-082	1
C114	10p 5% 500V NPO 1206 NiSn	Philips	1206CG100GGB-	46-11000-082	1
C115	33p 5% 500V NPO 1206 NiSn	Philips	1206CG330GGB-	46-13300-082	1
C116	100n 10% 50V X7R 0805 Nisn	Philips	08052R104K9BB	46-51000-282	1
C117	100n 10% 50V X7R 0805 Nisn	Philips	08052R104K9BB	46-51000-282	1
C118	100n 10% 50V X7R 0805 Nisn	Philips	08052R104K9BB	46-51000-282	1
C119	33n 10% 50V X7R 0805 NiSn	Philips	08052R333K9BB00	46-43300-281	1
C120	33n 10% 50V X7R 0805 NiSn	Philips	08052R333K9BB00	46-43300-281	1
C121	100p 5% 50V NPO 0805 NiSn	Philips	0805CG101J9B200	46-21000-081	1
C122	100p 5% 50V NPO 0805 NiSn	Philips	0805CG101J9B200	46-21000-081	1
C123	100p 5% 50V NPO 0805 NiSn	Philips	0805CG101J9B200	46-21000-081	1
C124	100p 5% 50V NPO 0805 NiSn	Philips	0805CG101J9B200	46-21000-081	1
C125	33n 10% 50V X7R 0805 NiSn	Philips	08052R333K9BB00	46-43300-281	1
C126	33n 10% 50V X7R 0805 NiSn	Philips	08052R333K9BB00	46-43300-281	1
C127	33n 10% 50V X7R 0805 NiSn	Philips	08052R333K9BB00	46-43300-281	1
C129	10u 20% 25V 6032 TA Cap	AVX	TAJC106M025R	47-11002-520	1
C130	10u 20% 25V 6032 TA Cap	AVX	TAJC106M025R	47-11002-520	1
C131	10u 20% 25V 6032 TA Cap	AVX	TAJC106M025R	47-11002-520	1
C132	1u 20% 35V 3528 TA Cap	AVX	TAJB105M035R	47-01003-520	1
C133	33n 10% 50V X7R 0805 NiSn	Philips	08052R333K9BB00	46-43300-281	1
C134	22p 5% 50V NPO 0805 NiSn	Philips	0805CG220J9B200	46-12200-081	1
C135	33n 10% 50V X7R 0805 NiSn	Philips	08052R333K9BB00	46-43300-281	1
C136	33n 10% 50V X7R 0805 NiSn	Philips	08052R333K9BB00	46-43300-281	1
C137	33n 10% 50V X7R 0805 NiSn	Philips	08052R333K9BB00	46-43300-281	1
C138	33n 10% 50V X7R 0805 NiSn	Philips	08052R333K9BB00	46-43300-281	1
C139	33n 10% 50V X7R 0805 NiSn	Philips	08052R333K9BB00	46-43300-281	1
C140	33n 10% 50V X7R 0805 NiSn	Philips	08052R333K9BB00	46-43300-281	1
C141	33n 10% 50V X7R 0805 NiSn	Philips	08052R333K9BB00	46-43300-281	1

08-05910-001 - Filter & Control PCB

BOM Revision
Date Valid On

09 -- Production
28.09.2006

Ref	Description	Manufacturer	Manufacturer's P/N	Codan P/N	Qty
C142	33n 10% 50V X7R 0805 NiSn	Philips	08052R333K9BB00	46-43300-281	1
C143	33n 10% 50V X7R 0805 NiSn	Philips	08052R333K9BB00	46-43300-281	1
C144	1u 20% 35V 3528 TA Cap	AVX	TAJB105M035R	47-01003-520	1
C145	1u 20% 35V 3528 TA Cap	AVX	TAJB105M035R	47-01003-520	1
C146	1u 20% 35V 3528 TA Cap	AVX	TAJB105M035R	47-01003-520	1
C147	1u 20% 35V 3528 TA Cap	AVX	TAJB105M035R	47-01003-520	1
C148	100p 5% 50V NPO 0805 NiSn	Philips	0805CG101J9B200	46-21000-081	1
C149	1u 20% 35V 3528 TA Cap	AVX	TAJB105M035R	47-01003-520	1
C150	1u 20% 35V 3528 TA Cap	AVX	TAJB105M035R	47-01003-520	1
C151	10u 20% 25V 6032 TA Cap	AVX	TAJC106M025R	47-11002-520	1
C153	33n 10% 50V X7R 0805 NiSn	Philips	08052R333K9BB00	46-43300-281	1
C154	1u 20% 35V 3528 TA Cap	AVX	TAJB105M035R	47-01003-520	1
C155	10u 20% 25V 6032 TA Cap	AVX	TAJC106M025R	47-11002-520	1
C156	33n 10% 50V X7R 0805 NiSn	Philips	08052R333K9BB00	46-43300-281	1
C157	100p 5% 50V NPO 0805 NiSn	Philips	0805CG101J9B200	46-21000-081	1
C158	47p 5% 500V NPO 1206 NiSn	Philips	1206CG470JDB2	46-14700-082	1
C159	27p 5% 500V NPO 1206 NiSn	Philips	1206CG270GBB-	46-12700-082	1
C160	68p 5% 500V NPO 1210 NiSn	Philips	1210CG680GBB-	46-16800-082	1
C161	22p 5% 500V NPO 1206 NiSn	Philips	1206CG220GBB-	46-12200-082	1
C162	27p 5% 500V NPO 1206 NiSn	Philips	1206CG270GBB-	46-12700-082	1
C163	22p 5% 500V NPO 1206 NiSn	Philips	1206CG220GBB-	46-12200-082	1
C164	220p 5% 500V NPO 1210 NiSn	Philips	1210CG221GBB-	46-22200-082	1
C165	56p 5% 500V NPO 1210 NiSn	Philips	1210CG560GBB-	46-15600-082	1
C166	100n 10% 50V X7R 0805 Nisn	Philips	08052R104K9BB	46-51000-282	1
C167	33n 10% 50V X7R 0805 NiSn	Philips	08052R333K9BB00	46-43300-281	1
D1	Diode, Schottky 70V 70mA SOT23	Siemens	BAS70	BAS70	1
D2	Diode, Schottky 70V 70mA SOT23	Siemens	BAS70	BAS70	1
D3	Diode, Si High speed 75V SOD80C	Philips	BAS32L/S	BAS32L/S	1
D4	Diode, Si High speed 75V SOD80C	Philips	BAS32L/S	BAS32L/S	1

08-05910-001 - Filter & Control PCB

BOM Revision
Date Valid On

09 -- Production
28.09.2006

Ref	Description	Manufacturer	Manufacturer's P/N	Codan P/N	Qty
D5	Diode, Si High speed 75V SOD80C	Philips	BAS32L/S	BAS32L/S	1
D6	Diode, Si High speed 75V SOD80C	Philips	BAS32L/S	BAS32L/S	1
D7	Diode, Si High speed 75V SOD80C	Philips	BAS32L/S	BAS32L/S	1
D8	Diode, Si High speed 75V SOD80C	Philips	BAS32L/S	BAS32L/S	1
D9	Diode,PIN 150V 1ohm@10mA 700nsTrr SC79	Infineon	BAR67-02V	BAR67-02V	1
D10	LED, Green PLCC SMD Non Diffused	Siemens	LGT670-L	65-61110-507	1
D11	Diode, Si High speed 75V SOT23	Philips	BAS16	BAS16	1
D12	Diode, Si High speed 75V SOT23	Philips	BAS16	BAS16	1
D14	Diode, Schottky 70V 70mA SOT23	Siemens	BAS70	BAS70	1
D15	Diode, Si High speed 75V SOT23	Philips	BAS16	BAS16	1
IC1	Reg, Voltage +10V IC	National Semiconduct	LM2940T-10	XB-02940-402	1
IC2	Micro prgmd, RFU Filter I/O	Arrow	90-20608-001	90-20608-001	1
IC3	Array, Transistor SOIC14	Motorola	MC1413D	XT-01413-700	1
IC4	Reg, Voltage +5V 0,1A SOIC8	National Semiconduct	LM78L05ACM	XB-07805-700	1
IC5	Amp, Oper Dual CMOS SOIC8	National Semiconduct	LMC662CM	XA-00662-700	1
IC6	Amp, Operational Dual SOIC8	National Semiconduct	LM358M	XA-00358-700	1
IC7	Comparator, Dual O/C Output SOIC8	National Semiconduct	LM393M	XD-00393-700	1
J1	Socket, Coax Mini Low Prof Fixed	Taiko Denki	TMP-J02X-A1	60-19390-002	1
J2	Socket, MCX Straight PCB	Chin Nan	27-05-TGN	60-19300	1
J3	Terminal Block 2 way PCB	Phoenix Mecano	AK300/2-5,0-GREY	61-10200-202	1
K1	Relay, 2C 12V 2A SMD 1028 Ohm	Matsushita	TQ2SL-12V	64-21225-310	1
K2	Relay, 2C 12V 2A SMD 1028 Ohm	Matsushita	TQ2SL-12V	64-21225-310	1
K3	Relay, 2C 12V 2A SMD 1028 Ohm	Matsushita	TQ2SL-12V	64-21225-310	1
K4	Relay, 2C 12V 2A SMD 1028 Ohm	Matsushita	TQ2SL-12V	64-21225-310	1
K5	Relay, 2C 12V 2A SMD 1028 Ohm	Matsushita	TQ2SL-12V	64-21225-310	1
K6	Relay, 2C 12V 2A SMD 1028 Ohm	Matsushita	TQ2SL-12V	64-21225-310	1
K7	Relay, 2C 12V 2A SMD 1028 Ohm	Matsushita	TQ2SL-12V	64-21225-310	1
K8	Relay, 2C 12V 2A SMD 1028 Ohm	Matsushita	TQ2SL-12V	64-21225-310	1
L2	Ind, 1mH 10% 1812	Coilcraft	1812LS-105XKBC	43-83100-000	1
L3	Ind, 2,1uH vi/gn/bn/rd	Fetronics	44-70512	44-70512	1
L4	Ind, 1,8uH gn/sl/gn	Fetronics	44-70466	44-70466	1

08-05910-001 - Filter & Control PCB

BOM Revision
Date Valid On

09 -- Production
28.09.2006

Ref	Description	Manufacturer	Manufacturer's P/N	Codan P/N	Qty
L5	Ind, 3u36 vi/gn/bk/ye	Fetronics	44-70504	44-70504	1
L6	Ind, 1,5uH sl/sl/vi	Codan	44-70370	44-70370	1
L7	Ind, 1u21 vi/gn/bk/rd	Fetronics	44-70502	44-70502	1
L8	Ind, 2u28 bl/bl/bl/bk	Fetronics	44-70476	44-70476	1
L9	Ind, 1,0uH sl/sl/or	Fetronics	44-70368	44-70368	1
L10	Ind, 837nH bl/bl/bl/gn	Fetronics	44-70477	44-70477	1
L11	Ind, 1,5uH sl/sl/vi	Codan	44-70370	44-70370	1
L12	Ind, 620nH vi/vi/wh	Fetronics	44-70393	44-70393	1
L13	Ind, 530nH bl/bl/bl/bn	Fetronics	44-70478	44-70478	1
L14	Ind, 1,0uH sl/sl/or	Fetronics	44-70368	44-70368	1
L15	Ind, 620nH vi/vi/wh	Fetronics	44-70393	44-70393	1
L16	Ind, 499nH vi/gn/bk/bn	Fetronics	44-70501	44-70501	1
L17	Ind, 530nH bl/bl/bl/bn	Fetronics	44-70478	44-70478	1
L18	Ind, 267nH vi/ye/wh/wh	Fetronics	44-70499	44-70499	1
L19	Ind, 244nH vi/gn/bn/bn	Fetronics	44-70511	44-70511	1
L20	Ind, 422nH bl/bl/bl/or	Fetronics	44-70479	44-70479	1
L22	Ind, 176nH bl/bl/bl/rd	Fetronics	44-70482	44-70482	1
L23	Ind, 152nH vi/gn/bn/bk	Fetronics	44-70510	44-70510	1
L24	Ind, 291nH vi/gn/bk/bk	Fetronics	44-70500	44-70500	1
L25	Ind, Common Mode 1.5A	Taiyo Yuden	CM05RA06	43-80000	1
L26	Choke, EMI/EMC 0A DC >1MHz 4516	Taiyo Yuden	FCFBMJ 4516 HS 110-T	43-90003	1
L27	Choke, EMI/EMC 0A DC >1MHz 4516	Taiyo Yuden	FCFBMJ 4516 HS 110-T	43-90003	1
L28	Choke, EMI/EMC 0A DC >1MHz 4516	Taiyo Yuden	FCFBMJ 4516 HS 110-T	43-90003	1
L29	Choke, EMI/EMC 0A DC >1MHz 4516	Taiyo Yuden	FCFBMJ 4516 HS 110-T	43-90003	1
L30	Ind, 4,7uH 10% 4532	Taiyo Yuden	LEM4532T4R7K	43-80470-000	1
L31	Ind, 4,7uH 10% 4532	Taiyo Yuden	LEM4532T4R7K	43-80470-000	1
L32	Ind, 4,7uH 10% 4532	Taiyo Yuden	LEM4532T4R7K	43-80470-000	1
L33	Ind, 4,7uH 10% 4532	Taiyo Yuden	LEM4532T4R7K	43-80470-000	1
L34	Ind, 4,7uH 10% 4532	Taiyo Yuden	LEM4532T4R7K	43-80470-000	1
P1	Not Fitted	Codan	**00000-001	99-00000-001	1
P2	Header (P) 16way 2row Boxed SMD 2,54mm	Neltron	2316SMD-16G	60-00160-003	1
P3	Header (P) 2way 1row Latch	JAE	IL-2P-S3EN2	60-00020-260	1
P4	Header (P) 16way 2row Boxed SMD 2,54mm	Neltron	2316SMD-16G	60-00160-003	1
R1	33k Ohm 5% 0,1W 0805	Philips	2322 730 61333	40-43300-111	1
R2	33k Ohm 5% 0,1W 0805	Philips	2322 730 61333	40-43300-111	1
R3	33k Ohm 5% 0,1W 0805	Philips	2322 730 61333	40-43300-111	1
R4	100 Ohm 2% 1,0W 2512 MELF	Vishay	SMM0207 100 100R2%BP	40-21000-135	1
R5	100 Ohm 2% 1,0W 2512 MELF	Vishay	SMM0207 100 100R2%BP	40-21000-135	1
R6	10k Ohm 5% 0,1W 0805	Philips	2322-730-61103	40-41000-111	1
R7	4,7k Ohm 5% 0,1W 0805	Philips	2322 730 61472	40-34700-111	1
R8	10k Ohm 5% 0,1W 0805	Philips	2322-730-61103	40-41000-111	1
R9	100k Ohm 5% 0,1W 0805	Philips	2322 730 61104	40-51000-111	1

08-05910-001 - Filter & Control PCB

BOM Revision
Date Valid On

09 -- Production
28.09.2006

Ref	Description	Manufacturer	Manufacturer's P/N	Codan P/N	Qty
R10	4,7k Ohm 5% 0,1W 0805	Philips	2322 730 61472	40-34700-111	1
R11	100k Ohm 5% 0,1W 0805	Philips	2322 730 61104	40-51000-111	1
R12	10k Ohm 5% 0,1W 0805	Philips	2322-730-61103	40-41000-111	1
R13	22k Ohm 5% 0,1W 0805	Philips	2322 730 61223	40-42200-111	1
R14	100 Ohm 5% 0,1W 0805	Philips	2322 730 61101	40-21000-111	1
R15	100 Ohm 5% 0,1W 0805	Philips	2322 730 61101	40-21000-111	1
R16	100 Ohm 5% 0,1W 0805	Philips	2322 730 61101	40-21000-111	1
R17	100 Ohm 5% 0,1W 0805	Philips	2322 730 61101	40-21000-111	1
R18	1k Ohm 5% 0,1W 0805	Philips	2322-730-61102	40-31000-111	1
R19	20k Ohm 1% 0,06W 0603	Phycomp	2322 704 62003	40-42000-125	1
R20	3,3k Ohm 5% 0,1W 0805	Philips	2322 730 61332	40-33300-111	1
R21	10k Ohm 5% 0,1W 0805	Philips	2322-730-61103	40-41000-111	1
R22	1k Ohm 5% 0,1W 0805	Philips	2322-730-61102	40-31000-111	1
R23	100 Ohm 5% 0,1W 0805	Philips	2322 730 61101	40-21000-111	1
R26	4,7k Ohm 5% 0,1W 0805	Philips	2322 730 61472	40-34700-111	1
R27	100 Ohm 5% 0,1W 0805	Philips	2322 730 61101	40-21000-111	1
R28	18k Ohm 5% 0,1W 0805	Philips	2322 730 61183	40-41800-111	1
R29	10k Ohm 5% 0,1W 0805	Philips	2322-730-61103	40-41000-111	1
R30	100 Ohm 5% 0,1W 0805	Philips	2322 730 61101	40-21000-111	1
R32	Pot,10k Lin MG Trim SMD	Bourns	3314 J-1-103	42-41004-000	1
R33	1,5k Ohm 5% 0,1W 0805	Philips	2322 730 61152	40-31500-111	1
R34	33k Ohm 5% 0,1W 0805	Philips	2322 730 61333	40-43300-111	1
R35	Pot,100k Lin MG Trim SMD	Bourns	3314 J-1-104	42-51060-001	1
R36	220 Ohm 5% 0,1W 0805	Philips	2322 730 61221	40-22200-111	1
R37	33k Ohm 5% 0,1W 0805	Philips	2322 730 61333	40-43300-111	1
R38	6,8k Ohm 5% 0,1W 0805	Philips	2322 730 61682	40-36800-111	1
R39	82k Ohm 5% 0,1W 0805	Philips	2322 730 61823	40-48200-111	1
R40	270k Ohm 5% 0,1W 0805	Philips	2322 730 61274	40-52700-111	1
R41	33k Ohm 5% 0,1W 0805	Philips	2322 730 61333	40-43300-111	1

08-05910-001 - Filter & Control PCB

BOM Revision
Date Valid On

09 -- Production
28.09.2006

Ref	Description	Manufacturer	Manufacturer's P/N	Codan P/N	Qty
R42	10k Ohm 5% 0,1W 0805	Philips	2322-730-61103	40-41000-111	1
R43	1,8k Ohm 5% 0,1W 0805	Philips	2322 730 61182	40-31800-111	1
R44	33k Ohm 5% 0,1W 0805	Philips	2322 730 61333	40-43300-111	1
R45	100k Ohm 5% 0,1W 0805	Philips	2322 730 61104	40-51000-111	1
R46	20k Ohm 1% 0,1W 0805	Philips	2322 734 62003	40-42000-115	1
R47	100k Ohm 5% 0,1W 0805	Philips	2322 730 61104	40-51000-111	1
R48	560k Ohm 5% 0,1W 0805	Philips	2322 730 61564	40-55600-111	1
R49	390k Ohm 5% 0,1W 0805	Philips	2322 730 61394	40-53900-111	1
R50	1k Ohm 5% 0,1W 0805	Philips	2322-730-61102	40-31000-111	1
R51	68k Ohm 5% 0,1W 0805	Philips	2322 730 61683	40-46800-111	1
R52	2,7k Ohm 5% 0,1W 0805	Philips	2322 730 61272	40-32700-111	1
R53	3,3k Ohm 5% 0,1W 0805	Philips	2322 730 61332	40-33300-111	1
R54	4,7k Ohm 5% 0,1W 0805	Philips	2322 730 61472	40-34700-111	1
R55	3,9k Ohm 5% 0,1W 0805	Philips	2322 730 61392	40-33900-111	1
R56	15k Ohm 5% 0,1W 0805	Philips	2322 730 61153	40-41500-111	1
R57	10k Ohm 5% 0,1W 0805	Philips	2322-730-61103	40-41000-111	1
R58	22 Ohm 5% 0,1W 0805	Philips	2322 730 61229	40-12200-111	1
R59	120k Ohm 5% 0,1W 0805	Philips	2322 730 61124	40-51200-111	1
R60	22k Ohm 5% 0,1W 0805	Philips	2322 730 61223	40-42200-111	1
R61	82 Ohm 5% 0,1W 0805	Philips	2322 730 61829	40-18200-111	1
R62	33k Ohm 5% 0,1W 0805	Philips	2322 730 61333	40-43300-111	1
R63	10k Ohm 5% 0,1W 0805	Philips	2322-730-61103	40-41000-111	1
R64	470k Ohm 5% 0,1W 0805	Philips	2322 730 61474	40-54700-111	1
R65	1k Ohm 5% 0,1W 0805	Philips	2322-730-61102	40-31000-111	1
R66	1k Ohm 5% 0,1W 0805	Philips	2322-730-61102	40-31000-111	1
R67	39k Ohm 5% 0,1W 0805	Philips	2322 730 61393	40-43900-111	1
R68	5,6k Ohm 5% 0,1W 0805	Philips	2322 730 61562	40-35600-111	1
R69	1 Ohm 5% 0,1W 0805	Philips	2322 730 61108	40-01000-111	1
R70	10k Ohm 5% 0,1W 0805	Philips	2322-730-61103	40-41000-111	1

08-05910-001 - Filter & Control PCB

BOM Revision
Date Valid On

09 -- Production
28.09.2006

Ref	Description	Manufacturer	Manufacturer's P/N	Codan P/N	Qty
R71	10k Ohm 5% 0,1W 0805	Philips	2322-730-61103	40-41000-111	1
R72	33k Ohm 5% 0,1W 0805	Philips	2322 730 61333	40-43300-111	1
R73	1k Ohm 5% 0,1W 0805	Philips	2322-730-61102	40-31000-111	1
R74	10k Ohm 1% 0,06W 0603	Phycomp	2322 704 61003	40-41000-125	1
R75	20k Ohm 1% 0,06W 0603	Phycomp	2322 704 62003	40-42000-125	1
R76	10k Ohm 1% 0,06W 0603	Phycomp	2322 704 61003	40-41000-125	1
R77	20k Ohm 1% 0,06W 0603	Phycomp	2322 704 62003	40-42000-125	1
R78	10k Ohm 1% 0,06W 0603	Phycomp	2322 704 61003	40-41000-125	1
R79	20k Ohm 1% 0,06W 0603	Phycomp	2322 704 62003	40-42000-125	1
R80	10k Ohm 1% 0,06W 0603	Phycomp	2322 704 61003	40-41000-125	1
R81	20k Ohm 1% 0,06W 0603	Phycomp	2322 704 62003	40-42000-125	1
R82	10k Ohm 1% 0,06W 0603	Phycomp	2322 704 61003	40-41000-125	1
R83	20k Ohm 1% 0,06W 0603	Phycomp	2322 704 62003	40-42000-125	1
R84	20k Ohm 1% 0,06W 0603	Phycomp	2322 704 62003	40-42000-125	1
R85	47k Ohm 5% 0,1W 0805	Philips	2322 730 61473	40-44700-111	1
R86	100 Ohm 5% 1,0W 2512	Phycomp	2322 762 60101	40-21000-141	1
R87	180 Ohm 5% 1,0W 2512	Phycomp	2322 762 60181	40-21800-141	1
R88	470k Ohm 5% 0,1W 0805	Philips	2322 730 61474	40-54700-111	1
R89	3,3M Ohm 5% 0,1W 0805	Philips	2322 730 61335	40-63300-111	1
R90	33k Ohm 5% 0,1W 0805	Philips	2322 730 61333	40-43300-111	1
R91	220k Ohm 5% 0,1W 0805	Philips	2322 730 61224	40-52200-111	1
R92	33k Ohm 5% 0,1W 0805	Philips	2322 730 61333	40-43300-111	1
R93	1M Ohm 5% 0,1W 0805	Philips	2322 730 61105	40-61000-111	1
T1	Txfr, RF or	Fetronics	44-80021	44-80021	1
V1	Transistor, NPN Si SOT23	Philips	BC847	BC847	1
V2	Transistor, PNP Si TO252	Motorola	MJD32C	MJD32C	1
V3	Transistor, NPN Si SOT23	Philips	BC817	BC817	1
V4	Transistor, NPN Si SOT23	Philips	BC847	BC847	1
V5	Transistor, PNP Si SOT23	Philips	BC858	BC858	1

08-05910-001 - Filter & Control PCB

BOM Revision
Date Valid On

09 -- Production
 28.09.2006

Ref	Description	Manufacturer	Manufacturer's P/N	Codan P/N	Qty
V6	MOSFET, N Chan Enhance SOT23	Philips	BST82	BST82	1
V7	Transistor, NPN Si SOT23	Philips	BC847	BC847	1
V8	Transistor, NPN Si SOT23	Philips	BC847	BC847	1
V9	Transistor, NPN Si SOT23	Philips	BC847	BC847	1
V10	Transistor, NPN Si SOT23	Philips	BC847	BC847	1
V11	MOSFET, N Chan Enhance SOT23	Philips	BST82	BST82	1
V12	Transistor, NPN Si SOT23	Philips	BC847	BC847	1
V13	Transistor, NPN Si SOT23	Philips	BC847	BC847	1
V14	MOSFET, N Chan Enhance SOT23	Philips	BST82	BST82	1
V15	MOSFET, N Chan Enhance SOT23	Philips	BST82	BST82	1
V16	Transistor, NPN Si SOT23	Philips	BC847	BC847	1
V17	MOSFET, N Chan Enhance SOT23	Philips	BST82	BST82	1
V18	Transistor, NPN Si SOT23	Philips	BC847	BC847	1
V19	MOSFET, N Chan Enhance SOT23	Philips	BST82	BST82	1

08-05511-001 - PA Assy c/w Heatsink

BOM Revision
Date Valid On

10 -- Production
27.09.2006

Ref	Description	Manufacturer	Manufacturer's P/N	Codan P/N	Qty
	Label, Serial/Barcode	Codan	06-02068	06-02068	1
	NGT PA Heatsink Assy			11-06036	1
	TP, NGT PA Alignment			10-00816	1
	PA & Filter			04-03169	1
	PA Assy c/w Heatsink			08-05511	1
	Build Standard, 2010			01-01252	1
	Heatsink	Diometrics	05-07059	05-07059	1
	Heat, Transfer Compound	Gensil	GENSIL 13 45gm Tube	71-31000-004	0.01
1	PCB, PA	IMP	07-01799-06	07-01799-06	1
3	Cable, CIB	Intertech	08-05483-001	08-05483-001	1
5	Cable, DC	Intertech	08-05485-001	08-05485-001	1
6	Cable, Ant control	Intertech	08-05486-001	08-05486-001	1
7	FET, RF Power, HF MRF255 Graded	Codan	23-20010	23-20010	2
9	Screw, M3x8 TAPTITE 2 P/Pozi	Ajax Fasteners	31-03008-580	31-03008-580	12
12	50 Ohm 80°C PTC Thermistor	Philips	2322-660-91008	41-11500-660	1
13	Lug, Solder 3,5mm	Cliford W Ltd	G410 CODE 330	61-30200-025	4
14	Tubing, Heatshrink 4,8x0,2 Bk	3M	FP-301 3/16" Black	71-80502-400	0.01
15	Spacer, Swaged	Routley & W		05-05569	2
16	Stake, Terminal	Autosplice	7-22461-5	61-40300-004	6
C200	1u 20% 35V 3528 TA Cap	AVX	TAJB105M035R	47-01003-520	1
C201	1u 20% 35V 3528 TA Cap	AVX	TAJB105M035R	47-01003-520	1
C202	100u 25V Ax EL Cap	Elna	RB	48-21002-551	1
C203	33n 10% 100V X7R 1206 NiSn	Philips	12062R333K0BB-	46-43300-280	1
C204	22p 5% 50V NPO 1206 NiSn	Philips	1206CG220J9BB-	46-12200-080	1
C205	33n 10% 100V X7R 1206 NiSn	Philips	12062R333K0BB-	46-43300-280	1
C206	33n 10% 100V X7R 1206 NiSn	Philips	12062R333K0BB-	46-43300-280	1
C207	15p 5% 500V NPO 1206 NiSn	Philips	1206CG150GBB-	46-11500-082	1
C208	100u 25V Ax EL Cap	Elna	RB	48-21002-551	1
C209	33n 10% 100V X7R 1206 NiSn	Philips	12062R333K0BB-	46-43300-280	1
C210	33n 10% 100V X7R 1206 NiSn	Philips	12062R333K0BB-	46-43300-280	1
C211	33n 10% 100V X7R 1206 NiSn	Philips	12062R333K0BB-	46-43300-280	1
C212	33n 10% 100V X7R 1206 NiSn	Philips	12062R333K0BB-	46-43300-280	1
C213	1n 5% 50V NPO 1206 NiSn	Philips	1206CG102J9BB-	46-31000-081	1
C214	100u 25V Ax EL Cap	Elna	RB	48-21002-551	1
C215	33n 10% 100V X7R 1206 NiSn	Philips	12062R333K0BB-	46-43300-280	1
C216	33n 10% 100V X7R 1206 NiSn	Philips	12062R333K0BB-	46-43300-280	1

08-05511-001 - PA Assy c/w Heatsink

BOM Revision
Date Valid On

10 -- Production
27.09.2006

Ref	Description	Manufacturer	Manufacturer's P/N	Codan P/N	Qty
C217	22p 5% 50V NPO 1206 NiSn	Philips	1206CG220J9BB-	46-12200-080	1
C218	22p 5% 50V NPO 1206 NiSn	Philips	1206CG220J9BB-	46-12200-080	1
C219	100p 5% 50V NPO 1206 NiSn	Philips	1206CG101J9BB-	46-21000-080	1
C220	10n 10% 100V X7R 1206 NiSn	Philips	12062R103K0BB-	46-41000-280	1
C221	10n 10% 100V X7R 1206 NiSn	Philips	12062R103K0BB-	46-41000-280	1
C222	100p 5% 50V NPO 1206 NiSn	Philips	1206CG101J9BB-	46-21000-080	1
C223	330p 5% 500V NPO 1210 NiSn	Philips	1210CG311GBB-	46-23300-082	1
C224	330p 5% 500V NPO 1210 NiSn	Philips	1210CG311GBB-	46-23300-082	1
C225	330p 5% 500V NPO 1210 NiSn	Philips	1210CG311GBB-	46-23300-082	1
C226	47p 5% 50V NPO 1206 NiSn	Philips	1206CG470J9BB-	46-14700-081	1
C227	33n 10% 100V X7R 1206 NiSn	Philips	12062R333K0BB-	46-43300-280	1
C228	100u 25V Ax EL Cap	Elna	RB	48-21002-551	1
C229	33n 10% 100V X7R 1206 NiSn	Philips	12062R333K0BB-	46-43300-280	1
C230	100n 10% 50V X7R 1206 NiSn	Philips	12062R104K9BB-	46-51000-281	1
C231	470n 10% 63V PE Cap	Philips	2222 370 18474	46-54700-521	1
C232	33n 10% 100V X7R 1206 NiSn	Philips	12062R333K0BB-	46-43300-280	1
C233	100p 5% 50V NPO 1206 NiSn	Philips	1206CG101J9BB-	46-21000-080	1
D200	Diode, Schottky 70V 70mA SOT23	Siemens	BAS70	BAS70	1
D201	Diode, Schottky SOT23	Philips	BAT54	BAT54	1
D202	Diode, Schottky 70V 70mA SOT23	Siemens	BAS70	BAS70	1
D203	Diode, Zener 15V 5% 0,2W SOT23	Philips	BZX84-C15	BZX84C15	1
D204	Diode, Si High speed 75V SOT23	Philips	BAS16	BAS16	1
D205	Diode, Si 400V 1A	Fairchild	1N4004	1N4004	1
IC200	Reg, Voltage +5V 0,1A SOIC8	National Semiconduct	LM78L05ACM	XB-07805-700	1
IC201	Amp, Operational Dual SOIC8	National Semiconduct	LM358M	XA-00358-700	1
IC202	Amp, Oper Dual CMOS SOIC8	National Semiconduct	LMC662CM	XA-00662-700	1
J200	Socket, Coax Mini Low Prof Fixed	Taiko Denki	TMP-J02X-A1	60-19390-002	1
K200	Relay, 1C 12V 16A 340 Ohm	Eberle	042901 62 0100	64-31125-234	1
L202	Ind, 1uH 10% 3028	Coilcraft	1008CS-102XKBC	43-80100-000	1
L205	Ind, PA DC feed or/wh/or	Fetronics	44-70457	44-70457	1

08-05511-001 - PA Assy c/w Heatsink

BOM Revision
Date Valid On

10 -- Production
27.09.2006

Ref	Description	Manufacturer	Manufacturer's P/N	Codan P/N	Qty
P200	Header (P) 16way 2row Boxed	Thomas & Betts	609-1627	60-00160-000	1
R200	47 Ohm 5% 0,125W 1206	Philips	2322 711 61479	40-14700-101	1
R201	47 Ohm 5% 0,125W 1206	Philips	2322 711 61479	40-14700-101	1
R202	56 Ohm 5% 0,125W 1206	Philips	2322 711 61569	40-15600-101	1
R203	330 Ohm 5% 0,125W 1206	Philips	2322 711 61331	40-23300-101	1
R204	330 Ohm 5% 0,125W 1206	Philips	2322 711 61331	40-23300-101	1
R205	Pot,100 Lin MG Trim SMD	Bourns	3314 J-1-101	42-21004-000	1
R206	27 Ohm 5% 0,125W 1206	Philips	2322 711 61279	40-12700-101	1
R207	10 Ohm 5% 0,125W 1206	Philips	2322 711 61109	40-11000-101	1
R208	47k Ohm 5% 0,125W 1206	Philips	2322 711 61473	40-44700-101	1
R209	3,9k Ohm 5% 0,125W 1206	Philips	2322 711 61392	40-33900-101	1
R210	10k Ohm 1% 0,125W 1206	Philips	2322-724-61003	40-41000-105	1
R211	4,7k Ohm 1% 0,125W 1206	Philips	2322 724 64702	40-34700-105	1
R212	10k Ohm 1% 0,125W 1206	Philips	2322-724-61003	40-41000-105	1
R213	680 Ohm 5% 0,125W 1206	Philips	2322 711 61681	40-26800-101	1
R214	680 Ohm 5% 0,125W 1206	Philips	2322 711 61681	40-26800-101	1
R215	470 Ohm 1% 0,125W 1206	Philips	2322 724 64701	40-24700-105	1
R216	4,7 Ohm 5% 0,125W 1206	Philips	2322 711 61478	40-04700-101	1
R217	22 Ohm 5% 0,125W 1206	Philips	2322 711 61229	40-12200-101	1
R218	4,7 Ohm 5% 0,125W 1206	Philips	2322 711 61478	40-04700-101	1
R219	22 Ohm 5% 0,125W 1206	Philips	2322 711 61229	40-12200-101	1
R220	4,7k Ohm 1% 0,125W 1206	Philips	2322 724 64702	40-34700-105	1
R221	180 Ohm 5% 0,125W 1206	Philips	2322 711 61181	40-21800-101	1
R222	Pot,1k Lin MG Trim SMD	Bourns	3314 J-1-102	42-31004-000	1
R223	10 Ohm 5% 0,125W 1206	Philips	2322 711 61109	40-11000-101	1
R224	1k Ohm 5% 0,125W 1206	Philips	2322 711 61102	40-31000-101	1
R225	22 Ohm 5% 0,125W 1206	Philips	2322 711 61229	40-12200-101	1
R226	15 Ohm 5% 0,125W 1206	Philips	2322 711 61159	40-11500-101	1
R227	15 Ohm 5% 0,125W 1206	Philips	2322 711 61159	40-11500-101	1

08-05511-001 - PA Assy c/w Heatsink

BOM Revision
Date Valid On

10 -- Production
27.09.2006

Ref	Description	Manufacturer	Manufacturer's P/N	Codan P/N	Qty
R228	15 Ohm 5% 0,125W 1206	Philips	2322 711 61159	40-11500-101	1
R229	15 Ohm 5% 0,125W 1206	Philips	2322 711 61159	40-11500-101	1
R230	15 Ohm 5% 0,125W 1206	Philips	2322 711 61159	40-11500-101	1
R231	15 Ohm 5% 0,125W 1206	Philips	2322 711 61159	40-11500-101	1
R232	22 Ohm 5% 0,125W 1206	Philips	2322 711 61229	40-12200-101	1
R233	2,2k Ohm 2% 0,125W 1206	Philips	2322 711 41222	40-32200-102	1
R234	100k Ohm 2% 0,125W 1206	Philips	2322-711-41104	40-51000-102	1
R235	1k Ohm 5% 0,125W 1206	Philips	2322 711 61102	40-31000-101	1
R236	270k Ohm 2% 0,125W 1206	Philips	2322 711 41274	40-52700-102	1
R237	1k Ohm 5% 0,125W 1206	Philips	2322 711 61102	40-31000-101	1
R238	4,7k Ohm 1% 0,125W 1206	Philips	2322 724 64702	40-34700-105	1
R239	5,6k Ohm 2% 0,125W 1206	Philips	2322-711-41562	40-35600-102	1
R240	Pot,10k Lin MG Trim SMD	Bourns	3314 J-1-103	42-41004-000	1
R241	5,6k Ohm 2% 0,125W 1206	Philips	2322-711-41562	40-35600-102	1
R242	100 Ohm 5% 0,125W 1206	Philips	2322 711 61101	40-21000-101	1
R243	39k Ohm 2% 0,125W 1206	Philips	2322-711-41393	40-43900-102	1
R244	Pot,100k Lin MG Trim SMD	Bourns	3314 J-1-104	42-51060-001	1
R245	27k Ohm 5% 0,125W 1206	Philips	2322 711 61273	40-42700-101	1
R246	47 Ohm 5% 0,125W 1206	Philips	2322 711 61479	40-14700-101	1
R247	47 Ohm 5% 0,125W 1206	Philips	2322 711 61479	40-14700-101	1
R248	47 Ohm 5% 0,125W 1206	Philips	2322 711 61479	40-14700-101	1
R249	47 Ohm 5% 0,125W 1206	Philips	2322 711 61479	40-14700-101	1
R250	330 Ohm 5% 0,125W 1206	Philips	2322 711 61331	40-23300-101	1
R251	330 Ohm 5% 0,125W 1206	Philips	2322 711 61331	40-23300-101	1
R252	4,7k Ohm 1% 0,125W 1206	Philips	2322 724 64702	40-34700-105	1
R253	Pot,10k Lin MG Trim SMD	Bourns	3314 J-1-103	42-41004-000	1
R254	4,7k Ohm 1% 0,125W 1206	Philips	2322 724 64702	40-34700-105	1
R255	470 Ohm 1% 0,125W 1206	Philips	2322 724 64701	40-24700-105	1
R256	270k Ohm 2% 0,125W 1206	Philips	2322 711 41274	40-52700-102	1

08-05511-001 - PA Assy c/w Heatsink

BOM Revision
Date Valid On

10 -- Production
27.09.2006

Ref	Description	Manufacturer	Manufacturer's P/N	Codan P/N	Qty
R257	270k Ohm 2% 0,125W 1206	Philips	2322 711 41274	40-52700-102	1
R258	4,7k Ohm 1% 0,125W 1206	Philips	2322 724 64702	40-34700-105	1
R259	4,7 Ohm 5% 0,125W 1206	Philips	2322 711 61478	40-04700-101	1
R260	10k Ohm 1% 0,125W 1206	Philips	2322-724-61003	40-41000-105	1
R261	Res, Voltage Dependent	Philips	2322-592-52506	41-22506-592	1
R263	2,7k Ohm 2% 0,125W 1206	Philips	2322 712 61272	40-32700-102	1
R264	22k Ohm 5% 0,125W 1206	Philips	2322 711 61223	40-42200-101	1
T200	Input Txfr	Protran	44-80270	44-80270	1
T201	Pre-Driver I/P Txfr	Protran	44-80271	44-80271	1
T202	Pre-Driver O/P Txfr	Protran	44-80272	44-80272	1
T203	Driver O/P Txfr	Protran	44-80273	44-80273	1
T204	Output Txfr	Codan	44-80274	44-80274	1
V200	Transistor, NPN Si SOT89	Philips	BFQ17	BFQ17	1
V201	Transistor, NPN Si SOT89	Philips	BFQ17	BFQ17	1
V202	JFET, N Channel SOT23	Motorola	MMBFJ310LT1	MMBFJ310LT1	1
V203	JFET, N Channel SOT23	Motorola	MMBFJ310LT1	MMBFJ310LT1	1
V204	Transistor, NPN Si SOT89	Philips	BFQ17	BFQ17	1
V205	Transistor, NPN Si SOT89	Philips	BFQ17	BFQ17	1
V206	Transistor, PNP Si SOT89	Philips	BC869	BC869	1
V207	Transistor, NPN Si SOT89	Philips	BFQ17	BFQ17	1
V208	Transistor, NPN Si SOT89	Philips	BFQ17	BFQ17	1
V209	Transistor, NPN Si SOT89	Philips	BFQ17	BFQ17	1
V210	Transistor, NPN Si SOT89	Philips	BFQ17	BFQ17	1
V211	Transistor, NPN Si SOT89	Philips	BFQ17	BFQ17	1
V212	Transistor, NPN Si SOT89	Philips	BFQ17	BFQ17	1
V213	Transistor, PNP Curr Mirror SOT143	Philips	BCV62B	BCV62B	1
V214	Transistor, NPN Curr Mirror SOT143	Philips	BCV61B	BCV61B	1
V217	Transistor, PNP Si SOT23	Philips	BC856	BC856	1
V218	Transistor, PNP Si SOT23	Philips	BC856	BC856	1
V219	Transistor, PNP Si SOT89	Philips	BC869	BC869	1
V220	Transistor, NPN Si SOT23	Philips	BC848	BC848	1

08-05988-001 - Audio & Interconnect PCB

BOM Revision
Date Valid On

07 -- Production
28.09.2006

Ref	Description	Manufacturer	Manufacturer's P/N	Codan P/N	Qty
	Audio & Interconnect PCB			08-05988	1
	Audio & Interconnect			04-03425	1
1	PCB, Audio & Interconnect	IMP	07-01994-03	07-01994-03	1
2	Label, Serial/Barcode	Codan	06-02068	06-02068	1
3	Tape, EPDM Rubber foam 12mmx3mm	Beirsdorf	TESA 61102	30-39301-002	25
4	Sleeve, Sil Rubber 6x0,5 Any Col	Jones Stroud	71-80605-199	71-80605-199	0.01
C1	33n 10% 50V X7R 0805 NiSn	Philips	08052R333K9BB00	46-43300-281	1
C2	1n 5% 50V NPO 0805 NiSn	Philips	0805CG102J9BB-	46-31000-082	1
C3	1n 5% 50V NPO 0805 NiSn	Philips	0805CG102J9BB-	46-31000-082	1
C4	1n 5% 50V NPO 0805 NiSn	Philips	0805CG102J9BB-	46-31000-082	1
C5	100n 10% 50V X7R 0805 Nisn	Philips	08052R104K9BB	46-51000-282	1
C6	100n 10% 50V X7R 0805 Nisn	Philips	08052R104K9BB	46-51000-282	1
C7	470u 16V Ax EL Cap	Jamicon	SKR470T1CG18	48-24701-651	1
C8	1000u 16V Ax EL Cap	Jamicon	SKR102T1CJ21	48-31001-651	1
C9	100p 5% 50V NPO 0805 NiSn	Philips	0805CG101J9B200	46-21000-081	1
C10	100p 5% 50V NPO 0805 NiSn	Philips	0805CG101J9B200	46-21000-081	1
C11	33n 10% 50V X7R 0805 NiSn	Philips	08052R333K9BB00	46-43300-281	1
C12	33n 10% 50V X7R 0805 NiSn	Philips	08052R333K9BB00	46-43300-281	1
C13	1n 5% 50V NPO 0805 NiSn	Philips	0805CG102J9BB-	46-31000-082	1
C14	100n 10% 50V X7R 0805 Nisn	Philips	08052R104K9BB	46-51000-282	1
C15	100u 25V 105°C SMD EL Cap Low ESR	Nippon Chemicon	MVY25VC100MF80	48-21002-502	1
C16	1u 20% 35V 3528 TA Cap	AVX	TAJB105M035R	47-01003-520	1
C17	470p 5% 50V NPO 0805 NiSn	Philips	0805CG471J9B200	46-24700-081	1
C18	470p 5% 50V NPO 0805 NiSn	Philips	0805CG471J9B200	46-24700-081	1
C19	100n 10% 50V X7R 0805 Nisn	Philips	08052R104K9BB	46-51000-282	1
C20	100n 10% 50V X7R 0805 Nisn	Philips	08052R104K9BB	46-51000-282	1
C21	33n 10% 50V X7R 0805 NiSn	Philips	08052R333K9BB00	46-43300-281	1
C22	33n 10% 50V X7R 0805 NiSn	Philips	08052R333K9BB00	46-43300-281	1
C23	100n 10% 50V X7R 0805 Nisn	Philips	08052R104K9BB	46-51000-282	1
C24	100n 10% 50V X7R 0805 Nisn	Philips	08052R104K9BB	46-51000-282	1
C25	33n 10% 50V X7R 0805 NiSn	Philips	08052R333K9BB00	46-43300-281	1

08-05988-001 - Audio & Interconnect PCB

BOM Revision
Date Valid On

07 -- Production
28.09.2006

Ref	Description	Manufacturer	Manufacturer's P/N	Codan P/N	Qty
C26	100n 10% 50V X7R 0805 Nisn	Philips	08052R104K9BB	46-51000-282	1
C27	33p 5% 50V NPO 0805 NiSn	Philips	0805CG330J9B200	46-13300-081	1
C28	33p 5% 50V NPO 0805 NiSn	Philips	0805CG330J9B200	46-13300-081	1
C29	1u 20% 35V 3528 TA Cap	AVX	TAJB105M035R	47-01003-520	1
C30	1u 20% 35V 3528 TA Cap	AVX	TAJB105M035R	47-01003-520	1
C31	1u 20% 35V 3528 TA Cap	AVX	TAJB105M035R	47-01003-520	1
C32	100n 10% 50V X7R 0805 Nisn	Philips	08052R104K9BB	46-51000-282	1
C33	10u 20% 25V 6032 TA Cap	AVX	TAJC106M025R	47-11002-520	1
C34	10u 20% 25V 6032 TA Cap	AVX	TAJC106M025R	47-11002-520	1
C35	1u 20% 35V 3528 TA Cap	AVX	TAJB105M035R	47-01003-520	1
C36	1u 20% 35V 3528 TA Cap	AVX	TAJB105M035R	47-01003-520	1
C37	33n 10% 50V X7R 0805 NiSn	Philips	08052R333K9BB00	46-43300-281	1
C38	100u 25V Ax EL Cap	Elna	RB	48-21002-551	1
C39	1u 20% 35V 3528 TA Cap	AVX	TAJB105M035R	47-01003-520	1
C40	1u 20% 35V 3528 TA Cap	AVX	TAJB105M035R	47-01003-520	1
C41	100n 10% 50V X7R 0805 Nisn	Philips	08052R104K9BB	46-51000-282	1
C42	100n 10% 50V X7R 0805 Nisn	Philips	08052R104K9BB	46-51000-282	1
C43	22p 5% 50V NPO 0805 NiSn	Philips	0805CG220J9B200	46-12200-081	1
C44	33n 10% 50V X7R 0805 NiSn	Philips	08052R333K9BB00	46-43300-281	1
C45	100n 10% 50V X7R 0805 Nisn	Philips	08052R104K9BB	46-51000-282	1
C46	1n 5% 50V NPO 0805 NiSn	Philips	0805CG102J9BB-	46-31000-082	1
C47	220p 5% 50V NPO 0805 NiSn	Philips	0805CG221J9BB	46-22200-081	1
C48	220p 5% 50V NPO 0805 NiSn	Philips	0805CG221J9BB	46-22200-081	1
C49	10u 20% 25V 6032 TA Cap	AVX	TAJC106M025R	47-11002-520	1
C50	33n 10% 50V X7R 0805 NiSn	Philips	08052R333K9BB00	46-43300-281	1
C51	1n 5% 50V NPO 0805 NiSn	Philips	0805CG102J9BB-	46-31000-082	1
C52	33n 10% 50V X7R 0805 NiSn	Philips	08052R333K9BB00	46-43300-281	1
C53	33n 10% 50V X7R 0805 NiSn	Philips	08052R333K9BB00	46-43300-281	1
C54	33n 10% 50V X7R 0805 NiSn	Philips	08052R333K9BB00	46-43300-281	1

08-05988-001 - Audio & Interconnect PCB

BOM Revision
Date Valid On

07 -- Production
28.09.2006

Ref	Description	Manufacturer	Manufacturer's P/N	Codan P/N	Qty
C55	33n 10% 50V X7R 0805 NiSn	Philips	08052R333K9BB00	46-43300-281	1
C56	100n 10% 50V X7R 0805 Nisn	Philips	08052R104K9BB	46-51000-282	1
C57	1u 20% 35V 3528 TA Cap	AVX	TAJB105M035R	47-01003-520	1
C58	470p 5% 50V NPO 0805 NiSn	Philips	0805CG471J9B200	46-24700-081	1
C59	33n 10% 50V X7R 0805 NiSn	Philips	08052R333K9BB00	46-43300-281	1
C60	100n 10% 50V X7R 0805 Nisn	Philips	08052R104K9BB	46-51000-282	1
C61	33n 10% 50V X7R 0805 NiSn	Philips	08052R333K9BB00	46-43300-281	1
C62	3,3n 10% 100V X7R 0805 NiSn	Philips	08052R332K0B200	46-33300-281	1
C63	1n 5% 50V NPO 0805 NiSn	Philips	0805CG102J9BB-	46-31000-082	1
C64	10u 20% 25V 6032 TA Cap	AVX	TAJC106M025R	47-11002-520	1
C65	1u 20% 35V 3528 TA Cap	AVX	TAJB105M035R	47-01003-520	1
C66	1n 5% 50V NPO 0805 NiSn	Philips	0805CG102J9BB-	46-31000-082	1
C67	1n 5% 50V NPO 0805 NiSn	Philips	0805CG102J9BB-	46-31000-082	1
C68	100p 5% 50V NPO 0805 NiSn	Philips	0805CG101J9B200	46-21000-081	1
C69	100p 5% 50V NPO 0805 NiSn	Philips	0805CG101J9B200	46-21000-081	1
C70	33n 10% 50V X7R 0805 NiSn	Philips	08052R333K9BB00	46-43300-281	1
C71	33n 10% 50V X7R 0805 NiSn	Philips	08052R333K9BB00	46-43300-281	1
C72	33n 10% 50V X7R 0805 NiSn	Philips	08052R333K9BB00	46-43300-281	1
C73	100n 10% 50V X7R 0805 Nisn	Philips	08052R104K9BB	46-51000-282	1
C74	100n 10% 50V X7R 0805 Nisn	Philips	08052R104K9BB	46-51000-282	1
C75	1n 5% 50V NPO 0805 NiSn	Philips	0805CG102J9BB-	46-31000-082	1
C76	1n 5% 50V NPO 0805 NiSn	Philips	0805CG102J9BB-	46-31000-082	1
C77	1n 5% 50V NPO 0805 NiSn	Philips	0805CG102J9BB-	46-31000-082	1
C78	1n 5% 50V NPO 0805 NiSn	Philips	0805CG102J9BB-	46-31000-082	1
C79	Not Fitted	Codan	** -00000-001	99-00000-001	1
C80	10u 20% 25V 6032 TA Cap	AVX	TAJC106M025R	47-11002-520	1
C81	33n 10% 50V X7R 0805 NiSn	Philips	08052R333K9BB00	46-43300-281	1
C82	33n 10% 50V X7R 0805 NiSn	Philips	08052R333K9BB00	46-43300-281	1
C83	33n 10% 50V X7R 0805 NiSn	Philips	08052R333K9BB00	46-43300-281	1

08-05988-001 - Audio & Interconnect PCB

BOM Revision
Date Valid On

07 -- Production
28.09.2006

Ref	Description	Manufacturer	Manufacturer's P/N	Codan P/N	Qty
C84	1u 20% 35V 3528 TA Cap	AVX	TAJB105M035R	47-01003-520	1
C89	100n 10% 50V X7R 0805 Nisn	Philips	08052R104K9BB	46-51000-282	1
C90	1u 20% 35V 3528 TA Cap	AVX	TAJB105M035R	47-01003-520	1
D1	Diode, 400V 1A SMA	On Semiconductor	MRA4004T3	MRA4004T3	1
D2	Diode, Si High speed 75V SOT23	Philips	BAS16	BAS16	1
D3	Diode, Schottky SOT23	Philips	BAT54	BAT54	1
D4	Diode, Zener 5,6V 5% 0,2W SOT23	Philips	BZX84-C5V6	BZX84C5V6	1
D5	Diode, Si High speed 75V SOT23	Philips	BAS16	BAS16	1
D6	Diode, Si High speed 75V SOT23	Philips	BAS16	BAS16	1
D7	Diode, Si High speed 75V SOT23	Philips	BAS16	BAS16	1
D8	Diode, Si High speed 75V SOT23	Philips	BAS16	BAS16	1
D9	Diode, Schottky SOT23	Philips	BAT54	BAT54	1
D10	Diode, Schottky SOT23	Philips	BAT54	BAT54	1
D11	TVS, Bidirec 15V wkg SMB	SGS Thomson	SMBJ15CA-TR	SMBJ15CA-TR	1
D12	TVS, Bidirec 15V wkg SMB	SGS Thomson	SMBJ15CA-TR	SMBJ15CA-TR	1
F1	0,1 Ohm nom 1,6A@20°C 16Vwkg SMD	Raychem	SMDH160	41-10010-000	1
G1	Cell, Lithium 3V, 35mAh PCB Mtg	National Semiconduct	BR1225-1VD	65-71000-002	1
H1	LED, Tricolour T-1 3/4 Diffused	Liteon	LTL-52RG	65-61110-901	1
IC1	Amp, Audio Power 2x11w SIL9P	Philips	TDA1519C	TDA1519C	1
IC2	Amp, Operational Dual SOIC8	National Semiconduct	LM358M	XA-00358-700	1
IC3	DTMF Tone Generator SOIC8	Philips	PCD3312CT-118	XE-03312-700	1
IC4	Pot, Digital 10k 256 Position SOIC16	Analog Devices	AD5242BR10	YN-05242-700	1
IC5	Mux/Demux, Analog, Triple 2ch SOIC16	Philips	HEF4053BT-653	YH-40053-701	1
IC6	Tcvr, CAN bus SOIC8	Philips	PCA82C250T	YI-82250-700	1
IC7	Reg, Voltage +5V 0,1A SOIC8	National Semiconduct	LM78L05ACM	XB-07805-700	1
IC8	Tcvr, RS232 Dual +5V SOIC16	Maxim	MAX202CSE	YI-00202-700	1
IC9	Micro prgmd, 2011 Audio I/O	Codan	90-20625-001	90-20625-001	1
IC10	Clock/Calendar/RAM IIC Bus SOIC8	SGS Thomson	MK41T56S00TR	YK-04156-700	1
IC12	Comparator, Quad O/C Output SOIC14	National Semiconduct	LM339M	XD-00339-700	1
IC13	Amp, Operational Dual SOIC8	National Semiconduct	LM358M	XA-00358-700	1
IC14	Mux/Demux, Analog, Triple 2ch SOIC16	Philips	HEF4053BT-653	YH-40053-701	1

08-05988-001 - Audio & Interconnect PCB

BOM Revision
Date Valid On

07 -- Production
28.09.2006

Ref	Description	Manufacturer	Manufacturer's P/N	Codan P/N	Qty
IC15	Flip Flop, D Dual SOIC14	Motorola	MC74HC74AD	YH-74074-700	1
IC16	Gate, NOR 2 Input Quad SOIC14	Motorola	MC74HC02AD	YH-74002-700	1
K1	Relay, 2C 9V Ltch SMD 2x579 Ohm	Matsushita	TQ2SL-L2-9V	64-21225-258	1
L1	Ind, Common Mode 5.5A	Taiyo Yuden	CMO8RA20	43-80001	1
L2	Choke, Common Mode (Data) SMD	Taiyo Yuden	CM04RC04	43-82470-000	1
L3	Choke, Common Mode (Data) SMD	Taiyo Yuden	CM04RC04	43-82470-000	1
L4	Choke, EMI/EMC 0A DC >1MHz 4516	Taiyo Yuden	FCFBMJ 4516 HS 110-T	43-90003	1
L5	Ind, 100uH 10% 4532	Taiyo Yuden	LEM 4532T101K	43-82100-134	1
L6	Ind, 100uH 10% 4532	Taiyo Yuden	LEM 4532T101K	43-82100-134	1
L7	Choke, EMI/EMC 0A DC >1MHz 4516	Taiyo Yuden	FCFBMJ 4516 HS 110-T	43-90003	1
L8	Ind, 100uH 10% 4532	Taiyo Yuden	LEM 4532T101K	43-82100-134	1
L9	Ind, 100uH 10% 4532	Taiyo Yuden	LEM 4532T101K	43-82100-134	1
L10	Ind, 10uH 10% 4532	Taiyo Yuden	LEM 4532T100K	43-81100-000	1
L11	Ind, 10uH 10% 4532	Taiyo Yuden	LEM 4532T100K	43-81100-000	1
L12	Choke, EMI/EMC 0A DC >1MHz 4516	Taiyo Yuden	FCFBMJ 4516 HS 110-T	43-90003	1
L13	Ind, 100uH 10% 4532	Taiyo Yuden	LEM 4532T101K	43-82100-134	1
L14	Ind, 100uH 10% 4532	Taiyo Yuden	LEM 4532T101K	43-82100-134	1
L15	Choke, EMI/EMC 0A DC >1MHz 4516	Taiyo Yuden	FCFBMJ 4516 HS 110-T	43-90003	1
L16	Ind, 100uH 10% 4532	Taiyo Yuden	LEM 4532T101K	43-82100-134	1
L17	Choke, EMI/EMC 0A DC >1MHz 4516	Taiyo Yuden	FCFBMJ 4516 HS 110-T	43-90003	1
L18	Choke, EMI/EMC 0A DC >1MHz 4516	Taiyo Yuden	FCFBMJ 4516 HS 110-T	43-90003	1
L19	Choke, EMI/EMC 0A DC >1MHz 4516	Taiyo Yuden	FCFBMJ 4516 HS 110-T	43-90003	1
P1	Header (P) 12way 2mm Latch Fixed	AMP	1-173981-2	60-00120-002	1
P2	Header (P) 16way 2row Boxed SMD 2,54mm	Neltron	2316SMD-16G	60-00160-003	1
P3	Header (P) 26way 2row Boxed SMD	Neltron	2316SMD-26G-CAP-TR	60-00260-002	1
P4	Header (P) 16way 2row Boxed SMD 2,54mm	Neltron	2316SMD-16G	60-00160-003	1
P5	Not Fitted	Codan	**00000-001	99-00000-001	1
P6	Header (P) 8way 2mm Latch Fixed	AMP	292161-8	60-00080-001	1
R1	47k Ohm 5% 0,1W 0805	Philips	2322 730 61473	40-44700-111	1
R2	47k Ohm 5% 0,1W 0805	Philips	2322 730 61473	40-44700-111	1
R3	22k Ohm 5% 0,1W 0805	Philips	2322 730 61223	40-42200-111	1
R4	22k Ohm 5% 0,1W 0805	Philips	2322 730 61223	40-42200-111	1
R5	10k Ohm 5% 0,1W 0805	Philips	2322-730-61103	40-41000-111	1
R6	4,7k Ohm 5% 0,1W 0805	Philips	2322 730 61472	40-34700-111	1

08-05988-001 - Audio & Interconnect PCB

BOM Revision
Date Valid On

07 -- Production
 28.09.2006

Ref	Description	Manufacturer	Manufacturer's P/N	Codan P/N	Qty
R7	10k Ohm 5% 0,1W 0805	Philips	2322-730-61103	40-41000-111	1
R8	47k Ohm 5% 0,1W 0805	Philips	2322 730 61473	40-44700-111	1
R9	1k Ohm 5% 0,1W 0805	Philips	2322-730-61102	40-31000-111	1
R10	47k Ohm 1% 0,1W 0805	Philips	2322 734 64703	40-44700-115	1
R11	100 Ohm 5% 0,1W 0805	Philips	2322 730 61101	40-21000-111	1
R12	100 Ohm 5% 0,1W 0805	Philips	2322 730 61101	40-21000-111	1
R13	100 Ohm 5% 0,1W 0805	Philips	2322 730 61101	40-21000-111	1
R14	100 Ohm 5% 0,1W 0805	Philips	2322 730 61101	40-21000-111	1
R15	100 Ohm 5% 0,1W 0805	Philips	2322 730 61101	40-21000-111	1
R16	100 Ohm 5% 0,1W 0805	Philips	2322 730 61101	40-21000-111	1
R17	100 Ohm 5% 0,1W 0805	Philips	2322 730 61101	40-21000-111	1
R18	0 Ohm Jumper 0805	Philips	2322 730 91002	40-00001-111	1
R19	0 Ohm Jumper 0805	Philips	2322 730 91002	40-00001-111	1
R20	2,2k Ohm 5% 0,1W 0805	Philips	2322 730 61222	40-32200-111	1
R21	2,2k Ohm 5% 0,1W 0805	Philips	2322 730 61222	40-32200-111	1
R22	100 Ohm 5% 0,1W 0805	Philips	2322 730 61101	40-21000-111	1
R23	1M Ohm 5% 0,1W 0805	Philips	2322 730 61105	40-61000-111	1
R24	1M Ohm 5% 0,1W 0805	Philips	2322 730 61105	40-61000-111	1
R25	1M Ohm 5% 0,1W 0805	Philips	2322 730 61105	40-61000-111	1
R26	100 Ohm 5% 0,1W 0805	Philips	2322 730 61101	40-21000-111	1
R27	100 Ohm 5% 0,1W 0805	Philips	2322 730 61101	40-21000-111	1
R28	1k Ohm 5% 0,1W 0805	Philips	2322-730-61102	40-31000-111	1
R29	1k Ohm 5% 0,1W 0805	Philips	2322-730-61102	40-31000-111	1
R30	10k Ohm 5% 0,1W 0805	Philips	2322-730-61103	40-41000-111	1
R31	10k Ohm 5% 0,1W 0805	Philips	2322-730-61103	40-41000-111	1
R32	10k Ohm 5% 0,1W 0805	Philips	2322-730-61103	40-41000-111	1
R33	10k Ohm 5% 0,1W 0805	Philips	2322-730-61103	40-41000-111	1
R34	10k Ohm 5% 0,1W 0805	Philips	2322-730-61103	40-41000-111	1
R35	10k Ohm 5% 0,1W 0805	Philips	2322-730-61103	40-41000-111	1
R36	10k Ohm 5% 0,1W 0805	Philips	2322-730-61103	40-41000-111	1

08-05988-001 - Audio & Interconnect PCB

BOM Revision
Date Valid On

07 -- Production
28.09.2006

Ref	Description	Manufacturer	Manufacturer's P/N	Codan P/N	Qty
R37	270 Ohm 5% 0,1W 0805	Philips	2322 730 61271	40-22700-111	1
R38	100 Ohm 5% 0,1W 0805	Philips	2322 730 61101	40-21000-111	1
R39	1k Ohm 5% 0,1W 0805	Philips	2322-730-61102	40-31000-111	1
R40	1k Ohm 5% 0,1W 0805	Philips	2322-730-61102	40-31000-111	1
R41	1k Ohm 5% 0,1W 0805	Philips	2322-730-61102	40-31000-111	1
R42	10 Ohm 5% 0,1W 0805	Philips	2322 730 61109	40-11000-111	1
R43	10 Ohm 5% 0,1W 0805	Philips	2322 730 61109	40-11000-111	1
R44	10k Ohm 5% 0,1W 0805	Philips	2322-730-61103	40-41000-111	1
R45	2,2k Ohm 5% 0,1W 0805	Philips	2322 730 61222	40-32200-111	1
R46	10 Ohm 5% 0,1W 0805	Philips	2322 730 61109	40-11000-111	1
R50	270 Ohm 5% 0,1W 0805	Philips	2322 730 61271	40-22700-111	1
R51	270 Ohm 5% 0,1W 0805	Philips	2322 730 61271	40-22700-111	1
R52	47 Ohm 5% 0,1W 0805	Philips	2322 730 61479	40-14700-111	1
R53	5,6k Ohm 5% 0,1W 0805	Philips	2322 730 61562	40-35600-111	1
R54	10k Ohm 5% 0,1W 0805	Philips	2322-730-61103	40-41000-111	1
R58	100 Ohm 5% 0,1W 0805	Philips	2322 730 61101	40-21000-111	1
R59	270 Ohm 5% 0,1W 0805	Philips	2322 730 61271	40-22700-111	1
R60	10k Ohm 5% 0,1W 0805	Philips	2322-730-61103	40-41000-111	1
R61	4,7k Ohm 5% 0,1W 0805	Philips	2322 730 61472	40-34700-111	1
R62	3,3k Ohm 5% 0,1W 0805	Philips	2322 730 61332	40-33300-111	1
R63	3,3k Ohm 5% 0,1W 0805	Philips	2322 730 61332	40-33300-111	1
R64	470 Ohm 5% 0,1W 0805	Philips	2322 730 61471	40-24700-111	1
R65	470 Ohm 5% 0,1W 0805	Philips	2322 730 61471	40-24700-111	1
R66	47 Ohm 5% 0,1W 0805	Philips	2322 730 61479	40-14700-111	1
R67	47 Ohm 5% 0,1W 0805	Philips	2322 730 61479	40-14700-111	1
R68	1k Ohm 5% 0,1W 0805	Philips	2322-730-61102	40-31000-111	1
R69	1k Ohm 5% 0,1W 0805	Philips	2322-730-61102	40-31000-111	1
R70	1k Ohm 5% 0,1W 0805	Philips	2322-730-61102	40-31000-111	1
R71	10k Ohm 5% 0,1W 0805	Philips	2322-730-61103	40-41000-111	1

08-05988-001 - Audio & Interconnect PCB

BOM Revision
Date Valid On

07 -- Production
28.09.2006

Ref	Description	Manufacturer	Manufacturer's P/N	Codan P/N	Qty
R72	10k Ohm 5% 0,1W 0805	Philips	2322-730-61103	40-41000-111	1
R73	10k Ohm 5% 0,1W 0805	Philips	2322-730-61103	40-41000-111	1
R74	10k Ohm 5% 0,1W 0805	Philips	2322-730-61103	40-41000-111	1
R75	10k Ohm 5% 0,1W 0805	Philips	2322-730-61103	40-41000-111	1
R78	47k Ohm 5% 0,1W 0805	Philips	2322 730 61473	40-44700-111	1
R79	47k Ohm 5% 0,1W 0805	Philips	2322 730 61473	40-44700-111	1
R80	10k Ohm 5% 0,1W 0805	Philips	2322-730-61103	40-41000-111	1
R81	10k Ohm 5% 0,1W 0805	Philips	2322-730-61103	40-41000-111	1
R82	680k Ohm 5% 0,1W 0805	Philips	2322 730 61684	40-56800-111	1
R83	680k Ohm 5% 0,1W 0805	Philips	2322 730 61684	40-56800-111	1
R84	680k Ohm 5% 0,1W 0805	Philips	2322 730 61684	40-56800-111	1
R85	Pot,10k Lin MG Trim SMD	Bourns	3314 J-1-103	42-41004-000	1
R86	10k Ohm 5% 0,1W 0805	Philips	2322-730-61103	40-41000-111	1
R87	100k Ohm 5% 0,1W 0805	Philips	2322 730 61104	40-51000-111	1
R88	100k Ohm 5% 0,1W 0805	Philips	2322 730 61104	40-51000-111	1
R89	100k Ohm 5% 0,1W 0805	Philips	2322 730 61104	40-51000-111	1
R90	220k Ohm 5% 0,1W 0805	Philips	2322 730 61224	40-52200-111	1
R91	100k Ohm 5% 0,1W 0805	Philips	2322 730 61104	40-51000-111	1
R92	68k Ohm 5% 0,1W 0805	Philips	2322 730 61683	40-46800-111	1
R93	22k Ohm 5% 0,1W 0805	Philips	2322 730 61223	40-42200-111	1
R94	100 Ohm 5% 0,1W 0805	Philips	2322 730 61101	40-21000-111	1
R95	100 Ohm 5% 0,1W 0805	Philips	2322 730 61101	40-21000-111	1
R96	100 Ohm 5% 0,1W 0805	Philips	2322 730 61101	40-21000-111	1
R97	100 Ohm 5% 0,1W 0805	Philips	2322 730 61101	40-21000-111	1
R98	1k Ohm 5% 0,1W 0805	Philips	2322-730-61102	40-31000-111	1
R99	1k Ohm 5% 0,1W 0805	Philips	2322-730-61102	40-31000-111	1
R100	10k Ohm 5% 0,1W 0805	Philips	2322-730-61103	40-41000-111	1
R101	10k Ohm 5% 0,1W 0805	Philips	2322-730-61103	40-41000-111	1
R102	10k Ohm 5% 0,1W 0805	Philips	2322-730-61103	40-41000-111	1

08-05988-001 - Audio & Interconnect PCB

BOM Revision
Date Valid On

07 -- Production
28.09.2006

Ref	Description	Manufacturer	Manufacturer's P/N	Codan P/N	Qty
R103	1M Ohm 5% 0,1W 0805	Philips	2322 730 61105	40-61000-111	1
R104	10k Ohm 5% 0,1W 0805	Philips	2322-730-61103	40-41000-111	1
R105	10k Ohm 5% 0,1W 0805	Philips	2322-730-61103	40-41000-111	1
R106	1,8k Ohm 5% 0,1W 0805	Philips	2322 730 61182	40-31800-111	1
R107	100k Ohm 5% 0,1W 0805	Philips	2322 730 61104	40-51000-111	1
R108	220k Ohm 5% 0,1W 0805	Philips	2322 730 61224	40-52200-111	1
R109	47k Ohm 5% 0,1W 0805	Philips	2322 730 61473	40-44700-111	1
R110	4,7k Ohm 5% 0,1W 0805	Philips	2322 730 61472	40-34700-111	1
R111	4,7k Ohm 5% 0,1W 0805	Philips	2322 730 61472	40-34700-111	1
R112	4,7k Ohm 5% 0,1W 0805	Philips	2322 730 61472	40-34700-111	1
R113	4,7k Ohm 5% 0,1W 0805	Philips	2322 730 61472	40-34700-111	1
R114	4,7k Ohm 5% 0,1W 0805	Philips	2322 730 61472	40-34700-111	1
R115	10k Ohm 5% 0,1W 0805	Philips	2322-730-61103	40-41000-111	1
R116	10k Ohm 5% 0,1W 0805	Philips	2322-730-61103	40-41000-111	1
V1	Transistor, PNP Si SOT23	Philips	BC857	BC857	1
V2	Diode, Zener 6,8V 5% 0,2W SOT23	Philips	BZX84C6V8	BZX84C6V8	1
V3	Transistor, NPN Si SOT23	Philips	BC847	BC847	1
V4	Transistor, NPN Si SOT23	Philips	BC847	BC847	1
V5	Transistor, NPN Si SOT23	Philips	BC847	BC847	1
V6	Transistor, NPN Si SOT23	Philips	BC847	BC847	1
V7	Transistor, NPN Si SOT23	Philips	BC847	BC847	1
V8	Transistor, NPN Si SOT23	Philips	BC847	BC847	1
V9	Transistor, PNP Si SOT23	Philips	BC857	BC857	1
V10	Transistor, NPN Si SOT23	Philips	BC847	BC847	1
V11	Transistor, NPN Si SOT23	Philips	BC847	BC847	1
Z1	Crystal 4MHz Up Grade SMD	HY-Q	QC49/SMD EB01C	65-90109	1
Z2	Crystal, 32,768kHz 12pF	HY-Q	TC38	65-90057-000	1

08-05987-001 - Appn Proc PCB,3V (Handset I/F)

BOM Revision
Date Valid On

06 -- Production
28.09.2006

Ref	Description	Manufacturer	Manufacturer's P/N	Codan P/N	Qty
	HTS, 2011 DSP PCB			01-01235	1
	Appn Proc, 3V (Handset I/F)			04-03424	1
	Application Processor PCB, 3V			08-05987	1
1	PCB, Appn Proc3V (Handset I/F)	IMP	07-01993-02	07-01993-02	1
2	Label, Identification/Barcode	Codan	06-01852	06-01852	1
3	Cable, Ribbon, Audio - DSP	Auto Assemblies	08-05490-001	08-05490-001	1
C1	33n 10% 25V X7R 0603 NiSn	Vitramon	VJ0603Y333KXXT	46-43300-282	1
C2	33n 10% 25V X7R 0603 NiSn	Vitramon	VJ0603Y333KXXT	46-43300-282	1
C3	33n 10% 25V X7R 0603 NiSn	Vitramon	VJ0603Y333KXXT	46-43300-282	1
C4	33n 10% 25V X7R 0603 NiSn	Vitramon	VJ0603Y333KXXT	46-43300-282	1
C5	33n 10% 25V X7R 0603 NiSn	Vitramon	VJ0603Y333KXXT	46-43300-282	1
C6	10u 20% 20V 3528 TA Cap	AVX	TAJB106M020R	47-11002-000	1
C7	100n 10% 16V X7R 0603 NiSn	Vitramon	VJ0603Y104KXJT	46-51000-283	1
C8	10u 20% 20V 3528 TA Cap	AVX	TAJB106M020R	47-11002-000	1
C9	33n 10% 25V X7R 0603 NiSn	Vitramon	VJ0603Y333KXXT	46-43300-282	1
C10	100u 25V 105°C SMD EL Cap Low ESR	Nippon Chemicon	MVY25VC100MF80	48-21002-502	1
C11	100u 25V 105°C SMD EL Cap Low ESR	Nippon Chemicon	MVY25VC100MF80	48-21002-502	1
C12	10n 5% 50V X7R 0603 NiSn	Philips	06032R103J9BB00	46-41000-080	1
C13	33n 10% 25V X7R 0603 NiSn	Vitramon	VJ0603Y333KXXT	46-43300-282	1
C14	100u 25V 105°C SMD EL Cap Low ESR	Nippon Chemicon	MVY25VC100MF80	48-21002-502	1
C15	10u 20% 20V 3528 TA Cap	AVX	TAJB106M020R	47-11002-000	1
C16	100n 10% 16V X7R 0603 NiSn	Vitramon	VJ0603Y104KXJT	46-51000-283	1
C17	33n 10% 25V X7R 0603 NiSn	Vitramon	VJ0603Y333KXXT	46-43300-282	1
C18	33n 10% 25V X7R 0603 NiSn	Vitramon	VJ0603Y333KXXT	46-43300-282	1
C19	100n 10% 16V X7R 0603 NiSn	Vitramon	VJ0603Y104KXJT	46-51000-283	1
C20	10u 20% 20V 3528 TA Cap	AVX	TAJB106M020R	47-11002-000	1
C21	100n 10% 16V X7R 0603 NiSn	Vitramon	VJ0603Y104KXJT	46-51000-283	1
C22	100p 5% 50V NPO 0603 NiSn	Philips	0603CG101J9B200	46-21000-083	1
C23	100p 5% 50V NPO 0603 NiSn	Philips	0603CG101J9B200	46-21000-083	1
C24	1u 10% 16V X7R 1206 NiSn	Philips	12062R105K7BB00	46-61000-280	1
C25	3,3n 10% 100V X7R 0603 NiSn	Vishay	VJ0603Y332KXBAC	46-33300-282	1

08-05987-001 - Appn Proc PCB,3V (Handset I/F)

BOM Revision
Date Valid On

06 -- Production
28.09.2006

Ref	Description	Manufacturer	Manufacturer's P/N	Codan P/N	Qty
C26	100p 5% 50V NPO 0603 NiSn	Philips	0603CG101J9B200	46-21000-083	1
C27	100p 5% 50V NPO 0603 NiSn	Philips	0603CG101J9B200	46-21000-083	1
C28	100p 5% 50V NPO 0603 NiSn	Philips	0603CG101J9B200	46-21000-083	1
C29	100p 5% 50V NPO 0603 NiSn	Philips	0603CG101J9B200	46-21000-083	1
C30	100p 5% 50V NPO 0603 NiSn	Philips	0603CG101J9B200	46-21000-083	1
C31	100p 5% 50V NPO 0603 NiSn	Philips	0603CG101J9B200	46-21000-083	1
C32	100p 5% 50V NPO 0603 NiSn	Philips	0603CG101J9B200	46-21000-083	1
C33	100p 5% 50V NPO 0603 NiSn	Philips	0603CG101J9B200	46-21000-083	1
C34	1u 10% 16V X7R 1206 NiSn	Philips	12062R105K7BB00	46-61000-280	1
C35	15p 5% 50V NPO 0603 NiSn	Philips	0603CG150C9BB00	46-11500-083	1
C36	15p 5% 50V NPO 0603 NiSn	Philips	0603CG150C9BB00	46-11500-083	1
C37	10n 5% 50V X7R 0603 NiSn	Philips	06032R103J9BB00	46-41000-080	1
C38	100n 10% 16V X7R 0603 NiSn	Vitramon	VJ0603Y104KXJT	46-51000-283	1
C39	100n 10% 16V X7R 0603 NiSn	Vitramon	VJ0603Y104KXJT	46-51000-283	1
C40	100n 10% 16V X7R 0603 NiSn	Vitramon	VJ0603Y104KXJT	46-51000-283	1
C41	100n 10% 16V X7R 0603 NiSn	Vitramon	VJ0603Y104KXJT	46-51000-283	1
C42	100n 10% 16V X7R 0603 NiSn	Vitramon	VJ0603Y104KXJT	46-51000-283	1
C43	100n 10% 16V X7R 0603 NiSn	Vitramon	VJ0603Y104KXJT	46-51000-283	1
C44	100n 10% 16V X7R 0603 NiSn	Vitramon	VJ0603Y104KXJT	46-51000-283	1
C45	100n 10% 16V X7R 0603 NiSn	Vitramon	VJ0603Y104KXJT	46-51000-283	1
C46	100n 10% 16V X7R 0603 NiSn	Vitramon	VJ0603Y104KXJT	46-51000-283	1
C47	100n 10% 16V X7R 0603 NiSn	Vitramon	VJ0603Y104KXJT	46-51000-283	1
C48	100n 10% 16V X7R 0603 NiSn	Vitramon	VJ0603Y104KXJT	46-51000-283	1
C49	100n 10% 16V X7R 0603 NiSn	Vitramon	VJ0603Y104KXJT	46-51000-283	1
C50	100n 10% 16V X7R 0603 NiSn	Vitramon	VJ0603Y104KXJT	46-51000-283	1
C51	100n 10% 16V X7R 0603 NiSn	Vitramon	VJ0603Y104KXJT	46-51000-283	1
C52	100n 10% 16V X7R 0603 NiSn	Vitramon	VJ0603Y104KXJT	46-51000-283	1
C53	33n 10% 25V X7R 0603 NiSn	Vitramon	VJ0603Y333KXXT	46-43300-282	1
C54	33n 10% 25V X7R 0603 NiSn	Vitramon	VJ0603Y333KXXT	46-43300-282	1

08-05987-001 - Appn Proc PCB,3V (Handset I/F)

BOM Revision
Date Valid On

06 -- Production
28.09.2006

Ref	Description	Manufacturer	Manufacturer's P/N	Codan P/N	Qty
C55	10u 20% 20V 3528 TA Cap	AVX	TAJB106M020R	47-11002-000	1
C56	33n 10% 25V X7R 0603 NiSn	Vitramon	VJ0603Y333KXXT	46-43300-282	1
C57	33n 10% 25V X7R 0603 NiSn	Vitramon	VJ0603Y333KXXT	46-43300-282	1
C58	10u 20% 20V 3528 TA Cap	AVX	TAJB106M020R	47-11002-000	1
C59	33n 10% 25V X7R 0603 NiSn	Vitramon	VJ0603Y333KXXT	46-43300-282	1
C60	10u 20% 20V 3528 TA Cap	AVX	TAJB106M020R	47-11002-000	1
C61	100n 10% 16V X7R 0603 NiSn	Vitramon	VJ0603Y104KXJT	46-51000-283	1
C62	Not Fitted	Codan	**00000-001	99-00000-001	1
C63	Not Fitted	Codan	**00000-001	99-00000-001	1
C64	33n 10% 25V X7R 0603 NiSn	Vitramon	VJ0603Y333KXXT	46-43300-282	1
C65	33n 10% 25V X7R 0603 NiSn	Vitramon	VJ0603Y333KXXT	46-43300-282	1
C66	10u 20% 20V 3528 TA Cap	AVX	TAJB106M020R	47-11002-000	1
D1	Diode, Schottky 40V 1A SMA	Taiwan Semiconductor	SS14	MBRA140T3	1
D2	Diode, Schottky SOT23	Philips	BAT54	BAT54	1
D3	Diode, Schottky SOT23	Philips	BAT54	BAT54	1
H1	Not Fitted	Codan	**00000-001	99-00000-001	1
H2	Not Fitted	Codan	**00000-001	99-00000-001	1
H3	Not Fitted	Codan	**00000-001	99-00000-001	1
H4	Not Fitted	Codan	**00000-001	99-00000-001	1
IC1	EPLD prgmd, 2011 RFU DSP	Braemac	90-20619-001	90-20619-001	1
IC2	DUART, 16 Byte FIFO 3-5V 4Mbps TQFP48	Exar	ST16C2550CQ48	YK-16550-900	1
IC3	Reg, Voltage +5V 0,1A SOIC8	National Semiconduct	LM78L05ACM	XB-07805-700	1
IC4	Reg, Voltage +1,8V 150mA LDO SOT23-5	Texas Instruments	TPS76318DBVT	XB-76318-700	1
IC5	Reg, Voltage +3,3V 0,5A Switch SOIC8	National Semiconduct	LM2674M-3.3TR	XB-02674-701	1
IC6	Micro prgmd, 2011 Master I/O	Codan	90-20624-001	90-20624-001	1
IC7	Codec, 16 Bit 22kSPS 3-5V TQFP48	Texas Instruments	TLV320AIC10C	YN-32010-900	1
IC8	Amp, Oper Dual CMOS SOIC8	National Semiconduct	LMC662CM	XA-00662-700	1
IC9	Serial Number, 48 bit SOT223	Dallas	DS2401Z	YM-02401-700	1
IC10	Supervisory, Dual 2,93 & 1,68V SOIC8	Texas Instruments	TPS3305-18DR	XD-03305-700	1
IC11	DSP, 32 Bit Fltng Point 60MIPS LQFP144	Texas Instruments	TMS320VC33PGE120	YP-32033-900	1
IC12	FLASH prgmd, RF Unit, D0- D15	Braemac	90-20617-101	90-20617-101	1
IC13	FLASH prgmd, RF Unit, D16- D31	Braemac	90-20617-201	90-20617-201	1

08-05987-001 - Appn Proc PCB,3V (Handset I/F)

BOM Revision
Date Valid On

06 -- Production
28.09.2006

Ref	Description	Manufacturer	Manufacturer's P/N	Codan P/N	Qty
IC14	RAM, CMOS 512kx16Bit 55ns 3V TSOP2-44	Samsung	K6X8016T3B-UF55T	YM-16512-710	1
IC15	RAM, CMOS 512kx16Bit 55ns 3V TSOP2-44	Samsung	K6X8016T3B-UF55T	YM-16512-710	1
IC16	Flash 1Mx8bit/512k x16bit 3V 70ns TSOP48	AMD	AM29LV800BB70EC	YM-29800-701	1
IC17	Supervisory, Pwr&reset 4,63V SOT23	Maxim	MAX810LEUR-T	XD-00810-700	1
IC18	Comparator, Rail-Rail I/O LP SOT23-5	National Semiconduct	LMC7221AIM5	XD-07221-700	1
L1	Ind, 680uH Switched Supply	Coilcraft	DS5022P-684	43-82680-000	1
L2	Ind, 10uH 10% 4532	Taiyo Yuden	LEM 4532T100K	43-81100-000	1
L3	Choke, EMI/EMC 0A DC >1MHz 4516	Taiyo Yuden	FCFBMJ 4516 HS 110-T	43-90003	1
L4	Choke, EMI/EMC 0A DC >1MHz 4516	Taiyo Yuden	FCFBMJ 4516 HS 110-T	43-90003	1
P1	Not Fitted	Codan	** -00000-001	99-00000-001	1
P2	Not Fitted	Codan	** -00000-001	99-00000-001	1
P3	Not Fitted	Codan	** -00000-001	99-00000-001	1
P4	Header (P) 26way 2row Boxed SMD	Neltron	2316SMD-26G-CAP-TR	60-00260-002	1
P5	Not Fitted	Codan	** -00000-001	99-00000-001	1
P6	Not Fitted	Codan	** -00000-001	99-00000-001	1
P7	Not Fitted	Codan	** -00000-001	99-00000-001	1
P8	Socket, 16way 1row ZIF 1mm Pitch SMD	Global Shine	GS008-16-G-1	60-00163-004	1
R1	33k Ohm 5% 0,06W 0603	Philips	2322 702 60333	40-43300-121	1
R2	33k Ohm 5% 0,06W 0603	Philips	2322 702 60333	40-43300-121	1
R3	1k Ohm 5% 0,06W 0603	Philips	2322 702 60102	40-31000-121	1
R4	1k Ohm 5% 0,06W 0603	Philips	2322 702 60102	40-31000-121	1
R5	1k Ohm 5% 0,06W 0603	Philips	2322 702 60102	40-31000-121	1
R6	1k Ohm 5% 0,06W 0603	Philips	2322 702 60102	40-31000-121	1
R7	33k Ohm 5% 0,06W 0603	Philips	2322 702 60333	40-43300-121	1
R8	33k Ohm 5% 0,06W 0603	Philips	2322 702 60333	40-43300-121	1
R9	33k Ohm 5% 0,06W 0603	Philips	2322 702 60333	40-43300-121	1
R10	33k Ohm 5% 0,06W 0603	Philips	2322 702 60333	40-43300-121	1
R15	2,2k Ohm 5% 0,06W 0603	Philips	2322 702 60222	40-32200-121	1
R16	33k Ohm 5% 0,06W 0603	Philips	2322 702 60333	40-43300-121	1
R17	33k Ohm 5% 0,06W 0603	Philips	2322 702 60333	40-43300-121	1
R18	33k Ohm 5% 0,06W 0603	Philips	2322 702 60333	40-43300-121	1
R19	10k Ohm 5% 0,06W 0603	Philips	2322 702 60103	40-41000-121	1
R20	33k Ohm 5% 0,06W 0603	Philips	2322 702 60333	40-43300-121	1

08-05987-001 - Appn Proc PCB,3V (Handset I/F)

BOM Revision
Date Valid On

06 -- Production
28.09.2006

Ref	Description	Manufacturer	Manufacturer's P/N	Codan P/N	Qty
R21	4,7k Ohm 5% 0,06W 0603	Philips	2322 702 60472	40-34700-121	1
R23	100k Ohm 5% 0,06W 0603	Philips	2322 702 60104	40-51000-121	1
R24	100k Ohm 5% 0,06W 0603	Philips	2322 702 60104	40-51000-121	1
R25	10k Ohm 5% 0,06W 0603	Philips	2322 702 60103	40-41000-121	1
R26	10k Ohm 5% 0,06W 0603	Philips	2322 702 60103	40-41000-121	1
R27	10k Ohm 5% 0,06W 0603	Philips	2322 702 60103	40-41000-121	1
R30	33k Ohm 5% 0,06W 0603	Philips	2322 702 60333	40-43300-121	1
R31	33k Ohm 5% 0,06W 0603	Philips	2322 702 60333	40-43300-121	1
R32	10 Ohm 5% 0,06W 0603	Philips	2322 702 60109	40-11000-121	1
R34	10k Ohm 5% 0,06W 0603	Philips	2322 702 60103	40-41000-121	1
R35	10k Ohm 5% 0,06W 0603	Philips	2322 702 60103	40-41000-121	1
R36	10k Ohm 5% 0,06W 0603	Philips	2322 702 60103	40-41000-121	1
R37	10k Ohm 5% 0,06W 0603	Philips	2322 702 60103	40-41000-121	1
R38	10k Ohm 5% 0,06W 0603	Philips	2322 702 60103	40-41000-121	1
R39	10k Ohm 5% 0,06W 0603	Philips	2322 702 60103	40-41000-121	1
R40	10k Ohm 5% 0,06W 0603	Philips	2322 702 60103	40-41000-121	1
R41	22k Ohm 5% 0,06W 0603	Philips	2322 702 60223	40-42200-121	1
R42	10k Ohm 5% 0,06W 0603	Philips	2322 702 60103	40-41000-121	1
R43	4,7k Ohm 5% 0,06W 0603	Philips	2322 702 60472	40-34700-121	1
R44	4,7k Ohm 5% 0,06W 0603	Philips	2322 702 60472	40-34700-121	1
R45	120 Ohm 5% 0,06W 0603	Philips	2322 702 60121	40-21200-121	1
R46	120 Ohm 5% 0,06W 0603	Philips	2322 702 60121	40-21200-121	1
R47	120 Ohm 5% 0,06W 0603	Philips	2322 702 60121	40-21200-121	1
R48	120 Ohm 5% 0,06W 0603	Philips	2322 702 60121	40-21200-121	1
R49	1k Ohm 5% 0,06W 0603	Philips	2322 702 60102	40-31000-121	1
R50	120 Ohm 5% 0,06W 0603	Philips	2322 702 60121	40-21200-121	1
R51	120 Ohm 5% 0,06W 0603	Philips	2322 702 60121	40-21200-121	1
R52	120 Ohm 5% 0,06W 0603	Philips	2322 702 60121	40-21200-121	1
R53	120 Ohm 5% 0,06W 0603	Philips	2322 702 60121	40-21200-121	1

08-05987-001 - Appn Proc PCB,3V (Handset I/F)

BOM Revision
Date Valid On

06 -- Production
28.09.2006

Ref	Description	Manufacturer	Manufacturer's P/N	Codan P/N	Qty
R54	33 Ohm 5% 0,06W 0603	Philips	2322 702 60339	40-13300-121	1
R55	33 Ohm 5% 0,06W 0603	Philips	2322 702 60339	40-13300-121	1
R56	120 Ohm 5% 0,06W 0603	Philips	2322 702 60121	40-21200-121	1
R57	2,2k Ohm 5% 0,06W 0603	Philips	2322 702 60222	40-32200-121	1
R58	120 Ohm 5% 0,06W 0603	Philips	2322 702 60121	40-21200-121	1
R59	2,2k Ohm 5% 0,06W 0603	Philips	2322 702 60222	40-32200-121	1
R60	120 Ohm 5% 0,06W 0603	Philips	2322 702 60121	40-21200-121	1
R61	120 Ohm 5% 0,06W 0603	Philips	2322 702 60121	40-21200-121	1
R63	4,7k Ohm 5% 0,06W 0603	Philips	2322 702 60472	40-34700-121	1
R65	10k Ohm 5% 0,06W 0603	Philips	2322 702 60103	40-41000-121	1
R66	33k Ohm 5% 0,06W 0603	Philips	2322 702 60333	40-43300-121	1
R67	220 Ohm 5% 0,06W 0603	Philips	2322 702 60221	40-22200-121	1
R68	10 Ohm 5% 0,06W 0603	Philips	2322 702 60109	40-11000-121	1
R69	33k Ohm 5% 0,06W 0603	Philips	2322 702 60333	40-43300-121	1
R70	33k Ohm 5% 0,06W 0603	Philips	2322 702 60333	40-43300-121	1
R71	10 Ohm 5% 0,06W 0603	Philips	2322 702 60109	40-11000-121	1
R72	33k Ohm 5% 0,06W 0603	Philips	2322 702 60333	40-43300-121	1
R73	33k Ohm 5% 0,06W 0603	Philips	2322 702 60333	40-43300-121	1
R74	4,7k Ohm 5% 0,06W 0603	Philips	2322 702 60472	40-34700-121	1
R75	4,7k Ohm 5% 0,06W 0603	Philips	2322 702 60472	40-34700-121	1
R76	33k Ohm 5% 0,06W 0603	Philips	2322 702 60333	40-43300-121	1
R77	Not Fitted	Codan	**00000-001	99-00000-001	1
R78	33k Ohm 5% 0,06W 0603	Philips	2322 702 60333	40-43300-121	1
R79	33k Ohm 5% 0,06W 0603	Philips	2322 702 60333	40-43300-121	1
R80	33k Ohm 5% 0,06W 0603	Philips	2322 702 60333	40-43300-121	1
R81	68k Ohm 5% 0,06W 0603	Philips	2322 702 60683	40-46800-121	1
R82	33k Ohm 5% 0,06W 0603	Philips	2322 702 60333	40-43300-121	1
R83	33k Ohm 5% 0,06W 0603	Philips	2322 702 60333	40-43300-121	1
R84	120 Ohm 5% 0,06W 0603	Philips	2322 702 60121	40-21200-121	1

08-05987-001 - Appn Proc PCB,3V (Handset I/F)

BOM Revision
Date Valid On

06 -- Production
28.09.2006

Ref	Description	Manufacturer	Manufacturer's P/N	Codan P/N	Qty
R85	10k Ohm 5% 0,06W 0603	Philips	2322 702 60103	40-41000-121	1
R86	0 Ohm Jumper 0603	Philips	2322 702 96001	40-00001-121	1
V1	Transistor, NPN Si SOT23	Philips	BC847	BC847	1
V2	MOSFET, Power N Channel TO252	Motorola	MTD3055V	MTD3055V	1
Z1	Crystal, 11059,2 kHz uP Grade	HY-Q	M/P QC49/SMD EB01C	65-90094	1

08-06261-001 - Audio Interconnect & Data I/O PCB

BOM Revision
Date Valid On

03 -- Production
28.09.2006

Ref	Description	Manufacturer	Manufacturer's P/N	Codan P/N	Qty
	Audio Interconnect & Data I/O			04-03499	1
	Audio Interconnect & Data I/O PCB			08-06261	1
1	PCB, Audio Interconnect & Data I/O	IMP	07-02073-03	07-02073-03	1
2	Label, Serial/Barcode	Codan	06-02068	06-02068	1
3	Tape, EPDM Rubber foam 12mmx3mm	Beirsdorf	TESA 61102	30-39301-002	15
4	Sleeve, Sil Rubber 6x0,5 Any Col	Jones Stroud	71-80605-199	71-80605-199	0.1
5	Jumper (S) 2way Open Top	Molex	15-38-1024	60-90410-001	2
C1	33n 10% 50V X7R 0805 NiSn	Philips	08052R333K9BB00	46-43300-281	1
C2	1n 5% 50V NPO 0805 NiSn	Philips	0805CG102J9BB-	46-31000-082	1
C3	1n 5% 50V NPO 0805 NiSn	Philips	0805CG102J9BB-	46-31000-082	1
C4	1n 5% 50V NPO 0805 NiSn	Philips	0805CG102J9BB-	46-31000-082	1
C5	100n 10% 50V X7R 0805 Nisn	Philips	08052R104K9BB	46-51000-282	1
C6	100n 10% 50V X7R 0805 Nisn	Philips	08052R104K9BB	46-51000-282	1
C7	470u 16V Ax EL Cap	Jamicon	SKR470T1CG18	48-24701-651	1
C8	1000u 16V Ax EL Cap	Jamicon	SKR102T1CJ21	48-31001-651	1
C9	100p 5% 50V NPO 0805 NiSn	Philips	0805CG101J9B200	46-21000-081	1
C10	100p 5% 50V NPO 0805 NiSn	Philips	0805CG101J9B200	46-21000-081	1
C11	33n 10% 50V X7R 0805 NiSn	Philips	08052R333K9BB00	46-43300-281	1
C12	33n 10% 50V X7R 0805 NiSn	Philips	08052R333K9BB00	46-43300-281	1
C13	1n 5% 50V NPO 0805 NiSn	Philips	0805CG102J9BB-	46-31000-082	1
C14	100n 10% 50V X7R 0805 Nisn	Philips	08052R104K9BB	46-51000-282	1
C15	100u 25V 105°C SMD EL Cap Low ESR	Nippon Chemicon	MVY25VC100MF80	48-21002-502	1
C16	1u 20% 35V 3528 TA Cap	AVX	TAJB105M035R	47-01003-520	1
C17	470p 5% 50V NPO 0805 NiSn	Philips	0805CG471J9B200	46-24700-081	1
C18	470p 5% 50V NPO 0805 NiSn	Philips	0805CG471J9B200	46-24700-081	1
C19	100n 10% 50V X7R 0805 Nisn	Philips	08052R104K9BB	46-51000-282	1
C20	100n 10% 50V X7R 0805 Nisn	Philips	08052R104K9BB	46-51000-282	1
C21	33n 10% 50V X7R 0805 NiSn	Philips	08052R333K9BB00	46-43300-281	1
C22	33n 10% 50V X7R 0805 NiSn	Philips	08052R333K9BB00	46-43300-281	1
C23	100n 10% 50V X7R 0805 Nisn	Philips	08052R104K9BB	46-51000-282	1

08-06261-001 - Audio Interconnect & Data I/O PCB

BOM Revision
Date Valid On

03 -- Production
28.09.2006

Ref	Description	Manufacturer	Manufacturer's P/N	Codan P/N	Qty
C24	100n 10% 50V X7R 0805 Nisn	Philips	08052R104K9BB	46-51000-282	1
C25	33n 10% 50V X7R 0805 NiSn	Philips	08052R333K9BB00	46-43300-281	1
C26	100n 10% 50V X7R 0805 Nisn	Philips	08052R104K9BB	46-51000-282	1
C27	33p 5% 50V NPO 0805 NiSn	Philips	0805CG330J9B200	46-13300-081	1
C28	33p 5% 50V NPO 0805 NiSn	Philips	0805CG330J9B200	46-13300-081	1
C29	1u 20% 35V 3528 TA Cap	AVX	TAJB105M035R	47-01003-520	1
C30	1u 20% 35V 3528 TA Cap	AVX	TAJB105M035R	47-01003-520	1
C31	1u 20% 35V 3528 TA Cap	AVX	TAJB105M035R	47-01003-520	1
C32	100n 10% 50V X7R 0805 Nisn	Philips	08052R104K9BB	46-51000-282	1
C33	10u 20% 25V 6032 TA Cap	AVX	TAJC106M025R	47-11002-520	1
C34	10u 20% 25V 6032 TA Cap	AVX	TAJC106M025R	47-11002-520	1
C35	1u 20% 35V 3528 TA Cap	AVX	TAJB105M035R	47-01003-520	1
C36	1u 20% 35V 3528 TA Cap	AVX	TAJB105M035R	47-01003-520	1
C37	33n 10% 50V X7R 0805 NiSn	Philips	08052R333K9BB00	46-43300-281	1
C38	100u 25V Ax EL Cap	Elna	RB	48-21002-551	1
C39	1u 20% 35V 3528 TA Cap	AVX	TAJB105M035R	47-01003-520	1
C40	1u 20% 35V 3528 TA Cap	AVX	TAJB105M035R	47-01003-520	1
C43	22p 5% 50V NPO 0805 NiSn	Philips	0805CG220J9B200	46-12200-081	1
C44	33n 10% 50V X7R 0805 NiSn	Philips	08052R333K9BB00	46-43300-281	1
C46	1n 5% 50V NPO 0805 NiSn	Philips	0805CG102J9BB-	46-31000-082	1
C47	220p 5% 50V NPO 0805 NiSn	Philips	0805CG221J9BB	46-22200-081	1
C48	220p 5% 50V NPO 0805 NiSn	Philips	0805CG221J9BB	46-22200-081	1
C49	10u 20% 25V 6032 TA Cap	AVX	TAJC106M025R	47-11002-520	1
C50	33n 10% 50V X7R 0805 NiSn	Philips	08052R333K9BB00	46-43300-281	1
C51	1n 5% 50V NPO 0805 NiSn	Philips	0805CG102J9BB-	46-31000-082	1
C52	33n 10% 50V X7R 0805 NiSn	Philips	08052R333K9BB00	46-43300-281	1
C53	33n 10% 50V X7R 0805 NiSn	Philips	08052R333K9BB00	46-43300-281	1
C54	33n 10% 50V X7R 0805 NiSn	Philips	08052R333K9BB00	46-43300-281	1
C55	33n 10% 50V X7R 0805 NiSn	Philips	08052R333K9BB00	46-43300-281	1

08-06261-001 - Audio Interconnect & Data I/O PCB

BOM Revision
Date Valid On

03 -- Production
28.09.2006

Ref	Description	Manufacturer	Manufacturer's P/N	Codan P/N	Qty
C56	100n 10% 50V X7R 0805 Nisn	Philips	08052R104K9BB	46-51000-282	1
C57	1u 20% 35V 3528 TA Cap	AVX	TAJB105M035R	47-01003-520	1
C58	470p 5% 50V NPO 0805 NiSn	Philips	0805CG471J9B200	46-24700-081	1
C59	33n 10% 50V X7R 0805 NiSn	Philips	08052R333K9BB00	46-43300-281	1
C60	100n 10% 50V X7R 0805 Nisn	Philips	08052R104K9BB	46-51000-282	1
C61	33n 10% 50V X7R 0805 NiSn	Philips	08052R333K9BB00	46-43300-281	1
C62	3,3n 10% 100V X7R 0805 NiSn	Philips	08052R332K0B200	46-33300-281	1
C63	1n 5% 50V NPO 0805 NiSn	Philips	0805CG102J9BB-	46-31000-082	1
C64	10u 20% 25V 6032 TA Cap	AVX	TAJC106M025R	47-11002-520	1
C65	1u 20% 35V 3528 TA Cap	AVX	TAJB105M035R	47-01003-520	1
C66	1n 5% 50V NPO 0805 NiSn	Philips	0805CG102J9BB-	46-31000-082	1
C67	1n 5% 50V NPO 0805 NiSn	Philips	0805CG102J9BB-	46-31000-082	1
C68	100p 5% 50V NPO 0805 NiSn	Philips	0805CG101J9B200	46-21000-081	1
C69	100p 5% 50V NPO 0805 NiSn	Philips	0805CG101J9B200	46-21000-081	1
C70	33n 10% 50V X7R 0805 NiSn	Philips	08052R333K9BB00	46-43300-281	1
C71	33n 10% 50V X7R 0805 NiSn	Philips	08052R333K9BB00	46-43300-281	1
C72	33n 10% 50V X7R 0805 NiSn	Philips	08052R333K9BB00	46-43300-281	1
C73	33n 10% 50V X7R 0805 NiSn	Philips	08052R333K9BB00	46-43300-281	1
C74	1n 5% 50V NPO 0805 NiSn	Philips	0805CG102J9BB-	46-31000-082	1
C75	1n 5% 50V NPO 0805 NiSn	Philips	0805CG102J9BB-	46-31000-082	1
C76	1n 5% 50V NPO 0805 NiSn	Philips	0805CG102J9BB-	46-31000-082	1
C77	1n 5% 50V NPO 0805 NiSn	Philips	0805CG102J9BB-	46-31000-082	1
C78	1n 5% 50V NPO 0805 NiSn	Philips	0805CG102J9BB-	46-31000-082	1
C79	1u 20% 35V 3528 TA Cap	AVX	TAJB105M035R	47-01003-520	1
C80	10u 20% 25V 6032 TA Cap	AVX	TAJC106M025R	47-11002-520	1
C81	33n 10% 50V X7R 0805 NiSn	Philips	08052R333K9BB00	46-43300-281	1
C82	33n 10% 50V X7R 0805 NiSn	Philips	08052R333K9BB00	46-43300-281	1
C83	33n 10% 50V X7R 0805 NiSn	Philips	08052R333K9BB00	46-43300-281	1
C84	1u 20% 35V 3528 TA Cap	AVX	TAJB105M035R	47-01003-520	1

08-06261-001 - Audio Interconnect & Data I/O PCB

BOM Revision
Date Valid On

03 -- Production
28.09.2006

Ref	Description	Manufacturer	Manufacturer's P/N	Codan P/N	Qty
C85	10u 20% 25V 6032 TA Cap	AVX	TAJC106M025R	47-11002-520	1
C86	3,3n 10% 100V X7R 0805 NiSn	Philips	08052R332K0B200	46-33300-281	1
C87	100n 10% 50V X7R 0805 Nisn	Philips	08052R104K9BB	46-51000-282	1
C88	3,3n 10% 100V X7R 0805 NiSn	Philips	08052R332K0B200	46-33300-281	1
C89	100n 10% 50V X7R 0805 Nisn	Philips	08052R104K9BB	46-51000-282	1
C90	1u 20% 35V 3528 TA Cap	AVX	TAJB105M035R	47-01003-520	1
C91	3,3n 10% 100V X7R 0805 NiSn	Philips	08052R332K0B200	46-33300-281	1
C92	3,3n 10% 100V X7R 0805 NiSn	Philips	08052R332K0B200	46-33300-281	1
C93	3,3n 10% 100V X7R 0805 NiSn	Philips	08052R332K0B200	46-33300-281	1
C94	3,3n 10% 100V X7R 0805 NiSn	Philips	08052R332K0B200	46-33300-281	1
C95	3,3n 10% 100V X7R 0805 NiSn	Philips	08052R332K0B200	46-33300-281	1
C96	10u 20% 25V 6032 TA Cap	AVX	TAJC106M025R	47-11002-520	1
C97	1u 20% 35V 3528 TA Cap	AVX	TAJB105M035R	47-01003-520	1
C98	10u 20% 25V 6032 TA Cap	AVX	TAJC106M025R	47-11002-520	1
C99	100n 10% 50V X7R 0805 Nisn	Philips	08052R104K9BB	46-51000-282	1
C100	10u 20% 10V X7R 1210 NiSn	Taiyo Yuden	LMK325BJ106MN	46-71000-280	1
C101	33n 10% 50V X7R 0805 NiSn	Philips	08052R333K9BB00	46-43300-281	1
C102	33n 10% 50V X7R 0805 NiSn	Philips	08052R333K9BB00	46-43300-281	1
C103	100n 10% 50V X7R 0805 Nisn	Philips	08052R104K9BB	46-51000-282	1
C104	100n 10% 50V X7R 0805 Nisn	Philips	08052R104K9BB	46-51000-282	1
C105	100n 10% 50V X7R 0805 Nisn	Philips	08052R104K9BB	46-51000-282	1
C106	100n 10% 50V X7R 0805 Nisn	Philips	08052R104K9BB	46-51000-282	1
C107	100n 10% 50V X7R 0805 Nisn	Philips	08052R104K9BB	46-51000-282	1
C108	10p 5% 50V NPO 0805 NiSn	Philips	0805CG100J9B200	46-11000-081	1
C109	1u 10% 10V X7R 0805 NiSn	Phycomp	2222-240-15663	46-61000-281	1
C110	10n 10% 100V X7R 0805 NiSn	Philips	08052R103K0B200	46-41000-281	1
C111	33n 10% 50V X7R 0805 NiSn	Philips	08052R333K9BB00	46-43300-281	1
C112	10p 5% 50V NPO 0805 NiSn	Philips	0805CG100J9B200	46-11000-081	1
C113	33n 10% 50V X7R 0805 NiSn	Philips	08052R333K9BB00	46-43300-281	1

08-06261-001 - Audio Interconnect & Data I/O PCB

BOM Revision
Date Valid On

03 -- Production
28.09.2006

Ref	Description	Manufacturer	Manufacturer's P/N	Codan P/N	Qty
C114	560p 5% 50V NPO 0603 NiSn	Philips	0603CG561J9BB00	46-25600-080	1
C115	10n 10% 100V X7R 0805 NiSn	Philips	08052R103K0B200	46-41000-281	1
C116	10p 5% 50V NPO 0805 NiSn	Philips	0805CG100J9B200	46-11000-081	1
D1	Diode, 400V 1A SMA	On Semiconductor	MRA4004T3	MRA4004T3	1
D2	Diode, Si High speed 75V SOT23	Philips	BAS16	BAS16	1
D3	Diode, Schottky SOT23	Philips	BAT54	BAT54	1
D4	Diode, Zener 5,6V 5% 0,2W SOT23	Philips	BZX84-C5V6	BZX84C5V6	1
D5	Diode, Si High speed 75V SOT23	Philips	BAS16	BAS16	1
D6	Diode, Si High speed 75V SOT23	Philips	BAS16	BAS16	1
D7	Diode, Si High speed 75V SOT23	Philips	BAS16	BAS16	1
D8	Diode, Si High speed 75V SOT23	Philips	BAS16	BAS16	1
D9	Diode, Schottky SOT23	Philips	BAT54	BAT54	1
D10	Diode, Schottky SOT23	Philips	BAT54	BAT54	1
D11	TVS, Bidirec 15V wkg SMB	SGS Thomson	SMBJ15CA-TR	SMBJ15CA-TR	1
D12	TVS, Bidirec 15V wkg SMB	SGS Thomson	SMBJ15CA-TR	SMBJ15CA-TR	1
D13	Diode, Si High speed 75V SOT23	Philips	BAS16	BAS16	1
F1	0,1 Ohm nom 1,6A@20°C 16Vwkg SMD	Raychem	SMDH160	41-10010-000	1
F2	0,1 Ohm nom 1,6A@20°C 16Vwkg SMD	Raychem	SMDH160	41-10010-000	1
G1	Cell, Lithium 3V, 35mAh PCB Mtg	National Semiconduct	BR1225-1VD	65-71000-002	1
H1	LED, Tricolour T-1 3/4 Diffused	Liteon	LTL-52RG	65-61110-901	1
IC1	Amp, Audio Power 2x11w SIL9P	Philips	TDA1519C	TDA1519C	1
IC2	Amp, Operational Dual SOIC8	National Semiconduct	LM358M	XA-00358-700	1
IC3	DTMF Tone Generator SOIC8	Philips	PCD3312CT-118	XE-03312-700	1
IC4	Pot, Digital 10k 256 Position SOIC16	Analog Devices	AD5242BR10	YN-05242-700	1
IC5	Mux/Demux, Analog, Triple 2ch SOIC16	Philips	HEF4053BT-653	YH-40053-701	1
IC6	Tcvr, CAN bus SOIC8	Philips	PCA82C250T	YI-82250-700	1
IC7	Reg, Voltage +5V 0,1A SOIC8	National Semiconduct	LM78L05ACM	XB-07805-700	1
IC9	Micro prgmd, 2011 Audio I/O	Codan	90-20625-001	90-20625-001	1
IC10	Clock/Calendar/RAM IIC Bus SOIC8	SGS Thomson	MK41T56S00TR	YK-04156-700	1
IC11	Tcvr, RS232 5Tx / 3Rx ESD Prot TSSOP24	Sipex	SP3249ECY	YI-03249-700	1
IC12	Comparator, Quad O/C Output SOIC14	National Semiconduct	LM339M	XD-00339-700	1

08-06261-001 - Audio Interconnect & Data I/O PCB

BOM Revision
Date Valid On

03 -- Production
28.09.2006

Ref	Description	Manufacturer	Manufacturer's P/N	Codan P/N	Qty
IC13	Amp, Operational Dual SOIC8	National Semiconduct	LM358M	XA-00358-700	1
IC14	Mux/Demux, Analog, Triple 2ch SOIC16	Philips	HEF4053BT-653	YH-40053-701	1
IC15	Flip Flop, D Dual SOIC14	Motorola	MC74HC74AD	YH-74074-700	1
IC16	Gate, NOR 2 Input Quad SOIC14	Motorola	MC74HC02AD	YH-74002-700	1
IC17	Gate, AND 2 Input Quad SOIC14	STMicroelectronics	74LCX08M	YX-74008-700	1
IC18	Buffer, Single Non-Inv T/State SOT323-5	STMicroelectronics	74V1T125CTR	YY-74125-700	1
IC19	Amp, Operational Dual SOIC8	Texas Instruments	TL082CD	XA-00082-700	1
IC20	Amp, Operational Dual SOIC8	Texas Instruments	TL082CD	XA-00082-700	1
IC21	Reg, Voltage +Adj 0,8A TO252	National Semiconduct	LM1117IDTX-ADJ	XB-01117-700	1
IC22	Tcvr, IrDA 115k2 bps Side-look SMD	Zilog	ZHX1810MV115THTR	YI-01810-700	1
K1	Relay, 2C 9V Ltch SMD 2x579 Ohm	Matsushita	TQ2SL-L2-9V	64-21225-258	1
K2	Relay, 2C 12V 2A SMD 1028 Ohm	Matsushita	TQ2SL-12V	64-21225-310	1
L1	Ind, Common Mode 5.5A	Taiyo Yuden	CMO8RA20	43-80001	1
L2	Choke, Common Mode (Data) SMD	Taiyo Yuden	CM04RC04	43-82470-000	1
L3	Choke, Common Mode (Data) SMD	Taiyo Yuden	CM04RC04	43-82470-000	1
L4	Choke, EMI/EMC 0A DC >1MHz 4516	Taiyo Yuden	FCFBMJ 4516 HS 110-T	43-90003	1
L5	Ind, 100uH 10% 4532	Taiyo Yuden	LEM 4532T101K	43-82100-134	1
L6	Ind, 100uH 10% 4532	Taiyo Yuden	LEM 4532T101K	43-82100-134	1
L7	Choke, EMI/EMC 0A DC >1MHz 4516	Taiyo Yuden	FCFBMJ 4516 HS 110-T	43-90003	1
L8	Ind, 100uH 10% 4532	Taiyo Yuden	LEM 4532T101K	43-82100-134	1
L9	Ind, 100uH 10% 4532	Taiyo Yuden	LEM 4532T101K	43-82100-134	1
L10	Ind, 10uH 10% 4532	Taiyo Yuden	LEM 4532T100K	43-81100-000	1
L11	Ind, 10uH 10% 4532	Taiyo Yuden	LEM 4532T100K	43-81100-000	1
L12	Choke, EMI/EMC 0A DC >1MHz 4516	Taiyo Yuden	FCFBMJ 4516 HS 110-T	43-90003	1
L13	Ind, 100uH 10% 4532	Taiyo Yuden	LEM 4532T101K	43-82100-134	1
L14	Ind, 100uH 10% 4532	Taiyo Yuden	LEM 4532T101K	43-82100-134	1
L15	Choke, EMI/EMC 0A DC >1MHz 4516	Taiyo Yuden	FCFBMJ 4516 HS 110-T	43-90003	1
L16	Ind, 100uH 10% 4532	Taiyo Yuden	LEM 4532T101K	43-82100-134	1
L17	Choke, EMI/EMC 0A DC >1MHz 4516	Taiyo Yuden	FCFBMJ 4516 HS 110-T	43-90003	1
L18	Choke, EMI/EMC 0A DC >1MHz 4516	Taiyo Yuden	FCFBMJ 4516 HS 110-T	43-90003	1
L19	Choke, EMI/EMC 0A DC >1MHz 4516	Taiyo Yuden	FCFBMJ 4516 HS 110-T	43-90003	1
L20	Choke, EMI/EMC 0A DC >1MHz 4516	Taiyo Yuden	FCFBMJ 4516 HS 110-T	43-90003	1
L21	Choke, EMI/EMC 0A DC >10MHz 0805	Taiyo Yuden	BK 2125 HS 330-T	43-90004	1
P1	Header (P) 12way 2mm Latch Fixed	AMP	1-173981-2	60-00120-002	1

08-06261-001 - Audio Interconnect & Data I/O PCB

BOM Revision
Date Valid On

03 -- Production
28.09.2006

Ref	Description	Manufacturer	Manufacturer's P/N	Codan P/N	Qty
P2	Header (P) 16way 2row Boxed	Thomas & Betts	609-1627	60-00160-000	1
P3	Header (P) 26way 2row Boxed Fix	Thomas & Betts	609-2627	60-00260-000	1
P4	Header (P) 16way 2row Boxed	Thomas & Betts	609-1627	60-00160-000	1
P5	Not Fitted	Codan	**-00000-001	99-00000-001	1
P6	Header (P) 8way 2mm Latch Fixed	AMP	292161-8	60-00080-001	1
P7	Header (P) 15way 2mm Latch Fixed	Chyao Shunn	JS-1125-15	60-00150-005	1
P8	Header (P) 10way 2row Boxed SMD 2,54mm	Neltron	2316SM-10G	60-00100-004	1
P9	Header (P) 3way 1row	Molex	22-03-2031	60-00031-100	1
P10	Header (P) 3way 1row	Molex	22-03-2031	60-00031-100	1
R1	47k Ohm 5% 0,1W 0805	Philips	2322 730 61473	40-44700-111	1
R2	47k Ohm 5% 0,1W 0805	Philips	2322 730 61473	40-44700-111	1
R3	22k Ohm 5% 0,1W 0805	Philips	2322 730 61223	40-42200-111	1
R4	22k Ohm 5% 0,1W 0805	Philips	2322 730 61223	40-42200-111	1
R5	10k Ohm 5% 0,1W 0805	Philips	2322-730-61103	40-41000-111	1
R6	4,7k Ohm 5% 0,1W 0805	Philips	2322 730 61472	40-34700-111	1
R7	10k Ohm 5% 0,1W 0805	Philips	2322-730-61103	40-41000-111	1
R8	47k Ohm 5% 0,1W 0805	Philips	2322 730 61473	40-44700-111	1
R9	1k Ohm 5% 0,1W 0805	Philips	2322-730-61102	40-31000-111	1
R10	47k Ohm 5% 0,1W 0805	Philips	2322 730 61473	40-44700-111	1
R11	100 Ohm 5% 0,1W 0805	Philips	2322 730 61101	40-21000-111	1
R12	100 Ohm 5% 0,1W 0805	Philips	2322 730 61101	40-21000-111	1
R13	100 Ohm 5% 0,1W 0805	Philips	2322 730 61101	40-21000-111	1
R14	100 Ohm 5% 0,1W 0805	Philips	2322 730 61101	40-21000-111	1
R15	100 Ohm 5% 0,1W 0805	Philips	2322 730 61101	40-21000-111	1
R16	100 Ohm 5% 0,1W 0805	Philips	2322 730 61101	40-21000-111	1
R17	100 Ohm 5% 0,1W 0805	Philips	2322 730 61101	40-21000-111	1
R18	0 Ohm Jumper 0805	Philips	2322 730 91002	40-00001-111	1
R19	0 Ohm Jumper 0805	Philips	2322 730 91002	40-00001-111	1
R20	2,2k Ohm 5% 0,1W 0805	Philips	2322 730 61222	40-32200-111	1
R21	2,2k Ohm 5% 0,1W 0805	Philips	2322 730 61222	40-32200-111	1
R22	100 Ohm 5% 0,1W 0805	Philips	2322 730 61101	40-21000-111	1

08-06261-001 - Audio Interconnect & Data I/O PCB

BOM Revision
Date Valid On

03 -- Production
28.09.2006

Ref	Description	Manufacturer	Manufacturer's P/N	Codan P/N	Qty
R23	1M Ohm 5% 0,1W 0805	Philips	2322 730 61105	40-61000-111	1
R24	1M Ohm 5% 0,1W 0805	Philips	2322 730 61105	40-61000-111	1
R25	1M Ohm 5% 0,1W 0805	Philips	2322 730 61105	40-61000-111	1
R26	100 Ohm 5% 0,1W 0805	Philips	2322 730 61101	40-21000-111	1
R27	100 Ohm 5% 0,1W 0805	Philips	2322 730 61101	40-21000-111	1
R28	1k Ohm 5% 0,1W 0805	Philips	2322-730-61102	40-31000-111	1
R29	1k Ohm 5% 0,1W 0805	Philips	2322-730-61102	40-31000-111	1
R30	100k Ohm 5% 0,1W 0805	Philips	2322 730 61104	40-51000-111	1
R31	100k Ohm 5% 0,1W 0805	Philips	2322 730 61104	40-51000-111	1
R32	100k Ohm 5% 0,1W 0805	Philips	2322 730 61104	40-51000-111	1
R37	270 Ohm 5% 0,1W 0805	Philips	2322 730 61271	40-22700-111	1
R38	100 Ohm 5% 0,1W 0805	Philips	2322 730 61101	40-21000-111	1
R39	1k Ohm 5% 0,1W 0805	Philips	2322-730-61102	40-31000-111	1
R40	1k Ohm 5% 0,1W 0805	Philips	2322-730-61102	40-31000-111	1
R41	1k Ohm 5% 0,1W 0805	Philips	2322-730-61102	40-31000-111	1
R42	10 Ohm 5% 0,1W 0805	Philips	2322 730 61109	40-11000-111	1
R43	10 Ohm 5% 0,1W 0805	Philips	2322 730 61109	40-11000-111	1
R44	10k Ohm 5% 0,1W 0805	Philips	2322-730-61103	40-41000-111	1
R45	2,2k Ohm 5% 0,1W 0805	Philips	2322 730 61222	40-32200-111	1
R46	10 Ohm 5% 0,1W 0805	Philips	2322 730 61109	40-11000-111	1
R50	270 Ohm 5% 0,1W 0805	Philips	2322 730 61271	40-22700-111	1
R51	270 Ohm 5% 0,1W 0805	Philips	2322 730 61271	40-22700-111	1
R52	47 Ohm 5% 0,1W 0805	Philips	2322 730 61479	40-14700-111	1
R53	5,6k Ohm 5% 0,1W 0805	Philips	2322 730 61562	40-35600-111	1
R54	10k Ohm 5% 0,1W 0805	Philips	2322-730-61103	40-41000-111	1
R58	100 Ohm 5% 0,1W 0805	Philips	2322 730 61101	40-21000-111	1
R59	270 Ohm 5% 0,1W 0805	Philips	2322 730 61271	40-22700-111	1
R60	10k Ohm 5% 0,1W 0805	Philips	2322-730-61103	40-41000-111	1
R61	4,7k Ohm 5% 0,1W 0805	Philips	2322 730 61472	40-34700-111	1

08-06261-001 - Audio Interconnect & Data I/O PCB

BOM Revision
Date Valid On

03 -- Production
28.09.2006

Ref	Description	Manufacturer	Manufacturer's P/N	Codan P/N	Qty
R62	3,3k Ohm 5% 0,1W 0805	Philips	2322 730 61332	40-33300-111	1
R63	3,3k Ohm 5% 0,1W 0805	Philips	2322 730 61332	40-33300-111	1
R64	470 Ohm 5% 0,1W 0805	Philips	2322 730 61471	40-24700-111	1
R65	470 Ohm 5% 0,1W 0805	Philips	2322 730 61471	40-24700-111	1
R66	47 Ohm 5% 0,1W 0805	Philips	2322 730 61479	40-14700-111	1
R67	47 Ohm 5% 0,1W 0805	Philips	2322 730 61479	40-14700-111	1
R68	1k Ohm 5% 0,1W 0805	Philips	2322-730-61102	40-31000-111	1
R69	1k Ohm 5% 0,1W 0805	Philips	2322-730-61102	40-31000-111	1
R70	1k Ohm 5% 0,1W 0805	Philips	2322-730-61102	40-31000-111	1
R71	10k Ohm 5% 0,1W 0805	Philips	2322-730-61103	40-41000-111	1
R72	10k Ohm 5% 0,1W 0805	Philips	2322-730-61103	40-41000-111	1
R73	10k Ohm 5% 0,1W 0805	Philips	2322-730-61103	40-41000-111	1
R74	10k Ohm 5% 0,1W 0805	Philips	2322-730-61103	40-41000-111	1
R75	10k Ohm 5% 0,1W 0805	Philips	2322-730-61103	40-41000-111	1
R78	47k Ohm 5% 0,1W 0805	Philips	2322 730 61473	40-44700-111	1
R79	47k Ohm 5% 0,1W 0805	Philips	2322 730 61473	40-44700-111	1
R80	10k Ohm 5% 0,1W 0805	Philips	2322-730-61103	40-41000-111	1
R81	10k Ohm 5% 0,1W 0805	Philips	2322-730-61103	40-41000-111	1
R82	680k Ohm 5% 0,1W 0805	Philips	2322 730 61684	40-56800-111	1
R83	680k Ohm 5% 0,1W 0805	Philips	2322 730 61684	40-56800-111	1
R84	680k Ohm 5% 0,1W 0805	Philips	2322 730 61684	40-56800-111	1
R85	Pot,10k Lin MG Trim SMD	Bourns	3314 J-1-103	42-41004-000	1
R86	10k Ohm 5% 0,1W 0805	Philips	2322-730-61103	40-41000-111	1
R87	100k Ohm 5% 0,1W 0805	Philips	2322 730 61104	40-51000-111	1
R88	100k Ohm 5% 0,1W 0805	Philips	2322 730 61104	40-51000-111	1
R89	100k Ohm 5% 0,1W 0805	Philips	2322 730 61104	40-51000-111	1
R90	220k Ohm 5% 0,1W 0805	Philips	2322 730 61224	40-52200-111	1
R91	100k Ohm 5% 0,1W 0805	Philips	2322 730 61104	40-51000-111	1
R92	68k Ohm 5% 0,1W 0805	Philips	2322 730 61683	40-46800-111	1

08-06261-001 - Audio Interconnect & Data I/O PCB

BOM Revision
Date Valid On

03 -- Production
28.09.2006

Ref	Description	Manufacturer	Manufacturer's P/N	Codan P/N	Qty
R93	22k Ohm 5% 0,1W 0805	Philips	2322 730 61223	40-42200-111	1
R94	100 Ohm 5% 0,1W 0805	Philips	2322 730 61101	40-21000-111	1
R95	100 Ohm 5% 0,1W 0805	Philips	2322 730 61101	40-21000-111	1
R96	100 Ohm 5% 0,1W 0805	Philips	2322 730 61101	40-21000-111	1
R97	100 Ohm 5% 0,1W 0805	Philips	2322 730 61101	40-21000-111	1
R98	1k Ohm 5% 0,1W 0805	Philips	2322-730-61102	40-31000-111	1
R99	1k Ohm 5% 0,1W 0805	Philips	2322-730-61102	40-31000-111	1
R100	10k Ohm 5% 0,1W 0805	Philips	2322-730-61103	40-41000-111	1
R101	10k Ohm 5% 0,1W 0805	Philips	2322-730-61103	40-41000-111	1
R102	10k Ohm 5% 0,1W 0805	Philips	2322-730-61103	40-41000-111	1
R103	1M Ohm 5% 0,1W 0805	Philips	2322 730 61105	40-61000-111	1
R105	100k Ohm 5% 0,1W 0805	Philips	2322 730 61104	40-51000-111	1
R106	1,8k Ohm 5% 0,1W 0805	Philips	2322 730 61182	40-31800-111	1
R107	100k Ohm 5% 0,1W 0805	Philips	2322 730 61104	40-51000-111	1
R108	220k Ohm 5% 0,1W 0805	Philips	2322 730 61224	40-52200-111	1
R109	47k Ohm 5% 0,1W 0805	Philips	2322 730 61473	40-44700-111	1
R110	100k Ohm 5% 0,1W 0805	Philips	2322 730 61104	40-51000-111	1
R111	100k Ohm 5% 0,1W 0805	Philips	2322 730 61104	40-51000-111	1
R115	10k Ohm 5% 0,1W 0805	Philips	2322-730-61103	40-41000-111	1
R116	10k Ohm 5% 0,1W 0805	Philips	2322-730-61103	40-41000-111	1
R117	560 Ohm 5% 0,1W 0805	Philips	2322 730 61561	40-25600-111	1
R118	100 Ohm 5% 0,1W 0805	Philips	2322 730 61101	40-21000-111	1
R119	10k Ohm 5% 0,1W 0805	Philips	2322-730-61103	40-41000-111	1
R120	1k Ohm 5% 0,1W 0805	Philips	2322-730-61102	40-31000-111	1
R121	1k Ohm 5% 0,1W 0805	Philips	2322-730-61102	40-31000-111	1
R122	1k Ohm 5% 0,1W 0805	Philips	2322-730-61102	40-31000-111	1
R123	1k Ohm 5% 0,1W 0805	Philips	2322-730-61102	40-31000-111	1
R124	100 Ohm 5% 0,1W 0805	Philips	2322 730 61101	40-21000-111	1
R125	100 Ohm 5% 0,1W 0805	Philips	2322 730 61101	40-21000-111	1

08-06261-001 - Audio Interconnect & Data I/O PCB

BOM Revision
Date Valid On

03 -- Production
28.09.2006

Ref	Description	Manufacturer	Manufacturer's P/N	Codan P/N	Qty
R126	100 Ohm 5% 0,1W 0805	Philips	2322 730 61101	40-21000-111	1
R127	100 Ohm 5% 0,1W 0805	Philips	2322 730 61101	40-21000-111	1
R128	560 Ohm 5% 0,1W 0805	Philips	2322 730 61561	40-25600-111	1
R129	330 Ohm 5% 0,1W 0805	Philips	2322 730 61331	40-23300-111	1
R130	33k Ohm 5% 0,1W 0805	Philips	2322 730 61333	40-43300-111	1
R131	33k Ohm 5% 0,1W 0805	Philips	2322 730 61333	40-43300-111	1
R132	33k Ohm 5% 0,1W 0805	Philips	2322 730 61333	40-43300-111	1
R133	100 Ohm 5% 0,1W 0805	Philips	2322 730 61101	40-21000-111	1
R134	100 Ohm 5% 0,1W 0805	Philips	2322 730 61101	40-21000-111	1
R135	100 Ohm 5% 0,1W 0805	Philips	2322 730 61101	40-21000-111	1
R136	10 Ohm 5% 0,1W 0805	Philips	2322 730 61109	40-11000-111	1
R137	10k Ohm 5% 0,1W 0805	Philips	2322-730-61103	40-41000-111	1
R138	4,7k Ohm 5% 0,1W 0805	Philips	2322 730 61472	40-34700-111	1
R139	6,8k Ohm 5% 0,1W 0805	Philips	2322 730 61682	40-36800-111	1
R140	18k Ohm 5% 0,1W 0805	Philips	2322 730 61183	40-41800-111	1
R141	18k Ohm 5% 0,1W 0805	Philips	2322 730 61183	40-41800-111	1
R142	10k Ohm 5% 0,1W 0805	Philips	2322-730-61103	40-41000-111	1
R143	10k Ohm 5% 0,1W 0805	Philips	2322-730-61103	40-41000-111	1
R146	4,7k Ohm 5% 0,1W 0805	Philips	2322 730 61472	40-34700-111	1
R147	10k Ohm 5% 0,1W 0805	Philips	2322-730-61103	40-41000-111	1
R148	100k Ohm 5% 0,1W 0805	Philips	2322 730 61104	40-51000-111	1
R149	100k Ohm 5% 0,1W 0805	Philips	2322 730 61104	40-51000-111	1
R150	100k Ohm 5% 0,1W 0805	Philips	2322 730 61104	40-51000-111	1
R151	100k Ohm 5% 0,1W 0805	Philips	2322 730 61104	40-51000-111	1
T1	Txfr, Line isolation SMD	Etal	P2781	43-30002	1
T2	Txfr, Line isolation SMD	Etal	P2781	43-30002	1
V1	Transistor, PNP Si SOT23	Philips	BC857	BC857	1
V2	Diode, Zener 6,8V 5% 0,2W SOT23	Philips	BZX84C6V8	BZX84C6V8	1
V3	Transistor, NPN Si SOT23	Philips	BC847	BC847	1
V4	Transistor, NPN Si SOT23	Philips	BC847	BC847	1

08-06261-001 - Audio Interconnect & Data I/O PCB

BOM Revision
Date Valid On

03 -- Production
 28.09.2006

Ref	Description	Manufacturer	Manufacturer's P/N	Codan P/N	Qty
V5	Transistor, NPN Si SOT23	Philips	BC847	BC847	1
V6	MOSFET, N Chan Enhance SOT23	Philips	BST82	BST82	1
V7	MOSFET, N Chan Enhance SOT23	Philips	BST82	BST82	1
V8	MOSFET, N Chan Enhance SOT23	Philips	BST82	BST82	1
V9	Transistor, PNP Si SOT23	Philips	BC857	BC857	1
V10	MOSFET, N Chan Enhance SOT23	Philips	BST82	BST82	1
V11	MOSFET, N Chan Enhance SOT23	Philips	BST82	BST82	1
V12	MOSFET, N Chan Enhance SOT23	Philips	BST82	BST82	1
V13	MOSFET, N Chan Enhance SOT23	Philips	BST82	BST82	1
V14	MOSFET, N Chan Enhance SOT23	Philips	BST82	BST82	1
Z1	Crystal 4MHz Up Grade SMD	HY-Q	QC49/SMD EB01C	65-90109	1
Z2	Crystal, 32,768kHz 12pF	HY-Q	TC38	65-90057-000	1

08-06260-001 - Appn Proc PCB, Handset & Data I/F

BOM Revision
Date Valid On

02 -- Production
28.09.2006

Ref	Description	Manufacturer	Manufacturer's P/N	Codan P/N	Qty
	Appn Proc PCB, Handset & Data I/F			08-06260	1
	Appn Proc, Handset & Data I/F			04-03498	1
1	PCB, Appn Proc Handset & Data	IMP	07-02072-02	07-02072-02	1
2	Label, Serial/Barcode	Codan	06-02068	06-02068	1
3	Cable, Ribbon, Audio - DSP	Auto Assemblies	08-05490-001	08-05490-001	1
4	Cable, Ribbon 10way 130mm	Auto Assemblies	08-06283-001	08-06283-001	1
C1	33n 10% 25V X7R 0603 NiSn	Vitramon	VJ0603Y333KXXT	46-43300-282	1
C2	33n 10% 25V X7R 0603 NiSn	Vitramon	VJ0603Y333KXXT	46-43300-282	1
C3	33n 10% 25V X7R 0603 NiSn	Vitramon	VJ0603Y333KXXT	46-43300-282	1
C4	33n 10% 25V X7R 0603 NiSn	Vitramon	VJ0603Y333KXXT	46-43300-282	1
C5	33n 10% 25V X7R 0603 NiSn	Vitramon	VJ0603Y333KXXT	46-43300-282	1
C6	10u 20% 20V 3528 TA Cap	AVX	TAJB106M020R	47-11002-000	1
C7	100n 10% 16V X7R 0603 NiSn	Vitramon	VJ0603Y104KXJT	46-51000-283	1
C8	10u 20% 20V 3528 TA Cap	AVX	TAJB106M020R	47-11002-000	1
C9	33n 10% 25V X7R 0603 NiSn	Vitramon	VJ0603Y333KXXT	46-43300-282	1
C10	100u 25V 105°C SMD EL Cap Low ESR	Nippon Chemicon	MVY25VC100MF80	48-21002-502	1
C11	100u 25V 105°C SMD EL Cap Low ESR	Nippon Chemicon	MVY25VC100MF80	48-21002-502	1
C12	10n 5% 50V X7R 0603 NiSn	Philips	06032R103J9BB00	46-41000-080	1
C13	33n 10% 25V X7R 0603 NiSn	Vitramon	VJ0603Y333KXXT	46-43300-282	1
C14	100u 25V 105°C SMD EL Cap Low ESR	Nippon Chemicon	MVY25VC100MF80	48-21002-502	1
C15	10u 20% 20V 3528 TA Cap	AVX	TAJB106M020R	47-11002-000	1
C16	100n 10% 16V X7R 0603 NiSn	Vitramon	VJ0603Y104KXJT	46-51000-283	1
C17	33n 10% 25V X7R 0603 NiSn	Vitramon	VJ0603Y333KXXT	46-43300-282	1
C18	33n 10% 25V X7R 0603 NiSn	Vitramon	VJ0603Y333KXXT	46-43300-282	1
C19	100n 10% 16V X7R 0603 NiSn	Vitramon	VJ0603Y104KXJT	46-51000-283	1
C20	10u 20% 20V 3528 TA Cap	AVX	TAJB106M020R	47-11002-000	1
C21	100n 10% 16V X7R 0603 NiSn	Vitramon	VJ0603Y104KXJT	46-51000-283	1
C22	100p 5% 50V NPO 0603 NiSn	Philips	0603CG101J9B200	46-21000-083	1
C23	100p 5% 50V NPO 0603 NiSn	Philips	0603CG101J9B200	46-21000-083	1
C24	1u 10% 16V X7R 1206 NiSn	Philips	12062R105K7BB00	46-61000-280	1

08-06260-001 - Appn Proc PCB, Handset & Data I/F

BOM Revision
Date Valid On

02 -- Production
28.09.2006

Ref	Description	Manufacturer	Manufacturer's P/N	Codan P/N	Qty
C25	3,3n 10% 100V X7R 0603 NiSn	Vishay	VJ0603Y332KXBAC	46-33300-282	1
C26	100p 5% 50V NPO 0603 NiSn	Philips	0603CG101J9B200	46-21000-083	1
C27	100p 5% 50V NPO 0603 NiSn	Philips	0603CG101J9B200	46-21000-083	1
C28	100p 5% 50V NPO 0603 NiSn	Philips	0603CG101J9B200	46-21000-083	1
C29	100p 5% 50V NPO 0603 NiSn	Philips	0603CG101J9B200	46-21000-083	1
C30	100p 5% 50V NPO 0603 NiSn	Philips	0603CG101J9B200	46-21000-083	1
C31	100p 5% 50V NPO 0603 NiSn	Philips	0603CG101J9B200	46-21000-083	1
C32	100p 5% 50V NPO 0603 NiSn	Philips	0603CG101J9B200	46-21000-083	1
C33	100p 5% 50V NPO 0603 NiSn	Philips	0603CG101J9B200	46-21000-083	1
C34	1u 10% 16V X7R 1206 NiSn	Philips	12062R105K7BB00	46-61000-280	1
C35	15p 5% 50V NPO 0603 NiSn	Philips	0603CG150C9BB00	46-11500-083	1
C36	15p 5% 50V NPO 0603 NiSn	Philips	0603CG150C9BB00	46-11500-083	1
C37	10n 5% 50V X7R 0603 NiSn	Philips	06032R103J9BB00	46-41000-080	1
C38	100n 10% 16V X7R 0603 NiSn	Vitramon	VJ0603Y104KXJT	46-51000-283	1
C39	100n 10% 16V X7R 0603 NiSn	Vitramon	VJ0603Y104KXJT	46-51000-283	1
C40	100n 10% 16V X7R 0603 NiSn	Vitramon	VJ0603Y104KXJT	46-51000-283	1
C41	100n 10% 16V X7R 0603 NiSn	Vitramon	VJ0603Y104KXJT	46-51000-283	1
C42	100n 10% 16V X7R 0603 NiSn	Vitramon	VJ0603Y104KXJT	46-51000-283	1
C43	100n 10% 16V X7R 0603 NiSn	Vitramon	VJ0603Y104KXJT	46-51000-283	1
C44	100n 10% 16V X7R 0603 NiSn	Vitramon	VJ0603Y104KXJT	46-51000-283	1
C45	100n 10% 16V X7R 0603 NiSn	Vitramon	VJ0603Y104KXJT	46-51000-283	1
C46	100n 10% 16V X7R 0603 NiSn	Vitramon	VJ0603Y104KXJT	46-51000-283	1
C47	100n 10% 16V X7R 0603 NiSn	Vitramon	VJ0603Y104KXJT	46-51000-283	1
C48	100n 10% 16V X7R 0603 NiSn	Vitramon	VJ0603Y104KXJT	46-51000-283	1
C49	100n 10% 16V X7R 0603 NiSn	Vitramon	VJ0603Y104KXJT	46-51000-283	1
C50	100n 10% 16V X7R 0603 NiSn	Vitramon	VJ0603Y104KXJT	46-51000-283	1
C51	100n 10% 16V X7R 0603 NiSn	Vitramon	VJ0603Y104KXJT	46-51000-283	1
C52	100n 10% 16V X7R 0603 NiSn	Vitramon	VJ0603Y104KXJT	46-51000-283	1
C53	33n 10% 25V X7R 0603 NiSn	Vitramon	VJ0603Y333KXXT	46-43300-282	1

08-06260-001 - Appn Proc PCB, Handset & Data I/F

BOM Revision
Date Valid On

02 -- Production
28.09.2006

Ref	Description	Manufacturer	Manufacturer's P/N	Codan P/N	Qty
C54	33n 10% 25V X7R 0603 NiSn	Vitramon	VJ0603Y333KXXT	46-43300-282	1
C55	10u 20% 20V 3528 TA Cap	AVX	TAJB106M020R	47-11002-000	1
C56	33n 10% 25V X7R 0603 NiSn	Vitramon	VJ0603Y333KXXT	46-43300-282	1
C57	33n 10% 25V X7R 0603 NiSn	Vitramon	VJ0603Y333KXXT	46-43300-282	1
C58	10u 20% 20V 3528 TA Cap	AVX	TAJB106M020R	47-11002-000	1
C59	33n 10% 25V X7R 0603 NiSn	Vitramon	VJ0603Y333KXXT	46-43300-282	1
C60	10u 20% 20V 3528 TA Cap	AVX	TAJB106M020R	47-11002-000	1
C61	100n 10% 16V X7R 0603 NiSn	Vitramon	VJ0603Y104KXJT	46-51000-283	1
C62	Not Fitted	Codan	** -00000-001	99-00000-001	1
C63	Not Fitted	Codan	** -00000-001	99-00000-001	1
C64	33n 10% 25V X7R 0603 NiSn	Vitramon	VJ0603Y333KXXT	46-43300-282	1
C65	33n 10% 25V X7R 0603 NiSn	Vitramon	VJ0603Y333KXXT	46-43300-282	1
C66	10u 20% 20V 3528 TA Cap	AVX	TAJB106M020R	47-11002-000	1
C67	33n 10% 25V X7R 0603 NiSn	Vitramon	VJ0603Y333KXXT	46-43300-282	1
C68	33n 10% 25V X7R 0603 NiSn	Vitramon	VJ0603Y333KXXT	46-43300-282	1
C69	100p 5% 50V NPO 0603 NiSn	Philips	0603CG101J9B200	46-21000-083	1
C70	100p 5% 50V NPO 0603 NiSn	Philips	0603CG101J9B200	46-21000-083	1
C71	100p 5% 50V NPO 0603 NiSn	Philips	0603CG101J9B200	46-21000-083	1
C72	100p 5% 50V NPO 0603 NiSn	Philips	0603CG101J9B200	46-21000-083	1
C73	100p 5% 50V NPO 0603 NiSn	Philips	0603CG101J9B200	46-21000-083	1
C74	100p 5% 50V NPO 0603 NiSn	Philips	0603CG101J9B200	46-21000-083	1
C75	100p 5% 50V NPO 0603 NiSn	Philips	0603CG101J9B200	46-21000-083	1
C76	100p 5% 50V NPO 0603 NiSn	Philips	0603CG101J9B200	46-21000-083	1
C77	100p 5% 50V NPO 0603 NiSn	Philips	0603CG101J9B200	46-21000-083	1
C78	100p 5% 50V NPO 0603 NiSn	Philips	0603CG101J9B200	46-21000-083	1
C79	33n 10% 25V X7R 0603 NiSn	Vitramon	VJ0603Y333KXXT	46-43300-282	1
C80	33n 10% 25V X7R 0603 NiSn	Vitramon	VJ0603Y333KXXT	46-43300-282	1
C81	33n 10% 25V X7R 0603 NiSn	Vitramon	VJ0603Y333KXXT	46-43300-282	1
D1	Diode, Schottky 40V 1A SMA	Taiwan Semiconductor	SS14	MBRA140T3	1
D2	Diode, Schottky SOT23	Philips	BAT54	BAT54	1

08-06260-001 - Appn Proc PCB, Handset & Data I/F

BOM Revision
Date Valid On

02 -- Production
28.09.2006

Ref	Description	Manufacturer	Manufacturer's P/N	Codan P/N	Qty
D3	Diode, Schottky SOT23	Philips	BAT54	BAT54	1
H1	Not Fitted	Codan	** -00000-001	99-00000-001	1
H2	Not Fitted	Codan	** -00000-001	99-00000-001	1
H3	Not Fitted	Codan	** -00000-001	99-00000-001	1
H4	Not Fitted	Codan	** -00000-001	99-00000-001	1
IC1	CPLD prgmd, 2012 RFU DSP	Braemac	90-20635-001	90-20635-001	1
IC2	UART, Quad 64b FIFO 3-5V w/IrDA TQFP64	Exar	ST16C654IQ64	YK-16654-910	1
IC3	Reg, Voltage +5V 0,1A SOIC8	National Semiconduct	LM78L05ACM	XB-07805-700	1
IC4	Reg, Voltage +1,8V 150mA LDO SOT23-5	Texas Instruments	TPS76318DBVT	XB-76318-700	1
IC5	Reg, Voltage +3,3V 0,5A Switch SOIC8	National Semiconduct	LM2674M-3.3TR	XB-02674-701	1
IC6	Micro prgmd, 2011 Master I/O	Codan	90-20624-001	90-20624-001	1
IC7	Codec, 16 Bit 22kSPS 3-5V TQFP48	Texas Instruments	TLV320AIC10C	YN-32010-900	1
IC8	Amp, Oper Dual CMOS SOIC8	National Semiconduct	LMC662CM	XA-00662-700	1
IC9	Serial Number, 48 bit SOT223	Dallas	DS2401Z	YM-02401-700	1
IC10	Supervisory, Dual 2,93 & 1,68V SOIC8	Texas Instruments	TPS3305-18DR	XD-03305-700	1
IC11	DSP, 32 Bit Fltng Point 60MIPS LQFP144	Texas Instruments	TMS320VC33PGE120	YP-32033-900	1
IC12	FLASH prgmd, NGT SRx D0-D15	Braemac	90-20636-101	90-20636-101	1
IC13	FLASH prgmd, NGT SRx D16-D32	Braemac	90-20636-201	90-20636-201	1
IC14	RAM, CMOS 512kx16Bit 55ns 3V TSOP2-44	Samsung	K6X8016T3B-UF55T	YM-16512-710	1
IC15	RAM, CMOS 512kx16Bit 55ns 3V TSOP2-44	Samsung	K6X8016T3B-UF55T	YM-16512-710	1
IC16	Flash 1Mx8bit/512k x16bit 3V 70ns TSOP48	AMD	AM29LV800BB-70EI	YM-29800-710	1
IC17	Supervisory, Pwr&reset 4,63V SOT23	Maxim	MAX810LEUR-T	XD-00810-700	1
IC18	Comparator, Rail-Rail I/O LP SOT23-5	National Semiconduct	LMC7221AIM5	XD-07221-700	1
IC19	Gate, OR 2 Input Quad TSSOP14	STMicroelectronics	74LCX32TTR	YX-74032-700	1
IC20	Buffer, Dual Bus T/State VSSOP8	Texas Instruments	SN74LVC2G125DCUT	YX-74125-700	1
J1	Socket, 16way 1row ZIF 1mm Pitch SMD	Global Shine	GS008-16-G-1	60-00163-004	1
L1	Ind, 680uH Switched Supply	Coilcraft	DS5022P-684	43-82680-000	1
L2	Ind, 10uH 10% 4532	Taiyo Yuden	LEM 4532T100K	43-81100-000	1
L3	Choke, EMI/EMC 0A DC >1MHz 4516	Taiyo Yuden	FCFBMJ 4516 HS 110-T	43-90003	1
L4	Choke, EMI/EMC 0A DC >1MHz 4516	Taiyo Yuden	FCFBMJ 4516 HS 110-T	43-90003	1
P1	Not Fitted	Codan	** -00000-001	99-00000-001	1
P2	Header (P) 10way 2row Boxed SMD 2,54mm	Neltron	2316SM-10G	60-00100-004	1
P3	Not Fitted	Codan	** -00000-001	99-00000-001	1

08-06260-001 - Appn Proc PCB, Handset & Data I/F

BOM Revision
Date Valid On

02 -- Production
28.09.2006

Ref	Description	Manufacturer	Manufacturer's P/N	Codan P/N	Qty
P4	Header (P) 26way 2row Boxed SMD	Neltron	2316SMD-26G-CAP-TR	60-00260-002	1
P5	Not Fitted	Codan	** -00000-001	99-00000-001	1
P6	Not Fitted	Codan	** -00000-001	99-00000-001	1
P7	Not Fitted	Codan	** -00000-001	99-00000-001	1
R1	33k Ohm 5% 0,06W 0603	Philips	2322 702 60333	40-43300-121	1
R2	33k Ohm 5% 0,06W 0603	Philips	2322 702 60333	40-43300-121	1
R3	1k Ohm 5% 0,06W 0603	Philips	2322 702 60102	40-31000-121	1
R4	1k Ohm 5% 0,06W 0603	Philips	2322 702 60102	40-31000-121	1
R5	1k Ohm 5% 0,06W 0603	Philips	2322 702 60102	40-31000-121	1
R6	1k Ohm 5% 0,06W 0603	Philips	2322 702 60102	40-31000-121	1
R7	33k Ohm 5% 0,06W 0603	Philips	2322 702 60333	40-43300-121	1
R8	33k Ohm 5% 0,06W 0603	Philips	2322 702 60333	40-43300-121	1
R9	33k Ohm 5% 0,06W 0603	Philips	2322 702 60333	40-43300-121	1
R10	33k Ohm 5% 0,06W 0603	Philips	2322 702 60333	40-43300-121	1
R11	33k Ohm 5% 0,06W 0603	Philips	2322 702 60333	40-43300-121	1
R12	33k Ohm 5% 0,06W 0603	Philips	2322 702 60333	40-43300-121	1
R13	120 Ohm 5% 0,06W 0603	Philips	2322 702 60121	40-21200-121	1
R14	120 Ohm 5% 0,06W 0603	Philips	2322 702 60121	40-21200-121	1
R16	33k Ohm 5% 0,06W 0603	Philips	2322 702 60333	40-43300-121	1
R17	33k Ohm 5% 0,06W 0603	Philips	2322 702 60333	40-43300-121	1
R18	33k Ohm 5% 0,06W 0603	Philips	2322 702 60333	40-43300-121	1
R19	10k Ohm 5% 0,06W 0603	Philips	2322 702 60103	40-41000-121	1
R20	33k Ohm 5% 0,06W 0603	Philips	2322 702 60333	40-43300-121	1
R21	4,7k Ohm 5% 0,06W 0603	Philips	2322 702 60472	40-34700-121	1
R22	120 Ohm 5% 0,06W 0603	Philips	2322 702 60121	40-21200-121	1
R23	100k Ohm 5% 0,06W 0603	Philips	2322 702 60104	40-51000-121	1
R24	100k Ohm 5% 0,06W 0603	Philips	2322 702 60104	40-51000-121	1
R25	10k Ohm 5% 0,06W 0603	Philips	2322 702 60103	40-41000-121	1
R26	10k Ohm 5% 0,06W 0603	Philips	2322 702 60103	40-41000-121	1
R27	10k Ohm 5% 0,06W 0603	Philips	2322 702 60103	40-41000-121	1

08-06260-001 - Appn Proc PCB, Handset & Data I/F

BOM Revision
Date Valid On

02 -- Production
28.09.2006

Ref	Description	Manufacturer	Manufacturer's P/N	Codan P/N	Qty
R28	120 Ohm 5% 0,06W 0603	Philips	2322 702 60121	40-21200-121	1
R29	120 Ohm 5% 0,06W 0603	Philips	2322 702 60121	40-21200-121	1
R30	33k Ohm 5% 0,06W 0603	Philips	2322 702 60333	40-43300-121	1
R31	33k Ohm 5% 0,06W 0603	Philips	2322 702 60333	40-43300-121	1
R32	10 Ohm 5% 0,06W 0603	Philips	2322 702 60109	40-11000-121	1
R33	120 Ohm 5% 0,06W 0603	Philips	2322 702 60121	40-21200-121	1
R34	10k Ohm 5% 0,06W 0603	Philips	2322 702 60103	40-41000-121	1
R35	10k Ohm 5% 0,06W 0603	Philips	2322 702 60103	40-41000-121	1
R36	10k Ohm 5% 0,06W 0603	Philips	2322 702 60103	40-41000-121	1
R37	10k Ohm 5% 0,06W 0603	Philips	2322 702 60103	40-41000-121	1
R38	10k Ohm 5% 0,06W 0603	Philips	2322 702 60103	40-41000-121	1
R39	10k Ohm 5% 0,06W 0603	Philips	2322 702 60103	40-41000-121	1
R40	10k Ohm 5% 0,06W 0603	Philips	2322 702 60103	40-41000-121	1
R41	22k Ohm 5% 0,06W 0603	Philips	2322 702 60223	40-42200-121	1
R42	10k Ohm 5% 0,06W 0603	Philips	2322 702 60103	40-41000-121	1
R43	4,7k Ohm 5% 0,06W 0603	Philips	2322 702 60472	40-34700-121	1
R44	4,7k Ohm 5% 0,06W 0603	Philips	2322 702 60472	40-34700-121	1
R45	120 Ohm 5% 0,06W 0603	Philips	2322 702 60121	40-21200-121	1
R46	120 Ohm 5% 0,06W 0603	Philips	2322 702 60121	40-21200-121	1
R47	120 Ohm 5% 0,06W 0603	Philips	2322 702 60121	40-21200-121	1
R48	120 Ohm 5% 0,06W 0603	Philips	2322 702 60121	40-21200-121	1
R49	1k Ohm 5% 0,06W 0603	Philips	2322 702 60102	40-31000-121	1
R50	120 Ohm 5% 0,06W 0603	Philips	2322 702 60121	40-21200-121	1
R51	120 Ohm 5% 0,06W 0603	Philips	2322 702 60121	40-21200-121	1
R52	120 Ohm 5% 0,06W 0603	Philips	2322 702 60121	40-21200-121	1
R53	120 Ohm 5% 0,06W 0603	Philips	2322 702 60121	40-21200-121	1
R54	33 Ohm 5% 0,06W 0603	Philips	2322 702 60339	40-13300-121	1
R55	33 Ohm 5% 0,06W 0603	Philips	2322 702 60339	40-13300-121	1
R56	120 Ohm 5% 0,06W 0603	Philips	2322 702 60121	40-21200-121	1

08-06260-001 - Appn Proc PCB, Handset & Data I/F

BOM Revision
Date Valid On

02 -- Production
28.09.2006

Ref	Description	Manufacturer	Manufacturer's P/N	Codan P/N	Qty
R57	2,2k Ohm 5% 0,06W 0603	Philips	2322 702 60222	40-32200-121	1
R58	120 Ohm 5% 0,06W 0603	Philips	2322 702 60121	40-21200-121	1
R59	2,2k Ohm 5% 0,06W 0603	Philips	2322 702 60222	40-32200-121	1
R60	120 Ohm 5% 0,06W 0603	Philips	2322 702 60121	40-21200-121	1
R61	120 Ohm 5% 0,06W 0603	Philips	2322 702 60121	40-21200-121	1
R62	120 Ohm 5% 0,06W 0603	Philips	2322 702 60121	40-21200-121	1
R63	4,7k Ohm 5% 0,06W 0603	Philips	2322 702 60472	40-34700-121	1
R64	120 Ohm 5% 0,06W 0603	Philips	2322 702 60121	40-21200-121	1
R65	10k Ohm 5% 0,06W 0603	Philips	2322 702 60103	40-41000-121	1
R66	33k Ohm 5% 0,06W 0603	Philips	2322 702 60333	40-43300-121	1
R67	220 Ohm 5% 0,06W 0603	Philips	2322 702 60221	40-22200-121	1
R68	10 Ohm 5% 0,06W 0603	Philips	2322 702 60109	40-11000-121	1
R69	33k Ohm 5% 0,06W 0603	Philips	2322 702 60333	40-43300-121	1
R70	33k Ohm 5% 0,06W 0603	Philips	2322 702 60333	40-43300-121	1
R71	10 Ohm 5% 0,06W 0603	Philips	2322 702 60109	40-11000-121	1
R72	33k Ohm 5% 0,06W 0603	Philips	2322 702 60333	40-43300-121	1
R73	33k Ohm 5% 0,06W 0603	Philips	2322 702 60333	40-43300-121	1
R74	4,7k Ohm 5% 0,06W 0603	Philips	2322 702 60472	40-34700-121	1
R75	4,7k Ohm 5% 0,06W 0603	Philips	2322 702 60472	40-34700-121	1
R76	33k Ohm 5% 0,06W 0603	Philips	2322 702 60333	40-43300-121	1
R77	Not Fitted	Codan	**_00000-001	99-00000-001	1
R78	33k Ohm 5% 0,06W 0603	Philips	2322 702 60333	40-43300-121	1
R79	33k Ohm 5% 0,06W 0603	Philips	2322 702 60333	40-43300-121	1
R80	33k Ohm 5% 0,06W 0603	Philips	2322 702 60333	40-43300-121	1
R81	68k Ohm 5% 0,06W 0603	Philips	2322 702 60683	40-46800-121	1
R82	33k Ohm 5% 0,06W 0603	Philips	2322 702 60333	40-43300-121	1
R83	33k Ohm 5% 0,06W 0603	Philips	2322 702 60333	40-43300-121	1
R84	120 Ohm 5% 0,06W 0603	Philips	2322 702 60121	40-21200-121	1
R85	10k Ohm 5% 0,06W 0603	Philips	2322 702 60103	40-41000-121	1
R86	0 Ohm Jumper 0603	Philips	2322 702 96001	40-00001-121	1

08-06260-001 - Appn Proc PCB, Handset & Data I/F

BOM Revision
Date Valid On

02 -- Production
 28.09.2006

Ref	Description	Manufacturer	Manufacturer's P/N	Codan P/N	Qty
R87	120 Ohm 5% 0,06W 0603	Philips	2322 702 60121	40-21200-121	1
R88	120 Ohm 5% 0,06W 0603	Philips	2322 702 60121	40-21200-121	1
R89	33k Ohm 5% 0,06W 0603	Philips	2322 702 60333	40-43300-121	1
R90	33k Ohm 5% 0,06W 0603	Philips	2322 702 60333	40-43300-121	1
R91	1k Ohm 5% 0,06W 0603	Philips	2322 702 60102	40-31000-121	1
R92	10k Ohm 5% 0,06W 0603	Philips	2322 702 60103	40-41000-121	1
V1	Transistor, NPN Si SOT23	Philips	BC847	BC847	1
V2	MOSFET, Power N Channel TO252	Motorola	MTD3055V	MTD3055V	1
Z1	Crystal, 11059,2 kHz uP Grade	HY-Q	M/P QC49/SMD EB01C	65-90094	1

08-05890-001 - 2nd Filter 500Hz PCB

BOM Revision
Date Valid On

03 -- Production
28.09.2006

Ref	Description	Manufacturer	Manufacturer's P/N	Codan P/N	Qty
	Switch, 2nd Filter			04-03379	1
	2nd Filter PCB			08-05890	1
*	2nd Filter PCB			08-05890	1
1	PCB, 2nd Filter	IMP	07-01962-02	07-01962-02	1
C1	27p 5% 50V NPO 0805 NiSn	Philips	0805CG270J9B200	46-12700-080	1
C2	27p 5% 50V NPO 0805 NiSn	Philips	0805CG270J9B200	46-12700-080	1
C3	33n 10% 50V X7R 0805 NiSn	Philips	08052R333K9BB00	46-43300-281	1
C4	1n 5% 50V NPO 0805 NiSn	Philips	0805CG102J9BB-	46-31000-082	1
D1	Diode, Si High speed 75V SOT23	Philips	BAS16	BAS16	1
K1	Relay, 2C 12V 2A SMD 1028 Ohm	Matsushita	TQ2SL-12V	64-21225-310	1
K2	Relay, 2C 12V 2A SMD 1028 Ohm	Matsushita	TQ2SL-12V	64-21225-310	1
P1	Header (P) 4way 1row	Molex	22-03-2041	60-00041-100	1
P2	Header (P) 4way 1row	Molex	22-03-2041	60-00041-100	1
P3	Header (P) 2way 1row	Molex	22-03-2021	60-00021-100	1
P4	Header (P) 2way 1row	Molex	22-03-2021	60-00021-100	1
R1	1,8k Ohm 5% 0,1W 0805	Philips	2322 730 61182	40-31800-111	1
R2	3,3k Ohm 5% 0,1W 0805	Philips	2322 730 61332	40-33300-111	1
R3	1k Ohm 5% 0,1W 0805	Philips	2322-730-61102	40-31000-111	1
Z1	Filter, 455 kHz 500 Hz BW	Rockwell	526-8693-010	65-91118	1

08-05890-002 - 2nd Filter 2,7kHz PCB

BOM Revision
Date Valid On

00 -- Pre-Production
28.09.2006

Ref	Description	Manufacturer	Manufacturer's P/N	Codan P/N	Qty
	Switch, 2nd Filter			04-03379	1
	2nd Filter PCB			08-05890	1
*	2nd Filter PCB			08-05890	1
1	PCB, 2nd Filter	IMP	07-01962-02	07-01962-02	1
C1	27p 5% 50V NPO 0805 NiSn	Philips	0805CG270J9B200	46-12700-080	1
C2	27p 5% 50V NPO 0805 NiSn	Philips	0805CG270J9B200	46-12700-080	1
C3	33n 10% 50V X7R 0805 NiSn	Philips	08052R333K9BB00	46-43300-281	1
C4	1n 5% 50V NPO 0805 NiSn	Philips	0805CG102J9BB-	46-31000-082	1
D1	Diode, Si High speed 75V SOT23	Philips	BAS16	BAS16	1
K1	Relay, 2C 12V 2A SMD 1028 Ohm	Matsushita	TQ2SL-12V	64-21225-310	1
K2	Relay, 2C 12V 2A SMD 1028 Ohm	Matsushita	TQ2SL-12V	64-21225-310	1
P1	Header (P) 4way 1row	Molex	22-03-2041	60-00041-100	1
P2	Header (P) 4way 1row	Molex	22-03-2041	60-00041-100	1
P3	Header (P) 2way 1row	Molex	22-03-2021	60-00021-100	1
P4	Header (P) 2way 1row	Molex	22-03-2021	60-00021-100	1
R1	1,8k Ohm 5% 0,1W 0805	Philips	2322 730 61182	40-31800-111	1
R2	3,3k Ohm 5% 0,1W 0805	Philips	2322 730 61332	40-33300-111	1
R3	1k Ohm 5% 0,1W 0805	Philips	2322-730-61102	40-31000-111	1
Z1	Filter, 455kHz 2,7kHz BW	Rockwell	526-8759-010	65-91123	1

08-05267-001 - Desk Console PCB

BOM Revision
Date Valid On

05 -- Production
27.09.2006

Ref	Description	Manufacturer	Manufacturer's P/N	Codan P/N	Qty
	Desk Console			04-03110	1
	Desk Console PCB			08-05267	1
	Desk Console PCB			11-06079	1
1	PCB, Desk Console	IMP	07-01743-04	07-01743-04	1
2	Label, Identification/Barcode	Codan	06-01852	06-01852	1
3	Stake, Terminal	Autosplice	7-22461-5	61-40300-004	2
C1	100p 5% 50V NPO 1206 NiSn	Philips	1206CG101J9BB-	46-21000-080	1
C2	100p 5% 50V NPO 1206 NiSn	Philips	1206CG101J9BB-	46-21000-080	1
C3	100p 5% 50V NPO 1206 NiSn	Philips	1206CG101J9BB-	46-21000-080	1
C4	22n 10% 100V X7R 1206 NiSn	Philips	12062R223K0BB-	46-42200-280	1
C5	22n 10% 100V X7R 1206 NiSn	Philips	12062R223K0BB-	46-42200-280	1
C6	22n 10% 100V X7R 1206 NiSn	Philips	12062R223K0BB-	46-42200-280	1
C7	22n 10% 100V X7R 1206 NiSn	Philips	12062R223K0BB-	46-42200-280	1
C9	Not Fitted	Codan	**_00000-001	99-00000-001	1
C10	100p 5% 50V NPO 1206 NiSn	Philips	1206CG101J9BB-	46-21000-080	1
C11	22n 10% 100V X7R 1206 NiSn	Philips	12062R223K0BB-	46-42200-280	1
C12	22n 10% 100V X7R 1206 NiSn	Philips	12062R223K0BB-	46-42200-280	1
C13	1u 20% 35V 3528 TA Cap	AVX	TAJB105M035R	47-01003-520	1
C14	100p 5% 50V NPO 1206 NiSn	Philips	1206CG101J9BB-	46-21000-080	1
C15	1n 5% 50V NPO 1206 NiSn	Philips	1206CG102J9BB-	46-31000-081	1
C16	1u 20% 35V 3528 TA Cap	AVX	TAJB105M035R	47-01003-520	1
C17	1u 20% 35V 3528 TA Cap	AVX	TAJB105M035R	47-01003-520	1
C18	1u 20% 35V 3528 TA Cap	AVX	TAJB105M035R	47-01003-520	1
C19	100n 10% 50V X7R 1206 NiSn	Philips	12062R104K9BB-	46-51000-281	1
H1	Not Fitted	Codan	**_00000-001	99-00000-001	1
H2	Not Fitted	Codan	**_00000-001	99-00000-001	1
H3	Not Fitted	Codan	**_00000-001	99-00000-001	1
H4	Not Fitted	Codan	**_00000-001	99-00000-001	1
H5	Not Fitted	Codan	**_00000-001	99-00000-001	1
H6	Not Fitted	Codan	**_00000-001	99-00000-001	1
IC1	Remote 8 Bit I/O For IIC Bus SOIC16	Philips	PCF8574T	YK-08574-700	1
IC2	Amp, Operational Dual SOIC8	National Semiconduct	LM358M	XA-00358-700	1
L1	Not Fitted	Codan	**_00000-001	99-00000-001	1
L2	Choke, EMI/EMC 0A DC >1MHz 4516	Taiyo Yuden	FCFBMJ 4516 HS 110-T	43-90003	1
L3	Choke, EMI/EMC 0A DC >1MHz 4516	Taiyo Yuden	FCFBMJ 4516 HS 110-T	43-90003	1
P1	Header (P) 10way 2row Boxed Fix	I-Technos	HDM410S02	60-00100-003	1

08-05267-001 - Desk Console PCB

BOM Revision
Date Valid On

05 -- Production
27.09.2006

Ref	Description	Manufacturer	Manufacturer's P/N	Codan P/N	Qty
P2	Header (P) 4way 2mm Latch Fixed	AMP	173981-4	60-00040-352	1
R1	Not Fitted	Codan	** -00000-001	99-00000-001	1
R2	Not Fitted	Codan	** -00000-001	99-00000-001	1
R3	Not Fitted	Codan	** -00000-001	99-00000-001	1
R4	Not Fitted	Codan	** -00000-001	99-00000-001	1
R5	1k Ohm 5% 0,1W 0805	Philips	2322-730-61102	40-31000-111	1
R6	330k Ohm 5% 0,1W 0805	Philips	2322 730 61334	40-53300-111	1
R7	4,7k Ohm 5% 0,1W 0805	Philips	2322 730 61472	40-34700-111	1
R8	4,7k Ohm 5% 0,1W 0805	Philips	2322 730 61472	40-34700-111	1
R9	2,2k Ohm 5% 0,1W 0805	Philips	2322 730 61222	40-32200-111	1
R10	1k Ohm 5% 0,1W 0805	Philips	2322-730-61102	40-31000-111	1
R11	22k Ohm 5% 0,1W 0805	Philips	2322 730 61223	40-42200-111	1
R12	10k Ohm 5% 0,1W 0805	Philips	2322-730-61103	40-41000-111	1
R13	47k Ohm 5% 0,1W 0805	Philips	2322 730 61473	40-44700-111	1
R14	47k Ohm 5% 0,1W 0805	Philips	2322 730 61473	40-44700-111	1
R15	330k Ohm 5% 0,1W 0805	Philips	2322 730 61334	40-53300-111	1
V1	Not Fitted	Codan	** -00000-001	99-00000-001	1
V2	Not Fitted	Codan	** -00000-001	99-00000-001	1
V3	Transistor, NPN Si SOT23	Philips	BC848	BC848	1
V4	MOSFET, N Chan Enhance SOT23	Philips	BST82	BST82	1

08-06320-001 - Desk Console PCB (Voice)

BOM Revision
Date Valid On

04 -- Production
28.09.2006

Ref	Description	Manufacturer	Manufacturer's P/N	Codan P/N	Qty
	Desk Console (Voice)			04-03514	1
	Desk Console PCB (Voice)			08-06320	1
	S/W mstr assy for 90-20637-001 ver 1.00			90-30637-001	1
	Label, 32 pin PLCC	Codan	06-01674	06-01674	1
1	PCB, Desk Console (Voice)	IMP	07-02085-02	07-02085-02	1
2	Label, Serial/Barcode	Codan	06-02068	06-02068	1
3	Stake, Terminal	Autosplice	7-22461-5	61-40300-004	2
C1	100n 10% 16V X7R 0603 NiSn	Vitramon	VJ0603Y104KXJT	46-51000-283	1
C2	100n 10% 16V X7R 0603 NiSn	Vitramon	VJ0603Y104KXJT	46-51000-283	1
C3	10u 20% 20V 3528 TA Cap	AVX	TAJB106M020R	47-11002-000	1
C4	1n 5% 25V NPO 0603 NiSn	AVX	06033A102JAT2A	46-31000-083	1
C5	1n 5% 25V NPO 0603 NiSn	AVX	06033A102JAT2A	46-31000-083	1
C6	100n 10% 16V X7R 0603 NiSn	Vitramon	VJ0603Y104KXJT	46-51000-283	1
C7	1n 5% 25V NPO 0603 NiSn	AVX	06033A102JAT2A	46-31000-083	1
C8	1n 5% 25V NPO 0603 NiSn	AVX	06033A102JAT2A	46-31000-083	1
C9	1u 10% 10V X7R 0805 NiSn	Phycomp	2222-240-15663	46-61000-281	1
C10	100n 10% 16V X7R 0603 NiSn	Vitramon	VJ0603Y104KXJT	46-51000-283	1
C11	1u 10% 10V X7R 0805 NiSn	Phycomp	2222-240-15663	46-61000-281	1
C12	100p 5% 50V NPO 0603 NiSn	Philips	0603CG101J9B200	46-21000-083	1
C13	22n 10% 25V X7R 0603 NiSn	AVX	06033C223KAT2A	46-42200-281	1
C14	22n 10% 25V X7R 0603 NiSn	AVX	06033C223KAT2A	46-42200-281	1
C15	100p 5% 50V NPO 0603 NiSn	Philips	0603CG101J9B200	46-21000-083	1
C16	1n 5% 25V NPO 0603 NiSn	AVX	06033A102JAT2A	46-31000-083	1
C17	100n 10% 16V X7R 0603 NiSn	Vitramon	VJ0603Y104KXJT	46-51000-283	1
C18	470p 5% 50V NPO 0805 NiSn	Philips	0805CG471J9B200	46-24700-081	1
C19	470p 5% 50V NPO 0805 NiSn	Philips	0805CG471J9B200	46-24700-081	1
C20	100n 10% 16V X7R 0603 NiSn	Vitramon	VJ0603Y104KXJT	46-51000-283	1
C21	100n 10% 16V X7R 0603 NiSn	Vitramon	VJ0603Y104KXJT	46-51000-283	1
C22	100n 10% 16V X7R 0603 NiSn	Vitramon	VJ0603Y104KXJT	46-51000-283	1
C23	100n 10% 16V X7R 0603 NiSn	Vitramon	VJ0603Y104KXJT	46-51000-283	1
C25	22n 10% 25V X7R 0603 NiSn	AVX	06033C223KAT2A	46-42200-281	1
C26	22n 10% 25V X7R 0603 NiSn	AVX	06033C223KAT2A	46-42200-281	1

08-06320-001 - Desk Console PCB (Voice)

BOM Revision
Date Valid On

04 -- Production
28.09.2006

Ref	Description	Manufacturer	Manufacturer's P/N	Codan P/N	Qty
C27	22n 10% 25V X7R 0603 NiSn	AVX	06033C223KAT2A	46-42200-281	1
C28	22n 10% 25V X7R 0603 NiSn	AVX	06033C223KAT2A	46-42200-281	1
C29	22n 10% 25V X7R 0603 NiSn	AVX	06033C223KAT2A	46-42200-281	1
C30	22p 5% 100V NPO 0603 NiSn	Philips	0603CG220J0B200	46-12200-083	1
C31	22p 5% 100V NPO 0603 NiSn	Philips	0603CG220J0B200	46-12200-083	1
D1	Diode, Si High speed 75V SOT23	Philips	BAS16	BAS16	1
D2	Diode, Si High speed 75V SOT23	Philips	BAS16	BAS16	1
D3	Diode, Si High speed 75V SOT23	Philips	BAS16	BAS16	1
D4	Diode, Si High speed 75V SOT23	Philips	BAS16	BAS16	1
H1	Not Fitted	Codan	** -00000-001	99-00000-001	1
H2	Not Fitted	Codan	** -00000-001	99-00000-001	1
IC1	Reg, Voltage +3,3V 150mA LDO SOT23-5	Texas Instruments	TPS76333DBVT	XB-76333-700	1
IC2	Mux/Demux, Analog, Triple 2ch SOIC16	Philips	HEF4053BT-653	YH-40053-701	1
IC3	Amp, Operational Quad SOIC14	National Semiconduct	LM324M	XA-00324-700	1
IC4	Tcvr, CAN bus 3,3v 1Mbps w/stby SOIC8	Texas Instruments	SN65HVD233D	YI-65233-700	1
IC5	MCU, 8 Bit 16k Flash 8 MHz TQFP44	Atmel	ATMEGA16L-8AI	YP-00016-910	1
L1	Choke, EMI/EMC 0A DC >1MHz 4516	Taiyo Yuden	FCFBMJ 4516 HS 110-T	43-90003	1
L2	Choke, Common Mode (Data) SMD	Taiyo Yuden	CM04RC04	43-82470-000	1
L3	Choke, Common Mode (Data) SMD	Taiyo Yuden	CM04RC04	43-82470-000	1
L4	Choke, Common Mode (Data) SMD	Taiyo Yuden	CM04RC04	43-82470-000	1
P1	Header (P) 10way 2mm Latch Fixed	AMP	1-173981-0	60-00100-351	1
P2	Header (P) 8way 2mm Latch Fixed	AMP	292161-8	60-00080-001	1
P3	Not Fitted	Codan	** -00000-001	99-00000-001	1
P4	Header (P) 10way 2row thin insul	Berg	67997-410H	60-00100-002	1
P5	Header (P) 4way 2mm Latch Fixed	AMP	173981-4	60-00040-352	1
R1	10k Ohm 5% 0,06W 0603	Philips	2322 702 60103	40-41000-121	1
R2	4,7k Ohm 5% 0,06W 0603	Philips	2322 702 60472	40-34700-121	1
R3	10k Ohm 5% 0,06W 0603	Philips	2322 702 60103	40-41000-121	1
R4	10k Ohm 5% 0,06W 0603	Philips	2322 702 60103	40-41000-121	1
R5	100k Ohm 5% 0,06W 0603	Philips	2322 702 60104	40-51000-121	1

08-06320-001 - Desk Console PCB (Voice)

BOM Revision
Date Valid On

04 -- Production
28.09.2006

Ref	Description	Manufacturer	Manufacturer's P/N	Codan P/N	Qty
R6	100k Ohm 5% 0,06W 0603	Philips	2322 702 60104	40-51000-121	1
R7	100k Ohm 5% 0,06W 0603	Philips	2322 702 60104	40-51000-121	1
R8	10k Ohm 5% 0,06W 0603	Philips	2322 702 60103	40-41000-121	1
R9	1k Ohm 5% 0,06W 0603	Philips	2322 702 60102	40-31000-121	1
R10	2,2k Ohm 5% 0,06W 0603	Philips	2322 702 60222	40-32200-121	1
R11	4,7k Ohm 5% 0,06W 0603	Philips	2322 702 60472	40-34700-121	1
R12	4,7k Ohm 5% 0,06W 0603	Philips	2322 702 60472	40-34700-121	1
R13	4,7k Ohm 5% 0,06W 0603	Philips	2322 702 60472	40-34700-121	1
R14	100k Ohm 5% 0,06W 0603	Philips	2322 702 60104	40-51000-121	1
R15	47k Ohm 5% 0,06W 0603	Philips	2322 702 60473	40-44700-121	1
R16	47k Ohm 5% 0,06W 0603	Philips	2322 702 60473	40-44700-121	1
R17	1k Ohm 5% 0,06W 0603	Philips	2322 702 60102	40-31000-121	1
R18	1k Ohm 5% 0,06W 0603	Philips	2322 702 60102	40-31000-121	1
R19	47k Ohm 5% 0,06W 0603	Philips	2322 702 60473	40-44700-121	1
R20	47k Ohm 5% 0,06W 0603	Philips	2322 702 60473	40-44700-121	1
R21	100k Ohm 5% 0,06W 0603	Philips	2322 702 60104	40-51000-121	1
R22	470 Ohm 5% 0,06W 0603	Philips	2322 702 60471	40-24700-121	1
R23	470 Ohm 5% 0,06W 0603	Philips	2322 702 60471	40-24700-121	1
R24	470 Ohm 5% 0,06W 0603	Philips	2322 702 60471	40-24700-121	1
R25	470 Ohm 5% 0,06W 0603	Philips	2322 702 60471	40-24700-121	1
R26	470 Ohm 5% 0,06W 0603	Philips	2322 702 60471	40-24700-121	1
R27	220 Ohm 5% 0,06W 0603	Philips	2322 702 60221	40-22200-121	1
R28	220 Ohm 5% 0,06W 0603	Philips	2322 702 60221	40-22200-121	1
R29	4,7k Ohm 5% 0,06W 0603	Philips	2322 702 60472	40-34700-121	1
R30	4,7k Ohm 5% 0,06W 0603	Philips	2322 702 60472	40-34700-121	1
R31	4,7k Ohm 5% 0,06W 0603	Philips	2322 702 60472	40-34700-121	1
R32	4,7k Ohm 5% 0,06W 0603	Philips	2322 702 60472	40-34700-121	1
V1	Transistor, PNP Si SOT23	Philips	BC857	BC857	1
V2	Diode, Zener 6,8V 5% 0,2W SOT23	Philips	BZX84C6V8	BZX84C6V8	1

08-06320-001 - Desk Console PCB (Voice)

BOM Revision
Date Valid On

04 -- Production
28.09.2006

Ref	Description	Manufacturer	Manufacturer's P/N	Codan P/N	Qty
V3	Transistor, NPN Si SOT23	Philips	BC847	BC847	1
V4	Transistor, NPN Si SOT23	Philips	BC847	BC847	1
V5	Transistor, NPN Si SOT23	Philips	BC847	BC847	1
Z1	Crystal, 3686,4 kHz uP Grade	HY-Q	M/P QC49/SMD EBO1C	65-90101	1

The drawings in this section consist of the mechanical and electrical diagrams required to maintain the NGT.

Table 51: NGT—list of drawings

Title	Drawing	Drawing number
Interconnection Diagram		
2010	Circuit diagram	04-03223
2030	Circuit diagram	04-03562
2011	Circuit diagram	04-03437
2012	Circuit diagram	04-03533
Handset Assembly		08-05513
Junction box Assembly		08-05514 (sheet 1) 08-05514 (sheet 2)
RF unit Assembly		
2010/2011/2012		08-05628 (sheet 1) 08-05628 (sheet 2) 08-05628 (sheet 3) 08-05628 (sheet 4)
Handset	Circuit diagram	04-03125
Handset PCB	PCB assembly	08-05300
Keypad PCB	PCB assembly	08-05522
PTT PCB	PCB assembly	08-05523
Power—Emergency PCB	PCB assembly	08-05524
Junction box		
Audio	Circuit diagram	04-03201
	PCB assembly	08-05470
	Circuit diagram	04-03423
	PCB assembly	08-05986 (sheet 1) 08-05986 (sheet 2)
Microprocessor	Circuit diagram	04-03133
	PCB assembly	08-05317

Table 51: NGT—list of drawings (cont.)

Title	Drawing	Drawing number
RF unit (2010)		
Audio Interface	Circuit diagram	04-03109
	PCB assembly	08-05266
Application Processor	Circuit diagram	04-03108 (sheet 1) 04-03108 (sheet 2)
	PCB assembly	08-05265
RF/IF		
RF Mixer	Circuit diagram	04-03106 (sheet 1)
455 kHz IF Modulator/Demodulator	Circuit diagram	04-03106 (sheet 2)
Synthesiser & Control	Circuit diagram	04-03106 (sheet 3)
	PCB assembly	08-05261 (sheet 1) 08-05261 (sheet 2)
Crystal Oven	Circuit diagram	04-03095
	PCB assembly	08-05235
Alternative RF/IF		
RF Mixer	Circuit diagram	04-03378 (sheet 1) , or 04-03378 (sheet 1) for PCB issue -06 or earlier
455 kHz IF Modulator/Demodulator	Circuit diagram	04-03378 (sheet 2) , or 04-03378 (sheet 2) for PCB issue -06 or earlier
Synthesiser & Control	Circuit diagram	04-03378 (sheet 3) , or 04-03378 (sheet 3) for PCB issue -06 or earlier
	PCB assembly	08-05889 (sheet 1) , or 08-05889 (sheet 1) for PCB issue -06 or earlier 08-05889 (sheet 2) , or 08-05889 (sheet 2) for PCB issue -06 or earlier
Crystal Oven	Circuit diagram	04-03410 04-03414
	PCB assembly	08-05963 08-05962 08-05973

Table 51: NGT—list of drawings (cont.)

Title	Drawing	Drawing number
PA Filter & Control	Circuit diagram	04-03169
Power Amplifier	PCB assembly	08-05415
Filter & Control	PCB assembly	08-05416
PA Assembly complete with heatsink	PCB assembly	08-05511 (sheet 1) 08-05511 (sheet 2)
Alternative PA Filter & Control	Circuit diagram	04-03369
Power Amplifier	PCB assembly	08-05869 (sheet 1) 08-05869 (sheet 2) 08-05869 (sheet 3)
Filter & Control	PCB assembly	08-05910 (sheet 1) for PCB issue -04 or earlier 08-05910 (sheet 2) for PCB issue -04 or earlier
Alternative PA Filter & Control	Circuit diagram	04-03542
Power Amplifier	PCB assembly	08-06461 (sheet 1) 08-06461 (sheet 2) 08-06461 (sheet 3)
Filter & Control	PCB assembly	08-05910 (sheet 1) 08-05910 (sheet 2)
RF unit (2011)		
Audio & Interconnect	Circuit diagram	04-03425
	PCB assembly	08-05988 (sheet 1) 08-05988 (sheet 2)
Application Processor Handset I/F 3 V	Circuit diagram	04-03424 (sheet 1) 04-03424 (sheet 2)
	PCB assembly	08-05987

Table 51: NGT—list of drawings (cont.)

Title	Drawing	Drawing number
RF/IF		
RF Mixer	Circuit diagram	04-03378 (sheet 1), or 04-03378 (sheet 1) for PCB issue -06 or earlier
455 kHz IF Modulator/Demodulator	Circuit diagram	04-03378 (sheet 2), or 04-03378 (sheet 2) for PCB issue -06 or earlier
Synthesiser & Control	Circuit diagram	04-03378 (sheet 3), or 04-03378 (sheet 3) for PCB issue -06 or earlier
	PCB assembly	08-05889 (sheet 1), or 08-05889 (sheet 1) for PCB issue -06 or earlier 08-05889 (sheet 2), or 08-05889 (sheet 2) for PCB issue -06 or earlier
Crystal Oven	Circuit diagram	04-03410 04-03414
	PCB assembly	08-05963 08-05962 08-05973
PA Filter & Control	Circuit diagram	04-03369
Power Amplifier	PCB assembly	08-05869 (sheet 1) 08-05869 (sheet 2) 08-05869 (sheet 3)
Filter and Control	PCB assembly	08-05910 (sheet 1) for PCB issue -04 or earlier 08-05910 (sheet 2) for PCB issue -04 or earlier
Alternative PA Filter & Control	Circuit diagram	04-03542
Power Amplifier	PCB assembly	08-06461 (sheet 1) 08-06461 (sheet 2) 08-06461 (sheet 3)
Filter & Control	PCB assembly	08-05910 (sheet 1) 08-05910 (sheet 2)
RF unit (2012)		
Audio Interconnect & Data I/O	Circuit diagram	04-03499 (sheet 1) 04-03499 (sheet 2)
	PCB assembly	08-06261 (sheet 1) 08-06261 (sheet 2)

Table 51: NGT—list of drawings (cont.)

Title	Drawing	Drawing number
Application Processor Handset & Data I/F	Circuit diagram	04-03498 (sheet 1)
		04-03498 (sheet 2)
	PCB assembly	08-06260
RF/IF		
RF Mixer	Circuit diagram	04-03378 (sheet 1), or
		04-03378 (sheet 1) for PCB issue
		-06 or earlier
455 kHz IF Modulator/Demodulator	Circuit diagram	04-03378 (sheet 2), or
		04-03378 (sheet 2) for PCB issue
		-06 or earlier
Synthesiser & Control	Circuit diagram	04-03378 (sheet 3), or
		04-03378 (sheet 3) for PCB issue
		-06 or earlier
	PCB assembly	08-05889 (sheet 1), or
		08-05889 (sheet 1) for PCB issue
		-06 or earlier
		08-05889 (sheet 2), or
		08-05889 (sheet 2) for PCB issue
		-06 or earlier
Crystal Oven	Circuit diagram	04-03410
		04-03414
	PCB assembly	08-05963
		08-05962
		08-05973
PA Filter & Control	Circuit diagram	04-03369
Power Amplifier	PCB assembly	08-05869 (sheet 1)
		08-05869 (sheet 2)
		08-05869 (sheet 3)
Filter and Control	PCB assembly	08-05910 (sheet 1) for PCB issue
		-04 or earlier
		08-05910 (sheet 2) for PCB issue
		-04 or earlier
Alternative PA Filter & Control	Circuit diagram	04-03542
Power Amplifier	PCB assembly	08-06461 (sheet 1)
		08-06461 (sheet 2)
		08-06461 (sheet 3)
Filter & Control	PCB assembly	08-05910 (sheet 1)
		08-05910 (sheet 2)

Table 51: NGT—list of drawings (cont.)

Title	Drawing	Drawing number
Second IF Filter Option	Circuit diagram	04-03379
	PCB assembly	08-05890
500 Hz Filter Option	Fitting instructions	15-10506-001
2700 Hz Filter Option	Fitting instructions	15-10514-001
Desk console (15-10471)	Circuit diagram	04-03110
	PCB assembly	08-05267
Desk console (15-00766)	Circuit diagram	04-03514
	PCB assembly	08-06320
Transceiver test unit	Circuit diagram	04-03272

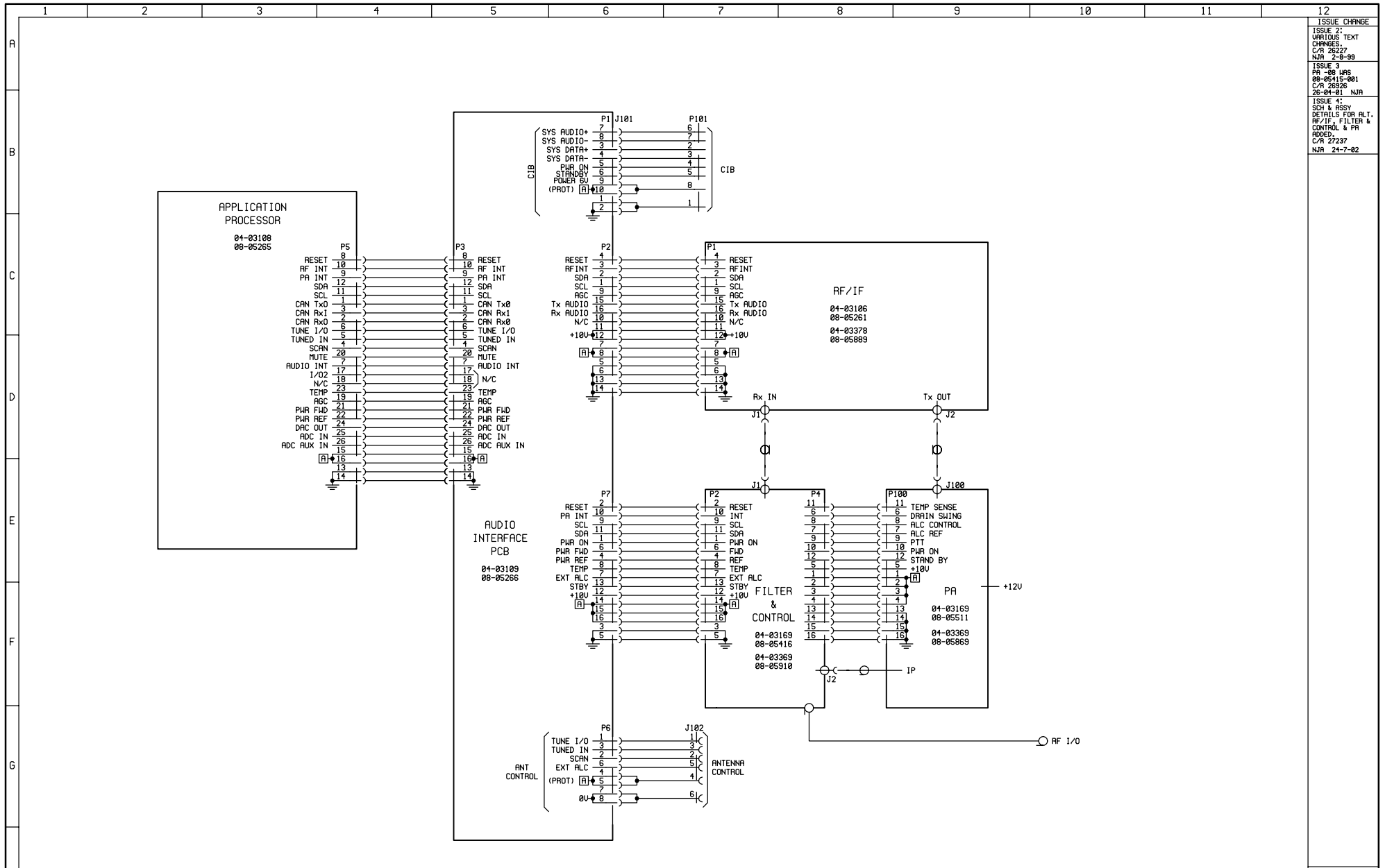

ISSUE CHANGE
ISSUE 2: VARIOUS TEXT CHANGES: C/R 26227 NJR 2-8-99
ISSUE 3 PA -08 1496 08-05416-001 C/R 26826 28-04-01 NJR
ISSUE 4: SCH & ASSY DETAILS FOR ALI, RF/IF - FILTER & CONTROL & PA ASSEMBLY: C/R 27237 NJR 24-7-02

FILE NAME
04\03223...4.X

	SCALE	DATE	© CODAN PTY. LTD., A.C.N. 087 530 685, 1998 TITLE 2010 INTERCONNECTION DIAGRAM
	DRN C G	14-5-99	
MATERIAL	CHKD NJR	8-7-99	DRAWING/DOC. NO 04-03223
FINISH	APPD NJR	8-7-99	
TOLERANCES UNLESS OTHERWISE STATED 2 PLACES DEC. ± 1 PLACE DEC. ± ANGULAR ±			ISS A1 04-03223
			SHT 1 OF 1

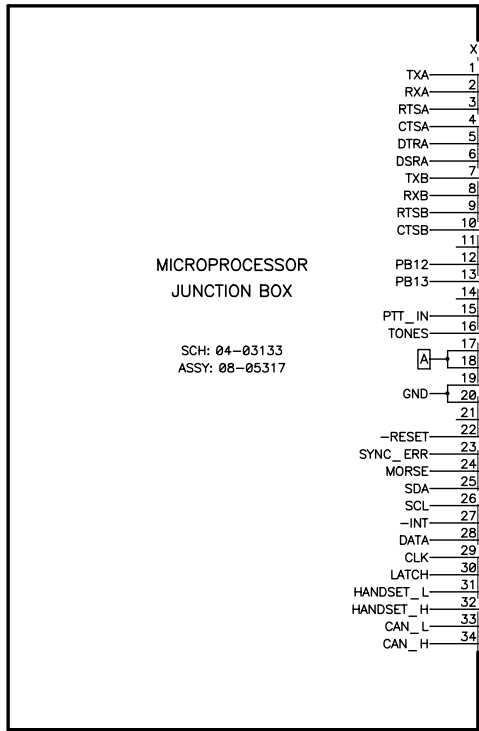

**MICROPROCESSOR
JUNCTION BOX**

SCH: 04-03133
ASSY: 08-05317

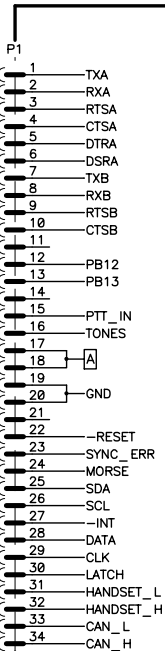

**AUDIO,
JUNCTION BOX**

OBSOLETE:
SCH: 04-03201
ASSY: 08-05740

SCH: 04-03423
ASSY: 08-05986

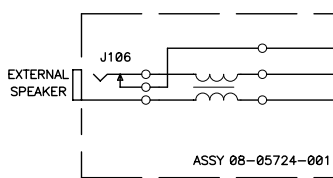
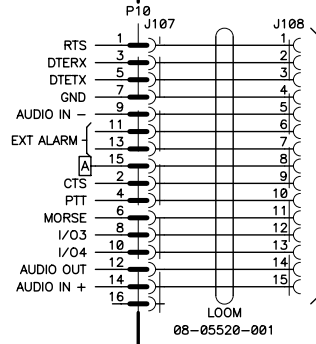
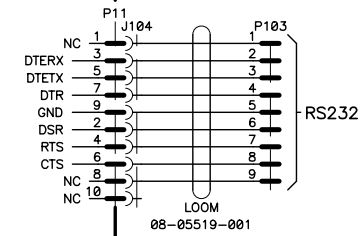
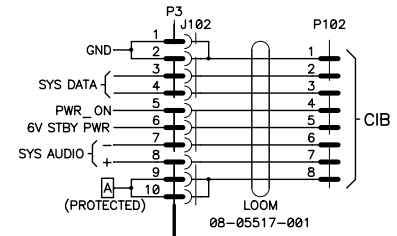
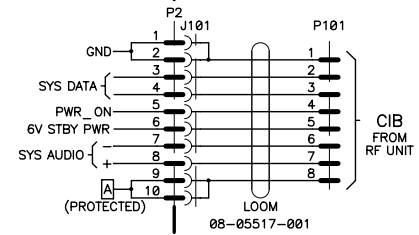

ASSY 08-05724-001

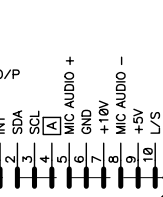

DESK CONSOLE

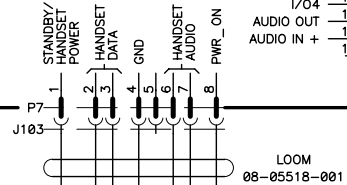

HANDSET/MIC

SCALE			© CODAN LIMITED, ACN 007 590 605, 2006 The information contained herein is proprietary to Codan Ltd. and is to be used by the recipient solely for the purpose for which it is supplied. Codan does not permit the recipient to copy, adapt, publish or disclose the information to third parties except as otherwise agreed with Codan in writing.
DRN	C G		
CHKD	D J	DATE	30-3-06
APPD		TITLE	A2 INTERCONNECT DIAGRAM 2030
ISS	1	DRAWING/DOC NO.	04-03562
		SHT. 1 OF 1	

FILE NAME
03562_1.SCH

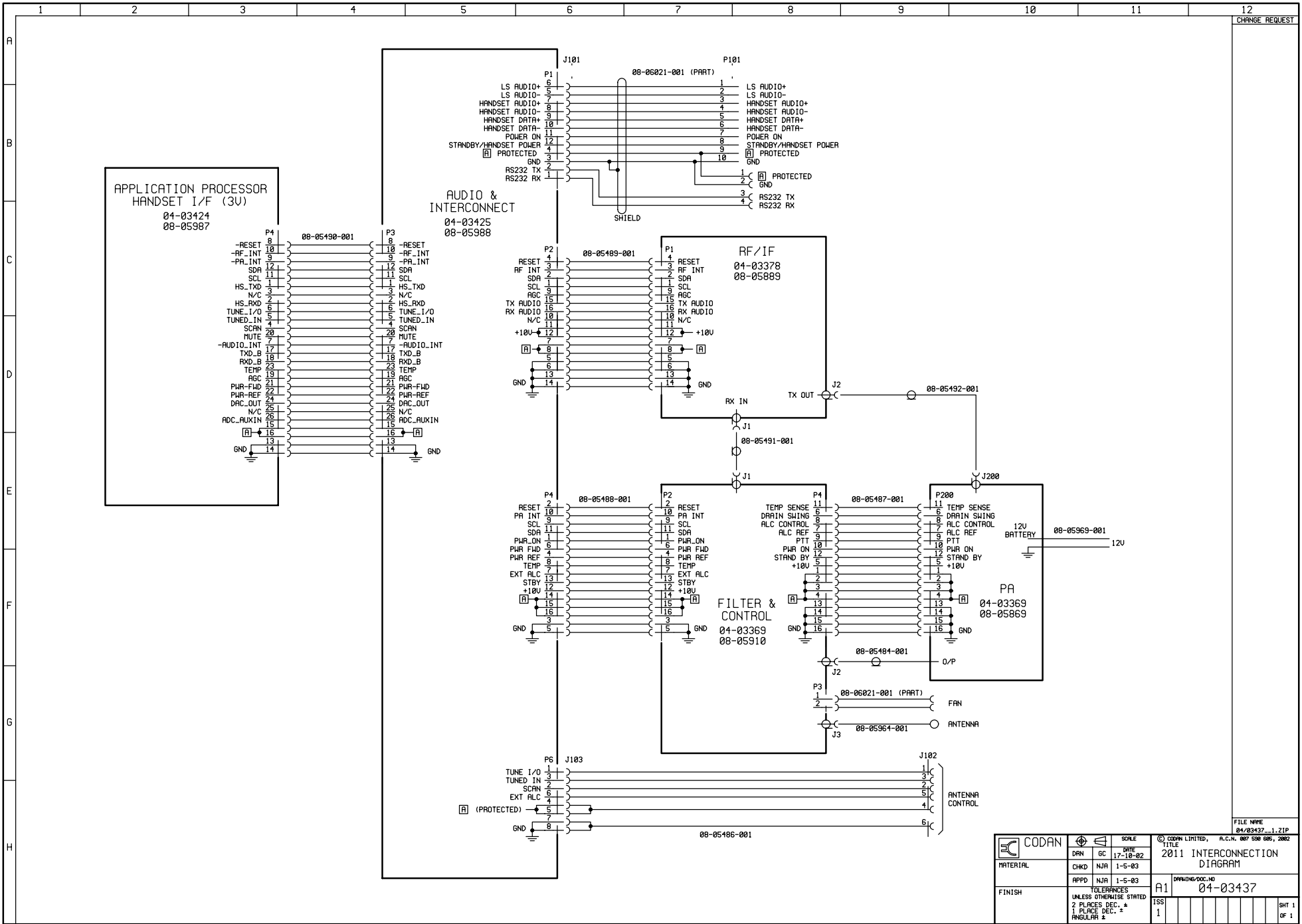

CHANGE REQUEST

		SCALE DRN GC DATE 17-10-02 CHKD NJR 1-5-03	© CODAN LIMITED, A.C.N. 007 500 000, 2002 TITLE 2011 INTERCONNECTION DIAGRAM
MATERIAL	APPD NJR 1-5-03	FINISH	DRWING/DOC. NO. 04-03437
TOLERANCES UNLESS OTHERWISE STATED 2 PLACES DEC. ± 1 PLACE DEC. ± ANGULAR ±		ISS 1	SHT 1 OF 1

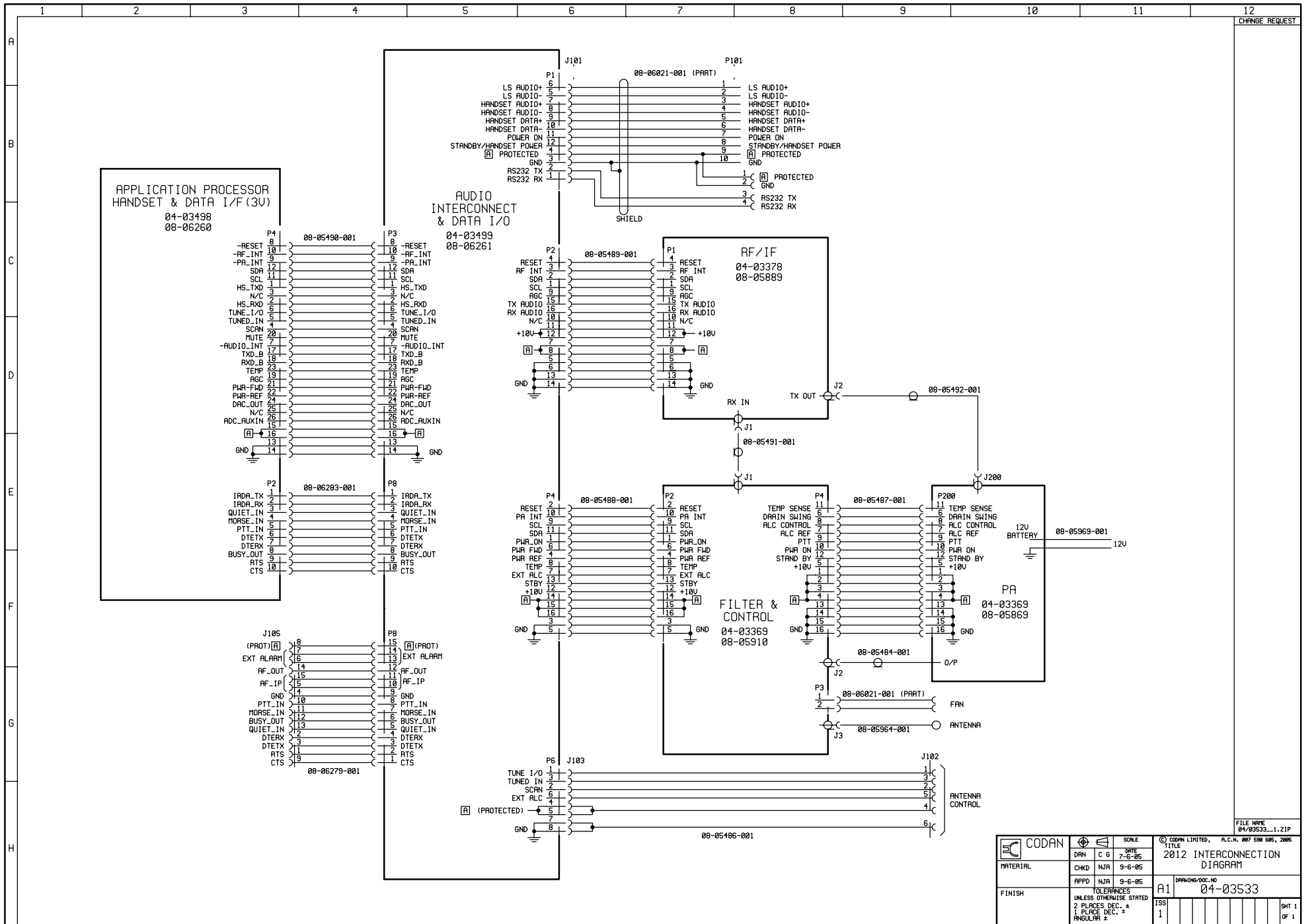

FILE NAME
04/03533...1.ZIP

CODAN		SCALE	© CODAN LIMITED, A.C.N. 007 530 085, 2005	
DRN	C G	DATE	TITLE	
CHKD	NJA	7-6-05	2012 INTERCONNECTION DIAGRAM	
APPD	NJA	9-6-05	DRAWING/DOC. NO.	
FINISH		TOLERANCES	04-03533	
		UNLESS OTHERWISE STATED	ISS	
		2 PLACES DEC. ±	1	
		1 PLACE DEC. ±		
		ANGULAR S		
			SHT 1	OF 1

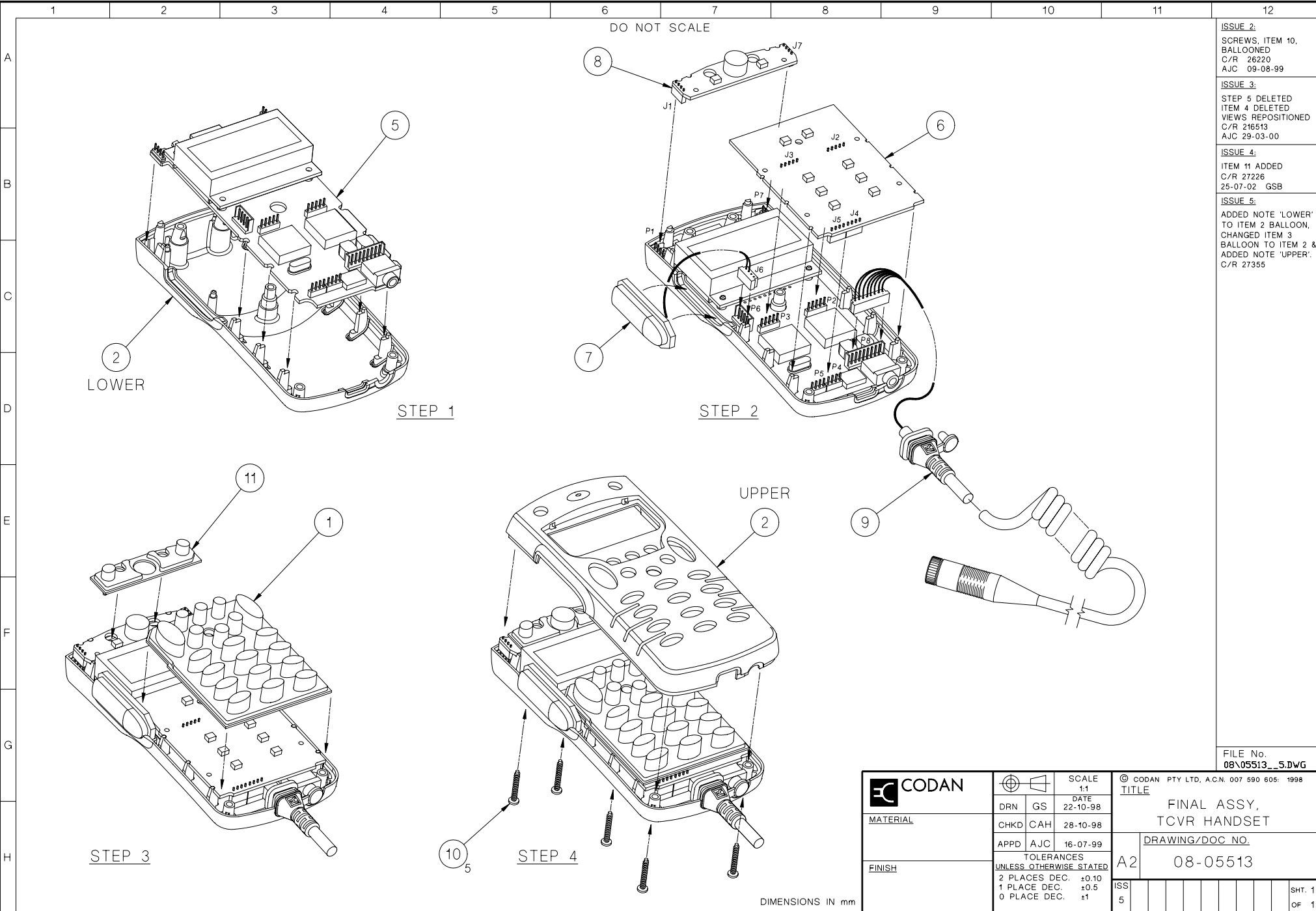

ISSUE 2:
SCREWS, ITEM 10,
BALLOONED
C/R 26220
AJC 09-08-99

ISSUE 3:
STEP 5 DELETED
ITEM 4 DELETED
VIEWS REPOSITIONED
C/R 216513
AJC 29-03-00

ISSUE 4:
ITEM 11 ADDED
C/R 27226
25-07-02 GSB

ISSUE 5:
ADDED NOTE 'LOWER'
TO ITEM 2 BALLOON,
CHANGED ITEM 3
BALLOON TO ITEM 2 &
ADDED NOTE 'UPPER'.
C/R 27355

FILE No.
08\05513_5.DWG

	SCALE 1:1		© CODAN PTY LTD, A.C.N. 007 590 605. 1998 TITLE FINAL ASSY, TCVR HANDSET
	DRN	GS	
MATERIAL	CHKD	CAH	28-10-98
FINISH	APPD	AJC	16-07-99
	TOLERANCES UNLESS OTHERWISE STATED		
	2 PLACES DEC. ±0.10 1 PLACE DEC. ±0.5 0 PLACE DEC. ±1		
DRAWING/DOC NO. 08-05513		ISS	5
DIMENSIONS IN mm			SHT. 1 OF 1

DO NOT SCALE

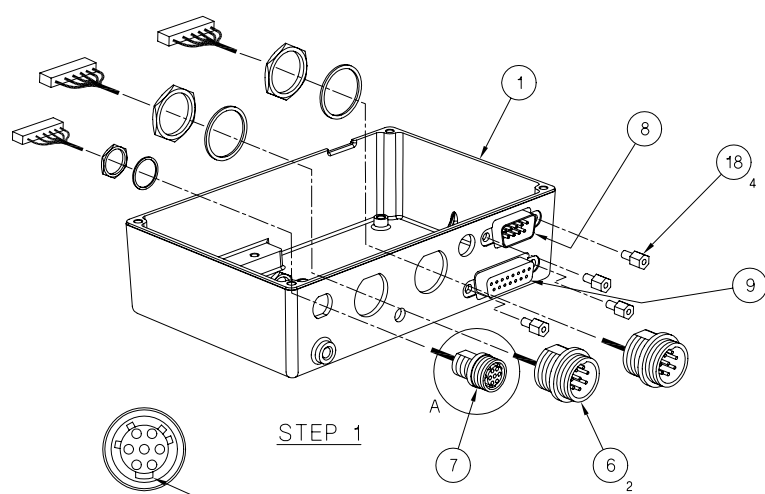

DETAIL A
SCALE 2:1
LARGE KEY
ORIENTATION - DOWN

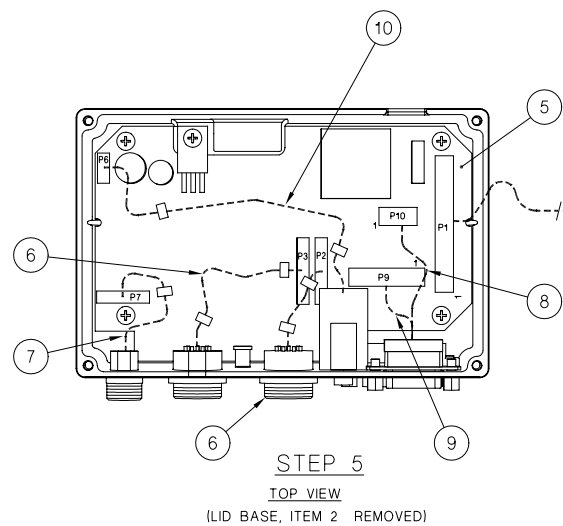
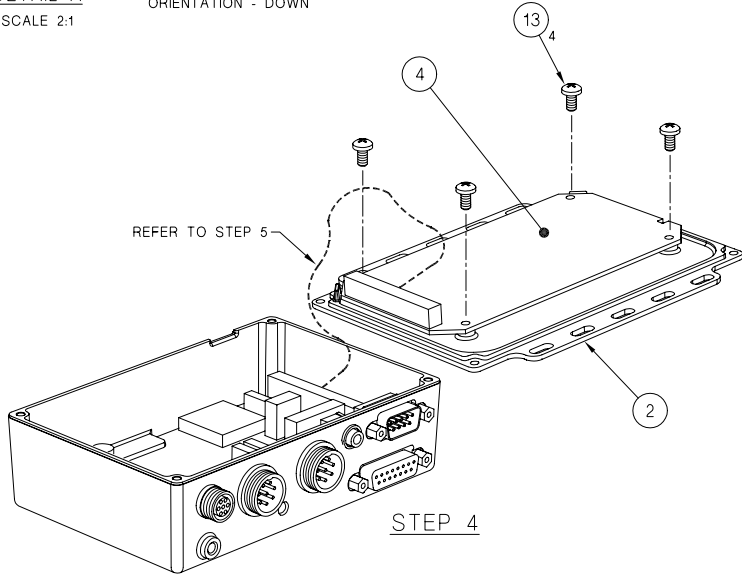
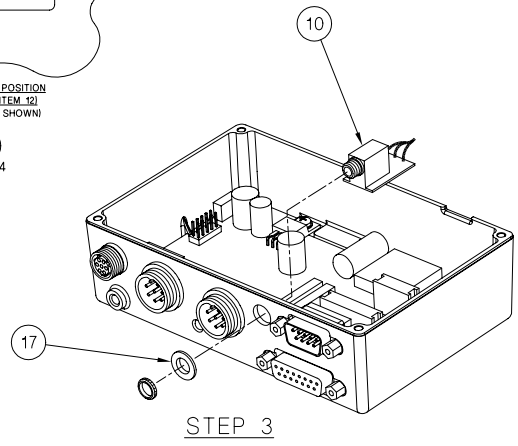
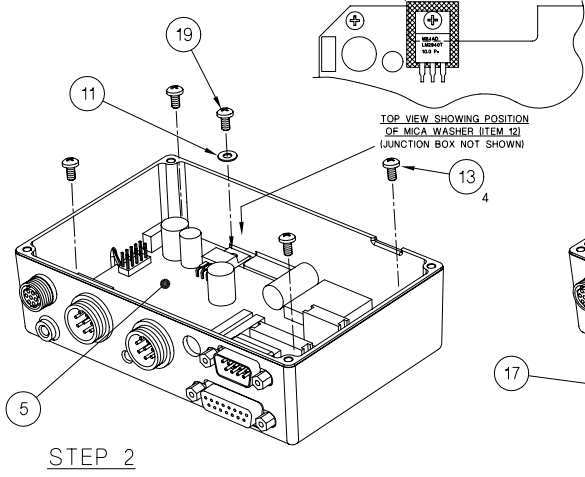

DESCRIPTION	ITEM No.	CONNECT TO
PCB, MICROPROCESSOR	4	P1
LOOM, CIB	6	P2
LOOM, CIB	6	P3
LOOM, HANDSET	7	P7
LOOM, SERIAL	8	P10
LOOM, GPIO	9	P9
ASSY, SPEAKER FILTER	10	P6

ISSUE B:
ITEMS 18&16 IN STEP 4
WERE SHOWN IN STEP 2
C/R 26888
P/M: 19-01-99

ISSUE C:
ITEM 10 CHANGED TO
SHOW PCB
TABLE UPDATED.
ITEM NOS ADDED TO
STEP 5 VIEW.
C/R 25984
N/A 22-3-99

ISSUE D:
ITEM 19 ADDED
QTY ITEM 13 WAS 6
C/R 26197
SSA 2-1-99

ISSUE E:
STEP 4 - EARTH SCREW
& WASHERS, ITEMS 15
& 16, DELETED
STEP 2 WAS STEP 3
NEW STEP 3 ADDED
REFER ALSO SH 2
C/R 26619
A/JC 29-03-00

ISSUE F:
STEP 1 - ITEM 9 WAS
ITEM 19 (CORRECTED)
LOOM ADDED PICTORIALY
TO ITEM 7
C/R 26953
A/JC 27-04-2001

ISSUE G:
C/R 27407
AUDIO BOARD (ITEM 6)
CHANGED.
J/D: 17-12-02

FILE No.
08\05514_4.DWG

ASSEMBLY, STAGE 1

ASSEMBLY STAGES	SHEET No.
ASSEMBLY, STAGE 1	SHEET 1
TEST, STAGE 2	SHEET 2

PART No. 08-05514-001
DIMENSIONS IN mm

CODAN	SCALE	NTS	© CODAN PTY LTD, ACN. 007 690 606- 1998	TITLE	TCVR JUNCTION BOX
	DRN	SMC			
MATERIAL	CHKD	CAH	04-11-98	DRAWING/DOC NO.	A1 08-05514
	APPD	AJC	16-07-99		
FINISH	TOLERANCES			ISS	SHT. 1 OF 2
	UNLESS OTHERWISE STATED				
	2 PLACES DEC.	10.25			
	1 PLACE DEC.	10.5			
0 PLACE DEC.	11				
ANGULAR	12*				

DO NOT SCALE

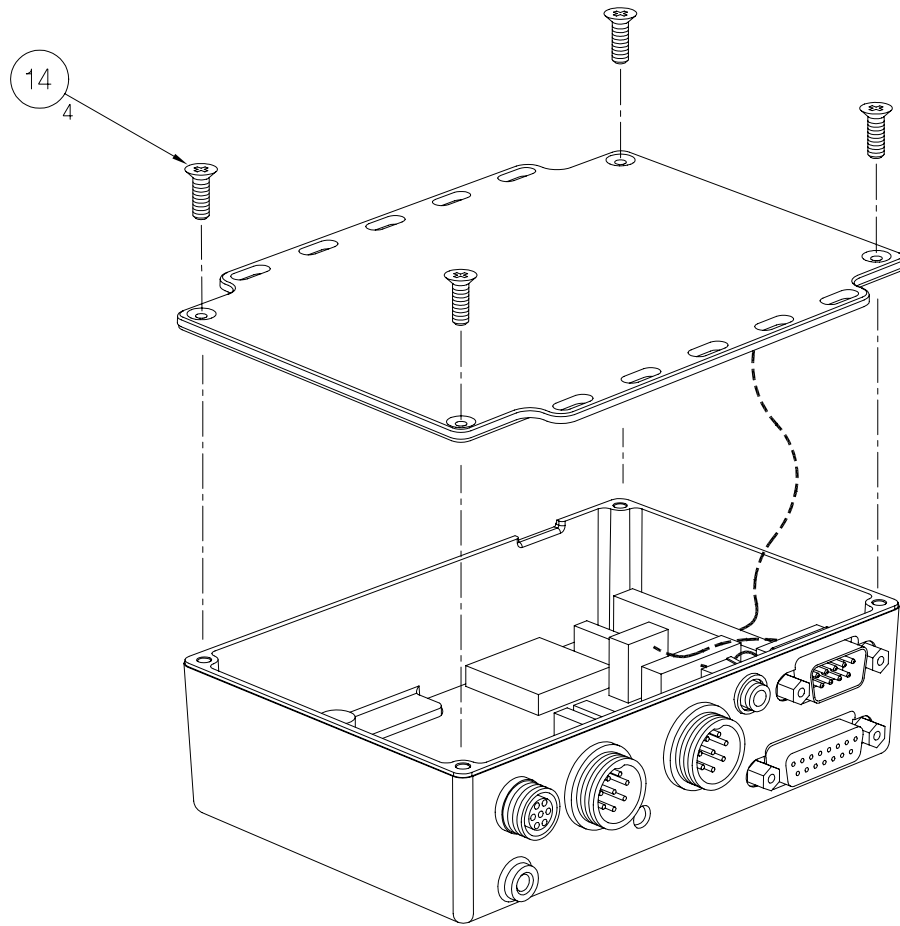

TEST, STAGE 2

DIMENSIONS IN mm

ASSEMBLY STAGES	SHEET No.
ASSEMBLY, STAGE 1	SHEET 1
TEST, STAGE 2	SHEET 2

ISSUE B: REF SH 1
ISSUE C: REFER SH 1 C/R 25984
ISSUE D: REFER SH 1 C/R 26187
ISSUE 2: VIEW OF JUNCTION BOX FULLY ASSEMBLED DELETED LABEL, ITEM 3, DELETED SH SIZE REDUCED EARTH SCREW DELETED REFER ALSO SH 1 C/R 26513
ISSUE 3: REFER SH 1 C/R 26953
ISSUE 4: REFER SH 1 C/R 27407

FILE No.
08\05514_4.DWG

			SCALE NTS	© CODAN PTY LTD, A.C.N. 007 590 605: 2000 TITLE TCVR JUNCTION BOX
	DRN	SMC	DATE 08-10-98	
MATERIAL	CHKD	CAH	DATE 04-11-98	DRAWING/DOC NO. 08-05514
FINISH	APPD	AJC	DATE 16-07-99	
	TOLERANCES UNLESS OTHERWISE STATED			A3
	2 PLACES DEC. ±0.25 1 PLACE DEC. ±0.5 0 PLACE DEC. ±1			
				ISS 4
				SHT. 2 OF 2

DO NOT SCALE

ISSUE 7
ADDED SRx AS
009 VARIANT1
CR 28178
NJA 22-09-2004

ISSUE 8
WASHERS ADDED.
SCREWS WERE 6 LG.
NOTE 2 ADDED.
TITLE CHANGED.
RIBBON CABLE ADDED
TO PCB, ITEM 103.
REFER ALSO SH 2
C/R 28471, 28472,
28320 & 28597
NJA 04-07-2005

ISSUE 9
ITEM 19 ADDED
TO SH 4
C/R 30095
08-02-06 KMW

ISSUE 10
VARIANT -010
ADDED SH 4
C/R 30194
NJA 03-03-08

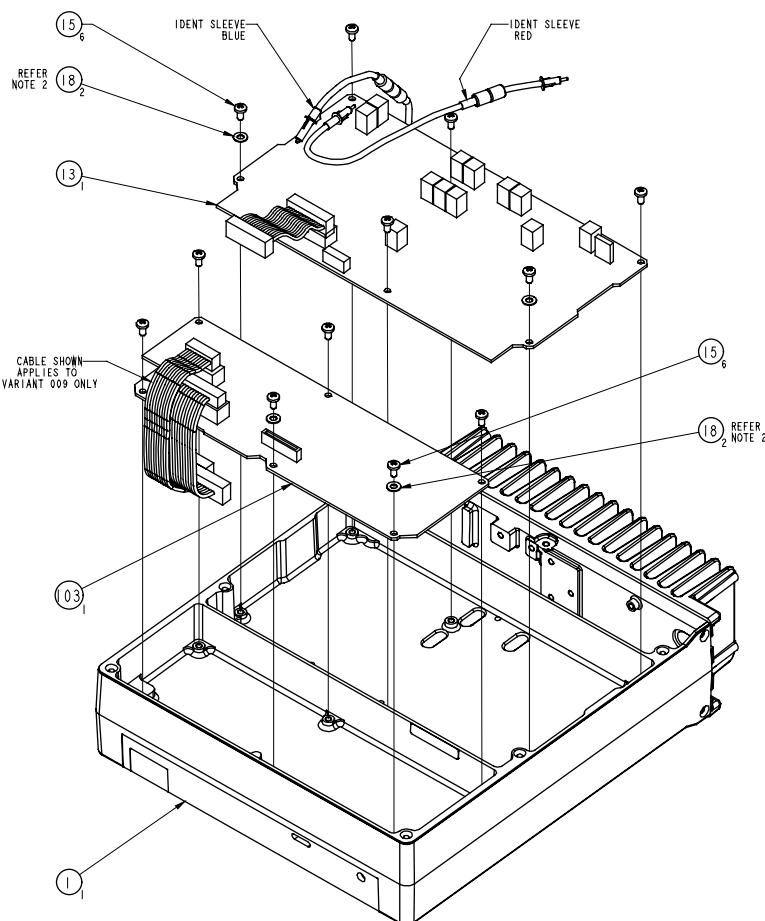

STEP 1
RF INTERMEDIATE FREQUENCY PCB AND
APPLICATION PROCESSOR PCB
UNDERNEATH SIDE ASSEMBLY

NOTES:
1. REFER SHEET 4 FOR PRODUCT VARIANT TABLE
2. MARK PCB AND ALL 8 SCREWS, ITEM 15, THAT REQUIRE
A WASHER, ITEM 18, WITH RED COLOURED PAINT MARKER.

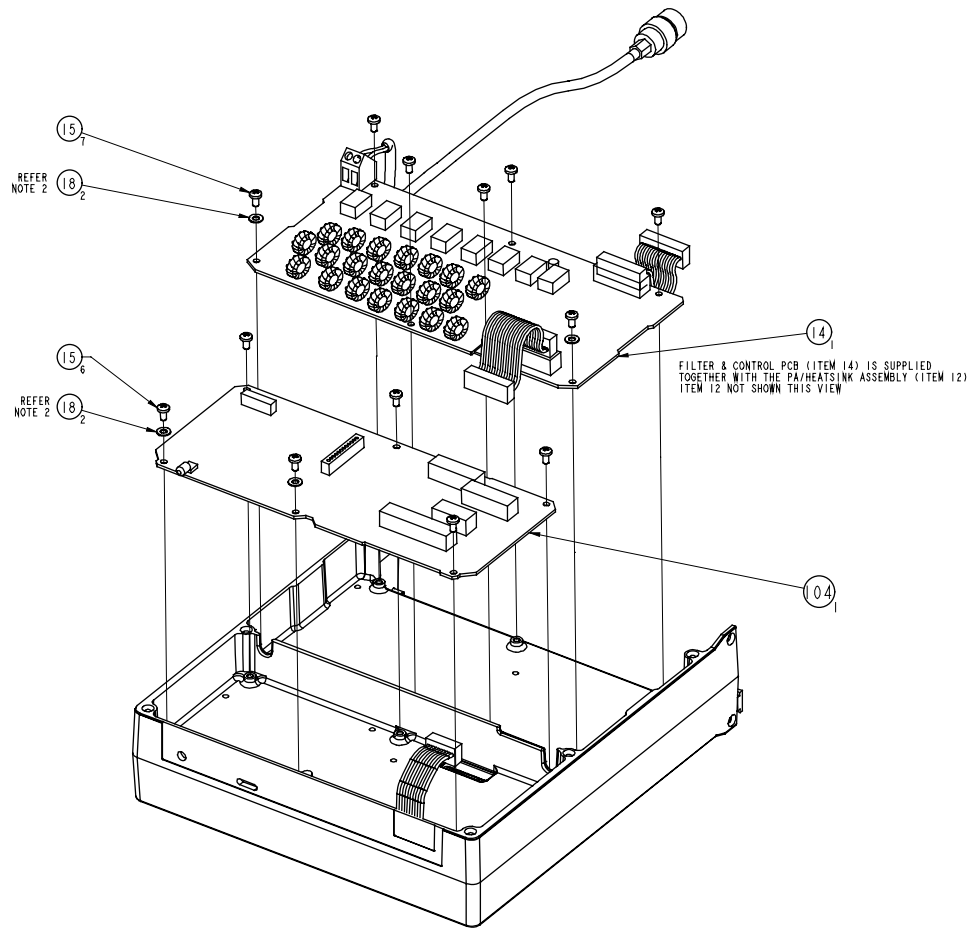

STEP 2
AUDIO / INTERCONNECT PCB
AND FILTER CONTROL PCB
TOP SIDE ASSEMBLY
NOTE: APPLY BARCODE / SERIAL No. LABEL (ITEM 8)
REF. MANUFACTURING WORK INSTRUCTIONS

DIMENSIONS IN mm

0.2 x 45° R0.2 max		SCALE 1.000		DATE 06-11-98		©CODAN LIMITED, ACN 007 590 603: 2009	
DRN DAB		MATERIAL		CHKD CAH		CODAN	
APPD SCS		FINISH		TOLERANCES UNLESS OTHERWISE SPECIFIED		TITLE	
LINEAR ± 0.2		A1		FINAL ASSEMBLY, NGT RF UNIT		100 DRAWING/DOC No.	
ANGULAR ± 0.5°		I/O		08-05628		SHT.1	
FLATNESS ± 0.2						OF 4	
ROUGHNESS 1.6 µmRa							

DO NOT SCALE

ISSUE 3
NEW SHT2 ADDED
(MAY BE SET OF 00-0001L.3)
C/R 27256
AJC 31-01-02

ISSUE 4
REF. SHT 1
CR27478
VIEW 'A' ALTERED
CRIMP LUG POS.
CR27479
AJC 24-02-03

ISSUE 5
REF. SHT 4
CR27576
SSJ 10-06-03

ISSUE 6
REF. SHT 1
CR 27720
CR 27801
CR 27769
KMW 12-1-04

ISSUE 7
REF. SHT 1
CR 28178
NJA 22-09-04

ISSUE 8
VARIANT 009 ADDED
TO BALLOON 105
REFER ALSO SH 1

ISSUE 9
REFER TO SHT 4

ISSUE 10
REFER TO SHT 4

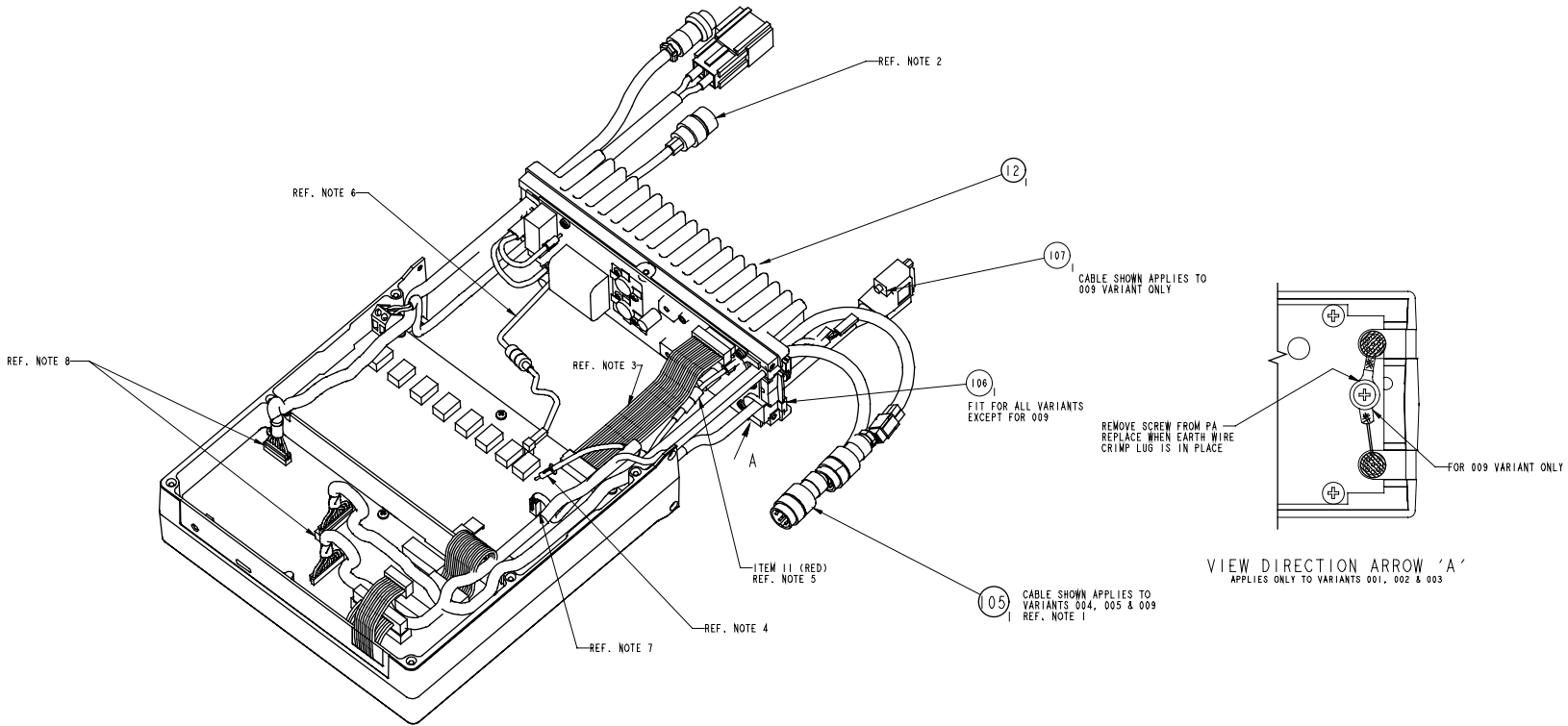

STEP 3
TOP SIDE CABLE ASSEMBLY ARRANGEMENT
REFER NOTES BELOW

- NOTES:
1. INSERT CABLE ITEM 105 AS SHOWN
 2. PRESS THE GROMMET OF THE CABLE FROM FILTER & CONTROL PCB ITEM 14 INTO THE HEATSINK AS SHOWN.
 3. CONNECT RIBBON CABLE FROM P4 ON FILTER & CONTROL PCB ITEM 14 TO P200 ON PA PCB ITEM 12 AS SHOWN.
 4. CONNECT COAX WITH BLUE SLEEVES ITEM 10 FROM J1 ON FILTER & CONTROL PCB ITEM 14 TO J1 ON RF/IF PCB ITEM 13 AS SHOWN.
 5. CONNECT COAX WITH RED SLEEVES ITEM 11 FROM J2 OF RF/IF PCB ITEM 13 TO J200 ON PA PCB ITEM 12 AS SHOWN.
 6. PLUG COAX FROM PA OUTPUT TRANSFORMER INTO J2 ON FILTER & CONTROL PCB ITEM 14 AS SHOWN.
 7. PLUG FAN CONTROL LOOM (RED AND BLACK TWISTED PAIR) FROM THE HEATSINK INTO P3 OF THE FILTER & CONTROL ITEM 14 AS SHOWN.
 8. PLUG REMAINING HEATSINK CABLES INTO AUDIO INTERCONNECT PCB ITEM 104 AS SHOWN.

VIEW DIRECTION ARROW 'A'
APPLIES ONLY TO VARIANTS 001, 002 & 003

DIMENSIONS IN mm

0.2 x 45° R0.2 max		SCALE 1:000	©CODAN LIMITED, ACN 007 590 603: 2009 The information contained herein is proprietary to Codan Limited and is to be used by the recipient only for the purpose for which it is supplied. Codan does not warrant the recipient the accuracy, reliability or absence of alterations to this product or any other information without the prior written approval of Codan.
MATERIAL	DRN DAB 06-11-98	DATE	
FINISH	CHKD CAH 11-11-98	DATE	TITLE FINAL ASSEMBLY, NGT RF UNIT
	APPD SCS 16-07-99	DATE	
TOLERANCES UNLESS OTHERWISE SPECIFIED LINEAR ± 0.2 ANGULAR ± 0.5° FLATNESS ± 0.2 ROUGHNESS 1.6 µmRa		A1	100 DRAWING/DOC NO. 08-05628
			SHT 2 OF 4

DO NOT SCALE

ISSUE 3
NEW SHT3 ADDED
[REV SHT3 OF 08-05612.3]
C/R 27256
AJC 31-01-03

ISSUE 4
REF. SHT 1
CR27478
AJC 24-02-03

ISSUE 5
REF. SHT 4
CR27576
SSJ 10-06-03

ISSUE 6
REF SHT 1
CR 27720
CR 27801
CR 27769
KMW 12-1-04

ISSUE 7
REF SHT 1
CR 28178
NJA 20-09-04

ISSUE 8
REFER SH 1 & 2

ISSUE 9
REFER TO SHT 4

ISSUE 10
REFER TO SHT 4

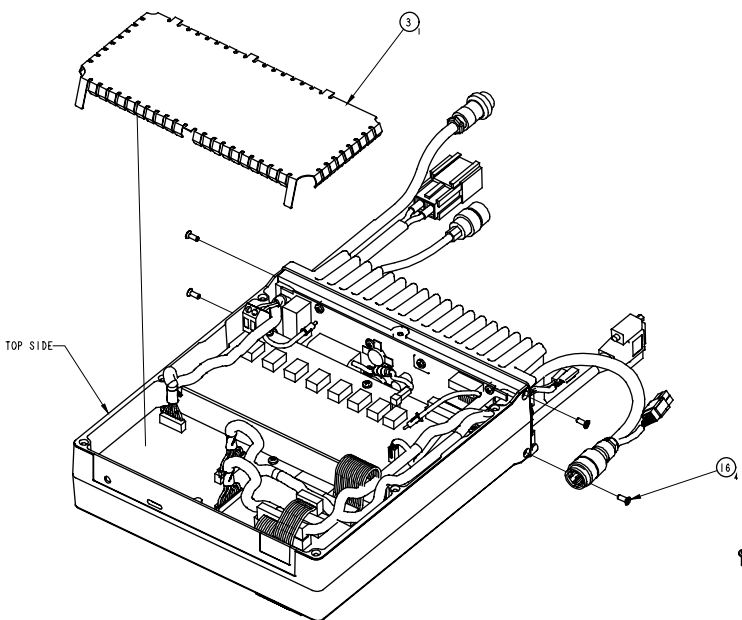

STEP 4
SCREEN, AUDIO INTERFACE
POSITION AT TOP SIDE AS SHOWN

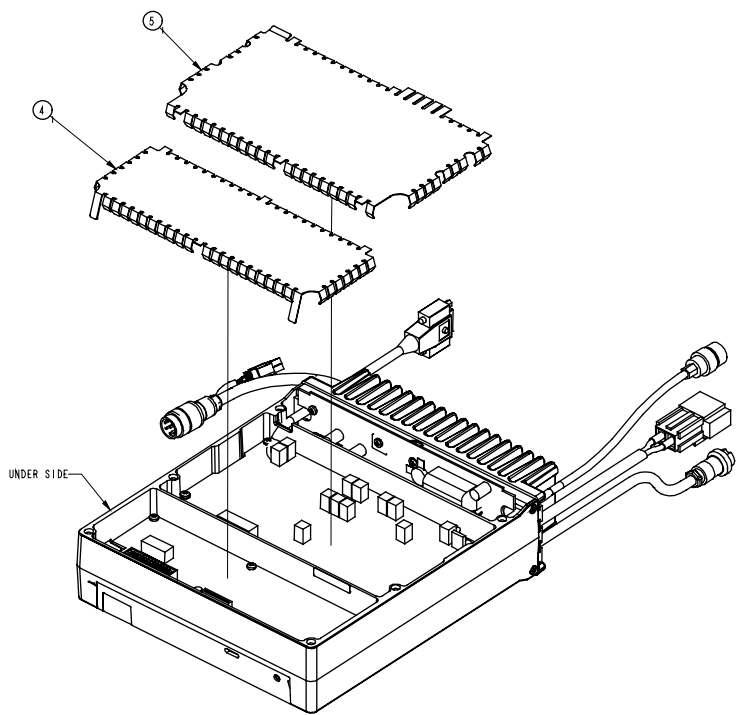

STEP 5
SCREENS - RF/IF AND APPLICATION PROCESSOR
INTERNAL CABLES NOT SHOWN IN THIS VIEW

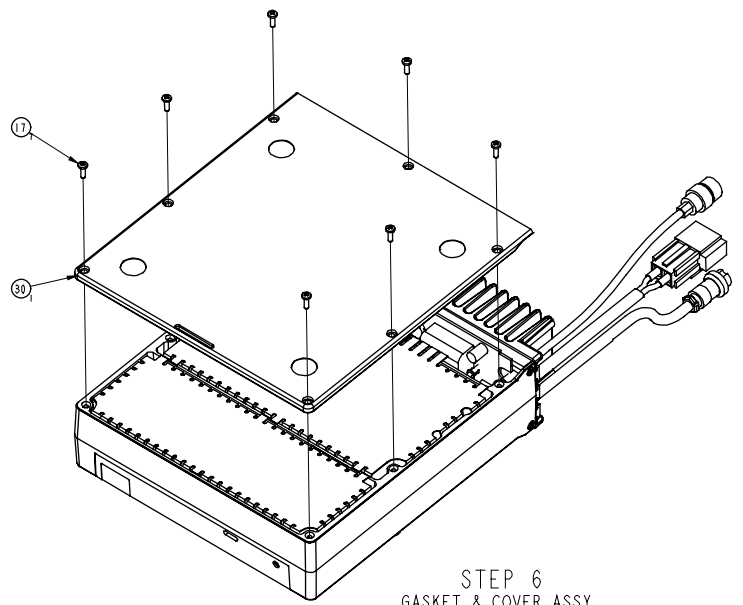

STEP 6
GASKET & COVER ASSY.
(UNDER SIDE ASSEMBLY)

0.2 x 45° R0.2 max		SCALE 1.000	©CODAN LIMITED, ACN 007 590 603: 2009 The information contained herein is proprietary to Codan Limited, and is to be used only for the purposes stated on the purchase order. No part of this information is to be disclosed or distributed to other parties without the prior written approval of Codan Limited.
MATERIAL	DRN DAB	DATE 06-11-98	
FINISH	CHKD CAH	11-11-98	TITLE FINAL ASSEMBLY, NGT RF UNIT
	APPD SCS	16-07-99	
TOLERANCES UNLESS OTHERWISE SPECIFIED		100	DRAWING/DOC NO. 08-05628
LINEAR	± 0.2	10	
ANGULAR	± 0.5°		SHT-3
FLATNESS	± 0.2		OF 4
ROUGHNESS	1.6 µmRa		

DIMENSIONS IN mm

DO NOT SCALE

ISSUE 8
 REF SH 1
 CR 27720
 CR 27601
 CR 27769
 KMW 12-01-2004

ISSUE 7
 REF SH 1
 CR 28178
 NJA 22-09-2004

ISSUE 6
 VARIANT -004
 DESCR CHANGED
 REFER SH 1 & 2

ISSUE 5
 ITEM 19 ADDED
 C/R 30695
 08-02-06 KMW

ISSUE 10
 VARIANT -010
 ADDED
 C/R 30194
 NJA 03-03-06

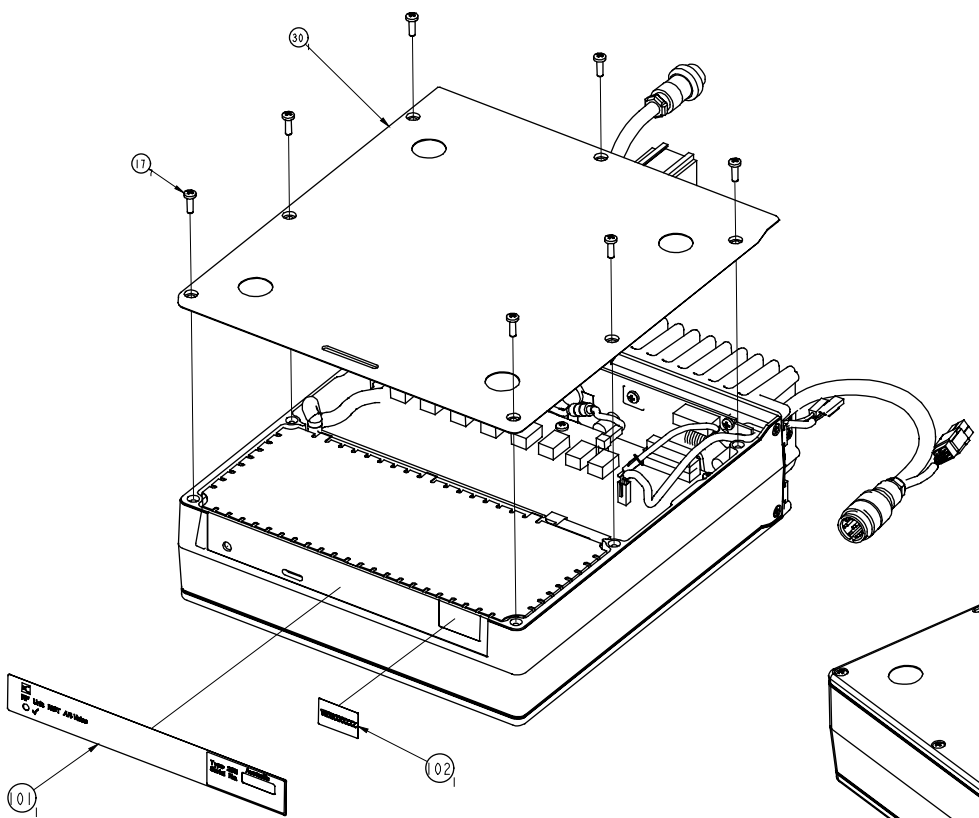

STEP 7
 TOP SIDE COVER & GASKET ASSEMBLY
 APPLY LABELS & ESCUTCHEON
 AT UNIT FRONT AS SHOWN

VARIANT	DESCRIPTION	S/No. FORMAT
08-05628-001	2010 SR	XX03138XXXX
08-05628-002	2010 VR	XX03139XXXX
08-05628-003	2010 AR	XX03140XXXX
08-05628-004	2011 VR	XX35024XXXX
08-05628-005	2011 AR VOICE	XX35025XXXX
08-05628-006	2010 SR SKD	XX35535XXXX
08-05628-007	2010 ASR	XX35590XXXX
08-05628-008	2010 ASR SKD	XX36726XXXX
08-05628-009	2012 SRx	XX38143XXXX
08-05628-010	2011 CR	XX40126XXXX

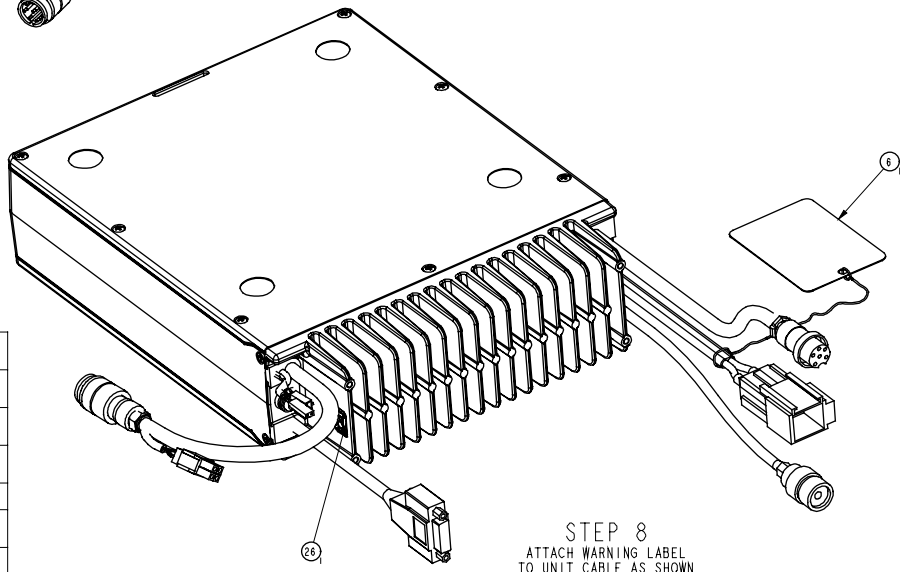

STEP 8
 ATTACH WARNING LABEL
 TO UNIT CABLE AS SHOWN
 AND ATTACH WEEE LABEL
 AS SHOWN.

0.2 x 45° R0.2 max		SCALE 1:000	©CODAN LIMITED, ACN 007 590 603: 2009 The information contained herein is proprietary to Codan Limited and is to be used only for the purposes stated on the purchase order. Codan does not warrant the recipient of this document, or any third party, against any claims or damages arising from its use.
MATERIAL	DRN DAB	DATE 06-11-98	
FINISH	CHKD CAH	11-11-98	TITLE FINAL ASSEMBLY, NGT RF UNIT
APPD SCS		16-07-99	100 DRAWING/DOC NO. 08-05628
TOLERANCES UNLESS OTHERWISE SPECIFIED		ANGULAR ± 0.5°	1 OF 4
		LINEAR ± 0.2	
		FLATNESS ± 0.2	
		ROUGHNESS 1.6 µmRa	

DIMENSIONS IN mm

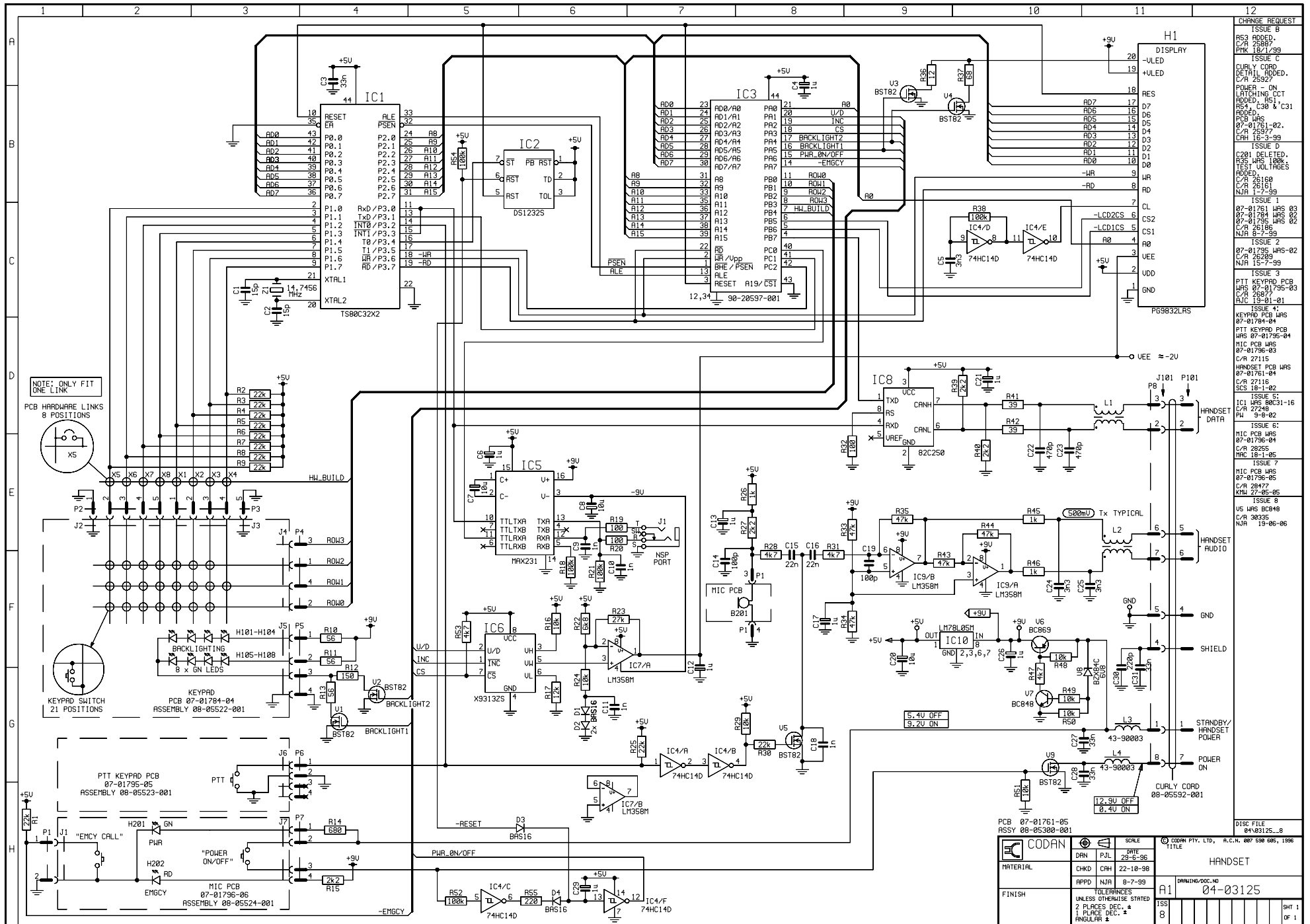

CHANGE REQUEST

ISSUE B
RS3 ADDED.
C/R 25487
PK 18-1-99

ISSUE C
CURLY CORD
DETAIL ADDED.
C/R 25927
POWER - ON
LATCHING CCT
ADDED. RS1
C30 & C31
ADDED.
PCB WRS
07-01761-02.
C/R 25977
C/R 18-3-99

ISSUE D
C201 DELETED.
RS5 WRS 100K
TEST JACKS
ADDED.
C/R 26101
C/R 26101
N/A 1-7-99

ISSUE 1
07-01761 WRS 03
07-01784 WRS 02
07-01795 WRS 02
C/R 26186
N/A 6-7-99

ISSUE 2
07-01795 WRS-02
C/R 26209
N/A 15-7-99

ISSUE 3
PTT KEYPAD PCB
WRS 07-01795-03
C/R 26877
A/C 19-01-01

ISSUE 4
KEYPAD PCB WRS
07-01784-04
PTT KEYPAD PCB
WRS 07-01795-04
MIC PCB WRS
07-01796-03
C/R 27115
HANDSET PCB WRS
07-01761-04
C/R 27116
SCS 18-1-02

ISSUE 5
IC1 WRS 80C31-16
C/R 27249
PK 9-8-02

ISSUE 6
MIC PCB WRS
07-01796-04
C/R 28255
MIC 18-1-05

ISSUE 7
MIC PCB WRS
07-01796-05
C/R 28477
KRL 27-05-05

ISSUE 8
US WRS BC848
C/R 30335
N/A 19-08-06

PCB 07-01761-05
RSSY 08-05300-001

DISC FILE
04*03125..8

CODAN
DRN P.J.L. DATE 28-5-96
MATERIAL CHKD CAH 22-18-98
APPD N/A 8-7-99
UNLESS OTHERWISE STATED
2 PLACES DEC. *
1 PLACE DEC. *
ANGULAR *
SCALE
HANDSET
DRAWING/DOC. NO
04-03125
SHT 1
OF 1

DO NOT SCALE

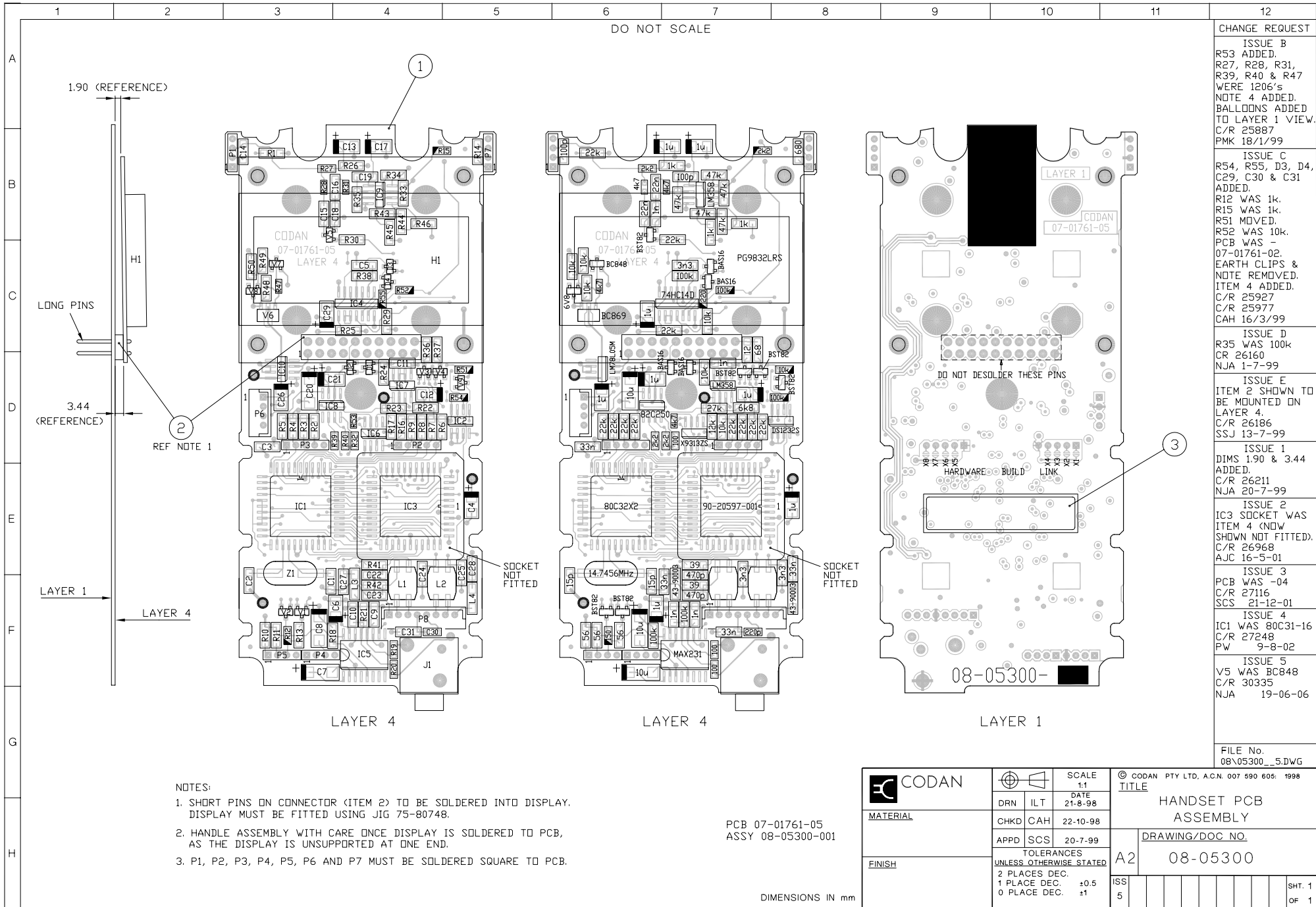

CHANGE REQUEST

- ISSUE B
R53 ADDED.
R27, R28, R31,
R39, R40 & R47
WERE 1206's
NOTE 4 ADDED.
BALLDONS ADDED
TO LAYER 1 VIEW.
C/R 25887
PMK 18/1/99
- ISSUE C
R54, R55, D3, D4,
C29, C30 & C31
ADDED.
R12 WAS 1k.
R15 WAS 1k.
R51 MOVED.
R52 WAS 10k.
PCB WAS -
07-01761-02.
EARTH CLIPS &
NOTE REMOVED.
ITEM 4 ADDED.
C/R 25927
C/R 25977
CAH 16/3/99
- ISSUE D
R35 WAS 100k
CR 26160
NJA 1-7-99
- ISSUE E
ITEM 2 SHOWN TO
BE MOUNTED ON
LAYER 4.
C/R 26186
SSJ 13-7-99
- ISSUE 1
DIMS 1.90 & 3.44
ADDED.
C/R 26211
NJA 20-7-99
- ISSUE 2
IC3 SOCKET WAS
ITEM 4 (NOW
SHOWN NOT FITTED).
C/R 26968
AJC 16-5-01
- ISSUE 3
PCB WAS -04
C/R 27116
SCS 21-12-01
- ISSUE 4
IC1 WAS 80C31-16
C/R 27248
PW 9-8-02
- ISSUE 5
V5 WAS BC848
C/R 30335
NJA 19-06-06

- NOTES:
1. SHORT PINS ON CONNECTOR (ITEM 2) TO BE SOLDERED INTO DISPLAY. DISPLAY MUST BE FITTED USING JIG 75-80748.
 2. HANDLE ASSEMBLY WITH CARE ONCE DISPLAY IS SOLDERED TO PCB, AS THE DISPLAY IS UNSUPPORTED AT ONE END.
 3. P1, P2, P3, P4, P5, P6 AND P7 MUST BE SOLDERED SQUARE TO PCB.

PCB 07-01761-05
ASSY 08-05300-001

DIMENSIONS IN mm

	SCALE	1:1	© CODAN PTY LTD, A.C.N. 007 590 605: 1998 TITLE HANDSET PCB ASSEMBLY
	DRN	ILT	
MATERIAL	CHKD	CAH	22-10-98
	APPD	SCS	20-7-99
FINISH	TOLERANCES UNLESS OTHERWISE STATED		DRAWING/DOC NO. 08-05300
	2 PLACES DEC.	±0.5	
	1 PLACE DEC.	±1	ISS 5
	0 PLACE DEC.		SHT. 1 OF 1

DO NOT SCALE

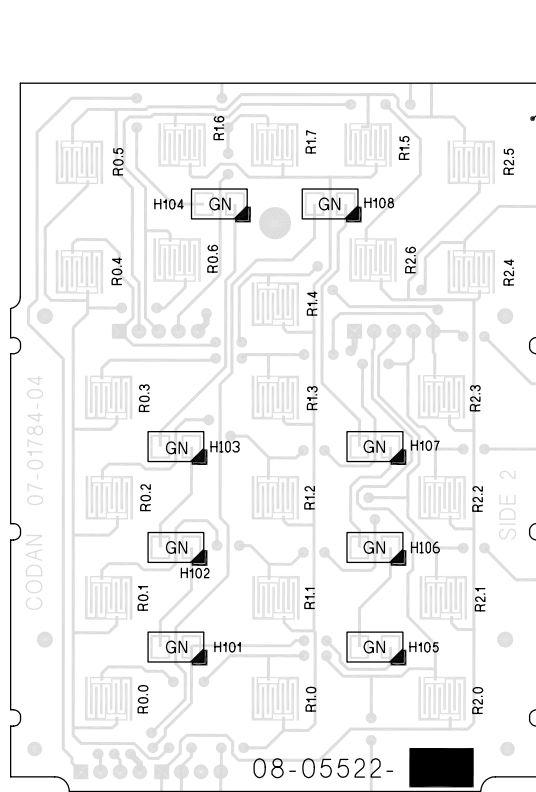

SIDE 2

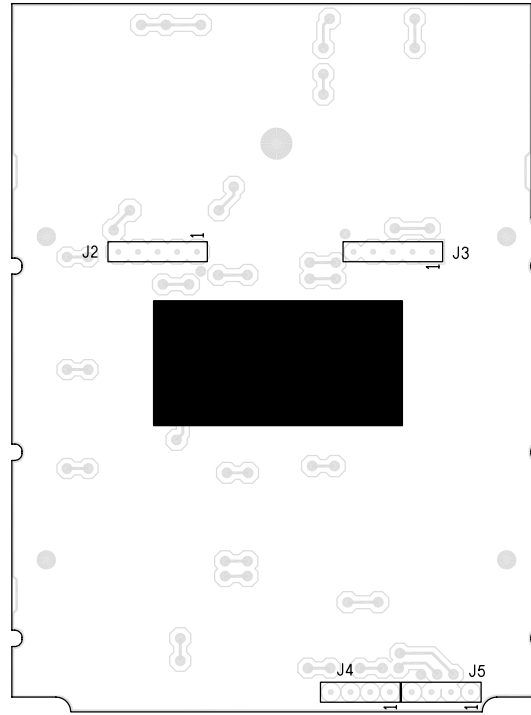

SIDE 1

PCB 07-01784-04
 ASSY 08-05522-001

CHANGE REQUEST

ISSUE B
 PCB WAS
 07-01784-01.
 C/R 25887
 PMK 18/1/99

ISSUE 1
 PCB WAS
 07-01784-02.
 C/R 26186
 SSJ 13-7-99

ISSUE 2:
 PCB WAS
 07-01784-03
 C/R 27115
 SCS 18-1-02

FILE No.
 08\05522__2.DWG

DIMENSIONS IN mm

	SCALE 2:1		© CODAN LIMITED, A.C.N. 007 590 605: 2001 TITLE				
	DRN	ILT	DATE 22-7-98				
	CHKD	CAH	29/10/98				
MATERIAL	APPD	SCS	16-7-99				
FINISH	TOLERANCES UNLESS OTHERWISE STATED			A3			
	2 PLACES DEC.						
	1 PLACE DEC. ±0.5 0 PLACE DEC. ±1						
		ISS					SHT. 1
		2					OF 1

KEYPAD PCB		DRAWING/DOC NO.	
08-05522			

DO NOT SCALE

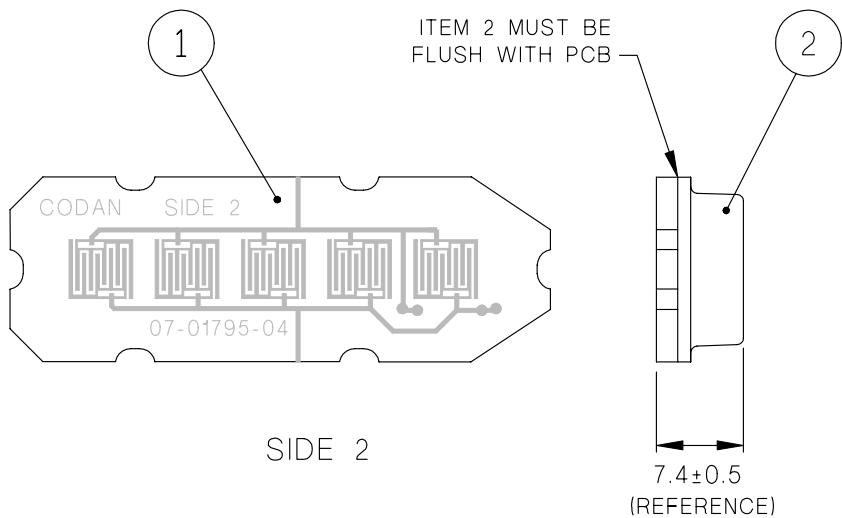

SIDE 2

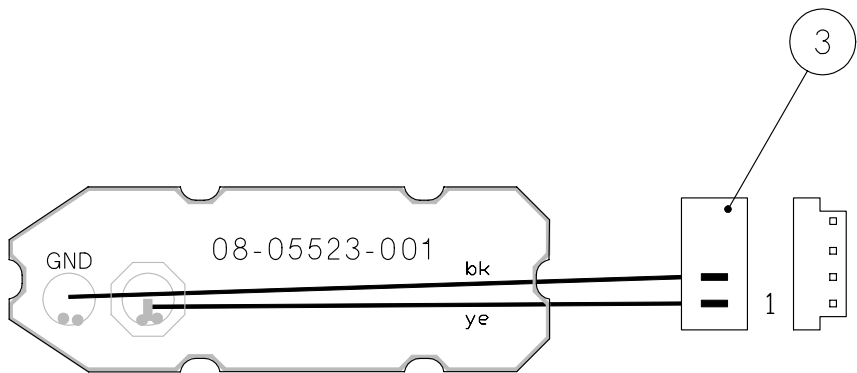

SIDE 1

CHANGE REQUEST

ISSUE B
PCB WAS 07-01795-01
C/R 25887
PMK 18/1/99

ISSUE C
NOTE 1 CHANGED.
LOOM DETAIL
DELETED.
PCB WAS 07-01795-02
C/R 26186
SSJ 13-7-99

ISSUE 1
NOTE & 7.4 DIM
ADDED.
C/R 26211
NJA 20-7-99

ISSUE 2
PCB WAS 07-01795-03
C/R 26877
AJC 19-01-01

ISSUE 3:
PCB WAS 07-01795-04
C/R 27115
SCS 18-1-02

ISSUE 4:
ADHESIVE WAS
LOCTITE 401
C/R 27370

NOTES

- AFFIX SILICONE BUTTON (ITEM 2) TO PCB USING JIG 75-80703. IT SHOULD BE ADHERED USING LOCTITE 770 PRIMER AND LOCTITE 460.

PCB 07-01795-05
ASSY 08-05523-001

FILE No.
08\05523__4.DWG

			SCALE 1:1	© CODAN PTY LTD, A.C.N. 007 590 605: 1998					
	DRN	ILT	DATE 26-10-98	TITLE PTT PCB					
MATERIAL	CHKD	CAH	29-10-98	DRAWING/DOC NO.					
FINISH	APPD	SCS	20-7-99	A 4	08-05523				
	TOLERANCES UNLESS OTHERWISE STATED				ISS 4				
	2 PLACES DEC.								SHT. 1
1 PLACE DEC. ±0.5								OF 1	
0 PLACE DEC. ±1									

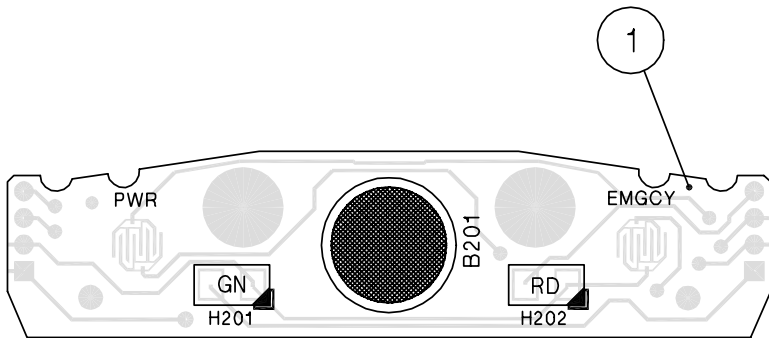
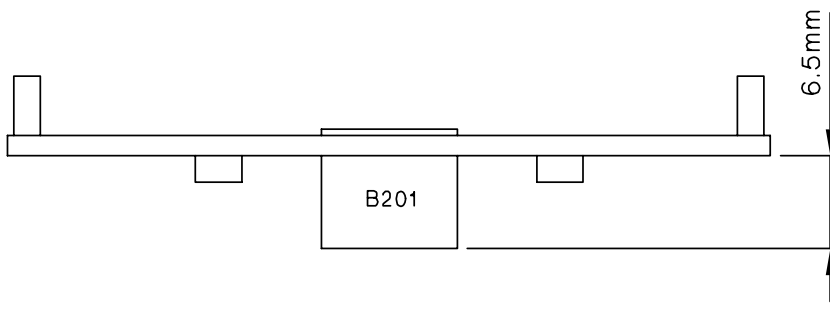

SIDE 2

NOTES:

1. USE MOUNTING JIG 75-80686 TO FIT B201.
2. SOLDER WIRES FROM MICROPHONE PINS TO PCB AS SHOWN USING 25 SWG TCW. WIRE FROM MICROPHONE CASE (& NEAREST PIN) TO BE TERMINATED TO "E" TRACK.

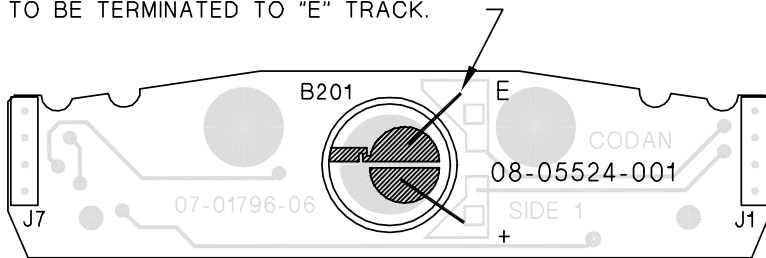

SIDE 1

PCB 07-01796-06
ASSY 08-05524-001

CHANGE REQUEST
ISSUE B PCB WAS 07-01796-01 B201 DIM WAS 7.0 B201 LEAD DIM & NOTE ADDED. C/R 25887 PMK 18/1/99
ISSUE 1 PCB WAS 07-01796-02 NOTE 1 ADDED. B201 CONTACTS CHANGED. C/R 26186 SSJ 13-7-99
ISSUE 2: PCB WAS 07-01796-03 C/R 27115 SCS 18-1-02
ISSUE 3: PCB WAS 07-01796-04 C/R 28255 MAC 18-1-05
ISSUE 4 PCB WAS 07-01796-05 C/R 28477 KMW 27-5-05

FILE No.
08\05524__4.DWG

			SCALE 1:1	© CODAN PTY LTD, A.C.N. 007 590 605: 1998				
	DRN	ILT	DATE 26-10-98	TITLE PWR-EMGCY PCB				
MATERIAL	CHKD	CAH	29-10-98	DRAWING/DOC NO.				
FINISH	APPD	SCS	16-7-99	A 4	08-05524			
	TOLERANCES UNLESS OTHERWISE STATED				ISS 4	SHT. 1 OF 1		
	2 PLACES DEC.		±0.5					
1 PLACE DEC.		±1						
0 PLACE DEC.								

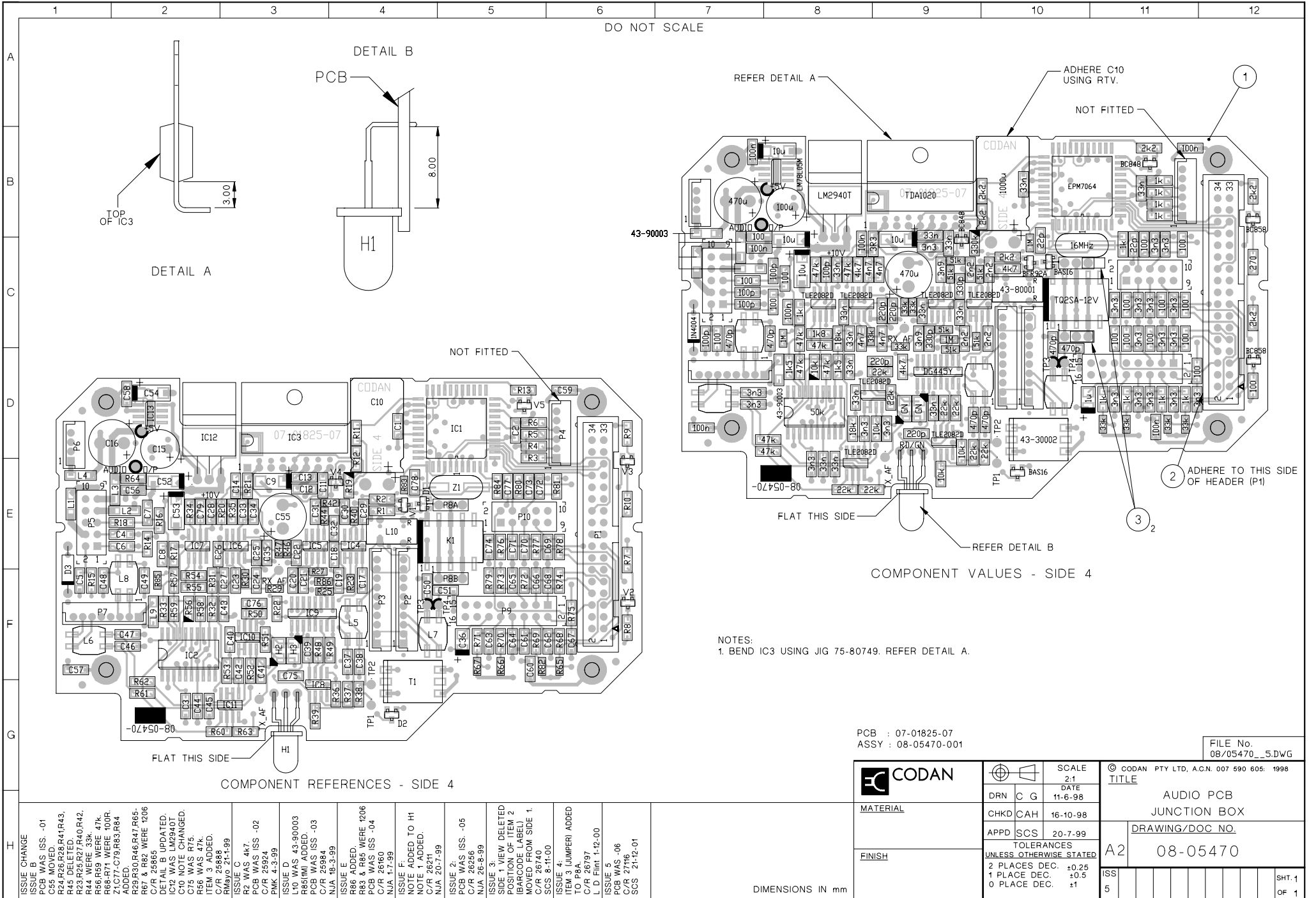

DETAIL A

DETAIL B

COMPONENT REFERENCES - SIDE 4

COMPONENT VALUES - SIDE 4

NOTES:
1. BEND IC3 USING JIG 75-80749. REFER DETAIL A.

PCB : 07-01825-07
ASSY : 08-05470-001

FILE No.
08/05470..._5.DWG



SCALE	2:1
DATE	11-6-98

© CODAN PTY LTD, A.C.N. 007 590 605. 1998
TITLE

MATERIAL

DRN	C	G
CHKD	CAH	16-10-98
APPD	SCS	20-7-99

AUDIO PCB
JUNCTION BOX

FINISH

TOLERANCES UNLESS OTHERWISE STATED	
2 PLACES DEC.	±0.25
1 PLACE DEC.	±0.5
0 PLACE DEC.	±1

DRAWING/DOC. NO.
08-05470

DIMENSIONS IN mm

ISS	5						SHT. 1 OF 1
-----	---	--	--	--	--	--	-------------

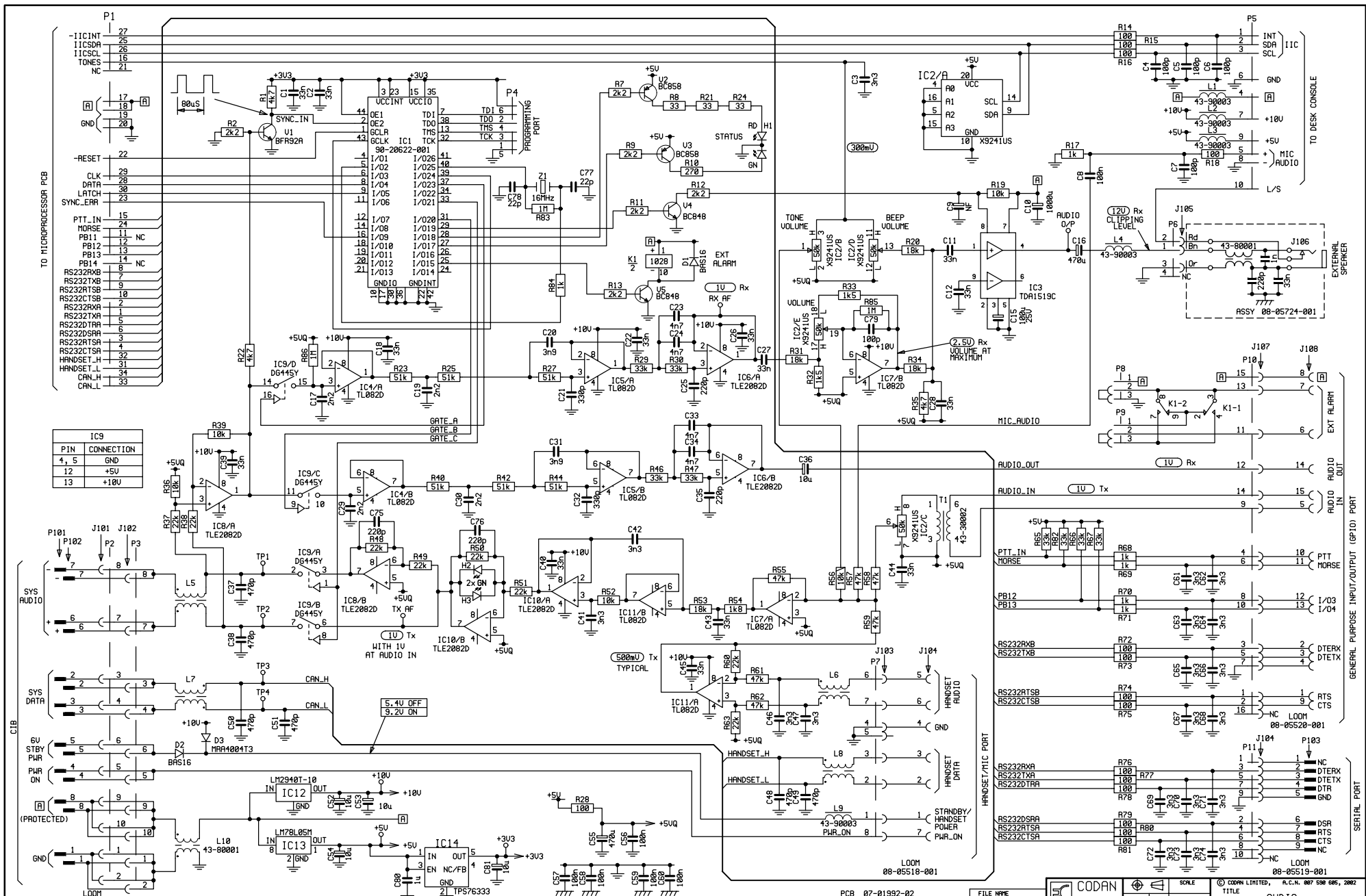

PIN	CONNECTION
4, 5	GND
12	+5V
13	+10V

NOTES:
 1. Rx LEVELS ARE MEASURED WITH ERSITALK OFF AND 100uV PRESENT ON THE RF UNIT ANTENNA CONNECTOR.

ISSUE CHANGE	DATE	BY	DESCRIPTION
1	07-19-82	JM	ISSUED FOR PRODUCTION
2	08-12-82	JM	REVISION TO ADD L10
3	08-22-82	JM	REVISION TO ADD L11
4	08-22-82	JM	REVISION TO ADD L12
5	08-22-82	JM	REVISION TO ADD L13
6	08-22-82	JM	REVISION TO ADD L14
7	08-22-82	JM	REVISION TO ADD L15
8	08-22-82	JM	REVISION TO ADD L16
9	08-22-82	JM	REVISION TO ADD L17
10	08-22-82	JM	REVISION TO ADD L18
11	08-22-82	JM	REVISION TO ADD L19
12	08-22-82	JM	REVISION TO ADD L20
13	08-22-82	JM	REVISION TO ADD L21
14	08-22-82	JM	REVISION TO ADD L22
15	08-22-82	JM	REVISION TO ADD L23
16	08-22-82	JM	REVISION TO ADD L24
17	08-22-82	JM	REVISION TO ADD L25
18	08-22-82	JM	REVISION TO ADD L26
19	08-22-82	JM	REVISION TO ADD L27
20	08-22-82	JM	REVISION TO ADD L28
21	08-22-82	JM	REVISION TO ADD L29
22	08-22-82	JM	REVISION TO ADD L30
23	08-22-82	JM	REVISION TO ADD L31
24	08-22-82	JM	REVISION TO ADD L32
25	08-22-82	JM	REVISION TO ADD L33
26	08-22-82	JM	REVISION TO ADD L34
27	08-22-82	JM	REVISION TO ADD L35
28	08-22-82	JM	REVISION TO ADD L36
29	08-22-82	JM	REVISION TO ADD L37
30	08-22-82	JM	REVISION TO ADD L38
31	08-22-82	JM	REVISION TO ADD L39
32	08-22-82	JM	REVISION TO ADD L40
33	08-22-82	JM	REVISION TO ADD L41
34	08-22-82	JM	REVISION TO ADD L42
35	08-22-82	JM	REVISION TO ADD L43
36	08-22-82	JM	REVISION TO ADD L44
37	08-22-82	JM	REVISION TO ADD L45
38	08-22-82	JM	REVISION TO ADD L46
39	08-22-82	JM	REVISION TO ADD L47
40	08-22-82	JM	REVISION TO ADD L48
41	08-22-82	JM	REVISION TO ADD L49
42	08-22-82	JM	REVISION TO ADD L50
43	08-22-82	JM	REVISION TO ADD L51
44	08-22-82	JM	REVISION TO ADD L52
45	08-22-82	JM	REVISION TO ADD L53
46	08-22-82	JM	REVISION TO ADD L54
47	08-22-82	JM	REVISION TO ADD L55
48	08-22-82	JM	REVISION TO ADD L56
49	08-22-82	JM	REVISION TO ADD L57
50	08-22-82	JM	REVISION TO ADD L58
51	08-22-82	JM	REVISION TO ADD L59
52	08-22-82	JM	REVISION TO ADD L60
53	08-22-82	JM	REVISION TO ADD L61
54	08-22-82	JM	REVISION TO ADD L62
55	08-22-82	JM	REVISION TO ADD L63
56	08-22-82	JM	REVISION TO ADD L64
57	08-22-82	JM	REVISION TO ADD L65
58	08-22-82	JM	REVISION TO ADD L66
59	08-22-82	JM	REVISION TO ADD L67
60	08-22-82	JM	REVISION TO ADD L68
61	08-22-82	JM	REVISION TO ADD L69
62	08-22-82	JM	REVISION TO ADD L70
63	08-22-82	JM	REVISION TO ADD L71
64	08-22-82	JM	REVISION TO ADD L72
65	08-22-82	JM	REVISION TO ADD L73
66	08-22-82	JM	REVISION TO ADD L74
67	08-22-82	JM	REVISION TO ADD L75
68	08-22-82	JM	REVISION TO ADD L76
69	08-22-82	JM	REVISION TO ADD L77
70	08-22-82	JM	REVISION TO ADD L78
71	08-22-82	JM	REVISION TO ADD L79
72	08-22-82	JM	REVISION TO ADD L80
73	08-22-82	JM	REVISION TO ADD L81
74	08-22-82	JM	REVISION TO ADD L82
75	08-22-82	JM	REVISION TO ADD L83
76	08-22-82	JM	REVISION TO ADD L84
77	08-22-82	JM	REVISION TO ADD L85
78	08-22-82	JM	REVISION TO ADD L86
79	08-22-82	JM	REVISION TO ADD L87
80	08-22-82	JM	REVISION TO ADD L88
81	08-22-82	JM	REVISION TO ADD L89
82	08-22-82	JM	REVISION TO ADD L90
83	08-22-82	JM	REVISION TO ADD L91
84	08-22-82	JM	REVISION TO ADD L92
85	08-22-82	JM	REVISION TO ADD L93
86	08-22-82	JM	REVISION TO ADD L94
87	08-22-82	JM	REVISION TO ADD L95
88	08-22-82	JM	REVISION TO ADD L96
89	08-22-82	JM	REVISION TO ADD L97
90	08-22-82	JM	REVISION TO ADD L98
91	08-22-82	JM	REVISION TO ADD L99
92	08-22-82	JM	REVISION TO ADD L100

PCB 07-01592-02
 ASSY 08-05386-001

FILE NAME
 01_03423...4.ZIP

CODAN		SOLE		CODAN LIMITED, A.C.N. 007 530 096, 2002	
MATERIAL	DRAWN	GC	27-3-82	TITLE	
	CHKD	JD	4-11-82	AUDIO, JUNCTION BOX	
	APPD	JD	20-1-83	DRAWING/DOC. NO	
FINISH	TOLERANCES			A1	
	UNLESS OTHERWISE STATED			04-03423	
	2 PLACES DEC. #			ISS	
	1 PLACE DEC. #			4	
	ANGULAR #			SMT 1	
				OF 1	

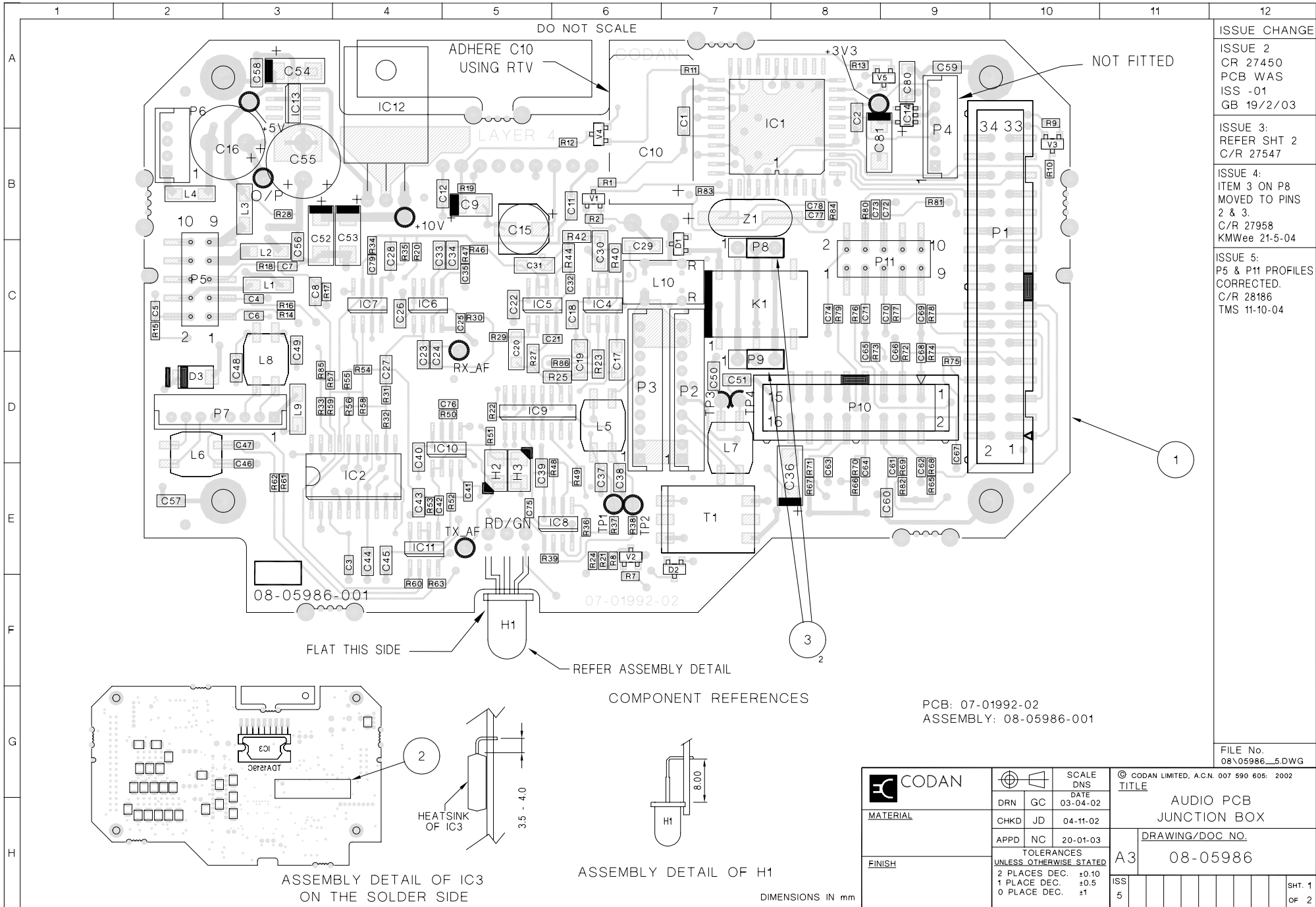

ISSUE CHANGE

ISSUE 2
CR 27450
PCB WAS
ISS -01
GB 19/2/03

ISSUE 3:
REFER SHT 2
C/R 27547

ISSUE 4:
ITEM 3 ON P8
MOVED TO PINS
2 & 3.
C/R 27958
KMWee 21-5-04

ISSUE 5:
P5 & P11 PROFILES
CORRECTED.
C/R 28186
TMS 11-10-04

COMPONENT REFERENCES

PCB: 07-01992-02
ASSEMBLY: 08-05986-001

FILE No.
08\05986_5.DWG

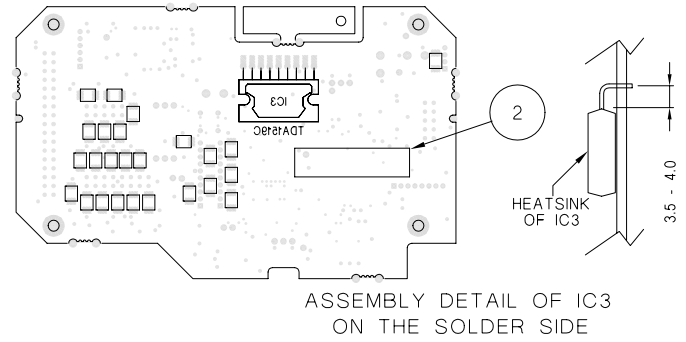

ASSEMBLY DETAIL OF IC3
ON THE SOLDER SIDE

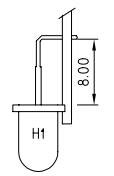

ASSEMBLY DETAIL OF H1

DIMENSIONS IN mm

	SCALE	DRN	GC	DATE	© CODAN LIMITED, A.C.N. 007 590 605: 2002 TITLE AUDIO PCB JUNCTION BOX DRAWING/DOC NO. 08-05986
	DNS	CHKD	JD	03-04-02	
	TOLERANCES UNLESS OTHERWISE STATED	APPD	NC	20-01-03	
MATERIAL	FINISH	2 PLACES DEC. +0.10 1 PLACE DEC. +0.5 0 PLACE DEC. ±1			ISS
					5
					SHT. 1 OF 2

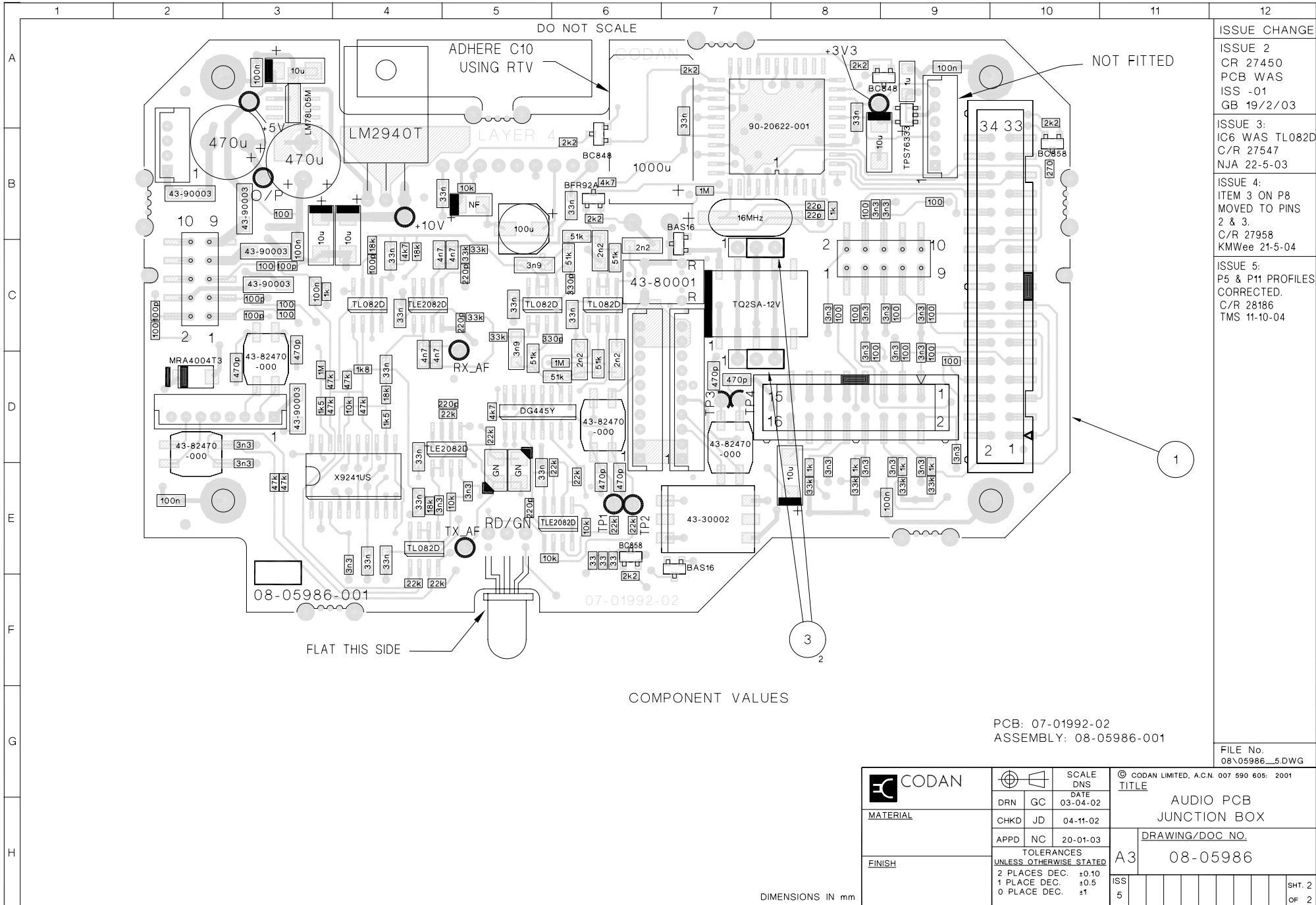

ISSUE CHANGE

ISSUE 2
CR 27450
PCB WAS
ISS -01
GB 19/2/03

ISSUE 3:
IC6 WAS TL082D
C/R 27547
NJA 22-5-03

ISSUE 4:
ITEM 3 ON P8
MOVED TO PINS
2 & 3.
C/R 27958
KMWee 21-5-04

ISSUE 5:
P5 & P11 PROFILES
CORRECTED.
C/R 28186
TMS 11-10-04

COMPONENT VALUES

PCB: 07-01992-02
ASSEMBLY: 08-05986-001

FILE No.
08\05986_5.DWG

	SCALE DNS		© CODAN LIMITED, A.C.N. 007 590 605. 2001 TITLE AUDIO PCB JUNCTION BOX DRAWING/DOC NO. 08-05986	
	DRN	GC		DATE 03-04-02
	CHKD	JD		04-11-02
MATERIAL	APPD	NC	20-01-03	
FINISH	TOLERANCES UNLESS OTHERWISE STATED		A3 ISS 5	
	2 PLACES DEC.	+0.10		
	1 PLACE DEC.	+0.5		
	0 PLACE DEC.	±1	SHT. 2 OF 2	

DIMENSIONS IN mm

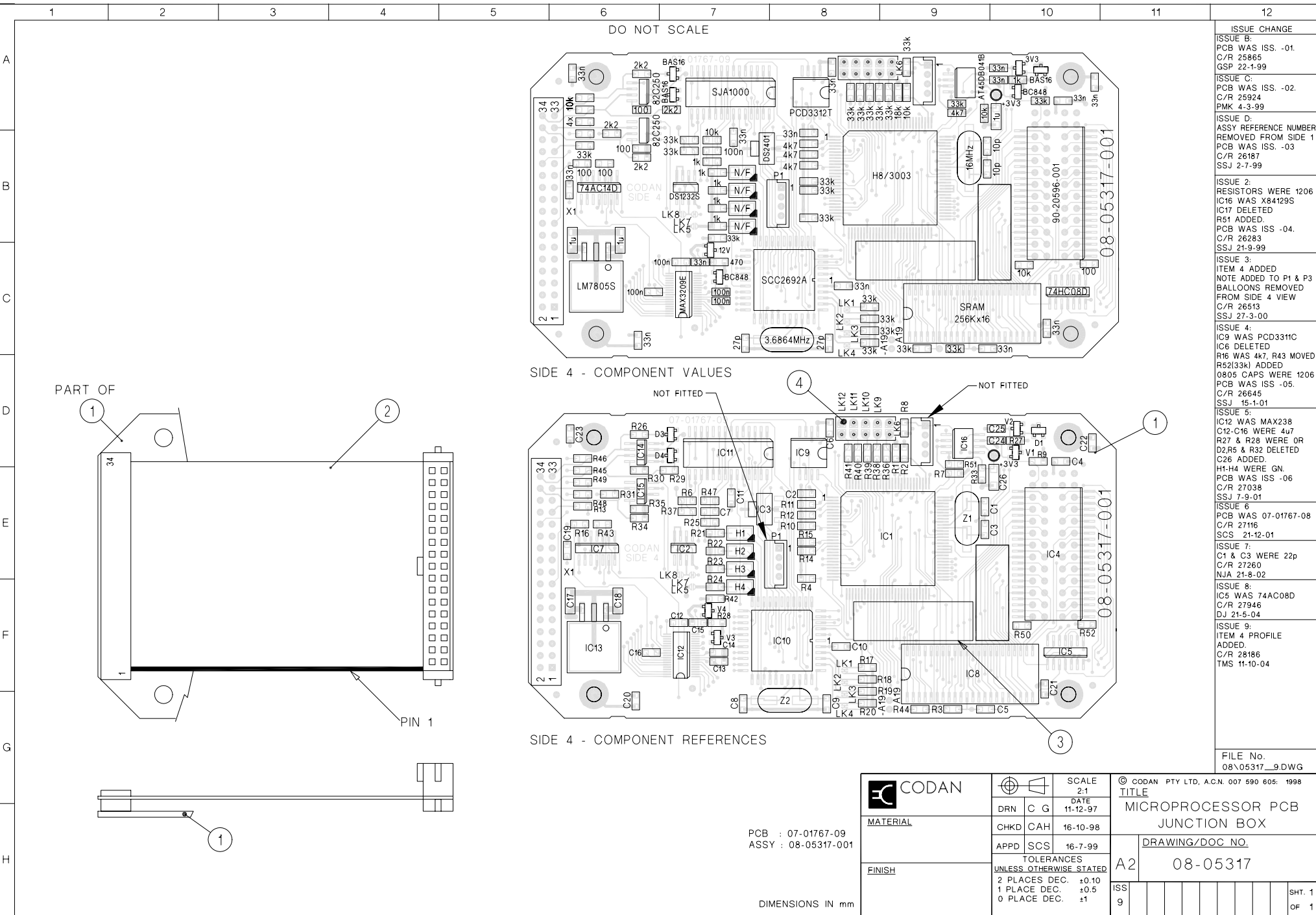

SIDE 4 - COMPONENT VALUES

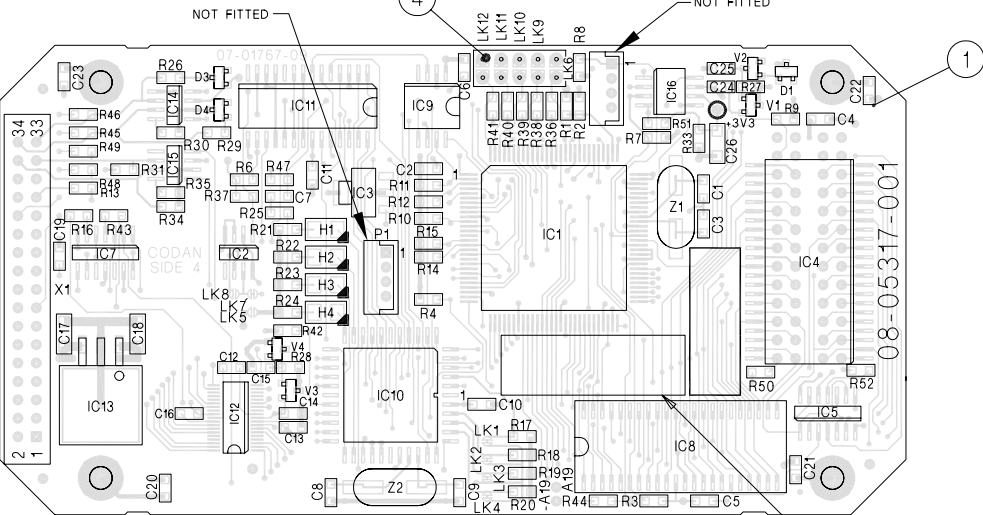

SIDE 4 - COMPONENT REFERENCES

ISSUE CHANGE

ISSUE B:
PCB WAS ISS. -01.
C/R 25865
GSP 22-1-99

ISSUE C:
PCB WAS ISS. -02.
C/R 25924
PMK 4-3-99

ISSUE D:
ASSY REFERENCE NUMBER
REMOVED FROM SIDE 1
PCB WAS ISS. -03
C/R 26187
SSJ 2-7-99

ISSUE 2:
RESISTORS WERE 1206
IC16 WAS X84129S
IC17 DELETED
R51 ADDED.
PCB WAS ISS. -04.
C/R 26283
SSJ 21-9-99

ISSUE 3:
ITEM 4 ADDED
NOTE ADDED TO P1 & P3
BALLOONS REMOVED
FROM SIDE 4 VIEW
C/R 26513
SSJ 27-3-00

ISSUE 4:
IC9 WAS PCD331C
IC6 DELETED
R16 WAS 4k7, R43 MOVED
R52(33k) ADDED
0805 CAPS WERE 1206
PCB WAS ISS. -05.
C/R 26645
SSJ 15-1-01

ISSUE 5:
IC12 WAS MAX238
C12-C16 WERE 4u7
R27 & R28 WERE 0R
D2,R5 & R32 DELETED
C26 ADDED.
H1-H4 WERE GN.
PCB WAS ISS. -06
C/R 27038
SSJ 7-9-01

ISSUE 6:
PCB WAS 07-01767-08
C/R 27116
SCS 21-12-01

ISSUE 7:
C1 & C3 WERE 22p
C/R 27260
NJA 21-8-02

ISSUE 8:
IC5 WAS 74AC08D
C/R 27946
DJ 21-5-04

ISSUE 9:
ITEM 4 PROFILE
ADDED.
C/R 28186
TMS 11-10-04

FILE No.
08\05317_9.DWG

PCB : 07-01767-09
ASSY : 08-05317-001

DIMENSIONS IN mm

		SCALE 2:1		© CODAN PTY LTD, A.C.N. 007 590 605: 1998	
		DRN	C G	DATE 11-12-97	TITLE MICROPROCESSOR PCB JUNCTION BOX
MATERIAL		CHKD	CAH	16-10-98	DRAWING/DOC NO. 08-05317
FINISH		APPD	SCS	16-7-99	
TOLERANCES UNLESS OTHERWISE STATED				ISS	SHT. 1 OF 1
2 PLACES DEC. +0.10					
1 PLACE DEC. +0.5					
0 PLACE DEC. ±1				9	

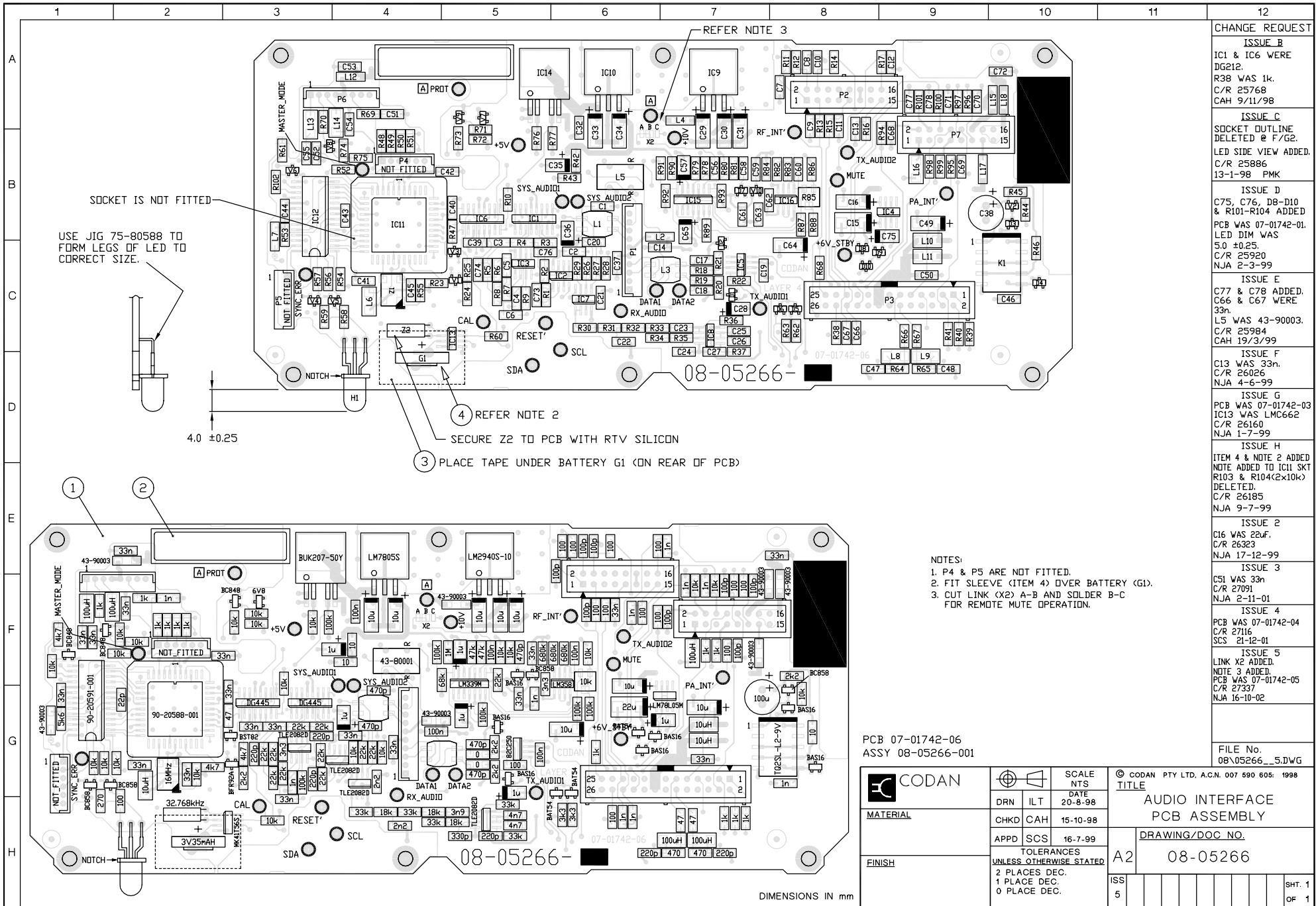

CHANGE REQUEST

ISSUE_B IC1 & IC6 WERE DG212. R38 WAS 1k. C/R 25768 CAH 9/11/98
ISSUE_C SOCKET OUTLINE DELETED @ F/G2. LED SIDE VIEW ADDED. C/R 25886 13-1-98 PMK
ISSUE_D C75, C76, D8-D10 & R101-R104 ADDED PCB WAS 07-01742-01. LED DIM WAS 5.0 ±0.25. C/R 25920 NJA 2-3-99
ISSUE_E C77 & C78 ADDED. C66 & C67 WERE 33n. L5 WAS 43-90003. C/R 25984 CAH 19/3/99
ISSUE_F C13 WAS 33n. C/R 26026 NJA 4-6-99
ISSUE_G PCB WAS 07-01742-03 IC13 WAS LMC662 C/R 26160 NJA 1-7-99
ISSUE_H ITEM 4 & NOTE 2 ADDED NOTE ADDED TO IC11 SKT R103 & R104(2x10K) DELETED. C/R 26185 NJA 9-7-99
ISSUE_2 C16 WAS 22uF. C/R 26323 NJA 17-12-99
ISSUE_3 C51 WAS 33n C/R 27091 NJA 2-11-01
ISSUE_4 PCB WAS 07-01742-04 C/R 27116 SCS 21-12-01
ISSUE_5 LINK X2 ADDED. NOTE 3 ADDED. PCB WAS 07-01742-05 C/R 27337 NJA 16-10-02
FILE No. 08\05266_5.DWG

- NOTES:
- P4 & P5 ARE NOT FITTED.
 - FIT SLEEVE (ITEM 4) OVER BATTERY (G1).
 - CUT LINK (X2) A-B AND SOLDER B-C FOR REMOTE MUTE OPERATION.

PCB 07-01742-06
ASSY 08-05266-001

	SCALE NTS DATE 20-8-98	© CODAN PTY LTD, A.C.N. 007 590 605: 1998 TITLE	
	MATERIAL CHKD CAH 15-10-98	AUDIO INTERFACE PCB ASSEMBLY	
FINISH UNLESS OTHERWISE STATED	APPD SCS 16-7-99	DRAWING/DOC NO.	
2 PLACES DEC. 1 PLACE DEC. 0 PLACE DEC.	TOLERANCES A2 08-05266	ISS 5	SHT. 1 OF 1

DIMENSIONS IN mm

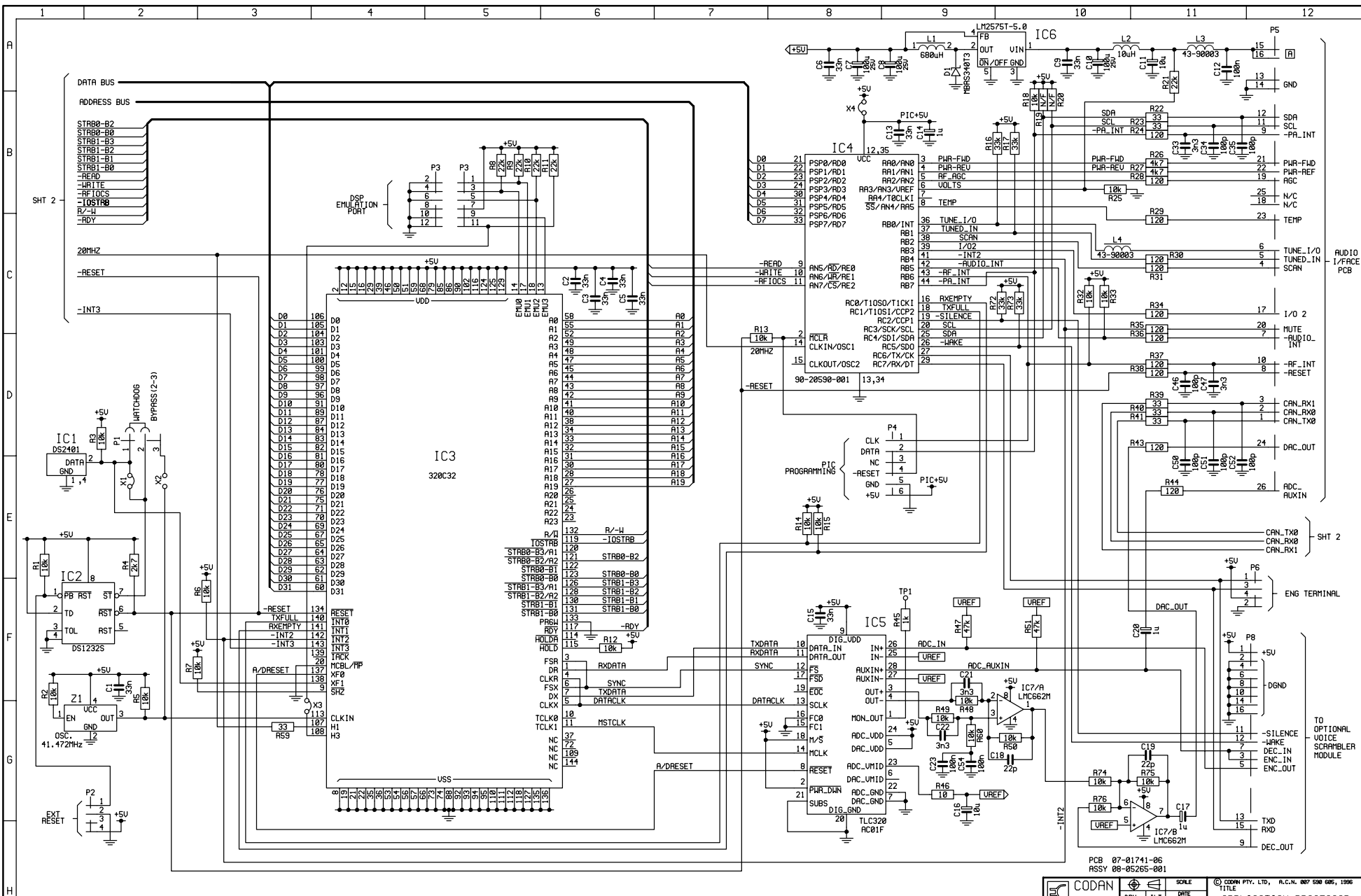

CHANGE REQUEST

ISSUE B C46 & C47 C48 & C49 DELETED G38-S2 HERE R24, R26-R31, R44-R48, R62, C/A 257-30 C/H 22-18-98	ISSUE C REMOVED SHT 2 LABELS ADDED AND SYMBOL CHANGED.	ISSUE D R27, R27 C/A 258-28 C/R 258-28 C/H 18/23-89	ISSUE 2 REF SHEET 2	ISSUE 3: C7, C8 & C10 HERE ADDED C/R 17-4-01	ISSUE 4 P8 ADDED. IC2/B CIRCUIT C/R 27202 S57 28-5-02	ISSUE 5 C2A, C22 & C23 PINS ADDED C/R 27383 S57 13-11-02	ISSUE 6 REF SHEET 2	ISSUE 7 C8 ADDED C/R 256-6-03 S57 25-6-03
---	--	---	------------------------	---	---	--	------------------------	--

CODAN	SCALE DIN 1LT Z3-36	© CODAN PVT. LTD., A.C.N. 087 538 685, 1996 TITLE APPLICATION PROCESSOR
MATERIAL	DRN CHKD APPD NJR 8-7-99	DRAWING NO. 04-03108
FINISH	TOLERANCES UNLESS OTHERWISE STATED 2 PLACES DEC. & 1 PLACE DEC. & ANGULAR 3	ISS X Z Z A A B B 7
		SHT 1 OF 2

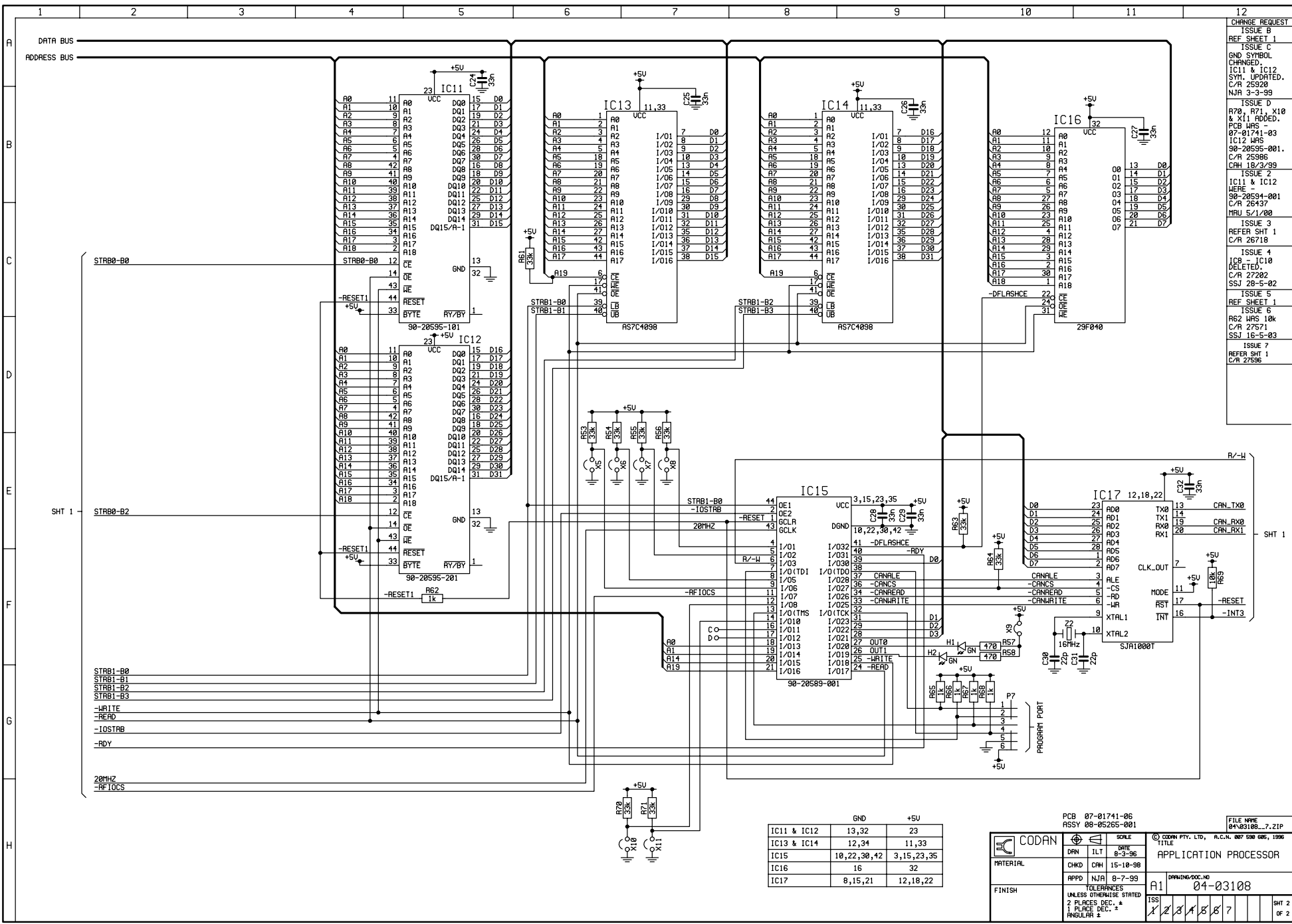

CHANGE REQUEST
 ISSUE B
 REF SHEET 1
 ISSUE C
 GND SYMBOL
 CHANGED.
 IC11 & IC12
 SYN. UPDATED.
 C/R 25320
 NJA 3-3-99

ISSUE D
 R70, R71, X10
 & X11 ADDED.
 PWB LMS -
 07-01741-03
 IC12 LMS
 90-20595-001.
 C/R 25986
 CAH 18/3/99

ISSUE 2
 IC11 & IC12
 DELETED.
 C/R 26437
 90-20594-001
 C/R 26437
 MRU 5/1/00

ISSUE 3
 REFER SHT 1
 C/R 26718

ISSUE 4
 IC8 - IC10
 DELETED.
 C/R 27202
 SSJ 28-5-02

ISSUE 5
 REF SHEET 1

ISSUE 6
 R62 LMS 10k
 C/R 27571
 SSJ 16-5-03

ISSUE 7
 REFER SHT 1
 C/R 27596

	GND	+5U
IC11 & IC12	13,32	23
IC13 & IC14	12,34	11,33
IC15	10,22,30,42	3,15,23,35
IC16	16	32
IC17	8,15,21	12,18,22

PCB 07-01741-06		FILE NAME 04-03108...7.ZIP	
ASSY 08-05265-001		SCALE 1:1	
DATE 8-2-96		TITLE APPLICATION PROCESSOR	
MATERIAL	CHKD CAH	DATE 15-10-98	
APPD NJA	8-7-99	DRAWING POC NO	04-03108
FINISH		ISS	1 2 3 4 5 6 7
UNLESS OTHERWISE STATED			
2 PLACES DEC. &			
1 PLACE DEC. *			
ANGULAR *			

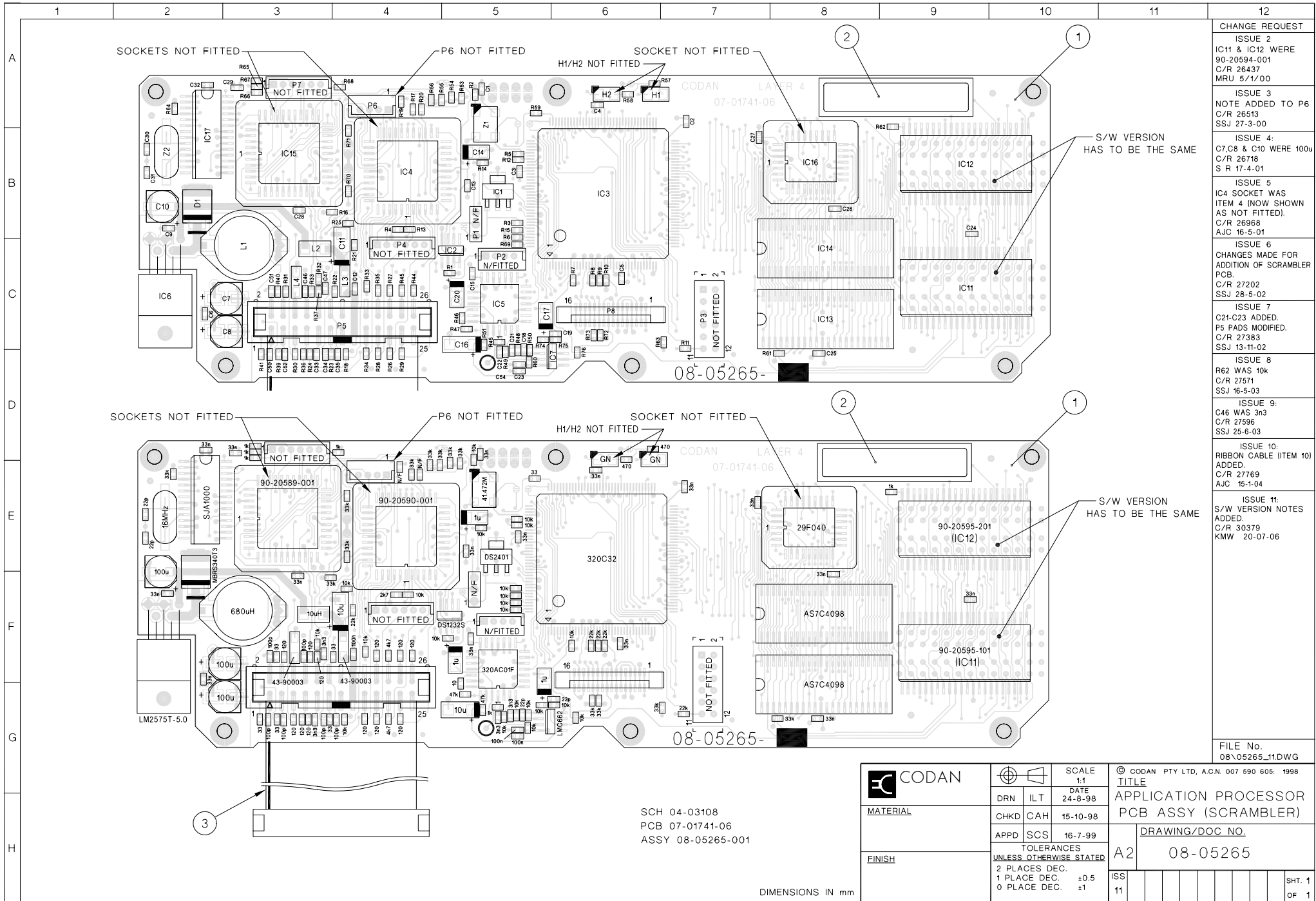

CHANGE REQUEST
ISSUE 2 IC11 & IC12 WERE 90-20594-001 C/R 26437 MRU 5/1/00
ISSUE 3 NOTE ADDED TO P6 C/R 26513 SSJ 27-3-00
ISSUE 4: C7,C8 & C10 WERE 100u C/R 26718 S R 17-4-01
ISSUE 5 IC4 SOCKET WAS ITEM 4 (NOW SHOWN AS NOT FITTED). C/R 26968 AJC 16-5-01
ISSUE 6 CHANGES MADE FOR ADDITION OF SCRAMBLER PCB. C/R 27202 SSJ 28-5-02
ISSUE 7 C21-C23 ADDED. P5 PADS MODIFIED. C/R 27383 SSJ 13-11-02
ISSUE 8 R62 WAS 10k C/R 27571 SSJ 16-5-03
ISSUE 9: C46 WAS 3n3 C/R 27596 SSJ 25-6-03
ISSUE 10: RIBBON CABLE (ITEM 10) ADDED. C/R 27769 AJC 15-1-04
ISSUE 11: S/W VERSION NOTES ADDED. C/R 30379 KMW 20-07-06
FILE No. 08\05265_11.DWG

SCH 04-03108
PCB 07-01741-06
ASSY 08-05265-001

DIMENSIONS IN mm

	SCALE 1:1		© CODAN PTY LTD, A.C.N. 007 590 605: 1998			
	DRN	ILT	DATE 24-8-98		TITLE APPLICATION PROCESSOR PCB ASSY (SCRAMBLER)	
MATERIAL	CHKD	CAH	15-10-98		DRAWING/DOC NO.	
FINISH	APPD	SCS	16-7-99		A2	
	TOLERANCES UNLESS OTHERWISE STATED				ISS	
	2 PLACES DEC. 1 PLACE DEC. +0.5 0 PLACE DEC. ±1				11	
						SHT. 1 OF 1

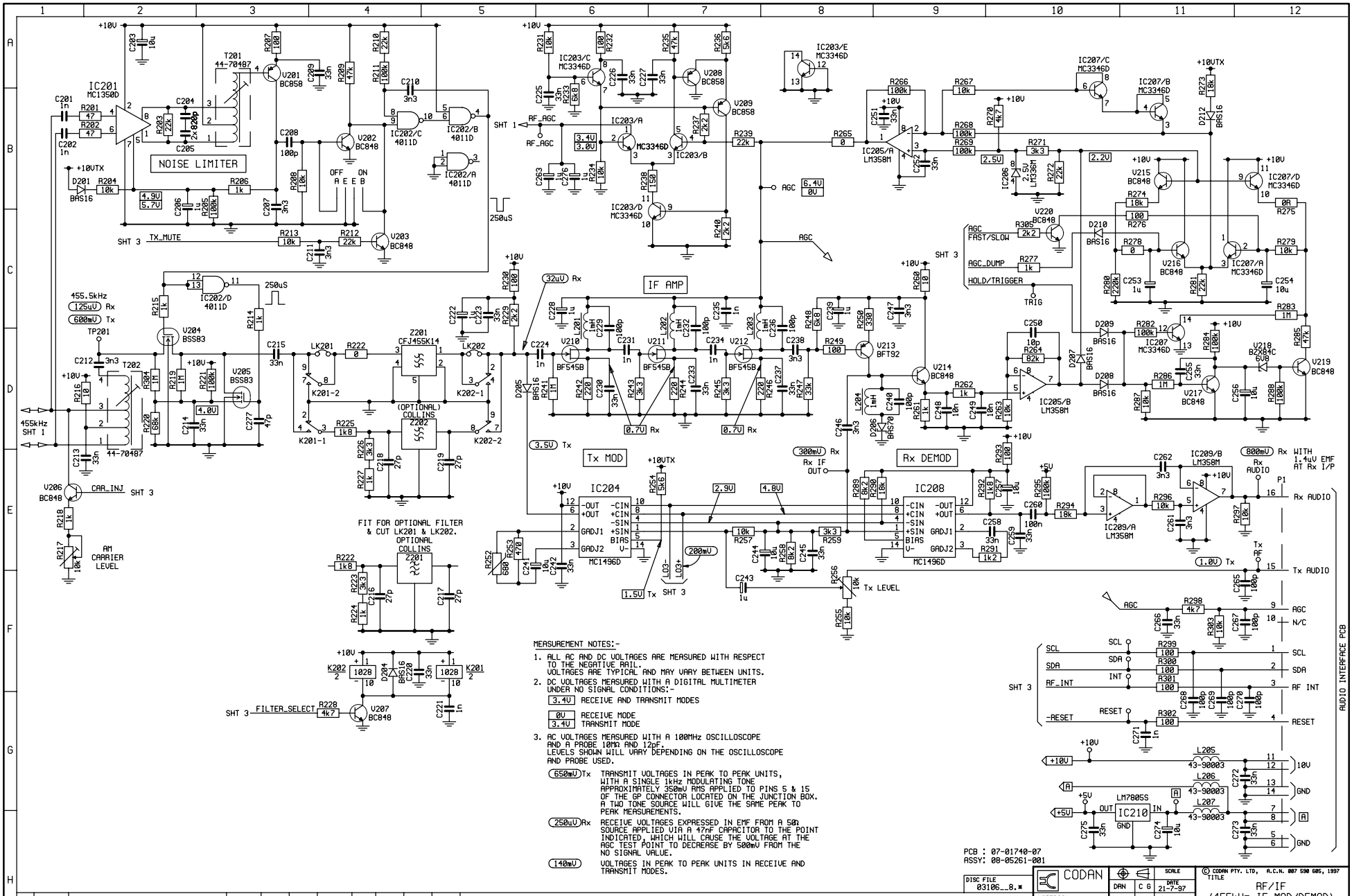

MEASUREMENT NOTES:-

1. ALL AC AND DC VOLTAGES ARE MEASURED WITH RESPECT TO THE NEGATIVE RAIL.
2. VOLTAGES ARE TYPICAL AND MAY VARY BETWEEN UNITS. UNDER NO SIGNAL CONDITIONS:

- [3.4U] RECEIVE AND TRANSMIT MODES
- [0U] RECEIVE MODE
- [3.4U] TRANSMIT MODE

3. AC VOLTAGES MEASURED WITH A 100MHz OSCILLOSCOPE AND A PROBE 10P AND 12P. LEVELS SHOWN WILL VARY DEPENDING ON THE OSCILLOSCOPE AND PROBE USED.

[650mU] Tx TRANSMIT VOLTAGES IN PEAK TO PEAK UNITS, WITH A SINGLE 1kHz MODULATING TONE APPROXIMATELY 350mV RMS APPLIED TO PINS 5 & 15 OF THE GP CONNECTOR LOCATED ON THE JUNCTION BOX. A TWO TONE SOURCE WILL GIVE THE SAME PEAK TO PEAK MEASUREMENTS.

[250uU] Rx RECEIVE VOLTAGES EXPRESSED IN EMF FROM A 50p SOURCE APPLIED VIA A 47pF CAPACITOR TO THE POINT INDICATED, WHICH WILL CAUSE THE VOLTAGE AT THE AGC TEST POINT TO DECREASE BY 500mV FROM THE NO SIGNAL VALUE.

[140mU] VOLTAGES IN PEAK TO PEAK UNITS IN RECEIVE AND TRANSMIT MODES.

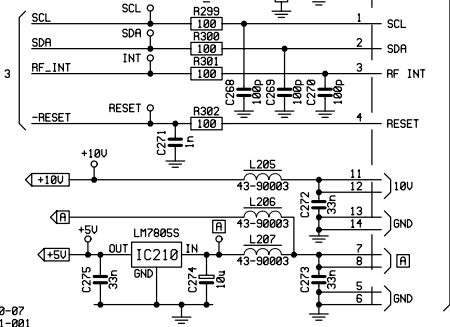

PCB : 07-01740-07
 ASSY: 08-05261-001

ISSUE CHANGE	ISSUE B ISS -01	ISSUE C	ISSUE D	ISSUE E	ISSUE F	ISSUE G	ISSUE H	ISSUE I	ISSUE J	ISSUE K	ISSUE L	ISSUE M	ISSUE N	ISSUE O	ISSUE P	ISSUE Q	ISSUE R	ISSUE S	ISSUE T	ISSUE U	ISSUE V	ISSUE W	ISSUE X	ISSUE Y	ISSUE Z	ISSUE AA	ISSUE AB	ISSUE AC	ISSUE AD	ISSUE AE	ISSUE AF	ISSUE AG	ISSUE AH	ISSUE AI	ISSUE AJ	ISSUE AK	ISSUE AL	ISSUE AM	ISSUE AN	ISSUE AO	ISSUE AP	ISSUE AQ	ISSUE AR	ISSUE AS	ISSUE AT	ISSUE AU	ISSUE AV	ISSUE AW	ISSUE AX	ISSUE AY	ISSUE AZ	ISSUE BA	ISSUE BB	ISSUE BC	ISSUE BD	ISSUE BE	ISSUE BF	ISSUE BG	ISSUE BH	ISSUE BI	ISSUE BJ	ISSUE BK	ISSUE BL	ISSUE BM	ISSUE BN	ISSUE BO	ISSUE BP	ISSUE BQ	ISSUE BR	ISSUE BS	ISSUE BT	ISSUE BU	ISSUE BV	ISSUE BV	ISSUE BW	ISSUE BX	ISSUE BY	ISSUE BZ	ISSUE CA	ISSUE CB	ISSUE CC	ISSUE CD	ISSUE CE	ISSUE CF	ISSUE CG	ISSUE CH	ISSUE CI	ISSUE CJ	ISSUE CK	ISSUE CL	ISSUE CM	ISSUE CN	ISSUE CO	ISSUE CP	ISSUE CQ	ISSUE CR	ISSUE CS	ISSUE CT	ISSUE CU	ISSUE CV	ISSUE CW	ISSUE CX	ISSUE CY	ISSUE CZ	ISSUE DA	ISSUE DB	ISSUE DC	ISSUE DD	ISSUE DE	ISSUE DF	ISSUE DG	ISSUE DH	ISSUE DI	ISSUE DJ	ISSUE DK	ISSUE DL	ISSUE DM	ISSUE DN	ISSUE DO	ISSUE DP	ISSUE DQ	ISSUE DR	ISSUE DS	ISSUE DT	ISSUE DU	ISSUE DV	ISSUE DV	ISSUE DW	ISSUE DX	ISSUE DY	ISSUE DZ	ISSUE EA	ISSUE EB	ISSUE EC	ISSUE ED	ISSUE EE	ISSUE EF	ISSUE EF	ISSUE EG	ISSUE EH	ISSUE EI	ISSUE EJ	ISSUE EK	ISSUE EL	ISSUE EM	ISSUE EN	ISSUE EO	ISSUE EP	ISSUE EQ	ISSUE ER	ISSUE ES	ISSUE ET	ISSUE EU	ISSUE EV	ISSUE EV	ISSUE EW	ISSUE EX	ISSUE EY	ISSUE EZ	ISSUE FA	ISSUE FB	ISSUE FC	ISSUE FD	ISSUE FE	ISSUE FF	ISSUE FF	ISSUE FG	ISSUE FH	ISSUE FI	ISSUE FJ	ISSUE FK	ISSUE FL	ISSUE FM	ISSUE FN	ISSUE FO	ISSUE FP	ISSUE FQ	ISSUE FR	ISSUE FS	ISSUE FT	ISSUE FT	ISSUE FU	ISSUE FV	ISSUE FV	ISSUE FW	ISSUE FX	ISSUE FY	ISSUE FZ	ISSUE GA	ISSUE GB	ISSUE GC	ISSUE GD	ISSUE GE	ISSUE GF	ISSUE GF	ISSUE GG	ISSUE GH	ISSUE GI	ISSUE GJ	ISSUE GK	ISSUE GL	ISSUE GM	ISSUE GN	ISSUE GO	ISSUE GP	ISSUE GQ	ISSUE GR	ISSUE GS	ISSUE GT	ISSUE GT	ISSUE GU	ISSUE GV	ISSUE GV	ISSUE GW	ISSUE GX	ISSUE GY	ISSUE GZ	ISSUE HA	ISSUE HB	ISSUE HC	ISSUE HD	ISSUE HE	ISSUE HF	ISSUE HF	ISSUE HG	ISSUE HH	ISSUE HI	ISSUE HJ	ISSUE HK	ISSUE HL	ISSUE HM	ISSUE HN	ISSUE HO	ISSUE HP	ISSUE HQ	ISSUE HR	ISSUE HS	ISSUE HT	ISSUE HT	ISSUE HU	ISSUE HV	ISSUE HV	ISSUE HW	ISSUE HX	ISSUE HY	ISSUE HZ	ISSUE IA	ISSUE IB	ISSUE IC	ISSUE ID	ISSUE IE	ISSUE IF	ISSUE IF	ISSUE IG	ISSUE IH	ISSUE II	ISSUE IJ	ISSUE IK	ISSUE IL	ISSUE IM	ISSUE IN	ISSUE IO	ISSUE IP	ISSUE IQ	ISSUE IR	ISSUE IS	ISSUE IT	ISSUE IT	ISSUE IU	ISSUE IV	ISSUE IV	ISSUE IW	ISSUE IX	ISSUE IY	ISSUE IZ	ISSUE JA	ISSUE JB	ISSUE JC	ISSUE JD	ISSUE JE	ISSUE JF	ISSUE JF	ISSUE JG	ISSUE JH	ISSUE JI	ISSUE JJ	ISSUE JK	ISSUE JL	ISSUE JM	ISSUE JN	ISSUE JO	ISSUE JP	ISSUE JQ	ISSUE JR	ISSUE JS	ISSUE JT	ISSUE JT	ISSUE JU	ISSUE JV	ISSUE JV	ISSUE JW	ISSUE JX	ISSUE JY	ISSUE JZ	ISSUE KA	ISSUE KB	ISSUE KC	ISSUE KD	ISSUE KE	ISSUE KF	ISSUE KF	ISSUE KG	ISSUE KH	ISSUE KI	ISSUE KJ	ISSUE KK	ISSUE KL	ISSUE KM	ISSUE KN	ISSUE KO	ISSUE KP	ISSUE KQ	ISSUE KR	ISSUE KS	ISSUE KT	ISSUE KT	ISSUE KU	ISSUE KV	ISSUE KV	ISSUE KW	ISSUE KX	ISSUE KY	ISSUE KZ	ISSUE LA	ISSUE LB	ISSUE LC	ISSUE LD	ISSUE LE	ISSUE LF	ISSUE LF	ISSUE LG	ISSUE LH	ISSUE LI	ISSUE LJ	ISSUE LK	ISSUE LM	ISSUE LN	ISSUE LO	ISSUE LP	ISSUE LQ	ISSUE LR	ISSUE LS	ISSUE LT	ISSUE LT	ISSUE LU	ISSUE LV	ISSUE LV	ISSUE LW	ISSUE LX	ISSUE LY	ISSUE LZ	ISSUE MA	ISSUE MB	ISSUE MC	ISSUE MD	ISSUE ME	ISSUE MF	ISSUE MF	ISSUE MG	ISSUE MH	ISSUE MI	ISSUE MJ	ISSUE MK	ISSUE ML	ISSUE MN	ISSUE MO	ISSUE MP	ISSUE MQ	ISSUE MR	ISSUE MS	ISSUE MT	ISSUE MT	ISSUE MU	ISSUE MV	ISSUE MV	ISSUE MW	ISSUE MX	ISSUE MY	ISSUE MZ	ISSUE NA	ISSUE NB	ISSUE NC	ISSUE ND	ISSUE NE	ISSUE NF	ISSUE NF	ISSUE NG	ISSUE NH	ISSUE NI	ISSUE NJ	ISSUE NK	ISSUE NL	ISSUE NM	ISSUE NO	ISSUE NP	ISSUE NQ	ISSUE NR	ISSUE NS	ISSUE NT	ISSUE NT	ISSUE NU	ISSUE NV	ISSUE NV	ISSUE NW	ISSUE NX	ISSUE NY	ISSUE NZ	ISSUE OA	ISSUE OB	ISSUE OC	ISSUE OD	ISSUE OE	ISSUE OF	ISSUE OF	ISSUE OG	ISSUE OH	ISSUE OI	ISSUE OJ	ISSUE OK	ISSUE OL	ISSUE OM	ISSUE ON	ISSUE OO	ISSUE OP	ISSUE OQ	ISSUE OR	ISSUE OS	ISSUE OT	ISSUE OT	ISSUE OU	ISSUE OV	ISSUE OV	ISSUE OW	ISSUE OX	ISSUE OY	ISSUE OZ	ISSUE PA	ISSUE PB	ISSUE PC	ISSUE PD	ISSUE PE	ISSUE PF	ISSUE PF	ISSUE PG	ISSUE PH	ISSUE PI	ISSUE PJ	ISSUE PK	ISSUE PL	ISSUE PM	ISSUE PN	ISSUE PO	ISSUE PP	ISSUE PQ	ISSUE PR	ISSUE PS	ISSUE PT	ISSUE PT	ISSUE PU	ISSUE PV	ISSUE PV	ISSUE PW	ISSUE PX	ISSUE PY	ISSUE PZ	ISSUE QA	ISSUE QB	ISSUE QC	ISSUE QD	ISSUE QE	ISSUE QF	ISSUE QF	ISSUE QG	ISSUE QH	ISSUE QI	ISSUE QJ	ISSUE QK	ISSUE QL	ISSUE QM	ISSUE QN	ISSUE QO	ISSUE QP	ISSUE QQ	ISSUE QR	ISSUE QS	ISSUE QT	ISSUE QT	ISSUE QU	ISSUE QV	ISSUE QV	ISSUE QW	ISSUE QX	ISSUE QY	ISSUE QZ	ISSUE RA	ISSUE RB	ISSUE RC	ISSUE RD	ISSUE RE	ISSUE RF	ISSUE RF	ISSUE RG	ISSUE RH	ISSUE RI	ISSUE RJ	ISSUE RK	ISSUE RL	ISSUE RM	ISSUE RN	ISSUE RO	ISSUE RP	ISSUE RQ	ISSUE RR	ISSUE RS	ISSUE RT	ISSUE RT	ISSUE RU	ISSUE RV	ISSUE RV	ISSUE RW	ISSUE RX	ISSUE RY	ISSUE RZ	ISSUE SA	ISSUE SB	ISSUE SC	ISSUE SD	ISSUE SE	ISSUE SF	ISSUE SF	ISSUE SG	ISSUE SH	ISSUE SI	ISSUE SJ	ISSUE SK	ISSUE SL	ISSUE SM	ISSUE SN	ISSUE SO	ISSUE SP	ISSUE SQ	ISSUE SR	ISSUE SS	ISSUE ST	ISSUE ST	ISSUE SU	ISSUE SV	ISSUE SV	ISSUE SW	ISSUE SX	ISSUE SY	ISSUE SZ	ISSUE TA	ISSUE TB	ISSUE TC	ISSUE TD	ISSUE TE	ISSUE TF	ISSUE TF	ISSUE TG	ISSUE TH	ISSUE TI	ISSUE TJ	ISSUE TK	ISSUE TL	ISSUE TM	ISSUE TN	ISSUE TO	ISSUE TP	ISSUE TQ	ISSUE TR	ISSUE TS	ISSUE TT	ISSUE TT	ISSUE TU	ISSUE TV	ISSUE TV	ISSUE TW	ISSUE TX	ISSUE TY	ISSUE TZ	ISSUE UA	ISSUE UB	ISSUE UC	ISSUE UD	ISSUE UE	ISSUE UF	ISSUE UF	ISSUE UG	ISSUE UH	ISSUE UI	ISSUE UJ	ISSUE UK	ISSUE UL	ISSUE UM	ISSUE UN	ISSUE UO	ISSUE UP	ISSUE UQ	ISSUE UR	ISSUE US	ISSUE UT	ISSUE UT	ISSUE UV	ISSUE UV	ISSUE UW	ISSUE UX	ISSUE UY	ISSUE UZ	ISSUE VA	ISSUE VB	ISSUE VC	ISSUE VD	ISSUE VE	ISSUE VF	ISSUE VF	ISSUE VG	ISSUE VH	ISSUE VI	ISSUE VJ	ISSUE VK	ISSUE VL	ISSUE VM	ISSUE VN	ISSUE VO	ISSUE VP	ISSUE VQ	ISSUE VR	ISSUE VS	ISSUE VT	ISSUE VT	ISSUE VU	ISSUE VV	ISSUE VV	ISSUE VW	ISSUE VX	ISSUE VY	ISSUE VZ	ISSUE WA	ISSUE WB	ISSUE WC	ISSUE WD	ISSUE WE	ISSUE WF	ISSUE WF	ISSUE WG	ISSUE WH	ISSUE WI	ISSUE WJ	ISSUE WK	ISSUE WL	ISSUE WM	ISSUE WN	ISSUE WO	ISSUE WP	ISSUE WQ	ISSUE WR	ISSUE WS	ISSUE WT	ISSUE WT	ISSUE WU	ISSUE WV	ISSUE WV	ISSUE WY	ISSUE WX	ISSUE WY	ISSUE WZ	ISSUE XA	ISSUE XB	ISSUE XC	ISSUE XD	ISSUE XE	ISSUE XF	ISSUE XF	ISSUE XG	ISSUE XH	ISSUE XI	ISSUE XJ	ISSUE XK	ISSUE XL	ISSUE XM	ISSUE XN	ISSUE XO	ISSUE XP	ISSUE XQ	ISSUE XR	ISSUE XS	ISSUE XT	ISSUE XT	ISSUE XU	ISSUE XV	ISSUE XV	ISSUE XW	ISSUE XX	ISSUE XY	ISSUE XZ	ISSUE YA	ISSUE YB	ISSUE YC	ISSUE YD	ISSUE YE	ISSUE YF	ISSUE YF	ISSUE YG	ISSUE YH	ISSUE YI	ISSUE YJ	ISSUE YK	ISSUE YL	ISSUE YM	ISSUE YN	ISSUE YO	ISSUE YP	ISSUE YQ	ISSUE YR	ISSUE YS	ISSUE YT	ISSUE YT	ISSUE YU	ISSUE YV	ISSUE YV	ISSUE YW	ISSUE YX	ISSUE YY	ISSUE YZ	ISSUE ZA	ISSUE ZB	ISSUE ZC	ISSUE ZD	ISSUE ZE	ISSUE ZF	ISSUE ZF	ISSUE ZG	ISSUE ZH	ISSUE ZI	ISSUE ZJ	ISSUE ZK	ISSUE ZL	ISSUE ZM	ISSUE ZN	ISSUE ZO	ISSUE ZP	ISSUE ZQ	ISSUE ZR	ISSUE ZS	ISSUE ZT	ISSUE ZT	ISSUE ZU	ISSUE ZV	ISSUE ZV	ISSUE ZW	ISSUE ZX	ISSUE ZY	ISSUE ZZ
	DISC FILE	83106...8..M	CODAN	SCALE	21-77-37	DATE	21-77-37	TITLE	RF/IF	(455kHz IF MOD/DEM)	DRN	C G	CHWD	PRU	26-10-98	APPD	NJA	8-7-99	FINISH	UNLESS OTHERWISE STATED	2 PLACES DEC. * RIGULAR DEC. *	ISS	A1	DRAWING/DOC NO	04-03106	SHT 2	OF 3																																																																																																																																																																																																																																																																																																																																																																																																																																																																																																																																																																																																																																																																																																																																																																	

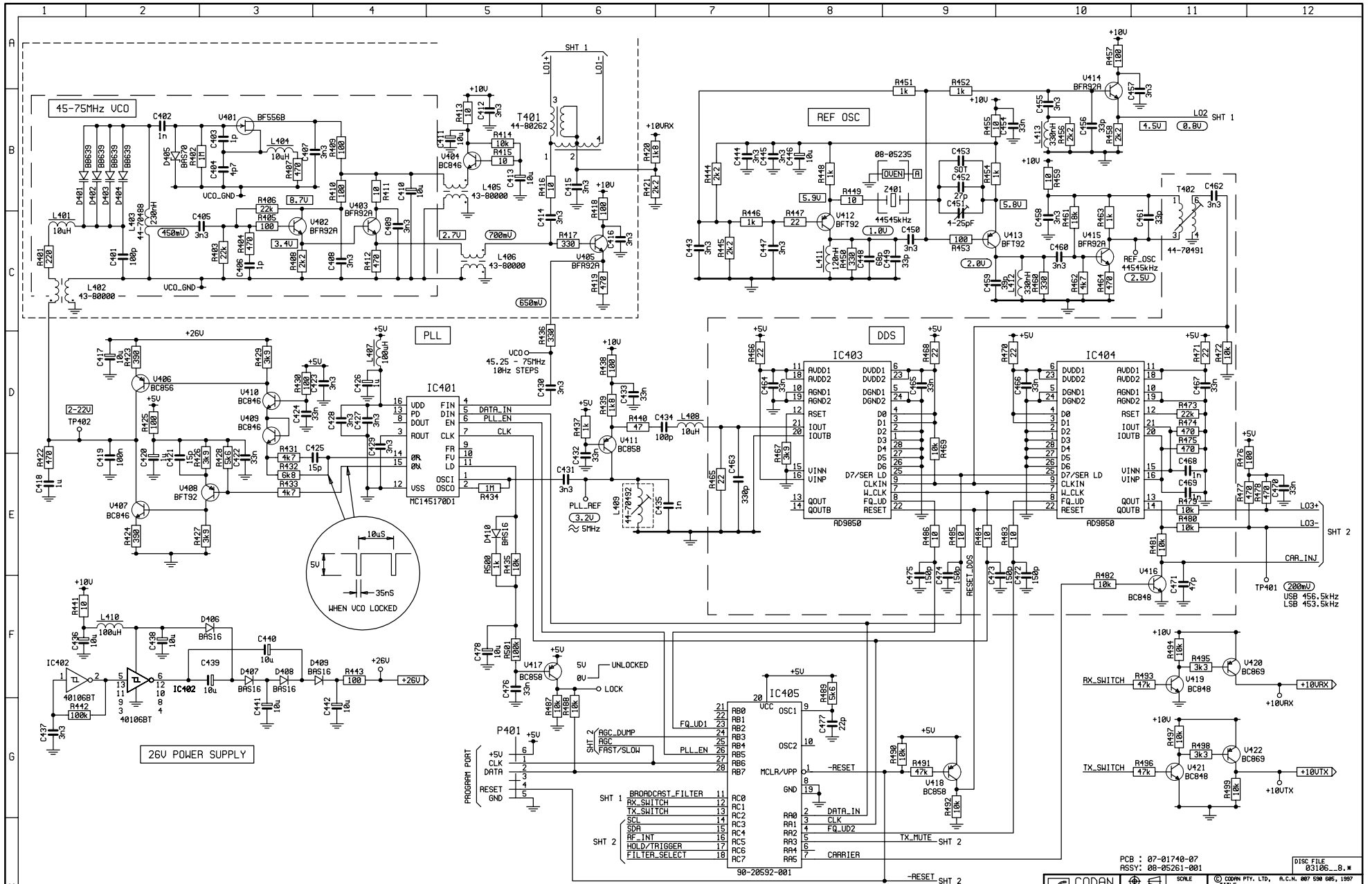

PCB : 07-01740-07		DISC FILE	
ASSY : 08-05261-001		03106_...*	
CODAN		SOKLE	
DRN C G		21-7-97	
CHKD RU		26-10-98	
APPD NJR		8-7-99	
TOLERANCES		DRAWING/DOC NO	
UNLESS OTHERWISE STATED		04-03106	
2 PLACES DEC. ±		1	
ANGULAR DEC. ±		2	
1		3	
2		4	
3		5	
4		6	
5		7	
6		8	
7		9	
8		10	
9		11	
10		12	
11		OF 3	
12			

- ISSUE B HERE
- ISSUE C HERE
- ISSUE D HERE
- ISSUE E HERE
- ISSUE F HERE
- ISSUE G HERE
- ISSUE H HERE
- ISSUE I HERE
- ISSUE J HERE
- ISSUE K HERE
- ISSUE L HERE
- ISSUE M HERE
- ISSUE N HERE
- ISSUE O HERE
- ISSUE P HERE
- ISSUE Q HERE
- ISSUE R HERE
- ISSUE S HERE
- ISSUE T HERE
- ISSUE U HERE
- ISSUE V HERE
- ISSUE W HERE
- ISSUE X HERE
- ISSUE Y HERE
- ISSUE Z HERE

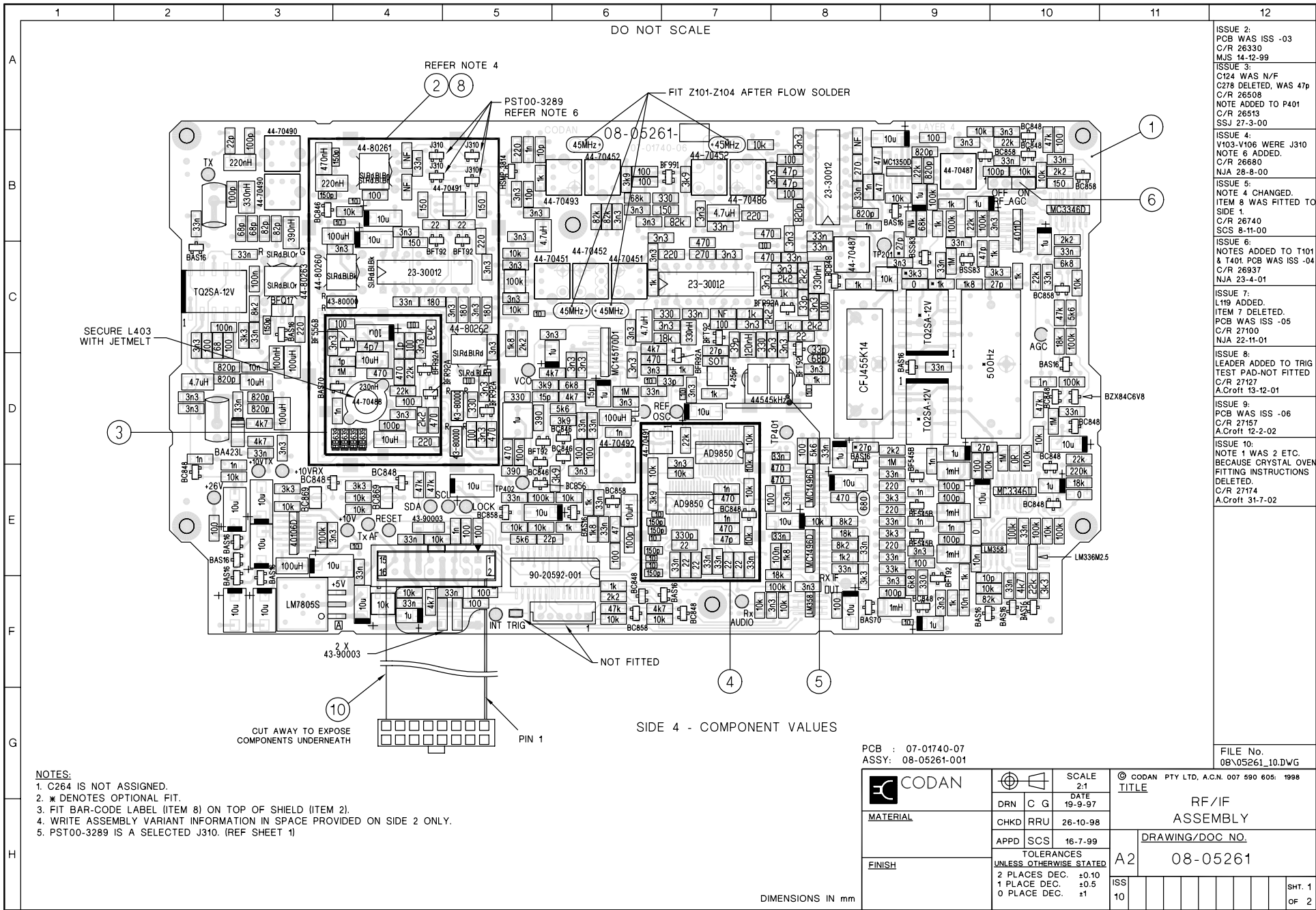

NOTES:

1. C264 IS NOT ASSIGNED.
2. * DENOTES OPTIONAL FIT.
3. FIT BAR-CODE LABEL (ITEM 8) ON TOP OF SHIELD (ITEM 2).
4. WRITE ASSEMBLY VARIANT INFORMATION IN SPACE PROVIDED ON SIDE 2 ONLY.
5. PST00-3289 IS A SELECTED J310. (REF SHEET 1)

- ISSUE 2:
PCB WAS ISS -03
C/R 26330
MJS 14-12-99
- ISSUE 3:
C124 WAS N/F
C278 DELETED, WAS 47p
C/R 26508
NOTE ADDED TO P401
C/R 26513
SSJ 27-3-00
- ISSUE 4:
V103-V106 WERE J310
NOTE 6 ADDED.
C/R 26680
NJA 28-3-00
- ISSUE 5:
NOTE 4 CHANGED.
ITEM 8 WAS FITTED TO
SIDE 1.
C/R 26740
SCS 8-11-00
- ISSUE 6:
NOTES ADDED TO T101
& T401. PCB WAS ISS -04
C/R 26937
NJA 23-4-01
- ISSUE 7:
L119 ADDED.
ITEM 7 DELETED.
PCB WAS ISS -05
C/R 27100
NJA 22-11-01
- ISSUE 8:
LEADER ADDED TO TRIG
TEST PAD-NOT FITTED
C/R 27127
A.Croft 13-12-01
- ISSUE 9:
PCB WAS ISS -06
C/R 27157
A.Croft 12-2-02
- ISSUE 10:
NOTE 1 WAS 2 ETC.
BECAUSE CRYSTAL OVEN
FITTING INSTRUCTIONS
DELETED.
C/R 27174
A.Croft 31-7-02

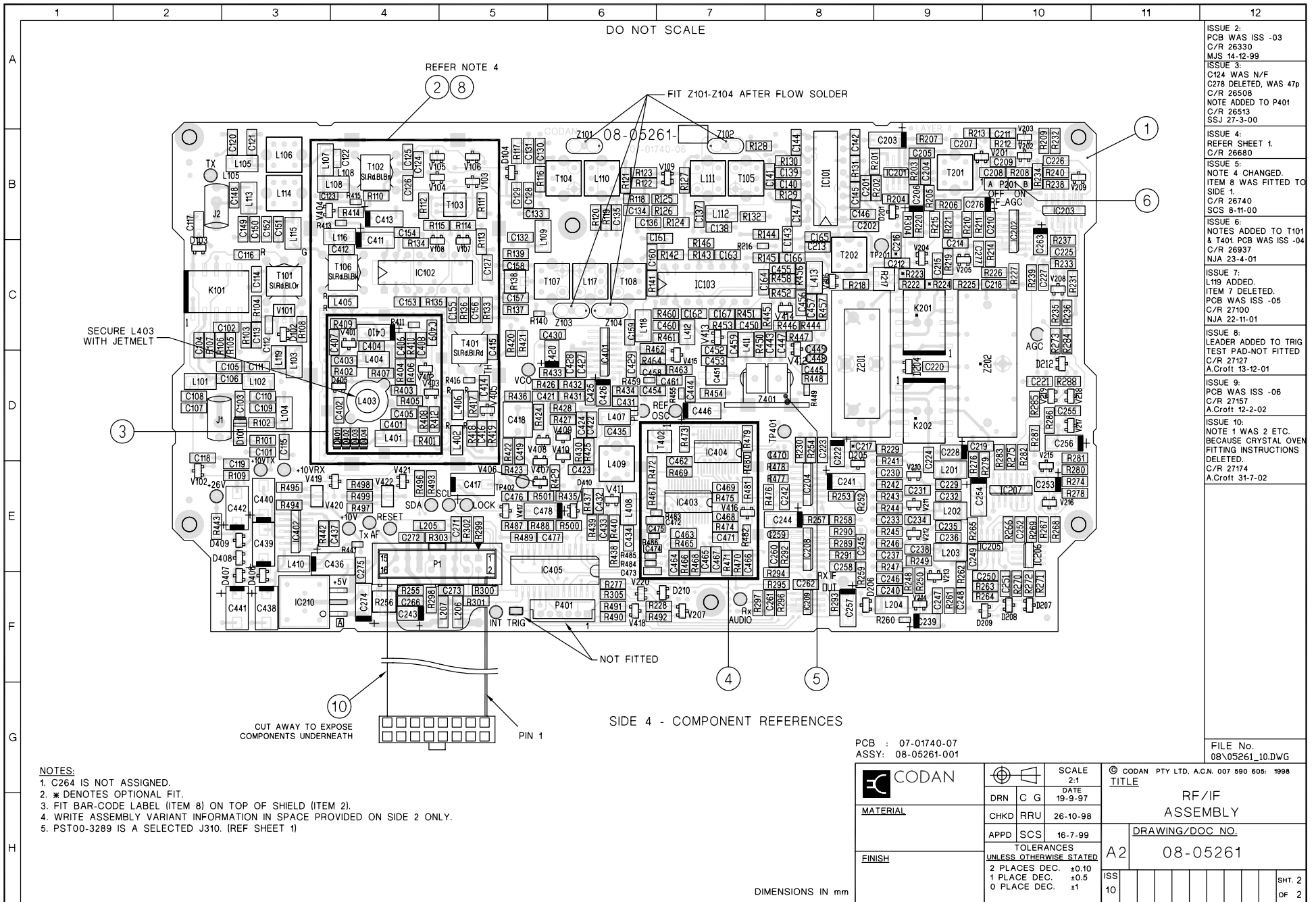

DO NOT SCALE

REFER NOTE 4

FIT Z101-Z104 AFTER FLOW SOLDER

SECURE L403 WITH JETMELT

NOT FITTED

CUT AWAY TO EXPOSE COMPONENTS UNDERNEATH

SIDE 4 - COMPONENT REFERENCES

PIN 1

NOTES:

1. C264 IS NOT ASSIGNED.
2. * DENOTES OPTIONAL FIT.
3. FIT BAR-CODE LABEL (ITEM 8) ON TOP OF SHIELD (ITEM 2).
4. WRITE ASSEMBLY VARIANT INFORMATION IN SPACE PROVIDED ON SIDE 2 ONLY.
5. PST00-3289 IS A SELECTED J310. (REF SHEET 1)

PCB : 07-01740-07
 ASSY: 08-05261-001



MATERIAL

CHKD RRU 26-10-98

APPD SCS 16-7-99

FINISH

SCALE	2:1
DATE	19-9-97
TOLERANCES UNLESS OTHERWISE STATED	
2 PLACES DEC.	±0.10
1 PLACE DEC.	±0.5
0 PLACE DEC.	±1

© CODAN PTY LTD, A.C.N. 007 590 605: 1998	
TITLE	
RF/IF ASSEMBLY	
DRAWING/DOC NO.	
A2 08-05261	
ISS	10
SHT.	2
OF	2

ISSUE 2:
 PCB WAS ISS -03
 C/R 26330
 MJS 14-12-99

ISSUE 3:
 C124 WAS N/F
 C278 DELETED, WAS 47p
 C/R 26508
 NOTE ADDED TO P401
 C/R 26513
 SSSJ 27-3-00

ISSUE 4:
 REFER SHEET 1.
 C/R 26680

ISSUE 5:
 NOTE 4 CHANGED.
 ITEM 8 WAS FITTED TO SIDE 1.
 C/R 26740
 SCS 8-11-00

ISSUE 6:
 NOTES ADDED TO T101 & T401 PCB WAS ISS -04
 C/R 26937
 NJA 23-4-01

ISSUE 7:
 L119 ADDED.
 ITEM 7 DELETED.
 PCB WAS ISS -05
 C/R 27100
 NJA 22-11-01

ISSUE 8:
 LEADER ADDED TO TRIG TEST PAD-NOT FITTED
 C/R 27127
 A.Croft 13-12-01

ISSUE 9:
 PCB WAS ISS -06
 C/R 27457
 A.Croft 12-2-02

ISSUE 10:
 NOTE 1 WAS 2 ETC. BECAUSE CRYSTAL OVEN FITTING INSTRUCTIONS DELETED.
 C/R 27174
 A.Croft 31-7-02

FILE No.
 08\05261_10.DWG

DIMENSIONS IN mm

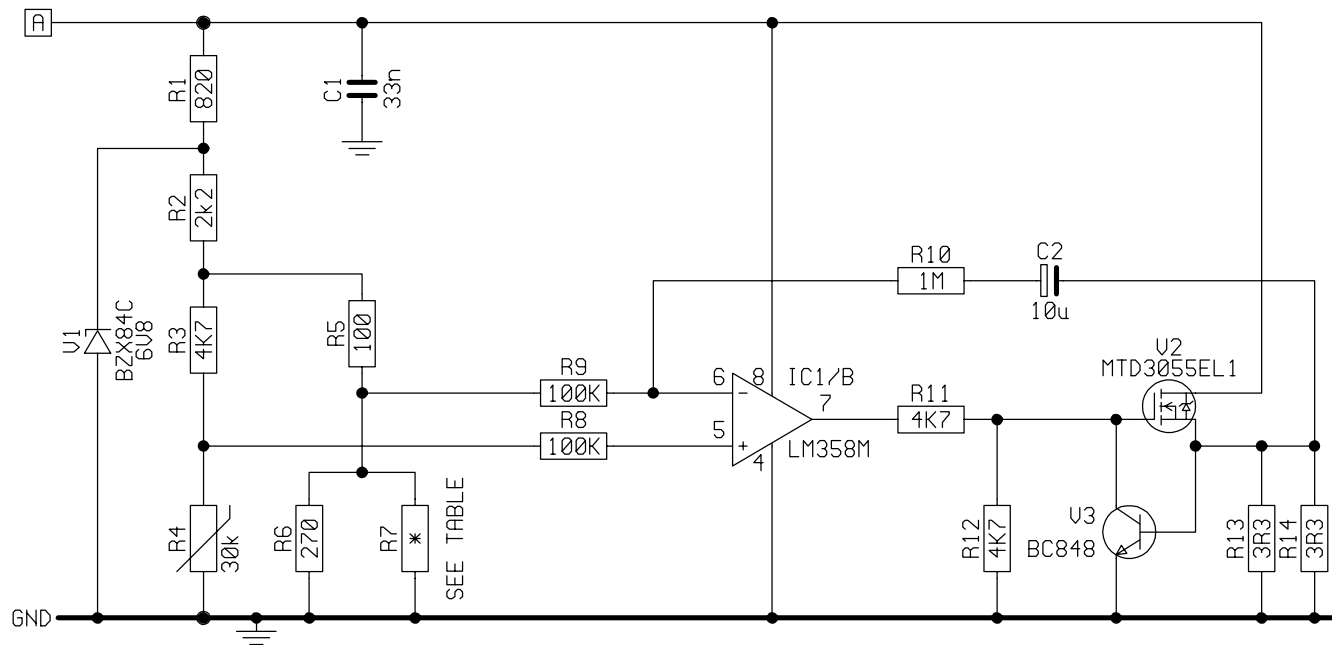

CHANGE REQUEST

ISSUE B
U1 WAS BCX20.
NOTE: CHGED.
C/R 24530
22-05-96 NJA

ISSUE 2
R9 WAS 270K
R1 WAS 4K7
R15, U3 ADDED
C/R 24987
04-07-97 MJS

ISSUE 3
RENUMBERED
R3,R8,R9,R10
R11 WERE 1206
R7 WAS 220
TABLE ADDED.
C/R 25721
09-11-98 ARU

ISSUE 4
PCB WAS ISS -03
C/R 26392
GDD 21/12/99

VERSION	R7
08-05235-001	220
08-05235-002	150

ALL DEVICES ARE VIEWED FROM THE TOP

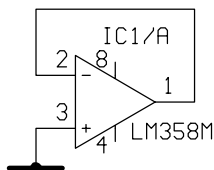
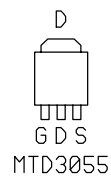
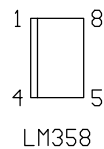
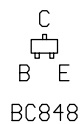
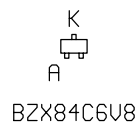

PCB 07-01732-04

FILE NAME
04\03095_4

		SCALE	© CODAN PTY. LTD, A.C.N. 007 590 605, 1995 TITLE	
	DRN	AML	DATE	CRYSTAL OVEN
MATERIAL	CHKD	NJA	08-02-96	
FINISH	APPD	NJA	04-10-96	DRAWING/DOC.NO
	TOLERANCES UNLESS OTHERWISE STATED 2 PLACES DEC. ± 1 PLACE DEC. ± ANGULAR ±			A3
			ISS	SHT 1 OF 1
			3 4	

DO NOT SCALE

NOTE:
E SHAPED BOARD (1B) IS BROKEN OFF
ALONG THIS EDGE, FITTED INTO
THE TWO SLOTS (1A) AND SOLDERED
WITH 0.5mm CLEARANCE

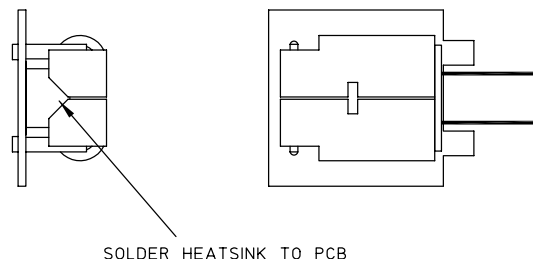
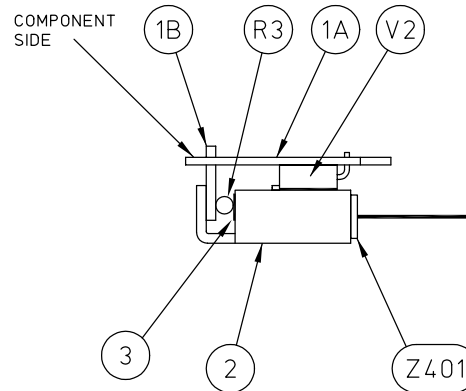
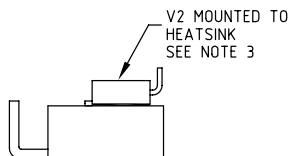
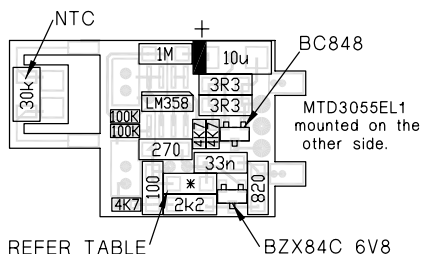
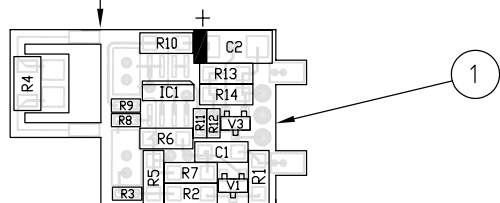

NOTES:

1. E-SHAPED BOARD IS FITTED USING 75-80602.
2. V2 LEADS ARE PREFORMED USING 75-80601.
3. V2 IS MOUNTED TO HEATSINK USING 75-80600.
4. CARE MUST BE TAKEN TO AVOID EXCESS HEAT AS THIS CAN CAUSE HEATSINK TO COLLAPSE.
5. TO FIT CRYSTAL:
 - A. APPLY ONE LAYER OF KAPTON TAPE TO THE TOP OF CRYSTAL (Z401). DO NOT COVER SIDES.
 - B. APPLY THERMA-FLOW COMPOUND TO THE TEMPERATURE SENSOR AND TOP AND SIDES OF CRYSTAL. SLIDE INTO THE OVEN ASSY. ENSURE CRYSTAL IS NOT LOOSE IN THE METAL CLIP AND THAT TOP OF CRYSTAL IS TOUCHING TEMPERATURE SENSOR.

CHANGE REQUEST

ISSUE B
V1 WAS BCX20
C/R 24530
NJA 22-05-96

ISSUE C
C3 POLARITY
ADDED.
C/R 24658
BCL 08-07-96

ISSUE 2
R9 WAS 270K
R1 WAS 4K7
R15, V3 ADDED.
C/R 24987
04-07-97 MJS

ISSUE 3
PCB SHORTENED,
COMPS RENUMB'RD
TABLE ADDED.
C/R 25721
09-11-98 RRU

ISSUE 4
NOTES 1-4 ADDED.
VIEW ADDED SHOWING V2
MOUNTED TO HEATSINK.
C/R 25886
13-198 PMK

ISSUE 5:
PCB WAS ISS -03
C/R 26392
GDD 21/12/99

ISSUE 6:
NOTE 5 ADDED.
C/R 27174
AJC 31-7-02

FILE NAME
08\05235_6.DWG

VERSION	R7
08-05235-001	220
08-05235-002	150

PCB 07-01732-04

			SCALE 2:1	© CODAN PTY LTD, A.C.N. 007 590 605. 1995									
	DRN	DB	DATE 09-01-96	TITLE CRYSTAL OVEN FINAL ASSEMBLY									
MATERIAL	CHKD	EF	26-02-96	DRAWING/DOC NO. 08-05235									
FINISH	APPD	JFB	30-09-96	TOLERANCES UNLESS OTHERWISE STATED	A3	ISS	1	2	3	4	5	6	SHT. 1 OF 1

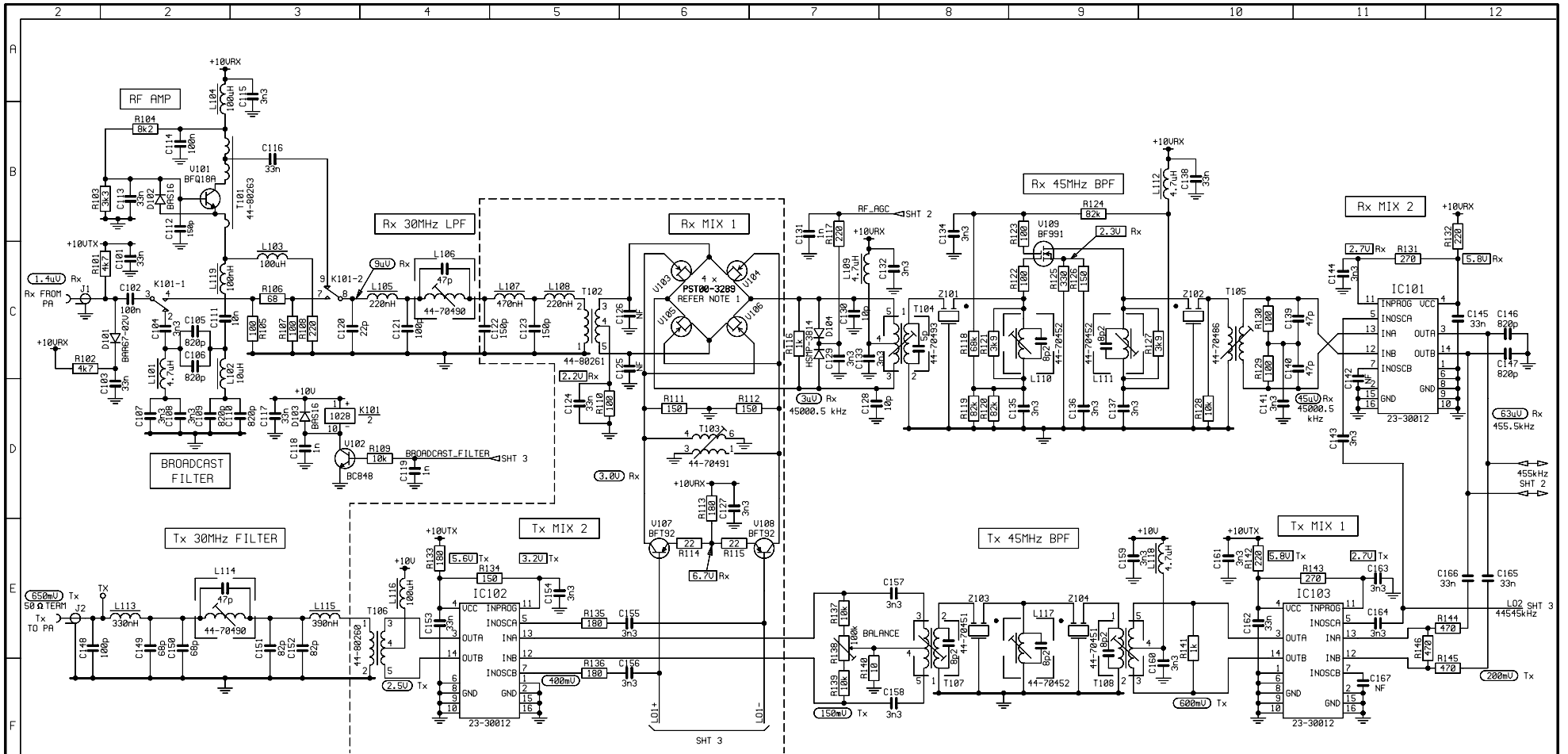

NOTES:
1. PST00-3289 IS A SELECTED J310.

ALL DEVICES ARE TOP VIEW

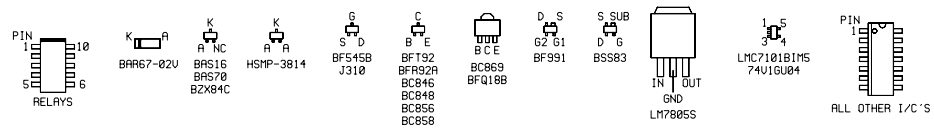

PCB : 07-01961-06
ASSY: 08-05889-001

CODAN		SCALE	DATE	DISC FILE
DRAWN	C G	4-5-81		04-03378_3.ZIP
CHECKED	J D	11-2-82	TITLE	RF/IF
APPD	J D	12-8-82		(RF MIXER)
FINISH			UNLESS OTHERWISE STATED	
			2 PLACES DEC. *	
			1 PLACE DEC. *	
			ANGULAR ±	
			DRAWING/DOC. NO	04-03378
			ISS	9
			SHT 1	3
			OF 3	

ISSUE CHANGE
ISSUE 2 18S -01
C/R 27238
REV. 14-10-82
PCB 08-155 -02
C/R 27245
ISSUE 4:08
PCB 07-217
ISSUE 5:1
PCB 08-155 -03
C/R 27257
ISSUE 6:1
PCB 08-155 -04
D181 HAS BAR72L
C/R 27258
C/R 27259
ISSUE 7:1
C/R 27259
ISSUE 8:1
C/R 27259
ISSUE 9:1
C/R 27259

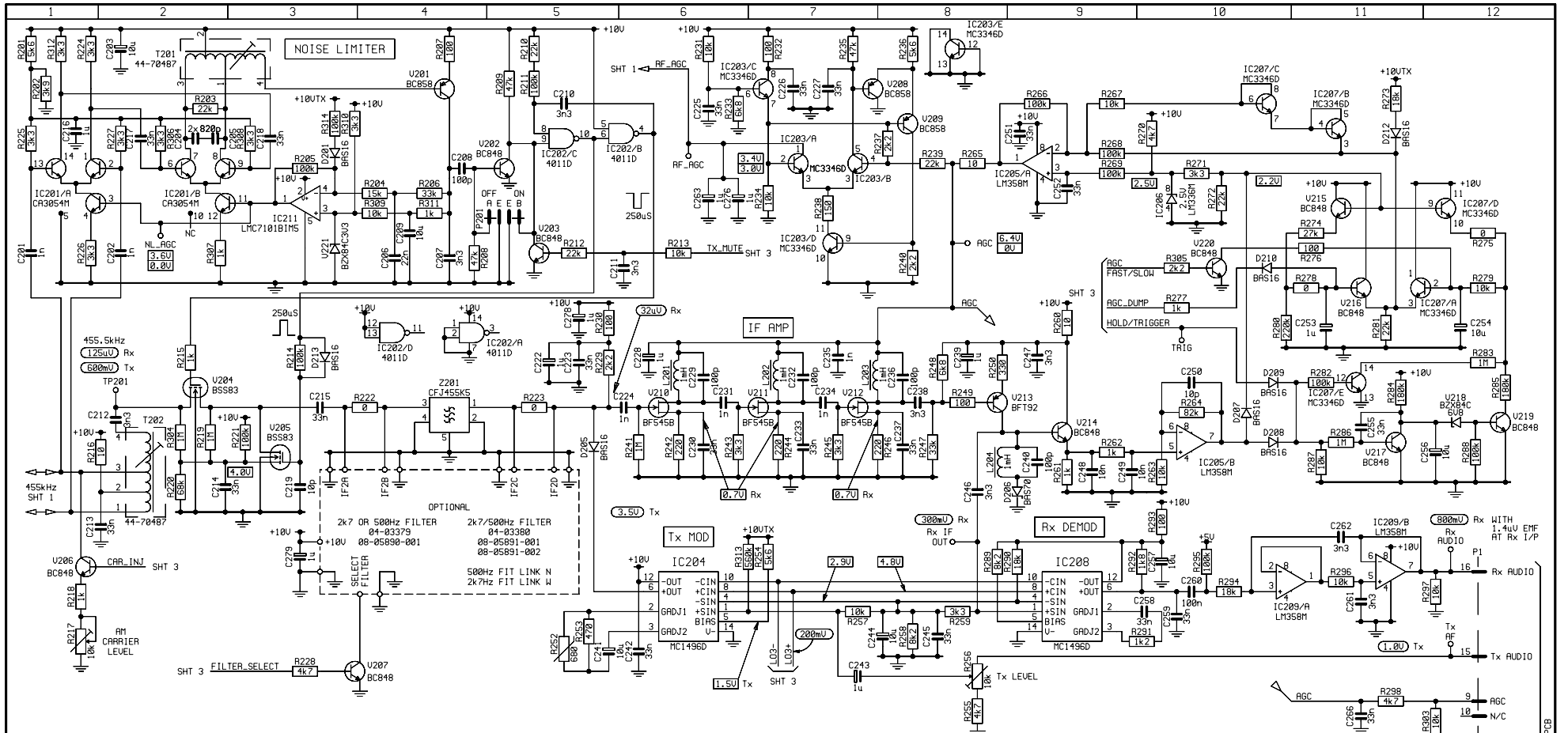

MEASUREMENT NOTES:-

- ALL AC AND DC VOLTAGES ARE MEASURED WITH RESPECT TO THE NEGATIVE RAIL. VOLTAGES ARE TYPICAL AND MAY VARY BETWEEN UNITS.
- DC VOLTAGES MEASURED WITH A DIGITAL MULTIMETER UNDER NO SIGNAL CONDITIONS:-
 - 3.4V RECEIVE AND TRANSMIT MODES
 - 0V RECEIVE MODE
 - 3.4V TRANSMIT MODE
- AC VOLTAGES MEASURED WITH A 100MHz OSCILLOSCOPE AND A PROBE 10pF AND 12pF LEVELS SHOWN WILL VARY DEPENDING ON THE OSCILLOSCOPE AND PROBE USED.
 - 650mV Tx TRANSMIT VOLTAGES IN PEAK TO PEAK UNITS, WITH A SINGLE 1kHz MODULATING TONE APPROXIMATELY 350mV RMS APPLIED TO PINS 5 & 15 OF THE GP CONNECTOR LOCATED ON THE JUNCTION BOX. A TWO TONE SOURCE WILL GIVE THE SAME PEAK TO PEAK MEASUREMENTS.
 - 250mV Rx RECEIVE VOLTAGES EXPRESSED IN EMF FROM A 50Ω SOURCE APPLIED VIA A 47pF CAPACITOR TO THE POINT INDICATED, WHICH WILL CAUSE THE VOLTAGE AT THE AGC TEST POINT TO DECREASE BY 500mV FROM THE NO SIGNAL VALUE.
 - 1.40mV VOLTAGES IN PEAK TO PEAK UNITS IN RECEIVE AND TRANSMIT MODES.

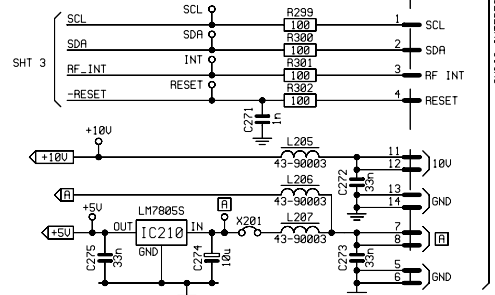

ISSUE CHANGE

ISSUE 2: ISS -01 PCB MFG ISS -01 B.C N-118-02

ISSUE 3: ISS -02 C.P.R 27-245 C.P.R 27-245 N.A.R 27-2-03

ISSUE 4: ISS -03 C.P.R 27-245 N.A.R 27-2-03

ISSUE 5: ISS -04 C.P.R 27-245 N.A.R 27-2-03

ISSUE 6: ISS -05 C.P.R 27-245 N.A.R 27-2-03

ISSUE 7: ISS -06 C.P.R 27-245 N.A.R 27-2-03

ISSUE 8: ISS -07 C.P.R 27-245 N.A.R 27-2-03

ISSUE 9: ISS -08 C.P.R 27-245 N.A.R 27-2-03

ISSUE 10: ISS -09 C.P.R 27-245 N.A.R 27-2-03

ISSUE 11: ISS -10 C.P.R 27-245 N.A.R 27-2-03

ISSUE 12: ISS -11 C.P.R 27-245 N.A.R 27-2-03

ISSUE 13: ISS -12 C.P.R 27-245 N.A.R 27-2-03

ISSUE 14: ISS -13 C.P.R 27-245 N.A.R 27-2-03

ISSUE 15: ISS -14 C.P.R 27-245 N.A.R 27-2-03

ISSUE 16: ISS -15 C.P.R 27-245 N.A.R 27-2-03

ISSUE 17: ISS -16 C.P.R 27-245 N.A.R 27-2-03

ISSUE 18: ISS -17 C.P.R 27-245 N.A.R 27-2-03

ISSUE 19: ISS -18 C.P.R 27-245 N.A.R 27-2-03

ISSUE 20: ISS -19 C.P.R 27-245 N.A.R 27-2-03

ISSUE 21: ISS -20 C.P.R 27-245 N.A.R 27-2-03

ISSUE 22: ISS -21 C.P.R 27-245 N.A.R 27-2-03

ISSUE 23: ISS -22 C.P.R 27-245 N.A.R 27-2-03

ISSUE 24: ISS -23 C.P.R 27-245 N.A.R 27-2-03

ISSUE 25: ISS -24 C.P.R 27-245 N.A.R 27-2-03

ISSUE 26: ISS -25 C.P.R 27-245 N.A.R 27-2-03

ISSUE 27: ISS -26 C.P.R 27-245 N.A.R 27-2-03

ISSUE 28: ISS -27 C.P.R 27-245 N.A.R 27-2-03

ISSUE 29: ISS -28 C.P.R 27-245 N.A.R 27-2-03

ISSUE 30: ISS -29 C.P.R 27-245 N.A.R 27-2-03

ISSUE 31: ISS -30 C.P.R 27-245 N.A.R 27-2-03

ISSUE 32: ISS -31 C.P.R 27-245 N.A.R 27-2-03

ISSUE 33: ISS -32 C.P.R 27-245 N.A.R 27-2-03

ISSUE 34: ISS -33 C.P.R 27-245 N.A.R 27-2-03

ISSUE 35: ISS -34 C.P.R 27-245 N.A.R 27-2-03

ISSUE 36: ISS -35 C.P.R 27-245 N.A.R 27-2-03

ISSUE 37: ISS -36 C.P.R 27-245 N.A.R 27-2-03

ISSUE 38: ISS -37 C.P.R 27-245 N.A.R 27-2-03

ISSUE 39: ISS -38 C.P.R 27-245 N.A.R 27-2-03

ISSUE 40: ISS -39 C.P.R 27-245 N.A.R 27-2-03

ISSUE 41: ISS -40 C.P.R 27-245 N.A.R 27-2-03

ISSUE 42: ISS -41 C.P.R 27-245 N.A.R 27-2-03

ISSUE 43: ISS -42 C.P.R 27-245 N.A.R 27-2-03

ISSUE 44: ISS -43 C.P.R 27-245 N.A.R 27-2-03

ISSUE 45: ISS -44 C.P.R 27-245 N.A.R 27-2-03

ISSUE 46: ISS -45 C.P.R 27-245 N.A.R 27-2-03

ISSUE 47: ISS -46 C.P.R 27-245 N.A.R 27-2-03

ISSUE 48: ISS -47 C.P.R 27-245 N.A.R 27-2-03

ISSUE 49: ISS -48 C.P.R 27-245 N.A.R 27-2-03

ISSUE 50: ISS -49 C.P.R 27-245 N.A.R 27-2-03

ISSUE 51: ISS -50 C.P.R 27-245 N.A.R 27-2-03

ISSUE 52: ISS -51 C.P.R 27-245 N.A.R 27-2-03

ISSUE 53: ISS -52 C.P.R 27-245 N.A.R 27-2-03

ISSUE 54: ISS -53 C.P.R 27-245 N.A.R 27-2-03

ISSUE 55: ISS -54 C.P.R 27-245 N.A.R 27-2-03

ISSUE 56: ISS -55 C.P.R 27-245 N.A.R 27-2-03

ISSUE 57: ISS -56 C.P.R 27-245 N.A.R 27-2-03

ISSUE 58: ISS -57 C.P.R 27-245 N.A.R 27-2-03

ISSUE 59: ISS -58 C.P.R 27-245 N.A.R 27-2-03

ISSUE 60: ISS -59 C.P.R 27-245 N.A.R 27-2-03

ISSUE 61: ISS -60 C.P.R 27-245 N.A.R 27-2-03

ISSUE 62: ISS -61 C.P.R 27-245 N.A.R 27-2-03

ISSUE 63: ISS -62 C.P.R 27-245 N.A.R 27-2-03

ISSUE 64: ISS -63 C.P.R 27-245 N.A.R 27-2-03

ISSUE 65: ISS -64 C.P.R 27-245 N.A.R 27-2-03

ISSUE 66: ISS -65 C.P.R 27-245 N.A.R 27-2-03

ISSUE 67: ISS -66 C.P.R 27-245 N.A.R 27-2-03

ISSUE 68: ISS -67 C.P.R 27-245 N.A.R 27-2-03

ISSUE 69: ISS -68 C.P.R 27-245 N.A.R 27-2-03

ISSUE 70: ISS -69 C.P.R 27-245 N.A.R 27-2-03

ISSUE 71: ISS -70 C.P.R 27-245 N.A.R 27-2-03

ISSUE 72: ISS -71 C.P.R 27-245 N.A.R 27-2-03

ISSUE 73: ISS -72 C.P.R 27-245 N.A.R 27-2-03

ISSUE 74: ISS -73 C.P.R 27-245 N.A.R 27-2-03

ISSUE 75: ISS -74 C.P.R 27-245 N.A.R 27-2-03

ISSUE 76: ISS -75 C.P.R 27-245 N.A.R 27-2-03

ISSUE 77: ISS -76 C.P.R 27-245 N.A.R 27-2-03

ISSUE 78: ISS -77 C.P.R 27-245 N.A.R 27-2-03

ISSUE 79: ISS -78 C.P.R 27-245 N.A.R 27-2-03

ISSUE 80: ISS -79 C.P.R 27-245 N.A.R 27-2-03

ISSUE 81: ISS -80 C.P.R 27-245 N.A.R 27-2-03

ISSUE 82: ISS -81 C.P.R 27-245 N.A.R 27-2-03

ISSUE 83: ISS -82 C.P.R 27-245 N.A.R 27-2-03

ISSUE 84: ISS -83 C.P.R 27-245 N.A.R 27-2-03

ISSUE 85: ISS -84 C.P.R 27-245 N.A.R 27-2-03

ISSUE 86: ISS -85 C.P.R 27-245 N.A.R 27-2-03

ISSUE 87: ISS -86 C.P.R 27-245 N.A.R 27-2-03

ISSUE 88: ISS -87 C.P.R 27-245 N.A.R 27-2-03

ISSUE 89: ISS -88 C.P.R 27-245 N.A.R 27-2-03

ISSUE 90: ISS -89 C.P.R 27-245 N.A.R 27-2-03

ISSUE 91: ISS -90 C.P.R 27-245 N.A.R 27-2-03

ISSUE 92: ISS -91 C.P.R 27-245 N.A.R 27-2-03

ISSUE 93: ISS -92 C.P.R 27-245 N.A.R 27-2-03

ISSUE 94: ISS -93 C.P.R 27-245 N.A.R 27-2-03

ISSUE 95: ISS -94 C.P.R 27-245 N.A.R 27-2-03

ISSUE 96: ISS -95 C.P.R 27-245 N.A.R 27-2-03

ISSUE 97: ISS -96 C.P.R 27-245 N.A.R 27-2-03

ISSUE 98: ISS -97 C.P.R 27-245 N.A.R 27-2-03

ISSUE 99: ISS -98 C.P.R 27-245 N.A.R 27-2-03

ISSUE 100: ISS -99 C.P.R 27-245 N.A.R 27-2-03

ISSUE 101: ISS -100 C.P.R 27-245 N.A.R 27-2-03

PCB : 07-01961-06
 ASSY: 08-05689-001

DISC FILE
 04-83378...9.ZIP

CODAN		SCALE	© CODAN PVT. LTD., A.C.N. 007 538 685, 2001
DRAWN	C.G.	DATE	4-5-01
CHECKED	J.D.	11-2-02	RF/IF (455kHz IF MOD/DEMOD)
APPD	J.D.	12-8-02	
FINISH		TOLERANCES	04-03378
		UNLESS OTHERWISE STATED	
		2 PLACES DEC. *	
		1 PLACE DEC. *	
		ANGULAR ±	
ISS			
REV			

AUDIO INTERFACE PCB

SMT 2
 OF 3

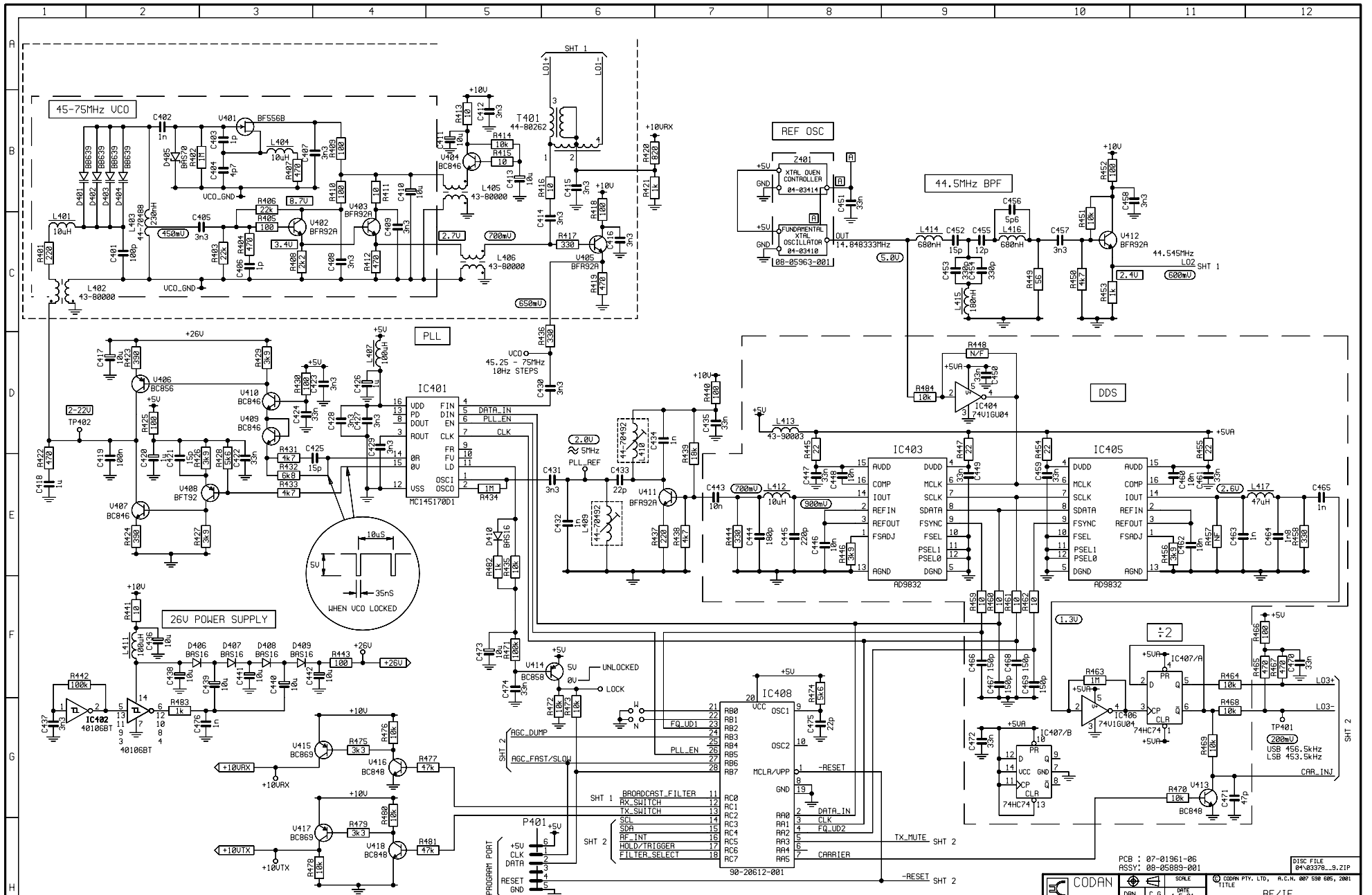

PCB : 07-01961-06		DISC FILE 04-W3378L-S.ZIP	
ASSY : 08-05883-001		A.C.N. 087 539 685, 2081	
CODAN		DATE 4-5-81	
MATERIAL		RF/IF (SYNTHESIZER & CONTROL)	
FINISH		DRAWING/DOC. NO 04-03378	
UNLESS OTHERWISE STATED		ISS 9	
2 PLACES DEC. *		SHT 3	
1 PLACE REC. *		OF 3	
ANGULAR 2 *			

ISSUE 2	ISS -01
C/A	27290
REV	11-8-82
ISSUE 3	ISS -02
P/A	1405
REV	5-1-83
ISSUE 4	ISS -03
C/A	27291
REV	5-1-83
ISSUE 5	ISS -04
P/A	1405
REV	5-1-83
ISSUE 6	ISS -05
C/A	27292
REV	5-1-83
ISSUE 7	ISS -06
C/A	27293
REV	5-1-83
ISSUE 8	ISS -07
C/A	27294
REV	5-1-83
ISSUE 9	ISS -08
C/A	27295
REV	5-1-83

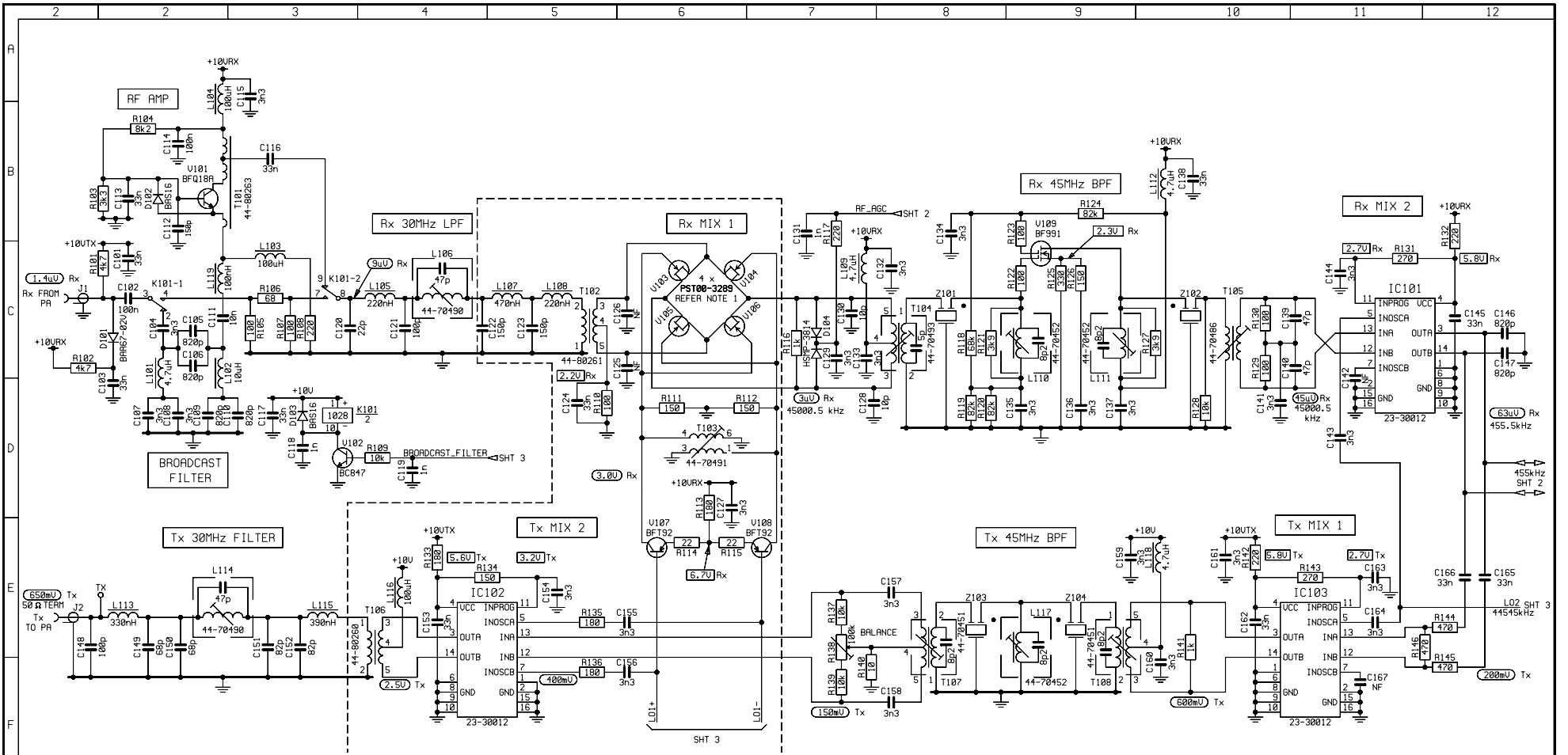

NOTES:
 1. PS100-3289 IS A SELECTED J310.

ALL DEVICES ARE TOP VIEW

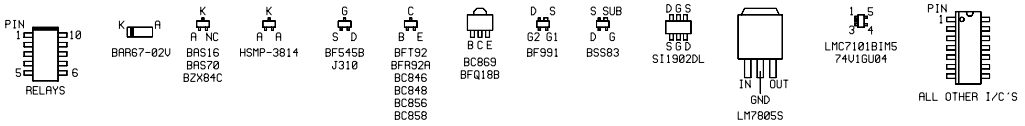

ALL OTHER 1/2'S

PCB : 07-01961-07
 ASSY: 08-05889-001

DISC FILE
 04-03378-11.ZIP

CODAN		SCALE DIN C G 4-5-01	DATE 11-2-02		DSC FILE 04-03378-11.ZIP	
MATERIAL	CHKD J.D	DATE 11-2-02		TITLE RF/IF (RF MIXER)		
FINISH	APPD J.D		DATE 12-8-02	DRAWING/DOC NO 04-03378		
UNLESS OTHERWISE STATED 2 PLACES DEC. * 1 PLACE DEC. *				TOLERANCES		
ISS	11	ISS	11	REV	SHT 1 OF 3	

ISSUE CHANGE	ISS - 01	DATE	BY
ISSUE CHANGE	ISS - 02	DATE	BY
ISSUE CHANGE	ISS - 03	DATE	BY
ISSUE CHANGE	ISS - 04	DATE	BY
ISSUE CHANGE	ISS - 05	DATE	BY
ISSUE CHANGE	ISS - 06	DATE	BY
ISSUE CHANGE	ISS - 07	DATE	BY
ISSUE CHANGE	ISS - 08	DATE	BY
ISSUE CHANGE	ISS - 09	DATE	BY
ISSUE CHANGE	ISS - 10	DATE	BY
ISSUE CHANGE	ISS - 11	DATE	BY
ISSUE CHANGE	ISS - 12	DATE	BY
ISSUE CHANGE	ISS - 13	DATE	BY
ISSUE CHANGE	ISS - 14	DATE	BY
ISSUE CHANGE	ISS - 15	DATE	BY
ISSUE CHANGE	ISS - 16	DATE	BY
ISSUE CHANGE	ISS - 17	DATE	BY
ISSUE CHANGE	ISS - 18	DATE	BY
ISSUE CHANGE	ISS - 19	DATE	BY
ISSUE CHANGE	ISS - 20	DATE	BY
ISSUE CHANGE	ISS - 21	DATE	BY
ISSUE CHANGE	ISS - 22	DATE	BY
ISSUE CHANGE	ISS - 23	DATE	BY
ISSUE CHANGE	ISS - 24	DATE	BY
ISSUE CHANGE	ISS - 25	DATE	BY

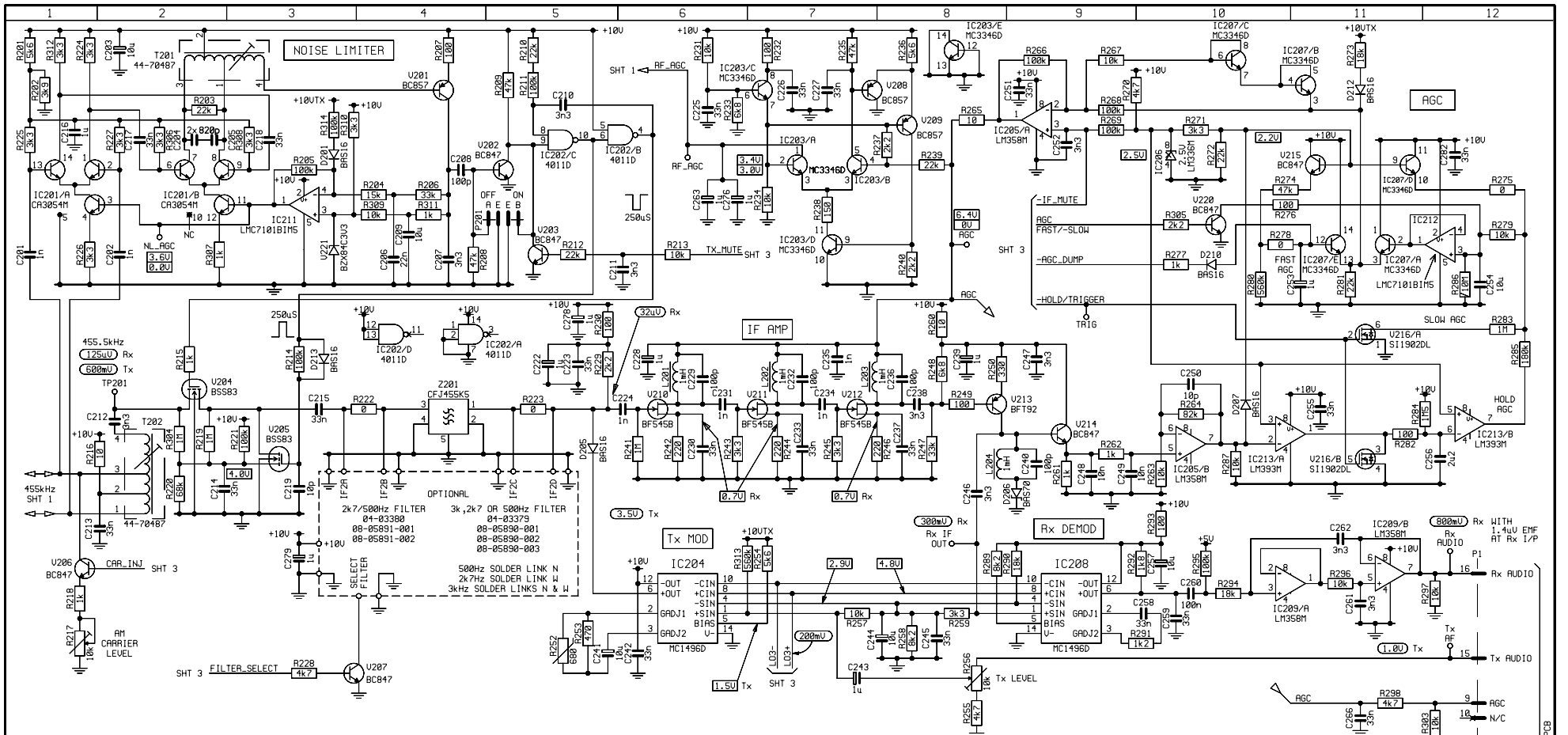

MEASUREMENT NOTES:-

- ALL AC AND DC VOLTAGES ARE MEASURED WITH RESPECT TO THE NEGATIVE RAIL.
VOLTAGES ARE TYPICAL AND MAY VARY BETWEEN UNITS.
- DC VOLTAGES MEASURED WITH A DIGITAL MULTIMETER UNDER NO SIGNAL CONDITIONS:-

3.4V	RECEIVE AND TRANSMIT MODES
0V	RECEIVE MODE
3.4V	TRANSMIT MODE
- AC VOLTAGES MEASURED WITH A 100MHz OSCILLOSCOPE AND A PROBE 10M Ω AND 12pF.
LEVELS SHOWN WILL VARY DEPENDING ON THE OSCILLOSCOPE AND PROBE USED.

650mV Tx	TRANSMIT VOLTAGES IN PEAK TO PEAK UNITS, WITH A SINGLE 1kHz MODULATING TONE APPROXIMATELY 350mV RMS APPLIED TO PINS 5 & 15 OF THE GP CONNECTOR LOCATED ON THE JUNCTION BOX. A TWO TONE SOURCE WILL GIVE THE SAME PEAK TO PEAK MEASUREMENTS.
250uV Rx	RECEIVE VOLTAGES EXPRESSED IN EMF FROM A 50 Ω SOURCE APPLIED VIA A 47nF CAPACITOR TO THE POINT INDICATED, WHICH WILL CAUSE THE VOLTAGE AT THE AGC TEST POINT TO DECREASE BY 500mV FROM THE NO SIGNAL VALUE.
140mV	VOLTAGES IN PEAK TO PEAK UNITS IN RECEIVE AND TRANSMIT MODES.

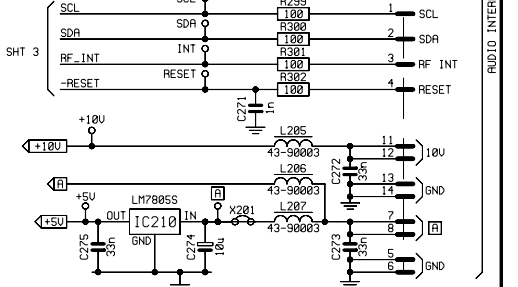

ISSUE CHANGE	DATE	BY
PCB AM5 ISS -01	14-10-02	AM
ISSUE 3: ISS -02		
C7A6 202x25		
ISSUE 4:		
C7B6 AM5 1u TR		
ISSUE 5:		
NOTES: RE-DESIGNED		
PCB AM5 ISS -03		
C7A6 202x25		
C7B6 AM5 1u TR		
ISSUE 6:		
PCB AM5 ISS -04		
ISSUE 7:		
ISSUE 8:		
ISSUE 9:		
ISSUE 10:		
ISSUE 11:		
ISSUE 12:		
ISSUE 13:		
ISSUE 14:		
ISSUE 15:		
ISSUE 16:		
ISSUE 17:		
ISSUE 18:		
ISSUE 19:		
ISSUE 20:		
ISSUE 21:		
ISSUE 22:		
ISSUE 23:		
ISSUE 24:		
ISSUE 25:		
ISSUE 26:		
ISSUE 27:		
ISSUE 28:		
ISSUE 29:		
ISSUE 30:		

PCB : 07-01961-07
ASSY: 08-05889-001

DISC FILE
04-03378_11.ZIP

CODAN	SCALE	DATE	FILE
	DRAWN	C G	4-9-01
MATERIAL	CHKD	J.D	11-2-02
FINISH	APPD	J.D	12-8-02
	TOLERANCES UNLESS OTHERWISE STATED		
ISS	PLACES DEC.	ANGULAR	
11			

AUDIO INTERFACE PCB

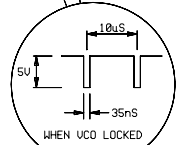
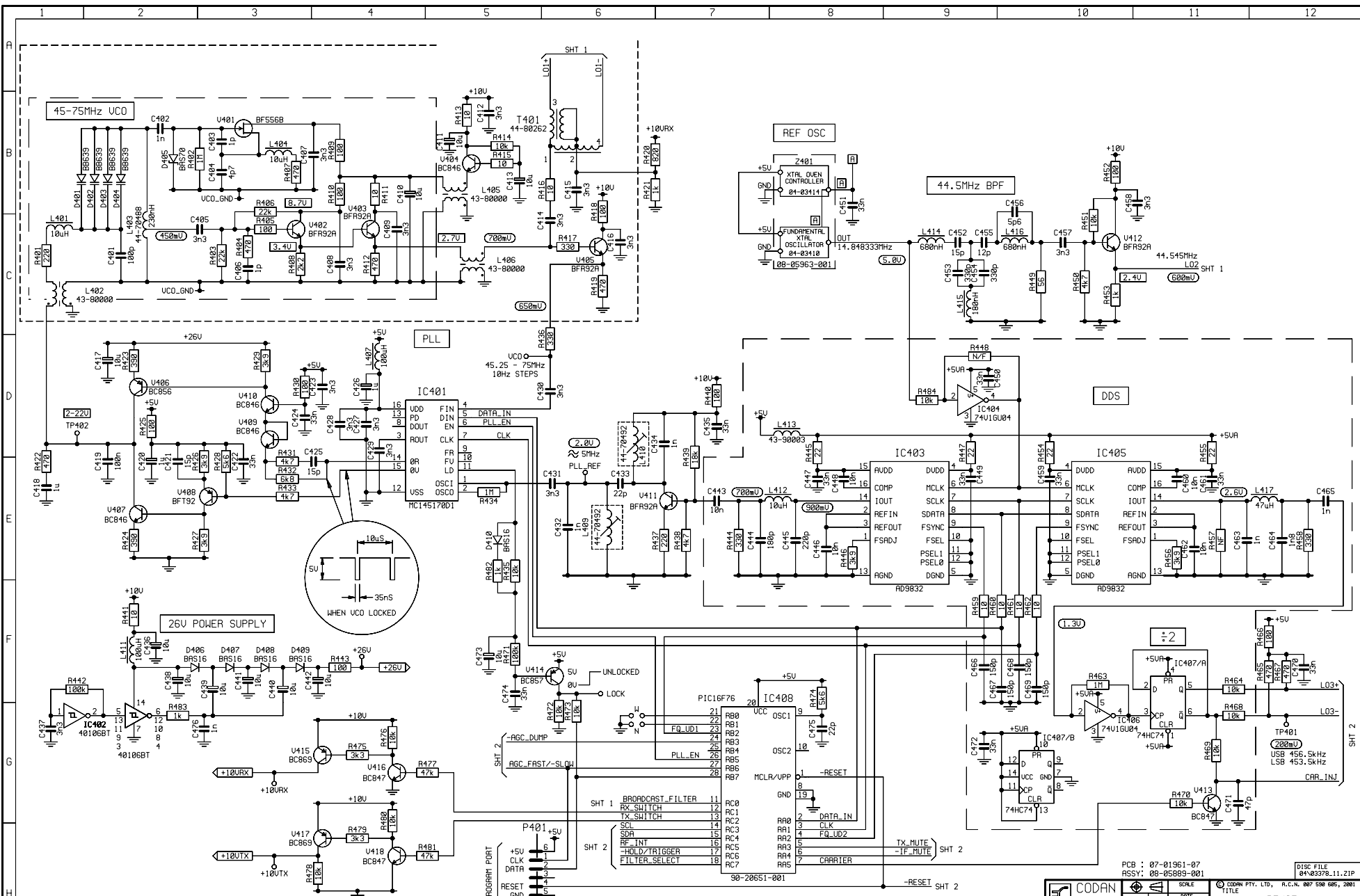

ISSUE CHANGE

ISSUE 2	ISS-01
PAGE 1	ISS-01
PAGE 2	ISS-02
PAGE 3	ISS-03
PAGE 4	ISS-04
PAGE 5	ISS-05
PAGE 6	ISS-06
PAGE 7	ISS-07
PAGE 8	ISS-08
PAGE 9	ISS-09
PAGE 10	ISS-10
PAGE 11	ISS-11
PAGE 12	ISS-12
PAGE 13	ISS-13
PAGE 14	ISS-14
PAGE 15	ISS-15
PAGE 16	ISS-16
PAGE 17	ISS-17
PAGE 18	ISS-18
PAGE 19	ISS-19
PAGE 20	ISS-20
PAGE 21	ISS-21
PAGE 22	ISS-22
PAGE 23	ISS-23
PAGE 24	ISS-24
PAGE 25	ISS-25
PAGE 26	ISS-26
PAGE 27	ISS-27
PAGE 28	ISS-28
PAGE 29	ISS-29
PAGE 30	ISS-30
PAGE 31	ISS-31
PAGE 32	ISS-32
PAGE 33	ISS-33
PAGE 34	ISS-34
PAGE 35	ISS-35
PAGE 36	ISS-36
PAGE 37	ISS-37
PAGE 38	ISS-38
PAGE 39	ISS-39
PAGE 40	ISS-40
PAGE 41	ISS-41
PAGE 42	ISS-42
PAGE 43	ISS-43
PAGE 44	ISS-44
PAGE 45	ISS-45
PAGE 46	ISS-46
PAGE 47	ISS-47
PAGE 48	ISS-48
PAGE 49	ISS-49
PAGE 50	ISS-50
PAGE 51	ISS-51
PAGE 52	ISS-52
PAGE 53	ISS-53
PAGE 54	ISS-54
PAGE 55	ISS-55
PAGE 56	ISS-56
PAGE 57	ISS-57
PAGE 58	ISS-58
PAGE 59	ISS-59
PAGE 60	ISS-60
PAGE 61	ISS-61
PAGE 62	ISS-62
PAGE 63	ISS-63
PAGE 64	ISS-64
PAGE 65	ISS-65
PAGE 66	ISS-66
PAGE 67	ISS-67
PAGE 68	ISS-68
PAGE 69	ISS-69
PAGE 70	ISS-70
PAGE 71	ISS-71
PAGE 72	ISS-72
PAGE 73	ISS-73
PAGE 74	ISS-74
PAGE 75	ISS-75
PAGE 76	ISS-76
PAGE 77	ISS-77
PAGE 78	ISS-78
PAGE 79	ISS-79
PAGE 80	ISS-80
PAGE 81	ISS-81
PAGE 82	ISS-82
PAGE 83	ISS-83
PAGE 84	ISS-84
PAGE 85	ISS-85
PAGE 86	ISS-86
PAGE 87	ISS-87
PAGE 88	ISS-88
PAGE 89	ISS-89
PAGE 90	ISS-90
PAGE 91	ISS-91
PAGE 92	ISS-92
PAGE 93	ISS-93
PAGE 94	ISS-94
PAGE 95	ISS-95
PAGE 96	ISS-96
PAGE 97	ISS-97
PAGE 98	ISS-98
PAGE 99	ISS-99
PAGE 100	ISS-100

PCB : 07-01961-07
 ASSY : 08-05809-001
 DISC FILE 04-03378-11.ZIP

CODAN		SCALE	CDOM PVT. LTD., R.C.N. 107 530 GPO, 2001
MATERIAL	DRN C G	DATE	4-5-01
	CHKD J.D	REV	11-2-02
	APPD J.D	REV	12-9-02
FINISH	TOLERANCES UNLESS OTHERWISE STATED		ISS
	2 PLACES DEC. *		11
	1 PLACE REC. *		
	ANGULAR *		
DRAWING/DOC. NO			04-03378
TITLE			RF/IF (SYNTHESIZER & CONTROL)
SHEET			SHT 3
OF			OF 3

DO NOT SCALE

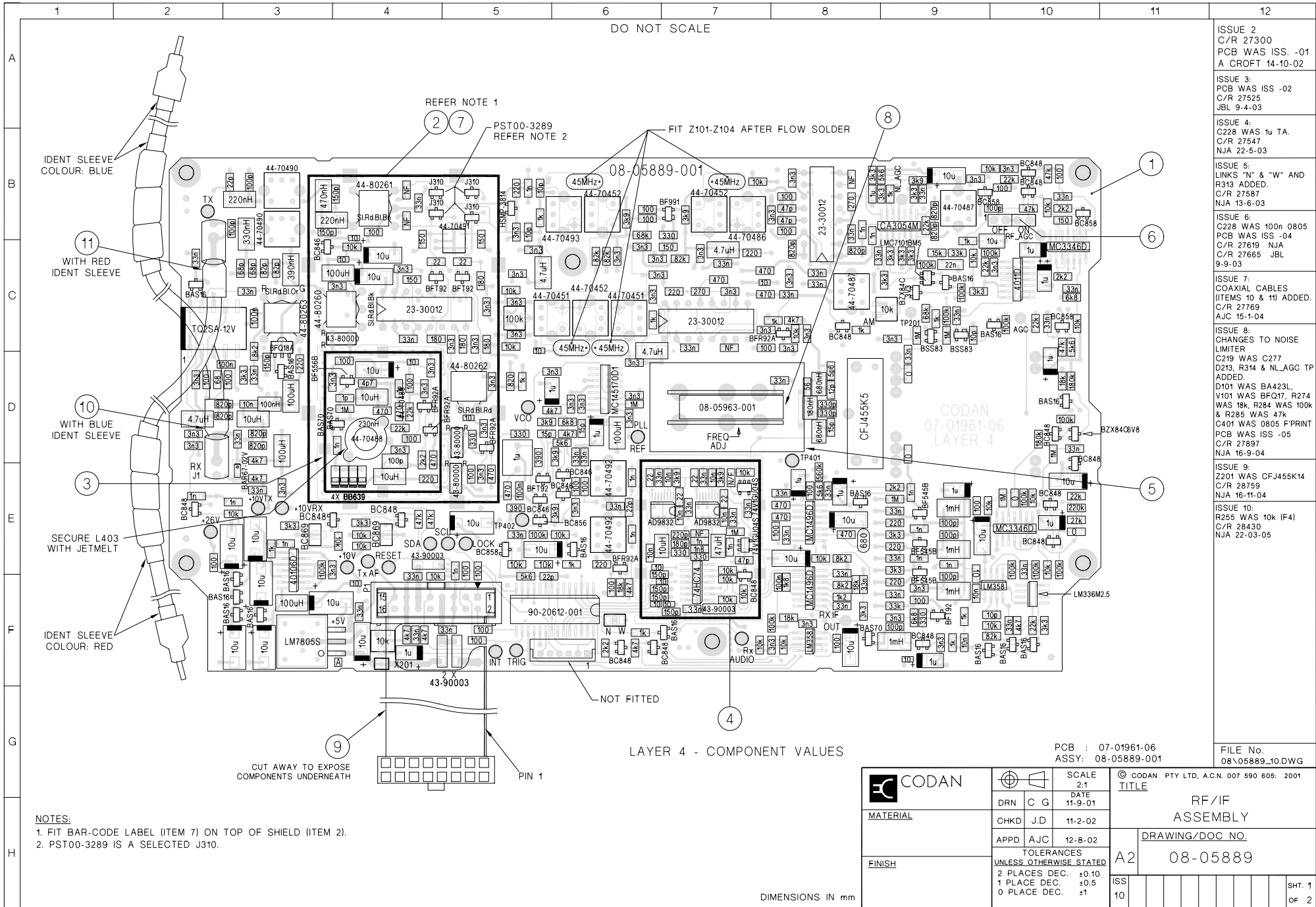

- ISSUE 2
C/R 27300
PCB WAS ISS. -01
A CROFT 14-10-02
- ISSUE 3:
PCB WAS ISS -02
C/R 27525
JBL 9-4-03
- ISSUE 4:
C228 WAS 1u TA.
C/R 27547
NJA 22-5-03
- ISSUE 5:
LINKS "N" & "W" AND
R313 ADDED.
C/R 27587
NJA 13-6-03
- ISSUE 6:
C228 WAS 100n 0805
PCB WAS ISS -04
C/R 27619 NJA
C/R 27665 JBL
9-9-03
- ISSUE 7:
COAXIAL CABLES
(ITEMS 10 & 11) ADDED.
C/R 27769
AJC 15-1-04
- ISSUE 8:
CHANGES TO NOISE
LIMITER
C219 WAS C277
D213, R314 & NL_AGC TP
ADDED.
D101 WAS BA423L,
V101 WAS BFQ17, R274
WAS 18k, R284 WAS 100k
& R285 WAS 47k
C401 WAS 0805 FPRINT
PCB WAS ISS -05
C/R 27897
NJA 16-9-04
- ISSUE 9:
Z201 WAS CFJ455K14
C/R 28759
NJA 16-11-04
- ISSUE 10:
R255 WAS 10k (F4)
C/R 28430
NJA 22-03-05

PCB : 07-01961-06
ASSY: 08-05889-001

FILE NO.
08\05889_10.DWG

LAYER 4 - COMPONENT VALUES

- NOTES:
1. FIT BAR-CODE LABEL (ITEM 7) ON TOP OF SHIELD (ITEM 2).
 2. PST00-3289 IS A SELECTED J310.

	DRN	C G	DATE
	CHKD	J.D	11-9-01
MATERIAL	APPD	AJC	12-8-02
FINISH	TOLERANCES UNLESS OTHERWISE STATED		
	2 PLACES DEC. +0.10		
	1 PLACE DEC. +0.5		
0 PLACE DEC. ±1			

SCALE	2:1
DATE	11-9-01
TITLE	RF/IF ASSEMBLY
DRAWING/DOC NO.	08-05889
ISS	10

© CODAN PTY LTD, A.C.N. 007 590 605: 2001	
TITLE	
RF/IF ASSEMBLY	
DRAWING/DOC NO.	
08-05889	
SHT. 1	OF 2

DIMENSIONS IN mm

1 2 3 4 5 6 7 8 9 10 11 12

DO NOT SCALE

A
B
C
D
E
F
G
H

ISSUE 2
C/R 27300
PCB WAS ISS.1
A CROFT 14-10-02

ISSUE 3:
PCB WAS ISS -02
C/R 27525
JBL 9-4-03

ISSUE 4:
REFER SHT 1
C/R 27547

ISSUE 5:
LINKS "N" & "W" AND
R313 ADDED.
C/R 27587
NJA 13-6-03

ISSUE 6:
C228 WAS 100n 0805
PCB WAS ISS -04
C/R 27619 NJA
C/R 27665 JBL
9-9-03

ISSUE 7:
COAXIAL CABLES
(ITEMS 10 & 11 ADDED.
C/R 27769
AJC 15-1-04

ISSUE 8:
CHANGES TO NOISE
LIMITER
C219 WAS C277
D213, R314 & NL_AGC TP
ADDED.
D101 WAS BA423L.
V101 WAS BFO17, R274
WAS 18k, R284 WAS 100k
& R285 WAS 47k
C401 WAS 0805 FPRINT
PCB WAS ISS -05
C/R 27891
NJA 16-9-04

ISSUE 9:
REFER SHT 1
C/R 28259

ISSUE 10:
REFER SHT 1
C/R 28430

FILE No.
08\05889_10.DWG

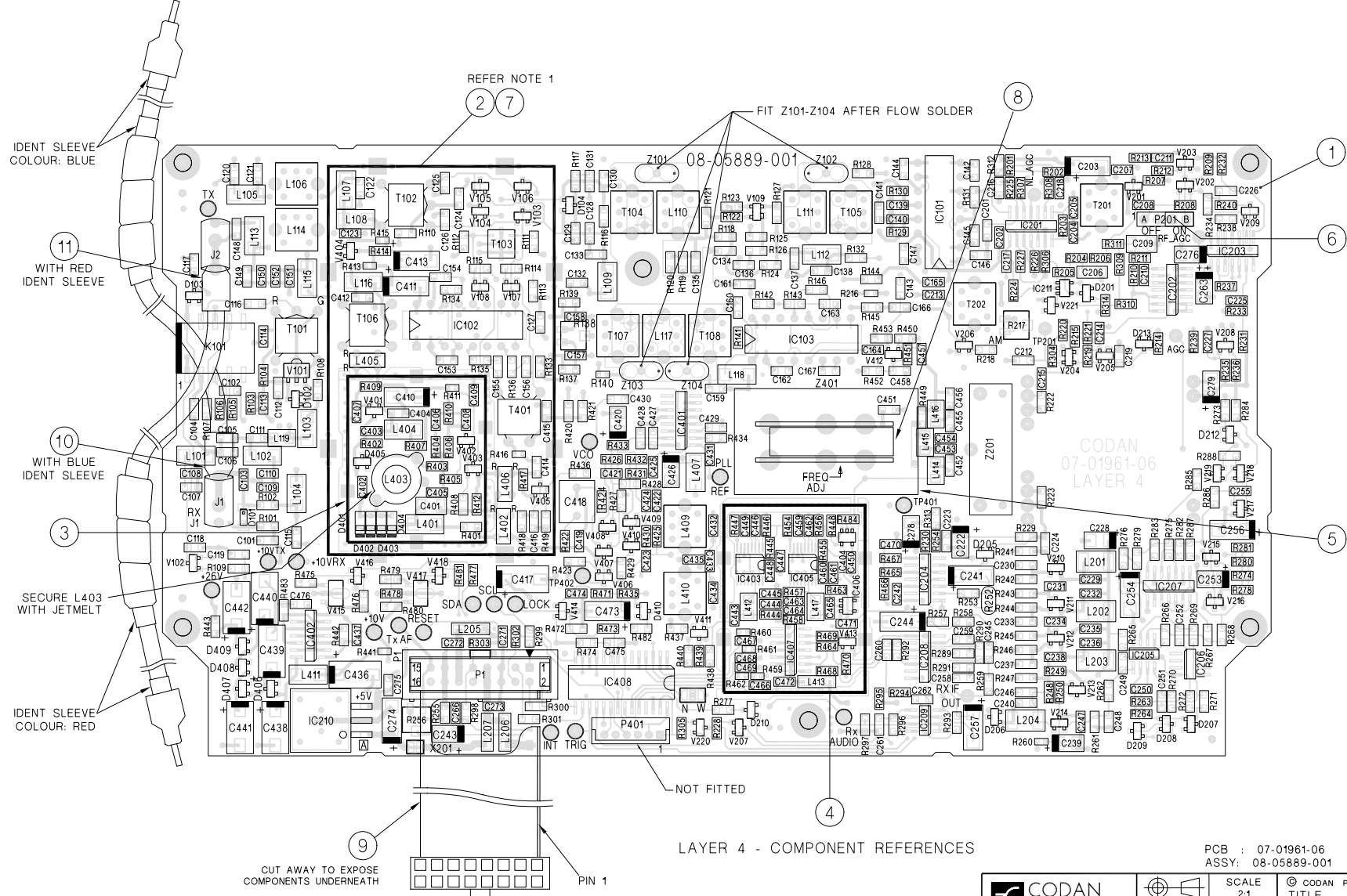

NOTES:
1. FIT BAR-CODE LABEL (ITEM 7) ON TOP OF SHIELD (ITEM 2).

LAYER 4 - COMPONENT REFERENCES

PCB : 07-01961-06
ASSY: 08-05889-001

DIMENSIONS IN mm

MATERIAL	CHKD	J.D	11-2-02
	APPD	AJC	12-8-02
FINISH	TOLERANCES UNLESS OTHERWISE STATED		
	2 PLACES DEC.	±0.10	
	1 PLACE DEC.	±0.5	
	0 PLACE DEC.	±1	

SCALE	2:1
DATE	11-9-01
DRN	C G
CHECKED	J.D
APPROVED	AJC
TOLERANCES UNLESS OTHERWISE STATED	
2 PLACES DEC.	±0.10
1 PLACE DEC.	±0.5
0 PLACE DEC.	±1

© CODAN PTY LTD, A.C.N. 007 590 605: 2001	
TITLE	
RF/IF ASSEMBLY	
DRAWING/DOC. NO.	
A2 08-05889	
ISS	10
SHT.	2
OF	2

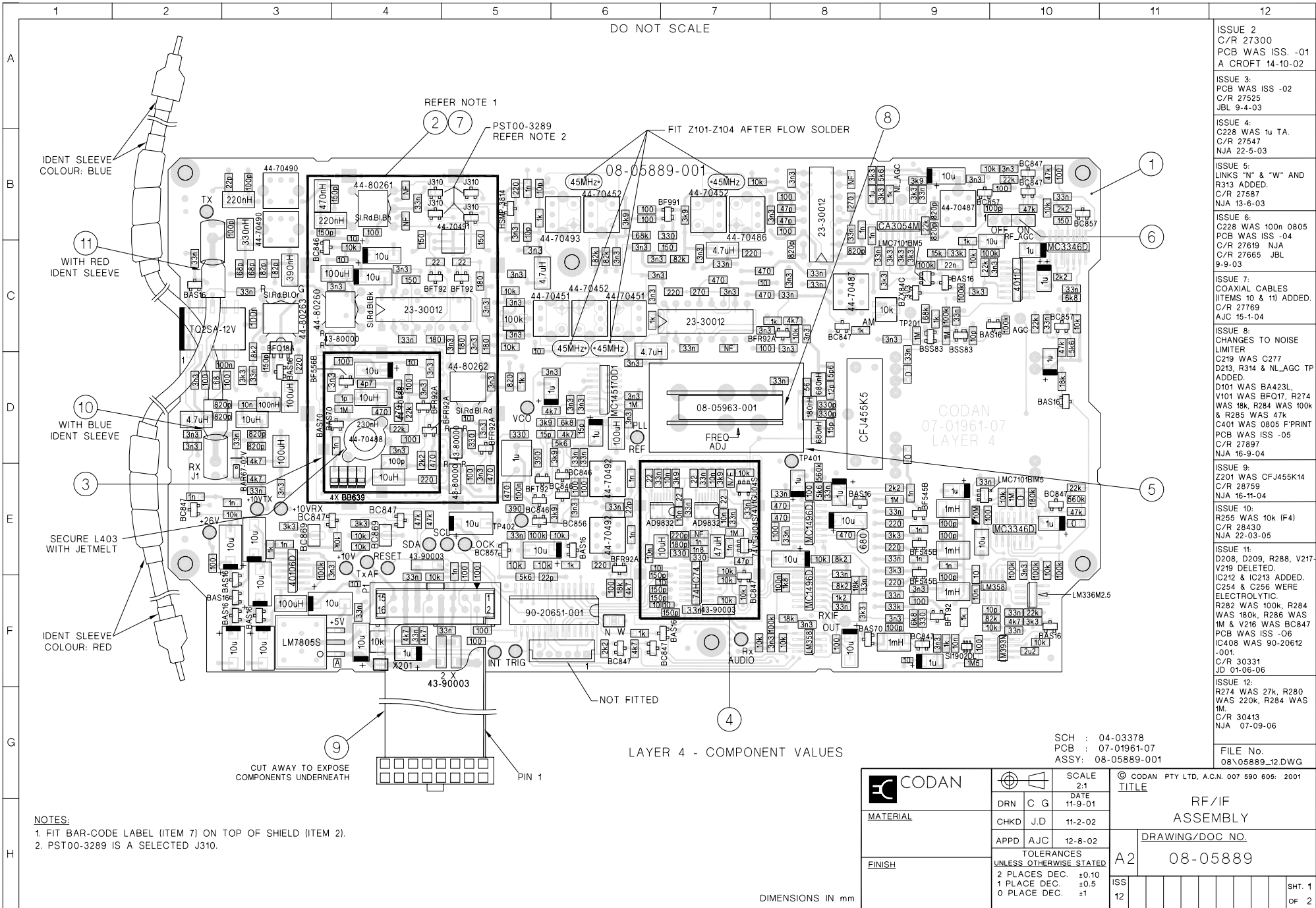

- NOTES:**
1. FIT BAR-CODE LABEL (ITEM 7) ON TOP OF SHIELD (ITEM 2).
 2. PST00-3289 IS A SELECTED J310.

- ISSUE 2
C/R 27300
PCB WAS ISS. -01
A CROFT 14-10-02
- ISSUE 3:
PCB WAS ISS -02
C/R 27525
JBL 9-4-03
- ISSUE 4:
C228 WAS 1u TA.
C/R 27547
NJA 22-5-03
- ISSUE 5:
LINKS "N" & "W" AND
R313 ADDED.
C/R 27587
NJA 13-6-03
- ISSUE 6:
C228 WAS 100n 0805
PCB WAS ISS -04
C/R 27619 NJA
C/R 27665 JBL
9-9-03
- ISSUE 7:
COAXIAL CABLES
(ITEMS 10 & 11) ADDED.
C/R 27769
AJC 15-1-04
- ISSUE 8:
CHANGES TO NOISE
LIMITER
C219 WAS C277
D213, R314 & NL_AGC TP
ADDED.
D101 WAS BA423L.
V101 WAS BFQ17, R274
WAS 18k, R284 WAS 100k
& R285 WAS 47k
C401 WAS 0805 FPRINT
PCB WAS ISS -05
C/R 27897
NJA 16-9-04
- ISSUE 9:
Z201 WAS CFJ455K14
C/R 28759
NJA 16-11-04
- ISSUE 10:
R255 WAS 10k (F4)
C/R 28430
NJA 22-03-05
- ISSUE 11:
D208, D209, R288, V217-
V219 DELETED.
IC212 & IC213 ADDED.
C254 & C256 WERE
ELECTROLYTIC.
R282 WAS 100k, R284
WAS 180k, R286 WAS
1M & V216 WAS BC847
PCB WAS ISS -06
IC408 WAS 90-20612
J-01.
C/R 30331
JD 01-06-06
- ISSUE 12:
R274 WAS 27k, R280
WAS 220k, R284 WAS
1M.
C/R 30413
NJA 07-09-06

SCH : 04-03378
PCB : 07-01961-07
ASSY: 08-05889-001

FILE No.
08\05889_12.DWG

	SCALE 2:1		© CODAN PTY LTD, A.C.N. 007 590 605: 2001	
	DRN	C G	DATE 11-9-01	
	CHKD	J.D	11-2-02	
MATERIAL	APPD	AJC	12-8-02	
FINISH	TOLERANCES UNLESS OTHERWISE STATED		DRAWING/DOC NO.	
	2 PLACES DEC. ±0.10		A2 08-05889	
1 PLACE DEC. ±0.5		ISS 12		SHT. 1 OF 2
0 PLACE DEC. ±1				

DIMENSIONS IN mm

DO NOT SCALE

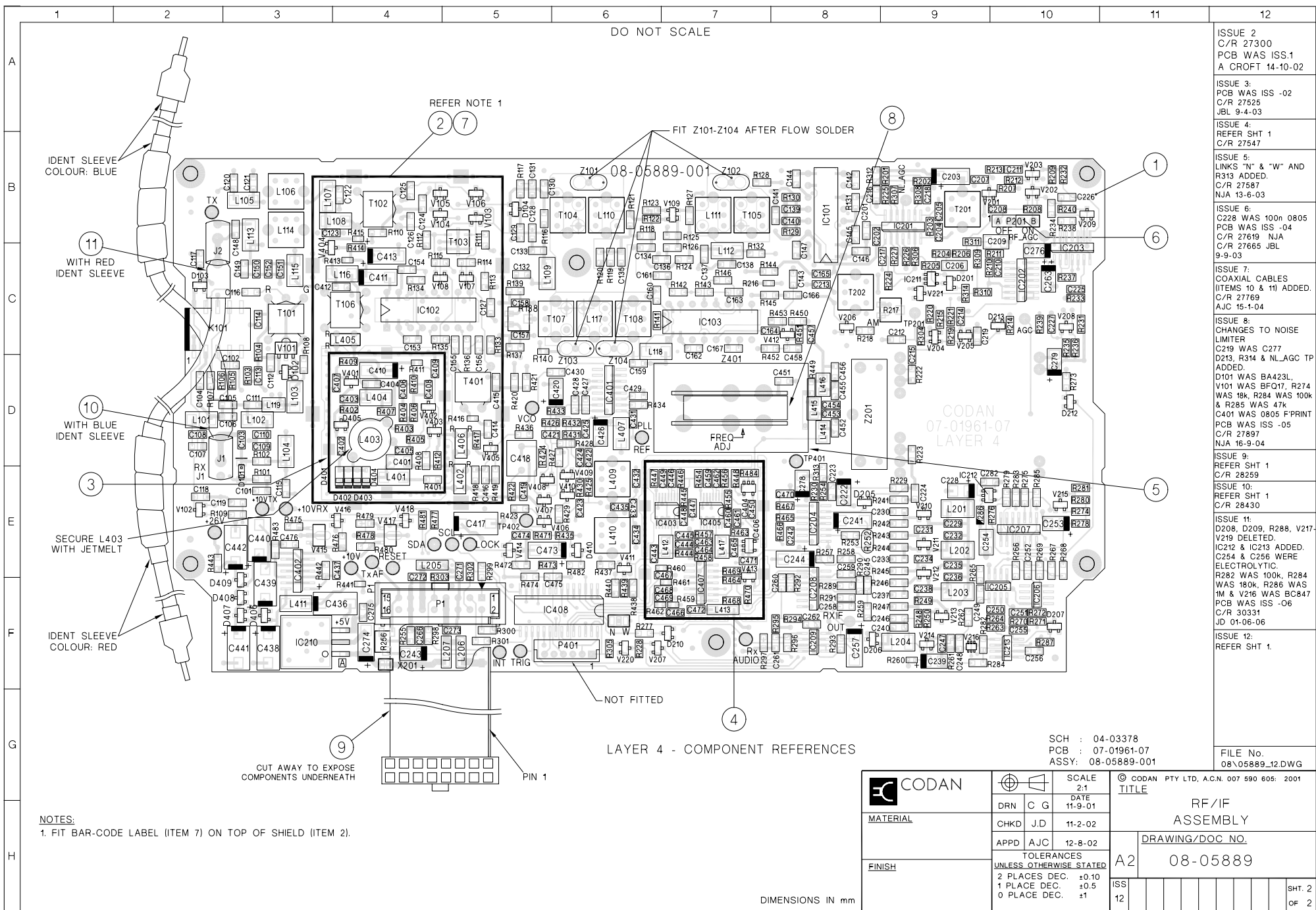

- ISSUE 2:
C/R 27300
PCB WAS ISS.1
A CROFT 14-10-02
- ISSUE 3:
PCB WAS ISS -02
C/R 27525
JBL 9-4-03
- ISSUE 4:
REFER SHT 1
C/R 27547
- ISSUE 5:
LINKS "N" & "W" AND
R313 ADDED.
C/R 27587
NJA 13-6-03
- ISSUE 6:
C228 WAS 100n 0805
PCB WAS ISS -04
C/R 27619 NJA
C/R 27665 JBL
9-9-03
- ISSUE 7:
COAXIAL CABLES
(ITEMS 10 & 11) ADDED.
C/R 27769
AJC 15-1-04
- ISSUE 8:
CHANGES TO NOISE
LIMITER
C219 WAS C277
D213, R314 & NL_AGC TP
ADDED.
D101 WAS BA423L.
V101 WAS BFO17, R274
WAS 18k, R284 WAS 100k
& R285 WAS 47k
C401 WAS 0805 47K
PCB WAS ISS -05
C/R 27897
NJA 16-9-04
- ISSUE 9:
REFER SHT 1
C/R 28259
- ISSUE 10:
REFER SHT 1
C/R 28430
- ISSUE 11:
D208, D209, R288, V217-
V219 DELETED.
IC212 & IC213 ADDED.
C254 & C256 WERE
ELECTROLYTIC.
R282 WAS 100k, R284
WAS 180k, R286 WAS
1M & V216 WAS BC847
PCB WAS ISS -06
C/R 30331
C/R 27710
JD 01-06-06
- ISSUE 12:
REFER SHT 1.

IDENT SLEEVE
COLOUR: BLUE

WITH RED
IDENT SLEEVE

WITH BLUE
IDENT SLEEVE

SECURE L403
WITH JETMELT

IDENT SLEEVE
COLOUR: RED

REFER NOTE 1

FIT Z101-Z104 AFTER FLOW SOLDER

08-05889-001

CODAN
07-01961-07
LAYER 4

LAYER 4 - COMPONENT REFERENCES

SCH : 04-03378
PCB : 07-01961-07
ASSY: 08-05889-001

FILE No.
08\05889-12.DWG

NOTES:
1. FIT BAR-CODE LABEL (ITEM 7) ON TOP OF SHIELD (ITEM 2).

	SCALE 2:1		© CODAN PTY LTD, A.C.N. 007 590 605: 2001 TITLE RF/IF ASSEMBLY
	DRN	C G	
MATERIAL	CHKD	J.D	11-2-02
FINISH	APPD	AJC	12-8-02
	TOLERANCES UNLESS OTHERWISE STATED		
2 PLACES DEC. +0.10			A2 DRAWING/DOC NO. 08-05889
1 PLACE DEC. +0.5			
0 PLACE DEC. ±1			ISS 12
DIMENSIONS IN mm			SHT. 2 OF 2

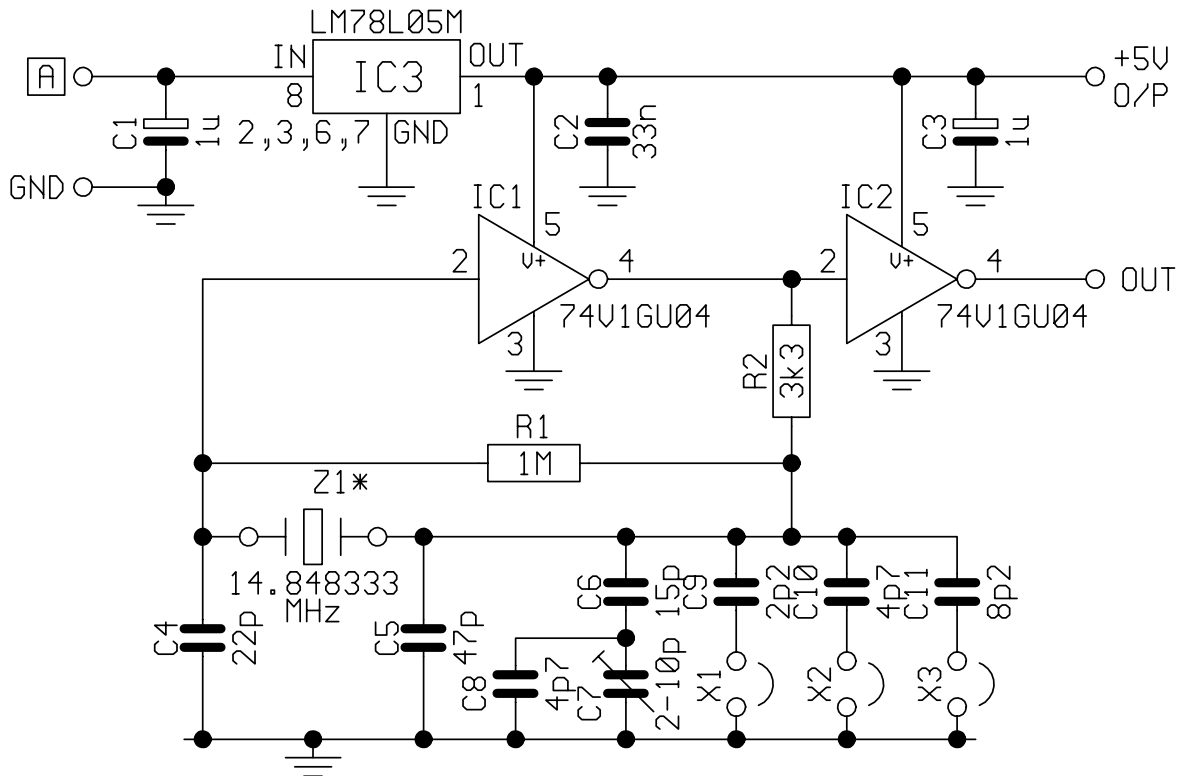

Notes:

- *Z1 is part of assembly 08-05963-001 and is shown for clarity.
- If frequency adjustment target cannot be met - soldering of a 8.2pF capacitor (CODAN P/N 46-08200-081) in parallel with C5 is allowed.

DEVICES ARE TOP VIEW

PIN

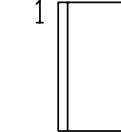

LM78L05M

PIN

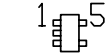

74V1GU04

PCB: 07-01980-03

ASSY: 08-05962-001

FILE NAME

04\03410_5.*

ISSUE CHANGE	ISSUE 2: C5 WAS 56p C/R 27270 J.D. 21-8-02	ISSUE 3: C/R 27339 C8,C11,X3 ADDED C6,C9,C10 CHANGED 14-10-02 JD	ISSUE 4: C5 WAS 47p NOTE 2 ADDED. C/R 27606 J.D. 12-9-03	ISSUE 4: C5 WAS 39p PCB WAS ISS -02 C/R 27676 NJA 17-11-03
--------------	---	--	--	--

	DRN	C G	SCALE
	CHKD	J.D	DATE 17-11-01
	APPD	J.D	5-2-02
FINISH	TOLERANCES UNLESS OTHERWISE STATED		12-8-02
	2 PLACES DEC. ± 1 PLACE DEC. ± ANGULAR ±		

© CODAN PTY. LTD, A.C.N. 007 590 605, 2001			
TITLE FUNDAMENTAL XTAL OSCILLATOR			
DRAWING/DOC.NO A4		04-03410	
ISS	2	3	4
			SHT 1 OF 1

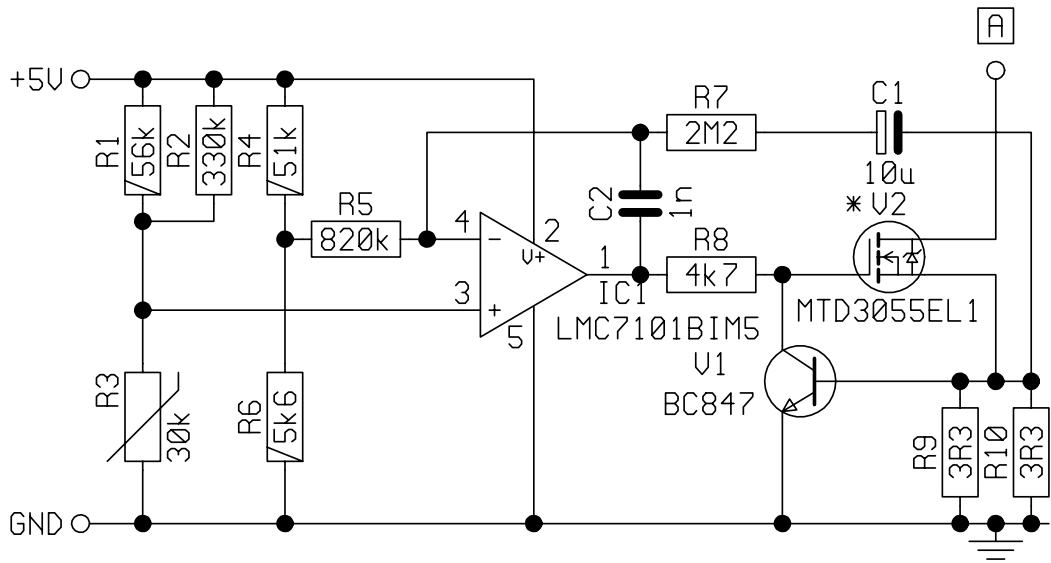

NOTES:

1. *U2 IS PART OF ASSEMBLY 08-05963-001 AND IS SHOWN FOR CLARITY.
2. NOMINAL TEMPERATURE SET TO 70.0°C.

DEVICES ARE TOP VIEW

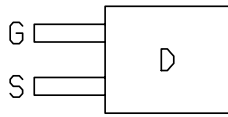

MTD3055EL1



LMC7101BIM5

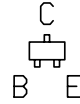

BC847

PCB 07-01905-02
 ASSY 08-05973-001

FILE NAME
 04\03414__3.ZIP

ISSUE CHANGE

ISSUE 2:
 R2 WAS 150k
 REF TO TEMP
 IN NOTE 2 WAS
 74.8.
 C/R 27638
 NJA 18-9-03

ISSUE 3:
 PCB WAS ISS
 -01.
 C/R 27926
 DMT 6-4-04



CODAN



SCALE

© CODAN PTY. LTD, A.C.N. 007 590 605, 2002

DRN

C G

DATE

TITLE

CONTROLLER
 CRYSTAL OVEN

MATERIAL

CHKD

J.D

5-2-02

APPD

J.D

12-8-02

A4

DRAWING/DOC.NO

04-03414

FINISH

TOLERANCES
 UNLESS OTHERWISE STATED
 2 PLACES DEC. ±
 1 PLACE DEC. ±
 ANGULAR ±

ISS
 3

SHT 1
 OF 1

DO NOT SCALE

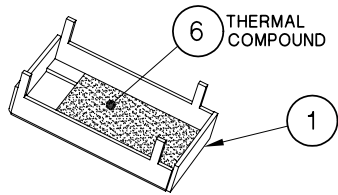

1. SMEAR THERMAL COMPOUND ACROSS INTERNAL HEATSINK AS SHOWN.

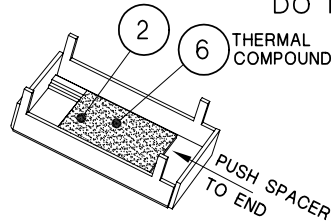

2. FIT SPACER OVER THERMAL COMPOUND AS SHOWN AND ADD MORE THERMAL COMPOUND.

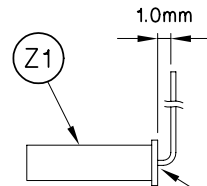

3. REMOVE WASHER BEFORE BENDING WIRES ON CRYSTAL, AS SHOWN.

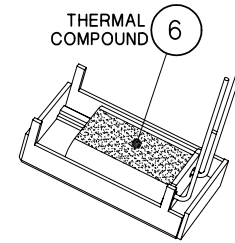

4. PLACE CRYSTAL IN HEATSINK AND SMEAR THERMAL COMPOUND OVER ENTIRE TOP SURFACE OF CRYSTAL.

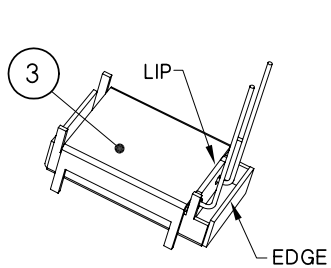

5. FIT TOP HEATSINK COVER AND ENSURE THE CRYSTAL LIP IS CLEAR FROM EDGE BUT FLUSH WITH ITEM 3 & SPACER PLATE.

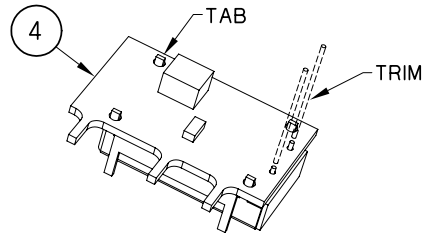

6. SOLDER 4 TABS TO OSC ASSEMBLY (ITEM 4), ENSURING THAT THE HEATSINK IS PARALLEL AND TIGHT, THEN SOLDER THE TWO CRYSTAL WIRES BEFORE TRIMMING.

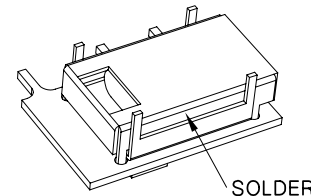

7. SOLDER TOGETHER ONE SIDE OF HEATSINK.

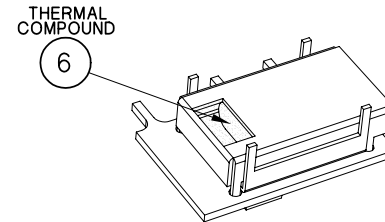

8. APPLY A LIBERAL AMOUNT OF THERMAL COMPOUND TO THE TOP OF THE CRYSTAL AS SHOWN UNTIL FLUSH WITH HOLE. THERE SHOULD BE NO AIR GAP BETWEEN THE COMPOUND AND THE CRYSTAL.

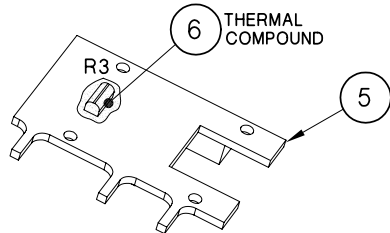

9. BEFORE FITTING THE CONTROLLER PCB (ITEM 5), COVER R3 WITH A SMALL QUANTITY OF THERMAL COMPOUND.

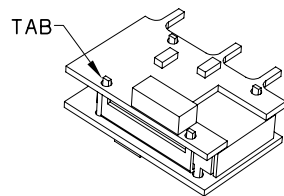

10. POSITION PCB ENSURING THAT R3 FITS INTO THE HEATSINK ASSEMBLY. THEN SOLDER THE (4) TABS TO THE PCB.

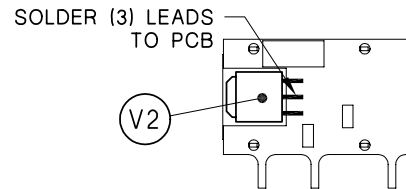

11. LIGHTLY PRE-TIN HEATSINK USING THICK TIP SOLDERING IRON (75-21000-023) SET TO 400°C & 0.56mm SOLDER. LIGHTLY PRE-TIN THE 3 PADS ON THE PCB. PRE-CUT LEGS OF V2 TO 3mm PRIOR TO SOLDERING. SOLDER 2 OUTER LEADS FIRST FOLLOWED BY THE CENTRE LEAD. USE MEDIUM TIP SOLDERING IRON

(75-21000-012) SET TO 350-380°C & 0.56mm SOLDER. SOLDER THE BODY OF V2 TO HEATSINK. ENSURE THERE IS PROPER WETTING UNDER V2. USE THICK SOLDERING TIP SET TO 400°C & 0.56mm SOLDER.

PART No. 08-05963-001

ISSUE 2
CHANGED
NOTES 1, 4, 7 & 8
& ILLUSTRATIONS
1, 2 & 4.
C/R 27493
20-03-03 JB

ISSUE 3
DETAILS 3, 7 & 11 CHANGED
C/R 27676
NJA 17-11-03

ISSUE 4:
DETAIL 11 CHANGED.
C/R 27957
KMWee 24-5-04

FILE No.
08\05963_4.DWG

NOTES:

THE PRO-ENGINEER MODEL/FILE GENERATED FROM THIS MODEL CONTAIN THE MASTER INFORMATION FOR THIS PART. DESIGN CHANGES MUST BE MADE TO THE PRO-ENGINEER MODEL. THE AUTOCAD DRAWINGS MUST BE UPDATED AND UP-ISSUED ACCORDINGLY. PRO-ENGINEER FILE No. 08\05963_x.ZIP USE JIG 75-80845 TO AID ASSY.

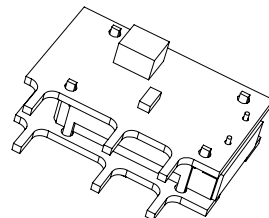

FINAL ASSEMBLY

DIMENSIONS IN mm

			SCALE NTS	© CODAN PTY LTD, A.C.N. 007 590 605: 2000 TITLE CRYSTAL OVEN ASSEMBLY
	DRN	C G	DATE	
MATERIAL	CHKD	J.D.	5-2-02	DRAWING/DOC NO.
	APPD	AJC	12-8-02	
FINISH	TOLERANCES UNLESS OTHERWISE STATED			A3
	2 PLACES DEC. ±0.10			
	1 PLACE DEC. ±0.5			
0 PLACE DEC. ±1			ISS	SHT. 1
			4	

DO NOT SCALE

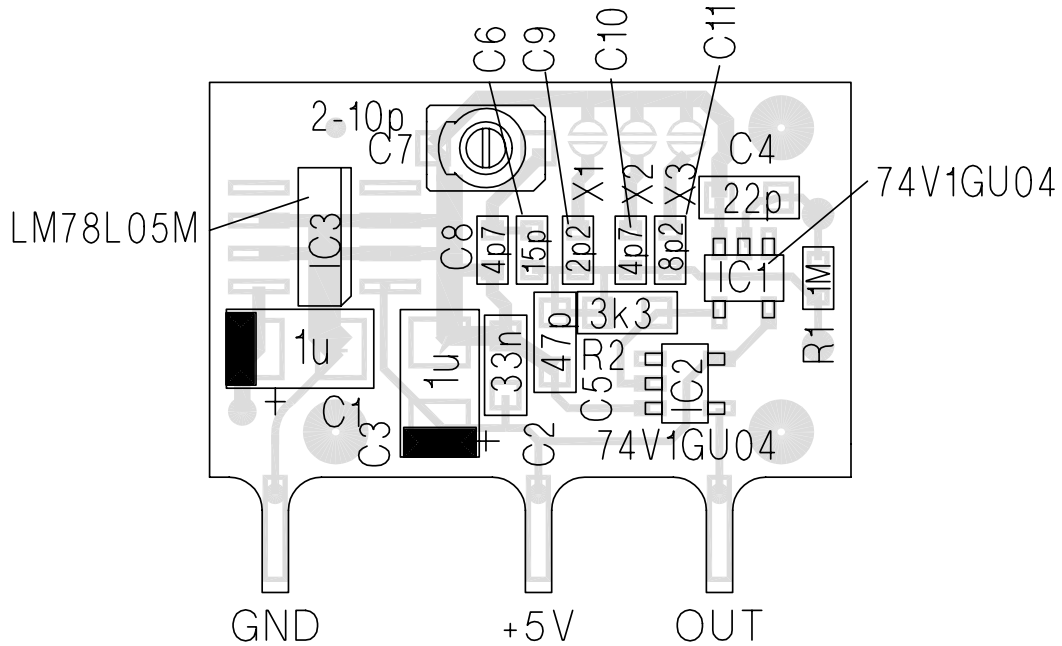

NOTES:

- IF FREQUENCY ADJUSTMENT TARGET CANNOT BE MET - SOLDERING OF 8.2pF CAPACITOR (CODAN P/N 46-08200-081) IN PARALLEL WITH C5 (ON TOP OF IT) IS ALLOWED.

ISSUE CHANGE	ISSUE 2: C5 WAS 56p C/R 27270 J.D. 21-8-02	ISSUE 3: CHANGED TO REFLECT ISS.2 PCB 14-10-02 JD	ISSUE 4: NOTE 1 ADDED C5 WAS 47p C/R 27606 J.D. 12-9-03	ISSUE 5: PCB WAS ISS -02 C5 WAS 39p C/R 27676 NJA 17-11-03	PCB : 07-01980-03 ASSY : 08-05962-001
					FILE No. 08\05962__5.DWG
DIMENSIONS IN mm					
			SCALE 4:1	© CODAN PTY LTD, A.C.N. 007 590 605: 2000	
	DRN	C G	DATE 19-11-01	TITLE FUNDAMENTAL CRYSTAL OSCILLATOR	
MATERIAL	CHKD	J.D.	5-2-02	DRAWING/DOC NO.	
FINISH	APPD	AJC	12-8-02	A4	
	TOLERANCES UNLESS OTHERWISE STATED			08-05962	
	2 PLACES DEC. ±0.10 1 PLACE DEC. ±0.5 0 PLACE DEC. ±1			ISS 5	SHT. 1 OF 1

DO NOT SCALE

ISSUE CHANGE
 ISSUE 2:
 R2 WAS 150k
 C/R 27638
 NJA 18-9-03
 ISSUE 3:
 PCB WAS ISS -01
 V1 WAS BC848
 C/R 27926
 DMT 6-4-04

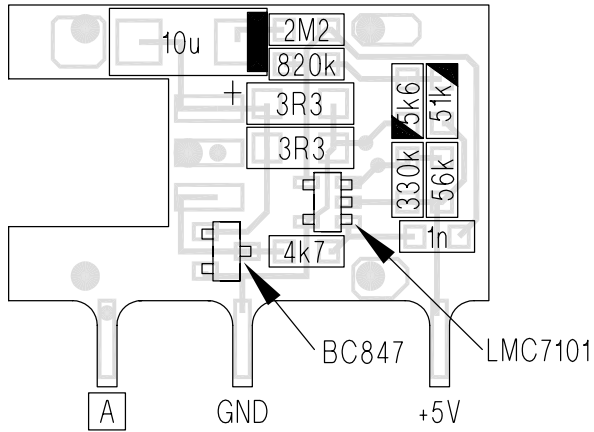

COMPONENT VALUES - SIDE 2

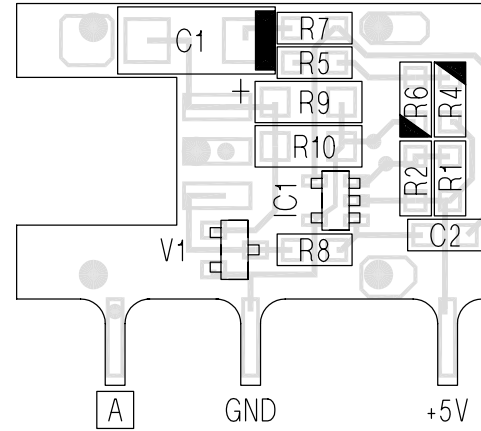

COMPONENT REFERENCES - SIDE 2

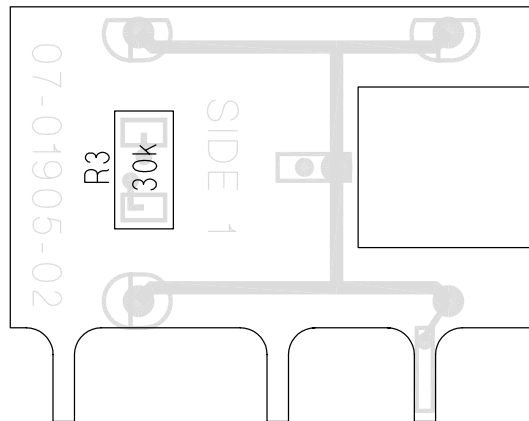

COMPONENT REFERENCE & VALUE - SIDE 1

DIMENSIONS IN mm

PCB : 07-01905-02
 ASSY: 08-05973-001

FILE No.
 08\05973_3.DWG

	SCALE 4:1		© CODAN PTY LTD, A.C.N. 007 590 605: 2002 TITLE CONTROLLER, CRYSTAL OVEN	
	DRN	C G		DATE 4-2-02
	CHKD	J.D.		5-2-02
MATERIAL	APPD	A.JC	12-8-02	
FINISH	TOLERANCES UNLESS OTHERWISE STATED		DRAWING/DOC NO. A3 08-05973	
	2 PLACES DEC.	±0.10		
	1 PLACE DEC.	±0.5		
	0 PLACE DEC.	±1	ISS 3	
			SHT. 1 OF 1	

DO NOT SCALE

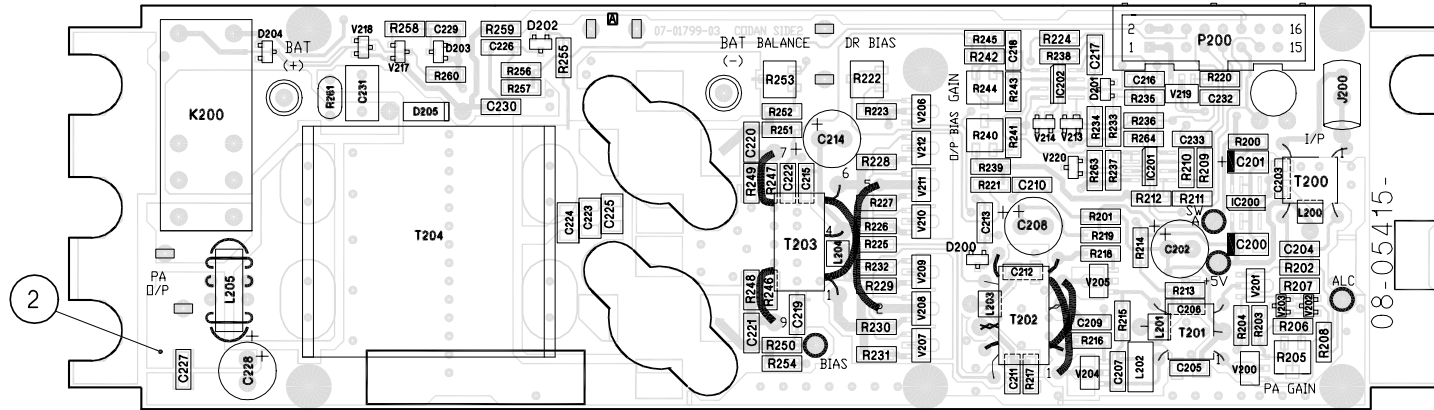

REFERENCE DESIGNATORS
SIDE 2

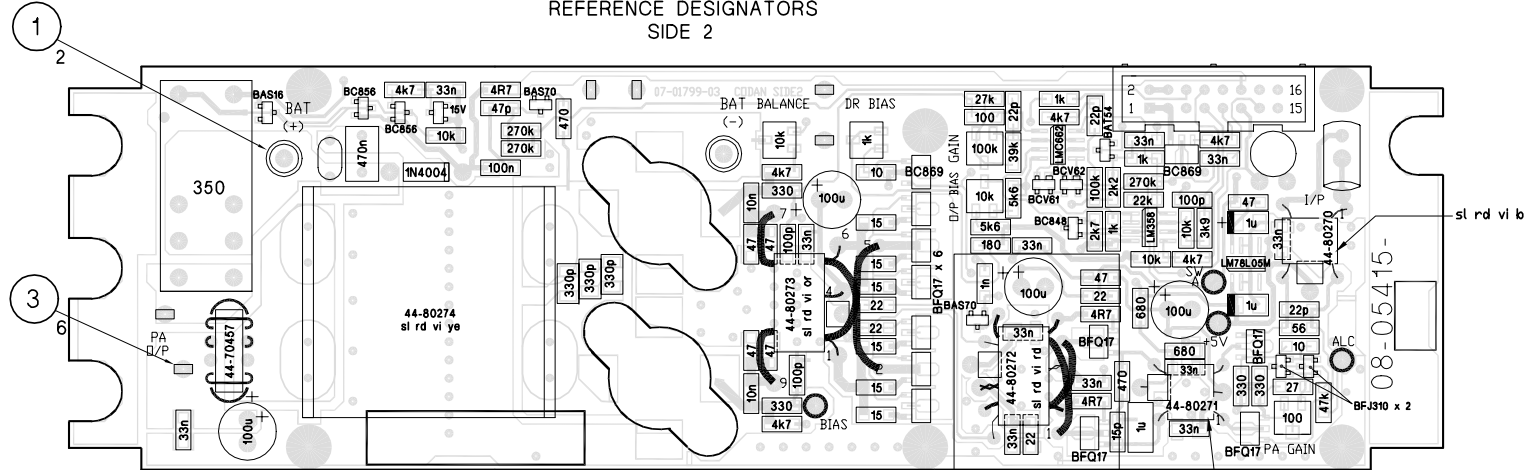

COMPONENT VALUES
SIDE 2

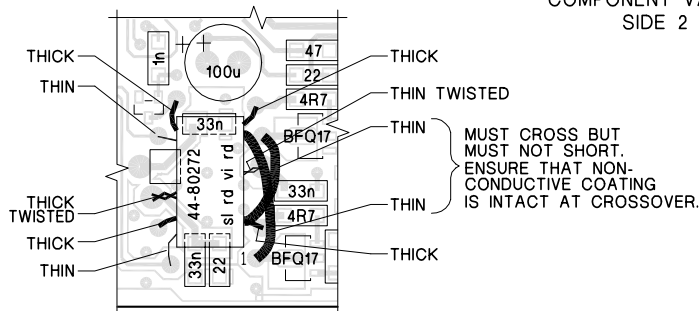

DETAIL "A"
SCALE 2:1
WIRING DETAIL FOR T202

DIMENSIONS IN mm

NOTES:

PCB: 07-01799-03
ASSY: 08-05415-001

- L200, L201, L203 AND L204 ARE PART OF THE ASSOCIATED TRANSFORMER.

FILE No.
08\05415__2.DWG

ISSUE B
PCB No. WAS 07-01800-01
ASSY No. WAS 08-05415-001
ITEM Nos. SHOWN & STANDOFFS (IT.3) DRAWN.
R233 WAS R232.
P200 REDRAWN.
NOTE 1 & DETAIL "A" ADDED.
FUSES & WIRE LINKS REMOVED.
C/R 25886
13-1-99 PMK

ISSUE C
PCB WAS "-01" EXT'D FOR EMC EARTHING
C/R 25975
18-03-99 NJA

ISSUE D
PCB WAS "-02" SILKSCREEN CHANGES
C/R 26185
09-07-99 NJA

ISSUE E:
NOTE RE FERRITE BEAD DELETED FROM DETAIL A
C/R 26211
NJA 20-7-99

ISSUE 2
R215 WAS 390
C207 WAS 18p
C/R 26423
MJS 22-12-99

	SCALE N/A		© CODAN PTY LTD, A.C.N. 007 590 605: 1998			
	DRN	AML	DATE	TITLE		
MATERIAL	CHKD	CAH	03-11-98	POWER AMPLIFIER ASSEMBLY		
FINISH	APPD	SCS	20-7-99	DRAWING/DOC NO.		
	TOLERANCES UNLESS OTHERWISE STATED			A3	08-05415	
2 PLACES DEC. ±0.25 1 PLACE DEC. ±0.5 0 PLACE DEC. ±1 ANGULAR ±2°			ISS	✓	✗	SHT. 1 OF 1

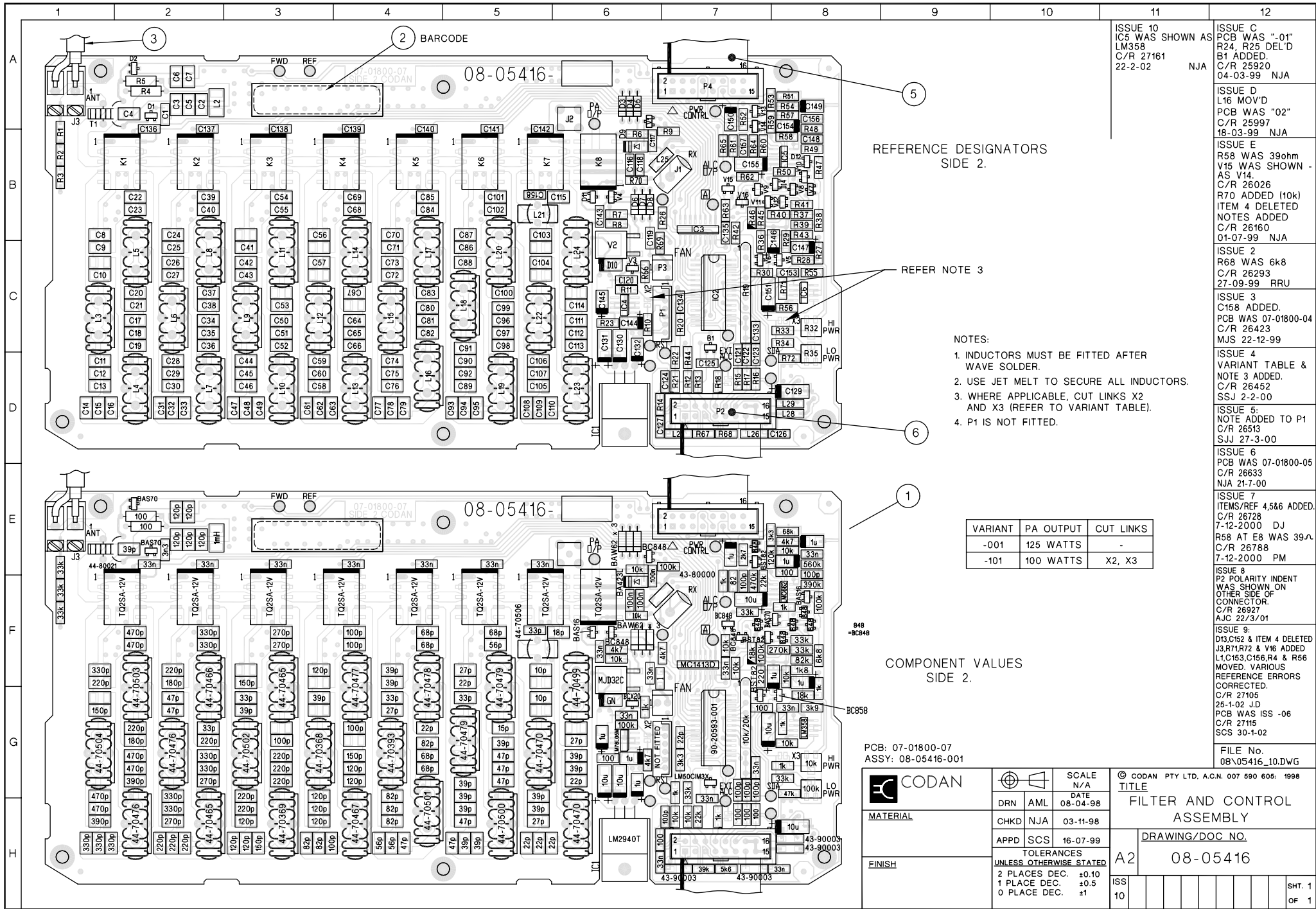

ISSUE 10
IC5 WAS SHOWN AS
LM358
C/R 27161
22-2-02

NJA

ISSUE C
PCB WAS "-01"
R24, R25 DEL'D
B1 ADDED.
C/R 25920
04-03-99 NJA

ISSUE D
L16 MOV'D
PCB WAS "02"
C/R 25997
18-03-99 NJA

ISSUE E
R58 WAS 39ohm
V15 WAS SHOWN -
AS V14.
C/R 26026
R70 ADDED (10k)
ITEM 4 DELETED
NOTES ADDED
C/R 26160
01-07-99 NJA

ISSUE 2
R68 WAS 6k8
C/R 26293
27-09-99 RRU

ISSUE 3
C158 ADDED.
PCB WAS 07-01800-04
C/R 26423
MJS 22-12-99

ISSUE 4
VARIANT TABLE &
NOTE 3 ADDED.
C/R 26452
SSJ 2-2-00

ISSUE 5:
NOTE ADDED TO P1
C/R 26513
SJJ 27-3-00

ISSUE 6
PCB WAS 07-01800-05
C/R 26633
NJA 21-7-00

ISSUE 7
ITEMS/REF 4,5&6 ADDED.
C/R 26728
7-12-2000 DJ
R58 AT E8 WAS 39k
C/R 26788
7-12-2000 PM

ISSUE 8
P2 POLARITY INDENT
WAS SHOWN ON
OTHER SIDE OF
CONNECTOR.
C/R 26927
AJC 22/3/01

ISSUE 9:
D13,C162 & ITEM 4 DELETED
J3,R17,R72 & V16 ADDED
L1,C153,C156,R4 & R56
MOVED. VARIOUS
REFERENCE ERRORS
CORRECTED.
C/R 27105
25-1-02 J.D
PCB WAS ISS -06
C/R 27115
SCS 30-1-02

FILE No.
08\05416_10.DWG

REFERENCE DESIGNATORS
SIDE 2.

REFER NOTE 3

- NOTES:
- INDUCTORS MUST BE FITTED AFTER WAVE SOLDER.
 - USE JET MELT TO SECURE ALL INDUCTORS.
 - WHERE APPLICABLE, CUT LINKS X2 AND X3 (REFER TO VARIANT TABLE).
 - P1 IS NOT FITTED.

VARIANT	PA OUTPUT	CUT LINKS
-001	125 WATTS	-
-101	100 WATTS	X2, X3

COMPONENT VALUES
SIDE 2.

PCB: 07-01800-07
ASSY: 08-05416-001

	SCALE N/A		© CODAN PTY LTD, A.C.N. 007 690 605: 1998	
	DRN	AML	TITLE FILTER AND CONTROL ASSEMBLY	
MATERIAL	CHKD	NJA	DATE 08-04-98	
FINISH	APPD	SCS	16-07-99	
	TOLERANCES UNLESS OTHERWISE STATED		DRAWING/DOC NO. 08-05416	
2 PLACES DEC. ±0.10		A2		ISS 10
1 PLACE DEC. ±0.5		SHT. 1		
0 PLACE DEC. ±1		OF 1		

DO NOT SCALE

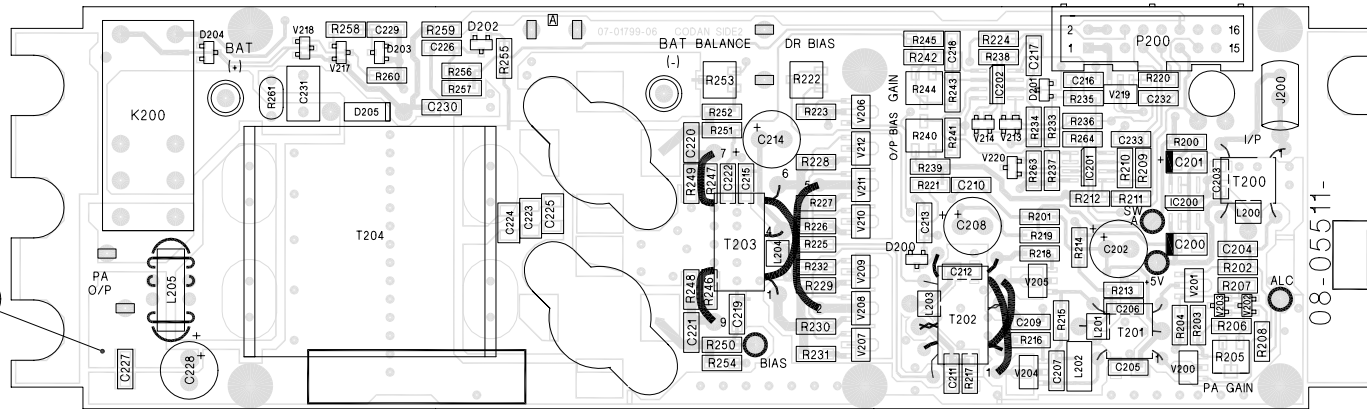

REFERENCE DESIGNATORS
SIDE 2

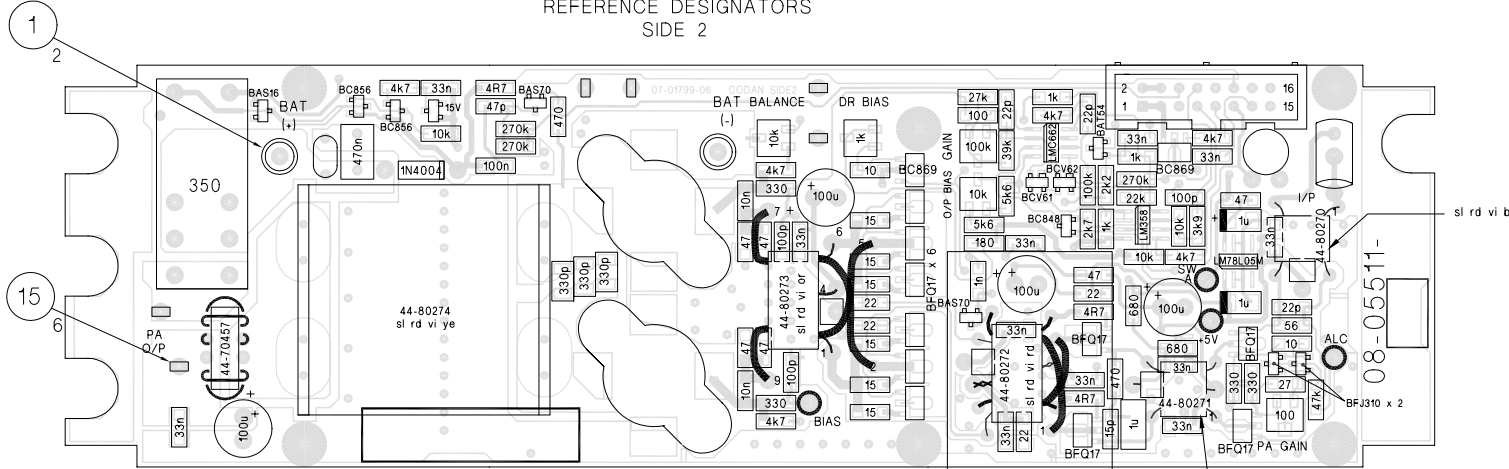

COMPONENT VALUES
SIDE 2

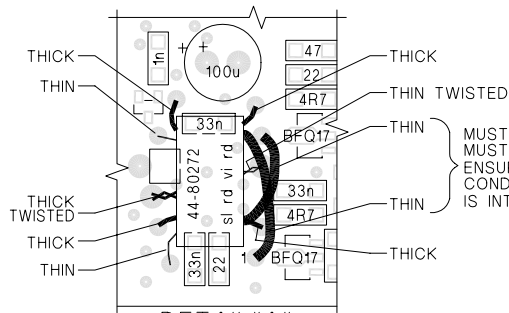

DETAIL "A"
SCALE 2:1
WIRING DETAIL FOR T202

STEP 1
PA PCB ASSEMBLY
(REFER SH 2 FOR
STEPS 2 TO 5)
DIMENSIONS IN mm

A

PCB: 07-01799-06
ASSY: 08-05511-001

NOTES:

- L200, L201, L203 AND L204 ARE PART OF THE ASSOCIATED TRANSFORMER.

FILE No.
08\05511_7.DWG

ISSUE 3
DRG RE-NUMBERED,
WAS 08-05415 ISS 2
ITEM 15 WAS ITEM 1
ITEM 16 WAS ITEM 3
PCB No.WAS 07-01799-03
ASSY No.WAS 08-05415-001
REFER ALSO SH 2
C/R 26926
AJC 24-04-2001

ISSUE 4
PCB WAS 07-01799-04
C/R 27050
17-08-01 AJC

ISSUE 5
REF SHT 2

ISSUE 6:
PCB WAS ISS -05
C/R 27115
SCS 30-1-02

ISSUE 7:
REFER SHT 2
C/R 27655

08-05511-

08-05511-

	DRN	SMC	SCALE N/A	© CODAN PTY LTD, A.C.N. 007 590 605: 1998				
	CHKD	NJA	DATE 23-10-98	TITLE PA ASSY c/w HEATSINK				
	APPD	AJC	23-07-99	DRAWING/DOC NO. 08-05511				
FINISH	TOLERANCES UNLESS OTHERWISE STATED			A3	ISS			
2 PLACES DEC. ±0.25 1 PLACE DEC. ±0.5 0 PLACE DEC. ±1 ANGULAR ±2°			7					SHT. 1 OF 2

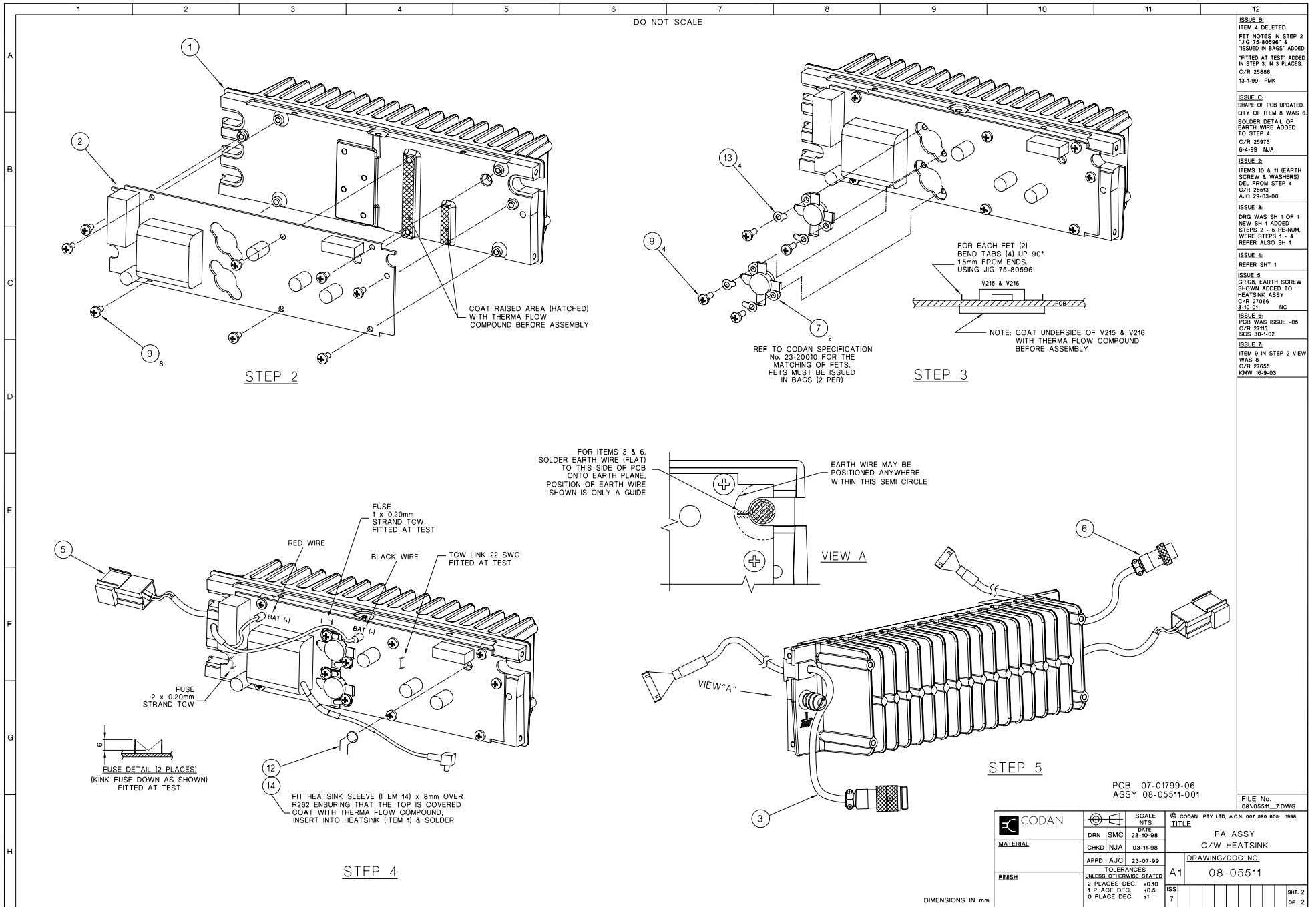

ISSUE B:
ITEM 4 DELETED.
FET NOTES IN STEP 2 "JIG 75-80596" & "ISSUED IN BAGS" ADDED.
"FITTED AT TEST" ADDED IN STEP 3, IN 3 PLACES.
C/R 25886
13-1-99 PMK

ISSUE C:
SHAPE OF PCB UPDATED, QTY OF ITEM 8 WAS 6.
SOLDER DETAIL OF EARTH WIRE ADDED TO STEP 4.
C/R 25975
8-4-99 N/A

ISSUE 2:
ITEMS 10 & 11 (EARTH SCREW & WASHERS) DEL FROM STEP 4
C/R 26513
A/JC 29-03-00

ISSUE 3:
DRG WAS SH 1 OF 1 NEW SH 1 ADDED
STEPS 2 - 5 RE-NUM, WHERE STEPS 1 - 4 REFER ALSO SH 1

ISSUE 4:
REFER SH 1

ISSUE 5:
GRG8, EARTH SCREW SHOWN ADDED TO HEATSINK ASSY
C/R 27066
3-10-01 NC

ISSUE 6:
PCB WAS ISSUE -06
C/R 27115
SCS 30-1-02

ISSUE 7:
ITEM 9 IN STEP 2 VIEW WAS 8
C/R 27655
KMW 16-9-03

CODAN		SCALE NTS	© CODAN PTY LTD, A/CN 007 990 606 1998
DRN SMC	DATE 23-10-98	TITLE PA ASSY	
CHKD NJA	DATE 03-11-98	C/W HEATSINK	
APPD A/JC	DATE 23-07-99	DRAWING/DOC NO. 08-05511	
FINISH		TOLERANCES UNLESS OTHERWISE STATED	A1
2 PLACES DEC. 10/10		1 PLACE DEC. 10/5	ISS 7
0 PLACE DEC. 1/1		SHT. 2 OF 2	

DIMENSIONS IN mm

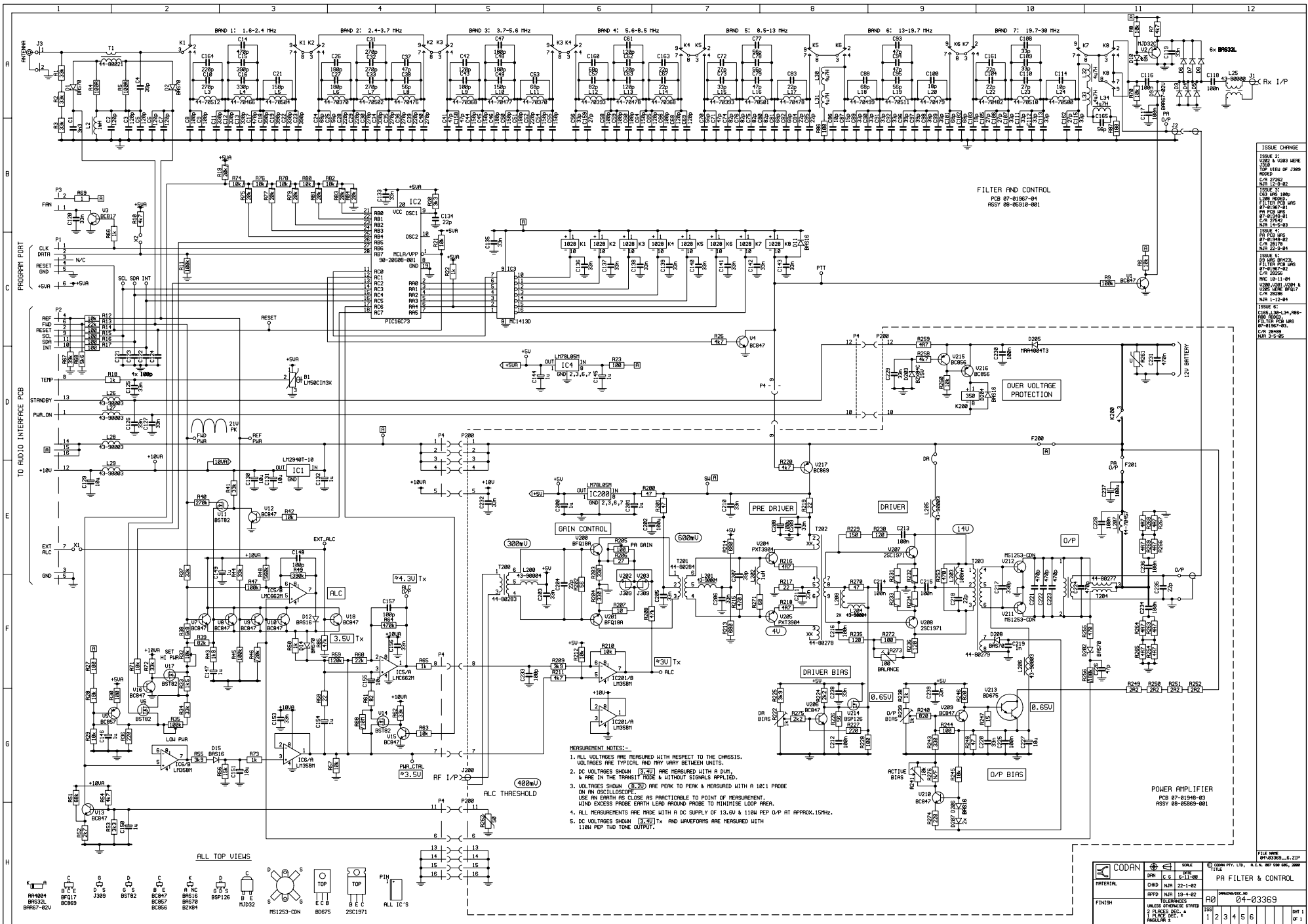

- ISSUE CHANGE**
- ISSUE 2: U208 & U208 WERE SWAP
 - ISSUE 3: U208 WERE SWAP
 - ISSUE 4: U208 WERE SWAP
 - ISSUE 5: U208 WERE SWAP
 - ISSUE 6: U208 WERE SWAP
 - ISSUE 7: U208 WERE SWAP
 - ISSUE 8: U208 WERE SWAP
 - ISSUE 9: U208 WERE SWAP
 - ISSUE 10: U208 WERE SWAP
 - ISSUE 11: U208 WERE SWAP
 - ISSUE 12: U208 WERE SWAP

FILTER AND CONTROL
PCB 07-01967-04
RSSY 06-0589-001

OVER VOLTAGE PROTECTION

POWER AMPLIFIER
PCB 07-01948-03
RSSY 06-0589-001

- MEASUREMENT NOTES:**
1. ALL VOLTAGES ARE MEASURED WITH RESPECT TO THE CHASSIS. VOLTAGES ARE TYPICAL AND MAY VARY BETWEEN UNITS.
 2. DC VOLTAGES SHOWN IN CIRCLES ARE MEASURED WITH A DVM, & ARE IN THE TRANSISTOR LEAD & WITHOUT SIGNALS APPLIED.
 3. VOLTAGES SHOWN IN SQUARES ARE PEAK TO PEAK & MEASURED WITH A 10:1 PROBE ON AN OSCILLOSCOPE. USE AN EARTH AS CLOSE AS PRACTICABLE TO POINT OF MEASUREMENT. WIND EXCESS PROBE EARTH LEAD AROUND PROBE TO MINIMISE LOOP AREA.
 4. ALL MEASUREMENTS ARE MADE WITH A DC SUPPLY OF 13.0V & 100mA PEP DVP AT APPROX. 15MHz.
 5. DC VOLTAGES SHOWN IN TRIANGLES AND WAVETOPS ARE MEASURED WITH 100uV PEP TONE OUTPUT.

ALL TOP VIEWS

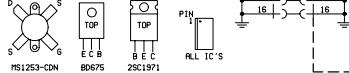
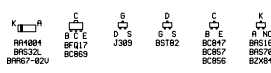

CODAN		DATE	REV	ISSUE	DATE
UNIVERSAL	070	C.6	6-11-88	PA FILTER & CONTROL	
FINISH	04	04-03369			
1	2	3	4	5	6
1	2	3	4	5	6

DO NOT SCALE

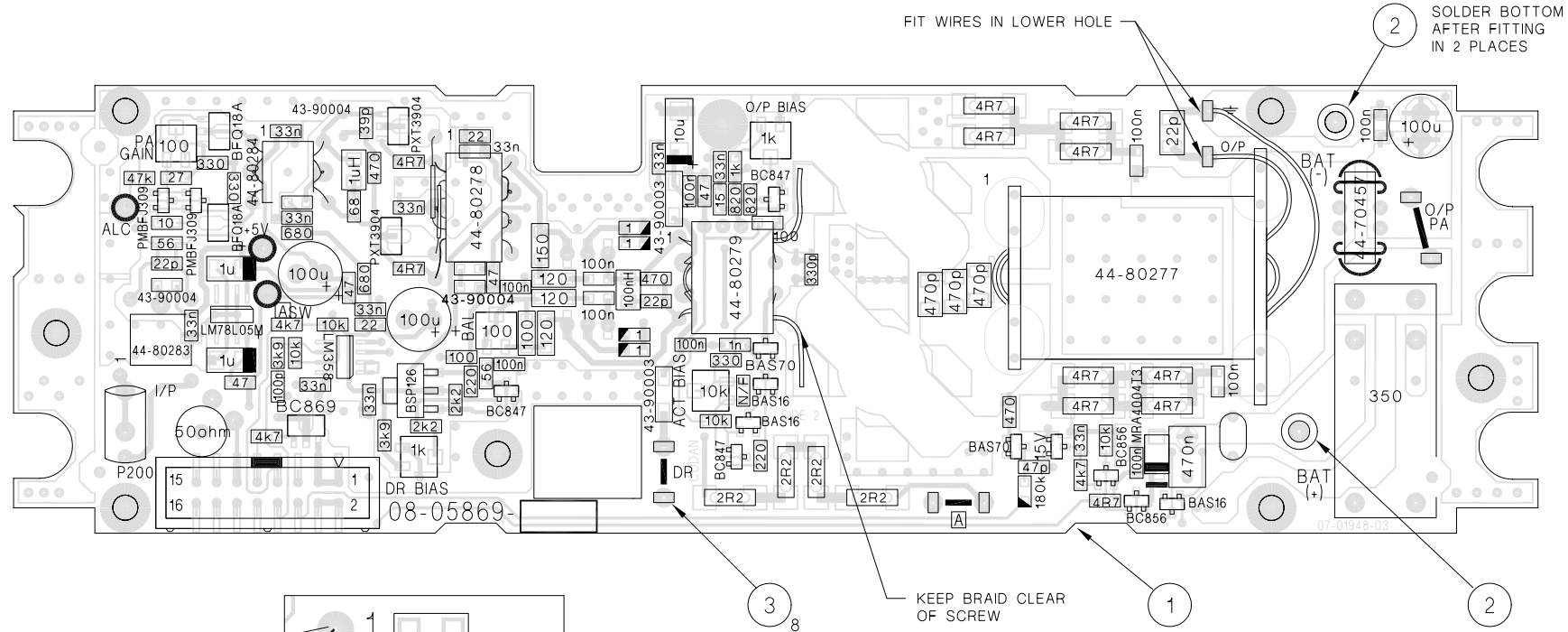

COMPONENT VALUES

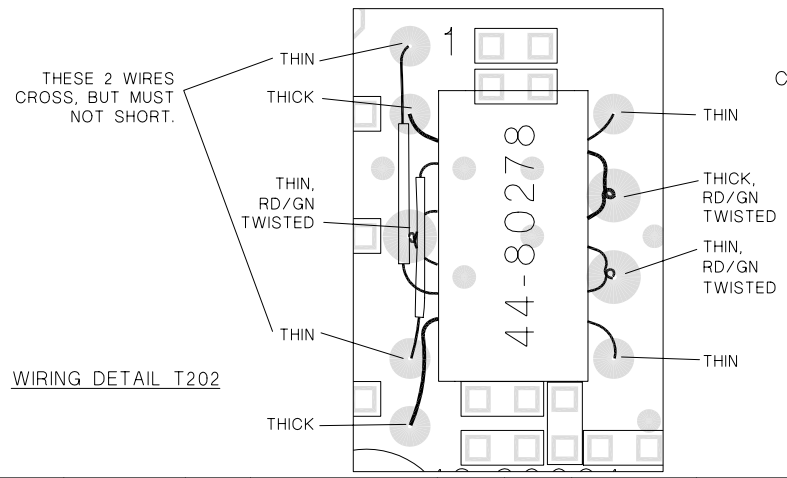

WIRING DETAIL T202

PCB :07-01948-03
 ASSY:08-05869-001
 FILE No.
 08\05869_8.DWG

ISSUE 1: VARIOUS NOTES ADDED C/R 27200 NJA 22-4-02	ISSUE 2: V202 & V203 WERE J301L1 C/R 27262 NJA 12-8-02 REFER SHT 3 C/R 27263	ISSUE 3: REFER SHT 3 C/R 27256	ISSUE 4: L208 ADDED PCB WAS ISS -01 C/R 27542 NJA 14-5-03 V210 WAS BAS16 D206 WAS BC847 C/R 27562 AJC 29-5-03	ISSUE 5: REFER SHT 3 C/R 27655	ISSUE 6: REFER SHT 3 C/R 27722	ISSUE 7: CUT OUT ADDED TO LH SIDE. FIDUCIAL MOVED. PCB WAS -02 C/R 28178 NJA 22-9-04	ISSUE 8: V200,V201,V204 & V205 WERE BF017 C/R 28286 NJA 1-12-04
---	---	--------------------------------------	---	--------------------------------------	--------------------------------------	---	---

MATERIAL	DRN	C G	SCALE
	CHKD	NJA	2:1
FINISH	APPD	NJA	DATE
			13-6-01
			TOLERANCES
			UNLESS OTHERWISE STATED
			2 PLACES DEC. ±0.10
			1 PLACE DEC. ±0.5
			0 PLACE DEC. ±1
			DIMENSIONS IN mm

© CODAN LIMITED, A.C.N. 007 590 605: 2001	
TITLE	
POWER AMPLIFIER PCB	
DRAWING/DOC NO.	
A3 08-05869	
ISS	SHT. 1
8	OF 3

DO NOT SCALE

FIT WIRES IN LOWER HOLE

2 SOLDER BOTTOM AFTER FITTING IN 2 PLACES

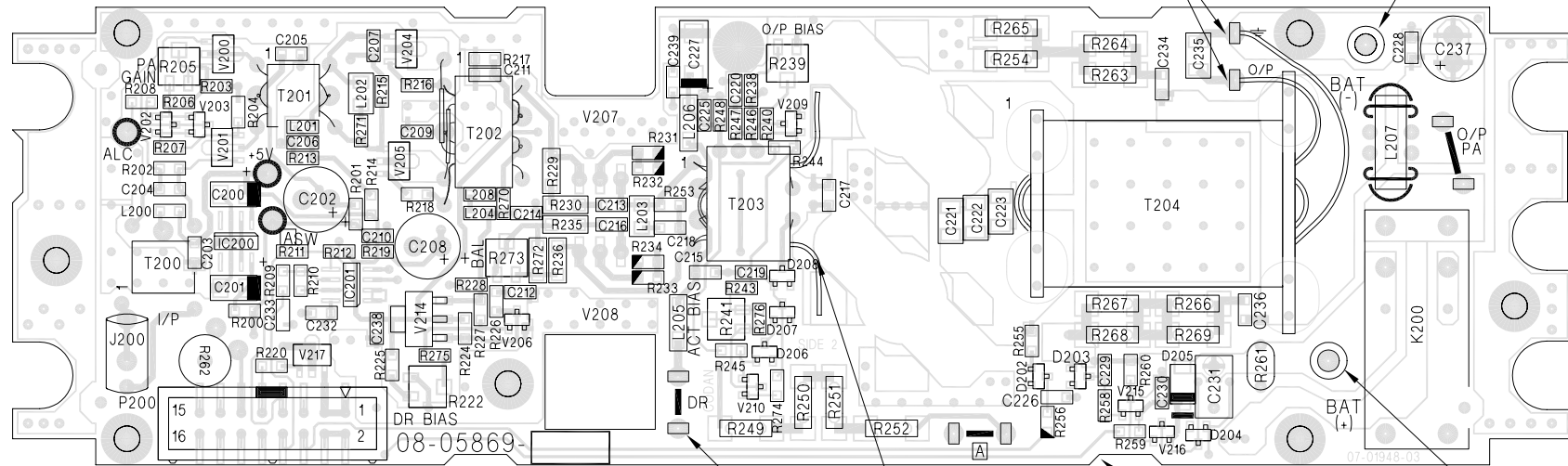

KEEP BRAID CLEAR OF SCREW

COMPONENT REFERENCES

THESE 2 WIRES CROSS, BUT MUST NOT SHORT.

WIRING DETAIL T202

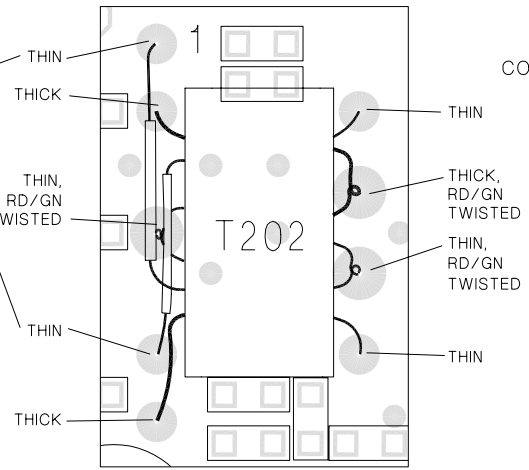

PCB :07-01948-03
ASSY:08-05869-001

FILE No.
08\05869__8_.DWG

ISSUE 1: VARIOUS NOTES ADDED C/R 27200 NJA 22-4-02	ISSUE 2: REFER SHT 1 C/R 27262 REFER SHT 3 C/R 27263	ISSUE 3: REFER SHT 3 C/R 27256	ISSUE 4: L208 ADDED. PCB WAS ISS -01 C/R 27542 NJA 14-5-03 REFER SHT 1 C/R 27562	ISSUE 5: REFER SHT 3 C/R 27655	ISSUE 6: REFER SHT 3 C/R 27722	ISSUE 7: CUT OUT ADDED TO LH SIDE FIDUCIAL MOVED. PCB WAS -02 C/R 28178 NJA 22-9-04	ISSUE 8: REFER SHT 3 C/R 28286
---	--	--------------------------------------	--	--------------------------------------	--------------------------------------	--	--------------------------------------

CODAN	DRN	C G	SCALE 2:1	© CODAN LIMITED, A.C.N. 007 590 605. 2001 TITLE POWER AMPLIFIER PCB
	CHKD	NJA	DATE 13-6-01	
MATERIAL	APPD	NJA	9-1-02	DRAWING/DOC NO. 08-05869
FINISH	TOLERANCES UNLESS OTHERWISE STATED			
	2 PLACE DEC. ±0.10 1 PLACE DEC. ±0.5 0 PLACE DEC. ±1 DIMENSIONS IN mm			A3
ISS 8				SHT. 2 OF 3

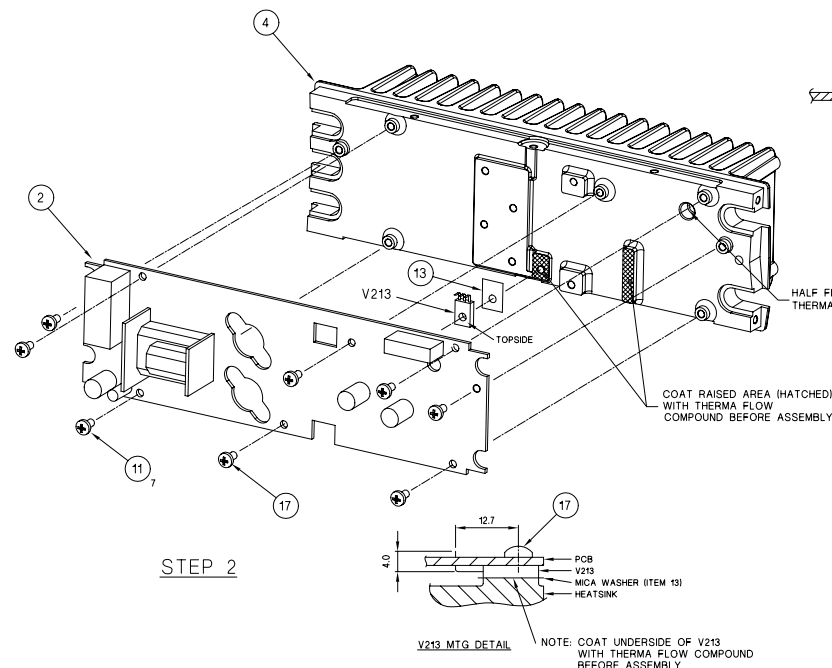

STEP 2

DO NOT SCALE

NOTE:
V211 & V212 MUST HAVE THE SAME MATCH CODE
(REFER 10-00895)

FOR EACH TRANSISTOR (2)
BEND TABS (4) UP 90°
1.5mm FROM ENDS.

V211 & V212

NOTE: COAT UNDERSIDE OF V211 & V212
WITH THERMA FLOW COMPOUND
BEFORE ASSEMBLY

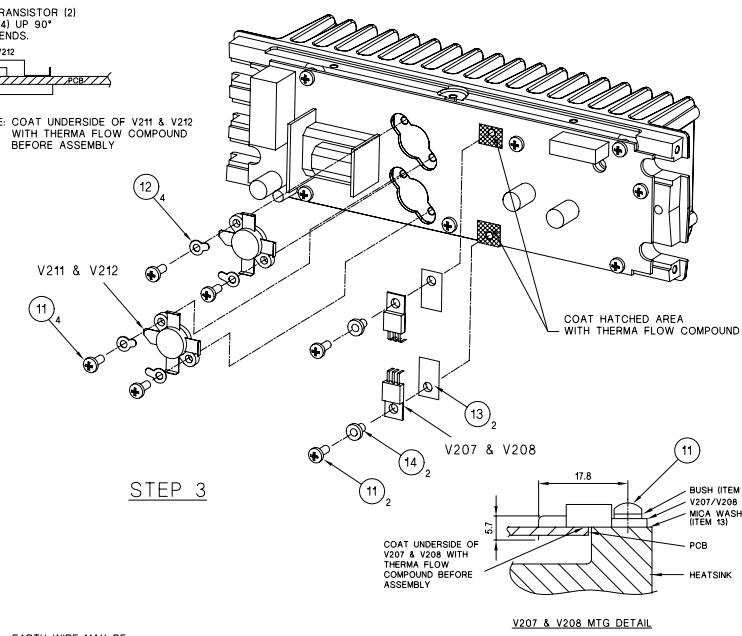

STEP 3

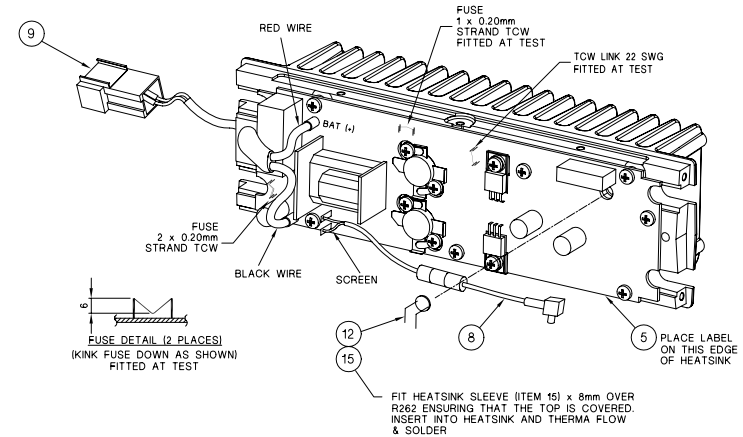
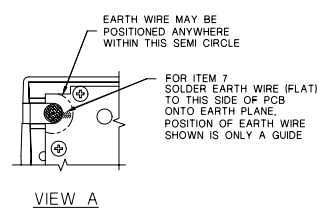

STEP 4

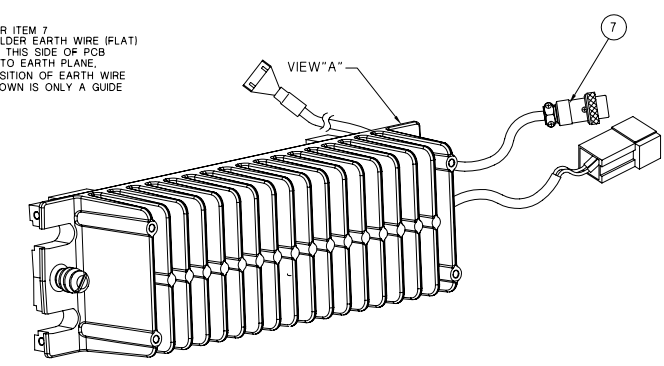

STEP 5

ISSUE 1
REFER SHTS 1 & 2
C/R 27262
C/R 27200

ISSUE 2:
REFER SHT 1
C/R 27262
ITEM 11 IN STEP 3
DETAIL & V207/V208
MTG DETAIL WERE
ITEM 10
C/R 27263
AUC 12-8-02

ISSUE 3:
CABLE ITEM 61
REMOVED
C/R 27256
AUC 31-01-03

ISSUE 4:
REFER SHTS 1 & 2
C/R 27542
C/R 27562

ISSUE 5:
ITEM 11 WAS 10
C/R 27565
KMW 16-9-03

ISSUE 6:
ITEM 9 MOVED FROM
BOTTOM POSITION
C/R 2772
KMW 15-11-03

ISSUE 7:
REFER SHTS 1 & 2
C/R 2819

ISSUE 8:
REFER SHT 2
C/R 28266

P/No. 08-05869-001

FILE No.
08\05869_B.DWG

	SCALE	NTS	© CODAN LIMITED, A.C.N. 007 690 605: 2001	TITLE	PA ASSY
	DRN	DB	DATE	18-12-01	C/W HEATSINK
MATERIAL	CHKD	NJA	9-1-02	APPD	NJA
	APPD	NJA	22-4-02	TOLERANCES	UNLESS OTHERWISE STATED
FINISH				2 PLACES DEC. ±0.25	1 PLACE DEC. ±0.5
				0 PLACE DEC. ±1	
				ISS	8
				SHT	3
				OF	3

DIMENSIONS IN mm

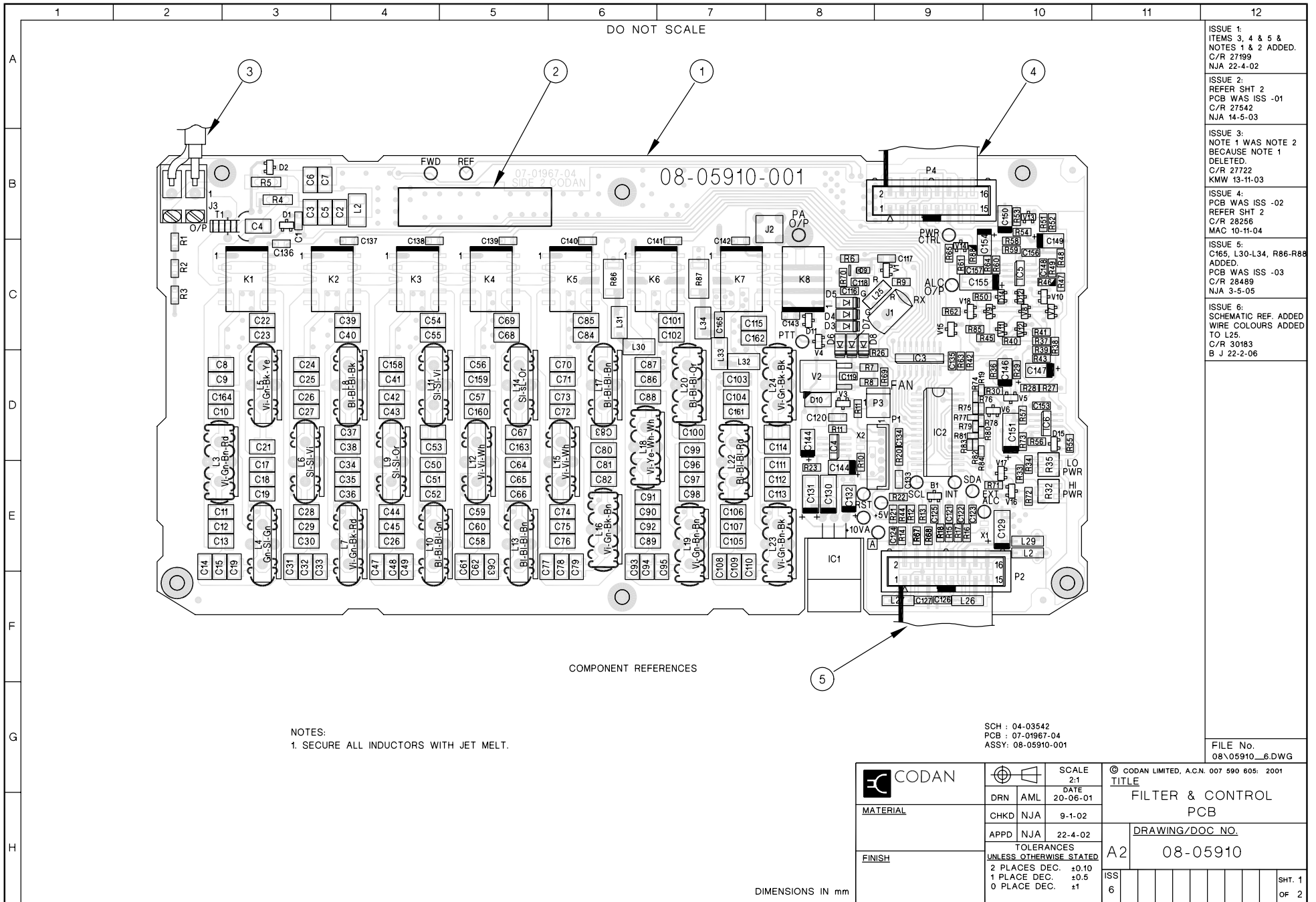

NOTES:
1. SECURE ALL INDUCTORS WITH JET MELT.

SCH : 04-03542
PCB : 07-01967-04
ASSY: 08-05910-001

ISSUE 1:
ITEMS 3, 4 & 5 &
NOTES 1 & 2 ADDED.
C/R 27199
NJA 22-4-02

ISSUE 2:
REFER SHT 2
PCB WAS ISS -01
C/R 27542
NJA 14-5-03

ISSUE 3:
NOTE 1 WAS NOTE 2
BECAUSE NOTE 1
DELETED.
C/R 27722
KMW 13-11-03

ISSUE 4:
PCB WAS ISS -02
REFER SHT 2
C/R 28256
MAC 10-11-04

ISSUE 5:
C165, L30-L34, R86-R88
ADDED.
PCB WAS ISS -03
C/R 28489
NJA 3-5-05

ISSUE 6:
SCHEMATIC REF. ADDED
WIRE COLOURS ADDED
TO L25.
C/R 30183
B J 22-2-06

FILE No.
08\05910_6.DWG

	SCALE 2:1	© CODAN LIMITED, A.C.N. 007 590 605: 2001 TITLE
	DRN AML DATE 20-06-01	FILTER & CONTROL PCB
MATERIAL CHKD NJA 9-1-02	APPD NJA 22-4-02	DRAWING/DOC NO. 08-05910
FINISH	TOLERANCES UNLESS OTHERWISE STATED 2 PLACES DEC. ±0.10 1 PLACE DEC. ±0.5 0 PLACE DEC. ±1	A2 ISS 6
DIMENSIONS IN mm	SHT. 1 OF 2	

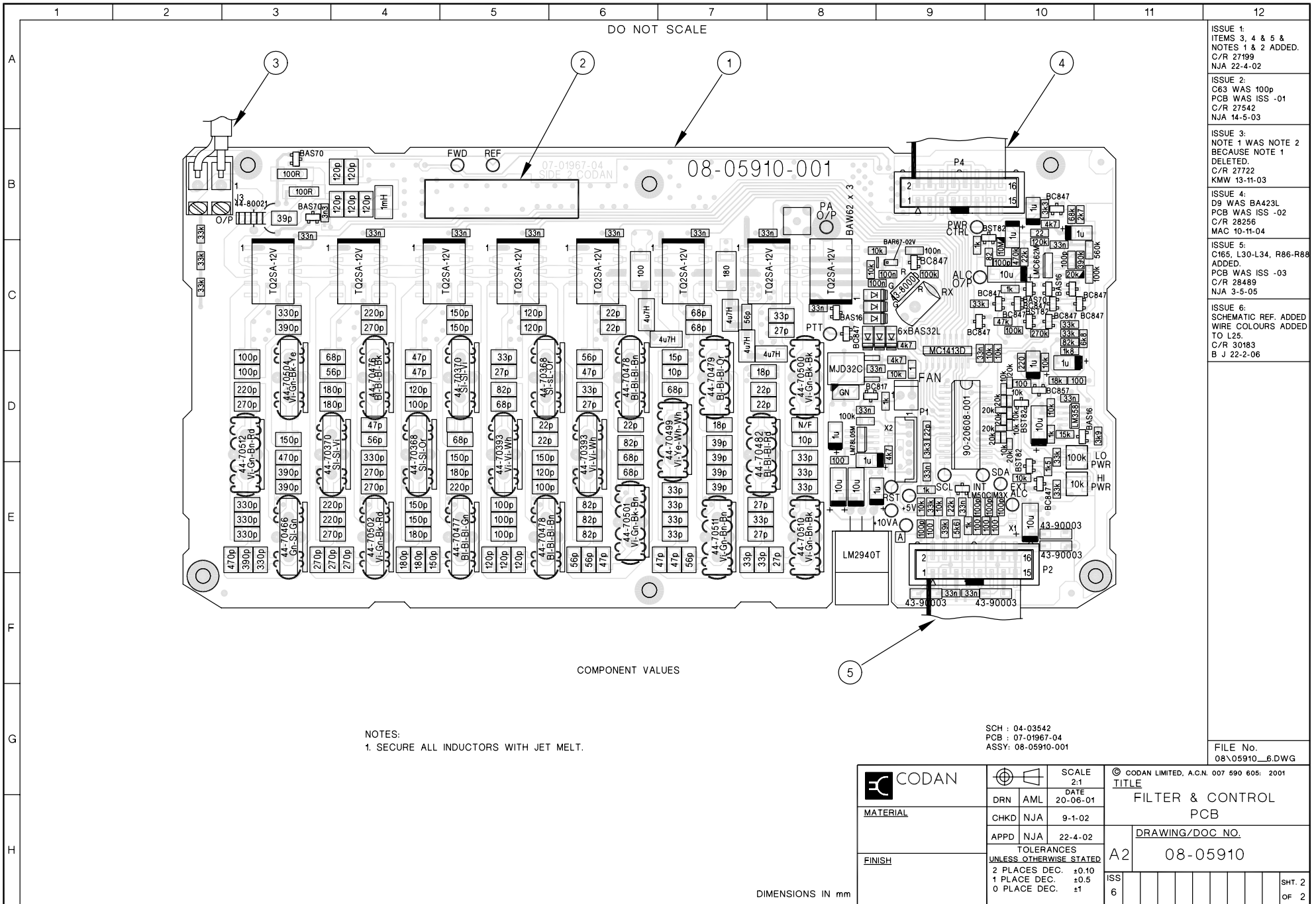

COMPONENT VALUES

NOTES:
1. SECURE ALL INDUCTORS WITH JET MELT.

SCH : 04-03542
PCB : 07-01967-04
ASSY: 08-05910-001

FILE No.
08\05910_6.DWG

	SCALE 2:1	© CODAN LIMITED, A.C.N. 007 590 605: 2001 TITLE FILTER & CONTROL PCB
	DRN AML DATE 20-06-01	
MATERIAL	CHKD NJA 9-1-02	DRAWING/DOC NO. 08-05910
FINISH	APPD NJA 22-4-02	
TOLERANCES UNLESS OTHERWISE STATED 2 PLACES DEC. ±0.10 1 PLACE DEC. ±0.5 0 PLACE DEC. ±1		A2 ISS 6
DIMENSIONS IN mm		SHT. 2 OF 2

ISSUE 1:
ITEMS 3, 4 & 5 &
NOTES 1 & 2 ADDED.
C/R 27199
NJA 22-4-02

ISSUE 2:
C63 WAS 100p
PCB WAS ISS -01
C/R 27542
NJA 14-5-03

ISSUE 3:
NOTE 1 WAS NOTE 2
BECAUSE NOTE 1
DELETED.
C/R 27722
KMW 13-11-03

ISSUE 4:
D9 WAS BA423L
PCB WAS ISS -02
C/R 28256
MAC 10-11-04

ISSUE 5:
C165, L30-L34, R86-R88
ADDED.
PCB WAS ISS -03
C/R 28489
NJA 3-5-05

ISSUE 6:
SCHEMATIC REF. ADDED
WIRE COLOURS ADDED
TO L25.
C/R 30183
B J 22-2-06

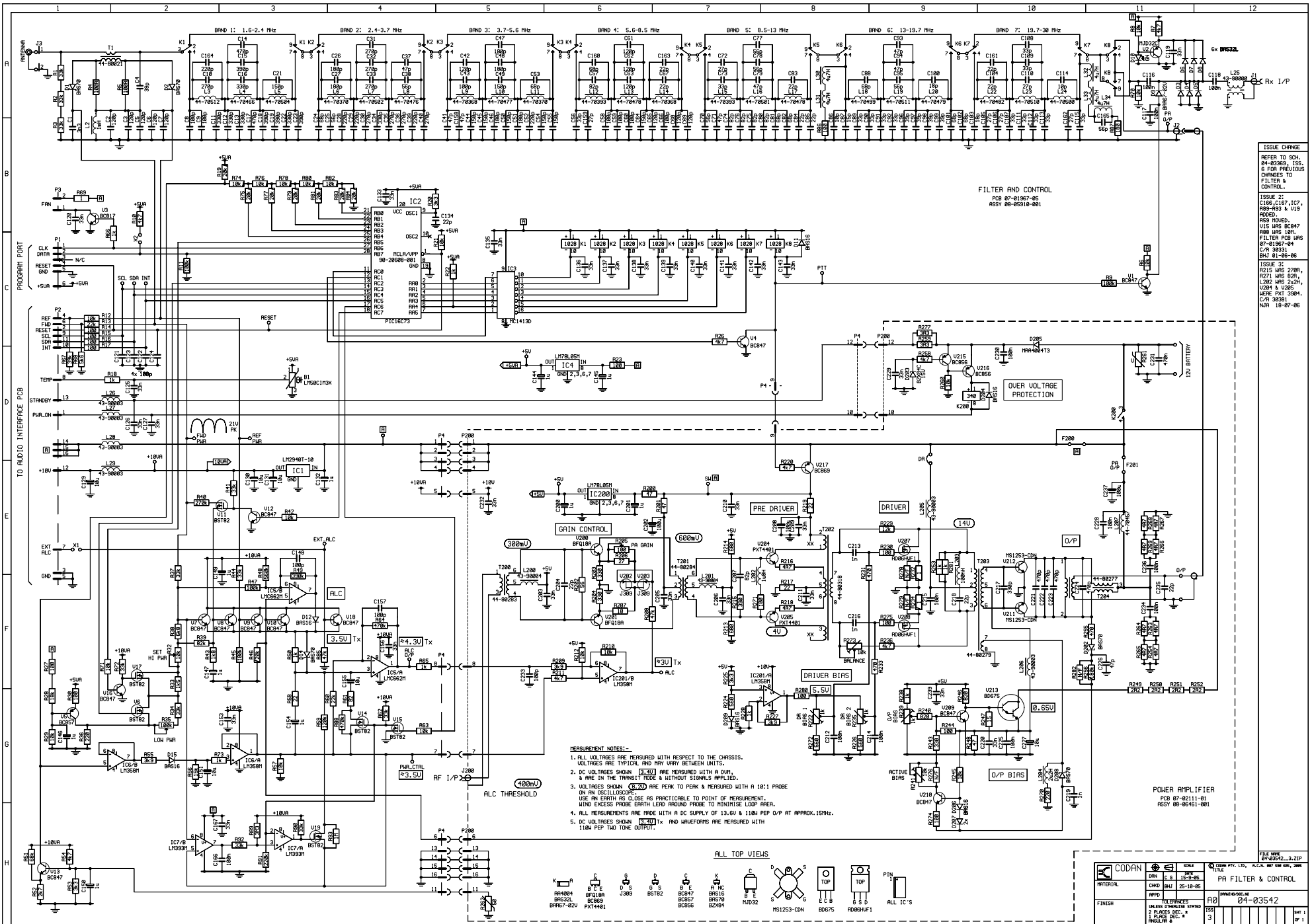

ISSUE CHANGE
 REFER TO SCH.
 04-82369, ISS.
 6 FOR PREVIOUS
 CHANGES TO
 FILTER &
 CONTROL.

ISSUE 2:
 C166, C167, IC7,
 R69-R83 & U15
 REDED.
 R59 REDED.
 U15 IHS BC847
 R69 IHS 10M.
 FILTER PCB IHS
 07-81567-04
 C/A 30331
 BUJ 01-85-06

ISSUE 3:
 R215 IHS 270K,
 R271 IHS 52K,
 L282 IHS 50uH,
 U204 & U205
 WERE DXT 5904.
 C/A 30381
 N/A 18-07-06

- MEASUREMENT NOTES:-**
1. ALL VOLTAGES ARE MEASURED WITH RESPECT TO THE CHASSIS. VOLTAGES ARE TYPICAL AND MAY VARY BETWEEN UNITS.
 2. DC VOLTAGES SHOWN [E.g. 4.0] ARE MEASURED WITH A D.M., & ARE IN THE TRANSISTOR & WITHOUT SIGNALS APPLIED.
 3. VOLTAGES SHOWN [E.g. 2.0] ARE PEAK TO PEAK & MEASURED WITH A 10:1 PROBE ON AN OSCILLOSCOPE. USE AN EARTH AS CLOSE AS PRACTICABLE TO POINT OF MEASUREMENT. WIND EXCESS PROBE EARTH LEAD AROUND PROBE TO MINIMISE LOOP AREA.
 4. ALL MEASUREMENTS ARE MADE WITH A DC SUPPLY OF 13.6V & 110uA PEP D/P AT APPROX. 15MHz.
 5. DC VOLTAGES SHOWN [E.g. 4.7] TX AND WAVEFORMS ARE MEASURED WITH 110uA PEP 1st TONE OUTPUT.

ALL TOP VIEWS

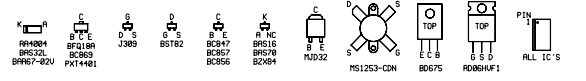

CODAN		SCALE	DATE
MATERIAL		CHKD	25-10-86
FINISH		ISS	3
PROJECT NO.		04-03542	
PAGE NO.		1 OF 1	

DO NOT SCALE

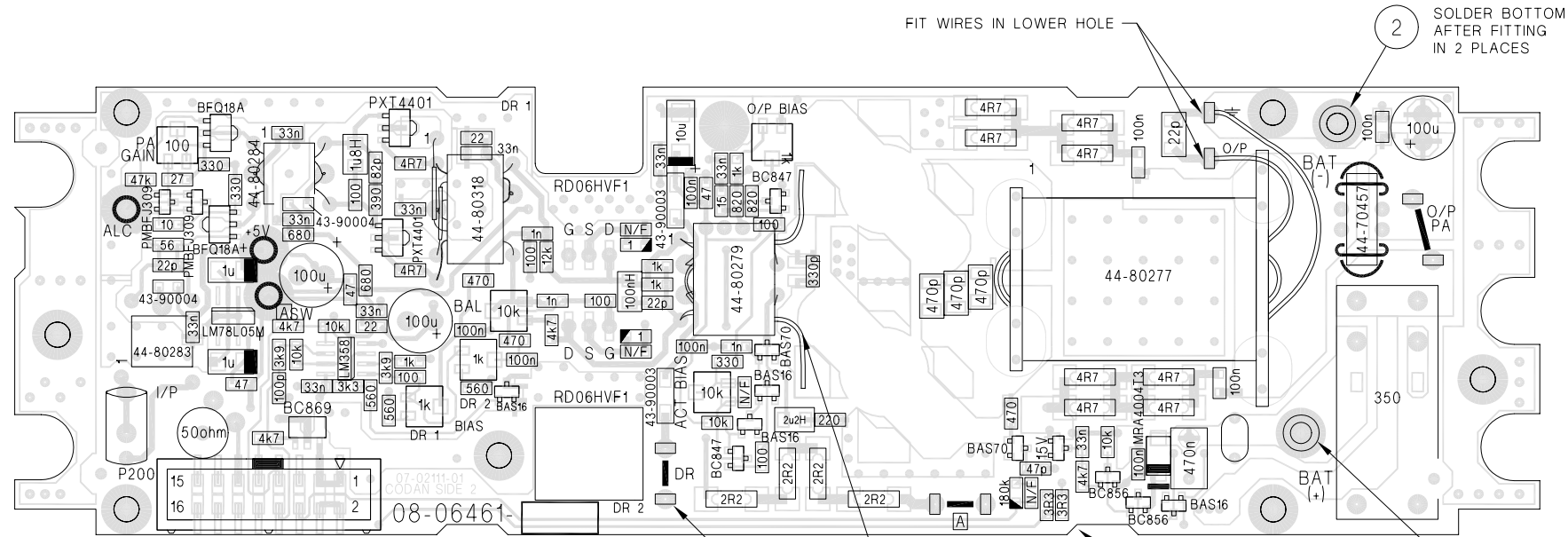

FIT WIRES IN LOWER HOLE

SOLDER BOTTOM AFTER FITTING IN 2 PLACES

KEEP BRAID CLEAR OF SCREW

COMPONENT VALUES

THESE 2 WIRES CROSS, BUT MUST NOT SHORT.

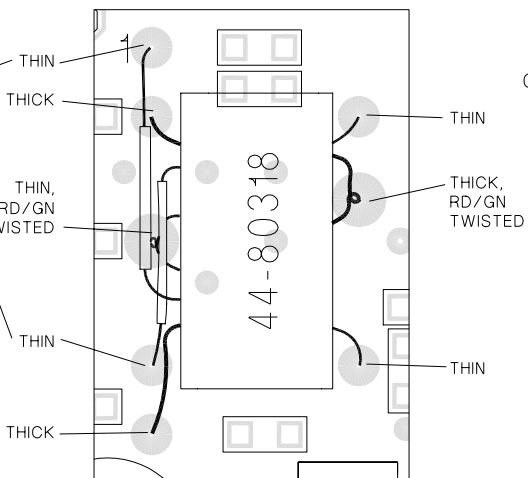

WIRING DETAIL T202

PCB :07-02111-01
 ASSY:08-06461-001
 FILE No.
 08\06461_3.DWG

ISSUE 2:
 V207 & V208 VALUE &
 REFERENCE ADDED.
 C/R 30186

ISSUE 3:
 V204 & V205 WERE
 PXT 3904, R215 WAS
 270R, R271 WAS 82R,
 L202 WAS 2u2H.
 C/R 30381
 N/A 18-07-06

	SCALE 2:1		© CODAN LIMITED, A.C.N. 007 590 605: 2005	
	DRN	C G	TITLE	
MATERIAL	CHKD	BHJ	POWER AMPLIFIER PCB	
FINISH	APPD	DRAWING/DOC NO.		
	TOLERANCES UNLESS OTHERWISE STATED			08-06461
2 PLACES DEC. ±0.10			ISS 3	SHT. 1 OF 3
1 PLACE DEC. ±0.5				
0 PLACE DEC. ±1				
DIMENSIONS IN mm				

DO NOT SCALE

FIT WIRES IN LOWER HOLE

2 SOLDER BOTTOM AFTER FITTING IN 2 PLACES

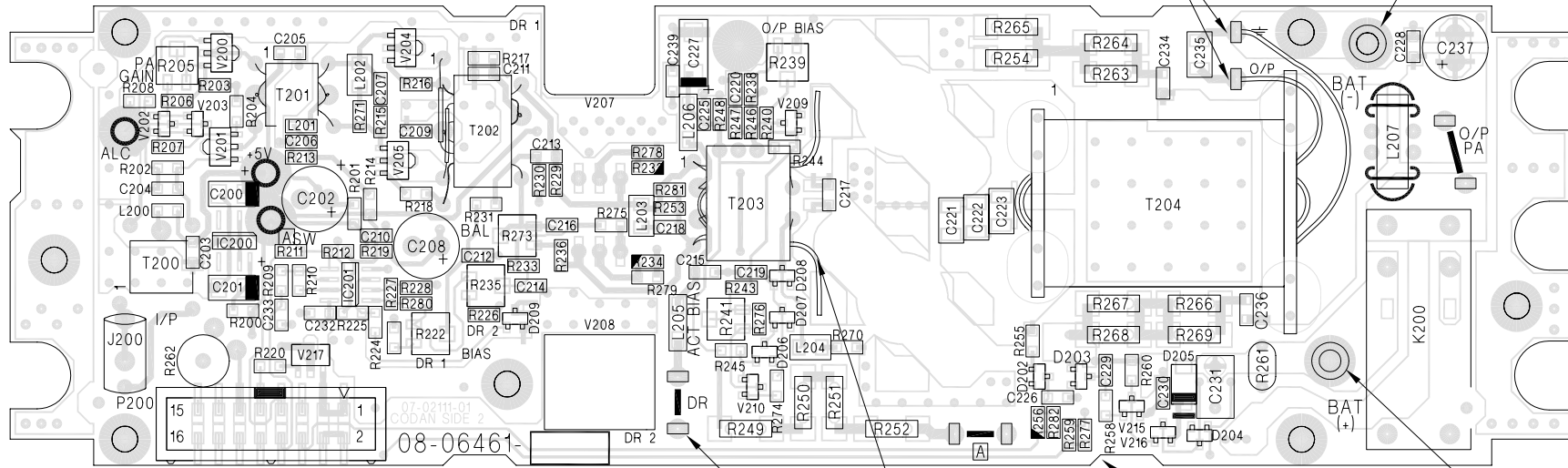

THESE 2 WIRES CROSS, BUT MUST NOT BE SHORT.

WIRING DETAIL T202

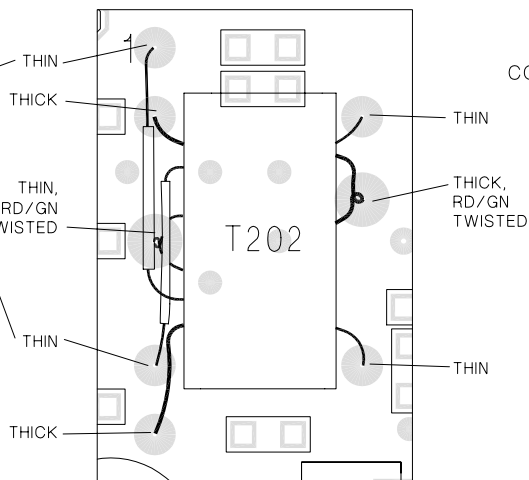

COMPONENT REFERENCES

PCB :07-02111-01
ASSY:08-06461-001

FILE No.
08\06461_3.DWG

ISSUE 2:
V207 & V208 VALUE &
REFERENCE ADDED.
C/R 30186

ISSUE 3:
REFER SHT 1

	SCALE 2:1		© CODAN LIMITED, A.C.N. 007 590 605: 2005			
	DRN	C G	DATE 5-10-05		TITLE	
MATERIAL	CHKD	BHJ	25-10-05		POWER AMPLIFIER PCB	
FINISH	APPD	TOLERANCES UNLESS OTHERWISE STATED			DRAWING/DOC NO.	
	2 PLACE DEC. ±0.10 1 PLACE DEC. ±0.5 0 PLACE DEC. ±1 DIMENSIONS IN mm			08-06461		
ISS 3			SHT. 2 OF 3			

DO NOT SCALE

ISSUE 2
REFER SHTS 1 & 2
C/R 30196
ISSUE 3
REFER SHT 1

NOTE:
V211 & V212 MUST HAVE THE SAME MATCH CODE
(REFER 10-00895)

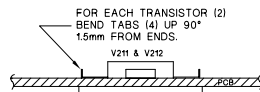

NOTE: COAT UNDERSIDE OF V211 & V212 WITH THERMA FLOW COMPOUND BEFORE ASSEMBLY

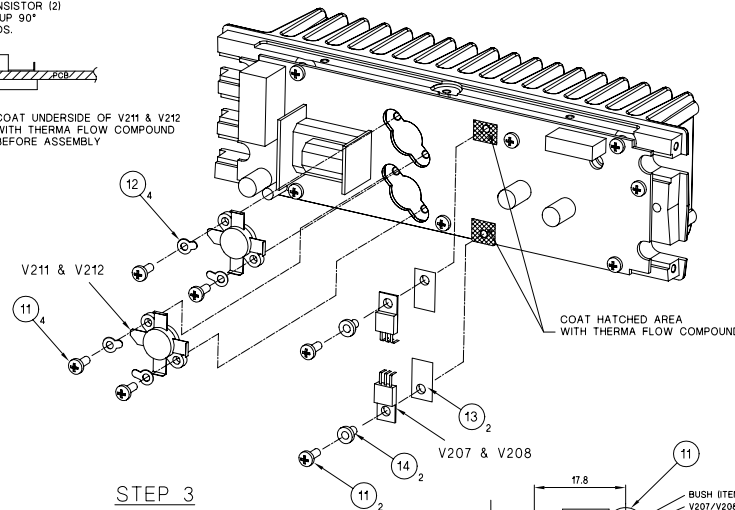

STEP 3

V207 & V208 MTG DETAIL

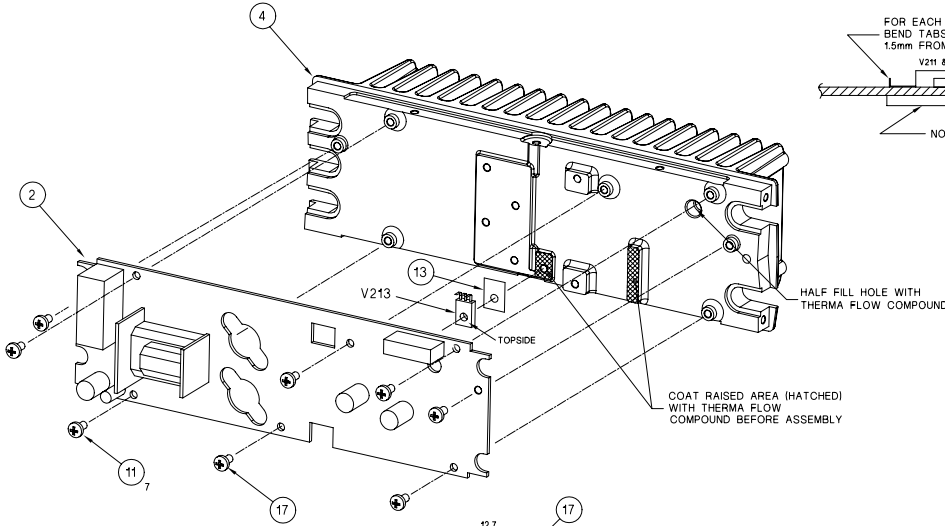

STEP 2

V213 MTG DETAIL

EARTH WIRE MAY BE POSITIONED ANYWHERE WITHIN THIS SEMI CIRCLE

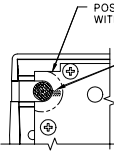

VIEW A

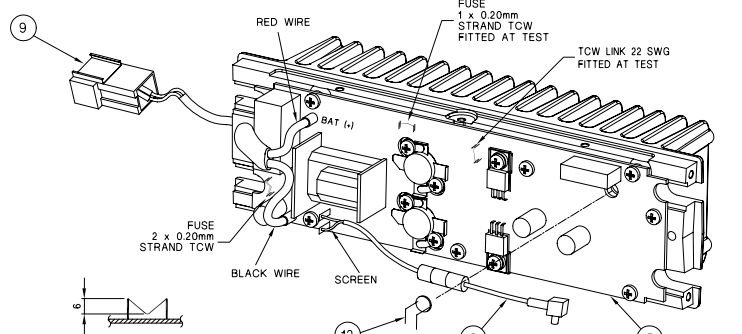

STEP 4

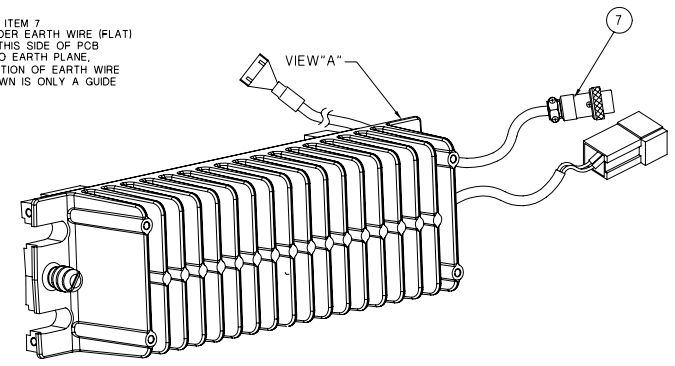

STEP 5

P/No. 08-06461-001

FILE No. 08\06461_3.DWG

	SCALE	NTS		TITLE	PA ASSY
	MATERIAL	DRN		C	G
	APPR	CHKD	BHJ	25-10-05	C/W HEATSINK
	FINISH	TOLERANCES UNLESS OTHERWISE STATED			DRAWING/DOC NO.
		2 PLACES DEC.	±0.25		A1
		1 PLACE DEC.	±0.5		ISS
		0 PLACE DEC.	+1		3
DIMENSIONS IN mm					SHT. 3
					OF 3

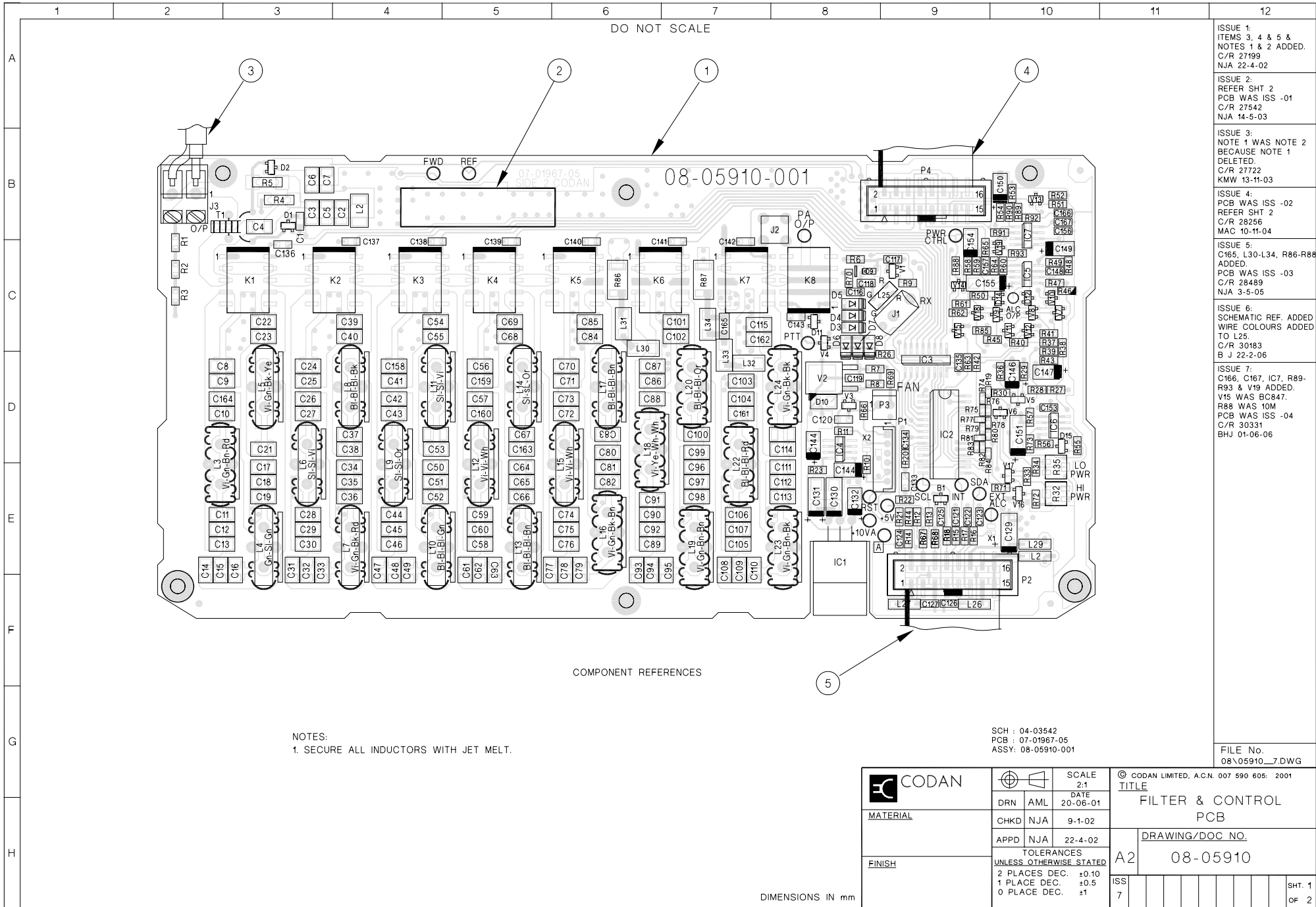

DIMENSIONS IN mm



DRN	AML	DATE
CHKD	NJA	20-06-01
APPD	NJA	22-4-02
TOLERANCES UNLESS OTHERWISE STATED		
2 PLACES DEC.		+0.10
1 PLACE DEC.		+0.5
0 PLACE DEC.		±1

SCALE		2:1
DATE		20-06-01
TITLE		
FILTER & CONTROL PCB		
DRAWING/DOC NO.		08-05910
ISS	7	
SHT	1	OF 2

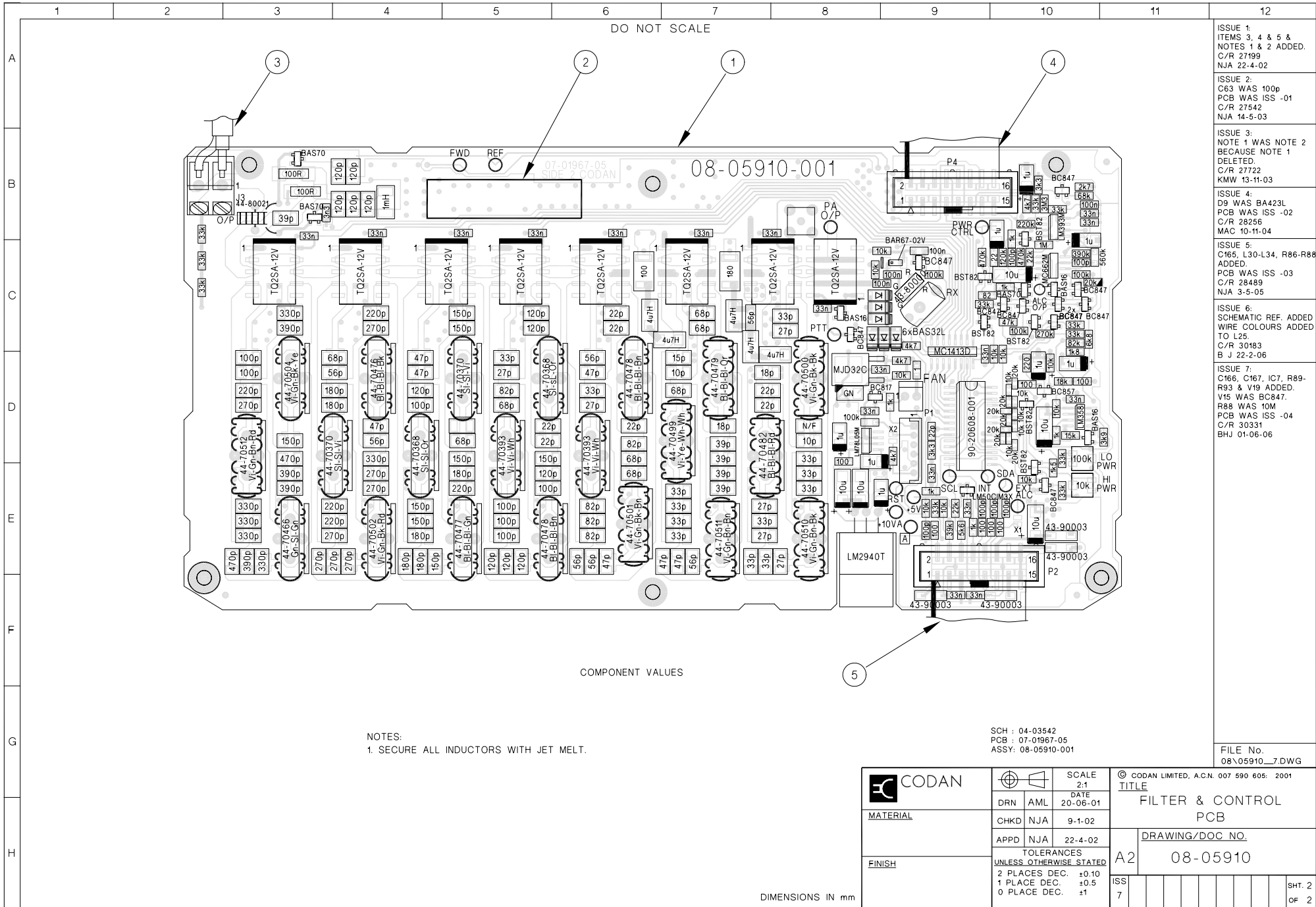

DO NOT SCALE

08-05910-001

COMPONENT VALUES

NOTES:
1. SECURE ALL INDUCTORS WITH JET MELT.

SCH : 04-03542
PCB : 07-01967-05
ASSY: 08-05910-001

FILE No.
08\05910_7.DWG

ISSUE 1:
ITEMS 3, 4 & 5 &
NOTES 1 & 2 ADDED.
C/R 27199
NJA 22-4-02

ISSUE 2:
C63 WAS 100p
PCB WAS ISS -01
C/R 27542
NJA 14-5-03

ISSUE 3:
NOTE 1 WAS NOTE 2
BECAUSE NOTE 1
DELETED.
C/R 27722
KMW 13-11-03

ISSUE 4:
D9 WAS BA423L
PCB WAS ISS -02
C/R 28256
MAC 10-11-04

ISSUE 5:
C165, L30-L34, R66-R88
ADDED.
PCB WAS ISS -03
C/R 28489
NJA 3-5-05

ISSUE 6:
SCHEMATIC REF. ADDED
WIRE COLOURS ADDED
TO L25.
C/R 30183
B J 22-2-06

ISSUE 7:
C166, C167, IC7, R89-
R93 & V19 ADDED.
V15 WAS BC847.
R88 WAS 10M
PCB WAS ISS -04
C/R 30331
BHJ 01-06-06

	SCALE	2:1	© CODAN LIMITED, A.C.N. 007 590 605: 2001 TITLE FILTER & CONTROL PCB		
	DRN	AML		DATE	20-06-01
	APPD	NJA		DATE	22-4-02
MATERIAL	CHKD	NJA	9-1-02	DRAWING/DOC NO.	
FINISH	TOLERANCES UNLESS OTHERWISE STATED				A2
			2 PLACES DEC. ±0.10	08-05910	
			1 PLACE DEC. ±0.5		
			0 PLACE DEC. ±1		ISS 7
				SHT. 2	
				OF 2	

DIMENSIONS IN mm

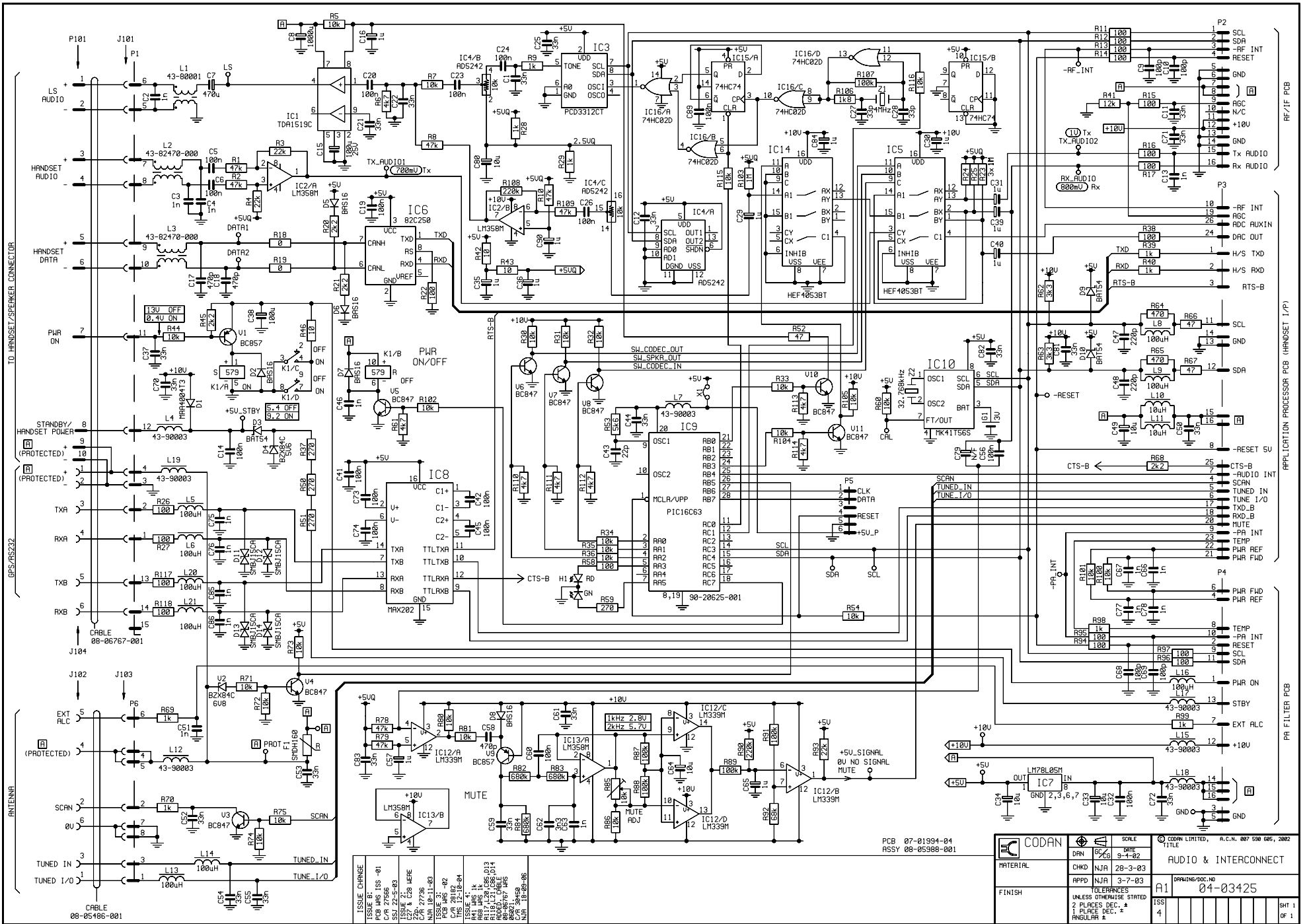

ISSUE CHANGE	ISSUE NO.	DATE
PCB WMS 01	01	9-4-82
C/A 27566	02	9-4-82
SSJ 27566	03	9-4-82
SSJ 27566	04	9-4-82
SSJ 27566	05	9-4-82
SSJ 27566	06	9-4-82
SSJ 27566	07	9-4-82
SSJ 27566	08	9-4-82
SSJ 27566	09	9-4-82
SSJ 27566	10	9-4-82
SSJ 27566	11	9-4-82
SSJ 27566	12	9-4-82
SSJ 27566	13	9-4-82
SSJ 27566	14	9-4-82
SSJ 27566	15	9-4-82
SSJ 27566	16	9-4-82
SSJ 27566	17	9-4-82
SSJ 27566	18	9-4-82
SSJ 27566	19	9-4-82
SSJ 27566	20	9-4-82
SSJ 27566	21	9-4-82
SSJ 27566	22	9-4-82
SSJ 27566	23	9-4-82
SSJ 27566	24	9-4-82
SSJ 27566	25	9-4-82
SSJ 27566	26	9-4-82
SSJ 27566	27	9-4-82
SSJ 27566	28	9-4-82
SSJ 27566	29	9-4-82
SSJ 27566	30	9-4-82
SSJ 27566	31	9-4-82
SSJ 27566	32	9-4-82
SSJ 27566	33	9-4-82
SSJ 27566	34	9-4-82
SSJ 27566	35	9-4-82
SSJ 27566	36	9-4-82
SSJ 27566	37	9-4-82
SSJ 27566	38	9-4-82
SSJ 27566	39	9-4-82
SSJ 27566	40	9-4-82
SSJ 27566	41	9-4-82
SSJ 27566	42	9-4-82
SSJ 27566	43	9-4-82
SSJ 27566	44	9-4-82
SSJ 27566	45	9-4-82
SSJ 27566	46	9-4-82
SSJ 27566	47	9-4-82
SSJ 27566	48	9-4-82
SSJ 27566	49	9-4-82
SSJ 27566	50	9-4-82
SSJ 27566	51	9-4-82
SSJ 27566	52	9-4-82
SSJ 27566	53	9-4-82
SSJ 27566	54	9-4-82
SSJ 27566	55	9-4-82
SSJ 27566	56	9-4-82
SSJ 27566	57	9-4-82
SSJ 27566	58	9-4-82
SSJ 27566	59	9-4-82
SSJ 27566	60	9-4-82
SSJ 27566	61	9-4-82
SSJ 27566	62	9-4-82
SSJ 27566	63	9-4-82
SSJ 27566	64	9-4-82
SSJ 27566	65	9-4-82
SSJ 27566	66	9-4-82
SSJ 27566	67	9-4-82
SSJ 27566	68	9-4-82
SSJ 27566	69	9-4-82
SSJ 27566	70	9-4-82
SSJ 27566	71	9-4-82
SSJ 27566	72	9-4-82
SSJ 27566	73	9-4-82
SSJ 27566	74	9-4-82
SSJ 27566	75	9-4-82
SSJ 27566	76	9-4-82
SSJ 27566	77	9-4-82
SSJ 27566	78	9-4-82
SSJ 27566	79	9-4-82
SSJ 27566	80	9-4-82
SSJ 27566	81	9-4-82
SSJ 27566	82	9-4-82
SSJ 27566	83	9-4-82
SSJ 27566	84	9-4-82
SSJ 27566	85	9-4-82
SSJ 27566	86	9-4-82
SSJ 27566	87	9-4-82
SSJ 27566	88	9-4-82
SSJ 27566	89	9-4-82
SSJ 27566	90	9-4-82
SSJ 27566	91	9-4-82
SSJ 27566	92	9-4-82
SSJ 27566	93	9-4-82
SSJ 27566	94	9-4-82
SSJ 27566	95	9-4-82
SSJ 27566	96	9-4-82
SSJ 27566	97	9-4-82
SSJ 27566	98	9-4-82
SSJ 27566	99	9-4-82
SSJ 27566	100	9-4-82

PCB 07-01994-04
 ASSY 08-05988-001

CODAN		SCALE	CODAN LIMITED, A.C.N. 807 590 685, 2002
DRAWN	DATE	TITLE	
CHKD	9-4-82	AUDIO & INTERCONNECT	
APPD	28-3-03	DRAWING/DOC NO	
FINISH	3-7-03	04-03425	
UNLESS OTHERWISE STATED		ISS	
2 PLACES DEC. *		4	
1 PLACE DEC. *		SHT 1	
ANGULAR ±		OF 1	

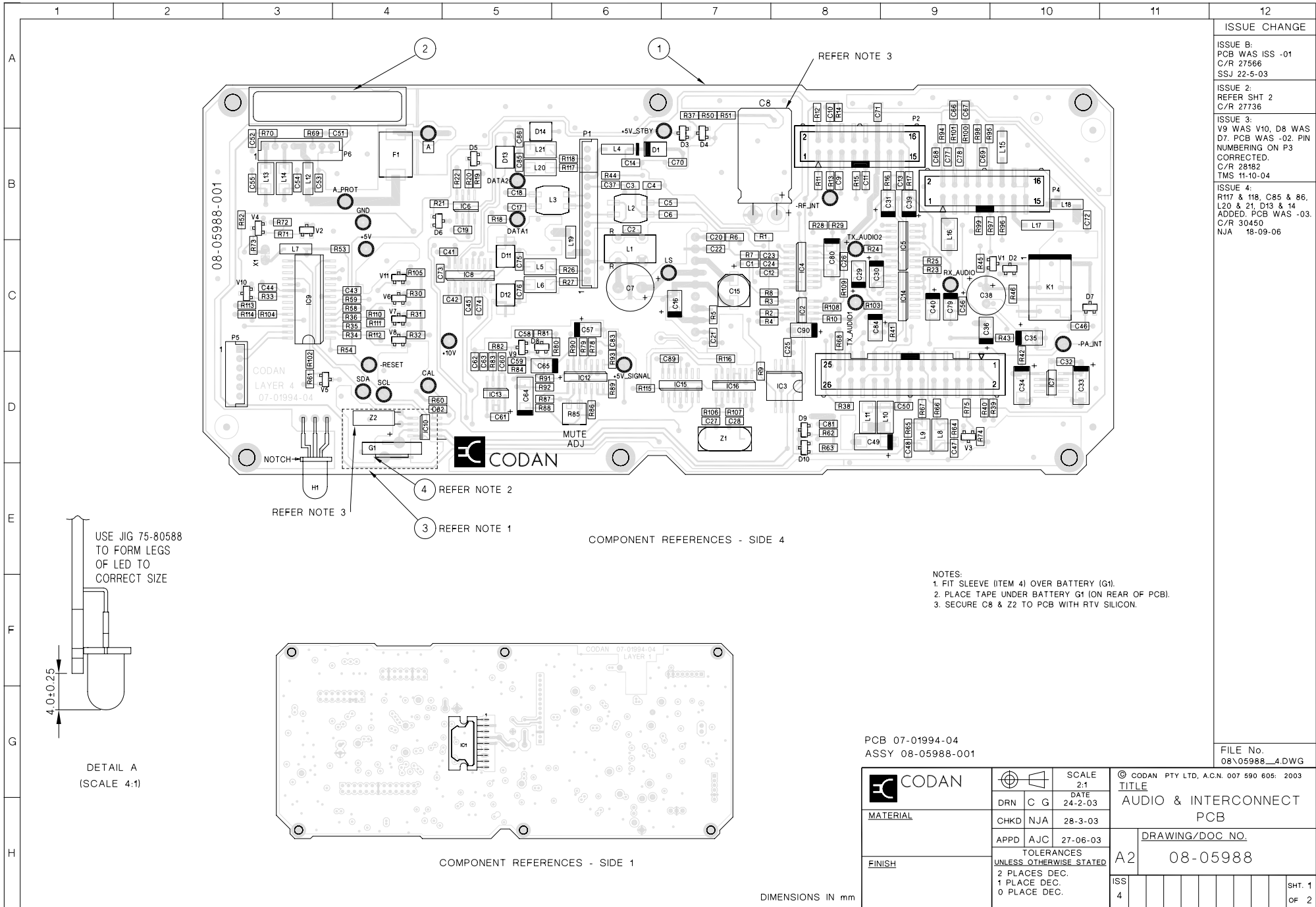

ISSUE CHANGE

ISSUE B:
PCB WAS ISS -01
C/R 27566
SSJ 22-5-03

ISSUE 2:
REFER SHT 2
C/R 27736

ISSUE 3:
V9 WAS V10, D8 WAS
D7. PCB WAS -02. PIN
NUMBERING ON P3
CORRECTED.
C/R 28182
TMS 11-10-04

ISSUE 4:
R117 & 118, C85 & 86,
L20 & 21, D13 & 14
ADDED. PCB WAS -03.
C/R 30450
NJA 18-09-06

COMPONENT REFERENCES - SIDE 4

COMPONENT REFERENCES - SIDE 1

- NOTES:
1. FIT SLEEVE (ITEM 4) OVER BATTERY (G1).
2. PLACE TAPE UNDER BATTERY G1 (ON REAR OF PCB).
3. SECURE C8 & Z2 TO PCB WITH RTV SILICON.

PCB 07-01994-04
ASSY 08-05988-001

FILE No.
08\05988_4.DWG

	SCALE 2:1		© CODAN PTY LTD, A.C.N. 007 590 605: 2003 TITLE AUDIO & INTERCONNECT PCB	
	DRN	C G	DATE 24-2-03	
MATERIAL	CHKD	NJA	28-3-03	
FINISH	APPD	AJC	27-06-03	
	TOLERANCES UNLESS OTHERWISE STATED 2 PLACES DEC. 1 PLACE DEC. 0 PLACE DEC.			
ISS		4		DRAWING/DOC NO. 08-05988
				SHT. 1 OF 2

DIMENSIONS IN mm

DETAIL A
(SCALE 4:1)

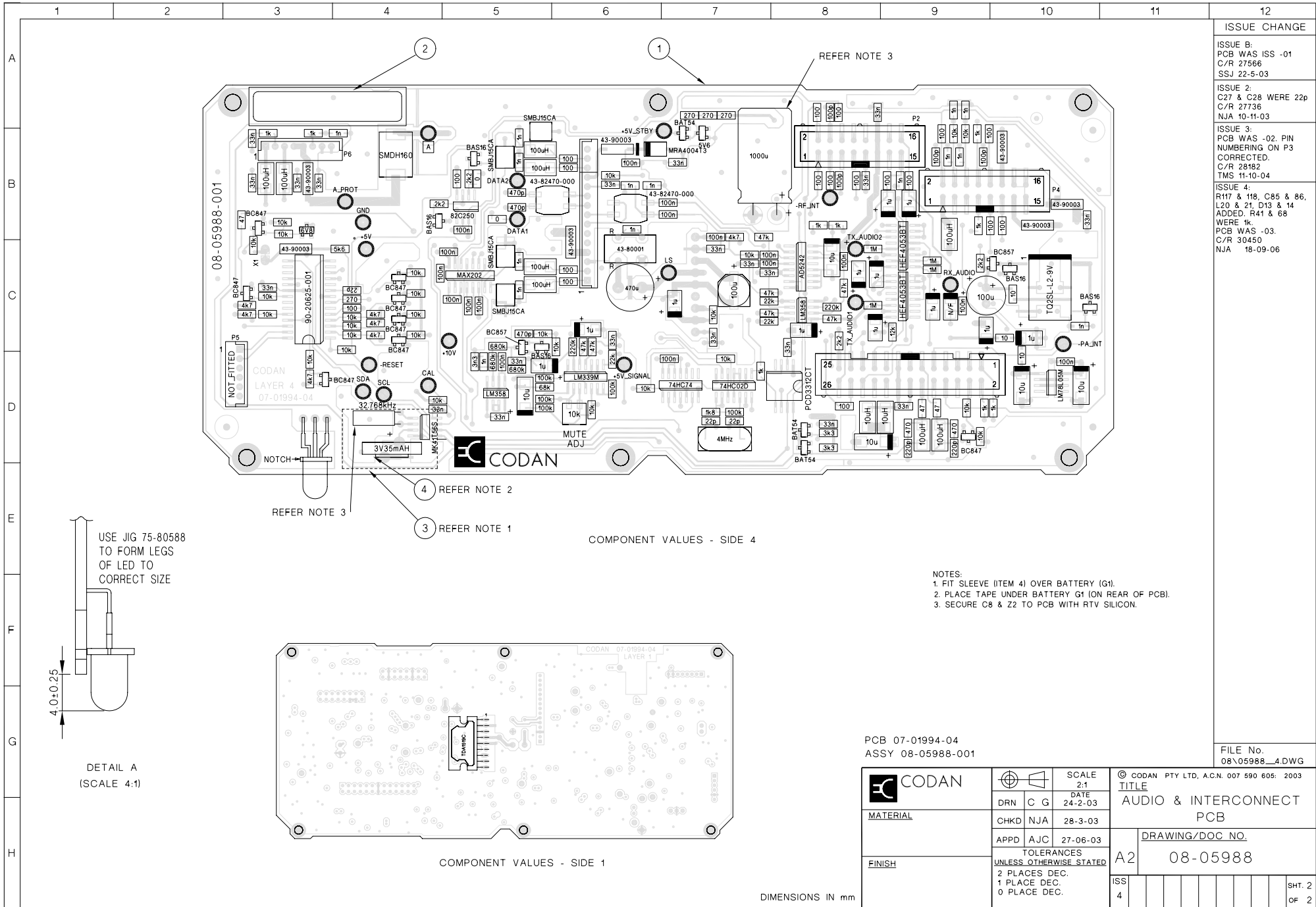

ISSUE CHANGE

- ISSUE 0:
PCB WAS ISS -01
C/R 27566
SSJ 22-5-03
- ISSUE 2:
C27 & C28 WERE 22p
C/R 27736
NJA 10-11-03
- ISSUE 3:
PCB WAS -02. PIN
NUMBERING ON P3
CORRECTED.
C/R 28182
TMS 11-10-04
- ISSUE 4:
R117 & 118, C85 & 86,
L20 & 21, D13 & 14
ADDED. R41 & 68
WERE 1k.
PCB WAS -03.
C/R 30450
NJA 18-09-06

COMPONENT VALUES - SIDE 4

COMPONENT VALUES - SIDE 1

- NOTES:
1. FIT SLEEVE (ITEM 4) OVER BATTERY (G1).
 2. PLACE TAPE UNDER BATTERY G1 (ON REAR OF PCB).
 3. SECURE C8 & Z2 TO PCB WITH RTV SILICON.

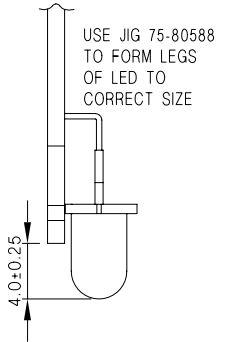

DETAIL A
(SCALE 4:1)

PCB 07-01994-04
ASSY 08-05988-001

FILE No.
08\05988_4.DWG

	SCALE 2:1		© CODAN PTY LTD, A.C.N. 007 590 605: 2003 TITLE AUDIO & INTERCONNECT PCB	
	DRN	C G	DATE	24-2-03
MATERIAL	CHKD	NJA	28-3-03	DRAWING/DOC NO. 08-05988
	APPD	AJC	27-06-03	
FINISH	TOLERANCES UNLESS OTHERWISE STATED			ISS 4
	2 PLACES DEC. 1 PLACE DEC. 0 PLACE DEC.			
				SHT. 2 OF 2

DIMENSIONS IN mm

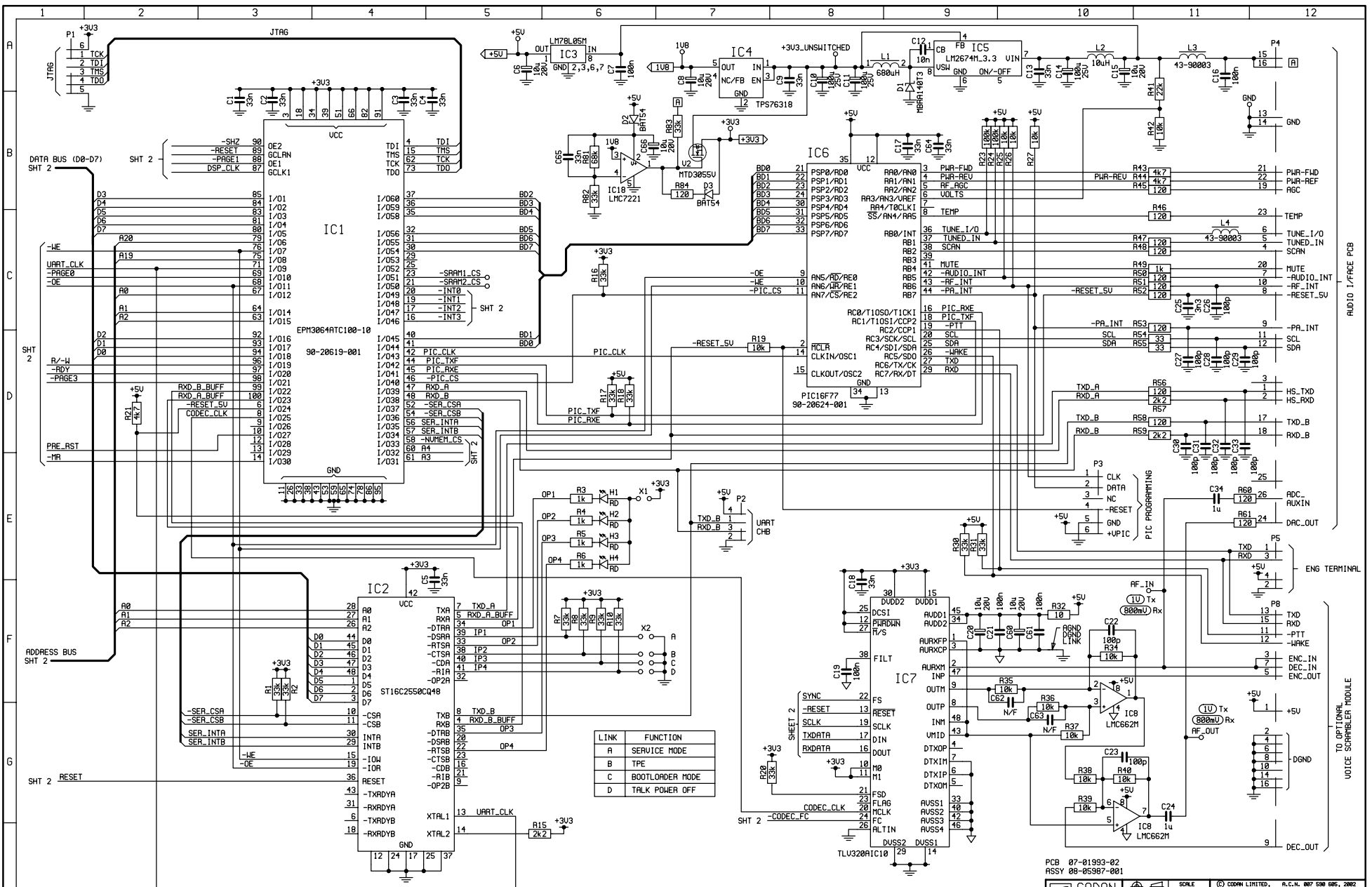

LINK	FUNCTION
A	SERVICE MODE
B	TPE
C	BOOTLOADER MODE
D	TALK POWER OFF

PCB 07-01993-02
 ASSY 08-05987-001

	SCALE	22-3-82	© CODAN LIMITED, A.C.N. 007 530 065, 2002 TITLE APPLICATION PROCESSOR HANDSET I/F 3U
	DRN	24-2-83	
MATERIAL	CHKD	SSJ	DRAWING NO. 04-03424
APPD	SSJ	3-7-83	
FINISH	TOLERANCES	UNLESS OTHERWISE STATED	ISS B 1
	2 PLACES DEC. & 1 PLACE DEC. *	ANGULAR	

CHANGE REQUEST
 ISSUE B
 IC18 (+3V3) CCT
 C/A 27561
 S5J 20-5-03

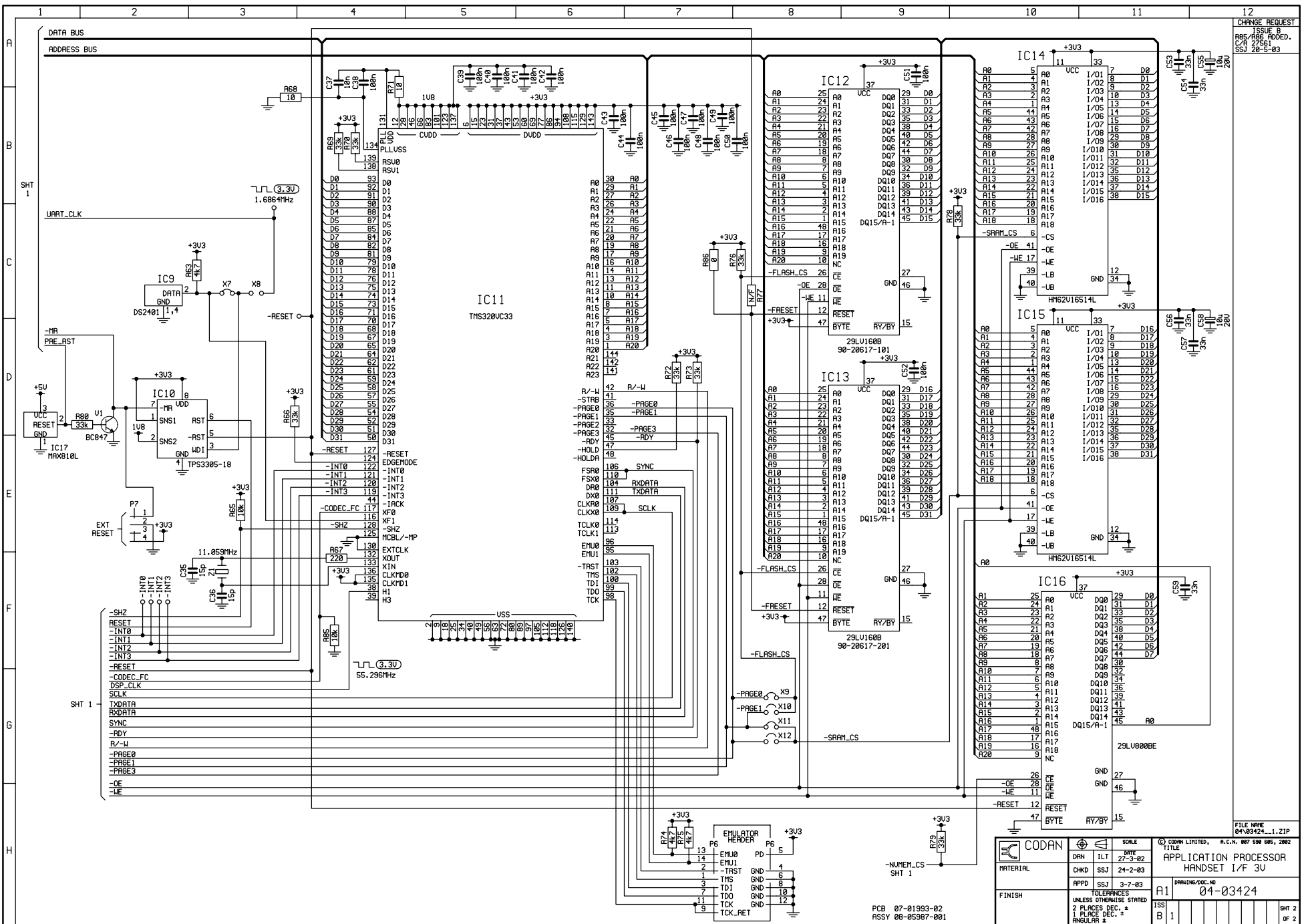

CHANGE REQUEST
 ISSUE B
 R85, R86 ADDED.
 C/A 27561
 SSJ 26-3-83

FILE NAME
 04-03424...1.ZIP

CODAN		SCALE	© CODAN LIMITED, A.C.N. 007 508 005, 2002
MATERIAL	DRN ILT	DATE	TITLE
	CHKD SSJ	27-3-82	APPLICATION PROCESSOR
	APPD SSJ	24-2-83	HANDSET I/F 3U
FINISH	TOLERANCES	3-7-83	
	UNLESS OTHERWISE STATED		
	2 PLACES DEC. &		
	1 PLACE DEC. *		
	ANGULAR ±		
	ISS	04-03424	DRAWING NO.
	B 1		
			SHT 2
			OF 2

PCB 07-01933-02
 ASSY 08-05987-001

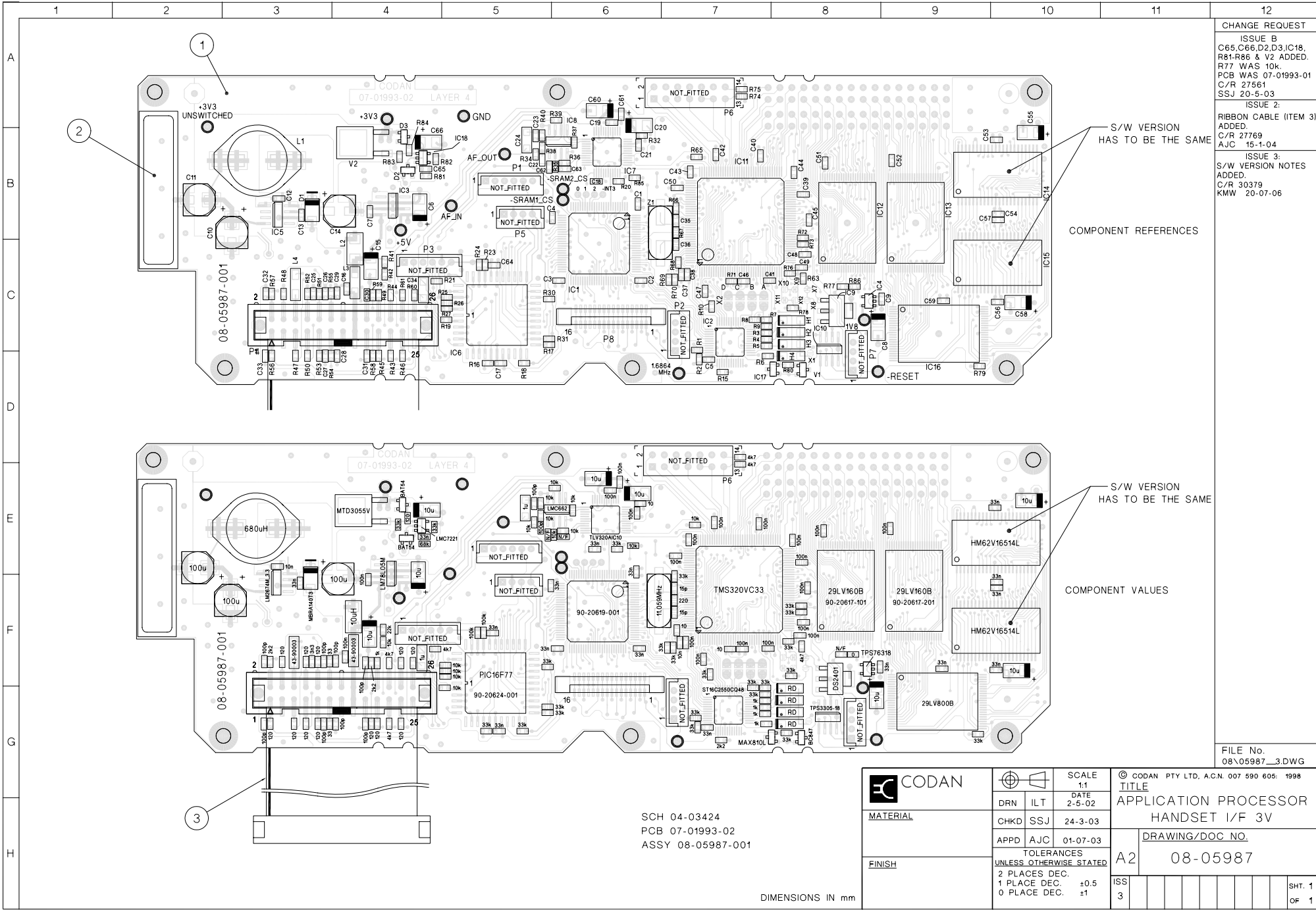

CHANGE REQUEST
 ISSUE B
 C65,C66,D2,D3,IC18,
 R81-R86 & V2 ADDED.
 R77 WAS 10k.
 PCB WAS 07-01993-01
 C/R 27561
 SSJ 20-5-03

ISSUE 2:
 RIBBON CABLE (ITEM 3)
 ADDED.
 C/R 27769
 AJC 15-1-04

ISSUE 3:
 S/W VERSION NOTES
 ADDED.
 C/R 30379
 KMW 20-07-06

S/W VERSION
 HAS TO BE THE SAME

COMPONENT REFERENCES

S/W VERSION
 HAS TO BE THE SAME

COMPONENT VALUES

FILE No.
 08\05987_3.DWG

SCH 04-03424
 PCB 07-01993-02
 ASSY 08-05987-001

DIMENSIONS IN mm

CODAN	
MATERIAL	
FINISH	

DRN	ILT	SCALE
CHKD	SSJ	DATE
APPD	AJC	2-5-02
		24-3-03
		01-07-03
TOLERANCES UNLESS OTHERWISE STATED		
2 PLACES DEC.		
1 PLACE DEC. ±0.5		
0 PLACE DEC. ±1		

© CODAN PTY LTD, A.C.N. 007 590 605: 1998	
TITLE	
APPLICATION PROCESSOR	
HANDSET I/F 3V	
DRAWING/DOC. NO.	
A2 08-05987	
ISS	3
SHT.	1 OF 1

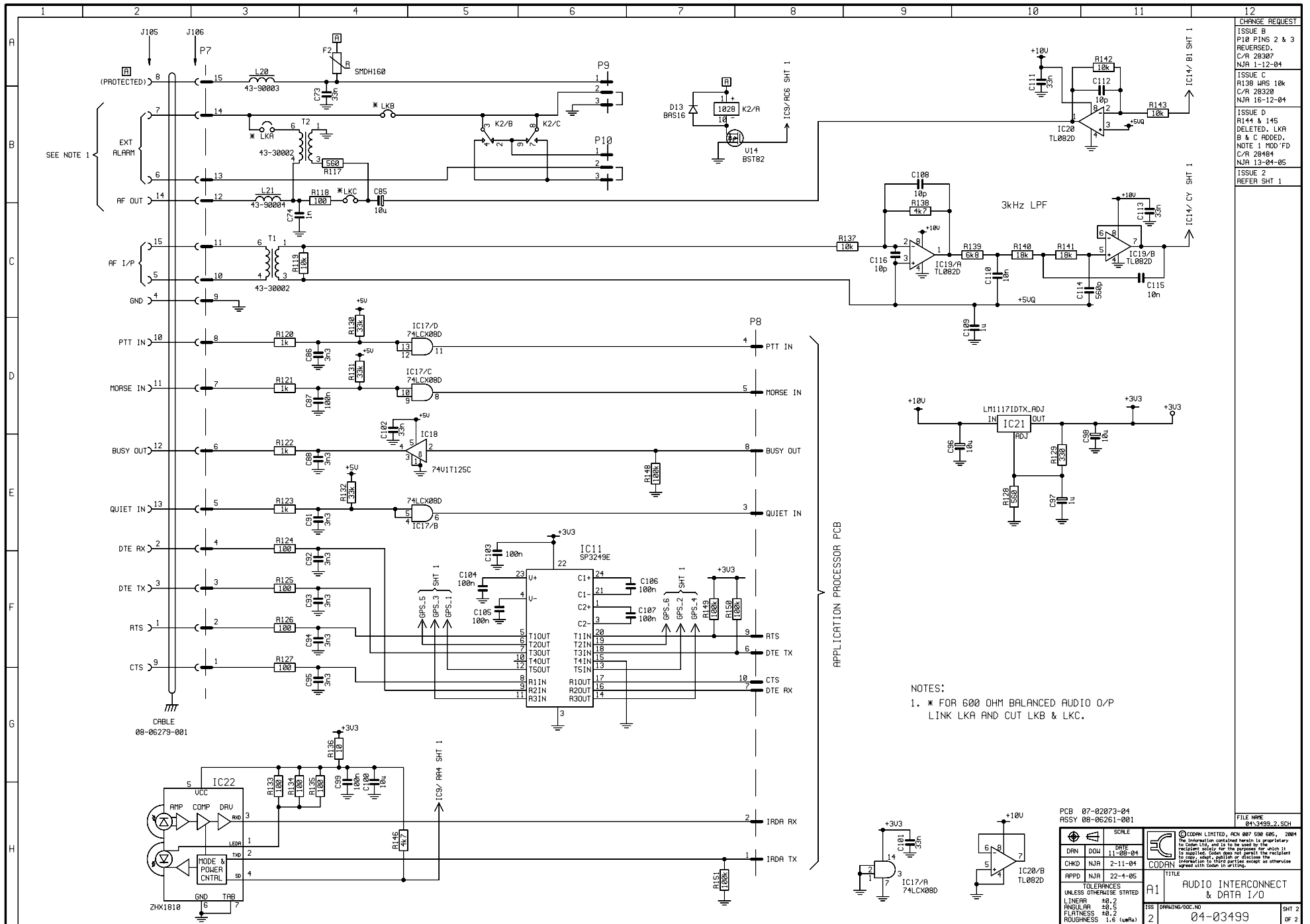

CHANGE REQUEST

ISSUE B
P10 PINS 2 & 3
REVERSED.
C/R 28307
NJA 1-12-04

ISSUE C
R138 WAS 10k
C/R 28320
NJA 16-12-04

ISSUE D
R144 & 145
DELETED. LKA
B & C ADDED.
NOTE 1 MOD 'FD
C/R 28484
NJA 13-04-05

ISSUE 2
REFER SHT 1

NOTES:
1. * FOR 600 OHM BALANCED AUDIO O/P
LINK LKA AND CUT LKB & LKC.

PCB 07-02073-04 ASSY 08-06261-001		SCALE		CODAN LIMITED, ACN 807 598 605, 2004 The information contained herein is proprietary to CODAN Pty. and is to be used by the recipient solely for the purposes for which it is supplied. Codan does not warrant the recipient for any loss or damage, or for any delay in performance or non-performance, except as otherwise agreed with Codan in writing.
DRN	DATE	DATE		
CHKD	NJA	2-11-04	CODAN	A1
APPD	NJA	22-4-05		
TOLERANCES		UNLESS OTHERWISE STATED		
LINEAR	#0.2			
ANGULAR	#0.5			
FLATNESS	#0.2			
ROUGHNESS	1.6 (µmRa)			
ISS	DRAWING/DOC. NO	2		04-03499
				SHT 2
				OF 2

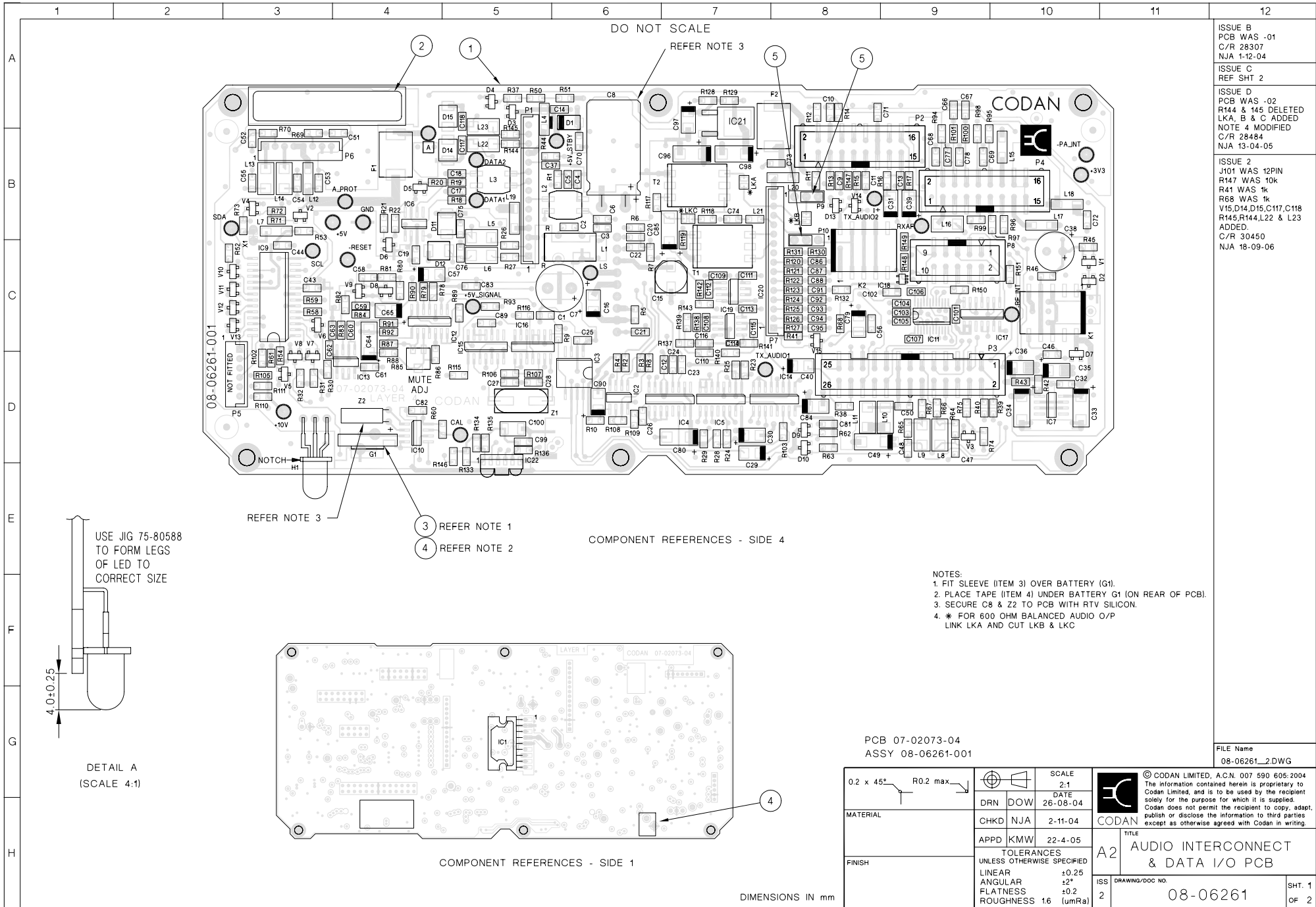

ISSUE B
PCB WAS -01
C/R 28307
NJA 1-12-04

ISSUE C
REF SHT 2

ISSUE D
PCB WAS -02
R144 & 145 DELETED
LKA, B & C ADDED
NOTE 4 MODIFIED
C/R 28484
NJA 13-04-05

ISSUE 2
J101 WAS 12PIN
R147 WAS 10K
R41 WAS 1k
R68 WAS 1k
V15, D14, D15, C117, C118
R145, R144, L22 & L23
ADDED.
C/R 30450
NJA 18-09-06

- REFER NOTE 3
- 1 REFER NOTE 1
 - 2 REFER NOTE 2
 - 3 REFER NOTE 1
 - 4 REFER NOTE 2

COMPONENT REFERENCES - SIDE 4

- NOTES:
1. FIT SLEEVE (ITEM 3) OVER BATTERY (G1).
 2. PLACE TAPE (ITEM 4) UNDER BATTERY G1 (ON REAR OF PCB).
 3. SECURE C8 & Z2 TO PCB WITH RTV SILICON.
 4. * FOR 600 OHM BALANCED AUDIO O/P LINK LKA AND CUT LKB & LKC

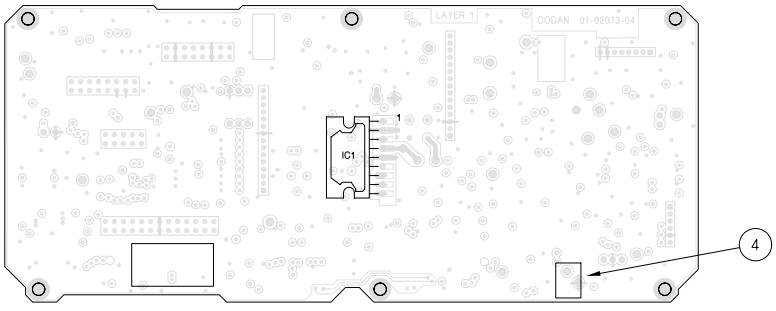

COMPONENT REFERENCES - SIDE 1

DIMENSIONS IN mm

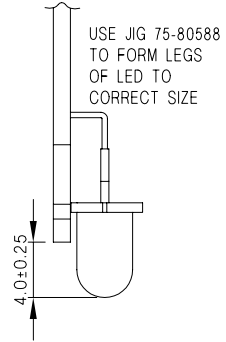

DETAIL A
(SCALE 4:1)

PCB 07-02073-04
ASSY 08-06261-001

0.2 x 45° R0.2 max		SCALE 2:1		<p>© CODAN LIMITED, A.C.N. 007 590 605-2004 The information contained herein is proprietary to Codan Limited, and is to be used by the recipient solely for the purpose for which it is supplied. Codan does not permit the recipient to copy, adapt, publish or disclose the information to third parties except as otherwise agreed with Codan in writing.</p>
DRN	DOW	DATE	26-08-04	
MATERIAL	CHKD NJA	2-11-04		<p>TITILE A2 AUDIO INTERCONNECT & DATA I/O PCB</p>
FINISH	APPD KMW	22-4-05		
<p>TOLERANCES UNLESS OTHERWISE SPECIFIED</p> <p>LINEAR ±0.25 ANGULAR ±2° FLATNESS ±0.2 ROUGHNESS 1.6 (µmRa)</p>				<p>ISS DRAWING/DOC NO. 2 08-06261</p>

FILE Name
08-06261_2.DWG

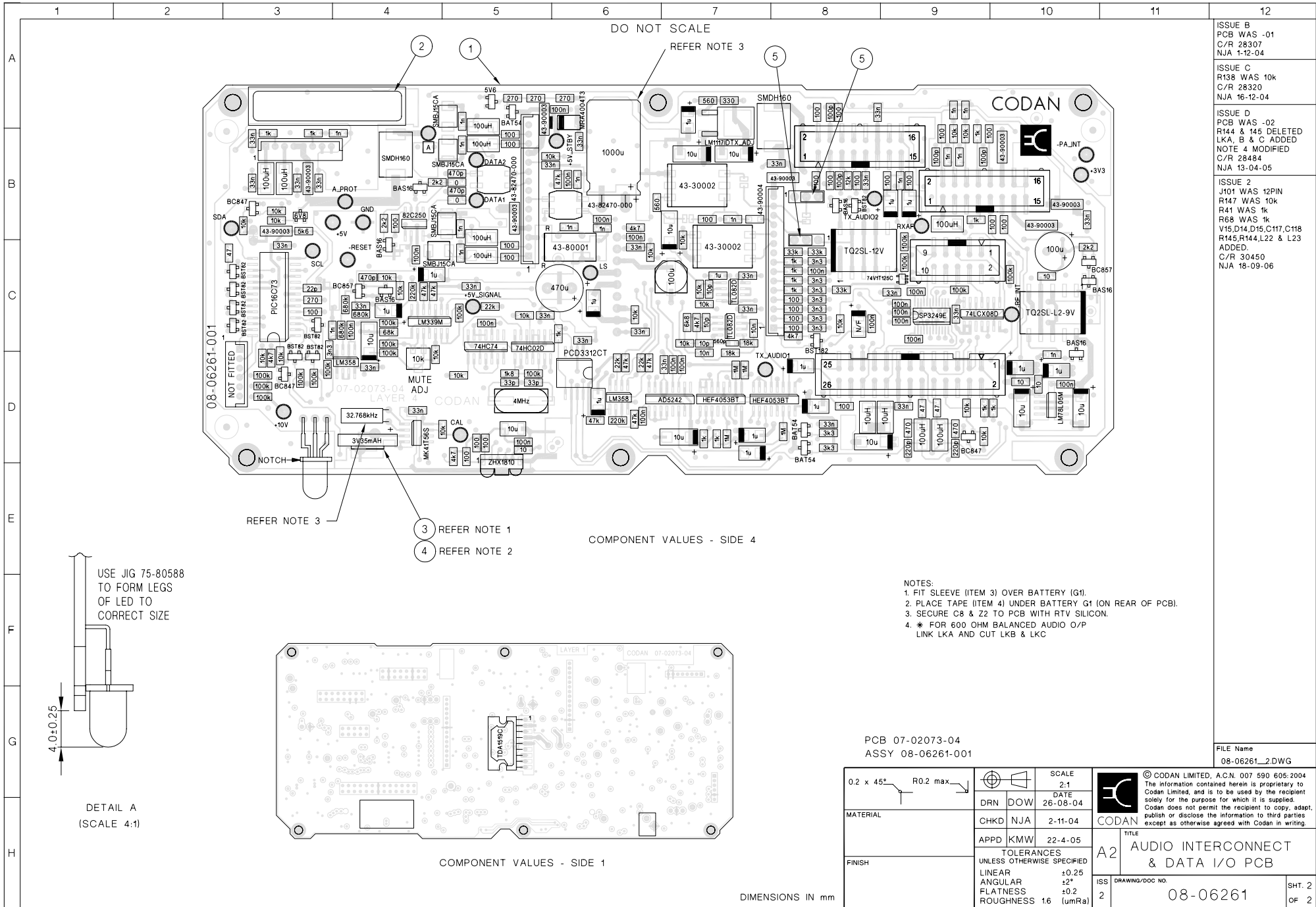

ISSUE B
PCB WAS -01
C/R 28307
NJA 1-12-04

ISSUE C
R138 WAS 10k
C/R 28320
NJA 16-12-04

ISSUE D
PCB WAS -02
R144 & 145 DELETED
LKA, B & C ADDED
NOTE 4 MODIFIED
C/R 28484
NJA 13-04-05

ISSUE 2
J101 WAS 12PIN
R147 WAS 10k
R41 WAS 1k
R68 WAS 1k
V15,D14,D15,C117,C118
R145,R144,L22 & L23
ADDED.
C/R 30450
NJA 18-09-06

COMPONENT VALUES - SIDE 4

COMPONENT VALUES - SIDE 1

DIMENSIONS IN mm

- NOTES:
1. FIT SLEEVE (ITEM 3) OVER BATTERY (G1).
 2. PLACE TAPE (ITEM 4) UNDER BATTERY G1 (ON REAR OF PCB).
 3. SECURE C8 & Z2 TO PCB WITH RTV SILICON.
 4. * FOR 600 OHM BALANCED AUDIO O/P LINK LKA AND CUT LKB & LKC

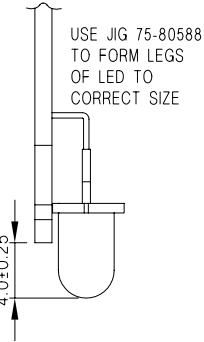

DETAIL A
(SCALE 4:1)

PCB 07-02073-04
ASSY 08-06261-001

FILE Name
08-06261_2.DWG

0.2 x 45° R0.2 max.		SCALE 2:1		<p>© CODAN LIMITED, A.C.N. 007 590 605-2004 The information contained herein is proprietary to Codan Limited, and is to be used by the recipient solely for the purpose for which it is supplied. Codan does not permit the recipient to copy, adapt, publish or disclose the information to third parties except as otherwise agreed with Codan in writing.</p>
DRN	DOW	DATE	26-08-04	
MATERIAL	CHKD NJA	2-11-04		<p>CODAN</p> <p>TITLE AUDIO INTERCONNECT & DATA I/O PCB</p>
APPD	KMW	22-4-05		
FINISH	TOLERANCES UNLESS OTHERWISE SPECIFIED			<p>ISS</p> <p>DRAWING/DOC NO. 08-06261</p>
	LINEAR	±0.25		
	ANGULAR	±2°		
	FLATNESS	±0.2		
	ROUGHNESS	1.6 (µmRa)		<p>SHT. 2</p> <p>OF 2</p>

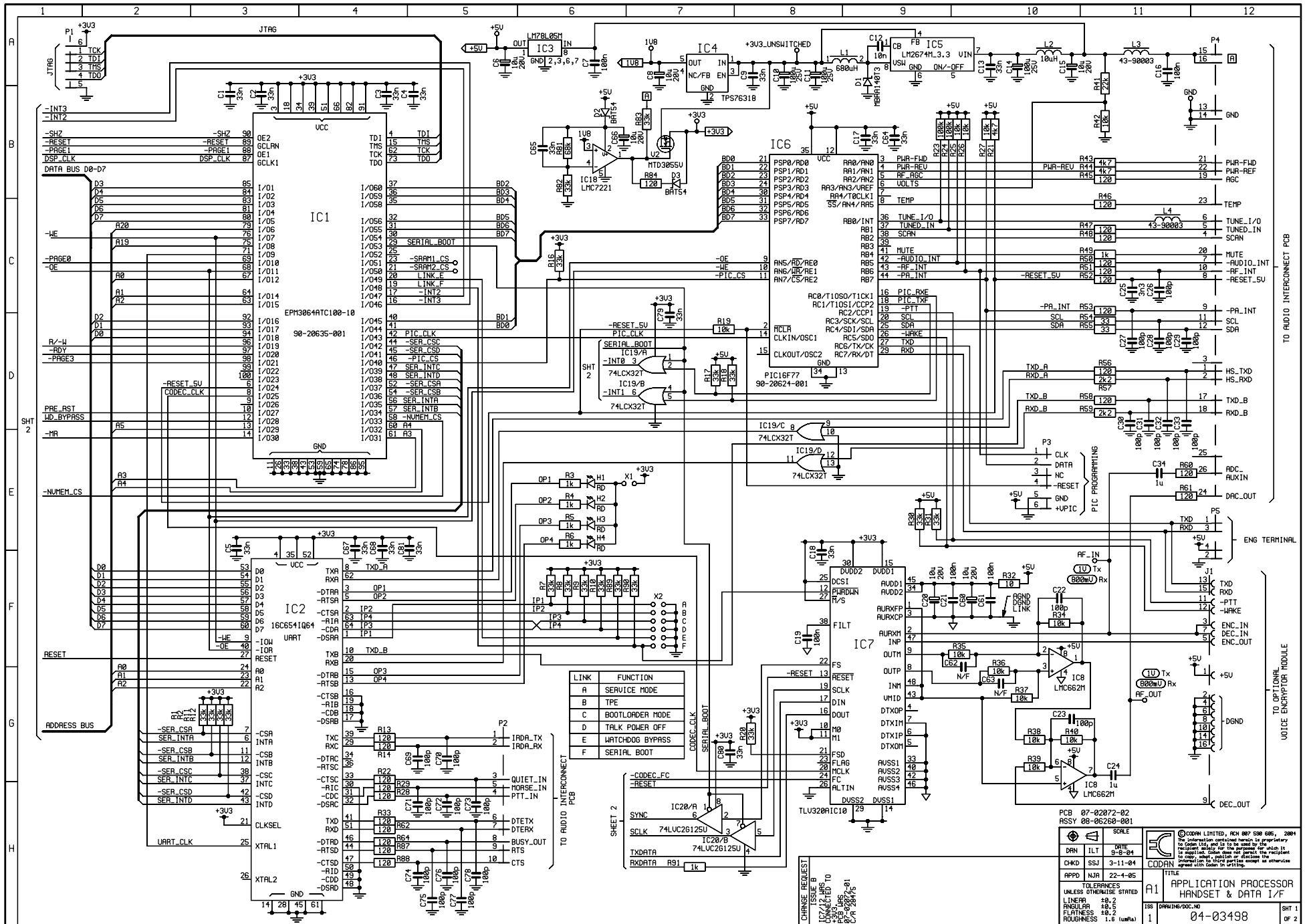

LINK	FUNCTION
A	SERVICE MODE
B	TPE
C	BOOTLOADER MODE
D	TALK POWER OFF
E	WATCHDOG BYPASS
F	SERIAL BOOT

PCB 07-02872-02
 ASSY 08-06260-001

SCALE	DATE
DRAWN	3-11-84
CHECKED	
APPD	22-4-85

TOLERANCES UNLESS OTHERWISE STATED

LINEAR	±0.2
ANGULAR	±0.5
FLATNESS	±0.2
ROUGHNESS	1.6 (µmRa)

TITLE APPLICATION PROCESSOR HANDSET & DATA I/S

04-03498

SHT 1 OF 2

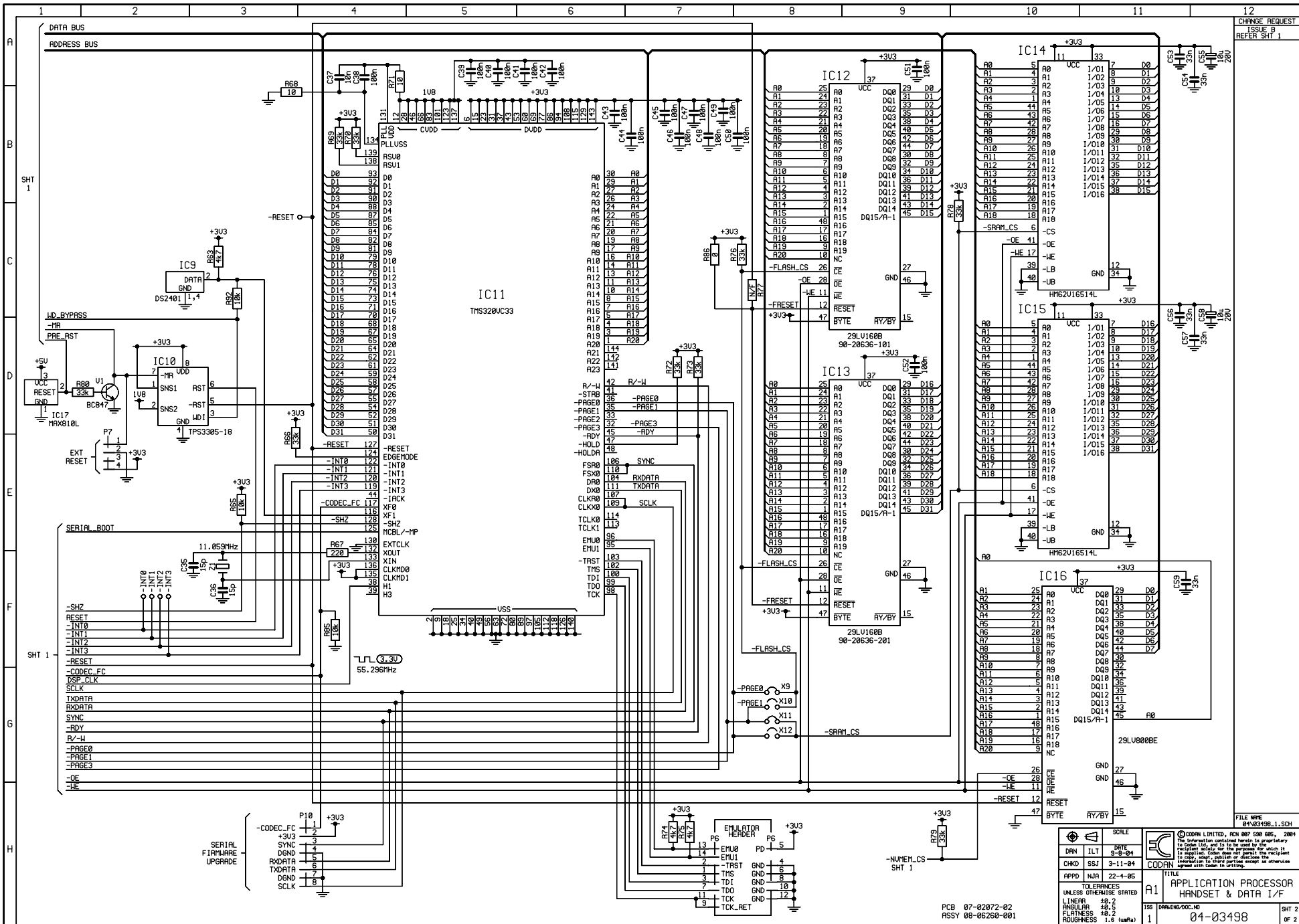

CHANGE REQUEST
ISSUE B
REFER SHT 1

FILE NAME
04-03498_1.SCH

SCALE		DATE	
DRAWN	ILT	9-8-04	
CHECKED	SSJ	3-11-04	
APPD	NJA	22-4-05	
TOLERANCES UNLESS OTHERWISE SPECIFIED		TITLE	
LINEAR	±0.2	A1 APPLICATION PROCESSOR	
ANGULAR	±0.5	HANDSET & DATA I/F	
FLATNESS	±0.2	188 DRAWING.DOC	
ROUGHNESS	1.6 (µmRa)	04-03498	

PCB 07-02072-02
ASSY 08-06260-001

SHT 2
OF 2

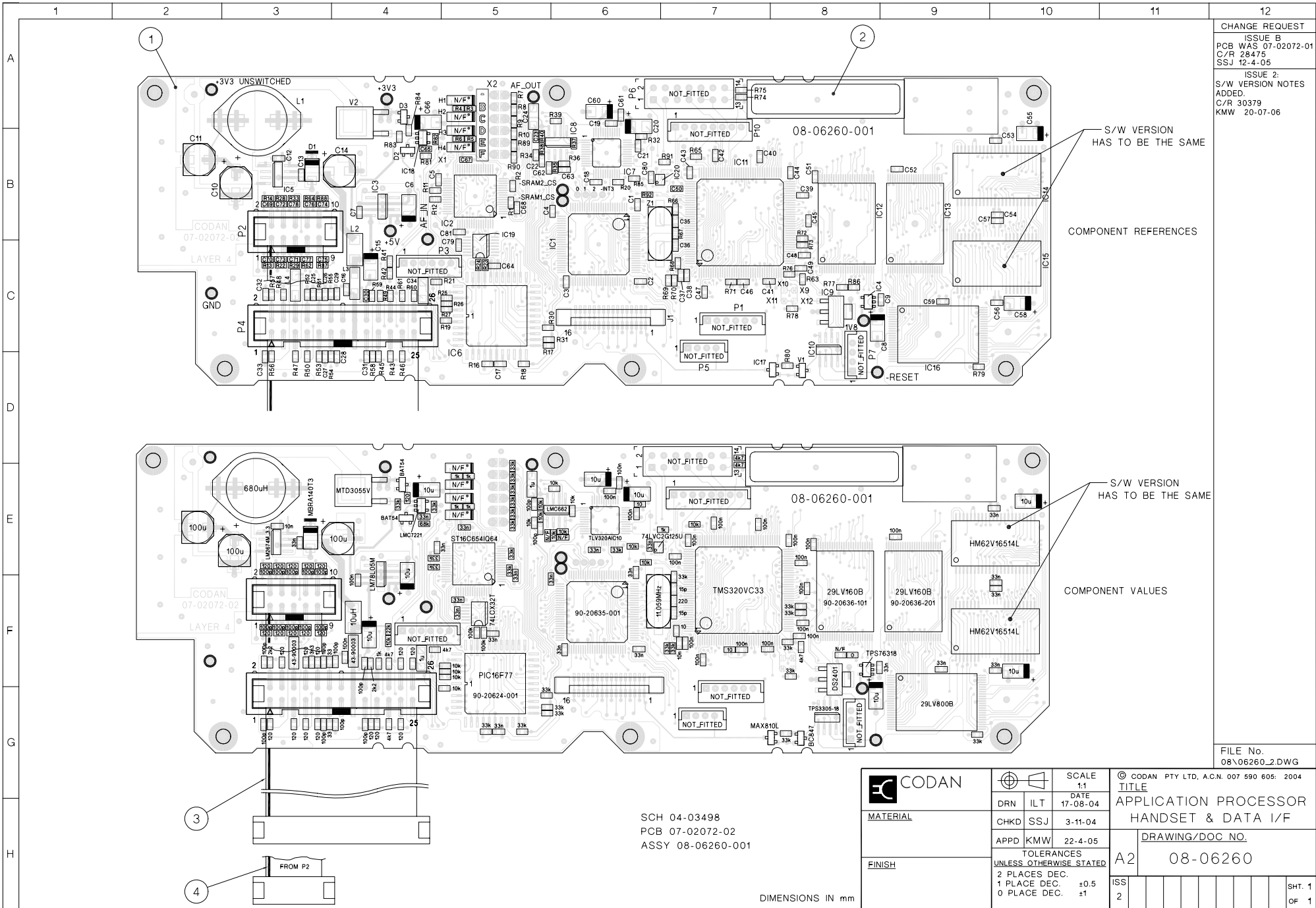

CHANGE REQUEST
 ISSUE B
 PCB WAS: 07-02072-01
 C/R: 28475
 SSJ: 12-4-05
 ISSUE 2:
 S/W VERSION NOTES
 ADDED.
 C/R: 30379
 KMW: 20-07-06

S/W VERSION
 HAS TO BE THE SAME

COMPONENT REFERENCES

S/W VERSION
 HAS TO BE THE SAME

COMPONENT VALUES

FILE No.
 08\06260_2.DWG

SCH 04-03498
 PCB 07-02072-02
 ASSY 08-06260-001

DIMENSIONS IN mm

	SCALE	1:1	© CODAN PTY LTD, A.C.N. 007 590 605: 2004 TITLE APPLICATION PROCESSOR HANDSET & DATA I/F		
	DRN	ILT		DATE	17-08-04
	CHKD	SSJ		DATE	3-11-04
	APPD	KMW	DATE	22-4-05	
MATERIAL	TOLERANCES UNLESS OTHERWISE STATED				
	2 PLACES DEC. 1 PLACE DEC. ±0.5 0 PLACE DEC. ±1				
FINISH	DRAWING/DOC NO.		A2		
	08-06260				
ISS	2	ISS	2		
		SHT.	1		
		OF	1		

ISSUE CHANGE

ISSUE B:
 ASSY VARIANT
 -002 ADDED.
 NOTE ADDED TO Z1
 TITLE WAS 500Hz
 PCB WAS ISS -01
 C/R 27380
 NJA 6-1-03

ISSUE 2:
 VARIANT TABLE
 MODIFIED. VAR
 -003 ADDED.
 C/R 28690
 GB 05-10-05

RF/IF
 (04-03378)

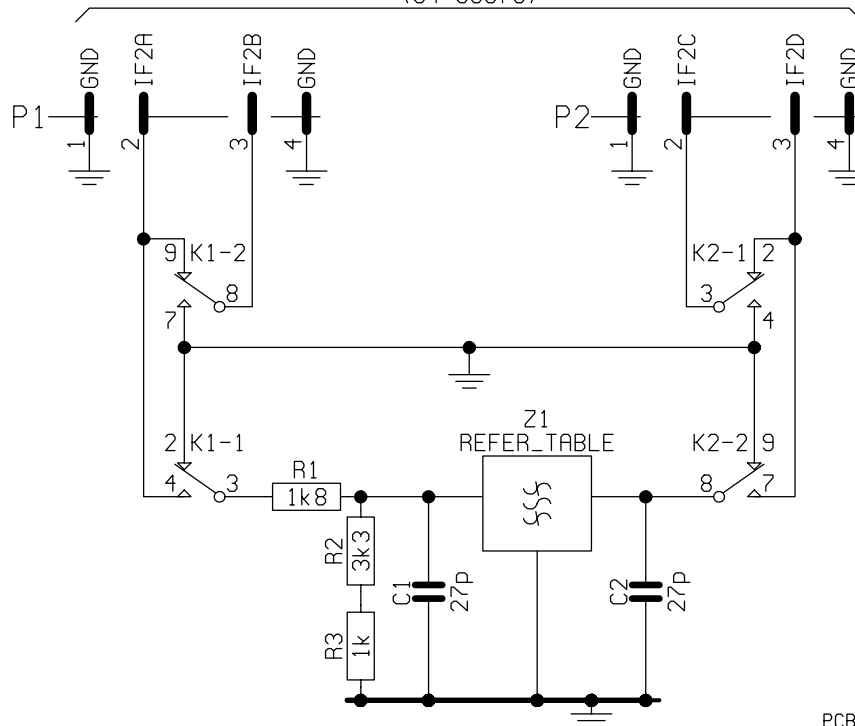

DEVICES ARE SHOWN TOP VIEW

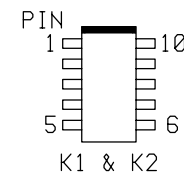
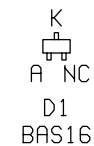

PCB : 07-01962-02

ASSEMBLY	Z1		Fc
	MANUF PART No	CODAN PART No	
08-05890-001	526-8693-010	65-91118	500Hz
08-05890-002	526-8759-010	65-91123	2700Hz
08-05890-003	526-8711-020	65-91125	3000Hz

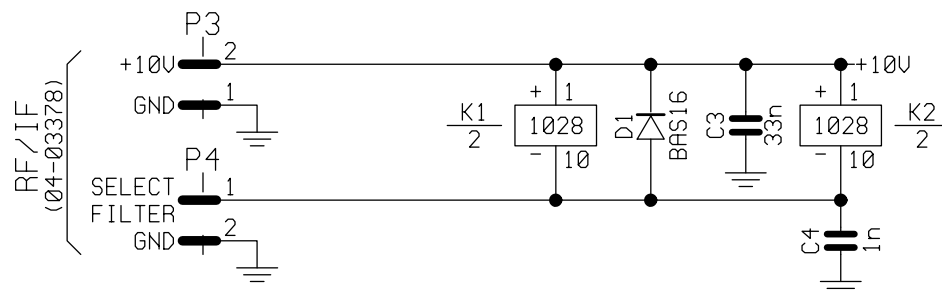

FILE NAME
 04\03379_2.*

	SCALE		© CODAN LIMITED, A.C.N. 007 590 605, 2001 TITLE	
	DRN	C G	DATE 7-5-01	
MATERIAL	CHKD	J.D	19-2-02	
FINISH	APPD	NJA	6-1-03	
	TOLERANCES UNLESS OTHERWISE STATED		DRAWING/DOC.NO 04-03379	
		A3		
ISS	2			SHT 1 OF 1

DO NOT SCALE

ISSUE B:
PCB WAS ISS -01
ASSY VARIANT -002
ADDED.
Z1 VALUE DELETED.
C/R 27380
NJA 6-1-03

ISSUE 2:
ASSY VARIANT TABLE
MODIFIED. -003 ADDED.
SCH No ADDED.
C/R 28690
GB 05-10-05

SIDE 2 - COMPONENTS

SIDE 1 - COMPONENTS

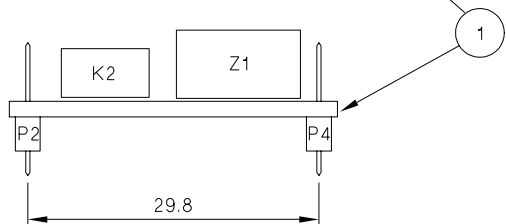
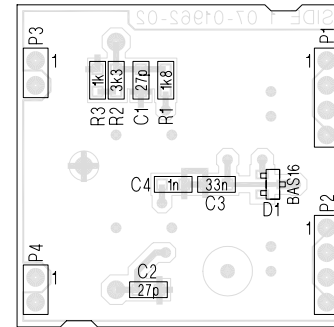
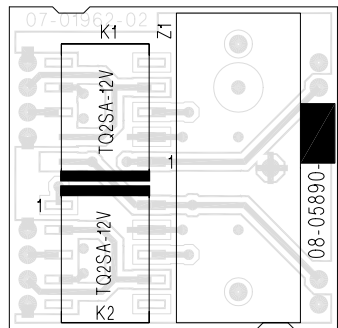

SCH : 04-03379
PCB : 07-01962-02

ASSEMBLY	Z1		Fc
	MANUF PART No.	CODAN PART No.	
08-05890-001	526-8693-010	65-91118	500Hz
08-05890-002	526-8759-010	65-91123	2700Hz
08-05890-003	526-8711-020	65-91125	3000Hz

NOTES:
1. CONNECTORS TO BE SQUARE.

FILE No.
08\05890_2.DWG

DIMENSIONS IN mm

			SCALE 2:1	© CODAN LIMITED, A.C.N. 007 590 605: 2001			
	DRN	C G	DATE 12-9-01	TITLE 2nd FILTER			
MATERIAL	CHKD	J.D	19-2-02	DRAWING/DOC NO.			
FINISH	APPD	NJA	6-1-03	A3		08-05890	
	TOLERANCES UNLESS OTHERWISE STATED			ISS			
2 PLACES DEC. ±0.10			2				SHT. 1
1 PLACE DEC. ±0.5							OF 1
0 PLACE DEC. ±1							

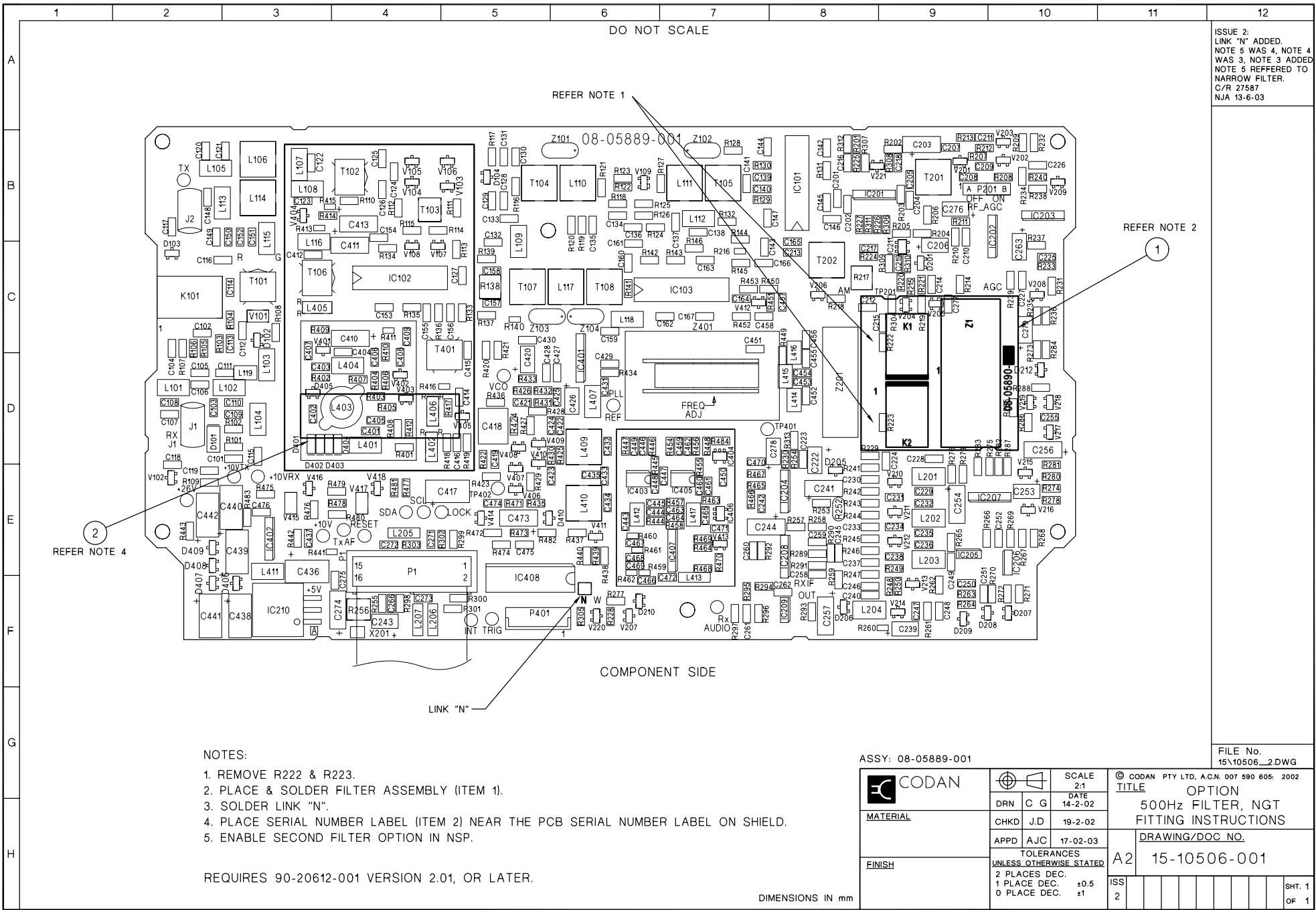

ISSUE 2:
LINK "N" ADDED.
NOTE 5 WAS 4, NOTE 4
WAS 3, NOTE 3 ADDED
NOTE 6 REFERRED TO
NARROW FILTER.
C/R 27587
NJA 13-6-03

- NOTES:
1. REMOVE R222 & R223.
 2. PLACE & SOLDER FILTER ASSEMBLY (ITEM 1).
 3. SOLDER LINK "N".
 4. PLACE SERIAL NUMBER LABEL (ITEM 2) NEAR THE PCB SERIAL NUMBER LABEL ON SHIELD.
 5. ENABLE SECOND FILTER OPTION IN NSP.

REQUIRES 90-20612-001 VERSION 2.01, OR LATER.

DIMENSIONS IN mm

1 2 3 4 5 6 7 8 9 10 11 12

DO NOT SCALE

ISSUE B:
LINK "W" ADDED.
NOTE 5 WAS 4, NOTE 4
WAS 3, NOTE 3 ADDED
NOTE 5 REFERRED TO
WIDE FILTER.
C/R 27587
NJA 13-6-03

A

B

C

D

E

F

G

H

REFER NOTE 1

REFER NOTE 2

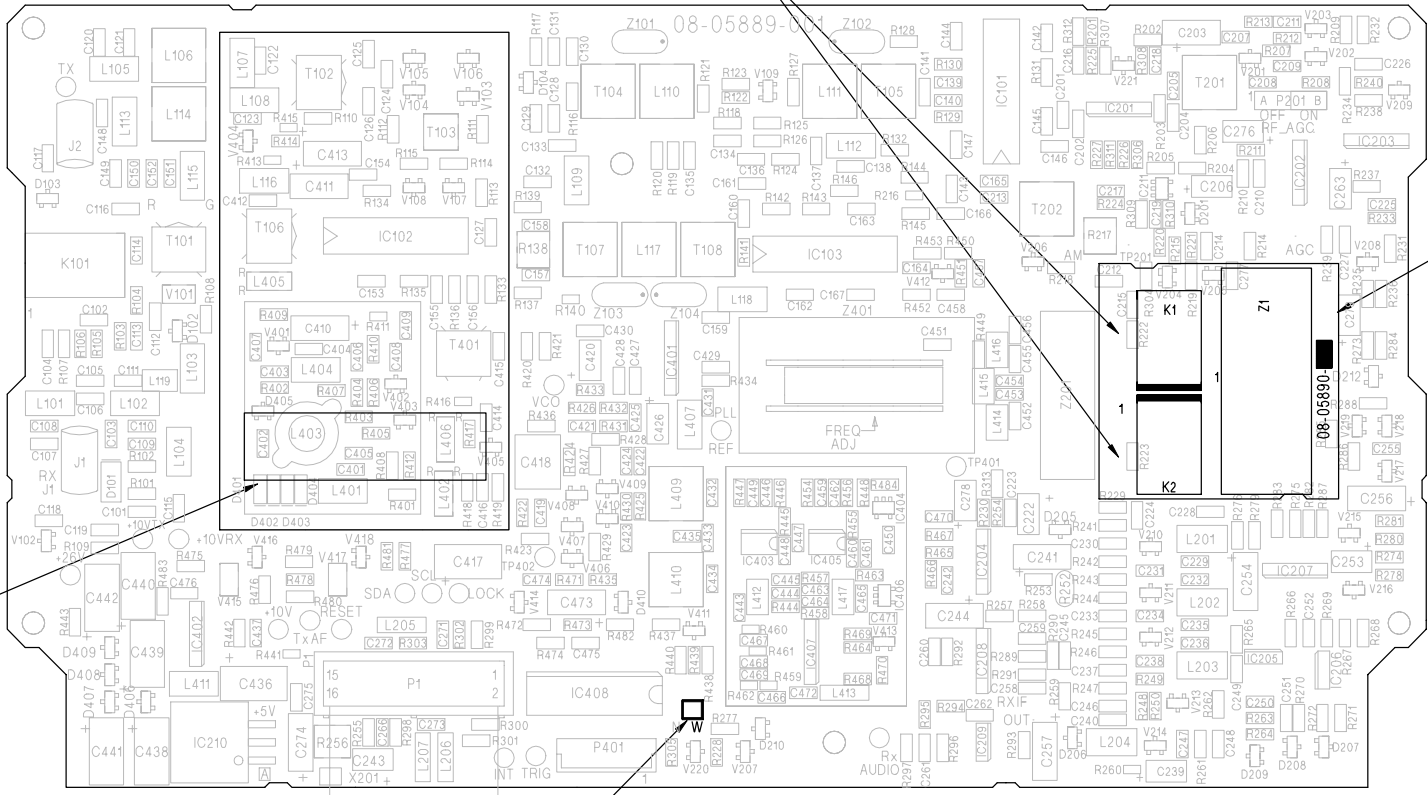

2

REFER NOTE 4

COMPONENT SIDE

LINK "W"

NOTES:

1. REMOVE R222 & R223.
2. PLACE & SOLDER FILTER ASSEMBLY (ITEM 1).
3. SOLDER LINK "W".
4. PLACE SERIAL NUMBER LABEL (ITEM 2) NEAR THE PCB SERIAL NUMBER LABEL ON SHIELD.
5. ENABLE SECOND FILTER OPTION IN NSP.

REQUIRES 90-20612-001 VERSION 2.01, OR LATER.

DIMENSIONS IN mm

ASSY: 08-05889-001

FILE No.
1510514_1.DWG

	SCALE 2:1		© CODAN PTY LTD, A.G.N. 007 990 605. 2002 TITLE OPTION 2700Hz FILTER, NGT FITTING INSTRUCTIONS
	DRN	ILT	
MATERIAL			TOLERANCES UNLESS OTHERWISE STATED 2 PLACES DEC. ±0.5 1 PLACE DEC. ±0.5 0 PLACE DEC. ±1
CHKD	NJA	DATE 25-11-02	
APPD		AJC	DATE 04-07-03
FINISH			A2 DRAWING/DOC NO. 15-10514-001
ISS			
			SHT. 1 OF 1

TO JUNCTION BOX AUDIO PCB - P5

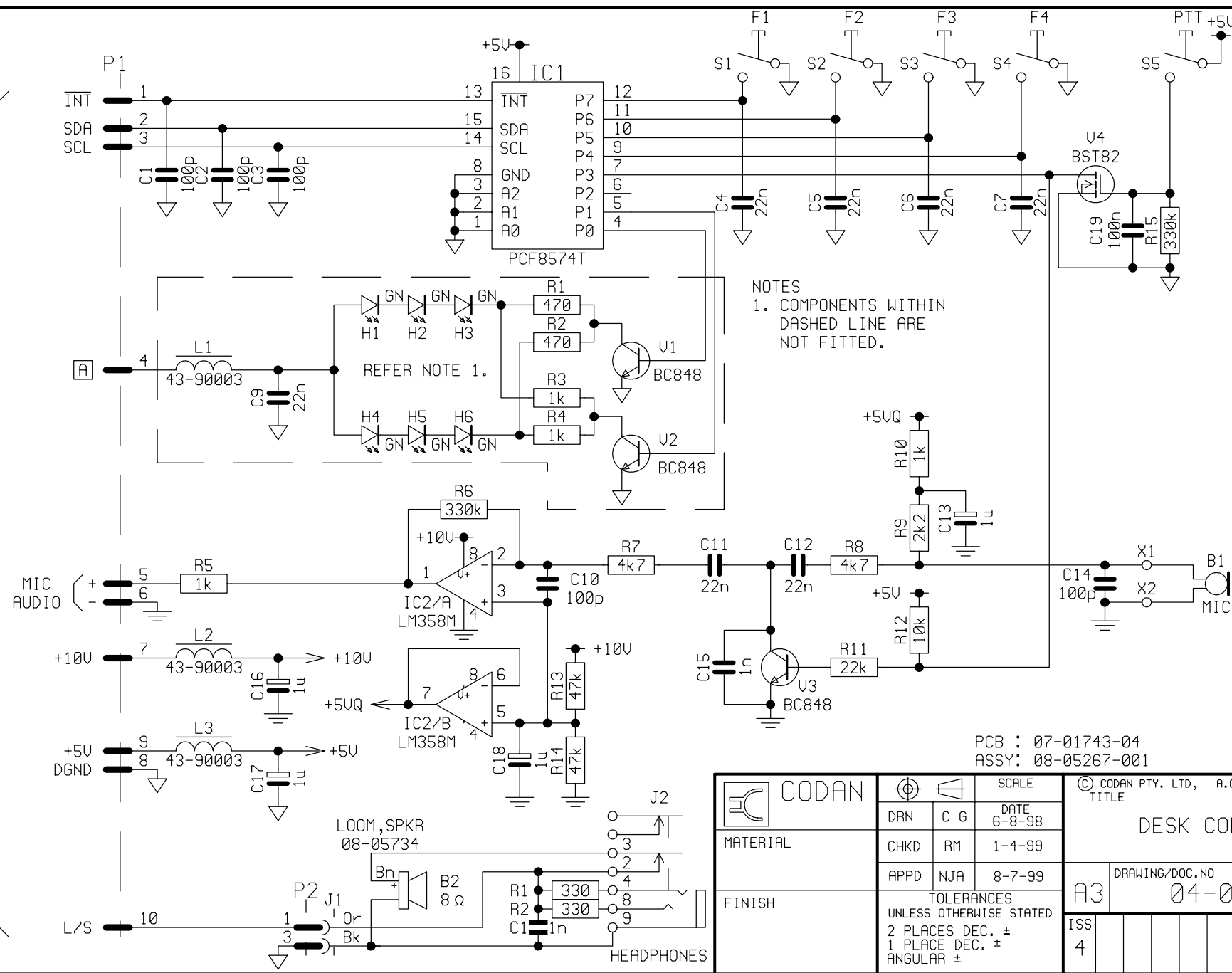

NOTES
1. COMPONENTS WITHIN
DASHED LINE ARE
NOT FITTED.

ISSUE CHANGE
ISSUE B: NOTES AND DASHED LINE ADDED. C/R 26074 SSJ 20-5-99
ISSUE 1 U4, C19 & R15 ADDED. C8 DELETED. C/R 26184 NJA 8-7-99
ISSUE 2: HEADPHONE JACK WIRING ADDED. C/R 26357 C E 25Nov99
ISSUE 3: R6 WAS 100K C/R 27338 CAM 10-10-02
ISSUE 4: PCB WAS -03 C/R 28183 TMS 12-10-04

PCB : 07-01743-04
ASSY: 08-05267-001

DISC FILE
04\03110_4

	SCALE DATE 6-8-98	© CODAN PTY. LTD, A.C.N. 007 590 605, 1998 TITLE DESK CONSOLE	
	MATERIAL CHKD RM APPD NJA	C G 1-4-99 8-7-99	DRAWING/DOC.NO A3 04-03110
FINISH	TOLERANCES UNLESS OTHERWISE STATED 2 PLACES DEC. ± 1 PLACE DEC. ± ANGULAR ±		ISS 4

1 2 3 4 5 6 7 8 9 10 11 12

DO NOT SCALE

A
B
C
D
E
F
G
H

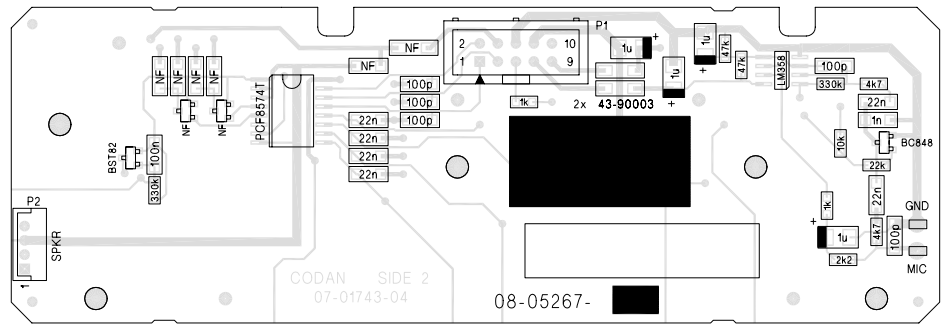

SIDE 2 - COMPONENT VALUES

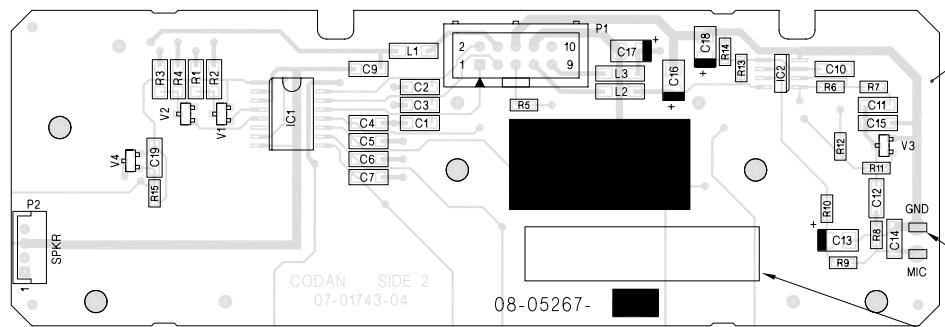

SIDE 2 - COMPONENT REFERENCES

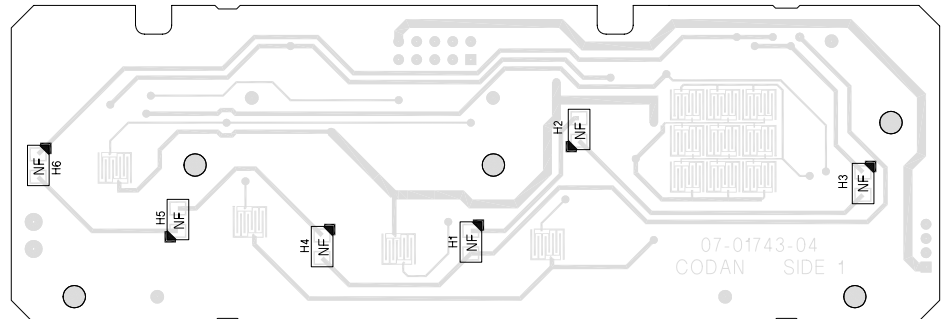

SIDE 1 - COMPONENT REFERENCES & VALUES

NOTE - HAND SOLDER OR MASK SIDE 1 AS NECESSARY TO PREVENT FLOW OF SOLDER ON TO GOLD PLATED PCB AREA.

H1 - H6 ARE NOT FITTED.

PCB : 07-01743-04
ASSY: 08-05267-001

FILE No.
08\05267_3.DWG

ISSUE B:
PCB WAS ISS -01
C9,H6,L1,R1,R4,V1 & V2
WERE FITTED.
P1 CHANGED & MOVED.
PRE-AMP CIRCUIT
MOVED.
C/R 26074

ISSUE C
V4, C19 & R15 ADDED.
PCB WAS 07-01743-02
C/R 26184
SSJ 13-7-99

ISSUE 1
NOTE ADDED TO SIDE 1 VIEW
C/R 26513
27-3-2000 SCS

ISSUE 2
R6 WAS 100K
C/R 27338
CAM 10-10-02

ISSUE 3
PCB WAS -03
C/R 28183
TMS 12-10-04

	SCALE 2:1		© CODAN PTY LTD, A.C.N. 007 590 605: 1998 TITLE DESK CONSOLE PCB ASSEMBLY	
	DRN	C G		DATE 2-11-98
	CHKD	RM		1-4-99
MATERIAL	APPD	SCS	27-3-00	
FINISH	TOLERANCES UNLESS OTHERWISE STATED			
	2 PLACES DEC. ±0.10			
	1 PLACE DEC. ±0.5			
0 PLACE DEC. ±1			DRAWING/DOC NO. 08-05267 ISS 3	
SHT. 1				
OF 1				

DIMENSIONS IN mm

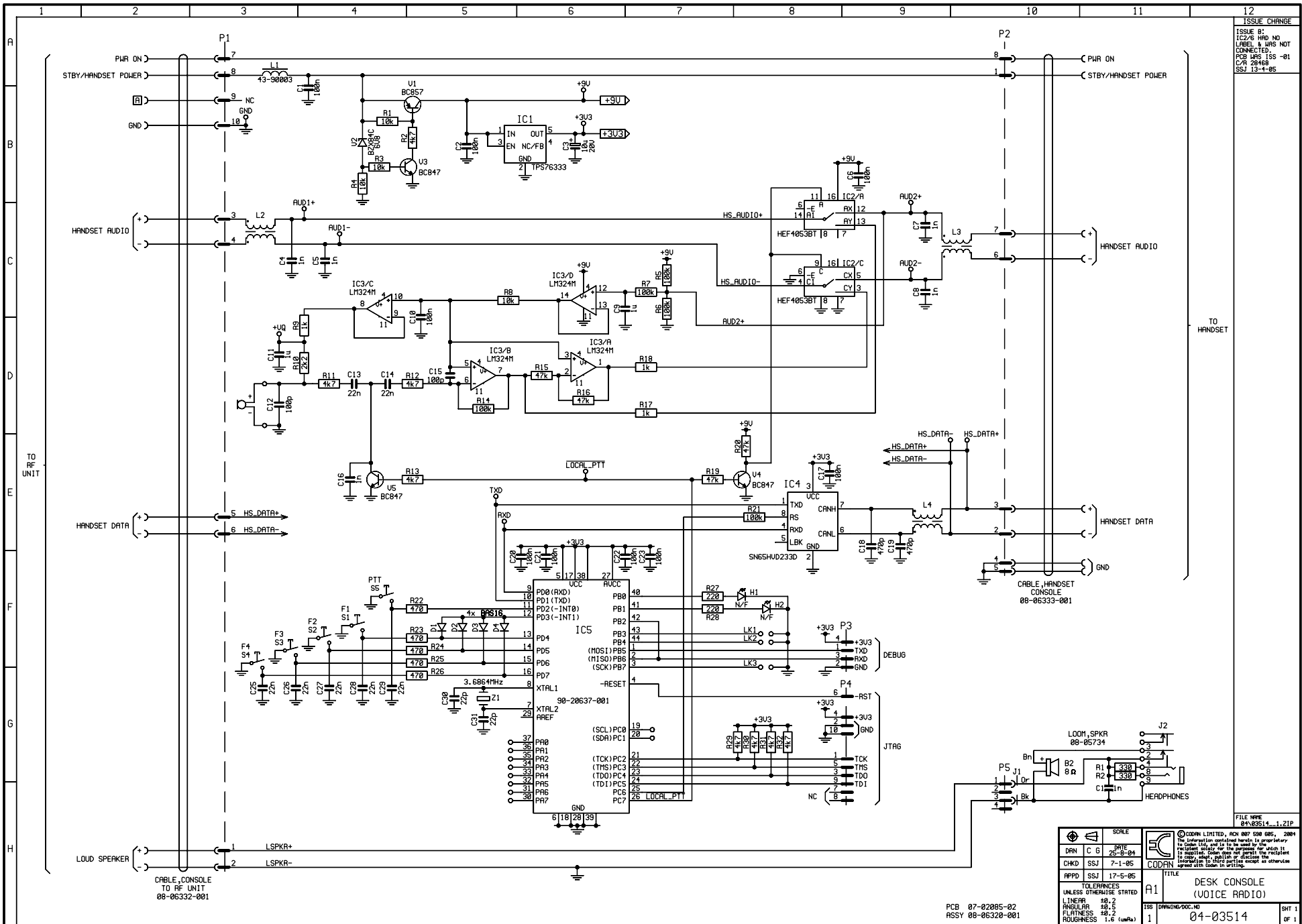

ISSUE CHANGE
 ISSUE BY:
 IC2/6 HARD NO
 LABEL 6 HAS NOT
 CONNECTED.
 PCB HAS ISS #01
 C/P 20460
 SSJ 13-1-85

FILE NAME
 0403514_1.21P

SCALE	CODAN LIMITED, PO BOX 598 085, 2004
DRAWN	The information contained herein is proprietary
DATE	to Codan Ltd and is to be used only for the
CHKD	purpose stated here. No part of this document
SSJ	is to be reproduced or transmitted in any form
APPD	or by any means, electronic, mechanical, or
SSJ	photocopying, recording, or by any information
17-5-05	storage system, without the prior written
TOLERANCES	agreement with Codan in writing.
UNLESS OTHERWISE STATED	
L INFER	±0.2
ANGULAR	±0.5
FLATNESS	±0.2
ROUGHNESS	1.6 (µmRa)
TITLE	DESK CONSOLE (VOICE RADIO)
ISS	0403514
DRAWING/DOC. NO	
1	

PCB 07-02095-02
 ASSY 08-06320-001

SHT 1
 OF 1

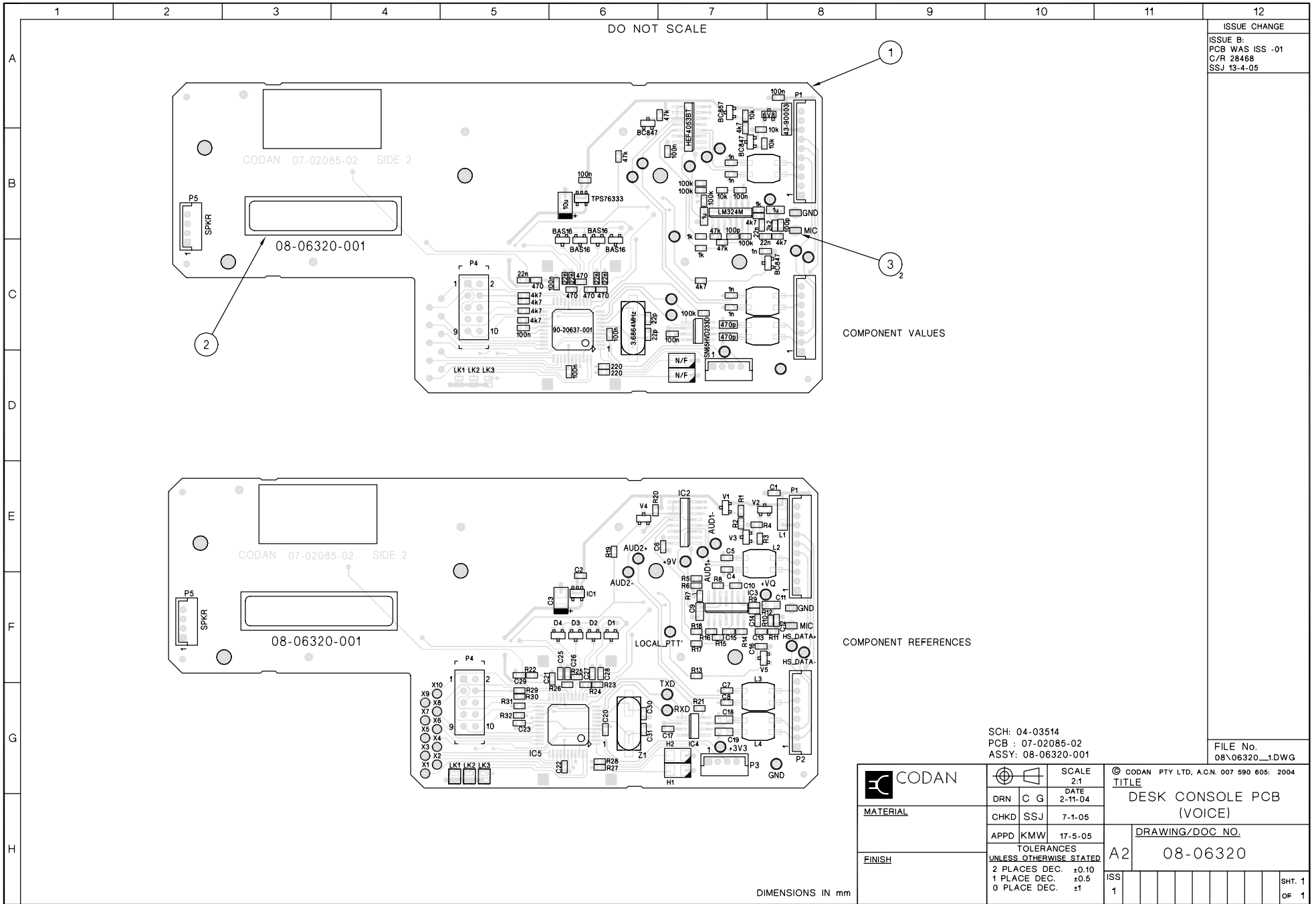

ISSUE CHANGE
 ISSUE B:
 PCB WAS ISS -01
 C/R 28468
 SSJ 13-4-05

COMPONENT VALUES

COMPONENT REFERENCES

SCH: 04-03514
 PCB : 07-02085-02
 ASSY: 08-06320-001

FILE No.
 08\06320_1.DWG

	SCALE 2:1		© CODAN PTY LTD, A.C.N. 007 590 605: 2004 TITLE DESK CONSOLE PCB (VOICE)	
	DRN	C G	DATE	2-11-04
MATERIAL	CHKD	SSJ	7-1-05	DRAWING/DOC NO. 08-06320
FINISH	APPD	KMW	17-5-05	
	TOLERANCES UNLESS OTHERWISE STATED			A2 2 PLACES DEC. ±0.10 1 PLACE DEC. ±0.5 0 PLACE DEC. ±1
DIMENSIONS IN mm			ISS 1	

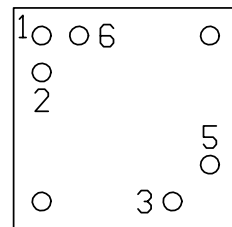
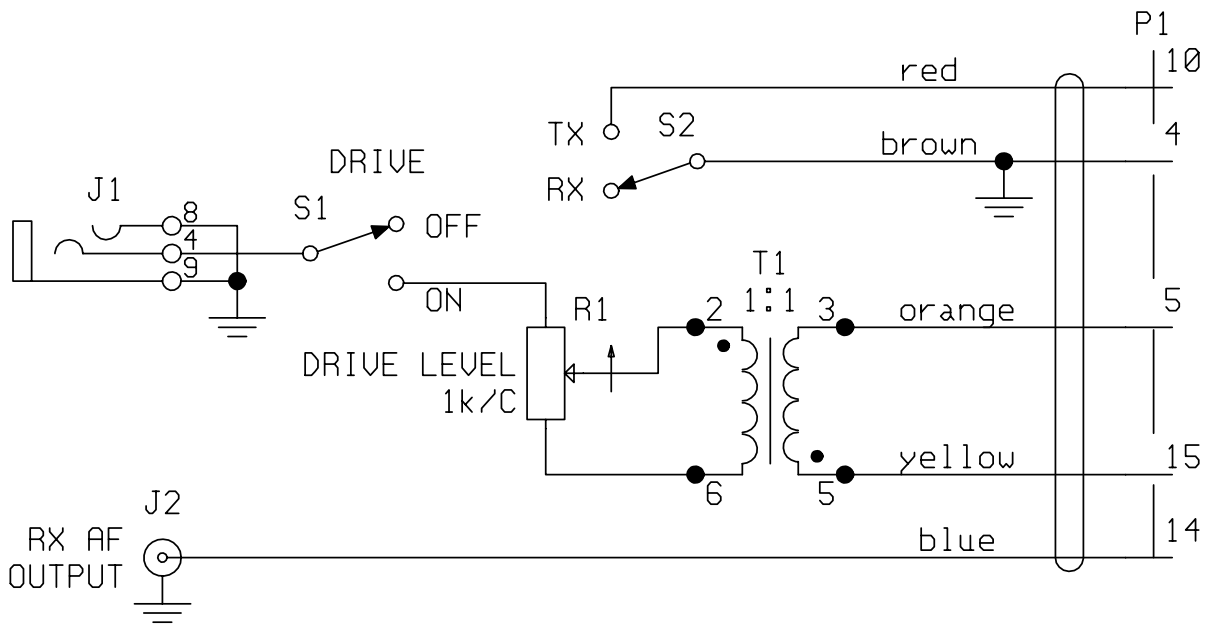



TOP VIEW

T1
44-30821

DISC FILE
04\03272_2

ISSUE 2:
T1 WAS 44-30714
TOP VIEW ADDED
C/R 27128
CAM 29-1-02

 CODAN	 		SCALE	© CODAN PTY. LTD, A.C.N. 007 590 605, 1999 TITLE				
	DRN	ILT	DATE 10-6-99	TRANSCEIVER TEST UNIT				
MATERIAL	CHKD	NJA	8-7-99					
	APPD	NJA	8-7-99	DRAWING/DOC.NO				
FINISH	TOLERANCES UNLESS OTHERWISE STATED			A4				
	2 PLACES DEC. ± 1 PLACE DEC. ± ANGULAR ±			04-03272				
ISS		1 2						SHT 1 OF 1

Numerics

3-way connector
pinouts 218

A

adjusting the power amplifier 239
ALC bridge 241
amplifier bias 239
amplifier output power 240
bar graph meter 240
input attenuator 242
power supply frequency 241
power supply operating area 242
adjustments 235
ALC adaptor
3-way connector 218
ALC/PTT Switch PCB
transmit path 228
ATU connector
pinouts 212, 215

B

brief description 219

C

Combiner 2-way (500 W) PCB
transmit path 228
Combiner 4-way (1 kW) PCB
transmit path 228
connectors
ALC adaptor
3-way 218
HPAC
ATU 215
Power Amp 216
TCVR 217
power amplifier
ATU 212
DC supply 214
IEC mains (10 A) 214
IEC mains (15 A) 214
TCVR 213

Control PCB
transmit path 229

D

DC supply connector
pinouts 214
drawings 247

E

external high-power amplifier
adjusting 243
external high-power systems 231

F

fault finding 235
power amplifier 237
Filter PCB
transmit path 229

G

general information 236

H

High-power ALC Adaptor PCB
transmit path 233
High-power PA & Antenna Control PCB
transmit path 232
high-power systems
3061/3062 227
external 231
HPAC
ATU connector 215
Power Amp connector 216
TCVR connector 217

I

IEC mains (10 A) connector
pinouts 214
IEC mains (15 A) connector
pinouts 214
indicators
internal faults 238

L

LED indicators
NGT with power amplifier 226

O

output transistors
replacing 239
overview 207, 208

P

- parts lists 245
- pin connections 211
 - ALC adaptor
 - 3-way connector 218
 - HPAC
 - ATU connector 215
 - Power Amp connector 216
 - TCVR connector 217
- power amplifier
 - ATU connector 212
 - DC supply connector 214
 - IEC mains (10 A) connector 214
 - IEC mains (15 A) connector 214
 - TCVR connector 213
- Power Amp connector
 - pinouts 216
- power amplifier
 - adjusting 239
 - ALC bridge 241
 - amplifier bias 239
 - amplifier output power 240
 - bar graph meter 240
 - input attenuator 242
 - power supply frequency 241
 - power supply operating area 242
- connectors
 - ATU 212
 - DC supply 214
 - IEC mains (10 A) 214
 - IEC mains (15 A) 214
 - TCVR 213
- fault finding 237
- Power Amplifier PCB
 - transmit path 228
- Power Supply PCB
 - transmit path 230

S

- size
 - power amplifier 210
 - power supply 210
- specifications 207, 209
- Splitter 2-way (500 W) PCB
 - transmit path 228
- Splitter 4-way (1 kW) PCB
 - transmit path 228
- supply voltages
 - 3061/3062 227
 - HPAC/ALC Adaptor 231

T

- TCVR connector
 - pinouts 213, 217
- technical description 225
 - 3061/3062 228
 - HPAC/ALC Adaptor 232
- transmit path
 - ALC/PTT Switch PCB 228
 - Combiner 2-way (500 W) PCB 228
 - Combiner 4-way (1 kW) PCB 228
 - Control PCB 229
 - Filter PCB 229
 - High-power ALC Adaptor PCB 233
 - High-power PA & Antenna Control PCB 232
 - Power Amplifier PCB 228
 - Power Supply PCB 230
 - Splitter 2-way (500 W) PCB 228
 - Splitter 4-way (1 kW) PCB 228

V

- vendor HPAs 231

W

- weight
 - power amplifier 210
 - power supply 210

High power—Overview and specifications

This section contains the following topics:

[Overview \(208\)](#)

[Specifications \(209\)](#)

[Pin connections \(211\)](#)

Overview

There are two solutions offered by Codan for power amplifiers used with NGT transceiver systems and an antenna. These provide additional RF output power for a fixed station. These solutions are:

- the Codan 500 W Power Amplifier 3061 and 1 kW Power Amplifier 3062 systems, and
- the Datron TW500 and TW1000 power amplifiers, which require Codan’s High-power PA and Antenna Controller (HPAC) module and ALC adaptor module to interface with the vendor equipment

The basic layouts of these systems are indicated below.

These amplifier systems can be enabled or disabled via the NGT handset.

Figure 1: Basic layout of a 3061/3062 high-power system

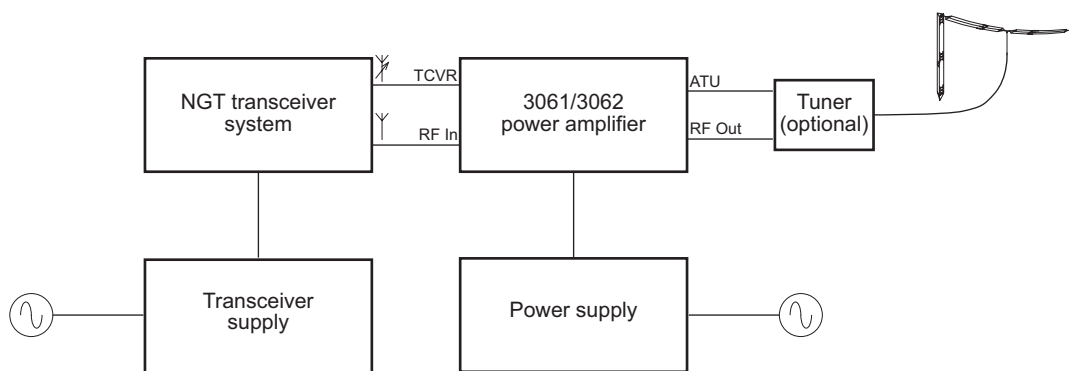
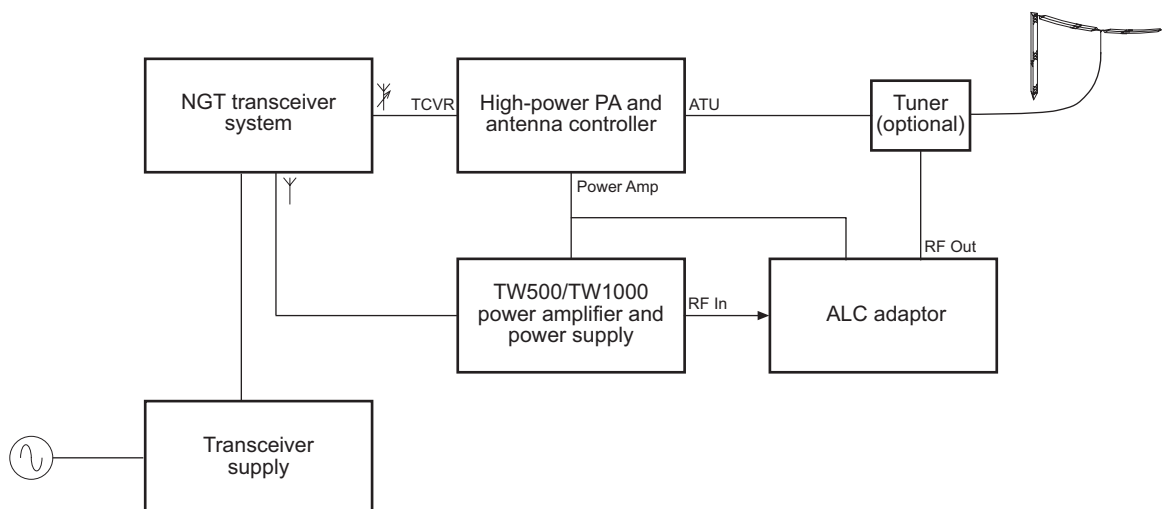

Figure 2: Basic layout of an HPAC module and an ALC adaptor module with vendor equipment



Specifications

The figures listed for specifications will normally be exceeded by production equipment. Where relevant, typical values are given in brackets []. All measurements are made with a modified NGT source (with Option F) and 50 Ω load unless otherwise specified.

NOTE These specifications indicate differences beyond the regular transmitter specifications for the NGT. For the standard transmitter specifications of the NGT see [page 39, Transmitter specifications](#).

Power amplifier specifications (3061/3062)

Table 1: Power amplifier specifications (3061/3062)

Item	Specification
Power output	3061: 500 W PEP \pm 1.0 dB, 300 W average 3062: 1 kW PEP \pm 1.0 dB, 600 W average CW or single tone: approximately 60% of PEP with average PEP control (average control disabled on handset PTT)
Duty cycle	100%: normal speech over full temperature range, -10 to 60°C (14 to 140°F) 100%: all modes up to a maximum ambient temperature of 45°C (113°F)
Supply	100–240 V AC \pm 10%, 50/60 Hz single phase 3061: 800 VA (two-tone), 900 VA maximum 3062: 1.6 kVA (two-tone), 1.8 kVA maximum
Protection	Safe under all load conditions Latching bypass under load in excess of 3:1 VSWR Latching bypass with heatsink temperature $> 70^{\circ}\text{C}$ (158°F) Latching bypass with internal fault conditions Fans operate at 45°C (113°F) (low speed) and 55°C (131°F) (high speed)
Spurious and harmonic emissions	Better than 60 [65] dB below PEP
Intermodulation (two-tone test)	26 [27] dB below each tone, 32 [33] dB below PEP
ALC	A 10 dB increase in signal input above compression threshold produces < 0.5 dB increase in power output Maximum ALC range > 30 dB ALC attack time approximately 2 ms

Table 1: Power amplifier specifications (3061/3062) (cont.)

Item	Specification		
Size	Amplifier:	483 mm W × 410 mm D × 222 mm H (19 in W × 16.1 in D × 8.7 in H)	
	Power supply:	483 mm W × 410 mm D × 222 mm H (19 in W × 16.1 in D × 8.7 in H)	
Weight	3061:	Amplifier:	15.4 kg (34.0 lb)
		Power supply:	6.7 kg (14.8 lb)
	3062:	Amplifier:	23.6 kg (52.0 lb)
		Power supply:	10.0 kg (22.0 lb)

Power amplifier specifications (TW500/TW1000)

Refer to the Datron handbook provided with the equipment.

Pin connections

Power amplifier (3061/3062)

Figure 3: Typical rear panel of a power amplifier

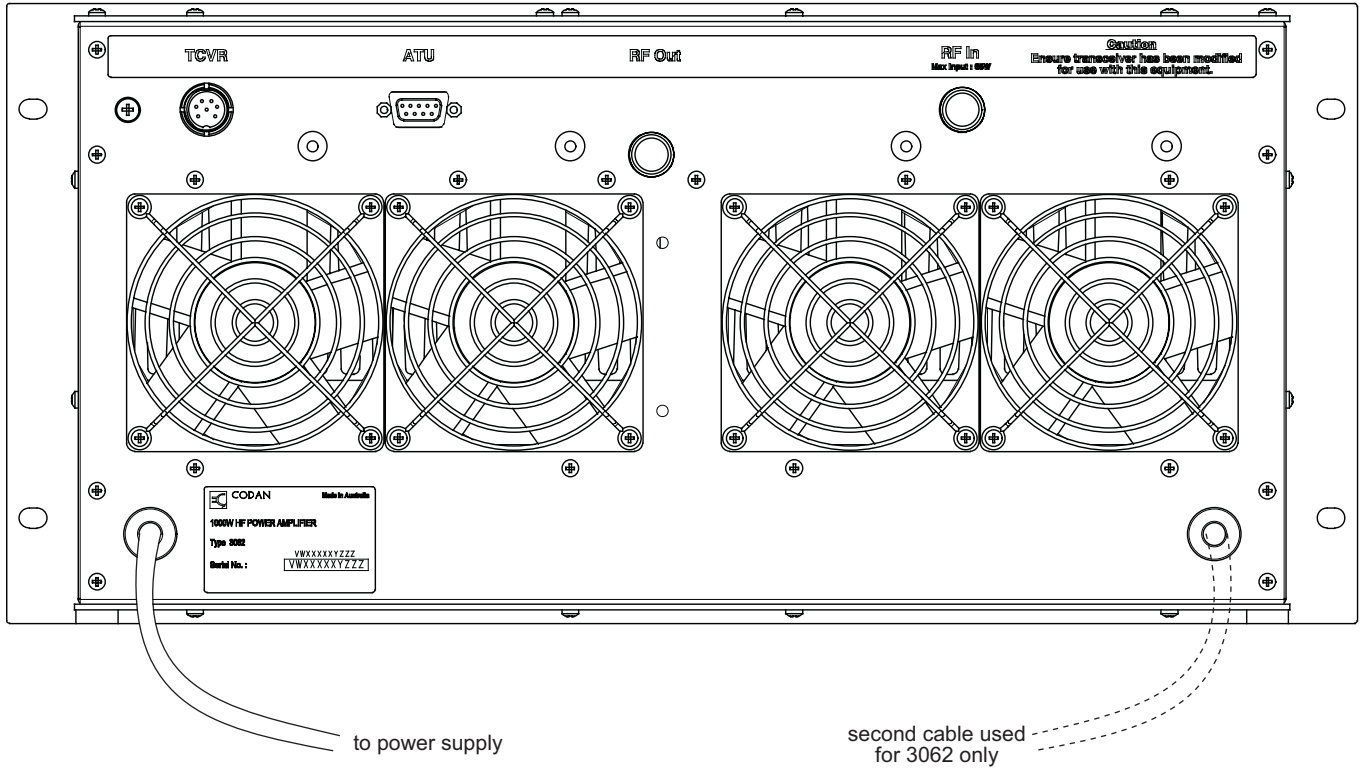

Pinouts of the ATU connector on the power amplifier

Figure 4: Front view of the ATU connector on the power amplifier

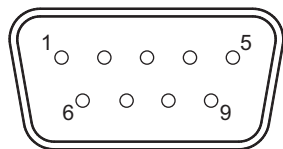

Table 2: Pinouts of the ATU connector on the power amplifier

Pin no.	Function	Input/output	Signal level
1	A rail	Output	13.6 V nominal
2			
3	Spare	Input/output	Logic level I/O
4	Tuner reset (scan)	Output	0 V = reset
5	Spare	Output	Active low
6	N/C		
7	N/C		
8	Ground		0 V
9			

Pinouts of the TCVR connector on the power amplifier

Figure 5: Front view of the TCVR connector on the power amplifier

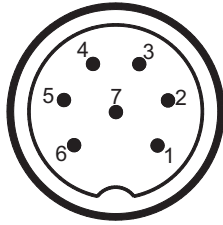

Table 3: Pinouts of the TCVR connector on the power amplifier

Pin no.	Function	Input/output	Signal level
1	N/C		
2	Ground		0 V
3	Data	Input/output	5 V TTL logic
4	Clock	Input	5 V TTL logic
5	PTT	Input	5 V TTL logic active low
6	ALC	Output	3.6 V when transmitting, nominally
7	A rail	Input	13.6 V nominal

Pinouts of the DC supply connector on the power amplifier

The DC supply connector is on a flying lead from the rear of the power amplifier. There are two DC supply connectors for the 1 kW power amplifier.

Figure 6: Front view of the DC supply connector on the power amplifier

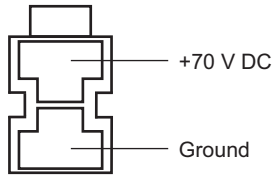

Pinouts of the IEC mains connector (10 A) on the power supply

The IEC mains connector (10 A) is used in the power supply for the 500 W power amplifier.

Figure 7: Front view of the IEC mains connector (10 A) on the power supply



Pinouts of the IEC mains connector (15 A) on the power supply

The IEC mains connector (15 A) is used in the power supply for the 1 kW power amplifier.

Figure 8: Front view of the IEC mains connector (15 A) on the power supply

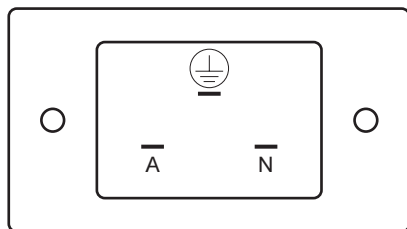

HPAC module (used with vendor equipment only)

Figure 9: Rear panel of the HPAC

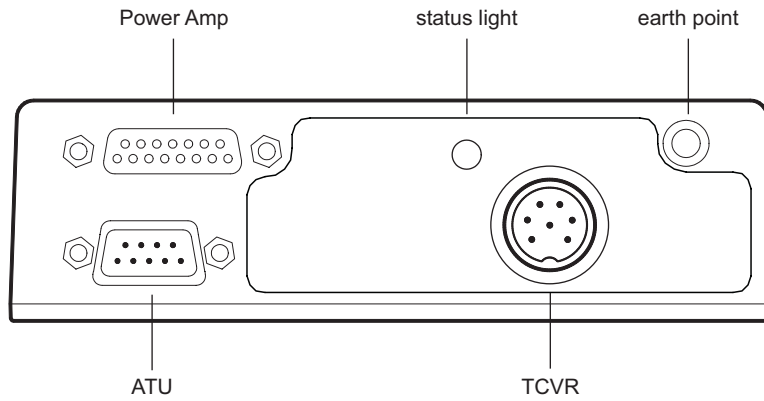

Pinouts of the ATU connector on the HPAC

Figure 10: Front view of the ATU connector on the HPAC

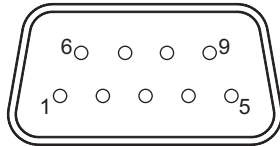

Table 4: Pinouts of the ATU connector on the HPAC

Pin no.	Function	Input/output	Signal level
1	A rail	Output	13.6 V nominal
2			
3	Spare I/O	Input/output	Logic level
4	Tuner reset (scan)	Output	0 V = reset
5	Spare	Output	Active low
6	N/C		
7	N/C		
8	Ground		0 V
9			

Pinouts of the Power Amp connector on the HPAC

Figure 11: Front view of the Power Amp connector on the HPAC

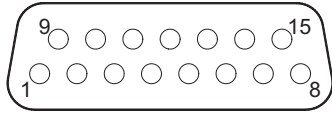

Table 5: Pinouts of the Power Amp connector on the HPAC

Pin no.	Function	Input/output	Signal level
1	A rail	Output	13.6 V nominal
2	Band 1	Input	0 V on selected band
3	Band 2	Input	
4	Band 3	Input	
5	Band 4	Input	
6	Band 5	Input	
7	Band 6	Input	
8	Band 7	Input	
9	N/C		
10	N/C		
11	ALC control	Output	3.6 V when transmitting
12	Ground		0 V
13	PTT	Input	0 V when transmitting
14	Fault detect TW500A	Input	12 V = OK
15	Fault detect TW500D	Input	0 V = OK

Pinouts of the TCVR connector on the HPAC

Figure 12: Front view of the TCVR connector on the HPAC

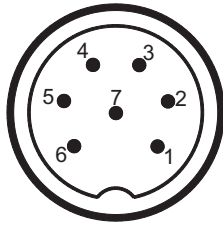
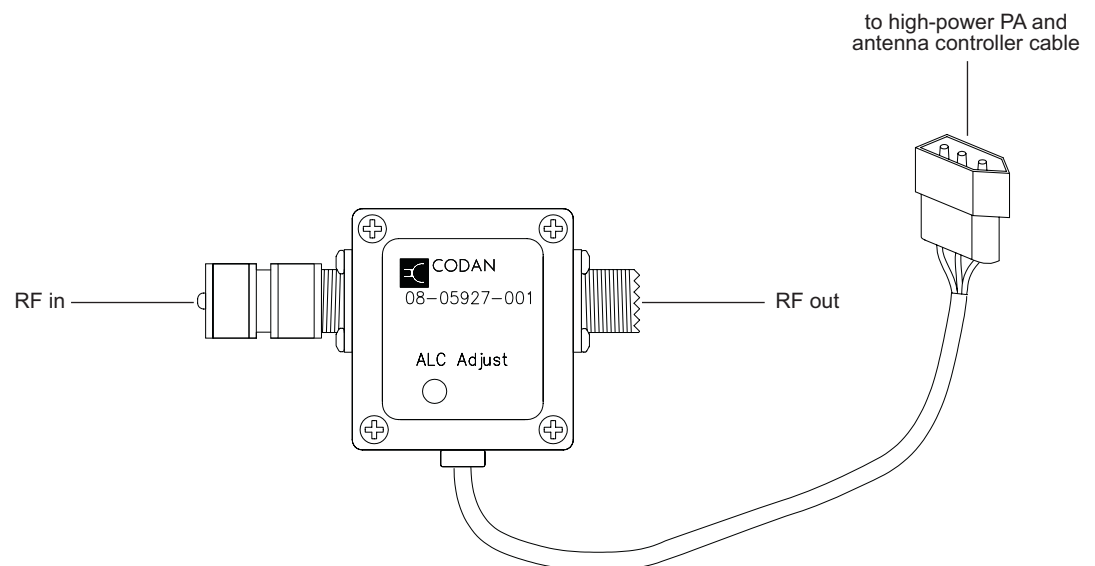

Table 6: Pinouts of the TCVR connector on the HPAC

Pin no.	Function	Input/output	Signal level
1	N/C		
2	Ground		0 V
3	Data	Input/output	5 V TTL logic
4	Clock	Input	5 V TTL logic
5	PTT	Input	5 V TTL logic active low
6	ALC	Output	3.6 V when transmitting
7	A rail	Input	13.6 V nominal

ALC adaptor module (used with vendor equipment only)

Figure 13: ALC adaptor



Pinouts of the 3-way connector on the ALC adaptor

Figure 14: Front view of the 3-way connector on the ALC adaptor



Table 7: Pinouts of the 3-way connector on the ALC adaptor

Pin no.	Function	Input/output	Signal level
1	A rail	Input	13.6 V nominal
2	ALC	Output	3.6 V when transmitting
3	Ground		0 V

High power—Brief description

This section contains the following topics:

[General information \(221\)](#)

[Power amplifier \(3061/3062\) \(222\)](#)

[HPAC and ALC adaptor modules with vendor equipment \(223\)](#)

For a detailed description of these functions see [page 225, *High power—Technical description*](#).

This page has been left blank intentionally.

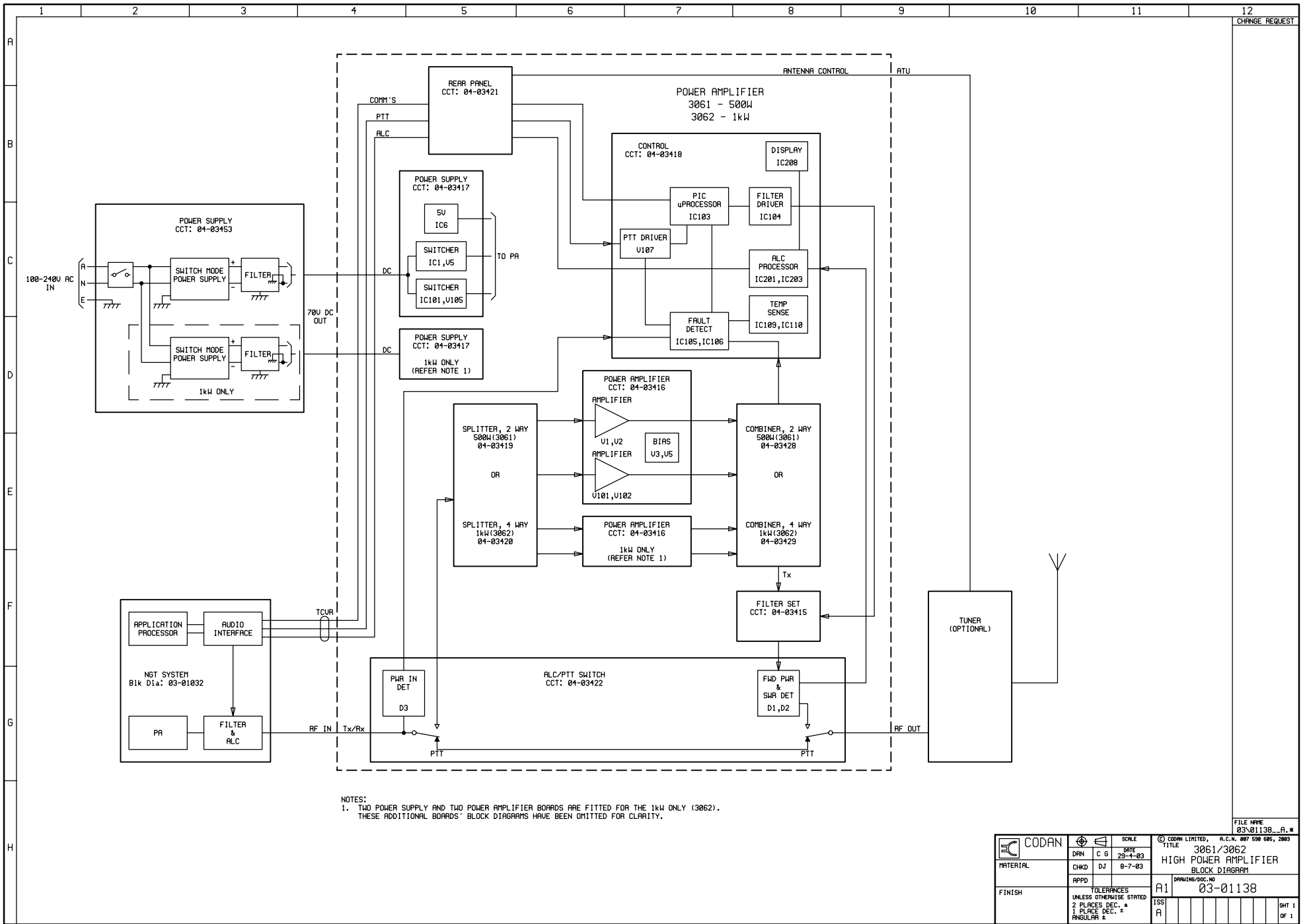

		SCALE DRN C G DATE 29-4-03 CHKD DJ 8-7-03 APPD	© CODAN LIMITED, A.C.N. 007 530 685, 2003 TITLE 3061/3062 HIGH POWER AMPLIFIER BLOCK DIAGRAM	FILE NAME 03-01138_A_M
FINISH UNLESS OTHERWISE STATED 2 PLACES DEC. ± 1 PLACE DEC. ± ANGULAR ±	TOLERANCES UNLESS OTHERWISE STATED 2 PLACES DEC. ± 1 PLACE DEC. ± ANGULAR ±	DRAWING/DOC. NO 03-01138	ISS A	SHEET 1 OF 1

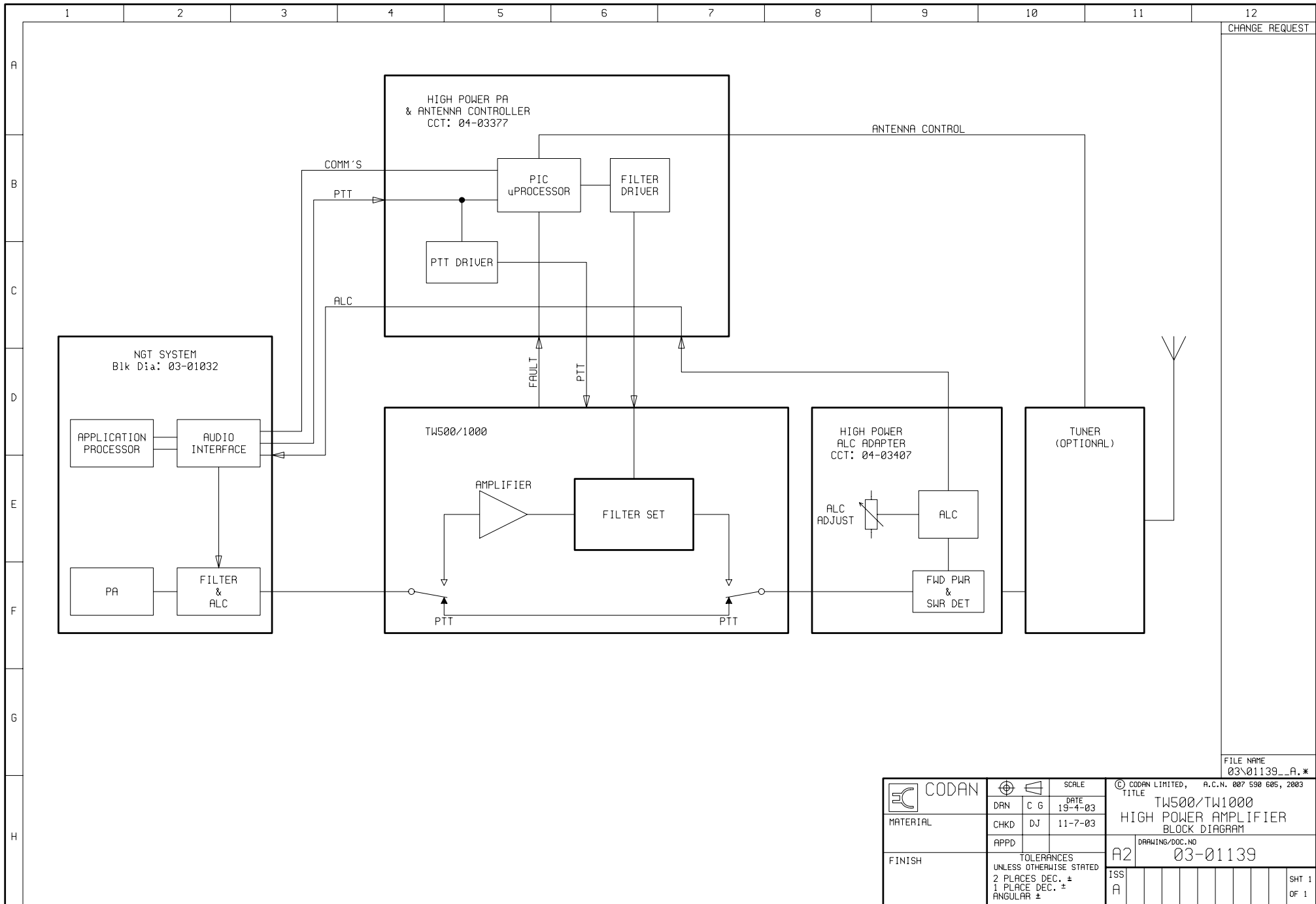

CHANGE REQUEST

FILE NAME
03\01139_A.*

	SCALE		© CODAN LIMITED, A.C.N. 007 590 605, 2003 TITLE TW500/TW1000 HIGH POWER AMPLIFIER BLOCK DIAGRAM	
	DRN	C G		DATE 19-4-03
	CHKD	DJ		11-7-03
MATERIAL	APPD		DRAWING/DOC. NO A2 03-01139	
FINISH	TOLERANCES UNLESS OTHERWISE STATED 2 PLACES DEC. ± 1 PLACE DEC. ± ANGULAR ±		ISS A	
			SHT 1 OF 1	

General information

NOTE The information in this section should be read in conjunction with the appropriate block diagram. See below to determine which block diagram you should be viewing.

For HPA system using...	See...
3061/3062 power amplifiers	03-01138
HPAC and ALC Adaptor modules with external vendor equipment	03-01139

Power amplifier (3061/3062)

The transmitter output from the NGT is connected to the input of the high-power amplifier. The amplifier is internally bypassed in receive, and when the amplifier is disabled. Normal NGT operation occurs in these instances. When the amplifier is enabled and PTT is active, the output transmitted by the NGT is split and delivered to the Power Amplifier PCB(s) (one PCB in 3061, two PCBs in 3062), then recombined and filtered before being delivered to the amplifier output.

Monitoring and control of amplifier operation is performed on the Control PCB. This PCB also provides the front panel indicators.

The raw power supply for the amplifier is provided by a switched mode supply in a separate unit. This is converted to the minimum possible supply voltage for correct operation in the amplifier's switched mode active supply (one supply in 3061, two supplies in 3062) on the Power Supply PCB. This ensures the best possible amplifier efficiency under all load conditions.

The amplifier power monitoring is provided by a forward and reflected power sensor, which supplies rectified forward and reflected power envelopes to the Control PCB.

Power Amplifier PCB

Each Power Amplifier PCB contains a single bias supply and two separate amplifiers. Each amplifier has feedback and impedance correction networks to ensure stable and consistent gain between amplifiers.

Control PCB

The Control PCB has a number of functions including:

- switching the band filters
- monitoring and latching faults
- controlling the cooling fans
- generating and conditioning the ALC voltage
- controlling the front panel indicators

If a fault is detected and latched, the Control PCB disables the PTT function of the amplifier, bypassing the amplifier.

Power Supply PCB

The Power Supply PCB is a switchmode DC–DC converter, which takes the raw 70 V DC supply from the power supply unit and efficiently converts it to between 33 and 50 V DC before delivering it to the amplifiers. The power supply is also current and power limited.

The output voltage is optimised to give the best amplifier efficiency, minimising power supply requirements.

HPAC and ALC adaptor modules with vendor equipment

The TW500 and TW1000 amplifiers are fixed-gain amplifiers with internal output filters controlled through an external control port. The control functions are provided by the HPAC module, and the power sensing required for ALC operation of the NGT is provided by the ALC adaptor module.

HPAC

The High-power PA & Antenna Control PCB has a microprocessor for filter band selection, and fault monitoring and reporting. It also includes an address switch to allow correct operation for the various versions of the TW series amplifiers.

ALC adaptor

The High-power ALC Adaptor PCB has a forward and reflected power sensor to generate ALC voltage to suit the NGT, based on forward peak and average powers, and reflected power.

This page has been left blank intentionally.

High power—Technical description

This section contains the following topics:

[LED indications on the NGT \(226\)](#)

[3061/3062 power amplifiers \(227\)](#)

[External high-power systems \(231\)](#)

This section should be read in conjunction with [page 247, *High power—Drawings*](#).

LED indications on the NGT

The ✓ LED on the front of the RF unit indicates the operating status of the NGT when it is connected to a high-power system.

Table 8: Status of ✓ LED and its meaning

LED status	Meaning
Steady green	Device is functioning correctly
Slow flashing green	Device is establishing communication with the NGT
Steady yellow	Device is being reset
Slow flashing red	Device has been requested to perform a command that is not available
Steady red	Device has a non-recoverable configuration error

3061/3062 power amplifiers

Supply voltages

The supply voltages for the power amplifiers are shown in [Table 9](#), [Table 10](#), and [Table 11](#).

Drawing [04-03418 \(sheet 1\)](#) and [04-03418 \(sheet 2\)](#)

Table 9: Supply voltages for the Control PCB in the power amplifier

Supply	Description	Source
+5 V	+5 V analog and digital supply	IC101
+13V6	13.6 V unregulated supply	from NGT RF unit

Drawing [04-03416](#)

Table 10: Supply voltages for the Power Amplifier PCB in the power amplifier

Supply	Description	Source
+5 V_BIAS	+5 V bias supply	from Power Supply PCB
PA+	Variable regulated supply	from Power Supply PCB

Drawing [04-03417](#)

Table 11: Supply voltages for the Power Supply PCB in the power amplifier

Supply	Description	Source
+5 VREF	+5 V reference supply	IC1
+13V6	13.6 V unregulated supply	via Control PCB
PWR_IN	+70 V regulated supply	from power supply unit

Transmit path

ALC/PTT Switch PCB

Drawing [04-03422](#)

The RF from the NGT is connected to the **RF In** connector. From here it is connected via the PTT relays to either the power amplifier path for high-power transmission, or to the output connector for receive or amplifier-disabled operation.

The path from the high-power transmitter filter to the PTT relay includes the forward/reflected power detector, comprising transformer T1 and diodes D1 and D2. This produces envelopes of forward and reflected power, which are used by the Control PCB for ALC control.

This assembly also detects a small amount of the input power for calculation of the amplifier gain, and as such, detects the low-gain fault state.

Splitter 2-way (500 W) PCB and Splitter 4-way (1 kW) PCB

Drawings [04-03419](#) and [04-03420](#)

The RF is presented to the splitter, which has an adjustable attenuator. This sets the overall amplifier gain and moves the input impedance closer to 50 Ω for the NGT. This attenuated signal is then split using standard hybrid splitter architecture.

Power Amplifier PCB

Drawing [04-03416](#)

The RF from the splitter is then fed to the amplifier sections, each of which is Class AB push-pull. These produce 250 W PEP from approximately 7 W PEP in. Gain stabilisation over the bandwidth is provided by feedback networks R7 and R10, and R8 and R9, and impedance correction networks across the amplifier inputs. V1 and V2 transistor collectors are coupled to the 50 Ω combiner input via a 1:2 transmission line transformer.

The power supply voltage is varied based on maintaining the VCE of the output transistors above a minimum saturation voltage. This minimum voltage is sensed by VCE_MIN detectors on the Power Amplifier PCB.

The common bias supply consists of a sense transistor V3 and a series pass transistor V5. This circuit produces a temperature-controlled bias voltage to set the crossover point of the Class AB output stage for minimum distortion.

Combiner 2-way (500 W) PCB and Combiner 4-way (1 kW) PCB

Drawings [04-03428](#) and [04-03429](#)

The amplifier outputs are fed to the combiner. Each combiner has standard hybrid combiner architecture, and includes detection windings that detect combiner imbalance, which may be caused by greatly differing amplifier outputs.

Filter PCB

Drawing [04-03415](#)

The filter assembly removes harmonics from the combined amplifier output. There are seven filter banks. Each filter bank has two relays switching the input and output of a 7-pole elliptic filter.

The output from the filter is fed to the amplifier output connector via the ALC/PTT Switch PCB.

Control PCB

Drawing [04-03418 \(sheet 1\)](#) and [04-03418 \(sheet 2\)](#)

The Control PCB has a number of functions:

- A microprocessor for filter band selection and fault monitoring and reporting.
- Fault detection and latching circuitry for amplifier protection. The faults that are monitored include:
 - power supply overvoltage (IC105/A)
 - power supply undervoltage (IC105/B)
 - loss of amplifier bias (IC106/B)
 - heatsink temperature over 70°C (158°F) (IC109/A)
 - load VSWR in excess of approximately 3:1 (IC202/A)
 - low gain of the amplifier (IC202/B)
 - excessive ALC voltage (IC205/A)
 - amplifier internal unbalance (IC207/A)

In the event of a fault, the fault state is latched, and the amplifier bypassed by disabling PTT.

- Temperature-based fan control. The fans operate at low speed when the heatsink temperature exceeds 45°C (113°F) and at high speed when the temperature exceeds 55°C (131°F).
- ALC control for connection back to the NGT. ALC voltage is generated based on peak output power, average output power, reflected output power and output transistor collector swing. There are LEDs on the Control PCB that indicate which of the ALC signals is controlling the output power level.
- Front panel indicator control. The front panel indicators show VSWR and overtemperature faults. A combination of all other monitored faults are indicated with the single **Fault** indicator. There is also a bar graph meter, which shows either amplifier PEP or current drain depending on the position of the meter switch.

Power Supply PCB

Drawing [04-03417](#)

The Power Supply PCB is a switchmode DC–DC converter with two separate channels, one for each amplifier stage. Each subconverter uses a LM3524 switchmode power controller part, one acting as the master controller (IC1), the other as the slave (IC101). The outputs from the master and slave are fed to the respective gates of the output drive FETs (V5 and V105) via a gate drive part (IC2 and IC102).

The output voltage is limited to a minimum voltage of approximately 33 V DC under no load, and can be increased to 50 V DC if required, depending on the minimum voltage swing of the amplifier output transistors. The output current is sensed by the output current mirror circuit (IC3 and IC103), which measures the current across a 5 m Ω resistor in the output path. A power limit is achieved by modifying the measured current with a sample of the output voltage, so the current limit becomes inversely proportional to the output voltage.

This process ensures the output voltage is the minimum voltage required by the amplifiers for the operating conditions, while still meeting specification and providing the best possible amplifier efficiency. This has the effect of minimising raw power supply requirements, and heating the amplifier.

External high-power systems

The external NGT high-power system comprises:

- an HPAC module
- an ALC adaptor module

These items are used to interface the NGT transceiver system with vendor high-power amplifiers.

Supply voltages

The supply voltages for the HPAC and the ALC adaptor modules are shown in [Table 12](#) and [Table 13](#).

Drawing [04-03377](#)

Table 12: Supply voltages for the High-power PA & Antenna Control PCB in the HPAC

Supply	Description	Source
+5 V	+5 V digital supply	IC1
+5 A	+5 V microprocessor supply	IC1
+12 V	+12 V unregulated supply	from NGT RF unit

Drawing [04-03407](#)

Table 13: Supply voltages for the High-power ALC Adaptor PCB in the ALC adaptor module

Supply	Description	Source
+12 V	+12 V unregulated supply	from NGT RF unit

Transmit path

High-power PA & Antenna Control PCB

Drawing [04-03377](#)

This unit provides the control interface between the NGT, the power amplifier and the SG235C antenna tuner. The NGT antenna control output is reconfigured to supply clock, data and PTT information to the antenna controller.

When the frequency band of the PA changes, the NGT sends data via the clock and data lines to the microprocessor IC3. IC3 decodes the data and drives IC4 to select one of the seven PA bands on J2. Switch S1 is read by IC3 and is used to set up the system for different external PA types.

Table 14: Position of digi switch S1

Digi switch position	Mode	Frequency range to band selection
0	Datron TW500A/TW1000A	Band1 Not used Band2 $0 \leq f < 3$ MHz Band3 $3 \leq f < 5$ MHz Band4 $5 \leq f < 8$ MHz Band5 $8 \leq f < 13$ MHz Band6 $13 \leq f < 20$ MHz Band7 $f \geq 20$ MHz
1	Datron TW500D/TW1000D	Band1 Not used Band2 $1.6 \leq f < 3$ MHz Band3 $3 \leq f < 5$ MHz Band4 $5 \leq f < 8$ MHz Band5 $8 \leq f < 13$ MHz Band6 $13 \leq f < 20$ MHz Band7 $f \geq 20$ MHz
2–15	Undefined	Future use

The PTT signal is connected to the PA via IC2/A/B V5 and V7. The microprocessor IC3 can disable the PTT by switching V6 on.

When the SG235C antenna tuner is connected to the system at J1, the tuner reset line is driven low when the NGT is scanning. IC3 also drives the ✓ LED (see [page 226](#), *LED indications on the NGT*).

High-power ALC Adaptor PCB

Drawing [04-03407](#)

This unit detects the output power from the external amplifier and the SWR of the antenna, then produces a control signal for the NGT. Under this control signal, the NGT varies the drive power to produce the appropriate output of 500 W or 1 kW PEP.

The output of the forward power detector D1 is applied to the base of V1. The output from the emitter of V1 is connected to the input of IC1 pin 3. The output of IC1 produces the ALC voltage to control the NGT. R15 (ALC ADJUST) varies the gain of IC1, which determines the nominal PEP output level of the amplifier when matched to a 50 Ω load.

The output of the forward detector D1 is also applied to V2 via an averaging circuit formed by R7, R9 and C10. When the average of the signal exceeds the peak detector circuit V1, V2 takes control and reduces the output power (this occurs on signal tones such as CW (Morse) and in some data transmissions).

The output of the reflected power detector D2 is applied to the base of V3. If the SWR is greater than 1.8:1, the output voltage of V3 will be greater than the signal on V1, so the power is reduced as the SWR increases.

This page has been left blank intentionally.

High power—Fault finding and adjustments

This section contains the following topics:

[General information \(236\)](#)

[Fault finding the power amplifiers \(3061/3062\) \(237\)](#)

[Adjusting the power amplifiers \(3061/3062\) \(239\)](#)

[Adjusting the external high-power amplifier \(243\)](#)

General information

There is no scheduled maintenance required for either the 3061/3062 power amplifiers, or the HPAC and ALC adaptor modules with the TW500/1000 amplifiers.

Fault finding the power amplifiers (3061/3062)

The power amplifiers have front panel LED indicators, which latch on in the event of a fault; this latch clears when the fault is resolved and the NGT is switched off then on again. The meanings of the LED indicators are provided in [Table 15](#).

Table 15: Meaning of LED indicators on the front panel of the power amplifier

Indicator	Latching	Likely cause	Action
Over Temp	No	Heatsink temperature over 70°C (158°F)	<p>Check that ambient room temperature is below 45°C (113°F)</p> <p>Check that airflow is unobstructed and that power amplifier fans are free to turn</p> <p>Fault will clear when amplifier returns to correct operating temperature</p>
High VSWR	Yes	Transmitter load VSWR exceeds approximately 3:1 on a particular frequency	<p>Check antenna VSWR at full power on the affected frequency</p> <p>If the high VSWR fault occurs on all frequencies, this indicates an internal fault in the power amplifier</p>
No power bar graph	No	Power amplifier disabled	Check that power amplifier is enabled at handset
		Power amplifier fault detected	Check that other amplifier fault indicators are not lit
Fault	Yes	Power supply fault	<p>Check that power supply unit switch is illuminated</p> <p>The fault may also be due to:</p> <ul style="list-style-type: none"> • low gain of the amplifier • ALC overvoltage • combiner unbalance

NOTE The type of fault indicated by the **Fault** LED can be individually identified on separate LEDs on the Control PCB, which is located beneath the top cover of the amplifier.

The power supply fault state may be due to external causes.

Internal fault indicators

Internal faults of the power amplifier can be further diagnosed using the LED indicators on the Control PCB inside the power amplifier. The meanings of the LED indicators are provided in [Table 16](#).

Table 16: Meaning of internal LED indicators on the Control PCB

Indicator	Cause	Action
LO GAIN	Overall amplifier gain too low	Check that the splitter and combiner are working correctly
PSU FAULT	Insufficient voltage at the Power Amplifier PCBs	Check that there is 70 V DC at DC input to Power Supply PCB Check that there is at least 33 V DC at DC input to the Power Amplifier PCBs
	Low bias supply	Check that there is 5 V at 5V_BIAS pin of the Power Amplifier PCBs
ALC OVERVOLTAGE	Amplifier ALC output not under control of the NGT	Check the continuity of the ALC control line between the amplifier and the NGT
COMBINER UNBAL	2- or 4-way Combiner PCBs giving unequal power	Check the amplifier power supplies and connections
		Check each amplifier output individually

Adjusting the power amplifiers (3061/3062)

Replacing output transistors

Drawing [08-05977 \(sheet 1\)](#) and drawings [08-05978 \(sheet 1\)](#), [08-05978 \(sheet 2\)](#) and [08-05978 \(sheet 3\)](#)

CAUTION If *any* of the output transistors on the Power Amplifier PCBs need to be replaced, *all* of the transistors must be replaced with a set of transistors of the *same gain*. The gain is indicated by a letter or colour marking on the device body.

Adjusting the amplifier bias

Drawing [08-05977 \(sheet 1\)](#)

NOTE The transceiver does not have to be in Service mode to perform this adjustment.

To adjust the amplifier bias:

- Ensure there is no audio drive to the NGT and disconnect the RF drive between the NGT and the amplifier.
- Connect a DC millivoltmeter across one of the 2-pin headers associated with the current sense resistors on the Power Supply PCB.
- Adjust the bias preset potentiometer on each Power Amplifier PCB fully counterclockwise.
- Switch on the NGT, *hold down* PTT, then adjust the relevant amplifier's bias preset potentiometer until the meter reads 2 mV (representing a bias current of 400 mA).
- Check that the voltage across the other 2-pin header of the same Power Supply PCB is 2 mV.
- Release PTT.
- Check the other Power Supply PCB/Power Amplifier PCB pair (3062 only).
- Switch off the NGT.
- Reconnect the RF drive.

Adjusting the bar graph meter

Drawing [08-05979 \(sheet 1\)](#) and [08-05979 \(sheet 2\)](#)

NOTE The transceiver does not have to be in Service mode to perform this adjustment.

To adjust the bar graph meter:

- Ensure the NGT is connected to the power amplifier and switched on.
- Adjust preset potentiometer R257 to give a voltage of 1.40 V DC at TP214.

Adjusting the amplifier output power

Drawing [08-05979 \(sheet 1\)](#) and [08-05979 \(sheet 2\)](#)

NOTE The transceiver does not have to be in Service mode to perform this adjustment.

To adjust the amplifier output power:

- Connect setup as per [page 180, Adjusting high output power](#).
- Select any channel below 10 MHz.
- Set the output power preset potentiometer R218 on the Control PCB fully counterclockwise.
- Hold down* PTT, then turn the output power preset potentiometer until the required output power is reached (see [Table 17](#)).

Table 17: Power output PEP vs measuring instrument (500 W/1 kW)

Power Output PEP	500 W	1 kW
Peak reading meter	500 W	1 kW
RMS reading meter	250 W	500 W
Average reading meter (e.g. Bird Model 43)	202.5 W	405 W
Oscilloscope	447 V p-p	632 V p-p

- Release PTT.

Adjusting the ALC bridge

Drawing [08-05985](#)

NOTE The transceiver does not have to be in Service mode to perform this adjustment.

To adjust the ALC bridge:

- Connect setup as per [page 180, *Adjusting high output power*](#).
- Select any channel near 15 MHz.
- Attach a load-matching transformer between the load and the amplifier output, so that the amplifier is presented with a 16.7 Ω load.
- Hold down* PTT.
- Adjust the capacitor C5 to give 150 W (3061) or 300 W (3062) PEP into the load.
- Release PTT.
- Reverse the load-matching transformer to present a 150 Ω load.
- Hold down* PTT, then check that the output power into the load is the same.
- Release PTT.
- If necessary, re-adjust the capacitor to give the same power for both load cases.

NOTE The **High VSWR** LED may illuminate while this adjustment is made. Switch the transceiver off then on again to reset this LED.

Adjusting the power supply frequency

Drawing [08-05978 \(sheet 1\)](#), [08-05978 \(sheet 2\)](#) and [08-05978 \(sheet 3\)](#)

NOTE The transceiver does not have to be in Service mode to perform this adjustment.

To adjust the power supply frequency:

- Switch off the NGT and remove solder link X1 from the Power Supply PCB in the power amplifier.
- Ensure there is no audio drive to the NGT.
- Hold down* PTT.
- Using a frequency counter on TP1, adjust R17 to give a frequency of 70 kHz \pm 100 Hz.
- Using a frequency counter on TP101, adjust R117 to give a frequency of 63 kHz \pm 100 Hz.
- Release PTT.
- Switch off the NGT and resolder link X1.

Adjusting the power supply operating area

Drawing [08-05978 \(sheet 1\)](#), [08-05978 \(sheet 2\)](#) and [08-05978 \(sheet 3\)](#)

NOTE The transceiver does not have to be in Service mode to perform this adjustment.

To adjust the power supply operating area:

- Ensure there is no audio drive to the NGT.
- Use a cliplead to connect +5 V (X4) to the 10-pin header pin 4 (P1/4).

NOTE The header can be removed for this adjustment.

- Hold down* PTT.
- Set the Voltage Adjust preset potentiometer R7 to give 50.0 V DC at X2.
- Remove the cliplead, and check that the voltage at X2 drops to approximately 33 V DC.
- Using an active load connected from X2 to ground, set the load current drain to 9.5 A.
- Adjust the Current Limit preset potentiometer R12 to give 43.6 V DC at X2.
- Move the active load to output terminal X3, and set the Current Limit preset potentiometer R112 to give 43.6 V DC at X3.
- Release PTT.
- Repeat the above tests for the other Power Supply PCB (3062 only).

Adjusting the input attenuator

Drawing [08-05997](#) or [08-05999](#)

If it is found during testing that the amplifier output is controlled by the NGT rather than the power amplifier, this indicates that the gain of the power amplifier is low. This can be increased by removing the link X1 from the Splitter 2-way (500 W) PCB or Splitter 4-way (1 kW) PCB.

Adjusting the external high-power amplifier

- NOTE Ensure the dummy load and power meter are rated to 1 kW PEP (500 W CW).
- NOTE The transceiver must be in Service mode to perform this adjustment (see [page 154, Accessing Service mode](#)).
- NOTE The output power is factory-set, so it is not likely to be outside the specified limits. Check that there are no faults with the transmitter circuits before attempting to adjust the power output.

To adjust the external high-power amplifier:

- Connect setup as per [page 180, Adjusting high output power](#), ensuring the NGT is set to 100 W output (Links X2 and X3 open on drawing [08-05416](#) or, if the power output is greater than 100 W PEP on a frequency below 10 MHz, solder Link X2 as per drawing [08-05910 \(sheet 1\)](#)).
- Select test channel 25.
- Set the ALC ADJUST control on the High-power ALC Adaptor PCB fully counterclockwise (minimum power).
- Hold down* PTT and note the output power.
- Turn the ALC ADJUST control slowly in a clockwise direction until the required output power is reached (see [Table 17 on page 240](#)).

The indicated PEP level with two-tone modulation depends on the type of measuring instrument, as shown in [Table 17 on page 240](#).

- Check that the two-tone waveform is clean and undistorted.
If it is not clean and undistorted, further analysis is required.
- Release PTT.

This page has been left blank intentionally.

Table 18: High power parts lists index

Title	Assembly number
ALC/PTT Switch	08-05985-001
Splitter 2-way (500 W)	08-05997-001
Splitter 4-way (1 kW)	08-05999-001
Power Amplifier	08-05977-001
Combiner 2-way (500 W)	08-05998-001
Combiner 4-way (1 kW)	08-06000-001
Filter	08-05976-001
Control	08-05979-001
Power Supply	08-05978-001
Rear Panel	08-05984-001
3061 Power Supply 500 W	08-06067-001
3062 Power Supply 1000 W	08-06102-001
HPAC	08-05927-001
ALC adaptor	08-05926-001

This page has been left blank intentionally.

08-05985-001 - ALC PTT Switch PCB 500W

BOM Revision
Date Valid On

03 -- Production
28.09.2006

Ref	Description	Manufacturer	Manufacturer's P/N	Codan P/N	Qty
	ALC PTT Switch PCB			08-05985	1
	ALC PTT Switch			04-03422	1
1	PCB, ALC PTT Switch	IMP	07-01991-01	07-01991-01	1
2	Stake, Terminal	Autossplice	7-22461-5	61-40300-004	3
C1	Not Assigned	Codan	**-00000-004	99-00000-004	1
C2	1n 5% 50V NPO 0805 NiSn	Philips	0805CG102J9BB-	46-31000-082	1
C3	SOT 5% 50V NPO 0805 NiSn	Philips	0805CG	46-00000-081	1
C4	150p 5% 50V NPO 0805 NiSn	Philips	0805CG151J9BB-	46-21500-081	1
C5	5,5-65p 250V Foil Trim Cap	Philips	2222 808 32659	49-30103	1
C6	47p 5% 50V NPO 0805 NiSn	Philips	0805CG470J9B200	46-14700-080	1
C7	56p 5% 50V NPO 0805 NiSn	Philips	0805CG560J9B200	46-15600-081	1
C8	1n 5% 50V NPO 0805 NiSn	Philips	0805CG102J9BB-	46-31000-082	1
C9	Not Assigned	Codan	**-00000-004	99-00000-004	1
C10	100n 10% 50V X7R 0805 Nisn	Philips	08052R104K9BB	46-51000-282	1
C11	33n 10% 50V X7R 0805 NiSn	Philips	08052R333K9BB00	46-43300-281	1
C12	33n 10% 50V X7R 0805 NiSn	Philips	08052R333K9BB00	46-43300-281	1
C13	1n 5% 50V NPO 0805 NiSn	Philips	0805CG102J9BB-	46-31000-082	1
D1	Diode, Schottky 70V 70mA SOT23	Siemens	BAS70	BAS70	1
D2	Diode, Schottky 70V 70mA SOT23	Siemens	BAS70	BAS70	1
D3	Diode, Schottky 70V 70mA SOT23	Siemens	BAS70	BAS70	1
D4	Diode, Schottky SOT23	Philips	BAT54	BAT54	1
D5	Diode, Si High speed 75V SOT23	Philips	BAS16	BAS16	1
J1	Socket, Coax Mini Vertical Fixed	Taiko Denki	TMP-J01X-V6	60-19390-001	1
J2	Socket, Coax Mini Vertical Fixed	Taiko Denki	TMP-J01X-V6	60-19390-001	1
K1	Relay, 2C Bif 12V 720 Ohm	Matsushita	DS2Y-S-DC12	64-21223-272	1
K2	Relay, Vert 1C 12V 8A 306 Ohm	Siemens	V23057-B0002-A101	64-31120-232	1
L1	Ind, 1mH 10% 1812	Coilcraft	1812LS-105XKBC	43-83100-000	1
L2	Ind, 1mH 10% 1812	Coilcraft	1812LS-105XKBC	43-83100-000	1
P1	Header (P) 10way 2row Boxed Fix	I-Technos	HDM410S02	60-00100-003	1
R1	10k Ohm 5% 0,1W 0805	Philips	2322-730-61103	40-41000-111	1
R2	10k Ohm 5% 0,1W 0805	Philips	2322-730-61103	40-41000-111	1
R3	10k Ohm 5% 0,1W 0805	Philips	2322-730-61103	40-41000-111	1
R4	1k Ohm 5% 0,1W 0805	Philips	2322-730-61102	40-31000-111	1

08-05985-001 - ALC PTT Switch PCB 500W

BOM Revision
Date Valid On

03 -- Production
28.09.2006

Ref	Description	Manufacturer	Manufacturer's P/N	Codan P/N	Qty
R5	27,4 Ohm 1% 0,4W MF Res	Philips	2322 156 12749	40-12740-501	1
R6	27,4 Ohm 1% 0,4W MF Res	Philips	2322 156 12749	40-12740-501	1
R7	27,4 Ohm 1% 0,4W MF Res	Philips	2322 156 12749	40-12740-501	1
R8	27,4 Ohm 1% 0,4W MF Res	Philips	2322 156 12749	40-12740-501	1
R9	1k Ohm 5% 0,1W 0805	Philips	2322-730-61102	40-31000-111	1
R10	1k Ohm 5% 0,1W 0805	Philips	2322-730-61102	40-31000-111	1
R11	6,8k Ohm 5% 0,1W 0805	Philips	2322 730 61682	40-36800-111	1
R12	1k Ohm 5% 0,1W 0805	Philips	2322-730-61102	40-31000-111	1
R13	100k Ohm 5% 0,1W 0805	Philips	2322 730 61104	40-51000-111	1
T1	Transformer, RF Current 30T	Protran	44-80302	44-80302	1

08-05997-001 - Splitter 2 way PCB 500W Amp

BOM Revision
Date Valid On

01 -- Production
28.09.2006

Ref	Description	Manufacturer	Manufacturer's P/N	Codan P/N	Qty
	Splitter 2 way 500W Amp			04-03419	1
*	Splitter 2 way PCB 500W Amp			08-05997	1
1	PCB, Splitter 2 way 500W Amp	Codan	07-01996-02	07-01996-02	1
2	Standoff, PCB 3,6x6	PEM	KFE-3,6-6ET	33-53604-060	4
C1	39p 2% 100V NPO CE Cap	Philips	2222 680 10399	46-13900-011	1
J1	Socket, Coax Mini Vertical Fixed	Taiko Denki	TMP-J01X-V6	60-19390-001	1
J2	Socket, Coax Mini Vertical Fixed	Taiko Denki	TMP-J01X-V6	60-19390-001	1
J3	Socket, Coax Mini Vertical Fixed	Taiko Denki	TMP-J01X-V6	60-19390-001	1
R4	200 Ohm 5% 0,33W CF Res	Philips	2322 211 13201	40-22000-020	1
R5	200 Ohm 5% 0,33W CF Res	Philips	2322 211 13201	40-22000-020	1
T1	Txfr Auto 50:25 Ohm 1,6- 30MHz 10W	Protran	44-80296	44-80296	1
T2	Txfr Input Splitter 2 way 1,6- 30MHz	Protran	44-80298	44-80298	1

08-05999-001 - Splitter 4 way PCB 1kW Amp

BOM Revision
Date Valid On

02 -- Production
28.09.2006

Ref	Description	Manufacturer	Manufacturer's P/N	Codan P/N	Qty
	Splitter 4 way 1kW Amp			04-03420	1
*	Splitter 4 way PCB 1kW Amp			08-05999	1
1	PCB, Splitter 4 way 1kW Amp	Codan	07-01998-02	07-01998-02	1
2	Tie, Cable 2,5mm W x 115mm Long	Richco	WIT 18 R	30-39100-004	1
3	Standoff, PCB 3,6x6	PEM	KFE-3,6-6ET	33-53604-060	4
4	Stake, Terminal	Autosplice	7-22461-5	61-40300-004	3
C1	39p 2% 100V NPO CE Cap	Philips	2222 680 10399	46-13900-011	1
C2	22p 2% 100V NPO CE Cap	Philips	2222 680 10229	46-12200-011	1
C3	22p 2% 100V NPO CE Cap	Philips	2222 680 10229	46-12200-011	1
J1	Socket, Coax Mini Vertical Fixed	Taiko Denki	TMP-J01X-V6	60-19390-001	1
J2	Socket, Coax Mini Vertical Fixed	Taiko Denki	TMP-J01X-V6	60-19390-001	1
J3	Socket, Coax Mini Vertical Fixed	Taiko Denki	TMP-J01X-V6	60-19390-001	1
J4	Socket, Coax Mini Vertical Fixed	Taiko Denki	TMP-J01X-V6	60-19390-001	1
J5	Socket, Coax Mini Vertical Fixed	Taiko Denki	TMP-J01X-V6	60-19390-001	1
R4	200 Ohm 5% 0,33W CF Res	Philips	2322 211 13201	40-22000-020	1
R5	200 Ohm 5% 0,33W CF Res	Philips	2322 211 13201	40-22000-020	1
R6	200 Ohm 5% 0,33W CF Res	Philips	2322 211 13201	40-22000-020	1
R7	200 Ohm 5% 0,33W CF Res	Philips	2322 211 13201	40-22000-020	1
R8	200 Ohm 5% 0,33W CF Res	Philips	2322 211 13201	40-22000-020	1
R9	200 Ohm 5% 0,33W CF Res	Philips	2322 211 13201	40-22000-020	1
R10	200 Ohm 5% 0,33W CF Res	Philips	2322 211 13201	40-22000-020	1
R11	200 Ohm 5% 0,33W CF Res	Philips	2322 211 13201	40-22000-020	1
T1	Txfr Auto 50:12,5 Ohm 1,6-30MHz 20W	Protran	44-80300	44-80300	1
T2	Txfr Input Splitter 2 way 1,6-30MHz	Protran	44-80298	44-80298	1
T3	Txfr Input Splitter 2 way 1,6-30MHz	Protran	44-80298	44-80298	1
T4	Txfr Input Splitter 2 way 1,6-30MHz	Protran	44-80298	44-80298	1

08-05977-001 - 500W HF Amp PCB

BOM Revision
Date Valid On

03 -- Production
28.09.2006

Ref	Description	Manufacturer	Manufacturer's P/N	Codan P/N	Qty
	500W HF Amp			04-03416	1
*	500W HF Amp PCB			08-05977	1
1	PCB, 500W Amp	Codan	07-01985-02	07-01985-02	1
3	Rivet, Tinned Brass Chobert 4,0dx9,5	Avdel	01143-00516	33-40340-095	2
4	Standoff, PCB 3,6x4	PEM	KFE-3,6-4ET	33-53604-040	5
5	Stake, Terminal	Autosplice	7-22461-5	61-40300-004	1
C1	56p 5% 500V N750 CE Cap	Murata	DD06 UJ 560J 500	46-15600-021	1
C2	68p 5% 500V N750 CE Cap	Murata	DD07 UJ 680J 500	46-16800-021	1
C3	120p 5% 500V NPO CE Cap	Murata	DD10 CH 121J 500	46-21200-020	1
C4	270p 2% 100V N750 CE Cap	Philips	2222 680 58271	46-22700-013	1
C5	220p 2% 100V N750 CE Cap	Philips	2222 680 58221	46-22200-013	1
C6	150p 5% 500V NPO CE Cap	Murata	DD11 CH 151J 500	46-21500-020	1
C7	150p 5% 500V NPO CE Cap	Murata	DD11 CH 151J 500	46-21500-020	1
C8	100n 10% 100V X7R CE Cap	Cinetech	RD20B104K2AL5B	46-51000-263	1
C9	100n 10% 100V X7R CE Cap	Cinetech	RD20B104K2AL5B	46-51000-263	1
C10	100n 10% 100V X7R CE Cap	Cinetech	RD20B104K2AL5B	46-51000-263	1
C11	100n 10% 100V X7R CE Cap	Cinetech	RD20B104K2AL5B	46-51000-263	1
C12	100n 10% 100V X7R CE Cap	Cinetech	RD20B104K2AL5B	46-51000-263	1
C13	100n 10% 100V X7R CE Cap	Cinetech	RD20B104K2AL5B	46-51000-263	1
C14	100n 10% 100V X7R CE Cap	Cinetech	RD20B104K2AL5B	46-51000-263	1
C15	100n 10% 100V X7R CE Cap	Cinetech	RD20B104K2AL5B	46-51000-263	1
C16	100n 10% 100V X7R CE Cap	Cinetech	RD20B104K2AL5B	46-51000-263	1
C17	100n 10% 100V X7R CE Cap	Cinetech	RD20B104K2AL5B	46-51000-263	1
C18	100n 10% 100V X7R CE Cap	Cinetech	RD20B104K2AL5B	46-51000-263	1
C19	100n 10% 100V X7R CE Cap	Cinetech	RD20B104K2AL5B	46-51000-263	1
C20	100n 10% 100V X7R CE Cap	Cinetech	RD20B104K2AL5B	46-51000-263	1
C21	100n 10% 100V X7R CE Cap	Cinetech	RD20B104K2AL5B	46-51000-263	1
C22	100n 10% 100V X7R CE Cap	Cinetech	RD20B104K2AL5B	46-51000-263	1
C23	100n 10% 100V X7R CE Cap	Cinetech	RD20B104K2AL5B	46-51000-263	1
C24	Not Fitted	Codan	**_00000-001	99-00000-001	1
C25	33n 10% 50V X7R 0805 NiSn	Philips	08052R333K9BB00	46-43300-281	1

08-05977-001 - 500W HF Amp PCB

BOM Revision
Date Valid On

03 -- Production
28.09.2006

Ref	Description	Manufacturer	Manufacturer's P/N	Codan P/N	Qty
C26	10n 20% 50V X7R CE Cap	AVX	SR175C103MAA	46-41000-261	1
C27	10u 20% 25V TA Cap	AVX	TAP106M025CCS	47-11002-510	1
C28	33n 20% 25V CE Cap	Murata	DD406SR333M25	46-43300-211	1
C29	33n 10% 100V PE Cap	Philips	2222 370 21333	46-43300-524	1
C30	100n 10% 100V X7R CE Cap	Cinetech	RD20B104K2AL5B	46-51000-263	1
C101	56p 5% 500V N750 CE Cap	Murata	DD06 UJ 560J 500	46-15600-021	1
C102	68p 5% 500V N750 CE Cap	Murata	DD07 UJ 680J 500	46-16800-021	1
C103	120p 5% 500V NPO CE Cap	Murata	DD10 CH 121J 500	46-21200-020	1
C104	220p 2% 100V N750 CE Cap	Philips	2222 680 58221	46-22200-013	1
C105	270p 2% 100V N750 CE Cap	Philips	2222 680 58271	46-22700-013	1
C106	150p 5% 500V NPO CE Cap	Murata	DD11 CH 151J 500	46-21500-020	1
C107	150p 5% 500V NPO CE Cap	Murata	DD11 CH 151J 500	46-21500-020	1
C108	100n 10% 100V X7R CE Cap	Cinetech	RD20B104K2AL5B	46-51000-263	1
C109	100n 10% 100V X7R CE Cap	Cinetech	RD20B104K2AL5B	46-51000-263	1
C110	100n 10% 100V X7R CE Cap	Cinetech	RD20B104K2AL5B	46-51000-263	1
C111	100n 10% 100V X7R CE Cap	Cinetech	RD20B104K2AL5B	46-51000-263	1
C112	100n 10% 100V X7R CE Cap	Cinetech	RD20B104K2AL5B	46-51000-263	1
C113	100n 10% 100V X7R CE Cap	Cinetech	RD20B104K2AL5B	46-51000-263	1
C114	100n 10% 100V X7R CE Cap	Cinetech	RD20B104K2AL5B	46-51000-263	1
C115	100n 10% 100V X7R CE Cap	Cinetech	RD20B104K2AL5B	46-51000-263	1
C116	100n 10% 100V X7R CE Cap	Cinetech	RD20B104K2AL5B	46-51000-263	1
C117	100n 10% 100V X7R CE Cap	Cinetech	RD20B104K2AL5B	46-51000-263	1
C118	100n 10% 100V X7R CE Cap	Cinetech	RD20B104K2AL5B	46-51000-263	1
C119	100n 10% 100V X7R CE Cap	Cinetech	RD20B104K2AL5B	46-51000-263	1
C120	100n 10% 100V X7R CE Cap	Cinetech	RD20B104K2AL5B	46-51000-263	1
C121	100n 10% 100V X7R CE Cap	Cinetech	RD20B104K2AL5B	46-51000-263	1
C122	100n 10% 100V X7R CE Cap	Cinetech	RD20B104K2AL5B	46-51000-263	1
C123	100n 10% 100V X7R CE Cap	Cinetech	RD20B104K2AL5B	46-51000-263	1
C124	Not Fitted	Codan	** -00000-001	99-00000-001	1
D1	Diode, Schottky HV	HP	5082-2800	5082-2800	1

08-05977-001 - 500W HF Amp PCB

BOM Revision
Date Valid On

03 -- Production
28.09.2006

Ref	Description	Manufacturer	Manufacturer's P/N	Codan P/N	Qty
D2	Diode, Schottky HV	HP	5082-2800	5082-2800	1
D3	Diode, Zener 30V 5% 0,4W	Philips	BZX79-C30	BZX79C30	1
D4	Diode, Si fast low cap high cond	Codan	23-10001	23-10001	1
D101	Diode, Schottky HV	HP	5082-2800	5082-2800	1
D102	Diode, Schottky HV	HP	5082-2800	5082-2800	1
D103	Diode, Zener 30V 5% 0,4W	Philips	BZX79-C30	BZX79C30	1
D104	Diode, Si fast low cap high cond	Codan	23-10001	23-10001	1
J1	Socket, Coax Mini Vertical Fixed	Taiko Denki	TMP-J01X-V6	60-19390-001	1
J101	Socket, Coax Mini Vertical Fixed	Taiko Denki	TMP-J01X-V6	60-19390-001	1
L1	Inductor (Amp in)	Lencom	44-70534	44-70534	1
L2	Inductor (Shunt in)	Lencom	44-70535	44-70535	1
L3	Ind, 1,8uH 10%	Epcos	B78108-T1182-K9	43-80180-002	1
L4	Inductor, DC Feed	Lencom	44-70536	44-70536	1
L5	Inductor, DC Feed	Lencom	44-70536	44-70536	1
L6	Choke, EMI/EMC 0A DC >1MHz	Taiyo Yuden	FBR07 HA 121 NB-00	43-90002	1
L101	Inductor (Amp in)	Lencom	44-70534	44-70534	1
L102	Inductor (Shunt in)	Lencom	44-70535	44-70535	1
L103	Ind, 1,8uH 10%	Epcos	B78108-T1182-K9	43-80180-002	1
L104	Inductor, DC Feed	Lencom	44-70536	44-70536	1
L105	Inductor, DC Feed	Lencom	44-70536	44-70536	1
L106	Choke, EMI/EMC 0A DC >1MHz	Taiyo Yuden	FBR07 HA 121 NB-00	43-90002	1
P1	Header (P) 10way 2row Boxed Fix	I-Technos	HDM410S02	60-00100-003	1
R1	180 Ohm 5% 3,0W MF Res	BC Components	2322 195 14181	40-21800-690	1
R2	180 Ohm 5% 3,0W MF Res	BC Components	2322 195 14181	40-21800-690	1
R3	180 Ohm 5% 3,0W MF Res	BC Components	2322 195 14181	40-21800-690	1
R4	180 Ohm 5% 3,0W MF Res	BC Components	2322 195 14181	40-21800-690	1
R5	180 Ohm 5% 3,0W MF Res	BC Components	2322 195 14181	40-21800-690	1
R6	200 Ohm 5% 2,0W MF Res	BC Components	2306 198 53201	40-22000-691	1
R7	470 Ohm 5% 3,0W MF Res	BC Components	2322 195 14471	40-24700-690	1
R10	470 Ohm 5% 3,0W MF Res	BC Components	2322 195 14471	40-24700-690	1
R11	100k Ohm 1% 0,4W MF Res	Philips	2322 156 11004	40-51000-501	1
R12	10,0k Ohm 1% 0,4W MF Res	Philips	2322 156 11003	40-41000-501	1
R13	470 Ohm 5% 0,33W CF Res	Philips	2322 211 13471	40-24700-020	1
R14	Not Assigned	Codan	** -00000-004	99-00000-004	1
R15	Pot,1k Lin MG Trim	Noble	VTP	42-31076-000	1
R16	470 Ohm 5% 0,33W CF Res	Philips	2322 211 13471	40-24700-020	1
R17	3,9k Ohm 5% 0,33W CF Res	Philips	2322 211 13392	40-33900-020	1

08-05977-001 - 500W HF Amp PCB

BOM Revision
Date Valid On

03 -- Production
28.09.2006

Ref	Description	Manufacturer	Manufacturer's P/N	Codan P/N	Qty
R18	47 Ohm 5% 0,33W CF Res	Philips	2322 211 13479	40-14700-020	1
R19	1k Ohm 5% 0,33W CF Res	Philips	2322 211 13102	40-31000-020	1
R20	10 Ohm 5% 0,33W CF Res	Philips	2322 211 13109	40-11000-020	1
R21	33 Ohm 5% 0,33W CF Res	Philips	2322 211 13339	40-13300-020	1
R22	1k Ohm 5% 0,33W CF Res	Philips	2322 211 13102	40-31000-020	1
R23	1k Ohm 5% 0,33W CF Res	Philips	2322 211 13102	40-31000-020	1
R24	1k Ohm 5% 0,33W CF Res	Philips	2322 211 13102	40-31000-020	1
R25	470 Ohm 5% 0,33W CF Res	Philips	2322 211 13471	40-24700-020	1
R26	1k Ohm 5% 0,33W CF Res	Philips	2322 211 13102	40-31000-020	1
R101	180 Ohm 5% 3,0W MF Res	BC Components	2322 195 14181	40-21800-690	1
R102	180 Ohm 5% 3,0W MF Res	BC Components	2322 195 14181	40-21800-690	1
R103	180 Ohm 5% 3,0W MF Res	BC Components	2322 195 14181	40-21800-690	1
R104	180 Ohm 5% 3,0W MF Res	BC Components	2322 195 14181	40-21800-690	1
R105	180 Ohm 5% 3,0W MF Res	BC Components	2322 195 14181	40-21800-690	1
R106	200 Ohm 5% 2,0W MF Res	BC Components	2306 198 53201	40-22000-691	1
R107	470 Ohm 5% 3,0W MF Res	BC Components	2322 195 14471	40-24700-690	1
R110	470 Ohm 5% 3,0W MF Res	BC Components	2322 195 14471	40-24700-690	1
R111	100k Ohm 1% 0,4W MF Res	Philips	2322 156 11004	40-51000-501	1
R112	10,0k Ohm 1% 0,4W MF Res	Philips	2322 156 11003	40-41000-501	1
R113	470 Ohm 5% 0,33W CF Res	Philips	2322 211 13471	40-24700-020	1
V3	Transistor, NPN Si	Philips	BC550C	BC550C	1
V4	Transistor, PNP Si	Philips	BC558	BC558	1
V6	MOSFET, Power N Channel	Motorola	MTD3055EL1	MTD3055EL1	1

08-05998-001 - Combiner 2 way PCB 500W Amp

BOM Revision
Date Valid On

01 -- Production
28.09.2006

Ref	Description	Manufacturer	Manufacturer's P/N	Codan P/N	Qty
	Combiner 2 way 500W Amp			04-03428	1
*	Combiner 2 way PCB 500W Amp			08-05998	1
1	PCB, Combiner 2 way 500W Amp	IMP	07-01997-03	07-01997-03	1
2	Standoff, PCB 3,6x4	PEM	KFE-3,6-4ET	33-53604-040	1
3	Standoff, PCB 3,6x6	PEM	KFE-3,6-6ET	33-53604-060	2
4	Stake, Terminal	Autosplice	7-22461-5	61-40300-004	6
C1	3,3n 10% 100V CE Cap	Philips	2222 630 03332	46-33300-200	1
C2	39p 5% 500V NPO CE Cap	Murata	DD07 CH 390J 500	46-13900-020	1
D1	Diode, Schottky HV	HP	5082-2800	5082-2800	1
J1	Socket, MCX Straight PCB	Chin Nan	27-05-TGN	60-19300	1
J2	Socket, MCX Straight PCB	Chin Nan	27-05-TGN	60-19300	1
R2	470 Ohm 5% 0,33W CF Res	Philips	2322 211 13471	40-24700-020	1
T1	Txfr Output Combine 2 way 1,6-30MHz 500W	Protran	44-80299	44-80299	1
T2	Txfr Auto 25:50 Ohm 1,6-30MHz 500W	Protran	44-80297	44-80297	1

08-06000-001 - Combiner 4 way PCB 1kW Amp

BOM Revision
Date Valid On

01 -- Production
28.09.2006

Ref	Description	Manufacturer	Manufacturer's P/N	Codan P/N	Qty
	PCB, Combiner 4 way 1kW Amp	Codan	07-01999-02	07-01999-02	1
	Combiner 4 way 1kW Amp			04-03429	1
*	Combiner 4 way PCB 1kW Amp			08-06000	1
2	Tie, Cable 3,6mm W x 150mm Long	Bowthorpe	T30R	30-39101-001	2
3	Standoff, PCB 3,6x4	PEM	KFE-3,6-4ET	33-53604-040	1
4	Standoff, PCB 3,6x6	PEM	KFE-3,6-6ET	33-53604-060	3
5	Stake, Terminal	Autosplice	7-22461-5	61-40300-004	6
C1	3,3n 10% 100V CE Cap	Philips	2222 630 03332	46-33300-200	1
C2	22p 5% 500V NPO CE Cap	Murata	DD05 CH 220J 500	46-12200-020	1
C3	22p 5% 500V NPO CE Cap	Murata	DD05 CH 220J 500	46-12200-020	1
C4	33p 5% 500V NPO CE Cap	Murata	DD07 CH 330J 500	46-13300-020	1
D1	Diode, Schottky HV	HP	5082-2800	5082-2800	1
D2	Diode, Schottky HV	HP	5082-2800	5082-2800	1
D3	Diode, Schottky HV	HP	5082-2800	5082-2800	1
J1	Socket, MCX Straight PCB	Chin Nan	27-05-TGN	60-19300	1
J2	Socket, MCX Straight PCB	Chin Nan	27-05-TGN	60-19300	1
J3	Socket, MCX Straight PCB	Chin Nan	27-05-TGN	60-19300	1
J4	Socket, MCX Straight PCB	Chin Nan	27-05-TGN	60-19300	1
R2	470 Ohm 5% 0,33W CF Res	Philips	2322 211 13471	40-24700-020	1
R3	470 Ohm 5% 0,33W CF Res	Philips	2322 211 13471	40-24700-020	1
R7	1,8k Ohm 5% 0,33W CF Res	Philips	2322 211 13182	40-31800-020	1
R8	560 Ohm 5% 0,33W CF Res	Philips	2322 211 13561	40-25600-020	1
T1	Txfr Output Combine 2 way 1,6-30MHz 500W	Protran	44-80299	44-80299	1
T2	Txfr Output Combine 2 way 1,6-30MHz 500W	Protran	44-80299	44-80299	1
T3	Txfr Output Combine 2 way 1,6-30MHz 1Kw	Protran	44-80303	44-80303	1
T4	Txfr Auto 12,5:50 Ohm 1,6-30MHz 1kW	Protran	44-80301	44-80301	1

08-05976-001 - 500/1000W HF Filter PCB

BOM Revision
Date Valid On

01 -- Production
28.09.2006

Ref	Description	Manufacturer	Manufacturer's P/N	Codan P/N	Qty
	Capacitors, 44pF +/-2%	Braemac	23-40024 TO 10-00936	23-40024	1
	Capacitors, 10pF +/-2%	Braemac	23-40050	23-40050	1
	Capacitors, 36pF +/-2%	Braemac	23-40049	23-40049	1
	Capacitors, 76pF +/-2%	Braemac	23-40048	23-40048	1
	Capacitors, 108pF +/-2%	Braemac	23-40047	23-40047	1
	Capacitors, 104pF +/-2%	Braemac	23-40046	23-40046	1
	Capacitors, 12pF +/-2%	Braemac	23-40045	23-40045	1
	Capacitors, 54pF +/-2%	Braemac	23-40044	23-40044	1
	Capacitors, 15pF +/-2%	Braemac	23-40043	23-40043	1
	Capacitors, 56pF +/-2%	Braemac	23-40042 TO DRG 10-00936	23-40042	1
	Capacitors, 120pF +/-2%	Braemac	23-40041 TO DRG 10-00936	23-40041	1
	Capacitors, 150pF +/-2%	Braemac	23-40040 TO DRG 10-00936	23-40040	1
	Capacitors, 166pF +/-2%	Braemac	23-40039 TO DRG 10-00936	23-40039	1
	Capacitors, 220pF +/-2%	Braemac	23-40008 TO 10-00936	23-40008	1
	Capacitors, 15pF +/-2%	Braemac	23-40038 TO DRG 10-00936	23-40038	1
	Capacitors, 74pF +/-2%	Braemac	23-40037 TO DRG 10-00936	23-40037	1
	Capacitors, 22pF +/-2%	Braemac	23-40036 TO DRG 10-00936	23-40036	1
	Capacitors, 89pF +/-2%	Braemac	23-40035 TO DRG 10-00936	23-40035	1
	Capacitors, 195pF +/-2%	Braemac	23-40034 TO DRG 10-00936	23-40034	1
	Capacitors, 224pF +/-2%	Braemac	23-40033 TO DRG 10-00936	23-40033	1
	Capacitors, 239pF +/-2%	Braemac	23-40032 TO DRG 10-00936	23-40032	1
	Capacitors, 27pF +/-2%	Braemac	23-40031 TO DRG 10-00936	23-40031	1
	Capacitors, 103pF +/-2%	Braemac	23-40030 TO 10-00936	23-40030	1
	Capacitors, 42pF +/-2%	Braemac	23-40029 TO 10-00936	23-40029	1
	Capacitors, 156pF +/-2%	Braemac	23-40028 TO 10-00936	23-40028	1
	Capacitors, 276pF +/-2%	Braemac	23-40027 TO 10-00936	23-40027	1
	Capacitors, 332pF +/-2%	Braemac	23-40026 TO 10-00936	23-40026	1
	Capacitors, 368pF +/-2%	Braemac	23-40025 TO 10-00936	23-40025	1
	Capacitors, 540pF +/-2%	Braemac	23-40007 TO 10-00936	23-40007	1
	Capacitors, 100pF +/-2%	Braemac	23-40010 TO 10-00936	23-40010	1
	Capacitors, 720pF +/-2%	Braemac	23-40013 TO 10-00936	23-40013	1
	Capacitors, 176pF +/-2%	Braemac	23-40023 TO 10-00936	23-40023	1
	Capacitors, 74pF +/-2%	Braemac	23-40022 TO 10-00936	23-40022	1
	Capacitors, 236pF +/-2%	Braemac	23-40021 TO 10-00936	23-40021	1
	Capacitors, 460pF +/-2%	Braemac	23-40020 TO 10-00936	23-40020	1
	Capacitors, 518pF +/-2%	Braemac	23-40019 TO 10-00936	23-40019	1
	Capacitors, 550pF +/-2%	Braemac	23-40018 TO 10-00936	23-40018	1
	Capacitors, 68pF +/-2%	Braemac	23-40017 TO 10-00936	23-40017	1
	Capacitors, 282pF +/-2%	Braemac	23-40016 TO 10-00936	23-40016	1
	Capacitors, 124pF +/-2%	Braemac	23-40015 TO 10-100936	23-40015	1
	Capacitors, 352pF +/-2%	Braemac	23-40014 TO 10-00936	23-40014	1
	Capacitors, 440pF +/-2%	Braemac	23-40009 TO 10-00936	23-40009	1
	Capacitors, 1080pF +/-2%	Braemac	23-40006 TO 10-00936	23-40006	1
	Capacitors, 1210pF +/-2%	Codan	23-40005 TO 10-00936	23-40005	1
	Capacitors, 1320pF +/-2%	Braemac	23-40004 TO 10-00936	23-40004	1

08-05976-001 - 500/1000W HF Filter PCB

BOM Revision
Date Valid On

01 -- Production
28.09.2006

Ref	Description	Manufacturer	Manufacturer's P/N	Codan P/N	Qty
	Capacitors, 150pF +/-2%	Braemac	23-40003 TO 10-00936	23-40003	1
	Capacitors, 720pF +/-2%	Braemac	23-40002 TO 10-00936	23-40002	1
	TP,500W/1kW Filter Alignment			10-00926	1
	500/1000W Filters			04-03415	1
	Capacitors, 860pF +/-2%	Braemac	23-40011 TP 10-00936	23-40011	1
	Capacitors, 800pF +/-2%	Braemac	23-40012 TO 10-00936	23-40012	1
*	500/1000W HF Filter PCB			08-05976	1
1	PCB, 500/1000W HF PA Filter	IMP	07-01977-02	07-01977-02	1
2	Rivet, Tinned Brass Chobert 4,0dx9,5	Avdel	01143-00516	33-40340-095	12
3	Stake, Terminal	Autosplice	7-22461-5	61-40300-004	2
C101	33n 20% 25V CE Cap	Murata	DD406SR333M25	46-43300-211	1
C102	33n 20% 25V CE Cap	Murata	DD406SR333M25	46-43300-211	1
C103	33n 20% 25V CE Cap	Murata	DD406SR333M25	46-43300-211	1
C104	33n 20% 25V CE Cap	Murata	DD406SR333M25	46-43300-211	1
C201	33n 20% 25V CE Cap	Murata	DD406SR333M25	46-43300-211	1
C202	33n 20% 25V CE Cap	Murata	DD406SR333M25	46-43300-211	1
C203	33n 20% 25V CE Cap	Murata	DD406SR333M25	46-43300-211	1
C204	33n 20% 25V CE Cap	Murata	DD406SR333M25	46-43300-211	1
C301	33n 20% 25V CE Cap	Murata	DD406SR333M25	46-43300-211	1
C302	33n 20% 25V CE Cap	Murata	DD406SR333M25	46-43300-211	1
C303	33n 20% 25V CE Cap	Murata	DD406SR333M25	46-43300-211	1
C304	33n 20% 25V CE Cap	Murata	DD406SR333M25	46-43300-211	1
C401	33n 20% 25V CE Cap	Murata	DD406SR333M25	46-43300-211	1
C402	33n 20% 25V CE Cap	Murata	DD406SR333M25	46-43300-211	1
C403	33n 20% 25V CE Cap	Murata	DD406SR333M25	46-43300-211	1
C404	33n 20% 25V CE Cap	Murata	DD406SR333M25	46-43300-211	1
C421	56p 5% 2kV NPO CE Cap	MMC	HS15SJCH560J	46-15600-090	1
C501	33n 20% 25V CE Cap	Murata	DD406SR333M25	46-43300-211	1
C502	33n 20% 25V CE Cap	Murata	DD406SR333M25	46-43300-211	1
C503	33n 20% 25V CE Cap	Murata	DD406SR333M25	46-43300-211	1
C504	33n 20% 25V CE Cap	Murata	DD406SR333M25	46-43300-211	1
C601	33n 20% 25V CE Cap	Murata	DD406SR333M25	46-43300-211	1

08-05976-001 - 500/1000W HF Filter PCB

BOM Revision
Date Valid On

01 -- Production
28.09.2006

Ref	Description	Manufacturer	Manufacturer's P/N	Codan P/N	Qty
C602	33n 20% 25V CE Cap	Murata	DD406SR333M25	46-43300-211	1
C603	33n 20% 25V CE Cap	Murata	DD406SR333M25	46-43300-211	1
C604	33n 20% 25V CE Cap	Murata	DD406SR333M25	46-43300-211	1
C701	33n 20% 25V CE Cap	Murata	DD406SR333M25	46-43300-211	1
C702	33n 20% 25V CE Cap	Murata	DD406SR333M25	46-43300-211	1
C703	33n 20% 25V CE Cap	Murata	DD406SR333M25	46-43300-211	1
C704	33n 20% 25V CE Cap	Murata	DD406SR333M25	46-43300-211	1
K101	Relay, Vert 1C 12V 8A 306 Ohm	Siemens	V23057-B0002-A101	64-31120-232	1
K102	Relay, Vert 1C 12V 8A 306 Ohm	Siemens	V23057-B0002-A101	64-31120-232	1
K201	Relay, Vert 1C 12V 8A 306 Ohm	Siemens	V23057-B0002-A101	64-31120-232	1
K202	Relay, Vert 1C 12V 8A 306 Ohm	Siemens	V23057-B0002-A101	64-31120-232	1
K301	Relay, Vert 1C 12V 8A 306 Ohm	Siemens	V23057-B0002-A101	64-31120-232	1
K302	Relay, Vert 1C 12V 8A 306 Ohm	Siemens	V23057-B0002-A101	64-31120-232	1
K401	Relay, Vert 1C 12V 8A 306 Ohm	Siemens	V23057-B0002-A101	64-31120-232	1
K402	Relay, Vert 1C 12V 8A 306 Ohm	Siemens	V23057-B0002-A101	64-31120-232	1
K501	Relay, Vert 1C 12V 8A 306 Ohm	Siemens	V23057-B0002-A101	64-31120-232	1
K502	Relay, Vert 1C 12V 8A 306 Ohm	Siemens	V23057-B0002-A101	64-31120-232	1
K601	Relay, Vert 1C 12V 8A 306 Ohm	Siemens	V23057-B0002-A101	64-31120-232	1
K602	Relay, Vert 1C 12V 8A 306 Ohm	Siemens	V23057-B0002-A101	64-31120-232	1
K701	Relay, Vert 1C 12V 8A 306 Ohm	Siemens	V23057-B0002-A101	64-31120-232	1
K702	Relay, Vert 1C 12V 8A 306 Ohm	Siemens	V23057-B0002-A101	64-31120-232	1
L101	Inductor, 3,6uH	Lencom	44-70513	44-70513	1
L102	Inductor, 1,92uH	Lencom	44-70514	44-70514	1
L103	Inductor, 2,2uH	Lencom	44-70515	44-70515	1
L201	Inductor, 2,37uH	Lencom	44-70516	44-70516	1
L202	Inductor, 1,3uH	Lencom	44-70517	44-70517	1
L203	Inductor, 1,3uH	Lencom	44-70517	44-70517	1
L301	Inductor, 1,5uH	Lencom	44-70518	44-70518	1
L302	Inductor, 835nH	Lencom	44-70519	44-70519	1
L303	Inductor, 835nH	Lencom	44-70519	44-70519	1
L401	Inductor, 1,02uH	Lencom	44-70520	44-70520	1
L402	Inductor, 555nH	Lencom	44-70521	44-70521	1
L403	Inductor, 555nH	Lencom	44-70521	44-70521	1
L501	Inductor, 555nH	Lencom	44-70521	44-70521	1
L502	Inductor, 364nH	Lencom	44-70525	44-70525	1
L503	Inductor, 405nH	Lencom	44-70526	44-70526	1
L601	Inductor, 428nH	Lencom	44-70522	44-70522	1

08-05976-001 - 500/1000W HF Filter PCB

BOM Revision
Date Valid On

01 -- Production
28.09.2006

Ref	Description	Manufacturer	Manufacturer's P/N	Codan P/N	Qty
L602	Inductor, 234nH	Lencom	44-70523	44-70523	1
L603	Inductor, 280nH	Lencom	44-70524	44-70524	1
L701	Inductor, 278nH	Lencom	44-70527	44-70527	1
L702	Inductor, 143nH	Lencom	44-70528	44-70528	1
L703	Inductor, 181nH	Lencom	44-70529	44-70529	1
P1	Header (P) 10way 2row Boxed Fix	I-Technos	HDM410S02	60-00100-003	1
P2	Header (P) 10way 2row Boxed Fix	I-Technos	HDM410S02	60-00100-003	1

08-05979-001 - Control PCB 500W HF Amp

BOM Revision
Date Valid On

05 -- Production
28.09.2006

Ref	Description	Manufacturer	Manufacturer's P/N	Codan P/N	Qty
	Control PCB 500/1000W HF Amp			08-05979	1
	Control 500/1000W Amp			04-03418	1
1	PCB, Control 500/1000W HF Amp	Codan	07-01987-02	07-01987-02	1
2	Wire, Eq bn V105 Thin 7/0,2	Hartland	HC0026 BN	66-03072-001	0.04
3	Wire, Eq rd V105 Thin 7/0,2	Hartland	HC0026 RD	66-03072-002	0.04
4	Wire, Eq or V105 Thin 7/0,2	Hartland	HC0026 OR	66-03072-003	0.04
C101	1u 20% 35V 3528 TA Cap	AVX	TAJB105M035R	47-01003-520	1
C102	1u 20% 35V 3528 TA Cap	AVX	TAJB105M035R	47-01003-520	1
C103	1u 20% 35V 3528 TA Cap	AVX	TAJB105M035R	47-01003-520	1
C104	100n 10% 50V X7R 0805 Nisn	Philips	08052R104K9BB	46-51000-282	1
C105	1n 10% 100V X7R 0805 NiSn	Philips	08052R102K0B200	46-31000-282	1
C106	1n 10% 100V X7R 0805 NiSn	Philips	08052R102K0B200	46-31000-282	1
C107	22p 5% 50V NPO 0805 NiSn	Philips	0805CG220J9B200	46-12200-081	1
C108	100n 10% 50V X7R 0805 Nisn	Philips	08052R104K9BB	46-51000-282	1
C109	100n 10% 50V X7R 0805 Nisn	Philips	08052R104K9BB	46-51000-282	1
C110	100n 10% 50V X7R 0805 Nisn	Philips	08052R104K9BB	46-51000-282	1
C111	100n 10% 50V X7R 0805 Nisn	Philips	08052R104K9BB	46-51000-282	1
C112	100n 10% 50V X7R 0805 Nisn	Philips	08052R104K9BB	46-51000-282	1
C113	33n 10% 50V X7R 0805 NiSn	Philips	08052R333K9BB00	46-43300-281	1
C114	33n 10% 50V X7R 0805 NiSn	Philips	08052R333K9BB00	46-43300-281	1
C115	1n 5% 50V NPO 0805 NiSn	Philips	0805CG102J9BB-	46-31000-082	1
C116	33n 10% 50V X7R 0805 NiSn	Philips	08052R333K9BB00	46-43300-281	1
C117	4,7u 20% 20V 6032 TA Cap	AVX	TAJC475M020R	47-04702-020	1
C118	100n 10% 50V X7R 0805 Nisn	Philips	08052R104K9BB	46-51000-282	1
C119	3,3n 10% 100V X7R 0805 NiSn	Philips	08052R332K0B200	46-33300-281	1
C120	3,3n 10% 100V X7R 0805 NiSn	Philips	08052R332K0B200	46-33300-281	1
C121	100n 10% 50V X7R 0805 Nisn	Philips	08052R104K9BB	46-51000-282	1
C122	100n 10% 50V X7R 0805 Nisn	Philips	08052R104K9BB	46-51000-282	1
C123	10n 10% 100V X7R 0805 NiSn	Philips	08052R103K0B200	46-41000-281	1

08-05979-001 - Control PCB 500W HF Amp

BOM Revision
Date Valid On

05 -- Production
28.09.2006

Ref	Description	Manufacturer	Manufacturer's P/N	Codan P/N	Qty
C124	1u 20% 35V 3528 TA Cap	AVX	TAJB105M035R	47-01003-520	1
C125	100n 10% 50V X7R 0805 Nisn	Philips	08052R104K9BB	46-51000-282	1
C126	100n 10% 50V X7R 0805 Nisn	Philips	08052R104K9BB	46-51000-282	1
C127	100n 10% 50V X7R 0805 Nisn	Philips	08052R104K9BB	46-51000-282	1
C128	100p 5% 50V NPO 0805 NiSn	Philips	0805CG101J9B200	46-21000-081	1
C201	1n 5% 50V NPO 0805 NiSn	Philips	0805CG102J9BB-	46-31000-082	1
C202	100n 10% 50V X7R 0805 Nisn	Philips	08052R104K9BB	46-51000-282	1
C203	4,7u 20% 20V 6032 TA Cap	AVX	TAJC475M020R	47-04702-020	1
C204	100n 10% 50V X7R 0805 Nisn	Philips	08052R104K9BB	46-51000-282	1
C205	100n 10% 50V X7R 1206 NiSn	Philips	12062R104K9BB-	46-51000-281	1
C206	Not Fitted	Codan	** -00000-001	99-00000-001	1
C207	100n 10% 50V X7R 0805 Nisn	Philips	08052R104K9BB	46-51000-282	1
C208	100n 10% 50V X7R 1206 NiSn	Philips	12062R104K9BB-	46-51000-281	1
C209	1u 10% 16V X7R 1206 NiSn	Philips	12062R105K7BB00	46-61000-280	1
C210	1n 5% 50V NPO 0805 NiSn	Philips	0805CG102J9BB-	46-31000-082	1
C211	4,7u 20% 20V 6032 TA Cap	AVX	TAJC475M020R	47-04702-020	1
C212	100n 10% 50V X7R 1206 NiSn	Philips	12062R104K9BB-	46-51000-281	1
C213	1u 10% 16V X7R 1206 NiSn	Philips	12062R105K7BB00	46-61000-280	1
C214	100n 10% 50V X7R 0805 Nisn	Philips	08052R104K9BB	46-51000-282	1
C215	100n 10% 50V X7R 0805 Nisn	Philips	08052R104K9BB	46-51000-282	1
C216	1u 20% 35V 3528 TA Cap	AVX	TAJB105M035R	47-01003-520	1
C217	100n 10% 50V X7R 1206 NiSn	Philips	12062R104K9BB-	46-51000-281	1
C218	Not Fitted	Codan	** -00000-001	99-00000-001	1
C219	1n 5% 50V NPO 0805 NiSn	Philips	0805CG102J9BB-	46-31000-082	1
C220	4,7u 20% 20V 6032 TA Cap	AVX	TAJC475M020R	47-04702-020	1
C221	Not Fitted	Codan	** -00000-001	99-00000-001	1
C222	100n 10% 50V X7R 0805 Nisn	Philips	08052R104K9BB	46-51000-282	1
C223	100n 10% 50V X7R 0805 Nisn	Philips	08052R104K9BB	46-51000-282	1
C224	33n 10% 50V X7R 0805 NiSn	Philips	08052R333K9BB00	46-43300-281	1
C225	4,7u 20% 20V 6032 TA Cap	AVX	TAJC475M020R	47-04702-020	1

08-05979-001 - Control PCB 500W HF Amp

BOM Revision
Date Valid On

05 -- Production
28.09.2006

Ref	Description	Manufacturer	Manufacturer's P/N	Codan P/N	Qty
C226	10u 20% 25V 6032 TA Cap	AVX	TAJ106M025R	47-11002-520	1
C227	Not Fitted	Codan	**00000-001	99-00000-001	1
D101	Diode, Schottky SOT23	Philips	BAT54	BAT54	1
D102	Diode, Si High speed 75V SOT23	Philips	BAS16	BAS16	1
D103	Diode, Schottky SOT23	Philips	BAT54	BAT54	1
D104	Diode, Si High speed 75V SOT23	Philips	BAS16	BAS16	1
D105	Diode, Schottky SOT23	Philips	BAT54	BAT54	1
D106	Diode, Si High speed 75V SOT23	Philips	BAS16	BAS16	1
D107	Diode, Si High speed 75V SOT23	Philips	BAS16	BAS16	1
D108	Diode, Schottky SOT23	Philips	BAT54	BAT54	1
D109	Diode, Si High speed 75V SOT23	Philips	BAS16	BAS16	1
D110	Diode, Si High speed 75V SOT23	Philips	BAS16	BAS16	1
D111	Diode, Si High speed 75V SOT23	Philips	BAS16	BAS16	1
D112	Diode, Si High speed 75V SOT23	Philips	BAS16	BAS16	1
D113	Diode, Si High speed 75V SOT23	Philips	BAS16	BAS16	1
D114	Diode, Schottky SOT23	Philips	BAT54	BAT54	1
D115	Diode, Si High speed 75V SOT23	Philips	BAS16	BAS16	1
D116	Diode, Si High speed 75V SOT23	Philips	BAS16	BAS16	1
D117	Diode, Si High speed 75V SOT23	Philips	BAS16	BAS16	1
D201	Diode, Si High speed 75V SOT23	Philips	BAS16	BAS16	1
D202	Diode, Si High speed 75V SOT23	Philips	BAS16	BAS16	1
D203	Diode, Si High speed 75V SOT23	Philips	BAS16	BAS16	1
D204	Diode, Si High speed 75V SOT23	Philips	BAS16	BAS16	1
D205	Diode, Si High speed 75V SOT23	Philips	BAS16	BAS16	1
D206	Diode, Si High speed 75V SOT23	Philips	BAS16	BAS16	1
D207	Diode, Si High speed 75V SOT23	Philips	BAS16	BAS16	1
D208	Diode, Si High speed 75V SOT23	Philips	BAS16	BAS16	1
D209	Diode, Si High speed 75V SOT23	Philips	BAS16	BAS16	1
D210	Diode, Si High speed 75V SOT23	Philips	BAS16	BAS16	1

08-05979-001 - Control PCB 500W HF Amp

BOM Revision
Date Valid On

05 -- Production
28.09.2006

Ref	Description	Manufacturer	Manufacturer's P/N	Codan P/N	Qty
D211	Diode, Si High speed 75V SOT23	Philips	BAS16	BAS16	1
D212	Diode, Schottky SOT23	Philips	BAT54	BAT54	1
D213	Diode, Schottky SOT23	Philips	BAT54	BAT54	1
D214	Diode, Si High speed 75V SOT23	Philips	BAS16	BAS16	1
H101	LED, Tricolour T-1 3/4 Diffused	Liteon	LTL-52RG	65-61110-901	1
H201	LED, Red HE T-1 3/4 Diffused	Liteon	LTL-4223	65-61110-207	1
H202	LED, Red HE T-1 3/4 Diffused	Liteon	LTL-4223	65-61110-207	1
H203	LED, Red HE T-1 3/4 Diffused	Liteon	LTL-4223	65-61110-207	1
H204	LED, Red PLCC SMD Non Diffused	Siemens	LST670-L	65-61110-216	1
H205	LED, Red PLCC SMD Non Diffused	Siemens	LST670-L	65-61110-216	1
H206	LED, Red PLCC SMD Non Diffused	Siemens	LST670-L	65-61110-216	1
H207	LED, Red PLCC SMD Non Diffused	Siemens	LST670-L	65-61110-216	1
H208	LED, Red PLCC SMD Non Diffused	Siemens	LST670-L	65-61110-216	1
H209	LED, Red PLCC SMD Non Diffused	Siemens	LST670-L	65-61110-216	1
H210	LED, Red PLCC SMD Non Diffused	Siemens	LST670-L	65-61110-216	1
H211	LED, Red PLCC SMD Non Diffused	Siemens	LST670-L	65-61110-216	1
H212	LED, Red SMD R/A Diffused	Dialight	595-2101-007	65-61110-218	1
H213	LED, Red SMD R/A Diffused	Dialight	595-2101-007	65-61110-218	1
H214	LED, Red SMD R/A Diffused	Dialight	595-2101-007	65-61110-218	1
H215	LED, Red SMD R/A Diffused	Dialight	595-2101-007	65-61110-218	1
H216	LED, Red SMD R/A Diffused	Dialight	595-2101-007	65-61110-218	1
H217	LED, Red SMD R/A Diffused	Dialight	595-2101-007	65-61110-218	1
H218	LED, Red SMD R/A Diffused	Dialight	595-2101-007	65-61110-218	1
H219	LED, Red SMD R/A Diffused	Dialight	595-2101-007	65-61110-218	1
H220	LED, Red SMD R/A Diffused	Dialight	595-2101-007	65-61110-218	1
H221	LED, Red SMD R/A Diffused	Dialight	595-2101-007	65-61110-218	1
IC101	Reg, Voltage +5V 1A TO263_3	National Semiconduct	LM7805S	XB-07805-701	1
IC102	Buffer, Hex Inverting Schmitt SOIC14	Motorola	MC74HC14D	YH-74014-700	1
IC103	Micro prgmd, Hi Pwr PA Cntrlr	Codan	90-20611-001	90-20611-001	1

08-05979-001 - Control PCB 500W HF Amp

BOM Revision
Date Valid On

05 -- Production
28.09.2006

Ref	Description	Manufacturer	Manufacturer's P/N	Codan P/N	Qty
IC104	Driver, 8 Bit Serial I/P,latched SOIC20	Allegro	A5841SLW	YK-05841-700	1
IC105	Amp, Op Rail-Rail I/O Dual SOIC8	National Semiconduct	LMC6482IM	XA-06482-700	1
IC106	Amp, Op Rail-Rail I/O Dual SOIC8	National Semiconduct	LMC6482IM	XA-06482-700	1
IC107	Buffer, Hex Inverting Schmitt SOIC14	Motorola	MC74HC14D	YH-74014-700	1
IC108	Gate, AND 2 Input Quad SOIC14	Motorola	MC74HC08AD	YH-74008-700	1
IC109	Amp, Op Rail-Rail I/O Dual SOIC8	National Semiconduct	LMC6482IM	XA-06482-700	1
IC110	Amp, Op Rail-Rail I/O Dual SOIC8	National Semiconduct	LMC6482IM	XA-06482-700	1
IC201	Amp, Op Rail-Rail I/O Dual SOIC8	National Semiconduct	LMC6482IM	XA-06482-700	1
IC202	Amp, Op Rail-Rail I/O Dual SOIC8	National Semiconduct	LMC6482IM	XA-06482-700	1
IC203	Amp, Op Rail-Rail I/O Dual SOIC8	National Semiconduct	LMC6482IM	XA-06482-700	1
IC204	Amp, Op Rail-Rail I/O Dual SOIC8	National Semiconduct	LMC6482IM	XA-06482-700	1
IC205	Amp, Op Rail-Rail I/O Dual SOIC8	National Semiconduct	LMC6482IM	XA-06482-700	1
IC206	Amp, Op Rail-Rail I/O Dual SOIC8	National Semiconduct	LMC6482IM	XA-06482-700	1
IC207	Amp, Op Rail-Rail I/O Dual SOIC8	National Semiconduct	LMC6482IM	XA-06482-700	1
IC208	Driver, Lin Dot/Bar Display PLCC20	National Semiconduct	LM3914V	XA-03914-900	1
P101	Header (P) 10way 2row Boxed Fix	I-Technos	HDM410S02	60-00100-003	1
P102	Header (P) 6way 2mm Latch Fixed	AMP	173981-6	60-00060-350	1
P103	Header (P) 10way 2row Boxed Fix	I-Technos	HDM410S02	60-00100-003	1
P104	Not Fitted	Codan	**-00000-001	99-00000-001	1
P105	Header (P) 10way 2row Boxed Fix	I-Technos	HDM410S02	60-00100-003	1
P106	Header (P) 10way 2row Boxed Fix	I-Technos	HDM410S02	60-00100-003	1
P107	Header (P) 10way 2row Boxed Fix	I-Technos	HDM410S02	60-00100-003	1
P201	Header (P) 10way 2row Boxed Fix	I-Technos	HDM410S02	60-00100-003	1
P202	Header (P) 10way 2row Boxed Fix	I-Technos	HDM410S02	60-00100-003	1
P203	Not Fitted	Codan	**-00000-001	99-00000-001	1
P204	Header (P) 2way 1row Latch	JAE	IL-2P-S3EN2	60-00020-260	1
R101	10k Ohm 5% 0,1W 0805	Philips	2322-730-61103	40-41000-111	1
R102	1k Ohm 5% 0,1W 0805	Philips	2322-730-61102	40-31000-111	1
R103	1k Ohm 5% 0,1W 0805	Philips	2322-730-61102	40-31000-111	1
R104	10k Ohm 5% 0,1W 0805	Philips	2322-730-61103	40-41000-111	1

08-05979-001 - Control PCB 500W HF Amp

BOM Revision
Date Valid On

05 -- Production
28.09.2006

Ref	Description	Manufacturer	Manufacturer's P/N	Codan P/N	Qty
R105	10k Ohm 5% 0,1W 0805	Philips	2322-730-61103	40-41000-111	1
R106	10k Ohm 5% 0,1W 0805	Philips	2322-730-61103	40-41000-111	1
R107	5,6k Ohm 5% 0,1W 0805	Philips	2322 730 61562	40-35600-111	1
R108	10k Ohm 5% 0,1W 0805	Philips	2322-730-61103	40-41000-111	1
R109	10k Ohm 5% 0,1W 0805	Philips	2322-730-61103	40-41000-111	1
R110	10k Ohm 5% 0,1W 0805	Philips	2322-730-61103	40-41000-111	1
R111	1k Ohm 5% 0,1W 0805	Philips	2322-730-61102	40-31000-111	1
R112	10k Ohm 5% 0,1W 0805	Philips	2322-730-61103	40-41000-111	1
R113	10k Ohm 5% 0,1W 0805	Philips	2322-730-61103	40-41000-111	1
R114	10k Ohm 5% 0,1W 0805	Philips	2322-730-61103	40-41000-111	1
R115	10k Ohm 5% 0,1W 0805	Philips	2322-730-61103	40-41000-111	1
R116	120 Ohm 5% 0,1W 0805	Philips	2322 730 61121	40-21200-111	1
R117	270 Ohm 5% 0,1W 0805	Philips	2322 730 61271	40-22700-111	1
R118	10k Ohm 5% 0,1W 0805	Philips	2322-730-61103	40-41000-111	1
R119	10k Ohm 5% 0,1W 0805	Philips	2322-730-61103	40-41000-111	1
R120	10k Ohm 5% 0,1W 0805	Philips	2322-730-61103	40-41000-111	1
R121	10k Ohm 5% 0,1W 0805	Philips	2322-730-61103	40-41000-111	1
R122	10k Ohm 5% 0,1W 0805	Philips	2322-730-61103	40-41000-111	1
R123	1k Ohm 5% 0,1W 0805	Philips	2322-730-61102	40-31000-111	1
R124	1k Ohm 5% 0,1W 0805	Philips	2322-730-61102	40-31000-111	1
R125	47k Ohm 5% 0,1W 0805	Philips	2322 730 61473	40-44700-111	1
R126	10k Ohm 5% 0,1W 0805	Philips	2322-730-61103	40-41000-111	1
R127	220k Ohm 5% 0,1W 0805	Philips	2322 730 61224	40-52200-111	1
R128	10k Ohm 5% 0,1W 0805	Philips	2322-730-61103	40-41000-111	1
R129	220k Ohm 5% 0,1W 0805	Philips	2322 730 61224	40-52200-111	1
R130	47k Ohm 5% 0,1W 0805	Philips	2322 730 61473	40-44700-111	1
R131	22k Ohm 5% 0,1W 0805	Philips	2322 730 61223	40-42200-111	1
R132	22k Ohm 5% 0,1W 0805	Philips	2322 730 61223	40-42200-111	1
R133	220k Ohm 5% 0,1W 0805	Philips	2322 730 61224	40-52200-111	1

08-05979-001 - Control PCB 500W HF Amp

BOM Revision
Date Valid On

05 -- Production
28.09.2006

Ref	Description	Manufacturer	Manufacturer's P/N	Codan P/N	Qty
R134	1k Ohm 5% 0,1W 0805	Philips	2322-730-61102	40-31000-111	1
R135	2,2M Ohm 5% 0,1W 0805	Philips	2322 730 61225	40-62200-111	1
R136	100k Ohm 5% 0,1W 0805	Philips	2322 730 61104	40-51000-111	1
R137	22k Ohm 5% 0,1W 0805	Philips	2322 730 61223	40-42200-111	1
R138	10k Ohm 5% 0,1W 0805	Philips	2322-730-61103	40-41000-111	1
R139	100k Ohm 5% 0,1W 0805	Philips	2322 730 61104	40-51000-111	1
R140	100k Ohm 5% 0,1W 0805	Philips	2322 730 61104	40-51000-111	1
R141	10k Ohm 5% 0,1W 0805	Philips	2322-730-61103	40-41000-111	1
R142	150k Ohm 5% 0,1W 0805	Philips	2322 730 61154	40-51500-111	1
R143	3,3k Ohm 5% 0,1W 0805	Philips	2322 730 61332	40-33300-111	1
R144	1k Ohm 5% 0,1W 0805	Philips	2322-730-61102	40-31000-111	1
R145	33k Ohm 5% 0,1W 0805	Philips	2322 730 61333	40-43300-111	1
R146	1,5k Ohm 1% 0,1W 0805	Philips	2322 734 61502	40-31500-115	1
R147	1M Ohm 5% 0,1W 0805	Philips	2322 730 61105	40-61000-111	1
R148	560 Ohm 1% 0,1W 0805	Philips	2322 734 65601	40-25600-115	1
R149	1M Ohm 5% 0,1W 0805	Philips	2322 730 61105	40-61000-111	1
R150	22k Ohm 5% 0,1W 0805	Philips	2322 730 61223	40-42200-111	1
R151	1k Ohm 1% 0,1W 0805	Philips	2322 734 61002	40-31000-115	1
R152	1k Ohm 1% 0,1W 0805	Philips	2322 734 61002	40-31000-115	1
R153	1M Ohm 5% 0,1W 0805	Philips	2322 730 61105	40-61000-111	1
R154	22k Ohm 5% 0,1W 0805	Philips	2322 730 61223	40-42200-111	1
R155	100k Ohm 5% 0,1W 0805	Philips	2322 730 61104	40-51000-111	1
R156	2,7k Ohm 1% 0,1W 0805	Philips	2322 734 62702	40-32700-115	1
R157	15 Ohm 5% 3,0W MF Res	BC Components	2322 195 14159	40-11500-690	1
R158	Not Fitted	Codan	** -00000-001	99-00000-001	1
R159	4,7k Ohm 1% 0,1W 0805	Philips	2322 734 64702	40-34700-115	1
R160	4,7k Ohm 1% 0,1W 0805	Philips	2322 734 64702	40-34700-115	1
R161	100k Ohm 5% 0,1W 0805	Philips	2322 730 61104	40-51000-111	1
R162	100k Ohm 5% 0,1W 0805	Philips	2322 730 61104	40-51000-111	1

08-05979-001 - Control PCB 500W HF Amp

BOM Revision
Date Valid On

05 -- Production
28.09.2006

Ref	Description	Manufacturer	Manufacturer's P/N	Codan P/N	Qty
R201	100k Ohm 5% 0,1W 0805	Philips	2322 730 61104	40-51000-111	1
R202	100 Ohm 5% 0,1W 0805	Philips	2322 730 61101	40-21000-111	1
R203	33k Ohm 5% 0,1W 0805	Philips	2322 730 61333	40-43300-111	1
R204	39k Ohm 1% 0,1W 0805	Philips	2322 734 63903	40-43900-115	1
R205	100k Ohm 5% 0,1W 0805	Philips	2322 730 61104	40-51000-111	1
R206	1k Ohm 5% 0,1W 0805	Philips	2322-730-61102	40-31000-111	1
R207	1k Ohm 5% 0,1W 0805	Philips	2322-730-61102	40-31000-111	1
R208	2,2M Ohm 5% 0,1W 0805	Philips	2322 730 61225	40-62200-111	1
R209	27k Ohm 5% 0,1W 0805	Philips	2322 730 61273	40-42700-111	1
R210	56k Ohm 5% 0,1W 0805	Philips	2322 730 61563	40-45600-111	1
R211	33k Ohm 5% 0,1W 0805	Philips	2322 730 61333	40-43300-111	1
R212	100k Ohm 5% 0,1W 0805	Philips	2322 730 61104	40-51000-111	1
R213	390 Ohm 5% 0,1W 0805	Philips	2322 730 61391	40-23900-111	1
R214	15k Ohm 5% 0,1W 0805	Philips	2322 730 61153	40-41500-111	1
R215	1k Ohm 5% 0,1W 0805	Philips	2322-730-61102	40-31000-111	1
R216	100k Ohm 5% 0,1W 0805	Philips	2322 730 61104	40-51000-111	1
R217	4,7k Ohm 5% 0,1W 0805	Philips	2322 730 61472	40-34700-111	1
R218	Pot,10k Lin MG Trim SMD	Bourns	3314 J-1-103	42-41004-000	1
R219	100 Ohm 5% 0,1W 0805	Philips	2322 730 61101	40-21000-111	1
R220	33k Ohm 5% 0,1W 0805	Philips	2322 730 61333	40-43300-111	1
R221	100k Ohm 5% 0,1W 0805	Philips	2322 730 61104	40-51000-111	1
R222	390 Ohm 5% 0,1W 0805	Philips	2322 730 61391	40-23900-111	1
R223	56k Ohm 5% 0,1W 0805	Philips	2322 730 61563	40-45600-111	1
R224	1,8k Ohm 5% 0,1W 0805	Philips	2322 730 61182	40-31800-111	1
R225	47k Ohm 5% 0,1W 0805	Philips	2322 730 61473	40-44700-111	1
R226	12k Ohm 5% 0,1W 0805	Philips	2322 730 61123	40-41200-111	1
R227	47k Ohm 5% 0,1W 0805	Philips	2322 730 61473	40-44700-111	1
R228	47k Ohm 5% 0,1W 0805	Philips	2322 730 61473	40-44700-111	1
R229	82k Ohm 5% 0,1W 0805	Philips	2322 730 61823	40-48200-111	1

08-05979-001 - Control PCB 500W HF Amp

BOM Revision
Date Valid On

05 -- Production
28.09.2006

Ref	Description	Manufacturer	Manufacturer's P/N	Codan P/N	Qty
R230	100k Ohm 5% 0,1W 0805	Philips	2322 730 61104	40-51000-111	1
R231	390 Ohm 5% 0,1W 0805	Philips	2322 730 61391	40-23900-111	1
R232	100k Ohm 5% 0,1W 0805	Philips	2322 730 61104	40-51000-111	1
R233	22k Ohm 5% 0,1W 0805	Philips	2322 730 61223	40-42200-111	1
R234	39k Ohm 5% 0,1W 0805	Philips	2322 730 61393	40-43900-111	1
R235	180k Ohm 5% 0,1W 0805	Philips	2322 730 61184	40-51800-111	1
R236	33k Ohm 5% 0,1W 0805	Philips	2322 730 61333	40-43300-111	1
R237	10k Ohm 1% 0,1W 0805	Philips	2322 734 61003	40-41000-115	1
R238	100k Ohm 5% 0,1W 0805	Philips	2322 730 61104	40-51000-111	1
R239	390 Ohm 5% 0,1W 0805	Philips	2322 730 61391	40-23900-111	1
R240	22k Ohm 5% 0,1W 0805	Philips	2322 730 61223	40-42200-111	1
R241	47k Ohm 5% 0,1W 0805	Philips	2322 730 61473	40-44700-111	1
R242	220k Ohm 5% 0,1W 0805	Philips	2322 730 61224	40-52200-111	1
R243	8,2k Ohm 5% 0,1W 0805	Philips	2322 730 61822	40-38200-111	1
R244	680k Ohm 5% 0,1W 0805	Philips	2322 730 61684	40-56800-111	1
R245	2,2M Ohm 5% 0,1W 0805	Philips	2322 730 61225	40-62200-111	1
R246	1,5k Ohm 5% 0,1W 0805	Philips	2322 730 61152	40-31500-111	1
R247	68k Ohm 5% 0,1W 0805	Philips	2322 730 61683	40-46800-111	1
R248	18k Ohm 5% 0,1W 0805	Philips	2322 730 61183	40-41800-111	1
R249	47k Ohm 5% 0,1W 0805	Philips	2322 730 61473	40-44700-111	1
R250	390 Ohm 5% 0,1W 0805	Philips	2322 730 61391	40-23900-111	1
R251	100k Ohm 5% 0,1W 0805	Philips	2322 730 61104	40-51000-111	1
R252	22k Ohm 5% 0,1W 0805	Philips	2322 730 61223	40-42200-111	1
R253	220k Ohm 5% 0,1W 0805	Philips	2322 730 61224	40-52200-111	1
R254	330k Ohm 5% 0,1W 0805	Philips	2322 730 61334	40-53300-111	1
R255	6,8k Ohm 5% 0,1W 0805	Philips	2322 730 61682	40-36800-111	1
R256	10k Ohm 5% 0,1W 0805	Philips	2322-730-61103	40-41000-111	1
R257	Pot,10k Lin MG Trim SMD	Bourns	3314 J-1-103	42-41004-000	1
R258	47k Ohm 5% 0,1W 0805	Philips	2322 730 61473	40-44700-111	1

08-05979-001 - Control PCB 500W HF Amp

BOM Revision
Date Valid On

05 -- Production
28.09.2006

Ref	Description	Manufacturer	Manufacturer's P/N	Codan P/N	Qty
R259	3,9k Ohm 5% 0,1W 0805	Philips	2322 730 61392	40-33900-111	1
R260	1k Ohm 5% 0,1W 0805	Philips	2322-730-61102	40-31000-111	1
R261	150k Ohm 5% 0,1W 0805	Philips	2322 730 61154	40-51500-111	1
S201	Switch, Toggle SPDT on-on	C&K	7101-P3-Y-Z-Q-E	62-01220-000	1
V101	Transistor, NPN Si SOT23	Philips	BC848	BC848	1
V102	Transistor, NPN Si SOT23	Philips	BC848	BC848	1
V103	Transistor, PNP Si SOT23	Philips	BC858	BC858	1
V104	Transistor, PNP Si SOT23	Philips	BC858	BC858	1
V105	Transistor, NPN Si SOT23	Philips	BC848	BC848	1
V106	Not Fitted	Codan	** -00000-001	99-00000-001	1
V107	MOSFET, Power N channel TO252	Motorola	MTD3055EL	MTD3055EL	1
V108	MOSFET, Power N channel TO252	Motorola	MTD3055EL	MTD3055EL	1
V109	MOSFET, Power N channel TO252	Motorola	MTD3055EL	MTD3055EL	1
V110	Transistor, NPN Si SOT23	Philips	BC848	BC848	1
V201	Transistor, NPN Si SOT23	Philips	BC848	BC848	1
V202	Transistor, NPN Si SOT23	Philips	BC848	BC848	1
V203	Transistor, NPN Si SOT23	Philips	BC848	BC848	1
V204	Transistor, PNP Si SOT23	Philips	BC858	BC858	1
V205	Transistor, NPN Si SOT23	Philips	BC848	BC848	1
V206	Transistor, NPN Si SOT23	Philips	BC848	BC848	1
V207	Transistor, NPN Si SOT23	Philips	BC848	BC848	1
V208	Transistor, NPN Si SOT23	Philips	BC848	BC848	1
V209	Transistor, NPN Si SOT23	Philips	BC848	BC848	1
V210	Transistor, NPN Si SOT23	Philips	BC848	BC848	1

08-05978-001 - PSU 500/1000 W PA PCB

BOM Revision
Date Valid On

02 -- Production
28.09.2006

Ref	Description	Manufacturer	Manufacturer's P/N	Codan P/N	Qty
	PSU 500/1000W Amp			04-03417	1
	PSU 500/1000 W PA PCB			08-05978	1
	TP,500W/1kW PSU Intermed Build			10-00925	1
1	PCB, PSU 500/1000W PA	IMP	07-01986-03	07-01986-03	1
2	Rivet, Tinned Brass Chobert 4,0dx9,5	Avdel	01143-00516	33-40340-095	4
3	Standoff, PCB 3,6x6	PEM	KFE-3,6-6ET	33-53604-060	6
4	Stake, Terminal	Autosplice	7-22461-5	61-40300-004	2
C1	2,2u 20% 20V 3528 TA Cap	AVX	TAJB225M020R	47-02202-000	1
C2	100n 10% 50V X7R 0805 Nisn	Philips	08052R104K9BB	46-51000-282	1
C3	1n 5% 50V NPO 0805 NiSn	Philips	0805CG102J9BB-	46-31000-082	1
C4	100n 10% 50V X7R 0805 Nisn	Philips	08052R104K9BB	46-51000-282	1
C5	33n 10% 50V X7R 0805 NiSn	Philips	08052R333K9BB00	46-43300-281	1
C7	100n 10% 50V X7R 0805 Nisn	Philips	08052R104K9BB	46-51000-282	1
C8	100u 25V 105°C SMD EL Cap Low ESR	Nippon Chemicon	MVY25VC100MF80	48-21002-502	1
C9	100n 10% 50V X7R 0805 Nisn	Philips	08052R104K9BB	46-51000-282	1
C10	100n 10% 250V PE Cap	BC Components	2222 370 41104	46-51000-522	1
C11	100n 10% 250V PE Cap	BC Components	2222 370 41104	46-51000-522	1
C12	1000u 160V 105°C Ra EL Cap Low ESR	Nippon Chemicon	KMH160VNSN1000M25 E	48-31016-000	1
C13	1000u 160V 105°C Ra EL Cap Low ESR	Nippon Chemicon	KMH160VNSN1000M25 E	48-31016-000	1
C14	1000u 160V 105°C Ra EL Cap Low ESR	Nippon Chemicon	KMH160VNSN1000M25 E	48-31016-000	1
C15	100n 10% 100V X7R CE Cap	Cinetech	RD20B104K2AL5B	46-51000-263	1
C16	100n 10% 100V X7R CE Cap	Cinetech	RD20B104K2AL5B	46-51000-263	1
C17	470n 10% 16V X7R 1206 NiSn	AVX	1206YC474KAT1A	46-54700-282	1
C18	330u 100V 105°C Ra EL Cap Low ESR	Nippon Chemicon	LXV100VB330ML30	48-23310-001	1
C19	330u 100V 105°C Ra EL Cap Low ESR	Nippon Chemicon	LXV100VB330ML30	48-23310-001	1
C20	330u 100V 105°C Ra EL Cap Low ESR	Nippon Chemicon	LXV100VB330ML30	48-23310-001	1
C21	3,3n 10% 100V X7R 0805 NiSn	Philips	08052R332K0B200	46-33300-281	1
C22	470p 5% 50V NPO 0805 NiSn	Philips	0805CG471J9B200	46-24700-081	1
C23	100n 10% 50V X7R 0805 Nisn	Philips	08052R104K9BB	46-51000-282	1
C24	100p 5% 500V NPO 1210 NiSn	Philips	1210CG101GBB-	46-21000-082	1
C25	100p 5% 50V NPO 0805 NiSn	Philips	0805CG101J9B200	46-21000-081	1

08-05978-001 - PSU 500/1000 W PA PCB

BOM Revision
Date Valid On

02 -- Production
 28.09.2006

Ref	Description	Manufacturer	Manufacturer's P/N	Codan P/N	Qty
C26	470u 25V 105°C Ra EL Cap Low ESR	Nippon Chemicon	LXJ25VB470M10X16	48-24702-500	1
C27	470u 25V 105°C Ra EL Cap Low ESR	Nippon Chemicon	LXJ25VB470M10X16	48-24702-500	1
C28	100n 10% 50V X7R 0805 NiSn	Philips	08052R104K9BB	46-51000-282	1
C29	100n 10% 50V X7R 0805 NiSn	Philips	08052R104K9BB	46-51000-282	1
C30	470u 25V 105°C Ra EL Cap Low ESR	Nippon Chemicon	LXJ25VB470M10X16	48-24702-500	1
C31	10u 20% 25V 6032 TA Cap	AVX	TAJC106M025R	47-11002-520	1
C32	470p 5% 500V NPO 1210 NiSn	Philips	1210CG471GBB-	46-24700-082	1
C33	4,7u 20% 20V 6032 TA Cap	AVX	TAJC475M020R	47-04702-020	1
C34	4,7u 20% 20V 6032 TA Cap	AVX	TAJC475M020R	47-04702-020	1
C35	1n 5% 50V NPO 0805 NiSn	Philips	0805CG102J9BB-	46-31000-082	1
C101	2,2u 20% 20V 3528 TA Cap	AVX	TAJB225M020R	47-02202-000	1
C102	100n 10% 50V X7R 0805 NiSn	Philips	08052R104K9BB	46-51000-282	1
C103	1n 5% 50V NPO 0805 NiSn	Philips	0805CG102J9BB-	46-31000-082	1
C104	100n 10% 50V X7R 0805 NiSn	Philips	08052R104K9BB	46-51000-282	1
C105	100n 10% 50V X7R 0805 NiSn	Philips	08052R104K9BB	46-51000-282	1
C107	100n 10% 50V X7R 0805 NiSn	Philips	08052R104K9BB	46-51000-282	1
C108	100u 25V 105°C SMD EL Cap Low ESR	Nippon Chemicon	MVY25VC100MF80	48-21002-502	1
C109	100n 10% 50V X7R 0805 NiSn	Philips	08052R104K9BB	46-51000-282	1
C110	100n 10% 250V PE Cap	BC Components	2222 370 41104	46-51000-522	1
C111	100n 10% 250V PE Cap	BC Components	2222 370 41104	46-51000-522	1
C112	1000u 160V 105°C Ra EL Cap Low ESR	Nippon Chemicon	KMH160VNSN1000M25 E	48-31016-000	1
C113	1000u 160V 105°C Ra EL Cap Low ESR	Nippon Chemicon	KMH160VNSN1000M25 E	48-31016-000	1
C114	1000u 160V 105°C Ra EL Cap Low ESR	Nippon Chemicon	KMH160VNSN1000M25 E	48-31016-000	1
C115	100n 10% 100V X7R CE Cap	Cinetech	RD20B104K2AL5B	46-51000-263	1
C116	100n 10% 100V X7R CE Cap	Cinetech	RD20B104K2AL5B	46-51000-263	1
C117	470n 10% 16V X7R 1206 NiSn	AVX	1206YC474KAT1A	46-54700-282	1
C118	330u 100V 105°C Ra EL Cap Low ESR	Nippon Chemicon	LXV100VB330ML30	48-23310-001	1
C119	330u 100V 105°C Ra EL Cap Low ESR	Nippon Chemicon	LXV100VB330ML30	48-23310-001	1
C120	330u 100V 105°C Ra EL Cap Low ESR	Nippon Chemicon	LXV100VB330ML30	48-23310-001	1

08-05978-001 - PSU 500/1000 W PA PCB

BOM Revision
Date Valid On

02 -- Production
28.09.2006

Ref	Description	Manufacturer	Manufacturer's P/N	Codan P/N	Qty
C132	470p 5% 500V NPO 1210 NiSn	Philips	1210CG471GBB-	46-24700-082	1
C135	1n 5% 50V NPO 0805 NiSn	Philips	0805CG102J9BB-	46-31000-082	1
D1	Diode, Si High speed 75V SOT23	Philips	BAS16	BAS16	1
D2	Diode, Si High speed 75V SOT23	Philips	BAS16	BAS16	1
D3	Diode, Si High speed 75V SOT23	Philips	BAS16	BAS16	1
D4	Diode, Si High speed 75V SOT23	Philips	BAS16	BAS16	1
D5	Diode, Si High speed 75V SOT23	Philips	BAS16	BAS16	1
D6	Diode, Si 200V 5A	General Electric	1N5624 (365-373)	1N5624	1
D7	Diode, Schottky 40V 3A SMC	Motorola	MBRS340T3	MBRS340T3	1
D8	Diode, Si High speed 75V SOT23	Philips	BAS16	BAS16	1
D9	Diode, Si High speed 75V SOT23	Philips	BAS16	BAS16	1
D11	Diode, Schottky SOT23	Philips	BAT54	BAT54	1
D101	Diode, Si High speed 75V SOT23	Philips	BAS16	BAS16	1
D102	Diode, Si High speed 75V SOT23	Philips	BAS16	BAS16	1
D103	Diode, Si High speed 75V SOT23	Philips	BAS16	BAS16	1
D104	Diode, Si High speed 75V SOT23	Philips	BAS16	BAS16	1
D105	Diode, Si High speed 75V SOT23	Philips	BAS16	BAS16	1
D106	Diode, Si 200V 5A	General Electric	1N5624 (365-373)	1N5624	1
IC1	Reg, Voltage, Switching SOIC16	National Semiconduct	LM3524DM	XB-03524-700	1
IC2	Driver, Half-Bridge MOSFET 600V SOIC14	IR	IR21834S	XF-21834-700	1
IC3	Amp, Rail to Rail I/O Low Offset SOT23-5	National Semiconduct	LMC7101AIM5	XA-07101-701	1
IC4	Comparator, Dual O/C Output SOIC8	National Semiconduct	LM393M	XD-00393-700	1
IC5	Gate, NAND 2 Input Quad SOIC14	Motorola	MC74HC00AD	YH-74000-700	1
IC101	Reg, Voltage, Switching SOIC16	National Semiconduct	LM3524DM	XB-03524-700	1
IC102	Driver, Half-Bridge MOSFET 600V SOIC14	IR	IR21834S	XF-21834-700	1
IC103	Amp, Rail to Rail I/O Low Offset SOT23-5	National Semiconduct	LMC7101AIM5	XA-07101-701	1
L1	Ind, 32uH 16A SMPS	Pulse	PE-51507	43-81320-000	1
L2	Ind, 32uH 16A SMPS	Pulse	PE-51507	43-81320-000	1
L3	Ind, 145uH 3A SMPS	Pulse	PE-92105K	43-82145-000	1
L101	Ind, 32uH 16A SMPS	Pulse	PE-51507	43-81320-000	1
L102	Ind, 32uH 16A SMPS	Pulse	PE-51507	43-81320-000	1
P1	Header (P) 10way 2row Boxed Fix	I-Technos	HDM410S02	60-00100-003	1
P2	Header (P) 2way 1row Latch	JAE	IL-2P-S3EN2	60-00020-260	1

08-05978-001 - PSU 500/1000 W PA PCB

BOM Revision
Date Valid On

02 -- Production
28.09.2006

Ref	Description	Manufacturer	Manufacturer's P/N	Codan P/N	Qty
P3	Header (P) 6way 2mm Latch Fixed	AMP	173981-6	60-00060-350	1
P102	Header (P) 2way 1row Latch	JAE	IL-2P-S3EN2	60-00020-260	1
R1	100k Ohm 5% 0,1W 0805	Philips	2322 730 61104	40-51000-111	1
R2	6,8k Ohm 1% 0,1W 0805	Philips	2322 734 66802	40-36800-115	1
R3	8,2k Ohm 1% 0,1W 0805	Philips	2322 734 68202	40-38200-115	1
R4	33k Ohm 1% 0,1W 0805	Philips	2322 734 63303	40-43300-115	1
R5	27k Ohm 1% 0,1W 0805	Philips	2322 734 62703	40-42700-115	1
R6	100 Ohm 5% 0,1W 0805	Philips	2322 730 61101	40-21000-111	1
R7	Pot,1k Lin MG Trim SMD	Bourns	3314 J-1-102	42-31004-000	1
R8	6,8k Ohm 5% 0,1W 0805	Philips	2322 730 61682	40-36800-111	1
R9	1k Ohm 5% 0,1W 0805	Philips	2322-730-61102	40-31000-111	1
R10	10k Ohm 1% 0,1W 0805	Philips	2322 734 61003	40-41000-115	1
R11	180 Ohm 5% 0,1W 0805	Philips	2322 730 61181	40-21800-111	1
R12	Pot,100 Lin MG Trim SMD	Bourns	3314 J-1-101	42-21004-000	1
R13	3,3k Ohm 5% 0,1W 0805	Philips	2322 730 61332	40-33300-111	1
R14	1,5k Ohm 1% 0,1W 0805	Philips	2322 734 61502	40-31500-115	1
R15	68k Ohm 5% 0,1W 0805	Philips	2322 730 61683	40-46800-111	1
R16	10k Ohm 5% 0,1W 0805	Philips	2322-730-61103	40-41000-111	1
R17	Pot,10k Lin MG Trim SMD	Bourns	3314 J-1-103	42-41004-000	1
R18	220k Ohm 5% 0,1W 0805	Philips	2322 730 61224	40-52200-111	1
R19	100k Ohm 5% 0,1W 0805	Philips	2322 730 61104	40-51000-111	1
R20	4,7k Ohm 5% 0,1W 0805	Philips	2322 730 61472	40-34700-111	1
R21	10 Ohm 5% 0,125W 1206	Philips	2322 711 61109	40-11000-101	1
R22	15 Ohm 5% 0,125W 1206	Philips	2322 711 61159	40-11500-101	1
R24	0,015 Ohm 1% 1,0W 2512	Vishay	WSL2512R0150FEA	40-00015-132	1
R25	0,015 Ohm 1% 1,0W 2512	Vishay	WSL2512R0150FEA	40-00015-132	1
R26	0,015 Ohm 1% 1,0W 2512	Vishay	WSL2512R0150FEA	40-00015-132	1
R27	220 Ohm 1% 0,1W 0805	Philips	2322 734 62201	40-22200-115	1
R28	2,2k Ohm 1% 0,1W 0805	Philips	2322 734 62202	40-32200-115	1

08-05978-001 - PSU 500/1000 W PA PCB

BOM Revision
Date Valid On

02 -- Production
28.09.2006

Ref	Description	Manufacturer	Manufacturer's P/N	Codan P/N	Qty
R29	680 Ohm 1% 0,1W 0805	Philips	2322 734 66801	40-26800-115	1
R30	100k Ohm 5% 0,1W 0805	Philips	2322 730 61104	40-51000-111	1
R31	4,7k Ohm 5% 0,1W 0805	Philips	2322 730 61472	40-34700-111	1
R32	22k Ohm 5% 0,1W 0805	Philips	2322 730 61223	40-42200-111	1
R33	22k Ohm 5% 0,1W 0805	Philips	2322 730 61223	40-42200-111	1
R34	4,7k Ohm 5% 0,1W 0805	Philips	2322 730 61472	40-34700-111	1
R35	100 Ohm 5% 0,125W 1206	Philips	2322 711 61101	40-21000-101	1
R36	1,5k Ohm 5% 0,1W 0805	Philips	2322 730 61152	40-31500-111	1
R37	47k Ohm 5% 0,1W 0805	Philips	2322 730 61473	40-44700-111	1
R38	3,3k Ohm 5% 0,1W 0805	Philips	2322 730 61332	40-33300-111	1
R39	100k Ohm 5% 0,1W 0805	Philips	2322 730 61104	40-51000-111	1
R40	4,7 Ohm 5% 0,125W 1206	Philips	2322 711 61478	40-04700-101	1
R41	10k Ohm 5% 0,1W 0805	Philips	2322-730-61103	40-41000-111	1
R42	470 Ohm 5% 0,1W 0805	Philips	2322 730 61471	40-24700-111	1
R43	47k Ohm 5% 0,1W 0805	Philips	2322 730 61473	40-44700-111	1
R44	100k Ohm 1% 0,1W 0805	Philips	2311 734 61004	40-51000-115	1
R45	4,7k Ohm 1% 0,1W 0805	Philips	2322 734 64702	40-34700-115	1
R46	680 Ohm 5% 0,1W 0805	Philips	2322 730 61681	40-26800-111	1
R47	2,2k Ohm 5% 0,1W 0805	Philips	2322 730 61222	40-32200-111	1
R48	8,2k Ohm 5% 0,1W 0805	Philips	2322 730 61822	40-38200-111	1
R101	100k Ohm 5% 0,1W 0805	Philips	2322 730 61104	40-51000-111	1
R102	6,8k Ohm 1% 0,1W 0805	Philips	2322 734 66802	40-36800-115	1
R103	8,2k Ohm 1% 0,1W 0805	Philips	2322 734 68202	40-38200-115	1
R104	33k Ohm 1% 0,1W 0805	Philips	2322 734 63303	40-43300-115	1
R105	27k Ohm 1% 0,1W 0805	Philips	2322 734 62703	40-42700-115	1
R106	100 Ohm 5% 0,1W 0805	Philips	2322 730 61101	40-21000-111	1
R108	2,2k Ohm 5% 0,1W 0805	Philips	2322 730 61222	40-32200-111	1
R110	10k Ohm 1% 0,1W 0805	Philips	2322 734 61003	40-41000-115	1
R111	180 Ohm 5% 0,1W 0805	Philips	2322 730 61181	40-21800-111	1

08-05978-001 - PSU 500/1000 W PA PCB

BOM Revision
Date Valid On

02 -- Production
28.09.2006

Ref	Description	Manufacturer	Manufacturer's P/N	Codan P/N	Qty
R112	Pot,100 Lin MG Trim SMD	Bourns	3314 J-1-101	42-21004-000	1
R113	3,3k Ohm 5% 0,1W 0805	Philips	2322 730 61332	40-33300-111	1
R114	1,5k Ohm 1% 0,1W 0805	Philips	2322 734 61502	40-31500-115	1
R115	68k Ohm 5% 0,1W 0805	Philips	2322 730 61683	40-46800-111	1
R116	11k Ohm 1% 0,1W 0805	Philips	2322 734 61103	40-41100-115	1
R117	Pot,10k Lin MG Trim SMD	Bourns	3314 J-1-103	42-41004-000	1
R118	220k Ohm 5% 0,1W 0805	Philips	2322 730 61224	40-52200-111	1
R119	68k Ohm 5% 0,1W 0805	Philips	2322 730 61683	40-46800-111	1
R120	4,7k Ohm 5% 0,1W 0805	Philips	2322 730 61472	40-34700-111	1
R121	10 Ohm 5% 0,125W 1206	Philips	2322 711 61109	40-11000-101	1
R122	15 Ohm 5% 0,125W 1206	Philips	2322 711 61159	40-11500-101	1
R124	0,015 Ohm 1% 1,0W 2512	Vishay	WSL2512R0150FEA	40-00015-132	1
R125	0,015 Ohm 1% 1,0W 2512	Vishay	WSL2512R0150FEA	40-00015-132	1
R126	0,015 Ohm 1% 1,0W 2512	Vishay	WSL2512R0150FEA	40-00015-132	1
R127	220 Ohm 1% 0,1W 0805	Philips	2322 734 62201	40-22200-115	1
R128	2,2k Ohm 1% 0,1W 0805	Philips	2322 734 62202	40-32200-115	1
R129	680 Ohm 1% 0,1W 0805	Philips	2322 734 66801	40-26800-115	1
R140	4,7 Ohm 5% 0,125W 1206	Philips	2322 711 61478	40-04700-101	1
R141	10k Ohm 5% 0,1W 0805	Philips	2322-730-61103	40-41000-111	1
T1	Txfr, Pulse 2:1+1 200Vus 3kHz-3MHz	Oxford Electrical	PT8	43-20000	1
TP2	Header (P) 2way 1row	Molex	22-03-2021	60-00021-100	1
TP102	Header (P) 2way 1row	Molex	22-03-2021	60-00021-100	1
V1	Transistor, NPN Si SOT23	Philips	BC848	BC848	1
V2	Transistor, NPN Si SOT23	Philips	BC848	BC848	1
V3	Transistor, NPN Si SOT23	Philips	BC848	BC848	1
V4	Diode, Zener 30V 5% 0,2W SOT23	Philips	BZX84-C30	BZX84C30	1
V7	Transistor, NPN Si SOT23	Philips	BC848	BC848	1
V8	Transistor, PNP Si 250V 50mA 0,25W SOT23	Philips	BF823	BF823	1
V9	Transistor, PNP Si 250V 50mA 0,25W SOT23	Philips	BF823	BF823	1
V10	MOSFET, N Channel Enhance SOT223	Philips	BSP126	BSP126	1

08-05978-001 - PSU 500/1000 W PA PCB

BOM Revision
Date Valid On

02 -- Production
28.09.2006

Ref	Description	Manufacturer	Manufacturer's P/N	Codan P/N	Qty
V11	Diode, Zener 6,8V 5% 0,2W SOT23	Philips	BZX84C6V8	BZX84C6V8	1
V101	Transistor, NPN Si SOT23	Philips	BC848	BC848	1
V102	Transistor, NPN Si SOT23	Philips	BC848	BC848	1
V103	Transistor, NPN Si SOT23	Philips	BC848	BC848	1
V104	Diode, Zener 30V 5% 0,2W SOT23	Philips	BZX84-C30	BZX84C30	1
V107	Transistor, NPN Si SOT23	Philips	BC848	BC848	1
V108	Transistor, PNP Si 250V 50mA 0,25W SOT23	Philips	BF823	BF823	1
V109	Transistor, PNP Si 250V 50mA 0,25W SOT23	Philips	BF823	BF823	1

08-05984-001 - Rear Panel PCB

BOM Revision
Date Valid On

02 -- Production
28.09.2006

Ref	Description	Manufacturer	Manufacturer's P/N	Codan P/N	Qty
	Rear Panel PCB			08-05984	1
	Rear Panel			04-03421	1
1	PCB,Rear Panel		07-01990-3	07-01990-03	1
2	Stake, Terminal	Autosplice	7-22461-5	61-40300-004	4
3	Socket, UHF Fixed	Marushin	MR-588	60-11360-588	1
C1	100n 10% 50V X7R 0805 Nisn	Philips	08052R104K9BB	46-51000-282	1
C2	100n 10% 50V X7R 0805 Nisn	Philips	08052R104K9BB	46-51000-282	1
C3	100n 10% 50V X7R 0805 Nisn	Philips	08052R104K9BB	46-51000-282	1
C4	100n 10% 50V X7R 0805 Nisn	Philips	08052R104K9BB	46-51000-282	1
C5	1n 5% 50V NPO 0805 NiSn	Philips	0805CG102J9BB-	46-31000-082	1
C6	10n 10% 100V X7R 0805 NiSn	Philips	08052R103K0B200	46-41000-281	1
C7	10n 10% 100V X7R 0805 NiSn	Philips	08052R103K0B200	46-41000-281	1
C8	1500u 25V 105°C Ra EL Cap Low ESR	Nippon Chemicon	LXJ25VB1500M16X20	48-31502-500	1
D1	Diode, Si High speed 75V SOT23	Philips	BAS16	BAS16	1
J1	Socket, 9way D Filtered Str. PCB w/Screw	Kycon	KF85-ED-9S-KJ	60-00093-003	1
L1	Choke, EM/EMC 0A DC >1MHz 4516	Taiyo Yuden	FCFBMJ 4516 HS 110-T	43-90003	1
L2	Choke, EM/EMC 0A DC >1MHz 4516	Taiyo Yuden	FCFBMJ 4516 HS 110-T	43-90003	1
L3	Ind, 100uH 10% 4532	Taiyo Yuden	LEM 4532T101K	43-82100-134	1
L4	Ind, 100uH 10% 4532	Taiyo Yuden	LEM 4532T101K	43-82100-134	1
P1	Header (P) 10way 2row Boxed Fix	I-Technos	HDM410S02	60-00100-003	1
P2	Header (P) 10way 2row Boxed Fix	I-Technos	HDM410S02	60-00100-003	1
P3	Plug, 7way Fixed	NS	1507L w/round nut	60-00070-601	1
R1	220 Ohm 5% 0,1W 0805	Philips	2322 730 61221	40-22200-111	1
R2	1k Ohm 5% 0,1W 0805	Philips	2322-730-61102	40-31000-111	1
R3	100k Ohm 5% 0,1W 0805	Philips	2322 730 61104	40-51000-111	1
R4	1k Ohm 5% 0,1W 0805	Philips	2322-730-61102	40-31000-111	1
R5	10k Ohm 1% 0,1W 0805	Philips	2322 734 61003	40-41000-115	1
R6	1k Ohm 5% 0,1W 0805	Philips	2322-730-61102	40-31000-111	1
R7	68 Ohm 5% 0,1W 0805	Philips	2322 730 61689	40-16800-111	1
R8	1k Ohm 5% 0,1W 0805	Philips	2322-730-61102	40-31000-111	1

08-06067-001 - 3061 Power Supply 500W

BOM Revision
Date Valid On

01 -- Production
25.10.2006

Ref	Description	Manufacturer	Manufacturer's P/N	Codan P/N	Qty
	Power Supply 3061/3062			04-03453	1
	Final Assy 500W PSU			11-06103	1
	TP, 500W/1kW PSU Final Assy			10-00937	1
*	Final Assy, 500W PSU			08-06067	1
1	Cover, Cable PSU HPPA	Codan	05-07338	05-07338	1
2	Panel, Base/Top, HPPA/PSU	Metalcraft	05-07347	05-07347	1
3	Label, Rating 500W PSU	Codan	06-02149-001	06-02149-001	1
4	Label, Chassis Earth	Entech	06-02162	06-02162	1
5	Structural Assy, 500W PSU	Codan	08-06066-001	08-06066-001	1
6	Cable, DC Filter to O/P	Auto Assemblies	08-06107-001	08-06107-001	1
7	Cable, AC I/P to Switch 3061	Auto Assemblies	08-06108-001	08-06108-001	1
8	Cable, DC (-) Filter to Earth	Auto Assemblies	08-06110-001	08-06110-001	1
9	Cable, SMPS Earth to Chassis	Auto Assemblies	08-06111-001	08-06111-001	1
10	Cable, DC (+) SMPS to Filters	Auto Assemblies	08-06112-001	08-06112-001	1
11	Cable, DC (-) SMPS to Filters	Auto Assemblies	08-06113-001	08-06113-001	1
12	Cable, Switch to SMPS Active	Auto Assemblies	08-06114-001	08-06114-001	1
13	Cable, Switch to SMPS Neutral	Auto Assemblies	08-06115-001	08-06115-001	1
14	Clamp, Cable Adhesive	Richco	SK3	30-05102-001	1
15	Clamp, Cable Adhesive	Richco	SK6	30-05102-002	3
16	Bush, Strain Relief	Heyco	1170 (BLACK)	30-03802-006	1
17	Label, Danger isolated mains	Farnell	143-548	30-23001-003	1
18	Tie, Cable 2,5mm W x 115mm Long	Richco	WIT 18 R	30-39100-004	3
19	Screw, M3x6 304 SS Pan Pozi	*	31-23006-580	31-23006-580	16
20	Screw, M3x8 304 SS Pan Pozi	*	31-23008-580	31-23008-580	8
21	Screw, M3x10 304 SS Bk Csk Pozi	Spec 01-00205	31-23010-782	31-23010-782	2
22	Nut, M3 304 SS Nyloc	James Glen	31-23000-780	31-23000-780	4
23	Washer, M4 304 SS Normal	*	31-24001-080	31-24001-080	4
24	Plug, 3way 250VAC 10A Free	Bulgin	PX0580/63	60-80030-000	1
25	Switch, Rocker DPST Illuminated 250V 16A	Arcoelectric	C1353VQNAC	62-02103	1
26	Filter, RFI 250VAC 20A Spade Connector	Schaffner	FN2020-20-06	78-06030	2
27	PSU, 90-264VAC in, 48-72VDCout750W SMPS	Amtex	ZX750-9660-CT	78-16021	1
28	Cable, Filter to Switch Active	Auto Assemblies	08-06218-001	08-06218-001	1
29	Cable, Filter to Switch Neutral	Auto Assemblies	08-06219-001	08-06219-001	1
30	Label, WEEE 10x15mm Black	Entech	06-02352-004	06-02352-004	1

08-06102-001 - 3062 Power Supply 1000W

BOM Revision
Date Valid On

01 -- Production
25.10.2006

Ref	Description	Manufacturer	Manufacturer's P/N	Codan P/N	Qty
	Final Assy 1kW PSU			11-06102	1
	Power Supply 3061/3062			04-03453	1
	TP, 500W/1kW PSU Final Assy			10-00937	1
*	Final Assy, 1kW PSU			08-06102	1
1	Cover, Cable PSU HPPA	Codan	05-07338	05-07338	1
2	Panel, Base/Top, HPPA/PSU	Metalcraft	05-07347	05-07347	1
3	Label, Rating 1kW PSU	Codan	06-02149-002	06-02149-002	1
4	Label, Chassis Earth	Entech	06-02162	06-02162	1
5	Structural Assy, 1kW PSU	Codan	08-06101-001	08-06101-001	1
6	Cable, DC Filter to O/P	Auto Assemblies	08-06107-001	08-06107-001	2
7	Cable, AC I/P to Switch 3062	Auto Assemblies	08-06109-001	08-06109-001	1
8	Cable, DC (-) Filter to Earth	Auto Assemblies	08-06110-001	08-06110-001	2
9	Cable, SMPS Earth to Chassis	Auto Assemblies	08-06111-001	08-06111-001	2
10	Cable, DC (+) SMPS to Filters	Auto Assemblies	08-06112-001	08-06112-001	2
11	Cable, DC (-) SMPS to Filters	Auto Assemblies	08-06113-001	08-06113-001	2
12	Cable, Switch to SMPS Active	Auto Assemblies	08-06116-001	08-06116-001	1
13	Cable, Switch to SMPS Neutral	Auto Assemblies	08-06117-001	08-06117-001	1
14	Clamp, Cable Adhesive	Richco	SK3	30-05102-001	2
15	Clamp, Cable Adhesive	Richco	SK6	30-05102-002	3
16	Bush, Strain Relief	Heyco	1170 (BLACK)	30-03802-006	2
17	Label, Danger isolated mains	Farnell	143-548	30-23001-003	1
18	Tie, Cable 2,5mm W x 115mm Long	Richco	WIT 18 R	30-39100-004	6
19	Screw, M3x6 304 SS Pan Pozi	*	31-23006-580	31-23006-580	16
20	Screw, M3x8 304 SS Pan Pozi	*	31-23008-580	31-23008-580	12
21	Screw, M3x10 304 SS Bk Csk Pozi	Spec 01-00205	31-23010-782	31-23010-782	2
22	Nut, M3 304 SS Nyloc	James Glen	31-23000-780	31-23000-780	6
23	Washer, M4 304 SS Normal	*	31-24001-080	31-24001-080	6
24	Plug, 3way 250VAC 16A Fixed	Schurter	60-80030-001	60-80030-001	1
25	Switch, Rocker DPST Illuminated 250V 16A	Arcoelectric	C1353VQNAC	62-02103	1
26	Filter, RFI 250VAC 20A Spade Connector	Schaffner	FN2020-20-06	78-06030	3
27	PSU, 90-264VAC in, 48-72VDCout750W SMPS	Amtex	ZX750-9660-CT	78-16021	2
28	Cable, Filter to Switch Active	Auto Assemblies	08-06218-001	08-06218-001	1
29	Cable, Filter to Switch Neutral	Auto Assemblies	08-06219-001	08-06219-001	1
30	Label, WEEE 10x15mm Black	Entech	06-02352-004	06-02352-004	1

08-05926-001 - High Pwr PA & Ant Controller

BOM Revision
Date Valid On

04 -- Production
28.09.2006

Ref	Description	Manufacturer	Manufacturer's P/N	Codan P/N	Qty
	TP, Hi Pwr PA & Ant Controller			10-00890	1
	High Pwr Amplifier Controller			04-03377	1
	Assy Proc,High Pwr PA&Ant Cntr			11-06066	1
	High Pwr PA & Ant Controller			08-05926	1
1	Junction Box	Diometrics	05-07066	05-07066	1
2	Junction Box, Base Plate	Diometrics	05-07067	05-07067	1
3	Escutcheon, Top,PA Controller	Entech	06-02099	06-02099	1
4	Escutcheon,Front,PA Controller	Entech	06-02100	06-02100	1
5	PCB, High Pwr Amp Controller	IMP	07-01960-01	07-01960-01	1
6	Screw, M3x8 TAPTITE 2 Csk Pozi	Ajax Fasteners	304SS Bk to 01-00205	31-03008-782	4
7	Standoff #4-40x7	Avdel	1115-4470	33-40504-070	4
8	Screw lock assy, 'D' 5,0mm Stud	ACD	1-024	60-91563-001	4
9	Washer, M3 304 SS Spring	W.J.Smith	31-23001-580	31-23001-580	2
C1	100n 10% 50V X7R 0805 Nisn	Philips	08052R104K9BB	46-51000-282	1
C2	100n 10% 50V X7R 0805 Nisn	Philips	08052R104K9BB	46-51000-282	1
C3	1u 20% 35V 3528 TA Cap	AVX	TAJB105M035R	47-01003-520	1
C4	1u 20% 35V 3528 TA Cap	AVX	TAJB105M035R	47-01003-520	1
C5	1u 20% 35V 3528 TA Cap	AVX	TAJB105M035R	47-01003-520	1
C6	10n 10% 100V X7R 0805 NiSn	Philips	08052R103K0B200	46-41000-281	1
C7	1n 5% 50V NPO 0805 NiSn	Philips	0805CG102J9BB-	46-31000-082	1
C8	1n 5% 50V NPO 0805 NiSn	Philips	0805CG102J9BB-	46-31000-082	1
C9	1u 20% 35V 3528 TA Cap	AVX	TAJB105M035R	47-01003-520	1
C10	100n 10% 50V X7R 0805 Nisn	Philips	08052R104K9BB	46-51000-282	1
C11	22p 5% 50V NPO 0805 NiSn	Philips	0805CG220J9B200	46-12200-081	1
C12	10n 10% 100V X7R 0805 NiSn	Philips	08052R103K0B200	46-41000-281	1
C13	1n 5% 50V NPO 0805 NiSn	Philips	0805CG102J9BB-	46-31000-082	1
C14	1n 5% 50V NPO 0805 NiSn	Philips	0805CG102J9BB-	46-31000-082	1
C15	100n 10% 50V X7R 0805 Nisn	Philips	08052R104K9BB	46-51000-282	1
C16	100n 10% 50V X7R 0805 Nisn	Philips	08052R104K9BB	46-51000-282	1
C17	100n 10% 50V X7R 0805 Nisn	Philips	08052R104K9BB	46-51000-282	1
C18	100n 10% 50V X7R 0805 Nisn	Philips	08052R104K9BB	46-51000-282	1

08-05926-001 - High Pwr PA & Ant Controller

BOM Revision
Date Valid On

04 -- Production
28.09.2006

Ref	Description	Manufacturer	Manufacturer's P/N	Codan P/N	Qty
C19	100n 10% 50V X7R 0805 Nisn	Philips	08052R104K9BB	46-51000-282	1
C20	100n 10% 50V X7R 0805 Nisn	Philips	08052R104K9BB	46-51000-282	1
C21	100n 10% 50V X7R 0805 Nisn	Philips	08052R104K9BB	46-51000-282	1
C22	100n 10% 50V X7R 0805 Nisn	Philips	08052R104K9BB	46-51000-282	1
C23	100n 10% 50V X7R 0805 Nisn	Philips	08052R104K9BB	46-51000-282	1
C24	100n 10% 50V X7R 0805 Nisn	Philips	08052R104K9BB	46-51000-282	1
C25	100n 10% 50V X7R 0805 Nisn	Philips	08052R104K9BB	46-51000-282	1
C26	100n 10% 50V X7R 0805 Nisn	Philips	08052R104K9BB	46-51000-282	1
C27	100n 10% 50V X7R 0805 Nisn	Philips	08052R104K9BB	46-51000-282	1
C28	100n 10% 50V X7R 0805 Nisn	Philips	08052R104K9BB	46-51000-282	1
C29	100n 10% 50V X7R 0805 Nisn	Philips	08052R104K9BB	46-51000-282	1
C30	1n 5% 50V NPO 0805 NiSn	Philips	0805CG102J9BB-	46-31000-082	1
C31	10n 10% 100V X7R 0805 NiSn	Philips	08052R103K0B200	46-41000-281	1
C32	10n 10% 100V X7R 0805 NiSn	Philips	08052R103K0B200	46-41000-281	1
D1	Diode, Si High speed 75V SOT23	Philips	BAS16	BAS16	1
D2	Diode, Si High speed 75V SOT23	Philips	BAS16	BAS16	1
D3	Diode, Si High speed 75V SOT23	Philips	BAS16	BAS16	1
D4	Diode, Si High speed 75V SOT23	Philips	BAS16	BAS16	1
D5	Diode, Si High speed 75V SOT23	Philips	BAS16	BAS16	1
D6	Diode, Si High speed 75V SOT23	Philips	BAS16	BAS16	1
D7	Diode, Si High speed 75V SOT23	Philips	BAS16	BAS16	1
D8	Diode, Si High speed 75V SOT23	Philips	BAS16	BAS16	1
D9	Diode, Si High speed 75V SOT23	Philips	BAS16	BAS16	1
H1	LED, Tricolour T-1 3/4 Diffused	Liteon	LTL-52RG	65-61110-901	1
IC1	Reg, Voltage +5V 0,1A SOIC8	National Semiconduct	LM78L05ACM	XB-07805-700	1
IC2	Buffer, Hex Inverting Schmitt SOIC14	Motorola	MC74HC14D	YH-74014-700	1
IC3	Micro prgmd, Hi Pwr PA Cntrlr	Codan	90-20611-001	90-20611-001	1
IC4	Driver, 8 Bit Serial I/P,latched SOIC20	Allegro	A5841SLW	YK-05841-700	1
J1	Socket, 9way D Strght PCB Fixed	ITT-Cannon	DE-9S-0L2	60-00093-092	1

08-05926-001 - High Pwr PA & Ant Controller

BOM Revision
Date Valid On

04 -- Production
 28.09.2006

Ref	Description	Manufacturer	Manufacturer's P/N	Codan P/N	Qty
J2	Socket, 15way D strght PCB Fixed	ITT-Cannon	DA-15S-OL2	60-00153-094	1
L1	Choke, EMI/EMC 0A DC >1MHz 4516	Taiyo Yuden	FCFBMJ 4516 HS 110-T	43-90003	1
L2	Ind, 100uH 10% 4532	Taiyo Yuden	LEM 4532T101K	43-82100-134	1
L3	Ind, 100uH 10% 4532	Taiyo Yuden	LEM 4532T101K	43-82100-134	1
L4	Ind, 100uH 10% 4532	Taiyo Yuden	LEM 4532T101K	43-82100-134	1
L5	Choke, EMI/EMC 0A DC >1MHz 4516	Taiyo Yuden	FCFBMJ 4516 HS 110-T	43-90003	1
L6	Choke, EMI/EMC 0A DC >1MHz 4516	Taiyo Yuden	FCFBMJ 4516 HS 110-T	43-90003	1
L7	Choke, EMI/EMC 0A DC >1MHz 4516	Taiyo Yuden	FCFBMJ 4516 HS 110-T	43-90003	1
L8	Choke, EMI/EMC 0A DC >1MHz 4516	Taiyo Yuden	FCFBMJ 4516 HS 110-T	43-90003	1
L9	Choke, EMI/EMC 0A DC >1MHz 4516	Taiyo Yuden	FCFBMJ 4516 HS 110-T	43-90003	1
L10	Choke, EMI/EMC 0A DC >1MHz 4516	Taiyo Yuden	FCFBMJ 4516 HS 110-T	43-90003	1
L11	Choke, EMI/EMC 0A DC >1MHz 4516	Taiyo Yuden	FCFBMJ 4516 HS 110-T	43-90003	1
L12	Choke, EMI/EMC 0A DC >1MHz 4516	Taiyo Yuden	FCFBMJ 4516 HS 110-T	43-90003	1
L13	Choke, EMI/EMC 0A DC >1MHz 4516	Taiyo Yuden	FCFBMJ 4516 HS 110-T	43-90003	1
L14	Choke, EMI/EMC 0A DC >1MHz 4516	Taiyo Yuden	FCFBMJ 4516 HS 110-T	43-90003	1
L15	Choke, EMI/EMC 0A DC >1MHz 4516	Taiyo Yuden	FCFBMJ 4516 HS 110-T	43-90003	1
L16	Choke, EMI/EMC 0A DC >1MHz 4516	Taiyo Yuden	FCFBMJ 4516 HS 110-T	43-90003	1
P1	Plug, 7way Fixed	NS	1507L w/round nut	60-00070-601	1
P3	Header (P) 6way 2mm Latch Fixed	AMP	173981-6	60-00060-350	1
R1	1k Ohm 5% 0,1W 0805	Philips	2322-730-61102	40-31000-111	1
R2	1k Ohm 5% 0,1W 0805	Philips	2322-730-61102	40-31000-111	1
R3	10k Ohm 5% 0,1W 0805	Philips	2322-730-61103	40-41000-111	1
R4	10k Ohm 5% 0,1W 0805	Philips	2322-730-61103	40-41000-111	1
R5	10k Ohm 5% 0,1W 0805	Philips	2322-730-61103	40-41000-111	1
R6	10k Ohm 5% 0,1W 0805	Philips	2322-730-61103	40-41000-111	1
R7	10k Ohm 5% 0,1W 0805	Philips	2322-730-61103	40-41000-111	1
R8	10k Ohm 5% 0,1W 0805	Philips	2322-730-61103	40-41000-111	1
R9	10k Ohm 5% 0,1W 0805	Philips	2322-730-61103	40-41000-111	1
R10	10k Ohm 5% 0,1W 0805	Philips	2322-730-61103	40-41000-111	1
R11	10k Ohm 5% 0,1W 0805	Philips	2322-730-61103	40-41000-111	1
R12	10k Ohm 5% 0,1W 0805	Philips	2322-730-61103	40-41000-111	1

08-05926-001 - High Pwr PA & Ant Controller

BOM Revision
Date Valid On

04 -- Production
28.09.2006

Ref	Description	Manufacturer	Manufacturer's P/N	Codan P/N	Qty
R13	1k Ohm 5% 0,1W 0805	Philips	2322-730-61102	40-31000-111	1
R14	68 Ohm 5% 0,1W 0805	Philips	2322 730 61689	40-16800-111	1
R15	1k Ohm 5% 0,1W 0805	Philips	2322-730-61102	40-31000-111	1
R16	10k Ohm 5% 0,1W 0805	Philips	2322-730-61103	40-41000-111	1
R17	10k Ohm 5% 0,1W 0805	Philips	2322-730-61103	40-41000-111	1
R18	10k Ohm 5% 0,1W 0805	Philips	2322-730-61103	40-41000-111	1
R19	10k Ohm 5% 0,1W 0805	Philips	2322-730-61103	40-41000-111	1
R20	220 Ohm 5% 0,1W 0805	Philips	2322 730 61221	40-22200-111	1
R21	220 Ohm 5% 0,1W 0805	Philips	2322 730 61221	40-22200-111	1
R22	220 Ohm 5% 0,1W 0805	Philips	2322 730 61221	40-22200-111	1
R23	68 Ohm 5% 0,1W 0805	Philips	2322 730 61689	40-16800-111	1
R24	10k Ohm 5% 0,1W 0805	Philips	2322-730-61103	40-41000-111	1
R25	1k Ohm 5% 0,1W 0805	Philips	2322-730-61102	40-31000-111	1
R26	1k Ohm 5% 0,1W 0805	Philips	2322-730-61102	40-31000-111	1
R27	10k Ohm 5% 0,1W 0805	Philips	2322-730-61103	40-41000-111	1
R28	100k Ohm 5% 0,1W 0805	Philips	2322 730 61104	40-51000-111	1
R29	10k Ohm 5% 0,1W 0805	Philips	2322-730-61103	40-41000-111	1
R30	10k Ohm 5% 0,1W 0805	Philips	2322-730-61103	40-41000-111	1
R31	10k Ohm 5% 0,1W 0805	Philips	2322-730-61103	40-41000-111	1
R32	10k Ohm 5% 0,1W 0805	Philips	2322-730-61103	40-41000-111	1
R33	Not Fitted	Codan	**_00000-001	99-00000-001	1
R34	1k Ohm 5% 0,1W 0805	Philips	2322-730-61102	40-31000-111	1
R35	1k Ohm 5% 0,1W 0805	Philips	2322-730-61102	40-31000-111	1
R36	220 Ohm 5% 0,1W 0805	Philips	2322 730 61221	40-22200-111	1
R37	Res, Voltage Dependent	Philips	2322-592-52506	41-22506-592	1
R39	1k Ohm 5% 0,1W 0805	Philips	2322-730-61102	40-31000-111	1
R40	1k Ohm 5% 0,1W 0805	Philips	2322-730-61102	40-31000-111	1
R41	10k Ohm 5% 0,1W 0805	Philips	2322-730-61103	40-41000-111	1
R42	1k Ohm 5% 0,1W 0805	Philips	2322-730-61102	40-31000-111	1
R43	10k Ohm 5% 0,1W 0805	Philips	2322-730-61103	40-41000-111	1

08-05926-001 - High Pwr PA & Ant Controller

BOM Revision
Date Valid On

04 -- Production
 28.09.2006

Ref	Description	Manufacturer	Manufacturer's P/N	Codan P/N	Qty
R44	100k Ohm 5% 0,1W 0805	Philips	2322 730 61104	40-51000-111	1
R45	10k Ohm 5% 0,1W 0805	Philips	2322-730-61103	40-41000-111	1
R46	10k Ohm 5% 0,1W 0805	Philips	2322-730-61103	40-41000-111	1
S1	Switch, Binary 16 Position	Copal	S1030	62-61623-001	1
V1	Transistor, NPN Si SOT23	Philips	BC848	BC848	1
V2	Diode, Schottky SOT23	Philips	BAT54	BAT54	1
V3	Transistor, PNP Si SOT23	Philips	BC858	BC858	1
V4	Transistor, PNP Si SOT23	Philips	BC858	BC858	1
V5	Transistor, NPN Si SOT23	Philips	BC848	BC848	1
V6	Transistor, NPN Si SOT23	Philips	BC848	BC848	1
V7	MOSFET, Power N channel TO252	Motorola	MTD3055EL	MTD3055EL	1
V8	Transistor, NPN Si SOT23	Philips	BC848	BC848	1

08-05927-001 - High Pwr SWR, ALC Adaptor

BOM Revision
Date Valid On

03 -- Production
28.09.2006

Ref	Description	Manufacturer	Manufacturer's P/N	Codan P/N	Qty
	High Pwr ALC Adaptor			04-03407	1
	TP, Hi Pwr SWR, ALC Adaptor			10-00891	1
	High Pwr SWR, ALC Adaptor			08-05927	1
	Assy Proc, High Pwr SWR,ALC Adaptor			11-06065	1
1	Box, High Pwr SWR ALC Adpator	Metalcraft	05-07242	05-07242	1
2	Escutcheon, Hi Pwr ALC Adaptor	Entech	06-02098	06-02098	1
3	PCB, High Pwr ALC Adaptor	IMP	07-01968-01	07-01968-01	1
4	Cable, ALC	Auto Assemblies	08-05950-001	08-05950-001	1
5	Bush, Strain Relief	Heyco	1017 (BLACK)	30-03802-003	1
6	Spacer, Threaded Hex M3x8mm	PSM Fasteners	SPA01-B-M3-8	30-37007-012	2
7	Screw, M3x5 304 SS Pan Pozi	*	31-23005-580	31-23005-580	2
8	Screw, M3x6 304 SS BI Csk Pozi	Spec 01-00205	31-23006-782	31-23006-782	2
9	Screw, M3x6 TAPTITE 2 P/Pozi	Ajax Fasteners	304 Stainless	31-03006-580	8
10	Socket, UHF Flange Fixed	Marushin	MR-589	60-11360-589	2
11	Adaptor, UHF Plug to Plug	Pasternack	PE9096	60-11800	1
12	Sleeve, Helsyn H20x19 Any Colour	Hellermann	2mmx0,75mmWallx19mm	71-92007-199	1
13	Stake, Terminal	Autosplice	7-22461-5	61-40300-004	2
14	Washer, M3x4,7OD 316S/S Small	C D Brown	KM48	31-23001-180	2
15	Washer, M3 304 SS Spring	W.J.Smith	31-23001-580	31-23001-580	2
C1	3,3n 10% 100V X7R 1206 NiSn	Philips	12062R332K0BB-	46-33300-280	1
C2	3,3n 10% 100V X7R 1206 NiSn	Philips	12062R332K0BB-	46-33300-280	1
C3	10p 5% 500V NPO 1206 NiSn	Philips	1206CG100GBB-	46-11000-082	1
C4	10p 5% 500V NPO 1206 NiSn	Philips	1206CG100GBB-	46-11000-082	1
C5	10p 5% 500V NPO 1206 NiSn	Philips	1206CG100GBB-	46-11000-082	1
C6	5,5-65p 250V Foil Trim Cap	Philips	2222 808 32659	49-30103	1
C7	390p 5% 500V NPO 1210 NiSn	Philips	1210CG391GBB-	46-23900-082	1
C8	33n 10% 100V X7R 1206 NiSn	Philips	12062R333K0BB-	46-43300-280	1
C9	33n 10% 100V X7R 1206 NiSn	Philips	12062R333K0BB-	46-43300-280	1
C10	4,7u 10% 16V 3528 TA Cap	AVX	TAJB475K016R	47-04701-600	1
C11	100p 5% 50V NPO 0805 NiSn	Philips	0805CG101J9B200	46-21000-081	1
C12	1n 10% 100V X7R 0805 NiSn	Philips	08052R102K0B200	46-31000-282	1
C13	47p 5% 500V NPO 1206 NiSn	Philips	1206CG470JDB2	46-14700-082	1
C14	Not Fitted	Codan	**_00000-001	99-00000-001	1

08-05927-001 - High Pwr SWR, ALC Adaptor

BOM Revision
Date Valid On

03 -- Production
28.09.2006

Ref	Description	Manufacturer	Manufacturer's P/N	Codan P/N	Qty
D1	Diode, Schottky 70V 70mA SOT23	Siemens	BAS70	BAS70	1
D2	Diode, Schottky 70V 70mA SOT23	Siemens	BAS70	BAS70	1
D3	Diode, Schottky 40V 3A SMC	Motorola	MBRS340T3	MBRS340T3	1
IC1	Amp, Rail to Rail I/O SOT23-5	National Semiconduct	LMC7101BIM5X	XA-07101-700	1
L1	Ind, 1mH 10% 1812	Coilcraft	1812LS-105XKBC	43-83100-000	1
L2	Choke, EMI/EMC 0A DC >1MHz 4516	Taiyo Yuden	FCFBMJ 4516 HS 110-T	43-90003	1
R1	27 Ohm 5% 0,33W CF Res	Philips	2322 211 13279	40-12700-020	1
R2	27 Ohm 5% 0,33W CF Res	Philips	2322 211 13279	40-12700-020	1
R3	27 Ohm 5% 0,33W CF Res	Philips	2322 211 13279	40-12700-020	1
R4	27 Ohm 5% 0,33W CF Res	Philips	2322 211 13279	40-12700-020	1
R5	39k Ohm 5% 0,1W 0805	Philips	2322 730 61393	40-43900-111	1
R6	10k Ohm 5% 0,1W 0805	Philips	2322-730-61103	40-41000-111	1
R7	100k Ohm 5% 0,1W 0805	Philips	2322 730 61104	40-51000-111	1
R8	33k Ohm 5% 0,1W 0805	Philips	2322 730 61333	40-43300-111	1
R9	1k Ohm 5% 0,1W 0805	Philips	2322-730-61102	40-31000-111	1
R10	10k Ohm 5% 0,1W 0805	Philips	2322-730-61103	40-41000-111	1
R11	3,3k Ohm 5% 0,1W 0805	Philips	2322 730 61332	40-33300-111	1
R12	6,8k Ohm 5% 0,1W 0805	Philips	2322 730 61682	40-36800-111	1
R14	33k Ohm 5% 0,1W 0805	Philips	2322 730 61333	40-43300-111	1
R15	Pot, 10k Lin MG Trim	Noble	VTP	42-41076-000	1
R16	1k Ohm 5% 0,1W 0805	Philips	2322-730-61102	40-31000-111	1
R17	100 Ohm 5% 0,1W 0805	Philips	2322 730 61101	40-21000-111	1
R18	100 Ohm 5% 0,1W 0805	Philips	2322 730 61101	40-21000-111	1
T1	Transformer, RF Current 30T	Codan	44-80285	44-80285	1
V1	Transistor, NPN Si SOT23	Philips	BC847	BC847	1
V2	Transistor, NPN Si SOT23	Philips	BC847	BC847	1
V3	Transistor, NPN Si SOT23	Philips	BC847	BC847	1
V4	Transistor, NPN Si SOT23	Philips	BC817	BC817	1

The drawings in this section consist of the mechanical and electrical diagrams required to maintain the 3061/3062 High-power Amplifiers, the HPAC module, and the ALC adaptor module.

Table 19: High power—list of drawings

Title	Drawing	Drawing number
ALC/PTT Switch	Circuit diagram	04-03422
	PCB assembly	08-05985
Splitter 2-way (500 W)	Circuit diagram	04-03419
	PCB assembly	08-05997
Splitter 4-way (1 kW)	Circuit diagram	04-03420
	PCB assembly	08-05999
Power Amplifier	Circuit diagram	04-03416
	PCB assembly	08-05977 (sheet 1)
Combiner 2-way (500 W)	Circuit diagram	04-03428
	PCB assembly	08-05998
Combiner 4-way (1 kW)	Circuit diagram	04-03429
	PCB assembly	08-06000
Filter	Circuit diagram	04-03415
	PCB assembly	08-05976 (sheet 1) 08-05976 (sheet 2)
Control	Circuit diagram	04-03418 (sheet 1) 04-03418 (sheet 2)
	PCB assembly	08-05979 (sheet 1) 08-05979 (sheet 2)
Power Supply	Circuit diagram	04-03417
	PCB assembly	08-05978 (sheet 1) 08-05978 (sheet 2) 08-05978 (sheet 3)
Rear Panel (500 W/1 kW)	Circuit diagram	04-03421
	PCB assembly	08-05984
3061/3062 Power Supply	Circuit diagram	04-03453
3061 Power Supply 500 W	Final assembly	08-06067 (sheet 1)
		08-06067 (sheet 2)

Table 19: High power—list of drawings (cont.)

Title	Drawing	Drawing number
3062 Power Supply 1000 W	Final assembly	08-06102 (sheet 1) 08-06102 (sheet 2)
HPAC	Circuit diagram	04-03377
	PCB assembly	08-05926 (sheet 1) 08-05926 (sheet 2)
ALC adaptor	Circuit diagram	04-03407
	PCB assembly	08-05927 (sheet 1) 08-05927 (sheet 2)

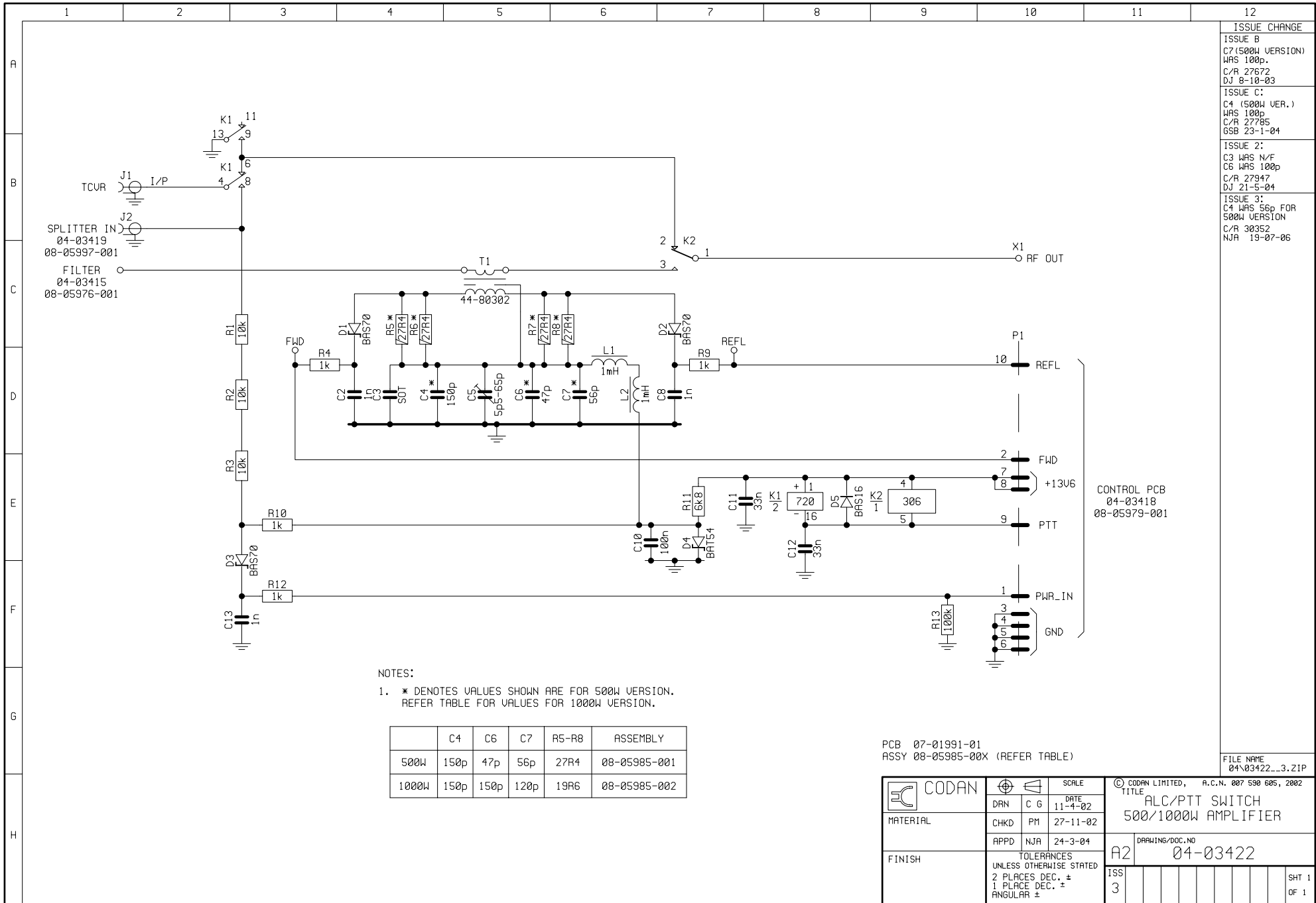

ISSUE CHANGE
 ISSUE B
 C7 (500W VERSION)
 WAS 100p.
 C/R 27672
 DJ 8-18-03
 ISSUE C:
 C4 (500W VER.)
 WAS 100p
 C/R 27785
 GSB 23-1-04
 ISSUE 2:
 C3 WAS N/F
 C6 WAS 100p
 C/R 27947
 DJ 21-5-04
 ISSUE 3:
 C4 WAS 56p FOR
 500W VERSION
 C/R 30352
 NJA 19-07-06

CONTROL PCB
 04-03418
 08-05979-001

NOTES:
 1. * DENOTES VALUES SHOWN ARE FOR 500W VERSION.
 REFER TABLE FOR VALUES FOR 1000W VERSION.

	C4	C6	C7	R5-R8	ASSEMBLY
500W	150p	47p	56p	27R4	08-05985-001
1000W	150p	150p	120p	19R6	08-05985-002

PCB 07-01991-01
 ASSY 08-05985-00X (REFER TABLE)

FILE NAME
 04\03422...3.21P

	SCALE	© CODAN LIMITED, A.C.N. 007 590 605, 2002 TITLE ALC/PTT SWITCH 500/1000W AMPLIFIER	
	DRN	C G	DATE 11-4-02
MATERIAL	CHKD	PM	27-11-02
FINISH	APPD	NJA	24-3-04
	TOLERANCES UNLESS OTHERWISE STATED 2 PLACES DEC. ± 1 PLACE DEC. ± ANGULAR ±		
DRAWING/DOC. NO A2 04-03422		ISS 3	SHT 1 OF 1

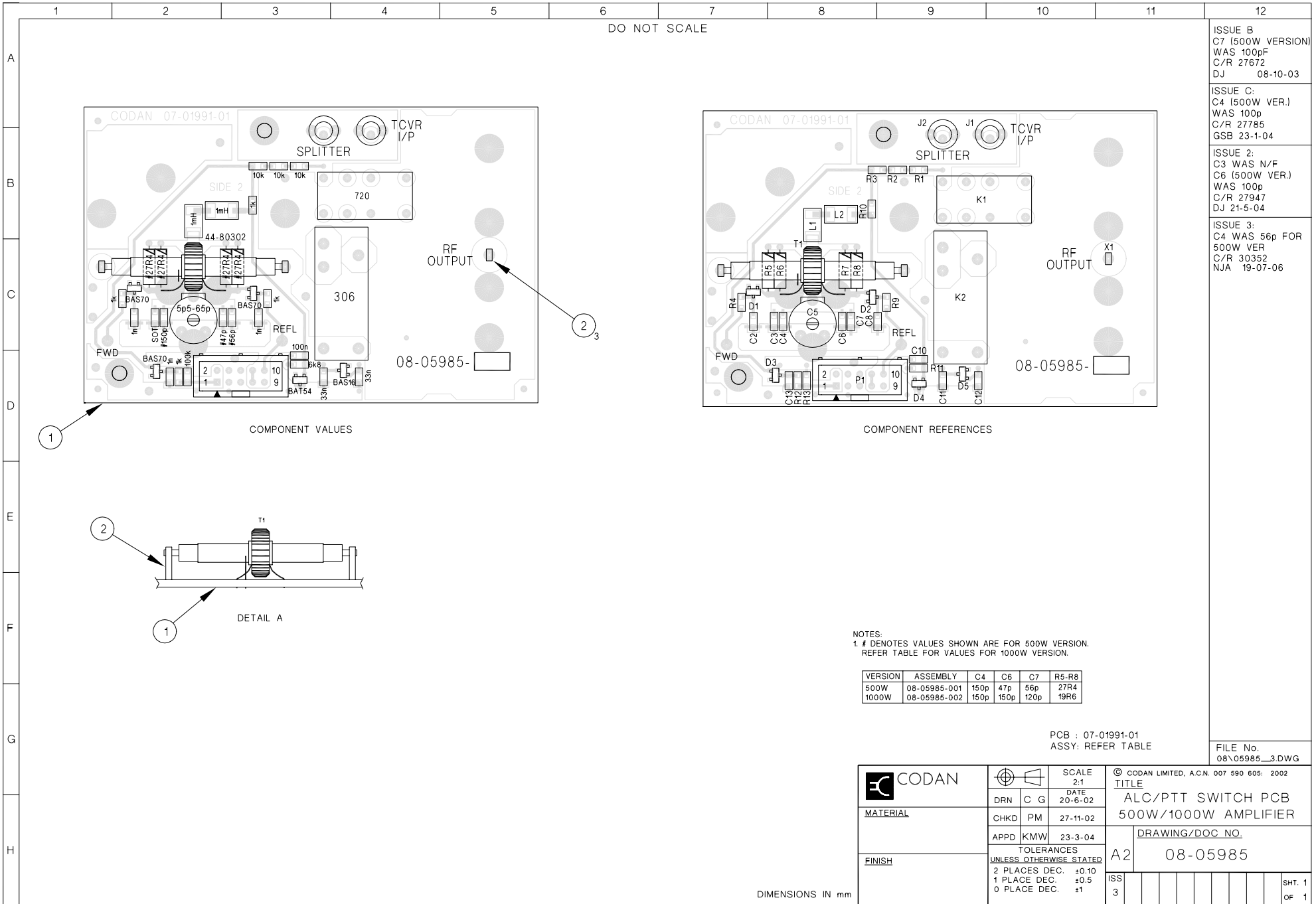

ISSUE B
C7 (500W VERSION)
WAS 100pF
C/R 27672
DJ 08-10-03

ISSUE C:
C4 (500W VER.)
WAS 100p
C/R 27785
GSB 23-1-04

ISSUE 2:
C3 WAS N/F
C6 (500W VER.)
WAS 100p
C/R 27947
DJ 21-5-04

ISSUE 3:
C4 WAS 56p FOR
500W VER
C/R 30352
NJA 19-07-06

NOTES:
1. # DENOTES VALUES SHOWN ARE FOR 500W VERSION.
REFER TABLE FOR VALUES FOR 1000W VERSION.

VERSION	ASSEMBLY	C4	C6	C7	R5-R8
500W	08-05985-001	150p	47p	56p	27R4
1000W	08-05985-002	150p	150p	120p	19R6

PCB : 07-01991-01
ASSY: REFER TABLE

FILE No.
08\05985_3.DWG

	SCALE 2:1		© CODAN LIMITED, A.C.N. 007 590 605: 2002	
	DRN	C G	TITLE	
MATERIAL	CHKD	PM	ALC/PTT SWITCH PCB	
	APPD	KMW	500W/1000W AMPLIFIER	
FINISH	TOLERANCES UNLESS OTHERWISE STATED		DRAWING/DOC NO.	
	2 PLACES DEC. ±0.10 1 PLACE DEC. ±0.5 0 PLACE DEC. ±1		A2 08-05985	
DIMENSIONS IN mm			ISS 3	SHT. 1 OF 1

ISSUE CHANGE
 ISSUE B:
 X1 ADDED.
 PCB WAS ISS -01
 C/R 27510
 DJ 28-3-03

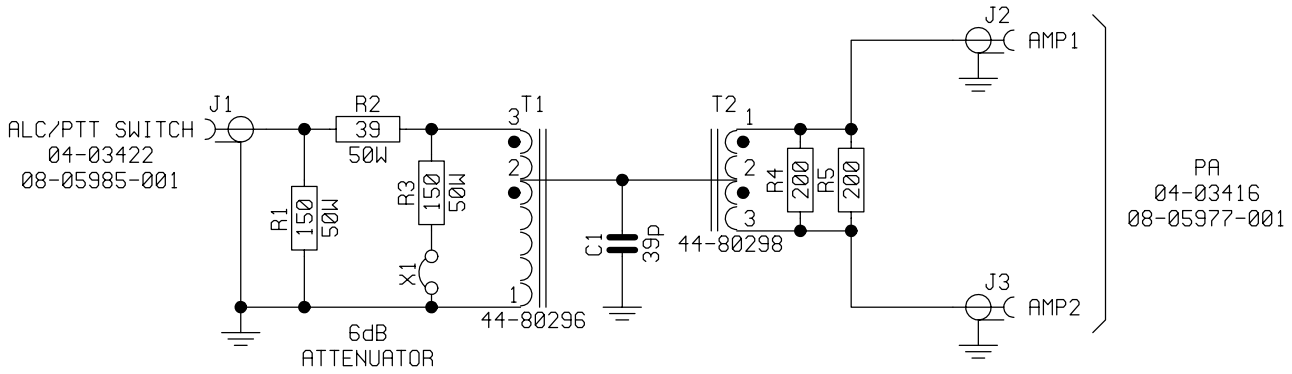

PA
 04-03416
 08-05977-001

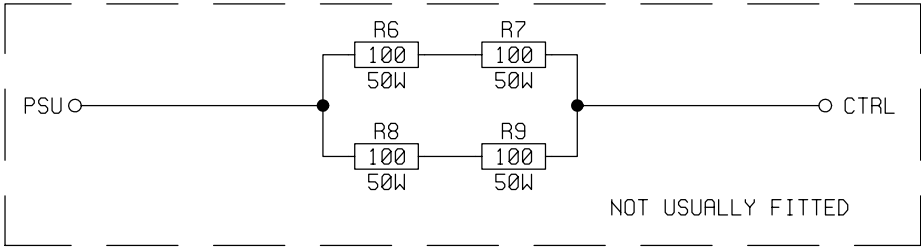

PCB : 07-01996-02
 ASSY: 08-05997-001

FILE NAME
 04\03419_1.*

	DRN	C G	SCALE	© CODAN LIMITED, A.C.N. 007 590 605, 2002 TITLE SPLITTER, 2 WAY 500W AMPLIFIER
	MATERIAL	CHKD	DATE	
	FINISH	APPD	DATE	
TOLERANCES UNLESS OTHERWISE STATED 2 PLACES DEC. ± 1 PLACE DEC. ± ANGULAR ±			5-8-04	DRAWING/DOC. NO 04-03419
ISS 1				SHT 1 OF 1

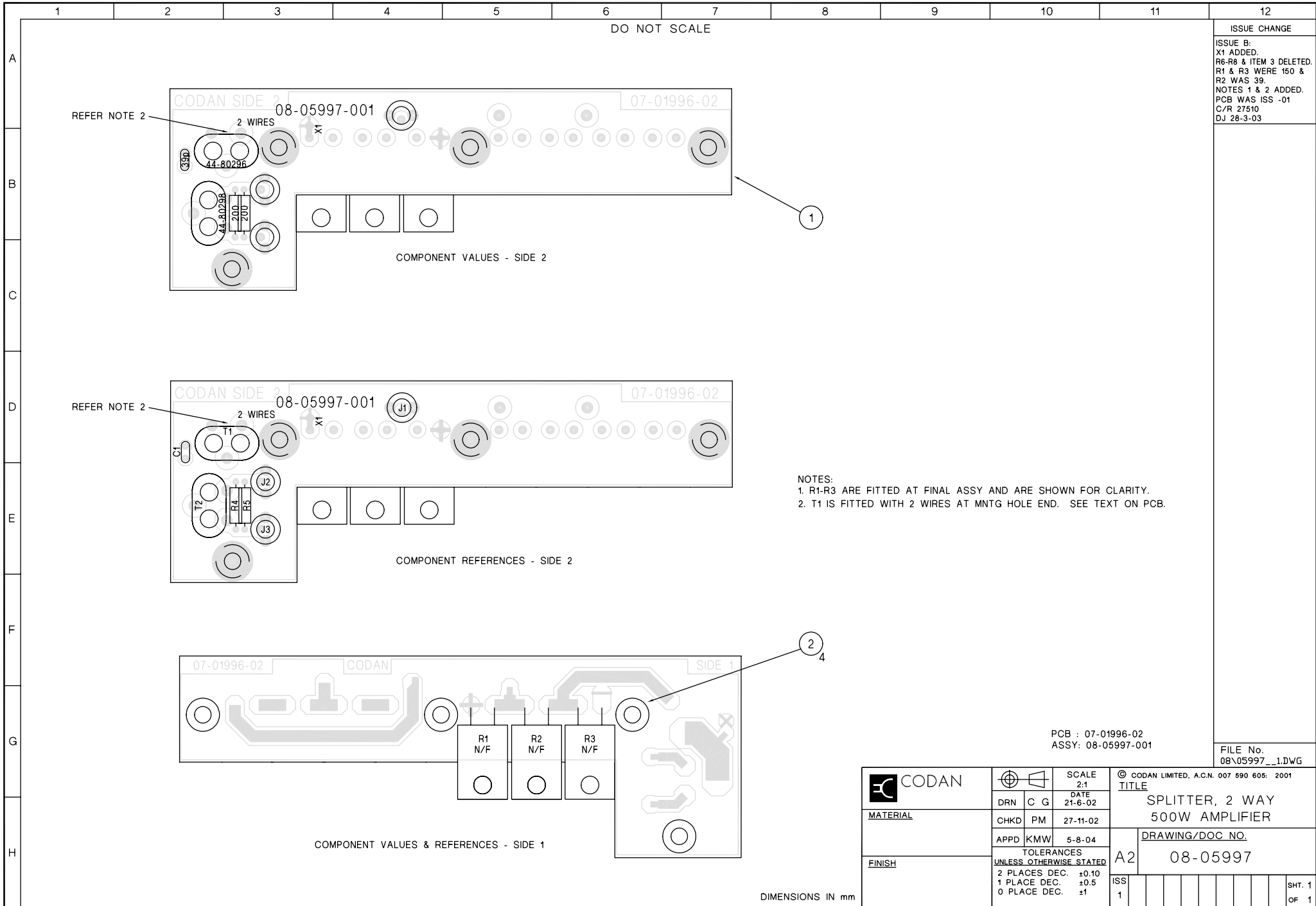

ISSUE CHANGE
 ISSUE B:
 X1 ADDED.
 R6-R8 & ITEM 3 DELETED.
 R1 & R3 WERE 150 &
 R2 WAS 39.
 NOTES 1 & 2 ADDED.
 PCB WAS ISS -01
 C/R 27510
 DJ 28-3-03

NOTES:
 1. R1-R3 ARE FITTED AT FINAL ASSY AND ARE SHOWN FOR CLARITY.
 2. T1 IS FITTED WITH 2 WIRES AT MNTG HOLE END. SEE TEXT ON PCB.

PCB : 07-01996-02
 ASSY: 08-05997-001

FILE No.
 08\05997_1.DWG

	SCALE 2:1		© CODAN LIMITED, A.C.N. 007 590 605: 2001	
	DRN C G	DATE 21-6-02	TITLE SPLITTER, 2 WAY 500W AMPLIFIER	
MATERIAL	CHKD PM	APPD KMW	DATE 27-11-02	DRAWING/DOC NO. 08-05997
FINISH	TOLERANCES UNLESS OTHERWISE STATED 2 PLACES DEC. ±0.10 1 PLACE DEC. ±0.5 0 PLACE DEC. ±1			A2
DIMENSIONS IN mm				ISS 1
				SHT. 1 OF 1

ISSUE CHANGE

ISSUE B:
 X1 ADDED.
 NOTE ADDED TO
 R12-R15 ETC
 3dB ATTENUATOR
 WAS 2dB ATTEN.
 PCB WAS ISS -01
 C/R 27512
 DJ 28-3-03

PA #1
 04-03416
 08-05977-001

PA #2
 04-03416
 08-05977-001

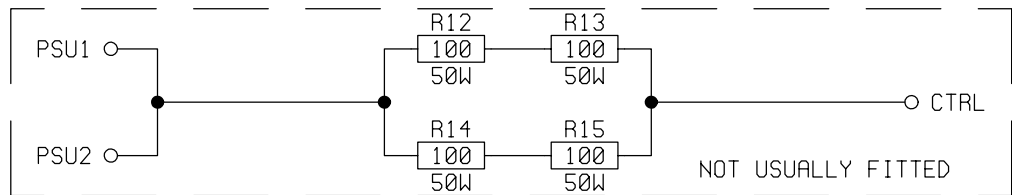
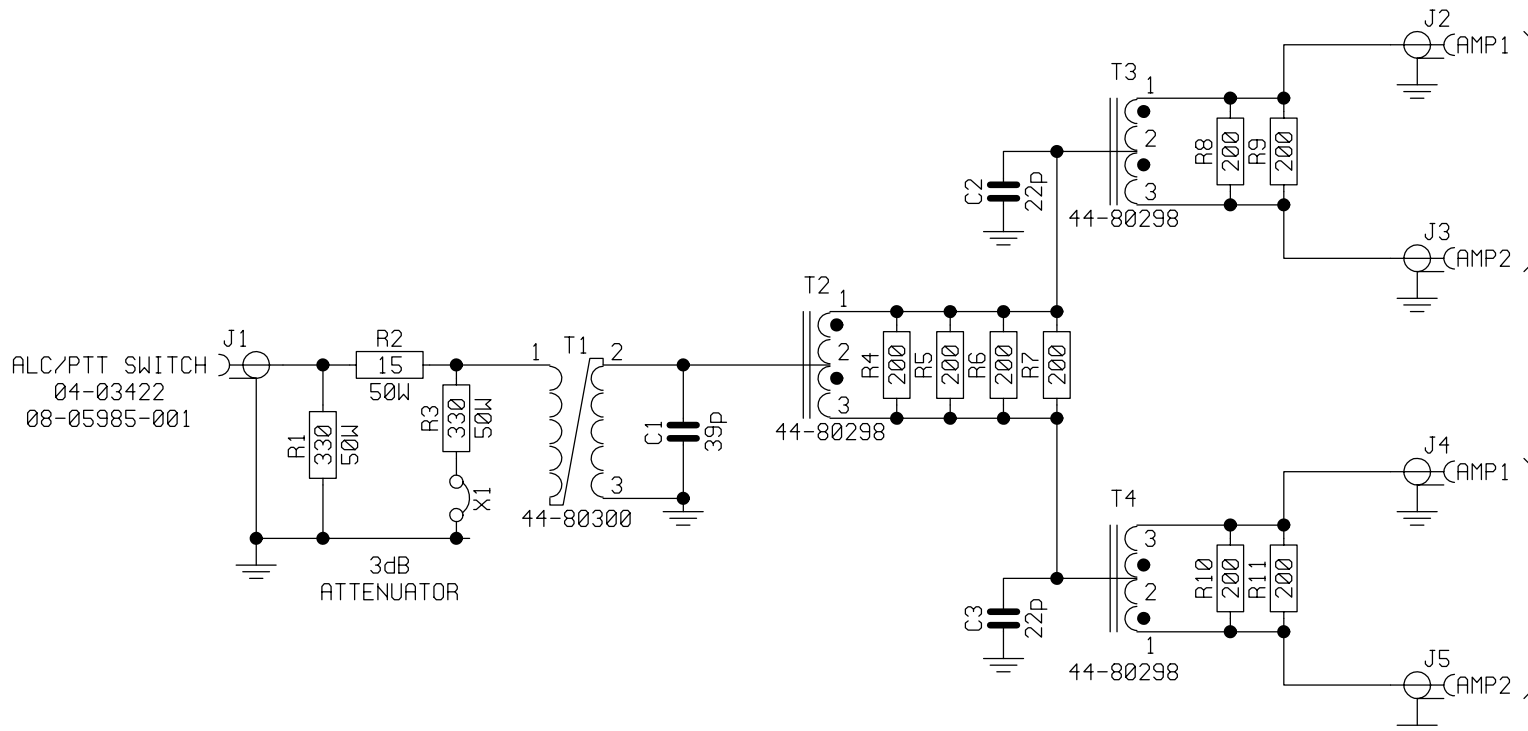

PCB : 07-01998-02
 ASSY: 08-05999-001

FILE NAME
 04\03420_1.ZIP

	SCALE		© CODAN LIMITED, A.C.N. 007 590 605, 2002 TITLE SPLITTER, 4 WAY 1kW AMPLIFIER
	DRN	C G	
MATERIAL	CHKD	PM	27-11-02
FINISH	APPD	NJA	24-3-04
	TOLERANCES UNLESS OTHERWISE STATED		A3 DRAWING/DOC.NO 04-03420
2 PLACES DEC. ± 1 PLACE DEC. ± ANGULAR ±		ISS 1	

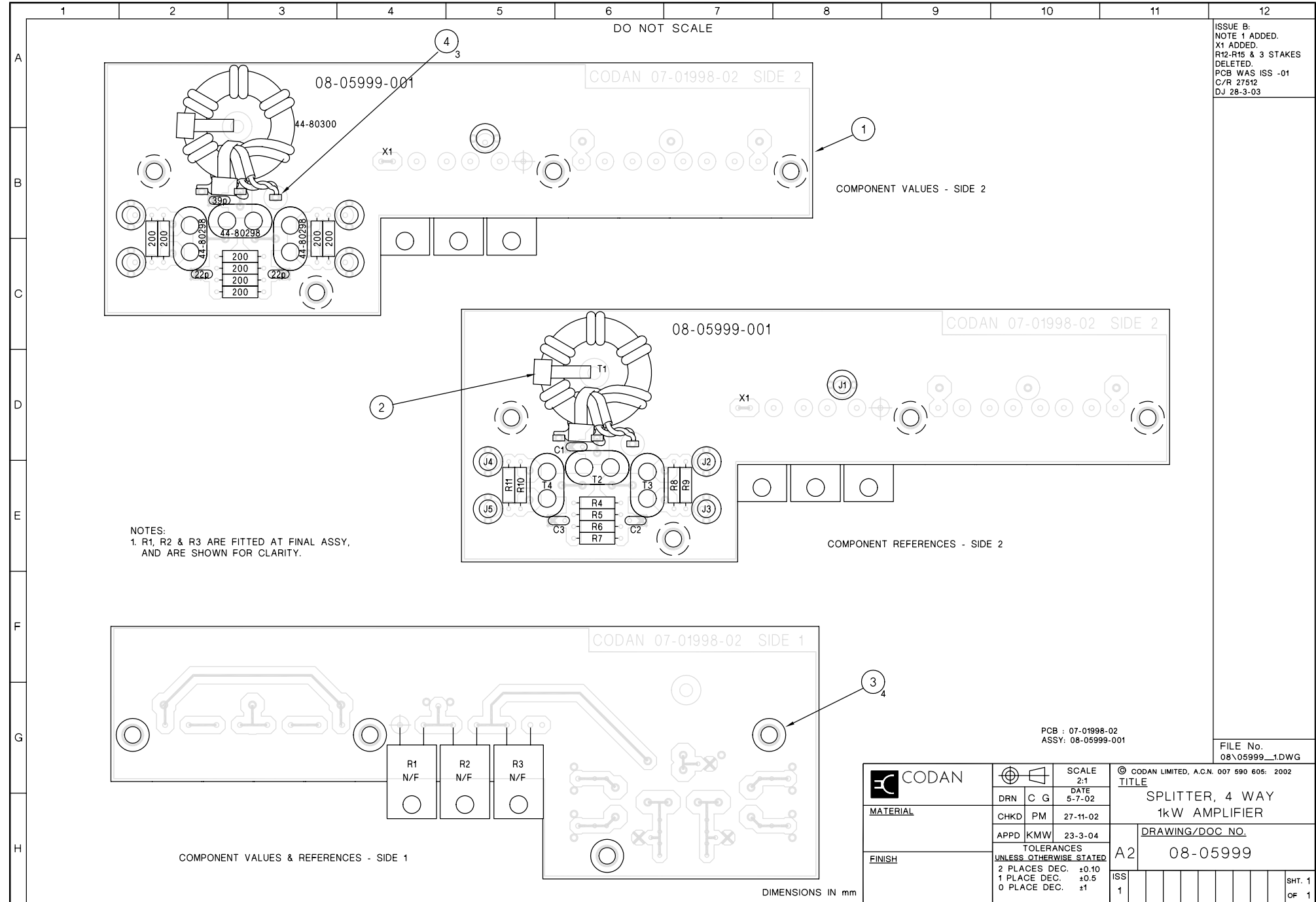

DO NOT SCALE

ISSUE B:
NOTE 1 ADDED.
X1 ADDED.
R12, R15 & 3 STAKES
DELETED.
PCB WAS ISS -01
C/R 27512
DJ 28-3-03

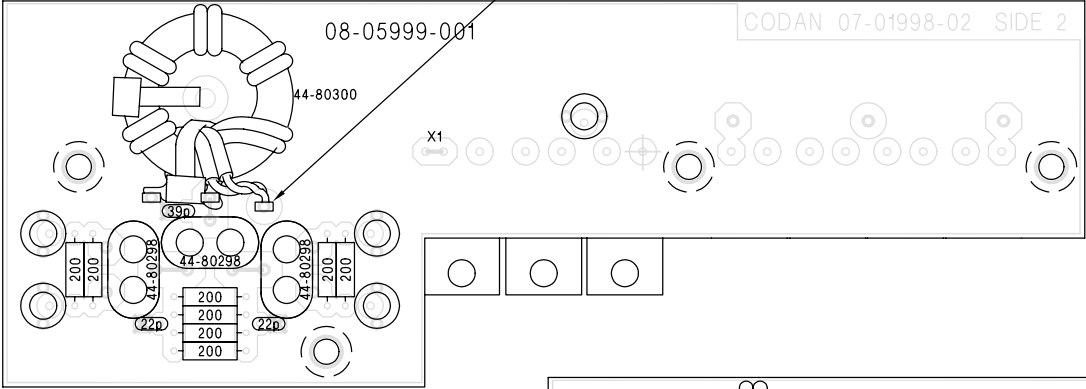

CODAN 07-01998-02 SIDE 2

COMPONENT VALUES - SIDE 2

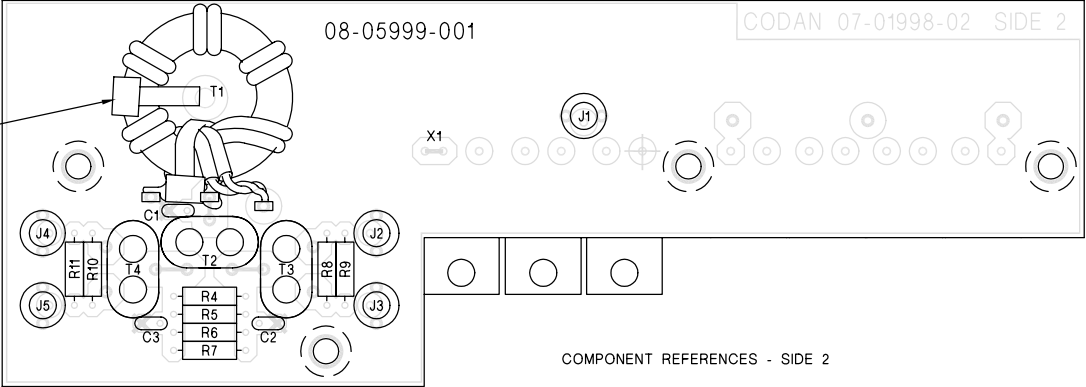

CODAN 07-01998-02 SIDE 2

COMPONENT REFERENCES - SIDE 2

NOTES:
1. R1, R2 & R3 ARE FITTED AT FINAL ASSY,
AND ARE SHOWN FOR CLARITY.

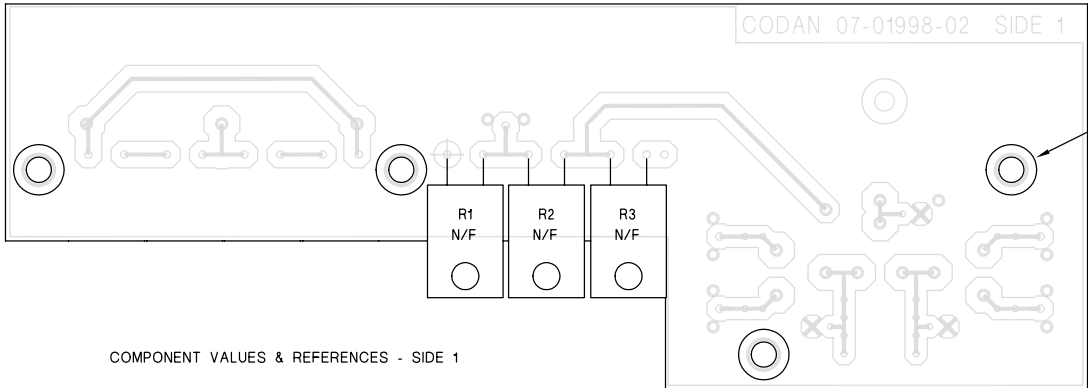

CODAN 07-01998-02 SIDE 1

COMPONENT VALUES & REFERENCES - SIDE 1

DIMENSIONS IN mm

PCB : 07-01998-02
ASSY: 08-05999-01

FILE No.
08\05999_1.DWG

	DRN	C	G	SCALE	© CODAN LIMITED, A.C.N. 007 590 605: 2002 TITLE SPLITTER, 4 WAY 1kW AMPLIFIER
	CHKD	PM	27-11-02	DATE 5-7-02	
MATERIAL	APPD	KMW	23-3-04	TOLERANCES UNLESS OTHERWISE STATED	DRAWING/DOC NO. 08-05999
FINISH	2 PLACES DEC. ±0.10 1 PLACE DEC. ±0.5 0 PLACE DEC. ±1			ISS	
				1	SHT. 1 OF 1

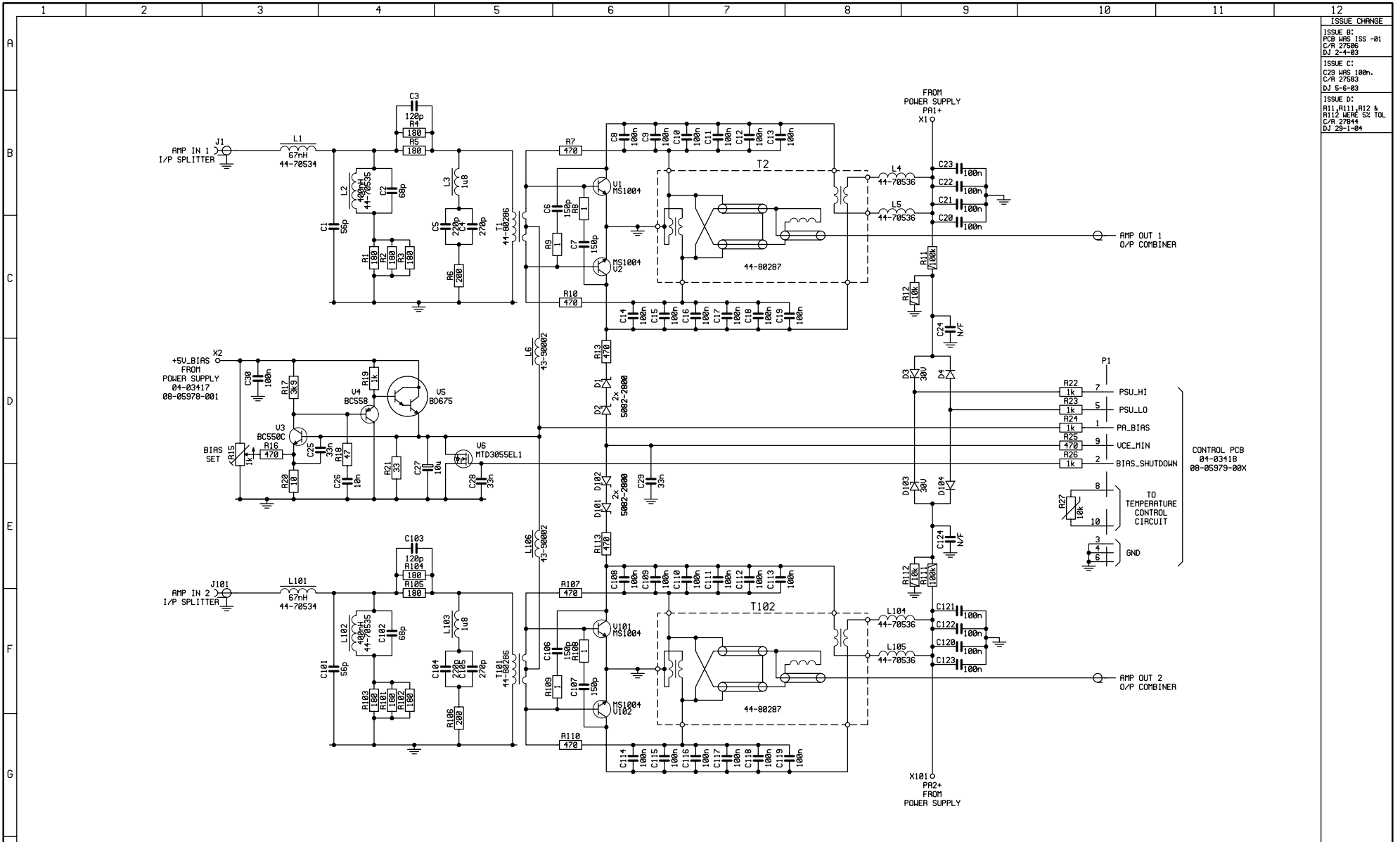

NOTES:
 1. DIODES ARE BAW62, OR EQUIVALENT, UNLESS STATED OTHERWISE.

ISSUE CHANGE
 ISSUE A:
 PCB NRS ISS-01
 C/R 27586
 DJ 2-1-03
 ISSUE C:
 C29 NRS 100n
 C/R 27583
 DJ 5-9-03
 ISSUE D:
 R11, R111, R12 &
 R112 WERE 5% TOL
 C/R 27844
 DJ 23-1-04

PCB : 07-01985-02
 ASSY: 08-05977-001

FILE NAME
 04-03416_1.21P

		SCALE DRN C 0 DATE 13-2-02	CODAN LIMITED, A.C.N. 887 538 685, 2882 TITLE POWER AMPLIFIER - 500W
MATERIAL	CHKD PJ	APPD NJR	DRAWING/DOC NO 04-03416
FINISH	UNLESS OTHERWISE STATED 2 PLACES DEC. ± 1 PLACE DEC. ± ANGULAR ±		TSS 1
			SH 1 OF 1

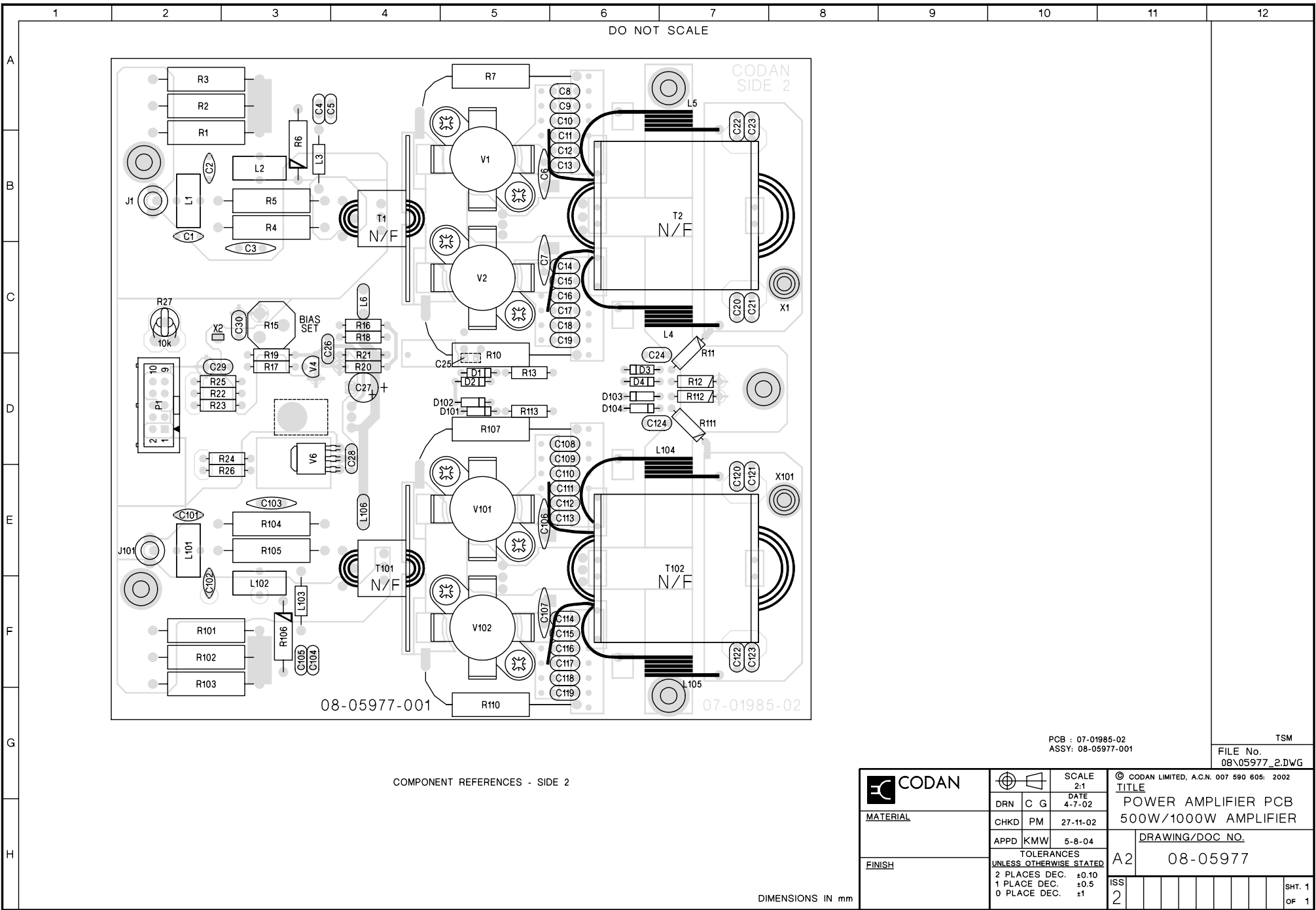

DO NOT SCALE

CODAN
SIDE 2

07-01985-02

08-05977-001

COMPONENT REFERENCES - SIDE 2

PCB : 07-01985-02
ASSY: 08-05977-001

TSM
FILE No.
08\05977_2.DWG

	SCALE	2:1	© CODAN LIMITED, A.C.N. 007 590 605: 2002 TITLE POWER AMPLIFIER PCB 500W/1000W AMPLIFIER
	DRN	C G	
MATERIAL	CHKD	PM	27-11-02
FINISH	APPD	KMW	5-8-04
	TOLERANCES UNLESS OTHERWISE STATED 2 PLACES DEC. ±0.10 1 PLACE DEC. ±0.5 0 PLACE DEC. ±1		
	ISS	2	
DRAWING/DOC NO.			A2 08-05977
DIMENSIONS IN mm			SHT. 1 OF 1

ISSUE CHANGE
 ISSUE B:
 C2 WAS 33p
 PCB WAS ISS -01
 C/R 27511
 DJ 28-3-03
 ISSUE C:
 PCB WAS ISS -02
 C/R 27672
 DJ 28-3-03

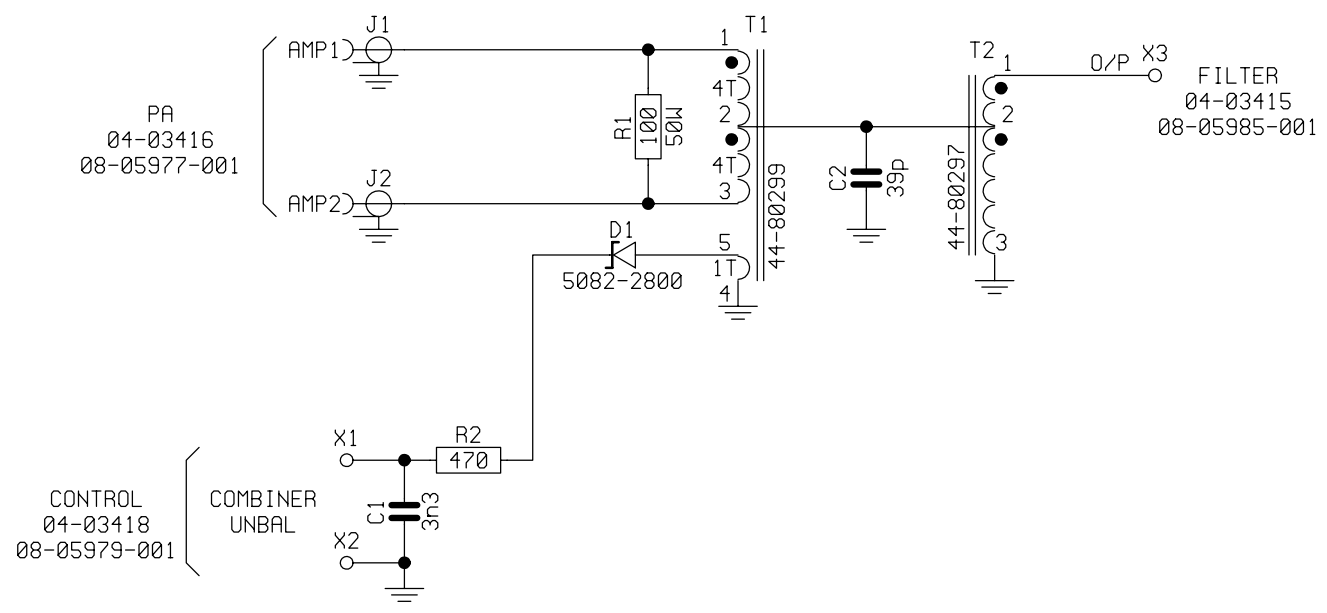

PCB : 07-01997-03
 ASSY: 08-05998-001

FILE NAME
 04\03428_1.*

	SCALE		© CODAN LIMITED, A.C.N. 007 590 605, 2002 TITLE COMBINER, 2 WAY 500W AMPLIFIER	
	DRN	C G		DATE 16-4-02
	CHKD	PM		27-11-02
MATERIAL	APPD	NJA	5-8-04	
FINISH	TOLERANCES UNLESS OTHERWISE STATED		DRAWING/DOC. NO 04-03428	
	2 PLACES DEC. ± 1 PLACE DEC. ± ANGULAR ±			
ISS			SHT 1	
1			OF 1	

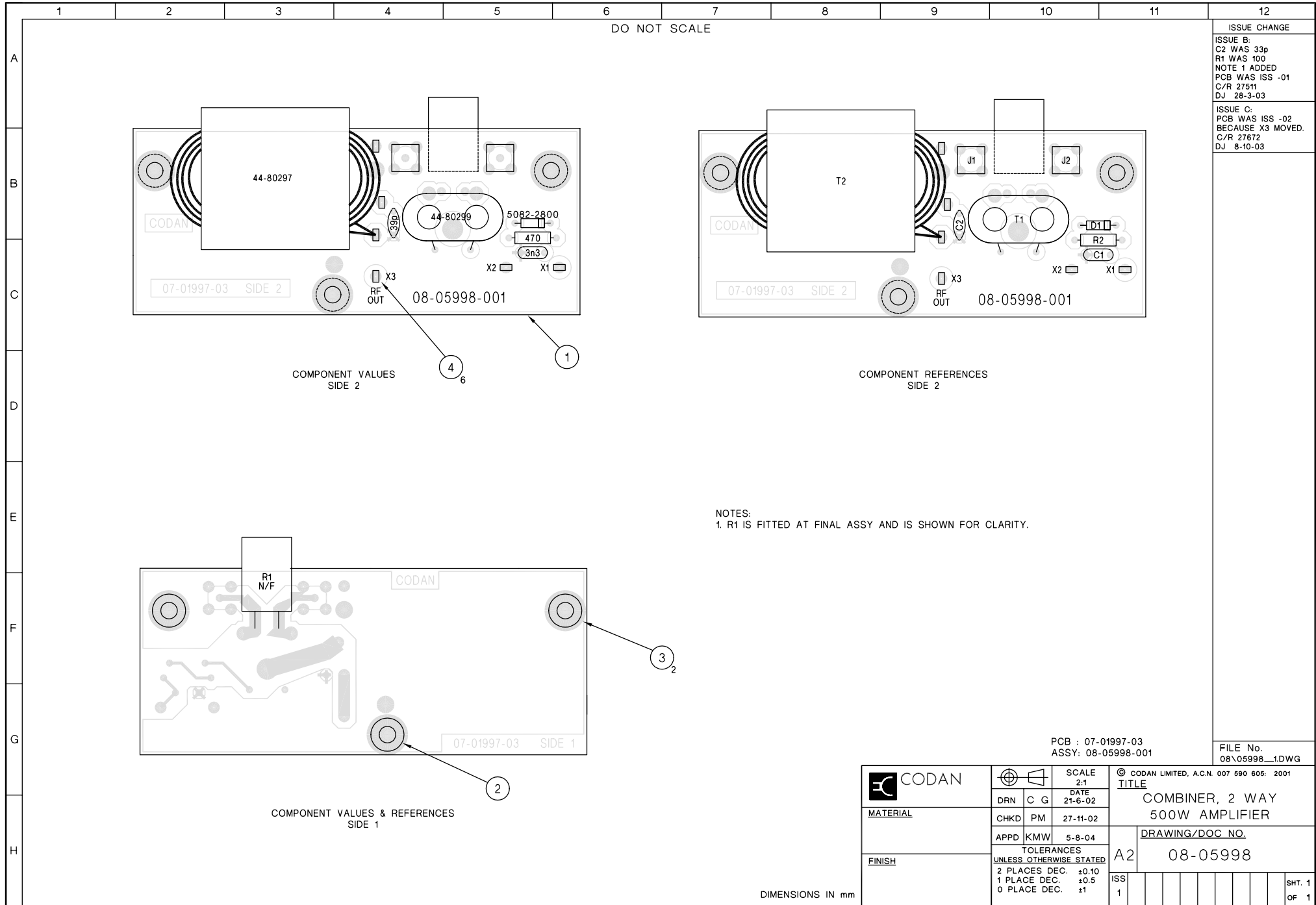

DO NOT SCALE

ISSUE CHANGE
 ISSUE B:
 C2 WAS 33p
 R1 WAS 100
 NOTE 1 ADDED
 PCB WAS ISS -01
 C/R 27511
 DJ 28-3-03
 ISSUE C:
 PCB WAS ISS -02
 BECAUSE X3 MOVED.
 C/R 27672
 DJ 8-10-03

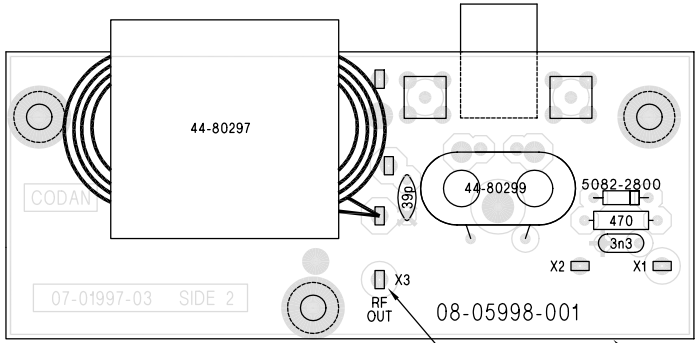

COMPONENT VALUES
SIDE 2

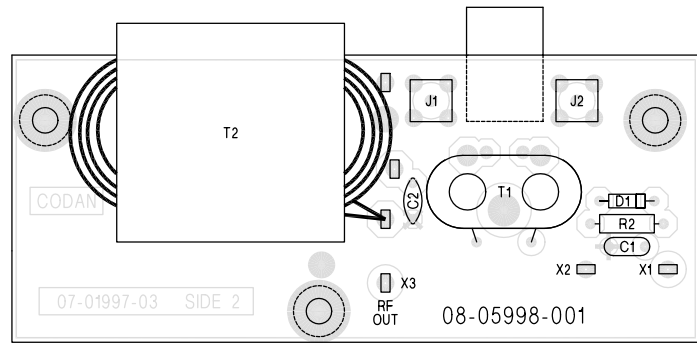

COMPONENT REFERENCES
SIDE 2

NOTES:
 1. R1 IS FITTED AT FINAL ASSY AND IS SHOWN FOR CLARITY.

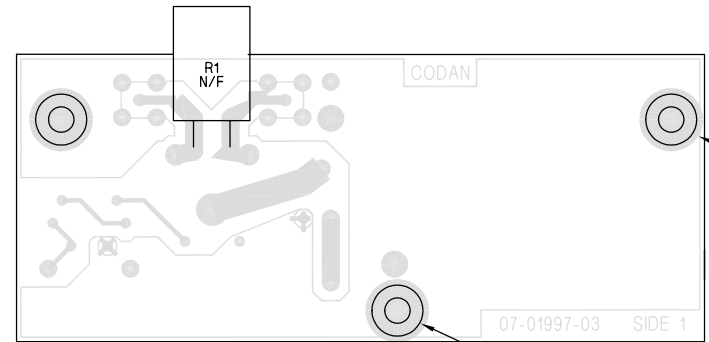

COMPONENT VALUES & REFERENCES
SIDE 1

PCB : 07-01997-03
 ASSY: 08-05998-001

FILE No.
 08\05998_1.DWG

	SCALE 2:1		© CODAN LIMITED, A.C.N. 007 590 606. 2001 TITLE COMBINER, 2 WAY 500W AMPLIFIER
	DRN	C G	
MATERIAL	CHKD	PM	27-11-02
FINISH	APPD	KMW	5-8-04
	TOLERANCES UNLESS OTHERWISE STATED 2 PLACES DEC. ±0.10 1 PLACE DEC. ±0.5 0 PLACE DEC. ±1		
DRAWING/DOC NO. 08-05998			ISS 1
DIMENSIONS IN mm			SHT. 1 OF 1

ISSUE CHANGE

ISSUE B:
PCB WAS ISS -01
C/R 27513
DJ 28-3-03

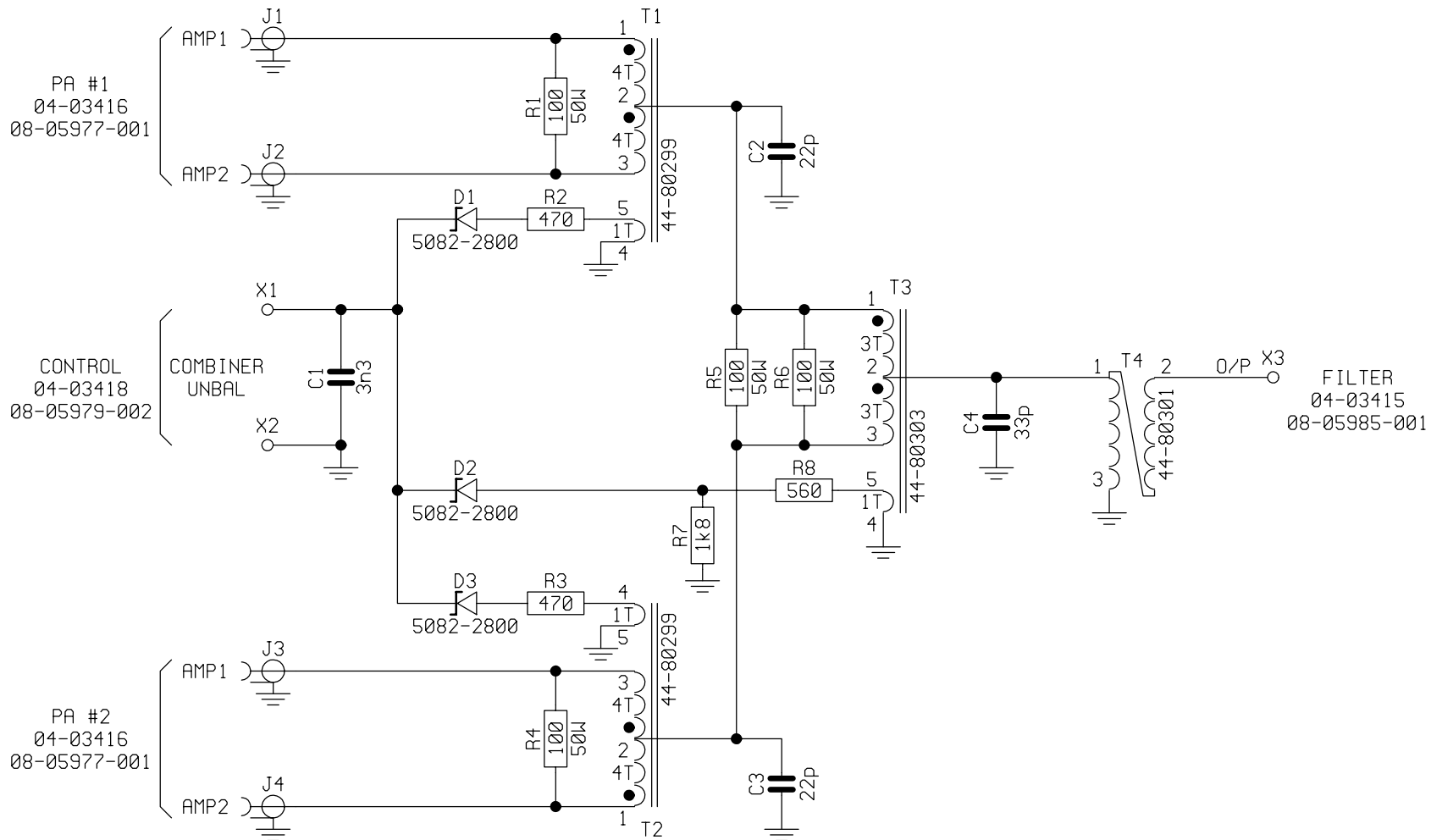

PA #1
04-03416
08-05977-001

CONTROL
04-03418
08-05979-002

PA #2
04-03416
08-05977-001

FILTER
04-03415
08-05985-001

PCB : 07-01999-02
ASSY: 08-06000-001

FILE NAME
04\03429_1.ZIP

	SCALE		© CODAN LIMITED, A.C.N. 007 590 605, 2002 TITLE COMBINER, 4 WAY 1kW AMPLIFIER
	DRN	C G	
MATERIAL	CHKD	PM	27-11-02
	APPD	NJA	24-3-04
FINISH	TOLERANCES UNLESS OTHERWISE STATED		DRAWING/DOC.NO A3 04-03429
	2 PLACES DEC. ± 1 PLACE DEC. ± ANGULAR ±		
	ISS		SHT 1 OF 1

1 2 3 4 5 6 7 8 9 10 11 12

A
B
C
D
E
F
G
H

DO NOT SCALE

ISSUE CHANGE

ISSUE B:
NOTE 1 ADDED.
R1, R4-R6 WERE 100ohm
ITEM 5 WAS 4, 4 WAS 3.
3 WAS 2, ITEM 2 ADDED.
PCB WAS ISS -01
C/R 27513
DJ 28-3-03

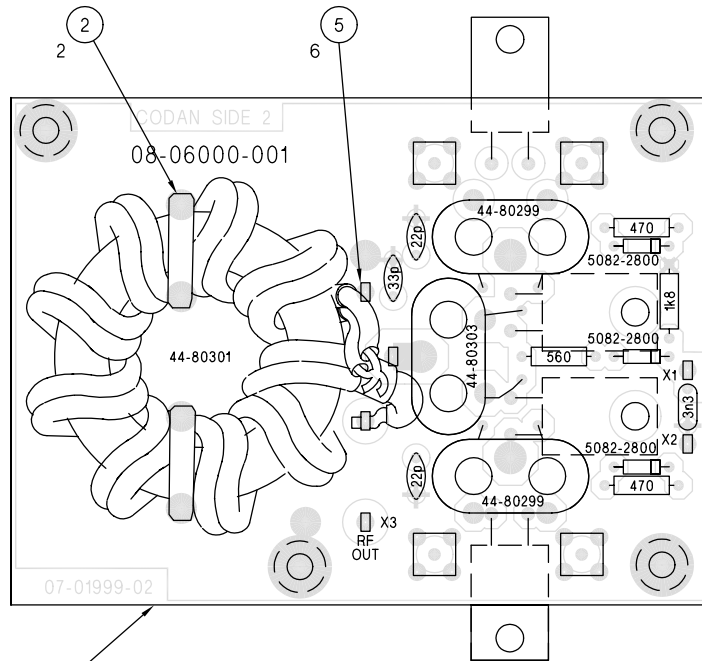

COMPONENT VALUES - SIDE 2

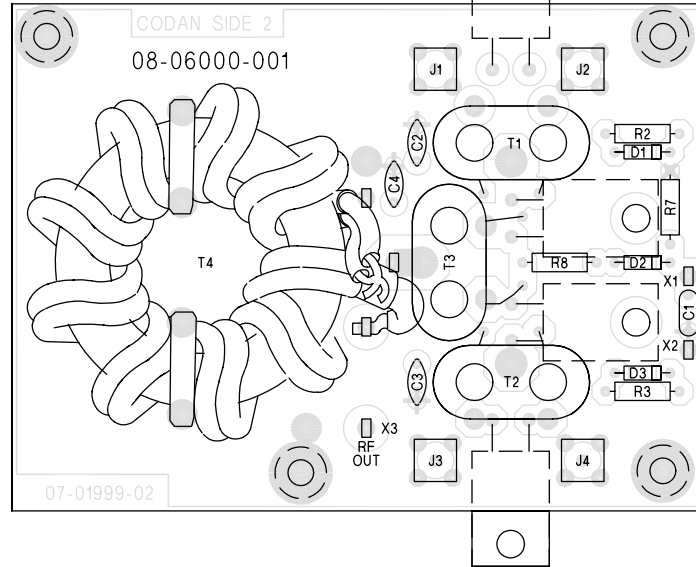

COMPONENT REFERENCES - SIDE 2

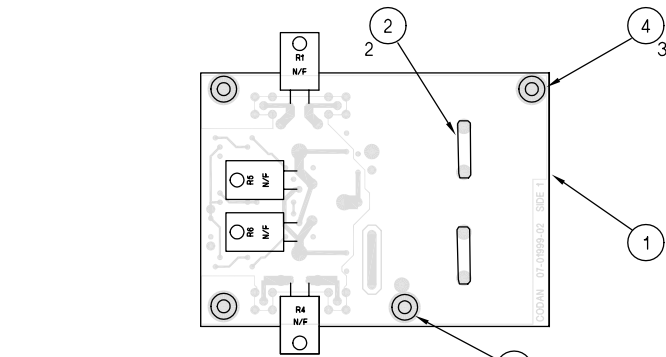

COMPONENT VALUES & REFERENCES - SIDE 1
SCALE 1:1

NOTES:
1. R1, R4, R5 & R6 ARE FITTED AT FINAL ASSY,
AND ARE SHOWN HERE FOR CLARITY.

PCB : 07-01999-02
ASSY: 08-06000-001

FILE No.
08\06000_1.DWG

	SCALE 2:1		© CODAN LIMITED, A.C.N. 007 590 605: 2002 TITLE COMBINER, 4 WAY 1kW AMPLIFIER
	DRN	C G	
MATERIAL	CHKD	PM	27-11-02
FINISH	APPD	KMW	23-3-04
	TOLERANCES UNLESS OTHERWISE STATED		
	2 PLACES DEC. ±0.10 1 PLACE DEC. ±0.5 0 PLACE DEC. ±1		
DRAWING/DOC NO.		ISS	SHT. 1 OF 1
A2 08-06000			

DIMENSIONS IN mm

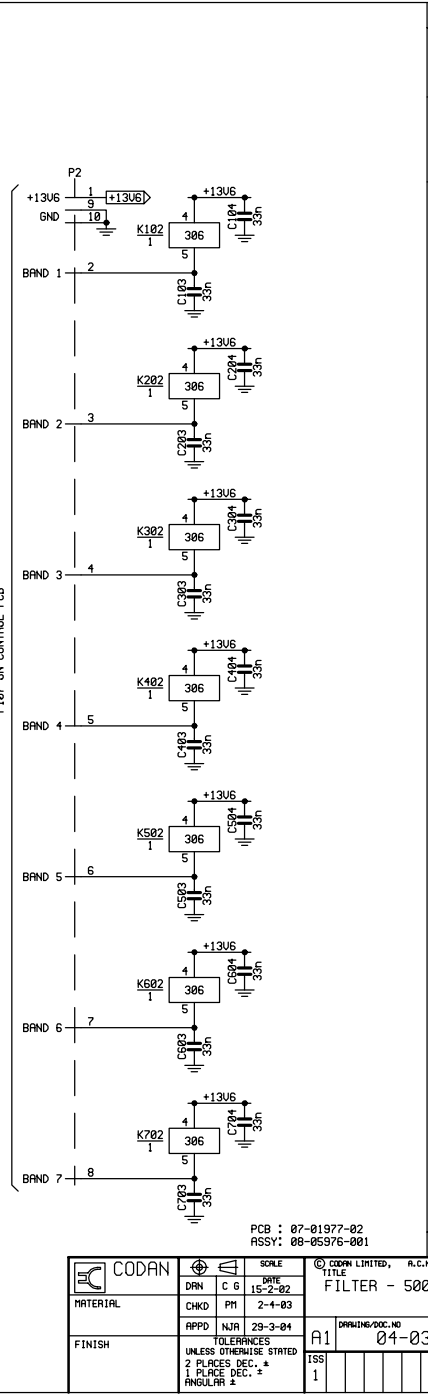
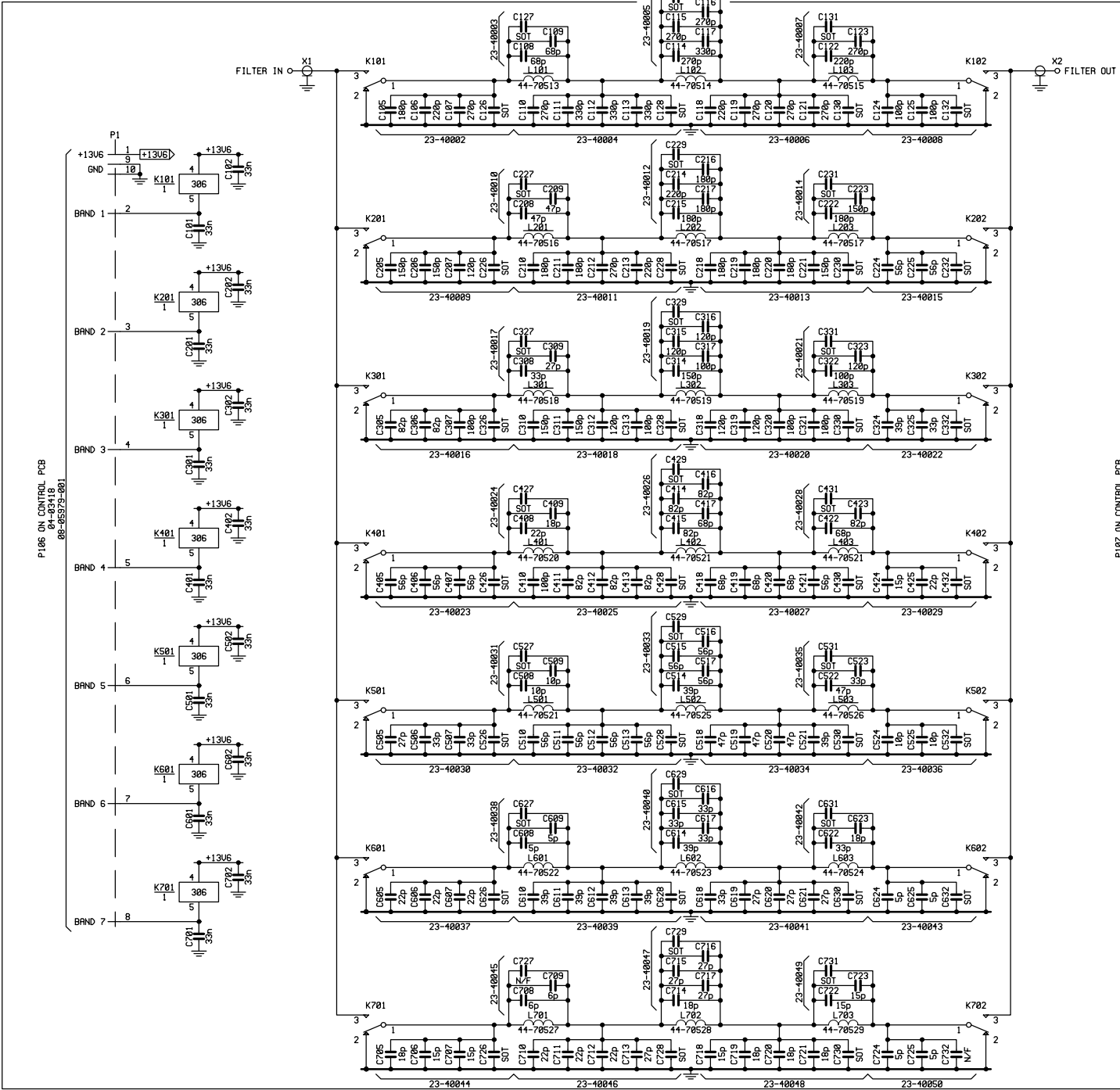

ISSUE CHANGE

ISSUE B:
CAPACITOR SET
PART NUMBERS
ADDED.
C/A 27582
D/A 5-6-83

ISSUE C:
AN ADDITIONAL
CAPACITOR ADDED
TO EACH SET.
SOME VALUES
CHANGED.
C/A 27873
P/N 29-3-84

PCB : 07-01977-02
ASSY: 08-05376-001

FILE NAME
04-03415...1.21P

CODAN	SCALE	CODAN LIMITED, A.C.N. 007 590 685, 2002	
	DRAWN	DATE	TITLE
MATERIAL	CHKD	PH	2-4-83
FINISH	APPD	NJRA	29-3-84
TOLERANCES UNLESS OTHERWISE STATED		DRAWING DOC. NO	
2 PLACES DEC. ±	1	04-03415	
1 PLACE DEC. ±	ISS		
ANGULAR ±			

SHT 1 OF 1

DO NOT SCALE

08-05976-001

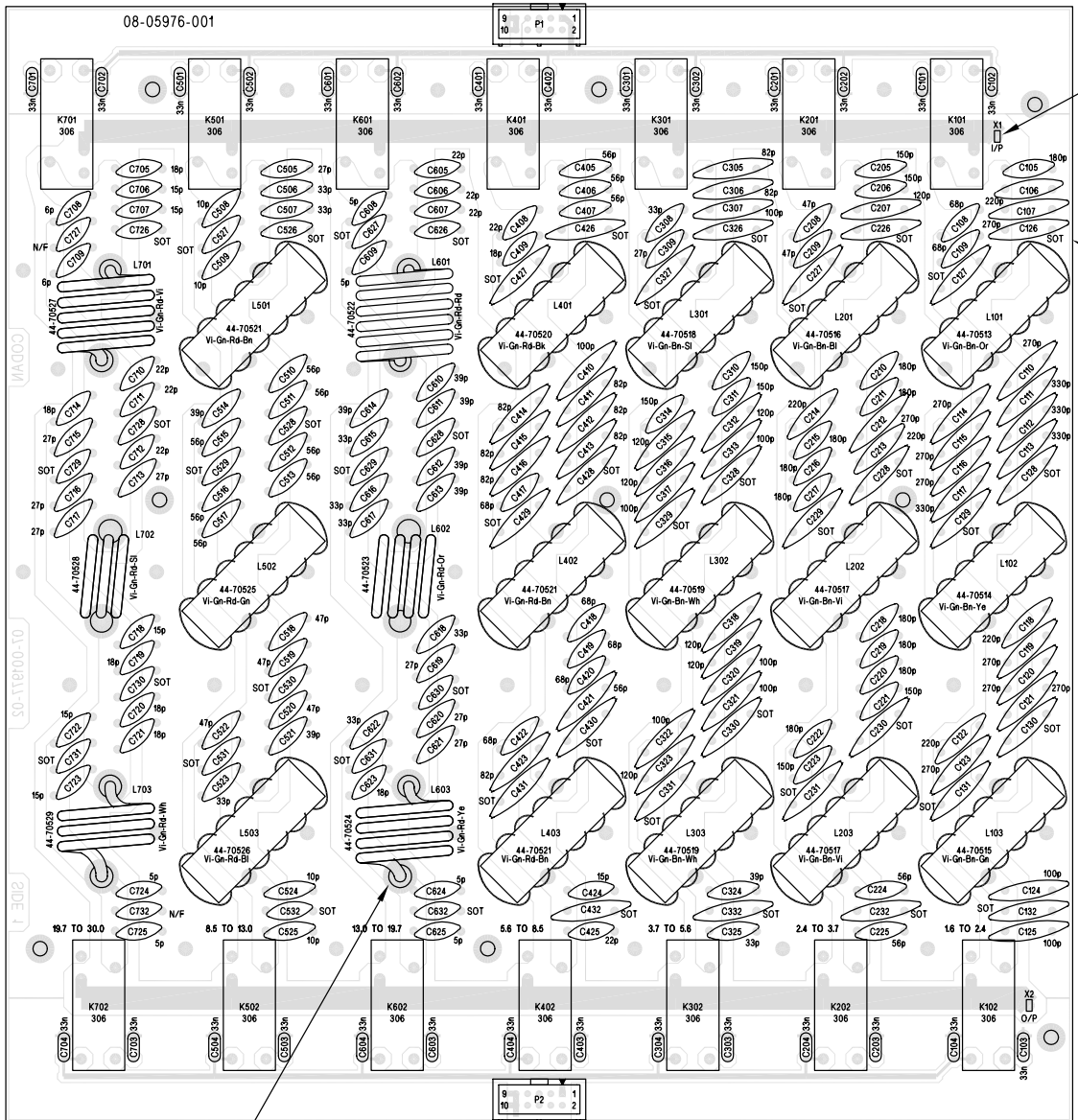

- NOTES:
 1. TO FIT L601-L603 & L701-L703:
 A. SOLDER LUGS (ITEM 2) TO PCB
 B. FIT INDUCTOR LEADS TO LUGS
 AND SOLDER.

PCB : 07-01977-02
 ASSY: 08-05976-001

ISSUE B:
 SHT 2 ADDED.
 C/R 27582
 DJ 5-6-03

ISSUE C:
 REFER SHT 2
 C/R 27669

ISSUE D:
 C126-C132, C226-C232,
 ETC ADDED.
 MOST CAP. VALUES
 CHANGED.
 PCB WAS ISS -01
 C/R 27873
 PM 29-3-04

FILE No.
 08\05976_1.DWG

COMPONENT VALUES & REFERENCES

DIMENSIONS IN mm



		SCALE 1:1	© CODAN LIMITED, A.C.N. 007 590 605: 2002	
DRN	C G	DATE 12-7-02	TITLE FILTER PCB	
CHKD	PM	2-4-03	500W/1000W AMPLIFIER	
APPD	KMW	5-8-04	DRAWING/DOC NO. 08-05976	
TOLERANCES UNLESS OTHERWISE STATED		A3	ISS 1	
2 PLACES DEC. ±0.10				SHT. 1
1 PLACE DEC. ±0.5				OF 2
0 PLACE DEC. ±1				



DO NOT SCALE

ISSUE B:
CAPACITOR SET PART NUMBERS ADDED.
C/R 27582
DJ 5-6-03

ISSUE C:
SOME CAPACITOR SET PRT NoS SWAPPED.
C/R 27669
KMW 12-9-03

ISSUE D:
AN ADDITIONAL CAPACITOR ADDED TO EACH SET.
REFER SHT 1
PCB WAS ISS -01
C/R 27873
PM 29-3-04

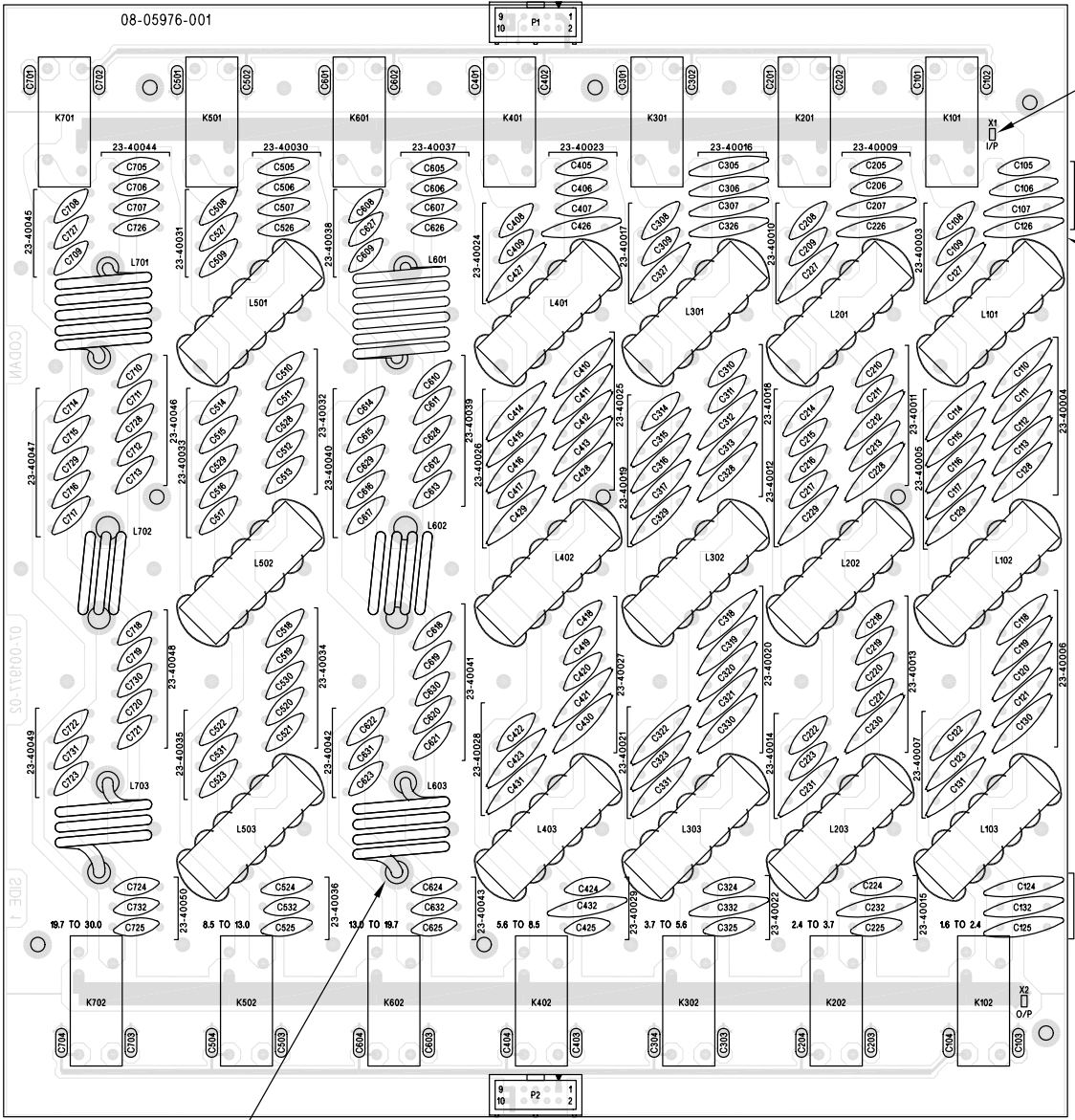

3
2

1

NOTES:
1. TO FIT L601-L603 & L701-L703:
A. SOLDER LUGS (ITEM 2) TO PCB
B. FIT INDUCTOR LEADS TO LUGS AND SOLDER.

PCB : 07-01977-02
ASSY: 08-05976-001

FILE No.
08\05976_1.DWG

COMPONENT REFERENCES
& CAPACITOR SET PART NUMBERS

DIMENSIONS IN mm



	SCALE 1:1
DRN	C G DATE 12-7-02
CHKD	PM 2-4-03
APPD	KMW 5-8-04
TOLERANCES UNLESS OTHERWISE STATED	
2 PLACES DEC. ±0.10	
1 PLACE DEC. ±0.5	
0 PLACE DEC. ±1	

© CODAN LIMITED, A.C.N. 007 590 605. 2002	
TITLE FILTER PCB 500W/1000W AMPLIFIER	
DRAWING/DOC NO. 08-05976	
A3	
ISS 1	SHT. 2 OF 2

2
12

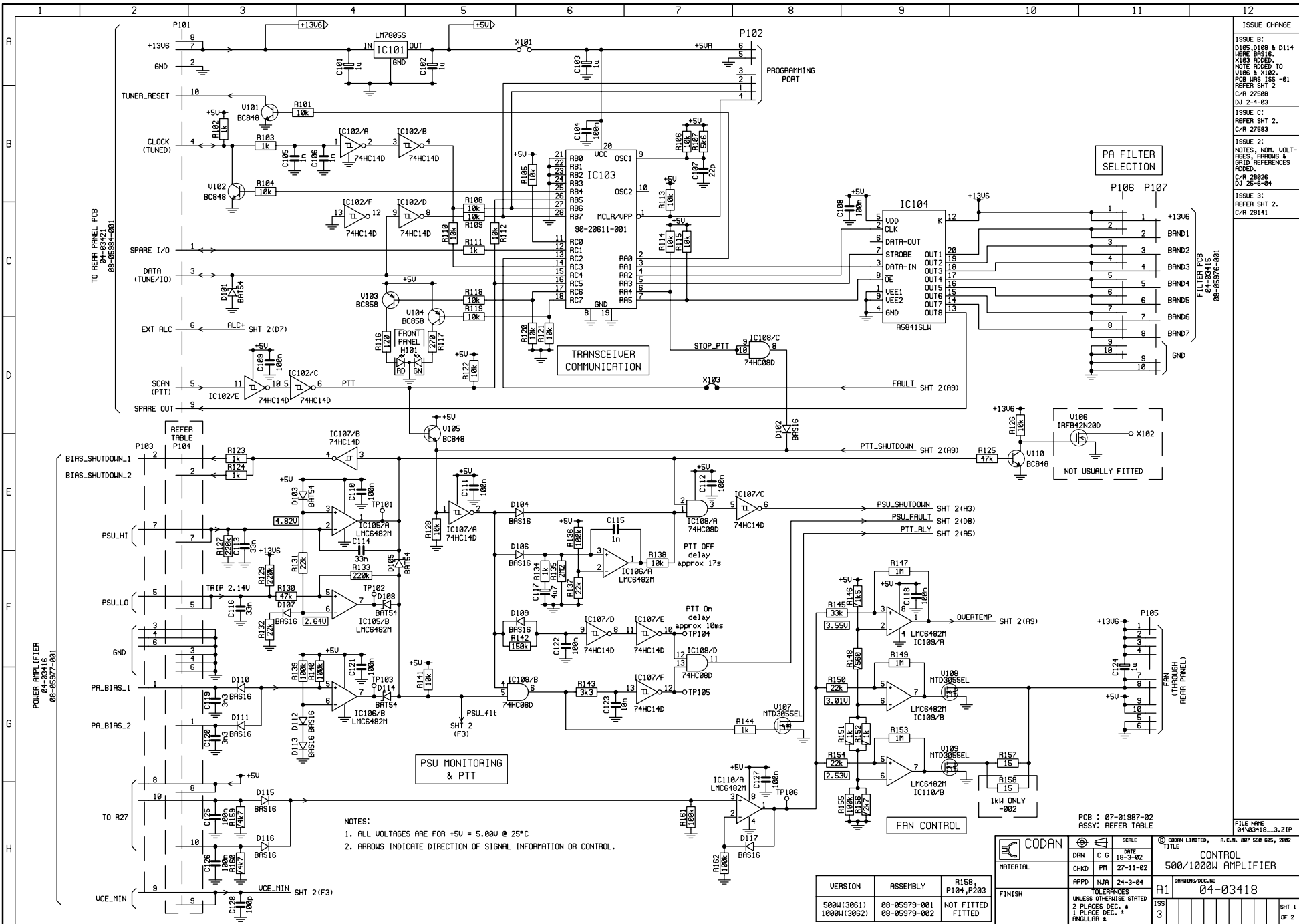

NOTES:
 1. ALL VOLTAGES ARE FOR +5V = 5.00V @ 25°C
 2. ARROWS INDICATE DIRECTION OF SIGNAL INFORMATION OR CONTROL.

ISSUE CHANGE
 ISSUE 0:
 D185, D188 & D114
 WERE BR516.
 X182 ADDED.
 NOTE ADDED TO
 U106 & X182.
 PCB WRS 155-01
 REFER SHT 2
 C/R 27508
 DJ 2-4-83
 ISSUE C:
 REFER SHT 2.
 C/R 27583
 ISSUE 2:
 NOTES, NOM. VOLT-
 AGES, PARTS &
 GRID REFERENCES
 ADDED.
 C/R 28026
 DJ 25-9-84
 ISSUE 3:
 REFER SHT 2.
 C/R 28141

PCB : 07-01987-02
 ASSY: REFER TABLE
 FILE NAME 04103418...3.21P

		SCALE 18-3-02	© CODAN LIMITED, R.C.N. 887 538 GNS, 2002 TITLE CONTROL 500/1000W AMPLIFIER
MATERIAL DPN C G CHKD PM	DATE 27-11-02	APPD NJA 24-3-04	DRAWING DOC NO 04-03418
FINISH UNLESS OTHERWISE STATED 2 PLACES DEC. ± 1 PLACE DEC. ± ANGULAR ±	TOLERANCES UNLESS OTHERWISE STATED 2 PLACES DEC. ± 1 PLACE DEC. ± ANGULAR ±	ISS 3	SHT 1 OF 2

VERSION	ASSEMBLY	R158, P104, P203
500W (3061)	08-05979-001	NOT FITTED
1000W (3062)	08-05979-002	FITTED

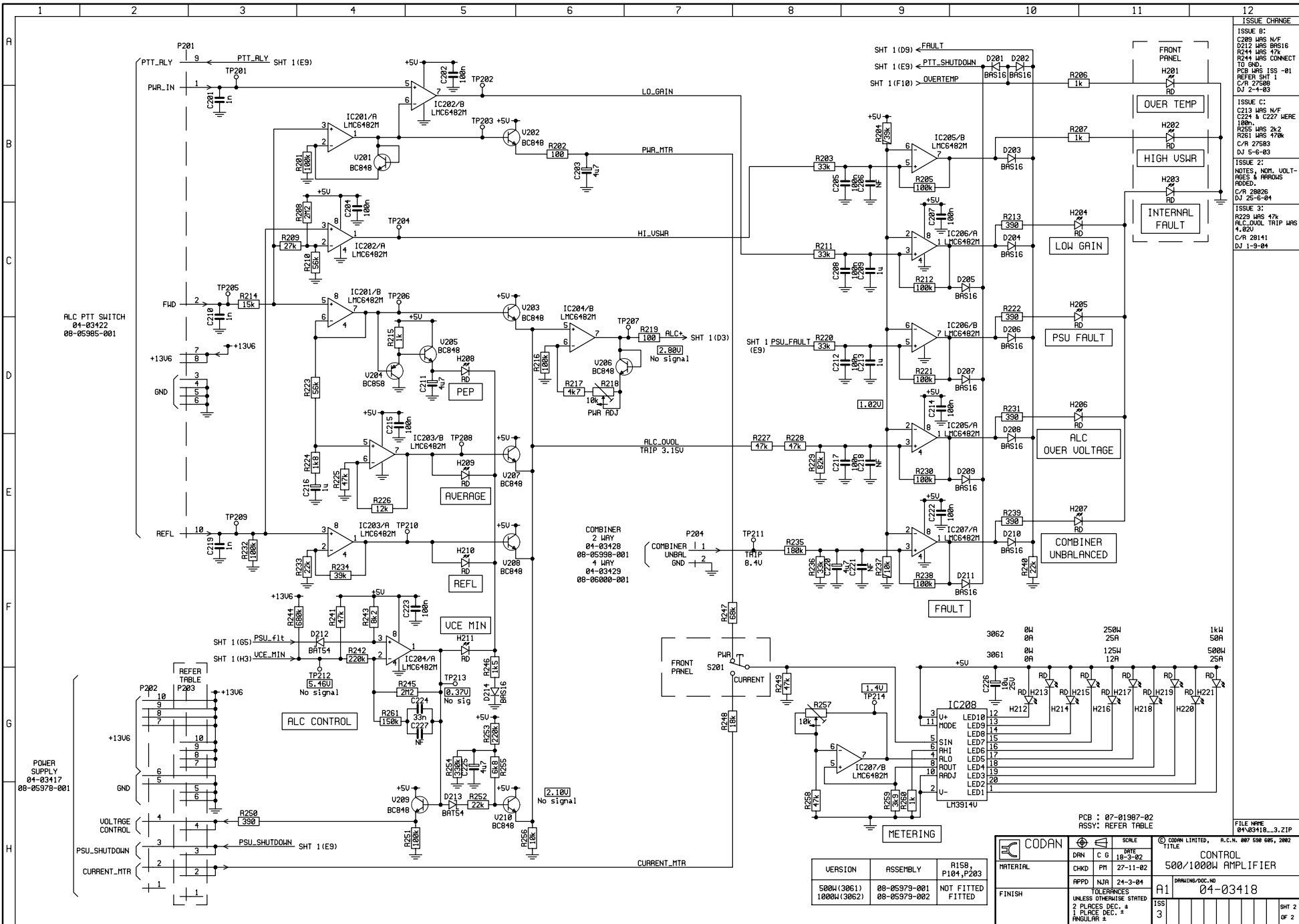

ISSUE CHANGE

ISSUE B:
 C205 WRS N/F
 D212 WRS BMS16
 R244 WRS 47k
 R244 WRS CONNECT TO GND.
 REFER SHT 1
 C/A 27588
 DJ 2-4-83

ISSUE C:
 IC213 WRS N/F
 C224 & C227 WERE 100n.
 R255 WRS 2k2
 R261 WRS 470k
 C/A 27583
 DJ 5-6-83

ISSUE D:
 NOTES, NOM. VOLT-AGES & PARASITICS ADDED.
 C/A 28026
 DJ 26-6-04

ISSUE E:
 R229 WRS 47k
 ALC-DUOL TRIP WRS 4.02U
 C/A 28141
 DJ 1-9-04

PCB : 07-01987-02
 ASSY: REFER TABLE

FILE NAME 04-03418...3.21P

CODAN		SCALE		© CODAN LIMITED, R.C.N. 887 538 685, 2002	
DRN	C G	DATE	TITLE		
18-3-02		27-11-02	CONTROL		
CHKD	PM	500/1000W AMPLIFIER			
APPD	NJA	24-3-04	DRAWING DOC. NO		
TOLERANCES			A1 04-03418		
UNLESS OTHERWISE STATED			ISS 3		
2 PLACES DEC. & 1 PLACE DEC. & ANGULAR ±			SHT 2 OF 2		

VERSION	ASSEMBLY	R158, P104, P203
500W (3061)	08-05379-001	NOT FITTED
1000W (3062)	08-05379-002	FITTED

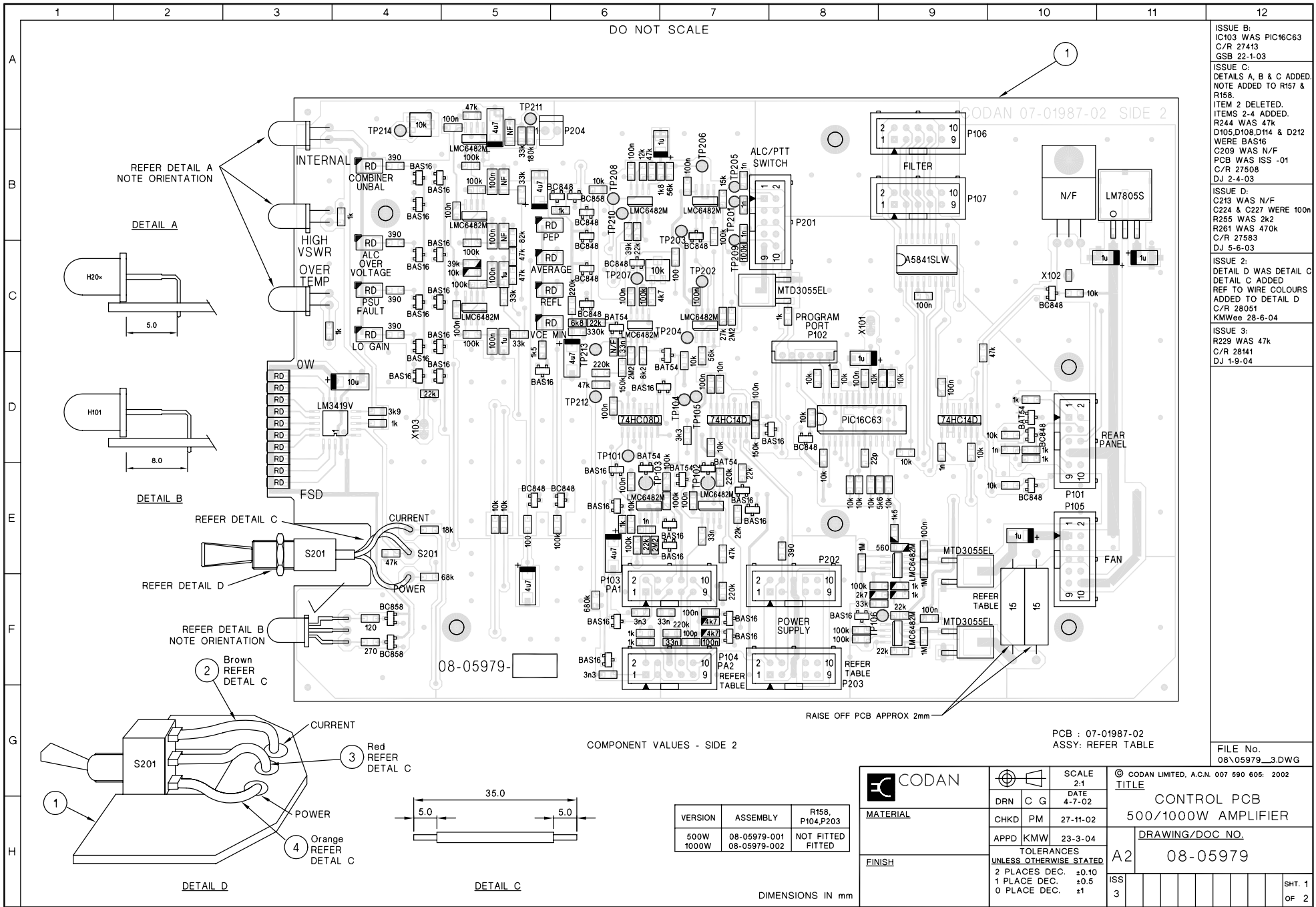

DO NOT SCALE

CODAN 07-01987-02 SIDE 2

REFER DETAIL A NOTE ORIENTATION

DETAIL A

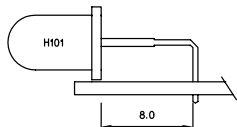
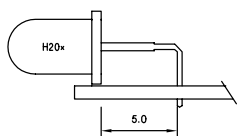

DETAIL B

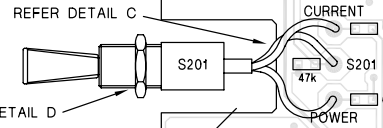

REFER DETAIL B NOTE ORIENTATION

2

3

4

DETAIL D

DETAIL C

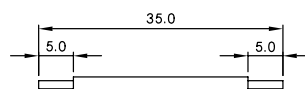

DIMENSIONS IN mm

COMPONENT VALUES - SIDE 2

VERSION	ASSEMBLY	R158, P104, P203
500W	08-05979-001	NOT FITTED
1000W	08-05979-002	FITTED

RAISE OFF PCB APPROX 2mm

PCB : 07-01987-02
ASSY: REFER TABLE

ISSUE B:
IC103 WAS PIC16C63
C/R 27413
GSB 22-1-03

ISSUE C:
DETAILS A, B & C ADDED.
NOTE ADDED TO R167 & R168.
ITEM 2 DELETED.
ITEMS 2-4 ADDED.
R244 WAS 47k
D105, D108, D114 & D212 WERE BAS16
C209 WAS N/F
PCB WAS ISS -01
C/R 27508
DJ 2-4-03

ISSUE D:
C213 WAS N/F
C224 & C227 WERE 100n
R255 WAS 2k2
R261 WAS 470k
C/R 27583
DJ 5-6-03

ISSUE 2:
DETAIL D WAS DETAIL C
DETAIL C ADDED
REF TO WIRE COLOURS
ADDED TO DETAIL D
C/R 28051
KMWee 28-6-04

ISSUE 3:
R229 WAS 47k
C/R 28141
DJ 1-9-04

FILE No.
08\05979_3.DWG

	SCALE 2:1	© CODAN LIMITED, A.C.N. 007 590 606: 2002 TITLE CONTROL PCB 500/1000W AMPLIFIER
	DATE 4-7-02	
MATERIAL	DRN C G	DRAWING/DOC NO. 08-05979
	CHKD PM	
	APPD KMW	TOLERANCES UNLESS OTHERWISE STATED
FINISH		ISS 3
		SHT. 1 OF 2

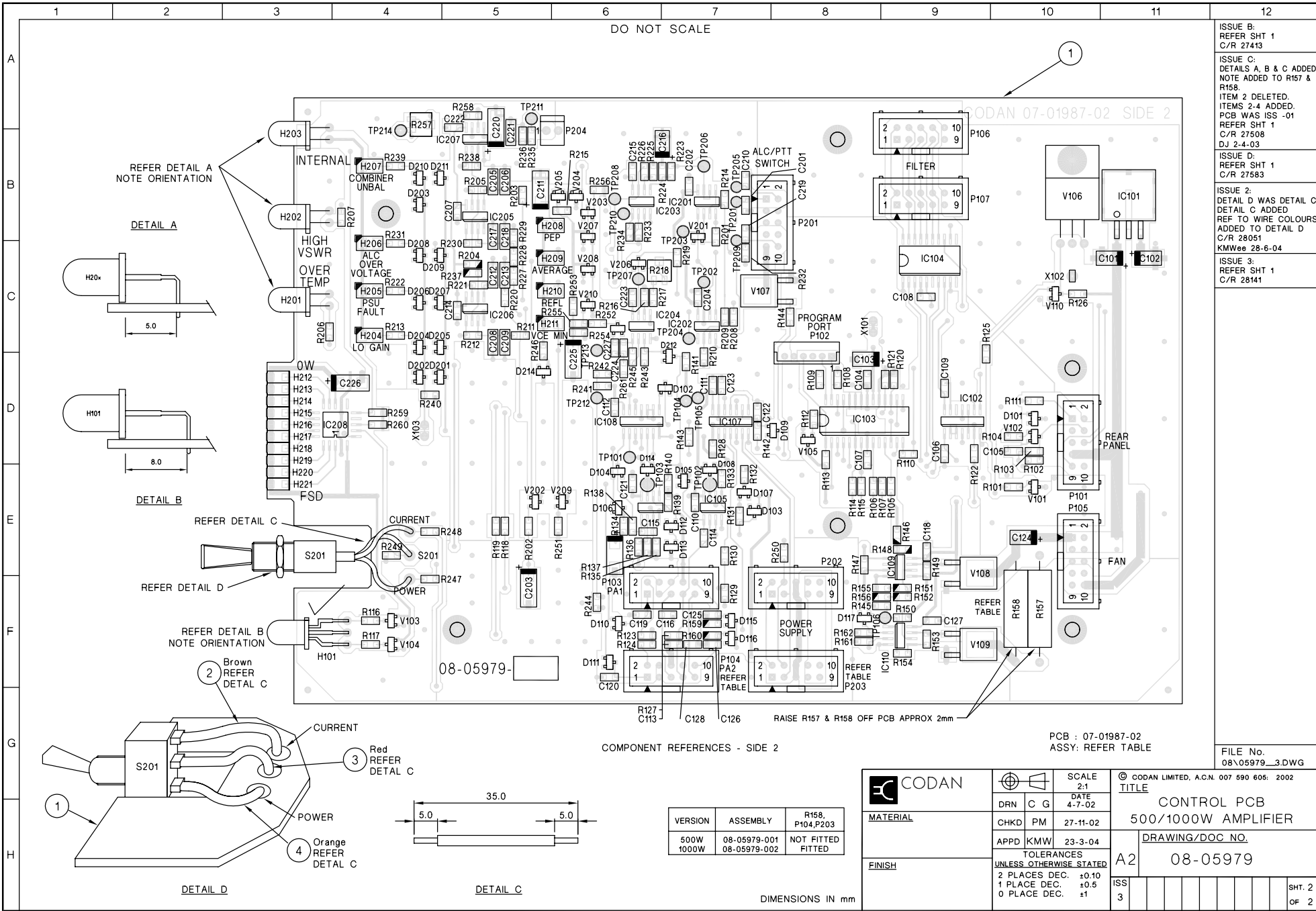

ISSUE B:
REFER SHT 1
C/R 27413

ISSUE C:
DETAILS A, B & C ADDED
NOTE ADDED TO R157 &
R158.
ITEM 2 DELETED.
ITEMS 2-4 ADDED.
PCB WAS ISS -01
REFER SHT 1
C/R 27508
DJ 2-4-03

ISSUE D:
REFER SHT 1
C/R 27583

ISSUE E:
DETAIL D WAS DETAIL C
DETAIL C ADDED
REF TO WIRE COLOURS
ADDED TO DETAIL D
C/R 28051
KMWee 28-6-04

ISSUE 3:
REFER SHT 1
C/R 28141

FILE No.
08\05979_3.DWG

COMPONENT REFERENCES - SIDE 2

PCB : 07-01987-02
ASSY: REFER TABLE

VERSION	ASSEMBLY	R158, P104, P203
500W	08-05979-001	NOT FITTED
1000W	08-05979-002	FITTED

	SCALE 2:1 DATE 4-7-02	© CODAN LIMITED, A.C.N. 007 590 605: 2002 TITLE CONTROL PCB 500/1000W AMPLIFIER
	MATERIAL CHKD PM 27-11-02 APPD KMW 23-3-04	TOLERANCES UNLESS OTHERWISE STATED 2 PLACES DEC. ±0.10 1 PLACE DEC. ±0.5 0 PLACE DEC. ±1
FINISH	REFER TABLE P203 REFER TABLE P105 REFER TABLE P102	ISS 3

DIMENSIONS IN mm

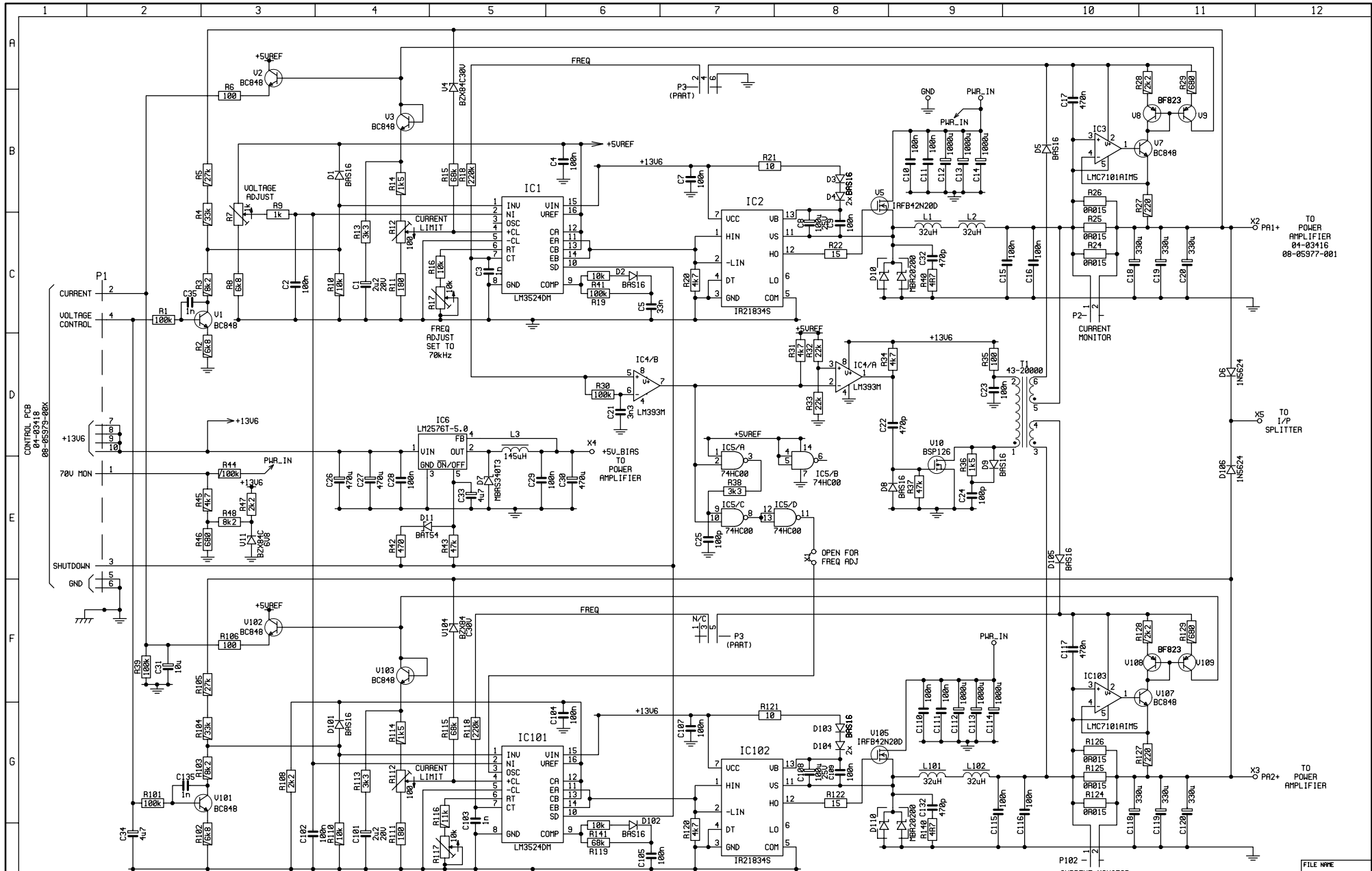

TO POWER AMPLIFIER
84-03416
08-05977-001

TO 1/P SPLITTER

TO POWER AMPLIFIER

ISSUE CHANGE
ISSUE B1 IS HERE
ISSUE C
ISSUE D
ISSUE E
ISSUE F
ISSUE G
ISSUE H

ISSUE 2: 21 TP2 & TP1A2 REPLACED BY TP1A3
ISSUE 3: 21 TP2 & TP1A2 REPLACED BY TP1A3
ISSUE 4: 21 TP2 & TP1A2 REPLACED BY TP1A3
ISSUE 5: 21 TP2 & TP1A2 REPLACED BY TP1A3
ISSUE 6: 21 TP2 & TP1A2 REPLACED BY TP1A3
ISSUE 7: 21 TP2 & TP1A2 REPLACED BY TP1A3
ISSUE 8: 21 TP2 & TP1A2 REPLACED BY TP1A3
ISSUE 9: 21 TP2 & TP1A2 REPLACED BY TP1A3
ISSUE 10: 21 TP2 & TP1A2 REPLACED BY TP1A3
ISSUE 11: 21 TP2 & TP1A2 REPLACED BY TP1A3
ISSUE 12: 21 TP2 & TP1A2 REPLACED BY TP1A3
ISSUE 13: 21 TP2 & TP1A2 REPLACED BY TP1A3
ISSUE 14: 21 TP2 & TP1A2 REPLACED BY TP1A3
ISSUE 15: 21 TP2 & TP1A2 REPLACED BY TP1A3
ISSUE 16: 21 TP2 & TP1A2 REPLACED BY TP1A3
ISSUE 17: 21 TP2 & TP1A2 REPLACED BY TP1A3
ISSUE 18: 21 TP2 & TP1A2 REPLACED BY TP1A3
ISSUE 19: 21 TP2 & TP1A2 REPLACED BY TP1A3
ISSUE 20: 21 TP2 & TP1A2 REPLACED BY TP1A3
ISSUE 21: 21 TP2 & TP1A2 REPLACED BY TP1A3
ISSUE 22: 21 TP2 & TP1A2 REPLACED BY TP1A3
ISSUE 23: 21 TP2 & TP1A2 REPLACED BY TP1A3
ISSUE 24: 21 TP2 & TP1A2 REPLACED BY TP1A3
ISSUE 25: 21 TP2 & TP1A2 REPLACED BY TP1A3
ISSUE 26: 21 TP2 & TP1A2 REPLACED BY TP1A3
ISSUE 27: 21 TP2 & TP1A2 REPLACED BY TP1A3
ISSUE 28: 21 TP2 & TP1A2 REPLACED BY TP1A3
ISSUE 29: 21 TP2 & TP1A2 REPLACED BY TP1A3
ISSUE 30: 21 TP2 & TP1A2 REPLACED BY TP1A3
ISSUE 31: 21 TP2 & TP1A2 REPLACED BY TP1A3
ISSUE 32: 21 TP2 & TP1A2 REPLACED BY TP1A3
ISSUE 33: 21 TP2 & TP1A2 REPLACED BY TP1A3
ISSUE 34: 21 TP2 & TP1A2 REPLACED BY TP1A3
ISSUE 35: 21 TP2 & TP1A2 REPLACED BY TP1A3
ISSUE 36: 21 TP2 & TP1A2 REPLACED BY TP1A3
ISSUE 37: 21 TP2 & TP1A2 REPLACED BY TP1A3
ISSUE 38: 21 TP2 & TP1A2 REPLACED BY TP1A3
ISSUE 39: 21 TP2 & TP1A2 REPLACED BY TP1A3
ISSUE 40: 21 TP2 & TP1A2 REPLACED BY TP1A3
ISSUE 41: 21 TP2 & TP1A2 REPLACED BY TP1A3
ISSUE 42: 21 TP2 & TP1A2 REPLACED BY TP1A3
ISSUE 43: 21 TP2 & TP1A2 REPLACED BY TP1A3
ISSUE 44: 21 TP2 & TP1A2 REPLACED BY TP1A3
ISSUE 45: 21 TP2 & TP1A2 REPLACED BY TP1A3
ISSUE 46: 21 TP2 & TP1A2 REPLACED BY TP1A3
ISSUE 47: 21 TP2 & TP1A2 REPLACED BY TP1A3
ISSUE 48: 21 TP2 & TP1A2 REPLACED BY TP1A3
ISSUE 49: 21 TP2 & TP1A2 REPLACED BY TP1A3
ISSUE 50: 21 TP2 & TP1A2 REPLACED BY TP1A3
ISSUE 51: 21 TP2 & TP1A2 REPLACED BY TP1A3
ISSUE 52: 21 TP2 & TP1A2 REPLACED BY TP1A3
ISSUE 53: 21 TP2 & TP1A2 REPLACED BY TP1A3
ISSUE 54: 21 TP2 & TP1A2 REPLACED BY TP1A3
ISSUE 55: 21 TP2 & TP1A2 REPLACED BY TP1A3
ISSUE 56: 21 TP2 & TP1A2 REPLACED BY TP1A3
ISSUE 57: 21 TP2 & TP1A2 REPLACED BY TP1A3
ISSUE 58: 21 TP2 & TP1A2 REPLACED BY TP1A3
ISSUE 59: 21 TP2 & TP1A2 REPLACED BY TP1A3
ISSUE 60: 21 TP2 & TP1A2 REPLACED BY TP1A3
ISSUE 61: 21 TP2 & TP1A2 REPLACED BY TP1A3
ISSUE 62: 21 TP2 & TP1A2 REPLACED BY TP1A3
ISSUE 63: 21 TP2 & TP1A2 REPLACED BY TP1A3
ISSUE 64: 21 TP2 & TP1A2 REPLACED BY TP1A3
ISSUE 65: 21 TP2 & TP1A2 REPLACED BY TP1A3
ISSUE 66: 21 TP2 & TP1A2 REPLACED BY TP1A3
ISSUE 67: 21 TP2 & TP1A2 REPLACED BY TP1A3
ISSUE 68: 21 TP2 & TP1A2 REPLACED BY TP1A3
ISSUE 69: 21 TP2 & TP1A2 REPLACED BY TP1A3
ISSUE 70: 21 TP2 & TP1A2 REPLACED BY TP1A3
ISSUE 71: 21 TP2 & TP1A2 REPLACED BY TP1A3
ISSUE 72: 21 TP2 & TP1A2 REPLACED BY TP1A3
ISSUE 73: 21 TP2 & TP1A2 REPLACED BY TP1A3
ISSUE 74: 21 TP2 & TP1A2 REPLACED BY TP1A3
ISSUE 75: 21 TP2 & TP1A2 REPLACED BY TP1A3
ISSUE 76: 21 TP2 & TP1A2 REPLACED BY TP1A3
ISSUE 77: 21 TP2 & TP1A2 REPLACED BY TP1A3
ISSUE 78: 21 TP2 & TP1A2 REPLACED BY TP1A3
ISSUE 79: 21 TP2 & TP1A2 REPLACED BY TP1A3
ISSUE 80: 21 TP2 & TP1A2 REPLACED BY TP1A3
ISSUE 81: 21 TP2 & TP1A2 REPLACED BY TP1A3
ISSUE 82: 21 TP2 & TP1A2 REPLACED BY TP1A3
ISSUE 83: 21 TP2 & TP1A2 REPLACED BY TP1A3
ISSUE 84: 21 TP2 & TP1A2 REPLACED BY TP1A3
ISSUE 85: 21 TP2 & TP1A2 REPLACED BY TP1A3
ISSUE 86: 21 TP2 & TP1A2 REPLACED BY TP1A3
ISSUE 87: 21 TP2 & TP1A2 REPLACED BY TP1A3
ISSUE 88: 21 TP2 & TP1A2 REPLACED BY TP1A3
ISSUE 89: 21 TP2 & TP1A2 REPLACED BY TP1A3
ISSUE 90: 21 TP2 & TP1A2 REPLACED BY TP1A3
ISSUE 91: 21 TP2 & TP1A2 REPLACED BY TP1A3
ISSUE 92: 21 TP2 & TP1A2 REPLACED BY TP1A3
ISSUE 93: 21 TP2 & TP1A2 REPLACED BY TP1A3
ISSUE 94: 21 TP2 & TP1A2 REPLACED BY TP1A3
ISSUE 95: 21 TP2 & TP1A2 REPLACED BY TP1A3
ISSUE 96: 21 TP2 & TP1A2 REPLACED BY TP1A3
ISSUE 97: 21 TP2 & TP1A2 REPLACED BY TP1A3
ISSUE 98: 21 TP2 & TP1A2 REPLACED BY TP1A3
ISSUE 99: 21 TP2 & TP1A2 REPLACED BY TP1A3
ISSUE 100: 21 TP2 & TP1A2 REPLACED BY TP1A3

PCB : 07-01986-03
ASSY : 08-05978-001

CODAN		SCALE	DATE	FILE NAME
DRAWN	C 6	7-3-02	TITLE	04*03417...2.ZIP
CHECKED	PH	27-11-02	POWER SUPPLY	
APPD	NJA	24-3-04	500/1000W AMPLIFIER	
FINISH			DRAWING/COD. NO	A1
			TOLERANCES	04-03417
			UNLESS OTHERWISE STATED	
			2 PLACES DEC. 4	
			PLACES DEC. 4	
			ANGULAR 2	
ISS	2			SHT 1
				OF 1

DO NOT SCALE

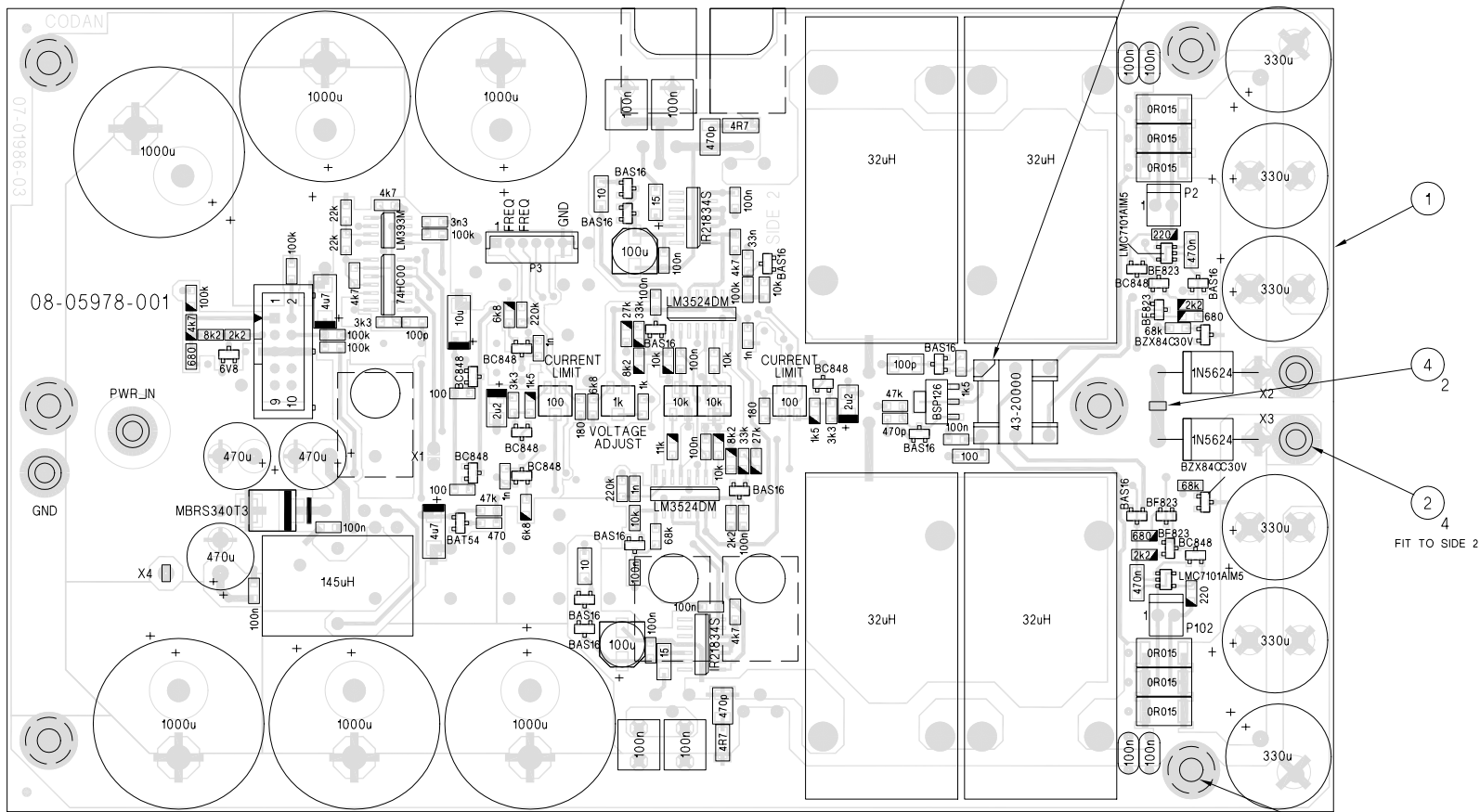

COMPONENT VALUES - SIDE 2

SCH: 04-03417
PCB: 07-01986-03
ASSY: 08-05978-001

FILE No.
08\05978_4.DWG

	SCALE		© CODAN LIMITED, A.C.N. 007 590 605: 2002 TITLE POWER SUPPLY 500/1000W AMPLIFIER
	DRN	C G	
MATERIAL	CHKD	PM	27-11-02
FINISH	APPD	KMW	23-3-04
	TOLERANCES UNLESS OTHERWISE STATED		
2 PLACES DEC. +0.10			A2 DRAWING/DOC NO. 08-05978
1 PLACE DEC. +0.5			
0 PLACE DEC. ±1			ISS
			4
			SHT. 1
			OF 3

DIMENSIONS IN mm

ISSUE B:
R15 & R115 WERE 56k.
C/R 27414
PM 9-1-03

ISSUE C:
REFER SHT 3.
PCB WAS ISS -01
C/R 27507
DJ 28-3-03

ISSUE 1:
R15 & R115 WERE 56k
C/R 27907
KMW 23-3-04

ISSUE 2:
NOTE RE ORIENTATION
OF T1 ADDED
C/R 28039
KMW 16-7-04

ISSUE 3:
TP1, TP101, TP3 & TP103
REPLACED WITH P3
P2 WAS TP2, P102 WAS
TP103. R44-R48 & V11
ADDED.
C/R 28660
GJC 31-8-05

ISSUE 4:
PCB WAS -02
C/R 30032
JBL 18-10-05

DO NOT SCALE

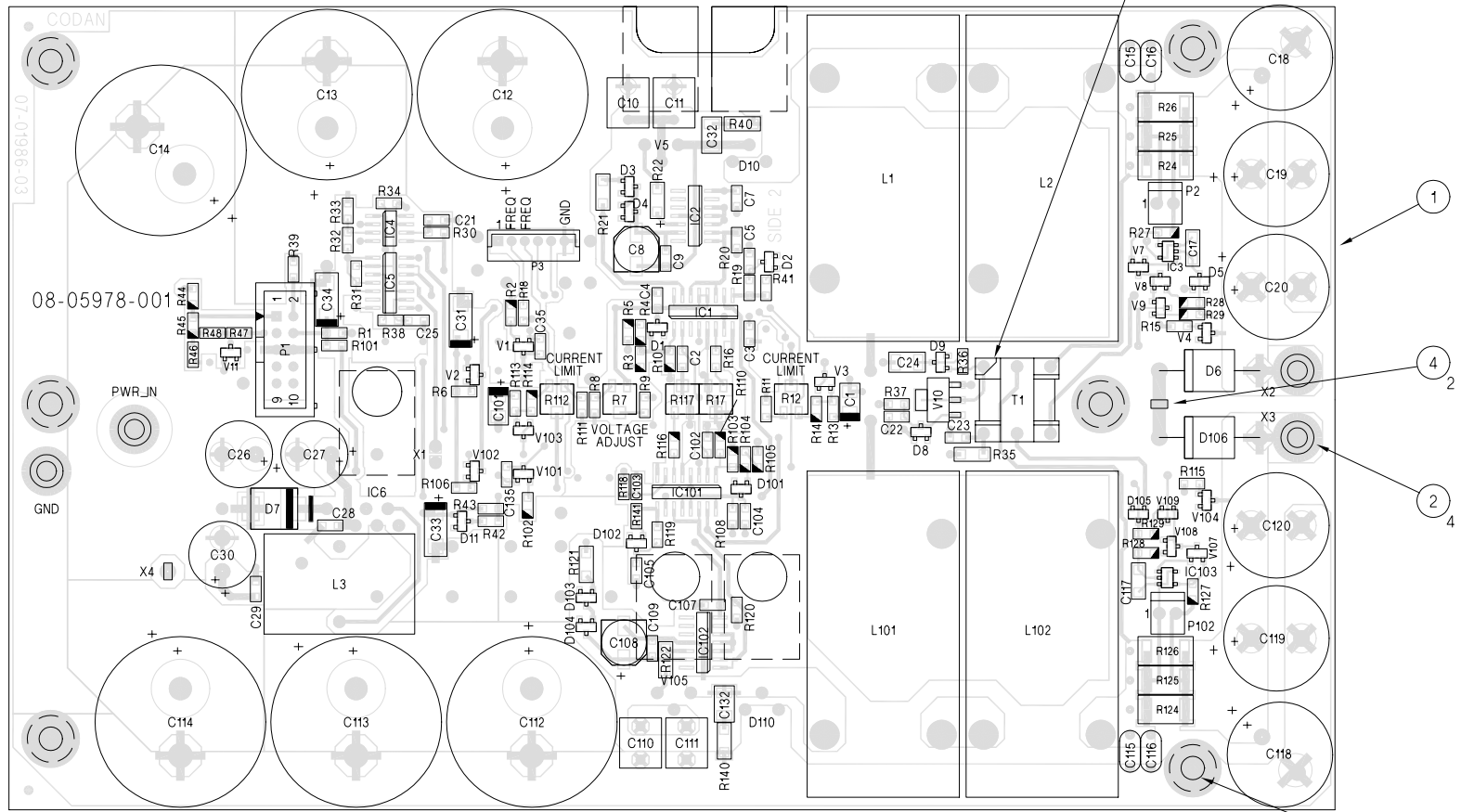

08-05978-001

COMPONENT REFERENCES - SIDE 2

ISSUE B:
REFER SHT 1.
C/R 27414

ISSUE C:
REFER SHT 3.
PCB WAS ISS -01
C/R 27507
DJ 28-3-03

ISSUE 1:
REFER SHT 1
C/R 27907

ISSUE 2:
NOTE RE ORIENTATION
OF T1 ADDED
C/R 28039
KMWee 16-7-04

ISSUE 3:
TP1,TP101,TP3 & TP103
REPLACED WITH P3
P2 WAS TP2, P102 WAS
TP103, R44-R48 & V11
ADDED.
C/R 28660
GJC 31-8-05

ISSUE 4:
PCB WAS -02
C/R 30032
18-10-05

SCH: 04-03417
PCB: 07-01986-03
ASSY:08-05978-001

FILE No.
08\05978_4.DWG

	SCALE		© CODAN LIMITED, A.C.N. 007 590 605: 2002 TITLE POWER SUPPLY 500/1000W AMPLIFIER
	DRN	C G	
MATERIAL	CHKD	PM	27-11-02
FINISH	APPD	KMW	23-3-04
	TOLERANCES UNLESS OTHERWISE STATED		
2 PLACES DEC. +0.10			A2
1 PLACE DEC. +0.5			
0 PLACE DEC. ±1			ISS
DIMENSIONS IN mm			SHT. 2
			OF 3

1 2 3 4 5 6 7 8 9 10 11 12

DO NOT SCALE

A
B
C
D
E
F
G
H

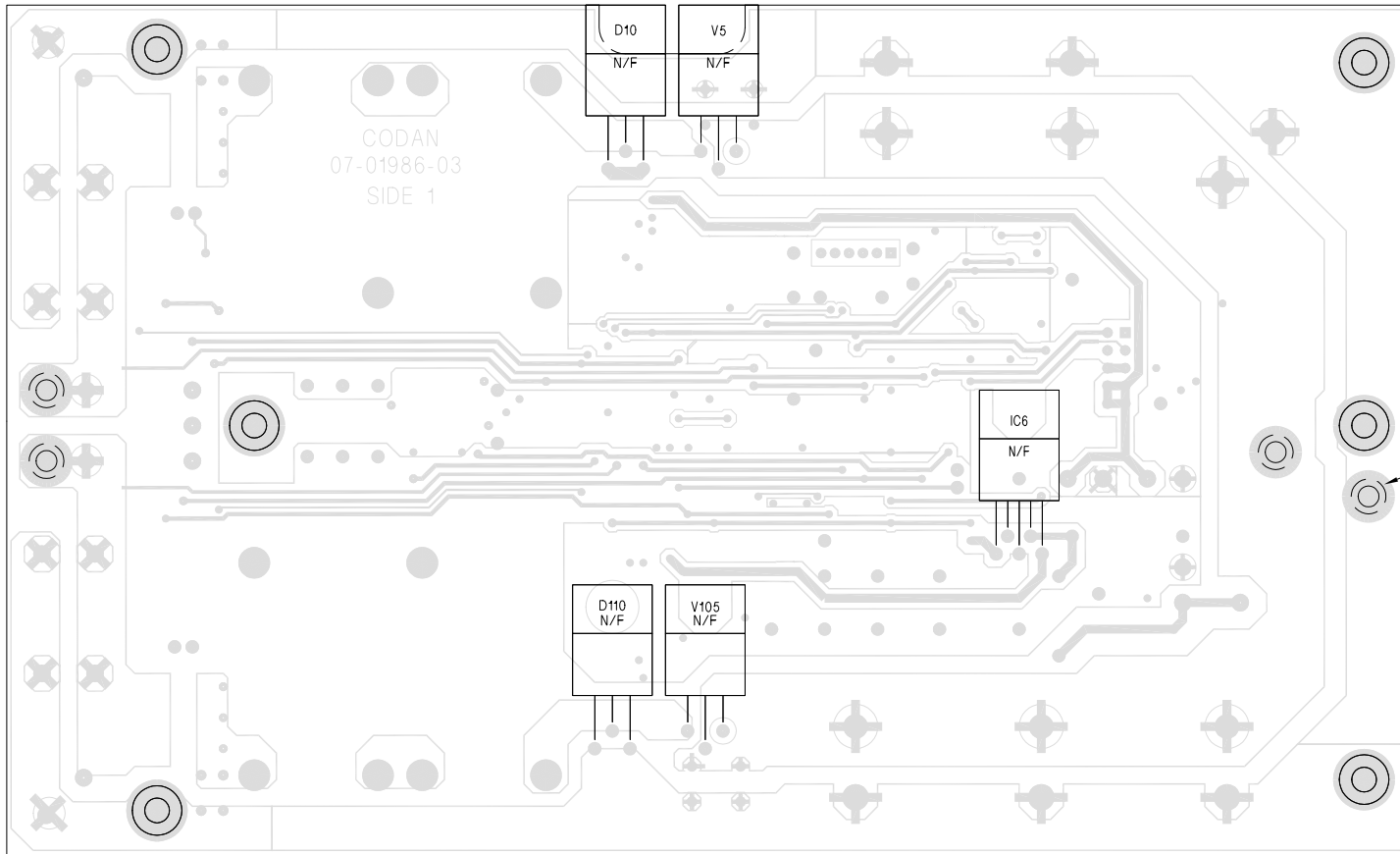

CODAN
07-01986-03
SIDE 1

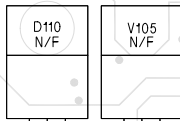
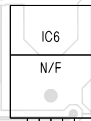
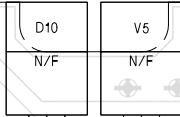

COMPONENT VALUES & REFERENCES - SIDE 1

NOTES:
1. D10, D110, IC6, V5 & V105 ARE FITTED AT FINAL ASSEMBLY, AND SHOWN FOR CLARITY.

SCH: 04-03417
PCB: 07-01986-03
ASSY:08-05978-001

FILE No.
08\05978_4.DWG

ISSUE B:
REFER SHT 1.
C/R 27414

ISSUE C:
D10 & D110 MOVED.
D10 & D110 WERE
LM2576T-5.0. V5 & V105
WERE IRFB42N20D.
NOTE 1 CHANGED.
PCB WAS ISS -01
C/R 27507
DJ 28-3-03

ISSUE 1:
REFER SHT 1
C/R 27907

ISSUE 2:
REFER SHTS 1 & 2
C/R 28039

ISSUE 3:
REFER SHTS 1 & 2
C/R 28660

ISSUE 3:
REFER SHTS 1 & 2
C/R 30032

DIMENSIONS IN mm

	SCALE		© CODAN LIMITED, A.C.N. 007 590 605: 2002 TITLE POWER SUPPLY 500/1000W AMPLIFIER
	DRN	C G	
MATERIAL	CHKD	PM	27-11-02
FINISH	APPD	KMW	23-3-04
	TOLERANCES UNLESS OTHERWISE STATED 2 PLACES DEC. +0.10 1 PLACE DEC. +0.5 0 PLACE DEC. ±1		
DRAWING/DOC NO.			A2 08-05978
ISS			
			SHT. 3
			OF 3

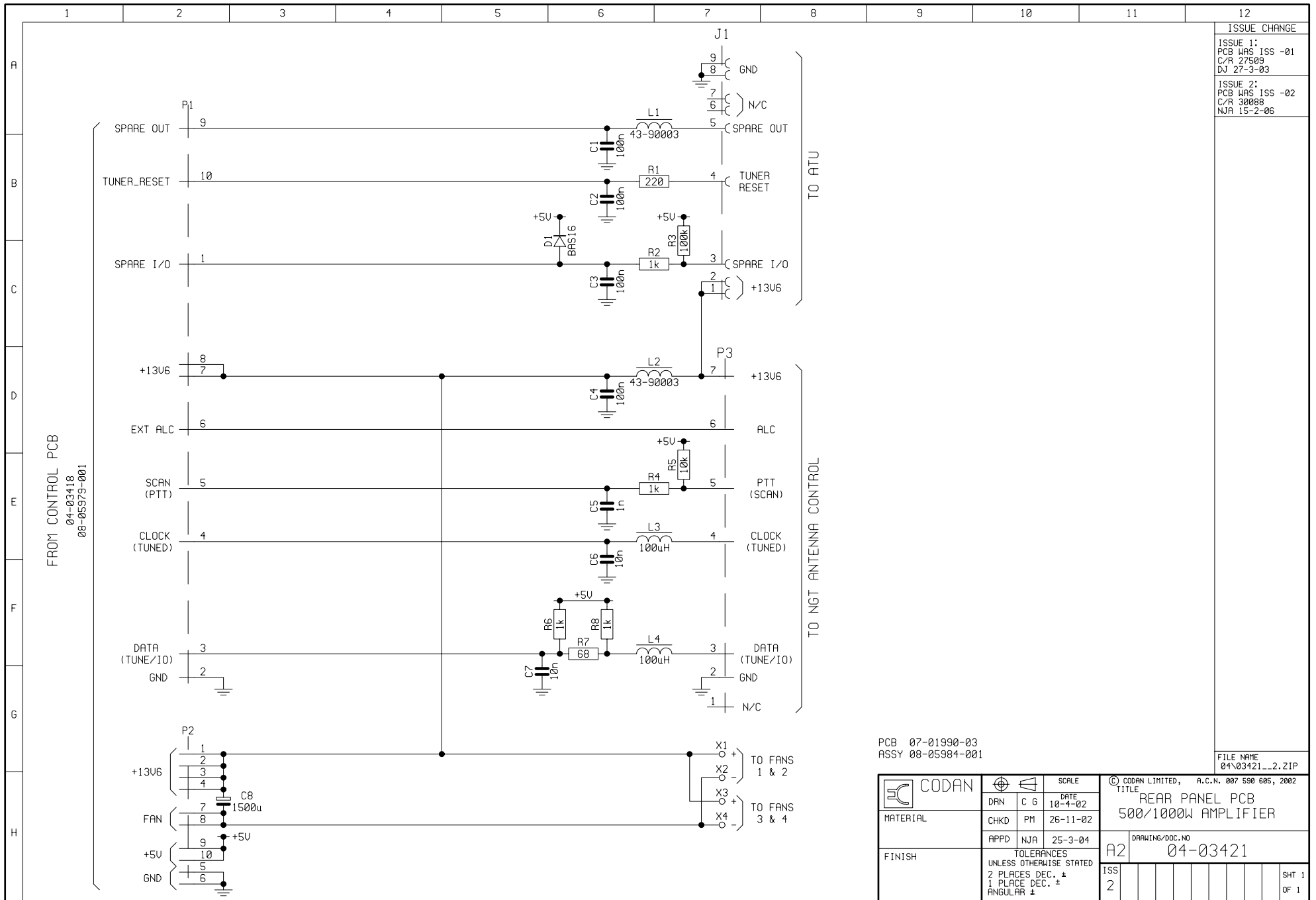

ISSUE CHANGE
ISSUE 1: PCB WAS ISS -01 C/R 27509 DJ 27-3-03
ISSUE 2: PCB WAS ISS -02 C/R 30088 NJR 15-2-06

FILE NAME
04\03421...2.ZIP

	DRN	C G	SCALE	© CODAN LIMITED, A.C.N. 007 590 695, 2002	
	DATE	10-4-02	TITLE	REAR PANEL PCB	
MATERIAL	CHKD	PM	26-11-02	500/1000W AMPLIFIER	
FINISH	APPD	NJR	25-3-04	DRAWING/DOC. NO	A2
	TOLERANCES UNLESS OTHERWISE STATED			ISS	04-03421
2 PLACES DEC. ±			2		SHT 1
1 PLACE DEC. ±					OF 1
ANGULAR ±					

DO NOT SCALE

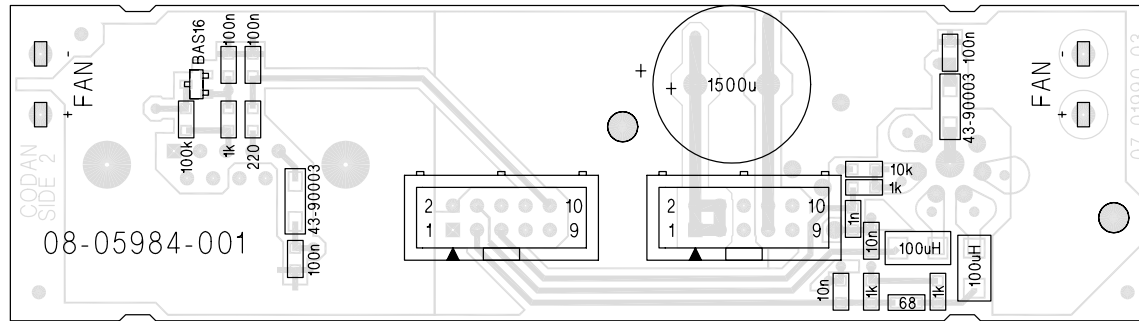

COMPONENT VALUES - SIDE 2

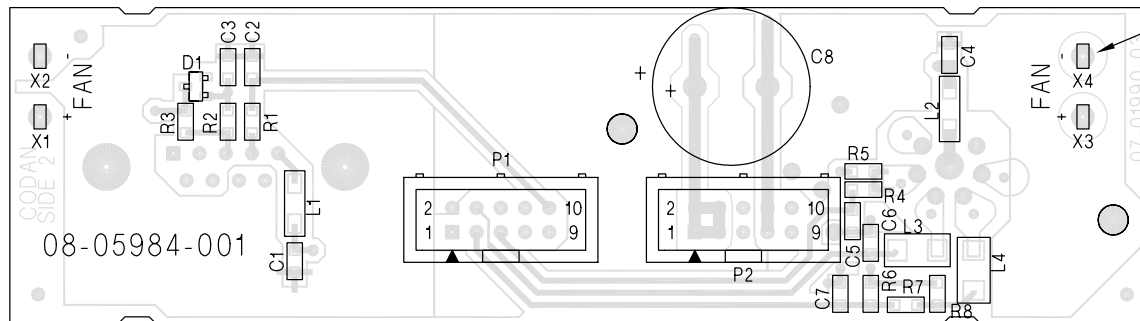

COMPONENT REFERENCES - SIDE 2

NOTES:

1. REMOVE LUG FROM CONNECTOR (ITEM 3) & DISCARD CONNECTOR. FIT OVER P3, FORM & SOLDER TO PCB, AS SHOWN.

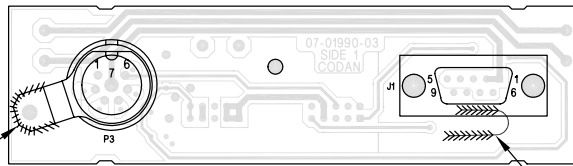
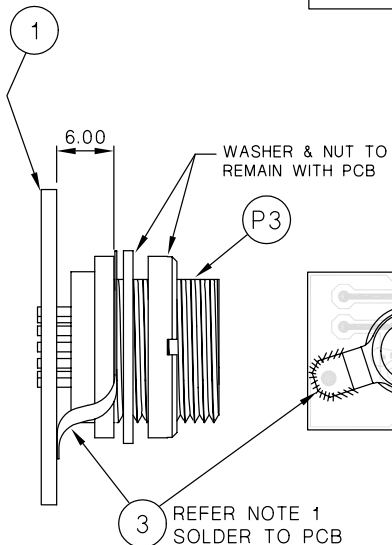

COMPONENT REFERENCES - SIDE 1
SCALE 1:1

PCB : 07-01990-03
ASSY: 08-05984-001

FILE No.
08\05984_2.DWG

ISSUE 1:
PCB WAS ISS -01
P3 DETAIL ADDED
C/R 27509
DJ 27-3-03

ISSUE 2:
PCB WAS ISS -02.
NOTE 1, SOLDER LUG
(ITEM 3) & TCW ADDED.
C/R 30088
NJA 15-2-06

DIMENSIONS IN mm

	SCALE	2:1	© CODAN LIMITED, A.C.N. 007 590 605: 2002 TITLE REAR PANEL PCB 500W/1000W AMPLIFIER
	DRN	C G	
MATERIAL	CHKD	PM	26-11-02
	APPD	KMW	23-3-04
FINISH	TOLERANCES UNLESS OTHERWISE STATED		DRAWING/DOC NO. A3 08-05984
	2 PLACES DEC.	±0.10	
	1 PLACE DEC.	±0.5	ISS 2
	0 PLACE DEC.	±1	

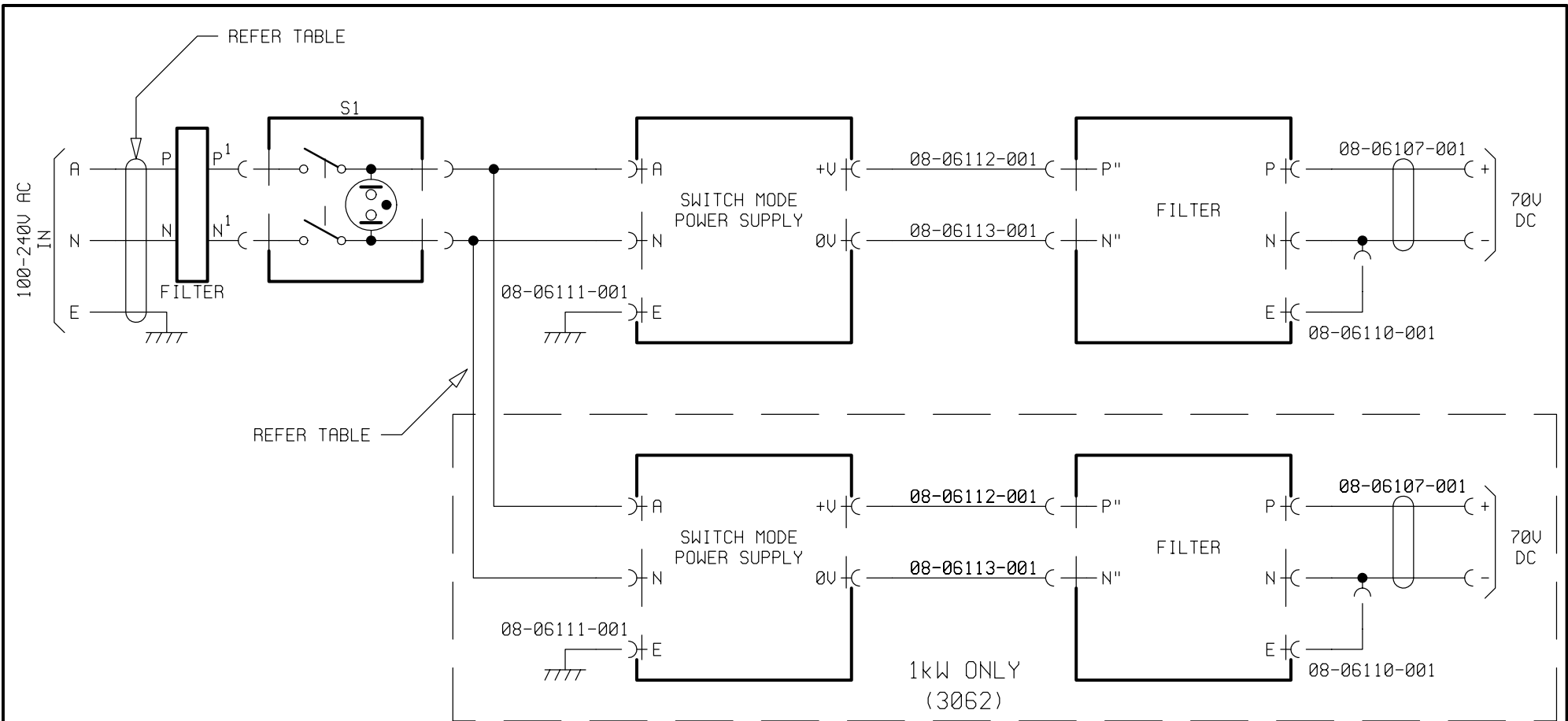

CONNECTION	3061	3062
AC Input to Filter	08-06108-001	08-06109-001
S1 to SMPS Active	08-06114-001	08-06116-001
S1 to SMPS Neutral	08-06115-001	08-06117-001

FILE NAME
04\03453_1.ZIP

ISSUE CHANGE
ISSUE B:
FILTER ADDED
C/R 28022
NJA 7-10-04

	DRN	C G	SCALE	© CODAN LIMITED, A.C.N. 007 590 605, 2003 TITLE 3061/3062 POWER SUPPLY
	CHKD	DJ	DATE 5-5-03	
	APPD	NJA	10-2-06	
FINISH	TOLERANCES UNLESS OTHERWISE STATED 2 PLACES DEC. ± 1 PLACE DEC. ± ANGULAR ±			DRAWING/DOC. NO A3 04-03453
				ISS 1 SHT 1 OF 1

DO NOT SCALE

ISSUE 0:
ONE FILTER ADDED
C/R 28022
NJA 06-10-04

ISSUE 1:
ADD VENTILATION
HOLES SIDE & BACK
CR 30027
GJC 14-02-06

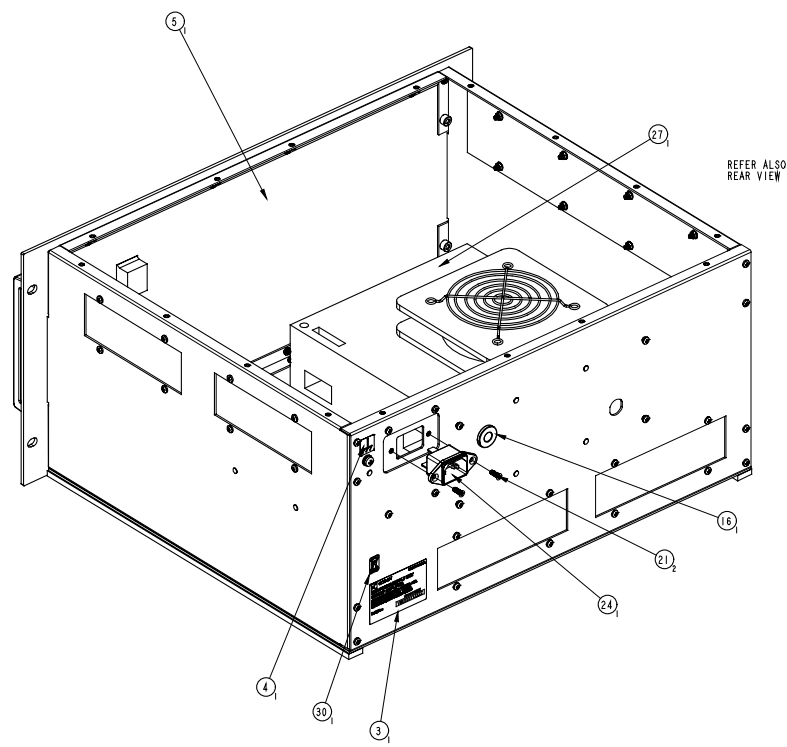

REFER ALSO
REAR VIEW

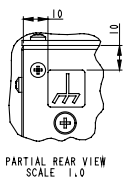
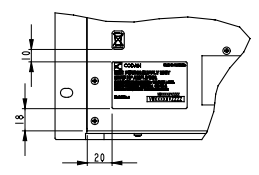
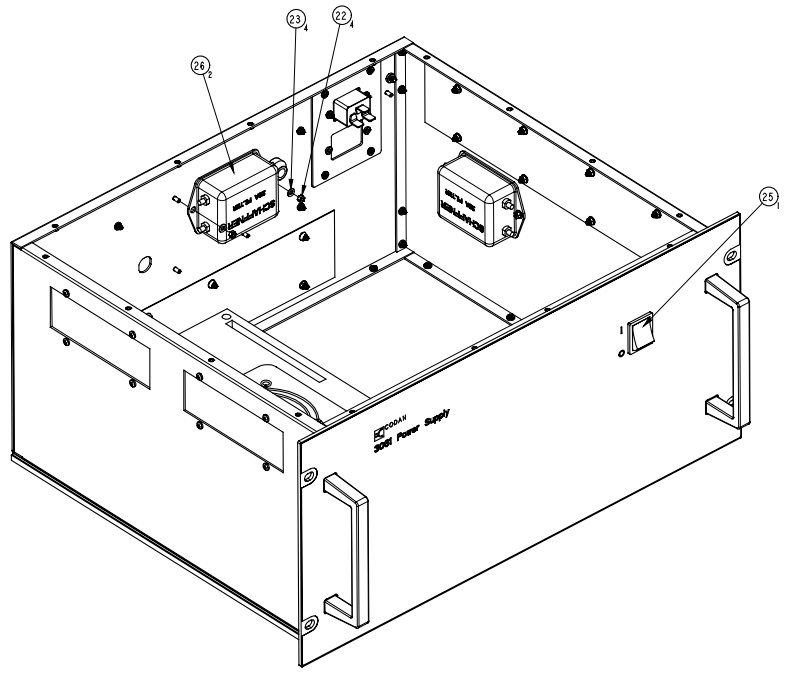

PARTIAL REAR VIEW
SCALE 1:0

ASSEMBLY - POWER SUPPLY UNIT

ASSEMBLY - POWER SUPPLY UNIT
PARTIAL REAR VIEW
SCALE 0.5:1

	SCALE	0.500	© CODAN LIMITED, A.C.N. 007 590 605: 2003 TITLE FINAL ASSY, 500W HIGH POWER AMPLIFIER - PSU
	DRN	DAB	
MATERIAL	CHKD	DJ	12-06-2003
FINISH	APPD	-	-
	TOLERANCES UNLESS OTHERWISE STATED		
	2 PLACES DEC.	±0.1	
	1 PLACE DEC.	±0.2	
	0 PLACE DEC.	±0.5	
DRAWING/DOC NO.			A1 08-06067
DIMENSIONS IN mm			ISS 1 ser. 1 of 2

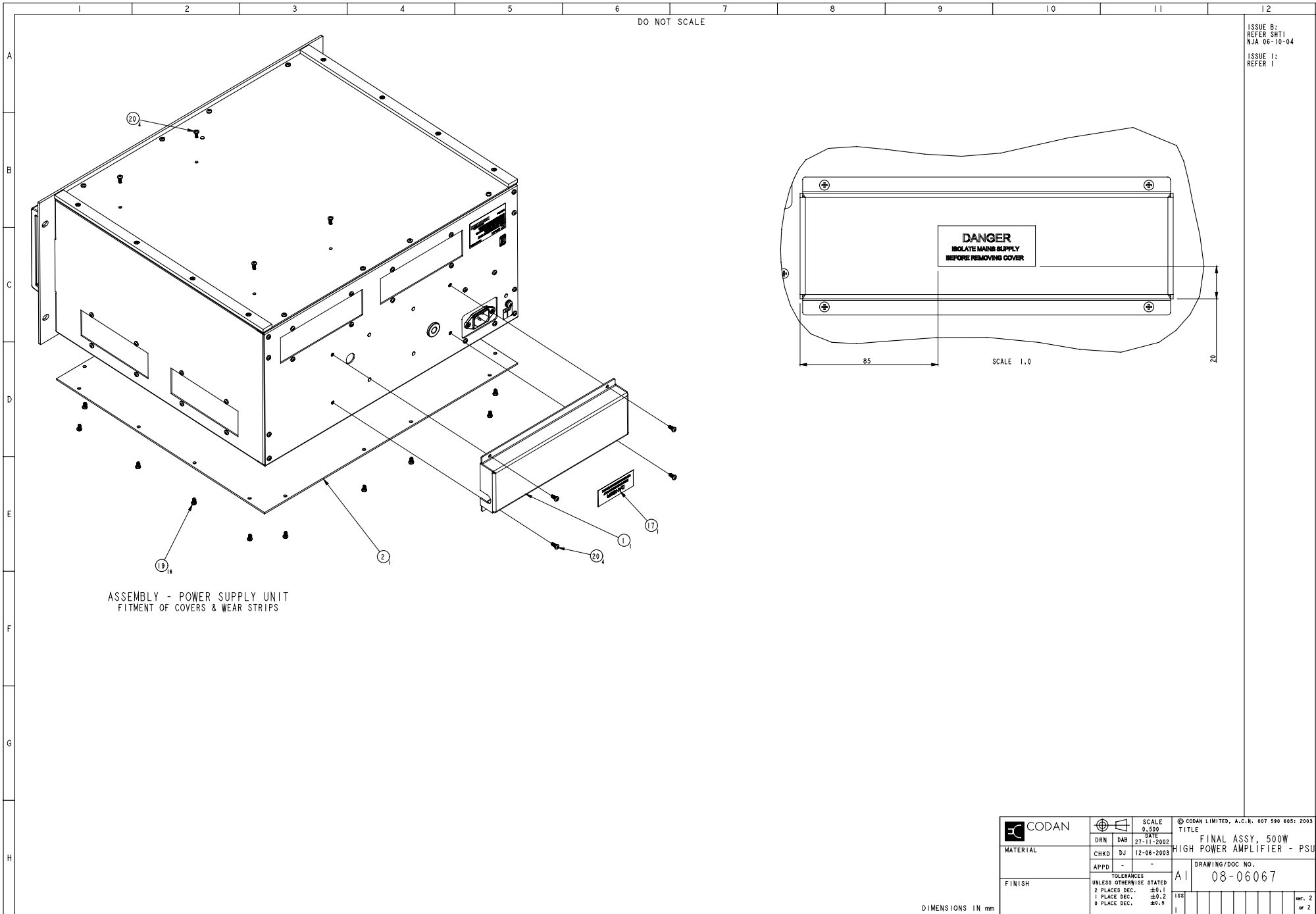

DIMENSIONS IN mm

	SCALE	0.500	© CODAN LIMITED, A.C.N. 007 590 605: 2003 TITLE FINAL ASSY, 500W HIGH POWER AMPLIFIER - PSU
	DRN	DAB	
MATERIAL	CHKD	DJ	12-06-2003
FINISH	APPD	-	DRAWING/DOC NO. 08-06067
	TOLERANCES UNLESS OTHERWISE STATED 2 PLACES DEC. ±0.1 1 PLACE DEC. ±0.2 0 PLACE DEC. ±0.5		
			ser. 2 of 2

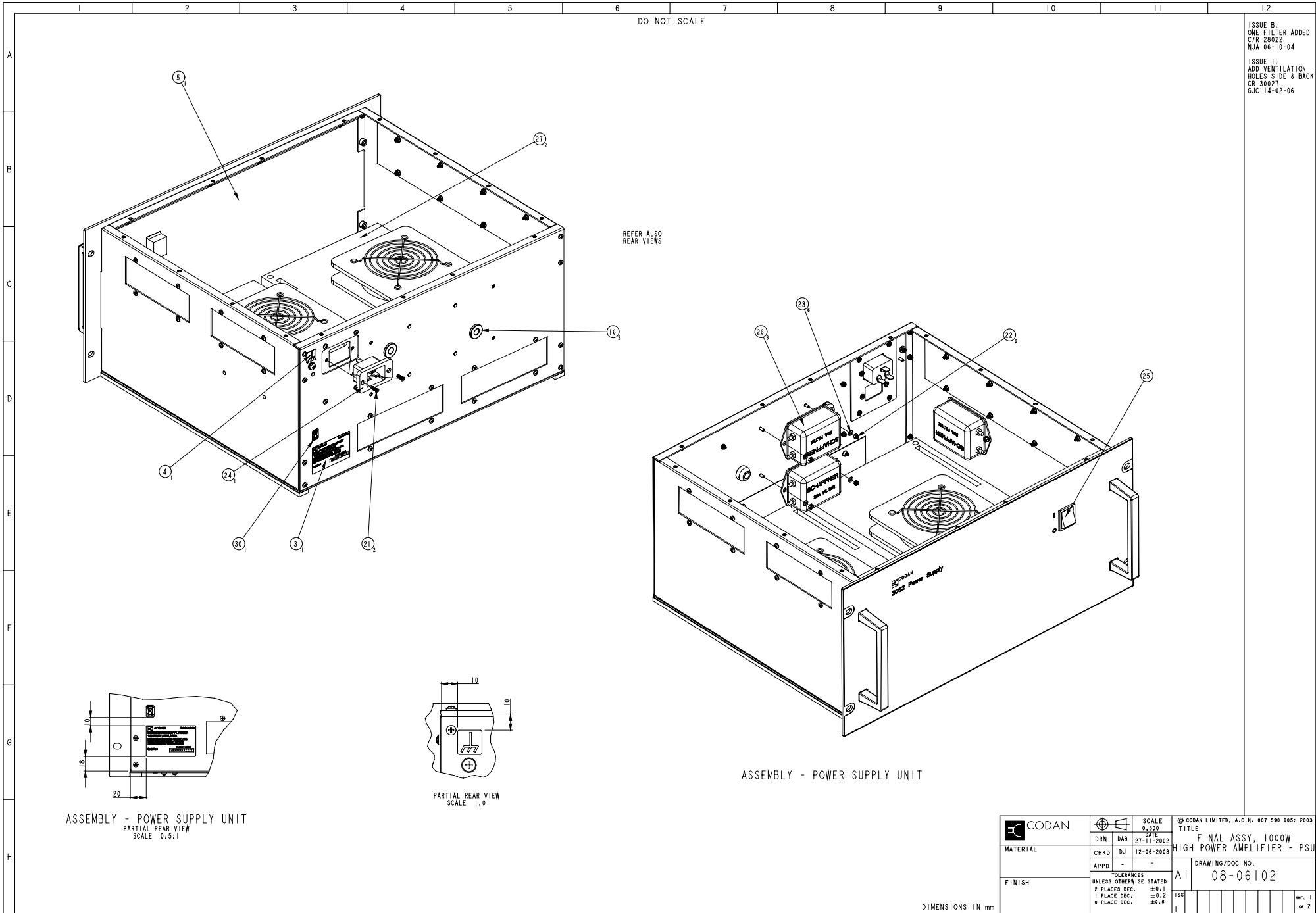

ISSUE B:
 ONE FILTER ADDED
 C/R 28022
 NJA 06-10-04

ISSUE I:
 ADD VENTILATION
 HOLES SIDE & BACK
 CR 30027
 GJC 14-02-06

DO NOT SCALE

REFER ALSO
 REAR VIEWS

ASSEMBLY - POWER SUPPLY UNIT

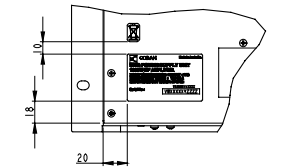

ASSEMBLY - POWER SUPPLY UNIT
 PARTIAL REAR VIEW
 SCALE 0.5:1

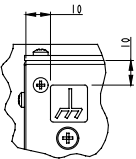

PARTIAL REAR VIEW
 SCALE 1:0

	SCALE	0.500	© CODAN LIMITED, A.C.N. 007 590 605: 2003 TITLE FINAL ASSY. 1000W HIGH POWER AMPLIFIER - PSU	
	DRN	DAB		DATE 27-11-2002
MATERIAL	CHKD	DJ	12-06-2003	
FINISH	APPD	-	DRAWING/DOC NO. A1 08-06102	
	TOLERANCES			150
	UNLESS OTHERWISE STATED			
	2 PLACES DEC.	±0.1		
1 PLACE DEC.	±0.2			
0 PLACE DEC.	±0.5	ser. 1 of 2		

DIMENSIONS IN mm

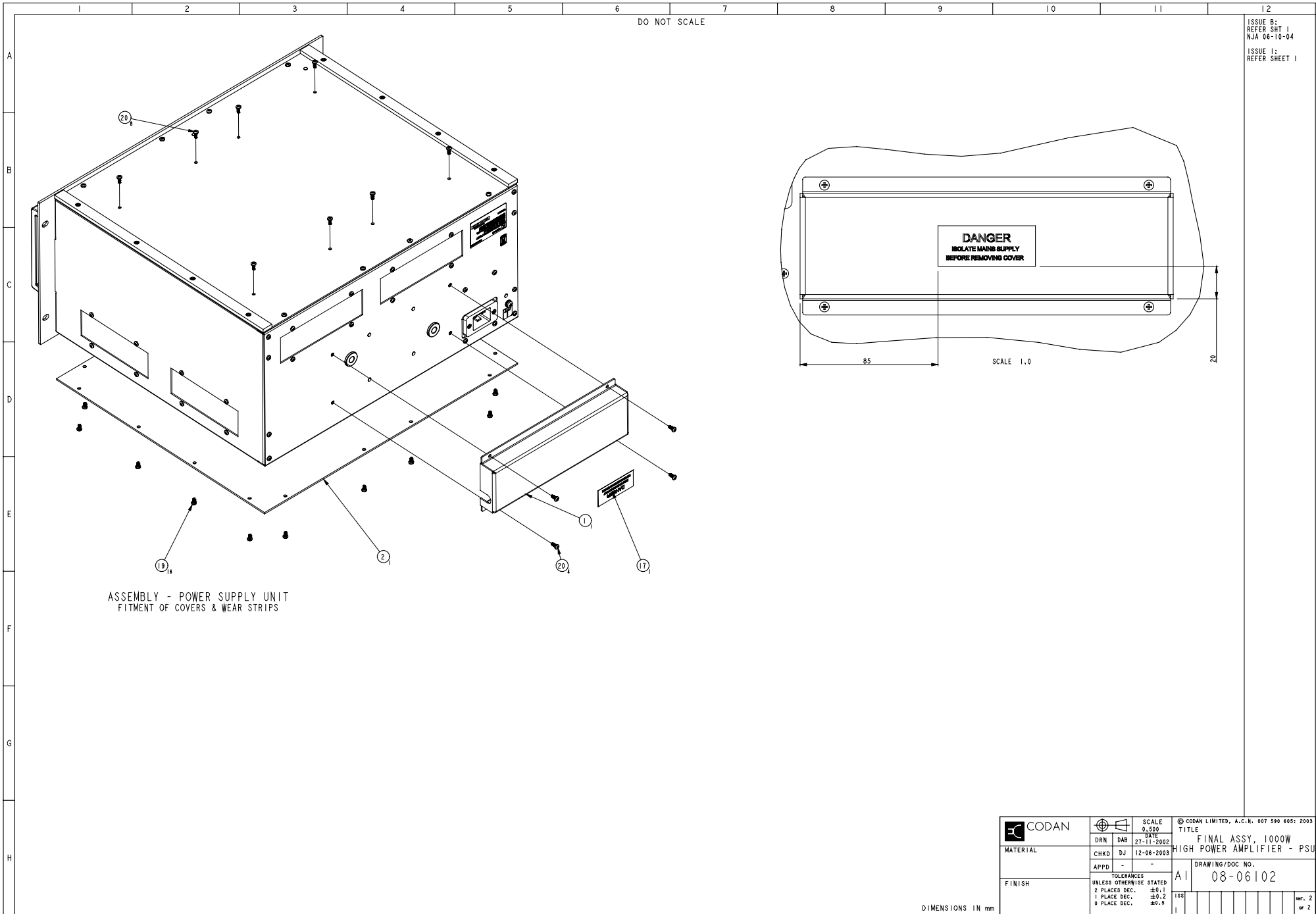

ASSEMBLY - POWER SUPPLY UNIT
FITMENT OF COVERS & WEAR STRIPS

DO NOT SCALE

ISSUE 8:
REFER SHT 1
NJA 06-10-04
ISSUE 15:
REFER SHEET 1

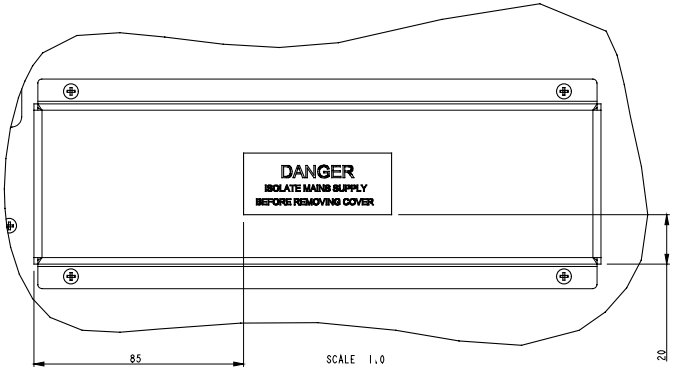

SCALE 1:1

	SCALE	0.500	© CODAN LIMITED, A.C.N. 007 590 605: 2003 TITLE FINAL ASSY, 1000W HIGH POWER AMPLIFIER - PSU
	DRN	DAB	
MATERIAL	CHKD	DJ	12-06-2003
FINISH	APPD	-	-
	TOLERANCES UNLESS OTHERWISE STATED 2 PLACES DEC. ±0.1 1 PLACE DEC. ±0.2 0 PLACE DEC. ±0.5		DRAWING/DOC NO. A1 08-06102
DIMENSIONS IN mm			150 ser. 2 of 2

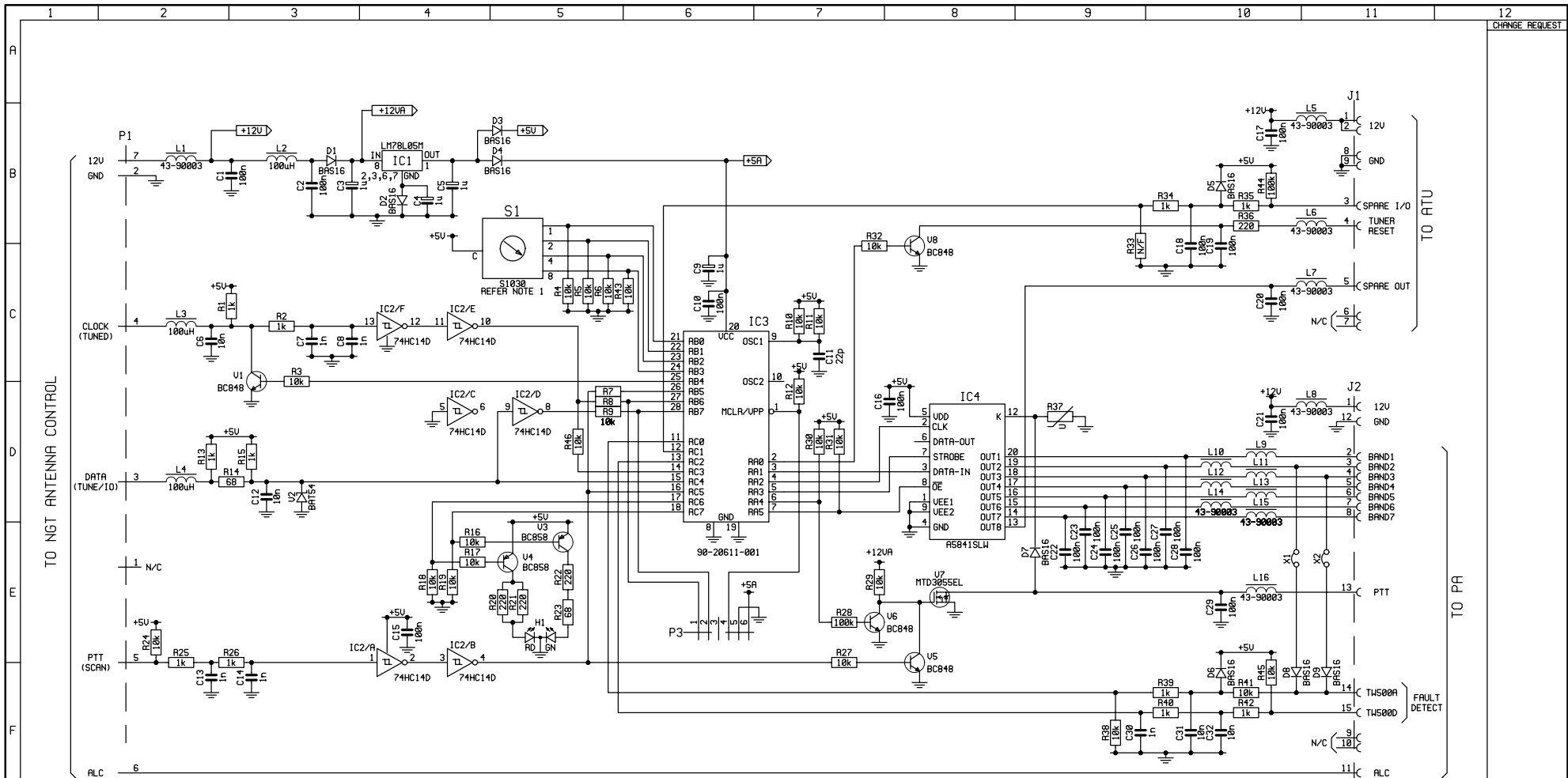

TO NGT ANTENNA CONTROL

TO ATU

TO PA

ALL DEVICES ARE TOP VIEW

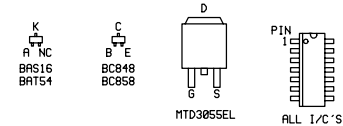

NOTES:
1. SELECT S1 FOR THE CORRECT PA TYPE.
REFER SYSTEM INSTRUCTIONS.

PCB : 07-01960-01
ASSY: 08-05926-001

FILE NAME
04-03377_1.M

CODAN	DRN	C 6	SCALE	DATE	18-4-01	© CODAN LIMITED, A.C.N. 007 530 085, 2001 HIGH POWER PA & ANTENNA CONTROLLER
	MATERIAL	CHKD	NJA	18-10-01		
FINISH	APPD	NJA	17-7-02	DRAWING/DOC. NO	04-03377	ISS 1 SHT 1 OF 1
UNLESS OTHERWISE STATED 2 PLACES DEC. ± 1 PLACE DEC. ± ANGULAR ±				ISS	1	

DO NOT SCALE

ISSUE B
H1(LED) DETAIL
ADDED.
C/R 27227
AJC 3/7/02

ISSUE 2
REFER TO SHEET 2
C/R 27448

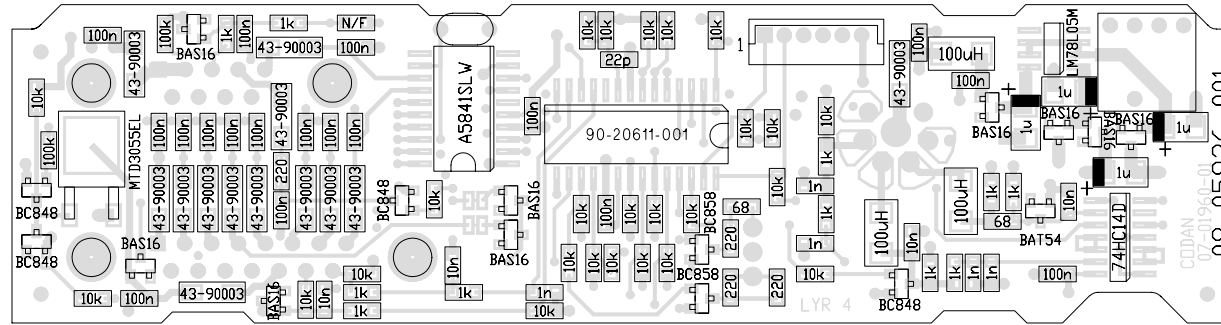

SIDE 4 - COMPONENT VALUES

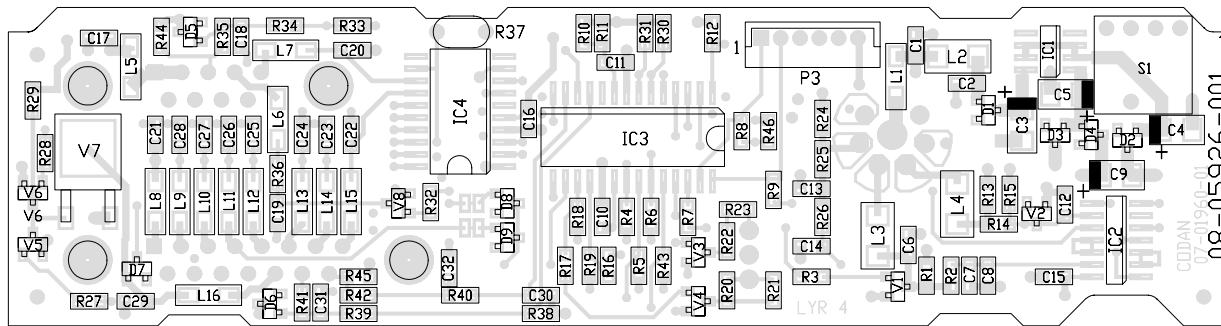

SIDE 4 - COMPONENT REFERENCES

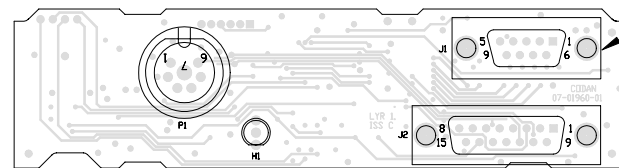
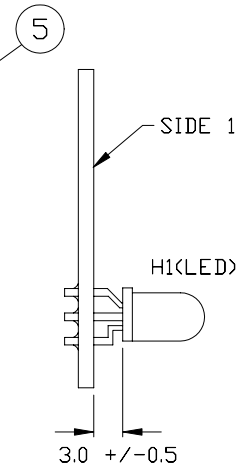

SIDE 1 - COMPONENT REFERENCES

FIT & SOLDER TO PCB
BEFORE FITTING J1 & J2

PCB 07-01960-01

FILE No.
08\05926_2.DWG

DIMENSIONS IN mm

	SCALE 1:1 & 2:1		© CODAN LIMITED, A.C.N. 007 590 605: 2001 TITLE HIGH POWER PA & ANTENNA CONTROL
	DRN	DB	
MATERIAL	CHKD	NJA	10-12-01
FINISH	APPD	AJC	3/7/02
	TOLERANCES UNLESS OTHERWISE STATED 2 PLACES DEC. ±0.25 1 PLACE DEC. ±0.5 0 PLACE DEC. ±1		
DRAWING/DOC NO. 08-05926		A3	ISS 2
SHT. 1 OF 2			

DO NOT SCALE

ISSUE B
REFER SHEET 1
ISSUE 2
ADDED ITEMS 9 (2)
C/R 27448

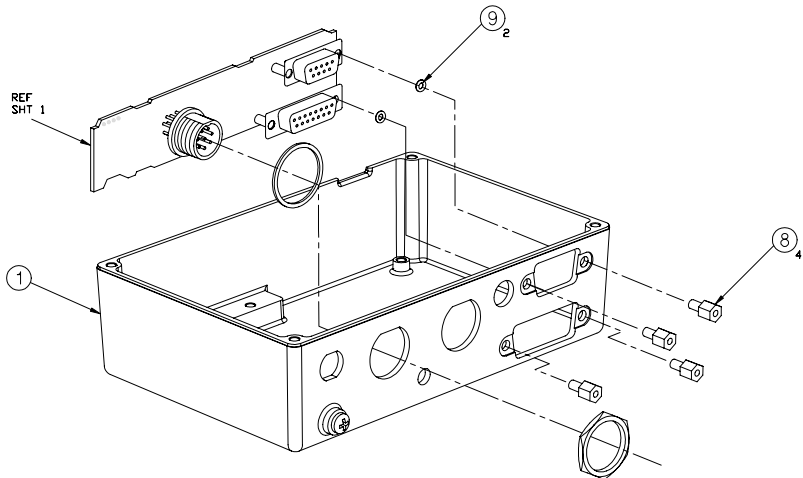

STEP 1

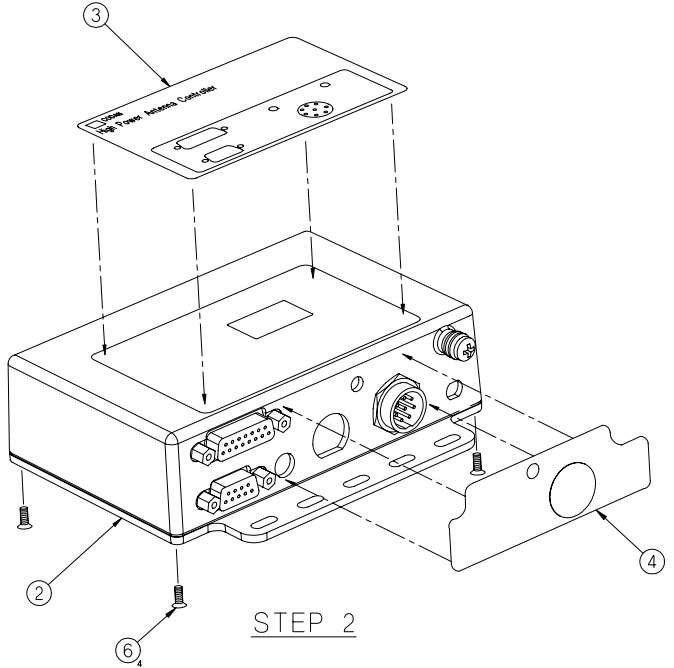

STEP 2

REMOVE BURRS & SHARP EDGES

FILE No.
08\05926...2.DWG

	SCALE	1:1	© CODAN LIMITED, A.C.N. 007 590 605: 2001 TITLE HIGH POWER PA & ANTENNA CONTROLLER
	DRN	DJ	
MATERIAL	CHKD	NJA	10-12-01
FINISH	APPD	AJC	3-7-02
	TOLERANCES UNLESS OTHERWISE STATED		A1 08-05926
2 PLACES DEC.		+0.25	
1 PLACE DEC.		+0.5	
0 PLACE DEC.		+1	ISS 2
DIMENSIONS IN mm			Sht. 2 OF 2

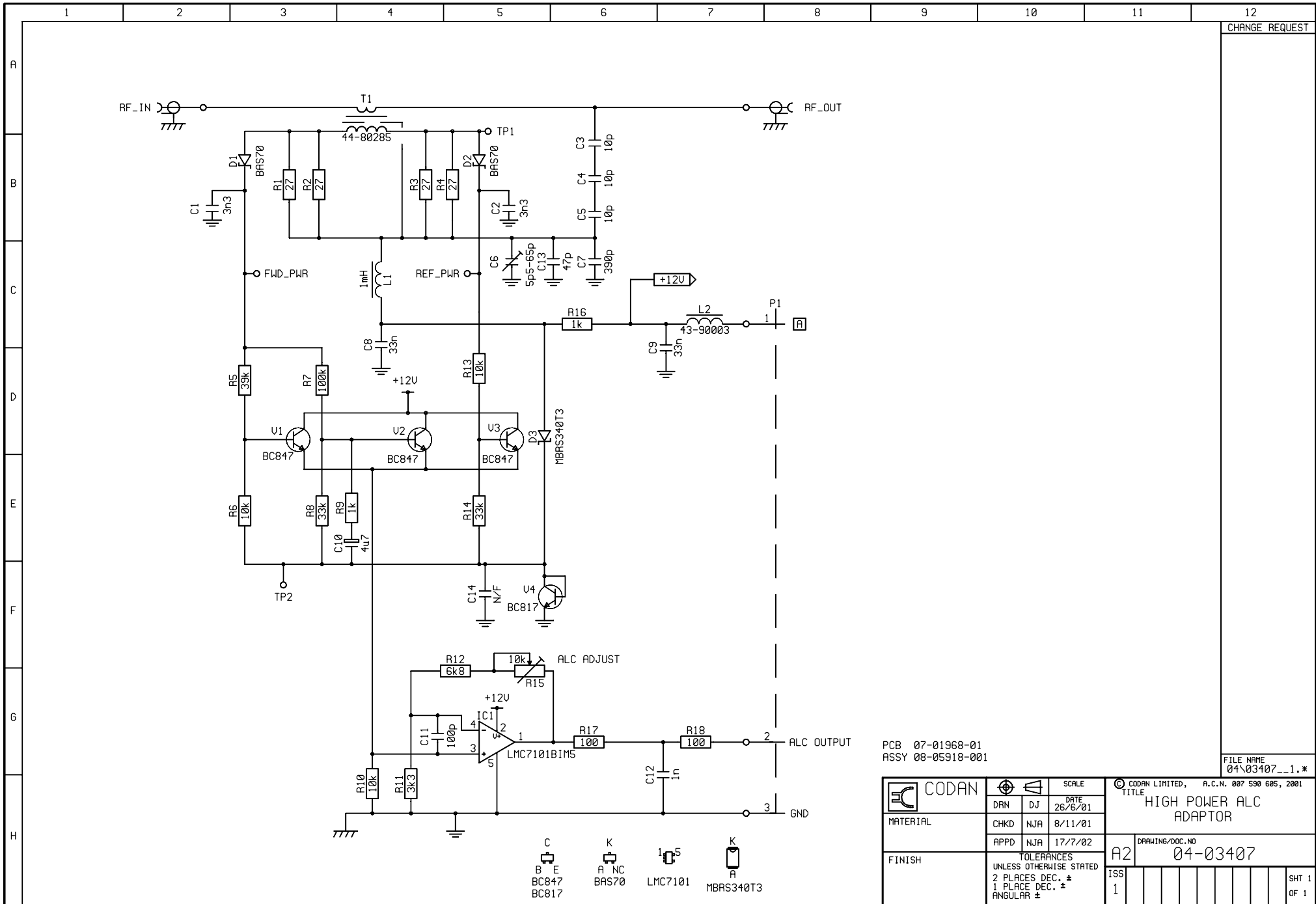

DO NOT SCALE

CHANGE REQUEST
ISSUE B
 ITEM 13 BALLOON
 ADDED.
 NOTE: "SOLDER T1
 AS SHOWN"
 C/R 27227
 AJC 3/7/02
 ISSUE 2
 REFER SHT 2

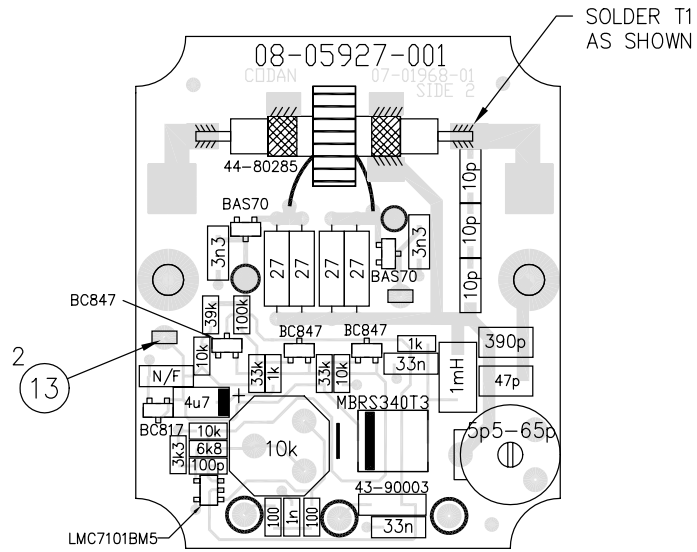
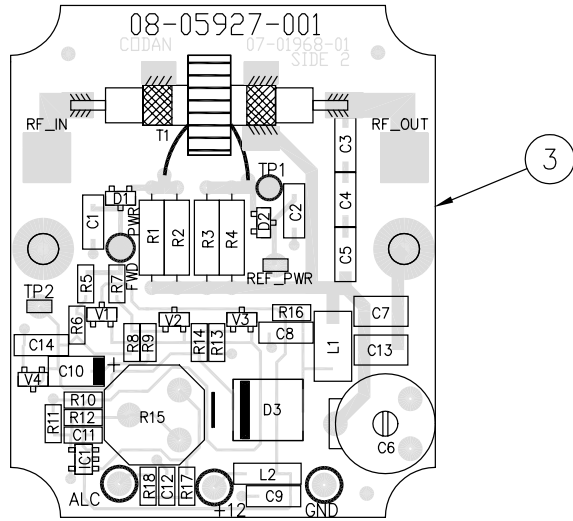

PCB - 07-01968-01
 ASSY - 08-05927-001

FILE No.
 08\05927__1.DWG

DIMENSIONS IN mm

	SCALE 2;1		© CODAN LIMITED, A.C.N. 007 590 605: 2001 TITLE	
	DRN	DB	DATE 3-12-01	
MATERIAL	CHKD	NJA	10-12-01	
	APPD	AJC	3/7/02	
FINISH	TOLERANCES UNLESS OTHERWISE STATED			
	2 PLACES DEC. ±0.25			
	1 PLACE DEC. ±0.5			
0 PLACE DEC. ±1				DRAWING/DOC NO. 08-05927
A3		ISS 2		
				SHT. 1 OF 2

DO NOT SCALE

CHANGE REQUEST

ISSUE B
ALC, +12 & GND
POS'NS ADDED TO
PCB.
WIRING TABLE "+12"
WAS "PWR"
C/R 27227
AJC 3/7/02

ISSUE 2
C/R 27368
ITEMS 14 & 15 ADDED.
NOTE 2 ADDED
AJC 21.11.02

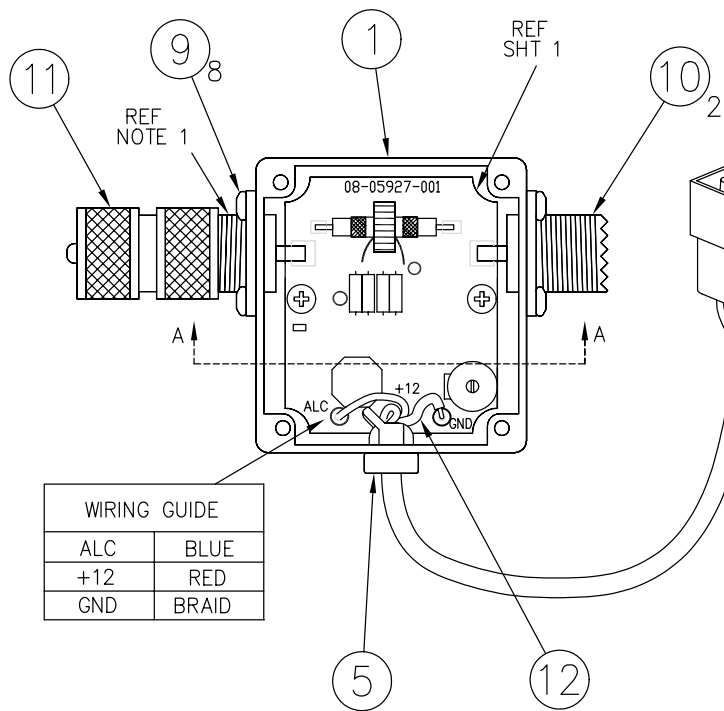

WIRING GUIDE	
ALC	BLUE
+12	RED
GND	BRAID

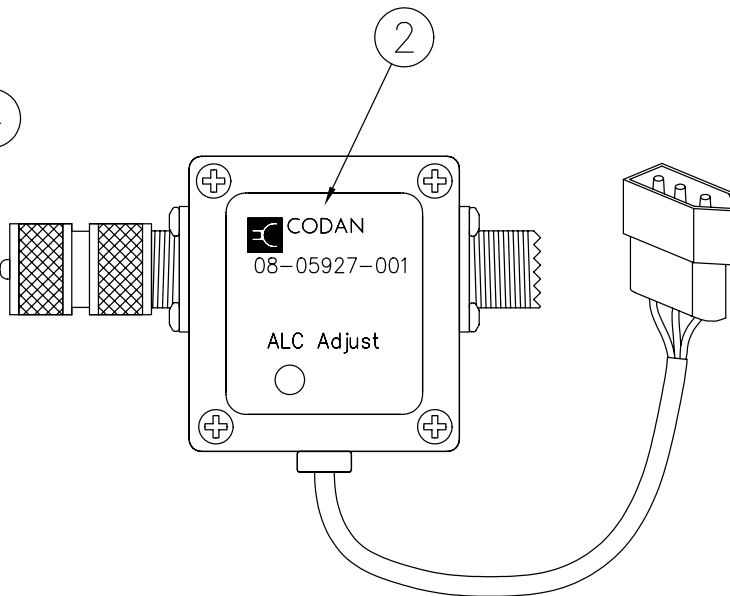

- Notes:
1. Apply Loctite 290 to thread of UHF connector before fitting Item 11
 2. Screws are supplied with case. Paint heads of supplied screws black.

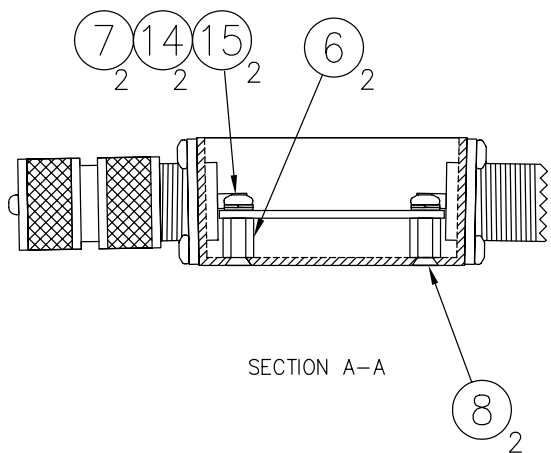

DIMENSIONS IN mm

FILE No.
08\05927_1.DWG

	SCALE 1:1		© CODAN LIMITED, A.C.N. 007 590 605: 2001	
	DRN	DJ	DATE 20/8/01	TITLE HIGH POWER ALC ADAPTOR
MATERIAL	CHKD	NJA	10-12-01	DRAWING/DOC NO.
FINISH	APPD	AJC	3/7/02	A3 08-05927
	TOLERANCES UNLESS OTHERWISE STATED			ISS
2 PLACE DEC. ±0.25			2	SHT. 2
1 PLACE DEC. ±0.5				OF 2
0 PLACE DEC. ±1				

A

accessing the inside 275
antenna
 description 251

B

brief description 259

C

CIB
 connector pinouts 256
 operation 265
components in NRI system
 description 250
connectors
 CIB 256
 DC power supply 257
 Modem 254
 Test 255
control point specifications 253

D

data modem
 description 251
DC power supply connector
 pinouts 257
dismantling 275
drawings 289

E

environmental specifications 252
error messages 272

F

fault finding 269

G

general specifications 252

H

handset
 description 250

J

junction box
 description 250
 remote control
 description 251

L

land line specifications 252
LED indicators 273
line modem
 description 251

M

microprocessor control 266
modem adaptor
 description 262
Modem connector
 pinouts 254

N

NRI 256
 description 251, 261
 testing 278
NRI Microcontroller PCB
 accessing 276
 technical description 265
 testing 280
NRI User Connect PCB
 accessing 276
 technical description 264
 testing 283
NRI Vocoder PCB
 accessing 276
 technical description 267
 testing 281

O

overview 249, 250

P

parts lists 287
PCB replacement 270
physical specifications 252
pin connections 254
 CIB connector 256
 DC power supply connector 257
 Modem connector 254
 Test connector 255
power supply and switching 265

R

remote control junction box
 description 251, 262
RF unit
 description 251

S

- serial interfaces 266
- size
 - NRI 252
 - remote control junction box 252
- specifications 249, 252
 - control points 253
 - environmental 252
 - general 252
 - land line 252
 - physical 252
- switchmode power supply
 - description 251
 - testing 277

T

- technical description 263
 - NRI Microcontroller PCB 265
 - NRI User Connect PCB 264
 - NRI Vocoder PCB 267
- Test connector
 - pinouts 255
- test procedures 277
 - NRI 278
 - NRI Microcontroller PCB 280
 - NRI User Connect PCB 283
 - NRI Vocoder PCB 281
 - switchmode power supply 277
- transceiver supply
 - description 251

U

- unit replacement 270
- upgrading firmware 271
 - control site 271
 - transceiver site 271

W

- weight
 - NRI 252
 - remote control junction box 252

NRI—Overview and specifications

This section contains the following topics:

[Overview \(250\)](#)

[Specifications \(252\)](#)

[Pin connections \(254\)](#)

Overview

The remote control NGT system can be used with NGT *AR*, *SR* and *ASR* Transceivers. It enables you to install your transceiver in a remote location and control it from another site. For example, you can install your RF unit and antenna at a site that benefits from low-level noise interference for improved reception, while controlling it with the handset from a convenient control point, such as an office.

The audio and control connection between the sites is achieved by using the latest in digital voice technology. The digital voice and control data signals are combined into a single RS232 data connection with a minimum line speed of 9600 bps in full duplex mode.

This document assumes that the RS232 data connection is achieved over a leased land line using two industrial-quality line modems. The maximum combined cable length between each site and the exchange is 19 km.

The basic layout of the remote control NGT system is shown in [Figure 1](#).

Figure 1: Basic layout of the remote control NGT system

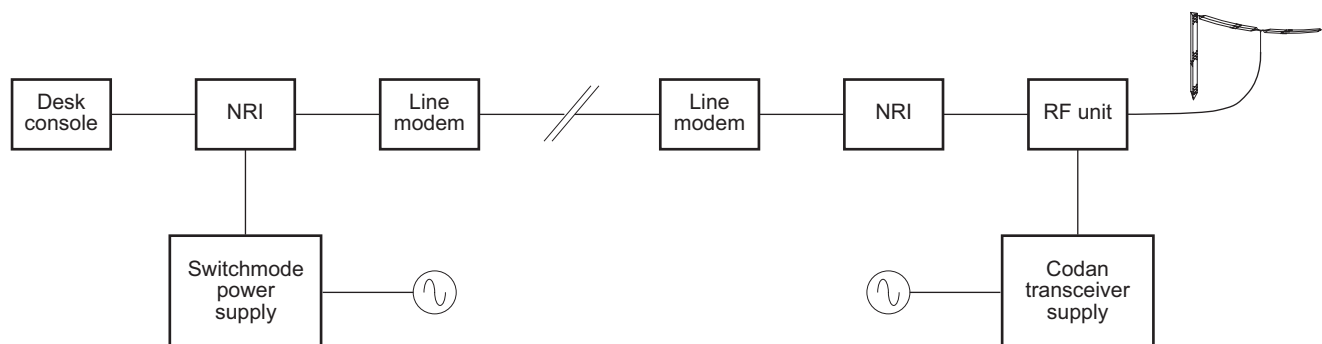

Components in a remote control NGT system

Handset

The handset is a hand-held device that has a microphone, PTT button, display and keypad. The microphone and PTT button are used for voice communication. The keypad enables you to control and configure the transceiver system. The handset is connected to the junction box.

Junction box

In a remote control NGT system, the junction box is the unit to which the handset, NRI, speaker and related units may be connected. It interprets the instructions you enter through the handset then sends them to the appropriate units in the system. Extra junction boxes, called remote control junction boxes (see [page 251, Remote control junction box](#)), are used to connect data modems into the system.

RF unit

The RF unit modulates audio signals onto radio frequencies that can be transmitted on air, and demodulates the radio frequencies it receives into audio signals.

NGT remote interface

The NRI provides a method of extending NGT CIB via an RS232 serial data link by converting CIB audio, control and status signals to and from RS232 data. For correct operation of the NRI, the RS232 link requires a minimum line speed of 9600 bps in full duplex mode. The RS232 introduces additional system delays for both audio and control signals. In conjunction with a line modem, the RS232 link is achieved across a 2-wire telephone line.

Switchmode power supply

The switchmode power supply is used to supply power to the NRI at the control site. This unit converts mains power supplies ranging from 90–260 V AC to a regulated 13.5 V DC supply, which is suitable to power the NRI and line modem.

Line modem

Refer to the documentation provided with the line modem. The line modems provide the RS232 link between the control and transceiver sites via a 2-wire telephone line.

Transceiver supply

A PSU, such as a 3020 Transceiver Supply, is used at the transceiver site to provide power to the transceiver, NRI and modem.

Antenna

The antenna receives and transmits the radio signal. For a detailed description of the types of fixed antenna available see the *NGT Transceiver Reference Manual* provided with your transceiver, or the *Antenna Matrix*.

Remote control junction box

A remote control junction box is used to provide an RS232 serial data connection between the control site and the HF data modem at the transceiver site.

HF data modem

The HF data modem provides an interface that enables data to be sent or received. Refer to the documentation provided with the HF data modem.

Specifications

General

Power consumption

NRI	Less than 350 mA @ 12 V DC
Line modem	300 mA maximum @ 12 V DC

Environmental

Temperature range	0 to +60°C (32 to 140°F)
Humidity operating range	0 to 95% relative humidity, non-condensing

Physical

Size

NGT Remote Interface 3030	210 mm W × 240 mm D × 65 mm H (8.4 in W × 9.5 in D × 2.6 in H)
Remote Control Junction Box 2030	135 mm W × 106 mm D × 38 mm H (5.4 in W × 4.3 in D × 1.5 in H)

Weight

NGT Remote Interface 3030	1.8 kg (4.0 lb)
Remote Control Junction Box 2030	0.4 kg (0.9 lb)

2-wire land line

Cable between each site and the exchange

Type	2-wire leased land line
Mode of operation	Duplex

Combined cable length between each site and the exchange (if using the line modems provided)	19 km maximum
Grade	10 lb line/0.64 mm diameter

NOTE The actual distance between the control site and the transceiver site can be greater depending on the configuration between the exchanges.

NOTE The grade of the line complies with the Telstra Australia standard grade line.

Control points

An NRI at the control site can support a daisy chain of up to five junction boxes with a maximum total CIB distance of 30 metres from the NRI.

Pin connections

Figure 2: Rear panel of the NRI

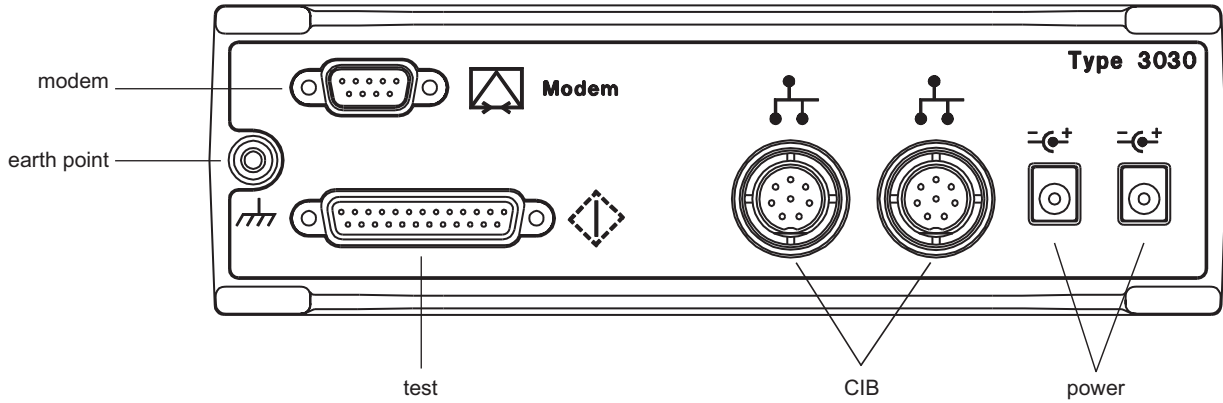

Pinouts of the Modem connector on the NRI

The **Modem** connector is an RS232 9-way male, D-type plug. It provides the interface between the NRI and the line modem.

Figure 3: Front view of the Modem connector on the NRI

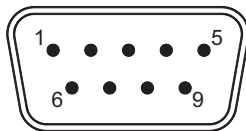

Table 1: Pinouts of the Modem connector on the NRI

Pin no.	Function	Input/output	Signal level
1	Carrier detect	Input	RS232
2	Receive data	Input	RS232
3	Transmit data	Output	RS232
4	Data terminal ready	Output	RS232
5	Signal ground		0 V
6	Data set ready	Input	RS232
7	Request to send	Output	RS232
8	Clear to send	Input	RS232
9	Ring indicator	Input	RS232

Pinouts of the Test connector on the NRI

The **Test** connector is a 25-way male, D-type plug. It provides the interface between the NRI and test equipment. The connector is for Codan's test purposes only.

Figure 4: Front view of the Test connector on the NRI

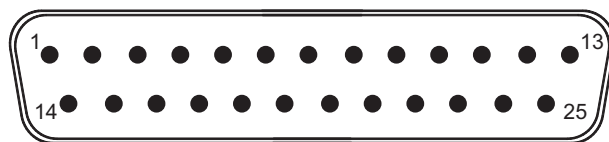

Table 2: Pinouts of the Test connector on the NRI

Pin no.	Function	Input/output	Signal level
1–6	Unassigned		
7	Signal ground		0 V
8–11	Unassigned		
12	12 V	Output	12 V (nominal)
13	Unassigned		
14	Transmit data	Output	RS232
15	N/C		
16	Receive data	Input	RS232
17	N/C		
18	N/C		
19–22	Unassigned		
23	Signal ground		0 V
24, 25	Unassigned		

Pinouts of the CIB connectors on the NRI

The NRI has two CIB connectors. The CIB connectors are 8-way NANA plugs. They provide the interface between the NRI and the RF unit, junction box or ancillary equipment, such as a remote control junction box.

Figure 5: Front view of a CIB connector on the NRI

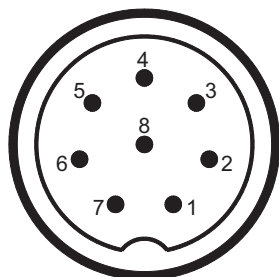

Table 3: Pinouts of a CIB connector on the NRI

Pin no.	Function	Input/output	Signal level
1	Signal ground		0 V
2	CAN high	Input/output	1 to 5 V logic
3	CAN low	Input/output	1 to 5 V logic
4	Power on request	Output	Momentary 0 V = PWR ON
5	Standby power	Output	6 V
6	System audio +	Input/output	5 to 10 V sync and TDM audio
7	System audio –	Input/output	0 to 5 V sync and TDM audio
8	A rail	Input	13.6 V (nominal)

Pinouts of the DC power supply connectors on the NRI

The NRI has two 2.5 mm DC barrel sockets that are wired in parallel. One is used to supply power to the NRI, while the other supplies power to the line modem.

Figure 6: Front view of a DC power supply connector on the NRI

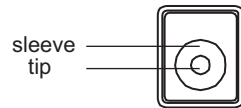

Table 4: Pinouts of a DC power supply connector on the NRI

Connection	Function
Tip	+13.6 V nominal
Sleeve	Ground

This page has been left blank intentionally.

NRI—Brief description

This section contains the following topics:

[General information \(261\)](#)

[NGT remote interface \(261\)](#)

[Remote control junction box \(262\)](#)

For a detailed description of these functions see [page 263, *NRI—Technical description*](#).

This page has been left blank intentionally.

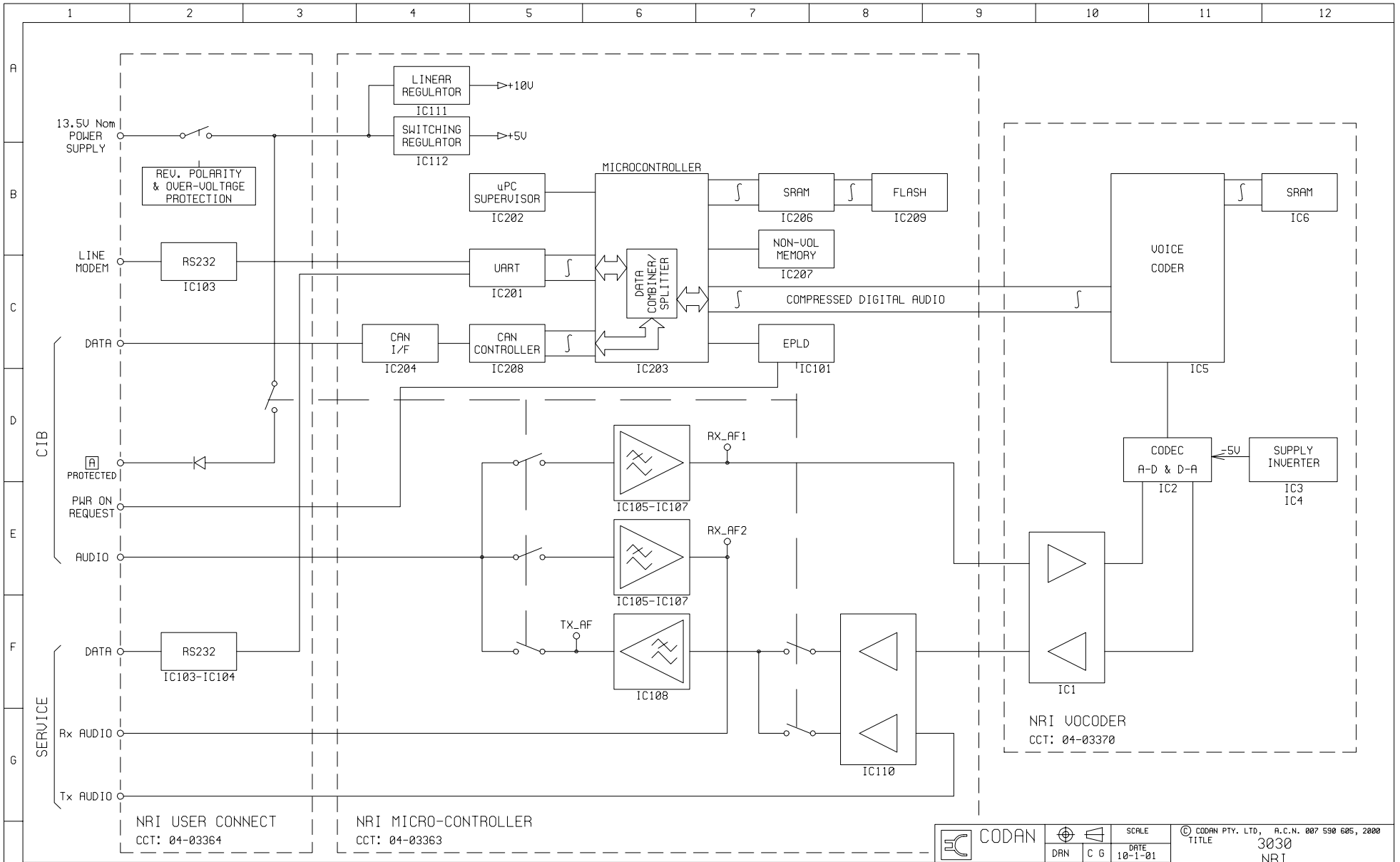

H
ISSUE CHANGE

MATERIAL	CODAN		SCALE	© CODAN PTY. LTD., A.C.N. 007 590 605, 2000 TITLE 3030 NRI BLOCK DIAGRAM
	DRAWN	C G	DATE	
	CHKD	SSJ	19-1-01	
FINISH	APPD	SSJ	30-03-01	DRAWING/DOC. NO 03-01079
	TOLERANCES			
	UNLESS OTHERWISE STATED 2 PLACES DEC. ± 1 PLACE DEC. ± ANGULAR ±			
ISS	A	1		SHT 1 OF 1

General information

NOTE The information in this section should be read in conjunction with the block diagram [03-01108](#).

A remote control NGT system operates in a similar manner to a standard NGT system. The handset, junction box and RF unit used in a remote control NGT system are standard NGT devices. A technical description of how an NGT system operates is provided on [page 69, NGT—Technical description \(2010\)](#). The operation of the line modem and HF Data Modem 3012 is described in the documentation provided with the product.

The operation of a remote control NGT system is distinct from other NGT systems due to the existence of two separate CIB segments at the control and transceiver sites. The NRI and line modem at each site operate together to connect the two CIB segments. Audio signals between the sites are transferred via the NRIs and line modems using digital speech coding technology. The use of digital speech coding technology for low bandwidth communication links such as long leased lines means that equipment such as HF data modems must be located at the transceiver site where a less processed audio signal is available. Remote control NGT data systems require remote control junction boxes to connect a PC at the control site with the HF data modem at the transceiver site.

The following information describes how the specific devices in a remote control NGT system work.

NGT remote interface

The function of the NRI is to provide the interface between the CIB device (that is, the junction box or RF unit) and the line modem at each end of the leased line. The NRI converts between CIB (CAN serial data and TDM analog audio) and RS232 serial data for transfer via the line modem. For correct operation of the NRI, the RS232 link requires a minimum line speed of 9600 bps in full duplex mode. The RS232 leased line link introduces additional system delays for both audio and control signals. Any additional delays introduced by other link types should be minimised and kept below 50 ms. Two NRI units, in addition to the basic NGT transceiver are necessary to provide the simplest remote control transceiver installation. The NRIs connected at the transceiver and control sites are identical.

The NRI is powered externally by a switchmode power supply at the control site, and via the transceiver supply at the transceiver site. The NRI supplies power to the attached line modem, and at the control site it typically supplies power to other CIB devices.

Remote control junction box

The RCJB can be configured to operate as one of the following:

- a modem adaptor
- an additional system connection point for the RTU–282/292

Modem adaptor

The modem adaptor is a remote control junction box that is used to connect an HF Data Modem 3012 into an NGT data system. The modem adaptor has been configured to act as a CIB interface for the 3012 at the transceiver site. It provides a connection for the transfer of serial data between the PC at the control site and the 3012 at the transceiver site. The modem adaptor also provides a 15-way port for system audio and control lines to and from the 3012.

NRI—Technical description

This section contains the following topics:

[NRI User Connect PCB \(264\)](#)

[NRI Microcontroller PCB \(265\)](#)

[NRI Vocoder PCB \(267\)](#)

This section should be read in conjunction with [page 289, *NRI—Drawings*](#).

NRI User Connect PCB

The main function of the NRI User Connect PCB is to physically support the connectors. The NRI has two power connectors, two CIB connectors, a standard serial port (providing the modem interface) and a test port, which provides a connection point for factory testing and future use. The NRI User Connect PCB also provides some input/output filtering, power switching, and level translation for the RS232 serial interfaces.

NRI Microcontroller PCB

The NRI Microcontroller PCB is the main component of the NRI. It contains the main microcontroller and associated memory, the CIB interfacing, and two peripheral devices (a DUART and a CAN controller) required by the microcontroller to communicate effectively with the system. It also supports the NRI Vocoder PCB.

Power supply and switching

Power to the NRI is from an external power supply, which is connected to either J101 or J102. Relay K101 and associated circuitry provide reverse polarity and overvoltage protection.

In Master Bus mode, IC102 supplies standby power, which is typically used for illuminating the handset **Ⓢ** key. A high-side switch, IC101, enables the NRI to supply current-limited power to the bus in Master Bus mode.

Different supply rails are required for different sections of the NRI internally. Most of the analog circuitry (such as CIB system audio de-multiplexing/filtering) is powered by the 10 V linear regulator IC111, which is of the low-dropout type so as to ensure that regulation is maintained as supply voltage drops. Switching regulator IC112 is used to generate an efficient high-current 5 V supply for the microcontroller and associated components. The Vocoder module operates from the main 5 V rail and has on-board regulators to generate any other rails required.

Codan interconnect bus

The NRI interfaces with components of the transceiver system using the CIB. For a comprehensive explanation of how the CIB works see [page 69, NGT—Technical description \(2010\)](#). The main components of the CIB include:

- a main power source
- a standby power source (always present)
- a TDM audio interface (comprising up to seven simplex audio channels)
- a 125 kbps serial data interface according to the CAN transfer protocol

ICs 102 to 110 provide the audio sampling/filtering, while a programmable logic device (IC101) generates the timing required to generate and reconstruct TDM signals. IC101 can either detect or generate synchronisation pulses as required by the master or slave configuration. The CAN digital data interface is provided by IC208 (a CAN controller IC) in conjunction with line driver IC204. The CAN protocol provides a high-speed serial data transfer interface that is highly reliable and noise immune. The interface links the NRI to other CIB devices, typically the NGT RF unit or junction box.

Serial interfaces

The NRI uses RS232-style serial ports as interfaces for the line modem and test port. The main microcontroller used in the NRI (Hitachi H8/3003) only supports two simple serial interfaces. A DUART is used in conjunction with the processor to provide two additional RS232 serial interfaces. Level translation from TTL level to RS232 level is accomplished by IC103 and IC104, located on the NRI User Connect PCB.

Microprocessor control

A 16-bit H8/3003 Hitachi microcontroller (IC203) controls the NRI. The H8/3003 executes from program memory stored in an 8 Mbps flash device (IC209), while a 4 Mbps static memory (IC206) is used during program execution for temporary variable storage. A non-volatile memory storage device (IC207) provides storage for configuration parameters that must be retained after a loss of power to the system. Microcontroller IC203 accesses the serial interfaces either directly or through DUART IC201, and CAN data is accessed through IC208, SJA1000 CAN controller. System audio control is achieved through a 3-wire serial interface to the programmable logic device.

NRI Vocoder PCB

The Vocoder is essential in the operation of the NRI. It is a small plug-in module that contains a special-purpose voice coding integrated circuit. The function of this module is to convert an incoming analog audio signal that represents voice, into a digitised compressed data stream suitable for transmission through the digital modem link. It also decodes an incoming digital data stream and reconstructs voice audio. Other components present on this module are used to regulate supply rails and to provide interfacing to the rest of the NRI unit. The vocoder interfaces to the microcontroller using an 8-bit parallel interface.

This page has been left blank intentionally.

NRI—Fault finding

This section contains the following topics:

[PCB and unit replacement \(270\)](#)

[Upgrading the NRI firmware \(271\)](#)

[Error messages \(272\)](#)

[LED indicators \(273\)](#)

[Dismantling the NRI \(275\)](#)

[Test procedures \(277\)](#)

PCB and unit replacement

NGT remote interface

The NRI is repairable by PCB replacement only. To determine that the NRI is the unit at fault, or to find the faulty PCB, see [page 277, Test procedures](#).

Line modem and switchmode power supply

The line modem and power supply are not repairable. The complete unit must be replaced if it is faulty.

Other units

For details on the repair and replacement of other units in a remote control NGT system see [page 145, NGT—Checks and adjustments](#).

PCBs and units available as replacements

The replacement PCBs and units available from Codan are listed in [Table 5](#).

Table 5: Replacement PCBs and units for the NRI

PCB or unit	Part number
Panel, Rear Assembly	08-05865-001
NRI Microcontroller PCB	08-05854-001
Final Assembly, NRI	08-05864-001
Line modem	78-13016
Switchmode power supply	78-16019

Upgrading the NRI firmware

The NRI firmware is upgraded using NSP. For information on using NSP see the *NGT System Programmer Help*.

Control site

To upgrade the NRI firmware at the control site:

- Connect a PC in which NSP has been installed to the handset via the programming jack.
- Use NSP to upgrade the NRI firmware.

NOTE If the firmware upgrade fails to commence, link pin 7 to pin 21 of the test connector on the rear panel of the NRI, then switch the switchmode power supply off then on again. This forces the NRI into its firmware upgrade mode, which may overcome problems that are not PC or cable related.

Transceiver site

To upgrade the NRI firmware at the transceiver site:

NOTE The firmware at the transceiver site cannot be upgraded from the handset at the control site.

- Temporarily connect a desk console or a junction box and handset to the CIB connector on the rear panel of the NRI.

NOTE You can temporarily borrow this equipment from the control site.

- Connect a PC in which NSP has been installed to the handset via the programming jack.
- Use NSP to upgrade the NRI firmware.

NOTE If the firmware upgrade fails to commence, link pin 7 to pin 21 of the test connector on the rear panel of the NRI, then switch the transceiver power supply off then on. This forces the NRI into its firmware upgrade mode, which may overcome problems that are not PC or cable related.

Error messages

When communication levels are inadequate for the equipment in a remote control NGT system to operate correctly, a system error message is displayed on the handset for five seconds. The system error message indicates the condition that is preventing the system from operating normally. While a connection with the transceiver site cannot be established, a timer symbol is displayed indicating the control site is waiting for information. When a connection between the control and transceiver sites is re-established, the timer symbol disappears and normal operation resumes. [Table 6](#) lists the error messages.

Table 6: Error messages

Error message	Indicates...
NRI link: connecting	The system is attempting to establish a link between the control and transceiver sites.
NRI link: failed	The link between the control and transceiver sites has failed. This may be a temporary condition while the modem is attempting to reconnect.
NRI link: degraded	The line quality between the control and transceiver sites is poor.
Modem/PC Data: system link not established	The link with the HF data modem or PC has not established within one minute of powering up.
Modem/PC Data: system link failed	The link with the HF data modem or PC has failed.

LED indicators

Most devices in a remote control NGT system have a LED indicator on their front panel. The different colours of the LED indicators and timing of flashes indicates the state of the device. The LED indicators are useful in detecting fault conditions of the units in your remote control NGT system.

Table 7: Description of LEDs

State of LED	Description
Off	The power to the system is off.
Constant green	The device is operating normally.
Fast flashing green	Firmware has been downloaded successfully to the device and the transceiver must be switched off then on again for the system to recognize the new firmware.
Slow flashing green	The device has successfully powered up but has not had any communication with another CIB device. This usually indicates a faulty CIB cable connection.
	During normal operation, the system is momentarily under a very high processing load.
Constant yellow	The device is in its powered up state, i.e. the device is on but not in use.
	The device is in the process of undergoing power up tests and start up procedures, i.e. most devices are in this state for a few seconds after the system is switched on.
Fast flashing yellow	The device is waiting for firmware to be downloaded.
Slow flashing yellow	The device is in test mode or running tests. In this state, the device cannot respond or is very slow to respond to service requests from the rest of the system.
Constant red	The device has a fatal error condition and the system ceases to operate.
Fast flashing red	The device has a temporary error condition. This is usually caused by an external fault condition, e.g. when an RF unit detects that the battery voltage has decreased to a low level. The LED remains in this state while the condition exists.
	During a firmware download, verification of the image is in progress.
Slow flashing red	The device is unused.

Table 7: Description of LEDs (cont.)

State of LED	Description
Fast alternating red/green	The lists stored on the device are being viewed on the handset. When viewing is complete, the LED switches off for a period of time before resuming the state it was before it displayed red/green.
	The firmware download has been successful and the device is verifying the status of other devices in the network.
Slow alternating red/yellow	The LED indicates the progress of a firmware download. It alternates colours on successive data packets received and at a rate dependent on packet size and type of interface.

Dismantling the NRI

To dismantle the NRI unit for testing see [Figure 7](#) and follow the procedures below.

Figure 7: Exploded view of the NRI

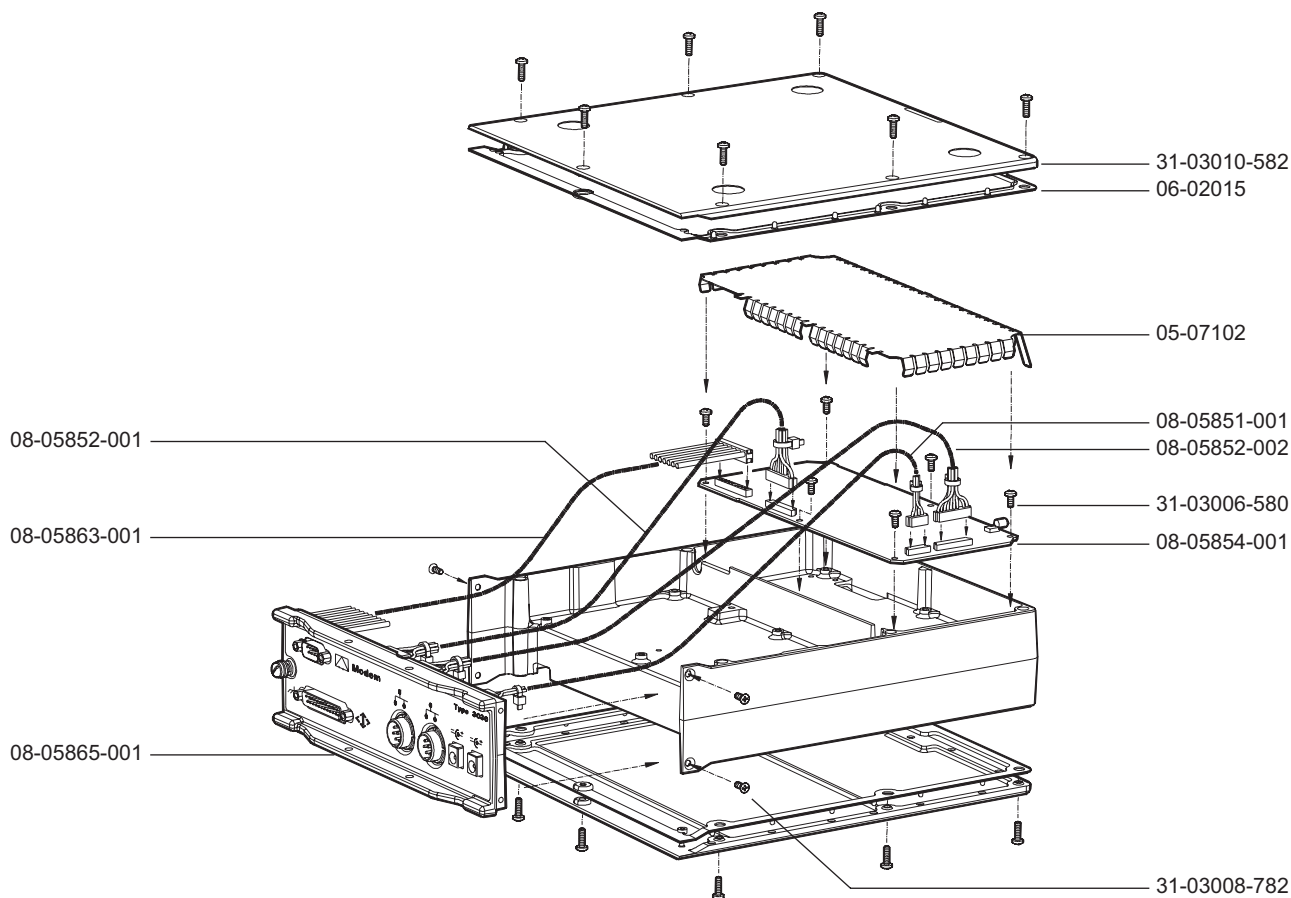

Accessing the inside of the NRI

To gain access to the inside of the NRI:

- Disconnect the cables from the NRI and remove it from the system.
- Remove the seven M3 taptite screws (Codan part number 31-03010-582) from the top cover of the NRI and remove the top cover and its sealing gasket (Codan part number 06-02015).

The shielding screen (Codan part number 05-07102) is exposed.

Accessing the NRI Microcontroller PCB

To gain access to the NRI Microcontroller PCB inside the NRI:

- Access the inside of the NRI (see [page 275, *Accessing the inside of the NRI*](#)).
- Remove the shielding screen by levering each corner of the screen with a screwdriver.

The NRI Microcontroller PCB (Codan part number 08-05854-001) and its plug-in NRI Vocoder PCB are exposed.

Accessing the NRI User Connect PCB

To gain access to the NRI User Connect PCB inside the NRI:

- Access the inside of the NRI (see [page 275, *Accessing the inside of the NRI*](#)).
- Remove the four countersunk M3 screws (Codan part number 31-03008-782) connecting the rear panel to the chassis of the NRI.
- Remove the single M3 taptite screw (Codan part number 31-03010-582) connecting the rear panel to the lower cover.
- Carefully unplug the four looms (Codan part numbers 08-05851-001, 08-05852-002, 08-05863-001, 08-05852-001) and remove the rear panel assembly with the NRI User Connect PCB (Codan part number 08-05865-001) attached.

Test procedures

CAUTION To avoid port failure, field service technicians using the **Test** connector of the NRI during NRI testing or debugging should run laptops from the internal battery instead of using the mains supply.

It is recommended that the NRI be tested in the following order:

- the switchmode power supply where applicable
- the NRI as a stand-alone unit
- the NRI Microcontroller PCB
- the NRI Vocoder PCB
- the NRI User Connect PCB

Testing the switchmode power supply

To test the switchmode power supply:

- Connect the switchmode power supply to a mains supply and switch it on.
- Follow the steps in [Figure 8](#) to assist in fault finding.

Figure 8: Power supply fault diagnosis chart

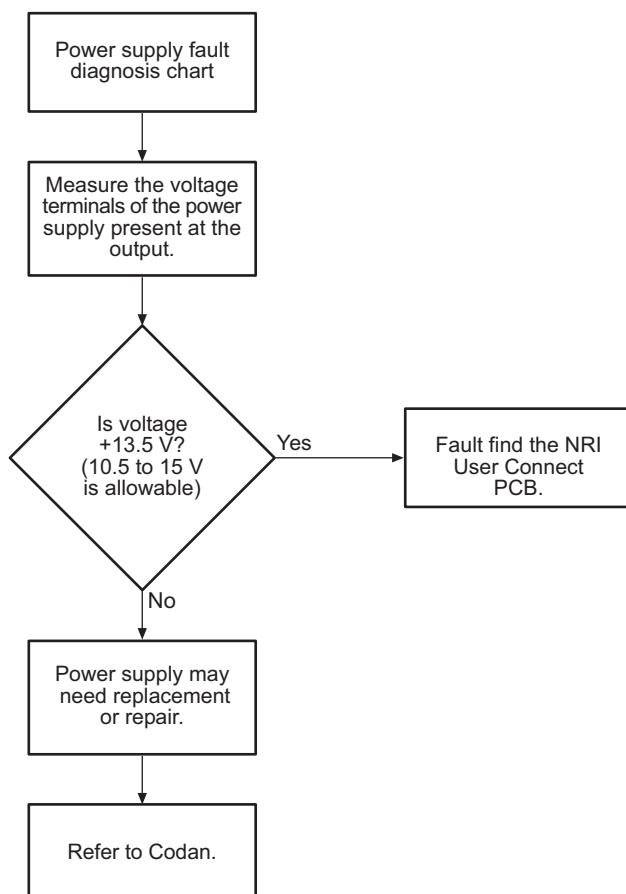

Testing the NRI unit

To test the NRI unit:

- Access the inside of the NRI (see [page 275, *Accessing the inside of the NRI*](#)).
- Connect the switchmode power supply or the transceiver supply unit to the NRI unit via the power adaptor cable (Codan part number 08-05868-001), then switch on the power supply.
- Follow the steps in [Figure 9](#) to assist in fault finding.

Figure 9: NRI fault diagnosis chart

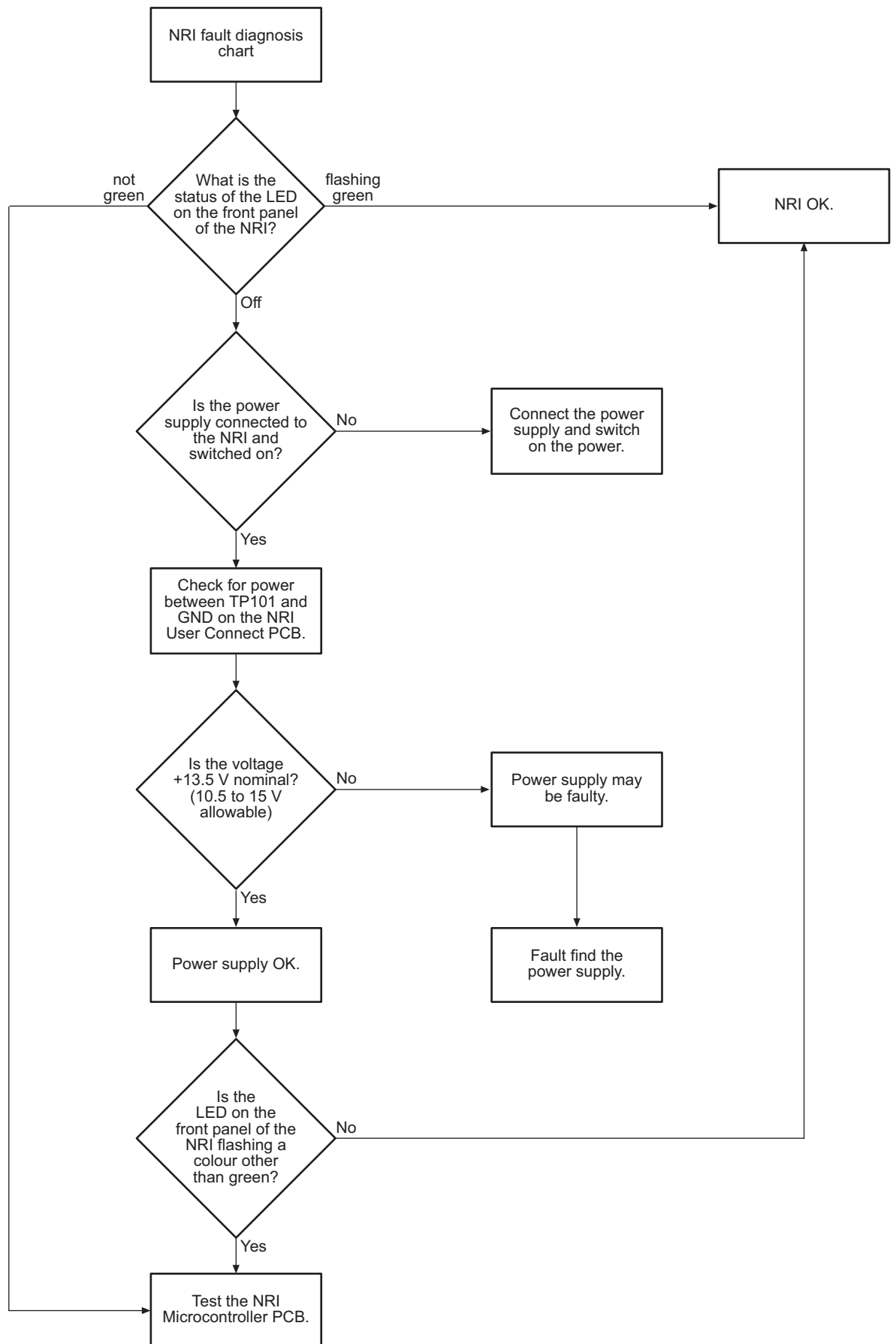

Testing the NRI Microcontroller PCB

Drawing [08-05854 \(sheet 1\)](#)

A number of test points are provided on the NRI Microcontroller PCB to enable measurements to be made that assist in fault finding. A multimeter and an oscilloscope (if available) may be used to measure the signals at each of these test points. [Table 8](#) shows the expected signals at the test points. If these signals fail to meet specification, [Table 8](#) provides the possible causes of the fault and the action required. It is important that each test point be measured in the order that they appear in [Table 8](#).

Table 8: Test points on the NRI Microcontroller PCB

Test point	Description	Acceptable signal/level	Possible fault causes	Action
+5 V	Regulated +5 V supply rail	+5.0 V \pm 0.1 V	No power input Failed switchmode controller Failed microcontroller, RAM or ROM chip	Check for +12 V across C139 Replace PCB Replace PCB
+10 V	Regulated +10 V supply rail	+10.0 V \pm 0.1 V	Failed regulator Failed analog component(s)	Replace PCB Replace PCB
16 MHz Clk	Microprocessor clock signal	16 MHz \pm 100 Hz 5 V p-p square wave	Failed microcontroller	Replace PCB
RESET	Active-high system reset signal	Logic-low just after system power supply connected	Failed microcontroller Corrupted program code	Replace PCB Replace PCB
+5 VQ	Regulated +5 V quiet supply	+5.0 V \pm 0.1 V	Failed analog component(s)	Replace PCB
RX_AF1	CIB receive audio path 1	+5.0 V \pm 0.1 V with no audio present	Failed analog component(s)	Replace PCB
TX_AF	CIB transmit audio path	+5.0 V \pm 0.1 V with no audio present	Failed analog component(s) Failed Vocoder PCB	Replace PCB See Table 9
AUD-	CIB system audio -	+5 V with ~ 6 μ s wide 5 V p-p low-going pulses every 80 μ s	Failed programmable logic device Failed analog component(s) Firmware failure	Replace PCB Replace PCB Attempt to reprogram if possible

Table 8: Test points on the NRI Microcontroller PCB (cont.)

Test point	Description	Acceptable signal/level	Possible fault causes	Action
AUD+	CIB system audio +	+5 V with ~ 6 μ s wide 5 V p-p high-going pulses every 80 μ s	Failed programmable logic device Failed analog component(s) Firmware failure	Replace PCB Replace PCB Attempt to reprogram if possible

NOTE For AUD– and AUD+, the NRI must be in Master Bus mode to make these measurements. This mode requires a standard type NGT Junction Box 2030 connected to the NRI via cable 08-05610-00X. The junction box must be connected when the power is off.

Testing the NRI Vocoder PCB

Drawing [08-05870](#)

The NRI Vocoder PCB features a highly integrated dedicated voice coding DSP (CT8020). Consequently it is difficult to diagnose faults with this PCB without the use of specialised test equipment. The following tests establish basic functionality of the Vocoder.

Table 9: Test points on the NRI Vocoder PCB

Test point	Description	Acceptable signal/level	Possible fault causes	Action
+10 V	Regulated +10 V supply rail from NRI Microcontroller PCB	+10.0 V \pm 0.1 V	Failed connection Failed +10 V supply on NRI Microcontroller PCB	Check condition of J1, and P206 on NRI Microcontroller PCB See Table 8
TP17	Charge-pump generated negative supply rail	-7.0 V \pm 0.5 V	Failed charge-pump component Failed -5 V regulator Failed CoDec	Replace PCB Replace PCB Replace PCB
-5 V	Regulated -5 V rail generated from above	-5.0 V \pm 0.1 V	Failed voltage regulator Failed CoDec	Replace PCB Replace PCB
TP7	Internally multiplied clock signal	40 MHz \pm 500 Hz 5 V p-p square wave	Failed connection Failed CT8020	Check condition of J1, and P206 on NRI Microcontroller PCB Replace PCB
TP13	SRAM Read Signal	Normally logic high with fast low pulses	Failed CT8020 Failed RAM IC	Replace PCB Replace PCB
TP14	SRAM Write Signal	Normally logic high with fast low pulses	Failed CT8020 Failed RAM IC	Replace PCB Replace PCB
TP15	SRAM Chip Select Signal	Normally logic high with fast low pulses	Failed CT8020 Failed RAM IC	Replace PCB Replace PCB
TP3	Codec Clock Signal	2 MHz \pm 100 Hz 5 V p-p square wave	Failed CT8020 Failed Codec	Replace PCB Replace PCB

Testing the NRI User Connect PCB

Drawing [08-05855](#)

To test the NRI User Connect PCB:

- Access the NRI User Connect PCB (see [page 276, *Accessing the NRI User Connect PCB*](#)).
- Connect the power supply, then switch on the power supply.
- Follow the steps in [Figure 10a](#) and [Figure 10b](#) to assist in fault finding.

Figure 10a: NGT remote interface User Connect PCB fault diagnosis chart

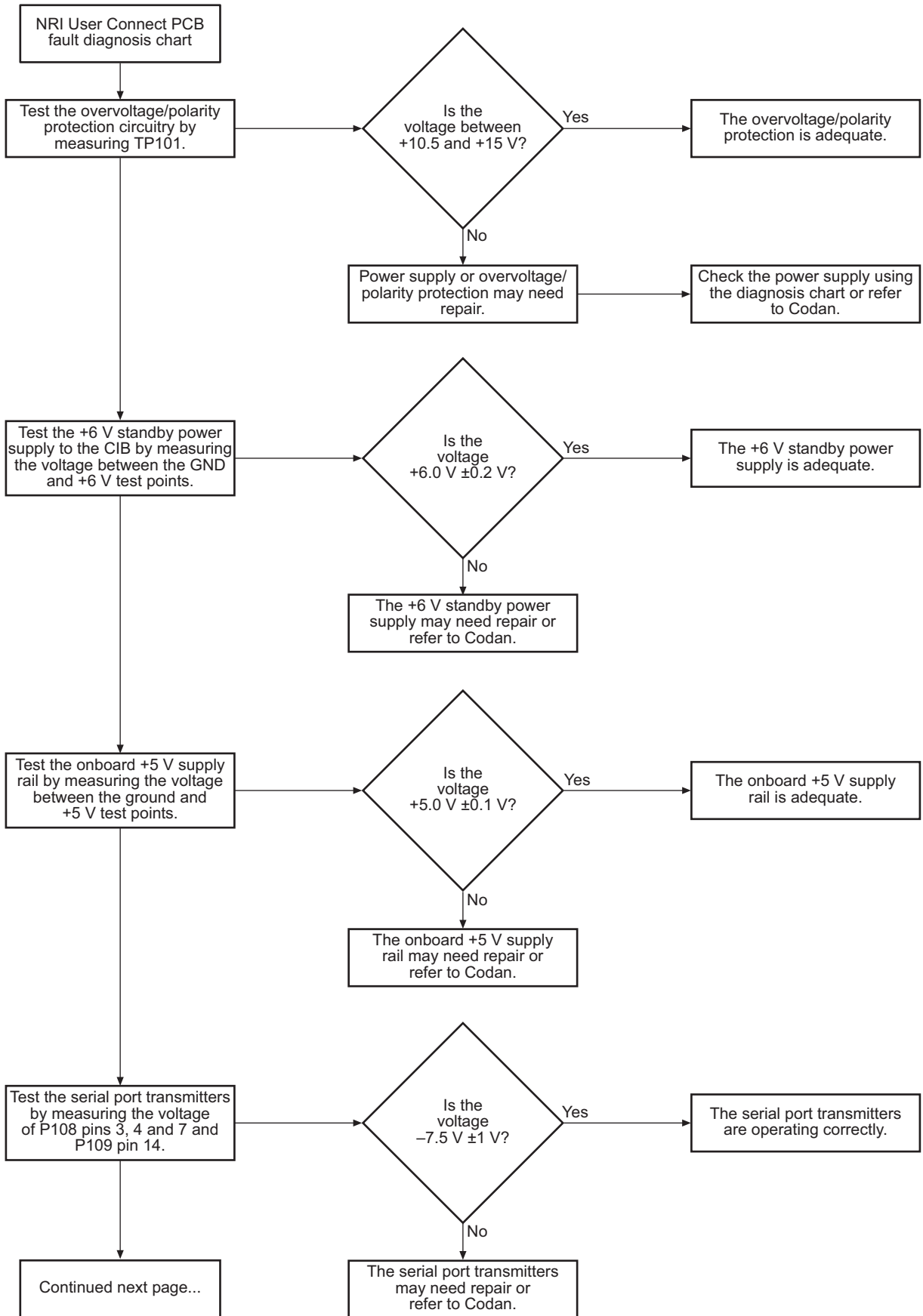
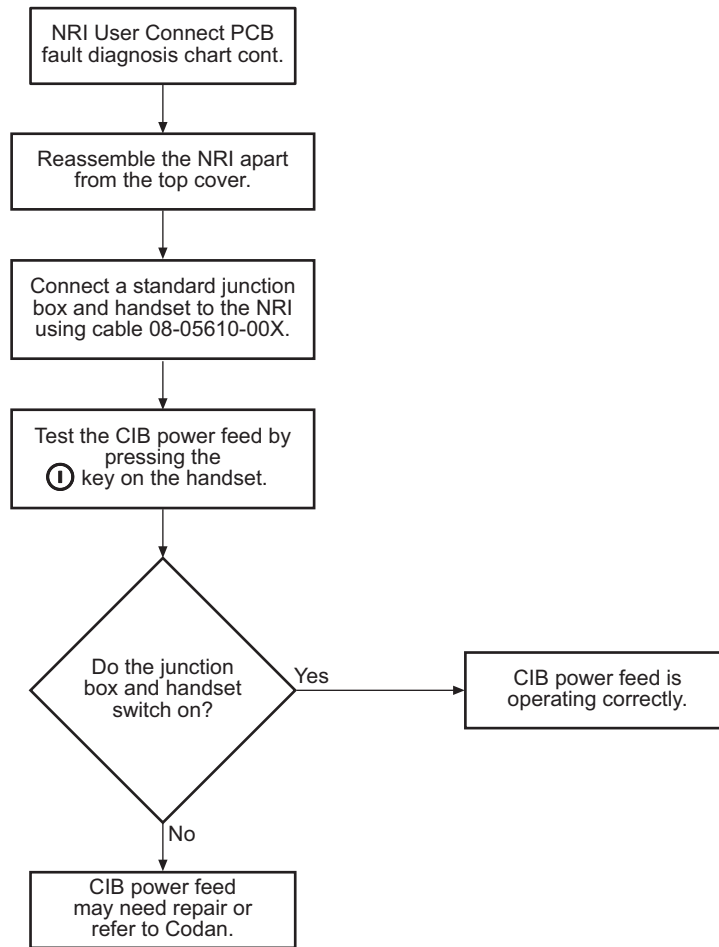

Figure 10b: NGT remote interface User Connect PCB fault diagnosis chart continued



This page has been left blank intentionally.

Table 10: NRI parts lists index

Title	Assembly number
NRI Microcontroller PCB	08-05854-001
NRI User Connect PCB	08-05855-001
NRI Vocoder PCB	08-05870-001

This page has been left blank intentionally.

08-05854-001 - NRI Micro-Controller PCB

BOM Revision
Date Valid On

07 -- Production
28.09.2006

Ref	Description	Manufacturer	Manufacturer's P/N	Codan P/N	Qty
	Header (P) 4way 2mm Latch Fixed	AMP	173981-4	60-00040-352	1
	Build Standard, 3030			01-01249	1
	NRI Micro-Controller			04-03363	1
	NRI Micro-Controller PCB			08-05854	1
1	PCB, NRI Micro-Controller	IMP	07-01942-03	07-01942-03	1
2	Label, Serial/Barcode	Codan	06-02068	06-02068	1
3	NRI Vocoder PCB	Codan	08-05870-001	08-05870-001	1
4	Fastener, PCB M3	PEM	KFS2-M3	33-53004-001	1
5	Spacer	Metalcraft	06-00025	06-00025	1
6	Screw, M3x12 304 SS Pan Pozi	*	31-23012-580	31-23012-580	1
C101	33n 10% 50V X7R 0805 NiSn	Philips	08052R333K9BB00	46-43300-281	1
C102	33n 10% 50V X7R 0805 NiSn	Philips	08052R333K9BB00	46-43300-281	1
C103	33n 10% 50V X7R 0805 NiSn	Philips	08052R333K9BB00	46-43300-281	1
C104	100n 10% 50V X7R 0805 Nisn	Philips	08052R104K9BB	46-51000-282	1
C105	2,2n 10% 100V X7R 0805 NiSn	Philips	08052R222K0B200	46-32200-281	1
C106	2,2n 10% 100V X7R 0805 NiSn	Philips	08052R222K0B200	46-32200-281	1
C107	3,9n 5% 50V NPO 1206 NiSn	Philips	1206CG392J9BB0C	46-33900-080	1
C108	330p 5% 50V NPO 0805 NiSn	Philips	0805CG331J9B200	46-23300-081	1
C109	4,7n 5% 50V NPO 1206 NiSn	Philips	1206CG472J9BB0C	46-34700-080	1
C110	4,7n 5% 50V NPO 1206 NiSn	Philips	1206CG472J9BB0C	46-34700-080	1
C111	220p 5% 50V NPO 0805 NiSn	Philips	0805CG221J9BB	46-22200-081	1
C112	100n 10% 50V X7R 0805 Nisn	Philips	08052R104K9BB	46-51000-282	1
C113	2,2n 10% 100V X7R 0805 NiSn	Philips	08052R222K0B200	46-32200-281	1
C114	33n 10% 50V X7R 0805 NiSn	Philips	08052R333K9BB00	46-43300-281	1
C115	2,2n 10% 100V X7R 0805 NiSn	Philips	08052R222K0B200	46-32200-281	1
C116	3,9n 5% 50V NPO 1206 NiSn	Philips	1206CG392J9BB0C	46-33900-080	1
C117	330p 5% 50V NPO 0805 NiSn	Philips	0805CG331J9B200	46-23300-081	1
C118	33n 10% 50V X7R 0805 NiSn	Philips	08052R333K9BB00	46-43300-281	1
C119	4,7n 5% 50V NPO 1206 NiSn	Philips	1206CG472J9BB0C	46-34700-080	1
C120	4,7n 5% 50V NPO 1206 NiSn	Philips	1206CG472J9BB0C	46-34700-080	1
C121	220p 5% 50V NPO 0805 NiSn	Philips	0805CG221J9BB	46-22200-081	1
C122	33n 10% 50V X7R 0805 NiSn	Philips	08052R333K9BB00	46-43300-281	1
C123	100n 10% 50V X7R 0805 Nisn	Philips	08052R104K9BB	46-51000-282	1

08-05854-001 - NRI Micro-Controller PCB

BOM Revision
Date Valid On

07 -- Production
28.09.2006

Ref	Description	Manufacturer	Manufacturer's P/N	Codan P/N	Qty
C126	220p 5% 50V NPO 0805 NiSn	Philips	0805CG221J9BB	46-22200-081	1
C127	220p 5% 50V NPO 0805 NiSn	Philips	0805CG221J9BB	46-22200-081	1
C128	4,7n 5% 50V NPO 1206 NiSn	Philips	1206CG472J9BB0C	46-34700-080	1
C129	4,7n 5% 50V NPO 1206 NiSn	Philips	1206CG472J9BB0C	46-34700-080	1
C130	33n 10% 50V X7R 0805 NiSn	Philips	08052R333K9BB00	46-43300-281	1
C131	3,9n 5% 50V NPO 1206 NiSn	Philips	1206CG392J9BB0C	46-33900-080	1
C132	330p 5% 50V NPO 0805 NiSn	Philips	0805CG331J9B200	46-23300-081	1
C133	2,2n 10% 100V X7R 0805 NiSn	Philips	08052R222K0B200	46-32200-281	1
C134	33n 10% 50V X7R 0805 NiSn	Philips	08052R333K9BB00	46-43300-281	1
C135	220p 5% 50V NPO 0805 NiSn	Philips	0805CG221J9BB	46-22200-081	1
C136	100n 10% 50V X7R 0805 Nisn	Philips	08052R104K9BB	46-51000-282	1
C137	220p 5% 50V NPO 0805 NiSn	Philips	0805CG221J9BB	46-22200-081	1
C138	100n 10% 50V X7R 0805 Nisn	Philips	08052R104K9BB	46-51000-282	1
C139	10u 20% 25V 6032 TA Cap	AVX	TAJC106M025R	47-11002-520	1
C140	10u 20% 25V 6032 TA Cap	AVX	TAJC106M025R	47-11002-520	1
C141	1u 20% 35V 3528 TA Cap	AVX	TAJB105M035R	47-01003-520	1
C142	10n 10% 100V X7R 0805 NiSn	Philips	08052R103K0B200	46-41000-281	1
C143	100u 20% 16V 7343H TA Cap Low ESR	AVX	TPSE107M016R0100	47-21001-600	1
C144	100u 20% 16V 7343H TA Cap Low ESR	AVX	TPSE107M016R0100	47-21001-600	1
C145	1u 20% 35V 3528 TA Cap	AVX	TAJB105M035R	47-01003-520	1
C146	33n 10% 50V X7R 0805 NiSn	Philips	08052R333K9BB00	46-43300-281	1
C201	33n 10% 50V X7R 0805 NiSn	Philips	08052R333K9BB00	46-43300-281	1
C202	100n 10% 50V X7R 0805 Nisn	Philips	08052R104K9BB	46-51000-282	1
C203	22p 5% 50V NPO 0805 NiSn	Philips	0805CG220J9B200	46-12200-081	1
C204	22p 5% 50V NPO 0805 NiSn	Philips	0805CG220J9B200	46-12200-081	1
C205	1n 5% 50V NPO 0805 NiSn	Philips	0805CG102J9BB-	46-31000-082	1
C206	33n 10% 50V X7R 0805 NiSn	Philips	08052R333K9BB00	46-43300-281	1
C207	33n 10% 50V X7R 0805 NiSn	Philips	08052R333K9BB00	46-43300-281	1
C208	1u 10% 10V X7R 0805 NiSn	Phycomp	2222-240-15663	46-61000-281	1

08-05854-001 - NRI Micro-Controller PCB

BOM Revision
Date Valid On

07 -- Production
28.09.2006

Ref	Description	Manufacturer	Manufacturer's P/N	Codan P/N	Qty
C209	33n 10% 50V X7R 0805 NiSn	Philips	08052R333K9BB00	46-43300-281	1
C210	33n 10% 50V X7R 0805 NiSn	Philips	08052R333K9BB00	46-43300-281	1
C211	33n 10% 50V X7R 0805 NiSn	Philips	08052R333K9BB00	46-43300-281	1
C212	27p 5% 50V NPO 0805 NiSn	Philips	0805CG270J9B200	46-12700-080	1
C213	27p 5% 50V NPO 0805 NiSn	Philips	0805CG270J9B200	46-12700-080	1
C214	33n 10% 50V X7R 0805 NiSn	Philips	08052R333K9BB00	46-43300-281	1
C215	33n 10% 50V X7R 0805 NiSn	Philips	08052R333K9BB00	46-43300-281	1
D101	Diode, Schottky 40V 3A SMC	Motorola	MBRS340T3	MBRS340T3	1
D201	Diode, Si High speed 75V SOT23	Philips	BAS16	BAS16	1
D202	Diode, Si High speed 75V SOT23	Philips	BAS16	BAS16	1
D203	Diode, Si High speed 75V SOT23	Philips	BAS16	BAS16	1
H201	LED, Tricolour T-1 3/4 Diffused	Liteon	LTL-52RG	65-61110-901	1
H203	LED, Green PLCC SMD Non Diffused	Siemens	LGT670-L	65-61110-507	1
H204	LED, Green PLCC SMD Non Diffused	Siemens	LGT670-L	65-61110-507	1
IC101	EPLD prgmd, NRI	Codan	90-20605-001	90-20605-001	1
IC102	Amp, Op Dual Fast SOIC8	Texas Instruments	TLE2082CD	XA-02082-700	1
IC103	Switch, Analog Quad Fast SOIC16	Harris	DG445DY	YI-00445-700	1
IC104	Switch, Analog Quad Fast SOIC16	Harris	DG445DY	YI-00445-700	1
IC105	Amp, Op Dual Fast SOIC8	Texas Instruments	TLE2082CD	XA-02082-700	1
IC106	Amp, Op Dual Fast SOIC8	Texas Instruments	TLE2082CD	XA-02082-700	1
IC107	Amp, Op Dual Fast SOIC8	Texas Instruments	TLE2082CD	XA-02082-700	1
IC108	Amp, Op Dual Fast SOIC8	Texas Instruments	TLE2082CD	XA-02082-700	1
IC109	Switch, Analog Quad Fast SOIC16	Harris	DG445DY	YI-00445-700	1
IC110	Amp, Op Dual Fast SOIC8	Texas Instruments	TLE2082CD	XA-02082-700	1
IC111	Reg, Voltage +10V LVD 1A TO263_3	National Semiconduct	LM2940S-10	XB-02940-700	1
IC112	Reg, Voltage +5V 0,5A Switch SOIC8	AVX	LM2674M-5.0	XB-02674-700	1
IC201	DUART, CMOS PLCC44	Philips	SC26C92C1A	YK-02692-900	1
IC202	Monitor, Micro SOIC8	Dallas	DS1232LPS-2	XD-01232-700	1
IC203	MicroC, 16 Bit CMOS QFP20112	Hitachi	HD6413003TF16	YP-83003-700	1

08-05854-001 - NRI Micro-Controller PCB

BOM Revision
Date Valid On

07 -- Production
28.09.2006

Ref	Description	Manufacturer	Manufacturer's P/N	Codan P/N	Qty
IC204	Tcvr, CAN bus SOIC8	Philips	PCA82C250T	YI-82250-700	1
IC205	Serial Number, 48 bit SOT223	Dallas	DS2401Z	YM-02401-700	1
IC206	SRAM, CMOS 256k x 16 Bit 20ns SOJ44	Alliance	AS7C4098-20JC	YM-74098-700	1
IC207	FLASH, Serial 512k x 8 Bit 3V SOIC8	Atmel	AT45DB041B-SC	YM-45041-700	1
IC208	Cntrl, CAN bus 2,0B SOIC28	Philips	SJA1000T/N1	YL-81000-700	1
IC209	FLASH prgmd, NRI	Codan	90-20604-101	90-20604-101	1
IC210	Gate, AND 2 Input Quad SOIC14	Motorola	MC74AC08D	YS-74008-700	1
IC211	Buffer, Single Non-Inv T/State SOT323-5	STMicroelectronics	74V1T125CTR	YY-74125-700	1
L101	Ind, 10uH 10% 4532	Taiyo Yuden	LEM 4532T100K	43-81100-000	1
L102	Ind, 100uH 1,2A SMPS SMD	Epcos	B82476-A1104-M	43-82100-003	1
P101	Header (P) 10way 2mm Latch Fixed	AMP	1-173981-0	60-00100-351	1
P201	Header (P) 26way 2row Boxed Fix	Thomas & Betts	609-2627	60-00260-000	1
P202	Header (P) 10way 2mm Latch Fixed	AMP	1-173981-0	60-00100-351	1
P204	Header (P) 50way 2row Fixed 1,27mmP SMD	Samtec	TFML-125-02-S-D	60-00500-000	1
R101	2,2k Ohm 5% 0,06W 0603	Philips	2322 702 60222	40-32200-121	1
R102	4,7k Ohm 5% 0,06W 0603	Philips	2322 702 60472	40-34700-121	1
R103	4,7k Ohm 5% 0,06W 0603	Philips	2322 702 60472	40-34700-121	1
R104	33k Ohm 5% 0,06W 0603	Philips	2322 702 60333	40-43300-121	1
R105	33k Ohm 5% 0,06W 0603	Philips	2322 702 60333	40-43300-121	1
R106	33k Ohm 5% 0,06W 0603	Philips	2322 702 60333	40-43300-121	1
R107	33k Ohm 5% 0,06W 0603	Philips	2322 702 60333	40-43300-121	1
R108	33k Ohm 5% 0,06W 0603	Philips	2322 702 60333	40-43300-121	1
R109	33k Ohm 5% 0,06W 0603	Philips	2322 702 60333	40-43300-121	1
R110	10k Ohm 5% 0,06W 0603	Philips	2322 702 60103	40-41000-121	1
R111	22k Ohm 5% 0,06W 0603	Philips	2322 702 60223	40-42200-121	1
R112	22k Ohm 5% 0,06W 0603	Philips	2322 702 60223	40-42200-121	1
R113	10k Ohm 5% 0,06W 0603	Philips	2322 702 60103	40-41000-121	1
R114	47 Ohm 5% 0,06W 0603	Philips	2322 702 60479	40-14700-121	1
R115	47 Ohm 5% 0,06W 0603	Philips	2322 702 60479	40-14700-121	1
R116	1M Ohm 5% 0,06W 0603	Philips	2322 702 60105	40-61000-121	1

08-05854-001 - NRI Micro-Controller PCB

BOM Revision
Date Valid On

07 -- Production
 28.09.2006

Ref	Description	Manufacturer	Manufacturer's P/N	Codan P/N	Qty
R117	51k Ohm 5% 0,1W 0805	Philips	2322 730 61513	40-45100-111	1
R118	51k Ohm 5% 0,1W 0805	Philips	2322 730 61513	40-45100-111	1
R119	51k Ohm 5% 0,1W 0805	Philips	2322 730 61513	40-45100-111	1
R120	33k Ohm 5% 0,06W 0603	Philips	2322 702 60333	40-43300-121	1
R121	33k Ohm 5% 0,06W 0603	Philips	2322 702 60333	40-43300-121	1
R122	1M Ohm 5% 0,06W 0603	Philips	2322 702 60105	40-61000-121	1
R123	51k Ohm 5% 0,1W 0805	Philips	2322 730 61513	40-45100-111	1
R124	51k Ohm 5% 0,1W 0805	Philips	2322 730 61513	40-45100-111	1
R125	51k Ohm 5% 0,1W 0805	Philips	2322 730 61513	40-45100-111	1
R126	33k Ohm 5% 0,06W 0603	Philips	2322 702 60333	40-43300-121	1
R127	33k Ohm 5% 0,06W 0603	Philips	2322 702 60333	40-43300-121	1
R128	22k Ohm 5% 0,06W 0603	Philips	2322 702 60223	40-42200-121	1
R129	22k Ohm 5% 0,06W 0603	Philips	2322 702 60223	40-42200-121	1
R130	33k Ohm 5% 0,06W 0603	Philips	2322 702 60333	40-43300-121	1
R131	33k Ohm 5% 0,06W 0603	Philips	2322 702 60333	40-43300-121	1
R132	51k Ohm 5% 0,1W 0805	Philips	2322 730 61513	40-45100-111	1
R133	51k Ohm 5% 0,1W 0805	Philips	2322 730 61513	40-45100-111	1
R134	22k Ohm 5% 0,06W 0603	Philips	2322 702 60223	40-42200-121	1
R135	22k Ohm 5% 0,06W 0603	Philips	2322 702 60223	40-42200-121	1
R136	22k Ohm 5% 0,06W 0603	Philips	2322 702 60223	40-42200-121	1
R137	22k Ohm 5% 0,06W 0603	Philips	2322 702 60223	40-42200-121	1
R138	1k Ohm 5% 0,06W 0603	Philips	2322 702 60102	40-31000-121	1
R139	Not Fitted	Codan	** -00000-001	99-00000-001	1
R201	33k Ohm 5% 0,06W 0603	Philips	2322 702 60333	40-43300-121	1
R202	33k Ohm 5% 0,06W 0603	Philips	2322 702 60333	40-43300-121	1
R203	33k Ohm 5% 0,06W 0603	Philips	2322 702 60333	40-43300-121	1
R204	4,7k Ohm 5% 0,06W 0603	Philips	2322 702 60472	40-34700-121	1
R205	33k Ohm 5% 0,06W 0603	Philips	2322 702 60333	40-43300-121	1
R206	4,7k Ohm 5% 0,06W 0603	Philips	2322 702 60472	40-34700-121	1

08-05854-001 - NRI Micro-Controller PCB

BOM Revision
Date Valid On

07 -- Production
 28.09.2006

Ref	Description	Manufacturer	Manufacturer's P/N	Codan P/N	Qty
R207	33k Ohm 5% 0,06W 0603	Philips	2322 702 60333	40-43300-121	1
R208	33k Ohm 5% 0,06W 0603	Philips	2322 702 60333	40-43300-121	1
R209	100 Ohm 5% 0,06W 0603	Philips	2322 702 60101	40-21000-121	1
R210	33k Ohm 5% 0,06W 0603	Philips	2322 702 60333	40-43300-121	1
R211	33k Ohm 5% 0,06W 0603	Philips	2322 702 60333	40-43300-121	1
R212	2,2k Ohm 5% 0,06W 0603	Philips	2322 702 60222	40-32200-121	1
R213	2,2k Ohm 5% 0,06W 0603	Philips	2322 702 60222	40-32200-121	1
R214	33k Ohm 5% 0,06W 0603	Philips	2322 702 60333	40-43300-121	1
R215	33k Ohm 5% 0,06W 0603	Philips	2322 702 60333	40-43300-121	1
R216	33k Ohm 5% 0,06W 0603	Philips	2322 702 60333	40-43300-121	1
R217	33k Ohm 5% 0,06W 0603	Philips	2322 702 60333	40-43300-121	1
R218	100 Ohm 5% 0,06W 0603	Philips	2322 702 60101	40-21000-121	1
R219	33k Ohm 5% 0,06W 0603	Philips	2322 702 60333	40-43300-121	1
R220	33k Ohm 5% 0,06W 0603	Philips	2322 702 60333	40-43300-121	1
R221	33k Ohm 5% 0,06W 0603	Philips	2322 702 60333	40-43300-121	1
R222	33k Ohm 5% 0,06W 0603	Philips	2322 702 60333	40-43300-121	1
R223	33k Ohm 5% 0,06W 0603	Philips	2322 702 60333	40-43300-121	1
R224	33k Ohm 5% 0,06W 0603	Philips	2322 702 60333	40-43300-121	1
R225	33k Ohm 5% 0,06W 0603	Philips	2322 702 60333	40-43300-121	1
R226	33k Ohm 5% 0,06W 0603	Philips	2322 702 60333	40-43300-121	1
R227	33k Ohm 5% 0,06W 0603	Philips	2322 702 60333	40-43300-121	1
R228	4,7k Ohm 5% 0,06W 0603	Philips	2322 702 60472	40-34700-121	1
R229	33k Ohm 5% 0,06W 0603	Philips	2322 702 60333	40-43300-121	1
R230	10k Ohm 5% 0,06W 0603	Philips	2322 702 60103	40-41000-121	1
R231	10k Ohm 5% 0,06W 0603	Philips	2322 702 60103	40-41000-121	1
R232	47 Ohm 5% 0,06W 0603	Philips	2322 702 60479	40-14700-121	1
R233	47 Ohm 5% 0,06W 0603	Philips	2322 702 60479	40-14700-121	1
R234	47 Ohm 5% 0,06W 0603	Philips	2322 702 60479	40-14700-121	1
R235	47 Ohm 5% 0,06W 0603	Philips	2322 702 60479	40-14700-121	1

08-05854-001 - NRI Micro-Controller PCB

BOM Revision
Date Valid On

07 -- Production
28.09.2006

Ref	Description	Manufacturer	Manufacturer's P/N	Codan P/N	Qty
R236	33k Ohm 5% 0,06W 0603	Philips	2322 702 60333	40-43300-121	1
R237	33k Ohm 5% 0,06W 0603	Philips	2322 702 60333	40-43300-121	1
R238	47 Ohm 5% 0,06W 0603	Philips	2322 702 60479	40-14700-121	1
R239	47 Ohm 5% 0,06W 0603	Philips	2322 702 60479	40-14700-121	1
R240	33k Ohm 5% 0,06W 0603	Philips	2322 702 60333	40-43300-121	1
R241	10k Ohm 5% 0,06W 0603	Philips	2322 702 60103	40-41000-121	1
R242	33k Ohm 5% 0,06W 0603	Philips	2322 702 60333	40-43300-121	1
R243	1k Ohm 5% 0,06W 0603	Philips	2322 702 60102	40-31000-121	1
R244	1k Ohm 5% 0,06W 0603	Philips	2322 702 60102	40-31000-121	1
R245	1k Ohm 5% 0,06W 0603	Philips	2322 702 60102	40-31000-121	1
R246	10k Ohm 5% 0,06W 0603	Philips	2322 702 60103	40-41000-121	1
V101	Transistor, NPN Si SOT23	Philips	BFR92A	BFR92A	1
V201	Transistor, PNP Si SOT23	Philips	BC858	BC858	1
V202	Transistor, PNP Si SOT23	Philips	BC858	BC858	1
V203	Transistor, PNP Si SOT23	Philips	BC858	BC858	1
V204	Transistor, NPN Si SOT23	Philips	BC848	BC848	1
V205	Diode, Zener 3,3V 5% 0,2W SOT23	Philips	BZX84-C3V3	BZX84C3V3	1
Z201	Crystal, 16000 kHz uP Grade	HY-Q	QC49/SMD	65-90103	1
Z202	Crystal, 3686,4 kHz uP Grade	HY-Q	M/P QC49/SMD EBO1C	65-90101	1

08-05855-001 - User Connect PCB, 3030

BOM Revision
Date Valid On

05 -- Production
28.09.2006

Ref	Description	Manufacturer	Manufacturer's P/N	Codan P/N	Qty
	Build Standard, 3030			01-01249	1
	User Connector PCB			11-06101	1
	User Connect PCB			08-05855	1
	User Connect			04-03364	1
	Jig, Alignment MIC Socket RearPanel		75-80982	75-80982	1
1	PCB, User Connect	IMP	07-01943-01	07-01943-01	1
2	Label, Serial/Barcode	Codan	06-02068	06-02068	1
3	Standoff #4-40x7	Avdel	1115-4470	33-40504-070	4
C101	470p 5% 50V NPO 0805 NiSn	Philips	0805CG471J9B200	46-24700-081	1
C102	470p 5% 50V NPO 0805 NiSn	Philips	0805CG471J9B200	46-24700-081	1
C103	470p 5% 50V NPO 0805 NiSn	Philips	0805CG471J9B200	46-24700-081	1
C104	470p 5% 50V NPO 0805 NiSn	Philips	0805CG471J9B200	46-24700-081	1
C105	33n 10% 50V X7R 0805 NiSn	Philips	08052R333K9BB00	46-43300-281	1
C106	1u 20% 35V 3528 TA Cap	AVX	TAJB105M035R	47-01003-520	1
C108	100n 10% 50V X7R 0805 Nisn	Philips	08052R104K9BB	46-51000-282	1
C109	33n 10% 50V X7R 0805 NiSn	Philips	08052R333K9BB00	46-43300-281	1
C110	1u 20% 35V 3528 TA Cap	AVX	TAJB105M035R	47-01003-520	1
C111	100n 10% 50V X7R 0805 Nisn	Philips	08052R104K9BB	46-51000-282	1
C112	100n 10% 50V X7R 0805 Nisn	Philips	08052R104K9BB	46-51000-282	1
C113	100n 10% 50V X7R 0805 Nisn	Philips	08052R104K9BB	46-51000-282	1
C114	100n 10% 50V X7R 0805 Nisn	Philips	08052R104K9BB	46-51000-282	1
C115	100n 10% 50V X7R 0805 Nisn	Philips	08052R104K9BB	46-51000-282	1
C116	100n 10% 50V X7R 0805 Nisn	Philips	08052R104K9BB	46-51000-282	1
C117	100n 10% 50V X7R 0805 Nisn	Philips	08052R104K9BB	46-51000-282	1
C118	100n 10% 50V X7R 0805 Nisn	Philips	08052R104K9BB	46-51000-282	1
C119	33n 10% 50V X7R 0805 NiSn	Philips	08052R333K9BB00	46-43300-281	1
C120	3,3n 10% 100V X7R 0805 NiSn	Philips	08052R332K0B200	46-33300-281	1
C121	3,3n 10% 100V X7R 0805 NiSn	Philips	08052R332K0B200	46-33300-281	1
C122	3,3n 10% 100V X7R 0805 NiSn	Philips	08052R332K0B200	46-33300-281	1
C123	3,3n 10% 100V X7R 0805 NiSn	Philips	08052R332K0B200	46-33300-281	1
C124	1u 20% 35V 3528 TA Cap	AVX	TAJB105M035R	47-01003-520	1
C125	100n 10% 50V X7R 0805 Nisn	Philips	08052R104K9BB	46-51000-282	1

08-05855-001 - User Connect PCB, 3030

BOM Revision
Date Valid On

05 -- Production
28.09.2006

Ref	Description	Manufacturer	Manufacturer's P/N	Codan P/N	Qty
C126	3,3n 10% 100V X7R 0805 NiSn	Philips	08052R332K0B200	46-33300-281	1
C127	3,3n 10% 100V X7R 0805 NiSn	Philips	08052R332K0B200	46-33300-281	1
C128	3,3n 10% 100V X7R 0805 NiSn	Philips	08052R332K0B200	46-33300-281	1
C129	3,3n 10% 100V X7R 0805 NiSn	Philips	08052R332K0B200	46-33300-281	1
C130	3,3n 10% 100V X7R 0805 NiSn	Philips	08052R332K0B200	46-33300-281	1
C131	3,3n 10% 100V X7R 0805 NiSn	Philips	08052R332K0B200	46-33300-281	1
C132	3,3n 10% 100V X7R 0805 NiSn	Philips	08052R332K0B200	46-33300-281	1
C133	3,3n 10% 100V X7R 0805 NiSn	Philips	08052R332K0B200	46-33300-281	1
C134	3,3n 10% 100V X7R 0805 NiSn	Philips	08052R332K0B200	46-33300-281	1
C135	3,3n 10% 100V X7R 0805 NiSn	Philips	08052R332K0B200	46-33300-281	1
C136	3,3n 10% 100V X7R 0805 NiSn	Philips	08052R332K0B200	46-33300-281	1
C137	3,3n 10% 100V X7R 0805 NiSn	Philips	08052R332K0B200	46-33300-281	1
C138	3,3n 10% 100V X7R 0805 NiSn	Philips	08052R332K0B200	46-33300-281	1
C139	3,3n 10% 100V X7R 0805 NiSn	Philips	08052R332K0B200	46-33300-281	1
C140	3,3n 10% 100V X7R 0805 NiSn	Philips	08052R332K0B200	46-33300-281	1
C141	3,3n 10% 100V X7R 0805 NiSn	Philips	08052R332K0B200	46-33300-281	1
C142	3,3n 10% 100V X7R 0805 NiSn	Philips	08052R332K0B200	46-33300-281	1
C143	3,3n 10% 100V X7R 0805 NiSn	Philips	08052R332K0B200	46-33300-281	1
C144	3,3n 10% 100V X7R 0805 NiSn	Philips	08052R332K0B200	46-33300-281	1
C145	3,3n 10% 100V X7R 0805 NiSn	Philips	08052R332K0B200	46-33300-281	1
C146	3,3n 10% 100V X7R 0805 NiSn	Philips	08052R332K0B200	46-33300-281	1
C147	3,3n 10% 100V X7R 0805 NiSn	Philips	08052R332K0B200	46-33300-281	1
C148	3,3n 10% 100V X7R 0805 NiSn	Philips	08052R332K0B200	46-33300-281	1
C149	3,3n 10% 100V X7R 0805 NiSn	Philips	08052R332K0B200	46-33300-281	1
C150	33n 10% 50V X7R 0805 NiSn	Philips	08052R333K9BB00	46-43300-281	1
C151	100n 10% 50V X7R 0805 Nisn	Philips	08052R104K9BB	46-51000-282	1
D101	Diode, Si High speed 75V SOT23	Philips	BAS16	BAS16	1
D102	Diode, Si High speed 75V SOT23	Philips	BAS16	BAS16	1
D103	Diode, Si High speed 75V SOT23	Philips	BAS16	BAS16	1

08-05855-001 - User Connect PCB, 3030

BOM Revision
Date Valid On

05 -- Production
28.09.2006

Ref	Description	Manufacturer	Manufacturer's P/N	Codan P/N	Qty
D104	Diode, Si High speed 75V SOT23	Philips	BAS16	BAS16	1
D105	Diode, Si High speed 75V SOT23	Philips	BAS16	BAS16	1
D106	Diode, Si High speed 75V SOT23	Philips	BAS16	BAS16	1
D107	Diode, Si High speed 75V SOT23	Philips	BAS16	BAS16	1
D108	Diode, Si High speed 75V SOT23	Philips	BAS16	BAS16	1
D109	Diode, Schottky 40V 3A SMC	Motorola	MBRS340T3	MBRS340T3	1
IC101	MOSFET, high side switch 4A SOT426	Philips	BUK207-50Y	BUK207-50Y	1
IC102	Reg, Voltage +5V 0,1A SOIC8	National Semiconduct	LM78L05ACM	XB-07805-700	1
IC103	Tcvr, RS232 6Tx / 10Rx ESD PROT TSSOP38	Maxim	MAX3209ECUU	YI-03209-700	1
IC105	Reg, Voltage +5V 0,1A SOIC8	National Semiconduct	LM78L05ACM	XB-07805-700	1
J101	Plug, 2way 2,5mm DC Power	Marushin	MJ-180LE	60-00020-003	1
J102	Plug, 2way 2,5mm DC Power	Marushin	MJ-180LE	60-00020-003	1
K101	Relay, 2C 12V 2A SMD 1028 Ohm	Matsushita	TQ2SL-12V	64-21225-310	1
L101	Choke, Common Mode (Data) SMD	Taiyo Yuden	CM04RC04	43-82470-000	1
L102	Choke, Common Mode (Data) SMD	Taiyo Yuden	CM04RC04	43-82470-000	1
L103	Ind, Common Mode 5.5A	Taiyo Yuden	CMO8RA20	43-80001	1
L104	Choke, EMI/EMC 0A DC >1MHz 4516	Taiyo Yuden	FCFBMJ 4516 HS 110-T	43-90003	1
L105	Ind, Common Mode 5.5A	Taiyo Yuden	CMO8RA20	43-80001	1
L106	Choke, EMI/EMC 0A DC >1MHz 4516	Taiyo Yuden	FCFBMJ 4516 HS 110-T	43-90003	1
L107	Choke, EMI/EMC 0A DC >1MHz 4516	Taiyo Yuden	FCFBMJ 4516 HS 110-T	43-90003	1
P101	Plug, 8way fixed w/round nut	Nisshin	NS1508L	60-00080-005	1
P102	Plug, 8way fixed w/round nut	Nisshin	NS1508L	60-00080-005	1
P104	Header (P) 10way 2mm Latch Fixed	AMP	1-173981-0	60-00100-351	1
P105	Header (P) 4way 2mm Latch Fixed	AMP	173981-4	60-00040-352	1
P106	Header (P) 26way 2row Boxed Fix	Thomas & Betts	609-2627	60-00260-000	1
P107	Header (P) 10way 2mm Latch Fixed	AMP	1-173981-0	60-00100-351	1
P108	Plug, 9way PCB Fixed	ITT-Cannon	DEPF-9P-Y4	60-00090-090	1
P109	Plug, 25way D Straight PCB Fixed	McMurdo	DB-25P-OL2	60-00250-093	1
R101	4,7k Ohm 5% 0,06W 0603	Philips	2322 702 60472	40-34700-121	1
R102	10k Ohm 5% 0,06W 0603	Philips	2322 702 60103	40-41000-121	1
R103	4,7k Ohm 5% 0,06W 0603	Philips	2322 702 60472	40-34700-121	1

08-05855-001 - User Connect PCB, 3030

BOM Revision
Date Valid On

05 -- Production
 28.09.2006

Ref	Description	Manufacturer	Manufacturer's P/N	Codan P/N	Qty
R104	Res, Voltage Dependent	Philips	2322-592-52506	41-22506-592	1
R105	33k Ohm 5% 0,06W 0603	Philips	2322 702 60333	40-43300-121	1
R106	4,7k Ohm 5% 0,06W 0603	Philips	2322 702 60472	40-34700-121	1
R107	1k Ohm 5% 0,06W 0603	Philips	2322 702 60102	40-31000-121	1
R108	1k Ohm 5% 0,06W 0603	Philips	2322 702 60102	40-31000-121	1
R109	1k Ohm 5% 0,06W 0603	Philips	2322 702 60102	40-31000-121	1
R110	1k Ohm 5% 0,06W 0603	Philips	2322 702 60102	40-31000-121	1
R111	100 Ohm 5% 0,06W 0603	Philips	2322 702 60101	40-21000-121	1
R112	100 Ohm 5% 0,06W 0603	Philips	2322 702 60101	40-21000-121	1
R113	100 Ohm 5% 0,06W 0603	Philips	2322 702 60101	40-21000-121	1
R114	100 Ohm 5% 0,06W 0603	Philips	2322 702 60101	40-21000-121	1
R115	100 Ohm 5% 0,06W 0603	Philips	2322 702 60101	40-21000-121	1
R116	100 Ohm 5% 0,06W 0603	Philips	2322 702 60101	40-21000-121	1
R117	100 Ohm 5% 0,06W 0603	Philips	2322 702 60101	40-21000-121	1
R118	100 Ohm 5% 0,06W 0603	Philips	2322 702 60101	40-21000-121	1
R119	100 Ohm 5% 0,06W 0603	Philips	2322 702 60101	40-21000-121	1
R120	100 Ohm 5% 0,06W 0603	Philips	2322 702 60101	40-21000-121	1
R121	100 Ohm 5% 0,06W 0603	Philips	2322 702 60101	40-21000-121	1
R122	100 Ohm 5% 0,06W 0603	Philips	2322 702 60101	40-21000-121	1
R123	100 Ohm 5% 0,06W 0603	Philips	2322 702 60101	40-21000-121	1
R124	100 Ohm 5% 0,06W 0603	Philips	2322 702 60101	40-21000-121	1
R125	100 Ohm 5% 0,06W 0603	Philips	2322 702 60101	40-21000-121	1
R126	100 Ohm 5% 0,06W 0603	Philips	2322 702 60101	40-21000-121	1
R127	100 Ohm 5% 0,06W 0603	Philips	2322 702 60101	40-21000-121	1
R128	100 Ohm 5% 0,06W 0603	Philips	2322 702 60101	40-21000-121	1
R129	100 Ohm 5% 0,06W 0603	Philips	2322 702 60101	40-21000-121	1
R130	100 Ohm 5% 0,06W 0603	Philips	2322 702 60101	40-21000-121	1
R131	1k Ohm 5% 0,06W 0603	Philips	2322 702 60102	40-31000-121	1
R132	1k Ohm 5% 0,06W 0603	Philips	2322 702 60102	40-31000-121	1

08-05855-001 - User Connect PCB, 3030

BOM Revision
Date Valid On

05 -- Production
28.09.2006

Ref	Description	Manufacturer	Manufacturer's P/N	Codan P/N	Qty
R133	1k Ohm 5% 0,06W 0603	Philips	2322 702 60102	40-31000-121	1
R134	100 Ohm 5% 0,06W 0603	Philips	2322 702 60101	40-21000-121	1
R135	10k Ohm 5% 0,06W 0603	Philips	2322 702 60103	40-41000-121	1
R136	2,2k Ohm 5% 0,06W 0603	Philips	2322 702 60222	40-32200-121	1
R137	10k Ohm 5% 0,06W 0603	Philips	2322 702 60103	40-41000-121	1
R138	10k Ohm 5% 0,06W 0603	Philips	2322 702 60103	40-41000-121	1
R139	10k Ohm 5% 0,06W 0603	Philips	2322 702 60103	40-41000-121	1
R140	100k Ohm 5% 0,06W 0603	Philips	2322 702 60104	40-51000-121	1
V101	Transistor, NPN Si SOT23	Philips	BC848	BC848	1
V102	Transistor, PNP Si SOT23	Philips	BC856	BC856	1
V103	Diode, Zener 15V 5% 0,2W SOT23	Philips	BZX84-C15	BZX84C15	1
V104	Transistor, PNP Si SOT23	Philips	BC856	BC856	1
V105	Transistor, PNP Si SOT23	Philips	BC858	BC858	1
V106	Transistor, NPN Si SOT23	Philips	BC848	BC848	1

08-05870-001 - NRI Vocoder PCB

BOM Revision
Date Valid On

01 -- Production
28.09.2006

Ref	Description	Manufacturer	Manufacturer's P/N	Codan P/N	Qty
	NRI Vocoder			04-03370	1
	NRI Vocoder PCB			08-05870	1
1	PCB, NRI Vocoder	Morris Productions	07-01949-02	07-01949-02	1
C1	220p 5% 50V NPO 0805 NiSn	Philips	0805CG221J9BB	46-22200-081	1
C2	220p 5% 50V NPO 0805 NiSn	Philips	0805CG221J9BB	46-22200-081	1
C3	10u 20% 25V 6032 TA Cap	AVX	TAJC106M025R	47-11002-520	1
C4	1u 20% 35V 3528 TA Cap	AVX	TAJB105M035R	47-01003-520	1
C5	10u 20% 25V 6032 TA Cap	AVX	TAJC106M025R	47-11002-520	1
C6	1u 20% 35V 3528 TA Cap	AVX	TAJB105M035R	47-01003-520	1
C7	10u 20% 25V 6032 TA Cap	AVX	TAJC106M025R	47-11002-520	1
C8	10u 20% 25V 6032 TA Cap	AVX	TAJC106M025R	47-11002-520	1
C9	33u 20% 16V 7343 TA Cap	AVX	TAJD336M016R	47-13301-600	1
C10	3,3n 10% 100V X7R 0805 NiSn	Philips	08052R332K0B200	46-33300-281	1
C11	1u 20% 35V 3528 TA Cap	AVX	TAJB105M035R	47-01003-520	1
C12	10u 20% 25V 6032 TA Cap	AVX	TAJC106M025R	47-11002-520	1
C13	100n 10% 50V X7R 0805 Nisn	Philips	08052R104K9BB	46-51000-282	1
C14	1n 5% 50V NPO 0805 NiSn	Philips	0805CG102J9BB-	46-31000-082	1
C15	10p 5% 50V NPO 0805 NiSn	Philips	0805CG100J9B200	46-11000-081	1
C16	10p 5% 50V NPO 0805 NiSn	Philips	0805CG100J9B200	46-11000-081	1
C17	10u 20% 25V 6032 TA Cap	AVX	TAJC106M025R	47-11002-520	1
C18	100n 10% 50V X7R 0805 Nisn	Philips	08052R104K9BB	46-51000-282	1
C19	100n 10% 50V X7R 0805 Nisn	Philips	08052R104K9BB	46-51000-282	1
C20	100n 10% 50V X7R 0805 Nisn	Philips	08052R104K9BB	46-51000-282	1
C21	100n 10% 50V X7R 0805 Nisn	Philips	08052R104K9BB	46-51000-282	1
C22	100n 10% 50V X7R 0805 Nisn	Philips	08052R104K9BB	46-51000-282	1
C23	10u 20% 25V 6032 TA Cap	AVX	TAJC106M025R	47-11002-520	1
C24	100n 10% 50V X7R 0805 Nisn	Philips	08052R104K9BB	46-51000-282	1
IC1	Amp, Op Dual Fast SOIC8	Texas Instruments	TLE2082CD	XA-02082-700	1
IC2	Codec, 8-bit Mu-Law Serial I/F SOIC16	Texas Instruments	TP3054BDW	YN-03054-700	1
IC3	300v, Voltage, Switching SOIC8	Linear Tech	LT1054CS8	XB-01054-700	1

08-05870-001 - NRI Vocoder PCB

BOM Revision
Date Valid On

01 -- Production
28.09.2006

Ref	Description	Manufacturer	Manufacturer's P/N	Codan P/N	Qty
IC4	Reg, Voltage -5V 0,1A SOIC8	National Semiconduct	LM79L05ACM	XB-07905-700	1
IC5	DSP, Speech Compression Duplex PQFP128	DSP Group	CT8020D11AQC	YP-08020-900	1
IC6	RAM, CMOS 64k x 8Bit 12nS SOJ28	Alliance	AS7C256-10JC	YM-07256-700	1
J1	Socket, 50way 2row Fixed 1,27mmPitch SMD	Samtec	SFML-125-T2-S-D	60-00503-000	1
L1	Ind, 100uH 10% 4532	Taiyo Yuden	LEM 4532T101K	43-82100-134	1
R1	22k Ohm 5% 0,06W 0603	Philips	2322 702 60223	40-42200-121	1
R2	22k Ohm 5% 0,06W 0603	Philips	2322 702 60223	40-42200-121	1
R3	22k Ohm 5% 0,06W 0603	Philips	2322 702 60223	40-42200-121	1
R4	10 Ohm 5% 0,06W 0603	Philips	2322 702 60109	40-11000-121	1
R5	22k Ohm 5% 0,06W 0603	Philips	2322 702 60223	40-42200-121	1
R6	10k Ohm 5% 0,06W 0603	Philips	2322 702 60103	40-41000-121	1
R7	10k Ohm 5% 0,06W 0603	Philips	2322 702 60103	40-41000-121	1
R8	22k Ohm 5% 0,06W 0603	Philips	2322 702 60223	40-42200-121	1
R9	150k Ohm 5% 0,06W 0603	Philips	2322 702 60154	40-51500-121	1
R10	10k Ohm 5% 0,06W 0603	Philips	2322 702 60103	40-41000-121	1
R11	33k Ohm 5% 0,06W 0603	Philips	2322 702 60333	40-43300-121	1
R12	33k Ohm 5% 0,06W 0603	Philips	2322 702 60333	40-43300-121	1
R13	33k Ohm 5% 0,06W 0603	Philips	2322 702 60333	40-43300-121	1
R14	33k Ohm 5% 0,06W 0603	Philips	2322 702 60333	40-43300-121	1
R15	100 Ohm 5% 0,06W 0603	Philips	2322 702 60101	40-21000-121	1
R16	10k Ohm 5% 0,06W 0603	Philips	2322 702 60103	40-41000-121	1
R17	10k Ohm 5% 0,06W 0603	Philips	2322 702 60103	40-41000-121	1
R18	10k Ohm 5% 0,06W 0603	Philips	2322 702 60103	40-41000-121	1
R19	10k Ohm 5% 0,06W 0603	Philips	2322 702 60103	40-41000-121	1
R20	10k Ohm 5% 0,06W 0603	Philips	2322 702 60103	40-41000-121	1
R21	10k Ohm 5% 0,06W 0603	Philips	2322 702 60103	40-41000-121	1
R22	10k Ohm 5% 0,06W 0603	Philips	2322 702 60103	40-41000-121	1
R23	1k Ohm 5% 0,06W 0603	Philips	2322 702 60102	40-31000-121	1
R24	100 Ohm 5% 0,06W 0603	Philips	2322 702 60101	40-21000-121	1

08-05870-001 - NRI Vocoder PCB

BOM Revision
Date Valid On

01 -- Production
28.09.2006

Ref	Description	Manufacturer	Manufacturer's P/N	Codan P/N	Qty
R25	1M Ohm 5% 0,06W 0603	Philips	2322 702 60105	40-61000-121	1
R26	10k Ohm 5% 0,06W 0603	Philips	2322 702 60103	40-41000-121	1
R27	10k Ohm 5% 0,06W 0603	Philips	2322 702 60103	40-41000-121	1
R28	10k Ohm 5% 0,06W 0603	Philips	2322 702 60103	40-41000-121	1
R29	10k Ohm 5% 0,06W 0603	Philips	2322 702 60103	40-41000-121	1
R30	10k Ohm 5% 0,06W 0603	Philips	2322 702 60103	40-41000-121	1
Z1	Crystal 4MHz Up Grade SMD	HY-Q	QC49/SMD EB01C	65-90109	1

The drawings in this section consist of the mechanical and electrical diagrams required to maintain the NGT remote interface.

Table 11: NRI—list of drawings

Title	Drawing	Drawing number
NRI Microcontroller PCB	Circuit diagram	04-03363 (sheet 1) 04-03363 (sheet 2)
	PCB assembly	08-05854 (sheet 1) 08-05854 (sheet 2) 08-05854 (sheet 3)
NRI User Connect PCB	Circuit diagram	04-03364
	PCB assembly	08-05855
NRI Vocoder PCB	Circuit diagram	04-03370
	PCB assembly	08-05870

This page has been left blank intentionally.

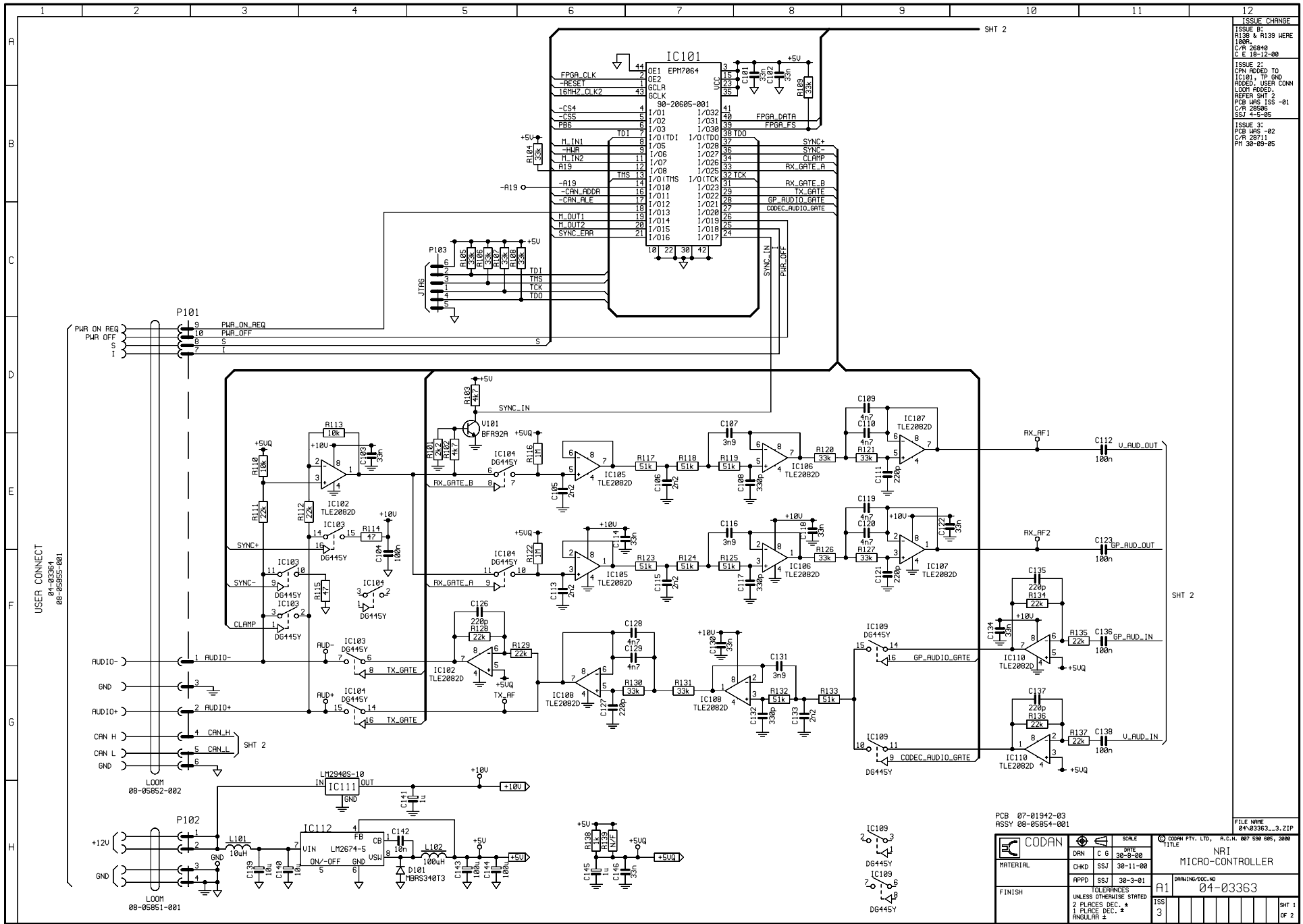

ISSUE CHANGE

ISSUE 01:
R138 & R139 WERE
100K.
C/P# 26840
C.E 18-12-08

ISSUE 02:
CPM ADDED TO
IC101 TP GND
MODED. USER CONN
LOAD ADDED.
REFER SHT 2
FOR LPS ISS -01
C/P# 28506
SSI 4-5-05

ISSUE 03:
PCB LPS -02
C/P# 28711
PH 30-09-05

USER CONNECT
04-03364
08-05855-001

PCB 07-01942-03
ASSY 08-05854-001

CODAN	DRAWN	C S	DATE	30-09-08	SCALE	© CODAN PVT. LTD., P.O. BOX 107, 580 005, 2000 NRI	TITLE	MICRO-CONTROLLER
	CHECKED	SSJ	30-11-08					
FINISH	APPD	SSJ	30-3-01	TOLERANCES UNLESS OTHERWISE STATED	ISS	3	A1	DRW/IND/DOC NO
								04-03363
						2 PLACES DEC. *	SHT 1	
						ENGLISH	OF 2	

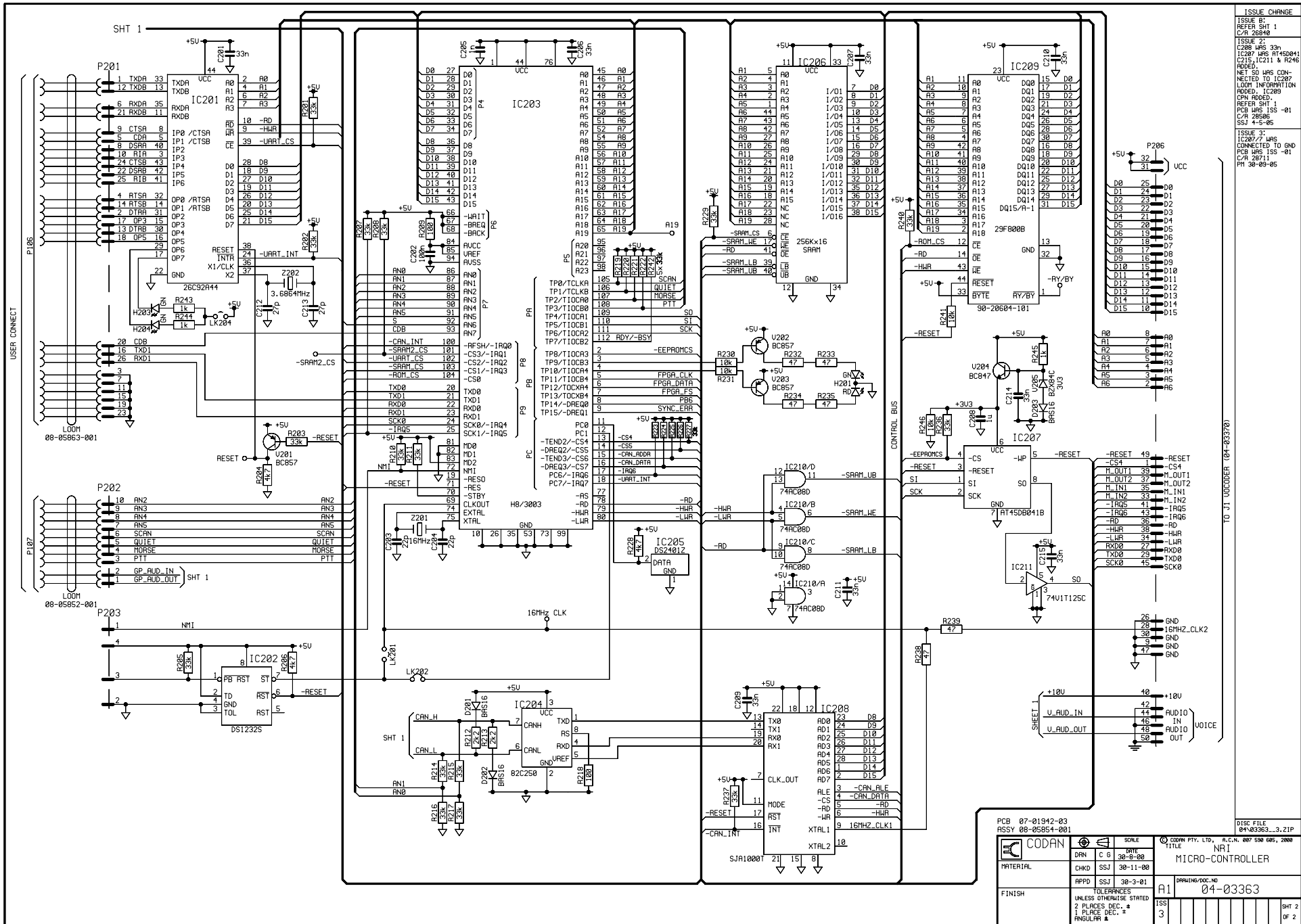

ISSUE CHANGE
 ISSUE 01:
 REFER SHT 1
 C/A 26840
 ISSUE 21:
 C208 WRS 33n
 IC207 WRS 9F450041
 C215, IC211 & R246
 ADDED.
 IC209
 OPN ADDED.
 REFER SHT 1
 PCB WRS 155 -01
 C/A 26846
 SSJ 4-5-05
 ISSUE 31:
 IC207 WRS
 CONNECTED TO GND
 PCB WRS 155 -01
 C/A 26811
 PH 30-09-05

TO J1 WOODR (04-03320)

PCB 07-01942-03 ASSY 08-05854-001		SCALE C 6 30-08-08		CODAN PLY. LTD., N.C.N. 007 530 085, 2000	
MATERIAL		DRN C 6 30-08-08		TITLE NPT	
FINISH		CHKD SSJ 30-11-08		MICRO-CONTROLLER	
TOLERANCES UNLESS OTHERWISE STATED 2 PLACES DEC. # 1 PLACE DEC. # ANGULAR #		APPD SCS 30-3-01		DRAWING/DOC. NO 04-03363	
ISS 3		SHT 2		OF 2	

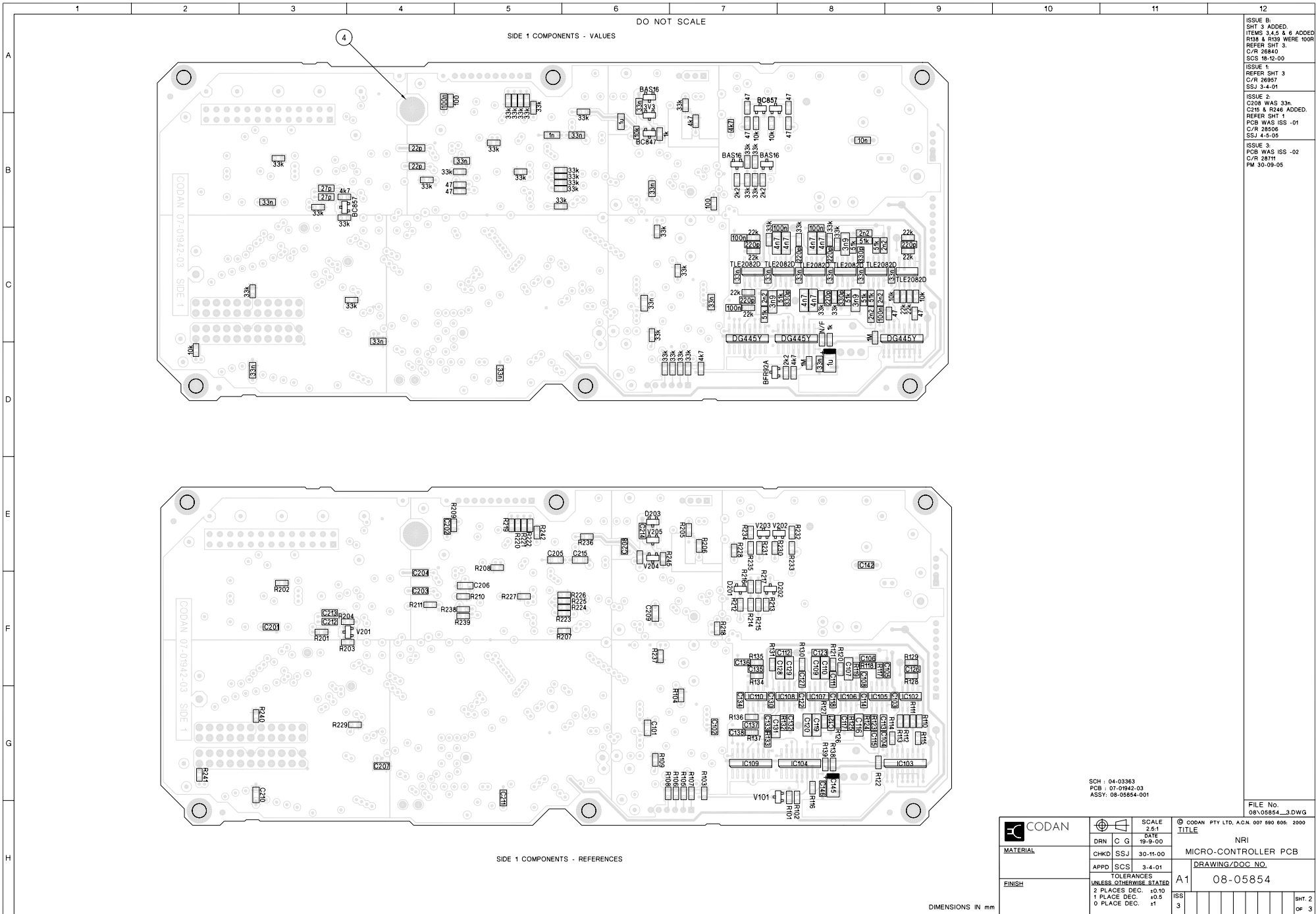

ISSUE B:
SHT 3 ADDED.
ITEMS 3,4,5 & 6 ADDED
R138 & R139 WERE 100R
REFER SHT 3
C/R 26840
SCS 18-12-00

ISSUE 1:
REFER SHT 3
C/R 26957
SSJ 3-4-01

ISSUE 2:
C208 WAS 33n
C216 & R246 ADDED.
REFER SHT 1
PCB WAS ISS -01
C/R 28506
SSJ 4-5-05

ISSUE 3:
PCB WAS ISS -02
C/R 28711
PM 30-09-05

SCH : 04-03363
PCB : 01-01842-03
ASSY: 08-05854-001

FILE No.
08-05854_3.DWG

	SCALE	2:1	© CODAN PTY LTD, ACN 007 690 806 2000 TITLE NRI MICRO-CONTROLLER PCB
	DRN	C G	
MATERIAL	CHKD	SSJ	30-11-00
FINISH	APPD	SCS	3-4-01
	TOLERANCES UNLESS OTHERWISE STATED		A1
2 PLACES DEC. ±0.10		ISS	
1 PLACE DEC. ±0.5			3
0 PLACE DEC. ±1		SHT. 2	
DIMENSIONS IN mm			OF 3

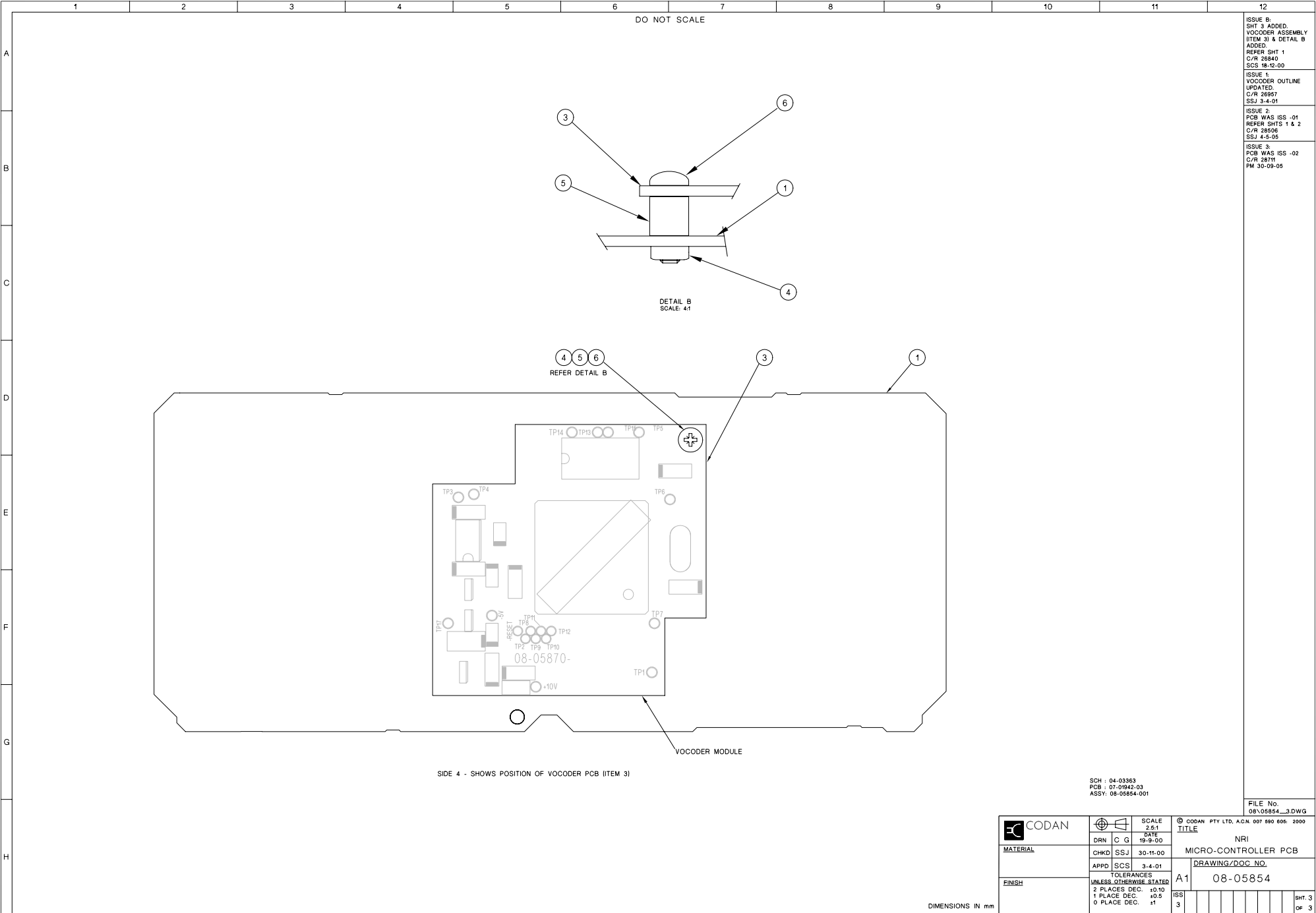

DO NOT SCALE

DETAIL B
SCALE: 4:1

REFER DETAIL B

VOCODER MODULE

SIDE 4 - SHOWS POSITION OF VOCODER PCB (ITEM 3)

ISSUE 8:
SHT 3 ADDED.
VOCODER ASSEMBLY
(ITEM 3) & DETAIL B
ADDED.
REFER SHT 1
C/R 28840
SCS 18-12-00

ISSUE 1:
VOCODER OUTLINE
UPDATED.
C/R 28867
SSJ 3-4-01

ISSUE 2:
PCB WAS ISS -01
REFER SHTS 1 & 2
C/R 28506
SSJ 4-2-05

ISSUE 3:
PCB WAS ISS -02
C/R 28711
PM 30-09-05

SCH : 04-03363
PCB : 07-01942-03
ASSY: 08-05854-001

FILE No.
08-05854_3.DWG

	SCALE	2:1	© CODAN PTY LTD, ACN 007 690 808 2000 TITLE NRI MICRO-CONTROLLER PCB
	DRN C G	DATE 19-9-00	
MATERIAL	CHKD SSJ	30-11-00	DRAWING/DOC NO. A1 08-05854
	APPD SCS	3-4-01	
FINISH	TOLERANCES		ISS 3
	UNLESS OTHERWISE STATED		
	2 PLACES DEC.	±0.10	
1 PLACE DEC.	±0.5		SHT. 3
0 PLACE DEC.	±1		OF 3

DIMENSIONS IN mm

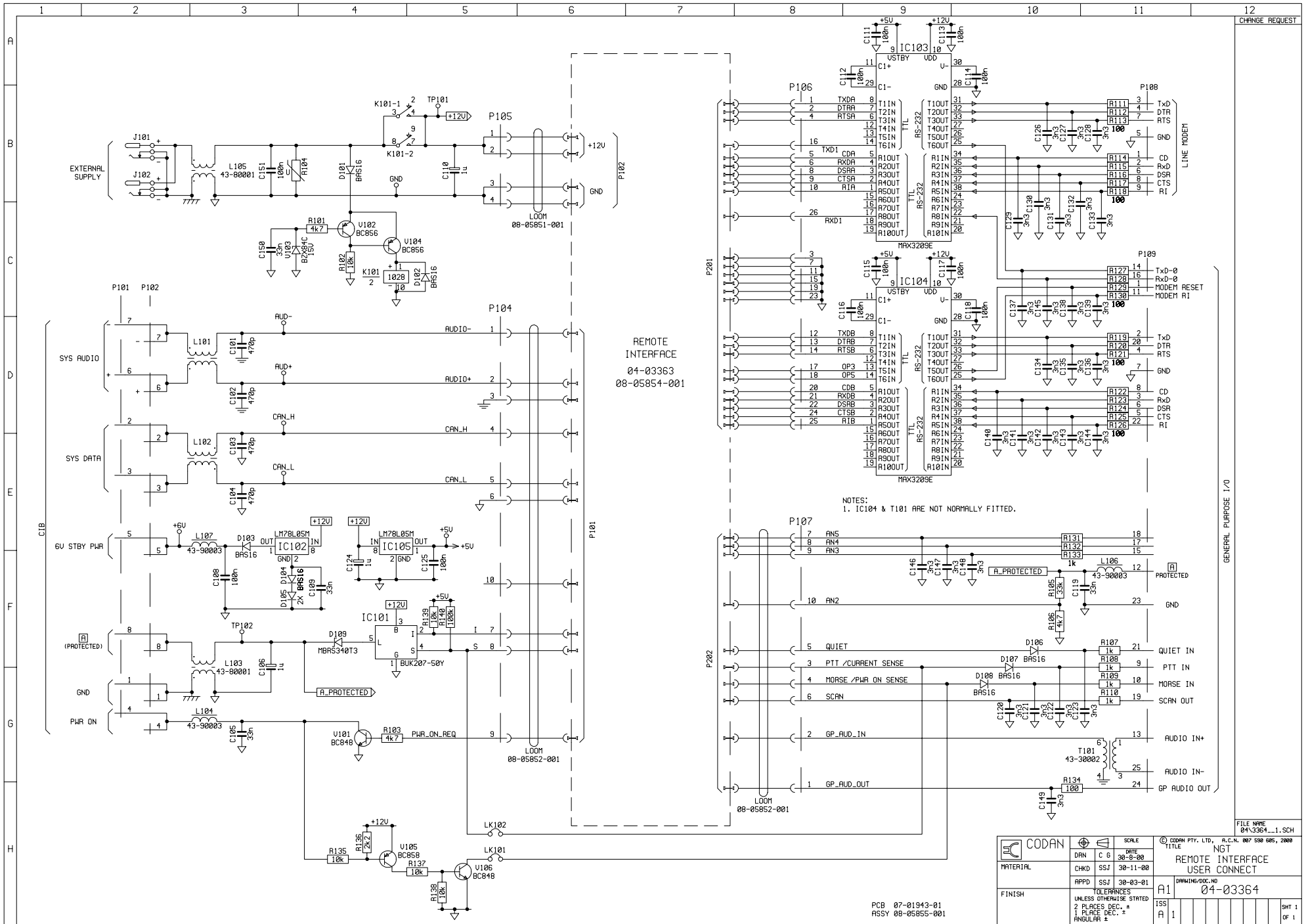

CHANGE REQUEST

GENERAL PURPOSE 1/0

FILE NAME
04-03364_1.SCH

		SCALE C 6	DATE 30-8-00	© CODAN PTY. LTD., A.C.N. 007 530 685, 2000 TITLE NGT
MATERIAL CHKD APPD	SSJ SSJ SSJ	30-11-00 30-03-01	30-11-00 30-03-01	REMOTE INTERFACE USER CONNECT
FINISH UNLESS OTHERWISE STATED 2 PLACES DEC. ± 1 PLACE DEC. ± ANGULAR ±	A1 A1	04-03364	DRWING/DOC. NO	SHEET 1 OF 1

PCB 07-01943-01
ASSY 08-05855-001

DO NOT SCALE

REMOTE INTERFACE USER CONNECT - SIDE 1

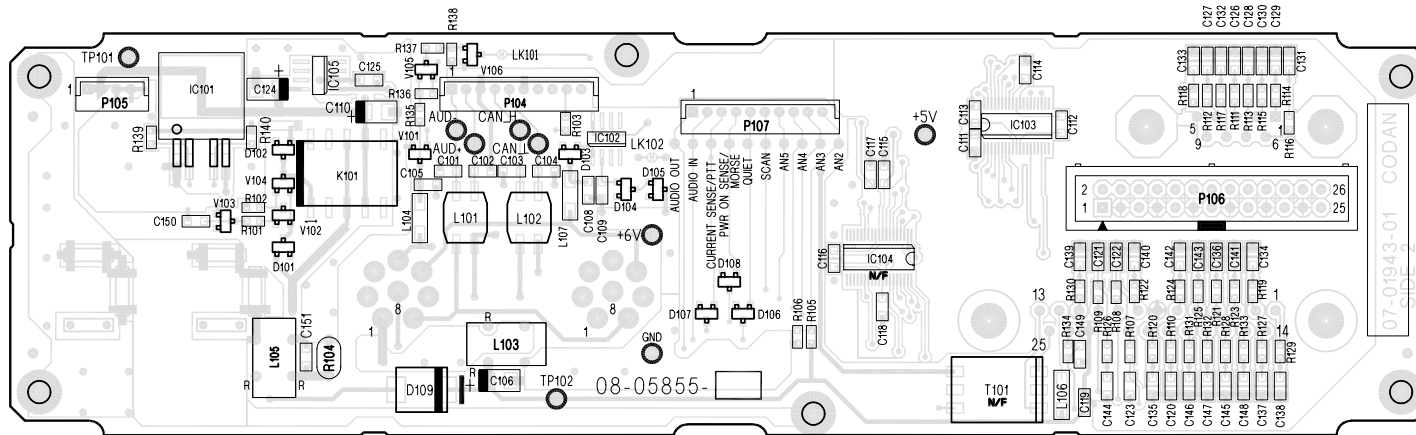
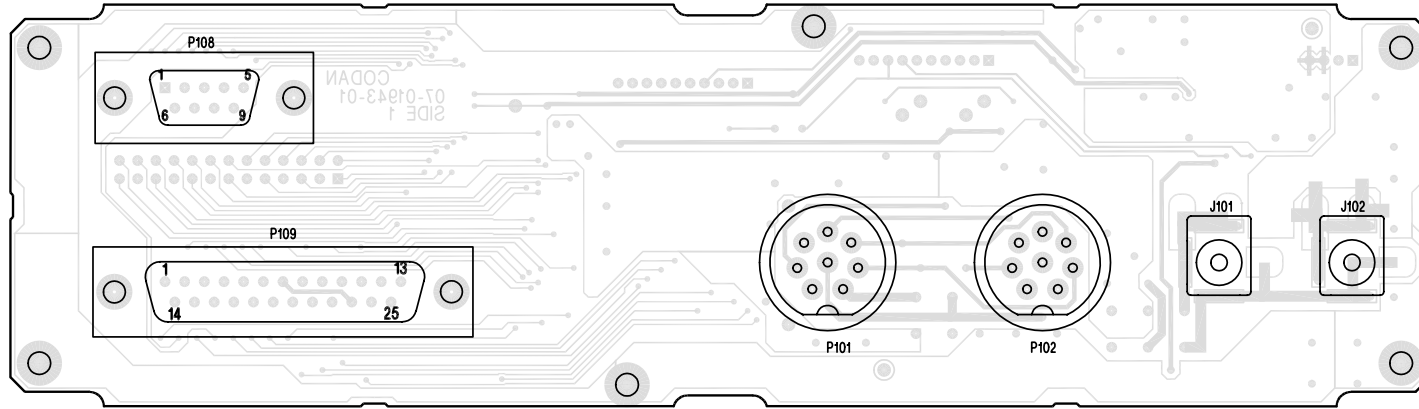

REMOTE INTERFACE USER CONNECT - SIDE 2

ISSUE B:
NO CHANGE TO TSM
C/R 26912

FILE No.
08\05855_1.DWG

TSM

PCB : 07-01943-01
ASSY: 08-05855-001

DIMENSIONS IN mm

	SCALE 2:1		© CODAN PTY LTD, A.C.N. 007 590 605: 2000 TITLE REMOTE INTERFACE - USER CONNECT PCB
	DRN	C G	
MATERIAL	CHKD	SSJ	30-11-00
FINISH	APPD	AJC	30-03-01
	TOLERANCES UNLESS OTHERWISE STATED		DRAWING/DOC NO. 08-05855
2 PLACES DEC. ±0.10		ISS	SHT. 1 OF 1
1 PLACE DEC. ±0.5			
0 PLACE DEC. ±1		B	1

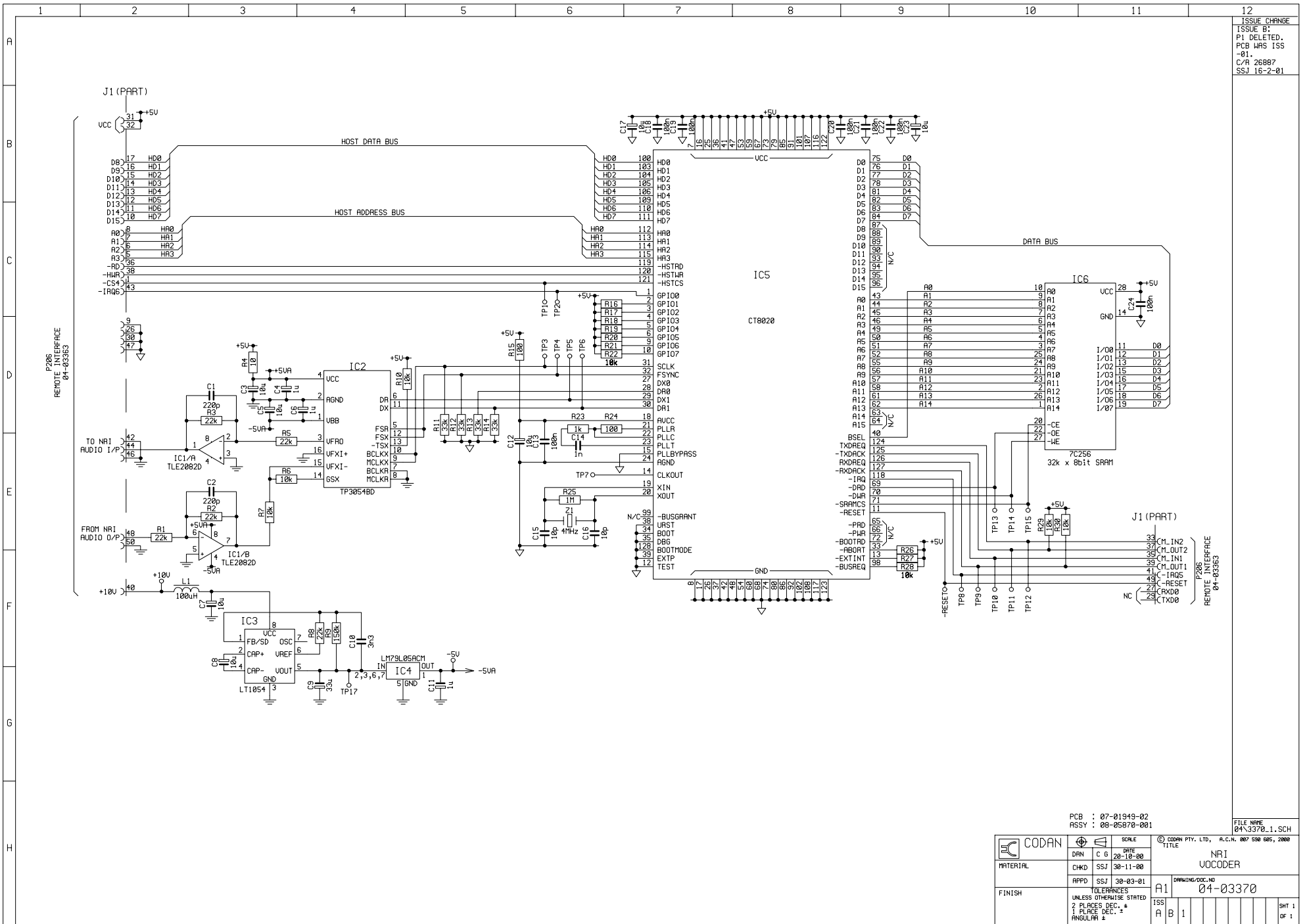

ISSUE CHANGE
 ISSUE B:
 R1 DELETED.
 PCB HAS ISS
 -01.
 C/R 26887
 SSJ 16-2-01

PCB : 07-01949-02
 ASSY : 08-05870-001

FILE NAME
 04-3370_1.SCH

	SCALE	DATE	© CODAN PTY. LTD., A.C.N. 007 590 085, 2000 TITLE NR1 VOCODER
	DRAWN	C 6	
MATERIAL	CHKD	SSJ	30-11-00
FINISH	APPD	SSJ	30-03-01
UNLESS OTHERWISE STATED		TOLERANCES	
2 PLACES DEC.		A1	
1 PLACES DEC.		04-03370	
ANGULAR ±		ISS	
		A B 1	
		SHT 1	
		OF 1	

DO NOT SCALE

ISSUE B:
PCB WAS ISSUE -01
NOTE 1 & P1 DELETED
ITEM 2 DELETED.
C/R 26887
SSJ 16-2-01

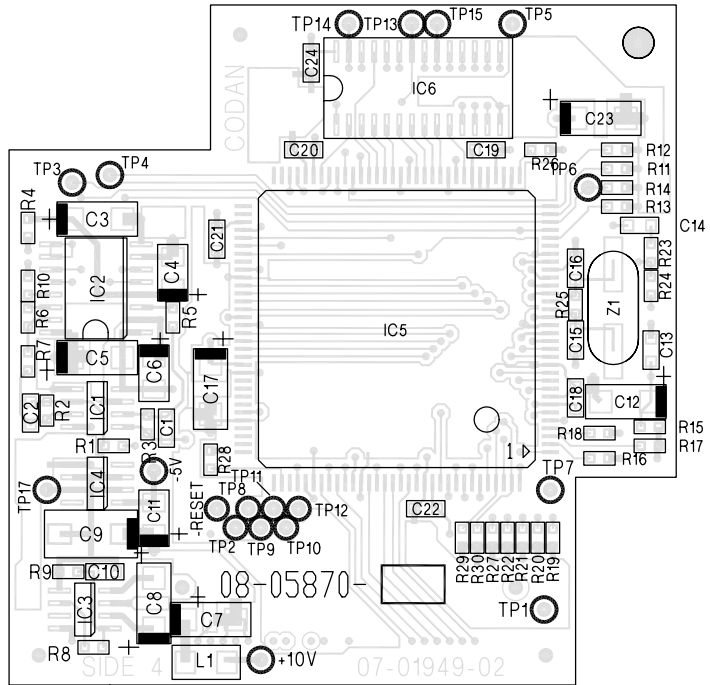

NRI VOCODER

PCB : 07-01949-02
ASSY: 08-05870-001

TSM

FILE No.
08\05870__1.DWG

DIMENSIONS IN mm

			SCALE 2:1	© CODAN PTY LTD, A.C.N. 007 590 605: 2000 TITLE		
	DRN	C G	DATE 1-11-00	NRI VOCODER		
MATERIAL	CHKD	SSJ	30-11-00	DRAWING/DOC NO. 08-05870		
FINISH	APPD	SCS	30-03-01	A3	ISS 1	
	TOLERANCES UNLESS OTHERWISE STATED					OF 1
	2 PLACE DEC. ±0.10 1 PLACE DEC. ±0.5 0 PLACE DEC. ±1					

Numerics

3012 297, 298

A

adjustments 308
audio output path
 testing 313

B

brief description 299
broadcast call 293
broadcast transmission 294

C

call
 broadcast 293
 group 293
 selective 293
channel selection 292
CoDec 304
connectors 297
 Terminal 297
 Transceiver 298

D

data mode 295
data modem
 dismantling 310
data transmission
 types 293
digital signal processor 304
drawings 317
DSP Modem PCB
 accessing 311
 technical description 304
 testing 313

E

environmental specifications 296

F

fault finding 307
 advanced 310
 basic 309
 power supply 312

G

general specifications 295
group call 293
group transmission 294

H

HF subsystem
 testing 313

I

interfacing 304

L

LED indicators 294, 295
link establishment 293
 mode 295
logic 304

M

memory 304
mounting 296

O

operating environment 296
overview 291, 292

P

parts lists 315
PCB replacement 308
physical specifications 296
pin connections
 Terminal connector 297
 Transceiver connector 298
power requirements 295
power supply 305
 fault finding 312

R

routine maintenance 308

S

selective call 293
selective transmission 294
serial interface
 testing 314
serial ports 306
size 296

- specifications 291, 295
 - environmental 296
 - general 295
 - physical 296
- system requirements 296

T

- technical description 303
 - DSP Modem PCB 304
 - User Connector PCB 306
- Terminal connector
 - pinouts 297
- test voltages
 - DSP Modem PCB 313
 - User Connector PCB 312
- testing
 - audio output path 313
 - HF subsystem 313
 - serial interface 314
- throughput 305
- transceiver
 - interface to 3012 306
- Transceiver connector
 - pinouts 298
- transmission protocol 293

U

- unit replacement 308
- User Connector PCB
 - technical description 306
 - testing 312

W

- weight 296

3012—Overview and specifications

This section contains the following topics:

[Overview \(292\)](#)

[Specifications \(295\)](#)

[Pin connections \(297\)](#)

Overview

The HF Data Modem 3012, when combined with the appropriate Codan HF transceiver and computer terminal, provides error-free transmission and reception of data on an HF channel. It is particularly useful for long-range communications in remote areas where existing communication infrastructures are poor or non-existent.

The data modem operates at 12 V DC in fixed base and mobile installations. The data modem receives DC power from the transceiver via its 15-way GPIO connector. It incorporates data compression to boost effective throughput, and is easily integrated with Codan voice and signalling networks.

A typical HF Data Modem 3012 station comprises:

- HF Data Modem 3012
- Codan ‘data-capable’ HF transceiver
- transceiver supply
- computer terminal with appropriate communications software
- antenna system

The basic layout of a 3012 data system is shown in [Figure 1](#).

Figure 1: Basic layout of a 3012 data system

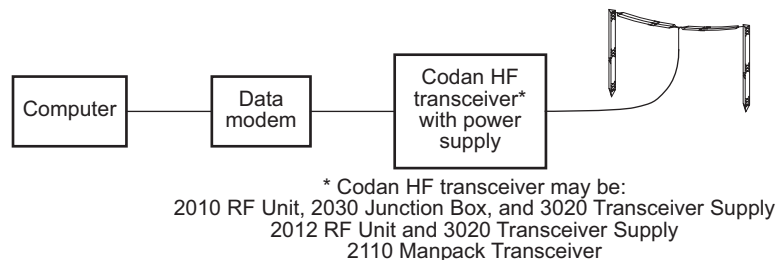

The data modem may be controlled using standard AT commands from a terminal. Virtually any software that operates on standard telephone modems will operate over HF via the AT commands.

The data modem is able to send email over HF with other third-party email software.

Channel selection

HF channels may be manually selected using the transceiver or the data modem.

If a data call is sent while the Codan HF transceiver is scanning an ALE/CALM network, the transceiver automatically selects a channel from the ALE/CALM network.

Types of data transmission

There are three types of data transmission:

- selective call
- group call
- broadcast call

Selective calls guarantee error-free transmission, while group and broadcast calls may be subject to errors under poor channel conditions.

Selective call

A selective call allows transmission of data to a single, specific station.

Once a link has been established using a selective call, data may be sent in both directions between the two stations.

The data modem has been optimised for data transfer, however interactive chat mode is possible between the two stations.

Group call

A group call allows transmission of data to as many as 99 stations at one time. Therefore, it is useful for sending a message to a number of stations without having to establish a separate link with each station.

Broadcast call

A broadcast call allows transmission of data to all stations that are ready and able to communicate on the channel selected.

Transmission protocol

Data link establishment

Before data can be transmitted to a receiving station, the data modem must establish a link. This is done using a robust signalling protocol that determines the address of the receiving station and the frequency offset between the sending and receiving stations.

Once the link has been established, control is transferred to a high-speed data transmission protocol to send the data.

The link establishment protocol is less sensitive to channel conditions than the high-speed signalling protocol. This means that under some channel conditions, link establishment may succeed, but data transmission may fail.

Selective transmissions

Selective transmissions involve a two-way communication process between two data modem stations. Data is transferred in information packets. Every packet contains error-detection information to let the receiving station know if the data was correctly received.

Notification of any corrupt transmissions is sent back to the sending station and re-transmitted in the next information packet.

Group and broadcast transmissions

Group and broadcast transmissions involve a one-way communication process used to send data to multiple data modem stations. During a transmission, a receiving station is unable to respond to the transmitting station.

The transmitting station sends information packets in the same way as in a selective transmission, but all packets are sent four times. After the transmission, a receiving station will have four copies of each packet of information from which to extract correct data. This is sufficient for most conditions. However, errors may occur under poor channel conditions, resulting in blocks of missing data.

For this reason, it is recommended that only text messages are sent in group and broadcast transmissions, as one error would be sufficient to make an encrypted or compressed message indecipherable.

Indicators

The data modem has a ✓ LED indicator and a **Throughput** indicator on the front of the unit. The ✓ LED indicator is a multicolour LED. The **Throughput** indicator comprises 10 red LEDs that form a bar graph of the potential data throughput.

Specifications

General

Power requirements

13.5 V DC nominal, 250 mA maximum (operating voltage range 10.5 to 15 V DC)

Data mode

High-speed selective repeat ARQ data transfer

2400 bps, 16-channel QPSK (selectable between 4 and 16 channels)

Effective transmission rate

uncompressed	1 475 bps (under optimum conditions)
compressed	Up to 6 000 bps

Link establishment mode

Proprietary link establishment 80 baud CHIRP

2400 bps HF modem

TMS320C31 32-bit digital signal processor, 27 MHz

TR.29 based 'AT' port, 9600 baud RS232

Data compression

Transceiver control lines and press-to-talk

Front panel indicators



1 × multicolour LED

Throughput

10 × red LEDs indicating approximately 100 bps per LED when using 16 channels QPSK

System requirements

HF SSB transceiver (data capable)

Maximum frequency offset error ± 100 Hz (between transceivers)

Audio pass-band 500 to 2500 Hz ± 1 dB

Power amplifier ALC—long time constant; peak limiting

Environmental

Operating environment

Operating temperature 0 to 55°C
(32 to 131°F)

Storage temperature -40 to +60°C
(-40 to 140°F)

Relative humidity 100%

Physical

Mechanical

Size 210 mm W \times 240 mm D \times 65 mm H
(8.4 in W \times 9.5 in D \times 2.6 in H)
(includes allowance for rear connectors)

Weight 1.9 kg
(4.2 lb)

Sealing IP64

Mounting Free standing
Flange
Mobile mounting cradle

Pin connections

Figure 2: Rear panel of the 3012

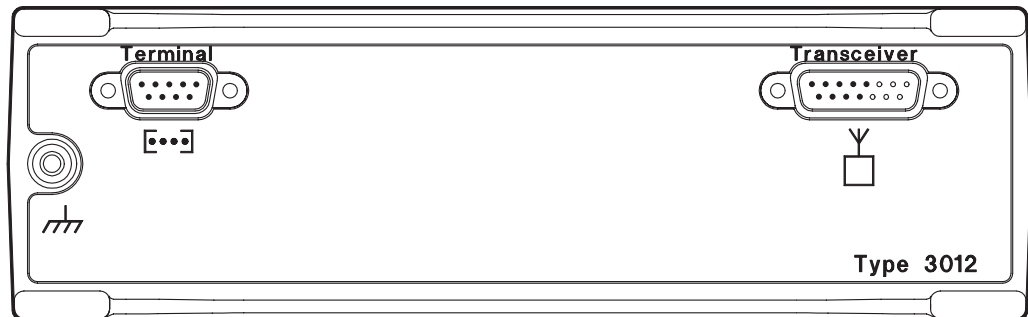

Pinouts of the Terminal connector on the 3012

The **Terminal** connector is a 9-pin D-type socket used to connect the data modem to a data terminal or PC.

Figure 3: Front view of the Terminal connector on the 3012

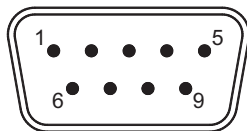

Table 1: Pinouts for the Terminal connector on the 3012

Pin no.	Function	Input/output	Signal description
1	N/C		
2	RxD	Input	Receive serial data
3	TxD	Output	Transmit serial data
4	CD	Output	Carrier detect
5	GND		Signal ground connected to case
6	Reset	Input	Modem reset
7	RTS	Output	Request to send (flow control)
8	CTS	Input	Clear to send (flow control)
9	N/C		

The CTS and RTS lines provide hardware flow control between the data modem and the terminal or PC.

Pinouts of the Transceiver connector on the 3012

The **Transceiver** connector is a 15-pin D-type socket used to connect the data modem to the transceiver. This interface also supplies switched DC power from the transceiver to the data modem.

Figure 4: Front view of the Transceiver connector on the 3012

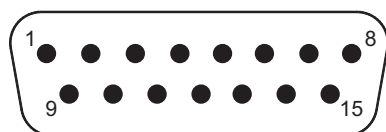

Table 2: Pinouts for the Transceiver connector on the 3012

Pin no.	Function	Input/output	Signal description
1	Power supply	Input	+12 V
2	Power supply	Input	+12 V
3	Serial control data Tx	Output	TTL
4	N/C		
5	Quiet	Output	+12 V when in data mode
6	Busy	Output	OC
7	PTT	Output	OC
8	Audio	Output	3 V p-p max
9	Ground		
10	Ground		
11	Scan	Input	
12	Spare		
13	Busy	Input	
14	Serial control data Rx	Input	TTL
15	Audio	Input	4 V p-p max

3012—Brief description

This section contains the following topics:

[General information \(301\)](#)

[DSP modem \(301\)](#)

[Transceiver interface \(301\)](#)

[Terminal interface \(301\)](#)

For a detailed description of these functions see [page 303, 3012—*Technical description*](#).

This page has been left blank intentionally.

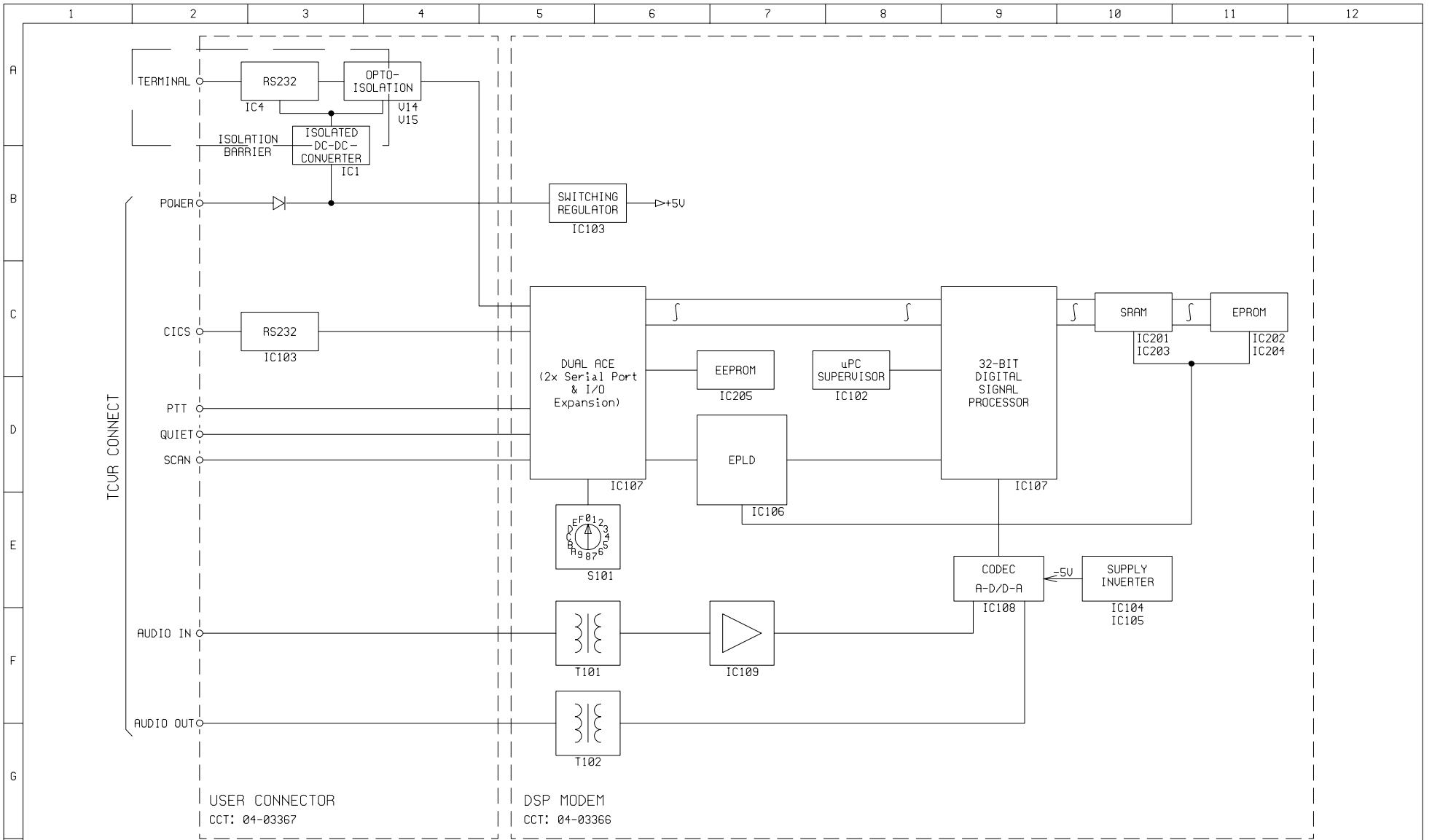

H ISSUE CHANGE	CODAN		SCALE	© CODAN PTY. LTD., A.C.N. 007 590 605, 2000	
	DRN	C G	DATE	TITLE	
	CHKD	SSJ	10-1-01	3012	
MATERIAL	APPD	SSJ	8-2-01	HF DATA MODEM	
FINISH	UNLESS OTHERWISE STATED			DRAWING/DOC. NO	
	2 PLACES DEC. ±			A2	
	1 PLACE DEC. ±			03-01080	
ANGULAR ±			ISS	SHT 1	
			A	1	OF 1

General information

NOTE The information in this section should be read in conjunction with the block diagram [03-01080](#).

DSP modem

Data modulation and demodulation is accomplished in firmware by a 32-bit DSP. Data compression may also be enabled, if required. 2400 bps, 16-channel QPSK modulation is used to provide up to 1475 bps effective uncompressed data rate.

Transceiver interface

The transceiver interface provides the modem with a switched supply rail. PTT, SCAN, BUSY and QUIET control lines are implemented through dedicated hardware signals. A CICS RS232 serial interface provides for additional communications between the transceiver and the modem. Transmit and receive analog audio signals are transformer-isolated and interfaced to the DSP via a CoDec, which contains an ADC and a DAC.

Terminal interface

Digital data exchange is facilitated through a conventional RS232 terminal interface, which is fully electrically isolated to minimise possible earth problems. This is interfaced to the DSP via a dual asynchronous communication element.

This page has been left blank intentionally.

3012—Technical description

This section contains the following topics:

[DSP Modem PCB \(304\)](#)

[User Connector PCB \(306\)](#)

This section should be read in conjunction with [page 317, 3012—Drawings](#).

DSP Modem PCB

The DSP Modem PCB comprises a 32-bit DSP and associated memory, interfacing and power supply components.

Digital signal processor and CoDec

Drawings [04-03366 \(sheet 1\)](#) and [04-03366 \(sheet 2\)](#)

A Texas Instruments TMS320C31 32-bit floating-point DSP (IC101) forms the heart of the data modem. It is interfaced to the transceiver transmit and receive audio paths via a CoDec (IC108), input differential amplifier (stages IC109/A and IC109/B), and audio isolation transformers (T101 and T102).

The CoDec (IC108) is an ADC/DAC, which interfaces to the DSP via a serial interface, using frame strobe and clock signals.

A watchdog/power on/reset IC (IC102) ensures that the DSP is held in reset until the power supply rails have stabilised, and also serves to reset the processor if unexpected code run-away stops the strobe line from being regularly toggled.

Memory

Drawings [04-03366 \(sheet 1\)](#) and [04-03366 \(sheet 2\)](#)

The program code for the data modem is stored in two 2 Mbit EPROMs (IC202/204), each organised as 128 k by 16-bit words. These are paralleled to create an effective 128 k of 32-bit memory.

The data modem also requires external SRAM, which is provided by devices IC201 and IC203. Each 128 k by 16-bit device is paralleled to provide a 128 k by 32-bit memory.

A small amount of non-volatile data storage is provided by a 2 kbit (256 by 8-bit) EEPROM (IC205), which is accessed serially using a 2-wire I²C-compatible serial interface.

Logic and interfacing

Drawings [04-03366 \(sheet 1\)](#) and [04-03366 \(sheet 2\)](#)

A 32-Macrocell programmable logic device (IC106) performs the ‘glue logic’ required to perform several functions, including:

- decoding the memory span of IC101 into the format required by the firmware
- generating read, write and chip-select signals for the memory devices
- inverting the interrupt request signals produced by a dual asynchronous communications element (IC107)

IC107 is a complex device, which features two complete serial communication interfaces with 16-byte FIFOs and an additional parallel port. The primary role of IC107 is to provide the serial interface between the RS232 interface of the data terminal equipment and the DSP.

As the DSP provides very little in terms of useable I/O, IC107 also acts as a peripheral device to provide required I/O functions, including:

- control interfacing to the transceiver (SCAN, PTT, BUSY and QUIET line functions)
- serial interfacing for the non-volatile memory (IC205)
- driving the LED indicators via shift registers IC206 and IC207

IC107 also connects the digi switch (S101) to the processor. This switch is used to select the operating mode, including special factory test modes.

Throughput indicator

Drawings [04-03366 \(sheet 1\)](#) and [04-03366 \(sheet 2\)](#)

Serial shift registers IC206 and IC207 control the modem's **Throughput** indicator and ✓ LED. The **Throughput** indicator on the DSP Modem PCB displays the current data throughput of the data modem. Each LED in the indicator represents approximately 100 bps of data.

NOTE If a modulation method other than 16 channels is selected, the **Throughput** indicator shows the capacity of that modulation method.

Power supply

Drawings [04-03366 \(sheet 1\)](#) and [04-03366 \(sheet 2\)](#)

In order to reduce overall power consumption, a high-efficiency 260 kHz switching regulator generates the main +5 V supply rail.

The switching regulator (IC103) works as a buck converter, together with an inductor (L102), a Schottky diode (D102) and low-ESR tantalum capacitors (C111 and C112) to create the supply. This is further filtered by L103 and C113 to provide a quiet analog +5 V supply to feed the CoDec (IC108).

For PCB issue 06 and earlier, the CoDec (IC108) also requires a negative supply rail, which is generated by a switched-capacitor generator (IC104). The resulting output at pin 5 is regulated at approximately -7 V. This rail has is post-regulated by a conventional 3-terminal linear regulator (IC105 (LM79L05)), providing a smooth -5 V DC rail to feed the CoDec.

User Connector PCB

Transceiver interface

Drawing [04-03367](#)

The data modem and the transceiver are interfaced through connector P1. This interface also provides power to the data modem via a filtering inductor (L1) and a polarity-protection diode (D1). This is a Schottky diode to ensure minimum voltage drop, thereby maximising efficiency and minimising overall current drain.

Power is fed through to the main DSP Modem PCB via connector P2.

The transceiver interface also supports transmit/receive audio, and PTT, SCAN, BUSY and QUIET lines, which allow control between the data modem and the transceiver. Transistor logic is used to interface these signals to IC107 on the DSP Modem PCB. These functions connect to the DSP Modem PCB via connector P3.

Serial ports

Drawing [04-03367](#)

The User Connector PCB also performs interfacing of the serial ports.

A conventional charge-pump RS232 driver (IC3) drives the CICS transceiver interface.

IC1, IC4, V14 and V15 combine to provide a more elaborate, fully optically isolated serial interface to a PC or data terminal equipment. Optical isolation on this interface is provided to eliminate possible problems with HF signals entering the PC, or large currents flowing in the grounds of serial cables.

A stand-alone isolated DC–DC converter module (IC1) generates isolated approximate +5 V and +10 V rails. These feed an RS232 driver (IC4), which uses an internal charge pump to generate a negative rail. Therefore, the TTL level signals from the DSP Modem PCB pass from connector P6, through the opto-couplers and IC4, to the terminal interface via P4.

3012—Fault finding

This section contains the following topics:

[Adjustments and routine maintenance \(308\)](#)

[Basic fault finding \(309\)](#)

[Advanced fault finding \(310\)](#)

Adjustments and routine maintenance

The data modem has been designed so that no routine adjustments or maintenance are required.

A newly commissioned data modem should not require testing as all units have passed a detailed and extensive test procedure at Codan before being despatched.

The data modem *is not* field serviceable. If a fault is identified, it should be returned to your Codan representative for repair.

PCBs and units available as replacements

The replacement PCBs and units available from Codan are listed in [Table 3](#).

Table 3: Replacement PCBs and units for the 3012

PCB or unit	Part number
DSP Modem PCB	08-05860-001
User Connector PCB	08-05861-001
Final Assembly, data modem	08-05877-001

Basic fault finding

To find basic faults that may occur with the data modem, follow the procedures outlined in the table below.

Table 4: Basic fault finding for the 3012

Condition	Action required
All lights on the data modem are off	The data modem is powered via the transceiver. Ensure the cable to the transceiver is firmly secured at both ends and the transceiver is switched on.
Strange characters appear on the screen of the terminal when text is entered	The data transfer rate (baud) setting for your terminal is incorrect.
When listening to the transceiver there is a lot of background noise	<p>Check that the data cable between the data modem and the transceiver has the lock nuts tightened at the transceiver end.</p> <p>Check that the earth cable is secure at the data modem and at the transceiver and that these are appropriately grounded.</p> <p>A humming noise on the transceiver may be caused by other equipment nearby. Try to identify the source of interference by switching off other equipment. If this is the case, move the transceiver and/or the antenna away from the source of interference.</p>

Advanced fault finding

It is strongly recommended that fault diagnosis be performed to board level only. If a faulty board is identified, the complete board should be replaced.

WARNING The following tests should only be performed by a technician familiar with the HF Data Modem 3012.

WARNING Removing or substituting components may damage them and/or the PCBs. In some cases, it is impossible to remove components without destroying them.

What you need

You may require a multimeter and a pozi-drive screwdriver (1 point) when conducting fault tests.

Dismantling the data modem

To dismantle the data modem for testing see [Figure 5](#) and follow the procedures below.

Figure 5: Exploded view of the 3012

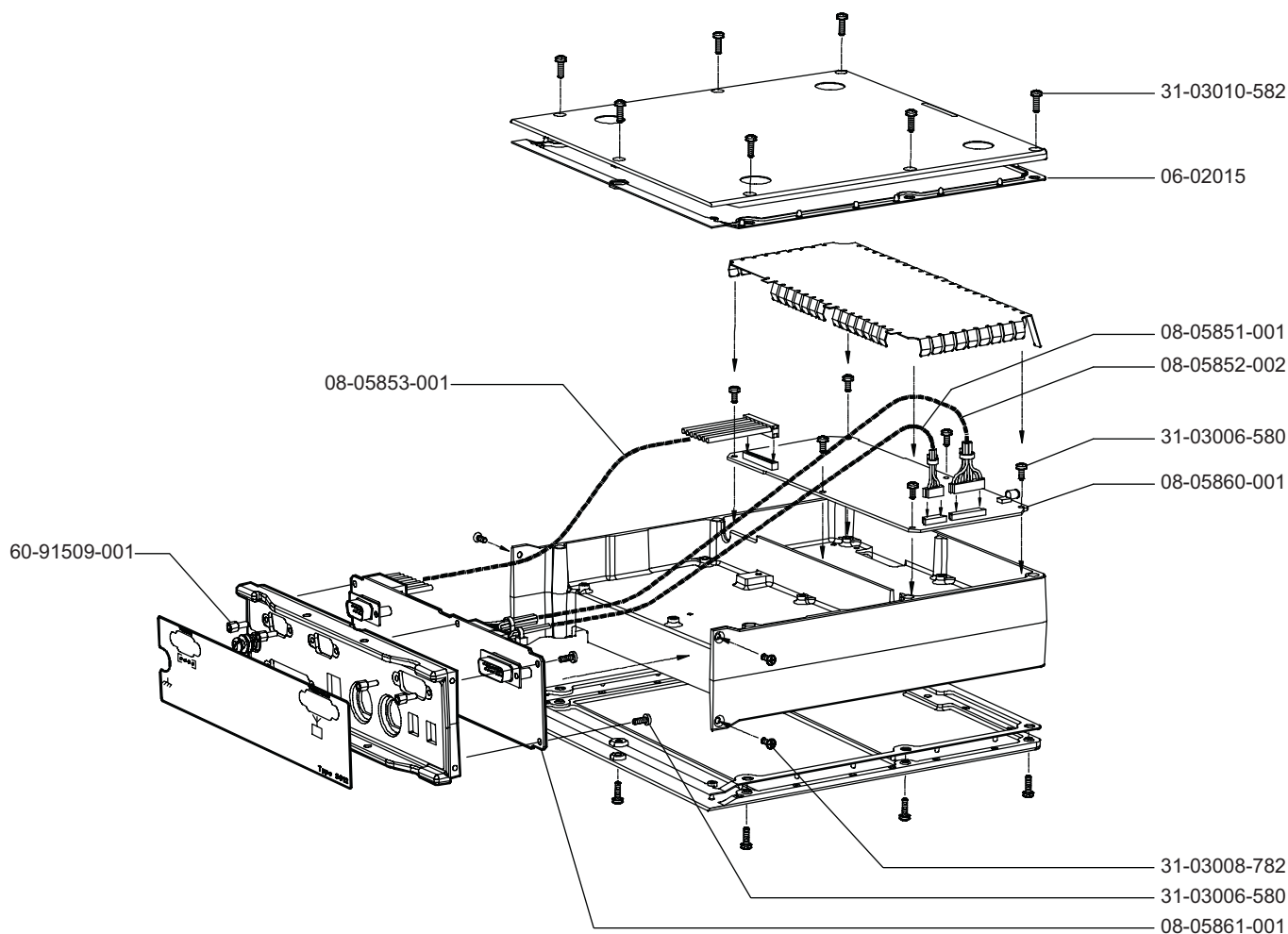

Accessing the inside of the data modem

To remove the top cover of the data modem:

- Unscrew the seven taptite screws retaining the top cover (see [Figure 5](#)).
- Lift and remove the top cover and its rubber sealing gasket.

Accessing the DSP Modem PCB

To access the DSP Modem PCB:

- Using a screwdriver, lever the shielding screen out of its position over the DSP Modem PCB.

Removing the rear panel assembly

To remove the rear panel assembly:

- Remove the top cover as described above.
- Unscrew the retaining screw in the centre of the bottom cover.
- Unplug the three wiring looms from the rear panel assembly.
- Unscrew the four countersunk retaining screws from the rear panel and withdraw the rear panel assembly.

Fault finding the power supply in the data modem

If a data modem is faulty, the first fault finding step is to test all the power supply rails.

Power supply rails need to be checked on the User Connector PCB first, then on the DSP Modem PCB.

Testing voltages on the User Connector PCB

To test the voltages on the User Connector PCB:

- Switch off power to the data modem (via the transceiver).
- Remove the top cover of the data modem (see [page 310, *Dismantling the data modem*](#)).
- Unplug the 4-way loom that connects to header P2.
This isolates the User Connector PCB from the DSP Modem PCB.
- Switch on power to the data modem (via the transceiver).
- Measure the voltage across the GND and \square test points on the User Connector PCB. (Test point \square is located near header P2.)

The voltage should nominally measure +13.5 V (+10.5 to +15 V is allowable). This confirms that the data modem is receiving supply from the transceiver.

If the voltage is not within these limits, check the cabling to the transceiver and check the transceiver power supply. Also, check D1 and L1 on the User Connector PCB.

- Measure the voltage across the GND and +5 V test points on the User Connector PCB.

The voltage should be +5.0 V \pm 0.1 V.

If the voltage is not within these limits, check the IC2 chip and its associated components (C36 and C37).

- Check the power supply of the isolated serial port by measuring across both the 0 V –ISOL and +5 V –ISOL test points, to the +10 V –ISOL test point.

These voltages should be +5.0 V \pm 0.5 V and 10 V \pm 1 V respectively.

If the voltages are not within these limits, check the isolated DC–DC converter chip IC1 and its associated components.

- Switch off power to the data modem.
- Reconnect the 4-way loom to header P2.

Testing voltages on the DSP Modem PCB

To test the voltages on the DSP Modem PCB:

- Remove the screen covering the DSP Modem PCB (see [page 310, *Dismantling the data modem*](#)).
- Re-measure the voltage across the GND and **A** test points on the User Connector PCB.

The voltage should nominally measure +13.5 V (+10.5 to +15 V is allowable).

If the voltage is not within these limits, but was within these limits when the User Connector PCB was tested in isolation, the DSP Modem PCB has a fault that is overloading the power source. In this case, the DSP Modem PCB must be repaired or replaced.

- Measure the voltage across the GND and +5 V points on the DSP Modem PCB.

The voltage should be +5.0 V \pm 0.1 V.

If this voltage is not within the specified limits, a component such as the power supply on the DSP Modem PCB has failed and the PCB must be repaired or replaced.

- If the PCB is issue 06 and earlier, measure the voltage across the GND and –5 V points on the DSP Modem PCB.

The voltage should be –5.0 V \pm 0.1 V.

If this voltage is not within specified limits, the analog negative supply rail has failed and the DSP Modem PCB must be repaired or replaced.

Testing the HF subsystem

To confirm the correct operation of the data modem audio output path:

- Switch off power to the data modem (via the transceiver).
- Remove the top cover (see [page 310, *Dismantling the data modem*](#)).
- Remove the screen covering the DSP Modem PCB.
- Turn the digi switch on the DSP Modem PCB to position E.

The DSP Modem PCB is now in service test mode.

- Switch on power to the data modem (via the transceiver).
- Turn the digi switch to position 0.

If the PCB is issue 06 and earlier, the DSP Modem PCB generates a 1 kHz tone of approximately 6 V p–p in the transmit audio path when measured at the AF_OUT test point on the DSP Modem PCB.

If a tone is not present, the DSP Modem PCB may be faulty.

Testing the serial interface

To test the serial interface:

- Switch off the entire data modem system.
- Ensure the digi switch is still in position 0.
- Ensure the system is set up correctly and all cables are secure.
- Connect a PC to the **Terminal** connector on the rear panel of the data modem.
- Start a communication session with the data modem using a terminal-emulation program such as HyperTerminal ©.
- Switch on the data modem system.

OK should be displayed on the terminal screen.

NOTE

If you cannot identify a particular faulty PCB after conducting the previous fault diagnosis tests, or if the data modem still does not work after replacing the PCBs specified, the complete data modem should be returned to Codan for servicing.

Table 5: 3012 parts lists index

Title	Assembly number
DSP Modem PCB	08-05860-001
User Connector PCB	08-05861-001

This page has been left blank intentionally.

08-05860-001 - DSP Modem PCB, 3012

BOM Revision
Date Valid On

04 -- Production
28.09.2006

Ref	Description	Manufacturer	Manufacturer's P/N	Codan P/N	Qty
	DSP Modem 3012PCB			08-05860	1
	DSP Modem 3012			04-03366	1
	Build Standard, 3012			01-01248	1
1	PCB, DSP Modem, 3012	IMP	C119-656	07-01945-06	1
2	Label, Serial/Barcode	Codan	06-02068	06-02068	1
3	Socket, 44PLCC IC, Surface mount	Methode	213-044-602	60-00443-610	2
C101	100n 10% 50V X7R 0805 Nisn	Philips	08052R104K9BB	46-51000-282	1
C102	100n 10% 50V X7R 0805 Nisn	Philips	08052R104K9BB	46-51000-282	1
C103	100n 10% 50V X7R 0805 Nisn	Philips	08052R104K9BB	46-51000-282	1
C105	22p 5% 50V NPO 0805 NiSn	Philips	0805CG220J9B200	46-12200-081	1
C106	22p 5% 50V NPO 0805 NiSn	Philips	0805CG220J9B200	46-12200-081	1
C107	33n 10% 50V X7R 0805 NiSn	Philips	08052R333K9BB00	46-43300-281	1
C108	10u 20% 25V 6032 TA Cap	AVX	TAJC106M025R	47-11002-520	1
C109	10u 20% 25V 6032 TA Cap	AVX	TAJC106M025R	47-11002-520	1
C110	10n 10% 100V X7R 0805 NiSn	Philips	08052R103K0B200	46-41000-281	1
C111	100u 20% 16V 7343H TA Cap Low ESR	AVX	TPSE107M016R0100	47-21001-600	1
C112	100u 20% 16V 7343H TA Cap Low ESR	AVX	TPSE107M016R0100	47-21001-600	1
C113	10u 20% 25V 6032 TA Cap	AVX	TAJC106M025R	47-11002-520	1
C114	10u 20% 25V 6032 TA Cap	AVX	TAJC106M025R	47-11002-520	1
C115	10u 20% 25V 6032 TA Cap	AVX	TAJC106M025R	47-11002-520	1
C116	33u 20% 16V 7343 TA Cap	AVX	TAJD336M016R	47-13301-600	1
C117	3,3n 10% 100V X7R 0805 NiSn	Philips	08052R332K0B200	46-33300-281	1
C118	1u 20% 35V 3528 TA Cap	AVX	TAJB105M035R	47-01003-520	1
C119	33n 10% 50V X7R 0805 NiSn	Philips	08052R333K9BB00	46-43300-281	1
C120	100n 10% 50V X7R 0805 Nisn	Philips	08052R104K9BB	46-51000-282	1
C121	100n 10% 50V X7R 0805 Nisn	Philips	08052R104K9BB	46-51000-282	1
C122	100n 10% 50V X7R 0805 Nisn	Philips	08052R104K9BB	46-51000-282	1
C123	100n 10% 50V X7R 0805 Nisn	Philips	08052R104K9BB	46-51000-282	1
C124	100n 10% 50V X7R 0805 Nisn	Philips	08052R104K9BB	46-51000-282	1
C125	470n 10% 16V X7R 1206 NiSn	AVX	1206YC474KAT1A	46-54700-282	1
C126	22u 20% 16V 5846 TA Cap	NEC	NRT226M16R	47-12201-620	1

08-05860-001 - DSP Modem PCB, 3012

BOM Revision
Date Valid On

04 -- Production
28.09.2006

Ref	Description	Manufacturer	Manufacturer's P/N	Codan P/N	Qty
C127	33n 10% 50V X7R 0805 NiSn	Philips	08052R333K9BB00	46-43300-281	1
C201	33n 10% 50V X7R 0805 NiSn	Philips	08052R333K9BB00	46-43300-281	1
C202	33n 10% 50V X7R 0805 NiSn	Philips	08052R333K9BB00	46-43300-281	1
C203	100n 10% 50V X7R 0805 Nisn	Philips	08052R104K9BB	46-51000-282	1
C204	100n 10% 50V X7R 0805 Nisn	Philips	08052R104K9BB	46-51000-282	1
C205	4,7u 20% 20V 6032 TA Cap	AVX	TAJC475M020R	47-04702-020	1
C206	33n 10% 50V X7R 0805 NiSn	Philips	08052R333K9BB00	46-43300-281	1
C207	33n 10% 50V X7R 0805 NiSn	Philips	08052R333K9BB00	46-43300-281	1
C208	4,7u 20% 20V 6032 TA Cap	AVX	TAJC475M020R	47-04702-020	1
C209	33n 10% 50V X7R 0805 NiSn	Philips	08052R333K9BB00	46-43300-281	1
C210	33n 10% 50V X7R 0805 NiSn	Philips	08052R333K9BB00	46-43300-281	1
C211	33n 10% 50V X7R 0805 NiSn	Philips	08052R333K9BB00	46-43300-281	1
D101	Diode, Schottky 70V 70mA SOT23	Siemens	BAS70	BAS70	1
D102	Diode, Schottky 40V 3A SMC	Motorola	MBRS340T3	MBRS340T3	1
D103	Diode, Schottky 70V 70mA SOT23	Siemens	BAS70	BAS70	1
D202	Diode, Si High speed 75V SOT23	Philips	BAS16	BAS16	1
D203	Diode, Si High speed 75V SOT23	Philips	BAS16	BAS16	1
H201	LED, Tricolour T-1 3/4 Diffused	Liteon	LTL-52RG	65-61110-901	1
H202	LED, Red SMD R/A Diffused	Dialight	595-2101-007	65-61110-218	1
H203	LED, Red SMD R/A Diffused	Dialight	595-2101-007	65-61110-218	1
H204	LED, Red SMD R/A Diffused	Dialight	595-2101-007	65-61110-218	1
H205	LED, Red SMD R/A Diffused	Dialight	595-2101-007	65-61110-218	1
H206	LED, Red SMD R/A Diffused	Dialight	595-2101-007	65-61110-218	1
H207	LED, Red SMD R/A Diffused	Dialight	595-2101-007	65-61110-218	1
H208	LED, Red SMD R/A Diffused	Dialight	595-2101-007	65-61110-218	1
H209	LED, Red SMD R/A Diffused	Dialight	595-2101-007	65-61110-218	1
H210	LED, Red SMD R/A Diffused	Dialight	595-2101-007	65-61110-218	1
H211	LED, Red SMD R/A Diffused	Dialight	595-2101-007	65-61110-218	1
IC101	Digital Signal Processor PQFP132	Texas Instruments	TMS320C31PQL27	YP-32031-700	1

08-05860-001 - DSP Modem PCB, 3012

BOM Revision
Date Valid On

04 -- Production
28.09.2006

Ref	Description	Manufacturer	Manufacturer's P/N	Codan P/N	Qty
IC102	Monitor, Micro SOIC8	Dallas	DS1232LPS-2	XD-01232-700	1
IC103	Reg, Voltage +5V 0,5A Switch SOIC8	AVX	LM2674M-5.0	XB-02674-700	1
IC104	300v, Voltage, Switching SOIC8	Linear Tech	LT1054CS8	XB-01054-700	1
IC105	Reg, Voltage -5V 0,1A SOIC8	National Semiconduct	LM79L05ACM	XB-07905-700	1
IC106	EPLD prgmd, 3012	Codan	90-20607-001	90-20607-001	1
IC107	DUART, FIFO & parallel port SQFP12x12-80	Texas Instruments	TL16C552APN	YK-16552-901	1
IC108	Voice-Band ADC & DAC 14Bit PLCC28	Texas Instruments	TLC32044EFN	YN-32044-900	1
IC109	Amp, Op Dual Fast SOIC8	Texas Instruments	TLE2082CD	XA-02082-700	1
IC201	RAM, CMOS 256k x 16 Bit 20nS TSOP2-44	Cypress	CY7C1041B-20ZC	YM-71041-700	1
IC202	EPROM prgmd, 3012 D0-D15	Codan	90-20606-101	90-20606-101	1
IC203	RAM, CMOS 256k x 16 Bit 20nS TSOP2-44	Cypress	CY7C1041B-20ZC	YM-71041-700	1
IC204	EPROM prgmd, 3012 D16-D31	Codan	90-20606-201	90-20606-201	1
IC205	EEPROM, CMOS 256x8 Bit IIC Bus SOIC8	SGS Thomson	ST24C02A M1	YM-02402-700	1
IC206	Shift Register, 8 Bit T/state SOIC16	Motorola	MC74HC595D	YH-74595-700	1
IC207	Shift Register, 8 Bit T/state SOIC16	Motorola	MC74HC595D	YH-74595-700	1
L101	Ind, 10uH 10% 4532	Taiyo Yuden	LEM 4532T100K	43-81100-000	1
L102	Ind, 100uH 1,2A SMPS SMD	Epcos	B82476-A1104-M	43-82100-003	1
L103	Ind, 10uH 10% 4532	Taiyo Yuden	LEM 4532T100K	43-81100-000	1
L104	Ind, 1,5uH 10% 3225	TOKO	380LB-1R5K	43-80150-000	1
P103	Header (P) 4way 2mm Latch Fixed	AMP	173981-4	60-00040-352	1
P105	Header (P) 16way 2row Boxed	Thomas & Betts	609-1627	60-00160-000	1
P106	Header (P) 10way 2mm Latch Fixed	AMP	1-173981-0	60-00100-351	1
R101	22k Ohm 5% 0,06W 0603	Philips	2322 702 60223	40-42200-121	1
R102	22k Ohm 5% 0,06W 0603	Philips	2322 702 60223	40-42200-121	1
R103	22k Ohm 5% 0,06W 0603	Philips	2322 702 60223	40-42200-121	1
R104	10k Ohm 5% 0,06W 0603	Philips	2322 702 60103	40-41000-121	1
R105	33k Ohm 5% 0,06W 0603	Philips	2322 702 60333	40-43300-121	1
R106	33k Ohm 5% 0,06W 0603	Philips	2322 702 60333	40-43300-121	1
R107	33k Ohm 5% 0,06W 0603	Philips	2322 702 60333	40-43300-121	1
R108	33k Ohm 5% 0,06W 0603	Philips	2322 702 60333	40-43300-121	1
R109	10k Ohm 5% 0,06W 0603	Philips	2322 702 60103	40-41000-121	1

08-05860-001 - DSP Modem PCB, 3012

BOM Revision
Date Valid On04 -- Production
28.09.2006

Ref	Description	Manufacturer	Manufacturer's P/N	Codan P/N	Qty
R110	2,7k Ohm 5% 0,06W 0603	Philips	2322 702 60272	40-32700-121	1
R111	33k Ohm 5% 0,06W 0603	Philips	2322 702 60333	40-43300-121	1
R112	10k Ohm 5% 0,06W 0603	Philips	2322 702 60103	40-41000-121	1
R113	22k Ohm 5% 0,06W 0603	Philips	2322 702 60223	40-42200-121	1
R114	150k Ohm 5% 0,06W 0603	Philips	2322 702 60154	40-51500-121	1
R115	1k Ohm 5% 0,06W 0603	Philips	2322 702 60102	40-31000-121	1
R116	1k Ohm 5% 0,06W 0603	Philips	2322 702 60102	40-31000-121	1
R117	1k Ohm 5% 0,06W 0603	Philips	2322 702 60102	40-31000-121	1
R118	1k Ohm 5% 0,06W 0603	Philips	2322 702 60102	40-31000-121	1
R120	10k Ohm 5% 0,06W 0603	Philips	2322 702 60103	40-41000-121	1
R121	10k Ohm 5% 0,06W 0603	Philips	2322 702 60103	40-41000-121	1
R122	10k Ohm 5% 0,06W 0603	Philips	2322 702 60103	40-41000-121	1
R123	10k Ohm 5% 0,06W 0603	Philips	2322 702 60103	40-41000-121	1
R124	33k Ohm 5% 0,06W 0603	Philips	2322 702 60333	40-43300-121	1
R125	22k Ohm 5% 0,06W 0603	Philips	2322 702 60223	40-42200-121	1
R126	22k Ohm 5% 0,06W 0603	Philips	2322 702 60223	40-42200-121	1
R127	33k Ohm 5% 0,06W 0603	Philips	2322 702 60333	40-43300-121	1
R128	1k Ohm 5% 0,06W 0603	Philips	2322 702 60102	40-31000-121	1
R129	1k Ohm 5% 0,06W 0603	Philips	2322 702 60102	40-31000-121	1
R130	680 Ohm 5% 0,06W 0603	Philips	2322 702 60681	40-26800-121	1
R131	220 Ohm 5% 0,06W 0603	Philips	2322 702 60221	40-22200-121	1
R132	22k Ohm 5% 0,06W 0603	Philips	2322 702 60223	40-42200-121	1
R133	22k Ohm 5% 0,06W 0603	Philips	2322 702 60223	40-42200-121	1
R201	33k Ohm 5% 0,06W 0603	Philips	2322 702 60333	40-43300-121	1
R202	33k Ohm 5% 0,06W 0603	Philips	2322 702 60333	40-43300-121	1
R203	33k Ohm 5% 0,06W 0603	Philips	2322 702 60333	40-43300-121	1
R204	33k Ohm 5% 0,06W 0603	Philips	2322 702 60333	40-43300-121	1
R205	10k Ohm 5% 0,06W 0603	Philips	2322 702 60103	40-41000-121	1
R206	10k Ohm 5% 0,06W 0603	Philips	2322 702 60103	40-41000-121	1

08-05860-001 - DSP Modem PCB, 3012

BOM Revision
Date Valid On

04 -- Production
28.09.2006

Ref	Description	Manufacturer	Manufacturer's P/N	Codan P/N	Qty
R207	10k Ohm 5% 0,06W 0603	Philips	2322 702 60103	40-41000-121	1
R208	47 Ohm 5% 0,06W 0603	Philips	2322 702 60479	40-14700-121	1
R209	47 Ohm 5% 0,06W 0603	Philips	2322 702 60479	40-14700-121	1
R210	10k Ohm 5% 0,06W 0603	Philips	2322 702 60103	40-41000-121	1
R211	100 Ohm 5% 0,06W 0603	Philips	2322 702 60101	40-21000-121	1
R212	100 Ohm 5% 0,06W 0603	Philips	2322 702 60101	40-21000-121	1
R213	2,7k Ohm 5% 0,06W 0603	Philips	2322 702 60272	40-32700-121	1
R214	10k Ohm 5% 0,06W 0603	Philips	2322 702 60103	40-41000-121	1
R215	10k Ohm 5% 0,06W 0603	Philips	2322 702 60103	40-41000-121	1
R216	2,2k Ohm 5% 0,06W 0603	Philips	2322 702 60222	40-32200-121	1
R217	2,2k Ohm 5% 0,06W 0603	Philips	2322 702 60222	40-32200-121	1
R218	2,2k Ohm 5% 0,06W 0603	Philips	2322 702 60222	40-32200-121	1
R219	2,2k Ohm 5% 0,06W 0603	Philips	2322 702 60222	40-32200-121	1
R220	2,2k Ohm 5% 0,06W 0603	Philips	2322 702 60222	40-32200-121	1
R221	2,2k Ohm 5% 0,06W 0603	Philips	2322 702 60222	40-32200-121	1
R222	2,2k Ohm 5% 0,06W 0603	Philips	2322 702 60222	40-32200-121	1
R223	2,2k Ohm 5% 0,06W 0603	Philips	2322 702 60222	40-32200-121	1
R224	2,2k Ohm 5% 0,06W 0603	Philips	2322 702 60222	40-32200-121	1
R225	2,2k Ohm 5% 0,06W 0603	Philips	2322 702 60222	40-32200-121	1
S101	Switch, Binary 16 Posn Smpl Code SMD	Copal	S-7070TB	62-61600	1
T101	Txfr, Line isolation SMD	Etal	P2781	43-30002	1
T102	Txfr, Line isolation SMD	Etal	P2781	43-30002	1
V101	Transistor, NPN Si SOT23	Philips	BC848	BC848	1
V201	Transistor, PNP Si SOT23	Philips	BC858	BC858	1
V202	Transistor, PNP Si SOT23	Philips	BC858	BC858	1
Z101	Crystal, 27,648 MHz 3rd O/T uPGrade SMD	HY-Q	27.648MHZ, QC49/SMD	65-90110	1

08-05861-001 - User Connector PCB, 3012

BOM Revision
Date Valid On

02 -- Production
28.09.2006

Ref	Description	Manufacturer	Manufacturer's P/N	Codan P/N	Qty
	Build Standard, 3012			01-01248	1
	DSP Modem 3012			04-03366	1
	User Connector PCB, 3012			08-05861	1
1	PCB, User Connector, 3012	IMP	C119-610	07-01946-02	1
2	Label, Serial/Barcode	Codan	06-02068	06-02068	1
3	Standoff #4-40x7	Avdel	1115-4470	33-40504-070	4
C1	100n 10% 50V X7R 0805 Nisn	Philips	08052R104K9BB	46-51000-282	1
C2	100n 10% 50V X7R 0805 Nisn	Philips	08052R104K9BB	46-51000-282	1
C3	10u 20% 25V 6032 TA Cap	AVX	TAJC106M025R	47-11002-520	1
C4	470p 5% 50V NPO 0805 NiSn	Philips	0805CG471J9B200	46-24700-081	1
C5	470p 5% 50V NPO 0805 NiSn	Philips	0805CG471J9B200	46-24700-081	1
C6	470p 5% 50V NPO 0805 NiSn	Philips	0805CG471J9B200	46-24700-081	1
C7	470p 5% 50V NPO 0805 NiSn	Philips	0805CG471J9B200	46-24700-081	1
C8	33n 10% 50V X7R 0805 NiSn	Philips	08052R333K9BB00	46-43300-281	1
C9	33n 10% 50V X7R 0805 NiSn	Philips	08052R333K9BB00	46-43300-281	1
C10	33n 10% 50V X7R 0805 NiSn	Philips	08052R333K9BB00	46-43300-281	1
C11	33n 10% 50V X7R 0805 NiSn	Philips	08052R333K9BB00	46-43300-281	1
C12	33n 10% 50V X7R 0805 NiSn	Philips	08052R333K9BB00	46-43300-281	1
C13	33n 10% 50V X7R 0805 NiSn	Philips	08052R333K9BB00	46-43300-281	1
C14	100n 10% 50V X7R 0805 Nisn	Philips	08052R104K9BB	46-51000-282	1
C15	100n 10% 50V X7R 0805 Nisn	Philips	08052R104K9BB	46-51000-282	1
C16	100n 10% 50V X7R 0805 Nisn	Philips	08052R104K9BB	46-51000-282	1
C17	100n 10% 50V X7R 0805 Nisn	Philips	08052R104K9BB	46-51000-282	1
C18	100n 10% 50V X7R 0805 Nisn	Philips	08052R104K9BB	46-51000-282	1
C19	3,3n 10% 100V X7R 0805 NiSn	Philips	08052R332K0B200	46-33300-281	1
C20	33n 10% 50V X7R 0805 NiSn	Philips	08052R333K9BB00	46-43300-281	1
C21	3,3n 10% 100V X7R 0805 NiSn	Philips	08052R332K0B200	46-33300-281	1
C22	100n 10% 50V X7R 0805 Nisn	Philips	08052R104K9BB	46-51000-282	1
C23	100n 10% 50V X7R 0805 Nisn	Philips	08052R104K9BB	46-51000-282	1
C24	100n 10% 50V X7R 0805 Nisn	Philips	08052R104K9BB	46-51000-282	1
C25	100n 10% 50V X7R 0805 Nisn	Philips	08052R104K9BB	46-51000-282	1
C26	3,3n 10% 100V X7R 0805 NiSn	Philips	08052R332K0B200	46-33300-281	1

08-05861-001 - User Connector PCB, 3012

BOM Revision
Date Valid On

02 -- Production
28.09.2006

Ref	Description	Manufacturer	Manufacturer's P/N	Codan P/N	Qty
C27	3,3n 10% 100V X7R 0805 NiSn	Philips	08052R332K0B200	46-33300-281	1
C28	3,3n 10% 100V X7R 0805 NiSn	Philips	08052R332K0B200	46-33300-281	1
C29	3,3n 10% 100V X7R 0805 NiSn	Philips	08052R332K0B200	46-33300-281	1
C30	3,3n 10% 100V X7R 0805 NiSn	Philips	08052R332K0B200	46-33300-281	1
C31	3,3n 10% 100V X7R 0805 NiSn	Philips	08052R332K0B200	46-33300-281	1
C32	4,7u 20% 20V 6032 TA Cap	AVX	TAJC475M020R	47-04702-020	1
C33	33n 10% 50V X7R 0805 NiSn	Philips	08052R333K9BB00	46-43300-281	1
C34	33n 10% 50V X7R 0805 NiSn	Philips	08052R333K9BB00	46-43300-281	1
C35	33n 10% 50V X7R 0805 NiSn	Philips	08052R333K9BB00	46-43300-281	1
C36	100n 10% 50V X7R 0805 Nisn	Philips	08052R104K9BB	46-51000-282	1
C37	100n 10% 50V X7R 0805 Nisn	Philips	08052R104K9BB	46-51000-282	1
D1	Diode, Schottky 40V 3A SMC	Motorola	MBRS340T3	MBRS340T3	1
D2	Diode, Si High speed 75V SOT23	Philips	BAS16	BAS16	1
D3	Diode, Si High speed 75V SOT23	Philips	BAS16	BAS16	1
D4	Diode, Si High speed 75V SOT23	Philips	BAS16	BAS16	1
IC1	Conv, DC-DC 12Vin, 5Vout SMD	C<(>&<)>D Technologies	NTA-1205MC	78-03021	1
IC2	Reg, Voltage +5V 0,1A SOIC8	National Semiconduct	LM78L05ACM	XB-07805-700	1
IC3	Tcvr, RS232 Dual +5V SOIC16	Maxim	MAX202CSE	YI-00202-700	1
IC4	Tcvr, RS232 6Tx / 10Rx ESD PROT TSSOP38	Maxim	MAX3209ECUU	YI-03209-700	1
L1	Ind, Common Mode 5.5A	Taiyo Yuden	CMO8RA20	43-80001	1
L2	Choke, Common Mode (Data) SMD	Taiyo Yuden	CM04RC04	43-82470-000	1
L3	Choke, Common Mode (Data) SMD	Taiyo Yuden	CM04RC04	43-82470-000	1
L4	Choke, EMI/EMC 0A DC >1MHz 4516	Taiyo Yuden	FCFBMJ 4516 HS 110-T	43-90003	1
L5	Choke, EMI/EMC 0A DC >1MHz 4516	Taiyo Yuden	FCFBMJ 4516 HS 110-T	43-90003	1
L6	Choke, EMI/EMC 0A DC >1MHz 4516	Taiyo Yuden	FCFBMJ 4516 HS 110-T	43-90003	1
L7	Choke, EMI/EMC 0A DC >1MHz 4516	Taiyo Yuden	FCFBMJ 4516 HS 110-T	43-90003	1
P1	Plug, 15way D Straight PCB Fixed	ITT-Cannon	DA-15P-OL2	60-00150-094	1
P2	Header (P) 4way 2mm Latch Fixed	AMP	173981-4	60-00040-352	1
P3	Header (P) 10way 2mm Latch Fixed	AMP	1-173981-0	60-00100-351	1

08-05861-001 - User Connector PCB, 3012

BOM Revision
Date Valid On

02 -- Production
28.09.2006

Ref	Description	Manufacturer	Manufacturer's P/N	Codan P/N	Qty
P4	Plug, 9way PCB Fixed	ITT-Cannon	DEPF-9P-Y4	60-00090-090	1
P6	Header (P) 16way 2row Boxed	Thomas & Betts	609-1627	60-00160-000	1
R1	10k Ohm 5% 0,06W 0603	Philips	2322 702 60103	40-41000-121	1
R2	2,7k Ohm 5% 0,06W 0603	Philips	2322 702 60272	40-32700-121	1
R3	10k Ohm 5% 0,06W 0603	Philips	2322 702 60103	40-41000-121	1
R4	10k Ohm 5% 0,06W 0603	Philips	2322 702 60103	40-41000-121	1
R5	10k Ohm 5% 0,06W 0603	Philips	2322 702 60103	40-41000-121	1
R6	2,7k Ohm 5% 0,06W 0603	Philips	2322 702 60272	40-32700-121	1
R7	1k Ohm 5% 0,06W 0603	Philips	2322 702 60102	40-31000-121	1
R8	470 Ohm 5% 0,06W 0603	Philips	2322 702 60471	40-24700-121	1
R9	1k Ohm 5% 0,06W 0603	Philips	2322 702 60102	40-31000-121	1
R10	1k Ohm 5% 0,06W 0603	Philips	2322 702 60102	40-31000-121	1
R11	1k Ohm 5% 0,06W 0603	Philips	2322 702 60102	40-31000-121	1
R12	470 Ohm 5% 0,06W 0603	Philips	2322 702 60471	40-24700-121	1
R13	1k Ohm 5% 0,06W 0603	Philips	2322 702 60102	40-31000-121	1
R14	1k Ohm 5% 0,06W 0603	Philips	2322 702 60102	40-31000-121	1
R15	470 Ohm 5% 0,06W 0603	Philips	2322 702 60471	40-24700-121	1
R16	1k Ohm 5% 0,06W 0603	Philips	2322 702 60102	40-31000-121	1
R17	10k Ohm 5% 0,06W 0603	Philips	2322 702 60103	40-41000-121	1
R18	2,7k Ohm 5% 0,06W 0603	Philips	2322 702 60272	40-32700-121	1
R19	100 Ohm 5% 0,06W 0603	Philips	2322 702 60101	40-21000-121	1
R20	100 Ohm 5% 0,06W 0603	Philips	2322 702 60101	40-21000-121	1
R21	100 Ohm 5% 0,06W 0603	Philips	2322 702 60101	40-21000-121	1
R22	100 Ohm 5% 0,06W 0603	Philips	2322 702 60101	40-21000-121	1
R23	100 Ohm 5% 0,06W 0603	Philips	2322 702 60101	40-21000-121	1
R24	100 Ohm 5% 0,06W 0603	Philips	2322 702 60101	40-21000-121	1
R25	100 Ohm 5% 0,06W 0603	Philips	2322 702 60101	40-21000-121	1
R26	100 Ohm 5% 0,06W 0603	Philips	2322 702 60101	40-21000-121	1
R27	100 Ohm 5% 0,06W 0603	Philips	2322 702 60101	40-21000-121	1

08-05861-001 - User Connector PCB, 3012

BOM Revision
Date Valid On

02 -- Production
28.09.2006

Ref	Description	Manufacturer	Manufacturer's P/N	Codan P/N	Qty
R28	100 Ohm 5% 0,06W 0603	Philips	2322 702 60101	40-21000-121	1
R29	100 Ohm 5% 0,06W 0603	Philips	2322 702 60101	40-21000-121	1
R30	1k Ohm 5% 0,06W 0603	Philips	2322 702 60102	40-31000-121	1
R31	1k Ohm 5% 0,06W 0603	Philips	2322 702 60102	40-31000-121	1
R32	1k Ohm 5% 0,06W 0603	Philips	2322 702 60102	40-31000-121	1
R33	1k Ohm 5% 0,06W 0603	Philips	2322 702 60102	40-31000-121	1
R34	1k Ohm 5% 0,06W 0603	Philips	2322 702 60102	40-31000-121	1
R35	1k Ohm 5% 0,06W 0603	Philips	2322 702 60102	40-31000-121	1
R36	1k Ohm 5% 0,06W 0603	Philips	2322 702 60102	40-31000-121	1
R37	1k Ohm 5% 0,06W 0603	Philips	2322 702 60102	40-31000-121	1
R38	1k Ohm 5% 0,06W 0603	Philips	2322 702 60102	40-31000-121	1
R39	1k Ohm 5% 0,06W 0603	Philips	2322 702 60102	40-31000-121	1
R40	1k Ohm 5% 0,06W 0603	Philips	2322 702 60102	40-31000-121	1
R41	1k Ohm 5% 0,06W 0603	Philips	2322 702 60102	40-31000-121	1
V1	Transistor, NPN Si SOT23	Philips	BC848	BC848	1
V2	Transistor, PNP Si SOT23	Philips	BC858	BC858	1
V3	Transistor, NPN Si SOT23	Philips	BC848	BC848	1
V4	Transistor, NPN Si SOT23	Philips	BC848	BC848	1
V5	Transistor, NPN Si SOT23	Philips	BC848	BC848	1
V6	Transistor, NPN Si SOT23	Philips	BC848	BC848	1
V7	Transistor, NPN Si SOT23	Philips	BC848	BC848	1
V14	Optocoupler, Quad SOT223/10	Infineon	SFH6943-4T	SFH6943	1
V15	Optocoupler, Quad SOT223/10	Infineon	SFH6943-4T	SFH6943	1

The drawings in this section consist of the mechanical and electrical diagrams required to maintain the 3012.

Table 6: 3012—list of drawings

Title	Drawing	Drawing number
DSP Modem	Circuit diagram	04-03366 (sheet 1) 04-03366 (sheet 2)
	PCB assembly	08-05860 (sheet 1) 08-05860 (sheet 2)
User Connector	Circuit diagram	04-03367
	PCB assembly	08-05861

This page has been left blank intentionally.

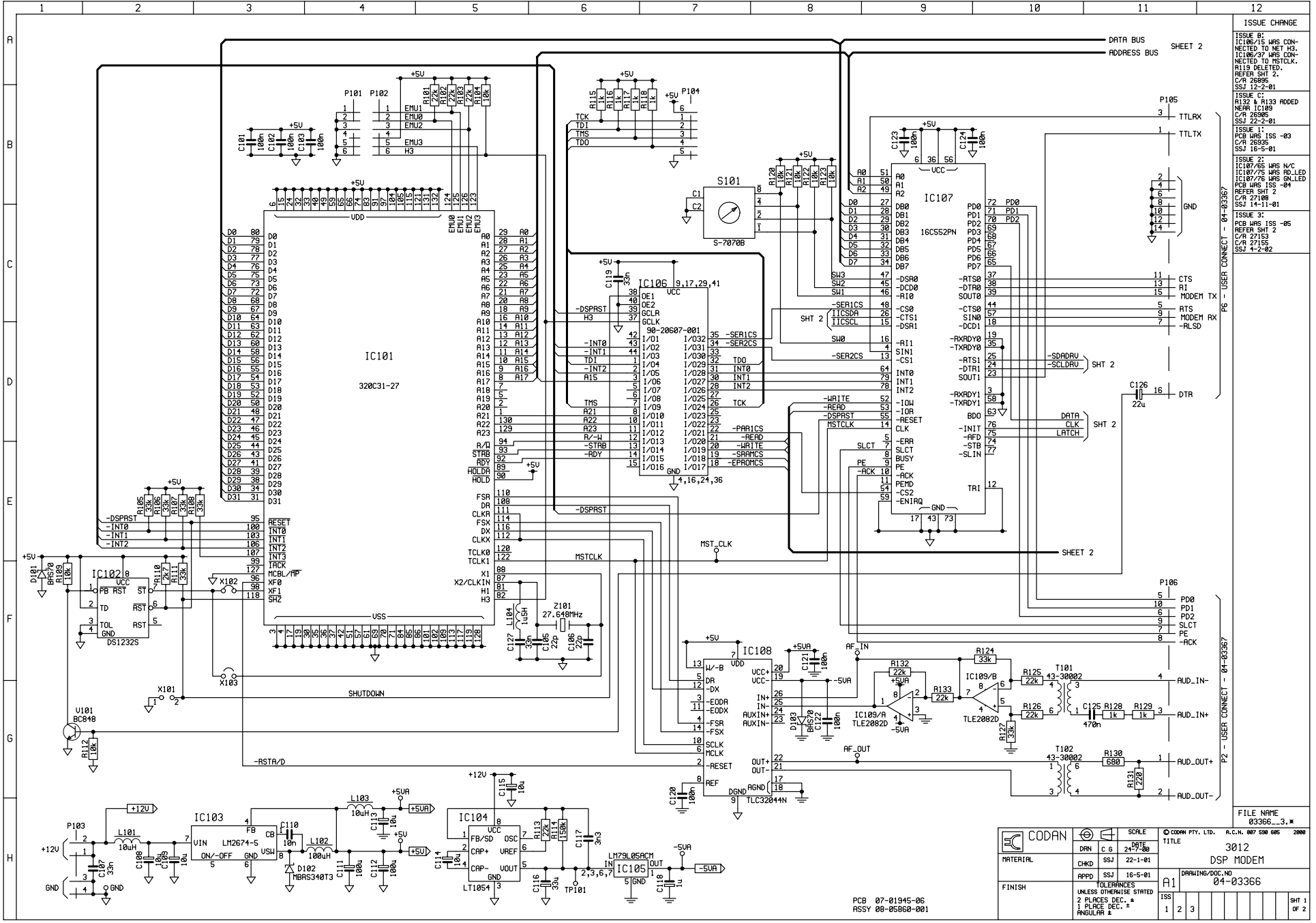

ISSUE CHANGE

ISSUE B:
IC106/15 WRS CON-
NECTED TO NET.H3.
IC106/37 WRS CON-
NECTED TO MSTCLK.
R119 DELETED.
REFER SHT 2.
C/R 2895
SSJ 12-2-81

ISSUE C:
R12 & R13 ADDED
NEAR IC108
C/R 2895
SSJ 22-2-81

ISSUE 1:
PCB WRS ISS -83
C/R 2895
SSJ 16-5-81

ISSUE 2:
IC107/65 WRS N/C
IC107/75 WRS AD_LED
IC107/76 WRS GILLED
PCB WRS ISS -84
REFER SHT 2
C/R 27108
SSJ 14-11-81

ISSUE 3:
PCB WRS ISS -85
REFER SHT 2
C/R 27153
R1 1-2-82

FILE NAME
03366...3.*

P2 - USER CONNECT - 04-03367

CODAN		SCALE	© CODAN PTY. LTD.	A.C.N. 087 530 085	2800
MATERIAL	DRAWN	C 6	24/9/80	3012	
FINISH	CHKD	SSJ	22-1-81	DSP MODEM	
	APPD	SSJ	16-5-81	DRAWING/DOC. NO	04-03366
	UNLESS OTHERWISE STATED			ISS	1 2 3
	2 PLACES DEC. #				
	1 PLACE DEC. #				
	ANGULAR #				
				SHT	1 OF 2

PCB 07-01945-06
ASSY 08-05860-001

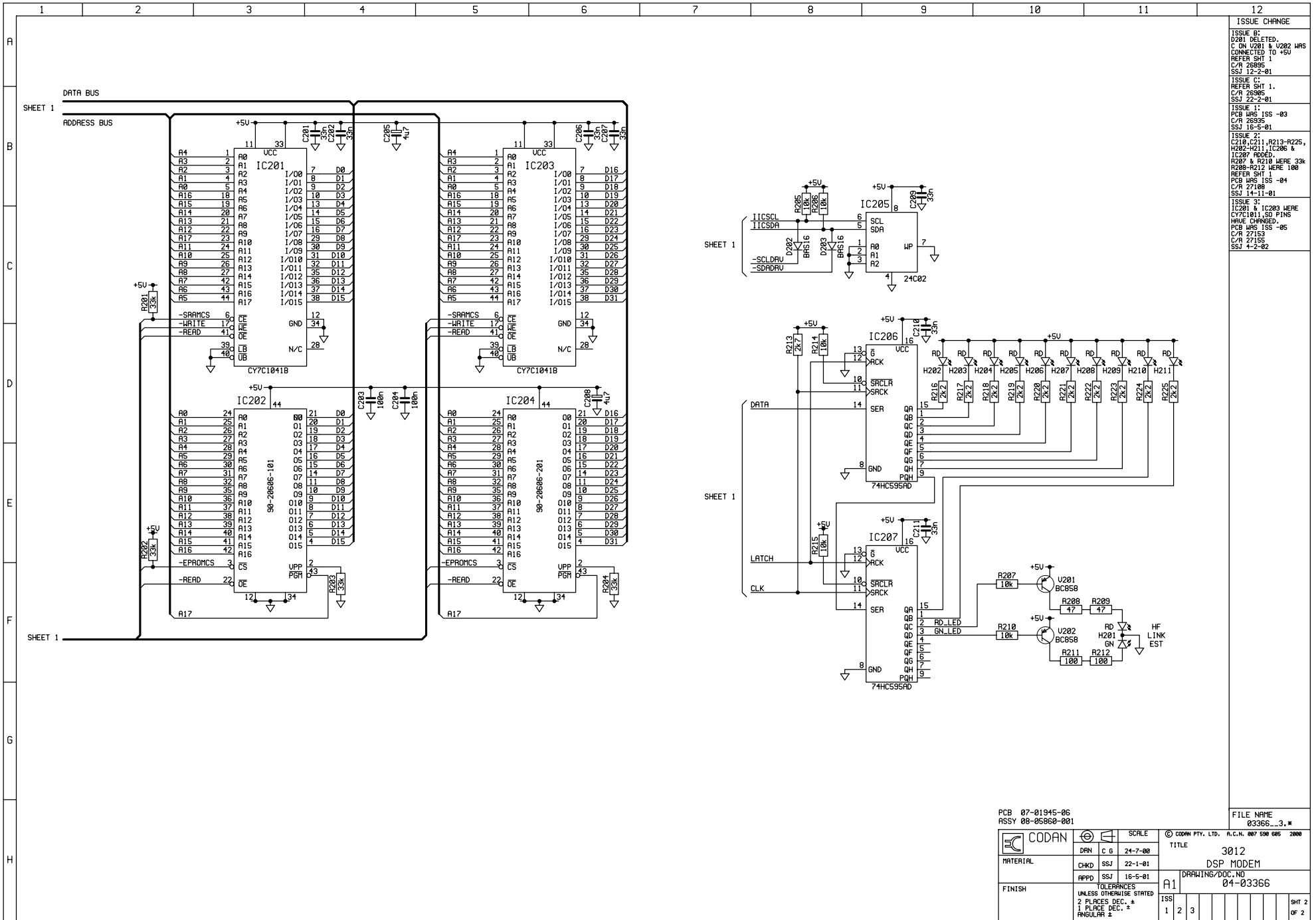

ISSUE CHANGE

ISSUE B:
 U201 DELETED.
 C ON U201 & U202 HAS
 CONNECTED TO +5V
 REFER SMT 1
 C/R 26895
 SSJ 12-2-01

ISSUE C:
 REFER SMT 1.
 C/R 26895
 SSJ 22-2-01

ISSUE 1:
 PCB HAS ISS -03
 C/R 26895
 SSJ 16-5-01

ISSUE 2:
 C210, C211, R213-R225,
 H202-H211, IC206 &
 IC207 MODEL.
 R207 & R210 WERE 33k
 R208-R212 WERE 100k
 REFER SMT
 PCB HAS ISS -04
 C/R 27188
 SSJ 14-11-01

ISSUE 3:
 IC201 & IC203 WERE
 CY7C1011, SD PINS
 HAVE CHANGED.
 PCB HAS ISS -05
 C/R 27153
 SSJ 4-2-02

PCB 07-01945-06 ASSY 08-05868-001		SCALE		© CODAN PTY. LTD. A.C.N. 807 598 085 2000	
CODAN		DRA C G 24-7-00		TITLE 3012	
MATERIAL		CHKD SSJ 22-1-01		DSP MODEM	
FINISH		APPD SSJ 16-5-01		DRAWING/DOC. NO 04-03366	
TOLERANCES UNLESS OTHERWISE STATED 2 PLACES DEC. * 1 PLACE DEC. * ANGULAR 5		ISS		SHT 2 OF 2	

1 2 3 4 5 6 7 8 9 10 11 12

DO NOT SCALE

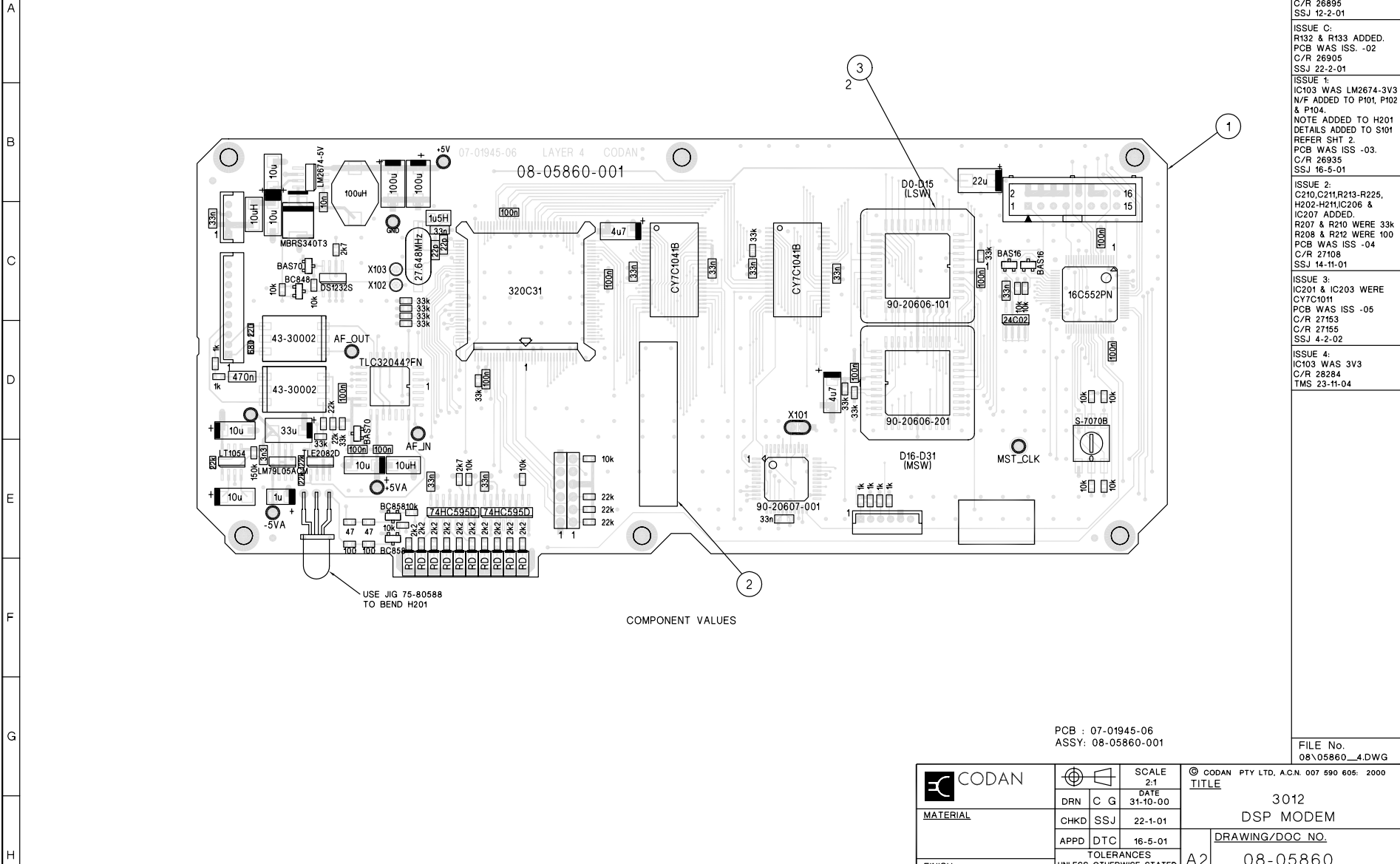

ISSUE B:
R119 & D201 DELETED
PCB WAS ISS -01
C/R 26896
SSJ 12-2-01

ISSUE C:
R132 & R133 ADDED.
PCB WAS ISS. -02
C/R 26906
SSJ 22-2-01

ISSUE 1:
IC103 WAS LM2674-3V3
N/F ADDED TO P101, P102 & P104.
NOTE ADDED TO H201
DETAILS ADDED TO S101
REFER SHT 2
PCB WAS ISS -03.
C/R 26935
SSJ 16-5-01

ISSUE 2:
C210,C211,R213-R225,
H202-H211,IC206 &
IC207 ADDED.
R207 & R210 WERE 33k
R208 & R212 WERE 100
PCB WAS ISS -04
C/R 27108
SSJ 14-11-01

ISSUE 3:
IC201 & IC203 WERE
CY7C1011
PCB WAS ISS -05
C/R 27153
C/R 27155
SSJ 4-2-02

ISSUE 4:
IC103 WAS 3V3
C/R 28284
TMS 23-11-04

FILE No.
08\05860_4.DWG

PCB : 07-01945-06
ASSY: 08-05860-001

	SCALE 2:1		© CODAN PTY LTD, A.C.N. 007 590 605: 2000 TITLE 3012 DSP MODEM
	DRN	C G	
MATERIAL	CHKD	SSJ	22-1-01
	APPD	DTC	16-5-01
FINISH	TOLERANCES UNLESS OTHERWISE STATED		A2 08-05860
	2 PLACES DEC.	±0.10	
	1 PLACE DEC.	±0.5	ISS 4
	0 PLACE DEC.	±1	
			SHT. 1 OF 2

DIMENSIONS IN mm

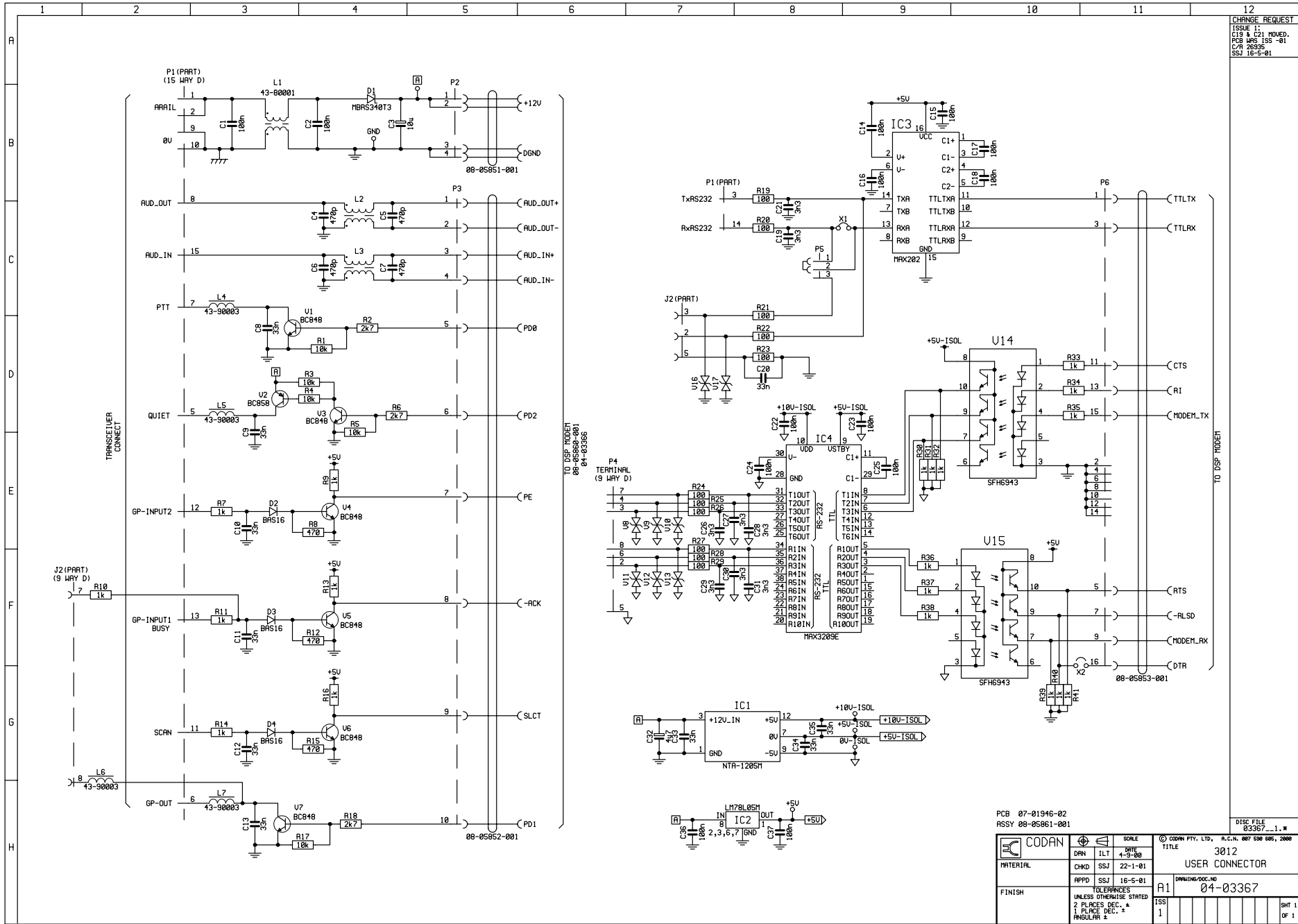

CHANGE REQUEST
 ISSUE 1:
 C19 & C21 MOVED.
 PCB WFS 155-01
 C/P# 26935
 SSI 16-5-01

TO DSP MODEM
 08-05850-001
 04-03366

TO DSP MODEM

PCB 07-01946-02
 ASSY 08-05861-001

CODAN		SCALE	© CODAN PVT. LTD., A.C.N. 007 530 045, 2000
DRN	ILT	DATE	3012
CHKD	SSJ	22-1-01	USER CONNECTOR
APPD	SSJ	16-5-01	DRAWING/DOC. NO
FINISH	TOLERANCES	A1	04-03367
	UNLESS OTHERWISE STATED		
	2 PLACES DEC.		
	1 PLACE DEC.		
	ANGULAR ±		
	ISS	1	SHT 1
			OF 1

1 2 3 4 5 6 7 8 9 10 11 12

DO NOT SCALE

SIDE 1 COMPONENTS

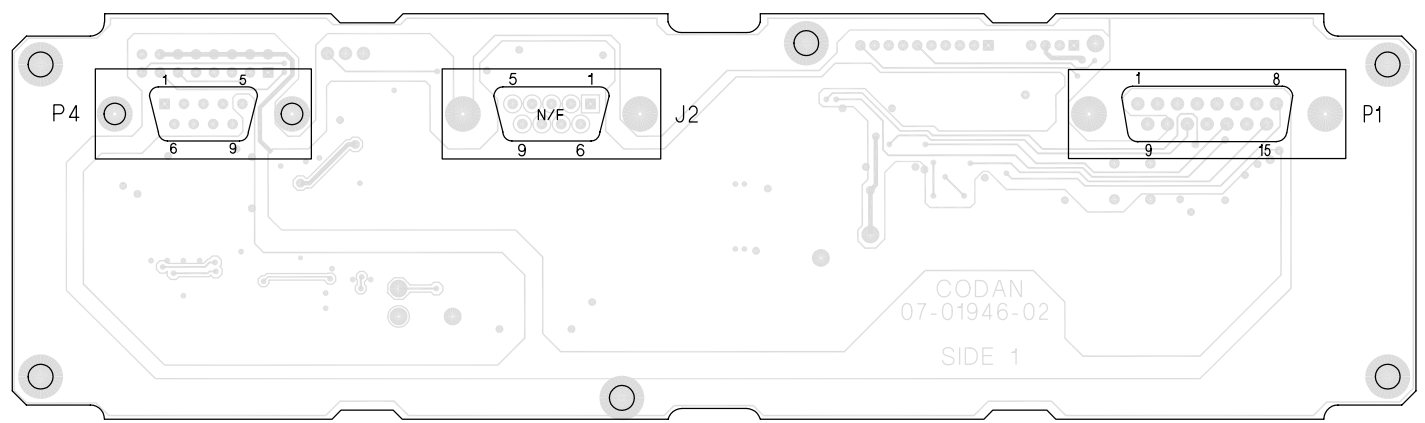

SIDE 2 COMPONENTS

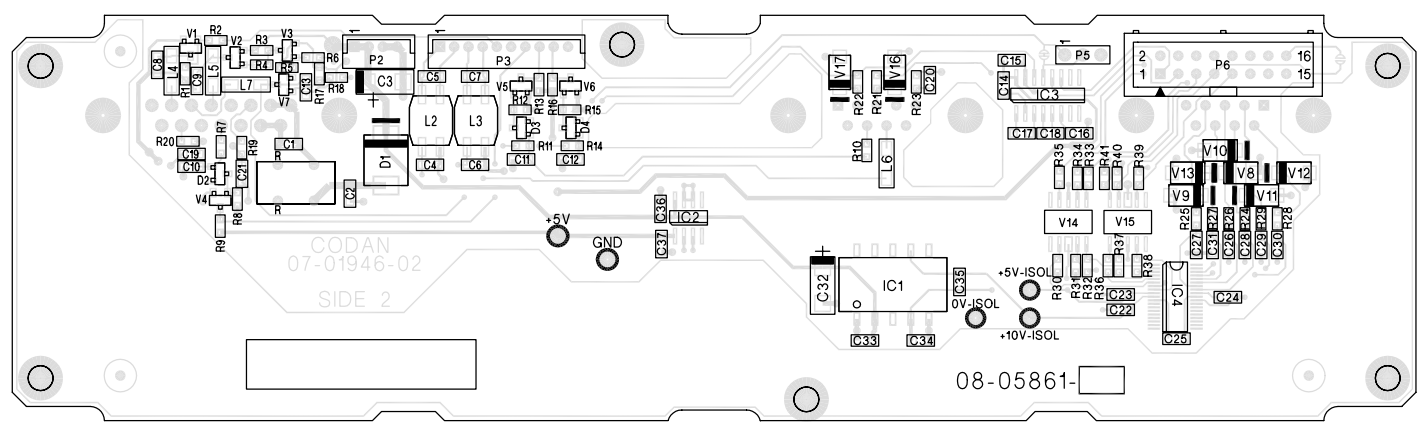

TSM
FILE No.
08\05861_1.DWG

PCB : 07-01946-01
ASSY: 08-05861-001

DIMENSIONS IN mm

		SCALE 2:1	© CODAN LIMITED, A.C.N. 007 590 605: 2000 TITLE 3012 USER CONNECT PCB
	DRN C G	DATE 31-10-00	
MATERIAL	CHKD SSJ	22-1-01	DRAWING/DOC NO. 08-05861
FINISH	APPD DTC	16-5-01	
TOLERANCES UNLESS OTHERWISE STATED			A2
2 PLACES DEC. ±0.10 1 PLACE DEC. ±0.5 0 PLACE DEC. ±1			
ISS 1			SHT. 1 OF 1

Numerics

- 15-way GPIO connector
 - pinouts 329
- 2-wire interface
 - receive path 338
 - transmit path 340
- 3-line capability 350
- 4-line capability 350
- 4-wire interface
 - receive path 339
 - transmit path 340

A

- audio
 - gate 338, 341
 - receive path 337
 - transmit path 340
- automatic equalisation 348

B

- backplane 336
- Backplane PCB
 - supply voltages 353
- brief description 331
- bus
 - internal 343
 - microcontroller 343
 - Rx audio 338
 - Tx audio 341

C

- connectors
 - 15-way GPIO 329
 - DC Supply 326
 - line 327
 - Option I/O 325
 - Tcvr Audio 325
 - Tcvr Control 324
- control tone
 - detection 344
 - generation 344

D

- DC Supply connector
 - pinouts 326
- dismantling 352
- drawings 363
- Dual Line Equaliser PCB
 - supply voltages 354

E

- environmental specifications 322
- equalisation 340
 - automatic 334, 348

F

- fault finding 351, 353
 - no reception, with signalling 356
 - no reception, without signalling 357
 - no signalling 354
 - no transmission, with signalling 359
 - voltage measurements 353
- filter
 - low-pass 341

G

- gain stage 340
- general specifications 322

H

- hybrid
 - receive path 338
 - transmit path 340

I

- internal bus 343

L

- line connector
 - pinouts 327
- line driver
 - receive path 338

M

- master control site
 - equipment 321
- microcontroller 334
 - bus 343
- microprocessor 343
- Microprocessor & TCVR Interface PCB
 - supply voltages 353

N

- notch filter
 - transmit path 342

O

- Option I/O connector
 - pinouts 325
- options
 - RS 346
- overview 319, 320

P

- parts lists 361
- physical specifications 323
- pin connections 324
 - 15-way GPIO connector 329
 - DC Supply connector 326
 - line connector 327
 - Option I/O connector 325
 - Tcvr Audio connector 325
 - Tcvr Control connector 324
- power supply 336

R

- receive path
 - 2-wire interface 338
 - 4-wire interface 339
 - audio 333, 337
 - audio compressor 337
 - hybrid 338
 - line driver 338
 - notch filter 337
- Rx audio bus 338

S

- signalling 334, 343
 - format 346
 - modem 345
- size 323
- slave site
 - equipment 321
- specifications 319, 322
 - environmental 322
 - general 322
 - physical 323
- split-site interface controller 329
- stage
 - gain 340
- supply voltages
 - Backplane PCB 353
 - Dual Line Equaliser PCB 354
 - Microprocessor & TCVR Interface PCB 353

T

- Tcvr Audio connector
 - pinouts 325
- Tcvr Control connector
 - pinouts 324
- technical description 335
- transceiver
 - control logic 346
 - Rx audio 337
- transmit audio path 334, 340
- transmit audio to transceiver 342
- transmit path
 - 2-wire interface 340
 - 4-wire interface 340
 - audio 340
 - hybrid 340
 - notch filter 342

V

- voltages
 - Backplane 353
 - Dual Line Equaliser 354
 - Microprocessor & TCVR Interface 353

W

- weight 323

8571—Overview and specifications

This section contains the following topics:

[Overview \(320\)](#)

[Specifications \(322\)](#)

[Pin connections \(324\)](#)

Overview

The split-site remote control NGT system provides flexibility in meeting the needs of the customer and site requirements.

The system provides access to all NGT functions, including channel scanning and selective calling. The operation of the split-site system is transparent to the NGT user following installation and setup.

The split-site remote control NGT system enables you to split control, transmit and receive functions of an HF radio system into one of three basic configurations:

- NGT remote split-site transmitter and receiver system
- NGT remote transceiver system
- NGT master transmitter, remote receiver system

In all of these configurations, there is a master control site and a slave site (up to four slave sites for the remote split-site transmitter and receiver system). The master control site is connected to a slave site via a 2-wire land line, or a 4-wire VHF/UHF radio/microwave link. Line loss and equalisation adjustments are made automatically by the system when requested by the user.

The basic layout for a split-site remote control NGT system is shown in [Figure 1](#).

Figure 1: Basic layout for a split-site remote control NGT system

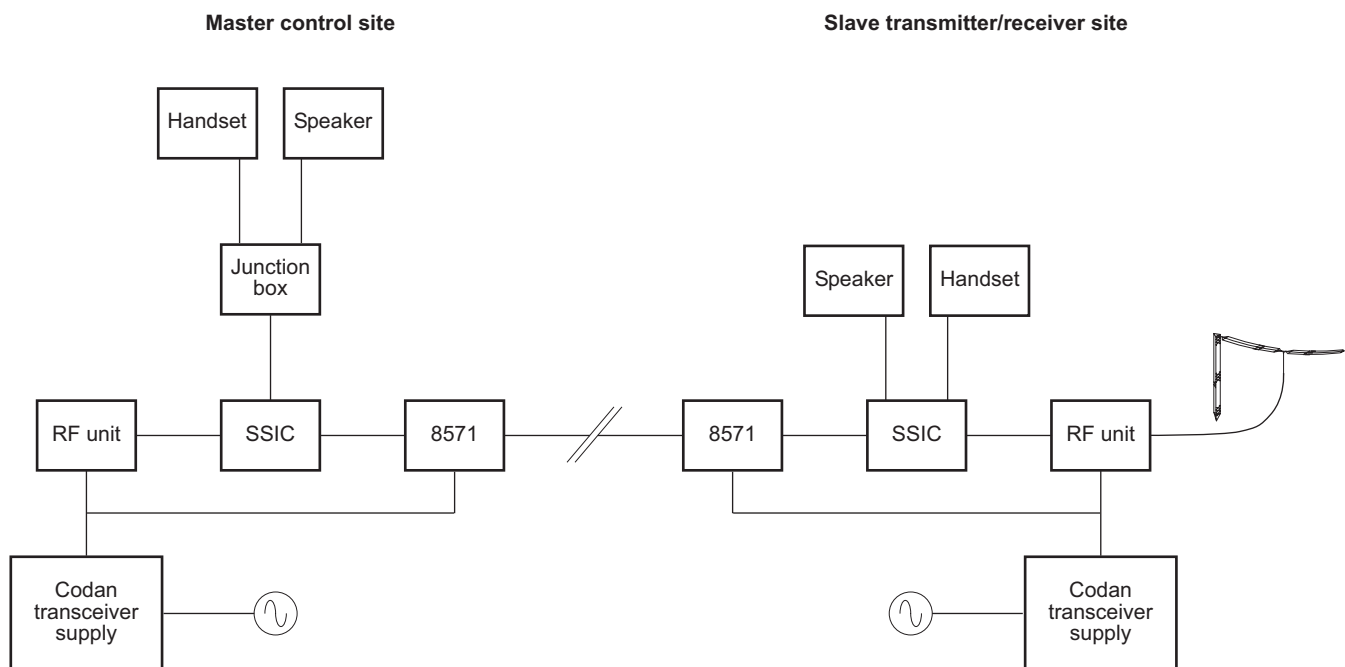

Master site

The master site controls the slave sites. In most cases, this site is the location of the user. As well as the controlling function over the system, the master site may also be the location of the transmitter and/or the standby receiver.

The minimum equipment at the master site comprises:

- an NGT RF Unit 2010, with fan if the site is used for transmission
- a Split-site Interface Controller 2030
- a Junction Box 2030
- a Handset 2020
- a loudspeaker
- an NGT Split-site Remote Interface 8571
- a transceiver supply
- an antenna, if the site is required to transmit or perform as a standby receiver

Slave sites

The slave sites are controlled by the master site. The function of these sites may be a slave receiver, a slave transmitter, or a slave transceiver.

The minimum equipment at a slave site comprises:

- an NGT RF Unit 2010, with fan if the site is used for transmission
- a 2030 Split-site Interface Controller
- a 2020 Handset
- a loudspeaker
- an 8571 NGT Split-site Remote Interface
- a transceiver supply
- an antenna

Specifications

General

Item	Specification
Line loss	Each line in a system can be up to 35 km (21.7 mi) of 0.64 mm (0.03 in) PIUT (copper conductor)
	<p>NOTE Telstra offers private lines with guaranteed performance levels.</p> <p>The system operates on standard grade lines Lines and radio links must be duplex</p>
Frequency response	400 Hz to 2.5 kHz \pm 3 dB
Noise	Signal-to-noise better than 45 dB (excludes line/radio link noise)
Signalling	1070 Hz and 1270 Hz FSK (part Bell 103) 550 baud Revertive by command echo and verification 300 Hz control tone used with signalling and for PTT
Power	11 to 16 V DC (12 V nom.) 200 mA, or 22 to 32 V DC (24 V nom.) 100 mA
AUSTEL permit number	A91/19/0129
Rear panel connectors	
Tcvr Control	8-way plug
Tcvr Audio	25-way D-type socket
DC Supply	4-way plug
Line—Option 2W	6-way 4-cct modular socket
Line—Option 4W	8-way plug

Environmental

Operating temperature	-30 to +50°C (-22 to 122°F)
-----------------------	--------------------------------

Physical

Size	250 mm W × 320 mm D × 78 mm H (9.8 in W × 12.6 in D × 3.1 in H)
Weight	2.5 kg (5.5 lb)

Pin connections

Figure 2: Rear panel of the 8571

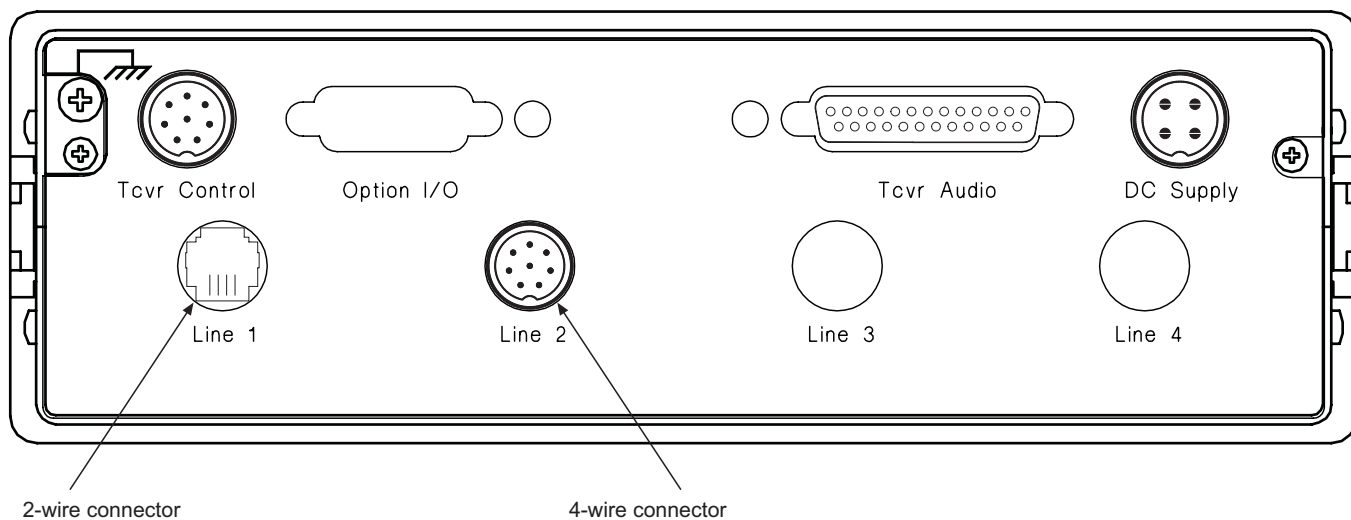

Pinouts of the Tcvr Control connector on the 8571

Figure 3: Front view of the Tcvr Control connector on the 8571

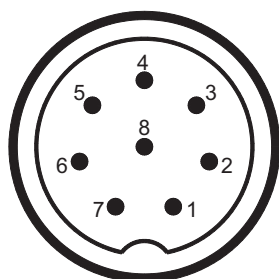

Table 1: Pinouts of the Tcvr Control connector on the 8571

Pin no.	Function	Signal level
1	Rx audio	1 V p-p
2-3	Ground	0 V
4	RxD	±10 V logic approx.
5	RTS	±10 V logic approx.
6	TxD	±10 V logic approx.
7	CTS	±10 V logic approx.
8	Rx audio ground	0 V

Pinouts of the Option I/O connector on the 8571

This connector is not used.

Pinouts of the Tcvr Audio connector on the 8571

Figure 4: Front view of the Tcvr Audio connector on the 8571

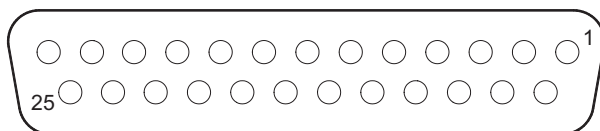

Table 2: Pinouts of the Tcvr Audio connector on the 8571

Pin no.	Function	Input/output	Signal level
1	N/C		
2	Remote PTT	Output	Active Low
3	N/C		
4	Power on	Output	Momentary Low
5–13	N/C		
14–15	Ground		0 V
16	Transmit audio	Output	Nom. 3 V p–p 10 k Ω balanced
17	Rx audio pre-mute	Input	Nom. 1.2 V p–p 10 k Ω balanced
18	Rx audio post-mute	Input	Nom. 1.2 V p–p 10 k Ω balanced
19–25	N/C		

Pinouts of the DC Supply connector on the 8571

Figure 5: Front view of the DC Supply connector on the 8571

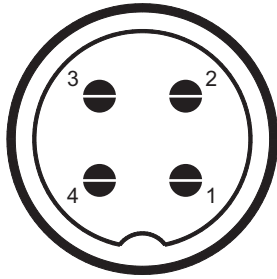

Table 3: Pinouts of the DC Supply connector on the 8571

Pin no.	Function	Input/output	Signal level
1	DC supply	Input	+12 V DC
2	DC supply	Input	+24 V DC
3	N/C		
4	Ground		0 V

Pinouts of the Line connectors on the 8571

The Line connectors may be fitted with either Option 2W or Option 4W.

Figure 6: Front view of the Option 2-wire connector on the 8571

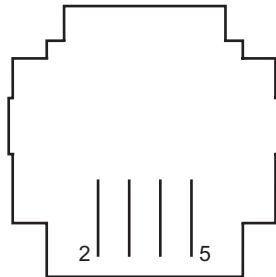

Table 4: Pinouts of the Option 2-wire connector on the 8571 (15-10509-001)

Pin no.	Function
1	N/C
2	Telephone line
3	N/C
4	N/C
5	Telephone line
6	N/C

In Australia, the 2-wire interface is supplied with a Telstra type 604 plug wired for modes 12 or 14 (2-wire circuit on pins 4 and 6).

Outside of Australia, the 2-wire interface is supplied with a modular telephone plug (conforming to FCC part 68), and a suitable wall-mounted socket. The 2-wire circuit is connected to pins 2 and 5.

Figure 7: Front view of the Option 4-wire connector on the 8571

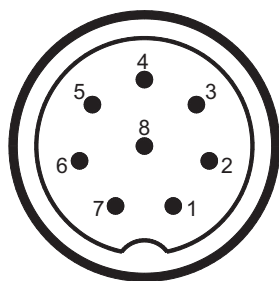

Table 5: Pinouts of the Option 4-wire connector on the 8571 (15-10510-001)

Pin no.	Function	Input/output	Signal level
1–2	Balanced Tx audio	Input	Impedance > 3 k Ω
3–4	Balanced Rx audio	Output	Impedance 600 Ω
5	Frame		
6	Ground		0 V
7–8	PTT relay contacts	Output	To key link transmitter

Pinouts of the 15-way GPIO connector on the split-site interface controller

Figure 8: Front view of the 15-way GPIO connector on the split-site interface controller

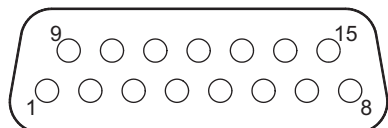

Table 6: Pinouts of the 15-way GPIO connector on the split-site interface controller

Pin no.	Function	Input/output	Signal level
1	RTS	Output	0 to 5 V
2	RS232 Receive data	Input	RS232
3	RS232 Transmit data	Output	RS232
4	Ground		0 V
5	Tx audio (50 k Ω balanced)	Input	300 mV p-p for ALC threshold
6	External alarm relay		Contacts rated 50 V, 1 A
7	External alarm relay		Closed for alarm
8	A rail	Output	+13.6 V nominal
9	CTS	Input	RS232
10	PTT	Input	5 V TTL logic active low
11	Morse	Input	5 V TTL logic active low
12	Spare	Input/output	5 V TTL logic
13	Spare	Input/output	5 V TTL logic
14	System audio	Output	1 V p-p (maximum load 1 k Ω)
15	Tx audio (50 k Ω balanced)	Input	300 mV p-p for ALC threshold

NOTE External alarm relay: internal link to select normally open or closed. This can be configured to switch to ground or the **A** rail.

This page has been left blank intentionally.

8571—Brief description

This section contains the following topics:

[General information \(333\)](#)

[Receive audio path \(333\)](#)

[Transmit audio path \(334\)](#)

[Microprocessor control and signalling \(334\)](#)

[Automatic line equalisation \(334\)](#)

For a detailed description of these functions see [page 335, 8571—*Technical description*](#).

This page has been left blank intentionally.

8571 REMOTE CONTROL INTERFACE (RCI)

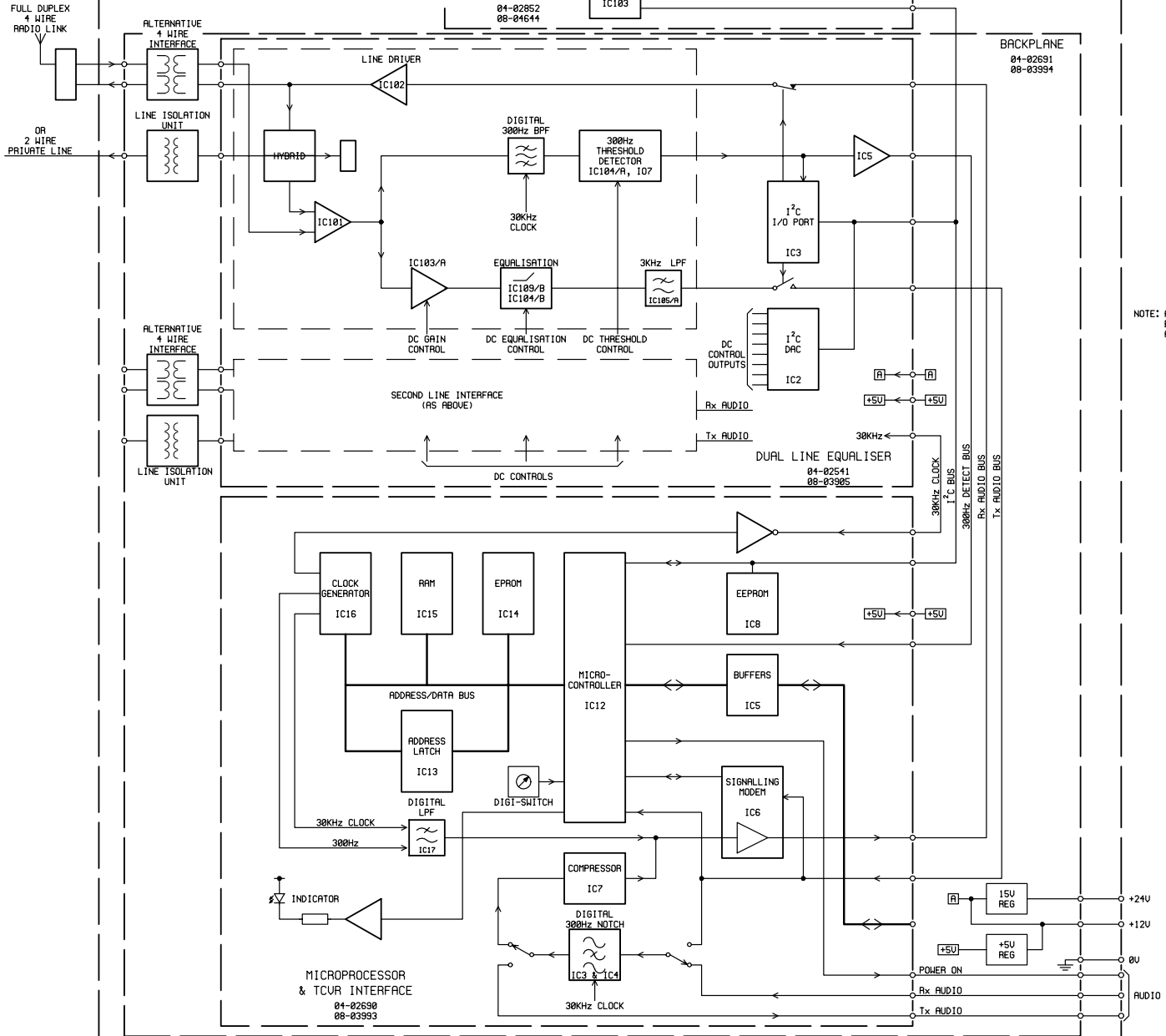

NOTE: A MAXIMUM OF 4 LINES/LINKS CAN BE ACCOMMODATED BY FITTING TWO 'DUAL LINE CIRCUIT INTERFACE' PCB'S AND 2-WIRE OR 4-WIRE INTERFACES AS REQUIRED.

FILE NAME 03-01108...1.M

		SCALE D/RN C G DATE 17-6-82	© CODAN LIMITED, A.C.N. 007 538 085, 2002 TITLE 8571
MATERIAL CHKD N/A 20-6-82	APPD N/A 20-6-82	TOLERANCES UNLESS OTHERWISE STATED 2 PLACES DEC. ± 1 PLACE DEC. ± ANGULAR ±	DRAWING/DOC. NO 03-01108
FINISH	A1	ISS 1	SHEET 1 OF 1

General information

NOTE The information in this section should be read in conjunction with the block diagram [03-01108](#).

Application of a 300 Hz control tone from any point removes all audio from the system in preparation for data signalling. Data is used to communicate to and from all microprocessors within the network and includes commands such as select Transmit mode (PTT), channel change, system status and so on.

In the absence of the control tone, the system provides an audio path from the transmitter/receiver through the 8571, via the land line (2-wire) or VHF/UHF radio link (4-wire), to one or more master control points.

When sending data, the control tone is present for the duration of the signalling, and on completion of the data transmission, reverts to the Receive mode. Data is transmitted in simplex mode at 550 baud using FSK.

The control tone is notched out of all external audio paths.

Receive audio path

In Receive mode, audio from the transceiver is applied to the Rx slave 8571 via an interface cable. The audio passes through a 300 Hz notch filter IC3 and IC4 to remove any 300 Hz that may be present in the receive audio that could possibly corrupt the performance of the system. The signal output from the filter is connected to a gain-controlled amplifier/compressor IC7 to maintain a constant audio output level.

At the output of IC7, the audio is fed via the signalling modem IC6 to the line driver IC102 and is then connected to either a 2-wire private line via the hybrid and first isolating transformer, or to a second isolating transformer for the 4-wire system.

At the other end of the 2-wire or 4-wire link, the received audio is applied to the 8571 via the appropriate isolation transformer to a hybrid and then to the first amplifier IC101. From the output of this amplifier, the 300 Hz control tone is fed via a 300 Hz BPF IC106 (to remove the receive audio) to a threshold detector IC104a/IC107. The receive audio is applied to a DC gain-controlled amplifier IC103a, then to a DC-controlled equaliser IC103b/IC104b. From here it passes via a 3 kHz LPF IC105a through a switch, selected to a 300 Hz notch filter, to remove the 300 Hz control tone, and finally via an interface cable to the split-site interface controller receive audio path.

Transmit audio path

In Transmit mode, microphone audio from the master junction box is applied to the 8571 via an interface cable. The audio passes through a 300 Hz notch filter IC3 and IC4 to remove any 300 Hz that may be present in the transmit audio that could possibly corrupt the performance of the system. The signal output from the filter is connected to a gain-controlled amplifier/compressor IC7 to maintain a constant audio output level.

At the output of IC7, the audio is fed via the signalling modem IC6 to the line driver IC102 and is then connected to either a 2-wire private line via the hybrid and first isolating transformer, or to a second isolating transformer for the 4-wire system.

At the other end of the 2-wire or 4-wire link, the transmit audio is applied to the 8571 via the appropriate isolation transformer, to a hybrid and then to the first amplifier IC101. From the output of this amplifier, the 300 Hz control tone is fed via a 300 Hz BPF IC106 (to remove the transmit audio) to a threshold detector IC104a/IC107. The transmit audio (still containing the control tone) is applied to a DC gain-controlled amplifier IC103a, then to a DC-controlled equaliser IC103b/IC104b. From here it passes via a 3 kHz LPF IC105a through a switch, selected to a 300 Hz notch filter (used also in the Receive mode) to remove the 300 Hz control tone, and finally via an interface cable to the transceiver transmit audio path.

Microprocessor control and signalling

All 8571s and transceivers in the system communicate via RS232 commands to the microprocessor IC103 on the General Purpose Input/Output PCB in the 8571s. The microprocessor then communicates via the I²C bus to IC12, which controls all of the transmit/receive audio path switching.

All 8571s in the system communicate with each other by means of the signalling modem IC6 using the same audio paths as the transmit and receive signals described earlier.

The signalling employed is FSK using tones of 1070 Hz and 1270 Hz. Signalling integrity is ensured by parity checks and echoing each command. Signalling time varies depending on the complexity of the information exchanged, but is typically 150 to 200 ms including acknowledgment.

Automatic line equalisation

When automatic line equalisation is initiated, the receive path is checked first. The slave 8571 sends a 300 Hz tone followed by a 2 kHz tone. These tones are received by the master 8571 and the levels measured by the microprocessor. The 300 Hz tone is adjusted for the correct level by the DC gain-controlled amplifier, and the 2 kHz signal level is adjusted by the DC-controlled equalisation circuit. Because both controls interact, the cycle is repeated until balance is achieved.

When equalisation of the receive path has been completed, the transmit path is then checked in the same way as described above.

8571—Technical description

This section contains the following topics:

[Backplane and power supply \(336\)](#)

[Receive audio path \(337\)](#)

[Transmit audio path \(340\)](#)

[Signalling and microprocessor \(343\)](#)

[Automatic equalisation \(348\)](#)

[Multi-line capability \(350\)](#)

This section should be read in conjunction with [page 363, 8571—Drawings](#).

Backplane and power supply

Drawings [04-02691](#) and [04-02541](#)

The Backplane PCB provides the interconnections between the PCBs fitted to the 8571. It contains the transmit audio bus and receive audio bus, the I²C bus, the 30 kHz clock, the 300 Hz detect and the regulators for the DC supplies.

The 8571 operates on 12 or 24 V. For 24 V operation, the DC is connected to two regulators (drawing [04-02691](#)), IC1 for 5 V (+5 rail) and IC2 for approximately 14 V (**A** rail). For 12 V operation, only IC1 is required and IC2 is bypassed by D4. Reverse voltage protection is achieved by the series diodes D1 and D2.

The Backplane PCB also provides connectors P6 and P105 for fitting links to disable the unused lines on the Dual Line Equaliser PCBs (drawing [04-02541](#)) as required. Also P303 and P304 provide the connectors for fitting the RS232 strapping.

All external input/output connections to the 8571 are made via interface cables connected to the Backplane PCB. Some interface cables include isolation transformer assemblies, which are required for 2-wire or 4-wire operation.

Receive audio path

Receive audio from transceiver

Drawings [04-02691](#) and [04-02690](#)

The receive audio is connected from pin 17 of the 15-way GPIO connector on the split-site interface controller via an interface cable to the 8571 Backplane PCB (drawing [04-02691](#)) connector P1 pin 8. From here it is connected to the input of transformer T1 on the Microprocessor & TCVR Interface PCB (drawing [04-02690](#)) via P1 pin 16a (ground pin 14a).

300 Hz notch filter and audio compressor

Drawing [04-02690](#)

From the secondary of transformer T1 on the Microprocessor & TCVR Interface PCB, the receive signal passes to an analog changeover switch IC2c and connects to the input of a 2-section digital filter, consisting of IC4, IC3a, IC3b, and associated components, to produce a 300 Hz notch filter. It has unity gain at frequencies above 300 Hz, but provides high attenuation (> -40 dB) at 300 Hz. IC4 is a dual active filter and is driven by a 30 kHz external clock generated from IC16. The high-pass output (pin 18) and the low-pass output (pin 20) of the first active filter are phase mixed at the input of amplifier IC3b, resulting in the required notch response. The output from IC3b is applied to the second active filter and again the high- and low-pass filter outputs are phase mixed at the input of IC3a. The two notch filters are slightly offset from each other to ensure the complete rejection of any signal on or close to 300 Hz that may possibly corrupt the operation of the system.

From the output of IC3a, the audio is fed via a second analog changeover switch IC2a to the input of the compressor amplifier IC7, the gain from which is controlled to maintain a constant output level for varying input levels.

In this circuit, the gain-controlled element (resistive cell delta G) is DC controlled by internally rectifying the amplified audio that is applied to IC7 pin 15. Above the threshold of AGC, set by resistor R29, an increase in the audio level at the input proportionally decreases the resistance of the cell. As this is part of the negative feedback, the output level remains constant. R26 and C18 form part of the DC feedback to the amplifier. C21 averages the rectified audio that is applied to the resistive element.

The receiver audio at the output of IC7 is connected to a mixer amplifier in the Bell 103 modem IC6 pin 1, and the output (pin 17) is coupled to connector P1 pin 30a (designated as Rx audio bus).

Receive audio bus and audio gate

Drawing [04-02541](#)

From the Rx audio bus line, the signal is fed via the Backplane PCB to the Dual Line Equaliser PCB (drawing [04-02541](#)) via connector P1 pins 30a and 30b. From here it continues via an isolating transformer T2, through the audio gate IC1 pins 1 and 2, to the input of the line driver IC102 pin 4.

The audio gate disables the Rx audio to the line driver during the Transmit mode.

Line driver and hybrid

Drawing [04-02541](#)

The line driver IC102 on the Dual Line Equaliser PCB has unity gain and is a power amplifier with a low output impedance. The output is connected to the Line Isolation Unit via P1 pins 28a and 28b. In the 2-wire system, the transmit and receive audio share the same land line between the 8571s. By the use of a hybrid circuit, it is possible to combine the two signals into one path and at the same time to isolate the transmit and receive paths from each other.

The hybrid, located on the Dual Line Equaliser PCB, consists of a bridge network. Resistors R106 and R107 form the top two parts of the bridge and the terminated land line plus the resistor/capacitor combination of R108/C101 form the lower third and fourth sections. The two opposite phased outputs of the receiver line driver IC102 are connected to the top and bottom points of the bridge (pin 5 to the junction of R106 and R107, and pin 8 to the junction of R108/C101 and one side of the line (pin 28b)). The two remaining bridge points (R106 to line pin 28a, and R107 to R108/C101) are connected to the differential inputs of amplifier IC101a via resistors R103 and R104.

When the land line impedance equals the R108/C101 combination, the two receive signals applied to IC101a are of equal amplitude and phase. Because they are connected to the input of a differential amplifier, the signals cancel and produce no output at IC101a pin 1. However, the line impedance rarely equals the R108/C101 combination, but still results in sufficient cancellation of the receiver signal to prevent overloading of the transmit path, and enable detection of the 300 Hz control tone.

2-wire interface

Drawing [04-02691](#)

Four lines may be connected on the 2-wire interface. Line 1 is always connected, lines 2, 3 and 4 are optional. The receive audio for line 1 is applied to connector P2 pins 1 and 2 located on the Backplane PCB, and then via an interface cable to the 2-wire interface assembly. Lines 2, 3 and 4 use connectors P5, P101, and P104 respectively.

The 2-wire Austel approved interface consists of an isolating transformer, a fuse, and an overvoltage protection device assembled in a fully insulated box. The output of the interface is connected to a modular telephone connector, and when terminated into a 600 Ω line, produces an audio level of 0 VU (–10 dBm for a single tone).

4-wire interface

Drawing [04-02691](#)

Four lines may be connected on the 4-wire interface. Line 1 is always connected, lines 2, 3 and 4 are optional. The receive audio for line 1 is applied to connector P3 pins 5 and 6 located on the Backplane PCB, and then via an interface cable to the 4-wire interface assembly. Lines 2, 3 and 4 use connectors P4, P102, and P103 respectively.

The 4-wire interface consists of two isolating transformers (providing separate Tx and Rx paths) and includes RF filter capacitors. The output of the Rx transformer connects via an interface cable to the **Tcwr Control** connector mounted on the rear of the 8571.

Transmit audio path

2-wire or 4-wire interface

Drawings [04-02487](#) and [04-02541](#)

With the 2-wire link version, the transmit audio is received by land line and is terminated into a modular telephone connector fitted on the rear panel of the 8571, and is connected to the 2-wire interface assembly (drawing [08-03817](#)). At the output of the interface module, the audio is connected via an interface cable to the Backplane PCB and then to the Dual Line Equaliser PCB.

When used with the 4-wire link, the transmit audio is connected to pins 1 and 2 of the **Tcvr Control** connector located at the rear of the 8571. It is applied via the Backplane PCB to the 4-wire interface assembly (drawing [08-03995](#)). At the output of the interface module, the audio is connected via an interface cable to the Backplane PCB and then to the Dual Line Equaliser PCB.

Hybrid

Drawing [04-02541](#)

In Transmit mode, the transmit audio for the 2-wire version is applied from pins 28a and 28b of connector P1 to the input of differential amplifier IC101a via resistors R103 and R104. As the signals at each input are opposite in phase, IC101a amplifies the signal by 6 dB ($\times 2$).

Gain and equalisation stage

Drawing [04-02541](#)

From the output of IC101a, the transmit audio is passed to a DC gain-controlled amplifier IC103a, the gain from which is set by the microprocessor to compensate for losses in the land line or radio link.

The gain-controlled element in the amplifier IC103a is a variable resistive cell (ΔG). Its resistance decreases as the DC current is increased at the control input pin 1. In this circuit, maximum gain occurs when the cell is at its highest resistance (pin 1 is at zero current). AC gain is set by the input resistor R117 and the total feedback resistance of R123 in series with the internal 20 k Ω resistor, resulting in a gain of approximately 14.5 dB ($\times 5$). As the resistive cell is connected in parallel to the feedback resistance, an increase in DC current to pin 1 results in a decrease of amplifier gain. Minimum gain is limited by the internally fitted 20 k Ω resistor in series with the cell, being about 3.5 dB ($\times 1.5$).

From the gain-controlled amplifier, the audio is passed to the first of two DC-controlled equalisation amplifiers IC103b and IC104b. Both amplifiers operate in a similar manner to amplifier IC103a described above, but are designed to give a DC-controlled treble boost to compensate for high-frequency loss on the land line. As both equalisers are almost identical, only a description of the first unit is necessary, except where detailed.

In this configuration, the resistive cell is in series with a 20 k Ω resistor and a 1 nF capacitor C113. The resulting series network is connected in parallel to the input resistor R124. Because the cell is in the input circuit, and not part of the feedback network used in the amplifier IC103a described previously, minimum gain occurs when the cell has a high resistance (DC current on pin 16 at zero). This has minimum effect on the AC gain of the amplifier, therefore the gain is set by the feedback resistor R127 in conjunction with input resistor R124. At this point the amplifier has a flat AC response, the first amplifier (IC103b) has unity gain, while the second amplifier (IC104b) attenuates the signal by 6 dB.

As the DC current on pin 16 of IC103b and IC104b is raised by the microprocessor-controlled DAC IC2, the resistance of the cell reduces. However, due to the AC reactance of the 1 nF capacitors C113 and C124, the gain increase is proportional to the rise in frequency. For example, there is approximately 2 dB increase at 100 Hz, rising to about 17 dB at 2 kHz for the first amplifier IC103b and, because of different resistor values, about 11 dB for the second amplifier IC104b. The combination of the two amplifiers has an overall minimum gain of -6 dB ($\times 0.5$) and a maximum gain of 28 dB at 2 kHz ($\times 25$). At the highest gain setting, the gain continues to rise with frequency until about 10 kHz, at which point it rolls off due to the influence of feedback capacitors C117 and C127.

Low-pass filter, audio gate and transmit audio bus

Drawings [04-02541](#) and [04-02691](#)

As the equalisation amplifiers have a rising gain with frequency (except at minimum gain), it is necessary to connect the output to a 3 kHz LPF to remove any high-frequency noise that may result from the high gain in the equalisation amplifiers. IC105a and its associated components form an active 3-pole LPF of conventional design.

At the output of the LPF, the audio is fed via an audio gate IC1 to the primary of transformer T1. From the secondary, the signal connects to the Backplane PCB via P1 pins 32a and 32b (designated as Tx audio bus).

300 Hz notch filter

Drawings [04-02691](#) and [04-02690](#)

From the Backplane PCB (drawing [04-02691](#)), the Tx audio bus is connected to the Microprocessor & TCVR Interface PCB (drawing [04-02690](#)) connector P1 pins 32a and 32b. It continues via an analog changeover switch IC2c selected to a 2-section digital filter, consisting of IC4, IC3b, IC3a and associated components, to produce a 300 Hz notch filter. It has unity gain at frequencies above 300 Hz, but produces high attenuation (> -40 dB) at 300 Hz. This removes the 300 Hz control tone from the final transmitted audio.

IC4 is a dual active filter and is driven by a 30 kHz external clock generated from the tone generator IC16. The high-pass output (pin 18) and the low-pass output (pin 20) of the first active filter are phase mixed at the input of amplifier IC3b, resulting in the required notch response. The output from IC3b is applied to the second active filter and again the high- and low-pass filter outputs are phase mixed at the input of IC3a. The two notch filters are slightly offset from each other to produce about a 25 Hz bandwidth rejection centred at 300 Hz.

Transmit audio to split-site interface controller and transceiver

Drawing [04-02690](#)

At the output of the 300 Hz notch filter (IC3b), the transmit audio is connected by a changeover analog switch (IC2a) to a simple passive LPF consisting of R23 and C8, then to the primary of isolating transformer T2. From the secondary, the audio is connected (P1 pins 13a and 15a) via an interface cable to the split-site interface controller transmit audio input.

Signalling and microprocessor

Microcontroller bus

Drawing [04-02690](#)

The microprocessor IC12 on the Microprocessor & TCVR Interface PCB is an 80C552 and is a member of the Intel 80C51 8-bit microprocessor family. It has 256 bytes of internal RAM, no internal program memory, two counter/timers, eight 8-bit ADC inputs, a watchdog timer, I²C bus, and an internal clock oscillator.

The microprocessor operates in a conventional 8-bit data, 16-bit address configuration. To minimise the pin count, the low-order address bits are multiplexed with the data on pins 50 to 57 onto a common 8-bit bus. IC13 is used to latch the low-order address bits to facilitate access to the external non-multiplexed devices. The ALE signal (IC12 pin 48) indicates to the latch when the address is present on the bus. The high-order address bits are provided directly on IC12 pins 39 to 46.

The following external devices are connected to the bus:

- IC14—an EPROM containing control firmware. The microcontroller selects the EPROM via the PSEN signal (pin 47).
- IC15—a RAM device supplementing the microcontroller's internal RAM. It is selected via the Read or Write signals (IC12 pins 30 and 31).
- IC16—a triple-tone generator used to generate control tone and digital filter clocks (see [page 344, 300 Hz control tone—generation and detection](#)).

A voltage detector and reset generator IC9 resets the microprocessor if the 5 V supply falls below 4.7 V.

Connected to the input ports of IC12 (pins 1, 66, 67, and 68) is a binary switch (designated as Mode Select).

Temperature sensing is monitored by the microprocessor at ADC input pin 62, by measuring the voltage at the resistor/thermistor circuit R36 and R37. Battery-voltage sensing is measured at the resistor-divider network R38 and R39 and is connected to ADC input pin 64.

Internal I²C bus

Drawing [04-02541](#)

Additional to the address and data bus lines, the microprocessor has an I²C bus that is connected to the backplane and is used to operate the following:

- IC2—DAC located on the Dual Line Equaliser PCB enables the microprocessor to select 64 DC steps between 0 to 9 V to control the threshold, gain, and equalisation amplifiers.
- IC3—I/O 8-bit expander located on the Dual Line Equaliser PCB that has outputs to control the transmit and receive audio paths.

The I²C bus is also used to communicate to the General Purpose Input/Output PCB.

300 Hz control tone—generation and detection

Drawings [04-02690](#) and [04-02541](#)

The 300 Hz control tone is generated by the tone generator IC16 on the Microprocessor & TCVR Interface PCB. The clock frequency of 3.579 MHz is supplied from the oscillator in the Bell 103 modem (IC6) and connected via buffer IC1e to the three clock inputs of the tone generator (pins 9, 15, and 18).

The internal dividers of IC16 are programmed by the microprocessor via the eight data lines and initiated by the two address lines (A0, A1) to produce a 300 Hz and two 30 kHz square wave outputs.

The first 30 kHz from the tone generator (pin 17) clocks the notch and digital filters (Dual Line Equaliser PCB, drawing [04-02541](#)) and runs continuously.

The 300 Hz square wave from the tone generator (pin 10) is applied via an RC network to the input of a digital LPF IC17 (pin 8). The second 30 kHz square wave from pin 13 is connected to the clock input (pin 1). The 300 Hz (pin 10) runs continuously, but the 30 kHz (pin 13) is enabled only when the 300 Hz sine wave is required at the output of the digital LPF (pin 5). The digital filter is disabled when the 30 kHz is removed.

From the output of filter IC17, the control tone is connected to the input of the mixer amplifier in the Bell 103 modem IC6. From the output (pin 17), the signal is passed via connector P1 pin 30a to the Rx audio bus on the Backplane PCB, and continues on the same path as the Rx audio through the Dual Line Equaliser PCB to the output of the 8571.

The 300 Hz received from the master 8571 is connected via the 2-wire or 4-wire interface and Backplane PCB to the Dual Line Equaliser PCB and follows the same path as the transmit audio to the output of the hybrid amplifier IC101a (see [page 340](#), *Transmit audio path*). At this point, the 300 Hz control tone (when in the Transmit mode) is applied to a 300 Hz digital BPF IC106.

The digital filter consists of two sections, the first connected as an LPF, followed by the second as an HPF. The two filters overlap each other, resulting in a very narrow BPF centred at 300 Hz. This removes the transmit audio but retains the 300 Hz control signal. The 30 kHz clock is supplied from the tone generator IC16 on the Microprocessor & TCVR Interface PCB.

From the output of the BPF, the control tone with the transmit audio removed is passed to a DC gain-controlled amplifier IC104a. The gain of this amplifier is set by the microprocessor for 6 dB above the threshold of the 300 Hz detector described below.

The gain-controlled element in amplifier IC104a is a variable resistive cell (ΔG). Its resistance decreases as the DC current is increased at the control pin 1 (controlled by the microprocessor via DAC IC2 (Dual Line Equaliser PCB)). Because the resistive cell is part of the input circuit to the amplifier, a rise in DC current at IC104a pin 1 results in an increase in the amplifier gain.

From the output of the gain-controlled amplifier, the 300 Hz is applied to the detector circuit consisting of IC107a, IC107b, IC105b and associated components. IC107a and IC107b function as comparators. Their DC inputs are set by the resistor divider chain R2, R3, R4 and R5 connected across the 10 V supply to form a window detector. When the control tone exceeds 2.0 V p-p, the positive peaks applied to the non-inverting input (IC107a pin 3) produce a positive output pulse at pin 1. The negative peaks applied to the inverting input (IC107b pin 6) produce a positive output pulse at pin 7. The outputs are ORed by D101 and D102 and connected to the input of control amplifier IC105b. Capacitor C130 and resistor R137 form a filter network to average the output pulses from the two comparators. When the average DC on pin 5 exceeds 5 V (threshold), the output pin 7 goes high. The 300 Hz detect line from IC105b is inverted by IC5b and connected to the 300 Hz detect bus on the Backplane PCB via connector P1 pin 31b.

From the Backplane PCB, the 300 Hz detect is fed to the Microprocessor & TCVR Interface PCB via connector P1 pin 31b. It is inverted by IC1a and is detected by the microprocessor on pin 18.

Signalling modem

Drawing [04-02690](#)

The signalling modem is compatible with the Bell 103 format, converting digital data into FSK using frequencies 1070 Hz and 1270 Hz at 550 baud rate.

The modem IC6 in the 8571 is located on the Microprocessor & TCVR Interface PCB. It uses a crystal-controlled oscillator at a frequency of 3.579 MHz to drive the FSK modulator, digital Rx filters and the FSK demodulator.

Control signals from the microprocessor enable the FSK modulator to transmit data by applying a low to pins 2 (ALB) and 14 (SQT), and a high to pin 13 (O/A). Serial data from the microprocessor's internal UART exits from pin 25 and is connected to the FSK modulator pin 11. Output from the modulator is mixed with the 300 Hz control tone, and the combined output signal at pin 17 follows the receive path to the output of the 8571 (see [page 337, Receive audio path](#)). The receive audio is disabled during the sending of FSK data, and on completion, the modulator is disabled by the control line pin 14 (SQT) going high (controlled by the microprocessor).

FSK data from the master 8571, received via the land line or radio link, follows the transmit audio path to the Tx audio bus. From pin 32a of P1, the FSK data is applied to the input amplifier of the modem IC6 pin 15 (RXA2). After amplification, it is fed via the Rx digital filters to the FSK demodulator and the carrier detector circuit. The carrier detector informs the microprocessor that data is being received by applying a low on pin 13 (CD). From the output of the FSK demodulator, the digital data is applied to the microprocessor input pin 24 (RxD) for processing.

Signalling format

To enable the microprocessors to communicate with each other it is necessary to provide a signalling format that is recognised by all microprocessors used within the remote control network.

Serial data from the UART in the microprocessor is converted to FSK format in the Bell 103 modem using tone frequencies of 1070 Hz and 1270 Hz at 550 baud. At the receiving terminal, the FSK is restored to digital data by a second modem and is read by the microprocessor from the UART input.

The following outlines the signalling format used in the system:

- The signalling sequence commences with sending the 300 Hz control tone. After 20 ms, under the control of the microprocessor, the modem sends FSK carrier (bit one) for a period of 20 ms followed by the FSK data. At the end of the data, the 300 Hz continues for a further 2 ms before it is disabled.
- At the receiving end, the microprocessor first detects the 300 Hz followed by the FSK carrier, enabling the microprocessor to be ready to receive data. The data is read, and on completion, the carrier and the 300 Hz detector are reset.

The signalling sequence is used for all data transmissions including PTT.

Transceiver control logic

Drawing [04-02852](#)

The transceiver is connected using a dual interface cable via the split-site interface controller to the 25-way D-type **Tcvr Audio** and 8-way **Tcvr Control** connectors located on the rear panel of the 8571.

The transceiver communicates with the 8571 via RS232 commands (CICS) to the microprocessor IC103 on the General Purpose Input/Output PCB in the 8571.

RS232 port

Drawing [04-02852](#)

The RS232 port provides the control interface with the transceiver. This functionality is provided through the **Tcvr Control** connector.

The RS232 interface is fitted with a microprocessor IC103 (80C552) that is a member of the Intel 80C51 8-bit microprocessor family. It has 256 bytes of internal RAM, no internal program memory, two counter/timers, eight 8-bit ADC inputs, a watchdog timer, I²C bus and an internal clock oscillator.

The microprocessor operates in a conventional 8-bit data, 16-bit address configuration. To minimise the pin count, the low-order address bits are multiplexed with the data on pins 50 to 57 onto a common 8-bit bus. IC104 is used to latch the low-order address bits to facilitate access to the external non-multiplexed devices. The ALE signal (IC103 pin 48) indicates to the latch when the address is present on the bus. The high-order address bits are provided directly on IC103 pins 39 to 46.

The following external devices are connected to the bus:

- IC105—an EPROM containing control firmware. The microprocessor selects the EPROM via the PSEN signal (pin 47).
- IC106—a RAM device supplementing the microprocessor's internal RAM. It is selected via the microprocessor's Read or Write signals (pins 30 and 31) in conjunction with address lines A13 and A15, and is used for chip select.
- IC107—UART, a bidirectional serial to parallel data converter.

The voltage detector and reset generator IC102 resets the microprocessor if the 5 V supply falls below 4.7 V.

Two 8-bit mode switches connected to the microprocessor input ports (pins 7 to 14 (S101) and pins 24 to 29 (S102)), select the RS232 format for correct operation of the external equipment (see the *Split-site Remote Control NGT Systems Reference Manual*).

The microprocessor IC12 on the Microprocessor & TCVR Interface PCB communicates to the RS232 microprocessor IC103 via the I²C bus, and is connected from the Backplane PCB to the General Purpose Input/Output PCB via connector P1 (pins 8a, 8b, and 7b) and applied directly to the microprocessor pins 19 (INT IN), 22 (SCL), and 23 (SDA). The interrupt output line from pin 20 (INT OUT) is combined via buffer IC101a and transistor V102 at P1 pin 7b, resulting in a bidirectional interrupt line at this point.

The operation control logic within the UART IC107 receives operation commands from the microprocessor and generates appropriate signals to control the device. The commands include the baud rate, parity selection, data width, and stop bit parameters set by the 8-bit mode switch S101. The commands permit the UART to communicate with the microprocessor via the data bus buffer.

Serial data from the external equipment is applied via the option interface cable to input pin 17 (RxD) of the level translator IC108, and the buffered data (pin 16) is applied to pin 2 of the UART IC107. The data is converted from serial to parallel, and applied via the data bus to the microprocessor.

Parallel data from the microprocessor is applied via the data bus to the UART IC107, and the resulting serial data at pin 3 (TxD) is connected to pin 15 of the level translator IC108. The output at pin 18 is connected via the interface cable to the external equipment.

The CTS and RTS control lines connected between the external equipment and the UART via the translator are part of the enable and handshake mechanism used when transferring data.

The analog input and output circuits connected to the microprocessor IC103 and the DSR and DTR lines connected to the level translator are not enabled but are included for future use if required.

Automatic equalisation

Drawings [04-02690](#) and [04-02541](#)

A request to commence equalisation of the 8571 may be initiated either by setting switch **S1** on the Microprocessor & TCVR Interface PCB to position E (see [Figure 9](#)) and switching the 8571 off then on again, or by sending a command from the handset of the transceiver.

Figure 9: Location of switch S1

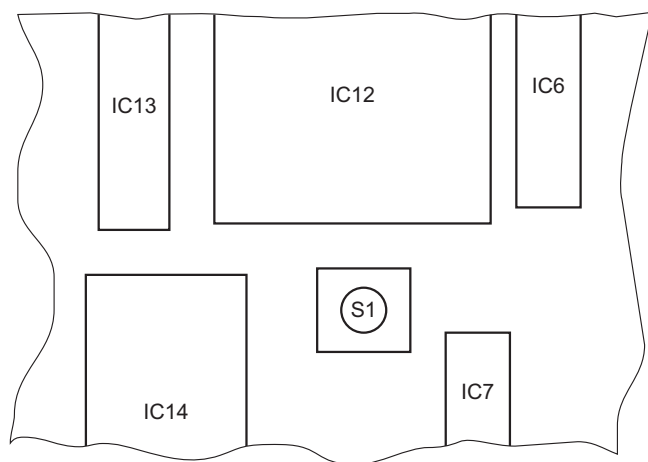

When this occurs, the microprocessor in the 8571 carries out the following procedure. The microprocessor sends a request via the signalling modem to the master 8571 to transmit a 300 Hz tone for approximately two seconds. During this period, the slave 8571 microprocessor first sets the 300 Hz threshold amplifier IC104a (on the Dual Line Equaliser PCB) to maximum gain. It then commences to decrease the gain by reducing the DC current on pin 1 until the 300 Hz detector output goes low (IC105b pin 7). The microprocessor then resets the control current for a gain of 6 dB above threshold and stores this gain setting.

The microprocessor then requests the master 8571 to repeat the 300 Hz transmission for five seconds. The microprocessor measures the level of audio on the Rx audio bus line (output of modem IC6) by using its internal ADC at pin 63. The microprocessor then changes the DC level output of the DAC IC2 pin 14 (on the Dual Line Equaliser PCB), which adjusts the gain of the amplifier IC103a. This continues until the level on the Rx audio bus line measures 200 mV RMS.

The microprocessor then requests a 2 kHz tone for five seconds from the master 8571. Again the level is monitored on the Rx audio bus and the microprocessor adjusts the gain of the equalisation amplifiers IC103b and IC104b (by adjusting the DC output of the DAC IC2 pin 15) for a level of 80 mV RMS on the audio bus line.

Because of the interaction between the two operations, the sequence is repeated for a maximum of 20 attempts to set both audio levels within ± 10 mV of the levels specified above.

If the ± 10 mV tolerance is attained, the slave 8571 microprocessor instructs the master 8571 to report **Optimal**. However, if after the 20 attempts the tolerance limits are not achieved, the microprocessor instructs the word **Acceptable** to be reported. If the latter is reported, it means the line has been equalised and although it did not achieve the optimum settings, performance should be satisfactory.

If the 300 Hz threshold fails to detect any 300 Hz tone after six attempts, the microprocessor aborts the process and instructs the microprocessor in the master 8571 to report **Failed**.

Multi-line capability

The information in this section should be read in conjunction with the following diagrams:

8571 Remote Control (NGT) Interface Assembly	08-05994 (sheet 1)
Backplane	08-05995
Option 2W	15-10509-001
Option 4W	15-10510-001

A second input/output line (2W or 4W), may be provided by fitting an additional line unit to the 8571.

The additions required for a second line are as follows:

- 2-wire line isolating assembly [08-03817](#), or
- 4-wire line isolating assembly [08-03995](#)

An additional third and fourth line (2W or 4W) require a second Dual Line Equaliser PCB.

The additions required for a third and fourth line are as follows:

- Dual Line Equaliser PCB [08-03905](#), and
- 2-wire line isolating assembly [08-03817](#), or
- 4-wire line isolating assembly [08-03995](#)

The Dual Line Equaliser PCB providing input/output lines 3 and 4 is identical to the PCB already fitted for input/output lines 1 and 2.

To enable the microprocessor to individually control either PCB, the ADC and input/output expander on each PCB is provided with a separate address (0, 1, 1, 0 for lines 1 and 2, and 0, 0, 1, 0 for lines 3 and 4). The address is set for each assembly when they are fitted to the appropriate connector on the Backplane PCB and is applied to P1 pins 10a, 10b, 11a and 11b. Once the addresses have been set for the PCBs, they remain the same even if the card positions are reversed.

8571—Fault finding

This section contains the following topics:

[Dismantling the NGT Split-site Remote Interface 8571 \(352\)](#)

[Fault finding \(353\)](#)

Dismantling the NGT Split-site Remote Interface 8571

To gain access to the PCBs inside the 8571 it is necessary to first remove the top cover from the interface unit.

To remove the top cover:

- Remove the two screws (one on each side), then lift and draw back the rear edge of the cover so the front edge is released from the front panel surround.

To remove the front panel and gain access to the PCBs:

- Remove the two countersunk screws located on each side of the front panel.
- Pull the panel forward to release it from the casing.
- Remove the PCBs by carefully pulling the boards forward and sliding them out of their runners.

Take care when refitting the PCBs to ensure the connectors are correctly aligned before pressing the PCB fully home.

- Reverse the procedure above to re-assemble the front panel.

Fault finding

Finding faults within the split-site remote control system requires the full system to be connected together.

The types of faults that can occur are:

- no reception, with or without signalling
- no transmission, with signalling
- no signalling

Voltage measurements

The circuit diagrams and the relevant circuit notes give voltages at various points under various conditions and are useful for locating the faulty section of the remote control equipment.

The parameters listed below should always be checked first.

Drawing [08-05995](#)

Table 7: Supply voltages for the Backplane PCB

Supply	Description	Voltage	Source
A rail	Unregulated DC supply	14 V nominal	external transceiver in 12 V systems
+5 rail	+5 V regulated supply	5 V \pm 0.4 V	IC1

Drawing [08-03993](#)

Table 8: Supply voltages for the Microprocessor & TCVR Interface PCB

Supply	Description	Voltage	Source
B rail	+10 V regulated supply	10 V \pm 0.2 V	IC10
+5 V	+5 V bias supply	5 V \pm 0.5 V	junction R44/R45
2.5 V	+2.5 V bias supply	2.5 V \pm 0.25 V	junction R34/R35
5 V ref	+5 V reference for ADCs	5 V \pm 0.2 V	V5/R42

Drawing [08-03905](#)

Table 9: Supply voltages for the Dual Line Equaliser PCB

Supply	Description	Voltage	Source
B rail	+10 V regulated supply	10 V \pm 0.2 V	IC6
+6 V bias	+6 V reference	6 V \pm 0.6 V	junction R2/R3
+5 V bias	+5 V reference	5 V \pm 0.5 V	junction R3/R4
+4 V bias	+4 V reference	4 V \pm 0.4 V	junction R4/R5

No signalling

No signalling can be due to a loss of one of the regulated supplies, a failure in the microprocessor and control circuit, or a problem in the transmit/audio paths.

A study of the technical description of the signalling system should assist in checking for a signalling fault.

If there is a second system available, then swap the units to assist in identifying the faulty unit. However, if this is not possible, it is necessary to carry out a number of the tests to locate the area in which the signalling has failed.

Checking the master 8571

To check the operation of the master 8571:

- Initiate a channel change and use an oscilloscope connected across the line to observe the control tone.

The 300 Hz control tone (nominally 700 mV p–p) combined with the FSK signal should be seen for a short period after the channel change.

- If there appears to be no activity when initiating a channel change, check all regulated DC supplies for the master 8571 (see [page 353](#), *Voltage measurements*).

If the signalling in the master 8571 appears to be working, then a fault could be due to a failure in the line, in the slave 8571, or the transceiver.

Checking other equipment

If the microprocessor and its associated circuits appear to be functioning, then check the tone generator, the Bell 103 modem, and the signal path for possible failure.

Checking the slave 8571

Drawings [08-03905](#) and [08-03993](#)

If the fault appears to be in the slave 8571, then unless the remote site is suitably equipped, it is recommended the equipment be returned to the workshop for the necessary repairs.

To check the slave 8571:

- Place both the master 8571 and the slave 8571 in close proximity (for ease of servicing) and connect them together via a 2-wire or 4-wire line. Incorporate a suitable attenuator to prevent overloading of the signals. Connect a transceiver and power supply to the master 8571.

- While pressing the **▶** or **◀** keys on the handset to change channels, use an oscilloscope to check for 300 Hz control and FSK signals through the slave 8571 signal path.

A fault in the 300 Hz control circuits can be traced by applying a 300 Hz signal at 100 mV p-p from an audio signal generator to the input of the slave 8571.

- With an oscilloscope, check for 300 Hz on the Dual Line Equaliser PCB at the outputs of the hybrid IC101a, the 300 Hz BPF IC106 (the clock frequency should be 30 kHz), and the threshold detector amplifier IC104a.

The measured level at the output of the 300 Hz threshold amplifier IC104a depends on the DC current applied to the control input pin 1.

- Set switch **S1** on the Microprocessor & TCVR Interface PCB to position D to check nominal levels shown on the circuit diagram [04-02541](#).
- Check that the output of the detector IC105b is high (5 V) when the control tone is present.
- Check that the output of combiner inverter IC5 is low (300 Hz detect bus).
- Check that the 300 Hz detect bus to the microprocessor IC12 pin 18 on the Microprocessor & TCVR Interface PCB goes high (5 V) while the 300 Hz is present.

Unless special equipment is available, continuous channel changing from the handset should be a sufficient signal source to enable the FSK signal to be traced through the signal path of the slave 8571.

- Commencing on the Dual Line Equaliser PCB with an oscilloscope, check for a burst of the FSK signal at the outputs of the hybrid IC101a, the gain-controlled amplifier IC103a, the equalisation amplifiers IC103b and IC104b, and finally the output of the 3 kHz LPF IC105a.

Levels depend on the input level to the 8571, and the gain settings of the gain-controlled amplifier IC103a and equalisation amplifiers IC103b and IC104b.

- Check the FSK on the Tx audio bus on the Microprocessor & TCVR Interface PCB (Tx and FSK share the same path at this point).
- Check that the FSK is applied to the modem input IC6 pin 15, that data appears at the demodulated output pin 5, and that FSK detect pin 3 goes low during the signal period.

NOTE By setting the equalisation to the default setting and input levels, the gains and signal levels can be measured. To set the equalisation to the default setting, disconnect the DC power, set switch **S1** on the Microprocessor & TCVR Interface PCB to position D, then reconnect the DC power. To return to automatic equalisation, repeat the above process, but select position E on switch **S1**.

No reception, with signalling

NOTE The following fault finding procedure is based on a remote control system consisting of a single master 8571, a single slave 8571, and a transceiver. In the case of multiple systems, consideration must be given to the other units within the network when tracing this type of fault.

If there is no reception, but the commands from the transceiver are functioning, then the 2- or 4-wire link between the 8571s and the shared receive and signal path in both units are unlikely to be at fault. Therefore, check the remaining sections of receive path in the 8571s and transceiver as follows.

Checking the 8571s

Drawings [08-03905](#) and [08-03993](#)

To check an 8571:

- Ensure that all units are connected to the line and equalised.
- Remove the 8571 NGT I/F controller cable (Codan part number 08-05990) at the 8571 end.
- Apply a 1 kHz tone at a level of 1.2 V p-p to the input of transformer T1 on the Microprocessor & TCVR Interface PCB (connector P1 pins 14a and 16a of the **Tcvr Audio** connector).
- Using an oscilloscope, check if the 1 kHz signal is present at the output of the line driver IC102 pin 5 on the Dual Line Equaliser PCB, and that it measures approximately 800 mV p-p.

If the 1 kHz signal is present, then the 8571 is operating properly.

- Check for possible faults in the transceiver and the interface cable.

If there is no audio at IC102, then the 1 kHz signal should be traced through the receive path on the Microprocessor & TCVR Interface PCB.

- Commence by checking the 1 kHz level at the secondary of the input transformer T1. If correct, continue checking the receive path through IC2c switch C, then at the output of the 300 Hz notch filter IC4, through IC2a switch A, then the output of Audio Compressor IC7, and finally at the Rx audio bus (via the modem IC6).

Refer to circuit diagram [04-02690](#) for levels.

From here the remaining receive path is shared with the signalling path and therefore is unlikely to be faulty.

- If the signal is absent at any of the test points, examining the neighbouring circuits should assist in locating the fault.

Checking the transceiver

If the interface cable is not at fault, then the transceiver should be checked (see [page 69](#), *NGT—Technical description (2010)*).

No reception, without signalling

NOTE The following fault finding procedure is based on a remote control system consisting of a single master 8571, a single slave 8571, and a transceiver. In the case of multiple systems, consideration must be given to the other units within the network when tracing this type of fault.

If there is no reception and commands are not functioning from the transceiver (such as channel changing) then the fault may be in an area shared by the receive and signal path. Alternatively, this may be the result of two separate faults: no receive, and no signalling. If a signalling fault still exists after repairing the receive fault, continue to check for a signalling fault (see [page 354](#), *No signalling*).

To assist in locating a receive fault, check the 2-wire or 4-wire link, the master 8571, the slave 8571, and the transceiver as follows.

Checking the line

To check the line:

- Check the 2-wire or 4-wire link using an audio amplifier with a speaker or an oscilloscope for receive noise.
- If there is no receive noise on the line and the 8571 proves to be operational, check the line by applying a known level of 1 kHz tone (say 0 dBm) from a 600 Ω source at one end, then measure the level at the other end when terminated into 600 Ω .
- Check the attenuation meets specification.
- Check both directions for a 4-wire system.

Checking the 8571s

To check an 8571:

- Check the DC input supply and the regulated supplies are correct for the 8571 (see [page 353, Voltage measurements](#)).
- Ensure that all units are connected to the line and equalised.
- Remove the 8571 NGT I/F controller cable (Codan part number 08-05990) at the 8571 end.
- Apply a 1 kHz tone at a level of 1.2 V p-p to the input of transformer T1 on the Microprocessor & TCVR Interface PCB (connector P1 pins 14a and 16a of the **Tcvr Audio** connector).
- Using an oscilloscope, check if the 1 kHz signal is present at the output of the line driver IC102 pin 5 on the Dual Line Equaliser PCB, and that it measures approximately 800 mV p-p.

If the 1 kHz signal is present, then the 8571 is operating properly.

- Check for possible faults in the transceiver and the interface cable.

If there is no audio at IC102, then the 1 kHz signal should be traced through the receive path on the Microprocessor & TCVR Interface PCB.

- Commence by checking the 1 kHz level at the secondary of the input transformer T1. If correct, continue checking the receive path through IC2c switch C, then at the output of the 300 Hz notch filter IC4, through IC2a switch A, then the output of Audio Compressor IC7, and finally at the Rx audio bus (via the modem IC6).

Refer to circuit diagram [04-02690](#) for levels.

- If the signal is absent at any of the test points, examining the neighbouring circuits should assist in locating the fault.

Checking the transceiver

If the interface cable is proved to be satisfactory, then the transceiver should be checked (see [page 69, NGT—Technical description \(2010\)](#)).

No transmission, with signalling

NOTE The following fault finding procedure is based on a remote control system consisting of a single master 8571, a single slave 8571, and a transceiver. In the case of multiple systems, consideration must be given to the other units within the network when tracing this type of fault.

If transmission is the only fault in the remote control system then the areas to be checked are the transmit audio path in the master 8571, the transmit audio path in the slave 8571, and the transceiver as follows.

Checking the master 8571

To check the master 8571:

- Talk into the microphone and check if the speech can be measured on the phone line with an oscilloscope.

If speech is present on the line, the problem is unlikely to be in the master 8571. In this case, continue at the next section, *Checking the slave 8571*.

If no speech is present, continue with this section.

NOTE If it is not possible to operate the PTT in the master 8571, a signalling fault may also exist. This should be repaired before continuing to investigate the fault causing no transmission (see [page 354, No signalling](#)).

- Check all regulated supplies for the master 8571 (see [page 353, Voltage measurements](#)).
- Apply 1 kHz audio at a level of 50 mV p-p to the local microphone input and operate the local PTT.
- If the signal is absent at any of the test points, examining the neighbouring circuits should assist in locating the fault.

Checking the slave 8571

Drawings [08-03905](#) and [08-03993](#)

To check the slave 8571:

- Hold down* PTT on the handset, then apply a 300 mV p-p 1 kHz audio to the local Tx audio input.
- With an oscilloscope, check the line input to the 8571 for a signal mixed with the 1 kHz transmit audio.

NOTE These signals may only measure a few millivolts and depend on the attenuation of the line.

- Check that Transmit mode has been selected in the slave 8571 by verifying that the PTT line is low (IC12 pin 11 on the Microprocessor & TCVR Interface PCB). If not selected, check the 300 Hz threshold detector and associated circuits on the Dual Line Equaliser PCB for possible faults.
- Check the transmit audio at the output of the hybrid IC101a on the Dual Line Equaliser PCB.
- Check for audio at outputs of the gain-controlled amplifier IC103a, equalisation amplifiers IC103b, IC104b, and the 3 kHz LPF IC105a.
- Check that transmit audio from the output of IC105a is present on the transmit bus (Backplane PCB), then at switch IC2c pins 3 and 4 on the Microprocessor & TCVR Interface PCB.
- Check for the 1 kHz tone at the output of the 300 Hz notch filter IC4 and then via IC2a pins 14 and 13 to the transmit audio input transformer T2.
- Release PTT.
- If the signal is absent at any of the test points, examining the neighbouring circuits should assist in locating the fault.

Checking the transceiver

If audio is present at the secondary of transformer T2, then the interface cable and the transceiver should be checked (see [page 69, NGT—Technical description \(2010\)](#)).

Table 10: 8571 parts lists index

Title	Assembly number
NGT Remote Control Interface	08-05994-001
Dual Line Equaliser PCB	08-03905-002
Microprocessor & TCVR Interface PCB	08-03993
Backplane PCB	08-05995-001
RS+I/O PCB	08-04644-001
Line Isolation Unit PCB	08-03817
4-wire Interface PCB	08-03995-001

This page has been left blank intentionally.

08-05994-001 - Remote Control I/F, 8571 (NGT)

BOM Revision
Date Valid On

01 -- Production
28.09.2006

Ref	Description	Manufacturer	Manufacturer's P/N	Codan P/N	Qty
*	Remote Control I/F, 8571 (NGT)			08-05994	1
1	Brkt, LHS	Codan	08-04128-001	08-04128-001	1
2	Brkt, RHS	Codan	08-04128-002	08-04128-002	1
3	Panel, LTU Mtg	Metalcraft	08-04129	08-04129	1
4	Panel, Rear	Codan	08-06032-001	08-06032-001	1
5	Panel, Front	Metalcraft	05-06671-000	05-06671-000	1
6	Card Frame-Front Plate	Metalcraft	08-04130	08-04130	1
7	Rail, Side	Metalcraft	05-05210	05-05210	2
8	Cover, Top	Metalcraft	05-07215	05-07215	1
9	Cover, Bottom	Metalcraft	05-07216	05-07216	1
10	Label	PMP	05-06514	05-06514	1
11	Plate, Blanking 15way D	Metalcraft	05-05347	05-05347	1
12	Card Guide	Metalcraft	06-01212	06-01212	3
13	Escutcheon, Front	Entech	06-02123	06-02123	1
14	Backplane PCB	Rapier Electronics	08-05995-001	08-05995-001	1
15	MicroP & Tcvt I/F PCB	Rapier Electronics		08-03993	1
16	Dual Line Equaliser PCB	Rapier Electronics	08-03905-002	08-03905-002	1
17	Opt RS PCB	Rapier Electronics	08-04644-001	08-04644-001	1
18	Loom, Power	Auto Assemblies	08-04157	08-04157	1
19	Cable, Ribbon, 16way to 25way D,F	Auto Assemblies	08-04158	08-04158	1
20	Plug Button (DP-625)	Heyco	2663 (Black)	30-31110-006	3
21	Screw Lock assy, 'D' 8,0mm Stud	ITT-Cannon	D20418-2	60-91509-001	2
22	Screw, M3x6 304 SS Bk Pan Pozi	Spec 01-00205	31-23006-582	31-23006-582	8
23	Cable, Opt PS	Auto Assemblies	08-03232	08-03232	1
24	Screw, M3x5 304 SS Csk Pozi	RGA Fasteners	31-23005-780	31-23005-780	12
25	Screw, M3x8 304 SS Bk Csk Pozi	Spec 01-00205	31-23008-782	31-23008-782	6
26	Screw, M3x10 304 SS Bk Csk Pozi	Spec 01-00205	31-23010-782	31-23010-782	4
27	Nut, M3 MS Zn PI Hex	Spec 01-00201	31-23000-001	31-23000-001	3
28	Screw, 4Bx1/2 S/Tap Pan Pozi	RGA Fasteners	STD ZN PLATE	31-00408-902	12
29	Rivet, Pop Al Dome 2,4dx2,4mm	Tucker	TAP/D/33/BS	33-23124-024	2
30	Screw, M4x8 MS Zn PI CH Slotted	Spec 01-00201	31-24008-301	31-24008-301	1
31	Washer, M4 MS Zn PI Bright Normal	Spec 01-00201	31-24001-001	31-24001-001	1
32	Surround, Front moulded	Cresta	06-01625	06-01625	1
33	Tape, Transfer 12mm	3M	969-12MMX16,4M ROLL	30-39308-004	40
34	Feet, Rubber Self Adhesive 15,7mm	Richco	RBS-15 black	30-11208-000	4
35	Line Isolation Unit Single Chl	Codan	08-03816-001	08-03816-001	1
36	Screw, M3x12 304 SS Bk Pan Pozi	Spec 01-00205	31-23012-582	31-23012-582	2

08-03905-002 - Dual Line Equaliser PCB

BOM Revision
Date Valid On

05 -- Production
27.09.2006

Ref	Description	Manufacturer	Manufacturer's P/N	Codan P/N	Qty
	Dual Line Equaliser			04-02541	1
*	Dual Line Equaliser PCB			08-03905	1
1	PCB, Dual Line Equaliser	Codan	07-01317	07-01317	1
2	Ejector, PCB Bottom Mtg	Critchley	031177	30-09900-001	1
3	Nut, M2,5 MS Zn PI Hex	Spec 01-00201	31-22500-001	31-22500-001	2
4	Screw, M2,5x10 304 SS Pan Pozi	*	31-22510-580	31-22510-580	2
5	Nut, M3 MS Zn PI Hex	Spec 01-00201	31-23000-001	31-23000-001	1
6	Screw, M3x6 304 SS Pan Pozi	*	31-23006-580	31-23006-580	1
7	Stake, Terminal	Autosplice	7-22461-5	61-40300-004	9
C1	1u 20% 35V TA Cap	AVX	TAP105M035CCS	47-01003-510	1
C2	1u 20% 35V TA Cap	AVX	TAP105M035CCS	47-01003-510	1
C3	1u 20% 35V TA Cap	AVX	TAP105M035CCS	47-01003-510	1
C4	1u 20% 35V TA Cap	AVX	TAP105M035CCS	47-01003-510	1
C5	100n 20% 50V X7R CE Cap	Vitramon	VP41BY104MA	46-51000-261	1
C6	10u 20% 25V TA Cap	AVX	TAP106M025CCS	47-11002-510	1
C7	47u 16V Ax EL Cap	Jamicon	SKR470T1CE11	48-14701-651	1
C8	1u 20% 35V TA Cap	AVX	TAP105M035CCS	47-01003-510	1
C9	1u 20% 35V TA Cap	AVX	TAP105M035CCS	47-01003-510	1
C101	100n 10% 63V PE Cap	Philips	2222 370 11104	46-51000-521	1
C102	47p 2% 100V N150 CE Cap	Philips	2222 680 34479	46-14700-012	1
C103	10p 2% 100V NPO CE Cap	Philips	2222 680 10109	46-11000-011	1
C104	220p 10% 100V CE Cap	Philips	2222 630 03221	46-22200-200	1
C105	1u 20% 35V TA Cap	AVX	TAP105M035CCS	47-01003-510	1
C106	1u 20% 35V TA Cap	AVX	TAP105M035CCS	47-01003-510	1
C107	1u 20% 35V TA Cap	AVX	TAP105M035CCS	47-01003-510	1
C108	33n 20% 25V CE Cap	Murata	DD406SR333M25	46-43300-211	1
C109	100n 10% 63V PE Cap	Philips	2222 370 11104	46-51000-521	1
C110	220p 2% 100V N750 CE Cap	Philips	2222 680 58221	46-22200-013	1
C111	220p 10% 100V CE Cap	Philips	2222 630 03221	46-22200-200	1
C112	33n 10% 100V PE Cap	Philips	2222 370 21333	46-43300-524	1
C113	1n 10% 100V PE Cap	Philips	2222 370 51102	46-31000-524	1
C114	100n 10% 63V PE Cap	Philips	2222 370 11104	46-51000-521	1

08-03905-002 - Dual Line Equaliser PCB

BOM Revision
Date Valid On

05 -- Production
27.09.2006

Ref	Description	Manufacturer	Manufacturer's P/N	Codan P/N	Qty
C115	33n 20% 25V CE Cap	Murata	DD406SR333M25	46-43300-211	1
C116	33n 20% 25V CE Cap	Murata	DD406SR333M25	46-43300-211	1
C117	100p 2% 100V N150 CE Cap	Philips	2222 680 34101	46-21000-012	1
C118	2,2u 20% 35V TA Cap	AVX	TAP225M035CCS	47-02203-510	1
C119	220p 10% 100V CE Cap	Philips	2222 630 03221	46-22200-200	1
C120	220p 2% 100V N750 CE Cap	Philips	2222 680 58221	46-22200-013	1
C121	2,2u 20% 35V TA Cap	AVX	TAP225M035CCS	47-02203-510	1
C122	220p 10% 100V CE Cap	Philips	2222 630 03221	46-22200-200	1
C123	33n 10% 100V PE Cap	Philips	2222 370 21333	46-43300-524	1
C124	1n 10% 100V PE Cap	Philips	2222 370 51102	46-31000-524	1
C125	33n 10% 100V PE Cap	Philips	2222 370 21333	46-43300-524	1
C126	33n 20% 25V CE Cap	Murata	DD406SR333M25	46-43300-211	1
C127	100p 2% 100V N150 CE Cap	Philips	2222 680 34101	46-21000-012	1
C128	Not Fitted	Codan	**_00000-001	99-00000-001	1
C129	220p 10% 100V CE Cap	Philips	2222 630 03221	46-22200-200	1
C130	33n 20% 25V CE Cap	Murata	DD406SR333M25	46-43300-211	1
C131	1n 2,5% 100V PP Cap	Roederstein	KP 1830-210/013	46-31000-702	1
C132	4,7n 2,5% 63V PP Cap	Roederstein	KP 1830-247/063	46-34700-702	1
C133	39p 2% 100V NPO CE Cap	Philips	2222 680 10399	46-13900-011	1
C134	100n 20% 50V X7R CE Cap	Vitramon	VP41BY104MA	46-51000-261	1
C135	33n 20% 25V CE Cap	Murata	DD406SR333M25	46-43300-211	1
C136	33n 20% 25V CE Cap	Murata	DD406SR333M25	46-43300-211	1
C201	100n 10% 63V PE Cap	Philips	2222 370 11104	46-51000-521	1
C202	47p 2% 100V N150 CE Cap	Philips	2222 680 34479	46-14700-012	1
C203	10p 2% 100V NPO CE Cap	Philips	2222 680 10109	46-11000-011	1
C204	220p 10% 100V CE Cap	Philips	2222 630 03221	46-22200-200	1
C205	1u 20% 35V TA Cap	AVX	TAP105M035CCS	47-01003-510	1
C206	1u 20% 35V TA Cap	AVX	TAP105M035CCS	47-01003-510	1
C207	1u 20% 35V TA Cap	AVX	TAP105M035CCS	47-01003-510	1

08-03905-002 - Dual Line Equaliser PCB

BOM Revision
Date Valid On

05 -- Production
27.09.2006

Ref	Description	Manufacturer	Manufacturer's P/N	Codan P/N	Qty
C208	33n 20% 25V CE Cap	Murata	DD406SR333M25	46-43300-211	1
C209	100n 10% 63V PE Cap	Philips	2222 370 11104	46-51000-521	1
C210	220p 2% 100V N750 CE Cap	Philips	2222 680 58221	46-22200-013	1
C211	220p 10% 100V CE Cap	Philips	2222 630 03221	46-22200-200	1
C212	33n 10% 100V PE Cap	Philips	2222 370 21333	46-43300-524	1
C213	1n 10% 100V PE Cap	Philips	2222 370 51102	46-31000-524	1
C214	100n 10% 63V PE Cap	Philips	2222 370 11104	46-51000-521	1
C215	33n 20% 25V CE Cap	Murata	DD406SR333M25	46-43300-211	1
C216	33n 20% 25V CE Cap	Murata	DD406SR333M25	46-43300-211	1
C217	100p 2% 100V N150 CE Cap	Philips	2222 680 34101	46-21000-012	1
C218	2,2u 20% 35V TA Cap	AVX	TAP225M035CCS	47-02203-510	1
C219	220p 10% 100V CE Cap	Philips	2222 630 03221	46-22200-200	1
C220	220p 2% 100V N750 CE Cap	Philips	2222 680 58221	46-22200-013	1
C221	2,2u 20% 35V TA Cap	AVX	TAP225M035CCS	47-02203-510	1
C222	220p 10% 100V CE Cap	Philips	2222 630 03221	46-22200-200	1
C223	33n 10% 100V PE Cap	Philips	2222 370 21333	46-43300-524	1
C224	1n 10% 100V PE Cap	Philips	2222 370 51102	46-31000-524	1
C225	33n 10% 100V PE Cap	Philips	2222 370 21333	46-43300-524	1
C226	33n 20% 25V CE Cap	Murata	DD406SR333M25	46-43300-211	1
C227	100p 2% 100V N150 CE Cap	Philips	2222 680 34101	46-21000-012	1
C228	Not Fitted	Codan	**_00000-001	99-00000-001	1
C229	220p 10% 100V CE Cap	Philips	2222 630 03221	46-22200-200	1
C230	33n 20% 25V CE Cap	Murata	DD406SR333M25	46-43300-211	1
C231	1n 2,5% 100V PP Cap	Roederstein	KP 1830-210/013	46-31000-702	1
C232	4,7n 2,5% 63V PP Cap	Roederstein	KP 1830-247/063	46-34700-702	1
C233	39p 2% 100V NPO CE Cap	Philips	2222 680 10399	46-13900-011	1
C234	100n 20% 50V X7R CE Cap	Vitramon	VP41BY104MA	46-51000-261	1
C235	33n 20% 25V CE Cap	Murata	DD406SR333M25	46-43300-211	1
C236	33n 20% 25V CE Cap	Murata	DD406SR333M25	46-43300-211	1
D1	Diode, Si small sig GP	Codan	23-10005	23-10005	1

08-03905-002 - Dual Line Equaliser PCB

BOM Revision
Date Valid On

05 -- Production
27.09.2006

Ref	Description	Manufacturer	Manufacturer's P/N	Codan P/N	Qty
D2	Diode, Si small sig GP	Codan	23-10005	23-10005	1
D101	Diode, Si small sig GP	Codan	23-10005	23-10005	1
D102	Diode, Si small sig GP	Codan	23-10005	23-10005	1
D201	Diode, Si small sig GP	Codan	23-10005	23-10005	1
D202	Diode, Si small sig GP	Codan	23-10005	23-10005	1
IC1	Switch, Bilateral Quad IC	National Semiconduct	CD4066BCN	YG-40066-000	1
IC2	Conv, D to A, 8x6 bit IIC	Philips	TDA8444	YN-08444-000	1
IC3	Remote 8 Bit I/O For IIC Bus IC	Philips	PCF8574P	YK-08574-000	1
IC4	Not Fitted	Codan	** -00000-001	99-00000-001	1
IC5	Array, Transistor IC	Motorola	MC1413P	XT-01413-000	1
IC6	Reg, Voltage +10V IC	National Semiconduct	LM2940T-10	XB-02940-402	1
IC101	Amp, Operational Dual LN IC	Signetics	NE5532N	XA-05532-000	1
IC102	Amp, Low power audio IC	Motorola	MC34119P	XA-34119-000	1
IC103	Compander, Audio IC	Signetics	NE571N	XA-00571-000	1
IC104	Compander, Audio IC	Signetics	NE571N	XA-00571-000	1
IC105	Amp, Operational Dual IC	National Semiconduct	LM358N	XA-00358-100	1
IC106	Filter, Switched Cap IC	National Semiconduct	MF10CCN	MF10CCN	1
IC107	Amp, Operational Dual IC	National Semiconduct	LM358N	XA-00358-100	1
IC201	Not Fitted	Codan	** -00000-001	99-00000-001	1
IC202	Amp, Low power audio IC	Motorola	MC34119P	XA-34119-000	1
IC203	Compander, Audio IC	Signetics	NE571N	XA-00571-000	1
IC204	Compander, Audio IC	Signetics	NE571N	XA-00571-000	1
IC205	Amp, Operational Dual IC	National Semiconduct	LM358N	XA-00358-100	1
IC206	Filter, Switched Cap IC	National Semiconduct	MF10CCN	MF10CCN	1
IC207	Amp, Operational Dual IC	National Semiconduct	LM358N	XA-00358-100	1
P1	Connector, 64way Male 90 deg PCB	ITT-Cannon	G06D064P4BEBL	60-51100-064	1
R1	33k Ohm 20% 0,1W SIL Com x5Res	Murata	RGSD5X333M	40-84330-500	1
R2	3,9k Ohm 5% 0,33W CF Res	Philips	2322 211 13392	40-33900-020	1
R3	1k Ohm 5% 0,33W CF Res	Philips	2322 211 13102	40-31000-020	1
R4	1k Ohm 5% 0,33W CF Res	Philips	2322 211 13102	40-31000-020	1
R5	3,9k Ohm 5% 0,33W CF Res	Philips	2322 211 13392	40-33900-020	1
R6	3,3k Ohm 20% 0,1W SIL Com x9Res	Murata	RGSD9X332M	40-83330-900	1
R7	22k Ohm 5% 0,33W CF Res	Philips	2322 211 13223	40-42200-020	1
R8	22k Ohm 5% 0,33W CF Res	Philips	2322 211 13223	40-42200-020	1
R9	3,3k Ohm 20% 0,1W SIL Com x5Res	Murata	RGSD5X332M	40-83330-500	1
R10	22k Ohm 5% 0,33W CF Res	Philips	2322 211 13223	40-42200-020	1
R11	22k Ohm 5% 0,33W CF Res	Philips	2322 211 13223	40-42200-020	1
R12	Not Fitted	Codan	** -00000-001	99-00000-001	1
R13	2,2k Ohm 5% 0,33W CF Res	Philips	2322 211 13222	40-32200-020	1

08-03905-002 - Dual Line Equaliser PCB

BOM Revision
Date Valid On

05 -- Production
27.09.2006

Ref	Description	Manufacturer	Manufacturer's P/N	Codan P/N	Qty
R14	2,2k Ohm 5% 0,33W CF Res	Philips	2322 211 13222	40-32200-020	1
R101	100k Ohm 5% 0,33W CF Res	Philips	2322 211 13104	40-51000-020	1
R102	100k Ohm 5% 0,33W CF Res	Philips	2322 211 13104	40-51000-020	1
R103	56k Ohm 5% 0,33W CF Res	Philips	2322 211 13563	40-45600-020	1
R104	56k Ohm 5% 0,33W CF Res	Philips	2322 211 13563	40-45600-020	1
R105	100k Ohm 5% 0,33W CF Res	Philips	2322 211 13104	40-51000-020	1
R106	560 Ohm 5% 0,33W CF Res	Philips	2322 211 13561	40-25600-020	1
R107	560 Ohm 5% 0,33W CF Res	Philips	2322 211 13561	40-25600-020	1
R108	1,2k Ohm 5% 0,33W CF Res	Philips	2322 211 13122	40-31200-020	1
R109	100k Ohm 5% 0,33W CF Res	Philips	2322 211 13104	40-51000-020	1
R110	150k Ohm 5% 0,33W CF Res	Philips	2322 211 13154	40-51500-020	1
R111	47k Ohm 5% 0,33W CF Res	Philips	2322 211 13473	40-44700-020	1
R112	150k Ohm 5% 0,33W CF Res	Philips	2322 211 13154	40-51500-020	1
R113	10k Ohm 2% 0,4W MF Res	Philips	2322 181 54103	40-41000-500	1
R114	270k Ohm 2% 0,4W MF Res	Philips	2322 181 54274	40-52700-500	1
R115	10k Ohm 2% 0,4W MF Res	Philips	2322 181 54103	40-41000-500	1
R116	47k Ohm 5% 0,33W CF Res	Philips	2322 211 13473	40-44700-020	1
R117	10k Ohm 5% 0,33W CF Res	Philips	2322 211 13103	40-41000-020	1
R118	100k Ohm 5% 0,33W CF Res	Philips	2322 211 13104	40-51000-020	1
R119	10k Ohm 2% 0,4W MF Res	Philips	2322 181 54103	40-41000-500	1
R120	270k Ohm 2% 0,4W MF Res	Philips	2322 181 54274	40-52700-500	1
R121	10k Ohm 2% 0,4W MF Res	Philips	2322 181 54103	40-41000-500	1
R122	150k Ohm 5% 0,33W CF Res	Philips	2322 211 13154	40-51500-020	1
R123	33k Ohm 5% 0,33W CF Res	Philips	2322 211 13333	40-43300-020	1
R124	100k Ohm 5% 0,33W CF Res	Philips	2322 211 13104	40-51000-020	1
R125	8,2k Ohm 5% 0,33W CF Res	Philips	2322 211 13822	40-38200-020	1
R126	47k Ohm 5% 0,33W CF Res	Philips	2322 211 13473	40-44700-020	1
R127	100k Ohm 5% 0,33W CF Res	Philips	2322 211 13104	40-51000-020	1
R128	100k Ohm 5% 0,33W CF Res	Philips	2322 211 13104	40-51000-020	1

08-03905-002 - Dual Line Equaliser PCB

BOM Revision
Date Valid On

05 -- Production
27.09.2006

Ref	Description	Manufacturer	Manufacturer's P/N	Codan P/N	Qty
R129	330k Ohm 5% 0,33W CF Res	Philips	2322 211 13334	40-53300-020	1
R130	39k Ohm 5% 0,33W CF Res	Philips	2322 211 13393	40-43900-020	1
R131	100k Ohm 5% 0,33W CF Res	Philips	2322 211 13104	40-51000-020	1
R132	100k Ohm 5% 0,33W CF Res	Philips	2322 211 13104	40-51000-020	1
R133	8,2k Ohm 5% 0,33W CF Res	Philips	2322 211 13822	40-38200-020	1
R134	56k Ohm 5% 0,33W CF Res	Philips	2322 211 13563	40-45600-020	1
R135	Not Fitted	Codan	**_00000-001	99-00000-001	1
R136	1k Ohm 5% 0,33W CF Res	Philips	2322 211 13102	40-31000-020	1
R137	330k Ohm 5% 0,33W CF Res	Philips	2322 211 13334	40-53300-020	1
R138	120k Ohm 2% 0,4W MF Res	Philips	2322 181 54124	40-51200-500	1
R139	130k Ohm 2% 0,4W MF Res	Philips	2322 181 54134	40-51300-500	1
R140	130k Ohm 2% 0,4W MF Res	Philips	2322 181 54134	40-51300-500	1
R141	Not Fitted	Codan	**_00000-001	99-00000-001	1
R142	Not Fitted	Codan	**_00000-001	99-00000-001	1
R143	4,7k Ohm 5% 0,33W CF Res	Philips	2322 211 13472	40-34700-020	1
R144	47k Ohm 5% 0,33W CF Res	Philips	2322 211 13473	40-44700-020	1
R145	15 Ohm 5% 0,33W CF Res	Philips	2322 211 13159	40-11500-020	1
R146	15 Ohm 5% 0,33W CF Res	Philips	2322 211 13159	40-11500-020	1
R201	100k Ohm 5% 0,33W CF Res	Philips	2322 211 13104	40-51000-020	1
R202	100k Ohm 5% 0,33W CF Res	Philips	2322 211 13104	40-51000-020	1
R203	56k Ohm 5% 0,33W CF Res	Philips	2322 211 13563	40-45600-020	1
R204	56k Ohm 5% 0,33W CF Res	Philips	2322 211 13563	40-45600-020	1
R205	100k Ohm 5% 0,33W CF Res	Philips	2322 211 13104	40-51000-020	1
R206	560 Ohm 5% 0,33W CF Res	Philips	2322 211 13561	40-25600-020	1
R207	560 Ohm 5% 0,33W CF Res	Philips	2322 211 13561	40-25600-020	1
R208	1,2k Ohm 5% 0,33W CF Res	Philips	2322 211 13122	40-31200-020	1
R209	100k Ohm 5% 0,33W CF Res	Philips	2322 211 13104	40-51000-020	1
R210	150k Ohm 5% 0,33W CF Res	Philips	2322 211 13154	40-51500-020	1
R211	47k Ohm 5% 0,33W CF Res	Philips	2322 211 13473	40-44700-020	1
R212	150k Ohm 5% 0,33W CF Res	Philips	2322 211 13154	40-51500-020	1

08-03905-002 - Dual Line Equaliser PCB

BOM Revision
Date Valid On

05 -- Production
27.09.2006

Ref	Description	Manufacturer	Manufacturer's P/N	Codan P/N	Qty
R213	10k Ohm 2% 0,4W MF Res	Philips	2322 181 54103	40-41000-500	1
R214	270k Ohm 2% 0,4W MF Res	Philips	2322 181 54274	40-52700-500	1
R215	10k Ohm 2% 0,4W MF Res	Philips	2322 181 54103	40-41000-500	1
R216	47k Ohm 5% 0,33W CF Res	Philips	2322 211 13473	40-44700-020	1
R217	10k Ohm 5% 0,33W CF Res	Philips	2322 211 13103	40-41000-020	1
R218	100k Ohm 5% 0,33W CF Res	Philips	2322 211 13104	40-51000-020	1
R219	10k Ohm 2% 0,4W MF Res	Philips	2322 181 54103	40-41000-500	1
R220	270k Ohm 2% 0,4W MF Res	Philips	2322 181 54274	40-52700-500	1
R221	10k Ohm 2% 0,4W MF Res	Philips	2322 181 54103	40-41000-500	1
R222	150k Ohm 5% 0,33W CF Res	Philips	2322 211 13154	40-51500-020	1
R223	33k Ohm 5% 0,33W CF Res	Philips	2322 211 13333	40-43300-020	1
R224	100k Ohm 5% 0,33W CF Res	Philips	2322 211 13104	40-51000-020	1
R225	8,2k Ohm 5% 0,33W CF Res	Philips	2322 211 13822	40-38200-020	1
R226	47k Ohm 5% 0,33W CF Res	Philips	2322 211 13473	40-44700-020	1
R227	100k Ohm 5% 0,33W CF Res	Philips	2322 211 13104	40-51000-020	1
R228	100k Ohm 5% 0,33W CF Res	Philips	2322 211 13104	40-51000-020	1
R229	330k Ohm 5% 0,33W CF Res	Philips	2322 211 13334	40-53300-020	1
R230	39k Ohm 5% 0,33W CF Res	Philips	2322 211 13393	40-43900-020	1
R231	100k Ohm 5% 0,33W CF Res	Philips	2322 211 13104	40-51000-020	1
R232	100k Ohm 5% 0,33W CF Res	Philips	2322 211 13104	40-51000-020	1
R233	8,2k Ohm 5% 0,33W CF Res	Philips	2322 211 13822	40-38200-020	1
R234	56k Ohm 5% 0,33W CF Res	Philips	2322 211 13563	40-45600-020	1
R235	Not Fitted	Codan	**_00000-001	99-00000-001	1
R236	1k Ohm 5% 0,33W CF Res	Philips	2322 211 13102	40-31000-020	1
R237	330k Ohm 5% 0,33W CF Res	Philips	2322 211 13334	40-53300-020	1
R238	120k Ohm 2% 0,4W MF Res	Philips	2322 181 54124	40-51200-500	1
R239	130k Ohm 2% 0,4W MF Res	Philips	2322 181 54134	40-51300-500	1
R240	130k Ohm 2% 0,4W MF Res	Philips	2322 181 54134	40-51300-500	1
R241	Not Fitted	Codan	**_00000-001	99-00000-001	1
R242	Not Fitted	Codan	**_00000-001	99-00000-001	1

08-03905-002 - Dual Line Equaliser PCB

BOM Revision
Date Valid On

05 -- Production
27.09.2006

Ref	Description	Manufacturer	Manufacturer's P/N	Codan P/N	Qty
R243	4,7k Ohm 5% 0,33W CF Res	Philips	2322 211 13472	40-34700-020	1
R244	47k Ohm 5% 0,33W CF Res	Philips	2322 211 13473	40-44700-020	1
R245	15 Ohm 5% 0,33W CF Res	Philips	2322 211 13159	40-11500-020	1
R246	15 Ohm 5% 0,33W CF Res	Philips	2322 211 13159	40-11500-020	1
T1	Txfr	Protran	44-30821	44-30821	1
T2	Txfr	Protran	44-30821	44-30821	1
V1	Transistor, NPN Si	Philips	BC548	BC548	1
V2	Transistor, NPN Si	Philips	BC548	BC548	1

08-03993 - MicroP & Tcvt I/F PCB

BOM Revision
Date Valid On

10 -- Production
27.09.2006

Ref	Description	Manufacturer	Manufacturer's P/N	Codan P/N	Qty
	MicroP & Tcvt I/F PCB	Rapier Electronics		08-03993	1
	MicroP & Tcvt I/F			04-02690	1
1	PCB, MicroP & Tcvt I/F	Codan	07-01347	07-01347	1
2	Ejector, PCB Bottom Mtg	Critchley	031177	30-09900-001	1
3	Nut, M2,5 MS Zn Pl Hex	Spec 01-00201	31-22500-001	31-22500-001	2
4	Screw, M2,5x10 304 SS Pan Pozi	*	31-22510-580	31-22510-580	2
5	Nut, M3 MS Zn Pl Hex	Spec 01-00201	31-23000-001	31-23000-001	1
6	Screw, M3x6 304 SS Pan Pozi	*	31-23006-580	31-23006-580	1
7	Socket, 28DIL IC L/Prof Machined	Texas Instruments	C72-28-59	60-00283-231	1
8	Socket, 68PLCC IC	AMP	821574-1	60-00683-351	1
9	Stake, Terminal	Autosplice	7-22461-5	61-40300-004	8
C1	1u 20% 35V TA Cap	AVX	TAP105M035CCS	47-01003-510	1
C2	100n 10% 63V PE Cap	Philips	2222 370 11104	46-51000-521	1
C3	1u 20% 35V TA Cap	AVX	TAP105M035CCS	47-01003-510	1
C4	1n 10% 100V PE Cap	Philips	2222 370 51102	46-31000-524	1
C5	33n 20% 25V CE Cap	Murata	DD406SR333M25	46-43300-211	1
C6	1n 10% 100V PE Cap	Philips	2222 370 51102	46-31000-524	1
C7	1n 10% 100V CE Cap	Vishay	2222 326 03102	46-31000-200	1
C8	1n 10% 100V CE Cap	Vishay	2222 326 03102	46-31000-200	1
C9	100n 10% 63V PE Cap	Philips	2222 370 11104	46-51000-521	1
C10	1u 10% 63V PE Cap	Philips	2222 370 11105	46-61000-521	1
C11	100n 10% 63V PE Cap	Philips	2222 370 11104	46-51000-521	1
C12	10u 20% 25V TA Cap	AVX	TAP106M025CCS	47-11002-510	1
C13	33n 20% 25V CE Cap	Murata	DD406SR333M25	46-43300-211	1
C14	220p 10% 100V CE Cap	Philips	2222 630 03221	46-22200-200	1
C15	33n 20% 25V CE Cap	Murata	DD406SR333M25	46-43300-211	1
C16	100n 10% 63V PE Cap	Philips	2222 370 11104	46-51000-521	1
C17	100n 10% 63V PE Cap	Philips	2222 370 11104	46-51000-521	1
C18	2,2u 20% 35V TA Cap	AVX	TAP225M035CCS	47-02203-510	1
C19	220p 10% 100V CE Cap	Philips	2222 630 03221	46-22200-200	1
C20	100n 10% 63V PE Cap	Philips	2222 370 11104	46-51000-521	1
C21	2,2u 20% 35V TA Cap	AVX	TAP225M035CCS	47-02203-510	1

08-03993 - MicroP & Tcwr I/F PCB

BOM Revision
Date Valid On

10 -- Production
27.09.2006

Ref	Description	Manufacturer	Manufacturer's P/N	Codan P/N	Qty
C22	100n 10% 63V PE Cap	Philips	2222 370 11104	46-51000-521	1
C23	100n 10% 63V PE Cap	Philips	2222 370 11104	46-51000-521	1
C24	47u 16V Ax EL Cap	Jamicon	SKR470T1CE11	48-14701-651	1
C25	33n 20% 25V CE Cap	Murata	DD406SR333M25	46-43300-211	1
C26	33n 20% 25V CE Cap	Murata	DD406SR333M25	46-43300-211	1
C27	33n 20% 25V CE Cap	Murata	DD406SR333M25	46-43300-211	1
C28	3,3n 10% 100V CE Cap	Philips	2222 630 03332	46-33300-200	1
C29	33n 20% 25V CE Cap	Murata	DD406SR333M25	46-43300-211	1
C30	100n 10% 63V PE Cap	Philips	2222 370 11104	46-51000-521	1
C31	10u 20% 25V TA Cap	AVX	TAP106M025CCS	47-11002-510	1
C32	1u 20% 35V TA Cap	AVX	TAP105M035CCS	47-01003-510	1
C33	22p 2% 100V NPO CE Cap	Philips	2222 680 10229	46-12200-011	1
C34	22p 2% 100V NPO CE Cap	Philips	2222 680 10229	46-12200-011	1
C35	1u 20% 35V TA Cap	AVX	TAP105M035CCS	47-01003-510	1
C36	3,3n 10% 100V CE Cap	Philips	2222 630 03332	46-33300-200	1
C37	1u 20% 35V TA Cap	AVX	TAP105M035CCS	47-01003-510	1
C38	33n 20% 25V CE Cap	Murata	DD406SR333M25	46-43300-211	1
C39	33n 20% 25V CE Cap	Murata	DD406SR333M25	46-43300-211	1
C40	33n 20% 25V CE Cap	Murata	DD406SR333M25	46-43300-211	1
C41	33n 20% 25V CE Cap	Murata	DD406SR333M25	46-43300-211	1
C42	33n 20% 25V CE Cap	Murata	DD406SR333M25	46-43300-211	1
C43	33n 20% 25V CE Cap	Murata	DD406SR333M25	46-43300-211	1
C44	33n 20% 25V CE Cap	Murata	DD406SR333M25	46-43300-211	1
C45	220p 2% 100V N750 CE Cap	Philips	2222 680 58221	46-22200-013	1
D1	Diode, Si small sig GP	Codan	23-10005	23-10005	1
H1	LED, Red T-1 Diffused	Liteon	LTL-4221	65-61110-209	1
IC1	Buffer, Hex Inverting Schmitt IC	Motorola	MC74HC14N	YH-74014-000	1
IC2	MUX/DEMUX, Analog Triple 2 Ch IC	National Semiconduct	CD4053BCN	YG-40053-000	1
IC3	Amp, Operational Dual IC	National Semiconduct	LM358N	XA-00358-100	1
IC4	Filter, Switched Cap IC	National Semiconduct	MF10CCN	MF10CCN	1

08-03993 - MicroP & Tcwr I/F PCB

BOM Revision
Date Valid On

10 -- Production
27.09.2006

Ref	Description	Manufacturer	Manufacturer's P/N	Codan P/N	Qty
IC5	Buffer, Hex Inverting Schmitt IC	Motorola	MC74HC14N	YH-74014-000	1
IC6	Modem, 300 baud, Bell 103 IC	National Semiconduct	MM74HC943N	YH-74943-000	1
IC7	Compander, Audio IC	Signetics	NE571N	XA-00571-000	1
IC8	EEPROM, CMOS 256 x 8 Bit IIC Bus	Philips	PCF8582AP	YM-08582-000	1
IC9	Supervisory, Pwr&reset 4.75V IC	Philips	PCF1252-OP	XD-01252-100	1
IC10	Reg, Voltage +10V IC	National Semiconduct	LM2940T-10	XB-02940-402	1
IC11	Array, Transistor IC	Motorola	MC1413P	XT-01413-000	1
IC12	MCU, 8bit 16MHz PLCC68	Philips	PCB80C552-5-16WP	YP-80552-900	1
IC13	Latch, Octal IC	Motorola	MC74HC573N	YH-74573-000	1
IC14	EPROM, prgmd NGT 8571	Codan	90-20613-001	90-20613-001	1
IC15	RAM, CMOS 8k x 8 Bit IC	Hitachi	HM6264P-15	YM-06264-000	1
IC16	Timer, Programmable CMOS IC	OKI Semi Cond	MSM82C53-2RS	YL-08253-001	1
IC17	Filter, Switched Cap LP IC	National Semiconduct	MF4CN-100	MF4CN-100	1
L1	Ind, 1mH 5%	Taiyo Yuden	LHL06 NB 102J	43-83100-097	1
L2	Ind, 1mH 5%	Taiyo Yuden	LHL06 NB 102J	43-83100-097	1
P1	Connector, 64way Male 90 deg PCB	ITT-Cannon	G06D064P4BEBL	60-51100-064	1
R1	10k Ohm 5% 0,33W CF Res	Philips	2322 211 13103	40-41000-020	1
R2	10k Ohm 5% 0,33W CF Res	Philips	2322 211 13103	40-41000-020	1
R3	15k Ohm 5% 0,33W CF Res	Philips	2322 211 13153	40-41500-020	1
R4	4,7k Ohm 2% 0,4W MF Res	Philips	2322 181 54472	40-34700-500	1
R5	5,6k Ohm 2% 0,4W MF Res	Philips	2322 181 54562	40-35600-500	1
R6	10k Ohm 2% 0,4W MF Res	Philips	2322 181 54103	40-41000-500	1
R7	10k Ohm 2% 0,4W MF Res	Philips	2322 181 54103	40-41000-500	1
R8	11,0k Ohm 1% 0,4W MF Res	Philips	2322 156 11103	40-41100-501	1
R9	10k Ohm 5% 0,33W CF Res	Philips	2322 211 13103	40-41000-020	1
R10	10k Ohm 5% 0,33W CF Res	Philips	2322 211 13103	40-41000-020	1
R11	470 Ohm 5% 0,33W CF Res	Philips	2322 211 13471	40-24700-020	1
R12	10k Ohm 5% 0,33W CF Res	Philips	2322 211 13103	40-41000-020	1
R13	5,6k Ohm 2% 0,4W MF Res	Philips	2322 181 54562	40-35600-500	1
R14	39k Ohm 2% 0,4W MF Res	Philips	2322 181 54393	40-43900-500	1
R15	10k Ohm 2% 0,4W MF Res	Philips	2322 181 54103	40-41000-500	1
R16	10k Ohm 2% 0,4W MF Res	Philips	2322 181 54103	40-41000-500	1

08-03993 - MicroP & Tcwr I/F PCB

BOM Revision
Date Valid On

10 -- Production
27.09.2006

Ref	Description	Manufacturer	Manufacturer's P/N	Codan P/N	Qty
R17	9,1k Ohm 2% 0,4W MF Res	Philips	2322 181 54912	40-39100-500	1
R18	10k Ohm 5% 0,33W CF Res	Philips	2322 211 13103	40-41000-020	1
R19	10k Ohm 5% 0,33W CF Res	Philips	2322 211 13103	40-41000-020	1
R20	10k Ohm 5% 0,33W CF Res	Philips	2322 211 13103	40-41000-020	1
R21	1k Ohm 5% 0,33W CF Res	Philips	2322 211 13102	40-31000-020	1
R22	Not Fitted	Codan	**-.00000-001	99-00000-001	1
R23	100 Ohm 5% 0,33W CF Res	Philips	2322 211 13101	40-21000-020	1
R24	56k Ohm 5% 0,33W CF Res	Philips	2322 211 13563	40-45600-020	1
R25	27k Ohm 5% 0,33W CF Res	Philips	2322 211 13273	40-42700-020	1
R26	33k Ohm 5% 0,33W CF Res	Philips	2322 211 13333	40-43300-020	1
R27	33k Ohm 5% 0,33W CF Res	Philips	2322 211 13333	40-43300-020	1
R28	4,7k Ohm 5% 0,33W CF Res	Philips	2322 211 13472	40-34700-020	1
R29	100k Ohm 5% 0,33W CF Res	Philips	2322 211 13104	40-51000-020	1
R30	10k Ohm 5% 0,33W CF Res	Philips	2322 211 13103	40-41000-020	1
R31	10k Ohm 5% 0,33W CF Res	Philips	2322 211 13103	40-41000-020	1
R32	10k Ohm 5% 0,33W CF Res	Philips	2322 211 13103	40-41000-020	1
R33	10k Ohm 5% 0,33W CF Res	Philips	2322 211 13103	40-41000-020	1
R34	2,2k Ohm 5% 0,33W CF Res	Philips	2322 211 13222	40-32200-020	1
R35	2,2k Ohm 5% 0,33W CF Res	Philips	2322 211 13222	40-32200-020	1
R36	2,7k Ohm 2% 0,4W MF Res	Philips	2322 181 54272	40-32700-500	1
R37	Temperature Sensor 1000 Ohm 1%	Philips	KTY81-110	KTY81-110	1
R38	15k Ohm 2% 0,4W MF Res	Philips	2322 181 54153	40-41500-500	1
R39	2,7k Ohm 2% 0,4W MF Res	Philips	2322 181 54272	40-32700-500	1
R40	100k Ohm 5% 0,33W CF Res	Philips	2322 211 13104	40-51000-020	1
R41	33k Ohm 20% 0,1W SIL Com x5Res	Murata	RGSD5X333M	40-84330-500	1
R42	1,5k Ohm 5% 0,33W CF Res	Philips	2322 211 13152	40-31500-020	1
R44	4,7k Ohm 5% 0,33W CF Res	Philips	2322 211 13472	40-34700-020	1
R45	4,7k Ohm 5% 0,33W CF Res	Philips	2322 211 13472	40-34700-020	1
R46	33k Ohm 20% 0,1W SIL Com x5Res	Murata	RGSD5X333M	40-84330-500	1

08-03993 - MicroP & Tcwr I/F PCB

BOM Revision
Date Valid On

10 -- Production
27.09.2006

Ref	Description	Manufacturer	Manufacturer's P/N	Codan P/N	Qty
R47	3,3k Ohm 20% 0,1W SIL Com x5Res	Murata	RGSD5X332M	40-83330-500	1
R48	100k Ohm 2% 0,4W MF Res	Philips	2322 181 54104	40-51000-500	1
R49	100k Ohm 2% 0,4W MF Res	Philips	2322 181 54104	40-51000-500	1
R50	220 Ohm 5% 0,33W CF Res	Philips	2322 211 13221	40-22200-020	1
S1	Switch, Binary 16 Position	Copal	S1030	62-61623-001	1
T1	Txfr	Protran	44-30821	44-30821	1
T2	Txfr	Protran	44-30821	44-30821	1
V1	Transistor, NPN Si	Philips	BC548	BC548	1
V2	Transistor, NPN Si	Philips	BC548	BC548	1
V3	Transistor, NPN Si	Philips	BC548	BC548	1
V4	Transistor, NPN Si	Philips	BC548	BC548	1
V5	Diode, Ref 5,0V 2% IC	National Semiconduct	LM336Z-5.0	XB-00336-505	1
Z1	Crystal, 3579,545 kHz uP Grade	HY-Q	M/P QC49 3579,545KHZ	65-90060-000	1
Z2	Crystal, 12000 kHz uP Grade	HY-Q	M/P QC49 12000KHZ	65-90014-000	1

08-05995-001 - Backplane PCB

BOM Revision
Date Valid On

01 -- Production
28.09.2006

Ref	Description	Manufacturer	Manufacturer's P/N	Codan P/N	Qty
	Backplane			04-02691	1
	PCB, Backplane	Codan	07-01348-03	07-01348-03	1
*	Backplane PCB			08-05995	1
2	Card Frame-Rear Plate	Metalcraft	08-04131	08-04131	2
3	Nut, M2,5 MS Zn PI Hex	Spec 01-00201	31-22500-001	31-22500-001	8
4	Screw, M2,5x6 304 SS Pan Pozi	James Glen	31-22506-580	31-22506-580	8
5	Nut, M3 MS Zn PI Hex	Spec 01-00201	31-23000-001	31-23000-001	2
6	Screw, M3x8 304 SS Pan Pozi	*	31-23008-580	31-23008-580	2
7	Jumper (S) 2way Open Top	Molex	15-38-1024	60-90410-001	6
8	Stake, Terminal	Autosplice	7-22461-5	61-40300-004	6
C1	1n 10% 100V CE Cap	Vishay	2222 326 03102	46-31000-200	1
C2	1n 10% 100V CE Cap	Vishay	2222 326 03102	46-31000-200	1
C3	1n 10% 100V CE Cap	Vishay	2222 326 03102	46-31000-200	1
C4	1n 10% 100V CE Cap	Vishay	2222 326 03102	46-31000-200	1
C5	1n 10% 100V CE Cap	Vishay	2222 326 03102	46-31000-200	1
C6	1n 10% 100V CE Cap	Vishay	2222 326 03102	46-31000-200	1
C7	1n 10% 100V CE Cap	Vishay	2222 326 03102	46-31000-200	1
C8	1n 10% 100V CE Cap	Vishay	2222 326 03102	46-31000-200	1
C9	1n 10% 100V CE Cap	Vishay	2222 326 03102	46-31000-200	1
C10	1n 10% 100V CE Cap	Vishay	2222 326 03102	46-31000-200	1
C11	1n 10% 100V CE Cap	Vishay	2222 326 03102	46-31000-200	1
C12	1n 10% 100V CE Cap	Vishay	2222 326 03102	46-31000-200	1
C13	100n 20% 50V X7R CE Cap	Vitramon	VP41BY104MA	46-51000-261	1
C14	2,2u 20% 35V TA Cap	AVX	TAP225M035CCS	47-02203-510	1
C15	100n 20% 50V X7R CE Cap	Vitramon	VP41BY104MA	46-51000-261	1
C16	2,2u 20% 35V TA Cap	AVX	TAP225M035CCS	47-02203-510	1
C101	1n 10% 100V CE Cap	Vishay	2222 326 03102	46-31000-200	1
C102	1n 10% 100V CE Cap	Vishay	2222 326 03102	46-31000-200	1
C103	1n 10% 100V CE Cap	Vishay	2222 326 03102	46-31000-200	1
C104	1n 10% 100V CE Cap	Vishay	2222 326 03102	46-31000-200	1
C301	1n 10% 100V CE Cap	Vishay	2222 326 03102	46-31000-200	1
C302	1n 10% 100V CE Cap	Vishay	2222 326 03102	46-31000-200	1
C303	1n 10% 100V CE Cap	Vishay	2222 326 03102	46-31000-200	1

08-05995-001 - Backplane PCB

BOM Revision
Date Valid On

01 -- Production
28.09.2006

Ref	Description	Manufacturer	Manufacturer's P/N	Codan P/N	Qty
C304	1n 10% 100V CE Cap	Vishay	2222 326 03102	46-31000-200	1
C305	1n 10% 100V CE Cap	Vishay	2222 326 03102	46-31000-200	1
C306	1n 10% 100V CE Cap	Vishay	2222 326 03102	46-31000-200	1
C307	1n 10% 100V CE Cap	Vishay	2222 326 03102	46-31000-200	1
C308	1n 10% 100V CE Cap	Vishay	2222 326 03102	46-31000-200	1
C309	1n 10% 100V CE Cap	Vishay	2222 326 03102	46-31000-200	1
C310	1n 10% 100V CE Cap	Vishay	2222 326 03102	46-31000-200	1
C311	1n 10% 100V CE Cap	Vishay	2222 326 03102	46-31000-200	1
C312	1n 10% 100V CE Cap	Vishay	2222 326 03102	46-31000-200	1
C313	1n 10% 100V CE Cap	Vishay	2222 326 03102	46-31000-200	1
C314	1n 10% 100V CE Cap	Vishay	2222 326 03102	46-31000-200	1
C315	1n 10% 100V CE Cap	Vishay	2222 326 03102	46-31000-200	1
D1	Diode, Si 400V 1A	Fairchild	1N4004	1N4004	1
D2	Diode, Si 400V 1A	Fairchild	1N4004	1N4004	1
D3	Diode, Si 400V 1A	Fairchild	1N4004	1N4004	1
D4	Diode, Si 400V 1A	Fairchild	1N4004	1N4004	1
IC1	Reg, Voltage +5V 1,5A IC	National Semiconduct	LM340T-5	XB-07805-400	1
IC2	Reg, Voltage +15V 1,5A IC	National Semiconduct	LM340T-15	XB-07815-400	1
J1	Connector, 64way Fem Solder PCB	ITT-Cannon	G06D064P3BBBL	60-51201-064	1
J2	Connector, 64way Fem Solder PCB	ITT-Cannon	G06D064P3BBBL	60-51201-064	1
J101	Connector, 64way Fem Solder PCB	ITT-Cannon	G06D064P3BBBL	60-51201-064	1
J301	Connector, 64way Fem Solder PCB	ITT-Cannon	G06D064P3BBBL	60-51201-064	1
L301	Ind, 1mH 10%	Taiyo Yuden	FL 5H 102K	43-83100-095	1
P1	Header (P) 16way 2row thin insul	Berg	67997-416H	60-00160-001	1
P2	Header (P) 2way 1row Latch	JAE	IL-2P-S3EN2	60-00020-260	1
P3	Header (P) 8way 1row	Molex	22-03-2081	60-00081-100	1
P4	Header (P) 8way 1row	Molex	22-03-2081	60-00081-100	1
P5	Header (P) 2way 1row Latch	JAE	IL-2P-S3EN2	60-00020-260	1
P6	Header (P) 4way 1row	Molex	22-03-2041	60-00041-100	1
P7	Header (P) 4way 1row Latch	JAE	IL-4P-S3EN2	60-00040-261	1
P101	Header (P) 2way 1row Latch	JAE	IL-2P-S3EN2	60-00020-260	1
P102	Header (P) 8way 1row	Molex	22-03-2081	60-00081-100	1
P103	Header (P) 8way 1row	Molex	22-03-2081	60-00081-100	1
P104	Header (P) 2way 1row Latch	JAE	IL-2P-S3EN2	60-00020-260	1
P105	Header (P) 4way 1row	Molex	22-03-2041	60-00041-100	1
P301	Header (P) 16way 2row	JAE	PS-16PE-D4T1-PN1	60-00160-260	1
P302	Header (P) 10way 2row	JAE	PS-10PE-D4T1-PN1	60-00100-260	1
P303	Header (P) 3way 1row	Molex	22-03-2031	60-00031-100	1
P304	Header (P) 3way 1row	Molex	22-03-2031	60-00031-100	1
P305	Header (P) 3way 1row	Molex	22-03-2031	60-00031-100	1
P306	Header (P) 3way 1row	Molex	22-03-2031	60-00031-100	1

08-05995-001 - Backplane PCB

BOM Revision

01 -- Production

Date Valid On

28.09.2006

Ref	Description	Manufacturer	Manufacturer's P/N	Codan P/N	Qty
P307	Header (P) 8way 1row	Molex	22-03-2081	60-00081-100	1
R1	3,3k Ohm 20% 0,1W SIL Com x5Res	Murata	RGSD5X332M	40-83330-500	1

08-04644-001 - Opt RS PCB

BOM Revision
Date Valid On

05 -- Production
27.09.2006

Ref	Description	Manufacturer	Manufacturer's P/N	Codan P/N	Qty
	Socket, 68PLCC IC	AMP	821574-1	60-00683-351	1
	Socket, 28DIL IC L/Prof Machined	Texas Instruments	C72-28-59	60-00283-231	1
	Screw, M2,5x10 304 SS Pan Pozi	*	31-22510-580	31-22510-580	2
	Nut, M2,5 MS Zn Pl Hex	Spec 01-00201	31-22500-001	31-22500-001	2
	Ejector, PCB Bottom Mtg	Critchley	031177	30-09900-001	1
	PCB, Gen. Purpose I/O	Codan	07-01601	07-01601	1
	Gen. Purpose I/O			04-02852	1
*	Gen. Purpose I/O PCB			08-04644	1
*	Gen. Purpose I/O PCB			08-04644	1
C101	1n 10% 100V CE Cap	Vishay	2222 326 03102	46-31000-200	1
C102	1n 10% 100V CE Cap	Vishay	2222 326 03102	46-31000-200	1
C103	1n 10% 100V CE Cap	Vishay	2222 326 03102	46-31000-200	1
C104	1n 10% 100V CE Cap	Vishay	2222 326 03102	46-31000-200	1
C105	1n 10% 100V CE Cap	Vishay	2222 326 03102	46-31000-200	1
C106	33n 20% 25V CE Cap	Murata	DD406SR333M25	46-43300-211	1
C107	27p 2% 100V NPO CE Cap	Philips	2222 680 10279	46-12700-011	1
C108	27p 2% 100V NPO CE Cap	Philips	2222 680 10279	46-12700-011	1
C109	33n 20% 25V CE Cap	Murata	DD406SR333M25	46-43300-211	1
C110	33n 20% 25V CE Cap	Murata	DD406SR333M25	46-43300-211	1
C111	33n 20% 25V CE Cap	Murata	DD406SR333M25	46-43300-211	1
C112	33n 20% 25V CE Cap	Murata	DD406SR333M25	46-43300-211	1
C113	33n 20% 25V CE Cap	Murata	DD406SR333M25	46-43300-211	1
C114	27p 2% 100V NPO CE Cap	Philips	2222 680 10279	46-12700-011	1
C115	27p 2% 100V NPO CE Cap	Philips	2222 680 10279	46-12700-011	1
C116	10u 20% 25V TA Cap	AVX	TAP106M025CCS	47-11002-510	1
C117	10u 20% 25V TA Cap	AVX	TAP106M025CCS	47-11002-510	1
C118	10u 20% 25V TA Cap	AVX	TAP106M025CCS	47-11002-510	1
C119	10u 20% 25V TA Cap	AVX	TAP106M025CCS	47-11002-510	1
C120	10u 20% 25V TA Cap	AVX	TAP106M025CCS	47-11002-510	1
C121	1n 10% 100V CE Cap	Vishay	2222 326 03102	46-31000-200	1
C122	1n 10% 100V CE Cap	Vishay	2222 326 03102	46-31000-200	1
C123	1n 10% 100V CE Cap	Vishay	2222 326 03102	46-31000-200	1

08-04644-001 - Opt RS PCB

BOM Revision
Date Valid On

05 -- Production
27.09.2006

Ref	Description	Manufacturer	Manufacturer's P/N	Codan P/N	Qty
C124	1n 10% 100V CE Cap	Vishay	2222 326 03102	46-31000-200	1
C125	1n 10% 100V CE Cap	Vishay	2222 326 03102	46-31000-200	1
C126	1n 10% 100V CE Cap	Vishay	2222 326 03102	46-31000-200	1
C127	33n 20% 25V CE Cap	Murata	DD406SR333M25	46-43300-211	1
D101	Diode, Si small sig GP	Codan	23-10005	23-10005	1
D102	Diode, Si small sig GP	Codan	23-10005	23-10005	1
IC101	Buffer, Hex Inverting Schmitt IC	Motorola	MC74HC14N	YH-74014-000	1
IC102	Supervisory, Pwr&reset 4.75V IC	Philips	PCF1252-OP	XD-01252-100	1
IC103	MCU, 8bit 16MHz PLCC68	Philips	PCB80C552-5-16WP	YP-80552-900	1
IC104	Latch, Octal IC	Motorola	MC74HC573N	YH-74573-000	1
IC105	EPROM prgmd, 8571 GPIO Opt RS	Codan	90-20500-001	90-20500-001	1
IC106	RAM, CMOS 8k x 8 Bit IC	Hitachi	HM6264P-15	YM-06264-000	1
IC107	UART, CMOS IC	Philips	SCC2691AC1N24	YK-02691-000	1
IC108	Tcvr, RS232 Dual IC	Maxim	MAX232CPE	YI-00232-000	1
P1	Connector, 64way Male 90 deg PCB	ITT-Cannon	G06D064P4BEBL	60-51100-064	1
R1	100k Ohm 20% 0,1W SIL Com x5Res	Murata	RGSD5X104M	40-85100-500	1
R101	1k Ohm 5% 0,33W CF Res	Philips	2322 211 13102	40-31000-020	1
R102	1k Ohm 5% 0,33W CF Res	Philips	2322 211 13102	40-31000-020	1
R103	100k Ohm 5% 0,33W CF Res	Philips	2322 211 13104	40-51000-020	1
R104	100k Ohm 5% 0,33W CF Res	Philips	2322 211 13104	40-51000-020	1
R105	100k Ohm 5% 0,33W CF Res	Philips	2322 211 13104	40-51000-020	1
R106	100k Ohm 5% 0,33W CF Res	Philips	2322 211 13104	40-51000-020	1
R108	470 Ohm 5% 0,33W CF Res	Philips	2322 211 13471	40-24700-020	1
R109	10k Ohm 5% 0,33W CF Res	Philips	2322 211 13103	40-41000-020	1
R110	100k Ohm 5% 0,33W CF Res	Philips	2322 211 13104	40-51000-020	1
R111	100k Ohm 5% 0,33W CF Res	Philips	2322 211 13104	40-51000-020	1
R112	1,5k Ohm 5% 0,33W CF Res	Philips	2322 211 13152	40-31500-020	1
R113	1M Ohm 5% 0,33W CF Res	Philips	2322 211 13105	40-61000-020	1
R114	1k Ohm 20% 0,1W SIL Sep x5Res	Murata	RGSD5Y102M	40-83101-500	1
R115	1k Ohm 5% 0,33W CF Res	Philips	2322 211 13102	40-31000-020	1
S101	Switch, DIP 8 way	AMP	435166-5	62-60829-001	1
S102	Switch, DIP 8 way	AMP	435166-5	62-60829-001	1

08-04644-001 - Opt RS PCB

BOM Revision
Date Valid On

05 -- Production
27.09.2006

Ref	Description	Manufacturer	Manufacturer's P/N	Codan P/N	Qty
V101	Diode, Ref 5,0V 2% IC	National Semiconduct	LM336Z-5.0	XB-00336-505	1
V102	Transistor, NPN Si	Philips	BC548	BC548	1
Z101	Crystal, 12000 kHz uP Grade	HY-Q	M/P QC49 12000KHZ	65-90014-000	1
Z102	Crystal, 3686,4 kHz uP Grade	HY-Q	M/P QC49	65-90007-000	1

08-03817 - Line Isolation Unit PCB

BOM Revision
Date Valid On

02 -- Production
27.09.2006

Ref	Description	Manufacturer	Manufacturer's P/N	Codan P/N	Qty
*	Line Isolation Unit PCB	Rapier Electronics	08-03817	08-03817	1
1	PCB, Line Isolation Unit	Codan	07-01257	07-01257	1
2	Stake, Terminal	Autosplice	7-22461-5	61-40300-004	2
F1	Fuse, STD Wire-end 100mA	Schurter	034.1906	63-00010-010	1
J1	Socket, 6way 4Cct Modular PCB 90	Molex	90077-0046	60-00063-102	1
R1	22 Ohm 5% 2,5W MF Res	Philips	2322 192 32209	40-12200-605	1
T1	Txfr, Line isolating	Ericsson	REKP4999030	43-30105-001	1
V1	Diode, Zener 5,1V 5% 5W	Motorola	1N5338B	1N5338B	1
V2	Diode, Zener 5,1V 5% 5W	Motorola	1N5338B	1N5338B	1

08-03995-001 - 4-Wire I/F PCB

BOM Revision
Date Valid On

03 -- Production
 27.09.2006

Ref	Description	Manufacturer	Manufacturer's P/N	Codan P/N	Qty
	Ind, Common Mode bn/or	Protran	44-80104	44-80104	2
*	4-Wire I/F PCB			08-03995	1
1	PCB, 4-Wire I/F	Codan	07-01349	07-01349	1
2	Standoff, PCB M3x4	PEM	KFE-M3-4ET	33-53004-040	4
3	Stake, Terminal	Autosplice	7-22461-5	61-40300-004	10
C1	1n 10% 100V CE Cap	Vishay	2222 326 03102	46-31000-200	1
C2	1n 10% 100V CE Cap	Vishay	2222 326 03102	46-31000-200	1
C3	1n 10% 100V CE Cap	Vishay	2222 326 03102	46-31000-200	1
C4	1n 10% 100V CE Cap	Vishay	2222 326 03102	46-31000-200	1
D1	Diode, Si small sig GP	Codan	23-10005	23-10005	1
K1	Relay, 2C Bif 12V 720 Ohm	Matsushita	DS2Y-S-DC12	64-21223-272	1
P1	Header (P) 8way 1row	Molex	22-03-2081	60-00081-100	1
P2	Header (P) 8way 1row	Molex	22-03-2081	60-00081-100	1
R1	620 Ohm 5% 0,33W CF Res	Philips	2322 211 13621	40-26200-020	1
T1	Txfr	Protran	44-30821	44-30821	1
T2	Txfr	Protran	44-30821	44-30821	1

The drawings in this section consist of the mechanical and electrical diagrams required to maintain the 8571.

Table 11: 8571—list of drawings

Title	Drawing	Drawing number
NGT Split-site Remote Interface 8571		
8571 Remote Control (NGT) Interface Assembly		08-05994 (sheet 1) 08-05994 (sheet 2)
Dual Line Equaliser	Circuit diagram	04-02541
	PCB assembly	08-03905
Microprocessor & Tcwr Interface	Circuit diagram	04-02690
	PCB assembly	08-03993
Backplane	Circuit diagram	04-02691
	PCB assembly	08-05995
General Purpose Input/Output	Circuit diagram	04-02852
	PCB assembly	08-04644
Line Interface		
Line Isolating Interface	Circuit diagram	04-02487
Line Isolating Unit	PCB assembly	08-03817
4-wire Interface	PCB assembly	08-03995
Options		
Option 2W 8571	Fitting instructions	15-10509-001
Option 4W 8571	Fitting instructions	15-10510-001

This page has been left blank intentionally.

1 2 3 4 5 6 7 8 9 10 11 12

DO NOT SCALE

ISSUE 2:
NOTE 1 ETC ADDED.
NOTE RE VIEW A
MOVED.
C/R 27410
GSB 16-9-03

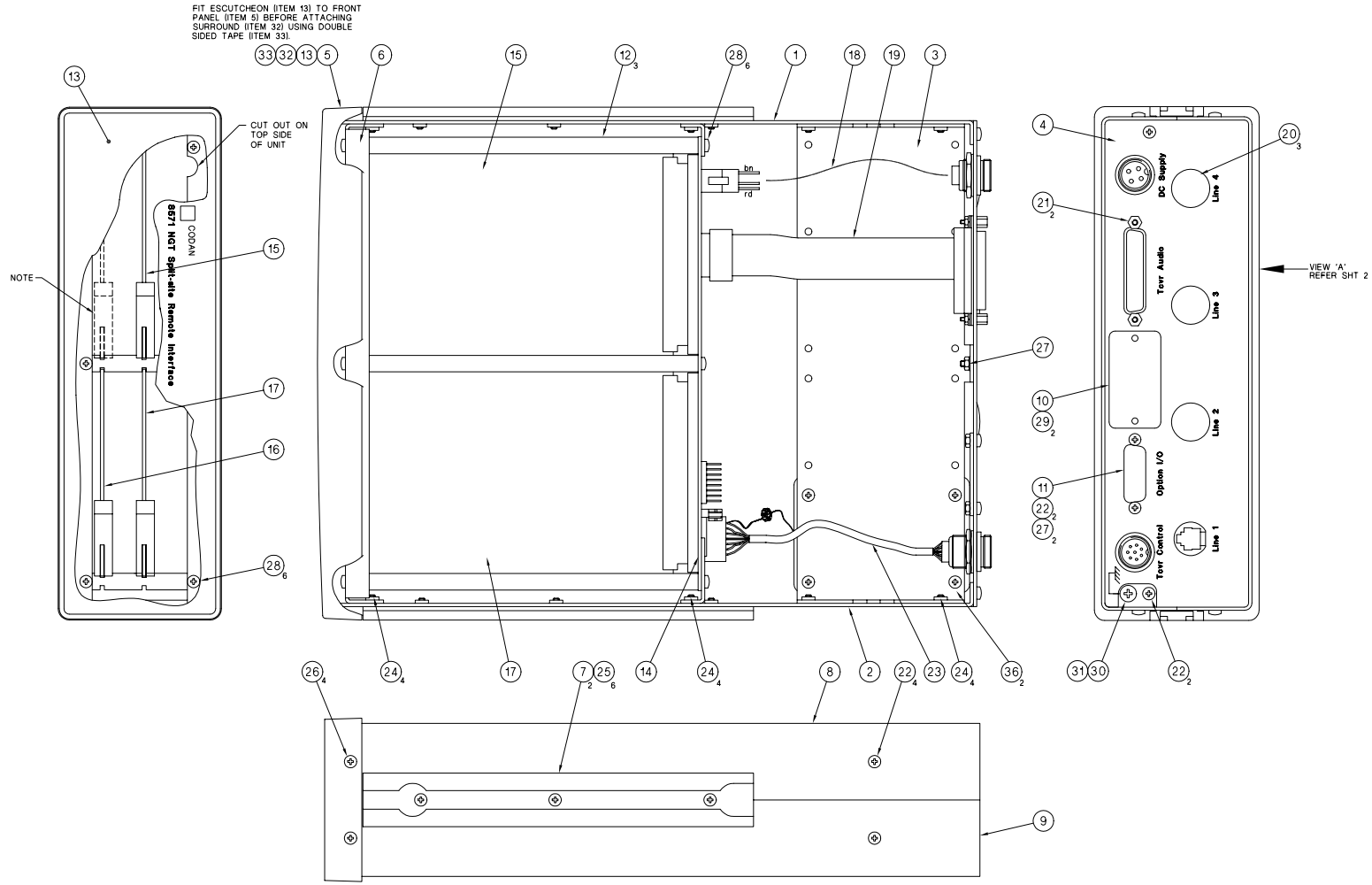

NOTES:

- FOR ADDITIONAL LINES - FIT AN EXTRA DUAL LINE EQUALISATION CARD (CODAN P/N 08-03905-002) AND THE REQUIRED 2-WIRE (CODAN P/N 08-03816-001) OR 4-WIRE (CODAN P/N 08-03995-001) LINES.
FOR FITTING INSTRUCTIONS, REFER TO DRAWINGS 15-10509 (2-WIRE) AND 15-10510 (4-WIRE).

FILE No.
08\05994_2.DWG

	SCALE	1:1	© CODAN PTY LTD, A.C.N. 007 590 605 1999
	DATE	26-07-02	TITLE
DRN	AP	26-07-02	8571 REMOTE CONTROL (NGT)
CHKD	GSB	04-09-02	INTERFACE - FINAL ASSY
APPD	AJC	19-3-03	DRAWING/DOC NO.
FINISH	TOLERANCES	UNLESS OTHERWISE STATED	A1
	2 PLACES DEC.	+0.25	ISS
	1 PLACE DEC.	+0.5	
	0 PLACE DEC.	±1	2
			SHT. 1
			OF 2

DIMENSIONS IN mm

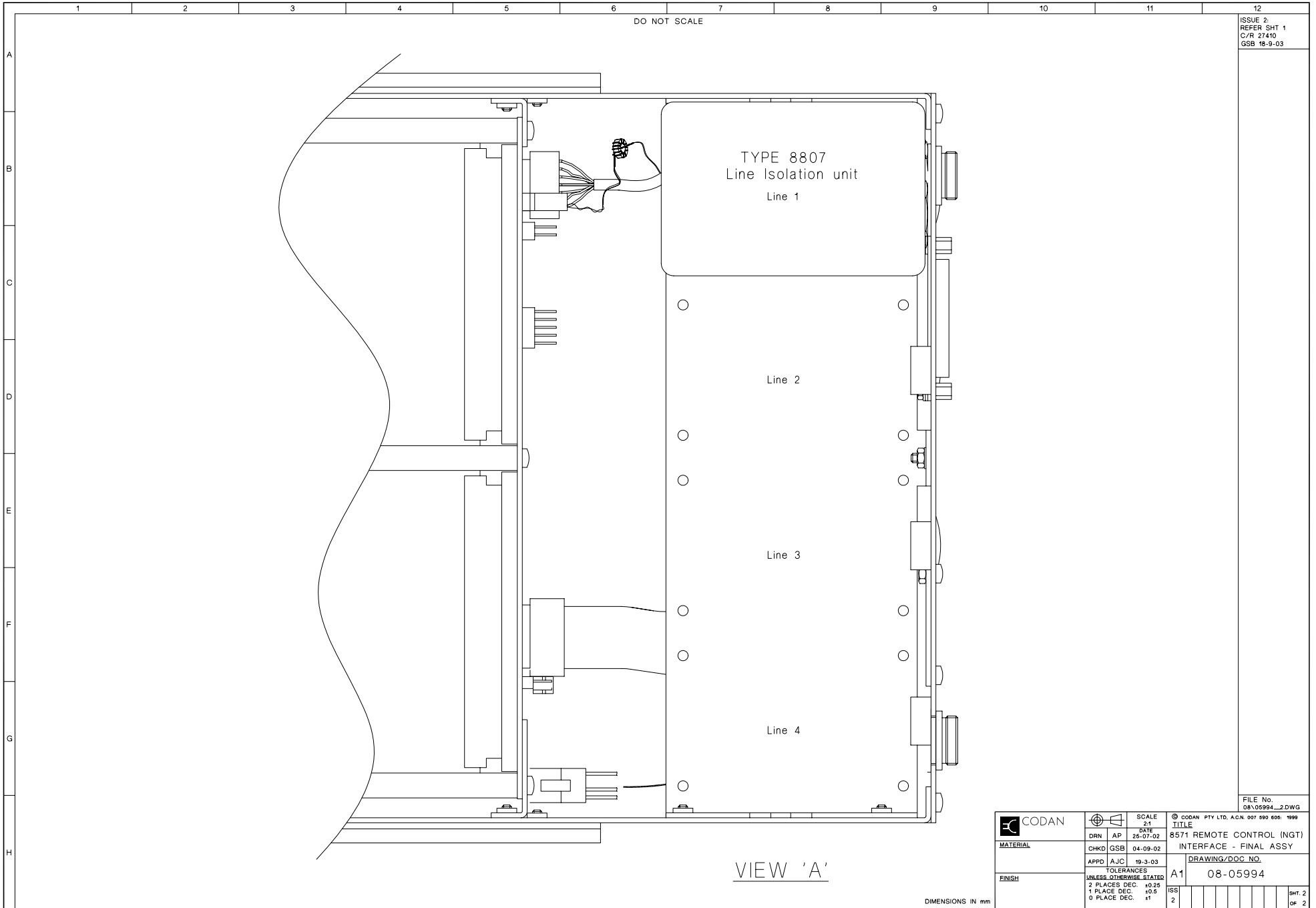

ISSUE 2
 REFER SHT 1
 C/R 27410
 GSB 18-9-03

FILE No.
 08\05994_2.DWG

	SCALE	21	© CODAN PTY LTD. A.C.N. 007 890 605: 1999
	DATE	25-07-02	TITLE
DRN	AP		8571 REMOTE CONTROL (NGT)
CHKD	GSB	04-09-02	INTERFACE - FINAL ASSY
APPD	AJC	19-3-03	DRAWING/DOC NO.
FINISH	TOLERANCES		A1
	UNLESS OTHERWISE STATED		08-05994
	2 PLACES DEC. ±0.25		ISS
	1 PLACE DEC. ±0.5		2
	0 PLACE DEC. 1 st		SHT. 2
			OF 2

DIMENSIONS IN mm

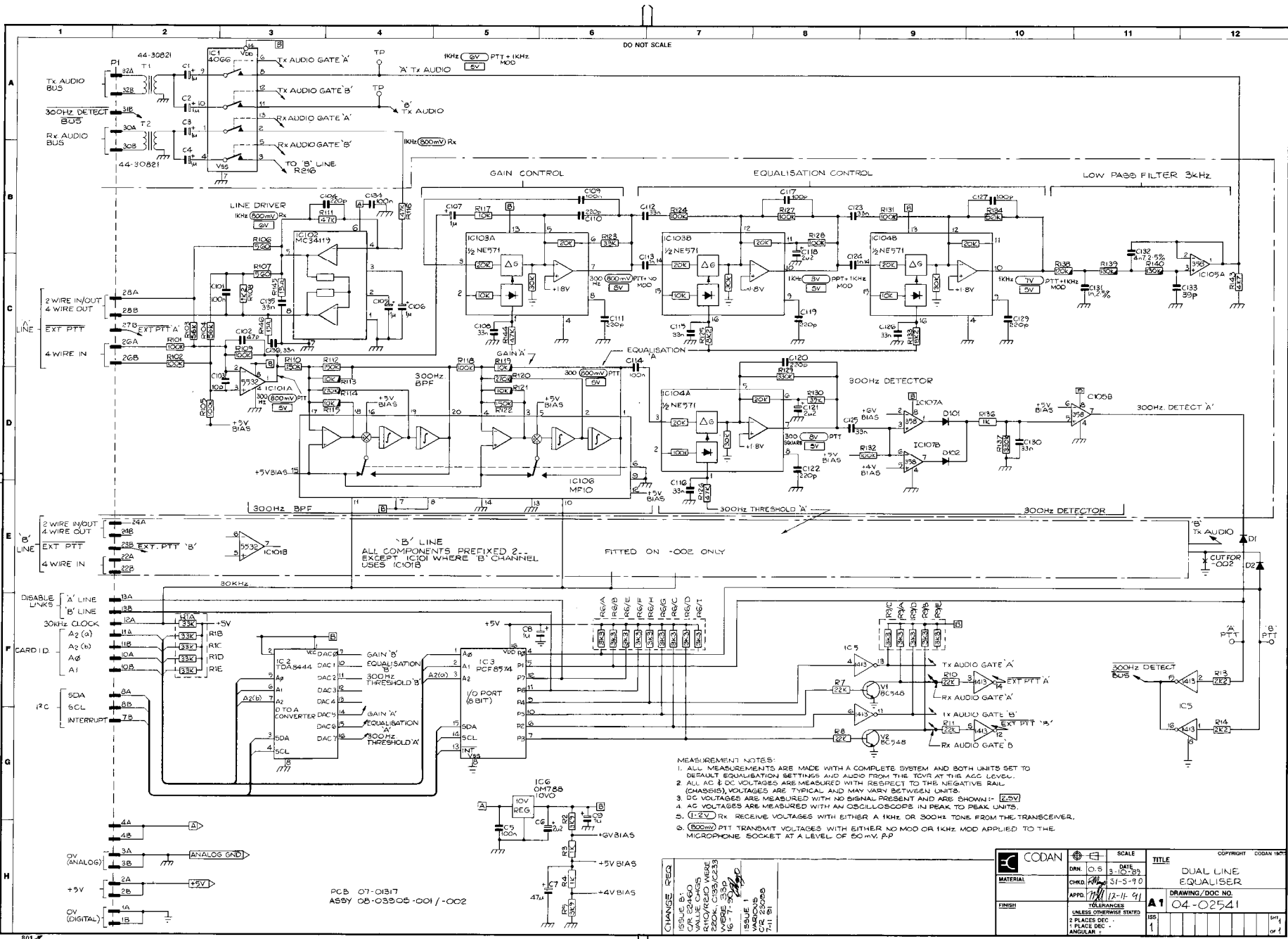

DO NOT SCALE

'B' LINE
ALL COMPONENTS PREFIXED 2--
EXCEPT IC10I WHERE 'B' CHANNEL
USES IC10IB

FITTED ON -002 ONLY

- MEASUREMENT NOTES:
1. ALL MEASUREMENTS ARE MADE WITH A COMPLETE SYSTEM AND BOTH UNITS SET TO DEFAULT EQUALISATION SETTINGS AND AUDIO FROM THE '00R AT THE AGC LEVEL.
 2. ALL AC & DC VOLTAGES ARE MEASURED WITH RESPECT TO THE NEGATIVE RAIL (CHASSIS). VOLTAGES ARE TYPICAL AND MAY VARY BETWEEN UNITS.
 3. DC VOLTAGES ARE MEASURED WITH NO SIGNAL PRESENT AND ARE SHOWN IN [] UNITS.
 4. AC VOLTAGES ARE MEASURED WITH AN OSCILLOSCOPE IN PEAK TO PEAK UNITS.
 5. (1.2V) RX RECEIVE VOLTAGES WITH EITHER A 1KHz OR 300Hz TONE FROM THE TRANSMITTER.
 6. (0.02mV) PTT TRANSMIT VOLTAGES WITH EITHER NO MOD OR 1KHz MOD APPLIED TO THE MICROPHONE SOCKET AT A LEVEL OF 50mV P/P.

PCB 07-01517
ASSY 08-03305-001 / -002

CHANGE RECORD
ISSUE NO. 01
VALUE CHGNS
R10/R10D WERE
220K/220K/220K
R16-17
R16-17
R16-17
ISSUE
VARIOUS
CIR 220K
P/HI 51

CODAN	SCALE	TITLE	DUAL LINE EQUALISER	DRAWING/DOC NO. 04-02541
	DRN: 0.5	DATE: 3-10-89		
MATERIAL	CHRD: 11-51-5-9.0	ISS	1	
FINISH	APPD: 11-12-4-91	TOLERANCES	UNLESS OTHERWISE STATED	
		2 PLACES DEC.	1	
		1 PLACE DEC.	1	
		ANGULAR	1	

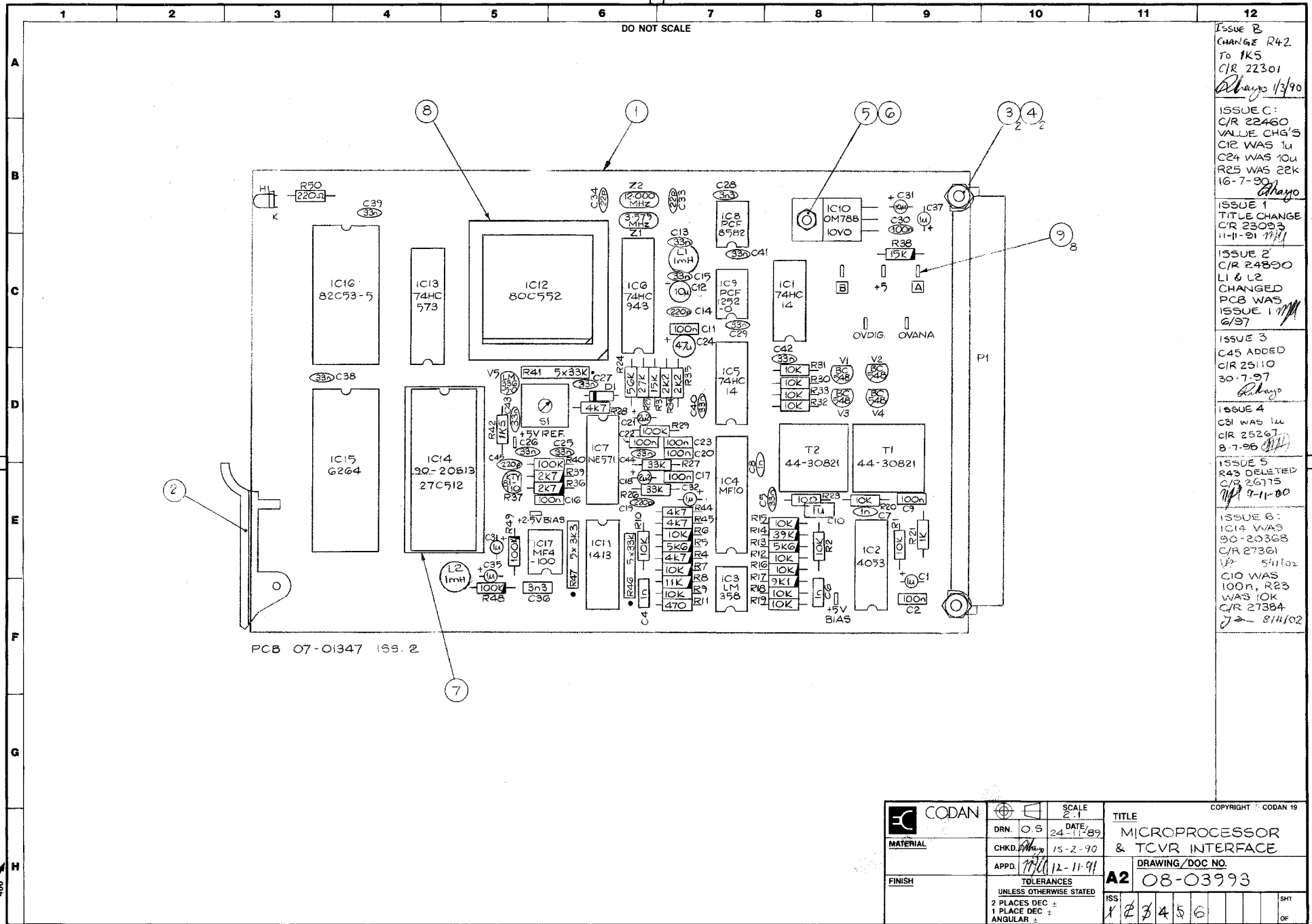

PCB 07-01347 ISS. 2

ISSUE B
CHANGE R42
TO 1K5
C/R 22301
Alhays 1/3/90

ISSUE C:
C/R 22460
VALUE CHG'S
C12 WAS 1u
C24 WAS 10u
R25 WAS 22K
16-7-90
Alhays

ISSUE 1
TITLE CHANGE
C/R 23093
11-11-91 *MM*

ISSUE 2
C/R 24890
L1 & L2
CHANGED
PCB WAS
ISSUE 1 *MM*
6/97

ISSUE 3
C45 ADDED
C/R 25110
30-7-97
Alhays

ISSUE 4
C81 WAS 1u
C/R 25267
8-7-98 *MM*

ISSUE 5
R43 DELETED
C/R 26775
MM 9-11-00

ISSUE 6:
IC14 WAS
90-20368
C/R 27361
V2 5u10z
C10 WAS
100n, R23
WAS 10K
C/R 27384
J 8/14/02

	DRN.	O.S.	SCALE	2:1	TITLE MICROPROCESSOR & TCVR INTERFACE	COPYRIGHT © CODAN 19	
	CHKD.	<i>Alhays</i>	DATE	24-11-89			
MATERIAL		APPD.	<i>MM</i>	12-11-91	DRAWING/DOC NO.	A2 08-03993	
FINISH		TOLERANCES UNLESS OTHERWISE STATED			ISS	1	2
		2 PLACES DEC ± 1 PLACE DEC ± ANGULAR ±				3	4
						5	6
							SHT OF

DO NOT SCALE

ISSUE B
 PART No. CHANGED FROM
 07-03148 ISS 2
 TO 07-01348-03
 C/R 27501
 07-04-03 AJC

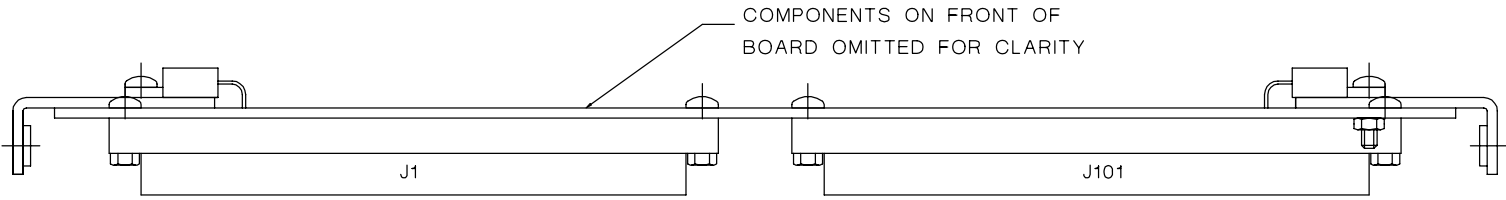
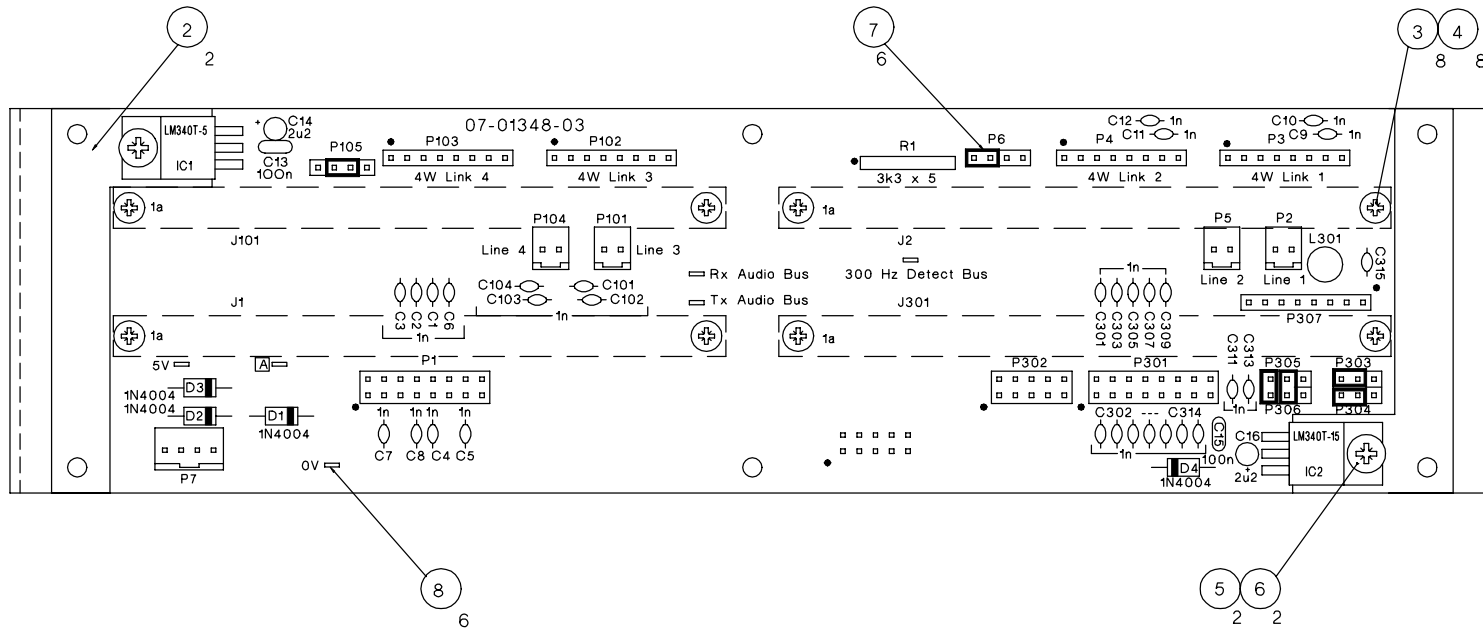

DIMENSIONS IN mm

FILE No.
 08-05995_1.DWG

	DRN	AP	SCALE	© CODAN LIMITED, A.C.N. 007 590 605: 2002 TITLE BACKPLANE
	CHKD	GSB	DATE	
	APPD	AJC	DATE	
MATERIAL			04-09-02	DRAWING/DOC NO.
FINISH			17-07-03	
TOLERANCES UNLESS OTHERWISE STATED				ISS
2 PLACES DEC. ±0.10				
1 PLACE DEC. ±0.5				
0 PLACE DEC. ±1				

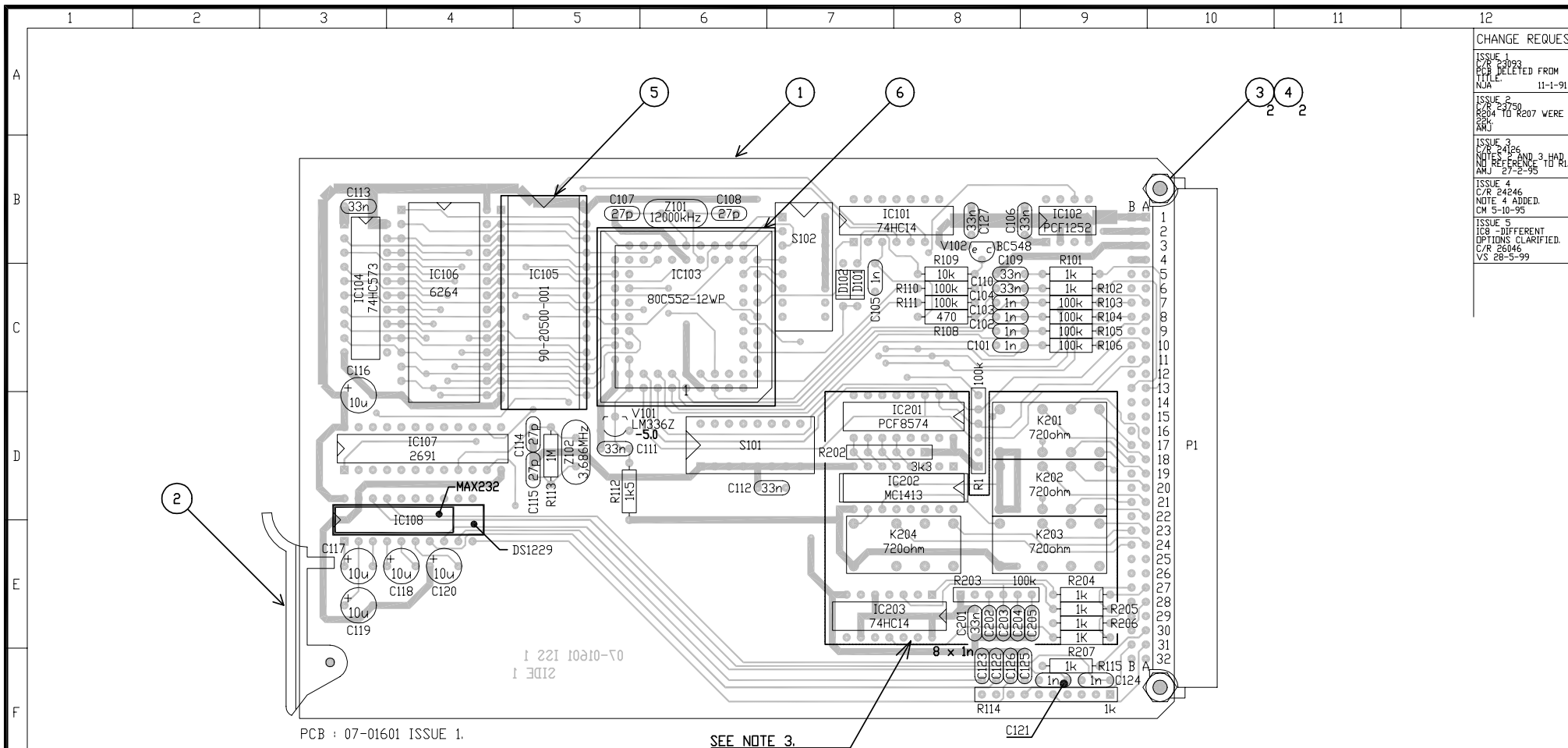

CHANGE REQUEST	
ISSUE 1 C/R 2423 R204 DELETED FROM TITLE	11-1-91
ISSUE 2 C/R 2424 R204 TO R207 WERE ADD	
ISSUE 3 C/R 2425 NOTES 2 AND 3 HAD NO REFERENCE TO R1. AND 27-2-95	
ISSUE 4 C/R 2424 NOTE 4 ADDED. CM 5-10-95	
ISSUE 5 IC8 DIFFERENT OPTIONS CLARIFIED. C/R 26046 VS 28-9-99	

- NOTES:
1. DIODES ARE BAW62, OR EQUIVALENT, UNLESS OTHERWISE STATED.
 2. ASSY 08-04644-001: USE COMPONENTS PREFIXED 1XX AND RESISTOR R1.
 3. ASSY 08-04644-002: USE COMPONENTS PREFIXED 2XX AND RESISTOR R1.
 4. ASSY 08-04644-003: USE ALL COMPONENTS.

DISK FILE
071601_LPCB

	SCALE 2:1	© CODAN PTY LTD, ACN. 007 590 605, 1995 GENERAL PURPOSE INPUT/OUTPUT ASSEMBLY
	DRN. C.G. DATE 25-2-91	
MATERIAL	CHKD. N.J.A. DATE 24-4-91	DRAWING/DOC No. 08-04644
FINISH	APPD. N.J.A. DATE 12-11-91	
TOLERANCES UNLESS OTHERWISE STATED		ISS 5 SHT 1
2 PLACES DEC ±		
1 PLACE DEC ±		

DO NOT SCALE

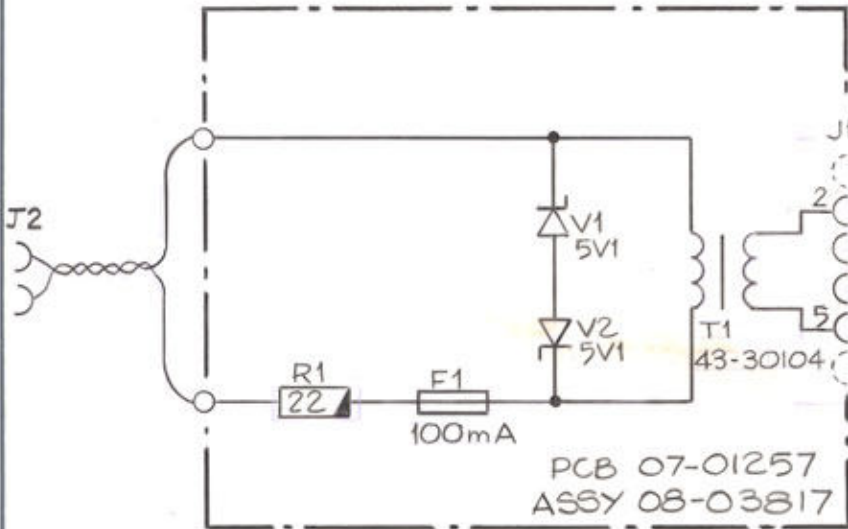

NOTE : D1 & D2 ARE IN5338B

ASSY. 08-03816

MASTER
 IF NOT IN RED
 CHECK STATUS

			SCALE	COPYRIGHT © CODAN 1989	
	DRN.	O.R.	DATE	TITLE LINE ISOLATION UNIT	
	CHKD.	<i>Ameyo</i>	24-5-89		
MATERIAL	APPD.	<i>Ameyo</i>	26-5-89	DRAWING/DOC NO. A4 04-02487	
FINISH	TOLERANCES UNLESS OTHERWISE STATED 2 PLACES DEC ± 1 PLACE DEC ± ANGULAR ±			ISS	SHT 1
				1	OF 1

← 280

180 →

DO NOT SCALE

ISSUE 2
 TRANS'R
 WAS
 43-30104
 C/R 22269
 23-1-90
Allygo

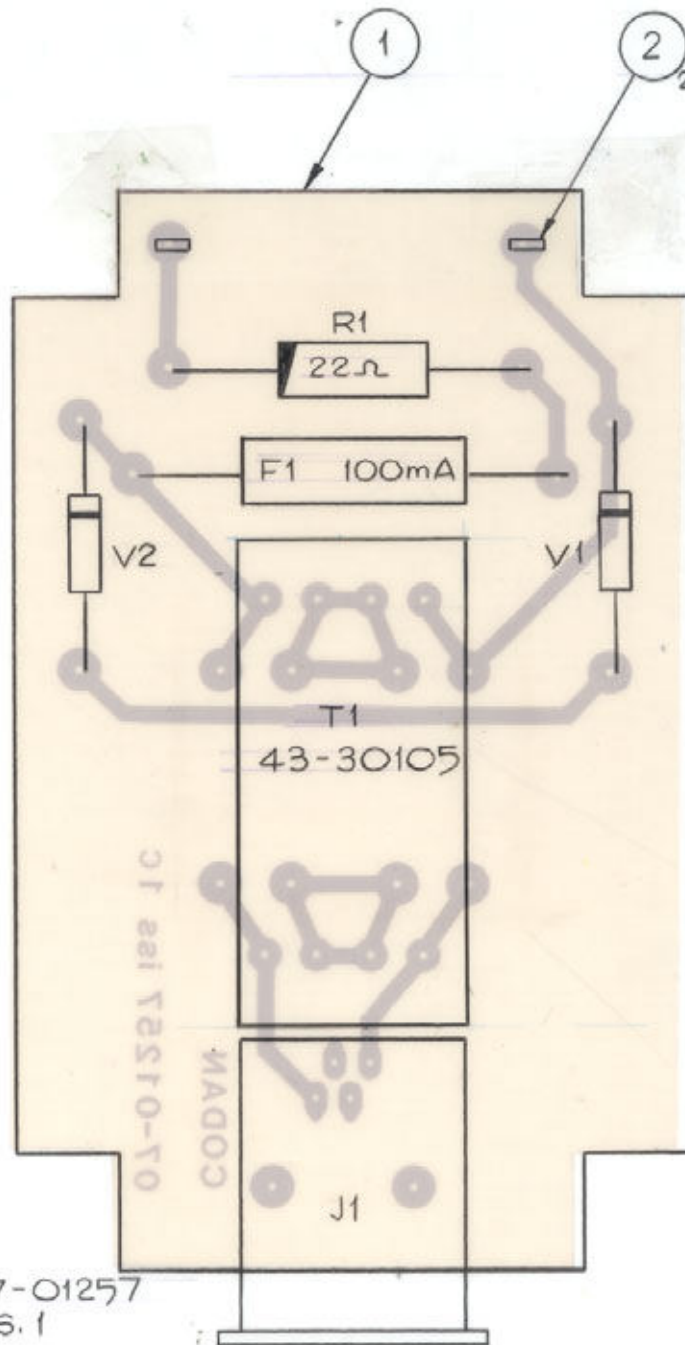

PCB: 07-01257
 ISS. 1

COPYRIGHT © CODAN 1989



CODAN

IF NOT IN RED
 CHECK STATUS



SCALE	2:1
DRN.	O.S.
DATE	23-5-89
CHKD.	<i>Allygo</i>
DATE	24-5-89
APPD.	<i>Am J</i>
DATE	26-5-89

TITLE

LINE ISOLATION UNIT
 P.C.B.

DRAWING/DOC NO.

A4 08-03817

FINISH

TOLERANCES
 UNLESS OTHERWISE STATED
 2 PLACES DEC ±
 1 PLACE DEC ±
 ANGULAR ±

ISS

X 2

SHT 1

OF 1

280

180

ISSUE B
DIODE
ADDED
ACROSS K1
C/R 22611
18-6-91

ISSUE 1
R1 ADDED
C/R 23376
27-7-92
AMJ

ISSUE 2
C/R 24266
R21, R22, R23,
R24, LINK1,
LINK2, LINK3
ADDED JCW
3-4-95

ISSUE 3
ITEM 2 NOW
DOTTED
C/R 24408
29-11-95

ISSUE 4
ITEM 3 QTY
WAS 4,
LINKS-TCW
NOTE ADDED
C/R 26000
28-4-99

DO NOT SCALE

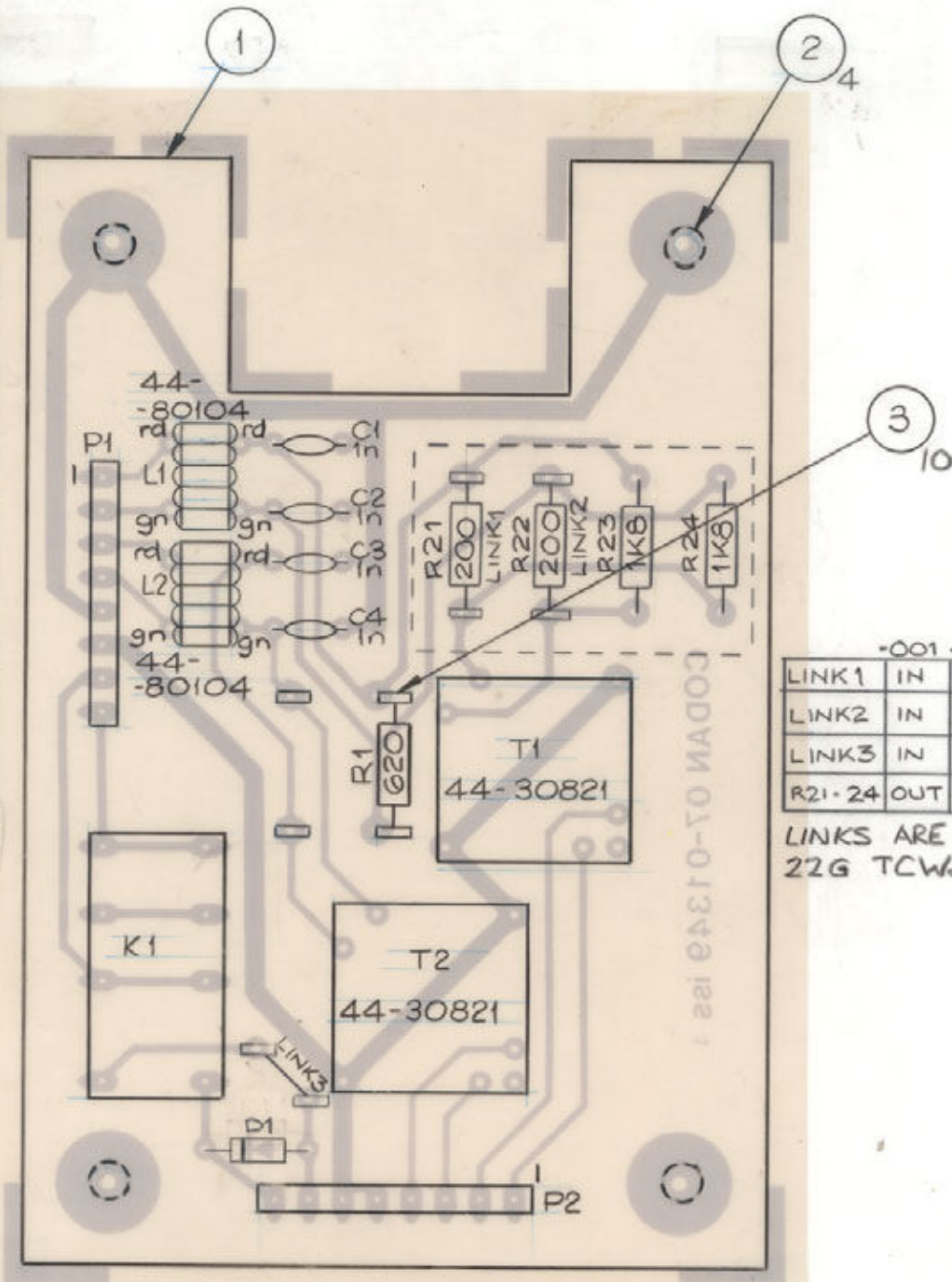

-001 -002		
LINK1	IN	OUT
LINK2	IN	OUT
LINK3	IN	IN
R21-24	OUT	IN

LINKS ARE
22G TCW

PCB 07-01349 ISS. 4

08-03995-001 AS DRAWN

COPYRIGHT © CODAN 1970

NOT IN RED
 CHECK STATUS
 MASTER

	DRN.	O.S.	SCALE	TITLE								
	CHKD.	<i>R. Mayo</i>	DATE	4 WIRE								
	APPD.	<i>AMJ</i>	16-2-90	INTERFACE								
FINISH	TOLERANCES			DRAWING/DOC NO.								
	UNLESS OTHERWISE STATED			A4 08-03995								
	2 PLACES DEC ±			ISS	A	B	X	2	3	4	SHT	1
	1 PLACE DEC ±										OF	1
	ANGULAR ±											

280

180

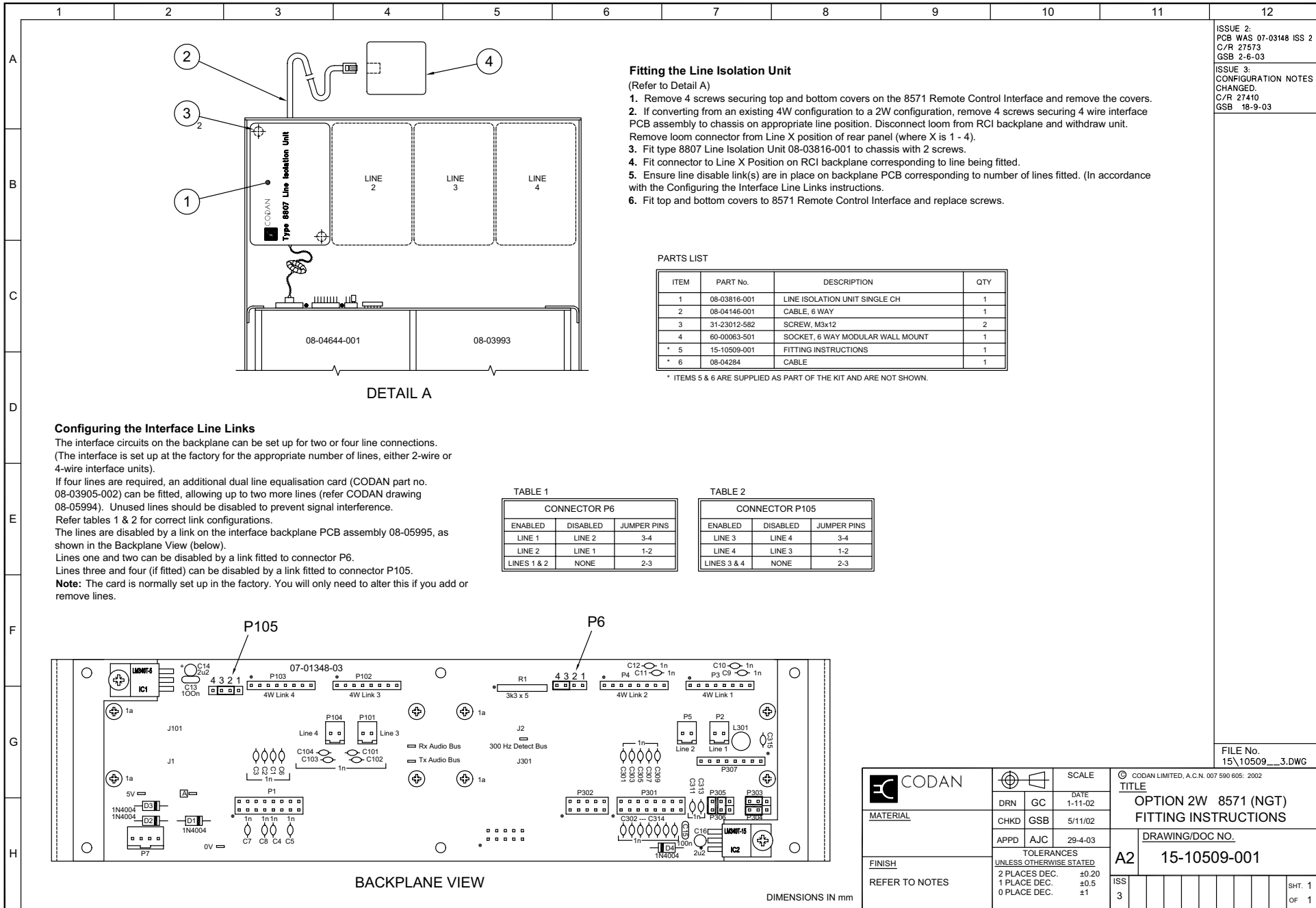

ISSUE 2:
PCB WAS 07-03148 ISS 2
C/R 27573
GSB 2-6-03

ISSUE 3:
CONFIGURATION NOTES
CHANGED.
C/R 27410
GSB 18-9-03

Fitting the Line Isolation Unit

(Refer to Detail A)

1. Remove 4 screws securing top and bottom covers on the 8571 Remote Control Interface and remove the covers.
2. If converting from an existing 4W configuration to a 2W configuration, remove 4 screws securing 4 wire interface PCB assembly to chassis on appropriate line position. Disconnect loom from RCI backplane and withdraw unit. Remove loom connector from Line X position of rear panel (where X is 1 - 4).
3. Fit type 8807 Line Isolation Unit 08-03816-001 to chassis with 2 screws.
4. Fit connector to Line X Position on RCI backplane corresponding to line being fitted.
5. Ensure line disable link(s) are in place on backplane PCB corresponding to number of lines fitted. (In accordance with the Configuring the Interface Line Links instructions).
6. Fit top and bottom covers to 8571 Remote Control Interface and replace screws.

PARTS LIST

ITEM	PART No.	DESCRIPTION	QTY
1	08-03816-001	LINE ISOLATION UNIT SINGLE CH	1
2	08-04146-001	CABLE, 6 WAY	1
3	31-23012-582	SCREW, M3x12	2
4	60-00063-501	SOCKET, 6 WAY MODULAR WALL MOUNT	1
* 5	15-10509-001	FITTING INSTRUCTIONS	1
* 6	08-04284	CABLE	1

* ITEMS 5 & 6 ARE SUPPLIED AS PART OF THE KIT AND ARE NOT SHOWN.

DETAIL A

Configuring the Interface Line Links

The interface circuits on the backplane can be set up for two or four line connections. (The interface is set up at the factory for the appropriate number of lines, either 2-wire or 4-wire interface units).

If four lines are required, an additional dual line equalisation card (CODAN part no. 08-03905-002) can be fitted, allowing up to two more lines (refer CODAN drawing 08-05994). Unused lines should be disabled to prevent signal interference.

Refer tables 1 & 2 for correct link configurations.

The lines are disabled by a link on the interface backplane PCB assembly 08-05995, as shown in the Backplane View (below).

Lines one and two can be disabled by a link fitted to connector P6.

Lines three and four (if fitted) can be disabled by a link fitted to connector P105.

Note: The card is normally set up in the factory. You will only need to alter this if you add or remove lines.

TABLE 1

CONNECTOR P6		
ENABLED	DISABLED	JUMPER PINS
LINE 1	LINE 2	3-4
LINE 2	LINE 1	1-2
LINES 1 & 2	NONE	2-3

TABLE 2

CONNECTOR P105		
ENABLED	DISABLED	JUMPER PINS
LINE 3	LINE 4	3-4
LINE 4	LINE 3	1-2
LINES 3 & 4	NONE	2-3

BACKPLANE VIEW

DIMENSIONS IN mm

FILE No.
15\10509...3.DWG

	SCALE		© CODAN LIMITED, A.C.N. 007 590 605: 2002 TITLE OPTION 2W 8571 (NGT) FITTING INSTRUCTIONS
	DRN	GC	
MATERIAL	CHKD	GSB	5/11/02
	APPD	AJC	29-4-03
FINISH	TOLERANCES		DRAWING/DOC NO. A2 15-10509-001
	UNLESS OTHERWISE STATED		
REFER TO NOTES	2 PLACES DEC.	±0.20	ISS 3
	1 PLACE DEC.	±0.5	
	0 PLACE DEC.	±1	
			SHT. 1 OF 1

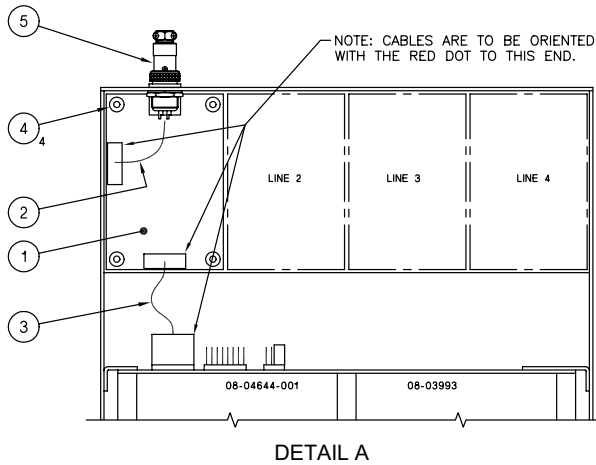

Fitting the Line Isolation Unit

(Refer to Detail A)

1. Remove 4 screws securing top and bottom covers on the 8571 Remote Control Interface and remove the covers.
2. If converting from an existing 2W configuration to a 4W configuration, remove 2 screws securing type 8807 Line Isolation Unit to chassis on appropriate line position. Disconnect plug connector from the backplane and withdraw unit.
3. Fit 8 pin connector on loom 08-04152 (ITEM 2) to line "X" (where X is 1 - 4) cut-out in chassis rear panel.
4. Fit 4 wire interface PCB assembly 08-03995-001 (ITEM 1) to chassis positioned according to the line being fitted using 4 screws (ITEM 4).
5. Fit loom 08-04152 (ITEM 2) to 4 wire interface PCB assembly connector ensuring red dot on the connector aligns as shown.
6. Fit loom 08-04153 (ITEM 3) to 4 wire interface PCB assembly & backplane PCB connector corresponding to the line being fitted. Ensure that the red dots on the connectors align as shown.
7. Ensure line disable link(s) are in place on backplane PCB corresponding to number of lines fitted. (In accordance with the Configuring the Interface Line Links instructions).
8. Fit top and bottom covers to 8571 Remote Control Interface and replace screws.

PARTS LIST

ITEM	PART No.	DESCRIPTION	QTY
1	08-03995-001	4 WIRE INTERFACE	1
2	08-04152	LOOM	1
3	08-04153	LOOM	2
4	31-23006-582	SCREW M3x6	1
5	60-00081-320	SOCKET, 8 WAY	1
* 6	15-10510-001	FITTING INSTRUCTIONS	1

* ITEM 6 IS SUPPLIED AS PART OF THE KIT AND IS NOT SHOWN.

Configuring the Interface Line Links

The interface circuits on the backplane can be set up for two or four line connections. (The interface is set up at the factory for the appropriate number of lines, either 2-wire or 4-wire interface units).

If four lines are required, an additional dual line equalisation card (CODAN part no. 08-03905-002) can be fitted, allowing up to two more lines (refer CODAN drawing 08-05994). Unused lines should be disabled to prevent signal interference. Refer tables 1 & 2 for correct link configurations.

The lines are disabled by a link on the interface backplane PCB assembly 08-05995, as shown in the Backplane View (below).

Lines one and two can be disabled by a link fitted to connector P6.

Lines three and four (if fitted) can be disabled by a link fitted to connector P105.

Note: The card is normally set up in the factory. You will only need to alter this if you add or remove lines.

TABLE 1

CONNECTOR P6		
ENABLED	DISABLED	JUMPER PINS
LINE 1	LINE 2	3-4
LINE 2	LINE 1	1-2
LINES 1 & 2	NONE	2-3

TABLE 2

CONNECTOR P105		
ENABLED	DISABLED	JUMPER PINS
LINE 3	LINE 4	3-4
LINE 4	LINE 3	1-2
LINES 3 & 4	NONE	2-3

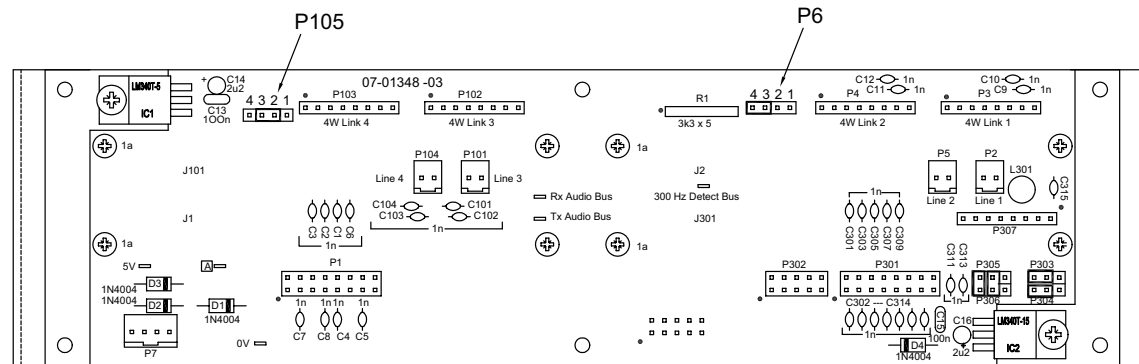

BACKPLANE VIEW

DIMENSIONS IN mm

VERSION TABLE

VERSION	DESCRIPTION
15-10510-002	MASTER
15-10510-003	Tx
15-10510-004	Rx

ISSUE 2
PCB No. & ISSUE
CHANGED ON
BACKPLANE
C/R 27410
02-06-03 GSB

ISSUE 3
CONFIGURATION NOTES
CHANGED.
C/R 27410
GSB 18-9-03

FILE No.
15\10510...3.DWG

	SCALE		© CODAN LIMITED, A.C.N. 007 590 605: 2002 TITLE OPTION 4W 8571 (NGT) FITTING INSTRUCTIONS	
	DRN	GC		DATE 1-11-02
	CHKD	GSB		12-11-02
	APPD	AJC		29-4-03
MATERIAL FINISH REFER TO NOTES	TOLERANCES UNLESS OTHERWISE STATED		DRAWING/DOC NO. A2 15-10510-001	
	2 PLACES DEC.	±0.20		
	1 PLACE DEC.	±0.5		
	0 PLACE DEC.	±1	ISS 3 SHT. 1 OF 1	