

Collins HF-380

owner's manual

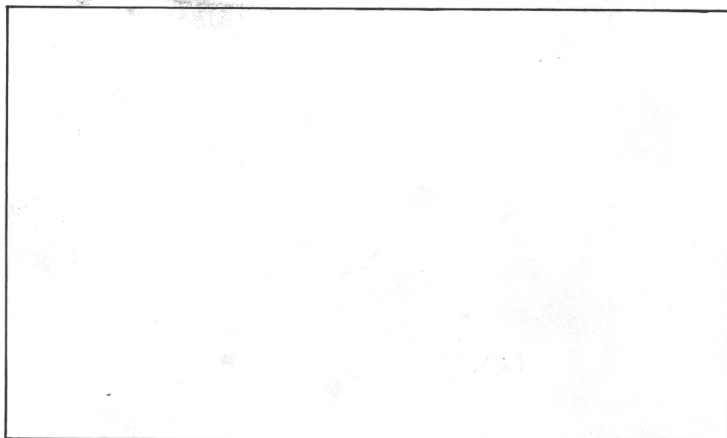

Rockwell International
Collins Telecommunications
Products Division
Defense Electronics Operations

●523-0769879-002217
2nd Edition, 1 April 1981

owner's manual

**Collins HF-380
Transceiver**

**Collins Telecommunications
Products Division
Defense Electronics Operations
Rockwell International
Cedar Rapids, Iowa 52406**

Printed in the United States of America

WARNING

THIS TRANSCEIVER, WHEN TRANSMITTING INTO AN ANTENNA EITHER DIRECTLY OR THROUGH AN ASSOCIATED ANTENNA COUPLER AND/OR POWER AMPLIFIER, MAY PRODUCE AN ELECTROMAGNETIC FIELD NEAR THE ANTENNA THAT IS IN EXCESS OF THE OCCUPATIONAL SAFETY AND HEALTH ADMINISTRATION (OSHA) MAXIMUM RECOMMENDED LIMITS.



This manual contains operating and installation information for the fully synthesized, all solid-state HF-380 Receiver-Transmitter, Collins part number 622-3580-001. (The receiver-transmitter is commonly called a transceiver and will be referred to as such throughout this manual.) Full coverage from 29.999 99 down to 1.6 MHz is standard. The pll synthesizer tunes in 10-Hz increments either manually or with an optional remote keypad control. Split vfo is standard, as is the digital frequency display driven directly by the microprocessor.

Because of the uniqueness of each individual station, the installation information found here is limited in scope. In-depth information can be found in numerous publications.

Test procedures in this manual require only simple test equipment to perform. The procedures are a guide in tracing malfunctions to a functionally related group of circuit cards. Detailed tests requiring laboratory-type test equipment and schematic diagrams are included in the HF-380 Transceiver Service Manual, Collins publication number 523-0769880, available through Rockwell-Collins Distributor/Service Agencies.

specifications

Physical

Size..... 394 mm (15.5 in) wide, 165 mm (6.5 in) high (does not include 25 mm (1 in) feet normally attached), 457 mm (18.0 in) deep

Weight..... 21.8 kg (48 lb) max

Primary power..... Strappable for: 105, 115, 125/210, 220, 230, 240, 250 V $\pm 5\%$, 50 to 60 Hz; or 12 to 15 V dc. 120 W max in receive; 600 W max in transmit

Receiver

Frequency..... 1.6 to 29.999 99 MHz, tunable in 10-Hz steps

Modes..... USB, LSB, AM, and CW

Sensitivity (at antenna terminals)..... 0.5 μV or better for 10 dB (s+n)/n, 2.0 to 30.0 MHz; 1.0 μV or better 1.8 to 2.0 MHz

Selectivity (3-dB min bandwidth)..... Selectable

8 kHz	*1.7 kHz
*6 kHz	*360 Hz
2.1 kHz	*140 Hz

If and image rejection..... Greater than 60 dB

Intermodulation distortion.... -50 dB or better for two signals of -10 dB mW each, 20 kHz apart

AGC..... Audio output variation not more than 8 dB for 4- μV to 200-mV open circuit rf input variation

Audio output..... Not less than 3.5 W into 4-ohm load, at 1 kHz, at not more than 10% total harmonic distortion

Line audio output: -10 dB mW nominal into 600 ohms

Frequency response: 300 to 2400 Hz with not more than 5 dB variation

Transmitter

Frequency..... 1.6000 through 29.9999 MHz, tunable in 10-Hz steps

Modes..... USB, LSB, and CW

Output power..... 100 W pep, nominal

In RTTY, automatic turndown to 50 W after 10 seconds, 50 percent duty cycle, key down 15 minutes, max.

With optional blower kit installed, power is 100 W continuous; key down 1 hour, max, at 25 °C; 30 minutes, max, at 50 °C for all modes.

*Optional filters

Unwanted signal suppression

Carrier	-50 dB or better
Undesired sideband, 1-kHz ref	-55 dB or better
Harmonics (all)	-40 dB or better
Mixer products	-50 dB or better
Third order distortion.....	25 dB below each tone of two-tone test

Synthesizer accuracy and stability

Accuracy within ± 5 Hz after 10 minutes warmup when 39.6- and 0.455-MHz oscillators are set to within ± 3 Hz

Stability within ± 150 Hz over temperature range of 0 to 50 °C

Rf load 50 ohms, nonreactive. Full power output with vswr of 2:1 or less. Automatic power output turndown with vswr greater than 2:1.

Audio inputs

Microphone..... Low or high impedance, dynamic

Line..... 600 ohm, unbalanced; 40-mV input sufficient for full rf power output

INSTALLATION

unpacking

The HF-380 may be shipped in two separate cartons, depending on the shipping carrier's requirements. One contains the power transformer, the other contains the transceiver. After carefully unpacking the cartons, check to be sure no shipping damage is evident. Should any damage be apparent, save the cartons and notify the delivery carrier immediately to file claim for damage.

The HF-380 is shipped strapped for 115 V ac operation.

power transformer installation

If the power transformer has been shipped separately, it can be quickly installed in five steps. A 3/8-in open-end wrench, no 12 (3/8-in) nutdriver, and a Phillips screwdriver are the only tools needed.

Figure 1 shows the transformer properly mounted.

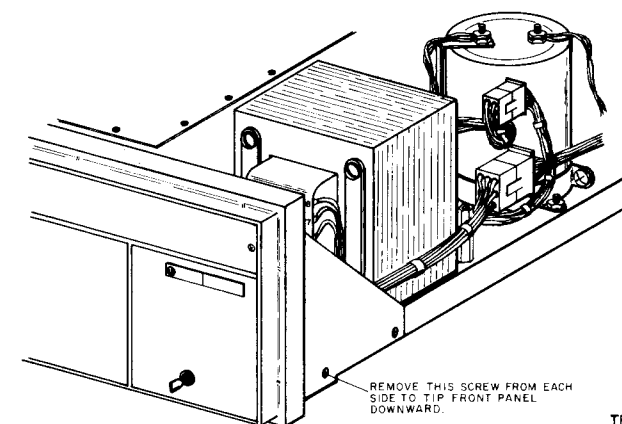

TPA-1655-011

Power Transformer Installation
Figure 1

- Using the screwdriver, remove four screws from the bottom of the transceiver (near the rubber feet at each corner) and slide the dust cover off over the heat sink.
- Remove the front one of the two Phillips-head screws securing the front panel braces to the sides of the chassis and tilt the panel forward.
- Turn the transformer so terminals 1 through 8 face the front panel. With the nutdriver, remove the four hexposts and lockwashers from the chassis mounting studs in the right front corner of the chassis and set the transformer over the studs.
- Using the wrench and nutdriver, secure the transformer to the studs with the four lockwashers and hexposts.
- Electrically connect the transformer to the transceiver with the two attached polarized connectors. Reattach the front panel, then replace the dust cover. Be careful when replacing the dust cover to avoid pinching or dislodging cables.

primary power requirements

WARNING

DO NOT ATTEMPT TO CHANGE VOLTAGE STRAPPING WHILE PRIMARY POWER IS APPLIED. ELECTRICAL SHOCK WILL OCCUR. DISCONNECT THE PRIMARY POWER CABLE FROM THE POWER SOURCE OR THE UNIT FIRST.

ac voltage operation

The HF-380 will operate from various 50- to 60-Hz voltages, depending on internal strapping connections. As shipped from the factory, the HF-380 is strapped for 115 V operation.

For input voltages listed, refer to figure 2 and strap TB1 as follows:

WIRE	105	115	125	210	220	230	240	250
BLACK	7	7	7	6	6	5	5	4
YELLOW	3	2	1	3	2	2	1	1
RED	6	5	4	3	2	2	1	1

Determine the average ac voltage at the primary power outlet where the transceiver is to be used. Remove the chassis dust cover and locate the protective cover plate near the left rear corner as viewed with chassis upside down. Remove the cover plate and refer to the preceding chart to make the connections indicated for the voltage nearest the primary power outlet voltage. If the outlet voltage is approximately halfway between two voltages listed, strap TB1 for the lower voltage.

Figure 2 shows TB1 correctly strapped for 105 or 240 volts.

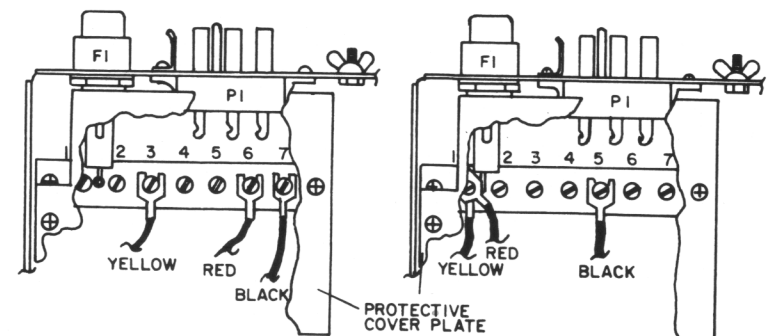

STRAPPING FOR 105 V AC

STRAPPING FOR 240 V AC

BOTTOM LEFT REAR CORNER OF TRANSCEIVER

TPA-1653-011

TB1 Strapping for 105 Volts or 240 Volts
Figure 2

dc voltage operation

The HF-380 will also accept 12 to 15 volts dc for backup emergency power. Power requirements are nominally 3 A in receive and 20 A in transmit. The AC-2821 DC Standby Power Cable is recommended for use with a user-supplied 12-V storage battery for emergency power. If a dc power cable is locally fabricated, the primary power connector must be wired as shown in figure 3.

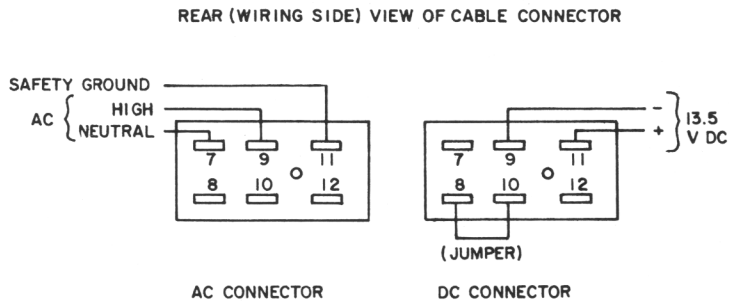

Power Connector Strapping for AC or DC Operation
Figure 3

operating location

The normal operating location should be chosen so the transceiver is away from heat vents and normal airflow around it is unobstructed. Do not lay objects on top or against the sides. It is especially important that the heat sink have a free flow of air about it. An automatic turndown circuit will reduce the rf output power if the heat sink overheats. This is for self-protection of the power amplifier output stages.

The AC-2808 Blower Kit is available for attaching to the heat sink. This blower supplies cooling air to permit normal operation in close quarters or high-duty cycle operation.

system interconnections

Figures 4 and 5 show typical hookups. Table 1 lists the signal parameters for all front and rear connectors except the primary and rf power.

For phone patch interconnections, 600- Ω audio input (J2), ptt (J9), and 4- to 8- Ω speaker output (J10) connectors are available on the HF-380 rear panel. Refer to the phone patch manufacturer's instructions for interconnect information.

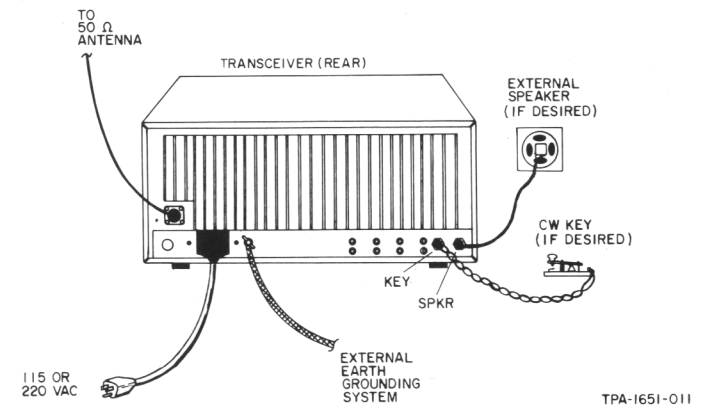

Transceiver Installation Connections
Figure 4

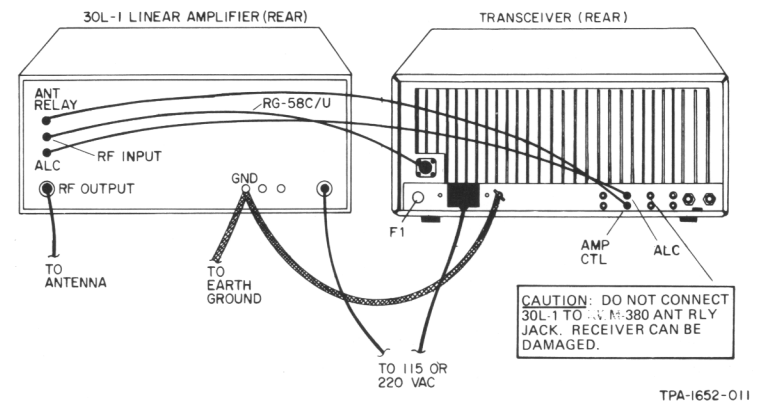

Transceiver and Linear Power Amplifier Installation Connections
Figure 5

Table 1. Controls, Indicators, Connectors, and Signal Parameters.

ITEM	FUNCTION
METER (switch)	Selects signal applied to meter during transmit.
ALC	Transmitter automatic level control voltage. Do not exceed S9 ALC level in transmit.
VC	Collector voltage for final amplifier stage.
PF	Forward rf power sampled at amplifier output.
PR	Reflected rf power sampled at amplifier output.
Meter	In receive, indicates relative signal strength in "S" units. (Rf input of 100 μ V at antenna terminals gives S9 indication.) In transmit, indicates signal selected by METER switch.
Function switches	Selects related function when switch is in position.
MOX	Manually operated receive-to-transmit switching. Places transceiver in transmit when pressed in.
VOX	Voice operated receive-to-transmit switching. Ptt switching also operable.
NB	Noise blanker.
PROC	Speech processor.
AGC	Receiver automatic control. (Switch must be in in position to enable AGC function.)
SLOW	Selects slow AGC action in in position; fast AGC when out. (AGC switch must be in in position for fast/slow action to be enabled).
DELAY	Adjustments for transmit-to-receive switching time delay.
CW	Delay between last keyup action and receive mode.
SSB	Delay between last microphone VOX input and receive mode.

Table 1. Controls, Indicators, Connectors, and Signal Parameters (Cont).



ITEM	FUNCTION
GAIN	Adjusts levels at which receive-to-transmit switching occurs.
VOX	Voice or line audio input signals.
ANTI	Speaker-to-microphone signals.
Frequency readout	Displays frequency in 10-Hz increments.
Frequency control switches	Selects frequency increments affected by tuning knob. Continuous tuning for any increment with roll-around at end limits.
	1-MHz increments.
SYNC	Loads displayed frequency in nonselected vfo register to synchronize both vfo frequencies.
LOCK	Dial lock prevents tuning knob from changing frequency when rotated. Release by pressing in any increment switch.
	1-kHz increments.
 (left)	100-Hz increments.
 (right)	10-Hz increments.
POWER	Primary power switch.
Tuning knob	Frequency selection control. (Provides 200 increments per revolution for all except MHz steps at 10 increments per revolution.) Works in conjunction with switches above knob.
SPOT	In CW mode only, enables 800-Hz tone to which received CW tone is matched to spot transmitted frequency to exact received frequency.
VFO	Selects frequency-storage register.
A	A register. Transmit and receive on same frequency.

Table 1. Controls, Indicators, Connectors, and Signal Parameters (Cont).

ITEM	FUNCTION
B	B register. Transmit and receive on same frequency.
RA-TB	Receive on A register frequency-transmit on B register frequency.
RB-TA	Receive on B register frequency-transmit on A register frequency.
SELECTIVITY	Controls selectivity of receiver.
PBT (small knob)	Passband tuning. Used to select USB, LSB, or CW during receive mode. Continuously varies position of passband (bandwidth selected by BW control) within 8-kHz passband of first if filter.
BW (large knob)	Selects filter bandwidth.
8.0	8.0-kHz filter (for AM, also selects optional 6-kHz AM filter if installed).
2.2	2.2-kHz filter (for normal SSB).
OPT 1,2,3	Three positions for optional filters.
MODE	Selects mode of transmit operation.
CW	Continuous wave.
USB	Upper sideband. } Receive sideband determined by setting of PBT control.
LSB	Lower sideband. }
AM RCV	Amplitude modulation in receive only. Transmitter does not operate in AM mode.
GAIN	Adjusts gain of receiver circuits.
AF (small knob)	Af amplifier gain.
RF (large knob)	Rf amplifier gain.

Table 1. Controls, Indicators, Connectors, and Signal Parameters (Cont).

ITEM	FUNCTION
MIC/CARRIER	In sideband operation adjusts microphone amplifier gain. In CW operation adjusts rf carrier level. Do not exceed S9 ALC indication.
PHONES (mates with PJ-055)	Output jack for low-impedance (4- to 8- Ω) headphones. Connecting phones inhibits speaker and SPKR (on rear panel) outputs. Tip—receiver audio; 4- to 8- Ω impedance, up to 3-W output Barrel—ground
MIC (mates with PJ-068)	Input jack for high- or low-impedance, dynamic microphone. Jack is also wired for ptt signal. Tip—ptt line; ground to transmit Ring—microphone audio; high- or low-impedance input, approx 5 mV in for full power output Barrel—common ground
Antenna (mates with PL-259)	Rf connector (type S0-239 with Teflon insert) for coaxial cable connection to antenna or linear amplifier.
Fuse	Primary power fuse (8 A for 110 V, 4 A for 220 V).
J1	Primary power connector.
Ground	Stud for earth-ground connection.
AUD IN (J2) (mates with phono plug)	Input for 600-ohm, unbalanced line audio: 40-mV input produces 100-W rf output.
ALC (J3) (mates with phono plug)	Negative ALC input signal from external power amplifier.
ANT RLY (J4) (mates with phono plug)	Receive contacts of internal antenna transfer relay. CAUTION: Do not connect linear amplifier control to J4. Damage to the receiver may result. External receiver may be connected to J4. (Jumpered to RCV IN (J8) if separate receive antenna not used. Cut internal jumper if separate antenna used.)

Table 1. Controls, Indicators, Connectors, and Signal Parameters (Cont).

ITEM	FUNCTION
XVTR OUT (J5) (mates with phono plug)	Exciter output signal for use with transmitting converter. Level adjusted by MIC/CARRIER control. Approximately 200-mW (100-mW, min) output from exciter into 50-ohm load. (To obtain output, connect this line to dc ground through a 1-mH rf choke.)
AUD OUT (J6) (mates with phono plug)	Output for 600-ohm, unbalanced line audio; -10 dB mW at AGC threshold. Level is independent of audio gain control.
AMP CTL (J7) (mates with phono plug)	Relay contacts for tr-switching external power amplifier. Normally open relay contacts; contacts grounded in transmit. 2 A, 28 V dc or 0.75 A, 115 V ac capacity.
RCV IN (J8) (mates with phono plug)	Receiver front end signal input. Bypasses antenna transfer relay and transmit low-pass filters. (Jumpered to ANT RLY (J4) if separate receive antenna not used. Cut internal jumper if separate antenna used.)
PTT (J9) (mates with phono plug)	Push-to-talk switch input. Ground to command transmit operation. (Line is connected to +5 V through 10-k Ω resistor.)
KEY (J10) (mates with PJ-055)	CW key input. (Line is connected to +5 V through 10-k Ω resistor.) Tip—keying line; ground to transmit Barrel—ground
SPKR (J11) (mates with PJ-055)	Output for 4- to 8-ohm speaker. Disconnects internal speaker when external speaker connected. (Inhibited when headphones connected to PHONES jack on front panel.) Tip—receiver audio; 4- to 8- Ω impedance, up to 4-W output Barrel—ground

grounding

The importance of a good ground system cannot be overemphasized. All units of the system should have ground interconnections through heavy wire (#12 AWG or larger) or ground strap (6-mm (1/4-in) wide or larger) between ground lugs. Use as short a length of ground wire or braid as practical between units or external ground.

Connect the HF-380 ground lug on the rear to a good earth or water-pipe ground.

Before using a water-pipe ground, check to make sure that no plastic, rubber, or other such insulating sections will interrupt the electrical continuity to ground. Install a jumper around any insulating sections found. Use heavy copper wire or ground braid and metal pipe clamps.

antennas

The antenna is one of the most important parts in the performance of any radio communications system. System performance is directly related to the efficiency of the antenna. Because each individual installation has unique characteristics, various types of antennas, their characteristics, and installation information cannot be covered in this manual. A number of excellent reference works on antennas are available.

The HF-380 is designed to operate into a nonreactive rf load of 50 ohms. Impedance mismatches producing vswr's lower than 2:1 are acceptable. For vswr's 2:1 or greater, the transceiver power amplifier output is automatically reduced in proportion to the reflected power.

OPERATION

introduction

Controls on the HF-380 have been labeled so that their function is self-explanatory. After referring to figures 6 and 7 and table 1, many operators will need no further explanation. The following paragraphs summarize operation of several of the controls and give checklists for initial control settings for each operating mode.

frequency selection

The large tuning knob and row of switches immediately above it control the transceiver frequency selection. When power is applied to the transceiver, the frequency is automatically set to 15.000 00 MHz. Frequency data is not retained in the vfo registers when power is turned off.

There is no need for a bandswitch since selection of the MHz tuning increment permits tuning from 0 to 29 MHz in three turns of the knob. This rate is effective for the MHz digits only. Selecting other increments automatically switches the tuning rate to 200 steps per turn. For example, selecting the 100-Hz increment gives 20 kHz per revolution of the tuning knob.



When a switch is depressed to select a frequency increment to be changed, that and all higher increments will change as the tuning knob rotates. For example, if the 100-Hz increment is selected, the 10-Hz digit remains where last set. Rotating the tuning knob clockwise causes the 100-Hz digits to increment

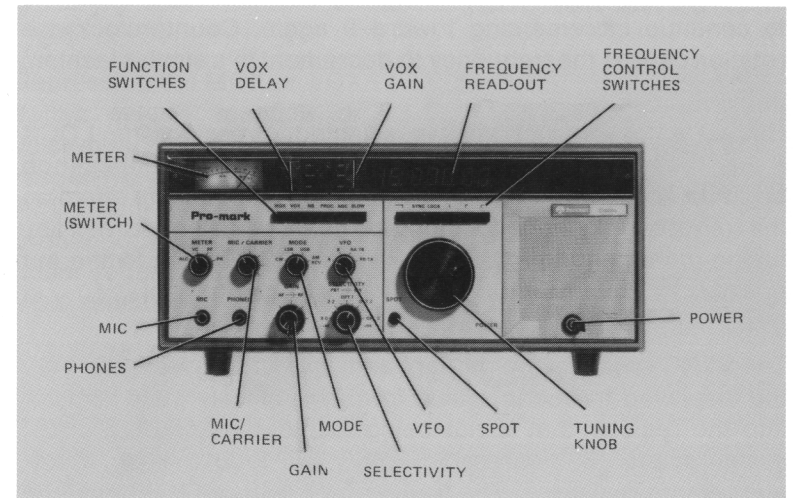

Front Panel Controls and Indicators
Figure 6

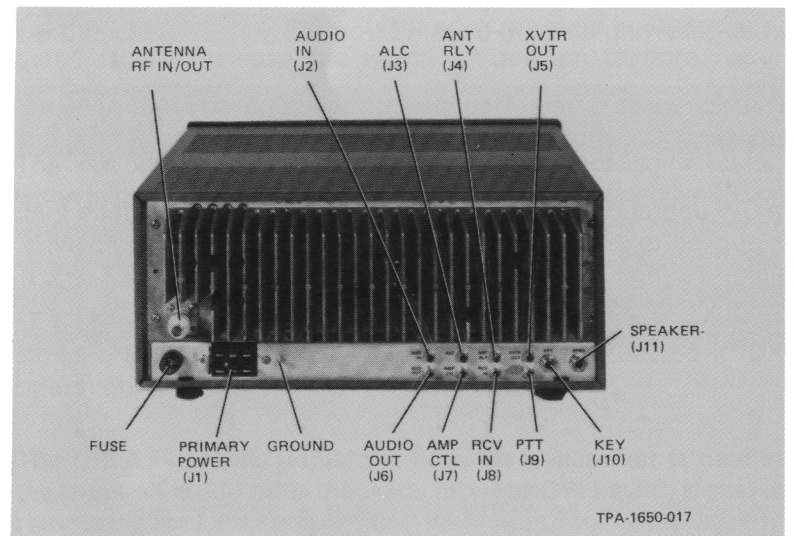

Rear Panel Connectors
Figure 7

up through 9, index the 1-kHz digit by one, and roll around to 0 to continue incrementing toward 9 again. Counterclockwise rotation causes the frequency to decrement in a similar fashion.

Once a chosen frequency is selected, pressing the LOCK switch to the in position electronically disables the tuning knob operation. In LOCK, rotation of the tuning knob has no effect on the frequency. To restore tuning control to the knob, press any tuning increment switch to return the LOCK switch to the out position.

The SYNC switch is momentary and when depressed, will load the displayed frequency value from the operating vfo register into the register that is not being displayed. For example, if using register B, depressing SYNC will load the same frequency into register A. The frequency in register B can then be changed without affecting the stored value in register A.

The A and B vfo registers may contain any two frequencies. Split-frequency operation is achieved by selecting RA-TB or RB-TA. With RA-TB chosen, the transceiver will receive on the frequency in the A register and transmit on the frequency in the B register. The frequency display shows the receive frequency when receiving and the transmit frequency when transmitting.

The vfo registers can be set up for split-frequency operation on any two frequencies, even within separate bands.

In CW operation, the SPOT switch enables an 800-Hz tone that is applied to the receiver audio output. By tuning the received signal so the CW audio frequency matches the 800-Hz SPOT frequency, the receiver frequency will be matched with the transmitted frequency.

function switches

Depressing the MOX or VOX switch selects manual- or voice-operated keying respectively. The rear panel PTT jack (J9), when grounded, will key the transmitter regardless of MOX or VOX selection.

When pressed to the in position, the MOX switch keeps the transceiver continuously keyed. For normal transmit-receive operation, the MOX

switch must be out. With MOX and VOX both out, the transceiver is keyed with the microphone ptt switch. Selecting VOX enables voice keying in sideband or CW keying in CW.

The AGC function can be enabled by depressing the AGC switch. The out position inhibits AGC operation. Release time of the AGC is controlled by the SLOW switch. The in position selects a slow release time. This is normally used in SSB operation. Fast AGC release, the switch out position, is more useful for CW reception.

The optional noise blanker and speech processor circuits, when installed, are selected by depressing the respective NB or PROC switch to the in position. The noise blanker reduces or eliminates pulse-type noise, such as from automobile ignition systems, from the receiver audio output. The speech processor increases the ratio of average to peak power in the rf output signal. This increases talk power and may be desired in DX operation.

The DELAY controls adjust the time the transceiver is held in the transmit mode after the voice input or CW keying signal is removed. Clockwise adjustment of either control increases the delay between the last input and automatic transmit-to-receive switching. Independently set these controls as desired for the preferred delay times.

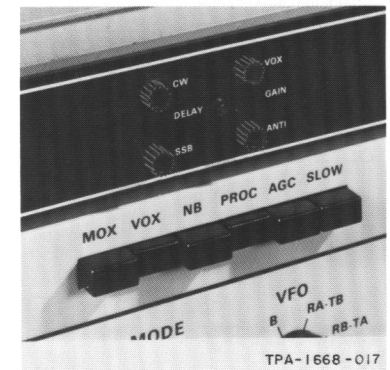

The GAIN controls adjust the sensitivity to microphone input signals from the operator (VOX) or from the receiver speaker (ANTI-VOX). Set the VOX GAIN so the normal voice level used during transmitting keeps the transceiver keyed. A level too high may cause background noises to key the transmitter while a level too low will require a loud voice input to the microphone for keying. In CW, advance VOX GAIN until an rf output is obtained when the transceiver is keyed in the VOX mode. Set the ANTI-VOX GAIN to the minimum gain (ccw) level that prevents the microphone pickup of the speaker output from tripping the VOX circuit.

selectivity

The large (rear) BW switch controls the receive bandwidth by selecting any one of the installed filters. Filter installation information is given in the following maintenance section. The 6-kHz AM filter (AC-3813) is particularly recommended for critical AM listening.

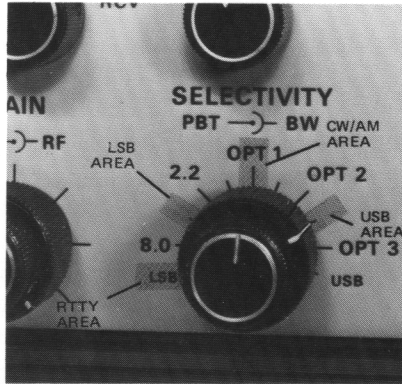

TPA-1666-017

The small (front) PBT control positions the passband of the selected filter within the 8-kHz passband of the receiver first if and is used to select the desired sideband in receive. For RTTY, position the pointer near LSB (left-most position); for LSB, position the pointer between 8.0 and 2.2; for AM or CW, near OPT 1; and for USB, between OPT 2 and OPT 3.

NOTE

The MODE switch does not determine which sideband is received. It only selects the desired transmit passband.

The PBT control can shift the position of the receive selectivity by adjusting the passband above or below the normal

frequency position. In either USB or LSB, rotating the control toward the vertical (OPT 1) position lowers the audio frequency passband. This produces a lower audio tone. Figure 8 illustrates this. Figure 9 illustrates how the passband can be tuned away from an interfering signal to put the signal outside the passband and eliminate the interference.

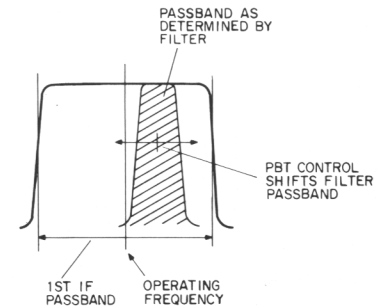

TPA-1665-011

Filter Passband Positioning With PBT Control
Figure 8

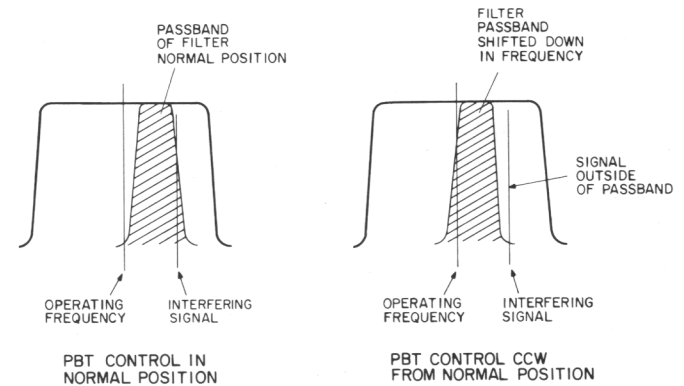

TPA-1664-011

Passband Tuning To Eliminate Interfering Signal
Figure 9

mic/carrier

The MIC/CARRIER control adjusts the audio modulation level or the CW carrier level to control the rf output power. For voice operation, set the METER switch to ALC. Key the transmitter and speak into the microphone or say "Ahhhh" in a normal operating-voice level while adjusting the MIC/CARRIER control until the meter indicates S5 to S9 on the S-unit scale. A more counterclockwise position of the control will give less than this full power output setting.

DO NOT EXCEED S9 ALC indication or distortion may be generated. Normal power output is 100 watts pep. In voice operation, this will produce an average power output of 15 to 25 watts on an average power wattmeter. Speech processing will increase this average by several dB.

For CW operation, set the METER switch to ALC. Key the transmitter and adjust the MIC/CARRIER control clockwise until the meter indicates S5 to S9. A more counterclockwise position of the control will give less than this full power setting.

operating checklists

Adjustments of the HF-380 controls will vary with individual operators. The following checklists give initial control settings for each mode of operation. After setting up the transceiver, the controls may be adjusted as desired during operation.

If a linear power amplifier is used with the HF-380, tune the amplifier by using the CW MODE of the HF-380. Since the CW key line is closed circuit, a key is not necessary. Simply depress VOX or MOX for transmit enable. If a key is used, it must be closed.

The rf input to the amplifier is controlled with the MIC/CARRIER control. This control should be slowly adjusted from minimum power (full counterclockwise position) upward to an output level adequate for tuning the amplifier. There is a short lag between control adjustment and rf output level change. Use caution to not overdrive the power amplifier.

For RTTY operation, the modem output (to the HF-380 line audio input, J2) must be AFSK: FSK will not work.

These checklists assume that the equipment is properly installed, the microphone or CW key connected, and the DELAY and GAIN controls adjusted.

CW operation

- Turn on POWER.
- Set MODE to CW.
- Select VFO A or B.
- Adjust RF and AF GAIN to desired levels.
- Select desired BW.
- Set PBT to midrange (vertical position).
- Select unused frequency near desired operating frequency.
- Set METER to ALC.
- Select VOX function.
- Key transceiver and adjust MIC/CARRIER for S5 to S9 ALC indication.

NOTE

VOX GAIN must be set to a high enough level to trigger the VOX circuit.

- Release key and tune to operating frequency.

SSB operation

- Turn on POWER.
- Set MODE to LSB or USB, as desired for band of operation.
- Select VFO A or B.
- Adjust RF and AF GAIN to desired levels.
- Select 2.2-kHz bw.

- Set PBT to between 8.0 and 2.2 (for LSB) or OPT 2 and OPT 3 (for USB).
- Select unused frequency near desired operating frequency.
- Set METER to ALC.
- Press in VOX function switch if ptt operation not desired.
- Key transmitter and speak into microphone while adjusting MIC/CARRIER to power output level desired (normally to level where meter indicates S5 to S9 on S-unit scale). Do not exceed S9.
- Unkey and tune to operating frequency.

RTTY operation

- Make sure microphone is disconnected. (Connect AFSK RTTY signal to AUD IN.)
- Turn on POWER.
- Set MODE to LSB.
- Select VFO A or B.
- Adjust RF and AF GAIN to desired levels.
- Select desired BW filter for receive. (Transmit function automatically selects 2.2-kHz filter.)
- Set PBT to LSB index mark (left-most position).
- Set METER to ALC.
- Select unused frequency near desired operating frequency.
- Press in MOX function switch (transceiver keys).
- Adjust MIC/CARRIER S5 to S9 ALC indication.
- Press MOX function to release to out (unkeyed) position. (VOX may be used if AFSK modem mutes tone during receive.)
- Tune to operating frequency.

AM operation (receive only)

- Turn on POWER.
- Set MODE to AM.
- Select VFO A or B.
- Adjust RF and AF GAIN to desired levels.
- Select 8.0 BW. (The operational AC-3813 6-kHz filter is recommended for optimum AM reception.)
- Set PBT to vertical position.
- Tune to desired frequency.

MAINTENANCE

Without extensive test equipment, only a limited amount of maintenance can be performed. The following information guides in determining general functional areas in which a detected malfunction may be located. A multimeter, frequency counter, power meter, dummy load, and rf voltmeter are required for tests.

Detailed test procedures, schematic diagrams, and parts list for the transceiver are contained in the HF-380 Transceiver Service Manual, Collins publication number 523-0769880.

If desired, repair may be done by a Rockwell-Collins Service Agency. Refer to any in the list at the end of this manual, or contact the dealer from whom the equipment was purchased.

In any correspondence about the transceiver, give the equipment type number and name, Collins 10-digit part number, and serial number. This is found on the equipment nameplate located at the bottom center of the rear of the chassis.

Figures 10 through 14 show a block diagram, circuit card locations, and cable interconnections in the HF-380. If cables are removed and replaced, make sure they are reconnected properly and lead dress is restored.

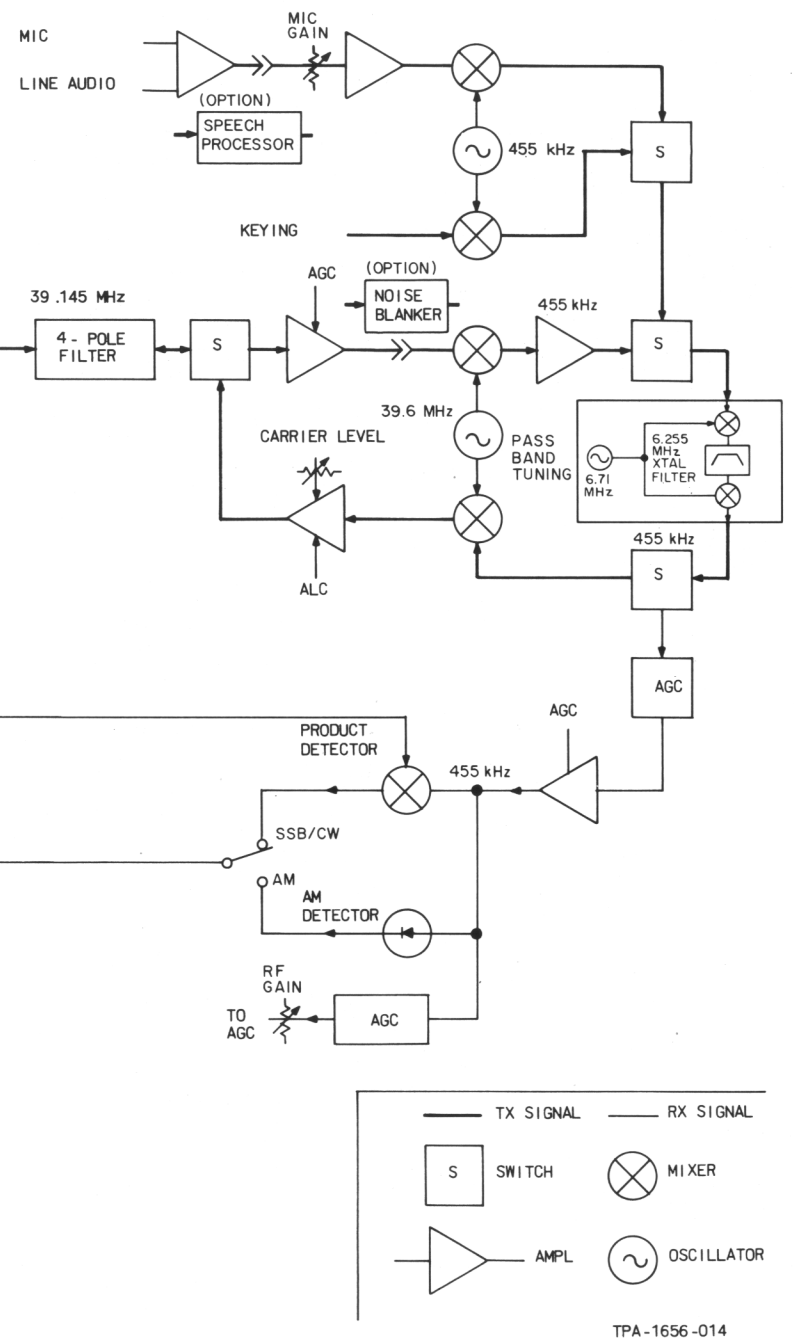
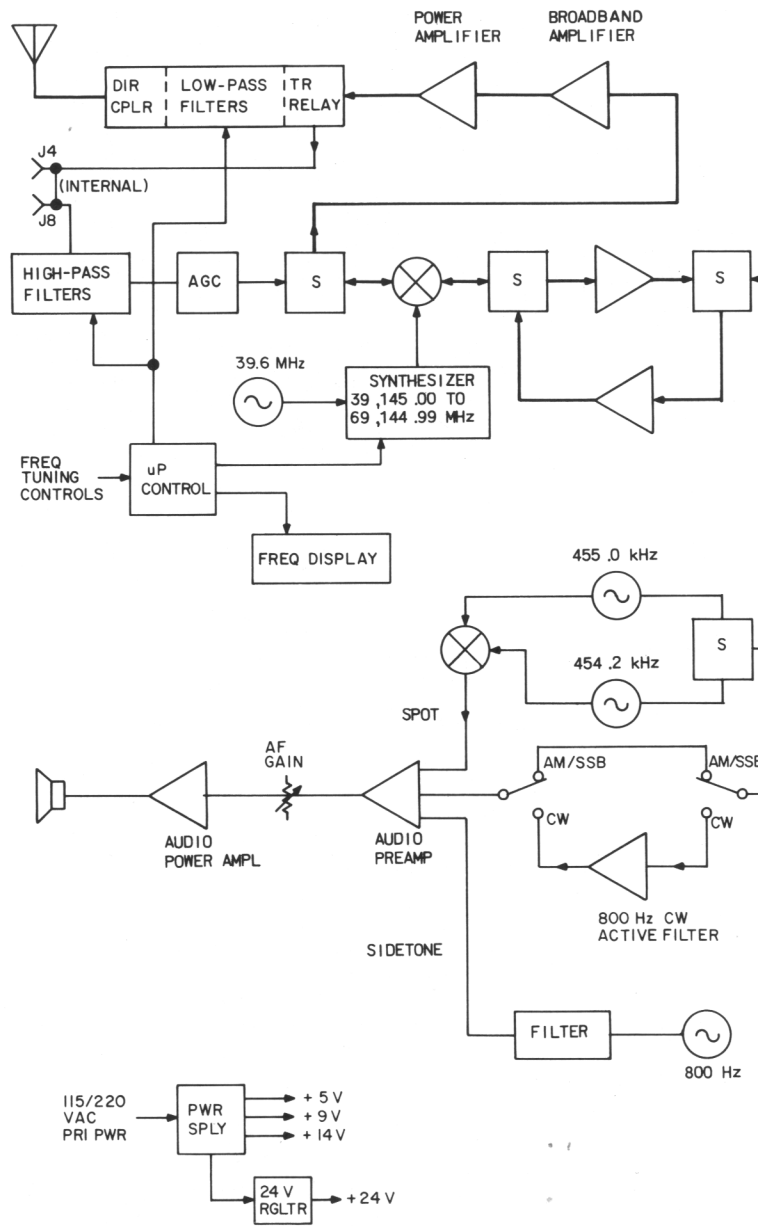

HF-380 Simplified Block Diagram
Figure 10

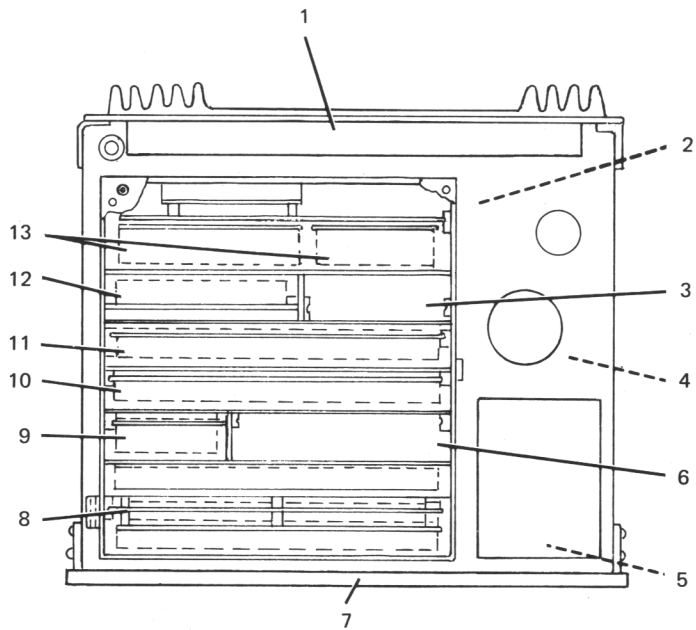

- | | |
|---------------------------------------|--|
| 1. POWER AMPLIFIER (A1A1) | 8. SYNTHESIZER (A5) |
| 2. RECEIVER-EXCITER (A3) | 9. OSCILLATOR (A7) |
| 3. SPEECH PROCESSOR (A12)
(OPTION) | 10. CONTROL CARD (A8) |
| 4. POWER SUPPLY
CONTROL (A9A1) | 11. PASS BAND TUNING (A4) |
| 5. +24 V REGULATOR
(A9A2) | 12. PASS BAND TUNING (A13)
(OPTION) |
| 6. NOISE BLANKER (A11)
(OPTION) | 13. LOW-PASS FILTER (A2) |
| 7. DISPLAY (A10A1) | |

TPA-3348-019

*Circuit Card Locations
Figure 11*

replaceable fuses and lamps

Primary power (located on rear panel) — 8 A, AGC for 100 V; 4 A, AGC for 220 V; -30A, AGC for dc operation (under power strapping cover plate).

14-volt supply (two fuses located on power supply card under chassis) — 2 A, AGC.

Panel meter lamps (wired into holder at top rear of meter) — T1 3/4, 14 V, 100 mA, type 7373.

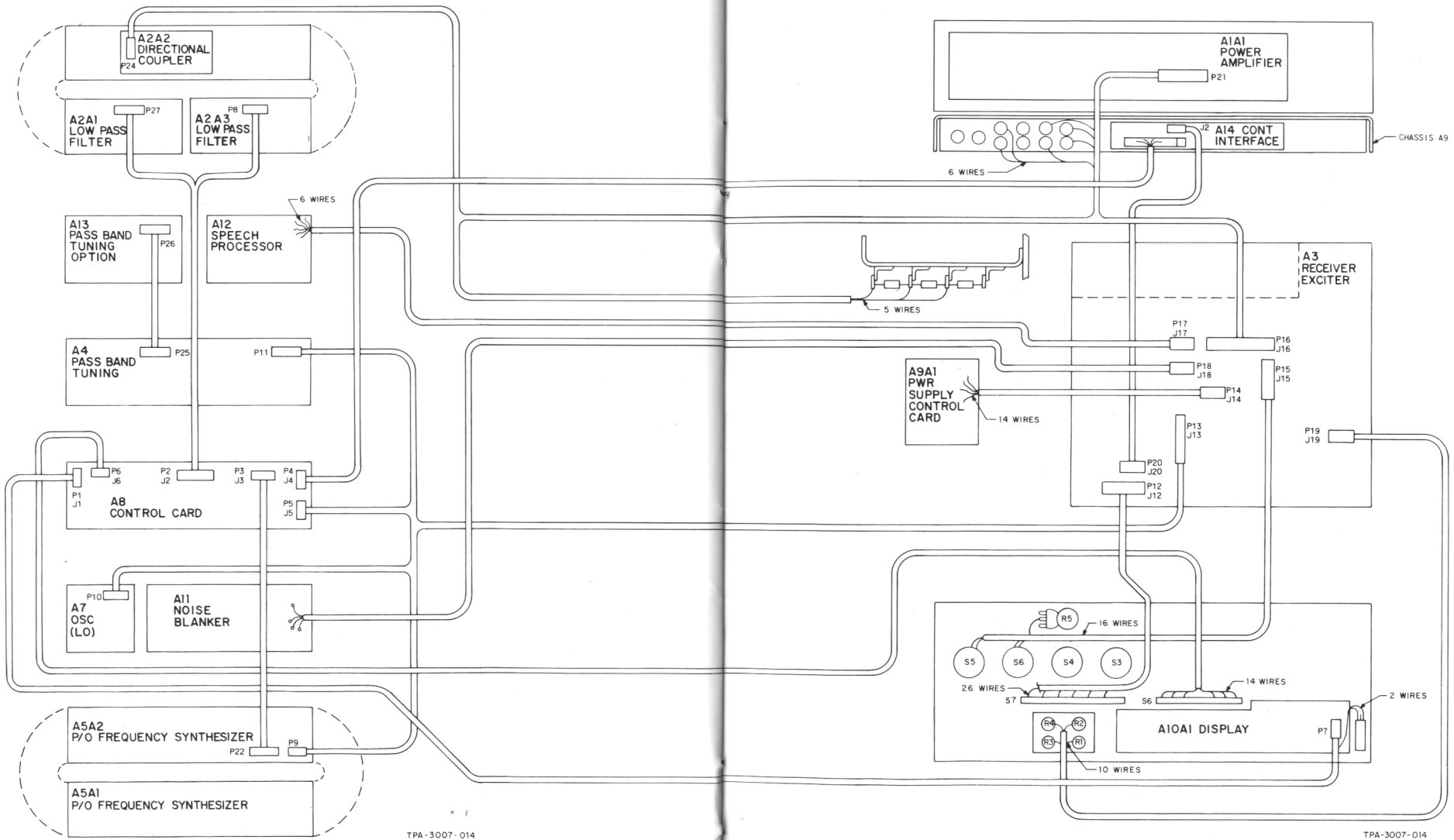

Ribbon Cable Wiring Diagram
Figure 12

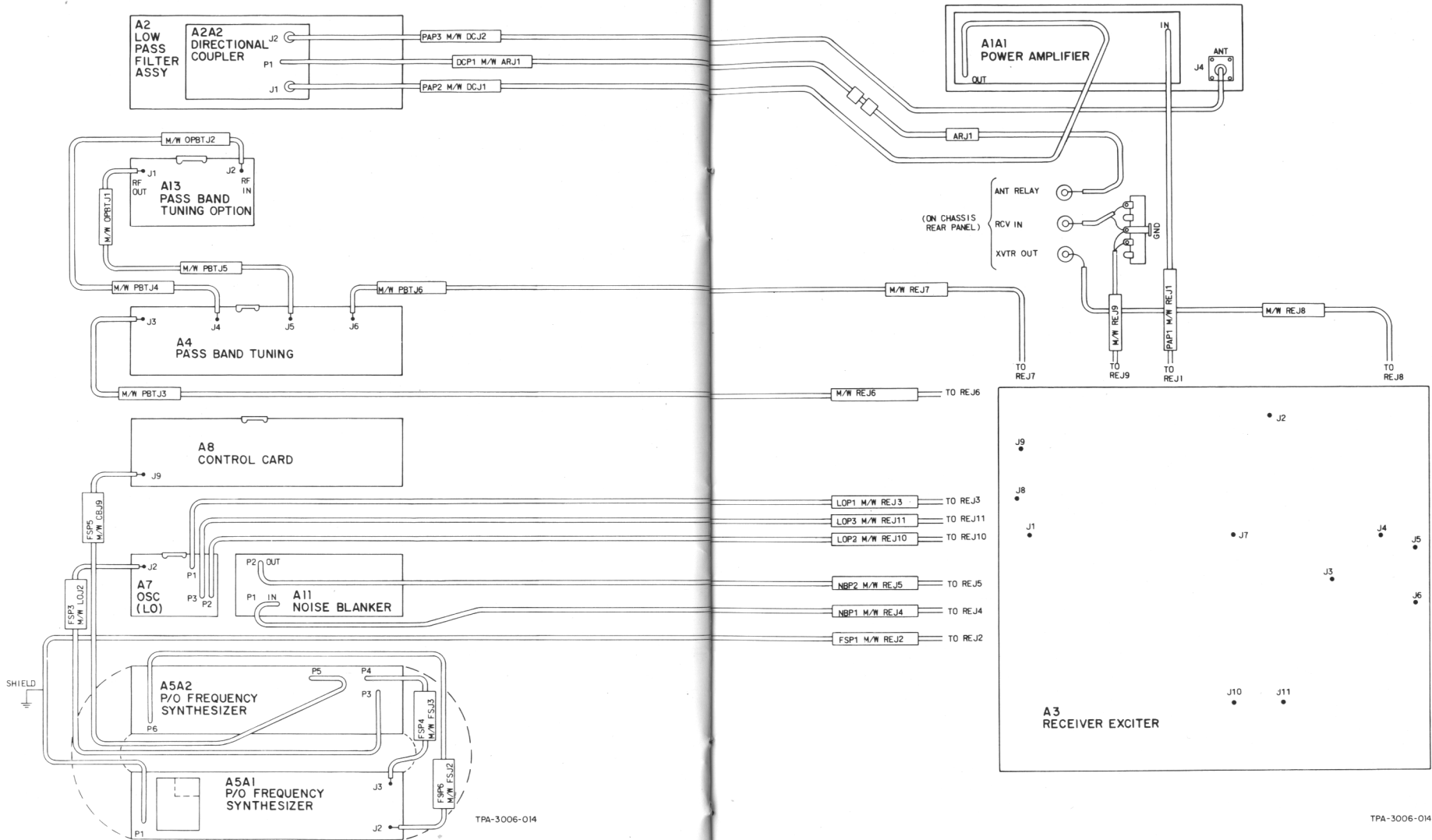

TPA-3006-014

TPA-3006-014

Coax Cable Wiring Diagram
Figure 13

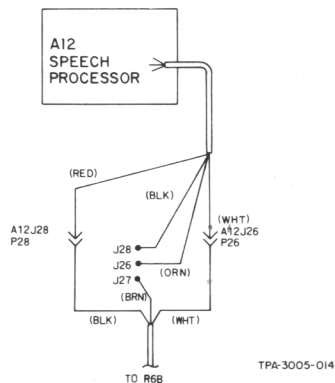
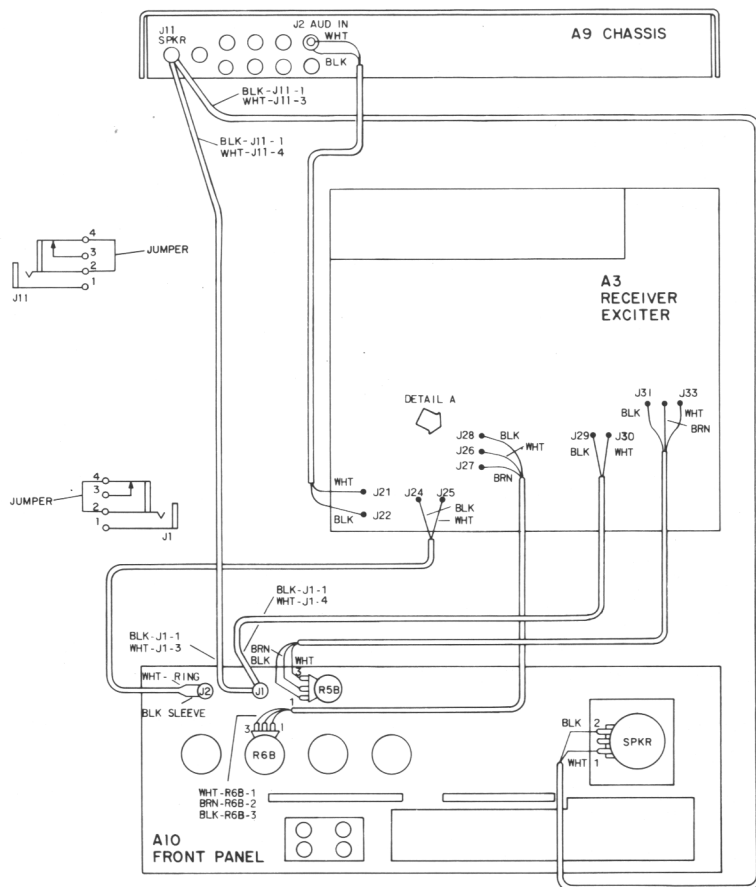

DETAIL A
WITH A12 INSTALLED, J26-J28
ARE CONNECTED AS SHOWN HERE

Shielded Wire Wiring Diagram
Figure 14

receiver-exciter sidetone and spot potentiometer adjustments

Refer to figure 15 for locations of sidetone frequency and level and spot tone level potentiometers. These potentiometers may be adjusted to the level or frequency desired by the operator.

DO NOT MAKE ANY OTHER ADJUSTMENTS ON THE RECEIVER-EXCITER BOARD WITHOUT THE INSTRUCTIONS AND TEST EQUIPMENT SETUP GIVEN IN THE HF-380 SERVICE MANUAL.

39.6-MHz and 455-kHz oscillator adjustments

The oscillator frequencies are adjustable over a limited range. The oscillators do not normally need adjusting, however the trimmer capacitors are readily accessible if adjustment is required. No test equipment is necessary.

The test for off-frequency operation and corrective adjustment procedures is as follows:

- Set MODE to USB.
- Set BW to 8.0 and PBT to vertical (OPT 1) position.
- Tune WWV at 15.000 00 MHz.
- Adjust dial frequency for exact zero-beat of station.
- Note dial frequency offset, if any.
- Repeat operation for 10.000 00 MHz and 5.000 00 MHz, noting frequency offset.
- If frequency offset is the same for each frequency, the 455-kHz oscillator needs adjusting. If offsets differ, the 39.6-MHz oscillator needs adjusting.
- To adjust either oscillator, remove unit dust cover and card cage cover. Lift oscillator A7 part way out of cage. Tune WWV at 15.000 00 MHz. Set dial frequency to 15.000 00 MHz. Adjust the appropriate control for zero-beat. (Refer to figure 16 for adjustment locations.)

- Recheck frequency offsets, as above. If both oscillators are off frequency, these steps may have to be repeated several times. Replace the oscillator and covers when adjustments are completed.

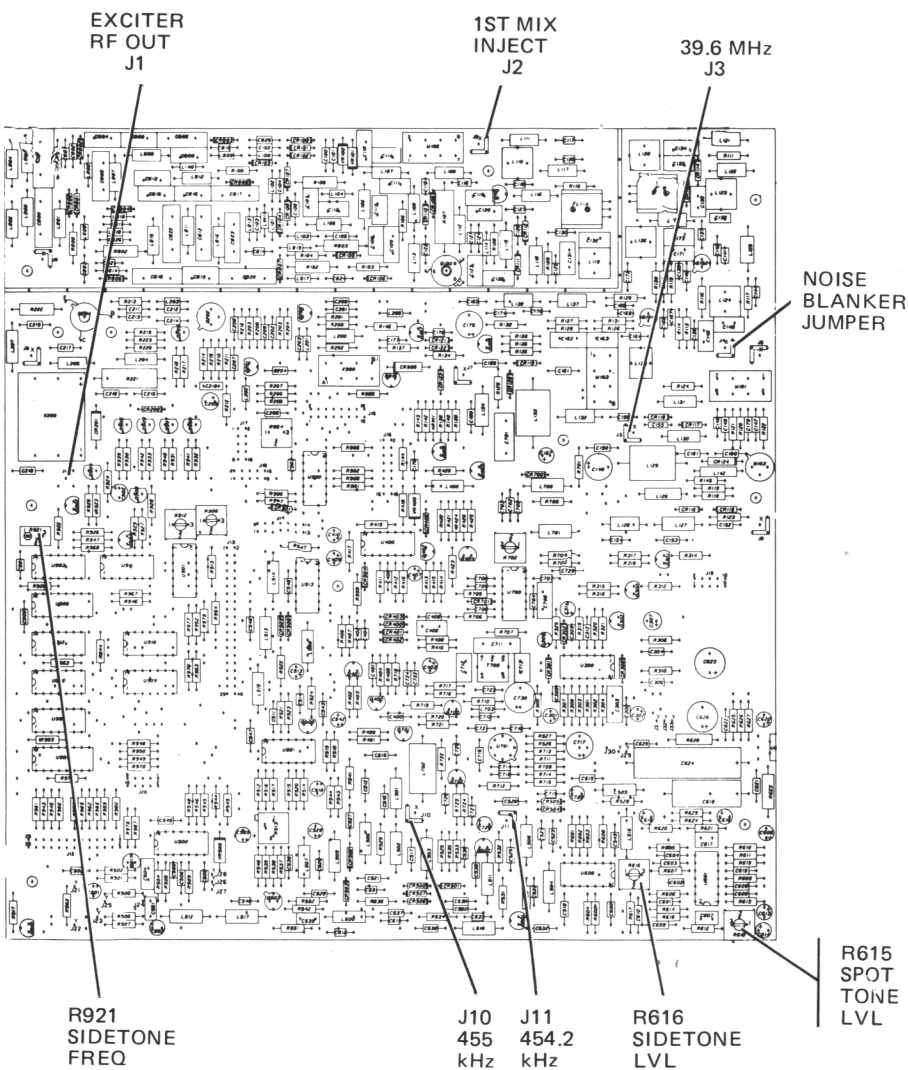

TPA-1663-019

Receiver-Exciter Connectors and Adjustments Locations
Figure 15

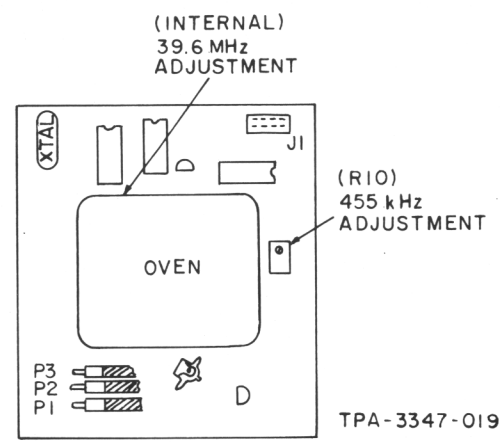

Oscillator A7, Frequency Adjustment Locations
Figure 16

general troubleshooting

dc voltages

Figure 17 shows the power supply input and output voltages. These should be checked along with other checks for any malfunction. Other than fuse replacement, repair should not be attempted without information in the Service Manual.

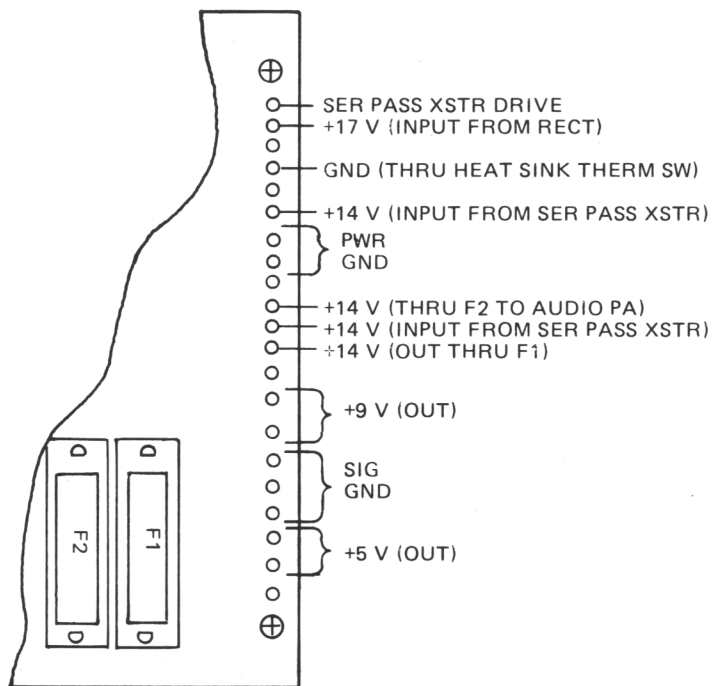

+14 V INPUT TO +24 V REGULATOR IS AT FEEDTHRU CAPACITOR NEAREST BOTH THE SHIELDING COVER AND FRONT PANEL.

+24 V OUTPUT FROM SHIELDED CIRCUIT ADJACENT TO POWER SUPPLY BOARD IS AT FEEDTHRU CAPACITOR NEAREST SHIELDING COVER AND FARTHEST FROM FRONT PANEL.

TPA-3017-011

Power Supply Input/Output Voltage
Figure 17

oscillator (fixed-frequencies) and synthesizer (variable-frequency) outputs

Refer to figure 15 for oscillator and synthesizer signal connector locations on the receiver-exciter board. Make the following measurements with an rf voltmeter and frequency counter. If the fixed-frequency signals are not correct, the oscillator is malfunctioning. If the variable-frequency signal is not correct, the synthesizer or control card is malfunctioning. Refer to the Service Manual.

39.600 00 MHz (J3) in receive or transmit — approx 0.5 V rms across 50 Ω

455 kHz (J10) in SSB receive — greater than 50 mV rms across 50 Ω

454.2 kHz (J11) in CW receive — greater than 50 mV rms across 50 Ω

1st mixer injection (J2) in receive or transmit; 39.145 MHz for 00.000 00 MHz dial frequency through 69.144 99 MHz for 29.999 99 MHz dial frequency — approx 0.5 V rms across 50 Ω

Rapid beeping in the speaker indicates the synthesizer is unlocked. This may be caused either by a faulty 5-, 9-, or 24-V power supply output, or by a malfunction in the synthesizer. Check the power supply outputs first, then check the coax cable between the synthesizer and oscillator. Check the oscillator and synthesizer output levels for values indicated above. If all these are correct, the synthesizer is malfunctioning.

receiver/low pass filter

If there is no audio output, check F1, F2, and the +14-V outputs at the power supply. If these are not faulty, check the oscillator and synthesizer outputs. If these are not faulty, the receiver circuits are malfunctioning. Refer to the Service Manual.

If the audio output is weaker than expected for a known input signal, connect the antenna to the RCV IN jack on the transceiver rear panel (to bypass the low-pass filter). If the audio output becomes normal, the low-pass filter or control card is malfunctioning. If the output remains weak, the receiver circuits are malfunctioning. Refer to the Service Manual.

exciter

Refer to figure 15 for the exciter rf output connector on the receiver-exciter board. Disconnect cable from J1. Set the MODE to CW, MIC/CARRIER to full maximum (clockwise position), and depress MOX. Measure the exciter output (at J1) with an rf voltmeter and frequency counter. The level should be approximately 3 V rms across 50 Ω and the frequency the same as the dial frequency. If the output is not correct, refer to the Service Manual. (Switch off MOX and reconnect cable at J1 when test is complete.)

power amplifier/low pass filter

Connect an rf power meter and dummy load to the transceiver rf connector. Set the MODE to CW and MIC/CARRIER to full maximum (clockwise position). In measuring rf power in the following steps note that, unless the AC-2808 Blower Kit is installed, the output will decrease to about half power within 30 seconds after the MOX switch is turned on. Read the power meter before the power decrease.

Measure the power amplifier output by tuning to a valid transmit frequency, switching on MOX, measuring the power, then switching off MOX. Make power measurements at approximately 1.8, 2.5, 3.5, 5, 8, 12, 15, and 25 MHz. If the output power is less than approximately 100 watts in all of the frequencies, the malfunction is probably in the power amplifier. If one or more of the frequencies show full output power, the malfunction is probably in the low-pass filter or control card. Refer to the Service Manual.

bandwidth (crystal) filter installation

The AC-3810 through AC-3813 Filter Kits may be installed individually or as a group to provide additional bandwidth selectivity in the HF-380. Except for the AC-3813 (AM Filter), the filters may be installed in any of the positions on the Pass Band Tuning or Pass Band Tuning Option card. Figures 18 and 19 and table 2 show the positions and list the BW SELECTIVITY switch position that enables the filter installed in that associated position. For operating convenience, it is suggested that the filters be installed in order of decreasing bandwidth.

To install a filter, remove the appropriate circuit card, place mica washers (supplied with the filter kit) on the filter terminals, then position the filter on the circuit card. Secure the filter with the supplied flat washers, lockwashers, and hexnuts (also supplied with the kit). Solder the filter terminals to the circuit pads on the card.

Before installing the AC-3813 AM Filter, the existing piggyback circuit board filter must be removed from the Pass Band Tuning card. Remove the mounting hardware from the board and unsolder the pins from the circuit pads on the card. Mount the AM filter as described for the other filters.

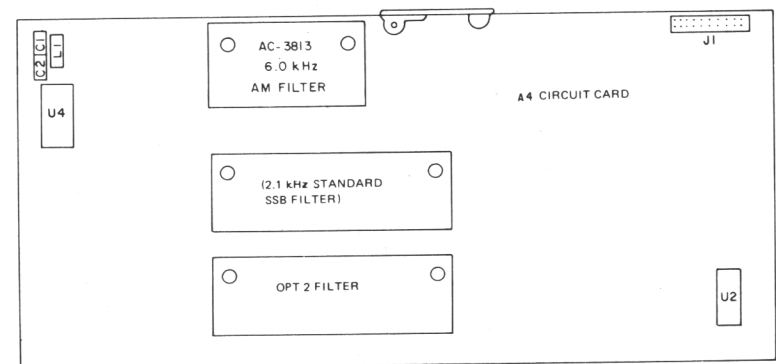

TPA-2213-019

Pass Band Tuning Card Filter Locations
Figure 18

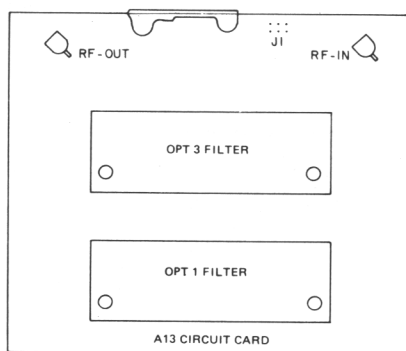

TPA-2214-019

Pass Band Tuning Option Card Filter Locations
Figure 19

Table 2. BW SELECTIVITY Switch and Filter Position Relationships.

BW SELECTIVITY SWITCH POSITION	FILTER POSITION ON CIRCUIT CARD
8.0	A4 card upper position
2.2	A4 card middle position
OPT 1	A13 card lower position
OPT 2	A4 card lower position
OPT 3	A13 card upper position

TYPE AND PART NUMBER

DESCRIPTION

AC-3801
641-7105-001

Noise Blanker
(For use in transceivers located in high impulse type rf noise environments)

AC-3802
642-2438-001

Speech Processor
(A processor that is inserted in the audio circuit path to increase the average "talk-power" in SSB transmission)

AC-3803
641-7150-001

Control Interface
(Provides control interface assembly within transceiver. Allows use of external keypad (not supplied) for frequency control)

AC-3810
642-2439-001

360-Hz CW Filter
(Carrier-centered, 360-Hz bandwidth filter at -3-dB points; 1250 Hz at -60 dB)

AC-3811
642-2440-001

140-Hz CW Filter
(Carrier-centered, 140-Hz bandwidth filter at -3-dB points; 600 Hz at -60 dB)

AC-3812
622-2441-001

1.7-kHz Narrow Sideband Filter
(Carrier-centered, 1.7-kHz bandwidth at -3-dB points; 3.4 kHz at -60 dB)

AC-3813
642-2442-001

6.0-kHz AM Filter
(Provides overall receive selectivity of 6-kHz bandwidth at -3-dB points; 25 kHz at -60 dB. This filter recommended in place of supplied AM filter if critical AM listening is planned.)

<u>TYPE AND PART NUMBER</u>	<u>DESCRIPTION</u>
AC-2801 622-3537-001	Rack Mount (Used for mounting transceiver in standard 19-in racks or cabinets)
AC-2808 622-3547-001	Blower Kit (Used to enable operation at continuous 100-watt power output; ac power from transceiver. Recommended for RTTY operation. Not usually needed for voice or CW.)
AC-2821 622-3564-001	DC Standby Power Cable (2-metre (6.5-foot) dc power cable for use with transceiver for emergency operation from 12-V battery; includes radio power connector, battery clamps, and installation instructions)
MM-280 020-0260-010	Microphone, Handheld (Handheld dynamic omnidirectional microphone with low impedance; has push-to-talk switch; color, black)
MM-281 020-0260-020	Microphone, Handheld (Handheld dynamic microphone with low impedance and noise-canceling characteristics; has push-to-talk switch; color, black)
SM-280 020-0261-010	Microphone, Desktop (Desktop dynamic microphone with low impedance and cardioid sound pattern; has push-to-talk bar; color, black)
SM-281 020-0261-020	Microphone, Desktop (Desktop dynamic microphone with low impedance and noise-canceling characteristic; has push-to-talk bar plus continuous-key switch; color, black)

<u>TYPE AND PART NUMBER</u>	<u>DESCRIPTION</u>
AC-2827 634-8545-001	Key, CW (Hand-operated CW key)
AC-2828 634-8546-001	Microphone Foot Switch (Foot switch for hands-free keying of microphone)
AC-2829 622-3571-001	Headphones, Standard (Standard headphones with 600-ohm impedance; has sound-blocking earmuffs)
AC-2830 622-3572-001	Headphones (Lightweight headphones with 500-ohm impedance; has comfort-designed earpieces)

**AUTHORIZED ROCKWELL-COLLINS WARRANTY
SERVICE AGENCIES**

Berlingieri Electronica
Pasco 572/80
Buenos Aires, Argentina

Selectronica Ltda
7A Avenida 1-48 Zona 9
Guatemala City, Guatemala

Kyokuto Boeki Kaisha Ltd
7th Floor New
Otemachi Bldg
2-1, 2-Chome, Otemachi
Chiyoda-Ku, Tokyo 100-91
Japan

Electronica Comercial S A
Via Bolivar
Apartado 6-492 El Dorado
Panama, Republic of
Panama

Tiesa S A
Av. Republica de
Panama 2349
Lima, Peru 13

Miltech Industries Inc
6th Floor Strata 100
Emerald St Ortigas Pasig
Metro Manila, Philippines

Siam Teltech Co Ltd
29/3 Saladaeng Road
SOI 1
Bangkok, Thailand

Rockwell-Collins
Customer Service Center
6001 Threadgill Ave.
El Paso, TX 79924
Telephone (915) 757-0793

ROCKWELL-COLLINS SUBSIDIARIES

Rockwell-Collins (Asia)
Maroondah Highway
Lillydale, Victoria 3140
Australia

Rockwell-Collins Division of
Rockwell Do Brasil Ltda
Rua Pio Correia 37 22.461
Rio De Janeiro RJ Brasil

Rockwell-Collins UK Ltd
Suttons Industrial Park
London Road, Earley
Reading, Berkshire RG61AZ
England

Rockwell-Collins France
6, Avenue Didier Durat
Zac Airport
31700 Blagnac, France

Rockwell-Collins Gmbh
Boschstrasse 4
D-6054 Rodgau 6
F.R. Germany

Rockwell-Collins
Italiana S P A
Via Pontina Vecchia
Km 32,300
00040 Pomezia (Rome)
Italy