

# FURUNO

## SERVICE MANUAL

SSB TRANSCEIVER

MODEL FS-1502



**FURUNO ELECTRIC CO., LTD.**

NISHINOMIYA, JAPAN

**©FURUNO ELECTRIC CO., LTD.**

9-52, Ashihara-cho,  
Nishinomiya, Japan 662

Telephone: 0798-65-2111  
Telefax: 0798-65-4200

·Your Local Agent/Dealer

All rights reserved.

Printed in Japan

FIRST EDITION : NOV 1992

(MAOS)

PUB. No. SME-55480-A  
FS-1502

---

# Table of Contents

<b>Specifications</b> .....	<b>iii</b>
-----------------------------	------------

## **Circuit Description**

Transceiver Unit .....	1-1
Transmitter Section .....	1-1
Local Oscillator Section .....	1-2
Receiver Section .....	1-3
Panel/CPU Section .....	1-4
Power Supply Section .....	1-4
Antenna Coupler Unit .....	1-6
Block Description .....	1-6

## **Adjustment**

Necessary Measuring Instruments .....	2-1
Line Voltage and Local OSC .....	2-2
Line Voltage Check .....	2-2
Local OSC Frequency/Level Check (TX/RX Board) .....	2-2
Transmitter .....	2-3
Tx Gain Adjustment .....	2-3
PA Bias Adjustment .....	2-3
Transmitter Output Level .....	2-4
Receiver .....	2-6
Antenna Coupler .....	2-7

## **Troubleshooting**

Self Test .....	3-1
Transceiver .....	3-1
Antenna Coupler .....	3-1
Replacement of Major Parts .....	3-2
Final Transistors Q3 and Q4 on the PA Board .....	3-2
Replacement of Printed Circuit Board .....	3-3

## **Parts Location**

Transceiver Unit .....	4-1
CPU Board 05P0456 .....	4-1
TX/RX Board 05P0451 .....	4-2
TX FIL Board 05P0273 .....	4-3
PA Board 05P0274 .....	4-3
Relay Board 05P0275 .....	4-3
SW REG Board 05P0276 .....	4-3
Antenna Coupler .....	4-4
Coupler Board 05P0278B .....	4-4

**Electrical Parts List.....E-1**

**Interconnection Diagrams**

FS-1502 ..... S-1  
FS-1502 + RB-500 ..... S-2  
FS-1502 + DB-500 + RB-500 ..... S-3  
Examples of BK Connection (Floating Ground) ..... S-4  
Examples of BK Connection (Negative Ground) ..... S-5

**Block Diagram.....S-6**

**Schematic Diagrams**

General ..... S-7  
CPU Board ..... S-8  
TX/RX Board ..... S-9  
VCO on the TX/RX Board ..... S-10  
TX FIL Board ..... S-11  
P.A. Board ..... S-12  
RELAY Board ..... S-13  
SW REG Board ..... S-14  
REMOTE(A) Board ..... S-15  
REMOTE(B) Board ..... S-16  
CONTROL Board ..... S-17  
IF AMP(Custom IC) ..... S-18  
NB DET(Custom IC) ..... S-19  
ALC AMP(Custom IC) ..... S-20  
Antenna Coupler ..... S-21  
AC Power Supply ..... S-22  
DC-DC Converter ..... S-23

**APPENDIX A**

PRESETTING INSTRUCTIONS FOR SSB RADIOTELEPHONE

---

# Specifications

## GENERAL

<b>Communication System</b>	Simplex or semi-duplex
<b>Frequency Range</b>	1.6 to 26.2 MHz (transmit) 0.1 to 30 MHz (receive)
<b>Frequency Resolution</b>	Transmit: 100 Hz Receive: 10 Hz
<b>Class of Emission</b>	J3E (LSB) J3E (USB) H3E (AM compatible) F1B, J2B (for NBDP terminal) J3C (Weather FAX, receive only)
<b>Frequency Stability</b>	±10 Hz
<b>Number Of Channels</b>	1) 64 semi-duplex or 128 simplex channels max., presetable 2) Factory preset ITU SSB, Telex, USA SSB channels 3) 2182 kHz (single action)
<b>Ambient Temperature Range</b>	-20°C to +55°C
<b>Relative Humidity</b>	93% at 40°C
<b>Power Supply &amp; Power Consumption</b>	13.6 VDC: -/+ 15% (floating ground) Receive: 1.5A Transmit speech: 18 A Transmit (max.): 30 A
<b>Frequency Selection</b>	Key or dial encoder
<b>Dimmer</b>	Illumination for keyboard and LCD (four levels incl. off)

**Display** Channel number, frequency, class of emission, status of controls, signal strength, transceiver output level

**I/O Connection** Standard: microphone, external antenna coupler, external speaker  
Option: 1) RS-232C port for connecting DP-5 NBDP Terminal  
2) Current loop port for connecting RB-500 Remote Station/DB-500 Distributor

**Coating Color** Cabinet: 2.5GY 5/1.5 Newtone #5  
Front panel: N-3.0

**Dimensions and Weight** 100 mm x 250 mm x 300 mm, 5.8 kg

## RECEIVER

**Receiving System** Double-conversion superheterodyne  
IF: 54.455 MHz and 455 kHz

**Sensitivity** Input level at 50 ohms to produce SINAD 20 dB  
J3E: 3 dB  $\mu\text{V}$  (1.4  $\mu\text{V}$ )  
H3E: 16 dB  $\mu\text{V}$  (6.3  $\mu\text{V}$ )

**Selectivity** 2.4 kHz at -6 dB (J3E)  
4.5 kHz at -60 dB (J3E)

**Spurious Response** Better than 70 dB

**Intermodulation** Better than 80 dB

**Audio Output** 3 W rated into internal speaker  
5 W max. into external 4 ohm speaker

**Other Features** RF Gain: Adjustable  
Squelch: ON/OFF, Activated by voice/signal level  
Dimmer: OFF/Low/Medium/High  
Speaker: ON/OFF (Handset always alive)  
AGC: always ON  
Noise blanker: always ON

**TRANSMITTER**

<b>Output Impedance</b>	50 ohms
<b>RF Output Power</b>	J3E/H3E: 150 W pep or 100 W pep F1B: 100 W Tune: 10 W approx. (greater than 70 W pep for 23 to 26.2 MHz)
<b>Power Reduction</b>	60 – 70 W pep
<b>Controls</b>	Output HI/LOW, test/send of two-tone alarm generator, 2182kHz single action key

**ANTENNA COUPLER**

<b>Tuning System</b>	CPU controlled fully automatic tuning system
<b>Frequency Range</b>	1.6 to 26.2 MHz
<b>Input Impedance</b>	50 ohms (viewed from transceiver)
<b>Antenna Required</b>	6 to 15 m wire or whip
<b>Power Capability</b>	150 W pep, 75 W continuous
<b>Tuning Power</b>	10 W
<b>VSWR</b>	Less than 1.5
<b>Tuning Time</b>	Within 2 to 15 seconds Within 0.5 seconds on pretuned bands
<b>Dummy Load</b>	External (10 ohms + 250 pF), optional supply
<b>Power Requirement</b>	15 VDC 0.6 A (supplied from transceiver)
<b>Ambient Temperature</b>	-30°C to +70°C at 95% relative humidity
<b>Construction</b>	Waterproof plastic cabinet, stainless steel mount
<b>Color</b>	White
<b>Dimensions and Weight</b>	267 mm (W) x 390 mm (H) x 90 mm (D), 2.9 kg approx.

---

# Circuit Description

The FS-1502 series SSB radiotelephone is of a modern, 2-unit design. The 2 units are transceiver unit and antenna coupler unit. The transceiver unit contains 6 printed circuit boards; the CPU board, TX/RX board, TX FIL board, PA board, RELAY board and the SW REG board. Refer to the general block diagram on page 1-7.

---

## Transceiver Unit

---

### Transmitter Section

Refer to the transmitter block diagram on page 1-8.

#### AF Signal

An audio signal applied to the microphone is amplified by U16 of the TX/RX board. U16 also compresses excessive level of speech to achieve proper modulation level.

#### Modulation-1

The compressed audio signal is switched by Hybrid IC U17 and applied to Double Balanced Modulator(DBM) CR18. The DBM modulates the audio signal with the 3rd local oscillation frequency 456.5kHz (Class of Emission: USB) and outputs a Double Side Band(DSB) signal with suppressed carrier.

The DSB signal is amplified by buffer amplifier Q16 and passed to crystal filter FL2 where unwanted upper side band(USB) component is rejected and only lower side band(LSB) is selected.

#### Carrier Injection

In order to inject the carrier for class of emission H3E, the 3rd local oscillation frequency 456.5kHz is injected at the output of FL2 and carrier level for H3E is adjusted by potentiometer R134.

#### Modulation-2

The LSB signal is mixed with the 2nd local oscillation frequency 54MHz by 2nd mixer CR8 DBM, resulting in the output of a 54.455MHz signal.

The 54.455MHz signal is amplified by buffer amplifier Q10 and passes through crystal filter FL1(54.455MHz) where unwanted components are deleted.

#### Modulation-3

1st mixer CR6 mixes the 54.455MHz signal with the 1st local oscillation frequency  $(f + 54.4565\text{MHz})$  to generate a transmit frequency from 1.6 to 26MHz.

The mixer outputs a USB signal of the transmit frequency.

The USB signal output goes to a combination of a low pass filter and a high pass filter consisting of coils L9 to L12 and capacitors C47 to C56 which delete unwanted components.

The USB signal is amplified by wideband amplifier U1 and buffer amplifiers Q6 and Q4 to a level required to drive the PA section.

### **Final Amplifier**

In the PA section an input from the TX/RX board is amplified by two push-pull amplifiers, consisting of Q1 and Q2, and Q3 and Q4, to a level of nominal output power.

### **OVER-TEMP Detector**

The power amplifier incorporates temperature detector, comprised of RT2 and U1, which monitors the temperature of the power amplifier transistors. When the temperature at the top of the transistors exceeds approx. 80 degrees, the temperature detector outputs DC voltage which is recognized as "over-temp" by MPU, resulting that the gain of wideband amplifier U1 of the TX/RX board is decreased.

The output of the PA passes through an LPF on the TX FIL board where harmonics of the signal are deleted. Spurious components contained in the signal output from the LPF are attenuated by at least 65dB relative to the wanted signal.

### **SWR Detector**

L14, CR1, CR2 and U1 of the TX FIL board form the SWR detector which detects excessive standing wave due to antenna matching failure or open-circuited or short-circuited antenna terminal. Should one of these occurs, the SWR detector reduces the gain of the wideband amplifier U1 on the TX/RX board to protect the PA against damage. U1 on the TX/RX board also controls power reduction, low power or OVER-TEMP, with DC voltage sent by the CPU.

### **ALC**

If the PA is driven to produce output power exceeding the rated power, the dc voltage of the ALC signal is increased, gain at U1 on the TX/RX board is decreased and the drive level (output level of the TX/RX board) is decreased so as not to exceed the rated output power.

## **Local Oscillator Section**

Refer to the local oscillator block diagram on page 1-9.

All local oscillation frequencies are generated by the VCO (Voltage Controlled Oscillator) section of the TX/RX board.

49.5MHz is oscillated by crystal Y1 in the oven and Q12. 49.5MHz is divided by 11 by U9, becoming 4.5MHz, which is used as the reference frequency for the phase locked loops.

Table 1-1 Local Oscillation Frequency

	USB	LSB	TLX	FAX	AM
1st LO	54456.5	54453.5	54455.0	54455.0	54455.0(RX) 54456.5(TX)
2nd LO	54000.0	54000.0	54000.0	54000.0	54000.0
3rd LO	456.5	453.5	456.7	456.9	456.5(TX)

(kHz)

**1st LO**

The 1st local oscillation frequency is generated by 2 phase locked loops, LOOP-1 and LOOP-2.

LOOP-2 (PLL IC U1 and VCO Q1) generates a frequency between 50.500 and 51.499MHz in 1kHz steps.

The resultant frequency is divided by 100 by U2 and mixed with 49.5MHz by U3 resulting in the generation of frequency between 50.00500 and 50.01499MHz in 10Hz steps.

LOOP-1 (PLL IC U4 and VCO Q4) generates a 1st local frequency in 10Hz steps by mixing a frequency with the output of LOOP-2 by U6.

**2nd LO**

The 2nd local oscillation frequency(54.0MHz) is synthesized with the crystal oscillation frequency(49.5MHz) and the reference frequency(4.5MHz).

**3rd LO**

LOOP-3 consisting of PLL IC U10 and VCO Q17 generates a frequency between 45.35 and 45.67MHz in 10kHz steps. This is divided by 100 by U11 to generate the 3rd local oscillation frequency(453.5 – 456.9kHz) depending on the class of emission.

**Receiver Section**

Refer to the receiver block diagram on page 1-10.

**RF Signal**

A received signal passes through the antenna matching network in the antenna coupler unit and it is sent to an LPF on the TX FIL board. The signal is filtered and amplified by the RF amplifier Q1 and Q2 through LPF on the TX/RX board. The amplified signal is supplied to the 1st mixer CR26 DBM.

**Demodulation**

The 1st mixer mixes the received signal with the 1st local oscillation frequency ( $f + 54.455\text{MHz}$ ). The 1st IF(54.455MHz) passes through the filter FL1 ( $\pm 4\text{kHz}$  bandwidth) for rejection of unwanted components and then is amplified by U4.

The amplified 1st IF signal is mixed with the 2nd local oscillation frequency (54.0MHz) by the 2nd mixer CR8 resulting in the output of the 455kHz 2nd IF signal. CR10, 11 and

the hybrid IC U5 cut spike noise in the 2nd IF signal. The 2nd IF signal is applied to bandpass filter FL2 or FL4 in accordance with the class of emission selected. It is amplified by IF amplifier U10 and supplied to detector CR18 thru a BPF and buffer amplifier Q19.

CR18 mixes the 2nd IF signal with the 3rd local oscillation frequency (456.5kHz, USB), which results in the output of an audio frequency signal.

For reception of an H3E(AM) signal, the detectors CR16 and CR17 are used to obtain the audio signal which is amplified by hybrid IC U13.

### **AGC (Automatic Gain Control)**

The RF signal through FL5 is amplified by Q17, then convert to dc by the AGC rectifiers CR14 and CR15. Q20 and Q21 function as dc amplifiers to develop the voltage needed for AGC control of IF amplifiers U4 and U10.

### **AF Output**

The audio signal is applied to hybrid IC U17 and then fed to line amplifier U20. The output of the line amplifier is used as "LINE OUT" signal, but also is applied to squelch control U9. The squelch control mutes audio output in the absence of a signal.

The audio signal is finally amplified by AF power amplifier U21 to drive the loudspeaker. The level of audio output is adjustable by the volume control on the front panel.

## **Panel/CPU Section**

MPU U1 of the CPU. board receives and processes key and channel selector operation.

ITU channel data is stored in the ROM section of the MPU. User-programmed channel data is stored in the EEPROM U5.

When a frequency is selected through the keyboard or the rotary knob, the MPU commands to display the frequency to the LCD driver and sends necessary data to each PLL on the TX/RX board.

For dimmer adjustment, the MPU controls the amount of current supplied to each illumination lamp in accordance with instructions received through the keyboard.

## **Power Supply Section**

Refer to the power supply block diagram on page 1-11.

The power supply section consists of RELAY and SW REG boards. The operating range of this section is 12VDC +30%,-10%.

The regulated power supply (model PR-270) is prepared for the AC ship's mains and the DC-DC converter (model PC-220), for 24/32VDC. When an external power supply unit is prepared locally, use a unit which outputs from 2A to max. 30A with minimum voltage fluctuation.

The 2m power cable with two 30A fuses in snap-in holders is supplied as standard. If another type of cable is used, ensure that it is properly "fused."

The negative terminal of the battery is floating. Input voltage is always applied to relay K1, overvoltage detector consisting of Q1, U1 and the oven even if the power is off.

When the power switch is turned on, relay K1 is driven and input voltage is applied to the switching regulator and PA circuit.

The PA circuit operates with the input voltage, but other circuits operate with internal +15V provided by the switching regulator or +5V produced from the +15V.

The antenna coupler is powered with +15V. The 1A breaker is provided in the coupler. +5V for the coupler is produced internally.

---

## Antenna Coupler Unit

---

### Block Description

Refer to the antenna coupler block diagram on page 1-12.

#### Tuning

When the PTT switch or [TUNE] key is pressed, "TUNE" signal is applied to the antenna coupler.

Relays K1 and K2 are activated (the phase detector and SWR detector circuits are connected to the matching network), and CW signal of approx. 10W is fed to the antenna coupler.

The antenna coupler starts tuning.

While tuning, "BUSY" signal(low level) is applied to the transceiver.

MPU U8 selects, according to signals sent from the phase detector and SWR detector, suitable constants with a combination of capacitors and coils. The initial constants are automatically defined by the MPU depending on the frequency which is read out by the counter consisting of Q1 and U1. The suitable value is stored in the memory of U8 as initial value, for use when the same frequency is selected later. This stored data is held for about one week by super capacitor C42.

After tuning, "BUSY" signal turns to high level and the LCD on the front panel displays "TUNE OK". (If tuning fails, error beep sounds and "TUNE" indication disappears.)

Switch S1 enables manual tuning.

#### LEDs

An LED is provided for each relay to indicate switching on or off capacitors and coils. LEDs CR53 and CR54 light while tuning (relays K1 and K2 are activated). LEDs CR33 to CR52 light when the relevant coil or capacitor is connected.

#### Internal Dummy Load

The 50 ohms dummy composed of R25 to R27 is incorporated for adjusting the VSWR detector. Shunt capacitors C16 – C18 are normally connected between antenna line and ground to reduce the antenna impedance. The connectors are provided to disconnect the shunt capacitor when only low frequencies are used.

#### "THRU" Signal

"THRU" signal is activated when;

- duplex channel (frequency) is selected in MF band(1.6 – 4MHz),
- RX scanning.

When "THRU" signal is applied to U8, all relays of the matching network go off in the receiving mode. (A receiving signal passes through the matching network with no capacitors C1 – C15.)

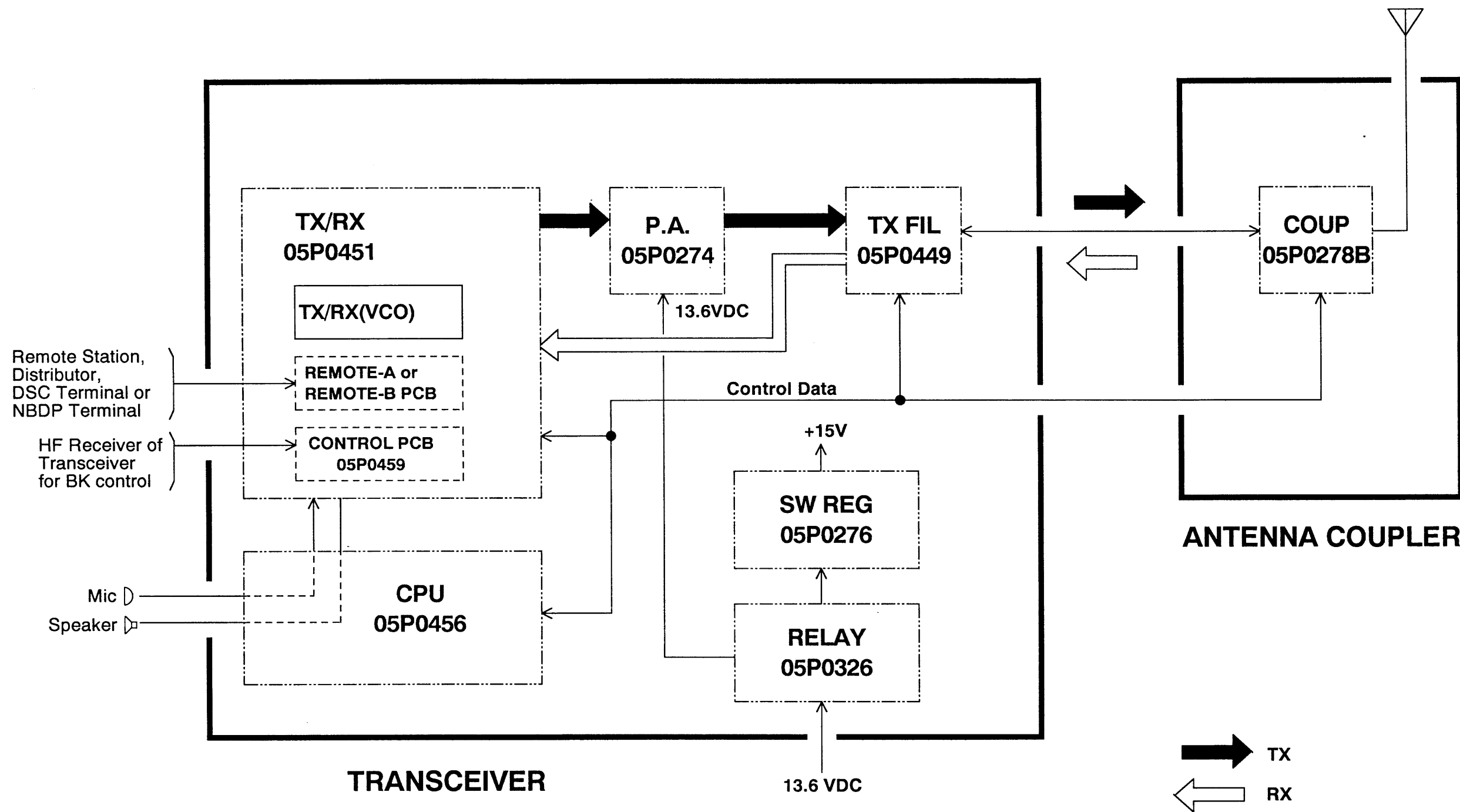

**FS-1502 BLOCK DIAGRAM**

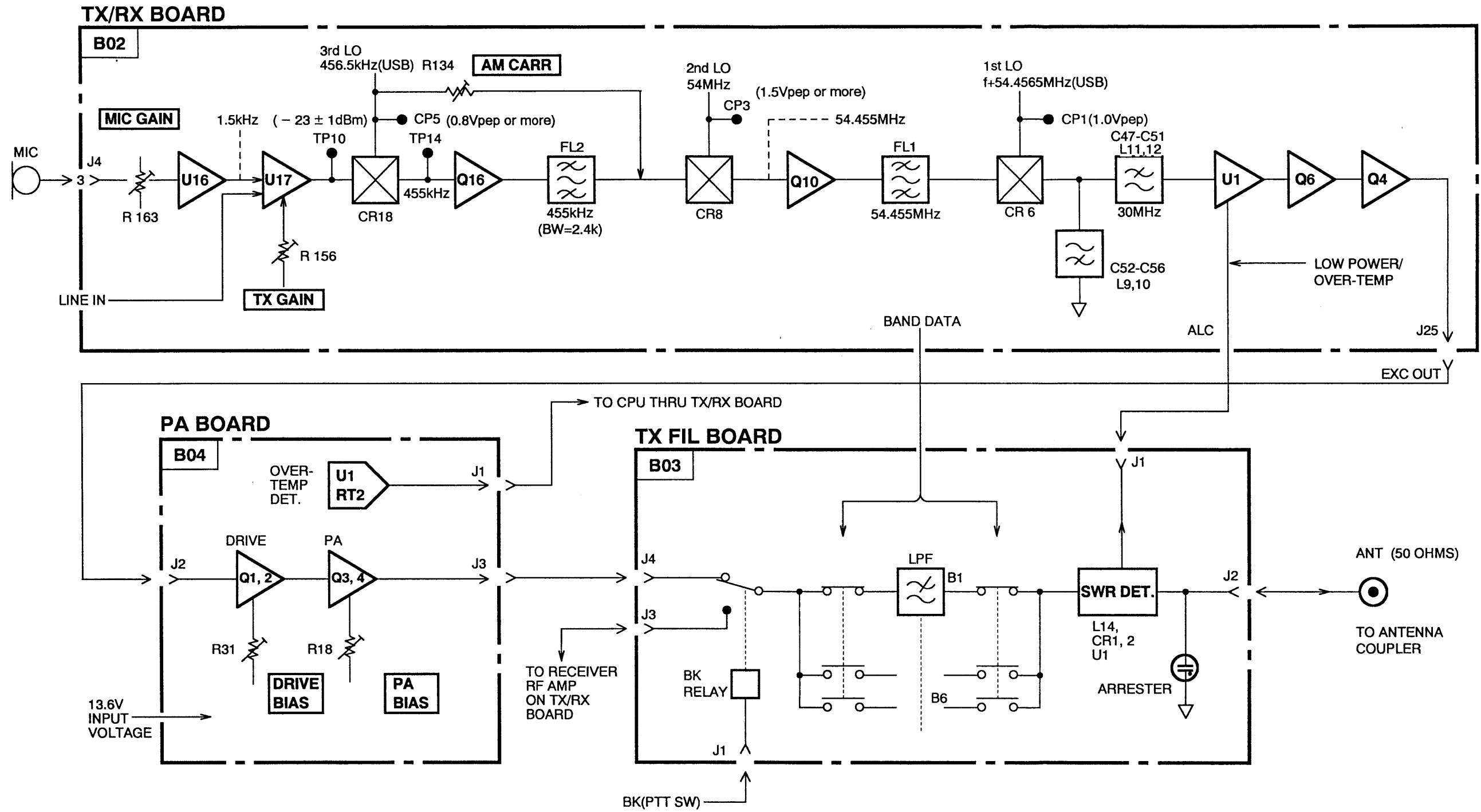

### FS-1502 TRANSMITTER SECTION

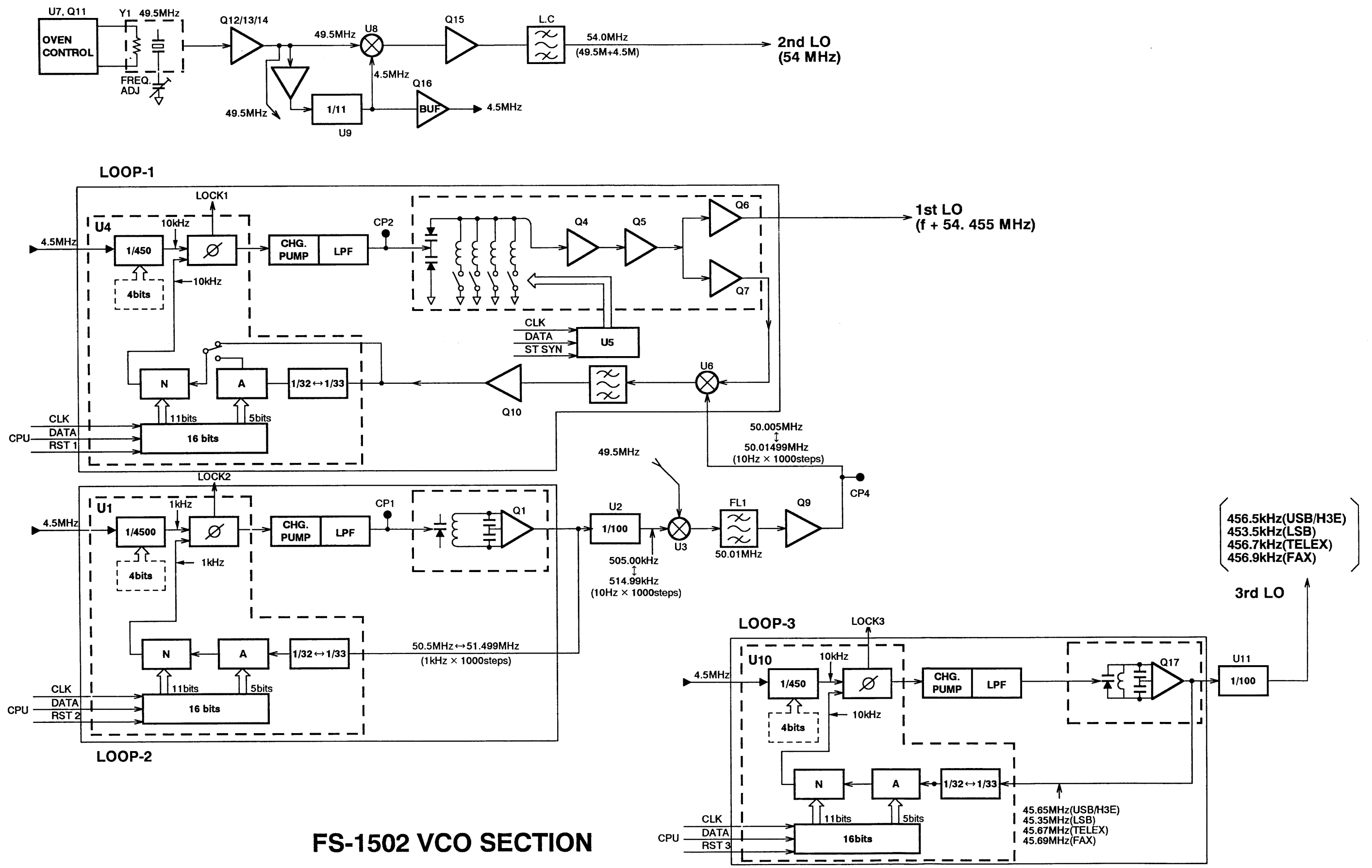

**TX/RX BOARD**

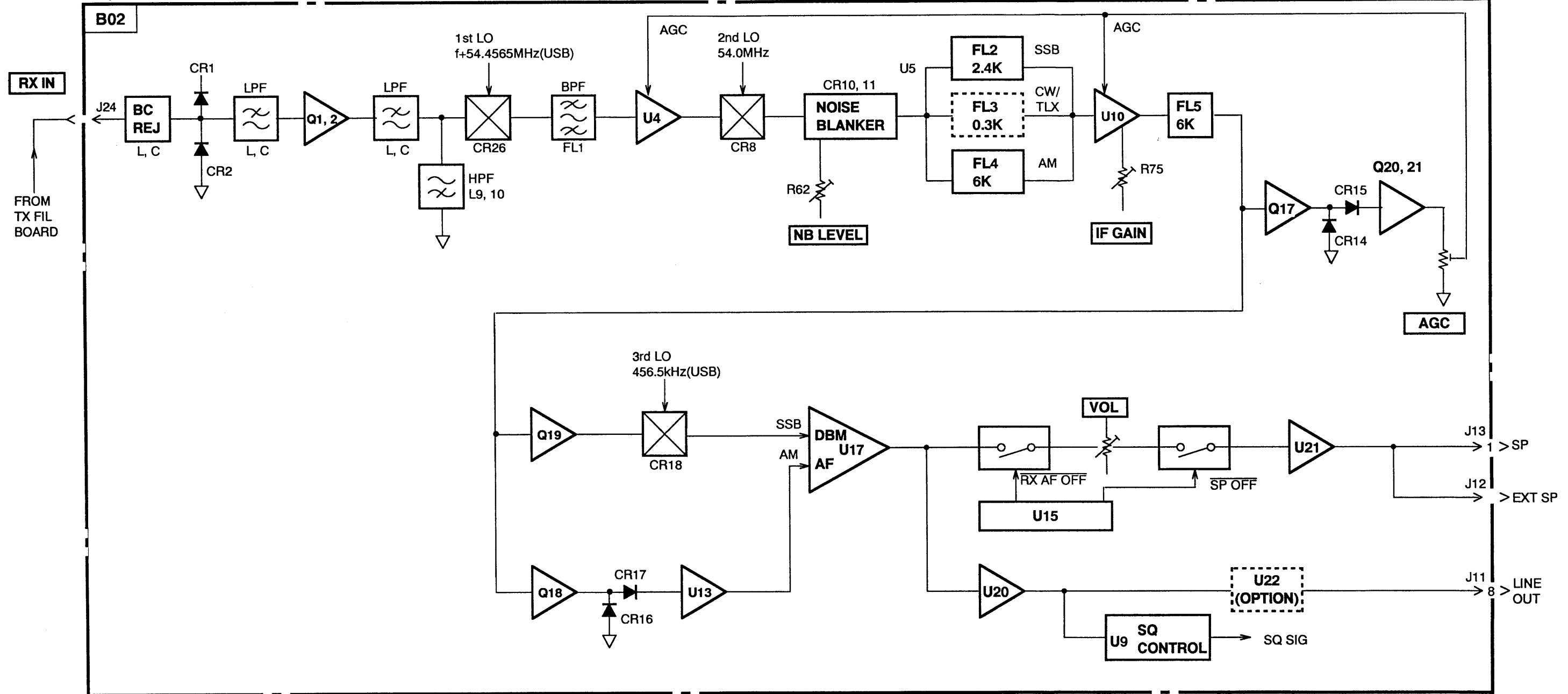

**FS-1502 RECEIVER SECTION**

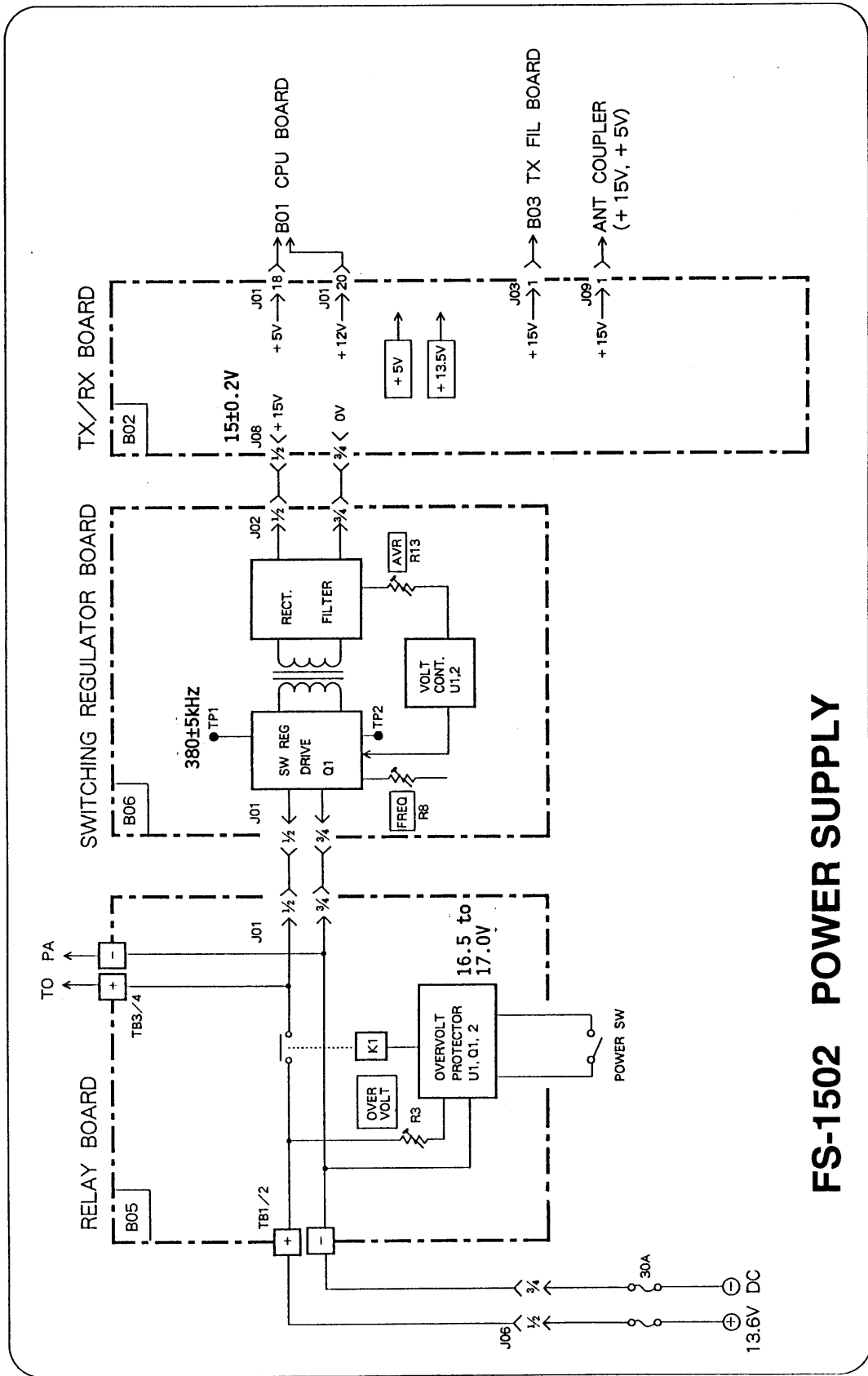

# FS-1502 POWER SUPPLY

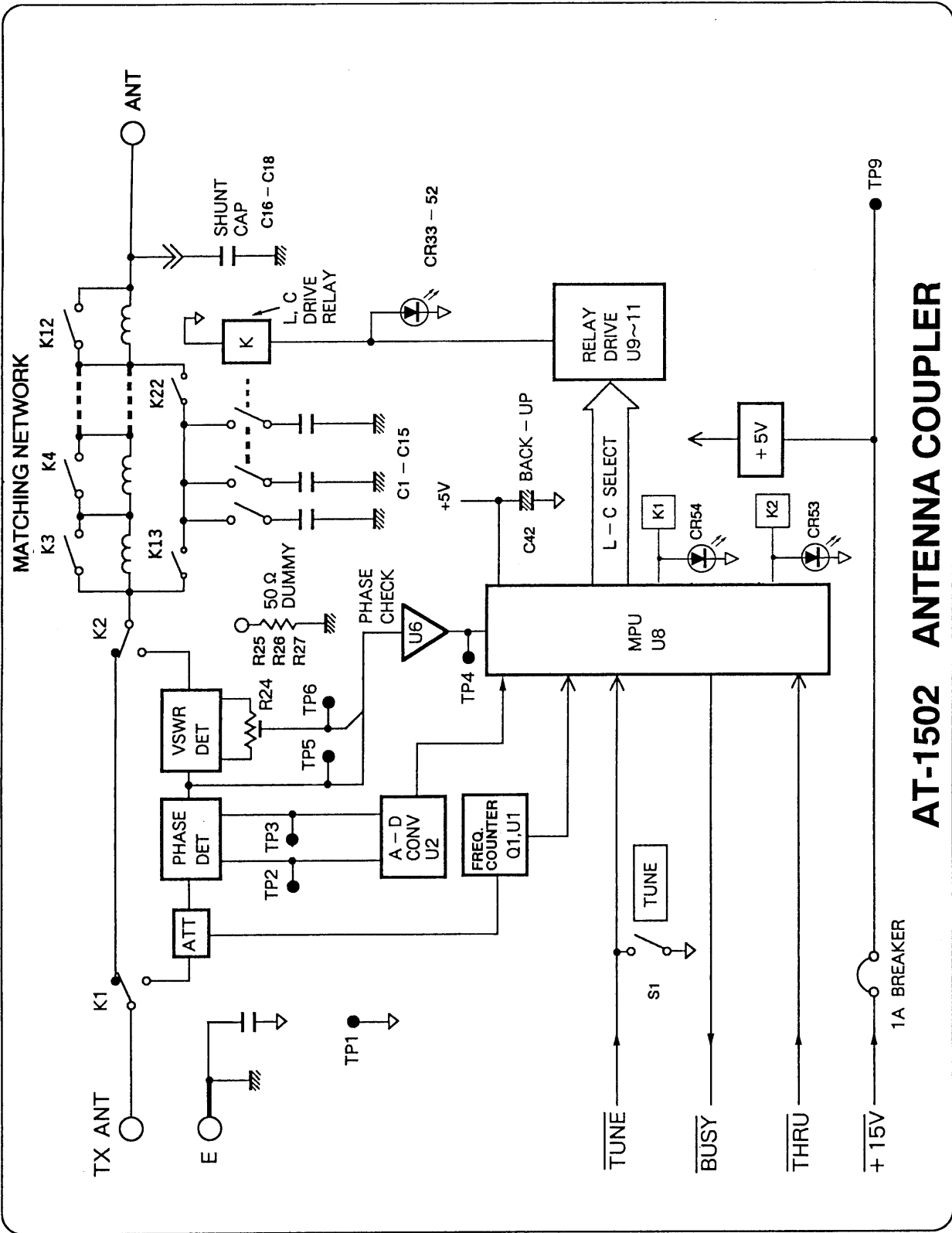

# AT-1502 ANTENNA COUPLER

# Adjustment

## Necessary Measuring Instruments

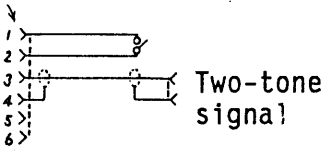
Measuring Instruments	Minimum Requirement	Use
Multimeter	10k ohms/Vdc	Voltage check
DC Ammeter	30A	Input current check
Frequency Counter	100MHz	Frequency check
AC Voltmeter with RF Probe	Volt Range: 1mV – 3V dB Range: -50 – +20dBm	Level check
Signal Generator	Freq. Range: 100kHz – 30MHz Output Level: -10 – +110dB $\mu$ Output Impedance: 50 ohms	Sensitivity check
Distortion Meter		Sensitivity check
Audio Dummy	8 ohms, 10W Enamelled Resistor with external speaker plug	Sensitivity check
Oscilloscope	Frequency Response: 50MHz	Waveform check
RF Power Meter	Dummy Terminated Type, Impedance: 50 ohms Capacity: 100W average Freq. Range: 50MHz	Power check
Dummy Antenna	10 ohms + 250pF(for 1.6 – 4MHz) 50 ohms(for 4 – 23MHz)	Performance check
SSB 2-tone Generator (or 2 AF Oscillators)	Freq. Range: 1 – 3kHz Impedance: 600 ohms Output Level: 0dBm(0.77Vrms) Attenuator: 60dB/1dB step	Power check
AF Signal Cable	MIC Plug: FM-10PS-6H  * prepare locally	Transmitter adjustment
DC Power Supply	13.6Vdc/30A or more	

## Line Voltage and Local OSC

### Line Voltage Check

Prior to the adjustment, check the followings.

No.	Item	Check Point		Ratings	Adjust	Condition /Remarks
		PCB	Point			
1	Input Voltage	RELAY	TB1(+) TB4	13.6V(12V, -10%, +30%)	—	—
2	+15V	SW REG	J2-1(+) J2-3	15±0.2V	R13[AVR]	If not, check SE REG frequency.
3	SW REG Frequency	SW REG	TP1(+) TP2	380±5kHz	R8[FREQ]	—
4	Over-voltage Protector	RELAY	TB3(+) TB4	13.6V(input voltage; 13.6V)	R3 [OVERVOLT]	Disconnect PA and SW REG.
				0V (input voltage; 16.5V or more)		

### Local OSC Frequency/Level Check (TX/RX Board)

No.	Check Item	Check Point	Ratings	Adjuster	Condition
<b>2nd Local Oscillator Section</b>					
1	2nd LO Level	CP3-CP4(TX/RX)	1.5V <sub>pep</sub> or more	T10, 11, 12(VCO), RT12(TX/RX)	
2	2nd LO Freq.	CP3-CP4(TX/RX)	54MHz ±20Hz	T13(VCO)	
3	2nd VCO-1	CP1(VCO)	3.0±0.1V	T1(VCO)	3999.9kHz H3E
4	2nd VCO-2	CP1(VCO)	3.6±0.2V		4000.0kHz H3E
5	2nd VCO-3	CP4	0.7V <sub>pep</sub>	T2,3,4(VCO)	4005.0kHz USB
<b>1st Local Oscillator Section</b>					
6	1st VCO-1	CP3(VCO)	7.7±0.3V		6000.0kHz USB
7	1st VCO-2	CP2(VCO)	9.0±0.1V	T8(VCO)	29999.9kHz USB
8	1st VCO-3	CP2(VCO)	5.5V or more		25500.0kHz USB
9	1st VCO-4	CP2(VCO)	9.0±0.1V	T7(VCO)	21499.9kHz USB
10	1st VCO-5	CP2(VCO)	5.5V or more		17500.0kHz USB
11	1st VCO-6	CP2(VCO)	9.0±0.1V	T6(VCO)	13499.9kHz USB
12	1st VCO-7	CP2(VCO)	5.5V or more		9500.0kHz USB
13	1st VCO-8	CP2(VCO)	9.0±0.1V	T5(VCO)	5999.9kHz USB
14	1st VCO-9	CP2(VCO)	5.5V or more		3000.0kHz USB
15	1st LO Level	CP1-CP2(TX/RX)	1.0V <sub>pep</sub>		4000.0kHz USB
<b>3rd Local Oscillator Section</b>					
16	3rd VCO-1	CP5(VCO)	3.0±0.1V	T14(VCO)	4000.0kHz USB
17	3rd VCO-2	CP5(VCO)	3.5V or less		4000.0kHz LSB
18	3rd LO Level	CP5-CP6(TX/RX)	0.8V <sub>pep</sub> or more	T15(VCO)	4000.0kHz USB

## Transmitter

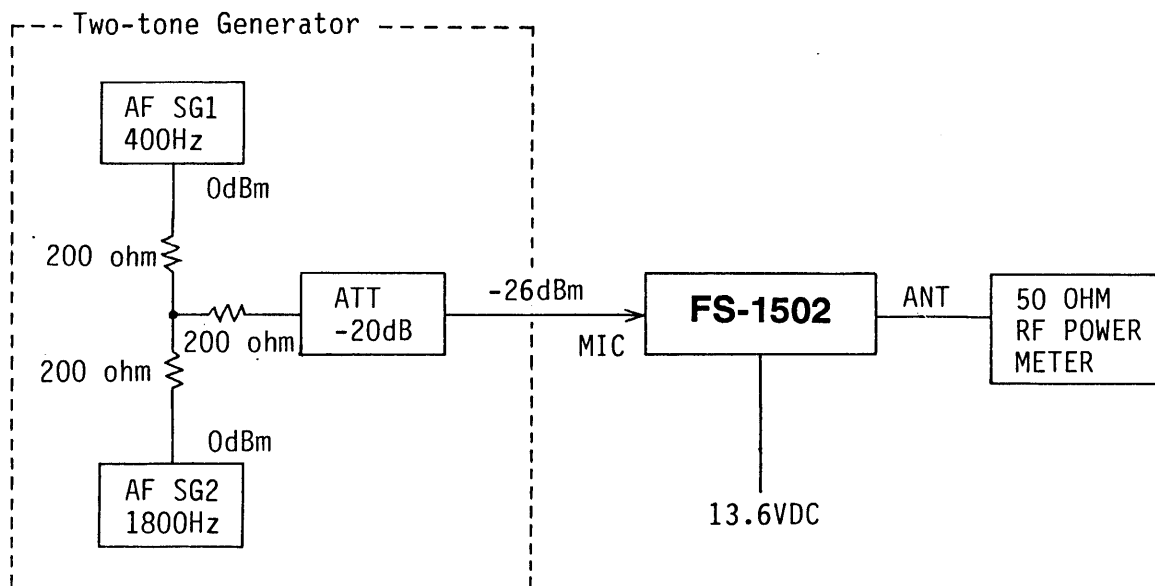

### Tx Gain Adjustment

No.	Item	Check Point	Ratings	Adjuster	Condition /Remarks
1	Tx Gain	CP7-CP8	-23±1dBm/600 ohms (AC Voltmeter)	R156[Tx Gain]	R163: center ITU 401 USB MIC input; -26dBm/600ohms 2-tone PTT ON

### PA Bias Adjustment

No.	Item	Check Point	Ratings	Adjuster	Condition /Remarks
1	Drive Bias	Across R32	35 – 45mV	R31	No AF signal to MIC input
2	PA Bias	Input Current	$\alpha + (500 \pm 50)\text{mA}$ (See Note.)	R18	Terminate transceiver with 50 ohm dummy.

### Note

1. Bias Adjustment: Turn R18 fully counterclockwise and adjust R31 for 35 to 40mV across R32(0.22ohm). Then adjust PA bias R18 so that the input current is  $500 \pm 50\text{mA}$  higher than the one " $\alpha$ " obtained by the drive bias adjustment.
2. When the components of the PA board are replaced, above check should be done.
3. If bias for PA stage is incorrectly adjusted, spurious emission may increase.

## Transmitter Output Level

No.	Item	Ratings		Adjuster	Condition/Remarks
		FS1502A/B	FS1502PH		
1	High Power	70W or more (U1#7 on TX/RX PCB; 2V or more)		R156	ITU ch1201 J3E MIC Input: 2-tone,-26dBm
		60-90W	40-60W	Power Data (System ch9930)	ITU ch401/801/2201/2182kHz MIC Input: 2-tone,-26dBm
2	Low Power	30-40W		Power Data (System ch9931)	ITU ch401 J3E MIC Input: 2-tone,-26dBm
3	Tune Power	15-20W		Power Data (System ch9933)	Ground J03#4 Then press [TUNE].
4	H3E Power	30-40W		R134	ITU ch401 Then press PTT switch.

### Note

- The output power is adjusted by changing the power data in the system channel. To access the system channel, refer to page 1 – 3 of APPENDIX A.
- Before performing the adjustment, the output level of SG1 should be adjusted so that the 100% modulation wave is observed at the antenna terminal.

100% Modulation Wave

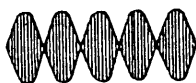

- Before starting the adjustment, the PA and TX FIL boards should be covered with the shield plate.
- Power difference of max. 30W (max. 90W, min. 60W) may be observed between the highest power band and lowest power band (not the highest frequency and the lowest frequency). This is due to the frequency response of the power amplifier. Disregard the difference.
- When the waveforms shown below are observed when the oscilloscope is coupled to the PA stage, readjustment of transmitter circuit may be required.

Waveform	Cause/Remedy
<p>Clipped at peak level</p>	Excessive drive. Check the mic gain.
<p>Unstable</p>	Incorrect amplifier bias. Readjust the bias current.

6. Peak output power of approx. 100W will be observed on the power meter when you whistle into the microphone.

## Receiver

### ■ CAUTION

Before beginning the adjustment, MIC plug (PTT switch) should be disconnected to prevent SSG from being damaged due to accidental emission.

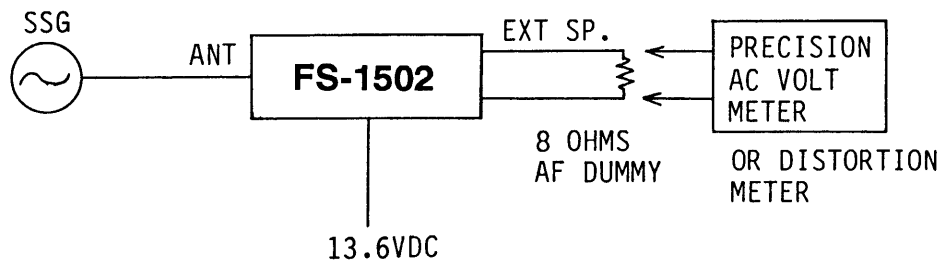



No.	Item	Check Point	Ratings	Adjuster	Condition /Remarks
1	IF Gain	S-meter	S = 1	R75 [IF GAIN]	Input signal; 4MHz 6dB $\mu$ S-meter respond gradually.
2	Overall Sensitivity	Check the SSG output level is 2dB $\mu$ $\pm$ 3dB when the distortion meter indicates 1W.			

### Quick Check of Receiver Sensitivity

1. Select J3E on any frequency of 4MHz band.
2. Connect SSG (Standard Signal Generator), set to receive frequency and output of approx. 30dB, to the antenna connector of transceiver unit.
3. Adjust SSG frequency precisely for maximum audio output.
4. Gradually decrease the SSG output until noise is slightly present.
5. Read out the SSG attenuator reading. If the reading is 0dB or less (-6dB), the receiver sensitivity is satisfactory.

### Intercom Input/Output Level

No.	Item	Potentiometer	Remarks
1	Intercom Input	R168 	
2	Intercom Output	R165 	

## Antenna Coupler

### Connection

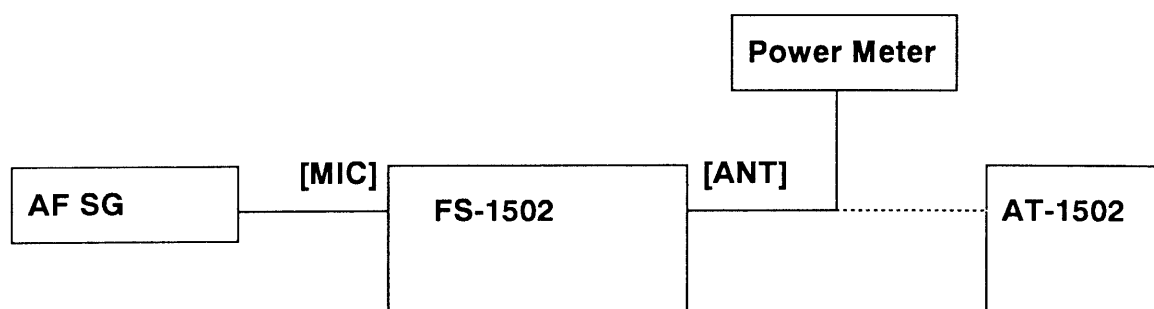

1. Connect AF SG to pin no. 3 and 4 of the mic connector on the FS-1502.
2. Connect Power Meter to ANT terminal of the FS-1502.

### Preparation

1. Disconnect the connector of J2 inside the AT-1502, then connect it to J3.(Internal dummy load is connected.)
2. Short TP7 and TP9 inside the AT-1502 to activate relay K1.
3. Select USB, 4MHz, low power on the FS-1502.
4. Set the AF SG output to 1500Hz.
5. Short the mic connector pin no. 1 and 2 to put in transmission.
6. Adjust the output power to  $10 \pm 0.5W$  with R161 [LOW] potentiometer on the TX/RX board.
7. Open the mic connector pin no. 1 and 2 to stop transmission.
8. Disconnect the power meter, then connect antenna coupler AT-1502.

No.	Item	Check Point	Ratings	Condition /Remarks
1	Tuning Detector Output Level	Short pin no. 1 and 2 of the mic connector.		
		TP6(+) – TP5(-)	-140 to -100mV	R24 fully CCW
			+140 to +180mV	R24 fully CW
			$0 \pm 1mV$	Adjust by R24
		TP3(+) – TP1(-)	1350 – 1650mV	
TP2(+) – TP1(-)	5mV or less			

---

# Troubleshooting

---

## Self Test

---

Both the transceiver and the antenna coupler contain a self test facility.

### Transceiver

The LCD and keyboard can be checked for proper operation by following the procedure below.

#### LCD

While pressing and holding down [ENT], turn on the transceiver. All LCD segments should appear.

#### Keyboard

1. Press a key. The corresponding hexadecimal of the key pressed appears on the first line of the display for two seconds. In addition, the program version no. appears on the second line of the display.
2. All LCD segments turn on again.
3. Repeat step 1 to test other keys.
4. You may escape from the self test at any time by turning off the transceiver.

### Antenna Coupler

The relays which select capacitor and coil can be checked for proper operation by following the procedure below.

1. Open the antenna coupler cover.
2. Open the shield cover inside the coupler.
3. Locate DIP switch S2 and turn No.2 on.
4. Press the TUNE switch in the antenna coupler.
5. The 20 LEDs (CR33 to CR52) should light one by one 1 second each. LED and corresponding relay are as follows.

CR33-K3	CR38-K8	CR43-K14	CR48-K19
CR34-K4	CR39-K9	CR44-K15	CR49-K20
CR35-K5	CR40-K10	CR45-K16	CR50-K21
CR36-K6	CR41-K11	CR46-K17	CR51-K13
CR37-K7	CR42-K12	CR47-K18	CR52-K22

6. Turn off No.2 of DIP switch S2.
7. Close the covers.

## Replacement of Major Parts

### Final Transistors Q3 and Q4 on the PA Board

1. Loosen two fixing bolts and unsolder four pins to release the defective transistor.
2. Put a thin coat of silicone grease on both sides of the transistor insulator.
3. Orientate the new transistors as shown below.
4. Tighten the fixing bolts and solder the transistors.

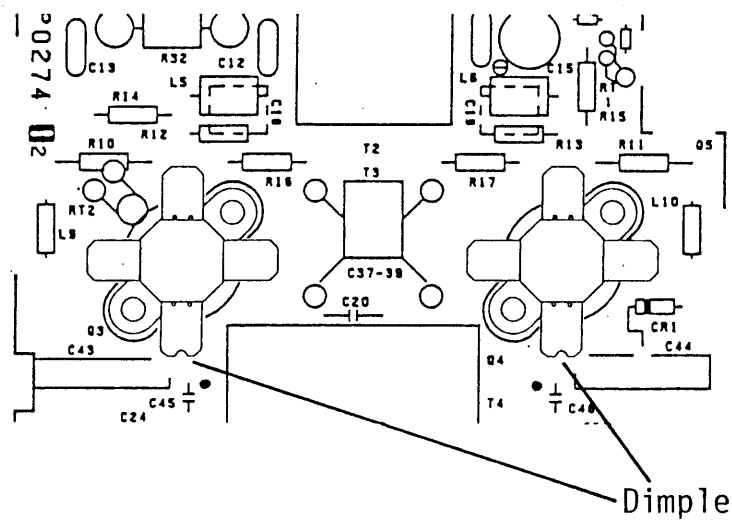

Figure 3-1 Direction of the transistor

# Replacement of Printed Circuit Board

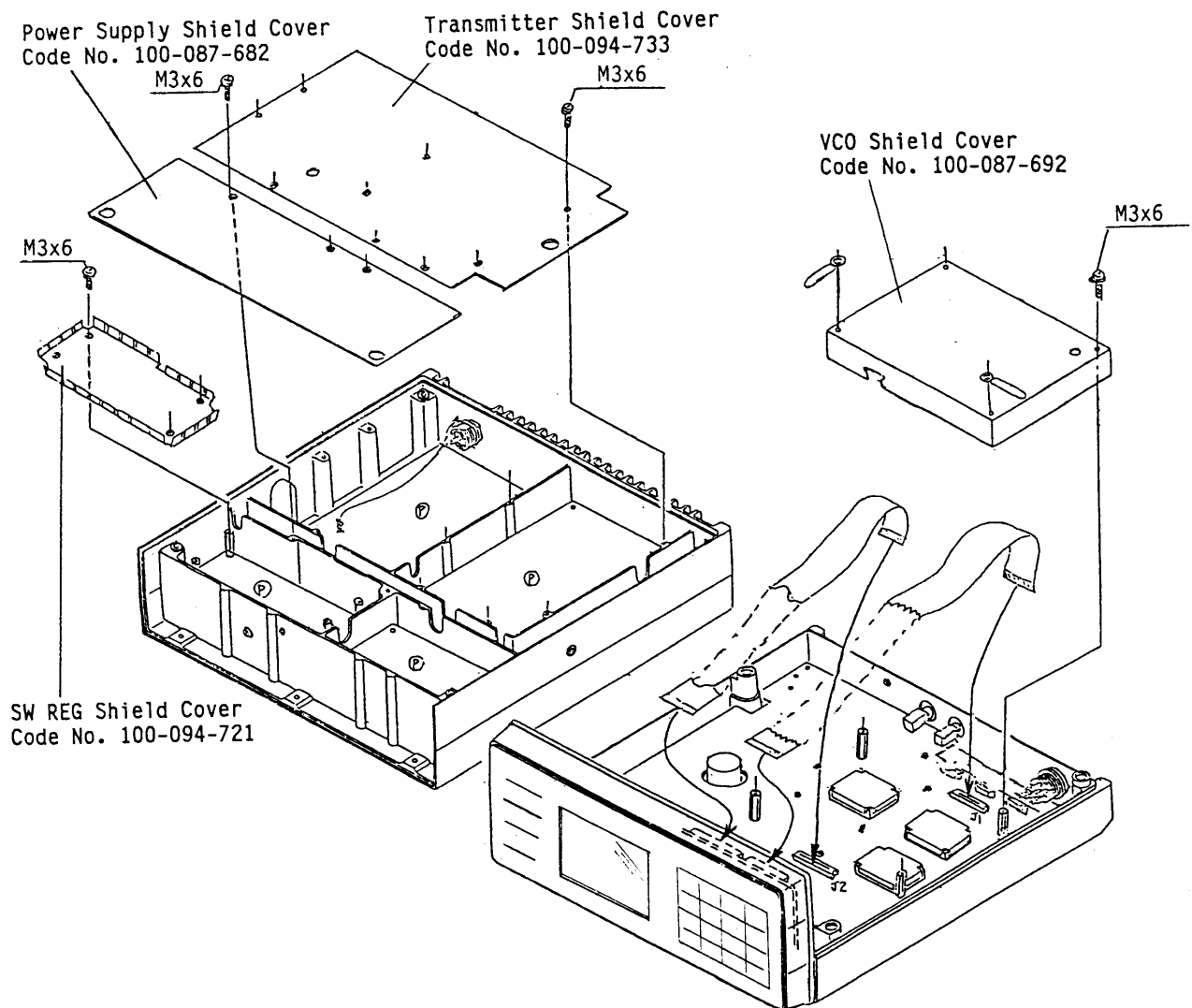

Figure 3-2 Transceiver Disassembly

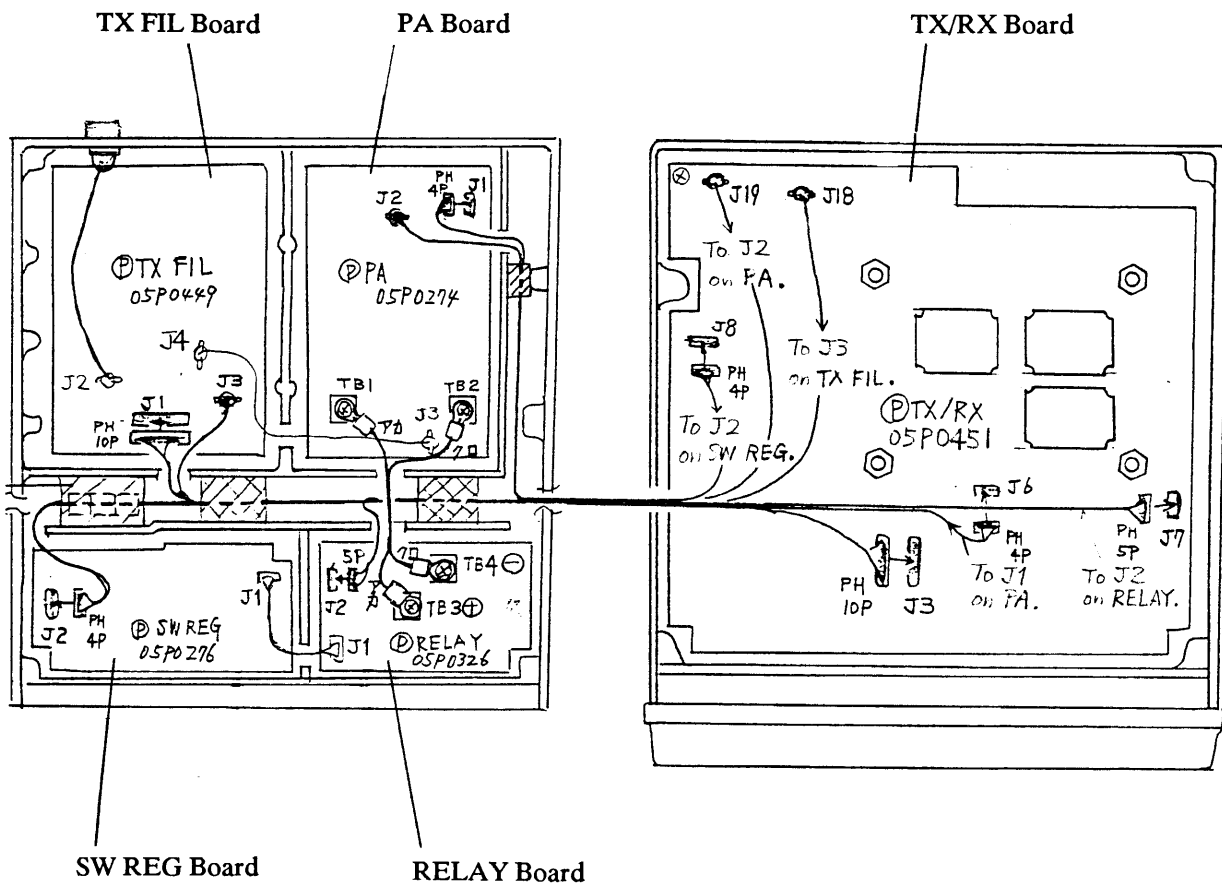

Figure 3-3 Cable Connections inside the transceiver

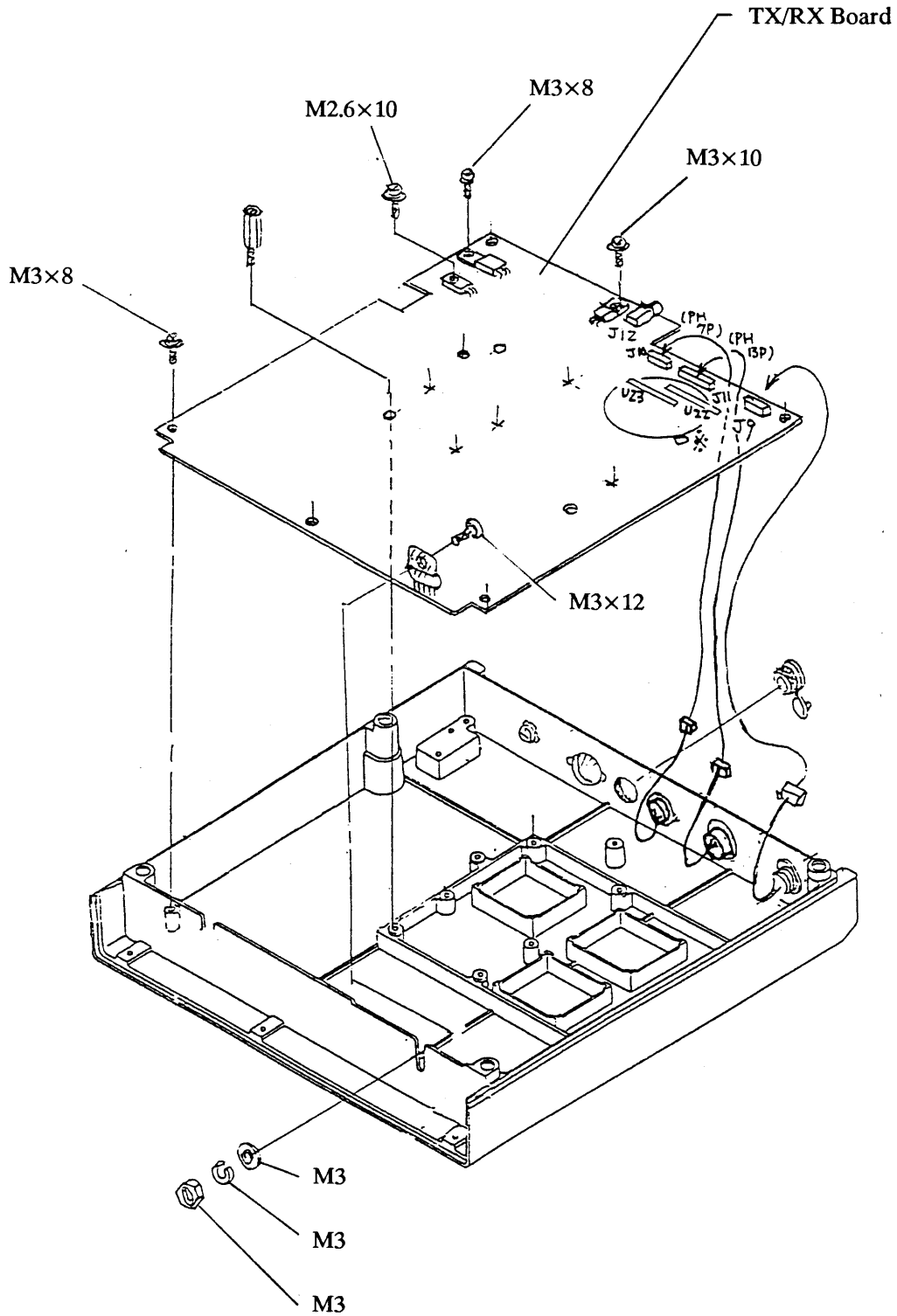

Figure 3-4 TX/RX Board Disassembly

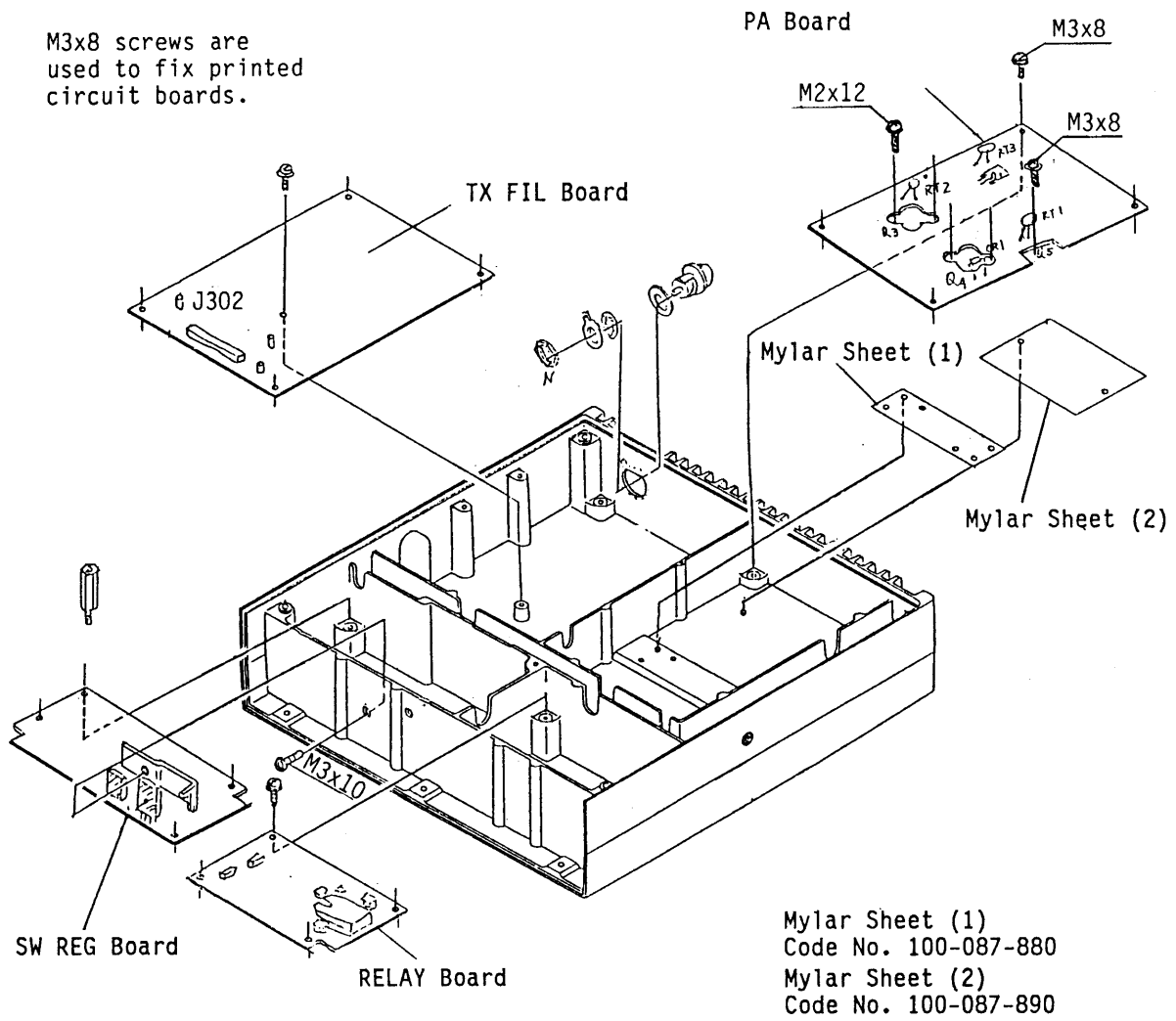

Figure 3-5 Disassembly of PCBs from Top Chassis

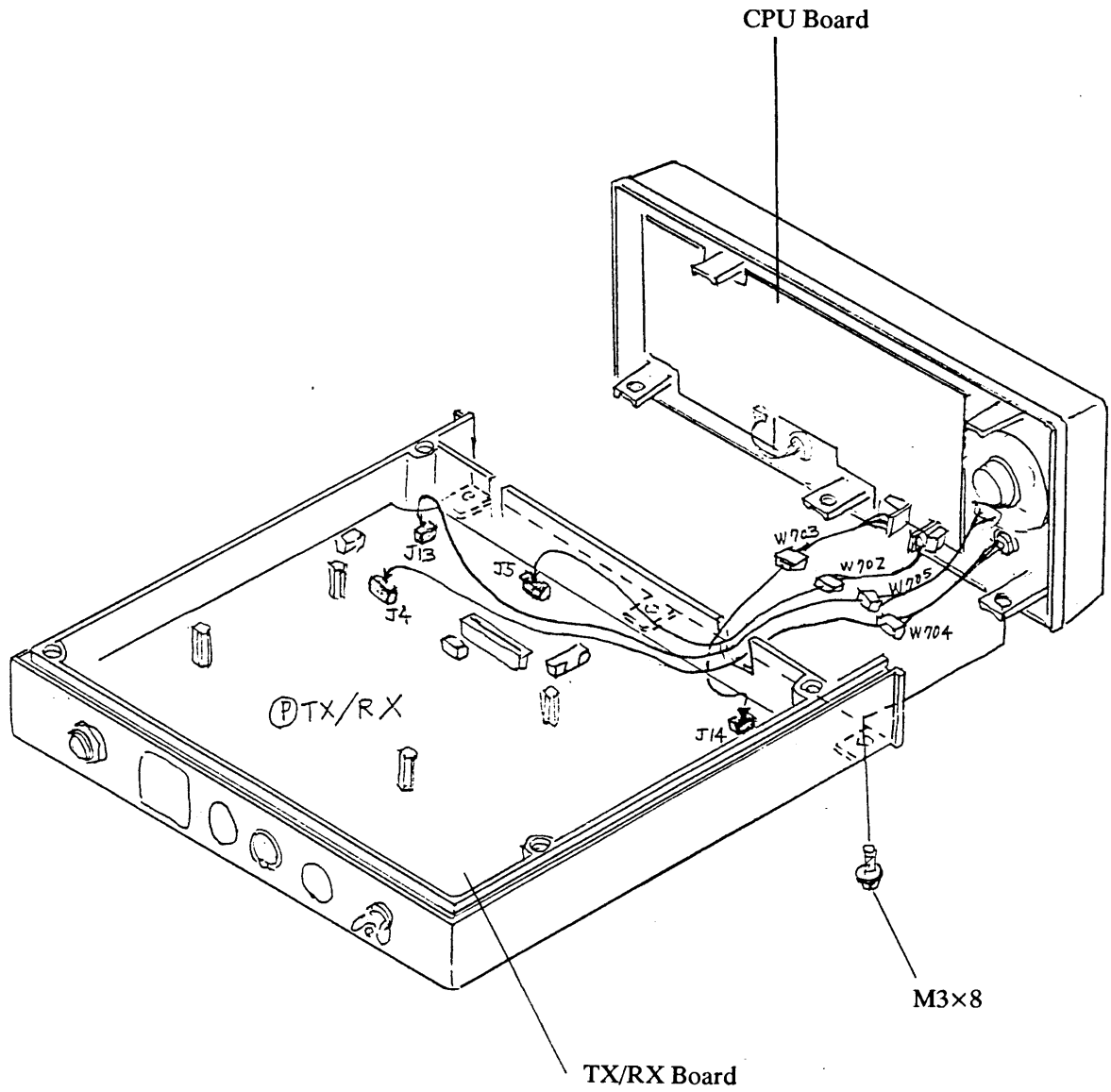

Figure 3-6 Front Panel Disassembly-1

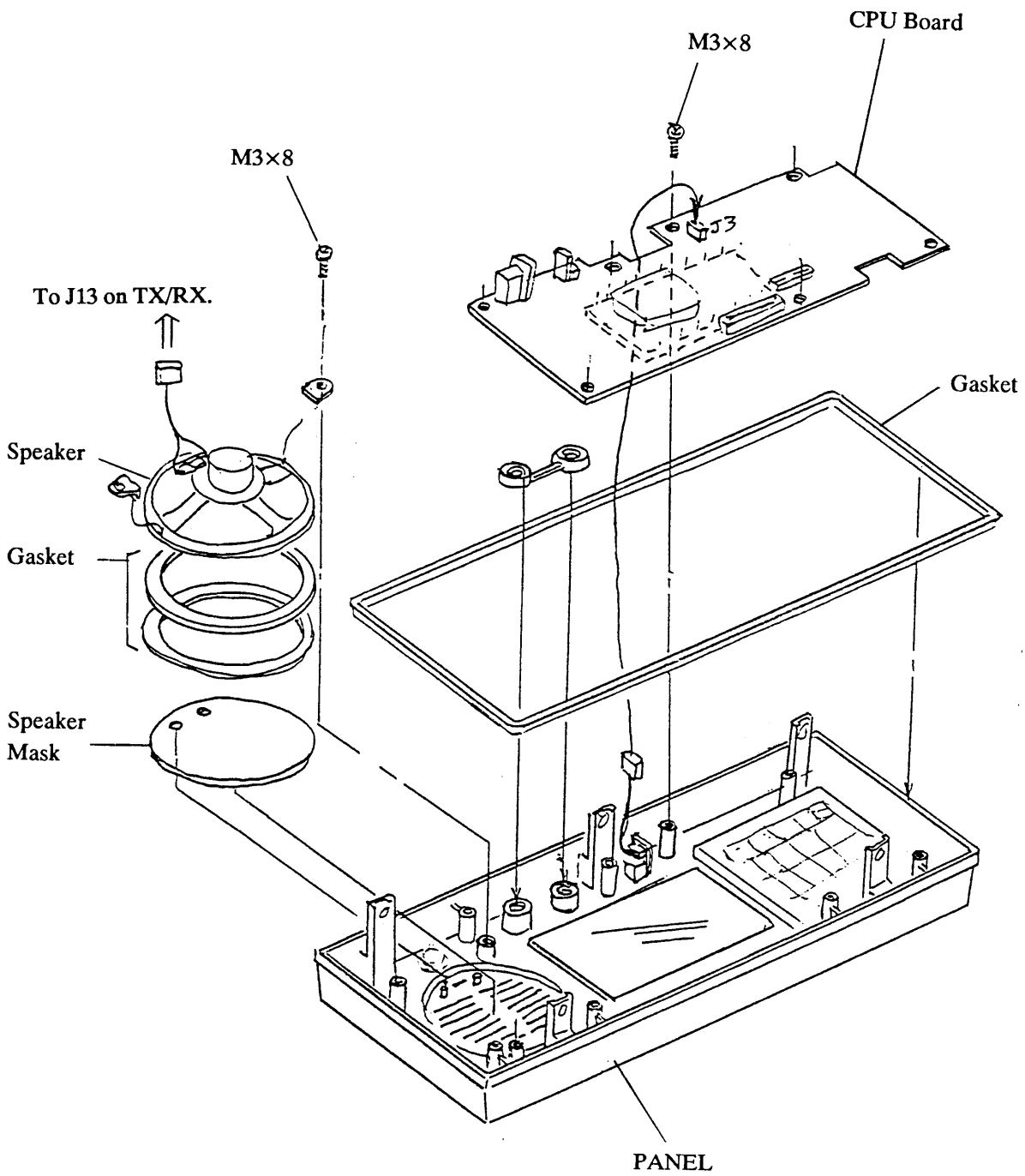

Figure 3-7 Front Panel Disassembly-2

---

# Parts Location

---

## Transceiver Unit

---

CPU Board 05P0456

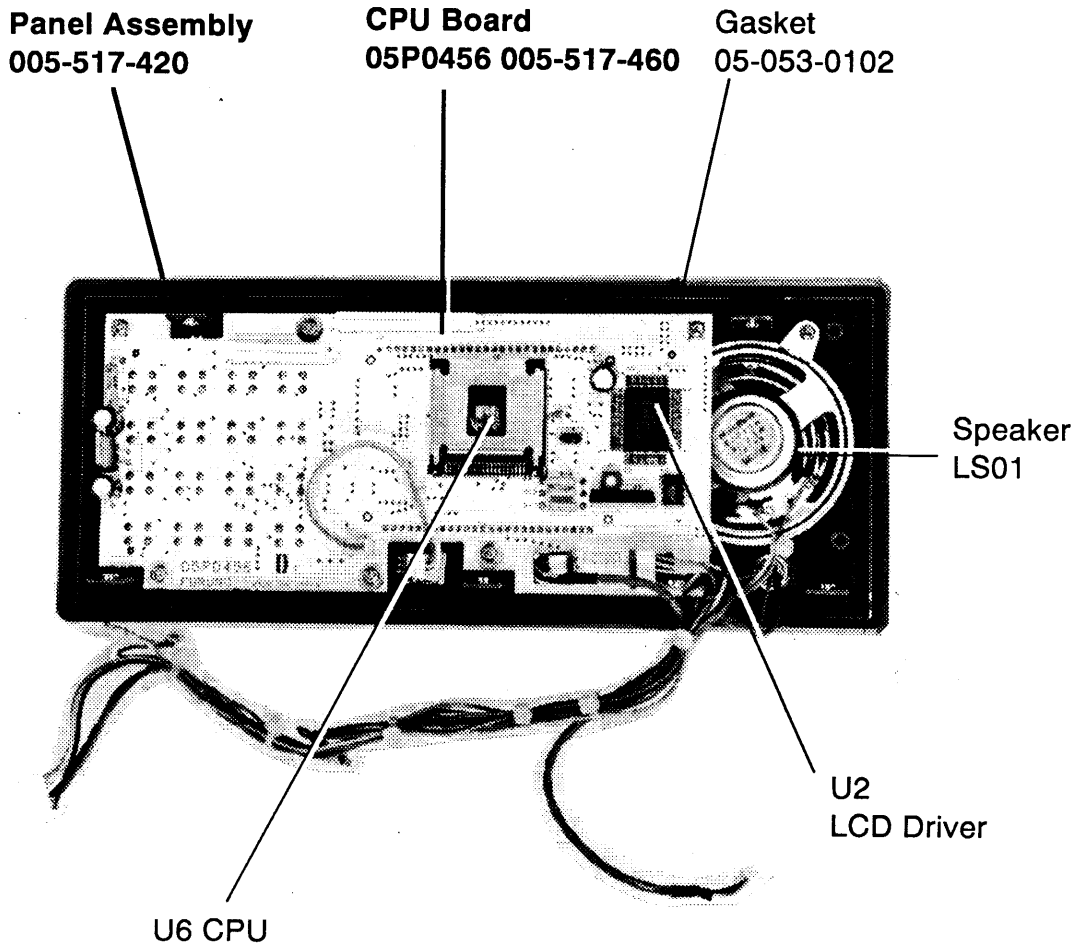

Figure 4-1 Transceiver, front panel, rear view

# TX/RX Board 05P0451

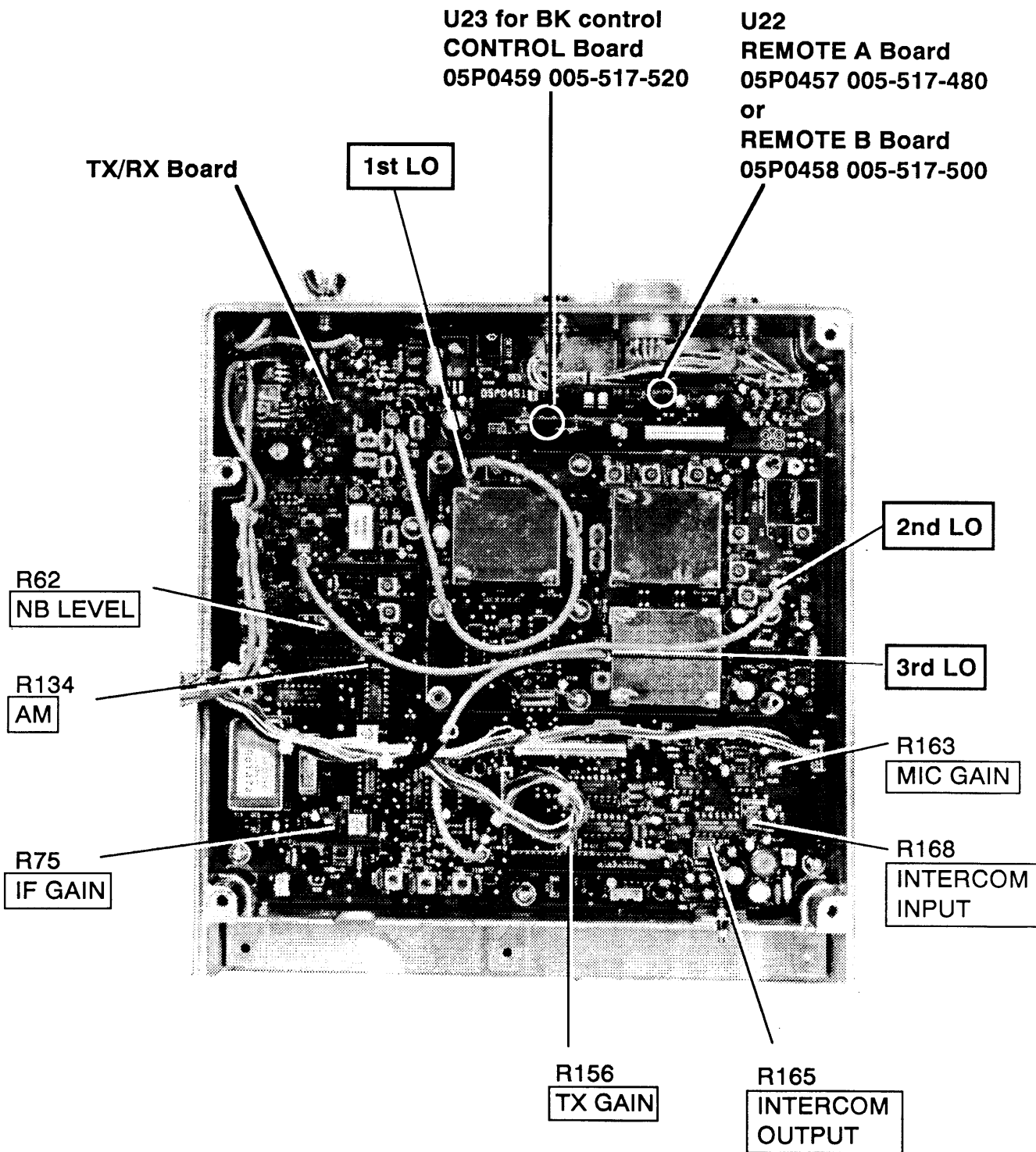

Figure 4-2 Transceiver, bottom view

TX FIL Board 05P0273  
 PA Board 05P0274  
 Relay Board 05P0275  
 SW REG Board 05P0276

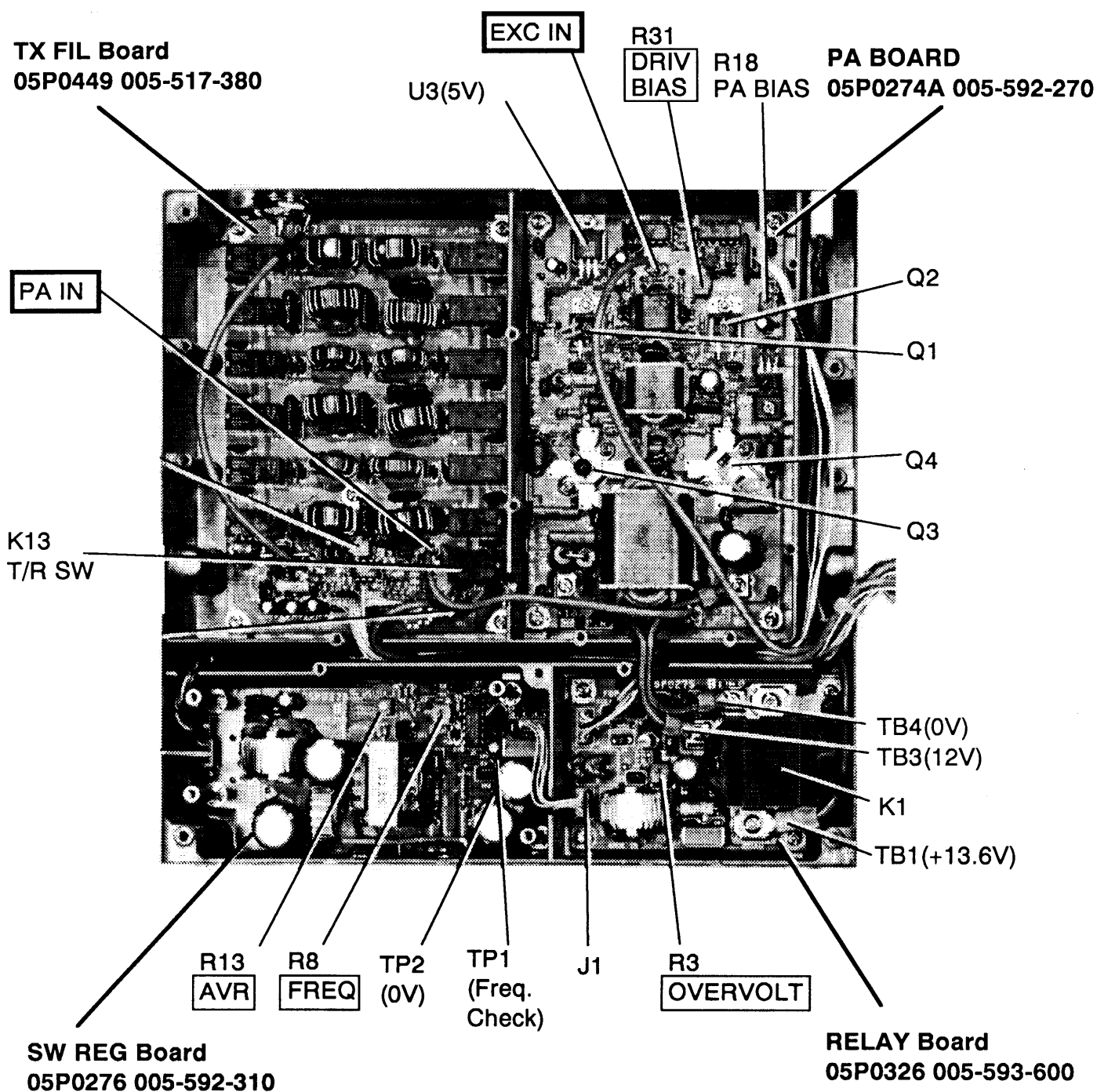

Figure 4-3 Transceiver, top view

# Antenna Coupler

## Coupler Board 05P0278B

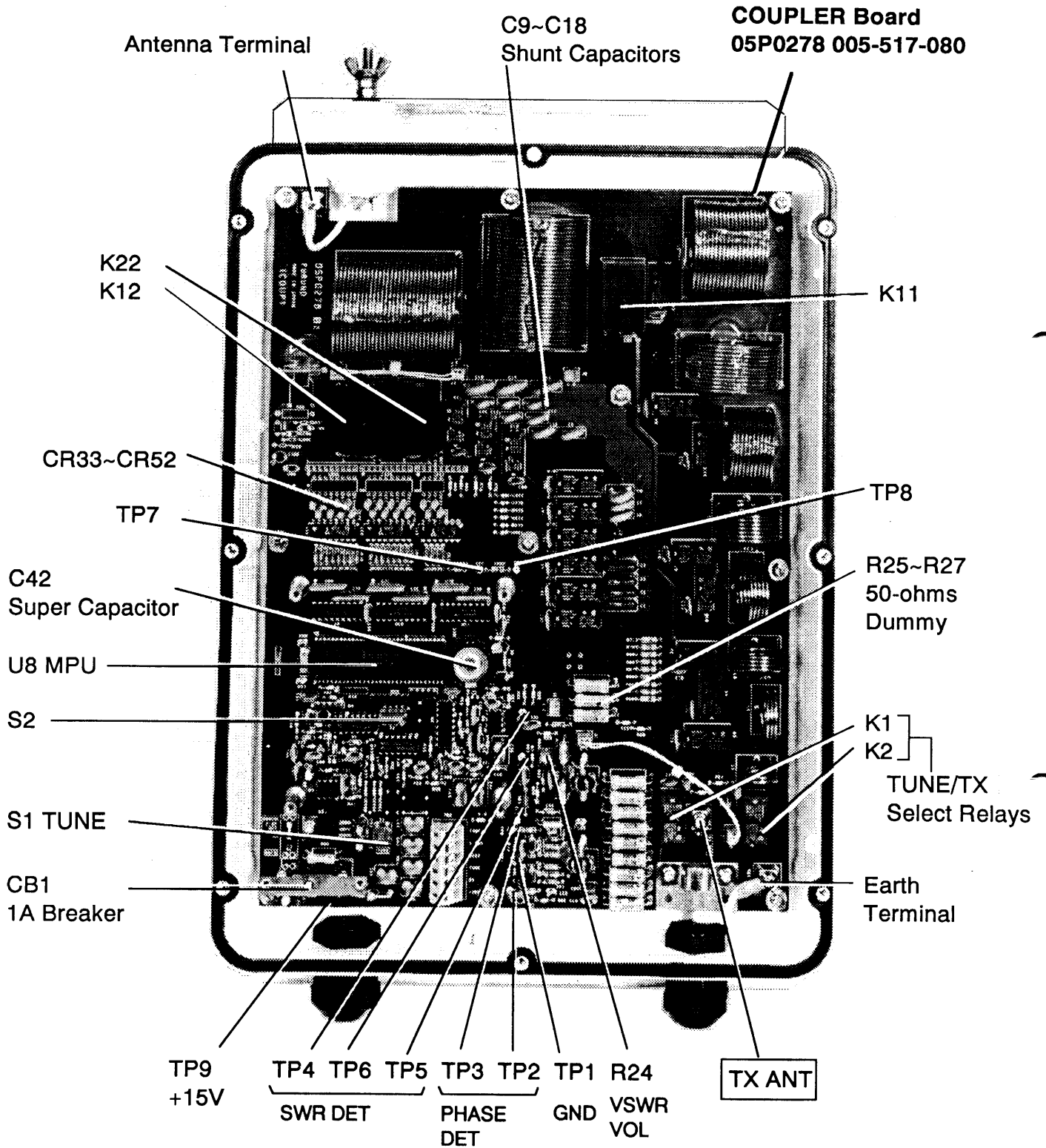

Figure 4-4 Antenna Coupler, cover removed, top view

**FURUNO**ELECTRICAL PARTS LIST  
電気部品表

1992- 9

MODEL	FS-1502		
UNIT	TRANSCEIVER UNIT 本体		PAGE
REF. DWG.	E5548-K04-A	BLOCK NO.	1B08
			1

SYMBOL	T Y P E	SPECIFICATIONS	CODE NO.	REMARKS
記号	型名	規格	コード番号	備考
PRINTED CIRCUIT BOARD		プリント基板		
1B01A0001	05P0453/4/6 CPU ASSY		005-517-460	
1B02A0001	05P0451 TX/RX		005-517-300	
1B03A0001	05P0449A TX FIL		005-517-380	
1B04A0001	05P0274 PA		005-592-270	
1B05A0001	05P0326 RELAY		005-593-600	
1B06A0001	05P0276 SW REG		005-592-310	
1B09A0001	05P0457 REMOTE A		005-517-480	OPTION
1B10A0001	05P0458 REMOTE B		005-517-500	OPTION
1B11A0001	05P0459 CONTROL		005-517-520	OPTION
-----				
JACK		ジャック		
J	2	M-BR-H*BS*	000-506-495	
J	3	FM14-6SM	000-113-528	
CABLE WITH CONNECTOR		コネクタ-ツケ-ケーブル		
W	801	SMCD-1.25-20-300-N	08S0070-1	000-119-781
W	802	SMCD-1.25-30-200-N	08C0070-1	000-119-519
W	803	05S4493-4	05S0481-0	000-113-475
W	804	05S0923-0		000-128-434
W	805	L-500	05S0046-0	000-113-466
W	806	05S4494-2	05S0481-0	000-113-476
W	807	L-520	07S0046-0	000-114-133
W	808	PH10D-450	05S0752-0	000-124-652
W	809	PH06S-50	05S0752-0	000-124-653
W	812	L-160	07S0047-0	000-522-099
W	813	05S0415-1		000-113-469
W	814	05S0461-0	05S0461-0	000-113-468
W	815	L-160	07S0046-0	000-522-075
W	816	05S4496-1	05S0481-0	000-113-478

UNIT	TRANSCEIVER UNIT	REF. DWG.	E5548-K02-A	BLOCK NO.	1B01	2
SYMBOL	T Y P E	SPECIFICATIONS	CODE NO.	REMARKS		
記号	型名	規格	コード番号	備考		
PRINTED CIRCUIT BOARD プリント基板						
OSP0456 CPU						
CAPACITOR コンデンサ						
C 1	ECE-A1E101E	100UF 25V	000-206-105			
C 2	ECU-X1E334ZF	02.0	000-124-654			
C 3	ECU-X1E334ZF	02.0	000-124-654			
C 4	ECU-X1E334ZF	02.0	000-124-654			
C 5	ECU-X1E334ZF	02.0	000-124-654			
C 6	ECU-X1E334ZF	02.0	000-124-654			
C 7	ECU-X1H102KBN	1000PF 50V	000-114-489			
C 8	ECU-X1H102KBN	1000PF 50V	000-114-489			
C 9	ECU-X1H102KBN	1000PF 50V	000-114-489			
C 10	ECU-X1H102KBN	1000PF 50V	000-114-489			
C 11	ECU-X1H102KBN	1000PF 50V	000-114-489			
C 12	ECU-X1H102KBN	1000PF 50V	000-114-489			
C 13	ECU-X1E104ZFG	0.1UF	000-119-373			
C 14	ECE-A1E101E	100UF 25V	000-206-105			
C 15	ECE-A1E101E	100UF 25V	000-206-105			
C 16	ECU-X1E334ZF	02.0	000-124-654			
C 17	ECU-X1H050CCN	5PF 50V	000-119-375			
C 18	ECU-X1H050CCN	5PF 50V	000-119-375			
C 20	ECU-X1H102KBN	1000PF 50V	000-114-489			
C 21	ECU-X1H102KBN	1000PF 50V	000-114-489			
C 22	ECU-X1H102KBN	1000PF 50V	000-114-489			
C 23	ECU-X1H102KBN	1000PF 50V	000-114-489			
C 24	ECU-X1H102KBN	1000PF 50V	000-114-489			
C 25	ECU-X1H102KBN	1000PF 50V	000-114-489			
C 26	ECU-X1H102KBN	1000PF 50V	000-114-489			
C 27	ECU-X1H102KBN	1000PF 50V	000-114-489			
C 28	ECU-X1H102KBN	1000PF 50V	000-114-489			
C 29	ECU-X1H102KBN	1000PF 50V	000-114-489			
C 30	ECU-X1H102KBN	1000PF 50V	000-114-489			
C 31	ECU-X1H102KBN	1000PF 50V	000-114-489			
C 32	ECU-X1H102KBN	1000PF 50V	000-114-489			
C 33	ECU-X1H102KBN	1000PF 50V	000-114-489			
C 34	ECU-X1H102KBN	1000PF 50V	000-114-489			
C 35	ECU-X1H102KBN	1000PF 50V	000-114-489			
C 36	ECU-X1H102KBN	1000PF 50V	000-114-489			
C 37	ECU-X1H102KBN	1000PF 50V	000-114-489			
C 38	ECU-X1H102KBN	1000PF 50V	000-114-489			
C 39	ECU-X1H102KBN	1000PF 50V	000-114-489			
C 40	ECU-X1E104ZFG	0.1UF	000-119-373			
C 41	ECU-X1E104ZFG	0.1UF	000-119-373			
C 42	ECU-X1E104ZFG	0.1UF	000-119-373			
C 43	ECU-X1E104ZFG	0.1UF	000-119-373			
C 44	ECU-X1E104ZFG	0.1UF	000-119-373			
C 45	ECU-X1E104ZFG	0.1UF	000-119-373			
C 46	ECU-X1E104ZFG	0.1UF	000-119-373			
C 47	ECU-X1E104ZFG	0.1UF	000-119-373			

UNIT	TRANSCEIVER UNIT	REF. DWG.	E5548-K02-A	BLOCK NO.	1B01	3
SYMBOL	T Y P E	SPECIFICATIONS	CODE NO.	REMARKS		
記号	型名	規格	コード番号	備考		
CAPACITOR コンデンサ						
C 48	ECU-X1E104ZFG	0.1UF	000-119-373			
C 49	ECU-X1E104ZFG	0.1UF	000-119-373			
C 50	ECU-X1E104ZFG	0.1UF	000-119-373			
C 51	ECU-X1H102KBN	1000PF 50V	000-114-489			
C 52	ECU-X1H102KBN	1000PF 50V	000-114-489			
C 53	ECU-X1H102KBN	1000PF 50V	000-114-489			
C 54	ECU-X1H102KBN	1000PF 50V	000-114-489			
C 55	ECU-X1H102KBN	1000PF 50V	000-114-489			
C 56	ECU-X1H102KBN	1000PF 50V	000-114-489			
C 57	ECU-X1H102KBN	1000PF 50V	000-114-489			
C 58	ECU-X1H102KBN	1000PF 50V	000-114-489			
C 59	ECU-X1H102KBN	1000PF 50V	000-114-489			
C 60	ECU-X1H102KBN	1000PF 50V	000-114-489			
C 61	ECU-X1E104ZFG	0.1UF	000-119-373			
C 62	ECU-X1E104ZFG	0.1UF	000-119-373			
C 63	ECU-X1E104ZFG	0.1UF	000-119-373			
C 64	ECU-X1E104ZFG	0.1UF	000-119-373			
C 65	ECU-X1E104ZFG	0.1UF	000-119-373			
C 66	ECU-X1E104ZFG	0.1UF	000-119-373			
C 67	ECU-X1E104ZFG	0.1UF	000-119-373			
C 68	ECU-X1E104ZFG	0.1UF	000-119-373			
C 69	ECU-X1E104ZFG	0.1UF	000-119-373			
DIODE ダイオード						
CR 1	LTZ-MR15	00S00B9-0	000-137-300			
CR 2	AY1101W		000-125-047			
CR 3	AY1101W		000-125-047			
CR 4	AY1101W		000-125-047			
CR 5	AY1101W		000-125-047			
CR 6	AY1101W		000-125-047			
CR 7	AY1101W		000-125-047			
CR 8	AY1101W		000-125-047			
CR 9	AY1101W		000-125-047			
CR 10	AY1101W		000-125-047			
CR 11	AY1101W		000-125-047			
CR 12	AY1101W		000-125-047			
CR 13	AY1101W		000-125-047			
CR 14	AY1101W		000-125-047			
CR 15	AY1101W		000-125-047			
CR 16	AY1101W		000-125-047			
CR 17	AY1101W		000-125-047			
CR 18	AY1101W		000-125-047			
CR 19	AY1101W		000-125-047			
CR 20	AY1101W		000-125-047			
CR 21	AY1101W		000-125-047			
CR 22	AY1101W		000-125-047			
CR 23	AY1101W		000-125-047			
CR 24	AY1101W		000-125-047			
CR 25	AY1101W		000-125-047			
CR 26	AY1101W		000-125-047			
CR 27	AY1101W		000-125-047			

UNIT	TRANSCEIVER UNIT	REF. DWG.	E5548-K02-A	BLOCK NO.	1B01	4
SYMBOL	T Y P E	SPECIFICATIONS	CODE NO.	REMARKS		
記号	型名	規格	コード番号	備考		
DIODE ダイオード						
CR 28	AY1101W		000-125-047			
CR 29	AY1101W		000-125-047			
JACK ジャック						
J 1	5597-20CPB	08S0075-0	000-113-403			
J 2	5597-30CPB	08S0075-0	000-107-998			
J 3	B3B-PH-K		000-108-355			
RESISTOR 抵抗						
R 1	EVM-MCGA01B16	00S0119-2	000-103-451			
R 2	ERJ-6GMYJ334	0.06W 330K	000-118-407			
R 3	ERJ-6GMYJ103	0.06W 10K	000-117-157			
R 4	ERJ-6GMYJ102	0.06W 1K	000-117-155			
R 5	ERJ-6GMYJ102	0.06W 1K	000-117-155			
R 6	ERJ-6GMYJ102	0.06W 1K	000-117-155			
R 7	ERJ-6GMYJ102	0.06W 1K	000-117-155			
R 8	ERJ-6GMYJ103	0.06W 10K	000-117-157			
R 9	ERJ-6GMYJ103	0.06W 10K	000-117-157			
R 10	ERJ-6GMYJ103	0.06W 10K	000-117-157			
R 11	ERJ-6GMYJ103	0.06W 10K	000-117-157			
R 12	ERG-1S J680P	00S0102-0	000-375-395			
R 13	ERG-3S J122P		000-375-540			
R 14	ERG-1S J471P	470	000-375-405			
R 15	ERJ-6GMYJ103	0.06W 10K	000-117-157			
R 16	ERJ-6GMYJ103	0.06W 10K	000-117-157			
R 17	ERJ-6GMYJ103	0.06W 10K	000-117-157			
R 18	ERJ-6GMYJ103	0.06W 10K	000-117-157			
R 19	ERJ-6GMYJ103	0.06W 10K	000-117-157			
R 20	ERG-2S J330P	00S0102-0	000-375-455			
R 21	ERJ-6GMYJ103	0.06W 10K	000-117-157			
R 22	ERJ-6GMYJ102	0.06W 1K	000-117-155			
R 23	ERJ-6GMYJ101	0.06W 100	000-117-154			
R 24	ERJ-6GMYJ101	0.06W 100	000-117-154			
R 25	ERJ-6GMYJ101	0.06W 100	000-117-154			
R 26	ERJ-6GMYJ101	0.06W 100	000-117-154			
R 27	ERJ-6GMYJ101	0.06W 100	000-117-154			
R 28	ERJ-6GMYJ101	0.06W 100	000-117-154			
R 29	ERJ-6GMYJ101	0.06W 100	000-117-154			
R 30	ERJ-6GMYJ101	0.06W 100	000-117-154			
R 31	ERJ-6GMYJ101	0.06W 100	000-117-154			
R 32	ERJ-6GMYJ101	0.06W 100	000-117-154			
R 33	ERJ-6GMYJ101	0.06W 100	000-117-154			
R 34	ERJ-6GMYJ101	0.06W 100	000-117-154			
R 35	ERJ-6GMYJ101	0.06W 100	000-117-154			
R 36	ERJ-6GMYJ101	0.06W 100	000-117-154			
R 37	ERJ-6GMYJ101	0.06W 100	000-117-154			
R 38	ERJ-6GMYJ101	0.06W 100	000-117-154			
R 39	ERJ-6GMYJ101	0.06W 100	000-117-154			
R 40	ERJ-6GMYJ101	0.06W 100	000-117-154			
R 41	ERJ-6GMYJ101	0.06W 100	000-117-154			

UNIT	TRANSCEIVER UNIT	REF. DWG.	E5548-K02-A	BLOCK NO.	1B01	5
SYMBOL	T Y P E	SPECIFICATIONS	CODE NO.	REMARKS		
記号	型名	規格	コード番号	備考		
RESISTOR 抵抗						
R 42	ERJ-6GMYJ101	0.06W 100	000-117-154			
R 43	ERJ-6GMYJ103	0.06W 10K	000-117-157			
R 44	ERJ-6GMYJ103	0.06W 10K	000-117-157			
R 45	ERJ-6GMYJ103	0.06W 10K	000-117-157			
R 46	ERJ-6GMYJ103	0.06W 10K	000-117-157			
R 47	ERJ-6GMYJ103	0.06W 10K	000-117-157			
R 48	ERJ-6GMYJ103	0.06W 10K	000-117-157			
R 49	ERJ-6GMYJ103	0.06W 10K	000-117-157			
R 50	ERJ-6GMYJ103	0.06W 10K	000-117-157			
R 51	ERJ-6GMYJ103	0.06W 10K	000-117-157			
R 52	ERJ-6GMYJ103	0.06W 10K	000-117-157			
R 53	ERJ-6GMYJ103	0.06W 10K	000-117-157			
R 54	ERJ-6GMYJ103	0.06W 10K	000-117-157			
R 55	ERJ-6GMYJ103	0.06W 10K	000-117-157			
R 56	ERJ-6GMYJ103	0.06W 10K	000-117-157			
R 57	ERJ-6GMYJ103	0.06W 10K	000-117-157			
R 58	ERJ-6GMYJ103	0.06W 10K	000-117-157			
R 59	ERJ-6GMYJ473	0.06W 47K	000-117-179			
R 60	ERJ-6GMYJ103	0.06W 10K	000-117-157			
R 61	ERJ-6GMYJ103	0.06W 10K	000-117-157			
R 62	ERJ-6GMYJ102	0.06W 1K	000-117-155			
R 63	ERJ-6GMYJ101	0.06W 100	000-117-154			
SWITCH スイッチ						
S 1	SKHHAP	22S0064	000-110-966			
S 2	SKHHAP</					

UNIT	TRANSCEIVER UNIT	REF. DWG.	E5548-K01-B	BLOCK NO.	1802	6
SYMBOL	T Y P E	SPECIFICATIONS	CODE NO.		REMARKS	
記号	型名	規格	コード番号		備考	
PRINTED CIRCUIT BOARD 印刷基板						
05P0451 TX/RX 005-517-300 VCO SECTIO						
CAPACITOR コンデンサ						
C 2	ECQ-B1H682JZ	6800PF 50V	000-102-680			
C 3	ECQ-B1H102JZ	1000PF 50V	000-100-753			
C 4	ECQ-B1H183JZ	0.018UF 50V	000-100-126			
C 5	ECQ-B1H152JZ	1500PF 50V	000-102-427			
C 6	ECU-X1E104ZFG	0.1UF	000-119-373			
C 7	ECU-X1H103K8G	0.01UF 50V	000-119-283			
C 8	ECU-X1H101JCG	220PF	000-119-341			
C 9	ECU-X1H150JCN	15PF	000-118-454			
C 10	ECU-X1H221JCG	220PF	000-119-343			
C 11	ECU-X1H101JCG	220PF	000-119-341			
C 12	ECU-X1H680JCG	68PF	000-119-331			
C 13	ECE-A1EU100E	10UF 25V	000-201-812			
C 14	ECU-X1H103K8G	0.01UF 50V	000-119-283			
C 15	ECU-X1H103K8G	0.01UF 50V	000-119-283			
C 16	ECU-X1H103K8G	0.01UF 50V	000-119-283			
C 17	ECU-X1H103K8G	0.01UF 50V	000-119-283			
C 18	ECE-A1EU100E	10UF 25V	000-201-812			
C 19	ECU-X1H103K8G	0.01UF 50V	000-119-283			
C 20	ECU-X1E104ZFG	0.1UF	000-119-373			
C 21	ECU-X1H103K8G	0.01UF 50V	000-119-283			
C 22	ECU-X1E104ZFG	0.1UF	000-119-373			
C 23	ECU-X1H103K8G	0.01UF 50V	000-119-283			
C 24	ECU-X1H103K8G	0.01UF 50V	000-119-283			
C 25	ECU-X1H103K8G	0.01UF 50V	000-119-283			
C 26	ECU-X1H103K8G	0.01UF 50V	000-119-283			
C 27	ECU-X1E104ZFG	0.1UF	000-119-373			
C 28	ECU-X1H103K8G	0.01UF 50V	000-119-283			
C 29	ECU-X1E104ZFG	0.1UF	000-119-373			
C 30	ECU-X1H103K8G	0.01UF 50V	000-119-283			
C 31	ECU-X1H103K8G	0.01UF 50V	000-119-283			
C 32	ECU-X1H103K8G	0.01UF 50V	000-119-283			
C 33	ECU-X1E104ZFG	0.1UF	000-119-373			
C 34	ECE-A1EU100E	10UF 25V	000-201-812			
C 35	ECU-X1H103K8G	0.01UF 50V	000-119-283			
C 36	ECU-X1H103K8G	0.01UF 50V	000-119-283			
C 37	ECU-X1H103K8G	0.01UF 50V	000-119-283			
C 38	ECE-A1EU100E	10UF 25V	000-201-812			
C 39	ECU-X1H103K8G	0.01UF 50V	000-119-283			
C 40	ECU-X1H103K8G	0.01UF 50V	000-119-283			
C 41	ECU-X1H103K8G	0.01UF 50V	000-119-283			
C 42	ECU-X1H103K8G	0.01UF 50V	000-119-283			
C 43	ECQ-B1H103JZ	0.01UF 50V	000-100-125			
C 44	ECU-X1H103K8G	0.01UF 50V	000-119-283			
C 45	ECU-X1H103K8G	0.01UF 50V	000-119-283			
C 46	ECU-X1H103K8G	0.01UF 50V	000-119-283			
C 47	ECU-X1H680JCG	68PF	000-119-331			

UNIT	TRANSCEIVER UNIT	REF. DWG.	E5548-K01-B	BLOCK NO.	1802	7
SYMBOL	T Y P E	SPECIFICATIONS	CODE NO.		REMARKS	
記号	型名	規格	コード番号		備考	
CAPACITOR コンデンサ						
C 48	ECU-X1H470JCG	47PF	000-119-347			
C 49	ECU-X1H181JCG	180PF	000-119-327			
C 50	ECU-X1H150JCN	15PF	000-118-454			
C 51	ECU-X1H101JCG	220PF	000-119-341			
C 52	ECU-X1H470JCG	47PF	000-119-347			
C 53	ECU-X1H181JCG	180PF	000-119-327			
C 54	ECU-X1H330JCG	33PF	000-119-329			
C 55	ECU-X1H471JCG	470PF	000-123-252			
C 56	ECU-X1H470JCG	47PF	000-119-347			
C 57	ECU-X1H102K8N	1000PF 50V	000-114-489			
C 58	ECU-X1H102K8N	1000PF 50V	000-114-489			
C 60	ECU-X1H102K8N	1000PF 50V	000-114-489			
C 61	ECU-X1H102K8N	1000PF 50V	000-114-489			
C 62	ECU-X1H30JCG	39PF	000-119-325			
C 63	ECU-X1H30JCG	39PF	000-119-325			
C 64	ECU-X1H181JCG	180PF	000-119-327			
C 65	ECU-X1H102K8N	1000PF 50V	000-114-489			
C 66	ECU-X1H102K8N	1000PF 50V	000-114-489			
C 67	ECU-X1H102K8N	1000PF 50V	000-114-489			
C 68	ECU-X1H102K8N	1000PF 50V	000-114-489			
C 69	ECU-X1H102K8N	1000PF 50V	000-114-489			
C 70	ECC-F1H150JV	15PF	000-255-260			
C 71	ECU-X1H102K8N	1000PF 50V	000-114-489			
C 72	ECE-A1EU100E	10UF 25V	000-201-812			
C 73	ECU-X1H102K8N	1000PF 50V	000-114-489			
C 74	ECU-X1H103K8G	0.01UF 50V	000-119-283			
C 75	ECC-F1H150JV	15PF	000-255-260			
C 76	ECU-X1H102K8N	1000PF 50V	000-114-489			
C 77	ECU-X1H102K8N	1000PF 50V	000-114-489			
C 78	ECU-X1H102K8N	1000PF 50V	000-114-489			
C 79	ECQ-P1H102JZ	1000PF 50V	000-262-713			
C 80	ECU-X1H101JCG	220PF	000-119-341			
C 81	ECQ-P1H102JZ	1000PF 50V	000-262-713			
C 82	ECE-A1EU100E	10UF 25V	000-201-812			
C 83	ECQ-P1H102JZ	1000PF 50V	000-262-713			
C 84	ECU-X1E104ZFG	0.1UF	000-119-373			
C 85	ECU-X1E104ZFG	0.1UF	000-119-373			
C 86	ECU-X1E104ZFG	0.1UF	000-119-373			
C 87	ECU-X1E104ZFG	0.1UF	000-119-373			
C 88	ECU-X1E104ZFG	0.1UF	000-119-373			
C 89	ECE-A1EU100E	10UF 25V	000-201-812			
C 90	ECE-A1EU220E	22UF 25V	000-201-813			
C 91	ECU-X1E104ZFG	0.1UF	000-119-373			
C 92	ECU-X1E104ZFG	0.1UF	000-119-373			
C 93	ECU-X1E104ZFG	0.1UF	000-119-373			
C 94	ECU-X1E104ZFG	0.1UF	000-119-373			
C 95	ECU-X1E104ZFG	0.1UF	000-119-373			
C 96	ECU-X1E104ZFG	0.1UF	000-119-373			
C 97	ECU-X1E104ZFG	0.1UF	000-119-373			
C 98	ECU-X1E104ZFG	0.1UF	000-119-373			
C 99	ECU-X1E104ZFG	0.1UF	000-119-373			

UNIT	TRANSCEIVER UNIT	REF. DWG.	E5548-K01-B	BLOCK NO.	1802	8
SYMBOL	T Y P E	SPECIFICATIONS	CODE NO.		REMARKS	
記号	型名	規格	コード番号		備考	
CAPACITOR コンデンサ						
C 100	ECU-X1H103K8G	0.01UF 50V	000-119-283			
C 101	ECE-A1EU220E	22UF 25V	000-201-813			
C 102	ECU-X1H103K8G	0.01UF 50V	000-119-283			
C 103	ECU-X1H103K8G	0.01UF 50V	000-119-283			
C 104	ECU-X1H103K8G	0.01UF 50V	000-119-283			
C 105	ECU-X1H103K8G	0.01UF 50V	000-119-283			
C 106	ECU-X1E104ZFG	0.1UF	000-119-373			
C 107	ECU-X1H103K8G	0.01UF 50V	000-119-283			
C 108	ECU-X1E104ZFG	0.1UF	000-119-373			
C 109	ECU-X1H103K8G	0.01UF 50V	000-119-283			
C 110	ECU-X1H101JCG	220PF	000-119-341			
C 111	ECQ-P1H102JZ	1000PF 50V	000-262-713			
C 112	ECU-X1H103K8G	0.01UF 50V	000-119-283			
C 113	ECU-X1H103K8G	0.01UF 50V	000-119-283			
C 114	ECU-X1E104ZFG	0.1UF	000-119-373			
C 115	ECQ-P1H102JZ	1000PF 50V	000-262-713			
C 116	ECU-X1E104ZFG	0.1UF	000-119-373			
C 117	ECU-X1E104ZFG	0.1UF	000-119-373			
C 118	ECU-X1E104ZFG	0.1UF	000-119-373			
C 119	ECE-A1EU100E	10UF 25V	000-201-812			
C 120	ECE-A1EU100E	10UF 25V	000-201-812			
C 121	ECE-A1EU47I	470UF 25V	000-201-723			
C 122	ECU-X1H330JCG	33PF	000-119-329			
C 123	ECU-X1E104ZFG	0.1UF	000-119-373			
C 124	ECQ-V1H104JZ	0.1UF 50V	000-261-524			
C 125	ECQ-B1H222JZ	2200PF 50V	000-111-076			
C 126	ECQ-V1H104JZ	0.1UF 50V	000-261-524			
C 127	ECU-X1E104ZFG	0.1UF	000-119-373			
C 128	ECU-X1E104ZFG	0.1UF	000-119-373			
C 129	ECE-A1EU100E	10UF 25V	000-201-812			
C 130	ECE-A1EU100E	10UF 25V	000-201-812			
C 131	ECE-A1HU010E	1UF 50V	000-206-115			
C 132	ECU-X1H103K8G	0.01UF 50V	000-119-283			
C 133	ECU-X1H103K8G	0.01UF 50V	000-119-283			
C 134	ECE-A1EU100E	10UF 25V	000-201-812			
C 135	ECQ-B1H103JZ	0.01UF 50V	000-100-125			
C 136	ECE-A1EU100E	10UF 25V	000-201-812			
C 137	ECE-A1HNO10SE	1UF 50V	000-206-108			
C 138	ECE-A1EU100E	10UF 25V	000-201-812			
C 139	ECQ-V1H104JZ	0.1UF 50V	000-261-524			
C 140	ECE-A1EU470E	47UF 25V	000-201-815			
C 141	ECE-A1EU100E	10UF 25V	000-201-812			
C 142	ECE-A1HNO10SE	1UF 50V	000-206-108			
C 143	ECQ-V1H104JZ	0.1UF 50V	000-261-524			
C 144	ECE-A1EU100E	10UF 25V	000-201-812			
C 145	ECQ-V1H104JZ	0.1UF 50V	000-261-524			
C 146	ECE-A1EU100E	10UF 25V	000-201-812			
C 147	ECE-A1EU100E	10UF 25V	000-201-812			
C 148	ECE-A1EU100E	10UF 25V	000-201-812			
C 149	ECU-X1H103K8G	0.01UF 50V	000-119-283			
C 150	EXC-EMT103DC	FM-2520	000-107-994			

UNIT	TRANSCEIVER UNIT	REF. DWG.	E5548-K01-B	BLOCK NO.	1802	9
SYMBOL	T Y P E	SPECIFICATIONS	CODE NO.		REMARKS	
記号	型名	規格	コード番号		備考	
CAPACITOR コンデンサ						
C 151	ECQ-V1H104JZ	0.1UF 50V	000-261-524			
C 152	ECQ-B1H102JZ	1000PF 50V	000-100-753			
C 153	ECQ-B1H102JZ	1000PF 50V	000-100-753			
C 154	ECE-A1EU470E	47UF 25V	000-201-815			
C 155	ECE-A1EU470E	47UF 25V	000-201-815			
C 156	ECE-A1EU47I	470UF 25V	000-201-723			
C 157	ECE-A1EU470E</					



UNIT	TRANSCEIVER UNIT	REF. DWG.	E5548-K01-B	BLOCK NO.	1B02	14
SYMBOL	T Y P E	SPECIFICATIONS		CODE NO.	REMARKS	
記号	型名	規格	格	コード番号	備考	
RESISTOR 抵抗						
R 105	ERJ-6GMYJ472	0.06W	4.7K	000-117-178		
R 106	ERJ-6GMYJ472	0.06W	4.7K	000-117-178		
R 107	ERJ-6GMYJ470	0.06W	4.7	000-117-176		
R 108	ERJ-6GMYJ184	0.06W	180K	000-118-366		
R 109	ERJ-6GMYJ333	0.06W	33K	000-117-174		
R 110	ERJ-6GMYJ333	0.06W	33K	000-117-174		
R 111	ERJ-6GMYJ153	0.06W	15K	000-118-462		
R 112	ERJ-6GMYJ561	Q2.0		000-117-183		
R 113	ERJ-6GMYJ472	0.06W	4.7K	000-117-178		
R 114	ERJ-6GMYJ471	0.06W	4.7	000-117-177		
R 115	ERJ-6GMYJ153	0.06W	15K	000-118-462		
R 116	ERJ-6GMYJ472	0.06W	4.7K	000-117-178		
R 117	ERJ-6GMYJ392	Q2.0		000-119-529		
R 118	ERJ-6GMYJ473	0.06W	4.7K	000-117-179		
R 119	ERJ-6GMYJ823	Q2.0		000-117-186		
R 120	ERJ-6GMYJ682	0.06W	6.8K	000-118-418		
R 121	ERJ-6GMYJ103	0.06W	10K	000-117-157		
R 122	ERJ-6GMYJ103	0.06W	10K	000-117-157		
R 123	ERJ-6GMYJ473	0.06W	4.7K	000-117-179		
R 124	ERJ-6GMYJ104	0.06W	100K	000-117-158		
R 125	ERJ-6GMYJ473	0.06W	4.7K	000-117-179		
R 126	ERJ-6GMYJ104	0.06W	100K	000-117-158		
R 127	ERJ-6GMYJ392	Q2.0		000-119-529		
R 128	ERJ-6GMYJ681	680		000-118-463		
R 129	ERJ-6GMYJ332	0.06W	3.3K	000-117-173		
R 130	ERJ-6GMYJ681	680		000-118-463		
R 131	ERJ-6GMYJ332	0.06W	3.3K	000-117-173		
R 132	ERJ-6GMYJ472	0.06W	4.7K	000-117-178		
R 133	ERJ-6GMYJ472	0.06W	4.7K	000-117-178		
R 134	EVM-MCGA01B53	5K		000-103-631		
R 135	ERJ-6GMYJ102	0.06W	1K	000-117-155		
R 136	ERJ-6GMYJ103	0.06W	10K	000-117-157		
R 137	ERJ-6GMYJ103	0.06W	10K	000-117-157		
R 138	ERJ-6GMYJ331	330		000-117-172		
R 139	ERJ-6GMYJ470	0.06W	4.7	000-117-176		
R 140	ERG-3SJ180P	00S0102-0		000-375-517		
R 141	ERJ-6GMYJ472	0.06W	4.7K	000-117-178		
R 144	ERJ-6GMYJ474	Q2.0		000-119-797		
R 145	ERJ-6GMYJ561	Q2.0		000-117-183		
R 146	ERJ-6GMYJ103	0.06W	10K	000-117-157		
R 147	ERJ-6GMYJ561	Q2.0		000-117-183		
R 148	ERJ-6GMYJ474	Q2.0		000-119-797		
R 149	ERJ-6GMYJ272	0.06W	2.7K	000-118-431		
R 150	ERJ-6GMYJ472	0.06W	4.7K	000-117-178		
R 151	EXB-F9E472J	0.125W	4.7K	000-100-758		
R 152	EXB-F9E472J	0.125W	4.7K	000-100-758		
R 153	ERJ-6GMYJ473	0.06W	4.7K	000-117-179		
R 154	ERJ-6GMYJ472	0.06W	4.7K	000-117-178		
R 155	ERJ-6GMYJ103	0.06W	10K	000-117-157		
R 156	EVM-MCGA01B53	5K		000-103-631		
R 157	ERJ-6GMYJ151	0.06W	150	000-117-160		

UNIT	TRANSCEIVER UNIT	REF. DWG.	E5548-K01-B	BLOCK NO.	1B02	15
SYMBOL	T Y P E	SPECIFICATIONS		CODE NO.	REMARKS	
記号	型名	規格	格	コード番号	備考	
RESISTOR 抵抗						
R 158	ERJ-6GMYJ472	0.06W	4.7K	000-117-178		
R 159	ERJ-6GMYJ102	0.06W	1K	000-117-155		
R 160	ERJ-6GMYJ472	0.06W	4.7K	000-117-178		
R 161	ERJ-6GMYJ103	0.06W	10K	000-117-157		
R 162	ERJ-6GMYJ101	0.06W	100	000-117-154		
R 163	EVM-MCGA01B52	500B		000-103-592		
R 164	ERJ-6GMYJ102	0.06W	1K	000-117-155		
R 165	EVM-MCGA01B54	50K		000-103-590		
R 166	ERJ-6GMYJ222	0.06W	2.2K	000-117-167		
R 167	ERJ-6GMYJ104	0.06W	100K	000-117-158		
R 168	EVM-MCGA01B54	50K		000-103-590		
R 169	ERJ-6GMYJ472	0.06W	4.7K	000-117-178		
R 170	ERJ-6GMYJ474	Q2.0		000-119-797		
R 171	ERJ-6GMYJ471	0.06W	4.7	000-117-177		
R 172	ERJ-6GMYJ472	0.06W	4.7K	000-117-178		
R 173	ERJ-6GMYJ472	0.06W	4.7K	000-117-178		
R 174	ERJ-6GMYJ472	0.06W	4.7K	000-117-178		
R 175	ERJ-6GMYJ474	Q2.0		000-119-797		
R 176	ERJ-6GMYJ331	330		000-117-172		
R 177	ERJ-6GMYJ474	Q2.0		000-119-797		
R 178	ERJ-6GMYJ472	0.06W	4.7K	000-117-178		
R 179	ERJ-6GMYJ473	0.06W	4.7K	000-117-179		
R 180	ERJ-6GMYJ472	0.06W	4.7K	000-117-178		
R 181	ERJ-6GMYJ150	15		000-118-330		
R 182	ERX-1SJ180P	1W 1.0		000-375-371		
R 183	ERJ-6GMYJ102	0.06W	1K	000-117-155		
R 184	ERJ-6GMYJ102	0.06W	1K	000-117-155		
R 185	ERJ-6GMYJ472	0.06W	4.7K	000-117-178		
R 186	ERJ-6GMYJ101	0.06W	100	000-117-154		
R 187	ERJ-6GMYJ101	0.06W	100	000-117-154		
R 188	ERJ-6GMYJ101	0.06W	100	000-117-154		
R 189	ERJ-6GMYJ101	0.06W	100	000-117-154		
R 190	ERJ-6GMYJ101	0.06W	100	000-117-154		
R 191	ERJ-6GMYJ101	0.06W	100	000-117-154		
R 192	ERJ-6GMYJ101	0.06W	100	000-117-154		
R 194	ERJ-6GMYJ470	0.06W	4.7	000-117-176		
R 195	ERJ-6GMYJ183	Q2.0		000-117-164		
R 196	ERJ-6GMYJ473	0.06W	4.7K	000-117-179		
R 197	ERJ-6GMYJ472	0.06W	4.7K	000-117-178		
R 198	ERJ-6GMYJ151	0.06W	150	000-117-160		
R 199	ERJ-6GMYJ122	0.06W	1.2K	000-118-424		
R 200	ERJ-6GMYJ222	0.06W	2.2K	000-117-167		
R 201	ERJ-6GMYJ472	0.06W	4.7K	000-117-178		
R 202	ERJ-6GMYJ103	0.06W	10K	000-117-157		
R 203	ERJ-6GMYJ103	0.06W	10K	000-117-157		
THERMISTOR 熱電阻						
RT 2	D-33A			000-180-625		
RT 3	D-33A			000-180-625		
RT 4	D-33A			000-180-625		

UNIT	TRANSCEIVER UNIT	REF. DWG.	E5548-K01-B	BLOCK NO.	1B02	16
SYMBOL	T Y P E	SPECIFICATIONS		CODE NO.	REMARKS	
記号	型名	規格	格	コード番号	備考	
TRANSFORMER トランス						
T 1	5T460	05S0355-0		000-109-054		
T 2	5T460	05S0355-0		000-109-054		
T 3	5T460	05S0355-0		000-109-054		
T 4	5T460	05S0355-0		000-109-054		
T 5	5T476	05S0420-0		000-113-389		
T 6	5T460	05S0355-0		000-109-054		
T 7	5T476	05S0420-0		000-113-389		
T 8	5T476	05S0417-0		000-113-390		
T 9	5T475A	05S0419-1		000-113-369		
T 10	5T460	05S0355-0		000-109-054		
T 11	5T460	05S0355-0		000-109-054		
T 12	5T475A	05S0419-1		000-113-369		
T 13	5T394	05S4395-0		000-107-604		
T 14	5T395	05S4395-0		000-107-603		
T 15	5T395	05S4395-0		000-107-603		
T 16	5T394	05S4395-0		000-107-604		
T 17	5T395	05S4395-0		000-107-603		
T 18	5T395	05S4395-0		000-107-603		
INTEGRATED CIRCUIT 集積回路						
U 1	SL1611C/DG			000-169-138		
U 2	NJM2904D			000-113-434		
U 3	NJM2904D			000-113-434		
U 4	05P0467			005-938-850		
U 5	05P0466			005-938-860		
U 6	AN7805F			000-113-496		
U 7	TC4066BP			000-163-264		
U 8	TC4066BP			000-163-264		
U 9	NJM082			000-113-396		
U 10	05P0467			005-938-850		
U 11	TC4066BP			000-163-264		
U 12	TC4066BP			000-163-264		
U 13	NJM2904D			000-113-434		
U 14	M54972P			000-113-380		
U 15	M54972P			000-113-380		
U 16	TA7658P			000-106-200		
U 17	05P0468			005-938-870		
U 18	TC4066BP			000-163-264		
U 19	TC4066BP			000-163-264		
U 20	NJM082			000-113-396		
U 21	UPC1242H	FM2510		000-110-984		
U 22	05P0457			005-517-480 OPTION		
U 23	05P0458			005-517-500 OPTION		
U 23	05P0459			005-517-520 OPTION		
POTENTIOMETER 可変抵抗器						
VR 1	HZ12A-1L	ZENER		000-113-383		
VR 2	HZ12A-1L	ZENER		000-113-383		
CABLE WITH CONNECTOR コネクタケーブル						
W 1	L-140	07S0046-0		000-522-074		

UNIT	TRANSCEIVER UNIT	REF. DWG.	E5548-K01-B	BLOCK NO.	1B02	17
SYMBOL	T Y P E	SPECIFICATIONS		CODE NO.	REMARKS	
記号	型名	規格	格	コード番号	備考	
CABLE WITH CONNECTOR コネクタケーブル						
W 2	L-250	07S0046-0		000-522-004		
W 3	L-170	07S0046-0		000-522-076		

UNIT	TRANSCEIVER UNIT	REF. DWG.	E5548-K03-A	BLOCK NO	1B16	18
SYMBOL	T Y P E	SPECIFICATIONS	CODE NO	REMARKS		
記号	型名	規格	コード番号	備考		
PRINTED CIRCUIT BOARD プリント基板						
A 1	05P0451	VCO SECTION				
CAPACITOR コンデンサ						
C 1	EXF-P4102ZF	1000PF 50V	000-106-078			
C 2	EXF-P4102ZF	1000PF 50V	000-106-078			
C 3	ECU-X1H103K8G	0.01UF 50V	000-119-283			
C 4	ECU-X1H102K8M	1000PF 50V	000-114-489			
C 5	ECU-X1H101CCN	1PF 50V	000-114-493			
C 6	ECQ-V1H104JZ	0.1UF 50V	000-261-524			
C 7	ECQ-B1H103JZ	0.01UF 50V	000-100-125			
C 8	ECU-X1H102K8M	1000PF 50V	000-114-489			
C 9	ECU-X1H330JCG	33PF	000-119-329			
C 10	ECU-X1H102K8M	1000PF 50V	000-114-489			
C 11	ECE-A1AU471	470UF 10V	000-201-704			
C 12	ECU-X1H102K8M	1000PF 50V	000-114-489			
C 13	ECU-X1H100DCN	10PF	000-119-335			
C 14	ECU-X1H150JCN	15PF	000-118-454			
C 15	EXC-EMT103DC	FM-2520	000-107-994			
C 16	ECE-A1AU471	470UF 10V	000-201-704			
C 17	ECU-X1H103K8G	0.01UF 50V	000-119-283			
C 18	EXC-EMT103DC	FM-2520	000-107-994			
C 19	ECU-X1H103K8G	0.01UF 50V	000-119-283			
C 20	ECU-X1E104ZFG	0.1UF	000-119-373			
C 21	ECE-A1CU471	470UF 16V	000-201-714			
C 22	ECE-A1EU100E	10UF 25V	000-201-812			
C 23	ECU-X1H101CCN	1PF 50V	000-114-493			
C 24	ECU-X1H102K8M	1000PF 50V	000-114-489			
C 25	ECU-X1H103K8G	0.01UF 50V	000-119-283			
C 26	ECU-X1H102K8M	1000PF 50V	000-114-489			
C 27	ECU-X1H102K8M	1000PF 50V	000-114-489			
C 28	ECU-X1H102K8M	1000PF 50V	000-114-489			
C 29	ECU-X1H103K8G	0.01UF 50V	000-119-283			
C 30	ECU-X1H102K8M	1000PF 50V	000-114-489			
C 31	ECE-A1EU100E	10UF 25V	000-201-812			
C 32	ECU-X1H102K8M	1000PF 50V	000-114-489			
C 33	ECU-X1H103K8G	0.01UF 50V	000-119-283			
C 34	ECE-A1EU100E	10UF 25V	000-201-812			
C 35	ECU-X1H102K8M	1000PF 50V	000-114-489			
C 36	ECC-F1H050CU	5PF 50V	000-257-104			
C 37	ECC-F1H050CU	5PF 50V	000-257-104			
C 38	ECU-X1H102K8M	1000PF 50V	000-114-489			
C 39	ECC-F1H150JV	15PF	000-255-260			
C 40	ECU-X1H103K8G	0.01UF 50V	000-119-283			
C 41	ECE-A1AU101E	100UF 10V	000-206-113			
C 42	ECU-X1H103K8G	0.01UF 50V	000-119-283			
C 43	ECU-X1H102K8M	1000PF 50V	000-114-489			
C 44	ECU-X1H102K8M	1000PF 50V	000-114-489			
C 45	ECU-X1H102K8M	1000PF 50V	000-114-489			
C 46	ECU-X1E104ZFG	0.1UF	000-119-373			

UNIT	TRANSCEIVER UNIT	REF. DWG.	E5548-K03-A	BLOCK NO	1B16	19
SYMBOL	T Y P E	SPECIFICATIONS	CODE NO	REMARKS		
記号	型名	規格	コード番号	備考		
CAPACITOR コンデンサ						
C 47	ECQ-B1H223JZ	0.22UF 50V	000-100-127			
C 48	ECQ-V1H104JZ	0.1UF 50V	000-261-524			
C 49	ECQ-V1H104JZ	0.1UF 50V	000-261-524			
C 50	ECE-A1CU471	470UF 16V	000-201-714			
C 51	ECU-X1H102K8M	1000PF 50V	000-114-489			
C 52	ECU-X1H102K8M	1000PF 50V	000-114-489			
C 53	ECU-X1H102K8M	1000PF 50V	000-114-489			
C 54	ECU-X1H102K8M	1000PF 50V	000-114-489			
C 55	ECU-X1H102K8M	1000PF 50V	000-114-489			
C 56	ECU-X1H102K8M	1000PF 50V	000-114-489			
C 57	ECU-X1H102K8M	1000PF 50V	000-114-489			
C 58	ECU-X1H102K8M	1000PF 50V	000-114-489			
C 59	ECU-X1H102K8M	1000PF 50V	000-114-489			
C 60	ECE-A1EU100E	10UF 25V	000-201-812			
C 61	ECU-X1E104ZFG	0.1UF	000-119-373			
C 62	ECU-X1H102K8M	1000PF 50V	000-114-489			
C 63	ECE-A1EU100E	10UF 25V	000-201-812			
C 64	ECU-X1H102K8M	1000PF 50V	000-114-489			
C 65	ECU-X1H101CCN	1PF 50V	000-114-493			
C 66	ECU-X1H100DCN	10PF	000-119-335			
C 67	ECU-X1H102K8M	1000PF 50V	000-114-489			
C 68	ECU-X1H102K8M	1000PF 50V	000-114-489			
C 69	ECU-X1H103K8G	0.01UF 50V	000-119-283			
C 70	ECU-X1H103K8G	0.01UF 50V	000-119-283			
C 71	ECU-X1H121JCG	120PF	000-119-349			
C 72	ECU-X1H470JCG	47PF	000-119-347			
C 73	ECU-X1H181JCG	180PF	000-119-327			
C 74	ECU-X1H150JCN	15PF	000-118-454			
C 75	ECU-X1H121JCG	120PF	000-119-349			
C 76	ECU-X1H470JCG	47PF	000-119-347			
C 77	ECU-X1H181JCG	180PF	000-119-327			
C 78	ECU-X1H330JCG	33PF	000-119-329			
C 79	ECU-X1H471JCG	470PF	000-123-252			
C 80	ECU-X1H470JCG	47PF	000-119-347			
C 81	ECU-X1H103K8G	0.01UF 50V	000-119-283			
C 82	ECU-X1H102K8M	1000PF 50V	000-114-489			
C 83	ECU-X1H102K8M	1000PF 50V	000-114-489			
C 84	ECU-X1H102K8M	1000PF 50V	000-114-489			
C 85	ECU-X1H100DCN	10PF	000-119-335			
C 86	ECU-X1H103K8G	0.01UF 50V	000-119-283			
C 87	ECU-X1H102K8M	1000PF 50V	000-114-489			
C 88	ECQ-V1H104JZ	0.1UF 50V	000-261-524			
C 89	ECQ-B1H103JZ	0.01UF 50V	000-100-125			
C 90	ECU-X1H101CCN	1PF 50V	000-114-493			
C 91	ECU-X1H102K8M	1000PF 50V	000-114-489			
C 92	ECU-X1H102K8M	1000PF 50V	000-114-489			
C 93	ECU-X1H330JCG	33PF	000-119-329			
C 94	ECU-X1H102K8M	1000PF 50V	000-114-489			
C 95	ECU-X1H330JCG	33PF	000-119-329			
C 96	ECU-X1H220JCN	22PF	000-118-353			
C 97	ECU-X1H103K8G	0.01UF 50V	000-119-283			

UNIT	TRANSCEIVER UNIT	REF. DWG.	E5548-K03-A	BLOCK NO	1B16	20
SYMBOL	T Y P E	SPECIFICATIONS	CODE NO	REMARKS		
記号	型名	規格	コード番号	備考		
CAPACITOR コンデンサ						
C 98	ECU-X1H102K8M	1000PF 50V	000-114-489			
C 99	ECU-X1H101CCN	1PF 50V	000-114-493			
C 100	ECU-X1H102K8M	1000PF 50V	000-114-489			
C 101	ECU-X1E104ZFG	0.1UF	000-119-373			
C 102	ECE-A1EU100E	10UF 25V	000-201-812			
C 103	ECE-A1CU101E	100UF 16V	000-206-112			
C 104	ECU-X1E104ZFG	0.1UF	000-119-373			
C 105	ECU-X1H102K8M	1000PF 50V	000-114-489			
C 106	ECU-X1H103K8G	0.01UF 50V	000-119-283			
C 107	ECU-X1H102K8M	1000PF 50V	000-114-489			
C 108	ECU-X1H102K8M	1000PF 50V	000-114-489			
C 109	ECE-A1EU100E	10UF 25V	000-201-812			
C 110	ECU-X1H103K8G	0.01UF 50V	000-119-283			
C 111	ECU-X1H102K8M	1000PF 50V	000-114-489			
C 112	ECC-F1H150JV	15PF	000-255-260			
C 113	ECU-X1H102K8M	1000PF 50V	000-114-489			
C 114	ECC-F1H150JV	15PF	000-255-260			
C 115	ECU-X1H030CCN	3PF 50V	000-115-046			
C 116	ECC-F1H150JV	15PF	000-255-260			
C 117	TZ03N100FR	10PF 50V	000-113-366			
C 118	ECU-X1H180JCN	18PF	000-119-345			
C 119	ECU-X1H103K8G	0.01UF 50V	000-119-283			
C 120	ECU-X1H050CCN	5PF 50V	000-119-375			
C 121	ECU-X1H270JCG	27PF	000-119-365			
C 122	ECU-X1H103K8G	0.01UF 50V	000-119-283			
C 123	ECU-X1H102K8M	1000PF 50V	000-114-489			
C 124	ECU-X1H100DCN	10PF	000-119-335			
C 125	ECU-X1H103K8G	0.01UF 50V	000-119-283			
C 126	ECU-X1H103K8G	0.01UF 50V	000-119-283			
C 127	ECU-X1H103K8G	0.01UF 50V	000-119-283			
C 128	ECU-X1H102K8M	1000PF 50V	000-114-489			
C 129	ECU-X1H103K8G	0.01UF 50V	000-119-283			
C 130	ECU-X1H102K8M	1000PF 50V	000-114-489			
C 131	ECU-X1H102K8M	1000PF 50V	000-114-489			
C 132	ECU-X1H102K8M	1000PF 50V	000-114-489			
C 133	ECU-X1H103K8G	0.01UF 50V	000-119-283			
C 134	ECU-X1H102K8M	1000PF 50V	000-114-489			
C 135	ECU-X1H103K8G	0.01UF 50V	000-119-283			
C 136	ECU-X1H102K8M	1000PF 50V	000-114-489			
C 137	ECU-X1H103K8G	0.01UF 50V	000-119-283			
C 138	ECU-X1H103K8G	0.01UF 50V	000-119-283			
C 139	ECE-A1HU010E	1UF 50V	000-206-115			
C 140	ECU-X1H102K8M	1000PF 50V	000-114-489			
C 141	ECE-A1AU471	470UF 10V	000-201-704			
DIODE ダイオード						
CR 1	1SV68	VARI.CAP.	000-114-120			
CR 2	1SS135		000-108-075			
CR 3	1SS135		000-108-075			
CR 4	1SS135		000-108-075			

UNIT	TRANSCEIVER UNIT	REF. DWG.	E5548-K03-A	BLOCK NO	1B16	21
SYMBOL	T Y P E	SPECIFICATIONS	CODE NO	REMARKS		
記号	型名	規格	コード番号	備考		
DIODE ダイオード						
CR 5	1SS135		000-108-075			
CR 6	1SV68	VARI.CAP.	000-114-120			
CR 7	1SV68	VARI.CAP.	000-114-120			
CR 8	1SV68	VARI.CAP.	000-114-120			
CR 9	1SV68	VARI.CAP.	000-114-120			
CR 10	1SS133		000-103-097			
CR 11	1SS133		000-103-097			
CR 12	1SV68	VARI.CAP.	000-114-120			
FILTER フィルタ						
FL 1	50M14A 50.01MHZ	05S0399-1	000-113-374			
FL 2	SFE4.5MB 4.5MHZ	05S0404-0	000-113-375			
JACK ジャック						
J 1	TMP-J01X-V6	05S0455	000-509-859			
J 2	TMP-J01X-V6	05S0455	000-509-859			
J 3	TMP-J01X-V6	05S0455	000-509-859			
COIL コイル						
L 1	LAL02NA100K	10UH	000-116-372			
L 2	LAL02NA100K	10UH	000-116-372			
L 3	LAL02NA100K	10UH				

UNIT	TRANSCEIVER UNIT	REF. DWG.	E5548-K03-A	BLOCK NO.	1B16	22
SYMBOL	T Y P E	SPECIFICATIONS		CODE NO.	REMARKS	
記号	型名	規格	格	コード番号	備考	
TRANSISTOR トランジスタ						
Q 13	2SC249B			000-126-200		
Q 14	2SK241-GR			000-110-986		
Q 15	2SK241-GR			000-110-986		
Q 16	2SK192A-GR			000-129-375		
Q 17	2SK192A-GR			000-129-375		
RESISTOR 抵抗						
R 1	ERJ-6GMYJ102	0.06W	1K	000-117-155		
R 2	ERJ-6GMYJ472	0.06W	4.7K	000-117-178		
R 3	ERJ-6GMYJ102	0.06W	1K	000-117-155		
R 4	ERJ-6GMYJ473	0.06W	47K	000-117-179		
R 5	ERJ-6GMYJ101	0.06W	100	000-117-154		
R 6	ERJ-6GMYJ101	0.06W	100	000-117-154		
R 7	ERJ-6GMYJ472	0.06W	4.7K	000-117-178		
R 8	ERJ-6GMYJ102	0.06W	1K	000-117-155		
R 9	ERJ-6GMYJ102	0.06W	1K	000-117-155		
R 10	ERJ-6GMYJ102	0.06W	1K	000-117-155		
R 11	ERJ-6GMYJ221	0.06W	220	000-117-166		
R 12	ERJ-6GMYJ101	0.06W	100	000-117-154		
R 13	ERX-1SJ4R7P	4.7,1W		000-375-379		
R 14	ERJ-6GMYJ222	0.06W	2.2K	000-117-167		
R 15	ERJ-6GMYJ222	0.06W	2.2K	000-117-167		
R 16	ERJ-6GMYJ184	0.06W	180K	000-118-366		
R 17	ERJ-6GMYJ682	0.06W	6.8K	000-118-418		
R 18	ERJ-6GMYJ682	0.06W	6.8K	000-118-418		
R 19	ERJ-6GMYJ680	0.06W	68	000-119-357		
R 20	EXB-F5E472J	0.125W	4.7KX4	000-379-073		
R 21	ERJ-6GMYJ152	1.5K		000-117-161		
R 22	ERJ-6GMYJ473	0.06W	47K	000-117-179		
R 23	ERJ-6GMYJ101	0.06W	100	000-117-154		
R 24	ERJ-6GMYJ102	0.06W	1K	000-117-155		
R 25	ERJ-6GMYJ101	0.06W	100	000-117-154		
R 26	ERJ-6GMYJ223	0.06W	22K	000-117-168		
R 27	ERJ-6GMYJ103	0.06W	10K	000-117-157		
R 28	ERJ-6GMYJ472	0.06W	4.7K	000-117-178		
R 29	ERJ-6GMYJ221	0.06W	220	000-117-166		
R 30	ERJ-6GMYJ101	0.06W	100	000-117-154		
R 31	ERJ-6GMYJ101	0.06W	100	000-117-154		
R 32	ERJ-6GMYJ101	0.06W	100	000-117-154		
R 33	ERJ-6GMYJ221	0.06W	220	000-117-166		
R 34	ERJ-6GMYJ102	0.06W	1K	000-117-155		
R 35	ERJ-6GMYJ102	0.06W	1K	000-117-155		
R 36	ERJ-6GMYJ102	0.06W	1K	000-117-155		
R 37	ERJ-6GMYJ471	0.06W	470	000-117-177		
R 38	ERJ-6GMYJ332	0.06W	3.3K	000-117-173		
R 39	ERJ-6GMYJ221	0.06W	220	000-117-166		
R 40	ERJ-6GMYJ102	0.06W	1K	000-117-155		
R 41	ERJ-6GMYJ102	0.06W	1K	000-117-155		
R 42	ERJ-6GMYJ221	0.06W	220	000-117-166		
R 43	ERJ-6GMYJ470	0.06W	47	000-117-176		
R 44	ERJ-6GMYJ101	0.06W	100	000-117-154		

UNIT	TRANSCEIVER UNIT	REF. DWG.	E5548-K03-A	BLOCK NO.	1B16	24
SYMBOL	T Y P E	SPECIFICATIONS		CODE NO.	REMARKS	
記号	型名	規格	格	コード番号	備考	
RESISTOR 抵抗						
R 97	ERJ-6GMYJ821	0.06W	820	000-117-185		
THERMISTOR 熱電素子						
RT 1	D-22A			000-180-617		
RT 2	PTH507B01BM500N016	0.5S0403-0		000-113-377		
TRANSFORMER トランス						
T 1	5T477	0.5S0421-0		000-113-367		
T 2	5T499A	0.5S0418-1		000-113-368		
T 3	5T499A	0.5S0418-1		000-113-368		
T 4	5T475A	0.5S0419-1		000-113-369		
T 5	5T477	0.5S0421-0		000-113-367		
T 6	5T478	0.5S0422-0		000-113-370		
T 7	5T479	0.5S0423-0		000-113-371		
T 8	5T480	0.5S0424-0		000-113-372		
T 9	5T460	0.5S0355-0		000-109-054		
T 10	5T475A	0.5S0419-1		000-113-369		
T 11	5T475A	0.5S0419-1		000-113-369		
T 12	5T475A	0.5S0419-1		000-113-369		
T 13	5T513	0.5S0425-0		000-113-373		
T 14	5T477	0.5S0421-0		000-113-367		
T 15	5T394	0.5S4394-0		000-107-604		
INTEGRATED CIRCUIT シリコンIC						
U 1	M54927P			000-113-378		
U 2	M54459L			000-150-912		
U 3	UPC1037H			000-113-379		
U 4	M54927P			000-113-378		
U 5	M54927P			000-113-380		
U 6	UPC1037H			000-113-379		
U 7	NJM2904D			000-113-434		
U 8	UPC1037H			000-113-379		
U 9	HD10551			000-162-270		
U 10	M54927P			000-113-378		
U 11	M54459L			000-150-912		
POTENTIOMETER *ポテンシオメータ						
VR 1	H212A-1L	ZENER		000-113-383		
VR 2	H26A2L			000-133-227		
CRYSTAL クリスタル						
Y 1		49.5MHZ	0.5S0593-0	000-116-695		

UNIT	TRANSCEIVER UNIT	REF. DWG.	E5548-K03-A	BLOCK NO.	1B16	23
SYMBOL	T Y P E	SPECIFICATIONS		CODE NO.	REMARKS	
記号	型名	規格	格	コード番号	備考	
RESISTOR 抵抗						
R 45	ERJ-6GMYJ472	0.06W	4.7K	000-117-178		
R 46	ERJ-6GMYJ103	0.06W	10K	000-117-157		
R 47	ERJ-6GMYJ221	0.06W	220	000-117-166		
R 48	ERJ-6GMYJ471	0.06W	470	000-117-177		
R 49	ERJ-6GMYJ152	1.5K		000-117-161		
R 50	ERJ-6GMYJ681	680		000-118-463		
R 51	ERJ-6GMYJ222	0.06W	2.2K	000-117-167		
R 52	ERJ-6GMYJ101	0.06W	100	000-117-154		
R 53	ERJ-6GMYJ680	0.06W	68	000-119-357		
R 55	ERJ-6GMYJ472	0.06W	4.7K	000-117-178		
R 56	ERJ-6GMYJ272	0.06W	2.7K	000-118-431		
R 57	ERJ-6GMYJ332	0.06W	3.3K	000-117-173		
R 58	ERJ-6GMYJ103	0.06W	10K	000-117-157		
R 59	ERJ-6GMYJ103	0.06W	10K	000-117-157		
R 60	ERJ-6GMYJ821	0.06W	820	000-117-185		
R 61	ERJ-6GMYJ473	0.06W	47K	000-117-179		
R 62	ERJ-6GMYJ101	0.06W	100	000-117-154		
R 63	ERJ-6GMYJ473	0.06W	47K	000-117-179		
R 64	ERJ-6GMYJ221	0.06W	220	000-117-166		
R 65	ERJ-6GMYJ471	0.06W	470	000-117-177		
R 66	ERJ-6GMYJ221	0.06W	220	000-117-166		
R 67	ERJ-6GMYJ101	0.06W	100	000-117-154		
R 68	ERJ-6GMYJ680	0.06W	68	000-119-357		
R 69	ERJ-6GMYJ101	0.06W	100	000-117-154		
R 70	ERJ-6GMYJ221	0.06W	220	000-117-166		
R 71	ERJ-6GMYJ470	0.06W	47	000-117-176		
R 72	ERJ-6GMYJ470	0.06W	47	000-117-176		
R 73	ERJ-6GMYJ150	15		000-118-330		
R 74	ERJ-6GMYJ152	1.5K		000-117-161		
R 75	ERJ-6GMYJ102	0.06W	1K	000-117-155		
R 76	ERJ-6GMYJ102	0.06W	1K	000-117-155		
R 77	ERJ-6GMYJ473	0.06W	47K	000-117-179		
R 78	ERJ-6GMYJ221	0.06W	220	000-117-166		
R 79	ERJ-6GMYJ101	0.06W	100	000-117-154		
R 80	ERJ-6GMYJ103	0.06W	10K	000-117-157		
R 81	ERJ-6GMYJ102	0.06W	1K	000-117-155		
R 82	ERJ-6GMYJ102	0.06W	1K	000-117-155		
R 83	ERJ-6GMYJ102	0.06W	1K	000-117-155		
R 84	ERJ-6GMYJ473	0.06W	47K	000-117-179		
R 85	ERJ-6GMYJ101	0.06W	100	000-117-154		
R 86	ERJ-6GMYJ472	0.06W	4.7K	000-117-178		
R 87	ERJ-6GMYJ222	0.06W	2.2K	000-117-167		
R 88	ERJ-6GMYJ560	56		000-117-182		
R 89	ERJ-6GMYJ101	0.06W	100	000-117-154		
R 90	ERJ-6GMYJ101	0.06W	100	000-117-154		
R 91	ERJ-6GMYJ101	0.06W	100	000-117-154		
R 92	ERJ-6GMYJ332	0.06W	3.3K	000-117-173		
R 93	ERJ-6GMYJ472	0.06W	4.7K	000-117-178		
R 94	ERJ-6GMYJ102	0.06W	1K	000-117-155		
R 95	ERJ-6GMYJ471	0.06W	470	000-117-177		
R 96	ERJ-6GMYJ222	0.06W	2.2K	000-117-167		

UNIT	TRANSCEIVER UNIT	REF. DWG.	E5548-K06-A	BLOCK NO.	1B03	25
SYMBOL	T Y P E	SPECIFICATIONS		CODE NO.	REMARKS	
記号	型名	規格	格	コード番号	備考	
PRINTED CIRCUIT BOARD プリント基板						
	05P0449A TX FIL			005-517-380		
CAPACITOR コンデンサ						
C 2	ECU-X1H103K8G	0.01UF	50V	000-119-283		
C 3	ECU-X1H103K8G	0.01UF	50V	000-119-283		
C 4	ECU-X1H103K8G	0.01UF	50V	000-119-283		
C 5	ECU-X1H103K8G	0.01UF	50V	000-119-283		
C 6	ECU-X1H103K8G	0.01UF	50V	000-119-283		
C 7	ECU-X1H103K8G	0.01UF	50V	000-119-283		
C 8	ECU-X1H103K8G	0.01UF	50V	000-119-283		
C 9	ECU-X1H103K8G	0.01UF	50V	000-119-283		
C 10	ECU-X1H103K8G	0.01UF	50V	000-119-283		
C 11	ECU-X1H103K8G	0.01UF	50V	000-119-283		
C 12	ECU-X1H103K8G	0.01UF	50V	000-119-283		
C 13	ECU-X1H103K8G	0.01UF	50V	000-		

UNIT	TRANSCEIVER UNIT	REF. DWG.	E554B-K06-A	BLOCK NO.	1B03	26
SYMBOL	T Y P E	SPECIFICATIONS	CODE NO.	REMARKS		
記号	型名	規格	コード番号	備考		
<b>CAPACITOR</b> コンデンサ						
C 48	ECU-X1H102KBN	1000PF 50V	000-114-489			
C 49	ECU-V1H224JZW	W5.0	000-124-666			
C 50	ECU-X1H103KB6	0.01UF 50V	000-119-283			
C 51	ECU-X1H103KB6	0.01UF 50V	000-119-283			
C 52	ECU-X1H103KB6	0.01UF 50V	000-119-283			
C 54	ECU-X1H103KB6	0.01UF 50V	000-119-283			
C 55	ECU-X1H103KB6	0.01UF 50V	000-119-283			
C 56	EXC-EMT103DC	FM-2520	000-107-994			
C 57	EXC-EMT103DC	FM-2520	000-107-994			
C 58	ECU-X1H102KBN	1000PF 50V	000-114-489			
C 59	ECU-X1H102KBN	1000PF 50V	000-114-489			
C 60	ECU-X1H102KBN	1000PF 50V	000-114-489			
C 61	ECU-X1H102KBN	1000PF 50V	000-114-489			
<b>DIODE</b> ダイオード						
CR 1	1SS82		000-114-021			
CR 2	1SS82		000-114-021			
CR 3	1SS82		000-114-021			
CR 4	1SS133		000-103-097			
CR 5	1SS133		000-103-097			
CR 6	1SS82		000-114-021			
CR 7	1SS82		000-114-021			
CR 8	1SS82		000-114-021			
CR 9	1SS82		000-114-021			
CR 10	1SS82		000-114-021			
CR 11	1SS82		000-114-021			
CR 12	1SS82		000-114-021			
<b>CARBON BRUSH</b> カーボン ブラシ						
E 1	Y08S-350B		000-123-645			
<b>JACK</b> ジャック						
J 1	B10B-PH-K		000-108-354			
J 2	TMP-J01X-V6	05S0455	000-509-859			
J 3	TMP-J01X-V6	05S0455	000-509-859			
J 4	TMP-J01X-V6	05S0455	000-509-859			
<b>RELAY</b> リレー						
K 1	G6B-1114P-US-AP-12V		000-114-405			
K 2	G6B-1114P-US-AP-12V		000-114-405			
K 3	G6B-1114P-US-AP-12V		000-114-405			
K 4	G6B-1114P-US-AP-12V		000-114-405			
K 5	G6B-1114P-US-AP-12V		000-114-405			
K 6	G6B-1114P-US-AP-12V		000-114-405			
K 7	G6B-1114P-US-AP-12V		000-114-405			
K 8	G6B-1114P-US-AP-12V		000-114-405			
K 9	G6B-1114P-US-AP-12V		000-114-405			
K 10	G6B-1114P-US-AP-12V		000-114-405			
K 11	G6B-1114P-US-AP-12V		000-114-405			

UNIT	TRANSCEIVER UNIT	REF. DWG.	E554B-K04-A	BLOCK NO.	1B07	28
SYMBOL	T Y P E	SPECIFICATIONS	CODE NO.	REMARKS		
記号	型名	規格	コード番号	備考		
<b>FRONT PANEL</b>						
<b>JACK</b> ジャック						
J 1	FM10RS(1)-6HA		000-113-456			
<b>LOUDSPEAKER</b> スピーカー						
LS 1	66P15N20 05S0450	FM-2510/2520	000-116-923			
<b>RESISTOR</b> リジスタ						
R 1	RK0971111(10KA)	05S0632-0	000-118-482			
R 2	RK09711100JOA(100KB)	05S0812-0	000-124-556			
<b>SWITCH</b> スイッチ						
S 1	SRBM1096A	05S0714	000-121-051			
<b>CABLE WITH CONNECTOR</b> コネクタ-ケーブル						
W 701	PH/SAN03-100	05S0753-0	000-124-667			
W 702	PH/SAN05-200-01	05S0809-0	000-124-668			
W 703	PH/SAN03-200-01	05S0810-0	000-124-669			
W 704	PH06S-300-01	05S0811-0	000-124-670			
W 705	PH02S-300	05S0752-0	000-124-671			

UNIT	TRANSCEIVER UNIT	REF. DWG.	E554B-K06-A	BLOCK NO.	1B03	27
SYMBOL	T Y P E	SPECIFICATIONS	CODE NO.	REMARKS		
記号	型名	規格	コード番号	備考		
<b>RELAY</b> リレー						
K 12	G6B-1114P-US-AP-12V		000-114-405			
K 13	G6B-2114P-US-AP-12V		000-114-406			
<b>TRANSISTOR</b> トランジスタ						
Q 1	UN4211		000-108-963			
<b>RESISTOR</b> リジスタ						
R 1	ERD-25PJ332	0.25W 3.3K	000-330-369			
R 2	ERG-25J680P	00S0102-0	000-375-460			
R 3	ERJ-66MYJ103	0.06W 10K	000-117-157			
R 4	ERJ-66MYJ103	0.06W 10K	000-117-157			
R 5	ERJ-66MYJ103	0.06W 10K	000-117-157			
R 7	ERJ-66MYJ103	0.06W 10K	000-117-157			
R 8	ERJ-66MYJ122	0.06W 1.2K	000-118-424			
R 9	ERJ-66MYJ103	0.06W 10K	000-117-157			
R 10	ERJ-66MYJ103	0.06W 10K	000-117-157			
R 11	ERJ-66MYJ474	Q2.0	000-119-797			
R 12	ERJ-66MYJ103	0.06W 10K	000-117-157			
R 13	ERJ-66MYJ103	0.06W 10K	000-117-157			
R 14	ERJ-66MYJ101	0.06W 100	000-117-154			
R 15	ERJ-66MYJ103	0.06W 10K	000-117-157			
R 16	ERJ-66MYJ103	0.06W 10K	000-117-157			
R 17	ERJ-66MYJ101	0.06W 100	000-117-154			
R 18	ERJ-66MYJ101	0.06W 100	000-117-154			
R 19	ERJ-66MYJ101	0.06W 100	000-117-154			
R 20	ERJ-66MYJ101	0.06W 100	000-117-154			
R 21	ERJ-66MYJ101	0.06W 100	000-117-154			
R 22	ERJ-66MYJ101	0.06W 100	000-117-154			
R 23	ERJ-66MYJ101	0.06W 100	000-117-154			
R 24	ERJ-66MYJ101	0.06W 100	000-117-154			
R 25	ERJ-66MYJ101	0.06W 100	000-117-154			
R 26	ERJ-66MYJ101	0.06W 100	000-117-154			
R 27	ERJ-66MYJ101	0.06W 100	000-117-154			
R 28	EXB-F9E472J	0.125W 4.7K	000-100-758			
<b>INTEGRATED CIRCUIT</b> システムIC						
U 1	NJM2904D		000-113-434			
U 2	M54972P		000-113-380			
U 3	TD62787AP		000-127-394			

**FURUNO**ELECTRICAL PARTS LIST  
電気部品表

1992-9

MODEL	AT-1502		
UNIT	ANTENNA COUPLER UNIT アンテナカプラー		PAGE
REF. DWG.	E5548-K05-A	BLOCK NO.	2B01
			34

SYMBOL	T Y P E	SPECIFICATIONS	CODE NO.	REMARKS
記号	型名	規格	コード番号	備考
PRINTED CIRCUIT BOARD		プリント基板		
	05P-0278B COUP	FS-1502/P	005-517-080	
CAPACITOR		コンデンサー		
C 1	DM19C122K5	1200PF, 500V	000-222-448	
C 2	DM19C122K5	1200PF, 500V	000-222-448	
C 3	DM19C122K5	1200PF, 500V	000-222-448	
C 4	DM19C122K5	1200PF, 500V	000-222-448	
C 5	DM19C122K5	1200PF, 500V	000-222-448	
C 6	DE1207SL151J3KV	150PF 3KV	000-106-212	
C 7	DE1207SL151J3KV	150PF 3KV	000-106-212	
C 8	DE1207SL151J3KV	150PF 3KV	000-106-212	
C 9	DE1207SL151J3KV	150PF 3KV	000-106-212	
C 10	DE1207SL151J3KV	150PF 3KV	000-106-212	
C 11	DE0907SL820J3KV	82PF 3KV	000-106-211	
C 12	DE0907SL820J3KV	82PF 3KV	000-106-211	
C 13	DE0807SL680J3KV	68PF 3KV	000-113-482	
C 14	DE0807SL680J3KV	68PF 3KV	000-113-482	
C 15	DE0807SL680J3KV	68PF 3KV	000-113-482	
C 16	DE1510SL151J6KV	150PF 6KV	000-113-483	
C 17	DE1510SL151J6KV	150PF 6KV	000-113-483	
C 18	DE1510SL151J6KV	150PF 6KV	000-113-483	
C 19	DD109E103P50V	0.01UF 50V	000-253-436	
C 20	ECQ-V1H104JZ	0.1UF 50V	000-261-524	
C 21	DD109E103P50V	0.01UF 50V	000-253-436	
C 22	DD109E103P50V	0.01UF 50V	000-253-436	
C 23	ECC-F1H150JC	15PF 50V	000-256-902	
C 24	RPE132CH331J50	330PF 50V	000-105-389	
C 25	ECC-F1H150JC	15PF 50V	000-256-902	
C 26	RPE132CH331J50	330PF 50V	000-105-389	
C 27	DD109E103P50V	0.01UF 50V	000-253-436	
C 28	ECC-F1H120JC	12PF 50VDC	000-255-212	
C 29	DD109E103P50V	0.01UF 50V	000-253-436	
C 30	DD109E103P50V	0.01UF 50V	000-253-436	
C 31	DD109E103P50V	0.01UF 50V	000-253-436	
C 33	DD109E103P50V	0.01UF 50V	000-253-436	
C 34	DD109E103P50V	0.01UF 50V	000-253-436	
C 35	DD109E103P50V	0.01UF 50V	000-253-436	
C 36	DSS310-75D223S50V	04S4163-0	000-103-745	
C 41	DD306F104Z25	00S0130-0	000-108-968	
C 42	EEC-F5R5U105	1F 5.5V	000-113-484	
C 43	DSS310-75D223S50V	04S4163-0	000-103-745	
C 44	DSS310-75D223S50V	04S4163-0	000-103-745	
C 45	ECC-F1H470JC	47PF 50VDC	000-255-226	
C 46	DD109E103P50V	0.01UF 50V	000-253-436	



UNIT	ANTENNA	COUPLER	UNIT	REF. DWG.	E5548-K05-A	BLOCK NO.	2B01	39
SYMBOL	T Y P E	SPECIFICATIONS		CODE NO.		REMARKS		
記号	型名	規格		コード番号		備考		
RESISTOR 7139								
R 39	ERD-16TJ103	0.16W	10K	000-330-802				
R 40	ERD-16TJ103	0.16W	10K	000-330-802				
R 46	ERD-16TJ471	0.16W	470	000-329-029				
R 47	ERD-16TJ472	0.16W	4.7K	000-330-812				
R 48	ERD-16TJ472	0.16W	4.7K	000-330-812				
R 49	EXB-F5E103J	0.125W	10KX4	000-379-082				
R 50	EXB-F5E103J	0.125W	10KX4	000-379-082				
R 51	ERD-16TJ102	0.16W	1K	000-330-801				
R 52	ERD-16TJ101	0.16W	100	000-329-013				
R 53	ERD-16TJ472	0.16W	4.7K	000-330-812				
R 54	ERD-16TJ472	0.16W	4.7K	000-330-812				
R 55	ERD-16TJ273	0.16W	27K	000-330-811				
R 56	EXB-F9E103J	0.125W	10K	000-378-901				
R 57	ERD-16TJ101	0.16W	100	000-329-013				
R 58	ERD-16TJ102	0.16W	1K	000-330-801				
R 59	ERD-16TJ101	0.16W	100	000-329-013				
R 60	ERG-25J100P	2W	10	000-375-449				
R 61	ERD-16TJ103	0.16W	10K	000-330-802				
R 62	ERD-16TJ103	0.16W	10K	000-330-802				
R 63	ERD-25PJ220	0.25W	22	000-330-317				
R 64	ERD-25PJ220	0.25W	22	000-330-317				
R 65	ERD-25PJ220	0.25W	22	000-330-317				
R 66	ERD-25PJ220	0.25W	22	000-330-317				
R 67	ERD-25PJ220	0.25W	22	000-330-317				
R 68	ERD-25PJ220	0.25W	22	000-330-317				
R 69	ERD-25PJ220	0.25W	22	000-330-317				
R 70	ERD-25PJ220	0.25W	22	000-330-317				
R 71	ERD-25PJ220	0.25W	22	000-330-317				
R 72	ERD-16TJ220	0.16W	22	000-330-847				
R 73	ERD-16TJ220	0.16W	22	000-330-847				
R 74	ERD-16TJ220	0.16W	22	000-330-847				
R 75	ERD-16TJ220	0.16W	22	000-330-847				
R 76	ERD-16TJ220	0.16W	22	000-330-847				
R 77	ERD-16TJ220	0.16W	22	000-330-847				
R 78	ERD-16TJ220	0.16W	22	000-330-847				
R 79	ERD-16TJ220	0.16W	22	000-330-847				
R 80	ERD-16TJ220	0.16W	22	000-330-847				
R 81	ERD-16TJ220	0.16W	22	000-330-847				
R 82	ERD-16TJ220	0.16W	22	000-330-847				
R 83	ERD-16TJ220	0.16W	22	000-330-847				
R 84	ERD-16TJ472	0.16W	4.7K	000-330-812				
R 85	ERD-16TJ220	0.16W	22	000-330-847				
R 86	ERD-16TJ472	0.16W	4.7K	000-330-812				
R 87	ERD-16TJ102	0.16W	1K	000-330-801				
R 88	ERD-16TJ103	0.16W	10K	000-330-802				
R 89	ERD-16TJ562	0.16W	5.6K	000-329-050				
R 90	ERD-16TJ103	0.16W	10K	000-330-802				
R 91	ERD-16TJ562	0.16W	5.6K	000-329-050				
R 92	ERD-16TJ103	0.16W	10K	000-330-802				

UNIT	ANTENNA	COUPLER	UNIT	REF. DWG.	E5548-K05-A	BLOCK NO.	2B01	40
SYMBOL	T Y P E	SPECIFICATIONS		CODE NO.		REMARKS		
記号	型名	規格		コード番号		備考		
SWITCH 5177								
S 1	62T-14			000-106-104				
S 2	51D-0401			000-106-105				
TRANSFORMER 1528								
T 1	5T031	05S4031-0		000-732-581				
T 2	5T031	05S4031-0		000-732-581				
INTEGRATED CIRCUIT 5128*210								
U 1	TC74HC390AP			000-115-918				
U 2	UPD7001C			000-112-375				
U 3	TC74HC14AP			000-116-140				
U 4	M51953BL			000-108-052				
U 5	NJM7805A			000-113-448				
U 6	NJM2403D			000-113-480				
U 8	HD63B01Y0E76P	05S0522-0		000-114-315				
U 9	M54563P			000-106-228				
U 10	M54563P			000-106-228				
U 11	M54563P			000-106-228				
U 12	EXB-R88-472J			000-379-055				
U 13	EXB-R88-472J			000-379-055				
U 14	EXB-R87-472J			000-112-256				
POTENTIOMETER **703031-3-								
VR 1	H23HA2			000-127-174				
VR 2	05A23.3Z			000-111-882				
CRYSTAL 01286								
Y 1	05S0480-0	4MHZ	05S0480-0	000-113-486				



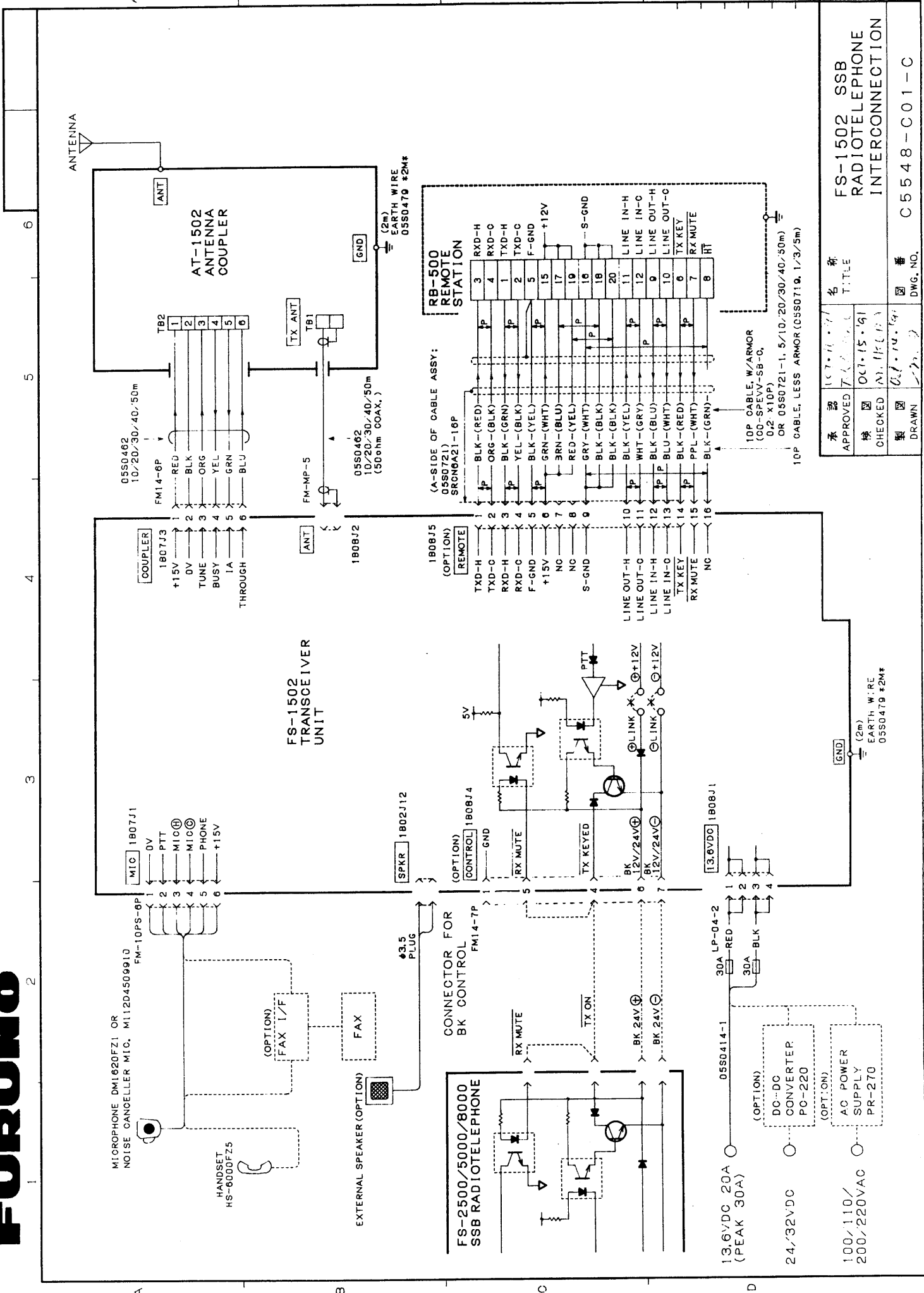

承認 APPROVED	名 稱 TITILE
検 査 CHECKED	製 図 DRAWN
製 図 DRAWN	製 図 DRAWN

承認 7/15/91  
 検 査 7/15/91  
 製 図 7/15/91

名 稱  
**FS-1502 SSB  
 RADIOTELEPHONE  
 INTERCONNECTION**

製 図  
 DWG. NO. **C5548-C01-C**

## FS-1502 SSB RADIOTELEPHONE

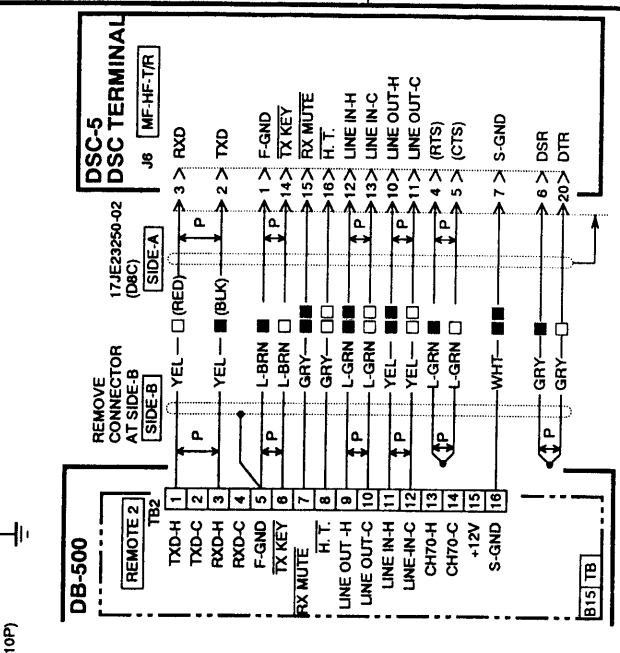
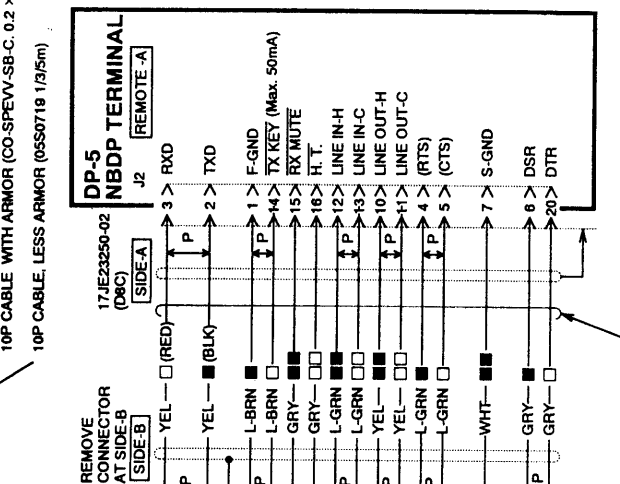
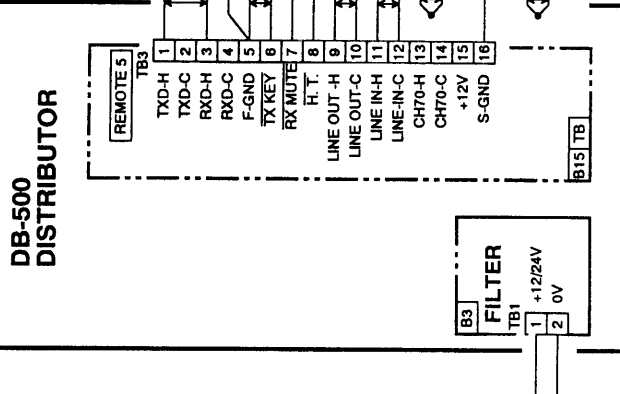
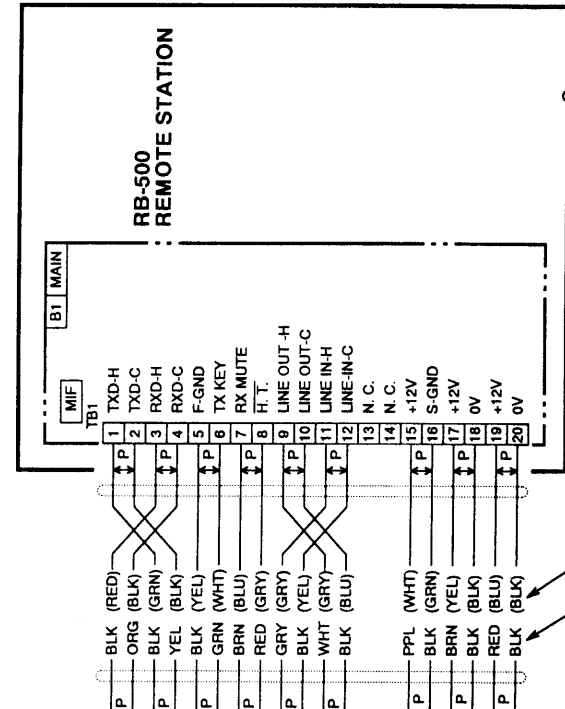
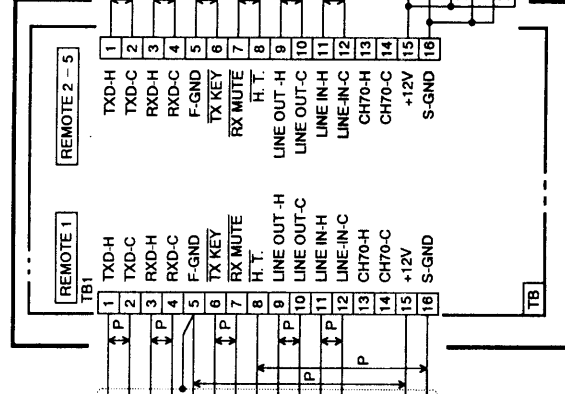
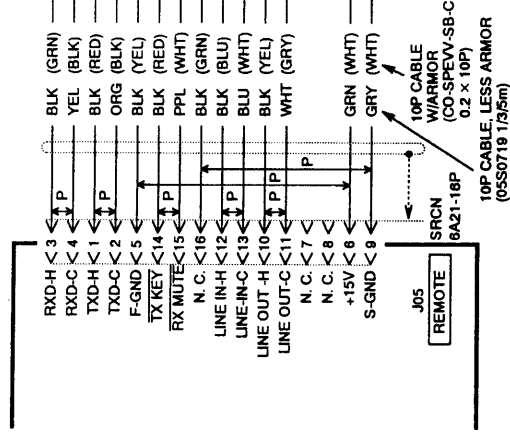

13P CABLE W/CONNECTORS  
(05S0783, 1/3/5m)

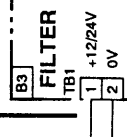

承認 APPROVED	名 稱 TITLE
検 査 CHECKED	FS-1502+DB-500 INTERCONNECTION DIAGRAM
製 図 DRAWN	図 番 DWG.NO
Aug. 25. '92 M. IKEDA	C5548-C02-B
Aug. 25. '92 M. ICHIKAWA	

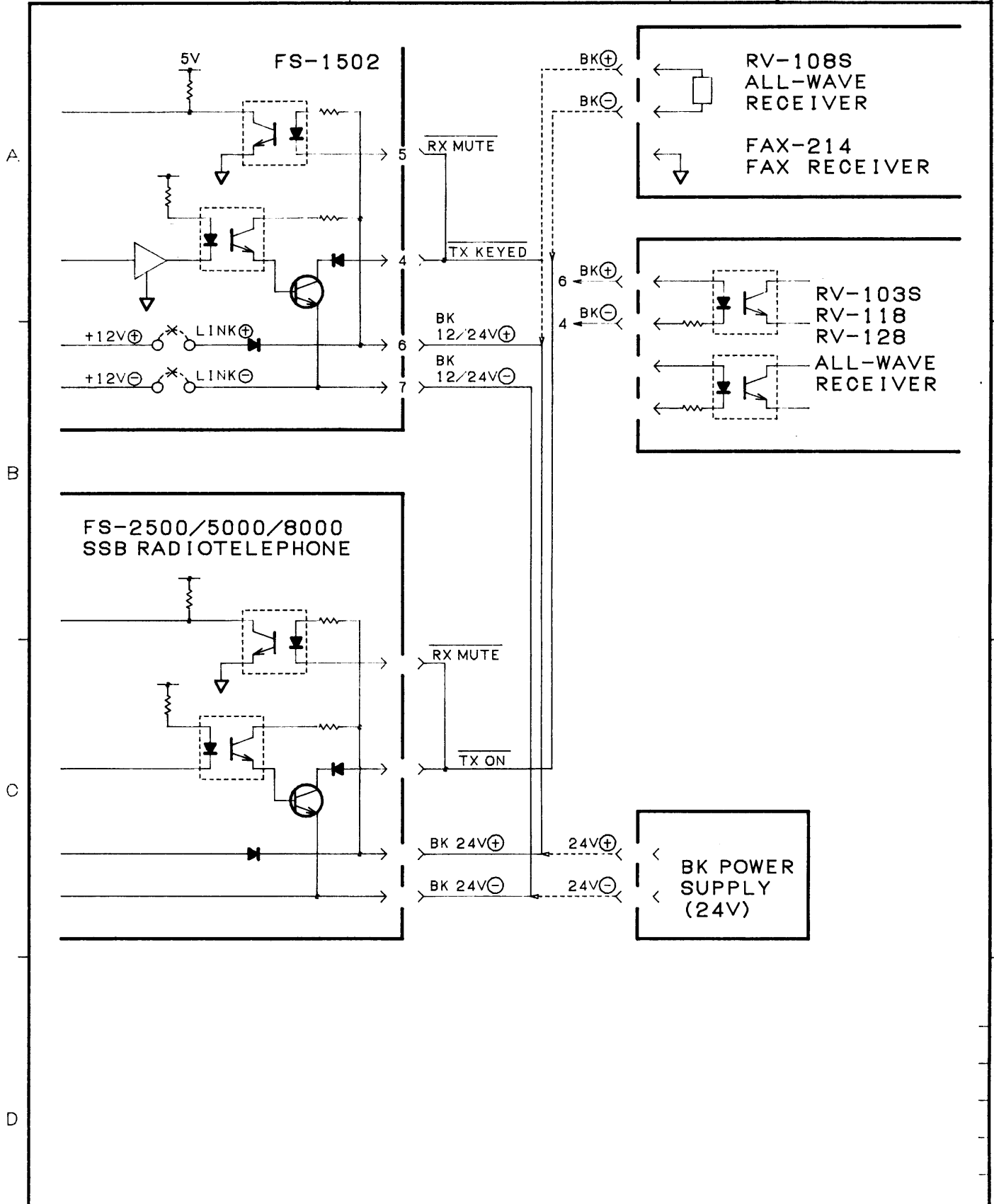

品番 ITEM	品名 NAME	材質 MATERIAL	数量 QTY	図番 DWG. NO.	摘要 REMARKS
承認 APPROVED	三角法 THIRD ANGLE PROJECTION	名称 TITLE EXAMPLES OF BK CONNECTION (FLOATING GROUND)			
検 CHECKED	尺度 SCALE				
製 DRAWN	重量 WEIGHT				

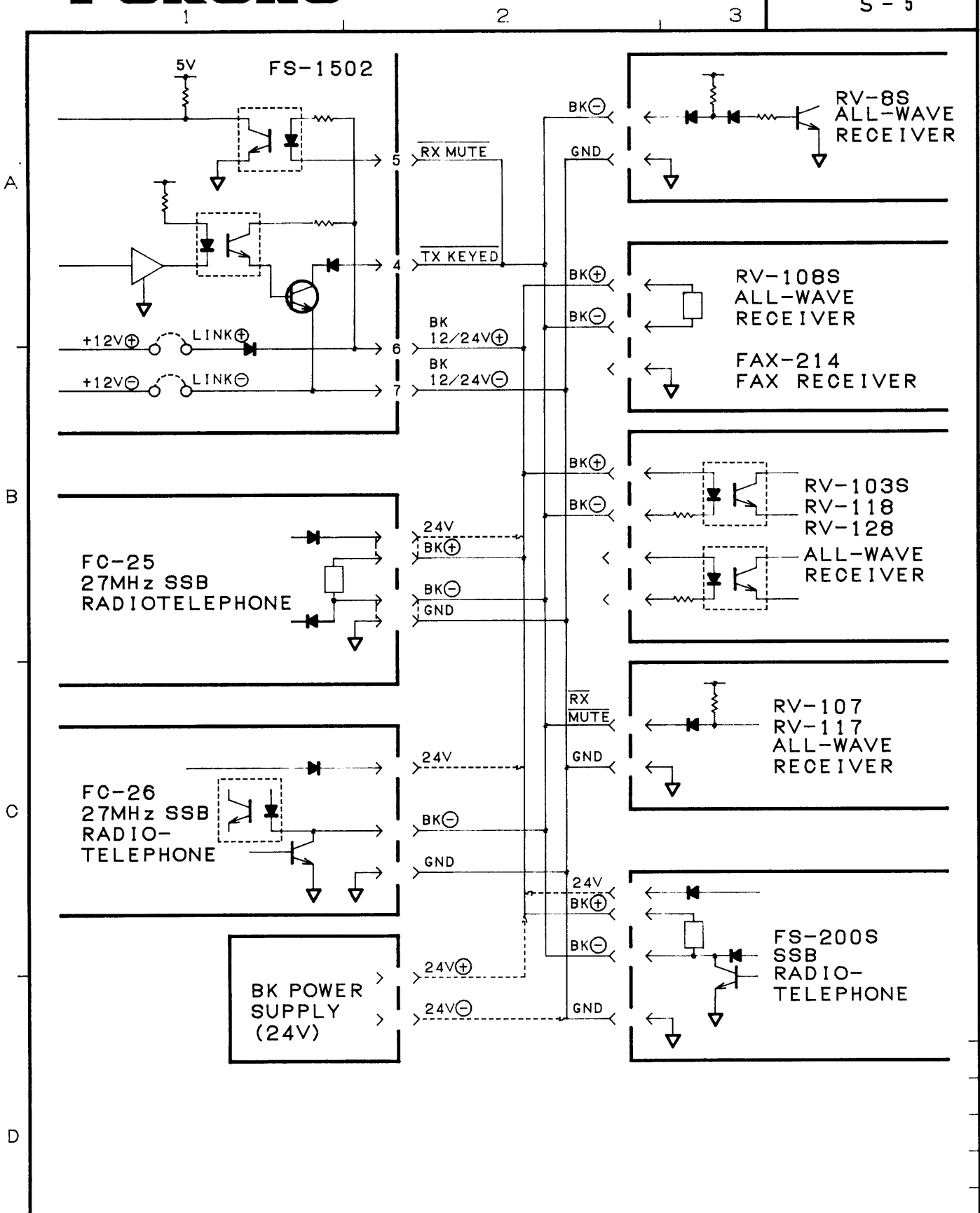

品番 ITEM	品名 NAME	材質 MATERIAL	数量 Q'TY	図番 DWG. NO.	摘要 REMARKS
------------	------------	----------------	------------	----------------	---------------

承認 APPROVED	Nov. 20 '91 T. LAYALC	三角法 THIRD ANGLE PROJECTION	名称 TITLE		
検 CHECKED	Nov. 20 '91 K. GOTO	尺度 SCALE	EXAMPLES OF BK CONNECTION (NEGATIVE GROUND)		
製 DRAWN	Nov. 20 '91 M. K. (12)	重量 WEIGHT	kg	図番 DWG. NO.	E5073-K02-A

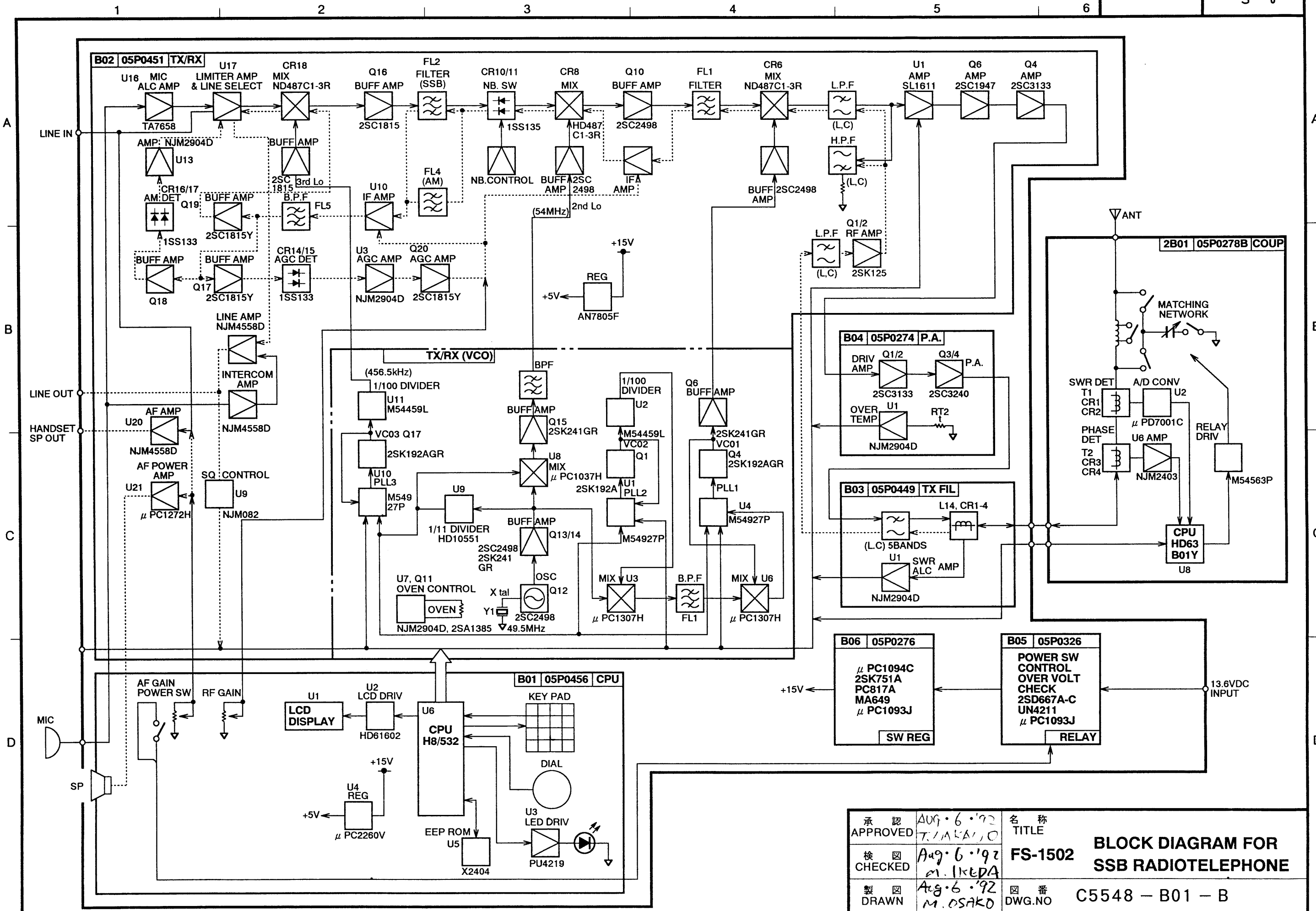

承認 APPROVED	AUG. 6 '92 T. IAKAJO	名称 TITLE	BLOCK DIAGRAM FOR SSB RADIOTELEPHONE
検 CHECKED	Aug. 6 '92 M. IkedA	図番 DWG. NO	
製 DRAWN	Aug. 6 '92 M. OSAKO	C5548 - B01 - B	

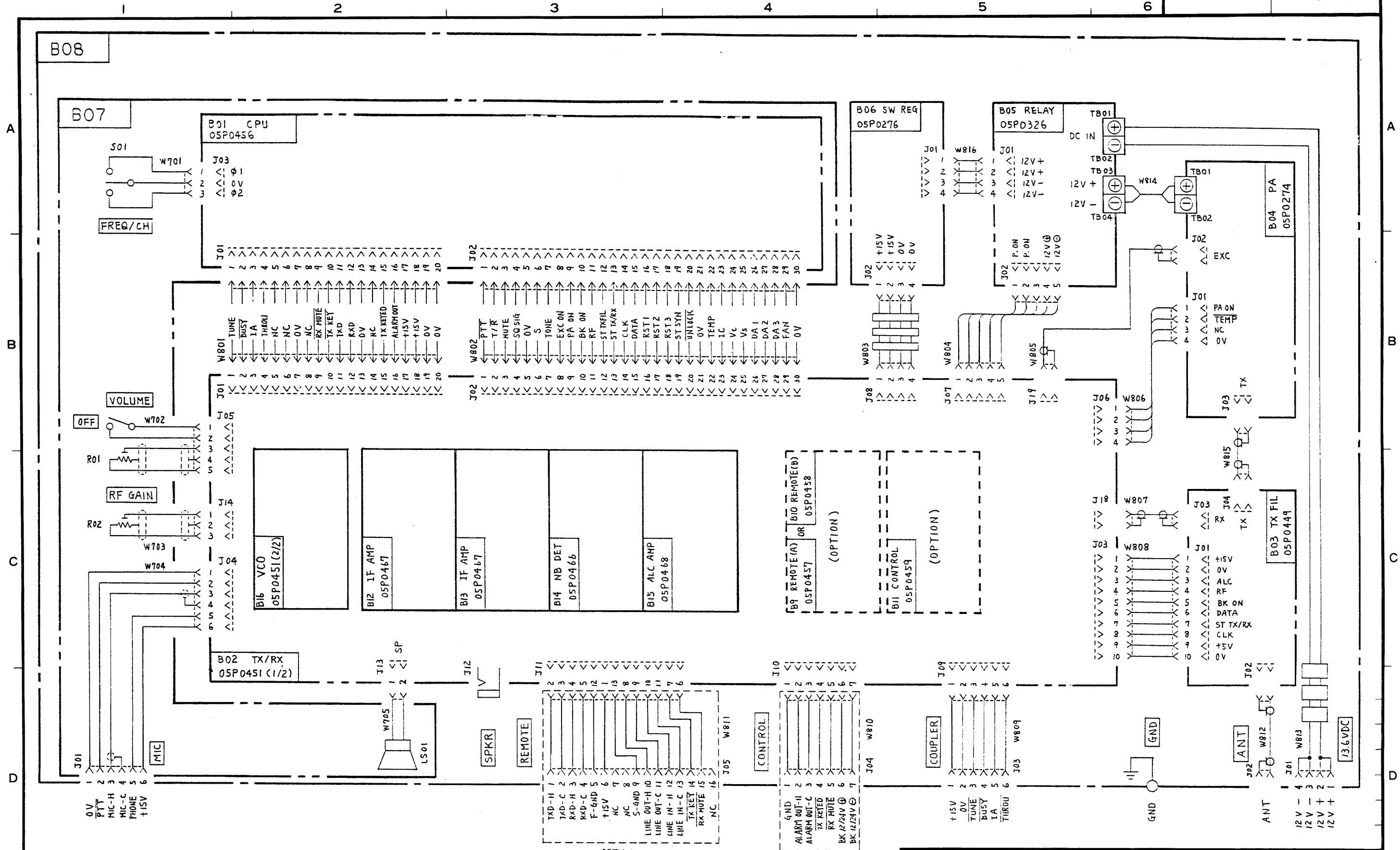

承認 APPROVED	KCV・22・91 T.IYAKAIO	名称 TITLE	SSB TRANSCEIVER GENERAL
検 CHECKED	Nov・20・91 M.IKEDA	番 NO.	FS-1502
製 DRAWN	Nov・20・91 Y.HAMANO	番 DWG.NO.	E5548-K04-A





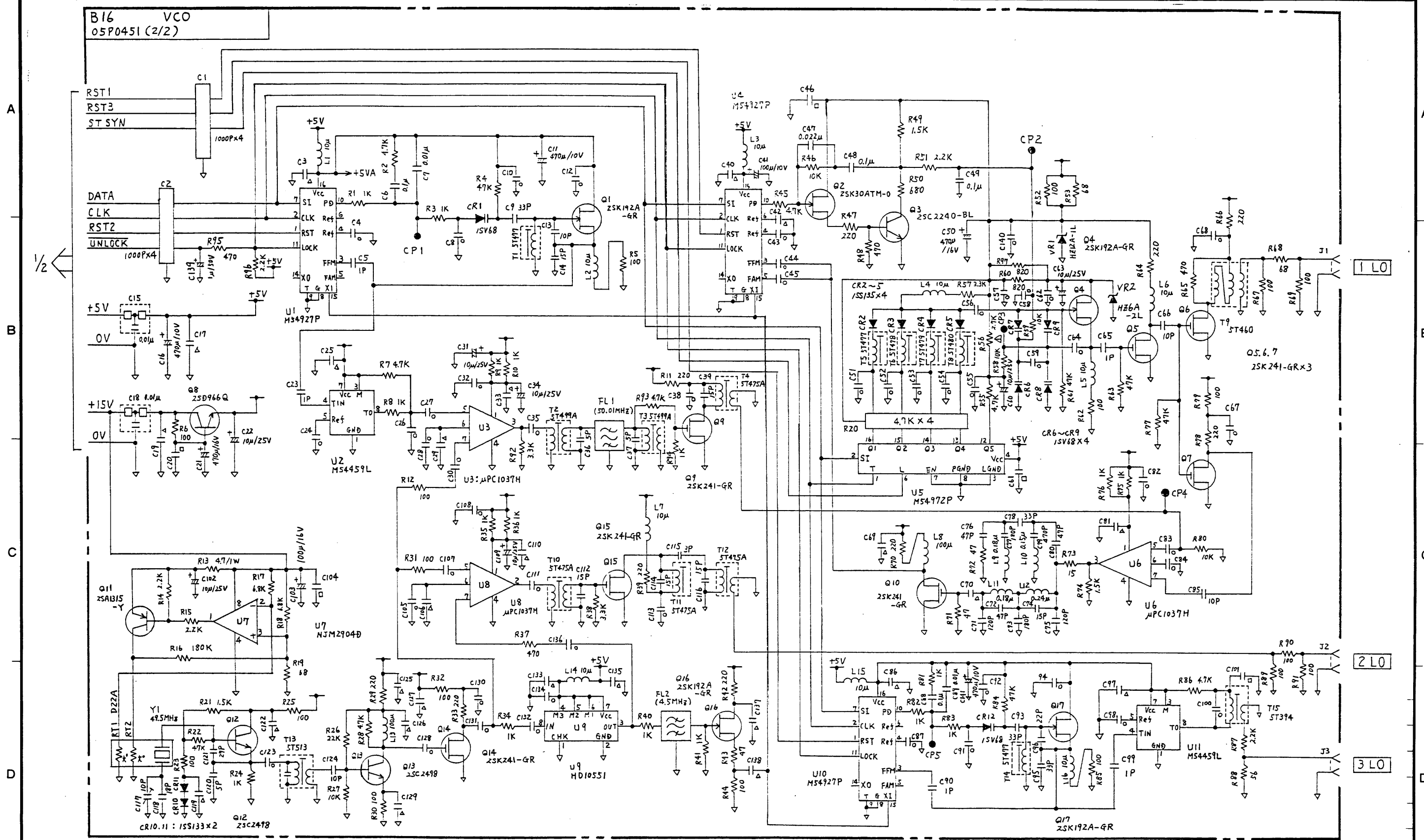

承認 APPROVED	NOV. 20 '91 T. UAKAJO	名称 TITLE	B16 05P0451 (2/2) VCO
検 CHECKED	NOV. 20 '91 M. IKEDA		
製 DRAWN	NOV. 20 '91 Y. H.	番 DWG. NO.	E5548-K03-A

FS-1501

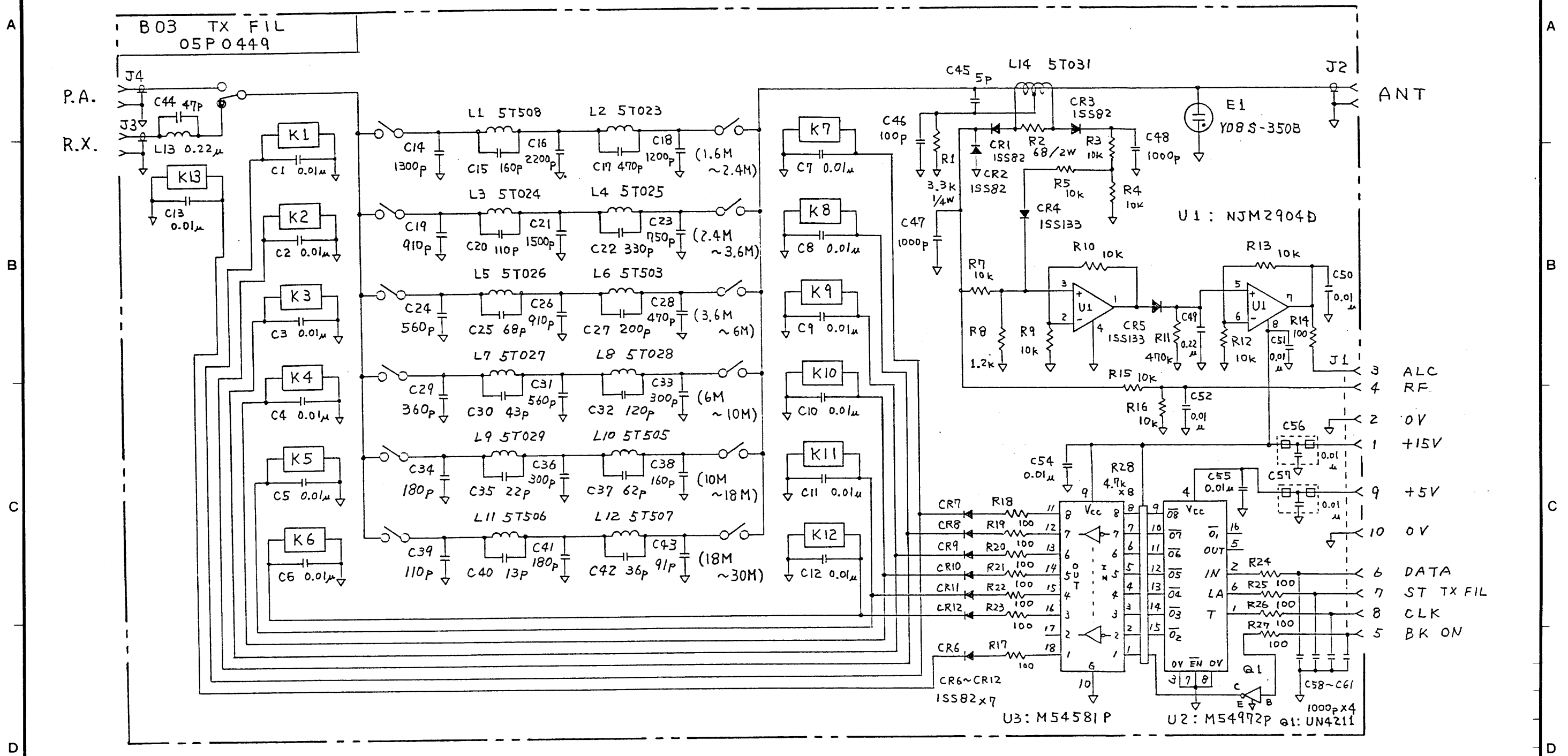

承認 APPROVED	ACU-20-91 T. UAKAWA	名称 TITLE	B03 05P0449 TX FIL
検 CHECKED	Nov-20-91 H. KUDA		
製 DRAWN	Nov-20-91 Y. HANAI	図番 DWG. NO.	E5548-K06-A

FS-1502

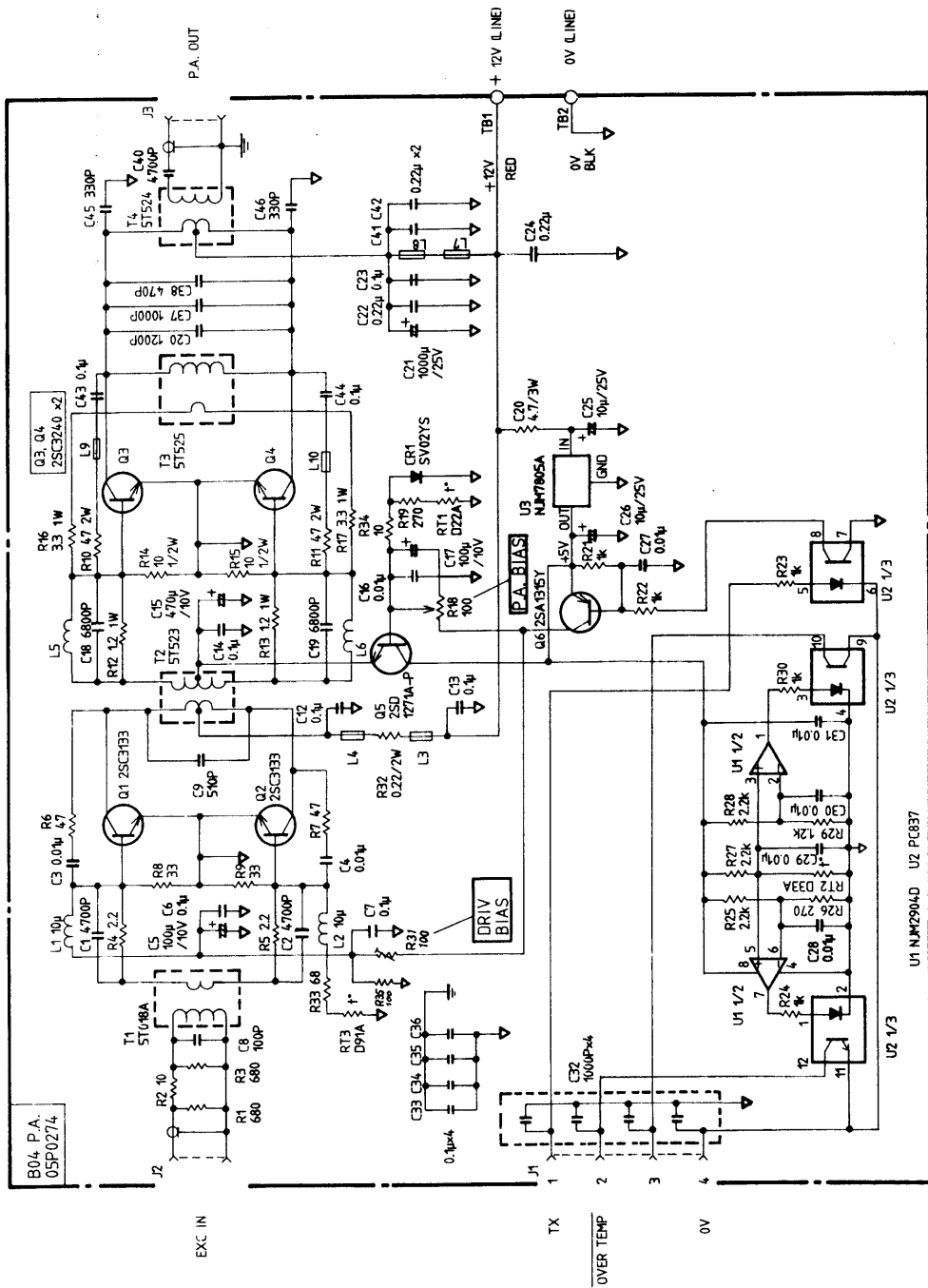

承認	名 稱
検 査	TITLE
製 図	B04 05P0274 P.A.
製 図	図 番
	DWG. NO. E5485-017-D

FS-1500 SERIES

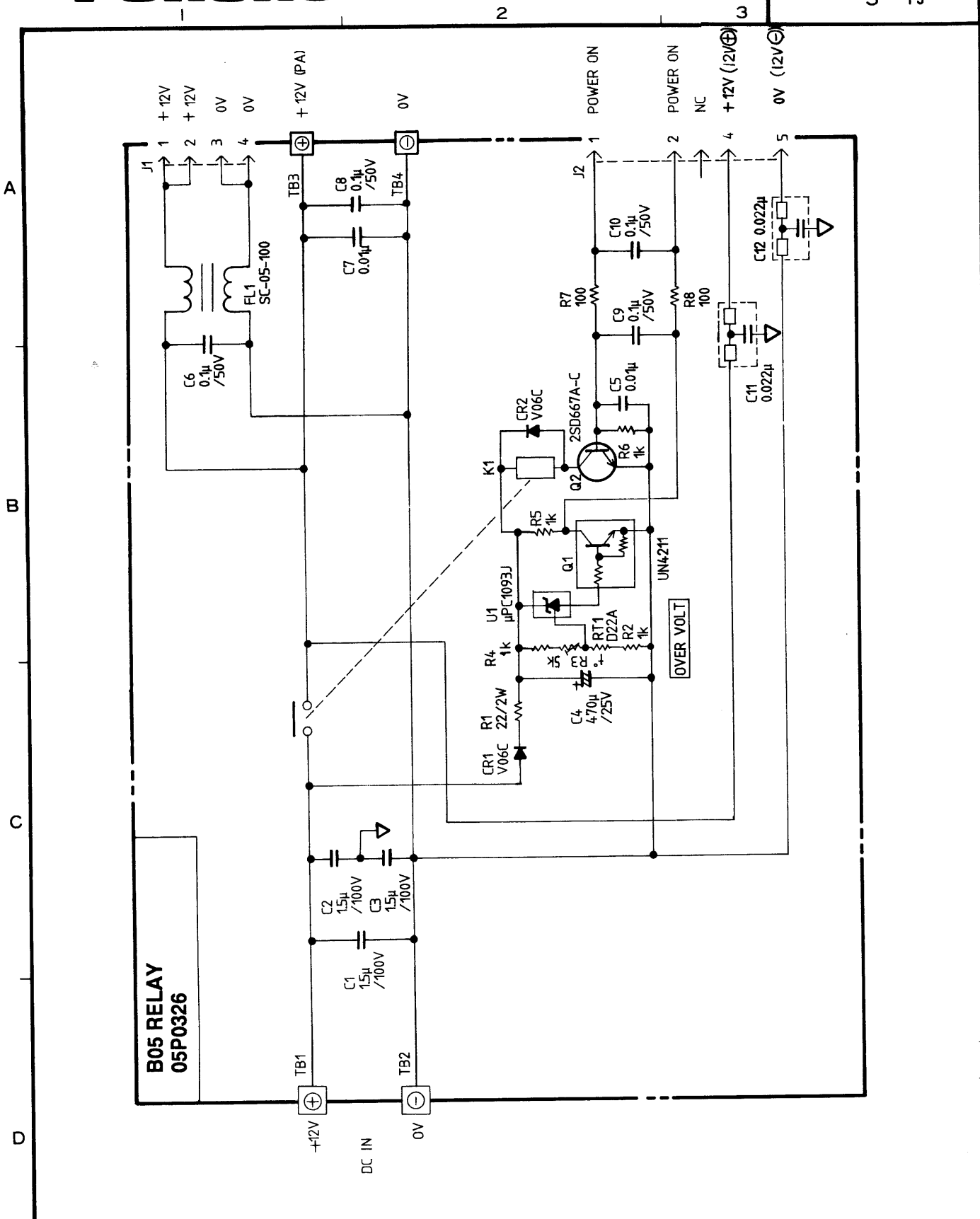

FS-1500 SERIES		品番 ITEM	品名 NAME	材質 MATERIAL	数量 Q'TY	図番 DWG.NO.	摘要 REMARKS
承認 APPROVED	MAY 31		三角法 THIRD ANGLE PROJECTION	名称 TITLE			
検 CHECKED	MAY 27 88		尺 SCALE	B05 05P0326 RELAY			
製 DRAWN	MAY 27 88		重 WEIGHT				





A

B

C

D

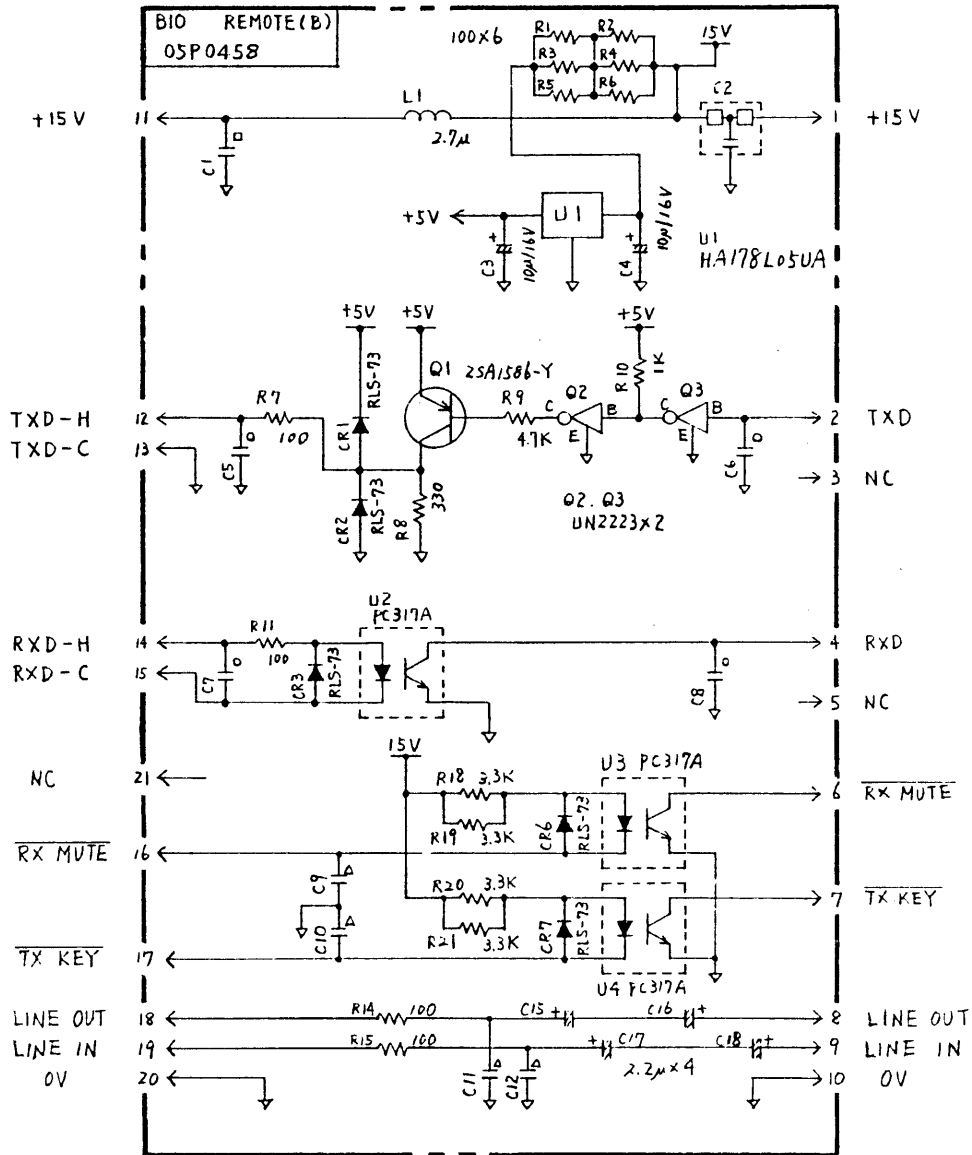

FS-1502

品番 ITEM	品名 NAME	材質 MATERIAL	數量 Q'TY	圖番 DWG.NO.	摘要 REMARKS
------------	------------	----------------	------------	---------------	---------------

承認 APPROVED	2002.09 T. IZUMI	三角法 THIRD ANGLE PROJECTION		名稱 TITLE B10 05P0458 REMOTE (B)	
檢 CHECKED	2002.09 M. IZUMI	尺 SCALE	/		
製 DRAWN	Y. IZUMI	重 WEIGHT	kg	圖番 DWG.NO.	E5548-K09-A

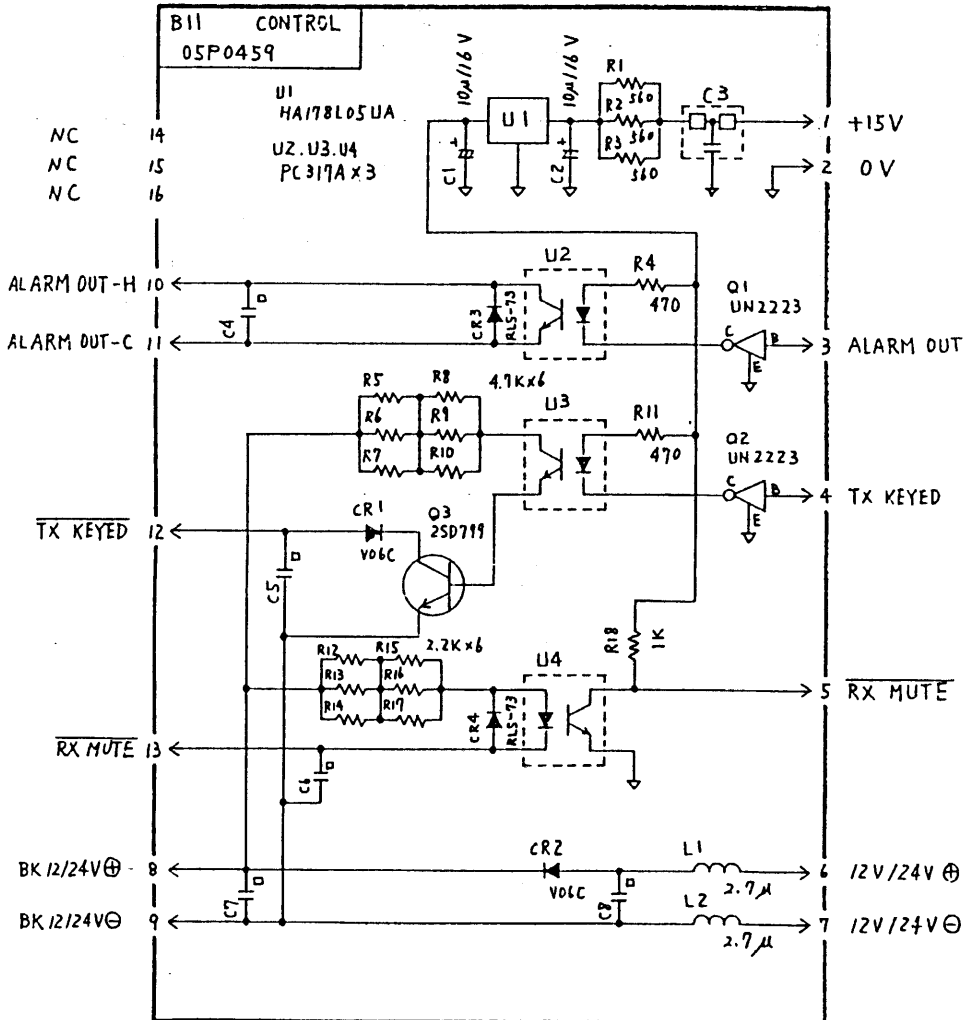

FS-1502

品番 ITEM	品名 NAME	材質 MATERIAL	数量 QTY	図番 DWG.NO.	摘要 REMARKS
------------	------------	----------------	-----------	---------------	---------------

承認 APPROVED		三角法 THIRD ANGLE PROJECTION		名称 TITLE	
検図 CHECKED	M. 20.91 M. IKEDA	尺度 SCALE	/	B11 05P0459 CONTROL	
製図 DRAWN	M. 20.91 Y. HARA	重量 WEIGHT	kg	図番 DWG.NO. E5548-K11-A	

A  
B  
C  
D

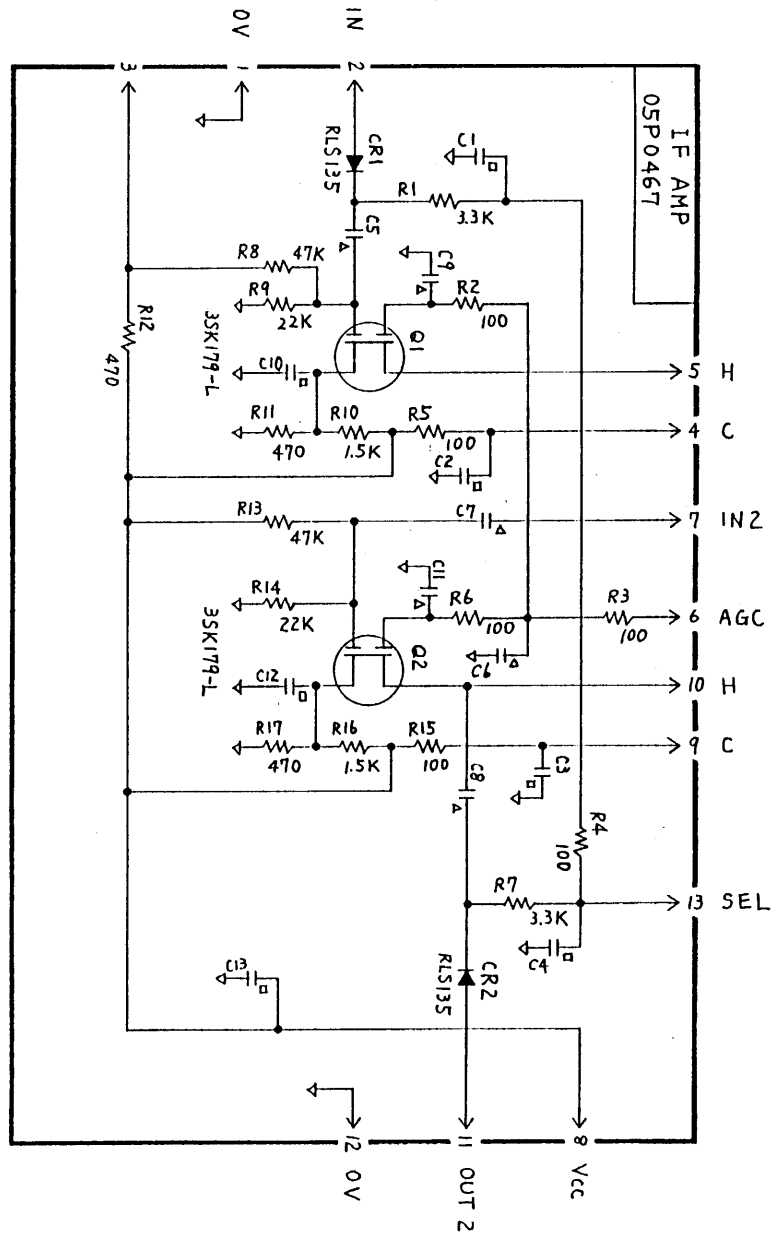

承認 APPROVED	品番 ITEM	品名 NAME	材質 MATERIAL	数量 Q'TY	図番 DWG.NO.	摘要 REMARKS
Nov. 22 '91 T. TAKAKU	FS-1502	三角法 THIRD ANGLE PROJECTION		B 12	05P0467	
檢 CHECKED	Nov. 20 '91 M. IKAEDA	尺 SCALE			IF AMP	
製 DRAWN	Nov. 20 '91 Y. IMAI	重 WEIGHT	kg	図番 DWG.NO.	E 5548-K07-A	

A  
B  
C  
D

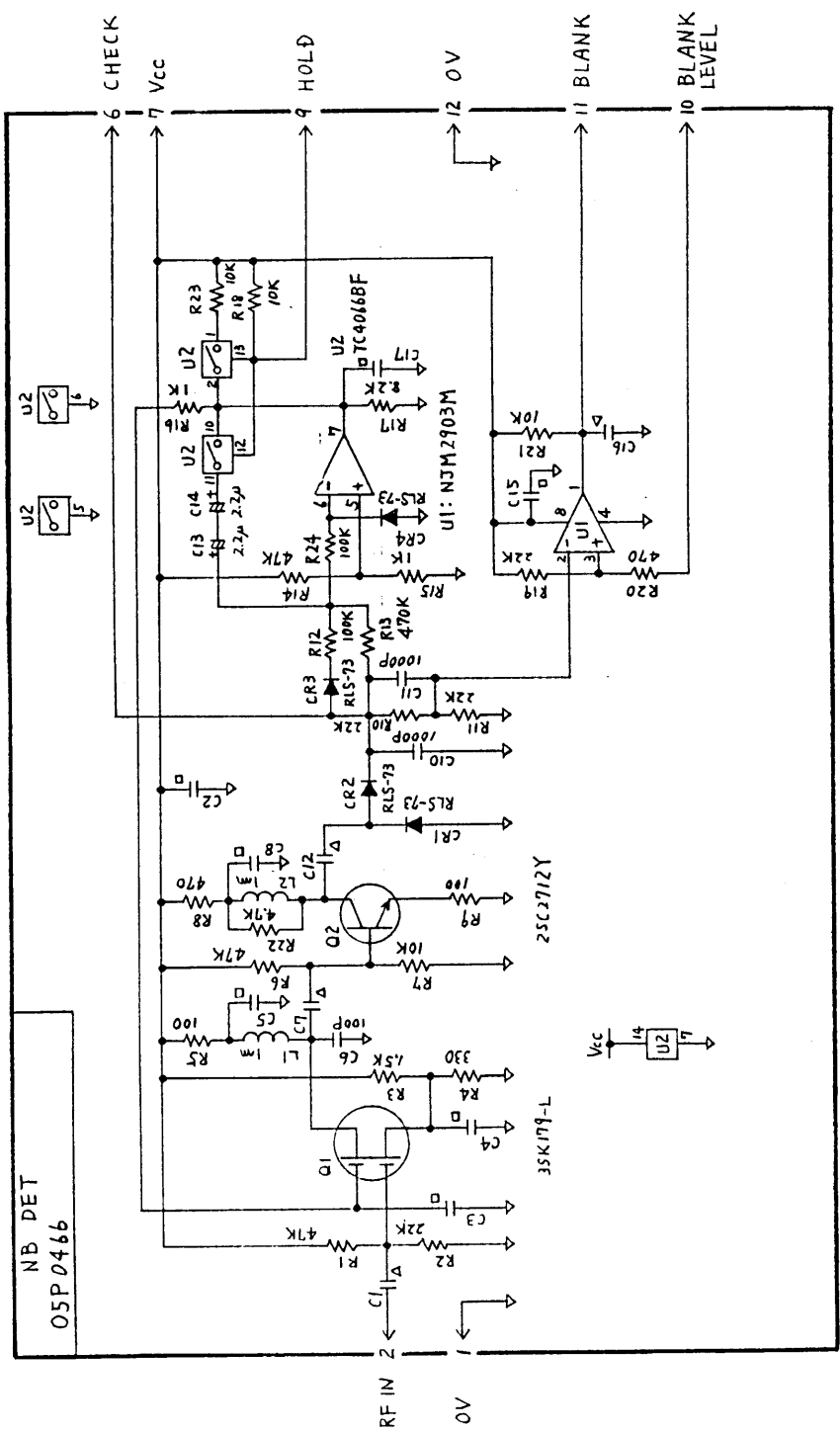

FS-1502

品番 ITEM	品名 NAME	材質 MATERIAL	数量 Q'TY	図番 DWG.NO.	摘要 REMARKS
------------	------------	----------------	------------	---------------	---------------

承認 APPROVED		三角法 THIRD ANGLE PROJECTION	名称 TITLE	B14 05 P 0 4 6 6	
檢 CHECKED	Nov. 20. 91 M. K. ED	尺 度 SCALE		N B D E T	
製 DRAWN	Nov. 20. 91 Y. H. H. W.	重 量 WEIGHT	kg	图 番 DWG.NO.	E 5 5 4 8 - K 1 2 - A



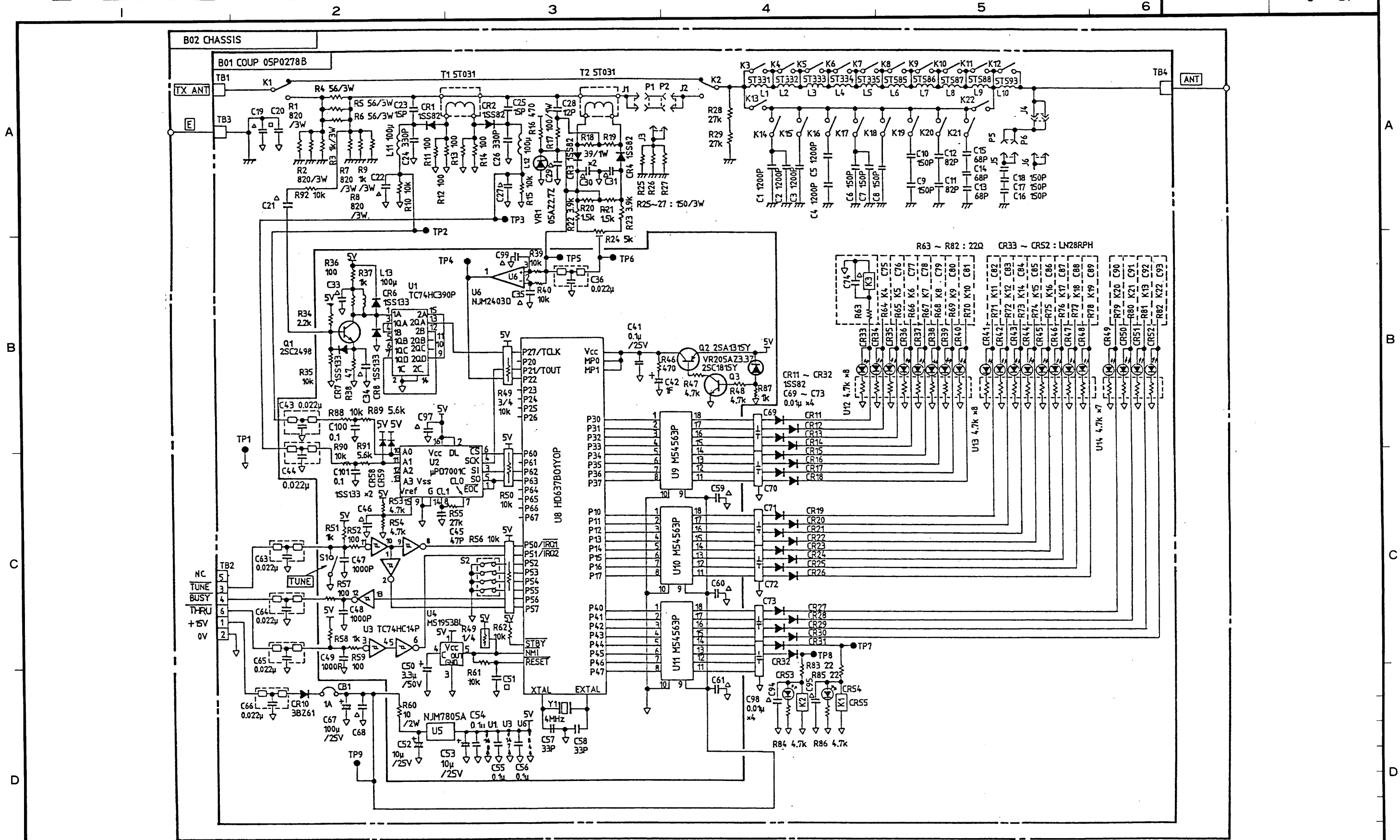

NOTE : (1) RESISTORS ARE IN  $\Omega$  (1/6W), CAPACITORS ARE IN F,  
INDUCTORS ARE IN H, UNLESS OTHERWISE NOTED.  
(2) MARKS  $\circ$  ARE 1000PF/50WV CAPACITORS  
 $\triangle$  ARE 0.01 $\mu$ F/50WV CAPACITORS AND  
 $\square$  ARE 0.1 $\mu$ F/25WV CAPACITORS.

承認 APPROVED	KOU.22.191 T. NAKAIC	名称 TITLE	05P0278B AT-1502 ANTENNA COUPLER
検 CHECKED	Nov.20.191 M. IKEDA	製 DRAWN	番 DWG. NO. E5548-K05-A

FS-1502



A

B

C

D

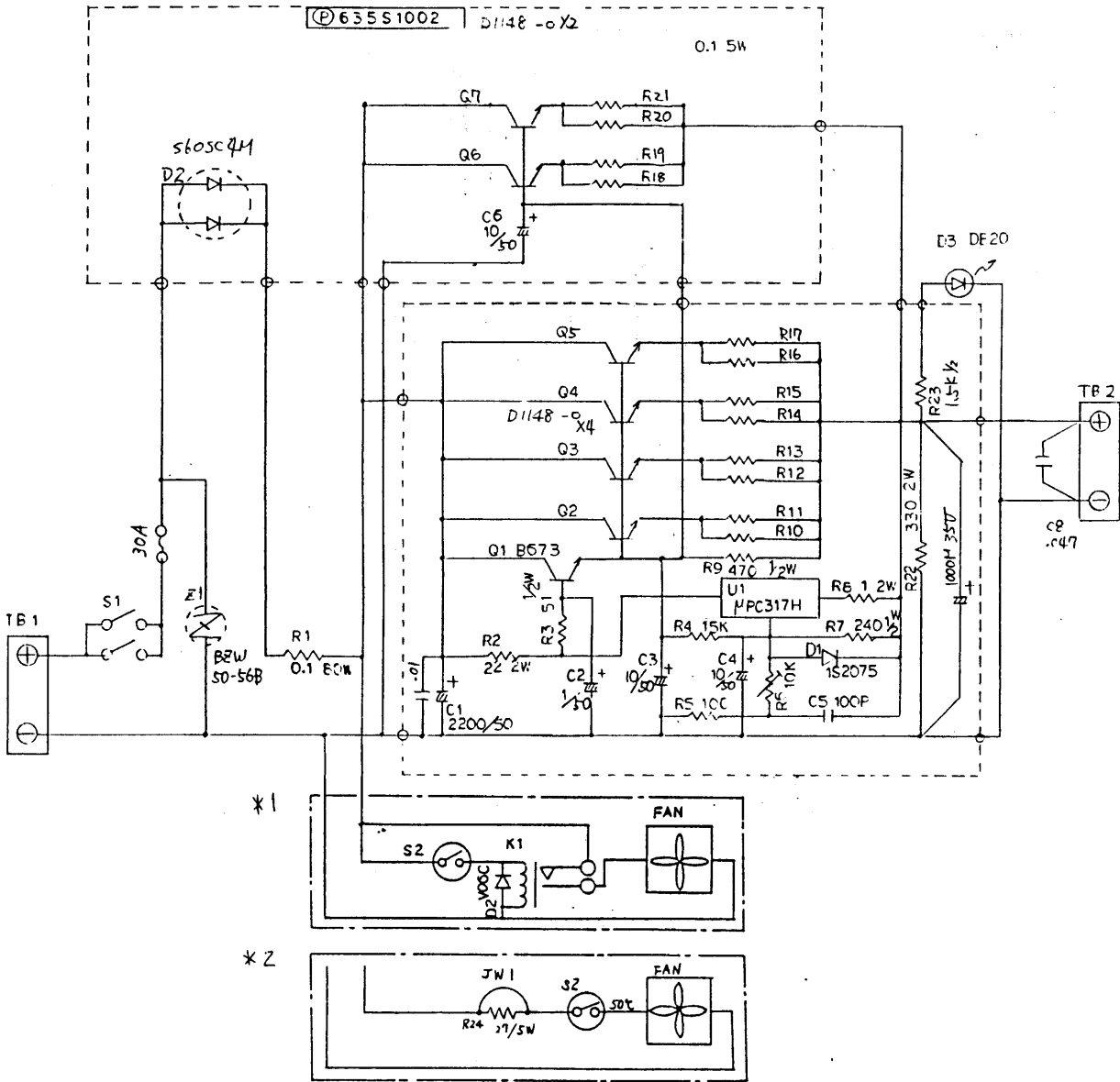

Circuit \*1 is for serial number 0150 and before.  
 Circuit \*2 is for serial number 0151 and after.

NOTE: All resistors are in ohm, capacitors are in microfarad, unless otherwise noted.

品番 ITEM	品名 NAME	材質 MATERIAL	数量 QTY	図番 DWG. NO.	摘要 REMARKS
承認 APPROVED	三角法 THIRD ANGLE PROJECTION	名称 TITLE	DC-DC コンバータ DC-DC CONVERTER		
検図 CHECKED	尺度 SCALE	PC-220			
製図 DRAWN	重量 WEIGHT	kg	図番 DWG. NO.	C5485-030-C	

No. : TI-E5548-0B

Date: 1992-10

# APPENDIX A

## PRESETTING INSTRUCTIONS FOR SSB RADIOTELEPHONE

**MODEL** FS-1502

(For the sets having configuration identification sticker.)

This manual is intended for use by authorized FURUNO service technicians for the presetting of this equipment. Under no circumstances should the contents of this manual be released to the user.

### CONTENTS

■ System Channels	1
■ Channel Programming	4
■ Selection of Input Voltage for PR-270	5
■ Selection of Input Voltage for PC-220	6



**FURUNO ELECTRIC CO., LTD.**  
NISHINOMIYA, JAPAN

---

# System Channels

The FS-1502 has 36 system settings (called "channels") which are set according to the country of delivery.

The hatched channels can be recalled with password "1502" on the system channel 9999, and the non-hatched channels can be recalled and changed by user.

## Procedure to select a hatched channel

1. While pressing and holding down [#], turn the power on to enter System Channel Mode.
2. Select channel 9999 by the FREQ/CH encoder.
3. Press [#], [1], [5], [0], [2], [ENT]. ("1502" is password.)
4. Select a desired channel by the FREQ/CH encoder.

# SYSTEM CHANNEL LIST

CH No.	Function	Setting				Factory Setting Configuration		
		0	1	2	3	A	B	PH
9900	Configuration	A	PH	B		0	2	1
9901	User Memory Clear		Clear					
9902	TX Frequency (NOTE 1)	Free/ ITU /Memory	ITU /Memory	Memory	Marine Free/ITU/ Memory	0	1	2
9903	RX Frequency (NOTE 1)	Free/ ITU /Memory	ITU /Memory	Memory	Marine Free/ITU/ Memory	0	0	2
9904	2182kHz Class of Emission	H3E(AM)	J3E(USB)			1	0	0
9905	System Delay	5-50ms				30	30	30
9906	Two-tone Alarm Duration	45sec.	Contiuous	Key pressed		0	0	0
9907	LSB Usage	TX/RX	RX	Disable		0	2	2
9908	H3E (AM) Usage	TX/RX	RX	Disable	2182kHz	0	3	3
9909	TLX (Telex) Usage	TX/RX	RX	Disable		0	2	2
9910	FAX (Weather Facsimile) Usage	TX/RX	RX	Disable		1	1	2
9911	TX Tune	Enable	Disable	Automatic		0	0	0
9912	Transmission of Test Alarm	Disable	Enable			0	0	0
9913	Test Alarm TX Frequency	Within permissible frequency range				2191k	2191k	2191k
9914	Remote Signal Format	MIF	TBUS			0	0	0
9915	Class of Emission for Selcall	Current	SSB	AM	TLX	0	0	0
9916	Key Response Tone	Off	On			1	1	1
9917	Scan Stop Signal Level	SQ level	1-10 of S-meter reading			3	3	3
9918	Scan Dwell Time	0-99s				2	2	2
9919	Sweep Width	10Hz-30MHz				100k	100k	100k
9920	Sweep Step Frequency	10Hz-30MHz				1k	1k	1k
9921	Noise Blanker	Off	On			1	1	1
9922	AGC	Off	On	Mode		1	1	1
9923	Squelch Activation (NOTE 2)	Voice	Level	V+L	V or L	3	3	3
9924	Squelch Level	0-10 				5	5	5
9925	TLX RX Bandwidth	Wide	Narrow			0	0	0
9926	Meter Indication (NOTE 3)	Ant Curr.	RF Power			1	1	1
9927	Clarifier	± 150Hz	± 100Hz			0	0	0
9928	Squelch Decay Time	500-4000ms				1000m	1000m	1000m
9929	Squelch Activating Frequency	500-2000Hz				1000	1000	1000
9930	TX RF Power (High)	0-255				0	0	0
9931	TX RF Power (Low)	0-255				50	50	50
9932	ITU Channel	Standard	U.S.A.			1	0	0
9933	Tune Power	0-255				100	100	100
9934	NBDP/DSC Connection	No	Yes			0	0	0
9935	User Memory Program	Enable	Disable			0	1	1
9999	Enter 1502 to access the hatched channels and to recall user channels in channel programming.							

**NOTE 1:**

Free: free synthesis, 100Hz step on TX, 10Hz step on RX

1.6 – 30MHz

Marine Free: free synthesis in marine bands

1606.5 – 4438kHz

6200 – 6525kHz

8100 – 8815kHz

12230 – 13200kHz

16360 – 17410kHz

18780 – 18900kHz

19680 – 19800kHz

22000 – 22855kHz

25070 – 25210kHz

26100 – 26175kHz

**NOTE 2:** Squelch activation is the condition which opens the squelch.

**Voice:** The squelch opens by audio frequencies lower than 1000Hz (factory setting) is detected. The squelch activating frequency can be changed between 500 – 2000Hz on system channel 9929.

**Level:** The squelch opens depending on signal strength. The factory setting is 5. You can change the level between 0 – 10 on system channel 9924.

**V + L:** The squelch opens depending on both audio frequency and signal strength .

**V or L:** The squelch opens by either audio frequency or signal strength.

**NOTE 3:** Antenna coupler AT-1502 does not have an antenna current detection circuit. If display of antenna current is required, use Antenna Coupler AT-1500. In this case, be sure to set system channel 9926 for "0".

---

# Channel Programming

The FS-1502 contains two memory banks (A and B) which can store up to 64 semi-duplex or 128 simplex user-programmed channels. In the case of semi-duplex channels, memory A stores SHIPS RX frequency and memory B, SHIPS TX. There is no protocol for writing in simplex channels.

## Procedure

1. While pressing and holding down [#], turn the power on to enter System Channel Mode.
2. Release [#] when "MEMO" appears on the display.
3. Select channel 9999 by the FREQ/CH encoder.
4. Press [#], [1], [5], [0], [2], [ENT].  
For configuration A, go to step 6.  
For configurations B and PH, go to step 5.
5. Select channel 9935, then press [#], [0], [ENT] to enable the channel programming.
6. Select desired channel number and memory (for example, SIMP-A 1, SIMP-B 1) by the FREQ/CH encoder.
7. Press [A B] to select either simplex or duplex. "SIMP" or "DUP" appears on the LCD.
8. Press [#], enter frequency and press [ENT].
9. Press [MODE] to choose class of emission.
10. To write another channel, repeat steps 6 to 9.
11. For configurations B and PH, select channel "9935", then press [#], [1], [ENT] to disable the channel programming.
12. To escape from System Channel Mode, turn off the transceiver.

# Selection of Input Voltage for PR-270

The input voltage of the model PR-270 Rectifier Unit can be set for AC voltage of 110, 120, 220, 230 or 240.

Remove the top cover of the rectifier and change the lead connection on the input terminal of power transformer. Also change the fuse if necessary.

**CAUTION:** To select the supply voltage, move only blue-lugged white wires. Leave the two yellow-lugged gray wires on 0V and 110V terminals, as they are connected to the fan. For 110V and 120V connection, use the jumper wire connected to first 120V terminal from the right.

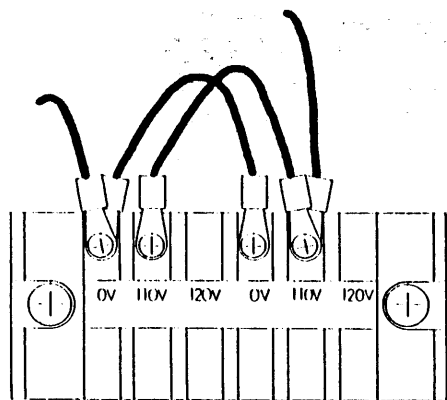

For 110VAC

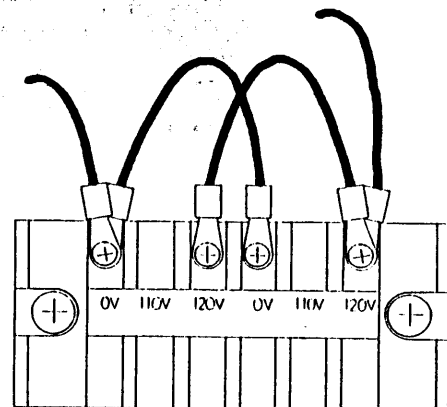

For 120VAC

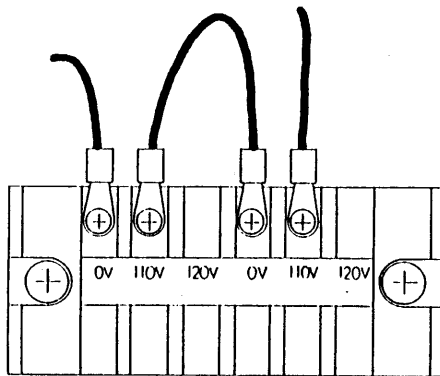

For 220VAC  
(Factory setting)

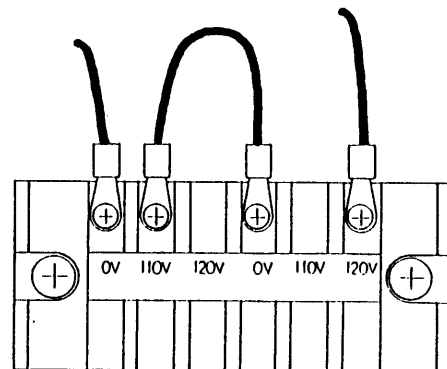

For 230VAC

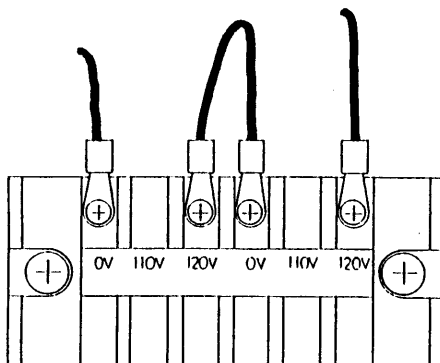

For 240VAC

Supply Voltage	Fuse Amperage
110/120VAC	10A
220/230/240VAC	5A

# Selection of Input Voltage for PC-220

The input voltage of the DC-DC converter can be set for either 24VDC (factory setting) or 32VDC. To enable 32VDC operation, remove the jumper link.

