

COMM-1A
TRANSCEIVER



GALAXY ELECTRONICS INC.

10 South 34th Street

COUNCIL BLUFFS, IOWA 51501

WARRANTY

GALAXY ELECTRONICS PRODUCTS ARE WARRANTED AGAINST DEFECTIVE MATERIALS AND WORKMANSHIP FOR A PERIOD OF 90 DAYS. PARTS OTHER THAN TUBES, LABOR AND SEMI-CONDUCTORS ARE WARRANTED FOR A PERIOD OF ONE YEAR FROM DATE OF PURCHASE BY THE ORIGINAL OWNER. THE WARRANTY APPLIES TO THE ORIGINAL PURCHASER ONLY AND IS NOT TRANSFERABLE. THIS WARRANTY DOES NOT COVER ANY TRANSPORTATION COSTS THAT MAY BE INCURRED AND OUR SOLE LIABILITY IS REPAIR OF ANY DEFECT. FOR THE PERIOD STATED.

NO PERSON SHALL ASSUME FOR US ANY OTHER LIABILITY IN CONNECTION WITH THE SALE OF THIS OR OTHER GALAXY PRODUCTS.

SPECIFICATIONS AND PRICE CHANGE PRIVILEGES RESERVED.

CONTENTS

WARRANTY

CONTENTS

LIST OF ILLUSTRATIONS

Section 1 INTRODUCTION

Section 2 INSTALLATION

Section 3 OPERATION

Section 4 THEORY OF OPERATION

Section 5 MAINTENANCE

Section 6 PARTS LIST & SCHEMATIC DIAGRAMS

SERVICE INFORMATION

Figure 1	Front View, Comm 1/A
Figure 2	Installation
Figure 3	Installation
Figure 4	Rear Panel, Comm 1/A
Figure 5	"S" Meter Zero
Figure 6	Chassis Layout
Figure 7	Front View, Comm 1/A
Figure 8	Block Diagram
Figure 9	12 VDC Board Schematic
Figure 10	Frequency Control Board Schematic
Figure 11	Audio/AVC Board Schematic
Figure 12	Frequency Change Diagram
Figure 13	Frequency Change Diagram
Figure 14	Frequency Change Diagram
Figure 15	Frequency Change Diagram



Figure #1

SECTION 1 -- INTRODUCTION

1.1 General Description

The COMM-1A transceiver is a versatile, long-range transmitting and receiving unit employing single-sideband emission. It is capable of effective communications through adverse atmospheric conditions and is ideal for operation in a variety of remote locations where larger and more elaborate equipment is not suitable. The COMM-1A is compatible with other single-sideband equipment which may now be used in a network.

The COMM-1A is light weight and even with accessories it is very portable and readily carried to any location by one man.

1.2 COMM-1A Transceiver Description

The COMM-1A transceiver is a high quality four channel unit which provides dependable single-sideband communication over a long range. The COMM-1A can be tuned to any channel, upper or lower sideband in the 3.0 to 7.5 MHz range. It has 200 watts PEP RF output and can operate with a wide range of antennas.

The COMM-1A has a CLARIFIER control to allow the operator to adjust the operating frequency to exactly coincide with that of other stations for "netting" purposes.

The transceiver is housed in a rugged aluminum cabinet. The front panel has mounting handles that serve a dual purpose, to protect the controls and to provide for ease of portability. The transceiver is compact to allow for mounting under a dashboard, even in small vehicles.

1.3 Specifications

Number of Channels.....	4
Frequency Range.....	3.0 to 7.5 MHz
Emission.....	Upper & Lower Sideband (selectable)
RF Output Power.....	200 Watts PEP
Output Impedance.....	52 ohms, nominal
IF Frequency.....	9 MHz
Circuitry (receiver).....	Single Conversion Superheterodyne
Harmonic Suppression.....	-40db
Carrier Suppression.....	-60db
Unwanted Sideband Suppression...	-50db
Frequency Stability.....	(.005%)
Transmitter Audio Range.....	500 to 2100 Hertz
Audio Input (Mic).....	High Impedance
Receiver Sensitivity.....	1 microvolt for 20 db S+N/N
AGC Type.....	Fast Attack Slow Release
Audio Output.....	2.5 Watts into 3.2 ohms
Size.....	10½"x11¼"x6"
Weight.....	13 pounds

1.4 COMM-1A Accessories

CAC-400.....	AC Power Supply 110/230 VAC
CG-500.....	DC Power Supply 12 VDC
CMMB.....	Mobile Mounting Bracket
CCC-1.....	Crystals (additional)
RC-1.....	Remote Control system
MRC-1.....	Mobile Remote Control Head
CAS-1.....	Remote Antenna Switch
COMM-1A Linear Amplifier.....	1000 Watt Linear
Antenna Packages.....	Fixed & Mobile

**COMM-1/1A
SYSTEMS ACCESSORIES**

CG-500
DC Power Supply,
12 VDC for COMM-
1 and COMM-1/1A.

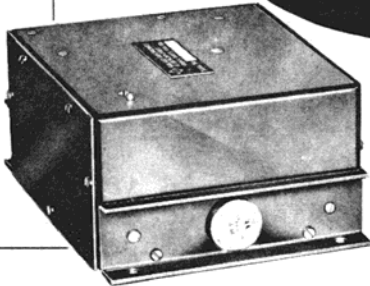

CMMB
Mobile Mounting
Bracket for the
COMM-1/1A.

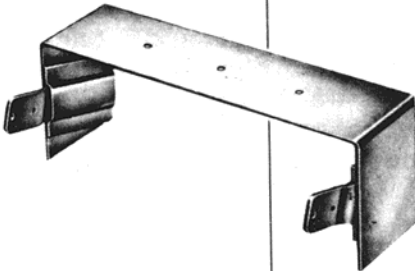

CCC-1
Additional Frequency Crystals
for the COMM-1 and the COMM-
1/A. Crystals should be ordered
for the exact operating
frequency. Specify unit
model number.

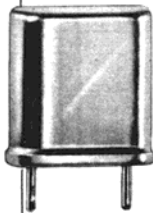

CAC-400
AC Power Supply,
110/230 VAC for
COMM-1/1A.

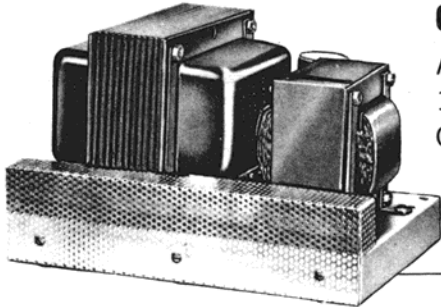

SECTION 2 -- INSTALLATION

2.1 General

The COMM-1A is normally supplied with optional accessories to suit the installation. Following are some examples of typical packages.

2.2 COMM-1A and AC Power Supply

A typical and standard package for the COMM-1A consists of the COMM-1A transceiver and the CAC-400 AC Power Supply. Figure #2 below shows a rear view of the two units and the proper cable connections to be made.

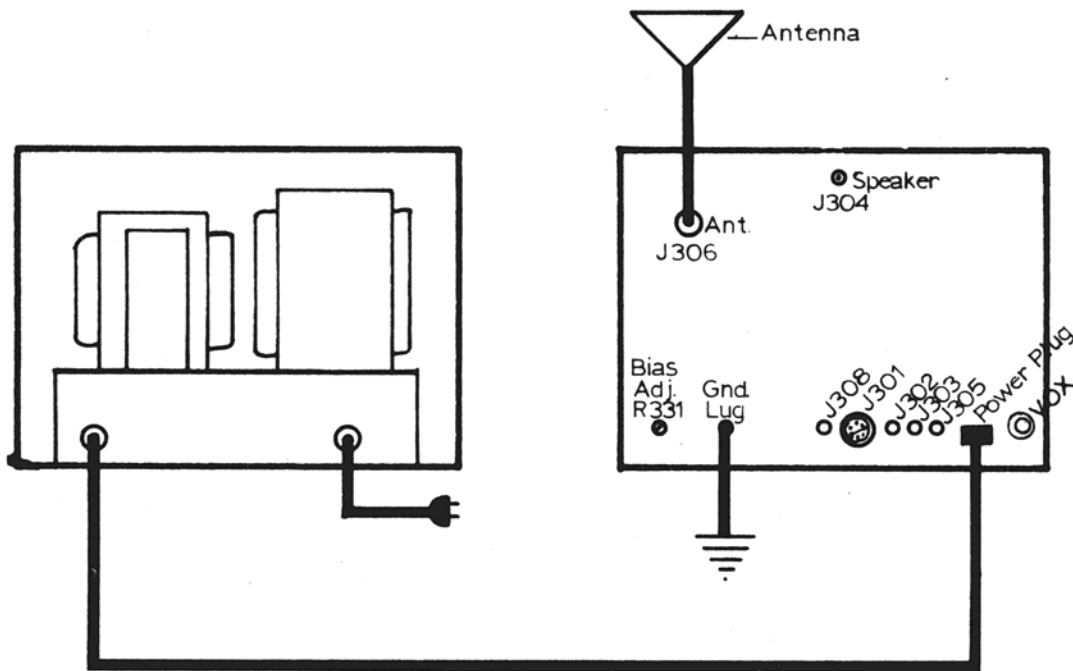

Figure # 2

2.3 COMM-1A and COMM LINEAR with Power Supplies

Another variation would be the use of the COMM LINEAR with the COMM-1A. Figure #3 shows these two units with their respective power supplies. You will note that the Linear's power supply is covered and comes with handle openings to allow easy movement and installation as well as protection from the HIGH VOLTAGES.

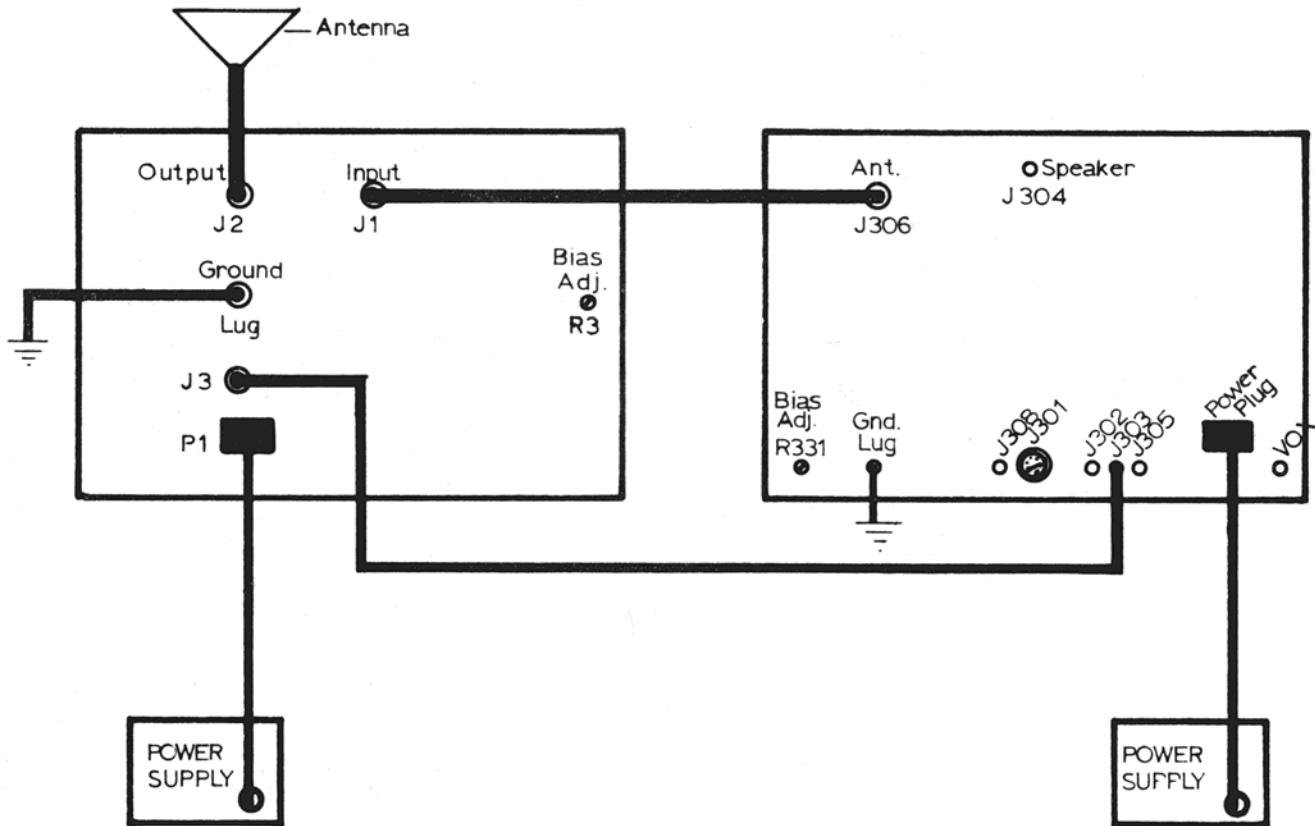

Figure #3

2.4 Primary Power Connections

It is IMPORTANT that all equipment be well grounded before any connections are made to a power source. Each unit (COMM-1A & COMM LINEAR) has a ground connection bolt on the rear panel. The two units should be bonded together at these points and an outside wire of not less than #12 guage connected to a good ground rod (8 foot long and at least 3/8" in diameter) making the connecting wire as short as possible. If this is impossible to do, at least make a good connection to a COLD water pipe. When the COMM-1A is being used mobile a good bond should be made between the chassis of the vehicle and the ground connection on the rear of the unit using a 1" strip of copper-tinned ground strap.

The CAC-400 AC power supply for the COMM-1A is supplied with a standard two prong "universal" plug. However, the 115/230 VAC version of this supply is delivered without any plug attached, and has a three wire cable rather than two wires. There is such a variety of 230 volt receptacles in use that a plug arbitrarily selected by us would seldom be suitable. The plug must be provided by the user and selected to match the receptacle in use. It is wired according to the information supplied in the CAC-400 manual.

2.5 Initial Adjustments

When initially installed, a competent technician should make the following adjustments on the COMM-1A:

- Bias Setting
- "S" Meter Zero Setting
- Antenna Matching
- "Netting"

NOTE -- NETTING on a control station frequency is not normally necessary when first installed due to the precision crystals supplied, but if found to be necessary see the paragraph on "NETTING". To make the adjustments be sure to read the paragraph first.

To make the adjustments called out on page six first connect the antenna, ground, primary power source, microphone and then proceed with the following steps:

- 1 - Check to insure the microphone PUSH-TO-TALK is OFF
- 2 - Set the Function Switch to OPERATE
- 3 - Select the desired channel (A-B-C-D)
- 4 - Set CLARIFIER control to zero (midpoint)
- 5 - Set sideband selector switch to SB2
- 6 - Set MIC control fully counter-clockwise
- 7 - Turn AUDIO control clockwise until switch clicks on
- 8 - Allow at least 20 minutes for WARM-UP

2.6 Bias Set and Check

Depress the microphone button to place the unit in a transmit condition. Read the meter, which should read between 4 and 5 on the scale. If it does, release the microphone switch and dis-regard the next step.

If the reading was above or below that required above, adjust R331 on the rear panel (See Figure #4) to bring the reading between 4 and 5 on the meter scale, then release the microphone button.



Figure # 4

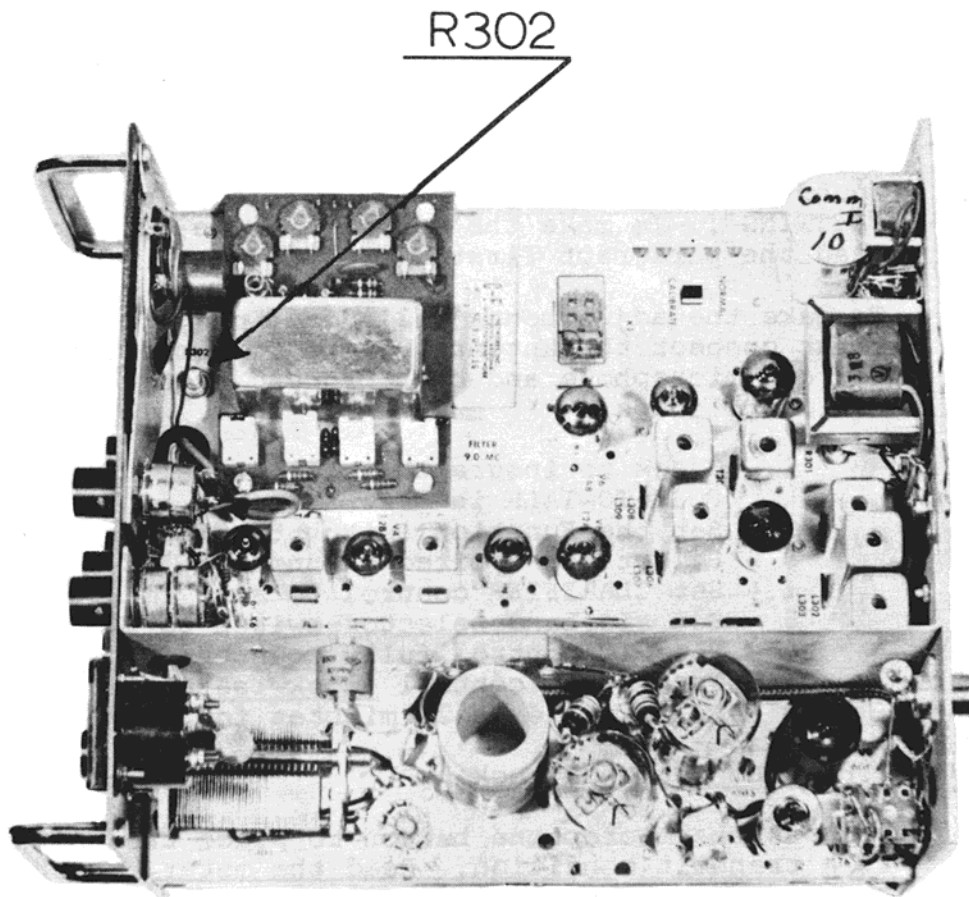

Figure #5

2.7 "S" Meter Zero Setting

Remove the antenna from the COMM-1A J306 so that no signal is being received. Refer to Figure #5 above, locate R302 and adjust it until the meter is at zero. Zero being the last mark on the left side of the meter.

2.8 Antenna Matching

Set the MIC control (front panel) fully clockwise and make the following adjustments with the channel selector (front panel) on A, then B, C & D respectively, for which crystals have been installed.

NOTE

The COMM-1A is factory pre-tuned for a 50 ohm load and settings will be very close for any 50 ohm antenna load.

Place the function switch (front panel) to the TEST position and quickly adjust the TUNE control for minimum meter reading. Now adjust the loading trimmer C324 (For Channel A) to increase the meter reading slightly above the TUNE mark on the meter -- then quickly re-adjust the TUNE control for a minimum reading on the meter. Repeat these two adjustments until the meter minimum reading falls exactly on the TUNE mark on the meter.

The TUNE control adjustment must always be the last adjustment. Return the function switch to OPERATE and select Channel B. Set the function switch back to TEST and repeat the adjustments as before using C325 the load trimmer for Channel B. Continue the sequence using C326 on Channel C and C327 on Channel D. Always be certain the function switch is returned to the OPERATE position before turning any switch. Also, the microphone switch or push-to-talk button must be in the OFF position when making these adjustments.

NOTE

Turning the loading trimmers clockwise opens them (less capacity) and it is necessary to take care not to open one too far or the trimmer screw will drop out of the trimmer inside the case.

Also when the above loading operation has been completed, write the TUNE control settings on the panel plate provided for future reference.

SECTION 3 -- OPERATION

3.1 General

The following instructions presume the COMM-1A has been correctly installed by a technician and all connections, including microphone, have been made.

3.2 TURN-ON and OPERATIONAL TESTS

- 1 - Check to insure the microphone push-to-talk is OFF
- 2 - Set the function switch to the OPERATE position
- 3 - Select desired Channel (A,B,C,D)
- 4 - Set CLARIFIER control to zero (midpoint)
- 5 - Set sideband switch to SB-2
- 6 - Set MIC control fully counter-clockwise
- 7 - Turn AUDIO control slightly clockwise until switch clicks to ON
- 8 - Allow at least two minutes for warm-up

3.3 Bias Set & Check

- 9 - Depress the microphone push-to-talk button, which places the COMM-1A in a transmit condition. Read the meter, it should be between 4 and 5 on the scale. If it does, release the push-to-talk button and dis-regard step 10
- 10 - If the meter reading is outside the 4 to 5 limits, turn the bias control located on the rear panel R331 to bring the reading within the limits of 4 to 5 on the meter scale. Release push-to-talk button.

3.4 Tuning Check

- 11 - Set MIC control fully clockwise and place function switch to the TUNE position. Turn the TUNE control slightly each way in a rocking manner to insure the meter is reading maximum. Return the function switch to the OPERATE position and re-set the MIC control to the full counter-clockwise position.

3.5 Operating

- 12 - To receive, adjust the VOLUME control for a comfortable level, and also adjust the CLARIFIER control for clear and understandable speech. Select the desired sideband SB-1 or SB-2.
- 13 - To transmit, depress the microphone push-to-talk button, turn the MIC control clockwise until normal speech level results in the meter swinging up to the TUNE mark on the meter scale. This is maximum allowable meter swing.

3.6 Netting

In the event it is determined there is an off frequency condition on a COMM-1A, there are two ways to re-set frequency. It may be checked with a frequency counter connected to the output of the COMM-1A or by comparison with another stations frequency where that station is received with fair signal strength. The latter system is normally used, since a frequency counter is not a common piece of test equipment.

Referring to Figures 5 and 6 locate the switch S2, marked "NORMAL" and "CALIBRATE" on the chassis. Also, locate the printed circuit board near the front that holds the crystals and frequency adjustment controls.

Now set the switch S2 to the "CALIBRATE" position. Set the CLARIFIER control to zero (midpoint). Set the sideband switch to SB2. Arrange for the control station to give a transmission of about one minute for test and calibration. If on Channel A, adjust the blue trimmer nearest the panel (R14), adjust for clear reception of the signal. Have the control station repeat this on each channel used, adjusting the blue trimmers R13 for Channel B, R12 for Channel C and R11 for Channel D. Now have the control station repeat the test call on SB1, adjusting the ceramic trimmers C6 thru C9 for clarity of reception. C6 for Channel B, C7 for Channel A C8 for Channel D and C9 for Channel C. It is important that the adjustments be made on SB2 FIRST, then on SB1. Now return the switch SB2 to the "NORMAL" position.

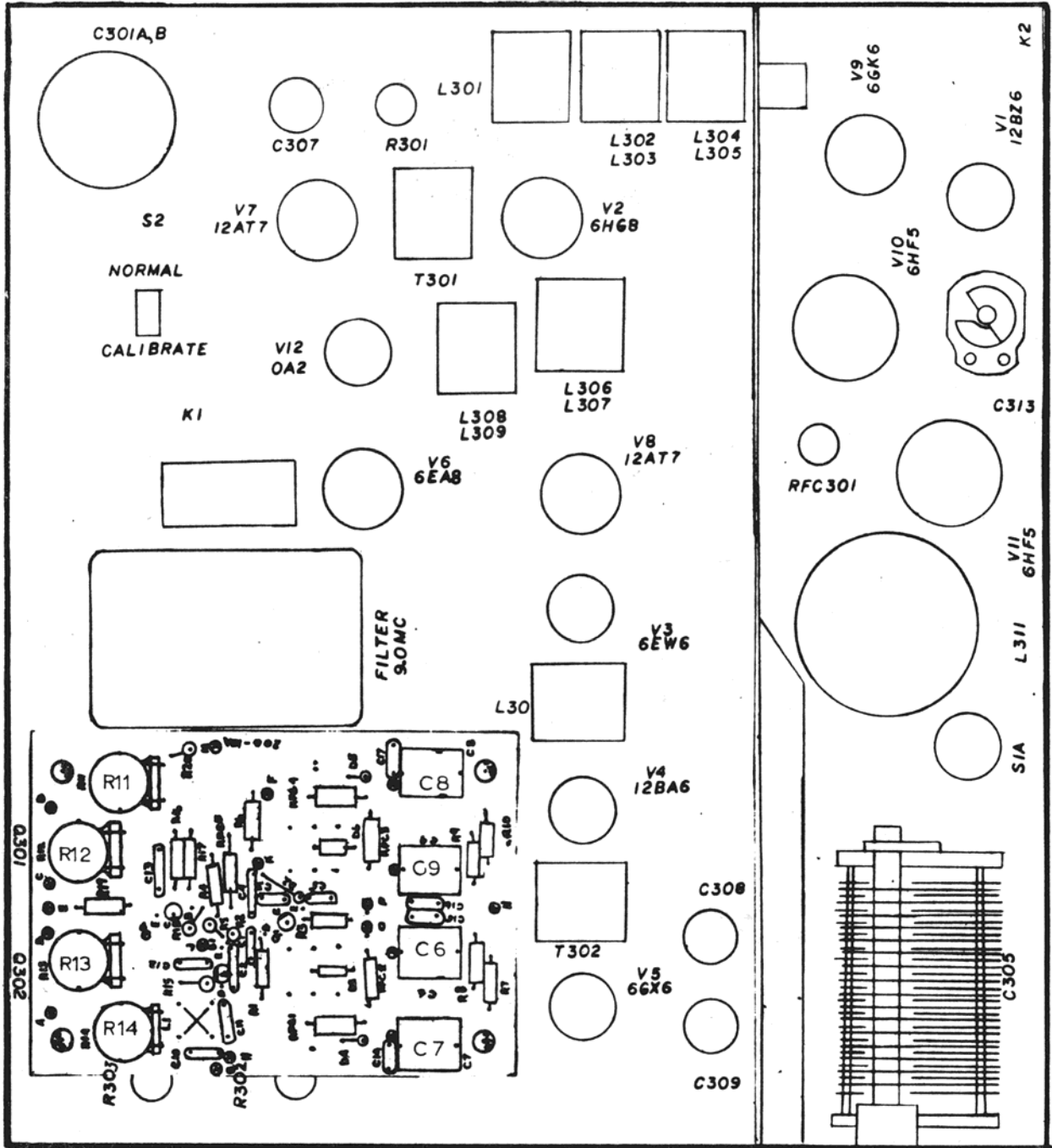

Figure #6

If the control station can not be tuned correctly when making the settings on SB2, it indicates that the error between stations is too great to be compensated by the adjustment and it will have to be determined which station has the error. Normally this will not occur due to the close tolerance of the crystals supplied but should the COMM-1A be used in a network of stations using other older equipment, it may be the net control station is actually too far from the correct frequency. Checks with some accurate frequency measuring equipment will have to be made to find which unit is in error. A good frequency counter is the best way to do this.

3.7 Function of Controls

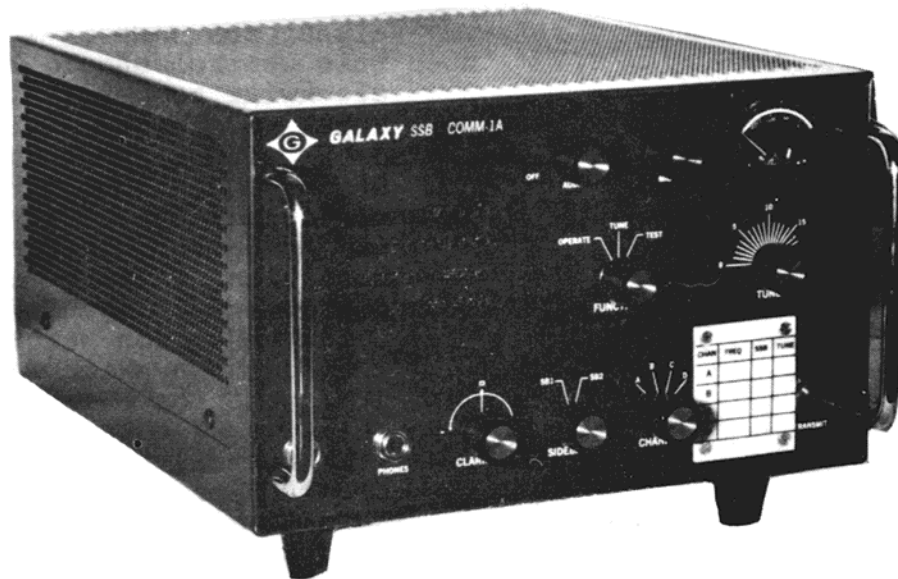

Figure # 7

OFF/AUDIO -- A control which has a switch controlling power. Turns ON primary power when turned slightly clockwise until the switch clicks. The associated potentiometer controls the receiver audio volume, being maximum when fully clockwise.

MIC -- Actually two controls on a single shaft. When the function switch is in the OPERATE position it regulates the microphone level and thereby directly controls power input under voice condition. When the function switch is in either the TUNE or TEST positions this control should be set fully clockwise to permit full power input for these conditions.

METER -- Indicates either received signal strength when the set is in a receiving condition, calibrated in "S" units. In the transmit condition it indicates transmitter performance, depending on the function switch setting. When the function switch is in the TUNE position the meter reads relative RF output power and will normally indicate around the TUNE mark on the meter, but this is only relative and normally used simply to tune for maximum meter reading. When the function switch is in the TEST position the meter reads final cathod current and typically used to indicate a "dip" of final tube current at about the TUNE mark on the meter. When in the OPERATE position the meter reads power input with voice variations. When talking the meter should swing up to the TUNE mark on the meter, which represents 200 watts PEP output.

- FUNCTION -- A selector switch for setting the operating conditions of the COMM-1A. When in the OPERATE position the unit is ready for voice operation and will be placed in a transmit condition when the microphone push-to-talk button is closed. When in the TUNE position this switch automatically places the unit in a transmit condition and the same occurs when in the TEST position.
- TUNE -- A variable capacitor which resonates the final amplifier resulting in maximum power output. Works in association with the load trimmers C324 thru C327.
- CLARIFIER -- An adjustable control to change only the received frequency for slight frequency errors of other stations and for variation of voice pitch most easily copied by individual operators.
- SIDEBAND -- Marked SB1 and SB2, it selects upper or lower sideband. It cannot be marked directly in upper and lower since this changes and is dependent on frequency used.
- CHANNEL -- A four position selector switch to select crystals.
- TRANSMIT -- Not a control but an indicator light (RED) which is illuminated when the unit is in a transmit condition.
- REAR PANEL --(See Figure #4)
- POWER PLUG -- A 12 pin polarized connector for connection to the appropriate power supply in use for fixed or mobile operation.
- J305 -- An RCA phono jack for remote audio connection normally used to connect telephone patch equipment.
- J303 -- An RCA phono jack connected to an internal relay, placing a ground on the center connection when in the transmit condition. Normally used to control COMM LINEAR operation.
- J302 -- An RCA phono jack for remote control of the push-to-talk circuit.

- J301 -- An octal socket with connections to the channel selector and the 12 VDC circuit. Used to control various pieces of accessory equipment.
- J308 -- An RCA phono jack delivering 12VAC normally used to supply illuminating voltage for accessories.
- GROUND LUG -- A bolt with lock-nuts for connection of an external ground.
- R331 -- Potentiometer to adjust proper operating bias voltage on the final amplifier tubes.
- J306 -- An SO-239 connector (UHF type) for connection to an antenna using a PL-259 connector.
- J304 -- An RCA phono jack for connection to an auxillary 3.2 ohm speaker.

SECTION 4 -- THEORY OF OPERATION

4.1 Transmit Condition

The microphone or telephone patch connection to the appropriate jack will be connected to the audio amplifier tube V6. The voice signal is amplified in the V6 triode-pentode tube and coupled to the V7 dual triode balanced modulator. The amount of voice signal coupled to the balanced modulator is regulated by the MIC control. Also being fed into the balanced modulator is 9001.25 KHz or 8998.75 KHz, which was generated in V5 and amplified by Q305. The balanced modulator combines the audio and RF signals and delivers a double sideband suppressed carrier signal at 9001.25 KHz for LOWER sideband or 8998.75 KHz for UPPER sideband. Maximum carrier suppression is made with R301 and C307. The double sideband signal is coupled from V7 through T301 to the 9 MHz filter which allows only one of the two sidebands to reach the IF amplifier V3. The single sideband suppressed carrier signal is amplified in V3, coupled to the transmit mixer V8 through coil L310. Crystals X1A through X4D generate a signal in the 12 to 16.5 MHz range in Q1. The 12 to 16.5 MHz signal is amplified in Q2 and coupled into the transmit mixer V8. The difference frequency is selected in the output of V8 by L306 through L309. The signal we have now generated is a single sideband signal in the 3 to 7.5 MHz range. This is amplified by the driver V9 and coupled through L302 through L305 to the amplifier tubes V10 and V11. The signal is coupled from the amplifier tubes through the pi-network and K2 (C303, L311 and C327) to the antenna. Diodes D303 and D304 detect any trace of control grid current in the final tubes V10 and V11, developing a negative DC bias voltage which is applied to the IF amplifier V3 to reduce the IF gain, whenever control grid current flows. This automatic level control keeps V10 and V11 in class AB1 at all times thereby reducing distortion and increasing talk-power.

4.2 Frequency Generation

The oscillator-detector tube V5 has two crystals, one of which is selected by the sideband switch. These two crystals generate a carrier frequency of 8998.750 KHz (LOW-Frequency Crystal) or 9001.250 KHz (HIGH-Frequency Crystal) which is adjusted by C308 and C309 respectively. The HF crystal minus the LF crystal is 2500 hertz. In order to keep the transmit and receive carrier frequency constant, a means is provided for adjustment of the main oscillator frequency. This is accomplished by C6 through C9 and the sideband switch. When the sideband switch is on the LF crystal, then X1A through X4D generate a signal in the 12 to 16.5 MHz range. Example:

Assume X1a has a crystal of 12998.750 KHz. When this frequency is combined with 8998.750 KHz in the transmit mixer V8, they will produce an output frequency which is the difference between the two -- 4000.000 KHz.

When the sideband switch is on the HF crystal the crystals X1A through X4D will generate a frequency that is moved 2500 hertz higher than before. Example:

Assume the 12998.750 KHz crystal is now moved up 2500 hertz to 13001.250 KHz. When this is combined with the HF crystal at 9001.250 KHz the difference is again 4000.000 KHz. However, the HF crystal generated lower sideband and the LF crystal generated upper sideband, even though the resulting carrier frequency is 4000.000 KHz in either case.

The exact frequency of X1A through X4D can be adjusted plus or minus 1000 hertz, when receiving only, by the front panel CLARIFIER control R305. This permits the operator to clearly receive stations that may be off the assigned frequency by no more than 1000 hertz.

The exact frequency of X1A through X4D can also be adjusted for transmitting by settings of R11 through R14, so transmission will be exactly on the assigned frequency. This procedure is detailed in the "NETTING" information found on page 11, para 3.6.

In order to keep crystals X1A through X4D on their exact and assigned frequencies to the greatest extent, they are placed in the main oscillator oven which controls their temperature to 75 degrees centigrade. The temperature of the HF and LF oscillator crystals are also controlled to 65 degrees centigrade by the carrier oscillator heater. These two ovens will keep the crystals very close to the assigned frequencies through reasonable variations of external temperature variations.

4.3 Receive Condition

The incoming signal from the antenna is selected by L306 through L309, and coupled to the RF amplifier V1. The output of V1 is tuned in the 3.0 to 7.5 MHz range by L302 through L305. The selected signal is coupled to the receive mixer tube V2 through the 9 MHz trap L301. This trap is to further attenuate any signal that may be present on 9 MHz. Also being fed into V2 is a signal in the 12 to 16.5 MHz range from amplifier Q2. The difference frequency of 9 MHz is selected by T301 and the 9 MHz filter. The signal is coupled through the filter to the 9 MHz IF amplifier V3. This signal is amplified in V3 and coupled to the second IF amplifier V4 through L310. The output of V4 is coupled to the oscillator-detector V5 by transformer T302. The result is an audio signal which is amplified by Q104. The output of Q104 feeds both the AVC amplifier Q103 and the audio driver Q102. The level of the audio signal being delivered to Q102 is adjustable by the audio gain control. The output signal drive the push-pull amplifier Q303 and Q304. The output is then coupled to the speaker. The output of the AVC amplifier Q103 is rectified by Q101 and fed to V1, V3 and V4 to control the gain of these stages keeping audio output as constant as possible.

4.4 12 Volt DC Regulator

12 to 15 VDC unregulated is applied to Q302. 9 volts of the 12 VDC regulated output of Q302 is obtained by R303. The DC voltage obtained by R303 is compared against the 9 volt reference Q201 by Q203. The resulting difference voltage is amplified by Q202 and applied back to Q302 in such a manner as to maintain 12 VDC out of the regulator regardless of the input voltage or output current.

Example: Assume the 12 VDC drops. When this happens the 9 VDC from R303 also drops which in turn causes the output of Q202 to raise, in turn causes Q302 to raise resulting in a higher output voltage. If the output voltage rises, then the 9 VDC from R303 rises turning off Q202, turning off Q302 and decreasing the output voltage.

4.5 Oven Control Circuits

Regulated 12 VDC is applied to the oven control switch Q301, which in turn applies 10 volts to the main oscillator oven heater and the carrier oscillator heater. As the heater warms up, the thermistor warms up and the accompanying DC voltage that is applied to the oven temperature sensing transistor Q204 decreases until it is equal to the DC voltage from the oven control reference transistor Q203. When this happens Q204 turns off, which in turn shuts off Q205 and that in turn switches off Q301. When the thermistor cools off the DC voltage on Q204 rises, turning on Q205 and Q301. This action of turning the heater on and off will maintain the oven temperature at 75 degrees centigrade.

HEATER CONTROL BOARD

PART 200-16

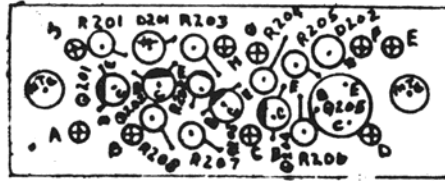

SCHEMATIC FOR BOARD ABOVE

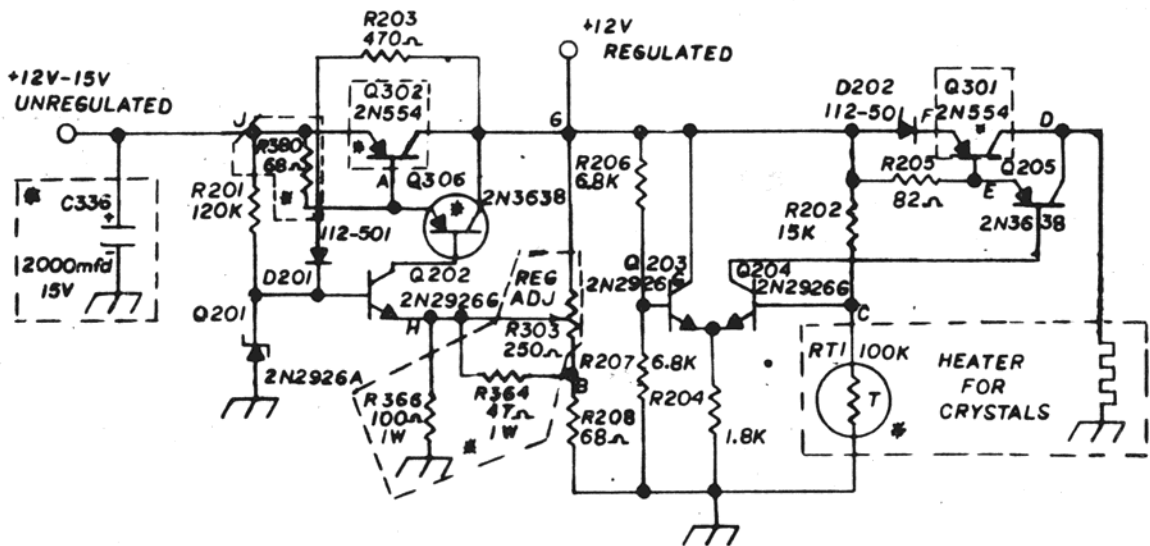
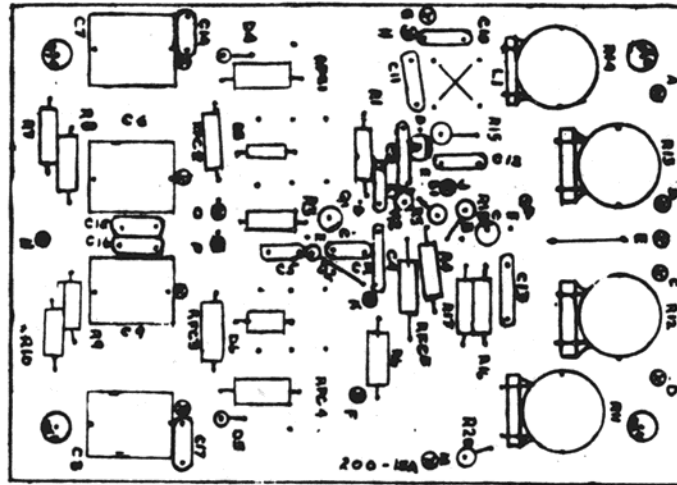

Figure # 9

X1-A - CRYSTAL, CR27ANU
 X2-B - CRYSTAL, CR27ANU
 X3-C - CRYSTAL, CR27ANU
 X4-D - CRYSTAL, CR27ANU



SCHEMATIC FOR BOARD ABOVE

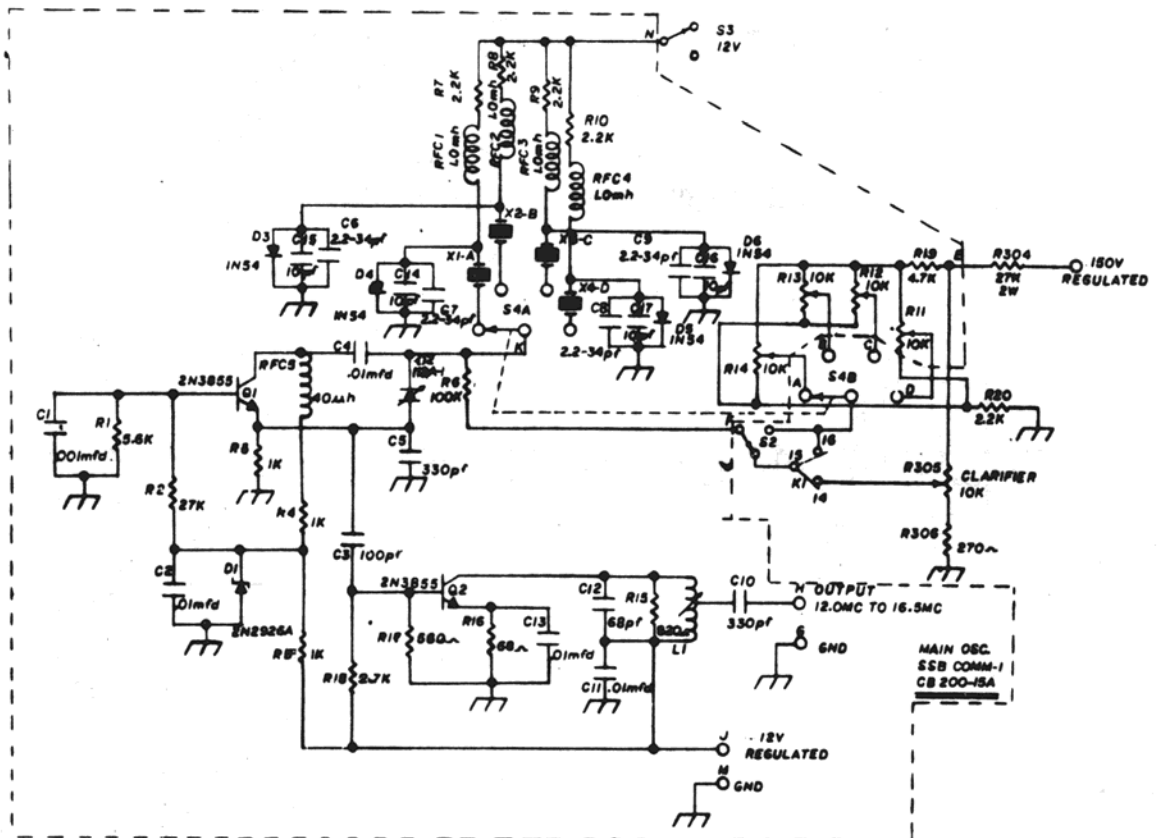
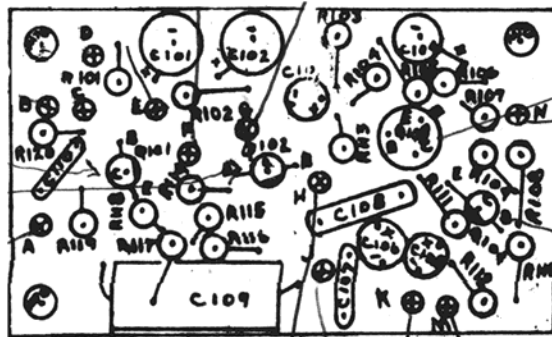

Figure #10

AUDIO - AVC BOARD PART 200-5A



SCHEMATIC FOR BOARD ABOVE

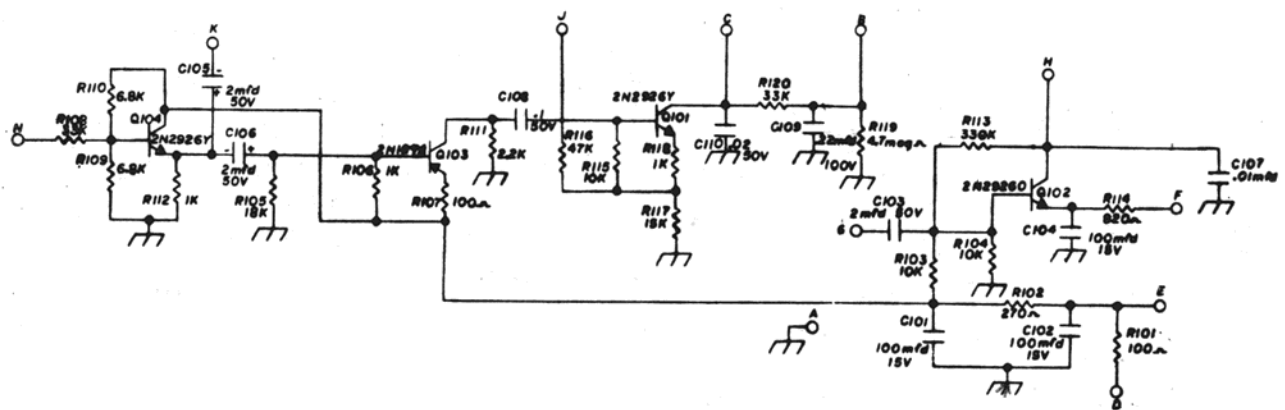

Figure #11

SECTION 5 -- MAINTENANCE

5.1 Changing Frequency (EXCITER)

Should changes of frequency be necessary after the COMM-1A has been placed in the field, the following information will enable the technician to make the proper adjustments.

First it is necessary to obtain crystals of the proper frequency. To order crystals with the correct characteristics, specify type CR27A/U. The frequency of the required crystal is obtained by adding the new operating frequency to the master oscillator frequency of 8998.750 KHz.

Example: To select the crystal frequency for operation on 6000.000 KHz, add that to 8998.750 KHz, giving a crystal frequency of 14998.750 KHz for the new frequency.

NOTE -- As supplied by us, all channels require the removal of a capacitor for operation in the range of 5.0-7.5 MHz unless we originally shipped the unit set-up for operation in this range. Therefore, to change a channel for operation in the 5.0-7.5 MHz range the capacitors C359A and C312A are deleted for Channel A, C311B and C360B for Channel B, C310C and C361C for Channel C, C306D and C362D for Channel D. See Figure #12 below for locations of these capacitors under the main chassis.

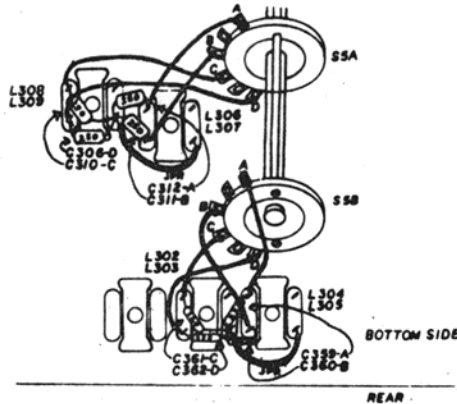

Figure # 12

When the required crystal has been obtained, to install it in the set first remove the cover to the crystals, then the hold-down springs, then the obsolete crystal. Install the new crystal in the correct channel socket and replace the springs and cover.

Notice that the tall coil cans on top of the chassis have been marked (see Figure #13) A-B-C-D, referring to the channels covered, with two adjustments required on each channel. A hex, non-metallic alignment tool is required. First, place the set in a receiving condition (it will be helpful if a station can transmit voice to facilitate alignment) and adjust the two coils for the particular channel either for maximum signal received according to the meter or by ear, or in the absence of a signal tune for maximum hiss noise. This will bring the settings very close, though they will be adjusted again more precisely.

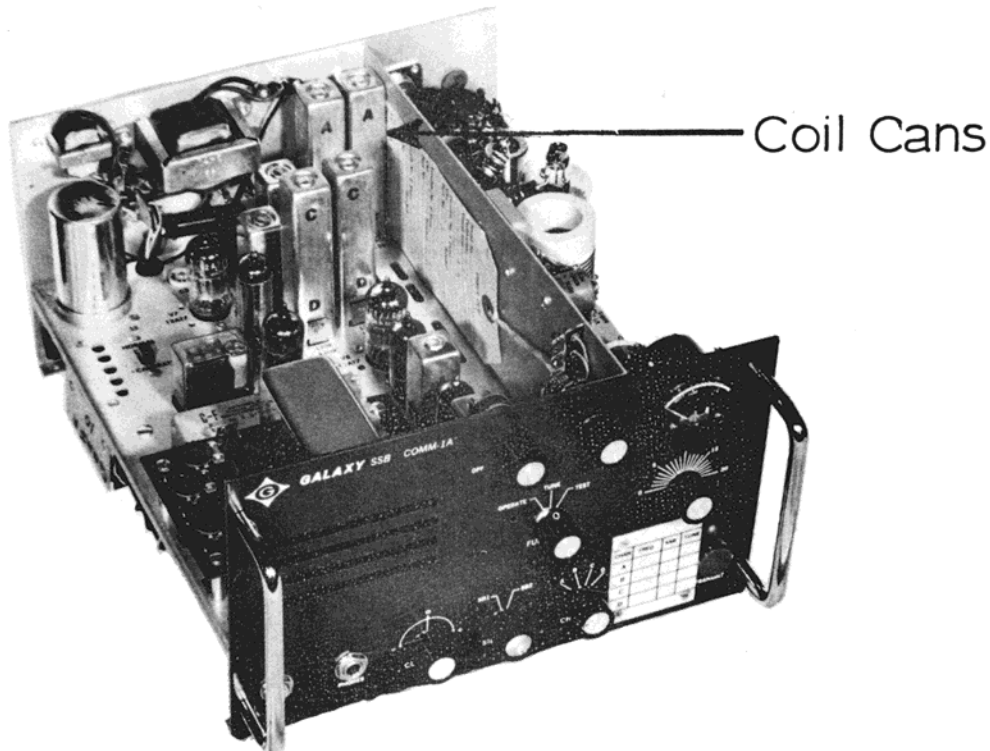
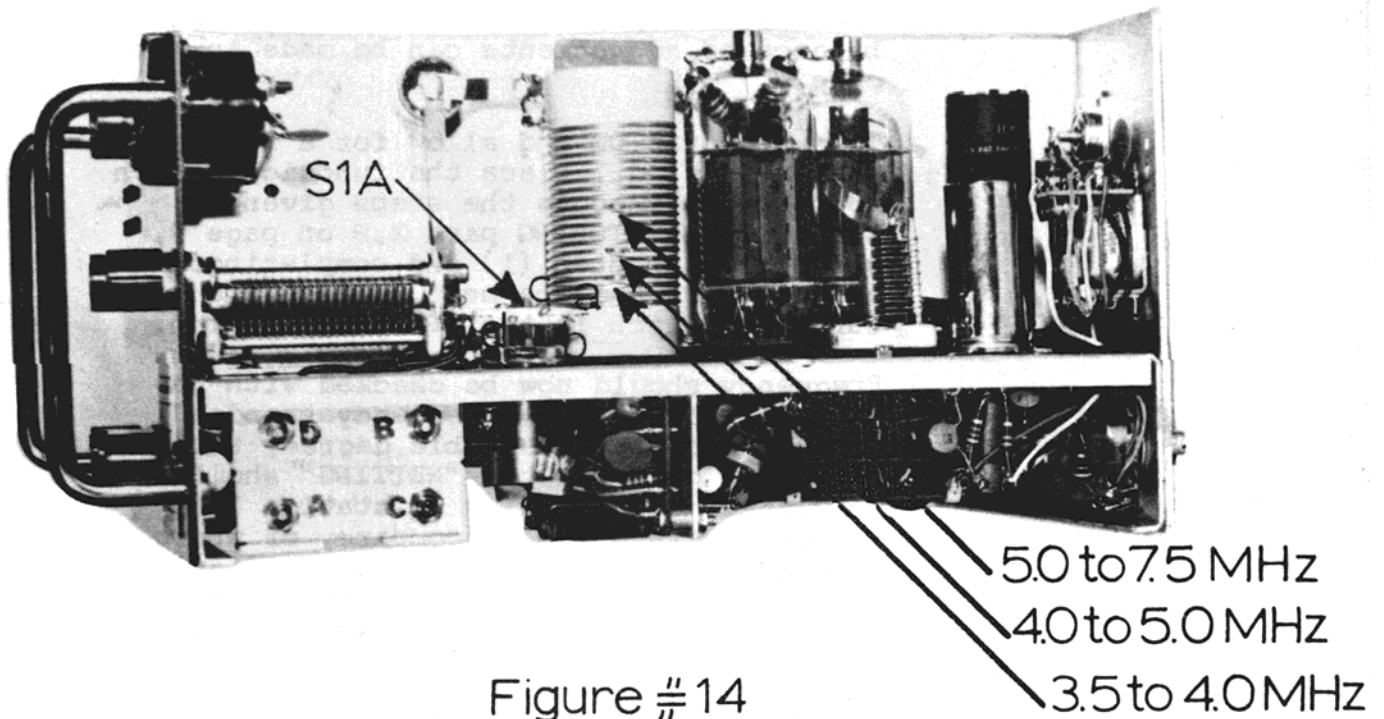

Figure # 13

5.2. Changing Frequency (FINAL)

Refer to Figure #14 for PA coil tapping information when changing frequency. If all channels will operate on frequencies within 3.0-3.5 MHz, then no taps are necessary from S1A to the coil L311. A tap is only made when the frequency will be changed outside the 3.0 to 3.5 MHz range to one of 3.5-4.0MHz, 4.0-5.0MHz, 5.0-7.5MHz. It is IMPORTANT to note that the lowest frequency MUST be in Channel A, the next lowest in Channel B, etc. with the highest being in Channel D. Notice in Figure #14 there is no tap connection from S1A to L311 indicating that all Channels are in the 3.0-3.5 MHz range. As another example, should the user have a frequency in every range there would have to be a tap from lug B of S1A to coil tap 3.5-4.0 MHz, a tap from lug C of S1A to coil tap 4.0-5.0 MHz, and a tap from lug D of S1A to coil tap 5.0-7.5 MHz.



After the final amplifier (PA) coil tapping changes have been made, as necessary, the balance of alignment, including precise exciter tuning can be completed. Refer to INITIAL ADJUSTMENTS para 2.5 on page 6. Execute steps 1 thru 8 then set the MIC control to fully clockwise turn the unit ON as in step 7 and allow for a 2 minute warm-up. Locate the loading capacitor for the channel being aligned (C324 through C327) and turn the screw in it counter-clockwise until the stop is reached. Place the function switch in the TUNE position and quickly adjust the TUNE control for a maximum reading on the meter. Now adjust the exciter coils for the desired channel (tall cans Figure #13) again adjusting for maximum meter reading. Place the function switch to OPERATE. Remove all power from the unit. Replace it in the case. The balance of adjustments can be made in the case.

Turn the unit ON and allow for a 2 minute warm-up period. Place the function switch to test and execute the steps given in the ANTENNA MATCHING para 2.8 on page 9, starting with step (1) and completing all on this page and the next. Place the function switch in the OPERATE position.

Frequency should now be checked with the control station or a frequency standard. If "off" to an appreciable degree, the alignment given in the "NETTING" should be completed. If there is no station being received with which to compare, or where this station is the control station and must individually determine the accuracy of all stations, these alternate procedures may be used.

COUNTER METHOD: This requires an electronic frequency counter which is capable of reading absolute frequency in the ranges for which operation is required. Connect the output of the COMM-1A into a 50 ohm dummy load capable of absorbing the 200 watts for the duration of the test.

Connect the counter input to the dummy load through a 10,000 ohm 1/2 watt resistor. Place the function switch in the OPERATE position, set the switch S2 to the CALIBRATE position. Place the sideband selector to SB2. Turn MIC gain control fully clockwise and then key the COMM-1A to a transmit condition with a dummy microphone plug inserted in the microphone jack (jumper from tip to sleeve on the dummy plug). Align the channel or channels starting with A, then B and so on. The controls adjusted are the same as given in the NETTING information, R14 for A, R13 for B, etc. When the channels have each been set to the exact frequency required, as indicated by the frequency counter, switch to SB1 and repeat the adjustments using C7 for A, C6 for B etc as before.

To peak the output coil L1, located on the main oscillator control board, determine which channel is closest to the center of all operating frequencies and switch to that channel. Connect an RF reading VTVM to the output terminal of L1 and adjust L1 for maximum meter reading. Return S2 to NORMAL position, remove the dummy plug and re-insert the microphone plug.

5.3 PA Neutralization

Place the MIC control fully clockwise and the function switch to the TUNE position. Rock the TUNE control for maximum meter reading. Now set the function switch to TEST, note the reading. Rock the TUNE control slightly to obtain minimum meter reading. Compare this with the reading just noted. If they are the same the unit is neutralized. If not, then the amplifier must be neutralized, which is done by changing the setting of C313 until the readings are the same.

5.4 9 MHz Trap Alignment

Apply a 9 MHz signal to the antenna connector J306. Adjust the generator output until the meter of the COMM-1A reads S9. Now tune L310 and T302 for maximum meter reading. Now adjust L301 for minimum meter reading.

5.5 Carrier Crystal Alignment

- 1 - Set the sideband selector switch to SB2.
- 2 - Set the function switch to OPERATE.
Connect an audio generator to the COMM-1A through the microphone jack using a jumper on the plug from the tip to the sleeve to place the COMM-1A in the transmit condition.
- 3 - Set the MIC control to 10 o'clock.
- 4 - Set the audio generator output control to obtain a reading on the COMM-1A meter from S6 to S8. Tune the audio generator in the 800 to 1300 hertz range to find where the COMM-1A meter has a maximum meter reading. Set the audio generator to obtain S9 once the maximum point has been reached.
- 5 - Reset the audio generator to 300 hertz exactly and adjust C308 for exactly S6 on the COMM-1A meter.
- 6 - Switch the sideband switch to SB1 and repeat steps 2 thru 5.
- 7 - Reset the audio generator to 300 hertz exactly and adjust C309 for S6 on the COMM-1A meter.

5.6 Carrier Balance

Tune the COMM-1A in the TUNE position for maximum meter reading. Set the function switch back to OPERATE position, insert a dummy microphone plug with a jumper from the tip to the sleeve to put the unit in transmit. Connect an RF reading VTVM to the antenna output J306. Set the MIC control fully counter-clockwise. Alternately adjust C307 and R301 until a minimum reading is obtained on the VTVM, which should be below 2/10 volt RMS.

5.7 Voltage/Resistance Measurements

The following charts provide typical voltage and resistance measurements made on a normally functioning unit as a guide. To make these tests, the controls must first be set as follows: Bandswitch--channel A; Clarifier--to midpoint; Sideband selector switch--SB1; Audio control--fully counter-clockwise; MIC control--fully counter-clockwise. In each column there are two sets of figures given; the top is with the set receiving (function switch in OPERATE) and the bottom measurement in transmit condition (function switch in TUNE condition), and in the last instance, the unit unit properly tuned if it's condition permits.

TRANSISTORS MEASURE TO CHASSIS READINGS ARE IN VOLTS

(On these measurements (R) means receiving and (T) is transmitting)
(ON and OFF refer to the oven control cycling while receiving)

TRANSISTOR	EMITTER	COLLECTOR	BASE
Q104 (R)	3.8v	8.9v	4.4v
Q103 (R)	8.9v	5.5v	8.8v
Q102 (R)	3.7v	9.6v	4.5v
Q102 (T)	12.5v	12.0v	5.0v
Q101 (R)	-24.0v	-.4v	23.5v
Q202 (R)	8.0v	12.2v	9.0v
Q302 (R)	13.7v	12.0v	12.7v
Q203(ON)	8.0v	12.0v	8.6v
Q203(OFF)	8.5v	12.6v	9.1v
Q204(ON)	8.0v	9.5v	8.6v
Q204(OFF)	8.5v	11.8v	9.0v
Q205(ON)	10.5v	10.5v	9.5v
Q205(OFF)	12.5v	0 v	11.8v
Q301(ON)	11.2v	10.5v	10.5v
Q301(OFF)	12.3v	0 v	12.5v
Q1(R)	1.1v	7.7v	1.5v
Q2(R)	1.4v	12.5v	2.1v
Q303(R)	12.0v	.1v	12.0v
Q304(R)	12.0v	.1v	12.0v
Q305(T)	0 v	2.6v	0 v

TUBE	PINS								
	1	2	3	4	5	6	7	8	9
V1(R)	-.35	.7	0	12.6	300	120	0	-	-
V1(T)	0	7.3	0	12.6	300	-40	0	-	-
V2(R)	.95	0	nc	12.6	6.2	0	42	300	42
V2(T)	7.3	-100	nc	12.6	6.2	0	-35	-35	-35
V3(R)	-.4	.62	6.2	0	290	162	0	-	-
V3(T)	-.42	.62	6.2	0	290	162	0	-	-
V4(R)	-.4	0	12.6	0	290	120	1.6	-	-
V4(T)	0	0	12.6	0	295	-40	7.3	-	-
V5(R)	2	3.8	6.3	0	150	150	0	-	-
V6(R)	290	-.1	39	6.3	12.6	87	.8	55	50
V7(R)	152	0	95	12.6	12.6	152	0	95	6.3
V7(T)	148	0	2.6	12.6	12.6	148	0	2.6	6.3
V8(R)	300	0	93	6.2	6.2	300	0	93	12.6
V8(T)	130	0	1.7	6.2	6.2	130	0	1.7	12.6
V9(R)	90	0	0	0	6.2	nc	400	400	0
V9(T)	4.2	0	0	0	6.2	nc	380	145	0
V12(R)	-	-	-	-	155	-	0	-	-

PINS

TUBE	1	2	3	4	5	6	7	8	9	10	11	12
V10(R)	6.1	nc	0	0	-70	0	nc	0	-70	0	0	0
V10(T)	6.1	nc	180	.1	-70	180	nc	180	-70	.1	180	0
V11(R)	6.1	nc	0	0	-70	0	nc	0	-70	0	0	12.3
V11(T)	6.1	nc	180	.1	-70	180	nc	180	-70	.1	180	12.3

The following resistance chart is taken with the power supply disconnected. Measurements are made from the tube pin specified to the chassis ground. The symbol(*) is infinity, (m) megohms, (k) thousands of ohms. A VTVM, rather than a VOM, should be used to take measurements for greatest accuracy.

TUBE	PINS											
	1	2	3	4	5	6	7	8	9	10	11	12
V1	5m	47	0	.5	11k	24k	0	-	-	-	-	-
V2	150	100k	nc	.5	.6	100k	55k	12k	55k	-	-	-
V3	5m	47	.6	0	12k	55k	0	-	-	-	-	-
V4	5m	0	.5	0	12k	24k	100	-	-	-	-	-
V5	2.2m	1k	1.3	0	240k	60k	22k	-	-	-	-	-
V6	12k	1m	1m	1.3	.5	240k	700	12k	12k	-	-	-
V7	11k	100k	*	.5	.5	11k	0	*	.6	-	-	-
V8	47k	.18	*	.5	.5	47k	.18	*	.5	-	-	-
V9	*	22k	0	0	.5	nc	12k	80k	0	-	-	-
V10	.5	nc	6.4k	2.5	8.5k	6.4k	nc	6.4k	8.5k	2.5	6.4k	.34
V11	.34	nc	6.4k	2.5	8.5k	6.4k	nc	6.4k	8.5k	2.5	6.4k	0
V12	-	-	-	-	8k	-	0	-	-	-	-	-

PARTS LIST

C37	.01 mfd disc. @600v	20-5
C17	.005mfd disc. @ 600v	20-3
C24	.001mfd disc. @ 600v	20-24
C301	2 x 40mfd electrolytic @ 450v	24-21
C302	100PF @ 1kv	20-23
C303	300pf air variable	25-15
C304/305	.01mfd disc. @ 600v	20-5
C306	250pf DSM	22-45
C307/308/309	5/25pf trimmer	26-6
C310/311/312	250 DSM	22-45
C313	4/22pf trimmer	25-11A
C314	110pf DSM	22-41
C315	100pf DSM	22-21
C316	.001mfd disc. @ 600v	20-24
C317	2000pf DSM	22-27
C318/319	.005mfd disc. @ 600v	20-3
C320 to C323	.001mfd disc. @ 600v	20-24
C324/325/327	800/1,970pf trimmer	26-9
C326	730/1,785pf trimmer	26-10
C328 to C335	.001mfd disc. @ 600v	20-24
C336	2,000mfd electro. @ 15vdc	24-20
C337/338	.005mfd disc. @ 600v	20-3
C339	.01mfd disc. @ 1.6kv	20-29
C340	.001mfd mica @ 5kv	22-18
C341	.005mfd disc. @ 600v	20-3
C342/344	33pf DSM	22-7
C343	300pf DSM	22-44
C345	.01mfd disc. @ 600v	20-5
C346	.005mfd disc. @ 600v	20-3
C347/349	.01mfd disc @ 600v	20-5
C348	.05mfd electrolytic @ 400v	23-6
C350	.001mfd mica @ 600v	22-28
C351	.001mfd disc. @ 1.6kv	20-24
C352	.005mfd disc. @ 600v	20-3
C353	.01mfd disc. @ 600v	20-5
C354	.1mfd electrolytic @ 200v	23-7
C355	.005mfd disc. @ 600v	20-3
C356	.001mfd disc. @ 1kv	20-24
C358	91pf DSM	22-43
C359 to C362	220pf disc. DSM	22-23
C363	.001mfd disc. 1kv	20-24
C364	.005mfd disc. @ 600v	20-3
C365	50 DSM	22-11

C366	120pf DSM	22-12
C367/C369	.01mfd disc. @ 600v	20-5
C368	100pf lkv	20-23
C370	5pf DSM	22-42
C371/372	.005mfd disc. @ 600v	20-3
C373	.01mfd disc. @ 600v	20-5
C374/376	.001mfd disc. @ 600v	20-24
C375	7pf N33D Tubular	20-21
C377/382	25pf disc. @ 600v	20-8
C378	.005mfd disc. @ 600v	20-3
C379	500pf lkv	20-37
C380	.01mfd disc. @ 600v	20-5
C381	4mfd electrolytic @350v	24-18
C383	.001mfd disc. @ 600v	20-24
C384	470pf disc. @ 600v	20-39
C385	50pf DSM	22-11
C386	7pf N33D Tubular	20-21
C387	.001mfd disc. @ 600v	20-24
C388	.01mfd disc. @ 600v	20-5
C389	.001mfd disc. @ 600v	20-24
C390	50pf DSM	22-11
C391	10pf disc. @ 600v	20-27
C392/393/394	.01mfd disc. @ 600v	20-5
C395	.47mfd paper @ 200v	23-16
C396	.01mfd disc. @ 600v	20-5
C397	.005mfd disc. @ 600v	20-3
C398	62pf DSM	22-9
C399/C401	500pf lkv	20-37
C400	43pf DSM	22-29
C402	.001mfd disc. @ 600v	20-24
C403/404	.01mfd disc. @ 600v	20-5
C405/406	.1mfd disc. @ 50v	20-38
C407/408	.01mfd disc. @ 600v	20-5
C409	.001mfd disc. @ 600v	20-24
C410	.01mfd disc. @ 600v	20-5
C411	100pf disc. @ 600v	20-23
C412	100mfd electrolytic 20v	29-9
C413 to C427	.01mfd disc. @ 600v	20-5
C428	100pf TCN-750 5kv	21-1
C429/430	.01mfd disc. @ 600v	20-5
C431 to C434	.005mfd disc. @ 600v	20-3

D301	diode, 1N54A	112-4
D302/D305	diode, 400PIV @ 750ma.	112-3
D303/D304	diode, 1N462	112-5
FILTER	9 Mc. crystal filter	117-4
K1	6PDT relay	116-7
K2	3PDT relay	116-8
L301	9 Mc. trap coil	42-36
L303/L302	Exciter coil C & D	42-46
L304/L305	Exciter coil A & B	42-46
L306/L307	Exciter coil A & B	42-46
L308/L309	Exciter coil C & D	42-46
L310	9 Mc. I.F. coil	42-27
L311	P.A. coil	42-25D
L312	Xmit mixer trap coil	42-47
-	Audio knob	130-14-6
-	Clarifier knob	130-14-6
-	Channel knob	130-14-7
-	Function knob	130-14-6
-	Mic gain knob	130-14-6
-	Sideband knob	130-14-6
-	Tune knob	130-14-6
-	Cabinet	140-13A
-	Dial Lamp #24, 12v	113-14
-	Front panel COMM-1	141-34
-	"Remote" jumper plug	109-1
-	Meter, special (fs-lma.)	115-6
PC301/302	Plate parasitic choke	33-5
Q301/302	40022, transistor	111-12
Q303/304	40022, matched pair	111-12
Q305	2N2926G, transistor	111-6
Q306	2N3638, transistor	111-10
R301	2.5k potentiometer	13-7
R302	50k potentiometer ("S" meter)	13-8
R303	250 Ohm potentiometer	13-17
R304	18k 2 watt	12-12
R305	10k potentiometer	13-25

R306	270 Ohm, 1/2 watt	10-68
R307/310	2.2k, 1/2 watt	10-31
R308/309	680 Ohm, 1/2 watt	10-72
R311	800 Ohm, 15 watt	11-1G
R312	10k, 1/2 watt	10-56
R313	22k, 1/2 watt	10-6
R314/316	100 Ohm, 1 watt	11-16
R315	68k, 1 watt	11-19
R317	1.2k, 1/2 watt	10-78
R318 to R321	10 Ohm, 1 watt	11-22
R322	100 Ohm, 1 watt	11-16
R323	39k, 2 watt	12-31
R324	15k, 1/2 watt	10-81
R325	3.5k, 10 watt	16-8
R326	6k, 10 watt	16-16
R327	3.3meg, 1/2 watt	10-57
R328	47k, 1/2 watt	10-13
R329	47 Ohm, 1/2 watt	10-29
R330	4.7k, 1 watt	11-4
R331	7.5k, potentiometer	13-12
R332	2.2k, 1/2 watt	10-31
R333	220 Ohm, 1 watt	11-18
R334/335	100k, 1/2 watt	10-32
R336	150 Ohm, 1/2 watt	10-43
R337	22k, 1 watt	11-10
R338	47k, 2 watt	12-11
R339	100k, 1/2 watt	10-32
R340	470 Ohm, 1/2 watt	10-53
R341	47 Ohm, 1/2 watt	10-29
R342	47k, 1/2 watt	10-13
R343/345	1k, 1/2 watt	10-42
R344	100k, 1/2 watt	10-32
R346	100 Ohm, 1/2 watt	10-7
R347	22k, 1/2 watt	10-6
R348	47k, 1 watt	11-9
R349	220k, 1/2 watt	10-4
R350	2.2 meg, 1/2 watt	10-2
R351	1k, 1/2 watt	10-42
R352	50 Ohm, 10 watt (two 25 Ohm)	11-11C
R353	330k, 1/2 watt	10-69
R354	10k, 1/2 watt	10-56
R355	27k, 1/2 watt	10-14
R356	68k, 1/2 watt	10-33

R357	10 Ohm, 1/2 watt	10-52
R358	330 Ohm, 1/2 watt	10-28
R359	150k, pot. with S7 switch	13-24
R360	100k, 2 watt	12-20
R361	1k, 1/2 watt	10-42
R362/363	1.5k, 1/2 watt	10-3
R364	47 Ohm, 1 watt	11-27
R365	100k, 1/2 watt	10-32
R366	100 Ohm, 1 watt	11-16
R367	4k, 10 watt	16-13
R368	1.5k, 1 watt	11-3
R369	10k, potentiometer	13-9
R370	10k, 1/2 watt	10-56
R371	120k, 1/2 watt	10-76
R372	1k, 1/2 watt	10-42
R373	680 Ohm, 1/2 watt	10-72
R374	220k, 1/2 watt	10-4
R375/376	1 meg, 1/2 watt	10-10
R377	10k, 1/2 watt	10-56
R378	33k, 2 watt	12-23
R379	560 Ohm, 1/2 watt	10-67
R380	68 Ohm, 1/2 watt	10-18
X301	9,001.25 kc. HF crystal	117-4A
X302	8,998.75 kc. LF crystal	117-4B
RFC301	Special plate choke	30-13
RFC302/306 to308	750 uh choke	30-3
RFC303/304/305	2.5 mh choke	30-9
RFC309	40 uh choke	30-11
RFC310	3 mh choke	30-16
RT301	Special thermistor	210-1
S1	2P, 4 position: P.A. switch	53-24
S2A/S2B	D.P.D.T. slide switch	51-04
S3	3P, 2 position: SB select	53-13
S4A/S4B	2P, 4 position: Osc. select	53-25
S5	4P, 4 position: Channel select	53-26
S6	4P, 3 position: Function select	53-23
S7	(Part of R359 potentiometer)	-----
T301	Balanced modulator coil	73-8
T302	I.F. transformer	73-06
T303	Audio driver transformer	74-05
T304	Audio output transformer	74-06
V1	12BZ6 tube	110-12BZ6
V2	6HG8 tube	110-6HG8
V3	6EW6 tube	110-6EW6

V4	12BA6 tube	110-12BA6
V5	6GX6 tube	110-6GX6
V6	6EA8 tube	110-6EA8
V7/V8	12AT7 tube	110-12AT7
V9	6GK6 tube	110-6GK6
V10/V11	6HF5 tube	110-6HF5
V12	OA2 regulator tube	110-OA2
-	Red lens	68-1
-	Lamp holder	67-3
-	FREQUENCY CONTROL BOARD	200-15-A
R1	5.6k, 1/2 watt	10-83
R2	27k, 1/2 watt	10-14
R3/4/5	1k, 1/2 watt	10-42
R6	100k, 1/2 watt	10-32
R7/8/9/10	2.2k, 1/2 watt	10-31
R11/12/13/14	10k miniature potentiometer	13-23
R15	820 Ohm, 1/2 watt	10-75
R16	68 Ohm, 1/2 watt	10-18
R17	560 Ohm, 1/2 watt	10-67
R18	2.7k, 1/2 watt	10-66
R19	not used	-----
R20	820 Ohm, 1/2 watt	10-75
RT-1	Thermistor QA51J1	210-2
C1	.001mfd @ 600v disc. ceramic	20-24
C2/C4	.01mfd @ 600v disc. ceramic	20-05
C3	100pf @ 600v disc. ceramic	20-23
C5	330pf DSM	22-39
C6/7/8/9	2.2/34pf miniature air variable	25-23
C10	330pf DSM	22-39
C11	.01mfd DSM	20-05
C12	68pf DSM	22-40
C13	.01mfd DSM	20-05
C14/15/16/17	18 @ 600v dip silver mica	22-24
RFC1/2/3/4	1mh choke	30-18
RFC5	39mh	30-21
Q1/2	2N3855 transistor	111-11
D1	2N2926A (diode connected)	111-6A
D2	Vari-Cap	112-A3
D3/4/5/6	1N270	112-10
L1	Output coil	42-45
X1/2/3/4	Crystals as applicable	117---
-	Mounting board	200-15A
500-01	Heater box ass.	500-01
-	XTAL hold-down springs	124-49
-	Crystal sockets	64-2

HEATER CONTROL BOARD #200-16

-	Mounting board	200-16
R201	120k, 1/2 watt	10-76
R202	15k, 1/2 watt	10-81
R203	470 Ohm, 1/2 watt	10-53
R204	1.8k, 1/2 watt	10-17
R205	82 Ohm, 1/2 watt	10-87
R206	6.8k, 1/2 watt	10-15
R207	6.8k, 1/2 watt	10-15
R208	68 Ohm, 1/2 watt	10-18
Q201	2N2926A transistor	111-6A
Q202/203/204	2N2926G transistor	111-6C
Q205	2N3638 transistor 111-10	
D201/202	Power diode	112-3

AUDIO/AVC BOARD #200-5A

	Mounting board	200-5A
R101	100 Ohm, 1/2 watt	10-7
R102	270 Ohm, 1/2 watt	10-68
R103/104	10k, 1/2 watt	10-56
R105	18k, 1/2 watt	10-80
R106	1k, 1/2 watt	10-42
R107	100 Ohm, 1/2 watt	10-7
R108	33k, 1/2 watt	10-65
R109/110	6.8k, 1/2 watt	10-15
R111	2.2k, 1/2 watt	10-31
R112	1k, 1/2 watt	10-42
R113	330k, 1/2 watt	10-69
R114	820 Ohm, 1/2 watt	10-75
R115	10k, 1/2 watt	10-56
R116	47k, 1/2 watt	10-13
R117	15k, 1/2 watt	10-81
R118	1k, 1/2 watt	10-42
R119	4.7 meg, 1/2 watt	10-70
R120	33k, 1/2 watt	10-65
C101/102/104	100mfd @ 2vdc electrolytic	29-9
C103/105/106	2mfd @ 50vdc electrolytic	29-12
C107	.01mfd disc. @ 600v	20-5
C108	.1mfd disc. @ 50v	20-38

C109	.22mfd paper @ 100vdc	23-15
C110	.02mfd disc. @ 50v	20-49
Q101/102	2N2926Y transistor	111-6Y
Q104	2N2926 transistor	111-6
Q103	2N1098 transistor	111-8

GENERAL INFORMATION

FIELD ENGINEERING SERVICE

Galaxy field service engineering assistance is available to all customers, to aid in selection of equipment, frequencies, antenna, and station accessories to fill specific system requirements. This service is available at no charge. Please call for specific detailed information.

FACTORY TRAINING

Galaxy Electronics will provide factory training for service technicians to assist in maintenance of our equipment. Full details of this service are available on request.

FACTORY SERVICE

Galaxy equipment requiring factory service must be delivered to one of our field service stations or direct to Galaxy Customer Service Department, transportation pre-paid. Service and return will be accomplished with minimum delay, C.O.D., unless prior arrangements have been made.

DELIVERY

All items in this catalog are normally in stock. Normal delivery time is 30 days or less, after receipt of purchase order. Where system adaptation will require modification of equipment or accessories, delivery time will be flexible. Inquiries are invited regarding full system deliveries.

WARRANTY INFORMATION

Specific warranty information is contained in each product manual. If you require specific information regarding our warranty policy, contact our customer service department.

CUSTOMER SERVICE INFORMATION

Galaxy Electronics maintains a customer service department capable of providing full assistance and service for individual products or complete systems. When service or information is desired, call (712) 328-2553, extension 76.