

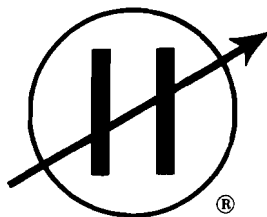

**VHF RECEIVER TRANSMITTER  
MODEL FM50A**

**MANUFACTURED BY THE HAMMARLUND MFG. CO.**



Established 1910

**INSTALLATION AND SERVICE MANUAL**

**MARKETING & DISTRIBUTION  
OUTERCOM ELECTRONICS CORP.  
502 Charlottetown Mall  
Charlotte, North Carolina**

**Telephone 333-8689 Area Code 704  
Cable Address "outercom"**



FRONT VIEW MODEL FM-50-A

FM-50-A TECHNICAL SPECIFICATIONS

<u>Frequency Range:</u>	147 to 174 Mcs, on any single channel (not necessarily the same for receiving and transmitting)
<u>Transmitter:</u>	
FCC File #	Hammarlund Type FM-50-A
Power Output into 50 ohm load:	117V AC operation, 35 watts ( $\pm 10\%$ ) 12V DC operation, 30 watts ( $\pm 10\%$ ) 6V DC operation, 20 watts ( $\pm 10\%$ )
Duty Cycle:	117V AC - 1 min. on, 1 min. off 12V DC - 1 min. on, 4 min. off 6V DC - 1 min. on, 4 min. off
Crystal Multiplication:	Twelve Times
Frequency Stability:	0.0005% ( $-30^{\circ}$ to $+60^{\circ}$ C ambient temperature range) OVEN CONTROLLED
Modulation:	16F3, $\pm 5$ Kc deviation for 100% modulation at 1000 cps
Modulation Limiting:	Instantaneous and automatic, .25V rms input at 1000 cps for thresh-hold of limiting
Audio Response:	$+1$ to $-3$ db from 300 to 3000 cps, 1000 cps reference
Distortion:	Less than 10% at 3.5 Kc deviation, 1000 cps modulating frequency
Spurious & Harmonic Radiation:	At least 60 db down
Hum & Noise:	At least 40 db below $\pm 3.3$ Kc deviation, 1000 cps reference
<u>Receiver:</u>	
Frequency Stability:	See transmitter specifications above
Sensitivity:	0.5 microvolt or less for 20 db quieting
Selectivity:	$\pm 5$ KC (or greater) at 6 db down $\pm 17$ KC (or less) at 100 db down
Spurious Response Attention:	At least 90 db down
Intermodulation Spurious Attention:	At least 65 db down
System Audio Response:	$\pm 2$ db from 300 to 2500 cps, 1000 cps reference
Audio Output:	At least 1.0 watt at less than 10% distortion into built-in speaker
Hum & Noise Level	Squelched, at least 50 db down from rated output Unsquelched, at least 40 db down from rated output
Squelch:	Signal to noise ratio type, front panel adjustable, .15 microvolt or less at thresh-hold
Duty Cycle:	Continuous
Crystal Frequency Formula:	<u>Signal Frequency -10.7 MC</u>

Tube Complement

6BS8	Receiver	Cascode RF Amplifier
6BR8	"	1st Oscillator/Multiplier and 1st Mixer
6BR8	"	1st IF Amplifier (10.7 mc) and Squelch Noise Amplifier
6BR8	"	2nd Oscillator and 2nd Mixer
6BH6	"	2nd IF Amplifier (1.65 mc)
6BH6	"	1st IF Limiter
6BN6	"	2nd IF Limiter and FM Detector
12AX7	"	1st Audio Amplifier and Squelch DC Amplifier
6AQ5	"	Audio Power Amplifier
6BR8	Transmitter	Crystal Oscillator and Phase Modulator
6AW8A	"	Buffer and 1st Frequency Multiplier
6360	"	2nd and 3rd Frequency Multipliers
6146	"	RF Power Amplifier
12AX7	"	1st and 2nd Audio Amplifiers

Semi-Conductor Complement

	IN 2482	Receiver Squelch Rectifier
(2)	2N 442	Power Supply Switching Transistors
(8)	IN 1490	Power Supply High Voltage Rectifiers
	IN 1490	Power Supply Relay Rectifier (AC Operation Only)
(2)	IN 2482	Transmitter Modulation Limiters

Power Requirements:

Nominal Input Voltage	117 volts	6V DC *	12V DC *
	(50 to 400 cycles)		
Receiving-Standby	50 watts	11.5 amps	5.75 amps
Receiving Ready to Transmit	70 watts	15 amps	7.5 amps
Transmitting	175 watts	25 amps	15 amps
Intermittent Xtal Oven Drain	4 watts	.6 amps	1.2 amps

SIZE 13" wide, 7" high, 7-3/8" deep

WEIGHT 21 lbs. less antenna and power cables

\* DC voltage tests are made using Electronics Industry Association Standards which are;  
 a) For 6 volt systems, standby voltage is 6.8V DC and transmit voltage is 6.3V DC.  
 b) For 12 volt systems, standby voltage is 13.6V DC and transmit voltage is 13.0V DC.

## DESCRIPTION

The FM-50-A is a rugged, compact communications unit designed to operate from any 6 or 12 volt d. c. (negative or positive ground) vehicle power source or a 117 volt a. c. 50 to 400 cycle land station power source.

The FM-50-A is designed for narrow-band phase/frequency modulation ( $\pm 5$ KC deviation) operation in the frequency range of 147 to 174 megacycles. The receiver and transmitter sections are designed for single channel, crystal controlled operation. The transmitter and receiver may be operated on the same channel (as in the business radio service) or on different channels (as in the taxicab radio service).

All necessary components for 6 or 12 volt d. c. operation of either polarity or 17 volt AC operation are built into the basic communications unit. The proper circuitry is selected by the wiring of the external power plug thereby eliminating the need for jumpers or switches in the basic unit. The FM-50-A may be interchanged in any 6, 12 or 117 volt system without modification.

## OPERATING INSTRUCTIONS

Control Functions: There are only three external controls. The left knob is a conventional volume control; the right knob controls the squelch. By turning the squelch knob clockwise, the sensitivity is increased and as this control is advanced clockwise, a point will be reached beyond which a loud hiss will be heard. However, there is a setting before this point where the receiver is operating at optimum sensitivity in a squelched (noiseless) condition.

The three-position power switch on the panel is "OFF" in the extreme left setting. In the center, or "STDBY" position, the receiver only is operating, and the transmitter filaments are turned off. In the "OPERATE" position, the receiver remains "ON" however the transmitter filaments are also "ON". After a warm-up period of about 20 seconds, the transmitter is ready for operation by depressing the "push-to-talk" switch on the microphone.

The "on-off" pilot lamp located to the left side of the power switch lights when the set is turned on. The pilot lamp on the right side lights only when the transmitter is on the air.

When the push-to-talk microphone switch is depressed, the transmitter section of the communication unit is actuated, the red transmit lamp lights and the receiver is muted. Release of the push-to-talk switch, turns the transmitter section off, extinguishes the red transmit lamp and actuates the receiver section. This sequence of events is in the "OPERATE" position of the power switch. When this switch is in the "STDBY" position the microphone push-to-talk circuitry is inoperative.

The use of the "STDBY" mode of operation is highly recommended where long periods of listening only is expected as lower power drain together with longer transmitter tube life will result.

The FM-50-A is a highly efficient receiver-transmitter and will provide reliable communications over great distances if properly used. Radio operating is an art that is easily learned with practice.

The limitations of a system installation in any particular area can be learned through use. Every system, regardless of the frequency or power, will have some locations where it is not possible to communicate. However, within its range, trees, buildings, small hills and similar obstructions will have little or no effect on communications. The range of a system is dependent on a few important factors, such as location and height of base station antenna power,

and nature of surrounding terrain. The use of a high gain type of antenna at the base station is highly recommended in all installations for best possible performance.

Assuming that the most efficient installation of the FM-50-A is made, one important consideration remains. This is correct operating procedure and a few important notes in this regard are:

1. Before transmitting, listen to the receiver and make certain no one else is on the channel.
2. Let the mobile operator get in the practice of calling the base station for instructions. Since the base station is in a known, fixed location, the mobile operator can call when he knows he is in a good location.
3. Show each mobile operator how radio actually helps him in his work by eliminating doubts about delivery, reducing unnecessary travel, etc.
4. If you are trying to contact a mobile unit from the base station, remember that he may be in a poor radio-location, he may have both hands busy in heavy traffic, or he may have stopped in the local diner. If you do not contact him after one or two quick calls, wait a few minutes before calling again.
5. Keep messages short and brief. Know what you are going to say before you depress the microphone button. Many 100 word discussions can be reduced to 10 word messages by thinking and planning before going "on-the-air".
6. Adopt a system of routine and preventative maintenance with your serviceman.
7. Become familiar with the F. C. C. rules and regulations concerning operation of two-way radio for your particular class of service.

#### Transmitter Tune-Up Procedure:

CAUTION - The plate capacity of the 6146 output stage is "hot" at all times when power is turned ON. This applies to both the "STANDBY" and "ON" positions of the power switch.

The transmitter duty cycle is one minute on, four minutes off; therefore, all adjustments should be made as quickly as possible, keying the transmitter only when ready for actual adjustment or measurement. To minimize interference, on-the-air testing (with antenna connected) should be kept to a minimum. The use of a 50 ohm dummy load is recommended for all but the final on-the-air use of the equipment.

If extended periods of testing and/or servicing the exciter stages of the transmitter are required it is recommended that the lead connecting R150 and R151 be opened. All tests up to and including the grid of the final stage can be made.

#### Test Equipment Required:

1. 0-100 micro-ammeter (2000 ohm internal resistance) see page 21 for recommended test meter circuit.
  2. RF wattmeter with 52 ohm dummy load.
  3. Modulation deviation meter.
  4. Frequency meter with an accuracy of at least .00025%.
- (a) With a 0-100 micro-ammeter connected from terminal 2 of J105 to ground (terminal 11) adjust L118 for maximum indication. (position 2 of recommended test meter)
- (b) With the micro-ammeter now connected from terminal 3 of J105 to ground, adjust L117 for maximum indication. (position 3 of recommended test meter)

- (c) With the micro-ammeter now connected from terminal 4 of J105 to ground, adjust L116 and L115 for maximum indication. (position 4 of recommended test meter)
- (d) With the micro-ammeter now connected across terminals 5 and 7 of J105, adjust C159 for maximum indication. The value of shunt R153 is such that a micro-ammeter with an internal resistance of 2000 ohms will actually read 10 milliamperes at full scale. When making this adjustment, a minimum of 2.5 milliamperes should be obtained. (position 5 of recommended test meter)
- (e) With the micro-ammeter connected across terminals 9 and 10 of J105, C154 and C153 should be adjusted for maximum radio frequency output as indicated on the dummy load. The value of meter shunt R149 is such that the micro-ammeter will read 200 milliamperes full scale. When making this adjustment, the final plate current should not exceed a value of 160 milliamperes. Excessive loading as indicated by abnormally high plate current may be corrected by increasing the spacing (decrease coupling) between L112 and L113.
- (f) Neutralization should be checked by removing the crystal from its socket Y201. With the crystal removed, the grid current of the final radio frequency stage should be zero. Rotating the plate tuning condenser C154 should not produce any grid current or radio frequency output. This test should be made with the final stage shield in place.
- (g) After making the above adjustments, the transmitter frequency should be set against a known standard. This adjustment is C183 associated with the crystal oscillator stage V113A.
- (h) After making the previous adjustments the deviation should be adjusted by applying a 1000 cycle tone of 1.0V rms amplitude to the microphone connector J104. Potentiometer R172 should be adjusted for  $\pm 5$  Kc deviation as indicated on a deviation meter. This adjustment should always follow step (g) above.

### CRYSTAL MULTIPLICATION

The following information is listed as a guide which will be helpful when retuning a transmitter from one end of the band to the other.

	Crystal Frequency, L118
2X	Crystal Frequency, L117
6X	Crystal Frequency, L115/L116
12X	Crystal Frequency, C159/C160
12X	Crystal Frequency, (Carrier) C153/C154

NOTE - When retuning the final stage it is suggested that a 100K, 1 watt resistor be temporarily in series with R150 and R151 to limit the plate dissipation to a safe value. A power output of 5 to 10 watts should be achievable when C159, C154, and C153 are properly resonated.

### COMPLETE RECEIVER ALIGNMENT PROCEDURE

#### TEST EQUIPMENT REQUIRED:

1. 0-100 micro-ammeter (2000 ohms internal resistance).
  2. DB audio output meter.
  3. Low frequency signal generator covering 1650 KC and 10.7 MC.
  4. High frequency FM signal generator covering 1363 to 174 MCS.
1. (a) Connect a 1650KC signal to pin 9 of V104A.
  - (b) Connect micro-ammeter from J105 pin 3 to ground. (position 3 of recommended test meter)
  - (c) Adjust top and bottom of T104 for maximum indication.

2. (a) Connect micro-ammeter from J105 pin 2 to ground. (position 2 of recommended test meter)  
 (b) Adjust top and bottom of T102 and T103 for maximum indication.  
 (c) As each adjustment is brought into resonance, the output of the signal generator should be decreased so as to produce a meter reading between 25 and 75 micro-amperes. This precaution is necessary so as to eliminate the possibility of overload which will result in false peak indications.
3. (a) Connect a 10.7 MC signal to pin 1 of V102A.  
 (b) Leave micro-ammeter connected to pin 2 of J105. (position 2 of recommended test meter)  
 (c) Adjust L106, L107 and L108 for maximum indication observing step 2(c) above.
4. (a) Connect micro-ammeter from pin 1 of J105 to ground. (position 1 of recommended test meter)  
 (b) Adjust L103 (oscillator) for maximum indication.
5. (a) Connect signal generator on signal frequency to antenna terminal, J102.  
 (b) Connect micro-ammeter from J102 pin 2 to ground. (position 2 of recommended test meter)  
 (c) Adjust T101, ZF101 and L105 for maximum indication observing precaution outlined in step 2(c).
6. (a) With an input signal of approximately .5 microvolt, touch up T101, ZF101, L105, L106, L107, L108, T102, T103 for maximum quieting. This will approximate the same resonance points as maximum 1st limiter grid current indication.
7. (a) Adjust L109 for maximum hiss level keeping the front panel volume control below the overload point.  
 (b) With an on-channel frequency modulated signal applied to the input of the receiver, readjust L109 for maximum recovered audio.
8. (a) Loosely couple an accurate 10.7 MC signal to the grid of V102A (Pin 1) and adjust L103 for an aural zero beat indication in the loud speaker with an on frequency signal applied to the antenna input terminal J102.  
 (b) With the same unmodulated input signal follow step 6(a).  
 (c) Adjust the FM detector coil L109 as outlined in steps 7(a) and 7(b). In lieu of this technique the modulation of an "on-frequency" base station or mobile transmitter may be used. In this instance L109 should be adjusted for maximum audio consistent with lowest distortion.

It is highly recommended that the service technician make a few practice runs on a normal operating unit. With a little practice the alignment may be accomplished in less time than that required to read the procedure outlined above.

#### RECEIVER ALIGNMENT PROCEDURE, FIELD SERVICE

The "Complete Receiver Alignment Procedure" will rarely be required in the field however it should be reviewed in order to become thoroughly familiar with the receiver section of the unit. Receiver field alignment should be accomplished as follows.

9. (a) With an input signal (unmodulated) strong enough to produce approximately 20 db quieting of the thermal noise (hiss) adjust L108 to zero the first oscillator with the incoming signal as outlined in step 8(a).

NOTE: In lieu of the use of a 10.7 MC signal, L108 may be adjusted in the center of the range over which quieting sensitivity falls off. It is extremely important when making this adjustment that the incoming signal be on frequency.

9. (b) Perform step 6(a) above.

### CABLE INSTALLATION

Certain precautions must be observed when installing the FM-50-A. It is very important that polarity be observed on vehicle installations. Using the power cable chart, at the rear of the manual, first, determine which cable is to be used. In most installations, you will find that modern vehicles employ a 12 volt negative ground system, therefore, be sure to use the cable required for 12 volt negative ground installations. If the vehicle is a positive ground system be sure to use the 12 volt positive ground cable, etc.

New vehicles will generally be no problem so far as polarity is concerned. On older vehicles, the best policy is to use a volt meter and check the battery voltage and polarity before proceeding with the installation. Experience will generally tell you what the voltage and polarity of the various make and type vehicles in the field are.

It is extremely important that polarity and voltage be observed because if the polarity is accidentally reversed, you will, almost without exception, burn out at least one of the power transistors. TO PREVENT BURNING OUT POWER TRANSISTORS, OBSERVE VOLTAGE AND POLARITY.

Once the proper cable has been installed in a vehicle, the FM-50-A receiver-transmitter unit may be exchanged or inter-changed throughout the fleet with no modification or switch selection required.

### COMMUNICATIONS UNIT INSTALLATION

There are generally three or four different ways that the unit may be mounted in the cab or in area that is accessible to the driver. In most business and industrial applications, it will be found that it is most desirable to locate the receiver-transmitter somewhere in the cab of the truck or the front seat area of the vehicle. This has the advantage of short battery cables with less voltage drop and less chance of abrasion and wear.

Floor Mount: Using the FM-50-A receiver-transmitter as a pattern, place it on the floor of the vehicle and various locations until the most convenient location is found. The best location will be one where the driver can tell at a glance whether his set is on or off and where he can reach the controls on the front panel. When setting up this location, be sure to give consideration to the length of the battery cable. After the location is found, secure the universal mounting bracket, Hammarlund Part No. PL26610-G1. When drilling through the floor of a vehicle, or through any other panel or part of it, use every precaution to avoid drilling through a gas line or electrical wiring, etc. Wherever it is not possible to use nuts and bolts, drill with a proper size drill for self tapping screws and, using a good long screw driver, drive the steel screws firmly into place. Always fasten parts securely to the vehicle to avoid noise from "shaky" installation.

Under-Dash Mount: Using the radio as a template, find the best location under the dash of the vehicle. Take into consideration, special handles found on dump trucks and controls found on various types of vehicles in the field. After a practical location is found, secure the universal mounting bracket in place with the proper hardware. Use every precaution to make the battery cable as short as possible and route it in such a way that it will not interfere with the various

controls under the dash. Wherever the cable goes through the chassis, use a heavy rubber grommet to prevent chafing and eventual short circuit. Extra precautions seldom take more time when the installation is being made, but can save many hours of future maintenance and possibly a dangerous situation for the driver.

**Remote Installations:** Whenever it is not practical or desirable to have the radio unit mounted in view of the driver, it should be mounted remotely. In a passenger car the most practical place is usually in the trunk; however, there are certain vehicles that adapt themselves to other locations. Always, bear in mind that the battery cable should be as short as possible and use the same precautions discussed for the floor mount. Place the unit in such a way that it will not interfere with loading and unloading of the trunk and find the shortest route from the unit to the battery, running the cable along this route. Avoid sharp metal, protrusions, and use every means to protect the cable from abrasion. Whenever it is necessary to run the battery cable on the outside of the vehicle under the floor, stay clear of areas that get extremely hot, such as the exhaust pipe or the muffler. The cable connecting the unit to the remote head, should be run on the inside of the vehicle unless it is possible to employ metal flexible tubing.

The remote control unit consists of an "on-off" switch, a volume control, a squelch control, speaker, and indicator lights. Since it is small and light, it can be mounted almost anywhere that is convenient to the driver. Wiring and installation instructions are furnished with the remote control kit.

**Battery Cable Installation:** The battery cable should be run from the unit to the battery in as short a line as possible. Somewhere near the battery, mount the fuse holder and fuse with the two sheet metal screws furnished. Terminate the "hot" lead at the fuse holder, cutting off any extra cable. Using this extra cable, run a lead from the other side of the fuse holder to the "hot" side of the battery. Terminate this "hot" lead at the battery terminal, or on the starter post. Never connect to a voltage point on the vehicle that has wire smaller than the starter cable. Do not substitute a wire that is of smaller diameter than that furnished with the installation kit.

The ground lead (black) must be securely bolted to the ground side of the battery, or to a good ground point near the battery. Take every precaution against abrasion, and make all connections tight to prevent future possible maintenance problems.

**Antenna Installation:** General installation instructions are furnished with the various antenna kits however there are certain precautions that must be observed when installing any antenna.

The most frequently used antenna will probably be the quarter wave whip. An ideal location for this antenna is usually on the roof of the vehicle, or on the deck of the trunk lid. Avoid mounting the antenna close to, or parallel to, metal objects such as windows, corner posts, etc. Generally, always mount a quarter wave whip as high as possible on the vehicle and with as much metal in a flat surface as possible under and around the antenna.

For best possible "car-to-car" communications, the antenna should be mounted at least 18 inches from the edge of the flat portion of the roof and preferably in the center.

1. After drilling a hole of the size called for in the antenna instruction sheet, clean all burrs above and below the hole. Remove as much of the sound deadening material as possible from the underside of the roof for a distance of about 1/4 inch around the hole.
2. Run an electricians snake (1/4" wide) through the hole in the roof to the area of the communications unit. It will usually be necessary to pull down one or more cross ribs to provide clearance for the snake. Use an awl or other small pointed tool to lever the ribs (or pull the

head lining away from welded in ribs). The small hole in the upholstery may be disguised by using a whisk broom after removing the tool from the upholstery.

3. Attach the transmission line of the antenna to the end of the snake protruding through the roof. The recommended procedure for attaching the cable to the snake is as follows.

- (a) Drill a small hole in the end of the snake (to clear #18 wire).
- (b) Skin the transmission line for approximately one inch, separate the braid and remove 3/4" of the inner conductor insulation.
- (c) Run the inner conductor through the small hole in the end of the snake and twist together with the braid.
- (d) Tape about three inches of this area with thin plastic electrical tape (such as Scotch Number 33 or equivalent).

NOTE: Before attempting to install the antenna in the vehicle, it is a good idea to try all pieces for fit to make sure that possible burrs or foreign matter might cause mating pieces to bind during final assembly.

Routing of Antenna Transmission Line: Always route the transmission line through the area which provides maximum clearance. AVOID SHARP BENDS. As the cable may go under upholstery, metal fittings, etc., be sure to place it in such a way that it will not be squeezed when the fittings, frames, etc., are put back in place. After replacing all trim and metal work, the co-axial cable and roof top antenna should be checked for continuity between the center conductor and the whip. The co-axial cable should next be checked for lack of continuity between its inner and outer conductors.

Attaching Co-Axial Cable Connector:

- (a) Cut cable off square at the proper length.
- (b) Cut off one and one-eighth inches of outside plastic insulation jacket.
- (c) Comb out copper shield.
- (d) Cut inner insulation off to expose five-eighths inches of inner conductor.
- (e) Trim stranded shielding so it is about one-sixteenth inch shorter than the inner insulation. Slide coupling through and adapter on cable, folding the combed strands over the adapter.
- (f) Tin center conductor and screw plug on cable and adapter.
- (g) Solder shield strands through holes in plug and solder center conductor of the cable to the plug end.

Use enough heat to get a good solder joint. Avoid using so much heat that the solder will flow the shell to the center conductor inside the plug. Avoid handling the cable and plug until the softened insulation between the center conductor and shield has had a chance to cool off and return to its firm state.

- (h) Recheck for continuity.

NOTE: The antenna should be cut to its proper operating frequency. First, determine the frequency being used then using the chart furnished with the antenna, cut the whip to the proper length. The steel used in the manufacture of the antenna whip is usually very tough, and could easily damage diagonal cutters. Therefore, diagonal pliers should be used only to lightly scar the whip at the correct point, and then break it by bending back and forth at that point.

After the installation is complete, insert a "thru-line" RF watt meter between the FM-50-A antenna output connector and the PL259 plug of the antenna. Tune the output stage for

maximum forward power and check reflected power which should normally not exceed 10%. Unusually high reflected power may be caused by one of the following reasons:

- (a) Incorrect whip length.
- (b) Damaged transmission line.
- (c) Break in outer shield of transmission line.
- (d) Antenna mounted in close proximity to other objects on the vehicle.  
In the latter instance (d) modifying the whip length from the "free space" dimension may correct the condition.

**FREQUENCY ADJUSTMENT:** The Federal Communications Commission requires that all transmitters of this type be checked for frequency upon installation and at least once every twelve months thereafter with an instrument having an accuracy of twice that of the equipment being measured. In this instance the measuring instrument should be rated at  $\pm .00025\%$ .

All transmitters are adjusted to frequency prior to shipment however the installer is required by the FCC to make this test upon completion of the installation.

# OUTERCOM FM-50-A STANDARD MODEL

## PARTS LIST AND SCHEMATIC

<u>SYMBOL</u>	<u>DESCRIPTION</u>	<u>PART NO.</u>	<u>DESCRIPTION</u>	<u>PART NO.</u>	
(NOTE: All capacitors are disc ceramic $\pm 20\%$ and 500V unless otherwise specified)					
C101	Temp. Comp., Disc. npo, 1mmf $\pm 1/4$ mmf, 1000V	K23010-33	C137	dur-mica dm-15 470 mmf $\pm 10\%$ , 500V.	K23006-96
C102	.005 mfd	M23034-31	C138	disc. ceramic .02 mfd $\pm 80\% - 20\%$ , 500V	M23034-27
C103	dur-mica dm-15 270 mmf $\pm 5\%$ , 500V	K23006-93	C140	dur-mica dm-15 470 mmf $\pm 10\%$ , 500V	K23006-96
C104	disc ceramic .1 mfd +80 -20%, 100V	M23034-29	C141	dur-mica dm-15 100 mmf $\pm 5\%$ , 500V	K23006-72
C105	dur-mica dm-15 12 mmf $\pm 5\%$ , 500V	K23006-94	C142	disc. ceramic .01 mfd +80-20%, 600V.	M23034-19
C106	disc ceramic .002 mfd gmV, 1000V	M23034-41	C143	mylar .047 mfd +20%, 400 V.	K23927-1
C107	disc ceramic .002 mfd gmV, 1000V	M23034-41	C144	.005 mfd	M23034-31
C108	temp. comp. disc. npo 2.2 mmf, $\pm 5\%$ , 1000V	K23010-34	C145	electrolytic 4 mfd 250V.	K23073-78
C109	temp. comp. disc. npo, 2.2 mmf, $\pm 5\%$ , 1000V	K23010-34	C146	.005 mfd	M23034-31
C110	Feed thru, special	K23094-1	C147	.005 mfd	M23034-31
C111	.0015 mfd, gmV,	M23034-42	C148	electrolytic 2 mfd 50V.	K23073-79
C112	.005 mfd	M23034-31	C149	disc. ceramic .01 mfd gmV, 1000V	M23034-8
C113	.005 mfd	M23034-31	C150	10 mmf, dur-mica DM-15, 500V	K23006-22
C114	disc. ceramic .01mfd +80-20%, 600V	M23034-19	C151	12 mmf, dur-mica DM-15, 500V	K23006-45
C115	dur-mica dm-15 270 mmf $\pm 5\%$ , 500V	K23006-93	C152	12 mmf, dur-mica DM-15, 500V	K23006-45
C116	dur-mica dm-15 270 mmf $\pm 5\%$ , 500V	K23006-93	C153	Variable Air 2.5 - 32 mmf 600V	K34660-G3
C117	.01 mfd	M23034-28	C154	Variable Air 3-25 mmf 1200V	K34453-G8
C118	dur-mica dm-15 100 mmf $\pm 5\%$ , 500V	K23006-72	C155	.0015 mfd, gmV	M23034-42
C119	disc. ceramic .002 mfd gmV, 1000V	K23034-41	C156	.0015 mfd, gmV	M23034-42
C120	dur-mica dm-15 47 mmf $\pm 5\%$ , 500V	K23006-71	C157	.0015 mfd, gmV	M23034-42
C121	temp. comp. disc. mpo, 6.8 mmf $\pm 5\%$ , 1000V	K23010-35	C159	Variable, npo, 5-25 mmf, 350V	K23038-3
C122	dur-mica dm-15 22 mmf $\pm 5\%$ , 500V	K23006-95	C161	.0015 mfd, gmV	M23034-42
C123	dur-mica dm-15 47 mmf $\pm 5\%$ , 500V	K23006-71	C162	disc. ceramic .1 mfd +80-20%, 100V	M23034-29
C125	.005 mfd	M23034-31	C163	temp. comp. disc. mpo, 1mmf $\pm 1/4$ mmf, 1000V	K23010-33
C126	.005 mfd	M23034-31	C164	dur-mica DM-15 100 mmf $\pm 5\%$ , 500V	K23006-72
C127	dur-mica dm-15 47 mmf $\pm 5\%$ , 500V	K23006-71	C167	disc. ceramic .1 mfd +80-20%, 100V	M23034-29
C128	disc. ceramic .01 mfd +80-20%, 600V	M23034-19	C168	disc. ceramic .1 mfd +80-20%, 100V	M23034-29
C129	.005 mfd	M23034-31	C169	dur-mica DM-15 47 mmf $\pm 5\%$ , 500V	K23006-71
C130	.005 mfd	M23034-31	C170	disc. ceramic .0015 mfd gmV, 500V	M23034-42
C131	dur-mica dm-15 47 mmf $\pm 5\%$ , 500V	M23006-71	C172	dur-mica DM-15 100 mmf $\pm 5\%$ , 500V	K23006-72
C132	disc. ceramic .1 mfd +80-20%, 100V	M23034-29	C173	.0015 mfd, gmV	M23034-42
C133	.005 mfd	M23034-31	C174	disc. ceramic .1 mfd $\pm 80 - 20\%$ , 100V	M23034-29
C134	disc. ceramic .01 mfd +80-20%, 600V	M23034-19	C176	dur-mica DM-15, 100 mmf $\pm 5\%$ , 500V	K23006-72
C135	disc. ceramic .01 mfd +80-20%, 600V	M23034-19	C177	.005 mfd	M23034-31
C136	temp. comp. disc npo, 2.2 mmf $\pm 5\%$ , 1000V	K23010-34	C178	.005 mfd	M23034-31
			C179	electrolytic 40-40-40-/450V, 40/25V	K15504-72

<u>SYMBOL</u>	<u>DESCRIPTION</u>	<u>PART NO.</u>	<u>SYMBOL</u>	<u>DESCRIPTION</u>	<u>PART NO.</u>
C180	temp. comp. disc. npo, 4.7 mmf $\pm$ 5%, 1000V	K23010-36	CR112	diode, (IN1490)	K41212-1
C181	dur-mica, DM-15, 24mmf $\pm$ 5 mmf, 500V	K23006-48	H101	oven, crystal, 6/12, volt	K26638-1
C182	dur-mica, DM-15, 10mmf $\pm$ 5 mmf, 500V	K23006-22	I101	neon pilot light, amber	K40913-1
C183	variable, npo, 5-25 mmf, 350V	K23038-3	I102	neon pilot light, red	K40913-2
C184	dur-mica, DM-15, 270mmf, $\pm$ 5%, 500V	K23006-93	J101	socket, power (24 pin), male	K41136-4
C185	disc. ceramic .002 mfd gmV, 1000V	M23034-41	J102	connector, receptacle (antenna)	K16111-1
C186	disc. ceramic .002 mfd, gmV, 1000V	M23034-41	J103	socket (8-pin) (remote)	K16083-1
C187	disc. ceramic .001 mfd, $\pm$ 10%, 1000V	M23034-22	J104	connector (Microphone)	K15972-1
C188	disc. ceramic .01 mfd +80-20%, 600V	M23034-19	J105	socket (11-pin) (test)	K15944-8
C189	dur-mica, DM-15, 470 mmf, $\pm$ 10%, 500V	K23006-96	K101	relay, 3pdt, 6/12 volt coil	K40351-6
C190	disc. ceramic .01 mfd +80-20%, 600V	M23034-19	L101	coil, image trap	K26627-1
C191	dur-mica, DM-15, 120 mmf, $\pm$ 5%, 500V	K23006-97	L102	coil, neutralization	K26628-1
C192	dur-mica, DM-19, 1000 mmf, $\pm$ 5%, 300V	K23027-9	L103	coil, xtal trimming	K26625-1
C193	dur-mica, DM-19, 1000 mmf, $\pm$ 5%, 300V	K23027-9	L104	coil, oscillator feed back	K26621-1
C194	disc. ceramic, .01 mfd +80-20%, 600V	M23034-19	L105	coil, xtal oscillator tuning	K26626-1
C197	electrolytic 200 mfd, 25V non-polarized D.C.	K23925-1	L106	coil, I.F. 10.7 mc	K26623-1
C198	disc. ceramic .0015 mfd gmV 500V	M23034-42	L107	coil, I.F. 10.7 mc	K26624-1
C199	feed thru, special	K23094-1	L108	coil, I.F. 10.7 mc	K26622-1
C200	.005 mfd,	M23034-31	L109	coil, quadrature detector 1650 kc	K26639-1
C201	.005 mfd,	M23034-31	L110	inductor, (Input)	K26679-1
C203	.0015 mfd, gmV	M23034-42	L111	inductor, (output)	K26680-1
C204	.0015 mfd, gmV	M23034-42	L112	coil, antenna	K26644-1
C205	electrolytic 40 mfd 450V	K23073-38	L113	coil, plate tank,	K26643-1
C206	disc. ceramic .1 mfd +80-20%, 100V	M23034-29	L114	choke, R.F.	K26640-1
C207	disc. ceramic .1 mfd +80-20%, 100V	M23034-29	L115	coil, driver grid	K26632-1
C208	disc. ceramic .01 mfd +80-20%, 600V	M23034-19	L116	second multiplier plate	K26631-1
C209	disc. ceramic .002 mfd gmV, 1000V	M23034-41	L117	first multiplier plate	K26630-1
C210	temp. comp. disc. npo, 27 mmf $\pm$ 5%, 1000V	K23010-39	L118	coil, buffer plate	K26629-1
C211	temp. comp. disc. npo, 100 mmf $\pm$ 20%, 1000V	K23010-40	L119	choke, rf	K26633-2
CR101	diode, silicon (IN2482)	K41211-1	L120	choke, rf	K26633-1
CR102	diode, silicon (IN2482)	K41211-1	L121	choke, audio, 3 hy	K26667-1
CR103	diode, silicon (IN2482)	K41211-1	L122	filter reactor 1.5hy	K26693-1
CR104	diode, (IN1490)	K41212-1	L124	choke, rf	K26640-1
CR105	diode, (IN1490)	K41212-1	L125	coil, driver plate	K26696-1
CR106	diode, (IN1490)	K41212-1	Q101	transistor, 2N442	K40764-1
CR107	diode, (IN1490)	K41212-1	Q102	transistor, 2N442	K40764-1
CR108	diode, (IN1490)	K41212-1	(NOTE: All resistors fixed $\pm$ 10% $\frac{1}{2}$ W. unless otherwise specified)		
CR109	diode, (IN1490)	K41212-1	R101	330K	K19309-109
CR110	diode, (IN1490)	K41212-1	R102	1.5k	K19309-53
CR111	diode, (IN1490)	K41212-1	R103	1 meg	K19309-121

<u>SYMBOL</u>	<u>DESCRIPTION</u>	<u>PART NO.</u>	<u>SYMBOL</u>	<u>DESCRIPTION</u>	<u>PART NO.</u>
R104	330 ohms	K19309-37	R146	330k	K19309-109
R105	33k	K19309-85	R147	470k	K19309-113
R106	15k, 1 w.	K19310-77	R148	470 ohms, 1W	K19310-41
R107	1.5k	K19309-53	R149	1 ohm $\pm 1\%$	K19443-1
R108	33k, 1W	K19310-85	R150	4.7k, 1W	K19310-65
R109	220 ohms	K19309-33	R151	8.2k, 1W	K19310-71
R110	470 ohms	K19309-41	R152	15k	K19309-77
R111	100k	K19309-97	R153	20 ohms $\pm 5\%$	K19309-188
R112	100k	K19309-97	R154	100k	K19309-97
R113	100k	K19309-97	R155	100k	K19309-97
R114	10k	K19309-73	R156	47k	K19309-89
R115	470k	K19309-113	R158	220k	K19309-105
R116	47k	K19309-89	R159	220 ohms	K19309-33
R117	47k	K19309-89	R160	100k	K19309-97
R118	47k	K19309-89	R161	2.2k	K19309-57
R119	1 meg.	K19309-121	R162	100k	K19309-97
R120	68k	K19309-93	R163	100k	K19309-97
R121	47k	K19309-89	R164	150k	K19309-101
R122	470k	K19309-113	R165	15k	K19309-77
R123	68 ohms	K19309-21	R166	220k	K19309-105
R124	100k	K19309-97	R167	3.3k	K19309-61
R125	1.5k	K19309-53	R168	470k	K19309-113
R126	1.5k	K19309-53	R169	470k	K19309-113
R128	100k	K19309-97	R170	180k	K19309-103
R129	1k, 1W	K19310-49	R171	100k	K19309-97
R130	47k	K19309-89	R172	.5 meg variable $\pm 30\%$ .2W	K15380-7
R131	1.5k	K19309-53	R173	2.2 meg.	K19309-129
R132	33k, 1W	K19310-85	R174	220k	K19309-105
R133	330k	K19309-109	R175	3.3k	K19309-61
R134	3.3 meg.	K19309-133	R176	220k	K19309-105
R135	vari. 20k $\pm 20\%$ , $\frac{1}{2}W$	K26218-11	R177	15k, 1W	K19310-77
R136	2.2K	K19309-57	R178	1k	K19309-49
R137	330k	K19309-109	R179	.47 ohms	M19302-51
R138	330k	K19309-109	R180	50, ohms, 10W.	K19430-15
R139	680k	K19309-117	R181	500 ohms, 10W.	K19430-27
R140	8.2 meg.	K19309-143	R183	120 ohms	K19309-27
R141	vari. 500k $\pm 30\%$ , $\frac{1}{2}W$	K26218-10	R184	120 ohms	K19309-27
R142	33k, 1W	K19310-85	R185	1.5k	K19309-53
R143	100k, 2W	K19304-66	R186	470 ohms	K19309-41
R144	100k, 1W	K19310-97	R187	10k, 1W.	K19310-73

<u>SYMBOL</u>	<u>DESCRIPTION</u>	<u>PART NO.</u>			
R188	330k, 1W.	K19310-109	V105	tube, electron-6BH6	K16299-1
R189	47k, 2W.	K19304-58	V106	tube, electron-6BH6	K16299-1
R190	10k	K19309-73	V107	tube, electron-6BN6	K40908-1
R191	150k	K19309-101	V108	tube, electron-12AX7	K16300-1
R192	47k	K19309-89	V109	tube, electron-6AQ5	K16387-1
S101	switch, slide (dpdt) (remote local)	K52015-2	V110	tube, electron-6146	K40898-2
S102	switch, toggle (dp-3 pos., special)	K26675-1	V111	tube, electron-6360	K40912-1
SP101	speaker, 4x6", 3.2 ohm	M26646-1	V112	tube, electron-6AW8A	K40911-1
T101	transformer, antenna	K26620-1	V113	tube, electron-6BR8	K40907-1
T102	transformer, IF, 1650kc	K26648-1	V114	tube, electron-12AX7	K16300-1
T103	transformer, IF, 1650kc	K26648-1	Y101	crystal, receiver <u>channel freq. 10.7 Mc</u> 3	M26678-1
T104	transformer, IF, 1650kc	K26648-1	Y102	crystal, transmitter <u>channel freq.</u> 12	M26678-2
T105	transformer, audio output	K26647-1	Y103	crystal 9050kc	K26673-1
T107	transformer, switching	M26672-1	Y103	crystal 12300kc	K26674-1 *see note
T108	transformer, power	P26649-2			
V101	tube, electron-6BS8	K40906-1		*Substitute Pt. No. K26674-1 (12300 kc crystal) for Pt. No. K22673-1 (9050kc crystal, "standard") when a harmonic of the 9050 kc crystal falls on the channel freq. ±60kc.	
V102	tube, electron-6BR8	K40907-1			
V103	tube, electron-6BR8	K40907-1	ZF101	filter, RF, assembly	M26650-1
V104	tube, electron-6BR8	K40907-1	ZF102	filter, crystal, 10.7 mc	K26677-1

### MISCELLANEOUS ITEMS

Connector female, 24 terminal (6 and 12 V. cables)	K41137-1	Knob, volume and squelch	K26609-1
Connector, female, 24 terminal (117 V. AC cable)	M41131-1	Centering washer, cabinet top	K50075-1
Fuseholder, mobile	K51024-1	Terminal, battery	K35090-10
Screw, self tapping #8x½" for fuseholder	K10081-10	Handle, cabinet	K50073-1
Solderless terminal for mobile cable	K35090-9	Cable, power 2# 10 GA (6 V. cables)	K16543-1
Fuse cartridge, 20 AMP (12 V. mobile)	K51025-2	Cable, power 2# 12 GA (12 V. cables)	K16542-1
Fuse cartridge, 30 AMP (6 V. mobile)	K51025-1		

BASIC OUTERCOM COMPLIMENT CHART

	<u>Hammarlund Type or Part Number</u>
Receiver/Transmitter Unit Consists of Receiver, Transmitter and Universal Power Supply in Cabinet with Palm Microphone and Microphone Mounting Hardware Channel Crystals and Instruction Book	FM50-A  PL-26600-G1
117V A. C. Power Cord Assembly (Factory Wired)	PL-26697-G1
6 Volt Mobile Power Cable Kit Consists of Connector, Cable, Fuse Holder and Fuse, Miscellaneous Hardware and Assembly Instructions for Positive or Negative Ground Systems	  PL-26698-G1
12 Volt Mobile Power Cable Kit Consists of Connector, Cable, Fuse Holder and Fuse, Miscellaneous Hardware and Assembly Instructions for Positive or Negative Ground Systems	  PL-26698-G2
12 Volt Mobile Power Cable (Factory Wired), includes Fuse Holder and Fuse and Miscellaneous Hardware	  PL-26698-G3
Universal Mounting Bracket for Mobile Applications, includes Mounting Hardware	  PL-26610-G1
Standard Mobile Antenna Kit Consists of Antenna Specialists Type ASP-126 Antenna Assembly with 12' RG58/U Cable attached. PL259 Connector and Cable Adapter supplied but not attached. Installation Instructions Supplied	    M-26705-1
High-Gain Mobile Antenna Kit Consists of Antenna Specialists Type ASP-177 Antenna Assembly (3 db gain) with 12' RG58-U Cable attached. PL259 Connector and Cable Adapter supplied but not attached. Installation Instructions Supplied	    M-26706-1
Utility Antenna Kit Consists of 1/4 Wave Whip with provisions for direct connection to Antenna Terminal on rear of FM50-A. Primarily for short range demonstration of FM50-A on 117V A. C. operation	    M-26707-1

Revised 3/24/61

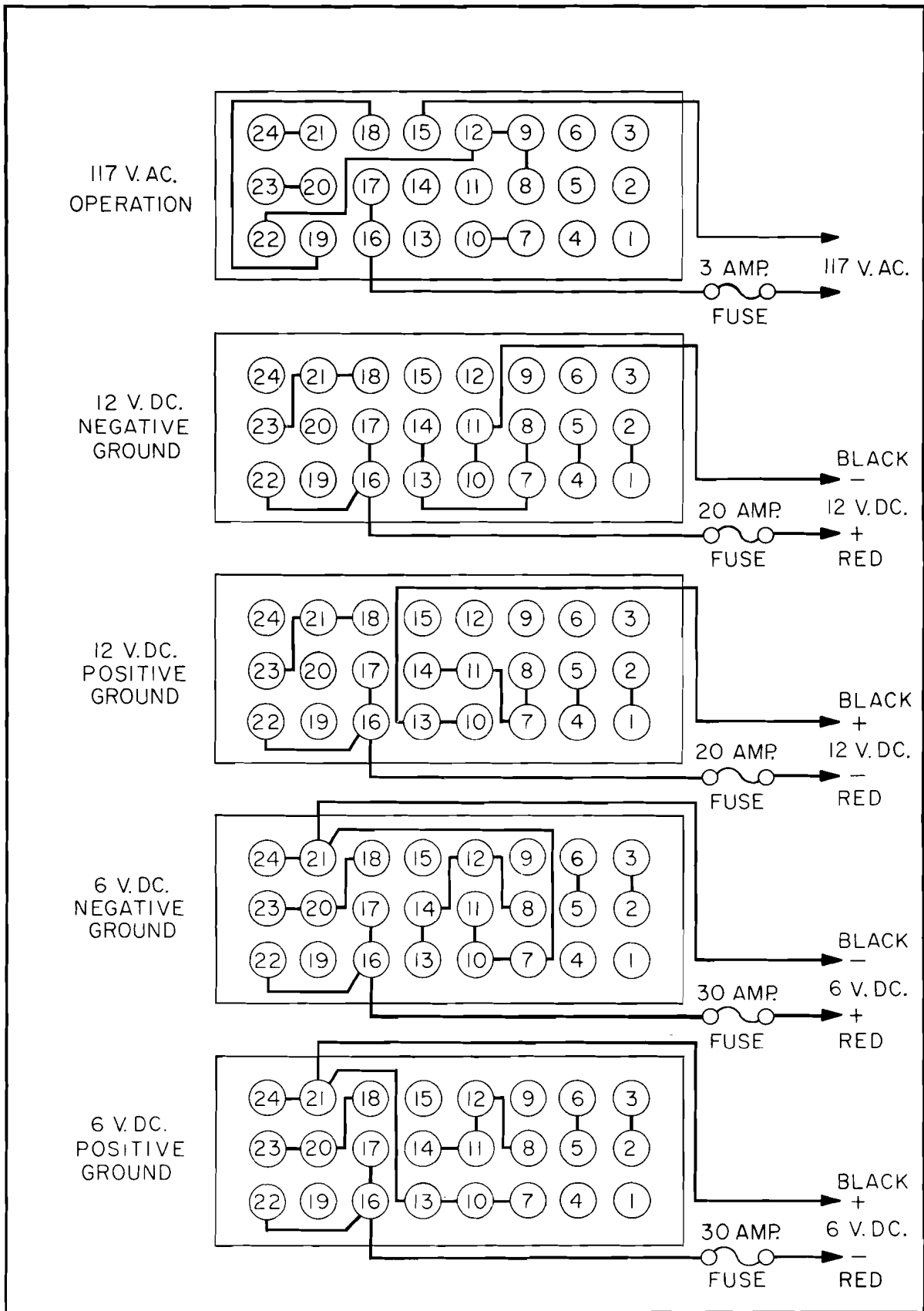

**INPUT PLUG JUMPERS**

COMPONENT LOCATION DIAGRAM

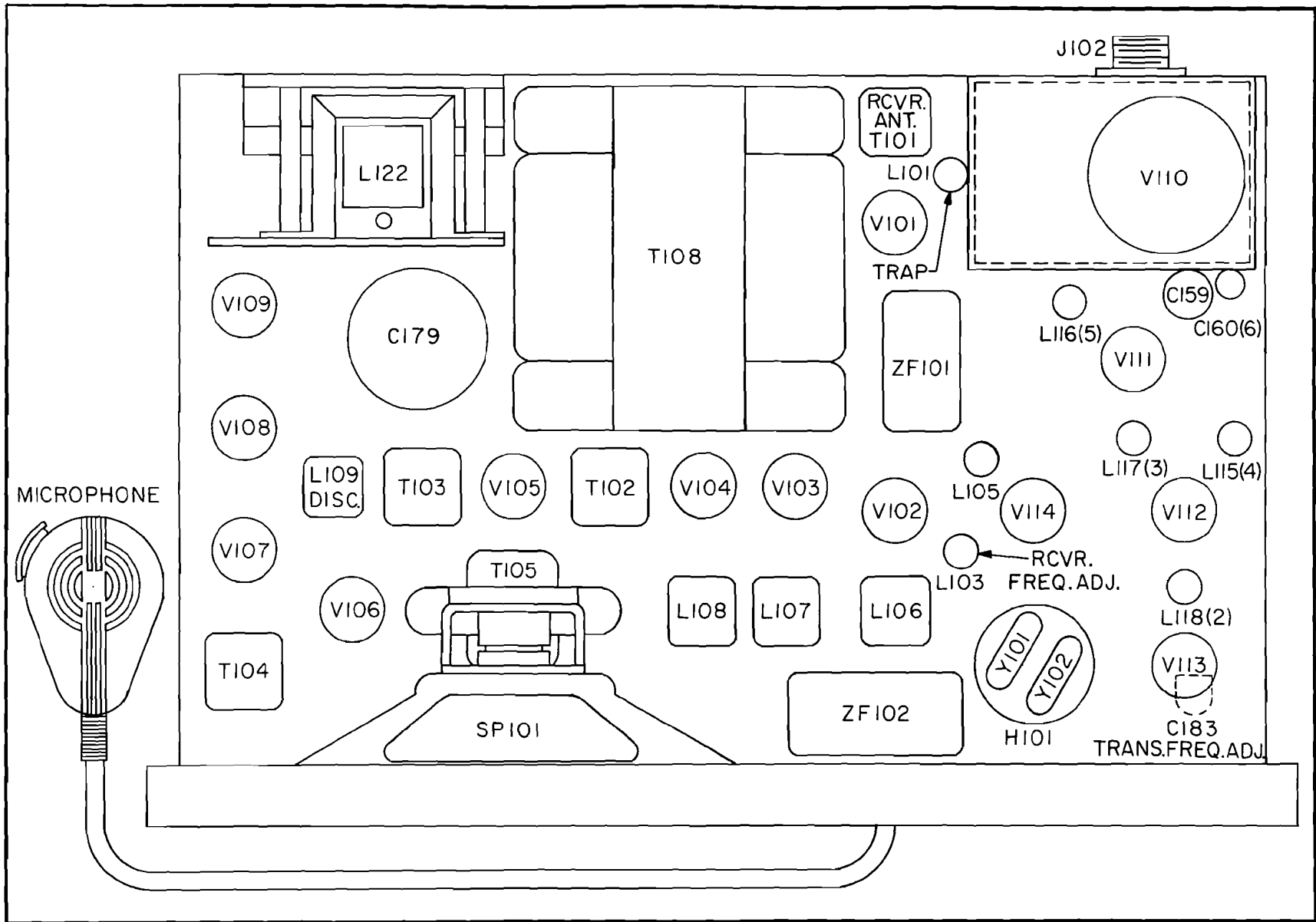

CABINET, REAR VIEW

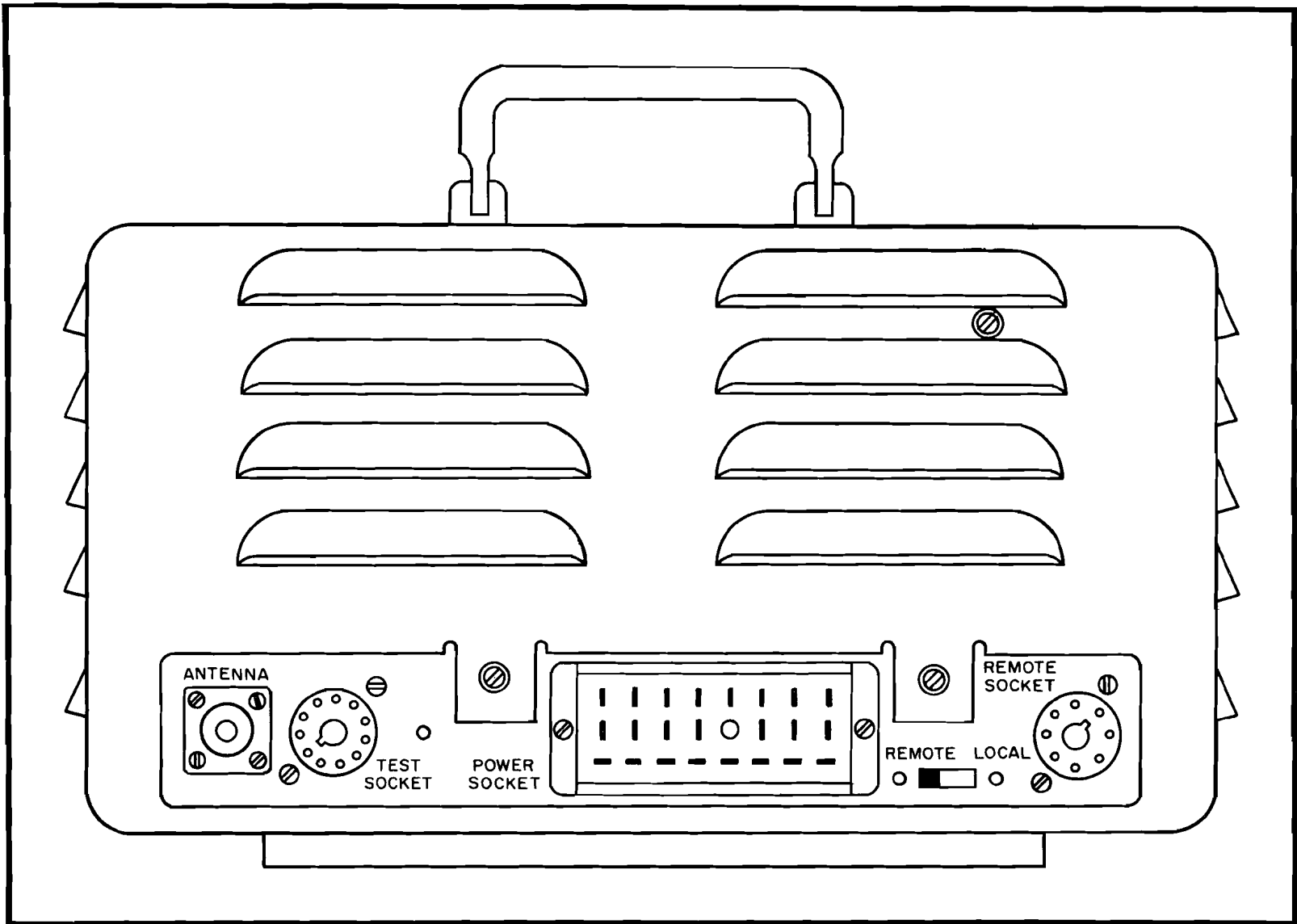

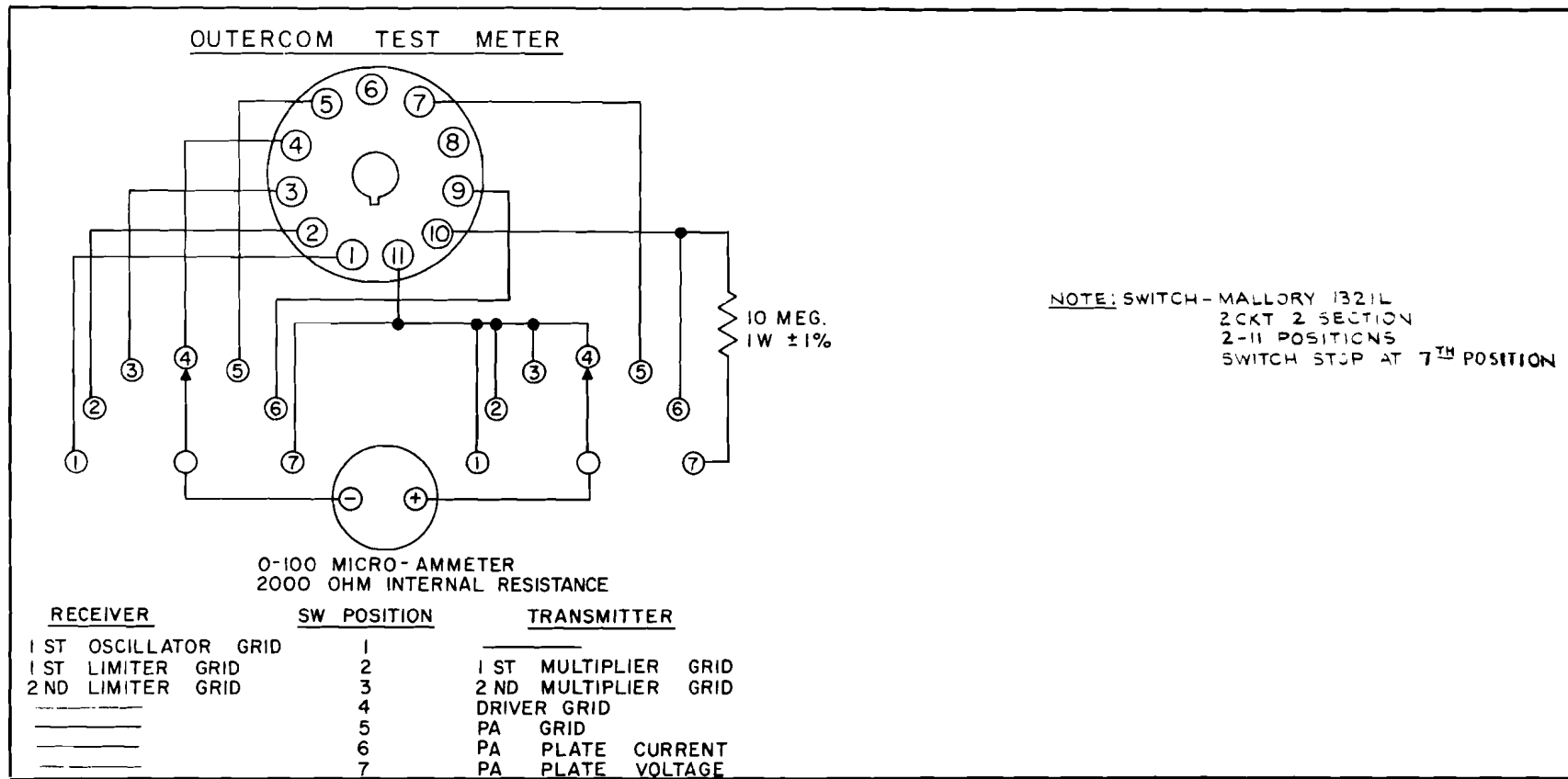

**SCHEMATIC (OUTERCOM TEST METER)**

THE HAMMARLUND MANUFACTURING COMPANY, INC.

STANDARD WARRANTY

The Hammarlund Manufacturing Company, Inc., warrants this equipment to be free from defects in workmanship and materials under normal and proper use and service for the uses and purposes for which it is designed, and agrees to repair or replace, without charge, all parts thereof showing such defects which are returned for inspection to the Company's factory, transportation prepaid, within a period of 90 days from date of delivery, provided such inspection discloses to the satisfaction of the Company that the defects are as claimed, and provided also, that the equipment has not been altered, repaired subjected to misuse, negligence or accident, or damaged by lightning, excessive current or otherwise, or had its serial number or any part thereof altered, defaced, or removed. Tubes shall be deemed to be covered by the manufacturer's standard warranty applicable thereto, and such items shall be and are hereby excluded from the provisions of this warranty. Pilot lamps and fuses are not guaranteed for length of service.

Except as herein specifically provided, no warranty, express or implied, other than that of title, shall apply to any equipment sold hereunder. In no event shall the Company be liable for damages by reason of the failure of the equipment to function properly or for any consequential damages.

This warranty is valid for the original owner of the equipment, and is contingent upon receipt of the warranty Registration Card by the Company. No equipment shall be returned to the factory for repairs under warranty unless written authorization is obtained by the Company, and the equipment is shipped prepaid by the owner. The Company maintains Authorized Service Stations, names and locations of which will be sent upon request of the owner.

**Hammarlund Manufacturing Company, Inc.**  
A *Giannini Scientific Co.*  
53 West 23rd Street, New York 10, N. Y.

This temporary manual has been issued to provide installation and service information until such time as the final manuals are received from the printer.

## PRODUCTION CHANGES STARTING WITH SERIAL NO. 1101

The following information should be considered as a supplement to the present installation and service manual of the FM50A communications unit. Future printings of the FM50A manual will contain this information. FM50A units starting with serial number 1101 differ from previous production as follows:

1. The transmitter frequency adjustment, C183 is accessible from the top of the chassis.
2. The IF filter ZF102 has been moved so as to permit the use of a "three crystal" oven (for two frequency transmitter application).
3. Space has been provided on the underside for a two frequency relay and second channel transmitter frequency adjustment.
4. Chassis removal from the cabinet has been simplified by the elimination of the grommet, cup washer and hold-down screw. The screw and clip fastening the rim of the front panel to the cabinet have also been eliminated.
5. The elimination of the items called for in step 4 was made possible by the addition of a brace from the power transformer to the front panel and by re-location of the two rear lower "chassis-to-cabinet" mounting screws.
- \*6. R175 in the cathode circuit of V114A was changed from 3.3K to 1K ( $\frac{1}{2}$  W.) to increase microphone sensitivity.
7. A 50 MFD, 25V electrolytic capacitor was added across terminals 11 and 13 of the power connector J101 (positive end of condenser to terminal 13) to provide additional transistor protection from primary power sources with poor regulation (DC operation only).

8. R179, .47 ohms which serves as a fuse as well as part of the transistor bias circuit, has been re-located to the outside of the component board to allow easy replacement if required.

\*9. In order to prevent RF feedback, a 250 mmfd mica capacitor (Underwood toothpick type) was added to the speech amplifier V114A pin 7 to ground, part number 23928-1.

The following notes also pertain to sets below serial number 1101:

\*10. In early production C158 was not incorporated. C158 when incorporated was originally a 7-45 MMF wired across R150 and later changed from terminal 3 of V110 to ground. In later production (below serial #1101) C158 was changed to a 5-25 MMF (Hammarlund part #23038-3) to improve neutralization at the high end of the band.

11. In early production C189 consisted of a single 470 MMF capacitor. In later production an additional 470 MMF capacitor (C215) was added in parallel to improve bass response of the transmitter. Starting with serial #1101 these capacitors were changed to a single .001 MFD.

\*12. In later production of the units below serial number 1101, R194 (1K,  $\frac{1}{2}$  watt) and C214 (4MFD 250V) were added to the standby bias circuit of the transmitter final stage to eliminate a weak self-oscillation condition during standby. This change also eliminates the standby plate current of the final stage.

\*THESE CHANGES ARE RECOMMENDED FOR OLD SETS BROUGHT IN FOR PREVENTATIVE MAINTENANCE.

## ADDITIONAL SERVICE NOTES

It has been found advisable to tune L106 and L107 off the "center-frequency" resonance peak for greater immunity to ignition noise as well as improved weak-signal bandpass. L106 and L107 should be peaked to an injected frequency of 10.7075 mc. (all other adjustments should be made in the IF frequency of 10.70 mc.). In some instances greater immunity to ignition noise may be achieved by further adjustment of L106 and L107 for maximum suppression of impulse noise in the presence of a weak on-frequency signal. L106 and L107 should not be detuned so far that the second limiter grid current (in the absence of a signal) drops below saturation.

All units shipped on and after September 11, 1961 are aligned with L106 and L107 resonated to 10.7075 mc.

## FREQUENCY NETTING

Frequency Netting and periodic frequency checks of narrow band equipment is extremely important especially during the early life of the equipment when crystals are aging at their fastest rate. It is recommended that all units be rechecked for frequency tolerance (and netted to the system in which they will be used) prior to placing same in service.

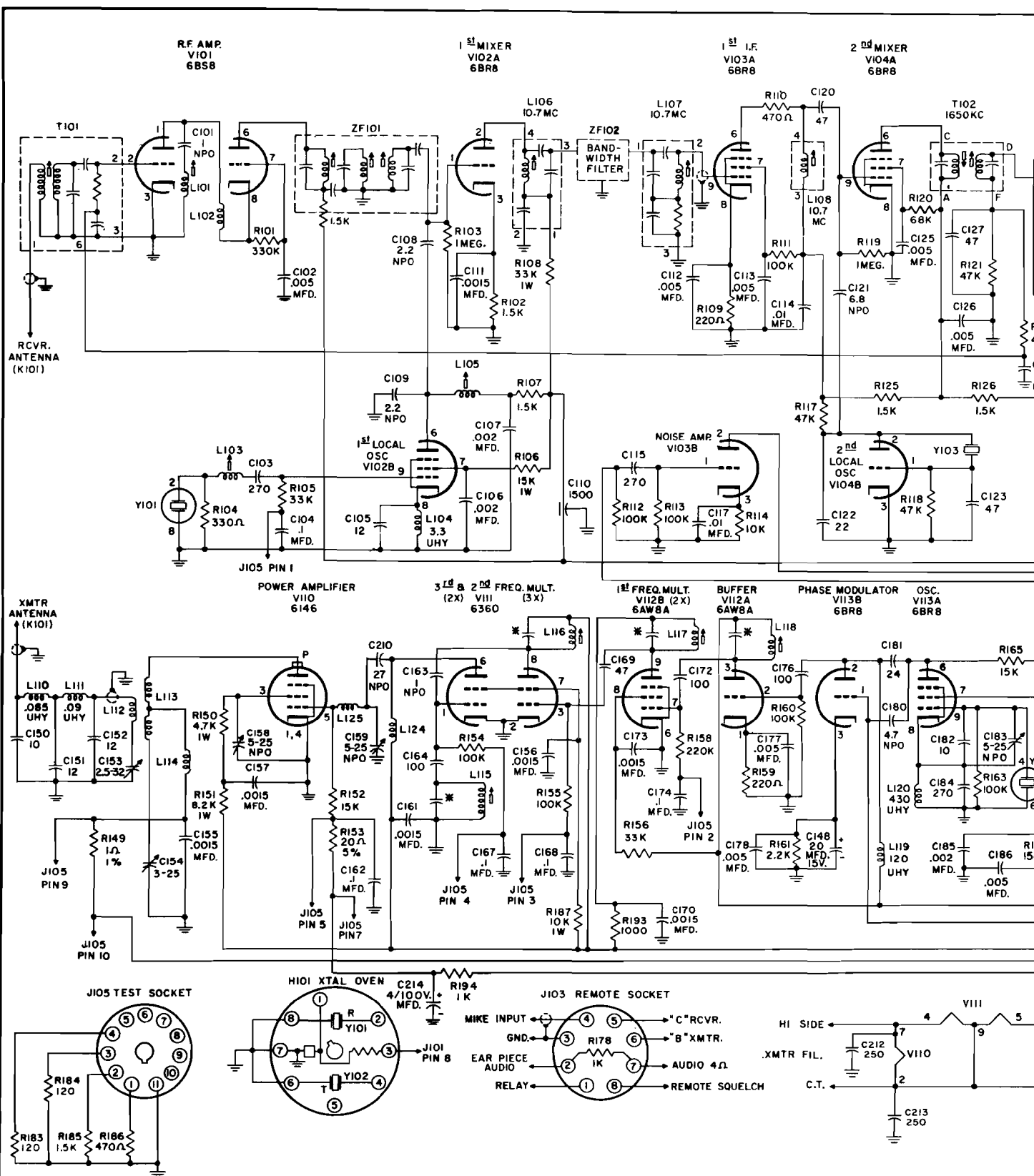

**NOTE**  
 ALL CAPACITOR VALUES ARE IN MICRO-MICRO UNLESS OTHERWISE SPECIFIED.  
 ALL RESISTOR ARE 1/2 W ± 10% UNLESS OTHERWISE SPECIFIED.  
 \* = THIS CAPACITOR SUPPLIED AS PART OF TYPE 6146 (V110) HAMMARLUND PART NO. K RECOMMENDED FOR BEST PERFORMANCE



RESISTANCE CHART FM50-A

RECEIVER SECTION

PIN #	V101	V102	V103	V104	V105	V106	V107	V108	V109
1	∞	1M	120K	47K	47K	100K	0	380K	500K
2	170K	> 50K	400K	> 80K	68 Ω	0	1.6K	10M	470 Ω
3	0	1.5K	10K	0	—	—	—	25K	—
4	0	0	—	0	—	—	—	—	—
5	—	—	—	—	> 30K	> 70K	> 70K	—	> 30K
6	> 30K	> 30K	> 30K	> 30K	> 100K	> 70K	4 Ω	680K	> 30K
7	∞	> 30K	160K	> 80K	0	0	380K	4M	470K
8	∞	0	2.2K	0	X	X	X	20K* 2.2K**	—
9	0	> 30K	50K	1M	X	X	X	0	—

TRANSMITTER SECTION

PIN #	V110	V111	V112	V113	V114
1	0	100K	220 Ω	100K - 600K	250K
2	—	0	100K	∞	1M
3	∞	100K	∞	220 Ω	3.3K
4	0	—	0	0	—
5	17K	0	—	—	—
6	0	∞	0	∞	220K
7	—	∞	220K	∞	220K
8	1.4K	∞	∞	12 Ω	1K***
9	X	—	∞	100K	0

\*=SQUELCH CONTROL MAXIMUM CLOCKWISE POSITION

\*\*=SQUELCH CONTROL MAXIMUM COUNTERCLOCKWISE POSITION

RCA TYPE WV-77A VTVM USED FOR ALL ABOVE MEASUREMENTS

LOCAL-REMOTE SWITCH IN LOCAL POSITION

\*\*\*=ON UNITS BELOW SERIAL NO 1101 RESISTANCE IS 3.3K

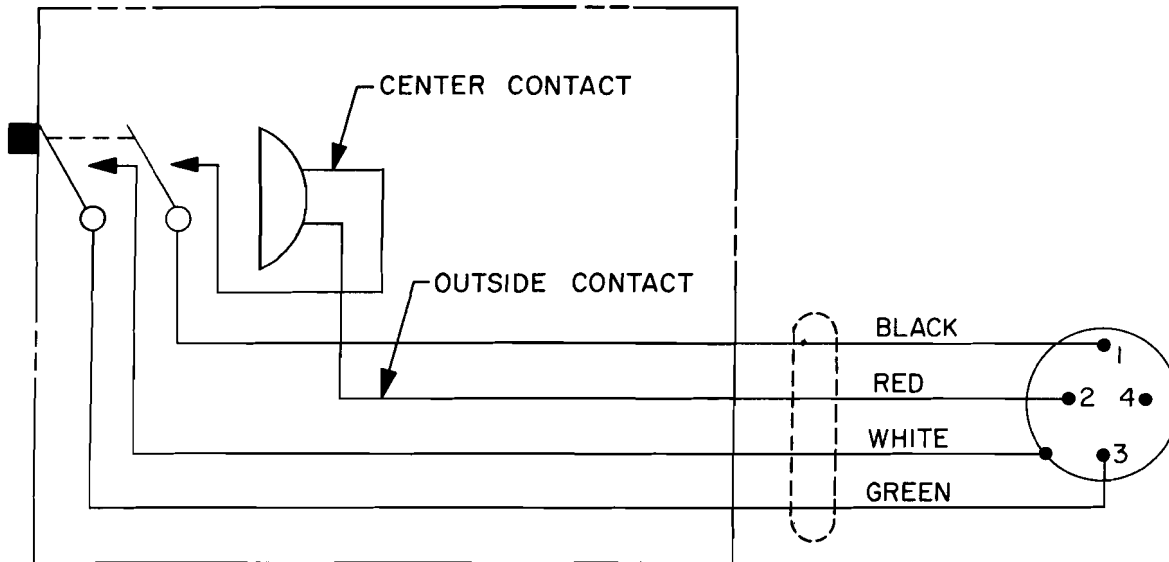

CARBON CARTRIDGE PALM MICROPHONE PT. NO. P26681-1

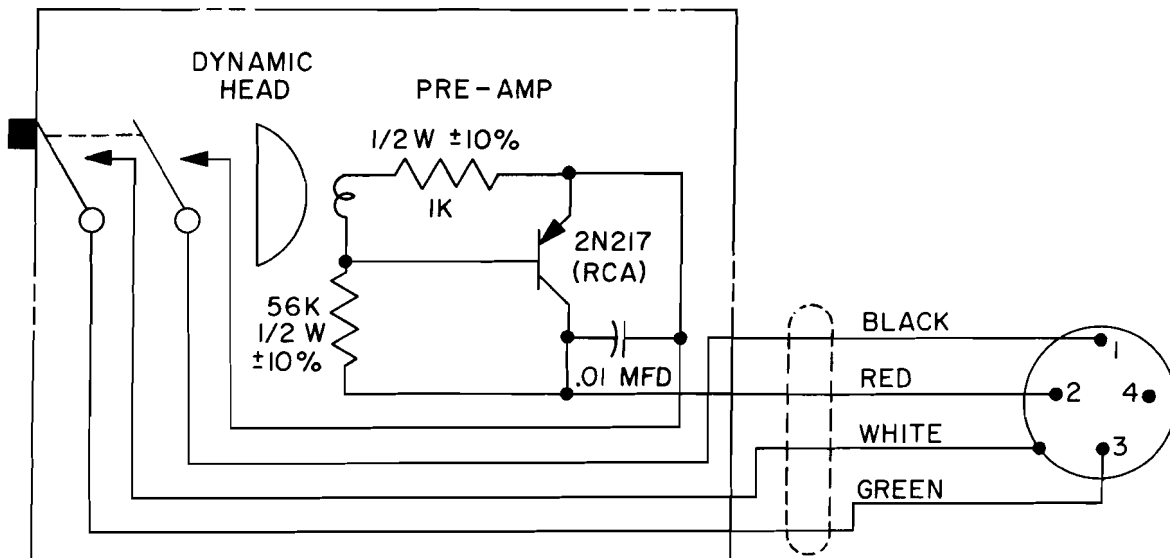

DYNAMIC CARTRIDGE/TRANSISTOR AMPLIFIER PALM MICROPHONE PT. NO. P26681-2

REPLACEMENT PARTS LIST

- CARBON MICROPHONE ELEMENT PT. NO. K 53029-1
- DYNAMIC MICROPHONE ELEMENT PT. NO. K 53030-1
- MICROPHONE SWITCH KNOB PT. NO. K 53031-1
- COILED CORD (SUPPLIED IN BULK OF 3FT. LENGTH) PT. NO. K 53032-1
- MOUNTING BRACKET & HARDWARE PT. NO. K 53033-1

VOLTAGE CHART FM50-A

RECEIVER SECTION

PIN #	V101	V102	V103	V104	V105	V106	V107	V108	V109
1	105	—	—	-12	—	—	—	125 *185	—
2	—	120	90	65	—	—	—	30 (1) 10 (2) *24 (1) *22 (2)	12 *16
3	—	5.5	4.0	—	—	—	—	60 *65	—
4	—	—	—	—	6.3 V. AC	6.3 V. AC	6.3 V. AC	6.3 V. AC	6.3 V. AC
5	6.3 V. AC	6.3 V. AC	6.3 V. AC	6.3 V. AC	200	75	60	6.3 V. AC	210 *250
6	205	205	165	180	75	85	—	55 (1) 20 (2) *42 (1) *40 (2)	220 *265
7	70	195	70	100	—	—	65	12 (1) 4.5 (2) *0 (1) *-1.0 (2)	—
8	105	—	1.0	—	<del>—</del>	<del>—</del>	<del>—</del>	44 (1) 5.0 (2) *0.5 (1) *0 (2)	<del>—</del>
9	—	—	—	-7.5	<del>—</del>	<del>—</del>	<del>—</del>	<del>—</del>	<del>—</del>

TRANSMITTER SECTION

PIN #	V110	V111	V112	V113	V114
1	—	—	*2.0	—	100 *115
2	6.3 V. AC	—	—	*265	—
3	*190	—	*265	*9.0	1.1 *1.3
4	—	—	—	—	6.3 V. AC
5	-40	—	6.3 V. AC	6.3 V. AC	6.3 V. AC
6	—	*255	—	*215	100 *115
7	—	*205	—	*100	—
8	-40	*255	*155	—	1.1 *1.4
9	<del>—</del>	6.3 V. AC	*225	—	—

**NOTES:** (1) SQUELCH CONTROL FULL CLOCKWISE  
 (2) SQUELCH CONTROL FULL COUNTERCLOCKWISE  
 UNIT OPERATED ON 117 V. AC FOR ABOVE TESTS  
 RCA TYPE WV-77A VTVM USED FOR ALL ABOVE MEASUREMENTS  
 \* = VOLTAGES ARE FOR TRANSMIT CONDITION

**CAUTION:** DO NOT MEASURE PLATE VOLTAGE AT CAP OF V110 (6146)  
 TRANSMITTER GRID AND RECEIVER 1st OSCILLATOR GRID CIRCUITS SHOULD BE MEASURED AT TEST SOCKET J105

# CONNECTOR TERMINALS AS VIEWED FROM REAR OF CHASSIS

## POWER SOCKET

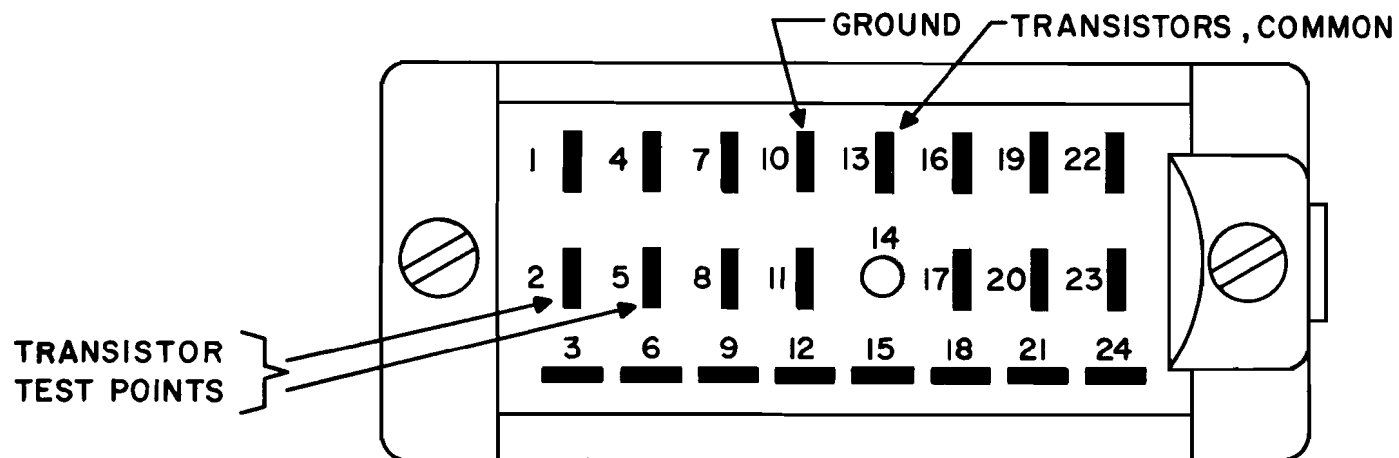

## TEST SOCKET

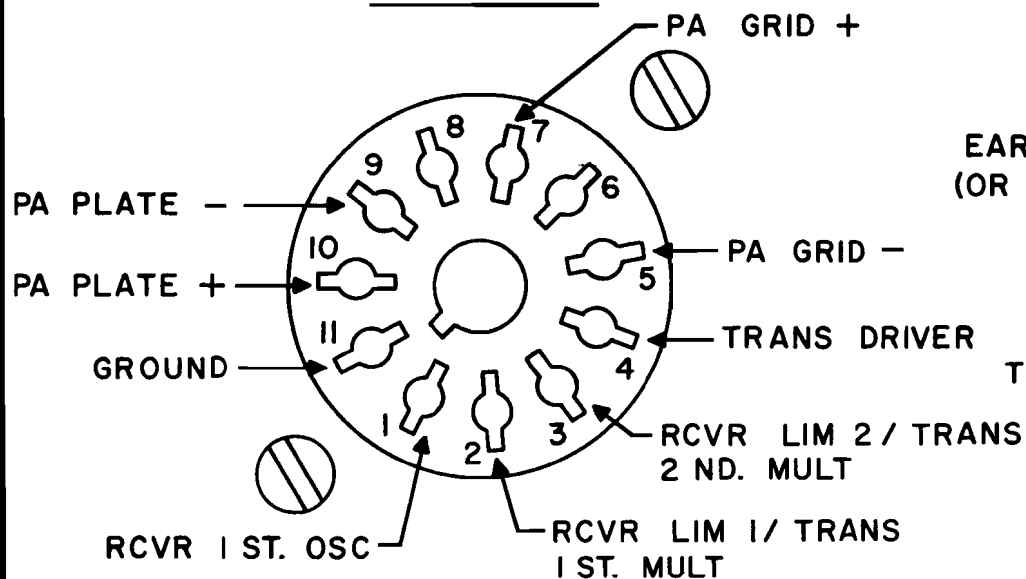

## REMOTE SOCKET

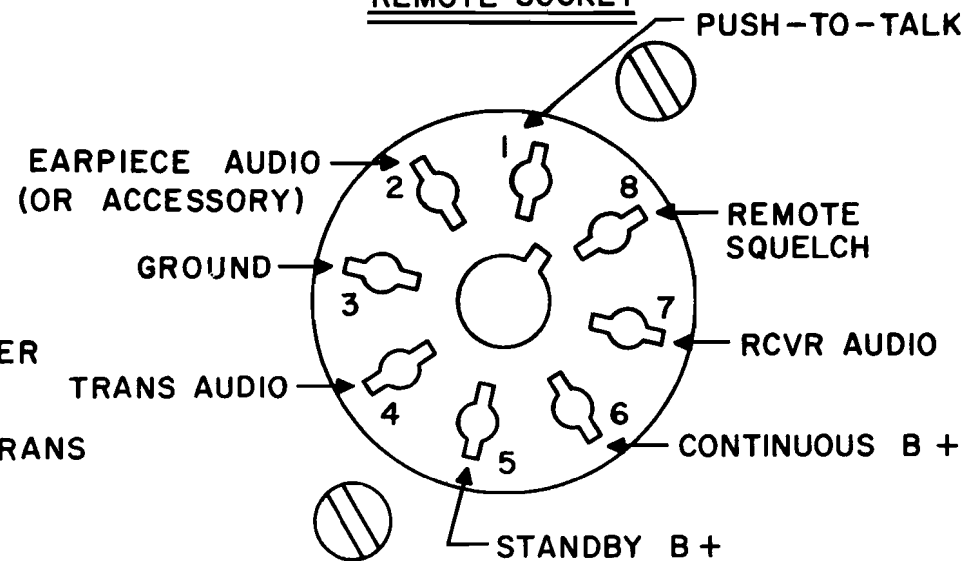

## PARTS LIST SUPPLEMENT & ERRATA SHEET

<u>Symbol</u>	<u>Description</u>	<u>Part No.</u>
C158	Capacitor Var. N500, 7-45 MMF, 500V.	K23059-3
C212	Capacitor, Silver Mica, 250 MMF, 350V	K23028-1
C213	Capacitor, Silver Mica, 250 MMF, 350V.	K23028-1
C214	Capacitor, Disc Ceramic, .01 MFD, GMV, 1000V.	M23034-8
R193	Resistor, Fixed 1K, 1/2 w. $\pm 10\%$	K19309-49

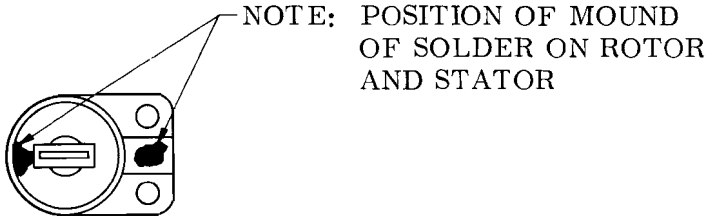

### NEUTRALIZATION INSTRUCTIONS

A variable 7-45 micro microfarad capacitor, C158 has been added from the screen grid, pin 3, of the radio frequency power amplifier, V110 (6146) to ground.

All units are shipped from the factory with this capacitor set at the correct point for optimum performance and under normal circumstances it need not be changed in the field unless the power amplifier tube V110 is changed or the transmitter is retuned to a different frequency.

The correct neutralization adjustment procedure is as follows:

- a) Set C158 for minimum capacity as shown in the above sketch. (Solder mound of rotor furthest position away from stator).
- b) Tune transmitter for maximum grid drive and maximum power output.
- c) Increase capacity of C158 by turning rotor either clockwise or counter-clockwise (solder mounds become closer) while observing plate current or final radio frequency stage. A point will be reached where plate current is lowest and then rises as capacity is further increased. Set neutralization capacitor C158 at lowest plate current point followed by re-tuning of the grid, plate and antenna loading adjustment of the final stage. Several adjustment cycles will be required for highest power output consistent with lowest plate current.
- d) Check for self oscillation by momentarily removing grid drive (remove

Neutralization Instructions (cont'd.)

crystal from socket). Under these conditions plate current should exceed 200 milliamperes, grid current and power output should drop to "0".

NOTE: WHEN MAKING THIS TEST DO NOT KEY TRANSMITTER FOR MORE THAN A FEW SECONDS AT A TIME.

e) If preceding step reveals no self oscillation leave C158 at its present setting. If oscillation persists reduce capacity of neutralization capacitor in small steps until self oscillation stops. Always re-adjust grid and plate tuning of the final stage for optimum performance when a re-adjustment of the neutralization capacitor has been made.

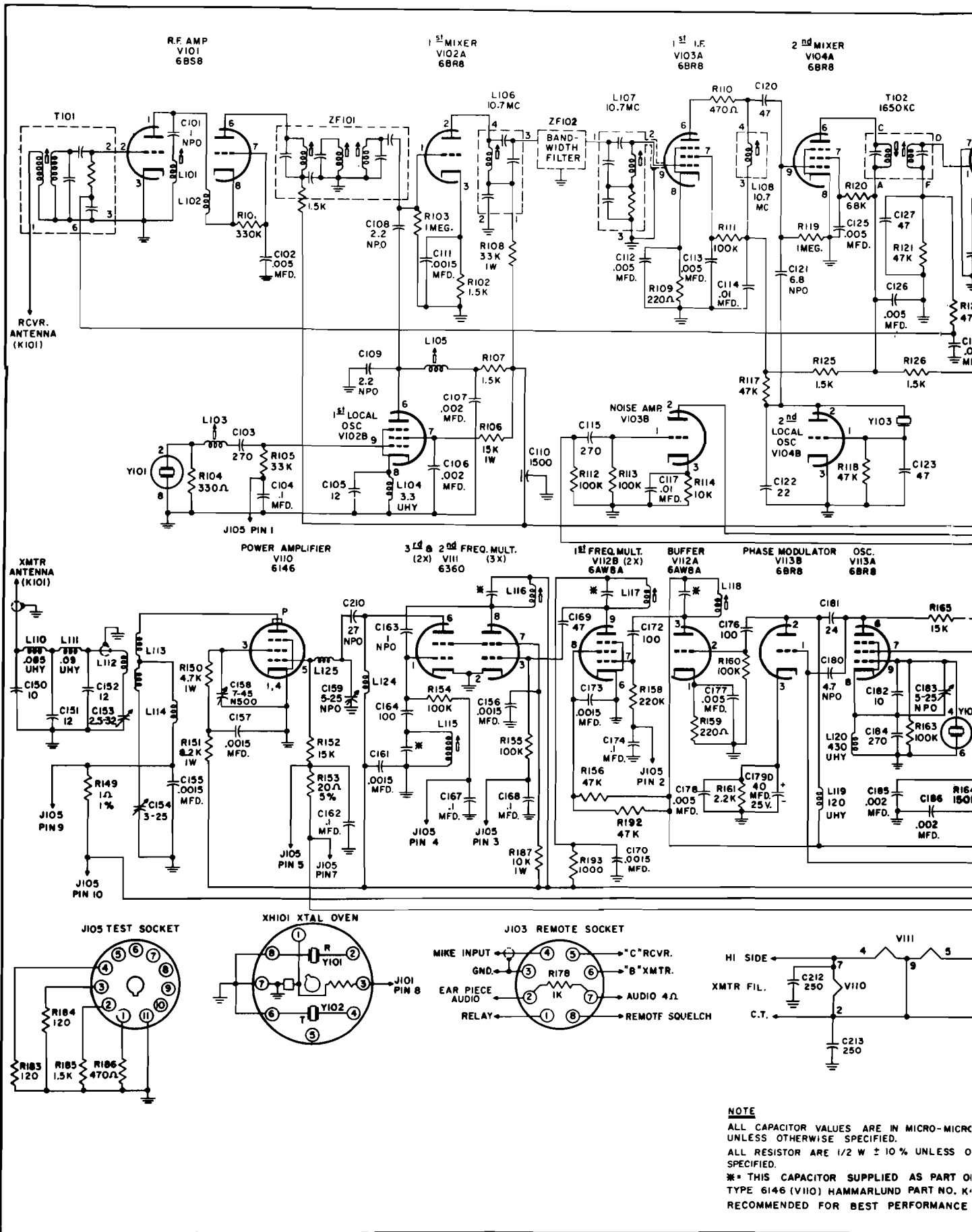

**NOTE**  
 ALL CAPACITOR VALUES ARE IN MICRO-MICRO UNLESS OTHERWISE SPECIFIED.  
 ALL RESISTOR ARE 1/2 W ± 10% UNLESS OTHERWISE SPECIFIED.  
 \* THIS CAPACITOR SUPPLIED AS PART OF TYPE 6146 (V10) HAMMARLUND PART NO. K- RECOMMENDED FOR BEST PERFORMANCE

