

MARCONI'S WIRELESS TELEGRAPH COMPANY LIMITED.

L O N D O N.

GENERAL DESCRIPTION AND OPERATING INSTRUCTIONS

FOR

RECEIVER TYPE CR.150

REFERENCE N<sup>o</sup>.

T/1845.



**GENERAL DESCRIPTION AND OPERATING INSTRUCTIONS**

**FOR**

**RECEIVER TYPE CR.150**

**C O N T E N T S**

---

<b><u>Section</u></b>	<b><u>Subject</u></b>	<b><u>Page</u></b>
-	DATA SUMMARY	
I	GENERAL CHARACTERISTICS	1
II	OPERATION	3
III	TECHNICAL DESCRIPTION	5
	a). General	5 - 9
	b). Detailed Circuit Description	9 - 11
	c). Mechanical Design	11 - 12
IV	PERFORMANCE	12
V	MAINTENANCE AND SERVICING	15
VI	PARTS LIST	35
APP. I.	GENERAL NOTES ON INSTALLATION	
APP. II.	SUPPLY UNIT TYPE 901.	



GENERAL DESCRIPTION AND OPERATING INSTRUCTIONS

FOR

RECEIVER TYPE CR.150

D R A W I N G   I N D E X

Circuit Diagram - (Supply Unit)	WZ.1790
Front Panel	WZ.1791
Upper Deck Plan	WZ.1792
Lower Deck Plan	WZ.1793
Resistance Boards	WZ.1794
Terminal and Supply Board	WZ.1795
Cord Drive Assembly	WZ.1796
L.F. Response	WZ.1797
L.F. Filter Response	WZ.1798
I.F. Response	WZ.1799
Selectivity (Two Signal)	WZ.1800
Overall Fidelity	WZ.1801
A.V.C. Response	WZ.1802
Frequency Drift	WZ.1803
Fixing of Feeder to Aerial Plug	WZ.1852
1st Oscillator Diversity Connections	WZ.1767
Circuit Diagram - (Receiver)	WZ.1779



# DATA SUMMARY

Frequency Range 2 - 60 Mc/s. in 5 bands.

Supply Requirements.

A. Batteries 65 mA. at 300 V.  
3.7 A. at 6.3 V.

B. Mains 230 V. 50 c.p.s.  
(80.W.)

Receiver Input.

75 Ohms, balanced or unbalanced. Fits feeders Uni-Radio 6 or Uni-Radio 18.

Sensitivity.

For 20 db signal to noise C.W. 1-2  $\mu$ V from 2 - 16 Mc/s.  
" " " " " " " 2-14 " " 16 - 60 "

Receiver Outputs

For telephones 1 mW.  
Line 1 mW., 600 Ohms.  
Loudspeaker 200 mW., 3 Ohms.

Weight and Dimensions.

	<u>Width.</u>	<u>Depth.</u>	<u>Height.</u>	<u>Weight.</u>	
Receiver Unit	16 $\frac{1}{2}$ "	17"	13 $\frac{1}{2}$ "	55 lbs.	} OVER- ALL.
Supply Unit	6"	17"	13 $\frac{1}{2}$ "	29 lbs.	



GENERAL DESCRIPTION AND OPERATING INSTRUCTIONS

FOR

RECEIVER TYPE CR.150.

REFERENCE NO. T.1845.

44114.

1. GENERAL CHARACTERISTICS.

The receiver and its associated power supply unit provides a mains operated equipment giving a very high order of performance in useful sensitivity, selectivity and general flexibility in use.

The instantaneous switch adjustment over a wide range of selectivity characteristics permits immediate adjustment to suit widely differing requirements. It may be used with aerials of the horizontal dipole type, or with any aerial system working through a 75 ohm screened concentric feeder, and thus provides for erecting the active portion of simple aerial systems away from heavy interference fields, and the output arrangements cover all normal requirements for head telephone, loudspeaker or line working.

It is of the double superheterodyne type, i.e., the signal is changed first to 1600 kc/s and then 465 kc/s in frequency before conversion to its audio frequency output. The salient features included are as briefly listed below.

Salient Features.

a). High Electrical Performance.

By the careful choice of valve types and high L/C ratios the inherent receiver noise is, at all frequencies below 30 Mc/s., reduced to the theoretical limit set by the thermal agitation of the first tuned circuit. From 30 - 60 Mc/s. first valve noise is the limiting factor.

By incorporating a double frequency change the image signal protection is maintained at over 40 db. at all frequencies below 30 Mc/s. From 30 - 60 Mc/s. it varies from 20 - 40 db.

The protection to adjacent channel interference is also made high by the use of double crystal pass-band filters.

b). Self-checking Calibration.

The receiver includes a 500 kc/s. crystal oscillator

switched on by a front panel control, and harmonics of the latter frequency may be introduced into the input circuit of the receiver. As these harmonics coincide with main calibration frequencies on the calibration dial, the calibration may be instantaneously checked to crystal standards of accuracy without the use of external apparatus.

c). Temperature Compensation.

The first frequency change oscillator is so compensated for thermal drift that this factor becomes negligible at frequencies below 20 Mc/s. within 30 minutes of switching on.

d). Stabilisation of Supplies.

A tube of the stabilovolt type ensures constancy of anode supply to those circuits in which this feature is desirable.

e). Electrical Band-spread.

In addition to a fine tuning control having reduction ratios of 150 to 1, and 25 to 1 as for the CR.100, a front of panel control gives a calibrated searching band of  $\pm 4$  kc/s. on either side of the nominal tuning point.

f). Power Supplies.

The power supply circuits are mounted in a separate unit, thus reducing the heat dissipation in the receiver cabinet.

g). Metering and Visual Tuning Indicator.

A meter is used in conjunction with a switch to measure the anode currents of essential valves and to work as a tuning indicator. The meter shunts are so arranged that the meter reads between 3 and 7 on the scale for all the valve feeds.

h). Diversity Reception.

The standard receiver forms the basis of the CRD.150 triple diversity equipment.

## II. OPERATION.

Assuming that the receiver has been correctly installed (See Appendix I), the following instructions give all the information essential for the correct use of the receiver.

Note that certain adjustments which are not used in the normal operation of the receiver, but should be attended to when first installing it, are dealt with in Appendix I. These refer to selection of optional A.G.C. time constants provided, and arranging the receiver for single channel use in diversity equipments CRD.150.

1. Switch on supplies to power unit. Warning lamp on power unit should light up.
2. Switch on supplies to receiver. Receiver scale lamps should light up. Place other controls as follows:
3. Operational Switch to C.W/MAN.
4. Pass-band Switch to 1500 c/s.
5. L.F. Gain to mid-position.
6. H.F. Gain to maximum, clockwise, reducing if necessary to give "comfortable" level in 'phones.
7. Band-change Switch. Select frequency band required. (The frequency calibration for each band is automatically brought into view on the calibration drum).
8. Tuning. Adjust pointer on calibration scale to desired frequency by larger tuning knob, and rock smaller knob slowly about one revolution on either side, until carrier of wanted station is heard. If R.T. (telephone) is to be received change operational switch (3) to MOD/MAN and re-tune slightly. Reduce signal to suitable level by turning H.F. gain (6) control counter-clockwise.

Always switch off supplies to power unit as well as receiver when closing down for long periods.

### General Notes.

#### Use of Pass-band Switch.

10,000 position gives best intelligibility of speech and makes tuning broader, but it can only be used when little interference is present. Switching to 5,000, 1,500 and then 500 cuts down

interference progressively, but the signal must be tuned more carefully and accurately. The 100 position demands very careful tuning and must only be used for C.W. It is most suitable for bands 1 and 2.

### N.B.

When receiving C.W. with Pass-band switch at 10,000 or 5,000, it will be found that on tuning through zero beat, the beat note obtained is equally strong on both sides of the latter, but when using positions 1,500, 500 and 100 one side will give a stronger note than the other. Always tune to the stronger of the two.

### Use of A.V.C.

A.V.C. should be switched off when searching or in the presence of strong interference.

### Use of Gain Controls.

A.V.C. on H.F. gain at maximum.

L.F. gain as desired.

A.V.C. off H.F. gain as desired.

L.F. gain at mid-position approx.

### Use of Calibrator.

The calibrate position of the operational switch, switches on a 0.5 Mc/s. crystal oscillator, so that a calibrating signal is heard every 0.5 Mc/s. up to 30 Mc/s. The calibrating signal is distinguished from others by switching from calibrate to C.W.

### Use of Signal Indicator and Meter Switch.

This switch in the signal indicator position connects the meter to give an indication of signal strength. It must be used only on A.V.C. and with the meter adjusted to read zero by means of the H.F. gain control. The other position of this switch will meter the valve feeds of V1 to V9 and the meter should read between 3 and 7 for all these valves when the H.F. gain control is at maximum.

### Use of Logging Scale.

This scale enables the operator to reset the receiver accurately to a station that has once been found.

Read the divisions from left to right, main divisions on the upper scale and sub-divisions on the lower scale. Note that the divisions on this scale decrease with increasing frequency.

The discrimination of this scale at the bottom, middle and top frequency of each band is given below. This is an approximation and will vary slightly between receivers.

	<u>Bottom.</u>	<u>Middle.</u>	<u>Top.</u>					
Band 1.	1.	2.	2.5 kc/s	per	small	division	(0.02).	
Band 2.	2.	4.	5.	"	"	"	"	"
Band 3.	4.	8.	10.	"	"	"	"	"
Band 4.	8.	16.	20.	"	"	"	"	"
Band 5.	16.	28.	32.	"	"	"	"	"

#### Warning Up.

The receiver takes a few minutes to warm up, and about 15 minutes to reach stability. Use "Off" position of operational switch to switch off for short breaks; as valve heaters are left on and receiver is ready for immediate use.

Operators are urged to study the circuit description in order to make the most of the receiver by an intelligent use of the controls. Additionally it should be noted that preset adjustment for the third oscillator must be set correctly in the first case and checked periodically in order to make the most of the high selectivity of the receiver in the narrow pass-band conditions.

The top of the third oscillator can have three marks. Either of the outside marks are the positions to which this oscillator should be set. In order to check this adjustment, proceed as follows:-

Set the pass-band switch to 100 c.p.s. and tune to any silent point on band one.

Adjust the third oscillator preset control until receiver noise reaches a sharp maximum.

### III. TECHNICAL DESCRIPTION.

#### a). GENERAL.

The valve complement of the receiver is as follows:-

<u>Type.</u>	<u>Number.</u>	<u>Use.</u>
EF.50	2.	Signal Frequency Amplifiers.
EF.50	1.	First Frequency Changer.
EF.50	1.	First Frequency change oscillator.
X.65 or X.66	1.	Second Frequency Changer.
KTW.63	2.	Intermediate Frequency Amplifiers.
DH.63	1.	Second Detector, A.V.C. rectifier, and low frequency amplifier.
DH.63	1.	Noise Limiter and Crystal Calibrator.
KTW.63	1.	Beat Frequency Oscillator.
L.63	1.	Output.
STV.280/40	1.	Voltage Stabiliser.
U.52 (in power pack)		Mains Rectifier.

As shown in the illustration, the receiver unit is very similar to the CR.100 in appearance and is mounted in a robust metal cabinet of simple form.

The power supply unit matches in general appearance.

Frequency Band.

The overall frequency band 2 - 60 Mc/s. is covered by 5 positions of the frequency bandswitch as follows:-

<u>Switch Position.</u>	<u>Frequency Band.</u>
1.	2 - 4 Mc/s.
2.	4 - 8 "
3.	8 - 16 "
4.	16 - 32 "
5.	32 - 60 "

Calibration and Tuning.

In addition to selecting the required coils, the band switch rotates a calibration roller, bringing into view the frequency scale of the band in use, as for the CR.100. The main tuning control moves a pointer across the frequency scale and also rotates the logging scale discs. This logging scale has an equivalent length of 18 feet and its 1250 divisions can be read to one quarter division. At 20 Mc/s. one scale division is equal to a 12 kc/s. change of frequency.

The electrical band-spread control to the left of the main tuning knob is normally set to central zone. It is calibrated in kc/s. and gives a change of 4 kc/s on each side of zero at all frequencies to which the receiver can be tuned.

Selectivity Range.

The five-position pass-band switch is directly calibrated to show the total band of frequencies passed with not more than 6 db attenuation in comparison with the mid-frequency,

Pass-bands available are:-

10,000	c.p.s.,	i.e.,	freqs.	±	5,000	c.p.s.	in	relation	to	the	carrier.
5,000	"	"	"	±	2,500	"	"	"	"	"	"
1,500	"	"	"	±	750	"	"	"	"	"	"
500	"	"	"	±	250	"	"	"	"	"	"
100	"	"	"	±	50	"	"	"	"	"	"

The fifth position introduces a low frequency circuit tuned to approximately 1,000 c.p.s. and having the pass-band stated, i.e., 100 c.p.s.

The gain of the receiver does not vary by more than a few db between any of the various pass-band conditions above.

Aerial Inputs.

The receiver input is arranged to give best sensitivity when working from a 75 Ohm balanced or unbalanced feeder.

Outputs.

Three types of output are available on the standard model.

- a). For head telephones from two front of panel jacks.  
The maximum output available when using high resistance telephones is about 1 mW., i.e., unpleasant aural shock is impossible. With low resistance 'phones the output is about 3 db. less.
- b). For a 3 Ohm speech coil from terminals at back of the cabinet giving a maximum output of 200 mW.
- c). For a 600 ohm line from terminals at the back of the cabinet. The maximum output is 1 mW.

N.B.

The output passed to line is unaffected by the insertion of the telephone for local monitoring. Removal of the loudspeaker plug is compensated for by the automatic insertion of a 3 Ohm load, so that line and telephone outputs are also unaffected by the use of the loudspeaker.

Supplies.

The receiver unit is fitted with a supply socket to which may be connected a heater supply of 3.7 amps. at 6.3 volts and a high tension supply of 65 mA. at 300 V.

For operation from A.C. mains the above supplies may be plugged into the receiver from the optional supply unit, which is designed to work from a 50 c.p.s. mains at 200 - 250 V. The mains consumption is approximately 80 W.

Controls.

The receiver controls are:-

Main tuning condenser.

Band-spread condenser.

Pass-band Selection.

Tuning band switch.

Operational switch (incorporating control of A.V.C., B.F.O. and Calibration.

Meter Switch.

H.F. gain.

L.F. gain.

On-off switch.

b). DETAILED CIRCUIT DESCRIPTION.

The receiver embodies two signal frequency amplifier stages followed by a pentode mixer with a separate first frequency change oscillator.

The first frequency change is 1.6 Mc/s. The first mixer is coupled directly to the second mixer at this frequency through a pair of coupled circuits. The second frequency change to 465 kc/s is made with a triode-hexode, which is followed by a two stage amplifier incorporating the main selective circuits and crystal filters.

The 465 kc/s intermediate frequency output is rectified by two diodes to provide A.V.C. and audio frequency outputs. The triode section of the double diode triode acts as first audio frequency amplifier and is followed by the power output stage. The beat frequency oscillator is coupled to the signal diode.

Signal Frequency Circuits.

The aerial input is taken to a coupling winding on the tuned grid coils of the first signal frequency amplifier. The two ends of the coupling coils are connected to concentric screened sockets, the plugs of which are suitable for use with Uni-Radio 6 or Uni-Radio 18 type feeders. For balanced inputs both connectors are used, but for unbalanced inputs the centre and outer of one socket are joined, the other socket being used for the aerial connection.

The gain of the signal frequency amplifier is sufficient to make the first circuit noise equal to, or greater than, other receiver noise at all frequencies up to 32 Mc/s (Bands 1 to 4). On band 5 (32 - 60 Mc/s) the first valve noise is equal to other noise.

The gain of the signal frequency amplifier is substantially constant on bands 1 - 4. Special coupling circuits are used to attain this.

Considerable precautions have been taken to ensure a high order of stability for the first frequency change oscillator. The tuning condenser is provided with an unusually robust frame, and the thickness of the vanes in the oscillator section, and the spacing between vanes are greater than usual. The coils for bands 3 and 4 are wound on ceramic formers. In addition to reducing the frequency drift of the oscillator as the receiver warms up by such precautions, the residual frequency drift is still further reduced by a thermally operated compensating condenser.

The signal frequency stages, mixer, first oscillator and the 1600 kc/s I.F. transformer are mounted on a removable plate, and this sub-assembly is mounted in the centre of the main receiver chassis on insulated bushes, which reduce the possibility of coupling between the second and third oscillators and the signal frequency circuits. By this means pick-up of harmonics of these oscillators is reduced to a low level.

#### Intermediate Frequency Amplifiers.

The 1600 kc/s I.F. unit is mounted on the H.F. sub-assembly, and output is taken by a flexible screened lead to the grid cap of the second mixer valve on the main receiver chassis.

The second mixer is a triode hexode with its oscillator operating at a frequency of 1135 kc/s. This oscillator has a panel controlled trimmer condenser giving a variation of four kilocycles on each side of the centre zero. This is the band-spread control and it tunes the receiver across the selectivity curve of the signal and first intermediate frequency circuits; these are designed so that the mistuning by the band-spread control does not lead to more than a decibel of asymmetry at the worst point.

The second I.F. amplifier (465 kc/s) controls the overall selectivity of the receiver for all positions of the selectivity switch except the 100 c.p.s. pass-band. The two widest pass-bands are determined by variations of coupling between the two tuned circuits.

For the 1,500 c.p.s. pass-band a double crystal filter is introduced and an additional double crystal filter controls the 500 c.p.s. pass-band. Both these double crystal filters remain in circuit when the tuned L.F. circuits are introduced.

#### Automatic Volume Control Circuits.

The input for the automatic volume control diode is taken from the primary of the final intermediate frequency transformer. The automatic volume control voltage is applied directly to the screened mixer and the first I.F. amplifier, and through a potentiometer to the two high frequency amplifiers. A choice of three time constants is possible by using a selector board inside the receiver. This facility is necessary for high speed recording applications.

The "On/Off" switch for automatic volume control operation is included in the "operational" switch. The latter covers six positions, i.e., stand-by; B.F.O. oscillator on (with and without A.V.C.); B.F.O. oscillator off, (with and without A.V.C.) and crystal calibrator and B.F.O. on.

### Beat Frequency Oscillator and Signal Detector.

The beat frequency oscillator is electron coupled to the signal diode, which obtains its intermediate frequency input from the secondary of the final intermediate frequency transformer. The oscillator amplitude is such that, whilst it will fully modulate the largest signal at the diode, it will not operate the automatic volume control diode. The efficient screening of the beat frequency oscillator circuit prevents its harmonics from interfering appreciably with the signal frequency input.

### Crystal Calibrator.

The frequency of this oscillator is controlled by an A.T. cut low temperature coefficient crystal. The circuit is dimensioned to give strong harmonics of the 0.5 Mc/s oscillation on its output, which is coupled to the first tuned circuit of the receiver.

### Low Frequency Circuits.

The triode low frequency amplifier is resistance capacity coupled to the output valve, except in the 100 c/s. position of the pass-band switch, in which case the coupling is through a 1,000 c/s. band-pass filter. The low frequency gain is the same with or without the filter.

### Diversity Working.

When the CR.150 is included in the CRD.150 diversity equipment, it is necessary to couple the automatic volume control circuits by an external combining unit, which also combines the audio frequency outputs of the receivers. The A.V.C. connections are taken to terminals at the back of the case, and when the receiver is used by itself, these are joined together.

For use in the above equipment there is also provision for injecting a common first oscillator output into the receiver. This is connected through a concentric socket at the back, a small wiring change being necessary at the oscillator tuning condenser above the chassis. It is also necessary to remove the oscillator valve when working with an external common oscillator.

### c). MECHANICAL DESIGN.

The receiver cabinet and chassis are made of 1/16" motor-body steel. The back, sides, and top of the receiver form one

member, which is screwed to the chassis, the front panel and bottom of the chassis forming separate plates.

This type of construction provides considerable rigidity for the chassis.

The chassis is the inverted tray type, a central section being cut away to receive the high frequency sub-assembly. The latter in turn is built up of smaller replacement assemblies, e.g., tuning condenser unit complete with calibration scales, and coil units for the H.F. and first oscillator stages.

The I.F. circuits, L.F. filters, etc., are made up as self-contained sub-assemblies for ease in servicing.

Access for valve replacements, circuit alignment, etc., is provided either through the hinged upper lid of the cabinet, or by removing the bottom plate from the chassis. For major servicing the chassis may be removed from the cabinet as a whole. In order to do this the control knobs are removed, the front panel taken off, and the main body of the container unscrewed from the chassis.

The bottom of the receiver is domed for table operation but may be reversed if the domes are not required.

Detailed instructions for removing various sub-assemblies are covered under maintenance instructions.

#### IV. PERFORMANCE.

##### Sensitivity.

The input required to give a 20 db. signal to noise ratio on an unmodulated signal or a 10 db signal to noise ratio on a signal modulated 40% at 400 c/s. is:-

1 - 2	microvolts	from	2 - 16	Mc/s.
2 - 4	"	"	16 - 32	"
7 - 14	"	"	32 - 60	"

under the following conditions.

A non-inductive resistance of 75 ohms is connected between the signal generator and one of the dipole terminals on the receiver, the other dipole terminal is connected to earth.

The pass band switch is at 5,000 c/s.

A.V.C.

The increase in the low frequency output when the signal input is increased by 60 db. above the inputs necessary to give the S/N ratios above quoted, is not more than 9 db.

Selectivity.

Signal Frequency.

The attenuation offered to the image signal by the signal frequency circuits is not less than the figures given below:

<u>Band.</u>	<u>Frequency.</u>	<u>Image Signal Protection.</u>
1	2 Mc/s.	100 db.
	3 "	90 "
	4 "	80 "
2	4 "	90 "
	6 "	80 "
	8 "	70 "
3	8 "	80 "
	12 "	70 "
	16 "	65 "
4	16 "	65 "
	24 "	55 "
	32 "	40 "
5	32 "	40 "
	48 "	22 "
	60 "	20 "

Intermediate Frequency.

The mid-band frequency of the second I.F. amplifier is  $405 \pm 0.1$  kc/s.

The bandwidths for the four nominal positions of the pass-band switch at 6 db. and 40 db. below peak are:-

<u>Switch Position.</u>	<u>- 6 db.</u>	<u>- 40 db.</u>
500	500 - 1,000 c/s.	1,500 - 3,000 c/s.
1,500	1,500 - 3,000 "	5,000 - 10,000 "
5,000	4,000 - 7,000 "	11,000 - 18,000 "
10,000	8,000 - 12,000 "	16,000 - 28,000 "

Drawing NZ.1799 shows typical I.F. responses for the four positions of the pass band switch.

#### Two Signal Generator Selectivity.

The overall selectivity at 2.2, 5.0 and 10 Mc/s. under the following conditions of test is shown on drawing D2A/1800.

The receiver is tuned to a signal at a constant frequency modulated to a depth of 10%, and input voltage of 1  $\mu$ V. The resultant output is noted and the modulation removed.

A second signal modulated 70% at 400 cycles is also applied and the level and frequency of this signal are adjusted to produce the same output as is obtained by the 10% modulation of the first signal.

#### Low Frequency Amplifier.

The L.F. response is within + 5 db. of a mean value for all frequencies between 100 and 6,000 c/s. Drawing NZ.1797 shows the L.F. response.

#### L.F. Filter.

The L.F. filter is inserted on the "100" position of the pass band switch.

The L.F. filter is tuned to 1,000 c/s (nominal).

The bandwidths at 6 db. and 20 db. below peak are 100 - 150 c/s. and 200 - 400 c/s. respectively.

The net filter loss is not more than 3 db. on its optimum frequency.

Drawing D2A/631 shows the L.F. filter response.

### Overall Fidelity.

The overall fidelity taken at 2 Mc/s with a 30% modulated signal for the four positions of the pass band switch is shown on drawing WZ.1801.

### Frequency Drift.

The frequency drift of the first oscillator is not more than 2,000 c/s per hour at any frequency below 20 Mc/s. after the first thirty minutes from switching on.

It does not exceed 5,000 c/s. per hour at any frequency up to 30 Mc/s.

## V. MAINTENANCE AND SERVICING.

The following sub-sections cover servicing the receiver according to the apparatus and facilities available. Apart from servicing for specific faults which may arise, routine maintenance calls for little comment.

It cannot be too strongly stated that random adjustments to trimmer condensers, etc., should never be undertaken. Such adjustments should only be touched by staff having the necessary experience after reading the servicing instructions below.

Always keep the lid of the receiver closed to avoid dust. Avoid harsh treatment of the aerial and supply sockets, e.g., do not drop them on the ground at the end of their leads. Occasional lubrication of the click register and wave-change mechanisms with a light machine oil of good quality is desirable, but do not lubricate the actual switch wafers and contacts under any circumstances. Do not touch the main tuning condenser except if it is absolutely essential to remove dust or other deposit on the plates, and then use nothing harsher than a feather or pipe cleaner gently between the plates. Tighten up the grub screws holding the operating handles on to their spindles if they work loose under constant use rather than let them tend to scratch a track on the spindle through slipping, and do not try to force the control knobs beyond their obvious "stop" position.

**ALWAYS SWITCH OFF BEFORE SERVICING THE RECEIVER OR  
POWER SUPPLY UNIT INTERNALLY.**

The receiver is safe when supplies are switched off on the supply unit. The supply unit is only completely safe when isolated from the mains.

Signal Indicator Adjustment.

The meter is used as a signal strength indicator by switching to the appropriate position. It is necessary to set this meter to give zero reading in the absence of a signal by potentiometer P.1 (See WZ.1793). Set the operational switch in the "AVC.-MOD" position and the H.F. gain control near maximum, adjusting the tuning control to a silentpoint and adjust the potentiometer until zero reading is obtained.

Emergency Servicing.

Fuse Replacements.

The power pack is fitted with two fuses which should be examined in case of failure in supplies to the receiver. The D.C. fuse mounted on the front of the supply unit near the main "On-Off" switch should be unscrewed and the cartridge fuse replaced, if necessary. Its rating is 500 mA. The main A.C. fuse, a double-ended plug on top of the mains transformer in the supply unit, should be fitted with a single strand of 2 amp. fuse wire. In an emergency a single strand of 38-44 SWG. may be used.

Valve replacements.

Keep a log of valve feeds indicated on the receiver meter and replace any of the valves V1 - V9 which steadily drop in feed below their correct minimum. All valve feeds should read between 3 and 7 on the meter with the H.F. gain at maximum.

For measuring the feeds of valves V10 and V11, and for accurate measurement of other valve feeds, use an avo-meter or similar external instrument. The bottom of the receiver cabinet should be removed and the meter clipped across the resistances shown in the table given later under "Valve Feeds".

Replacing Electrolytic Condenser.

The electrolytic condenser in the power pack unit is of

the plug-in type, and can be replaced by easing away the spring-loaded retainer and withdrawing.

Replacing the Calibration Drum Drive Cord.

Remove all knobs.

Take out P.K. screws and remove bottom plate and front panel.

Lift case off receiver chassis.

Fit a knob temporarily to the band-switch and set this to Band 5.

Check that all oak switches are correctly set to this band.

Take off the calibrated drum by removing bracket and cheek at right hand end and pulling the drum out of the left-hand cheek.

Take 6 feet of cord, bring ends together, and fold double. Pass loop through eyelet on the left-hand cheek "A". (See WZ.1796).

Tie knot in the loop end and locate in hole of cheek "A".

Take one cord (call this the L.H. cord). Pass this cord straight down over pulley "B", then on to pulleys "C" and "D" and round the operating drum "E" to the hole in "E".

The other cord (R.H. cord) is taken  $1\frac{1}{2}$  times round "A" and down to pulleys "G" and "F" and round to the hole in "E".

Both ends of the cord are then passed through the end of the spring in "E" and tied off.

Replacing the Pointer Drive Cord.

1. Remove knobs and front panel.
2. Set 0 - 25 Logging scale at 22.
3. Release pointer from old cord. Pull cord out through

- $1\frac{1}{2}$ " diameter inspection hole in front plate of drive, but do not detach from spring.
4. Thread new cord, which should be 44" long, through pointer slider and pass ends round the drum, the right-hand cord clockwise and the left hand cord counter-clockwise. Tuck the cords through the hole in periphery of drum. There should now be approximately  $1\frac{1}{3}$  turns of cord on the drum.
  5. Pull spring out through hole in plate by means of old cord. Thread ends of new cord through loop of spring and secure with a large knot about 1" from end. Cut off old cord.
  6. Pull cord back through hole in drum thus extending the spring and ease over small pulleys at each end of pulley guide.
  7. Fix pointer lightly to cord. Pointer to be at middle of scale when logging scale is 12.5.
  8. Check position of pointer on calibration scale by tuning receiver to a station of known frequency near middle of scale. Fix pointer firmly to cord taking care not to cut it.
  9. Replace panel and knobs.

#### Circuit Checks.

In the event of a receiver failure not due to valves, fuses, etc., endeavour to narrow down the possible fault by a logical sequence of tests, e.g., a failure observable on one of the frequency bands only would exonerate the I.F. and L.F. circuits, a failure on the narrowest position of the pass-band switch would be probably due to the L.F. filter, etc., etc.

If a fault can be narrowed down, it can very often be traced by the use of an avo-meter only and the following tables give circuit checks.

#### General Circuit Check.

The receiver to have no valves or lamps.

The H.F. gain control to be at maximum.

The L.F. gain control to be at minimum.

The operational switch to be at calibrate.

The selectivity control to be at 100.

The band switch to be at band 1.

The circuit resistance given below to be within  
+ 20%.

Tests Points.	Main Switch at "On".	Main Switch at "Off".
Supplies plug E pin and chassis	0 Ohms.	0 Ohms.
" H.T.+ " "	42,000 Ohms.	Infinity.
" L.T. " "	Infinity.	Infinity.
Loudspeaker sockets	0.4 Ohms.	0.4 Ohms.
Line Terminals	680 Ohms.	680 Ohms.
Phones Jack	4,700 Ohms.	4,700 Ohms.
A.G.C. terminal 1 and E	2.3 Megohms	2.3 Megohms.
A.G.C. terminal 2 and E	Infinity	Infinity.

Operational Switch Circuit Check.

Test Points	MOD. Switch Position C.W.					
	MAN	AVC	OFF	AVC	MAN	CALIBRATE
H.T.+ and 2 on S16	0	0	Inf.	0	0	0
H.T.+ and 3 on V9	Inf.	Inf.	Inf.	2,200	2,200	2,200
H.T.+ and 3 on V10	Inf.	Inf.	Inf.	Inf.	Inf.	22,000
E and Pin 8 on V10	160,000	160,000	160,000	160,000	160,000	0
E and Top Cap on V6	47,000	3 Mohm	47,000	3 Mohm.	47,000	3 Mohm.

Valveholders Circuit Check.

Test Points	V.1	V.2	V.3	V.4	V.5	V.6
E and Top Cap					3 MΩ	3 MΩ
E and Pin 1	Inf.	Inf.	Inf.	Inf.	Inf.	Inf.
E and Pin 2	84,000	84,000	47,000	48,000	0	0
E and Pin 4	0	0	100,000	48,000	70,000	190,000
E and Pin 5	0	0	0	Inf.	100,000	0
E and Pin 6	220	220	3,400	0	140,000	Inf.
E and Pin 6 (H.F. Min.)	2,200	2,200	3,400	0		
E and Pin 7	0.5 MΩ	0.5 MΩ	100,000	10,000	Inf.	Inf.
E and Pin 8	0	0	0	Inf.	330	1,000
E and Pin 8 (H.F. Min.)	0	0	0	Inf.	5,300	6,000
E and Pin 9	0	0	0	0		
L.T. and Pin 1.	0	0	0	0	Inf.	Inf.
L.T. and Pin 7.	Inf.	Inf.	Inf.	Inf.	0	0
H.T.+ and Pin 2.	52,000	52,000	15,000	16,000	42,000	42,000
H.T.+ and Pin 3.	10,000	10,000	15,000	16,000	10,000	10,000
H.T.+ and Pin 4.	42,000	42,000	142,000	16,000	38,000	155,000
H.T.+ and Pin 5.	42,000	42,000	42,000	Inf.	142,000	42,000
H.T.+ and Pin 6.	42,000	42,000	45,000	42,000	100,000	Inf.

cont'd.

Valveholder Circuit Check (cont'd).

Test Points	V.7	V.8	V.9	V.10	V.11	V.12
E and Top Cap	3 Ohm	10,000	110,000	1.1 MΩ		
E and Pin 1	Inf.	Inf.	44,000	Inf.	Inf.	37,000
E and Pin 2	0	0	0	0	0	0
E and Pin 4	47,000	Inf.	260,000	1.3 MΩ	Inf.	37,000
E and Pin 5	0	310,000	0	1.3 MΩ	560	470,000
E and Pin 6	2,000	44,000	Inf.	Inf.	42,000	
E and Pin 6 (H.P. Min.)						
E and Pin 7	Inf.	Inf.	Inf.	Inf.	Inf.	
E and Pin 8	470	11,000	10,000	0	1,000	
E and Pin 8 (H.P. Min.)	470	11,000	10,000	0	1,000	
E and Pin 9						
L.T. and Pin 1.	Inf.	Inf.	Inf.	Inf.	Inf.	Inf.
L.T. and Pin 7.	0	0	0	0	0	
H.T.+ and Pin 2	42,000	42,000	42,000	42,000	42,000	42,000
H.T.+ and Pin 3	2,200	69,000	2,200	22,000	600	5,000
H.T.+ and Pin 4	15,000	Inf.	222,000	1.4 MΩ	Inf.	5,000
H.T.+ and Pin 5	42,000	350,000	42,000	1.4 MΩ	42,000	0.5 MΩ
H.T.+ and Pin 6	42,000	2,200	Inf.	Inf.	0	

Meter Switch Circuit Check.

Test Points	Switch Position	Resistances	Remarks.
Across R.71		470 $\pm$ 5% Ohms	
12 on S.15 and 12 on S.16	1	3,000 $\pm$ 20% "	P.1 and P.4 at max.
do.	1	6,000 $\pm$ 20% "	" " " " min.
do.	2	96 $\pm$ 5%	
do.	3	96 "	
do.	4	179 "	
do.	5	56 "	
do.	6	470 "	
do.	7	2,200 "	
do.	8	167 "	
do.	9	40 "	
do.	10	250 "	
do.	11	82 "	

Voltages and Feeds.

The receiver will have its full complement of valves and lamps.

The band switch to be at band 1.

The operational switch to be at Calibrate.

The meter switch to be at V.1

The receiver to be fed from its power unit, ref. W.6111.

The voltage or current given below to be within  $\pm$  20%.

Test	Test Points	Voltage or Current	
		H.F. Max.	H.F. Min.
H.T. Volts	H.T.+ and E	300 Volts D.C.	310 Volts D.C.
Stabilised Line	Pin 1 on V12 and E	140 " "	140 " "
Heater Line	L.T. and E	6.3 " A.C.	6.3 " A.C.
H.F. Cathode Line	Slider on P3 and E	0 " D.C.	3.0 " D.C.
I.F. " "	Slider on P4 and E	0 " D.C.	10.0 " "
H.T. Current	Across S17 with S17 open, the L.T. side strapped.	65 mA. "	55 mA. "
L.T. Current	Across S17 with S17 open, the H.T. side strapped	3.7 amps. A.C.	3.7 amps. A.C.

Valve Feeds.

The feeds for valves V.1 to V.10 to be measured by connecting a milliammeter across the resistor given below.

The feed for V.11 to be measured by connecting a voltmeter across the resistor given below.

Check.	Test Points.	Gain Control	
		Max.	Min.
V.1 Feed	Across R.7	2.8 mA. $\pm$ 20%	0.1 mA $\pm$ 20%.
V.2 "	" R.14	2.8 mA. "	0.1 mA. "
V.3 "	" R.18	1.9 mA. "	1.9 mA. "
V.4 "	" R.22	3.6 mA. "	3.6 mA. "
V.5 "	" R.30	0.7 mA. "	0.2 mA. "
V.5 osc.Feed	" R.29	1.9 mA. "	1.8 mA. "
V.6 Feed	" R.35	2.5 mA. "	1.0 mA. "
V.7 "	" R.41	7.5 mA. "	7.5 mA. "
V.8 "	" R.49	1.7 mA. "	1.7 mA. "
V.9 "	" R.37	4.2 mA. "	4.3 mA. "
V.10 "	Break H.T.	0.9 mA. "	0.9 mA. "
V.11 "	Across R.53	9.0 Volts "	9.0 Volts "

N.B.

Resistances can be located by reference to drawings WZ.1793, and WZ.1794, but valve positions are given in drawing WZ.1792.

Receiver Alignment Tests.

From the following notes competent Staff can check stage by stage gains and response curves by the use of signal generator, a tone generator and an output meter. The latter should have input impedances suitable for the various output impedances of the receiver, i.e., 3, 600 and 5,000 Ohms. A spare output transformer from another receiver can be used to give the lower impedance from a meter having only a 5,000 Ohm impedance, but figures obtained will show the transformer loss, i.e., about 3 db.

L.F. Amplifier Test.

A tone generator with known output should be connected to the grid of V.8 through a 0.1  $\mu$ F condenser. The grid clip should also be attached to the valve top cap. Connect a 3 Ohm output meter to the loudspeaker socket. Make sure that the plug is right into the socket so that the loudspeaker dummy load is disconnected.

The input voltage for L.F. response measurements is 0.3 Volt.

The L.F. response should be within  $\pm 5$  db. of a mean value for all frequencies between 100 and 6,000 c/s.

The L.F. gain should be such that the input required at 1,000 c/s to give the following output is

Input	Output		
	L.S. terminals (3 ohms).	Line terminals (600 ohms).	Phone Jack (5,000 ohms).
0.3-0.4 V.	50 mW.	0.5 mW.	1.0 mW.

L.F. Filter Adjustment and Test.

Apply 0.3 Volt at 1,000 c/s to the grid of V.8. Clip a 100,000 Ohm resistor across the left hand circuit of the L.F. filter and tune the right hand circuit condenser to give maximum output. Change the resistor to the right hand circuit and tune the left hand circuit. If the filter will not tune on exactly 1,000 c/s a lower frequency, say, 970 c/s maybe tried.

A constant input of 0.3 Volt is used, as above, the output at the loudspeaker terminals being measured.

The insertion loss or gain of the L.F. filter is the loss or gain in output when the L.F. filter is switched in, the tone input being at the filter mid-band frequency.

The bandwidth of the L.F. filter at 6 db. and 20 db. below maximum should be 100 - 150 c/s and 200 - 400 c/s respectively.

The insertion loss should be not more than 3 db.

### I.F. Circuit Alignment.

Full alignment of the I.F. circuits which incorporate the crystal is impossible without special C.R.O. apparatus, and should only be undertaken by fully qualified engineers. The alignment oscilloscope type TF.852 A (Marconi Instruments Ltd.) has been designed specially for this purpose.

The following instructions therefore apply only to re-alignment of the I.F. for the 10 kc/s and 5 kc/s pass-band conditions. It is most unlikely that an I.F. thus re-aligned would give completely satisfactory operation on the crystal controlled pass-bands, i.e., 1500 cycles and 500 cycles.

The ganging tool for locking and adjusting the inductance cores W.8201/C. Sht.1., Edn.A., is available.

For I.F. alignment of the two widest positions of the pass-bands, proceed as follows:-

Set the operational switch to MOD-MANUAL, H.F. gain near maximum and Pass-band to 5,000.

Connect the signal generator to the grid of V.5 with the normal connection to the grid of V.5 removed and adjust the signal generator to 465 kc/s modulated 40% at 400 c/s.

Connect the 3 ohm output meter to the L.S. sockets.

Tune the inductance cores on the I.F.2, I.F.4 and I.F.6 transformers to give maximum output.

The 5,000 and 10,000 c/s position of the pass-band for the 465 kc/s I.F. amplifier should now be in correct alignment.

Next connect the signal generator to the grid of V.3 pin 7 through a 0.1  $\mu$ F condenser and adjust it to 1,600 kc/s modulated 40% at 400 c/s.

Set the Band Spread condenser to its mid-capacitance position, which should correspond to the knob being in the centre zero position.

Tune the inductance core in the second oscillator can to give maximum output.

Tune both cores on the I.F.1 transformer to give maximum output.

N.B. It is again emphasised that the above method of aligning only gives correct alignment for the 5,000 and 10,000 pass-band positions.

#### I.F. Amplifier Selectivity

The mid-band frequencies of the I.F. amplifiers are:-

I.F.1            1600 kc/s

I.F.2            465 ko/s

The bandwidths of the I.F. amplifiers for the five positions of the selectivity switch at 6 db and 40 db below maximum are:-

<u>Switch Position.</u>	<u>- 6 db</u>	<u>- 40 db</u>
100	350 - 850 c/s	1500 - 3000 c/s
500	350 - 850 "	1500 - 3000 "
1500	1200 - 2700 "	4000 - 9000 "
5000	3000 - 6000 "	10000 - 16000 "
10000	8000 - 12000 "	14000 - 22000 "

#### I.F. Amplifier Sensitivity

The H.F. and L.F. gain controls to be at maximum.

The operational switch to be C.W. MAN.

The selectivity switch to be at 5,000.

The unmodulated input required to give an output of 50 milliwatts is:-

<u>Frequency.</u>	<u>Input to grid of Valve.</u>	<u>Input Required.</u>
465 kc/s.	V.7	10,000 - 30,000 $\mu$ V.
" "	V.6	300 - 1,000 "
" "	V.5	30 - 100 "
1600 "	V.5	30 - 100 "

The unmodulated input required at the grid of V.5 to give an output of 50 milliwatts for the five positions of the selectivity switch, at the intermediate frequency of 465 kc/s. is:-

<u>Switch Position.</u>	<u>Input to be not more than:</u>
100	400 micro volts.
500	" " "
1500	200 " "
5000	100 " "
10,000	" " "

Second Oscillator Voltage.

The H.F. volts measured between pin 5 and earth of V.5 to be 7 volts  $\pm$  30%.

Third Oscillator Voltage.

The H.F. volts measured between pin 3 and earth of V.9 when the anode coil is tuned to give maximum volts to be 130 volts  $\pm$  30%.

N.B.

The anode coil will have to be retuned to give maximum output on the receiver after this test.

### H.F. Circuit Ganging.

It is unlikely that any but skilled servicing staff with full laboratory facilities can re-align the highest frequency band (30 - 60 Mc/s) accurately. The procedure for alignment of other frequency bands is as follows:-

Connect the signal generator to the grid of V.3 pin 7 through a 0.1  $\mu$ F blocking condenser, adjusted to 2.0 Mc/s.

Set the Band Change to Band 1.

Frequency calibration pointer to 2.0 Mc/s.

Pass Band to 1500.

Operational to C.W. Manual.

Use telephone and output meter.

Adjust the core of Band 1 oscillator coil L.16 until maximum C.W. output is obtained.

Switch to Bands 2, 3 and 4 and adjust L.17, L.18 and L.19 with the signal generator on 4, 8 and 16 Mc/s respectively.

Next tune to the signal generator at 4, 8, 16 and 32 Mc/s on Bands 1, 2, 3 and 4. The frequency calibration pointer should then coincide with the calibration marks. If it does not coincide, adjust the penny plate condenser to the right of the compensating condenser C.8.

Connect the signal generator through a 75 Ohm dummy aerial to one aerial socket. Short second aerial socket.

Switch receiver to Band 1 and signal generator to 2 Mc/s. Tune in the signal. Adjust the Band 1 H.F. cores in L.1, L.11 and L.6 to give maximum receiver output.

Set the signal generator to 4 Mc/s and tune in at the high frequency end of Band 1. Adjust the capacitance trimmers C.13, C.23 and C.18 to give maximum output. Repeat several times at the top and bottom frequencies until no further improvement in ganging is obtained.

Gang receiver on Bands 2 and 3 as above.

For Band 4, set the pass-band to 10,000 and care must be taken to retune the receiver oscillator for every adjustment of the trimmers.

First Oscillator Voltage.

The H.F. volts measured across the oscillator section of the ganged condenser to be within  $\pm 40\%$  of the figures given below.

<u>Band.</u>	<u>Frequency (Mc/s).</u>	<u>Volts H.F.</u>
1	2	20
	3	28
	4	30
2	4	17
	6	23
	8	24
3	8	17
	12	20
	16	18
4	16	11
	24	12
	32	9
5	32	4
	45	5
	60	4

H.F. Amplifier Stage Gain.

The gain from the aerial to the grid of V.1 to be taken with the signal generator connected through 75 Ohms to the aerial input terminals.

The other stage gains to be measured from grid to grid of the H.F. valves.

The H.F. gain control to have its slider connected to earth, so that the gain of the H.F. valves is kept at a maximum and control is only applied to the I.F. valves for this test.

The gains given below to be within  $\pm 30\%$ .

Band.	Frequency.	Aerial to V.1	V.1 - V.2	V.2 - V.3
1	2 Mc/s.	8	3.0	4
	3	9	1.5	5
	4	10	0.8	10
2	4	6	5	3
	6	7	3	4
	8	7	1.5	7
3	8	4	10	
	12	4	6	
	16	4	6	
4	16	1.5	10	10
	24	4	4	10
	32	2	4	10
5	32	1.2	3	2.5
	48	1.7	2	4
	60	1.7	4	3

#### H.F. Amplifier Selectivity.

The image signal protection taken from the aerial to be with the signal generator connected through 75 ohms to the aerial input terminal.

The image signal protection to be not less than the figures given below.

Band.	Frequency.	V.2 Grid.	V.1 Grid.	Aerial.
1	2 Mc/s.	24 db.	58 db.	100 db.
	3	24	56	90
	4	24	48	80
2	4	28	62	90
	6	28	52	80
	8	28	44	70
3	8	28	50	80
	12	26	44	70
	16	24	38	65
4	16	18	48	65
	24	14	40	55
	32	10	30	40
5	32	12	30	40
	48	10	18	22
	60	8	16	20

H.F. Amplifier Detune Ratios.

The aerial terminal to be connected to earth through 75 ohms.

The H.F. gain to be at maximum.

The selectivity switch to be at 5,000.

The detune ratio of the aerial circuit at any frequency in each band is within  $\pm 3$  db. of the figures given below:

Band.	Detune.
1	9 db.
2	9
3	6
4	5
5	0

Overall Performance.

The signal generator to be connected to the aerial terminal through 75 ohms.

The selectivity switch to be at 5,000.

C.W. Sensitivity.

The input required to give 20 db. signal to noise ratio to be within + 100% -50% of the figures given below.

MOD. Sensitivity.

With the signal generator modulated 40% at 400 c/s, the input required to give 10 db. signal to noise ratio to be within + 100% - 50% of the figures given below.

A.V.C.

The increase in output, when the signal is increased by 60 db. above the sensitivity figures given below, to be not more than 9 db.

Image Protection.

The attenuation offered to the image signal to be not less than the figures given below.

Band.	Frequency.	Sensitivity.	Image Protection
1	2 Mc/s.	1.0 $\mu$ V.	100 db.
	3	"	90
	4	"	80
2	4	"	90
	6	"	80
	8	"	70
3	8	"	80
	12	"	70
	16	"	65
4	16	2.0	65
	24	2.0	55
	32	2.0	40
5	32	7.0	40
	48	7.0	22
	60	7.0	20

1. RECEIVER (Sk. WZ.1779)CONDENSERS

Ref.	Section of WZ.1779	Description	Manufacturer's Dwg. Identity.
C.1	A		W.6230 Sht.1 Ed. A.
C.2	B	4 Gang Condenser 160 $\mu$ F Sweep.	
C.3	C		
C.4	D		
C.5	A		5 $\mu$ F Ceramic $\pm$ 1 Erie P.120K WIS.1784
C.6	B	" " " " " " " "	" "
C.7	C	" " " " " " " "	" "
C.8	D	Temp. Compensator	W.Sk.13730 Ed.A
C.9	A	3 - 30 $\mu$ F Mullard Trimmer	WIS.2848 Ref.1
C.10	A	" " " " " "	" "
C.11	A	" " " " " "	" "
C.12	A	" " " " " "	" "
C.13	A	" " " " " "	" "
C.14	C	" " " " " "	" "
C.15	C	" " " " " "	" "
C.16	C	" " " " " "	" "
C.17	C	" " " " " "	" "
C.18	C	" " " " " "	" "
C.19	B	" " " " " "	" "
C.20	B	" " " " " "	" "
C.21	B	" " " " " "	" "
C.22	B	" " " " " "	" "
C.23	B	" " " " " "	" "
C.24	A	20 $\mu$ F $\pm$ 2 Erie Ceramicon P.120 L	WIS.1784
C.25	C	20 $\mu$ F $\pm$ 2 Erie Ceramicon P.120 L	WIS.1784
C.26	B	30 $\mu$ F $\pm$ 3 Erie Ceramicon P.120M	WIS.1784
C.27	A	.002 $\mu$ F $\pm$ 20% Dub. 690 W.	
C.28	A	.01 $\mu$ F $\pm$ 20% Dub. 691 W.	

Ref.	Section of WZ.1779	Description	Manufacturer's Dwg. Identity
C.29	B	.01 $\mu$ F Dub. 691 W. $\pm$ 20%	
C.30	B	" " " " " "	
C.31	C	.002 $\mu$ F " 690 W " "	
C.32	C	.01 $\mu$ F " 691 W " "	
C.33	C	.01 $\mu$ F " " " "	
C.34	C	.01 $\mu$ F " " " "	
C.35	B	.002 $\mu$ F " 690 W " "	
C.36	B	.01 $\mu$ F " 691 W " "	
C.37	B	10 $\mu$ F $\pm$ 1 Ceramicon P.120K Erie.	WIS.1784
C.38	B	10 $\mu$ F $\pm$ 1 T.C.C. Type P.S.M.	WIS.2857 Sht.1 Ref.1
C.39	B	100 $\mu$ F $\pm$ 20% Dub. 635	
C.40	B	500 $\mu$ F $\pm$ 20% " "	
C.41	B	.002 $\mu$ F $\pm$ 20% " 690 W.	
C.42	D	.01 $\mu$ F $\pm$ 20% " 691 W.	
C.43	D	.01 $\mu$ F $\pm$ 20% " "	
C.44	D	10 $\mu$ F $\pm$ 1 Ceramic P.120 K	WIS.1784
C.45	D	.1 $\mu$ F Dub.	R/WIS.2375
C.46	D	500 $\mu$ F $\pm$ 20% Dub. 690 W.	
C.47	C	100 $\mu$ F Dub. 635	
C.48	B	1700 $\mu$ F $\pm$ 15% T.C.C. Type P.S.M.	WIS.2857 Sht.1 Ref.3
C.49	D	890 $\mu$ F $\pm$ 10% T.C.C. Type P.S.M.	WIS.2857 Sht.1 Ref.2
C.50	D	480 $\mu$ F $\pm$ 5% T.C.C. Type P.S.M.	WIS.2857 Sht.1 Ref.2
C.51	D	5 $\mu$ F $\pm$ 1 Ceramicon P.120K Erie	WIS.1784
C.52	D	263 $\mu$ F $\pm$ 5% T.C.C. Type P.S.M.	WIS.2857 Sht.1 Ref.2
C.53	D	100 $\mu$ F $\pm$ 10% Ceramic N.750	WIS.1784
C.54	D	100 $\mu$ F $\pm$ 10% " "	" "
C.55	A	1 $\mu$ F $\pm$ .5% Ceramic P.120K Erie	WIS.1784

Ref.	Section of WZ.1779	Description	Manufacturer's Dwg. Identity
C.56	D	3 - 30 $\mu$ F Mullard Trimmer	WIS.2848 Ref.1
C.57		5 $\mu$ F $\pm$ 1% Ceramicon P.120 K Erie	WIS.1784
C.58			
C.59	D	100 $\mu$ F $\pm$ 5% T.C.C. Type P.S.M.	WIS.2857 Sht.1 Ref.1
C.60	D	100 $\mu$ F $\pm$ 5% " " "	" " "
C.61	E	2000 $\mu$ F $\pm$ 10% T.C.C. Type PSM	" Ref.2
C.62	E	10 $\mu$ F Wingorve & Rogers C.802 Trimmer.	
C.63	E	500 $\mu$ F $\pm$ 5% T.C.C. Type PSM.	WIS.2857 Ref.2
C.64	E	100 $\mu$ F $\pm$ 5% " " "	" "
C.65	E	200 $\mu$ F $\pm$ 5% " " "	" "
C.66	E	200 $\mu$ F $\pm$ 5% " " "	" "
C.67	E	50 $\mu$ F $\pm$ 5% " " "	WIS.2857 Ref.1
C.68	F	200 $\mu$ F $\pm$ 5% " " "	WIS.2857 Ref.2
C.69	F	200 $\mu$ F $\pm$ 5% " " "	" "
C.70	F	50 $\mu$ F $\pm$ 5% " " "	" " 1
C.71	G	200 $\mu$ F $\pm$ 5% " " "	" " 2
C.72	G	200 $\mu$ F $\pm$ 5% " " "	" " 2
C.73	G	Wingrove & Rogers C.802 10 $\mu$ F	
C.74	G	420 $\mu$ F $\pm$ 5% T.C.C. Type PSM.	WIS.2857 Ref.2
C.75	G	2000 $\mu$ F $\pm$ 5% " " "	" " 3
C.76	G	100 $\mu$ F $\pm$ 5% " " "	" " 1
C.77	H	200 $\mu$ F $\pm$ 5% " " "	" " 2
C.78	G	30 $\mu$ F $\pm$ 5% " " "	" " 1
C.79	H	1000 $\mu$ F $\pm$ 5% " " "	" " 2
C.80	H	3100 $\mu$ F $\pm$ 2% Dub. S.691 W Trimmer	
C.81	H	Plessey Mica Trimmer Type 1760/7	
C.82	H	" " " " "	
C.83	H	3100 $\mu$ F $\pm$ 2% Dub. S.691 W	
C.84	E	0.02 $\mu$ F Dub. 24901/1A	WIS.2858 Ref.2

Ref.	Section of WZ.1779	Description	Manufacturer's Dwg. Identity.
C.85	H	0.1 $\mu$ F	
C.86	H	0.1 $\mu$ F	WIS.2708 Ref.2
C.87	H	0.1 $\mu$ F	
C.88	H	0.02 $\mu$ F Dub. 24901/1A	WIS.2858 Ref.2
C.89	H	2 - 30 $\mu$ F Mullard Trimmer	WIS.2848 Ref.1
C.90	H	20 $\mu$ F T.C.C. Type P.S.M.	WIS.2857 Ref.1
C.91	F	0.1 $\mu$ F	
C.92	F	0.1 $\mu$ F	WIS.2708 Ref.2
C.93	F	0.1 $\mu$ F	
C.94	H		
C.95	F	3 - 30 $\mu$ F Mullard Trimmer	WIS.2848 Ref.1
C.96	F	20 $\mu$ F T.C.C. Type P.S.M.	WIS.2857 Ref.1
C.97	G	500 $\mu$ F $\pm$ 5% T.C.C. Type P.S.M.	WIS.2857 Ref.2
C.98	G	0.1 $\mu$ F	
C.99	G	0.1 $\mu$ F	WIS.2708 Ref.2
C.100	G	0.1 $\mu$ F	
C.101	G	2 $\mu$ F $\pm$ 20% U.I.C. Pearl Type	
C.102	G	0.1 $\mu$ F	
C.103	G	0.1 $\mu$ F	WIS.2708 Ref.2
C.104	G	0.1 $\mu$ F	
C.105	G	100 $\mu$ F $\pm$ 20% Dub. Type 635	
C.106	G	100 $\mu$ F $\pm$ 20% " " "	
C.107	G	0.01 $\mu$ F Dub. 24901/4A	WIS.2858 Ref.4
C.108	G	100 $\mu$ F Dub. Type 635 $\pm$ 20%	
C.109	G	100 $\mu$ F " " " " "	
C.110	H	0.02 $\mu$ F Dub. 28903/1A	WIS.2858 Ref.2
C.111	G	1 $\mu$ F Dub.	WIS.2858 Ref.3
C.112	H	0.02 $\mu$ F Dub. 24901/1A	WIS.2858 Ref.2
C.113	G	1 $\mu$ F Dub.	WIS.2858 Ref.3
C.114	G	0.01 $\mu$ F Dub. 24901/4A	WIS.2858 Ref.4
C.115	H	0.1 $\mu$ F	WIS.2706

Ref.	Section of WZ.1779	Description	Manufacturer's Dwg. Identity
C.116	H	0.5 $\mu$ F Dub.	WIS.1560 Ref.4
C.117	G	100 $\mu$ F Dub. Type 635 $\pm$ 20%	
C.118	J	0.1 $\mu$ F Dub. WI	WIS.1560 Ref.1
C.119	H	0.1 $\mu$ F Dub.	" "
C.120	G	500 $\mu$ F Dub. Type 635	
C.121	"	10 $\mu$ F U.C. Disc Type	
C.122	G	30 $\mu$ F " " "	
C.123	J	0.1 $\mu$ F	
C.124	J	0.1 $\mu$ F	WIS.2708 Ref.2
C.125	J	0.1 $\mu$ F	
C.126	H	0.001 $\mu$ F Dub. 690 W	

RESISTANCES

(Tolerance  $\pm$  20% unless otherwise stated)

R.1	A	47,000 $\Omega$ Erie RMA.9	WIS.2630 Sht.1 Ref.8
R.2	A	47,000 $\Omega$ " "	" " "
R.3	A	10 $\Omega$ " "	" " "
R.4	A	220 $\Omega$ " "	" " "
R.5	B	47,000 $\Omega$ " "	" " "
R.6	B	47 $\Omega$ " "	" " "
R.7	B	10,000 $\Omega$ " "	" " "
R.8	B	10,000 $\Omega$ " "	" " "
R.9	C	100,000 $\Omega$ " "	" " "
R.10	C	10 $\Omega$ " "	" " "
R.11	B	220 $\Omega$ " "	" " "
R.12	C	47,000 $\Omega$ " "	" " "
R.13	C	10,000 $\Omega$ " "	" " "
R.14	C	10,000 $\Omega$ " "	" " "
R.15	C	100 $\Omega$ " "	" " "
R.16	C	3,300 $\Omega$ " "	" " "
R.17	D	10,000 $\Omega$ " "	" " "
R.18	D	10,000 $\Omega$ " "	" " "
R.19	D	22 $\Omega$ " "	" " "

Ref.	Section of WZ.1779	Description	Manufacturer's Dwg. Identity		
R. 20	D	10,000 Ω Erie RMA.9	WIS.2630	Sht.1	Ref.8
R. 21	D	10,000 Ω " RMA.2	"	"	Ref.3
R. 22	D	1,000 Ω " RMA.9	"	"	Ref.8
R. 23	D	100,000 Ω " "	"	"	"
R. 24	B	10,000 Ω " "	"	"	"
R. 25	B	10,000 Ω " "	"	"	"
R. 26	B	47,000 Ω " "	"	"	"
R. 27	E	33,000 Ω " "	"	"	"
R. 28	E	330 Ω " "	"	"	"
R. 29	E	100,000 Ω " "	"	"	"
R. 30	E	10,000 Ω " "	"	"	"
R. 31	E	47,000 Ω " "	"	"	"
R. 32	F	150,000 Ω " "	"	"	"
R. 33	F	47,000 Ω " RMA.8	"	"	Ref.7
R. 34	F	1,000 Ω " RMA.9	"	"	Ref.8
R. 35	F	10,000 Ω " "	"	"	"
R. 36	E	47,000 Ω " "	"	"	"
R. 37	G	2,200 Ω " "	"	"	"
R. 38	G	220,000 Ω " "	"	"	"
R. 39	G	10,000 Ω " "	"	"	"
R. 40	G	470 Ω " "	"	"	"
R. 41	G	2,200 Ω " "	"	"	"
R. 42	G	150,000 Ω " "	"	"	"
R. 43	G	150,000 Ω " "	"	"	"
R. 44	G	10,000 Ω " "	"	"	"
R. 45	G	1,000 Ω " "	"	"	"
R. 46	H	470,000 Ω " "	"	"	"
R. 47	H	2.2 MΩ " "	"	"	"
R. 48	G	47,000 Ω " "	"	"	"
R. 49	G	22,000 Ω " "	"	"	"
R. 50	H	1 MΩ " "	"	"	"
R. 51	J	2.2 MΩ " "	"	"	"
R. 52					

Ref.		Description	Manufacturer's Doc. Identity
R.53	J	1,000 $\Omega$ Erie RMA.9	WIS.2630 Sht.1 Ref.8
R.54			
R.55	J	150,000 $\Omega$ " "	" " "
R.56	J	5,000 $\Omega$ Painton P.302	WIS.2604 Sht.1 Ref.4
R.57	J	470,000 $\Omega$ Erie RMA.9	WIS.2630 Sht.1 Ref.8
R.58	J	47,000 $\Omega$ " "	" " "
R.59	J	680 $\Omega$ " "	" " "
R.60	J	3 $\Omega$ $\pm$ 5% Painton P.301	WIS.2604 Sht.1 Ref.3
R.61	G	82 $\Omega$ $\pm$ 5% " "	" " "
R.62	G	96 $\Omega$ $\pm$ 5% " "	" " "
R.63	G	96 $\Omega$ $\pm$ 5% " "	" " "
R.64	G	179 $\Omega$ $\pm$ 5% " "	" " "
R.65	G	56 $\Omega$ $\pm$ 5% " "	" " "
R.66	G	470 $\Omega$ $\pm$ 5% Erie RMA.9	WIS.2630 Sht.1 Ref.8
R.67	G	2,200 $\Omega$ $\pm$ 5% " "	" " "
R.68	G	167 $\Omega$ $\pm$ 5% " "	" " "
R.69	G	40 $\Omega$ $\pm$ 5% " "	" " "
R.70	G	250 $\Omega$ $\pm$ 5% " "	" " "
R.71	G	470 $\Omega$ $\pm$ 5% " "	" " "
R.72	G	150,000 $\Omega$ $\pm$ 20% Erie RMA.9	" " "
R.73	E	100,000 $\Omega$ " " "	" " "
R.74	G	100,000 $\Omega$ " " "	" " "
R.75	G	10,000 $\Omega$ " " "	" " "
R.76	H	22,000 $\Omega$ " " "	" " "
R.77	H	100,000 $\Omega$ " " "	" " "
R.78	J	4,700 $\Omega$ " " "	" " "
R.79	H	470,000 $\Omega$ " " "	" " "
R.80		1 M $\Omega$ " " "	" " "

POTENTIOMETERS

Ref.	Section of W.1779	Description	Manufacturer's Dwg. Identity.
P.1	F	Dub. Type C.T. Linear Law Curve A 2000 Ω	WIS.2239 Sht.1 Ref.2
P.2	G	Dub. Type C.T. Log Law Curve B 500,000 Ω	" " Ref.3
P.3 } P.4 }	J	2 Gang Inverse Log Law B 2000 Ω (Rear)	WIS.2863 Sht.1 Ref.1
	J	Type C.T., Straight Law "A" 5000 Ω (Front)	" " "

SWITCHES

S.1 & 2	A	H.F. Band Changer	WIS.1197 Sht.229
S.3	C	" " "	" Sht.230
S.4 & 5	B	" " "	" Sht.231
S.6 & 7	D	" " "	" Sht.232
S.8		I.F. Switch	WIS.1197 Sht.223
S.9		" " "	" "
S.10		" " "	" "
S.11		" " "	" "
S.12		" " "	" "
S.13	H	Operational Switch	" Sht.224
S.14	H	" "	" "
S.15	G	Meter Switch	" Sht.225
S.16	G	" "	" "
S.17	J	Maine Switch	W. Sk. 11706
S.18	H	Shunting Plate	WQ. 3244 Sht.18
J.1	J	Telephone Jack	WIS.2150/C Sht.1 Ref.1
J.2	J	" "	" " "

Section  
of W.1779

<u>Ref.</u>		<u>Description</u>	<u>Manufacturer's Dwg. Identity.</u>
<u>TRANSFORMERS</u>			
T.1	J	Output Transformer	WIS.2579
<u>CHOKES</u>			
CH.1	G	A.C.C. Circuit	PS.8838 Ed.C.
CH.2	G	3rd Osc. Heater circuit	EDW.716 Ed.A.
CH.3		Calibrator circuit	WQ.3244/C Sht.3
<u>METERS</u>			
M.1	G	E. Turner Model 909	WIS.2414 Sht.2 Ref.1
<u>I.F. UNITS</u>			
2nd Osc.	E	Complete Unit, wired	W.Sk.13160 Ed. A
IF.2	E	" " "	W.Sk.13158 Ed. A
IF.3	E	" " "	W.Sk.13159 Ed. A
IF.4	F	" " "	W.Sk.13158 Ed. B
IF.5	F	" " "	W.Sk.13159 Ed. B
IF.6	G	" " "	W.Sk.13288 Ed. A
3rd Osc.	G	" " "	W.Sk.13161 Ed. A
Cali- brator	H	" " "	W.Sk.13289 Ed. A
L.F. Filter	H	" " "	W.8133 Ed. A
<u>VALVES</u>			
V.1 - 4		6F.50	
V.5	E	X.66	
V.6	F	KFW.63	
V.7	G	KFW.63	
V.8	G	DE.63	
V.9	G	KFW.63	
V.10	H	DE.63	
V.11	J	L.63	
V.12	J	STV.280/40	

Ref.	Section of WZ.1779	Description	Manufacturer's Dwg. Identity.
<b>CRYSTALS</b>			
X.1 & 2	E		4.Sk.13496 Sht.1
X.3 & 4	F		7.Sk.13497 Sht.1
X.5	H	MS.120 (Crystal Dept)	
<b>COILS</b>			
L.1	A	Aerial Circuit, Band 1	WDW.672 Ed. Z
L.2	A	" " " 2	" Ed. S.
L.3	A	" " " 3	" Ed. T
L.4	A	" " " 4	WDW.671 Ed. A
L.5	A	" " " 5	WDW.719 Ed. A
L.6	C	Mixer Circuit, Band 1	WDW.672 Ed. AA
L.7	C	" " " 2	" Ed. U
L.8	C	" " " 3	" Ed. V
L.9	C	" " " 4	WDW.671 Ed. B
L.10	C	" " " 5	WDW.719 Ed. B
L.11	B	H.F. Circuit, Band 1	WDW.672 Ed. AB
L.12	B	" " " 2	" Ed. W
L.13	B	" " " 3	" Ed. X
L.14	B	" " " 4	WDW.671 Ed. C
L.15	B	" " " 5	WDW.719 Ed. C
L.16	D	1st Osc. Circuit, Band 1	WDW.672 Ed. AC
L.17	D	" " " " 2	" Ed. Y
L.18	D	" " " " 3	W.Sk.12740 Ed. G
L.19	D	" " " " 4	" Ed. F
L.20	D	" " " " 5	WDW.719 Ed. D
L.21	D	I.F. 1 Winding only	WDW.672 Ed. G
L.22	D	" " " "	" Ed. H
L.23	E	2nd Osc. " "	" Ed. N
L.24	E	I.F.2 " "	" Ed. J

Ref.	Section of WZ.1779	Description	Manufacturer's Dwg. Identity.
L.25	F	I.F. 2 Winding only	WDW.672 Ed. K
L.26	F	I.F. 3 " "	" Ed. L
L.27	F	I.F. 4 " "	" Ed. J
L.28	F	I.F. 4 " "	" Ed. K
L.29	F	I.F. 5 " "	" Ed. L
L.30	G	I.F. 6 " "	" Ed. M
L.31	G	I.F. 6 " "	" Ed. M
L.32	G	3rd Osc. " "	" Ed. P
L.33	G	I.F. 7 " "	" Ed. R <sub>r</sub>
L.34	H	Calibrator " "	" Ed. Q

MISCELLANEOUS ITEMS.

Z.1	Case for Set	W.6016 Ed.A
Z.2	Base Plate	W.6015/D Sht.1 Ref.2
Z.3	Front Panel	" Sht.2 Ref.3
Z.4	Chassis	W.6018 Ed.A
Z.5	H.F.Chassis	1/W.6017/D Sht.1
Z.6	Rectangular Escutcheon	6/W.5303/C
Z.7	" Window	W.6015/A Ref.7
Z.8	Round Escutcheon	WQ.3244/C Sht.8
Z.9	" Window	WQ.3244/C Sht.12
Z.10	Handle and Pointer (Small)	W.Sk.13614 Ed.C.
Z.11	Handle and Pointer (Medium)	W.Sk.13620 Ed.B.
Z.12	Handle Fast Motion complete with Plate and grub screws	W.8277/C Sht.1 Ed.A
Z.13	Scale Locking Clamp	W.8196 Ed.A
Z.14	Handle Slow Motion complete with grub screws	W.8276/C Sht.1 Ed.B
Z.15	Scale mounted on Tube Uncalibrated.	W.Sk.11072 Sht.3
Z.16	Crystal Holder	W.Sk.13346 Ed.A
Z.17	Valve Holder (Octal)	WIS.1894
Z.18	" " (9-pin octal complete with locking device)	WIS.2979 Sht.1 Ref.2
Z.19	Valve Holder (5-pin)	WIS.2059.

Ref.	Description	Manufacturer's Dwg. Identity.
Z.20	Crystal Holder	W.7024/C Sht.1 Ed.A
Z.21	" "	W.Sk.13346 Ed. B
Z.22	Valve Screening Cans	WIS.2345
Z.23	Valve Clip	WIS.2412
Z.24	Grid Lead for Calibrator Assy.	W.Sk.9800 Ed. AK
Z.25	" " " 3rd Osc. Assy.	W.7640/C Sht.1 Ed.A
Z.26	Terminal Board	W.Sk.13723 Ed.A
Z.27	Mains Plug Board 5 point	WCP.393
Z.28	" Socket, side entry 5 point	W.Sk.1904
Z.29	Screening Can for 3rd Osc.	43/W.6013/C
Z.30	Socket Air. Min Type.	
Z.31	Plug " " " 161	
Z.32	Grid Lead for I.F. 2 & I.F. 4	W.Sk.13767 Ed. A
Z.33	" " " V.6	W.Sk.13768 Ed. A
Z.34	" " " V.7	" "
Z.35	" " " V.8	" Ed. B
Z.36	Illuminating Lamp Garam OS.7588 8 V. 2 amp. 15 m/m Round Nos.	
Z.37	Slew Motion Drive. Includes Cord Drives and Pointer	W.6366 Sht.1 Ed. C
Z.38	Aerial Coil Unit. Includes coils Condensers, resistances and switch wafer.	W.Sk.13605 Ed. A
Z.39	H.F. Coil Unit. Includes coils, Condensers, resistances and switch wafer.	W.Sk.13607 Ed. A
Z.40	Mixer Coil Unit. Includes coils, condensers, resistances and switch wafer	W.Sk.13606 Ed. A
Z.41	Oscillator Coil Unit. Includes coils, condensers, resistances and switch wafer	W.Sk.13602 Ed. A
Z.42	Cord drive 7 ft 6 ins. sufficient for drum and pointer	

<u>Ref.</u>	<u>Description</u>	<u>Manufacturer's Dwg. Identity.</u>
<u>SUPPLY UNIT TYPE 901</u>		
S.1	Supply Switch	W.Sk.11706
L.1	Lamp 8 V. 0,2 amp Osram OS.7588	
F.1	Fuse, Clix, P62, 2 amp	
T.1	Transformer (Mains)	WQ.3244/C Sht.1
V.1	Valve Type U.52	
R.1	Resistance, 0.2 $\Omega$ MQ Mullard 1 Watt	
F.2	Fuse 250 mA 1 $\frac{1}{4}$ " Tubular	
CH.1	Choke B.H. 120 mA	WIS. 2504
CH.2	" " "	"
C.1 )	Condenser Electrolytic 8 + 8 + 8 $\mu$ F T.C.C. No. G.5361	WIS.2781
C.2 )		
C.3 )		
Z.1	Case	W.6112
Z.2	Valve Helder 8 pin Octal (Amphenel)	WIS.1894
Z.3	Valve Helder 5 pin Octal (Amphenel)	WIS.2059
Z.4	Terminal Block Concentra 6-way	WIS.1631



# APPENDIX NO. 1

## GENERAL NOTES ON INSTALLATION

### For Mains Working

The power supply circuits are contained in a separate unit type 901. This unit is fed from A.C. mains 230 Volts, 50 c/s, approximate consumption 80 Watts. Connection from this unit to the receiver is by means of a cable terminating in a 5 pin socket. This socket plugs into a 5 pin plug board situated at the left hand bottom corner of the back of the receiver.

The power transformer primary is provided with three taps to allow for mains voltage variations and selection of the appropriate tap is made by a combined fuse and distributor plug which is available on opening the power supply unit. The fuse wire in this mains fuse is rated to carry 2 amperes. An H.T. fuse is also provided on the front panel and this is rated to carry 500 milliamperes. The power supply unit should be fitted from a 5.A mains plug.

### For Batteries and other Supplies

Drawing WZ.1795 gives a view of the 5 pin plug board showing the H.T. and L.T. connections to the receiver. These supplies should be

H.T.            300 Volts, 65 mA. D.C.

L.T.            6 volts, 3.7 amps, A.C. or D.C.

### Aerial Input

Aerial input sockets are provided on the back of the receiver for a balanced input of 75 ohms. One of these sockets may be earthed by connecting the inner conductor to the sheath to provide for an unbalanced input.

### Outputs.

A twin plug and socket on the back of the receiver labelled L.S. is provided for connection to a 3 Ohm impedance loudspeaker.

Two terminals labelled "LINE" also on the back of the receiver are provided for connection to a 600 Ohm line.

Two telephone sockets, situated on the bottom right hand corner of the front panel are for use with either H.R. or L.R. telephones.

### A.G.C.

To enable the receiver to be used as part of a diversity equipment, the automatic gain control line is brought out to two terminals labelled A.G.C. on the back of the receiver, thus making it possible to control all the receivers of a diversity equipment from a common A.G.C. For normal receiver working these two terminals are strapped together.

### A.G.C. Time Constant Plug Board S.18.

This plug board - see drawing WZ.1792 - has three positions whereby the time constant of the A.G.C. circuits may be varied.

The middle position gives a time constant of approximately 0.2 secs. for both the "C.W." and "MOD". positions of the operational switch. This position is the one to be used when the receiver forms a part of a diversity equipment, where the time constant may then be changed by the control on the combining unit.

The position labelled 0.5  $\mu$ F. gives a time constant of approximately 0.2 secs for the "MOD" position and 1.75 secs. for the "C.W." positions of the operational switch. This position is the one to be used for normal receiver working.

The third position labelled 0.1  $\mu$ F. gives a time constant of approximately 0.5 secs. for both the "C.W." and "MOD". positions of the operational switch. This position is to be used for high

speed recording when the receiver is used with a type AB.150 bridge.

Diversity Oscillator Socket.

A socket labelled "Diversity Oscillator" at the back of the receiver is to be used only when the receiver forms a part of a diversity equipment. This socket enables the receiver to be fed from a common first oscillator and under these circumstances the oscillator valve V.4 would be removed from its socket. The connections from this socket to the oscillator circuits are shown on drawing WZ.1767 which gives the connections that have to be made for either normal receiver working or diversity working.



## APPENDIX II

### SUPPLY UNIT TYPE 901.

#### General Data.

Input	200/250 Volts.	50 c/s.
	(Three tapings are provided on the primary of the transformer to allow for the correct mains voltage to be used).	
Output	300 Volts.	65 mA. D.C.
	6.3 Volts.	4 Amps. A.C.
Consumption	80 Watts.	
Valve	Type U.52.	
Dimensions	Width	6"
	Depth	17"
	Height	13½"
	Weight	29 lbs.

#### Circuit Arrangement - See WZ.1790/C. Sheet 1.

The mains are brought in through the back of the unit and connected to two terminals labelled "Mains" on terminal strip which is placed on the back of the chassis. From these terminals, connection is made through an ON/OFF switch and mains fuse to the primary of the mains transformer. The mains fuse is a combined fuse and distributor plug, placed on top of the mains transformer and care is to be taken to see that this is in position for the correct main voltage. This fuse is rated to carry 2 amperes.

The H.T. secondary of the transformer is connected to a U.52 valve rectifier and the output from this valve is smoothed by means of a plug-in triple electrolytic condenser and two L. F. chokes. It is then taken back to the terminal strip and labelled H.T. and E. An H.T. fuse which is available on the front panel of the unit is connected between the centre tap of the H.T. winding and E. This H.T. fuse is rated to carry 500 mA.

There are two L.T. secondary windings on the transformer. One of these is used to heat the filament of the U.52 rectifier and the other is connected to the terminal strip and labelled 6 V. A.C. and E.

### Mechanical Description

The cabinet is made of 1/16" motor body steel in two parts, viz. case and combined front panel and chassis.

All the components are mounted on this combined front panel and chassis which slides into the case and is fixed to it by means of two knurled screws.





ISSUE No. 1	
CN No.	
DATE	
<b>UPPER DECK PLAN</b>	
RECEIVER TYPE CR.150.	
SHEET No. 4	
CONTIN. ON	
W.Z. 1792/c	

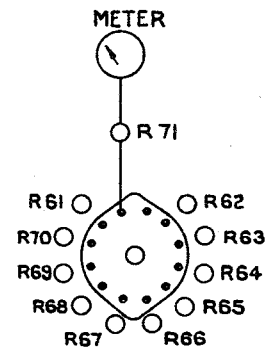
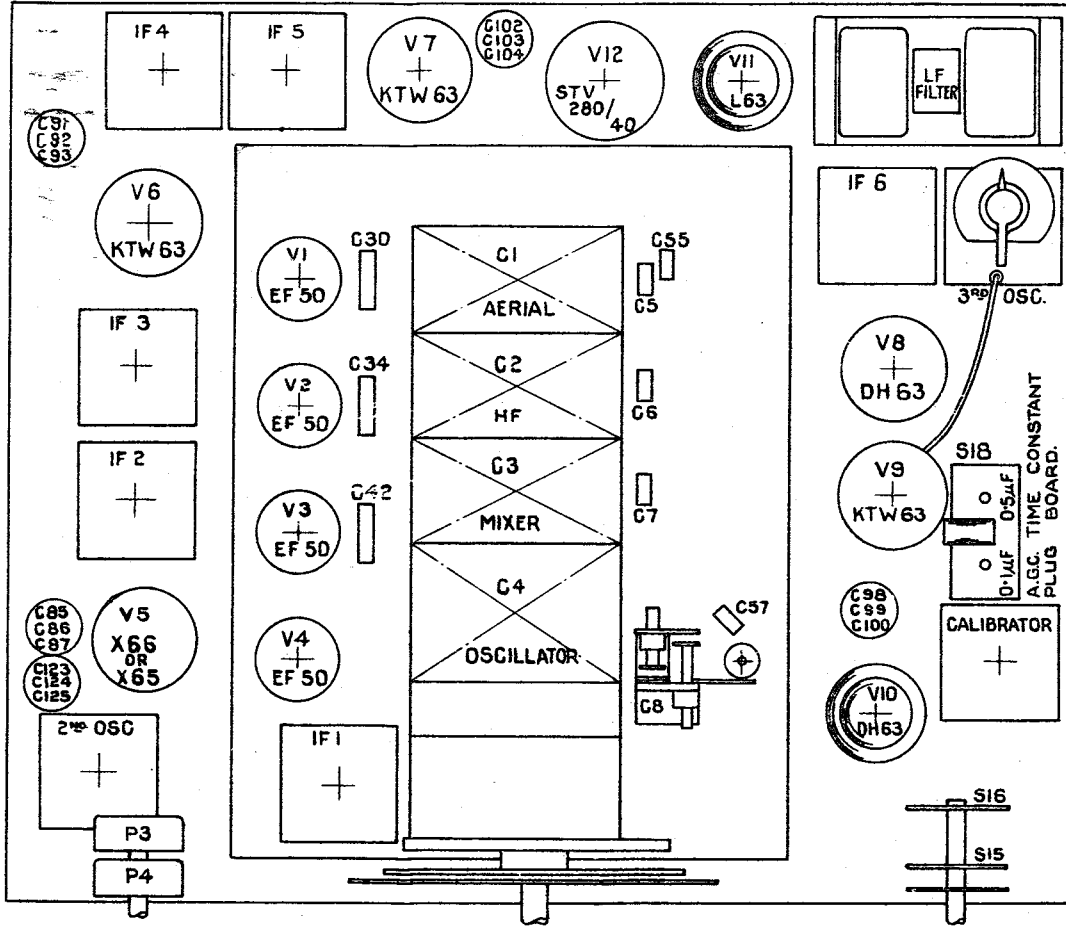

LOWER DECK PLAN RECEIVER TYPE CRISO	ISSUE No. 1
	CN. No.
W.Z. 1793 /c	DATE
	SHEET No. 1
	CONTIN. ON

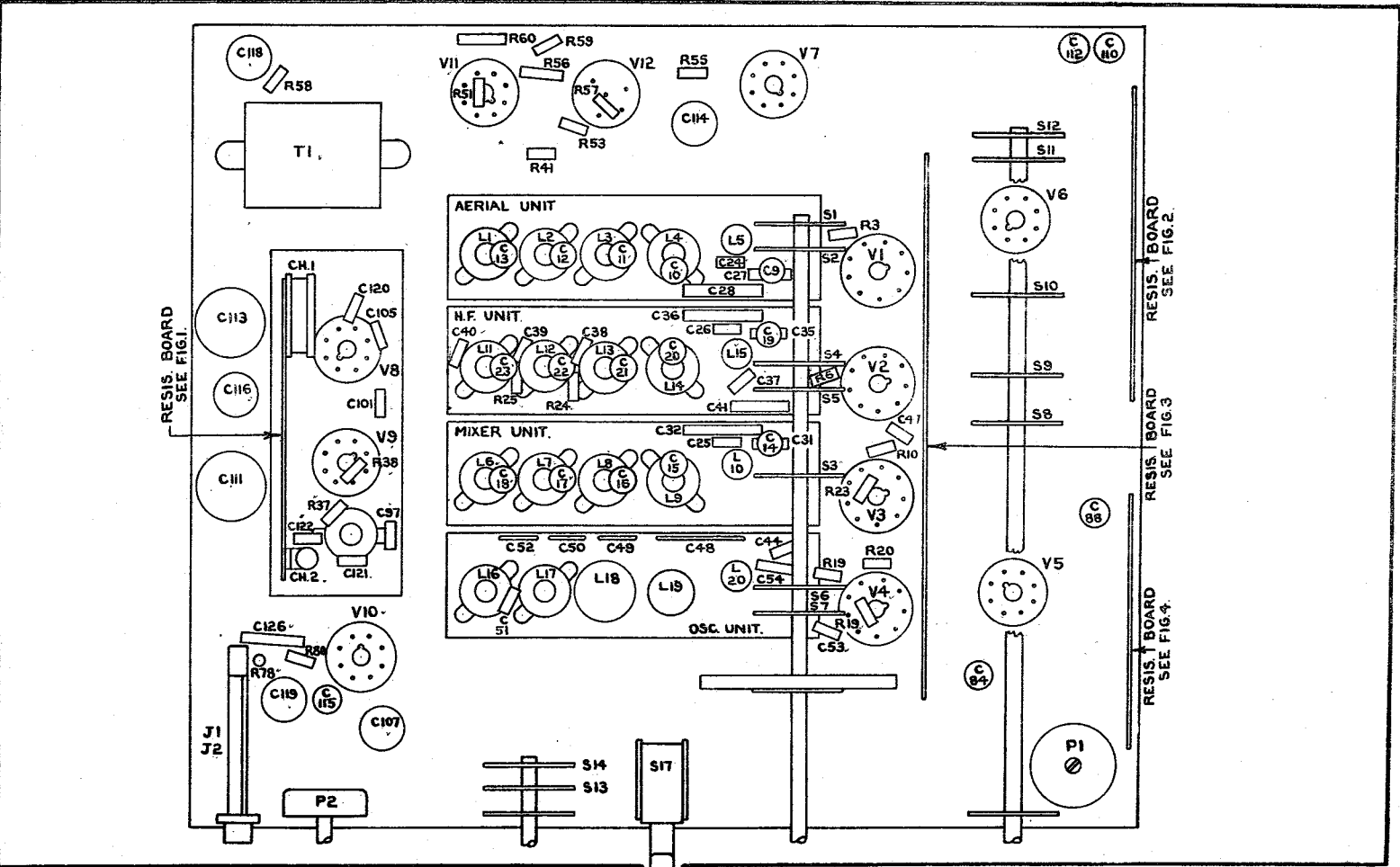

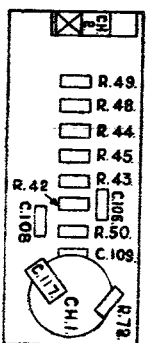

FIG. 1

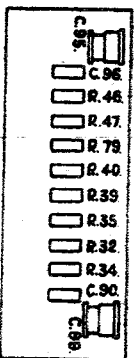

FIG. 2

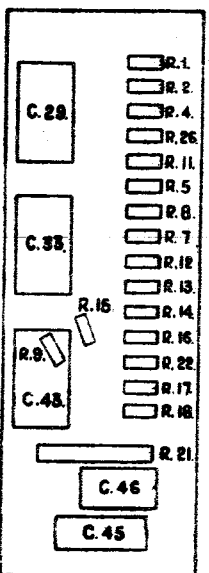

FIG. 3

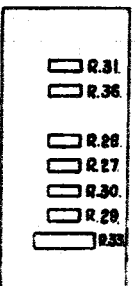

FIG. 4

ISSUE NO. 1	SHEET No. 1
CN. No.	CONTIN. ON
DATE	
RESISTANCE BOARDS RECEIVER TYPE. CR.150.	
WZ. 1794 /C	





ISSUE NO.  
SERIAL NO.  
DATE

1

SHEET NO. 1  
EDWTTN. ON

RECEIVER TYPE C.R. 150.  
L.F. RESPONSE CURVE.

W.Z. 1797.

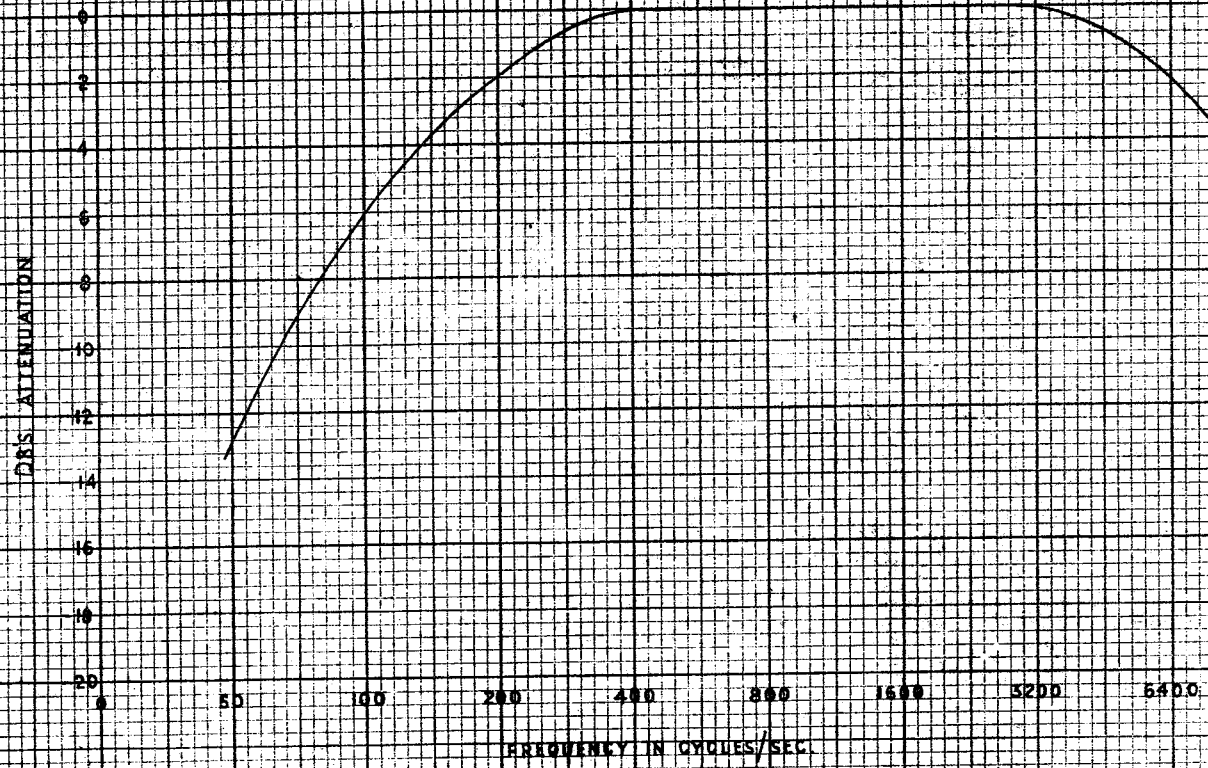

SCALE NO. 1  
C.M. NO.  
DATE

SHEET NO. 1  
CONTINUATION

RECEIVER TYPE C.R. 150.  
L.F. FILTER RESPONSE.

W.Z. 1798.

ATTENUATION IN DECIBELS

FREQUENCY IN C/S.

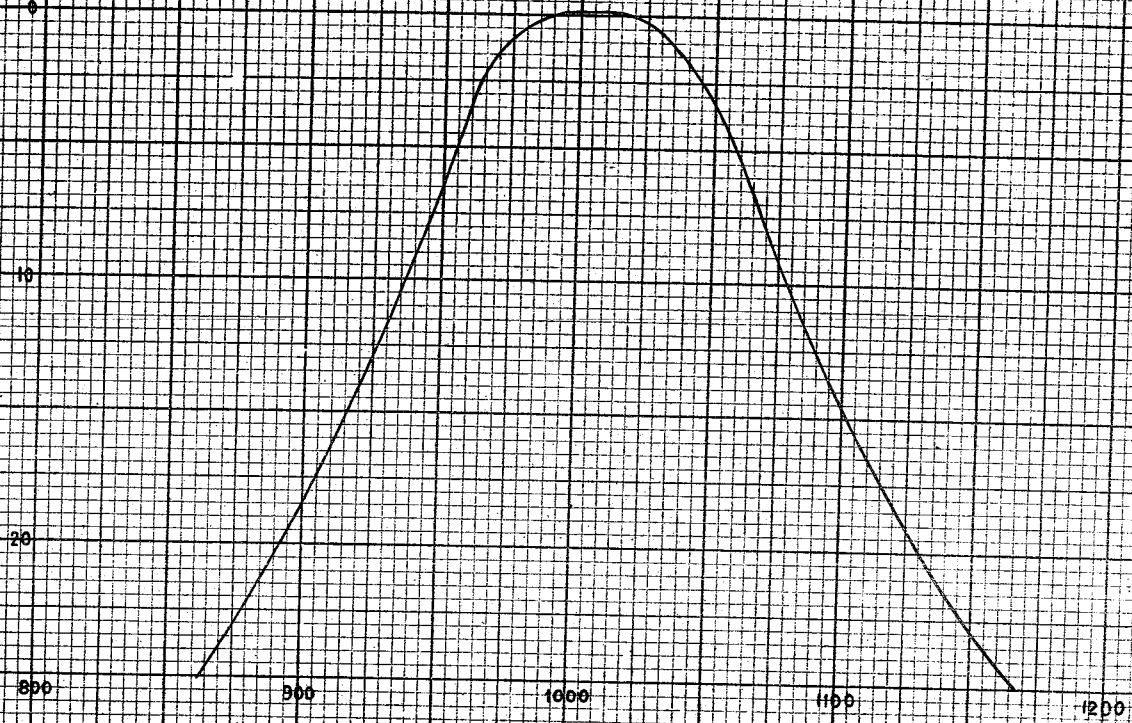

FORM NO. 1  
DATE

RECEIVER TYPE C.R. 150

SCALE IN

40 42 44 46 48 50 52 54 56 58 60 62 64 66 68 70 72 74 76 78 80

KILOMETRES PER SECOND

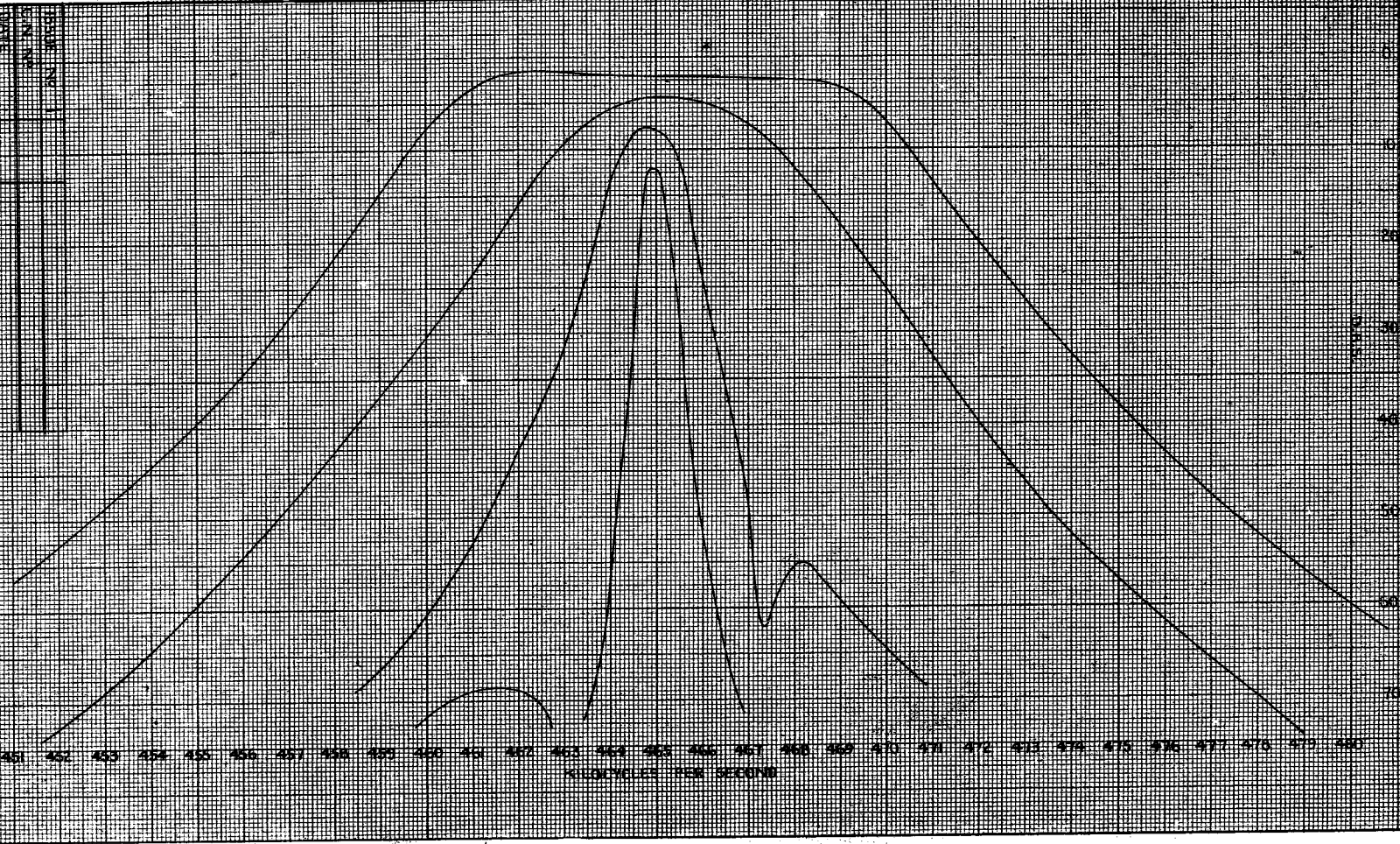

I.F. RESPONSE CURVES.

W.Z. 1799 / C.

CONT. ON

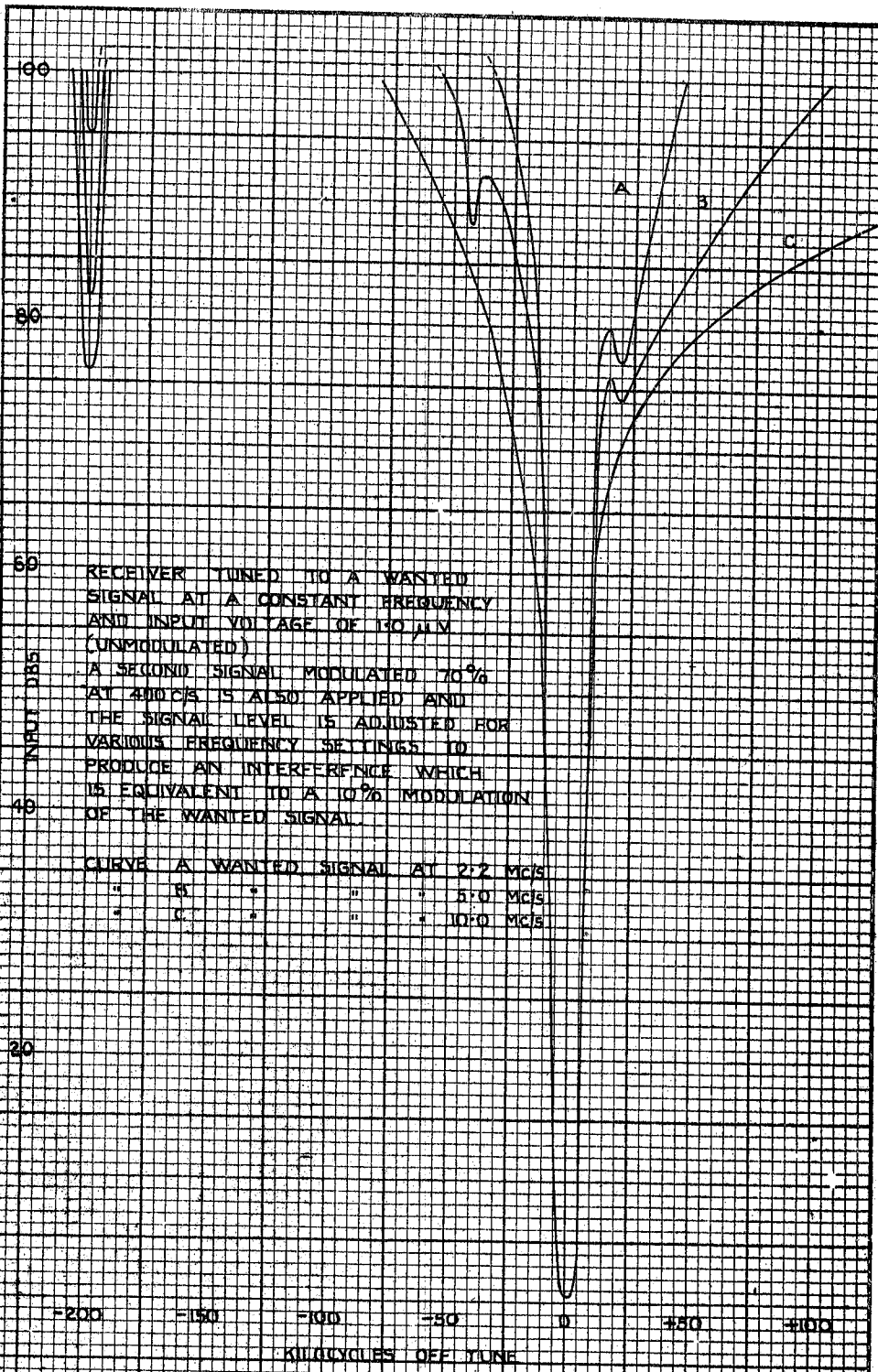

INPUT DB

RECEIVER TUNED TO A WANTED SIGNAL AT A CONSTANT FREQUENCY AND INPUT VOLTAGE OF 10 μV (UNMODULATED). A SECOND SIGNAL MODULATED 70% AT 400 C/S IS ALSO APPLIED AND THE SIGNAL LEVEL IS ADJUSTED FOR VARIOUS FREQUENCY SETTINGS TO PRODUCE AN INTERFERENCE WHICH IS EQUIVALENT TO A 10% MODULATION OF THE WANTED SIGNAL.

CURVE A WANTED SIGNAL AT 2.2 Mc/s  
 " B " " " 5.0 Mc/s  
 " C " " " 10.0 Mc/s

ISSUE NO.		SHT. NO.	
C.N. NO.		CONT. ON	
DATE			
RECEIVER TYPE CR 150 SELECTIVITY CURVES.		W.Z. 1800 / C	

SHEET NO. 1  
C.M.N. 4  
DATE

RECEIVER TYPE C.R. 150.  
OVERALL FIDELITY RESPONSE.

W.Z. 1801.

SHEET NO. 1  
C.M.N. 4  
DATE

ATTENUATION IN DECIBELS

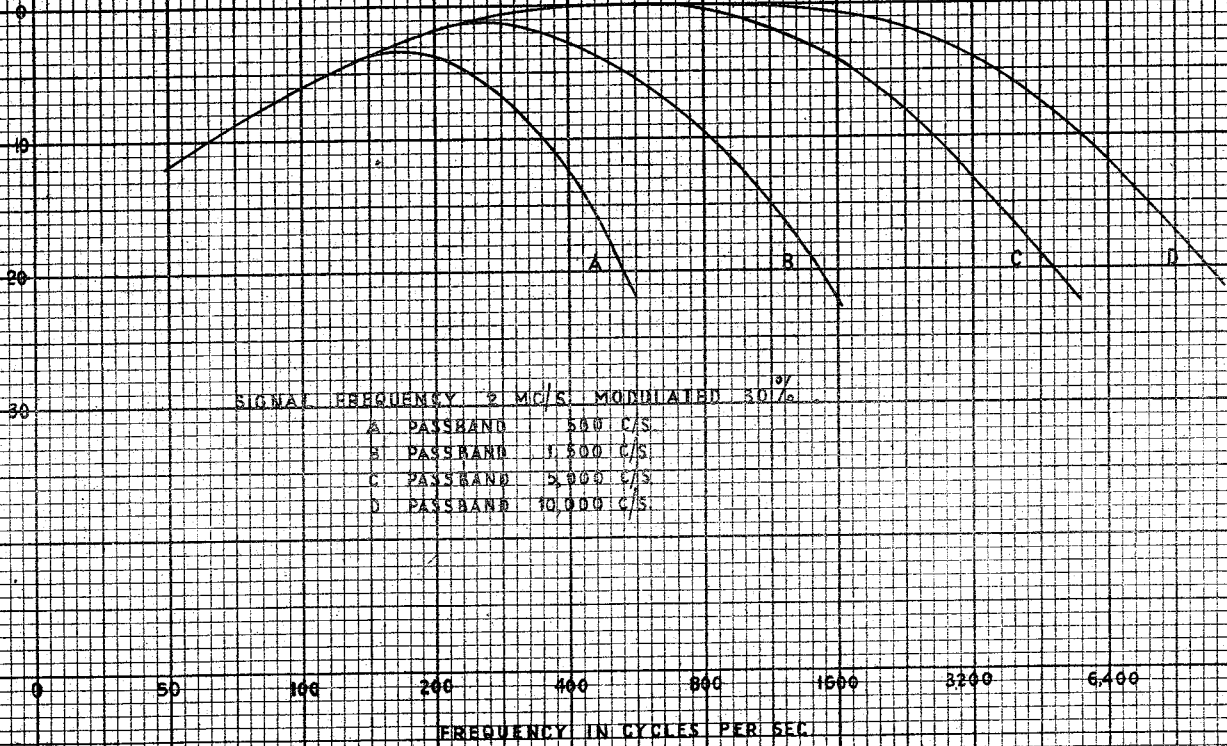

FORM NO. 1  
CAMP  
DATE

RECEIVER TYPE C.R. 150  
A. Y. C. RESPONSE.

SHEET NO.  
CONTIN. ON

W.Z. 1802

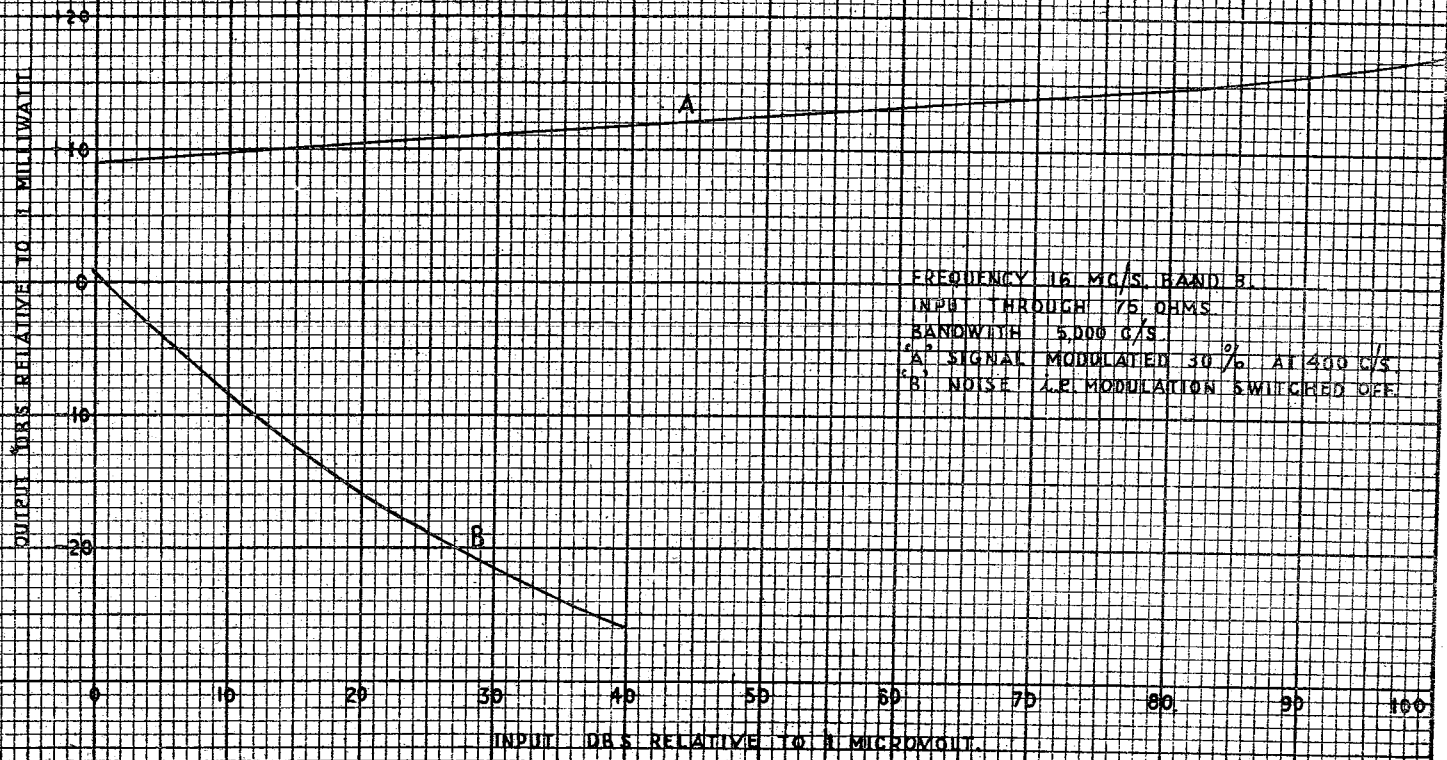

SHEET NO  
C.N. NO  
DATE

SHEET NO 1  
CONTIN. ON

RECEIVER TYPE CR. 150.  
FREQUENCY DRIFT.

W.Z. 1803.

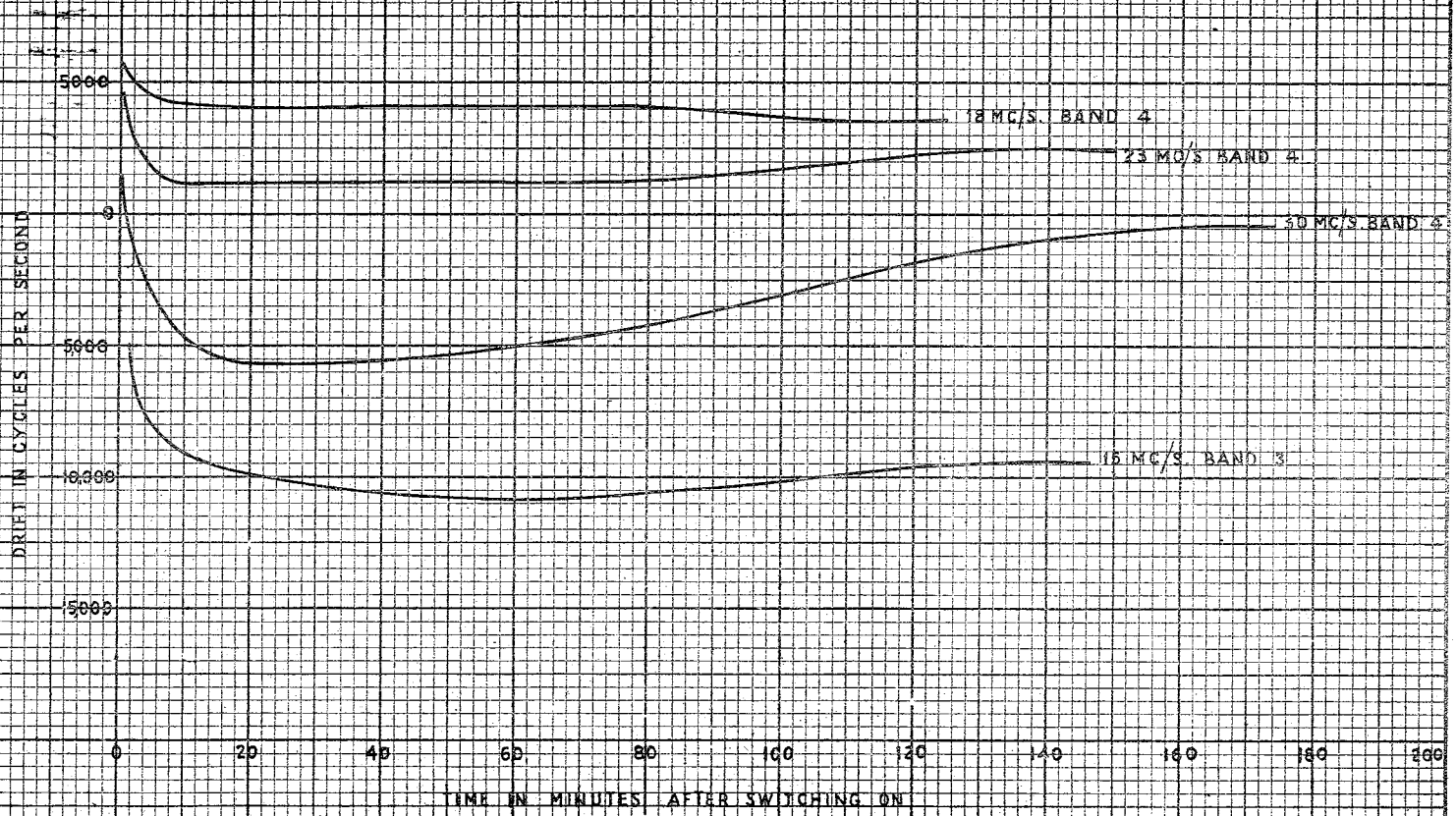

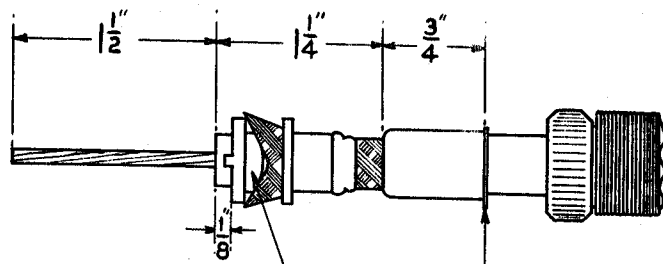

INNER SLEEVE.  
 OUTER COVERING  
 (IF FITTED).  
 ROLLED BACK.

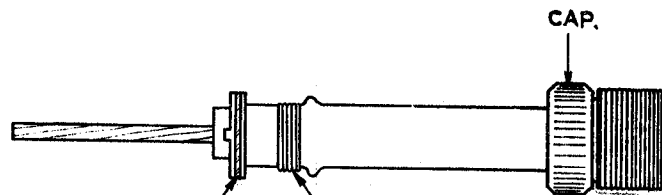

METAL BRAIDING CLAMPED  
 BETWEEN INNER & OUTER  
 SLEEVES & ENDS OF BRAIDING  
 TRIMMED FLUSH.

OUTER COVERING ROLLED  
 OVER OUTER SLEEVE &  
 BOUND WITH THREAD.

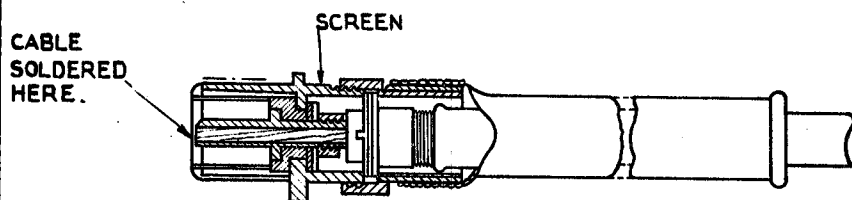

CONDUCTOR TO BE CLEANED & PASSED THROUGH HOLE IN PLUG.  
 PROJECTION ON INNER SLEEVE PLACED IN KEYWAY ON SCREEN OF  
 PLUG & CAP WITH GUARD SCREWED HOME.  
 CONDUCTOR SPLAYED OUT AT END AND SECURELY SOLDERED  
 AS SHOWN.  
 PROJECTING ENDS TO BE TRIMMED FLUSH WITH PLUG.  
 SUITABLE CABLES.

75.Ω UNIRADIO NOS. 1.18 & 19. TELCON A.S.42, A.S.42M. PT.29, PT.29M.  
 100.Ω UNIRADIO NOS. 31. TELCON AS.48M. PT.34, PT.34M.

ISSUE No												SHEET No.
CN No												CONTIN. ON
DATE												
METHOD OF FIXING FLEXIBLE AERIAL FEEDER CABLE TO PLUGS TYPE 160.											w.z.1852. /c	



SCALE DIAL LAMPS.



DIVERSITY  
OSCILLATOR

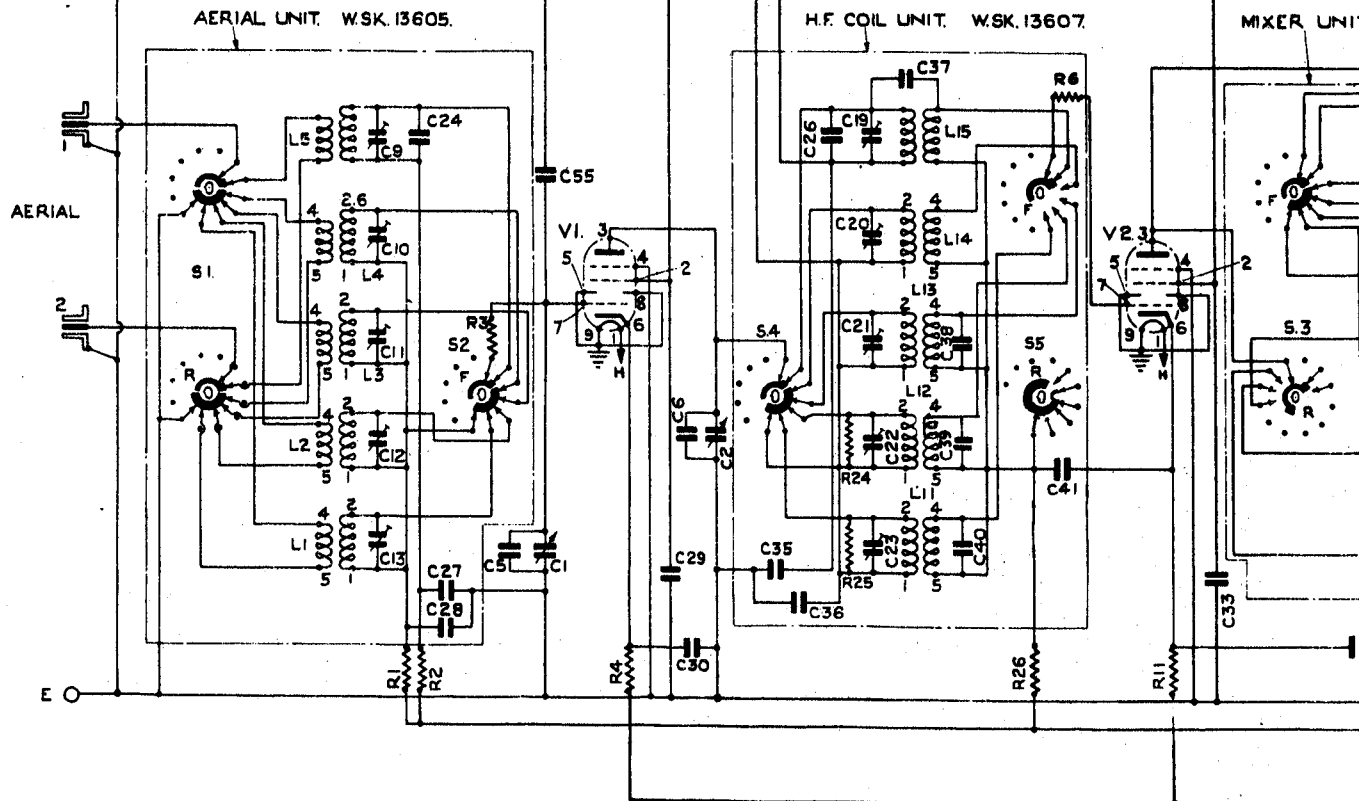

**B**

SWITCH S.3. (F&R) IS ONE WAFER  
& CONTACTS 2 & 3 ON FRONT & REAR  
ARE CONNECTED.  
SWITCH S.5. (F&R) IS ONE WAFER  
& CONTACTS 2,3,4,5 & 6 ON FRONT  
& REAR ARE CONNECTED.

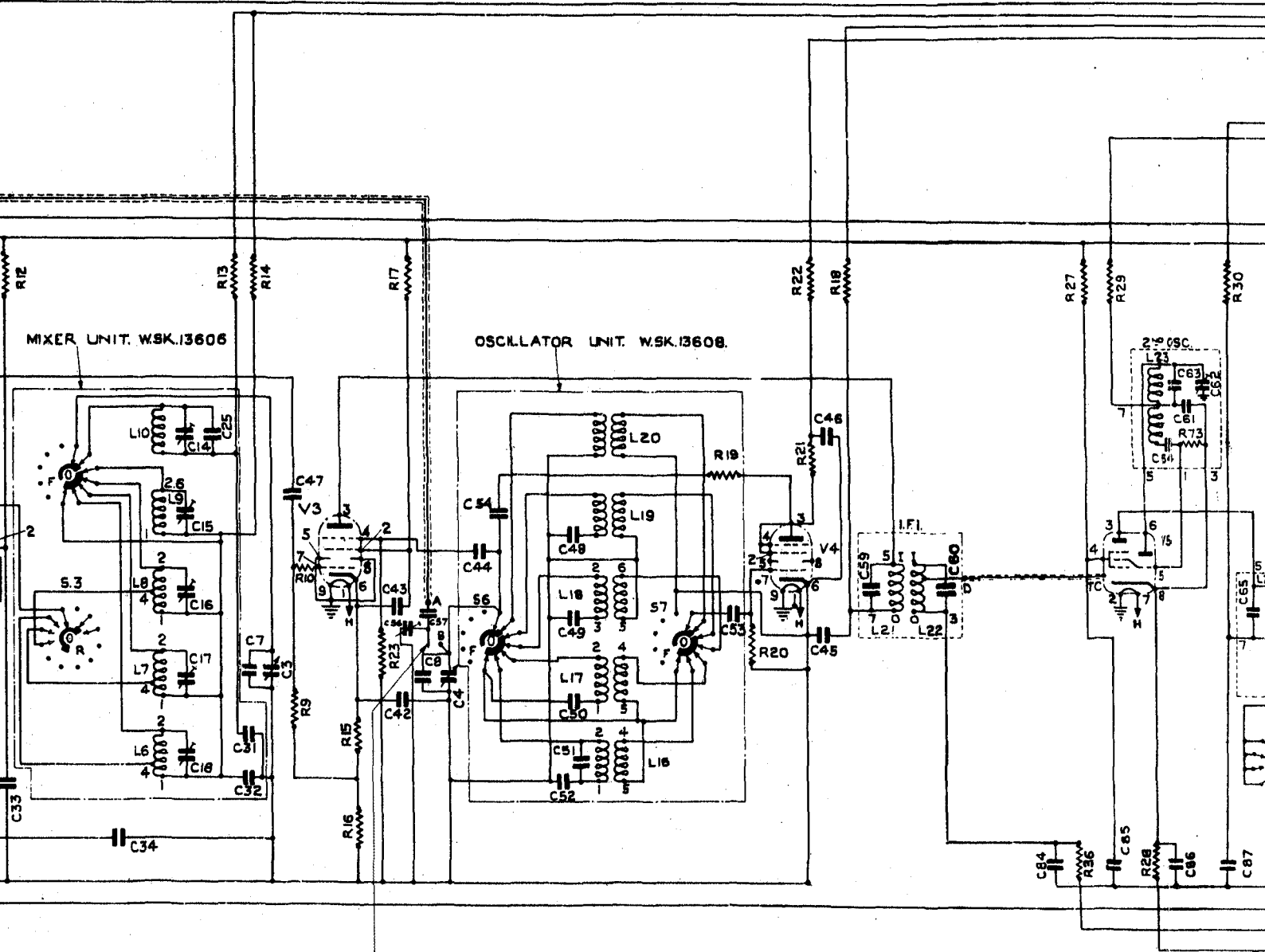

ONE WAFER  
FRONT & REAR

ONE WAFER  
6 ON FRONT  
CONNECTED.

WHEN RECEIVER FORMS PART OF A  
DIVERSITY EQUIPMENT THIS LEAD IS  
CONNECTED TO POINT B, C8 IS  
DISCONNECTED AND V4 REMOVED  
FROM ITS VALVE HOLDER.  
WHEN RECEIVER IS USED SINGLY  
THIS LEAD IS CONNECTED TO  
POINT A. BY TEST DEPT.

C

D

E

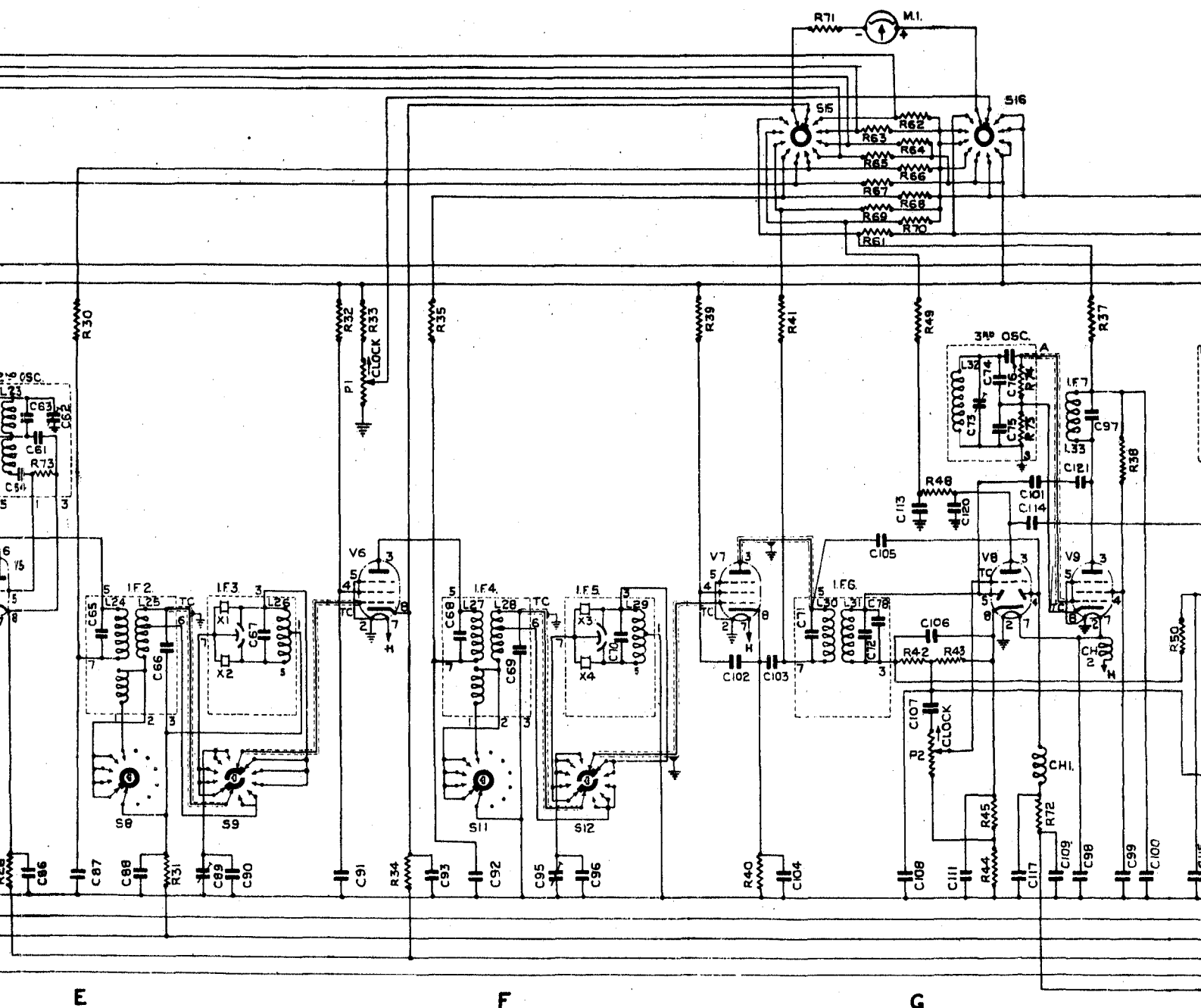

F

F

G

