



Rx-8

HANDBOOK FOR  
REDIFON TYPE R 50 M  
COMMUNICATIONS RECEIVER

The copyright of this document is reserved by  
REDIFON LIMITED; it is  
issued on condition that it is not copied,  
reproduced or disclosed to a third party, either  
wholly or in part without the consent in writing  
of REDIFON LIMITED.

REDIFON LIMITED  
Broomhill Road,  
LONDON, S.W.18.

C/JBB  
August, 1953

Telephone: VANDyke 7281.  
Telegrams: Redifon, Put, London.  
Cables: Redifon, London.

## CONTENTS

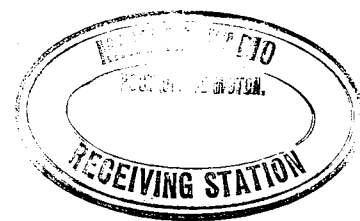

- 1.0 INTRODUCTION
- 2.0 DESIGN FEATURES
  - 2.1 Controls and Facilities
  - 2.2 Dimensions and Weights
  - 2.3 Valves
- 3.0 TYPICAL PERFORMANCE FIGURES
  - 3.1 Sensitivity, Image Discrimination and I.F. Response Ratios
  - 3.2 Selectivity
  - 3.3 Automatic Gain Control
  - 3.4 Stability
  - 3.5 Audio Quality
  - 3.6 Power Consumption
- 4.0 TECHNICAL DESCRIPTION
  - 4.1 Mechanical Details
  - 4.2 Electrical Details
  - 4.3 Circuit Details
    - 4.3.1 Signal Frequency Amplifier
    - 4.3.2 Oscillator
    - 4.3.3 Mixer
    - 4.3.4 Intermediate Frequency Amplifier
    - 4.3.5 Signal Detector and A.G.C. Rectifier
    - 4.3.6 Beat Frequency Oscillator
    - 4.3.7 Noise Suppressor
    - 4.3.8 Audio Frequency Amplifier
    - 4.3.9 Manual Gain Controls

## 5.0 INSTALLATION

- 5.1 Initial Adjustments
- 5.2 Fixing the Equipment
- 5.3 A.C. Mains Supply
- 5.4 D.C. Mains Supply
- 5.5 Aerial
- 5.6 Loudspeaker and Headphones
- 5.7 Muting

## 6.0 OPERATION

- 6.1 General
- 6.2 Automatic Gain Control
- 6.3 I.F. Bandwidth
- 6.4 Logging Scale
- 6.5 Standby
- 6.6 Gain Controls
- 6.7 Tuning Meter
- 6.8 Muting

## 7.0 MAINTENANCE

- 7.1 Routine Servicing
- 7.2 Fault Finding
  - 7.2.1 Power Unit
  - 7.2.2 Audio Frequency Amplifier
  - 7.2.3 Intermediate Frequency Amplifier
  - 7.2.4 Oscillator
  - 7.2.5 Signal Frequency Amplifier and Mixer
  - 7.2.6 A.G.C. and Noise Suppressor
  - 7.2.7 Beat Frequency Oscillator
- 7.3 Mechanical Adjustments
- 7.4 Circuit Alignment

## FIGURES

1. A.G.C. Curve
2. 110 kc/s Crystal Filter
3. Mains Transformer Tappings
4. Muting Circuit Connections

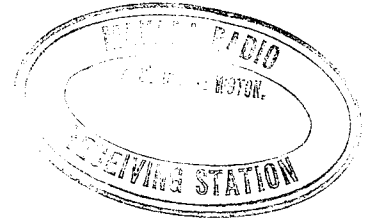

## TABLES

1. Sensitivity, Image Discrimination and I.F. Response Ratios
2. Mains Transformer Connections
3. Service Meter Readings
4. Test Point Voltages and Resistances
5. Signal Amplifier Gains

## APPENDIX

- I.F. Response Curves
- Receiver Diagram
- Components List (Receiver)
- Power Unit Diagram
- Components List (Power Unit)
- Inter-connecting Cable
- Components lay-out

## 1.0 INTRODUCTION

The Redifon R 50 M is a superheterodyne communications receiver of the highest grade covering the frequency ranges 13.5 kc/s to 26 kc/s and 95 kc/s to 32 Mc/s in eight bands. (See para 4.3.1) It meets the requirements of Part Two of Second Schedule of the Ministry of Transport Merchant Shipping (Radio) Rules, 1952, and has received the Type Approval Certificate issued by the Post Master General. Both rack mounting and cabinet versions are available.

The receiver has a high discrimination logging scale and employs two stages of signal frequency amplification and a hexode mixer with separate triode oscillator, followed by three stages of intermediate frequency amplification. Owing to the frequency coverage, two of the bands are operated with a different intermediate frequency from the remainder.

Five band widths are available on each of the I.F. channels, crystals being used for the two narrowest. A double diode is employed as an A.G.C. rectifier and signal detector, the latter feeding a pentode amplifier, resistance capacity coupled to the beam tetrode output valve, and a second double diode acts as a noise limiter. The A.G.C. voltage controls the gain of the two R.F. and the first two I.F. amplifiers and a high stability beat frequency oscillator is included for C.W. reception. Muting facilities are available should the receiver be used in conjunction with a nearby transmitter.

The A.C. power unit has the normal full wave rectifier with choke capacity smoothing and features a neon stabilised supply to the oscillator valves and the screen of the frequency changer. For D.C. mains operation, a DC/AC rotary converter is available for use with the A.C. power unit.

## 2.0 DESIGN FEATURES

### 2.1 Controls and Facilities

Slow motion and direct tuning controls  
Full vision scale and high discrimination  
logging scale  
B.F.O. - Standby - Muting switch  
Service meter and switch  
A.G.C. - Noise Suppressor switch  
Noise Suppressor control  
A.F. gain control  
R.F. - I.F. gain control  
Frequency range switch  
Aerial trimmer  
B.F.O. control  
I.F. bandwidth switch  
Full muting facilities available  
A.G.C. line taken to output socket so that  
receiver may be used in diversity

### 2.2 Dimensions and Weights

Height	Width	Depth	Weight
Chassis only			
12½ in.	19 in.	21½ in.	52 lb.
31.8 cm.	48.3 cm.	54.6 cm.	23.6 kg.
Cabinet Model			
14¾ in.	21 in.	21½ in.	89 lb.
37.6 cm.	53.5 cm.	54.6 cm.	40.5 kg.
A.C. Power Unit			
6¼ in.	17 in.	7 in.	25 lb.
15.8 cm.	43.2 cm.	17.8 cm.	11.4 kg.

### 2.3 Valves

V1 and V2, signal frequency amplifiers	EF39 ✓✓
V3, frequency changer,	ECH35 ✓
V4, oscillator,	L63 ✓
V5, V6 and V7, I.F. amplifiers,	EF39 ✓✓✓
V9, detector and A.G.C. rectifier,	EB34 or 6H6 ✓
V10, noise limiter,	EB34 or 6H6 ✓
V8, B.F.O.,	EF37A or EF36 ✓
V11, A.F. amplifier,	EF37A or EF36 ✓
V12, output amplifier,	6V6G ✓

### Power Unit Valves

V1, Neon stabiliser,	S.130
V2, Rectifier,	5Z4G

Substitution of equivalent types of valves will not cause any marked reduction in performance but where the receiver is installed in a ship subject to the M.O.T. Merchant Shipping (Radio) Rules, 1952, it should be noted that the Type Approval Certificate is granted for the equipment using the types shown above and that the use of others may give rise to difficulties at the Marine Inspector's Survey in U.K. ports.

### 3.0 TYPICAL PERFORMANCE FIGURES

#### 3.1 Sensitivity, Image Discrimination and I.F. Response Ratios

Details of sensitivity, image discrimination and I.F. response ratios are given in the table below. Sensitivity is measured as the input required to give an output of 50 mW with a signal/noise ratio of 10 db on Bandwidth 3. At 22 kc/s the figures are given for Bandwidth 2. The dummy aerial was 300 pF above 4 Mc/s and 80 ohms below this frequency. The MCW signal was 30% modulated at 400 c/s.

Frequency	CW Sensitivity	MCW Sensitivity	Image Discrimination	I.F. Response Ratios
25 Mc/s	<1.0 $\mu$ V	<1.0 $\mu$ V	40 db	>100 db
15 Mc/s	<1.0 $\mu$ V	1.5 $\mu$ V	51 db	>100 db
8 Mc/s	<1.0 $\mu$ V	2.0 $\mu$ V	71 db	>100 db
4 Mc/s	<1.0 $\mu$ V	2.5 $\mu$ V	92 db	>100 db
2 Mc/s	<1.0 $\mu$ V	2.5 $\mu$ V	>100 db	>100 db
1500 kc/s	1.5 $\mu$ V	5.0 $\mu$ V	>100 db	>100 db
600 kc/s	1.5 $\mu$ V	4.0 $\mu$ V	94 db	85 db
250 kc/s	5.0 $\mu$ V	18.0 $\mu$ V	>100 db	>100 db
100 kc/s	4.0 $\mu$ V	15.0 $\mu$ V	>100 db	>100 db
22 kc/s	3.0 $\mu$ V	-	>100 db	75 db

Sensitivity, Image Discrimination and I.F. Response Ratios

Table 1

3.2 Selectivity

110 kc/s I.F.

Attenuation.	Typical overall Bandwidths in kc/s. Switch position				
	1	2	3	4	5
6 db ...	-	1.2	4	10	12
30 db ...	1	4.5	8	13	16
60 db ...	6	8	12	18	21

465 kc/s I.F.

Attenuation.	Typical overall Bandwidths in kc/s. Switch position				
	1	2	3	4	5
6 db ...	-	1.2	4.5	12	17
30 db ...	0.8	4	11	20	25
60 db ...	6	8	18	27	32

I.F. response curves will be found in the appendix to this handbook.

### 3.3 Automatic Gain Control

The shape of the A.G.C. characteristic is shown in Figure 1, and was measured at 2 Mc/s on Bandwidth 3.

An increase in the input of 2 db results in an improvement in the Signal/Noise Ratio of approximately 19 db.

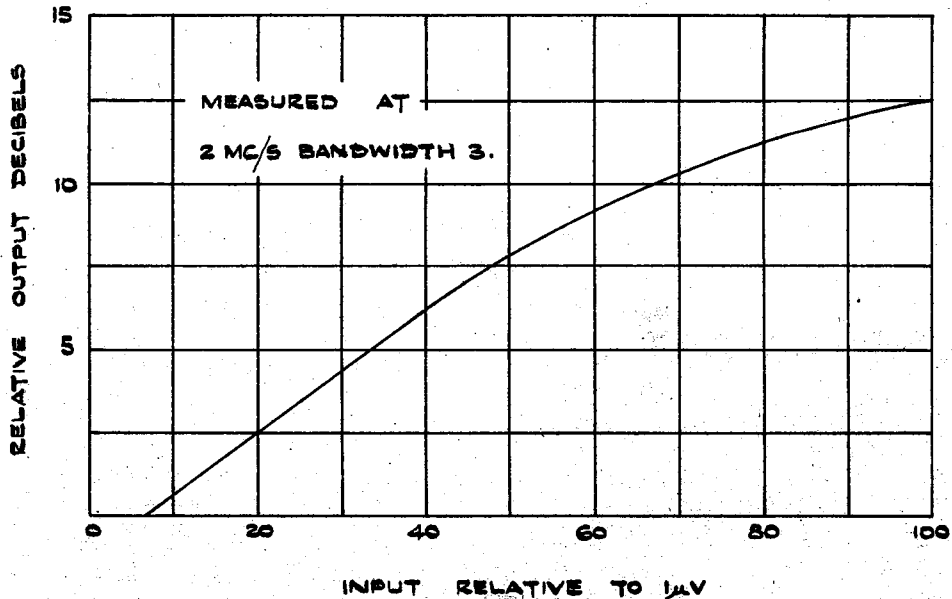

A. G. C. Curve

Figure 1

The time constants on "A.G.C." are approximately 0.1 seconds charge and discharge. On "N.S.-A.G.C." they are 0.1 and 1.0 seconds respectively.

### 3.4 Stability

Between five and ten minutes after switching on, the oscillator frequency does not change by more than

one part in  $10^4$  over the range 1.5 to 25 Mc/s. Below 1.5 Mc/s, stability is of the order of 3 parts in  $10^4$  and the drift is negligible after this time. Supply fluctuations of up to 5% do not affect these figures.

### 3.5 Audio Quality

The total harmonic distortion is less than 5% at 2 watts output and the hum level is at least 55 db below this figure.

The response is within 3 db from 250 c/s to 4000 c/s.

### 3.6 Power Consumption

The A.C. Power Unit consumes approximately 80 watts.

## 4.0 TECHNICAL DESCRIPTION

### 4.1 Mechanical Details

The basic chassis is designed to provide a strong light framework supporting the various units into which the receiver is divided, but which need not be disturbed for normal maintenance or servicing. The front panel is of  $\frac{1}{4}$  inch aluminium plate and assists in producing a rigid structure.

The sub-assemblies are as follows:-

(a) The I.F. unit, comprising the components for both the I.F. channels and their associated switches mounted in the main chassis on the right hand side.

(b) The output stage, which is mounted in the main chassis, immediately behind the front panel.

(c) The aerial stage, R.F. amplifiers, oscillator and mixer units are mounted side by side and a light alloy casting of generous dimensions, on which the tuning condenser is mounted, is bolted across them. The whole is flexibly mounted to prevent the transference of any shocks or vibrations.

The complete chassis is housed in a sheet metal cabinet finished in grey crackle enamel. It has a flush hinged lid with quick release catch and openings at the rear for access to the input and output sockets.

The power unit is simple and robust, all the components being mounted on one chassis with an aluminium cover.

#### 4.2 Electrical Details

All the components and wiring in the receiver and power unit comply with the normal Colonial and Service tropical requirements. No electrolytic condensers are used at high voltages, ceramic switch wafers and insulators are employed in critical circuits, and wiring is either bare tinned copper or insulated with P.V.C. or Polythene. The materials used in the framework and chassis are chosen and finished to produce the minimum contact potentials (not greater than 0.3 volts between adjacent metals).

#### 4.3 Circuit Details

##### 4.3.1 Signal Frequency Amplifier

Two stages of signal frequency amplification provide a degree of selectivity prior to the mixer stage, reducing cross modulation and blocking by strong interfering signals. At the same time, the higher signal level at the grid of the mixer valve, at which point circuit noise is chiefly introduced in a superheterodyne receiver, results in a considerable improvement in the overall signal/noise ratio.

The grid circuit of valve V1 and the grid/anode circuits of valves V1, V2 and V2, V3 each employ eight transformer couplings to cover the frequency range of the receiver and all coils not in use are short circuited by the range switch. The secondaries of the transformers are tuned by sections of the double four gang variable condenser, two sections in parallel being used on the long and medium wave bands D to H and one section only on the short wave bands A to C. Two series tuned I.F. circuits are provided, when the receiver is on bands E and G, to improve I.F. rejection.

The frequency bands are:-

Band A	15.5 - 32 Mc/s
" B	7.7 - 16 Mc/s
" C	3.8 - 8 Mc/s
" D	1.5 - 4 Mc/s
" E	585 - 1550 Kc/s
" F	240 - 600 Kc/s
" G	95 - 250 Kc/s
" H	13.5 - 26 Kc/s

Inductance and capacity trimming is provided in each tuned circuit, with the exception of the aerial coils, which have no capacity trimmers apart from the common aerial trimming condenser. The latter has a control on the front panel of the receiver and tunes the aerial coupling circuit which is designed for use with an 80 ohm unbalanced input on bands A B and C and an aerial of between 200 and 600 pF on the other bands. It is thus suitable for use with a ships open wire aerial.

#### 4.3.2 Oscillator

The first heterodyne oscillator valve V4, is aligned to track with the signal frequency amplifier at a frequency 110 kc/s higher on bands H and F and 465 kc/s higher on bands G,E,D,C,B and A.

A separate oscillator valve is employed with a tuned grid circuit controlled by one or two sections of the rear unit of the ganged variable condenser. One section is employed on range A, two sections on ranges B to H.

Radiation from the oscillator is reduced to a very low level by isolating the signal frequency and oscillator circuits.

Inductance as well as capacity trimming is provided in all tuned circuits and on ranges D to H the padder condensers have trimmers.

In order to compensate for changes of temperature and improve frequency stability, condensers with a negative temperature co-efficient are connected in parallel with the grid coils and padding condensers, and in addition a temperature compensated stage is included between oscillator and mixer.

Frequency variations due to mains supply fluctuations are minimised by the stabilised H.T. supply.

#### 4.3.3 Mixer

The mixer valve V3 is a triode hexode with a stabilised supply to the screen, the output of the oscillator being fed to the appropriate electrode via the grid of the triode section. The latter is used to reduce warm-up drift in conjunction with the thermistor between grid and cathode.

#### 4.3.4 Intermediate Frequency Amplifier

Three stages of I.F. amplification are provided by the variable mu R.F. pentodes V5, V6 and V7. Due to the coverage, it has been necessary to provide two channels at different frequencies and the appropriate one is automatically selected by the range switch.

Selectivity may be varied by means of the switch S.5. Five bandwidths are available ranging from "Xtal" to "Broad".

(See Appendix for response curves)

The narrow bands employ high stability vacuum mounted crystals as coupling elements between the first I.F. amplifier and the mixer.

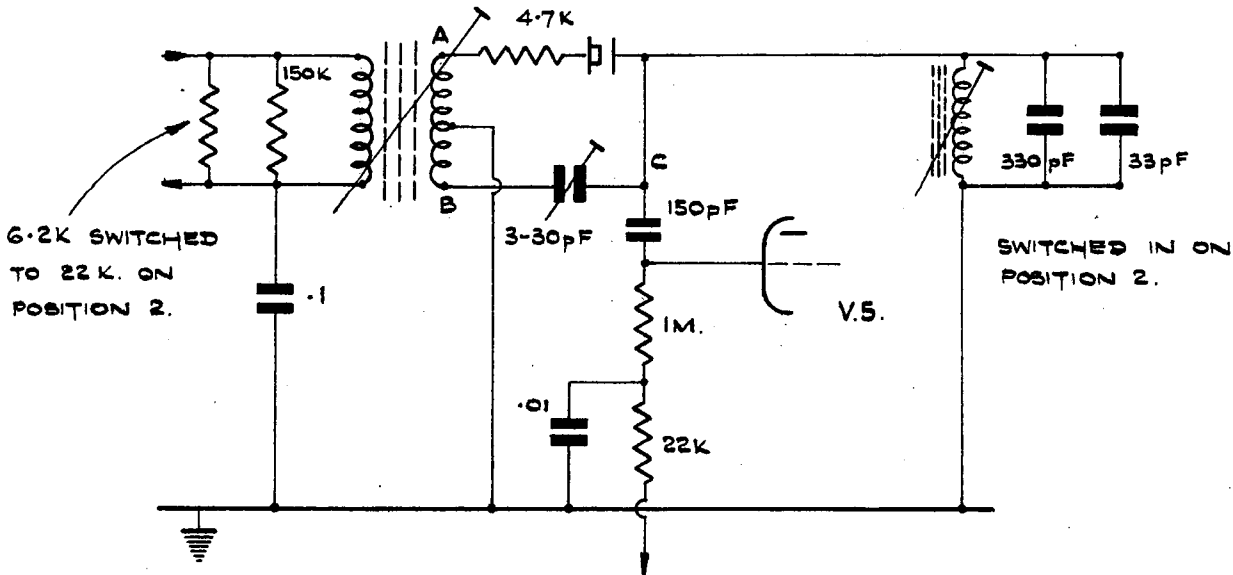

110 kc/s Crystal Filter

Figure 2

Figure 2 shows the 110 kc/s crystal filter when the selectivity switch is in Posn. 1. The changes when it is moved to Posn. 2 are indicated but for simplicity, the switches themselves are not shown.

The voltages induced in the secondary of the I.F. transformer are 180 degrees out of phase at the points A and B and if the preset phasing condenser is adjusted so that its capacity is equal to the crystal holder capacity, there will be no signal at C. At the resonant frequency, however, the crystal behaves as though it has a low resistance in parallel with it (say  $5K\Omega$ ) and in this case there will be a resultant output which is fed to the 1st I.F. valve via the 150 pF condenser.

In Posn. 2, the crystal damping coil in parallel with the two condensers is introduced between the point C and earth and this has the effect of widening the response.

In Posn. 3, the crystal filter is removed completely, and in Posns, 4 and 5 the response is still further widened by increasing the coupling of the I.F. transformers, of the second and third stages. The 465 kc/s channel is similar, but the filter employs two crystals.

#### 4.3.5 Signal Detector and A.G.C. Rectifier

One side of the double diode V9 is connected to the secondary of the final I.F. transformer and acts as the signal detector while the other side is connected to the anode of the final I.F. valve and produces delayed A.G.C. voltage controlling the R.F. valves and the first two I.F. valves.

#### 4.3.6 Beat Frequency Oscillator

The second heterodyne oscillator V8 is of the electron coupled variety and is coupled to the detector by a 10 pF condenser.

A trimmer condenser with a control on the front panel, trims the beat note to the desired audio frequency and a negative coefficient condenser results in high stability.

#### 4.3.7 Noise Suppressor

Noise suppression may be introduced with or without A.G.C. and is obtained by means of a double diode limiter circuit of the shunt series type. V 10 is the valve used. On CW and when the 465 kc/s channel is in use a bias is applied to the diode anode which improves the signal/noise ratio.

#### 4.3.8 Audio Frequency Amplifier

The voltage amplifier valve V11. is resistance capacity coupled to the output valve V.12. Negative feedback is introduced to reduce distortion and effective output impedance.

The output valve is of the beam tetrode type and will deliver 2 watts into a 3 or 12 ohm load, the secondary of the output transformer being split into two separate sections of 3 ohms each, for connection in series or parallel. The 12 ohm arrangement constitutes a satisfactory low impedance source for feeding a 600 ohm line. A telephone jack is permanently connected across one winding of the output transformer with a 600 ohm series limiting resistor to give an output suitable for use with headphones of 50 to 120 ohms resistance.

#### 4.3.9 Manual Gain Controls

There are two manual controls for adjustment of audio and RF/IF gain.

The audio control, which is used to adjust the output level of the receiver, varies the input to the grid of the first audio amplifier valve V11.

The RF/IF control adjusts the gain of the signal frequency stages and also that of the first two I.F. stages by varying the cathode resistance and hence the bias of these four valves.

### 5.0 INSTALLATION

#### 5.1 Initial Adjustments

The receiver and interconnecting cable are packed in a carton; for export packing this is protected by a wooden case, lined with shock absorbing material, also containing the power unit. Having unpacked the equipment proceed as follows:-

If the receiver is supplied in a cabinet

- (a) Remove the six front panel retaining screws.
- (b) Pull the chassis forward by means of the knobs provided.
- (c) Remove the transit bracket, which is temporarily fitted to prevent undue movement of the main sub-assembly during shipment. Four screws hold the bracket to the angle bracket on the front panel and two hold it to the centre screen on the sub-assembly. Replace the latter in the centre screen after removal of the bracket.
- (d) Check that all valves are firmly in their sockets.
- (e) Remove the power unit cover by withdrawing the four screws at the back and the one on top, adjust the mains voltage tapping (see para 5.3) and replace the cover.

If the receiver is supplied for 19 inch rack mounting.

- (a) Remove the two retaining screws at the back and slide off the top section of the cover.
- (b) Remove the transit bracket, temporarily fitted to prevent undue movement of the main sub-assembly during transit. Four screws hold the bracket to the angle bracket on the front panel and two hold it to the centre screen on the sub-assembly. Replace the two in the centre screen.
- (c) Check that all valves are firmly in their sockets.
- (d) Remove the power unit cover by withdrawing the four screws at the back and the one on top, adjust the mains voltage tapping (see para 5.3 over) and replace the cover.

## 5.2 Fixing the Equipment.

The R 50 M is mechanically very rigid but it is well to take care that the four rubber feet take the weight evenly when the receiver rests on a bench, to remove the possibility of distortion. It may be held in position by replacing the bolts for the rubber feet by longer bolts or wood screws into the bench.

When mounted in a rack, adequate support must be provided by angle runners or other devices, to take the chassis weight evenly along each side. The six front panel screws are to be used only for holding the receiver to the framework, not for taking its weight.

The power unit may be placed under the bench or in any other convenient position. For rack mounting, it has the standard 19 inch panel and is secured by four screws.

## 5.3 A.C. Mains Supply

Check that the voltage and frequency of the supply is within the range covered by the power unit and adjust the mains transformer taps as shown in the table below. All power units are adjusted for 240 volts working before leaving the works.

The values of the fuses F1 and F2, to be inserted into the fuse holders, are dependent upon the supply voltage and are 1 amp for 200 to 250 volts and 2 amp for 100 to 125 volts. The H.T. fuse F3 should be 250 mA in each case.

Connect the receiver to the power unit by means of the interconnecting cable provided. The plug end of the cable is inserted into the socket at the back of the power unit marked P.O. and the socket should be mated with the plug marked R.I. at the back of the receiver.

The mains input plug is on the right hand side of the power unit, viewed from the rear.

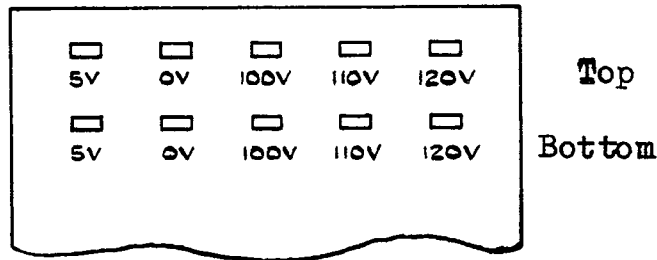

Mains Transformer Tappings

Figure 3

Mains Volts	Interconnections	Connect Mains Wires to
100	0 to 0 and 100 to 100	0 and 100
105	5 to 5 " 100 " 100	5 " 100
110	0 to 0 " 110 " 110	0 " 110
115	5 to 5 " 110 " 110	5 " 110
120	0 " 0 " 120 " 120	0 " 120
125	5 " 5 " 120 " 120	5 " 120
200	0 top to 100 bottom	0 bottom 100 top
205	5 " " 100 "	0 " 100 top
210	0 " " 100 "	0 " 110 top
215	5 " " 100 "	0 " 110 top
220	0 " " 100 "	0 " 120 top
225	5 " " 100 "	0 " 120 top
230	0 " " 120 "	0 " 110 top
235	5 " " 120 "	0 " 110 top
240	0 " " 120 "	0 " 120 top
245	5 " " 120 "	0 " 120 top
250	5 " " 120 "	5 " 120 top

Mains Transformer Connections

Table 2

#### 5.4 D.C. Mains Supply

For D.C. mains, the A.C. power unit is used with a D.C. to A.C. rotary converter capable of providing a power of approximately 120 watts at 220 volts 50 c/s. D.C. to A.C. converters for 24, 110 or 220 volts can be supplied as standard and units for other voltages are available to special order.

When the equipment is to be fitted in British Registered Vessels under the Merchant Shipping Rules 1952, approved type machines must be specified. The following machines, supplied by Redifon, meet the requirements:-

24 volts D.C. input	Type No. RED 3
110 volts D.C. input	Type No. RED 4
220 volts D.C. input	Type No. RED 5

It is important to check that the input taps on the mains transformer of the A.C. power unit are adjusted to the voltage output of the converter. This is usually 230 volts. Filters suppressing commutator interference are fitted on the machines.

### 5.5 Aerial

The receiver will function satisfactorily with any normal open wire aerial of between 25 and 250 feet in length and a normal earth connection.

Above 4 Mc/s it is designed to match an aerial of 80 ohms impedance. (see para 4.3).

The lead in should be passed through the hole in the back of the receiver and connected by means of the co-axial plug and socket mounted at the rear. The earth connection is also made at the rear of the unit.

There is no objection to a co-axial type aerial input being run from a single ended aerial switch, permitting the main transmitting aerial of a ship to be switched to the receiver for long distance working on the very low frequency band.

### 5.6 Loudspeaker and Headphones.

When a loudspeaker is used with the receiver, connections from the speech coil are taken from Pins 1 and 3 on the 12 way plug at the rear of the set. The loud speaker supplied by Redifon has a 3 ohm resistor which is connected when the speaker is switched off. This is necessary in order to avoid excessive voltages in the output transformer.

For an audio output of 3 ohms impedance, join terminals B to D and A to C on the output transformer, which is situated in the power unit.

For 12 ohms impedance join terminals B to C on the output transformer. This may also be used for a 600 ohms line.

A headphone jack socket is provided on the front panel of the receiver for headphones of 120 ohms resistance. It is essential that the resistance is correct. The use of a high resistance will result in a considerable reduction in sensitivity.

A 22000 ohms resistor R2 is connected across the primary winding of the output transformer to minimise the risk of damage should the receiver be operated under no load conditions. Receivers prior to Serial No. 802 may be without this and it is recommended that such are modified in accordance with the power unit diagram and components list included at the end of this handbook.

### 5.7 Muting

A Redifon Relay Unit is available to provide muting facilities when the receiver forms part of a main installation and is used in conjunction with a transmitter

The circuit diagram of this unit is given overleaf. Muting is accomplished by earthing the screen supply line and receiving aerial during "mark" periods, the change-over being performed by the contacts of relays 1 and 2 respectively, both energised from a D.C. supply when the telegraph key or "press-to-talk" switch is depressed for transmission. The screen supply line is taken to earth via a variable resistor R1, thus affording a convenient control of received volume when monitoring out-going transmissions.

Where the receiver is operated from an A.C. mains supply, a D.C. voltage of 12, 24, 110 or 220V must be provided for energising relays 1 and 2.

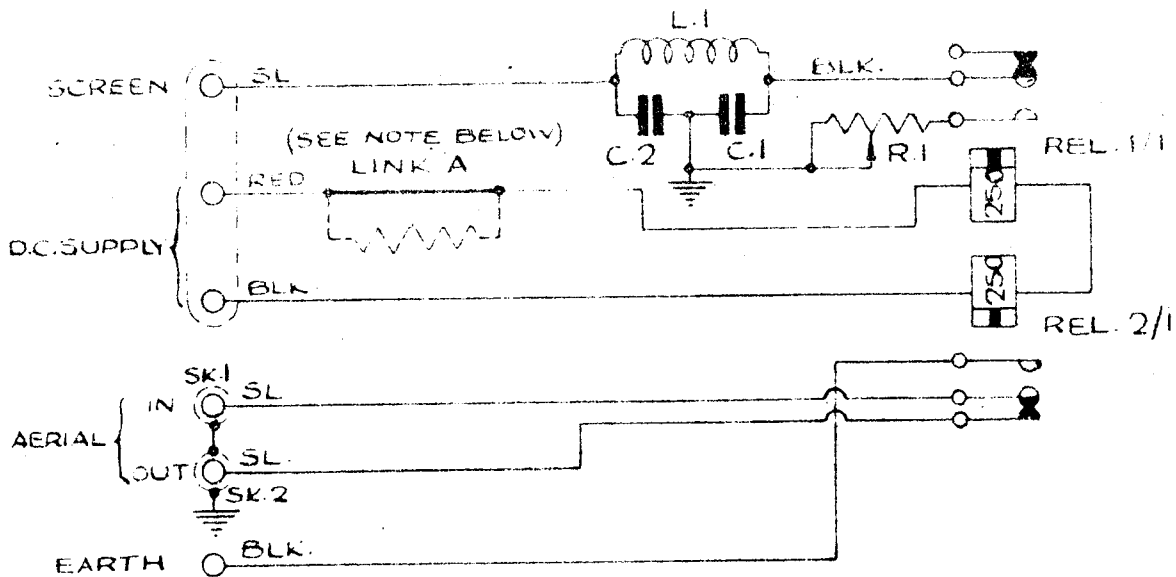

**Figure 4 - Muting Circuit Connections**

**NOTE**

- For 12 volts D.C. supply - Link A in position.
- For 24 volts D.C. supply - Replace Link A with resistor R2.
- For 110 volts D.C. supply - Replace Link A with resistor R3.
- For 220 volts D.C. supply - Replace Link A with resistor R4.

Unless otherwise specified the 24 volts unit is supplied.

## Components List.

Ref:	Value	Description	Remarks
C.1	0.001uF	Condenser CM20N 20%	Ex T.C.C.
C.2	0.001uF	Condenser CM20N 20%	Ex T.C.C.
L.1		Choke H.F.SW 68	Ex Bulgin
R.1	5000ohm	Pot. HNAR 50250	Ex Morganite
Rel	2250ohm	High speed relay H88T	Ex Siemens
Rel	2250ohm	High speed relay H88T	Ex Siemens
R.2	470ohm	$\frac{3}{4}$ watt	Ex Erie
R.3	3.9Kohms	6 watt Resistor AW3111	Ex Welwyn
R.4	8.2Kohms	10 watt AW 3112	Ex Welwyn

## 6.0 OPERATION

### 6.1 General

Turn the switch below the meter to "C.W." for continuous wave working or to "MOD" for telephony and M.C.W. The dial lamps will indicate that the set is switched on and a period of five minutes should be allowed for the valves to warm up and the R.F. circuits to stabilise. If there is a rotary converter, this should be switched on first.

Set the A.G.C. NOISE SUPPRESSOR Switch to "MAN." i.e. Manual gain control.

Switch the I.F. Bandwidth Control to Posn. 3.

Adjust the RF/IF Gain Control to maximum and the AF gain to give a reasonable noise level.

Turn the range switch to the band required.

Tune in the signal using the large knob for coarse adjustment and the small one for fine. For C.W., rotate the B.F.O. trimmer knob until the pitch of the beat note is satisfactory.

Rotate the Aerial Trimmer for maximum signal.

The I.F. bandwidth switch should now be adjusted to give the required degree of selectivity as detailed in para 6.3.

A.G.C., with or without noise suppression, may now be switched in, using the A.G.C.-N.S. switch and the suppressor control adjusted. Turn the N.S. control fully anti-clockwise and then advance it until the signal to noise ratio is at its optimum, or until distortion begins to appear. The noise suppressor should be used, however, only if conditions make it necessary.

If muting of the receiver is required, turn the switch under the meter to "Muting C.W." for continuous wave reception, or to "Muting Mod." for telephony.

## 6.2 Automatic Gain Control.

Maximum use should always be made of the A.G.C. since, not only does this circuit ensure that the output remains comparatively unchanged over a wide range of input levels, but it also improves the signal/noise ratio with any increase in input.

The exception to the use of A.G.C. is when listening to weak or elusive signals accompanied by static or signals of greater field strength, when the interference will operate the A.G.C. and this may reduce the gain sufficiently for the wanted signal to be lost altogether.

## 6.3 I.F. Bandwidths

Five bandwidths are provided on each of the two I.F. channels, ranging from Posn. 1, Xtal to Posn. 5, Broad, on the bandwidth switch. The latter should be set to Posn. 3, when searching on the lower frequency ranges and to Posn. 4. on the higher ones.

The two narrow bands give a high degree of selectivity for use on C.W. reception or whenever freedom from interfering signals on an adjacent frequency is required. Their use is not recommended for telephony.

The third position of the switch is suitable for the reception of C.W. under clear conditions and also for telephony subject to strong adjacent channel interference.

Posn. 4 should be used for telephony when some interference is experienced or when the signal is not strong, and Posn. 5 gives the best quality with strong signals.

#### 6.4 Logging Scale

A spring loaded gear mechanism is employed and the logging scale is made up of two parts, a fixed coarse scale divided into twenty four parts and traversed by the hair line on the cursor, and a scale of one hundred divisions which rotates once for each division of the coarse scale. There is thus a total of 2400 divisions over each frequency range.

To log a station, the fixed scale should be read first and then the rotating one. The same order of operations should be used when resetting.

#### 6.5 Standby

If the receiver is operated for long periods on intermittent duty, it should not be switched off but left on the "Standby" position. This ensures maximum stability and freedom from frequency drift which would arise from the warming up and cooling down of the valves and other components.

#### 6.6 Gain Controls

When receiving C.W. or telephony with A.G.C. in use, the RF/IF gain control should be set at maximum for all but the strongest signals. The A.F. gain control should be adjusted to give the output level required.

When receiving C.W. with the switch at "Manual" the A.F. gain control should be set to maximum gain and the RF/IF control turned down to give a comfortable signal level.

## 6.7 Tuning Meter

The service meter has a switch position marked "Tuning" and with the switch set to this and the A.G.C. on, it may be used as a tuning indicator, the tuning control being adjusted for minimum reading on the meter.

## 6.8 Muting

When the receiver is used in conjunction with a transmitter, the switch under the meter should be set to one of the muting positions. The muting relay described in para 5.7 will then reduce the gain of the receiver during marks to an extent depending on the setting of the side tone control R1 on the muting unit.

## 7.0 MAINTENANCE

### 7.1 Routine Servicing

Routine maintenance of the receiver should be limited to an occasional valve check with the service meter, the replacement of unservicable valves and dial lamps, and the cleaning of contacts as this becomes necessary.

A table of average meter readings is included below and space is left for the recording of the actual readings of the receiver with which this handbook is issued. If, on the routine checks, the reading of a valve is found to have fallen off appreciably, it should be changed and the new reading recorded once it has been ascertained that the change has restored the performance of the receiver to its original level. If this is not the case, then fault finding procedure should be carried out as detailed in para 7.2.

V1,2,3,4, are reached by removing the centre cover plate over the gang condenser.

V5, 6, 7, By removing the right hand cover over the I.F. unit.

V8, 11, by removing first the tops and then the bodies of the circular screening cans.

V9,10,12, are directly accessible (V12 is very close to mains switch: disconnect mains from power unit before removing)

Meter Switch Position	Full Scale Deflection	Average Readings	Actual Readings
V.1 Anode Current	10mA	5.7mA	
V.2 " "	10mA	5.7mA	
V.3 " "	10mA	2.8mA	
V.4 " "	10mA	4.0mA	
Tuning	10mA	5.7mA	
V.5 Anode Current	10mA	5.7mA	
V.6 " "	10mA	5.7mA	
V.7 " "	10mA	5.7mA	
V.8 " "	3mA	0.4mA	
V.11 " "	10mA	1.8mA	
H.T. volts	300 V	280 V	
V.12 Cathode Current	100mA	37mA	

NOTE:

The figures given are with no signal input, RF/IF gain control at maximum, and frequency band switch at position E.

Service Meter Readings

Table 3

The three dial lamps fitted to illuminate the scale are connected in parallel with a resistance in series to reduce the current through them. If a lamp fails, unscrew the two pillars securing the dial lamp unit behind the front panel, move the unit away from the dial, replace the faulty lamp and refix the unit into position.

Replacement lamps should be of the 6 volt 0.3 amp miniature Edison screw type. One spare lamp is supplied in a clip fixed to the top of the gang condenser cover inside the receiver.

## 7.2 Fault Finding

The following procedure should be adopted, should a fault be suspected, and will be of service in locating and correcting the majority of faults met with in operation.

- (a) Check the valve currents and H.T. voltage by means of the service meter as indicated in Table 3.
- (b) Ascertain whether the fault exists on all frequency ranges. Should it be only on one range, the appropriate oscillator and signal frequency section components and switches should be investigated without further preliminary.
- (c) Note any unusual sound effects as these will often give an indication of the trouble.
- (d) Make a visual examination for mechanical damage or broken down components.
- (e) If a test meter is available, make the voltage and resistance checks indicated in Table 4 below.

Measurements should be made on an Avometer Model 7, the anode and screen potentials on the 400 volt range and the cathode potentials on the 10 volt range. It should be noted that it is necessary to switch the receiver off before making the resistance checks.

Valves		V1&2	V3	V4	V5	V6	V7	V8	V11	V12
Anode	Volts to Chassis	250	250	95	250	250	250	70	70	270
	Ohms to H.T.Line	4.7K	4.7K	4.7K	4.7K	4.7K	4.7K	122K	105K	*
Screen	Volts to Chassis	95	104		95	95	95	45	130	280
	Ohms to H.T.Line	10K	4.7K		10K	10K	100K	100K	155K	0
Cathode	Volts to Chassis	2.4	2.4	0	2.4	2.4	2.4	0	4.8	18
	Ohms to Chassis	330	150	0	330	330	330	0	3.3K	470
Grid	Ohms to Chassis			68K				100K	100K	470K
Main H.T. 280 volts, Stabilised H.T. 114 volts, H.T. current 100mA										

\* Open circuit when the receiver is in the OFF position. 180 ohms when ON. (withdraw the mains plug in order to measure)

#### Test Point Voltages and Resistances

Table 4

It is possible that one of the above tests will give an indication of the location of the fault and the appropriate section of the receiver should be investigated. Otherwise, the sections should be tested in order. Details of the tests for the various sections are given below.

#### 7.2.1 Power Unit

If no L.T. or H.T. is available from the power unit, check that the mains supply is through to the input plug. Examine the mains fuses on the front

panel and make sure that the primary taps of the transformer are connected correctly. Check the input lead for broken wires.

If the L.T. is available but there is no H.T., examine the fuse F.3 on the front panel. A burnt out fuse indicates a low resistance path to earth from the H.T. line, either in the power unit or the receiver. Test both of the smoothing condensers for breakdown and measure the resistance from the H.T. line to earth. Using an A.C. voltmeter, check the rectifier heater and anode voltages. If these are normal, (5 and 365 volts A.C. respectively) the rectifier valve is probably at fault and should be replaced.

The stabilised H.T. supply is nominally 114 volts but if the stabiliser valve is open circuited or making bad contact in the holder, it may be almost 270 volts.

### 7.2.2 Audio Frequency Amplifier

A rapid test of the A.F. amplifier can be made by setting the gain control to maximum and touching the cathode (pin 6) of V11 intermittently with an earthed wire. A loud scatching noise will be produced in the telephone or loudspeaker, if the stage is functioning.

When making tests involving the shorting out of bias resistors, the service meter should be switched to another stage or it may be damaged.

If an audio frequency oscillator is available, the output should be injected into the grids of V12 and V11 in turn. Lack of response to the former indicates a fault in the output transformer or the leads to it in the interconnecting cable, or in the loudspeaker or telephone. If no response is obtained in the case of V11, check the coupling condenser and the associated wiring for an open circuit.

### 7.2.3 Intermediate Frequency Amplifier

Again, a rapid test can be made by touching the cathode of the valves V5, V6, and V7, with an earthed wire. The gain controls should be set at maximum for this. If a valve fails to produce any noise, and normal readings are obtained on the test meter, examine the link mechanism to the I.F. changeover switch as this may have slipped (see para 7.3.).

A signal generator and output meter, if available, can be used to measure the gain of each I.F. stage and the results compared with the average set below. The oscillator should not be stopped.

Valve	465 kc/s gain	110 kc/s gain
V3	2	1.5
V5	15	16
V6	15	16
V7 sensitivity	160 mV	100 mV

Sensitivity is given for 2 watts output with a signal modulated at 400 c/s to a depth of 30% and the selectivity switch to Posn. 3. This corresponds to 65 - 70  $\mu$ A current in the detector diode load R67. If the RF/IF gain control is tested with no aerial connected it will sound noisy due to the very high gain of these circuits. This type of noise should not be confused with that which will arise from a defective gain control.

### 7.2.4 Oscillator

Failure of the oscillator is usually indicated by a rise of anode current and reduced receiver noise, although there may be some signal heard. There will be no grid current. The anode current can be checked by means of the service meter while the grid current can be measured by inserting a meter in place of the shorting

link across C 61. It should be between 60 and 250 mA. Test earth connections and coils for continuity, fixed and variable condensers for short circuits and resistors for incorrect values.

### 7.2.5 Signal Frequency Amplifier and Mixer

Adjust the receiver to the setting for a strong signal and disconnect the aerial from its normal position. Touch it on the grids of V1, V2 and V3 in turn until the signal is heard. The fault lies on the aerial side of this point.

When a signal generator and output meter are available, they can be used to check the performance of each stage and the figures compared with the table given below:

Range	Frequency	Ae. Gain	V1 Gain	V2 Gain	V3 Sensitivity in $\mu V$
A	24 Mc/s	6	6	6	320 Bandwidth 4
B	12 Mc/s	5	14	15	400 Bandwidth 4
C	6 Mc/s	9	4	20	400 Bandwidth 4
D	3 Mc/s	9	11	4.4	400 Bandwidth 4
E	1 Mc/s	6	4.4	24	350 Bandwidth 3
F	425 kc/s	1.8	6	5	600 Bandwidth 3
G	170 kc/s	1.8	2.5	10	350 Bandwidth 3
H	20 kc/s	1.8	5.6	33	600 Bandwidth 2

Measured with dummy aerial of 80 ohms above 4Mc/s and 300 pF below 4Mc/s. V3 sensitivity is for 2 watts audio output on 400c/s, 30% modulated signal. R.F. and A.F. gain controls are at maximum.

### Signal Amplifier Gains

Table 5

### 7.2.6 A.G.C. and Noise Suppressor

The A.G.C. and noise suppressor operation should be checked in the following manner:-

Set the meter switch to "Tuning".

Set the A.G.C. - N.S. switch to N.S. - A.G.C.

Connect the aerial to the receiver, advance the gain controls, tune in strong carrier wave and note whether the meter reading falls.

Advance noise suppressor control when distortion and attenuation of a modulated carrier should result.

If the A.G.C. does not function correctly, check the continuity of the line from the diode (V9) to the grid return circuit of the R.F. and I.F. valves, including the decoupling resistances. The associated de-coupling condensers should also be tested as a breakdown in one of these would short to earth either the A.G.C. line or one of the valve grid returns.

Examine the switch contacts in the circuits i.e. on the A.G.C. - N.S. switch S.2, and on S.6/6 which effects the I.F. changeover and is mechanically coupled to the wave change switch.

Measure the delay at the cathode of V9 (pin 8). It should be 9 or 10 volts. If it is incorrect, check the values of R 75 and 76 which form a potential divider across the H.T.

If the noise suppressor is faulty, check the condensers, resistors and switches in this part of the circuit for breakdown, value and dirty contacts respectively.

### 7.2.7 Beat Frequency Oscillator

A high anode current reading when V8 is checked on the service meter, usually indicates that the valve is not oscillating and the associated components should be checked. If the valve appears to be oscillating but

the beat note is still inaudible, adjustments to the preset tuning control may be necessary (see para 7.4).

### 7.3 Mechanical Adjustments

The switch on the I.F. unit for changing from 110 to 465 kc/s operation, is rotated by means of an insulated link operated by a cam on the wave band switch shaft. The insulated portion of this link has two slotted holes at one end for adjustment of length. If, for any reason, the I.F. switch is not operating on the correct contacts, slacken the lock nuts and screws on the links, adjust to the correct position and retighten screws and locknuts. It is essential that the bearings of this switch are lubricated, (Microtime Type C is suitable) and this necessitates the removal of the receiver from the housing. The side cover must then be removed to render them accessible.

Should the clutch drive mechanism show a tendency to slip, which is indicated by an apparent sticking of the logging scale, this can be corrected as follows:-

The clutch is located between the dial drive mechanism and the variable condensers, immediately in front of the flexible coupling. Two O.B.A. hexagonal nuts in contact with plain washers at the rear ends of the clutch springs are provided for adjusting the tension. These should be moved about one sixth of a turn at a time until no slip is apparent. Each spring should be adjusted by an equal amount to avoid uneven pressure on the clutch plates.

Replacement of the glass tuning dial should be carried out in the following order, should this become necessary.

Remove the slow motion tuning knob from the main drive spindle by undoing the grub screws.

Remove the main tuning knob by unscrewing the two retaining bolts.

Remove the escutcheon.

The glass dial is held in position by two vertical metal strips, one on each side of the scale. Unscrew the bolts, top and bottom, and remove the strips and rubber packing. Clear out the broken glass and replace with the new scale. Replace the metal holding strips, taking care that the rubber packing is properly in position. Tighten the screws sufficiently to hold the glass in position and replace the main tuning knob.

The dial should now be aligned with the fine logging scale. This is done by obtaining a zero reading on the logging scale when the pointer on the dial lies in each of the following positions:-

- a) On the line between 1 and 2 of the coarse logging scale.
- b) On the line between 11 and 12.
- c) On the line between 22 and 23.

In the extreme positions, a mark will be found near the edge of the dial and the pointer should be lined up on this.

Gently tighten the screws so that the glass is held rigidly in position. Remove the main tuning knob and replace the escutcheon fastening the former back into position.

#### 7.4 Circuit Alignment

No attempt should be made to re-adjust the preset inductance and capacity trimmers of the receiver unless the appropriate test equipment is available and alignment should be undertaken only by experienced personnel when there is definite evidence that this is required.

##### I.F. Amplifier and B.F.O.

A signal generator and 0-0.5 mA meter are required, when aligning the I.F. circuits and if an oscilloscope is available and the generator can be frequency

modulated, it will be easier to obtain symmetry on bandwidths 3, 4 and 5. Unless special D.C. coupled equipment is available with a very low sweep rate, widths 1 and 2 must be checked by setting the signal generator each side of the intermediate frequency and comparing the outputs.

Typical I.F. response curves are given in the appendix and these should be referred to.

Free the I.F. cores with a solvent such as Amyl Acetate or Acetone and connect the output of the signal generator to the mixer grid and the 0-0.5mA meter between the bottom of the resistor R 67 and chassis. A deflection of 70 $\mu$ A should be taken as standard.

#### NOTE

The oscillator should not be stopped or the valve removed as this will have a detrimental effect on the mixer valve. The A.G.C. should be switched off and gain controls set at maximum.

#### 465kc/s Channel.

- a. Set the range switch to E.
- b. Set the bandwidth switch to Posn. 1 and the signal generator to 465kc/s, trimming the latter for maximum deflection of the meter. This ensures that the generator is set to the crystal resonance frequency.
- c. Set the bandwidth switch to Posn. 3 and peak all the channel I.F. transformers except transformers B and D.
- d. Set the bandwidth switch to Posn. 4 and adjust transformer B for symmetry of response with the oscilloscope across R67 and frequency modulating the generator.
- e. Set the bandwidth switch to Posn. 1 and adjust C65 for symmetry of response by rocking the generator frequency each side of the I.F.

- f. Set the bandwidth switch to Posn. 2 and adjust L9 and C67 until curve is both single humped and symmetrical in a similar manner.
- g. Set the bandwidth switch to Posn. 1, the B.F.O. panel control to its central position, check that this corresponds to half capacity and adjust L35 for zero beat on the oscilloscope.

There are two possible positions of the core and the inner one should be chosen.

### 110kc/s Channel.

- a. Set the range switch to F.
- b. Set the bandwidth switch to Posn. 1, the signal generator to 110kc/s, and trim the latter for maximum deflection of the meter.
- c. Set the bandwidth switch to Posn. 3 and adjust L39 and L40 and then the cores of the transformers G and J between V6 and V7 for maximum response.
- d. Unscrew the top cores of the transformers G and J between V5 and V6 and adjust the bottom cores for maximum response.
- e. Damp the grid of V6 using a 22K $\Omega$  resistor in series with a 0.1 $\mu$ F condenser.
- f. Adjust the top core of the V6 anode transformer J for maximum response. Remove the damper.
- g. Damp the anode of V5 and adjust the top core of the anode transformer G for maximum response. Remove the damper.
- h. Adjust the top core of the transformer for symmetry by rocking the generator frequency.
- i. Set the bandwidth switch to Posn. 4 and adjust the top core of transformer C for symmetry using the oscilloscope. (The dip, which can be seen here, will be filled by the R.F. response)

- j. Set the bandwidth switch to Posn. 1 and adjust C68 for symmetry by rocking the generator frequency.
- k. Set the bandwidth switch to Posn. 2 and adjust L10 for minimum height of peak. Care should be taken to adjust the generator continually to the resonance frequency as this is critical and varies slightly.
- l. Set the bandwidth switch to Posn. 5 and adjust C64 for symmetry using the oscilloscope.
- m. Set the bandwidth switch to Posn. 1, the B.F.O. panel control to the central position, and adjust L36 for zero beat, choosing the inner position of the core.

#### Signal Frequency Amplifier and Oscillator.

Each range is aligned separately, first the oscillator, then the two intervalve signal frequency circuits and finally the aerial coils.

The signal generator should be connected to the aerial input via an 80 ohm dummy aerial on bands A to C and via one of 300 pF on the remainder of the bands. The input level should be about 1 mV and the RF/IF gain control should be adjusted to give some 70 $\mu$ A current in the diode detector load. This should be measured by the 0-0.5 mA meter which should be connected between the diode load and earth.

The A.G.C. should be switched off and the gain controls set at maximum. The aerial trimmer should be at half capacity.

#### BAND A.

- a. Set the tuning control 17 Mc/s on the scale and the bandwidth switch to Posn. 3, Adjust LO 8, LM 8, LR 8 and LA 8 for maximum on a 17 Mc/s signal.
- b. Set the tuning control to 31 Mc/s and adjust TO 8, TM 8 and TR 8, for maximum with the appropriate signal.

- c. Check that the image frequency lies 0.93 Mc/s above the correct signal by connecting the generator to the grid of the mixer and tuning it for maximum output.
- d. Repeat a and b until no improvement can be obtained. The final adjustment should be at 31 Mc/s.

#### BAND B.

- a. Set the tuning control to 8.5 Mc/s on the scale and adjust LO 7, LM 7, LR 7 and LA 7 for maximum on an 8.5 Mc/s signal.
- b. Set the tuning control to 15.5 Mc/s and adjust TO 7, TM 7 and TR 7 for maximum with the appropriate signal.
- c. Repeat a and b until no further improvement can be obtained. The final adjustment should be at 15.5 Mc/s.

#### BAND C.

- a. Set the tuning control to 4 Mc/s on the scale and adjust LO 6, LM 6, LR 6 and LA 6 for maximum on a 4 Mc/s signal.
- b. Set the tuning control to 7.8 Mc/s and adjust TO 6, TM 6 and TR 6 for maximum on the appropriate signal.
- c. Repeat a and b until no further improvement can be obtained. The final adjustment should be at 7.8 Mc/s.

#### BAND D.

- a. Set the tuning control to 1.7 Mc/s on the scale and adjust LO 5, LM 5, LR 5, and LA 5 for maximum on a 1.7 Mc/s signal.
- b. Set the tuning control to 3.8 Mc/s and adjust TO 5, TM 5, and TR 5 for maximum on the appropriate signal.

- c. Set the signal generator to 2.8 Mc/s and tune the receiver for maximum output. If the scale reading is higher than 2.8 Mc/s the capacity of padder, PO 5, should be increased slightly. If it is lower, the capacity should be reduced.
- d. Repeat a, b and c until no further improvement can be obtained. The final adjustment should be at 3.8 Mc/s.

#### BAND E.

- a. Set the tuning control to 650kc/s on the scale and adjust LO 4, LM 4 LR 4 and LA 4 for maximum on a 650 kc/s signal.
- b. Set the tuning control to 1500 kc/s and adjust TO 4, TM 4 and TR 4 for maximum on the appropriate signal.
- c. Set the signal generator to 1050 kc/s and tune the receiver for maximum output. If the scale reading is higher than 1050 kc/s, the capacity of the padder PO 4, should be increased slightly. If it is lower, the capacity should be reduced.
- d. Repeat a, b and c until no further improvement can be obtained. The final adjustment should be at 1500 kc/s.

#### BAND F

- a. Set the tuning control to 275 kc/s on the scale and adjust LO 3, LM 3, LR 3, and LA 3 for maximum on a 275 kc/s signal.
- b. Set the tuning control to 575 kc/s and adjust TO 3, TM 3 and TR 3 for maximum on the appropriate signal.
- c. Set the signal generator to 425 kc/s and tune the receiver for maximum output. If the scale reading is then higher than 425 kc/s, the capacity of the padder, PO 3, should be increased slightly. If it is lower, the capacity should be reduced.

- d. Repeat a, b and c until no further improvement can be obtained. The final adjustment should be at 575 kc/s.

#### BAND G.

- a. Set the tuning control to 110 kc/s and the bandwidth switch to Posn. 2. Adjust LO 2, LM 2, LR 2 and LA 2 for maximum on a 110 kc/s signal.
- b. Set the tuning control to 240 kc/s and adjust TO 2, TM 2 and TR 2 for maximum on the appropriate signal.
- c. Set the signal generator to 170 kc/s, and tune the receiver for maximum output. If the scale reading is then higher than 170 kc/s, the capacity of the padder, PO 2, should be increased slightly. If it is lower, the capacity should be reduced.
- d. Repeat a, b and c until no further improvement can be obtained. The final adjustment should be at 240 kc/s.

#### BAND H.

- a. Set the tuning control to 14 kc/s on the scale and the bandwidth switch to Posn. 1. Adjust LO 1, LM 1, LR 1 and LA 1 for maximum on a 14 kc/s signal.
- b. Set the tuning control to 25 kc/s and adjust TO 1, TM 1 and TR 1 for maximum on the appropriate signal.
- c. Set the signal generator to 20 kc/s and tune the receiver for maximum output. If the scale reading is then higher than 20 kc/s, the capacity of the padder, PO 1, should be increased very slightly. If it is lower, the capacity should be reduced. The padder adjustments are extremely critical on this band.
- d. Repeat a, b and c until no further improvement can be obtained. The final adjustment should be at 25 kc/s.

## Adjustment of the I.F. Rejectors

Set the signal generator to the exact intermediate frequency by connecting it to the mixer grid and tuning for maximum output with the bandwidth switch to Posn. 1.

Transfer the signal generator to the grid of V1 and adjust the appropriate I.F. rejector for minimum output. A high level of input will be necessary in order to do this.

On range E adjust L 2 with the receiver tuning at the high frequency end of the scale. On range G adjust L 1 with the tuning at the low frequency end.

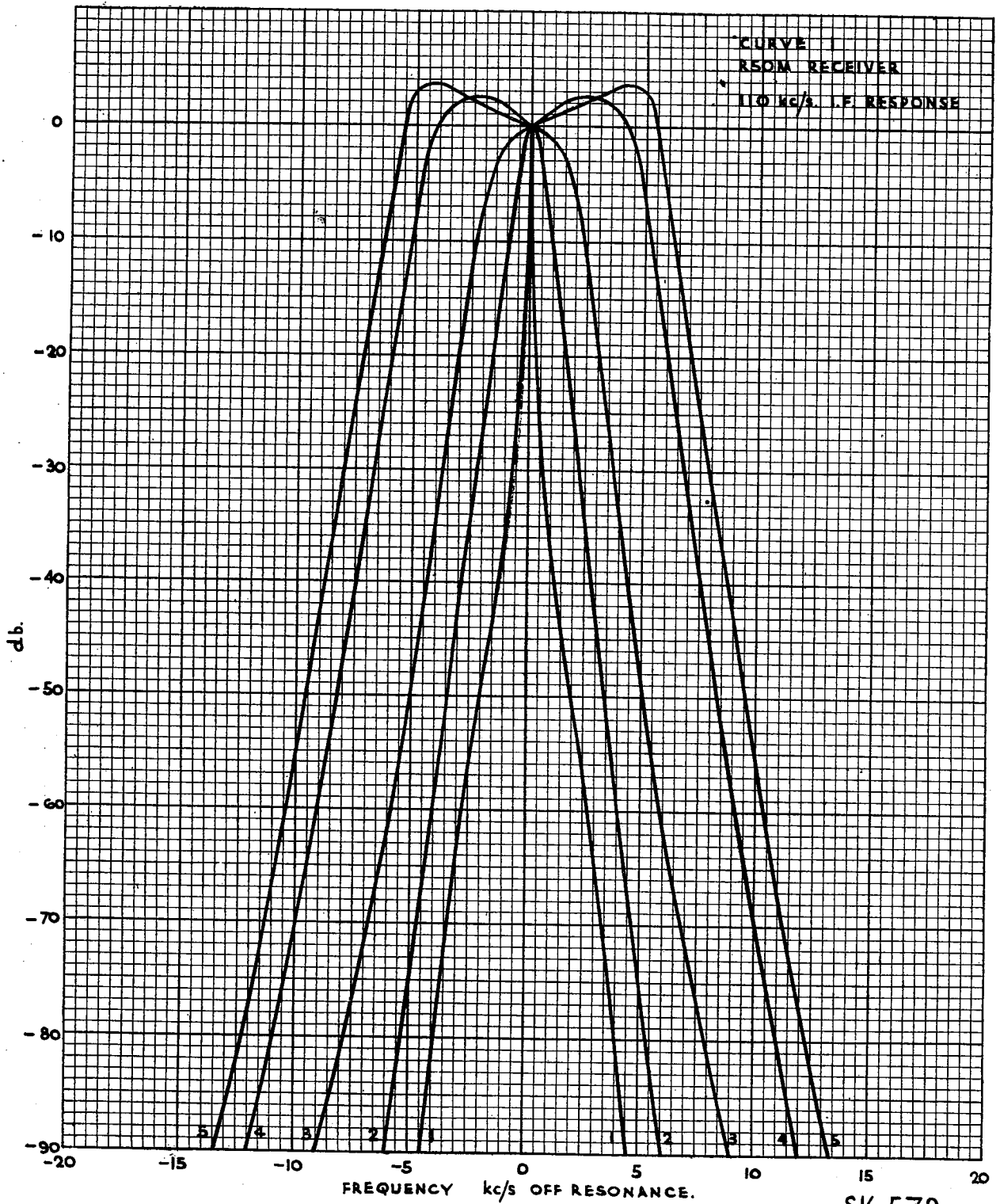

SK.572  
SHEET 1.

CURVE 2  
R50M RECEIVER  
400 kc/s IIF RESPONSE

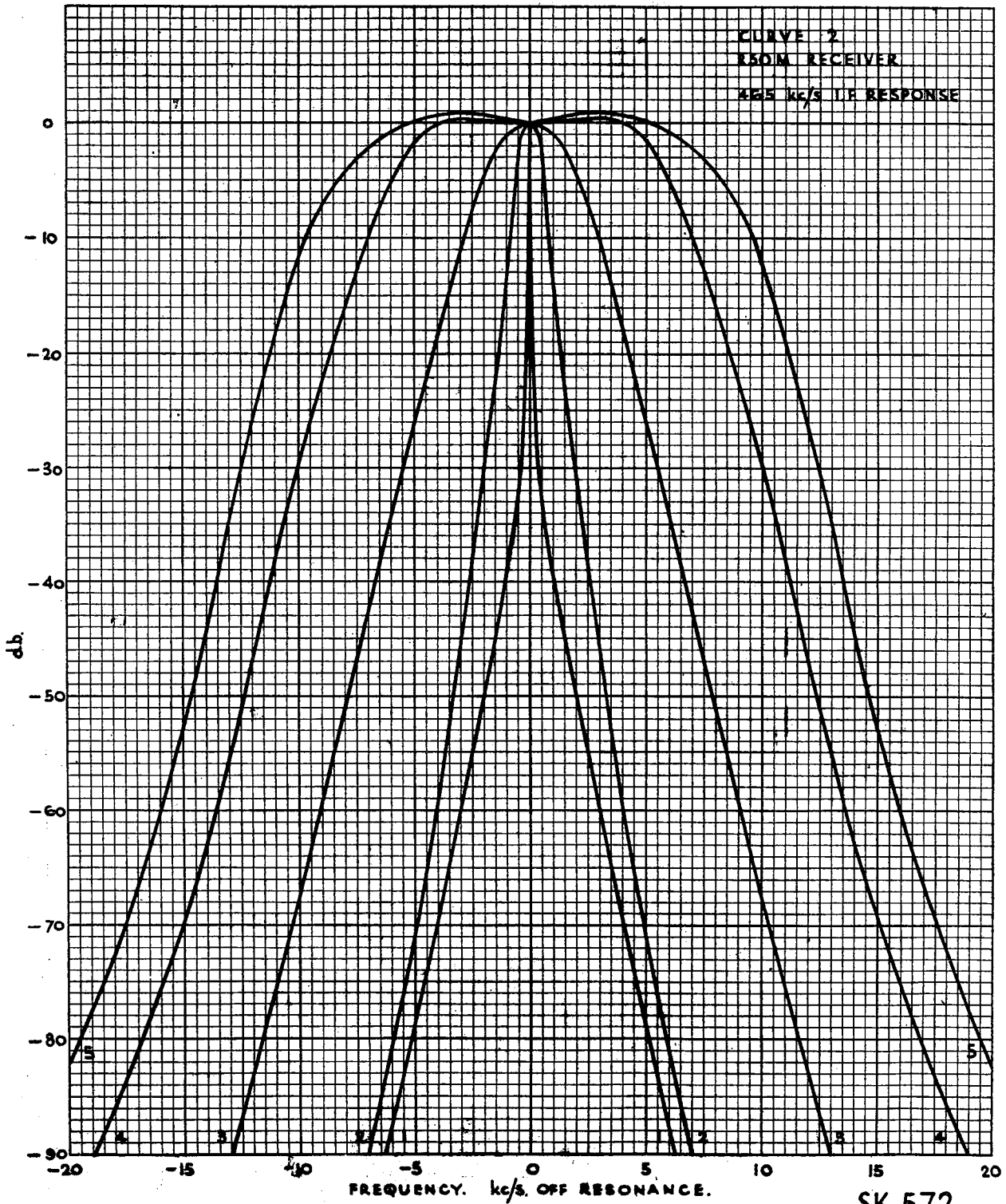

SK.572  
SHEET 2.



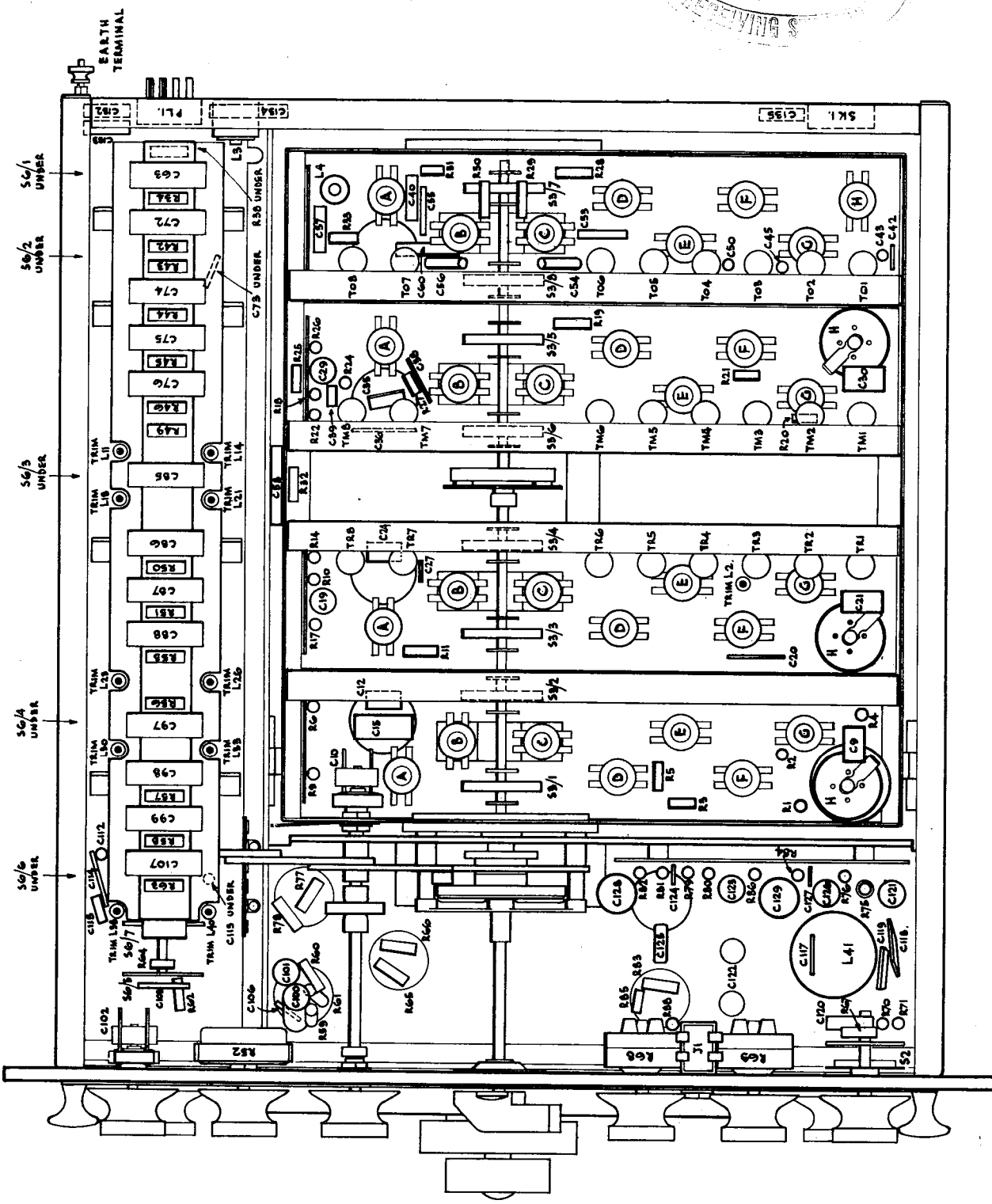



DRAWN. <i>H.</i> DATE				TYPED C.J. DATE 3.8.50.		ENGINEER <i>R.G.</i> DATE 19/2/51.		APPROVED <i>E.W.R.</i> DATE 19.2.51	
REF	VALUE	DESCRIPTION	REMARKS	REF.	VALUE	DESCRIPTION	REMARKS	ISSUE	
		CONDENSERS.		C19	.1 uF.	T.C.C. Type CP45N.	350v. D.C. Wkg.	1. 4.8.50.	
C1	14-224 pF.	Polar 4 gang Type C60-14/5.		C20	270 pF. ±10%	T.C.C. Type 425 SMP.	" " "		
C2	"			C21	68 pF. ±5%	T.C.C. Type 101 SMP.	350v. D.C. Wkg.		
C3	"			C22	5 pF. ±20%	T.C.C. Type SCP7.	500v. D.C. Wkg.		
C4	14-224 pF.			C23	.01 uF. ±20%	T.C.C. Type SM3N.	350v. D.C. Wkg.		
C5	14-224 pF.			C24	150 pF. ±20%	T.C.C. Type 401 SMP.	" " "		
C6	"			C25	.1 uF.	T.C.C. Type CP45N.	" " "		
C7	"			C26	.1 uF.	T.C.C. Type CP45N.	" " "		
C8	14-224 pF.			C27	150 pF. ±20%	T.C.C. Type 401 SMP.	" " "		
C9	33 pF. ±10%	T.C.C. Type 101 SMP.	350v. D.C. Wkg.	C28	.1 uF.	T.C.C. Type CP45N.	" " "		
C10	3.8-50 pF.	Polar Type C8-04.		C29	.1 uF.	T.C.C. Type CP45N.	" " "		
C11	150 pF. ±20%	T.C.C. Type 401 SMP.	350v. D.C. Wkg.	C30	68 pF. ±5%	T.C.C. Type 101 SMP.	350v. D.C. Wkg.		
C12	150 pF. ±20%	T.C.C. Type 401 SMP	" " "	C31	3-30 pF.	Mullard Type E.7864.			
C13	.1 uF.	T.C.C. Type CP45N.	" " "	C32	5 pF. ±20%	T.C.C. Type SCP7.	500v. D.C. Wkg.		
C14	.1 uF.	T.C.C. Type CP45N.	" " "	C33	150 pF. ±20%	T.C.C. Type 401 SMP.	350v. D.C. Wkg.		
C15	270 pF. ±20%	T.C.C. Type 425 SMP.	" " "	C34	.1 uF.	T.C.C. Type CP45N.	" " "		
C16	.1 uF.	T.C.C. Type CP45N.	" " "	C35	150 pF. ±20%	T.C.C. Type 401 SMP.	" " "		
C17	420 pF. ±2%	T.C.C. Type 501 SMP.	" " "	C36	360 pF. ±2%	T.C.C. Type 501 SMP.	" " "		
C18	420 pF. ±2%	T.C.C. Type 501 SMP.	350v. D.C. Wkg.	C37	.1 uF.	T.C.C. Type CP45N.	350v. D.C. Wkg.		

REDIFON LTD.  
LONDON.

TITLE R50M. RECEIVER

WD3/2719/S SHEET NO 3 CONT.

DRAWN. <i>J.K.</i> DATE				TYPED C.J. DATE 3.8.50.		ENGINEER <i>R.B.</i> DATE 19/2/51.		APPROVED <i>E.W.R.</i> DATE 19.2.51.	
REF	VALUE	DESCRIPTION	REMARKS	REF.	VALUE	DESCRIPTION	REMARKS	ISSUE	
C38	150 pF. ±20%	T.C.C. Type 401 SMP.	350v. D.C. Wkg.	C57	.01 uF.	Dubilier Type 691W.	350v. D.C. Wkg.	1.4.8.50.	
C39	.001 uF. ±20%	T.C.C. Type CM20N.	" " "	C58	.01 uF.	Dubilier Type 691W.	350v. D.C. Wkg.		
C40	.01 uF.	Dubilier Type 691W.	350v. D.C. Wkg.	C59	5 pF. ±20%	T.C.C. Type SCP7	500v. D.C. Wkg.		
C41	16 pF. ±10%	T.C.C. Type SCT1.	500v. D.C. Wkg.	C60	150 pF. ±10%	T.C.C. Type SCT3.	500v. D.C. Wkg.		
C42	100 pF. ±2%	T.C.C. Type 101 SMP.	350v. D.C. Wkg.	C61	.01 uF.	Dubilier Type 691W.	350v. D.C. Wkg.		
C43	32 pF. ±10%	T.C.C. Type SCT1.	500v. D.C. Wkg.	C62	.01 uF.	Dubilier Type 691W.	" " "		
C44	33 pF. ±20%	T.C.C. Type 101 SMP.	350v. D.C. Wkg.	C63	.1 uF.	T.C.C. Type CP45N.	350v. D.C. Wkg.		
C45	10 pF. ±10%	T.C.C. Type SCT1.	500v. D.C. Wkg.	C64	3-30 pF.	Mullard Type E.7864.			
C46	190 pF. ±5%	T.C.C. Type SCT3	500v. D.C. Wkg.	C65	2-8 pF.	Mullard Type E.7851.			
C47	750 pF. ±1%	T.C.C. Type 601 SMP.	350v. D.C. Wkg.	C66	5 pF. ±10%	T.C.C. Type SCD1	500v. D.C. Wkg.		
C48	95 pF. ±5%	T.C.C. Type SCT2	500v. D.C. Wkg.	C67	2-8 pF.	Mullard Type E.7851.			
C49	370 pF. ±2%	T.C.C. Type 501 SMP.	350v. D.C. Wkg.	C68	3-30 pF.	Mullard Type E.7864.			
C50	5 pF. ±20%	T.C.C. Type SCP7	500v. D.C. Wkg.	C69	100 pF. ±5%	T.C.C. Type 101 SMP.	350v. D.C. Wkg.		
C51	250 pF. ±5%	T.C.C. Type SCT3.	500v. D.C. Wkg.	C70	330 pF. ±2%	T.C.C. Type 501 SMP.	350v. D.C. Wkg.		
C52	1250 pF. ±1%	T.C.C. Type 601 SMP.	350v. D.C. Wkg.	C71	33 pF ±10%	Erie Ceramicon Type N.750K.			
C53	3560 pF. ±1%	T.C.C. Type 601 SMP.	350v. D.C. Wkg.	C72	.01 uF.	T.C.C. Type CP45W	500v. D.C. Wkg.		
C54	30 pF. ±5%	Erie Ceramicon Type N.220.		C73	150 pF. ±10%	T.C.C. Type 401 SMP.	350v. D.C. Wkg.		
C55	8,000 pF. ±10%	T.C.C. Type 901 SMP.	350v. D.C. Wkg.	C74	.1 uF.	T.C.C. Type CP45N.	" " "		
C56	30 pF. ±5%	Erie Ceramicon Type N.220.		C75	.1 uF.	T.C.C. Type CP45N.	350v. D.C. Wkg.		

REDIFON LTD.  
LONDON.

TITLE R50M RECEIVER

WD3/2719/S

SHEET NO 4 CONT.

DRAWN. <i>JK</i> DATE				TYPED C.J. DATE 3.8.50.		ENGINEER <i>R.L.</i> DATE 19/2/51.		APPROVED <i>E.W.R.</i> DATE 19.2.51.	
REF	VALUE	DESCRIPTION	REMARKS	REF.	VALUE	DESCRIPTION	REMARKS	ISSUE	
C76	.1 uF.	T.C.C. Type CP45N.	350v. D.C. Wkg.	C95	330 pF. $\pm 2\%$	T.C.C. Type 501 SMP.	350v. D.C. Wkg.	1. 4.8.50	
C77	360 pF. $\pm 2\%$	T.C.C. Type 501 SMP.	" " "	C96	330 pF. $\pm 2\%$	T.C.C. Type 501 SMP.	" " "		
C78	360 pF. $\pm 2\%$	T.C.C. Type 501 SMP.	" " "	C97	.1 uF.	T.C.C. Type CP45N.	" " "		
C79	330 pF. $\pm 2\%$	T.C.C. Type 501 SMP.	" " "	C98	.1 uF.	T.C.C. Type CP45N.	" " "		
C80	330 pF. $\pm 2\%$	T.C.C. Type 501 SMP.	" " "	C99	.1 uF.	T.C.C. Type CP45N.	" " "		
C81	360 pF. $\pm 2\%$	T.C.C. Type 501 SMP.	" " "	C100	.1 uF.	T.C.C. Type CP45N.	" " "		
C82	360 pF. $\pm 2\%$	T.C.C. Type 501 SMP.	" " "	C101	.1 uF.	T.C.C. Type CP45N.	350v. D.C. Wkg.		
C83	330 pF. $\pm 2\%$	T.C.C. Type 501 SMP.	" " "	C102	3.8-50 pF.	Polar Type C8-04.			
C84	330 pF. $\pm 2\%$	T.C.C. Type 501 SMP.	350v. D.C. Wkg.	C103	100 pF. $\pm 10\%$	T.C.C. Type 101 SMP.	350v. D.C. Wkg.		
C85	.01 uF.	T.C.C. Type CP45W.	1,000v. D.C. Wkg.	C104	330 pF. $\pm 2\%$	T.C.C. Type 501 SMP.	350v. D.C. Wkg.		
C86	.1 uF.	T.C.C. Type CP45N.	350v. D.C. Wkg.	C105	33 pF. $\pm 10\%$	Erie Ceramicon Type N.750K.			
C87	.1 uF.	T.C.C. Type CP45N.	" " "	C106	10 pF. $\pm 10\%$	T.C.C. Type 101 SMP.	350v. D.C. Wkg.		
C88	.1 uF.	T.C.C. Type CP45N.	" " "	C107	.1 uF.	T.C.C. Type CP45N.	" " "		
C89	360 pF. $\pm 2\%$	T.C.C. Type 501 SMP.	" " "	C108	360 pF. $\pm 2\%$	T.C.C. Type 501 SMP.	" " "		
C90	360 pF. $\pm 2\%$	T.C.C. Type 501 SMP.	" " "	C109	360 pF. $\pm 2\%$	T.C.C. Type 501 SMP.	" " "		
C91	330 pF. $\pm 2\%$	T.C.C. Type 501 SMP.	" " "	C110	330 pF. $\pm 2\%$	T.C.C. Type 501 SMP.	" " "		
C92	330 pF. $\pm 2\%$	T.C.C. Type 501 SMP.	" " "	C111	330 pF. $\pm 2\%$	T.C.C. Type 501 SMP.	350v. D.C. Wkg.		
C93	360 pF. $\pm 2\%$	T.C.C. Type 501 SMP.	" " "	C112	150 pF. $\pm 10\%$	T.C.C. Type SCT3.	500v. D.C. Wkg.		
C94	360 pF. $\pm 2\%$	T.C.C. Type 501 SMP.	350v. D.C. Wkg.	C113	12 pF. $\pm 10\%$	T.C.C. Type SCT1.	500v. D.C. Wkg.		

REDIFON LTD.  
LONDON.

TITLE R50M RECEIVER

WD3/2719/5

SHEET NO 5 CONT.

DRAWN. <i>J.A.</i> DATE		TYPED C.J. DATE 3.8.50.		ENGINEER R.L. DATE 19/2/51.		APPROVED E.W.R. DATE 19.2.51.		ISSUE
REF	VALUE	DESCRIPTION	REMARKS	REF.	VALUE	DESCRIPTION	REMARKS	ISSUE
C114	470 pF. $\pm 10\%$	T.C.C. Type 501 SMP.	350v. D.C. Wkg.	C133	.01 uF.	Dubilier Type 691W.	350v. D.C. Wkg.	1. 4.8.50
C115	150 pF. $\pm 10\%$	T.C.C. Type 401 SMP.	" " "	C134	.01 uF.	Dubilier Type 691W.	" " "	
C116	.1 uF.	T.C.C. Type CP45N.	" " "	C135	.01 uF.	Dubilier Type 691W	350v. D.C. Wkg.	
C117	150 pF. $\pm 10\%$	T.C.C. Type 401 SMP.	" " "					
C118	680 pF. $\pm 10\%$	S.R.C. Type 508.	" " "					
C119	680 pF. $\pm 10\%$	S.R.C. Type 508.	" " "					
C120	.01 uF. $\pm 20\%$	T.C.C. Type SM3N.	" " "					
C121	.1 uF.	T.C.C. Type CP45N.	" " "					
C122	1 uF.	T.C.C. Type 62 Inverted Mtg.	" " "					
C123	.1 uF.	T.C.C. Type CP45N.	" " "					
C124	150 pF. $\pm 10\%$	T.C.C. Type 401 SMP.	" " "			JACK.		
C125	.005 uF. $\pm 20\%$	Hunts. Type H34C.	" " "	J1	2 point.	Igranic Midget P.73.		
C126	.1 uF.	T.C.C. Type CP45N.	" " "					
C127	68 pF. $\pm 10\%$	T.C.C. Type 101 SMP.	350v. D.C. Wkg.					
C128	50 uF.	T.C.C. Type GE18C.	25v. D.C. Wkg.					
C129	50 uF.	T.C.C. Type GE18C	25v. D.C. Wkg.					
C130	.1 uF.	T.C.C. Type CP45N.	350v. D.C. Wkg.					
C131	.1 uF.	T.C.C. Type CP45N.	" " "					
C132	.01 uF.	Dubilier Type 691W.	350v. D.C. Wkg.					
REDIFON LTD. LONDON.		TITLE R50M. RECEIVER		WD3/2719/S		SHEET N2 6 CONT.		

DRAWN: <i>A.</i> DATE				TYPED C.J. DATE 3.8.50		ENGINEER R.B. DATE 17/2/51.		APPROVED f.w.r. DATE 19.2.51.	
REF	VALUE	DESCRIPTION	REMARKS	REF.	VALUE	DESCRIPTION	REMARKS	ISSUE	
		COILS.						1. 4. 8. 50.	
LA1		Aerial Coil Range H.	A.3301 Edn. "H"	LM1		Mixer Coil Range H.	A.3303 Edn. "H"		
LA2		" " " G.	" " "G"	LM2		" " " G.	" " "G"		
LA3		" " " F.	" " "F"	LM3		" " " F.	" " "F"		
LA4		" " " E.	" " "E"	LM4		" " " E.	" " "E"		
LA5		" " " D.	" " "D"	LM5		" " " D.	" " "D"		
LA6		" " " C.	" " "C"	LM6		" " " C.	" " "C"		
LA7		" " " B.	" " "B"	LM7		" " " B.	" " "B"		
LA8		Aerial Coil Range A.	A.3301 Edn. "A"	LM8		Mixer Coil Range A.	A.3303 Edn. "A"		
LR1		R.F. Coil Range H.	A.3302 Edn. "H"	LO1		Osc. Coil Range H.	A.3304 Edn. "H"		
LR2		" " " G.	" " "G"	LO2		" " " G.	" " "G"		
LR3		" " " F.	" " "F"	LO3		" " " F.	" " "F"		
LR4		" " " E.	" " "E"	LO4		" " " E.	" " "E"		
LR5		" " " D.	" " "D"	LO5		" " " D.	" " "D"		
LR6		" " " C.	" " "C"	LO6		" " " C.	" " "C"		
LR7		" " " B.	" " "B"	LO7		" " " B.	" " "B"		
LR8		R.F. Coil Range A.	A.3302 Edn. "A"	LO8		Osc. Coil Range A.	A.3304 Edn. "A"		
REDIFON LTD. LONDON.		TITLE	R50M RECEIVER			WD3/2719/S		SHEET NO 7 CONT.	

DRAWN. <i>A.</i> DATE				TYPED C.J. DATE 4.8.50.		ENGINEER <i>R.B.</i> DATE 19/2/51		APPROVED <i>F.W.R.</i> DATE 19.2.51	
REF	VALUE	DESCRIPTION	REMARKS	REF.	VALUE	DESCRIPTION	REMARKS	ISSUE	
L1	}	Suppressor	465 Kc/s. A.3297/A.	L20	}	Grid Trfr. 110 Kc/s.	A.3297/J.	1. 4.8.50	
L2				L21					
L3		R.F. Choke.	151/2719/S.	L22					
L4		Bulgin SW.68. R.F.Choke.	Waxed Finish.	L23					
L5	}	Xtal Input Trfr. 465 Kc/s.	A.3297/B.	L24	}	Anode Trfr. 465 Kc/s.	A.3297/F.		
L6				L25					
L7	}	Xtal Input Trfr. 110 Kc/s.	A.3297/C.	L26	}	Anode Trfr. 110 Kc/s.	A.3297/G.		
L8				L27					
L9		Xtal Damping Coil. .465 Kc/s.	A.3297/D.	L28					
L10		Xtal Damping Coil. .110 Kc/s.	A.3297/E.	L29					
L11	}	Anode Trfr. 465 Kc/s.	A.3297/F.	L30	}	Grid Trfr. 465 Kc/s.	A.3297/H.		
L12				L31					
L13				L32					
L14	}	Anode Trfr. 110 Kc/s.	A.3297/G.	L33	}	Grid Trfr. 110 Kc/s.	A.3297/J.		
L15				L34					
L16				L35		B.F.O. Coil. 465 Kc/s.	A.3297/K.		
L17				L36		B.F.O. Coil. 110 Kc/s.	A.3297/L.		
L18	}	Grid Trfr. 465 Kc/s.	A.3297/H.	L37	}	Diode Trfr. 465 Kc/s.	A.3297/M.		
L19				L38					

REDIFON LTD.  
LONDON.

TITLE 350M RECEIVER

WD3/2719/S SHEET NO 2 CONT.

DRAWN. <del>X</del> DATE				TYPED C.J. DATE 4.8.50.		ENGINEER R.G. DATE 19/2/51.		APPROVED E.W.R. DATE 19.2.51.	
REF	VALUE	DESCRIPTION	REMARKS	REF.	VALUE	DESCRIPTION	REMARKS	ISSUE	
L39		Diode Trfr. 110 Kc/s.	A.3297/E.			<u>SOCKET.</u>		1. 4. 8. 50.	
L40				SK1		Painton Socket 12 way 500482.			
L41		A.F. Choke.	A.3309/A.						
						<u>VALVES.</u>			
		<u>BULBS.</u>		V1		EF39.			
LP1		M.E.S. Bulb. 6v. .3A.		V2		EF39			
LP2		" " 6v. .3A.		V3		ECH35.			
LP3		M.E.S. Bulb. 6v. .3A.		V4		L63.			
				V5		EF39			
				V6		EF39			
		<u>METER.</u>		V7		EF39			
M1.		Turner Meter Mod. W.909		V8		EF37			
		0-1 mA F.S.D. 100 ohm		V9		EB34 or 6H6.			
		Calibrated 0-10 mA 0-30 mA.		V10		EB34 or 6H6.			
				V11		EF37			
				V12		6V6G.			
		<u>PLUG.</u>							
PL1		Painton Plug 12 way 500479.							

REDIFON LTD.  
LONDON.

TITLE 250M RECEIVER

WD3/2719/S

SHEET NO 9 CONT.

DRAWN <i>K.</i> DATE				TYPED 23.8.50. DATE C.J.		ENGINEER <i>R.V.</i> DATE 19/2/51.		APPROVED <i>L.V.R.</i> DATE 19.2.51.	
REF	VALUE	DESCRIPTION	REMARKS	REF	VALUE	DESCRIPTION	REMARKS	ISSUE	
	<u>OHMS.</u>	<u>RESISTORS.</u>		R19	2,200 $\pm 10\%$	Erie. R.M.A.8.		1. 4 ' 8. 50.	
R1	10K. $\pm 10\%$	Erie. R.M.A.9.		R20	100K. $\pm 10\%$	" R.M.A.9.			
R2	10K $\pm 10\%$	" "		R21	100K. $\pm 10\%$	" R.M.A.9.			
R3	10K $\pm 10\%$	" "		R22	4,700 $\pm 10\%$	" R.M.A.8.			
R4	470K. $\pm 10\%$	" "		R23	1 M. $\pm 20\%$	" R.M.A.9.			
R5	220K. $\pm 10\%$	Erie. R.M.A.9.		R24	1,500 $\pm 10\%$	" R.M.A.9.			
R6	10K. $\pm 10\%$	" R.M.A.8.		R25	10K. $\pm 10\%$	" R.M.A.8.			
R7	1 M. $\pm 20\%$	" "		R26	Thermistor.	Mullard Varite V.A.1002.			
R8	47K. $\pm 20\%$	" "		R27	150 $\pm 10\%$	Erie. R.M.A.9.			
R9	330. $\pm 10\%$	" "		R28	470 $\pm 10\%$	" R.M.A.8.			
R10	4,700. $\pm 10\%$	" "		R29	330 $\pm 10\%$	" R.M.A.8.			
R11	4,700. $\pm 10\%$	Erie. R.M.A.8.		R30	100 $\pm 10\%$	" R.M.A.8.			
R12	1.5 M. $\pm 10\%$	" R.M.A.9.		R31	2,200 $\pm 20\%$	" R.M.A.9.			
R13	1.5 M. $\pm 10\%$	" R.M.A.9.		R32	4,700 $\pm 10\%$	" R.M.A.8.			
R14	10K. $\pm 10\%$	" R.M.A.8.		R33	68K. $\pm 10\%$	" R.M.A.8.			
R15	220K. $\pm 10\%$	" "		R34	4,700 $\pm 10\%$	" R.M.A.8.			
R16	47K. $\pm 20\%$	" "		R35	120K. $\pm 10\%$	" R.M.A.9.			
R17	330 $\pm 10\%$	" "		R36	22K. $\pm 10\%$	" R.M.A.9.			
R18	4,700 $\pm 10\%$	" "		R37	6,200 $\pm 10\%$	Erie. R.M.A.9.			

REDIFON LTD.  
LONDON.

TITLE RSOM RECEIVER

WD3/2719/S SHEET NO 10. CONT.

DRAWN. <i>J.K.</i> DATE				TYPED C.J. DATE 23.8.50.				ENGINEER <i>R.B.</i> DATE 19/2/51.		APPROVED <i>E.W.P.</i> DATE 19.2.51	
REF	VALUE	DESCRIPTION	REMARKS	REF.	VALUE	DESCRIPTION	REMARKS	ISSUE			
R38	150K. $\pm 10\%$	Erie. R.M.A.8.		R57	330 $\pm 10\%$	Erie. R.M.A.8.		1. 4. 8. 50			
R39	1,800 $\pm 10\%$	" R.M.A.9.		R58	100K. $\pm 10\%$	" "					
R40	1,800 $\pm 10\%$	" R.M.A.9.		R59	100K. $\pm 10\%$	" "					
R41	4,700 $\pm 10\%$	" R.M.A.9.		R60	22K. $\pm 10\%$	" "					
R42	1 M. $\pm 10\%$	" R.M.A.8.		R61	100K. $\pm 10\%$	" "					
R43	22K. $\pm 20\%$	" R.M.A.8.		R62	100K. $\pm 10\%$	" "					
R44	330 $\pm 10\%$	" R.M.A.8.		R63	4,700 $\pm 10\%$	" R.M.A.8.					
R45	10K. $\pm 10\%$	" "		R64	470K. $\pm 20\%$	" R.M.A.9.					
R46	4,700 $\pm 10\%$	" "		R65	510K. $\pm 10\%$	" R.M.A.8.					
R47	10 $\pm 10\%$	" "		R66	680K. $\pm 10\%$	" "					
R48	27 $\pm 10\%$	" "		R67	32K. $\pm 10\%$	Erie. R.M.A.8.					
R49	22K. $\pm 20\%$	" "		R68	50K. Var.	Morganite HMAR.50810	OP.1198/S.				
R50	330 $\pm 10\%$	" "		R69	100K. Var.	Morganite HMAR.10410	OP.1198/S.				
R51	10K. $\pm 10\%$	Erie. R.M.A.8.		R70	150K. $\pm 10\%$	Erie. R.M.A.8.					
R52	5K. Var.	Reliance Type T.W.	OP.1430/S.	R71	22K. $\pm 10\%$	" "					
R53	4,700 $\pm 10\%$	Erie. R.M.A.8.		R72	42K. $\pm 10\%$	" R.M.A.8.					
R54	10 $\pm 10\%$	" "		R73	250K. $\pm 2\%$	Welwyn Type A.3634					
R55	30 $\pm 10\%$	Erie. R.M.A.8.		R74	20K. $\pm 10\%$	Welwyn Type AW.3112.					
R56	1 M. $\pm 10\%$	Erie. R.M.A.8.		R75	100K. $\pm 10\%$	Erie. R.M.A.8.					

REDIFON LTD.  
LONDON.

TITLE

R50M RECEIVER

WD3/2719/S

SHEET NO II CONT.

DRAWN. <i>J.A.</i> DATE				TYPED C.J. DATE 23.8.50.		ENGINEER <i>R.L.</i> DATE 19/2/51.		APPROVED <i>E.W.R.</i> DATE 19.2.51.	
REF	VALUE	DESCRIPTION	REMARKS	REF.	VALUE	DESCRIPTION	REMARKS	ISSUE	
R76	3,300 ±10%	Erie. R.M.A.8.				SWITCHES.		1. 4. 8. 50	
R77	3 M. ±10%	" "		S1		B.N.S.F. 2B. 4P. 6 pos.	OP.1188/S		
R78	100K. ±10.	" "		S2		" 1B. 2P. 4 pos.	OP.1189/S		
R79	150K. ±10%	" R.M.A.8.		S3		" 8B. 3P. 12 pos.	OP.1537/S OP.1538/S		
R80	4,700 ±20%	" R.M.A.9.		S4		" 2B. 1P. 12 pos.	OP.1536/S		
R81	100K. ±10%	" R.M.A.8.		S5		" 6B. 2P. 5 pos.	OP.1192/S		
R82	3,300 ±10%	" "		S6		B.N.S.F. 7B. 2P. 2 pos.	OP.1193/S		
R83	470K. ±10%	" R.M.A.8.		S7		Bulgin. D.P. On-Off Type	S.282. Tropical.		
R84	1.5 M. ±10%	" R.M.A.9.							
R85	1K. ±10%	" "				CRYSTALS.			
R86	470 ±10%	" R.M.A.8.		X1.X2	465 kc/s App.	G.E.C. Double Quartz	OP.1600/S		
R87	1	Welwyn AW.3115.				Crystal in common			
R88	680 ±20%	Erie. R.M.A.9.				holder Type QC.197-JCF.			
						Crystals to differ in Frequency by			
						from 950 to 1100 c/s.			
				X3	110 kc/s ±.2%	G.E.C. Single Quartz	OP.1601/S		
						Crystal in Holder			
						Type QC.197-JCF.			

REDIFON LTD.  
LONDON.

TITLE R50M RECEIVER

WD3/2719/S SHEET NO 12.

DRAWN J.H. DATE 2-6-50. TRACED Y.J. DATE 30-3-53. ENGINEER R.L. DATE 30-3-53. APPROVED E.H.N. DATE 30-3-53  
 ISSUE  
 1. 2, 8, 50  
 CONNECTIONS  
 REVERSED ON  
 C & D TERMINALS  
 CH/N/5524/L  
 12.2.51.  
 2. AN/0250/L  
 3. 88, 8, 52  
 REGRABN. -  
 WITHOUT ALTERATION  
 30-3-53

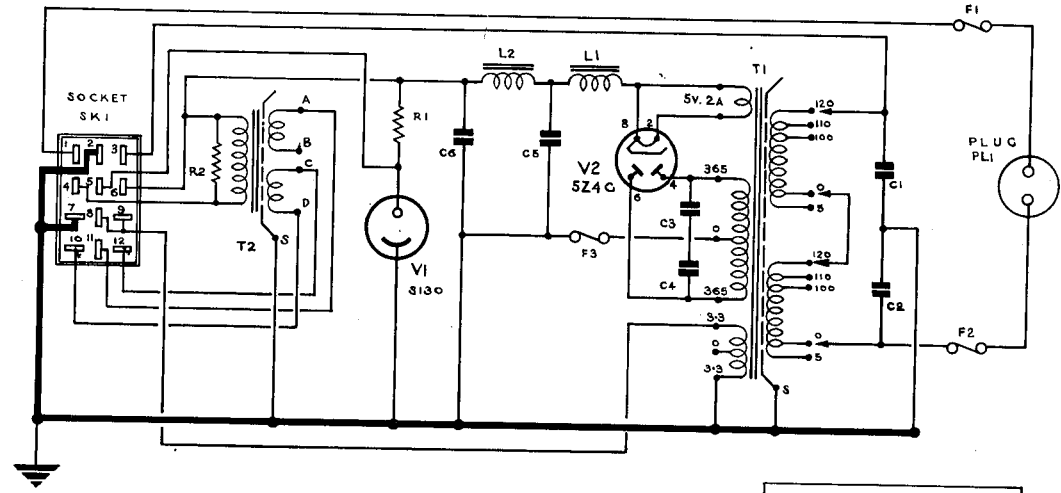

OUTPUT TRANSFORMER T2.  
 FOR 3Ω OUTPUT CONNECT B TO D: A TO C.  
 FOR 12Ω OUTPUT CONNECT B TO C.

COMPONENT VALUES	
CONDENSERS	
C1	.01μF
C2	.01μF
C3	.05μF
C4	.05μF
C5	8μF
C6	8μF
RESISTORS	
R1	5KΩ
R2	22KΩ
FUSES	
F1	1A, 200-250V, 2A, 100-125V.
F2	1A, 200-250V, 2A, 100-125V.
F3	250 m.A.

DRAWN. <i>J.H.</i> DATE 2.9.50 TYPED C.J. DATE 3.8.50.				ENGINEER <i>R.G.</i> DATE 2/9/1950. APPROVED <i>E.W.R.</i> DATE 5.10.50.				
REF.	VALUE	DESCRIPTION	REMARKS	REF.	VALUE	DESCRIPTION	REMARKS	ISSUE
<u>CONDENSERS.</u>				<u>VALVES.</u>				1.2.8.50 R2 ADDED C/N. 6250/L 2. 26.8.52. #
C1	.01 uF.	T.C.C. Type SM2N		V1		S.130		
C2	.01 uF.	T.C.C. Type SM3N.		V2		524G.		
C3	.05 uF.	T.C.C. Type 648						
C4	.05 uF.	T.C.C. Type 648						
C5	8 uF.	T.C.C. Type 82.	Rolled Edges.	R1	5 K.ohm.	Helwyn Type AW.3112.	12 watt.	
C6	8 uF.	T.C.C. Type 82.	Rolled Edges.	R2	22.k.ohm $\pm 20\%$	ERIC TYPE RMA.8.	1/2 WATT.	
				<u>RESISTORS.</u>				
				<u>TRANSFORMERS.</u>				
				T1	SR/T. 881.	Mains Transformer.		
				T2	SR/T. 987.	Output transformer.		
<u>CHOKES.</u>								
L1	SR/T443.	Varley Type D.P.10 20H.	Less case.					
L2	SR/T443.	Varley Type D.P.10 20H.	Less case.					
<u>FUSES.</u>								
				F1	1A. 200-250v. 2A. 100-125v.	1.1/4" Cartridge Type.)	Mounted in 3 Belling Lee	
<u>PLUGS.</u>				F2	1A. 200-250v. 2A. 100-125v.			1.1/4" Cartridge Type.)
PL1		Bulgin 2 pin Type. P.74.		F3	250 mA.	1.1/4" Cartridge Type.)	Holder L.356.	
<u>SOCKETS.</u>								
Sk1		Painton 12 way Type 500482.						

REDIFON LTD.  
LONDON.

TITLE P.U.74. A.C. POWER UNIT.

WD3/2767/S

SHEET NO 2.

CONNECTOR R.17669/m.

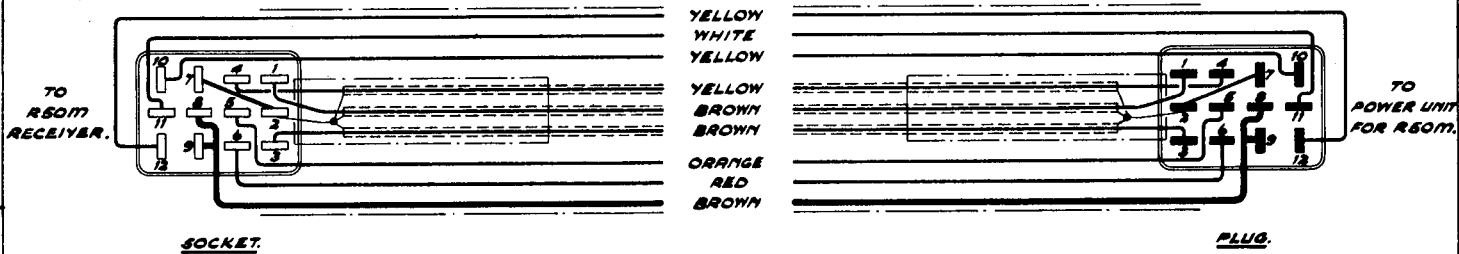

NOTE.  
 PLUG & SOCKET VIEWED FROM REAR. i.e. WIRING SIDE.

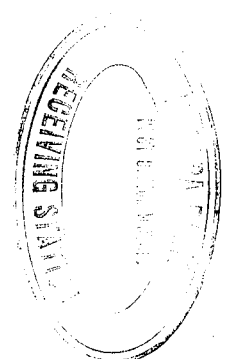

ISSUE	ISSUE 1, 27-11-61.	ISSUE	
DRAWN	<i>affleck</i>	ENGINEER	APPROVED <i>[Signature]</i>
	REDIFON LTD LONDON.	TYPED	DRG. NO SK. 623.
USED ON		TITLE INTERCONNECTING LEAD. RECEIVER R50M TO POWER UNIT	

R50M RECEIVERS MODIFIED FOR TELEPRINTER

OPERATION FROM A FREQUENCY SHIFTED INPUT

R.50M receivers specially required for teleprinter operation are modified to provide an output at the intermediate frequency for this purpose.

The output is taken from the primary of the last I.F. transformer, L37 via the centre tap of a capacity potential divider C108 - C136 and coaxial feeder to the output socket.

Modified receivers are identified by the type number - R.50M.S.