

White



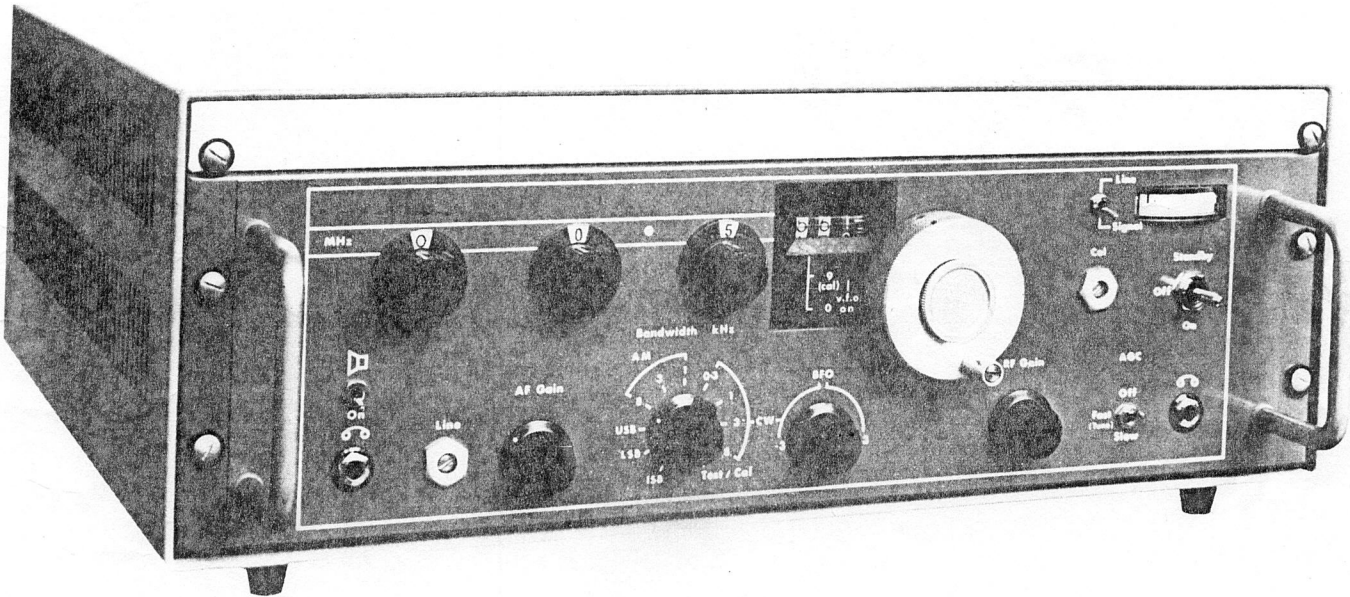

PLATE 1.2

R551C RECEIVER

1 BRIEF DESCRIPTION AND SPECIFICATION

1.1 BRIEF DESCRIPTION

The R551 Receiver is a general purpose SSB/DSB communications receiver providing continuous coverage over the MF/HF frequency range of 100kHz to 30MHz and operation down to 10kHz. The receiver meets Specification MPT1201: Performance Specification for a Radio Receiver for Double Sideband and Single Sideband reception of Radiotelegraphy and Radiotelephony for use on Merchant Ships over the range 100kHz to 30MHz.

Solid-state devices are used throughout to achieve compactness and ensure reliability, whilst the modular form of construction greatly facilitates servicing. Digital readout of frequency is incorporated.

A number of optional extras are available, which allow the receiver to be tailored to meet the requirements of individual systems.

The R551 is a double-conversion superhet providing reception on single sideband, DSB, MCW and CW, a choice of bandwidth being available on the latter three services.

Frequency setting is accomplished by a six-figure, in-line, digital decimal readout. The 10MHz, 1MHz and 100kHz positions are synthesised and are selected by rotary control knobs; the remaining 10kHz, 1kHz and 100Hz settings are presented on a three digit mechanical counter which controls a VFO. If required, full frequency synthesis, down to 100Hz steps, with or without 100Hz interpolation, may be realised by use of the ARU11B Synthesiser. When using the optional High Stability reference oscillator module provision is made for the connection of an external frequency standard if enhanced frequency stability is considered necessary.

A comprehensive AGC system is incorporated to give a large dynamic range with good linearity and a minimum of intermodulation products. Two interconnected AGC systems are employed; one in the RF amplifier, and one over four stages of IF amplification.

The front-end AGC system will operate in the presence of large unwanted signals which fall outside the IF but within the RF passband, thus minimising blocking and consequent cross-modulation. Circuit time constants are automatically selected by the Service Bandwidth kHz switch, but in conditions of rapid fading, a position of the AGC switch allows the decay times to be reduced to approximately $\frac{1}{3}$ th. An OFF setting of the AGC switch disables the AGC.

The sensitivity of the receiver is set by the Service Bandwidth kHz switch so that the AGC threshold comes into operation at a similar signal-to-noise ratio for all services.

An internal loudspeaker with associated On-Off switch is fitted and a 600 Ω line output; two front panel sockets also allow the use of headphones. If required, the

receiver will provide simultaneous outputs to the internal loudspeaker and 600 Ω line. When the headphone jacks are in use, the internal and external loudspeakers are automatically muted. The line level is set by a pre-set front panel Line Level control, in conjunction with a front panel Line/Signal meter. The maximum level for normal line operation is 10mW, but if necessary, an output of 1.25W into 600 Ω is available instead of the external loudspeaker output.

Signal strength is indicated on the Line/Signal meter, which can also be used in conjunction with the TEST/CAL position of the Service switch, to provide a function check of the receiver.

Front-end protection is afforded against inputs up to 30V, and even if this voltage is exceeded, an easily accessible fuse ensures that the receiver is not damaged.

When used with an associated transmitter, the R551 provides facilities for sidetone amplification, aerial muting and receiver desensitising.

An IF output of 1.4MHz is provided for test purposes.

A 115V or 230V $\pm 6\%$ AC supply is required to power the equipment, normal variations in supply voltage will not cause the performance of the equipment to be degraded. When emergency conditions so demand, it can be powered from a 24V DC supply with negative earth.

The R551 is designed to meet the British Ministry of Posts and Telecommunications Specification MPT1201 and the Performance Specification for a Reserve Receiver; it also meets the Climatic and Durability Class B clauses in Specification MPT1204, relevant clauses of British Defence Specification DEF 133, class L1, and the vibration test specified in Class L2 clauses 8.1B and 8.2B "Main Region".

The receiver is adaptable to many uses. The R551 version is intended for marine use and the R551C is mainly intended for general purpose communications, it may have the options of Lower Sideband and Independent Sideband reception by using adaptor ARU10A.

For A3A Lincomplex use, Carrier Tuning Adaptor ARU16 may be fitted.

A complete receiving terminal, comprising R551 Receiver and ARU11B Synthesiser in one cabinet is the R554A. If Carrier Tuning Adaptor ARU16 is fitted the type number is R554B. The R554 meets the requirements of MPT1201 and the environmental clauses of MPT1204 applicable to Class B equipment.

1.2 SPECIFICATION

Frequency Range:

100kHz to 30MHz continuous coverage. Extends down to 10kHz with degraded performance.

Frequency Presentation:

Fully digital. Sub-divisions of 20Hz provided on final digit.

R551 Receiver

10MHz, 1MHz and 100kHz set on synthesiser dials. VFO completes tuning over 100kHz range with dual concentric coarse and fine controls giving a resolution of 10Hz.

Using ARU11B Synthesiser

Full frequency synthesis in 100Hz steps, with or without 100Hz interpolation.

Frequency Accuracy:

R551 Receiver

Frequency is set with a typical accuracy of 20Hz and always better than 100Hz.

Using ARU11B Synthesiser

The major limitation is that imposed by the accuracy of the receiver internal or external frequency reference.

Calibration:

VFO calibrated against signal derived from internal frequency reference (necessary only at infrequent intervals).

Frequency Stability:

R551 Receiver

After a 30min warm-up period, the frequency drift over any subsequent 15min period is less than 20Hz, with constant or $\pm 10\%$ supply changes. After a 30min warm-up period whilst the temperature is raised 7°C in a time of one hour, it is less than 20Hz. When vibrated at frequencies up to 12.5Hz with an excursion of 0.32cm, the frequency deviation due to vibration is less than ± 25 Hz.

Using ARU11B Synthesiser

The long term stability is normally ± 1 part in 10^6 , but using the optional high stability module will be within 5 parts in 10^8 .

Modes of Operation:

R551
 A3J usb A3dsb A2 mcw A1 cw
 R551C
 A3J lsb A3J usb A3 dsb A2 mcw A1 cw
 A3B using ARU10 Adaptor

Selectivity:

Service	Nominal 6dB Bandwidths (Selectable)
A1 cw	Wide 8kHz
A2 mcw	Intermediate 3kHz
A3 dsb	Narrow 1kHz
A1 cw	Very Narrow 300Hz
A3J lsb	2.35kHz
	or 2.75kHz
A3J usb	or 5.5kHz

Noise Factor:

Typically 8dB, not worse than 10dB above 4MHz

Sensitivity:

Standard audio output is obtained, using the appropriate antenna, with the emf inputs indicated below:

(a) A3J lsb and A3J usb:

For frequencies between 4 and 30MHz
 2µV for 20dB SINAD

(b) A3 dsb and A1 cw:

For A3 dsb, a type A2 test signal is modulated 30% at 1kHz when the bandwidth is WIDE, or 30% at 400Hz, when the bandwidth is INTERMEDIATE

Frequency	Bandwidth	SINAD	Input for A1	Input for A2
100 to 160kHz	Narrow	10dB	4µV	—
160 to 525kHz	Narrow	10dB	5µV	—
160 to 525kHz	Intermediate	10dB	—	22µV
525 to 1605kHz	Intermediate	10dB	—	20µV
1605 to 4000kHz	Wide	20dB	—	20µV
4.0 to 30MHz	Wide	20dB	—	10µV
4.0 to 30MHz	Narrow	10dB	0.35µV	—

Cross Modulation:

The cross modulation level produced by an unwanted signal of 300mV in the presence of a wanted signal of 1mV is better than 30dB below the wanted output.

Intermodulation:

With a wanted signal of 30dB above 1µV, the unwanted output due to intermodulation will be less than the wanted output, when those unwanted levels are as below:

for frequencies 100 to 525kHz the unwanted levels are 100dB above 1µV

for frequencies 525 to 1605kHz the unwanted levels are 90dB above 1µV

for frequencies 1.6 to 30MHz the unwanted levels are 80dB above 1µV

Blocking:

The output resulting from an A2 wanted signal of 1mV will not be reduced by more than 3dB in the presence of an unwanted signal of 6V.

Spurious Responses:

(not including image or intermediate frequencies)

All spuriously received signals are at least 70dB below wanted signal for tune frequencies above 1.6MHz and at least 80dB for tune frequencies below 1.6MHz.

Aerial Impedance:

Below 4MHz: 10Ω in series with 200 to 700pF
 Above 4MHz: 50Ω unbalanced

Aerial Protection:

Withstands aerial emf of up to 30V
A fuse affords protection against damage by input emf in excess of 30V.

AGC:

2dB change in output for 100dB change in input, with respect to AGC threshold.

AGC Time-Constants:

DSB—attack 100mS, decay 1S
Other Services—attack 3mS, decay 10S

A switch (FAST position) reduces decay times to approximately one-eighth of above.

RF Gain Control Range:

At least 120dB

IF Output:

100mV across 50Ω at 1.4MHz (AGC ON)

AF Outputs:

- (a) +10dBm into a 600Ω load, with separate Set Level control
- (b) Two outputs, each 2mW into 600Ω headphones via front panel jacks or to headset outlets

also either

- (c) 0.5W into internal 10Ω loudspeaker, with
- (d) 1.5W into external 3Ω load.

OR

- (e) 0.5W into internal 10Ω loudspeaker, with
- (f) 1.25W into an external 600Ω load.

BFO:

Variable ± 3 kHz

Overall AF Distortion:

Less than 2%

AM Fidelity (8kHz bandwidth):

AF output variations are less than 5dB for modulation frequencies between 300 and 3000Hz

Radiation:

Not more than 20μV across 50Ω at the aerial input socket

IF Rejection:

38MHz (1st IF): better than 80dB
1.4MHz (2nd IF): better than 100dB

Image Rejection:

Better than 90dB and 80dB for 1st and 2nd conversion images respectively

Front Panel Meter:

Used for:

- (a) Signal strength indication
- (b) Line Level indication
- (c) Circuit check indication
- (d) Calibrate indication.

AC Power Supply:

106 to 124, 204 to 255V

Damage is not caused by 1mS transients of 100% over-voltage or by a sustained short circuit on the HT line.

DC Power Supply:

24V DC negative earth standard. The receiver tolerates voltage variations of $\pm 10\%$ without relaxation of the specification. An increase in voltage of 25% or reversal of supply will not cause damage to the equipment.

Power Consumption:

40W maximum

Operating Temperature:

-15°C to $+55^{\circ}\text{C}$

Storage Temperature:

-40°C to $+70^{\circ}\text{C}$

Climatic and Durability Standard:

MPT1204 for Class B equipment
DEF133 Class L1

Overall Dimensions and Weight (Without Cabinet)

height	width	depth	weight
13cm (5 $\frac{1}{4}$ in)	48cm (19in)	49cm (19 $\frac{1}{4}$ in)	17kg (38lb)

2 INSTALLATION AND SETTING UP

2.1 UNPACKING

2.2 SITING

2.3 EXTERNAL CONNECTIONS

2.3.1 25way Socket

2.3.2 8way Socket

2.3.3 Other External Connections

2.3.4 Aerial

2.3.5 AC Supply

2.3.6 DC Supply

2.3.7 Earthing

2.3.8 Aerial Muting

2.3.9 Desensitising and External RF Gain Control

2.3.10 AGC Out

2.3.11 AF Outputs

2.3.12 AF Inputs

2.3.13 100kHz Reference Input

2.3.14 1.4MHz IF Output

2.3.15 DC Out Facility

2.3.16 Use of External Crystal Oscillator

2.4 SETTING MAINS TRANSFORMER TAPS

Fig. 2.1 Mains Transformer Connections

2.5 SETTING LINK LK1

2.6 SETTING LINK LK2

2.7 BRIEF FUNCTIONAL CHECKS

Fig. 2.2 BNC Plug Assembly

Fig. 2.3 Earthing Configurations

Fig. 2.4 Bench Mounting Fixings

2 INSTALLATION AND SETTING UP

2.1 UNPACKING

On receipt of the equipment, check the packing cases for signs of damage, or for shortage if any components are packed separately. The carriers should be notified within three days if any severe damage or shortage exists.

If packing cases appear to be undamaged, unpack the equipment carefully, all packing materials being removed and any separately packed components fitted, as indicated in any reassembly instructions that may be sent with the equipment. Verify that no damage has been sustained by the equipment during transit.

CAUTION:

Avoid tearing any Kraft wrapping paper, otherwise the tar impregnation may soil the equipment panels.

2.2 SITING

To obtain satisfactory duplex working the location of the receiver and the manner of its installation are of vital importance.

Every effort should be made to keep the receiver as far away as possible from the ship's transmitters, their aerial output leads and the aerial switch.

It is important that sufficient space is provided for access to front panel control and for removal of the unit for servicing. Space requirements at the side should not be over-looked; allow sufficient space for the entry of external cables. The bench mounting version of the receiver should be secured by four fixing bolts to the shock absorbers on the cabinet or angled support frame (see fig. 2.4).

2.3 EXTERNAL CONNECTIONS

Listed below are all the external connections to the R551 Receiver. The extent to which these connections are used depends on individual installation requirements; full installation details are given in the relevant subsections, and appropriate supplementary handbooks, ARU11B (941-1) and ARU10A (909-1).

2.3.1 25way Socket SK15

This socket is used for the connection of external facilities listed below: the connections should be made via a Belling Lee L1328/P mating plug to the terminal blocks in the base of the cabinet.

SK15 Pin No	Used for	See Para
1	External aerial muting	2.3.8
2	DC Out facility	2.3.15
3	Not used	

4	External loudspeaker	
5	Low level 600Ω line	2.3.11
6	24v DC positive supply input	2.3.6
7	Low level 600Ω line	2.3.11
8	External loudspeaker (switched)	2.3.11
9	External loudspeaker	
10	AGC Out	2.3.10
11	AF sidetone input screen and earth	2.3.12
12	AF sidetone input	2.3.12
13	AF output from ARU10A	
14	AF output from ARU10A (screen)	
15	High level 600Ω external line screen	2.3.11
16	High level 600Ω external line	2.3.11
17	+20V to ARU10A	
18	AGC from ARU10A	
19	AGC to ARU10A	
20	Desensitising and external RF gain control	2.3.9
21	ISB muting ARU10A	
22	1.4MHz re-insertion oscillator output to ARU10A	
23	1.4MHz re-insertion oscillator output cable screen	
24	External loudspeaker (common)	2.3.11
25	Chassis	

2.3.2 8way Socket (SK37)

This socket is used for connections to the ARU11B Synthesiser. Details of the connections are given below. An inter-connecting cable type 5741A is supplied. If the ARU11B synthesiser is not installed with the R551 then pins 5 and 6 of SK37 must be linked.

Socket SK37 Pin No	Used for
1	Chassis Connection
2	See para. 4.2.20
3	See para. 4.2.20
4	+5V DC
5	+20V DC
6	+20V DC to VFO See para. 4.2.20
7	Not Used
8	+20V DC to VFO from ARU11B Synthesiser See para. 4.2.20

2.3.3 Other External Connections

Connection	Used for	See
SK1	Aerial	para. 2.3.4
SK10	100kHz from External Reference Source	para. 2.3.13
SK19	100kHz to ARU11B Synthesiser	ARU11B Hand-book 941-1
SK20	1.4MHz IF Output	para. 2.13.14
SK36	600 to 700kHz Output from ARU11B Synthesiser	ARU11B Hand-book 941-1
PL38	AC Mains Input	para. 2.3.5
JK1 JK2	Headphone Sockets	para. 2.3.11
Earth Terminal	Equipment Earthing	para. 2.3.7
SK12	ISB output to ARU10A	

2.3.4 Aerial

The aerial parameters should be as follows:

Below 4MHz: 10 Ω in series with 200 to 700pF unbalanced
Above 4MHz: 50 Ω unbalanced

The aerial lead-in must be connected to SK1 at the back of the R551 Receiver. The type of mating plug for this socket is Greenpar GE35070C10.

2.3.5 AC Supply

The mains cable should be connected to the Bulgin P430 socket which mates with plug PL38 at the back of the R551 Receiver.

CAUTION: Do not apply voltage to the cable until setting up instructions have been carried out (see Chapter 3).

2.3.6 DC Supply (24V negative earth)

Connect the supply cable to the 25way socket (SK15) at the rear of the receiver. The 24V positive lead must be connected to pin 6 and the negative lead connected to pin 25.

Ensure that the 24V supply is capable of providing a current of at least 4A, and that an internal 4A Fuse is used in the DC supply line.

CAUTION: Do not apply voltage to the cable until setting up instructions have been carried out (see Chapter 3).

2.3.7 Earthing

An earth bolt is provided at the rear of the cabinet, and should be connected to the cabinet earth via the connection provided. When the receiver is installed with other equipment e.g. transmitter, a separate earth lead is essential. (see Fig. 2.3).

2.3.8 Aerial Muting

The muting relay in the R551 Receiver is capable of 1mS operate and release times. At 30MHz, 50dB of muting is possible, increasing to 100dB at 200kHz. Muting can be reinforced by use of the desensitising facility (see para. 2.3.9).

Connect the external muting contacts between pins 1 and 25 of SK15. These external contacts must be normally closed, and must open to mute the receiver.

The current rating of the external contacts must not be less than 25mA.

If external muting is not required, then pins 1 and 25 of SK15 must be linked.

2.3.9 Desensitising and External RF Gain Control

It is possible to desensitise the receiver by the application of a positive voltage to pin 20 of the 25way socket SK15.

Desensitisation of up to 120dB is possible, with a desensitising attack time of less than 2mS.

The desensitising voltage must be 9V DC maximum from a source not greater than 100 Ω .

If required, the desensitising facility can be used in conjunction with the aerial muting facility (see para. 2.3.8).

2.3.10 AGC Out (Not normally used)

The AGC output at pin 10 of SK15 can be used for monitoring or for external control.

2.3.11 AF Outputs

The following AF outputs are available from the R551 Receiver:

Either (a) 1.5W in external 3 Ω load with 0.5W into internal loudspeaker

or (b) 1.25W into an external 600 Ω load with 0.5W into internal 10 Ω loudspeaker

and (c) +10dBm into a 600 Ω load (with separate Set Level Control).

(d) two outputs, each 2mW into 600 Ω headphones (JK1 and JK2.)

External 3 Ω Loudspeaker

Connect the external 3 Ω loudspeaker to pins 8 and 9 of the 25way socket SK15 (or to 4 and 9 if the loudspeaker is to be directly connected to the R551 Receiver output and not switched).

External 600 Ω line, high level

Connect the 600 Ω line to pins 16 and 15 (screen) of the 25way socket SK15.

External 600 Ω line, low level

Connect the 600 Ω line between pins 5 and 7 of the 25way cable SK15, and the screen to pin 13.

Line level adjustment is detailed in para. 3.3.12.

Headphones

Insert 600Ω headphones in the front panel sockets. The AF Gain control will vary the level of all the AF outputs simultaneously with the exception of the low level 600Ω line.

2.3.12 AF Input

Pin 12 of the 25way socket SK15 is used for the amplification of sidetone from an associated transmitter, full audio output resulting from an input of 0dBm at 1kHz.

2.3.13 100kHz Reference Input

A 100kHz external frequency standard can be connected to SK10 if it is required.

An input emf of 0.5V rms from a 50Ω source is necessary.

The mating plug is Greenpar GE35070C10.

Switch to EXT on the rear panel of the receiver. This requires use of the optional high stability reference oscillator module.

2.3.14 1.4MHz IF Output (Not normally used)

The 1.4MHz output at SK20 is 100mV ±1dB peak envelope voltage across 50Ω. This output is controlled by the AGC circuits and by the RF Gain control. When the AGC is switched off, the IF output can increase to approximately 350mV before overloading occurs.

The BFO or re-insertion oscillator level at the IF output, when loaded, will not be greater than 46dB below 100mV.

The mating plug type is Greenpar GE5070C10.

2.3.15 DC Out Facility (Not normally used)

The voltage at pin 2 of the 25way socket SK15 can be used to supply external circuits or equipment, and is available when the R551 Receiver Supply switch is set to STAND BY or ON.

When the R551 Receiver is being powered by an AC supply, the voltage at pin 2 is a nominal +24V unbalanced and the maximum current drawn must not exceed 200mA. If the emergency DC supply is being used, the voltage at pin 2 will be the same as the DC supply input at pin 6.

2.3.16 Use of External Crystal Oscillator

Socket SK36 is intended for use with the ARU11B Synthesiser.

2.4 SETTING MAINS TRANSFORMER TAPS

Taps on the Mains Transformer must be set to accommodate the supply voltage. Connect the trans-

former windings in parallel for 0-125V operation and in series for 200-250V operation.

Ensure that the correct fuses are fitted.

For 204 to 255V FS1 and FS2 are 1A 5920-99-142-2826

For 106 to 124V FS1 and FS2 are 2A 5920-99-119-8828

After adjustment replace the covers.

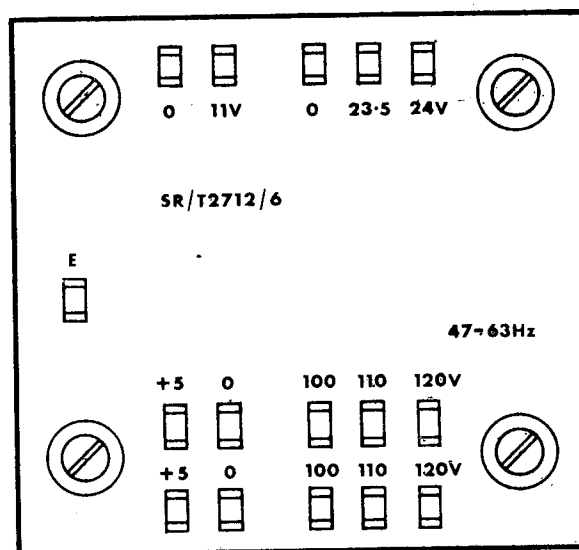

Fig. 2.1 Mains Transformer Connections

2.5 SETTING LINK LK1

The link is associated with the loudspeaker switch, and should be set to suit installation requirements. It should be removed when controlling the external loudspeaker.

2.6 SETTING LINK LK2

This link is used to complete the 20V supply to the 600 to 700kHz VFO in the R551 Receiver when the ARU11A Synthesiser has been removed from the receiver.

2.7 BRIEF FUNCTIONAL CHECKS

Carry out these brief functional checks before operating the equipment.

- (1) Ensure that all external connections are made.
- (2) Secure the equipment in its housing.
- (3) Set the R551 Receiver Off/Standby/On switch to OFF. (If the ARU11B Synthesiser is used, set the Synthesiser VFO/Synth/CLA switch to VFO position.)

- (4) Apply the supply voltage to the R551 Receiver supply cables.
- (5) Set the Off/Standby/On switch to STANDBY.
- (6) Set the Loudspeaker switch to the ON position.
- (7) Select an operational mode on the Service switch.
- (8) Set the AF Gain fully clockwise.
- (9) Set the RF Gain fully clockwise.
- (10) Set the Off/Standby/On switch to ON.
- (11) Check that the mechanical counter dial lamp lights.
- (12) Check that noise is heard from the loudspeaker. Switch to the other operational modes and check that noise is heard.
- (13) If both AC and 24V DC supplies are connected, switch off the AC supply and verify that the equipment remains operational.
- (14) When the ARU11B Synthesiser is employed, set the Synthesiser VFO/Synth/CLA switch to SYNTH position, confirm that the ARU11B Synthesiser front panel lamp is illuminated and the R551 Receiver mechanical counter dial lamp is extinguished.

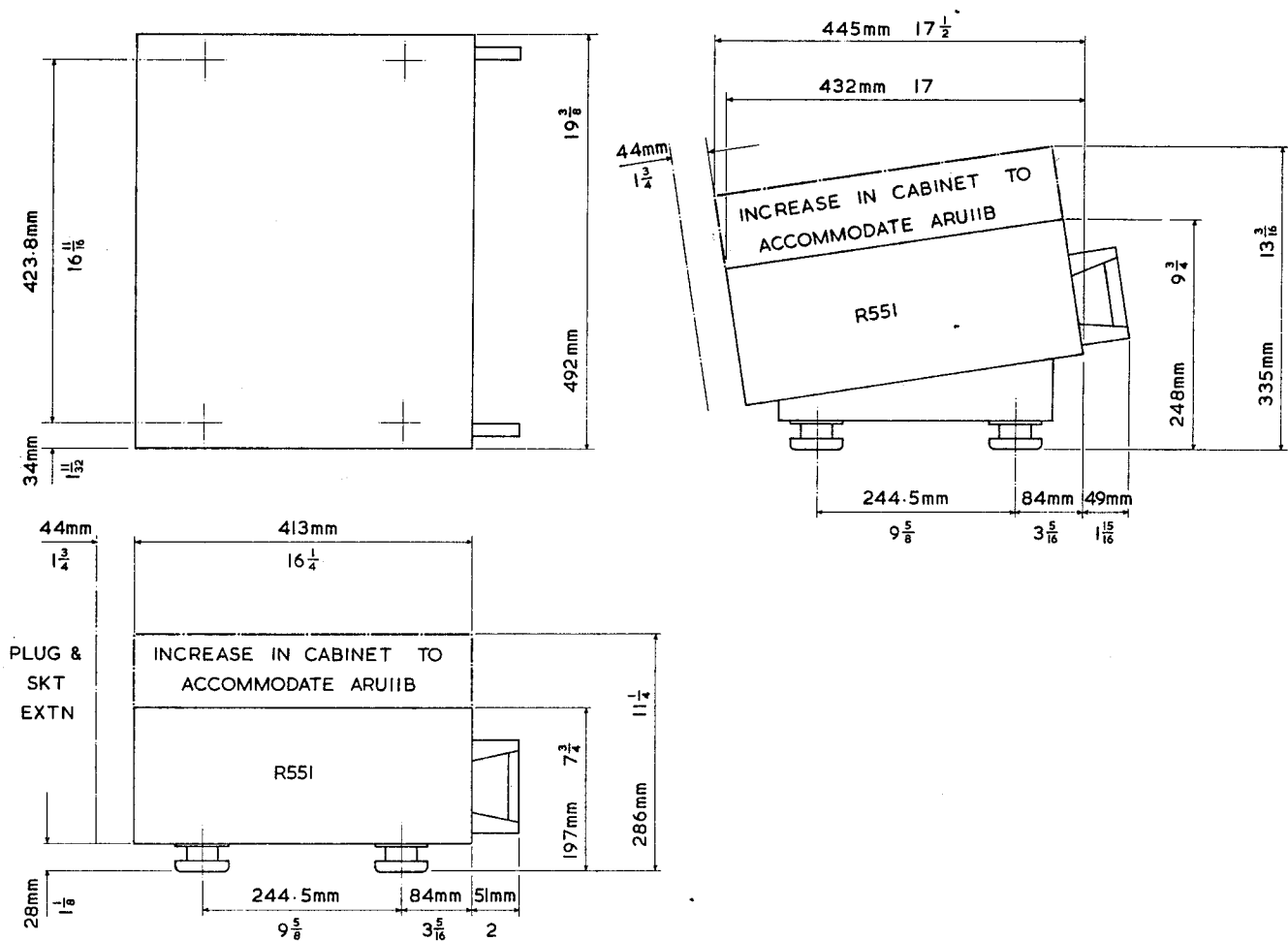

BENCH MOUNTING FIXINGS

3 OPERATING INSTRUCTIONS

3.1 INTRODUCTION

3.2 CONTROLS AND FACILITIES

- 3.2.1 Frequency Selection Controls**
- 3.2.2 0 and 9 (CAL) Indicator Lamps**
- 3.2.3 Front Panel Meter**
- 3.2.4 CAL Preset Control**
- 3.2.5 Off/Standby/On Switch**
- 3.2.6 Front Panel Lamp**
- 3.2.7 Loudspeaker Switch**
- 3.2.8 Line Preset Control**
- 3.2.9 AF Gain Control**
- 3.2.10 Service Bandwidth kHz Switch**
Table 3.1 Service Bandwidth kHz Switch Positions
- 3.2.11 BFO**
- 3.2.12 RF Gain Control**
- 3.2.13 AGC Switch**
- 3.2.14 Headphone Jacks**

3.3 OPERATING THE R551 RECEIVER

- 3.3.1 Initial Setting Up**
- 3.3.2 Tuning**
- 3.3.3 AF Gain Control and AGC**
- 3.3.4 RF Gain Control and AGC**
Table 3.2 Use of RF Gain Control and AGC Switch
- 3.3.5 Reception of Single Sideband A3J Signals**
- 3.3.6 Reception of Double Sideband A3, A2 Signals and Compatible AM A3H, A2H Signals**
- 3.3.7 Reception of DSB in the Presence of Very Heavy Interference**
- 3.3.8 Reception of CW**
- 3.3.9 Reception of CW in the Presence of Very Heavy Interference**
- 3.3.10 Reception of MCW A2 and A2H Signals**
- 3.3.11 Calibration**
- 3.3.12 Low Level Line Adjustment**
- 3.3.13 Test Facility**
- 3.3.14 Front-End Protection Fuse**

3 OPERATING INSTRUCTIONS

It is assumed that installation and setting up has been carried out as detailed in Chapter 2.

3.1 INTRODUCTION

In order that the operator may familiarise himself with the equipment, the operating instructions are preceded by a list of controls and their functions.

Refer to handbook 941-1 for the ARU11B Synthesiser, operating instructions, when necessary.

3.2 CONTROLS AND FACILITIES

3.2.1 Frequency Selection Controls

The selection frequency is represented by a six-figure digital decimal readout. On the left-hand side of the front panel are the 10MHz, 1MHz and 100kHz selection switches. In line with, and to the right of these knobs, is a mechanical counter which indicates the 10kHz, 1kHz and 100Hz settings. The last digit has five sub-divisions to allow an indicated frequency setting down to 20Hz. This counter is controlled by dual coarse (outer) and fine (inner) concentric knobs. The fine tune knob can be used as a speech clarifier on SSB operation.

The tuning knob drives the capacitor of the VFO, to which it is connected by a clutch mechanism. This clutch slips to protect the drive mechanism if it is rotated hard against the end stops. Such action should be avoided as it imposes unnecessary wear on the drive mechanism.

3.2.2 0 and 9 (CAL) Indicator Lamps

The VFO has an uncalibrated 'frequency overlap' at range edges.

The indicator lamps are provided to ensure that the VFO, and hence the associated mechanical counter readings, is kept within the calibrated range.

As the tuning control is rotated counter-clockwise towards 000, the 0 lamp lights just before 000 is reached on the counter, to warn the operator that he is approaching the LF calibration limit of the VFO. If the tuning control is rotated further counter-clockwise past 000, the extreme left-hand digit of the counter will change to 9. Thus, if the extreme left-hand digit of the counter is 9 and the 0 lamp is lit, the receiver is out of calibration. The operator must then switch to the next lower digit on the 100kHz switch and rotate the tuning control clockwise to tune in the receiver.

The procedure is similar at the HF end of the VFO range. As the tuning control is rotated clockwise towards 999, the 9 (CAL) lamp lights just before 999 is reached on the counter, to warn the operator that he is approaching the HF calibration limit of the VFO. If the tuning control is rotated further clockwise past 999, the ex-

treme left-hand digit of the counter will change to 0. Thus, in this case, if the extreme left-hand digit of the counter is 0 and the 9 (CAL) lamp is lit, the receiver is out of calibration. The operator must then switch to the next higher digit on the 100kHz switch and rotate the tuning control counter-clockwise to tune in the receiver.

The 9 (CAL) lamp is also used during calibration. The VFO is calibrated at the HF end of its range when the counter is set to 000; at this setting, the 9 (CAL) lamp lights. This facility ensures that the operator does not set the counter to 000 at the LF end of the VFO range during calibration.

3.2.3 Front Panel Meter

When the Line/Signal switch is set to LINE position, the meter indicates the low level line output, one scale of the meter being calibrated at three points: -10dBm , 0dBm and $+10\text{dBm}$ (note that the ballistic characteristic is not that of a VU meter).

An indication of signal strength is given when the switch is set to SIGNAL, allowing the meter to be used as a tuning indicator. Note that the AGC switch must be set to FAST or SLOW position and the RF Gain control fully clockwise or else a false reading will be obtained.

3.2.4 CAL Preset Control

The CAL control is used to calibrate the VFO.

3.2.5 Off/Standby/On Switch

In the OFF position, the supplies (AC and DC) are disconnected. When the switch is set to STANDBY, the input supplies are connected to allow energising voltages to be fed to the crystal oven, the VFO and to illuminate the meter lamp. In the ON position of the switch, the receiver is fully operational, all circuit voltages being applied.

The frequency accuracies to be expected when using the VFO after different periods of warm-up are as follows:

R551 Receiver switched ON from cold—accuracy within 1.5kHz.

R551 Receiver switched to STANDBY or ON for 10min—accuracy within 200Hz.

R551 Receiver switched to STANDBY or ON for 2hr or more—accuracy within 100Hz.

3.2.6 Front Panel Lamp

This lamp, which illuminates the mechanical counter readout, lights when the Off/Standby/On switch is set to ON, and the ARU11B Synthesiser VFO/Synth/CLA switch is set to VFO position.

3.3.1 Initial Setting Up

- (1) Set the Off/Standby/On switch to ON and check that the front panel indicator lamp lights.
- (2) Plug in headphones, if required, to the front panel jacks.
- (3) Set the AF and RF Gain controls fully clockwise.
- (4) Switch on the loudspeaker if required.
- (5) Set up the frequency on the frequency controls.

3.3.2 Tuning

The front panel meter can be used for tuning, a peak reading being obtained when the signal is tuned in.

On AM and MCW, unlike SSB and CW, fine tuning is not normally necessary once the frequency has been set up.

A FAST position on the AGC switch is available for tuning purposes.

3.3.3 AF Gain Control and AGC

The automatic gain control (AGC) keeps the audio output variations to within 10% for input signal changes of as much as 100dB, so it is possible to set the AF Gain control to a suitable position and then leave it.

3.3.4 RF Gain Control and AGC

When AGC is switched on, the output from the 1.4MHz IF stage, and consequently the input to the audio stages, is kept constant at a level which is the ideal level at which these stages should operate.

If the AGC is switched off, for example on SSB, and level adjustments made by use of the RF Gain control, the output of the IF stages may be too high and consequently cause distortion. On the other hand, if the level is set too low, the signal-to-noise ratio will be worsened. Thus, use of the AGC ensures optimum receiver performance.

Operators requiring to use the receiver with the minimum of adjustments, should simply set the AGC switch to FAST and the RF Gain fully clockwise. More sophisticated uses of the AGC switch and RF Gain control are detailed below.

AGC is normally switched off only when a signal is being received which is accompanied by regular bursts of interference that hold down the gain of the receiver. If the AGC is left on, the gain will take time to recover due to the AGC decay time. If the AGC is switched off, intelligibility will only be reduced whilst the interference is present.

When it is desired to operate the receiver with AGC switched off, either method (a) or (b) below should be adopted.

- (a) First switch the AGC on and set the AF Gain control to give the required audio output level. Switch off the AGC and adjust the RF Gain control to obtain the same audio output as that obtained when the AGC was switched on.

- (b) Set the RF Gain control to the maximum gain position, i.e. fully clockwise. Switch the AGC on and set the Line/Signal switch to SIGNAL. The meter now indicates the strength of the incoming signal by monitoring the AGC control line.

The RF Gain control should now be rotated counter-clockwise until the meter needle just moves up-scale slightly. A condition has been reached where the meter is indicating the voltage placed on the AGC line by the RF Gain control, this voltage having overridden the AGC voltage. The RF Gain has only just overridden the AGC so the receiver is still operating under optimum conditions and the AGC can be switched off.

A method of using the RF Gain and AGC which should prove useful when receiving signals of good strength is as follows:

- (c) Switch the AGC switch to FAST and the Line/Signal switch to SIGNAL. Set the RF Gain control fully clockwise. Adjust the AF Gain control for the required audio level. Rotate the RF Gain control counter-clockwise until the meter needle moves up-scale, and then rotate it clockwise through about 45 degrees.

The receiver will now be operating with the AGC on, and will cater for a drop in signal level, due to fading, of about 30dB. At the same time full AGC will be available for increase in signal strength. This method of operation, which is really a method of altering the AGC threshold, ensures that noise is not troublesome during gaps in transmission.

The R551 Receiver AGC system controls the incoming SSB, CW and MCW signals in 3ms (attack time). Because of this, it is possible to use AGC on SSB or CW, without getting audio 'thumping' when receiving a word or character. The AGC decay time is about 10 seconds in the modes of operation stated above, when the AGC switch is set to SLOW. This means that receiver gain will not change, and consequently noise will not be troublesome, between words or characters. So, providing that rapid fading of the signal is not taking place, or bad impulse noise is not present, it is advisable to set the AGC switch to SLOW.

The AGC switch should keep the AF output virtually constant, so if fading is noticed, the AGC is not recovering quickly enough and the AGC switch should be set to FAST. When exceptionally high interference is present the following should be tried.

- (d) Rotate the RF Gain control fully clockwise, set the AGC switch to FAST, and the Line/Signal switch to SIGNAL. Set the AF Gain control for a suitable audio output. Rotate the RF Gain control counter-clockwise until the meter needle just moves up-scale. The AGC will then be overridden and should be switched off. Now rotate the RF Gain control slowly clockwise, causing the signal (with interference) to increase

in amplitude at the final stage of the 1.4MHz IF amplifier. This stage is fitted with a symmetrical peak clipper so that as the RF Gain control is turned clockwise, the noise peaks start to be clipped, with further rotation of the RF Gain control even the wanted signal will be clipped. The RF Gain control must be set to a compromise position which allows clipping of interference spikes but not distortion of the wanted signal.

Many transmitters on CW, emit a certain amount of

carrier during the key-up condition. If the AGC were allowed to decay rapidly during this key-up period, the carrier leak may be received at almost the same level as the carrier, and communication would be impossible. This effect can be largely eliminated by setting the AGC switch to SLOW with the RF Gain control fully clockwise. However, for improved reception, the method detailed in (c) above should be employed.

A summary of the use of the RF Gain control and AGC switch under various operating conditions follows in Table 3.2.

Table 3.2 Use of RF Gain Control and AGC Switch

<i>Reception Mode</i>	<i>Reception Conditions</i>	<i>AGC Switch Position</i>	<i>RF Gain Control Setting</i>
A3 A3H	Very strong impulse noise interference	FAST	Carry out adjustments as detailed in (b) above
A3 A3H	Good signal with slow fading	SLOW	Fully clockwise
A2 A2H	Slight fast fading	FAST	Fully clockwise
	Deep fast fading	FAST	Fully clockwise
	Good signal with slow fading	SLOW	Carry out adjustments as detailed in (c) above
	Good signal with fast fading	FAST	Carry out adjustments as detailed in (c) above
A3J A1	Good signal with deep fading	FAST	Fully clockwise
	Heavy impulse noise interference	OFF	Carry out adjustments as detailed in (b) or (d) above
	Very heavy impulse noise interference	OFF	Carry out adjustments as detailed in (c) above
		FAST	Carry out adjustments as detailed in (b) above
A2 A2H	Heavy impulse noise interference	OFF	Carry out adjustments as detailed in (b) or (d) above. If reception impossible, try to receive on A3J or A1 positions

3.3.5 Reception of Single Sideband A3J Signals

The Service Bandwidth kHz switch has two positions for the reception of single sideband signals, A3J usb and A3J lsb. Speech can be clarified by use of the fine tuning control.

3.3.6 Reception of Double Sideband A3, A2 Signals and Compatible AM A3H, A2H Signals

The Service Bandwidth kHz switch has two positions for the reception of speech (or music): AM8 and AM3.

When listening to music or speech, the AM8 position should be selected, and should only be reduced if interference is bad. Use of the AM3 position is only justifiable if interference is severe, because this gives an audio bandwidth of only 1.5kHz which is virtually useless for music and not particularly good for speech.

However, the AM3 position is ideal for the reception of single sideband A3H signals, which use a carrier and one sideband. In this case the receiver can be detuned, when the audio bandwidth is almost 2.7kHz.

Unlike reception of A3J and A1, the accuracy of tune required for DSB reception is not great. Once the frequency has been set up, fine tuning is not normally necessary.

3.3.7 Reception of DSB in the Presence of Very Heavy Interference

When heavy adjacent-channel interference or bad selective fading is present, it is often advantageous to select A3J (usb or lsb—whichever has the least interference) on the Service Bandwidth kHz switch and receive the wanted DSB signal as if it were an SSB signal. In this condition of reception, the carrier is removed and replaced by an internal oscillator.

This is advantageous during selective fading, when fading of the incoming carrier without corresponding fading of the sidebands causes envelope distortion. This distortion is not apparent on SSB reception because an envelope detector is not used and, as stated, the carrier is replaced.

If an adjacent DSB station, for example 8kHz away, is breaking through into the wanted passband, an envelope detector will demodulate the sidebands of the unwanted signal to produce unwanted audio information along with the wanted audio information. However, if the wanted signal is being received on SSB, the unwanted signal will be demodulated to produce a nominal frequency of 8kHz—not nearly so annoying. Furthermore, if headphones are used, this unwanted frequency may be attenuated by the inherent frequency response of the headphones.

When a DSB signal is being received in the SSB mode, accurate tuning can be obtained by tuning in the carrier for a zero beat note.

3.3.8 Reception of CW

The Service Bandwidth kHz switch controls the BFO so that it is only available when A1 cw positions are selected.

When tuning in a CW signal, it is essential that it is first centred in the receiver passband before the BFO is adjusted for the desired tone. There are three methods of doing this. Methods (a) or (b) are only necessary when the exact frequency of transmission is not known or when the transmission accuracy is worse than 50Hz. Method (c) can be used when the frequency of reception is known exactly.

- (a) Set the Service switch to SSB and tune in the CW signal for a zero beat. The centre frequency (or zero) of the BFO is 1.4MHz, which is the same as the re-insertion oscillator frequency used on SSB; thus, if a CW signal is tuned in to give a zero beat note on SSB, then the incoming signal will have been translated to 1.4MHz at the receiver second IF stage. Next, set the Service Bandwidth kHz switch to either the A1 cw 1 or 0.3 positions and adjust the BFO for a zero beat with the incoming signal. The BFO will now be at 1.4MHz and therefore centred. Having zeroed the BFO, a received CW signal will be correctly in tune when it has been tuned in for zero beat. The BFO should then be adjusted to give the required tone.
- (b) This method is not as accurate as (a) but is slightly quicker and may be used when the narrowest bandwidth (0.3kHz) is not employed. Set the Service Bandwidth kHz switch to A1 cw 1, the Line/Signal switch to SIGNAL, and the AGC switch to FAST. Tune in the signal for maximum deflection on the meter, then adjust the BFO control for the desired tone. If conditions allow, return the AGC switch to SLOW.

- (c) This is the quickest method. If the transmitter frequency is known accurately (within 50Hz) and the receiver has been recently calibrated, it is only necessary to set the frequency on the receiver controls and adjust the BFO control for the desired tone.

The inherent frequency stability of the R551 Receiver allows the continuous use, under normal operating conditions, of the 0.3kHz bandwidth, ensuring better rejection of unwanted signals, and improved signal-to-noise ratio.

The 8kHz or 3kHz bandwidths are useful for 'searching'. Once the signal has been found, the bandwidth can be narrowed to 0.3kHz. Another use of the wider bandwidths may be found during 'netting' or listening on a calling channel when poor frequency accuracy of other stations is experienced.

3.3.9 Reception of CW in the Presence of Very Heavy Interference

Selection of the 0.3kHz bandwidth will reduce the interference from an adjacent channel signal if it is more than 150Hz off tune.

A further remedy is to adjust the BFO control to produce a zero beat with the interfering signal. The resultant audio output tone will be equal to the frequency difference between the wanted and unwanted signals.

3.3.10 Reception of MCW A2 and A2H Signals

A 3kHz bandwidth is normally required for MCW reception, although the 1kHz bandwidth can be used when a modulating frequency below 500Hz is employed.

3.3.11 Calibration

The highly stable synthesiser controlled by the three left-hand decade switches on the front panel requires no frequency check, the calibration facility being provided to allow the operator to make an occasional check of the VFO accuracy.

First set the Service Bandwidth kHz switch to TEST/CAL position. Set the AF Gain control fully clockwise; switch on the loudspeaker and switch AGC to FAST. Set the mechanical counter to 000 at the high frequency end by rotating the tune control clockwise. The 9(CAL) lamp should light to indicate that 000 has been set at the correct end of the range. An audio note should be heard and this should be adjusted for a zero beat note by means of the Cal control.

If enhanced accuracy is necessary the meter can be used. Set the Line/Signal switch to SIGNAL and observe the meter needle. Adjust the Cal control for minimum rate of meter needle flutter.

Once the receiver has had a few hours to warm up, only very occasional calibration will be necessary.

3.3.12 Low Level Line Adjustment

Set the Line/Signal switch to LINE and adjust the Line control for the desired level on the meter.

3.3.13 Test Facility

Use of the TEST position of the Service Bandwidth kHz switch is fully covered in para. 7.3.

3.3.14 Front-End Protection Fuse

A fuse FS1, protects the front-end circuits from very large signals. Signals large enough to blow this fuse are unlikely, but the operator should be aware of the possibility. FS1 is located on the rear panel of the receiver and the fuse replacement is 250mA (5920-99-914-0687).

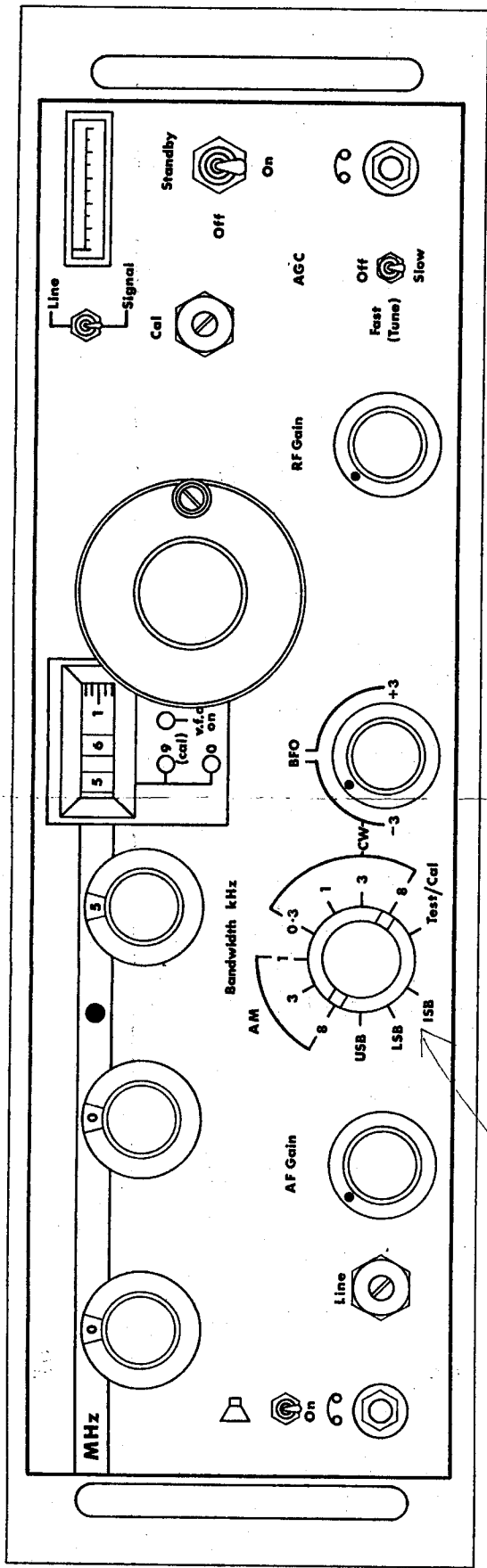

FRONT PANEL CONTROLS

FIG. 9.27

MARKINGS ON THIS SWITCH
 MAY VARY, DEPENDING ON
 VERSION OF RECEIVER.

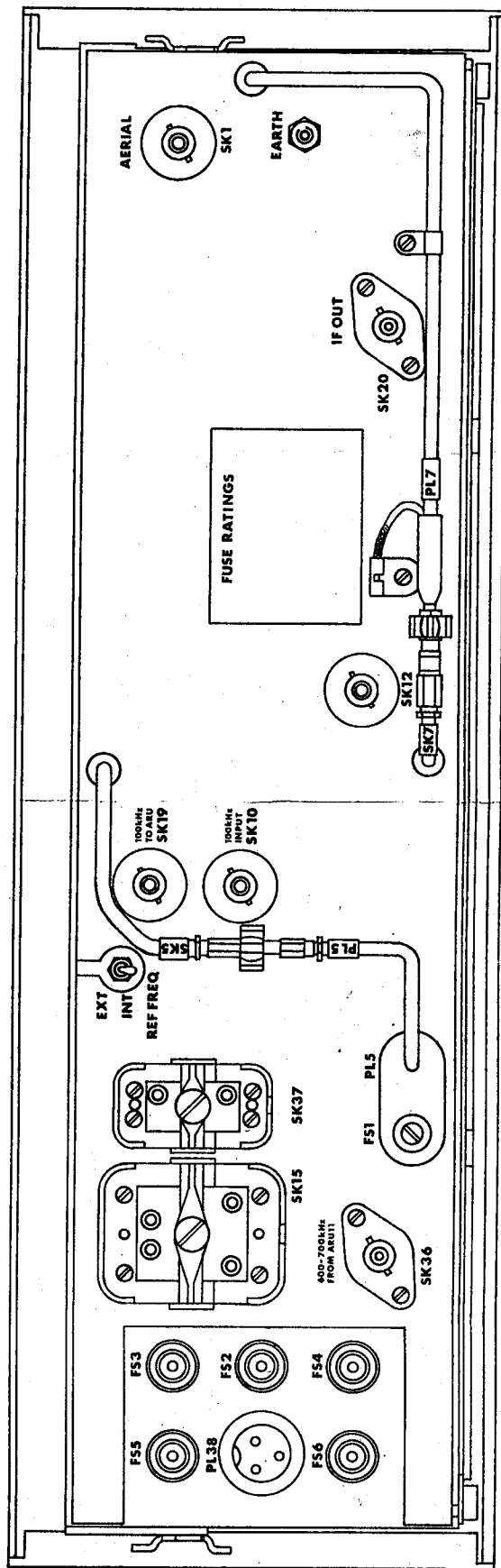

REAR PANEL CONTROLS

FIG. 9.28

1 BRIEF DESCRIPTION AND SPECIFICATION

PLATE 1.1 R551 RECEIVER

PLATE 1.2 R551C RECEIVER

1.1 BRIEF DESCRIPTION

1.2 SPECIFICATION

1 BRIEF DESCRIPTION AND SPECIFICATION

1.1 BRIEF DESCRIPTION

The R551 Receiver is a general purpose SSB/DSB communications receiver providing continuous coverage over the MF/HF frequency range of 100kHz to 30MHz and operation down to 10kHz. The receiver meets Specification MPT1201: Performance Specification for a Radio Receiver for Double Sideband and Single Sideband reception of Radiotelegraphy and Radiotelephony for use on Merchant Ships over the range 100kHz to 30MHz.

Solid-state devices are used throughout to achieve compactness and ensure reliability, whilst the modular form of construction greatly facilitates servicing. Digital readout of frequency is incorporated.

A number of optional extras are available, which allow the receiver to be tailored to meet the requirements of individual systems.

The R551 is a double-conversion superhet providing reception on single sideband, DSB, MCW and CW, a choice of bandwidth being available on the latter three services.

Frequency setting is accomplished by a six-figure, in-line, digital decimal readout. The 10MHz, 1MHz and 100kHz positions are synthesised and are selected by rotary control knobs; the remaining 10kHz, 1kHz and 100Hz settings are presented on a three digit mechanical counter which controls a VFO. If required, full frequency synthesis, down to 100Hz steps, with or without 100Hz interpolation, may be realised by use of the ARU11B Synthesiser. When using the optional High Stability reference oscillator module provision is made for the connection of an external frequency standard if enhanced frequency stability is considered necessary.

A comprehensive AGC system is incorporated to give a large dynamic range with good linearity and a minimum of intermodulation products. Two inter-connected AGC systems are employed; one in the RF amplifier, and one over four stages of IF amplification.

The front-end AGC system will operate in the presence of large unwanted signals which fall outside the IF but within the RF passband, thus minimising blocking and consequent cross-modulation. Circuit time constants are automatically selected by the Service Bandwidth kHz switch, but in conditions of rapid fading, a position of the AGC switch allows the decay times to be reduced to approximately $\frac{1}{4}$ th. An OFF setting of the AGC switch disables the AGC.

The sensitivity of the receiver is set by the Service Bandwidth kHz switch so that the AGC threshold comes into operation at a similar signal-to-noise ratio for all services.

An internal loudspeaker with associated On-Off switch is fitted and a 600 Ω line output; two front panel sockets also allow the use of headphones. If required, the

receiver will provide simultaneous outputs to the internal loudspeaker and 600 Ω line. When the headphone jacks are in use, the internal and external loudspeakers are automatically muted. The line level is set by a pre-set front panel Line Level control, in conjunction with a front panel Line/Signal meter. The maximum level for normal line operation is 10mW, but if necessary, an output of 1.25W into 600 Ω is available instead of the external loudspeaker output.

Signal strength is indicated on the Line/Signal meter, which can also be used in conjunction with the TEST/CAL position of the Service switch, to provide a function check of the receiver.

Front-end protection is afforded against inputs up to 30V, and even if this voltage is exceeded, an easily accessible fuse ensures that the receiver is not damaged.

When used with an associated transmitter, the R551 provides facilities for sidetone amplification, aerial muting and receiver desensitising.

An IF output of 1.4MHz is provided for test purposes.

A 115V or 230V $\pm 6\%$ AC supply is required to power the equipment, normal variations in supply voltage will not cause the performance of the equipment to be degraded. When emergency conditions so demand, it can be powered from a 24V DC supply with negative earth.

The R551 is designed to meet the British Ministry of Posts and Telecommunications Specification MPT1201 and the Performance Specification for a Reserve Receiver; it also meets the Climatic and Durability Class B clauses in Specification MPT1204, relevant clauses of British Defence Specification DEF 133, class L1, and the vibration test specified in Class L2 clauses 8.1B and 8.2B "Main Region".

The receiver is adaptable to many uses. The R551 version is intended for marine use and the R551C is mainly intended for general purpose communications, it may have the options of Lower Sideband and Independent Sideband reception by using adaptor ARU10A.

For A3A Lincompex use, Carrier Tuning Adaptor ARU16 may be fitted.

A complete receiving terminal, comprising R551 Receiver and ARU11B Synthesiser in one cabinet is the R554A. If Carrier Tuning Adaptor ARU16 is fitted the type number is R554B. The R554 meets the requirements of MPT1201 and the environmental clauses of MPT1204 applicable to Class B equipment.

1.2 SPECIFICATION

Frequency Range:

100kHz to 30MHz continuous coverage. Extends down to 10kHz with degraded performance.

Frequency Presentation:

Fully digital. Sub-divisions of 20Hz provided on final digit.

R551 Receiver

10MHz, 1MHz and 100kHz set on synthesiser dials. VFO completes tuning over 100kHz range with dual concentric coarse and fine controls giving a resolution of 10Hz.

Using ARU11B Synthesiser

Full frequency synthesis in 100Hz steps, with or without 100Hz interpolation.

Frequency Accuracy:

R551 Receiver

Frequency is set with a typical accuracy of 20Hz and always better than 100Hz.

Using ARU11B Synthesiser

The major limitation is that imposed by the accuracy of the receiver internal or external frequency reference.

Calibration:

VFO calibrated against signal derived from internal frequency reference (necessary only at infrequent intervals).

Frequency Stability:

R551 Receiver

After a 30min warm-up period, the frequency drift over any subsequent 15min period is less than 20Hz, with constant or $\pm 10\%$ supply changes. After a 30min warm-up period whilst the temperature is raised 7°C in a time of one hour, it is less than 20Hz. When vibrated at frequencies up to 12.5Hz with an excursion of 0.32cm, the frequency deviation due to vibration is less than $\pm 25\text{Hz}$.

Using ARU11B Synthesiser

The long term stability is normally ± 1 part in 10^6 , but using the optional high stability module will be within 5 parts in 10^6 .

Modes of Operation:

R551
 A3J usb A3dsb A2 mcw A1 cw
 R551C
 A3J lsb A3J usb A3 dsb A2 mcw A1 cw
 A3B using ARU10 Adaptor

Selectivity:

Service	Nominal 6dB Bandwidths (Selectable)
A1 cw	Wide 8kHz
A2 mcw	Intermediate 3kHz
A3 dsb	Narrow 1kHz
A1 cw	Very Narrow 300Hz
A3J lsb	2.35kHz or 2.75kHz
A3J usb	or 5.5kHz

Noise Factor:

Typically 8dB, not worse than 10dB above 4MHz

Sensitivity:

Standard audio output is obtained, using the appropriate antenna, with the emf inputs indicated below:

(a) A3J lsb and A3J usb:

For frequencies between 4 and 30MHz
 2 μV for 20dB SINAD

(b) A3 dsb and A1 cw:

For A3 dsb, a type A2 test signal is modulated 30% at 1kHz when the bandwidth is WIDE, or 30% at 400Hz, when the bandwidth is INTERMEDIATE

Frequency	Bandwidth	SINAD	Input for A1	Input for A2
100 to 160kHz	Narrow	10dB	4 μV	—
160 to 525kHz	Narrow	10dB	5 μV	—
160 to 525kHz	Intermediate	10dB	—	22 μV
525 to 1605kHz	Intermediate	10dB	—	20 μV
1605 to 4000kHz	Wide	20dB	—	20 μV
4.0 to 30MHz	Wide	20dB	—	10 μV
4.0 to 30MHz	Narrow	10dB	0.35 μV	—

Cross Modulation:

The cross modulation level produced by an unwanted signal of 300mV in the presence of a wanted signal of 1mV is better than 30dB below the wanted output.

Intermodulation:

With a wanted signal of 30dB above 1 μV , the unwanted output due to intermodulation will be less than the wanted output, when those unwanted levels are as below:

for frequencies 100 to 525kHz the unwanted levels are 100dB above 1 μV

for frequencies 525 to 1605kHz the unwanted levels are 90dB above 1 μV

for frequencies 1.6 to 30MHz the unwanted levels are 80dB above 1 μV

Blocking:

The output resulting from an A2 wanted signal of 1mV will not be reduced by more than 3dB in the presence of an unwanted signal of 6V.

Spurious Responses:

(not including image or intermediate frequencies)

All spuriously received signals are at least 70dB below wanted signal for tune frequencies above 1.6MHz and at least 80dB for tune frequencies below 1.6MHz.

Aerial Impedance:

Below 4MHz: 10 Ω in series with 200 to 700pF
 Above 4MHz: 50 Ω unbalanced

Aerial Protection:

Withstands aerial emf of up to 30V

A fuse affords protection against damage by input emf in excess of 30V.

AGC:

2dB change in output for 100dB change in input, with respect to AGC threshold.

AGC Time-Constants:

DSB—attack 100mS, decay 1S

Other Services—attack 3mS, decay 10S

A switch (FAST position) reduces decay times to approximately one-eighth of above.

RF Gain Control Range:

At least 120dB

IF Output:

100mV across 50Ω at 1.4MHz (AGC ON)

AF Outputs:

(a) +10dBm into a 600Ω load, with separate Set Level control

(b) Two outputs, each 2mW into 600Ω headphones via front panel jacks or to headset outlets

also either

(c) 0.5W into internal 10Ω loudspeaker, with

(d) 1.5W into external 3Ω load.

OR

(e) 0.5W into internal 10Ω loudspeaker, with

(f) 1.25W into an external 600Ω load.

BFO:

Variable \pm 3kHz

Overall AF Distortion:

Less than 2%

AM Fidelity (8k Hz bandwidth):

AF output variations are less than 5dB for modulation frequencies between 300 and 3000Hz

Radiation:

Not more than 20μV across 50Ω at the aerial input socket

IF Rejection:

38MHz (1st IF): better than 80dB

1.4MHz (2nd IF): better than 100dB

Image Rejection:

Better than 90dB and 80dB for 1st and 2nd conversion images respectively

Front Panel Meter:

Used for:

(a) Signal strength indication

(b) Line Level indication

(c) Circuit check indication

(d) Calibrate indication.

AC Power Supply:

106 to 124, 204 to 255V

Damage is not caused by 1mS transients of 100% over-voltage or by a sustained short circuit on the HT line.

DC Power Supply:

24V DC negative earth standard. The receiver tolerates voltage variations of \pm 10% without relaxation of the specification. An increase in voltage of 25% or reversal of supply will not cause damage to the equipment.

Power Consumption:

40W maximum

Operating Temperature:

-15°C to +55°C

Storage Temperature:

-40°C to +70°C

Climatic and Durability Standard:

MPT1204 for Class B equipment

DEF133 Class L1

Overall Dimensions and Weight (Without Cabinet)

height	width	depth	weight
13cm (5¼in)	48cm (19in)	49cm (19¼in)	17kg (38lb)

2 INSTALLATION AND SETTING UP

2.1 UNPACKING

2.2 SITING

2.3 EXTERNAL CONNECTIONS

2.3.1 25way Socket

2.3.2 8way Socket

2.3.3 Other External Connections

2.3.4 Aerial

2.3.5 AC Supply

2.3.6 DC Supply

2.3.7 Earthing

2.3.8 Aerial Muting

2.3.9 Desensitising and External RF Gain Control

2.3.10 AGC Out

2.3.11 AF Outputs

2.3.12 AF Inputs

2.3.13 100kHz Reference Input

2.3.14 1.4MHz IF Output

2.3.15 DC Out Facility

2.3.16 Use of External Crystal Oscillator

2.4 SETTING MAINS TRANSFORMER TAPS

Fig. 2.1 Mains Transformer Connections

2.5 SETTING LINK LK1

2.6 SETTING LINK LK2

2.7 BRIEF FUNCTIONAL CHECKS

Fig. 2.2 BNC Plug Assembly

Fig. 2.3 Earthing Configurations

Fig. 2.4 Bench Mounting Fixings

2 INSTALLATION AND SETTING UP

2.1 UNPACKING

On receipt of the equipment, check the packing cases for signs of damage, or for shortage if any components are packed separately. The carriers should be notified within three days if any severe damage or shortage exists.

If packing cases appear to be undamaged, unpack the equipment carefully, all packing materials being removed and any separately packed components fitted, as indicated in any reassembly instructions that may be sent with the equipment. Verify that no damage has been sustained by the equipment during transit.

CAUTION:

Avoid tearing any Kraft wrapping paper, otherwise the tar impregnation may soil the equipment panels.

2.2 SITING

To obtain satisfactory duplex working the location of the receiver and the manner of its installation are of vital importance.

Every effort should be made to keep the receiver as far away as possible from the ship's transmitters, their aerial output leads and the aerial switch.

It is important that sufficient space is provided for access to front panel control and for removal of the unit for servicing. Space requirements at the side should not be over-looked; allow sufficient space for the entry of external cables. The bench mounting version of the receiver should be secured by four fixing bolts to the shock absorbers on the cabinet or angled support frame (see fig. 2.4).

2.3 EXTERNAL CONNECTIONS

Listed below are all the external connections to the R551 Receiver. The extent to which these connections are used depends on individual installation requirements; full installation details are given in the relevant subsections, and appropriate supplementary handbooks, ARU11B (941-1) and ARU10A (909-1).

2.3.1 25way Socket SK15

This socket is used for the connection of external facilities listed below: the connections should be made via a Belling Lee L1328/P mating plug to the terminal blocks in the base of the cabinet.

SK15 Pin No	Used for	See Para
1	External aerial muting	2.3.8
2	DC Out facility	2.3.15
3	Not used	

4	External loudspeaker	
5	Low level 600Ω line	2.3.11
6	24v DC positive supply input	2.3.6
7	Low level 600Ω line	2.3.11
8	External loudspeaker (switched)	2.3.11
9	External loudspeaker	
10	AGC Out	2.3.10
11	AF sidetone input screen and earth	2.3.12
12	AF sidetone input	2.3.12
13	AF output from ARU10A	
14	AF output from ARU10A (screen)	
15	High level 600Ω external line screen	2.3.11
16	High level 600Ω external line	2.3.11
17	+20V to ARU10A	
18	AGC from ARU10A	
19	AGC to ARU10A	
20	Desensitising and external RF gain control	2.3.9
21	ISB muting ARU10A	
22	1.4MHz re-insertion oscillator output to ARU10A	
23	1.4MHz re-insertion oscillator output cable screen	
24	External loudspeaker (common)	2.3.11
25	Chassis	

2.3.2 8way Socket (SK37)

This socket is used for connections to the ARU11B Synthesiser. Details of the connections are given below. An inter-connecting cable type 5741A is supplied. If the ARU11B synthesiser is not installed with the R551 then pins 5 and 6 of SK37 must be linked.

Socket SK37 Pin No	Used for
1	Chassis Connection
2	See para. 4.2.20
3	See para. 4.2.20
4	+5V DC
5	+20V DC
6	+20V DC to VFO See para. 4.2.20
7	Not Used
8	+20V DC to VFO from ARU11B Synthesiser See para. 4.2.20

2.3.3 Other External Connections

Connection	Used for	See
SK1	Aerial	para. 2.3.4
SK10	100kHz from External Reference Source	para. 2.3.13
SK19	100kHz to ARU11B Synthesiser	ARU11B Hand-book 941-1
SK20	1.4MHz IF Output	para. 2.13.14
SK36	600 to 700kHz Output from ARU11B Synthesiser	ARU11B Hand-book 941-1
PL38	AC Mains Input	para. 2.3.5
JK1 JK2	Headphone Sockets	para. 2.3.11
Earth Terminal	Equipment Earthing	para. 2.3.7
SK12	ISB output to ARU10A	

2.3.4 Aerial

The aerial parameters should be as follows:
 Below 4MHz: 10 Ω in series with 200 to 700pF unbalanced
 Above 4MHz: 50 Ω unbalanced

The aerial lead-in must be connected to SK1 at the back of the R551 Receiver. The type of mating plug for this socket is Greenpar GE35070C10.

2.3.5 AC Supply

The mains cable should be connected to the Bulgin P430 socket which mates with plug PL38 at the back of the R551 Receiver.

CAUTION: Do not apply voltage to the cable until setting up instructions have been carried out (see Chapter 3).

2.3.6 DC Supply (24V negative earth)

Connect the supply cable to the 25way socket (SK15) at the rear of the receiver. The 24V positive lead must be connected to pin 6 and the negative lead connected to pin 25.

Ensure that the 24V supply is capable of providing a current of at least 4A, and that an internal 4A Fuse is used in the DC supply line.

CAUTION: Do not apply voltage to the cable until setting up instructions have been carried out (see Chapter 3).

2.3.7 Earthing

An earth bolt is provided at the rear of the cabinet, and should be connected to the cabinet earth via the connection provided. When the receiver is installed with other equipment e.g. transmitter, a separate earth lead is essential. (see Fig. 2.3).

2.3.8 Aerial Muting

The muting relay in the R551 Receiver is capable of 1mS operate and release times. At 30MHz, 50dB of muting is possible, increasing to 100dB at 200kHz. Muting can be reinforced by use of the desensitising facility (see para. 2.3.9).

Connect the external muting contacts between pins 1 and 25 of SK15. These external contacts must be normally closed, and must open to mute the receiver.

The current rating of the external contacts must not be less than 25mA.

If external muting is not required, then pins 1 and 25 of SK15 must be linked.

2.3.9 Desensitising and External RF Gain Control

It is possible to desensitise the receiver by the application of a positive voltage to pin 20 of the 25way socket SK15.

Desensitisation of up to 120dB is possible, with a desensitising attack time of less than 2mS.

The desensitising voltage must be 9V DC maximum from a source not greater than 100 Ω .

If required, the desensitising facility can be used in conjunction with the aerial muting facility (see para. 2.3.8).

2.3.10 AGC Out (Not normally used)

The AGC output at pin 10 of SK15 can be used for monitoring or for external control.

2.3.11 AF Outputs

The following AF outputs are available from the R551 Receiver:

- Either (a) 1.5W in external 3 Ω load with 0.5W into internal loudspeaker
 or (b) 1.25W into an external 600 Ω load with 0.5W into internal 10 Ω loudspeaker
 and (c) +10dBm into a 600 Ω load (with separate Set Level Control).
 (d) two outputs, each 2mW into 600 Ω headphones (JK1 and JK2.)

External 3 Ω Loudspeaker

Connect the external 3 Ω loudspeaker to pins 8 and 9 of the 25way socket SK15 (or to 4 and 9 if the loudspeaker is to be directly connected to the R551 Receiver output and not switched).

External 600 Ω line, high level

Connect the 600 Ω line to pins 16 and 15 (screen) of the 25way socket SK15.

External 600 Ω line, low level

Connect the 600 Ω line between pins 5 and 7 of the 25way cable SK15, and the screen to pin 13.

Line level adjustment is detailed in para. 3.3.12.
Headphones

Insert 600Ω headphones in the front panel sockets. The AF Gain control will vary the level of all the AF outputs simultaneously with the exception of the low level 600Ω line.

2.3.12 AF Input

Pin 12 of the 25way socket SK15 is used for the amplification of sidetone from an associated transmitter, full audio output resulting from an input of 0dBm at 1kHz.

2.3.13 100kHz Reference Input

A 100kHz external frequency standard can be connected to SK10 if it is required.

An input emf of 0.5V rms from a 50Ω source is necessary.

The mating plug is Greenpar GE35070C10.

Switch to EXT on the rear panel of the receiver. This requires use of the optional high stability reference oscillator module.

2.3.14 1.4MHz IF Output (Not normally used)

The 1.4MHz output at SK20 is 100mV ±1dB peak envelope voltage across 50Ω. This output is controlled by the AGC circuits and by the RF Gain control. When the AGC is switched off, the IF output can increase to approximately 350mV before overloading occurs.

The BFO or re-insertion oscillator level at the IF output, when loaded, will not be greater than 46dB below 100mV.

The mating plug type is Greenpar GE5070C10.

2.3.15 DC Out Facility (Not normally used)

The voltage at pin 2 of the 25way socket SK15 can be used to supply external circuits or equipment, and is available when the R551 Receiver Supply switch is set to STAND BY or ON.

When the R551 Receiver is being powered by an AC supply, the voltage at pin 2 is a nominal +24V unbalanced and the maximum current drawn must not exceed 200mA. If the emergency DC supply is being used, the voltage at pin 2 will be the same as the DC supply input at pin 6.

2.3.16 Use of External Crystal Oscillator

Socket SK36 is intended for use with the ARU11B Synthesiser.

2.4 SETTING MAINS TRANSFORMER TAPS

Taps on the Mains Transformer must be set to accommodate the supply voltage. Connect the trans-

former windings in parallel for 0-125V operation and in series for 200-250V operation.

Ensure that the correct fuses are fitted.

For 204 to 255V FS1 and FS2 are 1A 5920-99-142-2826

For 106 to 124V FS1 and FS2 are 2A 5920-99-119-8828

After adjustment replace the covers.

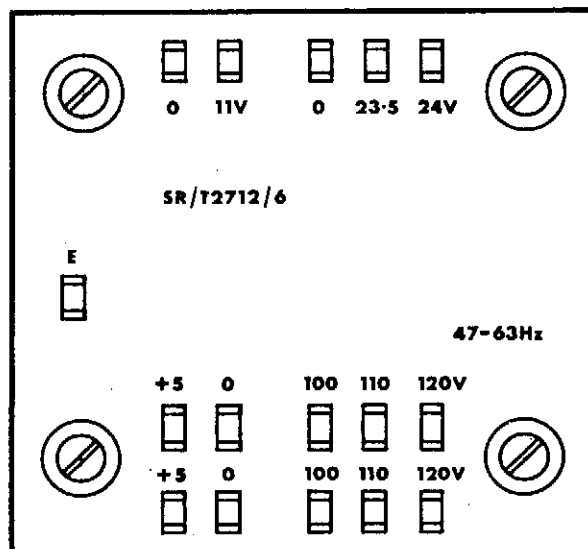

Fig. 2.1 Mains Transformer Connections

2.5 SETTING LINK LK1

The link is associated with the loudspeaker switch, and should be set to suit installation requirements. It should be removed when controlling the external loudspeaker.

2.6 SETTING LINK LK2

This link is used to complete the 20V supply to the 600 to 700kHz VFO in the R551 Receiver when the ARU11A Synthesiser has been removed from the receiver.

2.7 BRIEF FUNCTIONAL CHECKS

Carry out these brief functional checks before operating the equipment.

- (1) Ensure that all external connections are made.
- (2) Secure the equipment in its housing.
- (3) Set the R551 Receiver Off/Standby/On switch to OFF. (If the ARU11B Synthesiser is used, set the Synthesiser VFO/Synth/CLA switch to VFO position.)

- (4) Apply the supply voltage to the R551 Receiver supply cables.
- (5) Set the Off/Standby/On switch to STANDBY.
- (6) Set the Loudspeaker switch to the ON position.
- (7) Select an operational mode on the Service switch.
- (8) Set the AF Gain fully clockwise.
- (9) Set the RF Gain fully clockwise.
- (10) Set the Off/Standby/On switch to ON.

- (11) Check that the mechanical counter dial lamp lights.
- (12) Check that noise is heard from the loudspeaker. Switch to the other operational modes and check that noise is heard.
- (13) If both AC and 24V DC supplies are connected, switch off the AC supply and verify that the equipment remains operational.
- (14) When the ARU11B Synthesiser is employed, set the Synthesiser VFO/Synth/CLA switch to SYNTH position, confirm that the ARU11B Synthesiser front panel lamp is illuminated and the R551 Receiver mechanical counter dial lamp is extinguished.

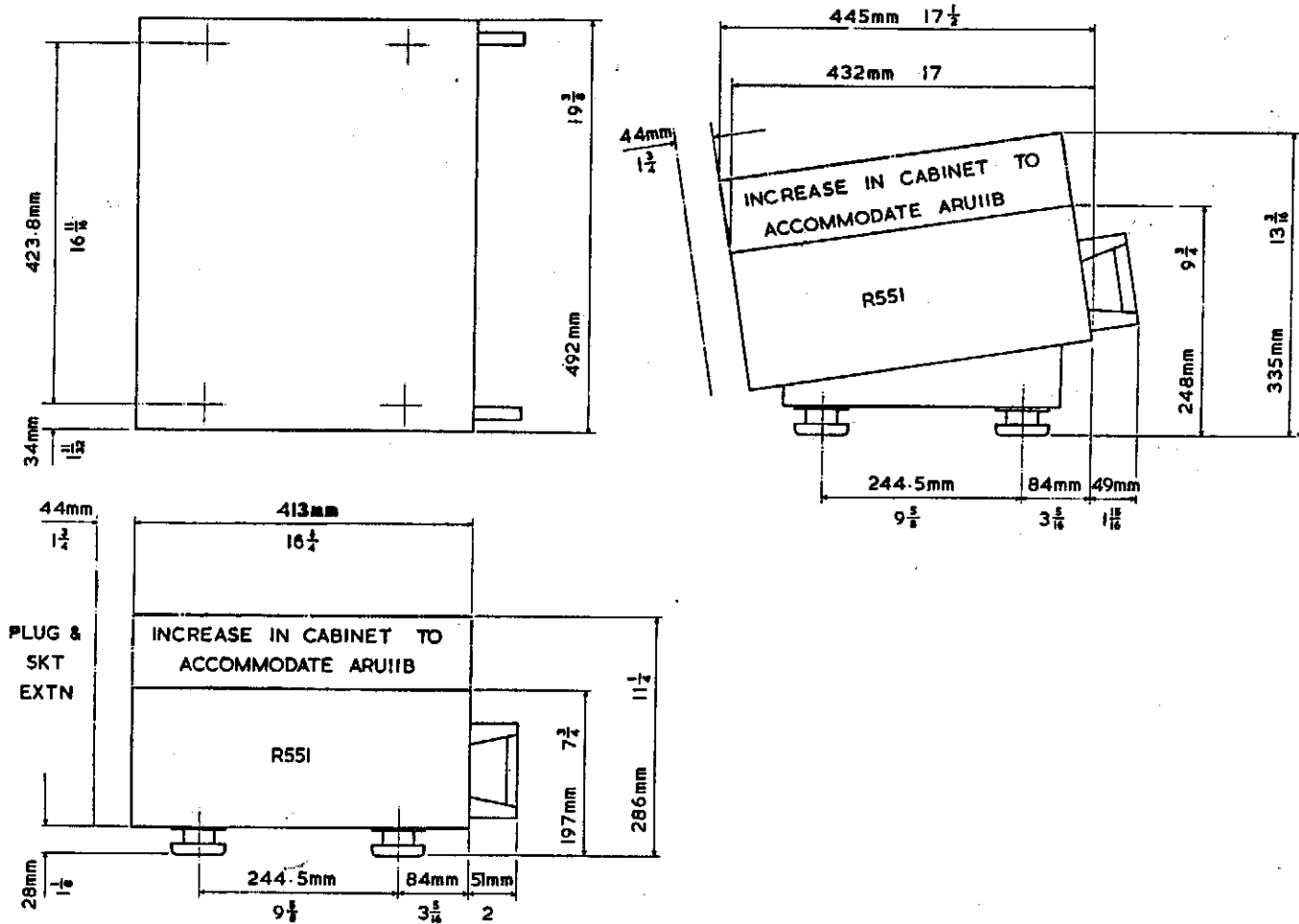

BENCH MOUNTING FIXINGS

3 OPERATING INSTRUCTIONS

3.1 INTRODUCTION

3.2 CONTROLS AND FACILITIES

- 3.2.1 Frequency Selection Controls**
- 3.2.2 0 and 9 (CAL) Indicator Lamps**
- 3.2.3 Front Panel Meter**
- 3.2.4 CAL Preset Control**
- 3.2.5 Off/Standby/On Switch**
- 3.2.6 Front Panel Lamp**
- 3.2.7 Loudspeaker Switch**
- 3.2.8 Line Preset Control**
- 3.2.9 AF Gain Control**
- 3.2.10 Service Bandwidth kHz Switch**
Table 3.1 Service Bandwidth kHz Switch Positions
- 3.2.11 BFO**
- 3.2.12 RF Gain Control**
- 3.2.13 AGC Switch**
- 3.2.14 Headphone Jacks**

3.3 OPERATING THE R551 RECEIVER

- 3.3.1 Initial Setting Up**
- 3.3.2 Tuning**
- 3.3.3 AF Gain Control and AGC**
- 3.3.4 RF Gain Control and AGC**
Table 3.2 Use of RF Gain Control and AGC Switch
- 3.3.5 Reception of Single Sideband A3J Signals**
- 3.3.6 Reception of Double Sideband A3, A2 Signals**
and Compatible AM A3H, A2H Signals
- 3.3.7 Reception of DSB in the Presence of**
Very Heavy Interference
- 3.3.8 Reception of CW**
- 3.3.9 Reception of CW in the Presence of**
Very Heavy Interference
- 3.3.10 Reception of MCW A2 and A2H Signals**
- 3.3.11 Calibration**
- 3.3.12 Low Level Line Adjustment**
- 3.3.13 Test Facility**
- 3.3.14 Front-End Protection Fuse**

3 OPERATING INSTRUCTIONS

It is assumed that installation and setting up has been carried out as detailed in Chapter 2.

3.1 INTRODUCTION

In order that the operator may familiarise himself with the equipment, the operating instructions are preceded by a list of controls and their functions.

Refer to handbook 941-1 for the ARU11B Synthesiser, operating instructions, when necessary.

3.2 CONTROLS AND FACILITIES

3.2.1 Frequency Selection Controls

The selection frequency is represented by a six-figure digital decimal readout. On the left-hand side of the front panel are the 10MHz, 1MHz and 100kHz selection switches. In line with, and to the right of these knobs, is a mechanical counter which indicates the 10kHz, 1kHz and 100Hz settings. The last digit has five sub-divisions to allow an indicated frequency setting down to 20Hz. This counter is controlled by dual coarse (outer) and fine (inner) concentric knobs. The fine tune knob can be used as a speech clarifier on SSB operation.

The tuning knob drives the capacitor of the VFO, to which it is connected by a clutch mechanism. This clutch slips to protect the drive mechanism if it is rotated hard against the end stops. Such action should be avoided as it imposes unnecessary wear on the drive mechanism.

3.2.2 0 and 9 (CAL) Indicator Lamps

The VFO has an uncalibrated 'frequency overlap' at range edges.

The indicator lamps are provided to ensure that the VFO, and hence the associated mechanical counter readings, is kept within the calibrated range.

As the tuning control is rotated counter-clockwise towards 000, the 0 lamp lights just before 000 is reached on the counter, to warn the operator that he is approaching the LF calibration limit of the VFO. If the tuning control is rotated further counter-clockwise past 000, the extreme left-hand digit of the counter will change to 9. Thus, if the extreme left-hand digit of the counter is 9 and the 0 lamp is lit, the receiver is out of calibration. The operator must then switch to the next lower digit on the 100kHz switch and rotate the tuning control clockwise to tune in the receiver.

The procedure is similar at the HF end of the VFO range. As the tuning control is rotated clockwise towards 999, the 9 (CAL) lamp lights just before 999 is reached on the counter, to warn the operator that he is approaching the HF calibration limit of the VFO. If the tuning control is rotated further clockwise past 999, the ex-

trême left-hand digit of the counter will change to 0. Thus, in this case, if the extreme left-hand digit of the counter is 0 and the 9 (CAL) lamp is lit, the receiver is out of calibration. The operator must then switch to the next higher digit on the 100kHz switch and rotate the tuning control counter-clockwise to tune in the receiver.

The 9 (CAL) lamp is also used during calibration. The VFO is calibrated at the HF end of its range when the counter is set to 000; at this setting, the 9 (CAL) lamp lights. This facility ensures that the operator does not set the counter to 000 at the LF end of the VFO range during calibration.

3.2.3 Front Panel Meter

When the Line/Signal switch is set to LINE position, the meter indicates the low level line output, one scale of the meter being calibrated at three points: -10dBm, 0dBm and +10dBm (note that the ballistic characteristic is not that of a VU meter).

An indication of signal strength is given when the switch is set to SIGNAL, allowing the meter to be used as a tuning indicator. Note that the AGC switch must be set to FAST or SLOW position and the RF Gain control fully clockwise or else a false reading will be obtained.

3.2.4 CAL Preset Control

The CAL control is used to calibrate the VFO.

3.2.5 Off/Standby/On Switch

In the OFF position, the supplies (AC and DC) are disconnected. When the switch is set to STANDBY, the input supplies are connected to allow energising voltages to be fed to the crystal oven, the VFO and to illuminate the meter lamp. In the ON position of the switch, the receiver is fully operational, all circuit voltages being applied.

The frequency accuracies to be expected when using the VFO after different periods of warm-up are as follows:

R551 Receiver switched ON from cold—accuracy within 1.5kHz.

R551 Receiver switched to STANDBY or ON for 10min—accuracy within 200Hz.

R551 Receiver switched to STANDBY or ON for 2hr or more—accuracy within 100Hz.

3.2.6 Front Panel Lamp

This lamp, which illuminates the mechanical counter readout, lights when the Off/Standby/On switch is set to ON, and the ARU11B Synthesiser VFO/Synth/CLA switch is set to VFO position.

3.2.7 Loudspeaker Switch

The function of this switch is to switch the internal loudspeaker on or off, or to monitor the audio from the ARU10A when in the UP position.

3.2.8 Line Preset Control

The setting of this control determines the 600Ω low level line output.

3.2.9 AF Gain Control

This control will vary simultaneously the level of all

the AF outputs, with the exception of the low level 600Ω output.

3.2.10 Service Bandwidth kHz Switch

In addition to setting the mode of operation and appropriate AGC time-constants, this switch provides simultaneous selection of the required bandwidth, with an extra position for calibrate and test facilities. Table 3.1 details the facilities available.

Table 3.1 Service Bandwidth kHz Switch Positions

Switch Position	Service Provided		Bandwidth kHz
	Modes	Sideband	
ISB*	A3B	independent	2.75 or 5.5*
LSB*	A3J, A3A	lower	2.35 or 2.75*
USB	A3J, A3A	upper	2.35 or 2.75*
AM8	A3, A2 A3H, A2H	either, or both with carrier	8.0
AM3	A3, A2 A3H, A2H	either, or both with carrier	3.0
AM1	A3, A2 A3H, A2H	either, or both with carrier	1.0
cw 0.3	A1	carrier only	0.3
cw 1	A1	carrier only	1.0
cw 3	A1	carrier only	3.0
cw 8	A1	carrier only	8.0
TEST/CAL	Used with CAL control and Meter for calibrating VFO. Also used with Meter for testing receiver.		

* Optional

3.2.11 BFO

Automatically switched into circuit by the Service Bandwidth kHz switch on A1 cw mode, this control provides a frequency variation of ± 3 kHz.

3.2.12 RF Gain Control

This control varies the RF and IF gain of the receiver.

3.2.13 AGC Switch

The three position control can switch the AGC out of circuit or determine the time constants of the AGC system:

- (a) OFF switches off the AGC
- (b) SLOW selects time constants for the mode of operation in use, as follows:

Mode	Attack time	Decay time
AM	70 to 150mS	0.7 to 1.6S
All other Modes	3mS	8 to 15S

- (c) FAST for use during tuning and conditions of rapid fading, the decay times being reduced to approximately $\frac{1}{4}$ th of those quoted above.

3.2.14 Headphone Jacks

Two headphone jacks are provided for the connection of 600Ω headphones. Loudspeaker output is not available when headphones are being used in the jack sockets.

3.3 OPERATING THE R551 RECEIVER

It is assumed that the operator has familiarised himself with the R551 Receiver controls detailed in para. 3.2.

The method of operation will depend on the type of service employed and conditions of reception, so it is suggested that the operator first carries out the initial setting up instructions detailed immediately below, and then refers to the following paragraphs as necessary.

3.3.1 Initial Setting Up

- (1) Set the Off/Standby/On switch to ON and check that the front panel indicator lamp lights.
- (2) Plug in headphones, if required, to the front panel jacks.
- (3) Set the AF and RF Gain controls fully clockwise.
- (4) Switch on the loudspeaker if required.
- (5) Set up the frequency on the frequency controls.

3.3.2 Tuning

The front panel meter can be used for tuning, a peak reading being obtained when the signal is tuned in.

On AM and MCW, unlike SSB and CW, fine tuning is not normally necessary once the frequency has been set up.

A FAST position on the AGC switch is available for tuning purposes.

3.3.3 AF Gain Control and AGC

The automatic gain control (AGC) keeps the audio output variations to within 10% for input signal changes of as much as 100dB, so it is possible to set the AF Gain control to a suitable position and then leave it.

3.3.4 RF Gain Control and AGC

When AGC is switched on, the output from the 1-4MHz IF stage, and consequently the input to the audio stages, is kept constant at a level which is the ideal level at which these stages should operate.

If the AGC is switched off, for example on SSB, and level adjustments made by use of the RF Gain control, the output of the IF stages may be too high and consequently cause distortion. On the other hand, if the level is set too low, the signal-to-noise ratio will be worsened. Thus, use of the AGC ensures optimum receiver performance.

Operators requiring to use the receiver with the minimum of adjustments, should simply set the AGC switch to FAST and the RF Gain fully clockwise. More sophisticated uses of the AGC switch and RF Gain control are detailed below.

AGC is normally switched off only when a signal is being received which is accompanied by regular bursts of interference that hold down the gain of the receiver. If the AGC is left on, the gain will take time to recover due to the AGC decay time. If the AGC is switched off, intelligibility will only be reduced whilst the interference is present.

When it is desired to operate the receiver with AGC switched off, either method (a) or (b) below should be adopted.

- (a) First switch the AGC on and set the AF Gain control to give the required audio output level. Switch off the AGC and adjust the RF Gain control to obtain the same audio output as that obtained when the AGC was switched on.

- (b) Set the RF Gain control to the maximum gain position, i.e. fully clockwise. Switch the AGC on and set the Line/Signal switch to SIGNAL. The meter now indicates the strength of the incoming signal by monitoring the AGC control line.

The RF Gain control should now be rotated counter-clockwise until the meter needle just moves up-scale slightly. A condition has been reached where the meter is indicating the voltage placed on the AGC line by the RF Gain control, this voltage having overridden the AGC voltage. The RF Gain has only just overridden the AGC so the receiver is still operating under optimum conditions and the AGC can be switched off.

A method of using the RF Gain and AGC which should prove useful when receiving signals of good strength is as follows:

- (c) Switch the AGC switch to FAST and the Line/Signal switch to SIGNAL. Set the RF Gain control fully clockwise. Adjust the AF Gain control for the required audio level. Rotate the RF Gain control counter-clockwise until the meter needle moves up-scale, and then rotate it clockwise through about 45 degrees.

The receiver will now be operating with the AGC on, and will cater for a drop in signal level, due to fading, of about 30dB. At the same time full AGC will be available for increase in signal strength. This method of operation, which is really a method of altering the AGC threshold, ensures that noise is not troublesome during gaps in transmission.

The R551 Receiver AGC system controls the incoming SSB, CW and MCW signals in 3mS (attack time). Because of this, it is possible to use AGC on SSB or CW, without getting audio 'thumping' when receiving a word or character. The AGC decay time is about 10 seconds in the modes of operation stated above, when the AGC switch is set to SLOW. This means that receiver gain will not change, and consequently noise will not be troublesome, between words or characters. So, providing that rapid fading of the signal is not taking place, or bad impulse noise is not present, it is advisable to set the AGC switch to SLOW.

The AGC switch should keep the AF output virtually constant, so if fading is noticed, the AGC is not recovering quickly enough and the AGC switch should be set to FAST. When exceptionally high interference is present the following should be tried.

- (d) Rotate the RF Gain control fully clockwise, set the AGC switch to FAST, and the Line/Signal switch to SIGNAL. Set the AF Gain control for a suitable audio output. Rotate the RF Gain control counter-clockwise until the meter needle just moves up-scale. The AGC will then be overridden and should be switched off. Now rotate the RF Gain control slowly clockwise, causing the signal (with interference) to increase

in amplitude at the final stage of the 1.4MHz IF amplifier. This stage is fitted with a symmetrical peak clipper so that as the RF Gain control is turned clockwise, the noise peaks start to be clipped, with further rotation of the RF Gain control even the wanted signal will be clipped. The RF Gain control must be set to a compromise position which allows clipping of interference spikes but not distortion of the wanted signal.

Many transmitters on CW, emit a certain amount of

carrier during the key-up condition. If the AGC were allowed to decay rapidly during this key-up period, the carrier leak may be received at almost the same level as the carrier, and communication would be impossible. This effect can be largely eliminated by setting the AGC switch to SLOW with the RF Gain control fully clockwise. However, for improved reception, the method detailed in (c) above should be employed.

A summary of the use of the RF Gain control and AGC switch under various operating conditions follows in Table 3.2.

Table 3.2 Use of RF Gain Control and AGC Switch

<i>Reception Mode</i>	<i>Reception Conditions</i>	<i>AGC Switch Position</i>	<i>RF Gain Control Setting</i>
A3 A3H	Very strong impulse noise interference	FAST	Carry out adjustments as detailed in (b) above
A3 A3H	Good signal with slow fading	SLOW	Fully clockwise
A2 A2H	Slight fast fading	FAST	Fully clockwise
	Deep fast fading	FAST	Fully clockwise
	Good signal with slow fading	SLOW	Carry out adjustments as detailed in (c) above
	Good signal with fast fading	FAST	Carry out adjustments as detailed in (c) above
A3J A1	Good signal with deep fading	FAST	Fully clockwise
	Heavy impulse noise interference	OFF	Carry out adjustments as detailed in (b) or (d) above
	Very heavy impulse noise interference	OFF	Carry out adjustments as detailed in (c) above
A2 A2H	Heavy impulse noise interference	FAST	Carry out adjustments as detailed in (b) above
		OFF	Carry out adjustments as detailed in (b) or (d) above. If reception impossible, try to receive on A3J or A1 positions

3.3.5 Reception of Single Sideband A3J Signals

The Service Bandwidth kHz switch has two positions for the reception of single sideband signals, A3J usb and A3J lsb. Speech can be clarified by use of the fine tuning control.

3.3.6 Reception of Double Sideband A3, A2 Signals and Compatible AM A3H, A2H Signals

The Service Bandwidth kHz switch has two positions for the reception of speech (or music): AM8 and AM3.

When listening to music or speech, the AM8 position should be selected, and should only be reduced if interference is bad. Use of the AM3 position is only justifiable if interference is severe, because this gives an audio bandwidth of only 1.5kHz which is virtually useless for music and not particularly good for speech.

However, the AM3 position is ideal for the reception of single sideband A3H signals, which use a carrier and one sideband. In this case the receiver can be detuned, when the audio bandwidth is almost 2.7kHz.

Unlike reception of A3J and A1, the accuracy of tune required for DSB reception is not great. Once the frequency has been set up, fine tuning is not normally necessary.

3.3.7 Reception of DSB in the Presence of Very Heavy Interference

When heavy adjacent-channel interference or bad selective fading is present, it is often advantageous to select A3J (usb or lsb—whichever has the least interference) on the Service Bandwidth kHz switch and receive the wanted DSB signal as if it were an SSB signal. In this condition of reception, the carrier is removed and replaced by an internal oscillator.

This is advantageous during selective fading, when fading of the incoming carrier without corresponding fading of the sidebands causes envelope distortion. This distortion is not apparent on SSB reception because an envelope detector is not used and, as stated, the carrier is replaced.

If an adjacent DSB station, for example 8kHz away, is breaking through into the wanted passband, an envelope detector will demodulate the sidebands of the unwanted signal to produce unwanted audio information along with the wanted audio information. However, if the wanted signal is being received on SSB, the unwanted signal will be demodulated to produce a nominal frequency of 8kHz—not nearly so annoying. Furthermore, if headphones are used, this unwanted frequency may be attenuated by the inherent frequency response of the headphones.

When a DSB signal is being received in the SSB mode, accurate tuning can be obtained by tuning in the carrier for a zero beat note.

3.3.8 Reception of CW

The Service Bandwidth kHz switch controls the BFO so that it is only available when A1 cw positions are selected.

When tuning in a CW signal, it is essential that it is first centred in the receiver passband before the BFO is adjusted for the desired tone. There are three methods of doing this. Methods (a) or (b) are only necessary when the exact frequency of transmission is not known or when the transmission accuracy is worse than 50Hz. Method (c) can be used when the frequency of reception is known exactly.

- (a) Set the Service switch to SSB and tune in the CW signal for a zero beat. The centre frequency (or zero) of the BFO is 1.4MHz, which is the same as the re-insertion oscillator frequency used on SSB; thus, if a CW signal is tuned in to give a zero beat note on SSB, then the incoming signal will have been translated to 1.4MHz at the receiver second IF stage. Next, set the Service Bandwidth kHz switch to either the A1 cw 1 or 0.3 positions and adjust the BFO for a zero beat with the incoming signal. The BFO will now be at 1.4MHz and therefore centred. Having zeroed the BFO, a received CW signal will be correctly in tune when it has been tuned in for zero beat. The BFO should then be adjusted to give the required tone.
- (b) This method is not as accurate as (a) but is slightly quicker and may be used when the narrowest bandwidth (0.3kHz) is not employed. Set the Service Bandwidth kHz switch to A1 cw 1, the Line/Signal switch to SIGNAL, and the AGC switch to FAST. Tune in the signal for maximum deflection on the meter, then adjust the BFO control for the desired tone. If conditions allow, return the AGC switch to SLOW.

- (c) This is the quickest method. If the transmitter frequency is known accurately (within 50Hz) and the receiver has been recently calibrated, it is only necessary to set the frequency on the receiver controls and adjust the BFO control for the desired tone.

The inherent frequency stability of the R551 Receiver allows the continuous use, under normal operating conditions, of the 0.3kHz bandwidth, ensuring better rejection of unwanted signals, and improved signal-to-noise ratio.

The 8kHz or 3kHz bandwidths are useful for 'searching'. Once the signal has been found, the bandwidth can be narrowed to 0.3kHz. Another use of the wider bandwidths may be found during 'netting' or listening on a calling channel when poor frequency accuracy of other stations is experienced.

3.3.9 Reception of CW in the Presence of Very Heavy Interference

Selection of the 0.3kHz bandwidth will reduce the interference from an adjacent channel signal if it is more than 150Hz off tune.

A further remedy is to adjust the BFO control to produce a zero beat with the interfering signal. The resultant audio output tone will be equal to the frequency difference between the wanted and unwanted signals.

3.3.10 Reception of MCW A2 and A2H Signals

A 3kHz bandwidth is normally required for MCW reception, although the 1kHz bandwidth can be used when a modulating frequency below 500Hz is employed.

3.3.11 Calibration

The highly stable synthesiser controlled by the three left-hand decade switches on the front panel requires no frequency check, the calibration facility being provided to allow the operator to make an occasional check of the VFO accuracy.

First set the Service Bandwidth kHz switch to TEST/CAL position. Set the AF Gain control fully clockwise; switch on the loudspeaker and switch AGC to FAST. Set the mechanical counter to 000 at the high frequency end by rotating the tune control clockwise. The 9(CAL) lamp should light to indicate that 000 has been set at the correct end of the range. An audio note should be heard and this should be adjusted for a zero beat note by means of the Cal control.

If enhanced accuracy is necessary the meter can be used. Set the Line/Signal switch to SIGNAL and observe the meter needle. Adjust the Cal control for minimum rate of meter needle flutter.

Once the receiver has had a few hours to warm up, only very occasional calibration will be necessary.

3.3.12 Low Level Line Adjustment

Set the Line/Signal switch to LINE and adjust the Line control for the desired level on the meter.

3.3.13 Test Facility

Use of the TEST position of the Service Bandwidth kHz switch is fully covered in para. 7.3.

3.3.14 Front-End Protection Fuse

A fuse FS1, protects the front-end circuits from very large signals. Signals large enough to blow this fuse are unlikely, but the operator should be aware of the possibility. FS1 is located on the rear panel of the receiver and the fuse replacement is 250mA (5920-99-914-0687).

4 CIRCUIT DESCRIPTION

4.1 PRINCIPLES OF OPERATION

- 4.1.1 COMPLETE RECEIVER
- 4.1.2 FREQUENCY DETERMINING CIRCUITS
- 4.1.3 AUTOMATIC GAIN CONTROL

4.2 DETAILED CIRCUIT DESCRIPTION

4.2.1 AERIAL CIRCUITS

- 4.2.1.1 Aerial Muting
- 4.2.1.2 Sub-Octave Filters
- 4.2.1.3 Front-End Protection
- 4.2.1.4 RF Amplifier
- 4.2.1.5 Mixer 1

4.2.2 38MHz IF CIRCUITS

- 4.2.2.1 38MHz Filter
- 4.2.2.2 38MHz IF Amplifier
- 4.2.2.3 Mixer 2

4.2.3 39.4MHz OSCILLATOR

4.2.4 38 TO 68MHz BANDPASS FILTER

4.2.5 1.4MHz IF CIRCUIT

- 4.2.5.1 IF Filters
- 4.2.5.2 IF Amplifier
- 4.2.5.3 Demodulation

4.2.6 AUDIO CIRCUITS

- 4.2.6.1 Audio Preamplifier
- 4.2.6.2 Audio Amplifier
- 4.2.6.3 Low Level Line Amplifier

4.2.7 AGC CIRCUITS

- 4.2.7.1 Peak Level Detector
- 4.2.7.2 AGC Time Constant Circuits
- 4.2.7.3 Manual Control of Receiver Gain
- 4.2.7.4 Receiver Desensitising and External RF Gain Control
- 4.2.7.5 AGC Attenuation
- 4.2.7.6 AGC Output Facility
- 4.2.7.7 Signal Level Indication

4.2.8 VARIABLE FREQUENCY OSCILLATOR (VFO)

4.2.9 VFO MECHANICAL DRIVE SWITCHES

4.2.10 MIXER 5

4.2.11 4.1 TO 5.0MHz VCO CIRCUITS

- 4.2.11.1 4.1 to 5.0MHz VCO
- 4.2.11.2 41 to 50 Variable Divider

- 4.2.11.3 Divide-by-2 Circuit (Bistable)
 - 4.2.11.4 Reference Frequency Divide-by-2 Circuit (Bistable)
 - 4.2.11.5 Phase Comparator
 - 4.2.11.6 DC Amplifier and Filter
 - 4.2.12 3.4 TO 4.4MHz STEP FILTER
 - 4.2.13 MIXER 3
 - 4.2.14 35 TO 36MHz FILTER AND AMPLIFIER
 - 4.2.15 38 TO 68MHz VCO CIRCUITS
 - 4.2.15.1 Mixer 4
 - 4.2.15.2 32MHz Low-Pass Filter and Amplifier
 - 4.2.15.3 Divide-by-10 Prescale
 - 4.2.15.4 3 to 32 Variable Divider
 - 4.2.15.5 Monostable
 - 4.2.15.6 Phase Comparator
 - 4.2.15.7 DC Amplifier and Filter
 - 4.2.15.8 In-Lock Sensing Circuits
 - 4.2.15.9 38 to 68MHz VCO
 - 4.2.16 INSERTION OSCILLATOR CIRCUITS AND BFO (OPTIONAL HIGH STABILITY UNIT)
 - 4.2.16.1 Circuit Operation
 - 4.2.16.2 1.4MHz Amplifier
 - 4.2.16.3 External Frequency Reference
 - 4.2.16.4 5.6MHz Frequency Reference Circuits
 - 4.2.16.5 Description of Reference Circuits
 - 4.2.17 1.4 MHz FREQUENCY REFERENCE AND BFO (NORMAL UNIT)
 - 4.2.17.1 1.4MHz Reference Oscillator
 - 4.2.17.2 Divide-by-14
 - 4.2.17.3 BFO
 - 4.2.17.4 1.4MHz Amplifier
 - 4.2.18 POWER SUPPLY AND STABILISATION
 - 4.2.18.1 Input Supplies
 - 4.2.18.2 Rectification Circuits
 - 4.2.18.3 20V DC Stabiliser
 - 4.2.18.4 5V DC Stabiliser
 - 4.2.19 TEST/CAL FACILITY
 - 4.2.19.1 Calibrate
 - 4.2.19.2 Test
 - 4.2.20 OPERATION OF ARU11B SYNTHESISER
- FIG. 4.1 BLOCK DIAGRAM OF R551 RECEIVER**

4 CIRCUIT DESCRIPTION

4.1 PRINCIPLES OF OPERATION

Refer to Fig. 4.1 which shows the block diagram of the receiver.

4.1.1 COMPLETE RECEIVER

The input signal is fed via an aerial muting relay, to a bank of sub-octave bandpass filters which attenuate out-of-band signals to reduce blocking and improve intermodulation performance. After filtering, the signal is passed to an RF amplifier which has its own front-end AGC system.

Following the RF amplifier is a 30MHz low-pass filter and then the first mixer, which accepts the full range of aerial frequencies (100kHz to 30MHz) and the output from the divide-by-N synthesiser (described separately) which is always 38MHz higher than the signal frequency. The required output frequency of the mixer is 38MHz (first IF), this being passed via the 8kHz band-pass filter centred on 38MHz which removes unwanted mixing products, to the 38MHz first IF amplifier. Output from this amplifier is applied to the second mixer. Also applied to this mixer is the output from the 39.4MHz oscillator.

Filters, selected by the Service Bandwidth kHz switch, extract the 1.4MHz second IF and pass it to the 1.4MHz amplifier.

In the second IF amplifier is a crystal filter having a pass-band of around 1kHz which is switched in circuit on 0.3kHz CW operation only to reduce the noise due to the high gain wide band amplifier.

From the second IF amplifier the signal is applied to the demodulator, this being a conventional type for DSB modes of operation. For SSB modes, the re-insertion frequency of 1.4MHz is derived from a standard or from the same oscillator as for the BFO on CW, except that the oscillator is phase locked to the standard reference frequency to provide exactly 1.4MHz. Note that a clarifier is not used, clarification being achieved by variation of the VFO frequency (see para. 4.1.2). A variable BFO is provided for CW operation.

Audio output from the demodulator is applied to an AF amplifier which provides loudspeaker and headphone outputs and also input to another amplifier which provides a low-level line output.

An AGC system which complements the front-end AGC system, is used over the IF stages (see para. 4.1.3).

4.1.2 FREQUENCY DETERMINING CIRCUITS

The frequency determining circuits are in the form of a divide-by-N synthesiser, this being a synthesiser in which the division ratio varies with output frequency.

As can be seen from the block diagram (Fig. 4.1) two phase-lock loops are employed in the frequency determining circuits: one associated with the 38 to

68MHz VCO (voltage controlled oscillator), and one associated with the 4.1 to 5.0MHz VCO.

When the operator tunes the receiver to the frequency he wishes to receive, he sets up the first three digits by means of rotary control knobs and the remaining three digits on a mechanical counter which is actuated when the front panel tuning control is rotated. Thus the standard R551 Receiver is part synthesised and part tunable. Full frequency synthesis is possible by use of the ARU11B Synthesiser.

The basic function of the frequency determining circuits can be best understood by considering what happens when a frequency, e.g. 25.8260MHz, is set up on the front panel.

The signal frequency is applied to Mixer 1, the output of which must contain 38MHz (first IF).

If an IF of 38MHz is to be produced, then the 38 to 68MHz VCO must supply an output of 63.8260MHz so that the required 38MHz difference frequency can be extracted from the mixer output.

Rotary control knobs on the front panel set the 38 to 68MHz VCO approximately to the frequency required, by selection of tuning elements in the oscillator. The 10MHz and 1MHz step switches are coarse controls and the 100kHz step switch is a fine control. In this way, the oscillator can cover the nominal frequency range of 38 to 68MHz in approximately 200kHz steps. In the case under discussion, the 10MHz switch is set to position 2, the 1MHz to position 5 and the 100kHz switch is set to 8 to give an approximate VCO output of 63.8MHz.

Thus, it can be seen that the nominal output of the VCO is always 38MHz above the setting of the 10MHz and 1MHz switches, i.e. $25 + 38 = 63$.

It has been shown how the VCO is set to the approximate frequency required and it now remains to show how it is set to the exact frequency required. To do this, it is convenient to start considering the VFO.

The VFO covers the frequency range of 600 to 700kHz and is set to the required frequency by the front panel tuning control, which also actuates a 3-digit mechanical counter. When this counter is set to 000 at the low frequency end, the VFO is oscillating at 600kHz, and when it is set to 000 at the high frequency end, the VFO is oscillating at 700kHz. The last three digits in the example under discussion, i.e. 260, are set on this counter to give a VFO output of 626.0kHz. This output is applied to Mixer 5. Also applied to this mixer is the output of another VCO, this covering the frequency range 4.1 to 5.0MHz in 100kHz steps. The 100kHz switch on the front panel sets the frequency of this VCO. When the switch is set to 0, the VCO is oscillating at 5.0MHz, and when it is set to 9, it is oscillating at 4.1MHz. In this example, the switch is set to position 8, to give a VCO output of 4.2MHz.

A phase locked loop is associated with the 4.1 to 5.0MHz VCO to bring it on to frequency. The VCO is set to approximate frequency by a wafer of the front panel 100kHz switch, the nominal VCO frequency being set higher on positions 0 to 5 than on positions 6 to 9. The output of the VCO is applied to a 41 to 50 variable divider, the division ratio of which is automatically set by the front panel 100kHz switch. For example, when the switch is set to 0, the divider divides by 50, whilst when it is set to 9, it divides by 41. The variable divider output is divided by 2 before being compared with the 50kHz reference signal. Any frequency difference between the two signals results in the production by the phase comparator of an error signal which is applied to the VCO via a DC amplifier and filter.

As mentioned in this example the 100kHz switch is set to 8. Assume that the coarse setting of the VCO is nominally 4.3MHz. The variable divider will be set to divide by 42 to produce an output of approximately 102kHz. This is then divided by 2 to give a frequency of approximately 51kHz.

When this frequency is compared with the reference frequency in the phase comparator, a correction signal will be produced to pull the VCO to the required frequency, exactly 4.2MHz. When the VCO is oscillating at this frequency, the output of the divide-by-2 prescale will be 50kHz; no error signal will therefore be produced by the phase comparator and the VCO will be locked at 4.2MHz. If the 100kHz switch is now set to 9, the coarse setting of the VCO would remain the same, but the variable divider would divide by 41, causing the VCO to lock at 4.1MHz.

It has been explained how Mixer 5 gets its mixing frequencies. In the example under discussion they are: 626kHz from the VFO and 4.2MHz from the 4.1 to 5.0MHz VCO. After mixing, a difference frequency of 3.5740MHz is extracted and applied to Mixer 3. Also applied to this mixer is the output of the 39.4MHz oscillator. Again the difference frequency is selected, this being 35.8260MHz.

Note that the 39.4MHz oscillator output is also applied to Mixer 2, and since the output of this oscillator is injected at two different points in the signal path, any frequency drift produced by it is nullified.

Applied to Mixer 4 is the difference frequency from Mixer 3, i.e. 35.8269MHz, and the output of the 38 to 68MHz VCO which in this case is a nominal 63.8MHz. It will be remembered, however, that the frequency output required from this VCO, in order that a signal of 25.8260MHz may be received, must be 63.8260MHz. This discrepancy is taken care of by a phase locked loop, the action of which is as follows.

The difference frequency of 27.974MHz (63.8-35.826MHz) is extracted from Mixer 4, this frequency being divided by 10 to give a frequency of 2.7974MHz. The output of the divide-by-10 circuit is then applied to a variable divider covering a division range of 3 to 32. The division ratio of this divider is automatically set by the front panel 10MHz and 1MHz switches, and

is always 3 higher than the number indicated by them. Thus in this example, the division ratio is $25 + 3 = 28$, to give an output frequency to the phase comparator of approximately 99.9kHz. Also applied to the phase comparator is a 100kHz reference signal from the frequency standard. As in the other phase locked loop, the two signals are compared and an error signal is produced to set the VCO to the exact required output frequency.

An in-lock sensing circuit reduces the filter bandwidth when the VCO frequency approaches the correct value.

4.1.3 AUTOMATIC GAIN CONTROL

Two AGC systems are employed. One is operated by the output from the RF amplifier and controls an attenuator at the front end. The other is fed from the last 1.4MHz IF stage and is applied progressively to the attenuators in the IF stages and the front end in the following order:

- (a) Fourth 1.4MHz IF stage attenuator
- (b) front-end attenuator
- (c) 38MHz attenuator
- (d) second 1.4MHz IF stage attenuator
- (e) third 1.4MHz IF stage attenuator

This sequence of AGC application ensures optimum signal-to-noise ratio at all times.

The front-end AGC system also operates on strong adjacent unwanted signals that fall outside the IF pass-band, but within the RF pass-band, which would otherwise cause blocking by failing to actuate the IF AGC detectors.

4.2 DETAILED CIRCUIT DESCRIPTION

4.2.1 AERIAL CIRCUITS

4.2.1.1 Aerial Muting

Refer to Fig. 10.8

The signal at the aerial socket SK1 is applied to the open contact of muting relay contacts RL1-1. The coil of relay RL1 is connected across the 20V supply via plug PL2 and socket SK3 (switched to chassis), and is consequently energised when the receiver is switched on. Contacts RL1-1 then change over to apply the signal to the input of the filters. Resistor R1 functions as a static leak.

Socket SK3 is connected to chassis via SK15/1 (on the rear panel of the receiver), or is earthed by the transmitter.

Note that the receiver is automatically protected against RF overloads if the power supply fails or if the receiver is switched off, as under this condition the

muting relay is unenergised and the aerial consequently is connected to chassis via the static leak resistor R1.

4.2.1.2 Sub-Octave Filters

Refer to Fig. 10.8

Sub-octave bandpass filters are employed to reduce the level of out-of-band signals. The switch wafers employed in the filter circuits are operated by the front panel frequency selection switches as follows:

Frequency Switch	Switch Wafers Operated		
10MHz	S1EBa	S1EBb	S1DF
1MHz	S2GF	S2FF	S2CB
	S2GB	S2EB	S2EF
100kHz	S3GF	S3GB	S3FB
	S3FF	S3HF	S3HB

When the frequency to be received is set up on the front panel, the filter switches automatically select the required filter. In addition, the 100 to 150kHz or 150 to 200kHz filter is switched by relay RL10 either from the VFO mechanism or the ARU11B Synthesiser.

4.2.1.3 Front-End Protection

Refer to Fig. 10.3

The output of the filters is fed via matching inductor L104 and fuse FS1, to matching transformer T37. The fuse is a front-end protection fuse. During large signal conditions, the RF amplifier transistors VT1 and VT2 are protected against overload voltages by the front-end AGC system, but if the overload voltage becomes excessive, FS1 will blow to protect the amplifier.

4.2.1.4 RF Amplifier

Refer to Fig. 10.3

Signal voltages are applied to a wideband amplifier via the electronic attenuator X1.

Transistors VT1 and VT2 are connected in class A push-pull. Individual negative feedback is provided by R5 and R6 (not decoupled) whilst overall negative feed-back is provided via R12. Damping resistor R10 minimises changes in impedance (and hence changes in feedback) presented by VT1 and VT2 during their conducting cycles. Connected to the secondary of T3 is a 30MHz low-pass filter with 38MHz IF rejection circuit (L58, C114).

Associated with the wideband amplifier is a front-end AGC system. This complements the main IF AGC system and controls very large unwanted signals falling within the RF passband but outside the IF passband, and which therefore do not operate the main AGC circuits. Such signals, if not controlled, would overload the RF amplifier and cause loss of wanted signals.

Wanted signals are also affected by this front-end attenuation. Thus, this AGC loop is arranged to come into operation not only for out-of-band signals, but for

large wanted signals which would otherwise cause intermodulation, cross-modulation, and blocking.

Transistors VT3, VT4, VT5 and VT6 form a DC coupled amplifier driving electronic attenuator X1, the attenuation of which increases with increase in current. RF signal voltage at the L58, R26 junction is applied via buffer resistor R26 and capacitor C121 to the base of VT6, a detector. Rectified RF pulses at VT6 collector are directly coupled to VT5 where they are amplified and smoothed by C118 in the collector circuit.

Immediately the local AGC circuits are activated and VT5 consequently conducting, a voltage is applied via isolating diode MR4 and PL6/C to the main IF AGC system to shorten the time-constants of this system. This ensures that the receiver is not 'blanked off' for long periods in the presence of high level transient signals.

The voltage at VT5 collector is fed to VT4 base via MR2 and buffer resistor R19. Also applied to the base of VT4 is a control voltage from the main AGC system, fed via PL6/B, MR3 and R18 (see para. 4.2.7.5). Diodes MR2 and MR3 isolate the main AGC from the front-end AGC to prevent interaction.

Transistor VT4 is directly coupled to VT3, which drives the electronic attenuator X1 via R13. Capacitor C116 decouples the attenuator drive line which is protected against excessive reverse voltage (caused by rectification of very large signals in the attenuator) by MR1.

4.2.1.5 Mixer 1

Refer to Fig. 10.3

This mixer comprises components T4, T5, T6 and diodes MR5, MR6, MR7 and MR8. Signal frequency voltages are applied to T4 primary whilst the output of the 38 to 68MHz VCO is fed, via a bandpass filter, to the primary of T5. Output from the mixer is taken from T6 secondary windings.

4.2.2 38MHz IF CIRCUITS

Refer to Fig. 10.3

4.2.2.1 38MHz Filter

FL14 is a crystal filter which selects the 38MHz first IF from the output of Mixer 1 and feeds it to the 38MHz IF amplifier.

4.2.2.2 38MHz IF Amplifier

The 38MHz IF Amplifier is a single class A push-pull stage comprising transistors VT7 and VT8. Individual feedback is provided by bias resistors R30, R31 and undecoupled emitter resistors R32, R33. Transformer T9 in conjunction with capacitor C126 tunes the amplifier to 38MHz. The output at T9 secondary is connected to Mixer 2 via L118 which is an image frequency rejector tuned to reject 40.8MHz.

4.2.2.3 Mixer 2

Comprising components T10, T11, MR9, MR10, MR11, MR12 and R38, this mixer accepts the output of the 38MHz amplifier (via T10) and the output of the 39.4MHz oscillator (via T11 primary).

The mixing products are fed via plug PL8, to filters which select the 1.4MHz second IF (see para. 4.2.5.1).

4.2.3 39.4MHz OSCILLATOR

Refer to Fig. 10.3

Transistor VT9 is connected in the common base configuration. Inductor L62 and capacitor C130 form a series resonant circuit tuned to 39.4MHz, causing 3rd overtone crystal XL1 to operate in the series mode with feedback applied via C133. Resistor R39 is a damping component.

The output at the emitter of VT9 is applied to two output amplifiers VT11 and VT12, which are both tuned stages. VT11 provides the necessary output via plug PL11 to the frequency synthesiser. VT12 provides the local

injection voltage for Mixer 2 via the tuned circuit comprising L126 and C406.

4.2.4 38 TO 68MHz BANDPASS FILTER

Refer to Fig. 10.3

This filter, comprising L106, L107 and associated components, passes the output of the 38 to 68MHz VCO to Mixer 1. (see paras. 4.2.1.5 and 4.2.15.9).

4.2.5 1.4MHz IF CIRCUIT

4.2.5.1 IF Filters

Refer to Fig. 10.2

The output of Mixer 2 is connected via socket SK8 to the wiper of Service Bandwidth kHz switch wafer S4AF. This wafer, in conjunction with wafers S4CF, S4CB, S4AB and S4AF, feeds the mixer output after filtering to the 1.4MHz amplifier. The 1.4MHz IF filter selected by the Service Bandwidth kHz switch provides the required bandwidth for the mode of operation in use, details being given in the table below.

For independent sideband use a LSB output is taken from the hybrid X2 to SK12 on the rear panel.

Service Bandwidth kHz Switch Position	1.4MHz IF Filter Selected	Bandwidth of 1.4MHz IF Filter
1 ISB†	FL18	2.75 or 5.5†
2 LSB†	FL19	2.35kHz or 2.75†
3 USB	FL18	2.35kHz or 2.75†
4 AM8	T11, C107, L64, C140 etc.	*8kHz
5 AM3	FL17	3kHz
6 AM1	FL16	1kHz
7 cw 0.3	FL15	0.3kHz
8 cw 1	FL16	1kHz
9 cw 3	FL17	3kHz
10 cw 8	T11, C107, L64, C140 etc.	*8kHz
11 TEST/CAL	See para. 4.20	—

*Bandwidth determined by 38MHz Filter FL14

†Optional

On the A1 cw 0.3 position the 0.3kHz filter FL15 is selected, further bandwidth restriction being carried out subsequent to IF amplification to reduce amplifier noise, by the filter circuit including crystal XL2.

4.2.5.2 IF Amplifier

Refer to Fig. 10.4

The 1.4MHz IF output of the filter is applied to a four-stage wideband amplifier comprising transistors VT13 to VT16 and then to a tuned amplifier VT17 which limits the bandwidth of the otherwise untuned IF section. In the CW 0.3kHz mode of operation, a crystal filter is switched into circuit to further reduce the bandwidth.

The filtered signal at PL13/A is applied to the first stage of IF amplification VT13. Shunt negative feedback is applied to this stage via C143 and R57, and series

negative feedback is applied via the undecoupled emitter resistor R61. Transformer T15 provides coupling to the next stage VT14, and resistor R64 provides damping of T15 secondary.

Emitter resistor R66 in VT14 stage is not decoupled and so provides negative feedback. From the collector, the output is directly coupled to the base of VT15. When VT14 stage is subjected to AGC action, the base circuit is shunted by a diode attenuator network (see para. 4.2.7.5).

The output of the amplifier VT15 is capacitively coupled to the base of transistor VT16, to which negative feedback is applied via R78. As VT14, the bases of these transistors are connected to diode attenuator networks.

From VT16 collector, the IF signal is directly coupled to the base of VT17—this stage is not subject to

AGC action. Three resistors R82, R83 and R84 in the emitter circuit, in conjunction with capacitor C160, determine the gain of this stage. The Service Bandwidth kHz switch wafer S4DB automatically sets the amount of emitter decoupling, and consequently the amount of negative feedback and the gain of the stage, to the optimum value for the mode of reception in use.

Two coupled tuned circuits comprising T16, C158 and T17, C162 are employed in the collector circuit of VT17. For all service modes except CW 0.3kHz, coupling is effected by capacitor C161. In this mode of operation C161 is disconnected and coupling is provided by crystal XL2 to restrict the noise bandwidth. Neutralising is carried out by trimmer C159. Wafer S4EB short-circuits the crystal when not in use.

Capacitor C163 couples the signal at T17 to the base of VT18. In the collector circuit of this transistor is wideband transformer T18, damped by resistor R91. Also included in the collector circuit are two limiter diodes MR13 and MR14, which limit the output of the IF amplifier. Reverse bias for these diodes is applied via the R88, R89, R86, R87 resistor chain.

Three outputs are taken from VT18 stage:

- (a) An output from the collector to the AGC system (see para. 4.2.7.1).
- (b) An output from the emitter to buffer amplifier

VT19. This amplifier supplies a 1.4MHz IF signal to socket SK20, via C167.

- (c) An output from the secondary of T18, to the wiper of Service Bandwidth kHz switch wafer S4HB via R94. This wafer, in conjunction with wafer S4HF, applies the IF signal to either a conventional envelope detector or a product detector, depending on the service selected.

4.2.5.3 Demodulation

Refer to Fig. 10.4

Two types of demodulator are employed:

- (a) Conventional diode envelope rectifier comprising MR15 loaded by R97.
- (b) Diode product detector comprising diodes MR16, MR17 and resistors R99 and R100. The re-insertion signal for this detector is taken from the 1.4MHz re-insertion amplifier and applied via PL14/R and PL14/P (see para. 4.2.16.2).

The input and output levels of the detectors are automatically set by the Service Bandwidth kHz switch so that the audio outputs are approximately equal on all modes of operation.

At each position of the Service Bandwidth kHz switch the demodulator circuit is as follows:

Service Bandwidth kHz Switch Position	Demodulator Circuit		
	Type	Input to	Output via
1 ISB†	Product Detector	Junction of MR16 and MR17	R101 to RF filter circuit
2 LSB†			
3 USB			
4 AM8	Envelope Rectifier	MR15	Junction of MR15 and R97 to RF filter circuit
5 AM3			
6 AM1			
7 cw 0.3	Product Detector	Junction of MR16 and MR17	R101 to RF filter circuit
8 cw 1			
9 cw 3			
10 cw 8			
11 TEST/CAL			

†Optional

4.2.6 AUDIO CIRCUITS

4.2.6.1 Audio Preamplifier

Refer to Fig. 10.4

The output of the demodulator is applied via an RF filter and DC blocking circuit to the base of preamplifier VT20 which in conjunction with VT21 forms a two-stage directly coupled amplifier. A connection to the junction of R103 and R104 allows amplification of sidetone (applied via PL14/V and SK15/12) from an associated transmitter. Feedback is applied to VT20 stage via the undecoupled emitter resistor R107.

The load of VT21 consists of the front panel AF

Gain control R168 and series resistor R169, in parallel with the Line Level potentiometer R167. This load is connected between PL14/D and chassis. The slider of each potentiometer is taken to a separate amplifier, namely, the AF amplifier and the line output amplifier. These are described in paras. 4.2.6.2 and 4.2.6.3 respectively.

4.2.6.2 Audio Amplifier

Refer to Fig. 10.4

From the slider of the AF Gain control R168, the AF voltage is applied via PL14/C to the base of VT22, the output of which is transformer coupled to a class AB push-pull stage comprising transistors VT23 and VT24.

Resistor R119 and capacitor C178 are feedback components. Transformer T20 has two output windings, 3Ω and 600Ω. The output of the 3Ω winding is applied via PL14/A and PL14/B to:

- (a) the front panel headphone sockets JK1 and JK2 (via series resistors)
- (b) the internal loudspeaker.

The front panel loudspeaker switch controls the internal loudspeaker.

4.2.6.3 Low Level Line Amplifier

Refer to Fig. 10.4

The voltage at R167 slider is capacitively coupled to VT32 base via PL13/E and C196. This transistor is an emitter follower and transformer T21 in the emitter circuit feeds the line output signal into a 600Ω line via PL13/H, PL13/F and SK15/5, SK15/7. Front panel meter ME1 monitors the line output level when the Line/Signal switch is set to LINE position. The meter circuit has an almost logarithmic characteristic, produced by the diode-resistor network connected between T21 secondary and the meter.

This network functions as follows. At a standard level of 0dBm, diode MR33 does not conduct and R161 is adjusted for a meter indication of 0dBm; at a standard high level of +10dBm, diode MR33 conducts and R162 is adjusted for a meter indication of +10dBm.

The meter is connected to the line output circuit via the Line/Signal switch and PL13/P, PL13/L.

4.2.7 AGC CIRCUITS

4.2.7.1 Peak Level Detector

Refer to Fig. 10.4

The AGC signal is taken from the collector of VT18 and applied to the base of VT29. This transistor, in conjunction with VT28, forms a peak level detector. The circuit does not conduct until the AGC threshold level is exceeded, the level being set by the R145, R146 arrangement.

When the peak level detector conducts, a charging current proportional to the signal level is fed to the time constant circuits which determine the attack and decay time.

4.2.7.2 AGC Time Constant Circuits

Refer to Fig. 10.4

Three capacitors are mainly associated with the time constant circuits: C190, C191 and C192. Capacitor C190 is the AGC attack time capacitor, whilst C191 and C192 are the decay time capacitors.

The optimum time constant values for the mode of operation in use are automatically selected by the Service Bandwidth kHz switch. Also included in the time constant circuits is an AGC switch which has three positions:

- (a) SLOW—for usual operating conditions

- (b) FAST—for conditions of rapid fading, and for when tuning the receiver

- (c) OFF—switches the AGC off.

Assume the AGC switch is set to SLOW position. On AM (8kHz and 3kHz bandwidth) operation (and also on TEST/CAL) a short circuit is connected across R142 by S4GB contacts, and resistors R143 and R144 are switched into circuit by S4FF contacts. The charging current to the two time constant capacitors is (ignoring R141) via R144. Note that C192 is short-circuited by the AGC switch (effectively short-circuiting PL13/H and PL13/F). This circuit arrangement provides a relatively slow attack time, as R143 is out of circuit, for AM operation. On all other modes of reception, R144 is short-circuited to decrease the attack time, whilst R143 is disconnected to increase the decay time.

The receiver cannot be blocked by the action of isolated interference pulses charging the AGC capacitors because random transients do not last long enough to charge C191, and although they will charge C190, this charge will decay rapidly.

The discharge of the AGC time constant circuits is also controlled by transistor VT27, which is connected across resistor R138. If a signal is received of sufficient amplitude to operate the front-end AGC system, then a voltage is applied to VT27 base to cause it to conduct. This action effectively short-circuits R138 and the decay time is considerably decreased.

When the AGC switch is set to FAST, the short circuit is removed from C192 which is then connected in series with C191 to reduce the total capacitance, and hence decay time. This facility is useful in conditions of rapid fading and for tuning.

4.2.7.3 Manual Control of Receiver Gain

Refer to Fig. 10.4

The RF Gain control is part of a resistor network fed from the 20V supply. This supply is connected by Service Bandwidth kHz switch wafer S4BB in all positions except TEST/CAL ensuring that the RF Gain control is overridden during TEST/CAL operation. Thermistor TH1 provides temperature compensation of any DC drift due to the temperature characteristic of the base-to-emitter junctions of VT25 and VT26.

The slider of the RF Gain potentiometer applies a potential, via PL13/K and diode MR27, as bias to the base of transistor VT26. The output from the AGC time constant network is also applied to the base of VT26 via diode MR28. Of the two voltages, the one which has the highest amplitude controls the transistor.

4.2.7.4 Receiver Desensitising and External RF Gain Control

Refer to Fig. 10.4

If required, a positive potential from an external source can be applied to PL13/K via SK15/20, to desensitise the R551 Receiver.

4.2.7.5 AGC Attenuation

Refer to Fig. 10.4

Transistors VT26 and VT25 form a compound emitter-follower which drives the AGC attenuators.

The AGC voltage is applied progressively to the attenuators in the following order:

- (a) Fourth IF stage attenuator
- (b) front-end attenuator
- (c) 38MHz attenuator
- (d) second IF stage attenuator
- (e) third IF stage attenuator.

This sequence of AGC application ensures optimum signal-to-noise ratio at all times.

From the emitter of VT25, the AGC voltage is applied via two delay diodes MR26a and MR26b and a low-pass filter comprising L67 and C186, to the attenuator in the fourth IF stage. A delay voltage, determined by the R128, R131 potential divider, is applied to the attenuator diodes MR22, MR23.

When the AGC voltage rises to a sufficiently high level, these diodes will conduct to shunt the signal at VT16 base. The maximum voltage across the attenuator diodes is limited by diodes MR25a and MR25b.

As the AGC voltage rises further, it is applied to the front-end attenuator via PL14/U (see para. 4.2.1.4). A further increase overcomes the delay introduced by MR61, R352 and R354 in the 38MHz attenuator.

A still further increase in AGC voltage overcomes the delay introduced by MR24 and causes attenuator diodes MR18 and MR19 to conduct via R126, and consequently shunt VT14 base circuit. Delay bias for these two diodes is applied at junction of R124 and R125.

Finally MR20a, MR20b, MR21a and MR21b conduct to shunt the signal at VT15 base. Note that the delay bias on these diodes is the same as on MR18, MR19, but because there are four in series, a higher AGC voltage is required to cause them to conduct.

Resistors R123 and R127 ensure a smooth AGC action over the full dynamic range.

4.2.7.6 AGC Output Facility

Refer to Fig. 10.4

AGC output, if required, is available at SK15/10 via PL14/T.

4.2.7.7 Signal Level Indication

Refer to Figs. 10.2 and 10.4

AGC voltage is taken from the junction of R134 and C188 and applied to meter ME1 via PL14/P and PL14/S and the Line/Signal switch. When the Line/Signal switch is set to SIGNAL position, the meter indicates the AGC level, and hence the signal strength when the RF Gain is set to maximum.

4.2.8 VARIABLE FREQUENCY OSCILLATOR (VFO)

Refer to Fig. 10.7

Transistor VT51 forms a modified Colpitts oscillator covering the frequency range 600 to 700kHz. Variable capacitors C355 and C356 form a 2 gang capacitor for tuning the oscillator over the frequency range. Preset inductor L98 is adjusted at the low frequency end of the range whilst capacitors C343 and C344 are adjusted at the high frequency end.

Diode MR49 is a varactor diode which is controlled, via plug PL31, by the preset control R286 (CAL), one side of this potentiometer being connected to the +20V supply. The CAL control, in conjunction with the varactor diode, allows the VFO to be pulled on to exact frequency during receiver calibration (see para. 4.2.19.1).

A front panel tuning knob drives the tuning capacitors and a mechanical counter which, when the tuning knob is being rotated in a clockwise direction, reads from 000 (VFO oscillating at 600kHz) to 999 (VFO oscillating at 699.9kHz).

The VFO has an uncalibrated 'frequency overlap' at range edges. Front panel lamps ILP1 and ILP2 are provided to ensure that the VFO, and hence the associated mechanical counter reading, are kept within the calibration range when the receiver is being tuned.

The output at VT51 collector is applied to buffer amplifiers VT52 and VT53 which have two outputs. One output is taken from the collector and fed via plug PL34 to the 1.4MHz reference source for calibration purposes. The other output is taken, again from the collector, and fed to Mixer 5 bandpass filter.

The collector and bias supplies for the oscillator transistor VT51, are connected whenever the front panel power supply switch is set to STANDBY or ON, the connection being made via plug PL39.

A +20V supply for the buffer amplifiers and diode gate is applied via plug PL32, link LK2 and inductor L102. This supply is only available when the front panel Off/Standby/On switch is set to ON and when the ARU11N Synthesiser is switched to VFO position. Indicator lamp ILP3 illuminates the mechanical counter readout and this lamp is only energised when the Off/Standby/On switch is set to ON.

Diodes MR50 and MR51 act as a switch to isolate the oscillator feedback path when the ARU11B Synthesiser is used and thus disable the oscillator. The switching voltage is applied via plug PL32. This arrangement allows the supplies to remain connected to VT51 oscillator when the ARU11B Synthesiser is being used, so that it remains stable should VFO operation be required at short notice.

4.2.9 VFO MECHANICAL DRIVE SWITCHES

Refer to Fig. 10.7

As the VFO ganged capacitor is rotated by the front panel control, the switches S9A and S9B operate at

certain points in the scan. S9A serves to illuminate the 0 and 9 (CAL) lamps on the front panel as explained in para. 3.2.2.

Switch S9B serves to operate relay RL10 in the aerial filter unit, which switches the filters for use on 100 to 150kHz and 150 to 200kHz tune frequencies.

The integrated circuit VX50 is a quad two input NAND gate with the two gates VX50a and VX50b connected as a bistable circuit. The inputs of these two gates are sent 'low' by the action of S9B, depending upon which contact of S9B is made. Only when the other gate is earthed, will the bistable change state, avoiding any flickering of the relay in the intermediate position.

Pin 9 of VX50c is held on when volts are applied to plug PL32, allowing the bistable action to pass VX50d, which is an inversion gate.

Diodes MR100 and MR101 act as an OR gate for VT70, the relay driver. The relay will only switch on the 100 to 200kHz band. The relay earthing via plug PL51 and switches S3J, S3GF, S1EF, ensures this restriction.

When no voltage appears on plug PL32, i.e. when switched to ARU11B Synthesiser, VX50c isolates the bistable from the relay. Plug PL33, which comes from the ARU11B Synthesiser may or may not have 20 volts on it, depending upon the decade switching in the ARU11B Synthesiser.

4.2.10 MIXER 5

Refer to Fig. 10.6

Comprising components T31, T32, MR48 and associated components, this mixer accepts the output of the 600 to 700kHz VFO (via plug PL30) and the output of the 4.1 to 5.0MHz VCO, via T31 centre tap. The mixing products are fed via T32 secondary to a 3.4 to 4.4MHz step filter (see para. 4.2.12).

4.2.11 4.1 TO 5.0MHz VCO CIRCUITS

Refer to Fig. 10.6

4.2.11.1 4.1 to 5.0MHz VCO

Transistor VT48 is employed in a modified Colpitts oscillator circuit.

Inductor L91, in conjunction with capacitors C304, C305 and C306, form the main tuning components. Capacitor C303 is switched in parallel with the tuned circuit by the front panel 100kHz switch wafer S3AB, on positions 6, 7, 8 and 9. Thus, the switch wafer acts as a coarse control of the oscillator frequency. Also connected across the tuned circuit is varactor diode MR47, this component being controlled by the DC output of the associated DC amplifier to vary the frequency of the VCO.

Output at the emitter of VT48 is applied to buffer emitter follower VT49. This transistor provides two outputs: one via C380 to VT50, and one to the following

amplifier stage VT60. Transistor VT50 amplifies the VCO output to drive the 41 to 50 variable divider stage, whilst VT60 drives Mixer 5.

4.2.11.2 41 to 50 Variable Divider

This variable divider employs JK flip-flops VX16, VX17, VX22a, b, VX23, VX25, VX26, VX27 and VX28, and NAND gates VX21a, b, c, and VX24a, b.

The division ratio is controlled by front panel frequency switch wafers S3CB, S3CF, S3BB and S3BF, such that the divider output is always a nominal 100kHz.

The divider input is taken from the 4.1 to 5.0MHz VCO via C308 in VT50 collector, the divider output being applied to a divide-by-2 circuit via VX21b.

4.2.11.3 Divide-by-2 Circuit (Bistable)

Comprising JK flip-flop VX18, this circuit divides the output of the 41 to 50 variable divider by 2 before supplying it, at a nominal 50kHz, to the phase comparator.

4.2.11.4 Reference Frequency Divide-by-2 Circuit (Bistable)

JK flip-flop VX19 accepts the 100kHz reference frequency via socket SK29 and divides it by 2 before applying it to the phase comparator VX20.

4.2.11.5 Phase Comparator

The phase comparator compares the frequency of two signals and produces an output voltage related to their phase difference. Thus, if the VCO frequency is incorrect, its phase is changing relative to the reference frequency and the phase comparator will produce an error voltage varying at the difference frequency. This voltage is used to control the VCO and bring it into phase lock with the reference frequency.

Two square-pulse inputs are applied to the digital two-bit parity generator VX20 (comprising four NAND gates). One input is the 50kHz reference voltage from VX19 whilst the other is the output from the 4.1 to 5.0MHz VCO, via the 41 to 50 variable divider and the divide-by-2 circuit.

When both input signals are of the same frequency, the output of the phase comparator will comprise a chain of pulses which are of constant mark-to-space ratio. The actual shape of the pulse chain will depend on the phase relationship between reference and oscillator signal, and this phase relationship will, in turn, govern the frequency of oscillation of the VCO.

If the two phase comparator signal inputs are not of the same frequency, the output will comprise a chain of pulses which have a varying mark-to-space ratio.

The resultant output pulse of the phase comparator must be converted into a suitable form for subsequent application to the VCO, so that it can control the VCO frequency. This is carried out by the DC amplifier and filter. (See para. 4.2.11.6).

4.2.11.6 DC Amplifier and Filter

The phase comparator output is applied to DC amplifier VT47, the collector circuit of which is connected to a 5kHz low-pass filter (integrator).

When the frequencies of the input signals to the phase comparator are the same, the filter output is a non-varying direct voltage, the level of which sets the frequency of oscillation of the VCO. When the frequencies of the comparator input signals are different (VCO frequency incorrect) a variation in DC output is obtained via the filter which serves to correct the VCO frequency and bring the system into lock.

The 5kHz low-pass filter incorporates a 50kHz trap (L89 and C300). This filter ensures that the VCO only responds to the DC signals, and especially not to the 50kHz or 100kHz component of the phase comparator output.

4.2.12 3.4 TO 4.4MHz STEP FILTER

Refer to Fig. 10.6

Mixer 5 output is applied, via L93 centre tap, to a 3.4 to 4.4MHz bandpass step filter which removes unwanted mixing products.

The filter passband is varied in 100kHz steps by capacitors switched into circuit by wafers S3EB and S3DF of the front panel 100kHz switch.

From the centre tap of L92, the filter output is applied to Mixer 3 via plug PL27.

4.2.13 MIXER 3

Refer to Fig. 10.5

This mixer comprises components T28, T29, MR45 and R253, and accepts the output from 3.4 to 4.4MHz filter via socket SK27 and an output from the 39.4MHz oscillator via plug PL42.

The secondary of transformer T28 is connected to the input of a 35 to 36MHz tuned amplifier (see para. 4.2.14).

4.2.14 35 TO 36MHz FILTER AND AMPLIFIER

Refer to Fig. 10.5

Inductor L79, L80 and associated capacitors form a 35 to 36MHz bandpass filter to remove unwanted frequencies from the output of Mixer 3.

The filter output is connected to tuned amplifier VT46, which has negative feedback applied via un-decoupled emitter resistor R249.

The output of VT46 is applied to Mixer 4.

4.2.15 38 TO 68MHz VCO CIRCUITS

Refer to Fig. 10.5

4.2.15.1 Mixer 4

Comprising components T25, T26, MR41, MR42, MR43, MR44 and R244, this mixer accepts the output from the 35 to 36MHz tuned amplifier via T26 primary

and the output from the 38 to 68MHz VCO via T26 secondary centre-tap.

The output at the secondary of transformer T25 is connected to a 32MHz low-pass filter.

4.2.15.2 32MHz Low-Pass Filter and Amplifier

The secondary of T25 is connected to a 32MHz low-pass filter, comprising inductors L77, L78 and associated capacitors, which remove unwanted mixing products from Mixer 4 output.

Connected to the filter output is transistor VT45, which is connected in the common base mode for correct impedance match. The collector of VT45 is directly coupled to emitter follower VT59.

10MHz switch wafer S1CB, connected in the emitter circuit of VT59, switches C283 into circuit on position 0 to restrict the bandwidth further.

4.2.15.3 Divide-by-10 Prescale

Comprising JK flip-flops VX11 to VX15, this circuit divides the output of the 32MHz amplifier by 10 before applying it to the 3 to 32 variable divider.

The input is applied via C262, whilst the output is fed via C258.

4.2.15.4 3 to 32 Variable Divider

This variable divider employs JK flip-flops VX3, VX4a, VX4b, VX6, VX8, VX9, VX10b and NAND gates VX5a to d and VX7a, b.

The division ratio is controlled by the front panel 10MHz and 1MHz frequency switch wafers S1CF, S1BF, and S2DB, S2DF, S2CB, S2BB and S2BF, such that the divider output is always a nominal 100kHz.

The divider output at VX10a is applied to a monostable. (See para. 4.2.15.5).

4.2.15.5 Monostable

Comprising VX1a and VX1c, this monostable is connected between the 3 to 32 divider and the phase comparator to alter the mark-to-space ratio, this being adjusted by potentiometer R179.

4.2.15.6 Phase Comparator

Two square-wave inputs are applied to the two-bit parity generator comprising NAND gates VX2a, b, c and d.

One input is the 100kHz reference input which is fed via socket SK40 and isolator VX1d. The other input is the output of the monostable, which is fed via VX1c.

The output of the comparator, which functions in the same way as that described in para. 4.2.11.5, is applied to the base of DC amplifier VT35.

Isolator VX1b feeds a 100kHz signal to the phase comparator circuit in the 4.1 to 5.0MHz VCO, via plug PL29.

4.2.15.7 DC Amplifier and Filter

The phase comparator output is applied to DC amplifier VT35, the collector of which is connected to a 50kHz low-pass filter (integrator). Inductor L70 is tuned to provide a notch at 100kHz.

Ignoring the associated in-lock sensing circuit, the principle of operation of the DC amplifier and filter is the same as that described in para. 4.2.11.6. The in-lock sensing circuit is described in the following paragraph, 4.2.15.8.

The filter output is applied, via R193 and R205, to the varactor diode pair MR37 in the VCO.

Link LK6 is used for test purposes only.

4.2.15.8 In-Lock Sensing Circuits

The 50kHz low-pass filter described above allows a 'capture' range of 50kHz, but as the oscillator locks on to frequency, and the difference frequency output of the phase comparator decreases, the cut-off frequency of the filter is automatically decreased to reduce noise components on the error correction line. This is accomplished as follows.

Transistors VT34, VT33 and VT36 form an in-lock sensing circuit, the input to which is applied via R183 and C208.

When the VCO is out-of-lock, the resultant difference frequency voltage on the filter line is applied to the base of VT34 causing the transistor to conduct on positive half-cycles. Capacitor C206 provides smoothing. Under this condition, transistor VT33 is non-conducting, and capacitor C203 is effectively out of circuit. The filter is then at maximum bandwidth.

As the VCO approaches lock, the difference frequency decreases, and a point is reached at which VT34 ceases to conduct. Transistor VT33 then conducts and earths one side of C203, causing the filter bandwidth to be appreciably reduced.

4.2.15.9 38 to 68MHz VCO

Transistor VT39 is used in a basic Colpitts circuit in which the frequency of oscillation is affected by three different circuits:

- (a) by the front panel 10MHz switch wafer S1AB, which switches in tuned circuits to alter the oscillator frequency in 10MHz steps
- (b) by the front panel 1MHz switch wafer S2AB which switches in extra capacitance to the tuned circuit already selected by the 10MHz switch and provides 1MHz step switching
- (c) by automatic application of a DC signal to varactor diodes MR37 and MR38. This voltage is derived from the phase comparator and 50kHz filter, and can cause a frequency swing of up to 1MHz. Also applied to the varactor diodes is a second DC signal, fed from a potential divider across the 20V supply. The divider comprises R324, R281 and the resistor selected by the 100kHz switch wafer S2AF. The wiper of

this switch is connected to one side of R281 via PL23/F and PL28/D. The action of this switch provides fine frequency control in 200kHz steps and ensures that the preset loop is applied to the varactor diodes to enable the phase loop to lock easily whenever the receiver frequency is changed. Variable resistor R281 sets the bias voltage.

The emitter of the oscillator VT39 is connected to the base of buffer amplifier VT40. From the emitter of VT40, the signal is applied to the base of amplifier VT41 which has negative feedback applied via undecoupled resistor R216. The collector of this transistor is transformer coupled to the base of VT42, and to the base of VT43 via R221.

Transistor VT42 provides an output to Mixer 1 via socket SK24 and the 38 to 68MHz bandpass filter.

Transistors VT43 and VT44 form a directly coupled amplifier providing an output to Mixer 4 via the secondary of transformer T24. Negative feedback is provided by the undecoupled emitter resistor R226.

4.2.16 INSERTION OSCILLATOR CIRCUITS AND BFO (Optional High Stability Unit)

Refer to Fig. 10.1

4.2.16.1 Circuit Operation

This unit has to provide several outputs from the 5-6MHz reference oscillator. At all times a signal is required at exactly 100kHz as a reference frequency to the synthesiser modules. On SSB, exactly 1.4MHz is required as the re-insertion carrier, and on CW a BFO frequency of 1.4MHz \pm 3kHz is required. Alternatively, the module will accept an external source of 100kHz as a reference (see para. 4.2.16.3).

The internal standard is an oscillator unit at 5.6MHz in a proportionally controlled oven. A coarse frequency control is fitted in the oscillator unit itself in addition to the external potentiometer R49 which provides for fine tune adjustment. The 5.6MHz frequency of the output signal from pin 1 of the oscillator base is divided by 56 in the circuit comprising VX5, VX6 and VX7. These circuits divide by 4, 7 and 2 respectively to provide the 100kHz output for the synthesiser.

Transistor VT1 is a varactor controlled LC oscillator at nominally 1.4MHz, which in the CW mode is tuned by the front panel potentiometer R177, and in the SSB mode is phase locked to 1.4MHz exactly.

The 100kHz frequency derived from the 5.6MHz oscillator is applied as reference to the phase comparator VX3. Also applied is the nominal 100kHz derived from the carrier insertion oscillator VT1 whose frequency is divided by 14 in VX1 and VX2. If the two input signals have exactly the same frequency, then the output of the comparator will have a 1:1 mark-to-space ratio of 200kHz prf. Otherwise the mark-to-space ratio is a time varying function which forms a closed loop error correction signal to the varactors via the low pass filtering of VT5, R33 and C19.

On SSB, PL18/L is at zero voltage. This ensures that the front panel BFO potentiometer does not affect the loop characteristic. MR5 is reverse biased, which again isolates the BFO control from the loop, and VT4 is cut off. Therefore, the gate VX4b is enabled to allow the correction signal into the loop.

Conversely on CW, PL18/L is at +20V. VT4 is now bottomed, which causes gate VX4b to be always in the high output state. Amplifier VT5 now receives no phase lock information and is bottomed.

The BFO voltage from the front panel controls the frequency of the oscillator VT1.

4.2.16.2 1-4MHz Amplifier

The output of oscillator VT1 is connected to the base of amplifier VT2 which provides three outputs:

- (a) One to the product detector via T1 secondary, PL18/E and PL18/F
- (b) 1-4MHz oscillator output via PL18/N and SK15/22
- (c) an output to the TEST/CAL position of the Service Bandwidth kHz switch wafer S4CF (see para. 4.2.19) via PL18/J.

4.2.16.3 External Frequency Reference

The 100kHz internal standard may be replaced by an external standard applied to socket SK10 on the rear panel. The level required is 0.5V rms emf from a 50Ω source. This signal is fed into an input impedance greater than 1kΩ and therefore the same source could feed into several receivers of the same type.

When the Ref Freq switch is set to EXT position the internal standard oscillator and its associated divider have their HT supplies removed. The external 100kHz signal is amplified up to logic level via VT6 and gate VX4d, which are then activated.

4.2.16.4 5-6MHz Frequency Reference Circuits

Refer to Fig. 10.9

This unit is contained within a screened plug-in box and should normally require no servicing except for frequency adjustment due to ageing. However, if this unit has failed and no replacement is available then emergency servicing may be attempted. (Refer to para. 5.2 for adjustment of frequency).

4.2.16.5 Description of Reference Circuits

The 5-6MHz crystal XL1 may be adjusted to its nominal frequency by either the core adjuster in the top of the can, which adjusts L1, or by means of R49 which adjusts the varactor MR1 DC supply.

The output from VT2 (the oscillator) is amplified by VT1 and the output taken from pins 1 and 6 via the tuned circuit comprising L2 and C6.

Transistors VT3, VT4 and VT5 form a DC amplifier whose input is varied by thermistor TH1 such that as the temperature is increased less current is drawn by VT5

and the heater element R12. A stable crystal temperature is therefore maintained.

4.2.17 1-4MHz FREQUENCY REFERENCE AND BFO (Normal Unit)

Refer to Fig. 10.10

4.2.17.1 (Circuit Description) 1-4MHz Reference Oscillator

Transistor VT3 is used in a basic Colpitts circuit, with the 1-4MHz crystal connected in the parallel mode. The crystal is fitted in a plug-in oven which is thermostatically controlled. The 24V AC oven supply is fed via pins B and C of PL18 and pins 1 and 7 of the oven plug-in unit, and is applied as soon as the front panel Off/Standby/On switch is set to STANDBY or ON.

Trimmer C14 is used to pull the crystal onto frequency. Transistor VT3 is directly coupled to buffer transistor VT4. This transistor provides two outputs: one to the divide-by-14 circuit via C19, and one to the 1-4MHz amplifier via C6.

4.2.17.2 (Circuit Description) Divide-By-14

This circuit comprises JK flip-flops VX2ab, VX3, VX4, and NAND gates VX1a, c and d. NAND gate VX1a accepts the 1-4MHz output from the oscillator; the divider output is taken from VX4 via SK19 to the phase discriminators as a reference frequency, and via PL22 to the ARU11B when used.

4.2.17.3 (Circuit Description) BFO

Transistor VT1 is employed in a basic Colpitts circuit, L1 being the main tuning inductor. Components MR1 and MR2 are varactor diodes, the control voltage for these diodes is applied via PL18 and the BFO potentiometer R177, this potentiometer provides a 3kHz swing either side of the nominal BFO frequency of 1-4MHz.

The BFO supply voltage is applied via pin L of PL18, pin M of PL14 and wafer S4FB of the service switch, the supply being connected only when the service switch is in the CW positions. Output at the emitter of VT1 is applied to the 1-4MHz amplifier via R6.

4.2.17.4 (Circuit Description) 1-4MHz Amplifier

The output from the 1-4MHz Reference Oscillator or BFO is connected to the base of transistor VT2. Diode MR3 is a switching diode, reverse bias being applied as necessary via pin K of PL18, pin J of PL14, and switch wafer S4GF of the service switch. This reverse bias voltage is applied to MR3 on the AM and CW positions of the service switch to switch off the output of the 1-4MHz insertion oscillator. On services where the insertion oscillator is required, i.e. single sideband and TEST/CAL, the bias is removed to allow the 1-4MHz insertion oscillator voltage to be amplified. Diode MR4 prevents breakthrough of the 1-4MHz oscillator onto the supply line.

The 1-4MHz amplifier provides three outputs:—

- (1) To the product detector via T1 secondary and pins E and F of PL18.

- (2) 1.4MHz oscillator output via pin E of PL18, pins of SK14 to pin 22 of SK15, for ARU10A operation:
- (3) To the TEST/CAL (position 11) of the service switch wafer S4CF (see sub-section 4.2.19) via pin J of PL18.

4.2.18 POWER SUPPLY AND STABILISATION

Refer to Fig. 10.2

4.2.18.1 Input Supplies

The AC supply is connected to plug PL38, both line and neutral inputs being protected by fuses FS3 and FS4 respectively. From the fuses, the mains input is applied to contacts S10b and S10c of the front panel Off/Standby/On switch.

In the ON and STANDBY positions of the switch, the mains input is applied to mains transformer T34, the two primary windings of which can be connected in series or parallel for either 204 to 255V or 106 to 124V AC operation, see Fig. 2.1.

4.2.18.2 Rectification Circuits

Mains transformer T34 has two secondary windings, each being connected to a full wave bridge rectifier.

Rectifier MR55, connected to a 24V rms winding, provides 33V DC input to the 20V DC stabiliser circuit (see para. 4.2.18.3) and MR57, connected to an 11V rms winding provides about 16V DC input to the 5V DC stabiliser (see para. 4.2.18.4).

4.2.18.3 20V DC Stabiliser

The output of rectifier MR55 is connected via fuse link FS5 to a stabiliser circuit comprising VT54, VT55 and VT56. Transistors VT55 and VT56 form a Darlington pair. Potentiometer R310 sets the output level of the 20V supply to its nominal value. Transistor VT54 samples the output voltage, and because its emitter is held at a constant potential by zener diodes MR56a and MR56b, provides a correction voltage to maintain the output at a constant voltage.

Diodes MR58a and MR58b, connected between one end of R310 and chassis, provide temperature compensation.

4.2.18.4 5V DC Stabiliser

A second stabiliser circuit is connected to the output of rectifier MR57 via fuse link FS6. This circuit comprises Darlington pair transistors VT57 and VT58. Base bias for these transistors is derived from the 20V stabilised supply, potentiometer R311 setting the base potential of VT57 to give a nominal 5V output at VT58 emitter.

Only when the supply switch contacts S10d are in the ON position, are the 20V and 5V supplies available. An exception to this is the 20V supply to the VFO and crystal oven, this being available as soon as the Off/Standby/On switch is set to STANDBY.

4.2.19 TEST/CAL FACILITY

4.2.19.1 Calibrate

Refer to Fig. 10.7

The calibrate facility enables the operator to make an occasional check on the accuracy of the VFO. To do this the controls are set as follows:

AF Gain set fully clockwise

Service Bandwidth kHz switch set to TEST/CAL position

Mechanical counter set to 000 at high frequency end (tuning knob fully clockwise)

When the VFO is set to 000 at the high frequency end, a nominal 700kHz output is applied via socket SK34 to the TEST/CAL position of the Service Bandwidth kHz switch wafer S4CF. This signal is fed through the 1.4MHz IF amplifier and applied to the product detector, to which is also applied the 1.4MHz reference signal. The CAL control on the front panel is then adjusted for a zero beat note. (Second harmonic of 700kHz from the VFO beats with 1.4MHz reference).

4.2.19.2 Test

Refer to Fig. 10.2

When the Service Bandwidth kHz switch is set to TEST/CAL position the 1.4MHz oscillator is applied to the 1.4MHz IF amplifier via PL18/J and Service Bandwidth kHz switch wafer S4CF. This causes the AGC circuits to be actuated to produce an indication on the front panel meter when the Line/Signal switch is set to SIGNAL position, and thus provides a check of the IF circuits.

Full use of the Test facility is detailed in Chapter 7 FAULTFINDING.

4.2.20 OPERATION OF ARU11B SYNTHESISER

Refer to Fig. 10.2

Link LK2 is disconnected when the ARU11B Synthesiser is used, allowing the 20V supply at SK37/5 to be controlled by the ARU11B Synthesiser VFO/Synth/CLA switch. When this switch is set to VFO position, the contacts perform the same function as link LK2. When the switch is set to SYNTH position the 20V supply at SK37/5 is applied to the ARU11B Synthesiser circuits, and to SK37/8 when the ARU11B Synthesiser is set to a frequency above 50kHz (see para. 4.2.1.2).

SK37/2 and SK37/3 are connected across DC dropping resistor R304 in the power supply. When the ARU11B Synthesiser VFO/Synth/CLA switch is set to SYNTH position a resistor in the ARU11B Synthesiser is connected in parallel with R304 to reduce the effective resistance value. This ensures that the 5V supply is maintained at nominal value when extra current is being drawn by the ARU11B Synthesiser.

The 5V supply to the ARU11B Synthesiser is applied via SK37/4.

Full information on the ARU11B Synthesiser can be found in Handbook 941-1.

5 MAINTENANCE

5.1 MECHANICAL

5.2 ELECTRICAL

5.2.1 Adjustment of Internal Reference Frequency Standard

5.2.2 Alternative Method of Adjustment of Internal Reference Frequency Standard

5.2.3 Calibrate Adjustment

5 MAINTENANCE

5.1 MECHANICAL

- (1) Remove R551 Receiver from Cabinet.
- (2) Remove bottom cover plate.
- (3) Carefully remove any dust using a vacuum cleaner and a soft brush.
- (4) Clean all switch wafer contacts with Switch Cleaning Fluid, e.g. Servisol.
- (5) Apply a small quantity of silicone grease, e.g. Midlands Silicones type MS4 to the switch index mechanisms.

5.2 ELECTRICAL

5.2.1 Adjustment of Internal Reference Frequency Standard

Before adjustment, allow 20min for the oven to totally stabilise.

Plug a frequency counter into socket SK19 on the rear panel of the receiver. The frequency at this point is nominally 100kHz and can only be set to as near to 100kHz as possible within the limitation of the internal standard of the frequency counter. As eight digits may need to be displayed, a long display period may be experienced when trying to measure the frequency of 100kHz. It may be advantageous to measure the period of the reciprocal of 100kHz, when a faster display is possible on the counter.

The optional high stability oscillator may be adjusted to exact frequency by either the fine control of R49 which is accessible through the top of the reference module cover, or by the coarser control of the inductor through the top of the reference oscillator itself. The finer tune of R49 should be used in preference to the inductor. (See Fig. 6.1 for location.)

The normal reference oscillator is adjusted by means of C14 through the module top cover.

5.2.2 Alternative Method of Adjustment of Internal Reference Frequency Standard

Test Equipment Required: (See section 7.7)
Oscilloscope CRETE SM111

- (1) Remove ARU11B Synthesiser if fitted.

- (2) Connect CH1 on oscilloscope, via a coaxial cable, to socket SK19 (100kHz output) on rear panel of R551 Receiver.
- (3) On oscilloscope:
 - (a) Set all controls to CAL position.
 - (b) Set Trig Mode switch to AUTO position.
 - (c) Set Trig Source switch to CH1 position.
 - (d) Set Mode switch to ALT position.
- (4) Set R551 Receiver, Radio Mains switch to ON position.
- (5) Set oscilloscope Mains switch to ON position.
- (6) Adjust TIME/cm and V/cm controls to display two full cycles of the waveform with an amplitude of 2cm peak-to-peak.
- (7) Connect a 100kHz signal from the 100kHz output of frequency counter CRETE CT488 to CH2 on oscilloscope.
- (8) Adjust CH2 V/cm control to display a similar waveform to that in (6).
- (9) Adjust CH1 and CH2 shift controls to superimpose the two waveforms in the centre of the screen.
- (10) Set Trig Source switch to CH2 position, locking the time base to the standard signal at CH2 input.
- (11) After 30 min, adjust R49 or C4 (see Fig. 6.1 for location) with a small screwdriver until the slowly drifting waveform is also stationary on the display.
- (12) Finally, check that any drift does not exceed $\frac{1}{2}$ cycle in 2 min.
- (13) Set R551 Receiver Mains switch to OFF position.
- (14) Disconnect test equipment.
- (15) Refit ARU11B Synthesiser.

5.2.3 Calibrate Adjustment

The VFO should be calibrated periodically in order to maintain the VFO readout accuracy.

Turn the AF gain control to maximum and the meter switch to SIGNAL position. Set AGC switch to FAST position and the Service Bandwidth kHz switch to TEST/CAL position. Turn the VFO control clockwise to read 000 at the HF end of the band. An audible note should be heard as 000 is approached. Adjust the CAL control on the front panel of the R551 Receiver for a very slow movement of the meter needle and zero beat in the loud-speaker.

6 REPAIR AND REPLACEMENT

6.1 REPLACING MODULES

- 6.1.1 Removing R551 Receiver Bottom Cover**
- 6.1.2 Indexing Switch Shafts**
- 6.1.3 Reference Oscillator/BFO Module**
- 6.1.4 IF/Audio Module**
- 6.1.5 35 to 68MHz VCO Module**
- 6.1.6 4.1 to 5.0MHz VCO Module**
- 6.1.7 RF Module**
- 6.1.8 VFO Module**
- 6.1.9 Aerial Filter Module**
- 6.1.10 Power Supply Module**

6.2 REPLACING THE 0, 9(CAL) AND FRONT PANEL LAMPS

FIG. 6.1 R551 RECEIVER—LOCATION OF MODULES

6 REPAIR AND REPLACEMENT

6.1 REPLACING MODULES

When fitting new modules, ensure that the adjustment of preset controls is not disturbed.

Refer to Fig. 6.1 for location of modules.

6.1.1 Removing R551 Receiver Bottom Cover

The R551 Receiver bottom cover is secured by nine 4BA screws.

6.1.2 Indexing Switch Shafts

When refitting modules containing switch sections, the shaft index mark, a black dot, must be visible and square to the module cover. The shaft will then align with the appropriate control at its index position i.e., Service Bandwidth kHz switch at A3J 1sb position and the Frequency switches all in 0 position. When removing or refitting a switch shaft in a module ensure that none of the switch bank rotors are displaced by 180°.

6.1.3 Reference Oscillator/BFO Module

- (1) Remove ARU11B Synthesiser if fitted.
- (2) Disconnect the coaxial plug PL22 from socket SK22.
- (3) Remove the module cover. This is secured by four 6BA screws.
- (4) Undo the two captive screws securing the module to the main chassis (these are accessible through holes in the top of the module).
- (5) Unplug the module from the main chassis.

6.1.4 IF/Audio Module

- (1) Remove the module cover. This is secured by twelve 6BA screws, one of which also secures the earth bonding link to the RF module.
- (2) Undo the Service Bandwidth kHz switch shaft coupling and push back the rotor shaft.
- (3) Undo the four screws securing the module to the chassis. Two are at the front and two at the rear (one situated on each side of the connection plugs PL13 and PL14).
- (4) Hold the front plug PL13 between finger and thumb, and pull it up to loosen it from the chassis-mounted socket SK13.
- (5) Loosen the rear plug PL14 by holding the rear metal lip of the module and pulling upwards away from socket SK14.
- (6) Lift the module clear of the chassis.

6.1.5 38 to 68MHz VCO Module

- (1) Remove the left side angle bar which covers capacitor C264.
- (2) Remove the module cover. This is secured by seven 6BA screws.

- (3) Set the 10MHz front panel switch to 2, and the 1MHz switch to 3.
- (4) Loosen the 6BA Allen grub screws on the couplings connecting the two switch spindles to the aerial filter module.
- (5) Loosen the 6BA Allen grub screws on the slotted side of the coupling connecting the two switches to the front panel.
- (6) Set the 10MHz and 1MHz switches to 0 position to bring the slots on the coupling to the vertical position.
- (7) Undo the three screws securing the module to the chassis. Two are just behind the front panel, and one at the centre rear of the module, on the inside.
- (8) Disconnect sockets SK22, SK24, and SK42.
- (9) Remove the cover from the 4.1 to 5.0MHz VCO module (there are six fixing screws) and disconnect socket SK27.
- (10) Disconnect plug PL29.
- (11) Unplug the 38 to 68MHz VCO from the main chassis.

When fitting a new module:

- (1) Remove the cover of the new module (seven fixing screws).
- (2) Remove the couplings from the old module and place them in the same position on the new module.
- (3) Connect plug PL29.
- (4) Slide the couplings of the module to engage with the switch shafts at the front and rear of the module. Ensure that the switches in the aerial filter module and the 38 to 68MHz module are in the 0 index position.
- (5) Fit the module in the chassis (three fixing screws).
- (6) Connect sockets SK22, SK24, SK27 and SK42.
- (7) Refit the cover to the 4.1 to 5.0MHz VCO module with six fixing screws.
- (8) Tighten the 6BA Allen grub screws on the couplings adopting the reverse procedure to that described in the removal instructions above.
- (9) Refit the 38 to 68MHz module cover.
- (10) Refit the left side angle bar.

6.1.6 4.1 to 5.0MHz VCO

- (1) Remove the module cover. This is secured by six screws.
- (2) Disconnect socket SK27 and plug PL30.
- (3) Set the front panel 100kHz switch to 0 position and note that the black dot is visible on switch shaft.
- (4) Undo the rear coupling screws.
- (5) Undo the front coupling screws.

- (6) Undo the three module fixing screws. There are two at the front (just inside the module) and one at the rear (on the inside of the module rear back plate).
- (7) Unplug the module.

When fitting a new module:

- (1) Remove the module cover.
- (2) Remove the rear coupling from the old module and fit in the new module in the same place.
- (3) Fit the module in the chassis (three screws).
- (4) Slide the rear coupling of the module to engage with the aerial filter switch shaft.
- (5) Slide the coupling on the 100kHz switch shaft to engage with the 4.1 to 5.0MHz module switch shaft.
- (6) Tighten the coupling screws ensuring that the switches in the aerial filter module and the 4.1 to 5.0MHz module are in the 0 position and that the black dots are visible on the spindles.
- (7) Reconnect socket SK27 and plug PL30.
- (8) Refit the module cover.

6.1.7 RF Module

- (1) Disconnect sockets SK5, SK7, SK11 and SK8.
- (2) Undo the four fixing screws through holes in the top of the module cover, one of which secures the earth bonding link to the IF/Audio module.
- (3) Unplug the module.

6.1.8 VFO Module

- (1) First remove the RF module as detailed in para. 6.1.7 and the Reference Oscillator/BFO module as detailed in para. 6.1.3.
- (2) Disconnect plug PL34 and sockets SK30 and SK35.
- (3) Disconnect sockets SK31, SK32, SK39 and SK41 on the small metal panel situated between the VFO and the power supply. Then disconnect plugs PL51 and PL52 on the VFO rotor board.
- (4) Remove the front panel tuning knobs, secured by four grub screws, using 6BA and 4BA Allen keys.
- (5) Using a 4BA Allen key, turn the hexagonal grub screw near the counter escutcheon, about 90° in a counter-clockwise direction to free the escutcheon.
- (6) Remove the two securing screws situated under the chassis, and two securing screws situated on the

part of the chassis normally occupied by the RF module.

- (7) Slide the VFO module to the rear of the receiver and lift it out.

6.1.9 Aerial Filter Module

- (1) Remove the module cover. This is secured by four screws.
- (2) Set the 10MHz, 1MHz and 100kHz switches on the front panel to the 0 positions.
- (3) Note that a black dot is visible on each switch shaft.
- (4) Slacken the three shaft couplings between the aerial filter module and the synthesiser modules.
- (5) Using a pair of long nose pliers, pull the switch shafts carefully to the rear of the receiver so that they are just disengaged from the couplings.
- (6) Disconnect plugs PL2, PL3 and PL50 at the side of the module.
- (7) Disconnect socket SK5 at the rear of the R551 Receiver.
- (8) Undo the two cheese head fixing screws on the module printed circuit board (one at each end).
- (9) Lift the module free from the chassis.

6.1.10 Power Supply Module

- (1) Disconnect socket SK4 which is situated underneath the chassis (the socket plate is secured by a screw).
- (2) Undo both screws securing the right-hand carrying handle of the receiver (viewed from front).
- (3) Undo the four screws (near the fuses) securing the power supply unit to the receiver back-plate.
- (4) Release the Off/Standby/On switch.
- (5) Remove the power supply unit.

6.2 REPLACING THE 0, 9(CAL) AND FRONT PANEL LAMPS

Remove the VFO tuning knobs (see para. 6.1.8 (4)) and turn the hexagonal fixing screw (using a 4BA Allen key) on the front of the escutcheon 90° counter-clockwise, allowing the escutcheon to be lifted from the right hand end.

The lamp replacement is 24V 1W LES 5mm (6240-99-995-1906).

7 FAULTFINDING

7.1 GENERAL

7.2 CHECKING POWER SUPPLIES

7.3 USE OF FRONT PANEL TEST FACILITIES

7.4 LOCATION OF A FAULT TO A MODULE

7.4.1 Aerial Filters

7.4.2 RF/AGC Amplifier

7.4.3 IF/AF Amplifier

7.4.4 38 to 68MHz VCO

7.4.5 4.1 to 5.0MHz VCO

7.4.6 VFO

7.4.7 Reference Oscillator/BFO

7.5 LOCATION OF A FAULT TO A COMPONENT

7.5.1 RF/AGC Amplifier

7.5.2 IF/AF Amplifier

Fig. 7.1 Resistive Attenuator

7.5.3 Reference Oscillator/BFO

7.5.4 VFO

7.5.5 4.1 to 5.0MHz VCO

7.5.6 38 to 68MHz VCO

7.6 TYPICAL TRANSISTOR DC MEASUREMENTS

FIG. 7.2 TRANSISTOR AND INTEGRATED CIRCUIT BASE CONNECTIONS

7.7 COMMERCIAL TEST EQUIPMENT EQUIVALENT TO CRETE ITEMS

7 FAULTFINDING

7.1 GENERAL

Before attempting faultfinding, check:

- (a) front panel control settings
- (b) all external connections.

The recommended faultfinding procedure is divided into four stages:

- (a) check of power supplies
- (b) location of a fault to a circuit area by use of the front panel test facilities
- (c) location of a fault to a module by checking input and output voltages.
- (d) location of a fault to a component by checking voltages within the modules.

All voltage levels are typical values unless otherwise stated. All DC levels should be measured with an AVO 8 or equivalent, on lowest ranges possible, with respect to chassis. All AC levels are rms unless otherwise stated.

The test instruments necessary for fault finding on the R551 Receiver are identified in this chapter by CRETE reference numbers. Commercial equivalents of these items are listed in para. 7.7.

7.2 CHECKING POWER SUPPLIES

Measure the power supply output voltages.

Refer to Fig. 10.2

Point of Measurement	V DC
SK4/H	20.0 ± 5%
SK4/J	20.0 ± 5%
SK4/A	5.0 ± 5%
SK4/B	20.0 ± 5%

If the readings are incorrect, measure the next set of typical voltages given below.

If maladjustment of the preset controls R310, R311 is suspected, refer to para. 8.3.

Point of Measurement	V DC
Junction of FS5 and R305	33.0 ± 10%
VT54 Collector	21.5 ± 10%
VT54 Base	14.2 ± 10%
VT54 Emitter	13.6 ± 10%
VT55 Collector	33.6 ± 10%
VT55 Emitter	21.0 ± 5%
VT56 Collector	32.0 ± 10%
VT56 Emitter	20.0 ± 5%
Junction of FS6 and R315	15.8 ± 10%
VT57 Collector	15.7 ± 10%
VT57 Base	6.2 ± 5%
VT57 Emitter	5.6 ± 5%
VT58 Collector	15.0 ± 10%
VT58 Emitter	5.0 ± 5%

7.3 USE OF FRONT PANEL TEST FACILITIES

The Test facilities can be used to provide a functional check of most of the R551 Receiver circuits. These checks are given below.

Checks (1) and (2) employ the Test facility proper and are mainly concerned with a check of the 1.4MHz IF and audio circuits. The 38MHz IF circuits and frequency generating circuits are checked by (3).

- (1) Set the mechanical counter to 995 and set the Service Bandwidth kHz switch to TEST/CAL position. A 1kHz audio output should be obtained.

This is achieved as follows. The VFO second harmonic output frequency is 1399kHz, and both this output and the 1.4MHz output from the 1.4MHz oscillator are applied to the IF/Audio module (immediately after the filters) where it is demodulated.

A check is thus provided of:

- (a) VFO
- (b) 1.4MHz oscillator
- (c) 1.4MHz IF amplifier
- (d) AF amplifier.

- (2) Set the VFO mechanical counter to the middle of its range (to ensure that meter needle 'flutter' is not experienced) and set the Service Bandwidth kHz switch to TEST/CAL position. Set the Line/Signal switch to SIGNAL and confirm that the meter reads approximately 3 divisions.

This is achieved as follows. The 1.4MHz oscillator output is applied to the IF/Audio module (immediately after the filters) causing the AGC circuits to operate and produce a meter reading. A check is thus provided of:

- (a) 1.4MHz oscillator
- (b) IF amplifier
- (c) AGC amplifiers.

- (3) Set all the Frequency switches to the 0 position, and the RF and AF Gain controls to maximum clockwise position. Set the AGC switch to FAST position and the Service Bandwidth kHz switch to A1 cw 1 position.

An audio output should be obtained, the frequency of which can be varied by the BFO control. An indication should be obtained on the front panel meter when the Line/Signal switch is set to SIGNAL. This is passed through the 38MHz IF amplifier and converted to an IF of 1.4MHz. An audio output is produced by use of the BFO.

A check is thus provided of most of the receiver circuits.

Judicious use of the above checks in conjunction with the block diagram will enable a fault to be located to a

circuit area. For example, if no audio output is produced by Check (1) but Check (2) is satisfactory, a fault in either the VFO or AF amplifier is indicated.

7.4 LOCATION OF A FAULT TO A MODULE

These checks will localise any major fault to a module. If the checks indicate that a module is suspect, the voltages within the module should be checked (see para. 7.5). Alternatively a tested replacement module can be tried.

Only test equipment normally found in most workshops is required. If a frequency counter is available, it should prove most useful to check output frequencies.

Ensure that connections are re-made as checks are completed.

7.4.1 Aerial Filters

Refer to Fig. 10.8

DC Checks

- (1) Check for +20V at plug PL2.
- (2) Check that plug PL3 is shorted to chassis.

Signal Checks

Test Equipment Required:

RF Signal Generator: CRETE CT452

RF Valve Voltmeter: CRETE CT471 with 50Ω probe

- (1) Disconnect socket SK5 and connect the 50Ω probe and RF valve voltmeter CT471 across it.
- (2) Connect the RF signal generator CT452 to socket SK1 and set it to the frequencies as shown below.
- (3) Set the R551 Receiver frequency controls to the same frequency as that of the RF signal generator.

RF Signal Generator Frequency (Output Level Set to 560mV emf)	Typical RF Valve Voltmeter Reading (Socket SK5 loaded by 50Ω probe)
30MHz	> 150mV
20MHz	> 150mV
15MHz	> 150mV
10MHz	> 150mV
7MHz	> 150mV
5MHz	> 150mV
3MHz	* > 80mV
2MHz	* > 50mV
1.5MHz	* > 25mV
1.0MHz	* > 25mV
700kHz	* > 20mV
500kHz	* > 10mV
300kHz	* > 10mV
200kHz	* > 10mV
100kHz	* > 10mV

*Note that these figures are obtained using a 50Ω signal source, the normal source impedance being 10Ω and 200 to 700pF at these lower frequencies.

7.4.2 RF/AGC Amplifier

Refer to Fig. 10.3

DC Check

Check for +20V at PL6/F.

Signal Checks

Test Equipment Required: _

RF Signal Generator: CRETE CT452

RF Valve Voltmeter: CRETE CT471 with 50Ω probe

- (1) Disconnect socket SK11 and connect the 50Ω probe of the RF valve voltmeter CT471 across plug PL11.
- (2) The RF valve voltmeter CT471 reading should be > 1.0 V rms.
- (3) Remove test equipment and replace socket SK11.
- (4) Disconnect plug PL7 and connect the 50Ω probe of the RF valve voltmeter CT471 across it.
- (5) The RF valve voltmeter CT471 reading should be 1.5V ± 0.5V.
- (6) Remove the test equipment and replace plug PL7.
- (7) Set the RF signal generator CT452 output level to 100mV emf at a frequency of 15MHz, and connect it to plug PL5 after disconnecting socket SK5.
- (8) Set the R551 Receiver frequency switches and VFO to 15.0000MHz.
- (9) Disconnect socket SK8 and connect the 50Ω probe of the RF valve voltmeter CT471 across plug PL8.
- (10) The valve voltmeter CT471 reading should be 180mV ± 40mV.
- (11) Set the RF signal generator CT452 output level to 600mV emf with frequency still at 15MHz.
- (12) The RF valve voltmeter CT471 reading should be 600mV ± 140mV (this checks the operation of the front end AGC).

7.4.3 IF/AF Amplifier

Refer to Fig. 10.4

DC Check

Check for +20V at PL14/E.

Signal Checks

Test Equipment Required:

RF Signal Generator: CRETE CT452

RF Valve Voltmeter: CRETE CT471 with 50Ω probe
Meter, Noise Level: CRETE CT454

- (1) Disconnect the coaxial lead from the wiper of Service Bandwidth kHz switch wafer S4CF and connect the RF signal generator CT452 to this lead.
- (2) Set the RF signal generator CT452 frequency to 1.4MHz and the output voltage to 11μV emf.
- (3) Connect the RF valve voltmeter CT471 with 50Ω probe across the IF Output socket SK20 on the rear panel of the R551 Receiver.
- (4) Connect the meter, noise level CT454, set to 600Ω impedance and High Pass Filter Out. to SK15/5 and SK15/7.

- (5) Set the Service Bandwidth kHz switch to A3J usb position and the Line Gain control fully clockwise.
- (6) Set the RF Gain control fully clockwise.
- (7) Tune the RF signal generator CT452 for maximum reading on the meter, noise level CT454.
- (8) Check that the meter, noise level CT454 reading is greater than 10mW (2.45V).
- (9) Check that the RF valve voltmeter CT471 reading is:
 - (a) approx 100mV with AGC switch in FAST position, and
 - (b) approx 270mV with AGC switch in OFF position.
 Note that if there is a reading on the RF valve voltmeter CT471 but not on the meter, noise level CT454, the 1.4MHz re-insertion oscillator output is suspect; see Reference Oscillator/BFO (para. 7.4.7).

7.4.4 38 to 68MHz VCO

Refer to Fig. 10.5

DC Checks

- (1) Check for +20V at PL23/C.
- (2) Check for +5V at PL23/A.

Signal Checks

Test Equipment Required:

RF Valve Voltmeter: CRETE CT471 with 50Ω probe
 Oscilloscope: CRETE CT484

- (1) Disconnect socket SK27 inside 100kHz synthesiser module.
- (2) Connect the RF valve voltmeter CT471 with 50Ω probe across plug PL27.
- (3) Check that the RF valve voltmeter CT471 reading is >40mV.
- (4) Remove test equipment and replace socket SK27.
- (5) Disconnect socket SK22 and connect oscilloscope CT484 across plug PL22.
- (6) Check that oscilloscope CT484 indicates 600mV pk-to-pk square wave.
- (7) Remove oscilloscope CT484 and replace socket SK22.
- (8) Disconnect socket SK11 located on RF module.
- (9) Connect RF valve voltmeter CT471 with 50Ω probe across plug PL11.
- (10) Check that the RF valve voltmeter CT471 reading is 0.4 to 1.5V.
- (11) Disconnect socket SK29.
- (12) Disconnect plug PL24 and connect the 50Ω probe of the RF valve voltmeter CT471 across socket SK24.
- (13) Check the following voltages using oscilloscope CT484.

Point of Measurement	V pk-to-pk
Socket SK24	3.0 to 6.0
Plug PL29	> 2.4 square wave

- (14) If a frequency counter CT488 is available, the frequency of the signal at socket SK24 should be checked. This should be approximately 38MHz higher than the front panel frequency setting. Incorrect frequency could be caused by a fault in the 4.1 to 5.0MHz VCO or the VFO (see paras. 7.4.5 and 7.4.6).

7.4.5 4.1 to 5.0MHz VCO

Refer to Fig. 10.6

DC Checks

- (1) Check for +20V at PL28/F.
- (2) Check for +5V at PL28/B.

Signal Checks

Test Equipment Required:

RF Valve Voltmeter: CRETE CT471 with 50Ω probe
 Oscilloscope: CRETE CT484

- (1) Disconnect socket SK29.
- (2) Check with oscilloscope CT484 that the voltage across plug PL29 is 2.4V pk-to-pk $\pm 10\%$ square wave.
- (3) Reconnect socket SK29.
- (4) Disconnect socket SK27.
- (5) Connect RF valve voltmeter CT471 with 50Ω probe across plug PL27.
- (6) Set the R551 Receiver frequency controls to 00.0000.
- (7) Rotate the 100kHz switch through its ten positions and check that the RF valve voltmeter reading is >40mV.
- (8) If a frequency counter CT488 is available, check the frequency at plug PL27. Incorrect frequency readings could be due to a fault in the VFO (see para. 7.4.6).

100kHz Switch Position	Frequency Measured MHz ± 50 Hz
0	4.4
1	4.3
2	4.2
3	4.1
4	4.0
5	3.9
6	3.8
7	3.7
8	3.6
9	3.5

- (9) Disconnect plug PL30 and connect RF valve voltmeter CT471 with 50Ω probe across socket SK30.
- (10) Check that the RF valve voltmeter CT471 reading is >300mV.

7.4.6 VFO

Refer to Fig. 10.7

DC Checks

- (1) Check for +20V at plug PL39.
- (2) Check for +20V at plug PL32.
- (3) Check for 0V at plug PL33.
- (4) Check that the voltage at plug PL31 varies between 20 and 1.7V DC with rotation of the CAL control on the front panel.

Signal Checks

Test Equipment Required:

RF Valve Voltmeter: CRETE CT471
Two 47Ω Resistors: (5905-99-013-5963).

- (1) Disconnect socket SK34 and connect a 47Ω resistor across plug PL34.
- (2) Disconnect plug PL30 and connect a 47Ω resistor across socket SK30.
- (3) Measure the voltages shown below.

Point of Measurement	mV rms
Socket SK34	> 2
Socket SK30	> 300

- (4) If a frequency counter CT488 is available, measure the frequency at socket SK30.

This should be 600.0kHz \pm 50Hz when the mechanical counter on the front panel is set to 000,

and 699.9kHz \pm 50Hz when the mechanical counter is set to 999.

7.4.7 Reference Oscillator/BFO

Refer to Fig. 10.1 for Optional High Stability Module.

DC Checks

- (1) Check for +5V at PL18/D.
- (2) Check for +20V at PL18/A.
- (3) Check for +20V at PL18/N on all Service Bandwidth kHz switch positions except AM8, AM3, A2 mcw 3 and AM1.
- (4) Check that the voltage at PL18/H varies between 0 and +3V with rotation of the BFO control when Service Bandwidth kHz switch is in any A1 cw position.
- (5) Check for +20V at PL18/L when Service Bandwidth kHz switch is in any A1 cw position.

Signal Checks

Test Equipment Required:

RF Valve Voltmeter: CRETE CT471
Oscilloscope: CRETE CT484

- (1) Disconnect socket SK22.
- (2) Disconnect plug PL19.
- (3) Disconnect socket SK34.
- (4) Measure the voltages shown below:

Point of Measurement	Service Bandwidth kHz Switch Position	mV pk-to-pk	Waveform
Socket SK19	—	> 600	Square
Plug PL22	—	> 600	Square
PL18/N	A3J 1sb A3J usb TEST/CAL	> 7.0	Sine
	A1 cw	1130 \pm 10%	Sine
PL18/E and PL18/F	A3J 1sb A3J usb TEST/CAL	1000 \pm 10%	Sine
	TEST/CAL	1.4 \pm 10%	Sine

Refer to Fig. 10.10 for Normal Stability Module.

DC Checks

- (1) Check for +5V at PL18/D
- (2) Check for +20V at PL18/M
- (3) Check for +20V at PL18/L on CW positions only

Signal Checks

Test Equipment Required

RF Valve Voltmeter CRETE 471.
Resistor $330\Omega \pm 5\% \frac{1}{4}W$.

Conditions: 330Ω connected across pins E and F of PL18.

Transistor	Special Test Conditions	AC Volts $\pm 20\%$		
		Emitter	Base	Collector
VT1	Pins L and K connected to M i.e. CW	570mV	1.1V	0V
VT2		40mV	150mV	3.3V
VT2	Pins L and K not connected to M i.e. SSB	20mV	37mV	1.7V
VT3		1.0V	1.7V	0V
VT4		1.0V	1.1V	0V

7.5 LOCATION OF A FAULT TO A COMPONENT

7.5.1 RF/AGC Amplifier

Refer to Fig. 10.3

DC Checks

Condition: No signal input.

Point of Measurement	V DC $\pm 5\%$
VT1 emitter	5.5
VT1 base	6.2
VT1 collector	14.9
VT2 emitter	5.5
VT2 base	6.2
VT2 collector	14.9
VT3 emitter	20.0
VT3 base	20.0
VT3 collector	0
VT4 emitter	0
VT4 base	0
VT4 collector	20.0
VT5 emitter	20.0
VT5 base	19.9
VT5 collector	0
VT6 emitter	0
VT6 base	0
VT6 collector	19.9
VT7 emitter	2.15
VT7 base	2.8
VT7 collector	17.5
VT8 emitter	2.15
VT8 base	2.8
VT8 collector	17.5
VT9 emitter	2.0
VT9 base	2.4
VT9 collector	8.4
VT11 emitter	7.2
VT11 base	7.8
VT11 collector	17.8
VT12 emitter	7.2
VT12 base	7.8
VT12 collector	18.0

Signal Checks

Test Equipment Required:

RF Valve Voltmeter: CRETE CT471
RF Signal Generator: CRETE CT452A
47 Ω Resistor: 5905-99-013-5963
Multimeter: CRETE AVO8SX

Condition (a): Inner of coaxial cable disconnected from pin 3 on Wideband Amplifier PCB Assembly, Fig. 9.6.
47 Ω resistor connected between pin 3 and chassis.

- (1) Disconnect socket SK5.
- (2) Connect RF signal generator to plug PL5.
- (3) Set RF signal generator frequency to 10MHz and output level to 100mV rms emf.

Point of Measurement		mV rms $\pm 20\%$
VT1	emitter	13.5
	base	15.0
	collector	875
VT2	emitter	13.5
	base	15.0
	collector	875
Junction of L58 and C114 (Pin 3)		340

Condition (b): Inner of coaxial cable disconnected from pin 3 on Wideband Amplifier PCB Assembly, Fig. 9.6.

47 Ω resistor connected between pin 3 and chassis.

RF valve voltmeter connected between pin 3 and chassis.

Multimeter connected between test point TP3 and chassis.

- (1) Disconnect socket SK5.
- (2) Connect RF signal generator to plug PL5.
- (3) Set multimeter to 10V DC range.
- (4) Set RF signal generator frequency to 10MHz and adjust output level until multimeter indicates +2.0V DC.

Limits: RF signal generator output between 180 and 320mV rms emf.

- (5) Note RF valve voltmeter reading.
Limits: Between 500 and 800mV rms.
- (6) Increase RF signal generator output level to 2.0V rms.
- (7) RF valve voltmeter indication should not vary more than 1.5dB from reading noted in (5).
- (8) Multimeter reading should be between 4 and 5V DC.

Condition (c): Inner of coaxial cable disconnected from output of 38MHz crystal filter FL14 at pin 1 on 38MHz Amplifier PCB Assembly Fig. 9.8.

Inner of coaxial cable disconnected from junction of C403 and C404.

47 Ω resistor connected from junction of C403 and C404 to chassis.

- (1) Connect RF signal generator to T36 primary, i.e. pins 1 and 2 (2 is "earth") on 38MHz Amplifier PCB (see Fig. 9.8).
- (2) Connect RF valve voltmeter across 47 Ω resistor.
- (3) Set RF signal generator frequency to 38.0MHz and output level to 100mV rms emf.

- (4) Adjust RF signal generator frequency for maximum indication on RF valve voltmeter.

Limit: > 360mV rms.

Point of Measurement		mV rms $\pm 20\%$
VT7	emitter	21
	base	32
	collector	1700
VT8	emitter	27
	base	32
	collector	1700

- (5) Disconnect socket SK11.
- (6) Remove 47 Ω resistor and RF valve voltmeter and reconnect both across plug PL11.
- (7) Check indication on RF valve voltmeter.
Limit: > 800mV rms.

7.5.2 IF/AF Amplifier

Refer to Fig. 10.4

DC Checks

Conditions: No input signal

Service Bandwidth kHz switch in A3J usb position

RF Gain control fully clockwise

Point of Measurement		V DC $\pm 5\%$
VT13	emitter	2.8
	base	3.6
	collector	7.6
VT14	emitter	8.8
	base	9.7
	collector	15.0
VT15	emitter	15.7
	base	15.0
	collector	7.6
VT16	emitter	1.93
	base	2.6
	collector	8.9
VT17	emitter	8.4
	base	8.9
	collector	19.2
VT18	emitter	9.8
	base	10.8
	collector	15.6
VT19	emitter	10.5
	base	9.8
	collector	0.8
VT20	emitter	1.26
	base	1.5
	collector	14.0

Point of Measurement		V DC $\pm 5\%$
VT21	emitter	14.8
	base	14.0
	collector	7.1
VT22	emitter	9.2
	base	10.0
	collector	14.7
VT23	emitter	19.2
	base	19.1
	collector	0.05
VT24	emitter	19.2
	base	19.1
	collector	0.05
VT25	emitter	0
	base	0
	collector	20.0
VT26	emitter	0
	base	0
	collector	20.0
VT27	emitter	0
	base	0
	collector	0
VT28	emitter	15.0
	base	14.8
	collector	0
VT29	emitter	14.8
	base	15.5
	collector	0
VT32	emitter	8.7
	base	9.2
	collector	15.3

Signal Checks

Test Equipment Required:

- RF Signal Generator: CRETE CT452A
- AF Power Meter: CRETE CT44
- AF Signal Generator: CRETE CT433A
- AF Valve Voltmeter: CRETE CT343 or CRETE CT454

Condition (a): Service Bandwidth kHz switch in A3J usb position
 RF Gain control fully clockwise
 AF Gain control fully clockwise
 AF power meter set to 600 Ω and connected between SK15/5 and SK15/7
 No signal input to aerial socket

- (1) Connect the RF signal generator to each of the following points in turn at the output level specified.
- (2) Adjust the RF signal generator frequency (1.4MHz nominal) to give approx a 1kHz AF output.

Connect Signal Generator to:	Signal Generator emf Required for 500mV (-4dBm) AF Output at 1kHz
VT18 base	25mV ± 6 dB
VT17 base	100mV ± 6 dB
VT16 base	2mV ± 6 dB
VT15 base	280 μ V ± 6 dB
VT14 base	63 μ V ± 6 dB
VT13 base	4 μ V ± 6 dB

Condition (b): R140 shorted to chassis by connecting a link between SK14/V and chassis
 Screened lead on pin 22 (see Fig. 9.11) disconnected
 AF power meter set to 600 Ω and connected between SK15/7 and SK15/5
 AF Gain and Line controls set fully clockwise

- (1) Connect 600 Ω output of AF signal generator to pin 22 (see Fig. 9.11) via resistive attenuator (see Fig. 7.1).
- (2) Set AF signal generator frequency to 1kHz and output level to give 1mW on 600 Ω output meter.
- (3) Measurements taken with AF valve voltmeter.

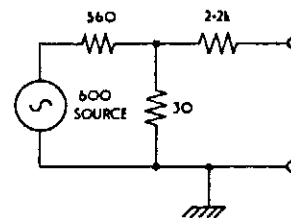

Fig. 7.1 Resistive Attenuator

Point of Measurement	mV rms $\pm 20\%$	
VT20	emitter	15
	base	17
	collector	500
VT21	emitter	480
	base	500
	collector	< 5
VT22	emitter	460
	base	465
	collector	1200
VT23	emitter	> 280
	base	> 570
	collector	> 10,000
VT24	emitter	> 280
	base	> 570
	collector	> 10,000
VT32	emitter	480
	base	490
	collector	< 20

7.5.3 Reference Oscillator/BFO

Refer to Fig. 10.1 for High Stability Module.

DC Checks

Conditions: Crystal oven removed
 L1 short circuited
 330Ω resistor 5905-99-013-5983 connected across PL18/E and PL18/F
 PL18/A, PL18/L and PL18/N linked together
 +20V supply connected to PL18/N
 +5V supply connected to PL18/D

Point of Measurement	V DC ±5%
VT1	emitter 9.2
	base 9.6
	collector 20.0
VT2	emitter 12.2
	base 12.2
	collector 19.0
VT3	emitter 8.5
	base 9.1
	collector 14.0
VT4	emitter 0
	base 0.65
	collector 0.1
VT5	emitter 0
	base 0.7
	collector 0.2
VT6	emitter 1.3
	base 2.0
	collector 2.7

Refer to Fig. 10.10 for Normal Stability Module.

DC Checks

Conditions: Crystal oven removed
 L1 short circuited
 330Ω resistor (5905-99-013-5983) connected across PL18/E and PL18/F
 PL18/L, PL18/M linked together
 +20V supply connected to PL18/M
 +5V supply connected to PL18/D

Point of Measurement	V DC ±5%
VT1	emitter 9.2
	base 9.6
	collector 20.0
VT2	emitter 12.2
	base 12.6
	collector 19.0
VT3	emitter 6.0
	base 6.5
	collector 14.0
VT4	emitter 5.3
	base 6.0
	collector 14.1

7.5.4 VFO

Refer to Fig. 10.7

Under no circumstances should the mechanical couplings between the gearbox and gang capacitor be undone as these require a special mechanical alignment procedure to enable the tracking and resetting accuracies to be achieved.

DC Checks

Point of Measurement	V DC ±5%
VT51	emitter 8.7
	base 8.3
	collector 19.8
VT52	emitter 5.3
	base 5.7
	collector 19.2
VT53	emitter 20.0
	base 19.2
	collector 9.5

Signal Checks

Test Equipment Required:

RF Valve Voltmeter: CRETE CT471 with 50Ω probe

- (1) Connect 50Ω probe of RF valve voltmeter across socket SK30.
- (2) Check RF valve voltmeter reading.

Limits: 300mV ±1dB at any frequency between 600 and 700kHz (i.e. between 000 and 999 on VFO control).

7.5.5 4.1 to 5.0MHz VCO

Refer to Fig. 10.6

Test Equipment Required:

Oscilloscope: CRETE CT484

Multimeter: CRETE AVO8SX

For correct operation this unit must have correct inputs from other modules. First check input signals to module.

DC Checks

Point of Measurement	V DC
SK28/B	5.0 ±5%
SK28/D	3.8 to 8.4
SK28/F	20.0 ±5%

Signal Checks

- (1) Connect oscilloscope to socket SK30.
- (2) Check that waveform is 200mV pk-to-pk ±10% and frequency is between 600 and 700kHz.
- (3) Connect oscilloscope to pin 2 on 50kHz Phase Discriminator PCB (see Fig. 9.21).
- (4) Check that waveform is 2.5V pk-to-pk ±10% square wave.

If the figures measured above are acceptable, but a fault condition exists, make the following measurements within the module.

DC Checks

Point of Measurement		V DC $\pm 5\%$
VT47	emitter	0
	base	1.0
	collector	2.0
VT48	emitter	9.2
	base	8.9
	collector	19.0
VT50	emitter	8.7
	base	9.2
	collector	18.8
VT60	emitter	4.4
	base	4.9
	collector	14.0

Signal Checks

- (1) Connect oscilloscope to pin 5 on 4.1 to 5.0MHz VCO PCB (see Fig. 9.18).
- (2) Check that waveform is 1.0V pk-to-pk $\pm 10\%$ and frequency is between 4.1 and 5.0MHz.
- (3) Connect oscilloscope to test point TP43 on Divider Output PCB (see Fig. 9.20).
- (4) Check that waveform is 2.5V pk-to-pk $\pm 10\%$ square wave and frequency is 50kHz.
- (5) Connect oscilloscope to pin 23 on Switch Filter PCB (see Fig. 9.19).
- (6) Check that waveform is 200mV pk-to-pk $\pm 10\%$ and frequency is between 3.4 and 4.4MHz.

7.5.6 38 to 68MHz VCO

Refer to Fig. 10.5

Test Equipment Required:

Multimeter: CRETE AVO8SX

Oscilloscope: CRETE CT484

RF Valve Voltmeter: CRETE CT471

DC Checks

See Fig.	Point of Measurement	V DC
	Socket SK23	20.0 $\pm 5\%$
	Across MR40	5.0 $\pm 5\%$
9.13	Test point TP38	14.0 $\pm 5\%$
9.17	Test point TP22	1.1 $\pm 5\%$
9.17	Test point TP21	4.75 to 8.4
9.16	Test point TP46	5.0 $\pm 5\%$

Point of Measurement		V DC $\pm 5\%$
VT33	emitter	0
	base	0.65
	collector	0.02
VT34	emitter	0
	base	0
	collector	1.1
VT35	emitter	0
	base	0.35
	collector	10.4

Point of Measurement		V DC $\pm 5\%$
VT39	emitter	5.7
	base	6.3
	collector	13.6
VT40	emitter	5.1
	base	5.7
	collector	13.6
VT41	emitter	4.6
	base	5.1
	collector	10.0
VT42	emitter	9.8
	base	10.0
	collector	18.0
VT43	emitter	5.6
	base	6.3
	collector	9.3
VT44	emitter	9.1
	base	9.3
	collector	17.0
VT45	emitter	2.35
	base	3.1
	collector	8.0
VT46	emitter	10.0
	base	10.5
	collector	19.5
VT59	emitter	7.2
	base	8.0
	collector	13.7

Signal Checks

- (1) Connect oscilloscope to socket SK40.
- (2) Check that waveform is 2.0V pk-to-pk $\pm 10\%$ square wave at 100kHz.
- (3) Connect oscilloscope to plug PL29.
- (4) Check that waveform is 2.0V pk-to-pk $\pm 10\%$ square wave at 100kHz.
- (5) Connect oscilloscope to test point TP18 (see 1-10MHz Phase Loop PCB Fig. 9.17).
- (6) Check that waveform is 2.0V pk-to-pk $\pm 10\%$ pulses at 100kHz.
- (7) Connect oscilloscope to test point TP19 (see 1-10MHz Phase Loop PCB Fig. 9.17).
- (8) Check that waveform is 2.0V pk-to-pk $\pm 10\%$ square wave at 100kHz.
- (9) Connect oscilloscope to test point TP20 (see 1-10MHz Phase Loop PCB Fig. 9.17).
- (10) Check that waveform is 10.0V pk-to-pk $\pm 10\%$ constant (but not necessarily 1:1) mark-to-space ratio rectangular wave at 200kHz.
- (11) Connect oscilloscope to test point TP36 (see Variable Divider PCB Fig. 9.16).
- (12) Check that waveform is 500mV pk-to-pk $\pm 10\%$ square wave. Frequency between 300kHz and 3.2MHz.

- (13) Connect RF valve voltmeter to test point TP28 (see VCO Amplifier PCB Fig. 9.15).
 (14) Check that signal level is 300V rms $\pm 20\%$.
 (15) Connect RF valve voltmeter to test point TP29 (see VCO Amplifier PCB Fig. 9.15).
 (16) Check that signal level is 2.5V rms $\pm 20\%$.
 (17) Connect RF valve voltmeter to test point TP30 (see VCO Amplifier PCB Fig. 9.15).
 (18) Check that signal level is 120mV rms $\pm 20\%$.
 (19) Connect multimeter to test point TP30 (see VCO Amplifier PCB Fig. 9.15).
 (20) Check that multimeter indicates 6.0V DC $\pm 5\%$.
 (21) Connect RF valve voltmeter to test point TP32 (see VCO Amplifier PCB Fig. 9.15).
 (22) Check that signal level is 1.4V rms $\pm 20\%$.

- (23) Connect RF valve voltmeter to test point TP37 (see 3 to 32MHz Filter Amplifier PCB Fig. 9.13).

7.6 TYPICAL TRANSISTOR DC MEASUREMENTS

Unless otherwise stated, the RF and AF Gain controls are at maximum clockwise position and Service Bandwidth kHz switch is in A1 cw 1 position.

Test Equipment Required:

Multimeter: CRETE AVO 8SX.

Multimeter used on lowest possible range.

Measured voltage within 10% should be satisfactory.

* Component references so marked are part of BFO Module (High Stability Unit).

† Component references so marked are part of BFO Module (Normal Stability Unit).

Comp Ref	Transistor Type	Function	See Fig. No	V DC		
				Emitter	Base	Collector
*VT1	40235	BFO	9.1	9.2	9.6	20.0
*VT2	BC107	Insertion Osc Ampl	9.1	12.2	12.6	19.0
*VT3	40235	Insertion Osc Ampl	9.2	8.5	9.1	14.0
*VT4	BC107	CW Switch Ampl	9.2	0	0.65	0.1
*VT5	BC107	DC Ampl	9.2	0	0.7	0.2
*VT6	BC107	Ext Osc Ampl	9.2	1.3	2.6	2.7
†VT1	40235	BFO	9.29	9.2	9.6	20.0
†VT2	2N3904	Insertion Osc Ampl	9.29	12.2	12.6	19.0
†VT3	40235	Insertion Osc Ampl	9.30	6.3	6.3	13.7
†VT4	2N3904	Insertion Osc Ampl	9.30	5.8	6.3	13.7
VT1	2N3866	RF Ampl	9.6	5.5	6.2	14.9
VT2	2N3866	RF Ampl	9.6	5.5	6.2	14.9
VT3	V410	DC Ampl	9.6	20.0	20.0	0
VT4	2N3904	DC Ampl RF Gain min	9.6	3.4	4.1	16.6
		RF Gain max		0	0	20.0
VT5	2N3906	AGC RF Ampl	9.6	20.0	19.9	0
VT6	40235	AGC RF Ampl	9.6	0	0	19.9
VT7	40235	38MHz Ampl	9.8	2.15	2.8	17.5
VT8	40235	38MHz Ampl	9.8	2.15	2.8	17.5
VT9	40235	39.4MHz Osc	9.9	2.0	2.4	8.4
VT11	2N3866	39.4MHz*Ampl	9.9	7.2	7.8	17.8
VT12	2N3866	39.4MHz Ampl	9.9	7.2	7.8	18.0
VT13	40235	1.4MHz Ampl	9.11	2.8	3.6	7.6
VT14	2N3904	1.4MHz Ampl	9.11	8.8	9.5	15.0
VT15	2N3906	1.4MHz Ampl	9.11	15.7	15.0	7.5
VT16	2N3904	1.4MHz Ampl	9.11	1.93	2.6	8.9
VT17	2N3904	1.4MHz Ampl	9.11	8.4	8.9	19.2
VT18	2N3904	1.4MHz Ampl	9.11	9.8	10.5	15.6
VT19	2N3906	1.4MHz Output Ampl	9.11	10.5	9.8	0.8
VT20	2N3904	AF Preamp	9.11	1.26	1.5	14.0
VT21	2N3906	AF Preamp	9.11	14.8	14.0	7.1
VT22	2N3904	AF Ampl	9.11	9.2	10.0	14.7
VT23	OC28	AF Output Ampl	9.11	19.2	19.1	0.05
VT24	OC28	AF Output Ampl	9.11	19.2	19.1	0.05
VT25	2N3904	AGC DC Ampl	9.11	0	0	20.0

Comp Ref	Transistor Type	Function	See Fig. No	V DC		
				Emitter	Base	Collector
VT26	2N3904	AGC DC Ampl	9.11	0	0	20-0
VT27	2N3904	AGC Time Constant Sw	9.11	0	0	0
VT28	2N3906	AGC IF Ampl	9.11	15-0	14-8	0
VT29	2N3906	AGC IF Ampl	9.11	14-8	15-5	0
VT32	2N3904	AF Line Ampl	9.11	8-7	9-2	15-3
VT33	BFY51	Phase Lock Switch	9.17	0	0-65	0-02
VT34	2N3904	In Lock Sensing Sw	9.17	0	0	1-1
VT35	2N3904	DC Ampl	9.17	0	0-35	10-4
VT39	40235	38 to 68MHz VCO	9.12	5-7	6-3	13-6
VT40	40235	VCO Ampl	9.12	5-1	5-7	13-6
VT41	40235	VCO Ampl	9.15	4-6	5-1	10-0
VT42	2N3866	VCO Ampl	9.15	9-8	10-0	18-0
VT43	40235	VCO Ampl	9.15	5-6	6-3	9-3
VT44	40235	VCO Ampl	9.15	9-1	9-3	17-0
VT45	40235	3 to 32MHz Ampl	9.13	2-35	3-1	8-0
VT46	40235	35 to 36MHz Ampl	9.14	10-0	10-5	19-5
VT47	BC107	DC Ampl	9.21	0	1-0	2-0
VT48	40235	4-1 to 5MHz VCO	9.18	9-2	8-9	19-0
VT50	2N3904	VCO Ampl	9.18	8-7	9-2	18-8
VT51	40235	VFO	9.24	8-7	8-3	19-8
VT52	BC107	VFO Ampl	9.24	5-3	5-7	19-2
VT53	BCY72	VFO Ampl	9.24	20-0	19-2	9-5
VT54	BC107	+20V Ref Ampl	9.3	13-6	14-2	21-5
VT55	2N1613	+20V Stab	9.3	21-0	21-5	33-0
VT56	40251	+20V Stab	9.26	20-0	21-0	32-0
VT57	2N1613	+5V Stab	9.3	5-6	6-2	15-4
VT58	40251	+5V Stab	9.26	5-0	5-6	15-0
VT59	40235	3 to 32MHz Ampl	9.13	7-2	8-0	13-7
VT60	2N3904	VCO Ampl	9.18	4-4	4-9	14-0
VT70	BC107	Relay Driver (unsw.)	9.26	0	0	20-0

**7.7 COMMERCIAL TEST EQUIPMENT
EQUIVALENT TO CRETE ITEMS**

Crete Commercial
AVO8SX AVO model 8 multimeter

CT452 Marconi TF144H Signal Generator
CT471 Airmec 301 Valve Voltmeter
SM111 Tektronix 543B dual beam oscilloscope
CT454 Marconi TF893 AF power meter
CT488 Hewlett Packard 5245L Frequency Counter

8 PERFORMANCE CHECKS AND ADJUSTMENTS

8.1 GENERAL

8.2 TEST EQUIPMENT REQUIRED

8.3 POWER SUPPLY

8.4 OVERALL PERFORMANCE CHECK

Table 8.1 Signal + Noise to Noise Ratio

8.5 AERIAL FILTER ALIGNMENT

8.5.1 Test Equipment Connections

8.5.2 Filters FL1, FL2, FL3, FL4, and FL5

8.5.3 Filter FL6

8.5.4 Filters FL7, FL8, FL9, FL10 and FL11

8.5.5 Filters FL12 and FL13

8.5.6 70 to 100kHz Band

Table 8.2 Alignment Frequencies and Inductor References

Table 8.3 Filter Insertion Loss

8.6 38MHz IF REJECTOR, 38MHz AMPLIFIER AND 39.4MHz OSCILLATOR

8.6.1 38MHz IF Rejector

8.6.2 38MHz Amplifier

8.6.3 39.4MHz Crystal Oscillator

8.7 8kHz AM FILTER

8.8 FRONT PANEL METER CIRCUIT

8.9 1.4MHz IF CIRCUITS

8.10 1.4MHz OSCILLATOR, BFO AND REFERENCE OSCILLATOR

8.11 VFO

8.12 4.1 TO 5.0MHz VCO

8.12.1 3.4 to 4.4MHz Filter

8.12.2 VCO

8.13 38 TO 68MHz VCO

8.13.1 50kHz Filter

8.13.2 30MHz Filter

8.13.3 35 to 36MHz Filter

8.13.4 VCO

Table 8.4 VCO Alignment Frequencies

8 PERFORMANCE CHECKS AND ADJUSTMENTS

8.1 GENERAL

The following procedures should be carried out as necessary:

- (a) when the settings of preset controls have been inadvertently disturbed
- (b) when it is considered that the replacement of a component in a circuit could affect the alignment of that circuit
- (c) if a check of alignment is considered necessary due to ageing of components.

It is recommended that the brief performance check contained in para. 8.4 be carried out after the alignment of any circuit (the power supply is an exception to this).

All test leads must be kept as short as possible.

8.2 TEST EQUIPMENT REQUIRED

The list of test equipment below includes all the items necessary to undertake all the performance checks detailed in the following paragraphs.

RF Signal Generator: Marconi TF144H CRETE CT452

AF Signal Generator: Advance H18 CRETE CT433A

RF Valve Voltmeter: Airmec 301 CRETE CT471 with 50 Ω probe

AF Valve Voltmeter: Advac VM77B CRETE CT343

AF Power Meter: Marconi TF893 CRETE CT44

Frequency Counter: Racal SA550 CRETE CT488

Multimeter (2 required): AVO-8 CRETE AVO8SX

Variable Mains Transformer: Variac V6HPSV

Power Supply: 20V DC at 0.5A

Dummy Aerial Network: See Fig. 8.1

AF Attenuator Network: See Fig. 8.2

8.3 POWER SUPPLY

Test Equipment Required (For details see para. 8.2)

Two Multimeters

Variable Mains Transformer

- (1) Set R551 Receiver Mains switch to OFF position.
- (2) Connect the AC mains supply to plug PL38 via the variable transformer.

- (3) Connect one of the multimeters across the receiver mains input at plug PL38.

- (4) Set multimeter to 250V AC range.

- (5) Switch on mains supply to variable transformer.

- (6) Adjust variable transformer until multimeter indicates nominal mains voltage for which mains transformer has been set (see para. 2.4).

- (7) Switch off mains supply to variable transformer.

- (8) Connect second multimeter to SK4/J and chassis, and set to 25V DC range. Do not disconnect socket SK4 (See Fig. 9.26).

- (9) Set Mains switch to ON position.

- (10) If necessary, adjust R310 until second multimeter indicates 20.0V DC (See Fig. 9.3).

- (11) Set Mains switch to OFF position.

- (12) Connect second multimeter to SK4/A and chassis, and set to 10V DC range.

- (13) Set Mains switch to ON position.

- (14) If necessary, adjust R311 until second multimeter indicates 5.0V DC (See Fig. 9.3).

- (15) Adjust variable transformer until first multimeter indicates highest specified mains voltage, i.e. 255V for nominal 230V supply, or 124V for nominal 115V supply.

- (16) Note that second multimeter indication does not change by more than 0.2V from 5.0V DC.

- (17) Adjust variable mains transformer until first multimeter indicates lowest specified mains voltage, i.e. 204V for nominal 230V supply, or 106V for nominal 115V supply.

- (18) Note that second multimeter indication does not change by more than 0.2V from 5.0V DC.

- (19) Set Mains switch to OFF position.

- (20) Connect second multimeter to SK4/J and chassis, and set to 25V DC range (See Fig. 9.26).

- (21) Set Mains switch to ON position.

- (22) Note that second multimeter indicates 20.0V DC $\pm 0.2V$.

- (23) Adjust variable transformer until first multimeter indicates highest specified mains voltage, i.e. 255V for nominal 230V supply, or 124V for nominal 115V supply.

- (24) Note that second multimeter indicates 20.0V DC $\pm 0.2V$.

Table 8.1 Signal+Noise to Noise Ratio

Service Bandwidth kHz Switch Position	R551 Receiver Frequency Controls		RF Signal Generator			Signal+Noise to Noise Ratio dB Minimum		
			Freqy	Service Mode	Output Level μV rms emf	Signal Source Impedance		
	Switches	VFO				10 Ω + 200pF	10 Ω + 700pF	50 Ω
A3J usb 3	00-1	*000	100kHz	CW	20	20	20	20
A3J usb 3	00-2	*000	200kHz	CW	20	20	20	20
A3J usb 3	00-2	500	250kHz	CW	20	20	20	20
A3J usb 3	00-2	990	299kHz	CW	20	20	20	20
A3J usb 3	00-3	010	301kHz	CW	20	20	20	20
A3J usb 3	00-4	*000	400kHz	CW	20	20	20	20
A3J usb 3	00-4	990	499kHz	CW	20	20	20	20
A3J usb 3	00-5	010	501kHz	CW	20	20	20	20
A3J usb 3	00-6	500	650kHz	CW	20	20	20	20
A3J usb 3	00-6	990	699kHz	CW	20	20	20	20
A3J usb 3	00-7	*000	700kHz	CW	20	20	20	20
A3J usb 3	00-7	010	701kHz	CW	20	20	20	20
A3J usb 3	00-9	990	999kHz	CW	20	20	20	20
A3J usb 3	01-0	*000	1-0MHz	CW	20	20	20	20
A3J usb 3	01-2	500	1-25MHz	CW	20	20	20	20
A3J usb 3	01-5	*000	1-5MHz	CW	20	20	20	20
A3J usb 3	01-7	500	1-75MHz	CW	2	13	13	13
A3J usb 3	02-0	*000	2-0MHz	CW	2	13	13	13
A3J usb 3	02-5	*000	2-5MHz	CW	2	13	13	13
A3J usb 3	03-0	*000	3-0MHz	CW	2	13	13	13
A3J usb 3	04-0	*000	4-0MHz	CW	2	—	—	20
A3J usb 3	05-0	*000	5-0MHz	CW	2	—	—	20
A3J usb 3	06-0	*000	6-0MHz	CW	2	—	—	20
A3J usb 3	07-0	*000	7-0MHz	CW	2	—	—	20
A3J usb 3	08-5	*000	8-5MHz	CW	2	—	—	20
A3J usb 3	10-0	*000	10-0MHz	CW	2	—	—	20
A3J usb 3	12-5	*000	12-5MHz	CW	2	—	—	20
A3J usb 3	15-0	*000	15-0MHz	CW	2	—	—	20
A3J usb 3	17-5	*000	17-5MHz	CW	2	—	—	20
A3J usb 3	20-0	*000	20-0MHz	CW	2	—	—	20
A3J usb 3	25-0	*000	25-0MHz	CW	2	—	—	20
A3J usb 3	29-9	*000	29-9MHz	CW	2	—	—	20
A1 cw 0-3	20-0	*000	20-0MHz	CW	0-5	—	—	20
A1 cw 1	20-0	*000	20-0MHz	CW	0-5	—	—	12
A1 cw 3	20-0	*000	20-0MHz	CW	0-5	—	—	10
A3 dsb 8	20-0	*000	20-0MHz	AM 30% Mod at 1kHz	3	—	—	10

* Set VFO to 000 at LF end (near maximum counter-clockwise)

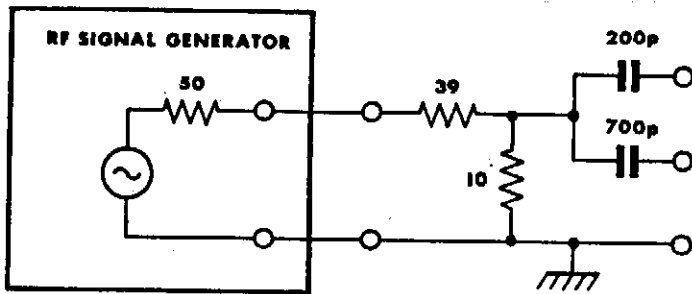

Fig. 8.1 Dummy Aerial Network

8.4 OVERALL PERFORMANCE CHECK

This check should be carried out after realignment, replacement of modules, when a deterioration of performance is suspected or after extensive faultfinding.

Test Equipment Required (For details see para. 8.2)

RF Signal Generator

AF Power Meter

Dummy Aerial Network

- (1) Set R551 Receiver Mains switch to OFF position.
- (2) Connect RF signal generator to aerial socket SK1.
- (3) Connect AF power meter to SK15/4 and SK15/9.
- (4) Set AF power meter input switch to 3Ω load impedance.
- (5) Set R551 Receiver Mains switch to ON position.
- (6) Set AGC switch to FAST position, and Service Bandwidth kHz switch to A3J usb 3 position.
- (7) Set RF Gain control to maximum.
- (8) Set Line/Signal switch to SIGNAL position.
- (9) Set R551 Receiver tune frequency to 00·1000MHz (VFO set to 000 at LF end—near maximum counter-clockwise).
- (10) Set RF signal generator frequency to 100kHz, mode to CW and output level to 20μV rms emf.
- (11) Adjust RF signal generator frequency carefully for maximum indication on R551 Receiver meter.
- (12) Note indication on AF power meter.
- (13) Adjust RF Gain control until AF power meter indication is 2dB below indication noted in (12).
- (14) Adjust AF Gain control until AF power meter indicates 100mW.
- (15) Switch RF signal generator CW signal OFF.
- (16) Note fall in power meter indication below 100mW. This is the Signal+Noise to Noise Ratio, which should be >20dB.

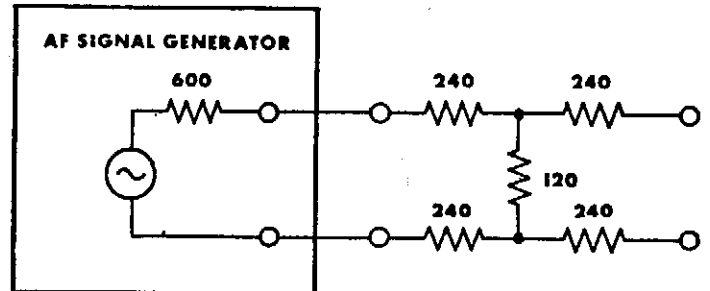

Fig. 8.2 AF Attenuator Network

- (17) Repeat (6) to (16) for other frequencies, position of service Bandwidth kHz switch, RF signal generator service mode and output level (and, if required, for other signal source impedances using the network in Fig. 8.1) as shown in Table 8.1.

8.5 AERIAL FILTER ALIGNMENT

Test Equipment Required (For details see para. 8.2)

RF Signal Generator

RF Valve Voltmeter

Dummy Aerial Network

Power Supply

Capacitor 390pF 5910-99-913-6618

8.5.1 Test Equipment Connections

- (1) Remove the Aerial Filter module as detailed in para. 6.1.9 and then remove the filter unit from module box.
- (2) Refit switch spindles to module without altering rotor positions.
- (3) Connect RF valve voltmeter 50Ω probe to socket SK5.
- (4) Connect power supply positive to plug PL2 and negative to socket SK3.
- (5) Switch on power supply and set output level to 20·0V DC.

8.5.2 Filters FL1, FL2, FL3, FL4 and FL5

- (1) Connect RF signal generator to socket SK1.
- (2) Set RF signal generator to frequencies in Table 8.2 for filter to be aligned, and output level to 2·0V rms emf.
- (3) Set the switch spindles (using a pair of pliers) so that the wafer switches are in the positions indicated in Table 8.2 for the filter to be aligned.
- (4) Adjust appropriate inductor indicator in Table 8.2 for maximum or minimum indication on RF valve voltmeter.
- (5) Sweep RF signal generator frequency slowly over the relevant band from just below frequency of $\frac{f_2}{2}$ to just above frequency of $2f_1$ (See Table 8.3 for f_1 and f_2).
- (6) If necessary, slightly re-adjust the relevant inductors to meet the response figures for the particular filter detailed in Table 8.3.

Table 8.2 Alignment Frequencies and Inductor References

Filter No	Switch Wafer Position			Filter Pass Band MHz	RF Signal Generator Frequency MHz	Inductor to Adjust		For Location of Inductors See Fig.
	10MHz	1MHz	100kHz			for MINIMUM Indication on RF Valve Voltmeter	for MAXIMUM Indication on RF Valve Voltmeter	
FL1	2	0	0	10 to 30	14.5	L2	L1 L4	9.5
					20.0	L3		
					30.0			
					40.5			
FL2	1	5	0	15 to 20	9.6	L6	L5 L8	9.4
					15.0	L7		
					20.0			
					33.0			
FL3	1	0	0	10 to 15	7.25	L10	L9 L12	9.5
					10.0	L11		
					15.0			
					21.25			
FL4	0	7	0	7 to 10	4.85	L14	L13 L16	9.4
					7.0	L15		
					10.0			
					14.65			
FL5	0	5	0	5 to 7	3.35	L18	L17 L20	9.5
					5.0	L19		
					7.0			
					10.6			
FL6	0	3	0	3 to 5	2.49	L22	L23 L21 L26 L24	9.4
					3.0	L25		
					5.0			
					6.1			
FL7	0	2	0	2 to 3	1.44	L28	L27 L30	9.4
					2.0	L29		
					3.0			
					4.25			
FL8	0	1	6	1.6 to 2	0.94	L32	L31 L34	9.5
					1.6	L33		
					2.0			
					3.2			
FL9	0	1	0	1.0 to 1.6	0.72	L36	L35 L38	9.4
					1.0	L37		
					1.6			
					2.125			
FL10	0	0	7	0.7 to 1.0	0.55	L40	L39 L42	9.5
					0.7	L41		
					1.0			
					1.25			

(Table 8.2 Continued)

Filter No	Switch Wafer Position			Filter Pass Band MHz	RF Signal Generator Frequency MHz	Inductor to Adjust		For Location of Inductors See Fig.
	10MHz	1MHz	100kHz			for MINIMUM Indication on RF Valve Voltmeter	for MAXIMUM Indication on RF Valve Voltmeter	
FL11	0	0	5	0.5 to 0.7	0.39	L44		9.5
					0.5		L43	
					0.7		L46	
					0.88	L45		
FL12	0	0	3	0.3 to 0.5	0.24	L48		9.5
					0.3		L47	
					0.5		L50	
					0.62	L49		
FL13	0	0	1	0.1 to 0.15	0.075	L52		9.4
					0.1		L51	
					0.15		L54	
					0.2	L53		

8.5.3 Filter FL6

- (1) Connect RF signal generator to socket SK1 via the 10Ω and 200pF dummy aerial network.
- (2) Repeat paras. 8.5.2 (2) to (4).
- (3) Sweep RF signal generator frequency slowly from just below frequency of 2.5 up to 4.0MHz.
- (4) If necessary, slightly re-adjust the relevant inductors to meet the response figures for filter FL6 detailed in Table 8.3.
- (5) Disconnect the dummy aerial network and connect RF signal generator to socket SK1.
- (6) Sweep RF signal generator frequency slowly from 4.0MHz to just above 6.0MHz.
- (7) If necessary, slightly re-adjust the relevant inductors to meet the response figures for filter FL6 detailed in Table 8.3.
- (8) Reconnect dummy aerial network between RF signal generator and socket SK1.
- (9) Repeat (3) to (8) until the response figures are as specified in Table 8.3 for the whole band.

8.5.4 Filters FL7, FL8, FL9, FL10 and FL11

- (1) Connect RF signal generator to socket SK1 via the 390pF capacitor.
- (2) Repeat paras. 8.5.2 (2) to (6).

8.5.5 Filters FL12 and FL13

NOTE: These filters have tapped inductors, enabling the capacitors to provide two mutually dependent filter responses. The inductors of filter FL12 are tuned for passband responses of 200 to 300kHz and 300 to 500kHz. Tuning the inductor for one band determines the response of the other.

- (1) Connect RF signal generator to socket SK1 via the 390pF capacitor.

- (2) Repeat paras. 8.5.2 (2) to (4) for filter FL12.
- (3) Sweep RF signal generator frequency slowly over the band 230 to 640kHz.
- (4) If necessary, slightly re-adjust the relevant inductors to meet the response figures in Table 8.3.
- (5) Set the switch positions for 0.2MHz.
- (6) Sweep RF signal generator frequency slowly over the band 130 to 430kHz.
- (7) If necessary, slightly re-adjust the inductors to meet the response figures in Table 8.3 for the whole band 130 to 640kHz.
- (8) Repeat paras. 8.5.2 (2) to (4) for filter FL13.
- (9) Sweep RF signal generator frequency slowly over the band 70 to 210kHz.
- (10) If necessary, slightly re-adjust the inductors to meet the response figures in Table 8.3.
- (11) Connect socket SK3 to socket SK50.
- (12) Sweep RF signal generator frequency slowly over the band 90 to 320kHz.
- (13) If necessary, slightly re-adjust the inductors to meet the response figures in Table 8.3 for the whole band 70 to 320kHz.
- (14) Disconnect link between socket SK50 and socket SK3.

8.5.6 70 to 100kHz Band

- (1) Connect RF signal generator to socket SK1 via the 10Ω and 200pF dummy aerial network.
- (2) Set the switch spindles so that the wafers are all in the 0 position (0.0MHz).
- (3) Sweep RF signal generator frequency slowly over the band 70 to 100kHz and check that response is within limits set in Table 8.3.

Table 8.3 Filter Insertion Loss

Filter No	Switch Wafer Positions			RF Signal Generator Source Impedance	Filter Pass Band f_1 to f_2		Insertion Loss dB		
	10MHz	1MHz	100kHz		f_1 MHz	f_2 MHz	Within Pass Band f_1 to f_2	At $\frac{f_2}{2}$ MHz	At $2f_1$ MHz
FL1	2	0	0	50Ω	20	30	1.5 to 4	±30	±30
FL2	1	5	0	50Ω	15	20	1 to 2	±30	±30
FL3	1	0	0	50Ω	10	15	1 to 2	±30	±30
FL4	0	7	0	50Ω	7	10	1 to 2	±30	±30
FL5	0	5	0	50Ω	5	7	1 to 2	±30	±30
FL6	0	3	0	50Ω	3	5	1 to 2	±30	±30
				10Ω and 200pF			(4 to 5MHz) (3 to 4MHz) 25 to 28		
FL7	0	2	0	50Ω and 390pF	2	3	7 to 9	±33	±33
FL8	0	1	6	50Ω and 390pF	1.6	2	9 to 11	±36	±36
FL9	0	1	0	50Ω and 390pF	1.0	1.6	18.5 to 20.5	±43	±43
FL10	0	0	7	50Ω and 390pF	0.7	1.0	18.5 to 20.5	±46	±46
FL11	0	0	5	50Ω and 390pF	0.5	0.7	22 to 24	±50	±50
FL12	0	0	3	50Ω and 390pF	0.3	0.5	23.5 to 25.5	±50	±50
	0	0	2		0.2	0.3			
FL13	0	0	1	50Ω and 390pF	*0.15 0.10	0.20 0.15	20.5 to 22.5	±50	±50
—	0	0	0	10Ω and 200pF	0.07	0.10	35 to 41	—	—

* Socket SK3 connected to socket SK50

8.6 38MHz IF REJECTOR, 38MHz AMPLIFIER AND 39.4MHz OSCILLATOR

Test Equipment Required (For details see para. 8.2)

RF Signal Generator

RF Valve Voltmeter

Two Resistors 47Ω (5905-99-013-5963)

- (1) Disconnect sockets SK5, SK8, SK11 and plug PL7.
- (2) Remove five screws securing RF module cover, and remove cover.

8.6.1 38MHz IF Rejector

Refer to Fig. 9.6

- (1) Disconnect coaxial inner lead from pin 3.
- (2) Connect RF valve voltmeter 50Ω probe to pin 3 and chassis on Wideband Amplifier PCB Assembly.
- (3) Connect RF signal generator to plug PL5.
- (4) Set RF signal generator frequency to 38.0MHz ±1kHz and output level to 100mV rms emf.

- (5) Set R551 Receiver Mains switch to ON position.
- (6) Adjust L58 for minimum indication on the RF valve voltmeter.
- (7) Set Mains switch to OFF position.
- (8) Disconnect test equipment and re-make coaxial inner lead to pin 3.

8.6.2 38MHz Amplifier

Refer to Fig. 9.8

- (1) Disconnect coaxial inner lead from pin 1 on 38MHz Amplifier PCB Assembly.
- (2) Disconnect coaxial inner lead from junction of C403 and C404 (see Fig. 9.26 for location).
- (3) Connect RF signal generator to pin 1 and chassis.
- (4) Connect RF valve voltmeter 50Ω probe to junction of C403 and C404, and chassis (pin 6).
- (5) Set RF signal generator frequency to 38.0MHz \pm 1kHz and output level to 100mV rms emf.
- (6) Set R551 Receiver Mains switch to ON position.
- (7) Adjust T9 for maximum indication on RF valve voltmeter.
Limit: > 360mV rms.
- (8) Set RF signal generator frequency to 40.8MHz \pm 1kHz.
- (9) Adjust L118 (see Fig. 9.26 for location) for minimum indication on RF valve voltmeter.
Limit: < 30mV rms.
- (10) Set Mains switch to OFF position.
- (11) Disconnect test equipment and re-make connections.

8.6.3 39.4MHz Crystal Oscillator

Refer to Fig. 9.9

- (1) Disconnect socket SK11.
- (2) Disconnect coaxial cable from pins 3 and 4 on 39.4MHz Crystal Oscillator PCB Assembly.
- (3) Connect one 47Ω resistor across plug PL11.
- (4) Connect a second 47Ω resistor between pins 3 and 4.
- (5) Connect RF valve voltmeter (without 50Ω probe) across plug PL11.
- (6) Set Mains switch to ON position.
- (7) Adjust L62 for maximum indication on RF valve voltmeter.
- (8) Adjust L125 (by carefully opening or closing the turns of the inductor) for maximum indication on the RF valve voltmeter.
Limit: > 0.5V rms.
- (9) Connect RF valve voltmeter (without 50Ω probe) between pins 3 and 4.
- (10) Adjust L126 (as for L125 in (8) above) for maximum indication on the RF valve voltmeter.
Limit: > 1.0V rms.

- (11) Set Mains switch to OFF position.
- (12) Disconnect test equipment.
- (13) Reconnect sockets SK5, SK8, SK11 and plug PL7.
- (14) Re-make coaxial cable to pins 3 and 4.
- (15) Refit module cover.

8.7 8kHz AM FILTER

Refer to Fig. 9.26

Test Equipment Required (For details see para. 8.2)

RF Signal Generator

AF Power Meter

- (1) Disconnect plug PL8 from socket SK8.
- (2) Connect RF signal generator to socket SK8.
- (3) Connect AF power meter to SK15/5 and SK15/7.
- (4) Set AGC switch to FAST position.
- (5) Set AF Gain control and RF Gain control both to maximum.
- (6) Set Service Bandwidth kHz switch to A3J usb 3 position.
- (7) Set AF power meter input to 600Ω.
- (8) Set Mains switch to ON position.
- (9) Set Loudspeaker switch to ON position.
- (10) Set RF signal generator output level to 4μV rms emf and mode to CW.
- (11) Adjust RF signal generator frequency accurately to 1.4MHz by listening to the audible beat in the loudspeaker, and carefully setting for zero beat.
- (12) Set Loudspeaker switch to OFF position.
- (13) Set Service Bandwidth kHz switch to A3 dsb 8 position.
- (14) Set AGC switch to OFF position.
- (15) Set RF signal generator mode to AM and set modulation depth to 60% at 1kHz.
- (16) Adjust L64 (see Fig. 9.26 for location) for maximum indication on AF power meter.
- (17) Set Mains switch to OFF position.
- (18) Disconnect test equipment.
- (19) Connect plug PL8 to socket SK8.

8.8 FRONT PANEL METER CIRCUIT

Refer to Fig. 9.11

Test Equipment Required (For details see para. 8.2)

AF Signal Generator

AF Valve Voltmeter

AF Attenuator Network (See Fig. 8.2)

Resistor 600Ω \pm 1% $\frac{1}{2}$ W

- (1) Remove twelve screws securing the cover over the 1F/AF module and remove the cover.
- (2) Connect 600Ω resistor between SK15/5 and SK15/7.

- (3) Connect AF valve voltmeter between SK15/5 and SK15/7.
- (4) Link pin 40 to chassis on IF/AF PCB Assembly.
- (5) Disconnect inner of screened lead at pin 22.
- (6) Connect 600Ω output terminals of AF signal generator via the AF attenuator network to pin 22 and chassis.
- (7) Set Mains switch to ON position.
- (8) Set AF Gain control to minimum position.
- (9) Set Line control (screwdriver slot) to maximum position (fully clockwise).
- (10) Set AF signal generator frequency to 1kHz.
- (11) Adjust AF signal generator output level until AF valve voltmeter indicates 2.45V rms (+10dBm).
- (12) Set Meter switch to LINE position.
- (13) Adjust R162 for indication of +10dBm on R551 Receiver Meter.
- (14) Adjust AF signal generator output level until AF valve voltmeter indicates 0.775V rms (0dBm).
- (15) Adjust R161 for indication of 0dBm on R551 Receiver Meter.
- (16) Adjust AF signal generator output level until AF valve voltmeter indicates 0.245V rms (-10dBm).
- (17) Check that R551 Receiver Meter indicates within $\frac{1}{4}$ division of the -10dBm mark.
- (18) Repeat (11) to (15).
- (19) If it is not possible to obtain accurate calibration of the Meter at all three points, +10dBm, 0dBm and -10dBm, ensure that the calibration at +10dBm and 0dBm is accurate.
- (20) Set Mains switch to OFF position.
- (21) Disconnect test equipment.
- (22) Re-make connections.
- (23) Refit module cover plate.

8.9 1.4MHz IF CIRCUITS

Refer to Fig. 9.11

Test Equipment Required (For details see para. 8.2)

RF Signal Generator

RF Valve Voltmeter

Frequency Counter

Multimeter

Resistor 47Ω (5905-99-013-5963).

- (1) Remove twelve screws securing the cover over the IF/AF module and remove the cover.
- (2) Disconnect coaxial lead to PL13/A and PL13/B from pins 1 and 2 respectively on IF/AF PCB Assembly.
- (3) Connect RF signal generator to pins 1 and 2.
- (4) Connect RF valve voltmeter 50Ω probe across socket SK20 (IF OUT on rear panel).
- (5) Connect multimeter positive lead to pin 37 on IF/AF PCB Assembly.
- (6) Connect multimeter negative lead to chassis.
- (7) Set multimeter to 2.5V DC range.
- (8) Set R551 Receiver Mains switch to ON position.
- (9) Set the RF signal generator frequency to 1.4MHz approximately and output level to 100μV rms emf.
- (10) Set Service Bandwidth kHz switch to A3J usb 3 position.
- (11) Set RF Gain control to maximum.
- (12) Set AGC switch to FAST position.
- (13) Set AF Gain control to maximum.
- (14) Set Loudspeaker switch to ON position.
- (15) Adjust RF signal generator frequency carefully for zero beat in loudspeaker.
- (16) Adjust T16 for maximum indication on RF valve voltmeter.
- (17) Adjust T17 for maximum indication on RF valve voltmeter.
- (18) Note that multimeter does not indicate. If it does, reduce RF signal generator output level until multimeter indicates zero.
- (19) Set the Service Bandwidth kHz switch to A1 cw 0.3 position.
- (20) Readjust T16 for maximum indication on RF valve voltmeter. Again, reduce RF signal generator output level if multimeter indicates above zero.
- (21) Connect frequency counter to RF signal generator.
- (22) Set RF signal generator frequency to 1398.0kHz \pm 20Hz and note indication on RF valve voltmeter.
- (23) Set RF signal generator frequency to 1402.0kHz \pm 20Hz and note indication on RF valve voltmeter. Limits: within 2dB (or 10%) of indication noted in (22).
- (24) If indication noted in (23) is not within limits, slightly adjust C159, and if necessary T16 until, after repeating (22) and (23) the indications are within limits.
- (25) Set R551 Receiver Mains switch to OFF position.
- (26) Disconnect test equipment.
- (27) Re-make connections.
- (28) Refit module cover plate.

8.10 1.4MHz OSCILLATOR, BFO AND REFERENCE OSCILLATOR

Refer to Figs. 9.1 and 9.11

Test Equipment Required (For details see para. 8.2)

Frequency Counter

- (1) Adjust the reference oscillator to exact frequency as detailed in para. 5.2.1 or as in para. 5.2.2
- (2) Set R551 Receiver Mains switch to OFF position.

- (3) Remove twelve screws securing the cover over the IF/AF module and remove the cover.
- (4) Set Service Bandwidth kHz switch to A1 cw 1 position.
- (5) Connect frequency counter to pin 17 on IF/AF PCB Assembly and chassis.
- (6) Set Mains switch to ON position.
- (7) Set BFO control to fully counter-clockwise position (-3 on scale).
- (8) Adjust L1 until frequency counter indicates $1395.5\text{kHz} \pm 20\text{Hz}$.
- (9) Set BFO control to fully clockwise position (+3 on scale).
- (10) Check that frequency counter indicates approximately 1404.5kHz .
- (11) Set Mains switch to OFF position.
- (12) Disconnect test equipment.
- (13) Refit module cover plate.

8.11 VFO

Refer to Fig. 9.24

Test Equipment Required (For details see para. 8.2)

Frequency Counter

NOTE: The mechanical couplings on the VFO are set in the factory and the securing screws should not be loosened, nor the coupling positions altered.

- (1) Connect the frequency counter to socket SK36 on the rear panel of the R551N Receiver.
- (2) Set the Mains switch to ON position.
- (3) Set the CAL control on the front panel to approximately mid-position.
- (4) Set VFO control to indicate 000 at the HF end of the range (VFO control turned clockwise).
- (5) Adjust C343a (and C343b if C343a provides insufficient range) for frequency counter indication of $700\text{kHz} \pm 10\text{Hz}$.
- (6) Set VFO control to indicate 000 at the LF end of the range (VFO control turned counter-clockwise).
- (7) Adjust L98 for frequency counter indication of $600\text{kHz} \pm 10\text{Hz}$.
- (8) Repeat (4) to (7) until frequency is within tolerance at both ends of range.
- (9) The VFO should now be satisfactory in nearly all cases as it would be unusual for the law of the gang to have changed between 600 and 700kHz. If, however this has happened, a plot should be made to observe the error within the oscillator range and the appropriate small vane trimmers on the gang's end blocks corrected when they are centralised against the earth blocks.
- (10) Set Mains switch to OFF position.
- (11) Disconnect test equipment.

8.12 4.1 TO 5.0MHz VCO

Test Equipment Required (For details see para. 8.2)

RF Valve Voltmeter

RF Signal Generator

Frequency Counter

Multimeter

Remove cover over 4.1 to 5.0MHz module.

8.12.1 3.4 to 4.4MHz Filter

Refer to Fig. 9.19

- (1) Disconnect inner of coaxial lead from pin 11 on Switch Filter PCB Assembly.
- (2) Connect RF signal generator to pin 11 and chassis.
- (3) Disconnect plug PL27 from socket SK27.
- (4) Connect RF valve voltmeter 50Ω probe to plug PL27.
- (5) Set 100kHz switch to position 9.
- (6) Set Mains switch to ON position.
- (7) Set RF signal generator frequency to $3.45\text{MHz} \pm 10\text{kHz}$, mode to CW and output level to 50mV rms emf.
- (8) Adjust L92 and L93 both for maximum indication on RF valve voltmeter.
- (9) Set Mains switch to OFF position.
- (10) Disconnect test equipment.
- (11) Re-make connections.

8.12.2 VCO

Refer to Fig. 9.18

- (1) Connect frequency counter to pin 5 on 4.1 to 5MHz VCO/Mixer PCB Assembly.
- (2) Connect multimeter positive lead to test point TP23, and negative lead to chassis.
- (3) Set multimeter to 2.5V DC range.
- (4) Set 100kHz switch to position 5.
- (5) Set Mains switch to ON position.
- (6) Adjust L91 until the multimeter indicates 1.0V DC.
- (7) Check that frequency is $4.50\text{MHz} \pm 10\text{Hz}$.
- (8) Lock L91.
- (9) Set Mains switch to OFF position.
- (10) Disconnect test equipment.

8.13 38 TO 68MHz VCO

Test Equipment Required (For details see para. 8.2)

Frequency Counter

RF Valve Voltmeter

RF Signal Generator

Remove cover over 38 to 68MHz VCO module.

8.13.1 50kHz Filter

Refer to Fig. 9.17

- (1) Disconnect link LK6.
- (2) Connect RF signal generator to test point TP20 and chassis on 1 and 10MHz Phase Loop PCB Assembly.
- (3) Connect RF valve voltmeter to test point TP21 and chassis.
- (4) Set RF signal generator frequency to 100.0kHz \pm 1kHz and output level to 2.0V rms emf.
- (5) Adjust L70 for minimum indication on RF valve voltmeter.
- (6) Disconnect test equipment.
- (7) Re-make link LK6.

8.13.2 30MHz Filter

Refer to Fig. 9.13

- (1) Connect RF signal generator to orange lead on T25 and chassis (i.e. across R241) on 3 to 32MHz Filter Amplifier PCB Assembly.
- (2) Connect RF valve voltmeter to test point TP37 and chassis.
- (3) Set Mains switch to ON position.
- (4) Set RF signal generator frequency to 35.50MHz \pm 10kHz and output level to 2.0V rms emf.
- (5) Adjust L78 for minimum indication on RF valve voltmeter.
- (6) Set Mains switch to OFF position.
- (7) Disconnect test equipment.

8.13.3 35 to 36MHz Filter

Refer to Fig. 9.14

- (1) Connect RF valve voltmeter to pin 1 on 35 to 36MHz Filter Amplifier PCB Assembly and chassis.
- (2) Set the 100kHz frequency switch to position 5.
- (3) Set Mains switch to ON position.
- (4) Adjust L79 for maximum indication on RF valve voltmeter.
- (5) Adjust L80 for maximum indication on RF valve voltmeter.

- (6) Adjust L124 for maximum indication on RF valve voltmeter.
- (7) Repeat (4) to (7) until no higher indication can be achieved.
- (8) Set the 100kHz frequency switch to all positions, 0 to 9, and check that the difference between highest and lowest indications on the RF valve voltmeter does not exceed 4dB.
- (9) Set Mains switch to OFF position.
- (10) Disconnect test equipment.

8.13.4 VCO

Refer to Fig. 9.12

- (1) Remove 38 to 68MHz VCO module sufficiently to obtain access to trimmers (see para. 6.1.5).
- (2) Connect frequency counter to socket SK42.
- (3) Set Mains switch to ON position.
- (4) Set Frequency switches to positions indicated for Test No 1 in Table 8.4.
- (5) Adjust R281 until frequency counter indicates 47.50MHz \pm 10kHz.
- (6) Set Frequency switches to positions indicated for Test No 2.
- (7) Adjust L73 until frequency counter indicates 38.50MHz \pm 10kHz.
- (8) Repeat (4) to (7) until both frequencies are within specified tolerance.
- (9) Check frequencies in Test Nos 3 to 10.
- (10) Repeat Test Nos 11 and 12 until both frequencies are within specified tolerance.
- (11) Repeat Test Nos 13 and 14 until both frequencies are within specified tolerance.
- (12) Lock all components which have been adjusted.
- (13) Recheck all fourteen test frequencies.
- (14) Set Mains switch to OFF position.
- (15) Disconnect frequency counter.
- (16) Refit module (see para. 6.1.5).

Table 8.4 VCO Alignment Frequencies

Test No	Frequency Switch Positions			Component to Adjust	Frequency Counter Reading
	10MHz	1MHz	100kHz		
1	0	9	5	R281	47.50MHz \pm 10kHz
2	0	0	5	L73	38.50MHz \pm 10kHz
3	0	1	5	C241	39.50MHz \pm 10kHz
4	0	2	5	C239	40.50MHz \pm 10kHz
5	0	3	5	C237	41.50MHz \pm 10kHz
6	0	4	5	C235	42.50MHz \pm 10kHz
7	0	5	5	C233	43.50MHz \pm 10kHz
8	0	6	5	C231	44.50MHz \pm 10kHz
9	0	7	5	C229	45.50MHz \pm 10kHz
10	0	8	5	C227	46.50MHz \pm 10kHz
11	1	9	5	C218	57.50MHz \pm 10kHz
12	1	0	5	L72	48.50MHz \pm 10kHz
13	2	9	5	C224	67.50MHz \pm 10kHz
14	2	0	5	L74	58.50MHz \pm 10kHz

10 CIRCUIT DIAGRAMS

- FIG. 10.1 BFO (OPTIONAL HIGH STABILITY UNIT)
- FIG. 10.2 INTERCONNECTIONS AND POWER SUPPLY
- FIG. 10.3 RF AND AGC STAGES
- FIG. 10.4 IF AND AF STAGES
- FIG. 10.5 38 TO 68MHz VCO
- FIG. 10.6 4.1 TO 5.0MHz VCO
- FIG. 10.7 VFO
- FIG. 10.8 AERIAL FILTERS
- FIG. 10.9 REFERENCE OSCILLATOR (OPTIONAL HIGH STABILITY UNIT)
- FIG. 10.10 1.4 MHz REFERENCE OSCILLATOR AND BFO (NORMAL UNIT)

8	6	5	3	2	1	R
9	7		4			
10		7	3	2026	1	C
		6	4			
L3						
T1	VT2	L2	VT1	L1	MR2	MR1
						Misc

MOD. RECORD					
1	2	3	4	5	6
7	8	9	10	11	12

SUPPLY AND

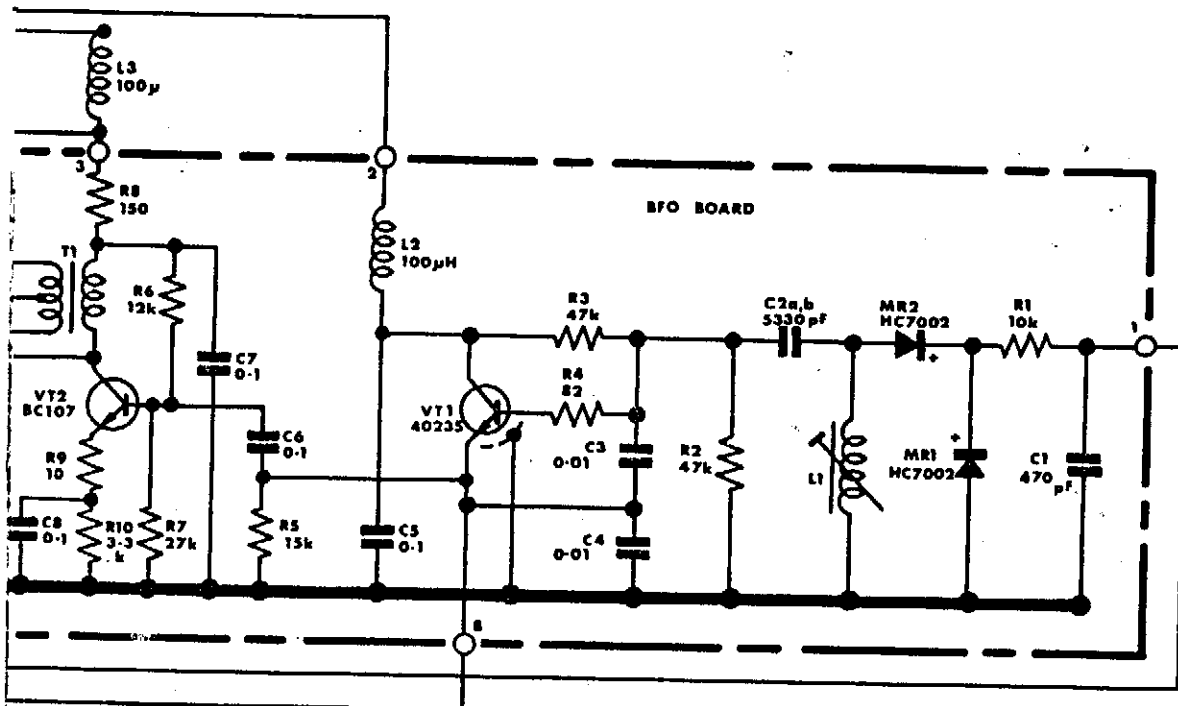

BFO (OPTIONAL HIGH STABILITY UNIT)

301

300

176

322

321

323

306

303

140

307

301	320	PL3	SK20	SK4	PL4	SK3	PL3	SK29	PL29	PL6	PL7	PL8, 11, 23, 24, 25, 30, 31, 32, 40, 41, 54 & 52	L64	X3	S4AP	SK27	SK10	SK2	PL10-19	SK10
V150	SK2	SK22	PL20	PL4			1730	SK29	PL29	SK6	SK7	SK8, 11, 23, 24, 25, 30, 31, 32, 40, 41, 54 & 52	L64	X3	S4AP	SK10	SK2	PL10-19	SK10	
V150	PL3	SK4	1204	SK20			1730	SK29	PL29	SK6	SK7	SK8, 11, 23, 24, 25, 30, 31, 32, 40, 41, 54 & 52	L64	X3	S4AP	SK10	SK2	PL10-19	SK10	
												SK22	L64	X3	S4AP	SK10	SK2	PL10-19	SK10	
												SK23	L64	X3	S4AP	SK10	SK2	PL10-19	SK10	
												SK24	L64	X3	S4AP	SK10	SK2	PL10-19	SK10	
												SK25	L64	X3	S4AP	SK10	SK2	PL10-19	SK10	
												SK26	L64	X3	S4AP	SK10	SK2	PL10-19	SK10	
												SK27	L64	X3	S4AP	SK10	SK2	PL10-19	SK10	
												SK28	L64	X3	S4AP	SK10	SK2	PL10-19	SK10	
												SK29	L64	X3	S4AP	SK10	SK2	PL10-19	SK10	
												SK30	L64	X3	S4AP	SK10	SK2	PL10-19	SK10	
												SK31	L64	X3	S4AP	SK10	SK2	PL10-19	SK10	
												SK32	L64	X3	S4AP	SK10	SK2	PL10-19	SK10	
												SK33	L64	X3	S4AP	SK10	SK2	PL10-19	SK10	
												SK34	L64	X3	S4AP	SK10	SK2	PL10-19	SK10	
												SK35	L64	X3	S4AP	SK10	SK2	PL10-19	SK10	
												SK36	L64	X3	S4AP	SK10	SK2	PL10-19	SK10	
												SK37	L64	X3	S4AP	SK10	SK2	PL10-19	SK10	
												SK38	L64	X3	S4AP	SK10	SK2	PL10-19	SK10	
												SK39	L64	X3	S4AP	SK10	SK2	PL10-19	SK10	
												SK40	L64	X3	S4AP	SK10	SK2	PL10-19	SK10	
												SK41	L64	X3	S4AP	SK10	SK2	PL10-19	SK10	
												SK42	L64	X3	S4AP	SK10	SK2	PL10-19	SK10	
												SK43	L64	X3	S4AP	SK10	SK2	PL10-19	SK10	
												SK44	L64	X3	S4AP	SK10	SK2	PL10-19	SK10	
												SK45	L64	X3	S4AP	SK10	SK2	PL10-19	SK10	
												SK46	L64	X3	S4AP	SK10	SK2	PL10-19	SK10	
												SK47	L64	X3	S4AP	SK10	SK2	PL10-19	SK10	
												SK48	L64	X3	S4AP	SK10	SK2	PL10-19	SK10	
												SK49	L64	X3	S4AP	SK10	SK2	PL10-19	SK10	
												SK50	L64	X3	S4AP	SK10	SK2	PL10-19	SK10	

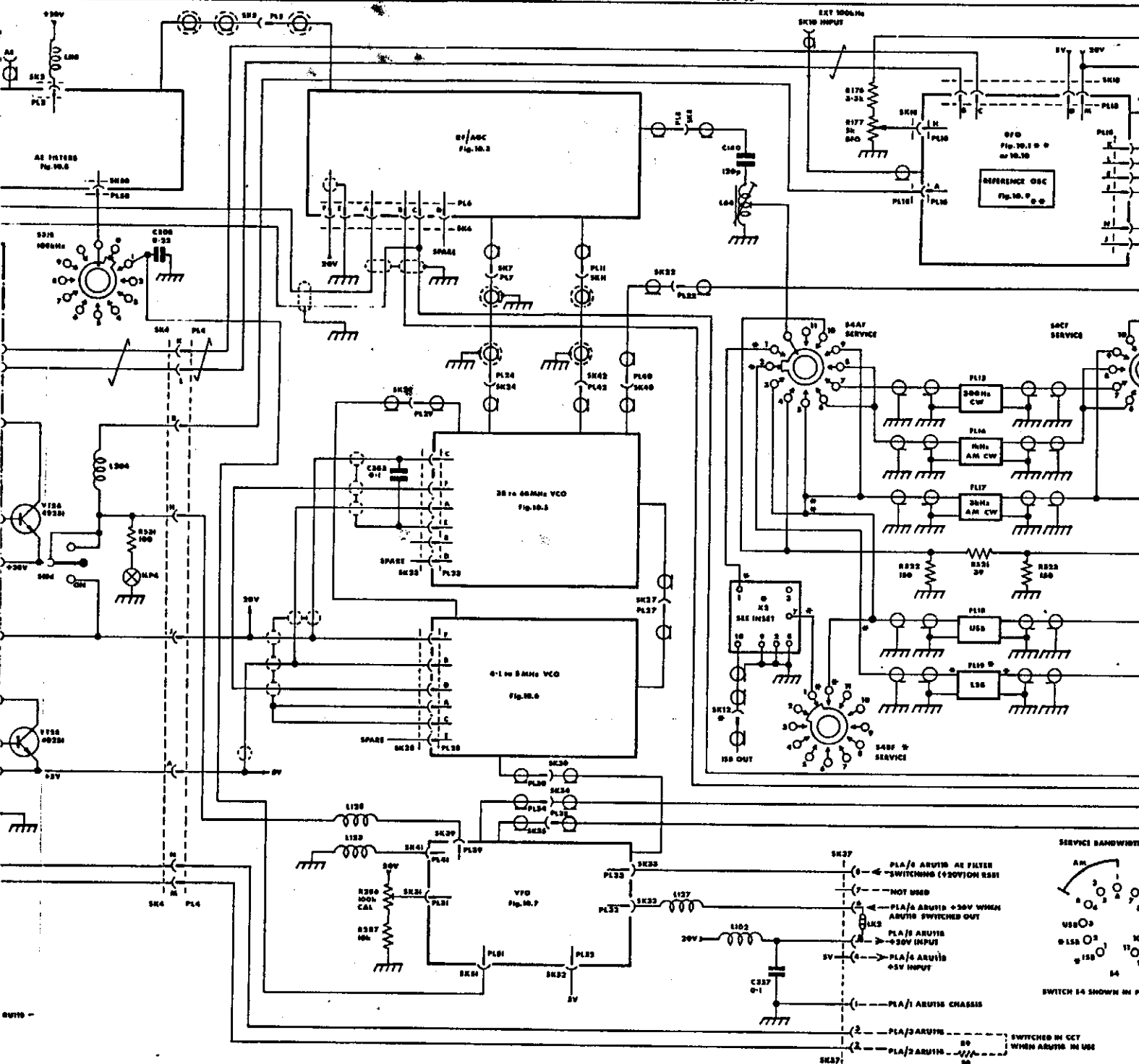

SERVICE BANDWIDTH

AM

USB

LSB

SWITCH 14 SHOWN IN P

SWITCHED IN CBY WHEN ARU16 IN USE

SWITCHED IN CBY WHEN ARU18 IN USE

B						303	304	305	306	307	308	
C		309		310		311	312	313	314	315	316	
MISC	F53 F53 F54 F55 F56		S40a S40b S40c	T24		MR53 MR54 R14	MR55 MR57		VT54 MR50a,b MR50c,b	VT55 VT57	MR1 VT56 VT58	L1 S1 P1

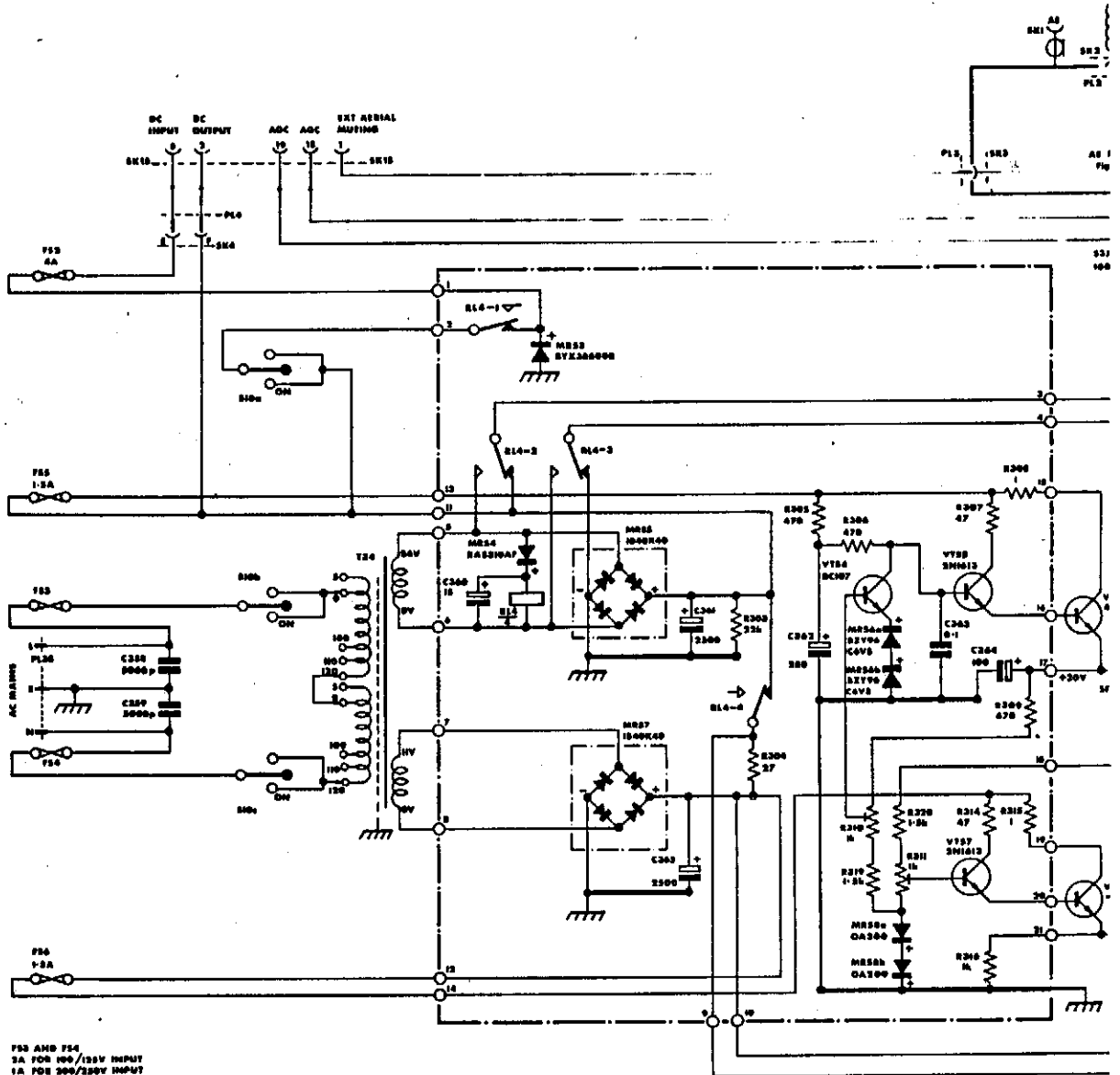

F53 AND F54
2A FOR 100/150V INPUT
1A FOR 200/250V INPUT

MOD. RECORD											
1	2	3	4	5	6						
7	8	9	10	11	12						

EXTERNAL CONNECTIONS MARKED ARBITR -
SEE FIG. 5.1 HANDBOOK 941-1

R		57	59	60	61	64	65	124	125	126	68	70	129	128	72	71		132	75		76	78	133	134	30	81	
C		142	143	144	180	145	181	182	146	147	66	67	148	149	183	150	151	185	152	63	154	184	185	187	155	157	82
MISC	SK13 PL13		TP9 VT3	TP5 VT5		MR18 MR19			VT14 MR20a,b		MR21a,b			VT15 TP10	L65 MR22		MR24	MR23	MR25a MR25b	VT16 PL14 SK14					MR26a,b VT17		

54CF
1-4 MHz IF
FILTERS
Fig 10-2

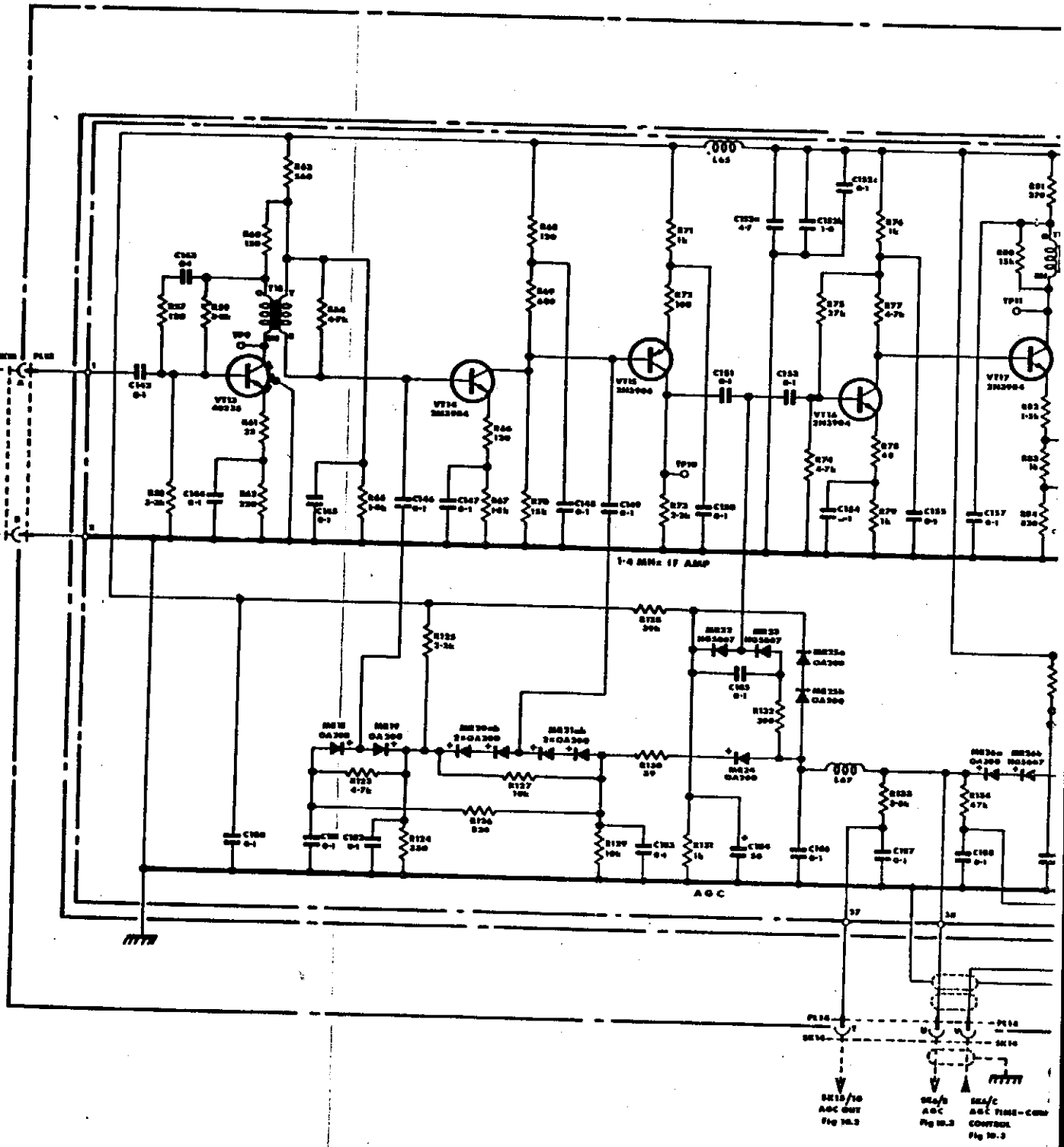

25	27	29	28	36 37	38 39	40	41	45 46
24	35 16		20			21	23	10

VX4c	VT3 VX5	VX4a VX6	VX1 VT6 VX7	VX2 VX4d	VX3
------	------------	-------------	-------------------	-------------	-----

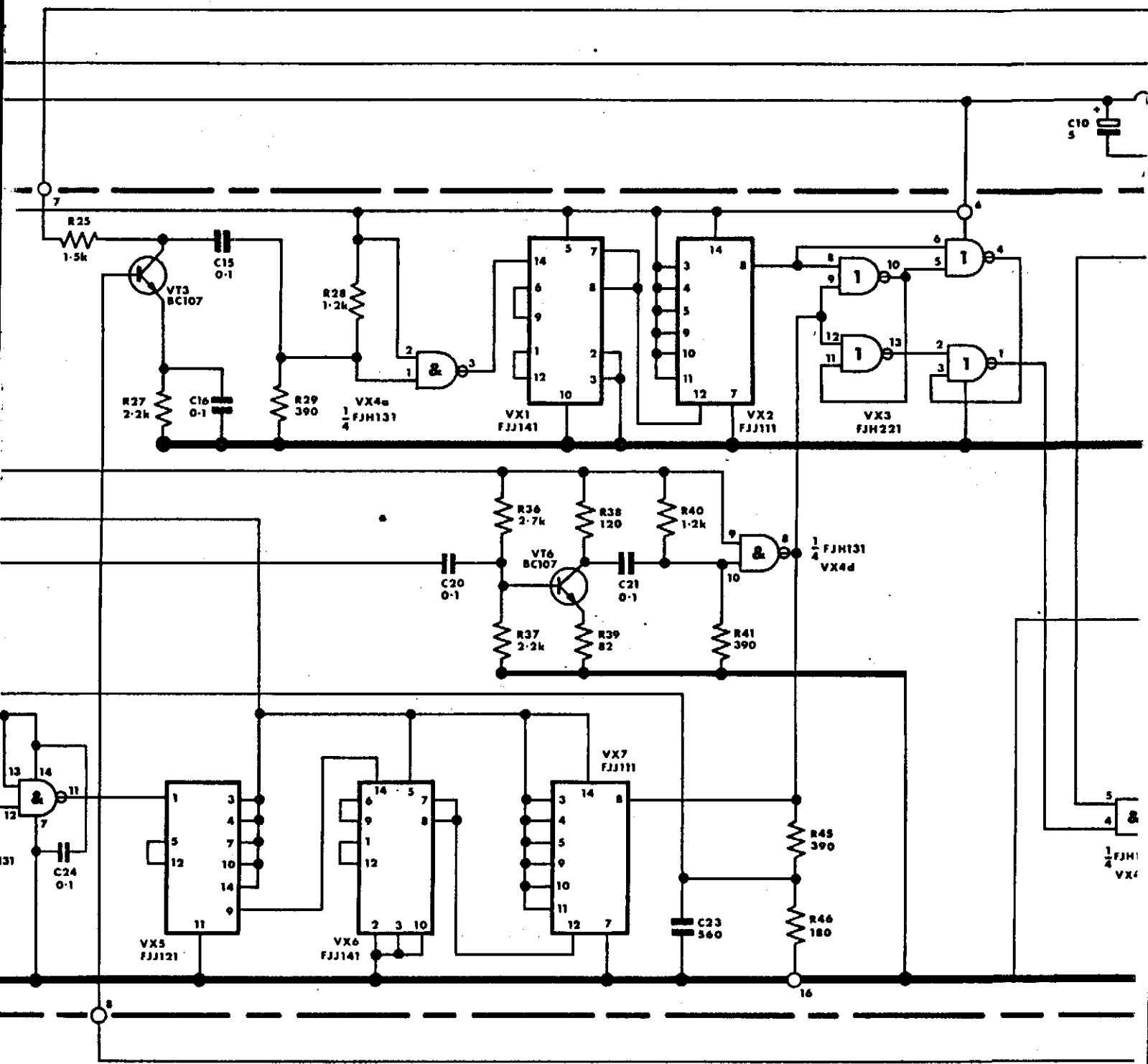

R		1	504	500 505 50A 507 501 506 507
C		298		
MISC.	PL1 BK1	518A 518B 770	485 BL1-1	5278 5279 5287 5277
				L202 L201

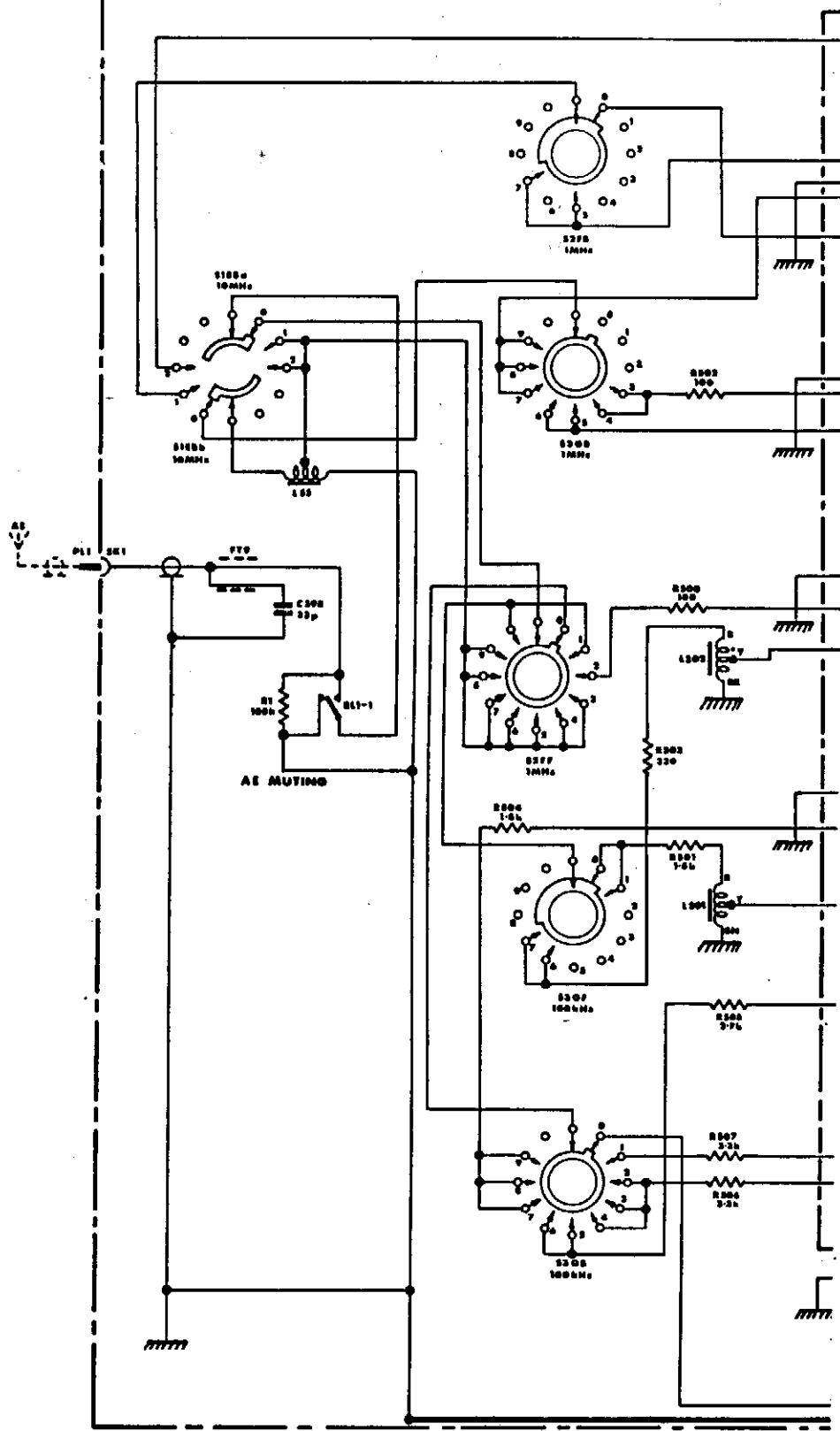

CDN5725/M SHT 7 Issue 3

981-1

116	117	119	120	162	122		R
160	118	161	121	163	164		C
198	178	41C	179				
VT23 MR33			VT24			PL13	SK13
VT24						PL14	SK14
				S4FB		S4CF	
						MISC	

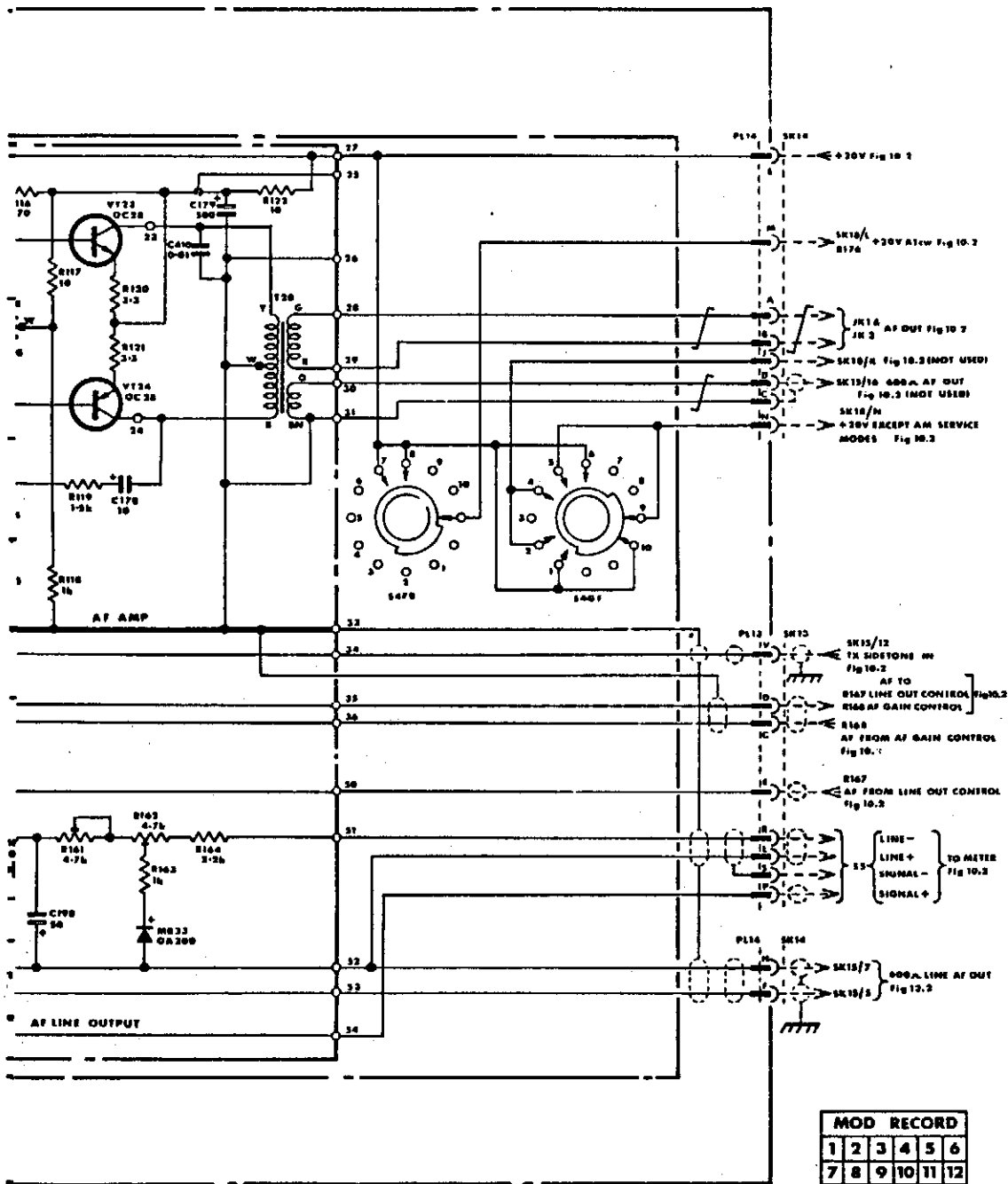

IF AND AF STAGES

FIG. 10.4

R6	Rx	R7	R10	R1	R11	
C6	C7	C9		C8		
1	L2	L3	TH1	MR3	VT4	VT5
2			VT3	MR4		

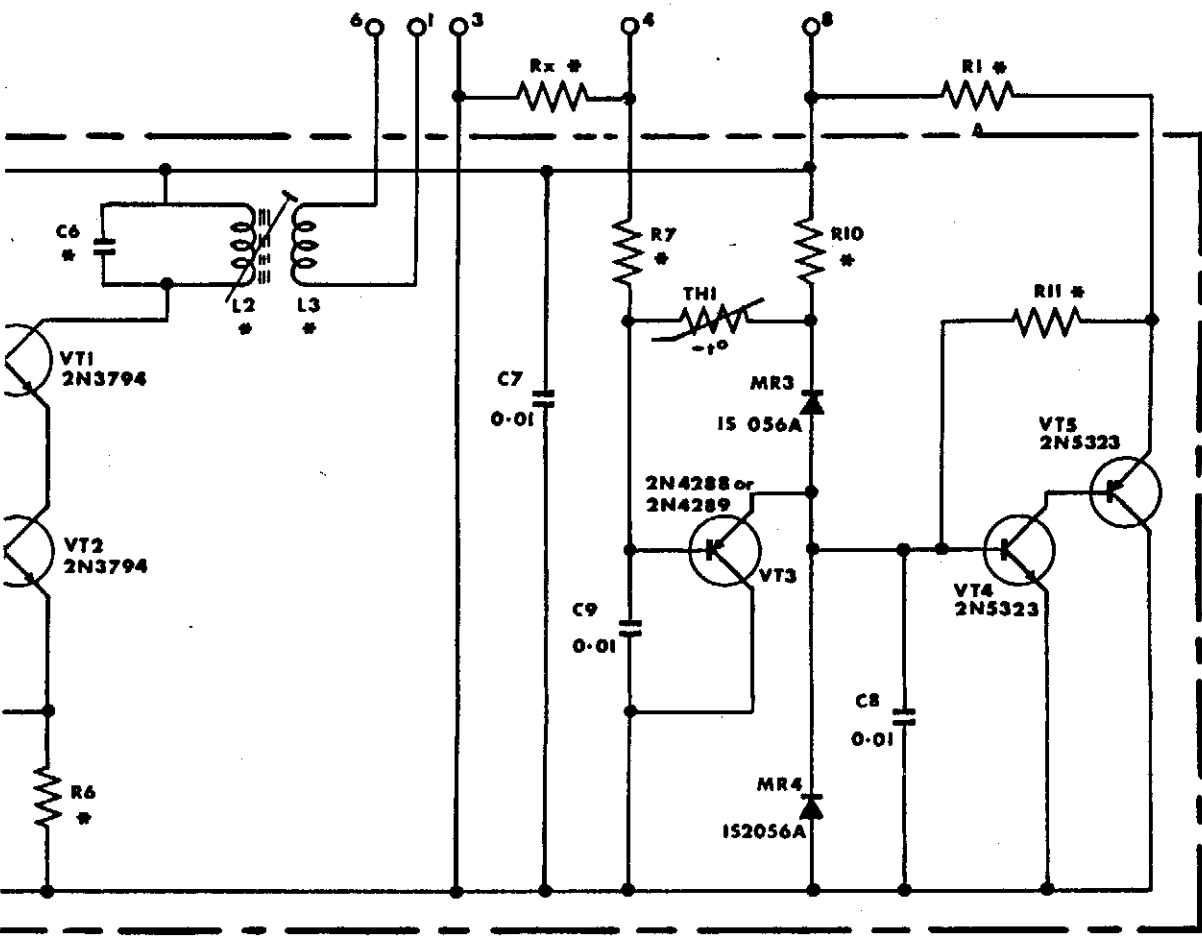

* SELECTED ON TEST

REFERENCE OSCILLATOR
(OPTIONAL HIGH STABILITY UNIT)

FIG. 10.9

81	85	86	88	90	91	93	94	95	96	97	145	98	155	147	99	100	154	102	103	105	106	107	156	108	111	158	112	159	103	114	115	117	118		
190	142	87	89	166	92	144	143	167	168	169	170	171	172	173	195	196	197	176	177	178	179	180	181	182	183	184	185	186	187	188	189	190	191	192	
MR13	MR14	TP12	VT19	MR15	VT28	MR16	MR17	L66	VT20	VT21	TP13	TP17	MR32	VT22	TP14																				
S4CB	S4CB	T18	S4FF	S4HB	S4HP	S4HP	VT29																												

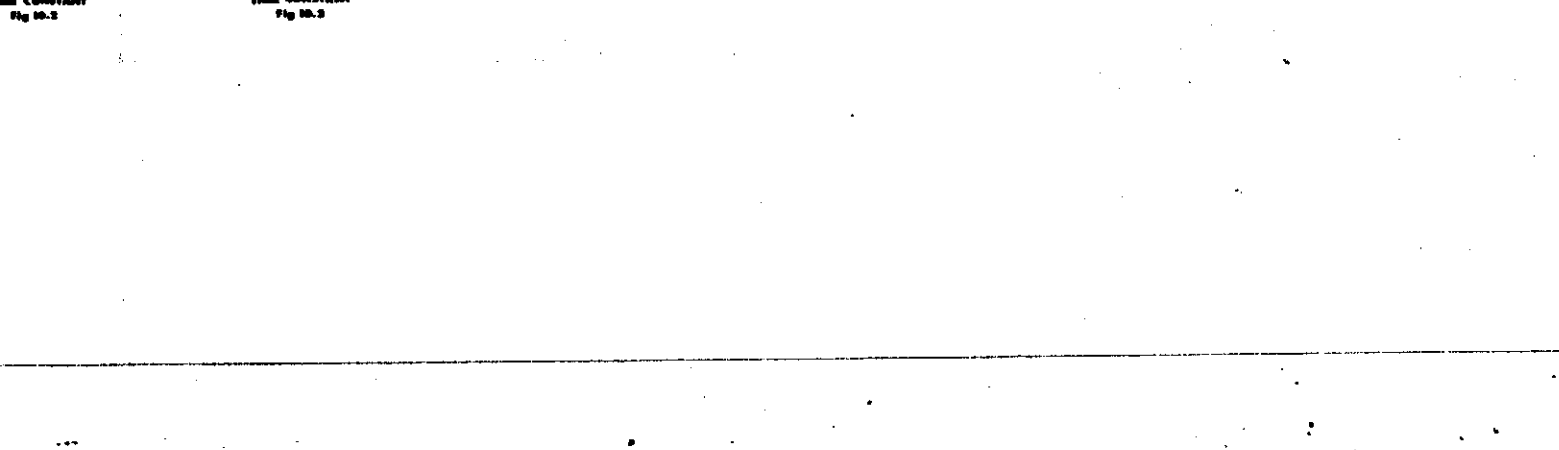
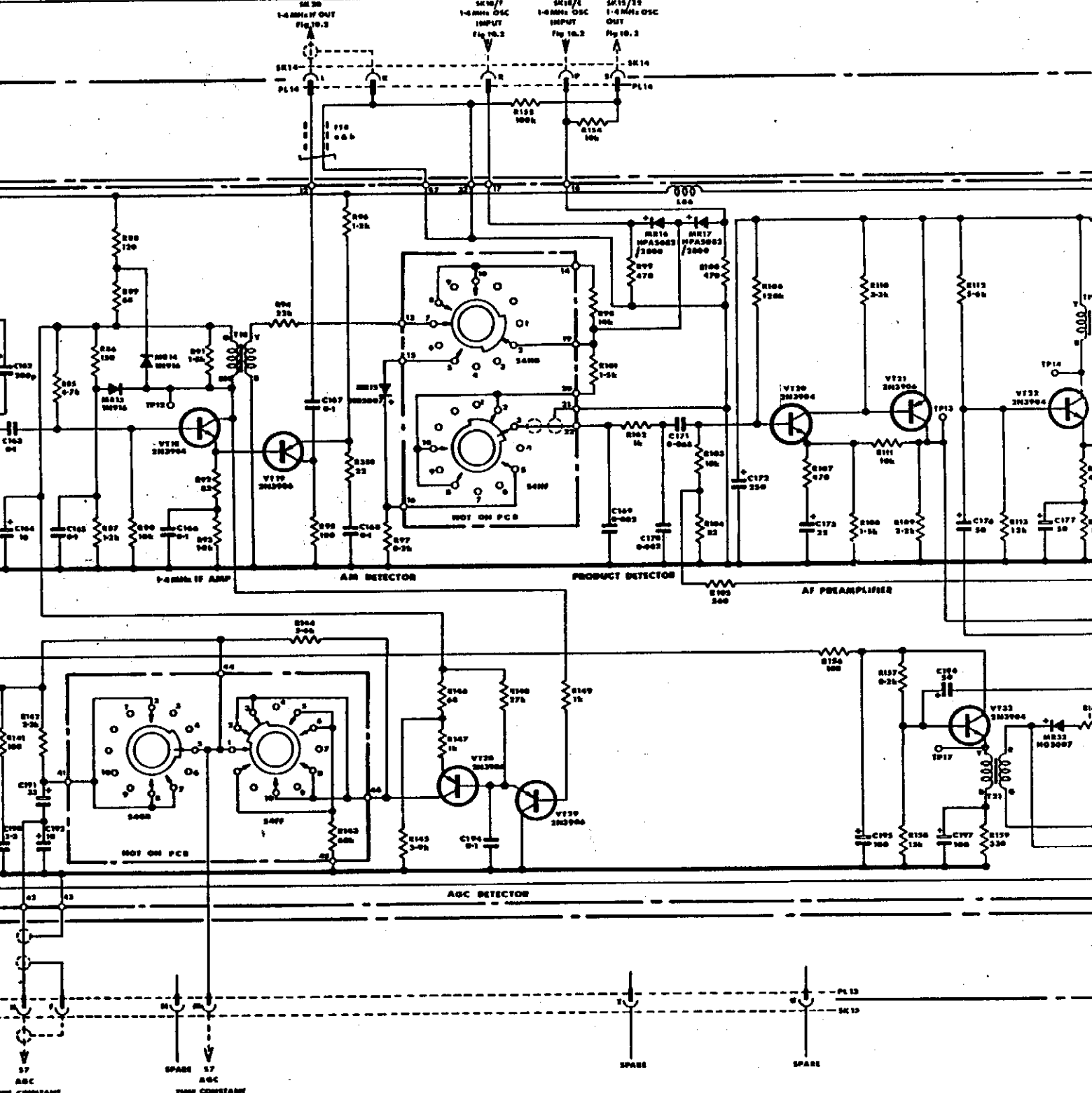

320	329	322	318a	318b	311	314	317		R
327	330				313	315	316		C
330	331	320			315	316	316		
		100	102			337B		PL37 PL30	MISC

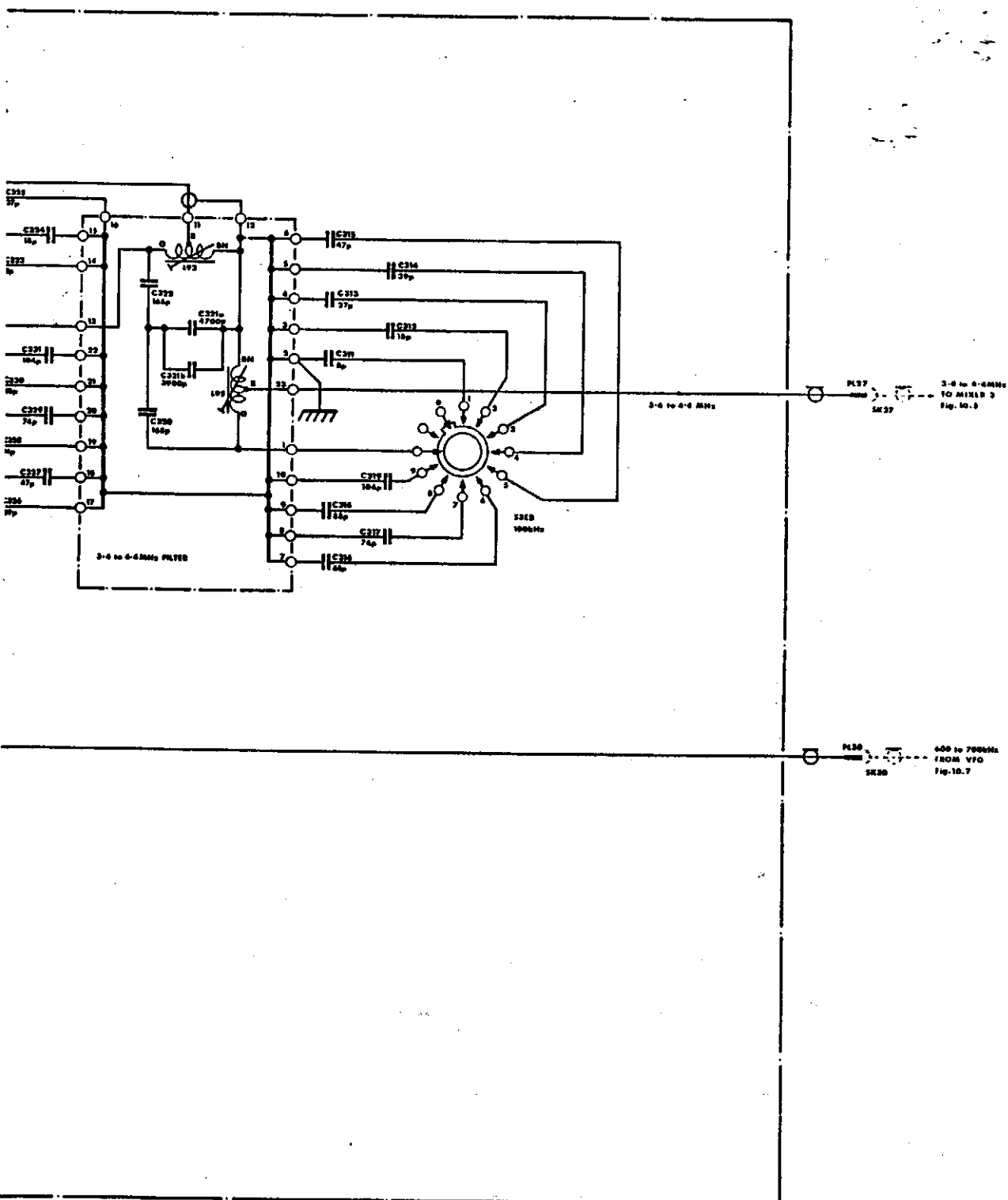

4.1 TO 5.0MHz VCO

FIG.10.6

26	267	258	257	256	270	240	271
267	270	268	230	230	200	210	260
V100		V100	T30	T31	M848	T32	

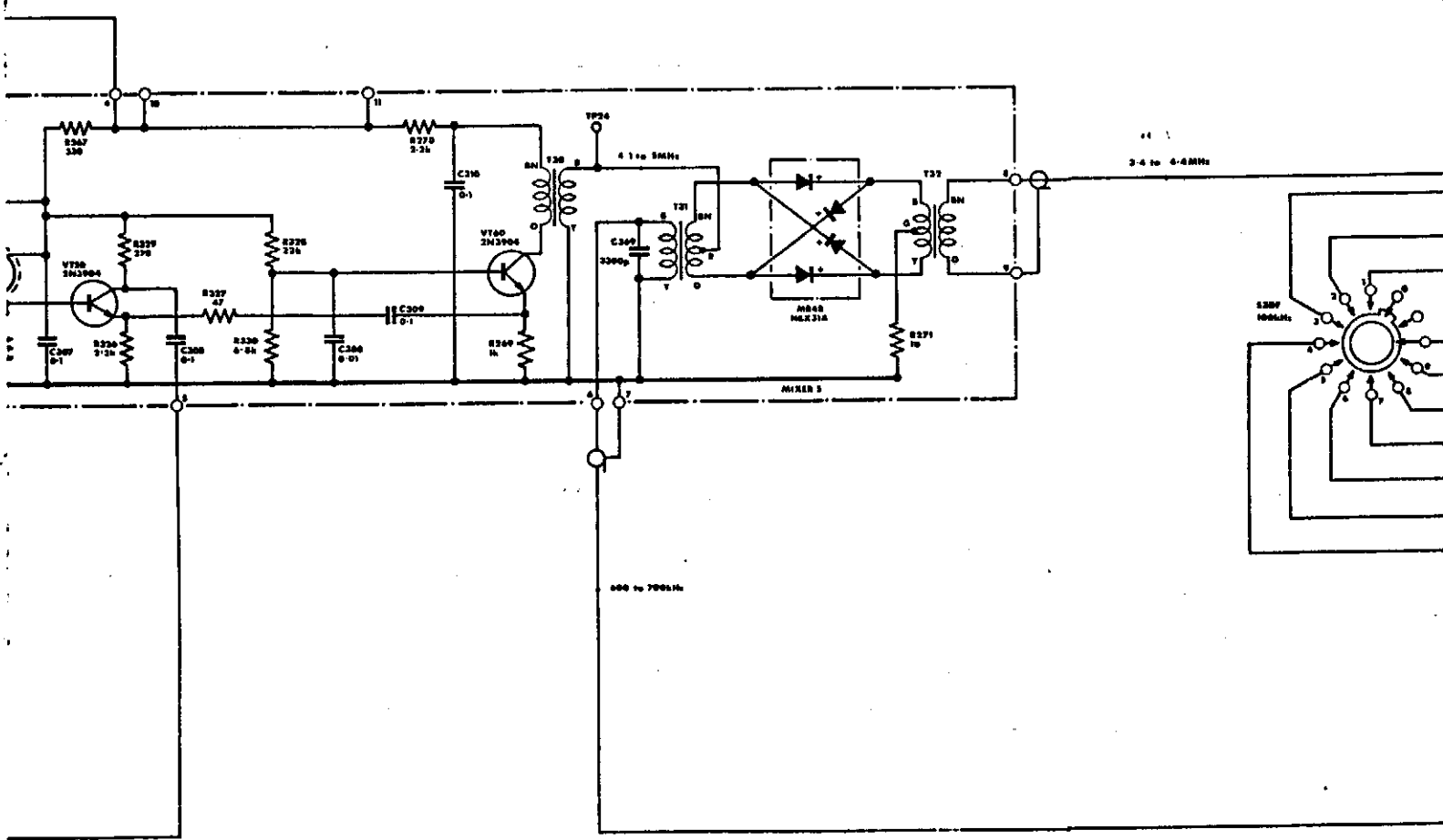

R		776	778	785	786	794	795	796	797	798	799	800	801	802	803	804	805	806	807	808	809	810	811	812	813	814	815	816	817	818	819	820	821	822	823	824	825	826	827	828	829	830	831	832	833	834	835	836	837	838	839	840	841	842	843	844	845	846	847	848	849	850	851	852	853	854	855	856	857	858	859	860	861	862	863	864	865	866	867	868	869	870	871	872	873	874	875	876	877	878	879	880	881	882	883	884	885	886	887	888	889	890	891	892	893	894	895	896	897	898	899	900	901	902	903	904	905	906	907	908	909	910	911	912	913	914	915	916	917	918	919	920	921	922	923	924	925	926	927	928	929	930	931	932	933	934	935	936	937	938	939	940	941	942	943	944	945	946	947	948	949	950	951	952	953	954	955	956	957	958	959	960	961	962	963	964	965	966	967	968	969	970	971	972	973	974	975	976	977	978	979	980	981	982	983	984	985	986	987	988	989	990	991	992	993	994	995	996	997	998	999	1000																																																																																																																																																																																																																																																																																																																																																																																																																																																																																																																			
C	290	291	292	293	294	295	296	297	298	299	300	301	302	303	304	305	306	307	308	309	310	311	312	313	314	315	316	317	318	319	320	321	322	323	324	325	326	327	328	329	330	331	332	333	334	335	336	337	338	339	340	341	342	343	344	345	346	347	348	349	350	351	352	353	354	355	356	357	358	359	360	361	362	363	364	365	366	367	368	369	370	371	372	373	374	375	376	377	378	379	380	381	382	383	384	385	386	387	388	389	390	391	392	393	394	395	396	397	398	399	400	401	402	403	404	405	406	407	408	409	410	411	412	413	414	415	416	417	418	419	420	421	422	423	424	425	426	427	428	429	430	431	432	433	434	435	436	437	438	439	440	441	442	443	444	445	446	447	448	449	450	451	452	453	454	455	456	457	458	459	460	461	462	463	464	465	466	467	468	469	470	471	472	473	474	475	476	477	478	479	480	481	482	483	484	485	486	487	488	489	490	491	492	493	494	495	496	497	498	499	500	501	502	503	504	505	506	507	508	509	510	511	512	513	514	515	516	517	518	519	520	521	522	523	524	525	526	527	528	529	530	531	532	533	534	535	536	537	538	539	540	541	542	543	544	545	546	547	548	549	550	551	552	553	554	555	556	557	558	559	560	561	562	563	564	565	566	567	568	569	570	571	572	573	574	575	576	577	578	579	580	581	582	583	584	585	586	587	588	589	590	591	592	593	594	595	596	597	598	599	600	601	602	603	604	605	606	607	608	609	610	611	612	613	614	615	616	617	618	619	620	621	622	623	624	625	626	627	628	629	630	631	632	633	634	635	636	637	638	639	640	641	642	643	644	645	646	647	648	649	650	651	652	653	654	655	656	657	658	659	660	661	662	663	664	665	666	667	668	669	670	671	672	673	674	675	676	677	678	679	680	681	682	683	684	685	686	687	688	689	690	691	692	693	694	695	696	697	698	699	700	701	702	703	704	705	706	707	708	709	710	711	712	713	714	715	716	717	718	719	720	721	722	723	724	725	726	727	728	729	730	731	732	733	734	735	736	737	738	739	740	741	742	743	744	745	746	747	748	749	750	751	752	753	754	755	756	757	758	759	760	761	762	763	764	765	766	767	768	769	770	771	772	773	774	775	776	777	778	779	780	781	782	783	784	785	786	787	788	789	790	791	792	793	794	795	796	797	798	799	800	801	802	803	804	805	806	807	808	809	810	811	812	813	814	815	816	817	818	819	820	821	822	823	824	825	826	827	828	829	830	831	832	833	834	835	836	837	838	839	840	841	842	843	844	845	846	847	848	849	850	851	852	853	854	855	856	857	858	859	860	861	862	863	864	865	866	867	868	869	870	871	872	873	874	875	876	877	878	879	880	881	882	883	884	885	886	887	888	889	890	891	892	893	894	895	896	897	898	899	900	901	902	903	904	905	906	907	908	909	910	911	912	913	914	915	916	917	918	919	920	921	922	923	924	925	926	927	928	929	930	931	932	933	934	935	936	937	938	939	940	941	942	943	944	945	946	947	948	949	950	951	952	953	954	955	956	957	958	959	960	961	962	963	964	965	966	967	968	969	970	971	972	973	974	975	976	977	978	979	980	981	982	983	984	985	986	987	988	989	990	991	992	993	994	995	996	997	998	999	1000
MISC	S233 PL23	MR40	LEF TP8 VX10a VX10b	VX10c VX10d VX10e	PL29 VX7a VX7b	MR39	VX8a VX8b VX8c	PL40 VX14 VX14a VX14b	TP33 VX2a VX2b VX2c	LE5 VX15 VX15a VX15b	VX2d VX2e VX2f	VX3a VX3b VX3c	VX4a VX4b VX4c	VX5a VX5b VX5c	VX6a VX6b VX6c	VX7c VX7d VX7e	LE6 VX8 VX8a VX8b	TP30 VX9 VX9a VX9b	LE7 VX10 VX10a VX10b	S2CB VX11 VX11a VX11b	TP31	LE8 VX12 VX12a VX12b	S2CF VX13 VX13a VX13b	TP8	VX14 VX14a VX14b	VX15 VX15a VX15b	VX16 VX16a VX16b	VX17 VX17a VX17b	VX18 VX18a VX18b	VX19 VX19a VX19b	VX20 VX20a VX20b	VX21 VX21a VX21b	VX22 VX22a VX22b	VX23 VX23a VX23b	VX24 VX24a VX24b	VX25 VX25a VX25b	VX26 VX26a VX26b	VX27 VX27a VX27b	VX28 VX28a VX28b	VX29 VX29a VX29b	VX30 VX30a VX30b	VX31 VX31a VX31b	VX32 VX32a VX32b	VX33 VX33a VX33b	VX34 VX34a VX34b	VX35 VX35a VX35b	VX36 VX36a VX36b	VX37 VX37a VX37b	VX38 VX38a VX38b	VX39 VX39a VX39b	VX40 VX40a VX40b	VX41 VX41a VX41b	VX42 VX42a VX42b	VX43 VX43a VX43b	VX44 VX44a VX44b	VX45 VX45a VX45b	VX46 VX46a VX46b	VX47 VX47a VX47b	VX48 VX48a VX48b	VX49 VX49a VX49b	VX50 VX50a VX50b	VX51 VX51a VX51b	VX52 VX52a VX52b	VX53 VX53a VX53b	VX54 VX54a VX54b	VX55 VX55a VX55b	VX56 VX56a VX56b	VX57 VX57a VX57b	VX58 VX58a VX58b	VX59 VX59a VX59b	VX60 VX60a VX60b	VX61 VX61a VX61b	VX62 VX62a VX62b	VX63 VX63a VX63b	VX64 VX64a VX64b	VX65 VX65a VX65b	VX66 VX66a VX66b	VX67 VX67a VX67b	VX68 VX68a VX68b	VX69 VX69a VX69b	VX70 VX70a VX70b	VX71 VX71a VX71b	VX72 VX72a VX72b	VX73 VX73a VX73b	VX74 VX74a VX74b	VX75 VX75a VX75b	VX76 VX76a VX76b	VX77 VX77a VX77b	VX78 VX78a VX78b	VX79 VX79a VX79b	VX80 VX80a VX80b	VX81 VX81a VX81b	VX82 VX82a VX82b	VX83 VX83a VX83b	VX84 VX84a VX84b	VX85 VX85a VX85b	VX86 VX86a VX86b	VX87 VX87a VX87b	VX88 VX88a VX88b	VX89 VX89a VX89b	VX90 VX90a VX90b	VX91 VX91a VX91b	VX92 VX92a VX92b	VX93 VX93a VX93b	VX94 VX94a VX94b	VX95 VX95a VX95b	VX96 VX96a VX96b	VX97 VX97a VX97b	VX98 VX98a VX98b	VX99 VX99a VX99b	VX100 VX100a VX100b																																																																																																																																																																																																																																																																																																																																																																																																																																																																																																																																																																																																																								

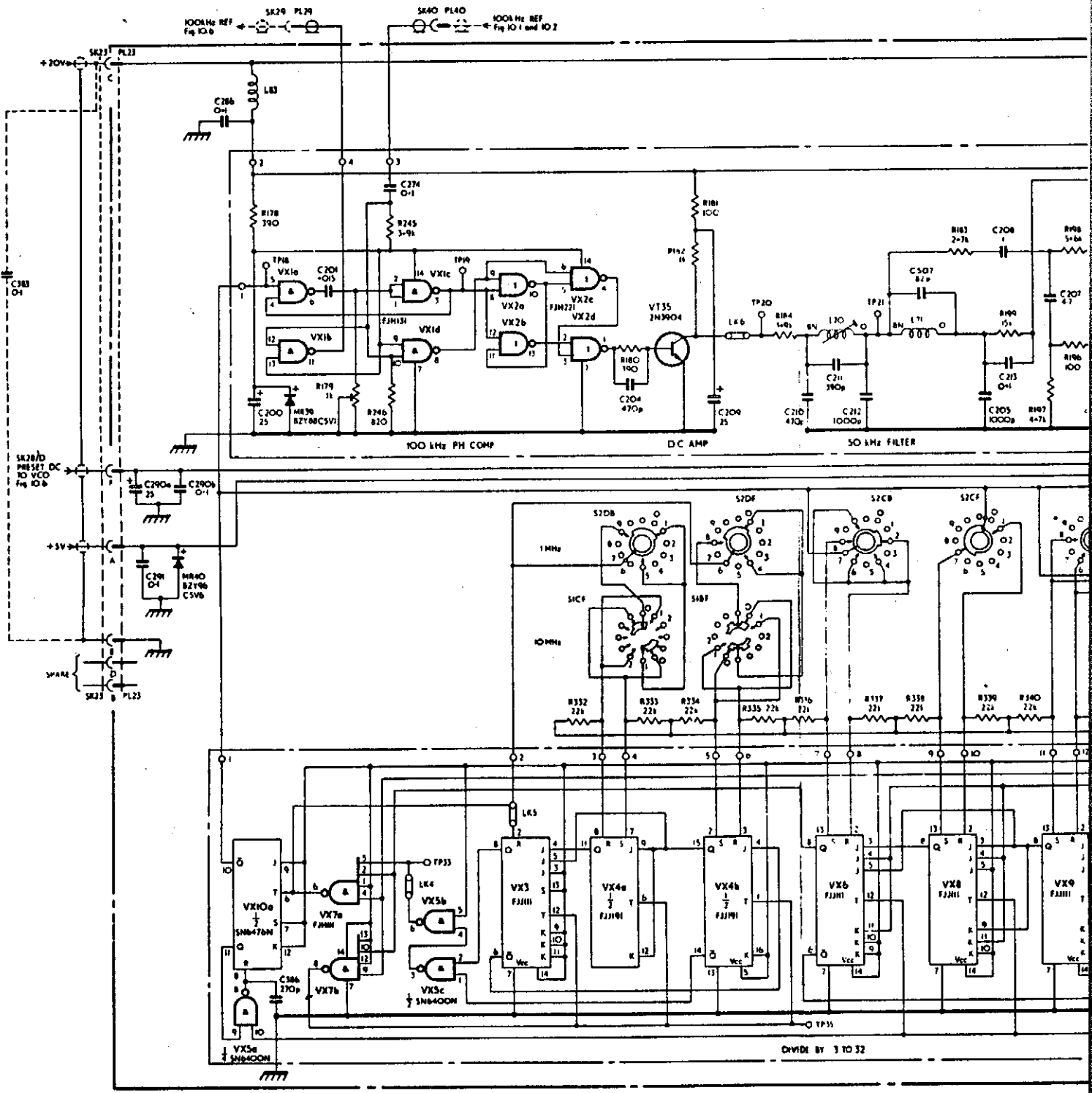

R	286	289		290		290a,b	291	292,294	295,296
C		341	344	355	342a,b	343a	343b	345	346
MISC	PL31	PR49	L90				ILP1	59b 59c	ILP2
							MR50	PL32	MR51
							VX50a	VX50b	ILP3
									VTS1
									VX50c

R286
PRESSET DC
(CAL CONTROL)
Fig 10.2

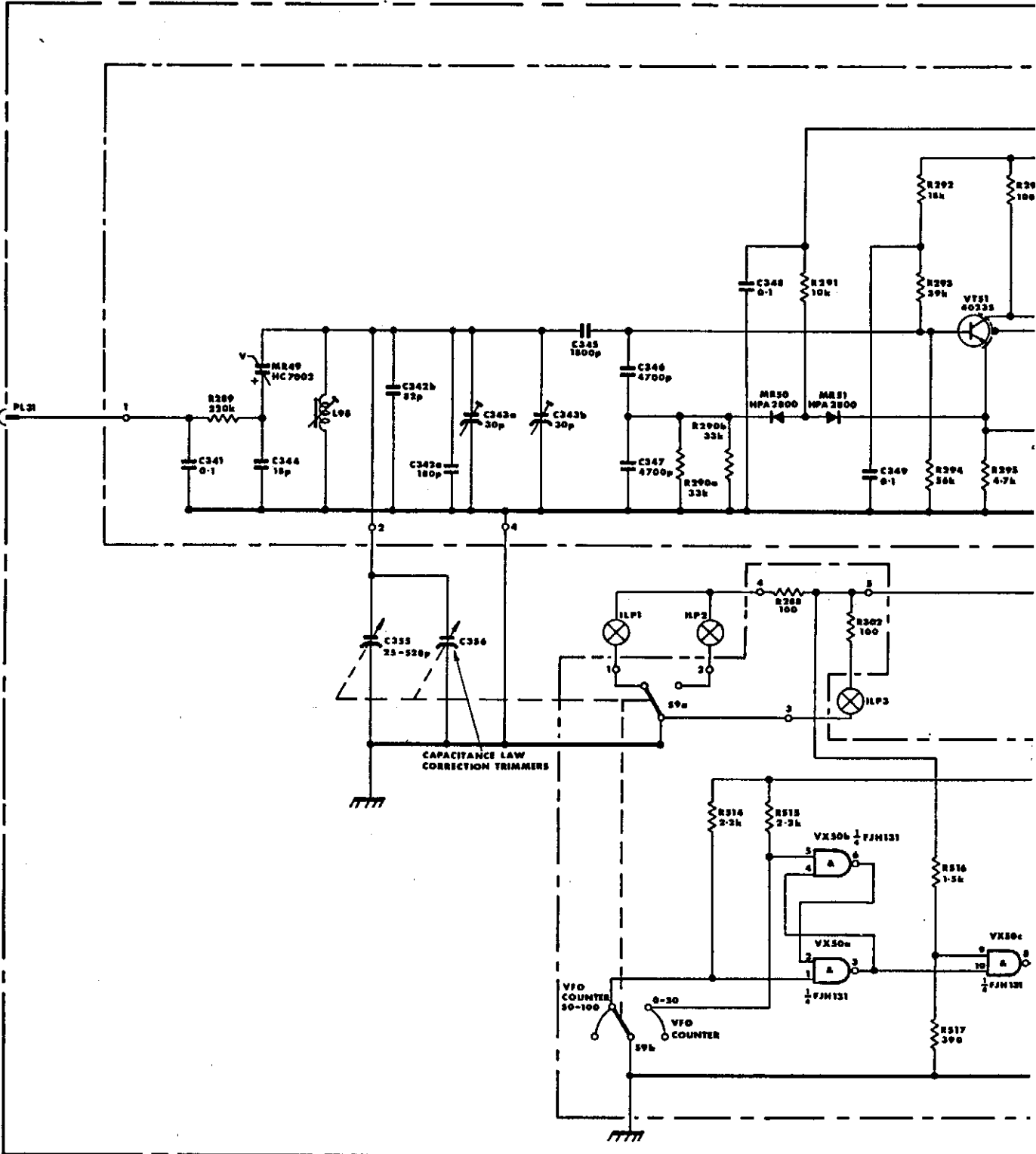

519	297 298	299	300 301	322	323	R
353	354	354	371	372		C
L99	MR100	MR101	VT52 VT70	PL52 PL51	Y33	L100 MR52
						PL32,33,34,35,41 SK32,33,34,35
						L128 L123 L127
						MISC

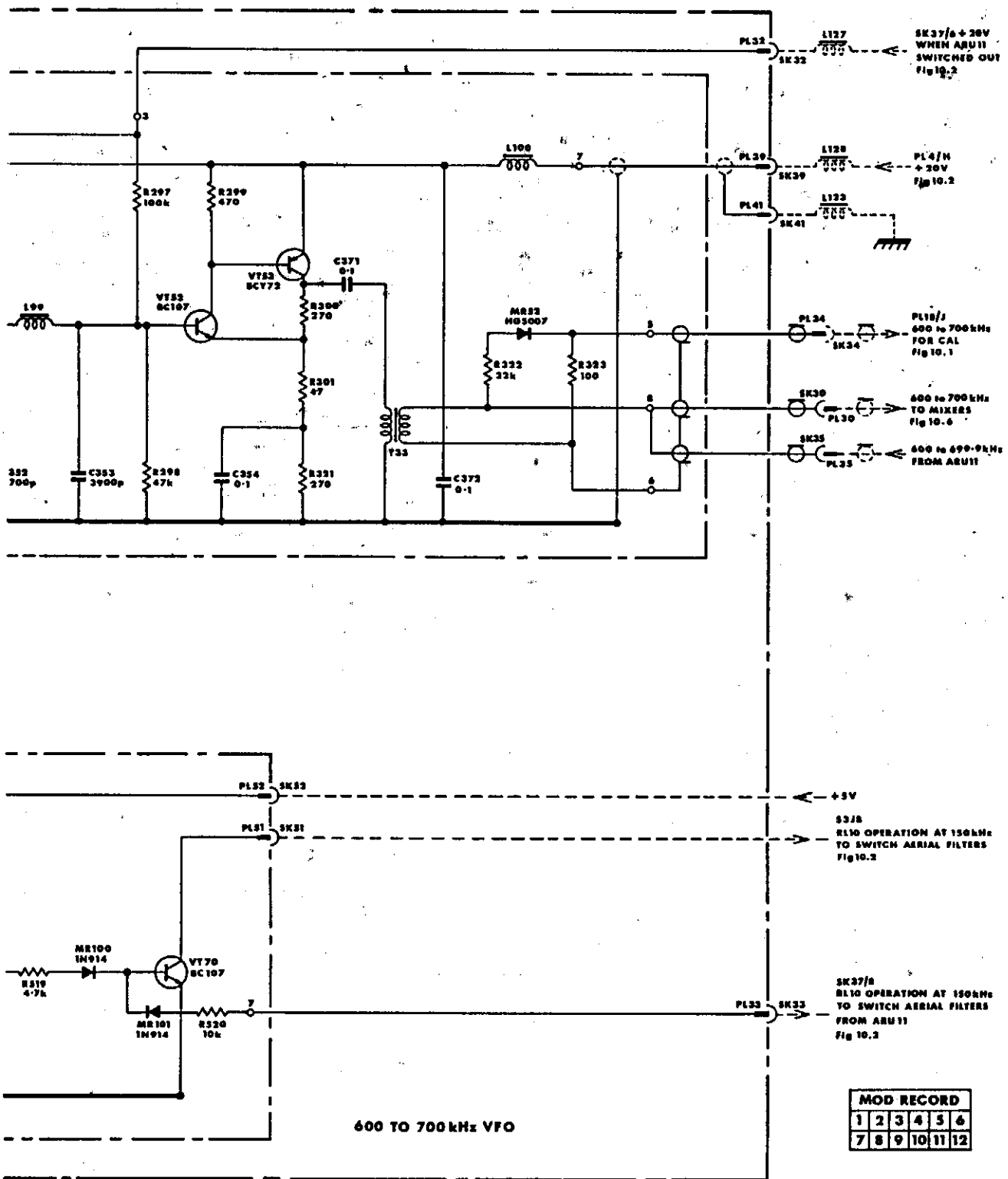

VFO

FIG. 10.7

337	338	339	340	341	342	343	344	345	346	347	348	349	350	351	352	353	354	355	356	357	358	359	360	361	362	363	364	365	366	367	368	369	370	371	372	373	374	375	376	377	378	379	380	381	382	383	384	385	386	387	388	389	390	391	392	393	394	395	396	397	398	399	400
337	338	339	340	341	342	343	344	345	346	347	348	349	350	351	352	353	354	355	356	357	358	359	360	361	362	363	364	365	366	367	368	369	370	371	372	373	374	375	376	377	378	379	380	381	382	383	384	385	386	387	388	389	390	391	392	393	394	395	396	397	398	399	400
337	338	339	340	341	342	343	344	345	346	347	348	349	350	351	352	353	354	355	356	357	358	359	360	361	362	363	364	365	366	367	368	369	370	371	372	373	374	375	376	377	378	379	380	381	382	383	384	385	386	387	388	389	390	391	392	393	394	395	396	397	398	399	400

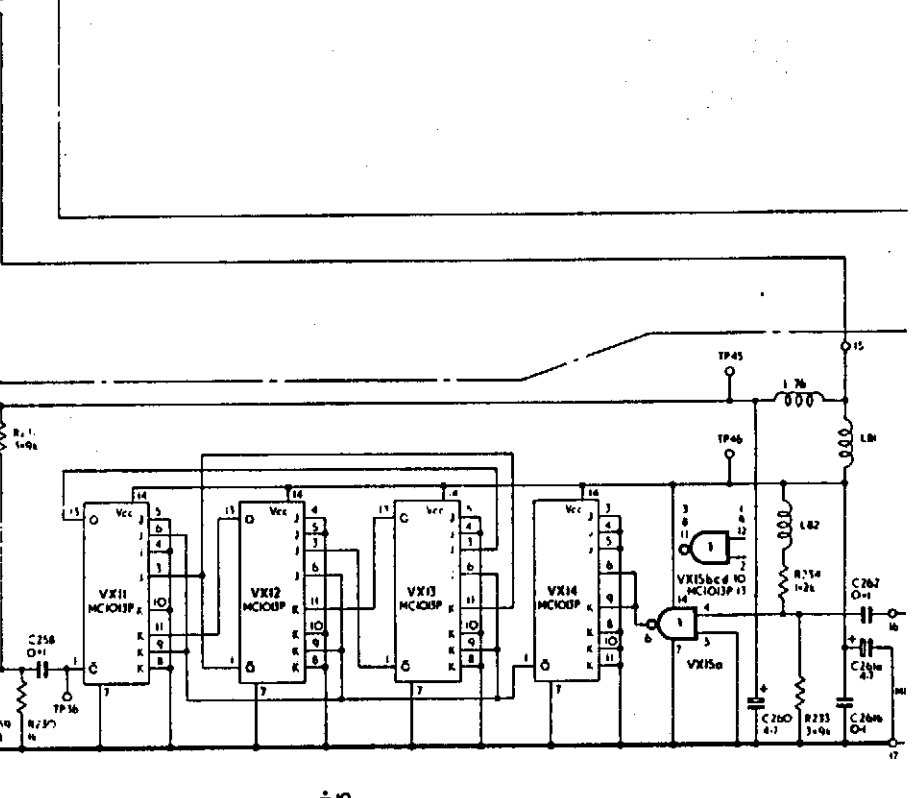
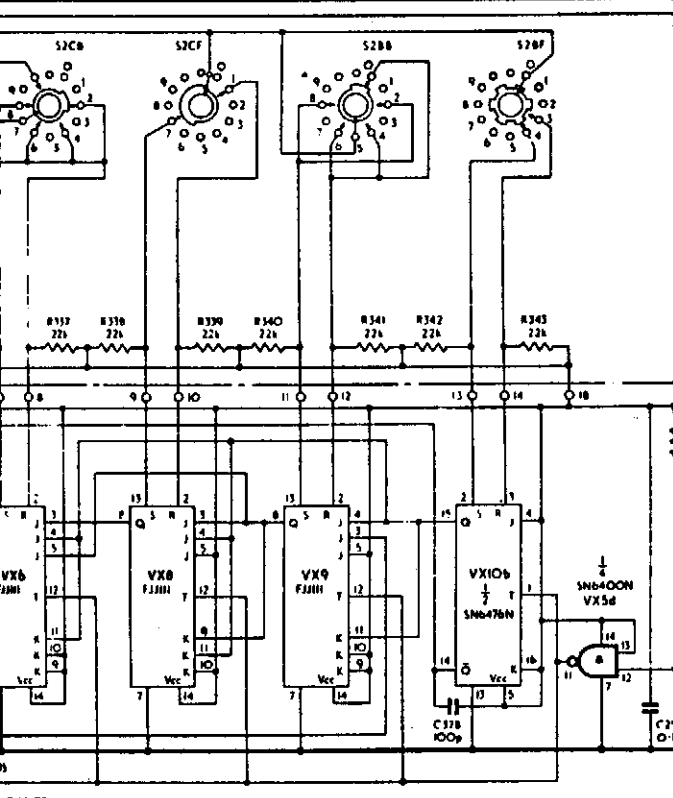
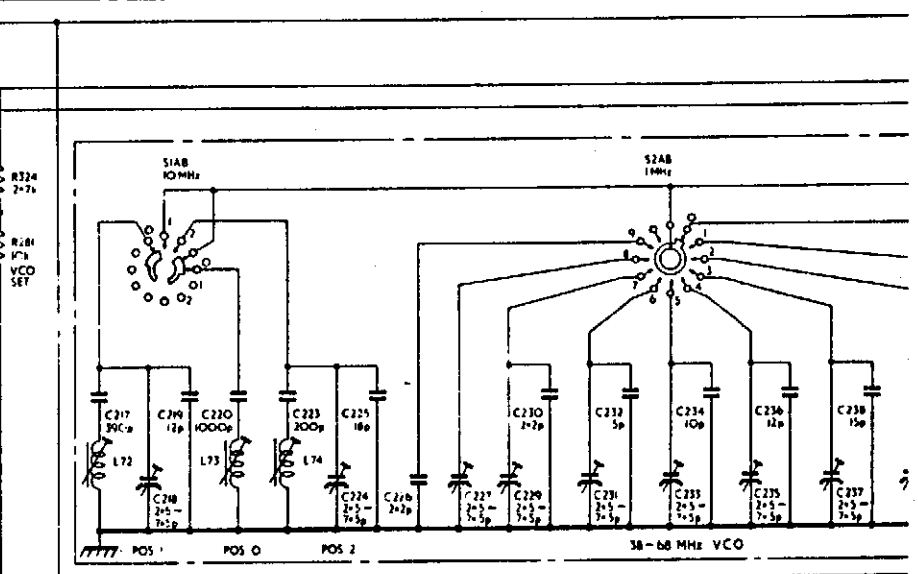
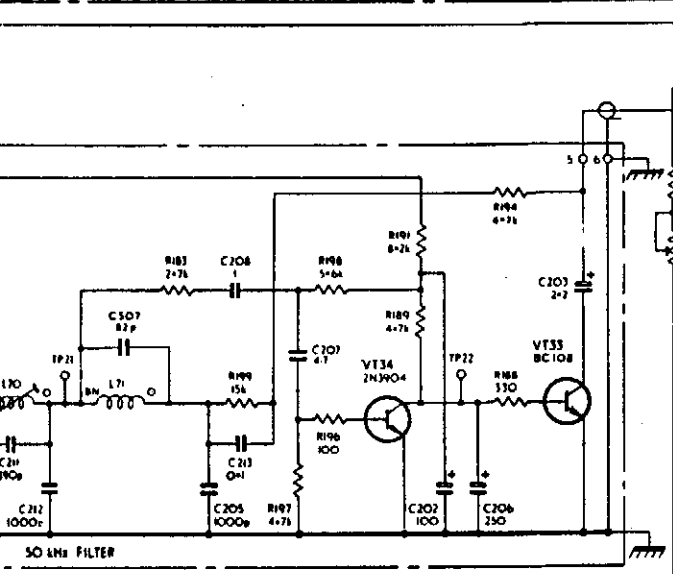

306	309	317	310	313	311	313	323	327	329	334	333	40	333	40	333	29	30	32	
373	373	304	300	3	301	303	123	128	329	340	123	43	43	43	43	31	33	44	45
110	110	14	MR4	MR5	MR6	MR7	76	FL14	L42	XL1	136	140	MR02-65	MR61	70	VT7	TP5	124	
MR7	PL7	1107	MR7	76	MR6	76	FL14	L42	XL1	136	140	MR02-65	MR61	70	VT7	TP5	124	124	
															VT9	VT8	TP6		

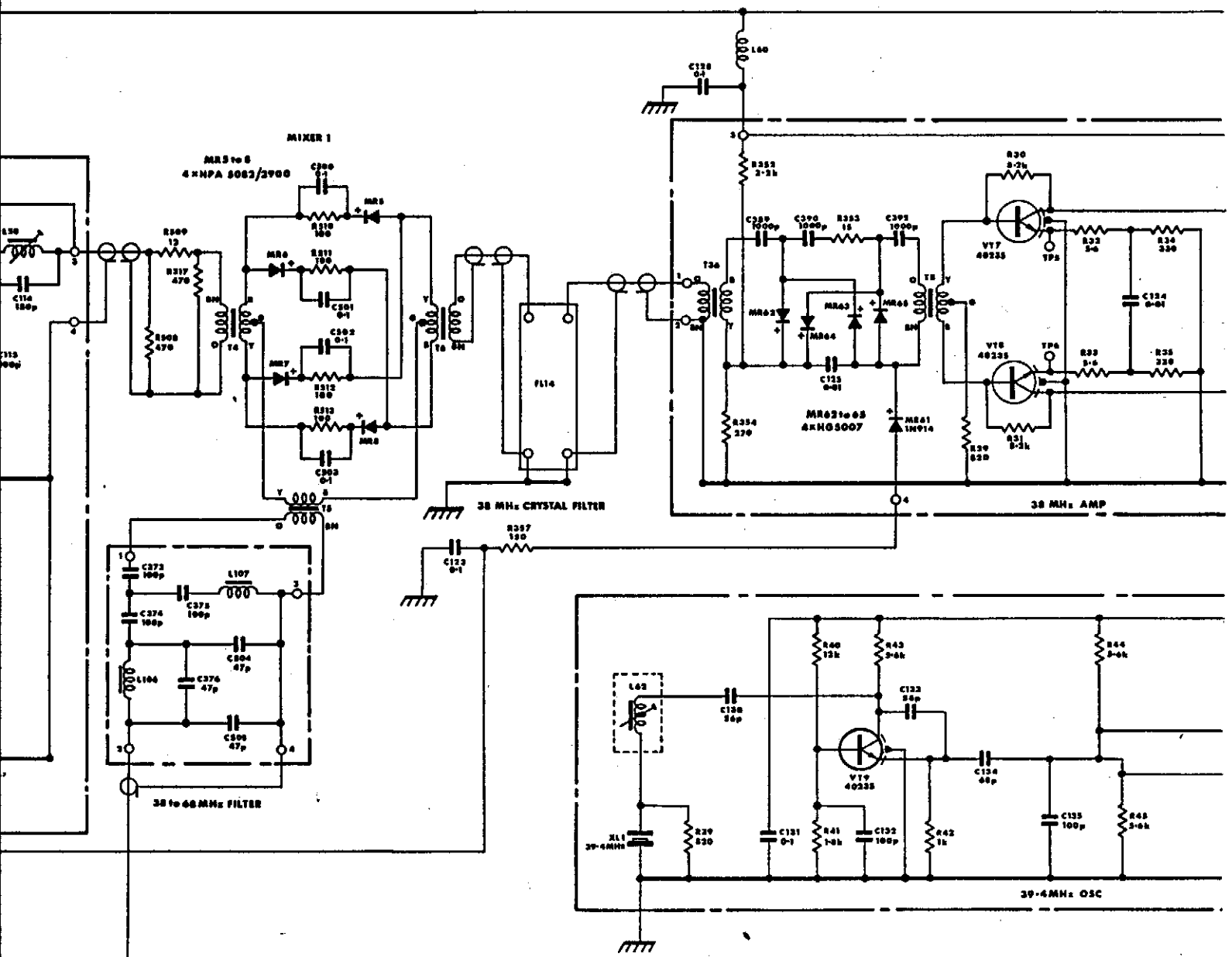

PL7
PL7
PL34
34 to 68 MHz
VCC INPUT
Fig 10-5

17	23	28	34	39	45	51	57	63	69
39	45	51	57	63	69	75	81	87	93
83	89	95	101	107	113	119	125	131	137

9	10	26	11	27	13	28	14	30	15	19	10	33
39	51	63	75	87	99	111	123	135	147	159	171	183
67	79	91	103	115	127	139	151	163	175	187	199	211

11	12	13	14	15	16	17	18	19	20
19	117	131	145	159	173	187	201	215	229
128	142	156	170	184	198	212	226	240	254

13	115	131	147	163	179	195	211	227	243
127	133	141	149	157	165	173	181	189	197
205	213	221	229	237	245	253	261	269	277

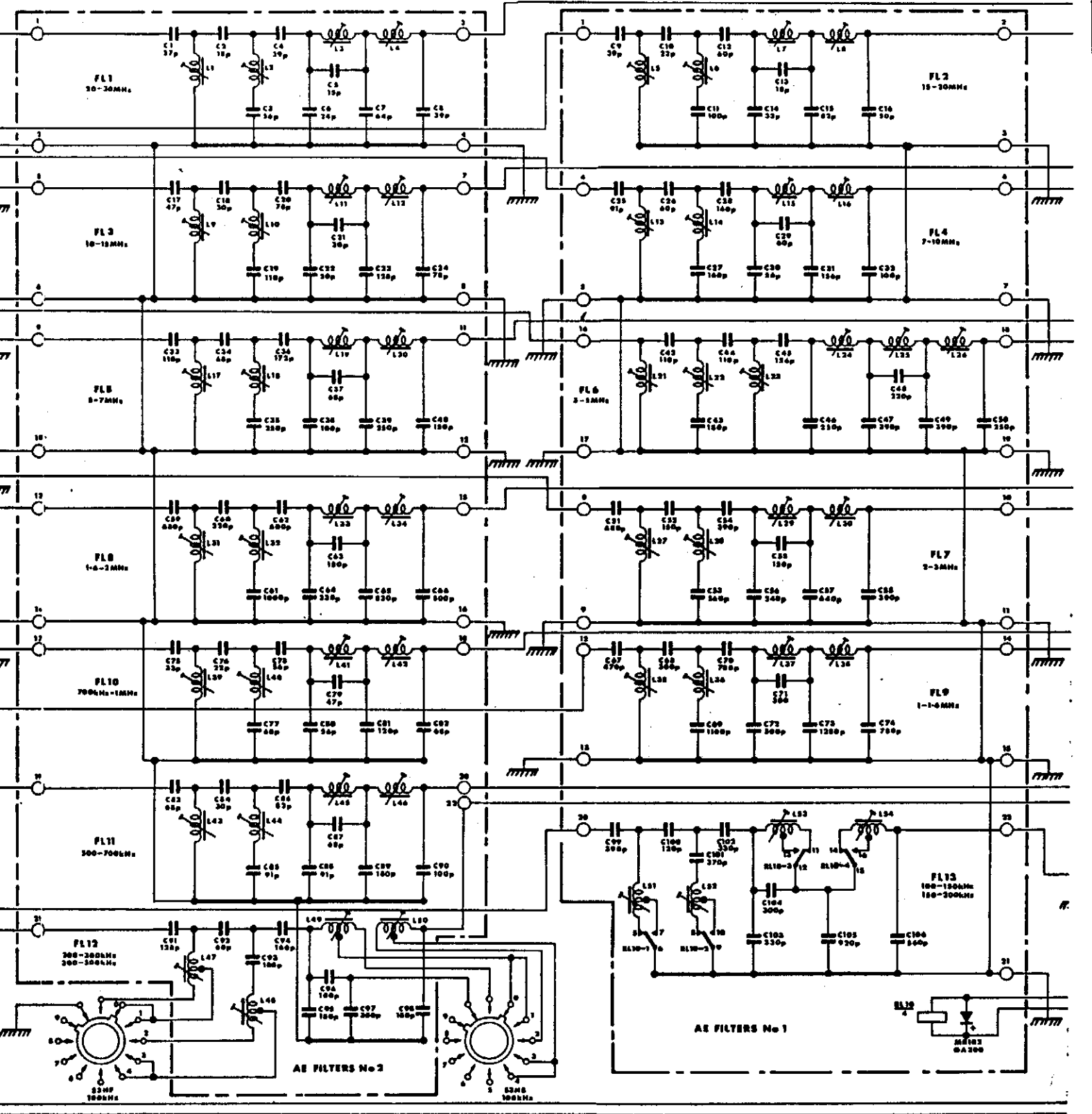

341	344	355	347a,b	345a	343a	345	346	347	290a,b	314	291	302	292 294	293 295 296	351	350	352
PL31	MR49	L98							ILP1	S9b S9c	ILP2	MR50	PL32	MR51	VY51	VX50a	VX50d

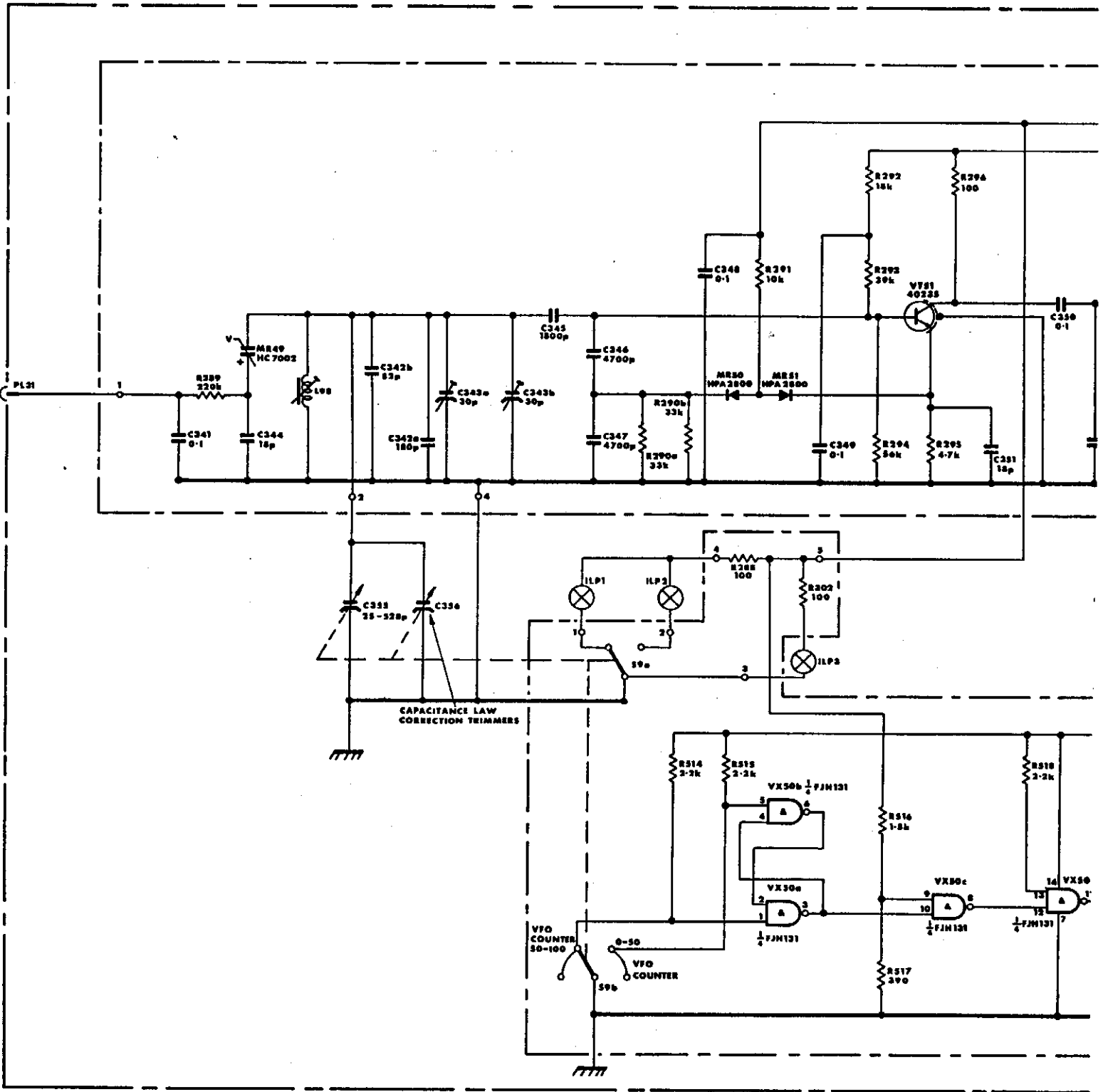

1 2 3 4 5 6 7 8 9 10 11 12 13 14 15 16 17 18 19 20 21 22 23 24 25 26 27 28 29 30 31 32 33 34 35 36 37 38 39 40

41 42 43 44 45 46 47 48 49 50 51 52 53 54 55 56 57 58 59 60 61 62 63 64 65 66 67 68 69 70 71 72 73 74 75 76 77 78 79 80 81 82 83 84 85 86 87 88 89 90 91 92 93 94 95 96 97 98 99 100

11 L1 L2 L3 L4 L5 L6 L7 L8 L9 L10 L11 L12 L13 L14 L15 L16 L17 L18 L19 L20 L21 L22 L23 L24 L25 L26 L27 L28 L29 L30 L31 L32 L33 L34 L35 L36 L37 L38 L39 L40 L41 L42 L43 L44 L45 L46 L47 L48 L49 L50 L51 L52 L53 L54 L55 L56 L57 L58 L59 L60 L61 L62 L63 L64 L65 L66 L67 L68 L69 L70 L71 L72 L73 L74 L75 L76 L77 L78 L79 L80 L81 L82 L83 L84 L85 L86 L87 L88 L89 L90 L91 L92 L93 L94 L95 L96 L97 L98 L99 L100

L1 L2 L3 L4 L5 L6 L7 L8 L9 L10 L11 L12 L13 L14 L15 L16 L17 L18 L19 L20 L21 L22 L23 L24 L25 L26 L27 L28 L29 L30 L31 L32 L33 L34 L35 L36 L37 L38 L39 L40 L41 L42 L43 L44 L45 L46 L47 L48 L49 L50 L51 L52 L53 L54 L55 L56 L57 L58 L59 L60 L61 L62 L63 L64 L65 L66 L67 L68 L69 L70 L71 L72 L73 L74 L75 L76 L77 L78 L79 L80 L81 L82 L83 L84 L85 L86 L87 L88 L89 L90 L91 L92 L93 L94 L95 L96 L97 L98 L99 L100

12HF

13MB

BL10 MR103

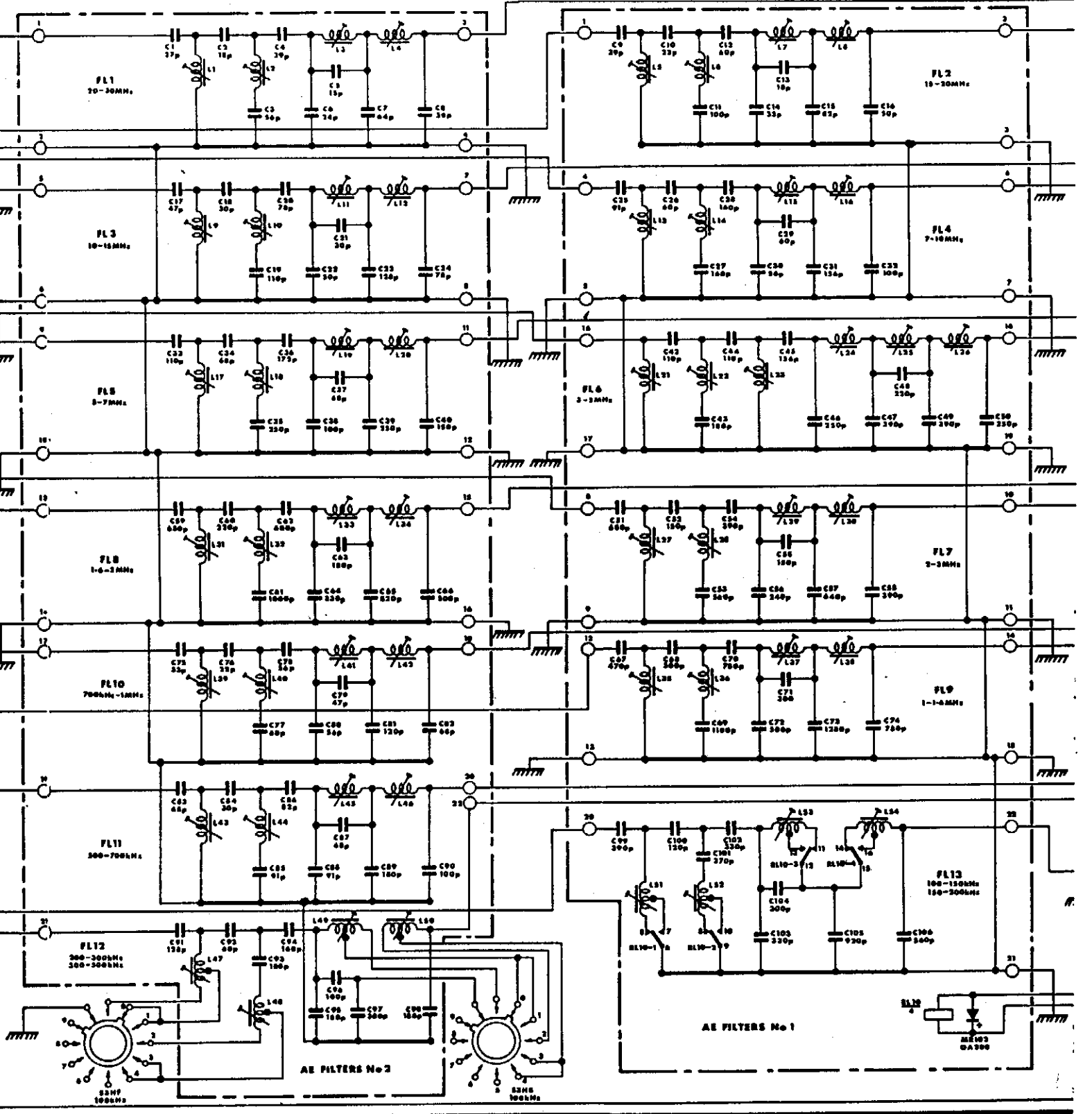

R	R2	R1		R3 R4		R5
C	C1	C2	C3	C4	C5	
Misc		MR1		L1	MR2	
				XL1		

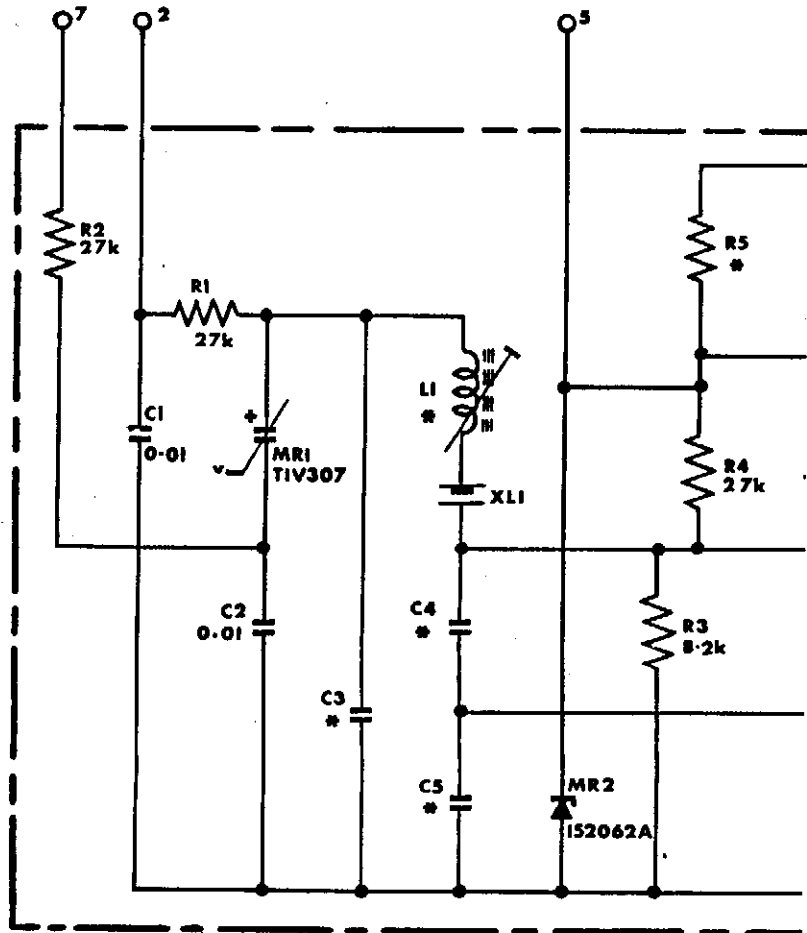

MOD. RECORD					
1	2	3	4	5	6
7	8	9	10	11	12

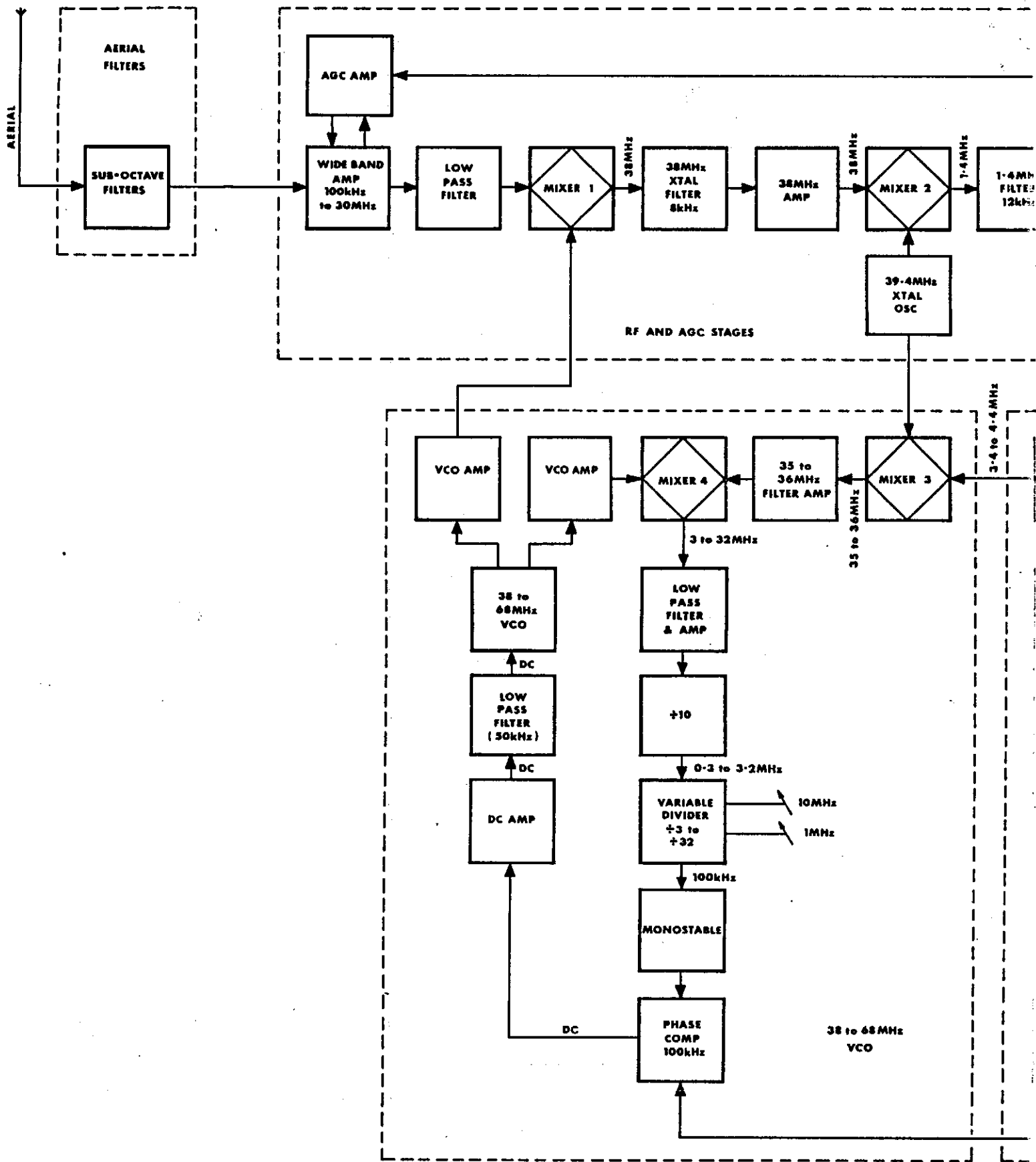

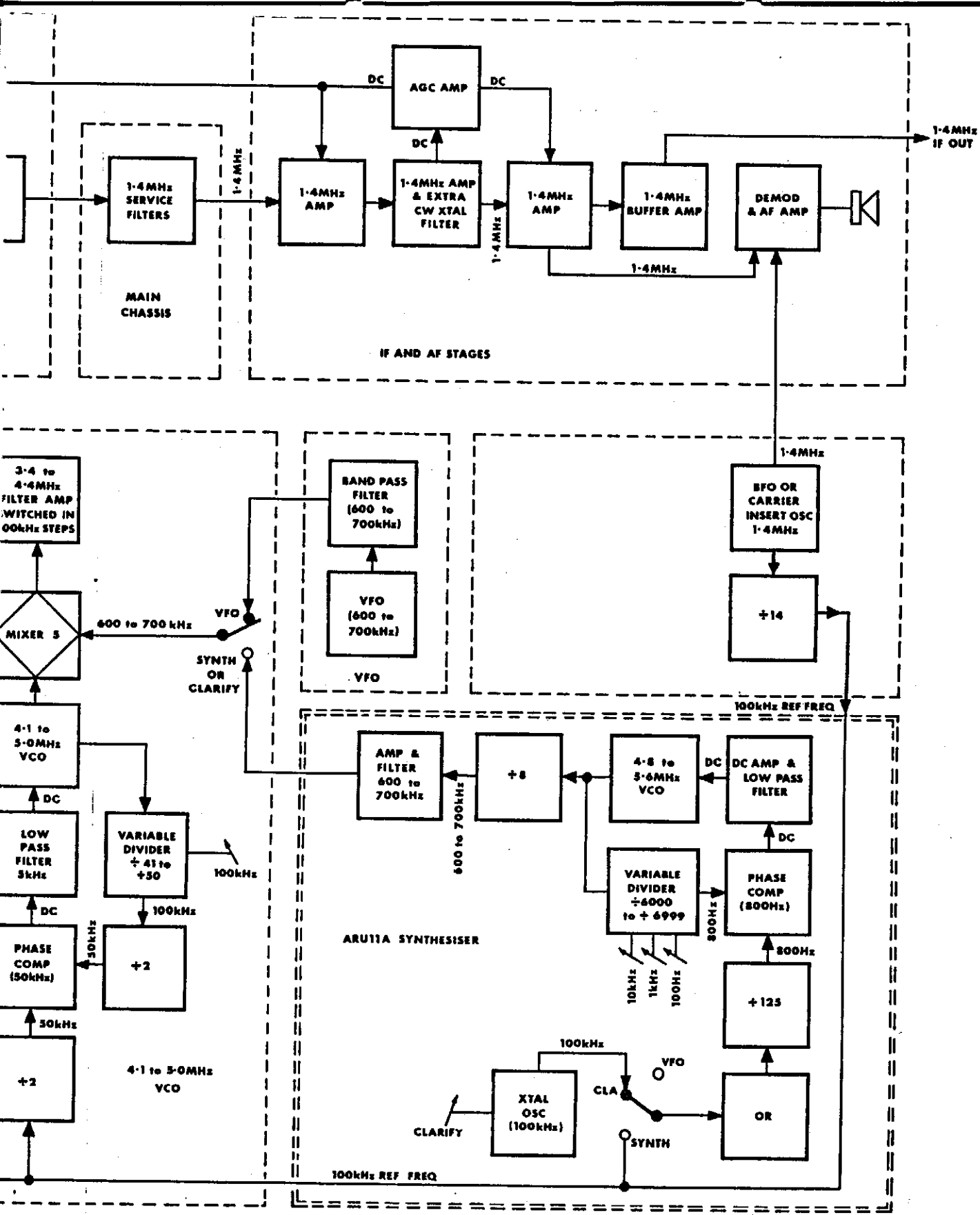

BLOCK DIAGRAM OF R551 RECEIVER

FIG. 4.1

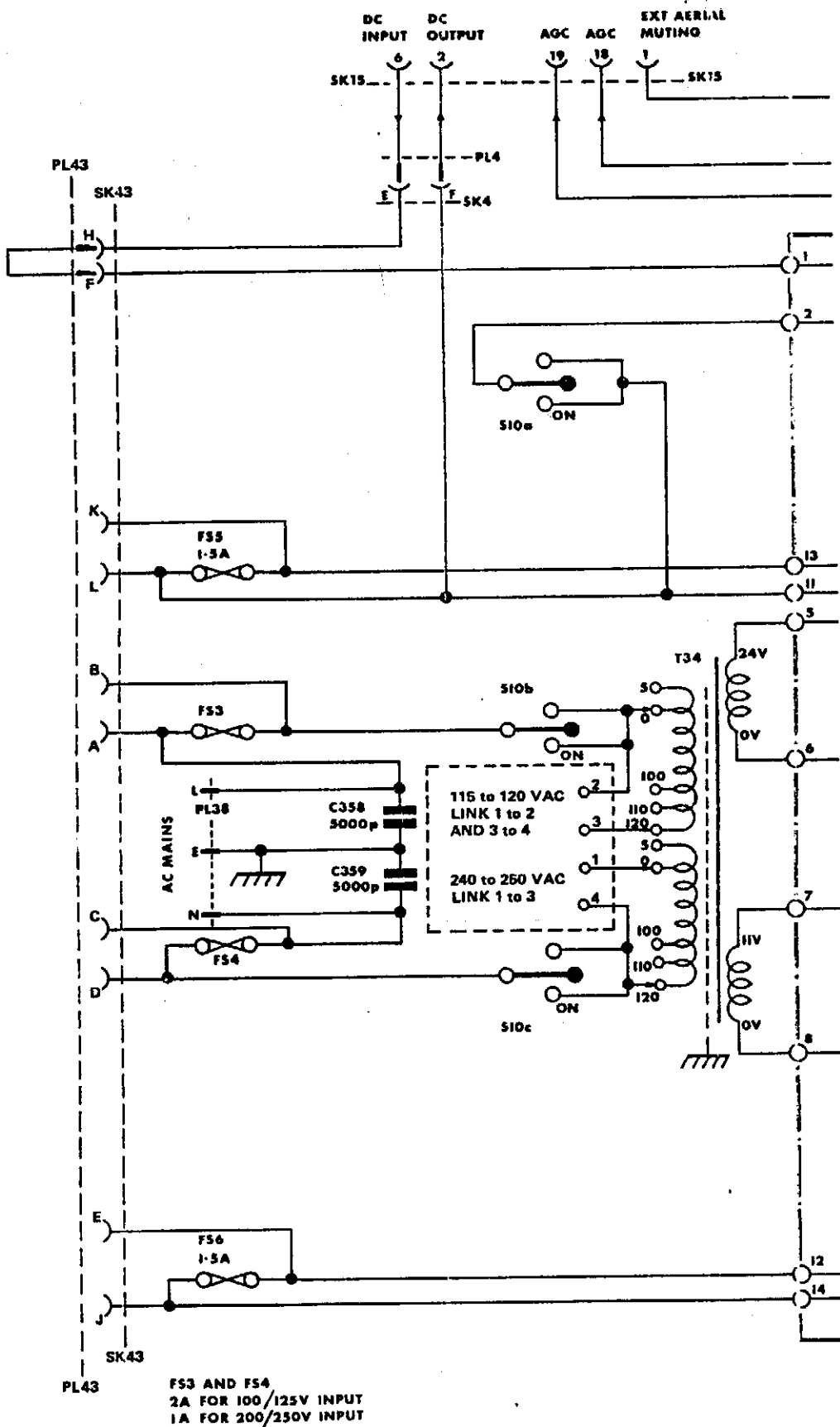

POWER UNIT INPUT

FIG.1A

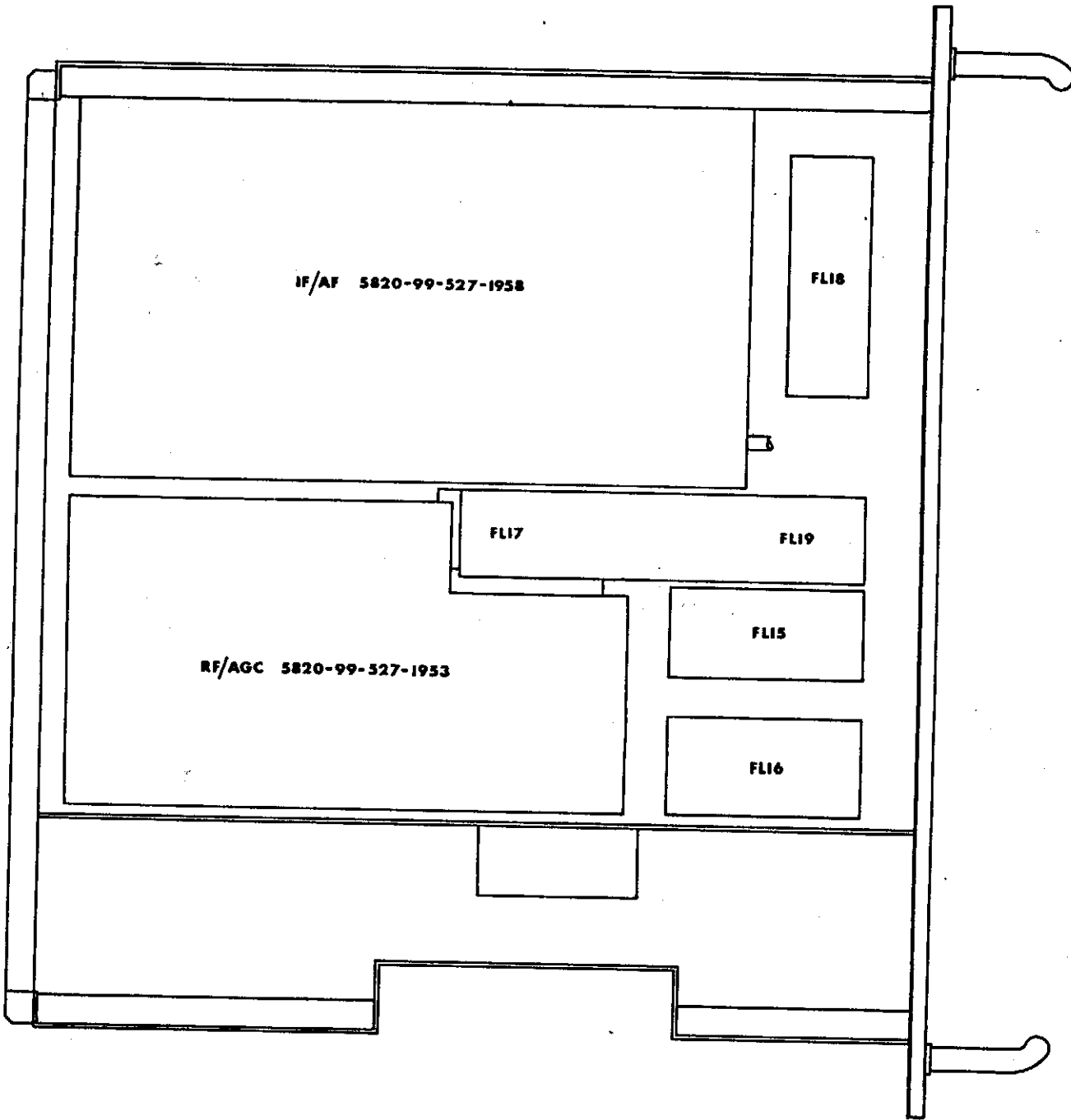

BOTTOM VIEW

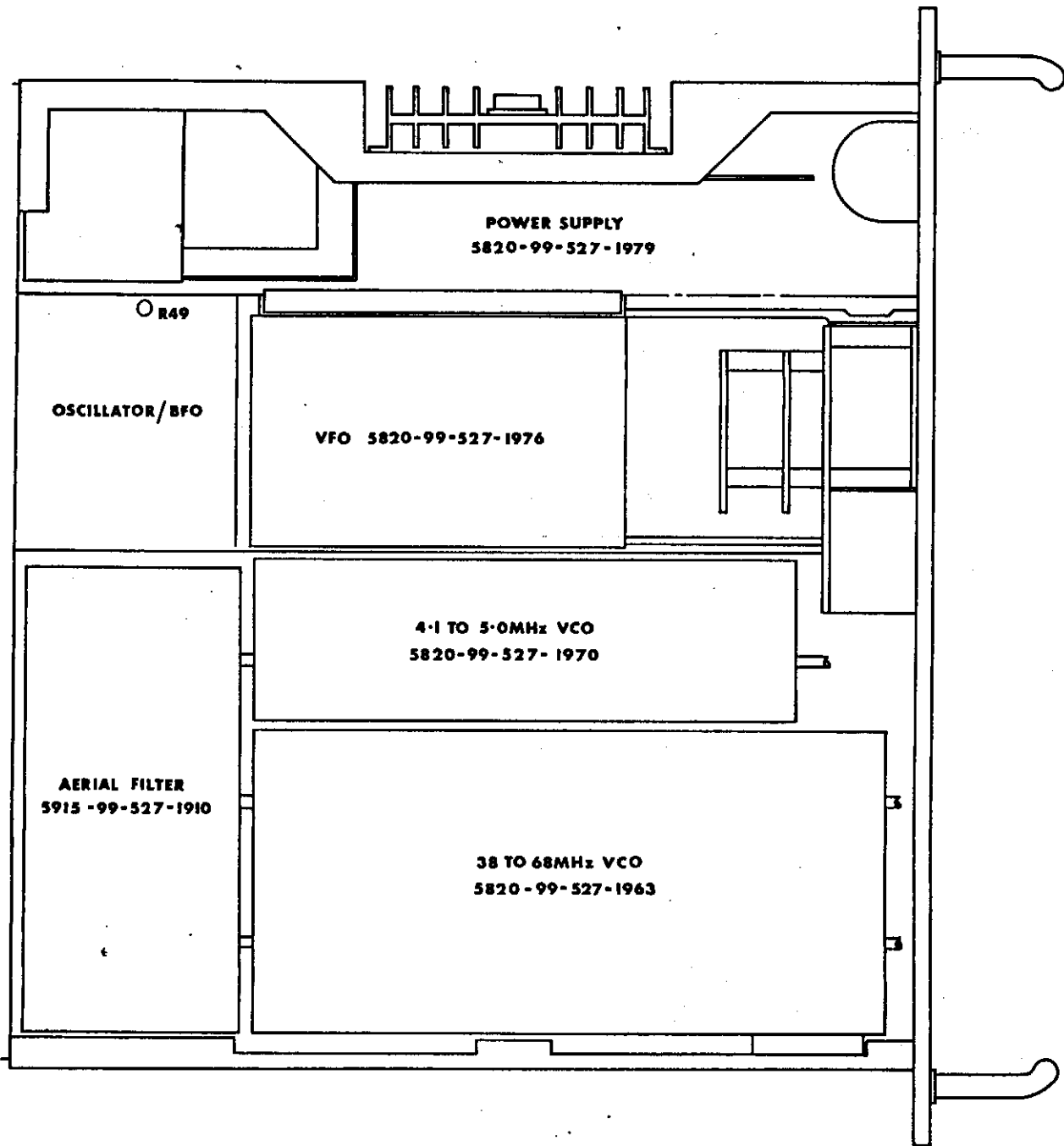

TOP VIEW

LOCATION OF MODULES

FIG. 6.1

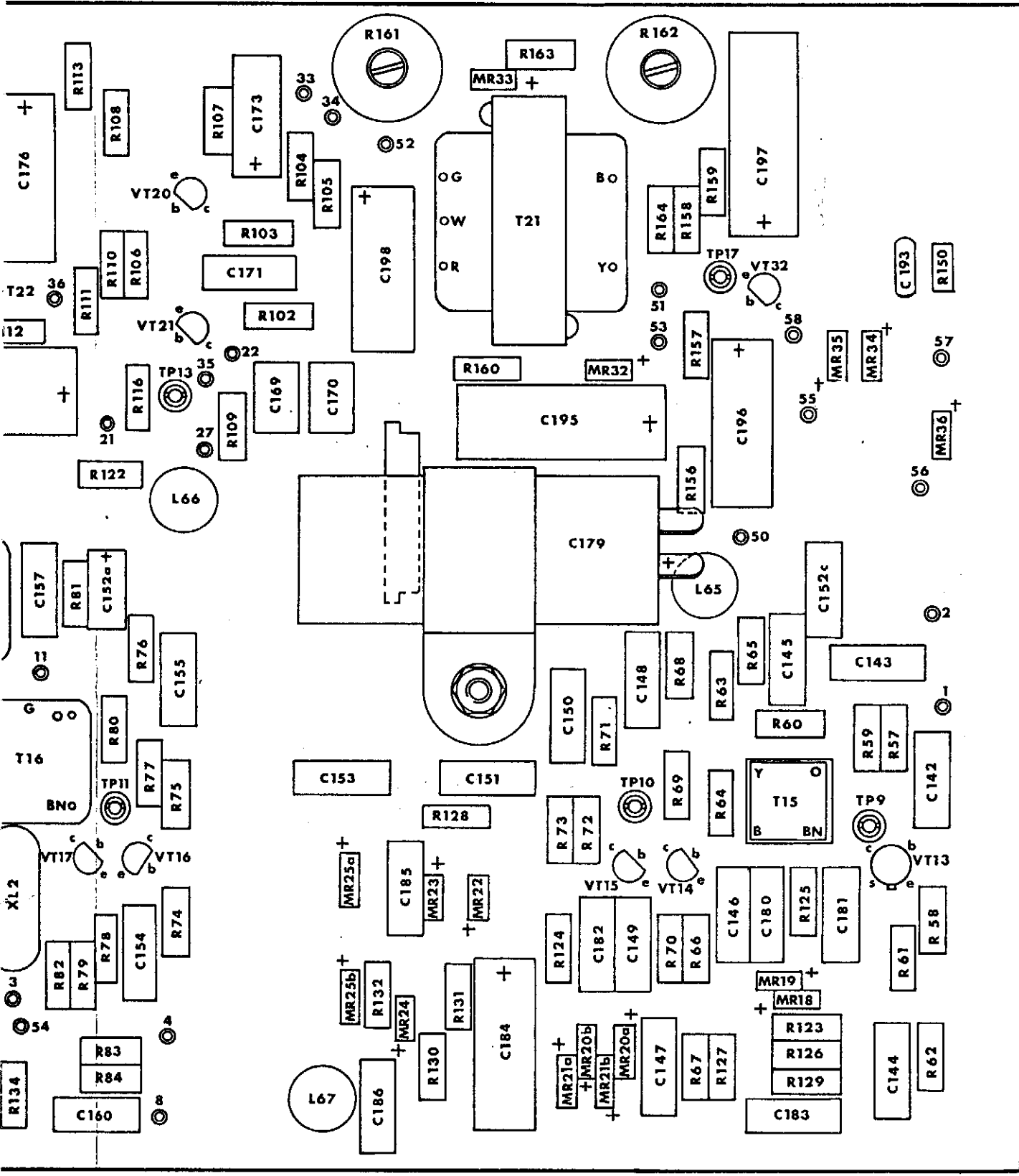

IF/AF PCB ASSEMBLY 5820-99-527-1959

FIG. 9.11

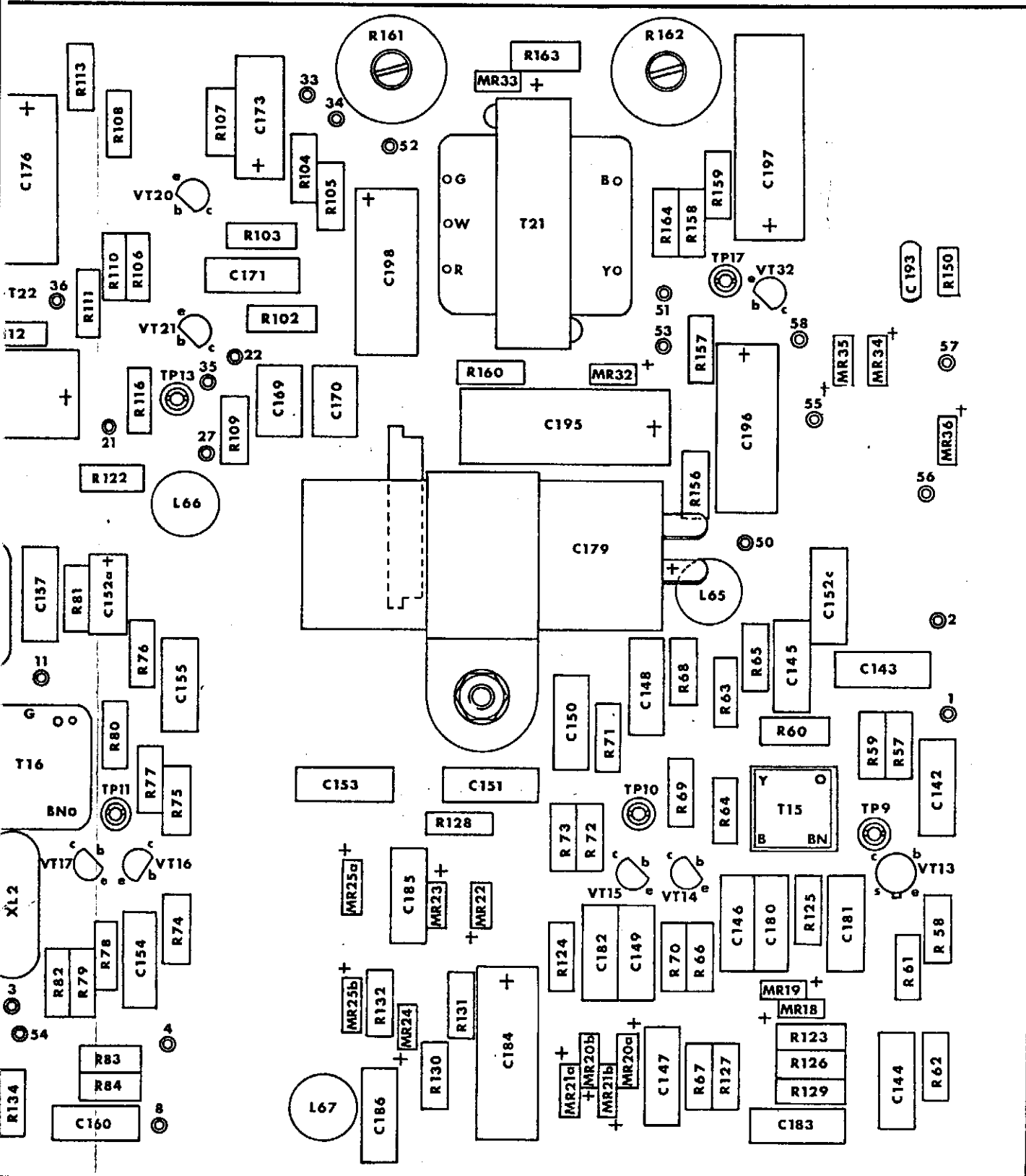

IF/AF PCB ASSEMBLY 5820-99-527-1959

FIG. 9.11

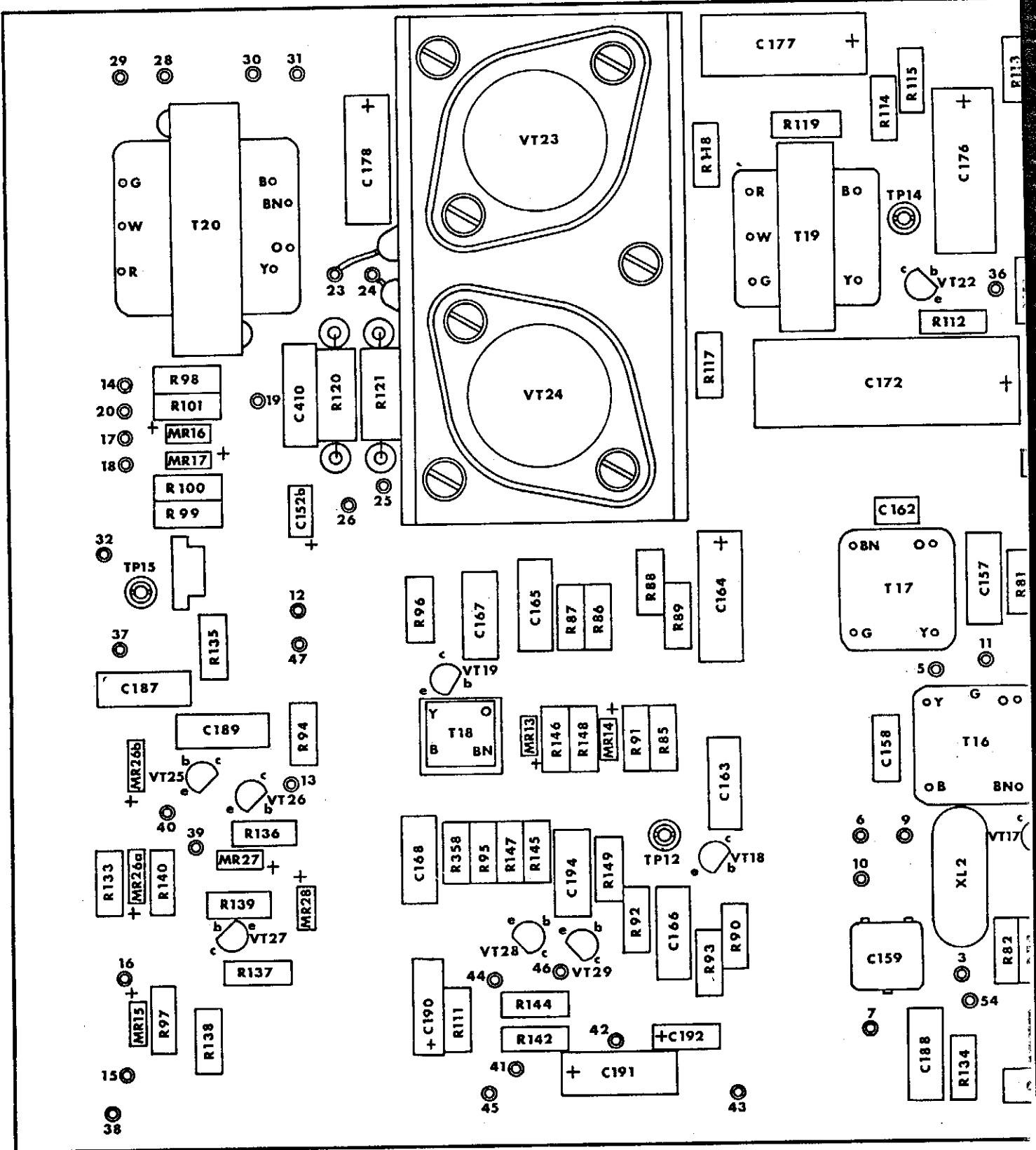

COMPONENT LIST

CAPACITORS

C360	15 μ F \pm 20% 75V Union Carbide K15J75S
C361	2500 μ F +50% -20% 40V Mullard C431 BR/G2500
C362	220 μ F +50% -20% 35V Wima Printilyt 1 Sleeved
C363	0.1 μ F \pm 20% 100V STC PMP0.1M100
C364	100 μ F +50% -20% 35V Wima Printilyt 1 Sleeved
C365	2500 μ F +50% -20% 40V Mullard C431 BR/G2500

RESISTORS

R303	22k Ω \pm 2% $\frac{1}{4}$ W Electrosil TR5
R304	27 Ω \pm 5% 9W Welwyn W23
R305	470 Ω \pm 2% $\frac{1}{4}$ W Electrosil TR5
R306	470 Ω \pm 2% $\frac{1}{4}$ W Electrosil TR5
R307	47 Ω \pm 2% $\frac{1}{4}$ W Electrosil TR5
R308	1 Ω 10% 6W Welwyn W22
R309	470 Ω \pm 2% $\frac{1}{4}$ W Electrosil TR5
R310	1k Ω Lin Plessey MP Dealer/PC
R311	1k Ω Lin Plessey MP Dealer/PC
R314	47 Ω \pm 2% $\frac{1}{4}$ W Electrosil TR5
R315	1 Ω \pm 10% 6W Welwyn W22
R316	1k Ω \pm 2% $\frac{1}{4}$ W Electrosil TR5
R319	1.5k Ω \pm 2% $\frac{1}{4}$ W Electrosil TR5
R320	1.5k Ω \pm 2% $\frac{1}{4}$ W Electrosil TR5

TRANSISTORS

VT54	Mullard BC107
VT55	Mullard 2N1613
VT57	Mullard 2N1613

DIODES

MR53	Mullard BYX38-600R
MR54	STC RAS310AF
MR55	Texas 1B40K40
MR56a	Mullard BZY96C6V8
MR56b	Mullard BZY96C6V8
MR57	Texas 1B40K40
MR58a	Mullard 0A200
MR58b	Mullard 0A200

RELAYS

RL4	Perivale Controls PC4/CA3/34
-----	------------------------------

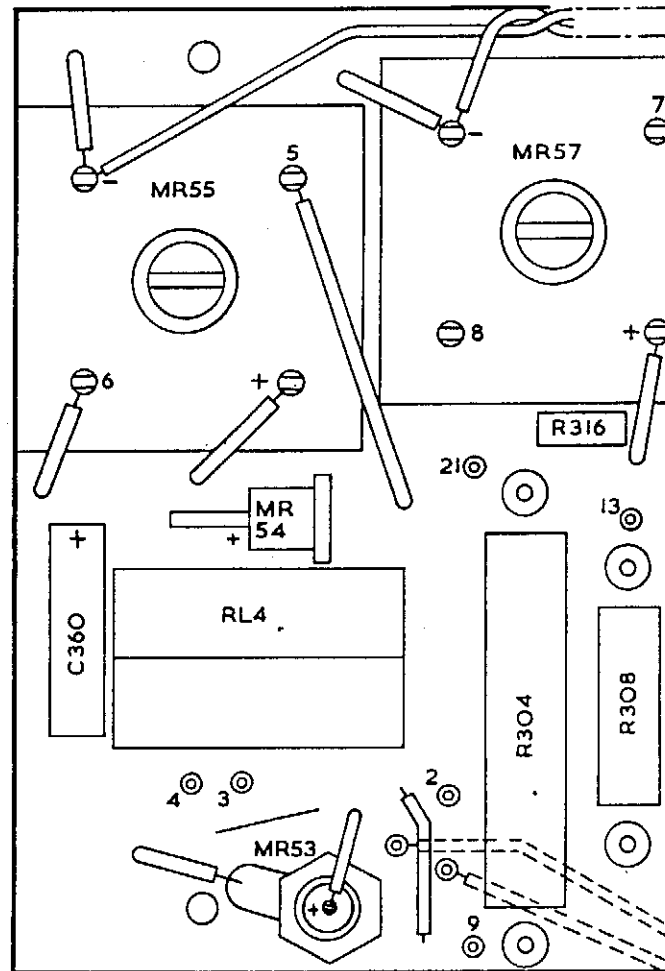

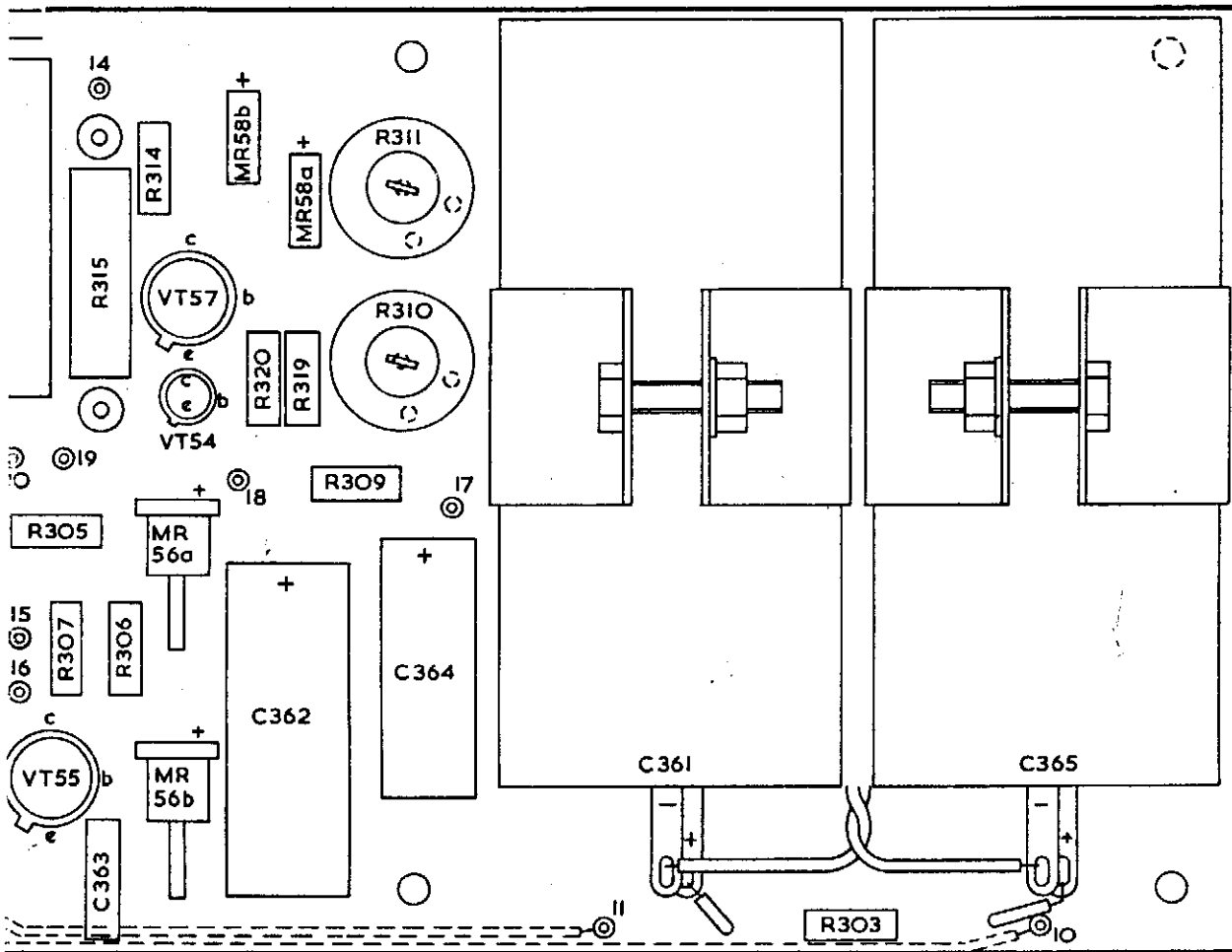

POWER SUPPLY PCB ASSEMBLY 5820-99-527-1980

FIG. 9.3

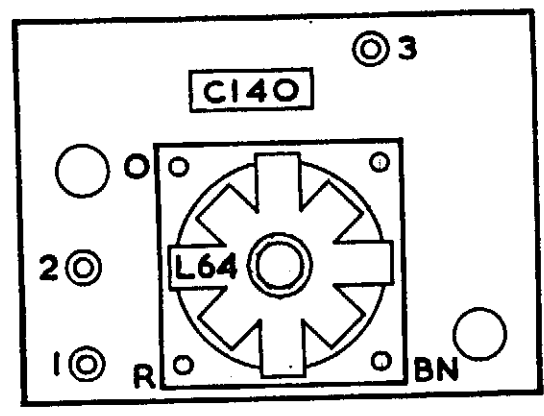
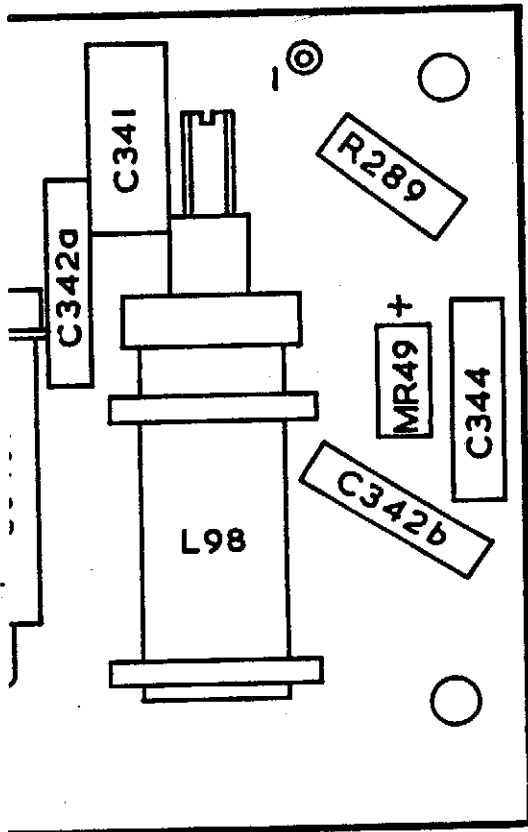

COMPONENT LIST

CAPACITOR

C140 120pF ±2pF 125V GEC PF

INDUCTOR

L64 Redifon P28105/S

FIG. 9.25 12kHz FILTER PCB ASSEMBLY 5820-99-527-1985

FIGS. 9.24 & 9.25

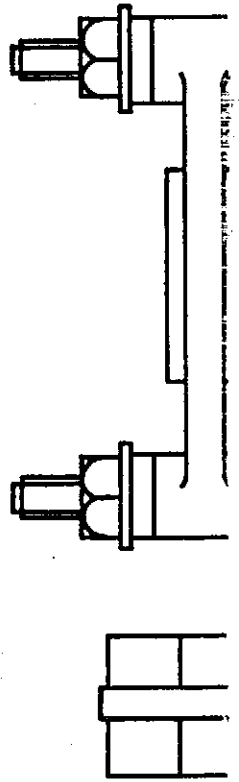
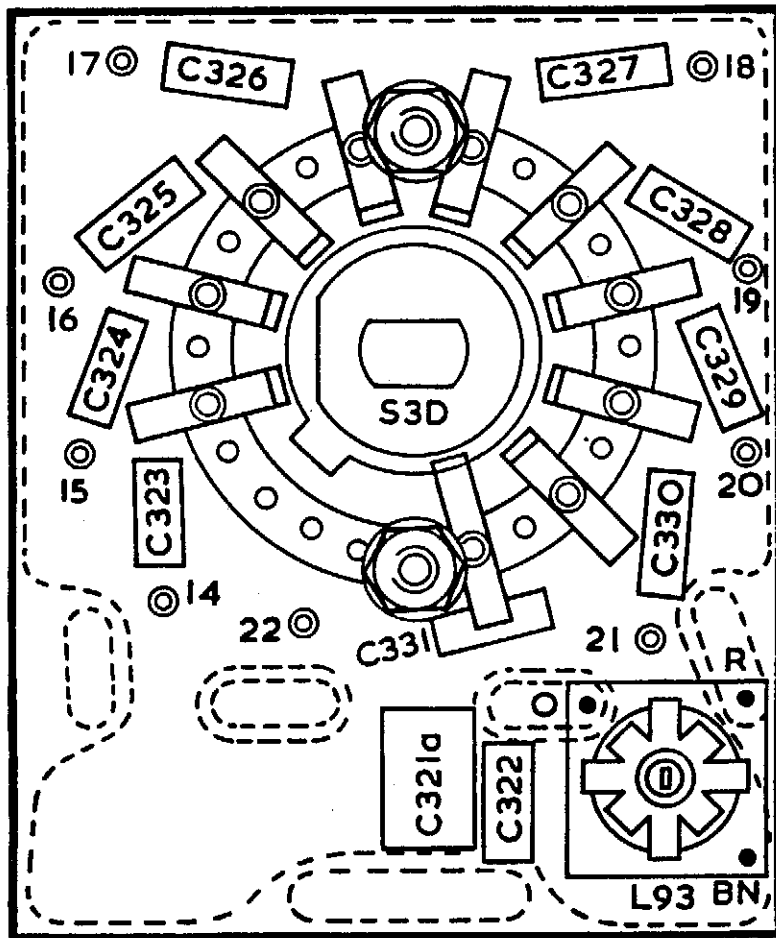

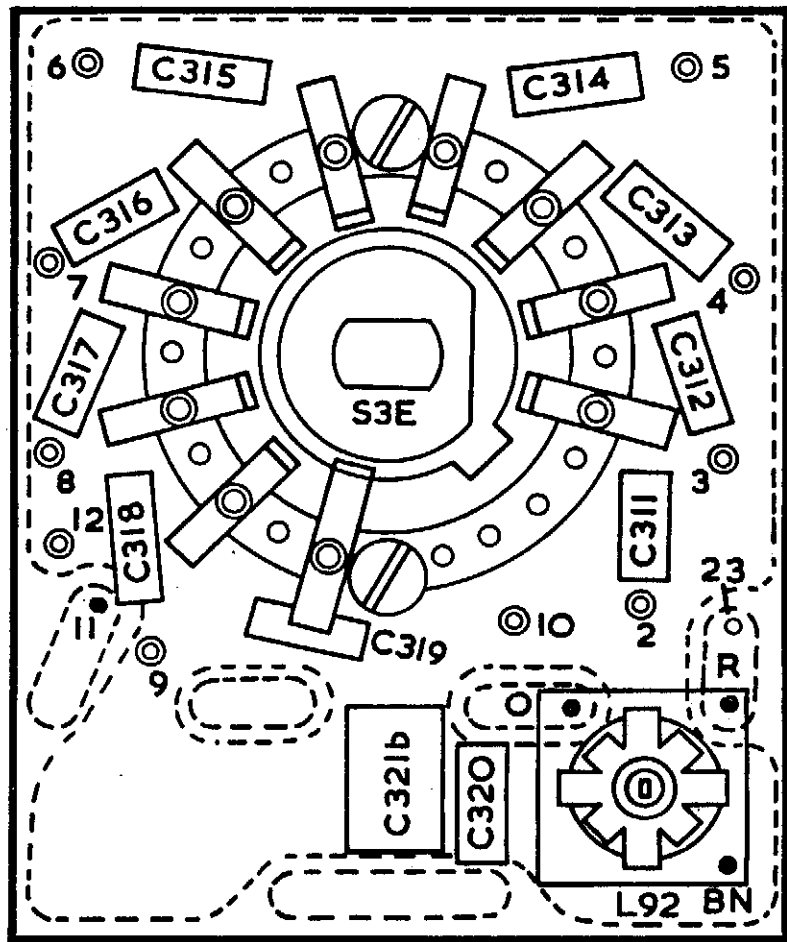
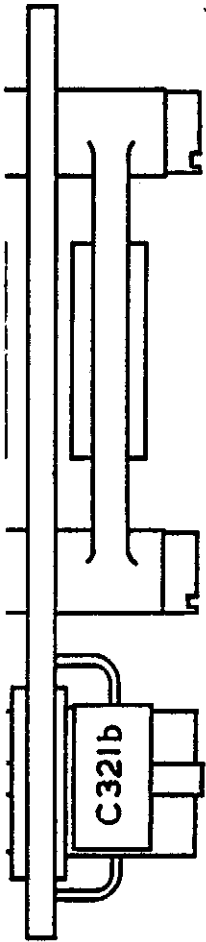

SWITCH FILTER PCB ASSEMBLY 5820-99-527-1971

FIG. 9.19

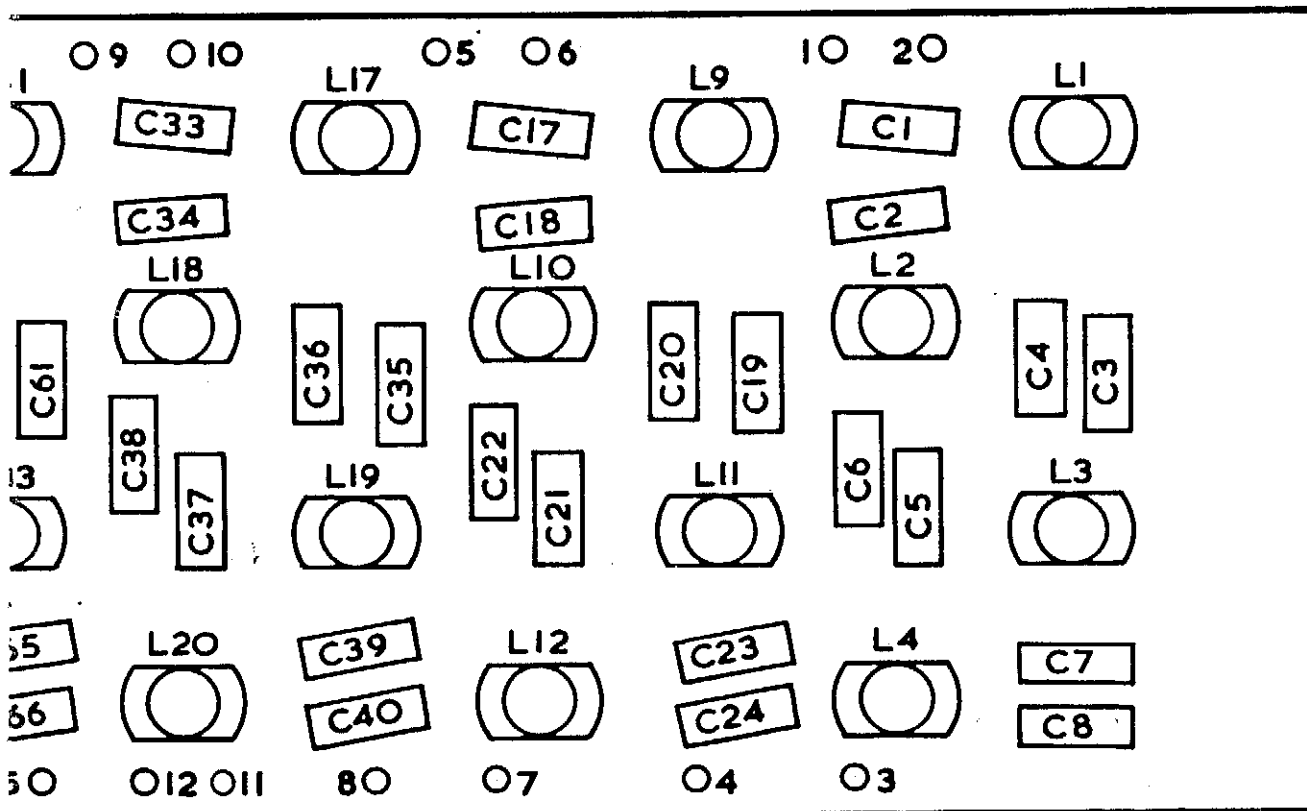

COMPONENT LIST

CAPACITORS

C9	39pF ±2pF 125V GEC PF
C10	22pF ±2pF 125V GEC PF
C11	100pF ±2pF 125V GEC PF
C12	60pF ±2pF 125V GEC PF
C13	18pF ±1pF 125V GEC PF
C14	33pF ±2pF 125V GEC PF
C15	82pF ±2pF 125V GEC PF
C16	50pF ±2pF 125V GEC PF
C25	91pF ±2pF 125V GEC PF
C26	60pF ±2pF 125V GEC PF
C27	160pF ±2% 125V GEC PF
C28	160pF ±2% 125V GEC PF
C29	60pF ±2pF 125V GEC PF
C30	56pF ±2pF 125V GEC PF
C31	156pF ±2% 125V GEC PF
C32	100pF ±2pF 125V GEC PF
C42	110pF ±2% 125V GEC PF
C43	180pF ±2% 125V GEC PF
C44	110pF ±2% 125V GEC PF
C45	156pF ±2% 125V GEC PF
C46	250pF ±2% 125V GEC PF
C47	390pF ±2% 125V GEC PF
C48	220pF ±2% 125V GEC PF
C49	390pF ±2% 125V GEC PF
C50	250pF ±2% 125V GEC PF
C51	680pF ±2% 125V GEC PF
C52	150pF ±2% 125V GEC PF
C53	560pF ±2% 125V GEC PF
C54	390pF ±2% 125V GEC PF
C55	150pF ±2% 125V GEC PF
C56	240pF ±2% 125V GEC PF
C57	640pF ±2% 125V GEC PF
C58	390pF ±2% 125V GEC PF
C67	470pF ±2% 125V GEC PF
C68	300pF ±2% 125V GEC PF
C69	1100pF ±2% 125V GEC PF
C70	780pF ±2% 125V GEC PF
C71	300pF ±2% 125V GEC PF
C72	500pF ±2% 125V GEC PF
C73	1280pF ±2% 125V GEC PF

C74	780pF ±2% 125V GEC PF
C99	390pF ±2pF 125V GEC PF
C100	120pF ±2pF 125V GEC PF
C101	370pF ±2pF 125V GEC PF
C102	330pF ±2pF 125V GEC PF
C103	330pF ±2pF 125V GEC PF
C104	300pF ±2pF GEC PF
C105	920pF ±2PF GEC PF
C106	560pF ±2pF GEC PF

INDUCTORS

L5	Redifon P28042
L6	Redifon P28048
L7	Redifon P28041
L8	Redifon P28043
L13	Redifon P28054
L14	Redifon P28057
L15	Redifon P28045
L16	Redifon P28050
L21	Redifon P28061
L22	Redifon P28070
L23	Redifon P28062
L24	Redifon P28059
L25	Redifon P28052
L26	Redifon P28058
L27	Redifon P28066
L28	Redifon P28071
L29	Redifon P28063
L30	Redifon P28064
L35	Redifon P28074
L36	Redifon P28075
L37	Redifon P28069
L38	Redifon P28072
L51	Redifon P51201
L52	Redifon P51202
L53	Redifon P51203
L54	Redifon P51204

RELAY

RL10	Perivale Controls T21/4CA/430Ω
------	--------------------------------

DIODE

MR102	Mullard 0A200
-------	---------------

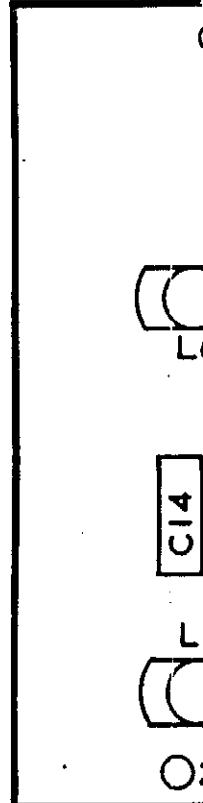

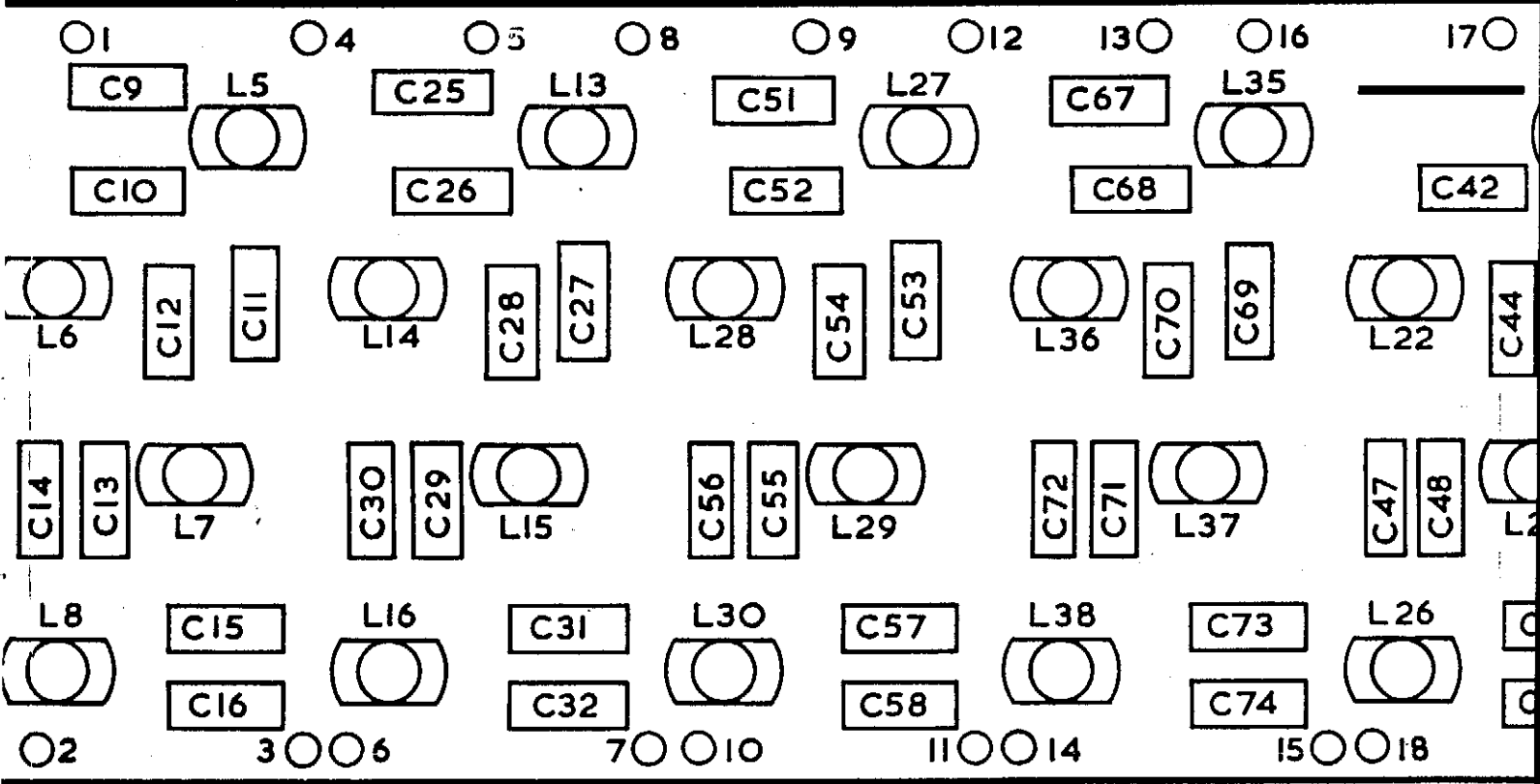

X

COMPONENT LIST

CAPACITORS

C341	0.1 μ F \pm 20% 100V STC PMP0-1M100
C342a	180pF \pm 1% 350V Lemco MS611/I/R/180PFP/350
C342b	82pF \pm 5% 500V Eric 811/N750
C343a	2 to 31pF Oxley TU/30/PC1
C343b	2 to 31pF Oxley TU/30/PC1
C344	18pF \pm 1pF 350V Lemco MS611/I/R/18PFP/350
C345	1800pF \pm 1% 350V Lemco MS611/I/R/1N8F/350
C346	4700pF \pm 1% 200V Lemco MS611/I/R/4N7F/200
C347	4700pF \pm 1% 200V Lemco MS611/I/R/4N7F/200
C348	0.1 μ F \pm 20% 100V STC PMP0-1M100
C349	0.1 μ F \pm 20% 100V STC PMP0-1M100
C350	0.1 μ F \pm 20% 100V STC PMP0-1M100
C351	18pF \pm 1pF 350V Lemco MS611/I/R/18PFP/350
C352	2700pF \pm 1% 350V Lemco MS611/I/R/2N7/350
C353	3900pF \pm 1% 350V Lemco MS611/I/R/3N9F/350
C354	0.1 μ F \pm 20% 100V STC PMP0-1M100
C371	0.1 μ F \pm 20% 100V STC PMP0-1M100
C372	0.1 μ F \pm 20% 100V STC PMP0-1M100

RESISTORS

R289	220k Ω \pm 2% $\frac{1}{2}$ W Electrosil TR5
R290a	33k Ω \pm 2% $\frac{1}{2}$ W Electrosil TR5
R290b	33k Ω \pm 2% $\frac{1}{2}$ W Electrosil TR5
R291	10k Ω \pm 2% $\frac{1}{2}$ W Electrosil TR5
R292	18k Ω \pm 2% $\frac{1}{2}$ W Electrosil TR5
R293	39k Ω \pm 2% $\frac{1}{2}$ W Electrosil TR5
R294	56k Ω \pm 2% $\frac{1}{2}$ W Electrosil TR5
R295	4.7k Ω \pm 2% $\frac{1}{2}$ W Electrosil TR5
R296	100 Ω \pm 2% $\frac{1}{2}$ W Electrosil TR5
R297	100k Ω \pm 2% $\frac{1}{2}$ W Electrosil TR5
R298	47k Ω \pm 2% $\frac{1}{2}$ W Electrosil TR5
R299	470 Ω \pm 2% $\frac{1}{2}$ W Electrosil TR5
R300	270 Ω \pm 2% $\frac{1}{2}$ W Electrosil TR5
R301	47 Ω \pm 2% $\frac{1}{2}$ W Electrosil TR5
R321	270 Ω \pm 2% $\frac{1}{2}$ W Electrosil TR5
R322	22k Ω \pm 2% $\frac{1}{2}$ W Electrosil TR5
R323	100 Ω \pm 2% $\frac{1}{2}$ W Electrosil TR5

TRANSISTORS

VT51	RCA 40235
VT52	STC BC107
VT53	Mullard BCY72

DIODES

MR52	Emihus HG5007
MR50	Hewlett Packard HPA5082/2800
MR51	Hewlett Packard HPA5082/2800
MR49	Emihus HC7002

INDUCTORS

L98	Redifon P28094/S
L99	22 μ H \pm 10% Painton C12-58/10/0013/10
L100	100 μ H \pm 10% Painton C12-58/10/0017/10

RF TRANSFORMER

T33	Redifon P44180/S
-----	------------------

FIG. 9.24 VFO PCB ASSEMBLY 5820-99-527-

COMPONENT LIST

CAPACITORS

<p>C142 0.1μF ±20% 100V STV PMP0-1M100 C143 0.1μF ±20% 100V STC PMP0-1M100 C144 0.1μF ±20% 100V STC PMP0-1M100 C145 0.1μF ±20% 100V STC PMP0-1M100 C146 0.1μF ±20% 100V STC PMP0-1M100</p> <p>C147 0.1μF ±20% 100V STC PMP0-1M100 C148 0.1μF ±20% 100V STC PMP0-1M100 C149 0.1μF ±20% 100V STC PMP0-1M100 C150 0.1μF ±20% 100V STC PMP0-1M100 C151 0.1μF ±20% 100V STC PMP0-1M100</p> <p>C152a 4.7μF +50% -10% 63V Mullard 015-90003 C152b 1μF ±20% Union Carbide K1J20S 20V C152c 0.1μF ±20% 100V STC PMP0-1M100 C153 0.1μF ±20% 100V STC PMP0-1M100 C154 0.1μF ±20% 100V STC PMP0-1M100</p> <p>C156 0.1μF ±20% 100V STC PMP0-1M100 C157 0.1μF ±20% 100V STC PMP0-1M100 C158 410pF ±2% 125V GEC PF C159 2.5-7.5pF Wingrove & Rogers C37-01/6 C160 0.1μF ±20% 100V STC PMP0-1M100</p> <p>C162 200pF ±2% 125V GEC PF C163 0.1μF ±20% 100V STC PMP0-1M100 C164 10μF +100% -20% 35V Wima Printilyt 1 Sleeved C165 0.1μF ±20% 100V STC PMP0-1M100 C166 0.1μF ±20% 100V STC PMP0-1M100</p> <p>C167 0.1μF ±20% 100V STC PMP0-1M100 C168 0.1μF ±20% 100V STC PMP0-1M100 C169 0.002μF ±2% 125V GEC PF C170 0.002μF ±2% 125V GEC PF C171 0.068μF ±20% 100V STC PMP0-068M100</p> <p>C172 220μF +50% -20% 35V Wima Printilyt 1 Sleeved C173 22μF +50% -20% 35V Wima Printilyt 1 Sleeved C176 47μF +50% -20% 35V Wima Printilyt 1 Sleeved C177 47μF +50% -20% 35V Wima Printilyt 1 Sleeved C178 10μF +100% -20% 35V Wima Printilyt 1 Sleeved</p> <p>C179 500μF +50% -10% 40V Mullard C431BR/G500 Sleeved C180 0.1μF ±20% 100V STC PMP0-1M100 C181 0.1μF ±20% 100V STC PMP0-1M100 C182 0.1μF ±20% 100V STC PMP0-1M100 C183 0.1μF ±20% 100V STC PMP0-1M100</p> <p>C184 47μF +50% -20% 35V Wima Printilyt 1 Sleeved C185 0.1μF ±20% 100V STC PMP0-1M100 C186 0.1μF ±20% 100V STC PMP0-1M100 C187 0.1μF ±20% 100V STC PMP0-1M100 C188 0.1μF ±20% 100V STC PMP0-1M100</p> <p>C189 0.1μF ±20% 100V STC PMP0-1M100 C190 3.3μF ±20% Union Carbide K3R3J20S C191 33μF ±20% 20V Union Carbide K33J20S C192 10μF ±20% 20V Union Carbide K10J20S C194 0.1μF ±20% 100V STC PMP0-1M100</p> <p>C195 100μF +50% -20% 35V Wima Printilyt 1 Sleeved C196 47μF +50% -20% 35V Wima Printilyt 1 Sleeved C197 100μF +50% -20% 35V Wima Printilyt 1 Sleeved C198 47μF +50% -20% 35V Wima Printilyt 1 Sleeved C410 0.01μF ±20% STC PMP0-01M100</p>	<p>R62 220Ω ±2% 1/4W ElectroSil TR5 R63 560Ω ±2% 1/4W ElectroSil TR5 R64 4.7kΩ ±2% 1/4W ElectroSil TR5 R65 1.8kΩ ±2% 1/4W ElectroSil TR5 R66 120Ω ±2% 1/4W ElectroSil TR5</p> <p>R67 1.8kΩ ±2% 1/4W ElectroSil TR5 R68 120Ω ±2% 1/4W ElectroSil TR5 R69 680Ω ±2% 1/4W ElectroSil TR5 R70 15kΩ ±2% 1/4W ElectroSil TR5 R71 1kΩ ±2% 1/4W ElectroSil TR5</p> <p>R72 100Ω ±2% 1/4W ElectroSil TR5 R73 2.2kΩ ±2% 1/4W ElectroSil TR5 R74 4.7kΩ ±2% 1/4W ElectroSil TR5 R75 27kΩ ±2% 1/4W ElectroSil TR5 R76 1kΩ ±2% 1/4W ElectroSil TR5</p> <p>R77 4.7kΩ ±2% 1/4W ElectroSil TR5 R78 68Ω ±2% 1/4W ElectroSil TR5 R79 1kΩ ±2% 1/4W ElectroSil TR5 R80 15kΩ ±2% 1/4W ElectroSil TR5 R81 270Ω ±2% 1/4W ElectroSil TR5</p> <p>R82 1.5kΩ ±2% 1/4W ElectroSil TR5 R83 1kΩ ±2% 1/4W ElectroSil TR5 R84 820Ω ±2% 1/4W ElectroSil TR5 R85 4.7kΩ ±2% 1/4W ElectroSil TR5 R86 150Ω ±2% 1/4W ElectroSil TR5</p> <p>R87 1.2kΩ ±2% 1/4W ElectroSil TR5 R88 120Ω ±2% 1/4W ElectroSil TR5 R89 68Ω ±2% 1/4W ElectroSil TR5 R90 10kΩ ±2% 1/4W ElectroSil TR5 R91 1.5kΩ ±2% 1/4W ElectroSil TR5</p> <p>R92 82Ω ±2% 1/4W ElectroSil TR5 R93 1.2kΩ ±2% 1/4W ElectroSil TR5 R94 22kΩ ±2% 1/4W ElectroSil TR5 R95 100Ω ±2% 1/4W ElectroSil TR5 R96 1.2kΩ ±2% 1/4W ElectroSil TR5</p> <p>R97 8.2kΩ ±2% 1/4W ElectroSil TR5 R98 10kΩ ±2% 1/4W ElectroSil TR5 R99 470Ω ±2% 1/4W ElectroSil TR5 R100 470Ω ±2% 1/4W ElectroSil TR5 R101 1.5kΩ ±2% 1/4W ElectroSil TR5</p> <p>R102 1kΩ ±2% 1/4W ElectroSil TR5 R103 18kΩ ±2% 1/4W ElectroSil TR5 R104 82Ω ±2% 1/4W ElectroSil TR5 R105 560Ω ±2% 1/4W ElectroSil TR5 R106 120kΩ ±2% 1/4W ElectroSil TR5</p> <p>R107 470Ω ±2% 1/4W ElectroSil TR5 R108 1.5kΩ ±2% 1/4W ElectroSil TR5 R109 2.2kΩ ±2% 1/4W ElectroSil TR5 R110 3.3kΩ ±2% 1/4W ElectroSil TR5 R111 10kΩ ±2% 1/4W ElectroSil TR5</p> <p>R112 5.6kΩ ±2% 1/4W ElectroSil TR5 R113 12kΩ ±2% 1/4W ElectroSil TR5 R114 47Ω ±2% 1/4W ElectroSil TR5 R115 1kΩ ±2% 1/4W ElectroSil TR5 R116 270Ω ±2% 1/4W ElectroSil TR5</p> <p>R117 10Ω ±2% 1/4W ElectroSil TR5 R118 1kΩ ±2% 1/4W ElectroSil TR5 R119 1.5kΩ ±2% 1/4W ElectroSil TR5 R120 3.3Ω ±10% 2 1/4W Welwyn W21 R121 3.3Ω ±10% 2 1/4W Welwyn W21</p> <p>R122 10Ω ±2% R123 4.7kΩ R124 330Ω R125 2.2kΩ R126 820Ω</p> <p>R127 10kΩ R128 39kΩ R129 10kΩ R130 39Ω ±2% R131 1kΩ ±2%</p> <p>R132 390Ω R133 3.3kΩ R134 47kΩ R135 330Ω R136 27kΩ</p> <p>R137 27kΩ R138 470kΩ R139 2.2kΩ R140 100kΩ R141 100Ω</p> <p>R142 2.2kΩ R144 5.6kΩ R145 3.9kΩ R146 68Ω ±2% R147 1kΩ ±2%</p> <p>R148 27kΩ R149 1kΩ ±2% R150 180Ω R157 8.2kΩ R158 15kΩ</p> <p>R159 330Ω R160 1kΩ ±2% R161 4.7kΩ R162 4.7kΩ R163 1kΩ ±2% R164 2.2kΩ R358 22Ω ±2%</p>
--	---

TRANSISTOR

<p>VT13 RCA VT14 Motor VT15 Motor VT16 Motor</p> <p>VT17 Motor VT18 Motor VT19 Motor VT20 Motor VT21 Motor VT22 Motor</p> <p>VT23 Mulla VT24 Mulla VT25 Motor VT26 Motor</p> <p>VT27 Motor VT28 Motor VT29 Motor VT32 Motor</p>

10Ω ±2% 1/4W ElectroSil TR5
4.7kΩ ±2% 1/4W ElectroSil TR5
330Ω ±2% 1/4W ElectroSil TR5
2.2kΩ ±2% 1/4W ElectroSil TR5
820Ω ±2% 1/4W ElectroSil TR5

10kΩ ±2% 1/4W ElectroSil TR5
39kΩ ±2% 1/4W ElectroSil TR5
10kΩ ±2% 1/4W ElectroSil TR5
39Ω ±2% 1/4W ElectroSil TR5
1kΩ ±2% 1/4W ElectroSil TR5

390Ω ±2% 1/4W ElectroSil TR5
3.3kΩ ±2% 1/4W ElectroSil TR5
47kΩ ±2% 1/4W ElectroSil TR5
330Ω ±2% 1/4W ElectroSil TR5
27kΩ ±2% 1/4W ElectroSil TR5

27kΩ ±2% 1/4W ElectroSil TR5
470kΩ ±2% 1/4W ElectroSil TR5
2.2kΩ ±2% 1/4W ElectroSil TR5
100kΩ ±2% 1/4W ElectroSil TR5
100Ω ±2% 1/4W ElectroSil TR5

2.2kΩ ±2% 1/4W ElectroSil TR5
5.6kΩ ±2% 1/4W ElectroSil TR5
3.9kΩ ±2% 1/4W ElectroSil TR5
68Ω ±2% 1/4W ElectroSil TR5
1kΩ ±2% 1/4W ElectroSil TR5

27kΩ ±2% 1/4W ElectroSil TR5
1kΩ ±2% 1/4W ElectroSil TR5
180Ω ±2% 1/4W ElectroSil TR5
8.2kΩ ±2% 1/4W ElectroSil TR5
15kΩ ±2% 1/4W ElectroSil TR5

330Ω ±2% 1/4W ElectroSil TR5
1kΩ ±2% 1/4W ElectroSil TR5
4.7kΩ Lin ±20% 1/4W Plessey MP Dealer/PC/
Black 404/8/92857 Series
4.7kΩ Lin ±20% 1/4W Plessey MP Dealer/PC/
Black 404/8/92857 Series
1kΩ ±2% 1/4W ElectroSil TR5
2.2kΩ ±2% 1/4W ElectroSil TR5
22Ω ±2% 1/4W ElectroSil TR5

ISTORS
RCA 40235
Motorola 2N3904
Motorola 2N3906
Motorola 2N3904

Motorola 2N3904
Motorola 2N3904
Motorola 2N3906
Motorola 2N3904
Motorola 2N3906
Motorola 2N3904

Mullard OC28
Mullard OC28
Motorola 2N3904
Motorola 2N3904

Motorola 2N3904
Motorola 2N3906
Motorola 2N3906
Motorola 2N3904

DIODES

MR13 Texas 1N916
MR14 Texas 1N916
MR15 Emihus HG5007
MR16 Hewlett Packard HPA5082/2800
MR17 Hewlett Packard HPA5082/2800

MR18 Mullard OA200
MR19 Mullard OA200
MR20a Mullard OA200
MR20b Mullard OA200
MR21a Mullard OA200

MR21b Mullard OA200
MR22 Emihus HG5007
MR23 Emihus HG5007
MR24 Mullard OA200
MR25a Mullard OA200

MR25b Mullard OA200
MR26a Mullard OA200
MR26b Emihus HG5007
MR27 Mullard OA200
MR28 Mullard OA200
MR32 Emihus HG5007
MR33 Mullard OA200

RF TRANSFORMERS

T15 Redifon P28122/S
T16 Redifon P28123/S
T17 Redifon P28124/S
T18 Redifon P28125/S

AF TRANSFORMERS

T19 Redifon SRT2652
T20 Redifon SRT2705
T21 Redifon SRT2698

INDUCTORS

L65 2.7mH ±10% Cambion 3635-42
L66 100μH ±10% Cambion 3635-25
L67 2.7mH ±10% Cambion 3635-42

CRYSTAL

XL2 Redifon OP9141/S

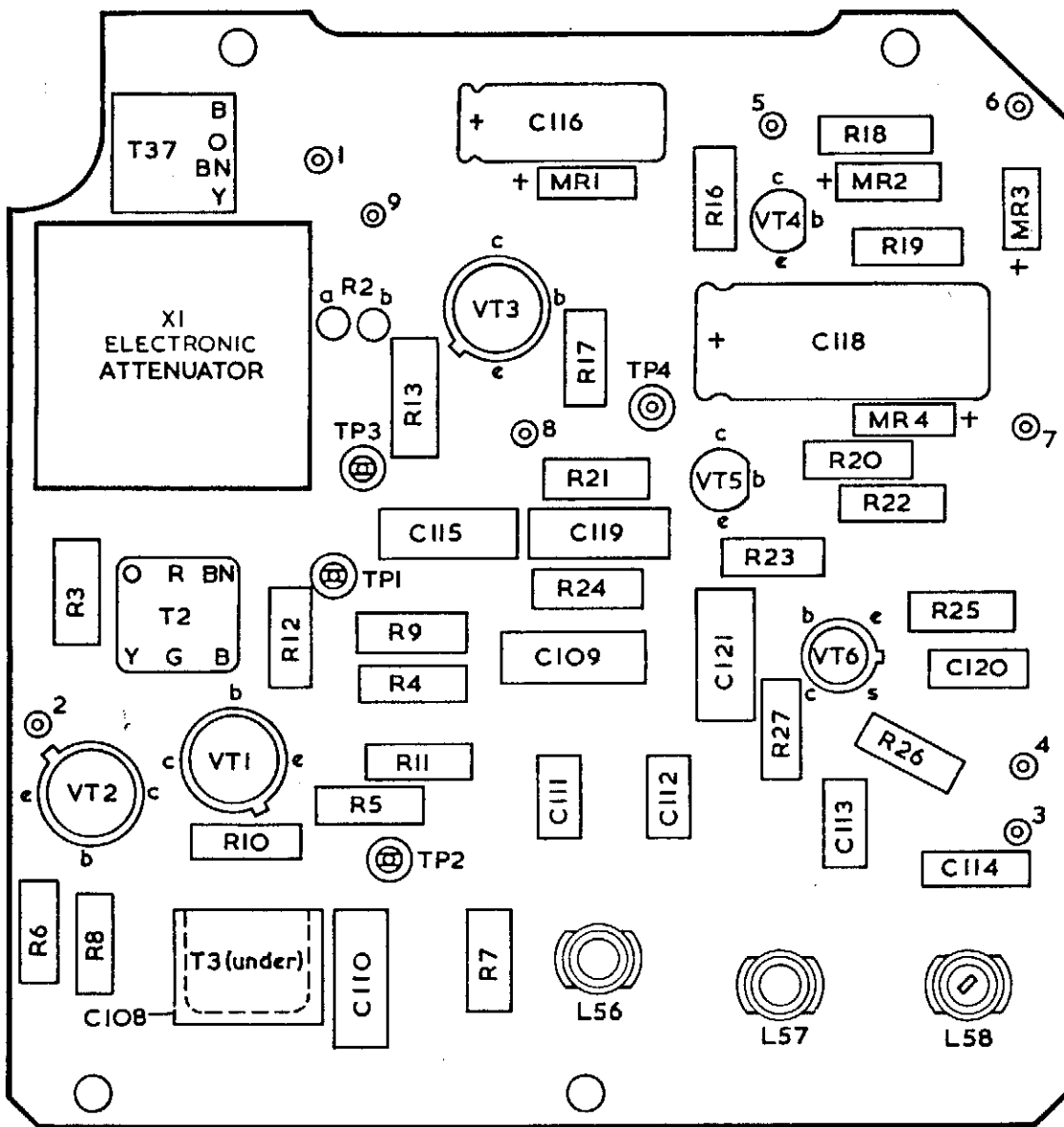

WIDEBAND AMPLIFIER PCB ASSEMBLY 5820-99-527-1957

FIG. 9.6

COMPONENT LIST

CAPACITORS

C108	1.0 μ F \pm 20% 100V STC PMP1-0M100
C109	0.1 μ F \pm 20% 100V STC PMP0-1M100
C110	0.1 μ F \pm 20% 100V STC PMP0-1M100
C111	1000pF \pm 2pF 125V GEC PF
C112	180pF \pm 2% 125V GEC PF
C113	1000pF \pm 2pF 125V GEC PF
C114	150pF \pm 2% 125V GEC PF
C115	0.1 μ F \pm 20% 100V STC PMP0-1M100
C116	47 μ F +50% -20% 35V Wima Printylit 1 Sleeved
C118	100 μ F +50% -20% 35V Wima Printylit 1 Sleeved
C119	0.1 μ F \pm 20% 100V STC PMP0-1M100
C120	47pF \pm 2pF 125V GEC PF
C121	0.1 μ F \pm 20% 100V STC PMP0-1M100

RESISTORS

R2a	56 Ω \pm 2% $\frac{1}{4}$ W Electrosil TR5
R2b	56 Ω \pm 2% $\frac{1}{4}$ W Electrosil TR5
R3	560 Ω \pm 2% $\frac{1}{4}$ W Electrosil TR5
R4	330 Ω \pm 2% $\frac{1}{4}$ W Electrosil TR5
R5	5.6 Ω \pm 5% $\frac{1}{4}$ W Iskra UPM
R6	5.6 Ω \pm 5% $\frac{1}{4}$ W Iskra UPM
R7	220 Ω \pm 2% $\frac{1}{4}$ W Electrosil TR5
R8	220 Ω \pm 2% $\frac{1}{4}$ W Electrosil TR5
R9	680 Ω \pm 2% $\frac{1}{4}$ W Electrosil TR5
R10	5.6k Ω \pm 2% $\frac{1}{4}$ W Electrosil TR5
R11	82 Ω \pm 2% $\frac{1}{4}$ W Electrosil TR5
R12	560 Ω \pm 2% $\frac{1}{4}$ W Electrosil TR5
R13	100 Ω \pm 10% $\frac{2}{4}$ W Welwyn W21
R16	470 Ω \pm 2% $\frac{1}{4}$ W Electrosil TR5
R17	470 Ω \pm 2% $\frac{1}{4}$ W Electrosil TR5
R18	1k Ω \pm 2% $\frac{1}{4}$ W Electrosil TR5
R19	2.7k Ω \pm 2% $\frac{1}{4}$ W Electrosil TR5
R20	47k Ω \pm 2% $\frac{1}{4}$ W Electrosil TR5
R21	22 Ω \pm 2% $\frac{1}{4}$ W Electrosil TR5
R22	150k Ω \pm 2% $\frac{1}{4}$ W Electrosil TR5

R23	560 Ω \pm 2% $\frac{1}{4}$ W Electrosil TR5
R24	1.5k Ω \pm 2% $\frac{1}{4}$ W Electrosil TR5
R25	1k Ω \pm 2% $\frac{1}{4}$ W Electrosil TR5
R26	560 Ω \pm 2% $\frac{1}{4}$ W Electrosil TR5
R27	5.6k Ω \pm 2% $\frac{1}{4}$ W Electrosil TR5

TRANSISTORS

VT1	RCA 2N3866
VT2	RCA 2N3866
VT3	Fairchild V410
VT4	Motorola 2N3904
VT5	Motorola 2N3906
VT6	RCA 40235

DIODES

MR1	Emihus HG5007
MR2	Mullard OA200
MR3	Mullard OA200
MR4	Mullard OA200

TRANSFORMERS

T2	Redifon P51247/S
T3	Redifon P51248/S
T37	Redifon P28120/S

INDUCTORS

L56	Redifon P28029/S
L57	Redifon P28030/S
L58	Redifon P28117/S

ELECTRONIC ATTENUATOR

X1	Redifon PL5643 Edn A
----	----------------------

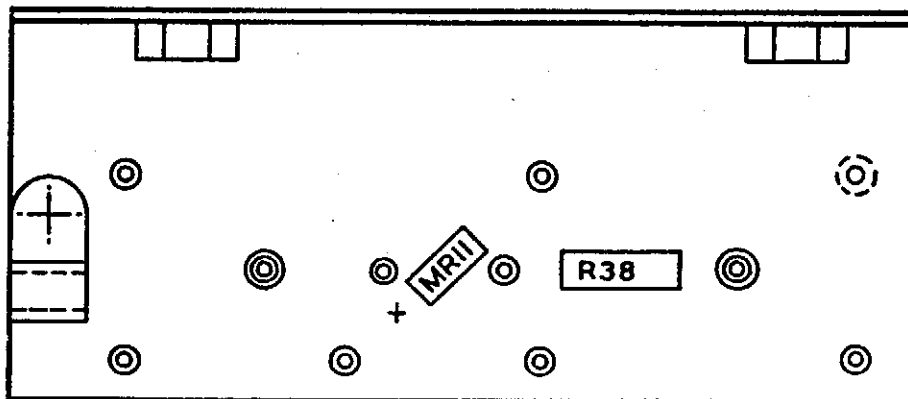
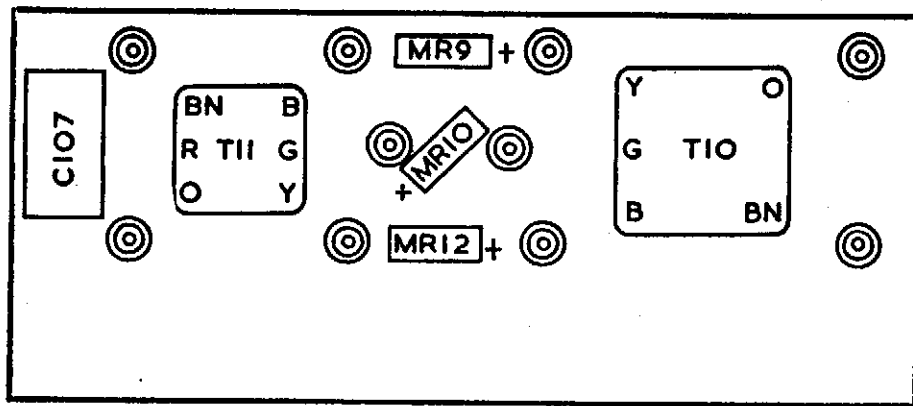

COMPONENT LIST

CAPACITOR

C107 1500pF $\pm 2\%$ 125 GEC PF

RESISTOR

R38 $10\Omega \pm 2\%$ $\frac{1}{4}$ W Electrosil TR5

DIODES

MR9 Hewlett Packard HPA 5082/2800

MR10 Hewlett Packard HPA 5082/2800

MR11 Hewlett Packard HPA 5082/2800

MR12 Hewlett Packard HPA 5082/2800

RF TRANSFORMERS

T10 Redifon 28101/S

T11 Redifon 28102/S

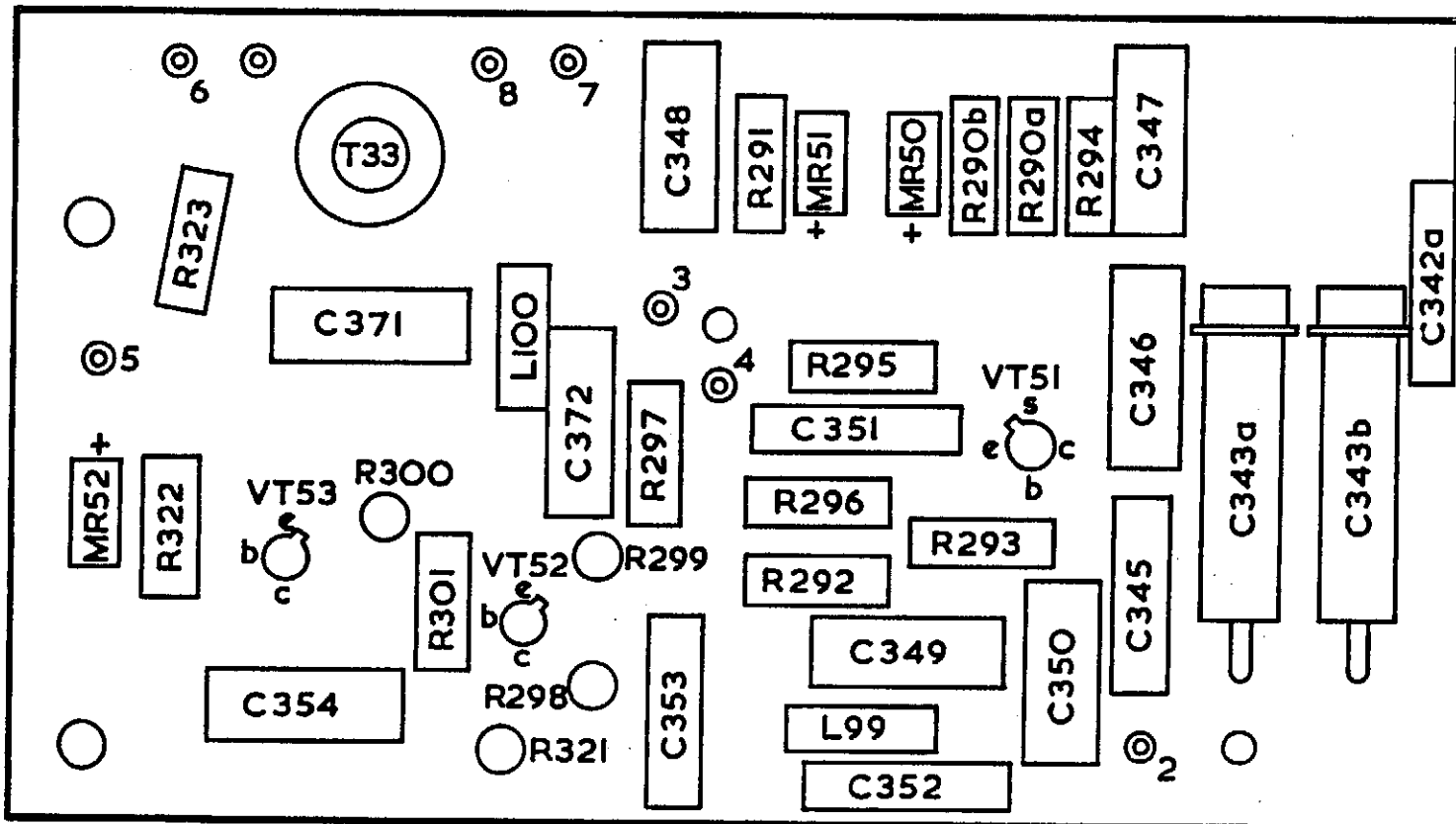

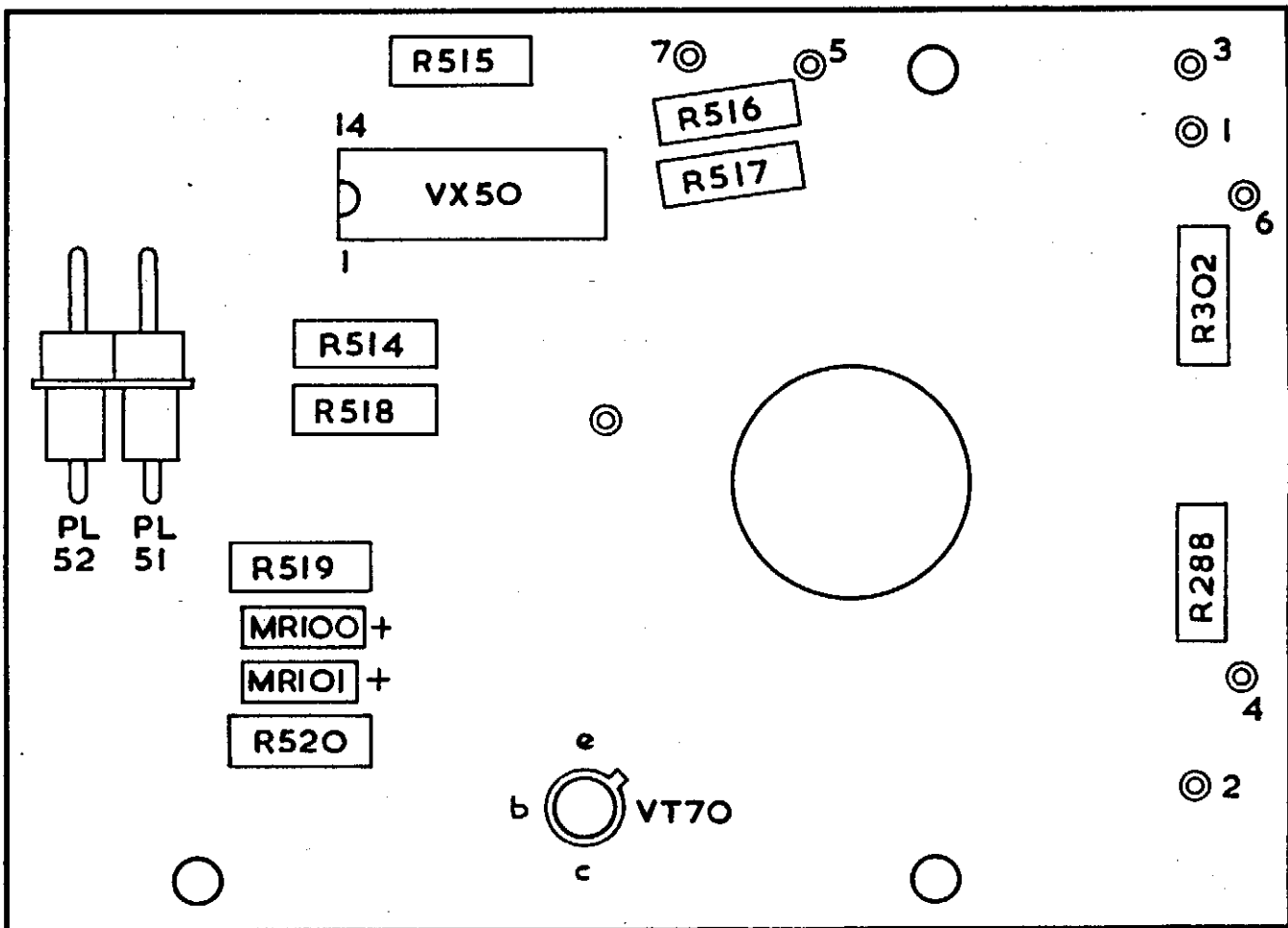

COMPONENT LIST

RESISTORS

R288	100Ω ±2%	1/4W	Electrosil TR5
R302	100Ω ±2%	1/4W	Electrosil TR5
R514	2.2kΩ ±2%	1/4W	Electrosil TR5
R515	2.2kΩ ±2%	1/4W	Electrosil TR5
R516	1.5kΩ ±2%	1/4W	Electrosil TR5
R517	390Ω ±2%	1/4W	Electrosil TR5
R518	2.2kΩ ±2%	1/4W	Electrosil TR5
R519	4.7kΩ ±2%	1/4W	Electrosil TR5
R520	10kΩ ±2%	1/4W	Electrosil TR5

TRANSISTOR

VT70 Mullard BC107

DIODES

MR100 Texas 1N914
MR101 Texas 1N914

INTEGRATED CIRCUIT

VX50 Mullard FJH131

PLUGS

PL51 Oxley 50FP/PCA 2 Outlet (Red)
PL52 Oxley 50FP/PCA 2 Outlet (Orange)

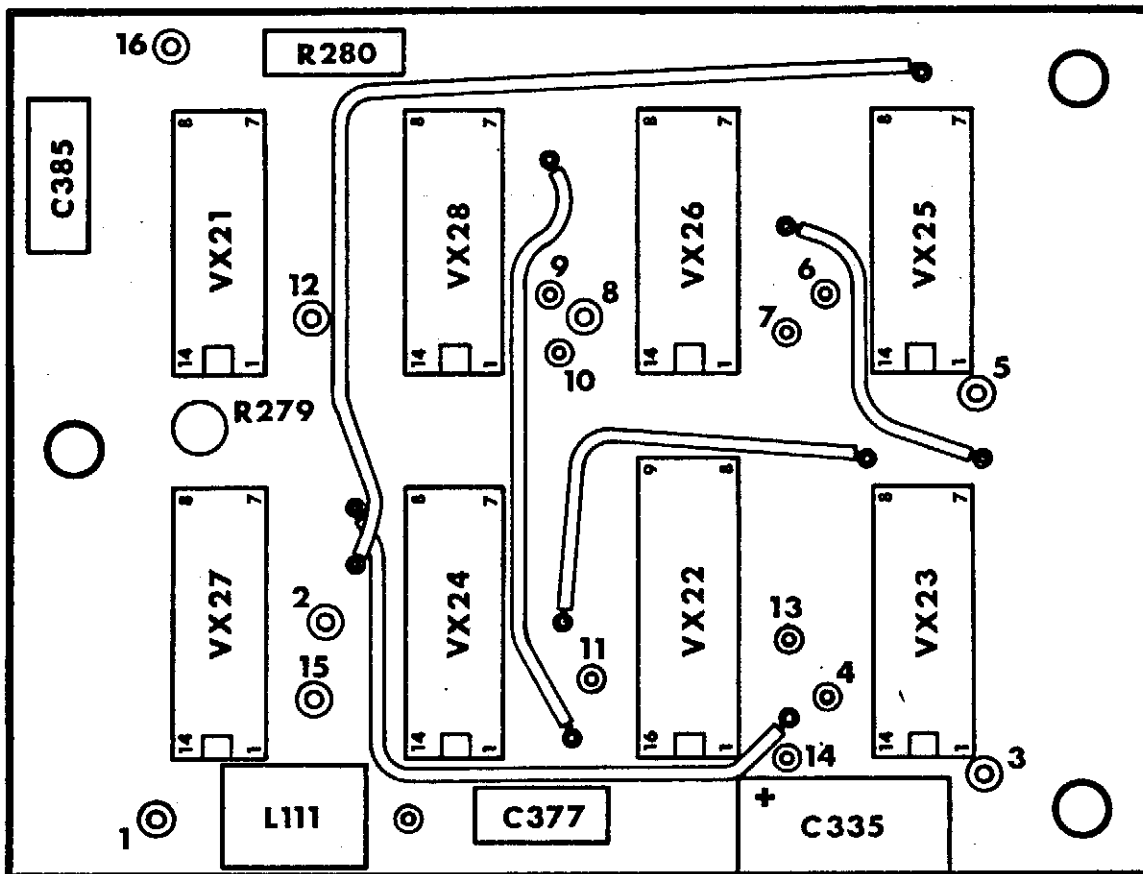

COMPONENT LIST

CAPACITORS

C335	4.7 μ F +50% -10% 63V Mullard 015-90003
C377	220pF \pm 2% 125V GEC PF
C385	270pF \pm 2% 125V GEC PF

RESISTORS

R279	3.9k Ω \pm 2% $\frac{1}{4}$ W Electrosil TR5
R280	1k Ω \pm 2% $\frac{1}{4}$ W Electrosil TR5

INTEGRATED CIRCUITS

VX21	Mullard FJH131 or Texas SN7400N
VX22	Mullard FJJ191 or Texas SN7476N
VX23	Mullard FJJ111 or Texas SN7472N
VX24	Mullard FJH111 or Texas SN7420N
VX25	Mullard FJJ111 or Texas SN7472N
VX26	Mullard FJJ111 or Texas SN7472N
VX27	Texas SN6472N
VX28	Mullard FJJ111 or Texas SN7472N

INDUCTOR

L111	56 μ H \pm 10% Cambion 3635-22
------	--------------------------------------

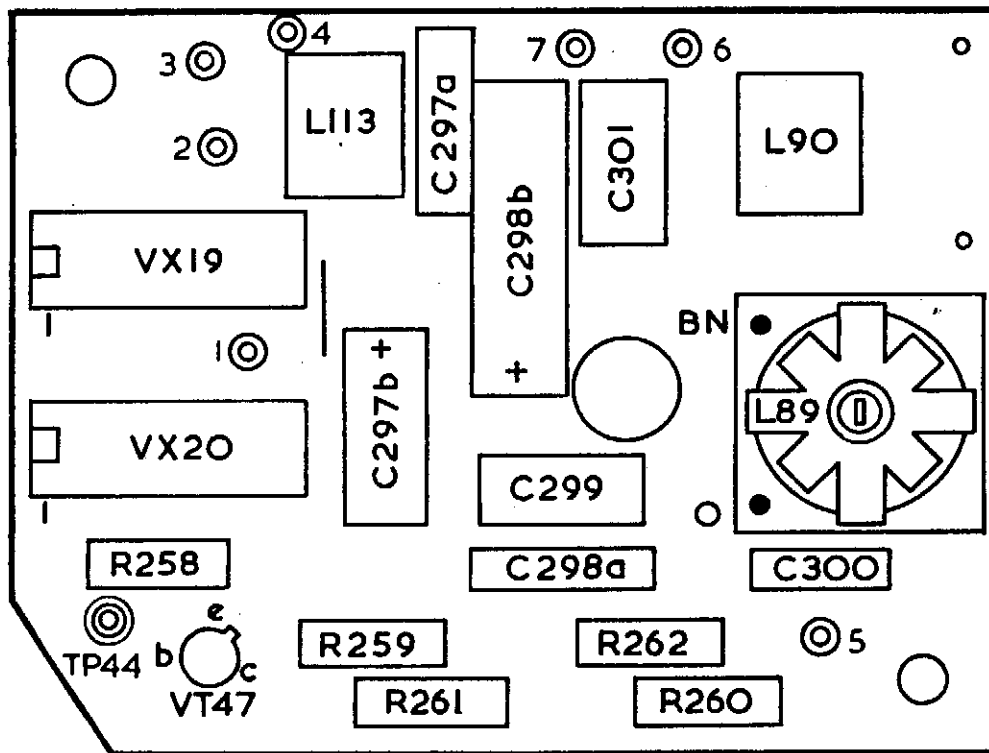

COMPONENT LIST

CAPACITORS

C297a	0.1 μ F \pm 20% 100V STC PMP0-1M100
C297b	4.7 μ F +50% -10% 63V Mullard 015-90003
C298a	0.1 μ F \pm 20% 100V STC PMP0-1M100
C298b	10 μ F +100% -20% 35V Wima Printilyt 1 Sleeved
C299	1800pF \pm 2% 125V GEC PF
C300	390pF \pm 2% 125V GEC PF
C301	5600pF \pm 20% 125V GEC PF

RESISTORS

R258	1k Ω \pm 2% $\frac{1}{4}$ W Electrosil TR5
R259	1k Ω \pm 2% $\frac{1}{4}$ W Electrosil TR5
R260	1k Ω \pm 2% $\frac{1}{4}$ W Electrosil TR5
R261	330 Ω \pm 2% $\frac{1}{4}$ W Electrosil TR5
R262	2.7k Ω \pm 2% $\frac{1}{4}$ W Electrosil TR5

TRANSISTOR

VT47 STC BC107

INTEGRATED CIRCUITS

VX19 Mullard FJJ111
 VX20 Mullard FJH221

INDUCTORS

L89 Redifon P28106/S
 L90 56mH \pm 10% Cambion 3635-58
 L113 560mH \pm 10% Cambion 3635-34

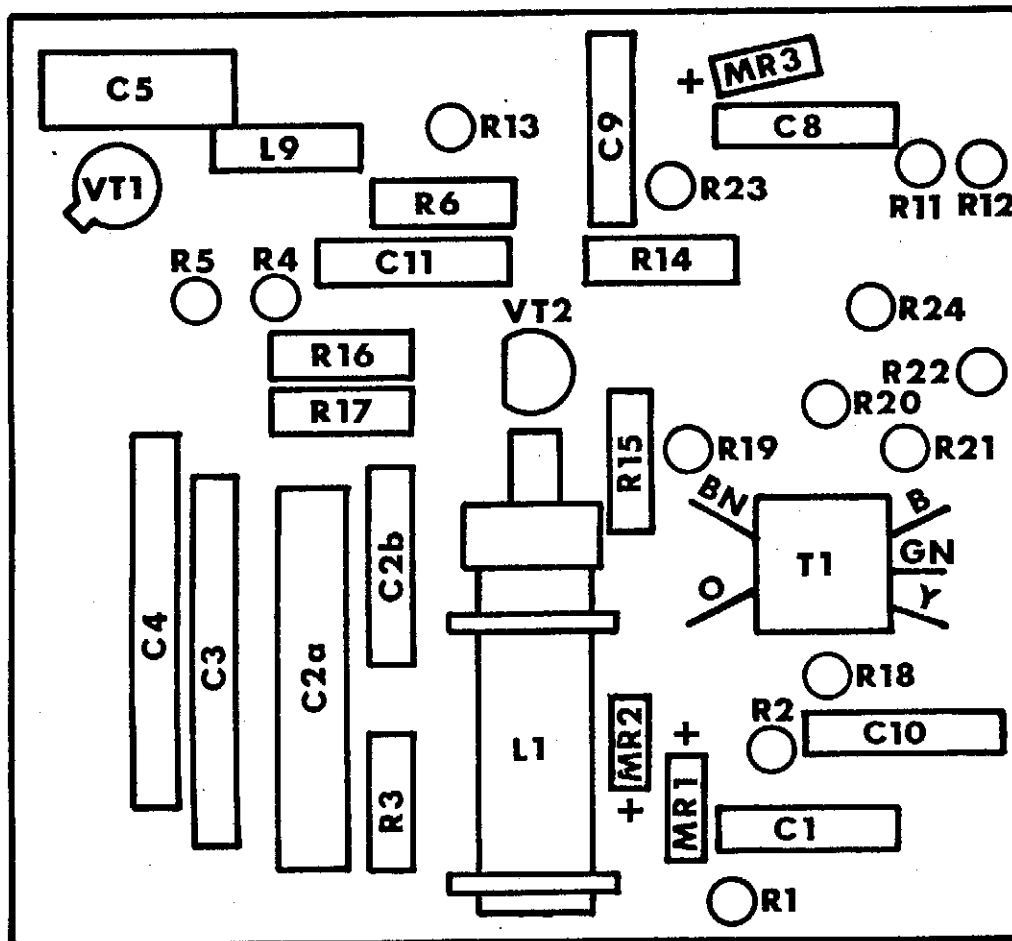

COMPONENT LIST

CAPACITORS

C1 0.1 μ F \pm 20% 100V STC PMP 0-1M100
 C2a 330pF \pm 10% 500V Erie B11-N2200
 C2b 5000pF \pm 2% 350V Lemco MS611/1/R5N6/350
 C3 10000pF \pm 2% 200V Lemco MS2515/1/R/10NG/200
 C4 10000pF \pm 2% 200V Lemco MS2515/1/R/10NG/200

C5 0.1 μ F \pm 20% 100V STC PMP 0-1M100
 C8 0.1 μ F \pm 20% 100V STC PMP 0-1M100
 C9 0.1 μ F \pm 20% 100V STC PMP 0-1M100
 C10 0.1 μ F \pm 20% 100V STC PMP 0-1M100
 C11 0.1 μ F \pm 20% 100V STC PMP 0-1M100

TRANSISTORS

VT1 RCA 40235
 VT2 Motorola 2N3904

DIODES

MR1 Emihus HC7002
 MR2 Emihus HC7002
 MR3 Mullard OA95

INDUCTORS

L1 Redifon P28127/S
 L9 100 μ H Painton C12 58/10/0017/10

RESISTORS

R1 820 Ω \pm 2% ElectroSil TR5
 R2 10k Ω \pm 20% ElectroSil TR5
 R3 47k Ω \pm 2% ElectroSil TR5
 R4 47k Ω \pm 2% ElectroSil TR5
 R5 82 Ω \pm 2% ElectroSil TR5

R6 1.5k Ω \pm 2% ElectroSil TR5
 R11 3.9k Ω \pm 2% ElectroSil TR5
 R12 10k Ω \pm 2% ElectroSil TR5
 R13 4.7k Ω \pm 2% ElectroSil TR5
 R14 27k Ω \pm 2% ElectroSil TR5

R15 12k Ω \pm 2% ElectroSil TR5
 R16 10k Ω \pm 2% ElectroSil TR5
 R17 3.3k Ω \pm 2% ElectroSil TR5
 R18 150 Ω \pm 2% ElectroSil TR5
 R19 8.2k Ω \pm 2% ElectroSil TR5

R20 270 Ω \pm 2% ElectroSil TR5
 R21 8.2k Ω \pm 2% ElectroSil TR5
 R22 51 Ω \pm 2% ElectroSil TR5
 R23 47k Ω \pm 2% ElectroSil TR5
 R24 100 Ω \pm 2% ElectroSil TR5

RF TRANSFORMERS

T1 Redifon P28126/S

COMPONENT LIST

CAPACITORS

- C6 0.1 μ F \pm 20% 100V STC PMP 0-1M100
 C7 0.1 μ F \pm 20% 100V STC PMP 0-1M100
 C14 3-30pF Mullard E7876
 C15 10pF \pm 1pF 350V Lemco MS611/1/R/10PFP/350
 C16 330pF \pm 2% 350V Lemco MS611/1/R/330 PG/350

 C17 470pF \pm 20% 350V Lemco MS611/1/R/470PG/350
 C18 0.1 μ F \pm 20% 100V STC PMP 0-1M100
 C19 0.01 μ F \pm 20% 100V STC PMP 0-01M100
 C20 4.7 μ F \pm 100% -20% 40V Plessey 439/1/02106/441
 C21 4.7 μ F \pm 100% -20% 40V Plessey 439/1/02106/441

 C22 560pF \pm 2% 125V GEC PF
 C24 0.1 μ F \pm 20% 100V STC PMP 0-1M100

RESISTORS

- R10 5.6k Ω \pm 2% Electrosil TR5
 R25 33k Ω \pm 2% Electrosil TR5
 R26 33k Ω \pm 2% Electrosil TR5
 R27 100 Ω \pm 2% Electrosil TR5
 R28 3.9k Ω \pm 2% Electrosil TR5

 R29 1.5k Ω \pm 2% Electrosil TR5
 R30 2.2k Ω \pm 2% Electrosil TR5

 R31 330 Ω \pm 2% Electrosil TR5
 R32 1k Ω \pm 2% Electrosil TR5
 R33 3.9k Ω \pm 2% Electrosil TR5
 R35 390 Ω \pm 2% Electrosil TR5
 R36 180 Ω \pm 2% Electrosil TR5

TRANSISTORS

- VT3 RCA40235
 VT4 Motorola 2N3904

INTEGRATED CIRCUITS

- VX1 Mullard FJH131
 VX2 Mullard FJJ121
 VX3 Mullard FJJ111
 VX4 Texas SN6472N

DIODES

- MR4 Mullard OA200

INDUCTORS

- L6 120 μ H \pm 10% Cambion 3635-26
 L8 100 μ H \pm 10% Painton C12 58/10/0017/10

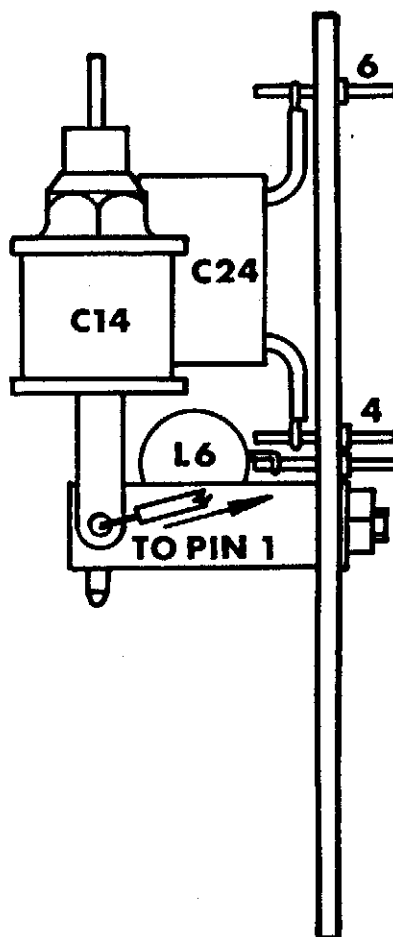

R28

5

8

7

R35

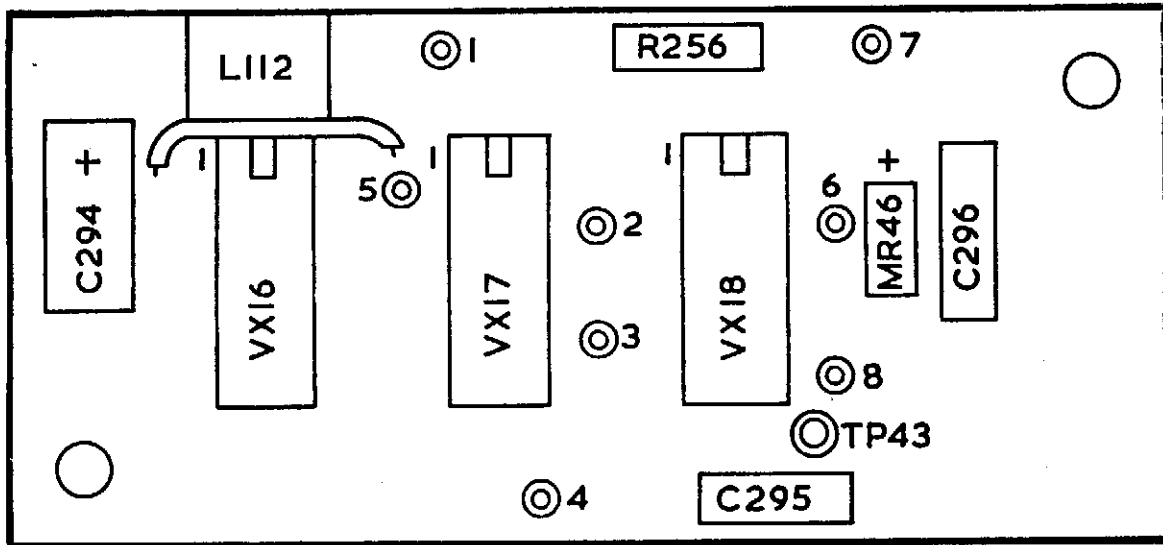

COMPONENT LIST

CAPACITORS

C294 4.7 μ F +50% -10% 63V Mullard 015-90003
 C295 390pF \pm 2% 125V GEC PF
 C296 0.1 μ F \pm 20% 100V STC PMP0-1M100

RESISTOR

R256 820 Ω \pm 2% $\frac{1}{2}$ W ElectroSil TR5

DIODE

MR46 Mullard BZY88C5V1 \pm 2%

INTEGRATED CIRCUITS

VX16 Mullard FJ111
 VX17 Mullard FJ111
 VX18 Mullard FJ111

INDUCTOR

L112 560 μ H \pm 10% Cambion 3635-34

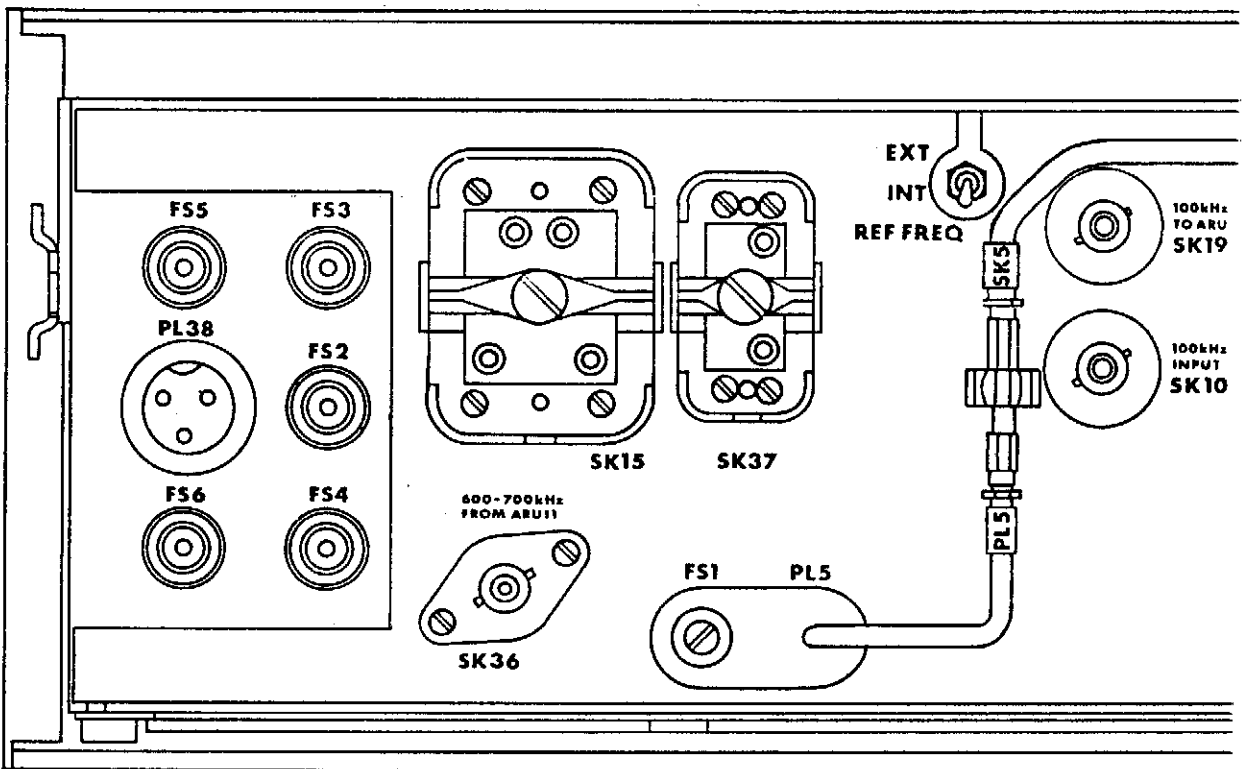
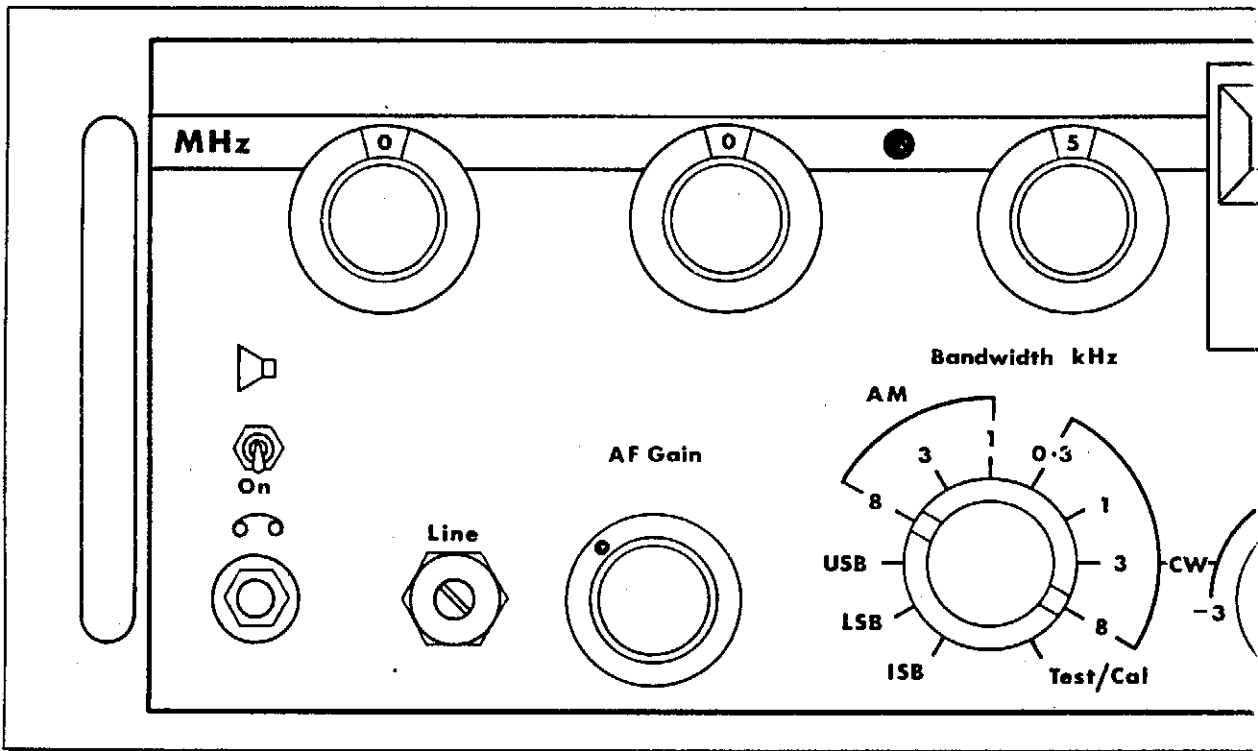

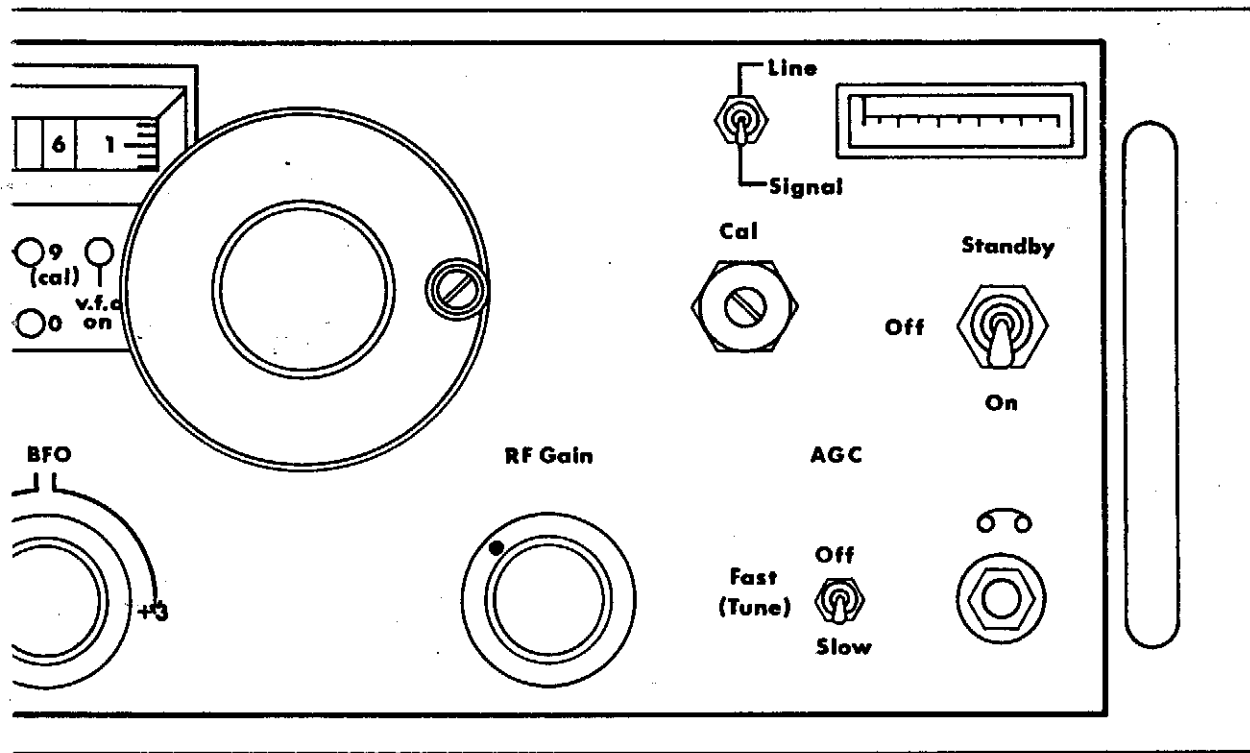

FRONT PANEL CONTROLS

FIG. 9.27

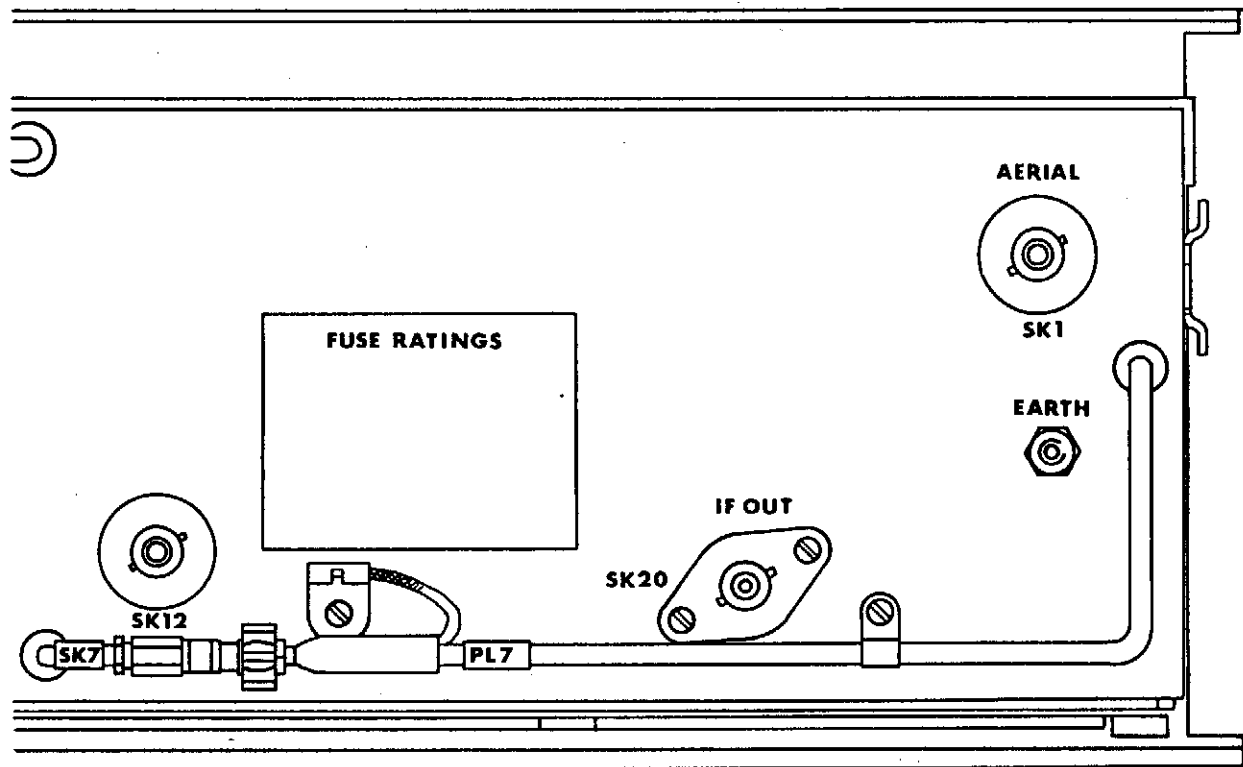

REAR PANEL CONTROLS

FIG. 9.28

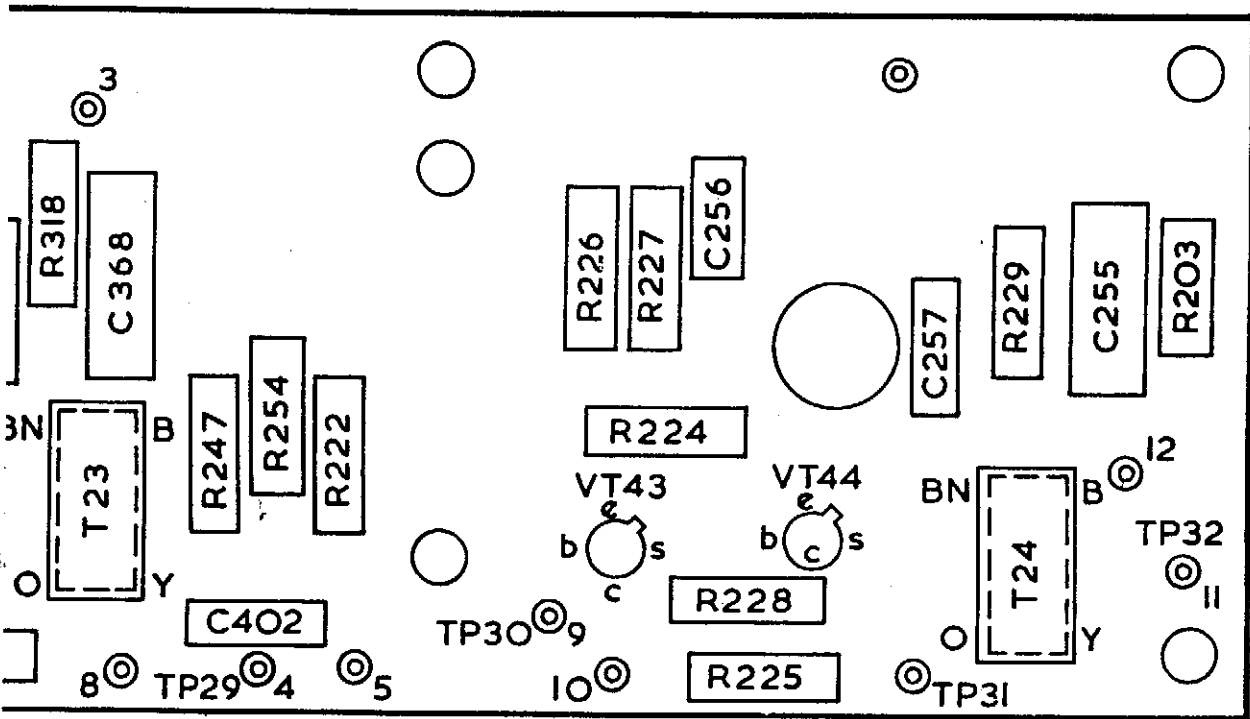

VCO AMPLIFIER PCB ASSEMBLY 5820-99-527-1967

FIG. 9.15

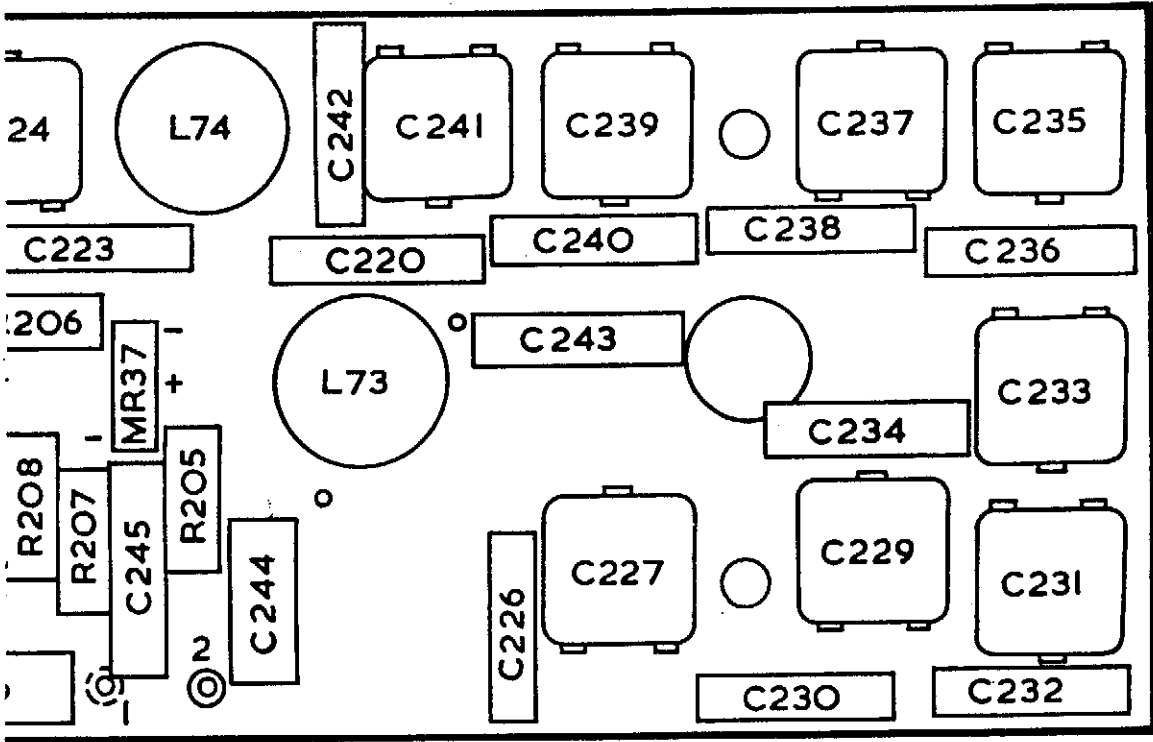

COMPONENT LIST

CAPACITORS

C200	22 μ F \pm 50% $-$ 20% 35V Wima Printilyt 1 Sleeved
C201	0.015 μ F \pm 20% 100V STC PMP0-015M100
C202	100 μ F \pm 50% $-$ 20% 35V Wima Printilyt 1 Sleeved
C203	2.2 μ F \pm 20% Union Carbide K2R2E35 or K2R2E20
C204	470pF \pm 2% 125V GEC PF
C205	1000pF \pm 2% 125V GEC PF
C206	220 μ F \pm 50% $-$ 20% 35V Wima Printilyt 1 Sleeved
C207	4.7 μ F \pm 50% $-$ 10% 63V Mullard 015-90003
C208	1 μ F \pm 20% 100V STC PMP1-0M100
C209	22 μ F \pm 50% $-$ 20% 35V Wima Printilyt 1 Sleeved
C210	470pF \pm 2% 125V GEC PF
C211	390pF \pm 2% 125V GEC PF
C212	1000pF \pm 2% 125V GEC PF
C213	0.1 μ F \pm 20% 100V STC PMP0-1M100
C274	0.1 μ F \pm 20% 100V STC PMP0-1M100
C507	82pF \pm 2pF 125V GEC PF

RESISTORS

R178	390 Ω \pm 2% $\frac{1}{2}$ W ElectroSil TR5
R179	1k Ω Lin \pm 20% $\frac{1}{2}$ W Plessey MP Dealer/PCBlack 404/8/02857
R180	390 Ω \pm 2% $\frac{1}{2}$ W ElectroSil TR5
R181	100 Ω \pm 2% $\frac{1}{2}$ W ElectroSil TR5
R182	1k Ω \pm 2% $\frac{1}{2}$ W ElectroSil TR5
R183	2.7k Ω \pm 2% $\frac{1}{2}$ W ElectroSil TR5
R184	3.9k Ω \pm 2% $\frac{1}{2}$ W ElectroSil TR5
R188	330 Ω \pm 2% $\frac{1}{2}$ W ElectroSil TR5
R189	4.7k Ω \pm 2% $\frac{1}{2}$ W ElectroSil TR5
R191	8.2k Ω \pm 2% $\frac{1}{2}$ W ElectroSil TR5
R194	4.7k Ω \pm 2% $\frac{1}{2}$ W ElectroSil TR5
R196	100 Ω \pm 2% $\frac{1}{2}$ W ElectroSil TR5
R197	4.7k Ω \pm 2% $\frac{1}{2}$ W ElectroSil TR5
R198	5.6k Ω \pm 2% $\frac{1}{2}$ W ElectroSil TR5
R199	15k Ω \pm 2% $\frac{1}{2}$ W ElectroSil TR5
R245	3.9k Ω \pm 2% $\frac{1}{2}$ W ElectroSil TR5
R246	820 Ω \pm 2% $\frac{1}{2}$ W ElectroSil TR5

TRANSISTORS

VT33	Mullard BC108
VT34	Motorola 2N3904
VT35	Motorola 2N3904

DIODE

MR39	Mullard BZY88C5V1 \pm 2%
------	----------------------------

INTEGRATED CIRCUITS

VX1	Mullard FJH131
VX2	Mullard FJH221

INDUCTORS

L70	Redifon P28110/S
L71	8.2mH \pm 10% Cambion 3635-48

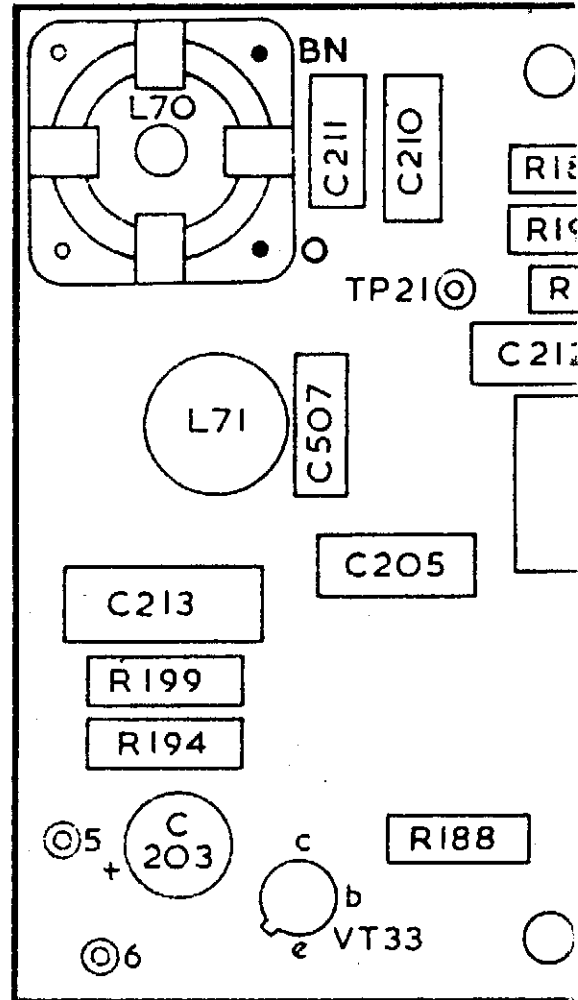

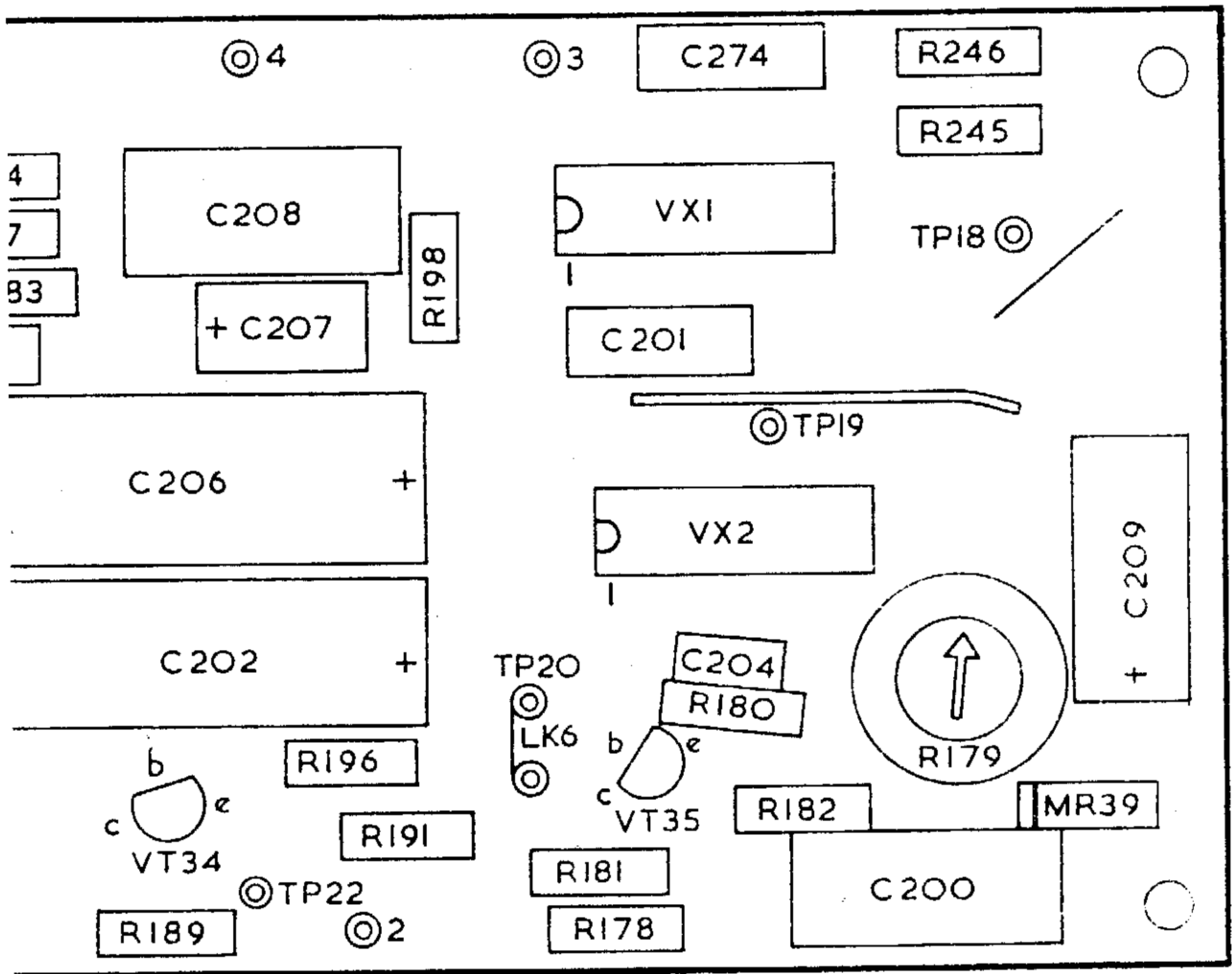

1 AND 10MHz PHASE LOOP PCB ASSEMBLY 5820-99-527-1969

FIG. 9.17

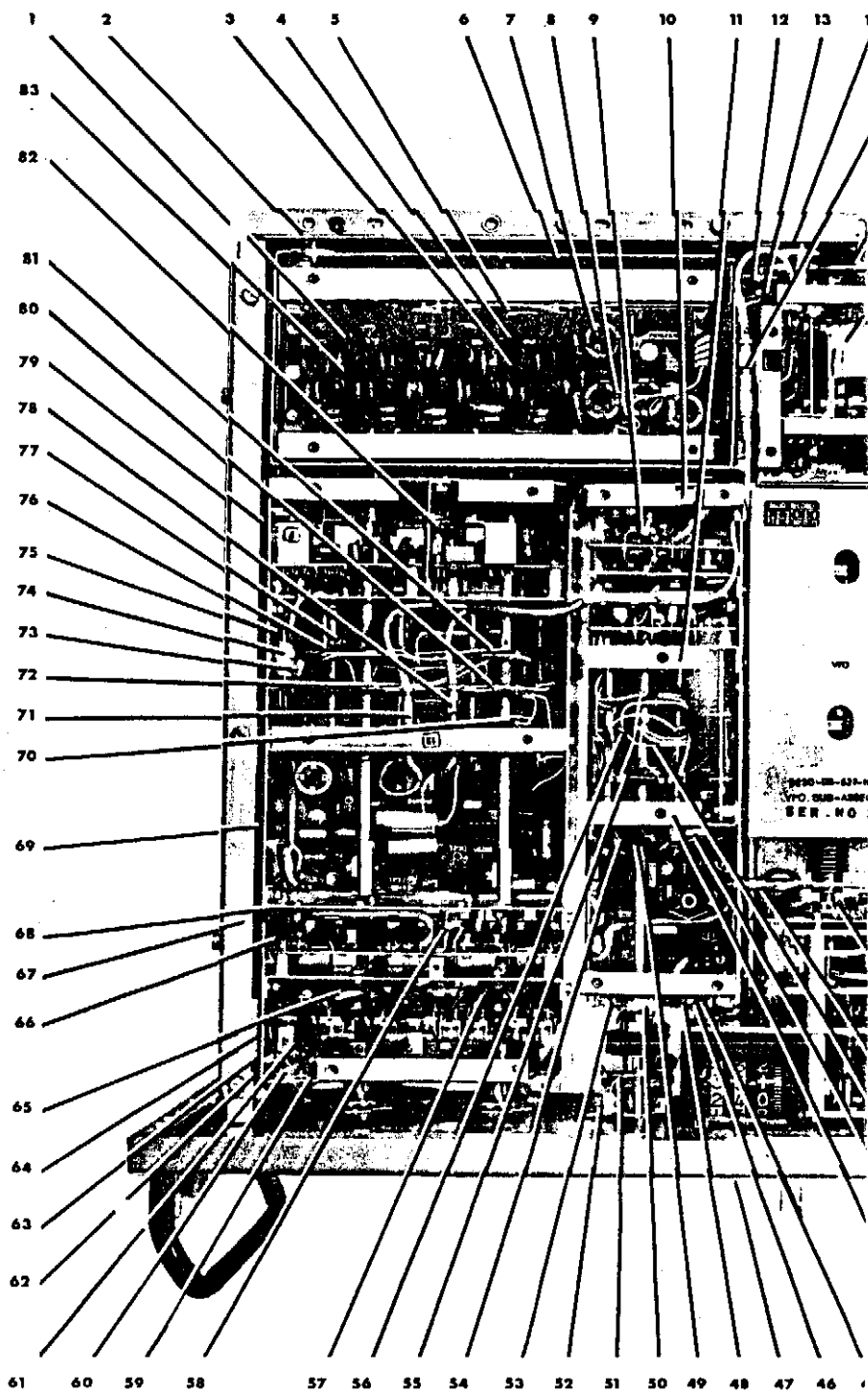

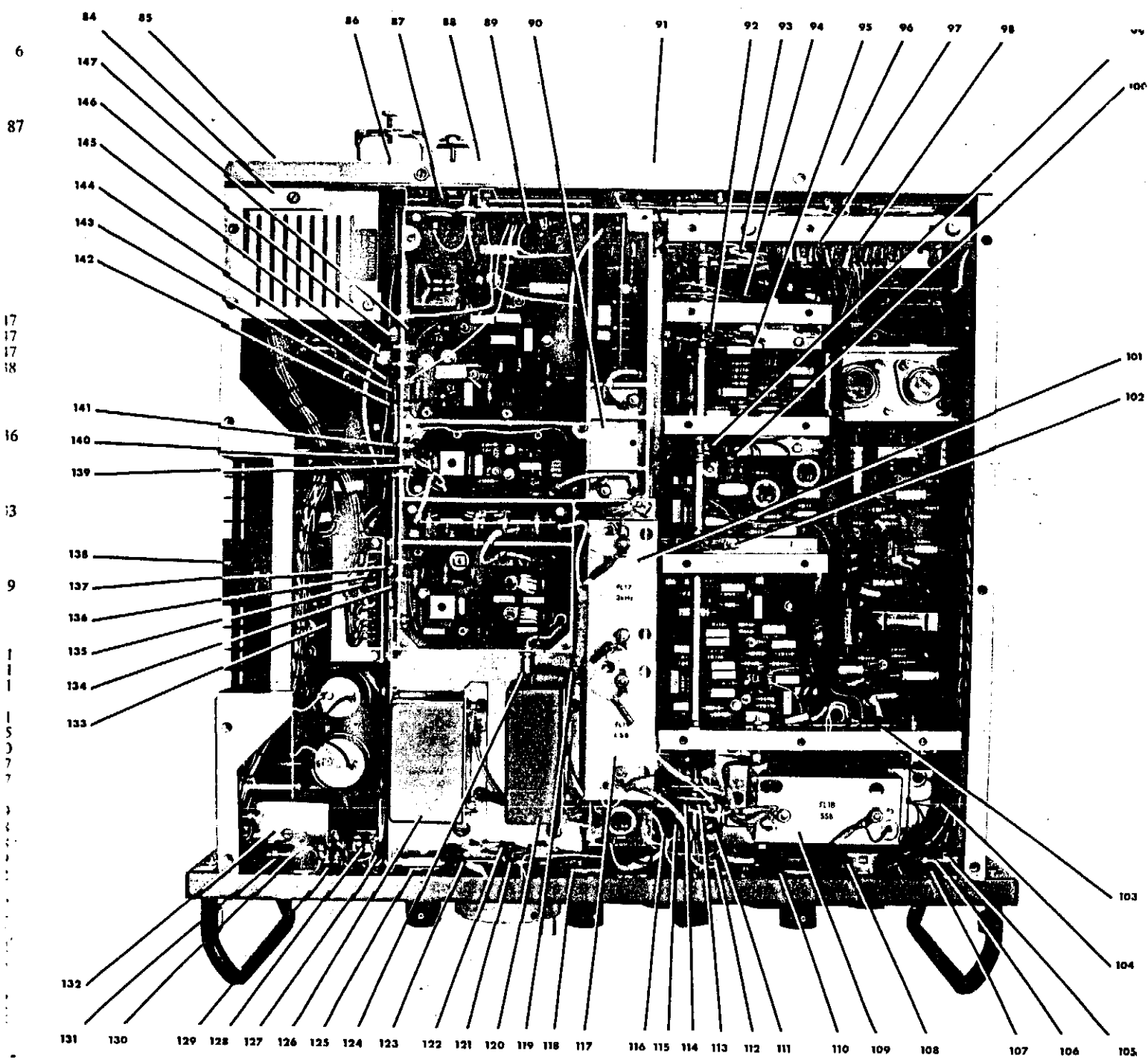

LIST OF MISCELLANEOUS COMPONENTS

TRANSFORMER

Redifon SRT2712 24

COILS

CA 40251 138
CA 40251 138

Redifon OP9514/S 89
Redifon I/OP9492/M 119
Redifon I/OP9491/M 125
Redifon I/OP9490/M 100
Redifon OP10235/M 109
Redifon I/OP9564/M 116

Redifon Soku MST305D 16
Redifon OP9450/S 65
Redifon OP9451/S 72
Redifon OP9452/S 76
Redifon OP9453/S 83

Redifon OP9540/S 1
Redifon OP9443/S 57
Redifon OP9444/S 70
Redifon OP9445/S 80
Redifon OP9446/S 81

Redifon OP9447/S 3
Redifon OP9541/S 4
Redifon OP9542/S 5
Redifon OP9436/S 54
Redifon OP9437/S 55

Redifon OP9438/S 56
Redifon OP9550/S 9
Redifon OP9551/S 8
Redifon OP9543/S 7
Redifon OP9539/S 51

Redifon P44763/S (Part) 112
Redifon P44763/S (Part) 116
Redifon P44763/S (Part) 114
Redifon OP9534/S 102
Redifon P44670/S 100

Redifon P44671/S 95
Redifon P44672/S 94
Redifon P44673/S 93
Redifon Soku MST205/N 39
Redifon Soku MST205/N 106

Redifon Soku MST205/N 129
Redifon P44272/S 40
Redifon SF 7693/K2 132

Greenpar GE35071C79 2
Oxley 40FP/156 Red 13
Oxley 30FP/093 Black 13
Amphenol 133-012-03 136
Sealectro 51-008-0000 88

Amphenol 133-006-13 89
Sealectro 51-043-0000 91
Sealectro 51-008-0000 119
Sealectro 51-043-0000 124
Amphenol 133-018-03 103

Amphenol 133-018-03 98
Belling and Lee L1328/P 20
Amphenol 133-012-13 19
Greenpar GE35070C10 14
Greenpar GE35070C10 96

*PL22 Sealectro 51-008-0000 15
PL23 Amphenol 133-006-13 62
PL24 Sealectro 51-008-0000 67
PL27 Sealectro 51-008-0000 10
PL28 Amphenol 133-006-03 45

PL29 Sealectro 51-043-0000 71
PL30 Sealectro 51-043-0000 41
PL31 Oxley 30P/093 White 32
PL32 Oxley 30P/093 Blue 31
PL33 Oxley 30P/093 Green 29

PL34 Sealectro 51-008-0000 30
PL35 Sealectro 51-008-0000 26
PL36 Greenpar GE35070C10 86
PL37 Belling and Lee L654/P 17
PL38 Bulgin P429 22

PL39 Oxley 30P/093 Red 28
PL40 Sealectro 51-008-0000 78
PL41 Oxley 30P/093 Black 27
PL42 Sealectro 51-008-0000 15
PL50 Oxley 30P/093 White 13

SOCKETS

SK1 Greenpar GE35085H 2
SK2 Oxley 40LS/156 Red 13
SK3 Oxley 30S/093 Black 13
SK4 Amphenol 143-012-01 136
SK5 Sealectro 51-007-0000 88

SK6 Amphenol 143-006-01 89
SK7 Sealectro 51-007-0000 100
SK8 Sealectro 51-007-0000 119
*SK10 Greenpar GE35085H 14
SK11 Sealectro 51-011-0000 124

SK13 Amphenol 143-018-01 103
SK14 Amphenol 143-018-01 98
SK15 Belling and Lee L1328/S 20
SK18 Amphenol 143-012-01 19
*SK19 Greenpar GE35085H 14

SK20 Greenpar GE35085H 96
SK22 Sealectro 51-007-0000 15
SK23 Amphenol 143-006-01 62
SK24 Sealectro 51-007-0000 67
SK27 Sealectro 51-007-0000 10

SK28 Amphenol 143-006-01 45
SK29 Sealectro 51-007-0000 71
SK30 Sealectro 51-007-0000 41
SK31 Oxley 30S/093 White 32
SK32 Oxley 30S/093 Blue 31

SK33 Oxley 30S/093 Green 29
SK34 Sealectro 51-007-0000 30
SK35 Sealectro 51-007-0000 26
SK36 Greenpar GE35085H 86
SK37 Belling and Lee L654/S 17

SK38 Bulgin P430/SE 22
SK39 Oxley 30S/093 Red 28
SK40 Sealectro 51-044-0000 78
SK41 Oxley 30S/093 Black 27
SK42 Sealectro 51-007-0000 15

SK43 Pye M10SNLWLR 85
SK50 Oxley 30S/093 White 13
SK51 Oxley 50LS/156 Red 37
SK52 Oxley 50LS/156 Orange 34
**SK12 Greenpar GE35085H

JACK SOCKETS

JK1 Rendar J521A 130
JK2 Rendar J521A 106

RELAY

RL1 Erg MEM01-1RC/G3/13V 6

FUSELINKS

FS1 250mA Belling and Lee L562 87
**FS3 { For 110V AC Operation 2A K. Beswick TDC134
For 230V AC Operation 1A K. Beswick TDC134
**FS4 { For 110V AC Operation 2A K. Beswick TDC134
For 230V AC Operation 1A K. Beswick TDC134
**FS5 1-5A K. Beswick TDC134
**FS6 1-5A K. Beswick TDC134
**FS2 4A Belling and Lee L562

INDICATOR LAMPS

ILP1 24V Vitality 687 E5/8 Cap 5mm LES 47
ILP2 24V Vitality 687 E5/8 Cap 5mm LES 47
ILP3 24V Vitality 687 E5/8 Cap 5mm LES 47
ILP4 24V Vitality 687 E5/8 Cap 5mm LES 38

METER

ME1 Redifon OP9461/S 36

LOUDSPEAKER

LS1 10Ω 3in Richard Allen 370S 33

REFERENCE FREQUENCY OSCILLATOR

*X1 5.6MHz H.C.D. Research HCD70 19

INDUCTORS

*L3 100μH ± 10% Painton C12 58/10/0017/10 21
*L4 120μH ± 10% Cambion 3635-26 21
*L6 560μH ± 10% Cambion 3635-34 21

L55 Redifon 28076/S 1
L59 100μH ± 10% Cambion 3635-25 145
L60 100μH ± 10% Painton C12 58/10/0017/10 140
L61 100μH ± 10% Cambion 3635-25 137
L69 100μH ± 10% Painton C12 58/10/0017/10 7

L83 100μH ± 10% Painton C12 58/10/0017/10 69
L85 100μH ± 10% Painton C12 58/10/0017/10 68
L86 100μH ± 10% Painton C12 58/10/0017/10 58
L87 100μH ± 10% Painton C12 58/10/0017/10 79
L88 100μH ± 10% Painton C12 58/10/0017/10 82

L94 100μH ± 10% Painton C12 58/10/0017/10 46
L95 100μH ± 10% Painton C12 58/10/0017/10 44
L96 100μH ± 10% Painton C12 58/10/0017/10 11
L102 100μH ± 10% Cambion 3635-25 12
L104 Redifon P51246/S 83

L109 2.7mH ± 10% Cambion 3635-42 146
L110 100μH ± 10% Cambion 3635-25 12
L114 100μH ± 10% Painton C12 58/10/0017/10 147
L116 4.7μH ± 10% Painton C11 58/10/0009/10 83
L118 Redifon P44140/S 139

L123 100μH ± 10% Painton C12 58/10/0017/10 133
L127 100μH ± 10% Painton C12 58/10/0017/10 133
L128 100μH ± 10% Painton C12 58/10/0017/10 133
L200 15mH Cambion 3635-51 9
L201 Redifon P51243 7

L202 Redifon P51244 7
L203 Redifon P51245 3
L204 4.7μH ± 10% Painton C11 58/10/0017/10 135

(optional)

**For location see Fig. 9.28

ICITORS

**REF
NO**

0-1μF ±20% 100V STC PMP0-1M100	19
4-7μF +50% -10% 63V Mullard 015-90003	19
4-7μF +50% -10% 63V Mullard 015-90003	19
0-1μF ±20% 100V STC PMP0-1M100	144
0-1μF ±20% 100V STC PMP0-1M100	142
0-1μF ±20% 100V STC PMP0-1M100	141
0-1μF ±20% 100V STC PMP0-1M100	134
15pF ±1pF 125V GEC PF	99
0-1μF ±20% 100V STC PMP0-1M100	115
100μF +50% -20% 35V Wima Printilyt 1 Sleeved	64
390pF ±2pF 125V GEC PF	77
0-1μF ±20% 100V STC PMP0-1M100	69
0-1μF ±20% 100V STC PMP0-1M100	68
0-1μF ±20% 100V STC PMP0-1M100	58
25μF +50% -20% 35V Wima Printilyt 1 Sleeved	61
0-1μF ±20% 100V STC PMP0-1M100	61
0-1μF ±20% 100V STC PMP0-1M100	74
0-1μF ±20% 100V STC PMP0-1M100	79
0-1μF ±20% 100V STC PMP0-1M100	82
0-1μF ±20% 100V STC PMP0-1M100	53
0-1μF ±20% 100V STC PMP0-1M100	43
0-1μF ±20% 100V STC PMP0-1M100	48
0-1μF ±20% 100V STC PMP0-1M100	44
0-1μF ±20% 100V STC PMP0-1M100	11
25pF to 528pF Redifon OP9172/S	25
0-1μF ±20% 100V STC PMP0-1M100	12
5000pF +20% -40% 350V Erie 1304/K350011	84
5000pF +20% -40% 350V Erie 1304/K350011	84
4-7μF +50% -10% 63V Mullard 015-90003	1
0-1μF ±20% 100V STC PMP0-1M100	1
0-1μF ±20% 100V STC PMP0-1M100	104
0-1μF ±20% 100V STC PMP0-1M100	5
0-033μF ±20% 100V STC PMP0-033M100	7
33pF ±1pF 350V Lemco MS611/I/R/33PFP/350	2
56pF ±2% 125V GEC PF	83
56pF ±2% 125V GEC PF	4
120pF ±2% 125V GEC PF	139
39pF ±2pF 125V GEC PF	139
0-1μF ±20% 100V STC PMP0-1M100	19
0-01μF ±20% 100V STC PMP0-01M100	73
1200pF ±2% 125V GEC PF	9
0-22μF ±20% 100V STC PMP0-22M100	52

STORS

10kΩ Lin Painton Mini-Flatpot 45/10/0002/34	23
180kΩ ±2% 1/4W Electrosil TR5	1
68kΩ ±2% 1/4W Electrosil TR5	92
10kΩ ±2% 1/4W Electrosil TR5	97
100kΩ ±2% 1/4W Electrosil TR5	97
680Ω ±2% 1/4W Electrosil TR5	130
680Ω ±2% 1/4W Electrosil TR5	107
5kΩ Log Redifon 1/OP5731/S	108
5kΩ Log Redifon 2/OP5707/S	110
15kΩ ±2% 1/4W Electrosil TR5	109
10kΩ Lin Redifon 1/OP5708/S	125
470Ω ±2% 1/4W Electrosil TR5	122
820Ω ±2% 1/4W Electrosil TR5	123
3-3kΩ ±2% 1/4W Electrosil TR5	118
5kΩ Log Redifon 2/OP5707/S	118
56Ω ±2% 1/4W Electrosil TR5	63
10kΩ Lin ±10% Painton 45/10/0002/34	59
3-9kΩ ±2% 1/4W Electrosil TR5	49
3-3kΩ ±2% 1/4W Electrosil TR5	49
2-7kΩ ±2% 1/4W Electrosil TR5	49
2-2kΩ ±2% 1/4W Electrosil TR5	49
100kΩ Log Redifon 3/OP5731/S	128
10kΩ ±2% 1/4W Electrosil TR5	127
1-8kΩ ±2% 1/4W Electrosil TR5	60
6kΩ ±2% 1/4W Electrosil TR5	49
1kΩ ±10% 0-1W Mullard CR16	76

R333	22kΩ ±10% 0-1W Mullard CR16	76
R334	22kΩ ±10% 0-1W Mullard CR16	72
R335	22kΩ ±10% 0-1W Mullard CR16	72
R336	22kΩ ±10% 0-1W Mullard CR16	80
R337	22kΩ ±10% 0-1W Mullard CR16	80
R338	22kΩ ±10% 0-1W Mullard CR16	80
R339	22kΩ ±10% 0-1W Mullard CR16	80
R340	22kΩ ±10% 0-1W Mullard CR16	70
R341	22kΩ ±10% 0-1W Mullard CR16	70
R342	22kΩ ±10% 0-1W Mullard CR16	70
R343	22kΩ ±10% 0-1W Mullard CR16	70
R344	22kΩ ±10% 0-1W Mullard CR16	42
R345	22kΩ ±10% 0-1W Mullard CR16	42
R346	22kΩ ±10% 0-1W Mullard CR16	42
R347	22kΩ ±10% 0-1W Mullard CR16	42
R348	22kΩ ±10% 0-1W Mullard CR16	42
R349	22kΩ ±10% 0-1W Mullard CR16	42
R350	22kΩ ±10% 0-1W Mullard CR16	42
R351	22kΩ ±10% 0-1W Mullard CR16	42
R357	150Ω ±2% 1/4W Electrosil TR5	143
R359	470Ω ±2% 1/4W Electrosil TR5	7
R500	100Ω ±2% 1/4W Electrosil TR5	4
R501	1-8kΩ ±2% 1/4W Electrosil TR5	8
R502	100Ω ±2% 1/4W Electrosil TR5	5
R503	220Ω ±2% 1/4W Electrosil TR5	8
R504	1-8kΩ ±2% 1/4W Electrosil TR5	8
R505	2-7kΩ ±2% 1/4W Electrosil TR5	8
R506	3-3kΩ ±2% 1/4W Electrosil TR5	8
R507	3-3kΩ ±2% 1/4W Electrosil TR5	8
R521	39Ω ±2% 1/4W Electrosil TR5	112
R522	150Ω ±2% 1/4W Electrosil TR5	113
R523	150Ω ±2% 1/4W Electrosil TR5	113
R524	18kΩ ±2% 1/4W Electrosil TR5	9
R525	1-2kΩ ±2% 1/4W Electrosil TR5	9
R526	18kΩ ±2% 1/4W Electrosil TR5	9
R527	56kΩ ±2% 1/4W Electrosil TR5	9
R528	18kΩ ±2% 1/4W Electrosil TR5	9
R529	1-2kΩ ±2% 1/4W Electrosil TR5	9
R530	18kΩ ±2% 1/4W Electrosil TR5	9
R531	100Ω ±2% 1/4W Electrosil TR5	35

FERRITE BEADS

FT2	Mullard FX1306 B3	8
FT3	Mullard FX1306 B3	8
FT4a	Mullard FX1115	58
FT4b	Mullard FX1115	58
FT6a	Mullard FX1115	66
FT6b	Mullard FX1115	66
FT7a	Mullard FX1115	19
FT7b	Mullard FX1115	19
FT8a	Mullard FX1306 B3	98
FT8b	Mullard FX1306 B3	98
FT9	Mullard FX1306 B3	2

DIODES

MR40	Mullard BZY96C5V6	74
MR60	Mullard BZY96C5V6	50
MR66	Hewlett Packard HPA5082/2800	75
MR67	Hewlett Packard HPA5082/2800	75

THERMISTOR

TH1	Mullard VA1038	121
-----	----------------	-----

MAINS TRANSFORMERS

T34	Redifon SRT
-----	-------------

TRANSISTORS

VT56	RCA 40251
VT58	RCA 40251

FILTERS

FL14	Redifon OP95
FL15	Redifon 1/OP
FL16	Redifon 1/OP
FL17	Redifon 1/OP
FL18	Redifon OP1C
FL19	Redifon 1/OP

SWITCHES

*S1	Fuji Soku MS
S1AB	Redifon OP94
S1BB	Redifon OP94
S1C	Redifon OP94
S1DF	Redifon OP94
S1E	Redifon OP95
S2AB	Redifon OP94
S2B	Redifon OP94
S2C	Redifon OP94
S2D	Redifon OP94
S2E	Redifon OP94
S2F	Redifon OP95
S2G	Redifon OP95
S3A	Redifon OP94
S3B	Redifon OP94
S3C	Redifon OP94
S3F	Redifon OP95
S3G	Redifon OP95
S3H	Redifon OP95
S3JB	Redifon OP95
S4AF	Redifon P447i
S4BF	Redifon P447i
S4CF	Redifon P447i
S4DB	Redifon OP95
S4E	Redifon P446

S4F	Redifon P446
S4G	Redifon P446
S4H	Redifon P446
S5	Fuji Soku MS
S6	Fuji Soku MS

S7	Fuji Soku MS
S9	Redifon P442
S10	NSF 7693/K2

PLUGS

PL1	Greenpar GE
PL2	Oxley 40FP/1
PL3	Oxley 30FP/0
PL4	Amphenol 13
PL5	Sealectro 51-C
PL6	Amphenol 13
PL7	Sealectro 51-C
PL8	Sealectro 51-C
PL11	Sealectro 51-C
PL13	Amphenol 13
PL14	Amphenol 13
PL15	Belling and L
*PL18	Amphenol 13
PL19	Greenpar GE
PL20	Greenpar GE

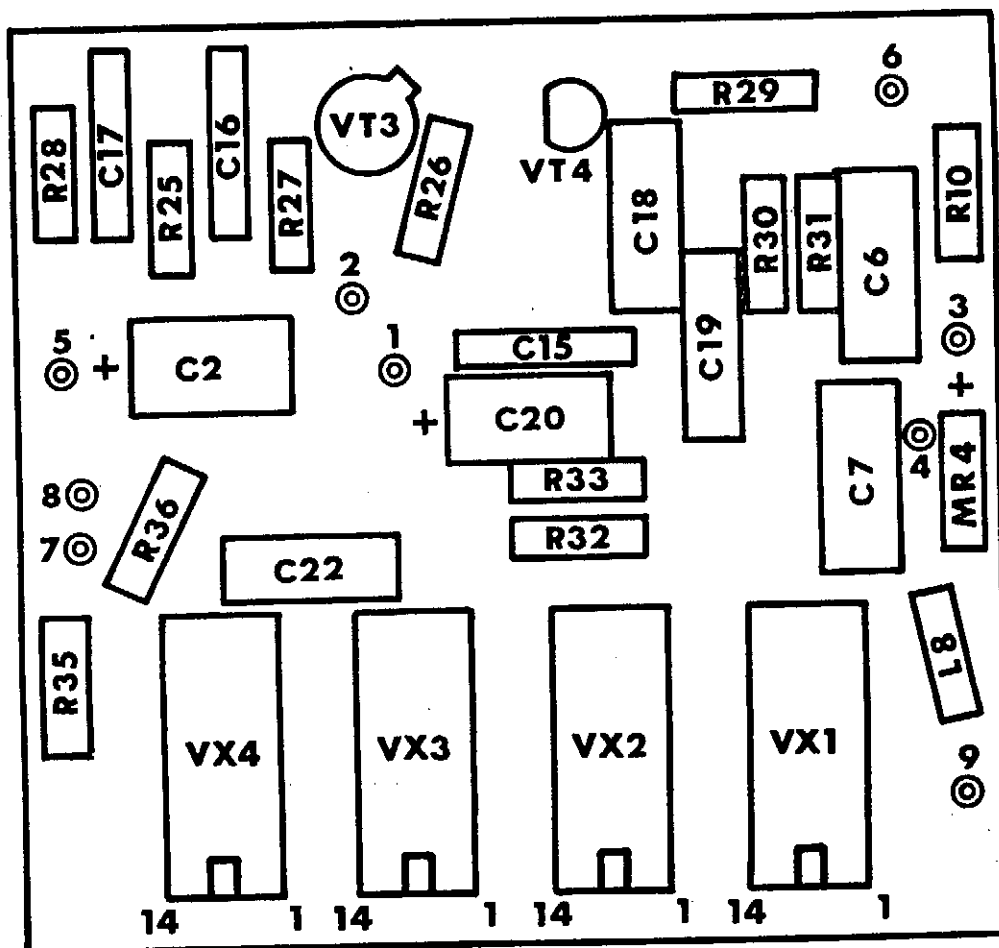
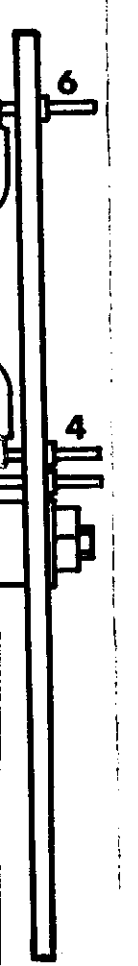

1.4MHz INSERTION OSCILLATOR PCB ASSEMBLY P43079

FIG. 9.30

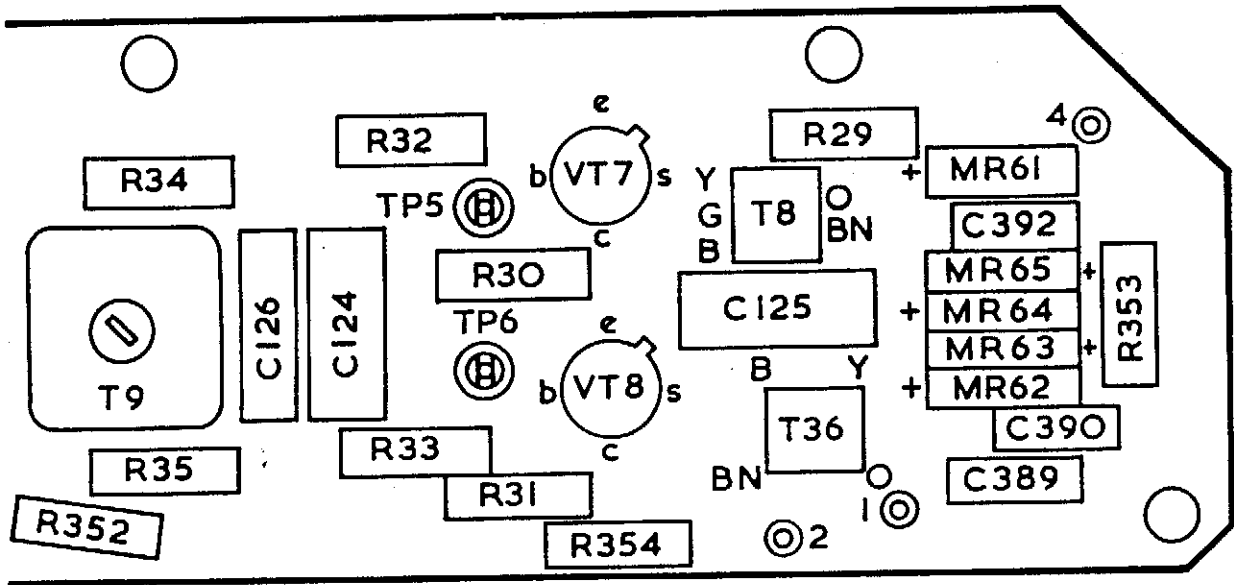

38MHz AMPLIFIER PCB ASSEMBLY 5820-99-527-1954

FIG. 9.8

COMPONENT LIST

CAPACITORS

C124	0.01 μ F \pm 20% 100V STC PMP0-01M100
C125	0.01 μ F \pm 20% 100V STC PMP0-01M100
C126	39pF \pm 1pF 350V Lemco MS611/I/R/39PFP/350
C389	1000pF \pm 20% 500V Erie 831/K350081
C390	1000pF \pm 20% 500V Erie 831/K350081
C392	1000pF \pm 20% 500V Erie 831/K350081

RESISTORS

R29	820 Ω \pm 2% $\frac{1}{4}$ W Electrosil TR5
R30	8.2k Ω \pm 2% $\frac{1}{4}$ W Electrosil TR5
R31	8.2k Ω \pm 2% $\frac{1}{4}$ W Electrosil TR5
R32	5.6 Ω \pm 5% $\frac{1}{4}$ W Iskra UPM
R33	5.6 Ω \pm 5% $\frac{1}{4}$ W Iskra UPM
R34	330 Ω \pm 2% $\frac{1}{4}$ W Electrosil TR5
R35	330 Ω \pm 2% $\frac{1}{4}$ W Electrosil TR5
R36	82 Ω \pm 2% $\frac{1}{4}$ W Electrosil TR5
R352	2.2k Ω \pm 2% $\frac{1}{4}$ W Electrosil TR5
R353	15 Ω \pm 2% $\frac{1}{4}$ W Electrosil TR5
R354	270 Ω \pm 2% $\frac{1}{4}$ W Electrosil TR5

TRANSISTORS

VT7	RCA 40235
VT8	RCA 40235

DIODES

MR61	Texas 1N914
MR62	Emihus HG5007
MR63	Emihus HG5007
MR64	Emihus HG5007
MR65	Emihus HG5007

TRANSFORMERS

T8	Redifon P28031/S
T9	Redifon P28032/S
T36	Redifon P28107/S

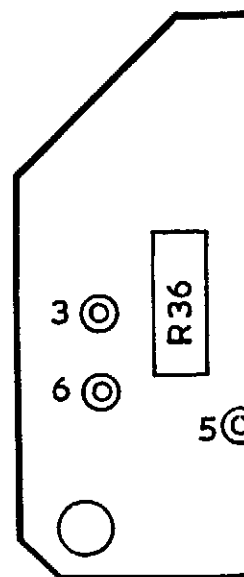

COMPONENT LIST

CAPACITORS

C1	470pF $\pm 2\%$ 125V GEC PF
C2a	330pF $\pm 10\%$ 500V Erie C-N2200
C2b	5000pF $\pm 2\%$ 200V Lemco MS611/I/R/5NG
C3	0.01 μ F $\pm 2\%$ 200V Lemco M2515/I/R/MO1G
C4	0.01 μ F $\pm 2\%$ 200V Lemco M2515/I/R/MO1G
C5	0.1 μ F $\pm 20\%$ 100V STC PMP0-1M100
C6	0.1 μ F $\pm 20\%$ 100V STC PMP0-1M100
C7	0.1 μ F $\pm 20\%$ 100V STC PMP0-1M100
C8	0.1 μ F $\pm 20\%$ 100V STC PMP0-1M100

RESISTORS

R1	10k Ω $\pm 2\%$ $\frac{1}{4}$ W Electrosil TR5
R2	47k Ω $\pm 2\%$ $\frac{1}{4}$ W Electrosil TR5
R3	47k Ω $\pm 2\%$ $\frac{1}{4}$ W Electrosil TR5
R4	82 Ω $\pm 2\%$ $\frac{1}{4}$ W Electrosil TR5
R5	15k Ω $\pm 2\%$ $\frac{1}{4}$ W Electrosil TR5
R6	12k Ω $\pm 2\%$ $\frac{1}{4}$ W Electrosil TR5
R7	27k Ω $\pm 2\%$ $\frac{1}{4}$ W Electrosil TR5
R8	150 Ω $\pm 2\%$ $\frac{1}{4}$ W Electrosil TR5
R9	10 Ω $\pm 2\%$ $\frac{1}{4}$ W Electrosil TR5
R10	3.3k Ω $\pm 2\%$ $\frac{1}{4}$ W Electrosil TR5
R11	8.2k Ω $\pm 2\%$ $\frac{1}{4}$ W Electrosil TR5
R12	47k Ω $\pm 2\%$ $\frac{1}{4}$ W Electrosil TR5
R13	18k Ω $\pm 2\%$ $\frac{1}{4}$ W Electrosil TR5
R14	270 Ω $\pm 2\%$ $\frac{1}{4}$ W Electrosil TR5
R16	100 Ω $\pm 2\%$ $\frac{1}{4}$ W Electrosil TR5

TRANSISTORS

VT1	RCA 40235
VT2	Mullard BC107

DIODES

MR1	Emihus HC7002
MR2	Emihus HC7002

INDUCTORS

L1	Redifon P28127/S
L2	100 μ H $\pm 10\%$ Painton C12 58/10/0017/10

RF TRANSFORMERS

T1	Redifon P28126/S
----	------------------

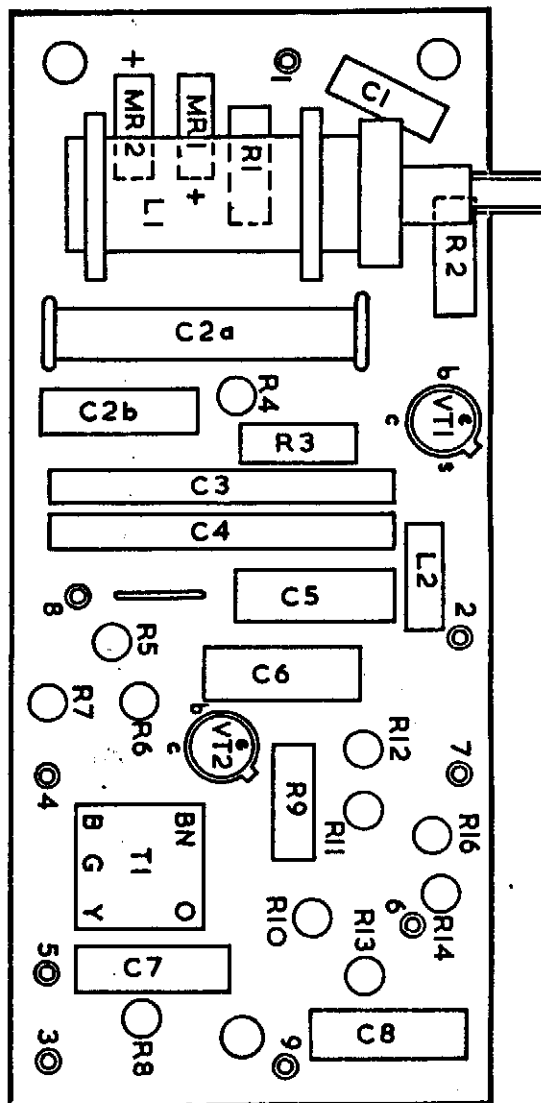

9 ILLUSTRATIONS AND COMPONENTS LISTS

- FIG. 9.1 BFO PCB ASSEMBLY 5820-99-527-1962 (OPTIONAL HIGH STABILITY UNIT)
- FIG. 9.2 OSCILLATOR LOCKING PCB ASSEMBLY 5820-99-527-1961 (OPTIONAL
HIGH STABILITY UNIT)
- FIG. 9.3 POWER SUPPLY PCB ASSEMBLY 5820-99-527-1980
- FIG. 9.4 AERIAL FILTER No 1 PCB ASSEMBLY 5820-99-527-1911
- FIG. 9.5 AERIAL FILTER No 2 PCB ASSEMBLY 5820-99-527-1952
- FIG. 9.6 WIDEBAND AMPLIFIER PCB ASSEMBLY 5820-99-527-1957
- FIG. 9.7 38 TO 68MHz FILTER PCB ASSEMBLY 5820-99-527-1956 AND MIXER 1
- FIG. 9.8 38MHz AMPLIFIER PCB ASSEMBLY 5820-99-527-1954
- FIG. 9.9 39.4MHz CRYSTAL OSCILLATOR PCB ASSEMBLY 5820-99-527-1955
- FIG. 9.10 MIXER 2 BRACKET ASSEMBLY
- FIG. 9.11 IF/AF PCB ASSEMBLY 5820-99-527-1959
- FIG. 9.12 38 TO 68MHz PCB ASSEMBLY 5820-99-527-1968
- FIG. 9.13 3 TO 32MHz FILTER PCB ASSEMBLY 5820-99-527-1964
- FIG. 9.14 35 TO 36MHz FILTER PCB ASSEMBLY 5820-99-527-1966
- FIG. 9.15 VCO AMPLIFIER PCB ASSEMBLY 5820-99-527-1967
- FIG. 9.16 VARIABLE DIVIDER PCB ASSEMBLY 5820-99-527-1965
- FIG. 9.17 1 AND 10MHz PHASE LOOP PCB ASSEMBLY 5820-99-527-1969
- FIG. 9.18 4:1 TO 5MHz VCO/MIXER PCB ASSEMBLY 5820-99-527-1972
- FIG. 9.19 SWITCH FILTER PCB ASSEMBLY 5820-99-527-1971
- FIG. 9.20 VARIABLE DIVIDER OUTPUT PCB ASSEMBLY 5820-99-527-1974
- FIG. 9.21 50kHz PHASE COMPARATOR PCB ASSEMBLY 5820-99-527-1973
- FIG. 9.22 VARIABLE DIVIDER INPUT PCB ASSEMBLY 5820-99-527-1975
- FIG. 9.23 VFO SWITCHING PCB ASSEMBLY 5820-99-527-1978
- FIG. 9.24 VFO PCB ASSEMBLY 5820-99-527-1977
- FIG. 9.25 12kHz FILTER PCB ASSEMBLY 5820-99-527-1985
- FIG. 9.26 LOCATION OF MISCELLANEOUS COMPONENTS
- FIG. 9.27 FRONT PANEL CONTROLS
- FIG. 9.28 REAR PANEL CONTROLS
- FIG. 9.29 BFO PCB ASSEMBLY P43078
- FIG. 9.30 1.4 MHz INSERTION OSCILLATOR PCB ASSEMBLY P43079

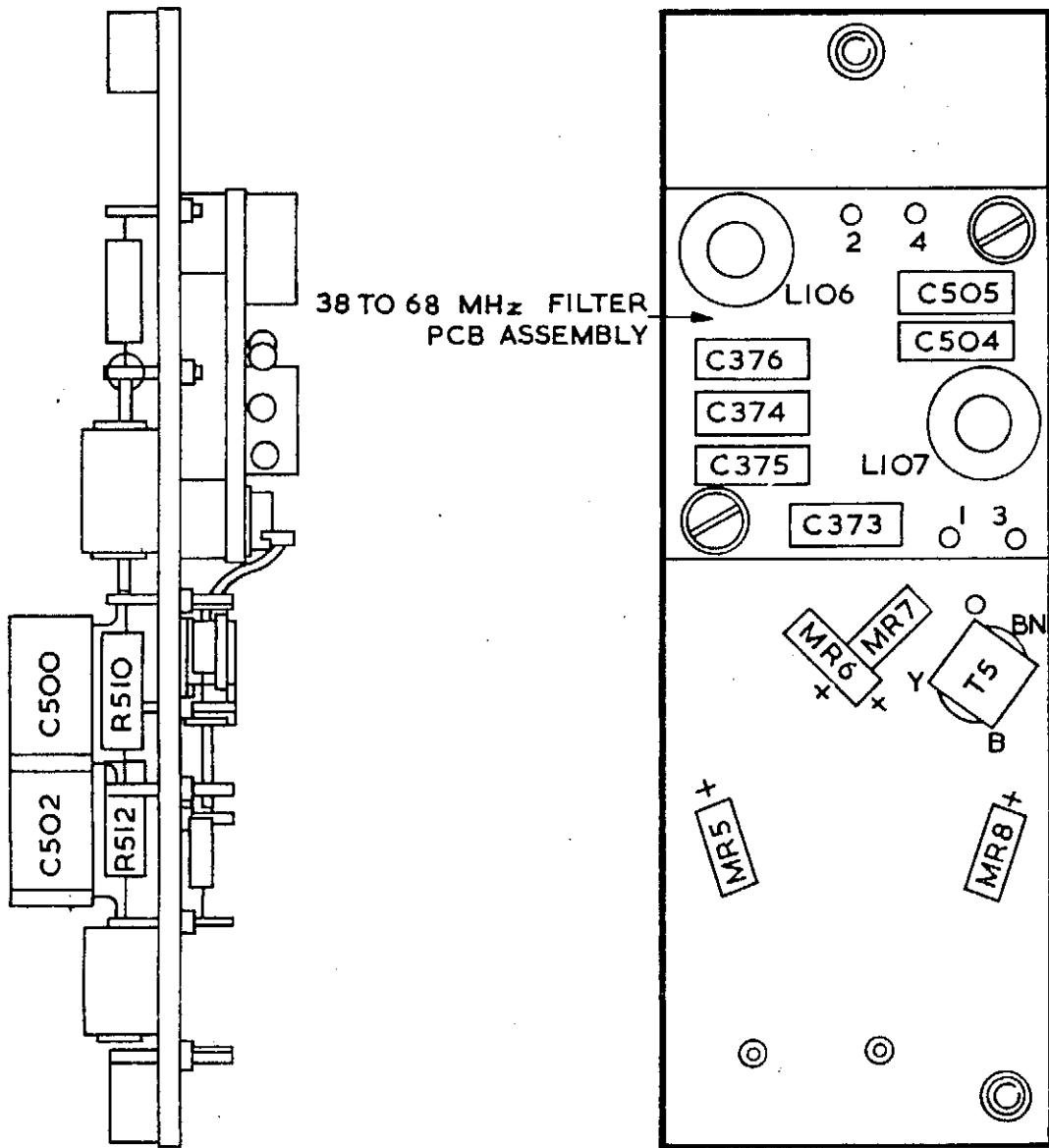

38 TO 68MHz FILTER PCB ASSEMBLY 5820-99-527-1956 AND MIXER 1

FIG. 9.7

ilyt I Sleeved
00
50
560PG/350

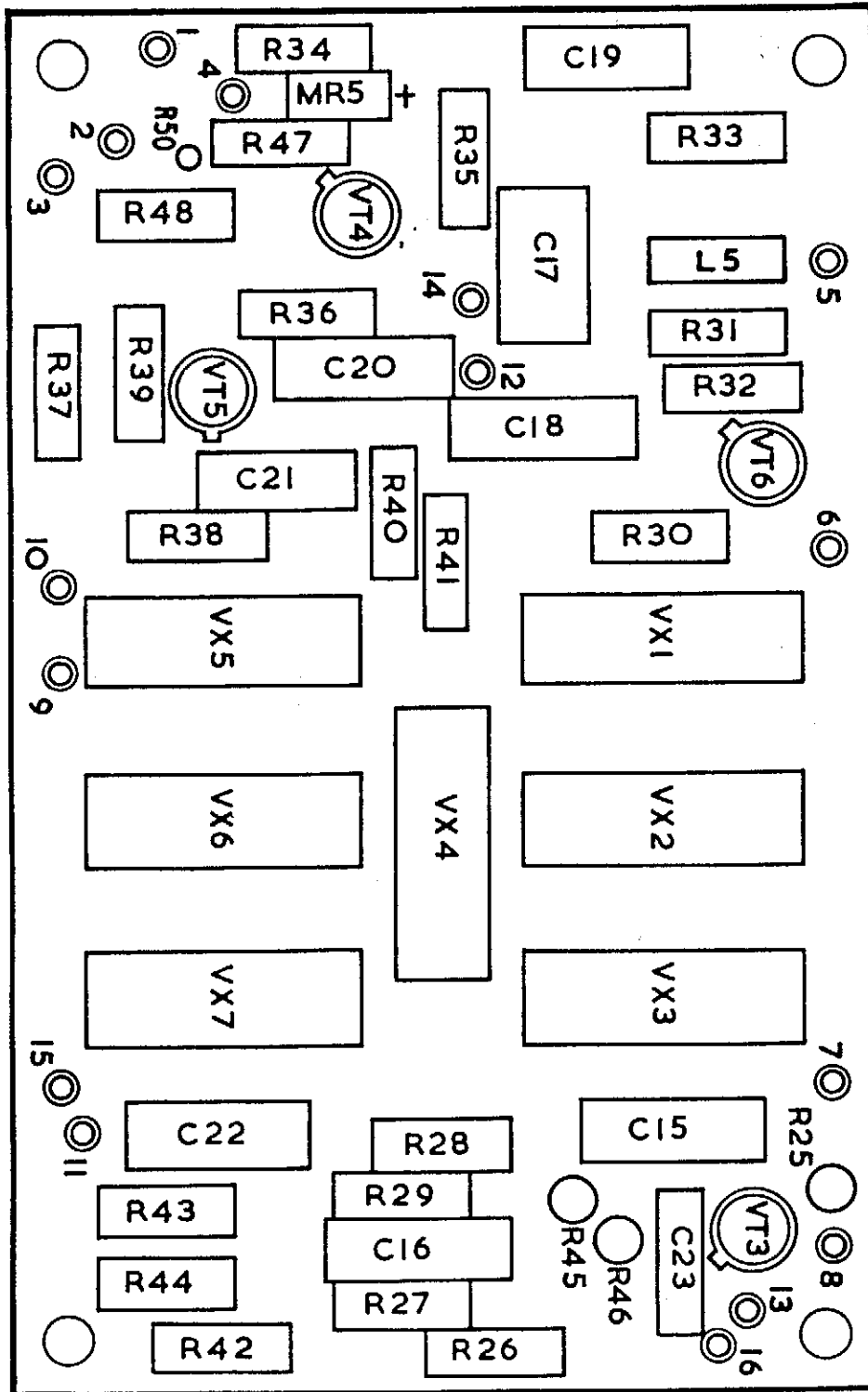

OSCILLATOR LOCKING PCB ASSEMBLY 5820-99-527-1961

FIG. 9.2

(OPTIONAL HIGH STABILITY UNIT)

COMPONENT LIST

CAPACITORS

C258 0.1 μ F \pm 20% 100V STC PMP0-1M100
 C259 0.1 μ F \pm 20% 100V STC PMP0-1M100
 C260 4.7 μ F \pm 50% -10% 63V Mullard 015-90003
 C261a 4.7 μ F \pm 50% -10% 63V Mullard 015-90003

C261b 0.1 μ F \pm 20% 100V STC PMP0-1M100
 C262 0.1 μ F \pm 20% 100V STC PMP0-1M100
 C378 100pF \pm 2pF 125V GEC PF
 C386 270pF \pm 2% 125V GEC PF

RESISTORS

R230 1k Ω \pm 2% $\frac{1}{4}$ W Electrosil TR5
 R231 3.9k Ω \pm 2% $\frac{1}{4}$ W Electrosil TR5
 R233 3.9k Ω \pm 2% $\frac{1}{4}$ W Electrosil TR5
 R234 1.2k Ω \pm 2% $\frac{1}{4}$ W Electrosil TR5

INTEGRATED CIRCUITS

VX3 Mullard FJJ111
 VX4 Mullard FJJ191
 VX5 Texas SN6400N
 VX6 Mullard FJJ111
 VX7 Mullard FJH111

VX8 Mullard FJJ111
 VX9 Mullard FJJ111
 VX10 Texas SN6476N
 VX11 Motorola MC1013P

VX12 Motorola MC1013P
 VX13 Motorola MC1013P
 VX14 Motorola MC1013P
 VX15 Motorola MC1010P

INDUCTORS

L76 47 μ H \pm 10% Cambion 3635-21
 L81 33 μ H \pm 10% Cambion 3635-19
 L82 100 μ H \pm 10% Painton C12-58/10/0017/10

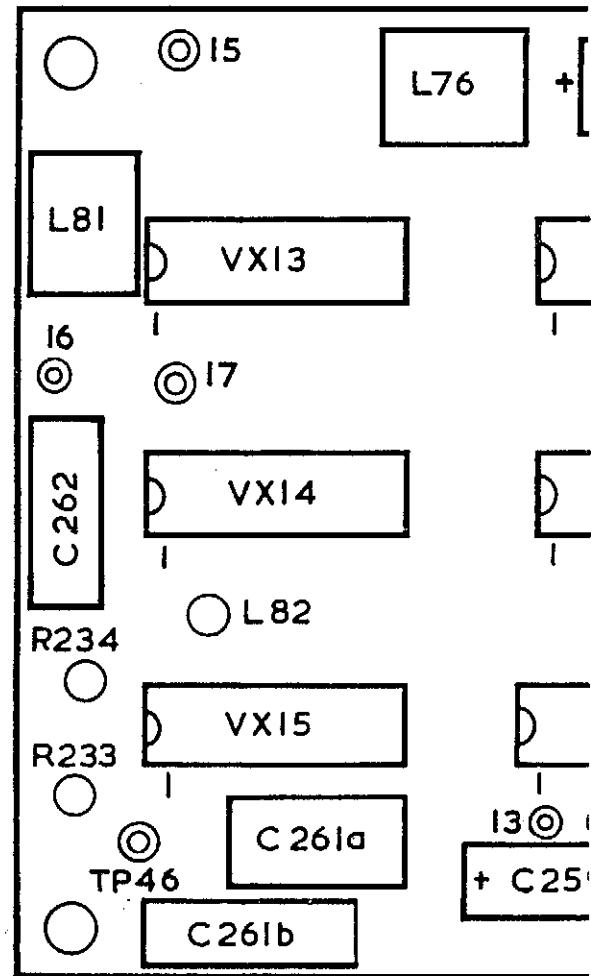

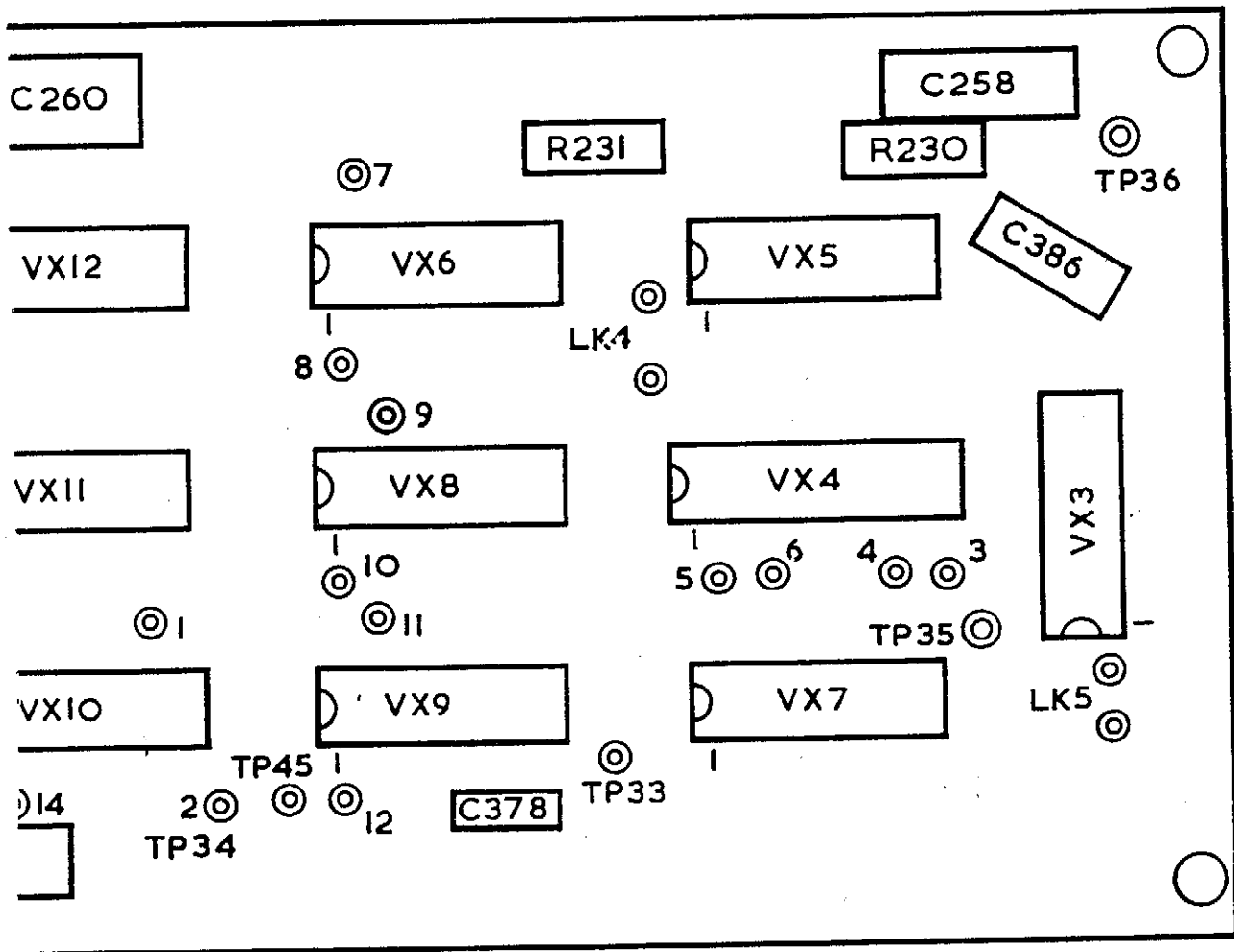

VARIABLE DIVIDER PCB ASSEMBLY 5820-99-527-1965

FIG. 9.16

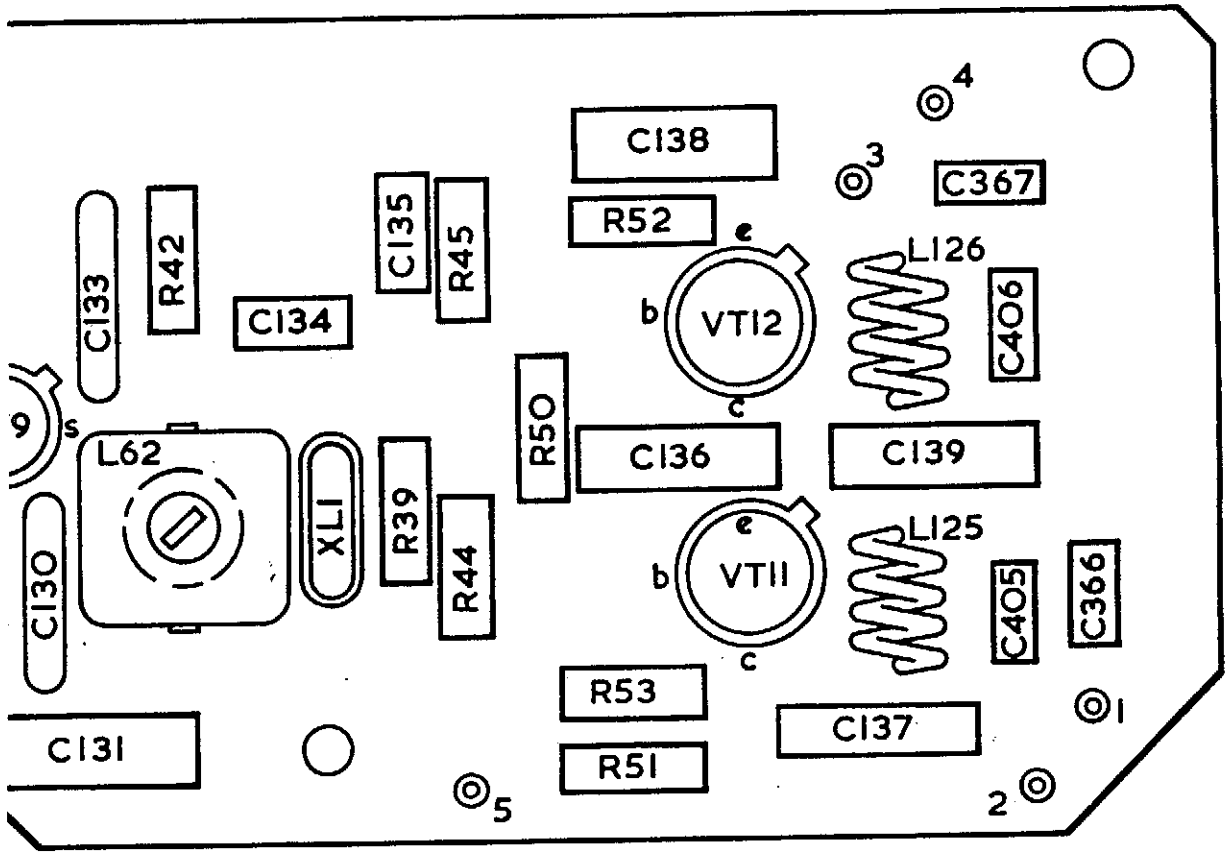

39.4MHz CRYSTAL OSCILLATOR PCB ASSEMBLY 5820-99-527-1955

FIG. 9.9

COMPONENT LIST

RESISTORS

R39	820Ω ±2% 1/4W Electrosil TR5
R40	8.2kΩ ±2% 1/4W Electrosil TR5
R41	1.8kΩ ±2% 1/4W Electrosil TR5
R42	1kΩ ±2% 1/4W Electrosil TR5
R43	2.7kΩ ±2% 1/4W Electrosil TR5
R44	5.6kΩ ±2% 1/4W Electrosil TR5
R45	5.6kΩ ±2% 1/4W Electrosil TR5
R50	560Ω ±2% 1/4W Electrosil TR5
R51	100Ω ±2% 1/4W Electrosil TR5
R52	560Ω ±2% 1/4W Electrosil TR5
R53	82Ω ±2% 1/4W Electrosil TR5

CAPACITORS

C130	56pF ±2% 350V Lemco MS611/I/R/56PG/350
C131	0.1μF ±20% 100V STC PMP0-1M100
C132	100pF ±2pF 125V GEC PF
C133	56pF ±2% 350V Lemco MS611/I/R/56PG/350
C134	68pF ±2pF 125V GEC PF
C135	100pF ±2pF 125V GEC PF
C136	0.1μF ±20% 100V STC PMP0-1M100
C137	0.1μF ±20% 100V STC PMP0-1M100
C138	0.1μF ±20% 100V STC PMP0-1M100
C139	0.1μF ±20% 100V STC PMP0-1M100
C366	22pF ±2pF 125V GEC PF
C367	22pF ±2pF 125V GEC PF
C405	150pF ±2% 125V GEC PF
C406	150pF ±2% 125V GEC PF

INDUCTORS

L62	Redifon P28024/S
L125	Redifon P44167/S
L126	Redifon P44167/S

TRANSISTORS

VT9	RCA 40235
VT11	RCA 2N3866
VT12	RCA 2N3866

CRYSTAL

XL1	Redifon OP9113/3
-----	------------------

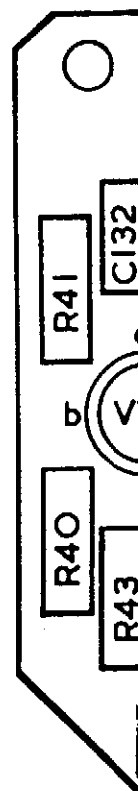

COMPONENT LIST

CAPACITORS

C1	27pF ±2pF 125V GEC PF
C2	18pF ±1pF 125V GEC PF
C3	56pF ±2pF 125V GEC PF
C4	39pF ±2pF 125V GEC PF
C5	15pF ±1pF 125V GEC PF
C6	24pF ±2pF 125V GEC PF
C7	64pF ±2pF 125V GEC PF
C8	39pF ±2pF 125V GEC PF
C17	47pF ±2pF 125V GEC PF
C18	30pF ±2pF 125V GEC PF
C19	110pF ±2% 125V GEC PF
C20	78pF ±2pF 125V GEC PF
C21	30pF ±2pF 125V GEC PF
C22	50pF ±2pF 125V GEC PF
C23	128pF ±2% 125V GEC PF
C24	78pF ±2pF 125V GEC PF
C33	110pF ±2% 125V GEC PF
C34	68pF ±2pF 125V GEC PF
C35	250pF ±2% 125V GEC PF
C36	172pF ±2% 125V GEC PF
C37	68pF ±2pF 125V GEC PF
C38	100pF ±2pF 125V GEC PF
C39	250pF ±2% 125V GEC PF
C40	150pF ±2% 125V GEC PF
C59	680pF ±2% 125V GEC PF
C60	220pF ±2% 125V GEC PF
C61	1000pF ±2% 125V GEC PF
C62	600pF ±2% 125V GEC PF
C63	180pF ±2% 125V GEC PF
C64	330pF ±2% 125V GEC PF
C65	820pF ±2% 125V GEC PF
C66	500pF ±2% 125V GEC PF
C75	33pF ±2pF 125V GEC PF
C76	22pF ±2pF 125V GEC PF
C77	60pF ±2pF 125V GEC PF
C78	56pF ±2pF 125V GEC PF
C79	47pF ±2pF 125V GEC PF
C80	56pF ±2pF 125V GEC PF
C81	56pF ±2pF 125V GEC PF
C82	56pF ±2pF 125V GEC PF
C83	47pF ±2pF 125V GEC PF
C84	30pF ±2pF 125V GEC PF
C85	91pF ±2pF 125V GEC PF
C86	82pF ±2pF 125V GEC PF
C87	68pF ±2pF 125V GEC PF

C88	91pF ±2pF 125V GEC PF
C89	240pF ±2pF 125V GEC PF
C90	150pF ±2pF 125V GEC PF
C91	128pF ±2pF 125V GEC PF
C92	60pF ±2% 125V GEC PF
C93	180pF ±2% 125V GEC PF
C94	160pF ±2% 125V GEC PF
C95	150pF ±2% 125V GEC PF
C96	100pF ±2pF 125V GEC PF
C97	300pF ±2% 125V GEC PF
C98	180pF ±2pF 125V GEC PF

INDUCTORS

L1	Redifon P28040/S
L2	Redifon P28046/S
L3	Redifon P28038/S
L4	Redifon P28039/S
L9	Redifon P28049/S
L10	Redifon P28053/S
L11	Redifon P28944/S
L12	Redifon P28047/S
L17	Redifon P28056/S
L18	Redifon P28060/S
L19	Redifon P28051/S
L20	Redifon P28055/S
L31	Redifon P28067/S
L32	Redifon P28073/S
L33	Redifon P28065/S
L34	Redifon P28068/S
L39	Redifon P28078/S
L40	Redifon P28979/S
L41	Redifon P44334/S
L42	Redifon P44335/S
L43	Redifon P44336/S
L44	Redifon P28083/S
L45	Redifon P44337/S
L46	Redifon P44338/S
L47	Redifon P51197/S
L48	Redifon P51198/S
L49	Redifon P51199/S
L50	Redifon P51200/S

C93

C95

C97

C93 C92
 C95 C94
 C97 C96

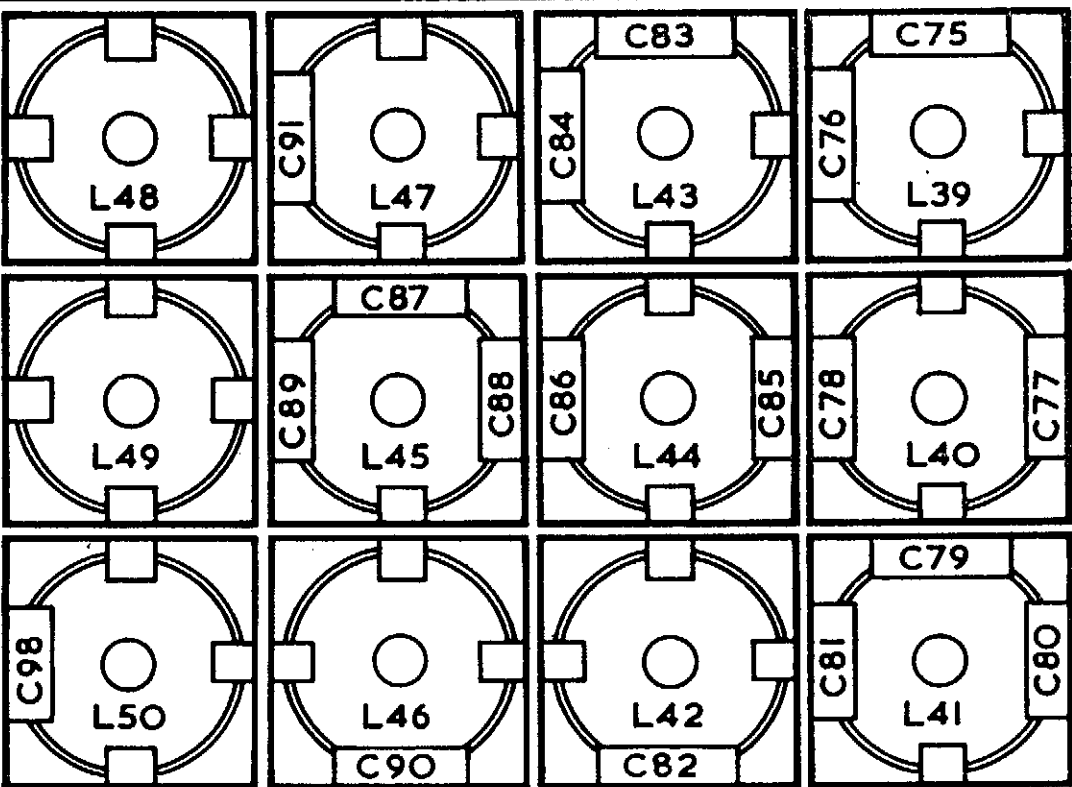

220

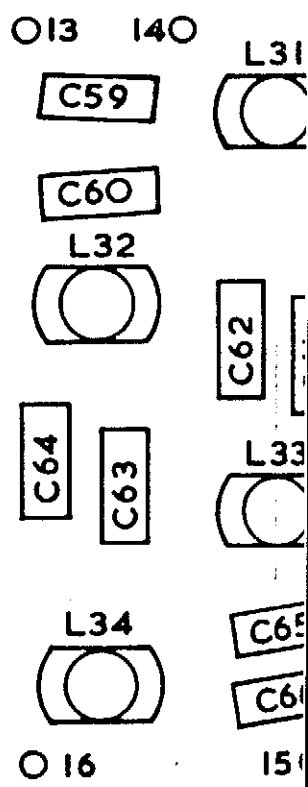

COMPONENT LIST

CAPACITORS

C311	8pF \pm 1pF 125V GEC PF
C312	18pF \pm 1pF 125V GEC PF
C313	27pF \pm 2pF 125V GEC PF
C314	39pF \pm 2pF 125V GEC PF
C315	47pF \pm 2pF 125V GEC PF
C316	61pF \pm 2pF 125V GEC PF
C317	74pF \pm 2pF 125V GEC PF
C318	88pF \pm 2pF 125V GEC PF
C319	104pF \pm 2% 125V GEC PF
C320	165pF \pm 2% 125V GEC PF
C321a	4700pF \pm 2% 125V GEC PF
C321b	3900pF \pm 2% 125V GEC PF
C322	165pF \pm 2% 125V GEC PF
C323	8pF \pm 1pF 125V GEC PF
C324	18pF \pm 1pF 125V GEC PF
C325	27pF \pm 2pF 125V GEC PF
C326	39pF \pm 2pF 125V GEC PF
C327	47pF \pm 2pF 125V GEC PF
C328	61pF \pm 2pF 125V GEC PF
C329	74pF \pm 2pF 125V GEC PF
C330	88pF \pm 2pF 125V GEC PF
C331	104pF \pm 2% 125V GEC PF

INDUCTORS

L92	Redifon P28114/S
L93	Redifon P28113/S

SWITCH WAFERS

S3DF	Redifon OP9439/S
S3EB	Redifon OP9440/S

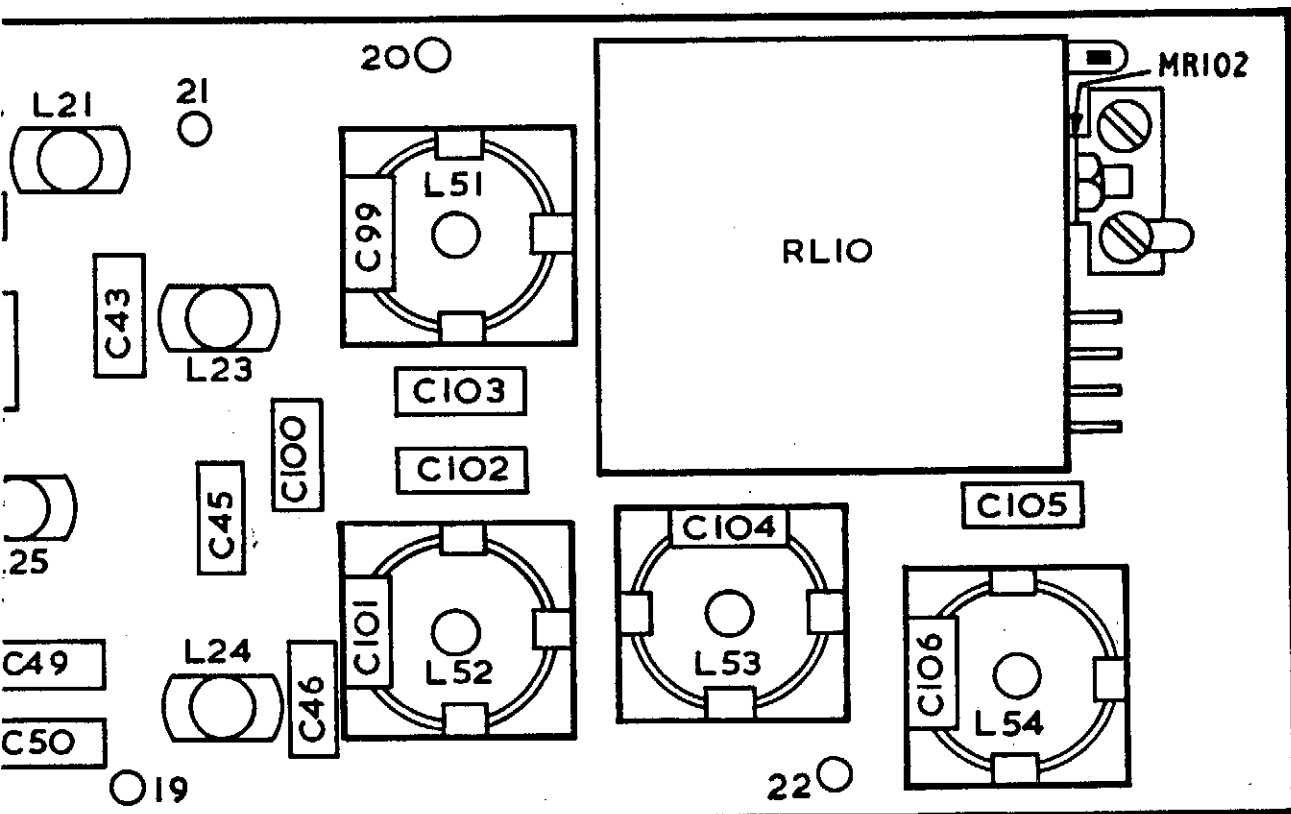

AERIAL FILTER No. 1 PCB ASSEMBLY 5820-99-527-1911

FIG. 9.4

COMPONENT LIST

S

- F ±2% 350V Lemco MS611/I/R/390PG/350
- ▷ 7.5pF Wingrove & Rogers C37-01/6
- ±1pF 350V Lemco MS611/I/R/12PFP/350
- ▷ F ±2% 350V Lemco MS611/I/R/1NG/350
- F ±2% 350V Lemco MS611/I/R/200PG/350

- ▷ 7.5pF Wingrove & Rogers C37-01/6
- ±1pF 350V Lemco MS611/I/R/18PFP/350
- ±1pF 350V Lemco MR1106/I/R/2P2DP/350
- ▷ 7.5pF Wingrove & Rogers C37-01/6
- ▷ 7.5pF Wingrove & Rogers C37-01/6

- ±1pF 350V Lemco MR1106/I/R/2P2DP/350
- ▷ 7.5pF Wingrove & Rogers C37-01/6
- ±1pF 350V Lemco MR1106/I/R/5PDP/350
- ▷ 7.5pF Wingrove & Rogers C37-01/6
- ±1pF 350V Lemco MS611/I/R/10PFP/350

- ▷ 7.5pF Wingrove & Rogers C37-01/6
- ±1pF 350V Lemco MS611/I/R/12PFP/350
- ▷ 7.5pF Wingrove & Rogers C37-01/6
- ±1pF 350V Lemco MS611/I/R/15PFP/350
- ▷ 7.5pF Wingrove & Rogers C37-01/6

- ±1pF 350V Lemco MS611/I/R/18PFP/350
- ▷ 7.5pF Wingrove & Rogers C37-01/6
- ±1pF 350V Lemco MS611/I/R/22PFP/350
- ±1pF 350V Lemco MS611/I/R/33PFP/350
- F ±2% 125V GEC PF

- ▷ F ±2% 350V Lemco MS611/I/R/1NG/350
- ±20% 100V STC PMP0-1M100
- ±1pF 350V Lemco MS611/I/R/10PFP/350
- ±20% 100V STC PMP0-1M100

- ±50% -10% 63V Mullard 015-90003
- ±1pF 350V Lemco MS611/I/R/47PFP/350
- ±1pF 350V Lemco MS611/I/R/47PFP/350
- ±20% 100V STC PMP0-1M100

- ▷ ±2% 1/4W Electrosil TR5
- ▷ ±2% 1/4W Electrosil TR5
- ▷ ±2% 1/4W Electrosil TR5
- ▷ ±2% 1/4W Electrosil TR5
- ▷ ±2% 1/4W Electrosil TR5

- ▷ ±2% 1/4W Electrosil TR5
- ▷ ±2% 1/4W Electrosil TR5
- ▷ ±2% 1/4W Electrosil TR5
- ±2% 1/4W Electrosil TR5
- ±2% 1/4W Electrosil TR5

RS

- ▷ 40235
- ▷ 40235

ens BB104 Blue
 ens BB104 Blue

S

- ▷ fon P28004/S
- ▷ fon P28005/S
- ▷ fon P28006/S

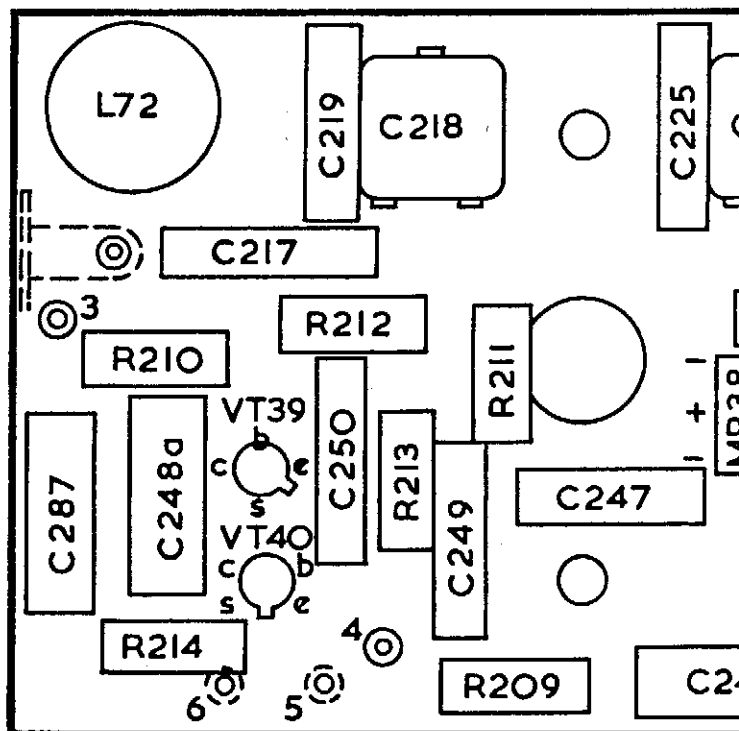
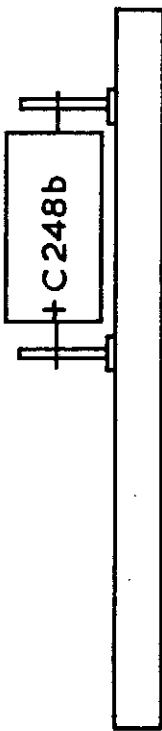

COMPONENT LIST

CAPACITORS

C200	22 μ F \pm 50% $-$ 20% 35V Wima Printilyt 1 Sleeved
C201	0.015 μ F \pm 20% 100V STC PMP0-015M100
C202	100 μ F \pm 50% $-$ 20% 35V Wima Printilyt 1 Sleeved
C203	2.2 μ F \pm 20% Union Carbide K2R2E35 or K2R2E20
C204	470pF \pm 2% 125V GEC PF
C205	1000pF \pm 2% 125V GEC PF
C206	220 μ F \pm 50% $-$ 20% 35V Wima Printilyt 1 Sleeved
C207	4.7 μ F \pm 50% $-$ 10% 63V Mullard 015-90003
C208	1 μ F \pm 20% 100V STC PMP1-0M100
C209	22 μ F \pm 50% $-$ 20% 35V Wima Printilyt 1 Sleeved
C210	470pF \pm 2% 125V GEC PF
C211	390pF \pm 2% 125V GEC PF
C212	1000pF \pm 2% 125V GEC PF
C213	0.1 μ F \pm 20% 100V STC PMP0-1M100
C274	0.1 μ F \pm 20% 100V STC PMP0-1M100
C507	82pF \pm 2pF 125V GEC PF

RESISTORS

R178	390 Ω \pm 2% 1/4W ElectroSil TR5
R179	1k Ω Lin \pm 20% 1/4W Plessey MP Dealer/PCBlack 404/8/02857
R180	390 Ω \pm 2% 1/4W ElectroSil TR5
R181	100 Ω \pm 2% 1/4W ElectroSil TR5
R182	1k Ω \pm 2% 1/4W ElectroSil TR5
R183	2.7k Ω \pm 2% 1/4W ElectroSil TR5
R184	3.9k Ω \pm 2% 1/4W ElectroSil TR5
R188	330 Ω \pm 2% 1/4W ElectroSil TR5
R189	4.7k Ω \pm 2% 1/4W ElectroSil TR5
R191	8.2k Ω \pm 2% 1/4W ElectroSil TR5
R194	4.7k Ω \pm 2% 1/4W ElectroSil TR5
R196	100 Ω \pm 2% 1/4W ElectroSil TR5
R197	4.7k Ω \pm 2% 1/4W ElectroSil TR5
R198	5.6k Ω \pm 2% 1/4W ElectroSil TR5
R199	15k Ω \pm 2% 1/4W ElectroSil TR5
R245	3.9k Ω \pm 2% 1/4W ElectroSil TR5
R246	820 Ω \pm 2% 1/4W ElectroSil TR5

TRANSISTORS

VT33	Mullard BC108
VT34	Motorola 2N3904
VT35	Motorola 2N3904

DIODE

MR39	Mullard BZY88C5V1 \pm 2%
------	----------------------------

INTEGRATED CIRCUITS

VX1	Mullard FJH131
VX2	Mullard FJH221

INDUCTORS

L70	Redifon P28110/S
L71	8.2mH \pm 10% Cambion 3635-48

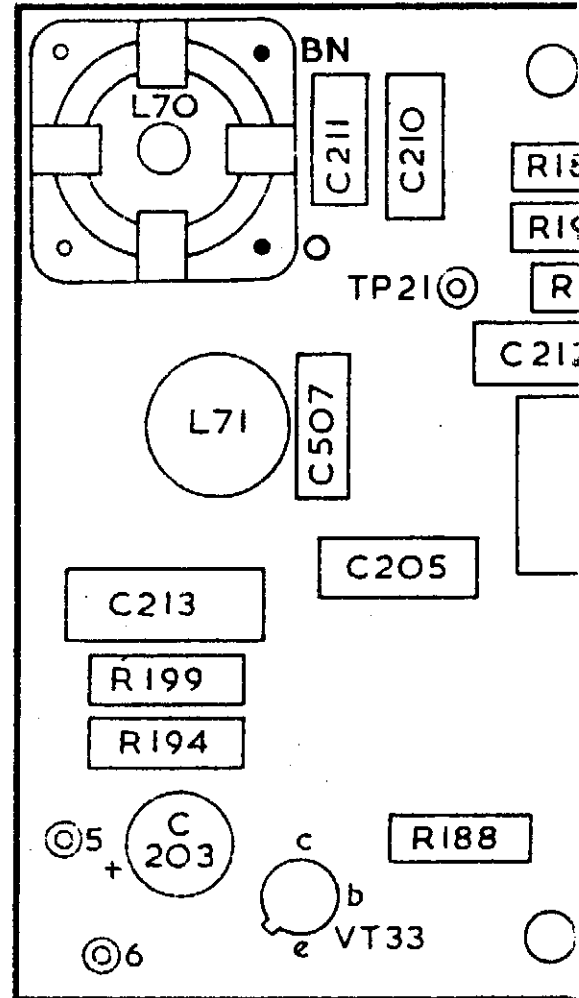

10Ω ±2% ¼W Electrosil TR5
4.7kΩ ±2% ¼W Electrosil TR5
330Ω ±2% ¼W Electrosil TR5
2.2kΩ ±2% ¼W Electrosil TR5
820Ω ±2% ¼W Electrosil TR5

10kΩ ±2% ¼W Electrosil TR5
39kΩ ±2% ¼W Electrosil TR5
10kΩ ±2% ¼W Electrosil TR5
39Ω ±2% ¼W Electrosil TR5
1kΩ ±2% ¼W Electrosil TR5

390Ω ±2% ¼W Electrosil TR5
3.3kΩ ±2% ¼W Electrosil TR5
47kΩ ±2% ¼W Electrosil TR5
330Ω ±2% ¼W Electrosil TR5
27kΩ ±2% ¼W Electrosil TR5

27kΩ ±2% ¼W Electrosil TR5
470kΩ ±2% ¼W Electrosil TR5
2.2kΩ ±2% ¼W Electrosil TR5
100kΩ ±2% ¼W Electrosil TR5
100Ω ±2% ¼W Electrosil TR5

2.2kΩ ±2% ¼W Electrosil TR5
5.6kΩ ±2% ¼W Electrosil TR5
3.9kΩ ±2% ¼W Electrosil TR5
68Ω ±2% ¼W Electrosil TR5
1kΩ ±2% ¼W Electrosil TR5

27kΩ ±2% ¼W Electrosil TR5
1kΩ ±2% ¼W Electrosil TR5
180Ω ±2% ¼W Electrosil TR5
8.2kΩ ±2% ¼W Electrosil TR5
15kΩ ±2% ¼W Electrosil TR5

330Ω ±2% ¼W Electrosil TR5
1kΩ ±2% ¼W Electrosil TR5
4.7kΩ Lin ±20% ¼W Plessey MP Dealer/PC/
Black 404/8/92857 Series
4.7kΩ Lin ±20% ¼W Plessey MP Dealer/PC/
Black 404/8/92857 Series
1kΩ ±2% ¼W Electrosil TR5
2.2kΩ ±2% ¼W Electrosil TR5
22Ω ±2% ¼W Electrosil TR5

DIODES

RCA 40235
Motorola 2N3904
Motorola 2N3906
Motorola 2N3904

Motorola 2N3904
Motorola 2N3904
Motorola 2N3906
Motorola 2N3904
Motorola 2N3906
Motorola 2N3904

Mullard OC28
Mullard OC28
Motorola 2N3904
Motorola 2N3904

Motorola 2N3904
Motorola 2N3906
Motorola 2N3906
Motorola 2N3904

DIODES

MR13 Texas 1N916
MR14 Texas 1N916
MR15 Emihus HG5007
MR16 Hewlett Packard HPA5082/2800
MR17 Hewlett Packard HPA5082/2800

MR18 Mullard OA200
MR19 Mullard OA200
MR20a Mullard OA200
MR20b Mullard OA200
MR21a Mullard OA200

MR21b Mullard OA200
MR22 Emihus HG5007
MR23 Emihus HG5007
MR24 Mullard OA200
MR25a Mullard OA200

MR25b Mullard OA200
MR26a Mullard OA200
MR26b Emihus HG5007
MR27 Mullard OA200
MR28 Mullard OA200
MR32 Emihus HG5007
MR33 Mullard OA200

RF TRANSFORMERS

T15 Redifon P28122/S
T16 Redifon P28123/S
T17 Redifon P28124/S
T18 Redifon P28125/S

AF TRANSFORMERS

T19 Redifon SRT2652
T20 Redifon SRT2705
T21 Redifon SRT2698

INDUCTORS

L65 2.7mH ±10% Cambion 3635-42
L66 100μH ±10% Cambion 3635-25
L67 2.7mH ±10% Cambion 3635-42

CRYSTAL

XL2 Redifon OP9141/S

COMPONENT LIST

CAPACITORS

C341	0.1 μ F \pm 20% 100V STC PMP0-1M100
C342a	180pF \pm 1% 350V Lemco MS611/I/R/180PFP/350
C342b	82pF \pm 5% 500V Erie 811/N750
C343a	2 to 31pF Oxley TU/30/PC1
C343b	2 to 31pF Oxley TU/30/PC1
C344	18pF \pm 1pF 350V Lemco MS611/I/R/18PFP/350
C345	1800pF \pm 1% 350V Lemco MS611/I/R/1N8F/350
C346	4700pF \pm 1% 200V Lemco MS611/I/R/4N7F/200
C347	4700pF \pm 1% 200V Lemco MS611/I/R/4N7F/200
C348	0.1 μ F \pm 20% 100V STC PMP0-1M100
C349	0.1 μ F \pm 20% 100V STC PMP0-1M100
C350	0.1 μ F \pm 20% 100V STC PMP0-1M100
C351	18pF \pm 1pF 350V Lemco MS611/I/R/18PFP/350
C352	2700pF \pm 1% 350V Lemco MS611/I/R/2N7/350
C353	3900pF \pm 1% 350V Lemco MS611/I/R/3N9F/350
C354	0.1 μ F \pm 20% 100V STC PMP0-1M100
C371	0.1 μ F \pm 20% 100V STC PMP0-1M100
C372	0.1 μ F \pm 20% 100V STC PMP0-1M100

RESISTORS

R289	220k Ω \pm 2% $\frac{1}{4}$ W Electrosil TR5
R290a	33k Ω \pm 2% $\frac{1}{4}$ W Electrosil TR5
R290b	33k Ω \pm 2% $\frac{1}{4}$ W Electrosil TR5
R291	10k Ω \pm 2% $\frac{1}{4}$ W Electrosil TR5
R292	18k Ω \pm 2% $\frac{1}{4}$ W Electrosil TR5
R293	39k Ω \pm 2% $\frac{1}{4}$ W Electrosil TR5
R294	56k Ω \pm 2% $\frac{1}{4}$ W Electrosil TR5
R295	4.7k Ω \pm 2% $\frac{1}{4}$ W Electrosil TR5
R296	100 Ω \pm 2% $\frac{1}{4}$ W Electrosil TR5
R297	100k Ω \pm 2% $\frac{1}{4}$ W Electrosil TR5
R298	47k Ω \pm 2% $\frac{1}{4}$ W Electrosil TR5
R299	470 Ω \pm 2% $\frac{1}{4}$ W Electrosil TR5
R300	270 Ω \pm 2% $\frac{1}{4}$ W Electrosil TR5
R301	47 Ω \pm 2% $\frac{1}{4}$ W Electrosil TR5
R321	270 Ω \pm 2% $\frac{1}{4}$ W Electrosil TR5
R322	22k Ω \pm 2% $\frac{1}{4}$ W Electrosil TR5
R323	100 Ω \pm 2% $\frac{1}{4}$ W Electrosil TR5

TRANSISTORS

VT51	RCA 40235
VT52	STC BC107
VT53	Mullard BCY72

DIODES

MR52	Emihus HG5007
MR50	Hewlett Packard HPA5082/2800
MR51	Hewlett Packard HPA5082/2800
MR49	Emihus HC7002

INDUCTORS

L98	Redifon P28094/S
L99	22 μ H \pm 10% Painton C12-58/10/0013/10
L100	100 μ H \pm 10% Painton C12-58/10/0017/10

RF TRANSFORMER

T33	Redifon P44180/S
-----	------------------

FIG. 9.24 VFO PCB ASSEMBLY 5820-99-527-

COMPONENT LIST

CAPACITORS

C142	0.1μF ±20%	100V STV PMP0-1M100
C143	0.1μF ±20%	100V STC PMP0-1M100
C144	0.1μF ±20%	100V STC PMP0-1M100
C145	0.1μF ±20%	100V STC PMP0-1M100
C146	0.1μF ±20%	100V STC PMP0-1M100
C147	0.1μF ±20%	100V STC PMP0-1M100
C148	0.1μF ±20%	100V STC PMP0-1M100
C149	0.1μF ±20%	100V STC PMP0-1M100
C150	0.1μF ±20%	100V STC PMP0-1M100
C151	0.1μF ±20%	100V STC PMP0-1M100
C152a	4.7μF +50%	-10% 63V Mullard 015-90003
C152b	1μF ±20%	Union Carbide K1J20S 20V
C152c	0.1μF ±20%	100V STC PMP0-1M100
C153	0.1μF ±20%	100V STC PMP0-1M100
C154	0.1μF ±20%	100V STC PMP0-1M100
C156	0.1μF ±20%	100V STC PMP0-1M100
C157	0.1μF ±20%	100V STC PMP0-1M100
C158	410pF ±2%	125V GEC PF
C159	2.5-7.5pF	Wingrove & Rogers C37-01/6
C160	0.1μF ±20%	100V STC PMP0-1M100
C162	200pF ±2%	125V GEC PF
C163	0.1μF ±20%	100V STC PMP0-1M100
C164	10μF +100%	-20% 35V Wima Printilyt 1 Sleeved
C165	0.1μF ±20%	100V STC PMP0-1M100
C166	0.1μF ±20%	100V STC PMP0-1M100
C167	0.1μF ±20%	100V STC PMP0-1M100
C168	0.1μF ±20%	100V STC PMP0-1M100
C169	0.002μF ±2%	125V GEC PF
C170	0.002μF ±2%	125V GEC PF
C171	0.068μF ±20%	100V STC PMP0-068M100
C172	220μF +50%	-20% 35V Wima Printilyt 1 Sleeved
C173	22μF +50%	-20% 35V Wima Printilyt 1 Sleeved
C176	47μF +50%	-20% 35V Wima Printilyt 1 Sleeved
C177	47μF +50%	-20% 35V Wima Printilyt 1 Sleeved
C178	10μF +100%	-20% 35V Wima Printilyt 1 Sleeved
C179	500μF +50%	-10% 40V Mullard C431BR/G500 Sleeved
C180	0.1μF ±20%	100V STC PMP0-1M100
C181	0.1μF ±20%	100V STC PMP0-1M100
C182	0.1μF ±20%	100V STC PMP0-1M100
C183	0.1μF ±20%	100V STC PMP0-1M100
C184	47μF +50%	-20% 35V Wima Printilyt 1 Sleeved
C185	0.1μF ±20%	100V STC PMP0-1M100
C186	0.1μF ±20%	100V STC PMP0-1M100
C187	0.1μF ±20%	100V STC PMP0-1M100
C188	0.1μF ±20%	100V STC PMP0-1M100
C189	0.1μF ±20%	100V STC PMP0-1M100
C190	3.3μF ±20%	Union Carbide K3R3J20S
C191	33μF ±20%	20V Union Carbide K33J20S
C192	10μF ±20%	20V Union Carbide K10J20S
C194	0.1μF ±20%	100V STC PMP0-1M100
C195	100μF +50%	-20% 35V Wima Printilyt 1 Sleeved
C196	47μF +50%	-20% 35V Wima Printilyt 1 Sleeved
C197	100μF +50%	-20% 35V Wima Printilyt 1 Sleeved
C198	47μF +50%	-20% 35V Wima Printilyt 1 Sleeved
C410	0.01μF ±20%	STC PMP0-01M100

RESISTORS

R57	120Ω ±2%	1/4W Electrosil TR5
R58	3.3kΩ ±2%	1/4W Electrosil TR5
R59	3.3kΩ ±2%	1/4W Electrosil TR5
R60	150Ω ±2%	1/4W Electrosil TR5
R61	22Ω ±2%	1/4W Electrosil TR5

R62	220Ω ±2%	1/4W Electrosil TR5
R63	560Ω ±2%	1/4W Electrosil TR5
R64	4.7kΩ ±2%	1/4W Electrosil TR5
R65	1.8kΩ ±2%	1/4W Electrosil TR5
R66	120Ω ±2%	1/4W Electrosil TR5
R67	1.8kΩ ±2%	1/4W Electrosil TR5
R68	120Ω ±2%	1/4W Electrosil TR5
R69	680Ω ±2%	1/4W Electrosil TR5
R70	15kΩ ±2%	1/4W Electrosil TR5
R71	1kΩ ±2%	1/4W Electrosil TR5
R72	100Ω ±2%	1/4W Electrosil TR5
R73	2.2kΩ ±2%	1/4W Electrosil TR5
R74	4.7kΩ ±2%	1/4W Electrosil TR5
R75	27kΩ ±2%	1/4W Electrosil TR5
R76	1kΩ ±2%	1/4W Electrosil TR5
R77	4.7kΩ ±2%	1/4W Electrosil TR5
R78	68Ω ±2%	1/4W Electrosil TR5
R79	1kΩ ±2%	1/4W Electrosil TR5
R80	15kΩ ±2%	1/4W Electrosil TR5
R81	270Ω ±2%	1/4W Electrosil TR5
R82	1.5kΩ ±2%	1/4W Electrosil TR5
R83	1kΩ ±2%	1/4W Electrosil TR5
R84	820Ω ±2%	1/4W Electrosil TR5
R85	4.7kΩ ±2%	1/4W Electrosil TR5
R86	150Ω ±2%	1/4W Electrosil TR5
R87	1.2kΩ ±2%	1/4W Electrosil TR5
R88	120Ω ±2%	1/4W Electrosil TR5
R89	68Ω ±2%	1/4W Electrosil TR5
R90	10kΩ ±2%	1/4W Electrosil TR5
R91	1.5kΩ ±2%	1/4W Electrosil TR5
R92	82Ω ±2%	1/4W Electrosil TR5
R93	1.2kΩ ±2%	1/4W Electrosil TR5
R94	22kΩ ±2%	1/4W Electrosil TR5
R95	100Ω ±2%	1/4W Electrosil TR5
R96	1.2kΩ ±2%	1/4W Electrosil TR5
R97	8.2kΩ ±2%	1/4W Electrosil TR5
R98	10kΩ ±2%	1/4W Electrosil TR5
R99	470Ω ±2%	1/4W Electrosil TR5
R100	470Ω ±2%	1/4W Electrosil TR5
R101	1.5kΩ ±2%	1/4W Electrosil TR5
R102	1kΩ ±2%	1/4W Electrosil TR5
R103	18kΩ ±2%	1/4W Electrosil TR5
R104	82Ω ±2%	1/4W Electrosil TR5
R105	560Ω ±2%	1/4W Electrosil TR5
R106	120kΩ ±2%	1/4W Electrosil TR5
R107	470Ω ±2%	1/4W Electrosil TR5
R108	1.5kΩ ±2%	1/4W Electrosil TR5
R109	2.2kΩ ±2%	1/4W Electrosil TR5
R110	3.3kΩ ±2%	1/4W Electrosil TR5
R111	10kΩ ±2%	1/4W Electrosil TR5
R112	5.6kΩ ±2%	1/4W Electrosil TR5
R113	12kΩ ±2%	1/4W Electrosil TR5
R114	47Ω ±2%	1/4W Electrosil TR5
R115	1kΩ ±2%	1/4W Electrosil TR5
R116	270Ω ±2%	1/4W Electrosil TR5
R117	10Ω ±2%	1/4W Electrosil TR5
R118	1kΩ ±2%	1/4W Electrosil TR5
R119	1.5kΩ ±2%	1/4W Electrosil TR5
R120	3.3Ω ±10%	2 1/4W Welwyn W21
R121	3.3Ω ±10%	2 1/4W Welwyn W21
R122	10Ω ±2%	
R123	4.7kΩ	
R124	330Ω	
R125	2.2kΩ	
R126	820Ω	
R127	10kΩ	
R128	39kΩ	
R129	10kΩ	
R130	39Ω ±2%	
R131	1kΩ ±2%	
R132	390Ω	
R133	3.3kΩ	
R134	47kΩ	
R135	330Ω	
R136	27kΩ	
R137	27kΩ	
R138	470kΩ	
R139	2.2kΩ	
R140	100kΩ	
R141	100Ω	
R142	2.2kΩ	
R144	5.6kΩ	
R145	3.9kΩ	
R146	68Ω ±2%	
R147	1kΩ ±2%	
R148	27kΩ	
R149	1kΩ ±2%	
R150	180Ω	
R157	8.2kΩ	
R158	15kΩ	
R159	330Ω	
R160	1kΩ ±2%	
R161	4.7kΩ	
R162	4.7kΩ	
R163	1kΩ ±2%	
R164	2.2kΩ	
R358	22Ω ±2%	

TRANSISTOR

VT13	RCA
VT14	Motor
VT15	Motor
VT16	Motor
VT17	Motor
VT18	Motor
VT19	Motor
VT20	Motor
VT21	Motor
VT22	Motor
VT23	Mulla
VT24	Mulla
VT25	Motor
VT26	Motor
VT27	Motor
VT28	Motor
VT29	Motor
VT32	Motor

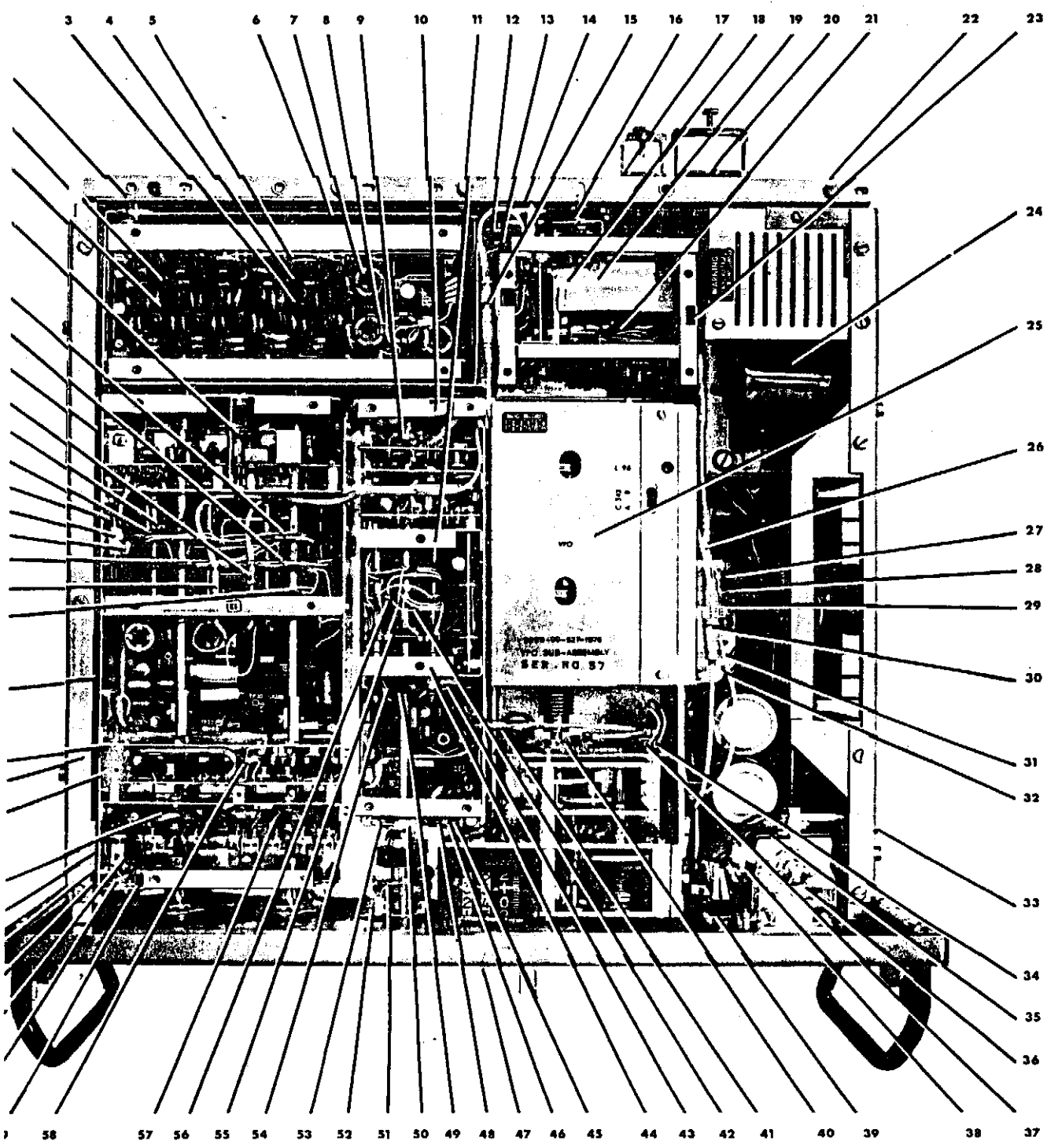

CAPACITORS

- *C9 0.1μF ±20%
- *C10 4.7μF +50%
- *C11 4.7μF +50%

- C122 0.1μF ±20%
- C123 0.1μF ±20%
- C128 0.1μF ±20%
- C129 0.1μF ±20%
- C161 15pF ±10%

- C199 0.1μF ±20%
- C264 100μF +50%
- C283 390pF ±20%
- C286 0.1μF ±20%
- C288 0.1μF ±20%

- C289 0.1μF ±20%
- C290a 25μF +50%
- C290b 0.1μF ±20%
- C291 0.1μF ±20%
- C292 0.1μF ±20%

- C293 0.1μF ±20%
- C336a 0.1μF ±20%
- C336b 0.1μF ±20%
- C337 0.1μF ±20%
- C338 0.1μF ±20%

- C339 0.1μF ±20%
- C355 25pF to 50pF
- C357 0.1μF ±20%
- C358 5000pF ±20%
- C359 5000pF ±20%

- C379a 4.7μF +50%
- C379b 0.1μF ±20%
- C383 0.1μF ±20%
- C387 0.1μF ±20%
- C388 0.033μF ±20%

- C398 33pF ±10%
- C399 56pF ±20%
- C400 56pF ±20%
- C403 120pF ±20%
- C404 39pF ±20%

- C407 0.1μF ±20%
- C408 0.01μF ±20%
- C506 1200pF ±20%
- C508 0.22μF ±20%

RESISTORS

- *R49 10kΩ Lin

- R1 180kΩ ±20%
- R143 68kΩ ±20%
- R154 10kΩ ±20%
- R155 100kΩ ±20%
- R156 680Ω ±20%

- R166 680Ω ±20%
- R167 5kΩ Log
- R168 5kΩ Log
- R170 15kΩ ±20%
- R171 10kΩ Lin

- R172 470Ω ±20%
- R173 820Ω ±20%
- R176 3.3kΩ ±20%
- R177 5kΩ Log
- R204 56Ω ±20%

- R281 10kΩ Lin
- R282 3.9kΩ ±20%
- R283 3.3kΩ ±20%
- R284 2.7kΩ ±20%
- R285 2.2kΩ ±20%

- R286 100kΩ Lin
- R287 10kΩ ±20%
- R324 6.8kΩ ±20%
- R325 5.6kΩ ±20%
- R332 22kΩ ±20%

3 4 5 6 7 8 9 10 11 12 13 14 15 16 17 18 19 20 21 22 23

58 57 56 55 54 53 52 51 50 49 48 47 46 45 44 43 42 41 40 39 38 37