



Publication Number: 91059/GPT750-E2

Issue Date: February 1991

MASTER COPY
DO NOT DESTROY

Technical Manual

for

Radio Transmitter

Models GPT-750D2 and GPT-750E2

MASTER COPY
DO NOT DESTROY

The Technical Materiel Corporation
700 Fenimore Road
Mamaroneck, New York 10543-0142 U.S.A.

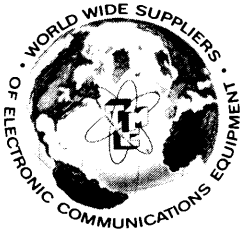

Publication Number: 91059/GPT750-E2

Issue Date: February 1991

Technical Manual
for
Radio Transmitter
Models GPT-750D2 and GPT-750E2

THE TECHNICAL MATERIEL CORPORATION
COMMUNICATIONS ENGINEERS



THE TECHNICAL MATERIEL CORPORATION

C O M M U N I C A T I O N S E N G I N E E R S

700 FENIMORE ROAD

MAMARONECK, N. Y.

W a r r a n t y

The Technical Materiel Corporation, hereinafter referred to as TMC, warrants the equipment (except electron tubes, *fuses, lamps, batteries and articles made of glass or other fragile or other expendable materials) purchased hereunder to be free from defect in materials and workmanship under normal use and service, when used for the purposes for which the same is designed, for a period of one year from the date of delivery F.O.B. factory. TMC further warrants that the equipment will perform in a manner equal to or better than published technical specifications as amended by any additions or corrections thereto accompanying the formal equipment offer.

TMC will replace or repair any such defective items, F.O.B. factory, which may fail within the stated warranty period, PROVIDED:

1. That any claim of defect under this warranty is made within sixty (60) days after discovery thereof and that inspection by TMC, if required, indicates the validity of such claim to TMC's satisfaction.
2. That the defect is not the result of damage incurred in shipment from or to the factory.
3. That the equipment has not been altered in any way either as to design or use whether by replacement parts not supplied or approved by TMC, or otherwise.
4. That any equipment or accessories furnished but not manufactured by TMC, or not of TMC design shall be subject only to such adjustments as TMC may obtain from the supplier thereof.

Electron tubes *furnished by TMC, but manufactured by others, bear only the warranty given by such other manufacturers. Electron tube warranty claims should be made directly to the manufacturer of such tubes.

TMC's obligation under this warranty is limited to the repair or replacement of defective parts with the exceptions noted above.

At TMC's option any defective part or equipment which fails within the warranty period shall be returned to TMC's factory for inspection, properly packed with shipping charges prepaid. No parts or equipment shall be returned to TMC, unless a return authorization is issued by TMC.

No warranties, express or implied, other than those specifically set forth herein shall be applicable to any equipment manufactured or furnished by TMC and the foregoing warranty shall constitute the Buyers sole right and remedy. In no event does TMC assume any liability for consequential damages, or for loss, damage or expense directly or indirectly arising from the use of TMC Products, or any inability to use them either separately or in combination with other equipment or materials or from any other cause.

*Electron tubes also include semi-conductor devices.

PROCEDURE FOR RETURN OF MATERIAL OR EQUIPMENT

Should it be necessary to return equipment or material for repair or replacement, whether within warranty or otherwise, a return authorization must be obtained from TMC prior to shipment. The request for return authorization should include the following information:

1. Model Number of Equipment.
2. Serial Number of Equipment.
3. TMC Part Number.
4. Nature of defect or cause of failure.
5. The contract or purchase order under which equipment was delivered.

PROCEDURE FOR ORDERING REPLACEMENT PARTS

When ordering replacement parts, the following information must be included in the order as applicable:

1. Quantity Required.
2. TMC Part Number.
3. Equipment in which used by TMC or Military Model Number.
4. Brief Description of the Item.
5. The *Crystal Frequency* if the order includes crystals.

PROCEDURE IN THE EVENT OF DAMAGE INCURRED IN SHIPMENT

TMC's Warranty specifically excludes damage incurred in shipment to or from the factory. In the event equipment is received in damaged condition, the carrier should be notified immediately. Claims for such damage should be filed with the carrier involved and not with TMC.

All correspondence pertaining to Warranty Claims, return, repair, or replacement and all material or equipment returned for repair or replacement, within Warranty or otherwise, should be addressed as follows:

THE TECHNICAL MATERIEL CORPORATION
Engineering Services Department
700 Fenimore Road
Mamaroneck, New York

NOTICE

THE CONTENTS AND INFORMATION CONTAINED IN THIS INSTRUCTION MANUAL IS PROPRIETARY TO THE TECHNICAL MATERIEL CORPORATION TO BE USED AS A GUIDE TO THE OPERATION AND MAINTENANCE OF THE EQUIPMENT FOR WHICH THE MANUAL IS ISSUED AND MAY NOT BE DUPLICATED EITHER IN WHOLE OR IN PART BY ANY MEANS WHATSOEVER WITHOUT THE WRITTEN CONSENT OF THE TECHNICAL MATERIEL CORPORATION.

RECORD OF REVISIONS

NO.	ISSUED	DESCRIPTION	ENTERED	BY
001				
002				
003				
004				
005				
006				
007				
008				
009				
010				

NOTE: Please file Technical Newsletters at back of manual for permanent record.

CHANGE NO. 1 GPT-750 D2 &
GPT-750 E2



INSTRUCTION BOOK CHANGE NOTICE

Date 5/19/65

Manual affected: Technical Manual for Radio Transmitter, Model GPT-750 D2 & GPT-750 E2 IN -315

1. Change paragraph 6-3c., on pages 6-5 and 6-6, as follows:
 - a. Step 1, from: "...indicator reads 2000 kc.," to "...indicator reads 1900 kc."
 - b. CAUTION, step 6 from: "2000.000 kc," to: "1900.000 kc." The error is in two places; correct both.
2. Change figure 6-9, pages 6-19/6-20, as follows:
 - a. Neatly cut out figure 1 (attached to this change notice) and appropriately affix it to figure 6-9 in the manual.
 - b. Add the following as NOTE 5: **UNLESS OTHERWISE SPECIFIED, ALL IDENTICALLY NUMBERED FRONT AND REAR TERMINALS ON SECTION A, OR SECTION B, OR SECTION C OF SWITCH S601 ARE ELECTRICALLY CONNECTED.**
 - c. Reverse diodes CR601 and CR602; they are drawn backwards.
3. Neatly cut out figure 2 (attached to this change notice) and appropriately affix it to figure 6-11 in the manual. (EMN 12880)
4. Change the parts list, page 7-19, as follows: (EMN 11585)
 - a. Delete description for C608.
 - b. Write the following description for C608: CAPACITOR: fixed; 4 uf, +10%; 1000 wvdc.
 - c. Write the following TMC part number for C608: CP40C2FG405KYY.
 - d. Change description for C609 from: "Same as C604," to: "Same as C608."

SHOULD ADDITIONAL COPIES OF THIS CHANGE NOTICE BE REQUIRED, PLEASE CONTACT:

THE TECHNICAL MATERIEL CORP., 700 Fenimore Road, Mamaroneck, New York

Attn.: Director of Eng. Services.

CHANGE NO. 2 GPT-750D2
GPT-750E2



INSTRUCTION BOOK CHANGE NOTICE

Date 3/9/68

Manual affected: Radio Transmitter, Models GPT-750D2 IN -315
and GPT-750E2 (Issue Date: 1 April 1964)

Page 6-6.

Change paragraph 6-5b to read as follows:

b. The following items should be cleaned with a soft cloth and trichloroethylene or ethylenedichloride.

SHOULD ADDITIONAL COPIES OF THIS CHANGE NOTICE BE REQUIRED, PLEASE CONTACT:

THE TECHNICAL MATERIEL CORP., 700 Fenimore Road, Mamaroneck, New York

CHANGE NO. 3 GPT-750 D-2
GPT-750 E-2



INSTRUCTION BOOK CHANGE NOTICE

Date 9/16/66

Manual affected: Radio Transmitter, Models IN -315
GPT-750 D-2 and GPT-750 E-2 (Issue Date: 1 April 1964)

Page 2-3. Paragraph 2-5 a.

Change the third sentence of paragraph 2-5 a. to read:

Relay TRL-3 is supplied for use with coaxial transmission lines of 50-ohm characteristic impedance; the TRL-4 is supplied for use with 70-ohm impedance coaxial transmission line.

SHOULD ADDITIONAL COPIES OF THIS CHANGE NOTICE BE REQUIRED, PLEASE CONTACT:

THE TECHNICAL MATERIEL CORP., 700 Fenimore Road, Mamaroneck, New York

Attn.: Director of Eng. Services.



INSTRUCTION BOOK CHANGE NOTICE

Date 6/29/67

Manual affected: Radio Transmitter Models GPT-750D-2 IN 315
Issue Date: 1 April 1964 GPT-750E-2

1. Page 4-13 Paragraph 4-3 (12) should read as follows:
"Keyer V202A and V202B, a dual triode," etc.
2. Figure 6-8, pages 6-17/6-18 change to conform to the following:

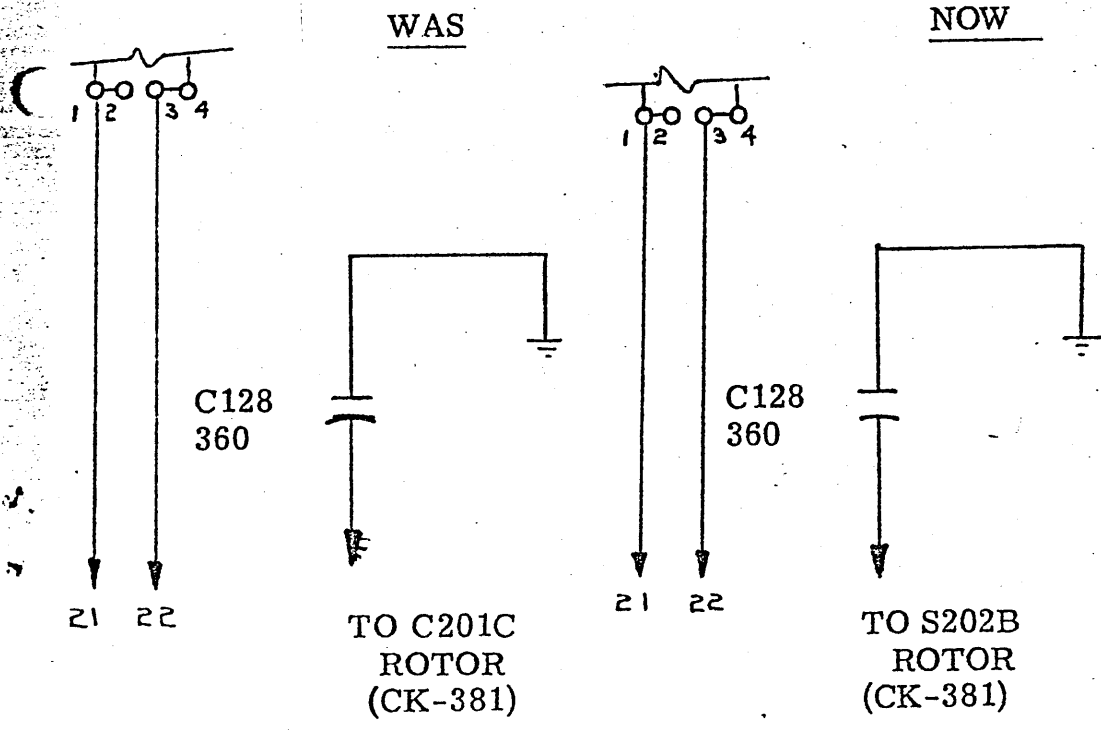

CHANGE NO. 5



INSTRUCTION BOOK CHANGE NOTICE

Date Oct. 11, 1967

Manual affected: GPT-750D2 and E2 IN 312 - 313 - 314

Paragraph 2-5. INSTALLATION OF ACCESSORIES. Add the following:

d. For interlock protection when more than one accessory are to be used with the transmitter, the interlock circuits of the accessories must be connected in series. Terminal 27 of E502 can be used to accomplish this.

Per EMN 18552

SHOULD ADDITIONAL COPIES OF THIS CHANGE NOTICE BE REQUIRED, PLEASE CONTACT:

THE TECHNICAL MATERIEL CORP., 700 Fenimore Road, Mamaroneck, New York

Attn.: Director of Eng. Services.



INSTRUCTION BOOK CHANGE NOTICE

Date June 16, 1971

Radio Transmitter Models
 GPT-750D2, GPT-750E2, GPT-750F2,
 GPT-750G2 and GPT-750H2

Manual affected: _____

IN 315

1. On Figure 6-9, page 6-19/6-20, add C614 as indicated below:

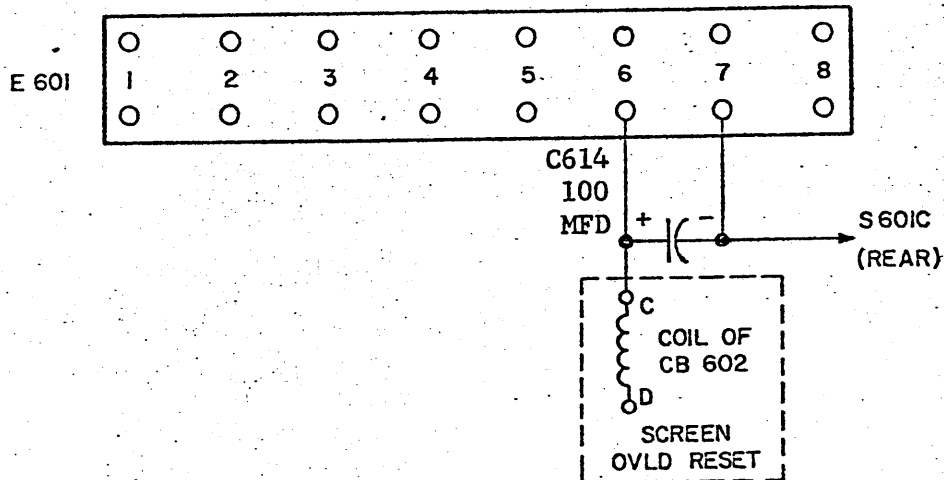

2. Change last symbol number column from C612 to C614.
3. Add the following component to the RTP-2 Parts Listing on page 7-19:

REF SYMBOL	DESCRIPTION	FUNCTION	TMC PART NO
C614	Capacitor, Fixed: Electrolytic 100MFD, 100WVDC	Final Screen Grid Overload Delay	CE105-100-100

SHOULD ADDITIONAL COPIES OF THIS CHANGE NOTICE BE REQUIRED, PLEASE CONTACT:

THE TECHNICAL MATERIEL CORP., 700 Fenimore Road, Mamaroneck, New York

Attn: Director of Eng. Services.

(SEE NOTE 5)

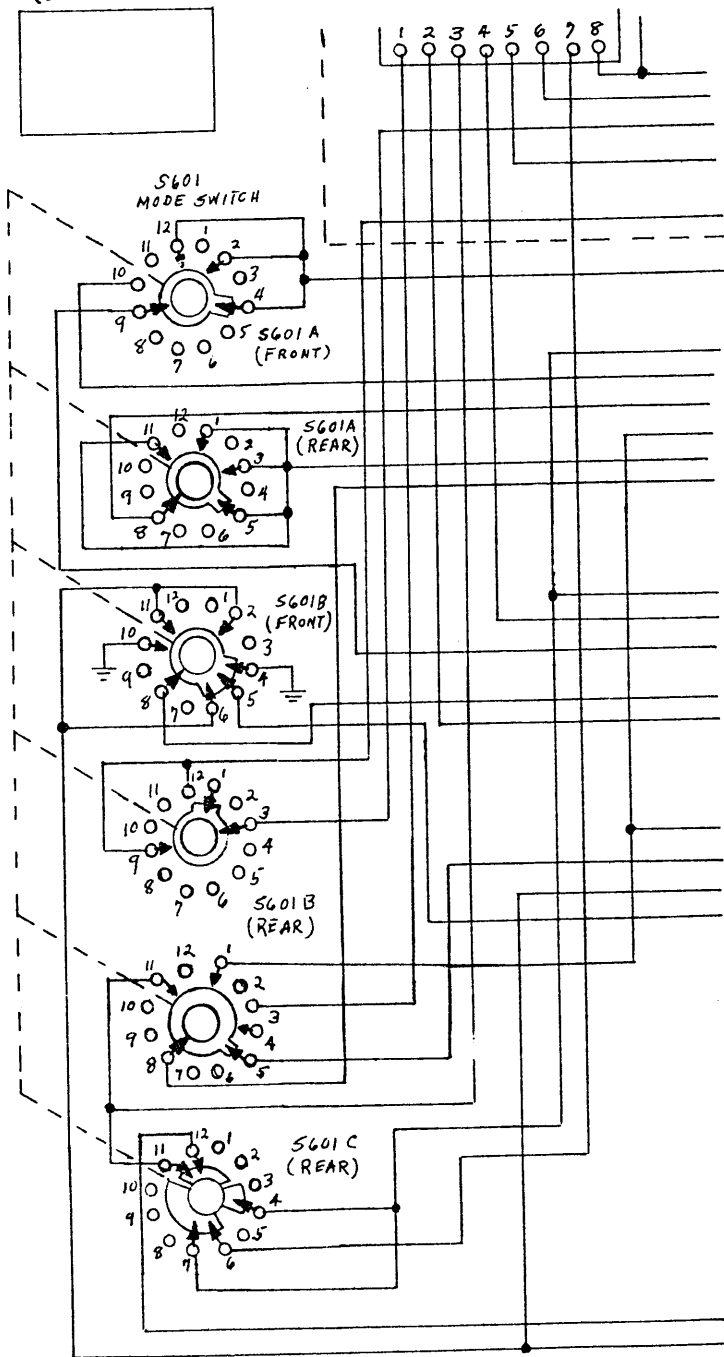

Figure 1

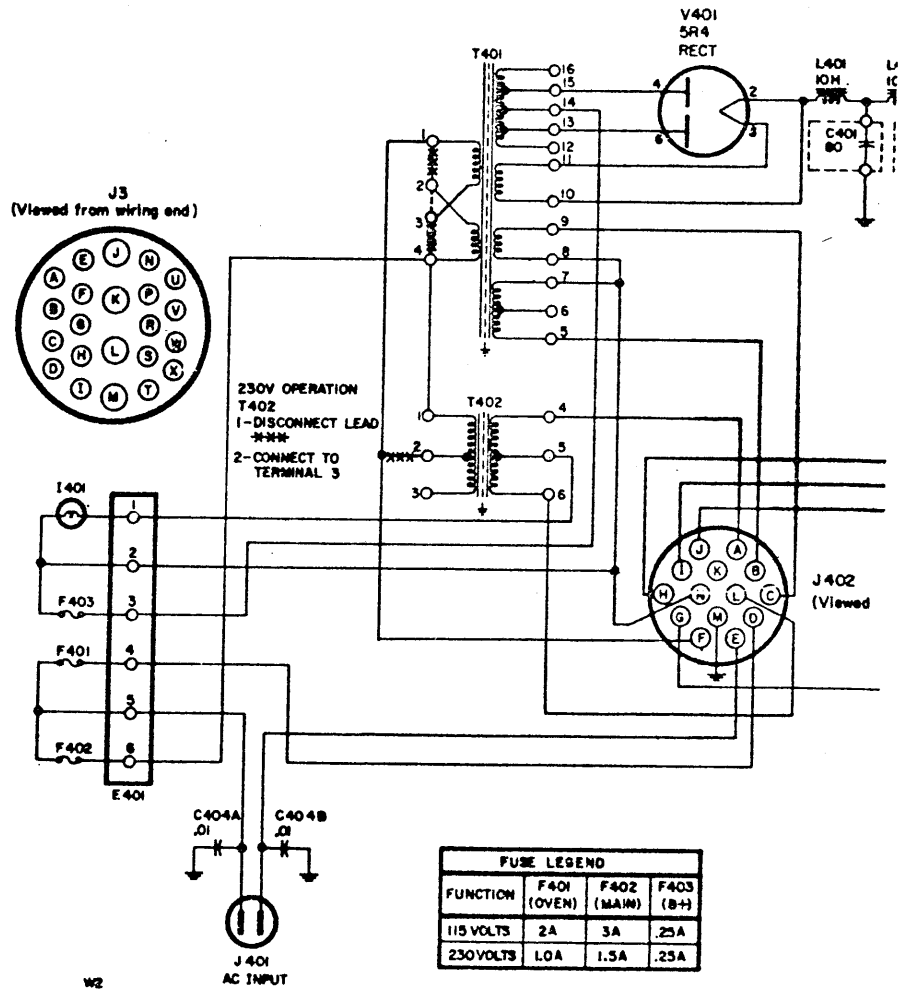

Figure 2

TABLE OF CONTENTS

SECTION 1—GENERAL DESCRIPTION

Paragraph	Page
1-1 Scope of Manual.	1-1
1-2 Description.	1-1
1-3 Functional System Description	1-3
1-4 Technical Characteristics	1-4
1-5 Equipment Supplied	1-4
1-6 Shipping Data	1-4
1-7 Equipment Required but Not Supplied	1-4
1-8 Tube and Fuse Complement	1-4
1-9 Reference Symbol Series Designations.	1-4

SECTION 2—INSTALLATION

2-1 Unpacking and Handling	2-0
2-2 Siting the Equipment.	2-0
2-3 Installation Procedures	2-0
2-4 Internal Cabling Connections	2-3
2-5 Installation of Accessories.	2-3
2-6 Auxiliary Equipment.	2-6
2-7 Preliminary Adjustments	2-6

SECTION 3—OPERATION

3-1 Introduction	3-1
3-2 Controls and Indicators	3-1
3-3 Calibration of VMO	3-6
3-4 Exciter MF Tuning	3-6
3-5 Exciter RF Tuning	3-11
3-6 RTF-2 Driver Tuning	3-11

Paragraph	Page
3-7 RTP-2 Power Amplifier Tuning.	3-11
3-8 Additional Procedures.	3-12
3-9 Operator's Maintenance	3-12

SECTION 4—PRINCIPLES OF OPERATION

4-1 Introduction	4-1
4-2 Functional Block Diagram Description.	4-1
4-3 Detailed Description.	4-7

SECTION 5—TROUBLE-SHOOTING

5-1 General	5-1
5-2 Trouble-Shooting Procedures.	5-1
5-3 Voltage and Resistance Data	5-1

SECTION 6—MAINTENANCE AND REPAIR

6-1 General	6-0
6-2 Tuning and Adjustment.	6-0
6-3 Replacement of Components	6-5
6-4 Inspection	6-6
6-5 Cleaning	6-7/6-8
6-6 Lubrication.	6-7/6-8
6-7 Schematic Diagrams.	6-7/6-8

SECTION 7—SPARE PARTS

LIST OF ILLUSTRATIONS

SECTION 1—GENERAL DESCRIPTION

Figure	Page
1-1 Radio Transmitters, Models GPT-750D-2 and GPT-750E-2	iv
1-2 Radio Transmitters, Simplified Block Diagram	1-3

SECTION 2—INSTALLATION

2-1 Transmitter Mounting Dimensions	2-1/2-2
2-2 Transmitter Cabling Connections	2-4
2-3 Cabinet Frame Assembly, CAB-7,	2-5
2-4 TRL-3 or TRL-4 Interconnections to Transmitter	2-5
2-5 Control C-1138/UR Interconnections to Transmitter	2-6
2-6 Remote Control Amplifier Model RTC, Interconnections to Transmitter	2-6
2-7 Radiophone Unit C-1207/UR Interconnections to Transmitter	2-7

SECTION 3—OPERATION

3-1 Transmitter Front Panel Controls and Indicators.	3-1
3-2 Radio Transmitter Model GPT-750D-2 Typical Tuning Chart.	3-7/3-8
3-3 Radio Transmitter Model GPT-750E-2 Typical Tuning Chart.	3-9/3-10

SECTION 4—PRINCIPLES OF OPERATION

4-1 Radio Transmitter, Detailed Block Diagram	4-3/4-4
4-2 Transmitting Mode Selector Model SBE-3, Detailed Block Diagram	4-5/4-6
4-3 Master and Calibrator Oscillators, Simplified Schematic Diagram.	4-8
4-4 Buffer Stage, Simplified Schematic Diagram	4-8
4-5 Crystal Oscillator/Amplifier, Schematic Diagram	4-9
4-6 Cathode Follower, Simplified Diagram	4-9
4-7 Mixer Stage, Simplified Schematic Diagram	4-10
4-8 Audio Amplifier, Simplified Schematic Diagram	4-10
4-9 Frequency Multiplier (NORMAL Mode) Simplified Schematic Diagram.	4-11
4-10 Frequency Multiplier (SSB Mode) Simplified Schematic Diagram.	4-12
4-11 Metering Circuit, Simplified Schematic Diagram	4-14

Figure	Page
4-12 115-Volt Line Distribution, Simplified Schematic Diagram.	4-15
4-13 Low-Voltage Supply, Simplified Schematic Diagram.	4-16
4-14 Low-Voltage Supply Distribution, Simplified Schematic Diagram.	4-17
4-15 Midvoltage Supply, Simplified Schematic Diagram	4-18
4-16 Midvoltage Supply Distribution, Simplified Schematic Diagram.	4-19
4-17 High-Voltage Supply, Simplified Schematic Diagram	4-19
4-18 High-Voltage Supply Distribution, Simplified Schematic Diagram.	4-20

SECTION 5—TROUBLE-SHOOTING

5-1 Voltage and Resistance Diagram, Model RTP-2	5-8
5-2 Voltage and Resistance Diagram, Model RTF-2	5-9
5-3 Voltage and Resistance Diagram, Model RTS-2	5-10
5-4 Tube Locations, Model RTP-2	5-10
5-5 Tube Locations, Model RTF-2	5-11
5-6 Tube Locations, Model RTS-2	5-11

SECTION 6—MAINTENANCE AND REPAIR

6-1 Internal Adjusting Controls, Model RTP-2	6-1
6-2 Internal Adjusting Controls, Model RTF-2	6-1
6-3 Vacuum Tube Capacitor C113, Replacement	6-6
6-4 Radio Transmitters Models GPT-750D-2 and GPT-750E-2 Schematic Diagram	6-9/6-10
6-5 Master Oscillator, Model RTF-2, Schematic Diagram	6-11/6-12
6-6 Interconnect Chassis, Model RTF-2, Schematic Diagram	6-13/6-14
6-7 Multiplier, Model RTF-2, Schematic Diagram	6-15/6-16
6-8 Power Amplifier, Model RTF-2, Schematic Diagram	6-17/6-18
6-9 Power Supply, Model RTP-2, Schematic Diagram	6-19/6-20
6-10 Cabinet Frame Assembly CAB-7, Schematic Diagram	6-21/6-22
6-11 Panel Chassis Assembly, Model RTS-2, Schematic Diagram.	6-23/6-24

LIST OF TABLES

SECTION 1—GENERAL DESCRIPTION

Table	Page
1-1 List of Manuals Supplied	1-1
1-2 Technical Characteristics	1-2
1-3 Equipment Supplied	1-4
1-4 Shipping Data	1-5
1-5 Equipment Required but Not Supplied. . .	1-5
1-6 Accessories.	1-6
1-7 Vacuum Tube Complement	1-6
1-8 Fuse Complement	1-7
1-9 Reference Symbol Series Assignments	1-7

SECTION 2—INSTALLATION

2-1 Primary Power Wiring Changes.	2-0
---	-----

SECTION 3—OPERATION

Table	Page
3-1 Model RTF-2, Front Panel Controls and Indicators.	3-1
3-2 Model RTP-2, Front Panel Controls and Indicators.	3-3
3-3 Model RTS-2, Front Panel Controls and Indicators.	3-4
3-4 Model SBE-2 and Model SBE-3, Front Panel Controls and Indicators.	3-5

SECTION 5—TROUBLE-SHOOTING

5-1 System Trouble-Shooting Chart	5-2
5-2 RTP-2 Trouble-Shooting Chart	5-3
5-3 RTF-2 Trouble-Shooting Chart	5-5
5-4 Amplifier-Oscillator RTF-2, Front Panel Meter Readings	5-7
5-5 Terminal Strip Voltages	5-7

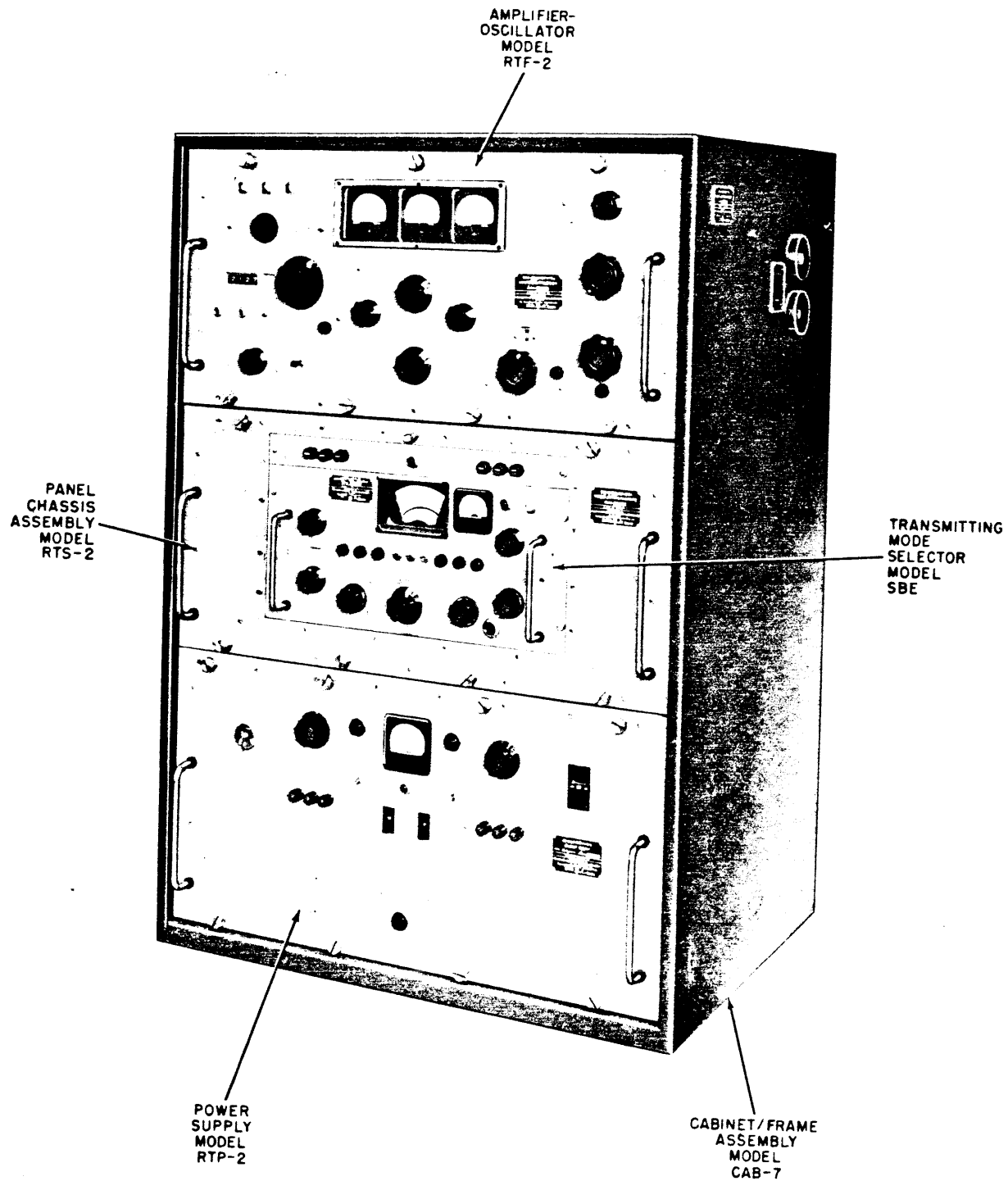

Figure 1-1. Radio Transmitters, Models GPT-750D-2 and GPT-750E-2

SECTION 1 GENERAL DESCRIPTION

1-1. SCOPE OF MANUAL.

a. This manual covers Radio Transmitter Model GPT-750D-2 and Model GPT-750E-2 (figure 1-1). The information contained in this manual is presented on a system basis and will aid operating and maintenance personnel in realizing the full performance capabilities of the equipment. An individual equipment manual covering the sideband exciter is also provided; depending on the radio transmitter model supplied. Refer to table 1-1. When detailed information regarding one of the units covered in the individual equipment manual is required, reference is made to the applicable equipment manual. Complete description, installation, system and unit trouble-shooting and maintenance instructions, and a parts list in the individual equipment manual provide all information required to order any repair part of the equipment.

b. With the exception of the exciter unit, the two models covered in this manual are identical. The difference in the models due to the exciter are explained later in this section. For the most part, the procedures and descriptions contained in this manual are applicable to both models; where there are differences, they are carefully pointed out.

TABLE 1-1. LIST OF MANUALS SUPPLIED

Technical Manual for Radio Transmitter Model GPT-750D-2, and Radio Transmitter Model GPT-750E-2.

Technical Manual for Transmitting Mode Selector Model SBE-2 (supplied with Model GPT-750D-2 only).

Technical Manual for Transmitting Mode Selector Model SBE-3 (supplied with Model GPT-750E-2 only).

1-2. DESCRIPTION.

a. The TMC Radio Transmitter Model GPT-750D-2 and Radio Transmitter Model GPT-750E-2 are designed and constructed on a modular basis. The two radio transmitters are similar; both employ the same Cabinet/Frame Assembly Model CAB-7, Amplifier-Oscillator Model RTF-2, Power Supply Model RTP-2, and Panel Chassis Assembly Model RTS-2. The difference between the two radio transmitters is in the exciters used for each: the Model GPT-750D-2 uses a Transmitting Mode Selector Model SBE-2, and the Model GPT-750E-2 uses the Model SBE-3. The audio bandpass characteristic of the exciters differs, which

accounts for the differences in the two models of the radio transmitter. These differences are indicated in table 1-2, Technical Characteristics.

b. The two radio transmitters operate in the frequency range 2 to 32 mc, with AM, CW, SSB, or ISB emission. The power output varies, depending upon the type of emission: maximum power output is 1000 watts. Operation in the MCW mode is possible with the use of an external source of keying tone, such as the TMC Remote Control Amplifier Model RTC.

c. The radio transmitter is completely contained in a reinforced steel cabinet equipped with cross braces and track slides for support of the three drawer components. The cabinet, an integral part of the transmitter, may be supplied with a reinforced steel base or mounted on heavy duty shock mounts. The main power transformer is mounted on the bottom of the cabinet. The rear panel of the center section contains the blower, input and output connection terminals and plugs, and the terminal boards containing power supply and RF filter components. The antenna and RF monitor connections are located on the right side of the cabinet. The antenna connector is a type UG-560/U coaxial connector; the monitor connector is a UHF type.

d. The lower drawer (figure 1-1) contains the Power Supply Model RTP-2 which provides operating Power for the Amplifier-Oscillator. Eight captive screws secure the unit in the cabinet. All operating controls and indicators are mounted on the front panel; other adjustments are located in the relay deck and on the main power supply chassis. Handles on the front panel facilitate removal of the unit or opening the drawer for access to the internal adjustments.

e. The center drawer consists of the Panel Chassis Assembly Model RTS-2 which contains the exciter unit, Model SBE. Power for the exciter unit supplied from the built-in power supply of the RTS-2. Power fuses, a power indicator lamp, and an RF monitor jack are located on a panel just above the exciter unit. This panel is part of the RTS-2. There are no internal adjustments on the power supply. The exciter unit slides into the panel and chassis assembly on the RTS-2, and is secured by four captive screws. All interconnections between the exciter and the RTS-2 and the transmitter are made through connectors and terminals accessible at the rear of the unit.

f. The Transmitting Mode Selectors Models SBE are filter-type sideband exciters. Each exciter provides at least 1 watt PEP for single or independent sideband operation, or 0.5-watt average power for other modes of operation. The exciters develop single or independent sideband transmissions with any degree of carrier insertion. The exciters are completely described in individual manuals supplied for the particular model radio transmitter.

g. The Amplifier-Oscillator Model RTF-2 comprises the top drawer of the radio transmitter. This

TABLE 1-2. TECHNICAL CHARACTERISTICS

Operating Frequency Range:	2 mc to 32 mc
Power Output:	1000 watts CW 750 watts PEP, sideband
Types of Emission:	CW; AM; ISB; SSB carrier
RTF-2 Crystal Oscillator Characteristics:	
Frequency Range:	2 to 4 mc
Number of Crystals:	3, selected from front panel
Type of Crystal:	CR-18/U
Master Oscillator Characteristics:	
Frequency Range:	2 to 4 mc continuously tunable
Stability:	Better than 20 cps/mc for a 30° C change in ambient temperature.
Line Voltage Effect:	Not more than 10 cps for a ±10% line voltage variation.
Oscillator Calibration:	Direct reading in cps.
Readability:	20 cps/mc
Frequency Calibration:	Oven-controlled 100-kc oscillator provides check points every 50 kc. Oscillator may be calibrated against primary standard.
Zero Beat Indication:	50-kc check points on neon light null indicator. Aural check points available with use of headset in PHONES jack.
Average Plate Efficiency	At least 50%
Signal to Distortion Ratio:	35 db at 750 watts PEP on standard 2 tone test 40 db at 500 watts PEP on standard 2 tone test
Output Impedance:	30 to 1000 ohms at angle 0° (equivalent SWR: 1:1); 50 to 700 ohms at angle +45° (equivalent SWR: 4:1) all unbalanced to ground.
Audio input:	Two independent 600-ohm channels, balanced or unbalanced.
Audio Response per Sideband Model GPT-750D-2 using Model SBE-2 exciter:	Within ±1.5 db from 350 cps to 3300 cps.
Model GPT-750E-2 using Model SBE-3 exciter:	Within ±1.5 db from 250 cps to 7500 cps.
Overload and Bias Protection:	Automatic protection.
Cooling:	Forced filtered air from two blowers; one in cabinet, one in RTF-2 power amplifier section.
Primary Power:	115/230 volts, 50/60 cps, single phase, approximately 2600 watts at -0.87 power factor.
Overall Dimensions:	Height - 47 in. without base or shock mounts 50-3/4 in. with base 49-3/8 in. with shock mounts Width - 37-5/8 in. Depth - 28-1/2 in. Weight - 822 lbs.

TABLE 1-2. TECHNICAL CHARACTERISTICS (CONT)

Unit Dimensions:	
Amplifier-Oscillator Model RTF-2:	Height - 14 in. Width - 31-1/4 in. Depth - 25 in. Weight - 108 lbs
Panel Chassis Assembly: (Including Exciter)	Height - 14 in. Width - 31-1/4 in. Depth - 21-1/4 in. Weight - 97 lbs
Power Supply Model RTP-2:	Height - 15-3/4 in. Width - 31-1/4 in. Depth - 24-1/2 in. Weight - 171 lbs

unit consists of a master oscillator, crystal oscillator, multiplier section, power amplifier, interconnect chassis and the front panel assembly. It is secured in the cabinet by seven captive screws. Operating controls and indicators are located on the front panel and on the chassis; other maintenance and periodic adjustment controls are located on the various subchassis. A lamp installing tool is supplied with the unit and is secured in a clip on the rear of the master oscillator housing; three hex wrenches for the various size set-screws are mounted in clips on the right side of the power amplifier housing.

1-3. FUNCTIONAL SYSTEM DESCRIPTION.

a. Figure 1-2 is a simplified block diagram of the SSB radio transmitting systems. The RTF-2 is shown as consisting basically of a master oscillator, amplifiers and power amplifier; the exciter unit basically comprises dual channel audio circuits, midfrequency and high frequency circuits; the power supply contains the high voltage, midvoltage, and two low voltage supplies, one for low level plate and screen voltage, and the other for bias voltages.

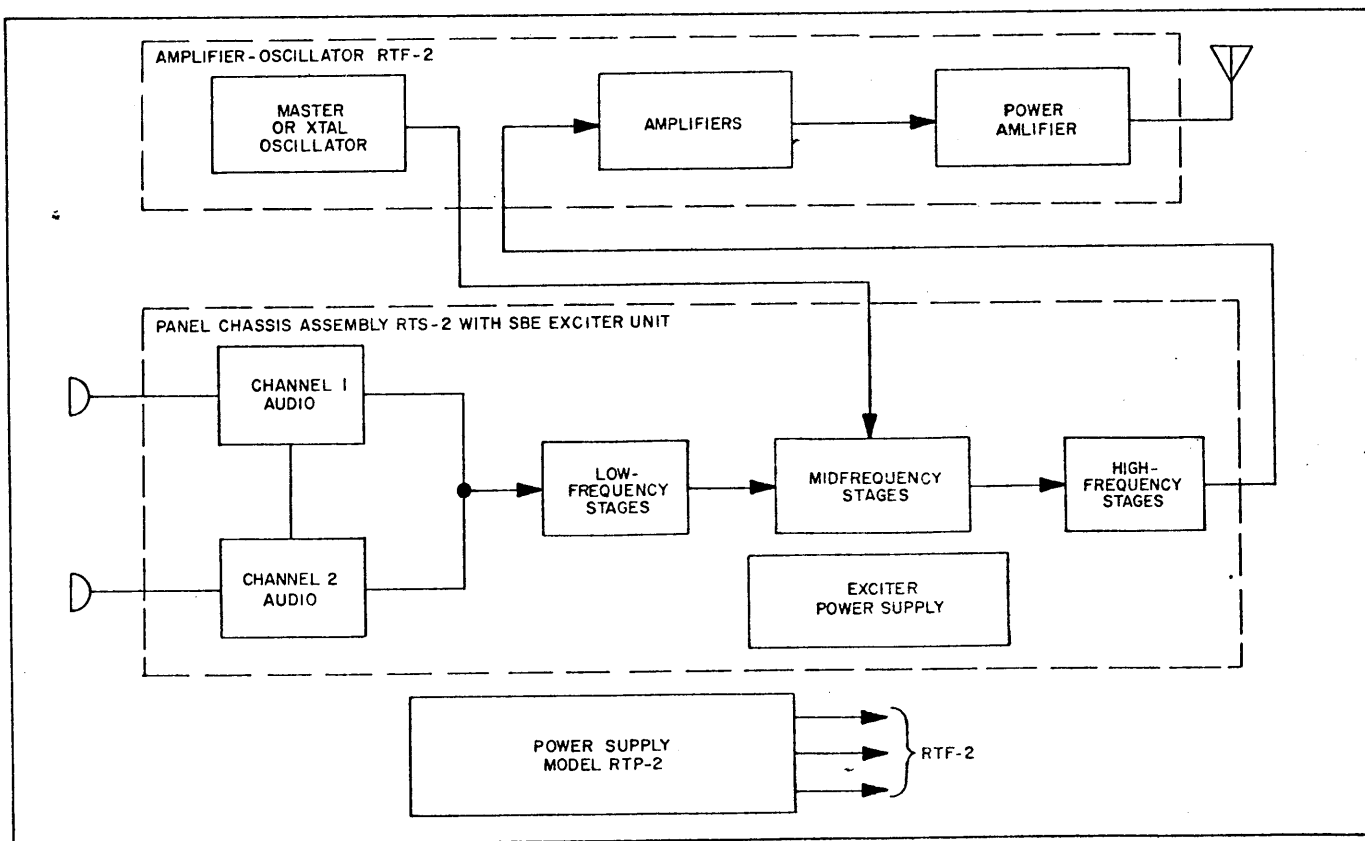

Figure 1-2. Radio Transmitters, Simplified Block Diagram

b. The master oscillator operates in the range of 2 to 4 mc. In the SSB or ISB modes, the master oscillator output is generally applied to the exciter unit as the injection frequency. The crystal-controlled oscillator also operates in the 2- to 4-mc range and may be used in place of the master oscillator to supply the injection frequency. When crystal oscillator operation is used, the master oscillator is disabled.

c. The modulated signal from the output of the exciter is applied to the amplifiers and driver which are tuned to the exciter frequency. The output of the driver is applied to the tuned power amplifier stage and to the transmitting antenna.

d. The exciter provides two audio channels which produce the sidebands for modulation of the rf carrier. In standard AM operation, the input to the audio channels is the same intelligence; in independent sideband operation, different intelligence is carried by each channel is use. During single sideband operation, intelligence is transmitted on one sideband only, the other sideband is suppressed.

e. Within the exciter, the injection signal from the RTF-2 is modulated and raised to the desired frequency for transmission. Ten internal crystals can be used to supply the injection frequency in place of the output from the RTF-2. The amplified modulated signal from the exciter is applied to the amplifier and driver and power amplifier in the RTF-2. These stages act as straight rf amplifiers in this mode of operation.

f. The power supply provides all necessary operating voltages for the amplifier-oscillator and controls the operating mode by means of front panel controls. Safety interlock circuits provide protection for the equipment and personnel. A more complete description of system operation is given in section 4 of this manual.

1-4. TECHNICAL CHARACTERISTICS.

Complete characteristics of the radio transmitters are given in table 1-2.

1-5. EQUIPMENT SUPPLIED.

Table 1-3 lists the equipment supplied to make up each radio transmitter. The manufacturer's nomenclature and model number, military designation, and common name are given. Throughout this manual the equipments will be referred to by their common name or manufacturer's designation.

1-6. SHIPPING DATA.

The equipment is packed and shipped in five wooden boxes in accordance with Specification MIL-P-1755(d) (SHIPS). The cabinet is shipped with either the steel base or shock mounts. Table 1-4 lists the box number, contents, and shipping weights and dimensions. The dimensions and weight of the individual units are given in table 1-2, Technical Characteristics.

1-7. EQUIPMENT REQUIRED BUT NOT SUPPLIED.

Table 1-5 lists the equipments required to complete the installation of the radio transmitter. Accessory items that can be used with either model of the radio transmitter and their application are listed in table 1-6.

1-8. TUBE AND FUSE COMPLEMENT.

Table 1-7 lists the tubes used in the units that comprise each transmitter except for the exciter unit. The tube complement for the exciter is listed in the applicable manual. Table 1-8 lists the fuses, their rating, and function. All line fuse ratings are shown for both 115-volt and 230-volt operation.

1-9. REFERENCE SYMBOL SERIES DESIGNATIONS.

The modular construction of the basic radio transmitter and the additional units such as the SBE-2 and SBE-3 exciters, result in duplicate reference symbol numbers being assigned in some of the equipments. Table 1-9 lists the reference symbol series assigned to each component of the radio transmitter.

TABLE 1-3. EQUIPMENT SUPPLIED

DESCRIPTION AND MODEL NO.	MILITARY DESIGNATION	COMMON NAME
Radio Transmitter Model GPT-750D-2	Radio Transmitting Set AN/URT-17A	Radio transmitter
Radio Transmitter Model GPT-750E-2	Radio Transmitting Set AN/FRT-55	Radio transmitter
Cabinet/Frame Assembly Model CAB-7	Cabinet, Electrical, CY-2660/URT-17A	Cabinet
Amplifier-Oscillator Model RTF-2	Amplifier-Oscillator AM-2771/URT-17A	RF deck
Panel Chassis Assembly Model RTS-2	Drawer, Electrical Equipment MT-2193/URT-17A	Panel Assembly
Transmitting Mode Selector Model SBE-2 (for GPT-750D-2 only)	Modulator, Power Supply Group AN/URA-23A	Exciter Unit
Transmitting Mode Selector Model SBE-3 (for GPT-750E-2 only)	Modulator, Power Supply Group AN/URA-28	Exciter Unit
Power Supply Model RTP-2	Power Supply PP-2396/URT-17A	Power Supply

TABLE 1-4. SHIPPING DATA

BOX NO.	ITEM	DIMENSIONS (in.)			WEIGHT (lbs)
		LENGTH	WIDTH	HEIGHT	
1	Cabinet/Frame Assembly Model CAB-7	38-1/2	31	56	610
2	Amplifier-Oscillator Model RTF-2	37	30-1/2	24-1/4	235
3	Panel Chassis Assembly Model RTS-2 (Including Transmitting Mode Selector SBE-2 or SBE-3)	37	30-1/2	24-1/2	222
4	Power Supply Model RTP-2	37	30-1/2	24-1/2	296
5	Assorted Items: Test Data, 1 set Technical Manuals, 2 each, TMC P/N IN-315 Tube, Electron, 2 each, Reference Symbols V606 and V607, TMC P/N 872-A (Removed from Power Supply Model RTP-2) Tube, Electron, 2 each, Reference Symbols V101 and V102, TMC P/N 4-250-A (Removed from Amplifier-Oscillator Model RTF-2) Cable, Power, 1 each, TMC P/N CA-103-72 Cover, Terminal, 1 each, TMC P/N MS-1505-C Tube, Electron, 1 each, Reference Symbol V401, TMC P/N-5R4, (Removed from Transmitting Mode Selector Model SBE-2 or SBE-3) Thumbscrew, Hexagon head, 22 each, TMC P/N SC-139 Plug, Electrical, 1 each, TMC P/N PL-134-NG Plug, Electrical, 3 each, TMC P/N PL-259-A Strip, Terminal, 2 each, F/U/WE501 and E502, located in Remote Control Amplifier Model RTC, TMC P/N TM-105-14-A1 Plug, Electrical, 1 each, TMC P/N UG-59-B/U Plug, Electrical, 3 each, TMC P/N UG-176/U Mounting Kit, Antenna Tuner to CAB-7, 1 each, consisting of: Washer, Flat, 8 each, TMC P/N FW-25-HBC Washer, Split, 4 each, TMC P/N LWS-25-MRC Nut, Wing, 4 each, TMC P/N NT110-2520BN Screw, Hexagon Head, 4 each, TMC P/N SCHH-2520-BC16 Nut, Spacer, 4 each, TMC P/N TE-2520-BC3H Washer, Fiber, 4 each, TMC P/N WA-101-6 Plug, Electrical, 1 each, TMC P/N PL-259-A Microphone, 1 each, TMC P/N MK-103 (When specified) Antenna Relay, 1 each, TMC P/N TRL04 (When specified) Plug, Electrical, 1 each, TMC P/N PL-132-3	24-1/8	13	20-7/8	65

TABLE 1-5. EQUIPMENT REQUIRED BUT NOT SUPPLIED

ITEM	CHARACTERISTICS AND USE	ITEM	CHARACTERISTICS AND USE
Power Cable	3-conductor cable for 115/230-volt ac, 3000-watt primary power input. Length as required.	Headset	For aural monitoring.
Coaxial cable	RG-8/U, RG-9/U, RG-11/U, or RG-12/U per station requirements. Length as required.	Crystals	Type CR-18/U for RTF-2. Operating frequencies should be specified on ordering.
		Antenna	50- or 70-ohm, unbalanced input

TABLE 1-6. ACCESSORIES

ITEM	USE	MANUAL
Transmit-Receive Relay Model TRL-3 (70-ohm impedance)	Antenna switching	Instruction Book for Antenna Tuning Unit Model TAC Technical Manual for Antenna Tuning System Model ATS-2 Technical Manual for Remote Control Amplifier Model RTC
Transmit-Receive Relay Model TRL-4 (50-ohm impedance)	Antenna switching	
Antenna Tuning Unit Model TAC	Antenna tuning	
Antenna Tuning System Model ATS-2	Antenna tuning	
Remote Control Amplifier Model RTC	Tone keying for MCW operation	
Power Supply A-1504	12 vdc power source for remote radio- phone units	

TABLE 1-7. VACUUM TUBE COMPLEMENT

REFERENCE SYMBOL	TYPE	FUNCTION
AMPLIFIER-OSCILLATOR MODEL RTF-2		
V101	4-250A	PA Final Stage
V102	4-250A	PA Final Stage
V201	6CL6	Amplifier-Doubler
V202	12AT7	Keyer-Driver
V203	OA2	Voltage Regulator
V204	6BF5	Doubler
V205	6146	Driver
V206	12AT7	Keyer Clamp
V301	6AB4	VMO
V302	12AU7	Cathode Follower
V401	OA2	Voltage Regulator
V402	6C4	Cathode Follower
V403	6AH6	Amplifier
V404	12AU7	Cathode Follower
V405	6BE6	Mixer
V406	12AU7	Amplifier

REFERENCE SYMBOL	TYPE	FUNCTION
POWER SUPPLY MODEL RTP-2		
V601	OB2	Bias Regulator
V602	OB2	Bias Regulator
V603	6X4	Low voltage rectifier
V604	5R46Y	Low voltage rectifier
V606	872A	High voltage rectifier
V607	872A	High voltage rectifier
V608	OA2	Screen grid regulator
V609	OA2	Screen grid regulator
V610	OA2	Screen grid regulator
V611	OA2	Screen grid regulator
PANEL CHASSIS ASSEMBLY MODEL RTS-2		
V401	5R4	Full-wave rectifier
V402	OA2	Voltage regulator

TABLE 1-8. FUSE COMPLEMENT

REFERENCE SYMBOL	RATING (AMPERES)		FUNCTION
	115V	230V	
INTERCONNECT CHASSIS ON AMPLIFIER-OSCILLATOR MODEL RTF-2.			
F401	2.0	2.0	Heater
POWER SUPPLY MODEL RTP-2			
F601	3.0	1.5	Master Oscillator oven
F602	3.0	1.5	Low voltage supply
F603	3.0	1.5	Midvoltage supply
F604	0.125	0.125	Low voltage B-

REFERENCE SYMBOL	RATING (AMPERES)		FUNCTION
	115V	230V	
POWER SUPPLY MODEL RTP-2 (CONT)			
F605	0.3	0.3	Low voltage B+
F606	0.3	0.3	Midvoltage B+
PANEL CHASSIS ASSEMBLY MODEL RTS-2			
F401	2.0	1.0	Oven fuse for exciter
F402	3.0	1.5	Main power
F403	0.25	0.25	B+

TABLE 1-9. REFERENCE SYMBOL SERIES ASSIGNMENTS

EQUIPMENT	REFERENCE SYMBOL SERIES
Amplifier-Oscillator Model RTF-2	100-499
Power Amplifier Section	100-199
Multiplier Section	200-299
Master Oscillator Section	300-399
Interconnect Chassis	400-499

EQUIPMENT	REFERENCE SYMBOL SERIES
Power Supply Model RTP-2	600-699
Cabinet/Frame Assembly Model CAB-7	500-599
Panel Chassis Assembly Model RTS-2	400-499
Transmitting Mode Selector Model SBE-2 (or SBE-3)	100-299

SECTION 2 INSTALLATION

2-1. UNPACKING AND HANDLING.

The radio transmitter is shipped in five wooden packing boxes. The contents of each box and the weights and dimensions are given in table 1-4. Each box is labeled as to its contents and also indicates the box number which contains the technical manuals with directions to open that particular box first. The boxes should be placed in the vicinity of the area selected for the installation. Each box is nailed and banded with steel strapping. Normal precautions should be used in removing the strapping and opening the boxes to avoid injury or damage to the equipment. Box number five contains the loose items including the tubes and a time delay relay and should be handled with extreme care. Inspect the contents of each box for any signs of damage that may have occurred in transit.

2-2. SITING THE EQUIPMENT.

a. The radio transmitter should be assembled at the operating position. In selecting the position for the installation, sufficient area should be allowed around the radio transmitter to permit access to the terminal board connections and plug connections at the rear of the radio transmitter and the antenna connections on the side. A minimum of 12 inches should be allowed at the rear of the transmitter. Two blowers are used for cooling, one in the main cabinet and one in the power amplifier section of the RTF-2, which both vent out the rear of the cabinet. Free flow of air must be considered when the installation is made. The top of the cabinet has holes drilled for mounting of certain accessory units. Sufficient overhead space must be allowed for the installation of these accessory units if they are to be used. Installation mounting details are shown in figure 2-1. If the radio transmitter is shipped with the two top shock mounts, usually for shipboard installations, standoffs will have to be provided by the installing activity to insure the required access at the rear of the radio transmitter.

b. Although the radio transmitter does not require a specially prepared and reinforced platform, the site should be level and be able to sustain the weight of the assembled radio transmitter. If the shock mounts are used rather than the steel base, suitable means of securing the shock mounts to the floor must be provided.

2-3. INSTALLATION PROCEDURES.

a. The primary power source must be 115/230 volts, 50/60-cps, single-phase, capable of supplying 3000 watts at a power factor of 0.87. The radio transmitter is shipped from the factory wired for 115-volt or 230-volt operation, as ordered, and the line fuses supplied with the equipment are rated accordingly. If the primary power source is changed, wiring changes must be made in all units. The necessary changes are

shown on schematic diagrams of the units, figures 6-4 through 6-10, and on the schematic diagram of the exciter unit in the exciter unit manual. Table 1-8 lists each fuse and the proper value for 115-volt and 230-volt operation. Table 2-1 lists the components in each unit that require wiring changes prior to 230-volt operation. Actual installation of the radio transmitter is accomplished as follows:

Step 1. Place the empty cabinet in the location selected. If the unit is equipped with shock mounts, bolt the shock mounts to the deck or platform. Check leveling of cabinet to avoid possible difficulty when installing the drawers.

Step 2. Each cabinet compartment is equipped with drawer slides which mate with rails on the sides of each drawer component. The Power Supply Model RTP-2 should be installed in the bottom compartment first to avoid any possibility of tipping the cabinet. Pull the center section of the slide out until it locks in the extended position. Engage the rails on the side of the drawer with the extended slides and ease the drawer into the slides. Hold the lock buttons on each rail depressed until the lock button passes into the slide. The lock button will engage the slot in the slide and prevent the drawer from entering further. Once again depress the lock button and the drawer will slide completely into the cabinet.

**TABLE 2-1. PRIMARY POWER
WIRING CHANGES**

UNIT	COMPONENT	FIGURE
Cabinet/Frame Assembly Model CAB-7	T501	6-10
Amplifier-Oscillator Model RTF-2	E301	6-5
	E302	
Panel Chassis Assembly Model RTS-2	T401	6-11
	T402	
Power Supply Model RTP-2	T601	6-9
	T602	
	T604	
	CB601	
Transmitting Mode Selector Model SBE-2 or SBE-3	TB101	Unit manual

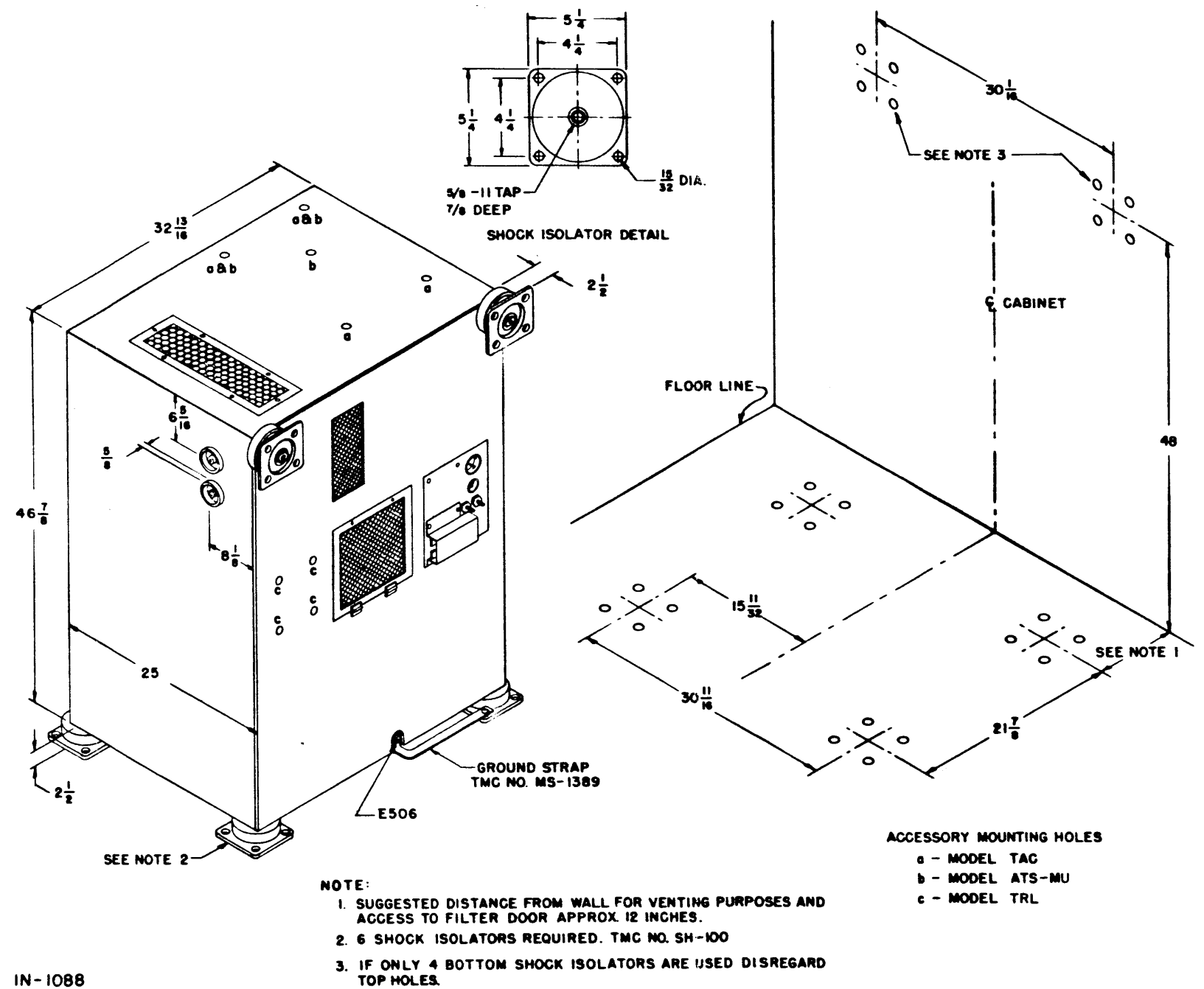

IN-1088

Figure 2-1. Transmitter Mounting Dimensions

Step 3. Install the RTS-2 with the Transmitting Mode Selector in the center drawer in the same manner.

Step 4. Install the RTF-2 RF deck in the top compartment of the transmitter.

Step 5. If any accessories are to be mounted on the transmitter cabinet, install them in accordance with the mounting details shown in figure 2-1 and refer to the instructions in paragraph 2-5.

Step 6. Connect the antenna, or dummy load, to J505 (HN type UG-560/U connector) on the side of the transmitter. The antenna cable must be fabricated locally. A mating plug, UG-59B/U, suitable for RG-8/U, RG-9/U, RG-11/U, or RG-12/U is supplied as a loose item.

Step 7. Connect the heavy copper ground strap between E506 at the lower rear of the cabinet and station ground.

2-4. INTERNAL CABLING CONNECTIONS.

A number of connections must be made between the three drawer units of the radio transmitter for which interconnecting cables are supplied separately or as an integral part of one of the units or cabinet. The rear panel of the cabinet should be removed to facilitate access to all the connections. Figure 2-2 illustrates the interconnections to be made and identifies the cables and connectors by reference symbol number and color code where applicable. Each cable is physically tagged with an identification label and plug and jack numbers are stamped on the various chassis. The cables should be installed or connected in the sequence shown below.

Step 1. Open the Power Supply Model RTP-2 drawer. Connect P502 of W502 to J601 on the RTP-2.

Step 2. Connect P503 of cable W501 to J602 on the RTP-2.

Step 3. Install both high-voltage rectifier tubes (V606 and V607) in their respective sockets. Be sure the tubes are firmly seated in the sockets. Connect one of the high-voltage leads from the main power transformer in the cabinet to each tube plate cap. The two leads are interchangeable and there is no danger in reversing them.

Step 4. Connect P512 of high-voltage cable W508 to J603 on the RTP-2 and P511 to J503 (part of W509) on the cabinet. Connect the other end of W509, J504, to P505 on W503.

Step 5. Remove the cover from the relay deck of the RTP-2 by loosening the twist lock fasteners and insert the time delay relay K602 and its shield.

Step 6. Install the remainder of the tubes in the RTP-2. (See figure 5-4.) Replace the cover on the relay rack.

Step 7. Close the RTP-2 drawer. Open the RTF-2 drawer and be sure it locks in its extended position.

Step 8. Connect P506 of cable W503 to J303 on the RTF-2.

Step 9. Connect P504 of cable W501 to J405 on the RTF-2.

Step 10. Connect P301 on the cable from the master oscillator compartment to J402 on the RTF-2 interconnect chassis. Connect P302 from the master oscillator to J401 on the interconnect chassis. Connect P401 from the interconnect chassis to J201 on the multiplier section of the RTF-2.

Step 11. Connect P508 (red) of cable W504 to J404 (red) on the interconnect chassis of the RTF-2.

Step 12. Connect P509 (blue) of cable W505 to J403 (blue) on the RTF-2 interconnect chassis.

Step 13. Install all tubes in the RTF-2. (See figure 5-5.)

Step 14. Close the RTF-2 drawer.

Step 15. Open the RTS-2 drawer. Connect P507 (red) of cable W504 to J2 (red) on the RTS-2.

Step 16. Connect P510 (blue) of cable W505 to J1 (blue) on the RTS-2.

Step 17. Connect P501 of cable W502 from the cabinet to J3 of the RTS-2.

Step 18. Connect P101 of cable CA-346 to J402 on the RTS-2. Connect P102 on the other end of CA-346 to J109 on the SBE.

Step 19. Check all other connections: P3 to J401, P1 to J104, P2 to J103, and J102 between the RTS-2 and the exciter unit to insure that all plugs are securely twist locked into their jacks.

Step 20. Close the RTS-2 drawer.

Step 21. The installation connections to terminal boards E501 and E502 on the rear of the cabinet are shown in figure 2-3.

Step 22. Connect the utility power input cable W510 to J502 on the rear of the cabinet. The input may be any dc, 60- or 400-cps single-phase source. Whatever power is applied to J502 is connected to the UTILITY OUTLET jack J604 on the front of the RTP-2 for use as required.

2-5. INSTALLATION OF ACCESSORIES.

a. The cabinet CAB-7 is supplied with mounting holes for particular accessories that can be used with the radio transmitter. These accessories include the coaxial antenna switch relays, TMC Models TRL-3 or TRL-4, Antenna Tuning Unit Model TAC, and Antenna Tuning System Model ATS-2. Relay TRL-3 is supplied for use with coaxial transmission lines of 70-ohm characteristic impedance; the TRL-4 is supplied for use with 50-ohm impedance coaxial transmission line. Whichever relay is used is to be mounted on the rear

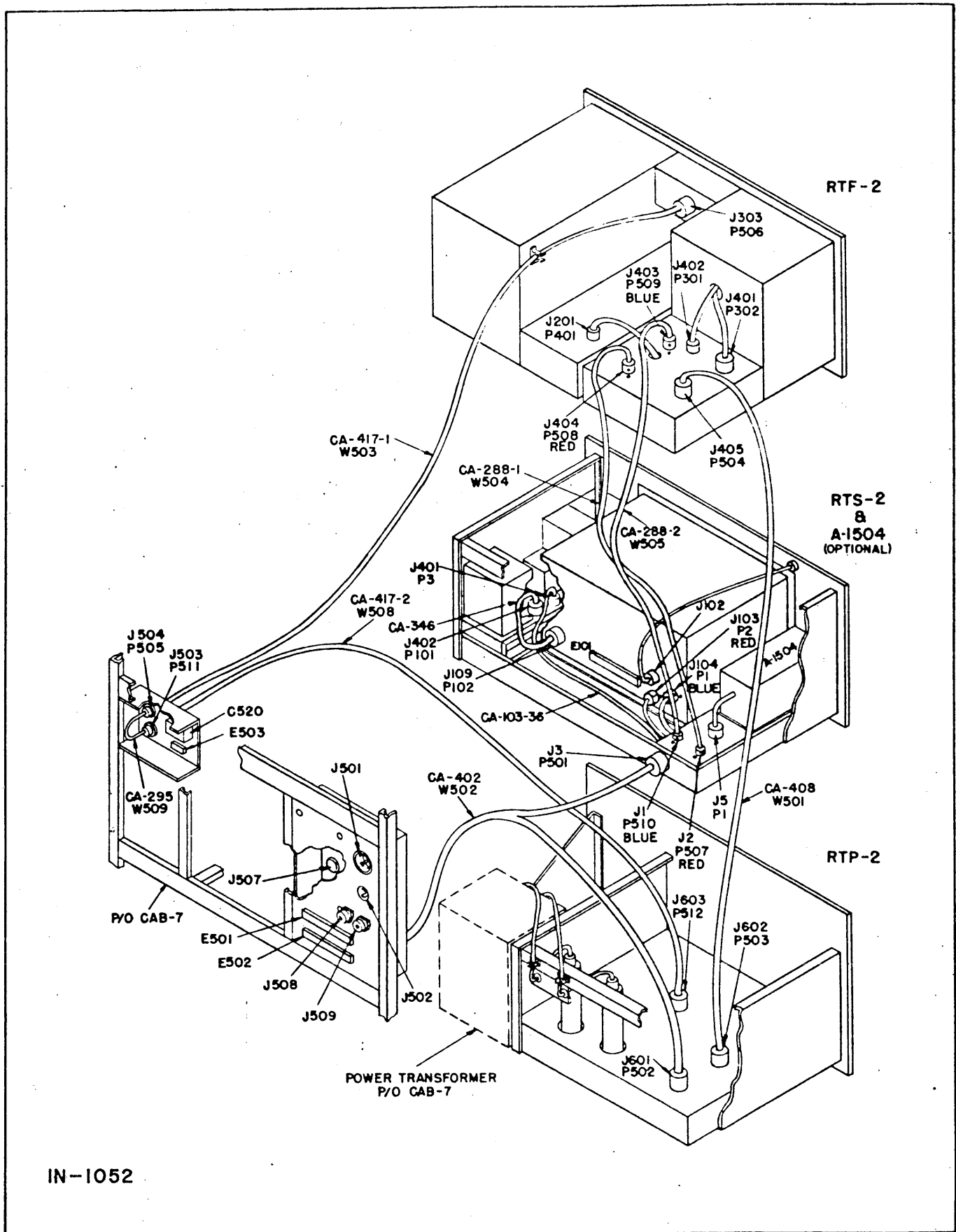

Figure 2-2. Transmitter Cabling Connections

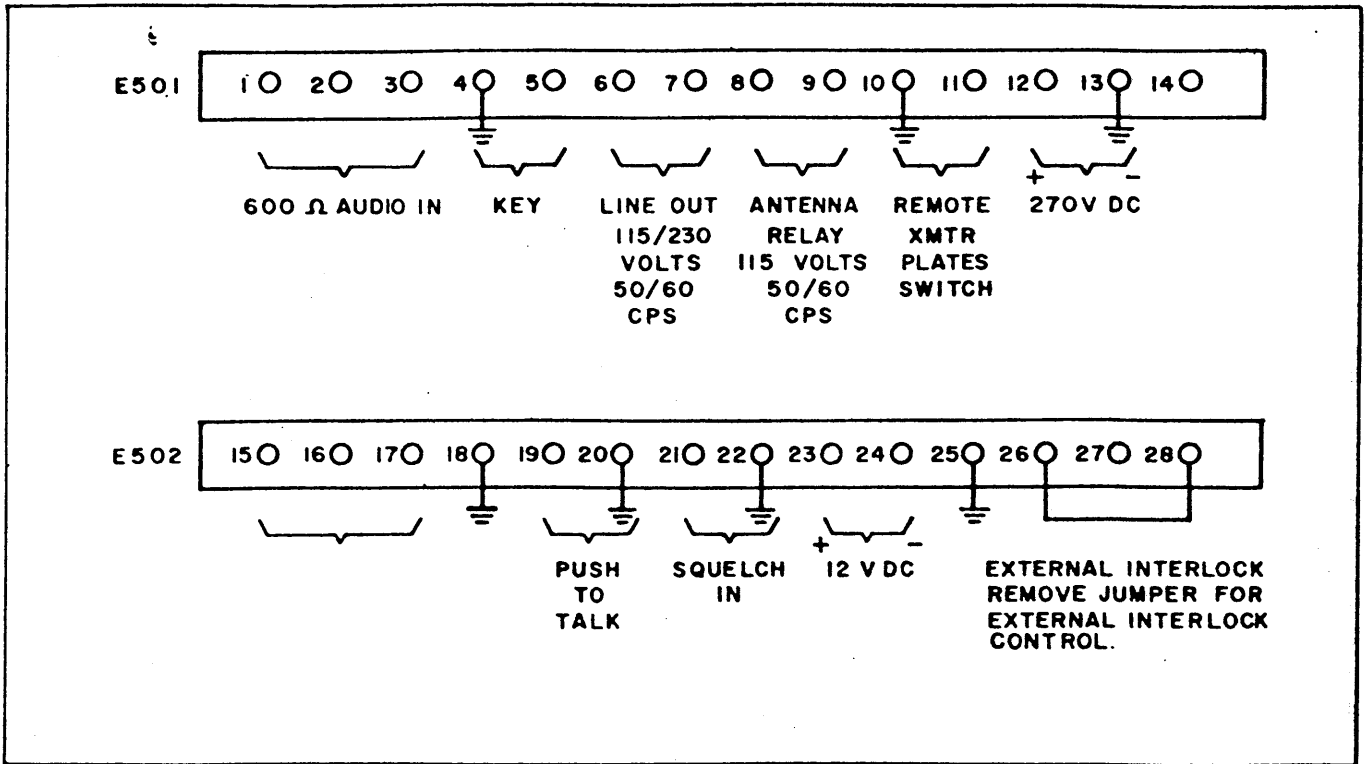

Figure 2-3. Cabinet Frame Assembly, CAB-7, Terminal Board Connections

of the cabinet by means of the camlock fasteners in the position labeled "c" in figure 2-1. Connect the 70- or 50-ohm coaxial cable, which is supplied, between the rf output jack J505 on the side of the transmitter and the coaxial relay. The antenna connections are to be made to the coaxial relay instead of J505. Wiring connections between terminal boards E501 and E502 on the rear of the cabinet and the TRL-3 or TRL-4 are shown in figure 2-4.

b. The Antenna Tuning Unit Model TAC, if used, is to be mounted on the top of the cabinet. The mounting holes are shown in figure 2-1 and labeled "a."

Mounting hardware is supplied in the assorted items box. The RTF-2 drawer may have to be removed to make this installation. Care should be taken to insure that the mounting hardware is secure within the cabinet to avoid any possibility of falling loose into the RTF-2 chassis. Refer to the applicable manual for interconnection data.

c. Antenna Tuning System Model ATS-2 can be provided for 50-ohm or 70-ohm input impedance. This system consists of three units. Refer to the applicable manual for installation instructions and interconnections.

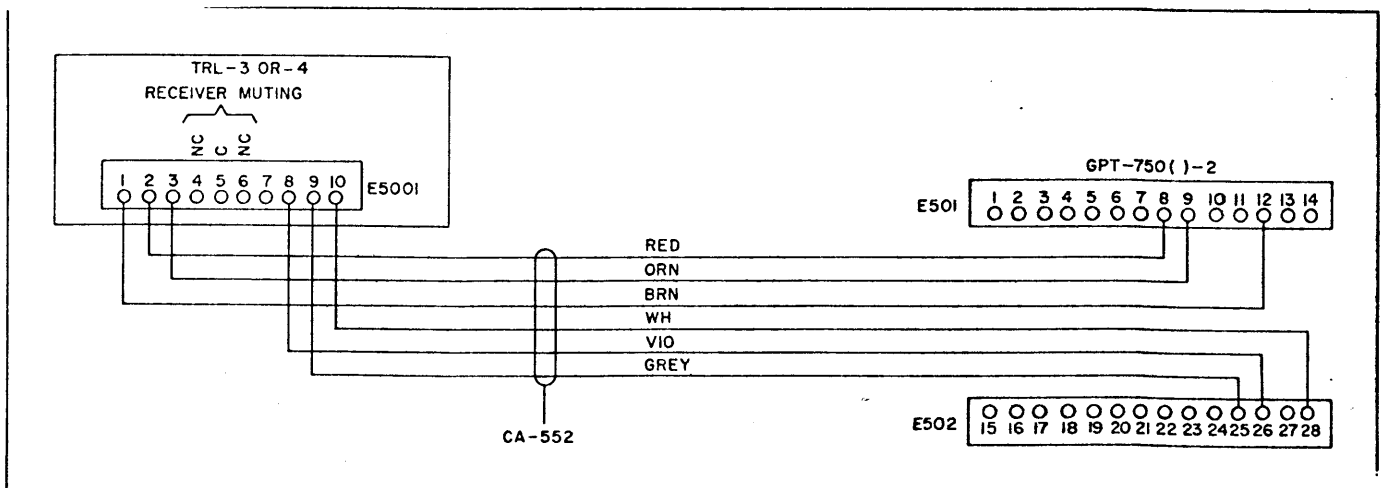

Figure 2-4. TRL-3 or TRL-4 Interconnections to Transmitter

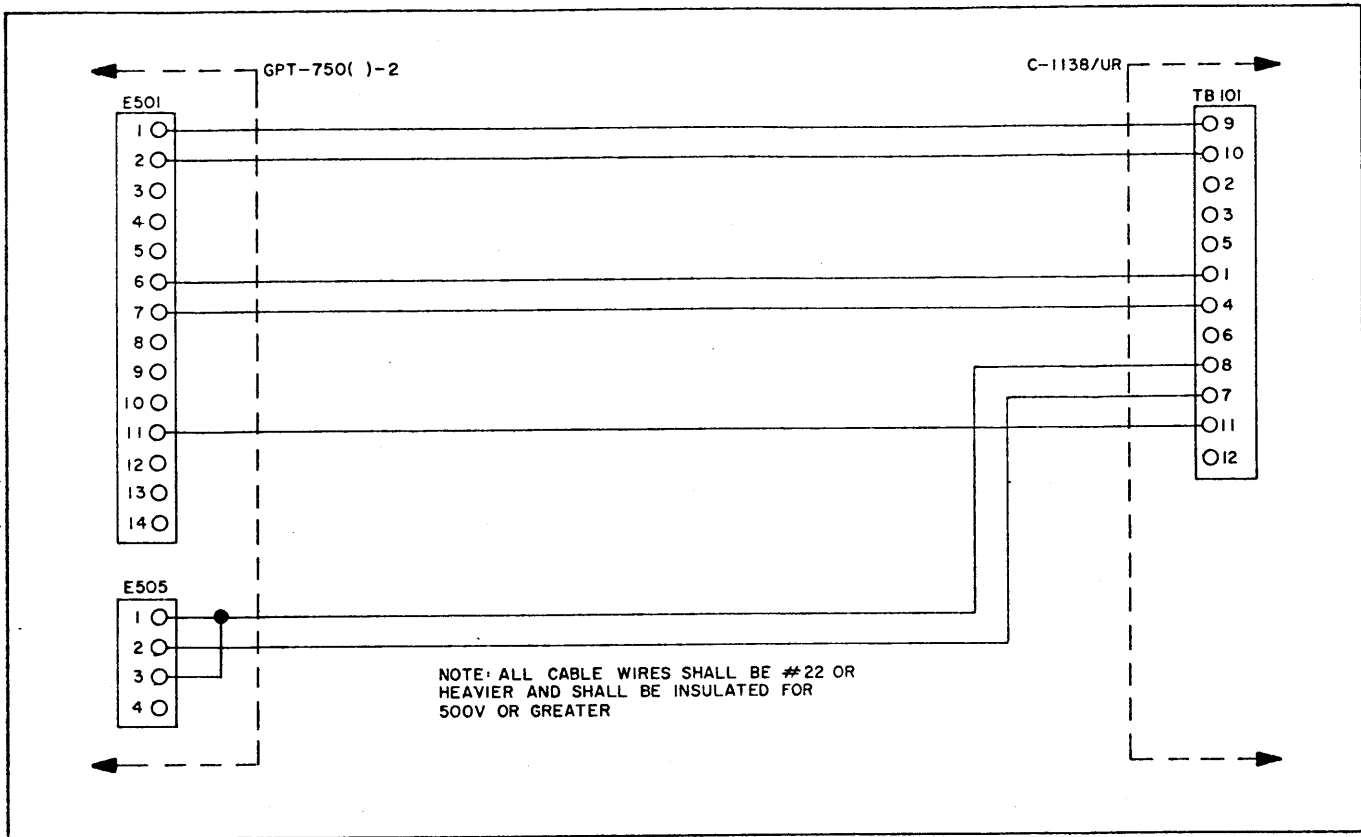

Figure 2-5. Control C-1138/UR Interconnections to Transmitter

2-6. AUXILIARY EQUIPMENT.

a. The radio transmitter is designed for use with external auxiliary equipments such as Control Unit C-1138/UR, Remote Control Amplifier Model RTC, and Radiophone Unit C-1207/UR. The wiring connections between the C-1138/UR and the radio transmitter are shown in figure 2-5; the connections between the transmitter and the RTC in figure 2-6.

b. If the remote Radiophone Unit C-1207/UR is to be used an auxiliary 12-volt power supply Model A-1504 must be mounted in the Panel Chassis Assembly Model RTS-2. The output cable of the power supply connects to J5 on the RTS-2 chassis. Wiring connections between the radio transmitter and the radiophone unit are shown in figure 2-7.

2-7. PRELIMINARY ADJUSTMENTS.

Prior to initial application of power, operate all controls to assure free movement. Check that no crystals are inserted in the position for X1 on the RTF-2 interconnect chassis or in the crystal oven. Set the controls on the various units of the radio transmitter in the positions indicated below. A complete list of the controls and their functions are given in section 3. These initial adjustments are aimed at checking static voltages to insure that all cabling is correctly installed. The adjustments should be accomplished with the radio transmitter working into a 1000-watt resistive 70-ohm or 50-ohm dummy load connected to the rf output jack J505 on the side of the cabinet.

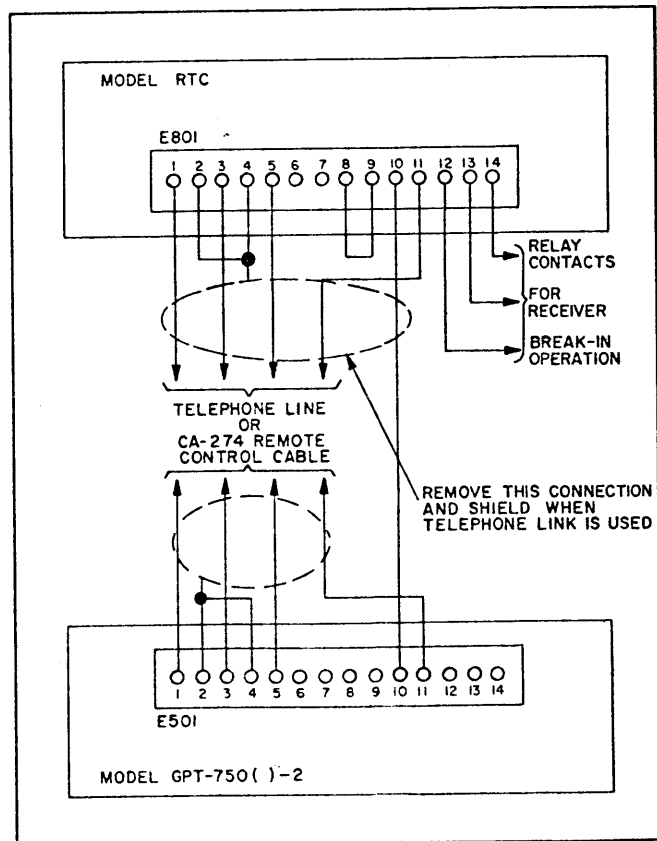

Figure 2-6. Remote Control Amplifier Model RTC, Interconnections to Transmitter

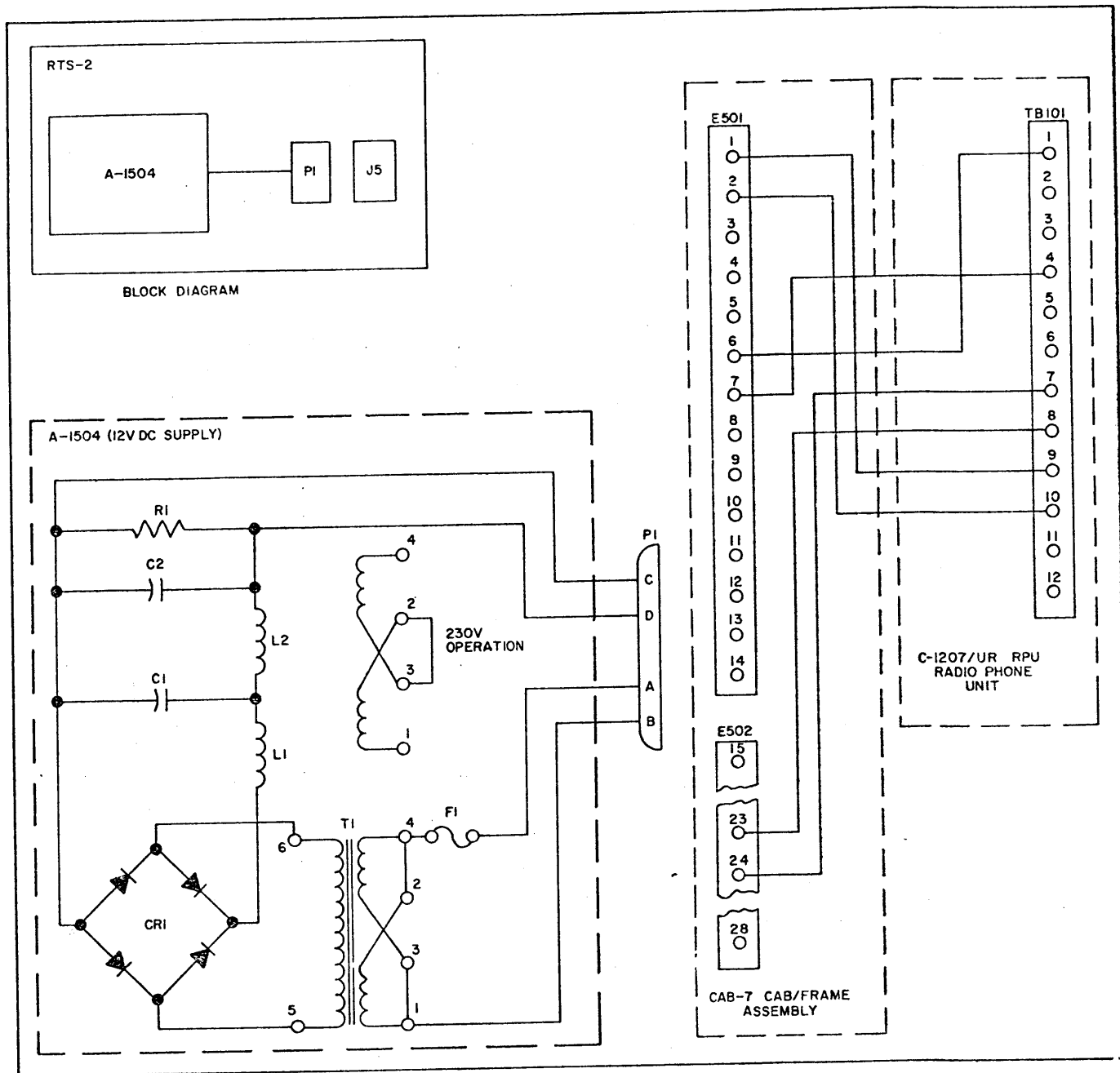

Figure 2-7. Radiophone Unit C-1207/UR, Interconnections to Transmitter

Step 1. Rotate DRIVE control on the front panel of the RTF-2 fully clockwise.

Step 2. Open the RTF-2 drawer and set NORMAL-SSB switch S204 on the multiplier section to NORMAL. Set EXCITATION SW. switch S402 on the interconnect chassis to SSB L. O. ON position.

Step 3. Set FILAMENT LINE ADJUST switch S605 on the front panel of the RTP-2 to position 2 from fully counterclockwise; TRANSMITTER PLATES switch S603 to OPERATE; FINAL OVERLOAD S. G. and PLATE to ON; MODE select switch to CW-FS; FINAL

PLATE switch S604 to OFF; and MAIN POWER circuit breaker CB601 to OFF.

Step 4. Connect primary power to the radio transmitter at J501 on the rear of the cabinet. Turn MAIN POWER circuit breaker to ON; MAIN POWER indicator lamp will light.

Step 5. Check FILAMENT LINE meter for a reading of 115 volts. Adjust FILAMENT LINE ADJUST switch S605 to obtain this reading if necessary.

Step 6. Check that the main blower B501 in the cabinet and the blower B101 in the power amplifier section of the RTF-2 are both operating properly.

WARNING

The following steps require measuring high voltages up to 1000 vdc. These voltages are dangerous. Voltages of 1000 vdc should be measured by turning power off, connecting probe to point to be measured, and turning power back on. In this way, possibilities of contact with lethal voltages is minimum.

Step 7. Check the voltage readings on terminal boards E601, E602, and E603 in the power supply. The readings should be as indicated below:

E601-1	+300 vdc
-2	-95 to -125 vdc
-5	-210 vdc
-8	+600 vdc
E602-9	+600 vdc
-10	+600 vdc
-11	0
-12	0
-17	+350 vdc
-18	+350 vdc
-19	0
-20	-105 vdc
E603-24	-105 vdc
-25	+350 vdc
-26	-105 vdc
-27	-210 vdc
-28	6 vdc

Step 8. Between terminal 31 of E603 and terminals 13, 14, 15, and 16 of E602 measure 115 vac.

Step 9. Set MODE switch on RTP-2 to SSB and FINAL PLATE switch to ON. On the RTF-2 set MULTIMETER switch to PA Ebb volts.

Step 10. On the relay deck of the RTP-2 power supply, set FINAL BIAS ADJ. control R605 until PA plate current reads 130-140 ma. on PA PLATE meter M302 on front panel of RTF-2. MULTIMETER M301 on the RTF-2 should read approximately 3 kv.

Step 11. Measure the voltage from terminals 6 and 7 of E601 in the RTP-2 to ground. Both readings should be +600 vdc.

Step 12. Set MODE switch S601 of the RTP-2 to CW-FS. The following voltages should be checked from the terminals indicated to ground.

E601-3	+580 vdc
-4	+1000 vdc
-6 & 7	+600 vdc
E603-29	+600 vdc
-2	-2 vdc

Step 13. The PA plate current on M302 on the RTF-2 should read between 80 and 110 ma.

Step 14. Set MODE switch on RTP-2 to TUNE. The voltage from terminals E601-6 and E601-7 to ground should be +300 vdc and the PA plate current on M302 should go to 0.

Step 15. Turn TRANSMITTER PLATES switch to STANDBY REMOTE and FINAL PLATE switch to OFF.

Step 16. Set NORMAL-SSB switch S204 of the RTF-2 to SSB, and EXCITATION SW. switch to SSB L.O. ON.

Step 17. On the RTP-2 set the MODE switch to SSB.

Step 18. On the exciter unit set the controls as follows:

POWER switch S103 to ON.

EXCITER switch S105 to OFF.

XMTR switch S104 to OFF.

USB switch S101 to CH1; and LSB switch S102 to OFF.

METER SW S109 to USB.

CARRIER INSERT control R106 fully counterclockwise.

SQUELCH GAIN control R129 fully counterclockwise.

VOX GAIN control R140 full counterclockwise.

Step 19. Connect the output of the TMC Model PTE-1, or equivalent, to terminals E501-1 and E501-3.

Step 20. Adjust USB GAIN control R129 for half-scale reading on multimeter M101 on the exciter unit. Increase the setting of the VOX GAIN control. EXCITER lamp on the front panel of the exciter will light and TRANSMITTER PLATES indicator I603 on the RTP-2 will light. The same can be accomplished by setting XMTR switch S104 and EXCITER switch S105 on the exciter unit to ON.

Step 21. Refer to Section 3, Operation, and tune the transmitter to the prescribed test frequencies using the VMO and crystal oscillator.

Note

The crystals used must be Type CR-18/U in the range 2 to 4 mc. The crystals are not supplied. Operating frequencies are determined by the using activity.

Step 22. Check the calibration of the master oscillator as indicated in Section 3.

SECTION 3 OPERATION

3-1. INTRODUCTION.

a. The radio transmitter can be operated in a variety of modes. Normally, the mode of operation, output frequency and output power are controlled by the exciter unit, SBE-2 or SBE-3. The midfrequency modulator section of the exciter is the frequency controlling stage of the transmitter. This section can be supplied with an injection frequency from the VMO of the RTF-2 or from its own crystal oscillator. Use of the internal exciter crystal oscillator insures the higher stability of crystal oscillator operation and permits selection of any one of ten preselected crystal frequencies. (Refer to appropriate exciter unit manual.) Operation with the injection frequency being supplied by the VMO of the RTF-2 has the advantage of continuous tuning over the entire output range of the transmitter with a high degree of stability.

b. A third source of injection frequency is available, the crystal oscillator of the RTF-2. Three different crystal frequencies in the range 2 to 4 mc can be available if desired. The crystal oscillator output of the RTF-2 is not normally used for this purpose but

is generally used when the radio transmitter is operated without the exciter unit in certain modes of operation.

c. The master oscillator in the RTF-2 is contained in a temperature-controlled oven. Optimum stability will be realized if the oven is left on at all times if the transmitter is in regular or standby service. This can be done by setting the MO BYPASS switch S602 on the RTP-2 chassis to BYPASS. This setting permits the oven to operate although the MAIN POWER circuit breaker on the RTP-2 is OFF.

3-2. CONTROLS AND INDICATORS.

The controls and indicators for each of the components of the radio transmitter are listed in tables 3-1 through 3-4 and the front panels of each component are illustrated in figure 3-1. Certain controls of the RTF-2 are located internally on the chassis. The location of these controls is referenced to adjustment location illustrations in section 6, Maintenance and Repair.

TABLE 3-1. MODEL RTF-2, FRONT PANEL CONTROLS AND INDICATORS

CONTROL OR INDICATOR	REFERENCE SYMBOL	FUNCTION
INNER OVEN lamp	I301	Lights when inner oven is warming.
ZERO BEAT lamp	I303	When lighted indicates zero beat in calibration of master oscillator during calibration procedure.
OUTER OVEN lamp	I302	Lights when outer oven is warming.
CALIBRATE control	L301	Calibrates the master oscillator during calibration procedure.
CALIBRATE control lock		Locks setting of CALIBRATE control when turned clockwise.
MULTIMETER meter	M301	Indicates current or voltage selected by MULTIMETER switch.
MULTIMETER rotary switch	S203	Selects current or voltage indicated on MULTIMETER meter.
PA PLATE meter	M302	Indicates PA plate current.
DRIVER TUNING control	C201	Adjusts PA driver tuning capacitor.
RF OUTPUT meter	M303	Indicates RF output current.
DRIVE control	R211	Varies amount of drive to PA grids.
AUX. LOADING rotary switch	S103	Selects an additional loading capacitor for lower impedance loads.
PA BAND rotary switch	S101 S102	Sets PA tank to proper output frequency band by tapping output coil.

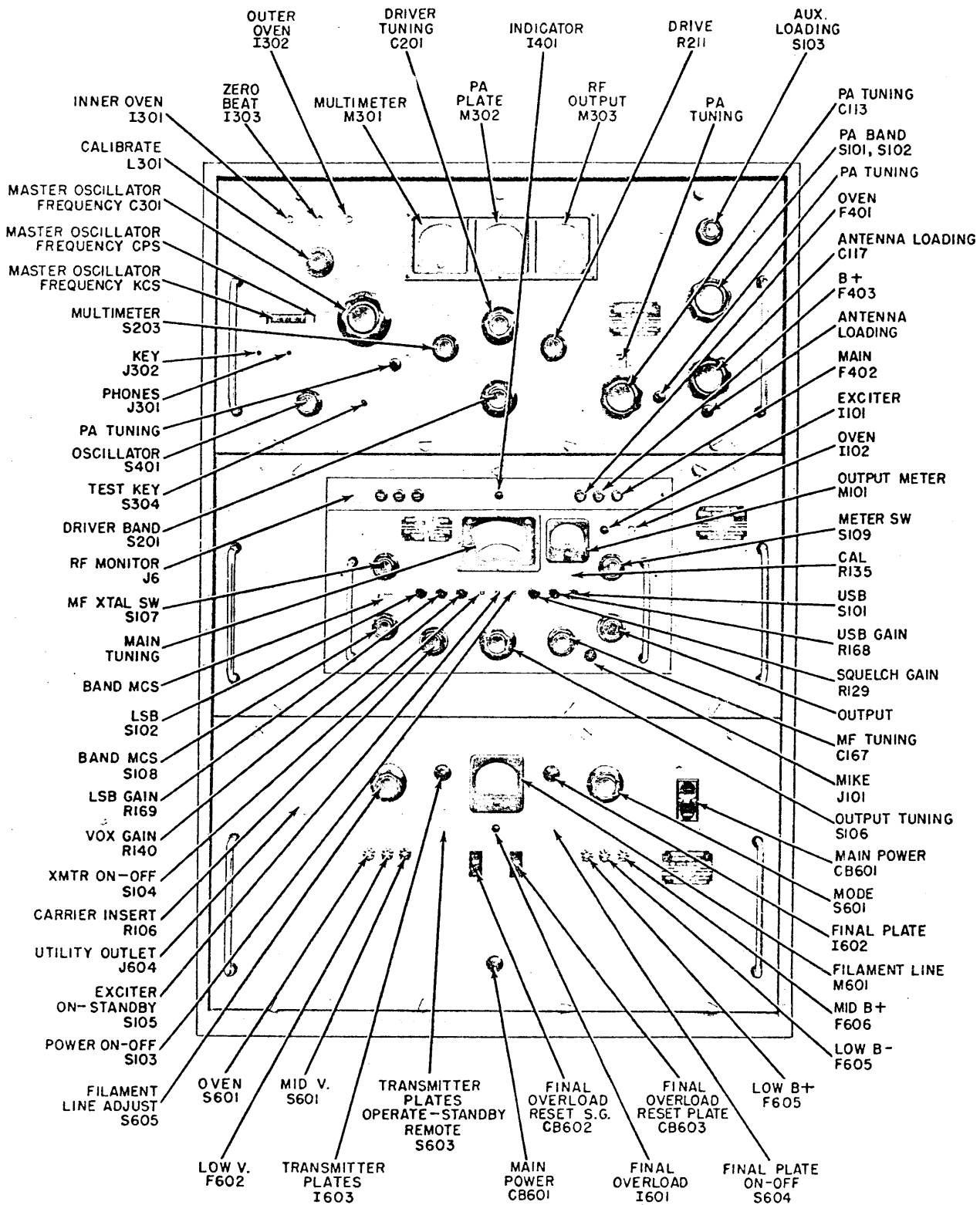

Figure 3-1. Transmitter Front Panel Controls and Indicators

TABLE 3-1. MODEL RTF-2, FRONT PANEL CONTROLS AND INDICATORS (CONT)

CONTROL OR INDICATOR	REFERENCE SYMBOL	FUNCTION
ANTENNA LOADING control	C117	Adjusts amount of coupling to load.
ANTENNA LOADING control lock		Locks setting of ANTENNA LOADING when turned clockwise.
PA TUNING dial		Indicates the setting of the PA TUNING control
PA TUNING control	C113	Adjusts main tuning vacuum capacitor, an integral part of PA pi tank.
PA TUNING control lock		Locks setting of PA TUNING control when turned clockwise.
DRIVER BAND rotary switch	S201 S202	Selects frequency range of driver and multiplier.
TEST KEY pushbutton	S304	Provides emergency and test keying.
OSCILLATOR rotary switch	S401	Selects source of frequency control for transmitter or calibration of MO.
PHONES jack	J301	Accepts earphones plug.
KEY jack	J302	Accepts key plug.
MASTER OSCILLATOR FREQUENCY control	C301 C302	Tunes master oscillator to desired frequency.
MASTER OSCILLATOR FREQUENCY control lock		Locks setting of MASTER OSCILLATOR FREQUENCY control when rotated clockwise.
MASTER OSCILLATOR FREQUENCY KCS dial		Indicates, in kilocycles, settings of MASTER OSCILLATOR FREQUENCY control.
MASTER OSCILLATOR FREQUENCY CPS dial		Indicates, in cycles, setting of MASTER OSCILLATOR FREQUENCY control.
NORMAL-SSB switch	S204	Establishes conditions for normal or SSB operation of amplifier-multiplier section. (See figure 6-2 for location.)
EXCITATION SW.	S402	Selects and routes oscillator output for SSB, FS, or CW/PHONE operation. (See figure 6-2 for location.)

TABLE 3-2. MODEL RTP-2, FRONT PANEL CONTROLS AND INDICATORS

CONTROL OR INDICATOR	REFERENCE SYMBOL	FUNCTION
UTILITY OUTLET jack	J604	Provides source of 115 vac.
FILAMENT LINE ADJUST control	S605	Selects tap on filament transformer to maintain 115 vac.
TRANSMITTER PLATES indicator light	I603	Lights when TRANSMITTER PLATES OPERATE-STANDBY/REMOTE switch is in OPERATE position.

TABLE 3-2. MODEL RTP-2, FRONT PANEL CONTROLS AND INDICATORS (CONT)

CONTROL OR INDICATOR	REFERENCE SYMBOL	FUNCTION
TRANSMITTER PLATES OPERATE-STANDBY REMOTE toggle switch	S603	Selects mode of operation for transmitter plates circuit.
FILAMENT LINE meter	M601	Indicates voltage of primary of filament transformer T603.
FINAL PLATE indicator light	I602	Lights when FINAL PLATE ON-OFF switch is in ON position.
FINAL PLATE ON-OFF toggle switch	S604	Applies high voltage to PA stage when placed in ON position.
MODE rotary switch	S601	Selects transmitter mode of operation.
MAIN POWER switch	CB601	Applies ac voltage to transmitter and provides automatic overload protection when placed in ON position.
MID B+ fuse	F606	Provides protection for mid B+ circuit.
LOW B- fuse	F604	Provides protection for low B- circuit.
Low B+ fuse	F605	Provides protection for low B+ circuit.
FINAL OVERLOAD indicator light	I601	Indicates excessive PA plate or screen grid current.
FINAL OVERLOAD RESET-S.G. switch	CB602	Resets overload relay system when tripped by excessive PA screen grid current.
FINAL OVERLOAD RESET-PLATE switch	CB603	Resets overload relay system when tripped by excessive PA plate current.
MID V. fuse	F603	Provides protection for midvoltage circuit.
LOW V. fuse	F602	Provides protection for low voltage circuit.
OVEN fuse	F601	Provides protection for oven circuit.

TABLE 3-3. MODEL RTS-2, FRONT PANEL CONTROLS AND INDICATORS

CONTROL OR INDICATOR	REFERENCE SYMBOL	FUNCTION
RF MONITOR jack	J6	Provides means of monitoring rf output.
Indicator light	I401	Lights when main power is applied.
OVEN fuse	F401	Provides protection for oven circuit.
B+ fuse	F403	Provides protection for B+ circuit.
MAIN fuse	F402	Provides protection for main power circuit.

TABLE 3-4. MODEL SBE-2 AND MODEL SBE-3, FRONT PANEL CONTROLS AND INDICATORS

CONTROL OR INDICATOR	REFERENCE SYMBOL	FUNCTION
MF XTAL SW rotary switch	S107	Selects either external VMO or proper internal crystal for medium frequency operation.
VOX GAIN control	R140	Adjusts gain of voice-operated exciter circuit
Main Tuning indicator dial		Upper sections indicates setting of OUTPUT TUNING control; lower section indicates setting of MF TUNING control.
XMTR ON-OFF	S104	In ON position applies high voltage to transmitter when TRANSMITTER PLATES OPERATE-STANDBY/REMOTE switch on RTP-2 is in STANDBY/REMOTE position; in OFF position permits operation by VOX or push-to-talk circuit when EXCITER ON-STANDBY switch is in STANDBY position.
EXCITER ON-STANDBY toggle switch	S105	In ON position activates rf stages of exciter without need for VOX or push-to-talk keying and without operating transmitter; in STANDBY permits VOX or push-to-talk to activate the rf stages of exciter and associated transmitter when XMTR ON-OFF is in OFF position.
POWER ON -OFF toggle switch	S103	Applies line voltage to SBE power supply in ON position.
SQUELCH GAIN control	R129	Adjusts gain of voice-operated exciter circuit in conjunction with VOX GAIN control.
Output meter	M101	Indicates signal levels of circuits selected by METER SW switch.
EXCITER indicator light	I101	Lights when EXCITER ON-STANDBY switch is in ON position or SBE is activated by VOX or push-to-talk operation.
OVEN indicator light	I102	Lights during operation when thermostats demand crystal-oven heating (automatic).
METER SW rotary switch	S109	Selects circuit whose signal level is to be indicated by output meter. CAL position is used to zero meter.
CAL screwdriver control	R135	Zero sets output meter when METER SW switch is in CAL position.
OUTPUT rotary switch		Adjusts SBE output level.
MIKE jack	J101	Microphone input jack (substitute for 600-ohm channel input).
USB rotary switch	S101	Selects audio input source for upper sideband channel.
USB-GAIN control	R168	Adjusts level of USB audio input.
MF TUNING control	C167	Adjusts setting of medium frequency stages as indicated in lower section of main tuning indicator dial.
OUTPUT TUNING rotary switch	S106	Selects output frequency band.
OUTPUT TUNING control	C181	Adjusts setting of output frequency as indicated in upper section of main tuning indicator dial.

TABLE 3-4. MODEL SBE-2 AND MODEL SBE-3, FRONT PANEL CONTROLS AND INDICATORS (CONT)

CONTROL OR INDICATOR	REFERENCE SYMBOL	FUNCTION
CARRIER INSERT rotary switch	R106	Selects level of carrier insertion.
BAND MCS control	S108	Adjusts injection frequency range of high-frequency modulator.
BAND MCS indicator dial		Indicates injection frequency range of high-frequency modulator in 2-mc increments.
LSB-GAIN control	R169	Adjusts level of LSB audio input.
LSB rotary switch	S102	Selects audio input source for lower sideband channel.

3-3. CALIBRATION OF VMO.

The operating procedure is based on using the VMO of the RTF-2 to supply the injection frequency for the exciter unit. Calibration of the master oscillator must be accomplished after the proper warmup using the internal 100-kc crystal oscillator of the RTF-2. Check points are available every 50 kc over the 2- to 4-mc range of the master oscillator. Calibration is accurate to 25 kc each side of check point frequency.

Step 1. On the RTF-2, set OSCILLATOR switch to CAL position.

Step 2. Select the check point frequency nearest the desired operating frequency. The check point to be used is the nearest one, regardless of whether it is higher or lower than the operating frequency.

Step 3. Insert a headset into the PHONES jack J302 on the front panel of the RTF-2.

Step 4. Unlock CALIBRATE control L301 on the RTF-2 and rotate the knob until a beat frequency of 5 cps or less is heard in the headset and observed on the ZERO BEAT indicator lamp. The lamp will flash very slowly as the zero beat is approached. Lock CALIBRATE control.

3-4. EXCITER MF TUNING.

The exciter unit used in each radio transmitter differs only in the audio bandpass. Front panel control designations on both exciters are identical and the general operation is identical. The following procedure is based on operating with the master oscillator of the RTF-2 supplying the MF injection frequency. If it is desired to use the crystal oscillator of the exciter, refer to the procedures in the exciter unit manual.

Step 1. Check that FINAL PLATE switch on the RTP-2 is OFF and exciter OUTPUT control fully counterclockwise.

Step 2. Place USB, LSB and XMTR switches to OFF.

Step 3. Turn TRANSMITTER PLATES switch on the RTP-2 to OPERATE.

Step 4. Turn exciter POWER switch to ON and allow a one-hour warmup period.

Step 5. Turn exciter METER SW to CAL position and zero the meter with CAL screwdriver adjustment R135 on the front panel of the exciter. This meter is used to make all necessary measurements within the exciter during tuning and operation.

Step 6. Turn VOX GAIN and SQUELCH GAIN controls fully counterclockwise.

Step 7. Place EXCITER switch in STANDBY position.

Step 8. Tune the master oscillator on the RTF-2 to the desired frequency. Refer to the tuning charts (figure 3-2 for the GPT-750D-2 and figure 3-3 for the GPT-750E-2) for the VMO frequency for the particular output frequency. For purposes of explanation, an output frequency of 10 mc is assumed using the GPT-750D-2. Unlock MASTER OSCILLATOR FREQUENCY control and tune to 2270 kcs on MASTER OSCILLATOR FREQUENCY dial. Carefully lock the tuning control. The output signal of the VMO is cabled to the input of the exciter at J1 through cable W505.

Step 9. Place METER SW on the exciter in MF position.

Step 10. Place MF XTAL SW in VMO position.

Step 11. Unlock MF TUNING control and tune to 2270 kc on the single scale MF DIAL.

Step 12. Turn CARRIER INSERT control fully clockwise. Adjust MF TUNING control for a peak reading on meter M101 on the exciter. Reduce the setting of CARRIER INSERT control to avoid an offscale reading. Very little movement should be required; be careful not to tune to an adjacent peak even though a higher reading may be obtained.

FREQ MC	SBE-2				DRIVER		POWER AMPLIFIER								
	VMO FREQ	MF TUNING	MOD BAND	OUTPUT BAND	BAND	TUNING	PA BAND	PA TUNING	PA LOADING	PA EG-RF	PA IP	S/D RATIO DB		CARRIER SUPPRESS	ANTENNA CURRENT
												USB	LSB		
2.0	2270	2270	0	2-4	2-4	2	2-2.5	058	10	40	240	-40	-40	-55	2.25
2.5	2770	2770	0	2-4	2-4	2.5	2-2.5	117	50	45	260	-40	-40	-55	2.25
2.5	2770	2770	0	2-4	2-4	2.5	2.5-3	067	5	45	270	-40	-40	-55	2.25
3.0	3270	3270	0	2-4	2-4	3	2.5-3	112	50	45	270	-40	-40	-55	2.25
3.0	3270	3270	0	2-4	2-4	3	3.0-4	067	1	45	275	-40	-40	-55	2.25
4.0	3730	4270	0	2-4	2-4	4	3.0-4	132	40	40	270	-40	-40	-55	2.25
4.0	3730	4270	0	4-8	4-8	2	4-6	084	1	40	265	-40	-40	-55	2.25
6.0	2270	2270	4	4-8	4-8	3	4-6	156	60	45	260	-40	-40	-55	2.25
6.0	2270	2270	4	4-8	4-8	3	6-8	112	30	40	270	-40	-40	-55	2.25
8.0	2270	2270	5	4-8	4-8	4	6-8	151	65	45	265	-40	-40	-55	2.25
8.0	2270	2270	5	8-16	8-16	2	6-8	152	55	45	260	-40	-40	-55	2.25
8.0	2270	2270	5	8-16	8-16	2	8-12	134	35	45	260	-40	-40	-55	2.25
10.0	2270	2270	6	8-16	8-16	2.5	8-12	159	70	45	265	-40	-40	-55	2.25
12.0	2270	2270	7	8-16	8-16	3	8-12	174	80	45	270	-40	-40	-55	2.25
12.0	2270	2270	7	8-16	8-16	3	12-16	166	50	45	270	-40	-40	-55	2.25
14.0	2270	2270	8	8-16	8-16	3.5	12-16	179	70	45	270	-40	-40	-55	2.25
16.0	2270	2270	9	8-16	8-16	4	12-16	196	80	40	265	-40	-40	-55	2.25
16.0	2270	2270	9	16-32	16-32	2	16-24	162	20	40	260	-40	-40	-55	2.25
18.0	2270	2270	10	16-32	16-32	2.25	10-24	170	20	45	270	-40	-40	-55	2.25
20.0	2270	2270	11	16-32	16-32	2.5	16-24	178	55	45	270	-40	-40	-55	2.25
22.0	2270	2270	12	16-32	16-32	2.75	16-24	189	50	45	265	-40	-40	-55	2.25
24.0	2270	2270	13	16-32	16-32	3	16-24	211	65	40	270	-40	-40	-55	2.25
24.0	2270	2270	13	16-32	16-32	3	24-32	173	28	45	270	-40	-40	-55	2.25
26.0	2270	2270	14	16-32	16-32	3.25	24-32	178	40	45	260	-40	-40	-55	2.25
28.0	2270	2270	15	16-32	16-32	3.5	24-32	183	60	45	275	-40	-40	-55	2.25
30.0	2270	2270	16	16-32	16-32	3.75	24-32	192	70	45	270	-40	-40	-55	2.25
32.0	2270	2270	17	16-32	16-32	4	24-32	205	75	45	290	-40	-40	-55	2.25

Figure 3-2. Radio Transmitter Model GPT-750D-2
Typical Tuning Chart

FREQ MC	VMO FREQ	SBE-3			DRIVER		POWER AMPLIFIER									
		MF TUNING	MOD BAND	OUTPUT BAND	BAND	TUNING	PA BAND	PA TUNING	ANTENNA LOADING	PA EG-RF	PA IP	S/D RATIO DB		CARRIER SUPPRESS	ANTENNA CURRENT	
												USB	LSB			
2.0	2250	2250	0	2-4	2-4	2.0	2-2.5	61	10	30	250	40	40	55	2.25	
2.5	2750	2750	0	2-4	2-4	2.5	2-2.5	118	50	30	240	41	41	55	2.25	
2.5	2750	2750	0	2-4	2-4	2.5	2.5-3	67	10	33	260	41	41	55	2.25	
3.0	3250	3250	0	2-4	2-4	3.0	2.5-3	111	35	35	260	41	41	55	2.25	
3.0	3250	3250	0	2-4	2-4	3.0	3.0-4	67	0	35	260	41	41	55	2.25	
4.0	3750	4250	0	2-4	2-4	4.0	3.0-4	131	45	36	250	40	40	55	2.25	
4.0	3750	4250	0	4-8	2-4	2.0	4-6	54	80	26	250	40	40	55	2.25	
6.0	2250	2250	4	4-8	4-8	3.0	4-6	143	45	38	240	41	41	55	2.25	
6.0	2250	2250	4	4-8	4-8	3.0	6-8	111	25	38	240	41	41	55	2.25	
8.0	2250	2250	5	4-8	4-8	4.0	6-8	152	65	36	250	41	41	55	2.25	
8.0	2250	2250	5	8-16	8-16	2.0	6-8	152	60	32	230	40	40	55	2.25	
8.0	2250	2250	5	8-16	8-16	2.0	8-12	134	45	35	240	40	40	55	2.25	
10.0	2250	2250	6	8-16	8-16	2.5	8-12	160	65	37	230	40	40	55	2.25	
12.0	2250	2250	7	8-16	8-16	3.0	8-12	174	80	36	250	40	40	55	2.25	
12.0	2250	2250	7	8-16	8-16	3.0	12-16	165	55	37	250	40	40	55	2.25	
14.0	2250	2250	8	8-16	8-16	3.5	12-16	178	60	32	240	40	40	55	2.25	
16.0	2250	2250	9	8-16	8-16	4.0	12-16	197	75	30	220	40	40	55	2.25	
16.0	2250	2250	9	16-32	16-32	2.0	16-24	160	25	37	250	40	40	55	2.25	
18.0	2250	2250	10	16-32	16-32	2.25	16-24	169	40	35	240	40	40	55	2.25	
20.0	2250	2250	11	16-32	16-32	2.5	16-24	177	50	35	240	40	40	55	2.25	
22.0	2250	2250	12	16-32	16-32	2.75	16-24	185	60	30	240	40	40	55	2.25	
24.0	2250	2250	13	16-32	16-32	3.0	16-24	199	65	30	240	40	40	55	2.25	
24.0	2250	2250	13	16-32	16-32	3.0	24-32	172	50	30	240	40	40	55	2.25	
26.0	2250	2250	14	16-32	16-32	3.25	24-32	177	55	30	240	40	40	55	2.25	
28.0	2250	2250	15	16-32	16-32	3.5	24-32	184	60	29	250	40	40	55	2.25	
30.0	2250	2250	16	16-32	16-32	3.75	24-32	190	70	29	240	40	40	55	2.25	
32.0	2250	2250	17	16-32	16-32	4.0	24-32	202	80	31	260	40	40	55	2.25	

Figure 3-3. Radio Transmitter Model GPT-750E-2
Typical Tuning Chart

3-5. EXCITER RF TUNING.

In tuning the rf section of the exciter, be careful not to alter the MF tuning.

Step 1. On the front panel set BAND MCS switch to the frequency range being used. The BAND MCS dial is calibrated in 2-mc increments. Set the switch so that dial reads halfway between the 6 and 8 markings, or 7 as indicated in the tuning chart.

Step 2. Set OUTPUT TUNING band switch to 8-16 position.

Step 3. Place METER SW in RF position.

Step 4. Tune OUTPUT TUNING control to read 10 mc on the multiscale output tuning dial.

Step 5. Turn EXCITER switch to ON. Advance OUTPUT control for any reading on multimeter M101.

Step 6. Slowly vary OUTPUT TUNING control for peak reading on meter. Very little movement should be necessary if the previous procedures have been carefully performed. Too much movement of the control indicates the circuits are being tuned to a harmonic, and the procedures will have to be repeated.

Step 7. Turn OUTPUT control to full counterclockwise. Place TRANSMITTER PLATES switch on the RTP-2 to STANDBY REMOTE, and EXCITER switch on the exciter unit to STANDBY. The exciter unit is fully tuned to supply the drive input to the RTF-2.

3-6. RTF-2 DRIVER TUNING.

The driver section of the RTF-2 is tuned using the input signal from the exciter unit. Each time the signal input is required, the XMTR switch on the exciter is turned to ON. With the settings of the controls on the transmitter as above, the XMTR switch will apply plate power to the RTF-2.

Step 1. On the front panel of the RTF-2, set DRIVER BAND switch to position 8-16.

Step 2. Set DRIVER TUNING switch to the position nearest the output frequency, in this case, 2.5 as explained below.

Note

The basic DRIVER TUNING range as indicated on the panel is 2 to 4 mc. When the DRIVER BAND switch is in the 4- to 8-mc position, the panel markings are multiplied by 2; in the 8 to 16 position, the markings are multiplied by 4; and in the 16 to 32 position, they are multiplied by 8.

Step 3. Set MULTIMETER switch to PA Eg Rf position.

Step 4. Place XMTR switch on the exciter unit to ON, and advance OUTPUT control to a setting of 3.

Step 5. Turn DRIVER TUNING control on the RTF-2 clockwise or counterclockwise until the PA Eg Rf reading is at a maximum.

Step 6. Return OUTPUT control on the exciter fully counterclockwise and turn XMTR switch to OFF.

3-7. RTP-2 POWER AMPLIFIER TUNING.

Note

Prior to tuning the power amplifier check that a 1000 watt, 50- or 70-ohm dummy load or an antenna is connected to the RF OUTPUT jack J505 on the side of the transmitter.

Step 1. Set PA BAND switch on the RTF-2 to the 8-12 position.

Step 2. Turn MODE switch on the RTP-2 to TUNE position and place FINAL PLATE switch ON.

Step 3. Turn ANTENNA LOADING control C117 counterclockwise. Set AUX LOADING switch S103 to +.

Step 4. Unlock PA TUNING control knob and with the control set PA TUNING to 159, the approximate setting for an output frequency of 10 mc.

Step 5. Turn XMTR switch on the exciter to ON. Turn OUTPUT control on the exciter until PA PLATE current meter M302 on the RTF-2 reads approximately 20 ma.

CAUTION

A shunting bar is provided inside the RTF-2 adjacent to the thermocouple, for the protection of the RF ammeter and thermocouple. It should be inserted in the clips on the thermocouple to prevent off scale reading of the RF ammeter under conditions of excessive VSWR.

Step 6. Rotate PA TUNING control until a definite dip in PA PLATE current is obtained on the meter.

Step 7. Set OUTPUT control on the exciter back to full counterclockwise.

Step 8. On the RTP-2, turn MODE switch to SSB position.

Step 9. Turn OUTPUT control on the exciter clockwise until a reading of approximately 20 is obtained on MULTIMETER with MULTIMETER switch in the PA Eg Rf position.

Step 10. Increase the setting of ANTENNA LOADING control until PA PLATE current meter reads approximately 300 ma. Readjust PA TUNING control until PA PLATE current reading dips. Set PA TUNING control for the minimum reading.

Step 11. The ANTENNA LOADING control should be advanced in increments, each time readjusting PA PLATE current, and decreasing the setting of OUTPUT control on the exciter. This should be continued until PA PLATE current reading is approximately 265 ma., with a minimum output from the exciter, indicated by a reading of approximately 45 on MULTIMETER in the PA Eg Rf position.

Step 12. Turn OUTPUT control and CARRIER INSERT control on the exciter to full counterclockwise.

Step 13. Turn FINAL PLATES switch on the RTP-2 OFF. The transmitter is now ready for operation.

Step 14. The settings of ANTENNA LOADING control and AUX. LOADING control are approximate. These controls balance out the reactance in the antenna system and therefore the type of antenna and the output frequency will affect the final settings of these controls. The AUX. LOADING control will seldom be used in the 0 position at frequencies above 4 mc. When tuning the upper end of the two highest bands, 16-24 and 24-32 mc, it will be necessary to advance ANTENNA LOADING control to almost the fully clockwise position in order to obtain a plate current dip with PA TUNING control.

3-8. ADDITIONAL PROCEDURES.

a. Although upon completion of the procedures given in paragraphs 3-3 through 3-7, the radio transmitter is tuned and ready for operation, additional procedures must be accomplished on the exciter unit. As mentioned previously, the exciter unit basically controls the operation if the GPT-750D-2 and the GPT-750E-2. The procedures given in the technical manual for the particular exciter, SBE-2 for the GPT-750D-2 and SBE-2 for the GPT-750E-2, fully explain the special procedures required for MF tuning at certain frequencies as well as the procedures for carrier insertion and apportionment of sidebands. Adjustment of the VOX circuit and the SQUELCH GAIN are also thoroughly explained.

b. OPERATING IN THE SSB OR ISB MODES. - Assuming all previous tuning procedures have been accomplished and all adjustments on the exciter unit made, actual operation of the transmitter is accomplished as follows:

Step 1. Turn OUTPUT control on the exciter unit full counterclockwise.

Step 2. Place FINAL PLATE switch on the RTP-2 in ON position.

Step 3. Turn MULTIMETER switch to PA Eg Rf volts position.

Step 4. Advance OUTPUT control of the exciter while modulating the input until PA PLATE current meter indicates approximately 250 ma. under steady state conditions, or does not exceed approximately 250 ma. on modulation peaks.

Step 5. Turn XMTR switch on the exciter to OFF. With VOX and SQUELCH GAIN controls properly set, the transmitter will be turned on by VOX circuits when

the operator is speaking directly into the microphone or by normal push-to-talk controls.

c. OPERATION IN CW MODE.

(1) Operation of the radio transmitter in the CW mode can be accomplished through the exciter unit, or by eliminating the exciter unit and using the RTF-2 only. To operate with the exciter, refer to the exciter manual for necessary connections and switch adjustments to the exciter. Connect a key or remote keying line to terminals 4 and 5 of E501 at the rear of the cabinet.

Step 1. Turn OUTPUT control of the exciter full counterclockwise.

Step 2. On the RTP-2, set MODE switch to CW-FS position.

Step 3. Place exciter XMTR switch in ON position.

Step 4. On the RTF-2, set MULTIMETER switch to PA Isg Ma position.

Step 5. On the RTP-2, turn FINAL PLATE switch ON. Press TEST KEY on the RTF-2 to key the transmitter.

Step 6. Adjust exciter OUTPUT control and the RTF-2 PA TUNING and ANTENNA LOADING controls for proper plate and antenna current, readjusting any tuning controls necessary.

Step 7. Release TEST KEY. The transmitter can be keyed by the remote key or a key inserted in KEY jack on the RTF-2.

(2) The transmitter can be operated in the CW mode without using the exciter unit. Keying can be accomplished locally or remotely in the same manner as described in paragraph 3-8c.

Step 1. Place EXCITATION switch on the interconnect chassis of the RTF-2 in CW PHONE position.

Step 2. Set OSCILLATOR switch on the front panel of the RTF-2 to MO or one of the three crystal positions.

Step 3. The output of the master oscillator or the crystal oscillator of the RTF-2 will now be applied directly to the driver rather than to the exciter unit. Tune the transmitter to the desired output frequency.

Step 4. Operate the transmitter by means of the local key inserted in KEY jack, or by the remote key.

3-9. OPERATOR'S MAINTENANCE.

Maintenance performed by the operator is limited to replacement of tubes and fuses. The fuses used in each of the units are listed in section 1. The tubes used in the individual units are listed in section 1 and in the exciter unit manual. The tube location for the RTF-2, RTP-2 and RTS-2 are shown in figures 5-4, 5-5 and 5-6; the tube location for the particular exciter unit will be found in the applicable manual.

SECTION 4

PRINCIPLES OF OPERATION

4-1. INTRODUCTION.

a. Radio Transmitter Model GPT-750D-2 and Radio Transmitter Model GPT-750E-2 are designed to operate primarily in the SSB or ISB modes. The radio transmitter also will operate in the AM and CW modes without the use of auxiliary equipment, or in the MCW and FSK modes using auxiliary equipment.

b. The principles of operation are explained covering the basic radio transmitter operation in SSB or ISB modes. The explanation is first presented on a system function. Following the system function discussion, complete details of the operation of the Amplifier-Oscillator Model RTF-2 and Power Supply Model RTP-2 are covered. The detailed discussion of the exciter unit and exciter unit power supply is contained in the applicable exciter unit manual. The theory of operation should be thoroughly understood to aid in isolating faults to a functional unit and circuit within the functional unit.

4-2. FUNCTIONAL BLOCK DIAGRAM DESCRIPTION.

a. AMPLIFIER-OSCILLATOR, MODEL RTF-2.

(1) MASTER OSCILLATOR STAGE. - Figure 4-1 is a block diagram of the radio transmitting system. The variable master oscillator is contained in a double oven to promote stability. The stage uses a triode tube V301 in a Colpitts oscillator circuit which is tunable from 2 to 4 mc. The output of the oscillator is coupled through cathode follower V302A, and buffer V402 to amplifier V403. The cathode follower, which is also in the oven, and buffer amplifier provide two stages of isolation for the oscillator from load variations in the following stages. Tuning of the master oscillator is controlled from the front panel by the MASTER OSCILLATOR FREQUENCY control C301 and C302. The frequency to which it is tuned is indicated on the MASTER OSCILLATOR FREQUENCY KCS dial. The master oscillator is disabled when crystal operation is selected.

(2) CRYSTAL OSCILLATOR-AMPLIFIER AND CATHODE FOLLOWER. - The output of buffer amplifier V402 is applied to the input of V403 when the master oscillator is used as the basic frequency source, determined by the front panel OSCILLATOR switch S401. If the switch is in any one of the three crystal positions the master oscillator, cathode follower, and buffer amplifier are disabled by the removal of plate voltage through the switch. Tube V403 is converted into an electron-coupled Pierce oscillator with the selected crystal controlling the frequency. The frequency range of the oscillator is 2 to 4 mc and the crystals may be selected within this range. Adjustment of the crystal oscillator is accomplished by an internal adjustment. The output of V403, when used either as an

amplifier or oscillator is applied through cathode follower V404 to LOCAL OSC OUTPUT jack J403. This output is used in SSB or ISB operation as the injection frequency to the MF stages of the exciter unit. Operation of the exciter unit is explained in paragraph 4-2c.

(3) GROUNDED GRID AMPLIFIER-DOUBLER. - The output signal of the exciter unit is taken from the rf amplifier stages and applied to the input of V201. This stage acts as an rf amplifier over the entire frequency range when operating in SSB mode and raises the power level of the signal. In other modes of operation, such as AM, CW, or MCW, this stage acts as an amplifier or doubler, depending upon the output frequency. The output of V201 is applied to the input of driver stage V205.

(4) DRIVER STAGE. - When operating in SSB mode, this stage operates as a driver amplifier to raise the power to sufficient level to drive the final amplifier. When operating in the other modes, the stage is an amplifier in the 2- to 16-mc range, and a doubler amplifier in the 16- to 32-mc range. The output level is controlled by a front panel control which controls the screen grid voltage level. The output of the driver is capacitor coupled to the grids of the power amplifier stage.

(5) POWER AMPLIFIER AND PI NETWORK. - The power amplifier stage employs two tubes in parallel to provide the rf output to the antenna system. When operating in SSB mode, the stage is operated as a class AB amplifier since low level modulation is used. The plate tank is tuned by PA TUNING control C113 on the front panel. Plate efficiency of the stage is at least 50% when operating in this mode. The output from the tuned plate load is applied through a pi network to the antenna system. The pi network serves as an impedance matching device between the power amplifier and the antenna circuit.

(6) CALIBRATION OSCILLATOR. - A 100-kc calibration oscillator is contained in the double oven with the master oscillator. This oscillator is crystal controlled and provides 50-kc check points for calibrating the master oscillator. The output of the oscillator is coupled to mixer stage V405; the output of the master oscillator taken from the buffer amplifier V402 is also coupled to the mixer. The two signals are heterodyned in the mixer to produce an audible beat frequency signal which is applied to two stages of audio amplification. The output of the second audio amplifier V406B is applied to the ZERO BEAT indicator on the front panel and to the PHONES jack.

(7) KEYS AND CLAMPER CIRCUITS. - When operating in the SSB mode, the keyer circuit acts as a protective stage for the RTF-2. If for any reason the low voltage supply is removed, this circuit will bias amplifier-doubler V201 and thereby protect all stages. When the stages are in use during CW or MCW operation, they key both amplifier-doubler V201 and driver V205 so as to minimize key clicks. Clamp tube V206

keeps the keying line above ground when the key is closed.

b. POWER SUPPLY MODEL RTP-2.

The RTP-2 supplies all required operating power to the RTF-2 and contains the high voltage control circuits, and mode selection circuits. Operating power is supplied from four separate supplies: a low B+, a low B- supply, a midvoltage supply, and a high voltage supply.

(1) LOW VOLTAGE SUPPLIES. - Transformer T601, rectifiers V603 and V604, and regulators V601 and V602 comprise the low B+ and B- supplies. Fuse F602 protects the primary input to transformer T601. Low B+ is provided by V604 and its LC filter network at a level of 270 vdc to the low level stages of the RTF-2. Certain stages have their screen grid voltage applied through the band switches which disable these stages by removing screen voltage when they are not in use. The regulated bias supply consisting of rectifier V603 and the RCL filter provides protective bias for the amplifier-multipliers, driver, and power amplifier in the RTF-2. Fuse F605 protects the low B+ and F604 the low B- supply. Ac voltage for the operation of the time delay relay K602 and relay K603 are provided by secondary winding 5-6-7 of T601.

(2) MIDVOLTAGE SUPPLY. - The midvoltage supply consists of transformer T602, rectifier V605, and the associated LC filter network. The primary input to T602 is fused by line fuse F603, and the output of the supply is fused by F606. The 500-vdc output of the midvoltage supply is applied to the keyer circuits in the RTF-2, and, during CW-FS or phone operation, to the PA screen grid. A reduced voltage is applied to the PA screen grid during tune operation. The output is applied to the multiplier section of the RTF-2 and to the screen of the final amplifier.

(3) HIGH VOLTAGE SUPPLY. - Primary plate power for the high voltage supply is supplied from transformer T501 located at the bottom of the cabinet. Transformer T603 provides the filament voltage. The output of +3000 vdc is applied by high voltage cable to the power amplifier section of the RTF-2. Circuit breaker CB601 protects the high voltage supply circuits.

c. TRANSMITTING MODE SELECTOR MODEL SBE-2.

Although the two exciter units used in the two models of the transmitter perform the same function, they are not completely identical internally. Figure 4-1 presents the block diagram of the SBE-2 exciter unit used in Radio Transmitter Model GPT-750D-2. Figure 4-2 presents the block diagram of the SBE-3 exciter used in Radio Transmitter Model GPT-750E-2. The explanation in this paragraph pertains to the SBE-2; the explanation for the SBE-3 is given in paragraph 4-2d. The power supply for the exciter is contained on the RTS-2 panel assembly. Circuitwise, this power supply is identical to the separate power supply described in detail in the exciter manuals, although the physical arrangement is different. Basically, the exciter consists of an audio input section, low frequency oscillator and balanced modulator, MF section, HF

section, squelch and VOX section, and metering circuits.

(1) AUDIO INPUT STAGES. - Individual inputs to channel 1 and 2 can be connected to the input terminals at the rear of the transmitter. When the microphone input is used, the signal is applied to an audio preamplifier. The output signals of the two channel inputs or the mike input are routed through selection switches and applied to the upper and lower side band audio amplifiers V102 and V103 respectively. The output of audio amplifier V102 is applied to balanced modulator CR102 which also receives the output of a stable 17-kc crystal oscillator. In the output of the balanced modulator, the two principle sidebands and the attenuated 17-kc carrier appear and are applied to an extremely sharp filter Z102 which passes only the upper sideband to the 17-kc notch filter. The notch filter reduces any 17-kc carrier to a negligible level. The output of V103 is applied to balanced modulator CR101 as is the output of 17-kc oscillator V104. The modulator output consisting of the principle sidebands and the 17-kc carrier is applied to filter Z101 which passes only the lower sideband and considerably reduces the 17-kc carrier. This lower sideband signal is applied to the 17-kc notch filter which further reduces the carrier signal level. The output of the notch filter consists of both the upper and lower sideband signals which are applied to the LF stages of the exciter.

(2) LF STAGES. - The low frequency stages of the exciter raise the frequency level of the sidebands by combining them with the output of stable crystal oscillator V105 which operates at 287 kc. The output of the notch filter contains only the upper and lower sideband signals and is applied to the LF amplifier V108. At this point, if desired, any degree of carrier insertion, that is the 17-kc carrier, may be reinserted by means of a front panel control. The output of the amplifier is applied to the LF balanced modulator where it is modulated with the output of the 287-kc crystal oscillator V105. The output of modulator CR103 now contains the original upper and lower sideband intelligence in the lower sideband of the 287-kc signal, that is, the intelligence is now centered around 270 kc. This signal is applied to tuned amplifier V109B; the output of the amplifier is applied to the MF stages.

(3) MF STAGES. - This section of the exciter consists of MF modulator V113 and MF amplifier V114 and operates in the 2- to 4-mc range. When the master oscillator of the RTF-2 is used to supply the injection frequency, the signal is applied to amplifier V115 and then to the input of the modulator. When the injection frequency is being supplied by the crystal oscillator within the exciter, V115 serves as the crystal oscillator. The MF modulator operates in a similar manner to LF balanced modulator. The intelligence contained in the 270-kc sidebands is modulated by the injection frequency effectively raising the frequency level to the 2- to 4-mc range. The output of the modulator is applied to the MF amplifier; when the operating frequency is in the 2- to 4-mc range, the output of the MF amplifier is applied to the input of the RF amplifier stages. When the operating frequency is above 4 mc, the output of the MF amplifier is applied to the input of HF modulator Z107.

(4) HF STAGES. - The high frequency stages of the exciter consist of crystal oscillator V117, ampli-

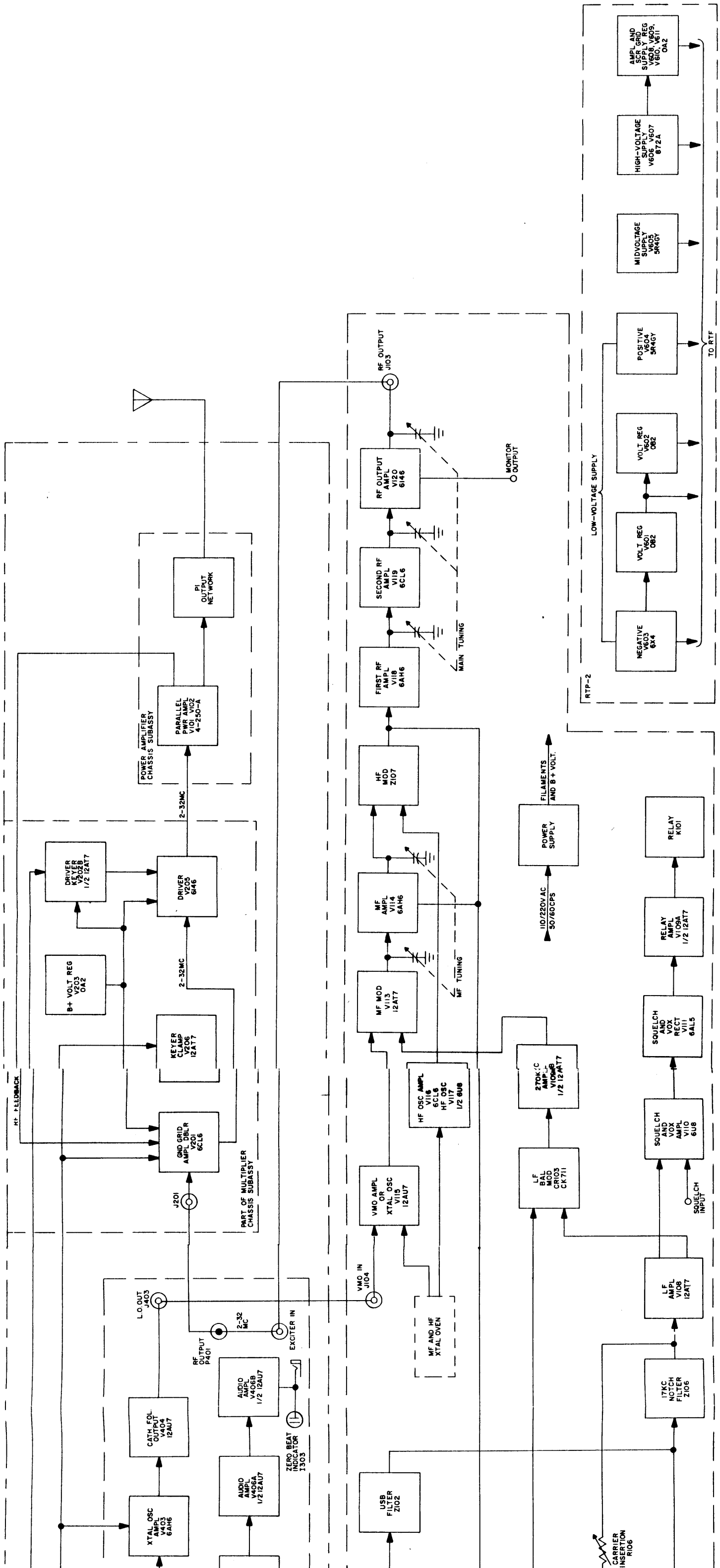

Figure 4-1. Radio Transmitter, Detailed Block Diagram

W

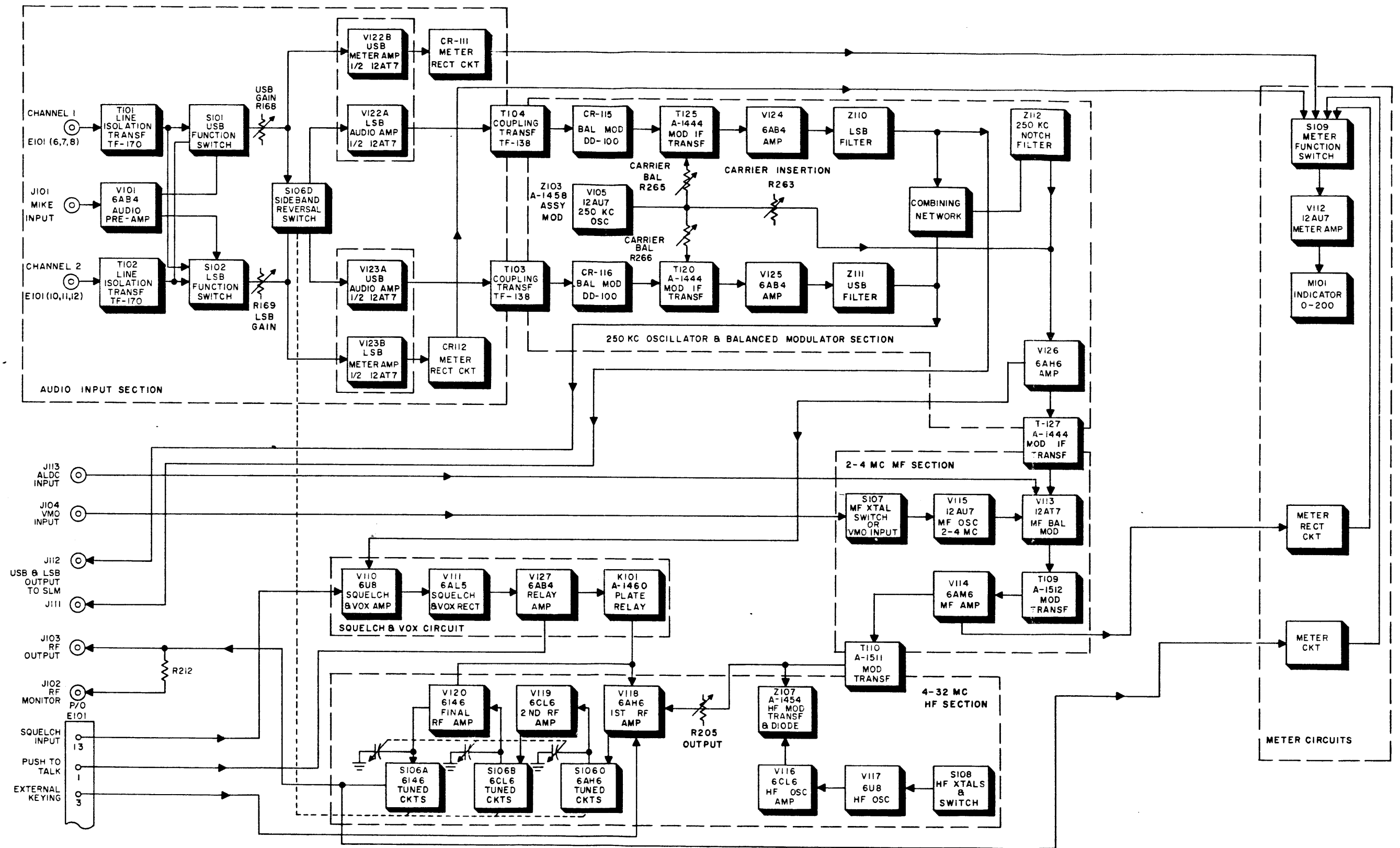

Figure 4-2. Transmitting Mode Selector Model SBE-3, Detailed Block Diagram

fier V116 and balanced modulator Z107. The oscillator may be operated at any one of the 10 preselected crystal frequencies to provide the modulating frequency for the sideband intelligence. The output of the oscillator is amplified by V116 and applied to modulator Z107 where it is combined with the output of the MF amplifier V114. The output of Z107 containing the initial sideband intelligence is applied to the input of the rf amplifier stages.

(5) RF AMPLIFIER STAGES. - Three stages of rf amplification are used to raise the power level of the signal to the full-rated output of the exciter. The rf amplifiers are V118, V119, and V120. The tuned circuit components are switched in accordance with the band switch and all three stages are gang tuned. The output of V120, at a maximum of 1 watt, is applied through a coaxial cable to the input of amplifier V201 in the RTF-2.

(6) SQUELCH AND VOX STAGES. - The squelch and VOX stages are used to key the transmitter without the need for press-to-talk operation. A portion of the 17-kc output from LF amplifier V108 is applied to VOX amplifier V110 the output of which is applied to rectifier V111 and relay amplifier V109A. When the operator speaks directly into the microphone, and depending upon the setting of the VOX GAIN control, relay K101 is actuated applying plate voltage to the HF section of the exciter. The purpose of the squelch circuit is to prevent any audio other than the operator's voice directly into the microphone from operating the VOX circuit.

d. TRANSMITTING MODE SELECTOR MODEL SBE-3.

The SBE-3 exciter unit is used in Radio Transmitter Model GPT-750E-2, and performs the same function as the SBE-2 in Radio Transmitter Model GPT-750D-2. Figure 4-2 is a block diagram of the SBE-3 exciter. Note that whereas the SBE-2 had a 17-kc and balanced modulator section and a low frequency section operating at 270 kc, the SBE-3 employs a 250-kc oscillator, balanced modulator, and notch filter to obtain the input to the MF section. The remaining sections of the exciter unit operate in the same manner as those described for the SBE-2.

e. PANEL CHASSIS ASSEMBLY RTS-2 POWER SUPPLY.

(1) Operating power for the exciter unit is provided by the power supply on the RTS-2 panel. Figure 6-11 is a complete schematic diagram of the RTS-2 including the power supply. If the primary power supply does not coincide with the wiring of the unit, wiring changes must be made as indicated on the schematic.

(2) Primary power input is applied to the primary of transformer T401. Rectifier V401 is used in a conventional full-wave rectifier circuit with an LC filter network to provide plate and screen voltage for the exciter stages. Four different levels of voltage are applied to the exciter: +250 vdc through J402H, +180 vdc through J402I; +125 vdc through J402J; and regulated +150 vdc through J402G. The regulated voltage is established at the desired level by V402 in series with R402.

4-3. DETAILED DESCRIPTION.

a. AMPLIFIER-OSCILLATOR, MODEL RTF-2.

(1) MASTER OSCILLATOR.

(a) The master oscillator stage uses triode V301 in a Colpitts oscillator circuit. (See figure 4-3.) The tuned grid circuit consists of L301, tuning capacitors C301 and C302, and padders C303, C304 and C319. The tank circuit is effectively tapped by C305 and C306 which parallel L302. The load is in the cathode circuit and the plate is placed at rf ground by C307. The output of the oscillator tube is taken from the cathode and applied to the grid of cathode follower V302A.

(b) The tuning range of the master oscillator is 2 to 4 mc. It is tuned by the front panel MASTER OSCILLATOR FREQUENCY control, which gang tunes C301 and C302. Plate voltage is applied to V301 only when the OSCILLATOR switch S401 is in the CAL or MO positions. When the switch is in any of the crystal positions, the master oscillator section is disabled by the removal of plate voltage.

(2) CATHODE FOLLOWER. - The cathode follower isolation stage V302A is provided at the output of the oscillator stage to reduce the effect of load variation on the oscillator frequency. (See figure 4-3.) This stage is located in the temperature-controlled oven for added stability and consists of V302A, plate decoupler L303 and plate bypass C308. The cathode output developed across R302 is connected to the MO output connector P301.

(3) 100-KC CALIBRATION OSCILLATOR.

(a) The second half of triode V302 is used for the 100-kc calibration oscillator. (See figure 4-3.) Crystal Y301 is placed in the temperature-controlled oven with V302B to insure stability. Plate voltage is applied to V302B by rotation of the OSCILLATOR switch S401 to CAL position. In all other positions of the switch, plate voltage is removed from V302B, thus disabling it.

(b) Tube V302B and crystal Y301 are connected as a Pierce oscillator which is fine tuned by capacitor C311. Feedback is obtained through capacitor C309 to the grid circuit. The output of the oscillator is developed across cathode resistor R305 and coupled to the grid of mixer V405.

(4) BUFFER. - Tube V402 is provided as a buffer at the output of the master oscillator circuit for additional isolation. (See figure 4-4.) Tube V402 is connected as a broadband amplifier. Coil L404 is used as a B+ filter with capacitor C427 as a B+ bypass. The output of V302B is applied through C402 to the grid. Cathode bias is developed by R406 and C401. The output from the plate is coupled through capacitor C418 to the input V403 through S401C when the switch is in the MO position

(5) CRYSTAL OSCILLATOR-AMPLIFIER.

(a) The crystal oscillator-amplifier circuit operates as a dual circuit controlled by OSCILLATOR

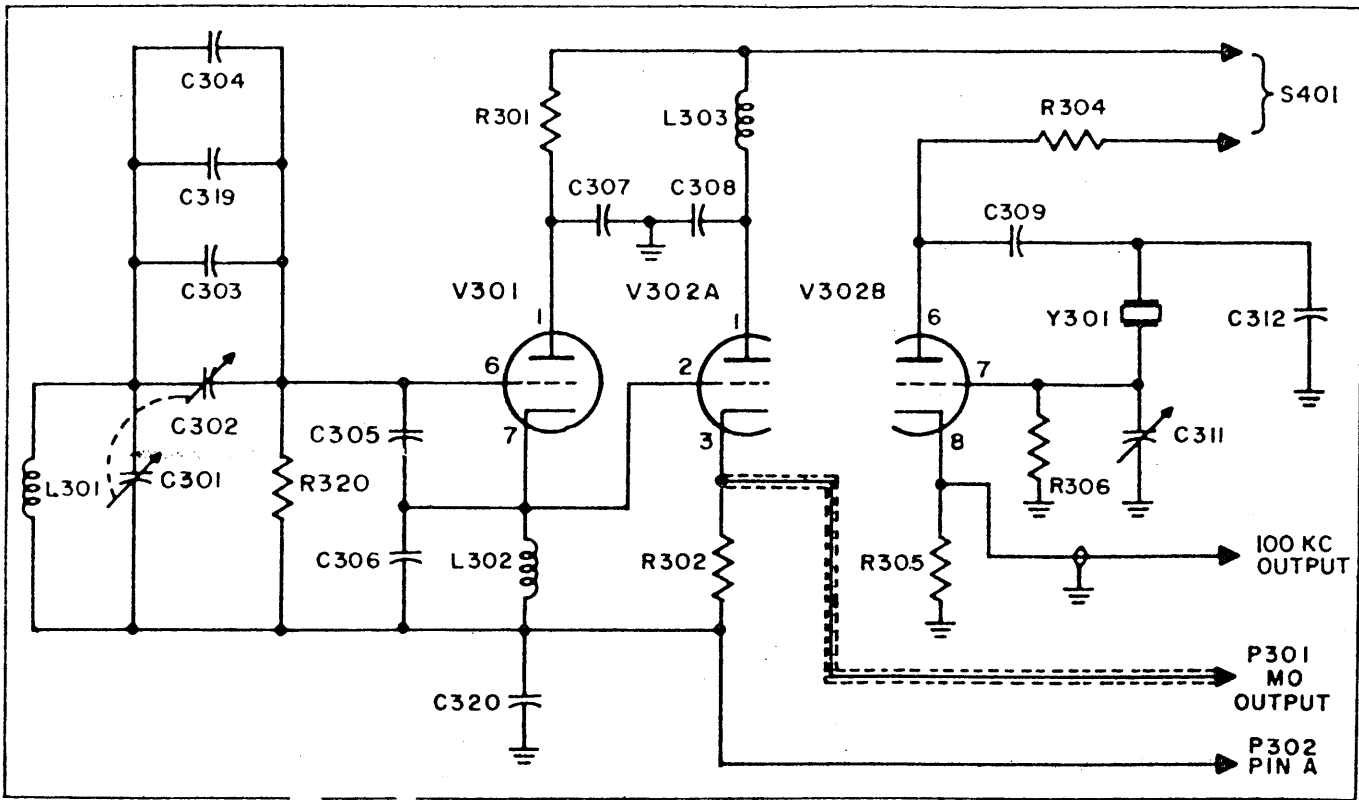

Figure 4-3. Master and Calibrator Oscillators, Simplified Schematic Diagram

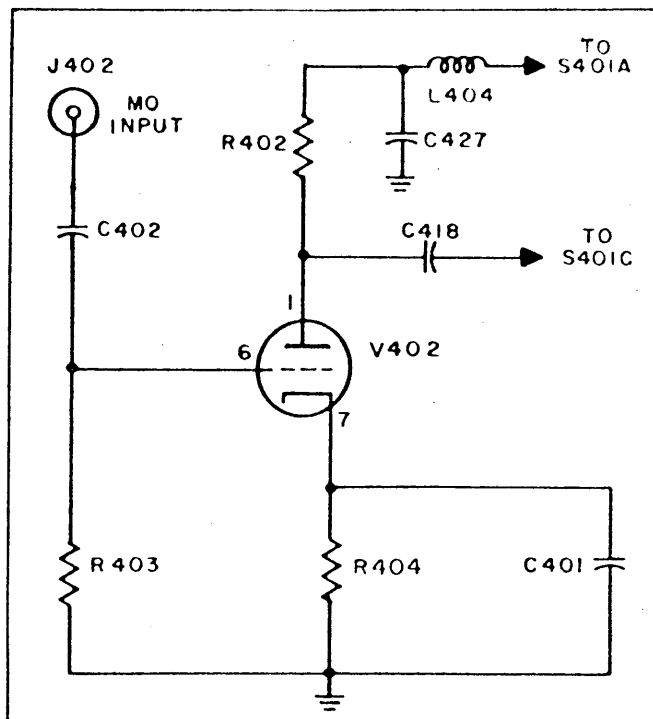

Figure 4-4. Buffer Stage, Simplified Schematic Diagram

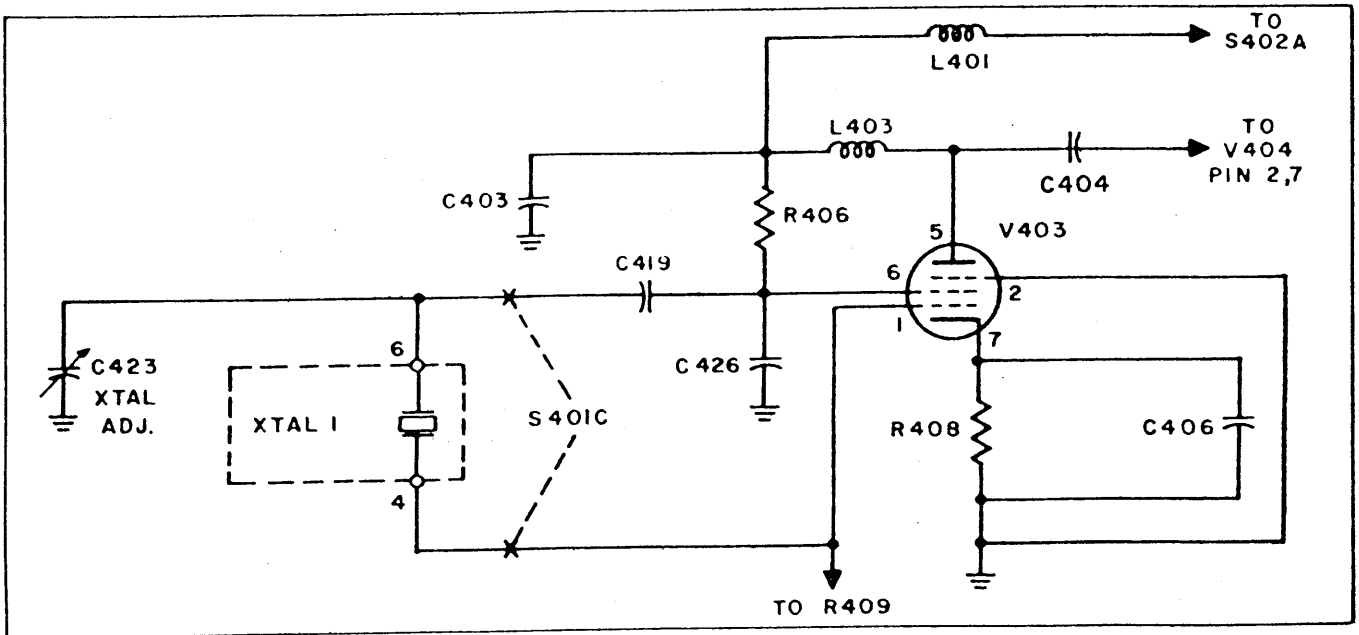

Figure 4-5. Crystal Oscillator/Amplifier, Simplified Schematic Diagram

switch S401. (See figure 4-5.) When the master oscillator is in use, and switch S401 in CAL or MO position, pentode V403 operates as a broadband rf amplifier. This amplifier stage is used to amplify the output of the buffer stage to obtain sufficient drive for the amplifier-doubler stage.

(b) When S401 is in the X1, X2, or X3 position, the master oscillator is disabled and V403 is reconnected as an electron-coupled Pierce oscillator (figure 4-5.) The screen grid is effectively the plate of the oscillator and feedback is obtained through C419. The oscillator output is electron-coupled to the plate circuit thereby isolating the oscillator from the load. The output of the stage is developed across plate load L403 and coupled through C404 to the input of V404. Grid bias is supplied from a negative supply when the stage is used as an oscillator.

(6) CATHODE FOLLOWER OUTPUT.

(a) A conventional cathode follower circuit is provided for the output of the oscillator circuits. (See figure 4-6.) The cathode follower circuit consists of dual-triode V404 connected in parallel, with T401 as the cathode load.

(b) The output of this circuit, matched to a 70-ohm line by tapping coil T401, is coupled through capacitor C408 to RF OUTPUT jack P401. The 70-ohm output impedance is provided to permit the use of longer interconnecting lines when external frequency shift or sideband exciters are driven by the transmitter oscillator.

(7) MIXER CIRCUIT.

(a) Mixer circuit V405 heterodynes the master oscillator signal and the calibration oscillator output to produce a beat note. (See figure 4-7.) A voltage output from the mixer stage is only obtained when the

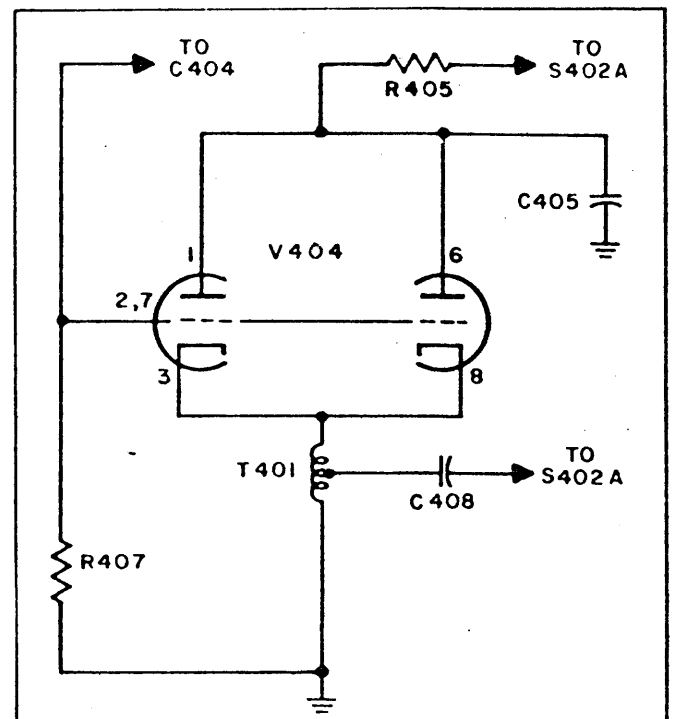

Figure 4-6. Cathode Follower, Simplified Schematic Diagram

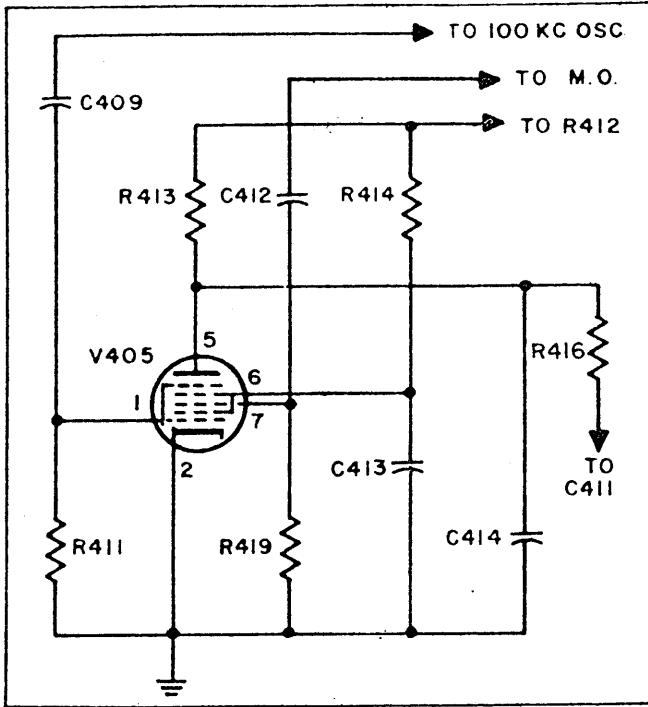

Figure 4-7. Mixer Stage, Simplified Schematic Diagram

two oscillators are within audio frequency range of each other. This is accomplished by passing the mixer output through a low pass filter consisting of C403, L401, C404, C415, and R416.

(b) Plate and screen voltage is applied to V405, a pentagrid converter, only when the OSCILLATOR switch is in the CAL position. The output of the 100-kc oscillator is coupled to the control grid through C409; and the output of the master oscillator to the injection grid through C412. Harmonics of the 100-kc oscillator are generated in the stage, one of which will beat with the master oscillator frequency to produce an audible beat note as the MO frequency is varied.

(8) AUDIO AMPLIFIER. - A two-stage audio amplifier V406 is used to amplify the audio output of the mixer stage. (See figure 4-8.) Plate voltage is applied to the amplifier only when S401 is in the CAL position. The output of V406B is applied across ZERO BEAT indicator I303 and to PHONES jack J301.

(9) GROUNDED GRID AMPLIFIER-DOUBLER.

(a) The operation of V201 (figure 4-9) is determined by the position of NORMAL-SSB S204. When S204 is in the SSB position, the stage is operated only as an amplifier since the output from the exciter is at the correct rf output frequency. When the switch is in the NORMAL position, that is, operating in modes other than SSB, the stage operates as an amplifier in the 2- to 4-mc range and as a doubler at frequencies above 4 mc.

(b) In SSB operation (figure 4-10), the input to the stage is applied to the cathode from the exciter at the frequency desired for transmission and containing the sideband intelligence. In this condition, the stage is operated as a straight rf amplifier to avoid distorting the intelligence. The output tank is isolated from B+ by C207. The tank circuit in the 2- to 4-mc range consists of L203 and C201A; above 4 mc, L203 is replaced by L204 through DRIVER BAND switch S201. Tuning capacitor C201A is gang tuned with C201C to insure tracking of the amplifier stages through the 2- to 32-mc operating range.

(c) In NORMAL operation, the input is taken from the output of cathode follower V404 and will be either the master oscillator signal or the crystal oscillator signal. In the 2- to 4-mc band, the stage operates as a voltage amplifier. At all frequencies above 4 mc, the stage is operated as a doubler. In the 2- to 4-mc and 4- to 8-mc settings of S201, the output of V201 is applied to the input of driver V205 through the switch. Above 8 mc, an additional doubler stage, V204, is used in the circuit. The output of V201 is then applied to the input of V204 through S201 and S204.

(10) DOUBLER.

(a) This stage is used only when operating in the NORMAL position of S204. (See figure 4-9.) Above 8 mc, additional multiplication of the output of V201 is required, so at these frequencies V204 has plate and screen voltage applied and the stage operates as a doubler. The stage operates with fixed bias and self-bias

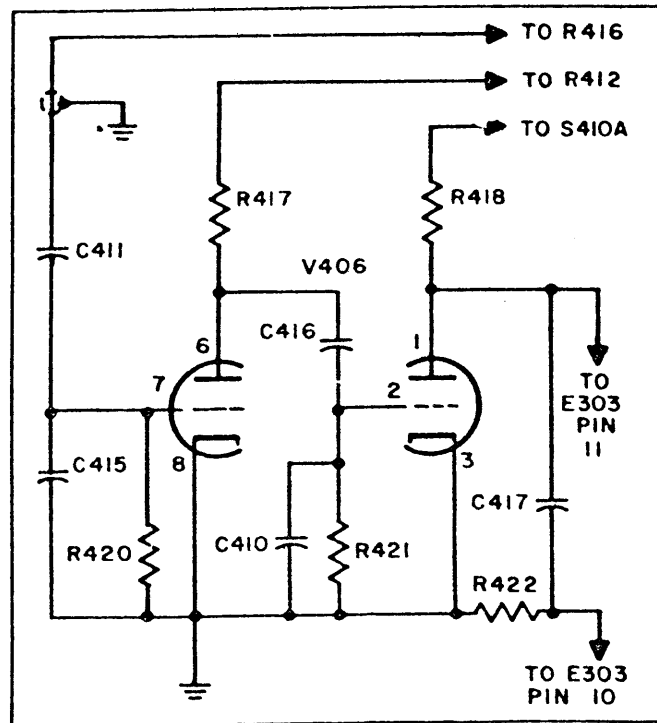

Figure 4-8. Audio Amplifier, Simplified Schematic Diagram

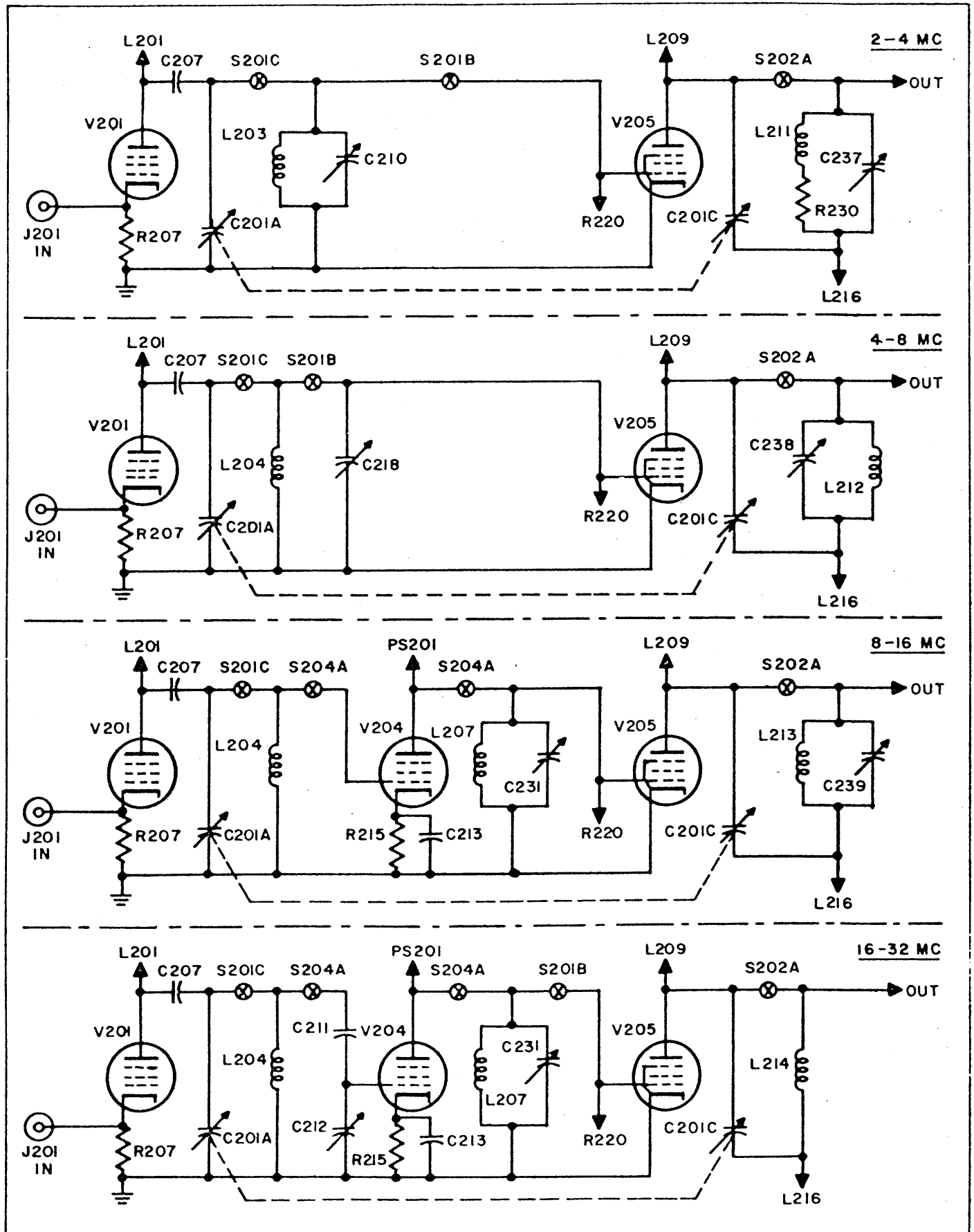

Figure 4-9. Frequency Multiplier (NORMAL Mode) Simplified Schematic Diagram

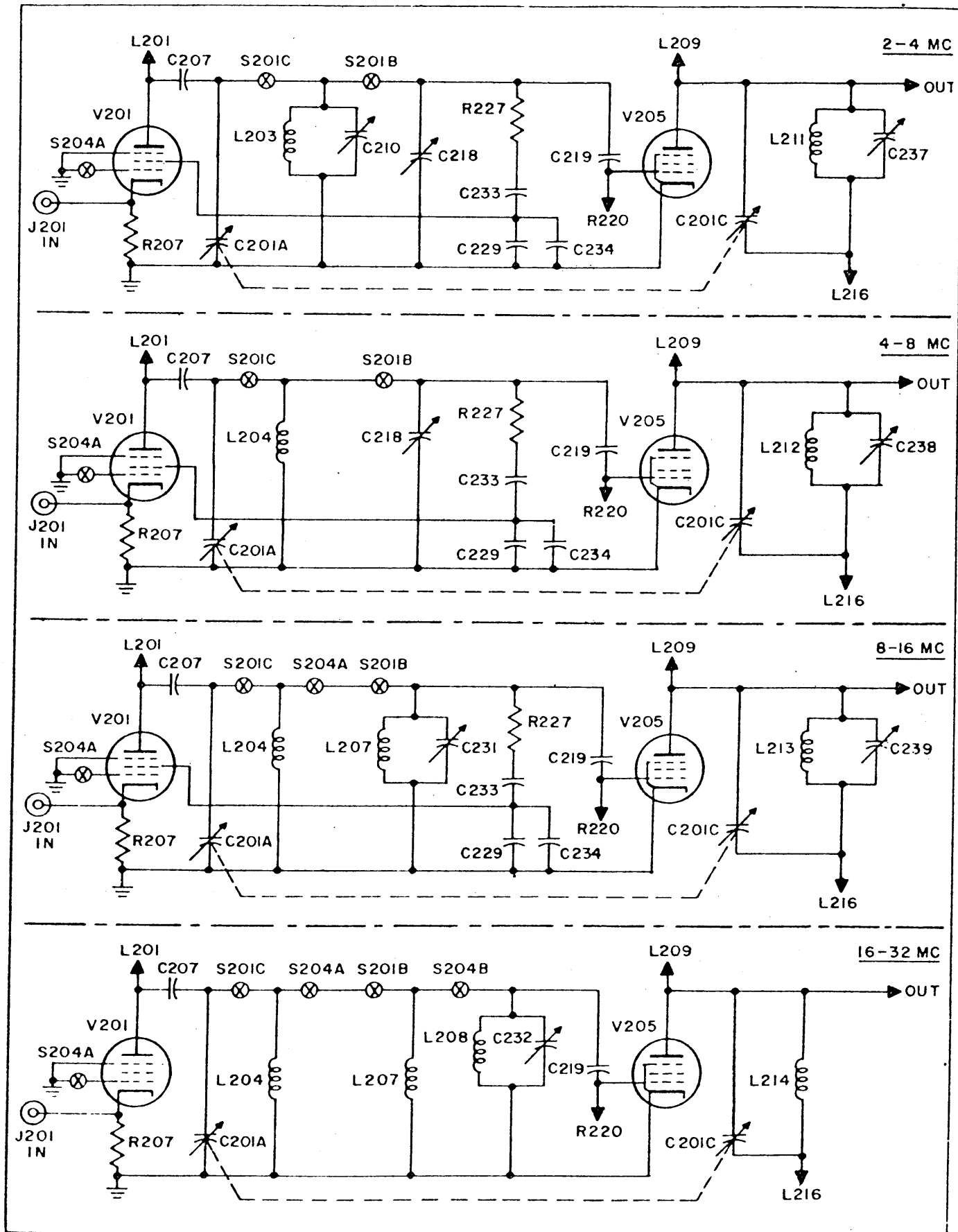

Figure 4-10. Frequency Multiplier (SSB Mode) Simplified Schematic Diagram

developed in the grid circuit. Parasitic suppressors are used in both grid and plate circuits.

(b) The tuned plate circuit consists of L207, C201B, and C231 isolated from B+ by C215. The output is gang tuned with V201 and V205 by C201B. The output, within the frequency range of 8 to 16 mc, is applied through S201 and S204 to the input of the driver.

(11) DRIVER.

(a) Driver stage V205 operates as a driver-amplifier at all frequencies when S204 is in the SSB position. (See figures 4-9 and 4-10.) When the switch is in the NORMAL position, the stage operates as an amplifier between 2 and 16 mc, and as a doubler from 16 to 32 mc.

(b) When operated in SSB, V205 is operated as an rf amplifier. Fixed bias is provided from the low B- supply, and the cathode is operated at ground potential. Main tuning capacitor C201C is gang tuned with amplifier V201. The plate tank coil and accompanying trimmer capacitor are switched into the circuit by S202. On the 16- to 32-mc band, no trimmer capacitor is used across the coil L214. The tank circuits and switching circuits are isolated from B+ by C222.

(c) When operating with S204 in the NORMAL position, driver V205 operates as an amplifier below 16 mc and as a doubler above 16 mc. The tank circuit components are the same as in SSB operation. However, when operating as a doubler, additional bias is developed in the grid circuit. The output of the driver tank circuit is directly coupled to the grids of parallel power amplifier tubes V101 and V102 at frequencies up to 16 mc. At frequencies above 16 mc, the output is coupled through RCL network R234, C226, and L218 to the grids of the power amplifier.

(12) KEYSER AND CLAMPER CIRCUIT. - Keyer V202A and V202B, a dual diode, is used to key the first multiplier and driver in sequence, by properly selected time constants, to obtain a slightly integrated output pulse. This serves to keep keyer "clicks" to a minimum. Second, if the low voltage supply should be removed for any reason, the keyer circuit will automatically bias the amplifier-doubler to cutoff and protect all stages. Clamp tube V206 is used to keep the keyer line above ground when the key is down,

(13) POWER AMPLIFIER.

(a) The power amplifier stage consists of tetrodes V101 and V102 connected in parallel. When operating with S204 in the SSB mode, the modulated signal from the exciter unit is applied to V201. The amplified output of V201 and V205 is applied to the input of the power amplifier. Since the sidebands carrying the intelligence are already imposed on the signal, the power amplifier cannot be overdriven and the stage operates at a reduced plate efficiency. Regulated B+ voltage is applied to the screen grids and regulated bias voltage to the control grids. The power output under these conditions will be approximately 500 watts PEP.

(b) When operating in any other mode, the stage is operated as a class C power amplifier and can deliver the full rated output. In these modes, the stage is operated with unregulated screen supply. Filament

voltage is supplied from transformer T101 in the power amplifier section.

(c) Band change switches S101 and S102 select the tuned tank circuit components in the output circuit. Coils L112 and L113 are tapped and various sections are switched into the circuit. PA TUNING control C113 is common to all bands. A portion of the output of the power amplifier is coupled through trimmer capacitor C104 and applied to V201. This feedback is the neutralizing signal to prevent spurious oscillations in the power amplifier.

(d) Control grid bias for the power amplifier is always adjusted in the SSB mode. This adjustment is set to bring plate current to 130 ma. when no drive is applied to the stage. When the stage is operated class C, additional bias is developed in the grid circuit.

(e) Metering circuits provide monitoring of control grid drive voltage, control grid current, screen grid current, and plate current. Rf grid voltage and current and screen grid current are metered through switch S203 and MULTIMETER M301. PA plate current is continuously displayed on PA PLATE meter M302. Rf output is continuously indicated on M403 through thermocouple TC101 which taps a portion of the output signal, rectifies it and applies it to the meter.

(14) METERING CIRCUIT. - Meter M301, depending upon the position of switch S203, measures PA Ebb, driver (V205) Ip, PA Isg, and PA Eg rf volts. (See figure 4-11.)

(a) With switch S203 in the PA Ebb position, a portion of the high voltage in the RTP-2 unit is applied across multimeter M301 for monitoring.

(b) When switch S203 is in the DRIVER Ip Ma position, plate current of driver V205 is measured by placing the metering circuit in series with the midvoltage supply output of the RTP-2 unit. Resistor R221, in shunt with meter M301, bypasses most of the current to prevent damage to the meter movement. Resistor R223, a multiplier, is in series with the meter in order to obtain the desired range.

(c) In the PA Isg Ma position of switch S203, screen grid current drawn by the screen grid circuit of the PA flows through the metering circuit back to the midvoltage supply in the RTP-2 unit. Resistor R216 in series with M301 acts as a multiplier while R210 shunts R216 and M301 to prevent high current from flowing through the meter.

(d) With switch S203 in the PA Isg Ma position, the current drawn by the grid circuit of the PA flows through the metering circuit. Resistor R233 acts as a multiplier for meter M301 while resistor R232 provides shunting. Capacitor C242 acts as an rf bypass.

(e) With switch S203 in the PA Eg RF volts position, rectified PA grid excitation voltage is measured by meter M301. Resistor R222 serves as a multiplier.

b. POWER SUPPLY MODEL RTP-2.

(1) PRIMARY POWER CIRCUITS. - The 115-volt ac line voltage to the RTP-2 unit is applied between pins J and K of plug J601. (See figure 4-12.) Line protection is provided by the MAIN POWER breaker.

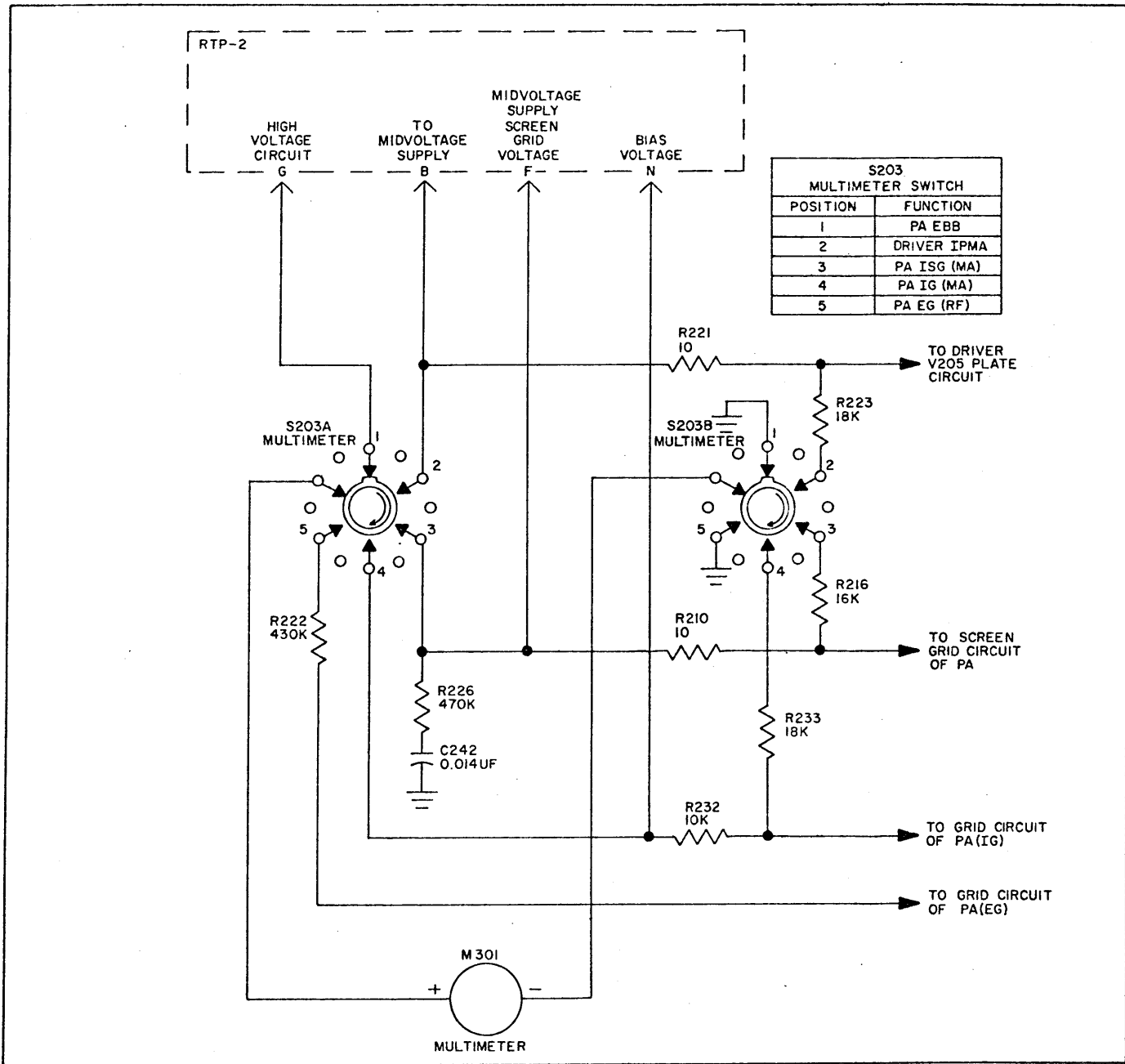

Figure 4-11. Metering Circuit, Simplified Schematic Diagram

The breaker trips automatically but must be reset manually. When MAIN POWER breaker CB601 is in the ON position, indicator I604 serves to visually indicate the presence of primary power. The BYPASS position of switch S602 permits line voltage to be applied to pins M and T of J602 even though MAIN POWER breaker CB601 is in the OFF position. Fuse F601 protects the circuit since the main power breaker is bypassed. The line voltage, after passing through CB601, is also applied as follows: through fuse F603 to the midvoltage supply; through fuse F602 to the low voltage supply; through FINAL PLATES switch S604 to normally open contacts of transmitter plates relay K601; and directly

to the 115-volt tap on switch S605. With FINAL PLATE switch S604 in the ON position and transmitter plates relay K601 energized, primary power is applied to pins M and L of J601 through external circuits to FINAL PLATES lamp I602, causing I602 to light. This voltage is also applied to the high voltage input transformer of the external circuits. Adjustable filament voltage is supplied through filament line switch S605. This switch connects the line to the various taps of transformer T603. The secondary of T603 supplies filament voltage for high-voltage rectifiers V606 and V607. Meter M601 provides a means for monitoring the voltage applied to T603.

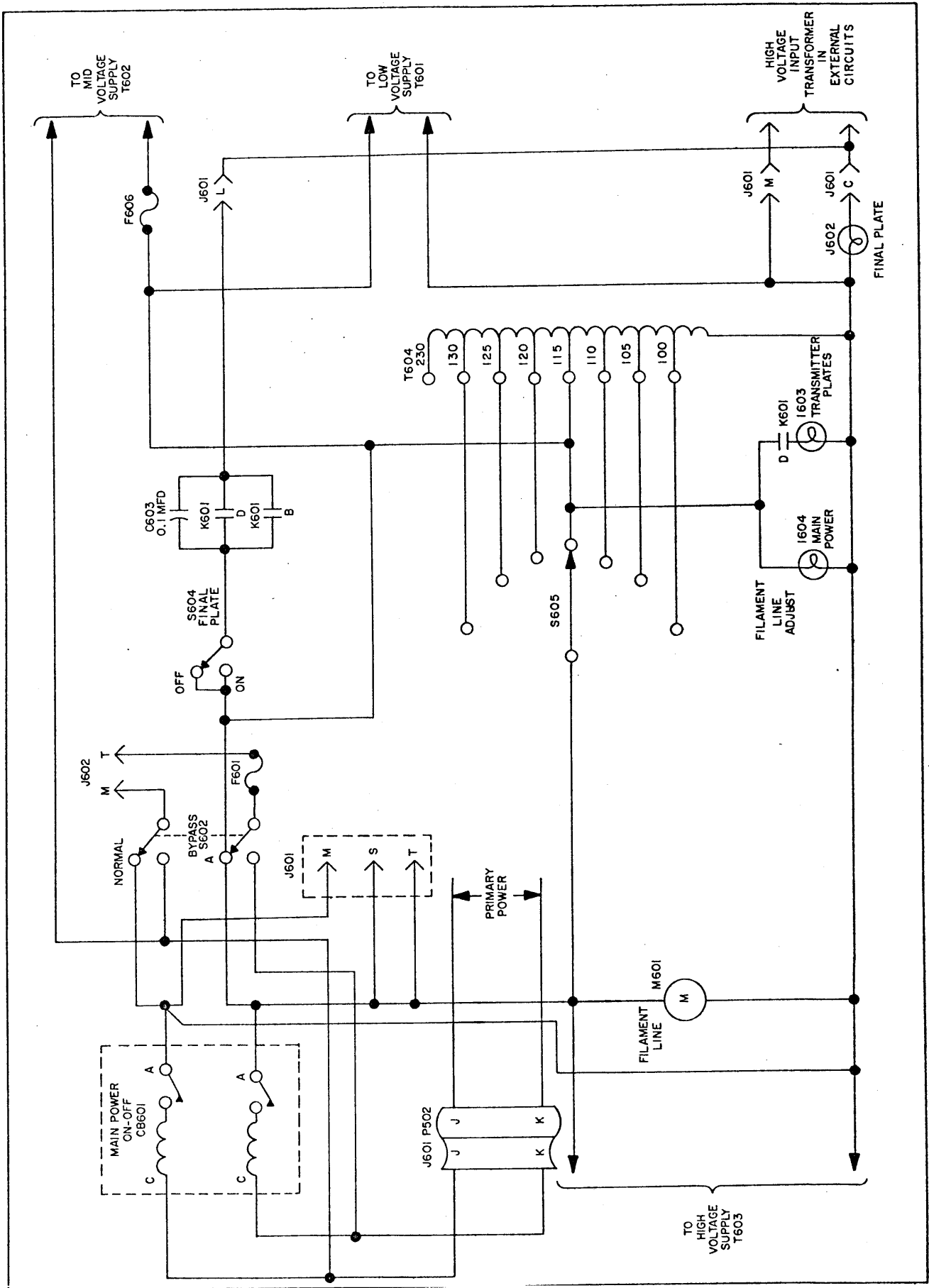

Figure 4-12. 115-Volt Line Distribution, Simplified Schematic Diagram

(2) LOW VOLTAGE SUPPLY.

(a) The low voltage power supply (figure 4-13) uses two rectification circuits, each of which produces a dc voltage of opposite polarity. The positive dc voltage is produced by a full-wave rectifier formed by dual-diode V604. Chokes L602 and L603 and capacitors C606 and C607 provide two networks of filtering while resistor R612 is used as a bleeder. Diode V603 is used as a half-wave rectifier and furnishes a negative output voltage. Filtering is provided by choke L601 and capacitors C604 and C605. Two regulated outputs are provided by use of regulators V601 and V602.

(b) The filtered output of the positive low voltage supply (figure 4-14) is applied through pin E of J602 to the grid circuit of V202 in the RTF-2 and through contacts (A) of K601 (when K601 is energized) to the plate circuits of the following tubes in the RTF-2: V201, V204, V402, V403, V404, V405, V406A, V406B, and through regulator V401 to V301 and V302. This voltage is also applied, in the RTF-2, to the cathode circuit of V202. During the first 60 seconds that primary power is applied, the low-voltage output is impressed, through normally closed contacts (B) of relay K604, across resistors R626 and R625.

(c) When primary ac power is initially applied, a secondary winding (pins 5 and 7) of transformer T601 develops 6.3 volts ac. (Refer to paragraph 4-3b(1).) This voltage is applied, through closed contacts (A) of relay K604, to thermal time delay relay K602. After 1 minute, K602 energizes and its contacts close, completing a current path for the winding of K604. Upon

energizing, K604 is held energized by a pair of its own contacts (normally open B contacts) while an alternate pair of its contacts (A) open and deenergize time delay relay K602. Resistor R625 is no longer in the circuit due to a third pair of K604 contacts (normally closed B contacts) opening.

(d) The regulated negative voltage output of regulators V601 and V602 is applied across a series connected network comprising resistor R606 and potentiometer R605. The output of regulator V601 is also applied through pin U of J602 to the RTF-2, grid circuits of V204 and V205, and plate circuit of V206. By adjustment of R605, a negative dc voltage can be obtained within the limits of supplied voltage. This voltage is applied through pin N of J602 to the grids of V101 and V102 in the RTF-2.

(e) Transmit relay K601 is energized by the voltage at the output of regulator V601 when the following conditions exist: switch S601 is in either the PHONE, TUNE or SSB position; relay K603 is energized; circuit breakers CB602 and CB603 are in the ON (closed position); and the pin h output of J602 is provided a ground path. Under any other condition, relay K601 is deenergized. When relay K601 energizes, the following occurs:

1. Positive low voltage supply output is applied through J602A to the RTF-2. (Refer to paragraph 4-3b(2)(b).)
2. Midvoltage supply output is applied to pins J602B, J601U and made available, after being divided, at contacts on switch S601C. (Refer to paragraph 4-3b(3)(b).)

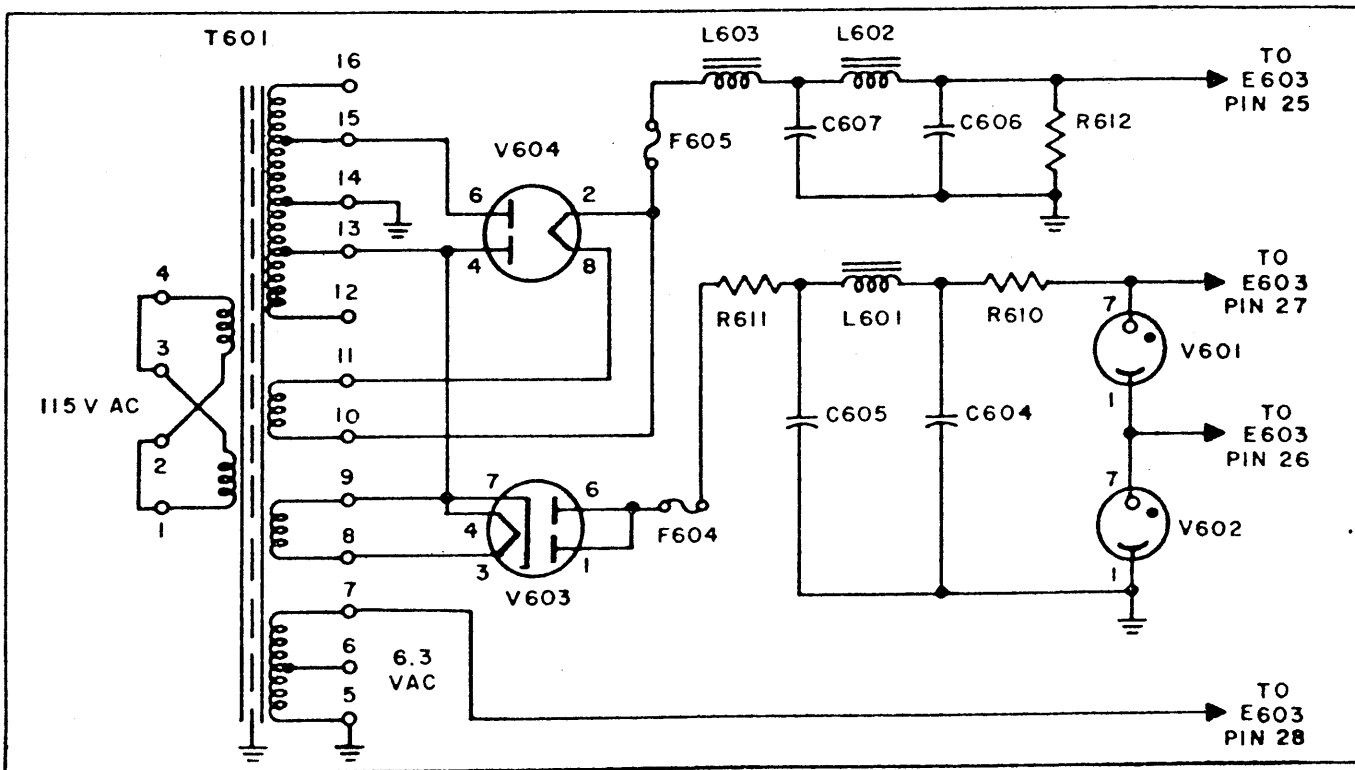

Figure 4-13. Low-Voltage Supply, Simplified Schematic Diagram

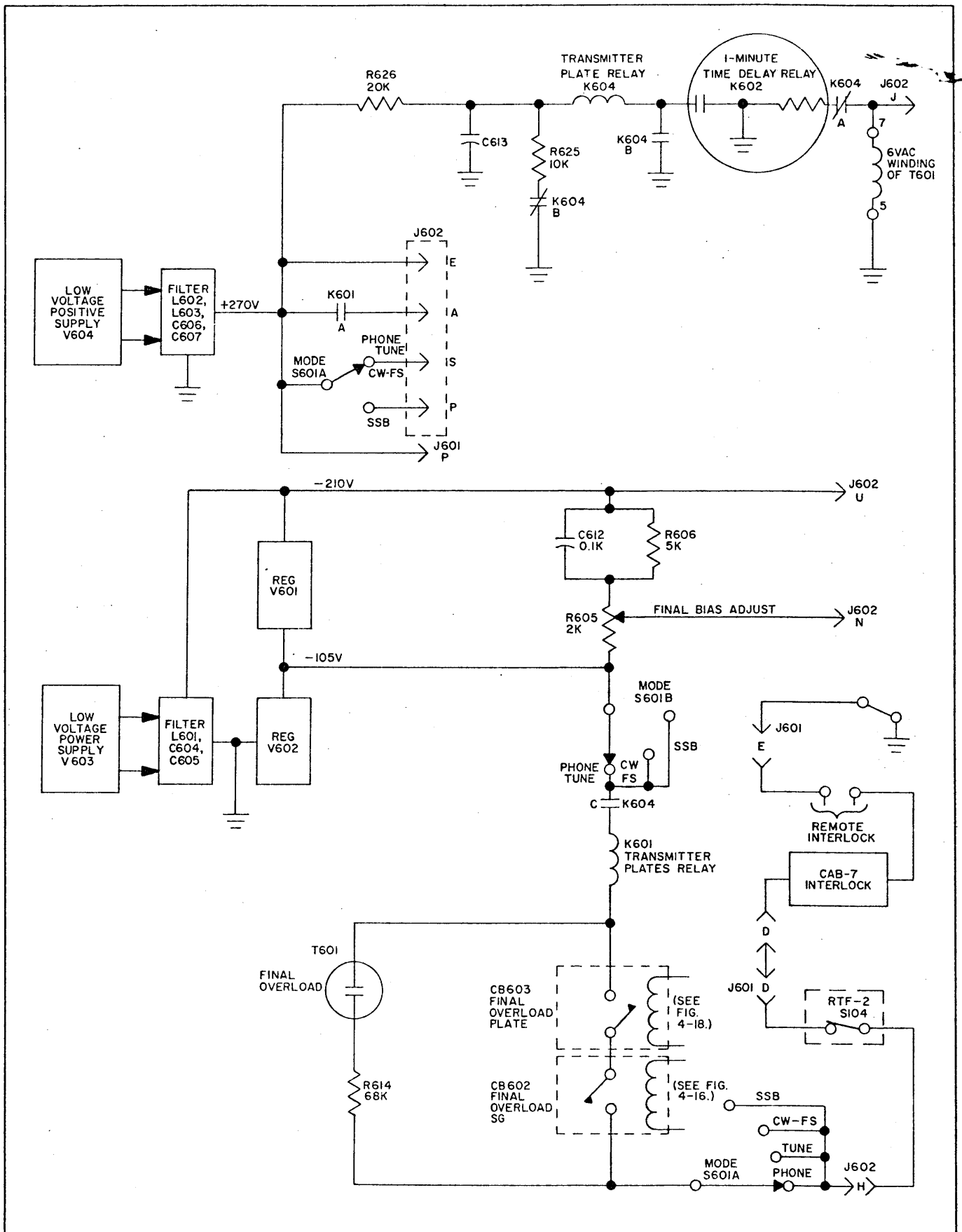

Figure 4-14. Low-Voltage Supply Distribution, Simplified Schematic Diagram

3. TRANSMITTER PLATES lamp I603 and FINAL PLATE lamp I604 light. (Refer to paragraph 4-3b(1).)

4. Continuity is provided between the wiper of one section of switch S604 and primary power is applied to the high voltage supply input transformer in the external circuits. (Refer to paragraph 4-3b(1).)

(f) Circuit breakers CB603 and CB602 provide overload protection by deenergizing when excessive current flows through their windings. If either circuit breaker deenergizes, current through K601 decreases, causing relay K601 to deenergize. A visual indication of an overload is provided by FINAL OVERLOAD lamp I601. Resistor R614 is a limiting resistor; its value is high enough to maintain K601 deenergized and low enough to light lamp I601.

(3) MIDVOLTAGE SUPPLY.

(a) The midvoltage power supply (figure 4-15) uses V605 in a full-wave rectifier circuit. Chokes L604 and L605 with capacitors C608 and C609 are used as a choke input filter. Filament voltage for the rectifier is applied from secondary winding 10-11 of T602.

(b) When relay K601 is deenergized, the midvoltage supply output, through normally closed contacts of K601, is terminated across resistor R607. Capacitor C611 serves to suppress sparking. (See figure 4-16.) The energizing of K601 makes the output of the midvoltage supply available at the CW-FS and PHONE positions of S601C. This output (500vdc) also is applied through J602B to the RTF-2 and the plate circuits of V202A and V203. An external connection between pin B of J602 and pin U of J601 enables this voltage to be applied to the PHONE contact of S601. This

voltage is also divided in half by resistors R601 and R602 and made available at the TUNE contact position of switch S601C. With switch S604 in the ON position, switch S601C connects either one of these three points through an overload network (circuit breaker CB602 in parallel with series connected resistor R604 and potentiometer R603) and J602F to the PA screen grids in the RTF-2. With switch S601C in the SSB position, regulated voltage from the high voltage supply is applied to the PA screen grids in the RTF-2. Circuit breaker CB602 now provides overload protection as determined by diodes CR601 and CR602. These diodes conduct to energize CB602 when the regulated voltage rises to an excessive value. When excessive current flows through CB602 its contacts open, causing relay K601 to deenergize and the output of the midvoltage supply to be terminated by resistor R607. Potentiometer R603 provides a means of adjusting the current through the winding of circuit breaker CB602, when switch S601 is in the PHONE, CW-FS or TUNE positions.

(4) HIGH VOLTAGE SUPPLY.

(a) The high voltage power supply (figure 4-17) uses two mercury vapor rectifiers, V606 and V607, for full-wave rectification. Choke L606 and capacitors C601, C602, and C610 are used as high voltage filters. Transformer T603 provides an input to the filaments of V606 and V607; transformer T501 in the cabinet provides the ac voltage to the plates of V606 and V607.

(b) The high voltage supply output is applied through jack J603 (figure 4-18) to the PA plates in the RTF-2. Resistors R618 and R619 divide a portion of

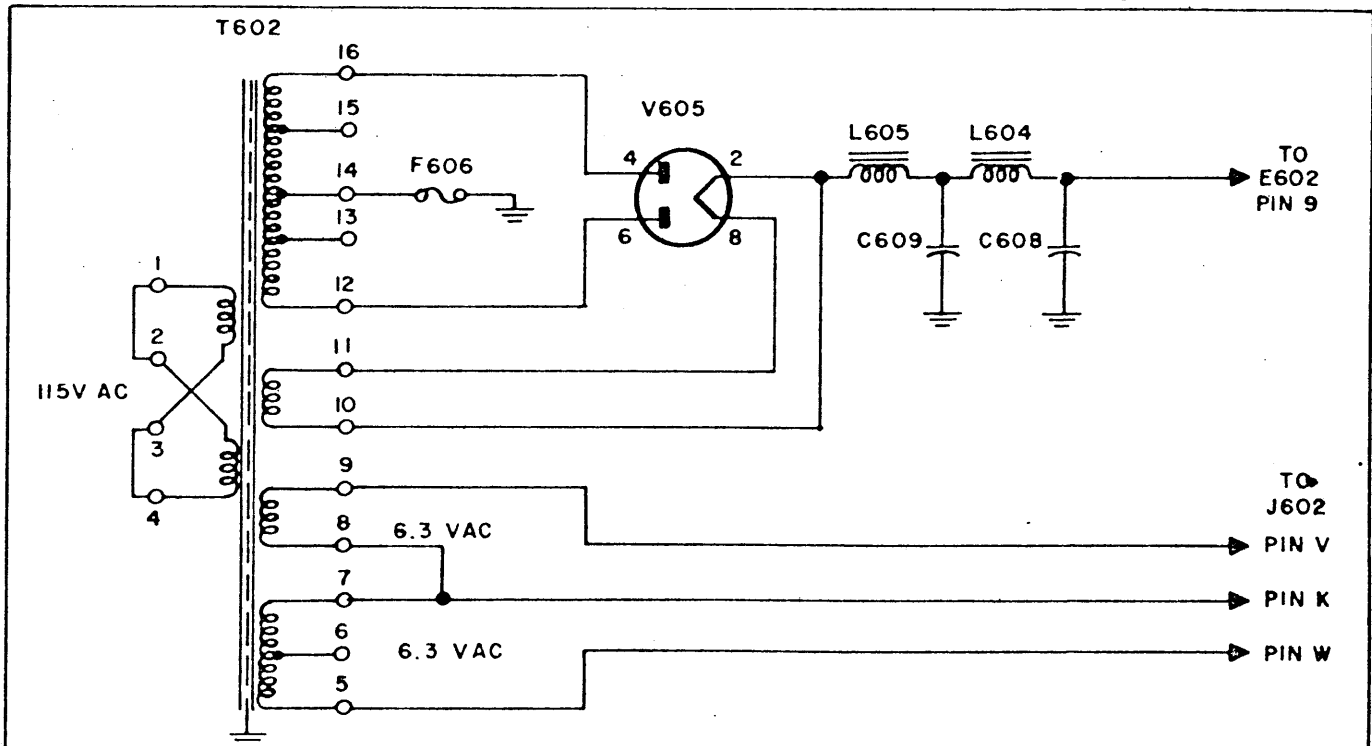

Figure 4-15. Midvoltage Supply, Simplified Schematic Diagram

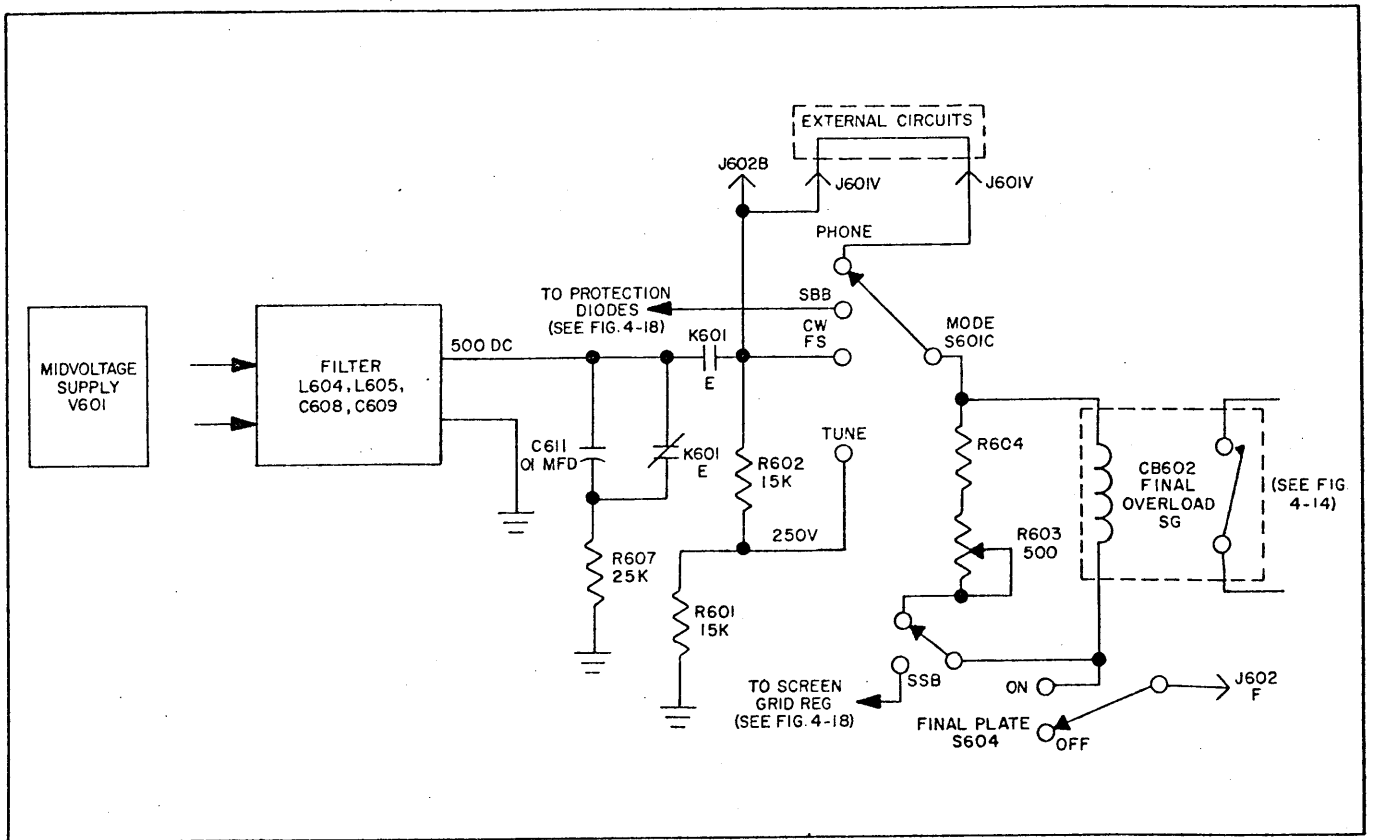

Figure 4-16. Midvoltage Supply Distribution, Simplified Schematic Diagram

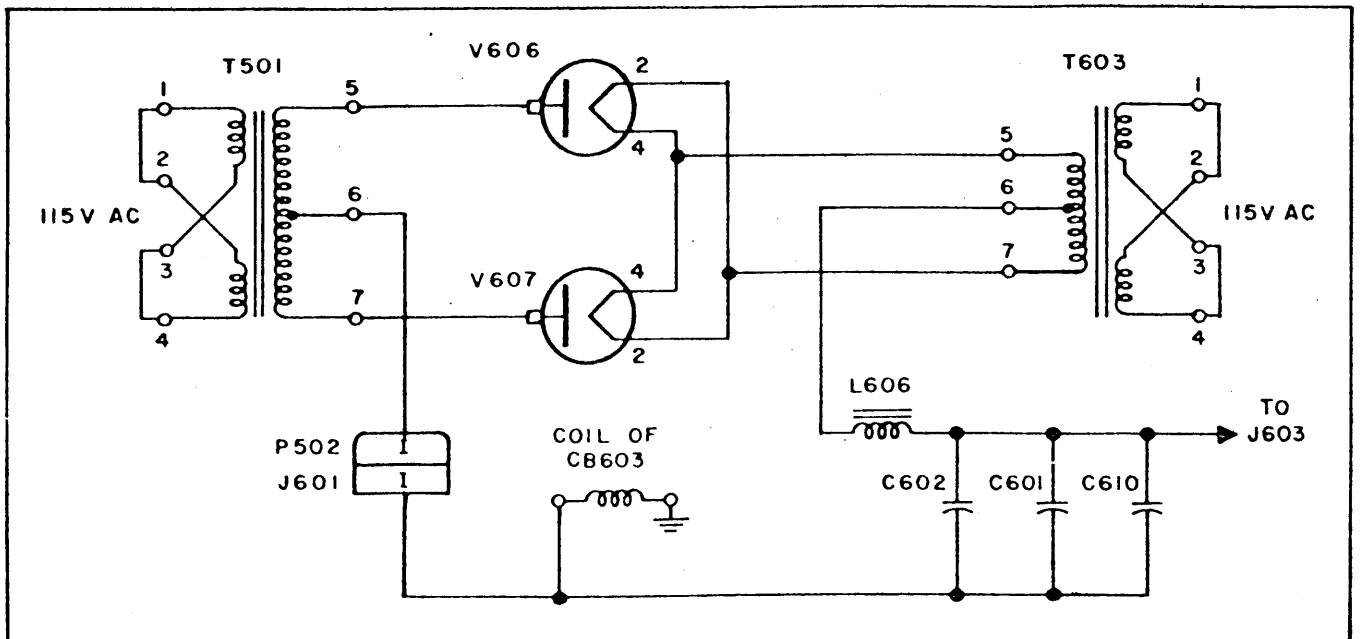

Figure 4-17. High-Voltage Supply, Simplified Schematic Diagram

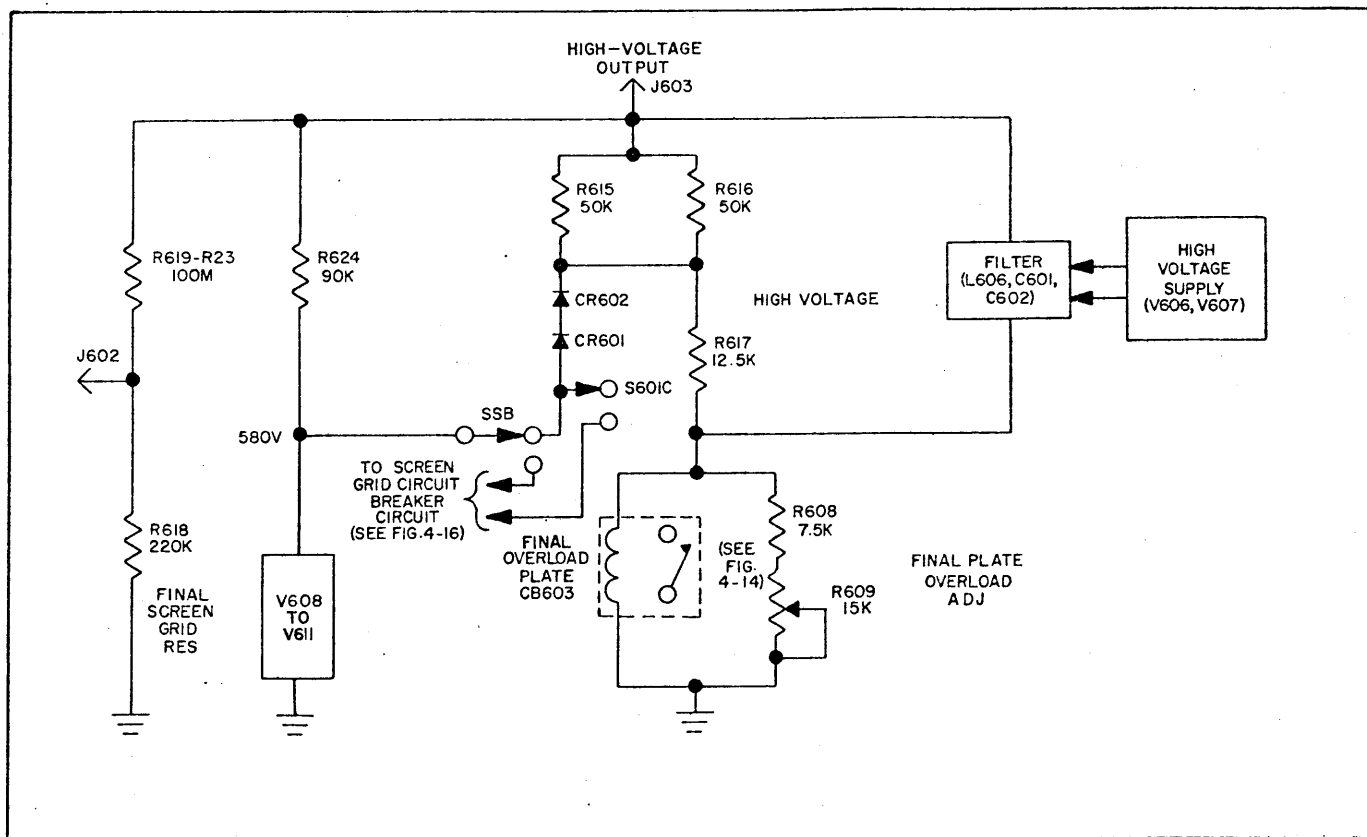

Figure 4-18. High-Voltage Supply Distribution, Simplified Schematic Diagram

this voltage for application to the metering circuit through J602G. A portion of the high voltage is also dropped across resistor R624 and regulated by screen grid regulators V608 through V611. With switch S601 in the SSB position, the regulated voltage is applied to one end of circuit breaker CB602 while diode CR601 is connected to the opposite end. Overload protection for the high output voltage is provided by FINAL PLATE OVERLOAD circuit breaker CB603. In the event of excessive current through the winding of CB603, its

contacts will open and deenergize relay K601. Potentiometer R609 provides a means for adjusting the current through the winding of circuit breaker CB603.

(c) TRANSMITTING MODE SELECTOR MODELS SBE-2 AND SBE-3 AND PANEL CHASSIS ASSEMBLY RTS-2 POWER SUPPLY. - A detailed description of the SBE-2 or SBE-3 exciter unit (depending on the radio transmitter model supplied) and the exciter unit power supply is contained in the applicable exciter unit manual.

SECTION 5 TROUBLE-SHOOTING

5-1. GENERAL.

a. The trouble-shooting procedures given in this section enable isolation of a fault to a particular unit of section of a unit and then to a particular stage. The best indications of malfunction of the equipment are obtained from the readings on the front panel meters of the RTF-2, SBE-2 or SBE-3, and the RTP-2. The various circuits that are metered will provide indication of the operation of specific sections of the radio transmitter. These indicating devices and the action and affect of the front panel controls will be used to isolate the fault. Certain voltage measurements, particularly of the supply voltages, are also used as a means of isolating the fault.

b. The trouble-shooting charts presented in this section are based on the operating procedure primarily. If the fault is related to misalignment of the stages of the RTF-2, reference will be made to the alignment procedures in section 6 of this manual. Alignment of the various stages in the exciter units will be referenced to the applicable manual. Malfunctions that cannot be remedied by proper alignment or tuning will be isolated to a particular unit in a system trouble-shooting chart. Following the system trouble-shooting, individual unit trouble-shooting charts are presented. Trouble-shooting of the exciter unit is contained in the applicable exciter unit manual. Trouble-shooting procedures for the exciter unit power supply contained on the RTS-2 panel assembly are covered in detail in this manual.

5-2. TROUBLE-SHOOTING PROCEDURES.

a. SYSTEM TROUBLE-SHOOTING.

(1) Throughout the trouble-shooting procedures reference will be made to the various front panel controls and indicators. Complete listings of these controls is given in table 3-1 through 3-4. The front panels of the units of the radiotransmitter are illustrated in figure 3-1. The internal adjustments of the units are described and illustrated in section 6.

(2) Table 5-1, the system trouble-shooting chart, presents the procedure in a general operating sequence with reference to the operating procedure in section 3 for the settings of the controls. The general sequence is to energize the radiotransmitter, calibrate and tune the master oscillator, and tune the following: the MF and HF stages of the exciter unit, the driver section of the RTF-2, the power amplifier section, and the antenna circuit. This procedure will ascertain the op-

erating condition of the carrier generation circuits, and of course, the power supplies. Modulating the transmitter will then verify the operation of the audio circuits of the exciter and the modulator circuits.

b. UNIT TROUBLE-SHOOTING. - Following the system trouble-shooting procedures, tables 5-2 and 5-3 present the RTP-2 and RTF-2 unit trouble-shooting procedures, respectively. These procedures enable isolation of a malfunction to a particular stage within these units. For detailed trouble-shooting procedures of the exciter unit, refer to the applicable exciter unit manual. The readings on this MULTIMETER, PA PLATE meter and RF OUTPUT meter are shown in table 5-4 for test frequencies of 2 mc, 16 mc, and 30 mc. These readings are nominal and a slight variation in readings is acceptable.

c. RTS-2 POWER SUPPLY TROUBLE-SHOOTING.

(1) Power for operation of the exciter is provided by the power supply built into the RTS-2. If, in operation, the exciter unit appears to be completely inoperative, the malfunction is most likely in the power supply. The fuses in the RTS-2 panel should be checked and replaced if necessary. The output of the supply is connected from J402 to J109 on the exciter unit by a cable. Check the cable for any defect and the connections for secure connections.

(2) Further trouble-shooting of the power supply to isolate defective circuit elements, requires the performance of voltage and resistance measurements.

5-3. VOLTAGE AND RESISTANCE DATA.

Figures 5-1, 5-2, and 5-3 contain voltage and resistance data of the RTP-2 power supply, RTF-2 amplifier-oscillator, and RTS-2 power supply, respectively. Further trouble-shooting, in addition to the procedures detailed in this manual and the applicable exciter unit manual, requires the use of voltage and resistance measurements to locate the particular circuit component that is malfunctioning. The voltage and resistance diagrams indicate the nominal value of voltage-to-ground and resistance-to-ground at the tube elements. Large deviations from the nominal values should be carefully investigated. The physical location of the tubes in the RTP-2 power supply, RTF-2 amplifier-oscillator, and RTS-2 power supply are shown in figures 5-4, 5-5, and 5-6, respectively. Table 5-4 lists the voltage readings that should be measured at various terminals of E601, E602, and E603 in the power supply RTP-2.

TABLE 5-1. SYSTEM TROUBLE-SHOOTING CHART

STEP	PRELIMINARY ACTION	NORMAL INDICATION	PROBABLE CAUSE AND REMEDY
<p>1.</p> <p>2.</p>	<p>Perform preliminary procedures to energize transmitter for SSB operation.</p> <p>Turn MAIN POWER switch on RTP-2 to ON.</p>	<p>MAIN POWER indicator lamp lights.</p> <p>FILAMENT LINE meter indicates 115 vac.</p> <p>Blowers in cabinet and power amplifier compartment of RTF-2 operate.</p> <p>Zero beat will be obtained at the check points with less than two turns of CALIBRATE control.</p>	<p>Power source failure. Check primary power source and input cable.</p> <p>Set FILAMENT LINE ADJUST for proper reading.</p> <p>Primary power circuits failure. Refer to table 5-2.</p> <p>If no zero beat is obtained, master oscillator, 100-kc crystal oscillator, mixer stage, and/or audio stages inoperative. Check for defective tubes. Check interconnecting cabling from RTP-2 to RTF-2.</p> <p>If excessive roatation of CALIBRATE control is required, re-adjust master oscillator and calibration oscillator in accordance with procedures in section 6.</p> <p>If zero beat obtained aurally but not visually, replace ZERO BEAT indicator.</p>
<p>3.</p>	<p>Tune master oscillator to a 2.0 mc test frequency. (Refer to tuning chart, figure 3-2.)</p> <p>On exciter unit, place MFXTALSW in MF position. Turn CARRIER INSERT control fully clockwise. Adjust MF TUNING control for VMO frequency and maximum reading on meter.</p>	<p>Maximum meter reading will approach full or exceed full scale. Reduce setting of CARRIER INSERT control to prevent off-scale reading.</p>	<p>If VMO previously found operative, check setting of S204 on RTF-2 for SSB position and S402 for SSB L. O. ON position.</p> <p>Check cabling from VMO to exciter in operative. Refer to applicable exciter manual.</p> <p>Exciter power supply inoperative.</p>
<p>4.</p>	<p>Tune driver section of RTF-2 to MO frequency.</p> <p>Place MULTIMETER switch to DRIVER Ip Ma position. Adjust DRIVER TUNING for dip in plate current.</p>	<p>MULTIMETER reads approximately 26 ma.</p>	<p>RF amplifier section of exciter unit inoperative. Refer to applicable exciter manual. Check cabling from exciter to RTF-2. Multiplier driver section of RTF-2 inoperative. Refer to table 5-3.</p>

TABLE 5-1. SYSTEM TROUBLE-SHOOTING CHART (CONT)

STEP	PRELIMINARY ACTION	NORMAL INDICATION	PROBABLE CAUSE AND REMEDY
4. (CONT)			If proper indication cannot be obtained at desired frequency, check alignment of driver stages. Refer to section 6.
5.	Place MULTIMETER switch to PA Isg Ma position.	MULTIMETER reads approximately 80 ma.	Driver stage inoperative. PA stage inoperative check interconnections from driver to power amplifier.
6.	Place MULTIMETER switch to PA Eg RF Volts position. Adjust DRIVER TUNING for maximum reading on meter.	MULTIMETER reads approximately 30-40 volts.	Driver section of RTF-2 inoperative.
7.	Tune power amplifier of RTF-2 to test frequency (Refer to paragraph 3-7.)	PA PLATE meter reads approximately 250 ma.	Power amplifier section of RTF-2 inoperative. Antenna loading controls inoperative.
8.	Adjust VOX and SQUELCH controls on exciter. Set transmitter controls for VOX keying. Speak directly into microphone.	PA PLATE current meter varies with modulation. Reading should not exceed 250 ma.	VOX circuits of exciter inoperative. Audio circuits of exciter inoperative.
9.	On exciter unit, place METER SW in LSB position and then USB position. Speak directly into microphone. Adjust LSB and USB GAIN controls.	Meter readings should be in same general range as steps 3 through 7.	Tuned circuits components for a particular band in RTF-2 and exciter may be defective. If meter readings appear erratic, stages may require alignment. Refer to procedures in section 6.

TABLE 5-2. RTP-2 TROUBLE-SHOOTING CHART

STEP	POINT OF TEST	PRELIMINARY ACTION	NORMAL INDICATION	PROBABLE CAUSE AND REMEDY
1.		Set front controls as follows: MODE to TUNE; FILAMENT ADJUST to extreme counterclockwise position. FINAL OVERLOAD circuit breakers (S. G. and PLATE) to ON; FINAL PLATE to ON; TRANSMITTER PLATE to OPERATE; MAIN POWER circuit breaker to ON.	When MAIN POWER circuit breaker is set to ON position, observe that FILAMENT LINE meter indicates 85 to 115 vac and MAIN POWER lamp lights. Observe that 60 seconds after MAIN POWER switch is set to ON, TRANSMITTER PLATES and FINAL PLATE lamps light.	If both indications are abnormal check for defective CB601. If lamp lights but meter indication is abnormal, check for defective M601 or S605. If meter indication is correct and lamp does not light, replace I603. If both lamps fail to light perform step 2. If measurement is normal in step 2, check for defective K601, K602, K604, R605, R606, S603, S601, CB602, CB603, or R626.

TABLE 5-2. RTP-2 TROUBLE-SHOOTING CHART (CONT)

STEP	POINT OF TEST	PRELIMINARY ACTION	NORMAL INDICATION	PROBABLE CAUSE AND REMEDY
2.	J602E		Vtvm measures +240 to +300 vdc.	<p>Check that primary power is present at input of T601. If not present, check for defective CB601.</p> <p>Check low voltage power supply for defective V605, L604, C605, C608, C609, T602, or F602. Replace if defective.</p>
3.	J602U		Vtvm measures -210 to -225 vdc.	<p>Check that primary power is present at input to T601. If not present, check for defective CB601.</p> <p>Check low voltage power supply for defective V603, T601, L601, F604, V601, V602, R610, or R611. Replace if defective.</p>
4.	J602N		Vtvm measures -95 to -125 vdc.	<p>Check setting of R605. (See paragraph 6-2a in section 6.</p> <p>Same as step 2.</p>
5.	J602F		Vtvm indicates +225 to +275 vdc with MODE switch in TUNE and +450 to +550 vdc with MODE switch in CW-FS or PHONE.	<p>Check that primary power is present at input of T602. If not present, check step 2.</p> <p>Check low voltage supply for defective L604, L605, C608, C609, V605, or T602. Replace if defective.</p> <p>Check for defective CB602, S601, S604. Replace if defective.</p>
6.	J602G	Set MODE switch to SSB position.	Vtvm measures +580 to +620 vdc.	<p>Check for defective V608, V609, V610, V611, CR601, CR602, or R624.</p> <div data-bbox="1025 1520 1268 1591" style="border: 2px solid black; padding: 5px; text-align: center; margin: 10px 0;"> <p>WARNING</p> </div> <p>Dangerous high voltages exist in this area. Set the MAIN POWER breaker to OFF. Discharge high voltage capacitors C601, C602, and C610 by connecting a heavily insulated shorting lead first to ground and then to terminal of one of the above capacitors.</p>

TABLE 5-3. RTF-2 TROUBLE-SHOOTING CHART

STEP	POINT OF TEST	PRELIMINARY ACTION	NORMAL INDICATION	PROBABLE CAUSE AND REMEDY
1.	ZERO BEAT lamp and head-set	Set controls as follows: DRIVE to extreme counterclockwise position; NORMAL SSB to NORMAL; EXCITATION to CW/PHONE; OSCILLATOR to CAL; MASTER OSCILLATOR FREQUENCY to check point frequency nearest to desired operating frequency. Note Check points are available every 50 kc over the 2- to 4-mc range.	Unlock the CALIBRATION control and rotate the knob until a frequency of 5 cps or less is heard in the head-set and is indicated by the ZERO BEAT lamp. (The lamp will flash very slowly as the zero beat is approached.)	Perform steps 2 through 5. If no trouble is encountered, check for defective V406.
2.	P301	Connect a frequency counter to point of test. Set MASTER OSCILLATOR FREQUENCY dial for 2000 kc.	Counter indicates 2000 kc.	Check for proper adjustment of C303. Check for defective V301. Replace if defective.
3.	V402-1	Remove counter and connect vtm to point of test.	Vtvm measures $155 \pm 10\%$ vdc.	Check for defective V302. Replace if defective.
4.	V405-1	Set OSCILLATOR switch to CAL position and connect counter to point of test.	Counter indicates 2000 kc.	Check for defective V302. Replace if defective.
5.	V405-7	Disconnect counter and connect with rf probe to point of test.	Vtvm measures $-10 \pm 10\%$ vdc.	Check for defective V402.
6.	Multimeter	Set controls as follows: OSCILLATOR to MO; MASTER OSCILLATOR FREQUENCY for 250 kc; DRIVE to extreme counterclockwise position; DRIVE BAND to desired position; MULTIMETER to PA Ig Ma; DRIVE TUNING to 2.5.	MULTIMETER can be adjusted to a peak reading by means of DRIVE TUNING control.	If indication is abnormal for all frequency bands, check for defective MULTIMETER circuit (V201, V205, V101, or V102.) If indication is abnormal at 8-16 and 16-32 bands only, check for defective V205 or V207, or C301 for proper adjustment or defect. If indication is abnormal at 2-4 mc band only, check L203, C210, L211, or C237 for proper adjustment of defect. If indication is abnormal at 4- to 8-mc band, check L204, C218, C238, or L212 for proper adjustment or defect.

TABLE 5-3. RTF-2 TROUBLE-SHOOTING CHART (CONT)

STEP	POINT OF TEST	PRELIMINARY ACTION	NORMAL INDICATION	PROBABLE CAUSE AND REMEDY
6. (CONT)				<p>If indication is abnormal for 4- to 16-mc band, check for proper adjustment or defect of L213 or C329.</p> <p>If indication is abnormal at 16- to 32-mc band, check for L214 proper adjustment or defect.</p>
7.	PA PLATE	Set controls as follows: PA BAND to correspond to desired output signal; ANTENNA LOADING fully counterclockwise; AUX. LOADING to +.	Advance DRIVE control until PA PLATE meter indicates reading in tuning chart.	Check for defective V205, V101, V102, C117A, C117B, S101, S102, S103, or M302.
8.	PA PLATE	TURN PA TUNING control for dip in PA meter.	Adjust PA TUNING control for minimum reading on PA meter.	Check for defective C113.
9.	Multi-meter	<p>Turn MULTIMETER switch to PA IsgMa position. Adjust DRIVE control for MULTIMETER reading indicated in tuning chart. Set controls as follows: PA Isg to MA; DRIVE CONTROL for MULTIMETER reading indicated in tuning chart; ANTENNA LOADING clockwise until MULTIMETER reading drops to zero and PA PLATE meter indicates rise in current; PA TUNING for dip on PA PLATE METER.</p> <p>Continue to advance the ANTENNA LOADING and DRIVE controls and returning the PA TUNING control for dip on PA PLATE meter until MULTIMETER and PA PLATE meter indicate PA Isg and PA Ip given in tuning chart.</p> <div style="border: 1px dashed black; padding: 2px; width: fit-content; margin: 10px auto;"> <p>CAUTION</p> </div> <p>The plate current dips must be obtained at the lowest possible PA TUNING setting to avoid doubling in the final amplifier.</p>	<p>Adjust PA TUNING control for minimum reading on PA meter.</p> <p>PA PLATE meter indicates PA Isg given in tuning chart; MULTIMETER indicates PA Ip given in tuning chart.</p>	<p>Check for defective C113.</p> <p>Check for defective V101, V102, C117A, or C117B.</p> <p>See step 6.</p>

TABLE 5-3. RTF-2 TROUBLE-SHOOTING CHART (CONT)

STEP	POINT OF TEST	PRELIMINARY ACTION	NORMAL INDICATION	PROBABLE CAUSE AND REMEDY
10.	PA PLATE and Multi-meter	Depress TEST KEY button. <div style="border: 1px dashed black; padding: 2px; display: inline-block;">CAUTION</div> Do not maintain TEST KEY button depressed for any long period of time.	PA PLATE meter indicates PA Ip given in tuning chart. MULTIMETER indicates PA Ig given in tuning chart. If these conditions are not obtained advance DRIVE control to increase PA Ig; advance ANTENNA LOADING CONTROL to increase PA Ip.	Check for defective V202, V203, or V206. Replace if defective.

TABLE 5-4. AMPLIFIER-OSCILLATOR RTF-2, FRONT PANEL METER READINGS

METER AND POSITION	2 MC	16 MC	30 MC
PA Ebb volts	2.9 kv	2.9 kv	2.9 kv
DRIVER Ip Ma.	26 ma.	54 ma.	72 ma.
PA Isg Ma.	90 ma.	90 ma.	90 ma.
PA Ig	10 ma.	8 ma.	10 ma.
PA Eg RF Volts	82 volts	82 volts	82 volts
PA PLATE	460 ma.	430 ma.	425 ma.
RF OUTPUT	4.3 amp	6.3 amp	4.2 amp

Note

Above readings based on transmitter being tuned for CW operation and 1000 watt output.

The readings on the MULTIMETER, PA PLATE meter and RF OUTPUT meter are shown in tables 5-4 for test frequencies of 2 mc, 16 mc, and 30 mc. These readings are nominal and a slight variation in readings is acceptable.

TABLE 5-5. TERMINAL STRIP VOLTAGES

TERMINAL	VOLTS	TERMINAL	VOLTS
E601-1	300	E602-9	620
-2	-130	-10	620
-3	600*	-11	0
-4	1000*	-12	0
-5	-210	-13	1v
-6	620	-14	1v
-7	620	-15	1v
-8	620	-16	1v

* - FINAL PLATE switch ON

TERMINAL	VOLTS	TERMINAL	VOLTS
E602-17	325	E603-25	325
-18	325	-26	-105
-19	0	-27	-210
-20	-105	-28	6.3 ac
E603-21	NC	-29	600*
-22	NC	-30	115 ac
-23	NC	-31	0
-24	-105	-32	-1.2*



V604
5R4
SEE NOTE 1

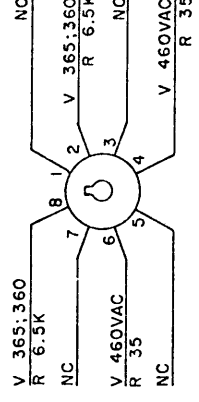

V608
0A2
SEE NOTE 3

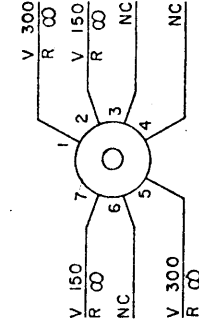

V609
0A2
SEE NOTE 3

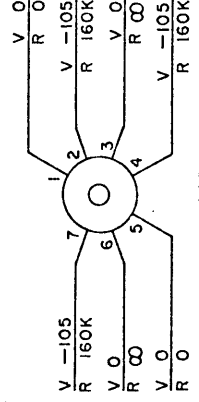

V602
0B2

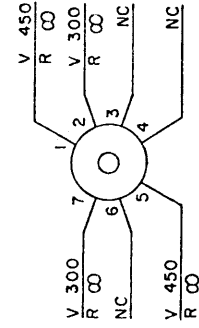

V610
0A2
SEE NOTE 3

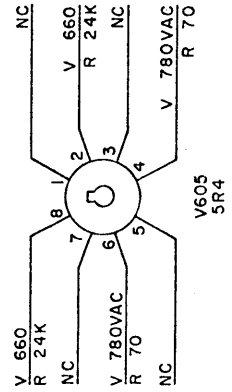

V605
5R4

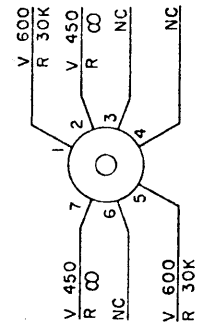

V611
0A2
SEE NOTE 3

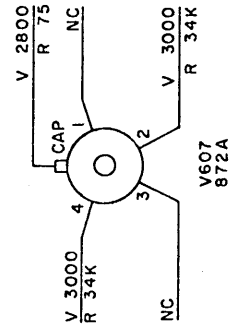

V607
872A

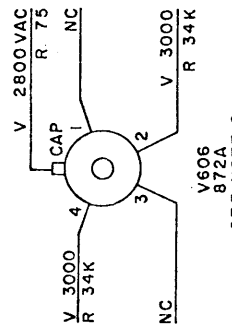

V606
872A
SEE NOTE 2

CONTROL SETTINGS - UNLESS OTHERWISE INDICATED

MAIN POWER switch ON
TRANSMITTER PLATES switch in OPERATE
FINAL PLATE switch OFF
MODE SWITCH in CW/FS
OSCILLATOR switch in X-1 (No crystal)
EXCITATION SW. in CW/PHONE
NORMAL-SSB switch in NORMAL
DRIVE control fully clockwise
LINE input 120 Vac.

VOLTAGE MEASUREMENTS

All dc volt measurements made with Hewlett - Packard HP-410B. All ac measurements made with Simpson 200.

- NOTES:
1. First voltage reading is in key up condition; second reading is key down condition. When only one reading shown reading is same for both conditions.
 2. Voltage at plate cap in key down condition only.
 3. Voltage readings obtainable with FINAL PLATE switch ON.

RESISTANCE MEASUREMENTS

MAIN POWER switch OFF
TRANSMITTER PLATES switch in STANDBY/REMOTE

Figure 5-1. Voltage and Resistance Diagram, Model RTP-2

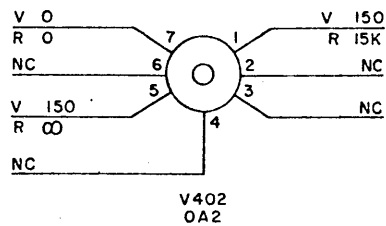

VOLTAGE MEASUREMENTS CONTROL SETTINGS UNLESS OTHERWISE NOTED

MAIN POWER switch ON
 TRANSMITTER PLATES switch in OPERATE
 FINAL PLATE switch OFF
 MODE switch in SSB
 OSCILLATOR switch in X-1 (No crystal)
 EXCITATION SW. in SSB L. O. ON
 NORMAL-SSB switch in SSB
 DRIVE control fully clockwise
 LINE input 120 Vac

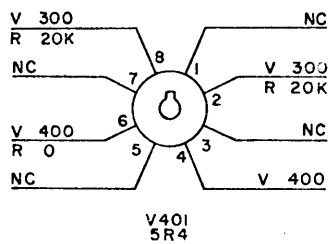

All dc voltage measurements made with Hewlett - Packard HP-410B. All ac measurements made with Simpson 260.

RESISTANCE MEASUREMENTS

MAIN POWER switch OFF
 TRANSMITTER PLATES switch in STANDBY/REMOTE

Figure 5-3. Voltage and Resistance Diagram, Model RTS-2

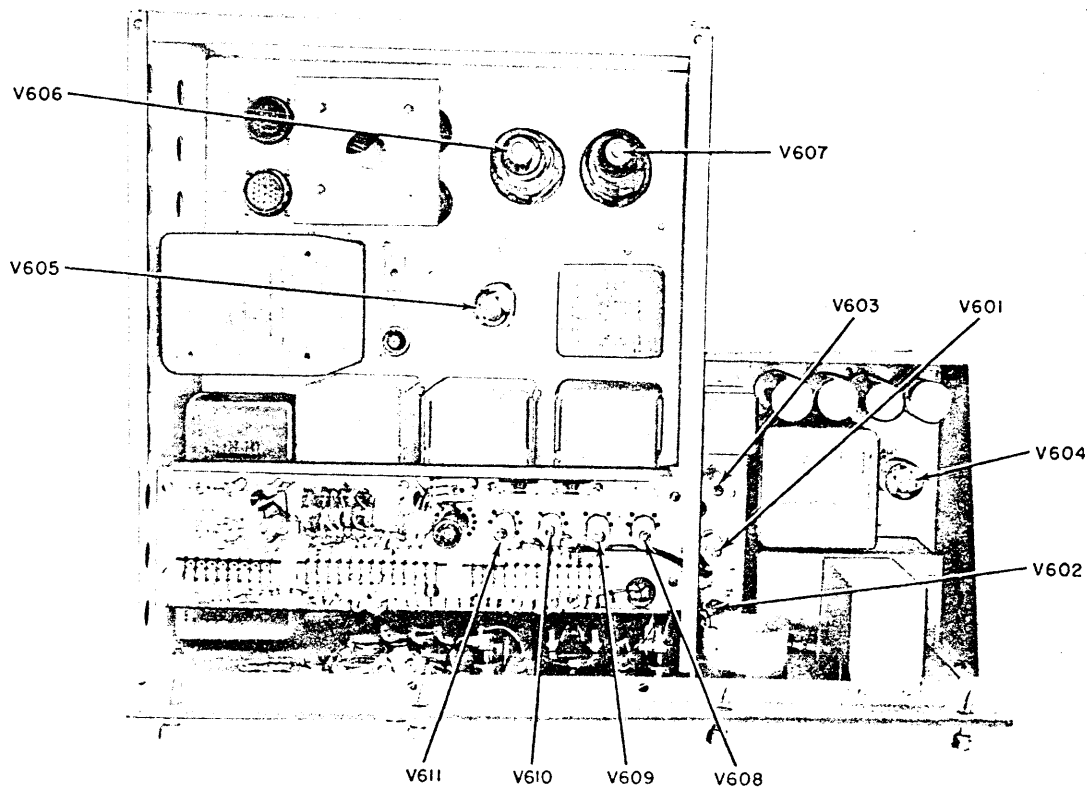

Figure 5-4. Tube Locations, Model RTP-2

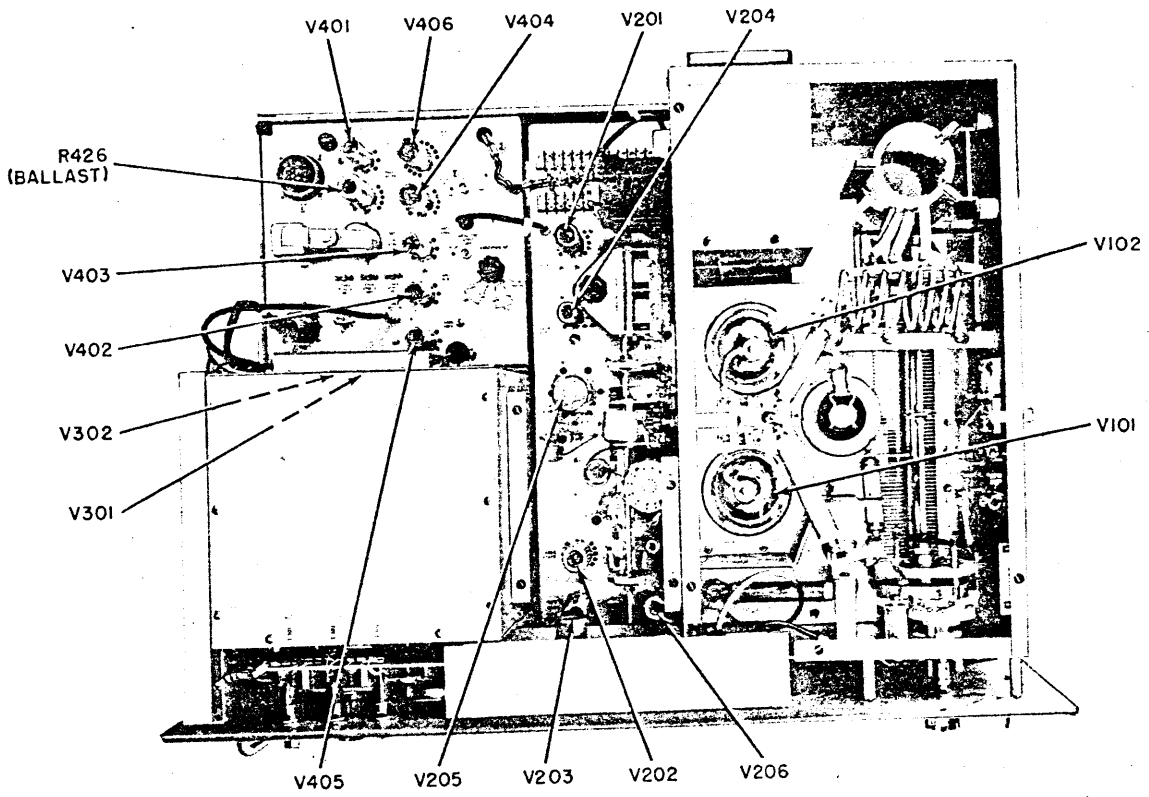

Figure 5-5. Tube Locations, Model RTF-2

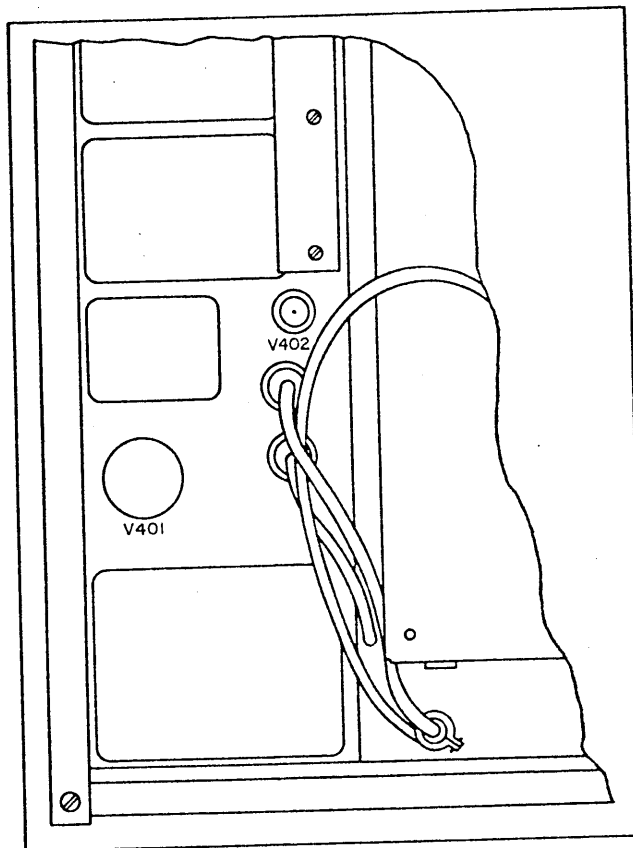

Figure 5-6. Tube Locations, Model RTS-2

SECTION 6 MAINTENANCE AND REPAIR

6-1. GENERAL.

This section contains information required to maintain and repair the radio transmitter. Strict adherence to the procedures detailed in this section will enable the realization of peak equipment performance, minimum repair, and longer life. The procedures contained in this section, in addition to the procedures detailed in the applicable exciter unit manual cover every aspect of maintenance and repair of the radio transmitter.

6-2. TUNING ADJUSTMENT. (See figures 6-1 and 6-2.)

a. **BIAS ADJUSTMENT.** - To adjust the bias output voltage of the RTP-2 power supply, proceed as follows:

Step 1. Connect a vtvm between J602N and ground.

Step 2. Place MODE switch in SSB, TUNE, or PHONE position.

Step 3. Adjust R605 for a vtvm indication of -110 volts.

Step 4. Tune radio transmitter for SSB operation at a test frequency.

Step 5. Set DRIVE control on exciter fully counterclockwise.

Step 6. With no excitation supplied to RTF-2, adjust FINAL BIAS ADJ. R605 until PA PLATE meter reads approximately 130 ma.

b. **CALIBRATION OF 100-KC AND MASTER OSCILLATORS.** - Relatively little rotation of the CALIBRATE control should be required to calibrate the master oscillator at any check point. When the CALIBRATE control requires more than two revolutions at any check point from a previous calibration setting, the 100-kc and master oscillators require calibration. The calibration procedure requires the use of a communications receiver that is tuneable to WWV and equipped with an S meter. If an S meter is not built into the receiver, a dc microammeter with a suitable series resistor connected across the output of the detector is an effective substitute. To calibrate the 100-kc and master oscillators, proceed as follows:

Step 1. Energize transmitter and allow a 24-hour warmup.

Step 2. Tune receiver to highest WWV frequency obtainable in area. WWV transmits at 2.5, 5, 10, 15, 20, and 25 mc.

Note

Do not use receiver bfo.

Step 3. Disconnect transmitting antenna and connect a 50- or 70-ohm, 1000-watt resistive dummy load to RF OUTPUT jack. Attach a short length of wire to transmitter RF MONITOR jack to provide local radiation for purposes of calibration.

Step 4. Consider a WWV frequency of 2.5 mc. Zero beat the master oscillator at nearest check point which, in this example, is 2.5 mc. Approach the zero beat from the high-frequency end toward the low-frequency end.

Step 5. Tune transmitter, at a low level, to the WWV frequency being monitored.

Note

Exercise care and precision when setting MASTER OSCILLATOR FREQUENCY dial to proper setting. Actual frequency indication at any dial setting may not be exact, but correction of frequency-to-dial setting relationship is object of this procedure. Approach final frequency setting of dial from same direction of rotation as check point.

CAUTION

Do not attempt to correct any master oscillator frequency-to-dial deviation by mechanical means such as slipping control shaft couplings, etc.

Step 6. Place OSCILLATOR switch in MO position.

Step 7. When transmitter frequency approaches WWV frequency, S meter will pulse at a rate proportional to frequency difference. Adjust transmitter frequency until S meter pulsation rate is a minimum. Transmitter frequency then matches WWV frequency which, in turn, is exact frequency of one master oscillator check point. Lock MASTER OSCILLATOR FREQUENCY and CALIBRATE controls.

Step 8. Place FINAL PLATE switch in OFF position.

Step 9. Place OSCILLATOR switch in CAL position.

Step 10. Open RTF-2 drawer for access to C311.

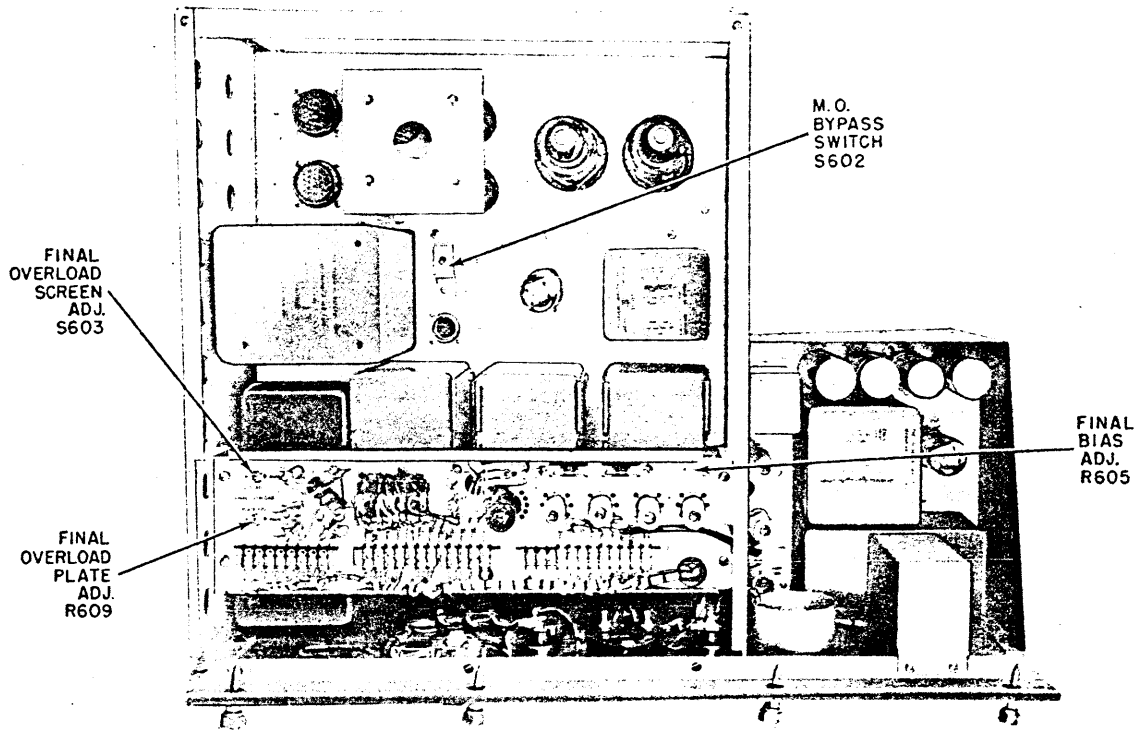

Figure 6-1. Internal Adjusting Controls, Model RTP-2

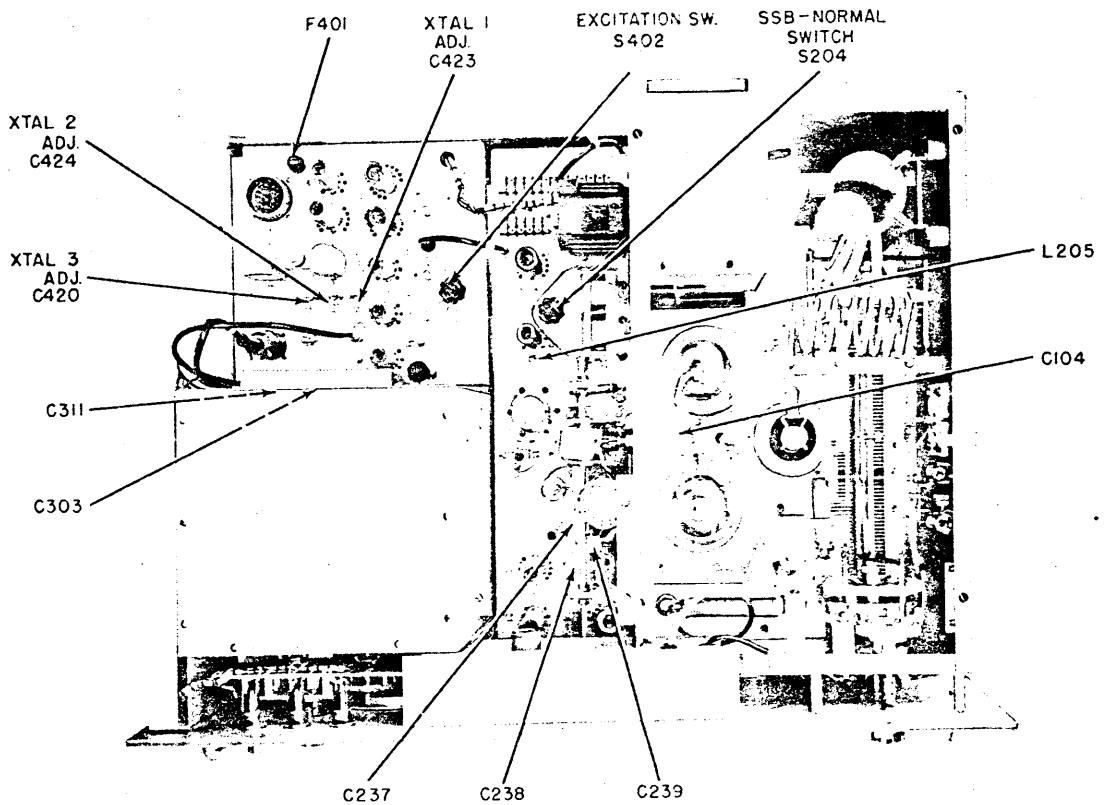

Figure 6-2. Internal Adjusting Controls, Model RTF-2 (Sheet 1 of 2)

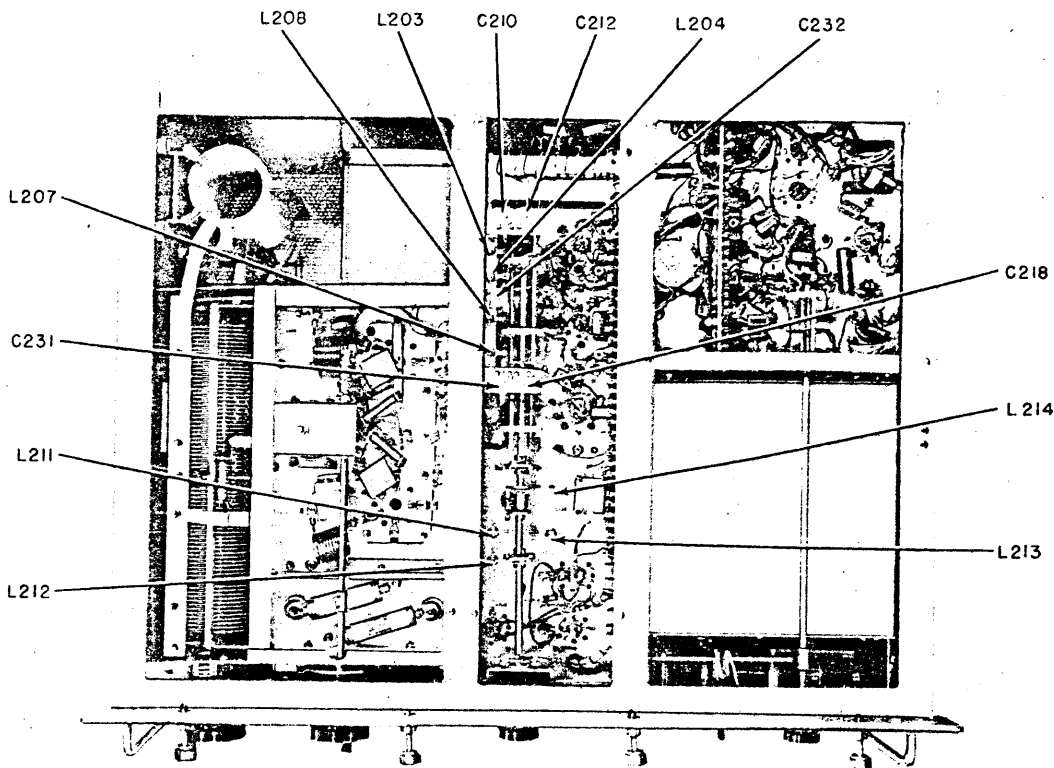

Figure 6-2. Internal Adjusting Controls, Model RTF-2 (Sheet 2 of 2)

Step 11. Adjust capacitor C311 until ZERO BEAT flashes at a minimum rate.

Step 12. Using MASTER OSCILLATOR FREQUENCY and CALIBRATE controls, tune transmitter to 2-mc keeping DRIVE control set at a minimum. Lock CALIBRATE control.

Step 13. Tune receiver to 4 mc.

Step 14. Tune transmitter to 4 mc. Remove cover from C303 access hole and use C303 in place of CALIBRATE control. Use receiver to ensure that C303 is being adjusted to 4 mc instead of some nearby check point.

Step 15. Repeat steps 12, 13, and 14 several times until master oscillator zero beats at 2- and 4-mc ends without necessity of adjusting CALIBRATE control or C303.

Step 16. Replace cover over C303 access hole.

c. ALIGNMENT OF MULTIPLIER AND DRIVER. Alignment of multiplier and driver requires the use of a signal generator having a frequency range of 2 to 32 mc. (The exciter unit may be used in place of a signal generator.) To align the multiplier and driver, proceed as follows:

WARNING

The FINAL PLATE switch must be in the OFF position throughout this procedure. However, dangerously high voltages of 600 vdc exist in other areas where adjustments must be performed.

Step 1. Connect a signal generator output to J201 on RTF-2. (If exciter is used in place of signal generator, connect in same manner as usually used for transmitting.)

Step 2. Place NORMAL-SSB switch in SSB position, MODE switch in TUNE position, EXCITATION SW. switch in SSB L. O. OFF position, DRIVER BAND switch in 4-8 position, MULTIMETER switch in DRIVER Ip Ma position, MAIN POWER switch in ON position, and TRANSMITTER PLATES switch in OPERATE position.

Step 3. Tune signal generator to 4 mc at a low output level. (If exciter is used, tune to 4 mc and adjust OUTPUT control for a low output level.)

Step 4. Place DRIVER TUNING control in 2.0 position.

Step 5. Increase signal generator output level until MULTIMETER indicates a current increase.

Step 6. Adjust L204 for maximum MULTIMETER deflection. If MULTIMETER reading goes off scale, decrease signal generator output level and retune L204 for maximum.

Step 7. Place MULTIMETER switch in PA Eg RF volts position.

Step 8. Adjust L212 for maximum MULTIMETER deflection while adjusting signal generator output level to maintain a reading of approximately 50 volts.

Step 9. Tune signal generator to 8 mc.

Step 10. Place DRIVER TUNING control in 4.0 position.

Step 11. Adjust C218 and C238 for maximum MULTIMETER deflection.

Step 12. Repeat steps 3 through 11 until adjustments are at optimum setting.

Step 13. Place DRIVER BAND switch in 8-16 position.

Step 14. Place DRIVER TUNING control in 2.0 position.

Step 15. Place MULTIMETER switch in DRIVER Ip Ma position.

Step 16. Increase signal generator output level until MULTIMETER indicates a current increase.

Step 17. Adjust L207 for maximum MULTIMETER deflection. If MULTIMETER reading goes off scale, decrease signal generator output level and retune L207 for maximum.

Step 18. Place MULTIMETER switch in PA Eg Rf volts position.

Step 19. Adjust L213 for maximum MULTIMETER deflection while adjusting signal generator output level to maintain a reading of approximately 50 volts.

Step 20. Place DRIVER TUNING control in 4.0 position.

Step 21. Tune signal generator to 16 mc.

Step 22. Adjust C231 and C239 for maximum MULTIMETER deflection.

Step 23. Repeat steps 13 through 22 until adjustments are at optimum setting.

Step 24. Place DRIVER BAND switch in 16-32 position.

Step 25. Place DRIVER TUNING control in 2.0 position.

Step 26. Adjust L208 and L214 for maximum MULTIMETER deflection.

Step 27. Tune signal generator to 32 mc.

Step 28. Place DRIVER TUNING control in 4.0 position.

Step 29. Adjust C232 for maximum MULTIMETER deflection.

Step 30. Repeat steps 24 through 29 until adjustments are at optimum setting.

Step 31. Lock all coil tuning slugs.

Step 32. Place DRIVER TUNING control in 2.0 position.

Step 33. Place NORMAL-SSB switch in NORMAL position.

Step 34. Place MULTIMETER switch in PA Ig Ma position, EXCITATION SW. switch in CW-FS position, and OSCILLATOR switch in MO position.

Step 35. Set MASTER OSCILLATOR FREQUENCY control for 2 mc.

Step 36. Place EXCITATION SW. switch in CW-PHONE position and rotate DRIVE control to extreme clockwise position.

Step 37. Adjust L205 for maximum MULTIMETER deflection.

Step 38. Place EXCITATION SW. switch in SSB L.O. OFF position and NORMAL-SSB switch in SSB position.

Step 39. Tune signal generator to 32 mc.

Step 40. Place DRIVER BAND switch in 16-32 position and adjust DRIVER TUNING control for maximum MULTIMETER deflection.

Step 41. Place EXCITATION SW, switch in CW-PHONE position and NORMAL-SSB switch in NORMAL position.

Step 42. Deenergize signal generator.

Step 43. Place OSCILLATOR switch in MO position.

Step 44. Set MASTER OSCILLATOR FREQUENCY control for 4 mc.

Step 45. Adjust C212 for maximum MULTIMETER deflection.

Step 46. If maximum MULTIMETER deflection is less than 30 ma., adjust L205 for a MULTIMETER indication of 30 ma. If maximum MULTIMETER deflec-

tion is greater than 30 ma., do not disturb setting of L205.

Step 47. Set MASTER OSCILLATOR FREQUENCY control for 2 mc.

Step 48. Adjust DRIVER TUNING control for maximum MULTIMETER deflection.

Step 49. Repeat step 46.

Step 50. Set MASTER OSCILLATOR FREQUENCY control for 4 mc and adjust DRIVER TUNING control for a MULTIMETER indication of 30 mc. If a MULTIMETER indication of 30 mc is unobtainable, adjust C212 for maximum MULTIMETER deflection.

Step 51. Place DRIVE BAND switch in 8-16 position.

Step 52. Set MASTER OSCILLATOR FREQUENCY control at 4 mc, check overall results of previous steps by placing DRIVER TUNING control in 4.0 position and placing DRIVER BAND switch in 8-16 and 4-8 positions.

Step 53. Set MASTER OSCILLATOR FREQUENCY control for 2 mc and check overall results as in step 52 by placing DRIVER TUNING control in 2.0 position and placing DRIVER BAND switch in 8-16 and 4-8 positions. MULTIMETER should indicate 30 ma. in each DRIVER BAND switch position.

Step 54. Place DRIVER BAND switch in 2-4 position and DRIVER TUNING control in 2.0 position.

Step 55. Adjust L203 and L211 for maximum MULTIMETER deflection.

Step 56. Set MASTER OSCILLATOR FREQUENCY control for 4 mc.

Step 57. Place DRIVER TUNING control in position 4.0 and adjust C201 and C237 for maximum MULTIMETER deflection.

Step 58. Repeat steps 54 through 57 as often as necessary to obtain a multimeter indication of 30 ma. at each tuned position.

Step 59. Set MASTER OSCILLATOR FREQUENCY control for 3 mc.

Step 60. Place DRIVER TUNING control in position 3.0.

Step 61. Place DRIVER BAND switch in each position and check that a MULTIMETER indication of 30 ma. is obtained in each position.

d. PA NEUTRALIZATION. - PA neutralization is required when either power amplifier tube is replaced or an erratic display by PA PLATE current meter indicates oscillation in the final stage when excitation is removed. PA neutralization requires the use of a vtm with an rf probe and an open-end 7/16-inch wrench. To perform PA neutralization, proceed as follows:

WARNING

The FINAL PLATE switch must be in the OFF position throughout this procedure. However, dangerously high voltage of 600 vdc exist in other areas where adjustments must be performed

Step 1. Clip vtm, through rf probe, to clamp on top of variable vacuum tuning capacitor C113. Connect rf probe grounding clip to chassis.

Step 2. Tune driver stages for output of 8 mc by observing a maximum MULTIMETER indication with MULTIMETER switch in PA Eg Rf volts position.

Step 3. Place MULTIMETER switch in DRIVER I p Ma position and adjust DRIVE control for a MULTIMETER indication of 20 ma.

Step 4. Tune final amplifier for a maximum vtm indication.

Step 5. Adjust neutralizing capacitor C104 for a minimum vtm indication.

Note

A vtm indication of less than 10 volts must be obtained. Usually, an indication of 6 to 8 volts can be obtained.

Step 6. Tune driver stages to 16 mc as in steps 2, 3, and 4.

Step 7. Place PA BAND switch in 12-16 position.

Step 8. Adjust PA TUNING control for a maximum vtm indication. If maximum vtm indication is greater than the reading obtained on 8 mc, or greater than 10 volts, readjust C104 slightly to decrease the voltage. By alternately switching between 8 and 16 mc, a setting of C104 can be obtained where little or no difference exists between the voltage indications, and these voltage indications must be less than 10 volts.

Step 9. Tighten the neutralizing capacitor locknuts with the open-end wrench.

Step 10. Tune driver stages to 32 mc as in steps 2, 3, and 4.

Step 11. Place PA BAND switch in 24-32 position.

Step 12. Observe that a piece of bare tinned wire is connected between C201 (tuning capacitor for driver stage V205) and button capacitor C128 (on wall of final amplifier compartment.) The size of the loop formed by this bare tinned wire affects the indications in the circuit. Adjust the final plate tuning capacitor for a maximum vtm indication. Adjust the loop size in small increments. Continue adjusting the loop size until a minimum vtm indication is obtained.

e. ADJUSTMENT OF FINAL PLATES OVERLOAD RESET CB603. - To adjust final plates overload reset CB603, proceed as follows:

CAUTION

Do not operate the transmitter in the condition outlined below for prolonged periods because of the excessive plate dissipation.

Step 1. Tune and load transmitter for cw operation.

Step 2. Adjust ANTENNA LOADING control so that DRIVE control can be used to adjust PA plate current to 600 ma.

Step 3. Unlock and adjust R609 to the point where a slight rise in PA plate current beyond 600 ma. causes CB603 and K601 to open.

Step 4. Repeat steps 1, 2, and 3, if necessary. Lock R609.

f. ADJUSTMENT OF FINAL SCREEN OVERLOAD RESET CB602. - To adjust final screen overload reset CB602, proceed as follows:

Step 1. Tune and load radiotransmitter for cw operation.

Step 2. Place MULTIMETER switch in PA Isg Ma position.

Step 3. Adjust DRIVE control for a MULTIMETER indication of 100 ma.

Step 4. Unlock and adjust R603 to the point where a slight rise in current causes CB602 and K601 to open.

6-3. REPLACEMENT OF COMPONENTS.

WARNING

Dangerously high voltages exist in the equipment. Place MAIN POWER breaker in OFF position and discharge high voltage capacitors to prevent accidents which can result in loss of life.

a. Except for the replacement of the master oscillator assembly and vacuum tube capacitor C113, there are no special replacement procedures.

CAUTION

Maintenance personnel should not attempt, under any circumstances, to replace any component on the master oscillator assembly with the exception of V301 and V302. Never remove V301 or V302 without first removing ballast R426, or setting the MAIN POWER breaker to OFF position.

b. REPLACEMENT OF VACUUM CAPACITOR C113. - To replace C113, proceed as follows:

Step 1. Turn the PA TUNING control fully clockwise until it stops (PA TUNING indicator reads 000).

Step 2. Remove the top connector from C113 and loosen the clamp at the base of the glass envelope.

Step 3. Carefully lift the old capacitor from its position. The PA TUNING indicator reading will change as the capacitor is withdrawn.

Step 4. Turn the control shaft and nylon gear (figure 6-3) on the new capacitor until the collar does not turn freely. Add one more quarter turn.

Step 5. Slowly lower the new capacitor into position. The nylon drive gear will engage the PA TUNING indicator stop limit mechanism and turn the indicator back to 000.

c. REPLACEMENT OF OSCILLATOR ASSEMBLY. - To replace the master oscillator assembly, refer to figure 6-2 and proceed as follows:

Step 1. Turn MASTER OSCILLATOR FREQUENCY dial until MASTER OSCILLATOR FREQUENCY indicator reads 2000 kc.

Step 2. Disconnect and tag all wires connected between the oscillator assembly and the two terminal boards located on the left side when viewing unit from front.

Step 3. Disengage oscillator assembly shaft from MASTER FREQUENCY OSCILLATOR control shaft by loosening two setscrews from shaft coupling.

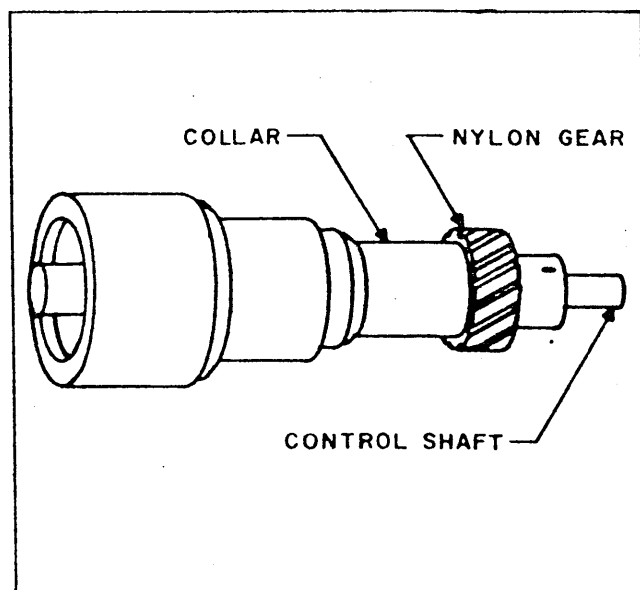

Figure 6-3. Vacuum Tube Capacitor C113, Replacement

Step 4. Remove screws securing the interconnect chassis.

Step 5. Remove eight front panel screws securing oscillator assembly. Withdraw the oscillator assembly from unit while insuring that it has a clear path.

Step 6. Set the new oscillator assembly into its position in the RTF-2, and perform assembly in reverse of disassembly.

CAUTION

Before engaging shaft coupling, insure that MASTER OSCILLATOR FREQUENCY indicator reads 2000.000 kc. All oscillator assemblies are factory set for 2000.000 kc.

d. **EXCITER POWER SUPPLY.** - Three circuits of the exciter power supply are fused; oven heaters, power supply primary, and high voltage. Because a partial short across the B+ line may not blow the line fuse, the separate high voltage fuse has been incorporated. If meter readings cannot be obtained or the EXCITER lamp fails to light when the POWER switch is in the ON position, check the B+ fuse. If dial lights and tube filaments fail to light when POWER switch is in the ON position, check the MAIN fuse. If, after a 1-hour warmup, the OVEN lamp fails to cycle every 4 to 5 minutes, check the OVEN fuse.

CAUTION

Never replace a fuse with one of higher rating unless continued operation is more important than probable damage to the equipment. If a fuse burns out immediately after replacement, has been located and corrected.

6-4. INSPECTION.

a. Operating or maintenance personnel should adhere to a daily inspection procedure, to insure optimum performance of the transmitter. These inspections should include:

- (1) Checking meters during operation for proper current and voltage readings.
- (2) Checking meters for zero adjustment.
- (3) Checking controls and control locks for proper operation.
- (4) Checking cables for secure connections.

b. At periodic intervals (at least every six months), remove the equipment from the cabinet for cleaning and inspection. Inspect wiring, and components for dirt, corrosion, charring, discoloring, or grease. Carefully inspect the tube sockets for deterioration. Remove dust with a soft brush or vacuum cleaner. Remove dirt or grease from electrical parts with trichloroethylene or ethylenedichloride. Remove dirt or grease from other parts with any good dry cleaning fluid.

WARNING

When using trichloroethylene or ethylenedichloride make sure that adequate ventilation exists.

c. While the unit is out of the cabinet, it is advisable to check the tubes, all of which are accessible from the top of the chassis. Carefully inspect for loose solder connections or screws, especially those on solder lugs. Recommended time interval is every 6 to 12 months, depending on the amount of vibration encountered in service.

6-5. CLEANING.

a. The following items should be cleaned with a soft brush and/or vacuum cleaner at intervals determined by general area conditions.

- (1) Chassis surfaces.
- (2) Tubes and sockets.
- (3) Cables
- (4) Terminal and barrier strips and insulators.
- (5) Switches.
- (6) Insulators.

b. The following items should be cleaned with crocus cloth and trichloroethylene or ethylenedichloride.

WARNING

When using trichloroethylene or ethylenedichloride make sure that adequate ventilation exists.

- (1) Meter glasses.
- (2) Front panels.
- (3) Blower blades.
- (4) Motor housings.

c. Clean dirty filters by immersing in a pan of solvent, such as gasoline, benzine, kerosene, methyl alcohol, and similar materials. Move the filter through the solvent to create an agitated current through the filter passages. After cleaning, allow filter to dry. When filter is dry, dip the filter in a pan of oil and allow it to drain, face downward, until dripping ceases. The oil used for this process should be one that will not run at the highest, nor solidify at the lowest, temperatures of the incoming air.

6-6. LUBRICATION.

Lubricate all gears and drawer slides with light oil.

CAUTION

Do not lubricate friction drive mechanism.

6-7. SCHEMATIC DIAGRAMS.

The schematic diagram of the radio transmitter is shown in figure 6-4. The schematic diagrams for each

assembly of the RTF-2 unit are shown in figures 6-5 through 6-8. The schematic diagram for the RTP-2 unit is shown in figure 6-9, the cabinet in figure 6-10, and the RTS-2 in figure 6-11.

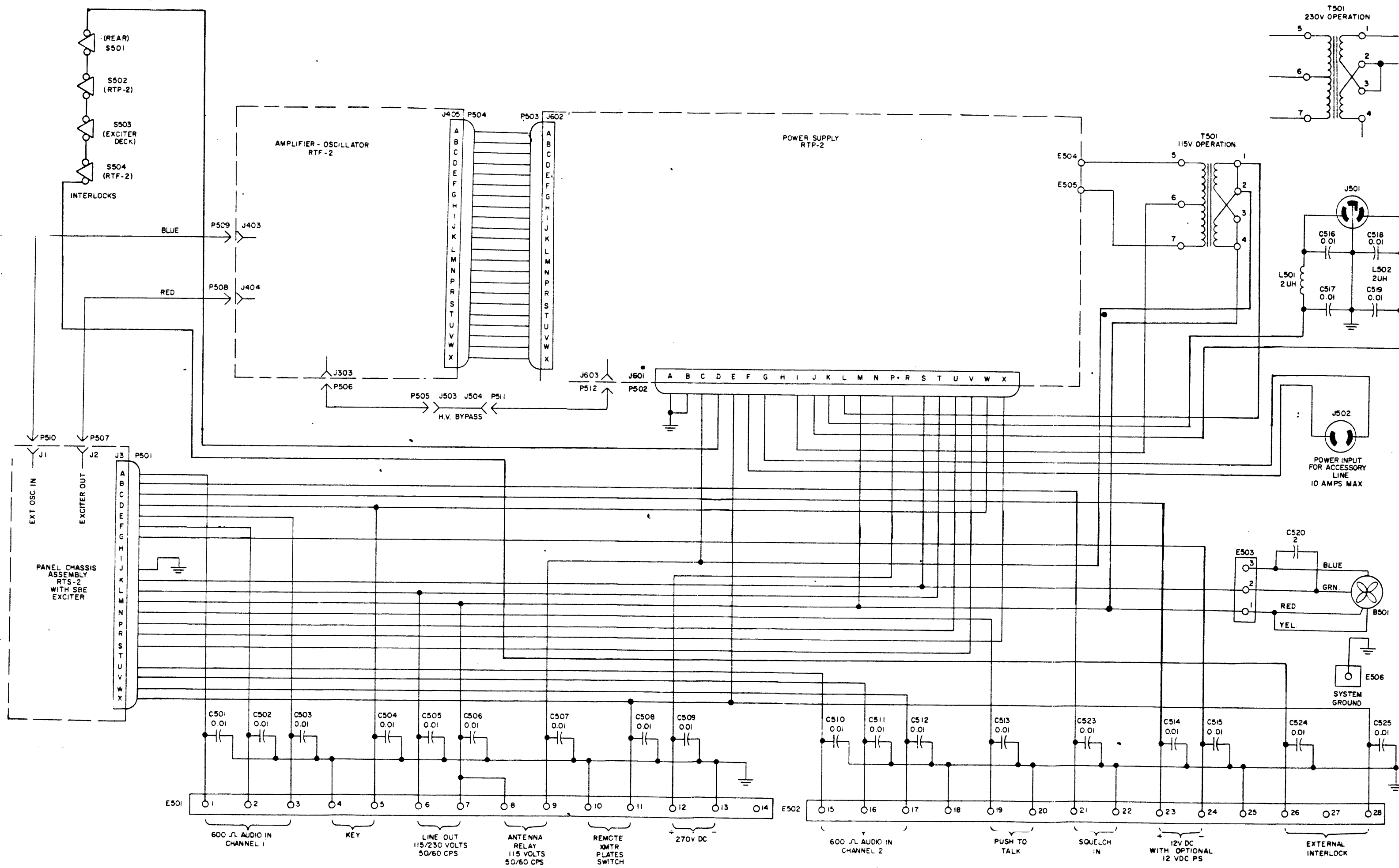
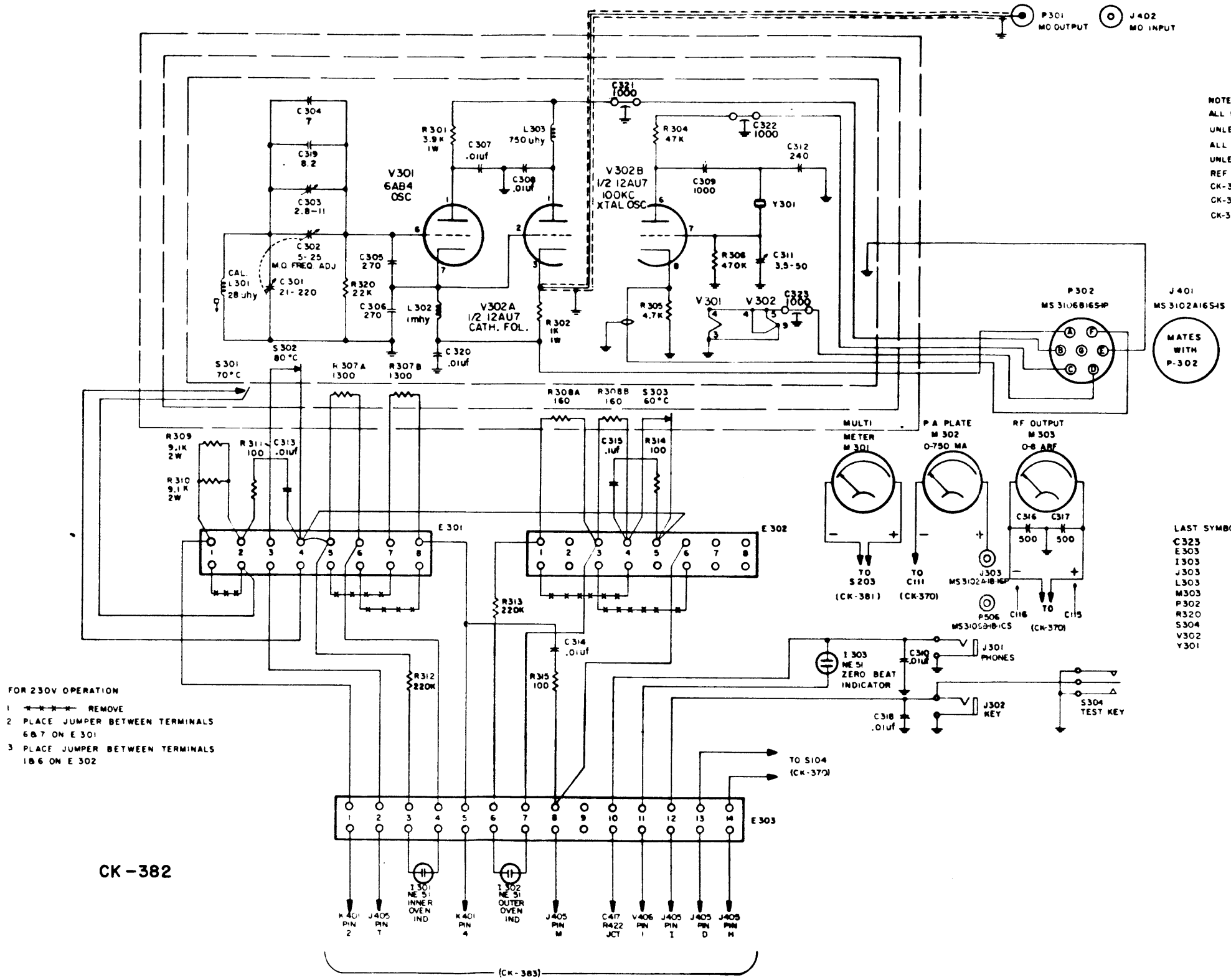

Figure 6-4. Radio Transmitter 6-9/6-10



NOTE
 ALL CAPACITANCE VALUES ARE IN UUF
 UNLESS OTHERWISE NOTED.
 ALL RESISTORS ARE 1/2 WATT
 UNLESS OTHERWISE NOTED
 REF SEE FIGURE
 CK-370 6-7
 CK-381 6-6
 CK-383 6-5

LAST SYMBOLS	MISSING SYMBOLS
C323	R303
E303	R316
I303	R317
J303	R318
L303	R319
M303	
P302	
R320	
S304	
V302	
V301	

FOR 230V OPERATION
 1. ~~-----~~ REMOVE
 2. PLACE JUMPER BETWEEN TERMINALS 6 & 7 ON E 301
 3. PLACE JUMPER BETWEEN TERMINALS 10 & 6 ON E 302

CK-382

Figure 6-5. Master Oscillator, Model RTF-2, Schematic Diagram

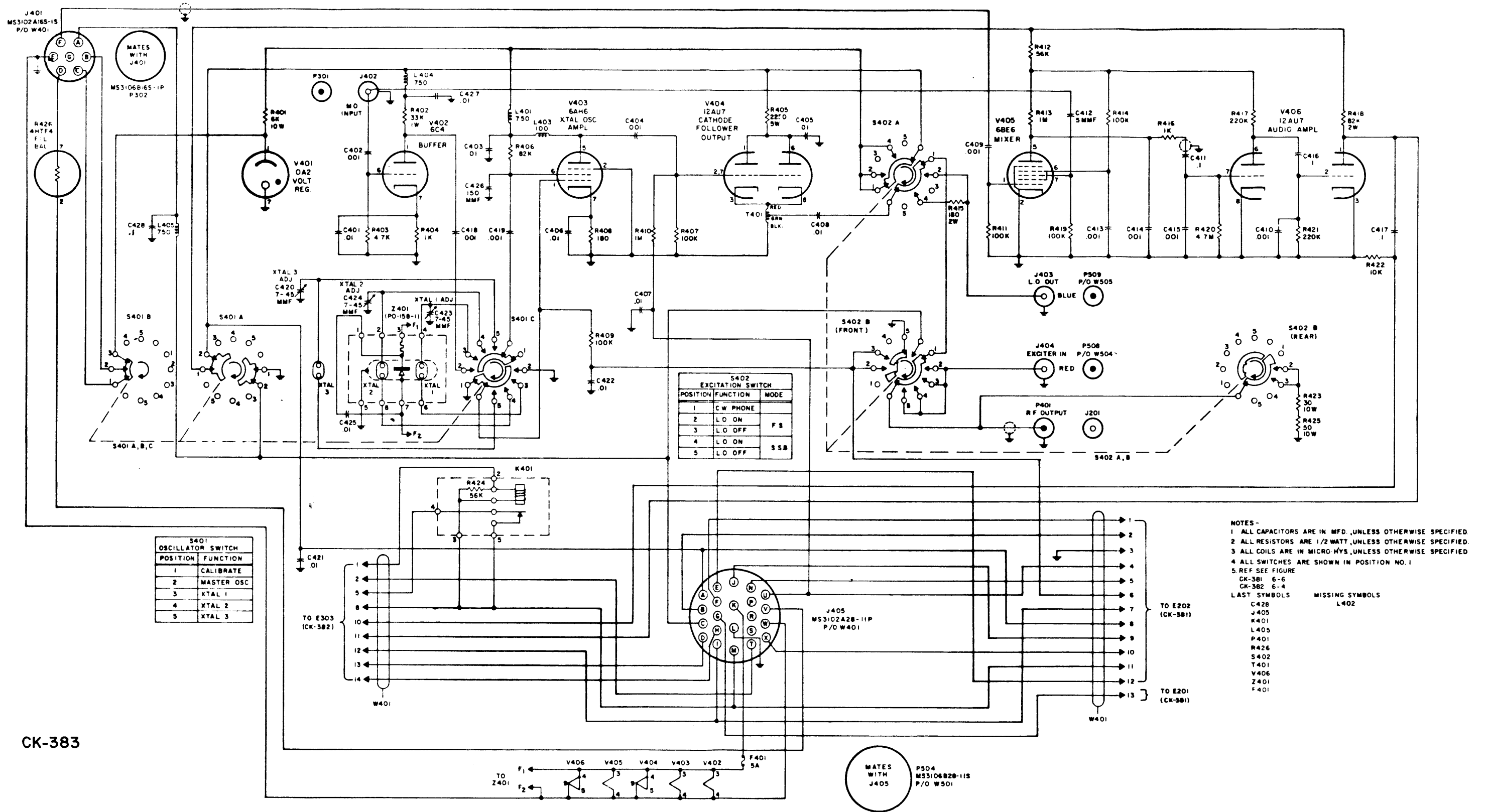

Figure 6-6. Interconnect Chassis, Model RTF-2, Schematic Diagram

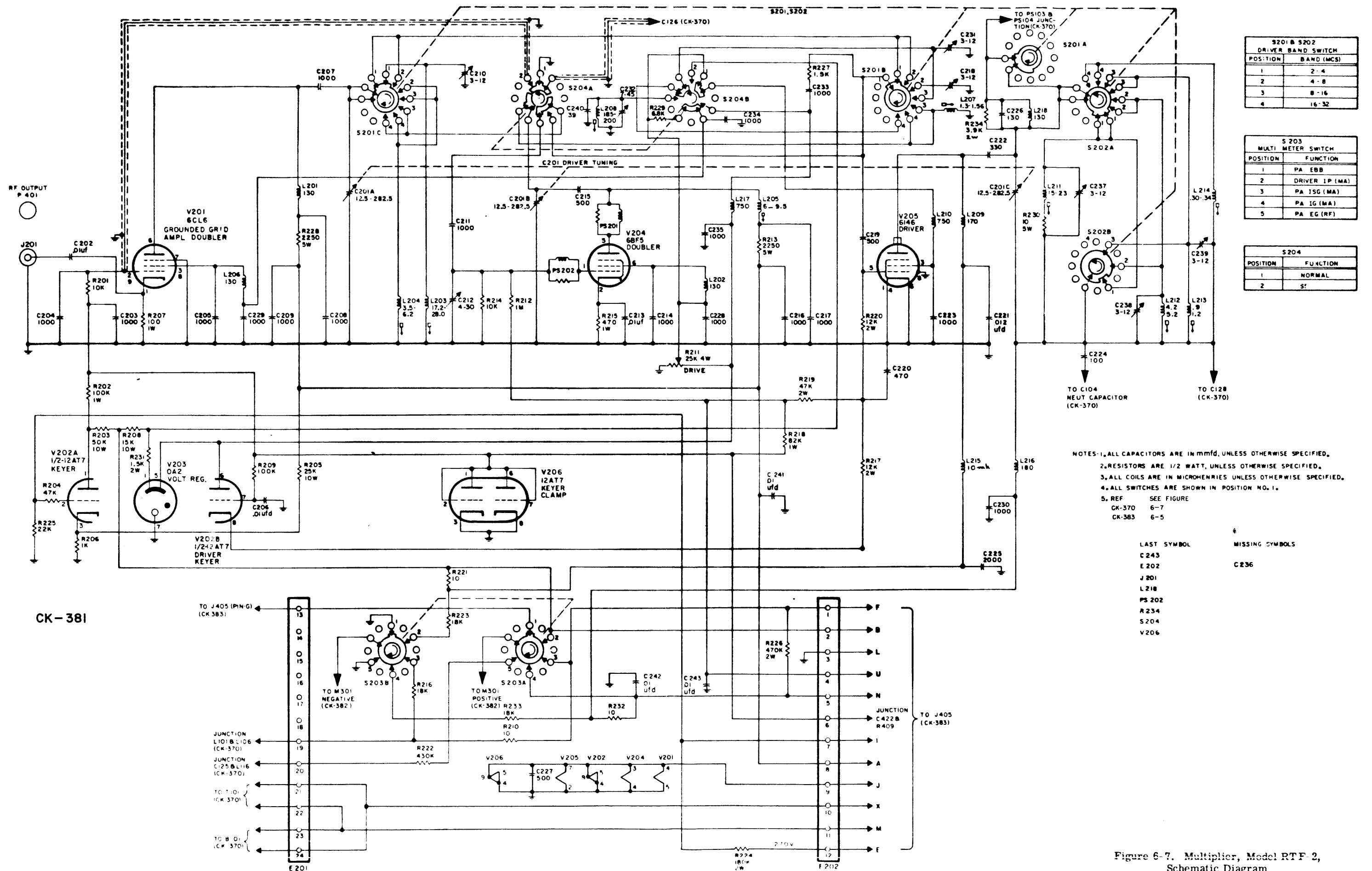
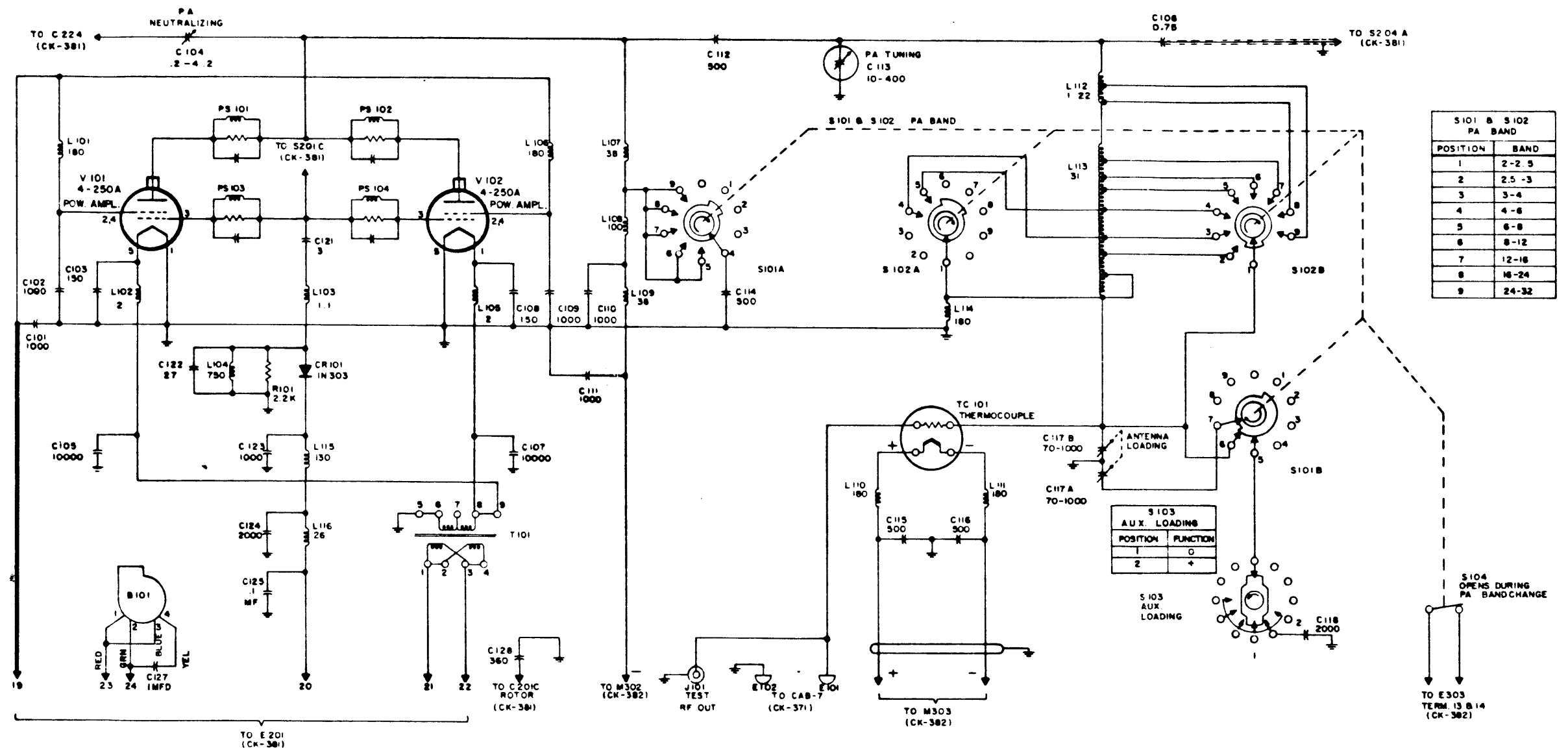

Figure 6-7. Multiplier, Model RTF 2, Schematic Diagram



S101 & S102 PA BAND	
POSITION	BAND
1	2-2.5
2	2.5-3
3	3-4
4	4-6
5	6-8
6	8-12
7	12-16
8	16-24
9	24-32

S103 AUX. LOADING	
POSITION	FUNCTION
1	0
2	+

CK-370

- NOTES:
- 1 ALL CAPACITORS ARE IN MMFD UNLESS OTHERWISE SPECIFIED.
 - 2 ALL RESISTORS ARE 1/2 WATT
 - 3 ALL COILS ARE IN MICROHENRIES
 - 4 ALL SWITCHES SHOWN IN POSITION NO. 1
 5. REF SEE FIGURE
 - CK-371 6-9
 - CK-381 6-6
 - CK-382 6-4

- | LAST SYMBOLS | MISSING SYMBOLS |
|--------------|-----------------|
| B 101 | C 119, 120, 126 |
| C 128 | |
| CR 101 | |
| E 102 | |
| J 101 | |
| L 116 | |
| PS 104 | |
| R 101 | |
| S 104 | |
| T 101 | |
| TC 101 | |
| V 102 | |

Figure 6-8. Power Amplifier, Model RTF-2, Schematic Diagram

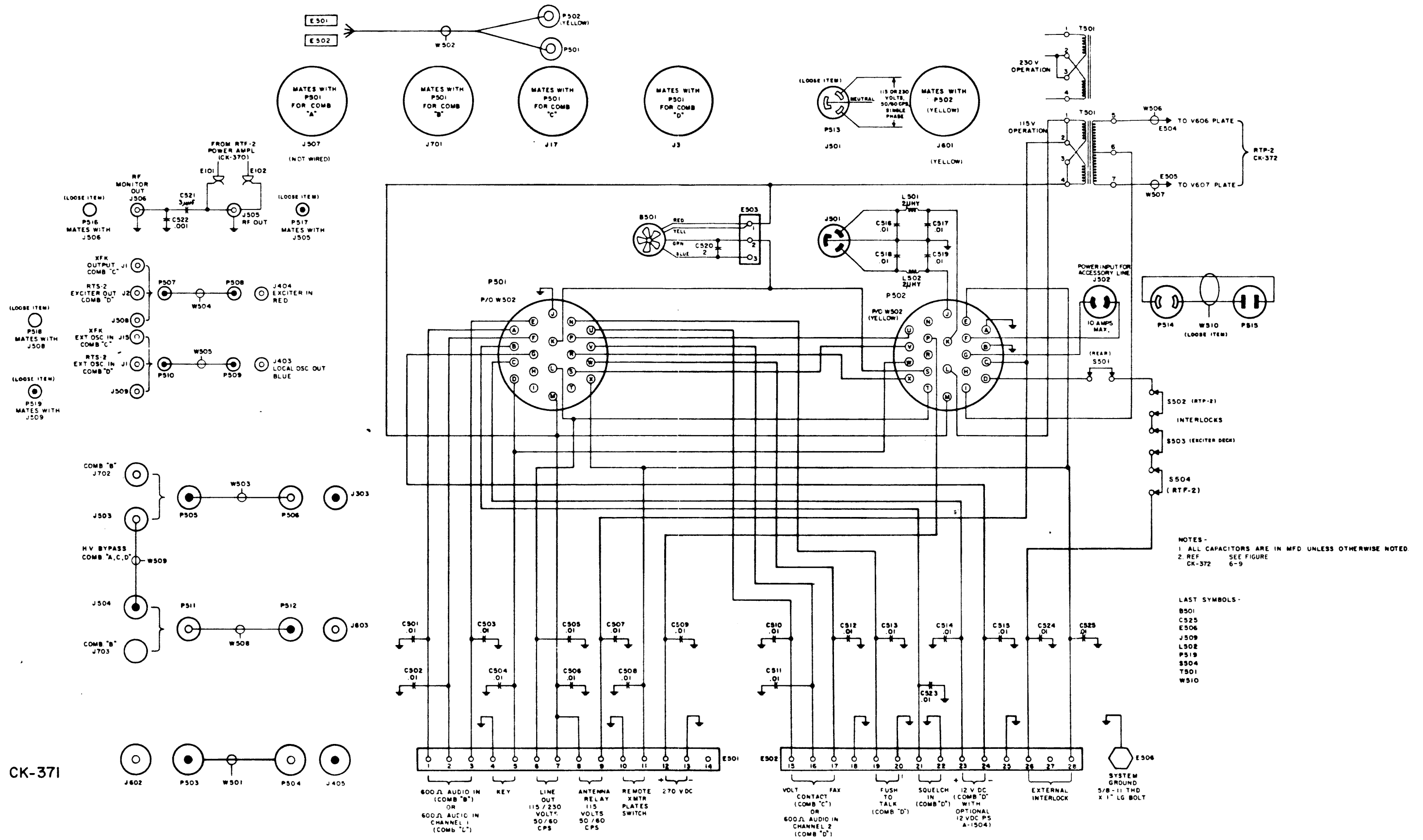

Figure 6-10. Cabinet Frame Assembly CAB-7, Schematic Diagram

**SECTION 7
SPARE PARTS**

**AMPLIFIER-OSCILLATOR MODEL RTF-2
FRONT PANEL (SYMBOL SERIES 300)**

REF SYMBOL	DESCRIPTION	FUNCTION	TMC PART NO.
C310	CAPACITOR, fixed: mica; .01 mfd., $\pm 10\%$, char. B; 300 wvdc	Bypass	CM35B103X
C318	Same as C310.	Bypass	
I301	LAMP, neon: miniature; 110 volts, 1/25 watt; T-3-1/4 clear bulb; bayonet base.	Inner Oven Indicator	BI-100-51
I302	Same as I301.	Outer Oven Indicator	
I303	Same as I301.	Zero Beat Indicator	
J301	JACK, telephone tip and sleeve.	Phones Jack	JJ-034
J302	Same as J301.	Key Jack	
M301	MILLIAMETER, D. C. : 0-100, black; 0-5K, red; 0-150, green scales; 3 in. x 3-1/8 in. case; four 4-36 mtg. studs on 2-1/4 inc. x 2-1/4 in. mtg. centers with an 2-3/4 in. dia. cutout.	Multimeter	MR-115
M302	METER, D. C. : 0-750 milliamps; 3 x 3-1/8 in. sq. case; four 4-40 mtg. studs on 2-1/4" x 2-1/4" mtg. centers with an 2-13/16" dia. coutout.	P. A. Plate	MR-110-750-S
M303	METER, R. F. : 0-8 amps; 3 x 3-1/8" sq. case; four 4-40 mtg. studs on 2-1/4 x 2-1/4" mtg. c centers with an 2-13/16 in. dia. cutout.	R. F. Output	MR-109
S304	SWITCH, lever: two position; nonlocking, silver contacts; 3 amp at 120 VAC.	Test Key	SW-186
XI301	LIGHT, indicator: w/clear white lens; for miniature bayonet base; T-3-1/4 bulb.	Inner Oven	TS-106-2
XI302	Same as XI301.	Outer Oven	
XI303	Same as XI301.	Zero Beat	

**AMPLIFIER-OSCILLATOR MODEL RTF-2
MASTER OSCILLATOR (SYMBOL SERIES 300)**

REF SYMBOL	DESCRIPTION	FUNCTION	TMC PART NO.
A301	OSCILLATOR ASSEMBLY, variable: consists of: C301, 302, 303, 304, 305, 306, 307, 308, 309, 311, 312, 319, 320, 321, 322, 323, L301, 302, 303, P301, 302, R301, 302, 304, 305, 306, 320, V301, 302, W301, 302, XV301, 302, XY301, Y301.	VMO Oscillator	AO-100
C301	CAPACITOR ASSEMBLY: variable: air dielectric; 21.0 to 220 mmfd. Not a replaceable item, see A301.	VMO Tuning V301	p/o AO-100
C302	CAPACITOR, variable: air dielectric; one section, 7 plates; 5 to 25 mmfd, ± 5 mmfd. Not a replaceable item, see A301.	VMO Correction	p/o AO-100
C303	CAPACITOR, variable: air dielectric; one section, 3 plates; 2- 8-11 mmfd; 1-17/32 in. lg. x 1-3/8 in. high o/a. Not a replaceable item, see A301.	VMO Trimmer Cap. V301	p/o AO-100
C304	CAPACITOR, fixed: ceramic; 10 mmfd, $\pm .25$ mmfd, 500 wvdc. Not a replaceable item, see A301.	VMO Padder Cap. V301	p/o AO-100
C305	CAPACITOR, fixed: ceramic; 270 mmfd, $\pm 5\%$, 500 wvdc. Not a replaceable item, see A301.	VMO Grid Coupling Cap. V301	p/o AO-100
C306	Same as C305. Not a replaceable item, see A301.	VMO Cathode Coupling Cap. V301	
C307	CAPACITOR, fixed: mica; .01 mfd, $\pm 10\%$; char. B; 300 wvdc. Not a replaceable item, see A301.	MO Plate Bypass V301	p/o AO-100
C308	Same as C307	Cath. Fol. Plate Bypass Cap. V302A	
C309	CAPACITOR, fixed: mica; 1000 mmfd, $\pm 5\%$; 500 wvdc, char. B. Not a replaceable item, see A301.	Plate Coup. Cap. 100 Kc Osc. V302B	p/o AO-100
C310	Same as C307.		
C311	CAPACITOR, fixed: mica; 240 mmfd, $\pm 5\%$; char. C, 500 wvdc. Not a replaceable item, see A301.	100 Kc Adjust V302B	p/o AO-100
C312	CAPACITOR, fixed: mica; 240 mmfd; $\pm 5\%$; char. C, 500 wvdc. Not a replaceable item, see A301.	Plate Coup. Cap. 100 Kc, V302B	p/o AO-100
C313	Same as C307	Inner Oven Ther. Arc Supp. E301	
C314	Same as C307	Relay Arc Supp. E301	
C315	CAPACITOR, fixed: paper; .1 mfd, $+40-10\%$; 400 wvdc; plastic tubular case.	Outer Oven Ther. Arc. Supp. E302	CN-100-4
C316	CAPACITOR, fixed: mica; 500 mmfd, $\pm 5\%$; 500 wvdc, char. B.	RF Meter Decoup. Cap. M303	CM20B501J
C317	Same as C316.	RF Meter Decoup. Cap. M303	

**AMPLIFIER-OSCILLATOR MODEL RTF-2
MASTER OSCILLATOR (SYMBOL SERIES 300)**

REF SYMBOL	DESCRIPTION	FUNCTION	TMC PART NO.
C318	Same as C307.	Bypass Cap.V302A	
C319	CAPACITOR, fixed: ceramic; 8.2 mmfd., $\pm 5\%$, 500 wvdc. Not a replaceable item, see A301.	VMO Temperature Compensation	p/o AO-100
C320	Same as C307. Not a replaceable item, see A301.	RF Bypass Cap. V301	
C321	CAPACITOR, feed thru type: 1000 uuf. $\pm 2\%$, 500 wvdc. char A. Not a replaceable item, see A301.	Bypass	p/o AO-100
C322	Same as C321. Not a replaceable item, see A301.	Bypass	
C323	Same as C321. Not a replaceable Item, see A301.	Bypass	
L301	COIL ASSEMBLY, R. F.:	VMO Tank Coil V301	p/o AO-100
L302	CHOKE, R. F.:	VMO Cathode Choke, V301	p/o AO-100
L303	CHOKE, R. F.:	Plate Decoup. Choke, V302A	p/o AO-100
R301	RESISTOR, fixed: composition; 3900 ohms, $\pm 10\%$; 1/2 watt. Not a replaceable item, see A301.	Plate Decoup. Res. V301	p/o AO-100
R302	RESISTOR, fixed: composition; 1000 ohms, $\pm 10\%$; 1 watt. Not a replaceable item, see A301.	Cathode Output Res., V302A	p/o AO-100
R303	NOT USED.		
R304	RESISTOR, fixed: composition; 47,000 ohms, $\pm 10\%$; 1/2 watt. Not a replaceable item, see A301.	Plate Load Res., V302B	p/o AO-100
R305	RESISTOR, fixed: composition; 4700 ohms, $\pm 10\%$; 1/2 watt. Not a replaceable item, see A301.	Cathode Output Res., V302B	p/o AO-100
R306	RESISTOR, fixed: Composition; 470,000 ohms, $\pm 10\%$; 1/2 watt. Not a replaceable item, see A301.	Grid Leak Res., V302B	p/o AO-100
R307 A & B	RESISTOR, fixed: wire wound; heater element, two sections, 1300 ohms each section, insulated.	Inner Oven Heaters	RR-106
R308 A & B	RESISTOR, fixed: wire wound; heater element, two sections, 160 ohms each section, insulated.	Outer Oven Heaters	RR-105
R309	RESISTOR, fixed: composition; 9100 ohms, $\pm 5\%$; 2 watts.	Relay Drop Res., 220 V oper. E301	RC42GF912J
R310	Same as R309.	Relay Drop Res., 220 V. oper. E301	
R311	RESISTOR, fixed: composition; 100 ohms, $\pm 10\%$; 1/2 watt.	Inner Thermo. Arc Suppressor	RC20GF101K
R312	RESISTOR, fixed; composition; 220,000 ohms, $\pm 10\%$; 1/2 watt.	Inner Oven Ind. Protector E301	RC20GF224K

**AMPLIFIER-OSCILLATOR MODEL RTF-2
MASTER OSCILLATOR (SYMBOL SERIES 300)**

REF SYMBOL	DESCRIPTION	FUNCTION	TMC PART NO.
R313	Same as R312.	Outer Oven Ind. Protector E302	
R314	Same as R311.	Outer Oven Therm Arc Supp. E302	
R315	Same as R311.	Relay Arc Supp. E303	
R316	NOT USED.		
R317	NOT USED.		
R318	NOT USED.		
R319	NOT USED.		
R320	RESISTOR, fixed: composition; 22,000 ohms, $\pm 10\%$; 1/2 watt. Not a replaceable item, see A301	VMO Grid Leak	RC20GF223K p/o AO-100
S301	SWITCH ASSEMBLY, thermostatic: bimetallic; operate at 70° C, $\pm 0.5^\circ$ C.	Inner Oven Thermostat	A-1236
S302	SWITCH, thermostatic: bimetallic; operate at 80° C, $\pm 2^\circ$ C.	Inner Oven Safety Thermostat	SS-100-3
S303	SWITCH, thermostatic: bimetallic; operate at 60° C, $\pm 2^\circ$ C.	Outer Oven Thermostat	SS-100-1
V301	TUBE, electron: HF power triode; 7 pin miniature	VMO	6AB4 p/o AO-100
V302	TUBE, electron: medium-mu duo-triode; 9 pin miniature.	Cathode Follower 100 Kc Osc.	12AU7 p/o AO-100
XV301	SOCKET, electron tube: 7 pin miniature. Not a replaceable item, see A301.	Socket for V301	p/o AO-100
XV302	SOCKET, electron tube: 9 pin miniature. Not a replaceable item, see A301.	Socket for V302	p/o AO-100
XY301	SOCKET, crystal: .487 in. spacing for .095 in. pins. Not replaceable item, see A301.	Socket for Y301	p/o AO-100
Y301	CRYSTAL UNIT, quartz; 100 Kcs. Not a replaceable item, see A301.	100 Kc Crystal	p/o AO-100

**AMPLIFIER-OSCILLATOR MODEL RTF-2
POWER AMPLIFIER (SYMBOL SERIES 100)**

REF SYMBOL	DESCRIPTION	FUNCTION	TMC PART NO.
A101	ASSEMBLY, switch-coils, consists of S102, L112, L113; 7-1/2 in. lg. x 6 in. wide x 5-1/2 in. high o/a.	Band Switching	AX-141
A102	COUPLER ASSEMBLY, indicator: consists of C115, C116, L110, L111, and TC101, terminal board and two leads w/solder lug terminals. Terminal board has four 6-32 threaded inserts on 1-3/4 x 5-3/8 in. mounting centers.	Low Pass Filter	AX-143
B101	BLOWER ASSEMBLY: 115 v, 50/60 cps, .34 watts, single phase; 3400 rpm, counterclockwise rotation. Consists of motor, blades and mounting plate.	Ventilation	AX-146
C101	CAPACITOR, fixed: mica; 1000 uufd, $\pm 10\%$, 2500 wvdc, char. B.	Screen Decoupling V101	CM45B102K
C102	Same as C101.	Screen Decoupling V101	
C103	CAPACITOR, fixed: mica; 150 uufd, $\pm 10\%$, 2500 wvdc, char. B.	Cathode Bypass V101	CM45B151K
C104	CAPACITOR, variable: teflon dielectric: 2-4.2 mmfd, consisting of: Aluminum Mounting Plate, neutralizer: aluminum Rotor Disc, neutralizer: teflon Plate, dielectric: teflon.	Neutralizing Cap. V101-V102	AM-107, MS-780 A-1338, PX-324 PX-325
C105	CAPACITOR, fixed: mica; 10,000 uufd, $\pm 5\%$, 300 wvdc, char. C.	p/o LP Filter V101	CM35C103J
C106	CAPACITOR, fixed: ceramic; 0.75 uufd, 10 kvdc, NPO temperature coef.; complete with brackets.	RF Feedback	AM-105
C107	Same as C105.	p/o LP Filter V102	
C108	Same as C103.	Cathode Bypass V102	
C109	Same as C101.	Screen Bypass V102	
C110	CAPACITOR, fixed: "trylar"; 1000 uufd, $\pm 10\%$, 8000 wvdc.	RF Bypass, S101	CX-102K-102P
C111	Same as C110.	RF Decoupling S101	
C112	CAPACITOR, fixed: "trylar"; 500 uufd, $\pm 10\%$, 8000 wvdc.	PL Plate Decoup. S101	CX-102K-501P
C113	CAPACITOR ASSEMBLY, variable: vacuum; 10-400 uufd, 7.5 kv; 42 amp; CW rotation decr. capacitance. Complete w/gear.	PA Tuning S101	AM-108
C114	Same as C112.	RF Bypass S101	

**AMPLIFIER-OSCILLATOR MODEL RTF-2
POWER AMPLIFIER (SYMBOL SERIES 100)**

REF SYMBOL	DESCRIPTION	FUNCTION	TMC PART NO.
C115	CAPACITOR, fixed: mica; 500 uufd, $\pm 5\%$, 500 wvdc, char. B. Suggested replacement assembly - A102.	p/o LP Filter M303	CM20B501J
C116	Same as C115. Suggested replacement assembly - A102.	p/o LP Filter M303	
C117	CAPACITOR, variable: air; 2 sections, 70-1000 mmfd ea.	Antenna Loading S103	CB-140
C118	CAPACITOR, fixed: "trylar"; 2000 uufd, $\pm 5\%$, 4000 wvdc.	Antenna Loading S103	CX-102J-202M
C119	NOT USED.		
C120	NOT USED.		
C121	CAPACITOR, fixed: ceramic; 3 uufd, $\pm .25$ uufd, 500 wvdc, char. SL.	p/o Divider Network	CC21SL030C
C122	CAPACITOR, fixed: mica; 27 uufd, $\pm 10\%$, 500 wvdc, char. B.	p/o Divider Network	CM20B270K
C123	CAPACITOR, fixed: mica; .001 ufd, $\pm 10\%$, 500 wvdc, char. B.	RF Filter	CM20B102K
C124	CAPACITOR, fixed: mica; 2000 uufd, $\pm 10\%$, 500 wvdc, char. B.	RF Filter	CM30B202K
C125	CAPACITOR, fixed: "mylar"; .1 ufd, $\pm 5\%$, 200 wvdc, char. B.	RF Filter	CN108B1003K
C126	NOT USED.		
C127	CAPACITOR, fixed: paper; bathtub case; 1 ufd, $\pm 10\%$ 600 wvdc, char. F.	Phase Shift B101	CP53B1FF105K
C128	CAPACITOR, fixed: button type; 360 uufd, $\pm 2\%$, 300 wvdc, char. D.	p/o PA Neutralization	CB21PD361G
CR101	DIODE, silicon.	Half Wave Rectifier	IN-303
J101	CONNECTOR, receptacle: female; BNC type.	RF Out, Test	UG-560/U
L101	COIL, R. F. :	Screen Decoupling Coil	CL-178
L102	COIL, R. F. :	p/o LP Filter V101	CL-120-2
L103	COIL, R. F. :	Filter	CL-139
L104	CHOKER, R. F. :	p/o Divider Network	CL-100-5
L105	Same as L102.	p/o LP Filter V102	
L106	Same as L101.	Screen Decoupling V102	

**AMPLIFIER-OSCILLATOR MODEL RTF-2
POWER AMPLIFIER (SYMBOL SERIES 100)**

REF SYMBOL	DESCRIPTION	FUNCTION	TMC PART NO.
L107	COIL, R. F.:	Plateload, Choke HF Band	A-1163
L108	CHOKE, R. F.:	Plate Load, Choke, LF Band	A-1529
L109	Same as L107.	RF Decoupling S101	
L110	Same as L101. Suggested replacement assembly - A102.	p/o LP Filter M303	
L111	Same as L101. Suggested replacement assembly - A102.	p/o LP Filter M303	
L112	COIL, R. F.: p/o A101, not a replaceable item.		A-1208
L113	COIL, R. F.: p/o A101, not a replaceable item.		A-1209
L114	Same as L101.	Safety Choke S102A	
L115	COIL, R. F.:	Filter	A-1045
L116	COIL, R. F.:	Filter	A-1076
PS101	SUPPRESSOR, parasitic; 124 Mc, ± 3 Mc.	To Plate V101	AX-144
PS102	Same as PS101.	To Plate V102	
PS103	SUPPRESSOR, parasitic; 105 Mc, ± 3 Mc.	To Control Grid V101	AX-155
PS104	Same as PS103.	To Control Grid V102	
R101	RESISTOR, fixed: composition; 2200 ohms, $\pm 5\%$, 1/2 watt.	p/o Divider Network	RC20GF222K
S101 A & B	SWITCH, rotary: 9 position; single section, 36 deg. detent; ceramic wafer and insulation; silver plated contacts and wiper.	p/o PA Band- switch	SW-165
S102	SWITCH, rotary: 9 position; single section; ceramic wafer and insulation; silver plated contacts and wiper; 30 amps max. current: p/o A101, not a replaceable item.		SW-166
S103	SWITCH, rotary: 2 position; single section; 60 deg. detent, non-shorting.	Aux. Loading	SW-234
S104	SWITCH, push-button: momentary contact; normally closed; SPST, 15 a. at 125, 250 or 460 VAC; 1/2 a. at 125 VDC; 1/4 a. at 250 VDC.	p/o PA Band- switch	SW-169
T101	TRANSFORMER, power: filament; pri. -115/230 VAC, 50/60 cps, single phase; insulation 1500 V peak; hermetically sealed metal case.	PA Filament	TF-155

**AMPLIFIER-OSCILLATOR MODEL RTF-2
POWER AMPLIFIER (SYMBOL SERIES 100)**

REF SYMBOL	DESCRIPTION	FUNCTION	TMC PART NO.
TC101	THERMOCOUPLE, meter: external; range 0-8. Suggested replacement assembly - A102.	Sensing Device M303	TH-100-8
V101	TUBE, electron: radial beam power pentode; 5 pin metal shell base and plate cap.	p/o PA Final Stage	4-250A
V102	Same as V101.	p/o PA Final Stage	
XV101	SOCKET, tube: giant 5 pin base.	Socket for V101	TS-125-2
XV102	Same as XV101.	Socket for V102	

**AMPLIFIER-OSCILLATOR MODEL RTF-2
MULTIPLIER (SYMBOL SERIES 200)**

REF SYMBOL	DESCRIPTION	FUNCTION	TMC PART NO.
C201 A & B	CAPACITOR, variable: air dielectric; two sections 12.5-282.5 uufd ea. section; ceramic insulation.	Driver Tuning	CB-127
C201C	CAPACITOR, variable: air dielectric; 12.5-282.5 ufd; ceramic insulation.	Driver Tuning	CB-128
C202	CAPACITOR, fixed: mica; .01 ufd, $\pm 5\%$, char. C, 300 wvdc.	Input Coupling	CM35C103J
C203	CAPACITOR, fixed: terminal type; 1000 uufd, $\pm 10\%$, char. W; terminal type Q.	RF Bypass	CB21QW102K
C204	Same as C203.	RF Bypass	
C205	Same as C203.	Screen Bypass	
C206	Same as C202.	p/o Key Click Filter	
C207	CAPACITOR, fixed: mica; 1000 uufd, $\pm 5\%$, char. B. 500 wvdc.	RF Coupling, V201	CM20B102J
C208	Same as C203.	RF Bypass V201	
C209	Same as C207.	Plate Decoupling V201	
C210	CAPACITOR, variable: ceramic; 3-12 uufd, 500 wvdc, char. A.	Tank Trimmer V201	CV11A120
C211	Same as C207	RF Coupling V204	
C212	CAPACITOR, variable: ceramic; 4-30 uufd, 500 wvdc, char. C.	p/o V201 Tank Capacity	CV11C300
C213	Same as C202.	Cathode Bypass V204	
C214	Same as C203.	Screen Bypass V204	
C215	CAPACITOR, fixed: mica; 500 uufd, $\pm 5\%$, 500 wvdc, Char. B.	RF Coupling V204	CM20B501J
C216	Same as C207.	Plate Decoupling V204	
C217	Same as C207	Plate Decoupling V204	
C218	Same as C210.	Trimmer Band 2	
C219	Same as C215.	RF Coupling V205	
C220	Capacitor, fixed: terminal type; 470 uufd, $\pm 10\%$, char. W; terminal type Q.	p/o LP Filter V202B	CB21QW471K

**AMPLIFIER-OSCILLATOR MODEL RTF-2
MULTIPLIER (SYMBOL SERIES 200)**

REF SYMBOL	DESCRIPTION	FUNCTION	TMC PART NO.
C221	CAPACITOR, fixed: mica; 12000 uufd, $\pm 5\%$, 600 wvdc, char. B.	Plate Decoupling	CM50B123J
C222	CAPACITOR, fixed: mica; 330 uufd, $\pm 10\%$, 2500 wvdc, char. B.	RF Coupling V205	CM45B331K
C223	Same as C203	Screen Bypass V205	
C224	CAPACITOR, fixed: mica; 100 uufd, $\pm 5\%$, 500 wvdc, char. D.	DC Blocking to C104	CM20D101J
C225	CAPACITOR, fixed: mica; 2200 uufd, $\pm 10\%$, 1200 wvdc, char. B.	p/o LP Filter V205	CM45B222K
C226	CAPACITOR, fixed: mica; 130 uufd, $\pm 10\%$, 500 wvdc, char. D.	RF Coupling	CM20D131G
C227	Same as C215.	RF Bypass V206 Fil.	
C228	Same as C207.	Screen Decoupling V204	
C229	Same as C207.	Screen Decoupling V201	
C230	Same as C207.	RF Bypass, M301	
C231	Same as C210.	Trimmer Band 3	
C232	CAPACITOR, variable: ceramic; 7-45 uufd, 500 wvdc, char. C.	Trimmer Band 4	CV11C450
C233	Same as C207.	DC Blocking	
C234	Same as C203.	RF Bypass S204B	
C235	Same as C207.	RF Bypass	
C236	NOT USED.		
C237	Same as C210.	Trimmer Band 1	
C238	Same as C210.	Trimmer Band 2	
C239	Same as C210.	Trimmer Band 3	
C240	CAPACITOR, fixed: mica; 3 uufd, $\pm 5\%$, 500 wvdc, char. C.	Resonating Cap., L208	CM20D390J
C241	Same as C202.	Bypass	
C242	Same as C202.	Bypass	
C243	Same as C202.	Bypass	

**AMPLIFIER-OSCILLATOR MODEL RTF-2
MULTIPLIER (SYMBOL SERIES 200)**

REF SYMBOL	DESCRIPTION	FUNCTION	TMC PART NO.
J201	CONNECTOR, coaxial: female; BNC type, single hole mtg.	RF Input V201	UG-625/U
L201	CHOKE, R. F.:	Plate Load Choke, V201	A-1045
L202	Same as L201.	Screen Decoupling V204	
L203	COIL ASSEMBLY,	Trimmer Band 1 V201	A-1103
L204	COIL ASSEMBLY,	Trimmer Band 2 V201	A-1104
L205	COIL ASSEMBLY,	Equalizer V209	A-1626
L206	Same as L201.	Screen Decoupling V201	
L207	COIL ASSEMBLY, 8-16 Mc;	Trimmer Band 3	A-1105
L208	COIL ASSEMBLY, 16-32 Mc;	Trimmer Band 4	A-1601
L209	CHOKE, plate:	Plate Load Choke V205	A-1096
L210	CHOKE, R. F.:	p/o LP Filter V205	CL-100-5
L211	SWITCH COIL ASSEMBLY: 2-4 Mc;	Trimmer Band 1	A-1108
L212	SWITCH COIL ASSEMBLY:	Output Tuning, V205	A-1628
L213	SWITCH COIL ASSEMBLY:	Output Tuning, V205	A-1627
L214	SWITCH COIL ASSEMBLY: 16-32 Mc;	Trimmer Band 4	A-1192
L215	COIL, R. F.:	p/o LP Filter V205	CL-101-4
L216	INDUCTOR, choke:	p/o LP Filter M301 CKT	A-1126
L217	Same as L210.	RF Choke	
L218	Same as L201.	RF Choke	
PS201	SUPPRESSOR, parasitic: 6 close wound turns #30 DSC wire on a 100 ohm $\pm 10\%$, 1/2 watt resistor.	PS, Plate Ckt. V204	A-1119
PS202	Same as PS201.	PS, Control Grid V204	A-1119
R201	RESISTOR, fixed: composition; 10,000 ohms, $\pm 10\%$, 1/2 watt.	Grid Leak V201	RC20GF103K

**AMPLIFIER-OSCILLATOR MODEL RTF-2
MULTIPLIER (SYMBOL SERIES 200)**

REF SYMBOL	DESCRIPTION	FUNCTION	TMC PART NO.
R202	RESISTOR, fixed: composition; 100,000 ohms, $\pm 10\%$, 1 watt.	p/o Keyer Load V202A	RC32GF104K
R203	RESISTOR, fixed: wire wound; 50,000 ohms, $\pm 5\%$, 10 watts.	Keyer Plate Load V202A	RW-109-43
R204	RESISTOR, fixed: composition; 47,000 ohms, $\pm 10\%$, 1/2 watt.	Grid Current Limiting	RC20GF473K
R205	RESISTOR, fixed: wire wound; 25,000 ohms, $\pm 5\%$, 10 watts.	p/o Cathode Bias V202A	RW-109-38
R206	RESISTOR, fixed: composition; 1000 ohms, $\pm 10\%$, 1/2 watt.	p/o Cathode Bias V202A	RC20GF102K
R207	RESISTOR, fixed: composition; 100 ohms, $\pm 10\%$, 1 watt.	Cathode Bias V201	RC32GF101K
R208	RESISTOR, fixed: wire wound; 15,000 ohms, $\pm 5\%$, 10 watts.	Volt. Dropping V203	RW-109-36
R209	RESISTOR, fixed: composition; 100,000 ohms, $\pm 10\%$, 1/2 watt.	p/o keyer Click Filter, V202B	RC20GF104K
R210	RESISTOR, fixed: composition; 10 ohms, $\pm 5\%$, 1/2 watt.	Meter Shunt M301	RC20GF100J
R211	RESISTOR, adjustable: wire wound; 25,000 ohms linear, $\pm 10\%$; 4 watts.	Driver Control V205	RA-109-TRD-253A
R212	RESISTOR, fixed: composition; 1 megohm, $\pm 10\%$, 1/2 watt.	p/o Voltage Divider	RC20GF105K
R213	RESISTOR, fixed: wire wound; 2250 ohms, 47 ma; 5 watts.	DC Dropping V204	RW-107-41
R214	Same as R201.	Grid Leak Bias V204	
R215	RESISTOR, fixed: composition; 470 ohms, $\pm 10\%$, 1 watt.	Cathode Bias V204	RC30GF471K
R216	RESISTOR, fixed: composition; 18,000 ohms, $\pm 5\%$, 1/2 watt.	Meter Multiplier M301	RC20GF183J
R217	RESISTOR, fixed: composition; 12,000 ohms, $\pm 10\%$, 2 watts.	p/o Voltage Divider V205	RC42GF123K
R218	RESISTOR, fixed: composition; 82,000 ohms, $\pm 10\%$, 1 watt.	p/o Keyer Load V202B	RC30GF823K
R219	RESISTOR, fixed: composition; 47,000 ohms, $\pm 10\%$, 2 watts.	p/o Voltage Divider V202B	RC42GF473K
R220	Same as R217.	Grid Leak Bias V205	
R221	Same as R210	Meter Shunt M301	

**AMPLIFIER-OSCILLATOR MODEL RTF-2
MULTIPLIER (SYMBOL SERIES 200)**

REF SYMBOL	DESCRIPTION	FUNCTION	TMC PART NO.
R222	RESISTOR, fixed: composition; 430,000 ohms, $\pm 5\%$, 1/2 watt.	Meter Multiplier M301	RC20GF434J
R223	Same as R216.	Meter Multiplier M301	
R224	RESISTOR, fixed: composition; 180,000 ohms, $\pm 10\%$, 2 watts.	p/o Voltage Divider V202A	RC42GF184K
R225	RESISTOR, fixed: composition; 22,000 ohms, $\pm 10\%$, 1/2 watt.	p/o Voltage Divider V202A	RC20GF223K
R226	RESISTOR, fixed: composition; 470,000 ohms, $\pm 10\%$, 2 watts.	PA Screen Protective	RC42GF474K
R227	RESISTOR, fixed: composition; 1500 ohms, $\pm 10\%$, 1/2 watt.	SSB Input S204B	RC20GF152K
R228	Same as R213.	Plate Load, V201	
R229	RESISTOR, fixed: composition 6800 ohms, $\pm 10\%$, 1/2 watt.	Voltage Dropping	RC20GF682K
R230	RESISTOR, fixed: wire wound; 10 ohms, $\pm 5\%$, 5 watts.	Driver Load Band 1	RR-114-10-W
R231	Same as R227.	Voltage Dropping	
R232	Same as R210.	Meter Shunt M301	
R233	Same as R216.	Multiplier M301	
R234	RESISTOR, fixed: composition; 3,900 ohms, $\pm 10\%$, 2 watts.	RF Filter	RC42GF392K
S201	BANDSWITCH, multiplier, rotary: 3 sections; no detent, non-shorting, ceramic wafers; silver plated; brass contacts.	p/o Driver Band Switch	SW-247
S202	SWITCH ASSY., rotary: 2 sections, 4 positions, ceramic, silver plated contacts and wipers.	p/o Driver Band Switch	AS-105
S203	SWITCH ASSY., rotary: 2 sections, 5 positions, 60 deg. angle of throw; non-shorting type; ceramic wafer and insulation, silver plated contacts and wipers.	Multi-Meter Switch	AS-107
S204	SWITCH ASSY., 2 sections, 2 positions, 30 deg. angle of throw; non-shorting type; ceramic wafer and insulation, silver plated contacts and wipers.	SSB Normal Switch	AS-103
V201	TUBE, electron: power pentode, 9 pin miniature.	Grounded Grid Amp. Doubler	6CL6
V202	TUBE, electron: duo diode, 9 pin miniature.	Keyer/Driver Keyer	12AT7
V203	TUBE, electron: voltage regulator; 7 pin miniature.	Voltage Reg.	OA2

**AMPLIFIER-OSCILLATOR MODEL RTF-2
MULTIPLIER (SYMBOL SERIES 200)**

REF SYMBOL	DESCRIPTION	FUNCTION	TMC PART NO.
V204	TUBE, electron: beam power amplifier; 7 pin miniature.	Doublor	6BF5
V205	TUBE, electron: beam power; large wafer octal base with sleeve.	Driver	6146
V206	Same as V202.	Keyer Clamp	
XV201	SOCKET, electron tube: miniature 9 pin.		TS103P01
XV202	Same as XV201.		
XV203	SOCKET, electron tube: miniature 7 pin.		TS102P01
XV204	Same as XV203.		
XV205	SOCKET, electron tube: octal base.		TS101P01
XV206	Same as SV201.		

**AMPLIFIER-OSCILLATOR MODEL RTF-2
INTERCONNECT CHASSIS (SYMBOL SERIES 400)**

REF SYMBOL	DESCRIPTION	FUNCTION	TMC PART NO.
C401	CAPACITOR, fixed: mica; .01 mfd., $\pm 5\%$; 300 wvdc; char. C.	Plate Bypass V402	CM20B102J
C402	CAPACITOR, fixed: mica; 1000 mmfd, $\pm 5\%$; 500 wvdc, char. B.	RF Input V402	CM20B102J
C403	Same as C401.	p/o LP Filter V403	
C404	Same as C402.	RF Coupling V404	
C405	Same as C401.	Plate Bypass V404	
C406	Same as C401	Cathode Bypass V403	
C407	Same as C401.	RF Bypass V404	
C408	Same as C401.	Output V404	
C409	Same as C402.	Input Coupling V405	
C410	Same as C402.	LP Filter V406	
C411	CAPACITOR, fixed: paper; .1 mfd., $\pm 40 -10\%$; 400 wvdc; plastic tubular case.	Input Coupling V406	CN-100-4
C412	CAPACITOR, fixed: mica; 5 mmfd, $\pm 20\%$; char. B, 500 wvdc.	DC Blocking V405	CM20B050M
C413	Same as C402.	Screen Bypass V405	
C414	Same as C402.	p/o LP Filter V405	
C415	Same as C402.	p/o LP Filter V405	
C416	Same as C411.	Audio Coupling V406	
C417	Same as C411.	Audio Coupling V406	
C418	Same as C402.	RF Coupling V402	
C419	Same as C402.	Screen Bypass V403	
C420	CAPACITOR, variable: air dielectric; one section, nineteen plates; 3.2 to 50 mmfd. 500 wvdc.	Xtal 3 Trimmer	CT-104-3
C421	Same as C401.	RF Bypass	
C422	Same as C401.	RF Bypass V403	
C423	Same as C420.	Xtal 1 Trimmer	

**AMPLIFIER-OSCILLATOR MODEL RTF-2
INTERCONNECT CHASSIS (SYMBOL SERIES 400)**

REF SYMBOL	DESCRIPTION	FUNCTION	TMC PART NO.
C424	Same as C420.	Xtal 2 Trimmer	
C425	Same as C401.	Arc Suppress Z401	
C426	CAPACITOR, fixed: mica; 150 mmfd; $\pm 2\%$; char. D. 500 wvdc.	Screen Bypass V403	CM20D151G
C427	Same as C401.	B+ Bypass	
C428	Same as C411.	B+ Bypass	
F401	FUSE, cartridge: 2 amps.		FU-102-2
F402	FUSE, cartridge: 3 amps.		FU-102-3
F403	FUSE, cartridge: .250 amps.		FU-102-.250
J401	CONNECTOR, receptacle: 7 contacts rated at 20 amps, 200 VDC, 150 VAC (RMS); mtg. dim. 1-1/32 in. mtg. centers.	Interconnect MO Power	MS3102A-16S-1S
J402	CONNECTOR, receptacle: electrical; 1 female contact; 52 ohms; BNC type.	MO Input	UG-625/U
J403	Same as J402.	LO Out	
J404	Same as J402.	Exciter In	
J405	CONNECTOR, receptacle; pin type; 4 contacts rated at 35 amps, 18 contacts rated at 20 amps; 200 VDC, 150 VDC (RMS); mtg. dim. 1.782 in. dia. cutout w/four 9/64 in. dia. holes on 1-9/16 in. mtg. centers	Interconnect RTF	MS3102A-28-11P
K401	RELAY ASSEMBLY, 4500 ohms DC; hermetically sealed.	Inner Oven Control Relay	A-123
L401	COIL, radio frequency:	p/o LP Filter V403	CL-100-5
L403	COIL, radio frequency:	Parasitic Choke V403	CL-172
L404	Same as L401.	B+ Filter	
L405	Same as L401.	B+ Filter	
R401	RESISTOR, fixed: wire wound; 6000 ohms, $\pm 5\%$, 10 watts.	Voltage Dropping V401	RW-109-45
R402	RESISTOR, fixed: composition; 33,000 ohms, $\pm 10\%$; 1 watt.	Plate Load, V402	RC32GF33K
R403	RESISTOR, fixed: composition; 4700 ohms, $\pm 10\%$; 1/2 watt.	Grid Leak, V402	RC20GF472K
R404	RESISTOR, fixed: composition; 1000 ohms, $\pm 10\%$; 1/2 watt.	Cathode Load, V402	RC20GF102K

**AMPLIFIER-OSCILLATOR MODEL RTF-2
INTERCONNECT CHASSIS (SYMBOL SERIES 400)**

REF SYMBOL	DESCRIPTION	FUNCTION	TMC PART NO.
R405	NOT USED.		
R406	RESISTOR, fixed: composition; 82,000 ohms, $\pm 10\%$; 1/2 watt.	Screen Dropping, V403	RC20GF823K
R407	RESISTOR, fixed: composition; 100,000 ohms, $\pm 10\%$; 1/2 watt.	Grid Leak, V404	RC20GF104K
R408	RESISTOR, fixed: composition; 160 ohms, $\pm 5\%$; 1/2 watt.	Cathode Bias V403	RC20GF181K
R409	Same as R407.	Grid Leak, V403	
R410	RESISTOR, fixed: composition; 1 megohm, $\pm 10\%$; 1/2 watt.	Cathode Bias V404	RC20GF105K
R411	Same as R407.	Grid Leak, V405	
R412	RESISTOR, fixed: composition; 56,000 ohms, $\pm 10\%$; 1/2 watt.	Voltage Dropping	RC20GF563K
R413	Same as R410.	Plate Load, V405	
R414	Same as R407.	Screen Dropping V405	
R415	NOT USED.		
R416	Same as R404.	p/o LP Filter V405	
R417	RESISTOR, fixed: composition; 220,000 ohms, $\pm 10\%$; 1/2 watt.	Plate Load, V406	RC20GF224K
R418	RESISTOR, fixed: composition; 82,000 ohms, $\pm 10\%$; 2 watts.	Plate Load, V406	RC42GF823K
R419	Same as R407.	Grid Leak Bias, V405	
R420	RESISTOR, fixed: composition; 4.7 megohms; $\pm 10\%$; 1/2 watt.	Grid Leak Bias, V406	RC20GF475K
R421	Same as R417.	Grid Leak Bias, V406	
R422	RESISTOR, fixed: composition; 10,000 ohms, $\pm 10\%$; 1/2 watt.	Output Load V406	RC20GF103K
R423	RESISTOR, fixed: wire wound; 30 ohms, $\pm 5\%$; 10 watts.	p/o RF Output Attenuator	RR-116-30-W
R425	RESISTOR, fixed: wire wound; 50 ohms, $\pm 5\%$; 10 watts.	p/o RF Output Attenuator	RR-116-50-W
R426	RESISTOR, current regulating; ballast vacuum tube type.	Ballast	RR-109

**AMPLIFIER-OSCILLATOR MODEL RTF-2
INTERCONNECT CHASSIS (SYMBOL SERIES 400)**

REF SYMBOL	DESCRIPTION	FUNCTION	TMC PART NO.
S401	SWITCH ASSY., rotary : 3 section; 5 position; wafer "A & B" bakelite, wafer "C" ceramic; contacts and wipers silver plated. 1/4 in. dia. drive shaft 10-1/2 in. lg.	Oscillator Switch	AS-106
S402	SWITCH ASSY., CW-FS: 2 section; 5 position; 30 deg. angle of throw; non-shorting; ceramic wafers; silver plated brass contacts; 1/4 in. shaft.	Excitation Switch	AS-108
T401	TRANSFORMER, H. F. : VMO output.	CF Load	TR-166
V401	TUBE, electron regulator; 7 pin miniature, operating at 150 VDC; 5 amps min.; 30 amps max. current.	Voltage Regulator	OA2
V402	TUBE, electron: HF power triode; 7 pin miniature.	Cathode Follower	6C4
V403	TUBE, electron: sharp cutoff R. F. pentode; 7 pin miniature.	Xtal Osc. Amp.	6AH6
V404	TUBE, electron: medium-mu duo-triode; 9 pin miniature.	Cathode Follower Osc. Output	12AU7
V405	TUBE, electron: heptode converter; 7 pin miniature.	Mixer	6BE6
V406	Same as V404.	Audio Amplifier	
XF401	FUSE, extractor post type; 250 v, 15 amp.	Holder for F401	FH-100-2
XK401	SOCKET, electron tube: octal.	Socket for K401	TS101P01
XR426	SOCKET, electron tube: 9 pin miniature.	Socket for R426	TS103P01
XV401	SOCKET, electron tube: 7 pin miniature.	Socket for V401	TS102P01
XV402	Same as XV401.	Socket for V402	
XV403	Same as XV401.	Socket for V403	
XV404	Same as XR426.	Socket for V404	
XV405	Same as XV401	Socket for V405	
XV406	Same as XR426.	Socket for V406	
XY401	SOCKET, crystal: .486 in. spacing for .050 in. pin dia.	Socket for Y401	TS-104-1
XZ401	Same as XK401.	Socket for Z401	
Z401.	OVEN, crystal: 6.3 v, 7.5 watt heater; 75 C \pm 2 C; 1-1/4 in. dia. x 2-5/8 in. lg; octal base.	Crystal Holder	PO-158-1

POWER SUPPLY MODEL RTP-2
(SYMBOL SERIES 600)

REF SYMBOL	DESCRIPTION	FUNCTION	TMC PART NO.
C601	CAPACITOR, fixed: paper dielectric; 4 ufd, $\pm 10\%$, 4000 wvdc; furnished with mounting clamps.	H. V. B+ Filter Cap., T603	CN-109
C602	Same as C601.	H. V. B+ Filter Cap., T603	
C603	CAPACITOR, fixed: 0.10 ufd, $+40 -10\%$, 600 wvdc.	Arc Suppressor Cap., E602	CN-100-22
C604	CAPACITOR, fixed: paper dielectric; 4 ufd, $\pm 10\%$, 600 wvdc.	B- Filter Cap., V601	CP40C2FF405K
C605	Same as C604.	B- Filter Cap., V602	
C606	CAPACITOR, fixed: dry electrolytic; polarized, 80 ufd, 450 wvdc.	B+ Filter Cap., V604	CE51C800R
C607	Same as C604.	B+ Filter Cap., V604	
C608	Same as C604.	B- Filter Cap., V605	
C609	Same as C604.	B+ Filter Cap., V605	
C610	Same as C601.	H. V. B+ Filter Cap., T603	
C611	CAPACITOR, fixed: paper dielectric; 10,000 uufd, $+30 -10\%$, 1000 wvdc.	Spark Suppressor Cap., K601	CN-110-103-G
C612	Same as C603.	Pulse Forming Cap., K602	
C613	CAPACITOR, fixed: dry electrolytic; polarized, 20 mfd, 250 wvdc.		CE-103-5
CB601	CIRCUIT BREAKER, main power: toggle lever type; DPST; connection A to B 250 VAC, 16A; A to C 250 VAC, 32A; manual reset, armature trip release.	Line Voltage Breaker	SW-164
CB602	CIRCUIT BREAKER, final S. G. overload reset; toggle lever type: 250 VAC, 15A; 1% ripple; .01 ADC, manual reset, armature trip release.	Final Screen Grid Overload Reset	SW-229
CB603	CIRCUIT BREAKER, final plate overload reset; toggle lever type: 250 VAC, 15A; 1% ripple; .1 ADC, manual reset, armature trip release.	Final Plates Overload Reset	SW-215
CR601	DIODE, silicon.	S. G. Protect	1N1084A
CR602	Same as CR601.	S. G. Protect	
F601	FUSE, time lag: cartridge type; 3 amps, 115 V.	M. O. Oven Fuse	FU-102-3
F602	Same as F601.	Low Voltage	

**POWER SUPPLY MODEL RTP-2
(SYMBOL SERIES 600)**

REF SYMBOL	DESCRIPTION	FUNCTION	TMC PART NO.
F602	Same as F601.	Low Voltage Supply Fuse	
F603	Same as F601.	Mid Voltage Supply Fuse	
F604	FUSE, time lag: cartridge type; .125 amp, 115 V.	Low B- Fuse	FU-102-.125
F605	FUSE, time lag: cartridge type; 0.3 amp; 115 V.	Low B+ Fuse	FU-102-.300
F606	Same as F605.	Mid B+ Fuse	
I601	LAMP, neon: miniature bayonet base; 110/125 V, type T-3-1/4.	Final Overload Indicator	BI-100-51H
I602	LAMP, incandescent: double contact bayonet base; 120 V, 3 watts, type 5-6.	Final Plate Indicator	BI-102-3
I603	Same as I602.	Xmtr. Plates Indicator	
I604	Same as I602.	Main Power Indicator	
J601	CONNECTOR, receptacle: male.	Power Input	MS3102A-28-11P. p/o CA406
J602	CONNECTOR, receptacle: female.	Power Output	MS3102A-28-11S. p/o CA406
J603	CONNECTOR, receptacle: female.	High Voltage Output	MS3102A-18-16S
J604	CONNECTOR, receptacle: female; A. C. ; two contacts.	Utility Outlet	JJ-169
K601	RELAY ASSY., transmitter plates: 115 VDC. 5000 ohm coil resistor; min. oper. amps. .015; furnished with cable	Transmitter Plates Relay	A-1270
K602	RELAY, thermostatic delay: 6 volts, normally open, 60 ±12 sec. delay; miniature 9 pin base, SPST; 2.5 watts.	Time Delay Relay	RL-111-6N060T
K604	RELAY, time delay: break-make type; 120 volts DC.	Time Delay Lock-In	RL-116-DC-3C-120
L601	REACTOR, filter:	Filter Choke V603	TF-166
L602	REACTOR, filter:	Filter Choke V604	TF-144
L603	Same as L602.	Filter Choke V604	
L604	Same as L602.	Filter Choke V605	

POWER SUPPLY MODEL RTP-2
(SYMBOL SERIES 600)

REF SYMBOL	DESCRIPTION	FUNCTION	TMC PART NO.
L605	Same as L602.	Filter Choke V605	
L606	REACTOR, filter:	High Voltage	TF-5012
M601	METER, A. C. volt: 0 to 150 range.	Filament Line	MR-108-150
R601	RESISTOR, fixed: wire wound; 15,000 ohms, 10 watts, 25.5 ma.	p/o PA SG Divider	RW-109-36
R602	Same as R601.	p/o PA SG Divider	
R603	RESISTOR, variable: wire wound; 500 ohms, $\pm 10\%$, 12.5 watts; linear taper.	PA SG Overload Adjust.	RP-100-X-H-501K
R604	RESISTOR, fixed: wire wound; 400 ohms, 10 watts, 158 ma.	p/o PA SG Overload Circuit	RW-109-17
R605	RESISTOR, variable: wire wound; 2000 ohms, $\pm 10\%$, 12.5 watts; linear taper.	Final Bias Adj.	RP-100-X-H-202K
R606	RESISTOR, fixed: wire wound; 5,000 ohms, 10 watts, 45 ma.	Bias Divider	RW-109-32
R607	RESISTOR, fixed: wire wound; 25,000 ohms, 20 watts, 16 ma.	Bleeder Res., K602	RW-110-36
R608	RESISTOR, fixed: wire wound; 7.5 ohms, 10 watts, 1.15 ma.	p/o PA Overload Circuit	RW-109-48
R609	RESISTOR, variable: wire wound; 15 ohms, $\pm 10\%$, 12.5 watts. linear taper.	Final Plate Overload Adjust	RP-100-X-H-150K
R610	RESISTOR, fixed: wire wound; 6,000 ohms, 10 watts, 41 ma.	Bleeder V601	RW-109-45
R611	RESISTOR, fixed: wire wound; 500 ohms 10 watts, 142 ma.	Peak Current Limiter	RW-109-19
R612	RESISTOR, fixed: wire wound; 50,000 ohms, 10 watts, 14 ma.	Bleeder V602	RW-109-43
R613	DELETED.		
R614	RESISTOR, fixed: composition: 68,000 ohms, $\pm 10\%$, 2 watts.	p/o PA Plates Overload Divider	RC42GF683K
R615	RESISTOR, fixed: wire wound; 50,000 ohms, $\pm 5\%$, 160 watts, 57 ma.	Bleeder HV	RW-117-35
R616	Same as R615.	Bleeder HV	
R617	RESISTOR, fixed: wire wound; 12,500 ohms, $\pm 5\%$, 160 watts, 113 ma.	Bleeder HV	RW-117-28
R618	RESISTOR, fixed: composition; 220,000 ohms, $\pm 10\%$, 2 watts.	p/o HV Divider	RC42GF224K

**POWER SUPPLY MODEL RTP-2
(SYMBOL SERIES 600)**

REF SYMBOL	DESCRIPTION	FUNCTION	TMC PART NO.
R619	RESISTOR, fixed: composition; 20 M ohms, $\pm 5\%$, 2 watts.	p/o HV Divider	RC42GF206J
R620	Same as R619.	p/o HV Divider	
R621	Same as R619.	p/o HV Divider	
R622	Same as R619.	p/o HV divider	
R623	Same as R619.	p/o HV Divider	
R624	RESISTOR, fixed: wire wound; 90,000 ohms, $\pm 5\%$, 160 watts, 42 ma.	PA SG Dropping	RW-117-39
R625	RESISTOR, fixed: wire wound; 10,000 ohms, $\pm 5\%$, 10 watts, 32 ma.		RW-109-34
R626	RESISTOR, fixed: wire wound; 20,000 ohms, $\pm 5\%$, 10 watts, 22 ma.		RW-109-37
S601	SWITCH, rotary: 3 sections, 4 positions, 60° angle of throw; non-shorting type; silver plated brass contacts; bakelite insulation.	Mode Switch	SW-228
S602	SWITCH, toggle: DPDT; 2 amps at 125 V; bat type toggle.	MO Bypass Switch	ST-22N
S603	SWITCH, toggle: DPST; 250 V at 20 amps; 1-1/2 horse-power 250 V.	Xmtr Plates	ST-104
S604	Same as S603.	Final Plate	
S605	SWITCH, rotary: 7 taps; 180° total rotation, 150 V, 10 amps AC; non-shorting type. NOTE: Main Power Transformer T501 is part of Model CAB-7.	Filament Line	SW-167-7
T601	TRANSFORMER, power: pri. - 115/230 VAC at 50/60 cps; sec 1 - 500 VDC at 200 ma; sec 2-5.0 VAC at 2.0 A; sec 3 - 6.3 VAC at 1.3 A; sec 4 - 6.3 VAC at 3 A, CT; hermetically sealed metal case.	LV Rect. Input	TF-161
T602	Same as T601.	MV Rect. Input	
T603	TRANSFORMER, filament power: pri. - 115/230 VAC at 50/60 cps; sec. 5 VAC at 15 A, C.T.; hermetically sealed metal case.	HV Rect. Input	TF-147
T604	TRANSFORMER, auto: input - 115/230 V, 50/60 cps; Output seven positions tapped in 5 V steps from 100 V to 13 V; Any tap - 3 A to load; hermetically sealed metal case.	Line Voltage Adjust	TF-164
V601	TUBE, electron: voltage regulator; 7 pin miniature.	Bias Reg.	OB2
V602	Same as V601.	Bias Reg.	

**POWER SUPPLY MODEL RTP-2
(SYMBOL SERIES 600)**

REF SYMBOL	DESCRIPTION	FUNCTION	TMC PART NO.
V603	TUBE, electron: full wave rectifier; 7 pin miniature.	LV Rect.	6X4
V604	TUBE, electron: full wave rectifier; octal base.	LV Rect.	5R4GY
V605	Same as V604.	MV Rect.	
V606	TUBE, electron: mercury vapor half wave rectifier; A4-29 base.	HV Rect.	872A
V607	Same as V606.	HV Rect.	
V608	TUBE, electron: Voltage Regulator, 7 pin miniature.	SG Reg.	OA2
V609	Same as V608.	SG Reg.	
V610	TUBE, electron: Voltage Regulator, 7 pin miniature.	SG Reg.	OA2
V611	Same as V608.	SG Reg.	
XC606	SOCKET, octal.	Cap. Socket for C606	TS101 P01
XCR601	BLOCK, mounting: polarized; albaloy plated bronze clips.	Socket for CR601	CU-128
XCR602	Same as XCR601.	Socket for CR602.	
XF601	HOLDER, fuse: solder lug terminals, phenolic body and cap.	Socket for F601	FH-103
XF602	Same as XF601.	Socket for F602	
XF603	Same as XF601.	Socket for F603	
XF604	Same as XF601.	Socket for F604	
XF605	Same as XF601.	Socket for F605	
XF606	Same as XF601.	Socket for F606	
XI601	SOCKET, miniature: bayonet base; w/red lens.	Socket for I601	TS-106-1
XI602	SOCKET, lamp: bayonet base; w/red lens.	Socket for I602	TS-124-1
XI603	Same as XI602.	Socket for I603.	
XI604	SOCKET, lamp: bayonet base; w/green lens.	Socket for I604.	TS-124-2
XK602	SOCKET, 9 pin miniature.	Socket for K602	TS-103-P01
XV601	SOCKET, 7 pin miniature.	Socket for V601	TS-102-P01
XV602	Same as XV601.	Socket for V602	
XV603	Same as XV601.	Socket for V603	
XV604	XC606 Same as	Socket for V604.	

**POWER SUPPLY MODEL RTP-2
(SYMBOL SERIES 600)**

REF SYMBOL	DESCRIPTION	FUNCTION	TMC PART NO.
XV605	Same as XC606.	Socket for V605	
XV606	SOCKET, tube: bayonet base; jumbo twist lock, 4 pin base.	Socket for V606	TS-123-211-1
XV607	Same as XV606.	Socket for V607	
XV608	Same as XV601.	Socket for V608	
XV609	Same as XV601.	Socket for V609	
XV610	Same as XV601.	Socket for V610	
XV611	Same as XV601.	Socket for V611	

**CABINET/FRAME ASSEMBLY MODEL CAB-7
(SYMBOL SERIES 500)**

REF SYMBOL	DESCRIPTION	FUNCTION	TMC PART NO.
B501	FAN, intake: includes motor, blade, frame, and mounting plate: 115 v. 50/60 cps, single phase: 2 ufd running capacitor, 1650 rpm, 38 watts full load.	Air Intake	AX-142
C501	CAPACITOR, fixed: mica: .01 ufd, $\pm 20\%$, char. B, 300 wvdc.	RF Filter	CM35B103M
C502	Same as C501.	RF Filter	
C503	Same as C501.	RF Filter	
C504	Same as C501.	RF Filter	
C505	Same as C501.	RF Filter	
C506	Same as C501.	RF Filter	
C507	Same as C501.	RF Filter	
C508	Same as C501.	RF Filter	
C509	Same as C501.	RF Filter	
C510	Same as C501.	RF Filter	
C511	Same as C501.	RF Filter	
C512	Same as C501.	RF Filter	
C513	Same as C501.	RF Filter	
C514	Same as C501.	RF Filter	
C515	Same as C501.	RF Filter	
C516	Same as C501.	RF Filter	
C517	Same as C501.	RF Filter	
C518	Same as C501.	RF Filter	
C519	Same as C501.	RF Filter	
C520	CAPACITOR, fixed: paper dielectric; 2 ufd. $\pm 10\%$, 600 wvdc, oil filled and impregnated; hermetically sealed bathtub case.	Phase Shift	CP53B1FF205K
C521	CAPACITOR, fixed: ceramic; high voltage; 3 ufd. $\pm 10\%$, 5000 wvdc.	Voltage Divider	CC-109-1
C522	CAPACITOR, fixed: mica; button type; 1000 ufd. $\pm 5\%$, char. D, 300 wvdc.	Voltage Divider	CB21PD102J
C523	Same as C501.	RF Filter	
C524	Same as C501.	RF Filter	
C525	Same as C501.	RF Filter	

**CABINET/FRAME ASSEMBLY MODEL CAB-7
(SYMBOL SERIES 500)**

REF SYMBOL	DESCRIPTION	FUNCTION	TMC PART NO.
J501	CONNECTOR, receptacle: male; recessed, locking type; 3 contacts, 20 amps.	Power Input	PL-133-NG
J502	CONNECTOR, receptacle: male; recessed, locking type; 2 contacts, 10 amps at 250 v, 15 amps at 125 v.	Power Input for Accessory Line	JJ-100
J503	Used on W509.		
J504	Used on W509.		
J505	CONNECTOR, receptacle: R. F. female.	RF Out	UG-560/U
J506	CONNECTOR, receptacle: R. F. female.	RF Monitor	SO-239
J507	CONNECTOR, receptacle: male, 22 contacts.	Interconnect	MS3102A28-11P
J508	ADAPTER, bulkhead: UHF type; one female contact on each end.	Interconnect	PL-274
J509	Same as J508.	Interconnect	
L501	INDUCTOR, choke:	Line Filter	CL-120-1
L502	Same as L501.	Line Filter	
MP502	FILTER, air: 10-1/8 x 11-3/8 x 1/2 in. o/a.	Air Filter	AD 103-2
MP503	FILTER, air: 7-5/8 x 16-7/8 x 1/2 inch o/a.	Air Filter	AD 103-5
P501	Used on W502.		
P502	Used on W502.		
P503	Used on W501.		
P504	Used on W501.		
P505	Used on W503.		
P506	Used on W503.		
P507	Used on W504.		
P508	Used on W504.		
P509	Used on W505.		
P510	Used on W505.		
P511	Used on W508.		
P512	Used on W508.		
P513	CONNECTOR, plug: female; locking type; polarized; 3 contacts, 20 amps (loose item, for J501.)	J501 Mating	PL-134NG
P514	Used on W510.		

**CABINET/FRAME ASSEMBLY MODEL CAB-7
(SYMBOL SERIES 500)**

REF SYMBOL	DESCRIPTION	FUNCTION	TMC PART NO.
P515	Used on W510.		
P516	CONNECTOR, plug: coaxial; UHF type; one contact, 500 vdc peak, mica insulation (loose item, for J506.)	J506 Mating	PL-259A
P517	CONNECTOR, plug: coaxial; HN type; 50 ohms, 5000 volts peak (loose item, for J505.)	J505 Mating	UG-59B/U
P518	Same as P516.	J508 Mating	
P519	Same as P516.	J509 Mating	
S501	SWITCH, interlock: push pull; SPDT, normally open, 15 amps; at 120/250 VAC; .2 amps (resistive) at 250 VDC.	Safety Switch	SW-230
S502	Same as S501.	Safety Switch	
S503	Same as S501.	Safety Switch	
S504	Same as S501.	Safety Switch	
T501	TRANSFORMER, power: step up; primary - 115/230 vac, 50/60 cps, single phase; secondary - to deliver 2800 v at 680 ma into load of 4120 ohms. Hermetically sealed rectangular steel case. Four 1/4-20 thd. mtg. inserts on 6 inch x 6 inch mtg. centers.	Power	Tf-193
W501	CABLE ASSEMBLY, power: 98 inch long o/a. Consists of 22 conductors, insulated sleeving: P503 (MS3106B-28-11P) on one end; P504 (MS3106B-28-11S) on other end; 2 each cable clamps.	Power Supply to RTF	CA-408
W502	CABLE ASSEMBLY, main: P501 and P502 on one end; terminal lugs on other end.	Interconnect CAB-7, RTP-2 and RTS-2, RTX-2 or RTM-2	CA-402
W503	CABLE ASSEMBLY, high voltage: 11 feet long o/a. Consists of single conductor, P505 (MS3108B-18-16P) on one end, P506 (MS3106B-18-16S) on other end. 2 each MS-3057-10 cable clamp.	High Voltage Cable	CA-417-1
W504	CABLE ASSEMBLY, R. F.: 90 inches long o/a. Consists of RG-59/U conductor; P507 (PL-259A-mica) on one end, P508 (UG-260/U) on other end; both plugs color coded red.	RF Cable	CA-288-1
W505	CABLE ASSEMBLY, R. F.: 90 inches long o/a. Consists of RG-59/U conductor; P509 (PL-259A-mica) on one end, P510 (UG-260/U) on other end; both plugs color coded blue.	RF Cable	CA-288-2

**CABINET/FRAME ASSEMBLY MODEL CAB-7
(SYMBOL SERIES 500)**

REF SYMBOL	DESCRIPTION	FUNCTION	TMC PART NO.
W508	CABLE ASSEMBLY, high voltage; 4 ft. 6 in. long o/a. Consists of single conductor, P511 (MS3108B-18-16S) on one end, P512 (MS3106B-18-16P) on other end. 2 each MS-3057-10 cable clamp.	High Voltage Cable	CA-417-2
W509	CABLE ASSEMBLY, high voltage; 7 inches long o/a. Consists of single conductor, J503 (MS3102A-18-16P) on one end, J504 (MS3102A-18-16S) on other end.	High Voltage Bypass Cable	CA-295
W510	CABLE ASSEMBLY, power: 6 ft. long o/a. Consists of double conductor, P514 female plug on one end, P515 two prong male plug on other end.	Power Cable	CA-103-72

PANEL CHASSIS ASSEMBLY MODEL RTS-2
(SYMBOL SERIES 400)

REF SYMBOL	DESCRIPTION	FUNCTION	TMC PART NO.
C401	CAPACITOR, fixed: dry electrolytic; polarized, 80 mf. 450 wvdc.	Filter Cap., V401	CE51F800R
C402	Same as C401.	Filter Cap., V401	
C403 A & B	CAPACITOR, fixed: dry electrolytic; polarized, 20 mf, 450 wvdc.	Filter Cap., V401	CE52E200R
C404 A & B	CAPACITOR, fixed: ceramic; disc type; two section; .01 mf, 500 wvdc each section.	Line Bypass Cap.	CC-100-23
F401	FUSE, cartridge: 2 amps.	Oven Fuse; 115 V operation	FU-102-2
F401	FUSE, cartridge: 1 amp.	Oven Fuse; 230 V operation	FU-102-1
F403	FUSE, cartridge: 1/4 amp.	B+ Fuse	FU-102-.250
F402	FUSE, cartridge: 3 amps.	Main Pwr. Fuse; 115 V operation	FU-102-3
F402	FUSE, cartridge: 1.5 amps.	Main Pwr. Fuse; 230 V operation	FU-102-1.5
I401	LAMP, incandescent: 6-8v; 150 ma; T-3-1/4 clear bulb; bayonet base.	Main Pwr. Ind.	BI-101-47
J1	CONNECTOR, jack series UHF. mica dielectric. Part of W403 and W404.	RF Input	SO-239A
J2	Same as J1.	RF Output	
J3	CONNECTOR, receptacle: AN pin type: 4 contacts rated at 35 amps, 18 contacts rated at 20 amps, 200 VDC, 150 VAC (RMS); mtg. dim. 1.782" dia. cutout with four 9/64" dia. holes on 1-9/16" mtg. centers.	Power Input	MS3102A-28-11P (p/o CA455)
J5	CONNECTOR, receptacle: AN socket type; 7 contacts rated at 20 amps, 200 VDC, 150 VAC (rms); mtg. dim. 1-1/32" mtg. centers.	For 12 volt Power Supply if used.	MS3102A-16S-1S
J401	CONNECTOR, receptacle: male; two contacts; 10 amps at 250 v., 15 amps at 125 v., twist lock type.	AC Input	JJ-100
J402	CONNECTOR, receptacle: female; AN pin type.	Power Inter-connect	MS3102A-20-27S (P/O CA344)
L401	REACTOR filter: 10 henries; DC resistance approx. 85 ohms, 200 ma DC, insulated for 1500 v., in a/w MIL-T-27 GR., 1 CL A. FAM. 04.	Filter Choke V401	TF-144
L402	Same as L401.	Filter Choke V401	

PANEL CHASSIS ASSEMBLY MODEL RTS-2
(SYMBOL SERIES 400)

REF SYMBOL	DESCRIPTION	FUNCTION	TMC PART NO.
R401	RESISTOR, fixed: composition; 15,000 ohms, $\pm 10\%$; 2 watts.	Voltage Dropping V402	RC42GF153K
R402	RESISTOR, fixed: wire wound; 7500 ohms, $\pm 5\%$; 10 watts.	Voltage Dropping V402	RC32GF33K
R403	RESISTOR, fixed: wire wound; 1,000 ohms, $\pm 5\%$; 10 watts.	Voltage Dropping	RW-109-24
R404	RESISTOR, fixed: wire wound; 15,000 ohms, $\pm 5\%$; 10 watts.	Bleeder Res.	RW-109-36
R405	RESISTOR, fixed: composition; 100,000 ohms, $\pm 10\%$; 1 watt.	Bleeder Res.	RC32GF104K
T401	TRANSFORMER, power; 115/230 VAC, 50/60 cycles; term 12 & 16 500 VDC, 13 & 15 270 VDC term 14 CT; at 200 ma; term. 10 & 11 5.0 VAC at 2 amps; 8 & 9 6.3 VAC at 1.2 amps; 5 & 7 6.3 VAC at 3 amps; CT insulated for 3000 volts in accordance with MIL-T-27 GR. 1 CL. A FAM. 03.	Power Xfmr.	TF-161
T402	TRANSFORMER, power: step-down primary 110 or 220 v, 50 to 60 cps; secondary 6.3 v at 4.125 A center tapped.	Fil. Xfmr.	TF-104
V401	TUBE, electron: duo diode: rectifier.	Rectifier	5R4
V402	TUBE, electron, voltage regulator, 7 pin miniature; operating at 150 VDC.	Voltage Regulator	OA2
XF401	FUSEHOLDER: extractor post type: 250 V. 15 amp.	Fuse Holder F401	FH-100-1
XF402	Same as XF401.	Fuse Holder F402	
XF403	Same as XF401.	Fuse Holder F403	
XC401	SOCKET, electron tube: octal.	Socket. C401	TS-101-P01
XC402	Same as XC401.	Socket. C402	
XC403	Same as XC401.	Socket. C403	
XI401	SOCKET, lens, miniature bayonet, red indicator lens.	Socket. I401	TS-106-1
XV401	Same as XC401.	Socket. V401	
XV402	SOCKET, electron tube: 7 pin miniature.	Socket. V402	TS-102-P01
W401	CABLE ASSY. power: consists of 13 conductors, MS3106B-20-27P on one end, MS3108B-20-27S on other end, 3 feet long cable clamp to cable clamp.	Power Cable	CA-471-3