

ГЛАВНОЕ УПРАВЛЕНИЕ ГРАЖДАНСКОГО ВОЗДУШНОГО ФЛОТА
ПРИ СОВЕТЕ МИНИСТРОВ СССР

— 24515 —

Техническое описание
и инструкция по эксплуатации
радиоприемника РПС

АТБ МОАГ
ТЭМ
БЛАГОУСТРОИТЕЛЬСКИЙ ЦЕНТР
М. М.



РЕДАКЦИОННО-ИЗДАТЕЛЬСКИЙ ОТДЕЛ АЭРОФЛОТА
МОСКВА 1962

ATTENTION!

With the purpose of increasing the strength of the Calibration signal on the lower part of a range, in 1959 the scheme of the quartz Calibrator has been changed. However, it has led to increase in harmonic output. Undesirable harmonics and to display of one of them in area around 3 MHz. For exception of an opportunity of Calibration of a scale on 3 MHz on a false signal, Calibration should be performed if the aerial's input is out-of-tune at the connector input of the aerial.

RPS Receiver

CHAPTER I

PURPOSE and SPECIFICATION of RADIO RECEIVER RPS

1. Purpose

Radio receiver RPS is intended for reception of not fading and voice-frequency radiotelegraphic signals and the modulated radio telephone signals by planes and transport aircraft. It can be used also and for ground installations of communication. The radio receiver can work as a complete system with the transmitter R-807 and intercommunication unit over the total range of frequencies:

2. Structure of the radio reception device Into the complete set of the receiver (see fig. 1) enter:

- 1) The Receiver with an shock-absorbing frame.
- 2) Rectifier-chassis "In " with an shock mount frame frame.
- 3) Converter MA-100M with a shock-absorbing frame.
- 4) The Complete set of cables. The full complete set on the receiver is specified in the specifications of the receiver.

3. Weight and overall dimensions of chassis of the radio reception device. The weight of chassis is specified without connecting cables and spare parts.

Characteristics of the receiver

The full complete set on the receiver is specified in the specifications of the receiver.

3. Weight and overall dimensions of chassis of the radio reception device. The weight of chassis is specified without connecting cables and spare kit.

Chassis	Length, mm	Width, mm	Height, mm	Weight, kg
Receiver	508	327	303	26.5
Rectifier – Chassis 'B'	195	120	118	26.5
Converter MA-100M	245	166	245	7.1

The radio receiver has a range of frequencies:

Long-wave 143 — 600 kHz (2100 — 500);

Short-wave 2—24 MHz (150 12.5).

The receiver's frequency range is broken into 7 subranges:

Subrange 1 143–280 kHz;

Subrange 2 280–600 kHz;

Subrange 3 2–4 MHz;

Subrange 4 4–7 MHz;

Subrange 5 7–12 MHz;

Subrange 6 12–18 MHz;
Subrange 7 18–24 MHz.

Graduation of frequencies is printed directly on the frequency scale of the receiver. The accuracy of graduation on long-wave (sub-range) 0,6 %, on short-wave-0,3 % are not worse.

The receiver receives power from a system of an alternating current with a voltage of 115V and frequency of 400 Hz. Power consumption will not exceed 70 Watts. The sensitivity of the receiver at an output voltage of 15V and at a noise of no more than 5V should be:

a) in the long-wave range:

In the telephone mode — is not worse 10 KHz, in a cable mode-not is worse 4 KHz

b) On a short-wave range:

in the telephone mode - not worse than 4 μV (microvolt), in the telegraphic mode - not worse than 1,5 μV .

In the receiver the fine adjustment of the input circuit (antenna adjust) is provided. The protection of the input, the protection of the feed circuits and SPU=Intercom from the interferences of the ultrahigh frequency (RF): manual and automatic sensitivity control (MANUAL VOLUME CONTROL and AUTOMATIC VOLUME CONTROL); manual volume control, the tone correction of telegraphic signals and quartz filter with the adjustable strip. Manual sensitivity control is achieved with switch on MANUAL VOLUME CONTROL, and manual volume control is produced with the change of toggle switch to the position AUTOMATIC VOLUME CONTROL. The passband of the receiver in the intermediate frequency can be constant or be regulated depending on that, is included or it is switched off quartz filter. With the turned-off quartz filter the passband of the receiver is constant and must be wider than 5 kHz at cut off by a factor of 2, and narrower than 13.5 KHz at cut off by a factor of 100, but with the switch on quartz filter - it can smoothly vary from "narrow" to "wide". With the switch on quartz filter and the position of regulator "strip" in the end left position the passband with the cut off 2 times must be not be narrower than 3 kHz, with the cut off 100 times - not wider than 11 kHz the passband with the cut off 2 times with the switch on quartz filter is regulated in the limits from 0,5 kHz to 3 kHz by knob "strip". "quartz-free" strip is used with the reception of telephone signals, while "quartz" - with the reception of telegraphic and telephone signals under the conditions of large interferences. In the receiver the checking of the anode currents of tubes and high voltage is provided. The receiver is designed to work with two pairs of high-resistance Headphones. Furthermore, it is possible to have the receiver connected through the aircraft intercom equipment and form a complete set with the transmitter. For this, the power supply cable has connections to the Intercom unit and to the receiver's switching relay.

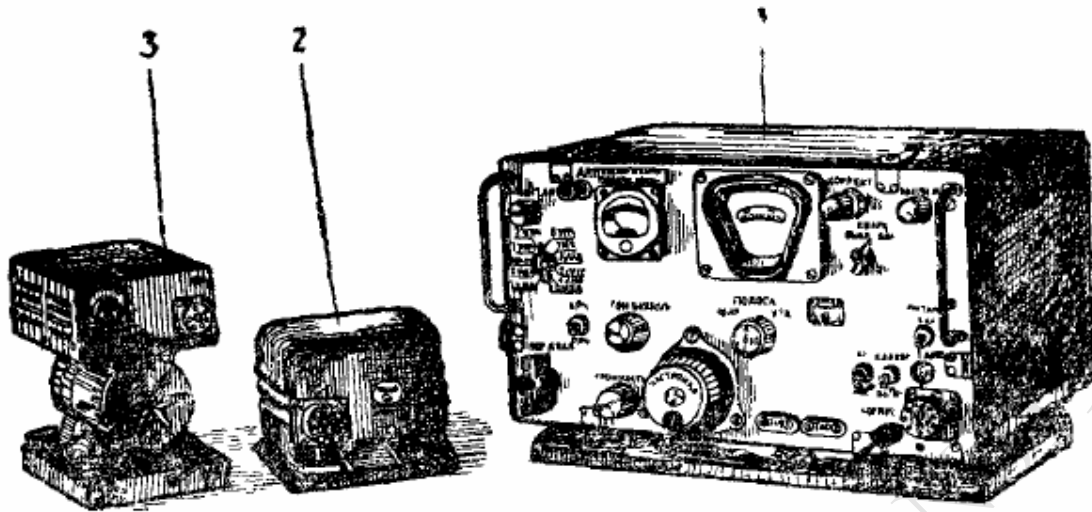

Fig. 1 Common form of radio receiver RPS: 1 receiver; 2 - rectifier; 3 - converter MA -100M.

CHAPTER IS THE II THE SCHEMATIC OF THE RADIO RECEIVER

The receiver is assembled according to the superheterodyne circuit with 11 indirect heating tubes (see Fig. 3) with it has the following cascades to the types of the tubes:

№ п/п.	Назначение каскада	Тип ламп и № по схеме
1	1-й усилитель высокой частоты	Пентод в. ч. типа 6К4 (J_2)
2	2-й усилитель высокой частоты	Пентод в. ч. типа 6К4 (J_3)
3	Смеситель	Пентагрид типа 6А7 (J_4)
4	1-й гетеродин	Пентод в. ч. типа 6Ж1П (J_6)
5	1-й усилитель промежуточной частоты	Пентод в. ч. типа 6К4 (J_7)
6	2-й усилитель промежуточной частоты	Пентод в. ч. типа 6К4 (J_8)
7	3-й усилитель промежуточной частоты	Пентод в. ч. типа 6К4 (J_9)
8	Детектор сигнала и детектор АРЧ	Двойной диод типа 6Х6С (J_{10})
9	2-й гетеродин	Пентагрид типа 6А7 (J_{10})
10	Кварцевый калибратор и предварительный каскад усилителя низкой частоты	Двойной триод типа 6Н8С (J_{12})
11	Выходной каскад усилителя низкой частоты	Выходной тетрод типа 6П6С (J_{11})

The fundamental receiver circuit is given in appendix 8. The description of the network elements in the text are given only for the first sub-band.

§ 1. The input device of radio receiver

The input device (antenna circuit) of receiver is designed to select the proper signal out of all input signals and pre-amplify it before the signal is applied to the grid of the first Tube of high-frequency amplifier. The input device (see Fig. 2) is executed according to asymmetrical diagram and is designed for the start of the antennas, which have equivalent capacities from 70 to 200 micromicrofarad (μF). For compensating the detuning, which appears with the connection to the

receiver of the antenna, along with the variability of other parameters, and also with the possibility of changing of the receiver to another frequency in parallel to adjustable capacitor of the input circuit C27 is connected the trimmer capacitor C30, whose axis is brought out to the front panel to the knob" tuning of ant."

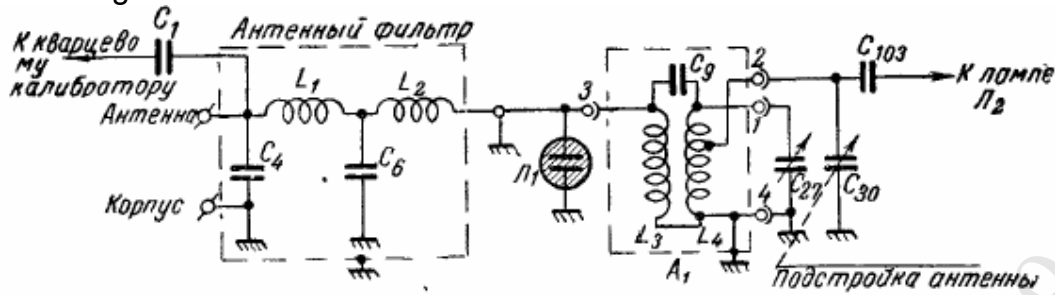

For the protection of the input circuit from the high voltages of radio frequency is used a neon discharger of the type MN-3 (Л1=Electronic Tube 1), included in parallel to the antenna coil L3. At 50 – 60 V, the discharger short circuits the receiver's input. The protection from the pulse interferences of ultrahigh frequencies is achieved with the aid of the antenna filter, which consists of 2 inductance coils L1 and L2 and 2 capacitors C4 and C6. The schematic of antenna filter taking into account the equivalent resistance of antenna and input resistance of receiver is usual three-link L-shaped filter. Antenna chain on 1, 2 and 3 sub-bands is connected with the input circuit with the aid of the reactance-capacity coupling, and on 4, 5, 6 and 7 sub-bands - are inductive (see appendix 7). Input circuit, as two subsequent circuits of high-frequency amplifier, consists of adjustable capacitor C27, to which can be connected 7 different inductance coils, depending on the working sub-band. Trimmer capacitors are connected in parallel to the coils to equalize the starting capacity of circuits. In circuits 4, 5, 6 and 7 sub-bands in series with adjustable capacitor are connected the capacitors of a constant capacity, which decrease the overlap. Adjustment of tuned circuit is achieved by a change in the inductance of coils with the aid of the carbonyl cores and by capacitors of semi-variable capacity. The stress of the input circuit through the isolating capacitor Of sy0e enters the grid of the tube of the 1st high-frequency amplifier. Switching inductance coils on the sub-bands is produced with the aid of drum type switch.

§ 2. High-frequency amplifier

The high-frequency amplifier (see Fig. 4) works on 2 6K4 electronic tubes (Л2 and Л3). The voltage of the signal through the capacitor C103 is fed from the input circuit (antenna circuits) to the control grid of the electronic tube. From the anode of the electronic tube of this cascade to the earth is included a series circuit, which consists of inductance L17 and capacity C36 tuned to the intermediate frequency of receiver. The function of this circuit is to decrease the interference level, which has a frequency, equal to the intermediate frequency. In the first cascade of high-frequency amplifier adapts the auto- transformer coupling of plate circuit (L18) with the anode of the tube in the second cascade - transformer (L46, L47), moreover in parallel to coupling coil is connected "extending" capacitor C134, which reduces the natural frequency of the anode circuit of the second amplifier stage. Alternation it is specific for connection in combination with the application of the "extending" capacitor it makes possible to obtain flat gain in the limits of sub-band. Both cascades are controlled by a system of automatic and manual sensitivity controls (see Chapter II, § 8). 'voltage on the anodes of tubes will be supplied through resistances of R1 and R28, bypassed by

the capacitors C68, C71, C163 and C164. Resistances R18 and R25 are shunts to the instrument, which measures the anode currents of tubes. A voltage drop across these resistances proportional to the anode currents of tubes is checked by the magnetic- electrical instrument, located on the front panel of receiver. Screen-grid voltage is removed from the voltage dividers, which consist of resistances of R14, R14a and R24, R24a. Capacitors C33 and C121 are decoupling capacities. Bias voltage is ensured by resistances in cathode R12 and R21 bypassed by capacitors C32, C32a and C113. There are decoupling resistors R11 and R20 as well as capacitors C28 and C70 in the circuit of control grids.

§ 3. Mixer

The mixer circuit (see Fig. 5) works on the tube 6A7 (Л4). In the mixer's circuit is used a double-grid conversion of frequency (on the first and on the third grids). To the first grid of mixer will be supplied voltage from the heterodyne, on third grid - the voltage of the incoming signal, amplified by high-frequency amplifiers. Second and fourth grids are screens, and the fifth grid is an anti-dynatron one. The anode current of tube changes under the action of the voltage of heterodyne and voltage of signal, in consequence of which it contains both the fundamental frequencies and frequencies, equal to sum and a difference in the frequencies of the heterodyne and signal. The frequency of heterodyne is selected so that the difference between the frequency of heterodyne and the signal frequency is always equal to 730 kHz.

$$f_{\text{гет.}} - f_{\text{сигн.}} = 730 \text{ кГц.}$$

To the anode circuit of frequency-mixer tube are connected filters of intermediate frequency, tuned to a frequency 730 kHz, which separates this difference frequency, called intermediate. The tube of mixer has the automatic displacement, obtained due to a voltage drop across the cathodic resistance of R33, bypassed by the capacitor C168. The mixer is not controlled by the system of automatic and manual sensitivity control, which ensures stability of its performance and stability of the frequency of the first heterodyne.

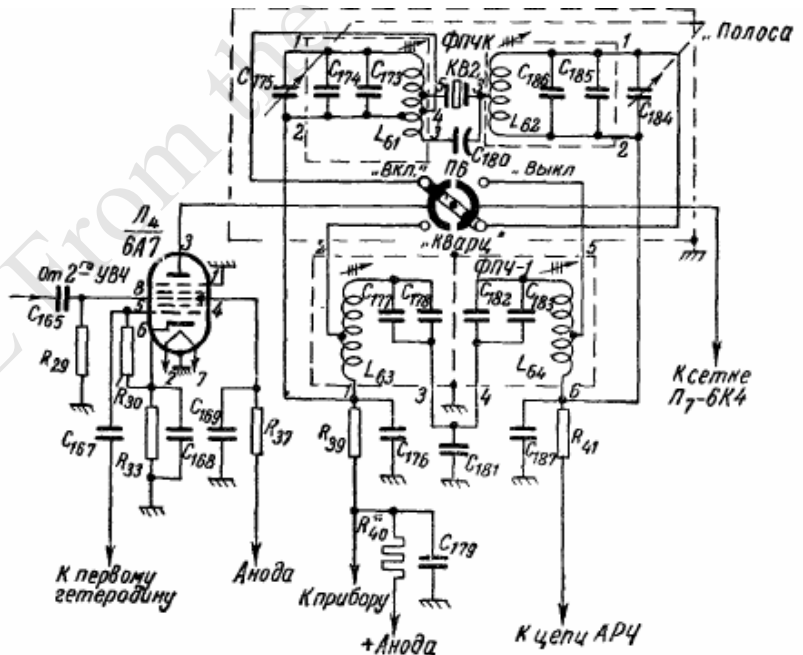

The screen grid of tube feeds by stabilized voltage through the dissipating resistance of R37, bypassed by the capacitor C169. Resistance R30 is a decoupling resistor of the heterodyne grid of mixer, resistance R29 - the decoupling resistor of the signal grid of mixer. In the anode circuit of mixer there are R39 is a decoupling resistance and C176 is a bypass capacitor. Furthermore, in the anode circuit is a resistance R40, which is the shunt of the instrument, which measures the anode current of tube. The connection of mixer with the high-frequency amplifier is achieved through capacitor C165. The mixer is connected to the first heterodyne by the capacitor of C167.

§ 4. The first heterodyne

The first heterodyne (see Fig. 6) is assembled on the tube 6Ж1П (Л6) according to the diagram of inductive three-point with the grounded anode plate. Tube is included as the triode (screen grid and the anode in the high frequency (RF) they are connected together through bypass capacitors). The circuit of the heterodyne is comprised of adjustable capacitor C114 and one of 7 inductance coils, alternately connected to it with the aid of drum type switch. In parallel to coils are connected semi-variable trimmer capacitors, and also ceramic capacitors of a constant capacity with the negative temperature capacitance coefficient (TKE). These capacitors are used for temperature compensation and stability of the heterodyne circuit, since inductance coil has a positive Temperature Inductance Coefficient (TIC), the inductance increasing with the temperature. If we parallel this coil with a capacitor with negative TKE (its capacity will decrease with the increase temperature), then by correct selection of TKE, TIC, C and L it is possible to ensure that the frequency of tuning circuit would not change with a change in the temperature, since the frequency of tuning circuit is defined by the product of LC. The frequency of tuning of heterodyne, as noted earlier, is higher than frequency of received signal by the value of intermediate frequency. For joining tuning the circuit of the first heterodyne with tuning of the circuit of high-frequency amplifier in series with adjustable capacitor C114 is connected "truncating" capacitor C81. High frequency (RF) stability of the first heterodyne with the change of ambient temperature is achieved:

1. by application of inductance coils with the ceramic body and the coil, substituted to the ceramics by the method of the brazing of silver and by the subsequent copper plating (on the short-wave sub-bands).
2. by application of brass cores for changing the inductance of heterodyne coils.
3. heterodyne section of adjustable capacitor is prepared from the special alloy (Invar), which possesses the low temperature coefficient of linear expansion.
4. anode and screen grid of the 1st heterodyne feed by stabilized voltage from the neon stabilizer of the type CF-4C (SG -4S) (Л5).



Рис 6 Первый гетеродин

Voltage on the anode of the 1st heterodyne will be supplied through resistance of R38, bypassed by capacitor C172; the voltage on the screen grid is taken from the divider of resistances R34 and R35, bypassed by capacitor C170. The displacement on the control grid automatic due to the grid current of tube, which creates a voltage drop across the resistance of grid leak R28. capacitor C125 connects the control grid of the 1st heterodyne with the circuit. The voltage of the 1st heterodyne is transferred to the mixer from the cathode of tube.

§ 5. IF amplifier

The IF amplifier (see Fig. 7) has three amplifier stages using three 6K4 tubes (Л7, Л8 and Л9). All stages are executed with the automatic displacement, which is accomplished by the start in the cathodic chains of the tubes of resistances R42, R48 and R58 bypassed by the capacitors C188, C198 and C210. In the anode circuits after the decoupling resistances of R45, R50 and R54 and decoupling capacitors of C189, C202, C212 are included resistances R46, R51, R55, bypassed by capacitors C191, C203, C204. these resistances are the shunts of instrument with the measurement of the anode current of tube. Voltage on the screen grids of the tubes of the 1st and 2nd IF amplifiers will be supplied from the dividers, comprised of resistances of R43, R46 and R49, R49a, to the screen grid the tubes of the 3rd amplifier - through resistance of R53. The resistances in the screen grids are bypassed by capacitors C190, C201 and C213.

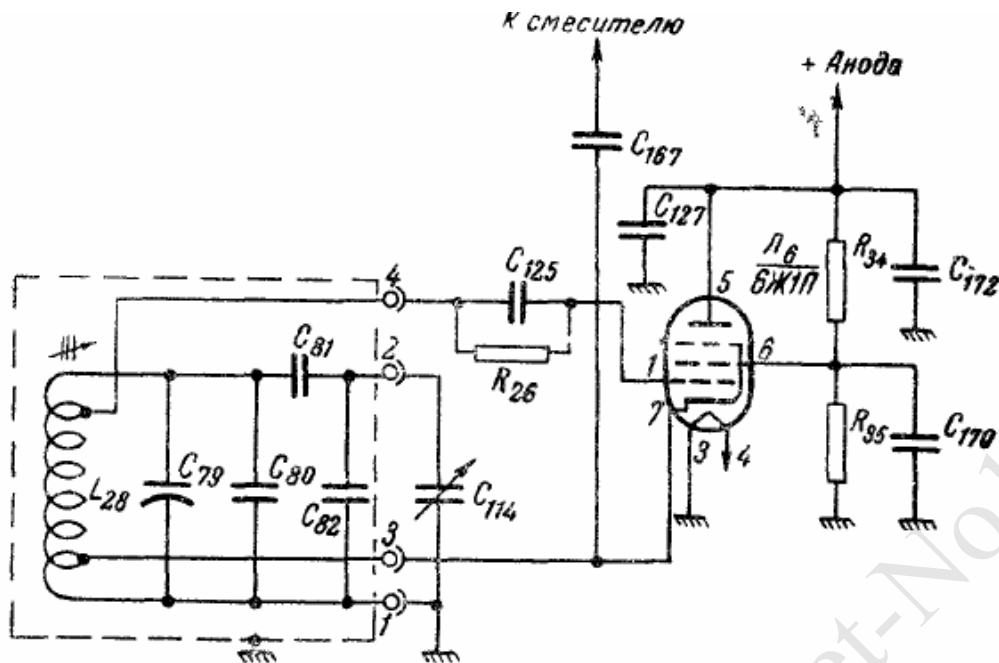
IF amplifier has three identical filters with an intra-capacitance coupling (C194, C206 and C217) between the circuits and one quartz filter. The tubes are connected to the part of the circuit of filter, the influence of tube on tuning of circuit and on its quality decreases thanks to which. At the entrance of the 1st IF amplifier, i.e. between the anode of the tube of mixer and the control grid of the tube of the 1st IF amplifier, via the commutation of switch "quartz" can be included either usual band-pass filter with an intra-capacitance coupling between the circuits, or quartz filter with the continuously adjustable passband.

§ 6. Quartz filter

for the purpose of obtaining high adjacent-channel selectivity and possibility of changing the passband between the mixer and the 1st IF amplifier is included the quartz filter (see Fig. 8). It provides obtaining the adjustable narrow strip, thanks to which noise signals are reduced and the signal to noise ratio is improved.

The Quartz filter consists of two circuits tuned for the intermediate frequency (I – L61, C175, C174 and C173 and II – L62, C184, C185 and C186), connected with the quartz plate KV -2, which is in the schematic of filter coupling element. Quartz plate with the defined parameters behaves as the circuit, which consists of series-connected capacity, resistance and the inductance, in parallel which connected the capacity of crystal holder.

At the frequency, which depends on the parameters of quartz, an in-series resonance occurs at which the resistance of the chain will be minimal, therefore maximum voltage will be transferred from the first circuit to the second one. The capacitance of chain sharply grows at the frequency lower than resonance, and higher than resonance - inductive reactance of chain. At the frequency higher than resonance appears the parallel resonance of chain, formed by the inductance of quartz, with the capacities of quartz and by crystal holders and with the resistance of quartz. The resistance of chain will be maximum at this frequency, i.e. chain will behave as wave trap and the transfer of voltage from the 1st circuit to the 2nd circuit will be minimal. The resonance characteristic of this chain will be very sharp, which makes it possible to obtain narrow passband. With the acceptor resonance the equivalent diagram of quartz presents series circuit. The oscillatory circuits of quartz filter prove to be connected to the chain of the equivalent



Рис. 8. Кварцевый фильтр.

the series circuit of quartz, and if these circuits are adjusted into the resonance with the equivalent series circuit of quartz, then their resistance will prove to be greatest, in consequence of which damping the equivalent series circuit of quartz will be greatest and the strip of comparatively wide. The staggering of filter decreases their resistance, in consequence of which damping the equivalent

series circuit of quartz decreases and passband becomes already. For obtaining the best symmetry in the narrow strip the circuits of filter are disturbed to the different sides. The detuning of these circuits is produced by the knob, brought out to the front panel with the inscription "bandwidth, wide-narrow".

The capacitance of crystal holder and circuit wiring is a detriment, distorting symmetry resonance characteristic of filter; therefore it is neutralized by the trimmer C180, connected to the additional winding of the 1st circuit. With the equality of capacities and the equality of the voltages of the intermediate frequency between the points 2–5 and 2–3 (see Fig. 8) of the 1st circuit the voltage between the points 2–3 of the 2nd circuit will be equal to zero, since the voltage between the points 2–5 and 2–3 of the 1st circuits are phase-shifted by 180° relative to each other.

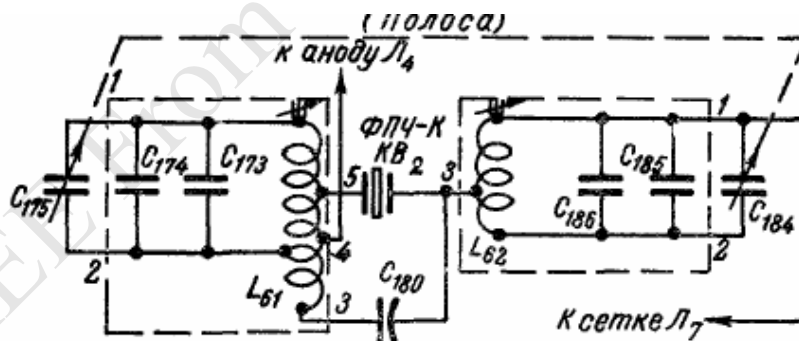
§ 7. Detector

As the detector of the signal (see Fig. 9) is used one of the diodes of a tube of the type 6X6C (Л10). The load of detector is the potentiometer, which consists of resistances of R56 and R57. In the regime AUTOMATIC VOLUME CONTROL the voltage of low frequency (audio), removed from the detector through the transitional capacity of C220, brings to variable resistor of R1, from which it enters the grid of the preliminary stage of audio frequency amplifier 'N8S (Ly2). Changing the value of this resistance, we change the value of sonic voltage, i.e. volume control is achieved.



Рис. 9. Детектор сигнала и детектор АРС.

As has already been indicated, the receiver has automatic (AUTOMATIC VOLUME CONTROL) and manual (MANUAL VOLUME CONTROL) sensitivity controls. Passage with AUTOMATIC VOLUME CONTROL to MANUAL VOLUME CONTROL and is back produced by toggle switch "AUTOMATIC VOLUME CONTROL- MANUAL VOLUME CONTROL", located on the front panel of receiver

§ 8. Automatic and manual sensitivity control

As the detector AUTOMATIC VOLUME CONTROL (see Fig. 10) is used the second diode of a tube of the type 6X6C (Л10). The voltage of intermediate frequency will be given to the anode of this diode from the plate circuit of the 3rd IF amplifier through the coupling capacitor C211. with the load of detector AUTOMATIC VOLUME CONTROL it appears resistance R59 the regulated stress AUTOMATIC VOLUME CONTROL is fed to on the grids of the cascades of high-frequency amplifier through filter R61 and C223 and the filters in the circuits of the grids C28, R11 and C70, R20, and to the grids of the 1st and 2nd cascades of IF amplifier through the filters in the chains

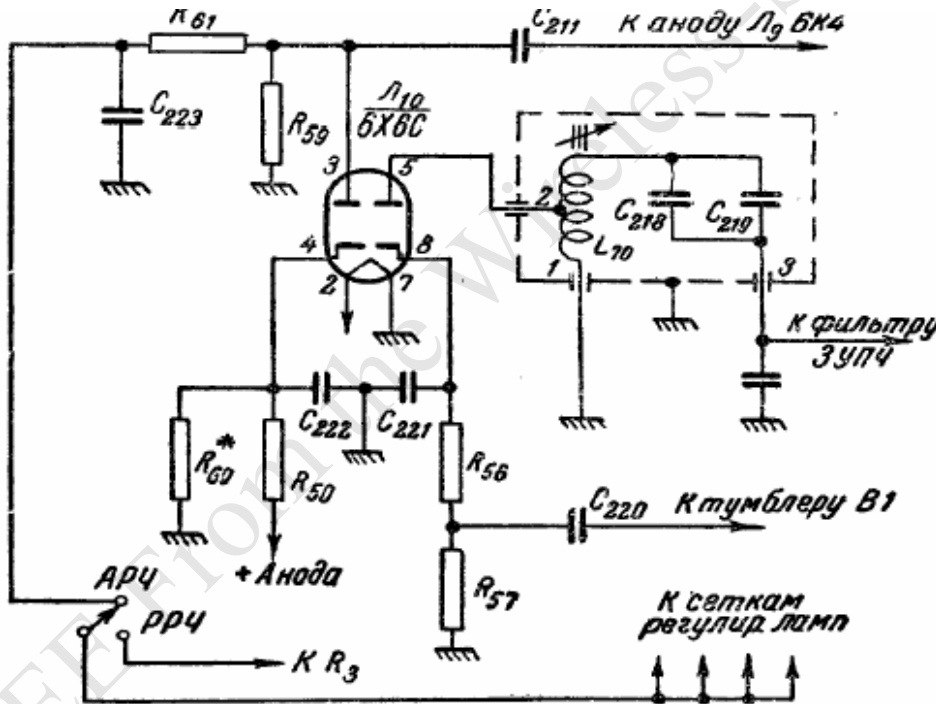

Рис. 10. Автоматическая и ручная регулировка чувствительности.

2. Зак. РИО 1939

grids of tubes R41, C187 and C47, C197. In the receiver the diagram of delayed AUTOMATIC VOLUME CONTROL is used. The voltage of delay on the cathode of diode is removed from the potentiometer, which consists of resistances of R58 and R60. the voltage of delay is selected such value, that with the installation of volume control in the position, which corresponds to maximum loudness, AUTOMATIC VOLUME CONTROL begins to work when the voltage of signal on the output exceeds 40 V with modulation 30% and frequency of modulation 1000 Hz. manual sensitivity control it is achieved by way on the dachas into the circuit of the grids of the adjustable tubes of negative stress. Negative stress by value 25 V is created on resistance of R44, ' locating in the rectifier. In parallel to it in the receiver stands potentiometer R3, from where voltage is removed and it will be given to the grids of tubes. Toggle switch "AUTOMATIC VOLUME CONTROL- MANUAL VOLUME CONTROL" in this case must be located in the position MANUAL VOLUME CONTROL. The potentiometer of manual volume control R1 and the potentiometer of sensitivity control R3 have the common axis, brought out to the front panel, and one knob "loudness".

§ 9. The second heterodyne

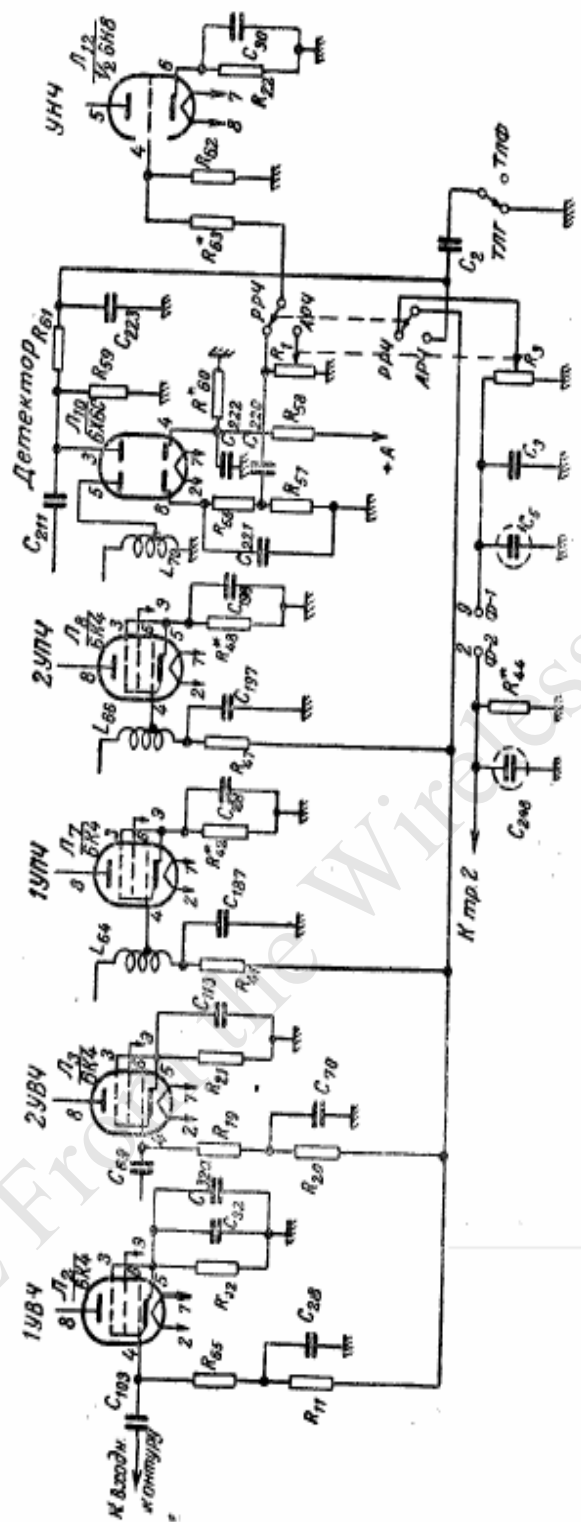
the second heterodyne (see Fig. 11) works on the tube of the type of 6A7 (Л13). The circuit of the second heterodyne is tuned to a frequency of 730 kHz this frequency can be smoothly changed to 2000 - 4000 Hz into both sides with the aid of trimmer capacitor C124, whose axis is brought out to the front panel to the knob "beat note".



Рис. 11. Второй гетеродин

For decreasing the intensity of harmonics the amplitude of the fluctuations of the second heterodyne is selected the smallest, and, furthermore, in the anode circuit is a U-shaped filter, which consists of two capacitors, C128 and C171 and damping resistance R32..

The second heterodyne is switched on and off by a toggle switch "TLF- TLG ": in the position OF "TLF" is turned off the anode voltage; in the position OF "TLG" is switched on the anode voltage and to the chain AUTOMATIC VOLUME CONTROL for an increase of the time constant of chain AUTOMATIC VOLUME CONTROL in the telegraphic regime is connected additional capacitor S2. Resistance R5 is the shunt of instrument for measuring the anode current of tube

§ 10. Quartz Calibrator

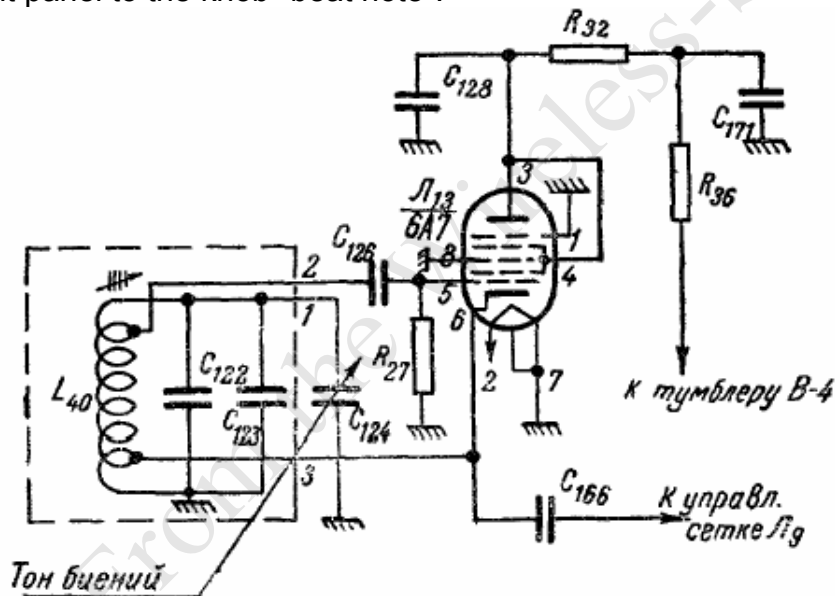
the quartz Calibrator (see Fig. 12) is assembled on one of the triodes of a tube of the type 6H8C (Л12). Quartz Calibrator is intended for the Calibration test of the scale of receiver on the short-wave sub-bands. The Calibrator is stabilized by quartz crystal KV -1 with a frequency of 1 MHz, which



Рис. 12. Кварцевый калибратор

is connected according to circuit diagram. The Quartz crystal is included between the anode and control grid. Through the capacitors C1 and C35 the signal from the quartz calibrator will be supplied to the input of the receiver. Calibration is produced with the 2nd heterodyne switch on, i.e. with the position of toggle switch "TLF- TLG" in the position of "TLG". In this case, the knob "beat note" (BFO) must stand by mark against the point on the front panel. Since the second heterodyne have a frequency of 730 kHz, with the dead spaces intermediate frequency must be 730 kHz when receiver is accurately receiving the incoming signal (in this case the signal from the calibrator). But since the quartz calibrator does not have a continuous frequency spectrum, but only the frequencies, equal to the integer of 1 megahertz (harmonic 1 MHz), then no signal will appear at tuning positions other than integers of 1 megahertz. These calibration points are noted on the scale of the receiver by circles. Since on the long-wave frequency band, signals of less than the 1st megahertz, Calibration accuracy on the 1st and 2nd sub-bands with the aid of the quartz calibrator in the receiver cannot be tested.

Constant capacitors C64, C72 and C175 and trim tab C37 are the elements of the feedback of generator. Resistance R4 is the shunt of the instrument, which measures the anode current of the tube of quartz calibrator. The start of quartz calibrator is produced by toggle switch "Calibrate.- or Off."

§ 11. Audio frequency amplifier

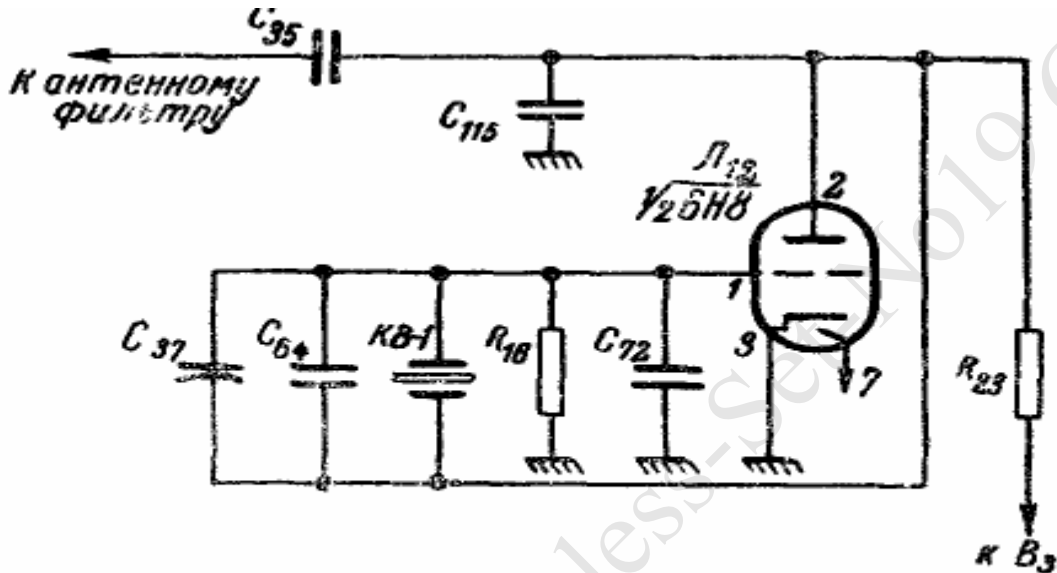
The audio frequency amplifier (see Fig. 13) has two cascades of amplification. In the first cascade of amplification (preliminary), uses one of the triodes of tube 6H8C (Л12). It is assembled according to amplifier circuit on the resistances with the automatic displacement.



Рис 13 Усилитель низкой частоты.

In the control grid, of the preliminary stage of the audio frequency amplifier, is a voltage divider, comprised of resistances of R62 and R63. A 6П6С (Л11) tube is used in the second, i.e. output stage of the low-frequency amplifier. The application of this tube makes it possible to obtain the necessary output voltage with the coefficient of nonlinear distortions of not more than 10%. For the matching of loads to the anode circuit of tube the output transformer tr, is connected; its secondary winding is connected to the connector OF "TLF", located on the front panel, where the connector for the high-resistance Headphones with direct-current resistance of 4400 ohms are included. The possibility for the connection of two pairs of Headphones are provided. The output of receiver is symmetrical. To start the aircraft intercom equipment (SPU), the output of receiver is brought to pins 5 and 7 on the power connector Ф-1. For the purpose of the decrease of nonlinear distortions, negative feedback is used in the cascade, which is achieved through R9. The decrease of nonlinear distortions it is achieved as follows: if in the amplifier nonlinear distortions appear, then from its output to the input through the feedback loop will be given not only the in phase signal at fundamental frequency (useful signal), but also all harmonics, which appear in this amplifier, and, since the feedback has negative sign, the phases of all harmonics, which enter from the feedback

loop to the input, will be such, that the output voltage of these harmonics will be subtracted. Consequently, due to the negative feedback, the voltage of all of the components at the output of amplifier, including all harmonics and interferences, which appear in the amplifier, will decrease. However, the voltage of the useful signal on the output can be brought to the previous level by an increase in this signal at the input proportional to the gain reduction of with the feedback. In this case, the relationship between useful and harmful voltage components on the output will be improved, i.e. nonlinear distortions will decrease with the retention of the constant amplitude of useful signal at the output.

§ 12. Receiver power supply

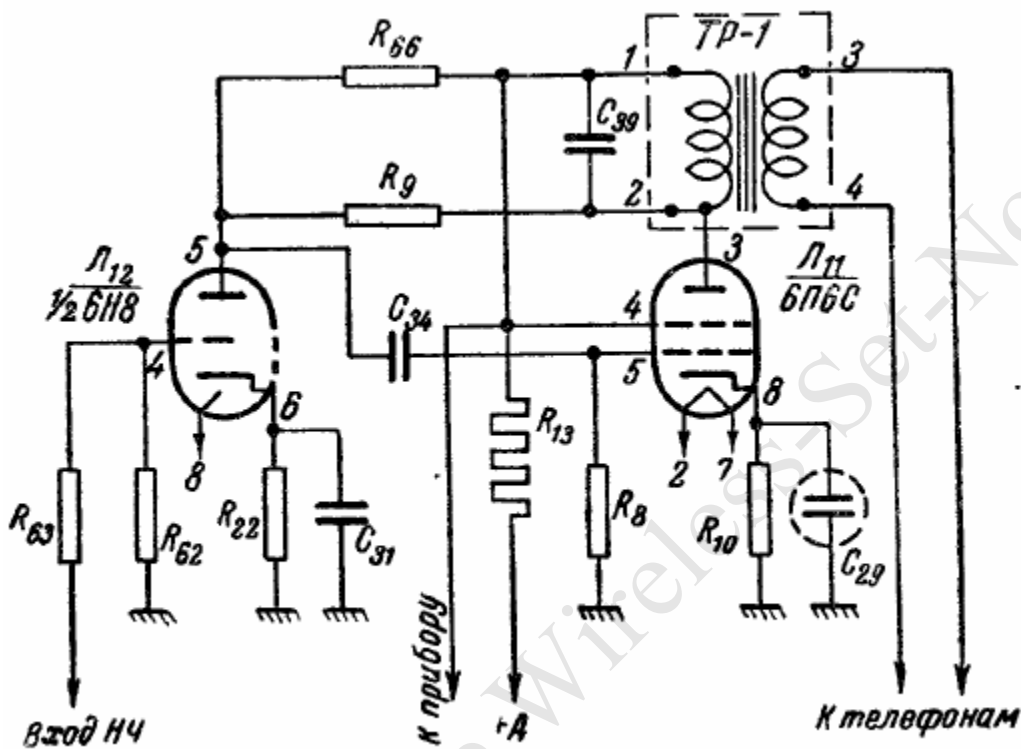
The receiver is powered from the network of alternating current with a voltage of 115 V and a frequency of 400 Hz. the conversion of this alternating 115V 400Hz power is done with using the full wave kenotron rectifier (see Fig.14) on the tube of the type 5Ц4С (Л14). The resultant DC high voltage is ripple filtered. The filter consists of capacitors C199, C200 also of choke L -1. bias voltage on the grids of tubes is taken from resistances of R44 and R44a, bypassed by capacitor C248. The filaments of the receiver tubes are powered from the special, 6.3V AC, winding of the power transformer. The 6.3V AC filament circuit for the tubes they are connected in parallel. The protection of the feed circuits and SPU from the high and ultrahigh frequency (RF) is provided. For this there are separate filters in the chains of low and high voltage. In the chain of low voltage the filter consists of the capacitors C67, C75, C118 and C131 and inductances L27, L37 and L43; in the chain of the high voltage - from the capacitors C65, C73, C116, C129, C66, C74, C117, C130 and inductances L25, L35, L41, L26, L36 and L42; in the chain SPU - capacitors C76, C119, C132, C77, C120, C133 and inductances L38, L44, L39 and L45. The main power input is protected by a 1 amp fuse located on the front panel.



Рис 11 Схема выпрямителя

CHAPTER III. CONSTRUCTION OF RADIO RECEIVER

The receiver is enclosed in movable case and it is structurally made from 4 main- chassis (see Fig. 15), completely interchanged in the production: the chassis of high frequency (RF) - OF "HF", the chassis intermediate frequency - "PCH", the chassis of low frequency (audio) - "LF" and front panel unit of the chassis bear all mechanical and electrical components, and also electrical installation of receiver. Electrically the individual chassis themselves are connected with the aid of junction boxes, which ensure the easy separation of each of the units of the receiver. The mechanical connection of each chassis with captive screws ensures the rapid dismantling of the receiver unit-by-unit. The outer case of the receiver is made from sheet aluminum. The receiver is attached in the case by six locks, which clip onto latches attached to the front panel. From below the case are fastened two bases with two rubber vibration dampeners. The receiver with the jacket is fixed on the frame of receiver with hinged fasteners to the frame.

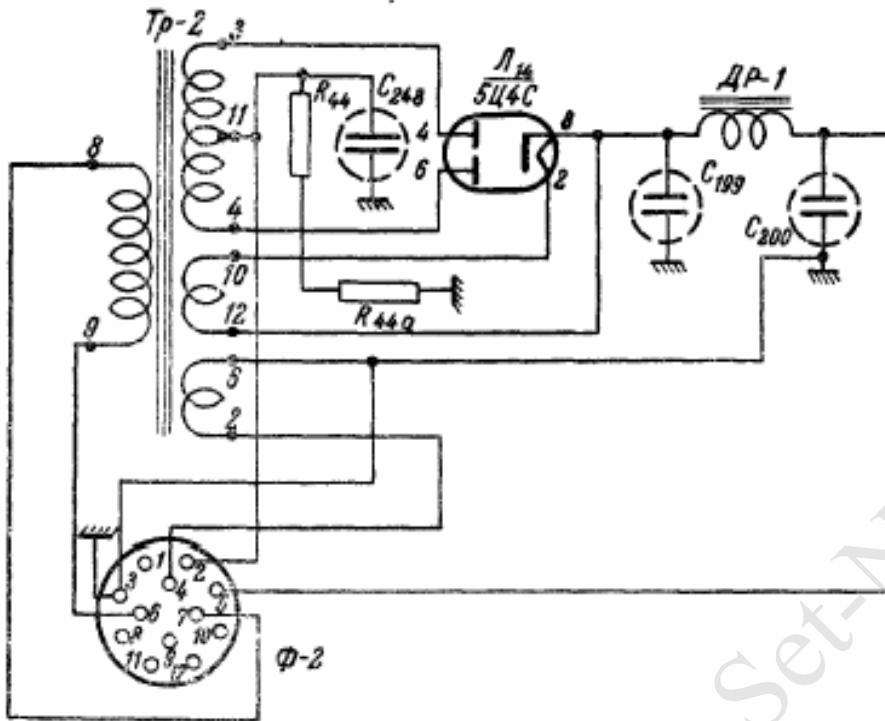

Рис. 15 Вид радиоприемника без кожуха.
 1—передняя панель; 2—блок В. Ч; 3—блок П. Ч; 4—блок Н. Ч;
 5—лампа L_{11} ; 6—лампа L_{12} ; 7—лампа L_{13} ; 8—лампа L_6 ; 9—лампа
 L_7 ; 10—фильтр промежуточной частоты, 11—лампа L_8 ; 12—тяга под-
 стройки антенны; 13—барабанный переключатель; 14—блок конден-
 саторов переменной емкости; 15—лампа L_{16} ; 16—контур 2-го гете-
 родина

§ 1. Front panel

The front panel (see Fig. 16) is made from sheet aluminum and serves for the installation of the controls for the receiver. From the inside of panel the electrical installation (see Fig. 17) is packed. The following control elements of the receiver are located on the face side of front panel: "Band Switch" - the band switch for changing the sub-bands of receiver (causes rotation of the frequency drum). "tuning" - the vernier for tuning the receiver to the working frequency (rotation of the rotor of adjustable capacitor). "Antenna tuning." - the fine adjustment of the input of the receiver (changes the capacity of the input circuit). The "BFO" - a change in the tone of telegraphic signals (change in the frequency 2- GO of heterodyne). The volume control "loudness" - manual volume control (with AUTOMATIC VOLUME CONTROL) and manual sensitivity control (with MANUAL VOLUME CONTROL). The quartz filter switch " - switching receiver for the work with the quartz filter and without it. "strip" - a change in the passband of frequency along the channel of IF amplifier with the work with the quartz filter. Dial adjustment "corrector" - is accomplished the displacement of viewfinder. the "illumination of the scale". Dial light control - rheostat in the chain of the lamps used for dial illumination. "Automatic Volume Control - Manual Volume Control" - the toggle switch of switching sensitivity control (automatic or manual). "TLF - tlg" - - the toggle switch, which includes 2-1 heterodyne, for the method of sustained oscillations or Calibration of frequency (TLG) or the turning off 2-1 heterodyne for the reception of the modulated fluctuations (TLF). "Calibrate. - Inclusive" - the toggle switch, which includes quartz Calibrator. the "anode currents of tubes" - the power on/off switch vкл. - the toggle switch, which switches on the power into the circuit of the primary winding of the power transformer.

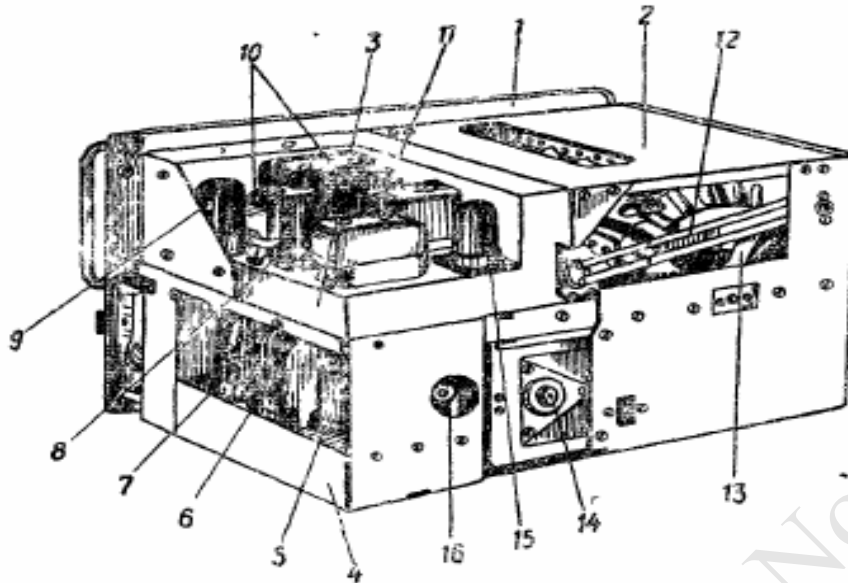

Рис. 16. Передняя панель:

1—ручка регулировки тона биений; 2—переключатель поддиапазонов; 3—тумблер для переключения РРЧ—АРЧ; 4—переключатель измерений; 5—ручка подстройки антенны; 6—клемма для подключения антенны; 7—прибор; 8—шкала; 9—ручка корректора шкалы; 10—ручка регулировки освещения шкалы; 11—переключатель включения кварцевого фильтра; 12—тумблер включения приемника; 13—предохранитель; 14—фишка для подключения питания; 15—клемма металлизации; 16—гнезда телефонов; 17—регулировка полосы пропускания кварцевого фильтра; 18—верньер настройки; 19—ручка регулировки громкости и чувствительности

§ 2. The construction of vernier drive

The tuning of receiver is done using the differential vernier tuning control, which is fastened to the front panel of the receiver. The device of vernier is shown in Fig. 18. The axis of vernier 4 and the axis of the driven gear on the chassis "HF" are connected with the use of a blade-joint. The fork-blade of the joint is fixed by screw 15 in the cut of the axis of the vernier. The driven gear is connected with the gear of the set of variable capacitors. Therefore, during the rotation of the knobs the vernier revolves the rotor of the set of variable capacitors. Large knob 2 and small knob 3 serve for the smooth and coarse adjustment of receiver. Coarse adjustment is accomplished by large knob 2. In this case simultaneously with the knob it revolves 4, which through the pair of gears revolves the rotor of the set of variable capacitors with the proper chosen speed. Smooth tuning is accomplished by small knob 3. During the rotation of the small knob, start up of bushing 9, rollers 8 and running washer 6. The relationship of the diameters of bushing 9, rollers 8 and running washer 6 provides the significant reduction of the rotation of axis 4 and, consequently, also the rotor of the set of variable capacitors. The effort to rotate the large knob is regulated by spring tension 5, which are forced against the base with the movement of ring 7 - in this case it increases friction between

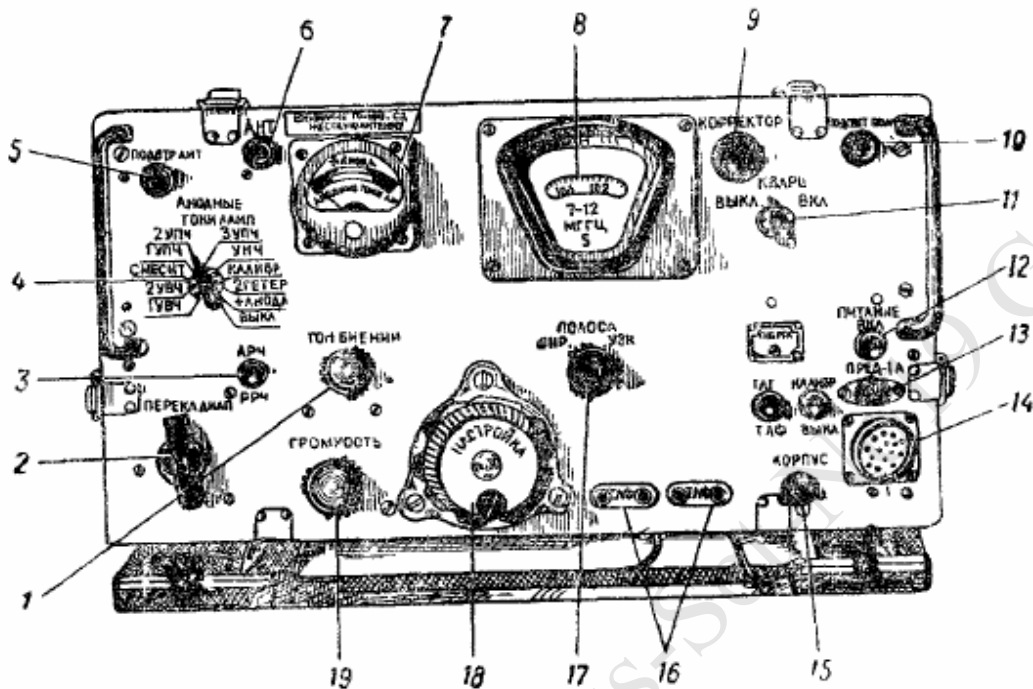
the plane of knob and the base. After installation the ring is plugged by screw 13. The effort of small knob depends on the pressure of bushing 9 on rollers 8. This effort is regulated by spring tension 10.



Рис. 18. Верньерный механизм
 1—основание; 2—ручка большая; 3—ручка малая; 4—ось верньера; 5—рес-
 сора; 6—шайба ходовая; 7—кольцо; 8—ролик; 9—втулка; 10—рессора;
 11—контргайка; 12—винт затяжной; 13—винт стопорный.

If the small knob revolves very easily, then a gap can occur, i.e. during the rotation of knob within small limits the scale remains fixed. In this case it is necessary to increase the tension of springs 10 to roller 8. For this it is necessary to let go lock nut 11 and turn counterclockwise the axis of the vernier, after which the lock nut should be tightened. With the dismantling of the receiver the vernier drive is not removed from the front panel.

§. Construction of the High-Frequency Block

3. The high frequency (RF) block is assembled on a cast aluminum frame (see Fig. 19). In the right upper part of the frame, (if we look from the side of front panel) is fastened a cast chassis of the chassis of high frequency (RF), on which are placed the tube panels and basic electrical installation. From below two dual 2- sectional units of adjustable capacitors are attached to the frame. In the center section of the frame is located the drum, which consists of 7 sections with respect to a quantity of sub-bands and the contact springs, installed on the ceramic boot-trees and fixed on the special cross connection of cast frame. The lower free ends of the springs come into contact with the contacts of the section of the working sub-band, and upper are unsoldered to the corresponding points of the installation of the chassis of high frequency (RF).

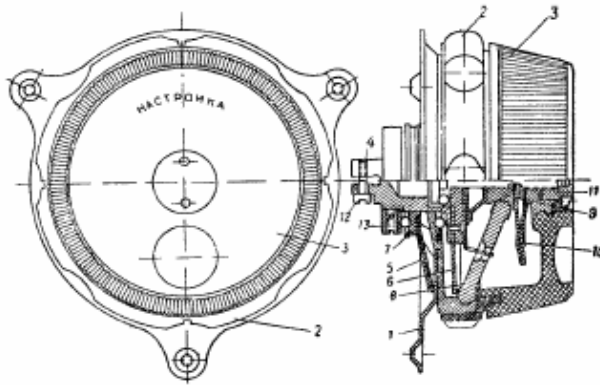

Рис 19. Блок «ВЧ»
 1—штепсельный разъем, 2—барабанный переключатель, 3—контактная группа;
 4—режекторный фильтр, 5—конденсатор подстройки антенны, 6—блок переменной емкости; 7—ведущая шестерня

The elements of switching system are located on 2 stamped aluminum banks, fastened to the cast frame. Each of 7 sections of the sub-bands of drum is installed on the cast aluminum base. The coil of inductance coils is produced on the ceramic bodies, and, the coil of the inductance coils of all circuits 5, 6 and 7 sub-bands and the circuit of the heterodyne of the 4th sub-band is executed by the method of the brazing of silver with the subsequent coating of copper in a galvanic manner. This device of inductance coil ensures the high stability of inductance with the significant fluctuations of ambient temperature. Coil of the inductance coils of remaining circuits and coupling coils are made of usual glazed wire and Litz wire (sort of RF cable). For increasing the hydrostability the coil undergoes impregnation. All the coils of inductance in the high-frequency amplifier are tuned with the help of carbonyl cores. In all circuits of heterodyne - by means of the brass cores. The circuit of all sub-bands have trimmer capacitors. The sections of the sub-bands (see Fig. 20) are located on the cast aluminum laths - bases. 4 circuits are located on each lath of the section of sub-band: the 1st heterodyne, 2-1 UHF, 1st UHF and input circuit, counting from the front panel. The sections of sub-bands are fastened with screws to the body of the drum, which revolves in the bronze bearings, established on the cast frame. The rotation of drum is accomplished through the gear of the frequency switching system. The fastening of drum in the position of the corresponding sub-band is produced with the aid of the catch, which consists of the steel disk with 7 grooves and the fixing lever with 2 rollers which alternately fall into one of the 7 grooves of the disk, and fix the drum in the required position. The mechanism of switching drum makes it possible to revolve the drum in both directions.

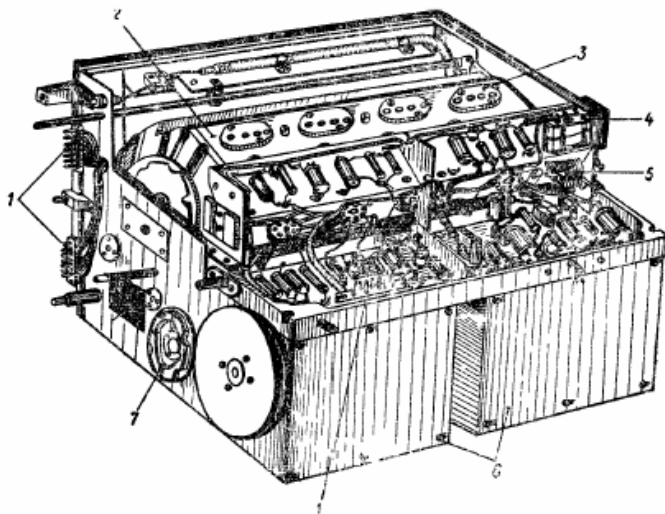

Рис 20. Секция барабана.

1—катушка контура; 2—подстроечный конденсатор; 3—катушка анодного контура 2-го УВЧ; 4—катушка анодного контура 1-го УВЧ; 5—входная катушка; 6—основание экрана; 7—«удлиняющий» конденсатор.

The set of adjustable capacitors is comprised of two double chassis, articulated between themselves with the aid of a blade-joint. This connection allows a certain misalignment of the axes of the adjustable capacitor banks, but at the same time ensures the absence of gaps and backlash. Each of the units of adjustable capacitors is installed in the cast aluminum housing, which ensures high mechanical strength and stability. Steel is used for preparing the sections of chassis, included in the cascades OF UHF. The section of the chassis, connected to the chain of heterodyne, is prepared from Invar, which ensures high frequency (RF) stability. Tuning receiver in the limits of each sub-band is produced by the rotation of the rotor of the units of adjustable capacitors with the aid of the differential vernier (see Chapter III § 2), connected with the chassis by means of the gear drive - free from play type. The scale is the disk comprised of two Plexiglas plates with a film with the scales of seven sub-bands in the form of concentric open rings glued between them. The indication of sub-bands is achieved with the aid of a blind with seven Automatic Volume Control cuts, placed on the axis before the scale. The rotation of the drum during the switching of the sub-bands is transferred with the aid of the pinion drive directly to the blind, whose cuts alternately open the corresponding sub-band of the scale. Frequency and numeration of sub-bands are painted on the blind. The scale is illuminated with two lamps, located behind it. The adjustment of the illumination of the scale is provided by the front panel illumination control. The high frequency (RF) block's electrical wiring (see Appendix 2) is made on four GETINAX (laminated bakelite insulation) boards. In the lower left angle under the drum is located the voltage stabilizer on the tube of the type SG -4S (СГ-4С (Л5)). The capacitor of the fine antenna input adjustment is fastened to the rear wall of chassis of chassis "HF". The transfer of rotation to the condenser spindle is realized with the aid of the crank system. The drum, contact springs, tube panels and adjustable capacitor banks are arranged so as to have the tube panel pins, adjustable capacitors and contact springs as close to each other as possible, to ensure simple and rigid installation of basic high-frequency circuits, preserving complete accessibility to all elements of installation, which is very important during the repair of receiver. The connection of the diagram of the chassis of high frequency (RF) with the general receiver circuit is attained with the aid of three junction boxes: one of them - with the chassis of intermediate frequency, and two by others - with the front panel of receiver.

§ 4. Construction of intermediate frequency block

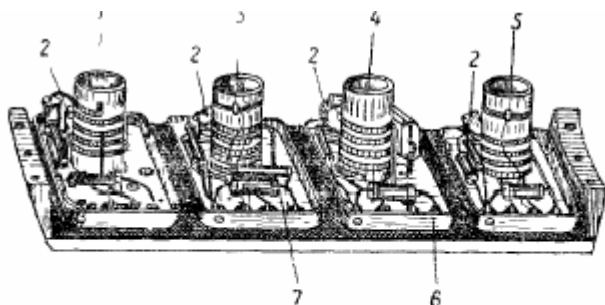
The intermediate frequency block - "ПЧ (=IF)" (see Fig. 21) is assembled on a cast aluminum frame. Connecting chassis "ПЧ (=IF)" with other the units of the receiver is done with the aid of three captive screws that are in the special sockets, into which the connectors from other chassis plug into and are fixed to chassis "ПЧ (=IF)" in a specific position. On the horizontal part (from above) there are a detector tube and three amplifier tubes, with four filters of intermediate frequency.



Рис. 21 Блок «ПЧ»:
1—штепсельный разъем; 2—лампа Л₁₀; 3—лампа Л₈; 4—штепсельный разъем; 5—конденсаторы С₁₇₈ и С₁₈₄; 6—лампа Л₇; 7—лампа Л₉.

Yes, it does. – end of § 4; start of

§ 5. "Construction of low-frequency block", including Fig.22.

by aluminum triangle. On the upper frame there are two receptacles for the RF (=HF) blocks and three columns, two of which are for coupling with the intermediate frequency block and one is for coupling with the front panel.

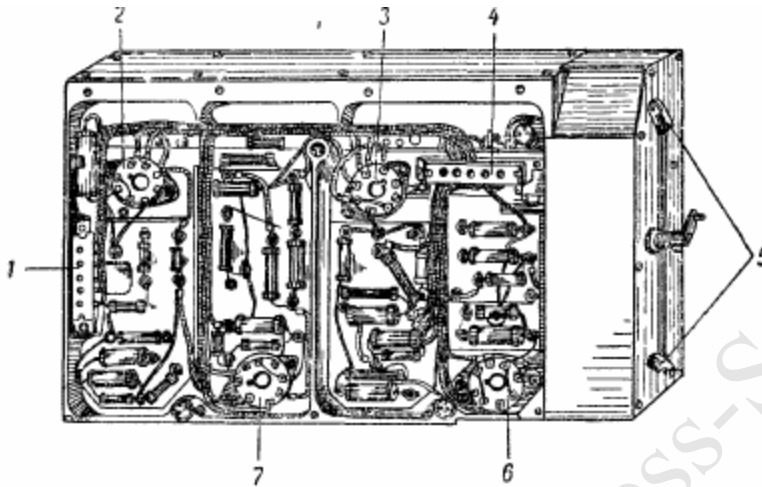
Structurally the "LF" block consists of two independent parts: the box of the signal filter (high-frequency and UHF filters in the feed circuits and SPU) and strictly the chassis of low frequency (audio), which includes 2-1 heterodyne UNCH and quartz Calibrator. The box of the signal filters is located nearer to the front panel. The box of filters has two connections: one of them is located inside the box and the signal from the chip, located on the front panel, the other is located on the cover. These are band pass filters and the voltage supply to the chassis of high frequency (RF) are passed through them. Every box of filters has three sections, the 1st high-pass filter is located in the first section. The 2-1 filters "HF", connected in series with the first and that intended for the protection of receiver from the interferences of high frequency (RF) on the feed circuits are located in the second and third sections. The quartz Calibrator and audio frequency amplifier is placed on one chassis, on which are placed the tubes 'N8S and 'P'S, quartz and hermetically sealed output transformer. The entire installation is placed below the chassis in two sections (see appendix 4). The quartz calibrator is turned on and off by the toggle switch, located on the front panel of receiver. The second mixer is executed on the separate chassis. The circuit of the 2nd mixer is structurally executed just as the circuits of the intermediate frequency filter. A change in the tone of telegraphic

signals is produced with the aid of an air capacitor, fastened above the circuit. Since the "BFO" knob is located on the left side, and the "LF" block from the right side of receiver, the mechanical connection is achieved with the aid of a rod and two cranks. The second heterodyne is screened. The second heterodyne is toggled On and Off by the toggle switch located on the front panel. The electric coupling of the chassis OF "LF" with the remaining chassis is achieved with the aid of four connections. The entire installation of the chassis of low frequency (audio) is from below sealed with an aluminum screen.

§ 6. The construction of rectifier

Structurally the rectifier (see Fig. 23) is executed in the form of a separate chassis. To the chassis are fastened all details: power transformer, choke, capacitors and the tube panel of tube 5U4(Lyya). On the PC board in the power supply, along with the power transformer are installed bias resistors R44 and R4b. The entire chassis of the power supply is covered with an aluminum enclosure, which on the front has an opening for the connector F -2. The power supply is installed on the vibration frame, which has four shock absorbers of the type "lord", and it is attached by 4 catches to the Aircraft mount. This is the early 400 hz power supply unit, the later one is solid state. I have not seen any of the tube type. The same basic schematic, just substitute solid state diodes for the 5U4.



Рис 23 Блок «В»

1—крепление амортизационной рамы, 2—дрессель фильтра; 3—трансформатор силовой; 4—конденсатор C_{200} , 5—фишка питания Ф-2, 6—лампа Л14, 7—сопротивления R_{44} , R_{44a} , 8—конденсатор C_{199}

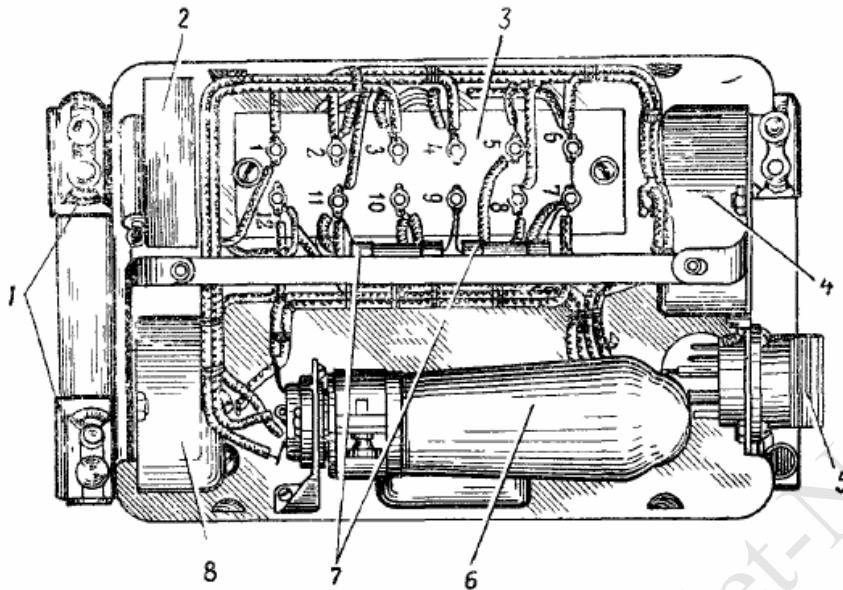

Рис. 24 Кинематическая схема элементов переключения и настройки

CHAPTER 4.

DISMANTLING and ASSEMBLING RADIO RECEIVER

Because of the modular construction and the application of junction boxes the receiver can be dismantled without unsoldering of the separate chassis: the chassis of intermediate frequency, the chassis of low frequency (audio), front panel and the chassis of high frequency (RF). Furthermore, the drum switch can be dismantled into separate sections. Each section is one sub-band of the receiver and contains 4 cavities, separated by efficient screens.

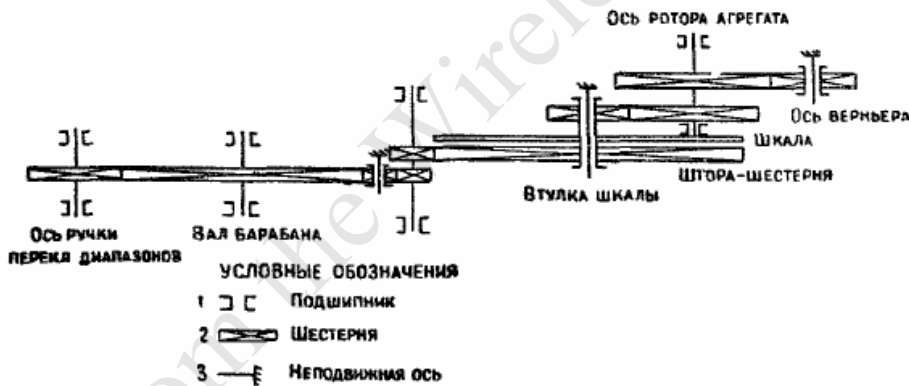
§ 1. The removal of the intermediate frequency chassis

In order to remove the intermediate frequency chassis, it is necessary to unscrew three screws, with which it is attached to the radio. Remove the screws attaching the IF chassis from "the HF" and "the LF", chassis, and one screw, which attaches the intermediate frequency chassis to the front panel. The "Bandwidth" knob must be turned to "narrow" position, and the "quartz" selector switch - in the mid-position. When all preliminary operations are made that are necessary to lift the chassis, raise the unit upward approximately 20 mm, in this case the pins must pull out of their connectors, and the screws from their guides. The removal of chassis "PCH" opens access to the installation of the chassis OF "HF".

§ 2. The removal of front panel

In order to remove front panel, it is necessary to remove knobs "tunings anta", the "beat note" and "Bandwidth Switch", then unscrew 6 screws. Unscrew the nut under the knob " Bandwidth Switch" and the screw that fixes the coaxial cable, which connects terminal "anta." with the input circuit, then remove the spring, which connects front panel with the view-finder, which stands on the chassis OF "HF". When removing the front panel, care should be taken not to damage the scale. Furthermore, not to catch the coming out gears - otherwise the ceramic axis of the unit of adjustable capacitors will break and the receiver be detuned. The receiver should be placed by front panel to upward and raise it. After the contacts of joints will leave the connection, and the guides of column they will leave their nests - panel will prove to be isolated from the chassis.

§ 3. The removal of the chassis of low frequency (audio)

It is necessary to dismember the chassis OF "LF" and the chassis OF "HF". For this it is necessary to unscrew the screw, which connects connecting rod with the crank, located on the chassis OF "LF", to unscrew 2 screws, that attach the chassis OF "LF" to the chassis OF "HF", after which to take away the chassis OF "LF" from the chassis OF "HF". The chassis OF "LF" is removed only when necessary to have an access to the unit of variable capacitors or when it is necessary to replace very chassis OF "LF".

§ 4. Dismantling of the chassis of high frequency (RF)

in order to have an access to the circuits BY "HF", located in the sections of drum, necessary to remove the lower screen (bottom) and the upper screen (cover). Then it only is evident that each section is attached with four screws to the cheeks of drum, after turning away which it is possible to take out necessary section. The screens of circuits are attached with two screws to the base. After removing them it is possible to examine the installation of any circuit of drum.

§ 5. Assembling receiver

Assembling receiver is conducted in the reverse order relative to dismantling. First are joined chassis OF "HF" and "LF". In the frame of chassis "HF" are two guides of column, while in the frame of chassis "LF" to them correspond nests. The chassis OF "LF" dresses for these guides of column. Inside the columns threaded, and into the nests are inserted the captive screws, with the aid of which both chassis are attracted to each other. Then connecting rod is screwed onto the crank. Further assembling can go differently: it is possible to first join chassis "PCH", and then - front panel and vice versa. To more conveniently first join front panel with the chassis "HF" and "LF", and then to establish chassis "PCH". On the chassis OF "HF" - to the left on the chassis OF "LF" - to the right at the identical height are two guides of the columns, to which dresses front panel. It is simultaneously necessary to follow, in order to axis from the knobs "beat note", the "tuning anta." and "perekl. of diap." they entered into their openings, and the axis of vernier was joined with the axis of the leading bushing, located on the chassis OF "HF".

WITH THE INSTALLATION OF FRONT PANEL IT IS NECESSARY THAT THE FORK, WHICH IS LOCATED ON THE AXIS OF VERNIER, WOULD ENTER THE GROOVES OF ROUND CLUTCH AND DURING THE ROTATION OF VERNIER WOULD NOT CATCH THE SCALE.

The front panel must by the small effort to force against chassis and to tighten 6 it is screw after this. To fasten screw in the connection of coaxial cable with the terminal "anta", to cover nut on the axis of wave-changing switch and to dress knobs. After installation and fastening of front panel is produced the installation of chassis "PCH". Guides with the installation of chassis "PCH" are three columns, pressed within the framework. Chassis "PCH" dresses to these columns and is pressed by screws. In this case it is necessary to follow so that the knob "strip" would be in the position, close k "it was narrow", and switch "quartz" - in the mid-position. Only then the guides, established on the chassis, will enter into the forks, located on the front panel. To the front panel the chassis "PCH" is attached with the screw, which passes through the guiding nest. Before shutting drum switch with screens, it is necessary to verify, completely are screwed on the sections of drum switch. When chassis and front panel are articulated, and drum switch is assembled, it is possible to place receiver in the case and to shut locks.

CHAPTER 5. OPERATING INSTRUCTIONS OF RADIO RECEIVER

§ 1. The installation of receiver on the aircraft

With the installation of receiver on the aircraft it is necessary: to avoid it is noise and cracks cables in the places of fastening to reliably fasten with the airplane fuselage, to avoid different kind of transitional joints, and in particular high-frequency. The long cables and the presence of additional joints lead to the superfluous electrical losses and worsening in the operating characteristics and reliability of the work of receiver. With the installation of receiver it is necessary to ensure the distance not less than 15 mm between the receiver and the surrounding objects, which will exclude the possibility of its impacts with the vibration on the amortization frame. The aforesaid above relates also to fastening of rectifier. Marking openings for fastening of amortization frame is given on

the dimensional- adjusting drawing (see appendix 6). After the installation of receiver to the amortization frame it is necessary to connect the receiver's "housing (=frame)" ear to the shock-absorbing frame with the use of metal bands. Wire from the antenna is terminated "anta", which is located on the front panel of receiver. The power cord, the wires of antenna and metallization must have a slack, which ensures the normal work of shock absorbers.

1) Turning on the receiver

Check whether the power supply cord, wires of antenna, metallization are properly connected. Plug in the Headphones into the appropriate socket in the front or SPU panel, turn on the "power" switch, adjust "illumination of the scale" to establish the desired illumination, set toggle switch "AUTOMATIC FREQUENCY CONTROL - MANUAL FREQUENCY CONTROL" to the position MANUAL FREQUENCY CONTROL, set the "beat note" knob against the dot, and set the "quartz" knob on "Off" position. If from the moment of switching on of receiver it passed approximately one minute, then during the rotation of knob "loudness" in the Headphones will be audible noise, which is changed in proportion to the rotation of this knob. It is necessary to Calibrate the frequency of receiver. Calibration is produced only on the short-wave sub-bands, since the frequency of quartz Calibrator has a frequency, equal to the integer of megahertz. For the Calibration it is necessary to include 2-1 heterodyne and quartz Calibrator, to be disposed to the dead spaces by knob "tuning", to turn away lock nut on the knob "corrector" and to establish view-finder it is accurate against the Calibrated point. In this case the knob of regulator "beat note" must be established "by mark against the point on the front panel. After Calibration the view-finder is locked with the nut, located on the knob "corrector". In the process of Calibration it is necessary to include and to turn off toggle switch "Calibrate. - Off", and if signal disappears with the disconnection of this toggle switch, then this is a Calibration signal, and not interference. With the large interferences it is expedient to disconnect antenna.

2) Reception of telephone transmission

Set toggle switch "TLF - TLG" to the position "TLF" and with the aid of the wave-changing switch to establish the necessary sub-band of frequencies. Quartz Calibrator must be switched off. Revolving the knob of coarse adjustment, to establish on the scale of receiver the necessary frequency, and then, slowly revolving the knob of smooth tuning, to produce the fine tuning of receiver to the correspondent. By the rotation of knob "tuning of anta." to attain the greatest loudness of received signal. If sound intensity proves to be great, - to change it to the desired value with the aid of the adjustment by knob "loudness". But if signal strength sharply changes, - to pass to the automatic sensitivity control, for which to turn on toggle switch "AUTOMATIC VOLUME CONTROL - Manual Volume Control" in the position OF "AUTOMATIC VOLUME CONTROL" and by knob "loudness" to again establish the desired sound intensity in the Headphones. The Automatic Volume Control for correspondent should be used only with the manual sensitivity control (MANUAL VOLUME CONTROL). Method under the conditions of interferences is recommended the conducting of with the switch on quartz filter (switch "quartz" - in the "OFF" position), knob "strip" - in the position "latitude."

. 3) the method of telegraphic continuous-wave transmission of a) maintenance of the receiver
Tuning for the frequency of correspondent is produced and by knob "beat note" is installed the

desired tone of signals. If in the process of work it is necessary to change the tone audible in the telephone, then should be turned knob "beat note" to that or other side before obtaining of the desired tone. Construction from the signals, which mix radio station with the radiotelegraph method, should be sometimes produced with knob "beat note" and simultaneously by knob "tuning". With strong electrical interference or interferences from the side of adjacent stations, for increasing the selectivity of receiver, should be maximally reduced the passband by the rotation of knob "strip" clockwise. In this case it is necessary to keep in mind that because of the contraction of passband will be required the finer tuning of receiver to the correspondent, the more thorough volume control and beat note. To avoid the loss of tuning, tone correction of beatings with the work with the narrow passband it follows to produce only with knob "beat note". Passage to the automatic sensitivity control is produced by the installation of toggle switch "AUTOMATIC VOLUME CONTROL - Manual Volume Control" to the position OF "AUTOMATIC VOLUME CONTROL", loudness level is regulated by knob "loudness". At the end of work to turn off receiver, for which toggle switch "nourishment" to place in the position to "Off".

§ 2. The operating instructions of radio receiver

a) maintenance of the receiver

for guaranteeing the normal work of receiver is required systematic care and control of its state. With the operation of receiver it is necessary to satisfy the following basic requirements: 1) to protect receiver from the pushes, the impacts and the drop. 2) to include receiver to the onboard electrical system with a stress not lower than 24,3 and not above 29,7 v. with the nonobservance of this rule is possible failure of converter MA -100M and radio tubes. One should remember that the reduced stress so is dangerous as increased. 3) to contain receiver in the cleanliness. 4) to protect receiver from the entry inside its water. 5) not to turn and not to bend at sharp angle the jumpers of headphones.

b) maintenance of converter MA -100M in the process of operation MA -100M it is necessary to be guided by the requirements, presented in the special description the "modernized converters MA -100M, MA -250M, MA -500M and MA -1500M".

§ 3. Routine maintenance

routine maintenance are called the works, carried out through the specific time intervals for checking the state of receiver, the determination of its fitness to further operation and bringing the state of receiver into the correspondence with the technical requirements. Order and periods of the maintenance of receiver are established by the maintenance regulations, developed for each aircraft type taking into account the special features of its operation. As a rule, regulations consists of the following it is specific the maintenance: a) preflight maintenance; b) post-flight maintenance; c) periodic maintenance.

a) Preflight maintenance is produced before the production of aircraft in the flight, independent of post-flight or periodic scheduled maintenance produced before this. and also with the delay of aircraft in the airport in the case of the cancellation of voyage after maintenance with the short-term stand it has as a goal to verify the state of receiver and the actual readiness of aircraft for the departure.

b) the post-flight maintenance of receiver the post-flight maintenance of receiver is produced predominantly in the base and terminal airports after film 20 + _ 5 it is hour from the moment of useful post-flight or periodic scheduled maintenance. Purpose of this checking - to verify the state of receiver after flights, to reveal malfunctions, to establish the reasons for their appearance and to remove these malfunctions. Approaching the post-flight inspection, it is necessary, first of all, to become acquainted with all observations of air crew from the work of radio receiver in flight. After this, it is necessary to approach the inspection. Should be inspected in the following order: 39.

1) to verify fastening chassis, after focusing attention on:

- a) the quality of fastening of cables,
- b) the quality of the connection of the joints of cables,
- c) the quality of the metallization of chassis and cables,
- d) proper working order of shock absorbers,
- e) absence of external mechanical damages, the strength of the locks on the jackets and of catches on the amortization frames.

2) to verify the work of receiver under the stress:

- a) the correctness of the position of volume control, reliability and the smoothness of work AUTOMATIC VOLUME CONTROL and MANUAL VOLUME CONTROL,
- b) the presence of noise in Headphones,
- c) to verify the work of quartz filter on the decrease of noise or interferences during the contraction of strip,
- d) clearness and the legibility of the method of any station,
- e) the clearness of the work of the switch of sub-bands and the smoothness of the rotation of the tuning knob of receiver.

To eliminate all noted external malfunctions and defects and, if receiver works properly, to limit to this.

c) periodic maintenance of receiver should be done at home airports after every 500 ± 50 and 1000 ± 100 hours of flight.

With the periodic maintenance of receiver for the basis the enumeration of required works on post-flight maintenance starts. Additionally can be carried out the works, the need of fulfilling which is revealed in the process of operating the receiver. Besides this, through every 1000 is hour film additionally to the sequential maintenance the receiver it is subject to checking to the correspondence to the standards of the technical parameters, by the affirmed chief engineer OF GUGVF, and in the absence of the latter - according to the characteristics, enumerated in Chapter 7 of the present user's manual. to: a) the quality of wiring, b) the quality of the connection of the joints of cables, c) the quality of the metallization of chassis and cables, d) proper working order of amortization, d) absence of external mechanical damages, the strength of the locks on the jackets and of catches on the amortization frames. 2) to verify the work of receiver under the stress:

CHAPTER 6. REPAIR OF RADIO RECEIVER

§ 1. General indications

on fault tracing of radio receiver the off-nominal operation of receiver or complete failure can occur in the majority of the cases for the following reasons:

1. change in the supply voltages over the allowed values.
2. malfunction of tubes.
3. malfunction in the antenna circuit.
4. malfunction of Headphone circuits.
5. faulty power cable.

Therefore with the attempts to restore the fitness for work of receiver, first of all it is necessary to be convinced of the fact that are observed all the conditions for the correct start of receiver, that the supply voltages will be given and are differed from rating not more than $\pm 10\%$, that in the antenna circuit there is no break or short circuit, that the Headphones are completely proper. In order rapidly to explain, where precisely, in what cascade of diagram the damage occurred, it is necessary with fault tracing to adhere to the specific sequence. With the aid of the instrument, located on the front panel of receiver, it is determined, which of the cascades of receiver refused in the work or works in the changed regime. Normal operation ' cascade characterizes the location of the pointer of instrument in the green sector of the scale. But if the external reasons for malfunction it is not discovered, then it is necessary to reveal receiver and rectifier and to verify the quality of tubes, changing them alternately by the deliberately suitable, beginning from the tube 16П6С. If replacement of tubes does not give result, then it is necessary to verify, does work audio frequency amplifier, after touching by the end of the screwdriver of the 4th leg of tube 6H8С. The presence in telephone of whistle speaks about proper working order of low-frequency circuit. Then it is necessary to verify the presence of method from the antenna. If there is no method during the supplying of signal to the entrance of receiver (terminal "anta"), then it is necessary to connect antenna alternately to the grid of the 1st and then 2nd high-frequency amplifier, and then - to the grid of converter. But if receiver does not work during the supplying of signal to the grid of converter, but audio frequency amplifier is exact, then it is necessary to learn, does generate the 1st heterodyne. To be convinced of the presence of the fluctuations of the 1st heterodyne possible with respect to a change in the current, which flowed through the tube Л5 of the voltage stabilizer. If with the closing through the capacity (1000 - 5000 micromicrofarad) to the earth of the contacts of the drum switch (switch on sub-band) of the circuit of heterodyne changes the glow of the voltage regulator tube of stress, then the 1st heterodyne generates.

After revealing the region of damage, it is necessary to study the more detailed inspection of the network elements for the precise explanation of defect. In this case it is necessary to resort to the measurement of the regime of the tubes (see table № 1) in the region of damage, and if it normal, then with the aid of the tester or the ohmmeter to establish, are not broken connections in the diagram. Measurement of the regime of tubes and checking connections usually give the possibility to determine the reasons for malfunction. With the presence of strong cracks it is noise should be

opened antenna and heard the receiver noise with its nourishment from onboard storage battery with the inoperative motors of aircraft. If in this case the interfering cracks will disappear, then the elements of electrical equipment of aircraft are the source of interferences. But if cracks in this case will not disappear, then it is necessary to verify converter MA -100M. The minimum of instruments, necessary for repairing the receiver in the workshop, is indicated in chapter of the vii present instruction. The indicated in the table № 1 voltage spread on the electrodes of tubes it is determined by the spread of the admittances of the elements of network and admittances for the tubes. Stresses are measured directly on the pins of tube, moreover the second conclusion of the high-resistance tube of volts of meter is joined to the housing of receiver. With the measurement of the filament voltage of tubes both outputs of high-resistance vacuum tube voltmeter are joined to the appropriate pins of tube panels. Measurements are made in the regime MANUAL VOLUME CONTROL, knob "by loudness must be located in the position of maximum loudness. Checking the regime of tubes is conducted with the voltage of supply $115\text{ V} \pm 0\%$. If the measured stresses are differed values differ from znachepny privedsnnykh=those presented in the table, then the thorough checking of chains and values of the resistances of diagram in accordance with the data of specification is produced. After checking of chains by ohmmeter it is necessary to verify the sensitivity of receiver on the chassis, giving the appropriate signal from the standard signal generator to the control grid of mixer, and also by the 1st and 2-1 cascades OF UHF. Is preliminarily checked with the aid of the audio frequency oscillator the sensitivity of the low-frequency circuit of receiver by supplying the audio frequency to the grid of tube 'N8S. This will help to find defective knot. The results of checking are compared with by the table № 2 given below. If measurement data do not correspond to table № 2, then it is necessary to reveal and to eliminate defect. With the adjustment of tuned circuits, produced in the case of necessity, it is necessary to have in the form a following:

In connection with

THE FACT THAT THE SCALES TO THE GIVEN RADIO RECEIVERS ARE MANUFACTURED WITH PHOTOGRAPHIC METHOD TO Each RADIO RECEIVER INDIVIDUALLY And ARE NOT INTERCHANGEABLE, TO TOUCH THE TUNING ELEMENTS OF THE CIRCUITS: THE INPUT CIRCUITS, 1st UHF 2- GO of uhf, the 1st and 2- GO of heterodyne - categorically IS FORBIDDEN. NONFULFILLMENT OF THIS will cause THE DISTURBANCE OF THE CALIBRATION OF RECEIVER. If necessary for the adjustment of tuned circuit of the circuit of intermediate frequency the latter should be produced only in that cascade, where this is necessary. It is necessary to note that the fine adjustment of the filters of intermediate frequency requires large accuracy and accuracy. The tuning precision of the filters of IF amplifier strongly influences the strengthening in the intermediate frequency and passband in the intermediate frequency.

Таблица 1

а) Примерный режим работы отдельных каскадов

№ ламп по схеме	Функция лампы	Тип лампы	Анод (в)	Экран. сетка (в)	Управ. сетка (в)	Катод (в)	Накал (в)
L_2	1-й усилитель высокой частоты.	6К4	От 75 до 110	От 80 до 105	—	От 1,0 до 1,7	От 5,7 до 6,9
L_3	2-й усилитель высокой частоты	6К4	От 75 до 105	От 80 до 105	—	От 1,0 до 1,7	От 5,7 до 6,9
L_4	Смеситель.	6А7	От 150 до 200	От 28 до 47	От 0 до -6,8	От 0,7 до 1,0	От 5,7 до 6,9
L_6	1-й гетеродин.	6Ж1П	От 120 до 160	От 20 до 50	От 0 до -2,5	—	От 5,7 до 6,9
L_7	1-й усилитель промежуточной частоты	6К4	От 70 до 130	От 80 до 100	—	От 1,0 до 3,0	От 5,7 до 6,9
L_8	2-й усилитель промежуточной частоты	6К4	От 70 до 130	От 80 до 100	—	От 1,0 до 3,0	От 5,7 до 6,9
L_9	3-й усилитель промежуточной частоты.	6К4	От 100 до 165	От 80 до 110	—	От 1,4 до 2,1	От 5,7 до 6,9
L_{10}	Детектор сигнала	$1/2$ 6X6C	—	—	—	От 0 до 1,0	От 5,7 до 6,9
L_{11}	Детектор АРЧ. Выходной каскад	$1/2$ 6X6C 6П6C	От 175 до 220	От 175 до 220	—	От 10 до 16	—
L_{12}	Предварительный каскад усилителя низкой частоты. Кварцевый калибратор.	$1/2$ 6Н8C $1/2$ 6Н8C	От 35 до 45 От 65 до 80	—	От 6,0 до -30	—	—
L_{13}	2-й гетеродин.	6А7	От 13 до 19	От 13 до 19	От 0 до -6,8	—	От 5,7 до 6,9

3

Text after a bunch of Charts

d) since the total current, consumed by receiver, on the average composes 0,56, and during the application of safety device 2 and with the short-term closings, caused by the defects of radio tubes to the fuse blowout, were possible the combustion of different elements of network - resistances, transformers, etc. For the purpose of the exception of this and of more effective work of safety device the latter is substituted from 2- ampere to the 1- the ampere; e) for the purpose of simplification in fastening receiver for the amortization frame is changed the construction of frame and articulation with the jacket of receiver. In this case the common overall sizes of article, and also sizes and arrangement of attaching holes remained without the change. 6. from January of the month of 1960 (from the receiver № 2114) installation is produced by the colored wire PMVG of 0 0,5 mm. CHAPTER THE IX SPECIFICATION to THE SCHEMATIC DIAGRAM OF RADIO RECEIVER together with the resistances of the type VS, indicated in the present specification, enterprise for preparing the radio receiver uses the resistance OF MLT. The resistances OF MLT are made by power from 0,5 W and it is above. Therefore the resistances OF VS-0,2SHCH and VS-0,SHCH are substituted on MLT-0,SHCH. The resistances OF VS-Y and VS-2 are substituted respectively on MLT-Y and MLT-2. Resistances of the type MLT, indicated in the specification, cannot be substituted by resistances of the type VS.

CHAPTER 6

THE FUNDAMENTAL ELECTRICAL CHARACTERISTICS OF RADIO RECEIVER and THE BRIEF PROCEDURE OF THEIR MEASUREMENT

The fundamental electrical characteristics of radio receiver RPS relate:

1. sensitivity of receiver.
2. Calibration error and the reserve of overlap against the range.
3. weakening frequency along the specular channel.
4. passband of IF amplifier.
5. nonlinear distortions.

Standards from the given parameters are given in Chapter 1, § 4 of the present manual.

With the measurement of the fundamental electrical characteristics of radio receiver RPS it is necessary to have the following measuring equipment:

1. standard signal generator of the type G.
2. output meter of the type IV-4.
3. gauge of frequency of the type ICH-SHCH or HICCUP.
4. audio frequency oscillator.
5. gauge of nonlinear distortions OF INI -10 type.
6. heterodyne wavemeter of the type 527. 7. voltmeter of alternating current with the limits of measurements to 300v, checked for the frequency 400 Hz. the measurement of the fundamental electrical characteristics of radio receiver to conduct with the normal climatic conditions and the nominal voltage of supply 115 v. all measurements of receiver to conduct with the normal load at the output - one pair of high-resistance Headphones.

§ 1. The measurement of the sensitivity of receiver

The sensitivity of receiver is called minimum value EMF in the antenna (at the entrance of receiver), which is necessary for obtaining on the termination of normal stress. For the receiver RPS by normal output voltage is 15 v. the order, the measurements of measurement are made at three points of each sub-band: one average and two extreme with AUTOMATIC VOLUME CONTROL and without AUTOMATIC VOLUME CONTROL with the nominal artificial antenna - by the capacity of 80 micromicrofarad in telephone and telegraphic regimes, a) receiver and G are included 10 min. prior to the beginning of measurements. Is established the depth of modulation $G M =$ by 30% frequency OF F = of 1000 Hz, AUTOMATIC VOLUME CONTROL of receiver switched off. Tuning receiver in the telephone regime on one of the frequencies is produced 10 minutes after switching on of feed. As the load of receiver serves one pair of high-resistance Headphones of the type CONCEALING the high-resistance voltmeter of alternating current (R = of 20000 ohms). The knob "loudness" of receiver is set in the position of maximum strengthening. To maximum sensitivity corresponds the stress of the signal generator, with which stress on the load equal to 15 v. with the determination of the value of sensitivity is produced the fine adjustment of the input circuits of receiver before obtaining of maximum strengthening. For the determination it is noise receiver with the presence of carrier modulation G it is turned off and it is measured noise voltage. 53 real sensitivity is measured with the relationship of noise voltage to the voltage of signal 1: 3. if noise voltage less than 5 V, then the measured maximum sensitivity is real. But if noise voltage more than 5 V, then by knob "loudness" somewhat decreases strengthening receiver before obtaining at the exit it is noise 5 v. then it is connected modulation G it increases input voltage of up to obtaining on the output 15 V and again it is measured noise voltage. After several sequential installations by knob "loudness" is located such position, with which noise voltage with the carrier it will be 5 V, and output voltage 15 v. obtained in this case voltage on the input of receiver will determine real sensitivity. Without reconstruction of receiver it is included BY AUTOMATIC VOLUME CONTROL and analogous measurements are made. b)



Рис. 25. Блок-схема измерения чувствительности приемника.

Without reconstruction of receiver it is included BY AUTOMATIC VOLUME CONTROL and analogous measurements are made. b) after the measurement of maximum and real sensitivity in the telephone regime without a change in tuning receiver is removed modulation G and receiver is switched into the telegraphic regime. AUTOMATIC VOLUME CONTROL is turned off. Knob "loudness" - - in the maximum position. By the knob of the sound corrector of the telegraphic signals of receiver is set to the gauge of frequency the beat note of 1000 ± 100 Hz. if in this case beat note it is obtained in two positions, then the knob of sound corrector is set on that position, with which is obtained large voltage on output. The value of voltage on the input of receiver is established by such that to obtain the stress of beatings on the output 15V. this value of input signal will determine the maximum sensitivity in the telegraphic regime. For ' the measurement of real sensitivity in the telegraphic regime is removed the voltage of signal G, the entrance of receiver will be short-circuited and is measured the stress of its own it is noise. Real sensitivity in the telegraphic regime is measured also with the relationship of noise voltage to the voltage of signal 1:3. if noise voltage less than 5 V, then the measured maximum sensitivity is real. But if noise voltage more than 5 V, then by knob "loudness" somewhat decreases strengthening receiver before obtaining on the output it is noise 5 v. then to the entrance of receiver it will be given carrying it is established input voltage of up to obtaining on the output 15 v. obtained in this case voltage on the input of receiver will determine real sensitivity in the telegraphic regime. Without reconstructing receiver, it is included BY AUTOMATIC VOLUME CONTROL and analogous measurements are produced. Sensitivity with switch on AUTOMATIC VOLUME CONTROL must not differ to more than 30% from measured in the position MANUAL VOLUME CONTROL. Then receiver is reconstructed consecutively for other frequencies and is measured sensitivity in the telephone and telegraphic regimes with AUTOMATIC VOLUME CONTROL and without AUTOMATIC VOLUME CONTROL. The chassis diagram of measurements is shown in Fig. 25.

§ 2. Measurement Calibration errors and reserve against the overlap of sub-band the order of the measurement of measurement are conducted in the telegraphic regime, the knob of regulator "beat note" is established by mark against the point. Is included toggle switch in position "caliber." and the

Calibration of the scale of receiver at the frequency of 15 Mhz is produced and view-finder is fixed. For measuring the Calibration error by the knob "tuning" of receiver is established on the checked frequency this position of the scale, in order to mark on the scale

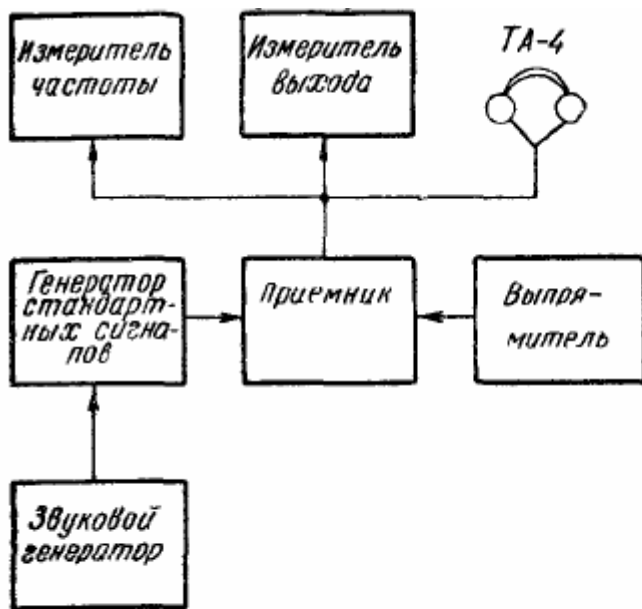

Рис. 26. Блок-схема измерения погрешности градуировки и запаса по перекрытию поддиапазона

it were located accurately against the view-finder on the shutter. At the appropriate frequency of range Calibrates heterodyne wavemeter ' and weakly it is connected with the entrance of receiver. They attain by the rotation of the tuning knob of heterodyne wavemeter dead spaces in the Headphones at the output of receiver, the full value of the frequency of tuning is determined according to the table of heterodyne wavemeter and a Calibration error is calculated. For determining the frequency band and reserve from the overlap are carried out the measurements, analogous to those describe above, with the only difference that the disk of the scale of receiver is established in the extreme right and extreme leftist of position alternately. The difference between the frequency of the tuning, measured with the end position of the disk of the scale of receiver, and the nominal extreme frequency of range is reserve of overlap at the particular point. Reserve on the overlap on the long-wave sub-bands must be not less than 8 kHz, on the short-wave - not less than 30 kHz the chassis diagram of measurements is shown in Fig. 26.

§ 3. The measurement of low signals

Signal along the specular channel by attenuating the signal along the specular channel is called the relation of sensitivity along the specular channel to the sensitivity at the fundamental frequency.

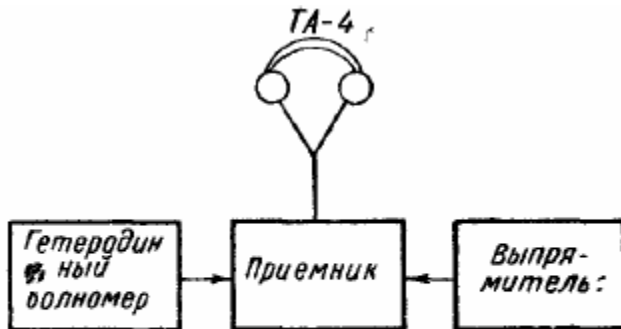
Order of measurement:

The scale of receiver is established on the highest frequency of sub-band. To the entrance of receiver from ГСС-6 will be given signal and is measured real sensitivity. Then, without touching the tuning knob of receiver, G is reconstructed to the side of an increase by the doubled intermediate frequency and is established the input signal of such value, that at the output of receiver there would be stress 15V. The voltage supplied from ГСС-6 to the entrance (input) of receiver, in this case, the sensitivity along the specular channel is determined.

Weakening of signal along the specular channel must be not less than 4000 times at frequencies 18 - 24 MHz not less than 1000 times. The block diagram of measurements is shown in Fig. 25.

§ 4. The measurement of the passband of IF amplifier

by the passband of the IF amplifier of receiver is called a difference in the frequencies, with which its sensitivity occurs into the given number of times of less than the sensitivity with the resonance. The order of measurement receiver is extracted from the jacket and to the eighth leg of tube Lya from G will be given the signal of the intermediate frequency $F = 730$ kHz with a frequency of modulation of 400 Hz and depths of modulation OF 20%. Toggle switch "AUTOMATIC VOLUME CONTROL - Manual Volume Control" - in the position MANUAL VOLUME CONTROL, the knob of volume control is located in the maximum position, "quartz" - is switched off, G accurately is tuned for the intermediate frequency on the maximum voltage on the output of receiver. Then on the output of signal generator is established the stress, with which the output voltage of receiver equally to 15 V.



Рис. 27. Блок-схема измерения полосы пропускания приемника.

After this, the ГСС-6 voltage doubles and the ГСС-6 frequency varies in either direction from resonance to obtaining on the output of the receiver of stress 15 v. the value of frequency with both detuning it is measured by heterodyne wavemeter. The value of detuning G into both sides is a passband of receiver with the weakening 2 times. Thus passband with the weakening 100 times is measured. In this case the signal from G increases 100. 56 then is included "quartz", the adjustment knob of strip is placed in the position "latitude." and by the method pointed out above is measured passband with the weakening 2 times and 100 times. Further is made the measurement of band of transmission with the weakening 2 times with the installation of the adjustment knob of strip to the position "it is narrow." Stress G is established by such so that at the output of receiver there would be stress 3 v. then stress from G it increases 2 times it is disturbed generator to obtaining on the output of the receiver of stress 3 v. after this it is turned off modulation G, the second heterodyne of receiver is included and by the rotation of knob "beat note" are established dead spaces on the output of receiver. Is turned off the second heterodyne of receiver, it is included modulation G, it is again disturbed BY G to the side, opposite to the first detuning, before obtaining on the output of receiver 3 V; modulation is turned off, are included 2-1 heterodyne of receiver and on the switch on to the output frequency meter is counted off the frequency, which corresponds to passband. The chassis diagram of measurements is shown in Fig. 27.

§ 5. The measurement of the coefficient of nonlinear distortions

the order of measurement to the entrance of receiver from G will be given the stress 50 V, modulated by the frequency of 1000 Hz with the depth of modulation 30%. To the output of receiver in parallel to load is connected distortion meter. By knob "loudness" is installed voltage on output 60 V and is measured the coefficient of nonlinear distortions, whose value must be not more than 8%.

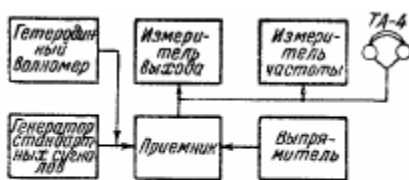

Рис. 28. Блок-схема измерения коэффициента нелинейных искажений.

With switch on AUTOMATIC VOLUME CONTROL the volume control of the receiver was placed in the position of maximum volume. At the input of receiver the signal will be given with value 0,1 V and again is measured the coefficient of nonlinear distortions, which must be not more than 10%. The list diagram of measurements is shown in Fig. 28.

§ 6. The measurement of the regimes of tubes

the regime of the tubes of receiver and rectifier is checked with the nominal supply voltage with the measurement of voltage with the aid of the vacuum tube voltmeter on the pins of tubes or at points with the same potential, but preventing influence on the regime in the high frequency (RF). The signal on the receiver will not be given with the measurement of stresses, sensitivity control is located in the position of maximum amplitude. With checking of the anode currents of tubes by instrument, which is located on the front panel of receiver, the pointer of instrument must be located in the green sector of the scale. This measurement is tested on all sub-bands, revolving knob "tuning" throughout entire scale range. The mode of operation of the mixer is checked on the 6th sub-band: the pointer of the meter must be within the limits of the green sector of the scale. A change in the anode current of the mixer beyond the limits of the green sector of dial face to the side of decrease is allowed on the remaining sub-bands.

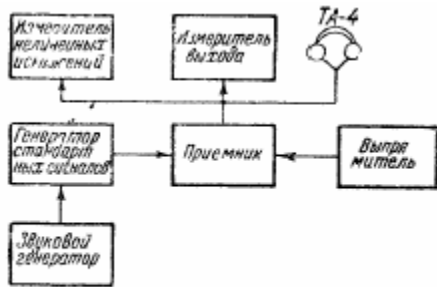
CHAPTER 8 THE BASIC CHANGES IN THE RADIO RECEIVER RPS

In the process of the production of the radio receivers RPS the following basic design and circuit changes were introduced:

1. from September 1956 a) for an improvement in joining the axis of the vernier of tuning with the driven gear the flexible joint is introduced, and for the purpose of relief of forces from the ceramic axis of rotor with its end positions back stops from the chassis KPE are delayed by driven gear; b) for an increase in the stability of the sensitivity of receiver with a change in the ambient temperature (because of a decrease in the quality of the insulation resistance of capacitors) ceramic trimmer capacitors of the type KPK -8/30 are substituted for the air capacitors. During the replacement in the operation of capacitors of the type KPK to the trim tabs with the air dielectric the latter are fastened in the section of sub-band with the aid of the specially given GETINAX (laminated bakelite insulation) washer. With setting of trim tab it is necessary to focus attention on the absence of closing the nut of fastening trim tab to GETINAX (laminated bakelite insulation) $\text{pax} = \text{board}$ in the section of sub-band.

2. from August 1957 for eliminating the springing out of the guide of view-finder in the end positions of snail is changed the construction of the corrector of the scale, in this case the knob of corrector acquired revolution.

3. from November 1957 in view of the frequent cases of closing the plates - the hermetically sealed trimmer capacitors of the type "keg" (in the heterodyne circuits) are substituted for the air capacitors.

4. from April 1958 for the purpose of the elimination of a breakdown in the scales - the glass scale is substituted to the scale from the organic glass. 5. from July 1959 (from the receiver № 2000) are introduced the following changes: a) for increasing frequency stability of the 1st heterodyne from a change in the signal is changed the schematic of the 1st heterodyne



Рис. 29. Схема первого гетеродина до изменения.

Лампа 6Ж3П (Л6) заменена на 6Ж1П с соответствующим изменением режима, в связи с чем изменились величины следующих элементов:

Обозначение элемента по принципиальной схеме	Величина до изменения	Величина после изменения
R_{26}	BC-0,25-1-56 ком-II	BC-0,25-1-1000-II
R_{34}	BC-0,5-1-5,1 ком-II	BC-0,5-1-33 ком-II
R_{35}	BC-1-1-51 ком-II	BC-0,5-1-15 ком-II
R_{31}	BC-1-1-10 ком-II	Исключено
C_{125}	КТК-3С-51-1	КТК-2С-27-1
C_{127}	КБГ-И-600-0,01-II	КТК-1Д-150-II

b) is changed the schematic of the screening of the sections of drum, since the screens of the cavities in the anode circuits of the 1st and 2nd UHF were located under the high voltage.

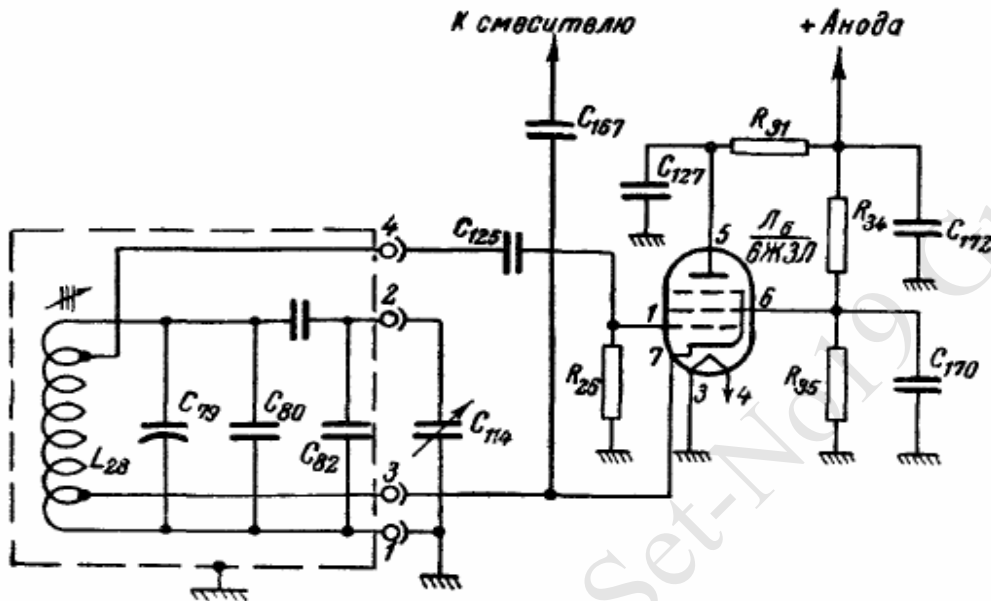

Рис. 30. Усилитель высокой частоты до изменения.

Entry into the drum switch of dust, moisture and so forth could lead to shorting of the anode circuit to the housing. For eliminating this deficiency the screens of all sections of drum are grounded. The diagram of the 1st and 2nd UHF to the change is given in Fig. 30; c) for guaranteeing the reserve with the adjustment with the fine-adjustment capacities (both in the process of tuning in enterprise and under operating conditions), is produced a change in the values of capacitors, which stand in parallel to them:

d) since the total current, consumed by receiver, on the average averages 0.56 amperes and during the application of safety device 2 and with the short-term over currents, caused by the cold filaments of the radio tubes causing the fuse to blowout, were possible the combustion of different components - resistances, transformers, etc. For the purpose of the exception of this and of more effective work of safety device the latter is changed from a 2- ampere fuse to a 1 ampere fuse) for the purpose of simplification in fastening the receiver into it's case is changed the construction of frame and joining with the case of the receiver. In this case the common overall sizes of article, and also sizes and arrangement of attaching holes remained without the change. 6. from January of the month of 1960 (from the receiver № 2114) installation is produced by the colored wire PMVG of 0 0,5 mm.

CHAPTER 9 SPECIFICATION to THE SCHEMATIC DIAGRAM OF RADIO RECEIVER

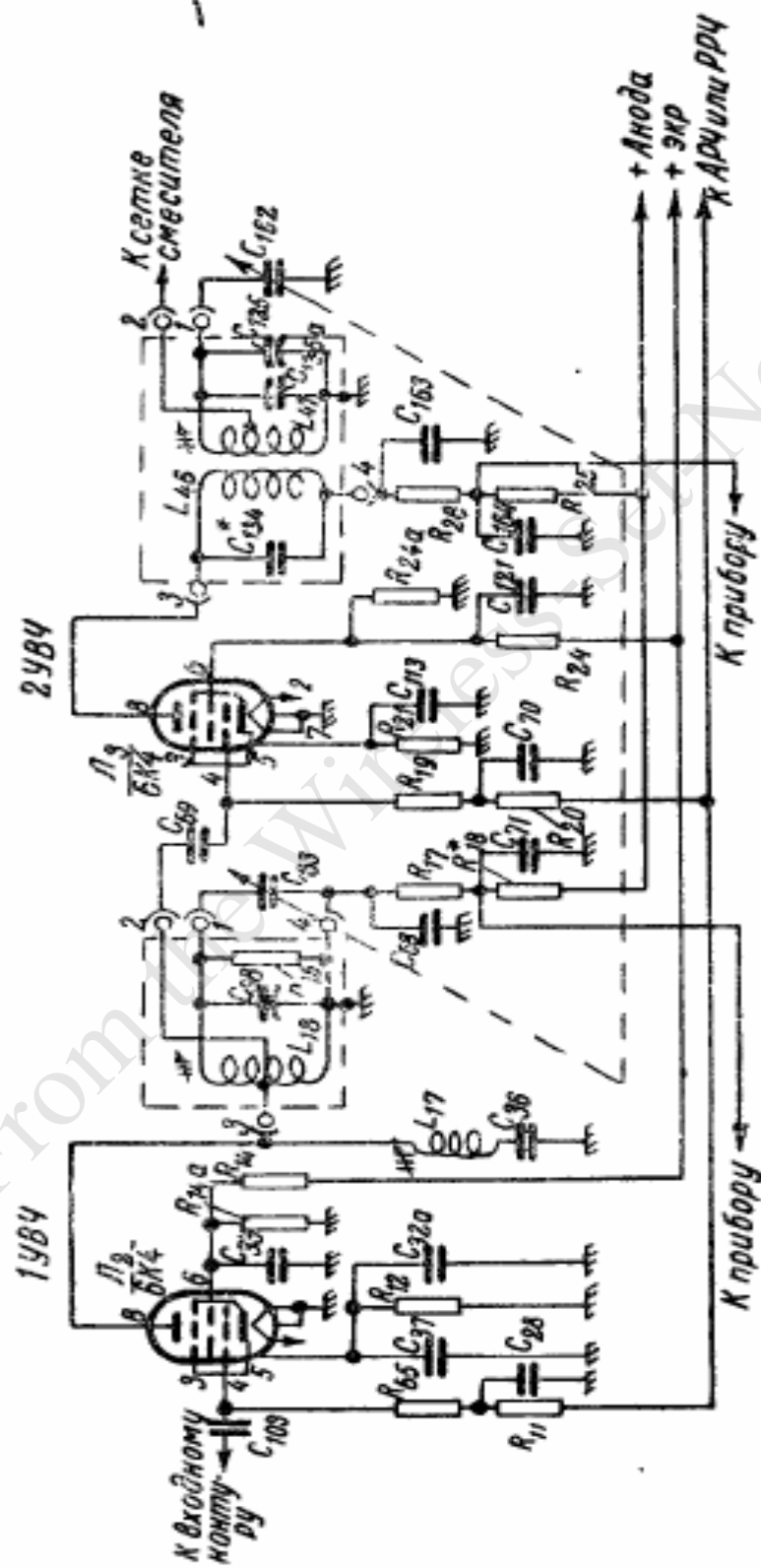
together with the resistances of the type VS, indicated in the present specification, enterprise for preparing the radio receiver uses MLT resistors. The resistances OF MLT are made by power from 0,5 W and it is above. Therefore the resistances OF VS-0.25 and VS-0.5 are substituted on MLT-0.5. The resistances OF VS-Y and VS-2 are substituted respectively on MLT-1 and MLT-2. Resistances of the type MLT, indicated in the specification, cannot be substituted by resistances of the type VS.

Обозначение элемента по принципиальной схеме	Величина до изменения	Величина после изменения
C ₅₇ C ₅₈ C ₅₉	КТК-1М-33-I КТК-1М-12-II КТК-1М-39-II	КТК-1М-39-II КТК-1М-5-II КТК-1М-33-II

ПРИЛОЖЕНИЕ 1

ЭЛЕКТРОМОНТАЖНАЯ СХЕМА ПЕРЕДНЕЙ ПАНЕЛИ

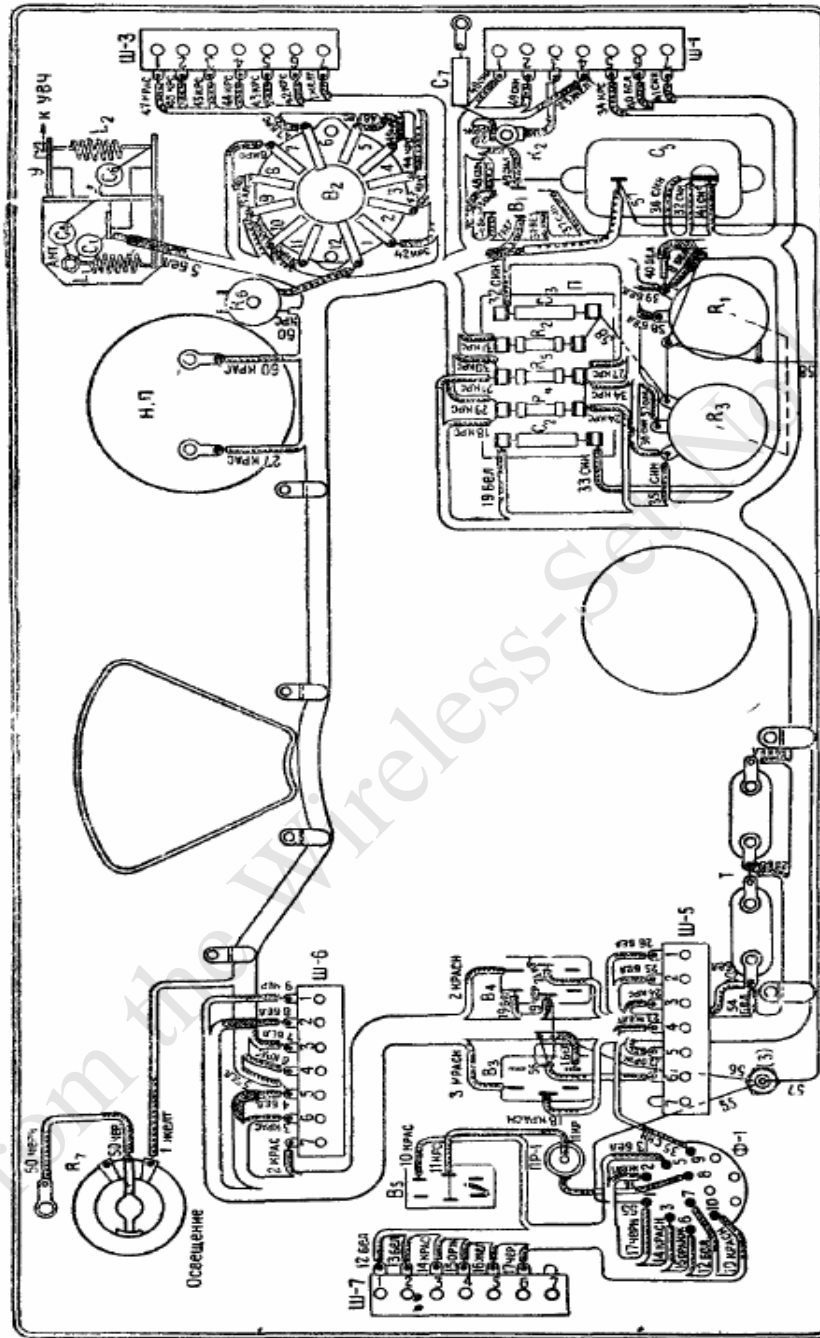

Примечание. Номера электрических элементов соответствуют номерам элементов принципиальной схемы

ЭЛЕКТРОМОНТАЖНАЯ СХЕМА БЛОКА НИЗКОЙ ЧАСТОТЫ

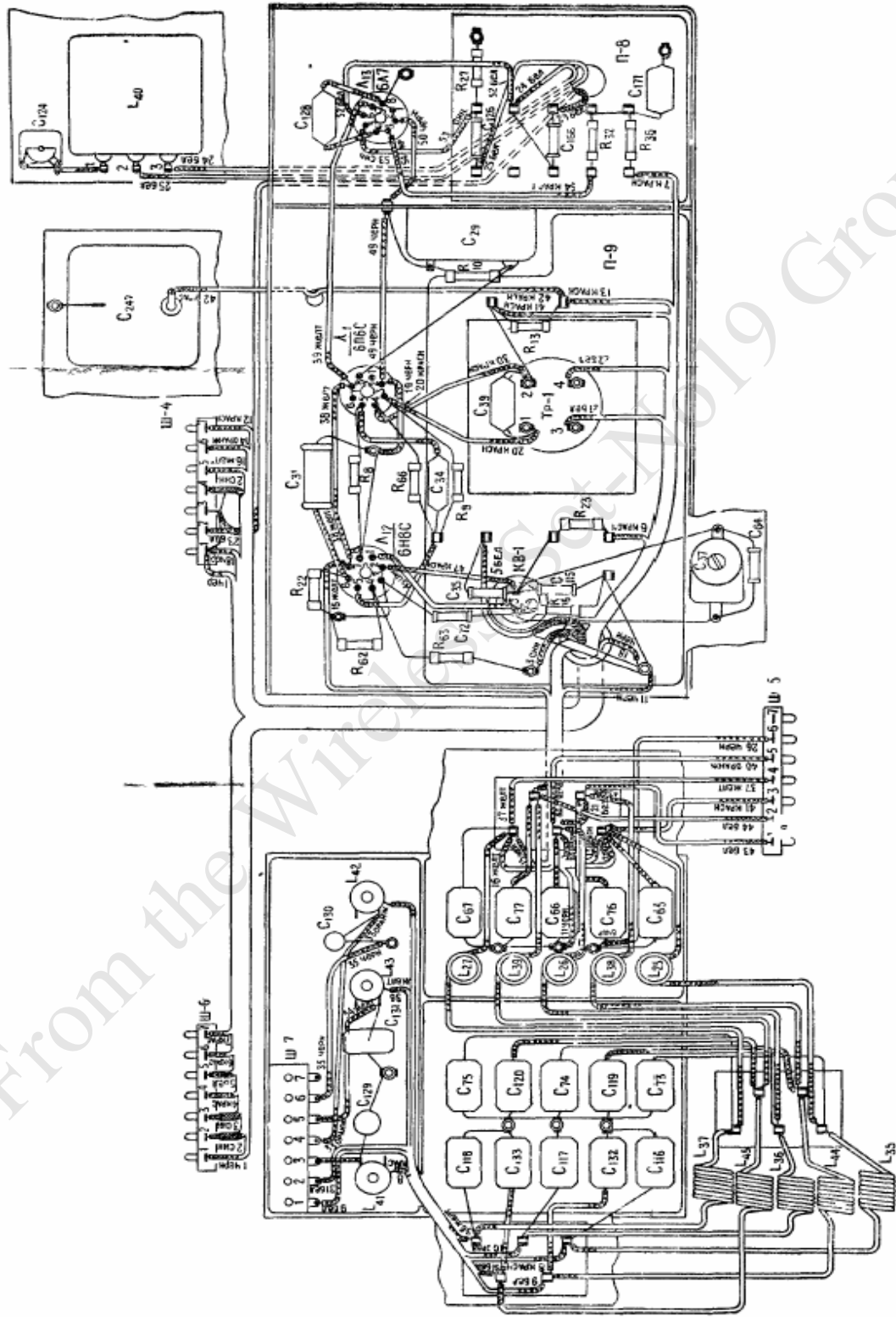

Примечание Номера электрических элементов соответствуют номерам элементов принципиальной схемы

ЧЕРТЕЖ РАДИОПРИЕМНИКА

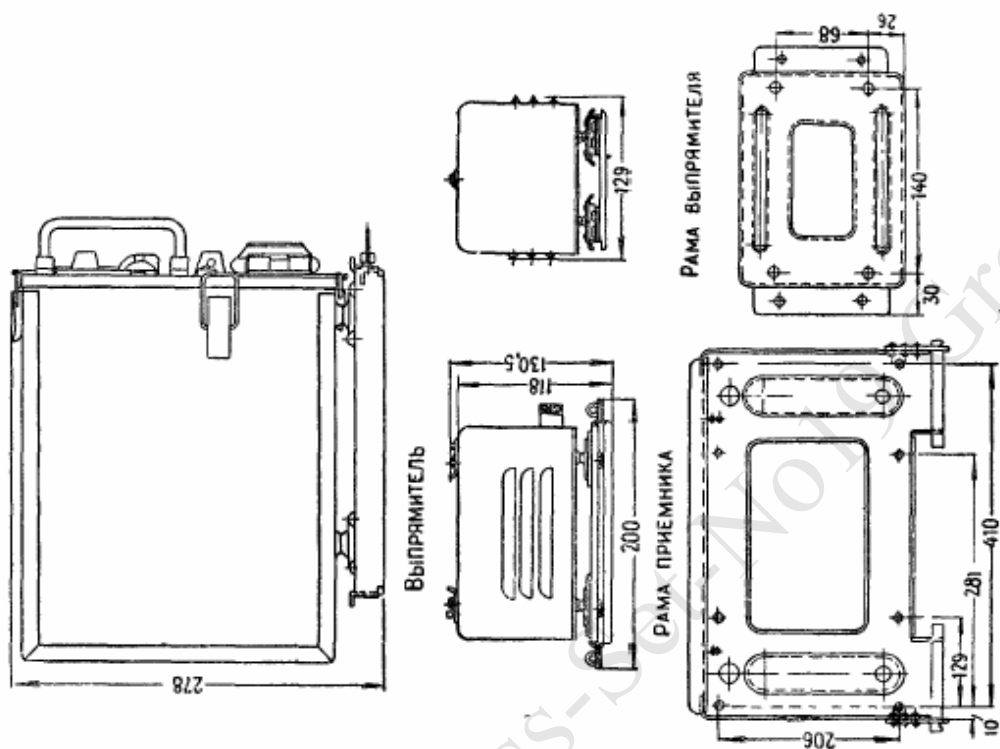

ГАБАРИТНО-УСТАНОВОЧНЫЙ

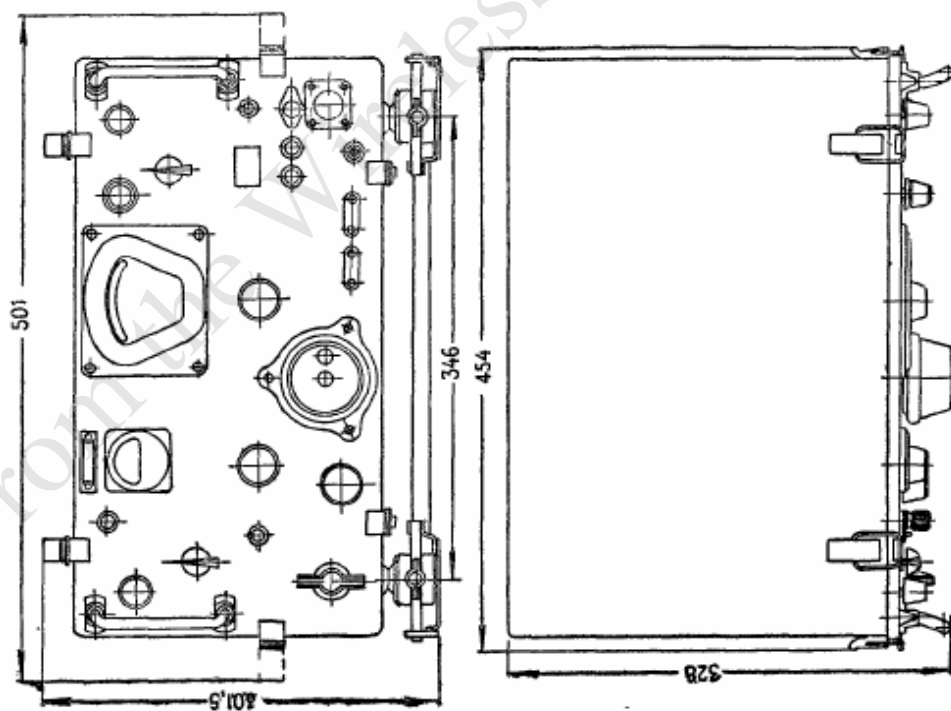

FRONT PANEL WIRING DIAGRAM
ЭЛЕКТРОМОНТАЖНАЯ СХЕМА ПЕРЕДНЕЙ ПАНЕЛИ

Enclosure 1
 ПРИЛОЖЕНИЕ 1

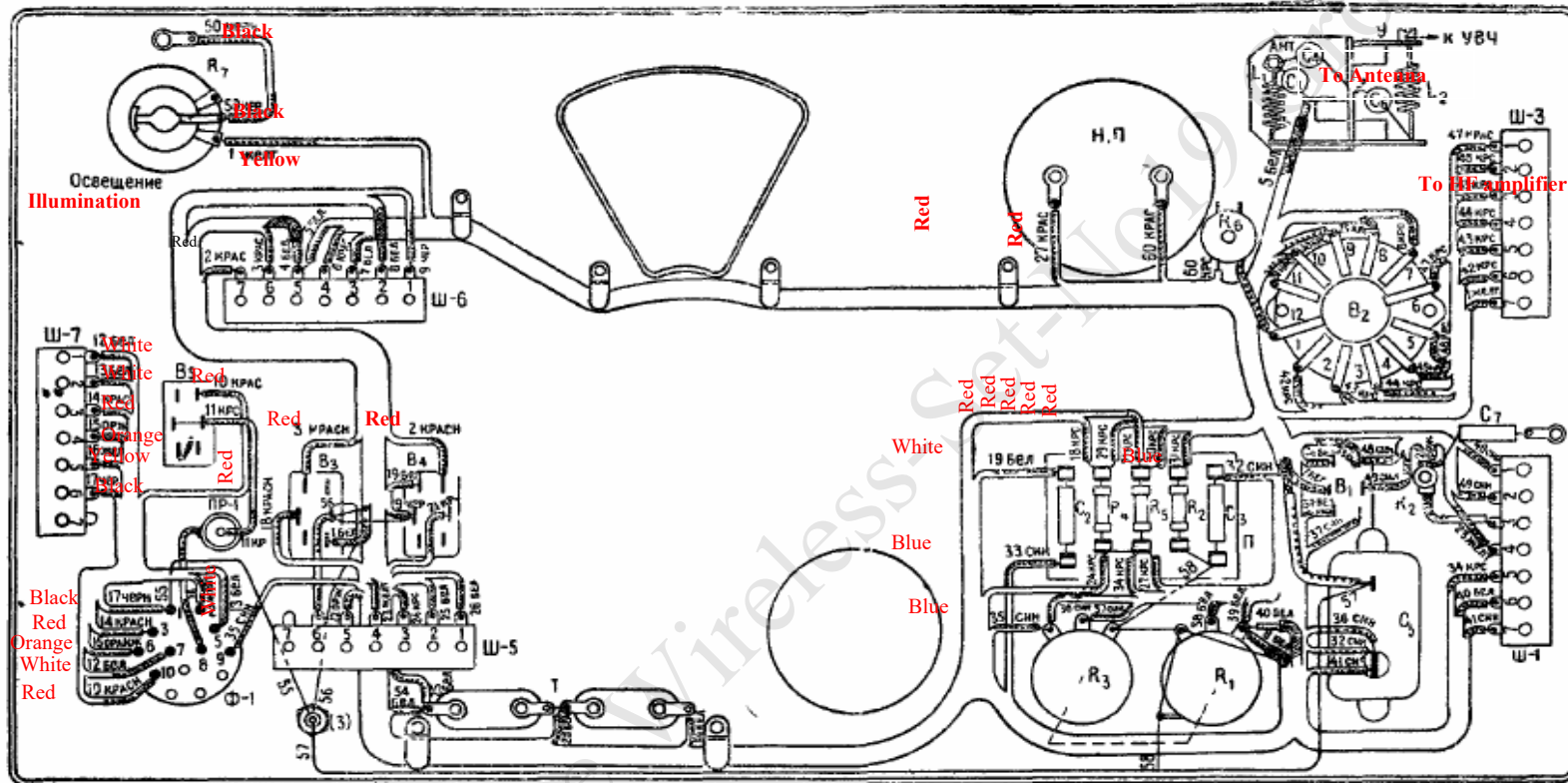

Примечание Номера электрических элементов соответствуют номерам элементов принципиальной схемы

NOTE : Numbering of wiring elements is the same as that in the circuit diagram.

SPECIFICATION OF TRANSFORMER AND CHOKE COILS

Table 3
Таблица 3

НАМОТОЧНЫЕ ДАННЫЕ ТРАНСФОРМАТОРОВ И ДРОССЕЛЕЙ

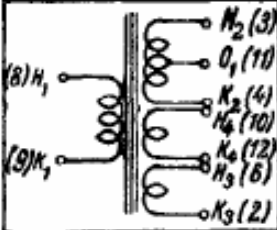
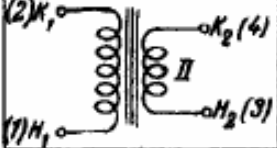
# № п/п	Part name Название детали	Designation in circuit diagram Обознач. в принцип. схеме	Drawing # №№ заводских чертежей	Coil label Обознач. обмоток	Number of turns Количество витков	Number of layers Количество слоев	Number of turns per layer Количество витков в слое	DC resistance Сопротивлен. постоянному току	Type of Wire Наименован. провода	Electric circuit Электрическая схема
1	Rectifier choke Дроссель выпрямителя	Др-1	ИЖ5.750 005	Coil label	~1680	24	70	70 ÷ 80 Ом	ПЭЛ Ø 0,2	
2	HF choke Дроссели высокой частоты	L ₂₅ , L ₃₅ , L ₄₁ L ₂₇ , L ₃₇ , L ₄₃ L ₂₆ , L ₃₆ , L ₄₂	ИЖ5 752 003 ИЖ5 752.002 ИЖ5 750 004		2×100 29 3×150	2секции 1 3секции	100 29 150	7,8 ÷ 8,9 Ом 0,02 ÷ 0,03 Ом 41 ÷ 51 Ом	ПЭЛШО Ø 0,15 ПЭЛ-1 Ø 1,0 ПЭЛШО Ø 0,1	
3	Power transformer Силовой трансформатор	Тр-2	ИЖ5.714 000	I II III IV	207 760 9 12	5 7 1 1	4 слоя-по 41 в 1 слой-43 в 6 сл-по 110 в 1 сл-100 в	2,18 ÷ 2,38 Ом 50 ÷ 60 Ом 0,042 ÷ 0,05 Ом 0,02 ÷ 0,036 Ом	ПЭЛ Ø 0,49 ПЭЛ Ø 0,2 ПЭЛ Ø 0,93 ПЭЛ Ø 1,35	
4	Output transformer Выходной трансформатор	Тр-1	В-13075-502	I II	~1900 ~1530	19 14	100 13 сл.-110 в 1 слой-400 в	220 ÷ 380 Ом 260 ÷ 400 Ом	ПЭЛ Ø 0,1 ПЭЛ Ø 0,09	

HF-UNIT'S WIRING DIAGRAM
 ЭЛЕКТРОМОНТАЖНАЯ СХЕМА БЛОКА ВЫСОКОЙ ЧАСТОТЫ

Enclosure 2
 ПРИЛОЖЕНИЕ 2

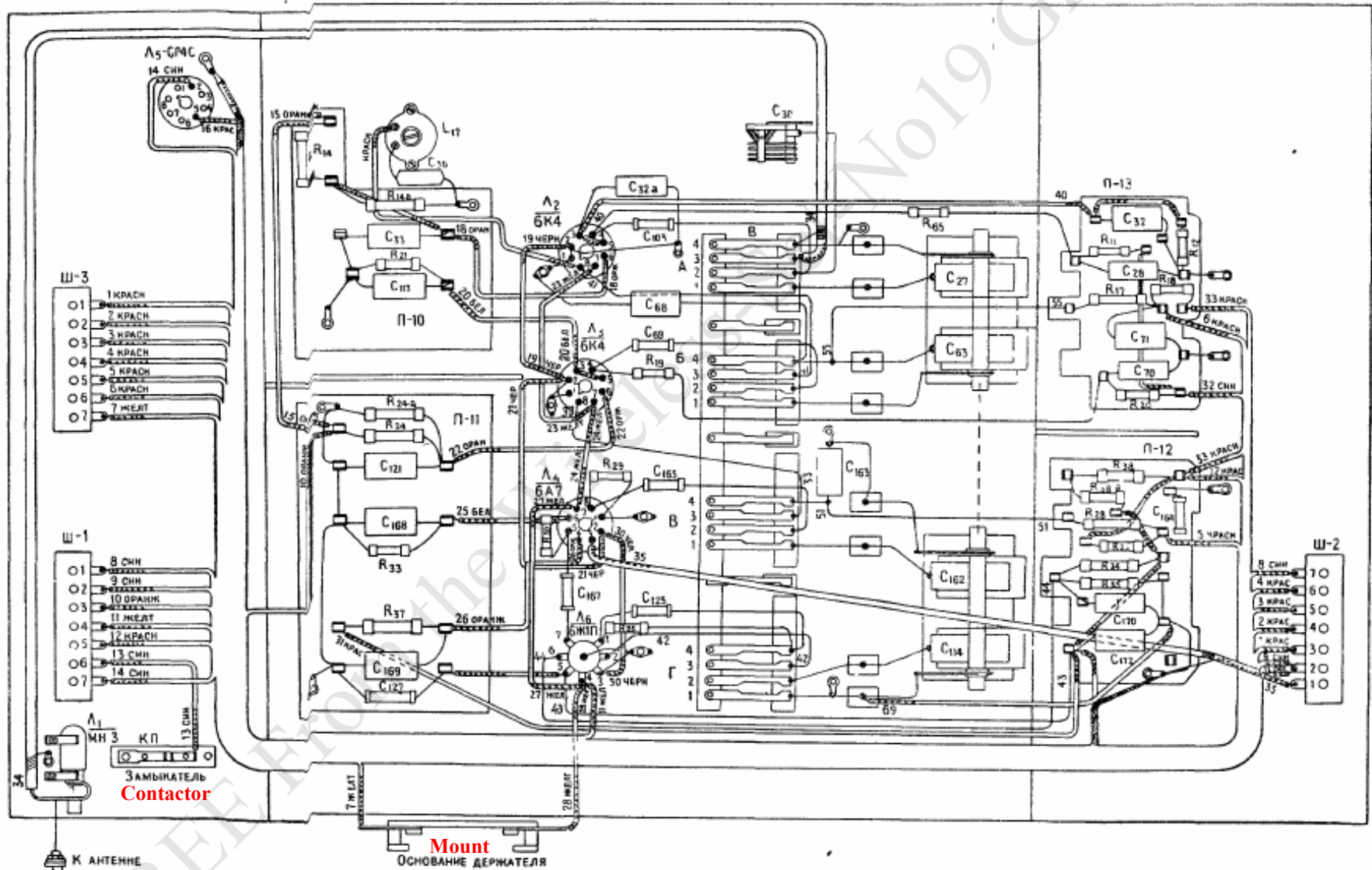

To the aerial

Примечание Номера электрических элементов соответствуют номерам элементов принципиальной схемы

NOTE: Numbering of wiring elements is the same as that in the circuit diagram.

IF-UNIT'S WIRING DIAGRAM
ЭЛЕКТРОМОНТАЖНАЯ СХЕМА БЛОКА ПРОМЕЖУТОЧНОЙ ЧАСТОТЫ

Enclosure 3
ПРИЛОЖЕНИЕ 3

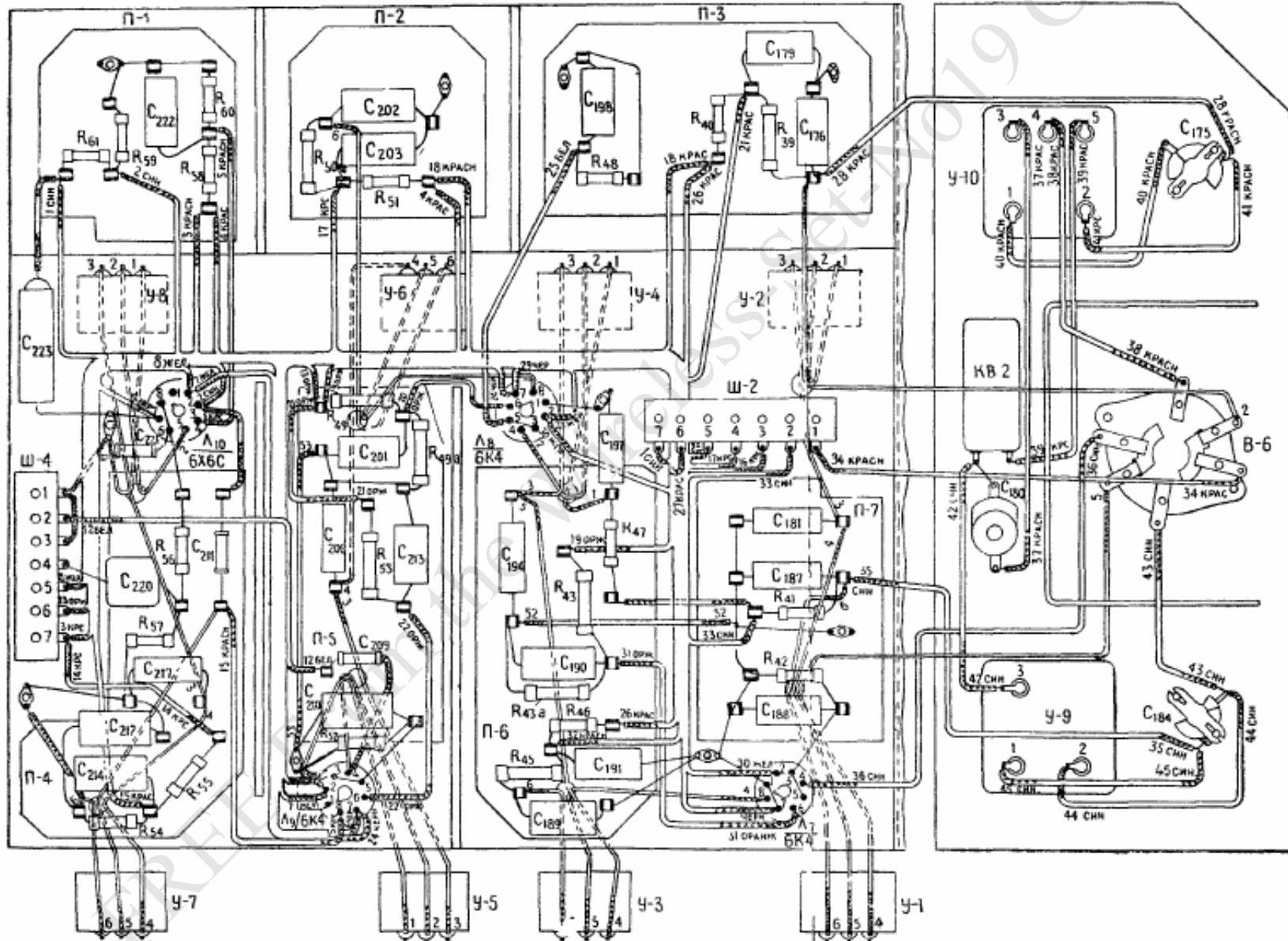

Примечание. Номера электрических элементов соответствуют номерам элементов принципиальной схемы.

NOTE: Numbering of wiring elements is the same as that in the circuit diagram.

WIRING DIAGRAM OF RECTIFIER
Note, My 400Hz power supply is solid
state, no 5U4 rectifier tube.

Enclosure 5

ЭЛЕКТРОМОНТАЖНАЯ СХЕМА ВЫПРЯМИТЕЛЯ . ПРИЛОЖЕНИЕ 5

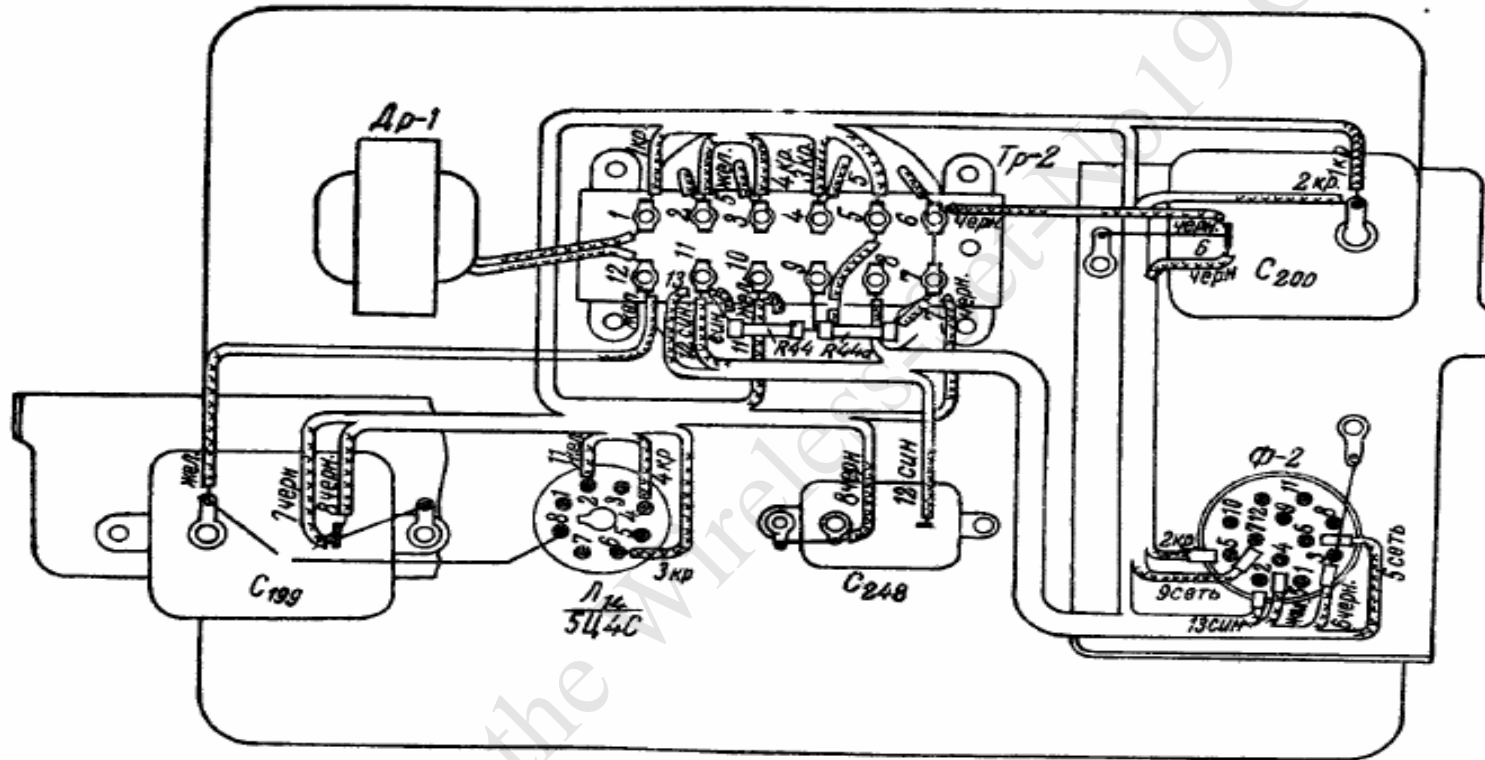

CHASSIS DIMENSIONS/INSTALLATION
 ГАБАРИТНО-УСТАНОВОЧНЫЙ ЧЕРТЕЖ РАДИОПРИЕМНИКА

Enclosure 6
 ПРИЛОЖЕНИЕ 6

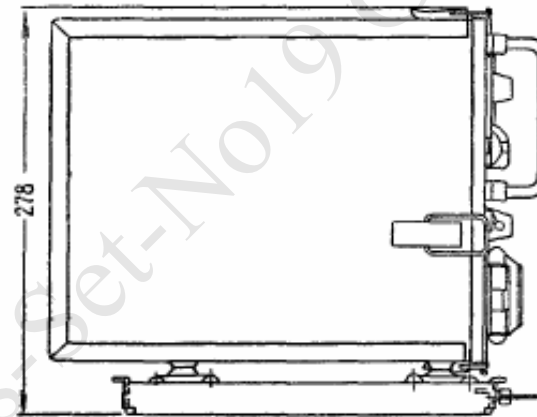
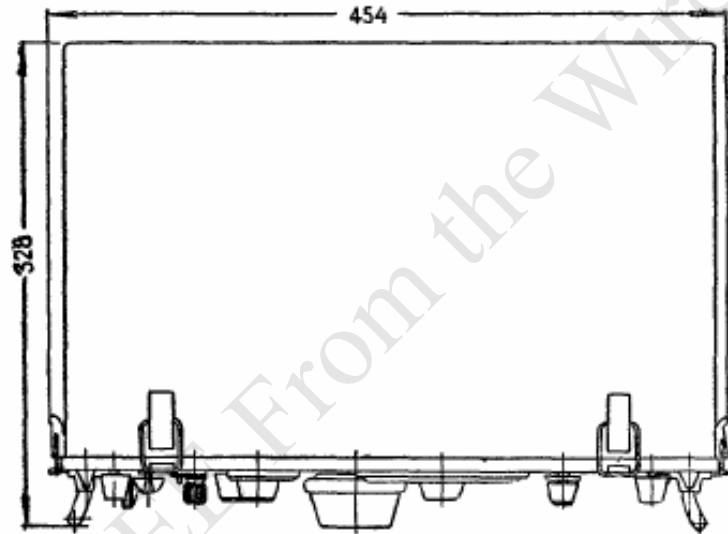
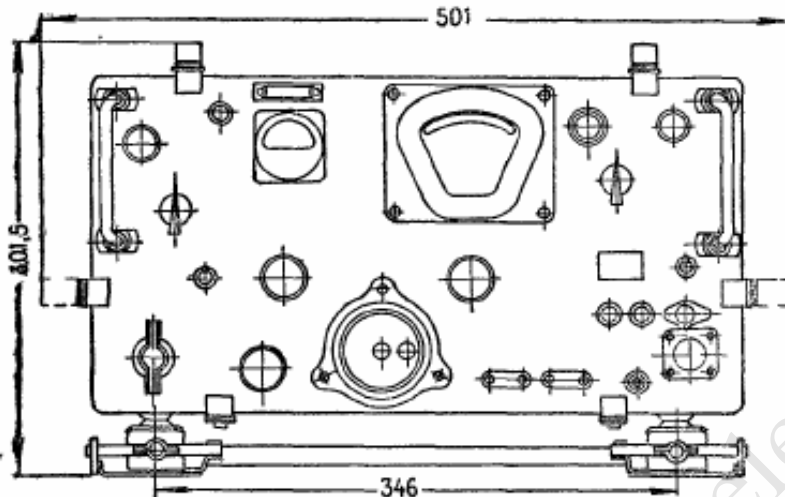

Выпрямитель

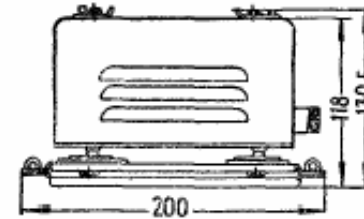

РАМА ПРИЕМНИКА

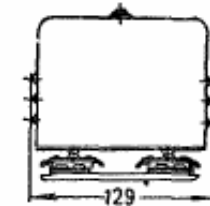

Rectifier

РАМА ВЫПРЯМИТЕЛЯ

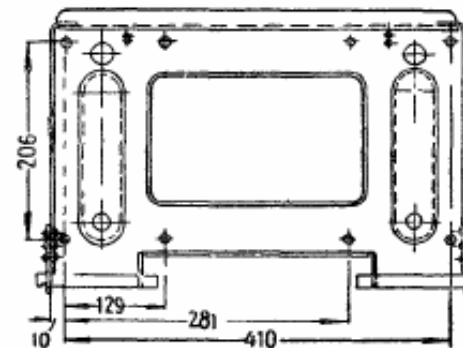

Receiver's mount

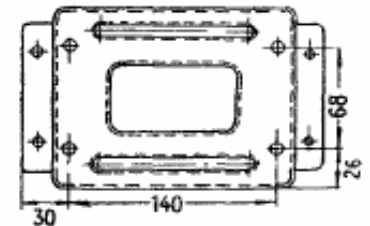

Rectifier mount

BARREL SWITCH SECTIONS DIAGRAM

ПРИЛОЖЕНИЕ 7

ПРИНЦИПИАЛЬНАЯ СХЕМА СЕКЦИЙ БАРАБАНА

Sub-range 1
143–280 kHz;

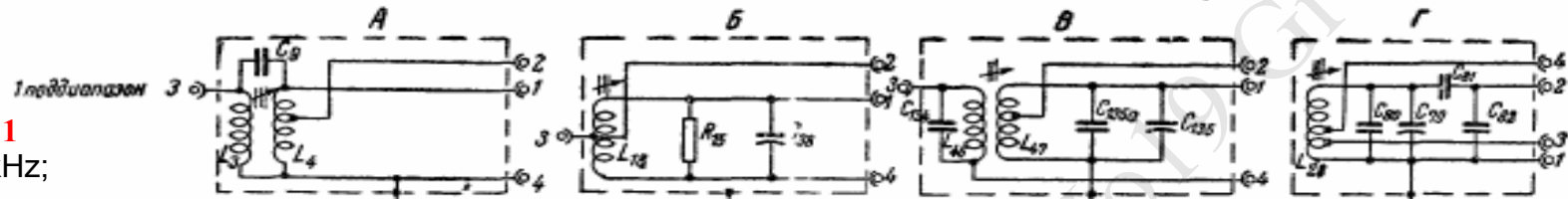

Sub-range 2
280–600 kHz;

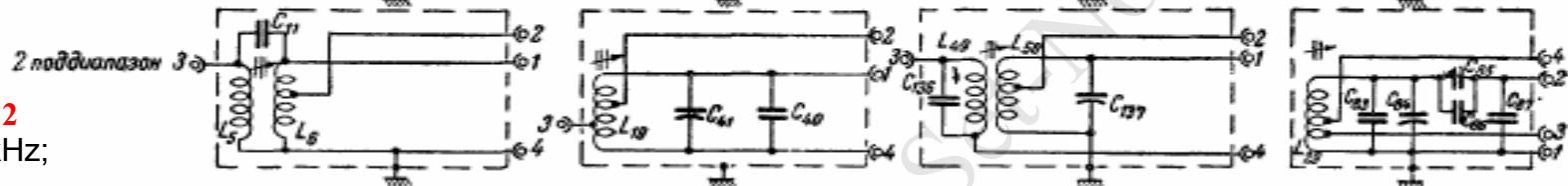

Sub-range 3
2–4 MHz

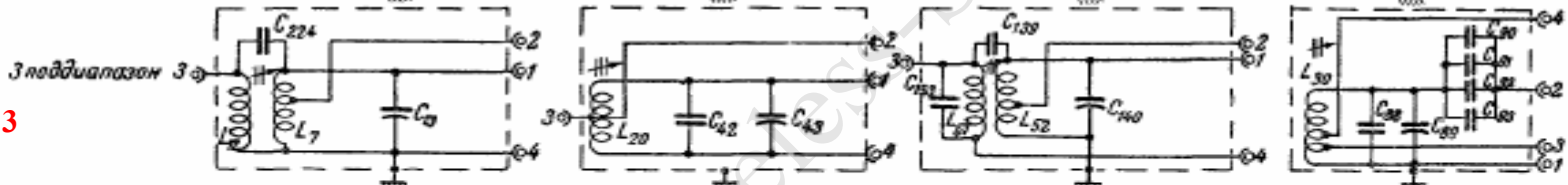

Sub-range 4
4–7 MHz

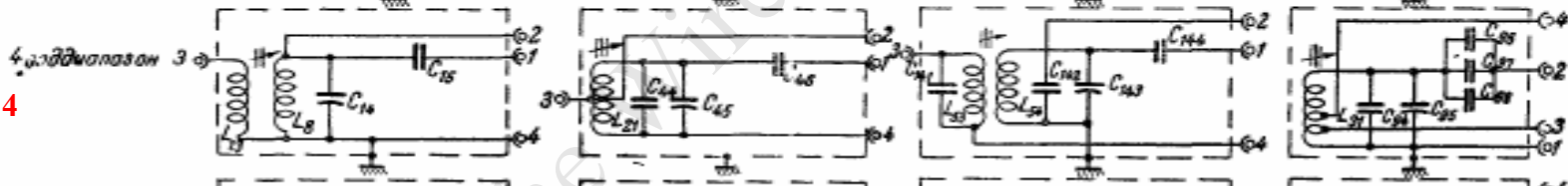

Sub-range 5
7–12 MHz;

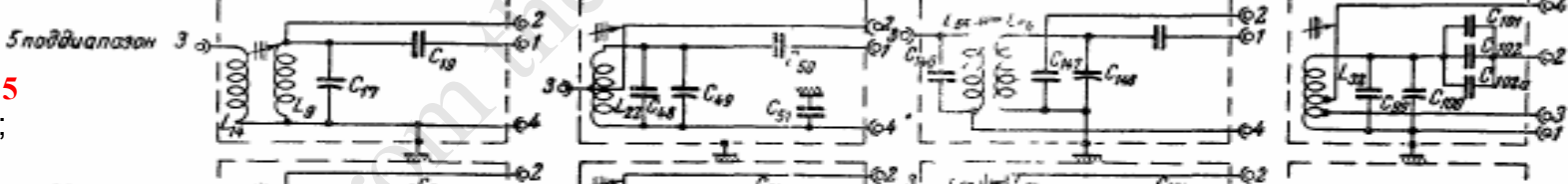

Sub-range 6
12–18 MHz

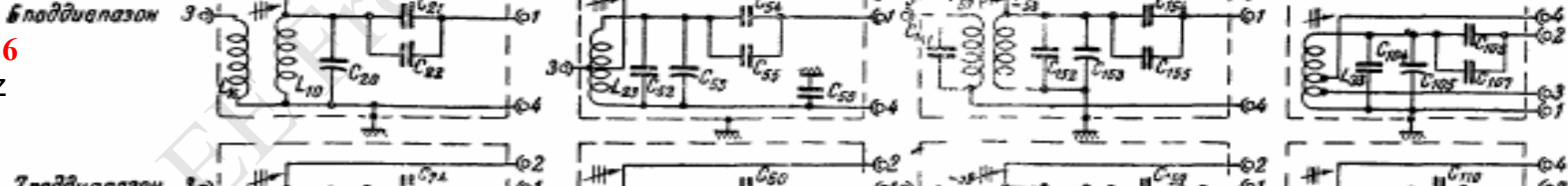

Sub-range 7
18–24 MHz.



ПРИНЦИПАЛЬНА СХЕМА РАДИОПРИЙМНИКА РІС

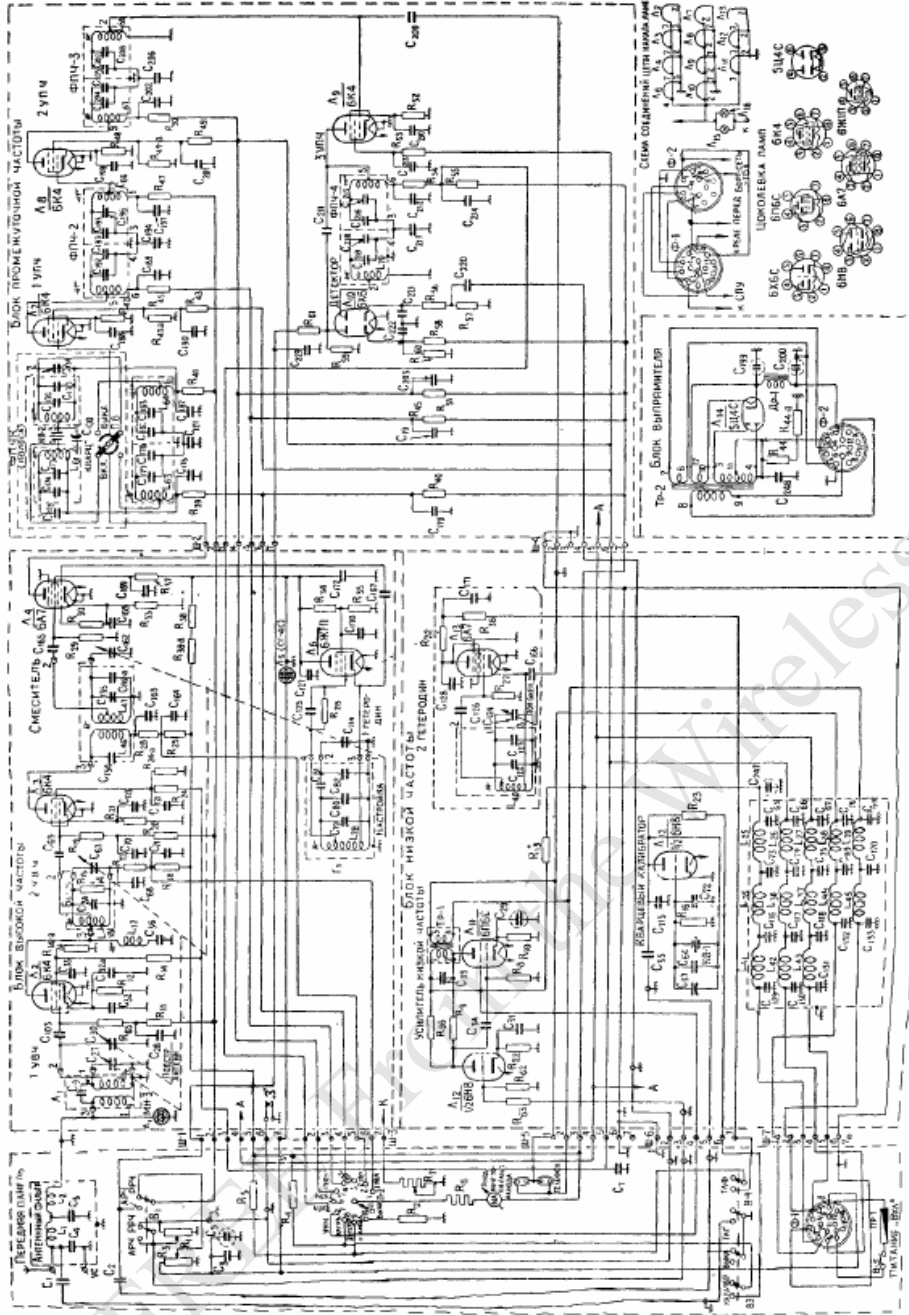

d) since the total current, consumed by receiver, on the average composes 0,56, and during the application of safety device 2 and with the short-term closings, caused by the defects of radio tubes to the fuse blowout, were possible the combustion of different elements of network - resistances, transformers, etc. For the purpose of the exception of this and of more effective work of safety device the latter is substituted from 2- ampere to the 1- the ampere; e) for the purpose of simplification in fastening receiver for the amortization frame is changed the construction of frame and articulation with the jacket of receiver. In this case the common overall sizes of article, and also sizes and arrangement of attaching holes remained without the change. 6. from January of the month of 1960 (from the receiver № 2114) installation is produced by the colored wire PMVG of 0 0,5 mm.

CHAPTER IX. SPECIFICATION to THE SCHEMATIC DIAGRAM OF RADIO RECEIVER

together with the resistances of the type VS, indicated in the present specification, enterprise for preparing the radio receiver uses the resistance OF MLT. The resistances OF MLT are made by power from 0,5 W and it is above. Therefore the resistances OF VS-0,2SHCH and VS-0,SHCH are substituted on MLT-0,SHCH. The resistances OF VS-Y and VS-2 are substituted respectively on MLT-Y and MLT-2. Resistances of the type MLT, indicated in the specification, cannot be substituted by resistances of the type VS.

ОГЛАВЛЕНИЕ

Стр.

ГЛАВА I

Назначение и основные данные радиоприемника РПС

§ 1. Назначение	3
§ 2. Состав радиоприемного устройства	—
§ 3. Вес и габаритные размеры блоков радиоприемного устройства	—
§ 4. Характеристики приемника	—

ГЛАВА II

Схема радиоприемника

§ 1. Входное устройство радиоприемника	6
§ 2. Усилитель высокой частоты	8
§ 3. Смеситель	—
§ 4. Первый гетеродин	11
§ 5. Усилитель промежуточной частоты	12
§ 6. Кварцевый фильтр	14
§ 7. Детектор	15
§ 8. Автоматическая и ручная регулировка чувствительности	16
§ 9. Второй гетеродин	18
§ 10. Кварцевый калибратор	19
§ 11. Усилитель низкой частоты	20
§ 12. Питание приемника	21

ГЛАВА III

Конструкция радиоприемника

1. Передняя панель	23
2. Конструкция верньерного механизма	—
3. Конструкция блока высокой частоты	26
4. Конструкция блока промежуточной частоты	29
5. Конструкция фильтра промежуточной частоты и кварцевого фильтра	30
6. Конструкция блока низкой частоты	31
7. Конструкция выпрямителя	32

ГЛАВА IV

Разборка и сборка радиоприемника

1. Снятие блока промежуточной частоты	34
2. Снятие передней панели	—
3. Снятие блока низкой частоты	35
4. Разборка блока высокой частоты	—
5. Сборка приемника	—

85

ГЛАВА V

Инструкция по эксплуатации радиоприемника

§ 1. Установка приемника на самолете	36
§ 2. Правила эксплуатации радиоприемника	38
а) уход за приемником	—
б) уход за преобразователем МА-100М	39
§ 3. Регламентные работы	—
а) предполетное техническое обслуживание приемника	—
б) послеполетное техническое обслуживание приемника	—
в) периодическое техническое обслуживание приемника	40

ГЛАВА VI

Ремонт радиоприемника

§ 1. Общие указания по отысканию повреждений радиоприемника	40
а) Примерный режим работы отдельных каскадов — таблица 1	43
б) Ориентировочная таблица чувствительности по каскадам при выходном напряжении 15 в и одной паре телефонов — таблица 2	44
§ 2. Список возможных неисправностей и способы их устранения	45
§ 3. Карта прозвонки монтажа радиоприемника	46
а) Карта прозвонки блока «ВЧ»	47
б) Карта прозвонки блока «ПЧ»	48
в) Карта прозвонки монтажа передней панели	49
г) Карта прозвонки монтажа блока «НЧ»	51

ГЛАВА VII

Основные электрические характеристики радиоприемника и краткая методика их измерения

§ 1. Измерение чувствительности приемника	53
§ 2. Измерение погрешности градуировки и запаса по перекрытию поддиапазона	55
§ 3. Измерение ослабления сигнала по зеркальному каналу	—
§ 4. Измерение полосы пропускания усилителя промежуточной частоты	56
§ 5. Измерение коэффициента нелинейных искажений	57
§ 6. Измерение режимов ламп	—

ГЛАВА VIII

Основные изменения, произведенные в радиоприемнике РПС

58

ГЛАВА IX

Спецификация к принципиальной схеме радиоприемника

61

Список рисунков

Рис. 1 — Общий вид радиоприемника РПС	4
Рис. 2 — Входное устройство радиоприемника	6
Рис. 3 — Блок-схема радиоприемника	7
Рис. 4 — Усилитель высокой частоты	9
Рис. 5 — Смеситель	10
Рис. 6 — Первый гетеродин	12

86

	Стр.
Рис. 7 — Усилитель промежуточной частоты	13
Рис. 8 — Кварцевый фильтр	15
Рис. 9 — Детектор сигнала и детектор АРЧ	16
Рис. 10 — Автоматическая и ручная регулировка чувствительности	17
Рис. 11 — Второй гетеродин	18
Рис. 12 — Кварцевый калибратор	19
Рис. 13 — Усилитель низкой частоты	20
Рис. 14 — Схема выпрямителя	22
Рис. 15 — Вид радиоприемника без кожуха	23
Рис. 16 — Передняя панель	24
Рис. 17 — Монтаж передней панели	25
Рис. 18 — Верньерный механизм	26
Рис. 19 — Блок «ВЧ»	27
Рис. 20 — Секция барабана	28
Рис. 21 — Блок «ПЧ»	30
Рис. 22 — Блок «НЧ»	31
Рис. 23 — Блок «В»	33
Рис. 24 — Кинематическая схема элементов переключения и настройки	—
Рис. 25 — Блок-схема измерения чувствительности приемника	54
Рис. 26 — Блок-схема измерения погрешности градуировки и запаса по перекрытию поддиапазона	55
Рис. 27 — Блок-схема измерения полосы пропускания приемника	56
Рис. 28 — Блок-схема измерения коэффициента нелинейных искажений	57
Рис. 29 — Схема 1-го гетеродина до изменения	59
Рис. 30 — Усилитель высокой частоты до изменения	60

Список таблиц

Таблица 1 — Примерный режим работы отдельных каскадов	43
Таблица 2 — Ориентировочная таблица чувствительности по каскадам при выходном напряжении 15 в и одной паре телефонов	44
Таблица 3 — Намоточные данные трансформаторов и дросселей	83

Список приложений

Приложения	84
----------------------	----