

FM 30-476

RADIO DIRECTION FINDING

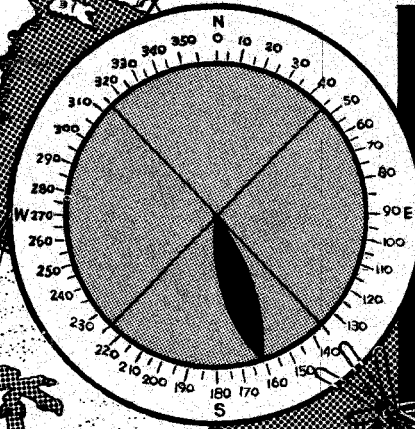

SE = BM - BI

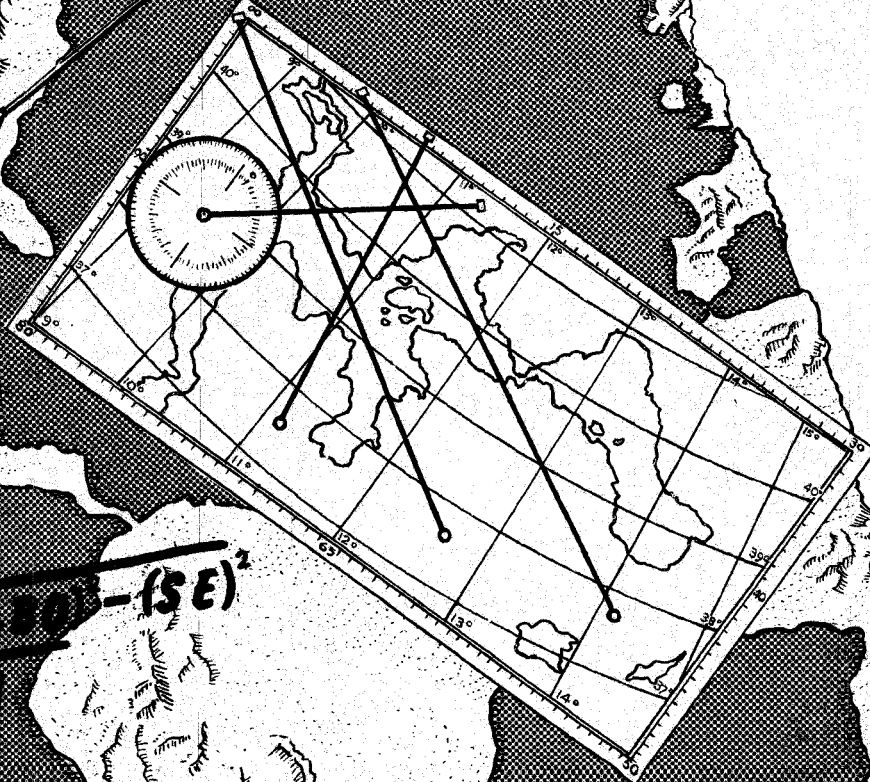

SD = YBM - BOB - (SE)²

HEADQUARTERS, DEPARTMENT OF THE ARMY

Field Manual)
)
 No. 30-476)

HEADQUARTERS
 DEPARTMENT OF THE ARMY
 Washington, DC, 8 April 1977

RADIO DIRECTION FINDING

		Paragraph	Page
Chapter	1. INTRODUCTION	1-1	1-1
	2. WAVE PROPAGATION THEORY		
Section	I. Propagation of electromagnetic waves	2-1	2-1
	II. Polarization of radio waves	2-6	2-5
	III. Propagation factors	2-10	2-8
	IV. VHF and UHF transmissions	2-21	2-18
Chapter	3. DF SYSTEM COMPONENTS AND CHARACTERISTICS		
Section	I. Radio DF antennas	3-1	3-1
	II. Transmission lines	3-14	3-27
	III. Coupling systems for DF equipment	3-15	3-27
	IV. Bearing indicators	3-20	3-34
	V. DF receivers	3-24	3-38
Chapter	4. TYPES OF DIRECTION-FINDING EFFORTS		
Section	I. Terminology associated with DF efforts	4-1	4-1
	II. Directwave direction finding	4-2	4-1
	III. Skywave direction finding	4-9	4-10
	IV. Airborne radio direction finding	4-11	4-10
Chapter	5. DIRECTION-FINDING TECHNIQUES		
Section	I. Maps	5-1	5-1
	II. DF site requirements	5-8	5-7
	III. DF errors	5-15	5-11
	IV. Plotting methods	5-22	5-15
	V. Evaluation of DF results	5-25	5-17
	VI. Determination of fix area	5-28	5-18
Chapter	6. TASKING AND REPORTING		
Section	I. Communications requirements for DF nets	6-1	6-1
	II. Tasking authority and command structure of DF nets	6-3	6-2
Chapter	7. DIRECTION FINDING COMPUTATIONS		
Section	I. Gnomonic projection correction techniques	7-1	7-1
	II. Great circle azimuths	7-4	7-5
	III. Statistical factors	7-7	7-10
Appendix	A. REFERENCES		A-1
	B. COMMON LOGARITHMS OF FUNCTIONS OF ANGLES IN DEGREES AND MINUTES		B-1
	C. DEAD RECKONING ALTITUDE AND AZIMUTH TABLE		C-1
Glossary		Glossary 1
Index		Index 1

LIST OF ILLUSTRATIONS

Figure No.	Title	Page
2-1	Electromagnetic wave radiation from a vertical antenna	2-2
2-2	E and H fields of a radiated wave	2-4
2-3	Components of an electromagnetic wave	2-4
2-4	Representation of magnetic and electric fields in horizontally and vertically polarized wave fronts	2-6
2-5	Representation of electric and magnetic fields in wave front polarized at an angle to the horizontal	2-6

*This manual supersedes TM 32-476, 25 April 1972.

<i>Figure No.</i>	<i>Title</i>	<i>Page</i>
2-6	Vertical and horizontal components of the electric field in directions other than vertical or horizontal	2-7
2-7	Successive directions of the electric field in a circularly polarized electromagnetic field	2-7
2-8	Successive directions of the electric field in an elliptically polarized electromagnetic field	2-7
2-9	Groundwaves and skywaves	2-8
2-10	Wave penetration	2-9
2-11	Approximate heights of ionospheric layers	2-10
2-12	Reflected and direct routes for radio waves	2-11
2-13	Atmospheric ducting and refracted routes for radio waves	2-12
2-14	Wave front of normally polarized wave	2-13
2-15	Horizontal and vertical components of electric force	2-14
2-16	Vertical electric force in a wave traveling over a high-conductivity surface	2-14
2-17	Elliptical electrical force in wave traveling over a low-conductivity surface	2-14
2-18	Reflection and refraction of a light beam	2-15
2-19	Reflection of a planar wave front	2-16
2-20	Bending of a wave front by refraction	2-16
2-21	Diffraction of waves around a solid object	2-17
2-22	Multihop transmission	2-18
3-1	Polar diagram	3-1
3-2	Simple loop antenna	3-2
3-3	Circular loop antenna	3-3
3-4	Loop antenna, figure-eight response pattern	3-4
3-5	Azimuth scales	3-5
3-6	Change in loop position versus change in signal voltage	3-6
3-7	Cardioid response pattern obtained by combination of circular and figure-eight voltages	3-6
3-8	Loop and sense antenna system, relationship of voltages	3-7
3-9	Relationship of voltages in loop and sense antenna systems when the loop has been rotated 180 degrees from the position shown in figure 3-8	3-8
3-10	Cardioid response pattern	3-9
3-11	Response pattern, low sense voltage, and correct phase position	3-10
3-12	Response pattern, low sense voltage, and correct phase relation	3-10
3-13	Response pattern, proper ratio of sense, and figure-eight voltage with correct phase relation	3-11
3-14	Response pattern, high sense voltage, and proper phase relation	3-11
3-15	Response pattern, low sense voltage, and incorrect phase relation	3-11
3-16	Method of balancing antenna effect	3-13
3-17	Effects of winding arrangement	3-15
3-18	Distributed capacities in solenoidal loop	3-16
3-19	Adcock antenna, effects of vertically polarized waves	3-18
3-20	Adcock antenna, effects of horizontally polarized waves	3-19
3-21	Simple U-Adcock antenna	3-19
3-22	Shielded U-Adcock antenna	3-20
3-23	Grounded H-Adcock antenna	3-21
3-24	Balanced H-Adcock antenna	3-21
3-25	Coupled H-Adcock antenna	3-21
3-26	Balanced-coupled Adcock antenna	3-22
3-27	Effects of tilting an Adcock antenna	3-23
3-28	Common spaced-loop types	3-24
3-29	Spaced-loop antenna response patterns	3-25
3-30	Doppler direction finding	3-26
3-31	Transmitter lies along a line perpendicular to the wave front	3-27
3-32	Quasi-Doppler direction finder antenna array	3-28
3-33	Direction finding by a Quasi-Doppler system	3-29
3-34	Basic goniometer circuit	3-31
3-35	Goniometer system, directional characteristics	3-32
3-36	Typical position of azimuth scale on instantaneous indicator (oscilloscope)	3-36

<i>Figure No.</i>	<i>Title</i>	<i>Page</i>
4-1	Direct wavepath	4-2
4-2	Wave reflection and reradiation	4-2
4-3	Reradiation of transmitted signal	4-3
4-4	Groundwave DF	4-6
4-5	Concave baseline	4-7
4-6	Convex baseline	4-7
4-7	DWDF net with curving baseline	4-7
4-8	Enemy transmitter masked to friendly DF stations	4-8
5-1	Cone and cylinder, developable surfaces	5-1
5-2	Great circles	5-2
5-3	Projection of a sphere showing the arrangement of longitudes and latitudes	5-2
5-4	Diagram of the globe indicating the derivation of longitude	5-3
5-5	Diagram of the globe indicating the derivation of latitude	5-3
5-6	Mercator projection on a cylinder indicating method and showing polar distortion	5-4
5-7	Azimuthal equidistant projection centered on New York	5-5
5-8	Map of the world showing typical zones of magnetic variation	5-6
5-9	Compass rose	5-7
5-10	Declination diagrams	5-8
5-11	Field pattern	5-10
5-12	Short scatter	5-12
5-13	Long scatter	5-12
5-14	Effects of skip zone reception on bearing error	5-13
5-15	Error caused by the refraction and reflection of a radio wave	5-14
5-16	Plotting a bearing	5-16
5-17	Plotting a cut	5-17
5-18	Plotting a perfect DF fix	5-18
5-19	Three-station fix, error triangle	5-19
5-20	Error triangle solution	5-20
5-21	Angle increase comparison	5-21
5-22	Plotting using reported bearings and data base	5-21
6-1	DF net control arrangement	6-3
7-1	Spherical right triangle	7-2
7-2	Right triangle computation worksheet	7-3
7-3	Spherical triangle	7-3
7-4	GCAD computation worksheet	7-4

LIST OF TABLES

<i>Table No.</i>	<i>Title</i>	<i>Page</i>
2-1	Frequency ranges and band designators	2-1
5-1	Preferred distance from obstacles	5-9

"The word "he" is intended to include both the masculine and the feminine genders and any exceptions to this will be so noted."

This publication was prepared by the US Army Intelligence School, Fort Devens for use by personnel assigned to US Army tactical support units.

CHAPTER 1

Introduction

1-1. Purpose.

This manual prescribes basic radio Direction-Finding (DF) principles and techniques for personnel responsible for the employment and operation of DF equipment.

1-2. Scope.

This manual includes information pertaining to:

- a. Propagation of radio waves.
- b. Directional properties and types of directional antennas.
- c. Types of DF efforts.
- d. DF plotting.

1-3. Comments and Recommendations.

Users of this publication are encouraged to submit recommended changes and comments to improve the publication. Comments should be keyed to the specific page, paragraph, and line of the text in which the change is recommended. Reasons should be provided for each comment to ensure understanding and complete evaluation. Comments should be prepared using DA Form 2028 (Recommended Changes to Publications) and forwarded direct to the Commander, US Army Intelligence School (Fort Devens), ATTN: ATSIIE-TD-TS-TL, Fort Devens, Massachusetts 01433.

1-4. Concept of Warfare.

The information contained in this manual is applicable to nonnuclear warfare.

1-5. Definition, Capabilities, and Limitations of Radio Direction Finding.

a. DF is concerned with determining the arrival direction of a radio wave. Unlike an ordinary radio receiver, a DF receiver, with associated equipment, indicates the approximate direction along an imaginary line on which a distant transmitter lies. While information obtained by DF may not always be accurate enough to direct artillery fire, the direction of a distant transmitter can be determined, in most cases, to an accuracy on the order of ± 2 degrees. One DF site can determine only the approximate direction of a distant transmitter. However, by the use of two DF sites, the approximate location of a transmitting antenna can be found. By the use of three DF sites, a fixed location can be found.

b. The theory of DF has remained reasonably static since the early history of the study of electromagnetic wave phenomena. Initially, attempts were made to obtain directional transmissions because early transmitters were relatively low powered and inefficient in their output and receivers were relatively insensitive. Efforts were undertaken to "direct" the transmitted wave toward the receiving device to ensure communications rather than to determine locations. The useful applications of DF were obtained almost simultaneously with the effort to provide directional transmissions.

1-6. Military Use of DF.

DF is extensively used as navigation aids, as sources of signal intelligence, and in electronic warfare support measures.

a. Navigation. As navigational devices, DF equipment is either used alone or in combination with radio communications systems, depending upon the service which is to be provided. Such service includes the positioning, controlling, and homing of ground, sea, and air forces. DF equipment is also used by rescue personnel as an essential part of air-sea rescue. Crash beacons on downed aircraft or disabled ships provide a signal which can be located or "homed-in" on by use of DF equipment.

b. Signal Intelligence. The use of radio in military communications has increased the

value of DF in furnishing signal intelligence. Even if a hostile force is extremely careful, his transmissions by radio can be intercepted and the location of his transmitters determined. This information is invaluable when used by traffic analysts in determining order of battle.

c. Electronic Warfare Support Measures. Electronic Warfare Support Measures (ESM) are those actions taken to search for, intercept, locate, record, and analyze radiated electromagnetic energy for the purpose of exploiting such radiations in support of military operations. ESM activities provide the operational information required to conduct Electronic Countermeasures (ECM), Electronic Counter-Countermeasures (ECCM), threat detection, warning, avoidance, target acquisition, and homing.

Wave Propagation Theory

Section I

PROPAGATION OF ELECTROMAGNETIC WAVES

2-1. General.

In order to understand how a radio receiver intercepts or "hears" signals from the atmosphere, a basic introduction to radio waves is necessary. This section describes the nature of radio waves and the basic principles involved in the propagation of radio waves from a transmitting station to a receiver or DF site. Since DF involves determination of the arrival direction of these waves, an understanding of these principles will improve the results obtained with DF equipment. If a more detailed study of wave transmission phenomena is required, additional information may be found in TM 11-666, Antennas and Radio Propagation, and TM 11-665, CW and AM Radio Transmitters and Receivers.

a. The frequency bands and their designators which are detailed in table 2-1 provide the commonly accepted limits of each band. Information which follows in this manual is primarily applicable to the DF effort on frequencies up through the High Frequency (HF) band.

b. Transmissions using frequencies in the Very High Frequency (VHF) and higher bands are identified as line-of-sight transmissions. This type of signal is used in communications and is vulnerable to DF but,

Table 2-1. Frequency Ranges and Band Designators

FREQUENCY RANGE	BAND DESIGNATOR
30 to 300 Hertz (Hz)	Extremely Low Frequency (ELF)
300 to 3000 Hz	Voice Frequency (VF)
3 to 300 Kiloherzt (kHz)	Very Low Frequency (VLF)
30 to 300 kHz	Low Frequency (LF)
300 to 3000 kHz	Medium Frequency (MF)
3 to 30 Megahertz (MHz)	High Frequency (HF)
30 to 300 MHz	Very High Frequency (VHF)
300 to 3000 MHz	Ultrahigh Frequency (UHF)
3 to 30 Gigahertz (GHz)	Superhigh Frequency (SHF)
30 to 300 GHz	Extremely High Frequency (EHF)

since it uses the directwave component of the groundwave (para 2-11), it is limited in effective range. Section IV of this chapter furnishes additional information concerning higher frequency uses.

2-2. Electrical Component of Radio Waves.

a. To transmit, an antenna must be coupled to a transmitter through a coil or other electrical device. The electromagnetic wave front, or wave, which is required for transmission consists of an electrical field and a magnetic field, identified in this manual as the E and H field respectively.

b. The analogy of a pebble dropped into a smooth pond or body of water, with the resulting waves or ripples traveling in concentric circles outward from the point of disturbance, has often been used to illustrate radio wave action from a transmitter. The wave front alternately reverses polarity due to changes in the voltage applied to the antenna. Capital A, figure 2-1 illustrates this principle with the electrical lines of force at any given instant showing a positive polarity. Since electrical charges of a like polarity repel one another, these lines of force are illustrated as bowed out but shortening themselves as much as possible to the earth since they cannot expand indefinitely. When the antenna

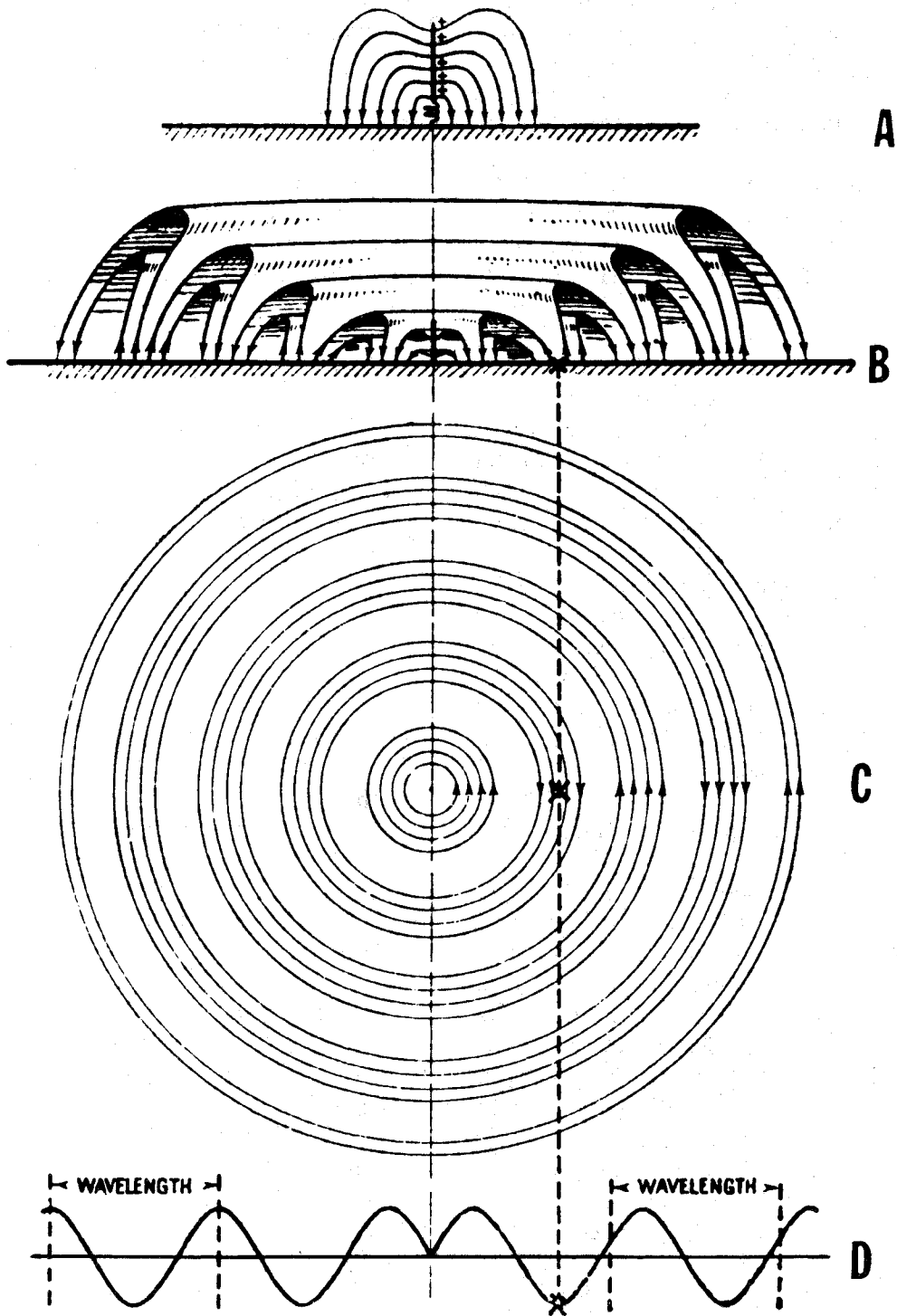

Figure 2-1. Electromagnetic wave radiation from a vertical antenna.

current changes polarity, the electrical field collapses momentarily, builds again, and assumes opposite polarity. The full cycle is illustrated in Capital B, figure 2-1. The arrowheads at the end of each line indicate the force reversing itself alternately. The electrical component of the wave continues to perform in this manner as long as the transmitter is keyed. This reversal of polarity is again observed at Capital C, figure 2-1, by the arrowheads reversing their direction periodically. Capital D, figure 2-1 equates this action to wavelength which is discussed later in this chapter. Shields, reflectors, or other devices may be attached to or installed near a transmitting antenna to make these electromagnetic waves highly directional; however, for this discussion, only omnidirectional transmissions are explained.

c. This manual does not discuss fully the electrical theory associated with electromagnetic wave propagation. To do so would involve an elaborate study of induction, flux fields and densities, right and left hand rules with regard to current flow, and many other details.

2-3. Magnetic Components of Radio Waves.

A magnetic component (H field) that cannot be dissociated from the electrical field at any time exists in the radiated wave. In paragraph 2-2, the continuing change of polarity, or oscillation, of the transmitted wave was discussed. Thus, oscillating electrical and magnetic fields are produced along the path of wave travel. The frequency of the oscillating fields is the same as the frequency of the antenna current, and the magnitudes of both fields vary continuously with this current. The variations in the magnitude of the electrical component (E field) and those of the magnetic component (H field) are in time phase, so that at every point in space the time-varying magnetic field induces a difference in voltage, which is the electric

field. Thus, the varying magnetic field produces a varying electric field, and the varying electric field, through its associated displacement current, sustains the varying magnetic field. Each field supports the other, and neither can be propagated by itself. Figure 2-2 illustrates the interrelationship of the two fields (components). It should be kept in mind that figure 2-2 illustrates only one transverse section of the entire wave front, which fills all the space shown in the figure.

2-4. Wavelength.

The conventional way of illustrating the electrical and magnetic force of any electromagnetic wave is by a sine curve, as in Capital D, figure 2-1. If a wave were visible, it would look like a sine curve, curving above and below a base line. The distance between the forces at maximum intensity in the same direction is known as the wavelength. Wavelength may also be defined as the distance between two points where the forces are identical in intensity and are changing in the same manner. Figure 2-3 is another method of illustrating the various components of the radio wave. Both elements of the wave are present regardless of polarity (which is discussed in section II, this chapter); however, all discussion and illustrations have dealt with the vertical element.

2-5. Frequency.

a. Frequency is the actual number of occurrences in one unit of time of the sine curve illustrated in Capital D, figure 2-1. The frequency of a transmitted wave is measured in Hertz (Hz), Kilohertz (kHz), Megahertz (MHz), or Gigahertz (GHz). Some existing manuals may contain frequency references using Cycles Per Second (c/s), Kilocycles (kc), Megacycles (Mc), or Gigacycles (Gc). The National Bureau of Standards and the Department of Defense (DOD) have adopted

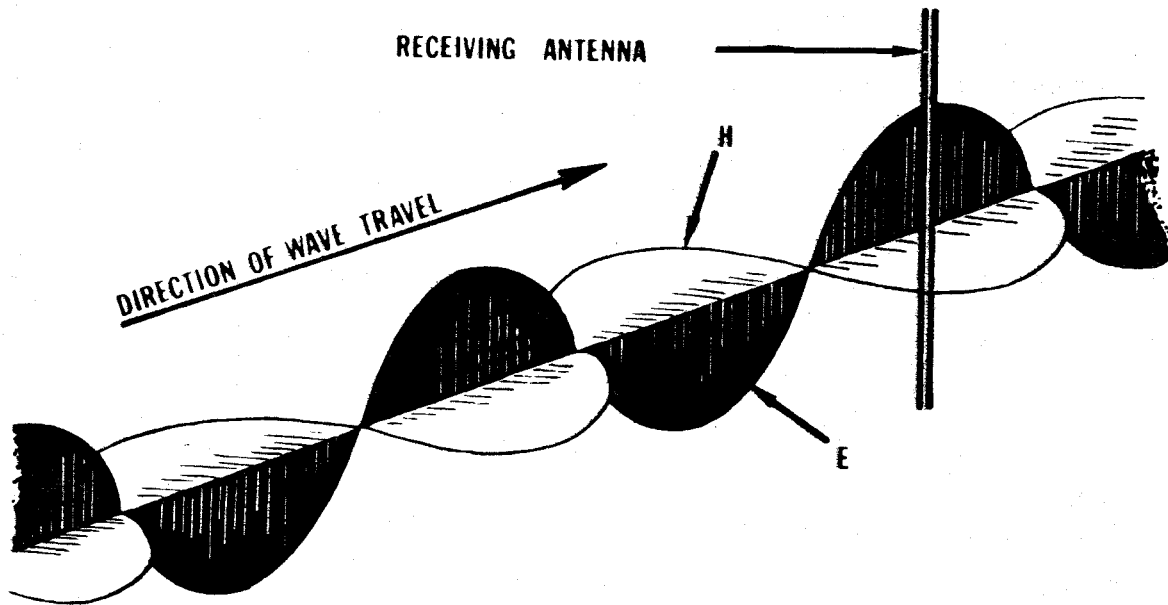

Figure 2-2. E and H fields of a radiated wave.

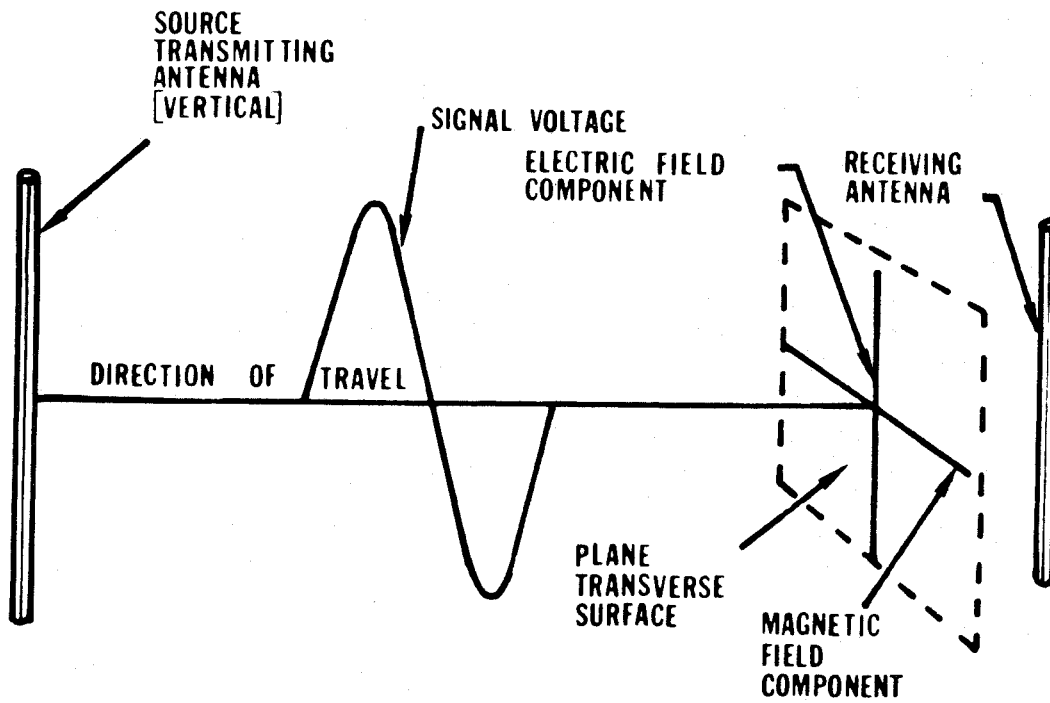

Figure 2-3. Components of an electromagnetic wave.

the term Hertz as the standard method of referring to frequency.

b. A conversion formula for wavelength and frequency is shown below. If the measurement in *Hertz* is known and a conversion to wavelength is desired, apply:

$$\text{Wavelength (meters)} = \frac{300,000,000^*}{\text{Frequency (Hz)}}$$

If wavelength (in meters) is known and a conversion to frequency (Hz) is desired, apply:

$$\text{Frequency (Hz)} = \frac{300,000,000}{\text{Wavelength (meters)}}$$

Section II

POLARIZATION OF RADIO WAVES

2-6. General.

Polarization, or the relationship of the different fields in the transmitted wave, may be either vertical, horizontal, or a mutation which adopts portions of the vertical and horizontal. The latter results in a circular or a hybrid form of a wave. This manual will deal primarily with vertical and horizontal polarization. If a whip or other vertical type transmitting antenna is used to propagate radio waves, the transmitted wave is considered to be vertically polarized. If the transmitting antenna is horizontal relative to the ground or earth's surface, the transmitted wave is horizontally polarized. The direction the electric field moves relative to the ground is taken as the reference point and determines the polarization of the wave.

2-7. Vertical Polarization.

Imagine a rope lying reasonably straight on the ground with one end attached firmly to a tree or other support. If the loose end of the

rope is raised, tightened, and given a violent up and down motion, a series of undulating "waves" will travel along the rope. Although the rope remains firmly attached and firmly grasped, the movement of the waves up and down, vertical to the ground, can be clearly observed. Radio waves perform in a manner similar to the waves produced along the rope. As long as the E field component of the waves moves up and down with reference to the earth, they are identified as being vertically polarized. Ocean waves are vertically polarized since the wave movement is up and down. There is a definite effect produced by these waves, although there is little horizontal movement of the water through which the wave passes.

2-8. Horizontal Polarization.

If the same rope had a movement applied in a horizontal manner, the waves would be in a horizontal plane and would be called horizontally polarized waves.

2-9. Plane Polarization.

From paragraphs 2-7 and 2-8, it is easy to imagine taking the same rope and giving it a violent shake in any particular angle relative to the earth resulting in a straight line, not necessarily vertical or horizontal. In all three cases, however, the wave would be polarized along a plane (plane polarized waves), a name given to any system of transverse wave motion which takes place in one plane due to the direction of propagation, whether it be vertical, horizontal, or any intermediate direction.

a. *Linear Polarization.* Vertical and horizontal polarization, illustrated in figure 2-4 are two examples of a form of polarization known as linear polarization. The term linear means that (except for the 180

*The speed of light in meters per second which is the speed at which radio waves travel.

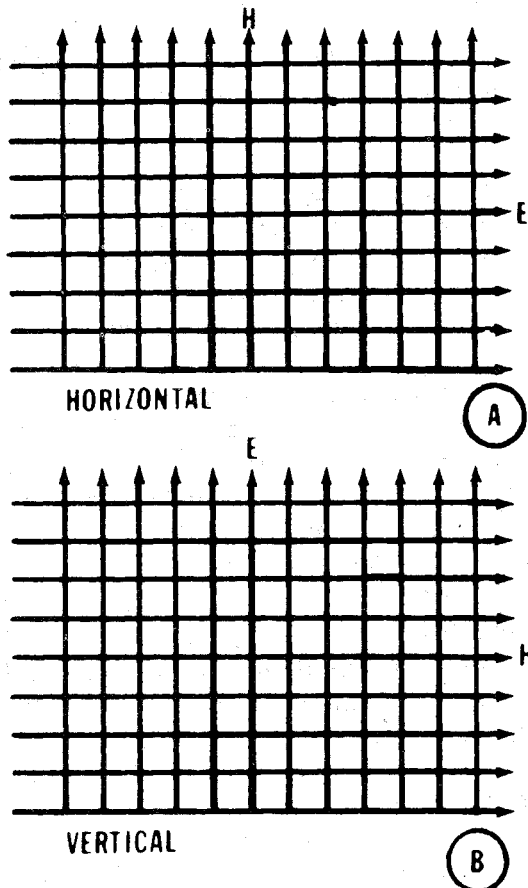

Figure 2-4. Representation of magnetic and electric fields in horizontally and vertically polarized wave fronts.

degree phase reversal during a cycle) the orientation of the electric field does not change. In other words, the electric field of a horizontally polarized wave always remains horizontal, and the electric field of a vertically polarized wave always remains vertical. By various means it is possible to produce a linearly polarized wave at any angle. A linearly polarized wave at an angle of 45 degrees from the horizontal is shown in figure 2-5. One method of producing this direction of polarization is to tilt a horizontally polarized aircraft antenna to a 45 degree angle. Tilting the electric field in this manner serves no useful purpose insofar as radiation in this form is concerned, but it can be used as a starting point for introducing another type of polarization, referred to as circular polarization.

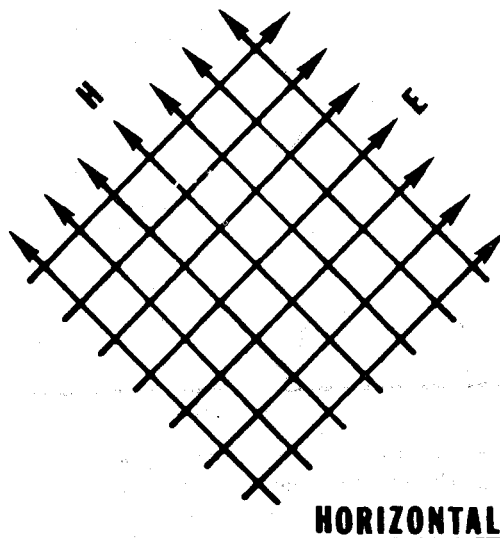

Figure 2-5. Representation of electric and magnetic fields in wave front polarized at an angle to the horizontal.

b. *Circular Polarization.* Assume that an electric field is tilted at a 45 degree angle as shown in figure 2-5 and further assume that by the use of some device it is possible to resolve this field into its horizontal (E_h) and vertical (E_v) components as shown in figure 2-6. These two components would still be in phase; that is, measured at a given point, both E_h and E_v would have the same relative amplitude at any given time. If either component is shifted in phase by 90 degrees, or one quarter wavelength, a new type of polarization becomes possible. If it is assumed that the horizontal component E_h has been retarded 90 degrees in phase, then when E_v has maximum amplitude, E_h is zero, and vice versa. The E vector is shown in figure 2-7 for several different conditions of E_h and E_v . To an observer standing in one spot and able to

“see” the electric field, the field would appear to have a circular motion and a constant amplitude.

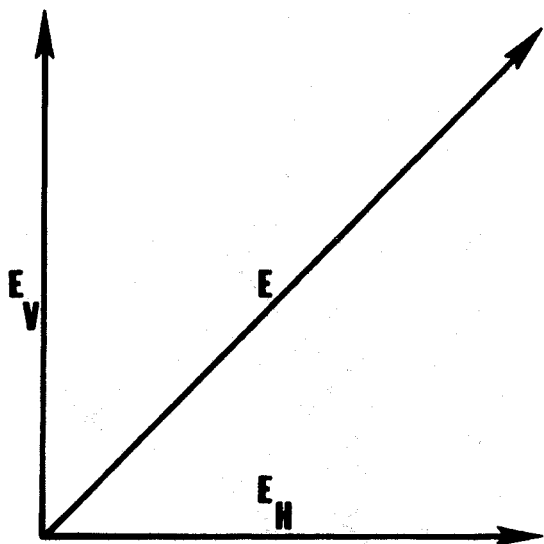

Figure 2-6. Vertical and horizontal components of the electric field in directions other than vertical or horizontal.

- AT $E_1; E_H = 0, E_V = \text{MAX POSITIVE}$
- AT $E_2; E_H = E_V, \text{ BOTH POSITIVE}$
- AT $E_3; E_V = 0, E_H = \text{MAX POSITIVE}$
- AT $E_4; E_H = 0, E_V = \text{MAX POSITIVE}$
- AT $E_5; E_V = 0, E_H = \text{MAX POSITIVE}$

c. *Elliptical Polarization.* In the development of a circularly polarized wave, any attenuation introduced by the phase-shifting device must produce the same effect on both E_H and E_V . If this condition is not obtained, the peak amplitudes of E_H and E_V will not be the same. As a result, the electric field as “seen” by the observer will vary in both amplitude and direction, and will describe an elliptical path. Hence, the resulting polarization is known as elliptical polarization. Two possibilities of elliptical polarization are shown in figure 2-8.

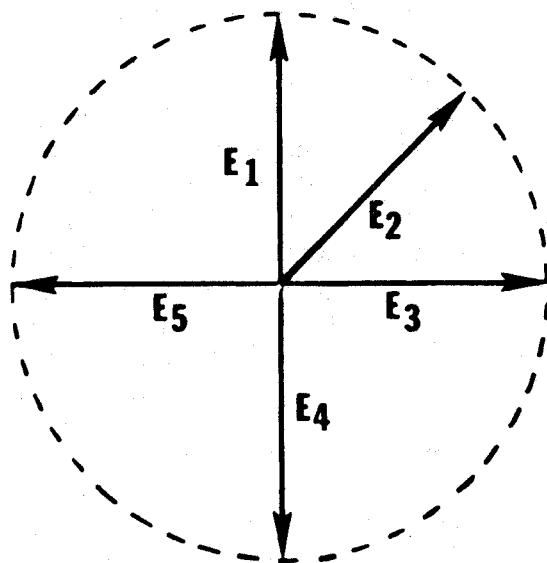

Figure 2-7. Successive directions of the electric field in a circularly polarized electromagnetic field.

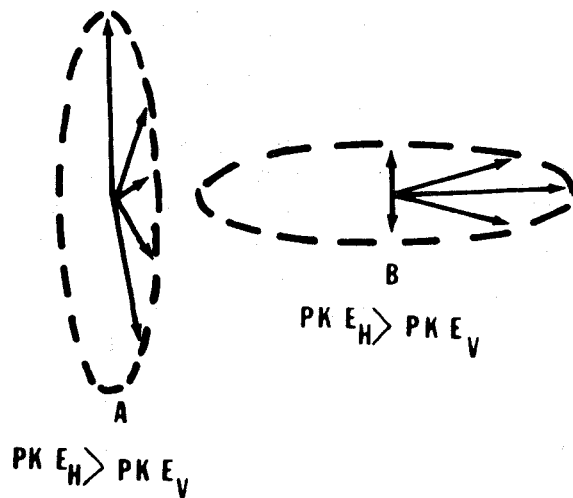

Figure 2-8. Successive directions of the electric field in an elliptically polarized electromagnetic field.

Section III
PROPAGATION FACTORS

2-10. Electrical Phenomena in Radio Wave Propagation.

Radio wave propagation is defined as extending or transmitting electromagnetic energy through space. There are numerous factors affecting radio propagation. Wavelength, frequency, and polarization, which have been discussed previously, are all essential elements of the actual wave. Space, or the medium through which waves travel, contributes or creates additional considerations which personnel engaging in or using DF results must understand.

2-11. Types of Radio Waves.

Radio waves may be classified as either groundwaves or skywaves (fig. 2-9).

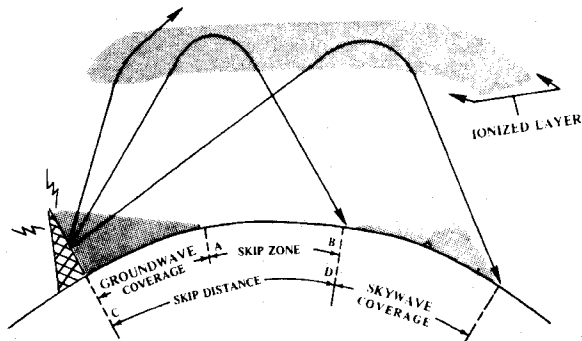

Figure 2-9. Groundwaves and skywaves.

a. Groundwaves are continuously in contact with the earth's surface and do not make use of reflection from the ionosphere. They have a tendency to be refracted and, in some cases, reflected into the lower atmosphere. At frequencies above 1500 kHz, a groundwave is affected very little by the time of day or season. The groundwave loses much of its strength and dissipates energy as

it travels over the earth's surface. However, less strength is lost when it travels over water.

b. Skywaves are transmitted upward with respect to the earth's surface. Skywaves would not be useful for communications were it not for the ionosphere, a region of ionized gases in the earth's atmosphere located some 50 to 400 kilometers above the earth's surface. Radio waves approaching the ionosphere at an angle are refracted (para 2-18) back to earth where they may be detected and used for communications purposes or for DF exploitation. Figure 2-10, similar to figure 2-9, represents the waves that penetrate the ionosphere and are lost for all practical purposes, and also those waves that return to earth for communications use.

2-12. The Ionosphere.

The ionosphere consists of a series of layers of ionized gases which occur at different levels and vary in intensity and height above the earth's surface during the course of the day. An important relationship between radio waves and the ionosphere is that the higher the frequency, the less will be its tendency to bend as it enters the ionized area. Dependent upon ionospheric conditions and the angle of the signal's arrival at the ionosphere, the bending will be so slight that the radio waves will not be sent back to earth, but will continue into space (fig. 2-10).

a. Factors which influence the ionosphere, and therefore its effect on radio waves, are the time of day, the season of the year, solar flares, magnetic storms, and certain manmade disturbances such as atomic detonations. More information may be obtained concerning this phenomena by consulting any standard reference encyclopedia and reading of the efforts of three physicists, Kennely, Heaviside, and Appleton, who were early pioneers in this area.

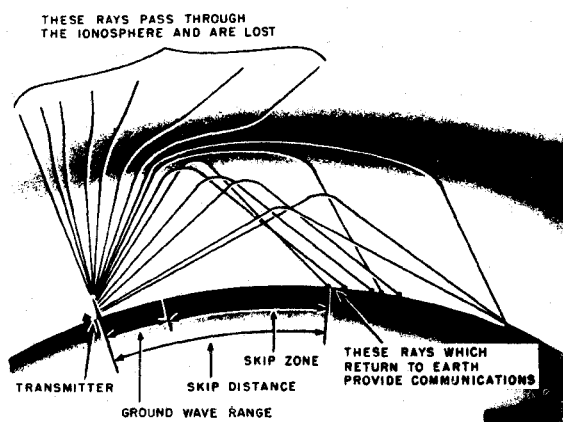

Figure 2-10. Wave penetration.

b. For the purpose of this manual, however, the reader must understand that there are essentially four layers (D, E, F1, and F2) of the ionosphere which affect communications, propagation, and DF.

(1) Some of these layers combine during periods of varying ionization. Exposure of the atmosphere to the sun causes ionization, and the degree of ionization is determined by the duration of exposure. During daylight hours, the ionization reaches a maximum intensity at approximately 400 kilometers above the earth's surface.

(2) To describe the term "varying ionization," it is necessary to briefly discuss the matter which is present in the ionosphere and the mechanics of ionization. Energy in the form of electromagnetic radiation of the proper wavelength and energy is capable of dislodging some loosely bound electrons from their atoms. When this occurs frequently in any gas, it is said to be ionized since it has atoms lacking electrons and free electrons dissociated from any atom. Atoms lacking their normal quota of electrons are called positive ions, and electrons dissociated from any atom are called negative ions. The term ion is, in fact, applied to any elemental

particle that has an electric charge. Although a few ions may exist in any gas, external energy must be applied to the atom in order to produce an abundance of ions. Ionization is said to exist when all or a large proportion of the particles in the gas are positive and negative ions. Although external energy may come from many sources, we are primarily interested in the ultraviolet rays the sun constantly gives off which ionize the gas particles of the upper atmosphere. This ionization is not static and recombination takes place continuously. The rate of recombination depends in part upon the density of the gas molecules. The atoms and ions in a gas are in constant motion, and frequent collisions take place. When an electron collides with a positive ion, it may combine with it to form a neutral atom of the gas. The time that it takes for recombination, or deionization, depends on several factors, but principally upon the average distance between the particles of the gas. If only a few particles are present, as in the upper atmosphere, collisions will not occur very frequently, and the particles remain ionized for relatively long periods.

c. Other changes in composition occur (F layers combine), and it becomes a thin layer at an altitude of approximately 270 kilometers. At night, the higher radio frequencies are more likely to penetrate the ionosphere and be lost. Therefore, as a rule, lower communications frequencies are used during the night. Conversely, during the day when the ionization of the atmosphere is more intense, higher communications frequencies can be used without undue loss of the signal because of penetration of the ionized layer. Changes in the relative proximity of the sun to the earth cause gradual changes in the ionosphere. The longer exposure of the ionosphere to the sun during the summer causes a greater degree of ionization during both night and day. Therefore, higher frequencies may be used for

summer operation. Figure 2-11 presents the approximate heights of the various layers of the ionosphere.

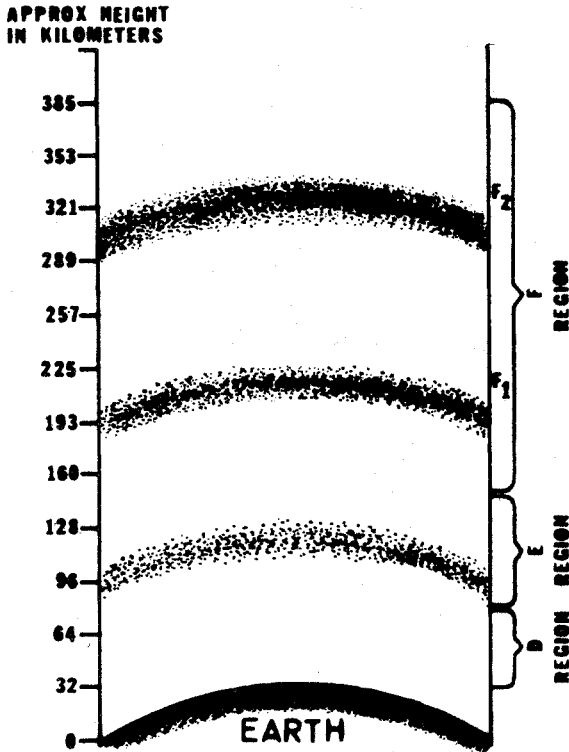

Figure 2-11. Approximate heights of ionospheric layers.

d. Remember, however, that the actual number of layers, their heights above the earth, and the relative intensity of ionization present, all vary from hour to hour, from day to day, from month to month, and from year to year. There are many ionospheric predictions generated to determine the best skywave frequencies over any transmission path at any time of day and for average conditions for the month. Ionospheric prediction information can be obtained from the Bureau of Standards. A pamphlet called the "Monthly Basic Radio Propagation Predictions" can be obtained 3 months in advance from the Central Radio Propagation Laboratories, National Bureau of Standards,

Washington, DC 20234. Information regarding radio wave propagation may also be obtained by writing to: Commander, USACEEIA, ATTN: ACCC-CED-RP, Fort Huachuca, AZ 85613.

2-13. The Stratosphere.

The stratosphere is that portion of the earth's atmosphere between the troposphere and the ionosphere. Since the temperature in this region is considered to be almost constant, it is also known as the isothermal region. The stratosphere has little if any effect on radio waves which are transmitted through it, and it is mentioned only to differentiate the three major regions of the earth's atmosphere.

2-14. The Troposphere.

a. The troposphere, which greatly influences communications, is that portion of the earth's atmosphere extending from the surface of the earth to heights of approximately 95-105 kilometers. In transmitting a wave, there are four distinct paths that the wave may take to reach the receiving antenna: direct, reflected, refracted, and tropospheric ducting. The direct and reflected paths shown in figure 2-12, are purposely exaggerated to enable the reader to clearly grasp the differences. The direct path goes directly from the transmitting to the receiving antenna. The reflected path "bounces" off the ionosphere, troposphere, or the surface of the earth at the same angle of arrival and continues to the receiving antenna. The refracted path is the path caused by the bending of the waves in the same manner light waves are bent when seen through water. If the waves are refracted by the earth, the distance they travel is severely limited due to large losses of energy in the form of heat dissipated into the earth's crust. By contrast, those waves refracted by the troposphere may travel great distances.

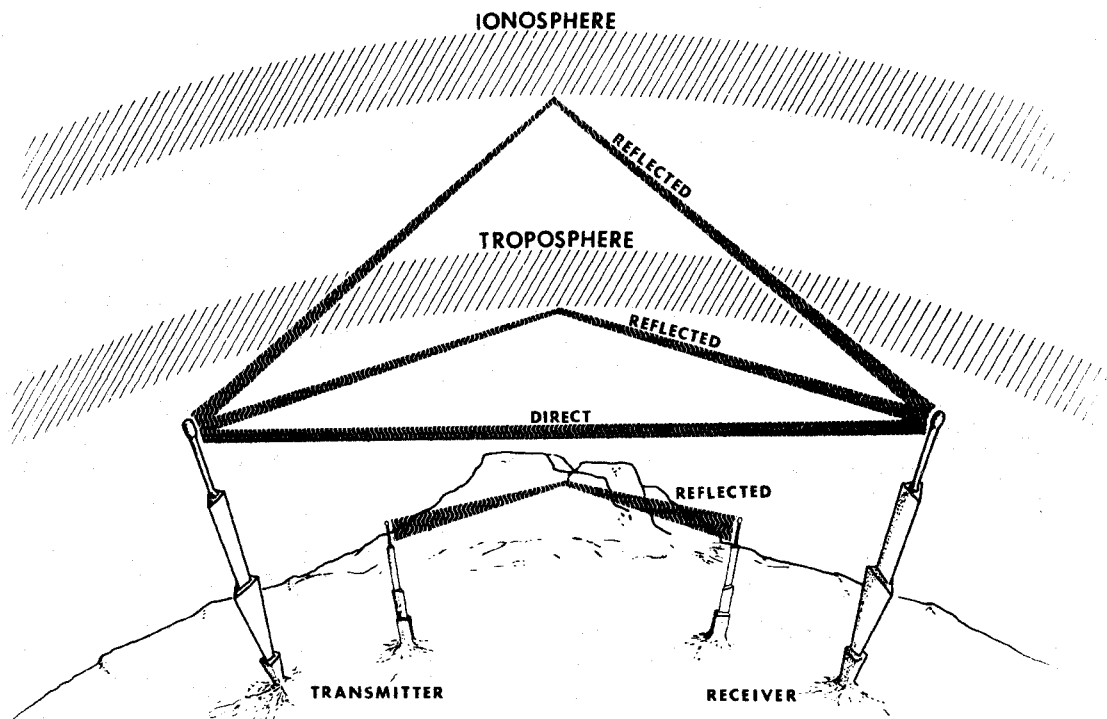

Figure 2-12. Reflected and direct routes for radio waves.

b. The tropospheric path is a combination of reflection, refraction, and certain "channeling" phenomena caused by the humidity and density of the atmosphere. The term tropospheric "scatter" is also widely used for descriptive purposes. The tropospheric wave is that component of the entire wave front which is refracted in the lower atmosphere by relatively steep gradients (rapid changes in respect to height) in atmospheric humidity, and sometimes by steep gradients in atmospheric density and temperature. At heights varying from a few hundred meters to a kilometer or so, huge masses of warm and cold air exist near each other, causing abrupt temperature differences and changes in density. The resulting tropospheric refraction and reflection make communications possible over distances far

greater than can be covered by the ordinary groundwave. Depending upon the dielectric constant and the moisture content of the troposphere, the radio waves may be refracted upward or downward, as depicted in figure 2-13. Since the amount of refraction increases as the frequency increases tropospheric refraction is more effective at the higher frequencies, providing more available communications possibilities at 50 MHz and above.

c. One common cause of tropospheric refraction is temperature inversion, which is the result of any of the following: a warm air mass overrunning a colder mass; the sinking of an air mass heated by compression; the rapid cooling of surface air after sunset; and the heating of air above a cloud layer by the

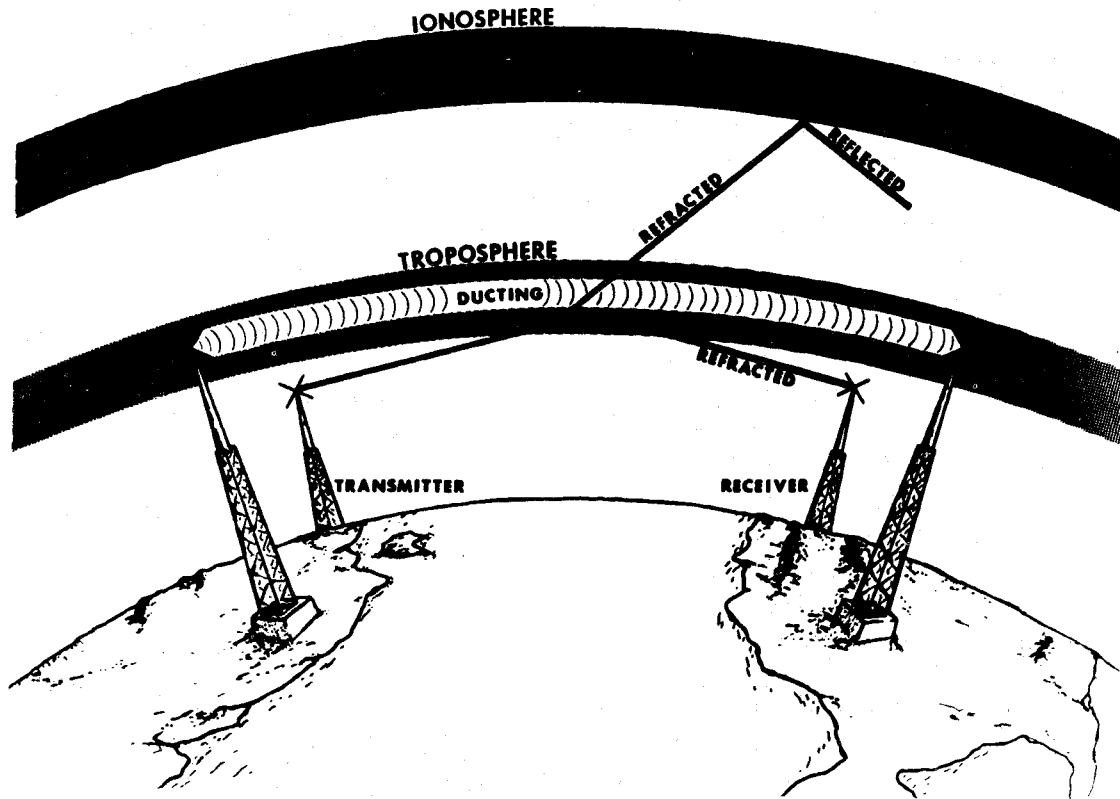

Figure 2-13. Atmospheric ducting and refracted routes for radio waves.

reflection of the sun's rays from the upper surface of the clouds. The effect of tropospheric propagation depends on weather conditions which vary from minute to minute, thus causing fading or variable field intensity. In tropospheric wave communications, the receiving and transmitting antennas should have the same polarization, since the tropospheric wave maintains essentially the same polarization throughout its travel.

2-15. Abnormal Effect of the Troposphere.

a. In the tropics and over large bodies of water, temperature inversions are present almost continuously at heights up to

approximately 1,000 meters, particularly from 50 to 150 meters. When the boundary of the inversion is defined sharply, waves traveling horizontally or at very low angles of elevation become trapped by the refracting layer of air and continue to be bent back toward the earth. Figure 2-13 shows how such a trapped wave follows a duct, the upper and lower walls of which are formed by the boundary and the earth. This is the channeling mentioned in paragraph 2-14. The waves are guided within this duct in much the same manner as in a metallic waveguide, and since attenuation in a waveguide is slight, the energy does not fall off inversely as the square of the distance. Thus, the waves follow the curvature of the

earth for distances far beyond the optical horizon of the transmitter, and in some localities they may consistently reach distances of many thousands of kilometers.

b. Tropospheric ducts also are formed by the waveguiding effect of two layers of air with sharply defined temperature inversions. The refraction from the upper boundary bends the wave down, and the refraction from the lower boundary bends the wave up, effectively trapping the energy within the layer. The height of the duct determines the minimum frequency, and if this height is only a few meters above the surface of the earth, or from boundary to boundary, transmission may be possible only at the UHF or SHF frequencies. Occasionally, the height and the dielectric characteristics of the layer are suitable for VHF transmissions. However, a necessary feature of duct transmission is that the angle of approach of the incident wave be approximately half a degree or less for the wave to be trapped. In addition, both the transmitting and the receiving antennas must be inside the duct if communication is to be established by this means. A transmitting antenna above the duct, as on a tower or promontory, will not operate into the duct, and no signals will be received by the receiving antenna. Moreover, a receiving antenna below a duct will not receive signals from an airplane flying in or above the duct, even though line-of-sight conditions prevail. From this it is apparent that accurate tropospheric propagation predictions are essential to establish reliable communications. Also, it should be obvious that due to the channeling effects of tropospheric returns, this means of communications, if used by unfriendly targets, would have little value to friendly DF efforts. Tropospheric information is included in this manual since supporting communications units make extensive use of it in normal communications, and the supported commander who receives DF information may, therefore, become

particularly attracted to this means of communications. Its value to the DF effort is of little, if any, consequence.

2-16. Influence of Soil Conductivity Relative to Wave Propagation.

A wave front is a surface of equal phase perpendicular to the direction of travel of the wave. As previously discussed, the wave front has been found to contain both electric and magnetic components as it is propagated. Within a few wavelengths of a transmitting antenna, the lines of both magnetic and electric force are appreciably curved. At greater distances the curvature becomes so slight that the network of horizontal and vertical lines becomes, for all practical purposes, a vertical plane presenting a wave front to a receiving antenna. This front is shown diagrammatically in figure 2-14. In

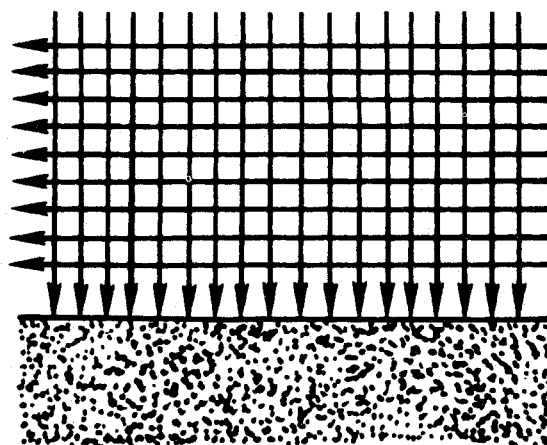

Figure 2-14. Wave front of normally polarized wave.

practice, the plane containing the electric and magnetic forces in the wave, constituting the wave front, is never truly vertical unless the wave is passing over a surface which has infinite conductivity, such as salt water, or is traveling in free space. The horizontal electric

force in a wave, in the direction of its travel, can lead to some confusion and is, therefore, worth consideration. To propose an extreme case, imagine a wave traveling over a perfect conducting surface, with the arrow AB in figure 2-15 representing the vertical

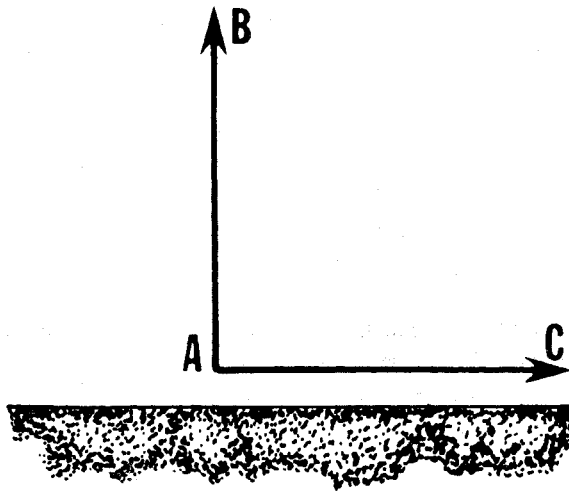

Figure 2-15. Horizontal and vertical components of electric force.

component of electric force and AC representing the horizontal component of electric force in direction and magnitude. For this to be true, there must be a potential difference between A and C. However, since the surface is a perfect conductor and has no resistance, there can be no difference of potential and likewise no lines of electric force. Therefore, AC cannot exist. The salt water of the ocean has high conductivity in this respect. Figure 2-16 shows a cross section of a wave front over the ocean with a vertical electric force being represented in direction and magnitude by the single arrow or vector AB. When a wave is transmitted over the earth's surface, with its low conductivity, there are losses into the semiconducting material which result in a horizontal component of electric force in the direction of wave travel, as shown by the two vectors in figure 2-17. The consideration becomes more

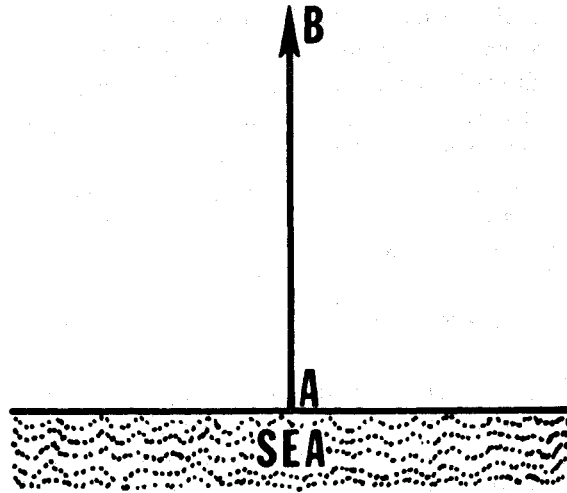

Figure 2-16. Vertical electric force in a wave traveling over a high-conductivity surface.

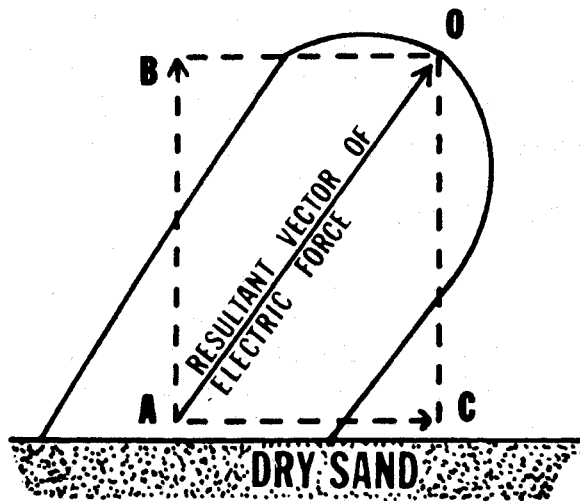

Figure 2-17. Elliptical electrical force in wave traveling over a low-conductivity surface.

complex because the vertical electrical force and the horizontal component are not usually in phase with one another, thus producing a rotating field of elliptical form, as illustrated in figure 2-17. The conductivity of the earth, or surface over which wave fronts pass, becomes very important when dealing with the different antennas used in DF operations, particularly the Adcock antenna. Although the values of conductivity and resistivity vary widely for soils of apparently similar types (they also vary with frequency), they are not appropriate to this manual.

2-17. Reflection.

When one observes himself in a mirror, the light beams or waves transmitted directly off the mirror's silver finish give the identical or "mirror" image, barring parallax or other optical distortions. Radio waves act in a similar manner to light waves, traveling at the same speed. Although light waves can be seen, radio waves must be detected by electronic equipment. Illustrations in this section will deal with both media. Figure 2-12 illustrates how radio waves are reflected off the ionosphere. Radio waves are reflected off the earth's surface, but are of little value unless the transmitting and receiving antennas are in close proximity of one another. The reflective and refractive components of light beams are illustrated in figure 2-18. The reflection of radio waves is illustrated in figure 2-19.

2-18. Refraction.

When the beam of a flashlight is directed at an angle on the smooth surface of water, some of the light will be reflected and the remaining portion will penetrate the water, as shown in figure 2-20. Refraction can also be observed by examining a glass of water into which a spoon is immersed. If viewed from an angle, the spoon appears broken or bent at the point where it enters the water because light waves travel at a slower speed through water than

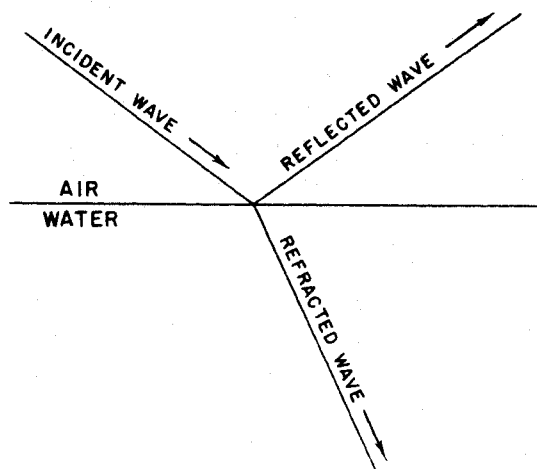

Figure 2-18. Reflection and refraction of a light beam.

through air causing a change in direction of travel of the refracted light. Figure 2-20 shows how this change in the direction of the light beam occurs. The parallel lines in this figure represent the wave front of a light beam incident to the surface of the water. Consider the wave front A-A1 (fig. 2-20), hitting the surface of the water. Since the speed of light is less in water than in air, point A will advance the distance d_1 in a given length of time, whereas point A1 will travel a greater distance (d_2) in the same length of time. As a result, the wave front will turn in a new direction. Note that refraction occurs only when the wave or beam of light approaches the new medium at an oblique angle. If the whole wave front arrives at the new medium at the same moment (perpendicularly), it is slowed uniformly and no bending occurs.

2-19. Diffraction.

If a beam of light in a dark room shines on the edge of an opaque screen, it will not form a perfectly outlined shadow because the light rays bend around the edge of the object, decreasing the area of total shadow. The diffraction or bending of a light wave around the edge of a solid object is slight. The lower

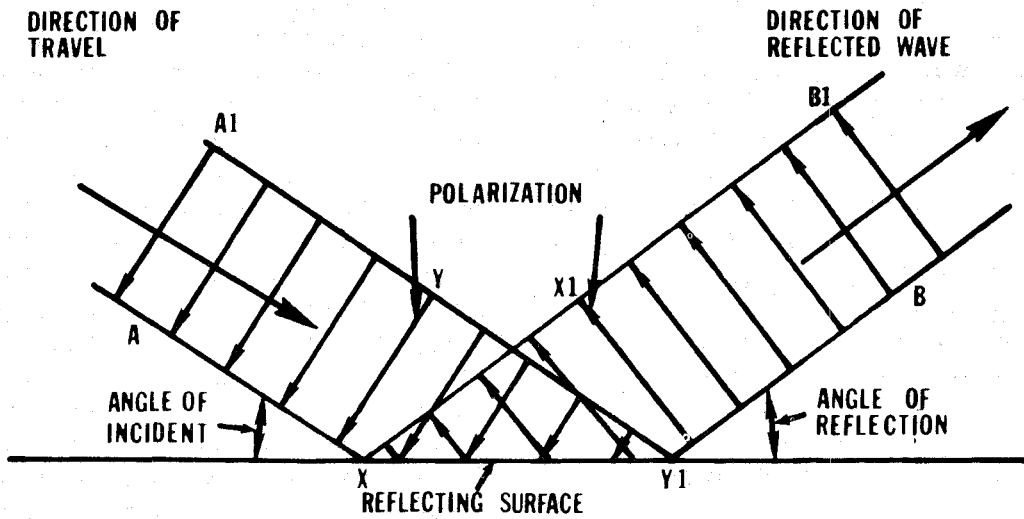

Figure 2-19. Reflection of a planar wave front.

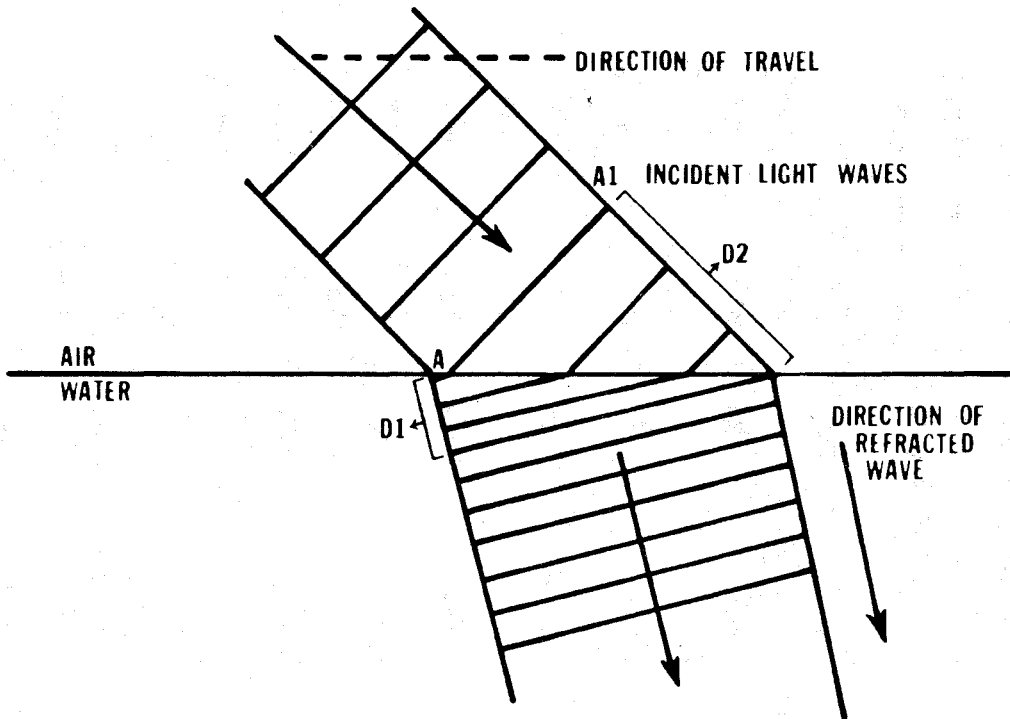

Figure 2-20. Bending of a wave front by refraction.

the wave frequency, or the longer the wavelength, the greater the bending of the wave. Therefore, radio waves are more readily diffracted than light waves, and sound waves more than radio waves. Figure 2-21 illustrates why radio waves of the proper frequency can be received on the far side of a hill or other natural obstruction, and why sound waves can be heard readily around the corner of a large building. Diffraction is an important consideration in the propagation of radio waves over long distances because the largest object to be contended with is the curvature of the earth, which prevents a direct passage of the waves from the transmitter to the receiver.

2-20. Skip Zones and Skip Distances.

In the foregoing discussion on propagation factors, the skip zones and skip distances have

been illustrated, although not explained. Simply stated, the skip zone is that area in which the groundwave can no longer be detected (area AB, fig. 2-9) and the skywave has not yet returned to earth after being reflected or refracted off the ionosphere or troposphere. The wave front has "outrun" the groundwave portion, and the skywave portion has not returned to earth after reflecting off the ionosphere. The skip distance is that area where no skywave reception will normally be possible (area CD in fig. 2-9) since the wave has not returned to earth after its first or subsequent bounce off the reflecting layer. Depending upon the frequency and the transmitter power, multihop transmissions are routinely used for communications; there will be, however, skip distances between the points of the waves' return at each hop. Figure 2-22 illustrates multihop transmissions.

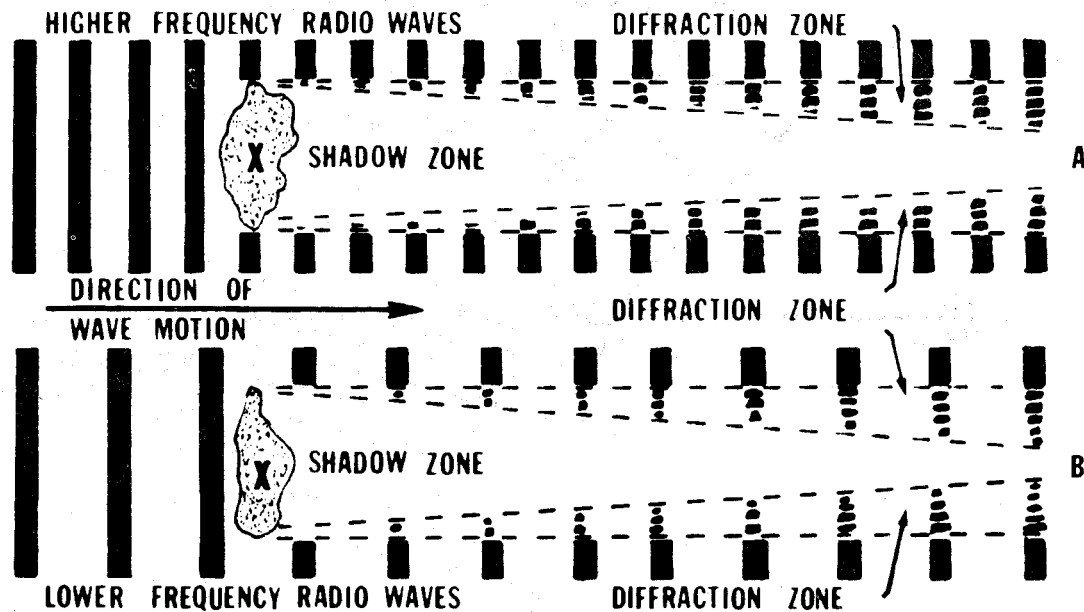

Figure 2-21. Diffraction of waves around a solid object.

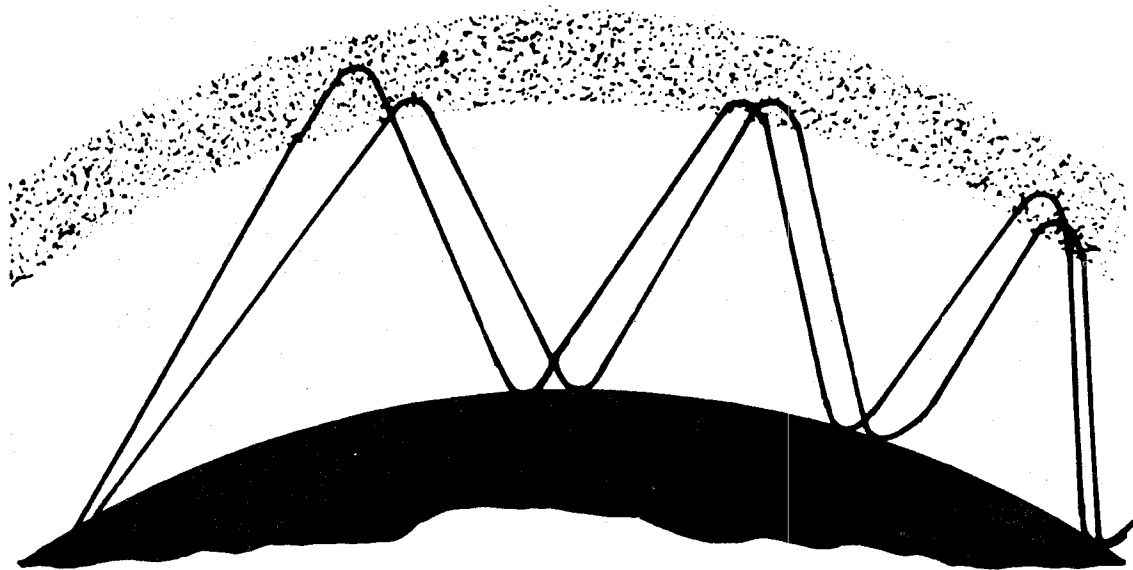

Figure 2-22. Multihop transmission.

Section IV

VHF AND UHF TRANSMISSIONS

2-21. VHF Transmissions.

The majority of all Frequency Modulated (FM) communications links operate within the frequency range of 30 to 300 MHz, (VHF band). Several FM radio sets are employed by US forces with speech security devices. This equipment provides secure communications in a wide variety of tactical situations. The planning range for this VHF equipment, with the transmitter and receiver located at ground level and no intervening hills, buildings, towers, or similar obstructions, is approximately 32 kilometers from a fixed location and 24 kilometers if moving. By increasing the height of the receiving antenna (as in an airborne platform) above the ground, it is readily apparent that the usable range of VHF signals for DF operations is greatly

increased. This portion of DF application is covered more fully in section IV, chapter 4, of this manual.

2-22. Secondary DF Applications of VHF Transmissions.

Particularly in helicopters or other slow, low-flying aircraft, the "homing" use of VHF transmissions is important. When weather conditions deteriorate and visibility is marginal, the aircraft commander, copilot, or observer may use a homing antenna or homing adaptor. By tuning the receiver to a known friendly frequency in the VHF band, having that station key its transmitter for extended periods (20-30 seconds), and rotating the antenna for a null, the general direction of the transmitter can be determined. This method will be explained in paragraph 3-1. By flying the aircraft in the direction indicated by the null, the VHF

signal becomes a ground navigational aid. Although this is DF homing instead of target locating, it is another useful application of the principles of DF.

2-23. UHF Transmissions.

Equipment is undergoing research and development, and in some cases field testing, for UHF DF applications. Since the principles and systems for UHF will be similar to those employed in VHF, they will not be discussed here.

CHAPTER 3

DF System Components and Characteristics

Section I

RADIO DF ANTENNAS**3-1. Polar Diagram of Antennas.**

In the study of DF, it is convenient to have some method of illustrating the receiving sensitivity of an antenna system for various angles of arrival of an incoming wave. A method to illustrate this for both transmitting and receiving antennas is the polar plane diagram.

a. In figure 3-1, the plus mark at the zero point represents the directive antenna system of a receiver. To indicate the antenna sensitivity (response pattern) for signals arriving from different directions move a portable transmitter in a circle around the antenna, keeping the transmitter power output and distance from the receiving antenna constant. Measure the receiver input and compare with the transmitter output at known angles (0, 10, 20 degrees, etc.). If radial lines are drawn from the central point with each line corresponding to the azimuth for which the receiver input was measured, and if the lengths of these lines correspond to the receiver input voltages, the curve obtained

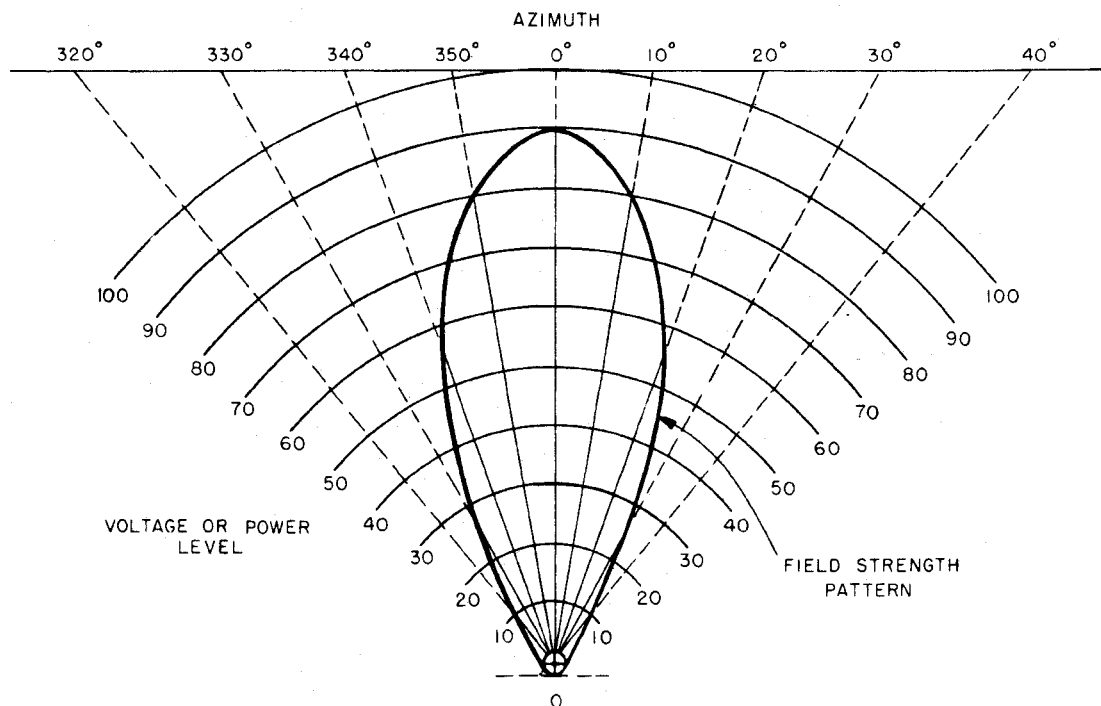

Figure 3-1. Polar diagram.

by joining the extremities of all these lines will give a clear picture of the directional properties of the antenna system. For example, in figure 3-1, the level of receiver input is 80 volts at 10 degrees, 69 volts at 15 degrees, 56 volts at 20 degrees, 27 volts at 30 degrees, etc.

b. When the polar diagram of a directional transmitting antenna is made, the process is reversed so that the receiver circles the antenna. In either case, the transmitter output and the receiver gain must be kept constant during the test so that the measured signal strength changes only because of directivity.

3-2. Loop Antennas.

Loop antennas are as old as radio itself. Heinrich Hertz used them in his original experiments with radio transmission and reception, and their directional properties were known long before there were enough radio transmitters to make direction finding worthwhile. A loop antenna consists of one or more turns of conductor, either self-supporting or wound on an insulated frame. The most commonly used styles are square (fig. 3-2) or circular (fig. 3-3) loops. The loop in figure 3-2 is illustrated as one turn of wire.

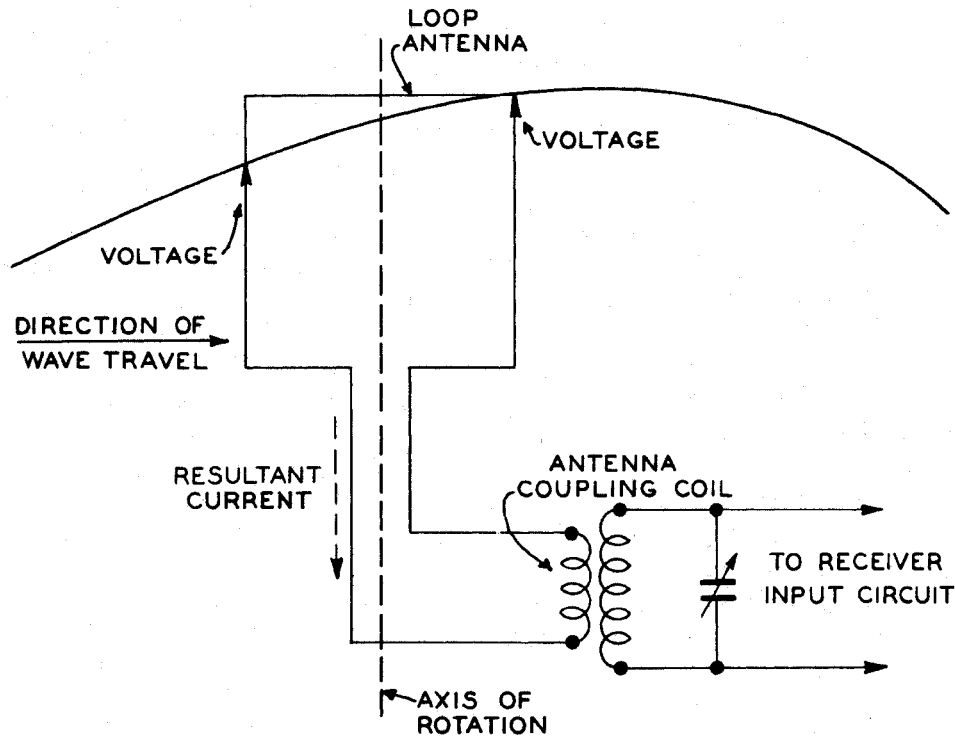

Figure 3-2. Simple loop antenna.

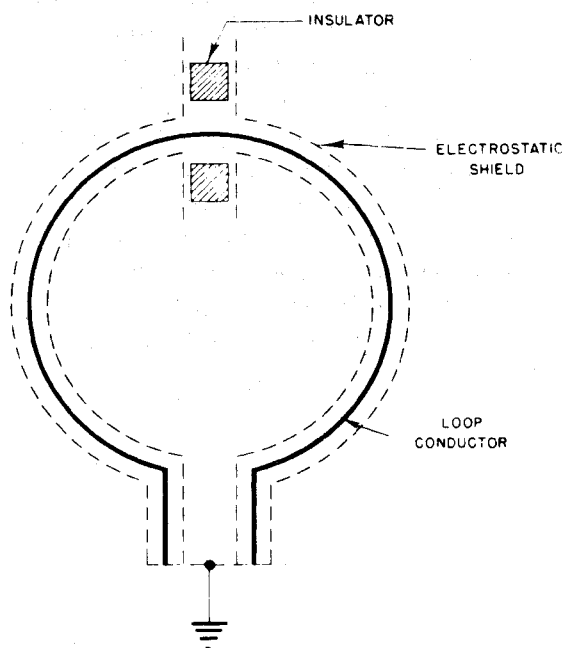

Figure 3-3. Circular loop antenna.

a. Maximum Reception. Consider the loop placed in the path of a vertically polarized wave with one side of the antenna closer to the transmitter than the other. With the plane of the loop parallel to the direction of wave travel the wave front reaches the vertical sides at slightly different times. Since wave polarization is spoken of in terms of the electric field, the magnetic component of a vertically polarized wave is horizontal (see fig. 2-2). This horizontal magnetic component induces voltages in both vertical arms of the loop but not in the horizontal arms since the wave travels parallel to them. The voltages induced in the vertical arms partly cancel each other across the antenna coupling coil because the amplitudes of the induced voltages differ at any given instant of time. The resultant voltage has a relative magnitude proportional to the field intensity of the wave.

b. Minimum Reception. If the loop is rotated about a central vertical axis until it is broadside to the oncoming wave (perpendicular to the direction of wave travel), the voltages induced in the vertical arms are equal and in phase, and will cancel across the antenna coupling coil to give minimum reception. This point of minimum response is called a null.

c. Pattern with Normal Polarization. When the incoming radio waves are vertically polarized, the condition under which a vertical loop would be used for direction finding, the loop antenna has a figure-eight response pattern. In figure 3-4, the loop appears in the 90-270 degree position; any signal received from either of these directions will induce maximum signal into the receiver. As the loop is turned away from the direction in which the wave is arriving (90-270 degrees), the received signal decreases, reaching a minimum when the loop is in either the 0 or 180 degree position. The line of direction (bearing, azimuth) to a transmitter can be determined by rotating the loop on its vertical axis until either a null or a maximum signal is produced. The transmitter direction will be broadside to the loop at the null or edgewise to the loop at the maximum. The appropriate direction will be indicated by an azimuth scale attached to the loop (fig. 3-5). It is customary to use the minimum rather than the maximum output of a loop when finding an azimuth since it permits a sharply defined indication and greater accuracy. The response pattern in figure 3-6 demonstrates the reason that this is so. In this instance, a maximum response of 100 microvolts (uv) is obtained with the loop edgewise to direction A (toward the transmitter). With the loop pointing toward B, a 10 degree rotation, there is only a 1.5 microvolt change in signal strength; this difference is not noticeable in the receiver input. But with the loop broadside to a transmitter at D, a null position, a similar 10

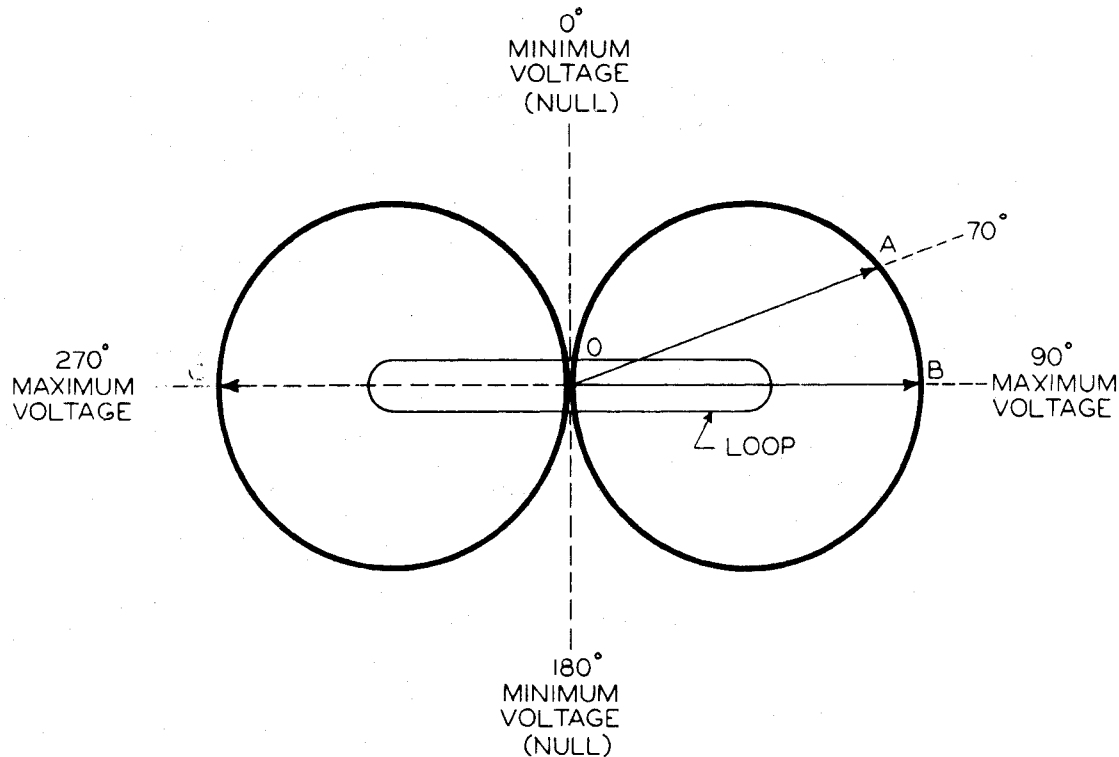

Figure 3-4. Loop antenna, figure-eight response pattern.

degree rotation causes a 17.4 microvolt change in signal intensity.

d. Pattern with Abnormal Polarization. Since vertical polarization is considered normal, any horizontally polarized wave is considered to be abnormally polarized for the simple loop direction finder. A horizontally polarized wave has no effect on vertical conductors, but it will induce voltage in horizontal conductors such as those at the top and bottom of a loop. For DF purposes, these horizontal conductors are considered to be ineffective and any induced current is considered inconsequential.

e. Ambiguity. Unless the general direction of the transmitter is known, a direction finder equipped with a simple loop

antenna cannot determine whether a transmitter lies forward of or behind the direction finder. This 180 degree ambiguity is caused by the two null positions of the loop. Without a sense antenna or sensing circuit, there can be no indication which of the two directions is the correct azimuth.

3-3. Loop and Sense Antennas.

a. Purpose. The sense antenna is usually an omnidirectional vertical whip or monopole placed at the vertical axis of the loop. Both the circular response pattern of the sense antenna and the figure-eight pattern of the loop are symmetrical, but when properly combined the two antennas produce a lopsided or unidirectional pattern (the cardioid pattern or "valentine-shaped heart"

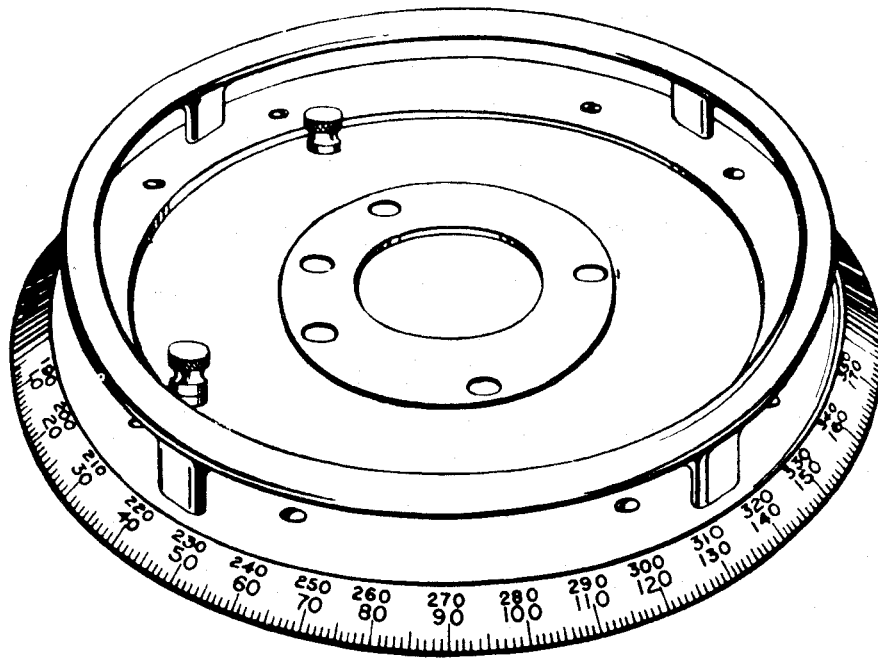

COUNTER CLOCKWISE SCALE

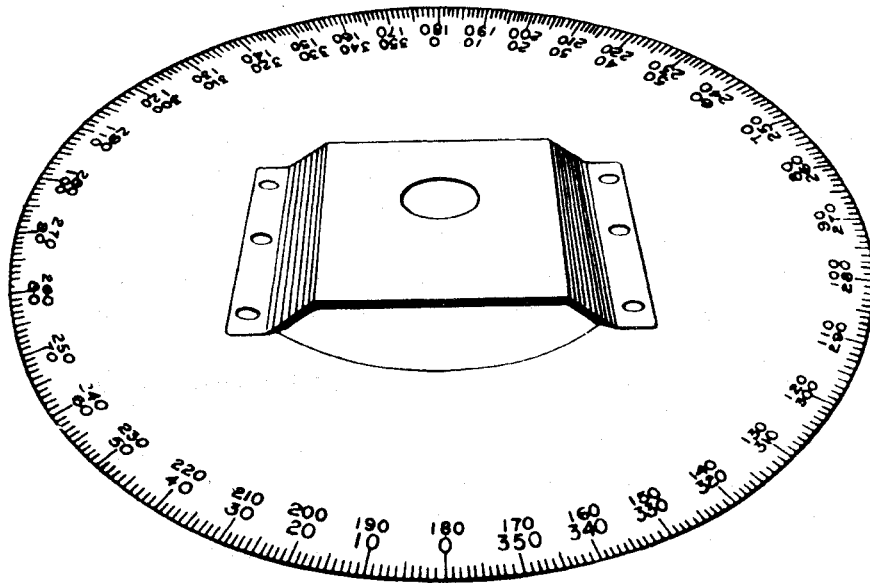

CLOCKWISE SCALE

Figure 3-5. Azimuth scales.

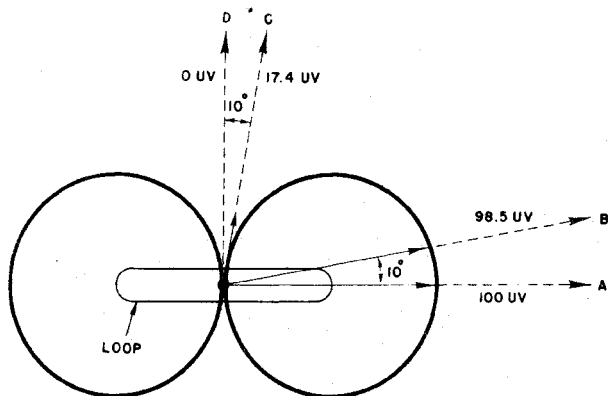

Figure 3-6. Change in loop position versus change in signal voltage.

in fig. 3-7). The large end of this pattern lies to the right of one null and to the left of the other null of the figure-eight pattern. By observing the relative position of the unidirectional pattern, the two nulls can be distinguished, thus resolving the 180 degree ambiguity of the simple loop. One null is

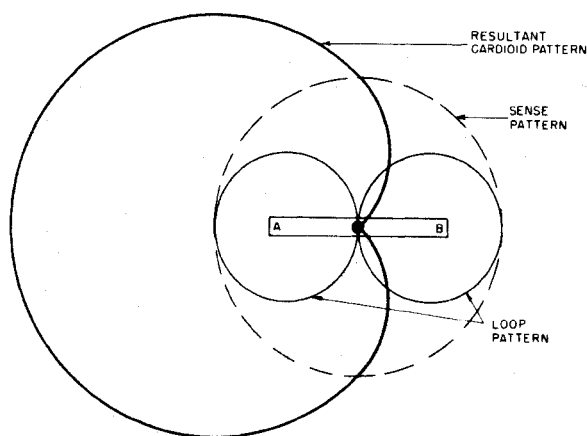

Figure 3-7. Cardioid response pattern obtained by combination of circular and figure-eight voltages.

arbitrarily designated as the front or direct null, while the other is called the back or reciprocal null.

b. *Application.* After the loop has been turned to a null, the direction may either be read from an azimuth scale or observed directly. The sense antenna is then placed in operation to change the response pattern from a figure eight to unidirectional. The null vanishes due to this change. Upon turning the loop 90 degrees to either side from the former null position, the response is found to be greater on one side than on the other. Which side is greater depends on whether the loop originally had the direct null facing toward or away from the transmitter. As a rule, if the response

increases as the loop is turned clockwise, increasing the azimuth scale reading, or if the response decreases as the azimuth reading decreases, the direct null was toward the transmitter. If the response changes in the opposite direction, the reciprocal null was toward the transmitter. This relationship is not always used. It can be reversed by transposing connections in the antenna circuit to reverse the relative polarity of loop and sense antennas, or by a 180 degree shift in the position of the azimuth scale or pointer relative to the loop. There are cases in which such a reversal has been made intentionally.

3-4. Cardioid Theory.

When the voltages from the loop and sense antennas are combined with the proper relative phase and amplitude, the resulting pattern is a heart-shaped curve known as a cardioid. A typical case is illustrated in figures 3-8 and 3-9.

a. A radio wave traveling past the loop, as indicated in capital A, figure 3-8, strikes leg No. 1 a short time before it strikes leg No. 2.

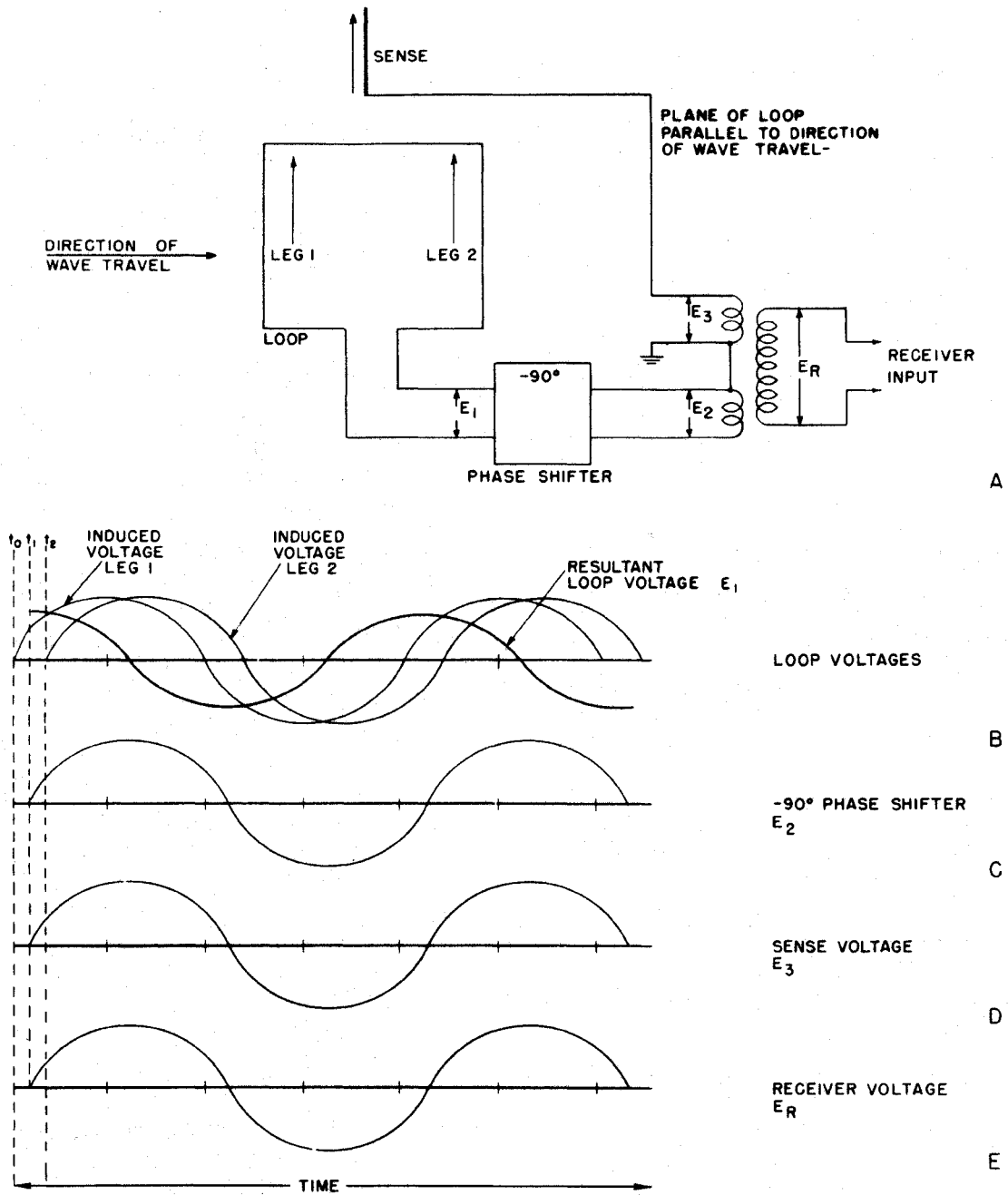

Figure 3-8. Loop and sense antenna system, relationship of voltages.

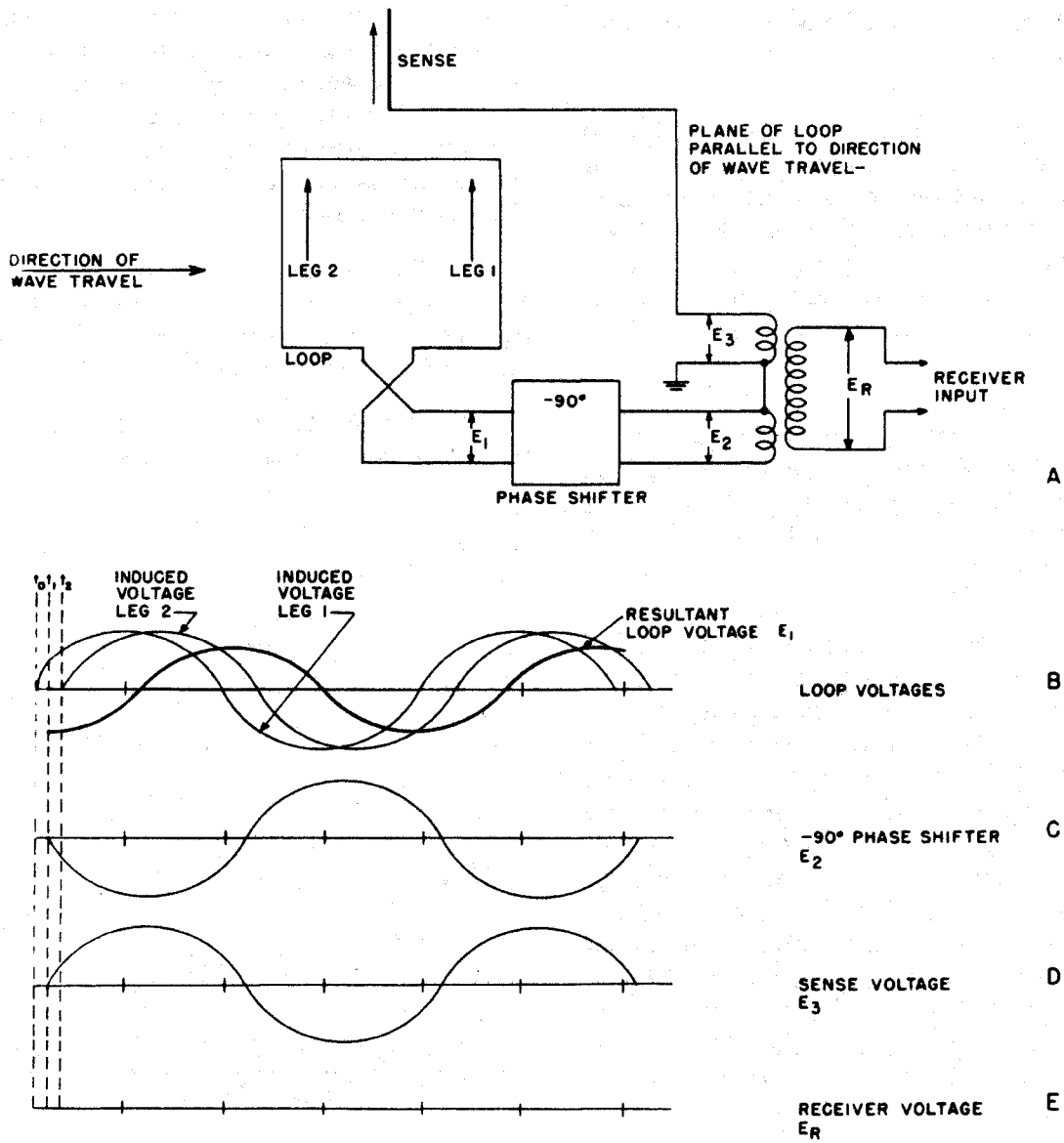

Figure 3-9. Relationship of voltages in loop and sense antenna systems when the loop has been rotated 180 degrees from the position shown in figure 3-8.

b. The voltages induced in the two vertical legs are connected in series opposition,

so that the net output of the loop depends on their potential difference.

c. As shown in Capital B, figure 3-8, the voltage in leg No. 1 is starting to rise at time zero (t_0); the voltage induced in leg No. 2 starts to rise a short time later (t_2). However, where the output of the loop is concerned, the voltage induced in leg No. 2 is out of phase and begins to subtract from the voltage in leg No. 1 at this time (t_1).

d. The resultant voltage (E_1) is developed across the output of the loop. This voltage is directly proportional to the time delay (phase shift) between the voltages induced in the legs of the loop. The greater the separation between t_0 and t_2 in Capital B, figure 3-8, the greater the resultant loop voltage.

e. It is apparent in Capital B that the resultant voltage leads the voltage induced in leg No. 1 by approximately 90 degrees and lags the voltage induced in leg No. 2 by the same amount.

f. Voltage E_3 induced in the vertical sense antenna is intermediate in phase between the voltages induced in the two legs of the loops, and therefore lags the resultant loop voltage E_1 by 90 degrees. To compensate for this phase difference (to have either an in-phase or out-of-phase relation between the resultant loop voltage E_1 and the sense voltage E_3), it is necessary to advance or retard the phase of the loop voltage by 90 degrees with a phase shifter. Retarded loop voltage E_2 is shown in Capital C, figure 3-8. If the loop voltage had been advanced, it would be shifted 180 degrees in phase from that shown in Capital C.

g. Notice that the retarded loop voltage E_2 and the sense voltage E_3 , beginning at the same instant (t_1), are in phase. These two voltages add in the input transformer; the receiver voltage E_R is maximum (Capital E, fig. 3-8).

h. If the antenna is rotated on its vertical axis through 180 degrees, the electromagnetic wave strikes leg No. 2 before it strikes leg No. 1 (fig. 3-9).

i. The voltages across both legs are induced in the same manner, producing a resultant voltage again proportional to the separation between the legs. However, because of the loop rotation, the voltages of the two legs are interchanged and the resultant output voltage E_1 is shifted 180 degrees in phase (Capital B, fig. 3-9).

j. The retarded loop voltage E_2 is therefore out of phase with the sense voltage, and the minimum signal E_R is applied to the receiver (Capitals C, D, and E, fig. 3-9).

k. Assume that the transmitter azimuth is 0 degrees as shown in figure 3-10. At

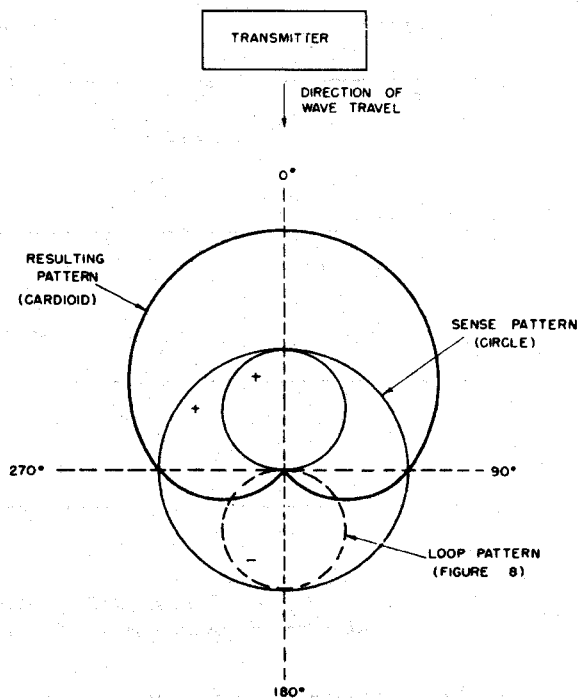

Figure 3-10. Cardioid response pattern.

intermediate points between the maximum and minimum positions of the loop, the following conditions exist:

(1) When the loop is rotated from 0 to 90 degrees, the loop voltage gradually decreases (the distance between the loop legs along the direction of wave travel becomes less). The sense voltage is constant and in phase with the loop voltage. The resultant receiver voltage is decreasing.

(2) When the loop is rotated from 90 to 180 degrees, the loop voltage gradually increases (the distance between the loop legs along the direction of wave travel becomes greater). The sense voltage is constant and 180 degrees out of phase with the loop voltage. The resultant receiver voltage decreases because of the out-of-phase condition.

(3) When the loop is rotated from 180 to 270 degrees, the loop voltage gradually decreases. The sense voltage is constant and 180 degrees out of phase with the loop voltage while the resultant receiver voltage increases.

(4) When the loop is rotated from 270 to 360 degrees, the loop voltage increases. The sense voltage is constant and in phase with the loop voltage while the resultant receiver voltage increases.

1. In practice, sense circuits are seldom adjusted to the ideal condition just described, and the resulting unidirectional pattern is not a perfect cardioid. If the sense voltage is very small, the resultant pattern is a slight lopsided figure eight. Increasing the sense voltage then makes the figure eight more and more lopsided, as shown in figures 3-11 and 3-12, until the sense voltage equals the maximum loop voltage. One lobe then disappears completely, making the pattern a perfect cardioid (fig. 3-13). Further increases of sense voltage increase the maximum and minimum resultant pattern (fig. 3-14), making it more and more like a circle. Either too little or too much sense voltage makes sense determination difficult, while any of the four patterns just mentioned would be acceptable. The

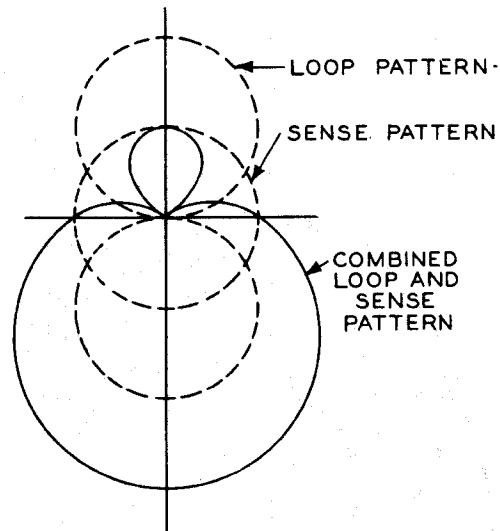

Figure 3-11. Response pattern, low sense voltage, and correct phase position.

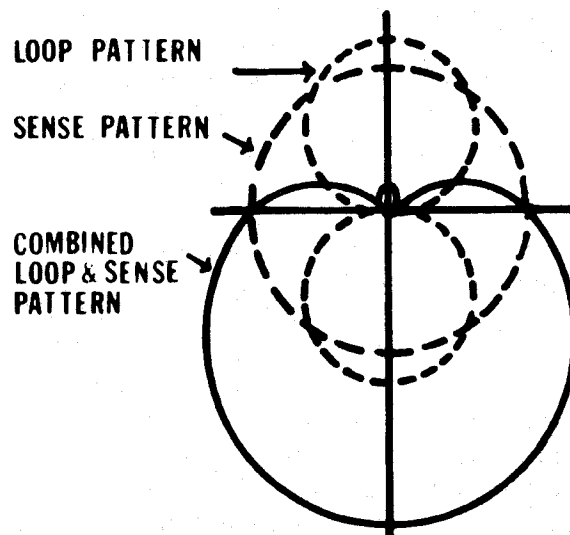

Figure 3-12. Response pattern, low sense voltage, and correct phase relation.

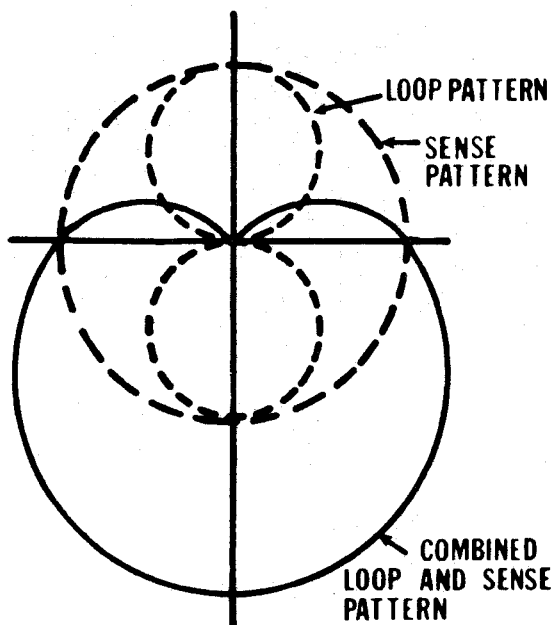

Figure 3-13. Response pattern, proper ratio of sense, and figure-eight voltage with correct phase relation.

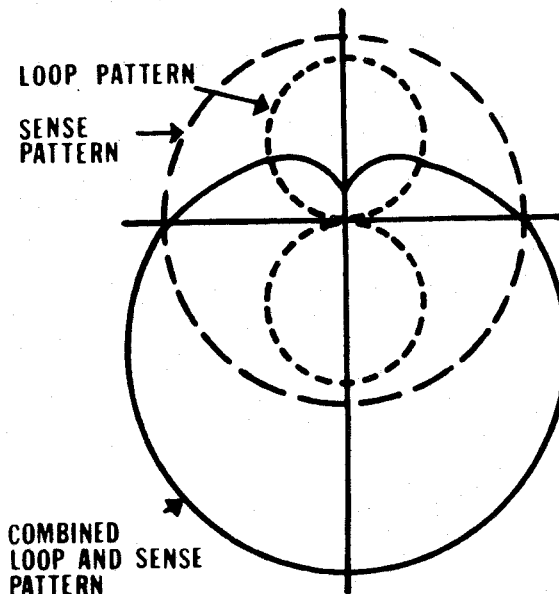

Figure 3-14. Response pattern, high sense voltage, and proper phase relation.

lopsidedness of the resultant pattern is readily distinguishable as long as the sense voltage is within ± 50 percent of the maximum loop voltage. If the sense voltage is out of phase with the loop voltage, the resultant pattern becomes nearly circular, and the amplitude relation must be kept closer to the ideal for satisfactory operation. Figure 3-15 shows a case in which both amplitude and phase relation are far from the ideal. Here the sense voltage has about half the amplitude shown in figure 3-11, and is 40 - 50 degrees out of phase with the loop voltage. The lopsidedness of the resulting pattern could be detected by comparing its two maximums on a visual indicator. The difference is too small to be detected by listening. If necessary (for example, if part of the sense antenna is lost), such a pattern can be used by observing which way the null shifts when the sense switch is operated; both nulls shift toward the small end of the lopsided figure-eight pattern.

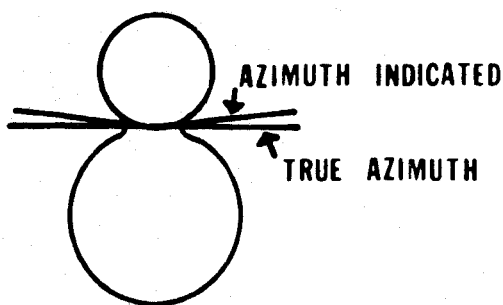

Figure 3-15. Response pattern, low sense voltage, and incorrect phase relation.

3-5. Loop Errors.

Several different factors can lead to undesired effects and incorrect azimuths. Some are peculiar to loops; others can affect any type of directional antenna. Errors arising from causes entirely outside the direction finder will not be discussed in detail here (see sec. III, chap. 5).

a. Antenna Effect. Antenna effect is the error in a loop antenna due to voltage loop imbalance.

(1) *Description.* When combined with the loop voltage, even a weak signal from the sense antenna may cause noticeable distortion of the figure-eight response pattern. If in phase or 180 degrees out of phase with the loop voltage, the sense-antenna voltage tends to make the figure eight lopsided, shifting the two nulls in opposite directions (fig. 3-11) so that they are no longer 180 degrees apart. If 90 degrees out of phase, the sense-antenna voltage tends to fill in the nulls, changing them to rounded minimums. At intermediate phase angles, both rounding and shifting of the nulls occur simultaneously (fig. 3-15). Usually the sense-antenna circuit is designed carefully to prevent any undesired addition to the loop voltage from that source, even though the same antenna effect is still applied to any pattern distortion caused by voltage from the sense antenna.

(2) *Causes.* Antenna effect may occur due to stray pick up. A small amount of signal may be picked up directly by an inadequately shielded receiver, or some circuit not intended as an antenna, e.g., power or telephone wires may pick up a signal and pass it along to the receiver. Probably the most important cause of antenna effect lies in the loop itself. Even when the loop is turned to a null position where the net loop voltage is zero, a relatively strong voltage is induced in each leg, just as in any vertical antenna of the same height. If the loop and associated circuits are properly balanced, this voltage has no

effect on the receiver, while a slight imbalance may combine part of it with the loop voltage in the receiver, producing antenna effect.

(3) *Balance adjustment.* One of the simplest types of imbalance is inequality between the capacitances from each side of the loop to the ground. Such an imbalance can be corrected, as illustrated in Capital A, figure 3-16, by adding a capacitor to each side, making one of them variable so that it can be adjusted for balance. Similar results can be attained with a differential capacitor (Capital B, fig. 3-16). Capacitive balance adjustment can be used even if the imbalance is inductive (unequal inductance in the two sides of the loop), but then a different adjustment is required for each signal frequency, since inductive and capacitive reactances vary in opposing fashion as the frequency changes. A third arrangement, illustrated in Capital C, figure 3-16, uses a differential capacitor to introduce an impulse from the sense antenna. The capacitor is adjusted to make the injected voltage equal and opposite to that entering accidentally. Balancing or neutralizing arrangements are sometimes called null-clearing devices because they are highly effective in eliminating the component of antenna effect which tends to fill in the figure-eight nulls. This component (90 degrees out of phase with loop voltage) is usually the most important. Antenna-effect voltage in the loop is initially 90 degrees out of phase with the desired loop voltage. Loop imbalance couples it into the circuit with little or no phase shift; therefore, the desired and undesired voltages follow the same path and undergo the same phase shifts, retaining their initial relation.

(4) *Shielding and grounding.* Antenna effect originating in the loop itself can be reduced greatly by using an electrostatic shield, as shown in figure 3-3. Similar results can be obtained by grounding the electrical center of the loop. This method is most effective when the loop has an even number of turns so that the center and the

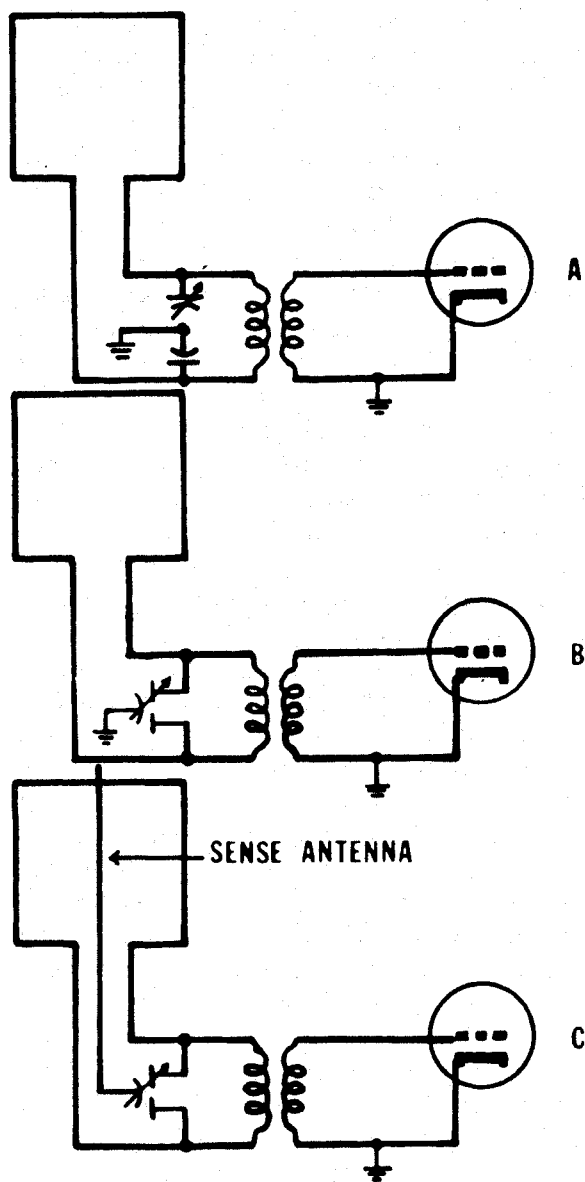

Figure 3-16. Method of balancing antenna effect.

terminals are close together and the ground connection is short. Despite this, it is still quite as effective as a shield. When an input transformer is used in the receiver, grounding the electrical center of the primary coil will reduce antenna effect. However, the electrical

center is more difficult to locate accurately in the coil than it is in the loop. At frequencies far below the natural resonance of the loop or primary coil, grounding and the centertap location need not be extremely accurate. At nearer the natural resonance of the coil frequencies, the tapped coil serves chiefly as an inductive balancing device in a manner similar to the split-stator capacitor in Capital B, figure 3-16. Since its adjustment is fixed by the manufacturer, the center tap must be placed very accurately, and may have to be some distance from the mechanical center of the winding.

(5) *Operating techniques.* Even though technological developments have reduced antenna effect so that it is scarcely noticeable, fairly accurate readings can be obtained from older direction finders in which antenna effect is unpleasantly large.

(a) In cases where the nulls are filled in, the bottom of the resulting minimum cannot be located directly with any great precision, even though the minimum level is definite. By turning the loop back and forth, the operator can locate two points on either side of the minimum where the response rises above the minimum level by the same small amount. The null position is midway between these two points, with a probability error of 10 to 20 percent of their separation, depending on the skill of the operator.

(b) If the two nulls are displaced from their normal 180 degree separation, each null will be in error by an equal but opposite amount (fig. 3-15), called the reciprocal error. This error can be eliminated by averaging the direct azimuths determined from observation of the two nulls. The corresponding direct azimuth is computed from the azimuth at the reciprocal null by adding or subtracting 180 degrees if it is not shown by a separate set of numbers on the azimuth scale.

b. *Weak Signal.*

(1) If the signal is weak or the

background noise is high, several azimuths should be taken when the signal appears strongest. These readings can be averaged to give a reasonably accurate azimuth.

(2) If it is impossible to use the null points, an approximate azimuth can be found by using the maximum points. Direct azimuth, when turned to maximum, is indicated by a signal strength increase when the sense switch is turned on. When the maximum point is used to determine the azimuth, the actual value is 90 degrees less (or more) than the reading of the azimuth indicator.

(3) Often when the noise level is high, the null can be located by averaging the azimuths (up to 90 degrees apart) at which the signal rises above or falls below the noise. Even with low noise levels it is sometimes easiest to locate the null by splitting the arc within which the signal is exceeded by the noise.

c. *Polarization Effects.* As explained in paragraph 3-4c, the response pattern of a loop antenna varies with the polarization of the radio waves received. Abnormal polarization may cause DF errors by rotating the whole pattern or by filling in the nulls, making them difficult to locate. These effects, already observed under several different conditions are:

(1) *Night effect.* When receiving only groundwave signals, a loop is free from polarization effect, both because it has a null in the horizontal direction for horizontally polarized waves, and because any transmitting antenna located near the ground also has a null (or a very small minimum) for horizontally polarized radiation in the horizontal direction. This justifies the assumption that groundwaves are vertically polarized. Skywaves, on the other hand, may have any kind of polarization since they come down at some angle above the horizontal. The loop then responds to the horizontally polarized component as well as to the vertically polarized component of the wave. At the low and medium frequencies used when radio first became popular, the

ionosphere was a much better reflector at night than in the daytime, and skywave reception was possible at night over distances far beyond the groundwave range. Thus polarization error, due to abnormal polarization in the skywave, was first observed at nightfall, and has been called a night effect ever since.

(2) *Fading and swinging.* When both groundwaves and skywaves are received simultaneously with nearly equal intensity, interference results. As the height of the ionosphere fluctuates, the skywaves change phase with respect to the groundwaves, sometimes adding to them, sometimes opposing them. The resultant intensity of the vertically polarized component varies widely, being sometimes much greater and sometimes much less than the horizontally polarized component. As a result, the polarization error varies, and the azimuth indication swings back and forth, making it very difficult to obtain an accurate reading. The amount of swing depends on the relative intensities of the skywaves and groundwaves, reading a maximum of ± 90 degrees if their vertically polarized components cancel each other in the loop.

(3) *Airplane effect.* Polarization error also occurs in direction finding on an airborne transmitter, particularly one using a trailing wire antenna. When the aircraft flies radially to or from the direction finder, vertically polarized radiation is received, and normal results are obtained by DF. When the aircraft follows a tangential course, the received signal has more horizontal than vertical polarization, and the target signal suffers from a polarization error which shifts the indicated azimuth toward the lower end of the trailing wire. Usually this end is to the rear of the aircraft. For courses intermediate between radial and tangential, the ratio of horizontal to vertical polarization is smaller, and so is the error.

d. *Winding Arrangement.* In an unshielded loop antenna, the arrangement of

turns may have an appreciable effect on the directivity pattern. The ideal figure-eight pattern applies exactly to a single turn loop, while more complicated patterns may be obtained when a number of turns are used, unless the turn arrangement is carefully chosen.

(1) *Symmetrical pancake winding.* If the loop turns are wound so that each turn is symmetrical (Capital A, fig. 3-17), the directivity of the loop will be the same as the directivity of any one of the turns. The vertical transition between turns is concentrated in one location with the upgoing and downcoming wires close together. As a result, the voltages induced in these opposing

wires are equal. Complete cancellation takes place, and only those voltages induced in the main portions of the loop affect the receiver.

(2) *Spiral pancake winding.* If the turns are wound spirally (Capital B, fig. 3-17) so that the upgoing side of each turn is longer or shorter than its downcoming side, the pancake loop becomes nonsymmetrical. The inductance and capacitance of the winding are unevenly distributed between the two sides, and this imbalance leads to an antenna effect. The loop circuit can be balanced as shown in figure 3-16, but the relative influence of inductive and capacitive imbalance changes with frequency, so that the compensating capacitor must be readjusted whenever the receiver is tuned to a different frequency. Theoretically, the difference in pick up of a symmetrical and nonsymmetrical pancake, due to the spirality of the latter, is equivalent to the pick up of a small pair of coplanar spaced loops. This tends to make the response pattern slightly sharper at its maximums. (See Capital C, fig. 3-17.) However, this spiral effect is imperceptible in any loop small enough to need more than one turn.

(3) *Skewness.* When a solenoid winding is used for a loop antenna, its form is usually helical, similar to that shown in Capital D, figure 3-17. As the winding progresses, one side of each turn is further advanced than the other by half the spacing between the turns. Thus, the turns are skewed slightly, and their nulls are turned a fraction of a degree from the axis of the helix. A skewed winding is equivalent to two windings without skew (i.e., a primary winding coaxial with the frame, and a smaller secondary winding at right angles with its horizontal part parallel to the axis of the actual helical winding). The secondary loop, figure-eight response pattern (Capital E, fig. 3-17) adds either in-phase or out-of-phase to the primary figure-eight loop voltage. The resultant pattern is also a figure eight, but it has its orientation rotated slightly (much less than that illustrated) from the primary figure-eight pattern.

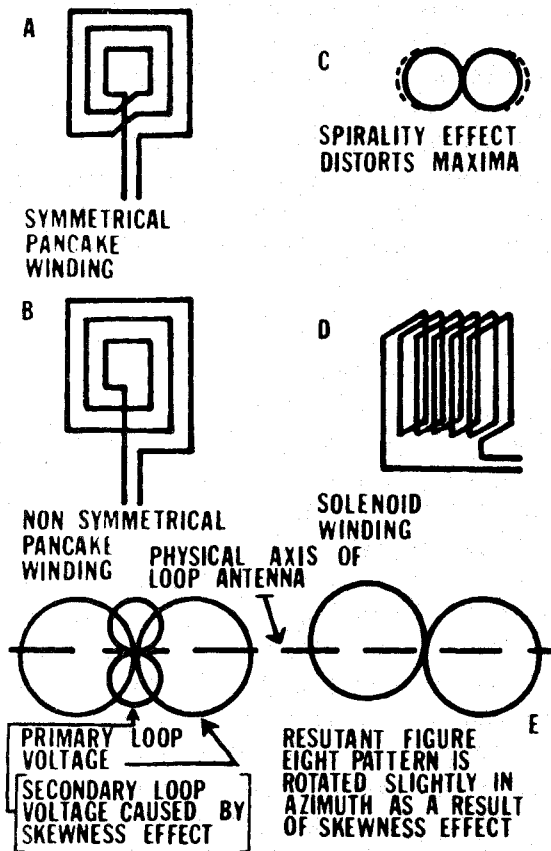

Figure 3-17. Effect of winding arrangement.

(4) *Width effect.* The capacitance between adjacent turns of a solenoid winding produces an effect similar, but with opposite polarity, to that of skewness. As shown in figure 3-18, these capacitances form horizontal members of a secondary loop which is oriented 90 degrees away from the primary loop. The effect of this secondary loop increases with increasing frequency, and becomes large enough to cancel the skewness effect at a frequency slightly below that at which resonance occurs within each turn. If there is leakage between turns due to poor

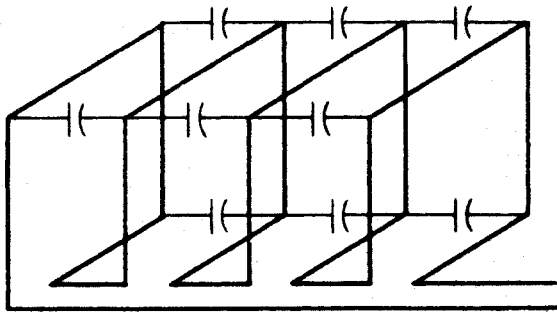

Figure 3-18. Distributed capacitances in solenoidal loop.

insulation, the capacitors shown in figure 3-18 may be considered shunted by resistance. This shifts the phase of the secondary loop voltage so that it fills in the nulls of the primary figure-eight pattern rather than rotating the pattern. The result resembles antenna effect. However, because the polarity of the two lobes of the secondary figure eight is opposite, while the circular pattern of actual antenna effect has the same polarity all around, width effect and antenna effect tend to add at one null and cancel at the other so that one becomes slightly more rounded than the other.

(5) *Combination windings.* The peculiarities explained in (2), (3), and (4) above are all attributable to dissymmetry in the loop windings, and can be reduced or eliminated by making the windings more

symmetrical. One symmetrical case is shown in Capital A, figure 3-17. Nearly the same results can be obtained with spiral windings if an even number of pie windings (a method of constructing coils from a number of individual washer-shaped coils called pies) are used, provided that the pies are wound in opposite directions; i.e., spiraling outward and inward alternately. This arrangement keeps the loop balanced and neutralizes the spiraling effect, but still leaves a little width effect. Both skewness and width effect in a solenoid winding can be neutralized by using an even number of layers, one layer being wound from left to right and the next from right to left. Similar results may be obtained with universal windings in which the axial progression of turns is reversed periodically by a cam in the winding machine. Balance still requires an even number of pies which again introduces width effect, which will be insignificant if the number of turns per pie is more than the number of pies. When many turns are used, shielding the loop is often the simplest and most effective solution, since it practically eliminates skewness and width effect. It also reduces antenna effect so that balance becomes less important.

3-6. Loop Construction.

a. Balance. The most important factor in the physical construction of a loop is its symmetry. When the loop is symmetrical, electrical balance follows automatically. If the balance is good enough, antenna effect will be insignificant. Any conducting material near the loop, such as the top of the radio receiver case, should be placed symmetrically, otherwise the loop might be balanced at some positions but unbalanced at others. In the case of a square loop, it is preferable to place a corner rather than a side at the bottom. This arrangement keeps the body of the loop farther away from the ground so that any irregularities (including metal items worn by the operator) are less likely to affect the loop balance.

b. Electrostatic Shield. Multiturn loops are often encased in an electrostatic shield. This is a metal case, or a film of metal on a case of some other material, which surrounds the loop winding almost completely (fig. 3-3). There is a gap in the top of the metal, and the opposite sides of the gap are insulated from each other to prevent the shield from forming a closed (short-circuited) loop. The shield is grounded near the loop terminals as far as possible from the insulated gap. As a vertical antenna, therefore, the shield is short-circuited. Consider the voltages induced by a passing radio wave made up of two components, one corresponding to the desired loop voltage, the other to the antenna effect. Although the former can produce very little current in the shield because of the insulated gap, it is fully effective in the loop having conductors crossing that gap. The latter causes a flow of current over the shield to the ground. Since the ground connection is short circuit, this current produces a counterelectromotive force in the shield equal to the original induced voltage. It induces a voltage in each loop conductor which nearly cancels the original antenna effect voltage induced there by the radio wave. The reduction ratio is substantially the same as the Q (reactance/resistance ratio), which the shield would have if connected as a loop. Since the Q is seldom less than 10, the residual antenna effect is seldom more than one-tenth the antenna effect with no shield. In addition to reducing antenna effect directly, the shield helps indirectly. Unless an external object is very close to the gap in the shield, it cannot affect the capacitance from loop to ground, and thus cannot change the capacitive balance of the loop. However, the shield affords no protection against inductive imbalance which might be caused by a scrap of metal placed too close to one side of the loop. The shield also eliminates the precipitation static caused by electrically charged rain drops striking the antenna and provides mechanical protection for the loop.

c. Loop Size. Except in some special VHF loops, which resemble groups of dipoles more than they do ordinary loops, the largest dimension of a loop antenna is usually a small fraction (0.1 at most) of a wavelength. The voltage picked up by such a small loop is proportional to the total area enclosed by its turns; i.e., the product of the number of turns by the average area of each turn. For maximum pick up, the turns should be as large as possible, subject to electrical limitations. Most receivers will not operate efficiently from a loop which is self-resonant at any point within the operating frequency range. Consequently, the number of turns must be small enough to keep the natural resonance higher than the highest operating frequency.

3-7. Crossed-Loop Antenna.

a. General. A crossed-loop antenna consists of two loops with identical characteristics, mounted at a fixed angle of 90 degrees to each other. Each loop has a figure-eight response pattern which is displaced 90 degrees in azimuth. As a result, the ratio of the two responses varies with direction. Several different systems have been devised to make use of this fact.

b. The Goniometer. In the Bellini-Tosi system, the two loops are connected to two stator windings, located 90 degrees apart. In operation a goniometer, whose rotor winding is connected to a radio receiver, is turned to a null or a position of minimum output so that its angle corresponds to the direction of the signal picked up by the loops. Since the loops themselves need not be rotated, they can be made large for the sake of sensitivity. The operation of the goniometer will be explained in detail in section III, chapter 3.

3-8. Adcock Antennas.

a. General. An Adcock antenna consists of two spaced vertical antennas connected in

opposition. Theoretically, it responds only to the vertically polarized component of an incoming radio wave, and therefore is not subject to polarization error. In practice, there is some polarization error due to various imperfections, but usually much less than in a loop antenna receiving the same signal. The Adcock antenna is preferable to a loop in radio DF when medium or high frequency signals must be received at a point beyond groundwave range.

b. Principle. The basic Adcock antenna consists of two vertical elements connected as shown in figure 3-19. The action of such an antenna, as far as vertically polarized waves are concerned, is identical with that of the loop antenna. A resultant current in output coil L is proportional to the vector difference of the voltages induced in the vertical members, exactly as in the case of the loop. Horizontally polarized components of descending skywaves do not affect the antenna because of the absence of the upper and lower horizontal members, and because the crossed arrangement of the center members effectively cancels the voltages induced in them. The response pattern of an Adcock antenna is the same figure-eight pattern typical of the loop antenna. Minimum and maximum response points are present in the Adcock pattern in the same respective positions as in the loop pattern. Thus, the directional properties of the Adcock and loop antennas are the same with respect to vertically polarized waves. The effects of various types of wave polarization on the Adcock circuit are as follows:

(1) *Vertical polarization.* The horizontal magnetic field of the vertically polarized wave cuts the two vertical antenna elements. Induced currents, while they are induced in phase in the vertical elements, oppose each other in the antenna coupling coil, producing a resultant voltage which leads the radiation field by 90 degrees. This resultant voltage is proportional to the

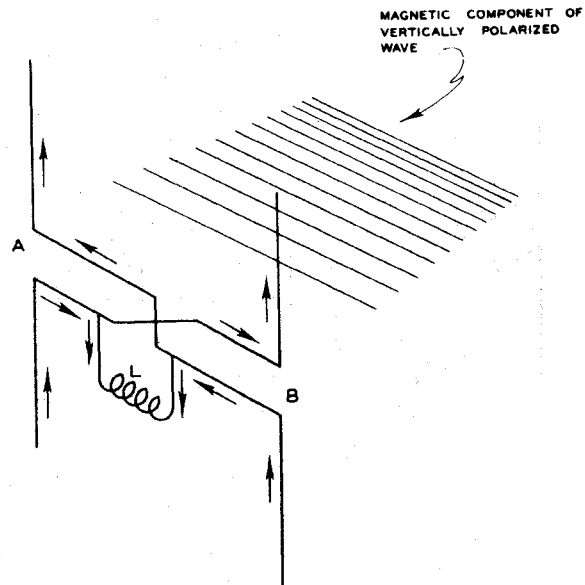

Figure 3-19. Adcock antenna, effects of vertically polarized waves.

separation between the two antenna elements along the direction of wave travel. Thus the action of the Adcock antenna system is identical to the action of the loop system, and can be used in conjunction with a sense antenna to obtain a unidirectional pattern.

(2) *Horizontal polarization.* As shown in figure 3-20, only the horizontal antenna members are in a position to respond to horizontally polarized waves. In a well-designed radio direction-finding system, efficient use is made of shielding and balancing to prevent any voltages induced in the horizontal members from reaching the input stage of the receiver. The residue is small in comparison with the response of a loop under similar circumstances, but it has the same directivity pattern. Thus, the maximum polarization error with an Adcock antenna is still 90 degrees, but is of a lesser magnitude than that of a loop antenna.

(3) *Other abnormal polarizations.* Radio waves usually contain both vertical and

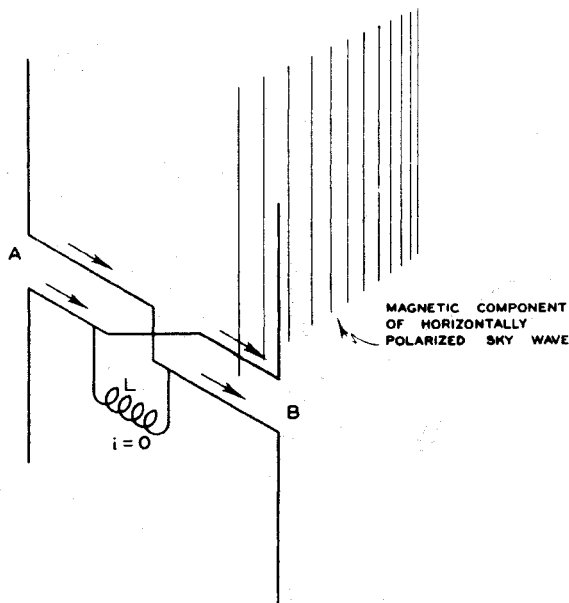

Figure 3-20. Adcock antenna, effects of horizontally polarized waves.

horizontal components of polarization which, in combination, produce an abnormal polarized wave. Although the vertical and horizontal components can be viewed as acting independently, their effect on the antenna is due to the combined action of both components. Because the response of an Adcock antenna is relatively small for the horizontally polarized component, its polarization error is likewise smaller than that of a loop antenna. This is true as long as the vertically polarized component does not entirely disappear. When the vertically polarized component predominates, the Adcock antenna's polarization error is scarcely noticeable.

c. *Types.* All Adcock antennas have the following general characteristics: first, the active antenna elements are vertically spaced wires; second, the horizontal members are arranged so that little or no voltage can be

induced in them; and third, the small voltage that is induced cancels across the output. The various types of Adcock antennas are:

(1) *Simple U-Adcock antenna.* This is the basic type of Adcock antenna (fig. 3-21). U-Adcock antennas are used chiefly in crossed-Adcock systems, which are nonrotatable.

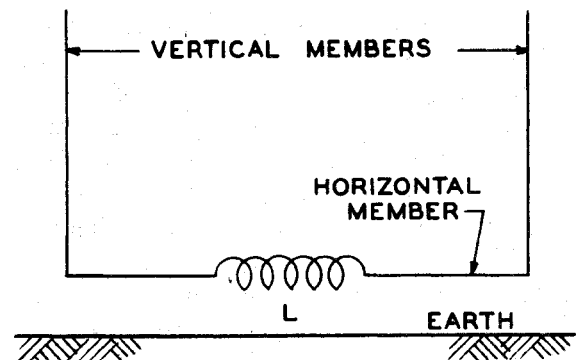

Figure 3-21. Simple U-Adcock antenna.

(2) *Shielded U-Adcock antenna.* The shielded U-Adcock reduces polarization error significantly by shielding the horizontal antenna element. When shielded, its response to horizontally polarized waves is minimized. However, the voltages and currents in the shield set up potentials at the extremities (Capital A, fig. 3-22) which induce voltage into the vertical antenna elements, thus introducing error. Connecting the ends of the shield to metallic plates buried in the ground (Capital B, fig. 3-22) reduces this undesired condition, but introduces another. The shield, ground connections, and earth form an untuned loop which responds to horizontally polarized waves.

(3) *Grounded H-Adcock antenna.* This antenna (fig. 3-23) differs from the others in that its horizontal members are grounded. Directivity, as in the case of the loop antenna, is the result of the differential

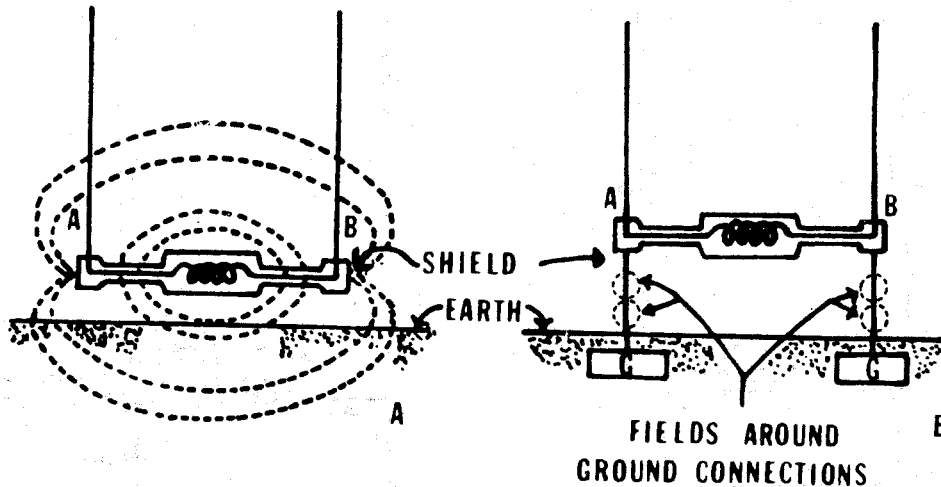

Figure 3-22. Shielded U-Adcock antenna.

action of the voltages in the two vertical antenna elements. The voltages induced in the horizontal antenna elements will cancel. This condition is demonstrated in Capital A, figure 3-23, which shows the distribution of potentials on the horizontal members at a given instant. If equal voltages are induced in all horizontal antenna elements, the resultant voltage across the coil is zero. A problem arises because the lower elements are connected to the ground forming an untuned loop which unbalances the system (Capital B, fig. 3-23). Some of the imbalance can be eliminated by inserting lumped constants in the lower vertical legs (fig. 3-24).

(4) *Elevated H-Adcock antenna.*

The elevated H-Adcock minimizes the imbalance caused by grounding the lower portion of the antenna. Balance is obtained through physical symmetry and by raising the antenna a reasonable height above the ground. Depending upon the antenna, balance will be achieved within a fixed height area above the ground. The degree of imbalance increases if the antenna is moved above or below the balance area because of the reduction or

increase in antenna-to-ground capacitance.

(5) *Coupled H-Adcock antenna.*

This type of antenna incorporates a highly effective method of reducing the pickup of the horizontal antenna elements and reducing polarization error. Azimuth error is minimized by making the impedance of the horizontal elements high to all currents except those induced in the vertical members. The high impedance is obtained by inserting two mutually coupled impedances in each vertical element (fig. 3-25). This method presents a high series impedance (very small capacitance between windings) to all current directly induced in the horizontal elements; however, a low impedance is presented to the voltages induced in the vertical elements since they are mutually coupled through the transformer and appear directly across the antenna coil. A further reduction in polarization error is obtained by carefully balancing the system of the balanced-coupled Adcock antenna (fig. 3-26).

d. *Tilting Adcock Antenna.* Compared to the loop, the Adcock antenna system is

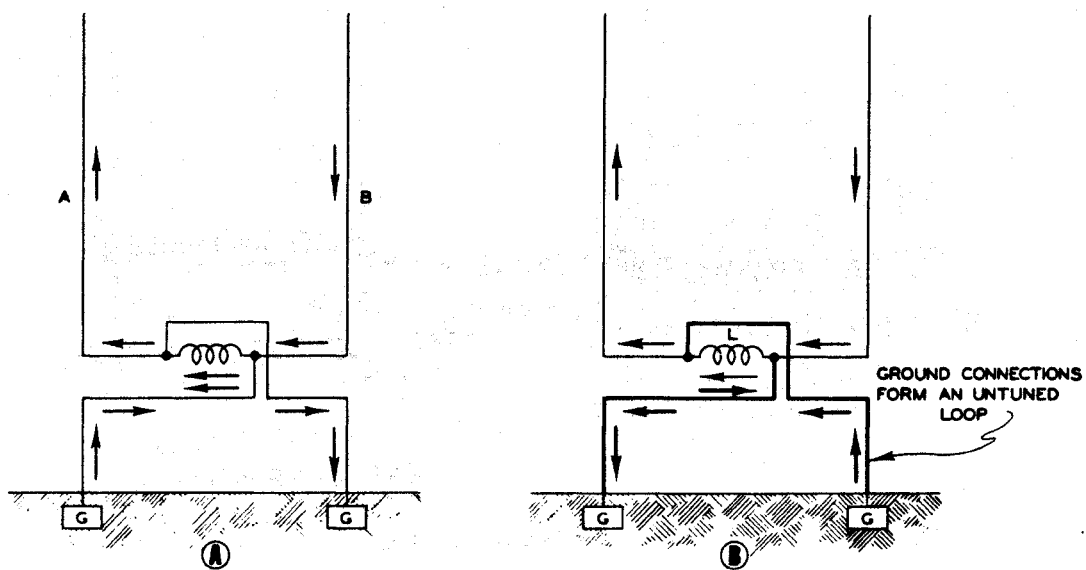

Figure 3-23. Grounded H-Adcock antenna.

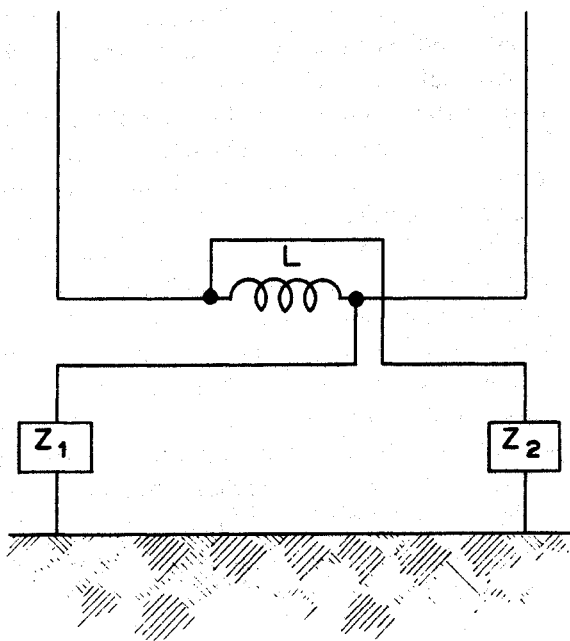

Figure 3-24. Balanced H-Adcock antenna.

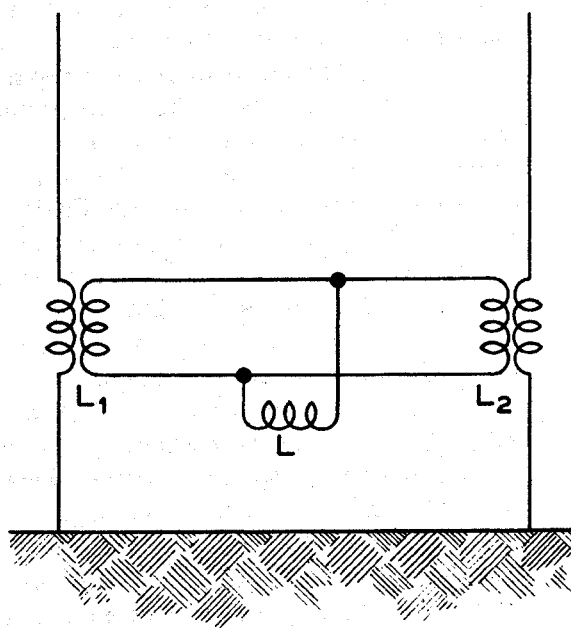

Figure 3-25. Coupled H-Adcock antenna.

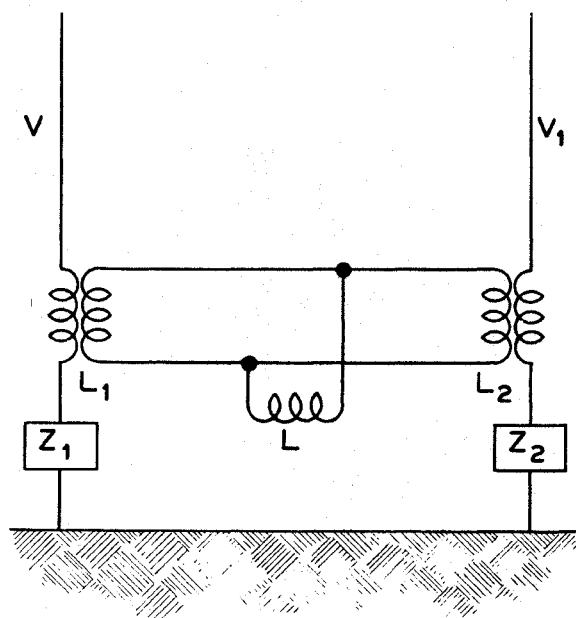

Figure 3-26. Balanced-coupled Adcock antenna.

insensitive to high angle radio waves, even if they are vertically polarized. There are two reasons: first, the spacing of the vertical antennas along the path of a radio wave (Capital A, fig. 3-27) grows smaller as the elevation angle increases or the incidence decreases; second, the effective length of each antenna, in the direction of the lines of electric force of the radio wave, is decreased by a similar factor as these lines tilt forward. The effective length reduction can be overcome by tilting the antenna backward, as shown in Capital C, figure 3-27, until it is perpendicular to the direction of the incoming waves, and therefore parallel to the lines of electric force. Tilting improves the system sensitivity when the Adcock antenna is near the direct azimuth. Conversely, sensitivity decreases near the reciprocal azimuth, since the tilt there is the wrong way.

Sense indication also deteriorates because the phase relation between voltages from the Adcock and sense antennas changes unless the sense antenna is also tilted. An Adcock antenna tilted 60 degrees from the vertical might be advantageous for aural-null DF on skywaves from a transmitter 80 to 320 kilometers away, or on signals from a high-flying aircraft 16 to 32 kilometers away, for which the elevation angle may be 45 to 75 degrees.

3-9. Adcock Antenna Errors.

The factors leading to undesired effects and incorrect azimuths when an Adcock antenna is used are similar to those encountered in loop installations. For errors involved in weak signals, antenna effect, and polarization error, see paragraph 3-7. The causes of imbalance (antenna effect) as it applies specifically to Adcock antennas are:

a. The terrain surrounding a radio direction finder is an important factor in obtaining accurate azimuth readings. To obtain the highest degree of accuracy, a DF set should always be operated on level ground, free from neighboring objects such as telephone lines, power lines, buildings, and metallic masses. The presence of such objects or peculiarities in the terrain may cause an imbalanced condition (antenna effect) to exist at the antenna, resulting in possible error. The antenna effect can be reduced by using a stationary Adcock; thus, the relation of the antenna to the ground and nearby objects is fixed, making the final problem of correction less difficult.

b. With a U-Adcock, irregularities in the ground at the base of each monopole may unbalance the system. This effect can be materially reduced with a counterpoise covering the ground between the spaced monopoles and extending beyond them a considerable distance in all directions.

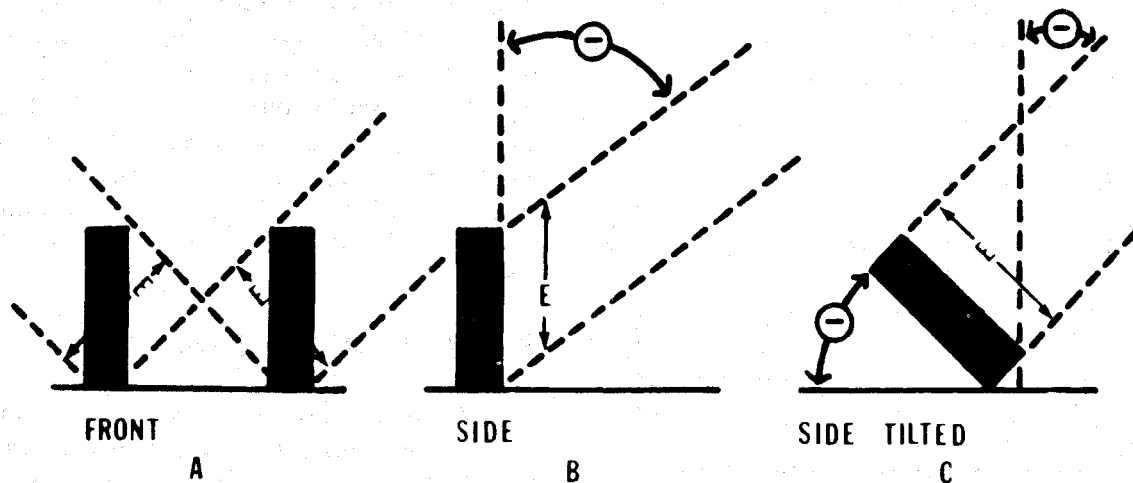

Figure 3-27. Effects of tilting an Adcock antenna.

c. With an elevated H-Adcock antenna, the mere existence of the ground causes a slight imbalance, and any conductors on the ground will make the imbalance worse because the lower ends of the dipoles are naturally closer to the ground than are the top ends. This imbalance leads to polarization error, rather than antenna effect. The difference between the ground is so far away, and the antenna effect resulting from it is rarely, if ever, perceptible.

d. In both types of Adcock systems, shielding of the horizontal transmission lines is useful and sometimes an indispensable guard against imbalance caused by adjacent objects (such as the DF operator). It also eliminates accidental capacitive coupling to other circuits in the vicinity.

e. Another important point in reducing antenna effect is to maintain perfect symmetry and spacing of the antenna elements. Imbalance is caused by having one element slightly larger than the corresponding one, or by having nonuniform spacing. Coupling coils must be identical in inductance and the number of couplings must be equal.

f. Antenna spacing in a rotatable H-Adcock system may be almost a full wavelength before the directional pattern becomes unusable. At spacing exceeding $1/2$ wavelength, the figure-eight pattern has a dimple in the middle of each lobe, which deepens with increasing frequency, becoming a null when the spacing reaches a full wavelength. Even then the antenna still has directional properties, but the extra nulls make interpretation difficult.

3-10. Crossed-Adcock Antennas.

a. *General.* A crossed-Adcock antenna consists of two identical Adcock antennas, oriented 90 degrees apart in azimuth. Crossed-Adcock antennas may be used in various ways similar to those mentioned in paragraph 3-7a. At low and medium frequencies, crossed-Adcock antennas can be made much larger than rotatable Adcock antennas, and are therefore more sensitive. At high frequencies, this advantage is small because of the limitations imposed by spacing effect or octantal error (para 3-19).

b. Spacing. In a crossed-Adcock system, the maximum spacing is one-half wavelength between adjacent antennas (0.707 wavelength between diagonally opposite antennas). Above this limit, the same indication may be obtained for signals coming from three different directions (six before sense determination).

3-11. Spaced-Loop Antennas.

a. General. The spaced-loop antenna consists of two parallel loops fixed to the ends of a boom which may be rotated about its center or on other "platforms" (various types of aircraft). Earlier models of DF equipment using spaced-loops had the loops mounted perpendicular to the boom, and were said to be coaxial. Since the two loops point in the same direction, the magnitude of the output voltage of each loop will vary in the same manner as the loop is rotated. Besides the normal loop directivity, the spaced-loop system has directivity due to the loop spacing; the latter directivity is not affected by polarization errors. There are two additional types of spaced-loop antenna systems called the vertical coplanar and the horizontal coplanar (fig. 3-28).

b. Pattern for Vertically Polarized Waves. The pattern for the coaxial spaced-loop system (Capital A, fig. 3-29) has four nulls spaced 90 degrees apart when vertically polarized waves are received. Two of the nulls occur when the planes of both loops are perpendicular to the direction of wave travel; the other two occur when the planes of both loops are parallel to the direction of wave travel. Although maximum signal is induced in both loops when their planes are parallel to the direction of wave travel, the outputs of both loops are in opposition and cancel across the antenna coupling coil. In this case, the wave strikes both loops at the same instant. If the boom is rotated, less voltage is induced in each loop.

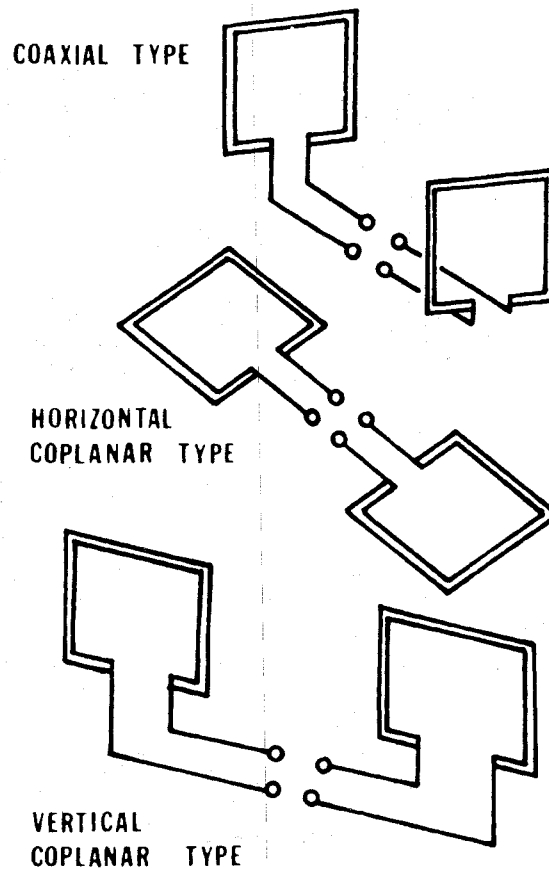

Figure 3-28. Common spaced-loop types.

The wave will strike one loop before it strikes the other, producing a resultant voltage across the antenna coil. If the boom is rotated 90 degrees, the separation between the two loops is maximum. Maximum voltage would be expected to appear in the output, however, this expected result does not occur. When the boom is rotated 90 degrees, each individual loop is perpendicular to the direction of wave travel, and there is no voltage induced in the loops. Therefore, there is a null point every 90 degrees. One set of null points results from the position of the individual loops, the other set from the position of the boom. There is a maximum point located between each

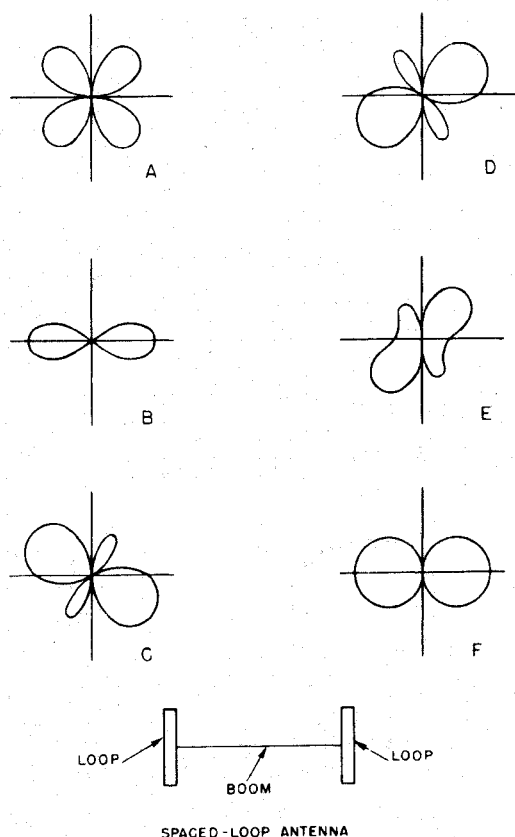

Figure 3-29. Spaced-loop antenna response patterns.

adjacent pair of nulls when both the plane of the loops and the antenna boom are at a 45 degree angle with respect to the null position.

c. Patterns for Abnormally Polarized Waves. Capitals B through F, figure 3-29, show typical response patterns obtained with a spaced-loop antenna (coaxial) when the polarization of the received waves is other than vertical.

(1) Capital B, figure 3-29, closely resembles the response pattern for a wave which is horizontally polarized. This type of polarization is rarely encountered. The pattern is similar to a flattened figure eight.

(2) Capitals C and D, figure 3-29,

show the distortion which occurs when the received waves contain both horizontal and vertical components of polarization. Note that two of the nulls are shifted in azimuth, while the other two nulls remain unaffected.

(3) Capitals E and F, figure 3-29, show typical patterns which may be obtained when receiving elliptically polarized waves (waves containing both horizontal and vertical components which are out of phase with each other).

d. Polarization Error. It is important to note that regardless of the polarization of the received wave, two of the nulls (or minimums) are affected by polarization and shift as the polarization changes. Thus the spacing nulls are free from polarization error, while the loop nulls are subject to it, just as in a single-loop antenna.

e. Taking an Azimuth. The correct null must be used when taking an azimuth with the spaced loop. Receiving a skywave or any other type of abnormally polarized wave, the correct set of nulls appear fixed, while the pair affected by polarization error is indefinite or continually shifting in position. The direct and reciprocal bearings of the correct set of nulls can be determined if the general direction of the transmitter is known, or if a bearing is taken by a loop and sense antenna combination to determine general direction. When the radio wave is vertically polarized and has traveled only a short distance, definite and fixed nulls are found every 90 degrees. The general direction of the transmitter must then be known by other means before the correct null can be selected. When azimuths from several DF sites are plotted on a map, the direct azimuths will intersect near the transmitter location, while reciprocal azimuths and false azimuths (from loop nulls) will either run off the edge of the map without intersection, or intersect at widely scattered points.

3-12. Theory of Doppler Direction Finding.

A signal which is received by a moving antenna will experience a phase modulation in accordance with Doppler's principle. The radiation field has an "equiphase surface" or "wave front" which is equidistant from the transmitter at all points along the wave front. When a receiving antenna is placed in rotational motion about a reference point (fig. 3-30), the signal processed by the receiver will exhibit a sinusoidal phase modulation or frequency change. As the antenna is moved from 0 to 180 degrees, the receiver will experience a frequency decrease because the antenna is moving away from the incoming wave front. When the antenna continues from 180 to 360 degrees, which is toward the incoming wave front, the receiver experiences a frequency increase. No frequency change or phase modulation will be experienced at the direction from which the wave front came nor at the back azimuth (180 degrees opposite). Measurement of this modulated frequency permits the arrival direction of the signal to be determined. This

type of system is used in Airborne Radio Direction Finding (ARDF).

3-13. Quasi-Doppler Direction Finding.

The Quasi-Doppler direction finder locates a wave front or plane and the direction from which it was transmitted is assumed to lie perpendicular to it.

a. Theory. Radio waves travel outward in space from a transmitting antenna at the speed of light and have the same phase at all points which are equidistant from the transmitting antenna. A wave front arriving at two or more distant points simultaneously (Capital A and D, fig. 3-31) is said to be in phase and lie on an imaginary wave front. All points along this wave front are equidistant from the transmitter. Wave fronts in free space are always spherical since all points equidistant from a single point must lie on the surface of a sphere. This point, the center of the imaginary sphere, is the transmitter site.

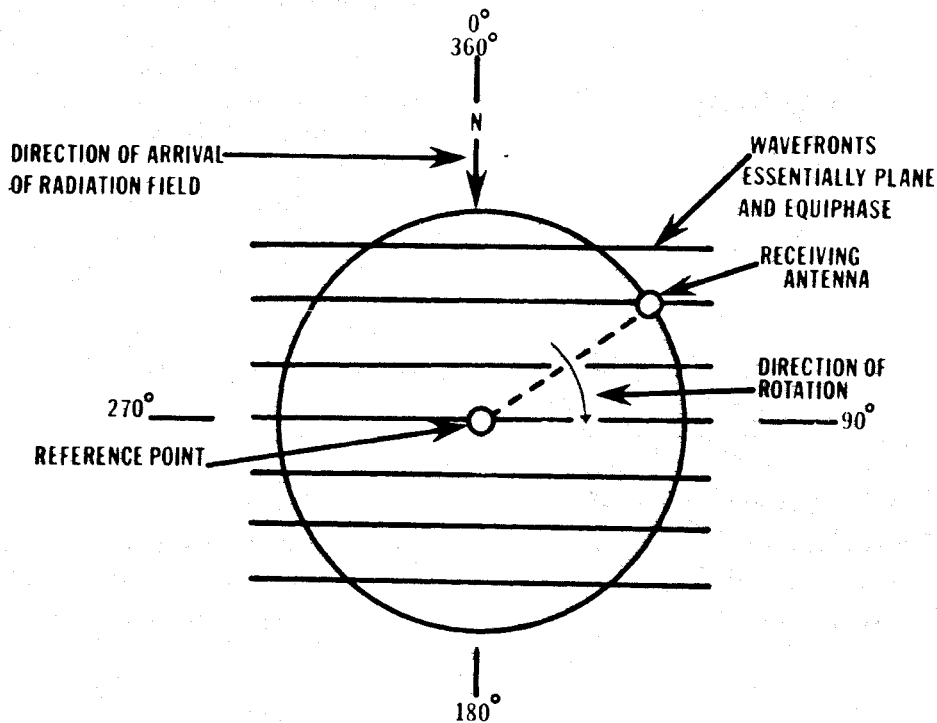

Figure 3-30. Doppler direction finding.

The spherical curvature of the wave front is quite pronounced near the transmitter site, but at greater distances, the curvature is so slight that the wave front may be considered to be a plane surface (Capitals A and D, and E and H, fig. 3-31). A line perpendicular to and bisecting the middle of this plane or wave front between two known points will pass through the transmitter site (Capitals B and C, and E and G, fig. 3-31).

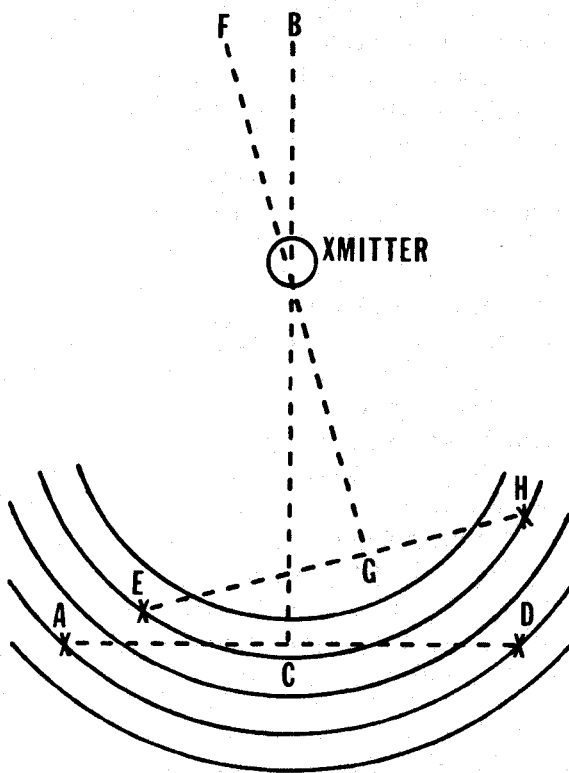

Figure 3-31. Transmitter lies along a line perpendicular to the wave front.

b. Principle of Operation. The Quasi-Doppler direction finder is similar to Doppler direction finding. Instead of physically rotating an antenna through the radiation field, the function is simulated by sampling the outputs of several fixed antennas spaced equally around a circumference equal to that normally traced out by the rotating antenna (fig. 3-32). As long as the number of antennas is sufficient to satisfy the sampling requirement, this system permits the determination of the transmitter's direction by construction of an imaginary plane or wave front (fig. 3-33). The arrival direction of the transmitted signal lies on a line that bisects the middle of, and is perpendicular to, this plane.

Section II

TRANSMISSION LINES

3-14. Transmission Lines Used with DF Equipment.

Transmission lines and coupling systems used to tie the actual DF equipment to the antenna system are very closely interrelated. To attempt to separate the information relating to transmission lines and coupling systems would not be in the best interests of this manual. Accordingly, information pertaining to transmission lines will be included in the following section on coupling systems.

Section III

COUPLING SYSTEMS FOR DF EQUIPMENT

3-15. General.

a. Coupling systems are defined as those elements of a DF system which serve to couple the directional antenna system to the radio receiver.

b. The coupling system must fulfill the following requirements for satisfactory operation:

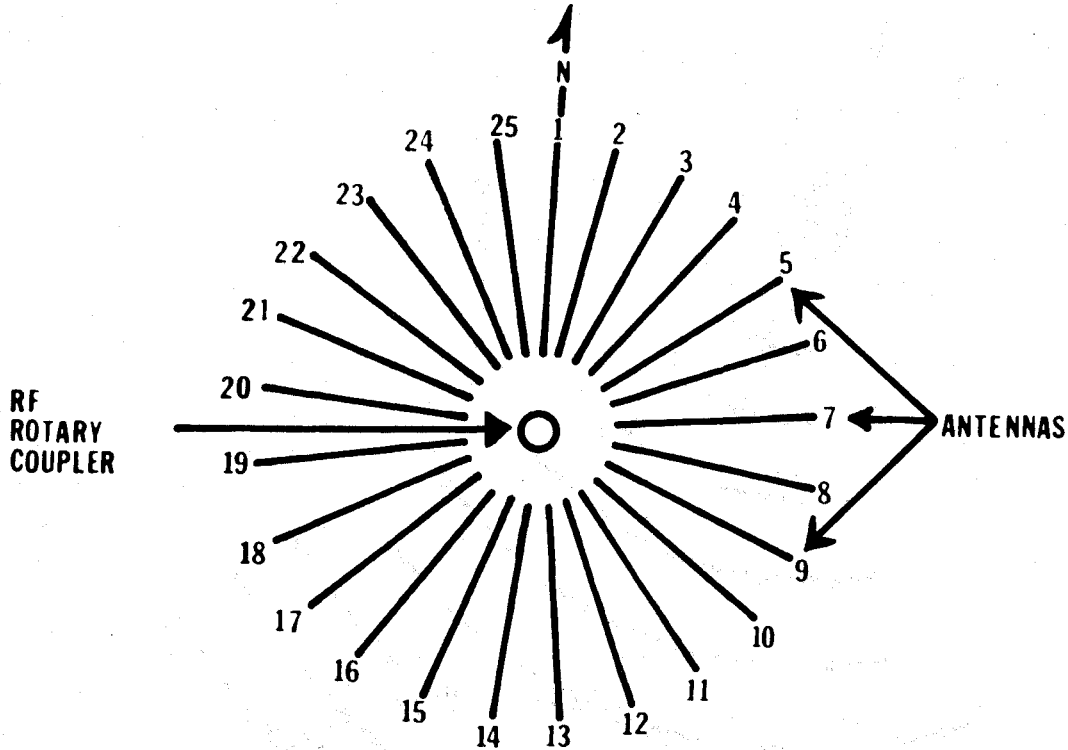

Figure 3-32. Quasi-Doppler direction finder antenna array.

(1) It must efficiently conduct the energy picked up by the antenna system to the radio receiver. If this requirement is not met, the DF will lack sensitivity.

(2) It must not pick up or otherwise introduce additional energy from the wanted signal. Failure to meet this requirement results in bearing errors.

(3) It must not introduce unwanted signals or noise. These effects, if present, produce interference and impair the bearing accuracy.

c. Coupling systems, as used in various types of DF equipment, differ in complexity and type. Common types in general use are discussed individually in two categories:

(1) Systems used with rotatable antennas.

(2) Systems used with fixed antennas.

3-16. Coupling Systems Used with Rotatable Antennas.

a. *Direct Coupling.* Direct coupling, as the name implies, is the simplest form of coupling. The antenna terminals are directly connected to the receiver input. It is used in those few cases where it is practical to design a DF system in which the radio receiver is located at the antenna terminals, and the antenna and receiver rotate together as a unit. Other directly coupled DF sets are small, hand-carried, transistorized receiving sets used by counterinsurgency personnel. The loop is generally the carrying handle, and the entire set is rotated to produce line bearings in the direction of the target transmitter.

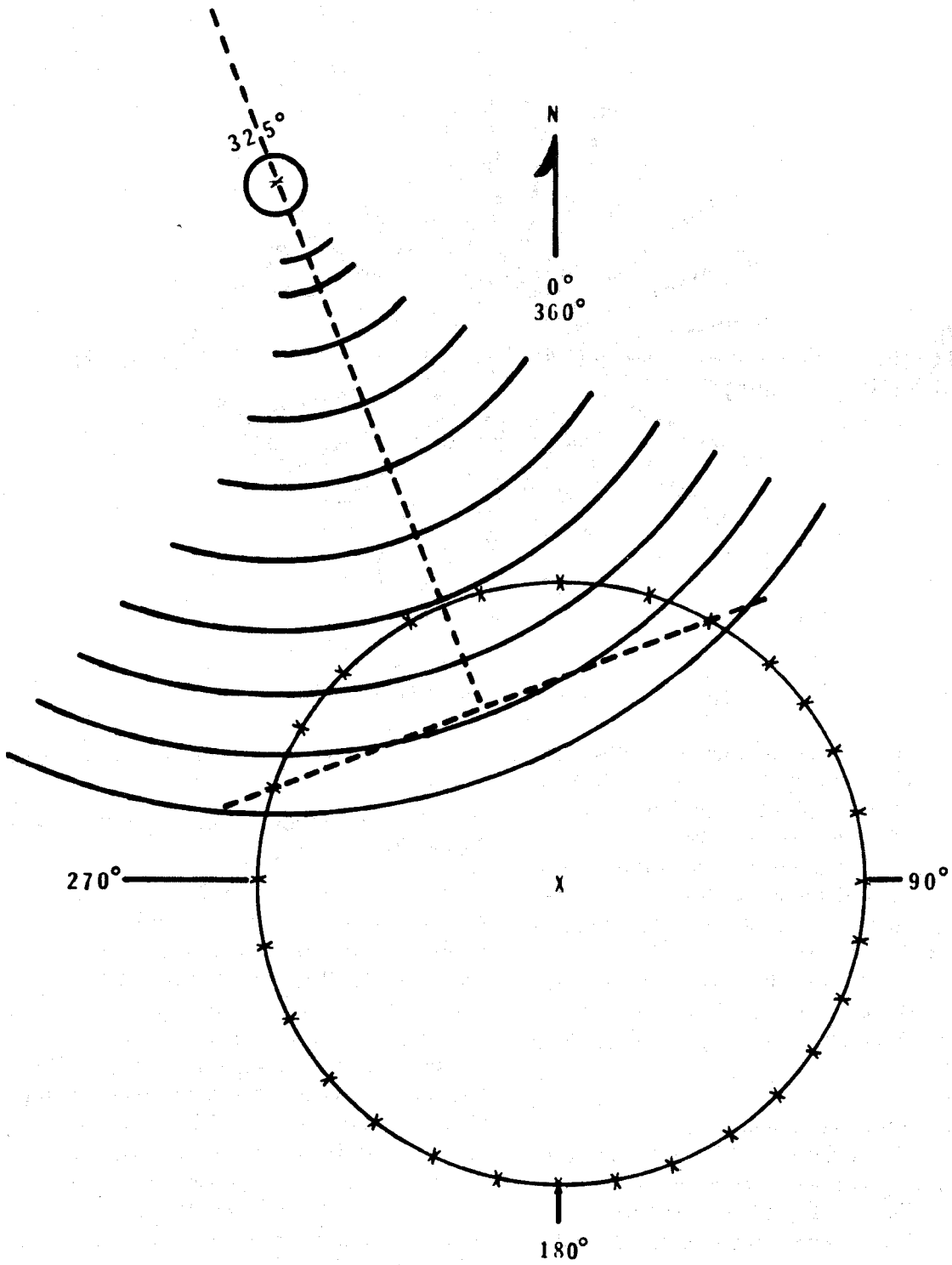

Figure 3-33. Direction finding by a Quasi-Doppler system.

b. Transmission Line Coupling. Transmission line coupling is used in its simplest form on DF sets in which the antenna system is placed some distance above, but is rotatable with its radio receiver.

(1) Construction of a transmission line coupling system is extremely simple. It is usually made up of a length of balanced, dual-conductor, shielded Radio Frequency (RF) cable, or two balanced lengths of single-conductor, coaxial, shielded cable. However, these place stringent requirements on its design since, by virtue of its length and position, the transmission line will, if its shielding or balance is not perfect, introduce unwanted energy causing bearing errors or impaired readability. In addition, if the length of the transmission line is an appreciable fraction of a wavelength or more, its characteristic impedance must accurately match the impedance of the receiver and the antenna, or a considerable loss of sensitivity will occur. In cases where the transmission line is short, such matching is not essential. However, the series impedance of the line must be small and its leakage impedance great in comparison with the sum of the antenna and receiver input impedances.

(2) The direct and transmission line systems of coupling the antenna to the receiver may be used when it is desired to rotate the antenna without rotating the receiver. This is accomplished by the addition of a rotatable coupling element. Several types of rotatable elements used in various DF sets are:

(a) *Slip rings.* Slip rings are insulated metal rings, in contact with sliding fingers or brushes, which permit rotation without interrupting the circuit. By mounting the rings on a shaft and providing fixed brushes, it is possible to conduct the antenna current to a stationary receiver while permitting the antenna to turn at will. It is customary to make the rings of silver and the brushes of a silver alloy which is either harder or softer than the rings in order to minimize

the variation of contact resistance as the rings are rotated. Such variations give rise to noise which is amplified in the radio receiver and may obscure the wanted signals.

(b) *Rotating transformer.* This rotatable coupling device consists of a transformer whose primary and secondary windings are coaxial. Under this condition, one winding may be rotated with respect to the other without changing the coupling which exists between them. This type of rotatable coupling device can serve as the input transformer of the DF receiver, with the secondary coil turned over a limited frequency range in unison with the rest of the receiver circuits. It can also be used for relatively wide frequency coverage in those cases where its primary and secondary load impedances are substantially uniform and resistive in nature.

(c) *Rotating capacitor.* This form of rotatable coupling element makes use of the fact that the capacitance between coaxial disks or rings is independent of their rotation. This method is customarily used only in VHF equipment since only a small value of capacitance is achievable with elements of reasonable size. At these frequencies, a small capacitance can provide adequate coupling.

3-17. Coupling Systems Used with Fixed Antennas.

In DF, the term goniometer is applied to a device used to couple two or more input circuits (usually connected to antennas) to an output circuit (usually connected to the radio receiver). This is done in such a manner that the degree of coupling varies with the rotation of a shaft. The coupling between one input circuit and the output circuit increases, while the coupling with the other input circuit decreases. When properly connected, a well-constructed goniometer provides an output, at each position of its shaft, identical to that which would be produced by a single

figure-eight pattern antenna oriented to the corresponding position. Thus, the goniometer provides an equivalent for the rotation of an antenna, and makes it possible to use large fixed antenna systems (either loop, Adcock, Circularly Disposed Antenna Arrays (CDAA), or others) which would in themselves be too bulky for an operator to rotate.

a. *Inductive Goniometer.* The inductive goniometer usually consists of two fixed windings arranged at right angles to each other and inclosing a third winding which is rotatable by means of a shaft (fig. 3-34).

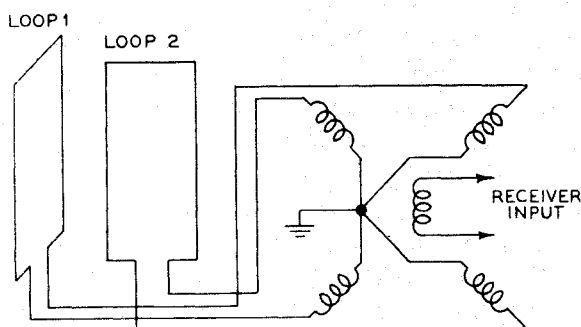

Figure 3-34. Basic goniometer circuit.

(1) When the two fixed windings, arranged at right angles, are connected to identical antennas having figure-eight patterns, the magnetic field within the goniometer will have a direction in relation to the fixed windings corresponding to the direction of arrival of the signal at the fixed antennas. As the internal winding, or search coil, of the goniometer is rotated, its output will vary from maximum to minimum twice per revolution, exactly as would the output of one of the antennas if it were rotated. The positions of minimum output, or nulls, are used to determine the bearing in exactly the same way as if a rotatable antenna was used. The goniometer may be rotated by hand, thus providing manual null-seeking, or it may be continuously rotated by a motor drive and

employed with an automatic visual bearing indicator.

(2) The effect of changing the direction of wave travel on the directional pattern of the goniometer system is shown in figure 3-35. The first column shows the position of the transmitter with respect to the loops, the second and third columns show the position of the goniometer rotor for maximum and minimum signals at each transmitter position, and the fourth column shows the position of the indicator pointer when the DF is set on the correct azimuth.

b. *Capacitive Goniometer.* The capacitive goniometer consists of two fixed sets of capacitor plates inclosing a rotatable set of plates. Operation of this type is similar to the inductive goniometer except that an electric field rather than a magnetic field is established within the goniometer. In practice, the capacitive goniometer is usually used at frequencies above 100 MHz since it is difficult to construct accurate and efficient inductive goniometers for these frequencies.

c. *Requirements.* In order to minimize errors, it is necessary to construct goniometers with extreme precision. The basic requirements for accuracy in a goniometer coupling system are:

(1) The fixed elements must be electrically identical.

(2) There must be a complete absence of coupling between the fixed elements.

(3) Accurate positioning of the fixed elements at the same angle as the antennas (usually 90 degrees) is necessary.

(4) Coupling between the rotating element and the fixed elements must vary with shaft revolution in accordance with the same law as the variation of antenna response with azimuth angle. Generally, this means cosine-law variation.

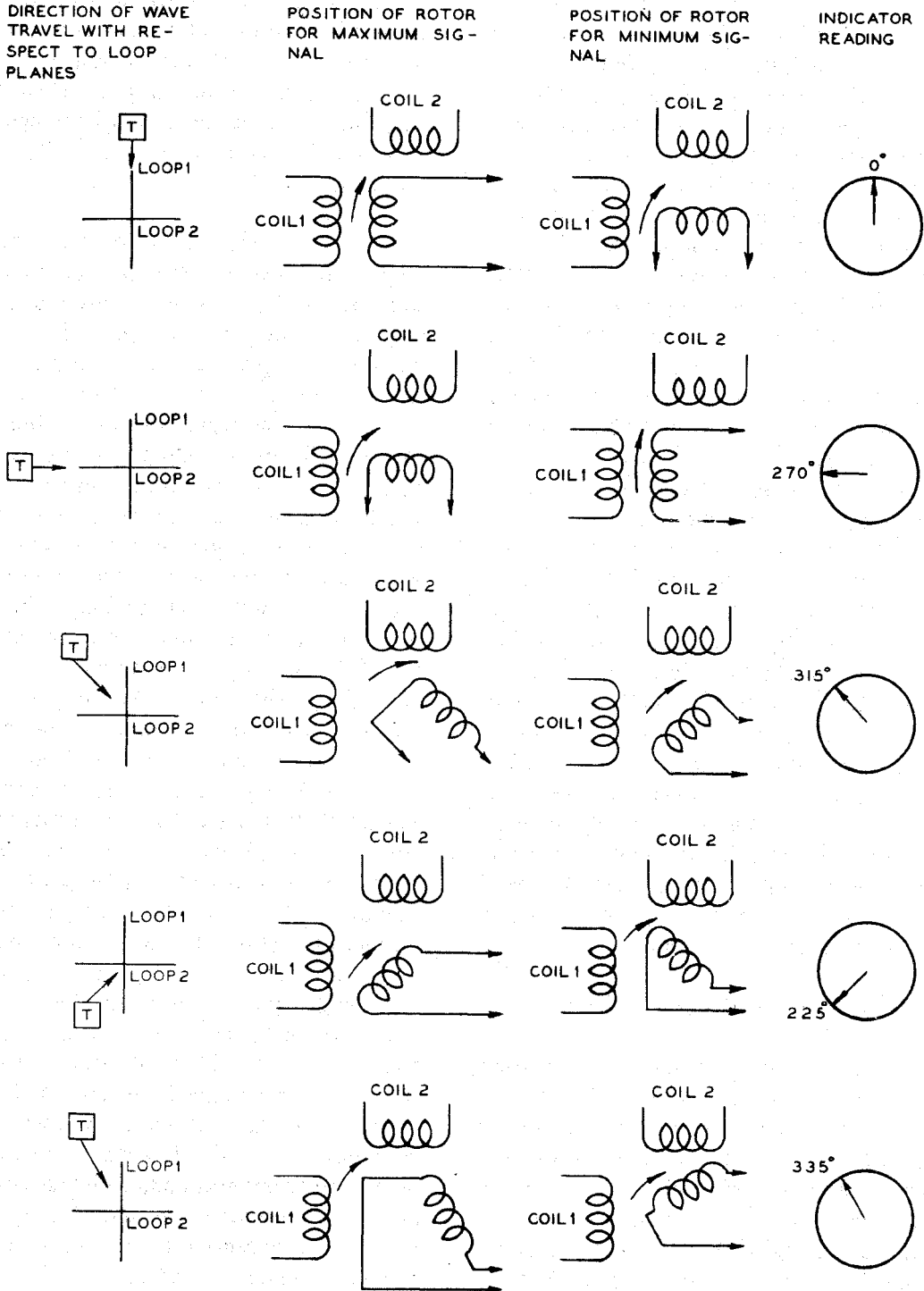

Figure 3-35. Goniometer system, directional characteristics.

Note: These requirements are met in practical goniometers to the extent that the maximum error is less than ± 1 degree.

d. Transmission Lines and Coupling Devices. In applying the goniometer to a practical DF system, it is often desirable to locate the goniometer some distance away from the antenna system. To accomplish this, it is necessary to provide transmission lines between the antenna and the goniometer. These lines must be well shielded and are usually balanced to ground to avoid stray pickup. In addition, the transmission lines connecting the several antennas to the goniometer must be electrically identical, particularly in time delay, over the entire frequency range of the equipment in order to preserve accuracy and provide deep nulls. Such systems customarily use shielded, balanced-type transmission lines laid on the ground. The antennas may be coupled to the transmission lines either through transformers designed to match the impedance of the antenna to the impedance of the transmission line or through amplification type coupling devices. The transmission line length is also critical as varying lengths will cause varied signal strengths to be received. Transmission line coupling must be precise and balanced throughout the system. All couplings must be clean and have maximum contact, if not, signal loss will result. A transmission line with three couplings will have a greater amount of signal loss than a line with two couplings.

3-18. Electronic Goniometer System.

a. This system, in which the varying coupling is provided by means of electronic circuits rather than by mutual inductance or capacitance, is an electronic equivalent of the inductive goniometer. In practice, it is desirable to make the electronic goniometer circuits an integral part of the antenna system. However, the electronic goniometer may be considered as a coupling system applicable to the same forms of antenna

systems as the inductive and capacitive goniometers. The electronic goniometer system is particularly useful with automatic bearing indication systems, since the effective rotation of the antenna system is produced entirely by electronic circuits. This permits the use of high speeds which would be unattainable with a mechanically rotated inductive circuit.

b. The basic unit of the electronic goniometer system is the balanced modulator. This device has two input circuits and one output circuit so arranged that if two different voltages are introduced into the two input circuits, the output voltage is proportional at every instant to the vector produced by these voltages. In the electronic goniometer, the two input voltages are the signal voltages picked up by the antenna and an Audio Frequency (AF) sine wave voltage of a frequency representing the desired rate of effective rotation of the antenna. The output of the balanced modulator, under these conditions, is a modulated envelope comprising the entire spectrum of signals picked up by the antenna. Each signal is completely modulated in amplitude by the audio frequency used. In other words, the output of the balanced modulator contains all the signals picked up by the antenna. However, each signal is varied periodically in amplitude by the AF voltage from its maximum value to zero and back to maximum with reversed polarity, just as if a figure-eight pattern were rotating at the AF rate. Two balanced modulators, upon having their outputs added together, form an electronic equivalent of the spinning inductive goniometer. The outputs of the two balanced modulators combine in such a way that each of the resulting modulated signals reaches its minimum or null at an instant during each AF cycle, corresponding to the direction from which the signal is arriving.

3-19. Octantal Error.

a. In addition to the errors common to the type antenna used, another error, known as octantal error, is introduced by the goniometer. This is caused by the nonuniformity of the flux fields within the stationary windings of the goniometer. In early types of goniometers, this nonuniformity was considerable and, as a result, octantal error was large. In more modern goniometers, however, the turns of both the stator and rotor windings are distributed in such a manner that almost perfect uniformity of the flux fields is obtained. Thus, this type of octantal error is practically eliminated.

b. Octantal errors are also introduced by the physical dimensions of the antenna system as related to the ground. When the spacing of the antenna elements is large with respect to wavelength, the relation between the planes of the antenna elements and the direction of wave arrival does not parallel at all points the relation between the goniometer rotor and the goniometer stationary windings. Instead, the true azimuth is found by adding a correction factor to the azimuth reading. Since the element spacing becomes increasingly longer with respect to wavelength as the frequency is increased, the correction also becomes greater. Generally, an octantal correction chart is supplied with the equipment.

Section IV

BEARING INDICATORS

3-20. Definition and General Characteristics.

a. After energy has been picked up by the antenna, passed through the coupling system, and amplified by the receiver, the bearing indicator translates this energy into an intelligible form from which the operator can determine the direction of the arriving signal. In addition, a bearing indicator may provide information enabling the operator to choose

the most satisfactory moment to read the bearing and to judge the probable accuracy of that bearing.

b. The type of bearing indicator used with any particular DF system depends on the type of DF system in use, the complexity and physical size permitted, and the accuracy desired for a particular DF application.

c. Many types of bearing indicators have been designed and used in DF systems, but those having greatest application can be grouped in the following general categories:

- (1) Aural indicators.
- (2) Instantaneous indicators (scope presentations).
- (3) Automatic bearing-seeking indicators (primarily in airborne application).
- (4) Digital read out.

d. Each type of indicator has certain specific characteristics and applications which are described in detail in this section. Many of these characteristics are closely related to, and cannot be separated from, characteristics of the DF system with which a particular indicator is used. For example, in an instantaneous DF system, many of the features exhibited by the indicator are not necessarily characteristic of the indicator alone, but are the combined characteristics of the antenna, coupling, and indicator system.

3-21. Aural Null.

An aural null is the decreased audio tone of the received signal when the antenna is at right angles to the arriving wave front and the signal components (phase relationship and signal strength) are identical. Electronically, when signals of equal value are "beat" (mixed together), these signals will, among other effects, cancel each other. This cancellation results in the decreased audio tone.

a. *Aural Indicator.* An aural indicator is a headset or loudspeaker connected to the DF

receiver audio circuit. It enables the operator to detect the signal bearing by changes in the audible receiver output as the antenna is rotated. In DF systems using aural indicators, the antenna system must be rotated to the bearing position. This position must be characterized by an abrupt change in the antenna response pattern and, therefore, in the receiver output.

b. Types. In the most common DF sets using aural indicators, the antenna is a rotatable loop or Adcock, or a fixed crossed-loop or crossed-Adcock effectively rotated by a goniometer. All these antennas have, or result in, a figure-eight response pattern with broad maximums and sharp nulls. Therefore, the nulls of the antennas are selected as the bearing points. Aural indicators used with DF sets having these types of antennas are commonly called aural-null indicators. At the higher frequencies (several hundred megahertz), directional arrays having response patterns with sharp maximums can be used. Aural indicators operating with these antennas might be called aural-maximum indicators. The remainder of this paragraph is limited to a discussion of aural-null indicators rather than aural-maximum indicators because they are the most common in DF equipment currently deployed.

c. Characteristics. The important characteristics of the aural-null indicator are as follows:

(1) It is the simplest indicator that can be used with a DF set since:

(a) It adds nothing to the DF because a headset or speaker is usually included for monitoring purposes.

(b) It can be used with simple-loop or Adcock antenna systems without the addition of complicated coupling systems.

(c) It reduces to a minimum the size, weight, and maintenance factors of the indicator.

(2) The indicator cannot detract from the accuracy of the remainder of the system.

(3) The readability of the indicator is not influenced by the type of signal received, whether it is Continuous Wave (CW), Interrupted Continuous Wave (ICW), or Modulated Continuous Wave (MCW).

(4) The readability of the indicator is high on weak signals in the presence of noise or interfering signals because the human ear can differentiate between desired and undesired signals.

(5) The readability of the indicator is poor on fading signals because it cannot discriminate between a fade and a null indication.

(6) An extra operation must be performed to determine sense.

3-22. Visual Bearing Indicator Systems.

More sophisticated equipment is required for systems providing visual bearing presentations. A meter or oscilloscope must be used to determine the bearing direction. Most DF equipment currently deployed has a scope integral to the circuitry. On the scope face, the signal bearing is displayed in a number of forms or shapes.

a. Instantaneous (Oscilloscope) Indicators. An instantaneous visual indicator using a Cathode-Ray Tube (CRT) continuously and automatically presents a pattern or trace on the tube screen that points toward the azimuth of the arriving signal or an azimuth scale around the face of the tube (fig. 3-36). The presentation of this pattern or trace is accomplished without manually rotating the DF antenna to the bearing position.

b. Application. The application of an instantaneous indicating device to a DF system is possible only if the antenna system is one of the following types:

(1) A fixed, oriented, crossed-loop, or crossed-Adcock variety that may be effectively rotated 360 degrees at a constant rate by a spinning mechanical or electronic goniometer.

(2) A fixed, oriented, crossed-loop, or crossed-Adcock variety, the outputs of each of the crossed-loop or Adcock antennas

maintained as separate signals through a dual-channel receiver, or through a system of antenna switching and a single-channel receiver, to individual channels in the indicator.

(3) A single-loop or Adcock that is continuously rotated 360 degrees by mechanical means at some constant rate.

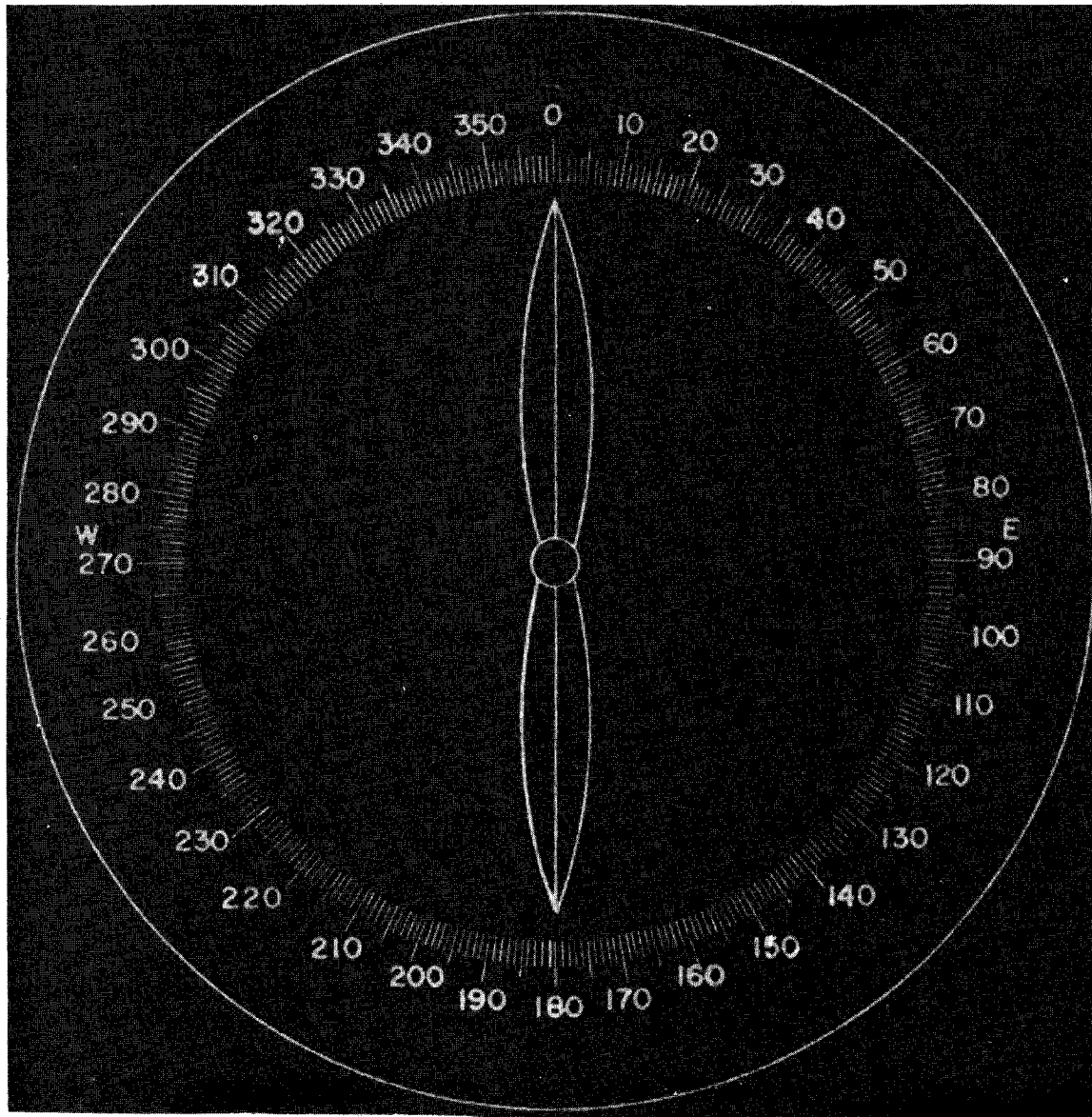

Figure 3-36. Typical position of azimuth scale on instantaneous indicator (oscilloscope).

(4) A Circular Disposed Antenna Array (CDAA) equipped with monitor beams, power combiners, and much greater sophistication than has thus far been discussed.

(5) Inverse LORAN.

(6) Single Site Position Assembly Location.

c. Characteristics. Because these special features must be incorporated in a DF system using an instantaneous indicator, its size, weight, power consumption, complexity of design, and maintenance are greater than in systems using aural-null indicators. When not prohibitive, these disadvantages are more than compensated for by the increased performance obtained when using this type of indicator. Characteristics of instantaneous indicators in comparison with similar characteristics of aural-null indicators are as follows:

(1) There is greater speed in obtaining bearings because the antenna is not manually rotated to the bearing position. Bearings can be taken as quickly as the receiver can be turned to the desired signal and the bearing read directly from the indicator. In autotune systems the productivity of a remoted DF site is greatly increased.

(2) Simplicity of operation is increased. Tuning the receiver and reading the bearing are the only operations necessary. Alinement and balancing procedures, although not difficult, must be carefully accomplished by experienced operators or maintenance personnel as appropriate.

(3) Readability is increased. Although its readability on strong signals is not appreciably greater than the aural-null system previously discussed, its readability on moderate and weak signals is considerably greater.

(4) There is equal readability on CW, ICW, and MCW signals.

(5) Readability on swinging signals is increased because the indication

continuously and instantaneously changes with the bearing swing, and thus permits the operator to choose the bearing that most likely is correct.

(6) Readability on fading signals is increased because the indicator has a high degree of discrimination between a change in signal level, due to fade, and a change in bearing.

(7) There is increased readability on combinations of swinging, fading, and unfavorably polarized signals, because the indicator exhibits certain features which tell the operator when conditions are most favorable for obtaining a bearing.

(8) Readability in the presence of interfering signals is fair, although not as good as aural indicators. This reverts back to the discrimination by the ear between two signals with only fractional frequency separation. Auto tune systems however, have largely eliminated adjacent channel interference by remotely tuning the DF receiver to within 25 Hz of the target frequency.

3-23. Bearing-Seeking Type Indicators.

a. A bearing-seeking type indicator is used with those DF sets in which the antenna system is automatically rotated by an electric motor to the true bearing position of the source of signal to which the DF receiver is tuned. The bearing indicator in such a system is the component which controls the rotation of the loop driving motor. It causes an indicating pointer to revolve and come to rest when pointing at the azimuth of a signal as read from a circular azimuth scale. The rotation of the antenna is quite often electronic instead of manual. The bearing presentation, however, is still as described above. This type indicator is used primarily in airborne applications and is identified as Automatic Direction Finding (ADF), or automatic radio compass. This information is included to ensure an overall understanding of DF. The ADF provides the pilot with a continuous and automatic indication of the

azimuth to the transmitter. In reality, the automatic radio compass is a left-right, loop-type DF with a servosystem (or electronic system) which automatically (or electronically) turns the loop to its true null.

b. The output of a left-right DF when the loop is off bearing is an audio signal at the loop switching frequency whose amplitude and phase are a function of the loop position with respect to the loop null. In an automatic radio compass, the variations in phase and amplitude of the receiver output voltage cause the loop to be driven by a reversible electric motor (or electronic switching system) to a point of null or zero pickup.

c. The widest application of a bearing-seeking type indicator is in homing type DF for aircraft where size and weight requirements do not permit the use of instantaneous indicators, but where an automatic DF (in the sense that operator/pilot does not have to rotate the antenna to the bearing position and the true bearing is continuously indicated) is required.

d. Characteristics of bearing-seeking type indicators are as follows:

(1) It has simplicity of operation comparable to that of instantaneous indicators. The only operational requirement is tuning the receiver to the desired signal and reading the bearing on the indicator.

(2) Readability on strong and moderate CW, ICW, and MCW signals is as good as that of indicators previously discussed.

(3) Readability on weak signals, swinging and fading signals, and on signals in the presence of adjacent channel interference is not comparable to the readability of instantaneous indicators.

(4) Automatic sense indication is coincidental with bearing indication.

Section V

DF RECEIVERS

3-24. DF Receivers.

Any good quality receiver that has excellent sensitivity and selectivity, and can be modified for compatibility with necessary auxiliary equipment, can be used as a DF receiver.

CHAPTER 4

Types of Direction-Finding Efforts

Section I

TERMINOLOGY ASSOCIATED WITH DF EFFORTS

4-1. General.

a. Directwave Direction Finding. Directwave Direction Finding (DWDF) is the term used to identify the DF effort against transmitters located close enough to the DF site that the direct component of the transmitted wave is used to locate the transmitter.

b. Skywave Direction Finding. Skywave Direction Finding (SWDF) is the term used to identify the DF effort against transmitters whose location is far enough away from the DF site that their radio waves have been reflected or refracted by the atmosphere prior to their interception by the DF site.

c. Airborne Radio Direction Finding. Airborne Radio Direction Finding (ARDF) is the term used to identify the DF effort conducted from an airborne platform.

Section II

DIRECTWAVE DIRECTION FINDING

4-2. DWDF Factors.

Radio wave propagation is an extremely important factor in all types of DF. Although a review of wave propagation was given in chapter 2, it is necessary to describe some important differences between wave behavior in the MF/HF frequency range and those in

the VHF/UHF range, since these effects have important operational effects on DWDF activities.

a. In the VHF/UHF frequency range (30 MHz and above):

(1) Communications are predominantly short range and line-of-sight.

(2) FM voice is the primary type of transmission.

(3) Transmitters are usually highly mobile, either manpacked or vehicle mounted. They commonly use whip antennas which are nondirectional and vertically polarized.

(4) Transmission is mostly by means of the direct component of the groundwave. Wave travel is primarily in a direct path from the transmitting antenna to the receiving or DF antenna (fig. 4-1).

(5) The directwave component is generally not greatly affected by the ground over which it travels. It is, however, subject to reflection and reradiation by objects above the ground in its wavepath (fig. 4-2).

b. At this point, it is necessary to discuss how reradiation affects the DF effort. Reradiation occurs when the wave front encounters an object composed of any material having high electrical conductivity, is of a size that approximates the wavelength (including fractions or multiples thereof), and has the same polarization. For example, an FM radio transmitting on a frequency of 50 MHz using a quarter-wave vertical whip antenna is located at point A in figure 4-3. The hill mass between the transmitter at A and the DF sets at B and C would ordinarily make it impossible for the transmitter to be heard at the DF sites. A metal fence post approximately 1.5 meters in height is located at point D. As the wave transmitted from the

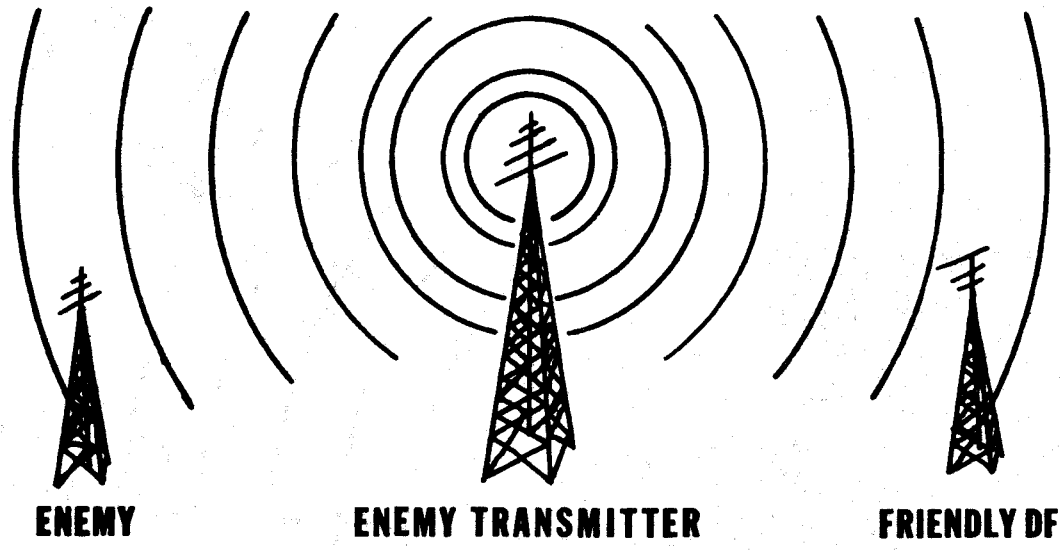

Figure 4-1. Direct wavepath.

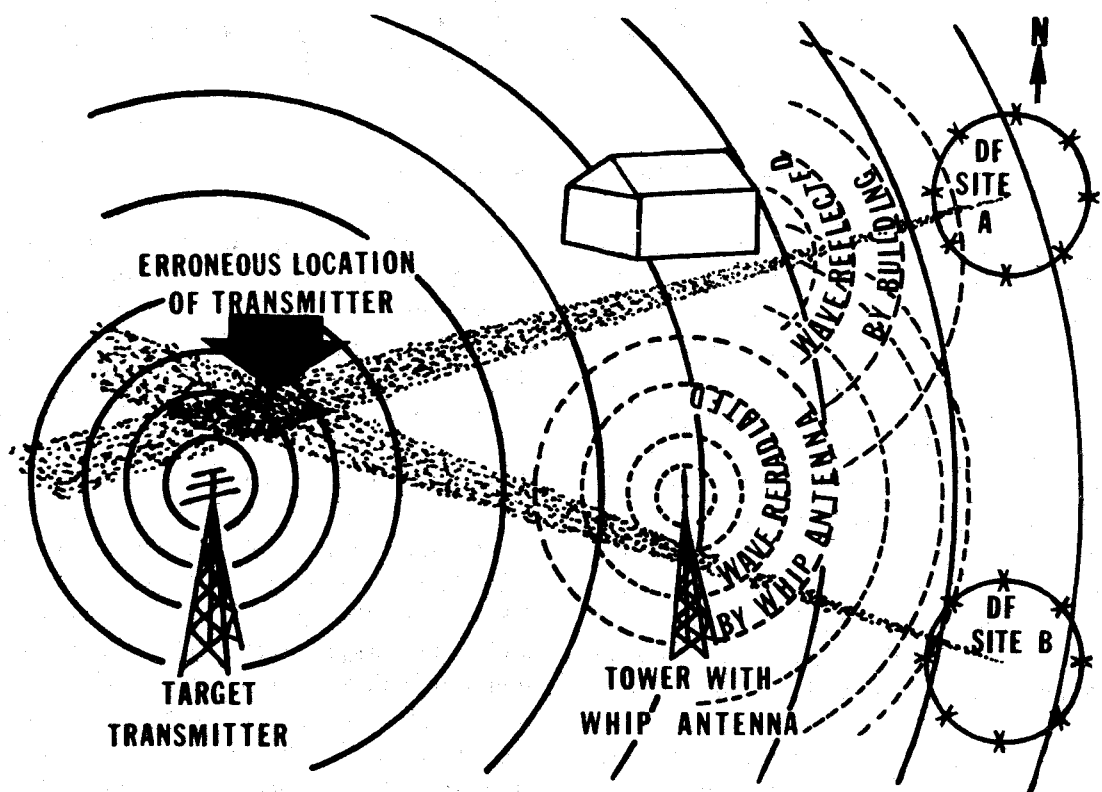

Figure 4-2. Wave reflection and reradiation.

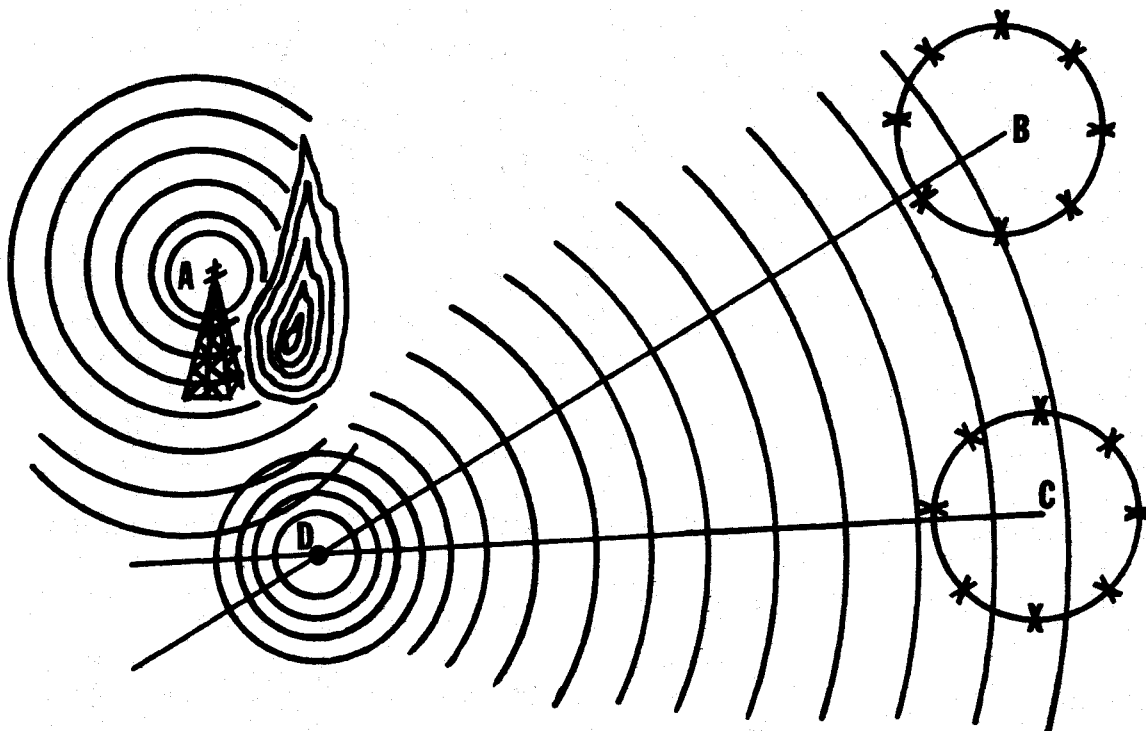

Figure 4-3. Reradiation of transmitted signal.

FM radio passes by the fence post, a small induction field is built up around the post. Since the 1.5 meter post is a quarter-wavelength of the radiated wave, a resonant radiation field is set up causing the wave to be reradiated from the fence post. In this instance, the DF sites will indicate an erroneous location for the transmitter. The reradiated wave is much weaker than the original wave, but when a directwave and a reradiated wave are present at the same time, as shown in figure 4-2, the weaker reradiated wave may still be of sufficient intensity to affect the accuracy of the DF bearing.

c. The discussion pertaining to wave propagation indicates that groundwaves are composed of several components. The waves

radiated from a transmitting antenna spread out into the atmosphere and along the earth, as well as into the earth. Because of the conducting properties of the earth, some of the energy is reflected from the earth's surface. The part of the wave not reflected enters the earth where the energy rapidly dissipates as heat. Other portions of the waves spread out along the earth and into the atmosphere and travel to the receiver, providing radio communications, and to the DF set. The field intensity of the groundwave and the range over which groundwave communications can be conducted depends upon many factors (see section III, chapter 2). Most of the received groundwave field intensity can usually be accounted for in terms of one or more of the factors discussed

previously. The resulting groundwave is, therefore, composed of one or more of the following wave components: direct, ground reflected, surface, and tropospheric.

(1) *Directwave.* This component travels directly from the transmitting antenna to the receiving antenna. The directwave is not appreciably affected by the earth's surface, but is subject to refraction in the atmosphere between the transmitter and the receiver. This refraction is particularly important in the UHF range. The directwave is the principal means of transmission in tactical VHF communications circuits, and therefore is of prime importance in DWDF operations above 30 MHz. The directwave (along with the ground-reflected wave) is also the most important wave component in Airborne Radio Direction Finding (ARDF) at all frequencies.

(2) *Ground-reflected wave.* This component reaches the receiver after being reflected off the ground.

(a) If both the transmitter and receiver (or DF set) are located on the ground, the difference in path lengths between the direct and the ground-reflected waves is small. These waves arrive almost exactly 180 degrees out of phase, resulting in almost complete cancellation. This is particularly true at frequencies below 30 MHz due to the relatively long wavelengths. The difference in path lengths between the direct and ground-reflected waves would have to be relatively large to compensate for the 180 degree phase shift at the point of reflection. Therefore, in this instance, DF of groundwave communications below 30 MHz are conducted primarily with the surfacewave component.

(b) As the height above the ground of the receiver antenna increases, the difference in the path lengths of the two components increases until a point is reached where the difference is equal to the 180 degree phase shift caused by reflection. When the two components are equal in phase, they

add together to produce a stronger signal than would be produced by either component alone. At still greater heights, the two waves again arrive out of phase, and cancellation occurs. At extremely high frequencies, many cycles of change from null to maximum occur. At 3,000 MHz, for instance, the nulls are only two degrees apart. In the HF band, there are usually only one or two such cycles because of the greater wavelengths at these frequencies.

(c) The height of the transmitting antenna above the ground plays an important part in determining the shape and vertical orientation of the lobes. For instance, if the transmitting antenna is a quarter-wavelength above the ground, the wave goes through a 90 degree phase change in its path from the antenna to the ground directly below, a 180 degree phase change caused by reflection, and a further 90 degree shift on its way back from the ground to the antenna. Thus, the wave front is exactly in phase with the next succeeding wave front emitted from the antenna, and the maximum signal strength is directly above the antenna. These patterns of radiation are very important in ARDF, which operates against a combination of the direct and the ground-reflected wave components.

(d) At frequencies above 30 MHz, the wavelengths are shorter and the in-phase condition between the direct and ground-reflected wave components occurs close to the ground. Since the surfacewave component loses strength rapidly at these frequencies above 30 MHz, communications are largely by means of the combined direct and ground-reflected wave components. Reception can be improved by increasing the height of the receiver antenna to increase the path length difference between the direct and ground-reflected wave components to maximize the phase relationship between the two components. Since a full wavelength at 30 MHz is only 10 meters and decreases to 1 meter at 300 MHz, a small adjustment in

antenna height may produce the desired results by trial and error. It should be pointed out that whenever operations are conducted over terrain which inhibits ground reflection, such as areas covered by low brush or rocky desert terrain, the ground-reflected wave may be absent, and communications above 30 MHz will use the directwave component only. In essence, a very low percentage of a VHF signal is adequately reflected to enhance the DF effort.

(3) *Surfacewave*. This component travels directly along the surface of the earth (although it extends above the ground, its strength diminishes with increased height), and is affected primarily by the conductivity and dielectric constant of the ground over which it travels. The surfacewave is the primary component acted upon by ground-based DWDF systems below 30 MHz. The three most important factors of this type wave propagation are:

(a) *Frequency*. The lower the frequency, and therefore, the longer the wavelength, the greater the range. The LF and VLF frequency bands are used for extremely long-range communications. These frequencies are commonly used as navigational aids for ships. The MF range, which includes the standard broadcast band, can support moderate-range communications when the transmitting equipment is specially designed for groundwave propagation. Over sea water, this frequency range can be used for distances up to approximately 5,000 kilometers. In the HF band, wavelengths become shorter, and the dielectric constant and conductivity of the ground become the most important factors in surfacewave propagation. Regardless of ground conductivity, however, as the frequency increases, the groundwave range decreases. In the vicinity of 20 MHz, the groundwave loses strength very rapidly, and above 30 MHz, it is virtually nonexistent for purposes of practical communications and DF. Most military communications below 30 MHz operate in the 2-20 MHz range (predominantly in

the 1.5-8 MHz band) and rely mainly on skywave propagation. Groundbased DWDF systems working against such transmitters are actually receiving groundwaves which are unintentional byproducts of transmissions whose main energy is directed towards the ionosphere rather than along the surface of the earth (fig. 4-4.)

(b) *Terrain*. The electrical characteristics of the ground over which the groundwave component travels can affect its range considerably. Sea water is the best conductor, having a conductivity factor approximately 5,000 times as great as dry soil.

(c) *Polarization*. When the surfacewave is horizontally polarized, the earth has a short-circuiting effect which causes the wave to dissipate rapidly into the ground. For this reason, surfacewaves are generally vertically polarized. If a transmitted wave has some degree of both vertical and horizontal polarization, the horizontal portion will be quickly absorbed and only the vertically polarized part of the wave will travel any appreciable distance. Because of this, surfacewaves can be considered to be vertically polarized. This is an important point, since most DWDF systems employed against surfacewaves use vertical loop or monopole antennas which are designed to receive vertically polarized waves.

(4) *Tropospheric waves*. See paragraphs 2-14 and 2-15.

d. In the MF/HF range, the enemy transmitters against which DWDF is being conducted are likely to be communicating with another station hundreds of kilometers away by the skywave mode of transmission. The groundwave received by the DWDF team is generally an unintentional byproduct of a skywave transmission (fig. 4-4).

(1) This wave travels along the surface of the earth and can be strongly affected by the earth and natural or manmade objects on its surface. Obstructions between the transmitting antenna and a DF site can

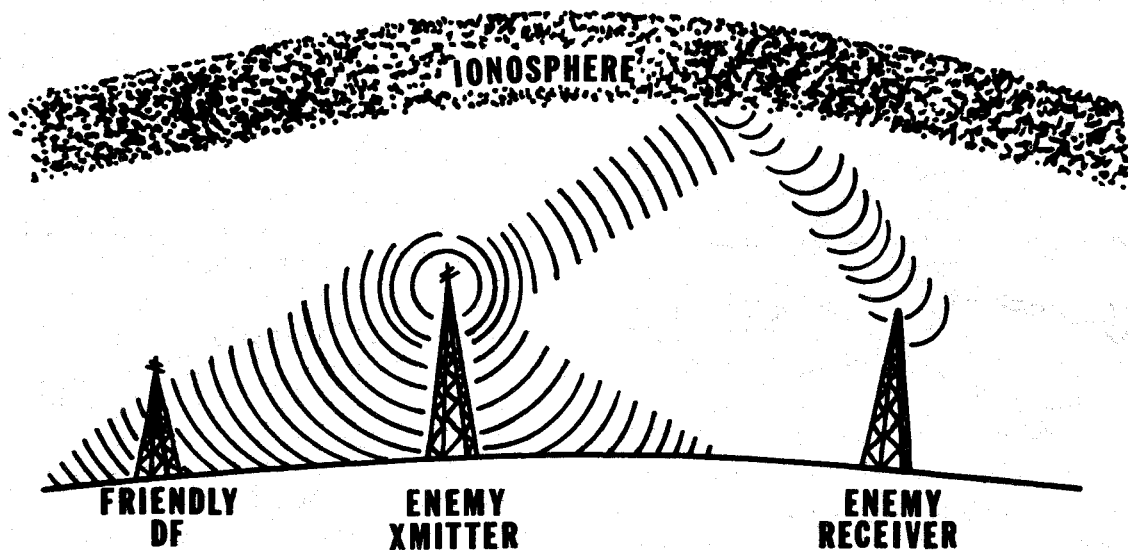

Figure 4-4. Groundwave DF.

cause the wave to deviate from a straight-line path and introduce wavewidth errors of varying degrees.

(2) The distance these groundwaves can be received by a DWDF set is subject to extreme variations and is affected by such factors as transmitter power output, antenna type, terrain, manmade objects, and operating frequency. Advance estimates of expected groundwave range in a given environment can be made if some knowledge of the enemy's communications equipment and operating techniques is available; however, some actual operating experience in each situation is usually required before reliable range estimates can be made.

4-3. The Baseline and Baseline Distance.

The establishment of a suitable baseline is affected by tactical, strategic, and technical considerations. A direction-finding baseline is identified as the imaginary line or axis along which the DF equipment of a DF network is deployed. Essentially, there are two types of

baseline configurations utilized for deployment of a DF network; concave or straight, and convex. The baseline distance is that straight line distance that separates the two outermost DF stations or sites. As a rule of thumb, a DF network fix capability is equal to the distance of the baseline measured from the center of the imaginary line joining the two outermost DF sites. For example, if the DF baseline is 80 km in length, the net location capability is 80 km in depth. Tactically, the deployment and movement plans of the friendly unit in whose area of operations the DWDF net is established will determine which areas are available for the siting of the DF equipment. However, the target area to be covered, depending upon a technically acceptable environment, will dictate the baseline configuration that is employed in any given situation.

a. Concave. If it is expected that the target locations will be in a rather compact, narrow but deep, frontal area, it is best to locate the direction finders on a concave or

even straight base line (fig 4-5). With this baseline, the azimuth angles are satisfactory at longer ranges and excellent at short ranges.

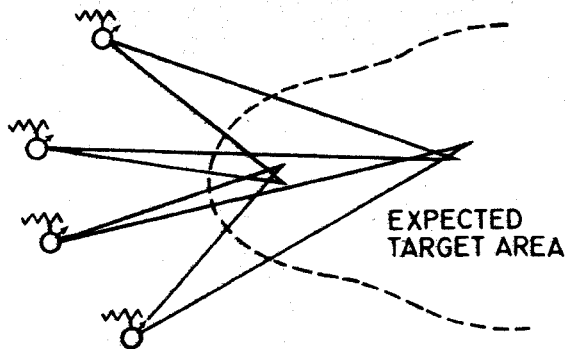

Figure 4-5. Concave baseline.

b. *Convex.* If target locations are anticipated to be located over a wide flanking, short-in-depth area, a triangular or convex (quadrilateral) baseline is suitable (fig 4-6). Using a convex baseline in this situation provides a reasonable azimuth angle over a wide front. It is probable that the convex baseline will satisfy the average situation.

4-4. Baseline Considerations.

The physical security of the DF site presents a combination of technical and tactical problems. Sites that are most suitable from a technical standpoint may be tactically undesirable, and vice versa. In many cases, a technically desirable site may be located in a risky area, and a suitable defensive perimeter must be established. If barbed wire is required in the vicinity of the DF site, or if armored vehicles are stationed near the DF antenna, these metallic objects will introduce DF errors that may completely negate the site's original technical advantages. DWDF equipment is subject to serious errors caused by poor siting. Siting criteria, which are applicable to all DF efforts, will be discussed in detail in a later paragraph of this chapter. While it is difficult

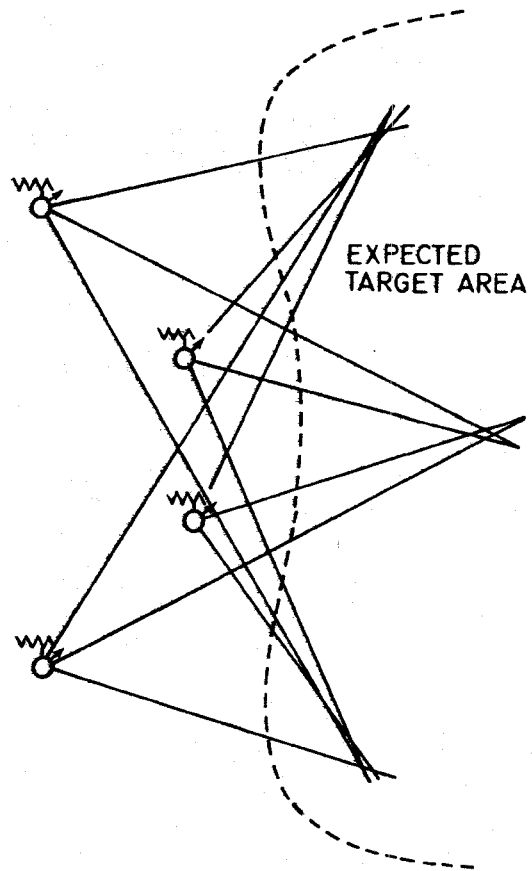

Figure 4-6. Convex baseline.

to locate a technically ideal site, it is essential that the siting criteria which follows be adhered to as closely as possible.

4-5. Terrain Considerations for Wavepath.

The terrain on which both the DF sets and the target area are located is an important factor in DWDF operations. In favorable terrain, such as flat areas with few obstructions, all of the DF sites may have a clear electronic "view" of the target area. The establishment of the baseline is largely a matter of placing the DF sets so that good bearing angles for triangulation within the

target area are possible. Ideally, each of the sites should have an unobstructed wavepath between the DF antenna and any point within the target area. In most cases, however, this is not possible. Sites should be arranged so that portions of the target area that are "masked" to one or more sites can still be covered by at least three other sites. This is similar to setting up interlocking fields of fire for weapons, except that in the case of DF sets, each area must be covered by three "lines of fire" instead of one or two (fig. 4-7).

4-6. Masking of Transmitters by the Enemy.

There are some situations in which the enemy can take advantage of terrain features to mask his communications from friendly groundbased DF sets. Such a situation is illustrated in figure 4-8. The transmitting antenna, being hidden behind a hill is electronically masked from the DF sites, yet is able to communicate effectively with his outstation. Although this type masking is most effective in line-of-sight communications, the possibility must be considered whenever the terrain features in the enemy's area of operations afford the opportunity.

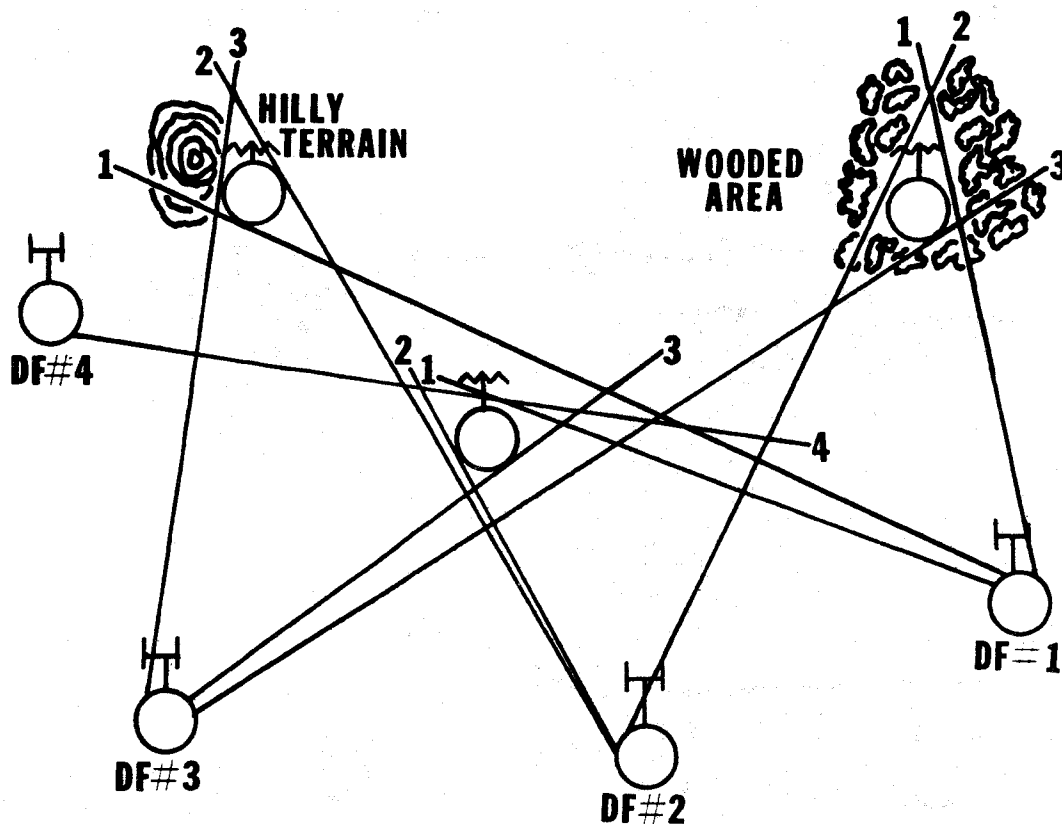

Figure 4-7. DWDF net with curving baseline.

4-7. Limitations of Baseline Establishment.

In some situations, conditions may be prohibitively unfavorable for DWDF operations because of impossible terrain conditions, unusual propagation factors, or baseline restraints. An example of a prohibitive baseline limitation is an amphibious operation with an assault on a very narrow beachhead. In this case, the area under friendly control is too small to establish an effective baseline, therefore, effective DF cannot be employed. In such a situation, it would be necessary to rely on ARDF support until the beachhead is expanded to accommodate a suitable baseline.

4-8. Map Reconnaissance for Establishing DWDF Nets.

The most important step in setting up the DWDF net is thorough planning of the operation. Maps of the area must be carefully studied to find favorable site locations that present the best possible wavepaths from the target areas. The size and shape of the deployment area must be considered, as well as the estimated transmission range of enemy transmitters. The number of DF sets available for deployment will heavily influence the planning estimates. Sites must be in good radio reception areas and as far removed as possible from all obstructions, particularly metallic objects. Even under particularly unfavorable conditions, acceptable DWDF results can be obtained if the operation is carefully planned, with proper attention paid to the fundamentals of DF site selection and wavepath considerations.

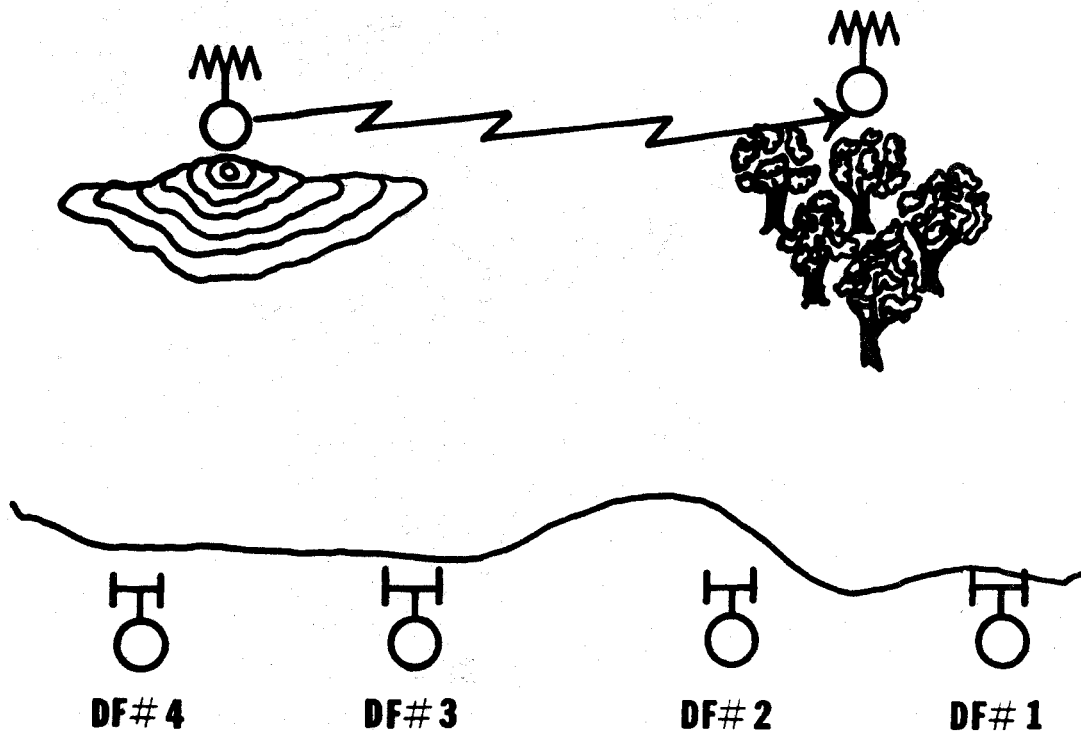

Figure 4-8. Enemy transmitter masked to friendly DF stations.

Section III

SKYWAVE DIRECTION FINDING

4-9. SWDF Factors.

This discussion of SWDF will deal only with the acquiring of bearings from skywaves arriving at DF antennas. The tactical and technical requirements discussed in paragraph 4-2 for DWDF site selection will also apply to most SWDF sites except where friendly DF sites are installed in CONUS or countries friendly to the United States and where physical security would not be a major requirement. DF sites which deal primarily with SWDF are quite often designed to provide strategic coverage over vast geographical areas, such as an entire continent. Nets of this nature will frequently have sites scattered along a baseline thousands of kilometers in length.

4-10. The Baseline.

Site acquisition for strategic DF nets in foreign countries will usually be a joint effort with the host country. The DF planner gives the site requirements to a consular office or an embassy which negotiates with the host country for the site. For those installations to be equipped with large CDAA, approximately 40 acres will be needed at each site. For smaller equipment sites, the baseline will usually remain in land areas where tactical superiority is exercised by friendly forces. Siting criteria, discussed in paragraphs 4-2 through 4-6, apply to SWDF as well as to DWDF.

Section IV

AIRBORNE RADIO DIRECTION FINDING

4-11. General.

In the ARDF effort, the aircraft is actually the DF site, consisting of a combination of dipole antennas, a coupling system, receivers,

integrated equipment that will resolve the ambiguity of the incoming RF signal, and air-to-ground communications equipment.

4-12. Concept of Employment.

Within TOE limitations, aviation companies with the ARDF capability are deployed so their product is available to all combat echelons. Tasking is done through a central control section at the supported command level. These ARDF aircraft are used to supplement groundbased collection systems by providing an airborne DF platform to extend the radio horizon. The mission of ARDF involves acquisition and location of targets within the supported commander's area of interest.

4-13. Aircraft.

Normally, the aircraft deployed for tactical ARDF missions is of a standard type modified to accommodate ARDF equipment.

4-14. Equipment Employed in ARDF Operations.

In addition to the normal complement of installed antennas, the ARDF aircraft will have some combination of the following antennas: two wing-mounted dipole antennas, two inboard nacelle dipole antennas, two horizontal stabilizer dipole antennas, one fuselage-mounted spaced-loop antenna, and a whip antenna used to search for targets. Some will also have a fuselage-installed antenna group for use with the radar navigational system. Other equipment necessary for ARDF is:

- a. Direction-finding receiver.
- b. C-11 gyroscopic compass system.
- c. C-12 gyroscopic compass system.

- d. Radio Magnetic Indicator (RMI).
- e. Inertial navigation system.

4-15. Crew Requirements.

The crew for a normal mission on an ARDF aircraft would consist of a pilot, a copilot, and one or more operators depending upon equipment on board.

4-16. Mission Configuration.

ARDF aircraft are configured with equipment to cover various frequency ranges. The aircraft configuration used would depend upon the supported commander's intelligence needs.

4-17. Navigational Requirements in ARDF Operations.

The pilot is responsible for the safety of his aircraft and accomplishment of the mission. To partially satisfy this requirement, he must know where he is at all times. For routine flying, arrival within one quarter of a mile of the destination is sufficiently accurate. He can adjust any minor navigational inaccuracies in the traffic pattern at his destination. Unless suitable adjustments for aircraft location are made, this criterion is intolerable in ARDF operations. The pilot must always know the precise location of his aircraft over the ground using dead reckoning and referring to visible landmarks on the ground and on his charts. New aircraft have instruments that operate in conjunction with satellites and ground stations which keep the pilot informed of his precise location.

4-18. General Operating Environment of ARDF Units.

Each aviation unit requires a base of operations from which the aircraft can fly. The aviation unit providing ARDF support requires an adequate operations area and a secure communications facility through which mission assignments can be received and results reported.

4-19. Flight Considerations for ARDF Operations.

Before the mission flight, the aircrew is given a thorough briefing of the target area. The current artillery advisory, in the mission area and enroute, is carefully studied because the ARDF aircraft operate at altitudes low enough to be vulnerable to high trajectory firing. The pilot then decides whether to fly a direct route or make some detour to avoid artillery and hazardous terrain. The pilot notes any emergency landing areas close to the intended route and studies the terrain features on the chart for suitable basepoints, such as distinctive patterns of railroad tracks or roads, sharp bends in rivers or trails, quarries, small lakes, and other easily identifiable terrain features.

4-20. Integration of Results.

Tasking, plotting, and reporting is generally handled within the channels that regularly process DWDF and SWDF reports. ARDF results on high priority targets in which a tactical unit has pressing and immediate interest may be passed directly to the supported commander by secure means. Although passed directly, the results will still be processed with the results from other DF efforts through a central control or plotting facility. ARDF contributes to the overall effort in much the same manner as the other efforts previously discussed.

Direction-Finding Techniques

Section I MAPS

5-1. Use of Map Projections with DF.

The basic method of DF plotting consists in the measurement, at a receiving or centralized plotting station, of the angle between the direction of a predetermined reference line (usually magnetic or true north) and the direction from which the electromagnetic waves arrived from a distant transmitting station. The results are plotted and evaluated on a map. For this reason, the more important types of map projections are explained below.

5-2. General.

a. Definition. A map as used for DF plotting, is a graphic representation of a portion of the earth's surface. Although drawn to scale, no map is absolutely accurate since it represents the earth as a plane or flat surface. Accuracy depends upon the method used in making the map, and certain properties must be sacrificed to obtain other desirable features in accordance with its specific use.

b. Introduction. No portion of the earth's surface can be spread out into a flat plane without some "stretching" or "tearing." This is illustrated by attempting to flatten either the cap of an orange peel or a portion of a hollow rubber ball. The outer portion must be stretched or torn before the central

part will flatten. However, there are some surfaces which can be spread out in a flat surface without stretching or tearing; these are called developable surfaces. Those surfaces which cannot be spread out in a flat surface, such as a sphere, are called nondevelopable surfaces. Two well-known developable surfaces are the cone and the cylinder. If a paper cone is cut from the base to the apex, the conical surface can be spread out in a flat surface without tearing or stretching (Capital A, fig. 5-1). If such a cone is flattened, any line or curve drawn on it will have exactly the same length as before. In the same manner, if a cylindrical surface is cut from base to base, the whole surface can be rolled out into a plane or a rectangle (Capital B, fig. 5-1). In this case there is no stretching or tearing of any part of its surface.

5-3. Reference Points on a Spheroid.

On a spheroid such as the earth, it is necessary to have some points or lines of reference so

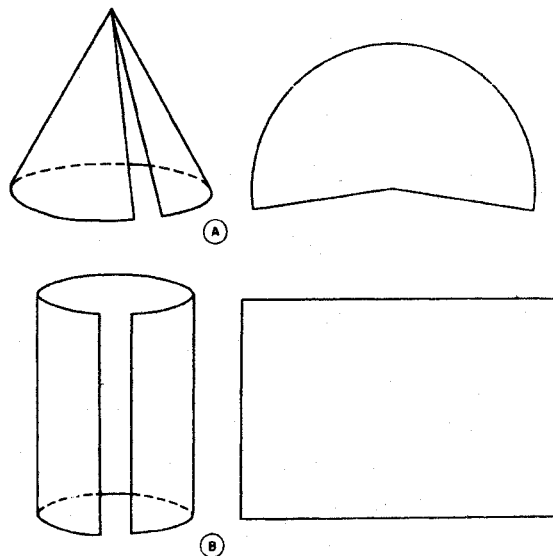

Figure 5-1. Cone and cylinder, developable surfaces.

that any point may be located with respect to them. Places on the earth are located by latitude and longitude, which form a network of lines running true east and west (parallels of latitude) and true north and south (meridians of longitude).

a. *Derivation of Reference Points on a Spheroid.* The ends of the earth's rotational axis are called the North Pole and the South Pole. With these as starting points, assume the earth is divided into two equal parts by a plane perpendicular to the axis midway between the poles. The circle formed by the intersection of this plane and the surface of the earth is the equator and divides the earth into the Northern Hemisphere and the Southern Hemisphere. Any circle upon the earth which divides it into two equal parts, such as the equator, is called a great circle (see fig. 5-2). It is customary in the United States to divide these great circles into 360 equal parts called degrees.

(1) *Meridians.* As shown in figure 5-3, any number of great circles can be drawn through the two poles, and each will cut the equator into two equal parts. Each circle may be divided into 360 degrees, with the equator 90 degrees from either pole. These great circles are called meridians.

(2) *Establishing meridians of longitude.* To further reference a point, it is necessary to number the meridians east and west from an established location. Most countries have adopted the meridian passing through the Greenwich Observatory in England as the zero meridian, or the prime meridian (0 degrees). The degrees of longitude are counted from 0 to 180 degrees east and west (fig. 5-4). The great circle that passes through the poles and Greenwich, England, is called the prime meridian on one side of the globe, and the 180th meridian on the other side, since at this point it is both 180 degrees east and west of the prime meridian. Thus, east-west reference points are provided.

(3) *Establishing parallels of latitude.*

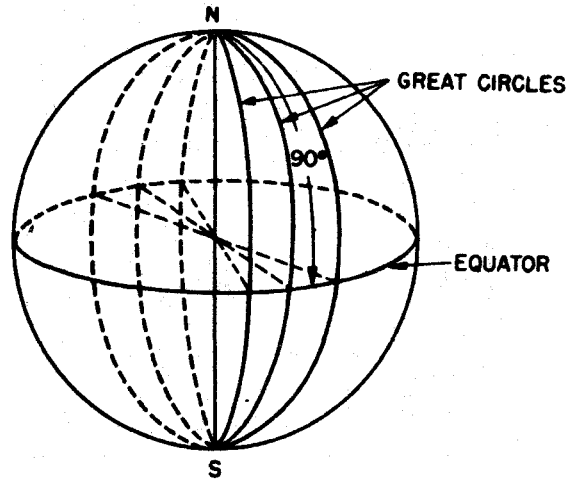

Figure 5-2. Great circles.

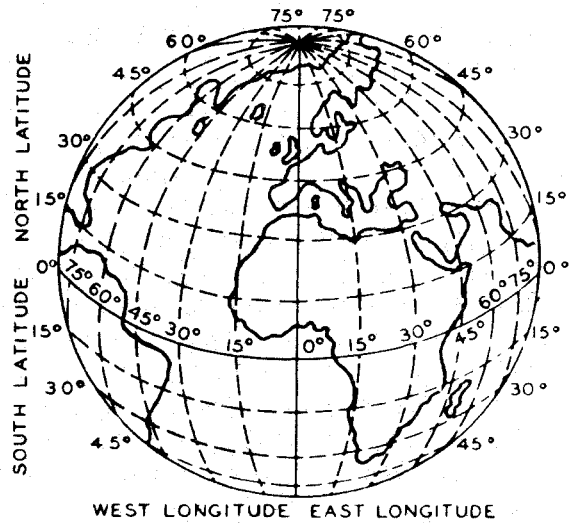

Figure 5-3. Projection of a sphere showing the arrangement of longitudes and latitudes.

Assume that on one of these meridians a point is taken 70 degrees north of the equator, and a plane is passed through this point perpendicular to the north-south axis

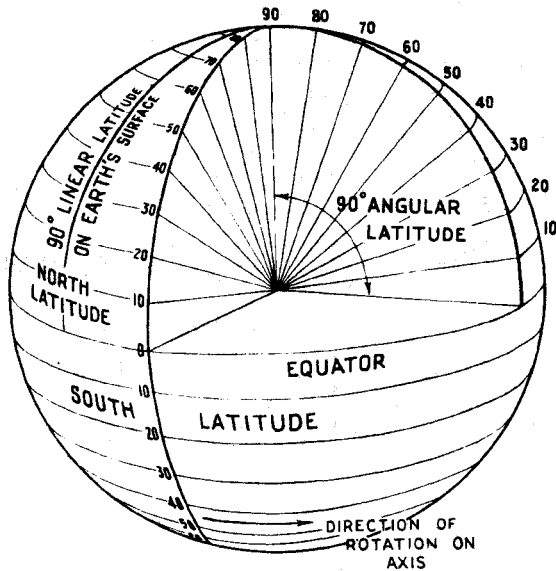

Figure 5-4. Diagram of the globe indicating the derivation of longitude.

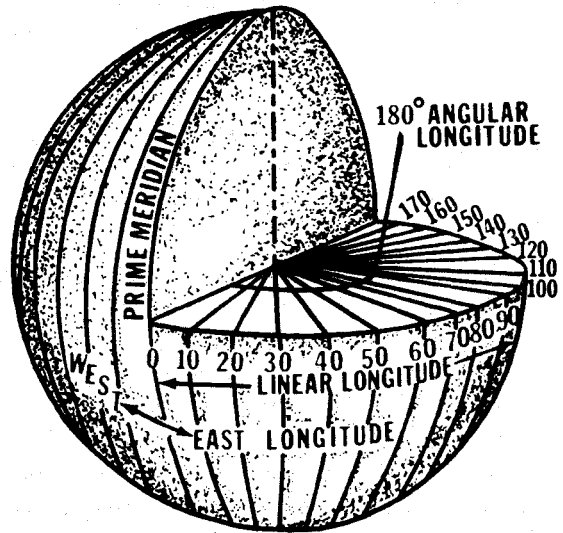

Figure 5-5. Diagram of the globe indicating the derivation of latitude.

(parallel to the plane of the equator). The intersection of this plane and the surface of the earth will form a small circle called a parallel of latitude (fig. 5-5). Every point on this circle will have a latitude of 70 degrees north. Other such circles can be formed at 20 degrees, 40 degrees, etc. Thus, since the equator was drawn as a great circle midway between the poles, a point north or south with reference to the poles can be located.

b. Initial Problem of Map Projection. A sphere constructed with meridians and parallels on it represents the earth with its imaginary meridians and parallels. As previously stated, a sphere is nondevelopable. Therefore, the problem of map projection is one involving a systematic drawing of lines representing meridians and parallels on a flat surface, either for the whole earth or any desired portion.

5-4. Selecting a Type of Map Projection.

The spheroidal shape of the earth cannot be represented on a plane without distortion, therefore, a compromise of desirable properties to obtain the most practical features for a specific use must be made. Many different types of map projections have been devised, each having special merits for their intended use, while compromising other features. The map projections used for DF plotting must be of a type that a straight line from a given point will indicate the true azimuth. Three map projections commonly used for DF plotting are:

a. Universal Transverse Mercator Projection. The Universal Transverse Mercator (UTM) system (fig. 5-6) is the most commonly used map projection method for military purposes. It can be easily oriented for combat situations and readily used with a compass to find a true azimuth from any given point on the map. This system, makes it possible to plot from point to point using a

straight line called a rhumb line. This rhumb line may be used to determine latitude and longitude of any point along its path, up to 300 kilometers. This is of great importance because it is only through use of a map projection system of this type that a flat presentation of a globular object may be displayed with the distortion minimized.

b. Gnomonic Projections.

(1) The gnomonic projection is the most commonly used map projection system for long range DF plotting. It is particularly



Figure 5-6. Mercator projection on a cylinder indicating method and showing polar distortion.

useful when plotting across great expanses of ocean.

(2) A gnomonic projection of the earth is derived by projecting the surface of the globe, from its center, upon a planar surface. This projection method represents all great circles as straight lines, and is the projection's chief merit. This property is important in DF, because the shortest route between two points (a straight line) is always a portion of the arc of a great circle. Radio waves travel more or less on great circle routes.

(3) The mathematical limit of this projection is a hemisphere. The practical limit is a quarter of the globe (90 degrees) since the distortion beyond that point becomes severe.

c. Equatorial Projection. This projection was rarely used in earlier DF efforts. However, with the installation of large fixed sites with DF multiband capabilities, this projection is essential for maximum accuracy and convenience. With the development of computer technology, the computer produces such projections from any given reference point. This projection has a relatively small scale error if it is not extended beyond a hemisphere. It is possible to show the whole earth, although distortion increases rapidly toward the perimeter. Figure 5-7 is a map representation of this projection centered on New York.

5-5. Aeronautical Charts.

Another type of map encountered in the plotting of DF results is the aeronautical chart. The major difference between aeronautical charts and standard Army maps is that the grid lines in aeronautical charts are straight and are oriented to true north, and the particular areas in which magnetic variation occurs are indicated by broken magenta-colored lines which follow the exact electrical variations in the earth's surface. These lines, called isogonic lines, waver and

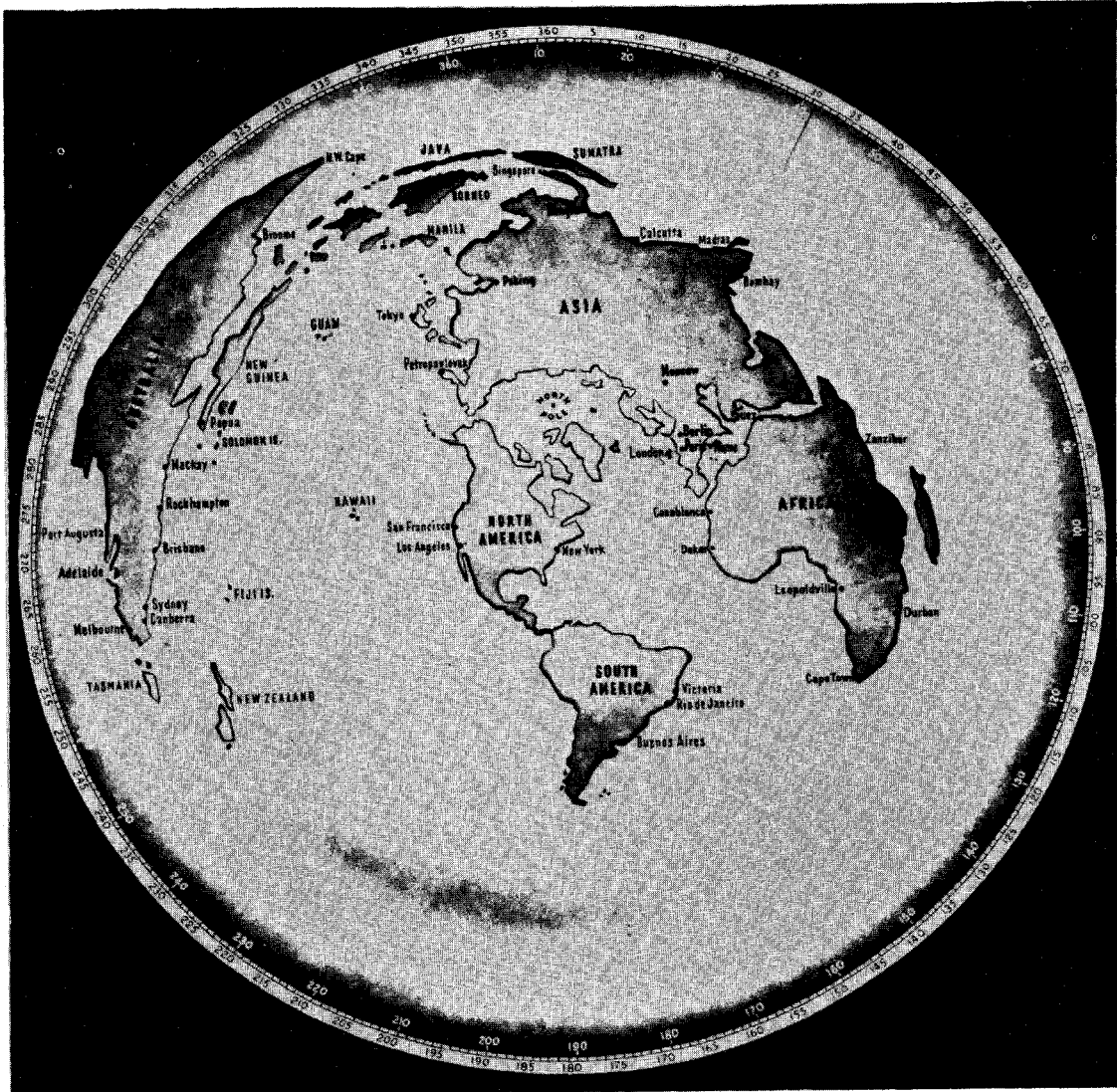

Figure 5-7. Azimuthal equidistant projection centered on New York.

slant to follow the electrical fields which they designate. Where true north and magnetic north are almost identical, these lines are called agonic lines, and there would be no deflection of the compass needle from true north indicated by the grid lines. As electrical fields in and around the earth do not respect the orderly requirements of the map makers for maximum accuracy, the user must

“average” the variation depending upon the distance he may be from an isogonic line.

5-6. Magnetic Variation and Use of the Compass Rose.

Magnetic north and true north do not coincide. True north and south (the poles) are used as the chart poles because they are fixed

and unvarying. Magnetic north is some 650 kilometers south of geographic north, and is constantly changing its exact location.

a. Variation. When a compass needle points north, it is not pointing to the north of the chart (true north), but rather to magnetic north. The amount of separation between these two points is called variation, and is expressed in degrees. The amount of variation differs with the locality, since it follows the magnetic channels between the poles. It may vary east or west of the true meridian, or it may not vary at all (fig. 5-8). This variation is a continually changing phenomenon which could not be represented on any map or chart perpetually. Therefore, maps should be obtained with the latest variations posted before planning any DF plotting effort.

b. Use of the Compass Rose. The amount of variation for each locality on

charts and maps is indicated by either a compass rose, a declination diagram, or a narrative statement, depending upon the age and type of map. A compass rose is a double graduated circle, the outer one marked in degrees and the inner one marked in compass points. Figure 5-9 illustrates the compass rose on a 1939 map. The outer circle, which is stationary, is oriented to true north. Its zero degree is true north. The inner circle is oriented to magnetic north for the year indicated in the center of the compass rose diagram. The difference between the two points is the variation in the year indicated in the center.

(1) The variation since the year the chart was published is obtained by multiplying the annual increase or decrease, indicated in the lower half of the center of the rose, by the number of years elapsed between printing and reading. Therefore, in figure 5-9, the variation in the year 1939 was

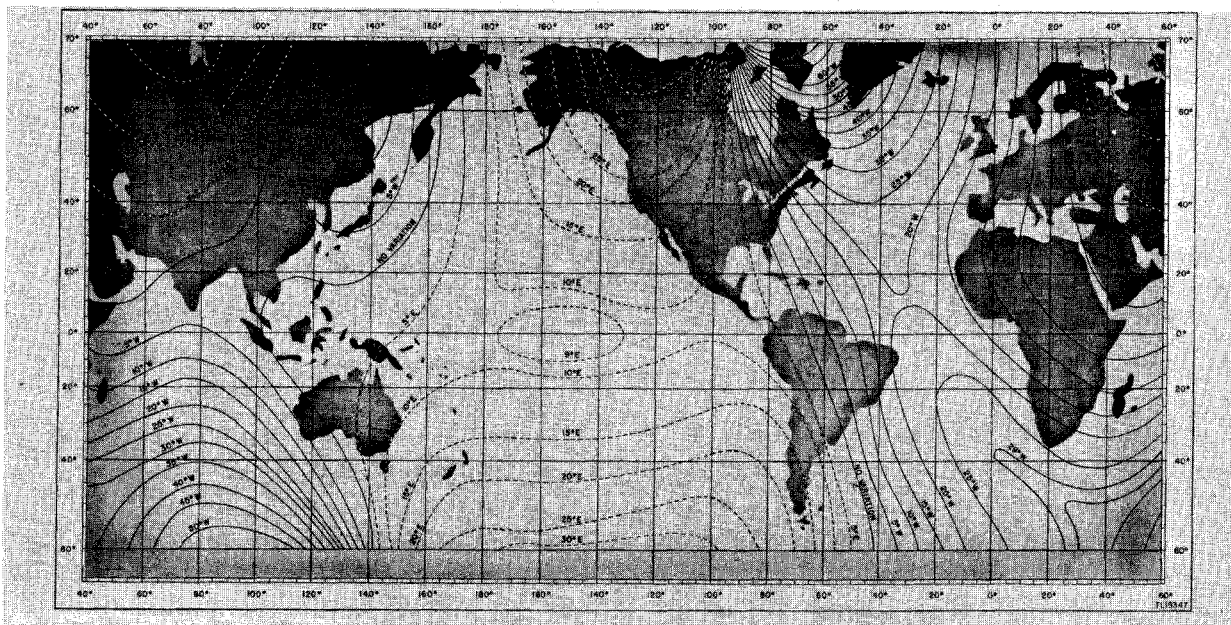

Figure 5-8. Map of the world showing typical zones of magnetic variation.

uncharted or inaccurately charted, and older maps may be the only references available.

5-7. Declination Diagrams.

a. A declination diagram is placed on most large-scale maps to enable the user to orient the map properly. The diagram shows the interrelationship of magnetic north, grid north, and true north. On medium-scale maps, declination information is shown by a note in the map margin.

b. Declination is the angular difference between true north and either magnetic or grid north. There are two declinations, magnetic and grid. Magnetic north, grid north, and true north (fig. 5-10) are indicated on the diagram by a half arrow, straight line, and star respectively. Since it is not the intent of this manual to discuss basic map reading, FM 21-26, Map Reading, should be used as a basic reference.

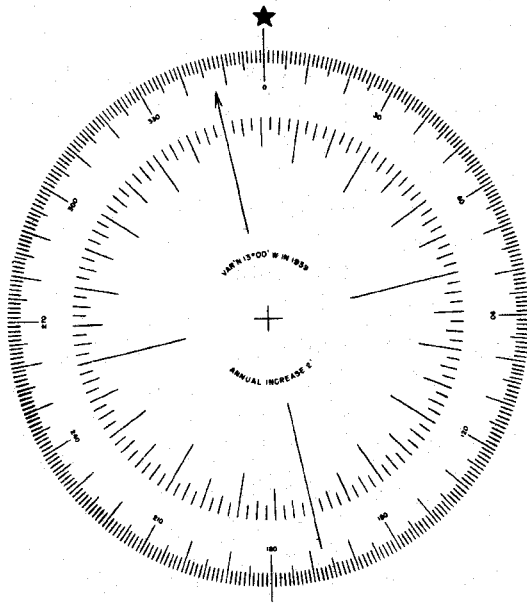

Figure 5-9. Compass rose.

13 degrees 00 minutes W and the variation increased 2 minutes each year, as indicated in the center of the rose. Therefore, the variation in 1946 would equal 7 (number of years between 1939 and 1946) times 2, or a total variation of 13 degrees 14 minutes W. If the variation had indicated an annual decrease, the amount would be subtracted from the 1939 variation.

(2) When a true direction reading from a map is changed to a magnetic direction, easterly variation is subtracted from the true course indicated, and westerly variation is added. A memory aid, in the form of a simple rhyme is, "East is least (subtract) but west is best (add)." The reverse is true when changing from a magnetic to a true course reading.

(3) The compass rose variation indicator is not used on many maps today. An explanation is included for its use since there are many parts of the world that remain

Section II

DF SITE REQUIREMENTS

5-8. General.

Whenever a DF site is set up in a new location, its antennas must be precisely oriented to a known reference point to produce an accurate measurement of the arrival angle of a wave front. Without this accuracy, the plotting of reported bearings would be valueless. DF stations of the US Army have their antennas oriented to true north. To establish a true north reference line on the map of the area in which the DF site is being erected, it is common to use celestial bodies and satellites for maximum accuracy. Alternatively, field expedient methods may be used. Chapter 5, FM 21-26 explains in detail those field expedients which may be used to determine the direction of true north.

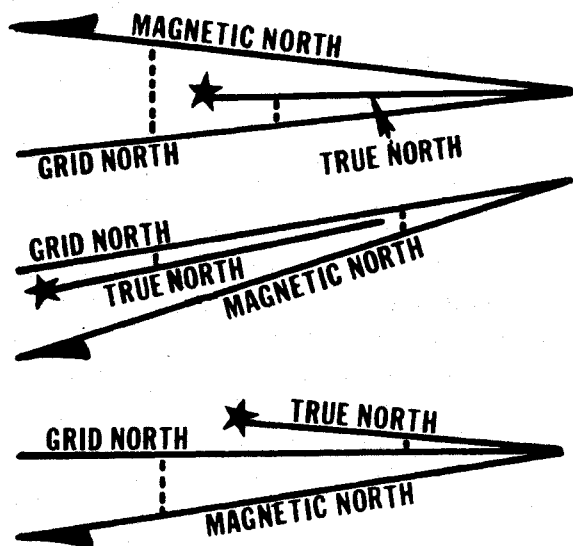

Figure 5-10. Declination diagrams.

5-9. Siting Errors.

Siting, as well as orientation, of DF antennas is extremely important in obtaining maximum DF accuracy. Since radio waves can be deflected from their paths by various obstacles, and DF equipment can only measure the angle of arrival where the DF antennas are located, the DF set should be positioned where the wavepath is least susceptible to outside influences. Then the DF set will give the most accurate representation of the true direction of wave travel. Obstructions in the near vicinity of the site are particularly objectionable; the closer the obstruction is to the DF site, the greater its adverse effect on the site. DF errors caused by obstructions in the vicinity of the DF site are known as site errors. Figure 4-2 illustrates site errors caused by reflecting or radiating objects located near the DF site.

5-10. Site Criteria.

5-8

a. The area should be substantially flat for approximately 90 meters from the DF antenna and have no more than a gentle slope for several times that distance.

b. The area should be the highest level area in the vicinity. A site in a valley is usually unsatisfactory.

c. Mountainous or hilly country should be avoided.

d. The area should be as far as possible from the shore line of large bodies of water (at least 5 wavelengths of the lowest frequency to be measured). If the installation must be made on or near the coast, the flattest area should be selected and the DF antenna should be oriented so that the azimuth arc to be measured is as nearly perpendicular to the coast as possible.

e. The earth at or around the site should have uniformly high conductivity and moisture content. Areas uniformly covered with grass or vegetation usually meet this requirement. Rock or sandy soil is poor as a DF site. Areas having low conductivity are preferable, however, to areas having high conductivity spotted with rock formations, sand, or a varying moisture content.

f. Regions where there are abrupt discontinuities of the earth should be avoided. Sharp changes in terrain elevation usually indicate the presence of rock or mineral outcroppings, or underground streams.

g. The site should be removed from tall trees, buildings, wire fences, power or telephone lines, radio antennas, railroad tracks, buried metal conductors (cables and pipelines), sharp ground contour changes (mountains, cliffs, and ravines), chimney stacks, water towers, rivers, lakes, and streams.

h. Distances to be maintained between the DF site and these obstructions to minimize their effect on accuracy are listed in table 5-1.

Table 5-1. Preferred Distance from Obstacles.

OBSTACLES	DISTANCE TO BE MAINTAINED
Scattered trees and single small buildings	185 meters
Wire fences	275 meters
High cliffs and deep ravines	1.6 kilometers or farther
Buried metallic conductors	275 meters
Chimney stacks and water towers	450 meters
Railroad tracks and overhead conductors (utility lines and antennas)	450 meters
Mountains	10 to 50 kilometers
Rivers, streams, and lakes	550 meters

5-11. Comparison of DWDF and SWDF Site Establishment.

In establishing large, fixed-installation DF sites, all of the technical considerations can usually be met. Tactical DF sites, however, present more of a problem since the areas available for sites are fewer, and such factors as physical security and logistical support become predominant considerations. Once a site has been installed, it is necessary to ensure that it remains free of obstructions. A restricted zone should be established for a distance of 150 to 300 meters in all directions from the center of the DF antenna array. This zone must be kept free of all construction and material storage. As a minimum, this area must be kept completely free of metallic buildings, vehicle parks, and other obstructions listed in the above table.

5-12. Site Testing.

In addition to the physical criteria specified previously, additional tests should be made on the DF site if time and the tactical situation permit.

a. Electrical Inspection.

(1) *Noise measurement.* Measure the noise level with a field strength meter or comparable equipment, at the major frequencies on which the DF set will be operated. If the equipment is to be used over a band of frequencies, measurements should be made throughout the band. For a suitable DF site, the noise level (other than temporary atmospheric noise) should be low, otherwise many signals of interest will be lost.

(2) *Field pattern.* This test is made to determine uniformity of reception for the DF site. An explanation of this test was detailed in paragraph 3-1a. Although the directivity of an installed antenna was discussed in the polar diagram section, the reader can compare the discussion with figure 5-11 and reasonably deduce how the test for uniform reception of the chosen site is made with the target transmitter and field strength meter instead of a receiver. The field strength measurements for each position of the target transmitter (as indicated in fig. 5-11) must be taken with all measurements marked accurately. Each frequency must be plotted on rectangular coordinate paper relating field strength to azimuth, and the resulting graph should be substantially a straight line. Any irregularities indicate an absorption or reflection of the wave which would affect the accuracy of the DF. If the variations exceed 25 percent of the average field strength, especially in azimuth arcs where maximum accuracy is desired, the site is unsuitable for DF. If the visual and electrical inspection discloses no objection to the use of the site, the DF antennas may be erected.

b. Tactical Requirements for Good Sites. In addition to security, other factors which should be considered are:

(1) Does it afford convenient approaches for vehicles?

(2) Is it located at a practical distance from the supply and ration point?

(3) What is its proximity to suitable bivouac areas?

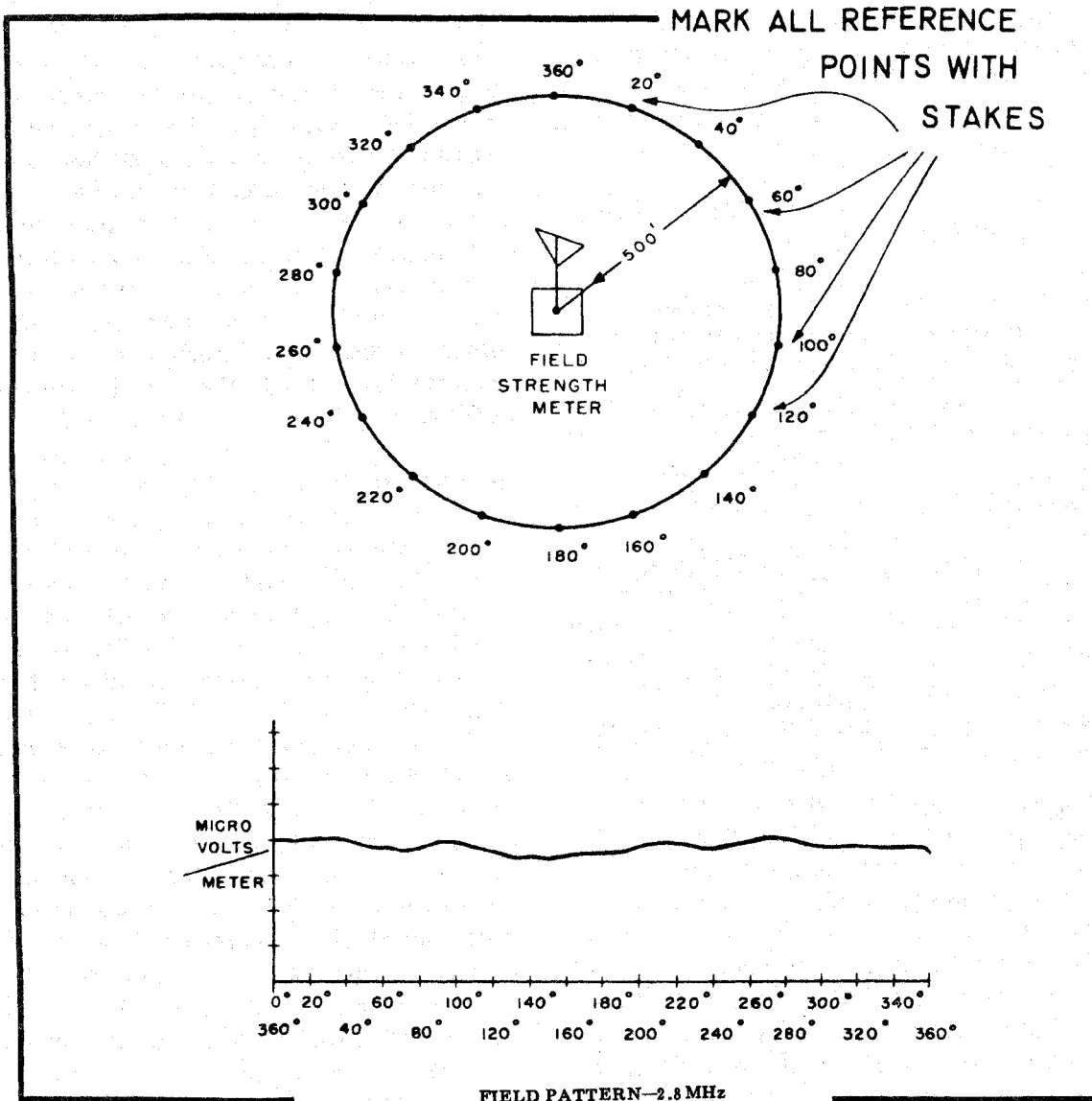

Figure 5-11. Field pattern.

5-13. Improvement of Sites.

The DF site selected, although the best possible, may be far from ideal. Nevertheless, definite measures for improving the site from a technical viewpoint can be undertaken. Areas which are not substantially flat for at least 90 meters from the DF antenna can be leveled off with a bulldozer or grader. If it is

impractical or even impossible to level the entire area for 360 degrees coverage, at least those areas within the azimuth arc of primary interest should be flattened. Natural objects such as trees and low vegetation should be cut down or uprooted. Manmade objects and personnel not actually engaged in operating the site should be kept away from the antenna system. Increasing the conductivity

of the ground is another measure that will aid in the overall efficiency of the system. Most DF antenna systems that are not manpacked or vehicular transportable are issued with a counterpoise, which are grounding devices installed under each dipole.

5-14. Periodic Checking of DF Equipment and the Site Selected.

a. Checking Instrumental Calibration and Adjustment. The various calibrations and adjustments of DF equipment described in technical manuals must be performed at regular intervals to ensure continued satisfactory performance and accurate results. Checks should be made at frequent intervals.

b. Daily Check of DF Accuracy. Take daily bearings on known transmitters to ascertain if the accuracy or calibration of the DF site is acceptable. Any appreciable deviation of the DF bearings from the known bearing, or the ones normally obtained, should be investigated immediately.

Section III DF ERRORS

5-15. General.

This section discusses the various types of errors which may be encountered in DF applications. How these errors may influence the accuracy of the equipment is explained, and how to minimize the influence of these errors to ensure optimum performance is included. An understanding of the information contained in this section will enable the operator to analyze the inferior performance of a DF set, to select and segregate the type or types of errors causing the inferior performance, and, in some cases, to decrease or eliminate the effects of these errors. For purposes of explanation, the various types of errors are grouped as source, path, polarization, site instrumental, and operator errors.

5-16. Source Error.

This error is introduced at or near the transmitting station. It may be caused by the particular type of directional antenna employed, or by ground conditions at the transmitter site which alter the normal radiation pattern of the antenna. If the DF site is more than 15 kilometers away from the transmitting antenna, the magnitude of the source error is usually small compared to other errors. It is, therefore, seldom a contributing factor to the overall accuracy of a DF bearing.

5-17. Path Error.

This is caused by deviations of the radio wave from the great-circle path between the transmitting antenna and the DF site. This deviation is caused by the radio wave being absorbed, reflected, reradiated, refracted, or a combination of these factors. The more important sources of path error and methods of reducing these errors are:

a. Scatter. In some instances, a small portion of the radio wave entering the ionosphere is scattered instead of being gradually bent and returned to the earth. This scattered radiation may be projected in any direction, and returns to earth at random angles (fig. 5-12 and 5-13). This accounts for signals sporadically received in regions that are normally in the skip zone of an HF transmitter (fig. 5-14). Under ordinary operating conditions, errors caused by the reception of scattered waves are not likely to occur. In some cases, however, when a powerful transmitter using a highly directional antenna is transmitting in a direction other than that of the DF site, an azimuth reading taken on this transmission may cause the apparent location of the transmitter to be somewhere along the course of its directed beam rather than in its correct position. This is caused when receiving a wave

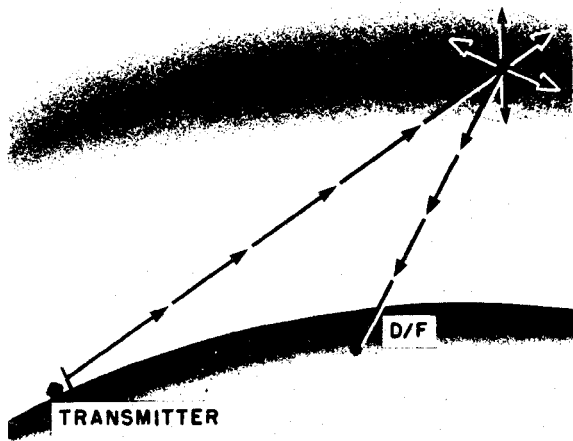

Figure 5-12. Short scatter.

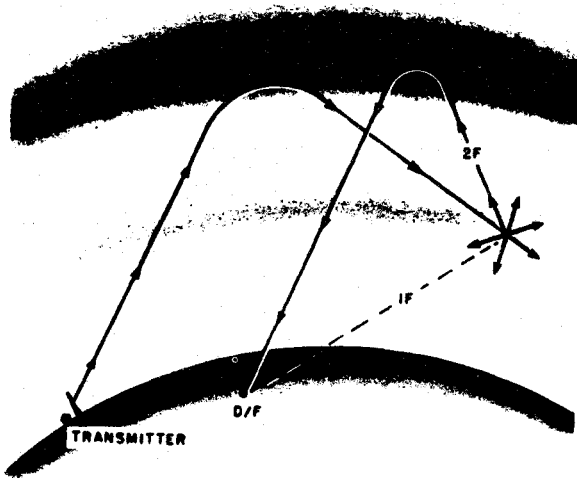

Figure 5-13. Long scatter.

radiated from the scattered source rather than from the transmitter itself.

b. Refraction. Radio waves, being electromagnetic in character, are bent or refracted from their normal path when they pass from one medium to another. A small

difference in the conductivity of the surface over which the wave is propagated or a change in the dielectric constant of the medium is sufficient to give rise to refraction. For example, the velocity of a radio wave over sea water is greater than its velocity over land. As a result, when a radio wave crosses a coast line at an oblique angle, its direction is appreciably altered (Capital A, fig. 5-15). The effect is particularly pronounced when either the DF site or the transmitting station is near the coast, especially if high ground intervenes. This effect also varies with the frequency of the wave.

c. Reflection. Incorrect azimuth readings are frequently obtained under conditions which suggest that reflection may sometimes be a contributing cause. Quite large and otherwise unaccountable errors are sometimes produced when a radio wave travels over or close to high cliffs, mountains, or buildings in its path to the direction finder (Capital B, fig. 5-15). Occasionally, conducting strata below the surface of the earth behave in the same manner as surface obstructions by reflecting the wave and causing errors. Generally, errors due to reflection are greatest when the reflecting mediums are in the vicinity of either the transmitter or DF set.

d. Reradiation. This effect occurs primarily as a result of the reradiation of the radio wave by metallic objects that are resonant at the frequency of the received wave. Even when the frequency of these objects is not resonant with the received waves, some reradiation may occur. The flux of such a reradiated wave will have a purely random phase with respect to the flux of the main wave. As a result, there will be a field composed partly of the strong main field and partly of the reradiated fields near the DF receiver, with different phase relations and polarization. These fields may combine to broaden the null, making the azimuth reading

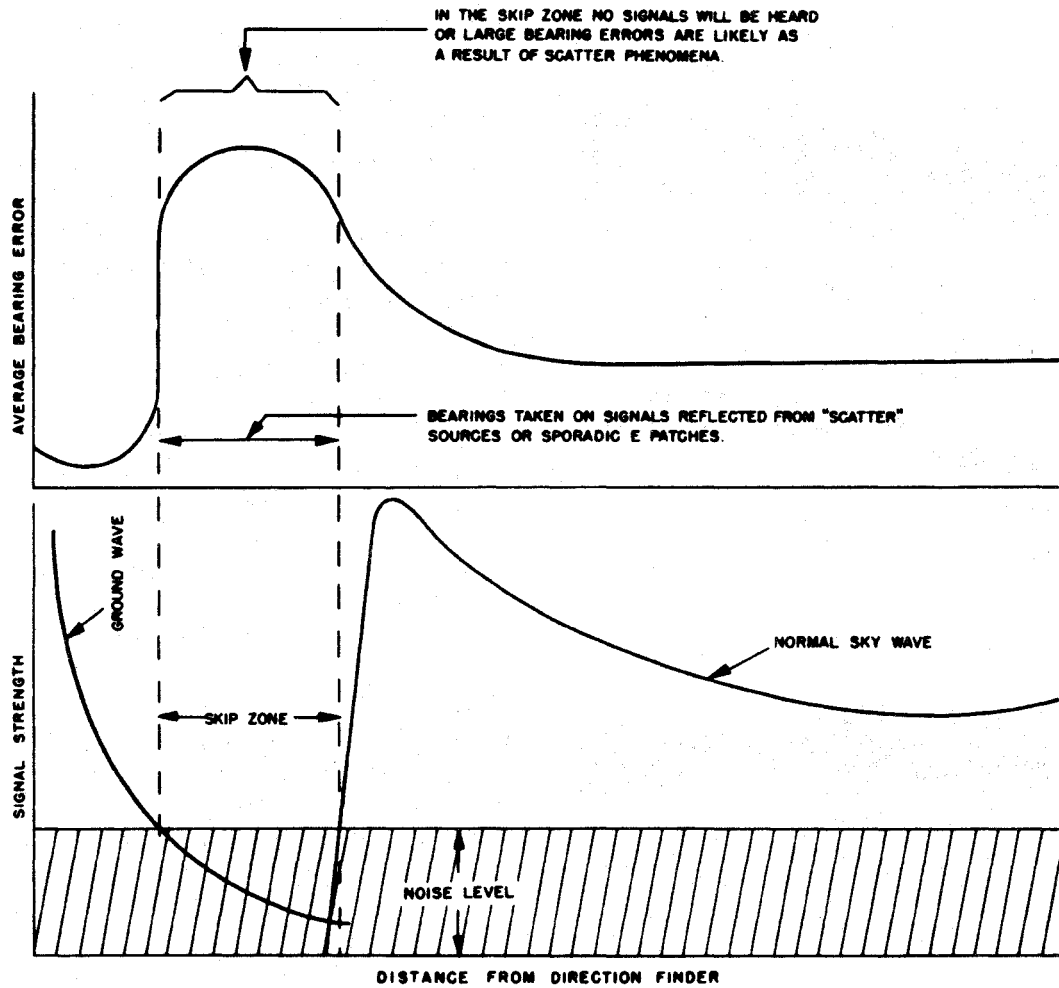

Figure 5-14. Effects of skip zone reception on bearing error.

indefinite and difficult to determine exactly. They also may combine to shift the null, causing error. Reradiation effects usually occur when the reradiating object is in the immediate vicinity of the DF site, although under some conditions, it may occur when the object is at a distance.

e. *Methods of Reducing Path Error.*

There is no practical method of reducing path errors originating from scatter, refraction, reflection, or reradiation. An exception to this can be made when the errors are due to the refraction, reflection, or reradiation of the radio wave in the immediate proximity of the DF site. In this case, the source of error may be removed, its effect adjusted by calibration, or the DF set moved to a more favorable

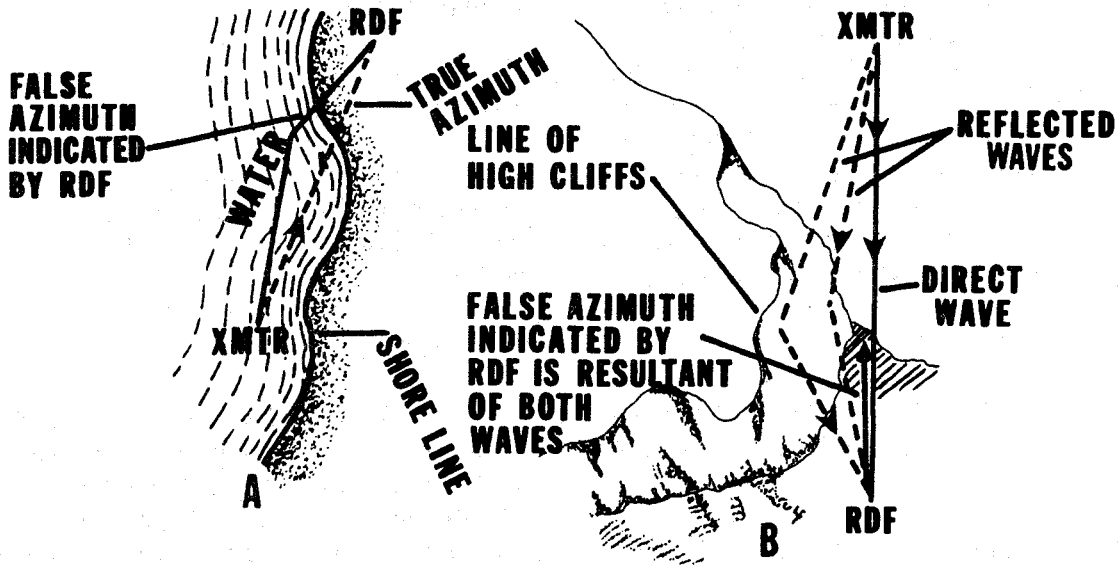

Figure 5-15. Error caused by the refraction and reflection of a radio wave.

location. Calibration for path errors a considerable distance from the DF set is usually not possible.

5-18. Polarization Error.

Polarization error occurs when the undesired component of a radio wave induces voltage in a DF antenna.

a. Effects. This voltage tends to blur the bearing, making the azimuth reading indefinite and difficult to determine. For example, vertical loop and Adcock antennas are designed to receive vertically polarized waves. If the wave is abnormally or randomly polarized (contains both vertically and horizontally polarized components), the voltage induced by the two components may combine to produce the effect mentioned above. The magnitude of the effect will depend upon the ability of the loop or

Adcock to discriminate between the desired component (vertically polarized) and the undesired component (horizontally polarized) of the received signal. Other types of antenna systems are designed to receive horizontally polarized waves. With these antennas, polarization errors occur when the vertically polarized components of the radio waves induce voltage. The ways in which radio waves with abnormal polarization originate are described in paragraph 3-5.

b. Methods of Reducing Polarization Error. The effect of polarization error can be reduced by using a direction finder that is relatively insensitive to incorrectly polarized waves. When randomly polarized waves are received, a direction finder using an Adcock antenna would have less polarization error than a loop set. Additionally, when receiving substantially horizontally polarized waves, a horizontally polarized DF antenna would be superior to a vertically polarized antenna.

5-19. Site Error.

This error occurs in the immediate vicinity of the DF site as a result of many factors, some of which were discussed earlier in this manual. Error is kept to a minimum when the DF equipment is located in the best possible site. Paragraph 5-10 and table 5-1 provide specific installation guidance to eliminate site error. Compensation and calibration are possible for site error, but only if the error is large and reasonably constant without regard to variations in frequency, azimuth, and time.

5-20. Instrument Error.

This error is introduced by the DF equipment itself. The amount of instrument error varies with the design, general condition, and adjustment of the DF equipment. Factors which may introduce instrument error are: low signal-to-noise ratio, antenna effects, and other facets of the equipment discussed in the technical manuals published for the users of the particular sets.

5-21. Operator Errors.

This type of error is self-explanatory. These errors are reduced to a minimum when the operators have sufficient training and experience in operating the specific DF equipment to which they are assigned. In addition, the operator must be alert at all times. When a fading signal is being received, or when the bearing is shifting, the operator must be able to obtain readings at those times when the signal is strongest or most stable. Under adverse conditions, an efficient operator will usually take several different readings and then determine the azimuth by averaging them.

Section IV**PLOTTING METHODS****5-22. Definitions.**

a. Line Bearing. This is the angular measurement of the arrival of a radio wave in degrees from true north after the null is obtained. A line bearing is sometimes called an azimuth or a shot.

b. Cut. This is the point of intersection of two DF bearings.

c. Fix. This is the probable location of a target transmitter's antenna when three or more DF bearings have been plotted on a chart or map.

5-23. Plotting.

a. Plotting a Bearing. The simplest method of plotting a bearing is with a protractor and straight edge. Point A in figure 5-16 represents the known location (by grid coordinates) of a DF station. This is entered as a tick mark (.) on the map or overlay. The index of the protractor is placed to coincide with point A and is accurately aligned along the north-south grid lines by using dividers or parallel rulers. The bearing taken by the DF station is measured in degrees from true north and is indicated by another tick mark at the appropriate degree on the protractor. The protractor is removed and the straight edge aligned along the two tick marks. The bearing is then plotted by drawing a line along the straight edge from the station location through the degree tick mark, extending a sufficient length into the target area so that the enemy transmitter may reasonably be expected to be located along this line.

b. Plotting a Cut. Using the method outlined above, the bearing from a second DF station is plotted. The intersection of the two bearings thus plotted is identified as a DF cut (fig. 5-17).

c. Plotting a Fix. If three DF stations are arranged along a baseline, the protractor may still be used. DF stations A, B, and C are

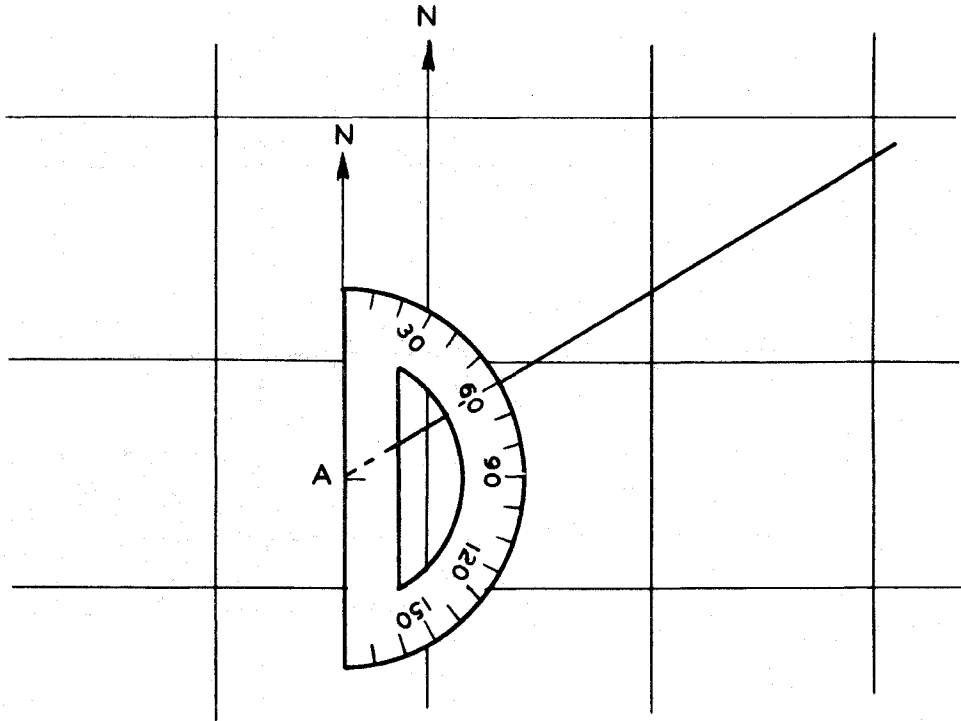

Figure 5-16. Plotting a bearing.

located as shown in figure 5-18, and have reported bearings of 132, 182, and 233 degrees respectively. Again the protractor and straight edge may be used to plot successively the bearings of each DF set at its map location; the lines may be extended to form a small triangle, or join at a point if the fix is perfect. A perfect DF is extremely rare, however, figure 5-18 illustrates a perfect fix.

d. Plotting Control and Evaluation Centers. The plotting procedures described above, while completely valid in terms of accuracy, are somewhat slow and laborious. With the advancement of DF and the greater number of bearings reported by individual stations, the plotter would find it difficult to plot all the DF results. Accordingly, DF plotting centers, with the capability of

analysis in depth, have been established. In such centers, plotting boards with the DF stations represented by strings which may be pulled out and lined on calibrated map-edge scales are used. The plotter simply notes the station, the reported bearing, and the calibrated edge scale for the particular reporting station. The compass rose around each DF station has been transferred to the map-edge scales mentioned above. When the string is pulled out and alined along the reported bearing on the map-edge scale, the bearing is plotted. Additional stations are also plotted, and the intersection of the bearings determines the probable target location. Evaluation of DF plotting will be discussed in greater depth in section V. Computerized plotting of DF results is possible in the SWDF nets dealing primarily with the strategic location of targets.

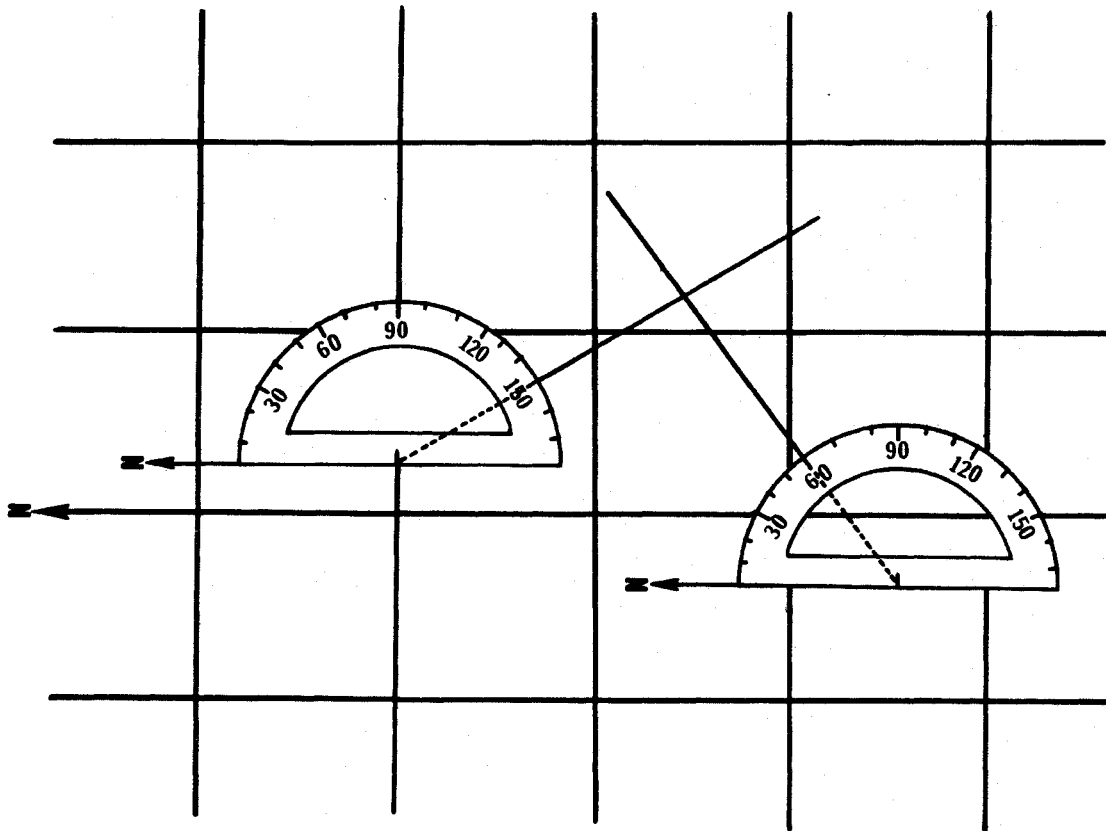

Figure 5-17. Plotting a cut.

5-24. Baselines.

The size and scale of the maps used in plotting will depend upon the range of bearings to be plotted and, of course, upon the length of the DF baseline. The baseline, in turn, is affected by the range of fixes to be obtained, and is limited by the terrain and the DF control net. The limit of an area in which the desired enemy targets will be expected to appear is not definite due to many variables, but experience will dictate the best layout for a given situation. A baseline, ideally, should be the same length as the expected depth of the target area. When these dimensions are observed, at least two of the DF stations will

be measuring arriving signals at nearly right angles which is the most desirable.

Section V

EVALUATION OF DF RESULTS

5-25. General.

In section IV, plotting was discussed in general terms with several illustrations given representing near-perfect conditions. In the practical application of DF plotting, the returned bearings are carefully evaluated by the plotters to determine the most nearly correct location of the target of interest. A perfect fix, with three or more bearings

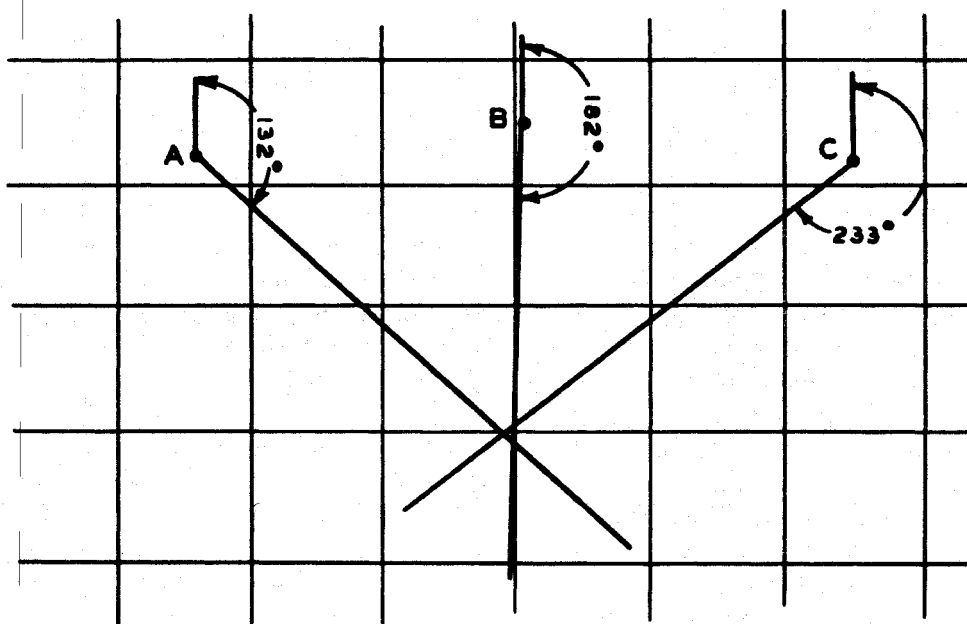

Figure 5-18. Plotting a perfect DF fix.

intersecting at an exact grid location, is so rare it is almost unknown. The plotter has many factors which he must resolve.

5-26. Evaluation by the DF Operator.

Initially, the bearing is obtained by the operator at the DF site and reported to the plotting center or control. The operator's experience, judgement, operating skills, and ability to read the bearings, are factors which affect the accuracy of the reported bearing. A system of evaluating the reliability of a bearing does exist; however, the specific details cannot be discussed within the classification limitations of this manual. Very basically, the operator affixes a designator which reflects a degree of confidence in target identification and a measure of signal conditions at the time the bearing was obtained.

5-27. Evaluation by the Plotter.

A DF plotter is substantially influenced by several human factors in his evaluation of bearings reported from the DF stations in his net. As his experience builds, and reported fix locations are confirmed by enemy contacts and other irrefutable means, the plotter will grant increasing credibility to one DF site over another. Known site error itself will, on many occasions, cause the plotter to reject, or accept on reduced reliability, bearings from certain stations. A change of operating personnel at a particular site, if known to the plotter, may also influence his decision on the reliability to assign a reported bearing. In spite of the standard assignment of reliability indicators, plotting is still very much influenced by these human factors.

Section VI

DETERMINATION OF FIX AREA

5-28. Methods Used to Determine Probable Target Locations.

DF fixes illustrated previously have been "perfect" with all bearings intersecting at an exact grid location. Of course, such a fix seldom occurs because of the inherent errors in DF operations. The continually changing electromagnetic environment of each DF site and the errors discussed previously contribute to these inherent errors. Consequently, fixes obtained after plotting three bearings may appear on the plotting map as indicated in figure 5-19. It is readily apparent that the triangle formed by the three plotted bearings could cover a substantial portion of the tactical area; therefore, methods had to be established to evaluate the most probable location of the target in the triangle. Some of the methods used are the bisection of the medians (sides) of a triangle, bisection of the angles of a triangle, and the Steiner point method. Of these three, the Steiner point method is the most commonly accepted, especially for tactical use. As illustrated in figure 5-20, there is little difference in the three solutions. Strategic DF nets will most

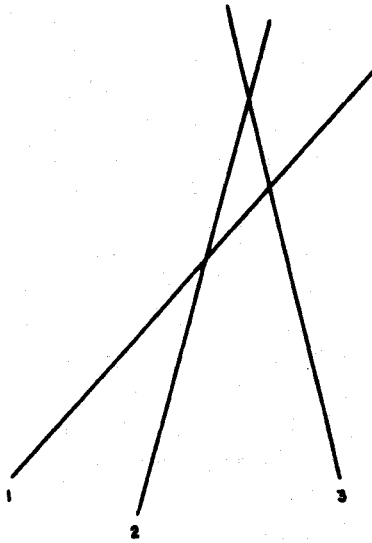

Figure 5-19. Three-station fix, error triangle.

often use the visual inspection method, but prior to using this method, a reliable data base must be established.

a. Bisection of the Medians of a Triangle. Evaluating a fix using this method, the plotter must draw a line from the midpoint of each median to the opposing angle. As shown in figure 5-20, a line is plotted from the midpoint of line AB to angle C, another from midpoint of line BC to angle A, and the last line from the midpoint of line AC to angle B. The error triangle solution or probable target emitter location is the point where the three lines intersect (A^1).

b. Bisection of the Angles of a Triangle. Determining the error triangle solution by bisecting the angles of the triangle is shown in figure 5-20. First, the plotter must determine the degree of each angle, then each angle must be bisected. In figure 5-20, the bisecting lines are drawn from angle A to point 1, from angle B to point 2, and last, from angle C to point 3. The solution (B^1) is the point where three lines intersect.

c. Steiner Point. The Steiner point method of determining the location of the target within the error triangle is probably the easiest and most accurate once a template is constructed. Draw a large circle on a sheet of clear plastic and drill a small hole in the exact center. Three lines are etched from the center to the outside of the circle exactly 120 degrees apart, thus trisecting the circle. Lay this template over the error triangle formed after the three bearings are plotted, rotate and maneuver it until each of the 120 degree lines is over the corners of the error triangle. Mark the location (C^1) with a pencil through the hole in the center of the template (fig. 5-20). This mark is reported, by grid coordinates, as the probable target location.

d. Visual Inspection. The visual inspection method of fix evaluation

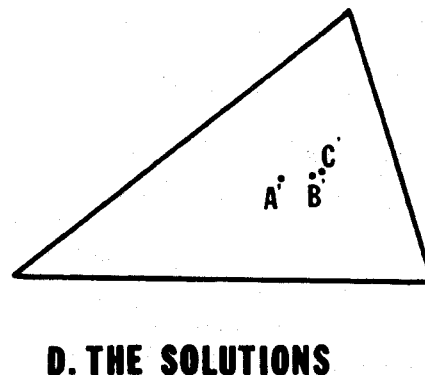
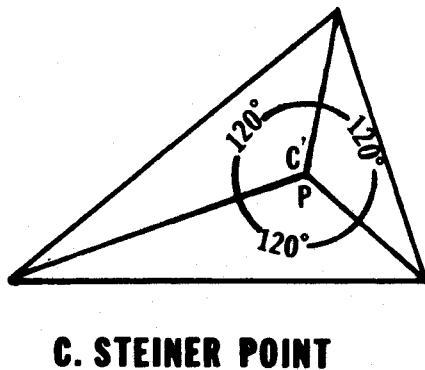
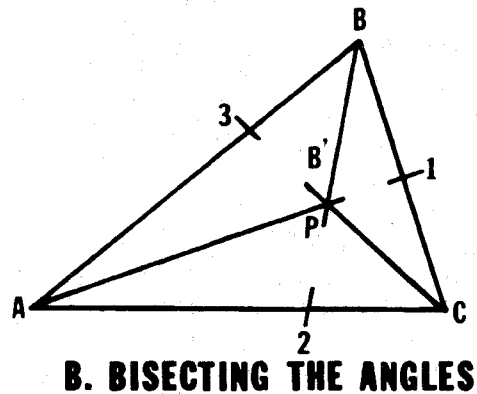
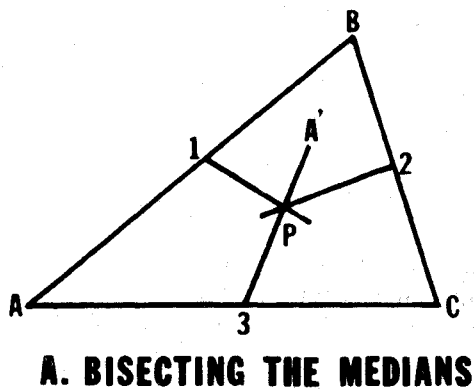

Figure 5-20. Error triangle solution.

encompasses several factors relating to the reported bearings. Paragraph 5-26 described how the operator assigns a classification or evaluation to the bearing. This factor is blended with the known reliability of the DF site based upon past performance. The distance that a radio wave travels before reaching the DF site as well as the terrain features around the DF site are also considered in the visual inspection method of fixing the probable location of a target

emitter. Angles that intersect at or near right angles are desirable and weigh heavily in producing the probable location of a target. As illustrated in figure 5-21, if the angle from point A is increased by 10 degrees, the area of increase is greater than that produced when the angle of point B is increased by 10 degrees. This is the reason angles near 90 degrees are desirable. To better illustrate visual inspection, the original bearings from four DF stations have been plotted (figure

5-22). The obvious error triangle is the one formed by lines plotted from bearings reported from stations 1, 2, and 4. However, the analyst in the plotting center knows that stations 1 and 2 have a huge body of water between them and the target area. From the data base, he knows that DF stations 1 and 2 have a plus 10 degrees bearing error for this particular frequency and angle. Using these known facts, the experienced plotter subtracts 10 degrees from the reported bearings of stations 1 and 2. The error triangle with the adjusted bearings is now located in a different and much smaller area formed by lines plotted from stations 1, 2, and 3 as shown in figure 5-22. The analyst has also determined that station 4 reported a bearing for a similar but different signal.

5-29. Deductions Relating to Probable Target Locations.

By using these methods to produce a probable target location, the plotter must examine the

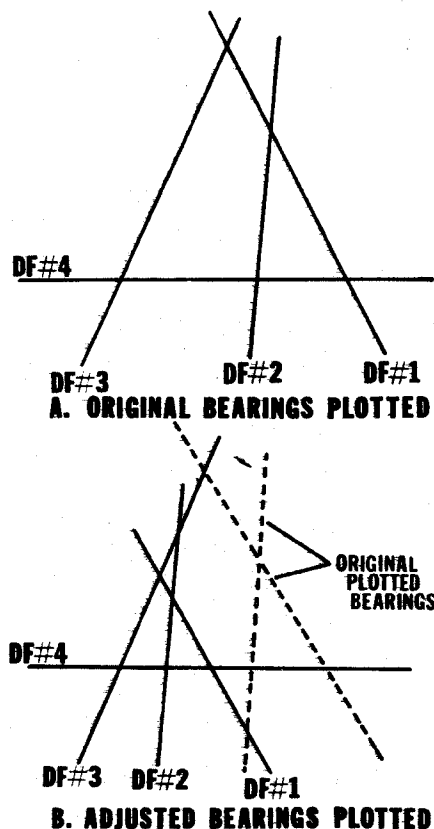

Figure 5-22. Plotting using reported bearings and data base.

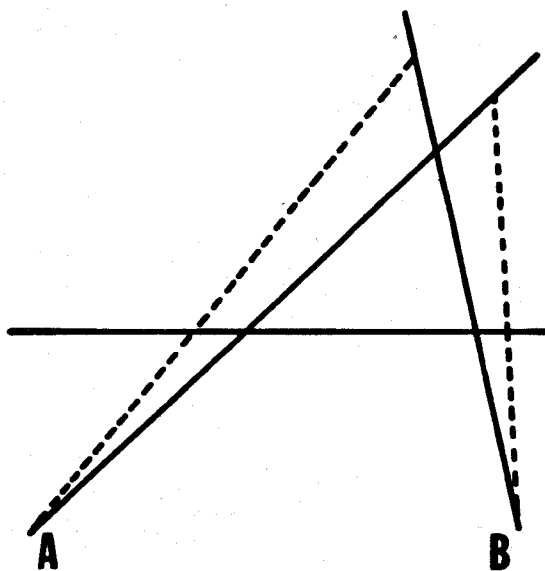

Figure 5-21. Angle increase comparison.

map in detail and study the geographical qualities of the fixes that have been produced. Should the location be indicated as the middle of a large lake, there is little likelihood that the transmitter would be accurately located if the target were serving a large headquarters. On the other hand; however, if the target is a low-powered, clandestine station about which little is known, and the fix is made during the hours of darkness, it may very well be accurate; e.g., a man-portable transmitter operating in a boat crossing the lake. If the fix point is located atop an inaccessible crag or butte, the plotter must once again apply a little logic and examine the terrain features adjacent to the indicated location. Transmitters usually serve a command or headquarters and are likely to be located where such troop units would logically be stationed or encamped. Camps,

trails, roads, water supplies, and similar terrain features must be evaluated in the formation of fix location.

5-30. Plotting with Four or More Bearings.

a. In larger plotting centers serving many outstations, several bearings may be received on the same target, requiring plotting from more than three bearings. The evaluative process mentioned above still applies. Ultimately, however, the plotter is confronted with a probable location triangle, quadrilateral, or other geometric figure formed by the plotted bearings. The details of these solutions are beyond the scope of this manual.

5-31. Mechanization of DF Plotting.

These methods of plotting to determine a fix point or fix area are predicated on the assumption that the plotting is done on a map board with a protractor and ruler at each DF site, or a string board on which the DF stations have been geographically located. Systematic errors and standard deviation have been interpolated according to all DF stations represented on the plotting board, and the map-edge scale is, therefore, accurate to that station's reported bearings. With the introduction of lightweight, portable computers rugged enough to withstand the exposures of field deployment, DF bearings reported in certain nets are translated into computer language, and determination of the fix areas or fix point is done electromechanically. The least square method of plotting is the basis for all computer plotting, however, because of its complexity, it is beyond the scope of this manual.

CHAPTER 6

Tasking and Reporting

Section I

COMMUNICATIONS REQUIREMENTS FOR DF NETS

6-1. Methods of Communications Within DF Nets.

The methods of communications used by DF nets are landline teletypewriter, radio teletypewriter, CW, and radiotelephone. All of these methods of communications must be secured with cryptosystems. A prime consideration of a DF net is the security and speed with which its users may effectively communicate.

a. The primary method of communications for strategic DF is secure, online teletypewriter using the Defense Special Security Communication System (DSSCS).

b. Methods of communications for tactical DF are CW, secured radio teletypewriter, and radiotelephone.

6-2. Problems of Control.

From the simplest to the most complex DF nets, there are certain functions which must be performed from the time a bearing is requested until the resultant bearings are obtained and the estimated target location is reported. These functions, in a reasonably chronological sequence, are:

a. The bearing to or position of a target station is required for intelligence purposes

(mission authorized action). Sufficient information concerning callsigns, frequency, and type of traffic passed must be furnished to permit identification of the target signal. This information is usually obtained from an intercept-search mission which identifies new stations of interest or substantiates the continuance of old stations with an interest in determining possible displacement. The completeness of this information is not always predictable. Generally, however, the DF operator does not spend his time searching the frequency bands for targets.

b. The mission, with all available information on the operation of the target station or net, is given to the radio intercept operator who searches for the desired signal and copies it to obtain traffic and keep the DF controller informed of the station's or net's activities.

c. As soon as the desired station or net is active, the radio intercept operator notifies the DF controller. He also provides the controller with any identifying details not already known.

d. The DF controller notifies all DF operators of the station's or net's activities, callsigns, frequencies, and other identifying information. This takes place over the flash net.

e. Bearings obtained by the DF operator are reported to net control. The reported bearings are plotted and the probable target location given to the commander who authorized or requested the mission. The assignment of the mission to the DF operator and the reporting of the results is accomplished by any of the means of communications mentioned above. If a DF

station happens to be colocated with the intercept facility, communication between the DF controller and the operator is within the confines of the facility, and requires none of the above. When only one DF set is used, only a line bearing can be obtained. In this situation, the commander desiring the bearing is usually in close proximity to the supporting DF site, and requests are made in person, with the results rendered in the same way. This single site DF effort is usually for close tactical support when a ground commander wishes to confirm his contacts or suspicions about the enemy's location. After the initial mission has been assigned to the operator, the controller can employ certain codes (if equipped with online cipher devices) or speak directly to the operator (if speech privacy equipment is available) to keep him informed as to exactly what the target station is doing. This is called "tracking" the station, and is used to ensure positive identification by the operator. Various DF missions will be assigned priorities depending upon the urgency of the tactical situation or the overall intelligence effort. When the missions terminate, the results are forwarded to control over a second net, called the reporting net.

Section II

TASKING AUTHORITY AND COMMAND STRUCTURE OF DF NETS

6-3. General.

Tasking, or mission assignment, is extremely complex, ranging from the tactical commander's request to requirements generated at the national level. A discussion of the detailed generation of missions is not within the scope of this manual. Such information may be obtained, if required, from the liaison officer assigned at each level of command who acts as a resources manager for the units providing DF support.

6-4. Basic Net Requirements for DF Support.

Without regard for the means of communications employed, a DF net requires communications circuits as shown in figure 6-1. The flash net, over which missions are assigned, is indicated by the solid lines, while the reporting net over which mission results are passed, is indicated by the broken lines. This is the basic communications requirement for any DF net. Tracking is conducted over the flash net after the missions are assigned. All bearings are returned over the reporting net.

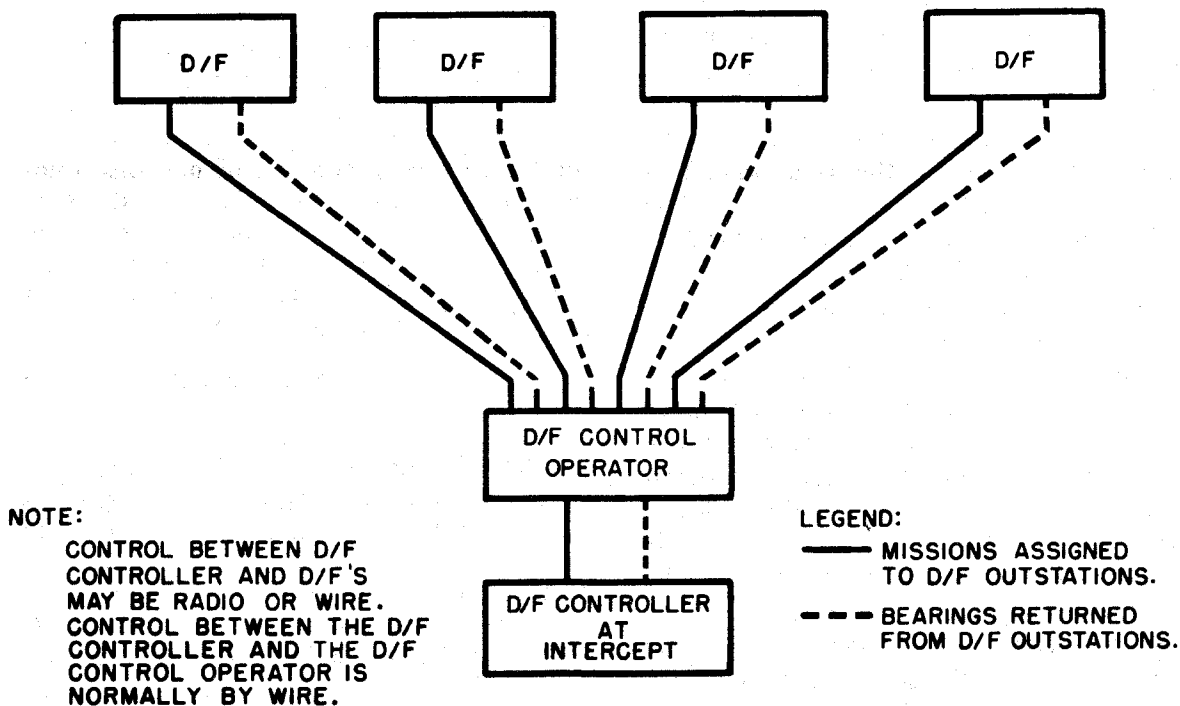

Figure 6-1. DF net control arrangement.

Direction-Finding Computations

Section I

GNOMONIC PROJECTION CORRECTION TECHNIQUES

7-1. General.

The gnomonic projection is the most common map used for long-range DF plotting. Its primary characteristic is the appearance of all great circles as straight lines. Distortion on the gnomonic is minimum at the point of tangency but increases as the distance from the point of tangency increases. For example, the boundaries near the edge of the projection are badly distorted and are practically useless for determining true shapes and distances. This distortion does not affect plotting activities if the DF equipment is located within a four degree radius from the point of map tangency, and bearings can be plotted to any point on the chart without any appreciable error. However, if the DF station is located outside the four degree radius, angular correction must be applied before its bearings can be accurately plotted. The computation methods used to correct this distortion are border coordinates and the corrected compass rose (CCR).

7-2. Border Coordinates.

Border coordinates not only correct angular distortion on a gnomonic chart, but provide what is perhaps considered the most accurate method of plotting DF bearings. Border coordinates divide the perimeter of the gnomonic chart into 1,000 equal spaces,

which are denoted by tick marks. Every tenth mark is numbered, starting with 00 at the upper left-hand corner and continuing clockwise to 100. The border coordinates are constructed on the chart so that 00 through 30 are located on the top border; 30 through 50 are located on the right border; 50 through 80 are on the bottom border; and 80 through 100 are located on the left border. The spaces between the tick marks can be mechanically interpolated into tenths, providing a total of 10,000 coordinates for plotting purposes. Tables are constructed for each DF site, providing coordinates for all azimuths. When a bearing is reported by a DF site it is converted to border coordinates and plotted on the gnomonic chart by drawing a line between the coordinate and the DF site. Border coordinates and conversion tables are machine computed and may be obtained on request to higher headquarters. The applicable gnomonic chart number and the exact latitude and longitude of each DF site location must be included in the request.

7-3. Corrected Compass Rose.

a. General. The corrected compass rose is nothing more than a compass rose which has been corrected or expanded to compensate for angular distortion. In other words, the degree marks have been placed closer together or moved farther apart, according to the amount of distortion present. When situated on the gnomonic plotting chart the CCR must have its center exactly over the direction-finding site location. Bearings can then be plotted from the CCR or the rose can be extended to a line around the edge of the map in the same manner as border coordinates.

b. Right-Triangle Method. Constructing a corrected compass rose by the right-triangle

method entails the computation of mathematical formulas and is time consuming; however, this is compensated by the high degree of accuracy and reliability it provides. Since radio waves follow great circle paths, the right-triangle method of error correction is concerned with spherical trigonometry. Under theoretical conditions, the equator and the selected meridian would intersect at a right angle (fig. 7-1). The azimuth from the direction-finding site would intersect both the equator and the selected meridian forming a right triangle. A common logarithm of functions of angles in degrees and minutes table (appendix B) is used to solve the unknown quantities of a spherical right triangle. For additional information on the principles and application of logarithms, reference TM 11-684.

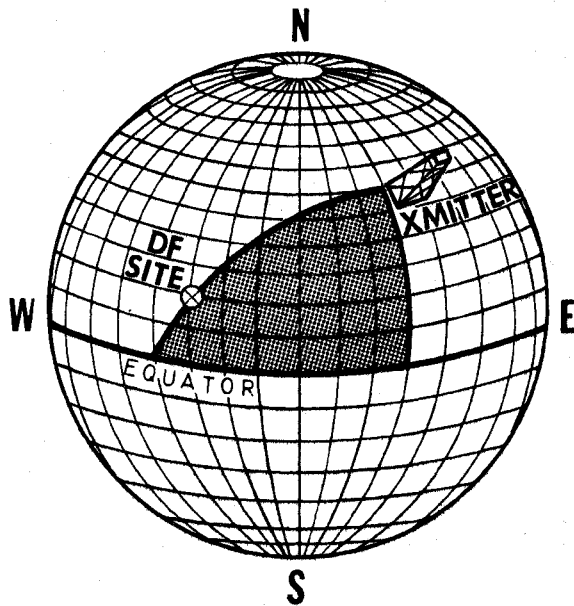

Figure 7-1. Spherical right triangle.

(1) The three known factors of the computation are:

(a) The latitude and longitude of the DF site.

(b) The longitude of the selected meridian.

(c) The desired azimuth.

(2) The selected meridian used during the computation should be in the approximate center of the area of interest. It also should be noted that one single meridian need not be used for the computation of the entire CCR.

(3) Figure 7-2 illustrates the formula used in the right-triangle method of computation.

(a) The bottom line marked 0 degrees represents the equator.

(b) Line a is the distance in degrees and minutes from the equator to the DF site, or the latitude of the site.

(c) Angle B is the desired azimuth which is to be corrected for angular map distortion.

(d) Angle A is the angle the desired azimuth makes at the equator. Note that angles A and B do not total 90 degrees as in a true right triangle because the right-triangle method deals with a right triangle only in theory and the functions are computed by spherical trigonometry.

(e) Line b is the distance in degrees and minutes of the difference in longitude between the DF site and the intersection of the azimuth with the equator.

(f) Line b'' is the distance in degrees and minutes from the DF site to the selected meridian.

(g) Line b' is the difference in longitude of the intersection of the azimuth with the equator and the selected meridian. Or, line b' is the sum of lines b and b''.

(h) The value of a' represents the latitude at which the bearing will intersect the selected meridian.

c. *Common Logarithms of Functions of Angles in Degrees and Minutes Table.*

(1) *Degrees.* Each page of the appendix B table is computed for eight

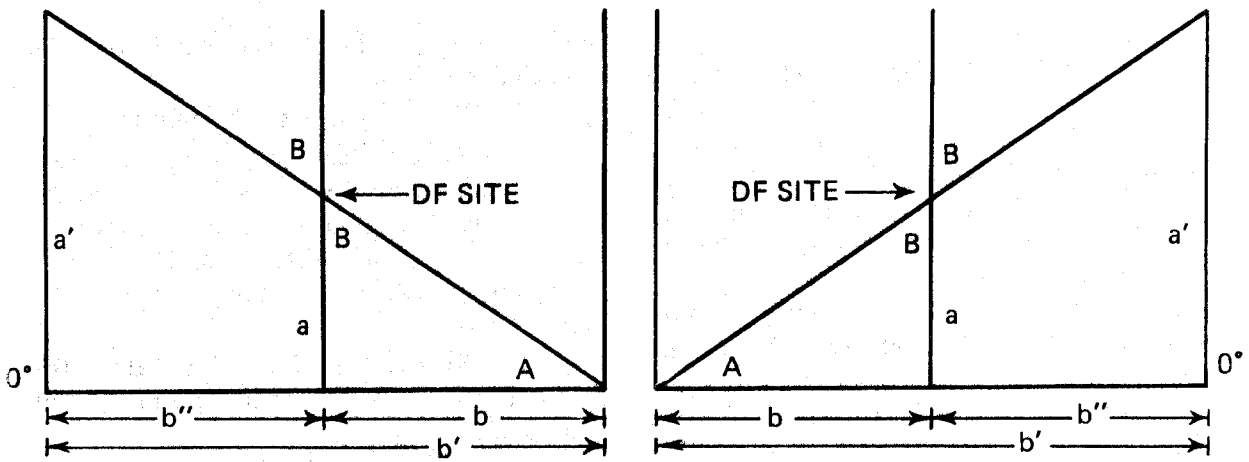

B= _____ a= _____ b''= _____ b= _____

a'= _____ A= _____ b'= _____

$(\log \tan b) = (\log \sin a) - (\log \cot B)$

log sin a: _____

log cot B: _____

Diff: _____ = log tan b

b= _____

$(\log \cos A) = (\log \cos a) + (\log \sin B)$

log cos a: _____

log sin B: _____

Sum: _____ = log cos A

A= _____

$(\log \tan a') = (\log \sin b') - (\log \cot A)$

log sin b': _____

log cot A: _____

Diff: _____ = log tan a'

a'= _____

Figure 7-2. Right triangle computation worksheet.

different angles, of which four are indicated in the upper left-hand corner and four in the lower right-hand corner. The fact that one page is sufficient for the functions of eight different angles is a result of the properties of trigonometric functions. For example, the sine of 0 degrees is numerically equal to the sine of 180 degrees and the cosine of 90 degrees is equal to the cosine of 270 degrees.

(2) *Minutes.* The minutes for each angle are found in the columns headed by the mathematical sign for minutes ('). The minutes for the angles in the upper left-hand corner are read *down* the left minute column. The minutes for the angles in the lower right-hand corner are read *up* the right minute column.

(3) *Use of the tables.*

(a) To determine the logarithm of an angle:

1. Locate the page containing the angle of the trigonometric function.

2. Follow the angle's minute column up or down, as required, until the exact minute reading is located.

3. Determine which function is appropriate by consulting the legend either at the top or the bottom of the table. Angle functions are *opposite* each angle or degree reading. The number found at the intersection of the function column and the logarithm row opposite the minute column is the logarithm of that angle.

(b) To determine the angle of a logarithm:

1. Locate the logarithm which is *nearest* the given logarithm in the appropriate function column.

2. The minute value will be selected from either the corresponding number in the left minute column or the right minute column.

3. Note the corresponding angles of the function column, top left-hand corner and bottom right-hand corner, and select the *lowest* of the four angles. If the

selected angle is at the top of the page, read the minute value from the left minute column. However, if the selected angle is taken from the bottom of the page, read the minute value from the right minute column.

d. Right-Triangle Method Example. The desired azimuth or angle B which is to be corrected for angular distortion is 10 degrees. The latitude of the DF site or line a is 36 degrees. The difference in longitude between the DF site and the selected meridian, or b'', is 5 degrees. (Reference appendix B for logarithm table.)

Step 1. Find b:

$$\begin{aligned} (\log \sin a) - (\log \cot B) &= (\log \tan b) \\ \log \sin 36^\circ &= 9.76922-10 \\ \log \cot 10^\circ &= \underline{0.75368} \\ \log \text{diff} &= 9.01554-10 \\ \log \tan b &= 9.01554-10 \\ b &= 5^\circ 55' \end{aligned}$$

Note. Always select the *lowest* degree and minute reading.

Step 2. Find b':

$$\begin{aligned} (b'') + (b) &= (b') \\ b'' &= 5^\circ \\ b &= \underline{5^\circ 55'} \\ b' &= 10^\circ 55' \end{aligned}$$

Step 3. Find A:

$$\begin{aligned} (\log \cos a) + (\log \sin B) &= (\log \cos A) \\ \log \cos 36^\circ &= 9.90796-10 \\ \log \sin 10^\circ &= \underline{9.23967-10} \\ \log \text{sum} &= 19.14763-20 \\ \log \cos A &= 9.14763-10 \\ A &= 81^\circ 55' \end{aligned}$$

Step 4. Find a':

$$\begin{aligned} (\log \sin b') - (\log \cot A) &= (\log \tan a') \\ \log \sin 10^\circ 55' &= 9.27734-10 \\ \log \cot 81^\circ 55' &= \underline{9.15236-10} \\ \log \text{diff} &= 0.12498 \\ \log \tan a' &= 0.12498 \\ a' &= 53^\circ 08' \end{aligned}$$

Step 5. A straightedge alined with 53 degrees and 8 minutes latitude on the selected meridian will indicate the corrected azimuth for 10 degrees. When

constructing a corrected compass rose a tick mark should be placed on the compass rose and numbered 10 degrees, or a tick mark placed on the edge of the plotting chart and numbered 10 degrees.

(1) It is apparent that logarithm tables are constructed in such a manner so that the area from 0 to 90 degrees will represent the entire 360 degree circle. Any computation using X degrees east as the selected meridian will also be correct for X degrees west and both reciprocals. Therefore, any single computation will yield four azimuths; 90 computations are required to complete the entire compass rose.

(2) A problem area may arise when computing desired azimuths around 90 or 270 degrees. To eliminate confusion, subtract the value of (b) from 90 degrees and complete the computations normally. This procedure should also be used approximately 5 degrees on either side of the 90 or 270 degree azimuth which will ensure standard accuracy.

Section II

GREAT CIRCLE AZIMUTHS

7-4. General.

Radio waves follow great circle paths between the transmitting and receiving antennas. When the exact location of the signal source is known, it is possible to compute the true or great circle azimuth and distance (GCAD) from the point of signal origin to any other point receiving the signal on the surface of the earth. The computations of great circle azimuths are based on spherical trigonometry and may be computed using the dead reckoning altitude and azimuth table in appendix C. This method is simpler and much faster than using other logarithmic methods and is accurate to within one-half a minute. Greater accuracy is possible by interpolating between table functions.

7-5. Dead Reckoning Altitude and Azimuth Table.

The dead reckoning altitude and azimuth table is arranged in parallel "A" and "B" columns. The "A" columns contain log cosecants multiplied by 100,000 and the "B" columns contain log secants multiplied by 100,000. The "A" columns decrease in value from the front of the table toward the rear, while the "B" columns increase in value from the front of the table to the rear. When determining degrees and minutes from the top of the table, read the minutes from the *left-hand* column. However, when reading the degrees and minutes from the bottom of the table, read the minutes from the *right-hand* column. It should also be noted that if the desired degrees and minutes exceed 180 degrees, it is necessary to subtract 180 degrees before entering the table.

7-6. Great Circle Azimuth and Distance Computation.

a. General. Great circle azimuth and distance computations are based on spherical trigonometry. A terrestrial triangle has curved sides and is commonly referred to as a spherical triangle. Refer to figure 7-3 and you will see that the shaded portion of the illustration is a spherical triangle. The determination of the true azimuth and distance is reduced to simply completing the worksheet (fig. 7-4) using the dead reckoning altitude and azimuth table.

b. Formula symbols. The following symbols are used in the GCAD formula (fig. 7-3):

- (1) L or lat is the latitude of the initial position or the DF site.
- (2) L' or lat' is the latitude of the final position or the check station.
- (3) $\angle B$ is the great circle azimuth from the check station to the DF site.
- (4) D arc is the great circle distance, in minutes of arc, between the target and the DF site. (One minute of arc equals one nautical mile.)

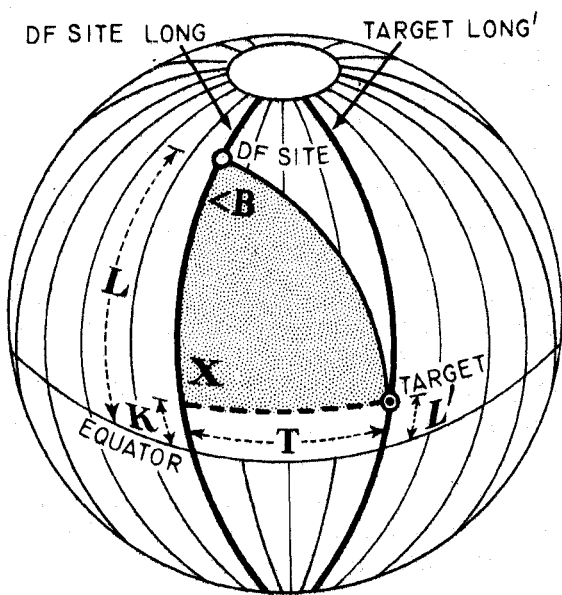
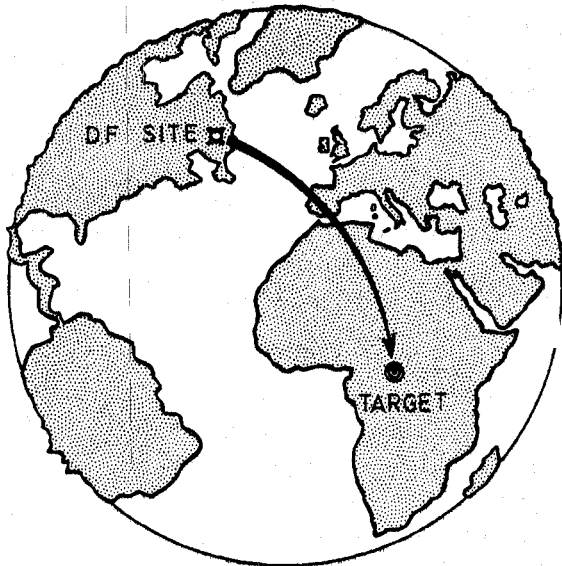

Figure 7-3. Spherical triangle.

(5) X is a factor introduced to simplify the computation and represents that point at which a great circle constructed perpendicular to the target's meridian crosses the meridian of the DF site.

(6) K is the latitude of point X or the arc from X to the equator (assumes the name of the latitude of the final position.)

(7) KL is the difference between K and L.

(8) Long is the longitude of the DF site.

(9) Long' is the longitude of the check station.

c. *Special Rules.* The fact that D arc may be greater than 90 degrees has necessitated the following rules.

(1) *Rule 1.* When L and L' are the same name (north or south) the following procedures are applicable.

(a) When T is *greater* than 90 degrees, select the K value from the bottom of the table. When T is *less* than 90 degrees, select the K value from the top of the table.

(b) Record $\angle B$ from the top of the table when K is *greater* than L. When K is *less* than L select $\angle B$ from the bottom of the table.

(c) D arc is recorded from the top of the table *except* when T and KL are *both greater* than 90 degrees.

(2) *Rule 2.* When L and L' are different names the following procedures are applicable.

(a) When T is *greater* than 90 degrees select the K value from the bottom of the table. When T is *less* than 90 degrees select the K value from the top of the table.

(b) Record $\angle B$ from the bottom of the table *except* when KL is *greater* than 180 degrees.

(c) D arc is recorded from the bottom of the table *except* when T and KL are *both less* than 90 degrees.

(d) When KL exceeds 180 degrees, subtract 180 degrees before making a table computation.

(3) *Rule 3. Computation of $\angle B$.*

(a) When the initial position is in the *Northern Hemisphere* and is *west* of the final position, $\angle B$ is the true bearing. If the initial position is *east* of the final position, $\angle B$ is subtracted from 360 degrees to obtain the true bearing.

(b) When the initial position is in the *Southern Hemisphere* and is *west* of the final position, subtract $\angle B$ from 180 degrees. If the initial position is *east* of the final position, add 180 degrees to $\angle B$ to obtain the true bearing.

d. *GCAD Worksheet.* To facilitate the computation process, a GCAD worksheet is illustrated in figure 7-4. It is divided into a heading and the step-by-step procedure for determining true azimuth and distance. An explanation of the worksheet and the GCAD formula follows.

(1) The heading contains the latitude and longitude of the direction-finding site and the selected check station. The following abbreviations are used:

(a) FROM: The name of the DF site.

(b) LAT or L: The latitude of the DF site.

(c) LONG: The longitude of the DF site.

(d) TO: The name of the target station.

(e) LAT' or L': The latitude of the target station.

(f) LONG': The longitude of the target station.

(g) To determine T, the following procedures should be followed:

1. If LONG and LONG' are in the same hemisphere, (same names) *subtract* to determine the T value.

2. If LONG and LONG' are in different hemispheres, (different names) *add* to determine the T value.

(2) The remainder of the worksheet is divided into the DEGREES/MINUTES

column and COL-1 through COL-4. The mathematical function is indicated at the top of each column. Logarithms are entered at the spaces "A" and "B" beginning with COL-1 and the appropriate function performed. If other logarithm tables are used instead of the dead reckoning altitude and azimuth table, column A will equate to the log cosecant and column B will equate to the log secant. Prior to beginning the computation, enter the T value in the appropriate space under the DEGREES/MINUTES column.

e. *Computation Procedures.*(1) *COL-1.*

(a) Locate the T value in the dead reckoning altitude and azimuth table (appendix C). Enter the figure found under the corresponding A column in the appropriate space under COL-1.

(b) Enter L' in the appropriate space under the DEGREES/MINUTES column.

(c) Locate the L' value in the table. Enter the corresponding B column number in the appropriate space under COL-1.

(d) Add the COL-1 A and B values. Enter the result under the final A space in COL-1.

(2) *COL-2.*

(a) Locate the L' value in the table. Enter the corresponding A column figure in the appropriate space under COL-2.

(b) Locate the COL-1 final A value in the table. Enter the corresponding B figure in the appropriate space under COL-2.

(c) Subtract the COL-2 B value from the COL-2 value. The result is entered as the final COL-2 A value.

(d) Locate the final COL-2 A value in the table. The corresponding degrees and minutes will be entered as the K value under the DEGREES/MINUTES column.

Note. Before the K value is determined, refer to the special rules 1 or 2 and determine which is applicable to the GCAD computation.

7-8 FROM: _____ TO: _____
 LAT: _____ LAT': _____
 LONG: _____ LONG': _____

T is determined by the following conditions: If long and long' are the same name SUBTRACT. If long and long' are different names ADD.

T _____

DEGREES/MINUTES	COL-1 (ADD)	COL-2 (SUBTRACT)	COL-3 (ADD)	COL-4 (SUBTRACT)
T: _____	A: _____			
L': _____	B: _____	A: _____		
	A: _____	B: _____	B: _____	A: _____
K: _____		A: _____		
L: _____				
KL: _____			B: _____	
D ARC: _____			B: _____	A: _____
60 X DEGREES _____				A: _____
+ MINUTES + _____				<B _____
TOTAL _____				
TRUE AZIMUTH _____				

Figure 7-4. GCAD computation worksheet.

If other logarithm tables are used instead of dead reckoning altitude and azimuth tables, column A equates to log cosecant, and column B equates to log secant.

(3) COL-3.

(a) The first COL-3 B value is a repeat of the COL-2 B value.

(b) Enter the LAT or L in the appropriate space under the DEGREES/MINUTES column.

(c) Determine the KL value under the DEGREES/MINUTES column, by subtracting the L or LAT value from the K value if the same name. Add K and L if different names.

(d) Locate the KL value in the table. Enter the corresponding B column value in the appropriate COL-3 space.

Note. If rule 2 is applicable to the computation, and the KL value exceeds 180 degrees, subtract 180 degrees before entering the table.

(e) Add the COL-3 B values. Enter the result as the final COL-3 B value.

(f) Locate the final COL-3 B value in the table. Enter the corresponding degrees and minutes as the D arc value under the DEGREES/MINUTES column.

Note. Refer to the applicable rule to determine if the D arc value is taken from the top or the bottom of the table.

(4) COL-4.

(a) The first COL-4 A value is a repeat of the final COL-1 A value.

(b) Locate the final COL-3 B value in the table. Enter the corresponding A value in the appropriate COL-4 A space.

(c) Subtract the COL-4 A values and enter the difference in the space provided.

(d) Locate the final COL-4 A value in the table. Enter the corresponding degrees and minutes as the COL-4 B value.

Note. Again refer to the applicable rule to determine if $\angle B$ is taken from the top or the bottom of the table, and if that value is the true azimuth.

(5) *Distance.* To compute the great circle azimuth distance:

(a) Multiply the number of D arc degrees by 60.

(b) Add the D arc minutes to the result. The sum indicates the distance in nautical miles. To obtain statute miles, multiply the nautical miles by 1.15.

f. *GCAD Example.* Determine the great circle azimuth and distance from Hetricks Villa, USA to London, England. The following information is provided.

Hetricks Villa, USA	Latitude: 42° 33' North
	Longitude: 71° 36' West
London, England	Latitude: 51° 32' North
	Longitude: 00° 05' West

Before beginning the computation, determine which rule is applicable. Since LONG and LONG' are the same name, *West*, rule 1 will apply.

Step 1. Determine the T value. Since LONG and LONG' are the same name, *West*, subtract to find the difference.

Hetricks Villa	LONG: 71° 36'
London	LONG': 00° 05'
	<u>T = 71° 31'</u>

Step 2. Locate the T value, 71° 31', in the dead reckoning and azimuth table. The corresponding COL-1 A value is 2300.

Step 3. Locate the L' value, 51° 32', in the table. The corresponding COL-1 B value is 20617.

Step 4. Add the COL-1 A and B values. The result, or 22917, is the final COL-1 A value.

A	2300
+	
B	<u>20617</u>
	22917

Step 5. Locate the L' value, 51° 32', in the table. The corresponding COL-2 A value is 10625.

Step 6. Locate the COL-1 final A value, 22917, in the table. The corresponding COL-2 B value is 9292.

FM 30-476

Step 7. Subtract the COL-2 B value, 9292, from the COL-2 A value, 10625. The remainder is 1333 and the final COL-2 A value.

$$\begin{array}{r} A \quad 10625 \\ - \\ B \quad \underline{9292} \\ \hline 1333 \end{array}$$

Step 8. Locate the final COL-2 A value, 1333, in the table. The corresponding degrees and minutes, 75° 52' 30" represents the K value.

Note. Refer to rule 1a to determine if K is selected from the top or the bottom of the table.

Step 9. Record the first COL-3 B value as 9292 since it is a repeat of the COL-2 B value.

Step 10. Enter the value for LAT, or 42° 33', under the DEGREES/MINUTES column in the appropriate space.

Step 11. Determine the value for KL by subtracting LAT, 42° 33' from the K value, 75° 52' ii. The remainder is 33° 19' 30".

$$\begin{array}{r} K \quad 75^\circ 52' 30'' \\ - \\ LAT \quad \underline{42^\circ 33'} \\ \hline KL = 33^\circ 19' 30'' \end{array}$$

Step 12. Locate the KL value, 33° 19' 30", in the table. The corresponding COL-3 B value is 7802.

Step 13. Add the COL-3 B values. The sum and final B value is 17094.

$$\begin{array}{r} B \quad 9292 \\ + \\ B \quad \underline{7802} \\ \hline B = 17094 \end{array}$$

Step 14. Record the first COL-4 A value as 22917 since it is a repeat of the final COL-1 A value.

Step 15. Locate the COL-3 final B value, 17094, in the table. The corresponding COL-4 A value is 13185.

Step 16. Subtract the COL-4 A value, 13185, from 22917. The final COL-4 value is 9732.

$$\begin{array}{r} A \quad 22917 \\ - \\ A \quad \underline{13185} \\ \hline A = 9732 \end{array}$$

Step 17. Locate the COL-4 final A value, 9732, in the table. Again refer to rule 1 and determine if ∠B is taken from the top or the bottom of the table. Since K is greater than L, ∠B is selected from the top of the table. Therefore, ∠B or the true azimuth from Hetricks Villa to London, England is 53° 03' 30". Again refer to the rule and determine if ∠B is the true bearing. As the initial position is west of the final position, 53° 03' 30" is the true azimuth.

Step 18. To determine D arc, locate the final COL-3 B value in the table. Refer to rule 1 to determine if D arc is taken from the top or the bottom of the table. Since T and KL are both less than 90 degrees, D arc is taken from the top of the table and is 47° 34' 30".

Step 19. To compute the distance from the initial to the final position in nautical miles, multiply D arc by 60. To obtain statute miles, multiply the total nautical miles by 1.15.

$$\begin{array}{r} D \text{ arc} = 47^\circ 34' 30'' \\ 47 \times 60 = 2820 \\ + \quad \underline{34.5} \\ \hline \text{Total nautical miles} = 2854.5 \\ 2854.5 \\ \times 1.15 \\ \hline 142725 \\ 28545 \\ \hline 28545 \\ \hline \text{Total statute miles} = 3282.675 \end{array}$$

Section III
STATISTICAL FACTORS

7-7. General.

Statistical analysis is an invaluable management tool for measuring direction-finding performance. Through the proper application of statistics, an estimate of the amount of error found in individual bearings can be provided, as well as the probable amount of error of the site, or even

the complete direction-finding net. Normally, plotting and evaluation activities are responsible for performing accuracy studies. However, direction-finding supervisors and analysts must be knowledgeable of statistical analysis procedures and must be able to compute the analytical computations outlined in this chapter.

7-8. Systematic Error.

Systematic error (SE) represents the difference between the true bearing and the mean bearing of a transmitter. The true bearing is determined by computing a great circle azimuth from the DF site to the selected target station. The average bearing is determined by taking a large number of bearings on the selected transmitter, a minimum of 200, and computing the average or mean bearing of the sample.

a. Consideration should be given to the following criteria when selecting a check station.

(1) The frequency should be compatible with operational targets.

(2) The location should be within the area of interest or a very close proximity thereof.

(3) The distance should not be significantly different than that of operational targets.

b. Systematic error is computed using the formula $SE = \text{Bearing Mean (BM)} - \text{Bearing True (BT)}$.

(1) BM is the mean bearing between the DF site and the selected check station.

(2) BT is the true bearing between the DF station and the selected check station.

c. The following steps outline the procedure for computing systematic error.

Step 1. Visually inspect the reported bearings and eliminate the obviously wild ones.

Step 2. Mathematically compute the mean bearing from the remaining bearings.

Step 3. Eliminate all bearings which deviate more than plus or minus 8 degrees from the computed mean bearing.

Step 4. Recompute the mean bearing.

Step 5. Determine the difference between the mean and true bearings. The difference is the systematic error.

Note. Systematic error must always be expressed as a negative or positive error. If the mean bearing is smaller than the true bearing, the error is negative. However, if the mean bearing is larger than the true bearing, the error is positive.

d. The following example illustrates the computation of systematic error using the formula $SE = BM - BT$. The true azimuth of the check station is 031 degrees. The following bearings were observed on the selected check station: 029°, 025°, 032°, 029°, 034°, 032°, 030°, 028°, 034°, and 027°.

Note. In practical applications at least 200 bearings must be obtained on the selected check station.

Step 1. A visual inspection proves there are no obvious wild bearings.

Step 2. Compute the mean bearing.

029°
 025°
 032°
 029°
 034°
 032°
 030°
 028°
 034°
027°
 300 / 10 = 030°

Steps 3 and 4. Since there are no bearings which deviate over plus or minus 8 degrees from the computed mean bearing, proceed to step 5.

Step 5. Determine the difference between the mean and true bearings. The difference is the systematic error.

$$\begin{aligned} SE &= BM - BT \\ SE &= 030^\circ - 031^\circ \\ SE &= -001^\circ \end{aligned}$$

7-9. Variance.

Variance is used as a reliability factor and indicates the quality of bearings used in the computation of the mean bearing. Variance provides the measure of spread, or the dispersion of bearings around the mean bearing. The analysis of either site or individual operator variance on selected check stations provides the supervisor with an additional management tool for evaluating efficiency.

a. The formula for computing variance is:

$$\frac{(BM - BO)^2}{N}$$

- (1) Σ indicates the algebraic sum.
- (2) $(BM - BO)^2$ is the observed bearing subtracted from the mean bearing. The difference or remainder is then squared.
- (3) N is the total number of bearings within plus or minus 8 degrees of the mean bearing.

b. The following steps outline the procedure for computing variance.

Step 1. Visually inspect all the reported bearings and eliminate the obviously wild ones.

Step 2. Mathematically compute the mean bearing from the remaining bearings.

Step 3. Eliminate any of the remaining bearings which deviate more than plus or minus 8 degrees from the computed mean.

Step 4. Recompute the mean if necessary.

Step 5. Determine the deviation of each observed bearing from the mean bearing and square each deviation.

Step 6. Add the squared deviations. Divide the sum by the total number of bearings used. The result is the variance.

Note. Due to the squaring process in step 5, variance has no sign.

c. The following bearings were observed on a selected check station: 330°, 326°, 333°, 334°, 325°, 330°, 331°, 329°, 328°, and 334°.

Note. In practical applications at least 200 bearings must be obtained on the selected check station.

Step 1. A visual inspection proves there are no obvious wild bearings.

Step 2. Compute the mean bearing.

$$\begin{array}{r} 330^\circ \\ 326^\circ \\ 333^\circ \\ 334^\circ \\ 325^\circ \\ 331^\circ \\ 330^\circ \\ 329^\circ \\ 328^\circ \\ \hline 334^\circ \\ \hline 3300 / 10 = 330^\circ \end{array}$$

Steps 3 and 4. Since there are no bearings which deviate over plus or minus 8 degrees from the computed mean, proceed to step 5.

Step 5. Determine the deviation of each observed bearing from the mean bearing and square each deviation.

BM	BO	Remainder	Squared
330°	330°	= 0 ²	= 0
330°	326°	= 4 ²	= 16
330°	333°	= -3 ²	= 9
330°	334°	= -4 ²	= 16
330°	325°	= 5 ²	= 25
330°	331°	= -1 ²	= 1
330°	330°	= 0 ²	= 0
330°	329°	= 1 ²	= 1
330°	328°	= 2 ²	= 4
330°	334°	= -4	= 16

Step 6. Add the squared deviations and divide by the number of bearings used. The result is the variance.

$$\begin{array}{r}
 0 \\
 16 \\
 9 \\
 16 \\
 25 \\
 1 \\
 0 \\
 1 \\
 4 \\
 \hline
 88 \\
 88 / 10 = 8.8
 \end{array}$$

The variance is 8.8.

7-10. Square Root.

Before standard deviation (SD), another direction-finding statistical factor, can be addressed it is necessary to be able to manually compute square root. Although pocket calculators and other machine aids can perform this function much faster, the need for manual computation of square root may arise.

a. The following steps outline the procedure for obtaining the square root of the number 3.4.

Step 1. Starting at the decimal point, mark off the digits in pairs in both directions. Add zeros as necessary.

$$\sqrt{03.40\ 00}$$

Step 2. Place the decimal point for the answer directly above the decimal point that appears under the radical sign.

$$\sqrt{\overset{\square}{0}3.40\ 00}$$

Step 3. Determine by inspection the largest number that can be squared without exceeding the first pair of digits - 03. The answer is 1, since the square of any number larger than 1 will be greater than 03. Place the 1 above the first pair of digits.

$$\begin{array}{r}
 1. \\
 03.40\ 00
 \end{array}$$

Step 4. Square 1 obtaining 1 and place it under the 03. Subtract 1 from 03 obtaining 2. Bring down the next pair of digits.

$$\begin{array}{r}
 1. \\
 \sqrt{03.40\ 00} \\
 \underline{1} \\
 240
 \end{array}$$

Step 5. Double the answer or quotient of 1 obtaining 2. Place the 2 to the immediate left of the 240. Determine the number that can be multiplied by 2 and that same number and not exceed 240. The answer is 8 since 28 X 8 = 224. The number 9 would prove to be too large since 29 X 9 = 261. Place the number 8 to the right of the decimal in the quotient. Subtract the 224 from 240 and bring down the next pair of numbers - 00.

$$\begin{array}{r}
 1.8 \\
 \sqrt{03.40\ 00} \\
 \underline{1} \\
 28 \quad \underline{2} \quad 40 \\
 \underline{2} \quad 24 \\
 16\ 00
 \end{array}$$

Step 6. Double the quotient 18, disregarding the decimal point, obtaining 36. Place the 36 to the left of the 1600. Determine the number that can be multiplied by 36 and that same number and not exceed 1600. The answer is 4 as 364 X 4 = 1456. The number 5 would be too large since 365 X 5 = 1825. Place the 4 above the second pair of digits.

$$\begin{array}{r}
 1.8\ \boxed{4} \\
 \sqrt{03.40\ 00} \\
 \underline{1} \\
 28 \quad \underline{2} \quad 40 \\
 \underline{2} \quad 24 \\
 36 \boxed{4} \quad \underline{16} \quad 00 \\
 \underline{14} \quad 56 \\
 1\ 44
 \end{array}$$

b. Depending on the degree of accuracy desired, one can continue the process indefinitely by adding zeros. For direction-finding purposes, two places to the right of the decimal are sufficient. For example, (1.84)² = 3.3856.

7-11. Standard Deviation (SD).

a. Standard deviation is perhaps the best statistical method of evaluating direction-finding site performance. Systematic error is indicative of average error, but standard deviation is representative of site reliability. SD is a probability figure which indicates the spread of bearings on one or more targets. In this respect, the smaller the number or SD, the greater the reliability that is attributed to the direction-finding site.

b. Standard deviation is computed using the formula:

$$SD = \frac{\sqrt{(BT - BO)^2 - (SE)^2}}{N}$$

(1) BT is the true bearing between the DF site and the selected check station.

(2) BO is the observed bearing of the selected check station.

(3) N is the total number of bearings, within plus or minus 8 degrees of the mean bearing, used in the computation.

(4) (SE)² is the systematic error squared.

c. The following steps outline the procedure for computing standard deviation.

Step 1. Compute the SE of a selected check station using a minimum of 200 bearings.

Step 2. Determine for each observed bearing the deviation in degrees from the true bearing. (If the true bearing on the selected check station is not known, a great circle azimuth must be computed.)

Step 3. Square each deviation.

Step 4. Add the squared deviations and divide the sum by the total number of bearings used in the computation, within plus or minus 8 degrees of the mean bearing. This step satisfies the $\frac{(BT - BO)^2}{N}$ portion of the formula.

Step 5. Square the SE obtained in step 1. Subtract the (SE)² from the number obtained in step 4.

Step 6. Compute the square root of the number obtained in step 5. The square root represents the standard deviation of the direction-finding site.

d. The following example illustrates the computation of standard deviation. To prevent a lengthy illustration, only 10 bearings are used and the following information is provided: SE = -001 degree, BT = 031 degrees. Bearings observed on the selected check station are: 029°, 025°, 032°, 029°, 034°, 032°, 030°, 028°, 034°, and 027°.

Step 1. An SE of -001 degree is provided.

Step 2. Subtract the BO from the BT.

BT	BO	Remainder
031°	- 029°	= 2°
031°	- 025°	= 6°
031°	- 032°	= -1°
031°	- 029°	= 2°
031°	- 034°	= -3°
031°	- 032°	= -1°
031°	- 030°	= 1°
031°	- 028°	= 3°
031°	- 034°	= -3°
031°	- 027°	= 4°

Step 3. Square the remainder obtained in step 2.

Remainder	Squared
2°	4
6°	36
-1°	1
2°	4
-3°	9
-1°	1
1°	1
3°	9
-3°	9
4°	16

Step 4. Add the squared deviations and divide by the total number of bearings used in the computation.

$$\begin{array}{r}
 4 \\
 36 \\
 1 \\
 4 \\
 9 \\
 1 \\
 1 \\
 9 \\
 9 \\
 \hline
 16 \\
 90 / 10 = 9
 \end{array}$$

This step satisfies $\frac{(BT - BO)^2}{N}$ portion of the formula.

Step 5. Square the SE and subtract the result from the number obtained in step 4.

$$\begin{array}{l}
 \sqrt{9 - (SE)^2} \\
 \sqrt{9 - (-001)^2} \\
 \sqrt{9 - 1} \\
 \sqrt{8}
 \end{array}$$

Step 6. Compute the square root.

$$\begin{array}{r}
 \sqrt{8} \\
 2. \quad 8 \quad 2 \\
 \hline
 \sqrt{08. \quad 00 \quad 00} \\
 4 \\
 48 \quad 4 \quad 00 \\
 3 \quad 84 \\
 \hline
 562 \quad 16 \quad 00 \\
 11 \quad 24 \\
 \hline
 4 \quad 76
 \end{array}$$

Standard deviation equals 2.82.

10/10/10

10/10/10
10/10/10
10/10/10

10/10/10

10

10/10/10

10/10/10

10/10/10

10/10/10

10/10/10

10/10/10

10/10/10

10/10/10

10/10/10

10/10/10

10/10/10

10/10/10

10/10/10

10/10/10

10/10/10

10/10/10

10/10/10

10/10/10

10/10/10

10/10/10

10/10/10

10/10/10

10/10/10

10/10/10

10/10/10

10/10/10

10/10/10

10/10/10

10/10/10

10/10/10

10/10/10

10/10/10

10/10/10

10/10/10

10/10/10

10/10/10

10/10/10

10/10/10

10/10/10

10/10/10

10/10/10

10/10/10

10/10/10

APPENDIX A

REFERENCES**A-1. Army Regulation (AR).**

310-25 Dictionary of United States Army Terms.

A-2. Field Manual (FM).

11-60 Communications-Electronics Fundamentals: Basic Principles
Direct Current.

21-26 Map Reading.

A-3. Technical Manual (TM).

11-665 CW and AM Radio Transmitters and Receivers.

11-666 Antennas and Radio Propagation.

11-681 Electrical Fundamentals (Alternating Current).

11-5825-231-25 Direction Finder Set AN/TRD-15.

A-4. USASA Regulation (USASA Reg).

(C-CC0) USASA Standard Criteria for Supervision and
Regulations Employment of USASA Direction Finding
105-13 Techniques (U).

A-5. Training Film (TF).

TF 32-4106 Direction Finder Set AN/TRD-15/23 (Pattern
Interpretation).

FM 30-476

A-2

Appendix B

COMMON LOGARITHMS OF FUNCTIONS OF
ANGLES IN DEGREES AND MINUTES

0°... 180°	L SIN	D	L TAN	CD	L COT	L COS		PROP. PTS.			
90°... 270°	L COS		L COT		L TAN	L SIN					
0	-		-		-	0.00 000	60				
1	6.46 373	30103	6.46 373	30103	3.53 627	0.00 000	59	3476	3218	2997	
2	6.76 476	17609	6.76 476	17609	3.23 524	0.00 000	58	348	322	300	
3	6.94 085	12494	6.94 085	12494	3.06 915	0.00 000	57	695	644	599	
4	7.06 579	9691	7.06 579	9691	2.93 421	0.00 000	56	1043	965	899	
5	7.16 270	7918	7.16 270	7918	2.83 730	0.00 000	55	1390	1287	1199	
6	7.24 188	6694	7.24 188	6694	2.75 812	0.00 000	54	1738	1609	1498	
7	7.30 882	5800	7.30 882	5800	2.69 118	0.00 000	53				
8	7.36 682	5115	7.36 682	5115	2.63 318	0.00 000	52	2802	2633	2483	
9	7.41 797	4576	7.41 797	4576	2.58 203	0.00 000	51	1	280	263	248
10	7.46 373	4139	7.46 373	4139	2.53 627	0.00 000	50	2	560	527	497
11	7.50 512	3779	7.50 512	3779	2.49 488	0.00 000	49	3	841	790	745
12	7.54 291	3476	7.54 291	3476	2.45 709	0.00 000	48	4	1121	1053	993
13	7.57 767	3218	7.57 767	3219	2.42 233	0.00 000	47	5	1401	1316	1242
14	7.60 985	2997	7.60 986	2996	2.39 014	0.00 000	46				
15	7.63 982	2802	7.63 982	2803	2.36 018	0.00 000	45	2227	2021	1848	
16	7.66 784	2633	7.66 785	2633	2.33 215	0.00 000	44	1	223	202	185
17	7.69 417	2483	7.69 418	2482	2.30 582	9.99 999	43	2	445	404	370
18	7.71 900	2348	7.71 900	2348	2.28 100	9.99 999	42	3	668	606	554
19	7.74 248	2227	7.74 248	2228	2.25 752	9.99 999	41	4	891	808	739
20	7.76 475	2119	7.76 476	2119	2.23 524	9.99 999	40	5	1113	1010	924
21	7.78 594	2021	7.78 595	2020	2.21 405	9.99 999	39				
22	7.80 615	1930	7.80 615	1931	2.19 385	9.99 999	38	1704	1579	1472	
23	7.82 545	1848	7.82 546	1848	2.17 454	9.99 999	37	1	170	158	147
24	7.84 393	1773	7.84 394	1773	2.15 606	9.99 999	36	2	341	316	294
25	7.86 166	1704	7.86 167	1704	2.13 833	9.99 999	35	3	511	474	442
26	7.87 870	1639	7.87 871	1639	2.12 129	9.99 999	34	4	682	632	589
27	7.89 509	1579	7.89 510	1579	2.10 490	9.99 999	33	5	852	789	736
28	7.91 088	1524	7.91 089	1524	2.08 911	9.99 999	32				
29	7.92 612	1472	7.92 613	1473	2.07 387	9.99 998	31	1379	1297	1223	
30	7.94 084	1424	7.94 086	1424	2.05 914	9.99 998	30	1	138	130	122
31	7.95 508	1379	7.95 510	1379	2.04 490	9.99 998	29	2	276	259	245
32	7.96 887	1336	7.96 889	1336	2.03 111	9.99 998	28	3	414	389	3367
33	7.98 223	1297	7.98 225	1297	2.01 775	9.99 998	27	4	552	519	489
34	7.99 520	1259	7.99 522	1259	2.00 478	9.99 998	26	5	690	649	612
35	8.00 779	1223	8.00 781	1223	1.99 219	9.99 998	25				
36	8.02 002	1190	8.02 004	1190	1.97 996	9.99 998	24	1158	1100	1046	
37	8.03 192	1158	8.03 194	1159	1.96 806	9.99 997	23	1	116	110	105
38	8.04 350	1128	8.04 353	1128	1.95 647	9.99 997	22	2	232	220	209
39	8.05 478	1100	8.05 481	1100	1.94 519	9.99 997	21	3	347	330	314
40	8.06 578	1072	8.06 581	1072	1.93 419	9.99 997	20	4	463	440	418
41	8.07 650	1046	8.07 653	1047	1.92 347	9.99 997	19	5	579	550	523
42	8.08 696	1022	8.08 700	1022	1.91 300	9.99 997	18				
43	8.09 718	999	8.09 722	998	1.90 278	9.99 997	17	999	954	914	
44	8.10 717	976	8.10 720	976	1.89 280	9.99 996	16	1	100	95	91
45	8.11 693	954	8.11 696	955	1.88 304	9.99 996	15	2	200	191	183
46	8.12 647	934	8.12 651	934	1.87 349	9.99 996	14	3	300	286	274
47	8.13 581	914	8.13 585	915	1.86 415	9.99 996	13	4	400	382	366
48	8.14 495	896	8.14 500	895	1.85 500	9.99 996	12	5	500	477	457
49	8.15 391	877	8.15 395	878	1.84 605	9.99 996	11				
50	8.16 268	860	8.16 273	860	1.83 727	9.99 995	10	877	843	812	
51	8.17 128	843	8.17 133	843	1.82 867	9.99 995	9	1	88	84	81
52	8.17 971	827	8.17 976	828	1.82 024	9.99 995	8	2	175	169	162
53	8.18 798	812	8.18 804	812	1.81 106	9.99 995	7	3	263	253	244
54	8.19 610	797	8.19 616	797	1.80 384	9.99 995	6	4	351	337	325
55	8.20 407	782	8.20 413	782	1.79 587	9.99 994	5	5	438	422	406
56	8.21 189	769	8.21 195	769	1.78 805	9.99 994	4				
57	8.21 958	755	8.21 964	756	1.78 036	9.99 994	3	782	755	730	
58	8.22 713	743	8.22 720	742	1.77 280	9.99 994	2	1	78	75	73
59	8.23 456	730	8.23 462	730	1.76 538	9.99 994	1	2	156	151	146
60	8.24 186		8.24 192		1.75 808	9.99 993	0	3	235	226	219
								4	313	302	292
								5	391	377	365
	L SIN	D	L TAN	CD	L COT	L COS			359°... 179°...		
	L COS		L COT		L TAN	L SIN			269°... 89°...		

1°... 181°		L SIN	D	L TAN	CD	L COT	L COS	PROP. PTS.		
91°... 271°		L COS		L COT		L TAN	L SIN			
0	8.24 186	717	8.24 192	718	1.75 808	9.99 993	60	717	695	673
1	8.24 903	706	8.24 910	706	1.75 090	9.99 993	59	71.7	69.5	67.3
2	8.25 609	695	8.25 616	696	1.74 384	9.99 993	58	143.4	139.0	134.6
3	8.26 304	684	8.26 312	684	1.73 688	9.99 993	57	215.1	208.5	201.9
4	8.26 988	673	8.26 996	673	1.73 004	9.99 992	56	286.8	278.0	269.2
5	8.27 661	663	8.27 669	663	1.72 331	9.99 992	55	358.5	347.5	336.5
6	8.28 324	653	8.28 332	654	1.71 668	9.99 992	54	653	634	616
7	8.28 977	644	8.28 986	643	1.71 014	9.99 992	53	65.3	63.4	61.6
8	8.29 621	634	8.29 629	634	1.70 371	9.99 992	52	130.6	126.8	123.2
9	8.30 255	624	8.30 263	625	1.69 737	9.99 991	51	195.9	190.2	184.8
10	8.30 871	616	8.30 888	617	1.69 112	9.99 991	50	261.2	253.6	246.4
11	8.31 465	608	8.31 505	607	1.68 495	9.99 991	49	326.5	317.0	308.0
12	8.32 103	599	8.32 112	599	1.67 888	9.99 990	48	599	583	568
13	8.32 702	590	8.32 711	591	1.67 289	9.99 990	47	59.9	58.3	56.8
14	8.33 292	583	8.33 302	584	1.66 698	9.99 990	46	119.8	116.6	113.6
15	8.33 875	575	8.33 886	575	1.66 114	9.99 990	45	179.7	174.9	170.4
16	8.34 450	568	8.34 461	568	1.65 539	9.99 989	44	239.6	233.2	227.2
17	8.35 018	560	8.35 029	561	1.64 971	9.99 989	43	299.5	291.5	284.0
18	8.35 578	553	8.35 590	553	1.64 410	9.99 989	42	553	539	526
19	8.36 131	547	8.36 143	546	1.63 857	9.99 989	41	55.3	53.9	52.6
20	8.36 678	539	8.36 689	540	1.63 311	9.99 988	40	110.6	107.8	105.2
21	8.37 217	533	8.37 229	533	1.62 771	9.99 988	39	165.9	161.7	157.8
22	8.37 750	526	8.37 762	527	1.62 238	9.99 988	38	221.2	215.6	210.4
23	8.38 276	520	8.38 289	520	1.61 711	9.99 987	37	276.5	269.5	263.0
24	8.38 796	514	8.38 809	514	1.61 191	9.99 987	36	514	502	490
25	8.39 810	506	8.39 823	509	1.60 677	9.99 987	35	51.4	50.2	49
26	8.39 818	502	8.39 832	502	1.60 168	9.99 986	34	102.8	100.4	98
27	8.40 320	496	8.40 334	496	1.59 666	9.99 986	33	154.2	150.6	147
28	8.40 816	491	8.40 830	491	1.59 170	9.99 986	32	205.6	200.8	196
29	8.41 307	485	8.41 321	486	1.58 679	9.99 985	31	257.0	251.0	245
30	8.41 792	480	8.41 807	480	1.58 193	9.99 985	30	480	470	460
31	8.42 272	474	8.42 287	475	1.57 713	9.99 985	29	48	47	46
32	8.42 746	470	8.42 762	470	1.57 238	9.99 984	28	96	94	92
33	8.43 216	464	8.43 232	464	1.56 768	9.99 984	27	144	141	138
34	8.43 680	459	8.43 696	460	1.56 304	9.99 984	26	192	188	184
35	8.44 139	455	8.44 156	455	1.55 844	9.99 983	25	240	235	230
36	8.44 594	450	8.44 611	450	1.55 389	9.99 983	24	450	440	430
37	8.45 044	445	8.45 061	446	1.54 939	9.99 983	23	45	44	43
38	8.45 489	441	8.45 507	441	1.54 493	9.99 982	22	90	88	86
39	8.45 930	436	8.45 948	437	1.54 052	9.99 982	21	135	132	129
40	8.46 366	433	8.46 385	432	1.53 615	9.99 982	20	180	176	172
41	8.46 799	427	8.46 817	428	1.53 183	9.99 981	19	225	220	215
42	8.47 226	424	8.47 245	424	1.52 755	9.99 981	18	420	410	400
43	8.47 650	419	8.47 669	420	1.52 331	9.99 981	17	42	41	40
44	8.48 069	416	8.48 089	416	1.51 911	9.99 980	16	84	82	80
45	8.48 485	411	8.48 505	412	1.51 495	9.99 980	15	126	123	120
46	8.48 896	408	8.48 917	408	1.51 083	9.99 979	14	168	164	160
47	8.49 304	404	8.49 325	404	1.50 675	9.99 979	13	210	205	200
48	8.49 708	400	8.49 729	401	1.50 271	9.99 979	12	390	380	370
49	8.50 108	396	8.50 130	397	1.49 870	9.99 978	11	39	38	37
50	8.50 504	393	8.50 527	393	1.49 473	9.99 978	10	78	76	74
51	8.50 897	390	8.50 920	390	1.49 080	9.99 977	9	117	114	111
52	8.51 287	386	8.51 310	386	1.48 690	9.99 977	8	156	152	148
53	8.51 673	382	8.51 696	383	1.48 304	9.99 977	7	195	190	185
54	8.52 055	379	8.52 079	380	1.47 921	9.99 976	6			
55	8.52 434	376	8.52 459	376	1.47 541	9.99 976	5			
56	8.52 810	373	8.52 835	373	1.47 165	9.99 975	4			
57	8.53 183	369	8.53 208	370	1.46 792	9.99 975	3			
58	8.53 552	367	8.53 578	367	1.46 422	9.99 974	2			
59	8.53 919	363	8.53 945	363	1.46 055	9.99 974	1			
60	8.54 282		8.54 308		1.45 692	9.99 974	0			
	L SIN	D	L TAN	CD	L COT	L COS		358°... 178°...		
	L COS		L COT		L TAN	L SIN		268°... 88°...		

2° ... 182°	L SIN	D	L TAN	CD	L COT	L COS	PROP. PTS.
	L COS		L COT		L TAN	L SIN	
0	8.54 282	360	8.54 308	361	1.45 692	9.99 974	60
1	8.54 642	357	8.54 669	358	1.45 331	9.99 973	59
2	8.54 999	355	9.55 027	355	1.44 973	9.99 973	58
3	8.55 354	351	9.55 382	352	1.44 618	9.99 972	57
4	8.55 705	349	8.55 734	349	1.44 266	9.99 972	56
5	8.56 054	346	8.56 083	346	1.43 917	9.99 971	55
6	8.56 400	343	8.56 429	344	1.43 571	9.99 971	54
7	8.56 743	341	8.56 773	341	1.43 227	9.99 970	53
8	8.57 084	337	8.57 114	338	1.42 886	9.99 970	52
9	8.57 421	336	8.57 452	336	1.42 548	9.99 969	51
10	8.57 757	332	8.57 788	333	1.42 212	9.99 969	50
11	8.58 089	330	8.58 121	330	1.41 879	9.99 968	49
12	8.58 419	328	8.58 451	328	1.41 549	9.99 968	48
13	8.58 747	325	8.58 779	326	1.41 221	9.99 967	47
14	8.59 072	323	8.59 105	323	1.40 895	9.99 967	46
15	8.59 395	320	8.59 428	321	1.40 572	9.99 967	45
16	8.59 715	318	8.59 749	319	1.40 251	9.99 966	44
17	8.60 033	316	8.60 068	316	1.39 932	9.99 966	43
18	8.60 349	313	8.60 384	314	1.39 616	9.99 965	42
19	8.60 662	311	8.60 698	311	1.39 302	9.99 964	41
20	8.60 973	309	8.61 009	310	1.38 991	9.99 964	40
21	8.61 282	307	8.61 319	307	1.38 681	9.99 963	39
22	8.61 589	305	8.61 626	305	1.38 374	9.99 963	38
23	8.61 894	302	8.61 931	303	1.38 069	9.99 962	37
24	8.62 196	301	8.62 234	301	1.37 766	9.99 962	36
25	8.62 497	298	8.62 535	299	1.37 465	9.99 961	35
26	8.62 795	296	8.62 834	297	1.37 166	9.99 961	34
27	8.63 091	294	8.63 131	295	1.36 869	9.99 960	33
28	8.63 385	293	8.63 426	292	1.36 574	9.99 960	32
29	8.63 678	290	8.63 718	291	1.36 282	9.99 959	31
30	8.63 963	288	8.64 009	289	1.35 991	9.99 959	30
31	8.64 256	287	8.64 298	287	1.35 702	9.99 958	29
32	8.64 543	284	8.64 585	285	1.35 415	9.99 958	28
33	8.64 827	283	8.64 870	284	1.35 130	9.99 957	27
34	8.65 110	281	8.65 154	281	1.34 846	9.99 956	26
35	8.65 391	279	8.65 435	280	1.34 565	9.99 956	25
36	8.65 670	277	8.65 715	278	1.34 285	9.99 955	24
37	8.65 947	276	8.65 993	276	1.34 007	9.99 955	23
38	8.66 223	274	8.66 269	274	1.33 731	9.99 954	22
39	8.66 497	272	8.66 543	273	1.33 457	9.99 954	21
40	8.66 769	270	8.66 816	271	1.33 184	9.99 953	20
41	8.67 039	269	8.67 087	269	1.32 913	9.99 952	19
42	8.67 308	267	8.67 356	268	1.32 644	9.99 952	18
43	8.67 575	266	8.67 624	266	1.32 376	9.99 951	17
44	8.67 841	263	8.67 890	264	1.32 110	9.99 951	16
45	8.68 104	263	8.68 154	263	1.31 846	9.99 950	15
46	8.68 367	260	8.68 417	261	1.31 583	9.99 949	14
47	8.68 627	259	8.68 678	260	1.31 322	9.99 949	13
48	8.68 886	258	8.68 938	258	1.31 062	9.99 948	12
49	8.69 144	256	8.69 196	257	1.30 804	9.99 948	11
50	8.69 400	254	8.69 453	255	1.30 547	9.99 947	10
51	8.69 654	253	8.69 708	254	1.30 292	9.99 946	9
52	8.69 907	252	8.69 962	252	1.30 038	9.99 946	8
53	8.70 159	250	8.70 214	251	1.29 786	9.99 945	7
54	8.70 409	249	8.70 465	249	1.29 535	9.99 944	6
55	8.70 658	247	8.70 714	248	1.29 286	9.99 944	5
56	8.70 905	246	8.70 962	246	1.29 038	9.99 943	4
57	8.71 151	244	8.71 208	245	1.28 792	9.99 942	3
58	8.71 395	243	8.71 453	244	1.28 547	9.99 942	2
59	8.71 638	242	8.71 697	243	1.28 303	9.99 941	1
60	8.71 880		8.71 940		1.28 060	9.99 940	0
	L SIN	D	L TAN	CD	L COT	L COS	357° ... 177°
	L COS		L COT		L TAN	L SIN	267° ... 87°

3°... 183°	L SIN	D	L TAN	CD	L COT	L COS	PROP. PTS.					
	L COS		L COT		L TAN	L SIN						
0	8.71 880	240	8.71 940	241	1.28 060	9.99 940	60	238	234	229		
1	8.72 120	239	8.72 181	239	1.27 819	9.99 940	59	1	23.8	23.4	22.9	
2	8.72 359	239	8.72 420	239	1.27 580	9.99 939	58	2	47.6	46.8	45.8	
3	8.72 597	237	8.72 659	237	1.27 341	9.99 938	57	3	71.4	70.2	68.7	
4	8.72 834	235	8.72 896	236	1.27 104	9.99 938	56	4	95.2	93.6	91.6	
5	8.73 069	234	8.73 132	234	1.26 868	9.99 937	55	5	119.0	117.0	114.5	
6	8.73 303	232	8.73 366	234	1.26 634	9.99 936	54	6	142.8	140.4	137.4	
7	8.73 535	232	8.73 600	232	1.26 400	9.99 936	53	7	166.6	163.8	160.3	
8	8.73 767	230	8.73 832	230	1.26 168	9.99 935	52	8	190.4	187.2	183.2	
9	8.73 997	229	8.74 063	229	1.25 937	9.99 934	51	9	214.2	210.6	206.1	
10	8.74 226	228	8.74 292	229	1.25 708	9.99 934	50		225	230	216	
11	8.74 454	226	8.74 521	227	1.25 479	9.99 933	49					
12	8.74 680	226	8.74 748	226	1.25 252	9.99 932	48	1	22.5	22.0	21.6	
13	8.74 906	224	8.74 974	225	1.25 026	9.99 932	47	2	45.0	44.0	43.2	
14	8.75 130	223	8.75 199	224	1.24 801	9.99 931	46	3	67.5	66.0	64.8	
15	8.75 353	222	8.75 423	222	1.24 577	9.99 930	45	4	90.0	88.0	86.4	
16	8.75 575	220	8.75 645	222	1.24 355	9.99 929	44	5	112.5	110.0	108.0	
17	8.75 795	220	8.75 867	220	1.24 133	9.99 929	43	6	135.0	132.0	129.6	
18	8.76 015	219	8.76 087	219	1.23 913	9.99 928	42	7	157.5	154.0	151.2	
19	8.76 234	217	8.76 306	219	1.23 694	9.99 927	41	8	180.0	176.0	172.8	
20	8.76 451	216	8.76 525	217	1.23 475	9.99 926	40	9	202.5	198.0	194.4	
21	8.76 667	216	8.76 742	216	1.23 258	9.99 926	39		212	208	204	
22	8.76 883	214	8.76 958	215	1.23 042	9.99 925	38	1	21.2	20.8	20.4	
23	8.77 097	213	8.77 173	214	1.22 827	9.99 924	37	2	42.4	41.6	40.8	
24	8.77 610	212	8.77 387	213	1.22 613	9.99 923	36	3	63.6	62.4	61.2	
25	8.77 522	211	8.77 600	211	1.22 400	9.99 923	35	4	84.8	83.2	81.6	
26	8.77 733	210	8.77 811	211	1.22 189	9.99 922	34	5	106.0	104.0	102.0	
27	8.77 943	209	8.78 022	210	1.21 978	9.99 921	33	6	127.2	124.8	122.4	
28	8.78 152	208	8.78 232	209	1.21 768	9.99 920	32	7	148.4	145.6	142.8	
29	8.78 360	208	8.78 441	208	1.21 559	9.99 920	31	8	169.6	166.4	163.2	
30	8.78 568	206	8.78 649	206	1.21 351	9.99 919	30	9	190.8	187.2	183.6	
31	8.78 774	205	8.78 855	206	1.21 145	9.99 918	29		201	197	193	
32	8.78 979	204	8.79 061	205	1.20 939	9.99 917	28	1	20.1	19.7	19.3	
33	8.79 138	203	8.79 266	204	1.20 734	9.99 917	27	2	40.2	39.4	38.6	
34	8.79 386	202	8.79 470	203	1.20 530	9.99 916	26	3	60.3	59.1	57.9	
35	8.79 588	201	8.79 673	202	1.20 327	9.99 915	25	4	80.4	78.8	77.2	
36	8.79 789	201	8.79 875	201	1.20 125	9.99 914	24	5	100.5	98.5	96.5	
37	8.79 990	199	8.80 076	201	1.19 924	9.99 913	23	6	120.6	118.2	115.8	
38	8.80 189	199	8.80 277	199	1.19 723	9.99 913	22	7	140.7	137.9	135.1	
39	8.80 388	197	8.80 476	198	1.19 524	9.99 912	21	8	160.8	157.6	154.4	
40	8.80 585	197	8.80 674	198	1.19 326	9.99 911	20	9	180.9	177.3	173.7	
41	8.80 782	196	8.80 872	196	1.19 128	9.99 910	19		189	185	181	
42	8.80 978	195	8.81 068	196	1.18 932	9.99 909	18	1	18.9	18.5	18.1	
43	8.81 173	194	8.81 264	195	1.18 736	9.99 909	17	2	37.8	37.0	36.2	
44	8.81 367	193	8.81 459	194	1.18 541	9.99 908	16	3	56.7	55.5	54.3	
45	8.81 560	192	8.81 653	193	1.18 347	9.99 907	15	4	75.6	74.0	72.4	
46	8.81 752	192	8.81 846	192	1.18 154	9.99 906	14	5	94.5	92.5	90.5	
47	8.81 944	190	8.82 038	192	1.17 962	9.99 905	13	6	113.4	111.0	108.6	
48	8.82 134	190	8.82 230	190	1.17 770	9.99 904	12	7	132.3	129.5	126.7	
49	8.82 324	189	8.82 420	190	1.17 580	9.99 904	11	8	151.2	148.0	144.8	
50	8.82 513	188	8.82 610	189	1.17 390	9.99 903	10	9	170.1	166.5	162.9	
51	8.82 701	187	8.82 799	188	1.17 201	9.99 902	9		4	3	2	1
52	8.82 888	187	8.82 987	188	1.17 013	9.99 901	8	1	0.4	0.3	0.2	0.1
53	8.83 075	186	8.83 175	186	1.16 825	9.99 900	7	2	0.8	0.6	0.4	0.2
54	8.83 261	185	8.83 361	186	1.16 639	9.99 899	6	3	1.2	0.9	0.6	0.3
55	8.83 446	184	8.83 547	185	1.16 453	9.99 898	5	4	1.6	1.2	0.8	0.4
56	8.83 630	183	8.83 732	184	1.16 268	9.99 898	4	5	2.0	1.5	1.0	0.5
57	8.83 813	183	8.83 916	184	1.16 084	9.99 897	3	6	2.4	1.8	1.2	0.6
58	8.83 996	181	8.84 100	182	1.15 900	9.99 896	2	7	2.8	2.1	1.4	0.7
59	8.84 177	181	8.84 282	182	1.15 718	9.99 895	1	8	3.2	2.4	1.6	0.8
60	8.84 358		8.84 464		1.15 536	9.99 894	0	9	3.6	2.7	1.8	0.9
	L SIN	D	L TAN	CD	L COT	L COS		356°... 176°...				
	L COS		L COT		L TAN	L SIN		266°... 86°...				

4°... 184°	L SIN	D	L TAN	CD	L COT	L COS	PROP. PTS.			
94°... 274°	L COS		L COT		L TAN	L SIN				
0	8.84 358	181	8.84 464	182	1.15 536	9.99 894	60	181	179	177
1	8.84 539	179	8.84 646	180	1.15 354	9.99 893	59			
2	8.84 718	179	8.84 826	180	1.15 174	9.99 892	58	1	18.1	17.9
3	8.84 897	178	8.85 006	179	1.14 994	9.99 891	57	2	36.2	35.8
4	8.85 075	177	8.85 185	178	1.14 815	9.99 891	56	3	54.3	53.7
								4	72.4	71.6
5	8.85 252	177	8.85 363	177	1.14 637	9.99 890	55	5	90.5	89.5
6	8.85 429	176	8.85 540	177	1.14 460	9.99 889	54	6	108.6	107.4
7	8.85 605	175	8.85 717	176	1.14 283	9.99 888	53	7	126.7	125.3
8	8.85 780	175	8.85 893	176	1.14 107	9.99 887	52	8	144.8	143.2
9	8.85 955	173	8.86 069	174	1.13 931	9.99 886	51	9	162.9	161.1
										159.3
10	8.86 128	173	8.86 243	174	1.13 757	9.99 885	50			
11	8.86 301	173	8.86 417	174	1.13 583	9.99 884	49			
12	8.86 474	171	8.86 591	172	1.13 409	9.99 883	48	1	17.5	17.3
13	8.86 645	171	8.86 763	172	1.13 237	9.99 882	47	2	35.0	34.6
14	8.86 816	171	8.86 935	171	1.13 065	9.99 881	46	3	52.5	51.9
								4	70.0	69.2
15	8.86 987	169	8.87 106	171	1.12 894	9.99 880	45	5	87.5	86.5
16	8.87 156	169	8.87 277	170	1.12 723	9.99 879	44	6	105.0	103.8
17	8.87 325	169	8.87 447	169	1.12 553	9.99 879	43	7	122.5	121.1
18	8.87 494	167	8.87 616	169	1.12 384	9.99 878	42	8	140.0	138.4
19	8.87 661	168	8.87 785	168	1.12 215	9.99 877	41	9	157.5	155.7
										153.9
20	8.87 829	166	8.87 953	167	1.12 047	9.99 876	40			
21	8.87 995	166	8.88 120	167	1.11 880	9.99 875	39			
22	8.88 161	165	8.88 287	166	1.11 713	9.99 874	38	1	16.8	16.6
23	8.88 326	164	8.88 453	165	1.11 547	9.99 873	37	2	33.6	32.2
24	8.88 490	164	8.88 618	165	1.11 382	9.99 872	36	3	50.4	49.8
								4	67.2	66.4
25	8.88 654	163	8.88 783	165	1.11 217	9.99 871	35	5	84.0	83.0
26	8.88 817	163	8.88 948	163	1.11 052	9.99 870	34	6	100.8	99.6
27	8.88 980	162	8.89 111	163	1.10 889	9.99 869	33	7	117.6	116.2
28	8.89 142	162	8.89 274	163	1.10 726	9.99 868	32	8	134.4	132.8
29	8.89 304	160	8.89 437	161	1.10 563	9.99 867	31	9	151.2	149.4
										147.6
30	8.89 464	161	8.89 598	162	1.10 402	9.99 866	30			
31	8.89 625	159	8.89 760	160	1.10 240	9.99 865	29			
32	8.89 784	159	8.89 920	160	1.10 080	9.99 864	28	1	16.2	15.9
33	8.89 943	159	8.90 080	160	1.09 920	9.99 863	27	2	32.4	31.8
34	8.90 102	158	8.90 240	159	1.09 760	9.99 862	26	3	48.6	47.7
								4	64.8	63.6
35	8.90 260	157	8.90 399	158	1.09 601	9.99 861	25	5	81.0	79.5
36	8.90 417	157	8.90 557	158	1.09 443	9.99 860	24	6	97.2	95.4
37	8.90 574	156	8.90 715	157	1.09 285	9.99 859	23	7	113.4	111.3
38	8.90 730	155	8.90 872	157	1.09 128	9.99 858	22	8	129.6	127.2
39	8.90 885	155	8.91 029	156	1.08 971	9.99 857	21	9	145.8	143.1
										141.3
40	8.91 040	155	8.91 185	155	1.08 815	9.99 856	20			
41	8.91 195	154	8.91 340	155	1.08 660	9.99 855	19			
42	8.91 349	153	8.91 495	155	1.08 505	9.99 854	18	1	15.5	15.3
43	8.91 502	153	8.91 650	153	1.08 350	9.99 853	17	2	31.0	30.6
44	8.91 655	152	8.91 803	154	1.08 197	9.99 852	16	3	46.5	45.9
								4	62.0	61.2
45	8.91 807	152	8.91 957	153	1.08 043	9.99 851	15	5	77.5	76.5
46	8.91 959	151	8.92 110	152	1.07 890	9.99 850	14	6	93.0	91.8
47	8.92 110	151	8.92 262	152	1.07 738	9.99 848	13	7	108.5	107.1
48	8.92 261	150	8.92 414	151	1.07 586	9.99 847	12	8	124.0	122.4
49	8.92 411	150	8.92 565	151	1.07 435	9.99 846	11	9	139.5	137.7
										135.9
50	8.92 561	149	8.92 716	150	1.07 284	9.99 845	10			
51	8.92 710	149	8.92 866	150	1.07 134	9.99 844	9			
52	8.92 859	148	8.92 016	149	1.06 984	9.99 843	8	1	14.9	14.7
53	8.93 077	147	8.93 165	148	1.06 835	9.99 842	7	2	29.8	29.4
54	8.93 154	147	8.93 313	149	1.06 687	9.99 841	6	3	44.7	44.1
								4	59.6	58.8
55	8.93 301	147	8.93 462	147	1.06 538	9.99 840	5	5	74.5	73.5
56	8.93 448	146	8.93 609	147	1.06 391	9.99 839	4	6	89.4	88.2
57	8.93 594	146	8.93 756	147	1.06 244	9.99 838	3	7	104.3	102.9
58	8.93 740	145	8.93 903	146	1.06 097	9.99 837	2	8	119.2	117.6
59	8.93 885	145	8.94 049	146	1.05 951	9.99 836	1	9	134.1	132.3
										0.9
60	8.94 030		8.94 195		1.05 805	9.99 834	0			
	L SIN	D	L TAN	CD	L COT	L COS		355°... 175°		
	L COS		L COT		L TAN	L SIN		265°... 85°		

5°... 185°	L SIN	D	L TAN	CD	L COT	L COS		PROP. PTS.			
								95°... 275°	L COS	L COT	L TAN
0	8.94 030	144	8.94 195	145	1.05 805	9.99 834	60				
1	8.94 174	143	8.94 340	145	1.05 660	9.99 833	59	145	143	141	
2	8.94 317	144	8.94 458	145	1.05 515	9.99 832	58	1	14.5	14.3	14.1
3	8.94 461	142	8.94 630	143	1.05 370	9.99 831	57	2	29.0	28.6	28.2
4	8.94 603	143	8.94 773	144	1.05 227	9.99 830	56	3	43.5	42.9	42.3
								4	58.0	57.2	56.4
5	8.94 746	141	8.94 917	143	1.05 083	9.99 829	55	5	72.5	71.5	70.5
6	8.94 887	142	8.95 060	142	1.04 940	9.99 828	54	6	87.0	85.8	84.6
7	8.95 029	141	8.95 202	142	1.04 798	9.99 827	53	7	101.5	100.1	98.7
8	8.95 170	140	8.95 344	142	1.04 656	9.99 825	52	8	116.0	114.4	112.8
9	9.95 310	140	8.95 486	141	1.04 514	9.99 824	51	9	130.5	128.7	126.9
10	8.95 450	139	8.95 627	140	1.04 373	9.99 823	50				
11	8.95 589	139	8.95 767	141	1.04 233	9.99 822	49				
12	8.95 728	139	8.95 908	139	1.04 092	9.99 821	48	1	13.9	13.8	13.6
13	8.95 867	138	8.96 047	140	1.03 953	9.99 820	47	2	27.8	27.6	27.2
14	8.95 005	138	8.96 187	138	1.03 813	9.99 819	46	3	41.7	41.4	40.8
								4	55.6	55.2	54.4
15	8.96 143	137	8.96 325	139	1.03 675	9.99 817	45	5	69.5	69.0	68.0
16	8.96 280	137	8.96 464	138	1.03 536	9.99 816	44	6	83.4	82.8	81.5
17	8.96 417	136	8.96 602	137	1.03 398	9.99 815	43	7	97.3	96.6	95.2
18	8.96 553	136	8.96 739	138	1.03 261	9.99 814	42	8	111.2	110.4	108.8
19	8.96 689	136	8.96 877	136	1.03 123	9.99 813	41	9	125.1	124.2	122.4
20	8.96 825	135	8.97 013	137	1.02 987	9.99 812	40				
21	8.96 960	135	8.97 150	135	1.02 850	9.99 810	39				
22	8.97 095	134	8.97 285	136	1.02 715	9.99 809	38	1	13.5	13.3	13.1
23	8.97 229	134	8.97 421	136	1.02 579	9.99 808	37	2	27.0	26.6	26.2
24	8.97 363	133	8.97 556	135	1.02 444	9.99 807	36	3	40.5	39.9	39.3
								4	54.0	53.2	52.4
25	8.97 496	133	8.97 691	134	1.02 309	9.99 806	35	5	67.5	66.5	65.5
26	8.97 629	133	8.97 825	134	1.02 175	9.99 804	34	6	81.0	79.8	78.6
27	8.97 762	132	8.97 959	133	1.02 041	9.99 803	33	7	94.5	93.1	91.7
28	8.97 894	132	8.98 002	133	1.01 908	9.99 802	32	8	108.0	106.4	104.8
29	8.98 026	131	8.98 225	133	1.01 775	9.99 801	31	9	121.5	119.7	117.9
30	8.98 157	131	8.98 358	132	1.01 642	9.99 800	30				
31	8.98 288	131	8.98 490	132	1.01 510	9.99 798	29				
32	8.98 419	130	8.98 622	131	1.01 378	9.99 797	28	1	12.9	12.8	12.6
33	8.98 549	130	8.98 753	131	1.01 247	9.99 796	27	2	25.8	25.6	25.2
34	8.98 679	129	8.98 884	131	1.01 116	9.99 795	26	3	38.7	38.4	37.8
								4	51.6	51.2	50.4
35	8.98 808	129	8.99 015	130	1.00 985	9.99 793	25	5	64.5	64.0	63.0
36	8.98 937	129	8.99 145	130	1.00 855	9.99 792	24	6	77.4	76.8	75.6
37	8.99 066	128	8.99 275	130	1.00 725	9.99 791	23	7	90.3	89.6	88.2
38	8.99 194	128	8.99 405	129	1.00 595	9.99 790	22	8	103.2	102.4	100.8
39	8.99 322	128	8.99 534	128	1.00 466	9.99 788	21	9	116.1	115.2	113.4
40	8.99 450	127	8.99 662	129	1.00 338	9.99 787	20				
41	8.99 577	127	8.99 791	128	1.00 209	9.99 786	19				
42	8.99 704	126	8.99 919	127	1.00 081	9.99 785	18	1	12.5	12.3	12.2
43	8.99 830	126	9.00 046	128	0.99 954	9.99 783	17	2	25.0	24.6	24.4
44	8.99 956	126	9.00 174	127	0.99 826	9.99 782	16	3	37.5	36.9	36.6
								4	50.0	49.2	48.8
45	9.00 082	125	9.00 301	126	0.99 699	9.99 781	15	5	62.5	61.5	61.0
46	9.00 207	125	9.00 427	126	0.99 573	9.99 780	14	6	75.0	73.8	73.2
47	9.00 332	124	9.00 553	126	0.99 447	9.99 778	13	7	87.5	86.1	85.4
48	9.00 456	125	9.00 679	126	0.99 321	9.99 777	12	8	100.0	98.4	97.6
49	9.00 581	123	9.00 805	125	0.99 195	9.99 776	11	9	112.5	110.7	109.8
50	9.00 704	124	9.00 930	125	0.99 070	9.99 775	10				
51	9.00 828	123	9.01 055	124	0.98 945	9.99 773	9				
52	9.00 951	123	9.01 179	124	0.98 821	9.99 772	8	1	12.1	12.0	0.1
53	9.01 074	122	9.01 303	124	0.98 697	9.99 771	7	2	24.2	24.0	0.2
54	9.01 196	122	9.01 427	123	0.98 573	9.99 769	6	3	36.3	36.0	0.3
								4	48.4	48.0	0.4
55	9.01 318	122	9.01 550	123	0.98 450	9.99 768	5	5	60.5	60.0	0.5
56	9.01 440	121	9.01 673	123	0.98 327	9.99 767	4	6	72.6	72.0	0.6
57	9.01 561	121	9.01 796	122	0.98 204	9.99 765	3	7	84.7	84.0	0.7
58	9.01 682	121	9.01 918	122	0.98 082	9.99 764	2	8	96.8	96.0	0.8
59	9.01 803	120	9.02 040	122	0.97 960	9.99 763	1	9	108.9	108.0	0.9
60	9.01 923		9.02 162		00.97 838	9.99 761	0				
	L SIN	D	L TAN	CD	L COT	L COS		354°... 174°			
	L COS		L COT		L TAN	L SIN		264°... 84°			

6°... 186°		L SIN	D	L TAN	CD	L COT	L COS	PROP. PTS.		
96°... 276°		L COS		L COT		L TAN	L SIN			
0	9.01 923	120	9.02 162	121	0.97 838	9.99 761	60	121	120	119
1	9.02 043	120	9.02 283	121	0.97 717	9.99 760	59			
2	9.02 163	120	9.02 404	121	0.97 596	9.99 759	58	1	12.1	12.0
3	9.02 283	119	9.02 525	120	0.97 475	9.99 757	57	2	24.2	24.0
4	9.02 402	118	9.02 645	121	0.97 355	9.99 756	56	3	36.3	36.0
								4	48.4	48.0
5	9.02 520	119	9.02 766	119	0.97 234	9.99 755	55	5	60.5	60.0
6	9.02 639	118	9.02 885	120	0.97 115	9.99 753	54	6	72.6	72.0
7	9.02 757	117	9.03 005	119	0.96 995	9.99 752	53	7	84.7	84.0
8	9.02 874	118	9.03 124	118	0.96 876	9.99 751	52	8	96.8	96.0
9	9.02 992	117	9.03 242	119	0.96 758	9.99 749	51	9	108.9	108.0
10	9.03 109	117	9.03 361	118	0.96 639	9.99 748	50			
11	9.03 226	116	9.03 479	118	0.96 521	9.99 747	49			
12	9.03 342	116	9.03 597	117	0.96 403	9.99 745	48	1	11.8	11.7
13	9.03 458	116	9.03 714	118	0.96 286	9.99 744	47	2	23.6	23.4
14	9.03 574	116	9.03 832	116	0.96 168	9.99 742	46	3	35.4	35.1
								4	47.2	46.8
15	9.03 690	115	9.03 948	117	0.96 052	9.99 741	45	5	59.0	58.5
16	9.03 805	115	9.04 065	116	0.95 935	9.99 740	44	6	70.8	70.2
17	9.03 920	114	9.04 181	116	0.95 819	9.99 738	43	7	82.6	81.9
18	9.04 034	115	9.04 297	116	0.95 703	9.99 737	42	8	94.4	93.6
19	9.04 149	113	9.04 413	115	0.95 587	9.99 736	41	9	106.2	105.3
20	9.04 262	114	9.04 528	115	0.95 472	9.99 734	40			
21	9.04 376	114	9.04 643	115	0.95 357	9.99 733	39			
22	9.04 490	113	9.04 758	115	0.95 242	9.99 731	38	1	11.5	11.4
23	9.04 603	112	9.04 873	114	0.95 127	9.99 730	37	2	23.0	22.8
24	9.04 715	113	9.04 987	114	0.95 013	9.99 728	36	3	34.5	34.2
								4	46.0	45.6
25	9.04 828	112	9.05 101	113	0.94 899	9.99 727	35	5	57.5	57.0
26	9.04 940	112	9.05 214	114	0.94 786	9.99 726	34	6	69.0	68.4
27	9.05 052	112	9.05 328	113	0.94 672	9.99 724	33	7	80.5	79.8
28	9.05 164	111	9.05 441	112	0.94 559	9.99 723	32	8	92.0	91.2
29	9.05 275	111	9.05 553	113	0.94 447	9.99 721	31	9	103.5	102.6
30	9.05 386	111	9.05 666	112	0.94 334	9.99 720	30			
31	9.05 497	110	9.05 778	112	0.94 222	9.99 718	29			
32	9.05 607	110	9.05 890	112	0.94 110	9.99 717	28	1	11.2	11.1
33	9.05 717	110	9.06 002	111	0.93 998	9.99 716	27	2	22.4	22.2
34	9.05 827	110	9.06 113	111	0.93 887	9.99 714	26	3	33.6	33.3
								4	44.8	44.4
35	9.05 937	109	9.06 224	111	0.93 776	9.99 713	25	5	56.0	55.5
36	9.06 046	109	9.06 335	110	0.93 665	9.99 711	24	6	67.2	66.6
37	9.06 155	109	9.06 445	111	0.93 555	9.99 710	23	7	78.4	77.7
38	9.06 264	108	9.06 556	110	0.93 444	9.99 708	22	8	89.6	88.8
39	9.06 372	109	9.06 666	109	0.93 334	9.99 707	21	9	100.8	99.9
40	9.06 481	108	9.06 775	110	0.93 225	9.99 705	20			
41	9.06 589	107	9.06 885	109	0.93 115	9.99 704	19			
42	9.06 696	108	9.06 994	109	0.93 006	9.99 702	18	1	10.9	10.8
43	9.06 804	107	9.07 103	108	0.92 897	9.99 701	17	2	21.8	21.6
44	9.06 911	107	9.07 211	109	0.92 789	9.99 699	16	3	32.7	32.4
								4	43.6	43.2
45	9.07 018	106	9.07 320	108	0.92 680	9.99 698	15	5	54.5	54.0
46	9.07 124	107	9.07 428	108	0.92 572	9.99 696	14	6	65.4	64.8
47	9.07 231	106	9.07 536	107	0.92 464	9.99 695	13	7	76.3	75.6
48	9.07 337	105	9.07 643	108	0.92 357	9.99 693	12	8	87.2	86.4
49	9.07 442	106	9.07 751	107	0.92 249	9.99 692	11	9	98.1	97.2
50	9.07 548	105	9.07 858	106	0.92 142	9.99 690	10			
51	9.07 653	105	9.07 964	107	0.92 036	9.99 689	9			
52	9.07 758	105	9.08 071	106	0.91 929	9.99 687	8	1	10.6	10.5
53	9.07 863	105	9.08 177	106	0.91 823	9.99 686	7	2	21.2	21.0
54	9.07 968	104	9.08 283	106	0.91 717	9.99 684	6	3	31.8	31.5
								4	42.4	42.0
55	9.08 072	104	9.08 389	106	0.91 611	9.99 683	5	5	53.0	52.5
56	9.08 176	104	9.08 495	105	0.91 505	9.99 681	4	6	63.6	63.0
57	9.08 280	103	9.08 600	105	0.91 400	9.99 680	3	7	74.2	73.5
58	9.08 383	103	9.08 706	105	0.91 295	9.99 678	2	8	84.8	84.0
59	9.08 486	103	9.08 810	104	0.91 190	9.99 677	1	9	95.4	94.5
60	9.08 589		9.08 914		0.91 086	9.99 675	0			
	L SIN	D	L TAN	CD	L COT	L COS		353°... 173°		
	L COS		L COT		L TAN	L SIN		263°... 83°		

7°... 187°		L SIN	D	L TAN	CD	L COT	L COS	PROP. PTS.				
97°... 277°		L COS		L COT		L TAN	L SIN					
0	9.08 589		103	9.08 914		0.91 086	9.99 675	60				
1	9.08 692		103	9.09 019	105	0.90 981	9.99 674	59	105	104	103	
2	9.08 795		102	9.09 123	104	0.90 877	9.99 672	58	1	10.5	10.4	10.3
3	9.08 897		102	9.09 227	103	0.90 773	9.99 670	57	2	21.0	20.8	20.6
4	9.08 999		102	9.09 330	104	0.90 670	9.99 669	56	3	31.5	31.2	30.9
5	9.09 101		101	9.09 434	103	0.90 566	9.99 667	55	4	42.0	41.6	41.2
6	9.09 202		102	9.09 537	103	0.90 463	9.99 666	54	5	52.5	52.0	51.5
7	9.09 304		101	9.09 640	102	0.90 360	9.99 664	53	6	63.0	62.4	61.8
8	9.09 405		101	9.09 742	103	0.90 258	9.99 663	52	7	73.5	72.8	72.1
9	9.09 506		100	9.09 845	102	0.90 155	9.99 661	51	8	84.0	83.2	82.4
									9	94.5	93.6	92.7
10	9.09 606		101	9.09 947	102	0.90 053	9.99 659	50				
11	9.09 707		100	9.10 049	101	0.89 951	9.99 658	49	102	101	100	
12	9.09 807		100	9.10 150	102	0.89 850	9.99 656	48	1	10.2	10.1	10.0
13	9.09 907		99	9.10 252	101	0.89 748	9.99 655	47	2	20.4	20.2	20.0
14	9.10 006		100	9.10 353	101	0.89 647	9.99 653	46	3	30.6	30.3	30.0
15	9.10 106		99	9.10 454	101	0.89 546	9.99 651	45	4	40.8	40.4	40.0
16	9.10 205		99	9.10 555	101	0.89 445	9.99 650	44	5	51.0	50.5	50.0
17	9.10 304		98	9.10 666	100	0.89 344	9.99 648	43	6	61.2	60.6	60.0
18	9.10 402		99	9.10 766	100	0.89 244	9.99 647	42	7	71.4	70.7	70.0
19	9.10 501		98	9.10 866	100	0.89 144	9.99 645	41	8	81.6	80.8	80.0
									9	91.8	90.9	90.0
20	9.10 599		98	9.10 956	100	0.89 044	9.99 643	40				
21	9.10 697		98	9.11 056	99	0.88 944	9.99 642	39			99	98
22	9.10 795		98	9.11 155	99	0.88 845	9.99 640	38	1	9.9	9.8	
23	9.10 893		97	9.11 254	99	0.88 746	9.99 638	37	2	19.8	19.6	
24	9.10 990		97	9.11 353	99	0.88 647	9.99 637	36	3	29.7	29.4	
25	9.11 087		97	9.11 452	99	0.88 548	9.99 635	35	4	39.6	39.2	
26	9.11 184		97	9.11 551	98	0.88 449	9.99 633	34	5	49.5	49.0	
27	9.11 281		96	9.11 649	98	0.88 351	9.99 632	33	6	59.4	58.8	
28	9.11 377		97	9.11 747	98	0.88 253	9.99 630	32	7	69.3	68.6	
29	9.11 474		96	9.11 845	98	0.88 155	9.99 629	31	8	79.2	78.4	
									9	89.1	88.2	
30	9.11 570		96	9.11 943	97	0.88 057	9.99 627	30				
31	9.11 666		95	9.12 040	98	0.87 960	9.99 625	29	97	96	95	
32	9.11 761		96	9.12 138	97	0.87 862	9.99 624	28	1	9.7	9.6	9.5
33	9.11 857		95	9.12 235	97	0.87 765	9.99 622	27	2	19.4	19.2	19.0
34	9.11 952		95	9.12 332	96	0.87 668	9.99 620	26	3	29.1	28.2	28.5
35	9.12 047		95	9.12 428	97	0.87 572	9.99 618	25	4	38.8	38.4	38.0
36	9.12 142		94	9.12 525	96	0.87 475	9.99 617	24	5	48.5	48.0	47.5
37	9.12 236		95	9.12 621	96	0.87 379	9.99 615	23	6	58.2	57.6	57.0
38	9.12 331		94	9.12 717	96	0.87 283	9.99 613	22	7	67.9	67.2	66.5
39	9.12 425		94	9.12 813	96	0.87 187	9.99 612	21	8	77.6	76.8	76.0
									9	87.3	86.4	85.5
40	9.12 519		93	9.12 909	95	0.87 091	9.99 610	20				
41	9.12 612		94	9.13 004	95	0.86 996	9.99 608	19	94	93	92	
42	9.12 706		93	9.13 099	95	0.86 901	9.99 607	18	1	9.4	9.3	9.2
43	9.12 799		93	9.13 194	95	0.86 806	9.99 605	17	2	18.8	18.6	18.4
44	9.12 892		93	9.13 289	95	0.86 711	9.99 603	16	3	28.2	27.9	27.6
45	9.12 985		93	9.13 384	94	0.86 616	9.99 601	15	4	37.6	37.2	36.8
46	9.13 078		93	9.13 478	95	0.86 522	9.99 600	14	5	47.0	46.5	46.0
47	9.13 171		92	9.13 573	94	0.86 427	9.99 598	13	6	56.4	55.8	55.2
48	9.13 263		92	9.13 667	94	0.86 333	9.99 596	12	7	65.8	65.1	64.4
49	9.13 355		92	9.13 761	93	0.86 239	9.99 595	11	8	75.2	74.4	73.6
									9	84.6	83.7	82.8
50	9.13 447		92	9.13 854	94	0.86 146	9.99 593	10				
51	9.13 539		91	9.13 948	93	0.86 052	9.99 591	9	91	90	2	
52	9.13 630		92	9.14 041	93	0.85 959	9.99 589	8	1	9.1	9.0	0.2
53	9.13 722		91	9.14 134	93	0.85 866	9.99 588	7	2	18.2	18.0	0.4
54	9.13 813		91	9.14 227	93	0.85 773	9.99 586	6	3	27.3	27.0	0.6
55	9.13 904		90	9.14 320	92	0.85 680	9.99 584	5	4	36.4	36.0	0.8
56	9.13 994		91	9.14 412	92	0.85 588	9.99 582	4	5	45.5	45.0	1.0
57	9.14 085		90	9.14 504	93	0.85 496	9.99 581	3	6	54.6	54.0	1.2
58	9.14 175		91	9.14 597	91	0.85 403	9.99 579	2	7	63.7	63.0	1.4
59	9.14 266		90	9.14 688	92	0.85 312	9.99 577	1	8	72.8	72.0	1.6
									9	81.9	81.0	1.8
60	9.14 356			9.14 780		0.85 220	9.99 575	0				
	L SIN		D	L TAN	CD	L COT	L COS				352°... 172°	
	L COS			L COT		L TAN	L SIN				262°... 82°	

8°... 188°	L SIN	D	L TAN	CD	L COT	L COS		PROP. PTS.			
98°... 278°	L COS		L COT		L TAN	L SIN					
0	9.14 356	89	9.14 780	92	0.85 220	9.99 575	60	92	91	90	
1	9.14 445	89	9.14 872	91	0.85 128	9.99 574	59				
2	9.14 535	89	9.14 963	91	0.85 037	9.99 572	58	1	9.2	9.1	9.0
3	9.14 624	89	9.15 054	91	0.84 946	9.99 570	57	2	18.4	18.2	18.0
4	9.14 714	89	9.15 145	91	0.84 855	9.99 568	56	3	27.6	27.3	27.0
								4	36.8	36.4	36.0
5	9.14 803	88	9.15 236	91	0.84 764	9.99 566	55	5	46.0	45.5	45.0
6	9.14 891	88	9.15 327	90	0.84 673	9.99 565	54	6	55.2	54.6	54.0
7	9.14 980	89	9.15 417	91	0.84 583	9.99 563	53	7	64.4	63.7	63.0
8	9.15 069	88	9.15 508	90	0.84 492	9.99 561	52	8	73.6	72.8	72.0
9	9.15 157	88	9.15 598	90	0.84 402	9.99 559	51	9	82.8	81.9	81.0
10	9.15 245	88	9.15 688	89	0.84 312	9.99 557	50		89	88	
11	9.15 333	88	9.15 777	90	0.84 223	9.99 556	49				
12	9.15 421	87	9.15 867	89	0.84 133	9.99 554	48	1	8.9	8.8	
13	9.15 508	88	9.15 956	89	0.84 044	9.99 552	47	2	17.8	17.6	
14	9.15 596	87	9.16 046	89	0.83 954	9.99 550	46	3	26.7	26.4	
								4	35.6	35.2	
15	9.15 683	87	9.16 135	89	0.83 865	9.99 548	45	5	44.5	44.0	
16	9.15 770	87	9.16 224	88	0.83 776	9.99 546	44	6	53.4	52.8	
17	9.15 857	87	9.16 312	89	0.83 688	9.99 545	43	7	62.3	61.6	
18	9.15 944	86	9.16 401	88	0.83 599	9.99 543	42	8	71.2	70.4	
19	9.16 030	86	9.16 489	88	0.83 511	9.99 541	41	9	80.1	79.2	
20	9.16 116	87	9.16 577	88	0.83 423	9.99 539	40		87	86	
21	9.16 203	86	9.16 665	88	0.83 335	9.99 537	39				
22	9.16 289	85	9.16 753	88	0.83 247	9.99 535	38	1	8.7	8.6	
23	9.16 374	86	9.16 841	87	0.83 159	9.99 533	37	2	17.4	17.2	
24	9.16 460	85	9.16 928	87	0.83 072	9.99 532	36	3	26.1	25.8	
								4	34.8	34.4	
25	9.16 545	86	9.17 016	87	0.82 984	9.99 530	35	5	43.5	43.0	
26	9.16 631	85	9.17 103	87	0.82 897	9.99 528	34	6	52.2	51.6	
27	9.16 716	85	9.17 190	87	0.82 810	9.99 526	33	7	60.9	60.2	
28	9.16 801	85	9.17 277	86	0.82 723	9.99 524	32	8	69.6	68.8	
29	9.16 886	84	9.17 363	87	0.82 637	9.99 522	31	9	78.3	77.4	
30	9.16 970	85	9.17 450	86	0.82 550	9.99 520	30		85	84	
31	9.17 055	84	9.17 536	86	0.82 464	9.99 518	29				
32	9.17 139	84	9.17 622	86	0.82 378	9.99 517	28	1	8.5	8.4	
33	9.17 223	84	9.17 708	86	0.82 292	9.99 515	27	2	17.0	16.8	
34	9.17 307	84	9.17 794	86	0.82 206	9.99 513	26	3	25.5	25.2	
								4	34.0	33.6	
35	9.17 391	83	9.17 880	85	0.82 120	9.99 511	25	5	42.5	42.0	
36	9.17 474	84	9.17 965	86	0.82 035	9.99 509	24	6	51.0	50.4	
37	9.17 558	83	9.18 051	85	0.81 949	9.99 507	23	7	59.5	58.8	
38	9.17 641	83	9.18 136	85	0.81 864	9.99 505	22	8	68.0	67.2	
39	9.17 724	83	9.18 221	85	0.81 779	9.99 503	21	9	76.5	75.6	
40	9.17 807	83	9.18 306	85	0.81 694	9.99 501	20		83	82	
41	9.17 890	83	9.18 391	84	0.81 609	9.99 499	19				
42	9.17 973	82	9.18 475	85	0.81 525	9.99 497	18	1	8.3	8.2	
43	9.18 055	82	9.18 560	84	0.81 440	9.99 495	17	2	16.6	16.4	
44	9.18 137	83	9.18 644	84	0.81 356	9.99 494	16	3	24.9	24.6	
								4	33.2	32.8	
45	9.18 220	82	9.18 728	84	0.81 272	9.99 492	15	5	41.5	41.0	
46	9.18 302	81	9.18 812	84	0.81 188	9.99 490	14	6	49.8	49.2	
47	9.18 383	82	9.18 899	83	0.81 104	9.99 488	13	7	58.1	57.4	
48	9.18 465	82	9.18 979	84	0.81 021	9.99 486	12	8	66.4	65.6	
49	9.18 547	81	9.19 063	83	0.80 937	9.99 484	11	9	74.7	73.8	
50	9.18 628	81	9.19 146	83	0.80 854	9.99 482	10		81	80	2
51	9.18 709	81	9.19 229	83	0.80 771	9.99 480	9				
52	9.18 790	81	9.19 312	83	0.80 688	9.99 478	8	1	8.1	8.0	0.2
53	9.18 871	81	9.19 395	83	0.80 605	9.99 476	7	2	16.2	16.0	0.4
54	9.18 952	81	9.19 478	83	0.80 522	9.99 474	6	3	24.3	24.0	0.6
								4	32.4	32.0	0.8
55	9.19 033	80	9.19 561	82	0.80 439	9.99 472	5	5	40.5	40.0	1.0
56	9.19 113	80	9.19 643	82	0.80 357	9.99 470	4	6	48.6	48.0	1.2
57	9.19 193	80	9.19 725	82	0.80 275	9.99 468	3	7	56.7	56.0	1.4
58	9.19 273	80	9.19 807	82	0.80 193	9.99 466	2	8	64.8	64.0	1.6
59	9.19 353	80	9.19 889	82	0.80 111	9.99 464	1	9	72.9	72.0	1.8
60	9.19 433		9.19 971		0.80 029	9.99 462	0				
	L SIN	D	L TAN	CD	L COT	L COS		351°... 171°			
	L COS		L COT		L TAN	L SIN		261°... 81°			

9°... 189°	L SIN	D	L TAN	CD	L COT	L COS	PROP. PTS.
	L COS		L COT		L TAN	L SIN	
0	9.19 433	80	9.19 971	82	0.80 029	9.99 462	60
1	9.19 513	79	9.20 053	81	0.79 947	9.99 460	59
2	9.19 592	80	9.20 134	82	0.79 866	9.99 458	58
3	9.19 672	79	9.20 216	81	0.79 784	9.99 456	57
4	9.19 751	79	9.20 297	81	0.79 703	9.99 454	56
5	9.19 830	79	9.20 378	81	0.79 622	9.99 452	55
6	9.19 909	79	9.20 459	81	0.79 541	9.99 450	54
7	9.19 988	79	9.20 540	81	0.79 460	9.99 448	53
8	9.20 067	78	9.20 621	80	0.79 379	9.99 446	52
9	9.20 145	78	9.20 701	81	0.79 299	9.99 444	51
10	9.20 223	79	9.20 782	80	0.79 218	9.99 442	50
11	9.20 302	78	9.20 862	80	0.79 138	9.99 440	49
12	9.20 380	78	9.20 942	80	0.79 058	9.99 438	48
13	9.20 458	77	9.21 022	80	0.78 978	9.99 436	47
14	9.20 535	78	9.21 102	80	0.78 898	9.99 434	46
15	9.20 613	78	9.21 182	79	0.78 818	9.99 432	45
16	9.20 691	77	9.21 261	80	0.78 739	9.99 429	44
17	9.20 768	77	9.21 341	79	0.78 659	9.99 427	43
18	9.20 845	77	9.21 420	79	0.78 580	9.99 425	42
19	9.20 922	77	9.21 499	79	0.78 501	9.99 423	41
20	9.20 999	77	9.21 578	79	0.78 422	9.99 421	40
21	9.21 076	77	9.21 657	79	0.78 343	9.99 419	39
22	9.21 153	76	9.21 736	78	0.78 264	9.99 417	38
23	9.21 229	77	9.21 814	79	0.78 186	9.99 415	37
24	9.21 306	76	9.21 893	78	0.78 107	9.99 413	36
25	9.21 382	76	9.21 971	78	0.78 029	9.99 411	35
26	9.21 458	76	9.22 049	78	0.77 951	9.99 409	34
27	9.21 534	76	9.22 127	78	0.77 873	9.99 407	33
28	9.21 610	75	9.22 205	78	0.77 795	9.99 404	32
29	9.21 685	76	9.22 283	78	0.77 717	9.99 402	31
30	9.21 761	75	9.22 361	77	0.77 639	9.99 400	30
31	9.21 836	76	9.22 438	78	0.77 562	9.99 398	29
32	9.21 912	75	9.22 516	77	0.77 484	9.99 396	28
33	9.21 987	75	9.22 593	77	0.77 407	9.99 394	27
34	9.22 062	75	9.22 670	77	0.77 330	9.99 392	26
35	9.22 137	74	9.22 747	77	0.77 253	9.99 390	25
36	9.22 211	75	9.22 824	77	0.77 176	9.99 388	24
37	9.22 286	75	9.22 901	76	0.77 099	9.99 385	23
38	9.22 361	74	9.22 977	77	0.77 023	9.99 383	22
39	9.22 435	74	9.23 054	76	0.76 945	9.99 381	21
40	9.22 509	74	9.23 130	76	0.76 870	9.99 379	20
41	9.22 583	74	9.23 206	77	0.76 794	9.99 377	19
42	9.22 657	74	9.23 283	76	0.76 717	9.99 375	18
43	9.22 731	74	9.23 359	76	0.76 641	9.99 372	17
44	9.22 805	73	9.23 435	75	0.76 565	9.99 370	16
45	9.22 878	74	9.23 510	76	0.76 490	9.99 368	15
46	9.22 952	73	9.23 586	75	0.76 414	9.99 366	14
47	9.23 025	73	9.23 661	76	0.76 339	9.99 364	13
48	9.23 098	73	9.23 737	75	0.76 263	9.99 362	12
49	9.23 171	73	9.23 812	75	0.76 188	9.99 359	11
50	9.23 244	73	9.23 887	75	0.76 113	9.99 357	10
51	9.23 317	73	9.23 962	75	0.76 038	9.99 355	9
52	9.23 390	72	9.24 037	75	0.75 963	9.99 353	8
53	9.23 462	73	9.24 112	74	0.75 888	9.99 351	7
54	9.23 535	72	9.24 186	75	0.75 814	9.99 348	6
55	9.23 607	72	9.24 261	74	0.75 739	9.99 346	5
56	9.23 679	73	9.24 335	75	0.75 665	9.99 344	4
57	9.23 752	71	9.24 410	74	0.75 590	9.99 342	3
58	9.23 823	72	9.24 484	74	0.75 516	9.99 340	2
59	9.23 895	72	9.24 558	74	0.75 442	9.99 337	1
60	9.23 967		9.24 632		0.75 368	9.99 335	0

9°... 189°	L SIN	D	L TAN	CD	L COT	L COS	PROP. PTS.
99°... 279°	L COS		L COT		L TAN	L SIN	
							350°... 170°...
							260°... 80°...

10° ... 190°	L SIN	D	L TAN	CD	L COT	L COS		PROP. PTS.		
100° ... 280°	L COS		L COT		L TAN	L SIN				
0	9.23 967	72	9.24 632	74	0.75 368	9.99 335	60		74	73
1	9.24 039	71	9.24 706	73	0.75 294	9.99 333	59	1	7.4	7.3
2	9.24 110	71	9.24 779	74	0.75 221	9.99 331	58	2	14.8	14.6
3	9.24 181	72	9.24 853	73	0.75 147	9.99 328	57	3	22.2	21.9
4	9.24 253	71	9.24 926	74	0.75 074	9.99 326	56	4	29.6	29.2
5	9.24 324	71	9.25 000	73	0.75 000	9.99 324	55	5	37.0	36.5
6	9.24 395	71	9.25 073	73	0.74 927	9.99 322	54	6	44.4	43.8
7	9.24 466	70	9.25 146	73	0.74 854	9.99 319	53	7	51.8	51.1
8	9.24 536	71	9.25 219	73	0.74 781	9.99 317	52	8	59.2	58.4
9	9.24 607	70	9.25 292	73	0.74 708	9.99 315	51	9	66.6	65.7
10	9.24 677	71	9.25 365	72	0.74 635	9.99 313	50		72	71
11	9.24 748	70	9.25 437	73	0.74 563	9.99 310	49	1	7.2	7.1
12	9.24 818	70	9.25 510	72	0.74 490	9.99 308	48	2	14.4	14.2
13	9.24 888	70	9.25 582	73	0.74 418	9.99 306	47	3	21.6	21.3
14	9.24 958	70	9.25 655	72	0.74 345	9.99 304	46	4	28.8	28.4
15	9.25 028	70	9.25 727	72	0.74 273	9.99 301	45	5	36.0	35.5
16	9.25 098	70	9.25 799	72	0.74 201	9.99 299	44	6	43.2	42.6
17	9.25 168	69	9.25 871	72	0.74 129	9.99 297	43	7	50.4	49.7
18	9.25 237	70	9.25 943	72	0.74 057	9.99 294	42	8	57.6	56.8
19	9.25 307	69	9.26 015	71	0.73 985	9.99 292	41	9	64.8	63.9
20	9.25 376	69	9.26 086	72	0.73 914	9.99 290	40		70	69
21	9.25 445	69	9.26 158	71	0.73 842	9.99 288	39	1	7.0	6.9
22	9.25 514	69	9.26 229	72	0.73 771	9.99 285	38	2	14.0	13.8
23	9.25 583	69	9.26 301	71	0.73 699	9.99 283	37	3	21.0	20.7
24	9.25 652	69	9.26 372	71	0.73 628	9.99 281	36	4	28.0	27.6
25	9.25 721	69	9.26 443	71	0.73 557	9.99 278	35	5	35.0	34.5
26	9.25 790	68	9.26 514	71	0.73 486	9.99 276	34	6	42.0	41.4
27	9.25 858	69	9.26 585	70	0.73 415	9.99 274	33	7	49.0	48.3
28	9.25 927	68	9.26 655	71	0.73 345	9.99 271	32	8	56.0	55.2
29	9.25 995	68	9.26 726	71	0.73 274	9.99 269	31	9	63.0	62.1
30	9.26 063	68	9.26 797	70	0.73 203	9.99 267	30		68	67
31	9.26 131	68	9.26 867	70	0.73 133	9.99 264	29	1	6.8	6.7
32	9.26 199	68	9.26 937	71	0.73 063	9.99 262	28	2	13.6	13.4
33	9.26 267	68	9.27 008	70	0.72 992	9.99 260	27	3	20.4	20.1
34	9.26 335	68	9.27 078	70	0.72 922	9.99 257	26	4	27.2	26.8
35	9.26 403	67	9.27 148	70	0.72 852	9.99 255	25	5	34.0	33.5
36	9.26 470	68	9.27 218	70	0.72 782	9.99 252	24	6	40.8	40.2
37	9.26 538	67	9.27 288	70	0.72 712	9.99 250	23	7	47.6	46.9
38	9.26 605	67	9.27 357	70	0.72 643	9.99 248	22	8	54.4	53.6
39	9.26 672	67	9.27 427	69	0.72 573	9.99 245	21	9	61.2	60.3
40	9.26 739	67	9.27 496	70	0.72 504	9.99 243	20		66	65
41	9.26 806	67	9.27 566	69	0.72 434	9.99 241	19	1	6.6	6.5
42	9.26 873	67	9.27 635	69	0.72 365	9.99 238	18	2	13.2	13.0
43	9.26 940	67	9.27 704	69	0.72 296	9.99 236	17	3	19.8	19.5
44	9.27 007	66	9.27 773	69	0.72 227	9.99 233	16	4	26.4	26.0
45	9.27 073	67	9.27 842	69	0.72 158	9.99 231	15	5	33.0	32.5
46	9.27 140	66	9.27 911	69	0.72 089	9.99 229	14	6	39.6	39.0
47	9.27 206	67	9.27 980	69	0.72 020	9.99 226	13	7	46.2	45.5
48	9.27 273	67	9.28 049	68	0.71 951	9.99 224	12	8	52.8	52.0
49	9.27 339	66	9.28 117	69	0.71 883	9.99 221	11	9	59.4	58.5
50	9.27 405	66	9.28 186	68	0.71 814	9.99 219	10		3	2
51	9.27 471	66	9.28 254	69	0.71 746	9.99 217	9	1	0.3	0.2
52	9.27 537	65	9.28 323	68	0.71 677	9.99 214	8	2	0.6	0.4
53	9.27 602	66	9.28 391	68	0.71 609	9.99 212	7	3	0.9	0.6
54	9.27 668	66	9.28 459	68	0.71 541	9.99 209	6	4	1.2	0.8
55	9.27 734	65	9.28 527	68	0.71 473	9.99 207	5	5	1.5	1.0
56	9.27 799	65	9.28 595	67	0.71 405	9.99 204	4	6	1.8	1.2
57	9.27 864	66	9.28 662	68	0.71 338	9.99 202	3	7	2.1	1.4
58	9.27 930	65	9.28 730	68	0.71 270	9.99 200	2	8	2.4	1.6
59	9.27 995	65	9.28 798	67	0.71 202	9.99 197	1	9	2.7	1.8
60	9.28 060		9.28 865		0.71 135	9.99 195	0			
	L SIN	D	L TAN	CD	L COT	L COS		349° ... 169°		
	L COS		L COT		L TAN	L SIN		259° ... 79°		

11°... 191°	L SIN	D	L TAN	CD	L COT	L COS		PROP. PTS.
101°... 261°	L COS		L COT		L TAN	L SIN		
0	9.28 060	65	9.28 865	68	0.71 135	9.99 195	60	
1	9.28 125	65	9.28 933	67	0.71 067	9.99 192	59	68 67
2	9.28 190	64	9.29 000	67	0.71 000	9.99 190	58	1 6.8 6.7
3	9.28 294	65	9.29 867	67	0.70 933	9.99 187	57	2 13.6 13.4
4	9.28 319	65	9.29 134	67	0.70 866	9.99 185	56	3 20.4 20.1
5	9.28 384	64	9.29 201	67	0.70 799	9.99 182	55	4 27.2 26.8
6	9.28 448	64	9.29 268	67	0.70 732	9.99 180	54	5 34.0 33.5
7	9.28 512	65	9.29 335	67	0.70 665	9.99 177	53	6 40.8 40.2
8	9.28 577	64	9.29 402	66	0.70 598	9.99 175	52	7 47.6 46.9
9	9.28 641	64	9.29 468	67	0.70 532	9.99 172	51	8 54.4 53.6
10	9.28 705	64	9.29 535	66	0.70 465	9.99 170	50	9 61.2 60.3
11	9.28 769	64	9.29 601	67	0.70 399	9.99 167	49	66 65
12	9.28 833	63	9.29 668	66	0.70 332	9.99 165	48	1 6.6 6.5
13	9.28 896	64	9.29 734	66	0.70 266	9.99 162	47	2 13.2 13.0
14	9.28 960	64	9.29 800	66	0.70 200	9.99 160	46	3 19.8 19.5
15	9.29 024	63	9.29 866	66	0.70 134	9.99 157	45	4 26.4 26.0
16	9.29 087	63	9.29 932	66	0.70 068	9.99 155	44	5 33.0 32.5
17	9.29 150	64	9.29 998	66	0.70 002	9.99 152	43	6 39.6 39.0
18	9.29 214	63	9.30 064	66	0.69 936	9.99 150	42	7 46.2 45.5
19	9.29 277	63	9.30 130	65	0.69 870	9.99 147	41	8 52.8 52.0
20	9.29 340	63	9.30 195	66	0.69 805	9.99 145	40	9 59.4 58.5
21	9.29 403	63	9.30 261	65	0.69 739	9.99 142	39	64 63
22	9.29 466	63	9.30 326	65	0.69 674	9.99 140	38	1 6.4 6.3
23	9.29 529	62	9.30 391	66	0.69 609	9.99 137	37	2 12.8 12.6
24	9.29 591	63	9.30 457	65	0.69 543	9.99 135	36	3 19.2 18.9
25	9.29 654	62	9.30 522	65	0.69 478	9.99 132	35	4 25.6 25.2
26	9.29 716	63	9.30 587	65	0.69 413	9.99 130	34	5 32.0 31.5
27	9.29 779	62	9.30 652	65	0.69 348	9.99 127	33	6 38.4 37.8
28	9.29 841	62	9.30 717	65	0.69 283	9.99 124	32	7 44.8 44.1
29	9.29 903	63	9.30 782	64	0.69 218	9.99 122	31	8 51.2 50.4
30	9.29 966	62	9.30 846	65	0.69 154	9.99 119	30	9 57.5 56.7
31	9.30 028	62	9.30 911	64	0.69 089	9.99 117	29	62 61
32	9.30 090	61	9.30 975	65	0.69 025	9.99 114	28	1 6.2 6.1
33	9.30 151	62	9.31 040	64	0.68 960	9.99 112	27	2 12.4 12.2
34	9.30 213	62	9.31 104	64	0.68 896	9.99 109	26	3 18.6 18.3
35	9.30 275	61	9.31 168	65	0.68 832	9.99 106	25	4 24.8 24.4
36	9.30 336	62	9.31 233	64	0.68 767	9.99 104	24	5 31.0 30.5
37	9.30 398	61	9.31 297	64	0.68 703	9.99 101	23	6 37.2 36.6
38	9.30 459	62	9.31 361	64	0.68 639	9.99 099	22	7 43.4 42.7
39	9.30 521	61	9.31 425	64	0.68 575	9.99 099	21	8 49.6 48.8
40	9.30 582	61	9.31 489	63	0.68 511	9.99 093	20	9 55.8 54.9
41	9.30 643	61	9.31 552	64	0.68 448	9.99 091	19	60 59
42	9.30 704	61	9.31 616	63	0.68 384	9.99 088	18	1 6.0 5.9
43	9.30 765	61	9.31 679	64	0.68 321	9.99 086	17	2 12.0 11.8
44	9.30 826	61	9.31 743	63	0.68 257	9.99 083	16	3 18.0 17.7
45	9.30 887	60	9.31 806	64	0.68 194	9.99 080	15	4 24.0 23.6
46	9.30 947	61	9.31 870	63	0.68 130	9.99 078	14	5 30.0 29.5
47	9.31 008	60	9.31 933	63	0.68 067	9.99 075	13	6 36.0 35.4
48	9.31 068	61	9.31 996	63	0.68 004	9.99 072	12	7 42.0 41.3
49	9.31 129	60	9.32 059	63	0.67 941	9.99 070	11	8 48.0 47.2
50	9.31 189	61	9.32 122	63	0.67 878	9.99 067	10	9 54.0 53.1
51	9.31 250	60	9.32 185	63	0.67 815	9.99 064	9	3 2
52	9.31 310	60	9.32 248	63	0.67 752	9.99 062	8	1 0.3 0.2
53	9.31 370	60	9.32 311	62	0.67 689	9.99 059	7	2 0.6 0.4
54	9.31 430	60	9.32 373	63	0.67 627	9.99 056	6	3 0.9 0.6
55	9.31 490	59	9.32 436	62	0.67 564	9.99 054	5	4 1.2 0.8
56	9.31 549	60	9.32 498	63	0.67 502	9.99 051	4	5 1.5 1.0
57	9.31 609	60	9.32 561	62	0.67 439	9.99 048	3	6 1.8 1.2
58	9.31 669	59	9.32 623	62	0.67 377	9.99 046	2	7 2.1 1.4
59	9.31 728	60	9.32 685	62	0.67 315	9.99 043	1	8 2.4 1.6
60	9.31 788		9.32 747		0.67 253	9.99 040	0	9 2.7 1.8
	L SIN	D	L TAN	CD	L COT	L COS		348°... 168°...
	L COS		L COT		L TAN	L SIN		258°... 78°...

FM 30-476

12° ... 192°		L SIN	D	L TAN	CD	L COT	L COS		PROP. PTS.	
102° ... 282°		L COS		L COT		L TAN	L SIN			
0	9.31 788	59	9.32 747	63	0.67 253	9.99 040	60		63	62
1	9.31 847	60	9.32 810	62	0.67 190	9.99 038	59	1	6.3	6.2
2	9.31 907	59	9.32 872	61	0.67 128	9.99 035	58	2	12.6	12.4
3	9.31 966	59	9.32 933	62	0.67 067	9.99 032	57	3	18.9	18.6
4	9.32 025	59	9.32 995	62	0.67 005	9.99 030	56	4	25.2	24.8
5	9.32 084	59	9.33 057	62	0.66 943	9.99 027	55	5	31.5	31.0
6	9.32 143	59	9.33 119	61	0.66 881	9.99 024	54	6	37.8	37.2
7	9.32 202	59	9.33 180	62	0.66 820	9.99 022	53	7	44.1	43.4
8	9.32 261	58	9.33 242	61	0.66 758	9.99 019	52	8	50.4	49.6
9	9.32 319	59	9.33 303	62	0.66 697	9.99 016	51	9	56.7	55.8
10	9.32 378	59	9.33 365	61	0.66 635	9.99 013	50		61	60
11	9.32 437	58	9.33 426	61	0.66 574	9.99 011	49			
12	9.32 495	58	9.33 487	61	0.66 513	9.99 008	48	1	6.1	6.0
13	9.32 553	59	9.33 548	61	0.66 452	9.99 005	47	2	12.2	12.0
14	9.32 612	58	9.33 609	61	0.66 391	9.99 002	46	3	18.3	18.0
15	9.32 670	58	9.33 670	61	0.66 330	9.99 000	45	4	24.4	24.0
16	9.32 728	58	9.33 731	61	0.66 269	9.98 997	44	5	30.5	30.0
17	9.32 786	58	9.33 792	61	0.66 208	9.98 994	43	6	36.6	36.0
18	9.32 844	58	9.33 853	60	0.66 147	9.98 991	42	7	42.7	42.0
19	9.32 902	58	9.33 913	61	0.66 087	9.98 989	41	8	48.8	48.0
20	9.32 960	58	9.33 974	60	0.66 026	9.98 986	40	9	54.9	54.0
21	9.33 018	57	9.34 034	61	0.65 966	9.98 983	39		59	
22	9.33 075	58	9.34 095	60	0.65 905	9.98 980	38	1	5.9	
23	9.33 133	57	9.34 155	60	0.65 845	9.98 978	37	2	11.8	
24	9.33 190	58	9.34 215	61	0.65 785	9.98 975	36	3	17.7	
25	9.33 248	57	9.34 276	60	0.65 724	9.98 972	35	4	23.6	
26	9.33 305	57	9.34 336	60	0.65 664	9.98 969	34	5	29.5	
27	9.33 362	58	9.34 396	60	0.65 604	9.98 967	33	6	35.4	
28	9.33 420	57	9.34 456	60	0.65 544	9.98 964	32	7	41.3	
29	9.33 477	57	9.34 516	60	0.65 484	9.98 961	31	8	47.2	
30	9.33 534	57	9.34 576	60	0.65 424	9.98 958	30	9	53.1	
31	9.33 591	56	9.34 635	59	0.65 365	9.98 955	29		58	57
32	9.33 647	57	9.34 695	60	0.65 305	9.98 953	28	1	5.8	5.7
33	9.33 704	57	9.34 755	59	0.65 245	9.98 950	27	2	11.6	11.4
34	9.33 761	57	9.34 814	60	0.65 186	9.98 947	26	3	17.4	17.1
35	9.33 818	56	9.34 874	59	0.65 126	9.98 944	25	4	23.2	22.8
36	9.33 874	57	9.34 933	59	0.65 067	9.98 941	24	5	29.0	28.5
37	9.33 931	56	9.34 992	59	0.65 008	9.98 938	23	6	34.8	34.2
38	9.33 987	56	9.35 051	60	0.64 949	9.98 936	22	7	40.6	39.9
39	9.34 043	57	9.35 111	59	0.64 889	9.98 933	21	8	46.4	45.6
40	9.34 100	56	9.35 170	59	0.64 830	9.98 930	20	9	52.2	51.3
41	9.34 156	56	9.35 229	59	0.64 771	9.98 927	19		56	55
42	9.34 212	56	9.35 288	59	0.64 712	9.98 924	18	1	5.6	5.5
43	9.34 268	56	9.35 347	58	0.64 653	9.98 921	17	2	11.2	11.0
44	9.34 324	56	9.35 405	59	0.64 595	9.98 919	16	3	16.8	16.5
45	9.34 380	56	9.35 464	59	0.64 536	9.98 916	15	4	22.4	22.0
46	9.34 436	55	9.35 523	58	0.64 477	9.98 913	14	5	28.0	27.5
47	9.34 491	56	9.35 581	59	0.64 419	9.98 910	13	6	33.6	33.0
48	9.34 547	55	9.35 640	58	0.64 360	9.98 907	12	7	39.2	38.5
49	9.34 602	56	9.35 698	59	0.64 302	9.98 904	11	8	44.8	44.0
50	9.34 658	55	9.35 757	58	0.64 243	9.98 901	10	9	50.4	49.5
51	9.34 713	56	9.35 815	58	0.64 185	9.98 898	9		3	2
52	9.34 769	55	9.35 873	58	0.64 127	9.98 896	8	1	0.3	0.2
53	9.34 824	55	9.35 931	58	0.64 069	9.98 893	7	2	0.6	0.4
54	9.34 879	55	9.35 989	58	0.64 011	9.98 890	6	3	0.9	0.6
55	9.34 934	55	9.36 047	58	0.63 953	9.98 887	5	4	1.2	0.8
56	9.34 989	55	9.36 105	58	0.63 895	9.98 884	4	5	1.5	1.0
57	9.35 044	55	9.36 163	58	0.63 837	9.98 881	3	6	1.8	1.2
58	9.35 099	55	9.36 221	58	0.63 779	9.98 878	2	7	2.1	1.4
59	9.35 154	55	9.36 279	57	0.63 721	9.98 875	1	8	2.4	1.6
60	9.35 209		9.36 336		0.63 664	9.98 872	0	9	2.7	1.8
	L SIN	D	L TAN	CD	L COT	L COS		347° ... 167°		
	L COS		L COT		L TAN	L SIN	257° ... 77°			

13°... 193°		L SIN	D	L TAN	CD	L COT	L COS	PROP. PTS.		
103°... 283°		L COS		L COT		L TAN	L SIN			
0	9.35 209	54	9.36 336	58	0.63 664	9.98 872	60			
1	9.35 263	55	9.36 394	58	0.63 606	9.98 869	59		58	57
2	9.35 318	55	9.36 452	57	0.63 548	9.98 867	58	1	5.8	5.7
3	9.35 373	54	9.36 509	57	0.63 491	9.98 864	57	2	11.6	11.4
4	9.35 427	54	9.36 566	58	0.63 434	9.98 861	56	3	17.4	17.1
								4	23.2	22.8
5	9.35 481	55	9.36 624	57	0.63 376	9.98 858	55	5	29.0	28.5
6	9.35 536	54	9.36 681	57	0.63 319	9.98 855	54	6	34.8	34.2
7	9.35 590	54	9.36 738	57	0.63 262	9.98 852	53	7	40.6	39.9
8	9.35 644	54	9.36 795	57	0.63 205	9.98 849	52	8	46.4	45.6
9	9.35 698	54	9.36 852	57	0.63 148	9.98 846	51	9	52.2	51.3
10	9.35 752	54	9.36 909	57	0.63 091	9.98 843	50		56	55
11	9.35 806	54	9.36 966	57	0.63 034	9.98 840	49			
12	9.35 860	54	9.37 023	57	0.62 977	9.98 837	48	1	5.6	5.5
13	9.35 914	54	9.37 080	57	0.62 920	9.98 834	47	2	11.2	11.0
14	9.35 968	54	9.37 137	56	0.62 863	9.98 831	46	3	16.8	16.5
								4	22.4	22.0
15	9.36 022	53	9.37 193	57	0.62 807	9.98 828	45	5	28.0	27.5
16	9.36 075	54	9.37 250	56	0.62 750	9.98 825	44	6	33.6	33.0
17	9.36 129	53	9.37 306	57	0.62 694	9.98 822	43	7	39.2	38.5
18	9.36 182	54	9.37 363	56	0.62 637	9.98 819	42	8	44.8	44.0
19	9.36 236	53	9.37 419	57	0.62 581	9.98 816	41	9	50.4	49.5
20	9.36 289	53	9.37 476	56	0.62 524	9.98 813	40		54	
21	9.36 342	53	9.37 532	56	0.62 468	9.98 810	39			
22	9.36 395	54	9.37 588	56	0.62 412	9.98 807	38	1	5.4	
23	9.36 449	53	9.37 644	56	0.62 356	9.98 804	37	2	10.8	
24	9.36 502	53	9.37 700	56	0.62 300	9.98 801	36	3	16.2	
								4	21.6	
25	9.36 555	53	9.37 756	56	0.62 244	9.98 798	35	5	27.0	
26	9.36 608	52	9.37 812	56	0.62 188	9.98 795	34	6	32.4	
27	9.36 660	53	9.37 868	56	0.62 132	9.98 792	33	7	37.8	
28	9.36 713	53	9.37 924	56	0.62 076	9.98 789	32	8	43.2	
29	9.36 766	53	9.37 980	55	0.62 020	9.98 786	31	9	48.6	
30	9.36 819	52	9.38 035	56	0.61 965	9.98 783	30		53	52
31	9.36 871	53	9.38 091	56	0.61 909	9.98 780	29			
32	9.36 924	52	9.38 147	55	0.61 853	9.98 777	28	1	5.3	5.2
33	9.36 976	52	9.38 202	55	0.61 798	9.98 774	27	2	10.6	10.4
34	9.37 028	53	9.38 257	56	0.61 743	9.98 771	26	3	15.9	15.6
								4	21.2	20.8
35	9.37 081	52	9.38 313	55	0.61 687	9.98 768	25	5	26.5	26.0
36	9.37 133	52	9.38 368	55	0.61 632	9.98 765	24	6	31.8	31.2
37	9.37 185	52	9.38 423	56	0.61 577	9.98 762	23	7	37.1	36.4
38	9.37 237	52	9.38 479	55	0.61 521	9.98 759	22	8	42.4	41.6
39	9.37 289	52	9.38 534	55	0.61 466	9.98 756	21	9	47.7	46.8
40	9.37 341	52	9.38 589	55	0.61 411	9.98 753	20		51	4
41	9.37 393	52	9.38 644	55	0.61 356	9.98 750	19			
42	9.37 445	52	9.38 699	55	0.61 301	9.98 746	18	1	5.1	0.4
43	9.37 497	52	9.38 754	54	0.61 246	9.98 743	17	2	10.2	0.8
44	9.37 549	51	9.38 808	55	0.61 192	9.98 740	16	3	15.3	1.2
								4	20.4	1.6
45	9.37 600	52	9.38 863	55	0.61 137	9.98 737	15	5	25.5	2.0
46	9.37 652	51	9.38 918	54	0.61 082	9.98 734	14	6	30.6	2.4
47	9.37 703	52	9.38 972	55	0.61 028	9.98 731	13	7	35.7	2.8
48	9.37 755	51	9.39 027	55	0.60 973	9.98 728	12	8	40.8	3.2
49	9.37 806	52	9.39 082	54	0.60 918	9.98 725	11	9	45.9	3.6
50	9.37 858	51	9.39 136	54	0.60 864	9.98 722	10		3	2
51	9.37 909	51	9.39 190	55	0.60 810	9.98 719	9			
52	9.37 960	51	9.39 245	54	0.60 755	9.98 715	8	1	0.3	0.2
53	9.38 011	51	9.39 299	54	0.60 701	9.98 712	7	2	0.6	0.4
54	9.38 062	51	9.39 353	54	0.60 647	9.98 709	6	3	0.9	0.6
								4	1.2	0.8
55	9.38 113	51	9.39 407	54	0.60 593	9.98 706	5	5	1.5	1.0
56	9.38 164	51	9.39 461	54	0.60 539	9.98 703	4	6	1.8	1.2
57	9.38 215	51	9.39 515	54	0.60 485	9.98 700	3	7	2.1	1.4
58	9.38 266	51	9.39 569	54	0.60 431	9.98 697	2	8	2.4	1.6
59	9.38 317	51	9.39 623	54	0.60 377	9.98 694	1	9	2.7	1.8
60	9.38 368		9.39 677		0.60 323	9.98 690	0			
	L SIN	D	L TAN	CD	L COT	L COS		346°... 166°		
	L COS		L COT		L TAN	L SIN		256°... 76°		

14° ... 194°	L SIN	D	L TAN	CD	L COT	L COS	D	PROP. PTS.
	L COS		L COT		L TAN	L SIN		
0	9.38 368	50	9.39 677	54	0.60 323	9.98 690	3	60
1	9.38 418	51	9.39 731	54	0.60 269	9.98 687	3	59
2	9.38 469	50	9.39 785	53	0.60 215	9.98 684	3	58
3	9.38 519	51	9.39 838	54	0.60 162	9.98 681	3	57
4	9.38 570	50	9.39 892	53	0.60 108	9.98 678	3	56
5	9.38 620	50	9.39 945	54	0.60 055	9.98 675	4	55
6	9.38 670	51	9.39 999	53	0.60 001	9.98 671	3	54
7	9.38 721	50	9.40 052	54	0.59 948	9.98 668	3	53
8	9.38 771	50	9.40 106	53	0.59 894	9.98 665	3	52
9	9.38 821	50	9.40 159	53	0.59 841	9.98 662	3	51
10	9.38 871	50	9.40 212	54	0.59 788	9.98 659	3	50
11	9.38 921	50	9.40 206	53	0.59 734	9.98 656	4	49
12	9.38 971	50	9.40 319	53	0.59 681	9.98 652	3	48
13	9.39 021	50	9.40 372	53	0.59 628	9.98 649	3	47
14	9.39 071	50	9.40 425	53	0.59 575	9.98 646	3	46
15	9.39 121	49	9.40 478	53	0.59 522	9.98 643	3	45
16	9.39 170	50	9.40 531	53	0.59 469	9.98 640	4	44
17	9.39 220	50	9.40 584	52	0.59 416	9.98 636	3	43
18	9.39 270	49	9.40 636	53	0.59 364	9.98 633	3	42
19	9.39 319	50	9.40 689	53	0.59 311	9.98 630	3	41
20	9.39 369	49	9.40 742	53	0.59 258	9.98 627	4	40
21	9.39 418	49	9.40 795	52	0.59 205	9.98 623	3	39
22	9.39 467	50	9.40 847	53	0.59 153	9.98 620	3	38
23	9.39 517	49	9.40 900	52	0.59 100	9.98 617	3	37
24	9.39 566	49	9.40 952	53	0.59 048	9.98 614	4	36
25	9.39 615	49	9.41 005	52	0.58 995	9.98 610	3	35
26	9.39 664	49	9.41 057	52	0.58 943	9.98 607	3	34
27	9.39 713	49	9.41 109	52	0.58 891	9.98 604	3	33
28	9.39 762	49	9.41 161	53	0.58 839	9.98 601	4	32
29	9.39 811	49	9.41 214	52	0.58 786	9.98 597	3	31
30	9.39 860	49	9.41 266	52	0.58 734	9.98 594	3	30
31	9.39 909	49	9.41 318	52	0.58 682	9.98 591	3	29
32	9.39 958	48	9.41 370	52	0.58 630	9.98 588	4	28
33	9.40 006	49	9.41 422	52	0.58 578	9.98 584	3	27
34	9.40 055	48	9.41 474	52	0.58 526	9.98 581	3	26
35	9.40 103	49	9.41 526	52	0.58 474	9.98 578	4	25
36	9.40 152	48	9.41 578	51	0.58 422	9.98 574	3	24
37	9.40 200	49	9.41 629	52	0.58 371	9.98 571	3	23
38	9.40 249	48	9.41 681	52	0.58 319	9.98 568	3	22
39	9.40 297	49	9.41 733	51	0.58 267	9.98 565	4	21
40	9.40 346	48	9.41 784	52	0.58 216	9.98 561	3	20
41	9.40 394	48	9.41 836	51	0.58 164	9.98 558	3	19
42	9.40 442	48	9.41 887	52	0.58 113	9.98 555	4	18
43	9.40 490	48	9.41 939	51	0.58 061	9.98 551	3	17
44	9.40 538	48	9.41 990	51	0.58 010	9.98 548	3	16
45	9.40 586	48	9.42 041	52	0.57 959	9.98 545	4	15
46	9.40 634	48	9.42 093	51	0.57 907	9.98 541	3	14
47	9.40 682	48	9.42 144	51	0.57 856	9.98 538	3	13
48	9.40 730	48	9.42 195	51	0.57 805	9.98 535	3	12
49	9.40 778	47	9.42 246	51	0.57 754	9.98 531	4	11
50	9.40 825	48	9.42 297	51	0.57 703	9.98 528	3	10
51	9.40 873	48	9.42 348	51	0.57 652	9.98 525	4	9
52	9.40 921	47	9.42 399	51	0.57 601	9.98 521	3	8
53	9.40 968	48	9.42 450	51	0.57 550	9.98 518	3	7
54	9.41 016	47	9.42 501	51	0.57 499	9.98 515	4	6
55	9.41 063	48	9.42 552	51	0.57 448	9.98 511	3	5
56	9.41 111	47	9.42 603	50	0.57 397	9.98 508	3	4
57	9.41 158	47	9.42 653	51	0.57 347	9.98 505	4	3
58	9.41 205	47	9.42 704	51	0.57 296	9.98 501	3	2
59	9.41 252	48	9.42 755	50	0.57 245	9.98 498	4	1
60	9.41 300		9.42 805		0.57 195	9.98 494		0
	L SIN	D	L TAN	CD	L COT	L COS	D	345° ... 165°
	L COS		L COT		L TAN	L SIN		255° ... 75°

15°... 195°	L SIN	D	L TAN	CD	L COT	L COS	D	PROP. PTS.
	L COS		L COT		L TAN	L SIN		
0	9.41 300	47	9.42 805	51	0.57 195	9.98 494	3	60
1	9.41 347	47	9.42 856	50	0.57 144	9.98 491	3	59
2	9.41 394	47	9.42 906	51	0.57 094	9.98 488	3	58
3	9.41 441	47	9.42 957	50	0.57 043	9.98 484	4	57
4	9.41 488	47	9.43 007	50	0.56 993	9.98 481	3	56
5	9.41 535	47	9.43 057	51	0.56 943	9.98 477	4	55
6	9.41 582	46	9.43 108	50	0.56 892	9.98 474	3	54
7	9.41 628	47	9.43 158	50	0.56 842	9.98 471	3	53
8	9.41 675	47	9.43 208	50	0.56 792	9.98 467	4	52
9	9.41 722	46	9.43 258	50	0.56 742	9.98 464	3	51
10	9.41 768	47	9.43 308	50	0.56 692	9.98 460	4	50
11	9.41 815	46	9.43 358	50	0.56 642	9.98 457	3	49
12	9.41 861	47	9.43 408	50	0.56 592	9.98 453	4	48
13	9.41 908	46	9.43 458	50	0.56 542	9.98 450	3	47
14	9.41 954	47	9.43 508	50	0.56 492	9.98 447	3	46
15	9.42 001	46	9.43 558	49	0.56 442	9.98 443	4	45
16	9.42 047	46	9.43 607	50	0.56 393	9.98 440	3	44
17	9.42 093	47	9.43 657	50	0.56 343	9.98 436	4	43
18	9.42 140	46	9.43 707	49	0.56 293	9.98 433	3	42
19	9.42 186	46	9.43 756	50	0.56 244	9.98 429	4	41
20	9.42 232	46	9.43 806	49	0.56 194	9.98 426	3	40
21	9.42 278	46	9.43 855	50	0.56 145	9.98 422	4	39
22	9.42 324	46	9.43 905	49	0.56 095	9.98 419	3	38
23	9.42 370	46	9.43 954	50	0.56 046	9.98 415	4	37
24	9.42 416	45	9.44 004	49	0.55 996	9.98 412	3	36
25	9.42 461	46	9.44 053	49	0.55 947	9.98 409	4	35
26	9.42 507	46	9.44 102	49	0.55 898	9.98 405	3	34
27	9.42 553	46	9.44 151	50	0.55 849	9.98 402	4	33
28	9.42 599	45	9.44 201	49	0.55 799	9.98 398	3	32
29	9.42 644	46	9.44 250	49	0.55 750	9.98 395	4	31
30	9.42 690	45	9.44 299	49	0.55 701	9.98 391	3	30
31	9.42 735	46	9.44 348	49	0.55 652	9.98 388	4	29
32	9.42 781	45	9.44 397	49	0.55 603	9.98 384	3	28
33	9.42 826	46	9.44 446	49	0.55 554	9.98 381	4	27
34	9.42 872	45	9.44 495	49	0.55 505	9.98 377	3	26
35	9.42 917	45	9.44 544	48	0.55 456	9.98 373	4	25
36	9.42 962	46	9.44 592	49	0.55 408	9.98 370	3	24
37	9.43 008	45	9.44 641	49	0.55 359	9.98 366	4	23
38	9.43 053	45	9.44 690	48	0.55 310	9.98 363	3	22
39	9.43 098	45	9.44 738	49	0.55 262	9.98 359	4	21
40	9.43 143	45	9.44 787	49	0.55 213	9.98 356	3	20
41	9.43 188	45	9.44 836	48	0.55 164	9.98 352	4	19
42	9.43 233	45	9.44 884	49	0.55 116	9.98 349	3	18
43	9.43 278	45	9.44 933	48	0.55 067	9.98 345	4	17
44	9.43 323	44	9.44 981	48	0.55 019	9.98 342	3	16
45	9.43 367	45	9.45 029	49	0.54 971	9.98 338	4	15
46	9.43 412	45	9.45 078	48	0.54 922	9.98 334	3	14
47	9.43 457	45	9.45 126	48	0.54 874	9.98 331	4	13
48	9.43 502	44	9.45 174	48	0.54 826	9.98 327	3	12
49	9.43 546	45	9.45 222	49	0.54 778	9.98 324	4	11
50	9.43 5591	44	9.45 271	48	0.54 729	9.98 320	3	10
51	9.43 635	45	9.45 319	48	0.54 681	9.98 317	4	9
52	9.43 680	44	9.45 367	48	0.54 633	9.98 313	3	8
53	9.43 724	45	9.45 415	48	0.54 585	9.98 309	4	7
54	9.43 769	44	9.45 463	48	0.54 537	9.98 306	3	6
55	9.43 813	44	9.45 511	48	0.54 489	9.98 302	4	5
56	9.43 857	44	9.45 559	47	0.54 441	9.98 299	3	4
57	9.43 901	45	9.45 606	48	0.54 394	9.98 295	4	3
58	9.43 946	44	9.45 654	48	0.54 346	9.98 291	3	2
59	9.43 990	44	9.45 702	48	0.54 298	9.98 288	4	1
60	9.44 034		9.45 750		0.54 250	9.98 284		0
	L SIN	D	L TAN	CD	L COT	L COS	D	344°... 164°
	L COS		L COT		L TAN	L SIN		254°... 74°

FM 30-476

16°... 196°	L SIN	D	L TAN	CD	L COT	L COS	D	PROP. PTS.	
106°... 286°	L COS		L COT		L TAN	L SIN			
0	9.44 034	44	9.45 750	47	0.54 250	9.98 284	3	60	
1	9.44 078	44	9.45 797	48	0.54 203	9.98 281	4	59	
2	9.44 122	44	9.45 845	47	0.54 155	9.98 277	4	58	
3	9.44 166	44	9.45 892	48	0.54 108	9.98 273	3	57	
4	9.44 210	43	9.45 940	47	0.54 060	9.98 270	4	56	48 47
5	9.44 253	44	9.45 987	48	0.54 013	9.98 266	4	55	1 4.8 4.7
6	9.44 297	44	9.46 035	47	0.53 965	9.98 262	3	54	2 9.6 9.4
7	9.44 341	44	9.46 082	48	0.53 918	9.98 259	4	53	3 14.4 14.1
8	9.44 385	43	9.46 130	47	0.53 870	9.98 255	3	52	4 19.2 18.8
9	9.44 428	44	9.46 177	47	0.53 823	9.98 251	4	51	5 24.0 23.5
10	9.44 472	44	9.46 224	47	0.53 776	9.98 248	3	50	6 28.8 28.2
11	9.44 516	43	9.46 271	48	0.53 729	9.98 244	4	49	7 33.6 32.9
12	9.44 559	43	9.46 319	47	0.53 681	9.98 240	3	48	8 38.4 37.6
13	9.44 602	44	9.46 366	47	0.53 634	9.98 237	4	47	9 43.2 42.3
14	9.44 646	43	9.46 413	47	0.53 587	9.98 233	3	46	
15	9.44 689	44	9.46 460	47	0.53 540	9.98 229	4	45	46 45
16	9.44 733	43	9.46 507	47	0.53 493	9.98 226	3	44	
17	9.44 776	43	9.46 554	47	0.53 446	9.98 222	4	43	1 4.6 4.5
18	9.44 819	43	9.46 601	47	0.53 399	9.98 218	3	42	2 9.2 9.0
19	9.44 862	43	9.46 648	46	0.53 352	9.98 215	4	41	3 13.8 13.5
20	9.44 905	43	9.46 694	47	0.53 306	9.98 211	3	40	4 18.4 18.0
21	9.44 948	44	9.46 741	47	0.53 259	9.98 207	4	39	5 23.0 22.5
22	9.44 992	43	9.46 788	47	0.53 212	9.98 204	3	38	6 27.6 27.0
23	9.45 035	42	9.46 835	46	0.53 165	9.98 200	4	37	7 32.2 31.5
24	9.45 077	43	9.46 881	47	0.53 119	9.98 196	3	36	8 36.8 36.0
25	9.45 120	43	9.46 928	47	0.53 072	9.98 192	4	35	9 41.4 40.5
26	9.45 163	43	9.46 975	46	0.53 025	9.98 189	3	34	
27	9.45 206	43	9.47 021	47	0.52 979	9.98 185	4	33	
28	9.45 249	43	9.47 068	46	0.52 932	9.98 181	3	32	44 43
29	9.45 292	42	9.47 114	46	0.52 886	9.98 177	4	31	
30	9.45 334	43	9.47 160	47	0.52 840	9.98 174	3	30	1 4.4 4.3
31	9.45 377	42	9.47 207	46	0.52 793	9.98 170	4	29	2 8.8 8.6
32	9.45 419	43	9.47 253	46	0.52 747	9.98 166	3	28	3 13.2 12.9
33	9.45 462	42	9.47 299	47	0.52 701	9.98 162	4	27	4 17.6 17.2
34	9.45 504	43	9.47 346	46	0.52 654	9.98 159	3	26	5 22.0 21.5
35	9.45 547	42	9.47 392	46	0.52 608	9.98 155	4	25	6 26.4 25.8
36	9.45 589	43	9.47 438	46	0.52 562	9.98 151	3	24	7 30.8 30.1
37	9.45 632	42	9.47 484	46	0.52 516	9.98 147	4	23	8 35.2 34.4
38	9.45 674	42	9.47 530	46	0.52 470	9.98 144	3	22	9 39.6 38.7
39	9.45 716	42	9.47 576	46	0.52 424	9.98 140	4	21	
40	9.45 758	43	9.47 622	46	0.52 378	9.98 136	3	20	42 41
41	9.45 801	42	9.47 668	46	0.52 332	9.98 132	4	19	1 4.2 4.1
42	9.45 843	42	9.47 714	46	0.52 286	9.98 129	3	18	2 8.4 8.2
43	9.45 885	42	9.47 760	46	0.52 240	9.98 125	4	17	3 12.6 12.3
44	9.45 927	42	9.47 806	46	0.52 194	9.98 121	3	16	4 16.8 16.4
45	9.45 969	42	9.47 852	45	0.52 148	9.98 117	4	15	5 21.0 20.5
46	9.46 011	42	9.47 897	46	0.52 103	9.98 113	3	14	6 25.2 24.6
47	9.46 053	42	9.47 943	46	0.52 057	9.98 110	4	13	7 29.4 28.7
48	9.46 095	41	9.47 989	46	0.52 011	9.98 106	3	12	8 33.6 32.8
49	9.46 136	42	9.48 035	45	0.51 965	9.98 102	4	11	9 37.8 36.9
50	9.46 178	42	9.48 080	46	0.51 920	9.98 098	3	10	
51	9.46 220	42	9.48 126	45	0.51 874	9.98 094	4	9	4 3
52	9.46 262	41	9.48 171	46	0.51 829	9.98 090	3	8	1 0.4 0.3
53	9.46 303	42	9.48 217	45	0.51 783	9.98 087	4	7	2 0.8 0.6
54	9.46 345	41	9.48 262	45	0.51 738	9.98 083	3	6	3 1.2 0.9
55	9.46 386	42	9.48 307	46	0.51 693	9.98 079	4	5	4 1.6 1.2
56	9.46 428	41	9.48 353	45	0.51 647	9.98 075	3	4	5 2.0 1.5
57	9.46 469	42	9.48 398	45	0.51 602	9.98 071	4	3	6 2.4 1.8
58	9.46 511	41	9.48 443	46	0.51 557	9.98 067	3	2	7 2.8 2.1
59	9.46 552	42	9.48 489	45	0.51 511	9.98 063	4	1	8 3.2 2.4
60	9.46 594		9.48 534		0.51 466	9.98 060	3	0	9 3.6 2.7
	L SIN	D	L TAN	CD	L COT	L COS	D		343°... 163°
	L COS		L COT		L TAN	L SIN			253°... 73°

17°... 197°		L SIN	D	L TAN	CD	L COT	L COS	D	PROP. PTS.		
107°... 287°		L COS		L COT		L TAN	L SIN				
0	9.46 594	41	9.48 534	45	0.51 466	9.98 060	4	60			
1	9.46 635	41	9.48 579	45	0.51 421	9.98 056	4	59			
2	9.46 676	41	9.48 624	45	0.51 376	9.98 052	4	58			
3	9.46 717	41	9.48 669	45	0.51 331	9.98 048	4	57			
4	9.46 758	42	9.48 714	45	0.51 286	9.98 044	4	56			
									45	44	
5	9.46 800	41	9.48 759	45	0.51 241	9.98 040	4	55	1	4.5	4.4
6	9.46 841	41	9.48 804	45	0.51 196	9.98 036	4	54	2	9.0	8.8
7	9.46 882	41	9.48 849	45	0.51 151	9.98 032	4	53	3	13.5	13.2
8	9.46 923	41	9.48 894	45	0.51 106	9.98 029	4	52	4	18.0	17.6
9	9.46 964	41	9.48 939	45	0.51 061	9.98 025	4	51	5	22.5	22.0
									6	27.0	26.4
									7	31.5	30.8
									8	36.0	35.2
10	9.47 005	40	9.48 984	45	0.51 016	9.98 021	4	50	9	40.5	39.6
11	9.47 045	41	9.49 029	44	0.50 971	9.98 017	4	49			
12	9.47 086	41	9.49 073	45	0.50 927	9.98 013	4	48			
13	9.47 127	41	9.49 118	45	0.50 882	9.98 009	4	47			
14	9.47 168	41	9.49 163	44	0.50 837	9.98 005	4	46			
										43	42
15	9.47 209	40	9.49 207	45	0.50 793	9.98 001	4	45	1	4.3	4.2
16	9.47 249	41	9.49 252	44	0.50 748	9.97 997	4	44	2	8.6	8.4
17	9.47 290	40	9.49 296	45	0.50 704	9.97 993	4	43	3	12.9	12.6
18	9.47 330	41	9.49 341	44	0.50 659	9.97 989	3	42	4	17.2	16.8
19	9.47 371	40	9.49 385	45	0.50 615	9.97 986	4	41	5	21.5	21.0
									6	25.8	25.2
20	9.47 411	41	9.49 430	44	0.50 570	9.97 982	4	40	7	30.1	29.4
21	9.47 452	40	9.49 474	45	0.50 526	9.97 978	4	39	8	34.4	33.6
22	9.47 492	41	9.49 519	44	0.50 481	9.97 974	4	38	9	38.7	37.8
23	9.47 533	40	9.49 563	44	0.50 437	9.97 970	4	37			
24	9.47 573	40	9.49 607	45	0.50 393	9.97 966	4	36			
										41	40
25	9.47 613	41	9.49 652	44	0.50 348	9.97 962	4	35	1	4.1	4.0
26	9.47 654	40	9.49 696	44	0.50 304	9.97 958	4	34	2	8.2	8.0
27	9.47 694	40	9.49 740	44	0.50 260	9.97 954	4	33	3	12.3	12.0
28	9.47 734	40	9.49 784	44	0.50 216	9.97 950	4	32	4	16.4	16.0
29	9.47 774	40	9.49 828	44	0.50 172	9.97 946	4	31	5	20.5	20.0
									6	24.6	24.0
30	9.47 814	40	9.49 872	44	0.50 128	9.97 942	4	30	7	28.7	28.0
31	9.47 854	40	9.49 916	44	0.50 084	9.97 938	4	29	8	32.8	32.0
32	9.47 894	40	9.49 960	44	0.50 040	9.97 934	4	28	9	36.9	36.0
33	9.47 934	40	9.50 004	44	0.49 996	9.97 930	4	27			
34	9.47 974	40	9.50 048	44	0.49 952	9.97 926	4	26			
										39	5
35	9.48 014	40	9.50 092	44	0.49 908	9.97 922	4	25	1	3.9	0.5
36	9.48 054	40	9.50 136	44	0.49 864	9.97 918	4	24	2	7.8	1.0
37	9.48 094	39	9.50 180	43	0.49 820	9.97 914	4	23	3	11.7	1.5
38	9.48 133	40	9.50 223	44	0.49 777	9.97 910	4	22	4	15.6	2.0
39	9.48 173	40	9.50 267	44	0.49 733	9.97 906	4	21	5	19.5	2.5
									6	23.4	3.0
40	9.48 213	39	9.50 311	44	0.49 689	9.97 902	4	20	7	27.3	3.5
41	9.48 252	40	9.50 355	43	0.49 645	9.97 898	4	19	8	31.2	4.0
42	9.48 292	40	9.50 398	44	0.49 602	9.97 894	4	18	9	35.1	4.5
43	9.48 332	39	9.50 442	43	0.49 558	9.97 890	4	17			
44	9.48 371	40	9.50 485	44	0.49 515	9.97 886	4	16			
										4	3
45	9.48 411	39	9.50 529	43	0.49 471	9.97 882	4	15	1	0.4	0.3
46	9.48 450	40	9.50 572	44	0.49 428	9.97 878	4	14	2	0.8	0.6
47	9.48 490	39	9.50 616	43	0.49 384	9.97 874	4	13	3	1.2	0.9
48	9.48 529	39	9.50 659	44	0.49 341	9.97 870	4	12	4	1.6	1.2
49	9.48 568	39	9.50 703	43	0.49 297	9.97 866	5	11	5	2.0	1.5
									6	2.4	1.8
50	9.48 607	40	9.50 746	43	0.49 254	9.97 861	4	10	7	2.8	2.1
51	9.48 647	39	9.50 789	44	0.49 211	9.97 857	4	9	8	3.2	2.4
52	9.48 686	39	9.50 833	43	0.49 167	9.97 853	4	8	9	3.6	2.7
53	9.48 725	39	9.50 876	43	0.49 124	9.97 849	4	7			
54	9.48 764	39	9.50 919	43	0.49 081	9.97 845	4	6			
55	9.48 803	39	9.50 962	43	0.49 038	9.97 841	4	5			
56	9.48 842	39	9.51 005	43	0.48 995	9.97 837	4	4			
57	9.48 881	39	9.51 048	44	0.48 952	9.97 833	4	3			
58	9.48 920	39	9.51 092	43	0.48 908	9.97 829	4	2			
59	9.48 959	39	9.51 135	43	0.48 865	9.97 825	4	1			
60	9.48 998		9.51 178		0.48 822	9.97 821		0			
	L SIN	D	L TAN	CD	L COT	L COS	D		342°... 162°		
	L COS		L COT		L TAN	L SIN			252°... 72°		

18°... 198°		L SIN	D	L TAN	CD	L COT	L COS	D	PROP. PTS.	
108°... 288°		L COS		L COT		L TAN	L SIN			
0	9.48 098	39	9.51 178	43	0.48 822	9.97 821	4	60		
1	9.49 037	39	9.51 221	43	0.48 779	9.97 817	4	59		
2	9.49 076	39	9.51 264	42	0.48 736	9.97 812	5	58	43	42
3	9.49 115	38	9.51 306	43	0.48 694	9.97 808	4	57	4.3	4.2
4	9.49 153	39	9.51 349	43	0.48 651	9.97 804	4	56	8.6	8.4
5	9.49 192	39	9.51 392	43	0.48 608	9.97 800	4	55	12.9	12.6
6	9.49 231	38	9.51 435	43	0.48 565	9.97 796	4	54	17.2	16.8
7	9.49 269	39	9.51 478	42	0.48 522	9.97 792	4	53	21.5	21.0
8	9.49 308	39	9.51 520	43	0.48 480	9.97 788	4	52	25.8	25.2
9	9.49 347	38	9.51 563	43	0.48 437	9.97 784	5	51	30.1	29.4
10	9.49 385	39	9.51 606	42	0.48 394	9.97 779	4	50	34.4	33.6
11	9.49 424	38	9.51 648	43	0.48 352	9.97 775	4	49	38.7	37.8
12	9.49 462	38	9.51 691	43	0.48 309	9.97 771	4	48		
13	9.49 500	39	9.51 734	43	0.48 266	9.97 767	4	47		
14	9.49 539	38	9.51 776	43	0.48 224	9.97 763	4	46	41	
15	9.49 577	38	9.51 819	42	0.48 181	9.97 759	5	45	4.1	
16	9.49 615	39	9.51 861	42	0.48 139	9.97 754	4	44	8.2	
17	9.49 654	38	9.51 903	43	0.48 097	9.97 750	4	43	12.3	
18	9.49 692	38	9.51 946	42	0.48 054	9.97 746	4	42	16.4	
19	9.49 730	38	9.51 988	43	0.48 012	9.97 742	4	41	20.5	
20	9.49 768	38	9.52 031	42	0.47 969	9.97 738	4	40	24.6	
21	9.49 806	38	9.52 073	42	0.47 927	9.97 734	5	39	28.7	
22	9.49 844	38	9.52 115	42	0.47 885	9.97 729	4	38	32.8	
23	9.49 882	38	9.52 157	43	0.47 843	9.97 725	4	37	36.9	
24	9.49 920	38	9.52 200	42	0.47 800	9.97 721	4	36		
25	9.49 958	38	9.52 242	42	0.47 758	9.97 717	4	35	39	38
26	9.49 996	38	9.52 284	42	0.47 716	9.97 713	5	34	3.9	3.8
27	9.50 034	38	9.52 326	42	0.47 674	9.97 708	4	33	7.8	7.6
28	9.50 072	38	9.52 368	42	0.47 632	9.97 704	4	32	11.7	11.4
29	9.50 110	38	9.52 410	42	0.47 590	9.97 700	4	31	15.6	15.2
30	9.50 148	37	9.52 452	42	0.47 548	9.97 699	5	30	19.5	19.0
31	9.50 185	38	9.52 494	42	0.47 506	9.97 691	4	29	23.4	22.8
32	9.50 223	38	9.52 536	42	0.47 464	9.97 687	4	28	27.3	26.6
33	9.50 261	37	9.52 578	42	0.47 422	9.97 683	4	27	31.2	30.4
34	9.50 298	38	9.52 620	41	0.47 380	9.97 679	5	26	35.1	34.2
35	9.50 336	38	9.52 661	42	0.47 339	9.97 674	4	25		
36	9.50 374	37	9.52 703	42	0.47 297	9.97 670	4	24		
37	9.50 411	38	9.52 745	42	0.47 255	9.97 666	4	23	37	36
38	9.50 449	37	9.52 787	42	0.47 213	9.97 662	5	22	3.7	3.6
39	9.50 486	37	9.52 829	41	0.47 171	9.97 657	4	21	7.4	7.2
40	9.50 523	38	9.52 870	42	0.47 130	9.97 653	4	20	11.1	10.8
41	9.50 561	37	9.52 912	41	0.47 088	9.97 649	4	19	14.8	14.4
42	9.50 598	37	9.52 953	42	0.47 047	9.97 645	5	18	18.5	18.0
43	9.50 635	38	9.52 995	42	0.47 005	9.97 640	4	17	22.2	21.6
44	9.50 673	37	9.52 037	41	0.46 963	9.97 636	4	16	25.9	25.2
45	9.50 710	37	9.53 078	42	0.46 922	9.97 632	4	15	29.6	28.8
46	9.50 747	37	9.53 120	41	0.46 880	9.97 628	5	14	33.3	32.4
47	9.50 784	37	9.53 161	41	0.46 839	9.97 623	4	13		
48	9.50 821	37	9.53 202	42	0.46 798	9.97 619	4	12		
49	9.50 858	38	9.53 244	41	0.46 756	9.97 615	5	11		
50	9.50 896	37	9.53 285	42	0.46 715	9.97 610	4	10	5	4
51	9.50 933	37	9.53 327	41	0.46 673	9.97 606	4	9	0.5	0.4
52	9.50 970	37	9.53 368	41	0.46 632	9.97 602	5	8	1.0	0.8
53	9.51 007	36	9.53 409	41	0.46 591	9.97 597	4	7	1.5	1.2
54	9.51 043	37	9.53 450	42	0.46 550	9.97 593	4	6	2.0	1.6
55	9.51 080	37	9.53 492	41	0.46 508	9.97 589	5	5	2.5	2.0
56	9.51 117	37	9.53 533	41	0.46 467	9.97 584	4	4	3.0	2.4
57	9.51 154	37	9.53 574	41	0.46 426	9.97 580	4	3	3.5	2.8
58	9.51 191	36	9.53 615	41	0.46 385	9.97 576	5	2	4.0	3.2
59	9.51 227	37	9.53 656	41	0.46 344	9.97 571	4	1	4.5	3.6
60	9.51 264		9.53 697		0.46 303	9.97 567		0		
	L SIN	D	L TAN	CD	L COT	L COS	D		341°... 161°	
	L COS		L COT		L TAN	L SIN			251°... 71°	

19°... 199°...	L SIN	D	L TAN	CD	L COT	L COS	D	PROP. PTS.			
109°... 289°...	L COS		L COT		L TAN	L SIN					
0	9.51 264	37	9.53 697	41	0.46 303	9.97 567	4	60			
1	9.51 301	37	9.53 738	41	0.46 262	9.97 563	5	59			
2	9.51 338	36	9.53 779	41	0.46 221	9.97 558	4	58	41	40	
3	9.51 374	37	9.53 820	41	0.46 180	9.97 554	4	57			
4	9.51 411	36	9.53 861	41	0.46 139	9.97 550	5	56	1	4.1	4.0
5	9.51 447		9.53 902		0.46 098	9.97 545		55	2	8.2	8.0
6	9.51 484	37	9.53 943	41	0.46 057	9.97 541	4	54	3	12.3	12.0
7	9.51 520	36	9.53 984	41	0.46 016	9.97 536	5	53	4	16.4	16.0
8	9.51 557	37	9.54 025	41	0.45 975	9.97 532	4	52	5	20.5	20.0
9	9.51 593	36	9.54 065	40	0.45 935	9.97 528	4	51	6	24.6	24.0
		36		41			5	50	7	28.7	28.0
10	9.51 629		9.54 106		0.45 894	9.97 523		49	8	32.8	32.0
11	9.51 666	37	9.54 147	41	0.45 853	9.97 519	4	48	9	36.9	36.0
12	9.51 702	36	9.54 187	40	0.45 813	9.97 515	4	47			
13	9.51 738	36	9.54 228	41	0.45 772	9.97 510	5	46			
14	9.51 774	36	9.54 269	41	0.45 731	9.97 506	4				
		37		40			5			39	
15	9.51 811		9.54 309		0.45 691	9.97 501		45	1	3.9	
16	9.51 847	36	9.54 350	41	0.45 650	9.97 497	4	44	2	7.8	
17	9.51 883	36	9.54 390	40	0.45 610	9.97 492	5	43	3	11.7	
18	9.51 919	36	9.54 431	41	0.45 569	9.97 488	4	42	4	15.6	
19	9.51 955	36	9.54 471	40	0.45 529	9.97 484	4	41	5	19.5	
		36		41			5	40	6	23.4	
20	9.51 991		9.54 512		0.45 488	9.97 479		39	7	27.3	
21	9.52 027	36	9.54 552	40	0.45 448	9.97 475	4	38	8	31.2	
22	9.52 063	36	9.54 593	41	0.45 407	9.97 470	4	37	9	35.1	
23	9.52 099	36	9.54 633	40	0.45 367	9.97 466	5	36			
24	9.52 135	36	9.54 673	40	0.45 327	9.97 461	4				
		36		41			4				
25	9.52 171		9.54 714		0.45 286	9.97 457		35			
26	9.52 207	36	9.54 754	40	0.45 246	9.97 453	4	34		37	36
27	9.52 242	35	9.54 794	40	0.45 206	9.97 448	5	33	1	3.7	3.6
28	9.52 278	36	9.54 835	41	0.45 165	9.97 444	4	32	2	7.4	7.2
29	9.52 314	36	9.54 875	40	0.45 125	9.97 439	5	31	3	11.1	10.8
		36		40			4		4	14.8	14.4
30	9.52 350		9.54 915		0.45 085	9.97 435		30	5	18.5	18.0
31	9.52 385	35	9.54 955	40	0.45 045	9.97 430	5	29	6	22.2	21.6
32	9.52 421	36	9.54 995	40	0.45 005	9.97 426	4	28	7	25.9	25.2
33	9.52 456	35	9.55 035	40	0.44 965	9.97 421	5	27	8	29.6	28.8
34	9.52 492	36	9.55 075	40	0.44 925	9.97 417	4	26	9	33.3	32.4
		35		40			5				
35	9.52 527		9.55 115		0.44 885	9.97 412		25			
36	9.52 563	36	9.55 155	40	0.44 845	9.97 408	4	24			
37	9.52 598	35	9.55 195	40	0.44 805	9.97 403	5	23			
38	9.52 634	36	9.55 235	40	0.44 765	9.97 399	4	22		35	34
39	9.52 669	35	9.55 275	40	0.44 725	9.97 394	5	21	1	3.5	3.4
		36		40			4		2	7.0	6.8
40	9.52 705		9.55 315		0.44 685	9.97 390		20	3	10.5	10.2
41	9.52 740	35	9.55 355	40	0.44 645	9.97 385	5	19	4	14.0	13.6
42	9.52 775	36	9.55 395	40	0.44 605	9.97 381	4	18	5	17.5	17.0
43	9.52 811	35	9.55 434	49	0.44 566	9.97 376	5	17	6	21.0	20.4
44	9.52 846	35	9.55 474	40	0.44 526	9.97 372	4	16	7	24.5	23.8
		35		40			5		8	28.0	27.2
45	9.52 881		9.55 514		0.44 486	9.97 367		15	9	31.5	30.6
46	9.52 916	35	9.55 554	39	0.44 446	9.97 363	4	14			
47	9.52 951	35	9.55 593	40	0.44 407	9.97 358	5	13			
48	9.52 086	35	9.55 633	40	0.44 367	9.97 353	4	12			
49	9.53 021	36	9.55 673	39	0.44 327	9.97 349	5	11			
										5	4
50	9.53 056		9.55 712		0.44 288	9.97 344		10	1	0.5	0.4
51	9.53 092	36	9.55 752	40	0.44 248	9.97 340	4	9	2	1.0	0.8
52	9.53 126	34	9.55 791	39	0.44 209	9.97 335	5	8	3	1.5	1.2
53	9.53 161	35	9.55 831	40	0.44 169	9.97 331	4	7	4	2.0	1.6
54	9.53 196	35	9.55 870	39	0.44 130	9.97 326	5	6	5	2.5	2.0
		35		40			4		6	3.0	2.4
55	9.53 231		9.55 910		0.44 090	9.97 322		5	7	3.5	2.8
56	9.53 266	35	9.55 949	39	0.44 051	9.97 317	5	4	8	4.0	3.2
57	9.53 301	36	9.55 989	40	0.44 011	9.97 312	4	3	9	4.5	3.6
58	9.53 336	35	9.56 028	39	0.43 972	9.97 308	5	2			
59	9.53 370	34	9.56 067	39	0.43 933	9.97 303	4	1			
		35		40			5				
60	9.53 405		9.56 107		0.43 893	9.97 299		0			
	L SIN	D	L TAN	CD	L COT	L COS	D	340°... 160°...			
	L COS		L COT		L TAN	L SIN		250°... 70°...			

20°... 200°	L SIN	D	L TAN	CD	L COT	L COS	D	PROP. PTS.
	L COS		L COT		L TAN	L SIN		
0	9.53 405	35	9.56 107	39	0.43 893	9.97 299	5	60
1	9.53 440	35	9.56 146	39	0.43 854	9.97 294	5	59
2	9.53 475	34	9.56 185	39	0.43 815	9.97 289	4	58
3	9.53 509	35	9.56 224	40	0.43 776	9.97 285	5	57
4	9.53 544	34	9.56 264	49	0.43 736	9.97 280	4	56
5	9.53 578	35	9.56 303	39	0.43 697	9.97 276	5	55
6	9.53 613	34	9.56 342	39	0.43 658	9.97 271	5	54
7	9.53 647	35	9.56 381	39	0.43 619	9.97 266	4	53
8	9.53 682	34	9.56 420	39	0.43 580	9.97 262	5	52
9	9.53 716	35	9.56 459	39	0.43 541	9.97 257	5	51
10	9.53 751	34	9.56 498	39	0.43 502	9.97 252	4	50
11	9.53 785	34	9.56 537	39	0.43 463	9.97 248	5	49
12	9.53 819	35	9.56 576	39	0.43 424	9.97 243	5	48
13	9.53 854	34	9.56 615	39	0.43 385	9.97 238	4	47
14	9.53 888	34	9.56 654	39	0.43 346	9.97 234	5	46
15	9.53 922	35	9.56 693	39	0.43 307	9.97 229	5	45
16	9.53 957	34	9.56 732	39	0.43 268	9.97 224	4	44
17	9.53 991	34	9.56 771	39	0.43 229	9.97 220	5	43
18	9.54 025	34	9.56 810	39	0.43 190	9.97 215	5	42
19	9.54 059	34	9.56 849	38	0.43 151	9.97 210	4	41
20	9.54 093	34	9.56 887	39	0.43 113	9.97 206	5	40
21	9.54 127	34	9.56 926	39	0.43 074	9.97 201	5	39
22	9.54 161	34	9.56 965	39	0.43 035	9.97 196	4	38
23	9.54 195	34	9.57 004	38	0.42 996	9.97 192	5	37
24	9.54 229	34	9.57 042	39	0.42 958	9.97 187	5	36
25	9.54 263	34	9.57 081	39	0.42 919	9.97 182	4	35
26	9.54 297	34	9.57 120	38	0.42 880	9.97 178	5	34
27	9.54 331	34	9.57 158	39	0.42 842	9.97 173	5	33
28	9.54 365	34	9.57 197	38	0.42 803	9.97 168	5	32
29	9.54 399	34	9.57 235	39	0.42 765	9.97 163	4	31
30	9.54 433	33	9.57 274	38	0.42 726	9.97 159	5	30
31	9.54 466	34	9.57 312	39	0.42 688	9.97 154	5	29
32	9.54 500	34	9.57 351	38	0.42 649	9.97 149	4	28
33	9.54 534	33	9.57 389	39	0.42 611	9.97 145	5	27
34	9.54 567	34	9.57 428	38	0.42 572	9.97 140	5	26
35	9.54 601	34	9.57 466	38	0.42 534	9.97 135	5	25
36	9.54 635	33	9.57 504	39	0.42 496	9.97 130	4	24
37	9.54 668	34	9.57 543	38	0.42 457	9.97 126	5	23
38	9.54 702	33	9.57 581	38	0.42 419	9.97 121	5	22
39	9.54 735	34	9.57 619	39	0.42 381	9.97 116	5	21
40	9.54 769	33	9.57 658	38	0.42 342	9.97 111	4	20
41	9.54 802	34	9.57 696	38	0.42 304	9.97 107	5	19
42	9.54 836	33	9.57 734	38	0.42 266	9.97 102	5	18
43	9.54 869	34	9.57 772	38	0.42 228	9.97 097	5	17
44	9.54 903	33	9.57 810	39	0.42 190	9.97 092	5	16
45	9.54 936	33	9.57 849	38	0.42 151	9.97 087	4	15
46	9.54 969	34	9.57 887	38	0.42 113	9.97 083	5	14
47	9.55 003	33	9.57 925	38	0.42 075	9.97 078	5	13
48	9.55 036	33	9.57 963	38	0.42 037	9.97 073	5	12
49	9.55 069	33	9.58 001	38	0.41 999	9.97 068	5	11
50	9.55 102	34	9.58 039	38	0.41 961	9.97 063	4	10
51	9.55 136	33	9.58 077	38	0.41 923	9.97 059	5	9
52	9.55 169	33	9.58 115	38	0.41 885	9.97 054	5	8
53	9.55 202	33	9.58 153	38	0.41 847	9.97 049	5	7
54	9.55 235	33	9.58 191	38	0.41 809	9.97 044	5	6
55	9.55 268	33	9.58 229	38	0.41 771	9.97 039	4	5
56	9.55 301	33	9.58 267	37	0.41 733	9.97 035	5	4
57	9.55 334	33	9.58 304	38	0.41 696	9.97 030	5	3
58	9.55 367	33	9.58 342	38	0.41 658	9.97 025	5	2
59	9.55 400	33	9.58 380	38	0.41 620	9.97 020	5	1
60	9.55 433		9.58 418		0.41 582	9.97 015		0
	L SIN	D	L TAN	CD	L COT	L COS	D	339°... 159°
	L COS		L COT		L TAN	L SIN		249°... 69°

22°... 202°	L SIN	D	L TAN	CD	L COT	L COS	D		PROP. PTS.	
									112°... 292°	L COS
0	9.57 358	31	9.60 641	36	0.39 359	9.96 717	6	60		
1	9.57 389	31	9.60 677	37	0.39 323	9.96 711	5	59	37	36
2	9.57 420	31	9.60 714	36	0.39 286	9.96 706	5	58		
3	9.57 451	31	9.60 750	36	0.39 250	9.96 701	5	57	1	3.7 3.6
4	9.57 482	32	9.60 786	37	0.39 214	9.96 696	5	56	2	7.4 7.2
									3	11.1 10.8
5	9.57 514	31	9.60 823	36	0.39 177	9.96 691	5	55	4	14.8 14.4
6	9.57 545	31	9.60 859	36	0.39 141	9.96 686	5	54	5	18.5 18.0
7	9.57 576	31	9.60 895	36	0.39 105	9.96 681	5	53	6	22.2 21.6
8	9.57 607	31	9.60 931	36	0.39 069	9.96 676	6	52	7	25.9 25.2
9	9.57 638	31	9.60 967	37	0.39 033	9.96 670	5	51	8	29.6 28.8
									9	33.3 32.4
10	9.57 669	31	9.61 004	36	0.38 996	9.96 665	5	50		
11	9.57 700	31	9.61 040	36	0.38 960	9.96 660	5	49		
12	9.57 731	31	9.61 076	36	0.38 924	9.96 655	5	48		
13	9.57 762	31	9.61 112	36	0.38 888	9.96 650	5	47		
14	9.57 793	31	9.61 148	36	0.38 852	9.96 645	5	46		35
									1	3.5
15	9.57 824	31	9.61 184	36	0.38 816	9.96 640	6	45	2	7.0
16	9.57 855	30	9.61 220	36	0.38 780	9.96 634	5	44	3	10.5
17	9.57 885	31	9.61 256	36	0.38 744	9.96 629	5	43	4	14.0
18	9.57 916	31	9.61 292	36	0.38 708	9.96 624	5	42	5	17.5
19	9.57 947	31	9.61 328	36	0.38 672	9.96 619	5	41	6	21.0
									7	24.5
20	9.57 978	30	9.61 364	36	0.38 636	9.96 614	6	40	8	28.0
21	9.58 008	31	9.61 400	36	0.38 600	9.96 608	5	39	9	31.5
22	9.58 039	31	9.61 436	36	0.38 564	9.96 603	5	38		
23	9.58 070	31	9.61 472	36	0.38 528	9.96 598	5	37		
24	9.58 101	30	9.61 508	36	0.38 492	9.96 593	5	36		
25	9.58 131	31	9.61 544	35	0.38 456	9.96 588	6	35		32 31
26	9.58 162	30	9.61 579	36	0.38 421	9.96 582	5	34		
27	9.58 192	31	9.61 615	36	0.38 385	9.96 577	5	33	1	3.2 3.1
28	9.58 223	30	9.61 651	36	0.38 349	9.96 572	5	32	2	6.4 6.2
29	9.58 253	31	9.61 687	35	0.38 313	9.96 567	5	31	3	9.6 9.3
									4	12.8 12.4
30	9.58 284	30	9.61 722	36	0.38 278	9.96 562	6	30	5	16.0 15.5
31	9.58 314	31	9.61 758	36	0.38 242	9.96 556	5	29	6	19.2 18.6
32	9.58 345	30	9.61 794	36	0.38 206	9.96 551	5	28	7	22.4 21.7
33	9.58 375	31	9.61 830	35	0.38 170	9.96 546	5	27	8	25.6 24.8
34	9.58 406	30	9.61 865	36	0.38 135	9.96 541	6	26	9	28.8 27.9
35	9.58 346	31	9.61 901	35	0.38 099	9.96 535	5	25		
36	9.58 467	30	9.61 936	36	0.38 064	9.96 530	5	24		
37	9.58 497	30	9.61 972	36	0.38 028	9.96 525	5	23		30 29
38	9.58 527	30	9.62 008	35	0.37 992	9.96 520	6	22	1	3.0 2.9
39	9.58 557	31	9.62 043	36	0.37 957	9.96 514	5	21	2	6.0 5.8
									3	9.0 8.7
40	9.58 588	30	9.62 079	35	0.37 921	9.96 509	5	20	4	12.0 11.6
41	9.58 618	30	9.62 114	36	0.37 886	9.96 504	6	19	5	15.0 14.5
42	9.58 648	30	9.62 150	35	0.37 850	9.96 498	5	18	6	18.0 17.4
43	9.58 678	31	9.62 185	36	0.37 815	9.96 493	5	17	7	21.0 20.3
44	9.58 709	30	9.62 221	35	0.37 779	9.96 488	5	16	8	24.0 23.2
									9	27.0 26.1
45	9.58 739	30	9.62 256	36	0.37 744	9.96 483	6	15		
46	9.58 769	30	9.62 292	35	0.37 708	9.96 477	5	14		
47	9.58 799	30	9.62 327	35	0.37 673	9.96 472	6	13		
48	9.58 829	30	9.62 362	36	0.37 638	9.96 467	5	12		
49	9.58 859	30	9.62 398	35	0.37 602	9.96 461	5	11		6 5
									1	0.6 0.5
50	9.58 889	30	9.62 433	35	0.37 567	9.96 456	5	10	2	1.2 1.0
51	9.58 919	30	9.62 468	36	0.37 532	9.96 451	6	9	3	11.8 1.5
52	9.58 949	30	9.62 504	35	0.37 496	9.96 445	5	8	4	2.4 2.0
53	9.58 979	30	9.62 539	35	0.37 461	9.96 440	5	7	5	3.0 2.5
54	9.59 009	30	9.62 574	35	0.37 426	9.96 435	6	6	6	3.6 3.0
									7	4.2 3.5
55	9.59 039	30	9.62 609	36	0.37 391	9.96 429	5	5	8	4.8 4.0
56	9.59 069	29	9.62 645	35	0.37 355	9.96 424	5	4	9	5.4 4.5
57	9.59 098	30	9.62 680	35	0.37 320	9.96 419	6	3		
58	9.59 128	30	9.62 715	35	0.37 285	9.96 413	5	2		
59	9.59 158	30	9.62 750	35	0.37 250	9.96 408	5	1		
60	9.59 188		9.62 785		0.37 215	9.96 403		0		
	L SIN	D	L TAN	CD	L COT	L COS	D		337°... 157°	
	L COS		L COT		L TAN	L SIN			247°... 67°	

23° ... 203°	L SIN	D	L TAN	CD	L COT	L COS	D	PROP. PTS.
113° ... 293°	L COS		L COT		L TAN	L SIN		
0	9.59 188	30	9.62 785	35	0.37 215	9.96 403	60	
1	9.59 218	29	9.62 820	35	0.37 180	9.96 397	59	
2	9.59 247	30	9.62 855	35	0.37 145	9.96 392	58	
3	9.59 277	30	9.62 890	36	0.37 110	9.96 387	57	
4	9.59 307	29	9.62 926	35	0.37 074	9.96 381	56	36 35
5	9.59 336	30	9.62 961	35	0.37 039	9.96 376	55	1 3.6 3.5
6	9.59 366	30	9.62 996	35	0.37 004	9.96 370	54	2 7.2 7.0
7	9.59 396	29	9.63 031	35	0.36 969	9.96 365	53	3 10.8 10.5
8	9.59 425	30	9.63 066	35	0.36 934	9.96 360	52	4 14.4 14.0
9	9.59 455	29	9.63 101	34	0.36 899	9.96 354	51	5 18.0 17.5
10	9.59 484	30	9.63 135	35	0.36 865	9.96 349	50	6 21.6 21.0
11	9.59 514	29	9.63 170	35	0.36 830	9.96 343	49	7 25.2 24.5
12	9.59 543	30	9.63 205	35	0.36 795	9.96 338	48	8 28.8 28.0
13	9.59 573	29	9.63 240	35	0.36 760	9.96 333	47	9 32.4 31.5
14	9.59 602	30	9.63 275	35	0.36 725	9.96 327	46	
15	9.59 632	29	9.63 310	35	0.36 690	9.96 322	45	34
16	9.59 661	29	9.63 345	34	0.36 655	9.96 316	44	1 3.4
17	9.59 690	30	9.63 379	35	0.36 621	9.96 311	43	2 6.8
18	9.59 720	29	9.63 414	35	0.36 586	9.96 305	42	3 10.2
19	9.59 749	29	9.63 449	35	0.36 551	9.96 300	41	4 13.6
20	9.59 778	30	9.63 484	35	0.36 516	9.96 294	40	5 17.0
21	9.59 808	29	9.63 519	34	0.36 481	9.96 289	39	6 20.4
22	9.59 837	29	9.63 553	35	0.36 447	9.96 284	38	7 23.8
23	9.59 866	29	9.63 588	35	0.36 412	9.96 278	37	8 27.2
24	9.59 895	29	9.63 623	34	0.36 377	9.96 273	36	9 30.6
25	9.59 924	30	9.63 657	35	0.36 343	9.96 267	35	
26	9.59 954	29	9.63 692	34	0.36 308	9.96 262	34	30 29
27	9.59 983	29	9.63 726	35	0.36 274	9.96 256	33	1 3.0 2.9
28	9.60 012	29	9.63 761	35	0.36 239	9.96 251	32	2 6.0 5.8
29	9.60 041	29	9.63 796	34	0.36 204	9.96 245	31	3 9.0 8.7
30	9.60 070	29	9.63 830	35	0.36 170	9.96 240	30	4 12.0 11.6
31	9.60 099	29	9.63 865	34	0.36 135	9.96 234	29	5 15.0 14.5
32	9.60 128	29	9.63 899	35	0.36 101	9.96 229	28	6 18.0 17.4
33	9.60 157	29	9.63 934	34	0.36 066	9.96 223	27	7 21.0 20.3
34	9.60 186	29	9.63 968	35	0.36 032	9.96 218	26	8 24.0 23.2
35	9.60 215	29	9.64 003	34	0.35 997	9.96 212	25	9 27.0 26.1
36	9.60 244	29	9.64 037	35	0.35 963	9.96 207	24	
37	9.60 273	29	9.64 072	34	0.35 928	9.96 201	23	
38	9.60 302	29	9.64 106	34	0.35 894	9.96 196	22	28
39	9.60 331	28	9.64 140	35	0.35 860	9.96 190	21	1 2.8
40	9.60 359	29	9.64 175	34	0.35 825	9.96 185	20	2 5.6
41	9.60 388	29	9.64 209	34	0.35 791	9.96 179	19	3 8.4
42	9.60 417	29	9.64 243	35	0.35 757	9.96 174	18	4 11.2
43	9.60 446	28	9.64 278	34	0.35 722	9.96 168	17	5 14.0
44	9.60 474	29	9.64 312	34	0.35 688	9.96 162	16	6 16.8
45	9.60 503	29	9.64 346	35	0.35 654	9.96 157	15	7 19.6
46	9.60 532	29	9.64 381	34	0.35 619	9.96 151	14	8 22.4
47	9.60 561	28	9.64 415	34	0.35 585	9.96 146	13	9 25.2
48	9.60 589	29	9.64 449	34	0.35 551	9.96 140	12	
49	9.60 618	28	9.64 483	34	0.35 517	9.96 135	11	
50	9.60 646	29	9.64 517	35	0.35 483	9.96 129	10	6 5
51	9.60 675	29	9.64 552	34	0.35 448	9.96 123	9	1 0.6 0.5
52	9.60 704	28	9.64 586	34	0.35 414	9.96 118	8	2 1.2 1.0
53	9.60 732	29	9.64 620	34	0.35 380	9.96 112	7	3 1.8 1.5
54	9.60 761	28	9.64 654	34	0.35 346	9.96 107	6	4 2.4 2.0
55	9.60 789	29	9.64 688	34	0.35 312	9.96 101	5	5 3.0 2.5
56	9.60 818	28	9.64 722	34	0.35 278	9.96 095	4	6 3.6 3.0
57	9.60 846	29	9.64 756	34	0.35 244	9.96 090	3	7 4.2 3.5
58	9.60 875	28	9.64 790	34	0.35 210	9.96 084	2	8 4.8 4.0
59	9.60 903	28	9.64 824	34	0.35 176	9.96 079	1	9 5.4 4.5
60	9.60 931		9.64 858		0.35 142	9.96 073	0	
	L SIN	D	L TAN	CD	L COT	L COS	D	336° ... 156°
	L COS		L COT		L TAN	L SIN		246° ... 66°

24° ... 204°		L SIN	D	L TAN	CD	L COT	L COS	D	PROP. PTS.	
114° ... 294°		L COS		L COT		L TAN	L SIN			
0	9.60 931	29	9.64 858	34	0.35 142	9.96 073	6	60		
1	9.60 960	28	9.64 892	34	0.35 108	9.96 067	5	59		
2	9.60 988	28	9.64 926	34	0.35 074	9.96 062	6	58		
3	9.61 016	29	9.64 960	34	0.35 040	9.96 056	6	57	34	33
4	9.61 045	28	9.64 994	34	0.35 006	9.96 050	5	56	1	3.4
5	9.61 073	28	9.65 028	34	0.34 972	9.96 045	6	55	2	6.8
6	9.61 101	28	9.65 062	34	0.34 938	9.96 039	5	54	3	10.2
7	9.61 129	29	9.65 096	34	0.34 904	9.96 034	6	53	4	13.6
8	9.61 158	28	9.65 130	34	0.34 870	9.96 028	6	52	5	17.0
9	9.61 186	28	9.65 164	33	0.34 836	9.96 022	5	51	6	20.4
10	9.61 214	28	9.65 197	34	0.34 803	9.96 017	6	50	7	23.8
11	9.61 242	28	9.65 231	34	0.34 769	9.96 011	6	49	8	27.2
12	9.61 270	28	9.65 265	34	0.34 735	9.96 005	5	48	9	30.6
13	9.61 298	28	9.65 299	34	0.34 701	9.96 000	6	47		
14	9.61 326	28	9.65 333	33	0.34 667	9.95 994	6	46		
15	9.61 354	28	9.65 366	34	0.34 634	9.95 988	6	45		
16	9.61 382	29	9.65 400	34	0.34 600	9.95 982	5	44	1	2.9
17	9.61 411	27	9.65 434	33	0.34 566	9.95 977	6	43	2	5.8
18	9.61 438	28	9.65 467	34	0.34 533	9.95 971	6	42	3	8.7
19	9.61 466	28	9.65 501	34	0.34 499	9.95 965	5	41	4	11.6
20	9.61 494	28	9.65 535	33	0.34 465	9.95 960	6	40	5	14.5
21	9.61 522	28	9.65 568	34	0.34 432	9.95 954	6	39	6	17.4
22	9.61 550	28	9.65 602	34	0.34 398	9.95 948	6	38	7	20.3
23	9.61 578	28	9.65 636	33	0.34 364	9.95 942	5	37	8	23.2
24	9.61 606	28	9.65 669	34	0.34 331	9.95 937	6	36	9	26.1
25	9.61 634	28	9.65 703	33	0.34 297	9.95 931	6	35		
26	9.61 662	27	9.65 736	34	0.34 264	9.95 925	5	34		
27	9.61 689	28	9.65 770	33	0.34 230	9.95 920	6	33		
28	9.61 717	28	9.65 803	34	0.34 197	9.95 914	6	32	1	2.8
29	9.61 745	28	9.65 837	33	0.34 163	9.95 908	6	31	2	5.6
30	9.61 773	27	9.65 870	34	0.34 130	9.95 902	5	30	3	8.4
31	9.61 800	28	9.65 904	33	0.34 096	9.95 897	6	29	4	11.2
32	9.61 828	28	9.65 937	34	0.34 063	9.95 891	6	28	5	14.0
33	9.61 856	27	9.65 971	33	0.34 029	9.95 885	6	27	6	16.8
34	9.61 883	28	9.66 004	34	0.33 996	9.95 879	6	26	7	19.6
35	9.61 911	28	9.66 038	33	0.33 962	9.95 873	5	25	8	22.4
36	9.61 939	27	9.66 071	33	0.33 929	9.95 868	6	24	9	25.2
37	9.61 966	28	9.66 104	34	0.33 896	9.95 862	6	23		
38	9.61 994	27	9.66 138	33	0.33 862	9.95 856	6	22		
39	9.62 021	28	9.66 171	33	0.33 829	9.95 850	6	21		
40	9.62 049	27	9.66 204	34	0.33 796	9.95 844	5	20	1	2.7
41	9.62 076	28	9.66 238	33	0.33 762	9.95 839	6	19	2	5.4
42	9.62 104	27	9.66 271	33	0.33 729	9.95 833	6	18	3	8.1
43	9.62 131	28	9.66 304	33	0.33 696	9.95 827	6	17	4	10.8
44	9.62 159	27	9.66 337	34	0.33 663	9.95 821	6	16	5	13.5
45	9.62 186	28	9.66 371	33	0.33 629	9.95 815	5	15	6	16.2
46	9.62 214	27	9.66 404	33	0.33 596	9.95 810	6	14	7	18.9
47	9.62 241	27	9.66 437	33	0.33 563	9.95 804	6	13	8	21.6
48	9.62 268	28	9.66 470	33	0.33 530	9.95 798	6	12	9	24.3
49	9.62 296	27	9.66 503	34	0.33 497	9.95 792	6	11		
50	9.62 323	27	9.66 527	33	0.33 463	9.95 786	6	10		
51	9.62 350	27	9.66 570	33	0.33 430	9.95 780	5	9	6	5
52	9.62 377	28	9.66 603	33	0.33 397	9.95 775	5	8	1	0.6
53	9.62 405	27	9.66 636	33	0.33 364	9.95 769	6	7	2	1.2
54	9.62 432	27	9.66 669	33	0.33 331	9.95 763	6	6	3	1.8
55	9.62 459	27	9.66 702	33	0.33 298	9.95 757	6	5	4	2.4
56	9.62 486	27	9.66 735	33	0.33 265	9.95 751	6	4	5	3.0
57	9.62 513	28	9.66 768	33	0.33 232	9.95 745	6	3	6	3.6
58	9.62 541	27	9.66 801	33	0.33 199	9.95 739	6	2	7	4.2
59	9.62 568	27	9.66 834	33	0.33 166	9.95 733	5	1	8	4.8
60	9.62 595		9.66 867		0.33 133	9.95 728		0	9	5.4
	L SIN	D	L TAN	CD	L COT	L COS	D			
	L COS		L COT		L TAN	L SIN				
									335° ... 155°	
									245° ... 65°	

25°... 205°	L SIN	D	L TAN	CD	L COT	L COS	D	PROP. PTS.
	L COS		L COT		L TAN	L SIN		
115°... 295°								
0	9.62 595	27	9.66 867	33	0.33 133	9.95 728	6	60
1	9.62 622	27	9.66 900	33	0.33 100	9.95 722	6	59
2	9.62 649	27	9.66 933	33	0.33 067	9.95 716	6	58
3	9.62 676	27	9.66 966	33	0.33 034	9.95 710	6	57
4	9.62 703	27	9.66 999	33	0.33 001	9.95 704	6	56
5	9.62 730	27	9.67 032	33	0.32 968	9.95 698	6	55
6	9.62 757	27	9.67 065	33	0.32 935	9.95 692	6	54
7	9.62 784	27	9.67 098	33	0.32 902	9.95 686	6	53
8	9.62 811	27	9.67 131	33	0.32 869	9.95 680	6	52
9	9.62 838	27	9.67 163	32	0.32 837	9.95 674	6	51
10	9.62 865	27	9.67 196	33	0.32 804	9.95 668	5	50
11	9.62 892	26	9.67 229	33	0.32 771	9.95 663	6	49
12	9.62 918	27	9.67 262	33	0.32 738	9.95 657	6	48
13	9.62 945	27	9.67 295	32	0.32 705	9.95 651	6	47
14	9.62 972	27	9.67 327	33	0.32 673	9.95 645	6	46
15	9.62 999	27	9.67 360	33	0.32 640	9.95 639	6	45
16	9.63 026	26	9.67 393	33	0.32 607	9.95 633	6	44
17	9.63 052	27	9.67 426	33	0.32 574	9.95 627	6	43
18	9.63 079	27	9.67 458	32	0.32 542	9.95 621	6	42
19	9.63 106	27	9.67 491	33	0.32 509	9.95 615	6	41
20	9.63 133	26	9.67 524	32	0.32 476	9.95 609	6	40
21	9.63 159	27	9.67 556	33	0.32 444	9.95 603	6	39
22	9.63 186	27	9.67 589	33	0.32 411	9.95 597	6	38
23	9.63 213	26	9.67 622	32	0.32 378	9.95 591	6	37
24	9.63 239	27	9.67 654	33	0.32 346	9.95 585	6	36
25	9.63 266	26	9.67 687	32	0.32 313	9.95 579	6	35
26	9.63 292	27	9.67 719	33	0.32 281	9.95 573	6	34
27	9.63 319	26	9.67 752	33	0.32 248	9.95 567	6	33
28	9.63 345	27	9.67 785	32	0.32 215	9.95 561	6	32
29	9.63 372	26	9.67 817	33	0.32 183	9.95 555	6	31
30	9.63 398	27	9.67 850	32	0.32 150	9.95 549	6	30
31	9.63 425	26	9.67 882	33	0.32 118	9.95 543	6	29
32	9.63 451	27	9.67 915	32	0.32 085	9.95 537	6	28
33	9.63 478	26	9.67 947	33	0.32 053	9.95 531	6	27
34	9.63 504	27	9.67 980	32	0.32 020	9.95 525	6	26
35	9.63 531	26	9.68 012	32	0.31 988	9.95 519	6	25
36	9.63 557	26	9.68 044	33	0.31 956	9.95 513	6	24
37	9.63 583	27	9.68 077	32	0.31 923	9.95 507	7	23
38	9.63 610	26	9.68 109	33	0.31 891	9.95 500	6	22
39	9.63 636	26	9.68 142	32	0.31 858	9.95 494	6	21
40	9.63 662	27	9.68 174	33	0.31 826	9.95 488	6	20
41	9.63 689	26	9.68 206	33	0.31 794	9.95 482	6	19
42	9.63 715	26	9.68 239	32	0.31 761	9.95 476	6	18
43	9.63 741	26	9.68 271	32	0.31 729	9.95 470	6	17
44	9.63 767	27	9.68 303	33	0.31 697	9.95 464	6	16
45	9.63 794	26	9.68 336	32	0.31 664	9.95 458	6	15
46	9.63 820	26	9.68 368	32	0.31 632	9.95 452	6	14
47	9.63 846	26	9.68 400	33	0.31 600	9.95 446	6	13
48	9.63 872	26	9.68 432	32	0.31 568	9.95 440	6	12
49	9.63 898	26	9.68 465	32	0.31 535	9.95 434	7	11
50	9.63 924	26	9.68 497	32	0.31 503	9.95 427	6	10
51	9.63 950	26	9.68 529	32	0.31 471	9.95 421	6	9
52	9.63 976	26	9.68 561	32	0.31 439	9.95 415	6	8
53	9.64 002	26	9.68 593	33	0.31 407	9.95 409	6	7
54	9.64 028	26	9.68 626	32	0.31 374	9.95 403	6	6
55	9.64 054	26	9.68 658	32	0.31 342	9.95 397	6	5
56	9.64 080	26	9.68 690	32	0.31 310	9.95 391	7	4
57	9.64 106	26	9.68 722	32	0.31 278	9.95 384	6	3
58	9.64 132	26	9.68 754	32	0.31 246	9.95 378	6	2
59	9.64 158	26	9.68 786	32	0.31 214	9.95 372	6	1
60	9.64 184		9.68 818		0.31 182	9.95 366		0
	L SIN	D	L TAN	CD	L COT	L COS	D	334°... 154°
	L COS		L COT		L TAN	L SIN		244°... 64°

26°... 206°	L SIN	D	L TAN	CD	L COT	L COS	D	PROP. PTS.	
116°... 296°	L COS		L COT		L TAN	L SIN			
0	9.64 184	26	9.68 818	32	0.31 182	9.95 366	6	60	
1	9.64 210	26	9.68 850	32	0.31 150	9.95 360	6	59	
2	9.64 236	26	9.68 882	32	0.31 118	9.95 354	6	58	32 31
3	9.64 262	26	9.68 914	32	0.31 086	9.95 348	7	57	
4	9.64 288	25	9.68 946	32	0.31 054	9.95 341	6	56	1 3.2 3.1
5	9.64 313	26	9.68 978	32	0.31 022	9.95 335	6	55	2 6.4 6.2
6	9.64 339	26	9.69 010	32	0.30 990	9.95 329	6	54	3 9.6 9.3
7	9.64 365	26	9.69 042	32	0.30 958	9.95 323	6	53	4 12.8 12.4
8	9.64 391	26	9.69 074	32	0.30 926	9.95 317	7	52	5 16.0 15.5
9	9.64 417	25	9.69 106	32	0.30 894	9.95 310	6	51	6 19.2 18.6
10	9.64 442	26	9.69 138	32	0.30 862	9.95 304	6	50	7 22.4 21.7
11	9.64 468	26	9.69 170	32	0.30 830	9.95 298	6	49	8 25.6 24.8
12	9.64 494	25	9.69 202	32	0.30 798	9.95 292	6	48	9 28.8 27.9
13	9.64 519	26	9.69 234	32	0.30 766	9.95 286	7	47	
14	9.64 545	26	9.69 266	32	0.30 734	9.95 279	6	46	26
15	9.64 571	25	9.69 298	31	0.30 702	9.95 273	6	45	1 2.6
16	9.64 596	26	9.69 329	32	0.30 671	9.95 267	6	44	2 5.2
17	9.64 622	25	9.69 361	32	0.30 639	9.95 261	6	43	3 7.8
18	9.64 647	26	9.69 393	32	0.30 607	9.95 254	7	42	4 10.4
19	9.64 673	25	9.69 425	32	0.30 575	9.95 248	6	41	5 13.0
20	9.64 698	26	9.69 457	31	0.30 543	9.95 242	6	40	6 15.6
21	9.64 724	25	9.69 488	32	0.30 512	9.95 236	7	39	7 18.2
22	9.64 749	26	9.69 520	32	0.30 480	9.95 229	6	38	8 20.8
23	9.64 775	25	9.69 552	32	0.30 448	9.95 223	6	37	9 23.4
24	9.64 800	26	9.69 584	31	0.30 416	9.95 217	6	36	
25	9.64 826	25	9.69 615	32	0.30 385	9.95 211	7	35	25
26	9.64 851	26	9.69 647	32	0.30 353	9.95 204	6	34	1 2.5
27	9.64 877	25	9.69 679	31	0.30 321	9.95 198	6	33	2 5.0
28	9.64 902	25	9.69 710	32	0.30 290	9.95 192	6	32	3 7.5
29	9.64 927	26	9.69 742	32	0.30 258	9.95 185	6	31	4 10.0
30	9.64 953	25	9.69 774	31	0.30 226	9.95 179	6	30	5 12.5
31	9.64 978	25	9.69 805	32	0.30 195	9.95 173	6	29	6 15.0
32	9.65 003	26	9.69 837	31	0.30 163	9.95 167	7	28	7 17.5
33	9.65 029	25	9.69 868	32	0.30 132	9.95 160	6	27	8 20.0
34	9.65 054	25	9.69 900	32	0.30 100	9.95 154	6	26	9 22.5
35	9.65 079	25	9.69 932	31	0.30 068	9.95 148	7	25	
36	9.65 104	26	9.69 963	32	0.30 037	9.95 141	6	24	
37	9.65 130	25	9.69 995	31	0.30 005	9.95 135	6	23	
38	9.65 155	25	9.70 026	32	0.29 974	9.95 129	6	22	24
39	9.65 180	25	9.70 058	31	0.29 942	9.95 122	7	21	1 2.4
40	9.65 205	25	9.70 089	32	0.29 911	9.95 116	6	20	2 4.8
41	9.65 230	25	9.70 121	31	0.29 879	9.95 110	7	19	3 7.2
42	9.65 255	26	9.70 152	32	0.29 848	9.95 103	6	18	4 9.6
43	9.65 281	25	9.70 184	31	0.29 816	9.95 097	7	17	5 12.0
44	9.65 306	25	9.70 215	32	0.29 785	9.95 090	6	16	6 14.4
45	9.65 331	25	9.70 247	31	0.29 753	9.95 084	6	15	7 16.8
46	9.65 356	25	9.70 278	31	0.29 722	9.95 078	7	14	8 19.2
47	9.65 381	25	9.70 309	32	0.29 691	9.95 071	6	13	9 21.6
48	9.65 406	25	9.70 341	31	0.29 659	9.95 065	6	12	
49	9.65 431	25	9.70 372	32	0.29 628	9.95 059	7	11	7 6
50	9.65 456	25	9.70 404	31	0.29 596	9.95 052	6	10	1 0.7 0.6
51	9.65 481	25	9.70 435	31	0.29 565	9.95 046	6	9	2 1.4 1.2
52	9.65 506	25	9.70 466	32	0.29 534	9.95 039	7	8	3 2.1 1.8
53	9.65 531	25	9.70 498	31	0.29 502	9.95 033	6	7	4 2.8 2.4
54	9.65 556	24	9.70 529	31	0.29 471	9.95 027	6	6	5 3.5 3.0
55	9.65 580	25	9.70 560	32	0.29 440	9.95 020	7	5	6 4.2 3.6
56	9.65 605	25	9.70 592	31	0.29 408	9.95 014	6	4	7 4.9 4.2
57	9.65 630	25	9.70 623	31	0.29 377	9.95 007	7	3	8 5.6 4.8
58	9.65 655	25	9.70 654	31	0.29 346	9.95 001	6	2	9 6.3 5.4
59	9.65 680	25	9.70 685	32	0.29 315	9.94 995	6	1	
60	9.65 705		9.70 717		0.29 283	9.94 988		0	
	L SIN	D	L TAN	CD	L COT	L COS	D	333° ... 153°	
	L COS		L COT		L TAN	L SIN		243° ... 63°	

27°... 207°	L SIN	D	L TAN	CD	L COT	L COS	D	PROP. PTS.			
117°... 297°	L COS		L COT		L TAN	L SIN					
0	9.65 705	24	9.70 717	31	0.29 283	9.94 988	6	60			
1	9.65 729	25	9.70 748	31	0.29 252	9.94 982	7	59			
2	9.65 754	25	9.70 779	31	0.29 221	9.94 975	7	58			
3	9.65 779	25	9.70 810	31	0.29 190	9.94 969	6	57	32	31	
4	9.65 804	24	9.70 841	32	0.29 159	9.94 962	7	56	1	3.2	3.1
5	9.65 828	25	9.70 873	31	0.29 127	9.94 956	7	55	2	6.4	6.2
6	9.65 853	25	9.70 904	31	0.29 096	9.94 949	3	54	3	9.6	9.3
7	9.65 878	24	9.70 935	31	0.29 065	9.94 943	6	53	4	12.8	12.4
8	9.65 902	25	9.70 966	31	0.29 034	9.94 936	7	52	5	16.0	15.5
9	9.65 927	25	9.70 997	31	0.29 003	9.94 930	6	51	6	19.2	18.6
10	9.65 952	24	9.71 028	31	0.28 972	9.94 923	7	50	7	22.4	21.7
11	9.65 976	25	9.71 059	31	0.28 941	9.94 917	6	49	8	25.6	24.8
12	9.66 001	24	9.71 090	31	0.28 910	9.94 911	6	48	9	28.8	27.9
13	9.66 025	24	9.71 121	32	0.28 879	9.94 904	7	47			
14	9.66 050	25	9.71 153	31	0.28 847	9.94 898	6	46			
15	9.66 075	24	9.71 184	31	0.28 816	9.94 891	7	45	30		
16	9.66 099	25	9.71 215	31	0.28 785	9.94 885	6	44	1	3.0	
17	9.66 124	24	9.71 246	31	0.28 754	9.94 878	7	43	2	6.0	
18	9.66 148	25	9.71 277	31	0.28 723	9.94 871	7	42	3	9.0	
19	9.66 173	24	9.71 308	31	0.28 692	9.94 865	6	41	4	12.0	
20	9.66 197	24	9.71 339	31	0.28 661	9.94 858	7	40	5	15.0	
21	9.66 221	25	9.71 370	31	0.28 630	9.94 852	6	39	6	18.0	
22	9.66 246	24	9.71 401	30	0.28 599	9.94 845	7	38	7	21.0	
23	9.66 270	25	9.71 431	31	0.28 569	9.94 839	6	37	8	24.0	
24	9.66 295	24	9.71 462	31	0.28 538	9.94 832	7	36	9	27.0	
25	9.66 319	24	9.71 493	31	0.28 507	9.94 826	6	35			
26	9.66 343	25	9.71 524	31	0.28 476	9.94 819	7	34	25	24	
27	9.66 368	24	9.71 555	31	0.28 445	9.94 813	6	33	1	2.5	2.4
28	9.66 392	24	9.71 586	31	0.28 414	9.94 806	7	32	2	5.0	4.3
29	9.66 416	25	9.71 617	31	0.28 383	9.94 799	6	31	3	7.5	7.2
30	9.66 441	24	9.71 648	31	0.28 352	9.94 793	7	30	4	10.0	9.6
31	9.66 465	24	9.71 679	30	0.28 321	9.94 786	6	29	5	12.5	12.0
32	9.66 489	24	9.71 709	31	0.28 291	9.94 780	7	28	6	15.0	14.4
33	9.66 513	24	9.71 740	31	0.28 260	9.94 773	6	27	7	17.5	16.8
34	9.66 537	25	9.71 771	31	0.28 229	9.94 767	7	26	8	20.0	19.2
35	9.66 562	24	9.71 802	31	0.28 198	9.94 760	6	25	9	22.5	21.6
36	9.66 586	24	9.71 833	30	0.28 167	9.94 753	7	24			
37	9.66 610	24	9.71 863	31	0.28 137	9.94 747	6	23			
38	9.66 634	24	9.71 894	31	0.28 106	9.94 740	7	22			
39	9.66 658	24	9.71 925	30	0.28 075	9.94 734	6	21	23		
40	9.66 682	24	9.71 955	31	0.28 045	9.94 727	7	20	1	2.3	
41	9.66 706	25	9.71 986	31	0.28 014	9.94 720	6	19	2	4.6	
42	9.66 731	24	9.72 017	31	0.27 983	9.94 714	7	18	3	6.9	
43	9.66 755	24	9.72 048	30	0.27 952	9.94 707	6	17	4	9.2	
44	9.66 779	24	9.72 078	31	0.27 922	9.94 700	7	16	5	11.5	
45	9.66 803	24	9.72 109	31	0.27 891	9.94 694	6	15	6	13.8	
46	9.66 827	24	9.72 140	30	0.27 860	9.94 687	7	14	7	16.1	
47	9.66 851	24	9.72 170	31	0.27 830	9.94 680	6	13	8	18.4	
48	9.66 875	24	9.72 201	30	0.27 799	9.94 674	7	12	9	20.7	
49	9.66 899	23	9.72 231	31	0.27 769	9.94 667	6	11			
50	9.66 922	24	9.72 262	31	0.27 738	9.94 660	7	10	7	6	
51	9.66 946	24	9.72 293	30	0.27 707	9.94 654	6	9	1	0.7	0.6
52	9.66 970	24	9.72 323	31	0.27 677	9.94 647	7	8	2	1.4	1.2
53	9.66 994	24	9.72 354	30	0.27 646	9.94 640	6	7	3	2.1	1.8
54	9.67 018	24	9.72 384	31	0.27 616	9.94 634	7	6	4	2.8	2.4
55	9.67 042	24	9.72 415	30	0.27 585	9.94 627	6	5	5	3.5	3.0
56	9.67 066	24	9.72 445	31	0.27 555	9.94 620	7	4	6	4.2	3.6
57	9.67 090	23	9.72 476	30	0.27 524	9.94 614	6	3	7	4.9	4.2
58	9.67 113	24	9.72 506	31	0.27 494	9.94 607	7	2	8	5.6	4.8
59	9.67 137	24	9.72 537	30	0.27 463	9.94 600	6	1	9	6.3	5.4
60	9.67 161		9.72 567		0.27 433	9.94 593		0			
	L SIN	D	L TAN	CD	L COT	L COS	D	332°... 153°			
	L COS		L COT		L TAN	L SIN		242°... 62°			

28°... 208°	L SIN	D	L TAN	CD	L COT	L COS	D	PROP. PTS.	
118°... 298°	L COS		L COT		L TAN	L SIN			
0	9.67 161	24	9.72 567	31	0.27 433	9.94 593	6	60	
1	9.67 185	23	9.72 598	30	0.27 402	9.94 587	7	59	
2	9.67 208	24	9.72 628	31	0.27 372	9.94 580	7	58	
3	9.67 232	24	9.72 659	30	0.27 341	9.94 573	7	57	
4	9.67 256	24	9.72 689	30	0.27 311	9.94 567	6	56	
				31			7		31 30
5	9.67 280	23	9.72 720	30	0.27 280	9.94 560	7	55	1 3.1 3.0
6	9.67 303	24	9.72 750	30	0.27 250	9.94 553	7	54	2 6.2 6.0
7	9.67 327	23	9.72 780	31	0.27 220	9.94 546	6	53	3 9.3 9.0
8	9.67 350	24	9.72 811	30	0.27 189	9.94 540	6	52	4 12.4 12.0
9	9.67 374	24	9.72 841	31	0.27 159	9.94 533	7	51	5 15.5 15.0
									6 18.6 18.0
10	9.67 398	23	9.72 872	30	0.27 128	9.94 526	7	50	7 21.7 21.0
11	9.67 421	24	9.72 902	30	0.27 098	9.94 519	6	49	8 24.8 24.0
12	9.67 445	23	9.72 932	31	0.27 068	9.94 513	7	48	9 27.9 27.0
13	9.67 468	24	9.72 963	30	0.27 037	9.94 506	7	47	
14	9.67 492	23	9.72 993	30	0.27 007	9.94 499	7	46	
									29
15	9.67 515	24	9.73 023	31	0.26 977	9.94 492	7	45	1 2.9
16	9.67 539	23	9.73 054	30	0.26 946	9.94 485	6	44	2 5.8
17	9.67 562	24	9.73 084	30	0.26 916	9.94 479	7	43	3 8.7
18	9.67 586	23	9.73 114	30	0.26 886	9.94 472	7	42	4 11.6
19	9.67 609	24	9.73 144	31	0.26 856	9.94 465	7	41	5 14.5
									6 17.4
20	9.67 633	23	9.73 175	30	0.26 825	9.94 458	7	40	7 20.3
21	9.67 656	24	9.73 205	30	0.26 795	9.94 451	6	39	8 23.2
22	9.67 680	23	9.73 235	30	0.26 765	9.94 445	7	38	9 26.1
23	9.67 703	23	9.73 265	30	0.26 735	9.94 438	7	37	
24	9.67 726	24	9.73 295	31	0.26 705	9.94 431	7	36	
									24 23
25	9.67 750	23	9.73 326	30	0.26 674	9.94 424	7	35	1 2.4 2.3
26	9.67 773	23	9.73 356	30	0.26 644	9.94 417	7	34	2 4.8 4.6
27	9.67 796	24	9.73 386	30	0.26 614	9.94 410	6	33	3 7.2 6.9
28	9.67 820	23	9.73 416	30	0.26 584	9.94 404	7	32	4 9.6 9.2
29	9.67 843	23	9.73 446	30	0.26 554	9.94 397	7	31	5 12.0 11.5
									6 14.4 13.8
30	9.67 866	24	9.73 476	31	0.26 524	9.94 390	7	30	7 16.8 16.1
31	9.67 890	23	9.73 507	30	0.26 493	9.94 383	7	29	8 19.2 18.4
32	9.67 913	23	9.73 537	30	0.26 463	9.94 376	7	28	9 21.6 20.7
33	9.67 936	23	9.73 567	30	0.26 433	9.94 369	7	27	
34	9.67 959	23	9.73 597	30	0.26 403	9.94 362	7	26	
									22
35	9.67 982	24	9.73 627	30	0.26 373	9.94 355	6	25	1 2.2
36	9.68 006	23	9.73 657	30	0.26 343	9.94 349	7	24	2 4.4
37	9.68 029	23	9.73 687	30	0.26 313	9.94 342	7	23	3 6.6
38	9.68 052	23	9.73 717	30	0.26 283	9.94 335	7	22	4 8.8
39	9.68 075	23	9.73 747	30	0.26 253	9.94 328	7	21	5 11.0
									6 13.2
40	9.68 098	23	9.73 777	30	0.26 223	9.94 321	7	20	7 15.4
41	9.68 121	23	9.73 807	30	0.26 193	9.94 314	7	19	8 17.6
42	9.68 144	23	9.73 837	30	0.26 163	9.94 307	7	18	9 19.8
43	9.68 167	23	9.73 867	30	0.26 133	9.94 300	7	17	
44	9.68 190	23	9.73 897	30	0.26 103	9.94 293	7	16	
									7 6
45	9.68 213	24	9.73 927	30	0.26 073	9.94 286	7	15	1 0.7 0.6
46	9.68 237	23	9.73 957	30	0.26 043	9.94 279	6	14	2 1.4 1.2
47	9.68 260	23	9.73 987	30	0.26 013	9.94 273	7	13	3 2.1 1.8
48	9.68 283	22	9.74 017	30	0.25 983	9.94 266	7	12	4 2.8 2.4
49	9.68 305	23	9.74 047	30	0.25 953	9.94 259	7	11	5 3.5 3.0
									6 4.2 3.6
50	9.68 328	23	9.74 077	30	0.25 923	9.94 252	7	10	7 4.9 4.2
51	9.68 351	23	9.74 107	30	0.25 893	9.94 245	7	9	8 5.6 4.8
52	9.68 374	23	9.74 137	29	0.25 863	9.94 238	7	8	9 6.3 5.4
53	9.68 397	23	9.74 166	30	0.25 834	9.94 231	7	7	
54	9.68 420	23	9.74 196	30	0.25 804	9.94 224	7	6	
									7 6
55	9.68 443	23	9.74 226	30	0.25 774	9.94 217	7	5	1 3.5 3.0
56	9.68 466	23	9.74 256	30	0.25 744	9.94 210	7	4	2 4.2 3.6
57	9.68 489	23	9.74 286	30	0.25 714	9.94 203	7	3	3 4.9 4.2
58	9.68 512	22	9.74 316	29	0.25 684	9.94 196	7	2	4 5.6 4.8
59	9.68 534	23	9.74 345	30	0.25 655	9.94 189	7	1	5 6.3 5.4
60	9.68 557		9.74 375		0.25 625	9.94 182		0	
	L SIN	D	L TAN	CD	L COT	L COS	D		331°... 151°
	L COS		L COT		L TAN	L SIN			241°... 61°

29°... 209°	L SIN	D	L TAN	CD	L COT	L COS	D	PROP. PTS.
119°... 299°	L COS		L COT		L TAN	L SIN		
0	9.68 557	23	9.74 375	30	0.25 625	9.94 182	7	60
1	9.68 580	23	9.74 405	30	0.25 595	9.94 175	7	59
2	9.68 603	22	9.74 435	30	0.25 565	9.94 168	7	58
3	9.68 625	23	9.74 465	29	0.25 535	9.94 161	7	57
4	9.68 648	23	9.74 494	30	0.25 506	9.94 154	7	56
5	9.68 671	23	9.74 524	30	0.25 476	9.94 147	7	55
6	9.68 694	22	9.74 554	29	0.25 446	9.94 140	7	54
7	9.68 716	23	9.74 583	30	0.25 417	9.94 133	7	53
8	9.68 739	23	9.74 613	30	0.25 387	9.94 126	7	52
9	9.68 762	22	9.74 643	30	0.25 357	9.94 119	7	51
10	9.68 784	23	9.74 673	29	0.25 327	9.94 112	7	50
11	9.68 807	22	9.74 702	30	0.25 298	9.94 105	7	49
12	9.68 829	23	9.74 732	30	0.25 268	9.94 098	8	48
13	9.68 852	23	9.74 762	29	0.25 238	9.94 090	7	47
14	9.68 875	22	9.74 791	30	0.25 209	9.94 083	7	46
15	9.68 897	23	9.74 821	30	0.25 179	9.94 076	7	45
16	9.68 920	22	9.74 851	29	0.25 149	9.94 069	7	44
17	9.68 942	23	9.74 880	30	0.25 120	9.94 062	7	43
18	9.68 965	22	9.74 910	29	0.25 090	9.94 055	7	42
19	9.68 987	23	9.74 939	30	0.25 061	9.94 048	7	41
20	9.69 010	22	9.74 969	29	0.25 031	9.94 041	7	40
21	9.69 032	23	9.74 998	30	0.25 002	9.94 034	7	39
22	9.69 055	22	9.75 028	30	0.24 972	9.94 027	7	38
23	9.69 077	23	9.75 058	29	0.24 942	9.94 020	8	37
24	9.69 100	22	9.75 087	30	0.24 913	9.94 012	7	36
25	9.69 122	22	9.75 117	29	0.24 883	9.94 005	7	35
26	9.69 144	23	9.75 146	30	0.24 854	9.93 998	7	34
27	9.69 167	22	9.75 176	29	0.24 824	9.93 991	7	33
28	9.69 189	23	9.75 205	30	0.24 795	9.93 984	7	32
29	9.69 212	22	9.75 235	29	0.24 765	9.93 977	7	31
30	9.69 234	22	9.75 264	30	0.24 736	9.93 970	7	30
31	9.69 256	23	9.75 294	29	0.24 706	9.93 963	8	29
32	9.69 279	22	9.75 323	30	0.24 677	9.93 955	7	28
33	9.69 301	22	9.75 353	29	0.24 647	9.93 948	7	27
34	9.69 323	22	9.75 382	29	0.24 618	9.93 941	7	26
35	9.69 345	23	9.75 411	30	0.24 589	9.93 934	7	25
36	9.69 368	22	9.75 441	29	0.24 559	9.93 927	7	24
37	9.69 390	22	9.75 470	30	0.24 530	9.93 920	8	23
38	9.69 412	22	9.75 500	29	0.24 500	9.93 912	7	22
39	9.69 434	22	9.75 529	29	0.24 471	9.93 905	7	21
40	9.69 456	23	9.75 558	30	0.24 442	9.93 898	7	20
41	9.69 479	22	9.75 588	29	0.24 412	9.93 891	7	19
42	9.69 501	22	9.75 617	30	0.24 383	9.93 884	8	18
43	9.69 523	22	9.75 647	29	0.24 353	9.93 876	7	17
44	9.69 545	22	9.75 676	29	0.24 324	9.93 869	7	16
45	9.69 567	22	9.75 705	30	0.24 295	9.93 862	7	15
46	9.69 589	22	9.75 735	29	0.24 265	9.93 855	8	14
47	9.69 611	22	9.75 764	29	0.24 236	9.93 847	7	13
48	9.69 633	22	9.75 793	29	0.24 207	9.93 840	7	12
49	9.69 655	22	9.75 822	30	0.24 178	9.93 833	7	11
50	9.69 677	22	9.75 852	29	0.24 148	9.93 826	7	10
51	9.69 699	22	9.75 881	29	0.24 119	9.93 819	8	9
52	9.69 721	22	9.75 910	29	0.24 090	9.93 811	7	8
53	9.69 743	22	9.75 939	30	0.24 061	9.93 804	7	7
54	9.69 765	22	9.75 969	29	0.24 031	9.93 797	8	6
55	9.69 787	22	9.75 998	29	0.24 002	9.93 789	7	5
56	9.69 809	22	9.76 027	29	0.23 973	9.93 782	7	4
57	9.69 831	22	9.76 056	30	0.23 944	9.93 775	7	3
58	9.69 853	22	9.76 086	29	0.23 914	9.93 768	7	2
59	9.69 875	22	9.76 115	29	0.23 885	9.93 760	8	1
60	9.69 897		9.76 144		0.23 856	9.93 753		0
	L SIN	D	L TAN	CD	L COT	L COS	D	330°... 150°
	L COS		L COT		L TAN	L SIN		240°... 60°

30°... 210°	L SIN	D	L TAN	CD	L COT	L COS	D	PROP. PTS.
120°... 300°	L COS		L COT		L TAN	L SIN		
0	9.69 897	22	9.76 144		0.23 856	9.93 753	7	60
1	9.69 919	22	9.76 173	29	0.23 827	9.93 746	8	59
2	9.69 941	22	9.76 202	29	0.23 798	9.93 738	7	58
3	9.69 963	21	9.76 231	30	0.23 769	9.93 731	7	57
4	9.69 984	22	9.76 261	29	0.23 739	9.93 724	7	56
5	9.70 006	22	9.76 290	29	0.23 710	9.93 717	8	55
6	9.70 028	22	9.76 319	29	0.23 681	9.93 709	7	54
7	9.70 050	22	9.76 348	29	0.23 652	9.93 702	7	53
8	9.70 072	21	9.76 377	29	0.23 623	9.93 695	8	52
9	9.70 093	22	9.76 406	29	0.23 594	9.93 687	7	51
10	9.70 115	22	9.76 435	29	0.23 565	9.93 680	7	50
11	9.70 137	22	9.76 464	29	0.23 536	9.93 673	8	49
12	9.70 159	21	9.76 493	29	0.23 507	9.93 665	7	48
13	9.70 180	22	9.76 522	29	0.23 478	9.93 658	8	47
14	9.70 202	22	9.76 551	29	0.23 449	9.93 650	7	46
15	9.70 224	21	9.76 580	29	0.23 420	9.93 643	7	45
16	9.70 245	22	9.76 609	30	0.23 391	9.93 636	8	44
17	9.70 267	21	9.76 639	29	0.23 361	9.93 628	7	43
18	9.70 288	22	9.76 668	29	0.23 332	9.93 621	7	42
19	9.70 310	22	9.76 697	28	0.23 303	9.93 614	8	41
20	9.70 332	21	9.76 725	29	0.23 275	9.93 606	7	40
21	9.70 353	22	9.76 754	29	0.23 246	9.93 599	8	39
22	9.70 375	21	9.76 783	29	0.23 217	9.93 591	8	38
23	9.70 396	21	9.76 812	29	0.23 188	9.93 584	7	37
24	9.70 418	21	9.76 841	29	0.23 159	9.93 577	8	36
25	9.70 439	22	9.76 870	29	0.23 130	9.93 569	7	35
26	9.70 461	21	9.76 899	29	0.23 101	9.93 562	8	34
27	9.70 482	22	9.76 928	29	0.23 072	9.93 554	7	33
28	9.70 504	21	9.76 957	29	0.23 043	9.93 547	8	32
29	9.70 525	22	9.76 986	29	0.23 014	9.93 539	7	31
30	9.70 547	21	9.77 015	29	0.22 985	9.93 532	7	30
31	9.70 568	22	9.77 044	29	0.22 956	9.93 525	8	29
32	9.70 590	21	9.77 073	28	0.22 927	9.93 517	7	28
33	9.70 611	22	9.77 101	29	0.22 899	9.93 510	8	27
34	9.70 633	21	9.77 130	29	0.22 870	9.93 502	7	26
35	9.70 654	21	9.77 159	29	0.22 841	9.93 495	8	25
36	9.70 675	22	9.77 188	29	0.22 812	9.93 487	7	24
37	9.70 697	21	9.77 217	29	0.22 783	9.93 480	8	23
38	9.70 718	21	9.77 246	28	0.22 754	9.93 472	7	22
39	9.70 739	22	9.77 274	29	0.22 726	9.93 465	8	21
40	9.70 761	21	9.77 303	29	0.22 697	9.93 457	7	20
41	9.70 782	21	9.77 332	29	0.22 668	9.93 450	8	19
42	9.70 803	21	9.77 361	29	0.22 639	9.93 442	7	18
43	9.70 824	22	9.77 390	28	0.22 610	9.93 435	8	17
44	9.70 846	21	9.77 418	29	0.22 582	9.93 427	7	16
45	9.70 867	21	9.77 447	29	0.22 553	9.93 420	8	15
46	9.70 888	21	9.77 476	29	0.22 524	9.93 412	7	14
47	9.70 909	22	9.77 505	28	0.22 495	9.93 405	8	13
48	9.70 931	21	9.77 533	29	0.22 467	9.93 397	7	12
49	9.70 952	21	9.77 562	29	0.22 438	9.93 390	8	11
50	9.70 973	21	9.77 591	28	0.22 409	9.93 382	7	10
51	9.70 994	21	9.77 619	29	0.22 381	9.93 375	8	9
52	9.71 015	22	9.77 648	29	0.22 352	9.93 367	7	8
53	9.71 036	22	9.77 677	29	0.22 323	9.93 360	8	7
54	9.71 058	21	9.77 706	28	0.22 294	9.93 352	7	6
55	9.71 079	21	9.77 734	29	0.22 266	9.93 344	8	5
56	9.71 100	21	9.77 763	28	0.22 237	9.93 337	7	4
57	9.71 121	21	9.77 791	29	0.22 209	9.93 329	8	3
58	9.71 142	21	9.77 820	29	0.22 180	9.93 322	7	2
59	9.71 163	21	9.77 849	28	0.22 151	9.93 314	8	1
60	9.71 184		9.77 877		0.22 123	9.93 307		0
	L SIN	D	L TAN	CD	L COT	L COS	D	329°... 149°
	L COS		L COT		L TAN	L SIN		239°... 59°

31°... 211°	L SIN	D	L TAN	CD	L COT	L COS	D	PROP. PTS.
121°... 301°	L COS		L COT		L TAN	L SIN		
0	9.71 184		9.77 877		0.22 123	9.93 307		60
1	9.71 205	21	9.77 906	29	0.22 094	9.93 299	8	59
2	9.71 226	21	9.77 935	29	0.22 065	9.93 291	8	58
3	9.71 247	21	9.77 963	28	0.22 037	9.93 284	7	57
4	9.71 268	21	9.77 992	29	0.22 008	9.93 276	8	56
		21		28			7	
5	9.71 289		9.78 020		0.21 980	9.93 269		55
6	9.71 310	21	9.78 049	29	0.21 951	9.93 261	8	54
7	9.71 331	21	9.78 077	28	0.21 923	9.93 253	8	53
8	9.71 352	21	9.78 106	29	0.21 894	9.93 246	7	52
9	9.71 373	21	9.78 135	29	0.21 865	9.93 238	8	51
		20		28			8	
10	9.71 393		9.78 163		0.21 837	9.93 230		50
11	9.71 414	21	9.78 192	29	0.21 808	9.93 223	7	49
12	9.71 435	21	9.78 220	28	0.21 780	9.93 215	8	48
13	9.71 456	21	9.78 249	29	0.21 751	9.93 207	8	47
14	9.71 477	21	9.78 277	28	0.21 723	9.93 200	7	46
		21		29			8	
15	9.71 498		9.78 306		0.21 694	9.93 192		45
16	9.71 519	21	9.78 334	28	0.21 666	9.93 184	8	44
17	9.71 539	20	9.78 363	29	0.21 637	9.93 177	7	43
18	9.71 560	21	9.78 391	28	0.21 609	9.93 169	8	42
19	9.71 581	21	9.78 419	28	0.21 581	9.93 161	8	41
		21		29			7	
20	9.71 602		9.78 448		0.21 552	9.93 154		40
21	9.71 622	20	9.78 476	28	0.21 524	9.93 146	8	39
22	9.71 643	21	9.78 505	29	0.21 495	9.93 138	8	38
23	9.71 664	21	9.78 533	28	0.21 467	9.93 131	7	37
24	9.71 685	21	9.78 562	29	0.21 438	9.93 123	8	36
		20		28			8	
25	9.71 705		9.78 590		0.21 410	9.93 115		35
26	9.71 726	21	9.78 618	28	0.21 382	9.93 108	7	34
27	9.71 747	21	9.78 647	29	0.21 353	9.93 100	8	33
28	9.71 767	20	9.78 675	28	0.21 325	9.93 092	8	32
29	9.71 788	21	9.78 704	29	0.21 296	9.93 084	8	31
		21		28			7	
30	9.71 809		9.78 732		0.21 268	9.93 077		30
31	9.71 829	20	9.78 760	28	0.21 240	9.93 069	8	29
32	9.71 850	21	9.78 789	29	0.21 211	9.93 061	8	28
33	9.71 870	20	9.78 817	28	0.21 183	9.93 053	8	27
34	9.71 891	21	9.78 845	28	0.21 155	9.93 046	7	26
		20		29			8	
35	9.71 911		9.78 874		0.21 126	9.93 038		25
36	9.71 932	21	9.78 902	28	0.21 098	9.93 030	8	24
37	9.71 952	20	9.78 930	28	0.21 070	9.93 022	8	23
38	9.71 973	21	9.78 959	29	0.21 041	9.93 014	8	22
39	9.71 994	21	9.78 987	28	0.21 013	9.93 007	7	21
		20		28			8	
40	9.72 014		9.79 015		0.20 985	9.92 999		20
41	9.72 034	20	9.79 043	28	0.20 957	9.92 991	8	19
42	9.72 055	21	9.79 072	29	0.20 928	9.92 983	8	18
43	9.72 075	20	9.79 100	28	0.20 900	9.92 976	7	17
44	9.72 096	21	9.79 128	28	0.20 872	9.92 968	8	16
		20		28			8	
45	9.72 116		9.79 156		0.20 844	9.92 960		15
46	9.72 137	21	9.79 185	29	0.20 815	9.92 952	8	14
47	9.72 157	20	9.79 213	28	0.20 787	9.92 944	8	13
48	9.72 177	20	9.79 241	28	0.20 759	9.92 936	8	12
49	9.72 198	21	9.79 269	28	0.20 731	9.92 929	7	11
		20		28			8	
50	9.72 218		9.79 297		0.20 703	9.92 921		10
51	9.72 238	20	9.79 326	29	0.20 674	9.92 913	8	9
52	9.72 259	21	9.79 354	28	0.20 646	9.92 905	8	8
53	9.72 279	20	9.79 382	28	0.20 618	9.92 897	8	7
54	9.72 299	20	9.79 410	28	0.20 590	9.92 889	8	6
		21		28			8	
55	9.72 320		9.79 438		0.20 562	9.92 881		5
56	9.72 340	20	9.79 466	28	0.20 534	9.92 874	7	4
57	9.72 360	20	9.79 495	29	0.20 505	9.92 866	8	3
58	9.72 381	21	9.79 523	28	0.20 477	9.92 858	8	2
59	9.72 401	20	9.79 551	28	0.20 449	9.92 850	8	1
		20		28			8	
60	9.72 421		9.79 579		0.20 421	9.92 842		0
	L SIN	D	L TAN	CD	L COT	L COS	D	328°... 148°
	L COS		L COT		L TAN	L SIN		238°... 58°

32°... 212°	L SIN	D	L TAN	CD	L COT	L COS	D	PROP. PTS.
122°... 302°	L COS		L COT		L TAN	L SIN		
0	9.72 421	20	9.79 579	28	0.20 421	9.92 842	8	60
1	9.72 441	20	9.79 607	28	0.20 393	9.92 834	8	59
2	9.72 461	21	9.79 635	28	0.20 365	9.92 826	8	58
3	9.72 482	20	9.79 663	28	0.20 337	9.92 818	8	57
4	9.72 502	20	9.79 691	28	0.20 309	9.92 810	8	56
5	9.72 522	20	9.79 719	28	0.20 281	9.92 803	8	55
6	9.72 542	20	9.79 747	28	0.20 253	9.92 795	8	54
7	9.72 562	20	9.79 776	28	0.20 224	9.92 787	8	53
8	9.72 582	20	9.79 804	28	0.20 196	9.92 779	8	52
9	9.72 602	20	9.79 832	28	0.20 168	9.92 771	8	51
10	9.72 622	21	9.79 860	28	0.20 140	9.92 763	8	50
11	9.72 643	20	9.79 888	28	0.20 112	9.92 755	8	49
12	9.72 663	20	9.79 916	28	0.20 084	9.92 747	8	48
13	9.72 683	20	9.79 944	28	0.20 056	9.92 739	8	47
14	9.72 703	20	9.79 972	28	0.20 028	9.92 731	8	46
15	9.72 723	20	9.80 000	28	0.20 000	9.92 723	8	45
16	9.72 743	20	9.80 028	28	0.19 972	9.92 715	8	44
17	9.72 763	20	9.80 056	28	0.19 944	9.92 707	8	43
18	9.72 783	20	9.80 084	28	0.19 916	9.92 699	8	42
19	9.72 803	20	9.80 112	28	0.19 888	9.92 691	8	41
20	9.72 823	20	9.80 140	28	0.19 860	9.92 683	8	40
21	9.72 843	20	9.80 168	27	0.19 832	9.92 675	8	39
22	9.72 863	19	9.80 196	28	0.19 805	9.92 667	8	38
23	9.72 883	20	9.80 223	28	0.19 777	9.92 659	8	37
24	9.72 902	20	9.80 251	28	0.19 749	9.92 651	8	36
25	9.72 922	20	9.80 279	28	0.19 721	9.92 643	8	35
26	9.72 942	20	9.80 307	28	0.19 693	9.92 635	8	34
27	9.72 962	20	9.80 335	28	0.19 665	9.92 627	8	33
28	9.72 982	20	9.80 363	28	0.19 637	9.92 619	8	32
29	9.73 002	20	9.80 391	28	0.19 609	9.92 611	8	31
30	9.73 022	19	9.80 419	28	0.19 581	9.92 603	8	30
31	9.73 041	20	9.80 447	27	0.19 553	9.92 595	8	29
32	9.73 061	20	9.80 474	28	0.19 526	9.92 587	8	28
33	9.73 081	20	9.80 502	28	0.19 498	9.92 579	8	27
34	9.73 101	20	9.80 530	28	0.19 470	9.92 571	8	26
35	9.73 121	19	9.80 558	28	0.19 442	9.92 563	8	25
36	9.73 140	20	9.80 586	28	0.19 414	9.92 555	9	24
37	9.73 160	20	9.80 614	28	0.19 386	9.92 546	8	23
38	9.73 180	20	9.80 642	27	0.19 358	9.92 538	8	22
39	9.73 200	19	9.80 669	28	0.19 331	9.92 530	8	21
40	9.73 219	20	9.80 697	28	0.19 303	9.92 522	8	20
41	9.73 239	20	9.80 725	28	0.19 275	9.92 514	8	19
42	9.73 259	19	9.80 753	28	0.19 247	9.92 506	8	18
43	9.73 278	20	9.80 781	27	0.19 219	9.92 498	8	17
44	9.73 298	20	9.80 808	28	0.19 192	9.92 490	8	16
45	9.73 318	19	9.80 836	28	0.19 164	9.92 482	9	15
46	9.73 337	20	9.80 864	28	0.19 136	9.92 473	8	14
47	9.73 357	20	9.80 892	27	0.19 108	9.92 465	8	13
48	9.73 377	19	9.80 919	28	0.19 081	9.92 457	8	12
49	9.73 396	20	9.80 947	28	0.19 053	9.92 449	8	11
50	9.73 416	19	9.80 975	28	0.19 025	9.92 441	8	10
51	9.73 435	20	9.81 003	27	0.18 997	9.92 433	8	9
52	9.73 455	19	9.81 030	28	0.18 970	9.92 425	9	8
53	9.73 474	20	9.81 058	28	0.18 942	9.92 416	8	7
54	9.73 494	19	9.81 086	27	0.18 914	9.92 408	8	6
55	9.73 513	20	9.81 113	28	0.18 887	9.92 400	8	5
56	9.73 533	19	9.81 141	28	0.18 859	9.92 392	8	4
57	9.73 552	20	9.81 169	27	0.18 831	9.92 384	8	3
58	9.73 572	19	9.81 196	28	0.18 804	9.92 376	9	2
59	9.73 591	20	9.81 224	28	0.18 776	9.92 367	8	1
60	9.73 611		9.81 252		0.18 748	9.92 359		0
	L SIN	D	L TAN	CD	L COT	L COS	D	227°... 147°
	L COS		L COT		L TAN	L SIN		237°... 57°

33°... 212°		L SIN	D	L TAN	CD	L COT	L COS	D	PROP. PTS.	
123°... 303°		L COS		L COT		L TAN	L SIN			
0	9.73 611	19	9.81 252	27	0.18 748	9.92 359	8	60		
1	9.73 630	20	9.81 279	28	0.18 721	9.92 351	8	59		
2	9.73 650	19	9.81 307	28	0.18 693	9.92 343	8	58	28	27
3	9.73 669	20	9.81 335	27	0.18 665	9.92 335	8	57		
4	9.73 689	19	9.81 362	28	0.18 638	9.92 326	9	56	1	2.8 2.7
							8		2	5.6 5.4
							8		3	8.4 8.1
5	9.73 708	19	9.81 390	28	0.18 610	9.92 318	8	55	4	11.2 10.8
6	9.73 727	20	9.81 418	27	0.18 582	9.92 310	8	54	5	14.0 13.5
7	9.73 747	19	9.81 445	28	0.18 555	9.92 302	9	53	6	16.8 16.2
8	9.73 766	19	9.81 473	27	0.18 527	9.92 293	9	52	7	19.6 18.9
9	9.73 785	20	9.81 500	28	0.18 500	9.92 285	8	51	8	22.4 21.6
							8		9	25.2 24.3
10	9.73 805	19	9.81 528	28	0.18 472	9.92 277	8	50		
11	9.73 824	19	9.81 556	27	0.18 444	9.92 269	9	49		
12	9.73 843	20	9.81 583	28	0.18 417	9.92 260	8	48		
13	9.73 863	19	9.81 611	27	0.18 389	9.92 252	8	47		
14	9.73 882	19	9.81 638	28	0.18 362	9.92 244	9	46		
										20
15	9.73 901	20	9.81 666	27	0.18 334	9.92 235	8	45	1	2.0
16	9.73 921	19	9.81 693	28	0.18 307	9.92 227	8	44	2	4.0
17	9.73 940	19	9.81 721	27	0.18 279	9.92 219	8	43	3	6.0
18	9.73 959	19	9.81 748	28	0.18 252	9.92 211	8	42	4	8.0
19	9.73 978	19	9.81 776	27	0.18 224	9.92 202	9	41	5	10.0
							8		6	12.0
20	9.73 997	20	9.81 803	28	0.18 197	9.92 194	8	40	7	14.0
21	9.74 017	19	9.81 831	27	0.18 169	9.92 186	8	39	8	16.0
22	9.74 036	19	9.81 858	28	0.18 142	9.92 177	9	38	9	18.0
23	9.74 055	19	9.81 886	27	0.18 114	9.92 169	8	37		
24	9.74 074	19	9.81 913	28	0.18 087	9.92 161	8	36		
							9			
25	9.74 093	20	9.81 941	27	0.18 059	9.92 152	8	35		
26	9.74 113	19	9.81 968	28	0.18 032	9.92 144	8	34		
27	9.74 132	19	9.81 996	27	0.18 004	9.92 136	8	33	1	1.9
28	9.74 151	19	9.82 023	28	0.17 977	9.92 127	9	32	2	3.8
29	9.74 170	19	9.82 051	27	0.17 949	9.92 119	8	31	3	5.7
									4	7.6
30	9.74 189	19	9.82 078	28	0.17 922	9.92 111	9	30	5	9.5
31	9.74 208	19	9.82 106	27	0.17 894	9.92 102	8	29	6	11.4
32	9.74 227	19	9.82 133	28	0.17 867	9.92 094	8	28	7	13.3
33	9.74 246	19	9.82 161	27	0.17 839	9.92 086	8	27	8	15.2
34	9.74 265	19	9.82 188	27	0.17 812	9.92 077	9	26	9	17.1
							8			
35	9.74 284	19	9.82 215	28	0.17 785	9.92 069	9	25		
36	9.74 303	19	9.82 243	27	0.17 757	9.92 060	8	24		
37	9.74 322	19	9.82 270	28	0.17 730	9.92 052	8	23		
38	9.74 341	19	9.82 298	27	0.17 702	9.92 044	9	22		
39	9.74 360	19	9.82 325	27	0.17 675	9.92 035	8	21		
										18
40	9.74 379	19	9.82 352	28	0.17 648	9.92 027	9	20	1	1.8
41	9.74 398	19	9.82 380	27	0.17 620	9.92 018	8	19	2	3.6
42	9.74 417	19	9.82 407	28	0.17 593	9.92 010	8	18	3	5.4
43	9.74 436	19	9.82 435	27	0.17 565	9.92 002	8	17	4	7.2
44	9.74 455	19	9.82 462	27	0.17 538	9.91 993	9	16	5	9.0
							8		6	10.8
45	9.74 474	19	9.82 489	28	0.17 511	9.91 985	8	15	7	12.6
46	9.74 493	19	9.82 517	27	0.17 483	9.91 976	9	14	8	14.4
47	9.74 512	19	9.82 544	27	0.17 456	9.91 968	8	13	9	16.2
48	9.74 531	19	9.82 571	28	0.17 429	9.91 959	8	12		
49	9.74 549	18	9.82 599	27	0.17 401	9.91 951	9	11		
50	9.74 568	19	9.82 626	27	0.17 374	9.91 942	8	10	9	8
51	9.74 587	19	9.82 653	28	0.17 347	9.91 934	9	9	1	0.9 0.8
52	9.74 606	19	9.82 681	27	0.17 319	9.91 925	8	8	2	1.8 1.6
53	9.74 625	19	9.82 708	27	0.17 292	9.91 917	8	7	3	2.7 2.4
54	9.74 644	18	9.82 735	27	0.17 265	9.91 908	8	6	4	3.6 3.2
									5	4.5 4.0
55	9.74 662	19	9.82 762	28	0.17 238	9.91 900	9	5	6	5.4 4.8
56	9.74 681	19	9.82 790	27	0.17 210	9.91 891	8	4	7	6.3 5.6
57	9.74 700	19	9.82 817	27	0.17 183	9.91 883	8	3	8	7.2 6.4
58	9.74 719	18	9.82 844	27	0.17 156	9.91 874	9	2	9	8.1 7.2
59	9.74 737	19	9.82 871	28	0.17 129	9.91 866	8	1		
							9			
60	9.74 756		9.82 899		0.17 101	9.91 857		0		
	L SIN	D	L TAN	CD	L COT	L COS	D		326°... 146°	
	L COS		L COT		L TAN	L SIN			236°... 50°	

34°... 214° 124°... 304°	L SIN	D	L TAN	CD	L COT	L COS	D	PROP. PTS.
	L COS		L COT		L TAN	L SIN		
0	9.74 756	19	9.82 899	27	0.17 101	9.91 857	8	60
1	9.74 775	19	9.82 926	27	0.17 074	9.91 849	9	59
2	9.74 794	18	9.82 953	27	0.17 047	9.91 840	8	58
3	9.74 812	19	9.82 980	28	0.17 020	9.91 832	9	57
4	9.74 831	19	9.83 008	27	0.16 992	9.91 823	8	56
5	9.74 850	18	9.83 035	27	0.16 956	9.91 815	9	55
6	9.74 868	19	9.83 062	27	0.16 938	9.91 806	8	54
7	9.74 887	19	9.83 089	28	0.16 911	9.91 798	9	53
8	9.74 906	18	9.83 117	27	0.16 883	9.91 789	8	52
9	9.74 924	19	9.83 144	27	0.16 856	9.91 781	9	51
10	9.74 943	18	9.83 171	27	0.16 829	9.91 772	9	50
11	9.74 961	19	9.83 198	27	0.16 802	9.91 763	8	49
12	9.74 980	19	9.83 225	27	0.16 775	9.91 755	9	48
13	9.74 999	18	9.83 252	28	0.16 748	9.91 746	8	47
14	9.75 017	19	9.83 280	27	0.16 720	9.91 738	9	46
15	9.75 036	18	9.83 307	27	0.16 693	9.91 729	9	45
16	9.75 054	19	9.83 334	27	0.16 666	9.91 720	8	44
17	9.75 073	18	9.83 361	27	0.16 639	9.91 712	9	43
18	9.75 091	19	9.83 388	27	0.16 612	9.91 703	8	42
19	9.75 110	18	9.83 415	27	0.16 585	9.91 695	9	41
20	9.75 128	19	9.83 442	28	0.16 558	9.91 686	9	40
21	9.75 147	18	9.83 470	27	0.16 530	9.91 677	8	39
22	9.75 165	19	9.83 497	27	0.16 503	9.91 669	9	38
23	9.75 184	18	9.83 524	27	0.16 476	9.91 660	9	37
24	9.75 202	19	9.83 551	27	0.16 449	9.91 651	8	36
25	9.75 221	18	9.83 578	27	0.16 422	9.91 643	9	35
26	9.75 239	19	9.83 605	27	0.16 395	9.91 634	9	34
27	9.75 258	18	9.83 632	27	0.16 368	9.91 625	8	33
28	9.75 276	18	9.83 659	27	0.16 341	9.91 617	9	32
29	9.75 294	19	9.83 686	27	0.16 314	9.91 608	9	31
30	9.75 313	18	9.83 713	27	0.16 287	9.91 599	8	30
31	9.75 331	19	9.83 740	28	0.16 260	9.91 591	9	29
32	9.75 350	18	9.83 768	27	0.16 232	9.91 582	9	28
33	9.75 368	19	9.83 795	27	0.16 205	9.91 573	8	27
34	9.75 386	18	9.83 822	27	0.16 178	9.91 565	9	26
35	9.75 405	18	9.83 849	27	0.16 151	9.91 556	9	25
36	9.75 423	18	9.83 876	27	0.16 124	9.91 547	9	24
37	9.75 441	18	9.83 903	27	0.16 097	9.91 538	8	23
38	9.75 459	19	9.83 930	27	0.16 070	9.91 530	9	22
39	9.75 478	18	9.83 957	27	0.16 043	9.91 521	9	21
40	9.75 496	18	9.83 984	27	0.16 016	9.91 512	8	20
41	9.75 514	19	9.84 011	27	0.15 989	9.91 504	9	19
42	9.75 533	18	9.84 038	27	0.15 962	9.91 495	9	18
43	9.75 551	18	9.84 065	27	0.15 935	9.91 486	9	17
44	9.75 569	18	9.84 092	27	0.15 908	9.91 477	8	16
45	9.75 587	18	9.84 119	27	0.15 881	9.91 469	9	15
46	9.75 605	19	9.84 146	27	0.15 854	9.91 460	9	14
47	9.75 624	18	9.84 173	27	0.15 827	9.91 451	9	13
48	9.75 642	18	9.84 200	27	0.15 800	9.91 442	9	12
49	9.75 660	18	9.84 227	27	0.15 773	9.91 433	8	11
50	9.75 678	18	9.84 254	26	0.15 746	9.91 425	9	10
51	9.75 696	18	9.84 280	27	0.15 720	9.91 416	9	9
52	9.75 714	19	9.84 307	27	0.15 693	9.91 407	9	8
53	9.75 733	18	9.84 334	27	0.15 666	9.91 398	9	7
54	9.75 751	18	9.84 361	27	0.15 639	9.91 389	8	6
55	9.75 769	18	9.84 388	27	0.15 612	9.91 381	9	5
56	9.75 787	18	9.84 415	27	0.15 585	9.91 372	9	4
57	9.75 805	18	9.84 442	27	0.15 558	9.91 363	9	3
58	9.75 823	18	9.84 469	27	0.15 531	9.91 354	9	2
59	9.75 841	18	9.84 496	27	0.15 504	9.91 345	9	1
60	9.75 859		9.84 523		0.15 477	9.91 336		0
	L SIN	D	L TAN	CD	L COT	L COS	D	325°... 145°
	L COS		L COT		L TAN	L SIN		235°... 55°

35° ... 215°		L SIN	D	L TAN	CD	L COT	L COS	D	PROP. PTS.			
125° ... 305°		L COS		L COT		L TAN	L SIN					
0	9.75 859	18	9.84 523	27	0.15 477	9.91 336	8	60				
1	9.75 877	18	9.84 550	26	0.15 450	9.91 328	9	59				
2	9.75 895	18	9.84 576	27	0.15 424	9.91 319	9	58				
3	9.75 913	18	9.84 603	27	0.15 397	9.91 310	9	57	27	26		
4	9.75 931	18	9.84 630	27	0.15 370	9.91 301	9	56	1	2.7	2.6	
5	9.75 949	18	9.84 657	27	0.15 343	9.91 292	9	55	2	5.4	5.2	
6	9.75 967	18	9.84 684	27	0.15 316	9.91 283	9	54	3	8.1	7.8	
7	9.75 985	18	9.84 711	27	0.15 289	9.91 274	9	53	4	10.8	10.4	
8	9.76 003	18	9.84 738	26	0.15 262	9.91 266	8	52	5	13.5	13.0	
9	9.76 021	18	9.84 764	27	0.15 236	9.91 257	9	51	6	16.2	15.6	
10	9.76 039	18	9.84 791	27	0.15 209	9.91 248	9	50	7	18.9	18.2	
11	9.76 057	18	9.84 818	27	0.15 182	9.91 239	9	49	8	21.6	20.8	
12	9.76 075	18	9.84 845	27	0.15 155	9.91 230	9	48	9	24.3	23.4	
13	9.76 093	18	9.84 872	27	0.15 128	9.91 221	9	47				
14	9.76 111	18	9.84 899	26	0.15 101	9.91 212	9	46				
15	9.76 129	17	9.84 925	27	0.15 075	9.91 203	9	45			18	
16	9.76 146	18	9.84 952	27	0.15 048	9.91 194	9	44	1	1.8		
17	9.76 164	18	9.84 979	27	0.15 021	9.91 185	9	43	2	3.6		
18	9.76 182	18	9.85 006	27	0.14 994	9.91 176	9	42	3	5.4		
19	9.76 200	18	9.85 033	26	0.14 967	9.91 167	9	41	4	7.2		
20	9.76 218	18	9.85 059	27	0.14 941	9.91 158	9	40	5	9.0		
21	9.76 236	17	9.85 086	27	0.14 914	9.91 149	8	39	6	10.8		
22	9.76 253	18	9.85 113	27	0.14 887	9.91 141	9	38	7	12.6		
23	9.76 271	18	9.85 140	26	0.14 860	9.91 132	9	37	8	14.4		
24	9.76 289	18	9.85 166	27	0.14 834	9.91 123	9	36	9	16.2		
25	9.76 307	17	9.85 193	27	0.14 807	9.91 114	9	35				
26	9.76 324	18	9.85 220	27	0.14 780	9.91 105	9	34			17	
27	9.76 342	18	9.85 247	26	0.14 753	9.91 096	9	33				
28	9.76 360	18	9.85 273	27	0.14 727	9.91 087	9	32	1	1.7		
29	9.76 378	17	9.85 300	27	0.14 700	9.91 078	9	31	2	3.4		
30	9.76 395	18	9.85 327	27	0.14 673	9.91 069	9	30	3	5.1		
31	9.76 413	18	9.85 354	26	0.14 646	9.91 060	9	29	4	6.8		
32	9.76 431	17	9.85 380	27	0.14 620	9.91 051	9	28	5	8.5		
33	9.76 448	18	9.85 407	27	0.14 593	9.91 042	9	27	6	10.2		
34	9.76 466	18	9.85 434	26	0.14 566	9.91 033	10	26	7	11.9		
35	9.76 484	17	9.85 460	27	0.14 540	9.91 023	9	25	8	13.6		
36	9.76 501	18	9.85 487	27	0.14 513	9.91 014	9	24	9	15.3		
37	9.76 519	18	9.85 514	26	0.14 486	9.91 005	9	23				
38	9.76 537	17	9.85 540	27	0.14 460	9.90 996	9	22			10	
39	9.76 554	18	9.85 567	27	0.14 433	9.90 987	9	21				
40	9.76 572	18	9.85 594	26	0.14 406	9.90 978	9	20	1	1.0		
41	9.76 590	17	9.85 620	27	0.14 380	9.90 969	9	19	2	2.0		
42	9.76 607	18	9.85 647	27	0.14 353	9.90 960	9	18	3	3.0		
43	9.76 625	17	9.85 674	26	0.14 326	9.90 951	9	17	4	4.0		
44	9.76 642	18	9.85 700	27	0.14 300	9.90 942	9	16	5	5.0		
45	9.76 660	17	9.85 727	27	0.14 273	9.90 933	9	15	6	6.0		
46	9.76 677	18	9.85 754	26	0.14 246	9.90 924	9	14	7	7.0		
47	9.76 695	17	9.85 780	27	0.14 220	9.90 915	9	13	8	8.0		
48	9.76 712	18	9.85 807	27	0.14 193	9.90 906	9	12	9	9.0		
49	9.76 730	17	9.85 834	26	0.14 166	9.90 896	10	11				
50	9.76 747	18	9.85 860	27	0.14 140	9.90 887	9	10			9	8
51	9.76 765	17	9.85 887	26	0.14 113	9.90 878	9	9	1	0.9	0.8	
52	9.76 782	18	9.85 913	27	0.14 087	9.90 869	9	8	2	1.8	1.6	
53	9.76 800	17	9.85 940	27	0.14 060	9.90 860	9	7	3	2.7	2.4	
54	9.76 817	18	9.85 967	26	0.14 033	9.90 851	9	6	4	3.6	3.2	
55	9.76 835	17	9.85 993	27	0.14 007	9.90 842	10	5	5	4.5	4.0	
56	9.76 852	18	9.86 020	26	0.13 980	9.90 832	9	4	6	5.4	4.8	
57	9.76 870	17	9.86 046	27	0.13 954	9.90 823	9	3	7	6.3	5.6	
58	9.76 887	17	9.86 073	27	0.13 927	9.90 814	9	2	8	7.2	6.4	
59	9.76 904	18	9.86 100	26	0.13 900	9.90 805	9	1	9	8.1	7.2	
60	9.76 922		9.86 126		0.13 874	9.90 796		0				
	L SIN	D	L TAN	CD	L COT	L COS	D		324° ... 144°			
	L COS		L COT		L TAN	L SIN			234° ... 54°			

36°... 216°		L SIN	D	L TAN	CD	L COT	L COS	D	PROP. PTS.			
126°... 306°		L COS		L COT		L TAN	L SIN					
0	9.76 922			9.86 126	27	0.13 874	9.90 796	9	60			
1	9.76 939		17	9.86 153	26	0.13 847	9.90 787	10	59			
2	9.76 957		17	9.86 179	27	0.13 821	9.90 777	9	58			
3	9.76 974		17	9.86 206	26	0.13 794	9.90 768	9	57		27	26
4	9.76 991		18	9.86 232	27	0.13 768	9.90 759	9	56	1	2.7	2.6
										2	5.4	5.2
5	9.77 009		17	9.86 259	26	0.13 741	9.90 750	9	55	3	8.1	7.8
6	9.77 026		17	9.86 285	27	0.13 715	9.90 741	10	54	4	10.8	10.4
7	9.77 043		18	9.86 312	26	0.13 688	9.90 731	9	53	5	13.5	13.0
8	9.77 061		17	9.86 338	27	0.13 662	9.90 722	9	52	6	16.2	15.6
9	9.77 078		17	9.86 365	27	0.13 635	9.90 713	9	51	7	18.9	18.2
										8	21.6	20.8
10	9.77 095		17	9.86 392	26	0.13 608	9.90 704	10	50	9	24.3	23.4
11	9.77 112		18	9.86 418	27	0.13 582	9.90 694	9	49			
12	9.77 130		17	9.86 445	26	0.13 555	9.90 685	9	48			
13	9.77 147		17	9.86 471	27	0.13 529	9.90 676	9	47			
14	9.77 164		17	9.86 498	26	0.13 502	9.90 667	10	46			
											18	
15	9.77 181		18	9.86 524	27	0.13 476	9.90 657	9	45	1	1.8	
16	9.77 199		17	9.86 551	26	0.13 449	9.90 648	9	44	2	3.6	
17	9.77 216		17	9.86 577	26	0.13 423	9.90 639	9	43	3	5.4	
18	9.77 233		17	9.86 603	27	0.13 397	9.90 630	10	42	4	7.2	
19	9.77 250		18	9.86 630	26	0.13 370	9.90 620	9	41	5	9.0	
										6	10.8	
20	9.77 268		17	9.86 656	27	0.13 344	9.90 611	9	40	7	12.6	
21	9.77 285		17	9.86 683	26	0.13 317	9.90 602	10	39	8	14.4	
22	9.77 302		17	9.86 709	27	0.13 291	9.90 592	9	38	9	16.2	
23	9.77 319		17	9.86 736	26	0.13 264	9.90 583	9	37			
24	9.77 336		17	9.86 762	27	0.13 238	9.90 574	9	36			
25	9.77 353		17	9.86 789	26	0.13 211	9.90 565	10	35			
26	9.77 370		17	9.86 815	27	0.13 185	9.90 555	9	34			
27	9.77 387		18	9.86 842	26	0.13 158	9.90 546	9	33	1	1.7	
28	9.77 405		17	9.86 868	26	0.13 132	9.90 537	10	32	2	3.4	
29	9.77 422		17	9.86 894	27	0.13 106	9.90 527	9	31	3	5.1	
										4	6.8	
30	9.77 439		17	9.86 921	26	0.13 079	9.90 518	9	30	5	8.5	
31	9.77 456		17	9.86 947	27	0.13 053	9.90 509	10	29	6	10.2	
32	9.77 473		17	9.86 974	26	0.13 026	9.90 499	9	28	7	11.9	
33	9.77 490		17	9.87 000	27	0.13 000	9.90 490	10	27	8	13.6	
34	9.77 507		17	9.87 027	26	0.12 973	9.90 480	9	26	9	15.3	
35	9.77 524		17	9.87 053	26	0.12 947	9.90 471	9	25			
36	9.77 541		17	9.87 079	27	0.12 921	9.90 462	10	24			
37	9.77 558		17	9.87 106	26	0.12 894	9.90 452	9	23			
38	9.77 575		17	9.87 132	26	0.12 868	9.90 443	9	22			
39	9.77 592		17	9.87 158	27	0.12 842	9.90 434	10	21			
											16	
40	9.77 609		17	9.87 185	26	0.12 815	9.90 424	9	20	1	1.6	
41	9.77 626		17	9.87 211	27	0.12 789	9.90 415	10	19	2	3.2	
42	9.77 643		17	9.87 238	26	0.12 762	9.90 405	9	18	3	4.8	
43	9.77 660		17	9.87 264	26	0.12 736	9.90 396	10	17	4	6.4	
44	9.77 677		17	9.87 290	27	0.12 710	9.90 386	9	16	5	8.0	
										6	9.6	
45	9.77 694		17	9.87 317	26	0.12 683	9.90 377	9	15	7	11.2	
46	9.77 711		17	9.87 343	26	0.12 657	9.90 368	10	14	8	12.8	
47	9.77 728		16	9.87 369	27	0.12 631	9.90 358	9	13	9	14.4	
48	9.77 744		17	9.87 396	26	0.12 604	9.90 349	10	12			
49	9.77 761		17	9.87 422	26	0.12 578	9.90 339	9	11			
50	9.77 778		17	9.87 448	27	0.12 552	9.90 330	10	10			
51	9.77 795		17	9.87 475	26	0.12 525	9.90 320	9	9			
52	9.77 812		17	9.87 501	26	0.12 499	9.90 311	10	8			
53	9.77 829		17	9.87 527	27	0.12 473	9.90 301	9	7			
54	9.77 846		16	9.87 554	26	0.12 446	9.90 292	10	6			
55	9.77 862		17	9.87 580	26	0.12 420	9.90 282	9	5			
56	9.77 879		17	9.87 606	27	0.12 394	9.90 273	10	4			
57	9.77 896		17	9.87 633	26	0.12 367	9.90 263	9	3			
58	9.77 913		17	9.87 659	26	0.12 341	9.90 254	10	2			
59	9.77 930		16	9.87 685	26	0.12 315	9.90 244	9	1			
60	9.77 946			9.87 711		0.12 289	9.90 235		0			
		L SIN	D	L TAN	CD	L COT	L COS	D			323°... 142°	
		L COS		L COT		L TAN	L SIN				233°... 53°	

37°... 217°		L SIN	D	L TAN	CD	L COT	L COS	D	PROP. PTS.
127°... 307°		L COS		L COT		L TAN	L SIN		
0	9.77 946	17	9.87 711	27	0.12 289	9.90 235	10	60	
1	9.77 963	17	9.87 738	26	0.12 262	9.90 225	9	59	
2	9.77 980	17	9.87 764	26	0.12 236	9.90 216	10	58	
3	9.77 997	17	9.87 790	27	0.12 210	9.90 206	9	57	
4	9.78 013	16	9.87 817	26	0.12 183	9.90 197	10	56	27
5	9.78 030	17	9.87 843	26	0.12 157	9.90 187	9	55	1 2.7
6	9.78 047	16	9.87 869	26	0.12 131	9.90 178	10	54	2 5.4
7	9.78 063	17	9.87 895	27	0.12 105	9.90 168	9	53	3 8.1
8	9.78 080	17	9.87 922	26	0.12 078	9.90 159	10	52	4 10.8
9	9.78 097	16	9.87 948	26	0.12 052	9.90 149	10	51	5 13.5
10	9.78 113	17	9.87 974	26	0.12 026	9.90 139	9	50	6 16.2
11	9.78 130	17	9.88 000	27	0.12 000	9.90 130	10	49	7 18.9
12	9.78 147	16	9.88 027	26	0.11 973	9.90 120	9	48	8 21.6
13	9.78 163	17	9.88 053	26	0.11 947	9.90 111	10	47	9 24.3
14	9.78 180	17	9.88 079	26	0.11 921	9.90 101	10	46	
15	9.78 197	16	9.88 105	26	0.11 895	9.90 091	9	45	26
16	9.78 213	17	9.88 131	27	0.11 869	9.90 082	10	44	1 2.6
17	9.78 230	16	9.88 158	26	0.11 842	9.90 072	9	43	2 5.2
18	9.78 246	17	9.88 184	26	0.11 816	9.90 063	10	42	3 7.8
19	9.78 263	17	9.88 210	26	0.11 790	9.90 053	10	41	4 10.4
20	9.78 280	16	9.88 236	26	0.11 764	9.90 043	9	40	5 13.0
21	9.78 296	17	9.88 262	27	0.11 738	9.90 034	10	39	6 15.6
22	9.78 313	16	9.88 289	26	0.11 711	9.90 024	9	38	7 18.2
23	9.78 329	17	9.88 315	26	0.11 685	9.90 014	10	37	8 20.8
24	9.78 346	16	9.88 341	26	0.11 659	9.90 005	9	36	9 23.4
25	9.78 362	17	9.88 367	26	0.11 633	9.89 995	10	35	
26	9.78 379	16	9.88 393	27	0.11 607	9.89 985	9	34	17
27	9.78 395	17	9.88 420	26	0.11 580	9.89 976	10	33	1 1.7
28	9.78 412	16	9.88 446	26	0.11 554	9.89 966	9	32	2 3.4
29	9.78 428	17	9.88 472	26	0.11 528	9.89 956	10	31	3 5.1
30	9.78 445	16	9.88 498	26	0.11 502	9.89 947	9	30	4 6.8
31	9.78 461	17	9.88 524	26	0.11 476	9.89 937	10	29	5 8.5
32	9.78 478	16	9.88 550	27	0.11 450	9.89 927	9	28	6 10.2
33	9.78 494	17	9.88 577	26	0.11 423	9.89 918	10	27	7 11.9
34	9.78 510	16	9.88 603	26	0.11 397	9.89 908	9	26	8 13.6
35	9.78 527	16	9.88 629	26	0.11 371	9.89 898	10	25	9 15.3
36	9.78 543	17	9.88 655	26	0.11 345	9.89 888	9	24	
37	9.78 560	16	9.88 681	26	0.11 319	9.89 879	10	23	16
38	9.78 576	16	9.88 707	26	0.11 293	9.89 869	9	22	1 1.6
39	9.78 592	17	9.88 733	26	0.11 267	9.89 859	10	21	2 3.2
40	9.78 609	16	9.88 759	27	0.11 241	9.89 849	9	20	3 4.8
41	9.78 625	17	9.88 786	26	0.11 214	9.89 840	10	19	4 6.4
42	9.78 642	16	9.88 812	26	0.11 188	9.89 830	9	18	5 8.0
43	9.78 658	16	9.88 838	26	0.11 162	9.89 820	10	17	6 9.6
44	9.78 674	17	9.88 864	26	0.11 136	9.89 810	9	16	7 11.2
45	9.78 691	16	9.88 890	26	0.11 110	9.89 801	10	15	8 12.8
46	9.78 707	16	9.88 916	26	0.11 084	9.89 791	9	14	9 14.4
47	9.78 723	16	9.88 942	26	0.11 058	9.89 781	10	13	
48	9.78 739	16	9.88 968	26	0.11 032	9.89 771	9	12	
49	9.78 756	17	9.88 994	26	0.11 006	9.89 761	10	11	10 9
50	9.78 772	16	9.89 020	26	0.10 980	9.89 752	9	10	1 1.0
51	9.78 788	17	9.89 046	27	0.10 954	9.89 742	10	9	2 2.0
52	9.78 805	16	9.89 073	26	0.10 927	9.89 732	9	8	3 3.0
53	9.78 821	16	9.89 099	26	0.10 901	9.89 722	10	7	4 4.0
54	9.78 837	16	9.89 125	26	0.10 875	9.89 712	9	6	5 5.0
55	9.78 853	16	9.89 151	26	0.10 849	9.89 702	10	5	6 6.0
56	9.78 869	17	9.89 177	26	0.10 823	9.89 693	9	4	7 7.0
57	9.78 886	16	9.89 203	26	0.10 797	9.89 683	10	3	8 8.0
58	9.78 902	16	9.89 229	26	0.10 771	9.89 673	9	2	9 9.0
59	9.78 918	16	9.89 255	26	0.10 745	9.89 663	10	1	
60	9.78 934		9.89 281		0.10 719	9.89 653		0	
		L SIN	L TAN	CD	L COT	L COS	D		322°... 142°
		L COS	L COT		L TAN	L SIN			232°... 52°

FM 30-476

38°... 218°		L SIN	D	L TAN	CD	L COT	L COS	D	PROP. PTS.		
128°... 308°		L COS		L COT		L TAN	L SIN				
0	9.78 934	16	9.89 281	26	0.10 719	9.89 653	10	60			
1	9.78 950	17	9.89 307	26	0.10 693	9.89 643	10	59			
2	9.78 967	16	9.89 333	26	0.10 667	9.89 633	10	58			
3	9.78 983	16	9.89 359	26	0.10 641	9.89 624	10	57			
4	9.78 999	16	9.89 385	26	0.10 615	9.89 614	10	56			
5	9.79 015	16	9.89 411	26	0.10 589	9.89 604	10	55	26	25	
6	9.79 031	16	9.89 437	26	0.10 563	9.89 594	10	54	1	2.6	2.5
7	9.79 047	16	9.89 463	26	0.10 537	9.89 584	10	53	2	5.2	5.0
8	9.79 063	16	9.89 489	26	0.10 511	9.89 574	10	52	3	7.8	7.5
9	9.79 079	16	9.89 515	26	0.10 485	9.89 564	10	51	4	10.4	10.0
10	9.79 095	16	9.89 541	26	0.10 459	9.89 554	10	50	5	13.0	12.5
11	9.79 111	17	9.89 567	26	0.10 433	9.89 544	10	49	6	15.6	15.0
12	9.79 128	16	9.89 593	26	0.10 407	9.89 534	10	48	7	18.2	17.5
13	9.79 144	16	9.89 619	26	0.10 381	9.89 524	10	47	8	20.8	20.0
14	9.79 160	16	9.89 645	26	0.10 355	9.89 514	10	46	9	23.4	22.5
15	9.79 176	16	9.89 671	26	0.10 329	9.89 504	10	45		17	
16	9.79 192	16	9.89 697	26	0.10 303	9.89 495	10	44	1	1.7	
17	9.79 208	16	9.89 723	26	0.10 277	9.89 485	10	43	2	3.4	
18	9.79 224	16	9.89 749	26	0.10 251	9.89 475	10	42	3	5.1	
19	9.79 240	16	9.89 775	26	0.10 225	9.89 465	10	41	4	6.8	
20	9.79 256	16	9.89 801	26	0.10 199	9.89 455	10	40	5	8.5	
21	9.79 272	16	9.89 827	26	0.10 173	9.89 445	10	39	6	10.2	
22	9.79 288	16	9.89 853	26	0.10 147	9.89 435	10	38	7	11.9	
23	9.79 304	15	9.89 879	26	0.10 121	9.89 425	10	37	8	13.6	
24	9.79 319	16	9.89 905	26	0.10 095	9.89 415	10	36	9	15.3	
25	9.79 335	16	9.89 931	26	0.10 069	9.89 405	10	35		16	15
26	9.79 351	16	9.89 957	26	0.10 043	9.89 395	10	34	1	1.6	1.5
27	9.79 367	16	9.89 983	26	0.10 017	9.89 385	10	33	2	3.2	3.0
28	9.79 383	16	9.90 009	26	0.09 991	9.89 375	11	32	3	4.8	4.5
29	9.79 399	16	9.90 035	26	0.09 965	9.89 364	10	31	4	6.4	6.0
30	9.79 415	16	9.90 061	25	0.09 939	9.89 354	10	30	5	8.0	7.5
31	9.79 431	16	9.90 086	26	0.09 914	9.89 344	10	29	6	9.6	9.0
32	9.79 447	16	9.90 112	26	0.09 888	9.89 334	10	28	7	11.2	10.5
33	9.79 463	16	9.90 138	26	0.09 862	9.89 324	10	27	8	12.8	12.0
34	9.79 478	15	9.90 164	26	0.09 836	9.89 314	10	26	9	14.4	13.5
35	9.79 494	16	9.90 190	26	0.09 810	9.89 304	10	25		11	
36	9.79 510	16	9.90 216	26	0.09 784	9.89 294	10	24	1	1.1	
37	9.79 526	16	9.90 242	26	0.09 758	9.89 284	10	23	2	2.2	
38	9.79 542	16	9.90 268	26	0.09 732	9.89 274	10	22	3	3.3	
39	9.79 558	15	9.90 294	26	0.09 706	9.89 264	10	21	4	4.4	
40	9.79 573	16	9.90 320	26	0.09 680	9.89 254	10	20	5	5.5	
41	9.79 589	16	9.90 346	25	0.09 654	9.89 244	11	19	6	6.6	
42	9.79 605	16	9.90 371	26	0.09 629	9.89 233	10	18	7	7.7	
43	9.79 621	15	9.90 397	26	0.09 603	9.89 223	10	17	8	8.8	
44	9.79 636	16	9.90 423	26	0.09 577	9.89 213	10	16	9	9.9	
45	9.79 652	16	9.90 449	26	0.09 551	9.89 203	10	15			
46	9.79 668	16	9.90 475	26	0.09 525	9.89 193	10	14			
47	9.79 684	15	9.90 501	26	0.09 499	9.89 183	10	13			
48	9.79 699	16	9.90 527	26	0.09 473	9.89 173	10	12			
49	9.79 715	16	9.90 553	25	0.09 447	9.89 162	11	11			
50	9.79 731	15	9.90 578	26	0.09 422	9.89 152	10	10	1	1.0	0.9
51	9.79 746	16	9.90 604	26	0.09 396	9.89 142	10	9	2	2.0	1.8
52	9.79 762	16	9.90 630	26	0.09 370	9.89 132	10	8	3	3.0	2.7
53	9.79 778	15	9.90 656	26	0.09 344	9.89 122	10	7	4	4.0	3.6
54	9.79 793	16	9.90 682	26	0.09 318	9.89 112	11	6	5	5.0	4.5
55	9.79 809	16	9.90 708	26	0.09 292	9.89 101	10	5	6	6.0	5.4
56	9.79 825	15	9.90 734	25	0.09 266	9.89 091	10	4	7	7.0	6.3
57	9.79 840	16	9.90 759	26	0.09 241	9.89 081	10	3	8	8.0	7.2
58	9.79 856	16	9.90 785	26	0.09 215	9.89 071	11	2	9	9.0	8.1
59	9.79 872	15	9.90 811	26	0.09 189	9.89 060	10	1			
60	9.79 887		9.90 837		0.09 163	9.89 050		0			
		L SIN	D	L TAN	CD	L COT	L COS	D	321°... 141°		
		L COS		L COT		L TAN	L SIN		231°... 51°		

39°... 219°	L SIN	D	L TAN	CD	L COT	L COS	D	PROP. PTS.
129°... 309°	L COS		L COT		L TAN	L SIN		
0	9.79 887	16	9.90 837	26	0.09 163	9.89 050	10	60
1	9.79 903	15	9.90 863	26	0.09 137	9.89 040	10	59
2	9.79 918	16	9.90 889	26	0.09 111	9.89 030	10	58
3	9.79 934	16	9.90 914	26	0.09 086	9.89 020	10	57
4	9.79 950	15	9.90 940	26	0.09 060	9.89 009	10	56
5	9.79 965	16	9.90 966	26	0.09 034	9.88 999	10	55
6	9.79 981	15	9.90 992	26	0.09 008	9.88 989	11	54
7	9.79 996	16	9.91 018	25	0.08 982	9.88 978	10	53
8	9.80 012	15	9.91 043	26	0.08 957	9.88 968	10	52
9	9.80 027	16	9.91 069	26	0.08 931	9.88 958	10	51
10	9.80 043	15	9.91 095	26	0.08 905	9.88 948	11	50
11	9.80 058	16	9.91 121	26	0.08 879	9.88 937	10	49
12	9.80 074	15	9.91 147	25	0.08 853	9.88 927	10	48
13	9.80 089	16	9.91 172	26	0.08 828	9.88 917	10	47
14	9.80 105	15	9.91 198	26	0.08 802	9.88 906	11	46
15	9.80 120	16	9.91 224	26	0.08 776	9.88 896	10	45
16	9.80 136	15	9.91 250	26	0.08 750	9.88 886	11	44
17	9.80 151	15	9.91 276	25	0.08 724	9.88 875	10	43
18	9.80 166	16	9.91 301	26	0.08 699	9.88 865	10	42
19	9.80 182	15	9.91 327	26	0.08 673	9.88 855	11	41
20	9.80 197	16	9.91 353	26	0.08 647	9.88 844	10	40
21	9.80 213	15	9.91 379	25	0.08 621	9.88 834	10	39
22	9.80 228	16	9.91 404	26	0.08 596	9.88 824	11	38
23	9.80 244	15	9.91 430	26	0.08 570	9.88 813	10	37
24	9.80 259	15	9.91 456	26	0.08 544	9.88 803	10	36
25	9.80 274	16	9.91 482	25	0.08 518	9.88 793	11	35
26	9.80 290	15	9.91 507	26	0.08 493	9.88 782	10	34
27	9.80 305	15	9.91 533	26	0.08 467	9.88 772	11	33
28	9.80 320	16	9.91 559	26	0.08 441	9.88 761	10	32
29	9.80 336	15	9.91 585	25	0.08 415	9.88 751	10	31
30	9.80 351	15	9.91 610	26	0.08 390	9.88 741	11	30
31	9.80 366	16	9.91 636	26	0.08 364	9.88 730	10	29
32	9.80 382	15	9.91 662	26	0.08 338	9.88 720	10	28
33	9.80 397	15	9.91 688	25	0.08 312	9.88 709	11	27
34	9.80 412	16	9.91 713	26	0.08 287	9.88 699	10	26
35	9.80 428	15	9.91 739	26	0.08 261	9.88 688	10	25
36	9.80 443	15	9.91 765	26	0.08 235	9.88 678	10	24
37	9.80 458	15	9.91 791	25	0.08 209	9.88 668	10	23
38	9.80 473	16	9.91 816	26	0.08 184	9.88 657	10	22
39	9.80 489	15	9.91 842	26	0.08 158	9.88 647	11	21
40	9.80 504	15	9.91 868	25	0.08 132	9.88 636	10	20
41	9.80 519	15	9.91 893	26	0.08 107	9.88 626	11	19
42	9.80 534	16	9.91 919	26	0.08 081	9.88 615	10	18
43	9.80 550	15	9.91 945	26	0.08 055	9.88 605	10	17
44	9.80 565	15	9.91 971	25	0.08 029	9.88 594	11	16
45	9.80 580	15	9.91 996	26	0.08 004	9.88 584	11	15
46	9.80 595	15	9.92 022	26	0.07 978	9.88 573	10	14
47	9.80 610	15	9.92 048	26	0.07 952	9.88 563	10	13
48	9.80 625	16	9.92 073	25	0.07 927	9.88 552	11	12
49	9.80 641	15	9.92 099	26	0.07 901	9.88 542	10	11
50	9.80 656	15	9.92 125	25	0.07 875	9.88 531	10	10
51	9.80 671	15	9.92 150	26	0.07 850	9.88 521	11	9
52	9.80 686	15	9.92 176	26	0.07 824	9.88 510	11	8
53	9.80 701	15	9.92 202	25	0.07 798	9.88 499	10	7
54	9.80 716	15	9.92 227	26	0.07 773	9.88 489	10	6
55	9.80 731	15	9.92 253	26	0.07 747	9.88 478	11	5
56	9.80 746	16	9.92 279	25	0.07 721	9.88 468	10	4
57	9.80 762	15	9.92 304	26	0.07 696	9.88 457	10	3
58	9.80 777	15	9.92 330	26	0.07 670	9.88 447	10	2
59	9.80 792	15	9.92 356	25	0.07 644	9.88 436	11	1
60	9.80 807		9.92 381		0.07 619	9.88 425		0
	L SIN	D	L TAN	CD	L COT	L COS	D	320°... 140°
	L COS		L COT		L TAN	L SIN		230°... 50°

FM 30-476

40°... 220°		L SIN	D	L TAN	CD	L COT	L COS	D	PROP. PTS.	
130°... 310°		L COS		L COT		L TAN	L SIN			
0	9.80 807	15	9.92 381	26	0.07 619	9.88 425	10	60		
1	9.80 822	15	9.92 407	26	0.07 593	9.88 415	11	59		
2	9.80 837	15	9.92 433	25	0.07 567	9.88 404	10	58		
3	9.80 852	15	9.92 458	26	0.07 542	9.88 394	11	57	26	
4	9.80 867	15	9.92 484	26	0.07 516	9.88 383	11	56	1	2.6
5	9.80 882	15	9.92 510	25	0.07 490	9.88 372	10	55	2	5.2
6	9.80 897	15	9.92 535	26	0.07 465	9.88 362	11	54	3	7.8
7	9.80 912	15	9.92 561	26	0.07 439	9.88 351	11	53	4	10.4
8	9.80 927	15	9.92 587	25	0.07 413	9.88 340	10	52	5	13.0
9	9.80 942	15	9.92 612	26	0.07 388	9.88 330	11	51	6	15.6
10	9.80 957	15	9.92 638	25	0.07 362	9.88 319	11	50	7	18.2
11	9.80 972	15	9.92 663	26	0.07 337	9.88 308	10	49	8	20.8
12	9.80 987	15	9.92 689	26	0.07 311	9.88 298	11	48	9	23.4
13	9.81 002	15	9.92 715	26	0.07 285	9.88 287	11	47		
14	9.81 017	15	9.92 740	25	0.07 260	9.88 276	10	46		
15	9.81 032	15	9.92 766	26	0.07 234	9.88 266	11	45	25	
16	9.81 047	14	9.92 792	25	0.07 208	9.88 255	11	44	1	2.5
17	9.81 061	15	9.92 817	26	0.07 183	9.88 244	11	43	2	5.0
18	9.81 076	15	9.92 843	25	0.07 157	9.88 234	10	42	3	7.5
19	9.81 091	15	9.92 868	26	0.07 132	9.88 223	11	41	4	10.0
20	9.81 106	15	9.92 894	26	0.07 106	9.88 212	11	40	5	12.5
21	9.81 121	15	9.92 920	25	0.07 080	9.88 201	11	39	6	15.0
22	9.81 136	15	9.92 945	26	0.07 055	9.88 191	10	38	7	17.5
23	9.81 151	15	9.92 971	25	0.07 029	9.88 180	11	37	8	20.0
24	9.81 166	14	9.92 996	26	0.07 004	9.88 169	11	36	9	22.5
25	9.81 180	15	9.93 022	26	0.06 978	9.88 158	10	35		15
26	9.81 195	15	9.93 048	25	0.06 952	9.88 148	11	34	1	1.5
27	9.81 210	15	9.93 073	26	0.06 927	9.88 137	11	33	2	3.0
28	9.81 225	15	9.93 099	25	0.06 901	9.88 126	11	32	3	4.5
29	9.81 240	14	9.93 124	26	0.06 876	9.88 115	10	31	4	6.0
30	9.81 254	15	9.93 150	25	0.06 850	9.88 105	11	30	5	7.5
31	9.81 269	15	9.93 175	26	0.06 825	9.88 094	11	29	6	9.0
32	9.81 284	15	9.93 201	26	0.06 799	9.88 083	11	28	7	10.5
33	9.81 299	15	9.93 227	25	0.06 773	9.88 072	11	27	8	12.0
34	9.81 314	14	9.93 252	26	0.06 748	9.88 061	10	26	9	13.5
35	9.81 328	15	9.93 278	25	0.06 722	9.88 051	11	25		
36	9.81 343	15	9.93 303	26	0.06 697	9.88 040	11	24		
37	9.81 358	14	9.93 329	25	0.06 671	9.88 029	11	23		
38	9.81 372	15	9.93 354	26	0.06 646	9.88 018	11	22		
39	9.81 387	15	9.93 380	26	0.06 620	9.88 007	11	21	14	
40	9.81 402	15	9.93 406	25	0.06 594	9.87 996	11	20	1	1.4
41	9.81 417	14	9.93 431	26	0.06 569	9.87 985	10	19	2	2.8
42	9.81 431	15	9.93 457	25	0.06 543	9.87 975	11	18	3	4.2
43	9.81 446	15	9.93 482	26	0.06 518	9.87 964	11	17	4	5.6
44	9.81 461	14	9.93 508	25	0.06 492	9.87 953	11	16	5	7.0
45	9.81 475	15	9.93 533	26	0.06 467	9.87 942	11	15	6	8.4
46	9.81 490	15	9.93 559	25	0.06 441	9.87 931	11	14	7	9.8
47	9.81 505	14	9.93 584	26	0.06 416	9.87 920	11	13	8	11.2
48	9.81 519	15	9.93 610	26	0.06 390	9.87 909	11	12	9	12.6
49	9.81 534	15	9.93 636	25	0.06 364	9.87 898	11	11		
50	9.81 549	14	9.93 661	26	0.06 339	9.87 887	10	10	11	10
51	9.81 563	15	9.93 687	25	0.06 313	9.87 877	11	9	1	1.1
52	9.81 578	14	9.93 712	26	0.06 288	9.87 866	11	8	2	2.2
53	9.81 592	15	9.93 738	25	0.06 262	9.87 855	11	7	3	3.3
54	9.81 607	15	9.93 763	26	0.06 237	9.87 844	11	6	4	4.4
55	9.81 622	14	9.93 789	25	0.06 211	9.87 833	11	5	5	5.5
56	9.81 636	15	9.93 814	26	0.06 186	9.87 822	11	4	6	6.6
57	9.81 651	14	9.93 840	25	0.06 160	9.87 811	11	3	7	7.7
58	9.81 665	15	9.93 865	26	0.06 135	9.87 800	11	2	8	8.8
59	9.81 680	14	9.93 891	25	0.06 109	9.87 789	11	1	9	9.9
60	9.81 694		9.93 916		0.06 084	9.87 778		0		9.0
		L SIN	D	L TAN	CD	L COT	L COS	D	319°... 139°...	
		L COS		L COT		L TAN	L SIN		229°... 49°...	

41°... 221°		L SIN	D	L TAN	CD	L COT	L COS	D	PROP. PTS.	
131°... 311°		L COS		L COT		L TAN	L SIN			
0	9.81 694		15	9.93 916	26	0.06 084	9.87 778	11	60	
1	9.81 709		14	9.93 942	25	0.06 058	9.87 767	11	59	
2	9.81 723		15	9.93 967	26	0.06 033	9.87 756	11	58	
3	9.81 738		14	9.93 993	25	0.06 007	9.87 745	11	57	26
4	9.81 752		15	9.94 018	26	0.05 982	9.87 734	11	56	1 2.6
5	9.81 767		14	9.94 044	25	0.05 956	9.87 723	11	55	2 5.2
6	9.81 781		15	9.94 069	26	0.05 931	9.87 712	11	54	3 7.8
7	9.81 796		14	9.94 095	25	0.05 905	9.87 701	11	53	4 10.4
8	9.81 810		15	9.94 120	26	0.05 880	9.87 690	11	52	5 13.0
9	9.81 825		14	9.94 146	25	0.05 854	9.87 679	11	51	6 15.6
10	9.81 839		15	9.94 171	26	0.05 829	9.87 668	11	50	7 18.2
11	9.81 854		14	9.94 197	25	0.05 803	9.87 657	11	49	8 20.8
12	9.81 868		15	9.94 222	26	0.05 778	9.87 646	11	48	9 23.4
13	9.81 882		14	9.94 248	25	0.05 752	9.87 635	11	47	
14	9.81 897		15	9.94 273	26	0.05 727	9.87 624	11	46	25
15	9.81 911		14	9.94 299	25	0.05 701	9.87 613	11	45	1 2.5
16	9.81 926		15	9.94 324	26	0.05 676	9.87 601	12	44	2 5.0
17	9.81 940		14	9.94 350	25	0.05 650	9.87 590	11	43	3 7.5
18	9.81 955		15	9.94 375	26	0.05 625	9.87 579	11	42	4 10.0
19	9.81 969		14	9.94 401	25	0.05 599	9.87 568	11	41	5 12.5
20	9.81 983		15	9.94 426	26	0.05 574	9.87 557	11	40	6 15.0
21	9.81 998		14	9.94 452	25	0.05 548	9.87 546	11	39	7 17.5
22	9.82 012		15	9.94 477	26	0.05 523	9.87 535	11	38	8 20.0
23	9.82 026		14	9.94 503	25	0.05 497	9.87 524	11	37	9 22.5
24	9.82 041		15	9.94 528	26	0.05 472	9.87 513	11	36	
25	9.82 055		14	9.94 554	25	0.05 446	9.87 501	11	35	15
26	9.82 069		15	9.94 579	26	0.05 421	9.87 490	11	34	
27	9.82 084		14	9.94 604	25	0.05 396	9.87 479	11	33	1 1.5
28	9.82 098		15	9.94 630	26	0.05 370	9.87 468	11	32	2 3.0
29	9.82 112		14	9.94 655	25	0.05 345	9.87 457	11	31	3 4.5
30	9.82 126		15	9.94 681	26	0.05 319	9.87 446	11	30	4 6.0
31	9.82 141		14	9.94 706	25	0.05 294	9.87 434	12	29	5 7.5
32	9.82 155		15	9.94 732	26	0.05 268	9.87 423	11	28	6 9.0
33	9.82 169		14	9.94 757	25	0.05 243	9.87 412	11	27	7 10.5
34	9.82 184		15	9.94 783	26	0.05 217	9.87 401	11	26	8 12.0
35	9.82 198		14	9.94 808	25	0.05 192	9.87 390	11	25	9 13.5
36	9.82 212		15	9.94 834	26	0.05 166	9.87 378	12	24	
37	9.82 226		14	9.94 859	25	0.05 141	9.87 367	11	23	14
38	9.82 240		15	9.94 884	26	0.05 116	9.87 356	11	22	
39	9.82 255		14	9.94 910	25	0.05 090	9.87 345	11	21	1 1.4
40	9.82 269		15	9.94 935	26	0.05 065	9.87 324	12	20	2 2.8
41	9.82 283		14	9.94 961	25	0.05 039	9.87 322	11	19	3 4.2
42	9.82 297		15	9.94 986	26	0.05 014	9.87 311	11	18	4 5.6
43	9.82 311		14	9.95 012	25	0.04 988	9.87 300	11	17	5 7.0
44	9.82 326		15	9.95 037	26	0.04 963	9.87 288	12	16	6 8.4
45	9.82 340		14	9.95 062	25	0.04 938	9.87 277	11	15	7 9.8
46	9.82 354		15	9.95 088	26	0.04 912	9.87 266	11	14	8 11.2
47	9.82 368		14	9.95 113	25	0.04 887	9.87 255	11	13	9 12.6
48	9.82 382		15	9.95 139	26	0.04 861	9.87 243	11	12	
49	9.82 396		14	9.95 164	25	0.04 836	9.87 232	11	11	
50	9.82 410		15	9.95 190	26	0.04 810	9.87 221	11	10	12 1.1
51	9.82 424		14	9.95 215	25	0.04 785	9.87 209	12	9	1 1.2
52	9.82 439		15	9.95 240	26	0.04 760	9.87 198	11	8	2 2.4
53	9.82 453		14	9.95 266	25	0.04 734	9.87 187	11	7	3 3.6
54	9.82 467		15	9.95 291	26	0.04 709	9.87 175	12	6	4 4.8
55	9.82 481		14	9.95 317	25	0.04 683	9.87 164	11	5	5 6.0
56	9.82 495		15	9.95 342	26	0.04 658	9.87 153	11	4	6 7.2
57	9.82 509		14	9.95 368	25	0.04 632	9.87 141	12	3	7 8.4
58	9.82 523		15	9.95 393	26	0.04 607	9.87 130	11	2	8 9.6
59	9.82 537		14	9.95 418	25	0.04 582	9.87 119	11	1	9 10.8
60	9.82 551		15	9.95 444	26	0.04 556	9.87 107	12	0	9.9
	L SIN		D	L TAN	CD	L COT	L COS	D		318°... 138°
	L COS			L COT		L TAN	L SIN			228°... 48°

42° ... 222°		L SIN	D	L TAN	CD	L COT	L COS	D	PROP. PTS.
132° ... 312°		L COS		L COT		L TAN	L SIN		
0	9.82 551	14	9.95 444	25	0.04 556	9.87 107	11	60	
1	9.82 565	14	9.95 469	26	0.04 531	9.87 096	11	59	
2	9.82 579	14	9.95 495	25	0.04 505	9.87 085	12	58	
3	9.82 593	14	9.95 520	25	0.04 480	9.87 073	11	57	
4	9.82 607	14	9.95 545	26	0.04 455	9.87 062	12	56	26
5	9.82 621	14	9.95 571	25	0.04 429	9.87 050	11	55	1 2.6
6	9.82 635	14	9.95 596	26	0.04 404	9.87 039	11	54	2 5.2
7	9.82 649	14	9.95 622	25	0.04 378	9.87 028	12	53	3 7.8
8	9.82 663	14	9.95 647	25	0.04 353	9.87 016	11	52	4 10.4
9	9.82 677	14	9.95 672	26	0.04 328	9.87 005	11	51	5 13.0
10	9.82 691	14	9.95 698	25	0.04 302	9.86 993	12	50	6 15.6
11	9.82 705	14	9.95 723	25	0.04 277	9.86 982	11	49	7 18.2
12	9.82 719	14	9.95 748	26	0.04 252	9.86 970	12	48	8 20.8
13	9.82 733	14	9.95 774	25	0.04 226	9.86 959	11	47	9 23.4
14	9.82 747	14	9.95 799	26	0.04 201	9.86 947	12	46	
15	9.82 761	14	9.95 825	25	0.04 175	9.86 936	11	45	25
16	9.82 775	13	9.95 820	25	0.04 150	9.86 924	12	44	1 2.5
17	9.82 788	14	9.95 875	26	0.04 125	9.86 913	11	43	2 5.0
18	9.82 802	14	9.95 901	25	0.04 099	9.86 902	12	42	3 7.5
19	9.82 816	14	9.95 926	26	0.04 074	9.86 890	11	41	4 10.0
20	9.82 830	14	9.95 952	25	0.04 048	9.86 879	12	40	5 12.5
21	9.82 844	14	9.95 977	25	0.04 023	9.86 867	11	39	6 15.0
22	9.82 858	14	9.96 002	26	0.03 998	9.86 855	12	38	7 17.5
23	9.82 872	13	9.96 028	25	0.03 972	9.86 844	11	37	8 20.0
24	9.82 885	14	9.96 053	25	0.03 947	9.86 832	12	36	9 22.5
25	9.82 899	14	9.96 078	26	0.03 922	9.86 821	11	35	
26	9.82 913	14	9.96 104	25	0.03 896	9.86 809	12	34	14
27	9.82 927	14	9.96 129	26	0.03 871	9.86 798	11	33	1 1.4
28	9.82 941	14	9.96 155	25	0.03 845	9.86 786	12	32	2 2.8
29	9.82 955	13	9.96 180	25	0.03 820	9.86 775	11	31	3 4.2
30	9.82 968	14	9.96 205	26	0.03 795	9.86 763	12	30	4 5.6
31	9.82 982	14	9.96 231	25	0.03 769	9.86 752	11	29	5 7.0
32	9.82 996	14	9.96 256	25	0.03 744	9.86 740	12	28	6 8.4
33	9.83 010	13	9.96 281	26	0.03 719	9.86 728	11	27	7 9.8
34	9.83 023	14	9.96 307	25	0.03 693	9.86 717	12	26	8 11.2
35	9.83 037	14	9.96 332	25	0.03 668	9.86 705	11	25	9 12.6
36	9.83 051	14	9.96 357	26	0.03 643	9.86 694	12	24	
37	9.83 065	14	9.96 383	25	0.03 617	9.86 682	11	23	
38	9.83 078	13	9.96 408	25	0.03 592	9.86 670	12	22	
39	9.83 092	14	9.96 433	26	0.03 567	9.86 659	11	21	13
40	9.83 106	14	9.96 459	25	0.03 541	9.86 647	12	20	1 1.3
41	9.83 120	13	9.96 484	26	0.03 516	9.86 635	11	19	2 2.6
42	9.83 133	14	9.96 510	25	0.03 490	9.86 624	12	18	3 3.9
43	9.83 147	14	9.96 535	25	0.03 465	9.86 612	11	17	4 5.2
44	9.83 161	13	9.96 560	26	0.03 440	9.86 600	12	16	5 6.5
45	9.83 174	14	9.96 586	25	0.03 414	9.86 589	11	15	6 7.8
46	9.83 188	14	9.96 611	25	0.03 389	9.86 577	12	14	7 9.1
47	9.83 202	14	9.96 636	26	0.03 364	9.86 565	11	13	8 10.4
48	9.83 215	13	9.96 662	26	0.03 338	9.86 554	12	12	9 11.7
49	9.83 229	13	9.96 687	25	0.03 313	9.86 542	11	11	
50	9.83 242	14	9.96 712	26	0.03 288	9.86 530	12	10	12 11
51	9.83 256	14	9.96 738	25	0.03 262	9.86 518	11	9	1 1.2 1.1
52	9.83 270	13	9.96 763	25	0.03 237	9.86 507	12	8	2 2.4 2.2
53	9.83 283	14	9.96 788	26	0.03 212	9.86 495	11	7	3 3.6 3.3
54	9.83 297	13	9.96 814	25	0.03 186	9.86 483	12	6	4 4.8 4.4
55	9.83 310	14	9.96 839	25	0.03 161	9.86 472	11	5	5 6.0 5.5
56	9.83 324	14	9.96 864	26	0.03 136	9.86 460	12	4	6 7.2 6.6
57	9.83 338	13	9.96 890	25	0.03 110	9.86 448	11	3	7 8.4 7.7
58	9.83 351	14	9.96 915	25	0.03 085	9.86 436	12	2	8 9.6 8.8
59	9.83 365	13	9.96 940	26	0.03 060	9.86 425	11	1	9 10.8 9.9
60	9.83 378		9.96 966		0.03 034	9.86 413		0	
		L SIN	L TAN		L COT	L COS			317° ... 137°
		L COS	L COT		L TAN	L SIN			227° ... 47°

43°... 223°	L SIN	D	L TAN	CD	L COT	L COS	D	PROP. PTS.
133°... 313°	L COS		L COT		L TAN	L SIN		
0	9.83 378	14	9.96 966	25	0.03 034	9.86 413	12	60
1	9.83 392	13	9.96 991	25	0.03 009	9.86 401	12	59
2	9.83 405	14	9.97 016	25	0.02 984	9.86 389	12	58
3	9.83 419	13	9.97 042	25	0.02 958	9.86 377	11	57
4	9.83 432	14	9.97 067	25	0.02 933	9.86 366	12	56
5	9.83 446	13	9.97 092	26	0.02 908	9.86 354	12	55
6	9.83 459	14	9.97 118	25	0.02 882	9.86 342	12	54
7	9.83 473	13	9.97 143	25	0.02 857	9.86 330	12	53
8	9.83 486	14	9.97 168	25	0.02 832	9.86 318	12	52
9	9.83 500	13	9.97 193	26	0.02 807	9.86 306	11	51
10	9.83 513	14	9.97 219	25	0.02 781	9.86 295	12	50
11	9.83 527	13	9.97 244	25	0.02 756	9.86 283	12	49
12	9.83 540	14	9.97 269	26	0.02 731	9.86 271	12	48
13	9.83 554	13	9.97 295	25	0.02 705	9.86 259	12	47
14	9.83 567	14	9.95 320	25	0.02 680	9.86 247	12	46
15	9.83 581	13	9.97 345	26	0.02 655	9.86 235	12	45
16	9.83 594	14	9.97 371	25	0.02 629	9.86 223	12	44
17	9.83 608	13	9.97 396	25	0.02 604	9.86 211	11	43
18	9.83 621	14	9.97 421	25	0.02 579	9.86 200	12	42
19	9.83 634	13	9.97 447	26	0.02 553	9.86 188	12	41
20	9.83 648	13	9.97 472	25	0.02 528	9.86 176	12	40
21	9.83 661	13	9.97 497	26	0.02 503	9.86 164	12	39
22	9.83 674	14	9.97 523	25	0.02 477	9.86 152	12	38
23	9.83 688	13	9.97 548	25	0.02 452	9.86 140	12	37
24	9.83 701	14	9.97 573	25	0.02 427	9.86 128	12	36
25	9.83 715	13	9.97 598	26	0.02 402	9.86 116	12	35
26	9.83 728	13	9.97 624	25	0.02 376	9.86 104	12	34
27	9.83 741	14	9.97 649	25	0.02 351	9.86 092	12	33
28	9.83 755	13	9.97 674	26	0.02 326	9.86 080	12	32
29	9.83 768	13	9.97 700	25	0.02 300	9.86 068	12	31
30	9.83 781	14	9.97 725	25	0.02 275	9.86 056	12	30
31	9.83 795	13	9.97 750	26	0.02 250	9.86 044	12	29
32	9.83 808	13	9.97 776	25	0.02 224	9.86 032	12	28
33	9.83 821	13	9.97 801	25	0.02 199	9.86 020	12	27
34	9.83 834	14	9.97 826	25	0.02 174	9.86 008	12	26
35	9.83 848	13	9.97 851	26	0.02 149	9.85 996	12	25
36	9.83 861	13	9.97 877	25	0.02 123	9.85 984	12	24
37	9.83 874	13	9.97 902	25	0.02 098	9.85 972	12	23
38	9.83 887	14	9.97 927	26	0.02 073	9.85 960	12	22
39	9.83 901	13	9.97 953	25	0.02 047	9.85 948	12	21
40	9.83 914	13	9.97 978	25	0.02 022	9.85 936	12	20
41	9.83 927	13	9.98 003	26	0.01 997	9.85 924	12	19
42	9.83 940	14	9.98 029	25	0.01 971	9.85 912	12	18
43	9.83 954	13	9.98 054	25	0.01 946	9.85 900	12	17
44	9.83 967	13	9.98 079	25	0.01 921	9.85 888	12	16
45	9.83 980	13	9.98 104	26	0.01 896	9.85 876	12	15
46	9.83 993	13	9.98 130	25	0.01 870	9.85 864	13	14
47	9.84 006	14	9.98 155	25	0.01 845	9.85 851	12	13
48	9.84 020	13	9.98 180	26	0.01 820	9.85 839	12	12
49	9.84 033	13	9.98 206	25	0.01 794	9.85 827	12	11
50	9.84 046	13	9.98 231	25	0.01 769	9.85 815	12	10
51	9.84 059	13	9.98 256	25	0.01 744	9.85 803	12	9
52	9.84 072	13	9.98 281	26	0.01 719	9.85 791	12	8
53	9.83 085	13	9.98 307	25	0.01 693	9.85 779	13	7
54	9.84 098	14	9.98 332	25	0.01 668	9.85 766	12	6
55	9.84 112	13	9.98 357	26	0.01 643	9.85 754	12	5
56	9.84 125	13	9.98 383	25	0.01 617	9.85 742	12	4
57	9.84 138	13	9.98 408	25	0.01 592	9.85 730	12	3
58	9.84 151	13	9.98 433	25	0.01 567	9.85 718	12	2
59	9.84 164	13	9.98 458	26	0.01 542	9.85 706	13	1
60	9.84 177		9.98 484		0.01 516	9.85 693		0
	L SIN	D	L TAN	CD	L COT	L COS	D	316°... 136°
	L COS		L COT		L TAN	L SIN		226°... 46°

44°... 224°		L SIN	D	L TAN	CD	L COT	L COS	D	PROP. PTS.	
134°... 314°		L COS		L COT		L TAN	L SIN			
0	9.84 177	13	9.98 484	25	0.01 516	9.85 693	12	60		
1	9.84 190	13	9.98 509	25	0.01 491	9.85 681	12	59		
2	9.84 203	13	9.98 534	26	0.01 466	9.85 669	12	58		
3	9.84 216	13	9.98 560	25	0.01 440	9.85 657	12	57		26
4	9.84 229	13	9.98 585	25	0.01 415	9.85 645	13	56	1	2.6
5	9.84 242	13	9.98 610	25	0.01 390	9.85 632	12	55	2	5.2
6	9.84 255	14	9.98 635	26	0.01 365	9.85 620	12	54	3	7.8
7	9.84 269	13	9.98 661	25	0.01 339	9.85 608	12	53	4	10.4
8	9.84 282	13	9.98 686	25	0.01 314	9.85 596	13	52	5	13.0
9	9.84 295	13	9.98 711	26	0.01 289	9.85 583	12	51	6	15.6
10	9.84 308	13	9.98 737	25	0.01 263	9.85 571	12	50	7	18.2
11	9.84 321	13	9.98 762	25	0.01 238	9.85 559	12	49	8	20.8
12	9.84 334	13	9.98 787	25	0.01 213	9.85 547	13	48	9	23.4
13	9.84 347	13	9.98 812	25	0.01 188	9.85 534	12	47		
14	9.84 360	13	9.98 838	26	0.01 162	9.85 522	12	46		25
15	9.84 373	12	9.98 863	25	0.01 137	9.85 510	13	45	1	2.5
16	9.84 385	13	9.98 888	25	0.01 112	9.85 497	12	44	2	5.0
17	9.84 398	13	9.98 913	25	0.01 087	9.85 485	12	43	3	7.5
18	9.84 411	13	9.98 939	26	0.01 061	9.85 473	12	42	4	10.0
19	9.84 424	13	9.98 964	25	0.01 036	9.85 460	13	41	5	12.5
20	9.84 437	13	9.98 989	26	0.01 011	9.85 448	12	40	6	15.0
21	9.84 450	13	9.99 015	25	0.00 985	9.85 436	13	39	7	17.5
22	9.84 463	13	9.99 040	25	0.00 960	9.85 423	12	38	8	20.0
23	9.8 76	13	9.99 065	25	0.00 935	9.85 411	12	37	9	22.5
24	9.84 489	13	9.99 090	26	0.00 910	9.85 399	13	36		
25	9.84 502	13	9.99 116	25	0.00 884	9.85 386	12	35		14
26	9.84 515	13	9.99 141	25	0.00 859	9.85 374	13	34		
27	9.84 528	13	9.99 166	25	0.00 834	9.85 361	12	33	1	1.4
28	9.84 540	12	9.99 191	25	0.00 809	9.85 349	12	32	2	2.8
29	9.84 553	13	9.99 217	26	0.00 783	9.85 337	13	31	3	4.2
30	9.84 566	13	9.99 242	25	0.00 758	9.85 324	12	30	4	5.6
31	9.84 579	13	9.99 267	26	0.00 733	9.85 312	13	29	5	7.0
32	9.84 592	13	9.99 293	25	0.00 707	9.85 299	12	28	6	8.4
33	9.84 605	13	9.99 318	25	0.00 682	9.85 287	13	27	7	9.8
34	9.84 618	12	9.99 343	25	0.00 657	9.85 274	12	26	8	11.2
35	9.84 630	13	9.99 368	26	0.00 632	9.85 262	12	25	9	12.6
36	9.84 643	13	9.99 394	25	0.00 606	9.85 250	13	24		
37	9.84 656	13	9.99 419	25	0.00 581	9.85 237	12	23		13
38	9.84 669	13	9.99 444	25	0.00 556	9.85 225	13	22		
39	9.84 682	12	9.99 469	26	0.00 531	9.85 212	12	21	1	1.3
40	9.84 694	13	9.99 495	25	0.00 505	9.85 200	13	20	2	2.6
41	9.84 707	13	9.99 520	25	0.00 480	9.85 187	12	19	3	3.9
42	9.84 720	13	9.99 545	25	0.00 455	9.85 175	13	18	4	5.2
43	9.84 733	12	9.99 570	26	0.00 430	9.85 162	12	17	5	6.5
44	9.84 745	13	9.99 596	25	0.00 404	9.85 150	13	16	6	7.8
45	9.84 758	13	9.99 621	25	0.00 379	9.85 137	12	15	7	9.1
46	9.84 771	13	9.99 646	26	0.00 354	9.85 125	13	14	8	10.4
47	9.84 784	12	9.99 672	25	0.00 328	9.85 112	12	13	9	11.7
48	9.84 796	13	9.99 697	25	0.00 303	9.85 100	12	12		
49	9.84 809	13	9.99 722	25	0.00 278	9.85 087	13	11		12
50	9.84 822	13	9.99 747	26	0.00 253	9.85 074	12	10	1	1.2
51	9.84 835	12	9.99 773	25	0.00 227	9.85 062	13	9	2	2.4
52	9.84 847	13	9.99 798	25	0.00 202	9.85 049	12	8	3	3.6
53	9.84 860	13	9.99 823	25	0.00 177	9.85 037	13	7	4	4.8
54	9.84 873	12	9.99 848	26	0.00 152	9.85 024	12	6	5	6.0
55	9.84 885	13	9.99 874	25	0.00 126	9.85 012	13	5	6	7.2
56	9.84 898	13	9.99 899	26	0.00 101	9.84 999	12	4	7	8.4
57	9.84 911	12	9.99 924	25	0.00 076	9.84 986	13	3	8	9.6
58	9.84 923	13	9.99 949	26	0.00 051	9.84 974	12	2	9	10.8
59	9.84 936	13	9.99 975	25	0.00 025	9.84 961	13	1		
60	9.84 949		0.00 000		0.00 000	9.84 949		0		
	L SIN	D	L TAN	CD	L COT	L COS	D		315°... 135°	
	L COS		L COT		L TAN	L SIN			225°... 45°	

Appendix C

DEAD RECKONING ALTITUDE AND AZIMUTH TABLE

WHEN LHA (E OR) W IS GREATER THAN 90°, TAKE "K" FROM BOTTOM OF TABLE

	0°00'		0°30'		1°00'		1°30'		2°00'		
	A	B	A	B	A	B	A	B	A	B	
0 0.0	0.0	205916 1.7	175814 6.6	158208 14.9	145718 26.5	30
	383730 0.0	205198 1.7	175454 6.7	157967 15.1	145538 26.7	
1	353627 0.0	204492 1.8	175097 6.8	157728 15.2	145358 26.9	29
	336018 0.0	203797 1.8	174742 7.0	157490 15.4	145179 27.1	
2	323524 0.0	203113 1.9	174391 7.1	157254 15.6	145000 27.3	28
	313833 0.0	202440 1.9	174042 7.2	157019 15.7	144823 27.6	
3	305915 0.0	201777 2.0	173696 7.3	156784 15.9	144646 27.8	27
	299221 0.0	201124 2.1	173352 7.4	156552 16.1	144470 28.0	
4	293421 0.0	200480 2.1	173012 7.5	156320 16.2	144295 28.3	26
	288306 0.0	199846 2.2	172674 7.6	156090 16.4	144120 28.5	
5	283730 0.0	199221 2.3	172339 7.8	155861 16.6	143946 28.7	25
	279591 0.1	198605 2.3	172006 7.9	155633 16.8	143773 28.9	
6	275812 0.1	197998 2.4	171676 8.0	155406 16.9	143600 29.2	24
	272336 0.1	197399 2.4	171348 8.1	155180 17.1	143428 29.4	
7	269118 0.1	196808 2.5	171023 8.2	154956 17.3	143257 29.6	23
	266121 0.1	196225 2.6	170700 8.4	154733 17.5	143086 29.9	
8	263318 0.1	195650 2.7	170379 8.5	154511 17.6	142916 30.1	22
	260685 0.1	195082 2.7	170061 8.6	154290 17.8	142747 30.4	
9	258203 0.1	194522 2.8	169745 8.7	154070 18.0	142579 30.6	21
	255855 0.2	193969 2.9	169432 8.9	153851 18.2	142411 30.8	
10	253627 0.2	193422 2.9	169121 9.0	153633 18.4	142243 31.1	20
	251508 0.2	192883 3.0	168811 9.1	153417 18.6	142077 31.3	
11	249488 0.2	192350 3.1	168505 9.3	153201 18.7	141911 31.5	19
	247558 0.2	191824 3.2	168200 9.4	152987 18.9	141745 31.8	
12	245709 0.3	191303 3.2	167897 9.5	152774 19.1	141581 32.0	18
	243936 0.3	190790 3.3	167597 9.7	152561 19.3	141417 32.3	
13	242233 0.3	190282 3.4	167298 9.8	152350 19.5	141253 32.5	17
	240594 0.3	189780 3.5	167002 9.9	152140 19.7	141090 32.8	
14	239015 0.4	189283 3.6	166708 10.1	151931 19.9	140928 33.0	16
	237491 0.4	188793 3.6	166415 10.2	151722 20.1	140766 33.3	
15	236018 0.4	188307 3.7	166125 10.3	151515 20.3	140605 33.5	15
	234594 0.4	187827 3.8	165836 10.5	151309 20.5	140445 33.7	
16	233215 0.5	187353 3.9	165550 10.6	151104 20.6	140285 34.0	14
	231879 0.5	186883 4.0	165265 10.8	150899 20.8	140125 34.2	
17	230583 0.5	186419 4.1	164982 10.9	150696 21.0	139967 34.5	13
	229324 0.6	185959 4.1	164701 11.0	150494 21.2	139809 34.7	
18	228100 0.6	185505 4.2	164422 11.2	150292 21.4	139651 35.0	12
	226910 0.6	185055 4.3	164144 11.3	150092 21.6	139494 35.3	
19	225752 0.7	184609 4.4	163868 11.5	149892 21.8	139338 35.5	11
	224624 0.7	184168 4.5	163594 11.6	149693 22.0	139182 35.8	
20	223525 0.7	183732 4.6	163322 11.8	149495 22.2	139027 36.0	10
	222452 0.8	183300 4.7	163052 11.9	149299 22.4	138872 36.3	
21	221406 0.8	182872 4.8	162783 12.1	149103 22.6	138718 36.5	9
	220384 0.9	182448 4.9	162516 12.2	148907 22.9	138564 36.8	
22	219385 0.9	182029 5.0	162250 12.4	148713 23.1	138411 37.1	8
	218409 0.9	181613 5.1	161986 12.5	148520 23.3	138258 37.3	
23	217455 1.0	181201 5.2	161724 12.7	148327 23.5	138106 37.6	7
	216521 1.0	180794 5.3	161463 12.8	148135 23.7	137955 37.9	
24	215607 1.1	180390 5.4	161204 13.0	147945 23.9	137804 38.1	6
	214711 1.1	179990 5.5	160946 13.1	147755 24.1	137653 38.4	
25	213834 1.1	179593 5.6	160690 13.3	147566 24.3	137504 38.6	5
	212974 1.2	179200 5.7	160435 13.4	147377 24.5	137354 38.9	
26	212130 1.2	178810 5.8	160182 13.6	147190 24.7	137205 39.2	4
	211303 1.3	178424 5.9	159930 13.8	147003 24.9	137057 39.4	
27	210491 1.3	178042 6.0	159680 13.9	146817 25.2	136909 39.7	3
	209695 1.4	177663 6.1	159431 14.1	146632 25.4	136761 40.0	
28	208912 1.4	177287 6.2	159184 14.2	146448 25.6	136615 40.3	2
	208143 1.5	176914 6.3	158938 14.4	146264 25.8	136468 40.5	
29	207388 1.5	176544 6.4	158693 14.6	146081 26.0	136322 40.8	1
	206646 1.6	176178 6.5	158450 14.7	145899 26.2	136177 41.1	
30	205916 1.7	175814 6.6	158208 14.9	145718 26.5	136032 41.4	0
	A	B	A	B	A	B	A	B	A	B	
	179°30'		179°00'		178°30'		178°00'		177°30'		

ALWAYS TAKE "Z" FROM BOTTOM OF TABLE, EXCEPT WHEN "K" IS SAME NAME AND GREATER THAN LATITUDE, IN WHICH CASE TAKE "Z" FROM TOP OF TABLE

	2°30'		3°00'		3°30'		4°00'		4°30'		
	A	B	A	B	A	B	A	B	A	B	
0	136032 ... 41.4	41.4	128120 ... 59.6	59.6	121432 ... 81.1	81.1	115641 ... 105.9	105.9	110536 ... 134.1	134.1	30
1	135888 ... 41.6	41.6	128000 ... 59.9	59.9	121329 ... 81.5	81.5	115551 ... 106.4	106.4	110455 ... 134.6	134.6	29
	135744 ... 41.9	41.9	127880 ... 60.2	60.2	121226 ... 81.9	81.9	115461 ... 106.8	106.8	110375 ... 135.1	135.1	
2	135600 ... 42.2	42.2	127760 ... 60.6	60.6	121124 ... 82.2	82.2	115371 ... 107.3	107.3	110296 ... 135.6	135.6	28
	135457 ... 42.5	42.5	127640 ... 60.9	60.9	121021 ... 82.6	82.6	115282 ... 107.7	107.7	110216 ... 136.1	136.1	
3	135315 ... 42.7	42.7	127521 ... 61.2	61.2	120919 ... 83.0	83.0	115192 ... 108.1	108.1	110136 ... 136.6	136.6	27
	135173 ... 43.0	43.0	127403 ... 61.6	61.6	120817 ... 83.4	83.4	115103 ... 108.6	108.6	110057 ... 137.1	137.1	
4	135031 ... 43.3	43.3	127284 ... 61.9	61.9	120715 ... 83.8	83.8	115014 ... 109.0	109.0	109977 ... 137.6	137.6	26
	134890 ... 43.6	43.6	127166 ... 62.2	62.2	120614 ... 84.2	84.2	114925 ... 109.5	109.5	109898 ... 138.1	138.1	
5	134749 ... 43.9	43.9	127049 ... 62.6	62.6	120513 ... 84.6	84.6	114836 ... 109.9	109.9	109819 ... 138.6	138.6	25
	134609 ... 44.2	44.2	126931 ... 62.9	62.9	120412 ... 85.0	85.0	114747 ... 110.4	110.4	109740 ... 139.1	139.1	
6	134469 ... 44.4	44.4	126814 ... 63.3	63.3	120311 ... 85.4	85.4	114659 ... 110.8	110.8	109662 ... 139.6	139.6	24
	134330 ... 44.7	44.7	126697 ... 63.6	63.6	120211 ... 85.8	85.8	114571 ... 111.3	111.3	109583 ... 140.1	140.1	
7	134191 ... 45.0	45.0	126581 ... 63.9	63.9	120110 ... 86.2	86.2	114483 ... 111.7	111.7	109505 ... 140.6	140.6	23
	134052 ... 45.3	45.3	126465 ... 64.3	64.3	120010 ... 86.6	86.6	114395 ... 112.2	112.2	109426 ... 141.1	141.1	
8	133914 ... 45.6	45.6	126349 ... 64.6	64.6	119910 ... 87.0	87.0	114307 ... 112.7	112.7	109348 ... 141.7	141.7	22
	133777 ... 45.9	45.9	126233 ... 65.0	65.0	119811 ... 87.4	87.4	114220 ... 113.1	113.1	109270 ... 142.2	142.2	
9	133640 ... 46.2	46.2	126118 ... 65.3	65.3	119711 ... 87.8	87.8	114133 ... 113.6	113.6	109192 ... 142.7	142.7	21
	133503 ... 46.5	46.5	126003 ... 65.7	65.7	119612 ... 88.2	88.2	114045 ... 114.0	114.0	109115 ... 143.2	143.2	
10	133367 ... 46.8	46.8	125888 ... 66.0	66.0	119513 ... 88.6	88.6	113958 ... 114.5	114.5	109037 ... 143.7	143.7	20
	133231 ... 47.1	47.1	125774 ... 66.4	66.4	119415 ... 89.0	89.0	113872 ... 114.9	114.9	108960 ... 144.2	144.2	
11	133096 ... 47.4	47.4	125660 ... 66.7	66.7	119316 ... 89.4	89.4	113785 ... 115.4	115.4	108882 ... 144.7	144.7	19
	132961 ... 47.6	47.6	125546 ... 67.1	67.1	119218 ... 89.8	89.8	113699 ... 115.9	115.9	108805 ... 145.2	145.2	
12	132826 ... 47.9	47.9	125433 ... 67.4	67.4	119120 ... 90.2	90.2	113612 ... 116.3	116.3	108728 ... 145.8	145.8	18
	132692 ... 48.2	48.2	125320 ... 67.8	67.8	119022 ... 90.6	90.6	113526 ... 116.8	116.8	108651 ... 146.3	146.3	
13	132558 ... 48.5	48.5	125207 ... 68.1	68.1	118925 ... 91.0	91.0	113440 ... 117.3	117.3	108574 ... 146.8	146.8	17
	132425 ... 48.8	48.8	125094 ... 68.5	68.5	118827 ... 91.4	91.4	113354 ... 117.7	117.7	108498 ... 147.3	147.3	
14	132292 ... 49.1	49.1	124982 ... 68.8	68.8	118730 ... 91.8	91.8	113269 ... 118.2	118.2	108421 ... 147.8	147.8	16
	132159 ... 49.4	49.4	124870 ... 69.2	69.2	118633 ... 92.3	92.3	113183 ... 118.7	118.7	108345 ... 148.4	148.4	
15	132027 ... 49.7	49.7	124759 ... 69.6	69.6	118537 ... 92.7	92.7	113098 ... 119.1	119.1	108269 ... 148.9	148.9	15
	131896 ... 50.0	50.0	124647 ... 69.9	69.9	118440 ... 93.1	93.1	113013 ... 119.6	119.6	108193 ... 149.4	149.4	
16	131764 ... 50.3	50.3	124536 ... 70.3	70.3	118344 ... 93.5	93.5	112928 ... 120.1	120.1	108117 ... 149.9	149.9	14
	131633 ... 50.7	50.7	124425 ... 70.6	70.6	118248 ... 93.9	93.9	112843 ... 120.5	120.5	108041 ... 150.5	150.5	
17	131503 ... 51.0	51.0	124315 ... 71.0	71.0	118152 ... 94.3	94.3	112759 ... 121.0	121.0	107965 ... 151.0	151.0	13
	131373 ... 51.3	51.3	124204 ... 71.3	71.3	118056 ... 94.7	94.7	112674 ... 121.5	121.5	107890 ... 151.5	151.5	
18	131243 ... 51.6	51.6	124095 ... 71.7	71.7	117961 ... 95.2	95.2	112590 ... 121.9	121.9	107814 ... 152.1	152.1	12
	131114 ... 51.9	51.9	123985 ... 72.1	72.1	117866 ... 95.6	95.6	112506 ... 122.4	122.4	107739 ... 152.6	152.6	
19	130985 ... 52.2	52.2	123875 ... 72.4	72.4	117771 ... 96.0	96.0	112422 ... 122.9	122.9	107664 ... 153.1	153.1	11
	130856 ... 52.5	52.5	123766 ... 72.8	72.8	117676 ... 96.4	96.4	112338 ... 123.4	123.4	107589 ... 153.6	153.6	
20	130728 ... 52.8	52.8	123657 ... 73.2	73.2	117581 ... 96.9	96.9	112255 ... 123.9	123.9	107514 ... 154.2	154.2	10
	130600 ... 53.1	53.1	123549 ... 73.5	73.5	117487 ... 97.3	97.3	112171 ... 124.3	124.3	107439 ... 154.7	154.7	
21	130473 ... 53.4	53.4	123441 ... 73.9	73.9	117393 ... 97.7	97.7	112088 ... 124.8	124.8	107364 ... 155.2	155.2	9
	130346 ... 53.7	53.7	123332 ... 74.3	74.3	117299 ... 98.1	98.1	112005 ... 125.3	125.3	107290 ... 155.8	155.8	
22	130219 ... 54.1	54.1	123225 ... 74.6	74.6	117205 ... 98.5	98.5	111922 ... 125.8	125.8	107216 ... 156.3	156.3	8
	130093 ... 54.4	54.4	123117 ... 75.0	75.0	117112 ... 99.0	99.0	111839 ... 126.2	126.2	107141 ... 156.9	156.9	
23	129967 ... 54.7	54.7	123010 ... 75.4	75.4	117018 ... 99.4	99.4	111757 ... 126.7	126.7	107067 ... 157.4	157.4	7
	129841 ... 55.0	55.0	122903 ... 75.8	75.8	116925 ... 99.8	99.8	111674 ... 127.2	127.2	106993 ... 157.9	157.9	
24	129716 ... 55.3	55.3	122796 ... 76.1	76.1	116832 ... 100.3	100.3	111592 ... 127.7	127.7	106919 ... 158.5	158.5	6
	129591 ... 55.7	55.7	122690 ... 76.5	76.5	116739 ... 100.7	100.7	111510 ... 128.2	128.2	106846 ... 159.0	159.0	
25	129466 ... 56.0	56.0	122584 ... 76.9	76.9	116647 ... 101.1	101.1	111428 ... 128.7	128.7	106772 ... 159.6	159.6	5
	129342 ... 56.3	56.3	122478 ... 77.3	77.3	116554 ... 101.6	101.6	111346 ... 129.2	129.2	106698 ... 160.1	160.1	
26	129218 ... 56.6	56.6	122372 ... 77.6	77.6	116462 ... 102.0	102.0	111264 ... 129.7	129.7	106625 ... 160.6	160.6	4
	129095 ... 56.9	56.9	122267 ... 78.0	78.0	116370 ... 102.4	102.4	111183 ... 130.1	130.1	106552 ... 161.2	161.2	
27	128972 ... 57.3	57.3	122161 ... 78.4	78.4	116278 ... 102.9	102.9	111101 ... 130.6	130.6	106479 ... 161.7	161.7	3
	128849 ... 57.6	57.6	122057 ... 78.8	78.8	116187 ... 103.3	103.3	111020 ... 131.1	131.1	106406 ... 162.3	162.3	
28	128727 ... 57.9	57.9	121952 ... 79.2	79.2	116096 ... 103.7	103.7	110939 ... 131.6	131.6	106333 ... 162.8	162.8	2
	128605 ... 58.2	58.2	121848 ... 79.5	79.5	116004 ... 104.2	104.2	110858 ... 132.1	132.1	106260 ... 163.4	163.4	
29	128483 ... 58.6	58.6	121743 ... 79.9	79.9	115913 ... 104.6	104.6	110777 ... 132.6	132.6	106187 ... 163.9	163.9	1
	128362 ... 58.9	58.9	121639 ... 80.3	80.3	115823 ... 105.0	105.0	110696 ... 133.1	133.1	106115 ... 164.5	164.5	
30	128240 ... 59.2	59.2	121536 ... 80.7	80.7	115732 ... 105.5	105.5	110616 ... 133.6	133.6	106043 ... 165.0	165.0	0
	128120 ... 59.6	59.6	121432 ... 81.1	81.1	115641 ... 105.9	105.9	110536 ... 134.1	134.1	105970 ... 165.6	165.6	
	A	B	A	B	A	B	A	B	A	B	
	177°00'		176°30'		176°00'		175°30'		175°00'		

WHEN LHA (E OR W) IS GREATER THAN 90°, TAKE "K" FROM BOTTOM OF TABLE

	5°00'		5°30'		6°00'		6°30'		7°00'		
	A	B	A	B	A	B	A	B	A	B	
0	105970 ... 165.6		101843 ... 200.4		98076 ... 239		94614 ... 280		91411 ... 325		30
	105898 ... 166.1		101777 ... 201.0		98017 ... 239		94559 ... 281		91359 ... 326		
1	105826 ... 166.7		101712 ... 201.6		97957 ... 240		94503 ... 281		91308 ... 326		29
	105754 ... 167.2		101646 ... 202.2		97897 ... 241		94448 ... 282		91257 ... 327		
2	105683 ... 167.8		101581 ... 202.8		97837 ... 241		94393 ... 283		91205 ... 328		28
	105611 ... 168.4		101516 ... 203.5		97777 ... 242		94338 ... 284		91154 ... 329		
3	105539 ... 168.9		101451 ... 204.1		97717 ... 243		94283 ... 284		91103 ... 330		27
	105468 ... 169.4		101386 ... 204.7		97658 ... 243		94228 ... 285		91052 ... 330		
4	105397 ... 170.0		101321 ... 205.3		97598 ... 244		94173 ... 286		91001 ... 331		26
	105325 ... 170.6		101256 ... 205.9		97539 ... 245		94118 ... 287		90950 ... 332		
5	105254 ... 171.1		101192 ... 206.5		97480 ... 245		94063 ... 287		90899 ... 333		25
	105183 ... 171.7		101127 ... 207.1		97420 ... 246		94009 ... 288		90848 ... 333		
6	105113 ... 172.3		101063 ... 207.8		97361 ... 247		93954 ... 289		90798 ... 334		24
	105042 ... 172.8		100998 ... 208.4		97302 ... 247		93899 ... 289		90747 ... 335		
7	104971 ... 173.4		100934 ... 209.0		97243 ... 248		93845 ... 290		90696 ... 336		23
	104901 ... 174.0		100870 ... 209.6		97184 ... 249		93790 ... 291		90646 ... 337		
8	104830 ... 174.5		100806 ... 210.3		97126 ... 249		93736 ... 292		90595 ... 337		22
	104760 ... 175.1		100742 ... 210.9		97067 ... 250		93682 ... 292		90545 ... 338		
9	104690 ... 175.7		100678 ... 211.5		97008 ... 251		93628 ... 293		90494 ... 339		21
	104620 ... 176.2		100614 ... 212.1		96950 ... 251		93573 ... 294		90444 ... 340		
10	104550 ... 176.8		100550 ... 212.8		96891 ... 252		93519 ... 295		90394 ... 341		20
	104480 ... 177.4		100487 ... 213.4		96833 ... 253		93465 ... 295		90344 ... 341		
11	104411 ... 178.0		100423 ... 214.0		96774 ... 253		93411 ... 296		90293 ... 342		19
	104341 ... 178.5		100360 ... 214.6		96716 ... 254		93358 ... 297		90243 ... 343		
12	104272 ... 179.1		100296 ... 215.3		96658 ... 255		93304 ... 298		90193 ... 344		18
	104202 ... 179.7		100233 ... 215.9		96600 ... 255		93250 ... 298		90143 ... 345		
13	104133 ... 180.3		100170 ... 216.5		96542 ... 256		93196 ... 299		90093 ... 345		17
	104064 ... 180.8		100107 ... 217.2		96484 ... 257		93143 ... 300		90044 ... 346		
14	103995 ... 181.4		100044 ... 217.8		96426 ... 257		93089 ... 301		89994 ... 347		16
	103926 ... 182.0		99981 ... 218.4		96368 ... 258		93036 ... 301		89944 ... 348		
15	103857 ... 182.6		99918 ... 219.1		96310 ... 259		92982 ... 302		89894 ... 349		15
	103788 ... 183.2		99856 ... 219.7		96253 ... 260		92929 ... 303		89845 ... 349		
16	103720 ... 183.7		99793 ... 220.3		96195 ... 260		92876 ... 304		89795 ... 350		14
	103651 ... 184.3		99731 ... 221.0		96138 ... 261		92823 ... 304		89746 ... 351		
17	103583 ... 184.9		99668 ... 221.6		96080 ... 262		92769 ... 305		89696 ... 352		13
	103515 ... 185.5		99606 ... 222.3		96023 ... 262		92716 ... 306		89647 ... 353		
18	103447 ... 186.1		99544 ... 222.9		95966 ... 263		92663 ... 307		89597 ... 353		12
	103379 ... 186.7		99481 ... 223.5		95909 ... 264		92610 ... 307		89548 ... 354		
19	103311 ... 187.2		99420 ... 224.2		95851 ... 264		92558 ... 308		89499 ... 355		11
	103243 ... 187.8		99357 ... 224.8		95795 ... 265		92505 ... 309		89450 ... 356		
20	103175 ... 188.4		99296 ... 225.5		95737 ... 266		93452 ... 310		89401 ... 357		10
	103107 ... 189.0		99234 ... 226.1		95681 ... 267		92399 ... 310		89352 ... 357		
21	103040 ... 189.6		99172 ... 226.8		95624 ... 267		92347 ... 311		89303 ... 358		9
	102973 ... 190.2		99110 ... 227.4		95567 ... 268		92294 ... 312		89254 ... 359		
22	102905 ... 190.8		99049 ... 228.1		95510 ... 269		92242 ... 313		89205 ... 360		8
	102838 ... 191.4		98988 ... 228.7		95454 ... 269		92189 ... 313		89156 ... 361		
23	102771 ... 192.0		98926 ... 229.4		95397 ... 270		92137 ... 314		89107 ... 362		7
	102704 ... 192.6		98865 ... 230.0		95341 ... 271		92085 ... 315		89059 ... 362		
24	102637 ... 193.2		98804 ... 230.7		95285 ... 271		92032 ... 316		89010 ... 363		6
	102570 ... 193.8		98743 ... 231.3		95228 ... 272		91980 ... 316		88961 ... 364		
25	102504 ... 194.4		98682 ... 232.0		95172 ... 273		91928 ... 317		88913 ... 365		5
	102437 ... 195.0		98621 ... 232.6		95116 ... 274		91876 ... 318		88864 ... 366		
26	102371 ... 195.6		98560 ... 233.3		95060 ... 274		91824 ... 319		88816 ... 366		4
	102304 ... 196.2		98499 ... 233.9		95004 ... 275		91772 ... 319		88767 ... 367		
27	102238 ... 196.8		98439 ... 234.6		94948 ... 276		91720 ... 320		88719 ... 368		3
	102172 ... 197.4		98378 ... 235.3		94892 ... 276		91668 ... 321		88671 ... 369		
28	102106 ... 198.0		98318 ... 235.9		94836 ... 277		91617 ... 322		88623 ... 370		2
	102040 ... 198.6		98257 ... 236.6		94781 ... 278		91565 ... 323		88574 ... 371		
29	101974 ... 199.2		98197 ... 237.2		94725 ... 279		91514 ... 323		88526 ... 371		1
	101908 ... 199.8		98137 ... 237.9		94670 ... 279		91462 ... 324		88478 ... 372		
30	101843 ... 200.4		98076 ... 238.6		94614 ... 280		91411 ... 325		88430 ... 373		0
	A	B	A	B	A	B	A	B	A	B	
	174°30'		174°00'		173°30'		173°00'		172°30'		

ALWAYS TAKE "Z" FROM BOTTOM OF TABLE, EXCEPT WHEN "K" IS SAME NAME AND GREATER THAN LATITUDE, IN WHICH CASE TAKE "Z" FROM TOP OF TABLE

	7°30'		8°00'		8°30'		9°00'		9°30'		
	A	B	A	B	A	B	A	B	A	B	
0	88430	.373	85644	.425	83030	.480	80567	.538	78239	.600	30
	88382	.374	85599	.426	82987	.481	80527	.539	78201	.601	
1	88334	.375	85555	.426	82945	.482	80487	.540	78164	.602	29
	88286	.376	85510	.427	82903	.482	80447	.541	78126	.603	
2	88239	.376	85465	.428	82861	.483	80407	.542	78088	.604	28
	88191	.377	85420	.429	82819	.484	80368	.543	78051	.605	
3	88143	.378	85376	.430	82777	.485	80328	.544	78013	.606	27
	88096	.379	85331	.431	82735	.486	80288	.545	77976	.607	
4	88048	.380	85286	.432	82693	.487	80249	.546	77938	.608	26
	88001	.381	85242	.433	82651	.488	80209	.547	77901	.609	
5	87953	.381	85197	.434	82609	.489	80170	.548	77863	.610	25
	87906	.382	85153	.434	82567	.490	80130	.549	77826	.611	
6	87858	.383	85108	.435	82526	.491	80091	.550	77788	.612	24
	87811	.384	85064	.436	82484	.492	80051	.551	77751	.614	
7	87764	.385	85020	.437	82442	.493	80012	.552	77714	.615	23
	87716	.386	84976	.438	82400	.494	79973	.553	77677	.616	
8	87669	.387	84931	.439	82359	.495	79933	.554	77639	.617	22
	87622	.387	84887	.440	82317	.496	79894	.555	77602	.618	
9	87575	.388	84843	.441	82276	.497	79855	.556	77565	.619	21
	87528	.389	84799	.442	82234	.498	79816	.557	77528	.620	
10	87481	.390	84755	.443	82193	.499	79777	.558	77491	.621	20
	87434	.391	84711	.444	82151	.500	79737	.559	77454	.622	
11	87387	.392	84667	.444	82110	.501	79698	.560	77417	.623	19
	87341	.392	84623	.445	82069	.502	79659	.561	77380	.624	
12	87294	.393	84579	.446	82027	.503	79620	.562	77343	.625	18
	87247	.394	84535	.447	81986	.504	79581	.563	77306	.626	
13	87201	.395	84492	.448	81945	.504	79542	.564	77269	.627	17
	87154	.396	84448	.449	81904	.505	79503	.565	77232	.629	
14	87107	.397	84404	.450	81863	.506	79465	.566	77195	.630	16
	87061	.398	84361	.451	81821	.507	79426	.567	77158	.631	
15	87015	.399	84317	.452	81780	.508	79387	.568	77122	.632	15
	86968	.399	84273	.453	81739	.509	79348	.569	77085	.633	
16	86922	.400	84230	.454	81698	.510	79309	.570	77048	.634	14
	86876	.401	84186	.454	81657	.511	79271	.571	77011	.635	
17	86829	.402	84143	.455	81617	.512	79232	.573	76975	.636	13
	86783	.403	84100	.456	81576	.513	79193	.574	76938	.637	
18	86737	.404	84056	.457	81535	.514	79155	.575	76902	.638	12
	86691	.405	84013	.458	81494	.515	79116	.576	76865	.639	
19	86645	.405	83970	.459	81453	.516	79078	.577	76828	.641	11
	86599	.406	83927	.460	81413	.517	79039	.578	76792	.642	
20	86553	.407	83884	.461	81372	.518	79001	.579	76756	.643	10
	86507	.408	83840	.462	81331	.519	78962	.580	76719	.644	
21	86461	.409	83797	.463	81291	.520	78924	.581	76683	.645	9
	86415	.410	83754	.464	81250	.521	78886	.582	76646	.646	
22	86370	.411	83711	.465	81210	.522	78847	.583	76610	.647	8
	86324	.411	83668	.466	81169	.523	78809	.584	76574	.648	
23	86278	.412	83626	.467	81129	.524	78771	.585	76537	.649	7
	86233	.413	83583	.467	81088	.525	78733	.586	76501	.650	
24	86187	.414	83540	.468	81048	.526	78694	.587	76465	.652	6
	86142	.415	83497	.469	81008	.527	78656	.588	76429	.653	
25	86096	.416	83455	.470	80967	.528	78618	.589	76393	.654	5
	86051	.417	83412	.471	80927	.529	78580	.590	76357	.655	
26	86006	.418	83369	.472	80887	.530	78542	.591	76320	.656	4
	85960	.418	83327	.473	80847	.531	78504	.592	76284	.657	
27	85915	.419	83284	.474	80807	.532	78466	.593	76248	.658	3
	85870	.420	83242	.475	80767	.533	78428	.594	76212	.659	
28	85825	.421	83199	.476	80727	.534	78390	.595	76176	.660	2
	85779	.422	83157	.477	80687	.535	78352	.597	76141	.661	
29	85734	.423	83114	.478	80647	.536	78315	.598	76105	.663	1
	85689	.424	83072	.479	80607	.537	78277	.599	76069	.664	
30	85644	.425	83030	.480	80567	.538	78239	.600	76033	.665	0
	A	B	A	B	A	B	A	B	A	B	
	172°00'		171°30'		171°00'		170°30'		170°00'		

WHEN LHA (E OR W) IS GREATER THAN 90°, TAKE "K" FROM BOTTOM OF TABLE

	10°00'		10°30'		11°00'		11°30'		12°00'		
	A	B	A	B	A	B	A	B	A	B	
0	76033	.665	73937	.733	71940	.805	70034	.881	68212	.960	30
	75997	.666	73903	.735	71908	.807	70003	.882	68182	.961	
1	75961	.667	73869	.736	71875	.808	69972	.883	68153	.962	29
	75926	.668	73835	.737	71843	.809	69941	.885	68123	.964	
2	75890	.669	73801	.738	71810	.810	69910	.886	68093	.965	28
	75854	.670	73767	.739	71778	.811	69879	.887	68064	.966	
3	75819	.672	73733	.740	71746	.813	69849	.888	68034	.968	27
	75783	.673	73699	.742	71713	.814	69818	.890	68005	.969	
4	75747	.674	73665	.743	71681	.815	69787	.891	67975	.970	26
	75712	.675	73631	.744	71649	.816	69756	.892	67945	.972	
5	75676	.676	73597	.745	71616	.818	69725	.894	67916	.973	25
	75641	.677	73563	.746	71584	.819	69694	.895	67886	.974	
6	75605	.678	73530	.747	71552	.820	69664	.896	67857	.976	24
	75570	.679	73496	.749	71520	.821	69633	.897	67828	.977	
7	75534	.680	73462	.750	71488	.823	69602	.899	67798	.978	23
	75499	.682	73429	.751	71455	.824	69571	.900	67769	.980	
8	75464	.683	73395	.752	71423	.825	69541	.901	67739	.981	22
	75428	.684	73361	.753	71391	.826	69510	.903	67710	.982	
9	75393	.685	73328	.755	71359	.828	69479	.904	67681	.984	21
	75358	.686	73294	.756	71327	.829	69449	.905	67651	.985	
10	75322	.687	73260	.757	71295	.830	69418	.907	67622	.987	20
	75287	.688	73227	.758	71263	.831	69387	.908	67593	.988	
11	75252	.690	73193	.759	71231	.833	69357	.909	67563	.989	19
	75217	.691	73160	.761	71199	.834	69326	.910	67534	.991	
12	75182	.692	73127	.762	71167	.835	69296	.912	67505	.992	18
	75147	.693	73093	.763	71135	.836	69265	.913	67476	.993	
13	75112	.694	73060	.764	71104	.838	69235	.914	67447	.995	17
	75077	.695	73026	.765	71072	.839	69204	.916	67417	.996	
14	75042	.696	72993	.766	71040	.840	69174	.917	67388	.997	16
	75007	.698	72960	.768	71008	.841	69144	.918	67359	.999	
15	74972	.699	72926	.769	70976	.843	69113	.920	67330	.1000	15
	74937	.700	72893	.770	70945	.844	69083	.921	67301	.1002	
16	74902	.701	72860	.771	70913	.845	69053	.922	67272	.1003	14
	74867	.702	72827	.772	70881	.846	69022	.924	67243	.1004	
17	74832	.703	72794	.774	70850	.848	68992	.925	67214	.1006	13
	74797	.704	72760	.775	70818	.849	68962	.926	67185	.1007	
18	74763	.706	72727	.776	70786	.850	68931	.928	67156	.1008	12
	74728	.707	72694	.777	70755	.851	68901	.929	67127	.1010	
19	74693	.708	72661	.779	70723	.853	68871	.930	67098	.1011	11
	74659	.709	72628	.780	70692	.854	68841	.932	67069	.1013	
20	74624	.710	72595	.781	70660	.855	68811	.933	67040	.1014	10
	74589	.711	72562	.782	70629	.856	68781	.934	67011	.1015	
21	74555	.712	72529	.783	70597	.858	68750	.935	66982	.1017	9
	74520	.714	72496	.785	70566	.859	68720	.937	66953	.1018	
22	74486	.715	72463	.786	70534	.860	68690	.938	66925	.1020	8
	74451	.716	72430	.787	70503	.862	68660	.939	66896	.1021	
23	74417	.717	72397	.788	70471	.863	68630	.941	66867	.1022	7
	74382	.718	72365	.790	70440	.864	68600	.942	66838	.1024	
24	74348	.719	72332	.791	70409	.865	68570	.943	66810	.1025	6
	74313	.721	72299	.792	70377	.867	68540	.945	66781	.1026	
25	74279	.722	72266	.793	70346	.868	68510	.946	66752	.1028	5
	74245	.723	72234	.794	70315	.869	68480	.947	66724	.1029	
26	74210	.724	72201	.796	70284	.870	68450	.949	66695	.1031	4
	74176	.725	72168	.797	70252	.872	68421	.950	66666	.1032	
27	74142	.726	72135	.798	70221	.873	68391	.951	66638	.1033	3
	74107	.728	72103	.799	70190	.874	68361	.953	66609	.1035	
28	74073	.729	72070	.800	70159	.876	68331	.954	66580	.1036	2
	74039	.730	72038	.802	70128	.877	68301	.955	66552	.1038	
29	74005	.731	72005	.803	70097	.878	68272	.957	66523	.1039	1
	73971	.732	71973	.804	70065	.879	68242	.958	66495	.1040	
30	73937	.733	71940	.805	70034	.881	68212	.960	66466	.1042	0
	A	B	A	B	A	B	A	B	A	B	
	169°30'		169°00'		168°30'		168°00'		167°30'		

ALWAYS TAKE "Z" FROM BOTTOM OF TABLE, EXCEPT WHEN "K" IS SAME NAME AND GREATER THAN LATITUDE, IN WHICH CASE TAKE "Z" FROM TOP OF TABLE

	12°30'		13°00'		13°30'		14°00'		14°30'		
	A	B	A	B	A	B	A	B	A	B	
0	66466	1042	64791	1128	63181	1217	61632	1310	60140	1406	30
	66438	1043	64764	1129	63155	1218	61607	1311	60116	1407	
1	66409	1045	64736	1130	63129	1220	61582	1313	60091	1409	29
	66381	1046	64709	1132	63103	1221	61556	1314	60067	1411	
2	66352	1047	64682	1133	63076	1223	61531	1316	60042	1412	28
	66324	1049	64655	1135	63050	1224	61506	1317	60018	1414	
3	66296	1050	64627	1136	63024	1226	61481	1319	59994	1416	27
	66267	1052	64600	1138	62998	1227	61455	1321	59969	1417	
4	66239	1053	64573	1139	62971	1229	61430	1322	59945	1419	26
	66211	1054	64546	1141	62945	1230	61405	1324	59921	1421	
5	66182	1056	64518	1142	62919	1232	61380	1325	59896	1422	25
	66154	1057	64491	1144	62893	1234	61355	1327	59872	1424	
6	66126	1059	64464	1145	62867	1235	61330	1329	59848	1425	24
	66098	1060	64437	1147	62841	1237	61304	1330	59824	1427	
7	66069	1061	64410	1148	62815	1238	61279	1332	59800	1429	23
	66041	1063	64383	1150	62789	1240	61254	1333	59775	1430	
8	66013	1064	64356	1151	62763	1241	61229	1335	59751	1432	22
	65985	1066	64329	1152	62737	1243	61204	1336	59727	1434	
9	65957	1067	64302	1154	62711	1244	61179	1338	59702	1435	21
	65928	1069	64275	1155	62685	1246	61154	1340	59679	1437	
10	65900	1070	64248	1157	62659	1247	61129	1341	59654	1439	20
	65872	1071	64221	1158	62633	1249	61104	1343	59630	1440	
11	65844	1073	64194	1160	62607	1250	61079	1344	59606	1442	19
	65816	1074	64167	1161	62581	1252	61054	1346	59582	1444	
12	65788	1076	64140	1163	62555	1253	61029	1348	59558	1445	18
	65760	1077	64113	1164	62529	1255	61004	1349	59534	1447	
13	65732	1079	64086	1166	62503	1257	60979	1351	59510	1449	17
	65704	1080	64059	1167	62477	1258	60954	1352	59486	1450	
14	65676	1081	64032	1169	62451	1260	60929	1354	59462	1452	16
	65648	1083	64005	1170	62425	1261	60904	1356	59438	1454	
15	65620	1084	63978	1172	62400	1263	60879	1357	59414	1455	15
	65592	1086	63952	1173	62374	1264	60855	1359	59390	1457	
16	65564	1087	63925	1175	62348	1266	60830	1360	59366	1459	14
	65537	1089	63898	1176	62322	1267	60805	1362	59342	1460	
17	65509	1090	63871	1178	62296	1269	60780	1364	59318	1462	13
	65481	1091	63845	1179	62271	1270	60755	1365	59294	1464	
18	65453	1093	63818	1181	62245	1272	60730	1367	59270	1465	12
	65425	1094	63791	1182	62219	1274	60706	1368	59246	1467	
19	65398	1096	63764	1184	62194	1275	60681	1370	59222	1469	11
	65370	1097	63738	1185	62168	1277	60656	1372	59198	1470	
20	65342	1099	63711	1187	62142	1278	60631	1373	59175	1472	10
	65314	1100	63684	1188	62117	1280	60607	1375	59151	1474	
21	65287	1101	63658	1190	62091	1281	60582	1377	59127	1475	9
	65259	1103	63631	1191	62065	1283	60557	1378	59103	1477	
22	65231	1104	63605	1193	62040	1284	60533	1380	59079	1479	8
	65204	1106	63578	1194	62014	1286	60508	1381	59055	1480	
23	65176	1107	63551	1196	61989	1288	60483	1383	59032	1482	7
	65148	1109	63525	1197	61963	1289	60459	1385	59008	1484	
24	65121	1110	63498	1199	61938	1291	60434	1386	58984	1485	6
	65093	1112	63472	1200	61912	1292	60410	1388	58960	1487	
25	65066	1113	63445	1202	61887	1294	60385	1390	58937	1489	5
	65038	1114	63419	1203	61861	1295	60360	1391	58913	1490	
26	65011	1116	63392	1205	61836	1297	60336	1393	58889	1492	4
	64983	1117	63366	1206	61810	1299	60311	1394	58866	1494	
27	64956	1119	63340	1208	61785	1300	60287	1396	58842	1495	3
	64928	1120	63313	1209	61759	1301	60262	1398	58818	1497	
28	64901	1122	63287	1211	61734	1303	60238	1399	58795	1499	2
	64873	1123	63260	1212	61709	1305	60213	1401	58771	1500	
29	64846	1125	63234	1214	61683	1306	60189	1403	58748	1502	1
	64819	1126	63208	1215	61658	1308	60164	1404	58724	1504	
30	64791	1128	63181	1217	61632	1310	60140	1406	58700	1506	0
	A	B	A	B	A	B	A	B	A	B	
	167°00'		166°30'		166°00'		165°30'		165°00'		

WHEN LHA (E OR W) IS GREATER THAN 90°, TAKE "K" FROM BOTTOM OF TABLE

	15°00'		15°30'		16°00'		16°30'		17°00'		
	A	B	A	B	B	B	A	B	A	B	
0	58700	1506	57310	1609	55966	1716	54666	1826	53406	1940	30
	58677	1507	57287	1611	55944	1718	54644	1828	53386	1942	
1	58653	1509	57265	1612	55922	1719	54623	1830	53365	1944	29
	58630	1511	57242	1614	55900	1721	54602	1832	53344	1946	
2	58606	1512	57219	1616	55878	1723	54581	1834	53324	1948	28
	58583	1514	57196	1618	55856	1725	54559	1836	53303	1950	
3	58559	1516	57174	1619	55834	1727	54538	1837	53283	1952	27
	58536	1517	57151	1621	55812	1728	54517	1839	53262	1954	
4	58512	1519	57128	1623	55790	1730	54496	1841	53241	1956	26
	58489	1521	57106	1625	55768	1732	54474	1843	53221	1958	
5	58465	1523	57083	1627	55746	1734	54453	1845	53200	1960	25
	58442	1524	57060	1628	55725	1736	54432	1847	53180	1962	
6	58418	1526	57038	1630	55703	1738	54411	1849	53159	1964	24
	58395	1528	57015	1632	55681	1739	54390	1851	53139	1966	
7	58372	1529	56992	1634	55659	1741	54368	1853	53118	1967	23
	58348	1531	56970	1635	55637	1743	54347	1854	53098	1969	
8	58325	1533	56947	1637	55615	1745	54326	1856	53077	1971	22
	58302	1534	56925	1639	55593	1747	54305	1858	53057	1973	
9	58278	1536	56902	1641	55572	1749	54284	1860	53036	1975	21
	58255	1538	56880	1642	55550	1750	54263	1862	53016	1977	
10	58232	1540	56857	1644	55528	1752	54242	1864	52995	1979	20
	58208	1541	56835	1646	55506	1754	54220	1866	52975	1981	
11	58185	1543	56812	1648	55484	1756	54199	1868	52954	1983	19
	58162	1545	56790	1649	55463	1758	54178	1870	52934	1985	
12	58138	1546	56767	1651	55441	1760	54157	1871	52914	1987	18
	58115	1548	56745	1653	55419	1761	54136	1873	52893	1989	
13	58092	1550	56722	1655	55397	1763	54115	1875	52873	1991	17
	58069	1552	56700	1657	55376	1765	54094	1877	52852	1993	
14	58046	1553	56677	1658	55354	1767	54073	1879	52832	1995	16
	58022	1555	56655	1660	55332	1769	54052	1881	52812	1997	
15	57999	1557	56632	1662	55311	1771	54031	1883	52791	1999	15
	57976	1559	56610	1664	55289	1772	54010	1885	52771	2001	
16	57953	1560	56588	1665	55267	1774	53989	1887	52751	2003	14
	57930	1562	56565	1667	55246	1776	53968	1889	52730	2005	
17	57907	1564	56543	1669	55224	1778	53947	1890	52710	2007	13
	57884	1565	56521	1671	55202	1780	53926	1892	52690	2009	
18	57860	1567	56498	1673	55181	1782	53905	1894	52670	2010	12
	57837	1569	56476	1674	55159	1783	53884	1896	52649	2012	
19	57814	1571	56454	1676	55138	1785	53864	1898	52629	2014	11
	57791	1572	56431	1678	55116	1787	53843	1900	52609	2016	
20	57768	1574	56409	1680	55095	1789	53822	1902	52588	2018	10
	57745	1576	56387	1682	55073	1791	53801	1904	52568	2020	
21	57722	1578	56365	1683	55051	1793	53780	1906	52548	2022	9
	57699	1579	56342	1685	55030	1795	53759	1908	52528	2024	
22	57676	1581	56320	1687	55008	1796	53738	1910	52508	2026	8
	57653	1583	56298	1689	54987	1798	53718	1911	52487	2028	
23	57630	1584	56276	1691	54965	1800	53697	1913	52467	2030	7
	57607	1586	56254	1692	54944	1802	53676	1915	52447	2032	
24	57584	1588	56231	1694	54922	1804	53655	1917	52427	2034	6
	57561	1590	56209	1696	54901	1806	53634	1919	52407	2036	
25	57538	1591	56187	1698	54880	1808	53614	1921	52387	2038	5
	57516	1593	56165	1700	54858	1809	53593	1923	52366	2040	
26	57493	1595	56143	1701	54837	1811	53572	1925	52346	2042	4
	57470	1597	56121	1703	54815	1813	53551	1927	52326	2044	
27	57447	1598	56099	1705	54794	1815	53531	1929	52306	2046	3
	57424	1600	56076	1707	54773	1817	53510	1931	52286	2048	
28	57401	1602	56054	1709	54751	1819	53489	1933	52266	2050	2
	57378	1604	56032	1710	54730	1821	53468	1935	52246	2052	
29	57356	1605	56010	1712	54708	1823	53448	1936	52226	2054	1
	57333	1607	55988	1714	54687	1824	53427	1938	52206	2056	
30	57310	1609	55966	1716	54666	1826	53406	1940	52186	2058	0
	A	B	A	B	A	B	A	B	A	B	
	164°30'		164°00'		163°30'		163°00'		162°30'		

ALWAYS TAKE "Z" FROM BOTTOM OF TABLE, EXCEPT WHEN "K" IS SAME NAME AND GREATER THAN LATITUDE, IN WHICH CASE TAKE "Z" FROM TOP OF TABLE

	17°30'		18°00'		18°30'		19°00'		19°30'		
	A	B	A	B	A	B	A	B	A	B	
0	52186	2058	51002	2179	49852	2304	48736	2433	47650	2565	30
	52166	2060	50982	2181	49833	2306	48717	2435	47633	2568	
1	52146	2062	50963	2183	49815	2309	48699	2437	47615	2570	29
	52126	2064	50943	2185	49796	2311	48681	2439	47597	2572	
2	52106	2066	50924	2188	49777	2313	48662	2442	47579	2574	28
	52086	2068	50905	2190	49758	2315	48644	2444	47561	2576	
3	52066	2070	50885	2192	49739	2317	48626	2446	47544	2579	27
	52046	2072	50866	2194	49720	2319	48608	2448	47526	2581	
4	52026	2074	50846	2196	49702	2321	48589	2450	47508	2583	26
	52006	2076	50827	2198	49683	2323	48571	2453	47490	2585	
5	51986	2078	50808	2200	49664	2325	48553	2455	47472	2588	25
	51966	2080	50788	2202	49645	2328	48534	2457	47455	2590	
6	51946	2082	50769	2204	49626	2330	48516	2459	47437	2592	24
	51926	2084	50750	2206	49608	2332	48498	2461	47419	2594	
7	51906	2086	50730	2208	49589	2334	48480	2463	47402	2597	23
	51886	2088	50711	2210	49570	2336	48462	2466	47384	2599	
8	51867	2090	50692	2212	49551	2338	48443	2468	47366	2601	22
	51847	2092	50673	2214	49533	2340	48425	2470	47348	2603	
9	51827	2094	50653	2216	49514	2343	48407	2472	47331	2606	21
	51807	2096	50634	2218	49495	2345	48389	2474	47313	2608	
10	51787	2098	50615	2221	49477	2347	48371	2477	47295	2610	20
	51767	2100	50596	2223	49458	2349	48352	2479	47278	2613	
11	51747	2102	50576	2225	49439	2351	48334	2481	47260	2615	19
	51728	2104	50557	2227	49421	2353	48316	2483	47242	2617	
12	51708	2106	50538	2229	49402	2355	48298	2485	47225	2619	18
	51688	2108	50519	2231	49383	2357	48280	2488	47207	2622	
13	51668	2110	50499	2233	49365	2360	48262	2490	47189	2624	17
	51649	2112	50480	2235	49346	2362	48244	2492	47172	2626	
14	51629	2114	50461	2237	49327	2364	48225	2494	47154	2628	16
	51609	2116	50442	2239	49309	2366	48207	2496	47137	2631	
15	51589	2118	50423	2241	49290	2368	48189	2499	47119	2633	15
	51570	2120	50404	2243	49271	2370	48171	2501	47101	2635	
16	51550	2122	50385	2246	49253	2372	48153	2503	47084	2637	14
	51530	2124	50365	2248	49234	2375	48135	2505	47066	2640	
17	51510	2126	50346	2250	49216	2377	48117	2507	47049	2642	13
	51491	2128	50327	2252	49197	2379	48099	2510	47031	2644	
18	51471	2130	50308	2254	49179	2381	48081	2512	47014	2646	12
	51451	2132	50289	2256	49160	2383	48063	2514	46996	2649	
19	51432	2134	50270	2258	49141	2385	48045	2516	46978	2651	11
	51412	2136	50251	2260	49123	2387	48027	2519	46961	2653	
20	51392	2138	50232	2262	49104	2390	48009	2521	46943	2656	10
	51373	2141	50213	2264	49086	2392	47991	2523	46926	2658	
21	51353	2143	50194	2266	49067	2394	47973	2525	46908	2660	9
	51334	2145	50175	2269	49049	2396	47955	2527	46891	2662	
22	51314	2147	50156	2271	49030	2398	47937	2530	46873	2665	8
	51294	2149	50137	2273	49012	2400	47919	2532	46856	2667	
23	51275	2151	50117	2275	48993	2403	47901	2534	46839	2669	7
	51255	2153	50098	2277	48975	2405	47883	2536	46821	2672	
24	51236	2155	50080	2279	48957	2407	47865	2539	46804	2674	6
	51216	2157	50061	2281	48938	2409	47847	2541	46786	2676	
25	51197	2159	50042	2283	48920	2411	47829	2543	46769	2678	5
	51177	2161	50023	2285	48901	2413	47811	2545	46751	2681	
26	51158	2163	50004	2287	48883	2416	47793	2547	46734	2683	4
	51138	2165	49985	2290	48864	2418	47775	2550	46716	2685	
27	51119	2167	49966	2292	48846	2420	47758	2552	46699	2688	3
	51099	2169	49947	2294	48828	2422	47740	2554	46682	2690	
28	51080	2171	49928	2296	48809	2424	47722	2556	46664	2692	2
	51060	2173	49909	2298	48791	2426	47704	2559	46647	2694	
29	51041	2175	49890	2300	48772	2429	47686	2561	46630	2697	1
	51021	2177	49871	2302	48754	2431	47668	2563	46612	2699	
30	51002	2179	49852	2304	48736	2433	47650	2565	46595	2701	0
	A	B	A	B	A	B	A	B	A	B	
	162°00'		161°30'		161°00'		160°30'		160°00'		

WHEN LHA (E OR W) IS GREATER THAN 90°, TAKE "K" FROM BOTTOM OF TABLE

L	20°00'		20°30'		21°00'		21°30'		22°00'		K
	A	B	A	B	A	B	A	B	A	B	
0	46595	2701	45567	2841	44567	2985	43592	3132	42642	3283	30
	46577	2704	45551	2844	44551	2988	43576	3135	42627	3286	
1	46560	2706	45534	2846	44534	2990	43560	3137	42611	3288	29
	46543	2708	45517	2848	44518	2992	43544	3140	42596	3291	
2	46525	2711	45500	2851	44501	2994	43528	3142	42580	3294	28
	46508	2713	45483	2853	44485	2997	43512	3145	42564	3296	
3	46491	2715	45466	2855	44468	2999	43496	3147	42549	3299	27
	46473	2717	45449	2858	44452	3002	43480	3150	42533	3301	
4	46456	2720	45433	2860	44436	3004	43464	3152	42518	3304	26
	46439	2722	45416	2862	44419	3007	43448	3155	42502	3306	
5	46422	2724	45399	2865	44403	3009	43432	3157	42486	3309	25
	46404	2727	45382	2867	44386	3012	43416	3160	42471	3312	
6	46387	2729	45365	2870	44370	3014	43400	3162	42455	3314	24
	46370	2731	45348	2872	44354	3016	43385	3165	42449	3317	
7	46353	2734	45332	2874	44337	3019	43369	3167	42424	3319	23
	46335	2736	45315	2877	44321	3021	43353	3170	42409	3322	
8	46318	2738	45298	2879	44305	3024	43337	3172	42393	3324	22
	46301	2741	45281	2881	44288	3026	43321	3175	42378	3327	
9	46284	2743	45265	2884	44272	3029	43305	3177	42362	3329	21
	46266	2745	45248	2886	44256	3031	43289	3180	42347	3332	
10	46249	2748	45231	2889	44239	3033	43273	3182	42331	3335	20
	46232	2750	45214	2891	44223	3036	43257	3185	42316	3337	
11	46215	2752	45198	2893	44207	3038	43241	3187	42300	3340	19
	46198	2755	45181	2896	44190	3041	43225	3190	42285	3342	
12	46181	2757	45164	2898	44174	3043	43210	3192	42269	3345	18
	46163	2759	45147	2901	44158	3046	43194	3195	42254	3347	
13	46146	2761	45131	2903	44142	3048	43178	3197	42238	3350	17
	46129	2764	45114	2905	44125	3051	43162	3200	42223	3353	
14	46112	2766	45097	2908	44109	3053	43146	3202	42207	3355	16
	46095	2768	45081	2910	44093	3056	43130	3205	42192	3358	
15	46078	2771	45064	2913	44077	3058	43114	3207	42176	3360	15
	46061	2773	45047	2915	44060	3060	43099	3210	42161	3363	
16	46043	2775	45031	2917	44044	3063	43083	3212	42145	3366	14
	46026	2778	45014	2920	44028	3065	43067	3215	42130	3368	
17	46009	2780	44997	2922	44012	3068	43051	3217	42115	3371	13
	45992	2782	44981	2924	43995	3070	43035	3220	42099	3373	
18	45975	2785	44964	2927	43979	3073	43020	3222	42084	3376	12
	45958	2787	44947	2929	43963	3075	43004	3225	42068	3379	
19	45941	2789	44931	2932	43947	3078	42988	3227	42053	3381	11
	45924	2792	44914	2934	43931	3080	42972	3230	42038	3384	
20	45907	2794	44898	2936	43914	3083	42956	3233	42022	3386	10
	45890	2797	44881	2939	43898	3085	42941	3235	42007	3389	
21	45873	2799	44864	2941	43882	3088	42925	3238	41991	3391	9
	45856	2801	44848	2944	43866	3090	42909	3240	41976	3394	
22	45839	2804	44831	2946	43850	3092	42893	3243	41961	3387	8
	45822	2806	44815	2949	43834	3095	42878	3245	41945	3399	
23	45805	2808	44798	2951	43818	3097	42862	3248	41930	3402	7
	45788	2811	44782	2953	43801	3100	42846	3250	41915	3404	
24	45771	2813	44765	2956	43785	3102	42830	3253	41899	3407	6
	45754	2815	44748	2958	43769	3105	42815	3255	41884	3410	
25	45737	2818	44732	2961	43753	3107	42799	3258	41869	3412	5
	45720	2820	44715	2963	43737	3110	42783	3260	41853	3415	
26	45703	2822	44699	2965	43721	3112	42768	3263	41838	3418	4
	45686	2835	44682	2968	43705	3115	42752	3266	41823	3420	
27	45669	2827	44666	2970	43689	3117	42736	3268	41808	3423	3
	45652	2829	44649	2973	43673	3120	42721	3271	41792	3425	
28	45635	2832	44633	2975	43657	3122	42705	3273	41777	3428	2
	45618	2834	44616	2978	43641	3125	42689	3276	41762	3431	
29	45601	2836	44600	2980	43624	3127	42674	3278	41746	3433	1
	45584	2839	44583	2982	43608	3130	42658	3281	41731	3436	
30	45567	2841	44567	2985	43592	3132	42642	3283	41716	3438	0
	A	B	A	B	A	B	A	B	A	B	
	159°30'		159°00'		158°30'		158°00'		157°30'		

ALWAYS TAKE "Z" FROM BOTTOM OF TABLE, EXCEPT WHEN "K" IS SAME NAME AND GREATER THAN LATITUDE, IN WHICH CASE TAKE "Z" FROM TOP OF TABLE

	22°30'		23°00'		23°30'		24°00'		24°30'		
	A	B	A	B	A	B	A	B	A	B	
0	41716	3438	40812	3597	39930	3760	39069	3927	38227	4098	30
	41701	3441	40797	3600	39915	3763	39054	3930	38213	4101	
1	41685	3444	40782	3603	39901	3766	39040	3932	38200	4103	29
	41670	3446	40768	3605	39886	3768	39026	3935	38186	4106	
2	41655	3449	40753	3608	39872	3771	39012	3938	38172	4109	28
	41640	3452	40738	3611	39857	3774	38998	3941	38158	4112	
3	41625	3454	40723	3613	39843	3777	38984	3944	38144	4115	27
	41609	3457	40708	3616	39828	3779	38969	3947	38130	4118	
4	41594	3459	40693	3619	39814	3782	38955	3949	38117	4121	26
	41579	3462	40678	3622	39799	3785	38941	3952	38103	4124	
5	41564	3465	40664	3624	39785	3788	38927	3955	38089	4127	25
	41549	3467	40649	3627	39771	3790	38913	3958	38075	4129	
6	41533	3470	40634	3630	39756	3793	38899	3961	38061	4132	24
	41518	3473	40619	3632	39742	3796	38885	3964	38048	4135	
7	41503	3475	40604	3635	39727	3799	38871	3966	38034	4138	23
	41488	3478	40590	3638	39713	3801	38856	3969	38020	4141	
8	41473	3480	40575	3640	39698	3804	38842	3972	38006	4144	22
	41458	3483	40560	3643	39684	3807	38828	3975	37992	4147	
9	41443	3486	40545	3646	39669	3810	38814	3978	37979	4150	21
	41427	3488	40530	3648	39655	3813	38800	3981	37965	4153	
10	41412	3491	40516	3651	39641	3815	38786	3983	37951	4155	20
	41397	3494	40501	3654	39626	3818	38772	3986	37937	4158	
11	41382	3496	40486	3657	39612	3821	38758	3989	37924	4161	19
	41367	3499	40471	3659	39597	3824	38744	3992	37910	4164	
12	41352	3502	40457	3662	39583	3826	38730	3995	37896	4167	18
	41337	3504	40442	3665	39569	3829	38716	3998	37882	4170	
13	41322	3507	40427	3667	39554	3832	38702	4000	37869	4173	17
	41307	3509	40413	3670	39540	3835	38688	4003	37855	4176	
14	41291	3512	40398	3673	39525	3838	38674	4006	37841	4179	16
	41276	3515	40383	3676	39511	3840	38660	4009	37828	4182	
15	41261	3517	40368	3678	39497	3843	38645	4012	37814	4185	15
	41246	3520	40354	3681	39482	3846	38631	4015	37800	4187	
16	41231	3523	40339	3684	39468	3849	38617	4017	37786	4190	14
	41216	3525	40324	3686	39454	3851	38603	4020	37773	4193	
17	41201	3528	40310	3689	39439	3854	38589	4023	37759	4196	13
	41186	3531	40295	3692	39425	3857	38575	4026	37745	4199	
18	41171	3533	40280	3695	39411	3860	38561	4029	37732	4202	12
	41156	3536	40266	3697	39396	3863	38547	4032	37718	4205	
19	41141	3539	40251	3700	39382	3865	38533	4035	37704	4208	11
	41126	3541	40236	3703	39368	3868	38520	4037	37691	4211	
20	41111	3544	40222	3705	39353	3871	38506	4040	37677	4214	10
	41096	3547	40207	3708	39339	3874	38492	4043	37663	4217	
21	41081	3549	40192	3711	39325	3876	38478	4046	37650	4220	9
	41066	3552	40178	3714	39311	3879	38464	4049	37636	4222	
22	41051	3555	40163	3716	39296	3882	38450	4052	37623	4225	8
	41036	3557	40149	3719	39282	3885	38436	4055	37609	4228	
23	41021	3560	40134	3722	39268	3888	38422	4057	37595	4231	7
	41006	3563	40119	3725	39254	3890	38408	4060	37582	4234	
24	40991	3565	40105	3727	39239	3893	38394	4063	37568	4237	6
	40976	3568	40090	3730	39225	3896	38380	4066	37554	4240	
25	40961	3571	40076	3733	39211	3899	38366	4069	37541	4243	5
	40946	3573	40061	3735	39197	3902	38352	4072	37527	4246	
26	40931	3576	40046	3738	39182	3904	38338	4075	37514	4249	4
	40916	3579	40032	3741	39168	3907	38324	4078	37500	4252	
27	40902	3581	40017	3744	39154	3910	38311	4080	37486	4255	3
	40887	3584	40003	3746	39140	3913	38297	4083	37473	4258	
28	40872	3587	39988	3749	39125	3916	38283	4086	37459	4261	2
	40857	3589	39974	3752	39111	3918	38269	4089	37446	4264	
29	40842	3592	39959	3755	39097	3921	38255	4092	37432	4266	1
	40827	3595	39945	3757	39083	3924	38241	4095	37419	4269	
30	40812	3597	39930	3760	39069	3927	38227	4098	37405	4272	0
	A	B	A	B	A	B	A	B	A	B	
	157°00'		156°30'		156°00'		155°30'		155°00'		

WHEN LHA (E OR W) IS GREATER THAN 90°, TAKE "K" FROM BOTTOM OF TABLE

	25°00'		25°30'		26°00'		26°30'		27°00'		
	A	B	A	B	A	B	A	B	A	B	
0	37405	4272	36602	4451	35816	4634	35047	4821	34295	5012	30
	37392	4275	36588	4454	35803	4637	35035	4824	34283	5015	
1	37378	4278	36575	4457	35790	4640	35022	4827	34270	5018	29
	37365	4281	36562	4460	35777	4643	35009	4830	34258	5022	
2	37351	4284	36549	4463	35764	4646	34997	4833	34246	5025	28
	37337	4287	36535	4466	35751	4649	34984	4837	34233	5028	
3	37324	4290	36522	4469	35738	4651	34971	4840	34221	5031	27
	37310	4293	36509	4472	35725	4656	34959	4843	34209	5034	
4	37297	4296	36496	4475	35712	4659	34946	4846	34196	5038	26
	37283	4299	36483	4478	35699	4662	34933	4849	34184	5041	
5	37270	4302	36469	4481	35686	4665	34921	4852	34172	5044	25
	37256	4305	36456	4484	35674	4668	34908	4856	34159	5047	
6	37243	4308	36443	4487	35661	4671	34896	4859	34147	5051	24
	37229	4311	36430	4490	35648	4674	34883	4862	34134	5054	
7	37216	4314	36417	4493	35635	4677	34870	4865	34122	5057	23
	37203	4317	36403	4496	35622	4680	34858	4868	34110	5060	
8	37189	4320	36390	4499	35609	4683	34845	4871	34097	5064	22
	37176	4323	36377	4503	35596	4686	34832	4875	34085	5067	
9	37162	4326	36364	4506	35583	4690	34820	4878	34073	5070	21
	37149	4329	36351	4509	35571	4693	34807	4881	34061	5073	
10	37135	4332	36338	4512	35558	4696	34795	4884	34048	5076	20
	37122	4334	36325	4515	35545	4699	34782	4887	34036	5080	
11	37108	4337	36311	4518	35532	4702	34770	4890	34024	5083	19
	37095	4340	36298	4521	35519	4705	34757	4894	34011	5086	
12	37081	4343	36285	4524	35506	4708	34744	4897	33999	5089	18
	37068	4346	36272	4527	35493	4711	34732	4900	33987	5093	
13	37055	4349	36259	4530	35481	4714	34719	4903	33974	5096	17
	37041	4352	36246	4533	35468	4718	34707	4906	33962	5099	
14	37028	4355	36233	4536	35455	4721	34694	4910	33950	5102	16
	37014	4358	36220	4539	35442	4724	34682	4913	33938	5106	
15	37001	4361	36206	4542	35429	4727	34669	4916	33925	5109	15
	36988	4364	36193	4545	35417	4730	34657	4919	33913	5112	
16	36974	4367	36180	4548	35404	4733	34644	4922	33901	5115	14
	36961	4370	36167	4551	35391	4736	34632	4925	33889	5119	
17	36948	4373	36154	4554	35378	4739	34619	4929	33876	5122	13
	36934	4376	36141	4557	35365	4742	34607	4932	33864	5125	
18	36921	4379	36128	4560	35353	4746	34594	4935	33852	5128	12
	36907	4382	36115	4563	35340	4749	34582	4938	33840	5132	
19	36894	4385	36102	4566	35327	4752	34569	4941	33827	5135	11
	36881	4388	36089	4569	35314	4755	34557	4945	33815	5138	
20	36867	4391	36076	4573	35302	4758	34544	4948	33803	5142	10
	36854	4394	36063	4576	35289	4761	34532	4951	33791	5145	
21	36841	4397	36050	4579	35276	4764	34519	4954	33779	5148	9
	36827	4400	36037	4582	35263	4769	34507	4957	33766	5151	
22	36814	4403	36024	4585	35251	4771	34494	4961	33754	5155	8
	36801	4406	36011	4588	35238	4774	34482	4964	33742	5158	
23	36787	4409	35998	4591	35225	4777	34469	4967	33730	5161	7
	36774	4412	35985	4594	35212	4780	34457	4970	33717	5164	
24	36761	4415	35972	4597	35200	4783	34445	4973	33705	5168	6
	36747	4418	35959	4600	35187	4786	34432	4977	33693	5171	
25	36734	4421	35946	4603	35174	4789	34420	4980	33681	5174	5
	36721	4424	35933	4606	35161	4793	34407	4983	33669	5178	
26	36708	4427	35920	4609	35149	4796	34395	4986	33657	5181	4
	36694	4430	35907	4612	35136	4799	34382	4989	33644	5184	
27	36681	4433	35894	4615	35123	4802	34370	4993	33632	5187	3
	36668	4436	35881	4619	35111	4805	34357	4996	33620	5191	
28	36655	4439	35868	4622	35098	4808	34345	4999	33608	5194	2
	36641	4442	35855	4625	35085	4811	34332	5002	33596	5197	
29	36628	4445	35842	4628	35073	4815	34320	5005	33584	5200	1
	36615	4448	35829	4631	35060	4818	34308	5009	33572	5204	
30	36602	4451	35816	4634	35047	4821	34295	5012	33559	5207	0
	A	B	A	B	A	B	A	B	A	B	
	154°30'		154°00'		153°30'		153°00'		152°30'		

ALWAYS TAKE "Z" FROM BOTTOM OF TABLE, EXCEPT WHEN "K" IS SAME NAME AND GREATER THAN LATITUDE, IN WHICH CASE TAKE "Z" FROM TOP OF TABLE

	27°30'		28°00'		28°30'		29°00'		29°30'		
	A	B	A	B	A	B	A	B	A	B	
0	33559	5207	32839	5406	32134	5610	31443	5818	30766	6030	30
1	33547	5210	32827	5410	32122	5614	31431	5822	30755	6034	29
	33535	5214	32815	5413	32110	5617	31420	5825	30744	6038	
2	33523	5217	32803	5417	32099	5620	31409	5829	30733	6041	28
	33511	5220	32792	5420	32087	5624	31397	5832	30721	6045	
3	33499	5224	32780	5423	32076	5627	31386	5836	30710	6048	27
	33487	5227	32768	5426	32064	5631	31375	5839	30699	6052	
4	33475	5230	32756	5430	32052	5634	31363	5843	30688	6055	26
	33462	5233	32744	5433	32041	5638	31352	5846	30677	6059	
5	33450	5237	32732	5437	32029	5641	31340	5850	30666	6062	25
	33438	5240	32720	5440	32018	5645	31329	5853	30655	6066	
6	33426	5243	32709	5443	32006	5648	31318	5857	30643	6070	24
	33414	5247	32697	5447	31994	5651	31306	5860	30632	6073	
7	33402	5250	32685	5450	31983	5655	31295	5864	30621	6077	23
	33390	5253	32673	5454	31971	5658	31284	5867	30610	6080	
8	33378	5257	32661	5457	31960	5662	31272	5871	30599	6084	22
	33366	5260	32649	5460	31948	5665	31261	5874	30588	6088	
9	33354	5263	32638	5464	31936	5669	31250	5878	30577	6091	21
	33342	5266	32625	5467	31925	5672	31238	5881	30566	6095	
10	33330	5270	32614	5470	31913	5675	31227	5885	30555	6098	20
	33318	5273	32602	5474	31902	5679	31216	5888	30544	6102	
11	33306	5277	32590	5477	31890	5682	31204	5892	30532	6106	19
	33293	5280	32579	5481	31879	5686	31193	5895	30521	6109	
12	33281	5283	32567	5484	31867	5689	31182	5899	30510	6113	18
	33269	5287	32555	5487	31856	5693	31170	5902	30499	6116	
13	33257	5290	32543	5491	31844	5696	31159	5906	30488	6120	17
	33245	5293	32532	5494	31833	5700	31148	5909	30477	6124	
14	33233	5296	32520	5498	31821	5703	31137	5913	30466	6127	16
	33221	5300	32508	5501	31809	5707	31125	5917	30455	6131	
15	33209	5303	32496	5504	31798	5710	31114	5920	30444	6134	15
	33197	5306	32484	5508	31786	5714	31103	5924	30433	6138	
16	33185	5310	32473	5511	31775	5717	31091	5927	30422	6142	14
	33173	5313	32461	5515	31763	5720	31080	5931	30411	6145	
17	33161	5316	32449	5518	31752	5724	31069	5934	30400	6149	13
	33149	5320	32438	5521	31740	5727	31058	5938	30389	6153	
18	33137	5323	32426	5525	31729	5731	31046	5941	30378	6156	12
	33125	5326	32414	5528	31717	5734	31035	5945	30367	6160	
19	33113	5330	32402	5532	31706	5738	31024	5948	30356	6163	11
	33101	5333	32391	5535	31694	5741	31013	5952	30345	6167	
20	33089	5336	32379	5538	31683	5745	31001	5955	30334	6171	10
	33077	5340	32367	5542	31672	5748	30990	5959	30322	6174	
21	33065	5343	32355	5545	31660	5752	30979	5963	30311	6178	9
	33054	5346	32344	5549	31648	5755	30968	5966	30300	6181	
22	33042	5350	32332	5552	31637	5759	30956	5970	30289	6185	8
	33030	5353	32320	5555	31626	5762	30945	5973	30278	6189	
23	33018	5356	32309	5559	31614	5766	30934	5977	30267	6192	7
	33006	5360	32297	5562	31603	5769	30923	5980	30256	6196	
24	32994	5363	32285	5566	31591	5773	30912	5984	30245	6200	6
	32982	5366	32274	5569	31580	5776	30900	5988	30235	6203	
25	32970	5370	32262	5572	31569	5780	30889	5991	30224	6207	5
	32958	5373	32250	5576	31557	5783	30878	5995	30213	6210	
26	32946	5376	32239	5579	31546	5787	30867	5998	30202	6214	4
	32934	5380	32227	5583	31534	5790	30856	6002	30191	6218	
27	32922	5383	32215	5586	31523	5794	30844	6005	30180	6221	3
	32910	5386	32204	5590	31511	5797	30833	6009	30169	6225	
28	32898	5390	32192	5593	31500	5801	30822	6012	30158	6229	2
	32887	5393	32180	5596	31488	5804	30811	6016	30147	6232	
29	32875	5396	32169	5600	31477	5808	30800	6020	30136	6236	1
	32863	5400	32157	5603	31466	5811	30788	6023	30125	6240	
30	32851	5403	32145	5607	31454	5815	30777	6027	30114	6243	0
	32839	5406	32134	5610	31443	5818	30766	6030	30103	6247	
	A	B	A	B	A	B	A	B	A	B	
	152°00'		151°30'		151°00'		150°30'		150°00'		

WHEN LHA (E OR W) IS GREATER THAN 90°, TAKE "K" FROM BOTTOM OF TABLE

	30°00'		30°30'		31°00'		31°30'		32°00'		
	A	B	A	B	A	B	A	B	A	B	
0	30103	6247	29453	6468	28816	6693	28191	6923	27579	7158	30
	30092	6251	29442	6472	28806	6697	28181	6927	27569	7162	
1	30081	6254	29432	6475	28795	6701	28171	6931	27559	7166	29
	30070	6258	29421	6479	28785	6705	28161	6935	27549	7170	
2	30059	6262	29410	6483	28774	6709	28150	6939	27539	7174	28
	30048	6265	29399	6487	28763	6712	28140	6943	27528	7178	
3	30037	6269	29389	6490	28753	6716	28130	6947	27518	7182	27
	30026	6273	29378	6494	28743	6720	28119	6951	27508	7186	
4	30016	6276	29367	6498	28732	6724	28109	6954	27498	7190	26
	30005	6280	29357	6501	28722	6728	28099	6958	27488	7193	
5	29994	6284	29346	6505	28711	6731	28089	6962	27478	7197	25
	29983	6287	29335	6509	28701	6735	28078	6966	27468	7201	
6	29972	6291	29325	6513	28690	6739	28068	6970	27458	7205	24
	29961	6294	29314	6516	28680	6743	28058	6974	27448	7209	
7	29950	6298	29303	6520	28669	6747	28047	6978	27438	7213	23
	29939	6302	29293	6524	28659	6750	28037	6982	27428	7217	
8	29928	6305	29282	6528	28648	6754	28027	6985	27418	7221	22
	29917	6309	29271	6531	28638	6758	28017	6989	27408	7225	
9	29907	6313	29261	6535	28627	6762	28006	6993	27398	7229	21
	29896	6316	29250	6539	28617	6766	27996	6997	27387	7233	
10	29885	6320	29239	6543	28606	6770	27986	7001	27377	7237	20
	29874	6324	29229	6546	28596	6773	27976	7005	27367	7241	
11	29863	6328	29218	6550	28586	6777	27965	7009	27357	7245	19
	29852	6331	29207	6554	28575	6781	27955	7013	27347	7249	
12	29841	6335	29197	6558	28565	6785	27945	7017	27337	7253	18
	29831	6339	29186	6561	28554	6789	27935	7021	27327	7257	
13	29820	6342	29175	6565	28544	6793	27925	7024	27317	7261	17
	29809	6346	29165	6569	28533	6796	27914	7028	27307	7265	
14	29798	6350	29154	6573	28523	6800	27904	7032	27297	7269	16
	29787	6353	29144	6576	28513	6804	27894	7036	27287	7273	
15	29776	6357	29133	6580	28502	6808	27884	7040	27277	7277	15
	29766	6361	29122	6584	28492	6812	27874	7044	27267	7281	
16	29755	6364	29112	6588	28481	6815	27863	7048	27257	7285	14
	29744	6368	29101	6591	28471	6819	27853	7052	27247	7289	
17	29733	6372	29091	6595	28461	6823	27843	7056	27237	7293	13
	29722	6375	29080	6599	28450	6827	27833	7060	27227	7297	
18	29711	6379	29069	6603	28440	6831	27823	7064	27217	7301	12
	29701	6383	29059	6606	28429	6835	27812	7067	27207	7305	
19	29690	6386	29048	6610	28419	6839	27802	7071	27197	7309	11
	29679	6390	29038	6614	28409	6842	27792	7075	27187	7313	
20	29668	6394	29027	6618	28398	6846	27782	7079	27177	7317	10
	29657	6398	29016	6622	28388	6850	27772	7083	27167	7321	
21	29647	6401	29006	6625	28378	6854	27761	7087	27157	7325	9
	29636	6405	28995	6629	28367	6858	27751	7091	27147	7329	
22	29625	6409	28985	6633	28357	6862	27741	7095	27137	7333	8
	29614	6412	28974	6637	28346	6865	27731	7099	27127	7337	
23	29604	6416	28964	6640	28336	6869	27721	7103	27117	7341	7
	29593	6420	28953	6644	28326	6873	27711	7107	27107	7345	
24	29582	6423	28942	6648	28315	6877	27701	7111	27098	7349	6
	29571	6427	28932	6652	28305	6881	27690	7115	27088	7353	
25	29560	6431	28921	6655	28295	6885	27680	7118	27078	7357	5
	29550	6435	28911	6659	28284	6889	27670	7122	27068	7361	
26	29539	6438	28900	6663	28274	6893	27660	7126	27058	7365	4
	29528	6442	28890	6667	28264	6896	27650	7130	27048	7369	
27	29517	6446	28879	6671	28253	6900	27640	7134	27038	7373	3
	29507	6449	28869	6674	28243	6904	27630	7138	27028	7377	
28	29496	6453	28858	6678	28233	6908	27619	7142	27018	7381	2
	29485	6457	28848	6682	28222	6912	27609	7146	27008	7385	
29	29475	6461	28837	6686	28212	6916	27599	7150	26998	7389	1
	29464	6464	28827	6690	28202	6920	27589	7154	26988	7393	
30	29453	6468	28816	6693	28191	6923	27579	7158	26978	7397	0
	A	B	A	B	A	B	A	B	A	B	
	149°30'		149°00'		148°30'		148°00'		147°30'		

ALWAYS TAKE "Z" FROM BOTTOM OF TABLE, EXCEPT WHEN "K" IS SAME NAME AND GREATER THAN LATITUDE, IN WHICH CASE TAKE "Z" FROM TOP OF TABLE

	32°30'		33°00'		33°30'		34°00'		34°30'		
	A	B	A	B	A	B	A	B	A	B	
0	26978	7397	26389	7641	25811	7889	25244	8143	24687	8401	30
1	26968	7401	26379	7645	25801	7893	25235	8147	24678	8405	29
	26958	7405	26370	7649	25792	7898	25225	8151	24669	8409	
2	26949	7409	26360	7653	25782	7902	25216	8155	24660	8414	28
	26939	7413	26350	7657	25773	7906	25206	8160	24650	8418	
3	26929	7417	26340	7661	25763	7910	25197	8164	24641	8422	27
	26919	7421	26331	7665	25754	7914	25188	8168	24632	8427	
4	26909	7425	26321	7670	25744	7919	25178	8172	24623	8431	26
	26899	7429	26311	7674	25735	7923	25169	8177	24614	8435	
5	26889	7433	26302	7678	25725	7927	25160	8181	24605	8440	25
	26879	7437	26292	7682	25716	7931	25150	8185	24595	8444	
6	26869	7441	26282	7686	25706	7935	25141	8189	24586	8448	24
	26860	7445	26273	7690	25697	7940	25132	8194	24577	8453	
7	26850	7449	26263	7694	25687	7944	25122	8198	24568	8457	23
	26840	7453	26253	7698	25678	7948	25113	8202	24559	8461	
8	26830	7458	26244	7702	25668	7952	25104	8207	24550	8466	22
	26820	7462	26234	7707	25659	7956	25094	8211	24540	8470	
9	26810	7466	26224	7711	25649	7961	25085	8215	24531	8475	21
	26800	7470	26214	7715	25640	7965	25076	8219	24522	8479	
10	26790	7474	26205	7719	25630	7969	25066	8224	24513	8483	20
	26781	7478	26195	7723	25621	7973	25057	8228	24504	8488	
11	26771	7482	26185	7727	25611	7977	25048	8232	24495	8492	19
	26761	7486	26176	7731	25602	7982	25038	8237	24486	8496	
12	26751	7490	26166	7736	25592	7986	25029	8241	24477	8501	18
	26741	7494	26157	7740	25583	7990	25020	8245	24467	8505	
13	26731	7498	26147	7744	25573	7994	25011	8249	24458	8510	17
	26722	7502	26137	7748	25564	7998	25001	8254	24449	8514	
14	26712	7506	26128	7752	25554	8003	24992	8258	24440	8518	16
	26702	7510	26118	7756	25545	8007	24983	8262	24431	8523	
15	26692	7514	26108	7760	25536	8011	24973	8267	24422	8527	15
	26682	7518	26099	7764	25526	8015	24964	8271	24413	8531	
16	26672	7522	26089	7769	25517	8020	24955	8275	24404	8536	14
	26663	7526	26079	7773	25507	8024	24946	8280	24395	8540	
17	26653	7531	26070	7777	25498	8028	24936	8284	24385	8545	13
	26643	7535	26060	7781	25488	8032	24927	8288	24376	8549	
18	26633	7539	26051	7785	25479	8037	24918	8292	24367	8553	12
	26623	7543	26041	7789	25469	8041	24909	8297	24358	8558	
19	26614	7547	26031	7793	25460	8045	24899	8301	24349	8562	11
	26604	7551	26022	7798	25451	8049	24890	8305	24340	8567	
20	26594	7555	26012	7802	25441	8053	24881	8310	24331	8571	10
	26584	7559	26002	7806	25432	8058	24872	8314	24322	8575	
21	26574	7563	25993	7810	25422	8062	24862	8318	24313	8580	9
	26565	7567	25983	7814	25413	8066	24853	8323	24304	8584	
22	26555	7571	25974	7818	25403	8070	24844	8327	24295	8589	8
	26545	7575	25964	7823	25394	8075	24835	8331	24286	8593	
23	26535	7579	25954	7827	25385	8079	24825	8336	24276	8597	7
	26526	7584	25945	7831	25375	8083	24816	8340	24267	8602	
24	26516	7588	25935	7835	25366	8087	24807	8344	24258	8606	6
	26506	7592	25926	7839	25356	8091	24798	8349	24249	8611	
25	26496	7596	25916	7843	25347	8096	24788	8353	24240	8615	5
	26486	7600	25907	7848	25338	8100	24779	8357	24231	8619	
26	26477	7604	25897	7852	25328	8104	24770	8362	24222	8624	4
	26467	7608	25887	7856	25319	8108	24761	8366	24213	8628	
27	26457	7612	25878	7860	25309	8113	24752	8370	24204	8633	3
	26447	7616	25868	7864	25300	8117	24742	8375	24195	8637	
28	26438	7620	25859	7868	25291	8121	24733	8379	24186	8641	2
	26428	7625	25849	7873	25281	8125	24724	8383	24177	8646	
29	26418	7629	25840	7877	25272	8130	24715	8388	24168	8650	1
	26409	7633	25830	7881	25263	8134	24706	8392	24159	8655	
30	26399	7637	25821	7885	25253	8138	24696	8396	24150	8659	0
	26389	7641	25811	7889	25244	8143	24687	8401	24141	8663	
	A	B	A	B	A	B	A	B	A	B	
	147°00'		146°30'		146°00'		145°30'		145°00'		

WHEN LHA (E OR W) IS GREATER THAN 90°, TAKE "K" FROM BOTTOM OF TABLE

	35°00'		35°30'		36°00'		36°30'		37°00'		
	A	B	A	B	A	B	A	B	A	B	
0	24141	8663	23605	8931	23078	9204	22561	9482	22054	9765	30
	24132	8668	23596	8936	23069	9209	22553	9487	22045	9770	
1	24123	8672	23587	8940	23061	9213	22544	9492	22037	9775	29
	24114	8677	23578	8945	23052	9218	22536	9496	22029	9779	
2	24105	8681	23569	8949	23043	9223	22527	9501	22020	9784	28
	24096	8686	23560	8954	23035	9227	22519	9505	22012	9789	
3	24087	8690	23551	8958	23026	9232	22510	9510	22003	9794	27
	24078	8694	23543	8963	23017	9236	22501	9515	21995	9798	
4	24069	8699	23534	8967	23009	9241	22493	9520	21987	9803	26
	24060	8703	23525	8972	23000	9246	22484	9524	21978	9808	
5	24051	8708	23516	8976	22991	9250	22476	9529	21970	9813	25
	24042	8712	23507	8981	22983	9255	22467	9534	21962	9818	
6	24033	8717	23498	8986	22974	9259	22459	9538	21953	9822	24
	24024	8721	23490	8990	22965	9264	22450	9543	21945	9827	
7	24015	8726	23481	8995	22957	9269	22442	9548	21937	9832	23
	24006	8730	23472	8999	22948	9273	22433	9552	21928	9837	
8	23997	8734	23463	9004	22939	9278	22425	9557	21920	9841	22
	23988	8739	23454	9008	22931	9282	22416	9562	21912	9846	
9	23979	8743	23446	9013	22922	9287	22408	9566	21903	9851	21
	23970	8748	23437	9017	22913	9292	22399	9571	21895	9856	
10	23961	8752	23428	9022	22905	9296	22391	9576	21887	9861	20
	23952	8757	23419	9026	22896	9301	22382	9581	21878	9865	
11	23943	8761	23410	9031	22887	9305	22374	9585	21870	9870	19
	23934	8766	23402	9035	22879	9310	22366	9590	21862	9875	
12	23925	8770	23393	9040	22870	9315	22357	9595	21853	9880	18
	23916	8775	23384	9044	22862	9319	22349	9599	21845	9885	
13	23907	8779	23375	9049	22853	9324	22340	9604	21837	9889	17
	23898	8783	23366	9054	22844	9329	22332	9609	21828	9894	
14	23889	8788	23358	9058	22836	9333	22323	9614	21820	9899	16
	23880	8792	23349	9063	22827	9338	22315	9618	21812	9904	
15	23871	8797	23340	9067	22818	9342	22306	9623	21803	9909	15
	23863	8801	23331	9072	22810	9347	22298	9628	21795	9913	
16	23854	8806	23323	9076	22801	9352	22289	9632	21787	9918	14
	23845	8810	23314	9081	22793	9356	22281	9637	21778	9923	
17	23836	8815	23305	9085	22784	9361	22272	9642	21770	9928	13
	23827	8819	23296	9090	22775	9366	22264	9647	21762	9933	
18	23818	8824	23288	9094	22767	9370	22256	9651	21754	9937	12
	23809	8828	23279	9099	22758	9375	22247	9656	21745	9942	
19	23800	8833	23270	9104	22750	9380	22239	9661	21737	9947	11
	23791	8837	23261	9108	22741	9384	22230	9665	21729	9952	
20	23782	8842	23252	9113	22732	9389	22222	9670	21720	9957	10
	23773	8846	23244	9117	22724	9394	22213	9675	21712	9962	
21	23764	8850	23235	9122	22715	9398	22205	9680	21704	9966	9
	23755	8855	23226	9126	22707	9403	22197	9684	21696	9971	
22	23747	8859	23218	9131	22698	9407	22188	9689	21687	9976	8
	23738	8864	23209	9136	22690	9412	22180	9694	21679	9981	
23	23729	8868	23200	9140	22681	9417	22171	9699	21671	9986	7
	23720	8873	23191	9145	22672	9421	22168	9703	21662	9990	
24	23711	8877	23183	9149	22664	9426	22154	9708	21654	9995	6
	23702	8882	23174	9154	22655	9431	22146	9713	21646	10000	
25	23693	8886	23165	9158	22647	9435	22138	9718	21638	10005	5
	23684	8891	23156	9163	22638	9440	22129	9722	21629	10010	
26	23675	8895	23148	9168	22630	9445	22121	9727	21621	10015	4
	23667	8900	23139	9172	22621	9449	22112	9732	21613	10019	
27	23658	8904	23130	9177	22612	9454	22104	9737	21605	10024	3
	23649	8909	23122	9181	22604	9459	22096	9741	21596	10029	
28	23640	8913	23113	9186	22595	9463	22087	9746	21588	10034	2
	23631	8918	23104	9190	22587	9468	22079	9751	21580	10039	
29	23622	8922	23095	9195	22578	9473	22070	9756	21572	10044	1
	23613	8927	23087	9200	22570	9477	22062	9760	21563	10049	
30	23605	8931	23078	9204	22561	9482	22054	9765	21555	10053	0
	A	B	A	B	A	B	A	B	A	B	
	144°30'		144°00'		143°30'		143°00'		142°30'		

ALWAYS TAKE "Z" FROM BOTTOM OF TABLE, EXCEPT WHEN "K" IS SAME NAME AND GREATER THAN LATITUDE, IN WHICH CASE TAKE "Z" FROM TOP OF TABLE

	37°30'		38°00'		38°30'		39°00'		39°30'		
	A	B	A	B	A	B	A	B	A	B	
0	21555	10053	21066	10347	20585	10646	20113	10950	19649	11259	30
	21547	10058	21058	10352	20577	10651	20105	10955	19641	11265	
1	21539	10063	21050	10357	20569	10656	20097	10960	19634	11270	29
	21531	10068	21042	10362	20561	10661	20089	10965	19626	11275	
2	21522	10073	21033	10367	20553	10666	20082	10970	19618	11280	28
	21514	10078	21025	10372	20545	10671	20074	10975	19611	11285	
3	21506	10082	21017	10376	20537	10676	20066	10980	19603	11291	27
	21498	10087	21009	10381	20529	10681	20058	10986	19595	11296	
4	21489	10092	21001	10386	20522	10686	20050	10991	19588	11301	26
	21481	10097	20993	10391	20514	10691	20043	10996	19580	11306	
5	21473	10102	20985	10396	20506	10696	20035	11001	19572	11311	25
	21465	10107	20977	10401	20498	10701	20027	11006	19565	11317	
6	21457	10112	20969	10406	20490	10706	20019	11011	19557	11322	24
	21448	10116	20961	10411	20482	10711	20012	11016	19549	11327	
7	21440	10121	20953	10416	20474	10716	20004	11021	19541	11332	23
	21432	10126	20945	10421	20466	10721	19996	11027	19534	11338	
8	21424	10131	20937	10426	20458	10726	19988	11032	19527	11343	22
	21416	10136	20929	10431	20450	10731	19980	11037	19519	11348	
9	21407	10141	20921	10436	20442	10736	19973	11042	19511	11353	21
	21399	10146	20913	10441	20435	10741	19965	11047	19504	11359	
10	21391	10151	20905	10446	20427	10746	19957	11052	19496	11364	20
	21383	10155	20897	10451	20419	10751	19949	11057	19488	11369	
11	21375	10160	20888	10456	20411	10756	19942	11063	19481	11374	19
	21367	10165	20880	10461	20403	10761	19934	11068	19473	11380	
12	21358	10170	20872	10466	20395	10767	19926	11073	19466	11385	18
	21350	10175	20864	10471	20387	10772	19919	11078	19458	11390	
13	21342	10180	20856	10476	20379	10777	19911	11083	19450	11395	17
	21334	10185	20848	10481	20371	10782	19903	11088	19443	11400	
14	21326	10190	20840	10486	20364	10787	19895	11094	19435	11406	16
	21318	10195	20832	10491	20356	10792	19888	11099	19428	11411	
15	21309	10199	20824	10496	20348	10797	19880	11104	19420	11416	15
	21301	10204	20816	10500	20340	10802	19872	11109	19412	11422	
16	21293	10209	20808	10505	20332	10807	19864	11114	19405	11427	14
	21285	10214	20800	10510	20324	10812	19857	11119	19397	11432	
17	21277	10219	20792	10515	20316	10817	19849	11124	19390	11437	13
	21269	10224	20784	10520	20309	10822	19841	11130	19382	11443	
18	21260	10229	20776	10525	20301	10827	19834	11135	19375	11448	12
	21252	10234	20768	10530	20293	10832	19826	11140	19367	11453	
19	21244	10239	20760	10535	20285	10838	19818	11145	19359	11458	11
	21236	10243	20752	10540	20277	10843	19810	11150	19352	11464	
20	21228	10248	20744	10545	20269	10848	19803	11156	19344	11469	10
	21220	10253	20736	10550	20261	10853	19795	11161	19337	11474	
21	21212	10258	20728	10555	20254	10858	19787	11166	19329	11479	9
	21204	10263	20720	10560	20246	10863	19779	11171	19321	11485	
22	21195	10268	20712	10565	20238	10868	19772	11176	19314	11490	8
	21187	10273	20704	10570	20230	10873	19764	11181	19306	11495	
23	21179	10278	20696	10575	20222	10878	19756	11187	19299	11501	7
	21171	10283	20688	10580	20214	10883	19749	11192	19291	11506	
24	21163	10288	20680	10585	20207	10888	19741	11197	19284	11511	6
	21155	10293	20672	10590	20199	10894	19733	11202	19276	11516	
25	21147	10298	20665	10595	20191	10899	19726	11207	19269	11522	5
	21139	10302	20657	10600	20183	10904	19718	11213	19261	11527	
26	21131	10307	20649	10605	20175	10909	19710	11218	19253	11532	4
	21122	10312	20641	10610	20167	10914	19703	11223	19246	11537	
27	21114	10317	20633	10615	20160	10919	19695	11228	19238	11543	3
	21106	10322	20625	10620	20152	10924	19687	11233	19231	11548	
28	21098	10327	20617	10625	20144	10929	19680	11239	19223	11553	2
	21090	10332	20609	10630	20136	10934	19672	11244	19216	11559	
29	21082	10337	20601	10635	20128	10939	19664	11249	19208	11564	1
	21074	10342	20593	10640	20121	10945	19657	11254	19201	11569	
30	21066	10347	20585	10646	20113	10950	19649	11259	19193	11575	0
	A	B	A	B	A	B	A	B	A	B	
	142°00'		141°30'		141°00'		140°30'		140°00'		

WHEN LHA (E OR W) IS GREATER THAN 90°, TAKE "K" FROM BOTTOM OF TABLE

	40°00'		40°30'		41°00'		41°30'		42°00'		
	A	B	A	B	A	B	A	B	A	B	
0	19193 ... 11575	19186 ... 11580	18746 ... 11895	18738 ... 11901	18306 ... 12222	18298 ... 12228	17873 ... 12554	17866 ... 12560	17449 ... 12893	17442 ... 12898	30
1	19178 ... 11585	19171 ... 11590	18731 ... 11906	18723 ... 11912	18291 ... 12233	18284 ... 12238	17859 ... 12566	17852 ... 12571	17435 ... 12904	17428 ... 12910	29
2	19163 ... 11596	19156 ... 11601	18716 ... 11917	18709 ... 11922	18277 ... 12244	18269 ... 12249	17845 ... 12577	17838 ... 12582	17421 ... 12915	17414 ... 12921	28
3	19148 ... 11606	19141 ... 11612	18701 ... 11928	18694 ... 11933	18262 ... 12255	18255 ... 12260	17831 ... 12588	17824 ... 12593	17407 ... 12927	17400 ... 12932	27
4	19133 ... 11617	19126 ... 11622	18686 ... 11939	18679 ... 11944	18248 ... 12266	18240 ... 12271	17816 ... 12599	17809 ... 12605	17393 ... 12938	17386 ... 12944	26
5	19118 ... 11628	19111 ... 11633	18672 ... 11949	18664 ... 11955	18233 ... 12277	18226 ... 12282	17802 ... 12610	17795 ... 12616	17379 ... 12950	17372 ... 12955	25
6	19103 ... 11638	19096 ... 11644	18657 ... 11960	18650 ... 11966	18219 ... 12288	18211 ... 12293	17788 ... 12622	17781 ... 12627	17365 ... 12961	17358 ... 12967	24
7	19088 ... 11649	19081 ... 11654	18642 ... 11971	18635 ... 11977	18204 ... 12299	18197 ... 12305	17774 ... 12633	17767 ... 12638	17351 ... 12972	17344 ... 12978	23
8	19073 ... 11660	19066 ... 11665	18627 ... 11982	18620 ... 11987	18190 ... 12310	18182 ... 12316	17760 ... 12644	17752 ... 12650	17337 ... 12984	17330 ... 12990	22
9	19058 ... 11670	19051 ... 11676	18613 ... 11993	18605 ... 11998	18175 ... 12321	18168 ... 12327	17745 ... 12655	17738 ... 12661	17323 ... 12995	17316 ... 13001	21
10	19043 ... 11681	19036 ... 11686	18598 ... 12004	18591 ... 12009	18161 ... 12332	18154 ... 12338	17731 ... 12667	17724 ... 12672	17309 ... 13007	17302 ... 13012	20
11	19028 ... 11692	19021 ... 11697	18583 ... 12014	18576 ... 12020	18146 ... 12343	18139 ... 12349	17717 ... 12678	17710 ... 12683	17295 ... 13018	17288 ... 13024	19
12	19013 ... 11702	19006 ... 11708	18569 ... 12025	18561 ... 12031	18132 ... 12354	18125 ... 12360	17703 ... 12689	17696 ... 12695	17281 ... 13030	17274 ... 13035	18
13	18998 ... 11713	18991 ... 11718	18554 ... 12036	18547 ... 12042	18117 ... 12365	18110 ... 12371	17689 ... 12700	17681 ... 12706	17267 ... 13041	17260 ... 13047	17
14	18983 ... 11724	18976 ... 11729	18539 ... 12047	18532 ... 12053	18103 ... 12376	18096 ... 12382	17674 ... 12711	17667 ... 12717	17253 ... 13053	17246 ... 13058	16
15	18968 ... 11734	18961 ... 11740	18525 ... 12058	18517 ... 12063	18089 ... 12387	18081 ... 12393	17660 ... 12723	17653 ... 12728	17239 ... 13064	17232 ... 13070	15
16	18953 ... 11745	18946 ... 11750	18510 ... 12069	18503 ... 12074	18074 ... 12398	18067 ... 12404	17646 ... 12734	17639 ... 12740	17225 ... 13075	17218 ... 13081	14
17	18939 ... 11756	18931 ... 11761	18495 ... 12080	18488 ... 12085	18060 ... 12410	18053 ... 12415	17632 ... 12745	17625 ... 12751	17212 ... 13087	17205 ... 13093	13
18	18924 ... 11766	18916 ... 11772	18481 ... 12091	18473 ... 12096	18045 ... 12421	18038 ... 12426	17618 ... 12757	17611 ... 12762	17198 ... 13098	17191 ... 13104	12
19	18909 ... 11777	18901 ... 11782	18466 ... 12102	18459 ... 12107	18031 ... 12432	18024 ... 12437	17604 ... 12768	17597 ... 12774	17184 ... 13110	17177 ... 13116	11
20	18894 ... 11788	18886 ... 11793	18451 ... 12112	18444 ... 12118	18017 ... 12443	18010 ... 12448	17590 ... 12779	17583 ... 12785	17170 ... 13121	17163 ... 13127	10
21	18879 ... 11799	18872 ... 11804	18437 ... 12123	18429 ... 12129	18002 ... 12454	17995 ... 12460	17575 ... 12790	17568 ... 12796	17156 ... 13133	17149 ... 13139	9
22	18864 ... 11809	18857 ... 11815	18422 ... 12134	18415 ... 12140	17988 ... 12465	17981 ... 12471	17561 ... 12802	17554 ... 12807	17142 ... 13144	17135 ... 13150	8
23	18849 ... 11820	18842 ... 11825	18408 ... 12145	18400 ... 12151	17974 ... 12476	17966 ... 12482	17547 ... 12813	17540 ... 12819	17128 ... 13156	17121 ... 13162	7
24	18834 ... 11831	18827 ... 11836	18393 ... 12156	18386 ... 12162	17959 ... 12487	17952 ... 12493	17533 ... 12824	17526 ... 12830	17114 ... 13168	17107 ... 13173	6
25	18820 ... 11842	18812 ... 11847	18378 ... 12167	18371 ... 12173	17945 ... 12499	17938 ... 12504	17519 ... 12836	17512 ... 12841	17100 ... 13179	17093 ... 13185	5
26	18805 ... 11852	18797 ... 11858	18364 ... 12178	18357 ... 12184	17931 ... 12510	17924 ... 12515	17505 ... 12847	17498 ... 12853	17087 ... 13191	17080 ... 13196	4
27	18790 ... 11863	18783 ... 11868	18349 ... 12189	18342 ... 12195	17916 ... 12521	17909 ... 12526	17491 ... 12859	17484 ... 12864	17073 ... 13202	17066 ... 13208	3
28	18775 ... 11874	18768 ... 11879	18335 ... 12200	18327 ... 12205	17902 ... 12532	17895 ... 12538	17477 ... 12870	17470 ... 12876	17059 ... 13214	17052 ... 13220	2
29	18760 ... 11885	18753 ... 11890	18320 ... 12211	18313 ... 12216	17888 ... 12543	17881 ... 12549	17463 ... 12881	17456 ... 12887	17046 ... 13225	17039 ... 13231	1
30	18746 ... 11895		18306 ... 12222		17873 ... 12554		17449 ... 12893		17032 ... 13237		0
	A	B	A	B	A	B	A	B	A	B	
	139°30'		139°00'		138°30'		138°00'		137°30'		

ALWAYS TAKE "Z" FROM BOTTOM OF TABLE, EXCEPT WHEN "K" IS SAME NAME AND GREATER THAN LATITUDE, IN WHICH CASE TAKE "Z" FROM TOP OF TABLE

	42°30'		43°00'		43°30'		44°00'		44°30'		
	A	B	A	B	A	B	A	B	A	B	
0	17032	13237	16622	13587	16219	13944	15823	14307	15434	14676	30
	17025	13243	16615	13593	16212	13950	15816	14313	15427	14682	
1	17018	13248	16608	13599	16205	13956	15810	14319	15421	14688	29
	17011	13254	16601	13605	16199	13962	15803	14325	15414	14694	
2	17004	13260	16595	13611	16192	13968	15797	14331	15408	14701	28
	16997	13266	16588	13617	16186	13974	15790	14337	15402	14707	
3	16990	13272	16581	13623	16179	13980	15784	14343	15395	14713	27
	16983	13277	16574	13628	16172	13986	15777	14349	15389	14719	
4	16977	13283	16567	13634	16166	13992	15771	14355	15382	14726	26
	16970	13289	16561	13640	16159	13998	15764	14362	15376	14732	
5	16963	13295	16554	13646	16152	14004	15758	14368	15370	14738	25
	16956	13301	16547	13652	16146	14010	15751	14374	15363	14744	
6	16949	13306	16540	13658	16139	14016	15744	14380	15357	14750	24
	16942	13312	16534	13664	16132	14022	15738	14386	15350	14757	
7	16935	13318	16527	13670	16126	14028	15731	14392	15344	14763	23
	16928	13324	16520	13676	16119	14034	15725	14398	15338	14769	
8	16922	13330	16513	13682	16112	14040	15718	14404	15331	14775	22
	16915	13336	16507	13688	16106	14046	15712	14411	15325	14782	
9	16908	13341	16500	13694	16099	14052	15705	14417	15318	14788	21
	16901	13347	16493	13700	16093	14058	15699	14423	15312	14794	
10	16894	13353	16487	13705	16086	14064	15692	14429	15306	14800	20
	16887	13359	16480	13711	16079	14070	15686	14435	15299	14807	
11	16880	13365	16473	13717	16073	14076	15679	14441	15293	14813	19
	16874	13370	16466	13723	16066	14082	15673	14447	15286	14819	
12	16867	13376	16460	13729	16060	14088	15666	14453	15280	14825	18
	16860	13382	16453	13735	16053	14094	15660	14460	15274	14831	
13	16853	13388	16446	13741	16046	14100	15653	14466	15267	14838	17
	16846	13394	16439	13747	16040	14106	15647	14472	15261	14844	
14	16839	13400	16433	13753	16033	14112	15640	14478	15255	14850	16
	16833	13405	16426	13759	16027	14118	15634	14484	15248	14857	
15	16826	13411	16419	13765	16020	14124	15627	14490	15242	14863	15
	16819	13417	16413	13771	16013	14130	15621	14496	15235	14869	
16	16812	13423	16406	13777	16007	14136	15614	14503	15229	14875	14
	16805	13429	16399	13783	16000	14142	15608	14509	15223	14882	
17	16798	13435	16392	13789	15994	14149	15602	14515	15216	14888	13
	16792	13440	16386	13794	15987	14155	15595	14521	15210	14894	
18	16785	13446	16379	13800	15980	14161	15589	14527	15204	14900	12
	16778	13452	16372	13806	15974	14167	15582	14533	15197	14907	
19	16771	13458	16366	13812	15967	14173	15576	14540	15191	14913	11
	16764	13464	16359	13818	15961	14179	15569	14546	15184	14919	
20	16757	13470	16352	13824	15954	14185	15563	14552	15178	14925	10
	16751	13476	16346	13830	15947	14191	15556	14558	15172	14932	
21	16744	13481	16339	13836	15941	14197	15550	14564	15166	14938	9
	16737	13487	16332	13842	15934	14203	15543	14570	15159	14944	
22	16730	13493	16325	13848	15928	14209	15537	14577	15153	14951	8
	16723	13499	16319	13854	15921	14215	15530	14583	15146	14957	
23	16717	13505	16312	13860	15915	14221	15524	14589	15140	14963	7
	16710	13511	16305	13866	15908	14227	15517	14595	15134	14969	
24	16703	13517	16299	13872	15901	14233	15511	14601	15127	14976	6
	16696	13523	16292	13878	15895	14240	15505	14608	15121	14982	
25	16689	13528	16285	13884	15888	14246	15498	14614	15115	14988	5
	16683	13534	16279	13890	15882	14252	15492	14620	15108	14995	
26	16676	13540	16272	13896	15875	14258	15485	14626	15102	15001	4
	16669	13546	16265	13902	15869	14264	15479	14632	15096	15007	
27	16662	13552	16259	13908	15862	14270	15472	14639	15089	15014	3
	16656	13558	16252	13914	15856	14276	15466	14645	15083	15020	
28	16649	13564	16245	13920	15849	14282	15459	14651	15077	15026	2
	16642	13570	16239	13926	15842	14288	15453	14657	15070	15033	
29	16635	13575	16232	13932	15836	14294	15447	14663	15064	15039	1
	16628	13581	16225	13938	15829	14300	15440	14670	15058	15045	
30	16622	13587	16219	13944	15823	14307	15434	14676	15051	15051	0
	A	B	A	B	A	B	A	B	A	B	
	137°00'		136°30'		136°00'		135°30'		135°00'		

WHEN LHA (E OR W) IS GREATER THAN 90°, TAKE "K" FROM BOTTOM OF TABLE

	45°00'		45°30'		46°00'		46°30'		47°00'		
	A	B	A	B	A	B	A	B	A	B	
0	15051	15051	14676	15434	14307	15823	13944	16219	13587	16622	30
	15045	15058	14670	15440	14300	15829	13938	16225	13581	16628	
1	15039	15064	14663	15447	14294	15836	13932	16232	13575	16635	29
	15033	15070	14657	15453	14288	15842	13926	16239	13570	16642	
2	15026	15077	14651	15459	14282	15849	13920	16245	13564	16649	28
	15020	15083	14645	15466	14276	15856	13914	16252	13558	16656	
3	15014	15089	14639	15472	14270	15862	13908	16259	13552	16662	27
	15007	15096	14632	15479	14264	15869	13902	16265	13546	16669	
4	15001	15102	14626	15485	14258	15875	13896	16272	13540	16676	26
	14995	15108	14620	15492	14252	15882	13890	16279	13534	16683	
5	14988	15115	14614	15498	14246	15888	13884	16285	13528	16689	25
	14982	15121	14608	15505	14240	15895	13878	16292	13523	16696	
6	14976	15127	14601	15511	14233	15901	13872	16299	13517	16703	24
	14969	15134	14595	15517	14227	15908	13866	16305	13511	16710	
7	14963	15140	14589	15524	14221	15915	13860	16312	13505	16717	23
	14957	15146	14583	15530	14215	15921	13854	16319	13499	16723	
8	14951	15153	14577	15537	14209	15928	13848	16325	13493	16730	22
	14944	15159	14570	15543	14203	15934	13842	16332	13487	16737	
9	14938	15165	14564	15550	14197	15941	13836	16339	13481	16744	21
	14932	15172	14558	15556	14191	15947	13830	16346	13476	16751	
10	14925	15178	14552	15563	14185	15954	13824	16352	13470	16757	20
	14919	15184	14546	15569	14179	15961	13818	16359	13464	16764	
11	14913	15191	14540	15576	14173	15967	13812	16366	13458	16771	19
	14907	15197	14533	15582	14167	15974	13806	16372	13452	16778	
12	14900	15204	14527	15589	14161	15980	13800	16379	13446	16785	18
	14894	15210	14521	15595	14155	15987	13794	16386	13440	16792	
13	14888	15216	14515	15602	14149	15994	13788	16392	13435	16798	17
	14882	15223	14509	15608	14142	16000	13783	16399	13429	16805	
14	14875	15229	14503	15614	14136	16007	13777	16406	13423	16812	16
	14869	15235	14496	15621	14130	16013	13771	16413	13417	16819	
15	14863	15242	14490	15627	14124	16020	13765	16419	13411	16826	15
	14857	15248	14484	15634	14118	16027	13759	16426	13405	16833	
16	14850	15255	14478	15640	14112	16033	13753	16433	13400	16839	14
	14844	15261	14472	15647	14106	16040	13747	16439	13394	16846	
17	14838	15267	14466	15653	14100	16046	13741	16446	13388	16853	13
	14831	15274	14460	15660	14094	16053	13735	16453	13382	16860	
18	14825	15280	14453	15666	14088	16060	13729	16460	13376	16867	12
	14819	15286	14447	15673	14082	16066	13723	16466	13370	16874	
19	14813	15293	14441	15679	14076	16073	13717	16473	13365	16880	11
	14807	15299	14435	15686	14070	16079	13711	16480	13359	16887	
20	14800	15306	14429	15692	14064	16086	13705	16487	13353	16894	10
	14794	15312	14423	15699	14058	16093	13699	16493	13347	16901	
21	14788	15318	14417	15705	14052	16099	13694	16500	13341	16908	9
	14782	15325	14411	15712	14046	16105	13688	16507	13336	16915	
22	14775	15331	14404	15718	14040	16112	13682	16513	13330	16922	8
	14769	15338	14398	15725	14034	16119	13676	16520	13324	16928	
23	14763	15344	14392	15731	14028	16126	13670	16527	13318	16935	7
	14757	15350	14386	15738	14022	16132	13664	16534	13312	16942	
24	14750	15357	14380	15744	14016	16139	13658	16540	13306	16949	6
	14744	15363	14374	15751	14010	16146	13652	16547	13300	16956	
25	14738	15370	14368	15758	14004	16152	13646	16554	13295	16963	5
	14732	15376	14362	15764	13998	16159	13640	16561	13289	16970	
26	14725	15382	14355	15771	13992	16166	13634	16567	13283	16977	4
	14719	15389	14349	15777	13986	16172	13628	16574	13277	16983	
27	14713	15395	14343	15784	13980	16179	13623	16581	13272	16990	3
	14707	15402	14337	15790	13974	16185	13617	16588	13266	16997	
28	14701	15408	14331	15797	13968	16192	13611	16595	13260	17004	2
	14694	15414	14325	15803	13962	16199	13605	16601	13254	17011	
29	14688	15421	14319	15810	13956	16205	13599	16608	13248	17018	1
	14682	15427	14313	15816	13950	16212	13593	16615	13243	17025	
30	14676	15434	14307	15823	13944	16219	13587	16622	13237	17032	0
	A	B	A	B	A	B	A	B	A	B	
	134°30'		134°00'		133°30'		133°00'		132°30'		

ALWAYS TAKE "Z" FROM BOTTOM OF TABLE, EXCEPT WHEN "K" IS SAME NAME AND GREATER THAN LATITUDE, IN WHICH CASE TAKE "Z" FROM TOP OF TABLE

	47°30'		48°00'		48°30'		49°00'		49°30'		
	A	B	A	B	A	B	A	B	A	B	
0	13237	17032	12893	17449	12554	17873	12222	18306	11895	18746	30
	13231	17039	12887	17456	12549	17881	12216	18313	11890	18753	
1	13225	17045	12881	17463	12543	17888	12211	18320	11885	18760	29
	13220	17052	12876	17470	12538	17895	12205	18327	11879	18768	
2	13214	17059	12870	17477	12532	17902	12200	18335	11874	18775	28
	13208	17066	12864	17484	12526	17909	12195	18342	11868	18783	
3	13202	17073	12859	17491	12521	17916	12189	18349	11863	18790	27
	13196	17080	12853	17498	12515	17924	12184	18357	11858	18797	
4	13191	17087	12847	17505	12510	17931	12178	18364	11852	18805	26
	13185	17094	12841	17512	12504	17938	12173	18371	11847	18812	
5	13179	17101	12836	17519	12499	17945	12167	18378	11842	18820	25
	13173	17108	12830	17526	12493	17952	12162	18386	11836	18827	
6	13168	17114	12824	17533	12487	17959	12156	18393	11831	18834	24
	13162	17121	12819	17540	12482	17966	12151	18400	11825	18842	
7	13156	17128	12813	17547	12476	17974	12145	18408	11820	18849	23
	13150	17135	12807	17554	12471	17981	12140	18415	11815	18857	
8	13144	17142	12802	17561	12465	17988	12134	18422	11809	18864	22
	13139	17149	12796	17568	12460	17995	12129	18429	11804	18872	
9	13133	17156	12790	17576	12454	18002	12123	18437	11799	18879	21
	13127	17163	12785	17583	12448	18010	12118	18444	11793	18886	
10	13121	17170	12779	17590	12443	18017	12112	18451	11788	18894	20
	13116	17177	12774	17597	12437	18024	12107	18459	11782	18901	
11	13110	17184	12768	17604	12432	18031	12102	18466	11777	18909	19
	13104	17191	12762	17611	12426	18038	12096	18473	11772	18916	
12	13098	17198	12757	17618	12421	18045	12091	18481	11766	18924	18
	13093	17205	12751	17625	12415	18053	12085	18488	11761	18931	
13	13087	17212	12745	17632	12410	18060	12080	18495	11756	18939	17
	13081	17218	12740	17639	12404	18067	12074	18503	11750	18946	
14	13075	17225	12734	17646	12398	18074	12069	18510	11745	18953	16
	13070	17232	12728	17653	12393	18081	12063	18517	11740	18961	
15	13064	17239	12723	17660	12387	18089	12058	18525	11734	18968	15
	13058	17246	12717	17667	12382	18096	12053	18532	11729	18976	
16	13053	17253	12711	17674	12376	18103	12047	18539	11724	18983	14
	13047	17260	12706	17681	12371	18110	12042	18547	11718	18991	
17	13041	17267	12700	17689	12365	18117	12036	18554	11713	18998	13
	13035	17274	12695	17696	12360	18125	12031	18561	11708	19006	
18	13030	17281	12689	17703	12354	18132	12025	18569	11702	19013	12
	13024	17288	12683	17710	12349	18139	12020	18576	11697	19021	
19	13018	17295	12678	17717	12343	18146	12014	18583	11692	19028	11
	13012	17302	12672	17724	12338	18154	12009	18591	11686	19036	
20	13007	17309	12666	17731	12332	18161	12004	18598	11681	19043	10
	13001	17316	12661	17738	12327	18168	11998	18605	11676	19051	
21	12995	17323	12655	17745	12321	18175	11993	18613	11670	19058	9
	12990	17330	12650	17752	12316	18182	11987	18620	11665	19066	
22	12984	17337	12644	17760	12310	18190	11982	18627	11660	19073	8
	12978	17344	12638	17767	12305	18197	11976	18635	11654	19081	
23	12972	17351	12633	17774	12299	18204	11971	18642	11649	19088	7
	12967	17358	12627	17781	12293	18211	11966	18650	11644	19096	
24	12961	17365	12622	17788	12288	18219	11960	18657	11638	19103	6
	12955	17372	12616	17795	12282	18226	11955	18664	11633	19111	
25	12950	17379	12610	17802	12277	18233	11949	18672	11628	19118	5
	12944	17386	12605	17809	12271	18240	11944	18679	11622	19126	
26	12938	17393	12599	17816	12266	18248	11939	18686	11617	19133	4
	12932	17400	12593	17824	12260	18255	11933	18694	11612	19141	
27	12927	17407	12588	17831	12255	18262	11928	18701	11606	19148	3
	12921	17414	12582	17838	12249	18269	11922	18709	11601	19156	
28	12915	17421	12577	17845	12244	18277	11917	18716	11596	19163	2
	12910	17428	12571	17852	12238	18284	11912	18723	11590	19171	
29	12904	17435	12566	17859	12233	18291	11906	18731	11585	19178	1
	12898	17442	12560	17866	12227	18298	11901	18738	11580	19186	
30	12893	17449	12554	17873	12222	18306	11895	18746	11575	19193	0
	A	B	A	B	A	B	A	B	A	B	
	132°00'		131°30'		131°00'		130°30'		130°00'		

WHEN LHA (E OR W) IS GREATER THAN 90°, TAKE "K" FROM BOTTOM OF TABLE

	50°00'		50°30'		51°00'		51°30'		52°00'		
	A	B	A	B	A	B	A	B	A	B	
0	11575 ... 19193	11569 ... 19201	11259 ... 19649	11254 ... 19657	10950 ... 20113	10945 ... 20121	10646 ... 20585	10640 ... 20593	10347 ... 21066	10342 ... 21074	30
1	11564 ... 19208	11559 ... 19216	11249 ... 19664	11244 ... 19672	10939 ... 20128	10934 ... 20136	10635 ... 20601	10630 ... 20609	10337 ... 21082	10332 ... 21090	29
2	11553 ... 19223	11548 ... 19231	11239 ... 19680	11233 ... 19687	10929 ... 20144	10924 ... 20152	10625 ... 20617	10620 ... 20625	10327 ... 21098	10322 ... 21106	28
3	11543 ... 19238	11537 ... 19246	11228 ... 19695	11223 ... 19703	10919 ... 20160	10914 ... 20167	10615 ... 20633	10610 ... 20641	10317 ... 21114	10312 ... 21122	27
4	11532 ... 19253	11527 ... 19261	11218 ... 19710	11213 ... 19718	10909 ... 20175	10904 ... 20183	10605 ... 20649	10600 ... 20657	10307 ... 21131	10302 ... 21139	26
5	11522 ... 19269	11516 ... 19276	11207 ... 19726	11202 ... 19733	10899 ... 20191	10894 ... 20199	10595 ... 20665	10590 ... 20672	10298 ... 21147	10293 ... 21155	25
6	11511 ... 19284	11506 ... 19291	11197 ... 19741	11192 ... 19749	10888 ... 20207	10883 ... 20214	10585 ... 20680	10580 ... 20688	10288 ... 21163	10283 ... 21171	24
7	11501 ... 19299	11495 ... 19306	11187 ... 19756	11181 ... 19764	10878 ... 20222	10873 ... 20230	10575 ... 20696	10570 ... 20704	10278 ... 21179	10273 ... 21187	23
8	11490 ... 19314	11485 ... 19321	11176 ... 19772	11171 ... 19779	10868 ... 20238	10863 ... 20246	10565 ... 20712	10560 ... 20720	10268 ... 21195	10263 ... 21204	22
9	11479 ... 19329	11474 ... 19337	11166 ... 19787	11161 ... 19795	10858 ... 20254	10853 ... 20261	10555 ... 20728	10550 ... 20736	10258 ... 21212	10253 ... 21220	21
10	11469 ... 19344	11464 ... 19352	11156 ... 19803	11150 ... 19810	10848 ... 20269	10843 ... 20277	10545 ... 20744	10540 ... 20752	10248 ... 21228	10243 ... 21236	20
11	11458 ... 19359	11453 ... 19367	11145 ... 19818	11140 ... 19826	10838 ... 20285	10832 ... 20293	10535 ... 20760	10530 ... 20768	10239 ... 21244	10234 ... 21252	19
12	11448 ... 19375	11443 ... 19382	11135 ... 19834	11130 ... 19841	10827 ... 20301	10822 ... 20308	10525 ... 20776	10520 ... 20784	10229 ... 21260	10224 ... 21269	18
13	11437 ... 19390	11432 ... 19397	11124 ... 19849	11119 ... 19857	10817 ... 20316	10812 ... 20324	10515 ... 20792	10510 ... 20800	10219 ... 21277	10214 ... 21285	17
14	11427 ... 19405	11421 ... 19412	11114 ... 19864	11109 ... 19872	10807 ... 20332	10802 ... 20340	10505 ... 20808	10500 ... 20816	10209 ... 21293	10204 ... 21301	16
15	11416 ... 19420	11411 ... 19428	11104 ... 19880	11099 ... 19888	10797 ... 20348	10792 ... 20356	10496 ... 20824	10491 ... 20832	10199 ... 21309	10195 ... 21318	15
16	11406 ... 19435	11400 ... 19443	11094 ... 19895	11088 ... 19903	10787 ... 20364	10782 ... 20371	10486 ... 20840	10481 ... 20848	10190 ... 21326	10185 ... 21334	14
17	11395 ... 19450	11390 ... 19458	11083 ... 19911	11078 ... 19918	10777 ... 20379	10772 ... 20387	10476 ... 20856	10471 ... 20864	10180 ... 21342	10175 ... 21350	13
18	11385 ... 19466	11380 ... 19473	11073 ... 19926	11068 ... 19934	10767 ... 20395	10761 ... 20403	10466 ... 20872	10461 ... 20880	10170 ... 21358	10165 ... 21367	12
19	11374 ... 19481	11369 ... 19488	11063 ... 19942	11057 ... 19949	10756 ... 20411	10751 ... 20419	10456 ... 20888	10451 ... 20897	10160 ... 21375	10155 ... 21383	11
20	11364 ... 19496	11359 ... 19504	11052 ... 19957	11047 ... 19965	10746 ... 20427	10741 ... 20435	10446 ... 20905	10441 ... 20913	10151 ... 21391	10146 ... 21399	10
21	11353 ... 19511	11348 ... 19519	11042 ... 19973	11037 ... 19980	10736 ... 20442	10731 ... 20450	10436 ... 20921	10431 ... 20929	10141 ... 21407	10136 ... 21416	9
22	11343 ... 19527	11338 ... 19534	11032 ... 19988	11027 ... 19996	10726 ... 20458	10721 ... 20466	10426 ... 20937	10421 ... 20945	10131 ... 21424	10126 ... 21432	8
23	11332 ... 19542	11327 ... 19549	11021 ... 20004	11016 ... 20012	10716 ... 20474	10711 ... 20482	10416 ... 20953	10411 ... 20961	10121 ... 21440	10116 ... 21448	7
24	11322 ... 19557	11317 ... 19565	11011 ... 20019	11006 ... 20027	10706 ... 20490	10701 ... 20498	10406 ... 20969	10401 ... 20977	10112 ... 21457	10107 ... 21465	6
25	11311 ... 19572	11306 ... 19580	11001 ... 20035	10996 ... 20043	10696 ... 20506	10691 ... 20514	10396 ... 20985	10391 ... 20993	10102 ... 21473	10097 ... 21481	5
26	11301 ... 19588	11296 ... 19595	10991 ... 20050	10986 ... 20058	10686 ... 20522	10681 ... 20529	10386 ... 21001	10381 ... 21009	10092 ... 21489	10087 ... 21498	4
27	11291 ... 19603	11285 ... 19611	10980 ... 20066	10975 ... 20074	10676 ... 20537	10671 ... 20545	10376 ... 21017	10372 ... 21025	10082 ... 21506	10078 ... 21514	3
28	11280 ... 19618	11275 ... 19626	10970 ... 20082	10965 ... 20089	10666 ... 20553	10661 ... 20561	10367 ... 21033	10362 ... 21042	10073 ... 21522	10068 ... 21531	2
29	11270 ... 19634	11265 ... 19641	10960 ... 20097	10955 ... 20105	10656 ... 20569	10651 ... 20577	10357 ... 21050	10352 ... 21058	10063 ... 21539	10058 ... 21547	1
30	11259 ... 19649		10950 ... 20113		10646 ... 20585		10347 ... 21066		10053 ... 21555		0
	A	B	A	B	A	B	A	B	A	B	
	129°30'		129°00'		128°30'		128°00'		127°30'		

ALWAYS TAKE "Z" FROM BOTTOM OF TABLE, EXCEPT WHEN "K" IS SAME NAME AND GREATER THAN LATITUDE, IN WHICH CASE TAKE "Z" FROM TOP OF TABLE

	52°30'		53°00'		53°30'		54°00'		54°30'		
	A	B	A	B	A	B	A	B	A	B	
0	10053 ... 21555	10049 ... 21563	9765 ... 22054	9760 ... 22062	9482 ... 22561	9477 ... 22570	9204 ... 23078	9200 ... 23087	8931 ... 23605	8927 ... 23613	30
1	10044 ... 21572	10039 ... 21580	9756 ... 22070	9751 ... 22079	9473 ... 22578	9468 ... 22587	9195 ... 23095	9190 ... 23104	8922 ... 23622	8918 ... 23631	29
2	10034 ... 21588	10029 ... 21596	9746 ... 22087	9741 ... 22096	9463 ... 22595	9459 ... 22604	9186 ... 23113	9181 ... 23122	8913 ... 23640	8909 ... 23649	28
3	10024 ... 21605	10019 ... 21613	9737 ... 22104	9732 ... 22112	9454 ... 22612	9449 ... 22621	9177 ... 23130	9172 ... 23139	8904 ... 23658	8900 ... 23667	27
4	10015 ... 21621	10010 ... 21629	9727 ... 22121	9722 ... 22129	9445 ... 22630	9440 ... 22638	9168 ... 23148	9163 ... 23156	8895 ... 23675	8891 ... 23684	26
5	10005 ... 21638	9981 ... 21646	9718 ... 22138	9713 ... 22146	9435 ... 22647	9431 ... 22655	9158 ... 23165	9154 ... 23174	8886 ... 23693	8882 ... 23702	25
6	9995 ... 21654	9990 ... 21662	9708 ... 22154	9703 ... 22163	9426 ... 22664	9421 ... 22672	9149 ... 23183	9145 ... 23191	8877 ... 23711	8873 ... 23720	24
7	9986 ... 21671	9981 ... 21679	9699 ... 22171	9694 ... 22180	9417 ... 22681	9412 ... 22690	9140 ... 23200	9136 ... 23209	8868 ... 23729	8864 ... 23738	23
8	9976 ... 21687	9971 ... 21696	9689 ... 22188	9684 ... 22197	9407 ... 22698	9403 ... 22707	9131 ... 23218	9126 ... 23226	8859 ... 23747	8855 ... 23755	22
9	9966 ... 21704	9962 ... 21712	9680 ... 22205	9675 ... 22213	9398 ... 22715	9394 ... 22724	9122 ... 23235	9117 ... 23244	8850 ... 23764	8846 ... 23773	21
10	9957 ... 21720	9952 ... 21729	9670 ... 22222	9665 ... 22230	9389 ... 22732	9384 ... 22741	9113 ... 23252	9108 ... 23261	8842 ... 23782	8837 ... 23791	20
11	9947 ... 21737	9942 ... 21745	9661 ... 22239	9656 ... 22247	9380 ... 22750	9375 ... 22758	9104 ... 23270	9099 ... 23279	8833 ... 23800	8828 ... 23809	19
12	9937 ... 21754	9933 ... 21762	9651 ... 22256	9647 ... 22264	9370 ... 22767	9366 ... 22775	9094 ... 23288	9090 ... 23296	8824 ... 23818	8819 ... 23827	18
13	9928 ... 21770	9923 ... 21778	9642 ... 22272	9637 ... 22281	9361 ... 22784	9356 ... 22793	9085 ... 23305	9081 ... 23314	8815 ... 23836	8810 ... 23845	17
14	9918 ... 21787	9913 ... 21795	9632 ... 22289	9628 ... 22298	9352 ... 22801	9347 ... 22810	9076 ... 23323	9072 ... 23331	8806 ... 23854	8801 ... 23863	16
15	9909 ... 21803	9904 ... 21812	9623 ... 22306	9618 ... 22315	9342 ... 22818	9338 ... 22827	9067 ... 23340	9063 ... 23349	8797 ... 23871	8792 ... 23880	15
16	9899 ... 21820	9894 ... 21828	9614 ... 22323	9609 ... 22332	9333 ... 22836	9329 ... 22844	9058 ... 23358	9054 ... 23366	8788 ... 23889	8783 ... 23898	14
17	9889 ... 21837	9885 ... 21845	9604 ... 22340	9599 ... 22349	9324 ... 22853	9319 ... 22862	9049 ... 23375	9044 ... 23384	8779 ... 23907	8775 ... 23916	13
18	9880 ... 21853	9875 ... 21862	9595 ... 22357	9590 ... 22366	9315 ... 22870	9310 ... 22879	9040 ... 23393	9035 ... 23402	8770 ... 23925	8766 ... 23934	12
19	9870 ... 21870	9865 ... 21878	9585 ... 22374	9581 ... 22382	9305 ... 22887	9301 ... 22896	9031 ... 23410	9026 ... 23419	8761 ... 23943	8757 ... 23952	11
20	9861 ... 21887	9856 ... 21895	9576 ... 22391	9571 ... 22399	9296 ... 22905	9292 ... 22913	9022 ... 23428	9017 ... 23437	8752 ... 23961	8748 ... 23970	10
21	9851 ... 21903	9846 ... 21912	9566 ... 22408	9562 ... 22416	9287 ... 22922	9282 ... 22931	9013 ... 23446	9008 ... 23454	8743 ... 23979	8739 ... 23988	9
22	9841 ... 21920	9837 ... 21928	9557 ... 22425	9552 ... 22433	9278 ... 22939	9273 ... 22948	9004 ... 23463	8999 ... 23472	8734 ... 23997	8730 ... 24006	8
23	9832 ... 21937	9827 ... 21945	9548 ... 22442	9543 ... 22450	9269 ... 22957	9264 ... 22965	8995 ... 23481	8990 ... 23490	8726 ... 24015	8721 ... 24024	7
24	9822 ... 21953	9818 ... 21962	9538 ... 22459	9534 ... 22467	9259 ... 22974	9255 ... 22983	8985 ... 23498	8981 ... 23507	8717 ... 24033	8712 ... 24042	6
25	9813 ... 21970	9808 ... 21978	9529 ... 22476	9524 ... 22484	9250 ... 22991	9246 ... 23000	8976 ... 23516	8972 ... 23525	8708 ... 24051	8703 ... 24060	5
26	9803 ... 21987	9798 ... 21995	9520 ... 22493	9515 ... 22501	9241 ... 23009	9236 ... 23017	8967 ... 23534	8963 ... 23543	8699 ... 24069	8694 ... 24078	4
27	9794 ... 22003	9789 ... 22012	9510 ... 22510	9505 ... 22519	9232 ... 23026	9227 ... 23035	8958 ... 23551	8954 ... 23560	8690 ... 24037	8686 ... 24096	3
28	9784 ... 22020	9779 ... 22029	9501 ... 22527	9496 ... 22536	9223 ... 23043	9218 ... 23052	8949 ... 23569	8945 ... 23578	8681 ... 24105	8677 ... 24114	2
29	9775 ... 22037	9770 ... 22045	9491 ... 22544	9487 ... 22553	9213 ... 23061	9209 ... 23069	8940 ... 23587	8936 ... 23596	8672 ... 24123	8668 ... 24132	1
30	9765 ... 22054		9482 ... 22561		9204 ... 23078		8931 ... 23605		8663 ... 24141		0
	A	B	A	B	A	B	A	B	A	B	
	127°00'		126°30'		126°00'		125°30'		125°00'		

WHEN LHA (E OR W) IS GREATER THAN 90°, TAKE "K" FROM BOTTOM OF TABLE

	55°00'		55°30'		56°00'		56°30'		57°00'		
	A	B	A	B	A	B	A	B	A	B	
0	8663	24141	8401	24687	8143	25244	7889	25811	7641	26389	30
	8659	24150	8396	24696	8138	25253	7885	25821	7637	26399	
1	8655	24159	8392	24706	8134	25263	7881	25830	7633	26409	29
	8650	24168	8388	24715	8130	25272	7877	25840	7629	26418	
2	8646	24177	8383	24724	8125	25281	7873	25849	7624	26428	27
	8641	24186	8379	24733	8121	25291	7868	25859	7620	26438	
3	8637	24195	8375	24742	8117	25300	7864	25868	7616	26447	27
	8633	24204	8370	24752	8113	25309	7860	25878	7612	26457	
4	8628	24213	8366	24761	8108	25319	7856	25887	7608	26467	26
	8624	24222	8362	24770	8104	25328	7852	25897	7604	26477	
5	8619	24231	8357	24779	8100	25338	7848	25907	7600	26486	25
	8615	24240	8353	24788	8096	25347	7843	25916	7596	26496	
6	8611	24249	8349	24798	8092	25356	7839	25926	7592	26506	24
	8606	24258	8344	24807	8087	25366	7835	25935	7588	26516	
7	8602	24267	8340	24816	8083	25375	7831	25945	7584	26526	23
	8597	24276	8336	24825	8079	25385	7827	25954	7579	26535	
8	8593	24286	8331	24835	8075	25394	7823	25964	7575	26545	22
	8589	24295	8327	24844	8070	25403	7818	25974	7571	26555	
9	8584	24304	8323	24853	8066	25413	7814	25983	7567	26565	21
	8580	24313	8318	24862	8062	25422	7810	25993	7563	26574	
10	8575	24322	8314	24872	8058	25432	7806	26002	7559	26584	20
	8571	24331	8310	24881	8053	25441	7802	26012	7555	26594	
11	8567	24340	8305	24890	8049	25451	7798	26022	7551	26604	19
	8562	24349	8301	24899	8045	25460	7793	26031	7547	26614	
12	8558	24358	8297	24909	8041	25469	7789	26041	7543	26623	18
	8553	24367	8292	24918	8036	25479	7785	26051	7539	26633	
13	8549	24376	8288	24927	8032	25488	7781	26060	7535	26643	17
	8545	24385	8284	24936	8028	25498	7777	26070	7531	26653	
14	8540	24395	8280	24946	8024	25507	7773	26079	7526	26663	16
	8536	24404	8275	24955	8020	25517	7769	26089	7522	26672	
15	8531	24413	8271	24964	8015	25526	7764	26099	7518	26682	15
	8527	24422	8267	24973	8011	25536	7760	26108	7514	26692	
16	8523	24431	8262	24983	8007	25545	7756	26118	7510	26702	14
	8518	24440	8258	24992	8003	25554	7752	26128	7506	26712	
17	8514	24449	8254	25001	7998	25564	7748	26137	7502	26722	13
	8510	24458	8249	25011	7994	25573	7744	26147	7498	26731	
18	8505	24467	8245	25020	7990	25583	7740	26157	7494	26741	12
	8501	24477	8241	25029	7986	25592	7736	26166	7490	26751	
19	8496	24486	8237	25038	7982	25602	7731	26176	7486	26761	11
	8492	24495	8232	25048	7977	25611	7727	26185	7482	26771	
20	8488	24504	8228	25057	7973	25621	7723	26195	7478	26781	10
	8483	24513	8224	25066	7969	25630	7719	26205	7474	26790	
21	8479	24522	8219	25076	7965	25640	7715	26214	7470	26800	9
	8475	24531	8215	25085	7961	25649	7711	26224	7466	26810	
22	8470	24540	8211	25094	7956	25659	7707	26234	7462	26820	8
	8466	24550	8207	25104	7952	25668	7702	26244	7458	26830	
23	8461	24559	8202	25113	7948	25678	7698	26253	7453	26840	7
	8457	24568	8198	25122	7944	25687	7694	26263	7449	26850	
24	8453	24577	8194	25132	7940	25697	7690	26273	7445	26860	6
	8448	24586	8189	25141	7935	25706	7686	26282	7441	26869	
25	8444	24595	8185	25150	7931	25716	7682	26292	7437	26879	5
	8440	24605	8181	25160	7927	25725	7678	26302	7433	26889	
26	8435	24614	8177	25169	7923	25735	7674	26311	7429	26899	4
	8431	24623	8172	25178	7919	25744	7670	26321	7425	26909	
27	8427	24632	8168	25188	7914	25754	7665	26331	7421	26919	3
	8422	24641	8164	25197	7910	25763	7661	26340	7417	26929	
28	8418	24650	8160	25206	7906	25773	7657	26350	7413	26939	2
	8414	24660	8155	25216	7902	25782	7653	26360	7409	26949	
29	8409	24669	8151	25225	7898	25792	7649	26370	7405	26958	1
	8405	24678	8147	25234	7893	25801	7645	26379	7401	26968	
30	8401	24687	8143	25244	7889	25811	7641	26389	7397	26978	0
	A	B	A	B	A	B	A	B	A	B	
	124°30'		124°00'		123°30'		123°00'		122°30'		

ALWAYS TAKE "Z" FROM BOTTOM OF TABLE, EXCEPT WHEN "K" IS SAME NAME AND GREATER THAN LATITUDE, IN WHICH CASE TAKE "Z" FROM TOP OF TABLE

	57°30'		58°00'		58°30'		59°00'		59°30'		
	A	B	A	B	A	B	A	B	A	B	
0	7397	26978	7158	27579	6923	28191	6693	28816	6468	29453	30
	7393	26988	7154	27589	6920	28202	6690	28827	6464	29464	
1	7389	26998	7150	27599	6916	28212	6686	28837	6460	29475	29
	7385	27008	7146	27609	6912	28222	6682	28848	6457	29485	
2	7381	27018	7142	27619	6908	28233	6678	28858	6453	29496	28
	7377	27028	7138	27630	6904	28243	6674	28869	6449	29507	
3	7373	27038	7134	27640	6900	28253	6671	28879	6446	29517	27
	7369	27048	7130	27650	6896	28264	6667	28890	6442	29528	
4	7365	27058	7126	27660	6892	28274	6663	28900	6438	29539	26
	7361	27068	7122	27670	6889	28284	6659	28911	6434	29550	
5	7357	27078	7118	27680	6885	28295	6655	28921	6431	29560	25
	7353	27088	7115	27690	6881	28305	6652	28932	6427	29571	
6	7349	27098	7111	27701	6877	28315	6648	28942	6423	29582	24
	7345	27107	7107	27711	6873	28326	6644	28953	6420	29593	
7	7341	27117	7103	27721	6869	28336	6640	28964	6416	29604	23
	7337	27127	7099	27731	6865	28346	6637	28974	6412	29614	
8	7333	27137	7095	27741	6862	28357	6633	28985	6409	29625	22
	7329	27147	7091	27751	6858	28367	6629	28995	6405	29636	
9	7325	27157	7087	27761	6854	28378	6625	29006	6401	29647	21
	7321	27167	7083	27772	6850	28388	6622	29016	6397	29657	
10	7317	27177	7079	27782	6846	28398	6618	29027	6394	29668	20
	7313	27187	7075	27792	6842	28409	6614	29038	6390	29679	
11	7309	27197	7071	27802	6839	28419	6610	29048	6386	29690	19
	7305	27207	7068	27812	6835	28429	6607	29059	6383	29701	
12	7301	27217	7064	27823	6831	28440	6603	29069	6379	29711	18
	7297	27227	7060	27833	6827	28450	6599	29080	6375	29722	
13	7293	27237	7056	27843	6823	28461	6595	29091	6372	29733	17
	7289	27247	7052	27853	6819	28471	6591	29101	6368	29744	
14	7285	27257	7048	27863	6815	28481	6588	29112	6364	29755	16
	7281	27267	7044	27874	6812	28492	6584	29122	6361	29766	
15	7277	27277	7040	27884	6808	28502	6580	29133	6357	29776	15
	7273	27287	7036	27894	6804	28513	6576	29144	6353	29787	
16	7269	27297	7032	27904	6800	28523	6573	29154	6349	29798	14
	7265	27307	7028	27914	6796	28533	6569	29165	6346	29809	
17	7261	27317	7024	27925	6792	28544	6565	29175	6342	29820	13
	7257	27327	7021	27935	6789	28554	6561	29186	6338	29831	
18	7253	27337	7017	27945	6785	28565	6558	29197	6335	29841	12
	7249	27347	7013	27955	6781	28575	6554	29207	6331	29852	
19	7245	27357	7009	27965	6777	28586	6550	29218	6327	29863	11
	7241	27367	7005	27976	6773	28596	6546	29229	6324	29874	
20	7237	27377	7001	27986	6770	28607	6543	29239	6320	29885	10
	7233	27387	6997	27996	6766	28617	6539	29250	6316	29896	
21	7229	27398	6993	28006	6762	28627	6535	29261	6313	29907	9
	7225	27408	6989	28017	6758	28638	6531	29271	6309	29917	
22	7221	27418	6985	28027	6754	28648	6528	29282	6305	29929	8
	7217	27428	6982	28037	6750	28659	6524	29293	6302	29939	
23	7213	27438	6978	28047	6747	28669	6520	29303	6298	29950	7
	7209	27448	6974	28058	6743	28680	6516	29314	6294	29961	
24	7205	27458	6970	28068	6739	28690	6513	29325	6291	29972	6
	7201	27468	6966	28078	6735	28701	6509	29335	6287	29983	
25	7197	27478	6962	28089	6731	28711	6505	29346	6283	29994	5
	7193	27488	6958	28099	6728	28722	6502	29357	6280	30005	
26	7190	27498	6954	28109	6724	28732	6498	29367	6276	30015	4
	7186	27508	6951	28119	6720	28743	6494	29378	6272	30026	
27	7182	27518	6947	28130	6716	28753	6490	29389	6269	30037	3
	7178	27528	6943	28140	6712	28763	6487	29399	6265	30048	
28	7174	27539	6939	28150	6709	28774	6483	29410	6261	30059	2
	7170	27549	6935	28161	6705	28784	6479	29421	6258	30070	
29	7166	27559	6931	28171	6701	28795	6475	29432	6254	30081	1
	7162	27569	6927	28181	6697	28806	6472	29442	6251	30092	
30	7158	27579	6923	28191	6693	28816	6468	29453	6247	30103	0
	A	B	A	B	A	B	A	B	A	B	
	122°00'		121°30'		121°00'		120°30'		120°00'		

WHEN LHA (E OR W) IS GREATER THAN 90°, TAKE "K" FROM BOTTOM OF TABLE

	60°00'		60°30'		61°00'		61°30'		62°00'		
	A	B	A	B	A	B	A	B	A	B	
0	6247	30103	6030	30766	5818	31443	5610	32134	5406	32839	30
	6243	30114	6027	30777	5815	31454	5607	32145	5403	32851	
1	6240	30125	6023	30788	5811	31466	5603	32157	5400	32863	29
	6236	30136	6020	30800	5808	31477	5600	32169	5396	32875	
2	6232	30147	6016	30811	5804	31488	5596	32180	5393	32887	28
	6229	30158	6012	30822	5801	31500	5593	32192	5390	32898	
3	6225	30169	6009	30833	5797	31511	5590	32204	5386	32910	27
	6221	30180	6005	30844	5794	31523	5586	32215	5383	32922	
4	6218	30191	6002	30856	5790	31534	5583	32227	5380	32934	26
	6214	30202	5998	30867	5787	31546	5579	32239	5376	32946	
5	6210	30213	5995	30878	5783	31557	5575	32250	5373	32958	25
	6207	30224	5991	30889	5780	31569	5572	32262	5370	32970	
6	6203	30235	5987	30900	5776	31580	5569	32274	5366	32982	24
	6200	30245	5984	30912	5773	31591	5566	32285	5363	32994	
7	6196	30256	5980	30923	5769	31603	5562	32297	5360	33006	23
	6192	30267	5977	30934	5766	31614	5559	32309	5356	33018	
8	6189	30278	5973	30945	5762	31626	5555	32320	5353	33030	22
	6185	30289	5970	30956	5759	31637	5552	32332	5350	33042	
9	6181	30300	5966	30968	5755	31649	5549	32344	5346	33054	21
	6178	30311	5963	30979	5752	31660	5545	32355	5343	33066	
10	6174	30322	5959	30990	5748	31672	5542	32367	5340	33077	20
	6171	30334	5955	31001	5745	31683	5538	32379	5336	33089	
11	6167	30345	5952	31013	5741	31694	5535	32391	5333	33101	19
	6163	30355	5948	31024	5738	31706	5532	32402	5330	33113	
12	6160	30367	5945	31035	5734	31717	5528	32414	5326	33125	18
	6156	30378	5941	31046	5731	31729	5525	32426	5323	33137	
13	6152	30389	5938	31058	5727	31740	5521	32438	5320	33149	17
	6149	30400	5934	31069	5724	31752	5518	32449	5316	33161	
14	6145	30411	5931	31080	5720	31763	5515	32461	5313	33173	16
	6142	30422	5927	31091	5717	31775	5511	32473	5310	33185	
15	6138	30433	5924	31103	5714	31786	5508	32484	5306	33197	15
	6134	30444	5920	31114	5710	31798	5504	32496	5303	33209	
16	6131	30455	5917	31125	5707	31809	5501	32508	5300	33221	14
	6127	30466	5913	31137	5703	31821	5498	32520	5296	33233	
17	6124	30477	5909	31148	5700	31833	5494	32532	5293	33245	13
	6120	30488	5906	31159	5696	31844	5491	32543	5290	33257	
18	6116	30499	5902	31170	5693	31856	5487	32555	5286	33269	12
	6113	30510	5899	31182	5689	31867	5484	32567	5283	33281	
19	6109	30521	5895	31193	5686	31879	5481	32579	5280	33293	11
	6106	30532	5892	31204	5682	31890	5477	32590	5276	33306	
20	6102	30544	5888	31216	5679	31902	5474	32602	5273	33318	10
	6098	30555	5885	31227	5675	31913	5470	32614	5270	33330	
21	6095	30566	5881	31238	5672	31925	5467	32625	5266	33342	9
	6091	30577	5878	31250	5669	31936	5464	32638	5263	33354	
22	6088	30588	5874	31261	5665	31948	5460	32649	5260	33366	8
	6084	30599	5871	31272	5662	31960	5457	32661	5257	33378	
23	6080	30610	5867	31284	5658	31971	5454	32673	5253	33390	7
	6077	30621	5864	31295	5655	31983	5450	32685	5250	33402	
24	6073	30632	5860	31306	5651	31994	5447	32697	5247	33414	6
	6070	30643	5857	31318	5648	32006	5443	32709	5243	33426	
25	6066	30655	5853	31329	5644	32018	5440	32720	5240	33438	5
	6062	30666	5850	31340	5641	32029	5437	32732	5237	33450	
26	6059	30677	5846	31352	5638	32041	5433	32744	5233	33462	4
	6055	30688	5843	31363	5634	32052	5430	32756	5230	33475	
27	6052	30699	5839	31375	5631	32064	5427	32768	5227	33487	3
	6048	30710	5836	31386	5627	32076	5423	32780	5224	33499	
28	6045	30721	5832	31397	5624	32087	5420	32792	5220	33511	2
	6041	30733	5829	31409	5620	32099	5417	32803	5217	33523	
29	6037	30744	5825	31420	5617	32110	5413	32815	5214	33535	1
	6034	30755	5822	31431	5614	32122	5410	32827	5210	33547	
30	6030	30766	5818	31443	5610	32134	5406	32839	5207	33559	0
	A	B	A	B	A	B	A	B	A	B	
	119°30'		119°00'		118°30'		118°00'		117°30'		

ALWAYS TAKE "Z" FROM BOTTOM OF TABLE, EXCEPT WHEN "K" IS SAME NAME AND GREATER THAN LATITUDE, IN WHICH CASE TAKE "Z" FROM TOP OF TABLE

	62°30'		63°00'		63°30'		64°00'		64°30'		
	A	B	A	B	A	B	A	B	A	B	
0	5207	33559	5012	34295	4821	35047	4634	35816	4451	36602	30
1	5204	33572	5009	34308	4818	35060	4631	35829	4448	36615	29
	5200	33584	5005	34320	4815	35073	4628	35842	4445	36628	
2	5197	33596	5002	34332	4811	35085	4625	35855	4442	36641	28
	5194	33608	4999	34345	4808	35098	4622	35868	4439	36655	
3	5191	33620	4996	34357	4805	35111	4619	35881	4436	36668	27
	5187	33632	4993	34370	4802	35123	4615	35894	4433	36681	
4	5184	33644	4989	34382	4799	35136	4612	35907	4430	36694	26
	5181	33657	4986	34395	4796	35149	4609	35920	4427	36708	
5	5178	33669	4983	34407	4793	35161	4606	35933	4424	36721	25
	5174	33681	4980	34420	4789	35174	4603	35946	4421	36734	
6	5171	33693	4977	34432	4786	35187	4600	35959	4418	36747	24
	5168	33705	4973	34444	4783	35200	4597	35972	4415	36761	
7	5164	33717	4970	34457	4780	35212	4594	35985	4412	36774	23
	5161	33730	4967	34469	4777	35225	4591	35998	4409	36787	
8	5158	33742	4964	34482	4774	35238	4588	36011	4406	36801	22
	5155	33754	4961	34494	4771	35251	4585	36024	4403	36814	
9	5152	33766	4957	34507	4767	35263	4582	36037	4400	36827	21
	5148	33779	4954	34519	4764	35276	4579	36050	4397	36841	
10	5145	33791	4951	34532	4761	35289	4576	36063	4394	36854	20
	5142	33803	4948	34544	4758	35302	4573	36076	4391	36867	
11	5138	33815	4945	34557	4755	35314	4569	36089	4388	36881	19
	5135	33827	4941	34569	4752	35327	4566	36102	4385	36894	
12	5132	33840	4938	34582	4749	35340	4563	36115	4382	36907	18
	5128	33852	4935	34594	4746	35353	4560	36128	4379	36921	
13	5125	33864	4932	34607	4742	35365	4557	36141	4376	36934	17
	5122	33876	4929	34619	4739	35378	4554	36154	4373	36948	
14	5119	33889	4925	34632	4736	35391	4551	36167	4370	36961	16
	5115	33901	4922	34644	4733	35404	4548	36180	4367	36974	
15	5112	33913	4919	34657	4730	35417	4545	36193	4364	36988	15
	5109	33925	4916	34669	4727	35429	4542	36206	4361	37001	
16	5106	33938	4913	34682	4724	35442	4529	36220	4358	37014	14
	5102	33950	4910	34694	4721	35455	4536	36233	4355	37028	
17	5099	33962	4906	34707	4718	35468	4533	36246	4352	37041	13
	5096	33974	4903	34719	4714	35481	4530	36259	4349	37055	
18	5093	33987	4900	34732	4711	35493	4527	36272	4346	37068	12
	5089	33999	4897	34744	4708	35506	4524	36285	4343	37081	
19	5086	34011	4894	34757	4705	35519	4521	36298	4340	37095	11
	5083	34024	4890	34770	4702	35532	4518	36311	4337	37108	
20	5080	34036	4887	34782	4699	35545	4515	36325	4334	37122	10
	5076	34048	4884	34795	4696	35558	4512	36338	4332	37135	
21	5073	34061	4881	34807	4693	35571	4509	36351	4329	37149	9
	5070	34073	4878	34820	4690	35583	4506	36364	4326	37162	
22	5067	34085	4875	34832	4686	35596	4503	36377	4323	37176	8
	5064	34097	4871	34845	4683	35609	4500	36390	4320	37189	
23	5060	34110	4868	34858	4680	35622	4497	36403	4317	37203	7
	5057	34122	4865	34870	4677	35635	4493	36417	4314	37216	
24	5054	34134	4862	34883	4674	35648	4490	36430	4311	37229	6
	5051	34147	4859	34896	4671	35661	4487	36443	4308	37243	
25	5047	34159	4856	34908	4668	35674	4484	36456	4305	37256	5
	5044	34172	4852	34921	4665	35686	4481	36469	4302	37270	
26	5041	34184	4849	34933	4662	35699	4478	36483	4299	37283	4
	5038	34196	4846	34946	4659	35712	4475	36496	4296	37297	
27	5034	34209	4843	34959	4656	35725	4472	36509	4293	37310	3
	5031	34221	4840	34971	4652	35738	4469	36522	4290	37324	
28	5028	34233	4837	34984	4649	35751	4466	36535	4287	37337	2
	5025	34246	4833	34997	4646	35764	4463	36549	4284	37351	
29	5022	34258	4830	35009	4643	35777	4460	36562	4281	37365	1
	5018	34270	4827	35022	4640	35790	4457	36575	4278	37378	
30	5015	34283	4824	35035	4637	35803	4454	36588	4275	37392	0
	5012	34295	4821	35047	4634	35816	4451	36602	4272	37405	
	A	B	A	B	A	B	A	B	A	B	
	117°00'		116°30'		116°00'		115°30'		115°00'		

WHEN LHA (E OR W) IS GREATER THAN 90°, TAKE "K" FROM BOTTOM OF TABLE

	65°00'		65°30'		66°00'		66°30'		67°00'		
	A	B	A	B	A	B	A	B	A	B	
0	4272	37405	4098	38227	3927	39069	3760	39930	3597	40812	30
1	4269	37419	4095	38241	3924	39083	3757	39945	3595	40827	29
	4266	37432	4092	38255	3921	39097	3755	39959	3592	40842	
	4264	37446	4089	38269	3918	39111	3752	39974	3589	40857	
2	4261	37459	4086	38283	3916	39125	3749	39988	3587	40872	28
	4258	37473	4083	38297	3913	39140	3746	40003	3584	40887	
3	4255	37487	4080	38311	3910	39154	3744	40017	3581	40902	27
	4252	37500	4078	38324	3907	39168	3741	40032	3579	40916	
4	4249	37514	4075	38338	3904	39182	3738	40046	3576	40931	26
	4246	37527	4072	38352	3902	39197	3735	40061	3573	40946	
5	4243	37541	4069	38366	3899	39211	3733	40076	3571	40961	25
	4240	37554	4066	38380	3896	39225	3730	40090	3568	40976	
6	4237	37568	4063	38394	3893	39239	3727	40105	3565	40991	24
	4234	37582	4060	38408	3890	39254	3725	40119	3563	41006	
7	4231	37595	4057	38422	3888	39268	3722	40134	3560	41021	23
	4228	37609	3055	38436	3885	39282	3719	40149	3557	41036	
8	4225	37623	4052	38450	3882	39296	3716	40163	3555	41051	22
	4222	37636	4049	38464	3879	39311	3714	40178	3552	41066	
9	4220	37650	4046	38478	3876	39325	3711	40192	3549	41081	21
	4217	37663	4043	38492	3874	39339	3708	40207	3547	41096	
10	4214	37677	4040	38506	3871	39353	3705	40222	3544	41111	20
	4211	37691	4037	38520	3868	39368	3703	40236	3541	41126	
11	4208	37704	4035	38533	3865	39382	3700	40251	3539	41141	19
	4205	37718	4032	38547	3863	39396	3697	40266	3536	41156	
12	4202	37732	4029	38561	3860	39411	3695	40280	3533	41171	18
	4199	37745	4026	38575	3857	39425	3692	40295	3531	41186	
13	4196	37759	4023	38589	3854	39439	3689	40310	3528	41201	17
	4193	37773	4020	38603	3851	39454	3686	40324	3525	41216	
14	4190	37786	4017	38617	3849	39468	3684	40339	3523	41231	16
	4187	37800	4015	38631	3846	39482	3681	40354	3520	41246	
15	4185	37814	4012	38645	3843	39497	3678	40368	3517	41261	15
	4182	37828	4009	38660	3840	39511	3676	40383	3515	41276	
16	4179	37841	4006	38674	3838	39525	3673	40398	3512	41291	14
	4176	37855	4003	38688	3835	39540	3670	40413	3509	41307	
17	4173	37869	4000	38702	3832	39554	3667	40427	3507	41322	13
	4170	37882	3998	38716	3829	39569	3665	40442	3504	41337	
18	4167	37896	3995	38730	3826	39583	3662	40457	3502	41352	12
	4164	37910	3992	38744	3824	39597	3659	40471	3499	41367	
19	4161	37924	3989	38758	3821	39612	3657	40486	3496	41382	11
	4158	37937	3986	38772	3818	39626	3654	40501	3494	41397	
20	4155	37951	3983	38786	3815	39641	3651	40516	3491	41412	10
	4153	37965	3981	38800	3813	39655	3648	40530	3488	41427	
21	4150	37979	3978	38814	3810	39669	3646	40545	3486	41443	9
	4147	37992	3975	38828	3807	39684	3643	40560	3483	41458	
22	4144	38006	3972	38842	3804	39698	3640	40575	3480	41473	8
	4141	38020	3969	38856	3801	39713	3638	40590	3478	41488	
23	4138	38034	3966	38871	3799	39727	3635	40604	3475	41503	7
	4135	38048	3964	38885	3796	39742	3632	40619	3473	41518	
24	4132	38061	3961	38899	3793	39756	3630	40634	3470	41533	6
	4129	38075	3958	38913	3790	39771	3627	40649	3467	41549	
25	4127	38089	3955	38927	3788	39785	3624	40664	3465	41564	5
	4124	38103	3952	38941	3785	39799	3622	40678	3462	41579	
26	4121	38117	3949	38955	3782	39814	3619	40693	3459	41594	4
	4118	38130	3947	38969	3779	39828	3616	40708	3457	41609	
27	4115	38144	3944	38984	3777	39843	3613	40723	3454	41625	3
	4112	38158	3941	38998	3774	39857	3611	40738	3452	41640	
28	4109	38172	3938	39012	3771	39872	3608	40753	3449	41655	2
	4106	38186	3935	39026	3768	39886	3605	40768	3446	41670	
29	4103	38200	3933	39040	3766	39901	3603	40782	3444	41685	1
	4101	38213	3930	39054	3763	39915	3600	40797	3441	41701	
30	4098	38227	3927	39069	3760	39930	3597	40812	3438	41716	0
	A	B	A	B	A	B	A	B	A	B	
	114°30'		114°00'		113°30'		113°00'		112°30'		

ALWAYS TAKE "Z" FROM BOTTOM OF TABLE, EXCEPT WHEN "K" IS SAME NAME AND GREATER THAN LATITUDE, IN WHICH CASE TAKE "Z" FROM TOP OF TABLE

	67°30'		68°00'		68°30'		69°00'		69°30'		
	A	B	A	B	A	B	A	B	A	B	
0	3438	41716	3283	42642	3132	43592	2985	44567	2841	45567	30
	3436	41731	3281	42658	3130	43608	2982	44583	2839	45584	
1	3433	41746	3278	42674	3127	43624	2980	44600	2836	45601	29
	3431	41762	3276	42689	3125	43641	2978	44616	2834	45618	
2	3428	41777	3273	42705	3122	43657	2975	44633	2832	45635	28
	3425	41792	3271	42721	3120	43673	2973	44649	2829	45652	
3	3423	41808	3268	42736	3117	43689	2970	44666	2827	45669	27
	3420	41823	3266	42752	3115	43705	2968	44682	2825	45686	
4	3418	41838	3263	42768	3112	43721	2965	44699	2822	45703	26
	3415	41853	3260	42783	3110	43737	2963	44715	2820	45720	
5	3412	41869	3258	42799	3107	43753	2961	44732	2818	45737	25
	3410	41884	3255	42815	3105	43769	2958	44748	2815	45754	
6	3407	41899	3253	42830	3102	43785	2956	44765	2813	45771	24
	3404	41915	3250	42846	3100	43801	2953	44782	2811	45788	
7	3402	41930	3248	42862	3097	43818	2951	44798	2808	45805	23
	3399	41945	3245	42878	3095	43834	2949	44815	2806	45822	
8	3397	41961	3243	42893	3092	43850	2946	44831	2804	45839	22
	3394	41976	3240	42909	3090	43866	2944	44848	2801	45856	
9	3391	41991	3237	42925	3088	43882	2941	44864	2799	45873	21
	3389	42007	3235	42941	3085	43898	2939	44881	2797	45890	
10	3386	42022	3233	42956	3083	43914	2936	44898	2794	45907	20
	3384	42038	3230	42972	3080	43931	2934	44914	2792	45924	
11	3381	42053	3227	42988	3078	43947	2932	44931	2789	45941	19
	3379	42068	3225	43004	3075	43963	2929	44947	2787	45958	
12	3376	42084	3222	43020	3073	43979	2927	44964	2785	45975	18
	3373	42099	3220	43035	3070	43995	2924	44981	2782	45992	
13	3371	42115	3217	43051	3068	44012	2922	44997	2780	46009	17
	3368	42130	3215	43067	3065	44028	2920	45014	2778	46026	
14	3366	42145	3212	43083	3063	44044	2917	45031	2775	46043	16
	3363	42161	3210	43099	3060	44060	2915	45047	2773	46061	
15	3360	42176	3207	43114	3058	44077	2913	45064	2771	46078	15
	3358	42192	3205	43130	3056	44093	2910	45081	2768	46095	
16	3355	42207	3202	43146	3053	44109	2908	45097	2766	46112	14
	3353	42223	3200	43162	3051	44125	2905	45114	2764	46129	
17	3350	42238	3197	43178	3048	44142	2903	45131	2761	46146	13
	3348	42254	3195	43194	3046	44158	2901	45147	2759	46163	
18	3345	42269	3192	43210	3043	44174	2898	45164	2757	46181	12
	3342	42285	3190	43225	3041	44190	2896	45181	2755	46198	
19	3340	42300	3187	43241	3038	44207	2893	45198	2752	46215	11
	3337	42316	3185	43257	3036	44223	2891	45214	2750	46232	
20	3335	42331	3182	43273	3033	44239	2889	45231	2748	46249	10
	3332	42347	3180	43289	3031	44256	2886	45248	2745	46266	
21	3329	42362	3177	43305	3029	44272	2884	45265	2743	46284	9
	3327	42378	3175	43321	3026	44288	2881	45281	2741	46301	
22	3324	42393	3172	43337	3024	44305	2879	45298	2738	46318	8
	3322	42409	3170	43353	3021	44321	2877	45315	2736	46335	
23	3319	42424	3167	43369	3019	44337	2874	45332	2734	46353	7
	3317	42440	3165	43385	3016	44354	2872	45348	2731	46370	
24	3314	42455	3162	43400	3014	44370	2870	45365	2729	46387	6
	3312	42471	3160	43416	3012	44386	2867	45382	2727	46404	
25	3309	42486	3157	43432	3009	44403	2865	45399	2724	46422	5
	3306	42502	3155	43448	3007	44419	2862	45416	2722	46439	
26	3304	42518	3152	43464	3004	44436	2860	45433	2720	46456	4
	3301	42533	3150	43480	3002	44452	2858	45449	2717	46473	
27	3299	42549	3147	43496	2999	44468	2855	45466	2715	46491	3
	3296	42564	3145	43512	2997	44485	2853	45483	2713	46508	
28	3294	42580	3142	43528	2994	44501	2851	45500	2711	46525	2
	3291	42596	3140	43544	2992	44518	2848	45517	2708	46543	
29	3289	42611	3137	43560	2990	44534	2846	45534	2706	46560	1
	3286	42627	3135	43576	2987	44551	2844	45551	2704	46577	
30	3283	42642	3132	43592	2985	44567	2841	45567	2701	46595	0
	A	B	A	B	A	B	A	B	A	B	
	112°00'		111°30'		111°00'		110°30'		110°00'		

WHEN LHA (E OR W) IS GREATER THAN 90°, TAKE "K" FROM BOTTOM OF TABLE

	70°00'		70°30'		71°00'		71°30'		72°00'		
	A	B	A	B	A	B	A	B	A	B	
0	2701	46595	2565	47650	2433	48736	2304	49852	2179	51002	30
1	2699	46612	2563	47668	2431	48754	2302	49871	2177	51021	29
	2697	46630	2561	47686	2429	48772	2300	49890	2175	51041	
2	2694	46647	2559	47704	2427	48791	2298	49909	2173	51060	28
	2692	46664	2556	47722	2424	48809	2296	49928	2171	51080	
3	2690	46682	2554	47740	2422	48828	2294	49947	2169	51099	27
	2688	46699	2552	47758	2420	48846	2292	49966	2167	51119	
4	2685	46716	2550	47775	2418	48864	2290	49985	2165	51138	26
	2683	46734	2547	47793	2416	48883	2287	50004	2163	51158	
5	2681	46751	2545	47811	2413	48901	2285	50023	2161	51177	25
	2678	46769	2543	47829	2411	48920	2283	50042	2159	51197	
6	2676	46786	2541	47847	2409	48938	2281	50061	2157	51216	24
	2674	46804	2539	47865	2407	48957	2279	50080	2155	51236	
7	2672	46821	2536	47883	2405	48975	2277	50098	2153	51255	23
	2669	46839	2534	47901	2403	48993	2275	50117	2151	51275	
8	2667	46856	2532	47919	2400	49012	2273	50137	2149	51294	22
	2665	46873	2530	47937	2398	49030	2271	50156	2147	51314	
9	2662	46891	2528	47955	2396	49049	2269	50175	2145	51334	21
	2660	46908	2525	47973	2394	49067	2266	50194	2143	51353	
10	2658	46926	2523	47991	2392	49086	2264	50213	2141	51373	20
	2656	46943	2521	48009	2390	49104	2262	50232	2138	51392	
11	2653	46961	2519	48027	2387	49123	2260	50251	2136	51412	19
	2651	46978	2516	48045	2385	49141	2258	50270	2134	51432	
12	2649	46996	2514	48063	2383	49160	2256	50289	2132	51451	18
	2646	47014	2512	48081	2381	49179	2254	50308	2130	51471	
13	2644	47031	2510	48099	2379	49197	2252	50327	2128	51491	17
	2642	47049	2507	48117	2377	49216	2250	50346	2126	51510	
14	2640	47066	2505	48135	2375	49234	2248	50365	2124	51530	16
	2637	47084	2503	48153	2372	49253	2246	50385	2122	51550	
15	2635	47101	2501	48171	2370	49271	2243	50404	2120	51570	15
	2633	47119	2499	48189	2368	49290	2241	50423	2118	51589	
16	2631	47137	2496	48207	2366	49309	2239	50442	2116	51609	14
	2628	47154	2494	48226	2364	49327	2237	50461	2114	51629	
17	2626	47172	2492	48244	2362	49346	2235	50480	2112	51649	13
	2624	47189	2490	48262	2360	49365	2233	50499	2110	51668	
18	2622	47207	2488	48280	2358	49383	2231	50519	2108	51688	12
	2619	47225	2485	48298	2355	49402	2229	50538	2106	51708	
19	2617	47242	2483	48316	2353	49421	2227	50557	2104	51728	11
	2615	47269	2481	48334	2351	49439	2225	50576	2102	51747	
20	2613	47278	2479	48352	2349	49458	2223	50596	2100	51767	10
	2610	47295	2477	48371	2347	49477	2221	50615	2098	51787	
21	2608	47313	2474	48389	2345	49495	2218	50634	2096	51807	9
	2606	47331	2472	48407	2343	49514	2216	50653	2094	51827	
22	2604	47348	2470	48425	2340	49533	2214	50673	2092	51847	8
	2601	47366	2468	48443	2338	49551	2212	50692	2090	51867	
23	2599	47384	2466	48462	2336	49570	2210	50711	2088	51886	7
	2597	47402	2463	48480	2334	49589	2208	50730	2086	51906	
24	2594	47419	2461	48498	2332	49608	2206	50750	2084	51926	6
	2592	47437	2459	48516	2330	49626	2204	50769	2082	51946	
25	2590	47455	2457	48534	2328	49645	2202	50788	2080	51966	5
	2588	47472	2455	48553	2325	49664	2200	50808	2078	51986	
26	2585	47490	2453	48571	2323	49683	2198	50827	2076	52006	4
	2583	47508	2450	48589	2321	49702	2196	50846	2074	52026	
27	2581	47526	2448	48608	2319	49720	2194	50866	2072	52046	3
	2579	47544	2446	48626	2317	49739	2192	50885	2070	52066	
28	2576	47561	2444	48644	2315	49758	2190	50905	2068	52086	2
	2574	47579	2442	48662	2313	49777	2188	50924	2066	52106	
29	2572	47597	2439	48681	2311	49796	2185	50943	2064	52126	1
	2570	47615	2437	48699	2309	49815	2183	50963	2062	52146	
30	2568	47633	2435	48717	2306	49833	2181	50982	2060	52166	0
	2565	47650	2433	48736	2304	49852	2179	51002	2058	52186	
	A	B	A	B	A	B	A	B	A	B	
	109°30'		109°00'		108°30'		108°00'		107°30'		

ALWAYS TAKE "Z" FROM BOTTOM OF TABLE, EXCEPT WHEN "K" IS SAME NAME AND GREATER THAN LATITUDE, IN WHICH CASE TAKE "Z" FROM TOP OF TABLE

	72°30'		73°00'		73°30'		74°00'		74°30'		
	A	B	A	B	A	B	A	B	A	B	
0	2058	52186	1940	53406	1826	54666	1716	55966	1609	57310	30
	2056	52206	1938	53427	1824	54687	1714	55988	1607	57333	
1	2054	52226	1936	53448	1823	54708	1712	56010	1605	57356	29
	2052	52246	1935	53468	1821	54730	1710	56032	1604	57378	
2	2050	52266	1933	53489	1819	54751	1709	56054	1602	57401	28
	2048	52286	1931	53510	1817	54773	1707	56076	1600	57424	
3	2046	52306	1929	53531	1815	54794	1705	56099	1598	57447	27
	2044	52326	1927	53551	1813	54815	1703	56121	1597	57470	
4	2042	52346	1925	53572	1811	54837	1701	56143	1595	57493	26
	2040	52366	1923	53593	1809	54858	1700	56165	1593	57516	
5	2038	52387	1921	53614	1808	54880	1698	56187	1591	57538	25
	2036	52407	1919	53634	1806	54901	1696	56209	1590	57561	
6	2034	52427	1917	53655	1804	54922	1694	56231	1588	57584	24
	2032	52447	1915	53676	1802	54944	1692	56254	1586	57607	
7	2030	52467	1913	53697	1800	54965	1691	56276	1584	57630	23
	2028	52487	1911	53718	1798	54987	1689	56298	1583	57653	
8	2026	52508	1910	53738	1796	55008	1687	56320	1581	57676	22
	2024	52528	1908	53759	1795	55030	1685	56342	1579	57699	
9	2022	52548	1906	53780	1793	55051	1683	56365	1578	57722	21
	2020	52568	1904	53801	1791	55073	1682	56387	1576	57745	
10	2018	52588	1902	53822	1789	55095	1680	56409	1574	57768	20
	2016	52609	1900	53843	1787	55116	1678	56431	1572	57791	
11	2014	52629	1898	53864	1785	55138	1676	56454	1571	57814	19
	2012	52649	1896	53884	1783	55159	1674	56476	1569	57837	
12	2010	52670	1894	53905	1782	55181	1673	56498	1567	57860	18
	2009	52690	1892	53926	1780	55202	1671	56521	1565	57884	
13	2007	52710	1890	53947	1778	55224	1669	56543	1564	57907	17
	2005	52730	1889	53968	1776	55246	1667	56565	1562	57930	
14	2003	52751	1887	53989	1774	55267	1665	56588	1560	57953	16
	2001	52771	1885	54010	1772	55289	1664	56610	1559	57976	
15	1999	52791	1883	54031	1771	55311	1662	56632	1557	57999	15
	1997	52812	1881	54052	1769	55332	1660	56655	1555	58022	
16	1995	52832	1879	54073	1767	55354	1658	56677	1553	58046	14
	1993	52852	1877	54094	1765	55376	1657	56700	1552	58069	
17	1991	52873	1875	54115	1763	55397	1655	56722	1550	58092	13
	1989	52893	1873	54136	1761	55419	1653	56745	1548	58115	
18	1987	52914	1871	54157	1760	55441	1651	56767	1546	58138	12
	1985	52934	1870	54178	1758	55463	1650	56790	1545	58162	
19	1983	52954	1868	54199	1756	55484	1648	56812	1543	58185	11
	1981	52975	1866	54220	1754	55506	1646	56835	1541	58208	
20	1979	52995	1864	54242	1752	55528	1644	56857	1540	58232	10
	1977	53016	1862	54263	1750	55550	1642	56880	1538	58255	
21	1975	53036	1860	54284	1749	55572	1641	56902	1536	58278	9
	1973	53057	1858	54305	1747	55593	1639	56925	1534	58302	
22	1971	53077	1856	54326	1745	55615	1637	56947	1533	58325	8
	1969	53098	1854	54347	1743	55637	1635	56970	1531	58348	
23	1967	53118	1853	54368	1741	55659	1634	56992	1529	58372	7
	1966	53139	1851	54390	1739	55681	1632	57015	1528	58395	
24	1964	53159	1849	54411	1738	55703	1630	57038	1526	58418	6
	1962	53180	1847	54432	1736	55725	1628	57060	1524	58442	
25	1960	53200	1845	54453	1734	55746	1627	57083	1523	58465	5
	1958	53221	1843	54474	1732	55768	1625	57106	1521	58489	
26	1956	53241	1841	54496	1730	55790	1623	57128	1519	58512	4
	1954	53262	1839	54517	1728	55812	1621	57151	1517	58536	
27	1952	53283	1837	54538	1727	55834	1619	57174	1516	58559	3
	1950	53303	1836	54559	1725	55856	1618	57196	1514	58583	
28	1948	53324	1834	54581	1723	55878	1616	57219	1512	58606	2
	1946	53344	1832	54602	1721	55900	1614	57242	1511	58630	
29	1944	53365	1830	54623	1719	55922	1612	57265	1509	58653	1
	1942	53386	1828	54644	1718	55944	1611	57287	1507	58677	
30	1940	53406	1826	54666	1716	55966	1609	57310	1506	58700	0
	A	B	A	B	A	B	A	B	A	B	
	107°00'		106°30'		106°00'		105°30'		105°00'		

WHEN LHA (E OR W) IS GREATER THAN 90°, TAKE "K" FROM BOTTOM OF TABLE

	75°00'		75°30'		76°00'		76°30'		77°00'		
	A	B	A	B	A	B	A	B	A	B	
0	1506	58700	1406	60140	1310	61632	1217	63181	1128	64791	30
	1504	58724	1404	60164	1308	61658	1215	63208	1126	64819	
1	1502	58748	1403	60189	1306	61683	1214	63234	1125	64846	29
	1500	58771	1401	60213	1305	61709	1212	63260	1123	64873	
2	1499	58795	1399	60238	1303	61734	1211	63287	1122	64901	28
	1497	58818	1398	60262	1301	61759	1209	63313	1120	64928	
3	1495	58842	1396	60287	1300	61785	1208	63340	1119	64956	27
	1494	58866	1394	60311	1299	61810	1206	63366	1117	64983	
4	1492	58889	1393	60335	1297	61836	1205	63392	1116	65011	26
	1490	58913	1391	60360	1295	61861	1203	63419	1114	65038	
5	1489	58937	1390	60385	1294	61887	1202	63445	1113	65066	25
	1487	58960	1388	60410	1292	61912	1200	63472	1112	65093	
6	1485	58984	1386	60434	1291	61938	1199	63498	1110	65121	24
	1484	59008	1385	60459	1289	61963	1197	63525	1109	65148	
7	1482	59032	1383	60483	1288	61989	1196	63551	1107	65176	23
	1480	59055	1381	60508	1286	62014	1194	63578	1106	65204	
8	1479	59079	1380	60533	1284	62040	1193	63605	1104	65231	22
	1477	59103	1378	60557	1283	62065	1191	63631	1103	65259	
9	1475	59127	1377	60582	1281	62091	1190	63658	1101	65287	21
	1474	59151	1375	60607	1280	62117	1188	63684	1100	65314	
10	1472	59175	1373	60631	1278	62142	1187	63711	1099	65342	20
	1470	59198	1372	60656	1277	62168	1185	63738	1097	65370	
11	1469	59222	1370	60681	1275	62194	1184	63764	1096	65398	19
	1467	59246	1368	60706	1274	62219	1182	63791	1094	65425	
12	1465	59270	1367	60730	1272	62245	1181	63818	1093	65453	18
	1464	59294	1365	60755	1270	62271	1179	63845	1091	65481	
13	1462	59318	1364	60780	1269	62296	1178	63871	1090	65509	17
	1460	59342	1362	60805	1267	62322	1176	63898	1089	65537	
14	1459	59366	1360	60830	1266	62348	1175	63925	1087	65564	16
	1457	59390	1359	60855	1264	62374	1173	63952	1086	65592	
15	1455	59414	1357	60879	1263	62400	1172	63978	1084	65620	15
	1454	59438	1356	60904	1261	62425	1170	64005	1083	65648	
16	1452	59462	1354	60929	1260	62451	1169	64032	1081	65676	14
	1450	59486	1352	60954	1258	62477	1167	64059	1080	65704	
17	1449	59510	1351	60979	1257	62503	1166	64086	1079	65732	13
	1447	59534	1349	61004	1255	62529	1164	64113	1077	65760	
18	1445	59558	1348	61029	1253	62555	1163	64140	1076	65788	12
	1444	59582	1346	61054	1252	62581	1161	64167	1074	65816	
19	1442	59606	1344	61079	1250	62607	1160	64194	1073	65844	11
	1440	59630	1343	61104	1249	62633	1158	64221	1071	65872	
20	1439	59654	1341	61129	1247	62659	1157	64248	1070	65900	10
	1437	59679	1340	61154	1246	62685	1155	64275	1069	65928	
21	1435	59703	1338	61179	1244	62711	1154	64302	1067	65957	9
	1434	59727	1336	61204	1243	62737	1152	64329	1066	65985	
22	1432	59751	1335	61229	1241	62763	1151	64356	1064	66013	8
	1430	59775	1333	61254	1240	62789	1150	64383	1063	66041	
23	1429	59800	1332	61279	1238	62815	1148	64410	1061	66069	7
	1427	59824	1330	61304	1237	62841	1147	64437	1060	66098	
24	1425	59848	1329	61330	1235	62867	1145	64464	1059	66126	6
	1424	59872	1327	61355	1234	62893	1144	64491	1057	66154	
25	1422	59896	1325	61380	1232	62919	1142	64518	1056	66182	5
	1421	59921	1324	61405	1230	62945	1141	64546	1054	66211	
26	1419	59945	1322	61430	1229	62971	1139	64573	1053	66239	4
	1417	59969	1321	61456	1227	62998	1138	64600	1052	66267	
27	1416	59994	1319	61481	1226	63024	1136	64627	1050	66296	3
	1414	60018	1317	61506	1224	63050	1135	64655	1049	66324	
28	1412	60042	1316	61531	1223	63076	1133	64682	1047	66352	2
	1411	60067	1314	61556	1221	63103	1132	64709	1046	66381	
29	1409	60091	1313	61582	1220	63129	1130	64736	1045	66409	1
	1407	60116	1311	61607	1218	63155	1129	64764	1043	66438	
30	1406	60140	1310	61632	1217	63181	1128	64791	1042	66466	0
	A	B	A	B	A	B	A	B	A	B	
	104°30'		104°00'		103°30'		103°00'		102°30'		

ALWAYS TAKE "Z" FROM BOTTOM OF TABLE, EXCEPT WHEN "K" IS SAME NAME AND GREATER THAN LATITUDE, IN WHICH CASE TAKE "Z" FROM TOP OF TABLE

	77°30'		78°00'		78°30'		79°00'		79°30'		
	A	B	A	B	A	B	A	B	A	B	
0	1042	66466	960	68212	881	70034	805	71940	733	73937	30
	1040	66495	958	68242	879	70065	804	71973	732	73971	
1	1039	66523	957	68272	878	70097	803	72005	731	74005	29
	1038	66552	955	68301	877	70128	802	72038	730	74039	
2	1036	66580	954	68331	876	70159	800	72070	729	74073	28
	1035	66609	953	68361	874	70190	799	72103	728	74107	
3	1033	66638	951	68391	873	70221	798	72136	726	74142	27
	1032	66666	950	68421	872	70252	797	72168	725	74176	
4	1031	66695	949	68450	870	70284	796	72201	724	74210	26
	1029	66724	947	68480	869	70315	794	72234	723	74245	
5	1028	66752	946	68510	868	70346	793	72266	722	74279	25
	1026	66781	945	68540	867	70377	792	72299	721	74313	
6	1025	66810	943	68570	865	70409	791	72332	719	74348	24
	1024	66838	942	68600	864	70440	790	72365	718	74382	
7	1022	66867	941	68630	863	70471	788	72397	717	74417	23
	1021	66896	939	68660	862	70503	787	72430	716	74451	
8	1020	66925	938	68690	860	70534	786	72463	715	74486	22
	1018	66953	937	68720	859	70566	785	72496	714	74520	
9	1017	66982	935	68750	858	70597	783	72529	712	74555	21
	1015	67011	934	68781	856	70629	782	72562	711	74589	
10	1014	67040	933	68811	855	70660	781	72595	710	74624	20
	1013	67069	932	68841	854	70692	780	72628	709	74659	
11	1011	67098	930	68871	853	70723	779	72661	708	74693	19
	1010	67127	929	68901	851	70755	777	72694	707	74728	
12	1008	67156	928	68931	850	70786	776	72727	706	74763	18
	1007	67185	926	68962	849	70818	775	72760	704	74797	
13	1006	67214	925	68992	848	70850	774	72794	703	74832	17
	1004	67243	924	69022	846	70881	772	72827	702	74867	
14	1003	67272	922	69053	845	70913	771	72860	701	74902	16
	1002	67301	921	69083	844	70945	770	72893	700	74937	
15	1000	67330	920	69113	843	70976	769	72926	699	74972	15
	999	67359	918	69144	841	71008	768	72960	698	75007	
16	997	67388	917	69174	840	71040	767	72993	696	75042	14
	996	67417	916	69204	839	71072	765	73026	695	75077	
17	995	67447	914	69235	838	71104	764	73060	694	75112	13
	993	67476	913	69265	836	71135	763	73093	693	75147	
18	992	67505	912	69296	835	71167	762	73127	692	75182	12
	991	67534	910	69326	834	71199	761	73160	691	75217	
19	989	67563	909	69357	833	71231	759	73193	690	75252	11
	988	67593	908	69387	831	71263	758	73227	688	75287	
20	987	67622	907	69418	830	71295	757	73260	687	75322	10
	985	67651	905	69449	829	71327	756	73294	686	75358	
21	984	67681	904	69479	828	71359	755	73328	685	75393	9
	982	67710	903	69510	826	71391	753	73361	684	75428	
22	981	67739	901	69541	825	71423	752	73395	683	75464	8
	980	67769	900	69571	824	71455	751	73429	682	75499	
23	978	67798	899	69602	823	71488	750	73462	680	75534	7
	977	67828	897	69633	821	71520	749	73496	679	75570	
24	976	67857	896	69664	820	71552	747	73530	678	75605	6
	974	67886	895	69694	819	71584	746	73563	677	75641	
25	973	67916	894	69725	818	71616	745	73597	676	75676	5
	972	67945	892	69756	816	71649	744	73631	675	75712	
26	970	67975	891	69787	815	71681	743	73665	674	75747	4
	969	68005	890	69815	814	71713	742	73699	673	75783	
27	968	68034	888	69849	813	71746	740	73733	672	75819	3
	966	68064	887	69879	811	71778	739	73767	670	75854	
28	965	68093	886	69910	810	71810	738	73801	669	75890	2
	964	68123	885	69941	809	71843	737	73835	668	75926	
29	962	68153	883	69972	808	71875	736	73869	667	75961	1
	961	68182	882	70003	807	71908	735	73903	666	75997	
30	960	68212	881	70034	805	71940	733	73937	665	76033	0
	A	B	A	B	A	B	A	B	A	B	
	102°00'		101°30'		101°00'		100°30'		100°00'		

WHEN LHA (E OR W) IS GREATER THAN 90°, TAKE "K" FROM BOTTOM OF TABLE

	80°00'		80°30'		81°00'		81°30'		82°00'		
	A	B	A	B	A	B	A	B	A	B	
0	665	.76033	600	.78239	538	.80567	480	.83030	425	.85644	30
	664	.76069	599	.78277	537	.80607	479	.83072	424	.85689	
1	663	.76105	598	.78315	536	.80647	478	.83114	423	.85734	29
	661	.76141	597	.78352	535	.80687	477	.83157	422	.85779	
2	660	.76176	596	.78390	534	.80727	476	.83199	421	.85825	28
	659	.76212	594	.78428	533	.80767	475	.83242	420	.85870	
3	658	.76248	593	.78466	532	.80807	474	.83284	419	.85915	27
	657	.76284	592	.78504	531	.80847	473	.83327	418	.85960	
4	656	.76320	591	.78542	530	.80887	472	.83369	418	.86006	26
	655	.76357	590	.78580	529	.80927	471	.83412	417	.86051	
5	654	.76393	589	.78618	528	.80967	470	.83455	416	.86096	25
	653	.76429	588	.78656	527	.81008	469	.83497	415	.86142	
6	652	.76465	587	.78694	526	.81048	468	.83540	414	.86187	24
	650	.76501	586	.78733	525	.81088	467	.83583	413	.86233	
7	649	.76537	585	.78771	524	.81129	467	.83626	412	.86278	23
	648	.76574	584	.78809	523	.81169	466	.83668	411	.86324	
8	647	.76610	583	.78847	522	.81210	465	.83711	411	.86370	22
	646	.76646	582	.78886	521	.81250	464	.83754	410	.86415	
9	645	.76683	581	.78924	520	.81291	463	.83797	409	.86461	21
	644	.76719	580	.78962	519	.81331	462	.83840	408	.86507	
10	643	.76756	579	.79001	518	.81372	461	.83884	407	.86553	20
	642	.76792	578	.79039	517	.81413	460	.83927	406	.86599	
11	641	.76828	577	.79078	516	.81453	459	.83970	405	.86645	19
	639	.76865	576	.79116	515	.81494	458	.84013	405	.86691	
12	638	.76902	575	.79155	514	.81535	457	.84056	404	.86737	18
	637	.76938	574	.79193	513	.81576	456	.84100	403	.86783	
13	636	.76975	573	.79232	512	.81617	455	.84143	402	.86829	17
	635	.77011	571	.79271	511	.81657	454	.84186	401	.86876	
14	634	.77048	570	.79309	510	.81698	454	.84230	400	.86922	16
	633	.77085	569	.79348	509	.81739	453	.84273	399	.86968	
15	632	.77122	568	.79387	508	.81780	452	.84317	399	.87015	15
	631	.77158	567	.79426	507	.81821	451	.84361	398	.87061	
16	630	.77195	566	.79465	506	.81863	450	.84404	397	.87107	14
	629	.77232	565	.79503	505	.81904	449	.84448	396	.87154	
17	627	.77269	564	.79542	504	.81945	448	.84492	395	.87201	13
	626	.77306	563	.79581	504	.81986	447	.84535	394	.87247	
18	625	.77343	562	.79620	503	.82027	446	.84579	393	.87294	12
	624	.77380	561	.79659	502	.82069	445	.84623	392	.87341	
19	623	.77417	560	.79698	501	.82110	444	.84667	392	.87387	11
	622	.77454	559	.79737	500	.82151	444	.84711	391	.87434	
20	621	.77491	558	.79777	499	.82193	443	.84755	390	.87481	10
	620	.77528	557	.79816	498	.82234	442	.84799	389	.87528	
21	619	.77565	556	.79855	497	.82276	441	.84843	388	.87575	9
	618	.77602	555	.79894	496	.82317	440	.84887	387	.87622	
22	617	.77639	554	.79933	495	.82359	439	.84931	387	.87669	8
	616	.77677	553	.79973	494	.82400	438	.84976	386	.87716	
23	615	.77714	552	.80012	493	.82442	437	.85020	385	.87764	7
	614	.77751	551	.80051	492	.82484	436	.85064	384	.87811	
24	612	.77788	550	.80091	491	.82526	435	.85109	383	.87858	6
	611	.77826	549	.80130	490	.82567	434	.85153	382	.87906	
25	610	.77863	548	.80170	489	.82609	434	.85197	381	.87953	5
	609	.77901	547	.80209	488	.82651	433	.85242	381	.88001	
26	608	.77938	546	.80249	487	.82693	432	.85286	380	.88048	4
	607	.77976	545	.80288	486	.82735	431	.85331	379	.88096	
27	606	.78013	544	.80328	485	.82777	430	.85376	378	.88143	3
	605	.78051	543	.80368	484	.82819	429	.85420	377	.88191	
28	604	.78088	542	.80407	483	.82861	428	.85465	376	.88239	2
	603	.78126	541	.80447	482	.82903	427	.85510	376	.88286	
29	602	.78164	540	.80487	482	.82945	426	.85555	375	.88334	1
	601	.78201	539	.80527	481	.82987	426	.85599	374	.88382	
30	600	.78239	538	.80567	480	.83030	425	.85644	373	.88430	0
	A	B	A	B	A	B	A	B	A	B	
	99°30'		99°00'		98°30'		98°00'		97°30'		

ALWAYS TAKE "Z" FROM BOTTOM OF TABLE, EXCEPT WHEN "K" IS SAME NAME AND GREATER THAN LATITUDE, IN WHICH CASE TAKE "Z" FROM TOP OF TABLE

	82°30'		83°00'		83°30'		84°00'		84°30'		
	A	B	A	B	A	B	A	B	A	B	
0	373	88430	325	91411	280	94614	238.6	98076	200.4	101843	30
1	372	88478	324	91462	279	94670	237.9	98137	199.8	101908	29
	371	88526	323	91514	279	94725	237.2	98197	199.2	101974	
2	371	88574	323	91565	278	94781	236.6	98257	198.6	102040	28
	370	88623	322	91617	277	94836	235.9	98318	198.0	102106	
3	369	88671	321	91668	276	94892	235.3	98378	197.4	102172	27
	368	88719	320	91720	276	94948	234.6	98439	196.8	102238	
4	367	88767	319	91772	275	95004	233.9	98499	196.2	102304	26
	366	88816	319	91824	274	95060	233.3	98560	195.6	102371	
5	366	88864	318	91876	274	95116	232.6	98621	195.0	102437	25
	365	88913	317	91928	273	95172	232.0	98682	194.4	102504	
6	364	88961	316	91980	272	95228	231.3	98743	193.8	102570	24
	363	89010	316	92032	271	95285	230.7	98804	193.2	102637	
7	362	89059	315	92085	271	95341	230.0	98865	192.6	102704	23
	362	89107	314	92137	270	95397	229.4	98926	192.0	102771	
8	361	89156	313	92189	269	95454	228.7	98988	191.4	102838	22
	360	89205	313	92242	269	95510	228.1	99049	190.8	102905	
9	359	89254	312	92294	268	95567	227.4	99111	190.2	102973	21
	358	89303	311	92347	267	95624	226.8	99172	189.6	103040	
10	357	89352	310	92399	267	95681	226.1	99234	189.0	103107	20
	357	89401	310	92452	266	95737	225.5	99296	188.4	103175	
11	356	89450	309	92505	265	95795	224.8	99357	187.8	103243	19
	355	89499	308	92558	264	95851	224.2	99419	187.2	103311	
12	354	89548	307	92610	264	95909	223.5	99482	186.7	103379	18
	353	89597	307	92663	263	95966	222.9	99544	186.1	103447	
13	353	89647	306	92716	262	96023	222.3	99606	185.5	103515	17
	352	89696	305	92769	262	96080	221.6	99668	184.9	103583	
14	351	89746	304	92823	261	96138	221.0	99731	184.3	103651	16
	350	89795	304	92876	260	96195	220.3	99793	183.7	103720	
15	349	89845	303	92929	260	96253	219.7	99856	183.2	103788	15
	349	89894	302	92982	259	96310	219.1	99918	182.6	103857	
16	348	89944	301	93036	258	96368	218.4	99981	182.0	103926	14
	347	89994	301	93089	257	96426	217.8	100044	181.4	103995	
17	346	90044	300	93143	257	96484	217.2	100107	180.8	104064	13
	345	90093	299	93196	256	96542	216.5	100170	180.3	104133	
18	345	90143	298	93250	255	96600	215.9	100233	179.7	104202	12
	344	90193	298	93304	255	96658	215.3	100296	179.1	104272	
19	343	90243	297	93358	254	96716	214.6	100360	178.5	104341	11
	342	90293	296	93411	253	96774	214.0	100423	178.0	104411	
20	341	90344	295	93465	253	96833	213.4	100487	177.4	104480	10
	341	90394	295	93519	252	96891	212.8	100550	176.8	104550	
21	340	90444	294	93573	251	96950	212.1	100614	176.2	104620	9
	339	90494	293	93628	251	97008	211.5	100678	175.7	104690	
22	338	90545	292	93682	250	97067	210.9	100742	175.1	104760	8
	337	90595	292	93736	249	97126	210.3	100806	174.5	104830	
23	337	90646	291	93790	249	97184	209.6	100870	174.0	104901	7
	336	90696	290	93845	248	97243	209.0	100934	173.4	104971	
24	335	90747	289	93899	247	97302	208.4	100998	172.8	105042	6
	334	90798	289	93954	247	97361	207.8	101063	172.3	105113	
25	333	90848	288	94009	246	97420	207.1	101127	171.7	105183	5
	333	90899	287	94063	245	97480	206.5	101192	171.1	105254	
26	332	90950	287	94118	245	97539	205.9	101256	170.6	105325	4
	331	91001	286	94173	244	97598	205.3	101321	170.0	105397	
27	330	91052	285	94228	243	97658	204.7	101386	169.5	105468	3
	330	91103	284	94283	243	97717	204.1	101451	168.9	105539	
28	329	91154	284	94338	242	97777	203.5	101516	168.4	105611	2
	328	91205	283	94393	241	97837	202.8	101581	167.8	105683	
29	327	91257	282	94448	241	97897	202.2	101646	167.2	105754	1
	326	91308	281	94503	240	97957	201.6	101712	166.7	105826	
30	326	91359	281	94559	239	98017	201.0	101777	166.0	105898	0
	325	91411	280	94614	239	98076	200.4	101843	165.6	105970	
	A	B	A	B	A	B	A	B	A	B	
	97°00'		96°30'		96°00'		95°30'		95°00'		

WHEN LHA (E OR W) IS GREATER THAN 90°, TAKE "K" FROM BOTTOM OF TABLE

	85°00'		85°30'		86°00'		86°30'		87°00'		
	A	B	A	B	A	B	A	B	A	B	
0	165.6	105970	134.1	110536	105.9	115641	81.1	121432	59.6	128120	30
	165.0	106043	133.6	110616	105.5	115732	80.7	121536	59.2	128241	
1	164.5	106115	133.1	110696	105.0	115823	80.3	121639	58.9	128362	29
	163.9	106187	132.6	110777	104.6	115913	79.9	121743	58.6	128483	
2	163.4	106260	132.1	110858	104.2	116004	79.5	121848	58.2	128605	28
	162.8	106333	131.6	110939	103.7	116096	79.2	121952	57.9	128727	
3	162.3	106406	131.1	111020	103.3	116187	78.8	122057	57.6	128849	27
	161.7	106479	130.6	111101	102.9	116278	78.4	122161	57.3	128972	
4	161.2	106552	130.1	111183	102.4	116370	78.0	122267	56.9	129095	26
	160.6	106625	129.6	111264	102.0	116462	77.6	122372	56.6	129218	
5	160.1	106698	129.2	111346	101.6	116554	77.3	122478	56.3	129342	25
	159.6	106772	128.7	111428	101.1	116647	76.9	122584	56.0	129466	
6	159.0	106846	128.2	111510	100.7	116739	76.5	122690	55.7	129591	24
	158.5	106919	127.7	111592	100.3	116832	76.1	122796	55.3	129716	
7	157.9	106993	127.2	111674	99.8	116925	75.8	122903	55.0	129841	23
	157.4	107067	126.7	111757	99.4	117018	75.4	123010	54.7	129967	
8	156.9	107141	126.2	111839	99.0	117112	75.0	123117	54.4	130093	22
	156.3	107216	125.8	111922	98.5	117205	74.6	123225	54.1	130219	
9	155.8	107290	125.3	112005	98.1	117299	74.3	123332	53.7	130346	21
	155.2	107364	124.8	112088	97.7	117393	73.9	123441	53.4	130473	
10	154.7	107439	124.3	112171	97.3	117487	73.5	123549	53.1	130600	20
	154.2	107514	123.8	112255	96.8	117581	73.2	123657	52.8	130728	
11	153.6	107589	123.4	112338	96.4	117676	72.8	123766	52.5	130856	19
	153.1	107664	122.9	112422	96.0	117771	72.4	123875	52.2	130985	
12	152.6	107739	122.4	112506	95.6	117866	72.1	123985	51.9	131114	18
	152.1	107814	121.9	112590	95.2	117961	71.7	124095	51.6	131243	
13	151.5	107890	121.5	112674	94.7	118056	71.3	124204	51.3	131373	17
	151.0	107965	121.0	112759	94.3	118152	71.0	124315	51.0	131503	
14	150.5	108041	120.5	112843	93.9	118248	70.6	124425	50.7	131633	16
	149.9	108117	120.1	112928	93.5	118344	70.3	124536	50.3	131764	
15	149.4	108193	119.6	113013	93.1	118440	69.9	124647	50.0	131896	15
	148.9	108269	119.1	113098	92.7	118537	69.5	124759	49.7	132027	
16	148.4	108345	118.7	113183	92.3	118633	69.2	124870	49.4	132159	14
	147.8	108421	118.2	113269	91.8	118730	68.8	124982	49.1	132292	
17	147.3	108498	117.7	113354	91.4	118827	68.5	125094	48.8	132425	13
	146.8	108574	117.3	113440	91.0	118925	68.1	125207	48.5	132558	
18	146.3	108651	116.8	113526	90.6	119022	67.8	125320	48.2	132692	12
	145.8	108728	116.3	113612	90.2	119120	67.4	125433	47.9	132826	
19	145.2	108805	115.9	113699	89.8	119218	67.1	125546	47.6	132961	11
	144.7	108882	115.4	113785	89.4	119316	66.7	125660	47.3	133096	
20	144.2	108960	114.9	113872	89.0	119415	66.4	125774	47.1	133231	10
	143.7	109037	114.5	113958	88.6	119513	66.0	125888	46.8	133367	
21	143.2	109115	114.0	114045	88.2	119612	65.7	126003	46.5	133503	9
	142.7	109192	113.6	114133	87.8	119711	65.3	126118	46.2	133640	
22	142.2	109270	113.1	114220	87.4	119811	65.0	126233	45.9	133777	8
	141.6	109348	112.7	114307	87.0	119910	64.6	126349	45.6	133914	
23	141.1	109426	112.2	114395	86.6	120010	64.3	126465	45.3	134052	7
	140.6	109505	111.7	114483	86.2	120110	63.9	126581	45.0	134191	
24	140.1	109583	111.3	114571	85.8	120211	63.6	126697	44.7	134330	6
	139.6	109662	110.8	114659	85.4	120311	63.3	126814	44.4	134469	
25	139.1	109740	110.4	114747	85.0	120412	62.9	126931	44.2	134609	5
	138.6	109819	109.9	114836	84.6	120513	62.6	127049	43.9	134749	
26	138.1	109898	109.5	114925	84.2	120614	62.2	127166	43.6	134890	4
	137.6	109978	109.0	115014	83.8	120715	61.9	127284	43.3	135031	
27	137.1	110057	108.6	115103	83.4	120817	61.6	127403	43.0	135173	3
	136.6	110136	108.1	115192	83.0	120919	61.2	127521	42.7	135315	
28	136.1	110216	107.7	115282	82.6	121021	60.9	127640	42.5	135457	2
	135.6	110296	107.3	115371	82.2	121124	60.6	127760	42.2	135600	
29	135.1	110375	106.8	115461	81.9	121226	60.2	127880	41.9	135744	1
	134.6	110455	106.4	115551	81.5	121329	59.9	128000	41.6	135888	
30	134.1	110536	105.9	115641	81.1	121432	59.6	128120	41.4	136032	0
	A	B	A	B	A	B	A	B	A	B	
	94°30'		94°00'		93°30'		93°00'		92°30'		

ALWAYS TAKE "Z" FROM BOTTOM OF TABLE, EXCEPT WHEN "K" IS SAME NAME AND GREATER THAN LATITUDE. IN WHICH CASE TAKE "Z" FROM TOP OF TABLE

	87°30'		88°00'		88°30'		89°00'		89°30'		
	A	B	A	B	A	B	A	B	A	B	
0	41.4	136032	26.5	145718	14.9	158208	6.6	175814	1.7	205916	30
	41.1	136177	26.2	145899	14.7	158450	6.5	176178	1.6	206646	
1	40.8	136322	26.0	146081	14.6	158693	6.4	176544	1.5	207388	29
	40.5	136468	25.8	146264	14.4	158938	6.3	176914	1.5	208143	
2	40.3	136615	25.6	146448	14.2	159184	6.2	177287	1.4	208912	28
	40.0	136761	25.4	146632	14.1	159431	6.1	177663	1.4	209695	
3	39.7	136909	25.2	146817	13.9	159680	6.0	178042	1.3	210491	27
	39.4	137057	24.9	147003	13.7	159930	5.9	178424	1.3	211303	
4	39.2	137205	24.7	147190	13.6	160182	5.8	178810	1.2	212130	26
	38.9	137354	24.5	147377	13.4	160435	5.7	179200	1.2	212974	
5	38.6	137503	24.3	147566	13.3	160690	5.6	179593	1.1	213834	25
	38.4	137653	24.1	147755	13.1	160946	5.5	179990	1.1	214711	
6	38.1	137804	23.9	147945	13.0	161204	5.4	180390	1.1	215607	24
	37.8	137955	23.7	148135	12.8	161463	5.3	180794	1.0	216521	
7	37.6	138106	23.5	148327	12.7	161724	5.2	181201	1.0	217455	23
	37.3	138258	23.3	148520	12.5	161986	5.1	181613	0.9	218409	
8	37.1	138411	23.1	148713	12.4	162250	5.0	182029	0.9	219385	22
	36.8	138564	22.8	148907	12.2	162516	4.9	182448	0.9	220384	
9	36.5	138718	22.6	149103	12.1	162783	4.8	182872	0.8	221406	21
	36.3	138872	22.4	149299	11.9	163052	4.7	183300	0.8	222452	
10	36.0	139027	22.2	149495	11.8	163322	4.6	183732	0.7	223525	20
	35.8	139182	22.0	149693	11.6	163594	4.5	184168	0.7	224624	
11	35.5	139338	21.8	149892	11.5	163868	4.4	184609	0.7	225752	19
	35.3	139494	21.6	150092	11.3	164144	4.3	185055	0.6	226910	
12	35.0	139651	21.4	150292	11.2	164422	4.2	185505	0.6	228100	18
	34.7	139809	21.2	150494	11.0	164701	4.1	185959	0.6	229324	
13	34.5	139967	21.0	150696	10.9	164982	4.1	186419	0.5	230583	17
	34.2	140125	20.8	150899	10.8	165265	4.0	186883	0.5	231879	
14	34.0	140285	20.6	151104	10.6	165550	3.9	187353	0.5	233215	16
	33.7	140445	20.5	151309	10.5	165836	3.8	187827	0.4	234594	
15	33.5	140605	20.3	151515	10.3	166125	3.7	188307	0.4	236018	15
	33.2	140766	20.1	151722	10.2	166415	3.6	188793	0.4	237491	
16	33.0	140928	19.9	151931	10.1	166708	3.6	189283	0.4	239015	14
	32.8	141090	19.7	152140	9.9	167002	3.5	189780	0.3	240594	
17	32.5	141253	19.5	152350	9.8	167298	3.4	190282	0.3	242233	13
	32.3	141417	19.3	152561	9.7	167597	3.3	190790	0.3	243936	
18	32.0	141581	19.1	152774	9.5	167897	3.2	191303	0.3	245709	12
	31.8	141745	18.9	152987	9.4	168200	3.2	191824	0.2	247558	
19	31.5	141911	18.7	153201	9.3	168505	3.1	192350	0.2	249488	11
	31.3	142077	18.6	153417	9.1	168811	3.0	192883	0.2	251508	
20	31.1	142243	18.4	153633	9.0	169121	2.9	193422	0.2	253627	10
	30.8	142411	18.2	153851	8.9	169432	2.9	193969	0.2	255855	
21	30.6	142579	18.0	154070	8.7	169745	2.8	194522	0.1	258203	9
	30.4	142747	17.8	154290	8.6	170061	2.7	195082	0.1	260685	
22	30.1	142916	17.6	154511	8.5	170379	2.7	195650	0.1	263318	8
	29.9	143086	17.5	154733	8.4	170700	2.6	196225	0.1	266121	
23	29.6	143257	17.3	154956	8.2	171023	2.5	196808	0.1	269118	7
	29.4	143428	17.1	155180	8.1	171348	2.4	197399	0.1	272336	
24	29.2	143600	16.9	155406	8.0	171676	2.4	197998	0.1	275812	6
	28.9	143773	16.8	155633	7.9	172006	2.3	198605	0.1	279591	
25	28.7	143946	16.6	155861	7.8	172339	2.3	199221	0.0	283730	5
	28.5	144120	16.4	156090	7.6	172674	2.2	199846	0.0	288306	
26	28.3	144295	16.2	156320	7.5	173012	2.1	200480	0.0	293421	4
	28.0	144470	16.1	156552	7.4	173352	2.1	201124	0.0	299221	
27	27.8	144646	15.9	156784	7.3	173696	2.0	201777	0.0	305915	3
	27.6	144823	15.7	157019	7.2	174042	1.9	202440	0.0	313833	
28	27.4	145000	15.6	157254	7.1	174391	1.9	203113	0.0	323524	2
	27.1	145179	15.4	157490	6.9	174742	1.8	203797	0.0	336018	
29	26.9	145358	15.2	157728	6.8	175097	1.8	204492	0.0	353627	1
	26.7	145538	15.1	157967	6.7	175454	1.7	205198	0.0	383730	
30	26.5	145718	14.9	158208	6.6	175814	1.7	205916	0.0		0
	A	B	A	B	A	B	A	B	A	B	
	92°00'		91°30'		91°00'		90°30'		90°00'		

○

40 300

○

40 300

○

—

GLOSSARY

A

Amplification—The process of increasing the electrical strength of a signal.

Antenna—An electrical conductor or a system of conductors used to radiate or receive radio waves.

Array (Antenna)—An arrangement of antenna elements to achieve desirable directional characteristics.

B

Basepoint—Any point on the earth's surface whose exact location is known by grid coordinates and over which (while airborne) accuracy adjustments to Doppler radar navigational systems may be made.

Bearing—The angular measurement in degrees from true north of an arriving radio wave with relation to the DF site. A bearing is often called a "shot."

Bidirectional—Responsive in two opposite directions. An ordinary loop antenna is bidirectional because it has maximum response from the two opposite directions that are in the plane of the loop.

C

Checkpoint—The exact location of an ARDF aircraft over the ground, identified by grid coordinates, when a DF bearing is obtained from that aircraft.

Coaxial cable—A transmission line consisting of two conductors, one inside the other, and separated by insulating material. The inner conductor may be a small copper tube or wire; the outer conductor may be metallic tubing or braid. Radiation loss from this type of line is practically zero. Coaxial cable is also called concentric line.

Conductivity—The relative ability of a material to allow the flow or passage of an electrical current.

Counterpoise—(1) A system of wires and other conductors that is elevated above and insulated from the ground to form a lower system of conductors for a transceiver antenna. (2) A system which is electrically connected to earth and positioned beneath receiving antenna elements, such as the wire mesh screens used with the AN/TRD-15 direction finder set.

Critical angle—The smallest angle from the vertical at which a radiated wave of a given frequency will still be reflected by the ionosphere. At smaller angles the radio waves penetrate the ionosphere and are not returned to earth.

Cut—The point of intersection of two DF bearings.

D

Dead reckoning—Determination of the approximate position of a vehicle by combining vectors for speed, direction, and other factors with the last known position.

Directional antenna—An antenna which radiates or receives radio waves more effectively in some directions than others. The term is usually applied to antennas whose directivity is greater than that of a half-wave dipole.

DF fix—The probable location of a target transmitter's antenna when three or more DF bearings have been plotted on a chart or map. Sometimes called a fix area.

DF plot (plotting)—The placing of DF bearings on a chart or map so that a target's location can be determined by reference to grid coordinates.

Direct path—A path that has no intervening obstacles and is said to be line-of-sight.

E

E region—The region of the ionosphere, between about 88 and 156 kilometers above the surface of the earth, that contains ionized layers capable of bending (reflecting or refracting) radio waves.

Electromagnetic field—The magnetic field that an electric current produces around the conductor through which it flows.

F

F region—The region of the ionosphere between about 200 and 310 kilometers above the earth's surface.

F1 layer—One of the regular ionospheric layers at an average height of about 225 kilometers which occurs during the daylight hours.

F2 layer—The most useful of the ionospheric layers for radio wave propagation. It is the most highly ionized and highest of the layers, having an average height of 225 kilometers and a midday height of about 400 kilometers.

Fading—Variations in the strength of a received radio signal caused by changes in the characteristics of the propagation or transmission medium.

Frequency—The number of complete cycles per second (Hertz) existing in any form of electrical or sound wave motions.

G

Goniometer—An instrument for measuring angles. Used to calculate and resolve mathematical problems or electrical functions as well as to establish direction phase difference between transmitted or received signals.

Great circle—Any circle described on the surface of the earth or other sphere so that its plane passes through the center of the sphere. Radio waves follow great-circle routes in their passage around the earth.

H

Hop—The path of a radio wave from the earth to the ionosphere and back to earth, in traveling from one point to another. It is usually used in expressions such as single hop, double hop, and multihop. The number of hops is called the order of reflection.

I

Indirect path—Any path, other than a direct path, between two stations.

Interference—Any electrical disturbance from a different source which causes undesirable responses in electronic equipment.

O

Octantal error—The erroneous reading of an arriving signal caused by the nonuniformity of the flux fields within the stationary winding of a goniometer (when used in DF sites).

P

Path—That part of the atmosphere through which the radiated wave passes.

Polarity—An electrical condition determining the direction in which current tends to flow. By common usage, the discharge current is said to flow from the positive electrode through the external circuit.

Polarization—The direction of the electrical field component of radiated energy.

R

Radiate—To send out energy into space, as in the case of RF waves.

S

Siting—Properly locating an antenna, radio set, or DF set to obtain optimum performance.

Skip distance—The minimum separation at which radio waves of a specified frequency can be transmitted at a specified time between two points on the earth by reflection from the regular ionized layers of the ionosphere.

Skywave—A radio wave that reaches the receiving station after returning from the ionosphere (as distinguished from groundwave).

W

Winding—One or more turns of wire forming a continuous coil for a transformer, relay, rotating machine, antenna, or other electrical device.

INDEX

	Paragraph	Page
A		
Abnormal		
Effects of the troposphere	2-15	2-12
Polarization	3-2 <i>d</i> , 3-8 <i>b</i> (3)	3-4, 3-19
Adcock antennas	3-8	3-18
Errors	3-9	3-22
Advantage of		
Gnomonic projection	5-4 <i>b</i>	5-4
Mercator projections with DF	5-4 <i>a</i>	5-3
Aeronautical charts	5-5	5-4
Aircraft employed in ARDF	4-13	4-10
Airborne DF site	4-11	4-10
Airborne radio direction finding	4-1 <i>c</i> , 4-11	4-1, 4-10
Airplane effect for loop error	3-5 <i>c</i> (3)	3-14
Ambiguity		
Resolution	3-3	3-4
With loop antennas	3-2 <i>e</i>	3-4
Amplitude of signal in loop antenna	3-2	3-2
Antenna		
Balance adjustment	3-5	3-12
Capacitance	3-5 <i>d</i> (4)	3-16
Effect	3-5 <i>a</i>	3-12
Antennas and radio propagation, TM 11-666	2-1	2-1
ARDF equipment	4-14	4-10
ARDF navigational requirements	4-17	4-11
ARDF report	4-20	4-11
Aural indicators	3-21 <i>a</i>	3-34
Aural null	3-21	3-34
Automatic bearing-seeking indicators	3-20 <i>c</i> (3), 3-23	3-34, 3-37
B		
Balance adjustment for antenna effects	3-5 <i>a</i> (3)	3-12
Balance in loop construction	3-6 <i>a</i>	3-16
Baseline considerations	4-4	4-7
Baseline, DWDF effort	4-3	4-6
Baseline, SWDF effort	4-10	4-10
Baseline, plotting	5-24	5-17
Basic net requirements for DF communications	6-4	6-2
Bearing		
Indicators	3-20	3-34
Reports	6-2 <i>e</i>	6-1
Seeking type indicators	3-23	3-37
Behavior of electrical waves	2-2	2-1
Border coordinates	7-2	7-1
C		
Callsign, frequency, mission information	6-2 <i>a</i>	6-1
Capacitive goniometer	3-17 <i>b</i>	3-31

	Paragraph	Page
Cardioid		
Response of antenna	3-4a	3-6
Theory	3-4	3-6
Cathode-ray tube indicators	3-22	3-35
Cause of antenna effect	3-5a(2)	3-12
Changes to manual	1-3	1-1
Characteristics		
Of bearing indicators	3-20, 3-21, 3-22, 3-23	3-34, 3-35, 3-37
Circular		
Loop antenna	3-2	3-2
Polarization	2-9b	2-6
Response of sense antenna	3-5b	3-13
Coaxial spaced-loop antennas	3-11	3-24
Combination winding-loop antennas	3-5d(5)	3-16
Comments on manual	1-3	1-1
Communications requirements for DF nets	6-1	6-1
Comparison of DWDF and SWDF site establishment	5-11	5-9
Compass Rose	5-6b	5-6
Concept of warfare	1-4	1-1
Conductivity, soil	2-16	2-13
Cone and cylinder developable surfaces	5-2b	5-1
Construction requirements for goniometers	3-17c	3-31
Contents of airborne DF site	4-11	4-10
Corrected Compass Rose (CCR)	7-3	7-1
Coupled H-Adcock antenna	3-8c(5)	3-20
Coupling systems for DF equipment	3-15	3-27
Crew requirements, ARDF aircraft	4-15	4-11
Crossed-Adcock antennas	3-10	3-23
Crossed-loop antennas	3-7	3-17
Cross reference formula, frequency to meters	2-5b	2-5
Cross reference formula, meters to wavelength	2-5b	2-5
CRT indicators	3-22	3-35
Cryptoprotection on DF net communications	6-1, 6-2e	6-1
Curve, sine	2-4	2-3
Cut	5-22b, 5-23b	5-15
CW and AM radio transmitters and receivers	2-1	2-1

D

D-layer ionosphere	2-12	2-8
DA Form 2028	1-3	1-1
Daily Check of DF accuracy	5-14b	5-11
Declination		
Definition of	5-7b	5-7
Diagrams	5-7a	5-7
Deduction relating to probable target locations	5-29	5-21
Deployment of ARDF companies	4-12	4-10
Derivation of reference points on a sphere	5-3a	5-2
Determination of fix areas	5-28	5-18
Developable surfaces for map making	5-2b	5-1
Dielectric constant of air	2-14	2-10
Diffraction	2-19	2-15
Direct coupling systems	3-16a	3-280
Direction finding		
Accuracy check	5-14	5-11
Errors	5-15	5-11
Plotting	5-22, 5-23	5-15

	Paragraph	Page
Receivers	3-24	3-38
Theory	1-5	1-1
Distance requirements for site installation	5-10 <i>h</i>	5-9
Doppler DF	3-12	3-25
DWDF site installation	4-2	4-1

E

E-layer ionosphere	2-12	2-8
Earth's axis	5-3 <i>a</i>	5-2
Effective distance for line-of-sight transmissions	2-21	2-18
Efficiency of conductors in transmission lines	3-15 <i>b</i>	3-27
Electrical		
Components of radio waves	2-2	2-1
Field	2-3	2-3
Phenomena	2-10	2-8
Electronic goniometer systems	3-18	3-33
Electronic warfare support measures	1-6 <i>c</i>	1-2
Electrostatic shield in loop constructions	3-6 <i>b</i>	3-17
Elements within radio waves	2-2, 2-3	2-1, 2-3
Elevated H-Adcock antenna	3-8 <i>c</i> (4)	3-20
Elliptical polarization	2-9 <i>c</i>	2-7
Environmental ARDF considerations	4-18	4-11
Equator	5-3 <i>a</i>	5-2
Equatorial projection	5-4 <i>c</i>	5-4
Error triangle solution	5-28	5-18
Errors caused by reradiation	4-2 <i>b</i>	4-1
Establishing		
Meridians of longitude	5-3 <i>a</i> (2)	5-2
Parallels of latitude	5-3 <i>a</i> (3)	5-2
Establishment of baseline for DWDF effort	4-3	4-6
Evaluation		
Of results by operator	5-26	5-18
Of results by plotter	5-27	5-18
Exposure to sun causing ionization	2-12	2-8
Extremely High Frequency (EHF)	2-1	2-1

17

F-layer ionosphere	2-12	2-8
F1-layer ionosphere	2-12 <i>b</i>	2-9
Factors affecting ionospheric action	2-12	2-8
Fading or variable field intensity	2-14 <i>c</i>	2-11
Field pattern site testing	5-12 <i>a</i> (2)	5-9
Fix	5-22 <i>c</i> , 5-23 <i>c</i>	5-15
Flight environment for ARDF operations	4-19	4-11
FM communications links	2-21	2-18
Formation of tropospheric ducts	2-15	2-12
Frequency	2-5 <i>a</i>	2-3
Band designators	2-1 <i>a</i>	2-1
Modulation	2-21	2-18

G

Gnomonic projections	5-4 <i>b</i>	5-4
Goniometer	3-7 <i>b</i>	3-17
Electronic capacitive	3-17 <i>b</i>	3-31
Inductive	3-17 <i>a</i>	3-31

	Paragraph	Page
Pattern presentations	3-18	3-33
Great circles	5-3a	5-2
Great Circle Azimuth and Distance (GCAD)	7-4	7-5
Ground conductivity in DF sites	5-10e	5-8
Ground-reflected waves	4-2c(2)	4-4
Grounded H-Adcock antenna	3-8c(3)	3-19
Groundwave	2-11a	2-8

H

H-Adcock antenna construction	3-8a, c	3-17, 3-19
Heaviside, physicist, ionospheric studies	2-12a	2-8
Heights of ionospheric layers	2-12	2-8
Hertz (Hz)	2-5	2-3
High Frequency (HF)	2-1	2-1
Homing with DF equipment	2-22	2-18
Horizontal		
Polarization	2-6, 2-8	2-5
Polarization with Adcock antenna	3-8b	3-18
Humidity and density for tropospheric channeling	2-14b	2-11

I

Identification by tracking practices	6-2e	6-1
Improvements of DF sites	5-13	5-10
Incorrect azimuths due to loop errors	3-5	3-12
Induced voltages in loop antennas	3-2a	3-3
Inductive goniometers	3-17a	3-31
Influence of soil conductivity	2-16	2-13
Initial problem of map projection	5-3b	5-3
Instantaneous indicators	3-22	3-35
Instrument		
Adjustment	5-14	5-11
Calibration	5-14	5-11
Error	5-20	5-15
Interpretation of DF results	5-31	5-22
Intersection		
Of angle bisectors	5-28b	5-19
Of medians in error solution	5-28a	5-19
Ionized gases above the surface	2-11b	2-8
Ionosphere	2-12	2-8
Ionospheric		
Layers	2-12b	2-9
Predictions	2-12d	2-10
Isothermal region	2-13	2-10

K

Kennely, physicist, ionospheric studies	2-12a	2-8
---	-------	-----

L

Layer, combination, ionospheric	2-12c	2-9
Limitations of baseline establishment, DV/DF	4-7	4-9
Line bearing	5-22a, 5-23a	5-15
Linear polarization	2-9a	2-5
Lines and coupling devices for goniometers	3-17d	3-33
Logical application of probable target locations	5-29	5-21
Loop and sense antennas	3-2, 3-3	3-2, 3-4

	Paragraph	Page
Loop		
Antenna application	3-2, 3-3b	3-2, 3-6
Construction	3-6	3-16
Errors	3-5	3-12
Patterns	3-2	3-2
Size	3-6c	3-17
Lopsided pattern of sense antenna combined	3-3	3-4
Low Frequency (LF)	2-1	2-1

M

Magnetic components of radio waves	2-3	2-3
Magnetic field	2-3	2-3
Magnetic variation	5-6a	5-6
Manager of DF resources	6-3	6-2
Map		
Definition of	5-2a	5-1
Equatorial projection	5-4c	5-4
Gnomonic projection	5-4b	5-4
Making factors	5-2b	5-1
Reconnaissance for DWDF sites	4-8	4-9
Transverse Mercator projection	5-4a	5-3
Masking of transmitters to DWDF effort	4-6	4-8
Means of communications within DF nets	6-1	6-1
Mechanization of DF plotting	5-31	5-22
Medium Frequency (MF)	2-1	2-1
Mercator projection	5-4a	5-3
Meridians	5-3a(1)	5-2
Meridians of longitude	5-3a(2)	5-2
Method		
Of reducing path error	5-17e	5-13
Of reducing polarization error	5-18b	5-14
Used to determine probable target locations	5-28	5-18
MF/HF range, surfacewave DF effort	4-2c(3)	4-5
Mirror action reflection	2-17	2-15
Mission		
Assignment	6-3	6-2
Information for DF targets	6-2a, b, c	6-1
Of ARDF resources	4-12	4-10
Multihop transmission	2-20	2-17
Multiple bearings on targets	5-30	5-22

N

Net requirements for DF support	6-4	6-2
Night effect		
To cause loop errors	3-5c(1)	3-14
Noise measurement, site testing	5-12a(1)	5-9
Nonnuclear warfare	1-4	1-1
Northern Hemisphere	5-3a	5-2

O

Octantal errors with goniometers	3-19	3-33
Operations area for ARDF units	4-18	4-11
Operator		
Changes influencing plotting	5-27	5-18
Errors	5-21	5-15

	Paragraph	Page
Evaluation	5-26	5-18
Orientation of DF equipment	5-8	5-7
Other abnormal polarizations	3-8b(3)	3-18

P

Parallax or optical distortion	2-17	2-15
Parallels of latitude	5-3a(3)	5-2
Path error	5-17	5-11
Pattern		
With abnormal polarization	3-2d	3-4
With normal polarization	3-2c	3-3
Penetration of ionosphere	2-11b, 2-12	2-8
Phase voltage in loop antennas	3-2	3-2
Plane		
Polar diagram of radio wave	3-1	3-1
Polarization	2-9	2-5
Plotter evaluation	5-27	5-18
Polar		
Diagram of antennas	3-1	3-1
Reference on maps	5-3	5-1
Polarity	2-2b	2-1
Polarization		
Causing loop errors	3-5c	3-14
Circular	2-9b	2-6
Error	5-18	5-14
Errors with spaced-loop antennas	3-11d	3-25
Linear	2-9a	2-5
Of oceanwaves	2-7	2-5
Of radio waves	2-6	2-5
Of surfacewaves	4-2c(3)(c)	4-5
Positive Charge	2-2	2-1
Principle of the Adcock antenna	3-8b	3-18
Problems of control of DF nets	6-2	6-1
Propagation		
Factors	2-10	2-8
Of electromagnetic waves	2-1	2-1
Purpose		
Of manual	1-1	1-1
Of sense antenna	3-3a	3-4

Q

Quasi-Doppler DF	3-13	3-26
----------------------------	------	------

R

Radio horizons in ARDF operations	4-12	4-10
Receivers, DF	3-24	3-38
Recombination of ionosphere	2-12	2-8
Reflection	2-17	2-15
Refraction		
Definition of	2-11b, 5-17b	2-8, 5-12
Of radio waves	2-14a, 2-18	2-10, 2-15
Reliability of plotting and fix production	5-26	5-18
Requests for DF support	6-2e, 6-3	6-1, 6-2

	Paragraph	Page
Reradiation	5-17d	5-12
Reradiation for DWDF efforts	4-2b	4-1
Response pattern, crossed-loop antennas	3-7a	3-17
Right-triangle method	7-3b	7-1
Rotating		
Capacitor coupling	3-16b(2)(c)	3-30
Transformer coupling	3-16b(2)(b)	3-30
Rotation of loop antenna to vary response	3-2	3-2

S

Scatter	2-14b, 5-17a	2-11, 5-11
Scope	1-2	1-1
Searching by operators on DF sites	6-2a	6-1
Secure voice nets for DF communications	6-1	6-1
Selection of map projection types for DF	5-4	5-3
Shielded U-Adcock antenna	3-8c(2)	3-19
Shielding and grounding to remedy antenna effect	3-5a(4)	3-12
Signal Intelligence	1-6b	1-2
Simple U-Adcock antenna	3-8c(1)	3-19
Sine curve	2-4	2-3
Single site DF efforts, tactical support	6-2e	6-1
Site		
Criteria	5-10	5-8
Errors equated to plotting	5-19	5-15
Testing	5-12	5-9
Siting errors in DF installations	5-9	5-8
Skewness in loop antennas	3-5d(3)	3-15
Skip		
Distance	2-20	2-17
Zone	2-20	2-17
Skywave direction finding	4-1b, 4-9	4-1, 4-10
Skywaves	2-11b	2-8
Slip ring coupling systems	3-16b(2)(a)	3-30
Soil conductivity	2-16	2-13
Source error	5-16	5-11
Southern Hemisphere	5-3a	5-2
Spaced-loop antennas	3-11	3-24
Spacing with crossed-Adcock antennas	3-10b	3-24
Spiral pancake winding of loop antennas	3-5d(2)	3-15
Square loop antennas	3-2	3-2
Square root	7-10	7-13
Standard Deviation (SD)	7-11	7-14
Statistical factors	7-11	7-14
Steiner point method of error solution	5-28c	5-19
Stratosphere	2-13	2-10
Stretching or tearing developable surfaces	5-2b	5-1
Super High Frequency (SHF)	2-1	2-1
Surfacewave	4-2c(3)	4-5
SWDF site factors	4-9	4-10
Symmetrical pancake winding of loop antennas	3-5d(1)	3-15
Systematic Error (SE)	7-8	7-11

T

Tactical requirements for site testing	5-12b	5-9
Taking an azimuth with spaced-loop antennas	3-11e	3-25

	Paragraph	Page
Target location, determination of	5-28, 5-29	5-18, 5-21
Targets in DF missions	4-12, 5-22, 6-2	4-10, 5-15, 6-1
Tasking and reporting of DF facilities	6-2e	6-1
Tasking assignment	6-3	6-2
Tasking authority	6-3	6-2
Tasking of ARDF resources	4-12	4-10
Technical improvement of DF sites	5-13	5-10
Techniques to overcome antenna effect	3-5a	3-12
Teletypewriter communications in DF nets	6-1a, b	6-1
Temperature inversion	2-15	2-12
Template, Steiner point evaluation method	5-28c	5-19
Terrain regarding Adcock antenna errors	3-9a	3-22
Terrain, surfacewave	4-2c(3)(b)	4-5
Three-station fix, error triangle	5-28	5-18
Tilting Adcock antenna	3-8d	3-20
Transmission line coupling	3-16b	3-30
Transmission lines with antennas	3-14	3-27
Transverse Mercator projections	5-4a	5-3
Transverse wave motion	2-9	2-5
Triangle		
Bisection of angles	5-28b	5-19
Bisection of medians	5-28a	5-19
Troposphere	2-14	2-10
Tropospheric		
Bounce	2-14a	2-10
Duct	2-15	2-12
Height above earth	2-14	2-10
Scatter	2-14	2-10
Types of		
Adcock antennas	3-8c	3-19
DF communications	6-1b	6-1
DF effort	4-1	4-1
Directional antennas	3-2, 3-8, 3-9	3-2, 3-17, 3-22
Radio waves	2-11	2-8
Windings in loop antennas	3-5d	3-14
Typical ARDF equipment installations	4-14	4-10

U

U-Adcock antenna	3-8	3-17
UHF transmissions	2-23	2-19
Ultrahigh Frequency (UHF)	2-1	2-1
Ultraviolet rays	2-12	2-8
Undulating waves	2-7	2-5
Universal Mercator projection	5-4a	5-3
Use of		
Map projection with DF	5-1, 5-4, 5-5	5-1, 5-3, 5-4
The compass rose	5-6	5-5
The goniometer with crossed-loop	3-7b	3-17

V

Variance	7-9	7-12
Varying		
Height of ionospheric waves	2-12	2-8
Ionization	2-12	2-8
Vertical		
Polarization	2-7	2-5
Polarization with Adcock antennas	3-8b(1)	3-18
Vertically polarized waves	2-7	2-5
Very High Frequency (VHF)	2-1	2-1
Very Low Frequency (VLF)	2-1	2-1
VHF transmission	2-21	2-18
Visual inspection	5-28d	5-19
Visual null	3-22	3-35
Voice nets, planning range	2-21	2-18

W

Wave front cross section	2-16	2-13
Waveguide action with tropospheric transmissions	2-15	2-12
Wavelength	2-4	2-3
Wavepath considerations DWDF effort	4-5	4-7
Wave propagation theory	2-1	2-1
Waves lost for communications	2-11b	2-8
Weak signal causing loop errors	3-5b	3-13
Whip antenna	2-6	2-5
Winding arrangement of loop antennas	3-5d	3-14

[The page contains extremely faint and illegible text, likely bleed-through from the reverse side of the document. The text is scattered across the page and cannot be transcribed accurately.]



FM 30-476

8 APRIL 1977

By Order of the Secretary of the Army:

BERNARD W. ROGERS
General, United States Army
Chief of Staff

Official:

PAUL T. SMITH
Major General, United States Army
The Adjutant General

DISTRIBUTION:

Active Army, USAR, and ARNG: To be distributed in accordance with DA Form 12-11 B, Requirements for Combat Intelligence (Qty rqr block no. 273); Military Intelligence Battalion, Field Army (Qty rqr block no. 274); Technical Intelligence (Qty rqr block no. 279); Intelligence Collection Operations (Qty rqr block no. 282); USASA in support of Tactical Operations (Qty rqr block no. 323); Electronic Warfare (Qty rqr block no. 325).

Additional copies can be requisitioned (DA Form 17) from the US Army Adjutant General Publications Center, 2800 Eastern Boulevard, Baltimore, MD 21220.

