

★  
(USAF) T.O. 12R2-2ARR7-2  
(NAVY) AN 16-30ARR7-2

**HANDBOOK  
MAINTENANCE INSTRUCTIONS**

**RADIO RECEIVING SETS**  
**AN/ARR-7            AN/ARR-7AX**

THIS PUBLICATION REPLACES AN 16-30ARR7-2 DATED 25 APRIL 1945.

PUBLISHED UNDER AUTHORITY OF THE SECRETARY OF THE AIR FORCE  
AND THE CHIEF OF THE BUREAU OF AERONAUTICS

★  
15 OCTOBER 1954

**AN 16-30ARR7-2**

Reproduction for non-military use of the information or illustrations contained in this publication is not permitted without specific approval of the issuing service (BuAer or USAF). The policy for use of Classified Publications is established for the Air Force in AFR 205-1 and for the Navy in Navy Regulations, Article 1509.

**LIST OF REVISED PAGES ISSUED**

**INSERT LATEST REVISED PAGES. DESTROY SUPERSEDED PAGES.**

**NOTE:** The portion of the text affected by the current revision is indicated by a vertical line in the outer margins of the page.

\* The asterisk indicates pages revised, added or deleted by the current revision.

**ADDITIONAL COPIES OF THIS PUBLICATION MAY BE OBTAINED AS FOLLOWS:**

**USAF ACTIVITIES.**—In accordance with Technical Order No. 00-5-2.  
**NAVY ACTIVITIES.**—Submit request to nearest supply point listed below, using form NavAer-140; NASD, Philadelphia, Pa.; NAS, Alameda, Calif.; NAS, Jacksonville, Fla.; NAS, Norfolk, Va.; NAS, San Diego, Calif.; NAS, Seattle, Wash.; ASD, NSC, Guam.  
For listing of available material and details of distribution see Naval Aeronautics Publications Index NavAer 00-500.

## TABLE OF CONTENTS

<i>Section</i>	<i>Page</i>
I. GENERAL DESCRIPTION . . . . .	1
1- 1. General . . . . .	1
1- 6. Description of Parts . . . . .	2
II. INSTALLATION AND ADJUSTMENT . . . . .	3
2- 1. Preliminary Procedure . . . . .	3
2- 4. Installation Procedure . . . . .	3
2- 9. Adjustment . . . . .	4
III. OPERATION . . . . .	5
3- 1. Starting and Stopping Equipment . . . . .	5
3- 4. Operation — Radio Receiving Set R-45/ARR-7 . . . . .	5
3-16. Operation — Radio Receiving Set R-595/ARR-7AX . . . . .	7
IV. PRINCIPLES OF OPERATION . . . . .	9
4- 1. General Description . . . . .	9
4- 6. Radio Receiver R-45/ARR-7 . . . . .	9
4-35. Radio Receiver R-595/ARR-7AX . . . . .	13
4-63. Rectifier Power Unit PP-32/AR . . . . .	17
V. MAINTENANCE . . . . .	17
5- 2. Preflight Inspection . . . . .	17
5- 3. 25-Hour Inspection . . . . .	17
5- 4. 100-Hour Inspection . . . . .	18
5- 5. Trouble Shooting Installed Radio Receiver and Rectifier Power Unit . . . . .	18
5- 8. Trouble Shooting at Repair Station . . . . .	18
5-13. Replacement of Fuses and Lamps . . . . .	24
5-18. Special Maintenance Operations . . . . .	24
5-24. Alignment — Radio Receiver R-45/ARR-7 . . . . .	25
5-30. Alignment — Radio Receiver R-595/ARR-7AX . . . . .	27
VI. SUPPLEMENTARY DATA . . . . .	32
VII. DRAWINGS . . . . .	35

## LIST OF TABLES

<i>Table</i>	<i>Page</i>
I. Equipment Supplied . . . . .	1
II. Equipment Required but not Supplied . . . . .	2
III. Power Requirements . . . . .	2
IV. Trouble Shooting Chart — Installed Equipment . . . . .	19
V. Trouble Shooting Chart — Detached Equipment . . . . .	20
VI. Voltage Readings — Radio Receiver R-45/ARR-7 . . . . .	21
VII. Voltage Readings — Radio Receiver R-595/ARR-7AX . . . . .	22
VIII. Voltage Readings — Rectifier Power Unit PP-32/AR . . . . .	22
IX. Resistance Readings — Radio Receiver R-45/ARR-7 . . . . .	23
X. Resistance Readings — Radio Receiver R-595/ARR-7AX . . . . .	23
XI. Resistance Readings Rectifier Power Unit PP-32/AR . . . . .	24
XII. Radio Receiver R-45/ARR-7 — Resistance and Inductance Data for Filter Choke and Motor Armature . . . . .	24
XIII. Rectifier Power Unit PP-32/AR — Resistance and Inductance Data for Filter Choke and Power Transformer . . . . .	24
XIV. R-F and Oscillator Alignment Chart — Radio Receiver R-45/ARR-7 . . . . .	27
XV. R-F and Oscillator Alignment Chart — Radio Receiver R-595/ARR-7AX . . . . .	31
XVI. I-F Selectivity Characteristics . . . . .	32
XVII. Radio Receiver R-45/ARR-7 — AVC Action . . . . .	33
XVIII. Tube Complement . . . . .	34
XIX. Pilot Light Complement . . . . .	34

RADIO RECEIVER  
R-45/ARR-7

RECTIFIER POWER UNIT  
PP-32/AR

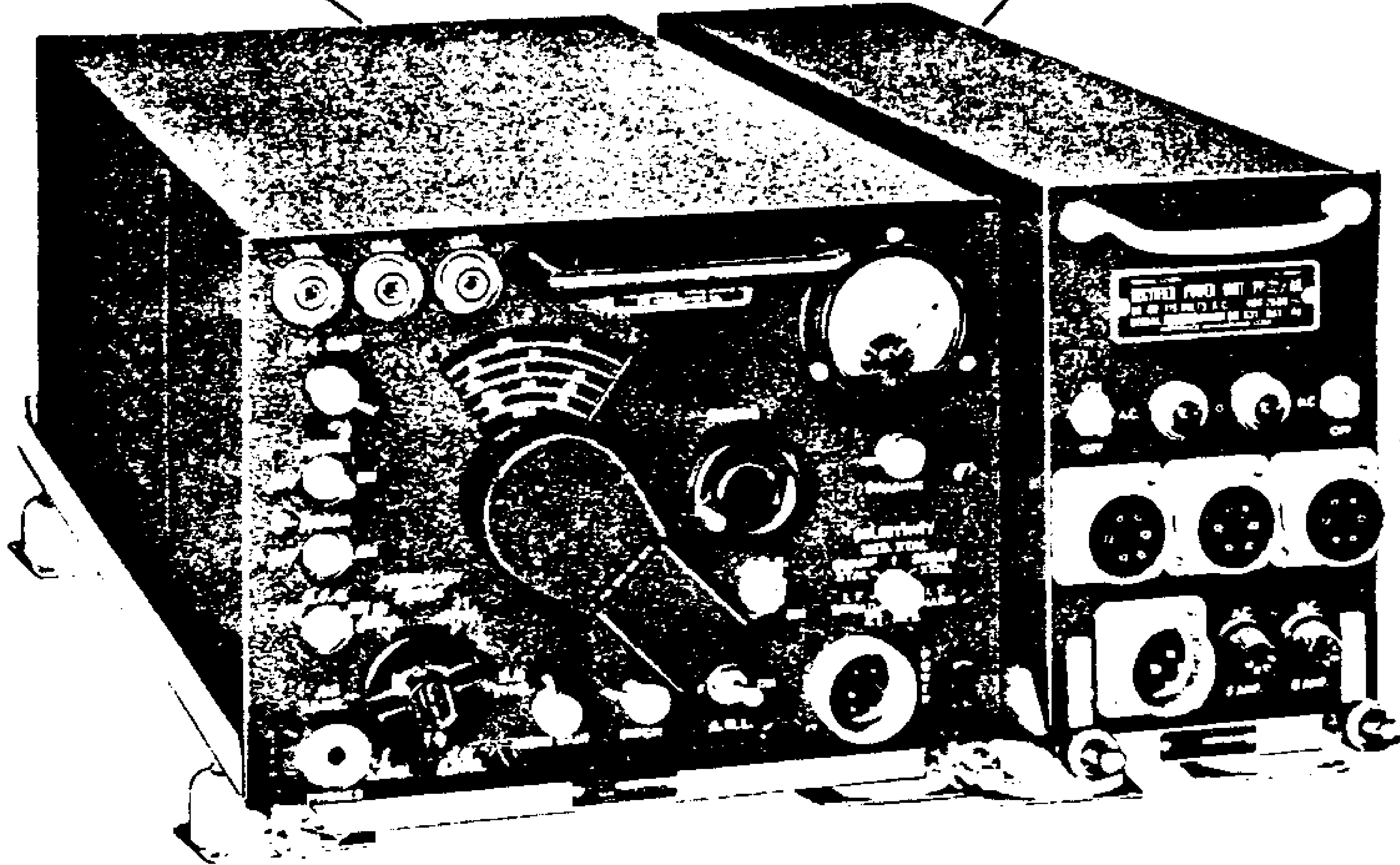

RADIO RECEIVER  
R-595/ARR-7AX

RECTIFIER POWER UNIT  
PP-32/AR

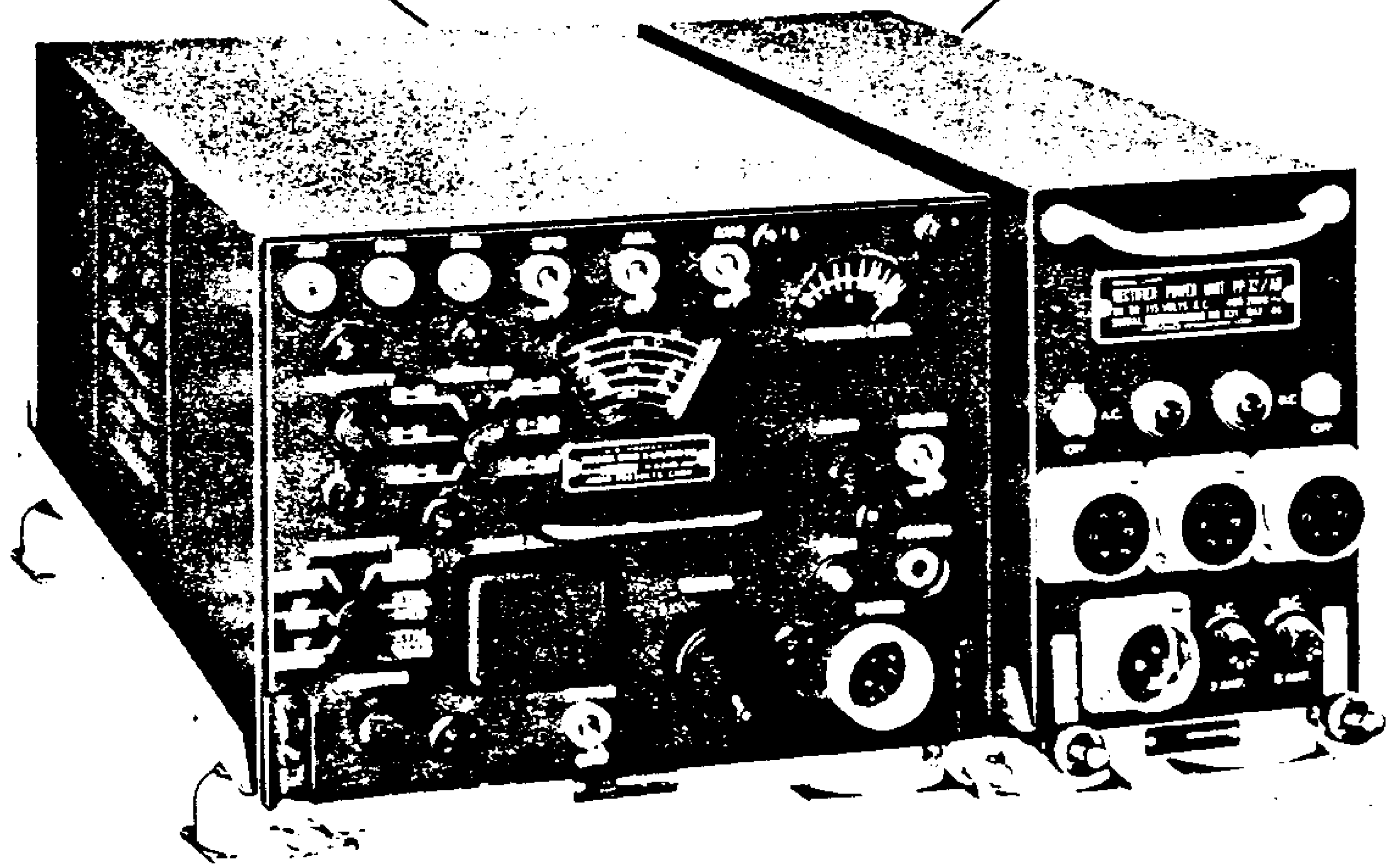

Figure 1-1. Radio Receiving Sets AN/ARR-7 (Upper) and AN/ARR-7AX (Lower)

## SECTION I GENERAL DESCRIPTION

### 1-1. GENERAL. (See figure 1-1)

1-2. Radio Receiving Sets AN/ARR-7 and AN-ARR-7AX are airborne search receivers designed to locate radio frequency channels of radar and communication signals in the frequency range of 0.55 to 42.0 megacycles.

1-3. These receivers are designed to be used with equipment which will indicate visually and aurally the presence and character of received signals over a pre-determined sector of a given tuning band. They may be operated in conjunction with Radar Indicator Assem-

bly AN/APA-6 or AN/APA-11 and/or Panoramic Adapters AN/APA-10 or BC-1050. No provision is made for remote control of the receivers.

1-4. Radio Receiving Set AN/ARR-7 consists of Radio Receiver R-45/ARR-7 and Rectifier Power Unit PP-32/AR while the AN/ARR-7AX equipment consists of Radio Receiver R-595/ARR-7AX in conjunction with Rectifier Power Unit PP-32/AR. Both sets are provided with mounting bases, connecting cables, and accessories as listed in Table I, Equipment Supplied. Equipment required but not supplied is listed in Table II.

Table I

EQUIPMENT SUPPLIED					
Quantity per Equipment	Name of Unit	USAF Type Designation	Navy Type Designation	Overall Dimensions (Inches)	Weight (Pounds)
1	*Radio Receiver	R-45/ARR-7	R-45/ARR-7	21-5/8 x 10-7/16 x 7-3/4	36.7
1	Radio Receiver	R-595/ARR-7AX	R-595/ARR-7AX	20-1/4 x 10-7/16 x 7-1/4	29.0
1	Mounting Base	MT-171/U	MT-171/U	22-3/4 x 10-3/8 x 2-1/2	2.18
1	Rectifier Power Unit	PP-32/AR	PP-32/AR	21 x 5-1/8 x 7-3/4	25.0
1	Mounting Base	MT-167/U	MT-167/U	22-3/4 x 6 x 2-1/2	1.81
1	Antenna Support	AB-27/A	AB-27/A		
1	Insulator	IN-88			
3	Plug	PL-259		3/4 dia. x 1-1/2 long	0.05 ea.
1	Plug	AN3108-22-4S	AN3108-22-4S	1-19/32 dia. rt. angle 2-11/32 x 1-5/16	0.24
3	Plug	AN3108-22-5P	AN3108-22-5P	1-19/32 dia. x 2-1/8 long	0.14 ea.
1	Plug	AN3108-22-5S	AN3108-22-5S	1-19/32 dia. rt. angle 2-11/32 x 1-5/16	0.23
4	Adapter	M-359		23/32 dia. rt. angle 17/32 x 13/16	0.076 ea.
5	Cable Adapter	AN3057-12	AN3057-12		
1	Tension Unit in accordance with U. S. AAF Drawing 43A-17812				
1	Thimble	AN100-3	AN100-3		
30 ft.	Radio Frequency Cable	RG-8/U	RG-8/U		
40 ft.	Wire	W-106-A			

\*Used with Radio Receiving Set AN/ARR-7  
|Used with Radio Receiving Set AN/ARR-7AX

Table II

EQUIPMENT REQUIRED BUT NOT SUPPLIED				
Quantity per Equipment	Name of Unit	USAF Type Designation	Navy Type Designation	Required Characteristics
1	Headset	HS-23 or HS-33		600 ohms 8000 ohms
1	Cord	CD-307A		Extension for phones

1-5. Radio Receiving Sets AN/ARR-7 and AN/ARR-7AX are designed to accept CW or ICW code signals or amplitude modulated telephone signals. Each receiver is provided with a phone jack for use of a headset, and has receptacles on the operating panel for connection of video and recording equipment. Motor driven sweep mechanism is incorporated in each receiver for automatic scanning operation.

**1-6. DESCRIPTION OF PARTS.** (See figure 1-1).

1-7. RADIO RECEIVER R-45/ARR-7.—The receiver is mounted in a standard aircraft radio case B1-D1, with all receptacles and controls except the motor speed control and the "S" meter zero adjustment control located on the front panel. The receiver is attached to Mounting Base MT-171/U by means of a swivel locking mechanism which allows attachment without the use of tools.

1-8. RADIO RECEIVER R-595/ARR-7AX. This receiver is also mounted in a standard aircraft radio case, B1-D1. All receptacles and controls with exception of the motor speed control are mounted on its front panel. The R-F, I-F, BFO, and AUDIO sections are replaceable units which are provided with connecting cables fitted with plugs for connection to the main chassis. The POWER section is integral with the main chassis and the control panel. The receiver is mounted on shock Mounting Base MT-171/U.

1-9. RECTIFIER POWER UNIT PP-32/AR. The power unit is provided with three receptacles for the simultaneous operation of three receivers. The unit is mounted in standard aircraft radio case, A1-D, with all controls, receptacles and fuses located on the front panel.

1-10. Power requirements of the equipment are listed in Table III.

Table III

POWER REQUIREMENTS		
Voltage	Current (amperes)	DC- Watts or AC-V.A.
	Radio Receiver R-45/ARR-7	
270.0 dc	0.135	36.4
24.0 dc	*0.35	* 8.4
6.3 ac	4.0	25.2
	Radio Receiver R-595/ARR-7AX	
270.0 dc	0.120	32.4
27.5 dc	*1.2	*33.0
6.3 ac	4.04	25.5
	Rectifier Power. Unit PP-32/AR	
115 ac, 380 to 1000 cps	1 receiver 1.5	170
	2 receivers 2.0	225
	3 receivers 2.7	305

\*Sweep motor in operation.

## SECTION II

### INSTALLATION AND ADJUSTMENT

#### 2-1. PRELIMINARY PROCEDURE.

2-2. UNPACKING. Carefully unpack and inspect the components for evidence of mechanical damage during shipment. Check to determine whether or not all necessary components are contained in the packages. In case of damage or loss of components in shipment, file an unsatisfactory report form.

#### 2-3. BENCH TEST.

a. With the receiver and rectifier power unit dust covers removed, make sure that all tubes are seated firmly in their sockets.

b. Manipulate each control on the front panel of the receiver to insure proper mechanical operation.

c. Make sure that the fuses located in the holders on the front panel of the rectifier power unit are in place and intact. (See figure 3-1).

#### 2-4. INSTALLATION PROCEDURE.

2-5. ANTENNA INSTALLATION. Use a single wire or fan-type antenna. The installation features for each installation are determined at the time of mock-up. A 7-foot single wire antenna broken by an insulator at 4½ feet is usually used. For high band operation, run a lead into a 4½-foot section. For low band operation, place a jumper across the center insulator so that the antenna length will be the entire seven feet.

2-6. RADIO RECEIVER R-45/ARR-7 or R-595/ARR-7AX AND RECTIFIER POWER UNIT PP-32/AR.

a. If possible fasten Mounting Base MT-171/U for the receiver and Mounting Base MT-167/U for the rectifier power unit side by side within the aircraft so that:

(1) They will be relatively close to the antenna lead-in.

(2) They will be conveniently near the power source.

(3) Ventilation will not be obstructed.

(4) They will be at least two inches away from the fuselage to allow free passage of cordage and connecting cables.

(5) The front panels of the components are adequately illuminated and are easily accessible for manipulation of the controls.

(6) They will not interfere with the operation of other equipment.

b. Securely fasten the radio receiver and rectifier power unit to their respective mounting bases. Tighten the knurled locking nuts at each side of the front panels. Tie down these nuts with safety wire, threading the wire through the holes provided in the knurled locking nut and the ball cap.

#### 2-7. CABLING. (See figure 7-1).

a. Construct the interconnecting cable between the rectifier power unit and the radio receiver by connecting similarly lettered terminals of plug AN3108-22-5S and plug AN3108-22-5P with suitable lengths of No. 12 wire for terminals "B" and "F". Use No. 16 wire for connecting the remaining terminals.

b. Construct the power wiring cable by connecting wires to plug AN3108-22-4S thus:

(1) Ungrounded (hot a-c lead to terminal "A".

(2) Positive d-c lead to terminal "B".

(3) Grounded (neutral) a-c lead to terminal "C".

(4) Negative d-c lead (ground) to terminal "D".

#### Note

The scanning mechanism will not reverse automatically if the d-c polarity is reversed.

#### 2-8. INTERCONNECTION OF UNITS.

(See figure 7-1).

a. Insert plug AN3108-22-5S in the receptacle marked "POWER" on the control panel of Radio Receiver R-45/ARR-7, or R-595/ARR-7AX and plug AN3108-22-5P in any one of the three identical power outlet receptacles on the panel of Rectifier Power Unit PP-32/AR.

#### Note

Do not insert plug AN3108-22-4S until all interconnecting cables have been installed and checked.

b. Connect the power cord to the plane's source of power and after checking the wiring of all interconnecting cables and setting the a-c and d-c power switches on the rectifier power unit at "OFF", insert plug AN3108-22-4S into the power receptacle on the panel of the power unit.

## 2-9. ADJUSTMENT.

As the receiver is properly aligned before shipment and the aligning adjustments are sealed, realignment is unnecessary before installation.

## 2-10. AFTER INSTALLATION TESTS.

### WARNING

Voltages exposed within the receiver and the power unit are high. Care must be taken to prevent contacting high voltage leads when working on the equipment with the protective housings removed.

## 2-11. VISUAL.

a. Before operating the equipment, check the following to make sure that:

- (1) The a-c power source is operating and has the correct voltage and frequency.
- (2) The d-c power source of the aircraft is operating and has the correct voltage and polarity.
- (3) All interconnecting cables are correctly connected and securely positioned.
- (4) All tubes are in place.
- (5) All components are securely mounted.
- (6) Adequate ventilation is provided for the rectifier power unit.

b. The following components on the panels of the radio receiver and rectifier power unit should be in place and securely fastened:

- (1) Power connections.
- (2) Sector adjustment mechanism cover.
- (3) Two 5-ampere fuses located on the panel of the rectifier power unit.

## 2-12. OPERATIONAL. (See figures 3-1, 3-2, and 3-3.)

- a. Plug a headset (600 ohm impedance) into the jack marked "PHONES" located on the front panel of receiver.
- b. Open the sector adjustment cover on the front panel and loosen the thumb screw. Close the cover.
- c. Set the "A.C." and "D.C." power switches on the Rectifier Power Unit PP-32/AR at "ON".
- d. Turn the receiver "POWER" switch on.
- e. Test the operating characteristics of the receiver by aural reception of signals in each band, actuating each control to determine proper functioning. The receiver should be manually tuned for this test.
- f. If the noise level is excessive because of the location in which the test is made, it may be attenuated by setting the "SELECTIVITY" switch at one of the

"XTAL" positions or actuating the "A.N.L." switch, or both.

2-13. Check the "S" or "CARRIER LEVEL" meter adjustment as follows:

### Note

When receiving amplitude modulated signals, the "S" or "CARRIER LEVEL" meter indicates the relative strength of the received carrier. On both receivers, the "A.V.C." switch must be on and the "B.F.O." switch must be off or the meter will not operate properly.

- a. Remove the antenna connection.
- b. Advance the "SENSITIVITY" control ("R.F. GAIN" on Radio Receiver R-45/ARR-7.) clockwise as far as it will go.
- c. Using a screw driver, turn the "S ADJ" control slightly until the meter needle rests on zero.

### Note

The "S ADJ" control is located on the front panel of Radio Receiver R-595/ARR-7AX. On Radio Receiver R-45/ARR-7, this control is mounted internally between the "OSC" coil and the front panel.

2-14. Test the motor driven sweep mechanism as follows:

- a. Set the scanning sector cams for full bandwidth operation. (Refer to par. 3-8 for these adjustments on Radio Receiver R-45/ARR-7 or to par 3-20 for those on Radio Receiver R-595/ARR-7AX.)
- b. Start the sweep motor by turning the "MOTOR" switch on. The 180-degree sweep of the tuning capacitor should be completed in from 17 to 35 seconds.

2-15. If motor noise is encountered in the output of Radio Receiver R-45/ARR-7 when operating the motor at maximum speed, it is necessary to adjust the motor speed control. Proceed as follows:

- a. Remove the receiver from its mounting, and remove receiver dust cover.
- b. Locate the motor speed control on the top of the chassis proper at the rear.
- c. Using a screw driver, turn the control slightly in a counterclockwise direction. Do not turn the control too far as this will affect the speed of the motor materially.

2-14. On completion of the installation tests, turn all controls and switches on the receiver and rectifier power unit to the "OFF" position.

## SECTION III OPERATION

### 3-1. STARTING AND STOPPING EQUIPMENT.

#### 3-2. TO START THE EQUIPMENT.

(See figures 3-1, 3-2, and 3-3).

a. Set the a-c and d-c power switches located on the front panel of the Rectifier Power Unit PP-32/AR at "ON".

b. Set the "POWER" switch on the panel of the receiver at "ON". (At "POWER" on Radio Receiver R-595/ARR-7AX.)

#### 3-3. TO STOP THE EQUIPMENT.

a. Turn off sweep motor, if in use, by setting "MOTOR" switch to "OFF".

b. Set "POWER" switch on radio receiver to "OFF" position.

c. Set a-c and d-c switches on the rectifier power unit to "OFF" positions.

### 3-4. OPERATION—RADIO RECEIVING SET R-45/ARR-7. (See figure 3-2).

#### 3-5. PRELIMINARY.

a. Start the equipment.

b. Plug a headset into the jack marked "PHONES".

### 3-6. FOR RECEPTION OF AMPLITUDE- MODULATED SIGNALS.

a. Tune the receiver manually for this operation by first opening the sector dust cover and loosening the thumb screw within. Close cover.

b. Set the "FREQUENCY RANGE" switch to the desired band.

c. Turn the "R.F." control clockwise as far as it will go.

d. Turn the "SELECTIVITY" control to "I.F. BROAD" position.

e. Set the "A.V.C." switch at its "ON" position. The "PITCH" control is now inoperative.

f. Turn the "AUDIO GAIN" control counterclockwise as far as it will go.

g. Advance the "AUDIO GAIN" control in a clockwise direction until the background noise is audible.

h. Tune to the desired frequency by means of the "TUNING" control.

i. Adjust the "AUDIO GAIN" control until the signal level is suitable.

#### Note

When receiving amplitude modulated signals according to the foregoing instructions, the tuning or "S" meter indicates the strength of the received carrier. To compare relative carrier strengths of two or more signals, do not reset the "R.F. GAIN" control as this adjustment affects the meter indication.

### 3-7. FOR RECEPTION OF CONTINUOUS- WAVE SIGNALS.

a. Set the "B.F.O." switch to the "ON" position.

b. Tune in the signal with the "TUNING" control until zero beat is obtained.

c. Vary the "PITCH" control until a beat note of the desired pitch is obtained.

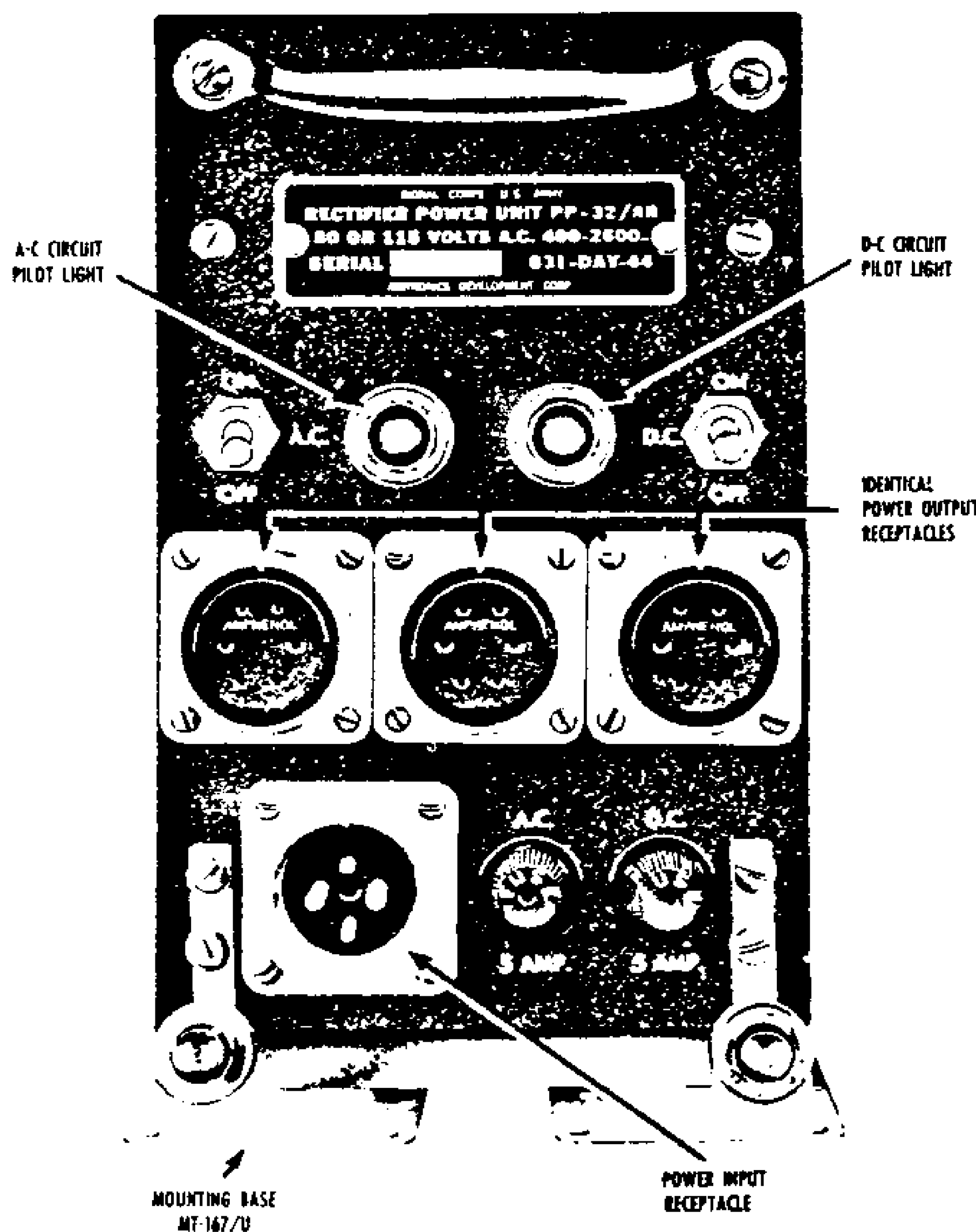

Figure 3-1. Rectifier Power Unit PP-32/AR—  
Front Panel

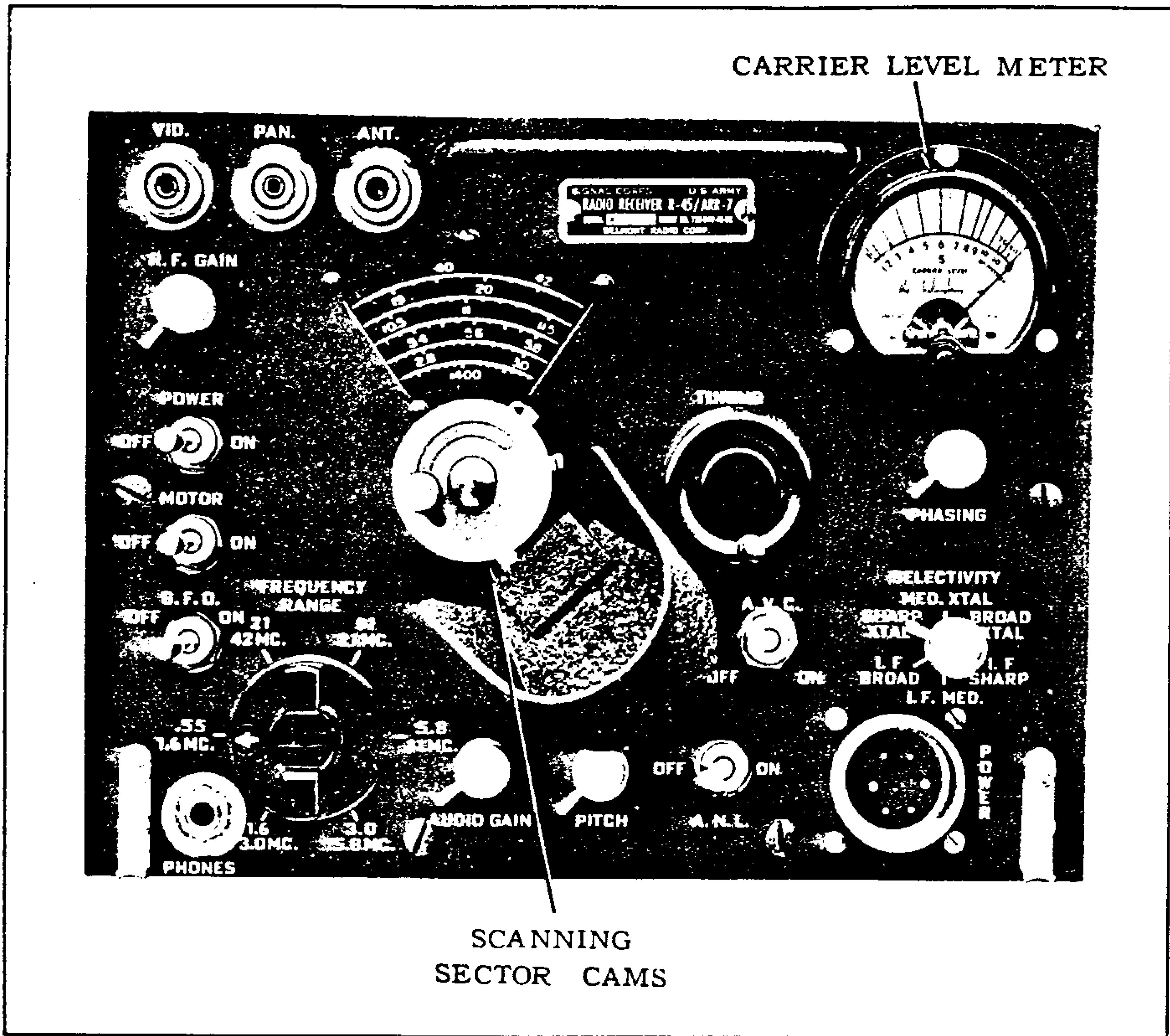

Figure 3-2. Radio Receiver R-45/ARR7—Operating Controls

**Note**

The beat frequency oscillator whistle may also be used to locate weak phone signals. Tune the signal in with the "B.F.O." switch "ON" until zero beat is obtained; then switch the "B.F.O." to the "OFF" position.

**Note**

The thumb screw locking the sector cams should be loose when the automatic scanning drive is not being used. The screw is captivated and will not drop off.

**3-8. FOR AUTOMATIC SCANNING OPERATION.**

a. Select the frequency band to be scanned and set the "FREQUENCY RANGE" control to this band.

b. Manually tune the receiver to the lowest frequency in the band to be covered, first opening the sector cam dust cover and loosening the thumb screw within.

c. With the tripping arms hanging down, swing the arm nearest the reversing switch in a counterclockwise direction until it rests against the reversing switch handle. Tighten the thumb screw just sufficiently for the cam to hold this position.

d. Tune the receiver with the "TUNING" control to the highest frequency in the sector to be covered.

e. Hold the tripping arm of the sector sweep which was previously set in position; loosen the thumb screw and swing the remaining tripping arm in a clockwise direction until it rests against the reversing switch handle. Tighten the thumb screw firmly, thus locking the sweep mechanism in place.

f. Set the "MOTOR" switch to its "ON" position and check the scanning range. Readjust the cams slightly, if necessary, to cover the desired range.

g. Close dust cover.

### 3-9. OPERATION EMPLOYING SPECIAL CONTROLS.

3-10. "SELECTIVITY" CONTROL. Position the "SELECTIVITY" control to "I.F. BROAD" position when interference is not present and it is desired to pass all of the sideband components of the received signals. In this condition, the fidelity of the reproduced signal will be maximum.

3-11. The "I.F. MED." and "I.F. SHARP" positions provided increasingly sharper i-f. channels and reduce fidelity, but produce a better signal to noise ratio.

#### Note

Use the three crystal positions only for the reception of code signals since their use produces a serious cutting of sidebands.

3-12. The "XTAL BROAD" position provides a selectivity similar to "I.F. SHARP" but produces a cleaner cutting of sidebands.

3-13. Operate on the "XTAL SHARP" position only when interference from unwanted signals is excessive. This position provides the maximum degree of selectivity.

3-14. "PHASING" CONTROL. The "PHASING" control is used to remove heterodyne interference and other forms of interference having a predominance of high-frequency components such as static and interference from electrically operated devices. It is operative only when used with any one of the three "XTAL" positions on the "SELECTIVITY" control. Phasing is performed in the following manner:

a. Tune in a strong CW code signal.

b. On tuning across this signal two peak amplitudes will be noted, one considerably weaker than the other. A definite minimum will exist between the two peaks. Tune carefully to the weaker of the two peaks.

c. Adjust the "PHASING" control until this weaker peak disappears or falls to a minimum value.

d. Retune to the remaining peak for reception. This phasing operation will hold with no further adjustment for a particular condition of interference.

3-15. "A.N.L." CONTROL. The *automatic noise limiter* control aids materially in reducing interference by limiting the amplitude to which a transient noise im-

pulse may rise. Leave the "A.N.L." switch in its "ON" position only if it brings about a noticeable reduction of noise.

### 3-16. OPERATION—RADIO RECEIVING SET AN/ARR-7AX. (See figure 3-3).

a. After putting the equipment into operation according to paragraph 3-2, set the "RANGE MC" switch to the desired band.

b. Turn the "SENSITIVITY" control clockwise as far as it will go.

c. Set the "SELECTIVITY" control to "I.F. BROAD".

d. Set the "AVC" switch at its "AVC" position.

e. Turn the "AUDIO" control counterclockwise as far as it will go.

f. Advance the "AUDIO" control in a clockwise direction until the background noise is audible.

g. Tune to the desired frequency by means of the "TUNING" control.

h. Adjust the "AUDIO" control until the signal level is suitable.

#### Note

When receiving amplitude modulated signals according to the foregoing instructions the "CARRIER LEVEL" meter indicates the strength of the received carrier. To compare relative carrier strengths, do not reset the "SENSITIVITY" control as this adjustment affects the meter indication.

i. If the desired signal is a continuous wave, set the "B.F.O." switch to the "B.F.O." position and the "A.V.C." switch at "OFF". Tune in the signal with the "TUNING" control until a beat note of the desired pitch is obtained.

#### Note

The beat frequency oscillator whistle may also be used to locate weak phone signals. Tune the signal in with the "B.F.O." switch at "B.F.O." until zero beat is obtained, then switch the "B.F.O." to the "OFF" position.

### 3-17. ADJUSTING SELECTIVITY.

3-18. Six degrees of selectivity are provided by the "SELECTIVITY" control ranging from "I.F. BROAD" for wide band width to "XTAL SHARP", a very narrow band for use where interference is excessive. With the "SELECTIVITY" control on "I.F. BROAD", "I.F. MED.", and "I.F. SHARP" the crystal filter is short circuited. The "I.F. BROAD" may be used where interference is not present and it is desired to pass all of the sideband components of the received signal. Then the fidelity of the reproduced signal will be maximum. The "I.F. MED." and "I.F. SHARP" pro-

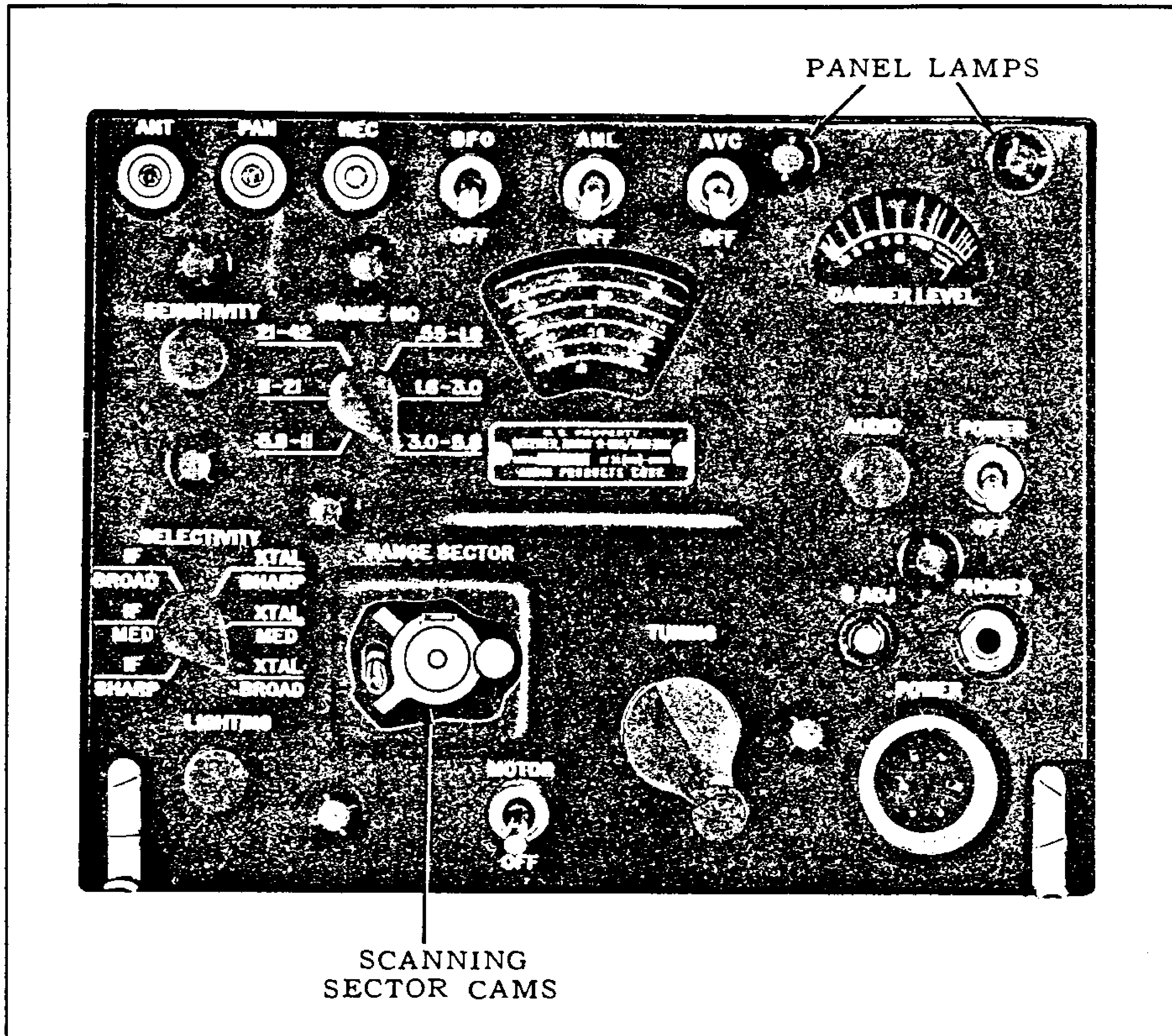

Figure 3-3. Radio Receiver R-595/ARR-7AX—Operating Controls

vide increasingly sharper i-f channels, reducing fidelity but provides a better signal-to-noise ratio. The use of any of the three crystal positions produces a serious cutting of sidebands and is only recommended for the reception of code signals. The "XTAL BROAD" provides a selectivity similar to "I.F. SHARP" but produces a cleaner cutting of sidebands. The "XTAL MED." produces a greatly increased cutting of sidebands and removes most of the high frequency components from the output. The "XTAL SHARP" provides the maximum degree of selectivity and is used only where interference from unwanted signals is excessive.

3-19. The "A.N.L." (Automatic Noise Limiter) control aids materially in reducing interference by limiting the amplitude to which a transient noise impulse

may rise. Leave the "A.N.L." switch in its "A.N.L." position only if a noticeable reduction of noise is apparent.

**3-20. MOTOR DRIVE SCANNING.** (See figure 3-3).

3-21. Procedure for motor drive scanning is as follows:

- a. Select the frequency band to be scanned and set the "RANGE MC" control to this band.
- b. Manually tune the receiver to the lowest frequency in the band to be covered.
- c. Open the dust cover over the sector sweep adjustment mechanism on the front panel. The dust cover, housing the sector cams and the reversing switch handle, is hinged. It may be opened by pulling the top toward the operator.

- d. Set the reversing switch in its downward position.
- e. Rotate the sector cam nearest the panel in a counterclockwise direction until its tripping arm is against the reversing switch handle.
- f. Rotate the sector cam furthest from the panel counterclockwise to provide maximum sweep. Tighten the thumbscrew just sufficiently to hold the cams in this position.
- g. Manually tune the receiver to the highest frequency in the sector to be covered.
- h. Set the reversing switch in its upward position.
- i. Holding the sector cam nearest the panel, in position; loosen the thumbscrew and swing the cam furthest from the panel clockwise until it rests against the reversing switch handle. Tighten the thumbscrew firmly, locking the sweep mechanism in place.

- j. Set the "MOTOR" switch to the "MOTOR" position and check the scanning range. If the sweep obtained is shorted than desired, it may be modified by repeating steps e thru i with compensated dial settings.
- k. Close the dust cover.

#### Note

The thumbscrew locking the sector cams should be loose when the automatic scanning drive is not being used. The thumbscrew is captivated and will not drop off.

### 3-22. ANTI-JAMMING PROCEDURES.

- 3-23. For the best anti-jamming operation set the "SELECTIVITY" switch to the "I.F" SHARP" position and tune in the desired signal.

## SECTION IV PRINCIPLES OF OPERATION

### 4-1. GENERAL DESCRIPTION.

4-2. Radio Receiving Sets AN/ARR-7 and AN/ARR-7AX are airborne search receivers designed to locate CW or ICW code signals or amplitude modulated telephone signals in a frequency range between 0.55 and 42.0 megacycles.

4-3. Radio Receiving Set AN/ARR-7 is provided with Radio Receiver R-45/ARR-7 and Rectifier Power Unit PP-32/AR while Radio Receiving Set AN/ARR-7AX provides Radio Receiver R-595/ARR-7AX together with Rectifier Power Unit PP-32/AR.

4-4. Radio Receivers R-45/ARR-7 and R-595/ARR-7AX employ conventional superheterodyne circuits preceded with two stages of tuned radio frequency amplification. The input of these receivers accepts a nominally 50 ohm line with three outputs available: the i-f frequency at the "PAN" receptacle; a 50 ohm output, and the detected signal at "PHONES" and "REC" (VID.) receptacles; a 600 ohm and a 150 ohm output respectively. Motor driven adjustable sweep is provided as well as manual tuning. There are six bandwidths available: "IF BROAD", "IF MED", "IF SHARP", and three crystal-filtered steps. The "BFO", "ANL", and "AVC" are controlled from front panel switches marked accordingly. A "CARRIER LEVEL" meter indicates the relative strength of the r-f input signal.

4-5. Rectifier Power Unit PP-32/AR supplies all operating voltages for the receiver used and is capable of supplying two additional receivers having similar power and voltage requirements.

### 4-6. RADIO RECEIVER R-45/ARR-7.

4-7. GENERAL CIRCUIT FUNCTIONING.  
(See figure 4-1.)

4-8. Two tuned r-f amplification stages are used on the four higher frequency bands covered by this receiver. On the two lower bands, the first r-f amplifier is by-passed and the signal is fed into the second r-f stage.

4-9. The r-f amplifier is preceded by a re-radiation suppressor stage. The purpose of this stage is to reduce the oscillations which are generated within the receiver and radiated by the antenna.

4-10. A separate tube, JAN-6SA7 (V-4), with its associated circuit, is used for generation of high frequency oscillations. Its output is combined with an incoming signal in a mixer stage to provide an intermediate frequency (455 KC).

4-11. Output of mixer tube, JAN-6SA7 (V-3), feeds the intermediate frequency amplifier and provides an i-f signal to the "PAN" (panoramic) receptacle located on the front panel of the receiver. (See figure 3-2.)

4-12. A two stage intermediate frequency amplifier is provided. The first stage uses a crystal filter circuit which has several degrees of bandwidth adjustment.

4-13. A combination detector, automatic volume control and automatic noise limiter circuit is employed. Audio output of the detector section is fed to the first a-f amplifier and from this amplifier to the output stage.

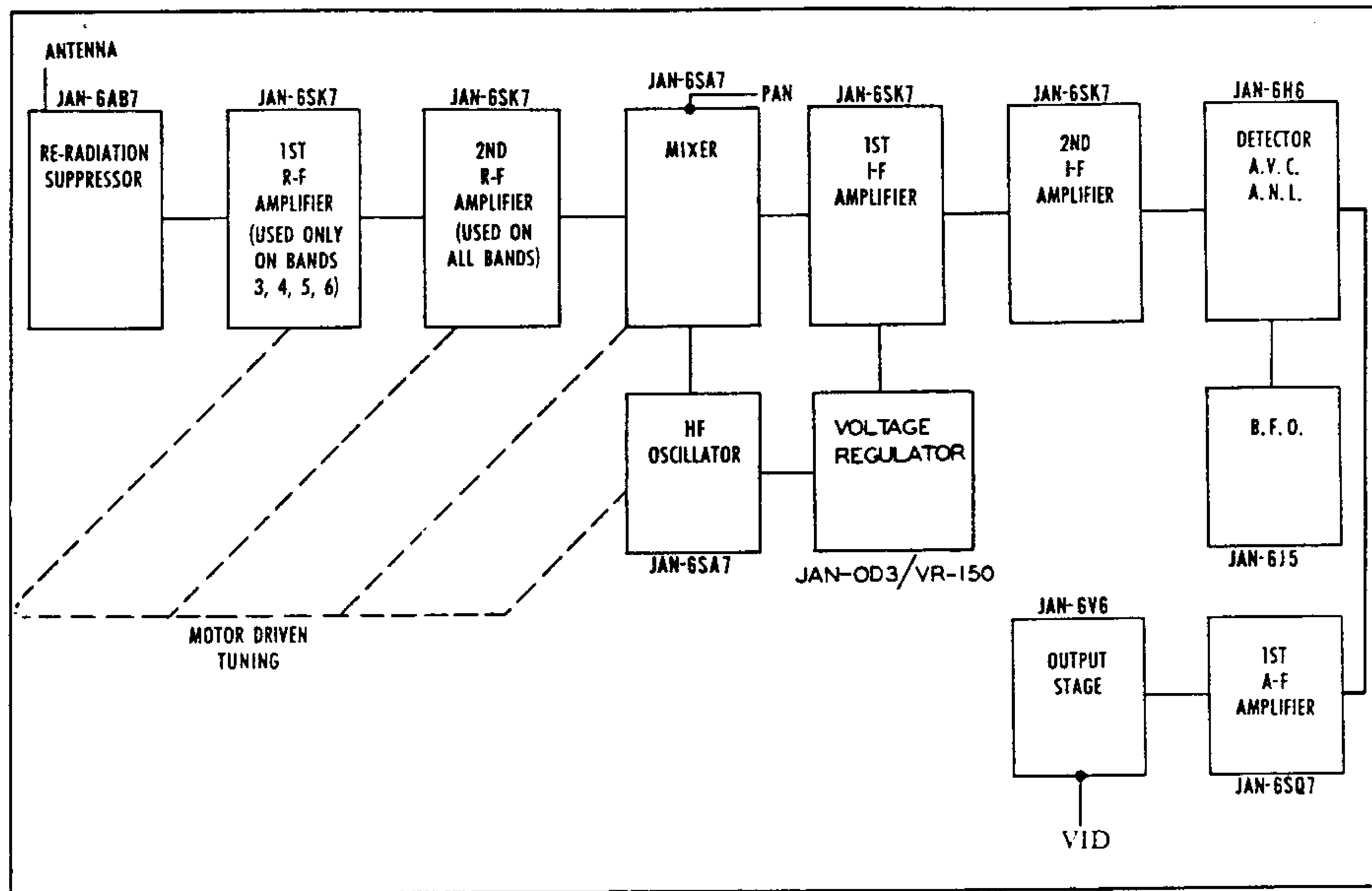

Figure 4-1. Radio Receiver R-45/ARR-7 — Block Diagram

4-14. Provision is made, in the cathode circuit of the final output stage, to obtain an output for observation of the received signal characteristics. Connection for this output is at a receptacle on the front panel marked "VID". (See figure 3-2.)

4-15. Output of the final audio stage is through a jack marked "PHONES" on the front panel. A headset, having an impedance of 600 or 8000 ohms, is plugged into this jack when aural reception is desired.

4-16. Adjustable sector motor-drive scanning is provided for sweeping across any desired bandwidth when searching for a signal exact frequency of which is not known.

4-17. DETAILED CIRCUIT FUNCTIONING.

4-18. RE-RADIATION SUPPRESSOR CIRCUIT. The re-radiation suppressor circuit reduces oscillations generated within the receiver and radiated by the antenna. The output of the re-radiation suppressor tube (V-12) is coupled to the first r-f amplifier stage by r-f transformer (T-8, T-7, T-6, or T-5) for the four high frequency bands. The first r-f stage is by-passed for the two low frequency bands by feeding the output of the re-radiation suppressor stage to the second r-f amplifier through r-f transformer T-10 or T-9. Secondaries of

these r-f transformers, as well as the oscillator coils and mixer grid coils, are tuned by the ganged tuning capacitor. Each transformer secondary is trimmed by a separate adjustable capacitor. Band switching of all circuits is accomplished by a single switch, the "FREQUENCY RANGE" switch (SW-7).

4-19. R-F STAGES. Output of the first r-f stage, for the four frequency bands, is inductively coupled to the second r-f amplifier stage by transformer (T-14, T-13, T-12, or T-11). Output of the second r-f stage is coupled to the mixer stage by r-f transformer (T-20, T-19, T-18, T-16, or T-15).

4-20. HIGH FREQUENCY OSCILLATOR. (See figure 4-2.) A separate JAN-6SA7 tube (V-4) is used as the high frequency oscillator. Output of the oscillator is taken from its cathode and fed to the mixer tube (V-3) through an injector grid. Voltage supplied to the plate of the oscillator tube is stabilized by a voltage regulator tube JAN-OD3/VR-150 (V-11).

4-21. MIXER. A signal output to be used for supplying Panoramic Adapter AN/APA-10 is taken from the mixer tube, JAN-6SA7 (V-3), through an isolating resistor (R-15) to a socket (SO-3) on the front panel. The mixer stage output is fed to the i-f amplifier through i-f transformer (T-1).

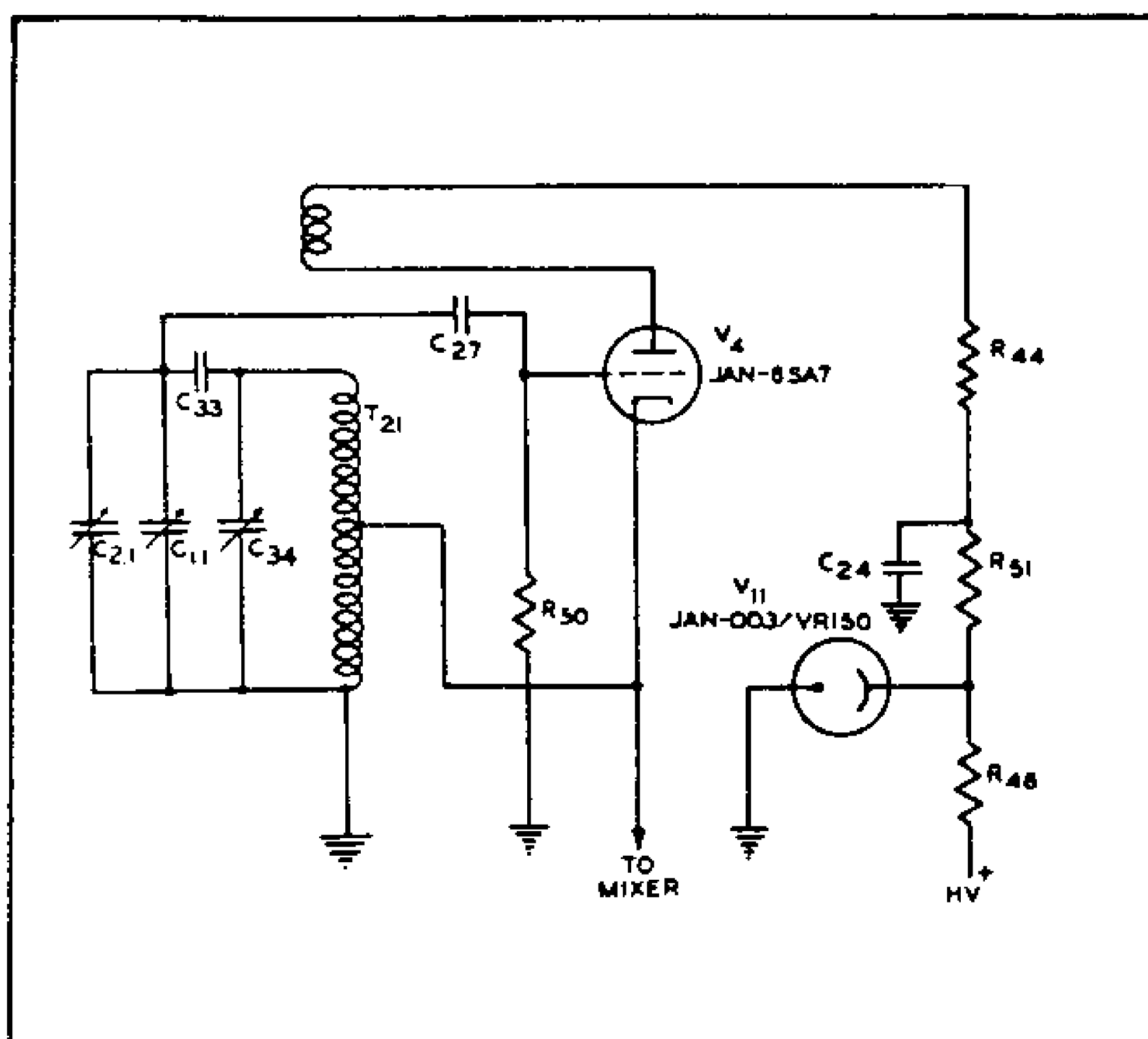

Figure 4-2. Radio Receiver R-45, ARR-7  
Simplified Schematic of High Frequency Oscillator

4-22. I-F STAGES. In the i-f amplifier stages which use two JAN-6SK7 tubes (V5 and V-6), the primary and secondary of i-f transformers (T-1, T-2 and T-3) are permeability tuned; the secondary feeds the crystal filter circuit. Transformer (T-3) feeds tube JAN-6H6 (V-7) which is used in a combination detector, automatic volume control and automatic noise limiter. (See figure 4-4.) Tuning meter (M-1) is connected in the plate circuit of the first i-f amplifier stage which is under control of the automatic volume control voltage. This meter will therefore indicate relative carrier levels when the "R-F. GAIN" control is positioned properly.

4-23. CRYSTAL FILTER CIRCUIT. (See figure 4-3.) A conventional bridge circuit, controlled by switch (SW-6-2), is used in conjunction with the crystal to provide six conditions of selectivity as follows:

- (1) I.F. BROAD (for high fidelity reception).
- (2) I.F. MED. (more selectivity—less highs).
- (3) I.F. SHARP (reduces annoying interference — far fewer highs).
- (4) BROAD XTAL (similar to sharp i-f but cleaner cutting of sidebands).
- (5) MED. XTAL (next selectivity step to (4) — greatly increased sideband cutting — more pronounced crystal slot for interference — very few high frequency components present).
- (6) SHARP XTAL (position of extreme selectivity — practically no sideband content, very pronounced crystal slot).

4-24. The graphic effects of the different steps of selectivity on a signal are shown in figures 6-1 and 6-2. As illustrated in figure 4-3, in positions 1, 2 and 3 the crystal is short circuited. In position 4, the short across the crystal is opened, the iron core in the sec-

ondary of transformer (T-1) has been adjusted for broad crystal action and at this point is accurately tuned to the crystal frequency. Due to the close, coupling of the secondary to the crystal, the sharply rising resonance curve of the crystal causes, in contrast, a sharply falling resonance curve in the secondary. The combined action of these two characteristics results in a relatively broad resonance curve for the "BROAD XTAL" selectivity setting. In the "MED. XTAL" position 5, capacitor (C-62) has been adjusted for selectivity midway between the "BROAD XTAL" and "SHARP XTAL," settings. In position 6, or "SHARP XTAL," the trimmer capacitor (C-63) has been adjusted for the sharpest crystal action. Under this condition, the secondary is slightly detuned from the resonant crystal frequency sufficiently so that its resonance curve is not greatly affected by the crystal but still coupled tightly enough so that it can transfer energy to the crystal circuit. As this point is reached, it is indicated by a rise in the output. Two such points of increased output will normally occur, one of each adjustment of the secondary on either side of the resonant frequency of the crystal.

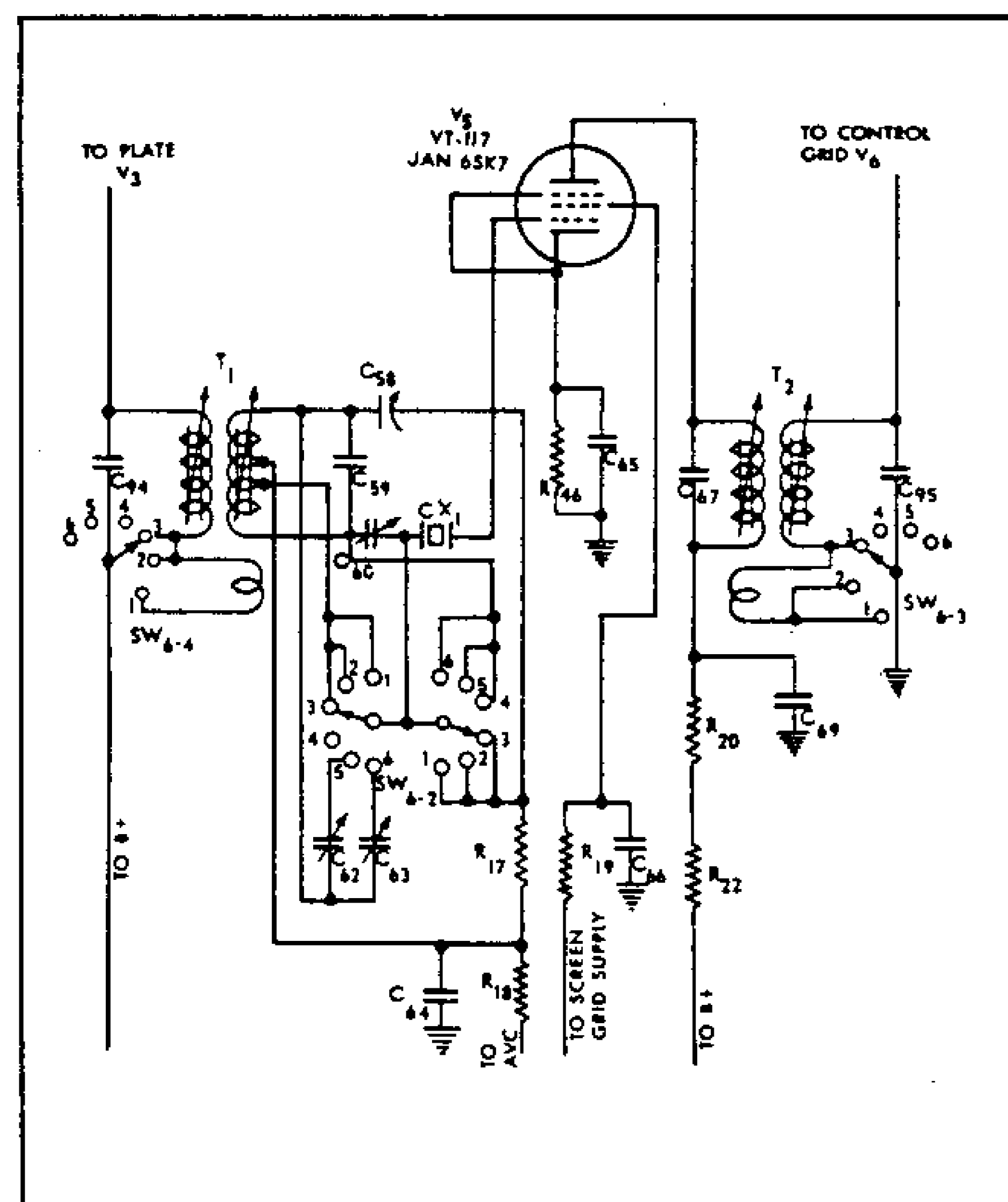

Figure 4-3. Radio Receiver R-45, ARR-7  
Crystal Filter Schematic

4-25. AUTOMATIC VOLUME CONTROL. (See figure 4-4.) Automatic volume control voltage is obtained by the rectified signal voltage drop across resistor (R-28). This voltage drop is applied through isolating resistor (R-29) to the re-radiation suppressor (V-12), r-f stages (V-1 and V-2), mixer (V-3), and i-f



vent damage due to overdrive of the tuning capacitor shaft beyond its stops. This will occur during automatic scanning if the sector selector set screw adjustment is loose, since the reversing switch must be tripped at the end of each scanning run.

4-34. The sector selecting mechanism is located on the panel under the hinged cover. It consists of a pair of adjustable discs equipped with tripping arms that engage the reversing switch handle as they rotate.

#### 4-35. RADIO RECEIVER R-595/ARR-7AX.

4-36. GENERAL CIRCUIT FUNCTIONING.  
(See figure 4-5.)

4-37. Radio Receiver R-595/ARR-7AX utilizes thirteen miniature type tubes in a superheterodyne circuit. Dual conversion is employed on the two higher bands covered. On the four lower bands, the circuit is conventional, the second converter being by-passed and the output of the mixer fed directly into the i-f amplifier.

4-38. The R-F, I-F, and Audio Sections of the receiver are replaceable units which mount on the chassis and are provided with cables for electrical connection to the circuit. The BFO, a single tube Hartley oscillator, is packaged as a unit and plugs directly into the chassis.

4-39. The receiver contains two r-f amplifiers, JAN-5670 (V-101), in cascade and a pentode JAN-5749 (V-102). A separate tube, JAN-6100/CT (V-104), is used as local oscillator. On the four lower bands, the

local oscillator operates at signal frequency plus 455 kc; output of the mixer JAN-5750 (V-103) is fed into the i-f amplifier. For the two higher bands, where dual conversion is used to maintain a high image rejection ratio, the local oscillator operates at signal frequency plus 2.0 mc. Under this condition the output of the mixer is fed to the second converter, JAN-5750 (V-105), where it is converted to 455 kc and then fed to the i-f amplifier.

4-40. A two stage i-f amplifier is provided. It consists of two JAN-5749 pentodes (V-201 and V-202), with three double tuned band pass transformers. The first stage uses a crystal filter circuit, controlled by "Selectivity" switch (S-202). This switch provides means of selecting the three conditions of crystal filtering plus a means of short circuiting the crystal in the selection of three i-f bandwidths.

4-41. Twin diode, JAN-6097/CT (V-203) is used in a combination detector and automatic volume control circuit. Germanium diode, JAN-IN126 (CR-201) is used in the automatic noise limiting circuit.

4-42. Audio output of the detector is fed through the "AUDIO" control (R-2), to twin triode JAN-12AT7 (V-300), which, in cascade, provides initial amplification. This drives beam power pentode, JAN-6095/CT (V-301), output of which is coupled to jack (J-6), on the front panel. A portion of the output of pentode (V-301) is fed into two sections of twin triode, JAN-5687 (V-302), connected in parallel as a cathode fol-

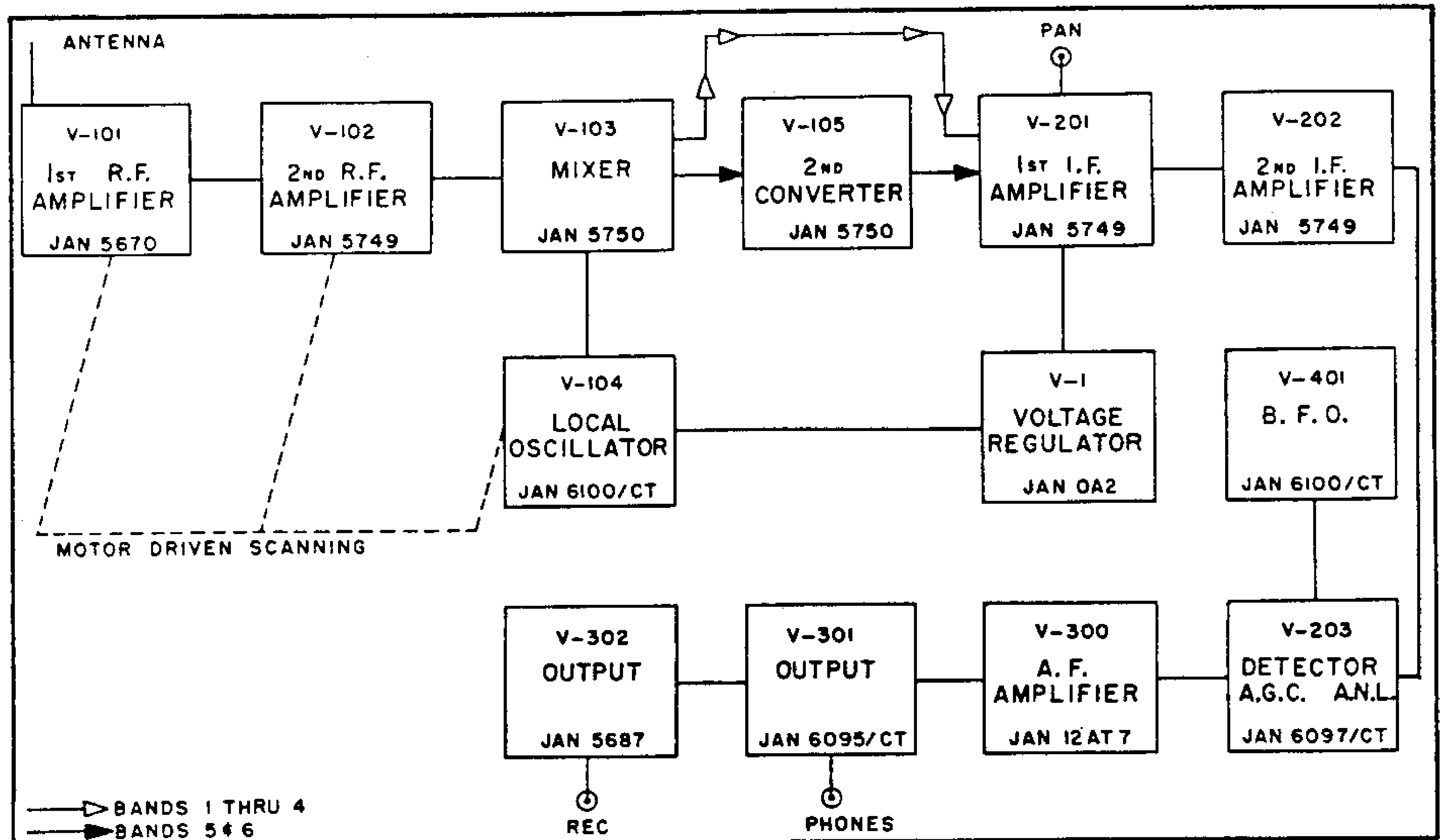

Figure 4-5. Radio Receiver R-595/ARR-7AX — Block Diagram

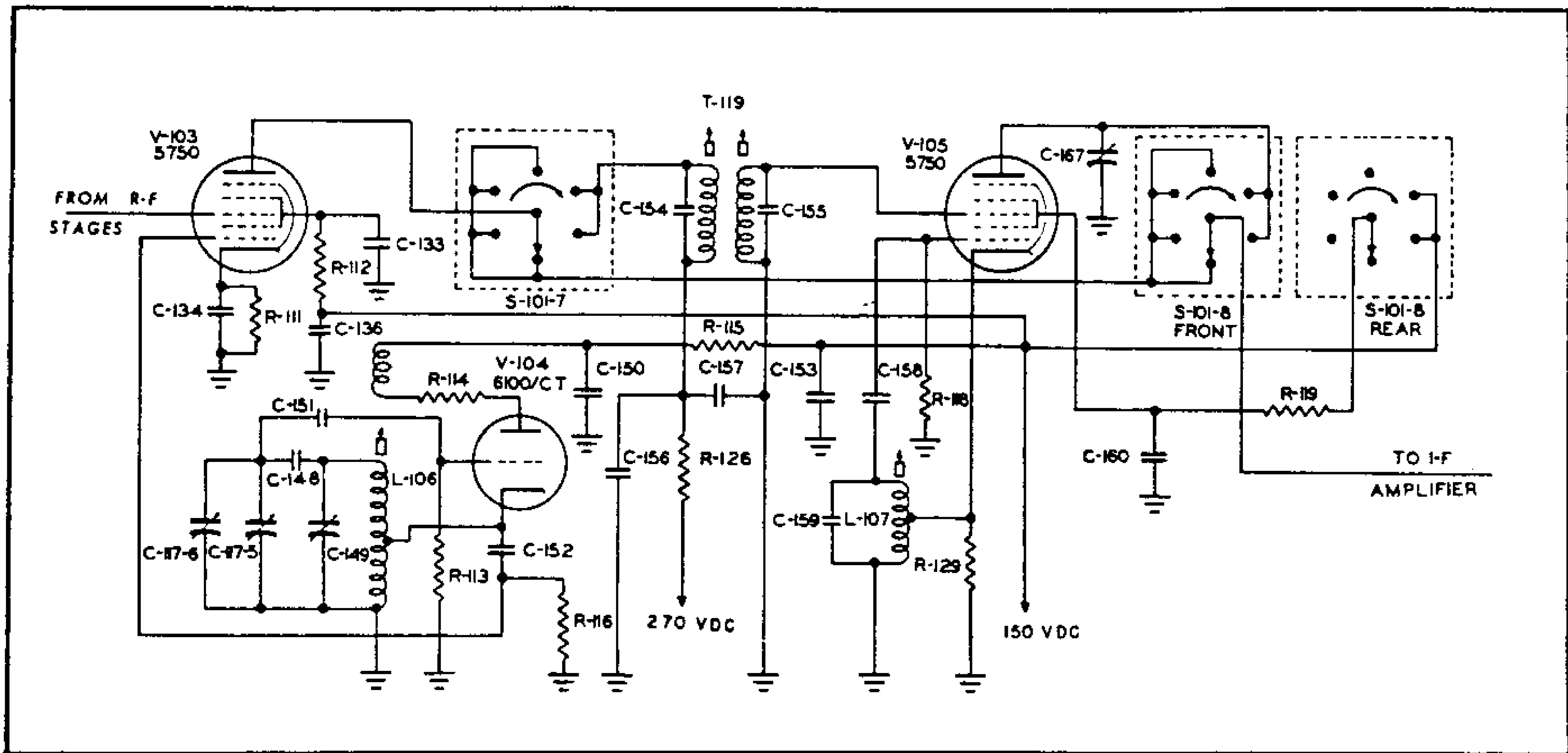

Figure 4-6. Radio Receiver R-595/ARR-7AX Mixer, Local Oscillator, Second Converter Schematic

lower. The low impedance, 150 ohm output of this tube is fed to the "REC" receptacle on the front panel. 4-43. The beat frequency oscillator using tube JAN-6100/CT (V-401) in conjunction with slug tuned coil (L-401), is controlled by the "BFO" switch and feeds into the detector circuit to produce a heterodyning frequency necessary to make CW signals audible.

4-44. DETAILED CIRCUIT FUNCTIONING.

4-45. R-F SECTION. (See figure 5-5.) This section is a replaceable unit which is used to amplify the r-f energy of the incoming signal and convert it to the i-f frequency. It consists of a cascode and a pentode amplification stage, a local oscillator, a mixer, and a second converter.

4-46. Twin triode JAN-5670 (V-101), in cascade, provides initial high gain amplification. The input of the first triode section is coupled, through capacitor (C-101), to the "ANT" receptacle on the front panel of the receiver. Since the triode sections of this tube are in series, a-v-c bias which is applied to the first triode affects both sections. The output of the stage is inductively coupled to the pentode stage by an r-f transformer (T-101, T-102, T-103, T-104, T-105 or T-106), selected in band switching. The r-f transformer secondaries and the oscillator coils are premeability tuned and each is trimmed by a separate adjustable capacitor. On the low frequency band (0.55-1.6 mc), two parallel sections of tuning capacitor (C-117) are used in tuning each stage, while on the remaining five bands, a single section tunes each stage. The "SENSITIVITY" control (R-4), is connected in the cathode circuit of pentode (V-102), to provide for control of r-f gain.

4-47. A separate tube JAN-6100/CT (V-104), is used as local oscillator. Output of the stage is taken from the cathode and capacitively, coupled to the mixer tube (V-103), through an injector grid. On the four lower bands, the local oscillator is tuned to signal frequency plus 455 kc; output of the mixer is fed through "RANGE" switch sections (S-101-7 and S-101-8), directly into the i-f amplifier. For the two higher bands, where dual conversion is used, the local oscillator is tuned to signal frequency plus 2.0 mc. Under this condition, output of the mixer is directed by "RANGE" switch sections (S-101-7 and S-101-8) through transformer (T-119), to the second converter (V-105), where it is converted to 455 kc and then fed to the i-f amplifier.

4-48. I-F SECTION. (See figure 5-5.) The I-F Section is a replaceable unit consisting of two pentode amplification stages plus diode detection, automatic volume control, and automatic noise limiting circuits.

4-49. In the i-f amplifier stages, two JAN-5749 tubes (V-201 and V-202), are used in conjunction with band pass transformers (T-201, T-202 and T-203). Both primary and secondary of these transformers are premeability tuned. Panoramic receptacle, marked "PAN" and located on the front panel of the receiver, is coupled by resistor R-221 to the plate of the first i-f amplifier (V-201). "CARRIER LEVEL" meter (M-1), is connected in the plate circuit of (V-201) which is controlled by a-v-c voltage. The meter will therefore indicate relative carrier levels when the "SENSITIVITY" control is positioned properly.

4-50. A conventional bridge circuit, (See figure 4-7) controlled by "SELECTIVITY" switch (S-202), is used

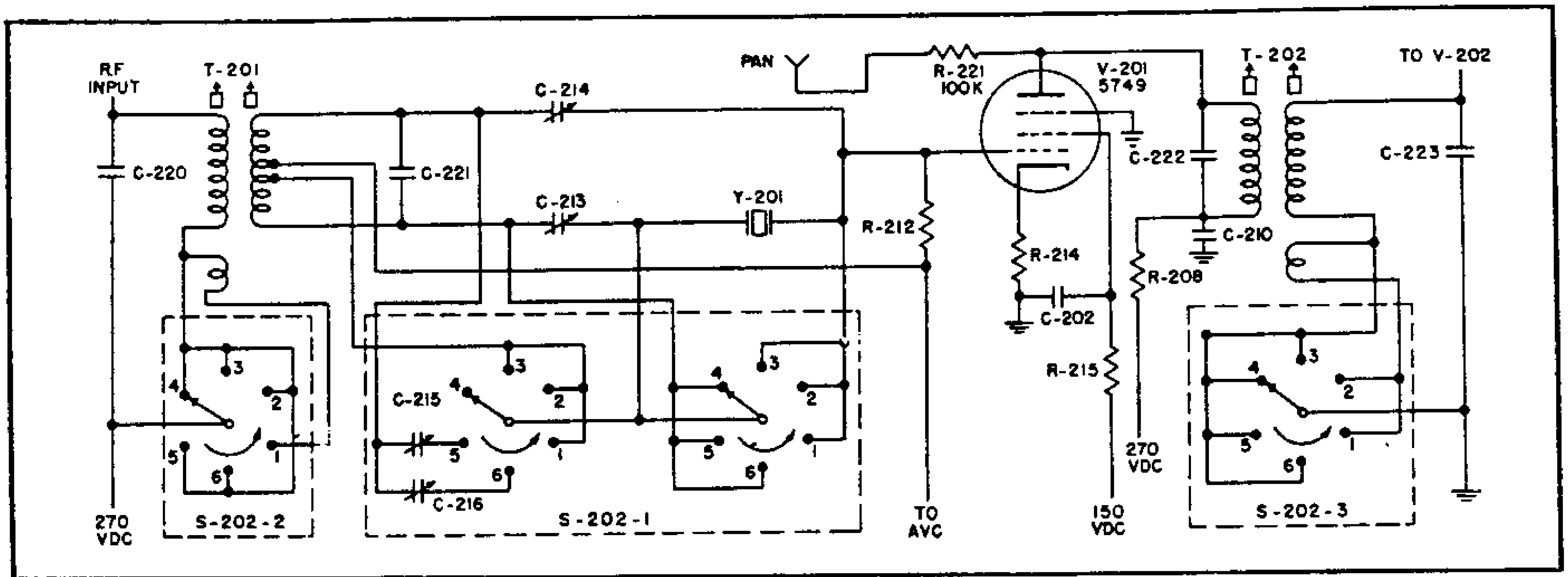

Figure 4-7. Radio Receiver R-595/ARR-7AX Crystal Filter Schematic

in conjunction with crystal (Y-201), to provide six conditions of selectivity as follows:

- (1) IF BROAD (for high fidelity reception).
- (2) IF MED. (more selectivity—less highs).
- (3) IF SHARP (reduces interference—far fewer highs).
- (4) XTAL BROAD (similar to i-f sharp but cleaner sidebands).
- (5) XTAL MED. (greatly increased sideband cutting—more pronounced crystal slot for interference—very few high frequency components present).
- (6) XTAL SHARP (Position of extreme selectivity—practically no sideband content—very pronounced crystal slot).

4-51. The graphic effects of the different steps of selectivity on a signal are shown in figures 6-1 and 6-2. As illustrated in figure 4-7, in positions 1, 2, and 3 the crystal is short circuited. In position 4, the short across the crystal is open, the iron core in the secondary of transformer (T-201) has been adjusted for broad crystal action and at this point is accurately tuned to the crystal frequency. Due to the close coupling of the transformer secondary to the crystal, the sharply rising resonance curve of the crystal causes, in contrast, a sharply falling resonance curve in the secondary. The combined action of these two characteristics results in a relatively broad resonance curve of the "XTAL BROAD" selectivity setting. In the "XTAL MED," position 5, capacitor (C-215) has been adjusted for selectivity midway between the "XTAL BROAD" and "XTAL SHARP" settings. In position 6, "XTAL SHARP", trimmer (C-216), has been adjusted for the sharpest crystal action. Under this condition, the secondary of transformer (T-201), is slightly detuned from the resonant crystal frequency sufficiently so that its resonance curve is not greatly affected but still coupled tightly enough so that it can transfer energy to the crystal circuit. As this point is reached, it is indicated by a rise in the output. Two such points of

increased output will normally occur, one for each adjustment of the secondary on either side of resonant frequency of the crystal.

4-52. AUTOMATIC VOLUME CONTROL (See figure 4-8). Automatic volume control voltage is obtained by the rectified signal voltage drop across resistor (R-218). Since it is desirable to maintain the receivers r-f and i-f gain at a maximum value on a weak signal, the cathode of the first diode of (V-203) is biased at +6 volts through the action of voltage divider (R-217) and biasing resistor (R-216). The delayed a-v-c voltage, so obtained, is filtered by action of resistor (R-201), and condenser, (C-206) then passed through decoupling resistor (R-219) to the a-v-c controlled stages.

4-53. AUTOMATIC NOISE LIMITER. (See figure 4-8.) Function of the automatic noise limiter circuit is to suppress strong impulses of short duration which are received and reach the detector stage of the receiver. Operation of the circuit is as follows:

(1) When a normal signal is received, current flows through the second diode section of tube (V-203) and resistors (R-202, R-203, and R-220); point (B) consequently becomes negative with respect to ground, likewise point (A) becomes even more negative. Both points (A) and (B) follow the detected signal with point (B) being coupled through capacitor (C-207) to the audio stage.

(2) To eliminate sudden noise pulses of short duration, the cathode of germanium diode (CR-201) is connected to point (B) and its anode through resistor (R-213), to point (A). By action of the RC network, composed of resistor (R-213) and capacitor (C-205), the potential at point (C), or the anode of the germanium diode, tends to follow the average of point (A) voltage, thus causing the anode to be negative with respect to the cathode and the diode to be non-conductive.

(3) As a sudden noise pulse is received; points **A** and **B** swing negative, however the time constant of resistor (R-213) and capacitor (C-205), prevent point

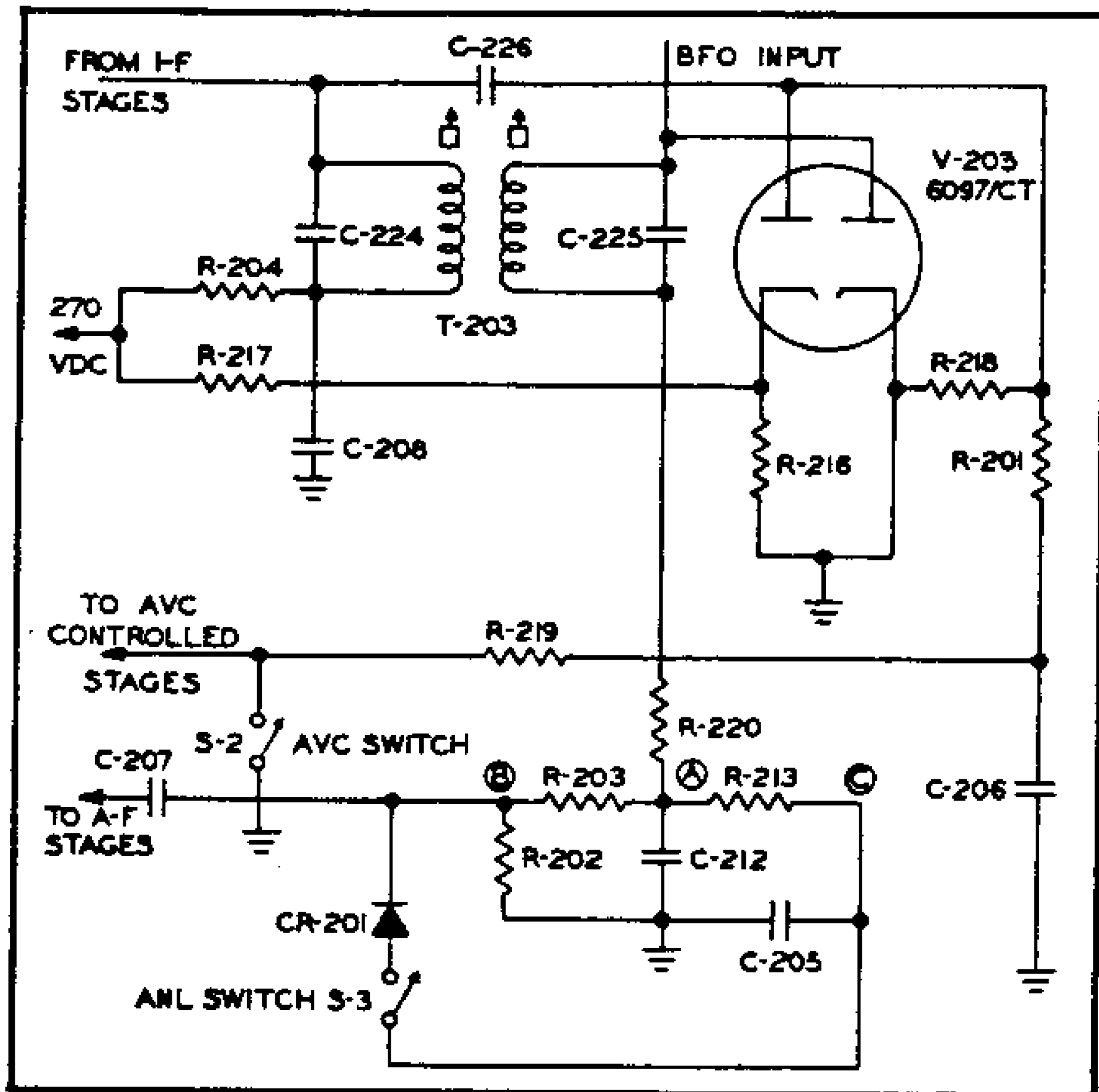

Figure 4-8. Radio Receiver R-595/ARR-7AX Detector, AVC and ANL Schematic

**C** from going negative as quickly as point **A**, therefore a sharp pulse of short duration will cause point **B** to go negative sufficient for diode (CR-201) to conduct, canceling the pulse to be sent on to the audio stage.

4-54. BEAT FREQUENCY OSCILLATOR. (See figure 4-8.) The B.F.O. consists of a single tube Hartley oscillator which is packaged as a plug in unit controlled by the "BFO" switch (S-4), on the front panel of the receiver. Frequency of the unit is varied with a pre-

meability tuned coil which is adjustable through the top of the case.

4-55. Output of the B.F.O. is fed into the detector circuit and provides a signal which is 1000 cps removed from the center frequency of the i-f strip. When a carrier signal with no modulation is received, and the r-f section is tuned to give center frequency i-f output, the two signals will mix with a resulting 1000 cps note available at the output of the detector.

4-56. AUDIO SECTION. (See figure 4-8). The audio section is a replaceable unit which utilizes two twin triodes and a beam power pentode.

4-57. Two sections of twin triode JAN-12AT7 (V-300), in cascade, are used for initial amplification. This drives beam power pentode JAN-6095/CT (V-301), which is coupled through capacitor (C-301), to the "PHONES" jack on the front panel. Feedback is employed around this stage to improve frequency response and distortion characteristics. A portion of the output of pentode (V-301) is fed into two sections of twin triode JAN-5687 (V-302), which is connected in parallel as a cathode follower, to give a low impedance output. The output of this stage is connected to the "REC" receptacle on the front panel of the receiver.

4-58. SCANNING MECHANISM. The sector sweep or scanning mechanism consists of a motor assembly, a magnetic clutch, a gear train, and a sector selector mechanism. The motor assembly and magnetic clutch are held in a cast aluminum frame.

4-59. The motor consists of a high-speed armature rotating in the field of a permanent magnet. The motor drives a speed reducing gear train which in turn drives the magnetic clutch.

4-60. The magnetic clutch consists of a solenoid housed in a steel shell. When energized, the magnetic field pulls the wall of the adjacent gear, which is driven by the worm gear, up against the clutch housing which

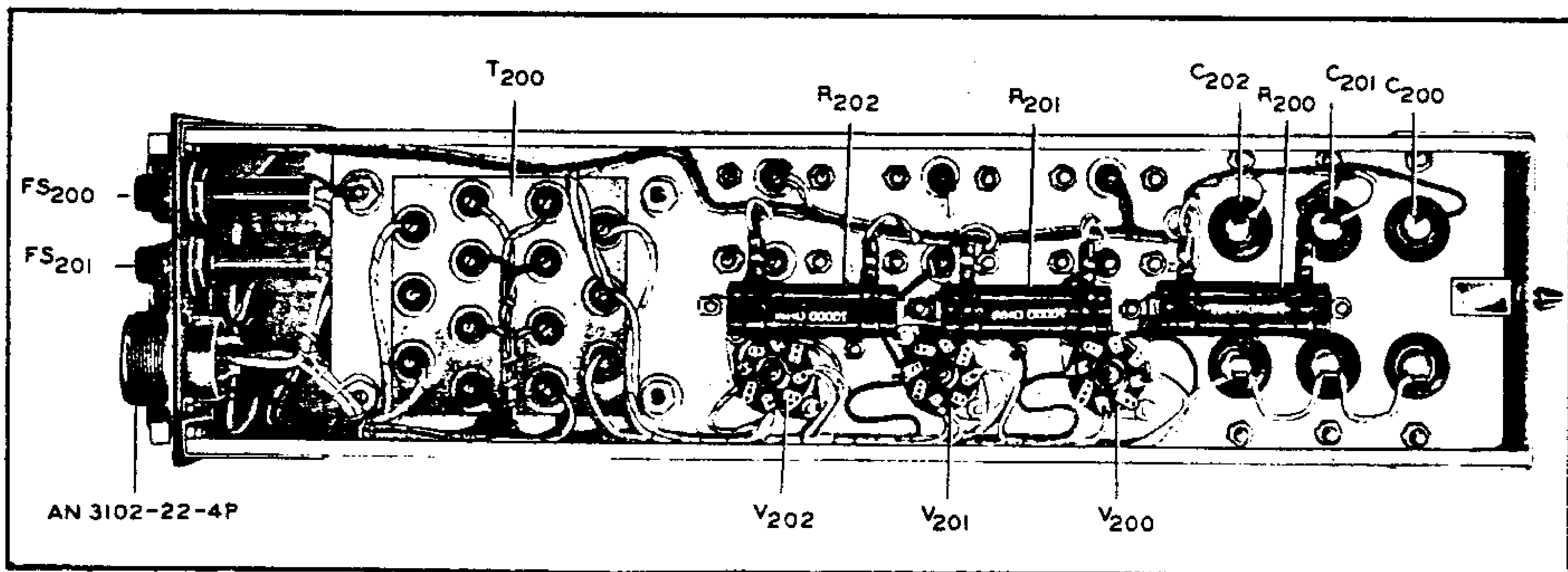

Figure 4-9. Rectifier Power Unit PP-32/AR — Bottom View

then transmits the motion to the gear train driving the tuning capacitor of the receiver. The magnetic clutch winding is connected to the "MOTOR" switch so that the clutch is engaged only while the motor is running. This allows the tuning capacitor to be turned manually, free of the motor drive gear train.

4-61. The tuning capacitor gear train consists of spring-loaded gears to prevent backlash or lost motion. The "TUNING" control and clutch are connected to the gear train by a spring-loaded slip-type clutch to prevent damage due to overdrive of the tuning capacitor shaft beyond its stops. This will occur during automatic scanning if the sector selector set screw adjustment is loose, since the reversing switch must be tripped at the end of each scanning run.

4-62. The sector selecting mechanism is located on the panel under the hinged cover. (See figure 3-3.) It consists of a pair of adjustable discs equipped with tripping arms that engage the reversing switch handle as they rotate.

#### 4-63. RECTIFIER POWER UNIT.

(See figures 1-1 and 7-6.)

4-64. Rectifier Power Unit PP-32/AR is connected to the aircraft's a-c and d-c power source through power input receptacle AN3102-22-4S.

4-65. Voltage (24 vdc) goes through the d-c line fuse and switch to the three outlet receptacles AN3102-22-5S. The d-c pilot light is wired in on the load side of the switch so it indicates when d-c voltage is available at the three outlets.

4-66. The a-c is fed through the a-c line fuse and switch to the primary of the power transformer which has one high voltage secondary winding, three 5-volt rectifier filament windings, and one 6-3-volt filament winding for the receiver tubes. The pilot light (LM-201) is connected across the 6-3-volt winding. The plates of the three rectifier tubes JAN-5R4GY are operated in parallel as full-wave rectifiers, but with their filaments wired to separate filament windings so that three separate high voltage sources are available. Each high voltage source is filtered with a choke and capacitor connected as a low-pass L-section filter with choke input. A bleeder resistor is connected to the three receptacles AN3102-22-5S located on the front panel of the power unit. The bottom view of Rectifier Power Unit PP-32/AR is shown in figure 4-9.

## SECTION V MAINTENANCE

### 5-1. INSPECTION.

#### Note

Periodic inspections prescribed herein represent minimum requirements. If, because of local conditions, peculiarities of equipment, or abnormal usage, they are found insufficient to attain satisfactory operation of equipment, local authorities should not hesitate to increase their scope or frequency.

### 5-2. PREFLIGHT.

a. Check the mounting of the radio receiver and power unit to make sure that the units are firmly attached to their bases and that the bases are securely in place.

b. Make sure that all plugs are firmly seated in their sockets.

c. Turn the equipment on as outlined in paragraph 3-2 and make an aural check of reception using the headset. With the "R.F. GAIN" and "AUDIO GAIN" controls ("SENSITIVITY" and "AUDIO" controls on

Radio Receiver R-595/ARR-7AX) advanced to maximum, test across each wave band by tuning in signals or by noting the presence of high background noise.

d. Turn the "MOTOR" switch on. Make sure that the motor reversing switch is functioning normally.

e. The two pilot lights on the rectifier power unit should be illuminated indicating normal functioning of the power unit.

f. Check for normal operation of the r-f and i-f circuits by tuning across a voice-modulated signal with the "AVC" switch on. The "CARRIER LEVEL" meter will indicate relative signal strengths when the circuits are functioning normally.

#### Note

On Radio Receiver R-45/ARR-7, the "B.F.O." switch must be at "OFF" for operation of the "CARRIER LEVEL" meter.

### 5-3. 25-HOUR INSPECTION.

a. Remove all connecting cables from the operating panels of the radio receiver and the rectifier power unit.

b. Remove the radio receiver and the rectifier power unit from their mounting bases. Remove receiver and rectifier power assemblies from their respective dust covers and make sure that all tubes are firmly seated in their sockets.

c. Check the mechanical operation of all controls. Make sure that all control knobs are firmly attached to control shafts.

d. Reassemble the receiver and the power unit chassis in housings and replace on mounting bases. Attach the connecting cords and cables after inspecting to make sure that all connections are intact. Make sure that the shock absorber movement of both mounting bases is unobstructed.

e. Check aurally the operation of the receiver on all bands and under all conditions of operation by positioning the various controls as outlined in paragraphs 3-4 through 3-21.

f. Check the operating condition of the indicator dial lamps on the power unit and the receiver operating panels.

g. With the antenna lead removed and the "R.F. GAIN" and "A.F. GAIN" controls ("Sensitivity" and "Audio" controls on Radio Receiver R-595/ARR-7AX) advanced to maximum, check aurally for the presence of unwanted oscillation. Jar the receiver during the test to determine the absence of intermittent operational characteristics.

h. Determine the accuracy of calibration by tuning in a signal of known frequency in each operating band. A calibrated signal generator should be used to provide an accurate signal at the high, middle, and low frequency positions of each band.

#### 5-4. 100-HOUR INSPECTION.

a. Remove the interconnecting cords and cables from the receiver and the power unit.

b. Remove the receiver and power unit chassis from their respective mountings and disassemble chassis from housings.

c. Clean dust accumulations from chassis with a clean, dry cloth, being careful not to displace internal wiring or components. If available, a clean, dry air stream may be used to blow dust from the chassis.

d. Check the functioning of the "FREQUENCY RANGE" switch ("RANGE MC" on Radio Receiver R-595/ARR7AX) noting particularly any slipping between the switch assembly and the control knob as the control knob is rotated.

e. Check switch contacts for cleanliness and proper tension.

f. Check each tube in both the receiver and the power unit and replace any not reaching an approved standard.

g. Check the operation of the motor sweep drive, noting the time interval of sweep operation.

h. Check the operating controls for proper operation and freedom of shaft rotation.

i. Inspect the gears for dust and foreign particles and clean if necessary. A slight amount of oil, Specification VV-O-526, should be placed on the gear surfaces.

j. Check the brushes in the scanning motor and replace if worn beyond the acceptable limit.

k. Check condition of pilot lamps.

l. After reassembly, check positioning and condition of interconnecting cables and cords and make sure that all plug prongs are clean.

### 5-5. TROUBLE SHOOTING INSTALLED RADIO RECEIVER AND RECTIFIER POWER UNIT

#### 5-6. GENERAL.

a. Make sure the aircraft's power supply is on and all power cables are correctly connected.

b. Note pilot lights on the rectifier power unit operating panel. A fuse failure in the input circuit will be indicated by the failure of the pilot lamp, associated with this circuit, to light. Check the pilot light bulb and the fuses. Replace them if it is necessary.

c. Failure of the pilot lamp to illuminate the tuning dial may be due to a faulty or broken interconnecting cable. The pilot light is across the filament supply.

d. Lack of headset signal or background noise with all pilot lamps illuminated may be due to a faulty headset cord, defective phone plug, or open cord connection. Substitute a headset assembly known to be in operating condition to test for this defect.

e. A cool tube shell may indicate tube failure. Observe safety precautions when determining tube condition by touch.

5-7. If the preceding list of quickly applied tests does not result in the location and correction of the trouble, TABLE IV, TROUBLE SHOOTING CHART INSTALLED EQUIPMENT, should be used for a more detailed search.

#### 5-8. TROUBLE SHOOTING AT REPAIR STATION.

5-9. Troubles listed in TABLE V assume that trouble shooting of installed equipment has failed to locate the trouble.

#### 5-10. DETAILED.

a. Inspect the circuit components of the receiver and the rectifier power unit for visual evidence of malfunctioning.

b. Measure the voltage input to the receiver from the rectifier power unit. If it is 270 volts dc 20 per-

cent, perform a voltage check of the receiver following the voltage chart TABLE VI or VII. If the voltage is considerably below this value, rising to normal when the power switch on the receiver is turned off, a short is indicated in the receiver and a continuity test of the receiver should be made according to the resistance chart TABLE IX or TABLE X.

5-11. If signal tracing equipment is available, the progress of the signal may be traced to the circuit at fault. This method fails where a failure of a component in a

circuit which supplies operating voltage to a number of stages is involved.

**Note**

Test points are provided on Radio Receiver R-595/ARR-7AX (see figure 5-6). A voltage check at J-11, J-12 and J-13, while progressively removing plugs, P-101, P-201 and P-304, and the BFO unit, aids in tracing voltage trouble to the defective section.

**TABLE V**

**TROUBLE SHOOTING CHART—DETACHED EQUIPMENT**

<i>Trouble</i>	<i>Probable Cause</i>	<i>Remedy</i>
No click heard in headset as audio tube V-9 (R-45/ARR-7 equipment) or V-301 (R-595/ARR-7AX equipment) is removed.	No plate voltage.	Check circuit in accordance with paragraph 5-10b.
	Open plate coupling capacitor.	Replace capacitor.
	Defective headset jack.	Replace jack.
	Open cathode circuit.	Check circuit in accordance with applicable resistance chart.
No click heard in headset as first audio tube, V-8 (R-45/ARR-7) or V-300 (R-595/ARR-7AX), is removed from socket.	No plate voltage.	Check circuit in accordance with paragraph 5-10b.
	Open plate coupling capacitor.	Replace capacitor.
	Open cathode circuit.	Check circuit in accordance with applicable resistance chart.
Receiver fails to produce audio signal when receiving unmodulated carrier with "BFO" switch on.	Defective tube or component in "BFO" circuit.	Replace defective tube or component.
Received signal does not increase in intensity as "R.F GAIN" control ("SENSITIVITY" on R-595/ARR-7AX) is advanced.	Shorted cathode bypass capacitor in circuits associated with tubes V-1, V-2, V-6 (R-45/ARR-7) V-102. (R-595/ARR-7AX)	Replace defective capacitor.
	Shorted sensitivity control bypass capacitor, C-2, on Radio Receiver R-595/ARR-7AX.	Replace defective capacitor.
Signals received only over high frequency portion of a given tuning band.	Defective local or high frequency oscillator tube.	Replace tube.
	Low plate potential on oscillator tube.	Check and correct plate circuit.
Signals received over only a portion of each tuning band.	Ganged tuning capacitor shorted.	Correct short between rotor and stator of shorted tuning capacitor section.
Carrier Level meter indicates low value when tuned to strong local station.	Receiver circuits in need of alignment.	Align circuits in accordance with paragraphs.
Phasing control inoperative on three "XTAL" selectivity positions. (R-45/ARR-7 only)	Defective crystal or crystal circuit component.	Check crystal circuit and correct.
One of the three identical power output receptacles on Rectifier Power Unit fails to provide voltage output.	Defective tube or filter component in output circuit of individual section.	Check circuit (see figure 8-6) and replace defective component.

5-12. Voltage and resistance readings indicated in the following tables were taken from the tube socket, with the tube removed from the socket under test. Readings

were taken with a Weston Model 772 Analyzer with a meter sensitivity of 20,000 ohms per volt. Voltages are all dc unless otherwise noted.

**TABLE VI**  
**VOLTAGE READINGS—RADIO RECEIVER R-45/ARR-7**

Tubes	Pin Number							
	1	2	3	4	5	6	7	8
1st r-f amp. (V-1)	0	0	3	0	3	110	6.3 a.c.	260
2nd r-f amp. (V-2)	0	0	5	0	5	145	6.3 a.c.	280
Mixer (V-3)	0	0	265	135	0	5	6.3 a.c.	0
H.F. osc. (V-4)	0	0	120	120	-5	0	6.3 a.c.	120
1st i-f amp. (V-5)	0	0	5	0	5	150	6.3 a.c.	265
2nd i-f amp. (V-6)	0	0	4.4	0	4.4	150	6.3 a.c.	265
Detector "A.V.C.", "A.N.L." (V-7) ("A.N.L." switch "ON")	0	0	-1	-1	0	NC	6.3 a.c.	0
1st a-f amp. (V-8)	0	0	1.2	1.2	1.2	135	6.3 a.c.	0
2nd a-f amp. (V-9)	0	0	175	100	0	NC	6.3 a.c.	17
B.F.O. (V-10) ("B.F.O." switch "ON")	0	0	250	NC	-19	NC	6.3 a.c.	0
Voltage Regulator (V-11)	0	0	160	0	160	NC	160	NC
Re-radiation Suppr. (V-12)	0	0	1.5	0	1.5	150	6.3 a.c.	265

All readings were made to the chassis, with the controls set as indicated unless otherwise noted:

"POWER" switch "ON"  
"R.F. GAIN" maximum (clockwise)  
"B.F.O." switch "OFF"  
"A.N.L." switch "OFF"

"A.F. GAIN" maximum (clockwise)  
"FREQUENCY RANGE" switch 3 to 5.8 MC.  
"A.V.C." switch "ON"  
"SELECTIVITY" control "BROAD I.F."

Antenna and headset disconnected.  
Input plate voltage from power supply, 270 volts.  
(NC) indicates no connection.)

**TABLE VII**  
**VOLTAGE READINGS—RADIO RECEIVER R-595/ARR-7AX**

Tubes	Pin Number								
	1	2	3	4	5	6	7	8	9
Voltage Regulator (V-1)	150	0	0	0	150	0	0	—	—
1st r-f amplifier (V-101)	0	127	98	250	0	127	.15	0	6.3ac
2nd r-f amplifier (V-102)	0	0	6.3ac	0	250	138	3.4	—	—
Mixer (V-103)	0	1.95	6.3ac	0	260	130	0	—	—
Local oscillator (V-104)	130	0	6.3ac	0	130	-.2	0	—	—
2nd converter (V-105)	-.15	0	6.3ac	0					
1st i-f amplifier (V-201)	0	0	0	6.3ac	248	123	2.1	—	—

TABLE VII (cont)

## VOLTAGE READINGS—RADIO RECEIVER R-595/ARR-7AX

Tubes	Pin Number								
	1	2	3	4	5	6	7	8	9
2nd i-f amplifier (V-202)	0	0	0	6.3ac	238	116	3	—	—
Detector AVC, ANL (V-203) (ANL switch on.)	0	0	0	6.3ac	4.9	0	—0.25	—	—
1st a-f amplifier (V-300)	115	0	1.45	0	0	167	0	1.65	6.3ac
a-f amplifier (V-301)	0	6.2	0	6.3ac	150	150	0	—	—
Recorder output (V-302)	260	0	15.1	0	0	15.1	0	6.3ac	260
BFO (V-401) (BFO switch on.)	245	0	0	6.3ac	245	—180	.65rf	—	—

All readings were made to the chassis, with the controls set as indicated unless otherwise noted: SENSITIVITY at maximum; AUDIO at minimum; ANTENNA input grounded; RANGE MC at 11 mc to 21 mc position. The following are in the "OFF" position unless otherwise specified: AVC; ANL; BFO. A-C voltages taken with 1,000 OHM/VOLT meter.

TABLE VIII

## VOLTAGE READINGS—RECTIFIER POWER UNIT PP-32/AR

Tubes	Pin Number							
	1	2	3	4	5	6	7	8
Rectifier V-200	NC	290	NC	350 a.c.	NC	350 a.c.	NC	290
Rectifier V-201	NC	290	NC	350 a.c.	NC	350 a.c.	NC	290
Rectifier V-202	NC	290	NC	350 a.c.	NC	350 a.c.	NC	290

TABLE IX

## RESISTANCE READINGS—RADIO RECEIVER R-45/ARR-7

Tubes	Pin Number							
	1	2	3	4	5	6	7	8
1st r-f amp. (V-1)	0	0	360	1.25 meg.	360	35000	.5	17000
2nd r-f amp. (V-2)	0	0	360	1.25 meg.	360	13000	.5	19000
Mixer (V-3)	0	0	19000	12500	50000	440	.5	1.25 meg.
H.F. osc. (V-4)	0	0	22000	22000	55000	0	.5	24000
1st i-f amp. (V-5)	0	0	310	1.25 meg.	310	21000	.5	17000
2nd i-f amp. (V-6)	0	0	1600u	7	1600	13000	.5	17000
Detector "A.V.C.", "A.N.L." (V-7) ("A.N.L." switch "ON")	0	0	1.8 meg.	.65 meg.	.8 meg.	NC	.5	0

TABLE IX (cont)

## RESISTANCE READINGS—RADIO RECEIVER R-45/ARR-7

Tubes	Pin Number							
	1	2	3	4	5	6	7	8
1st a-f amp. (V-8)	0	1 meg.	2500	2500	2500	9500	.5	0
2nd a-f amp. (V-9)	0	0	23000	90000	.41 meg.	NC	.5	360
R.F.O. (V-10) (B.F.O. "ON")	0	0	19000	NC	46000	NC	.5	0
Voltage Regulator (V-11)	0	0	20000	0	20000	NC	20000	NC
Re-radiation Suppr. (V-12)	0	0	180	1.7 meg.	180	59000	.5	17000

TABLE X

## RESISTANCE READINGS—RADIO RECEIVER R-595/ARR-7AX

Tubes	Pin Number								
	1	2	3	4	5	6	7	8	9
Voltage Regulator V-1)	34K	INF.	INF.	INF.	INF.	INF.	0	—	—
1st r-f amplifier (V-101)	0	INF.	INF.	34K	0	INF.	450K	0	0
2nd r-f amplifier (V-102)	92K	0	0	0	32K	70K	370	—	—
Mixer (V-103)	22K	220	0	0	35K	43K	100K	—	—
Local oscillator (V-104)	INF.	INF.	1	0	39K	43K	0	—	—
2nd converter (V-105)	18F	0	1	0	33K	40K	1	—	—
1st i-f amplifier (V-201)	90F	0	0	0	33K	45K	220	—	—
2nd i-f amplifier (V-202)	3	0	0	0	35K	62K	220	—	—
Detector AVC, ANL (V-203) (ANL switch on.)	0	500K	0	0	1.7K	0	500K	—	—
a-f amplifier (V-300)	130K	10	1K	0	0	63K	420K	575	—
Audio Output (V-301)	15K	200	0	0	39K	39K	INF.	—	—
Recorder output (V-302)	36K	160	10K	0	0	10K	160	0	36K
BFO (V-401) (BFO switch on.)	INF.	INF.	1.5	0	34K	420K	0	—	—

Tube removed from socket under test.  
Conditions same as for voltage measurements.

TABLE XI

## RESISTANCE READINGS—RECTIFIER POWER UNIT PP-32/AR

Tubes	Pin Number							
	1	2	3	4	5	6	7	8
Rectifier V-200	NC	10000	NC	3.4	NC	3.4	NC	10000
Rectifier V-201	NC	10000	NC	3.4	NC	3.4	NC	10000
Rectifier V-202	NC	10000	NC	3.4	NC	3.4	NC	10000

TABLE XII

**RADIO RECEIVER R-45/ARR-7  
RESISTANCE AND INDUCTANCE DATA FOR  
FILTER CHOKE AND MOTOR ARMATURE**

Circuit Symbol	Component	Inductance	Resistance
L-1	Filter choke	3 henries $\pm 30\%$	85 ohms $\pm 10\%$
—	Motor armature	—	30 ohms

5-13. REPLACEMENT OF FUSES AND LAMPS.

5-14. FUSES. The a-c and d-c circuits of the rectifier power unit are protected by 5-ampere fuses which are contained in fuse-holder plugs located on the operate it from the circuit by turning the extractor post in a counter-clockwise direction and pulling outward. Replace with a spare fuse provided (figure 5-1), making sure that the replacement fuse is identical in rating with the original. Frequent blowing of either fuse indicates a circuit defect which should be found and corrected.

5-15. PILOT LAMPS.

5-16. The pilot lamps in the rectifier power unit indicate the condition of the fuses in the input and output circuits. Replace a burned-out lamp immediately with the spare supplied.

5-17. The pilot lamp illuminating the tuning scale on Radio Receiver R-45/ARR-7 serves as a visual indication of the presence of filament voltage from the rectifier power unit. Replace with a spare lamp immediately on

TABLE XIII

**RECTIFIER POWER UNIT PP-32/AR  
RESISTANCE AND INDUCTANCE DATA FOR  
FILTER CHOKES AND POWER TRANSFORMER**

Circuit Symbol	Component	Inductance	Resistance
L-200	Filter choke	2 henries	30 ohms
L-201	Filter choke	2 henries	30 ohms
L-201	Filter choke	2 henries	30 ohms
T-200	Power Transformer		
	(1) 80V. primary	—	0.121
	(2) 115V. primary	—	0.172
	(3) 5.0V. secondary	—	0.041
	(4) 6.3V. secondary	—	.054
	(5) H.V. secondary	—	6.85 ohms

failure. Pilot and panel lamps on Radio Receiver R-595/ARR-7AX receive their power from the 28 vdc source which supplies the sweep motor. Operation of the sweep motor is therefore an indication that 28 vdc is entering the set. Panel lamps on this receiver are located behind screw caps on the front panel. The pilot lamp is located behind the tuning dial.

5-18. SPECIAL MAINTENANCE OPERATIONS.

5-19. "CARRIER LEVEL" Meter Adjustment. Refer to paragraph 2-13 for this adjustment.

5-20. Scanning Motor Speed Adjustment. Refer to paragraph 2-14 for this adjustment.

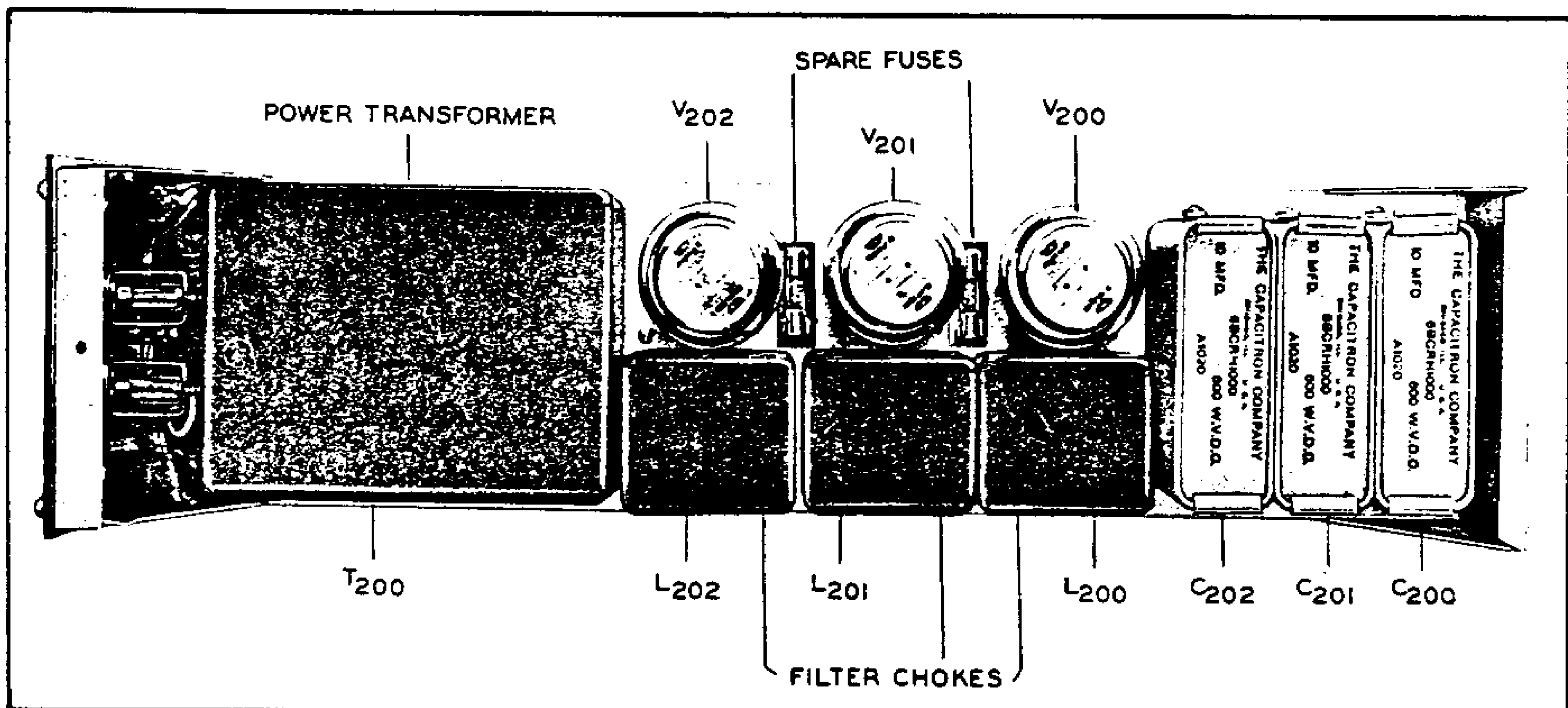

Figure 5-1. Rectifier Power Unit PP-32/AR — Top View

**5-21. ALIGNMENT. — GENERAL.**

5-22. Radio Receivers R-45/ARR-7 and R-595/ARR-7AX have been carefully aligned at the factory and the adjustments have been sealed. Realignment is not necessary unless the receiver shows a marked loss of sensitivity or the adjustments are known to have been tampered with.

5-23. EQUIPMENT. The following equipment is necessary for alignment:

(1) A modulated signal generator capable of producing an accurately calibrated signal from 450 kc to 43 mc (GR-605B or equal).

(2) Non-metallic screw driver.

(3) Output meter with phone plug (GR-583A or equal).

**5-24. ALIGNMENT. — RADIO RECEIVER R-45/ARR-7.**

5-25. The receiver should be removed from its housing, connected to its power supply source, and should be in operating condition with its controls set as follows:

- a. "POWER" switch "ON."
- b. "B.F.O." switch "OFF."
- c. "R.F. GAIN" maximum (clockwise).
- d. "MOTOR" switch "OFF."

e. "A.V.C." switch "OFF."

f. "AUDIO GAIN" maximum (clockwise).

g. "FREQUENCY RANGE" switch 0.55 to 1.6 mc for i-f alignment; on band being aligned for i-f alignment.

h. "PITCH" control inoperative.

i. "A.N.L." switch "OFF."

j. "SELECTIVITY" control at "I.F BROAD" except as noted.

k. Disconnect antenna.

**5-26. I-F ALIGNMENT. (See figure 5-2.)**

a. Set main dial at 1400 kc on 0.55 to 1.6 MC band.

b. Connect output meter to receiver output through "PHONES" jack on front panel. Set output meter for 8000-ohm load.

c. Connect hot lead of signal generator to terminal No. 8 of the JAN-6SA7 (V-3) mixer tube. Connect ground lead of signal generator to receiver chassis. Adjust signal generator to produce a 455 KC modulated signal. Adjust signal generator output amplitude for convenient output meter indication.

d. Adjust alignment screws of T-1 for maximum output.

e. Adjust C-60 for maximum output.

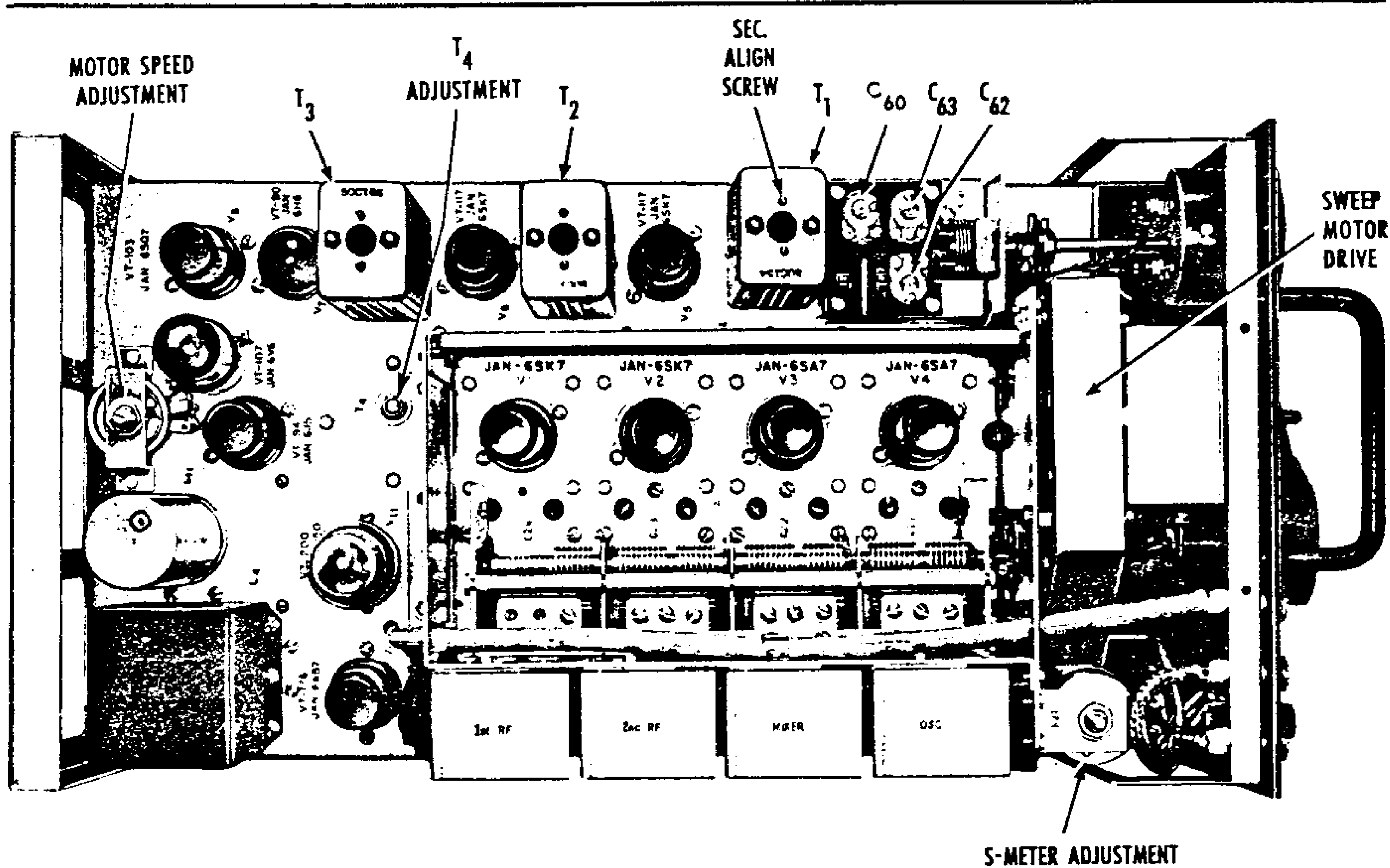

Figure 5-2. Radio Receiver R-45/ARR-7 — Top View, Showing Adjustments for Alignment

f. Adjust alignment screws on T-2 for maximum output meter reading.

g. Adjust alignment screws on T-3 for maximum output.

5-27. CRYSTAL ADJUSTMENT.

a. Adjust signal generator to produce an unmodulated signal. Turn on the "B.F.O." switch and adjust the "PITCH" control to produce an indication on the output meter.

b. Switch to "BROAD XTAL" position.

c. Vary the frequency of the signal about the 455 kc setting while adjusting the T-1 secondary screw for maximum output.

d. Adjust the "PHASING" control for maximum selectivity and back off the T-1 secondary alignment screw until the output reaches a minimum value between the two maximum values first noted.

e. Switch "SELECTIVITY" control to "SHARP XTAL" and adjust C-63 for maximum output while varying the signal generator frequency about the 455 KC frequency. Two points of maximum output will be noted corresponding to two adjustments of C-63. Either one of these points may be used for setting of C-63.

f. Switch to "MEDIUM XTAL" and adjust C-62 until the output is midway between output reached

while aligning "SHARP XTAL" and "BROAD XTAL" positions.

g. Switch again to "SHARP XTAL" and set signal generator to exact crystal frequency as indicated by maximum response of the output meter.

h. Turn off "B.F.O." switch.

i. Switch again to "I.F. SHARP" and carefully realign the i-f transformers as previously described in paragraphs 5-26d to 5-26g, this section.

5-28. B.F.O. ADJUSTMENT. (See figure 5-2).

a. Set "PITCH" control so that extension handle points directly down.

b. Turn "B.F.O." switch "ON."

c. Adjust signal generator to produce an unmodulated signal at exact crystal frequency. Signal generator is connected to receiver as for i-f alignment.

d. Adjust screw on B.F.O. transformer (T-4), after loosening lock nut, to zero beat as indicated by minimum or zero reading of output meter. Phones may be substituted for output meter to check zero beat adjustment.

e. Tighten lock nut on T-4 adjustment screw.

5-29. R-F AND OSCILLATOR ADJUSTMENT.

(See figures 5-3 and 5-4.)

a. With controls set as for i-f alignment, connect hot

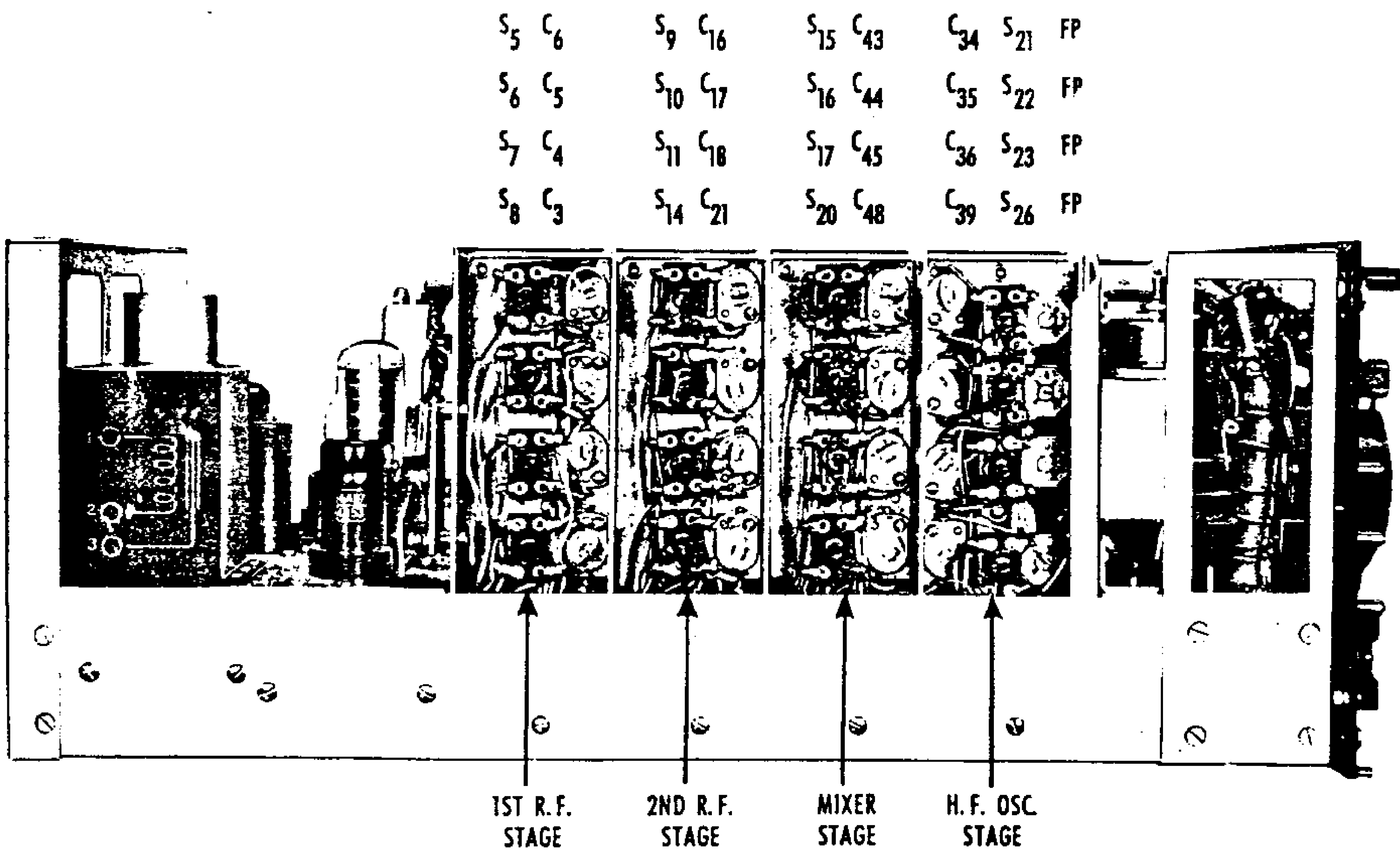

Figure 5-3. Radio Receiver R-45/ARR-7 — Side View, Showing Adjustments for Alignment

TABLE XIV

R-F AND OSCILLATOR ALIGNMENT CHART  
RADIO RECEIVER R-45/ARR-7

Band	Receiver Dial Setting	1st R-F Stage	2d R-F Stage	Mixer Stage	H-F OSC Stage
1	1.5 MC	—	C-16	C-43	C-34
1	.6	—	S-9	S-15	S-21
2	3.0	—	C-17	C-44	C-35
2	1.8	—	S-10	S-16	S-22
3	5.4	C-6	C-18	C-45	C-36
3	3.0	S-5	S-11	S-17	S-23
4	11.0	C-5	C-19	C-46	C-37
4	6.0	S-6	S-12	S-18	S-24
5	20.0	C-4	C-20	C-47	C-38
5	12.0	S-7	S-13	S-19	S-25
6	36.0	C-3	C-21	C-48	C-39
6	24.0	S-8	S-14	S-20	S-26

lead of signal generator to "ANT" receptacle. Connect ground lead of signal generator to chassis.

b. Make adjustments indicated in TABLE XIV for maximum indication on output meter.

**Note**

"S" indicates an adjustable slug for permeability tuning. As an example, S-5 indicates the slug which tunes transformer T-5.

**5-30. ALIGNMENT. — RADIO RECEIVER R-595/ARR-7AX.**

5-31. GENERAL. The receiver should be removed from its case, connected to a power source, and should be in operating condition with controls set as follows:

"POWER" switch at "POWER".

"BFO" switch at "OFF".

"SENSITIVITY" maximum (clockwise).

"MOTOR" switch at "OFF".

"AVC" switch at "OFF".

"AUDIO" maximum (clockwise).

"RANGE MC" switch at 0.55 to 1.6 mc position for i-f alignment; on band being aligned, for r-f alignment.

**5-32. I-F ALIGNMENT. (See figure 5-5.)**

a. Set main dial at 0.55 mc on the 0.55 to 1.6 mc band.

b. Connect output meter to receiver output through the "PHONES" jack on front panel.

c. Connect hot lead of signal generator to "ANT" receptacle on the front panel. Connect ground lead to receiver chassis.

d. Adjust signal generator to produce a 455 kc modulated. Adjust output amplitude of signal generator for convenient output meter indication.

e. Set "SELECTIVITY" control to "I-F SHARP".

f. Adjust alignment screws of T-201 for maximum output, keeping output level less than 5 volts rms by adjusting the output level of signal generator.

g. Adjust alignment screws of T-202 for maximum output.

h. Adjust alignment screws of T-203 for maximum output.

**5-33. CRYSTAL ADJUSTMENT. (See figure 5-5.)**

a. Connect signal generator as for i-f alignment.

b. Set "SELECTIVITY" control at "XTAL BROAD".

c. Vary frequency of signal about the 455 kc setting while adjusting T-201 secondary alignment screw (upper) for maximum output. Two settings of the signal generator will be found where a maximum output occurs.

d. Adjust C-214 for maximum symmetry. Symmetry may be observed by the rate at which needle of output meter falls at equal frequency deviations from peak output frequency.

e. Adjust T-201 secondary alignment screw (upper) until output reaches a minimum value between peaks noted in step c.

f. Set "SELECTIVITY" control to "XTAL SHARP" and adjust C-216 for maximum output while varying

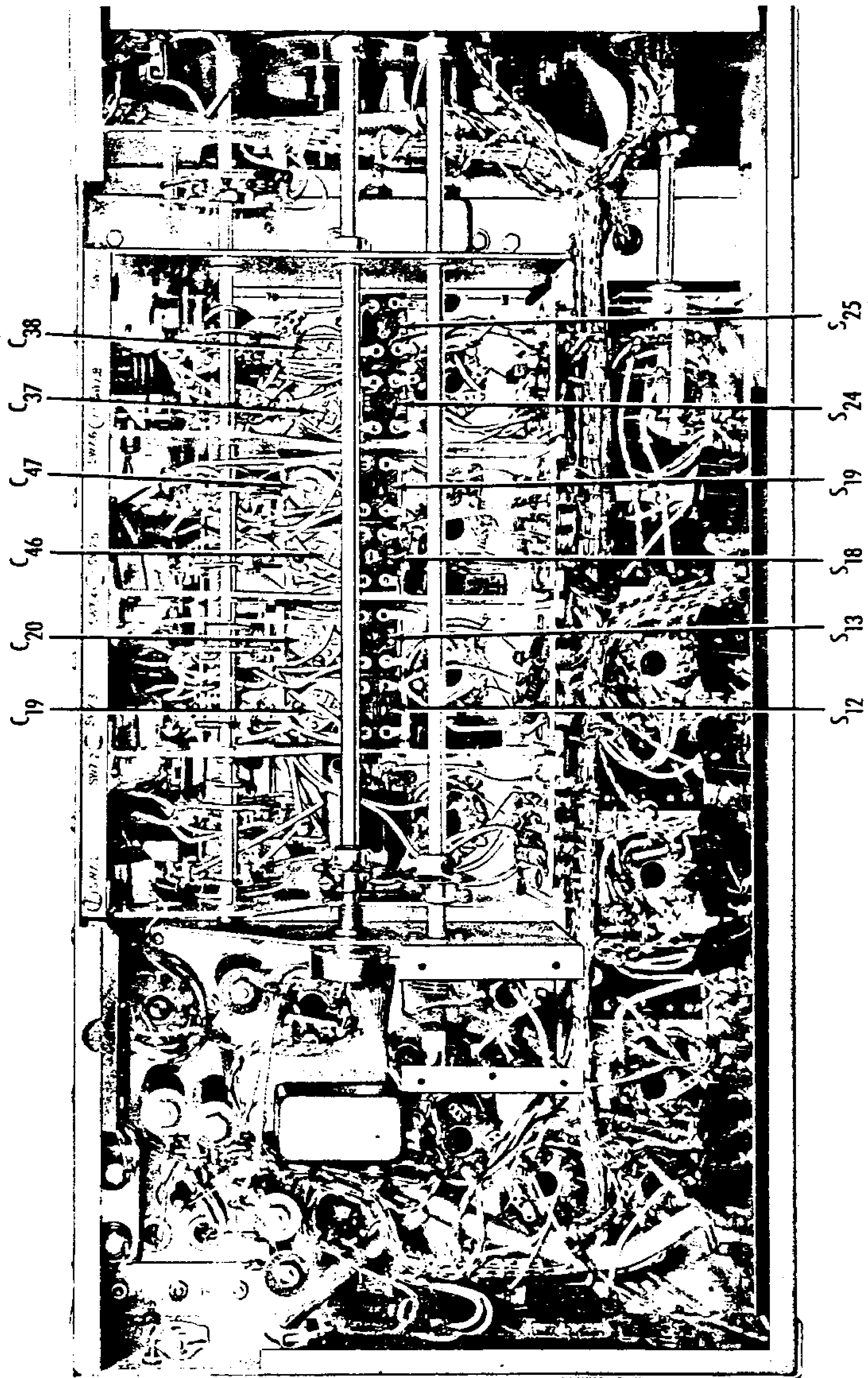

Figure 5-4. Radio Receiver R-45/ARR-7 — Bottom View, Showing Adjustments for Alignment

signal generator frequency about the 455 kc setting. Two frequencies of maximum output will be noted. Either of these two points may be used for setting C-216.

g. Switch to "XTAL SHARP" and set signal generator to exact crystal frequency as indicated by maximum response of output meter.

h. Switch to "I-F SHARP" and carefully realign i-f transformers as described in steps e, f, and g, paragraph 5-31.

#### 5-34. BFO ADJUSTMENT. (See figure 5-6.)

a. Connect signal generator as for i-f alignment.

b. Set "BFO" switch at "BFO".

c. Adjust signal generator to produce an unmodulated signal at exact crystal frequency.

d. Adjust screw on BFO transformer (L-401) to zero beat as indicated by zero or minimum reading on output meter. Phones may be substituted for output meter to check zero beat adjustment.

#### 5-35. SECOND CONVERTER ALIGNMENT.

(See figures 5-6 and 5-7.)

a. Remove shield from r-f section and remove tube, V-104.

b. Remove shield from tube, V-103, and wrap two or three turns of wire around tube.

c. Set signal generator to 2.0 mc and connect its output to the turns of wire on V-103.

d. Turn L-107 adjustment screw in flush then screw out slowly until an output is seen on the output meter. Peak carefully keeping signal generator output down so that output does not exceed 5.5 volts.

e. Peak T-119 primary and secondary carefully.

f. Adjust C-167 for maximum output.

#### 5-36. R-F AND OSCILLATOR ALIGNMENT.

(See figures 5-6 and 5-7.)

a. Set the "RANGE MC" switch to the 0.55 to 1.6 mc position.

b. Set receiver dial and signal generator to 0.63 mc and feed signal into antenna input.

c. Adjust L-106 to minimum inductance (slug out) and then screw in until an output is seen.

#### Note

The oscillator is tuned above the r-f input frequency. An output may be found when the oscillator is tuned below the r-f frequency, the wrong tuning point.

d. Turn T-106 and T-112 adjustment screws in flush, then screw out slowly until maximum output is obtained.

e. Set receiver dial and signal generator at 1.6 mc.

f. Peak C-149. An output can be obtained at two settings of C-149, the minimum capacity setting being correct.

#### Note

Minimum capacity settings of C-149, C-145, C-143, C-141, and C-138 are found at a point where the metallic (soldered) portion or the rotor is farther from the mounting screws.

g. Adjust C-128 and C-112 for maximum output.

h. Repeat steps b through g, this paragraph.

i. Align bands 2, 3, 4, 5 and 6, following steps b through g, this paragraph, using settings given in TABLE XV, R-F AND OSCILLATOR ALIGNMENT CHART.

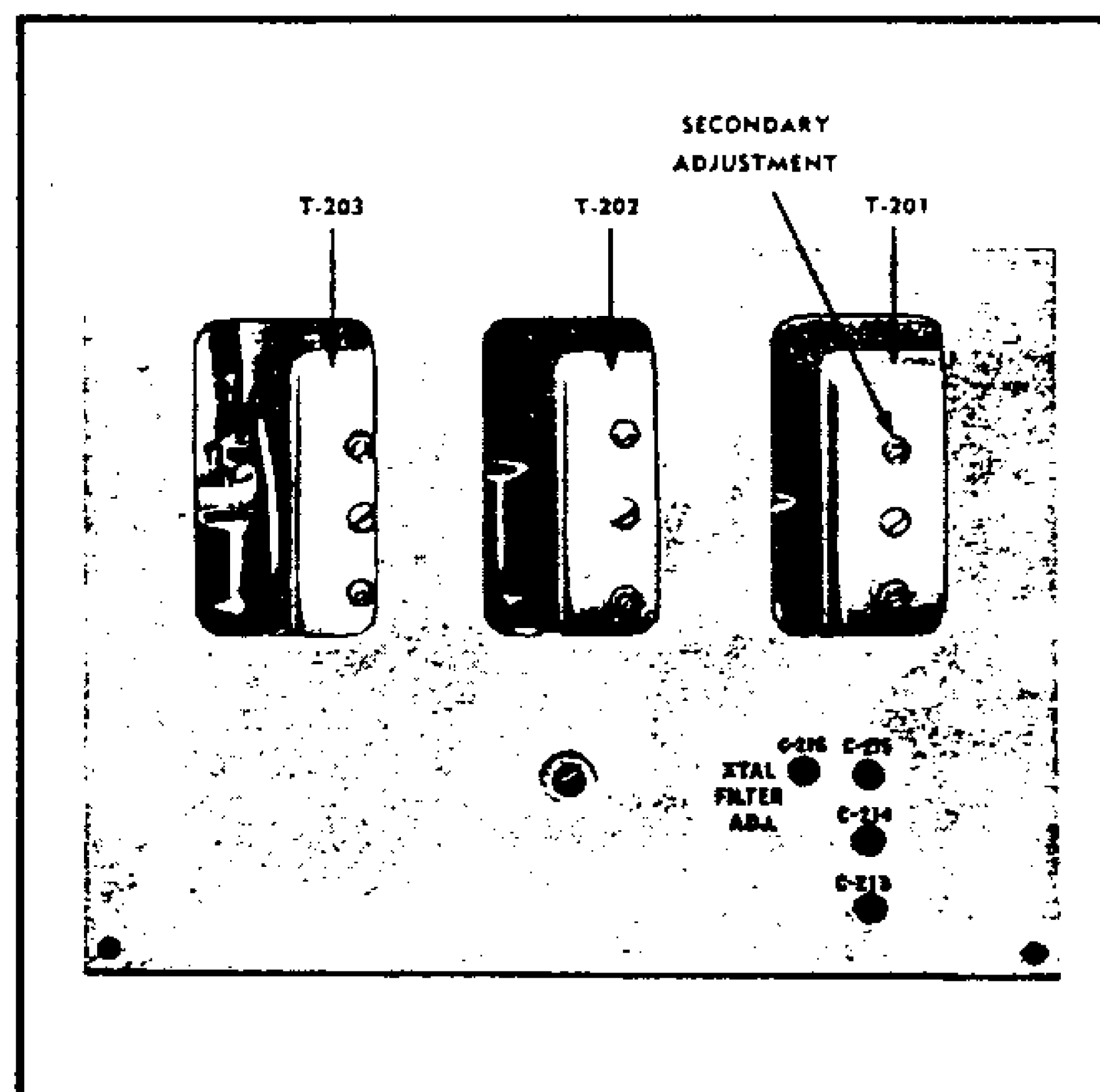

Figure 5-5. Radio Receiver R-595/ARR-7AX Rear View, Showing Adjustments for I-F Alignment

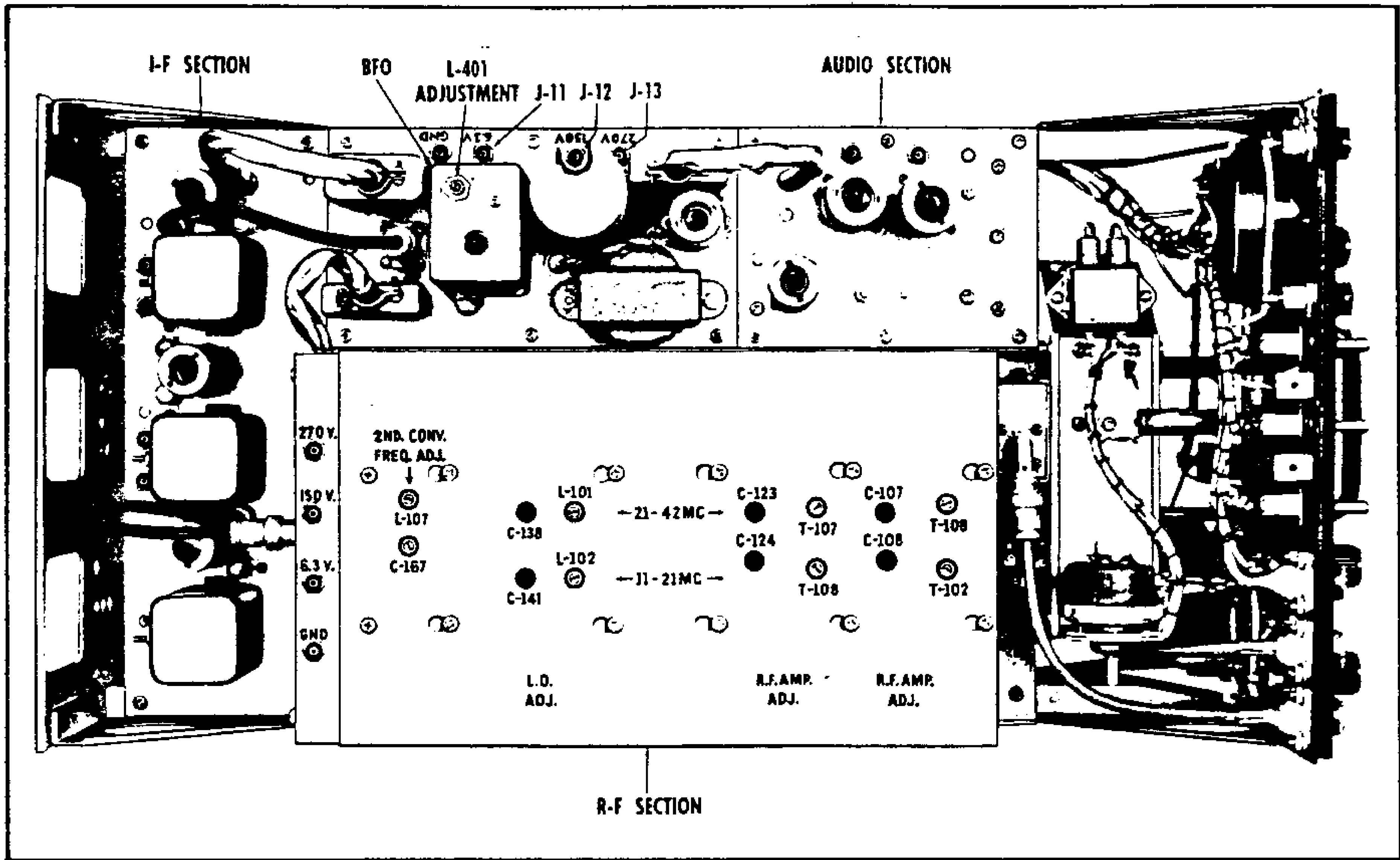

Figure 5-6. Radio Receiver R-595/ARR-7AX  
Top View, Showing Replaceable Sections and Adjustments for Alignment

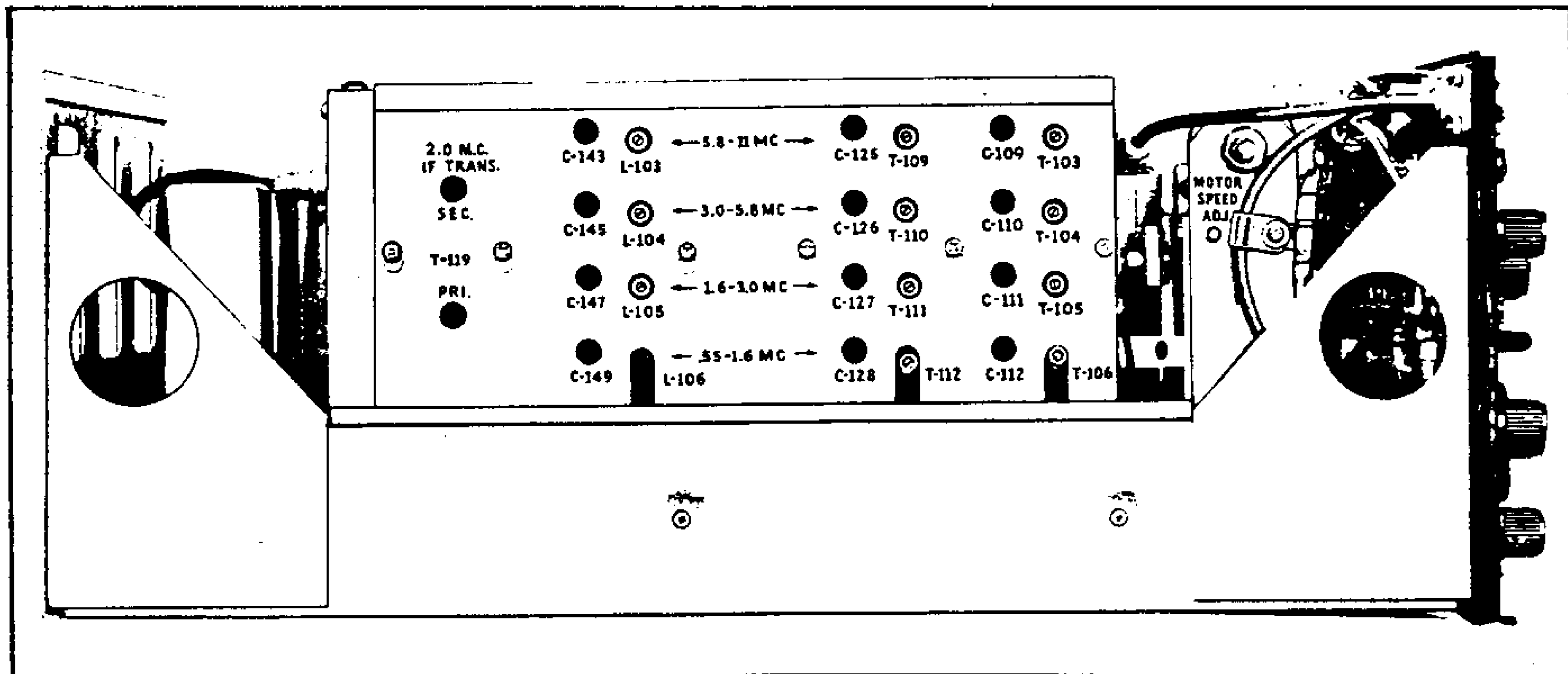

Figure 5-7. Radio Receiver R-595/ARR-7AX — Side View, Showing Adjustments for Alignment

TABLE XV

**R-F AND OSCILLATOR ALIGNMENT CHART  
 RADIO RECEIVER R-595/ARR-7AX**

<i>Band</i>	<i>Receiver Dial Setting</i>	<i>1st R-F Stage</i>	<i>2nd R-F Stage</i>	<i>Local Osc.</i>
1	1.6 mc	C-112	C-128	C-149
1	0.63	T-106	T-112	L-106
2	3.0	C-111	C-127	C-147
2	1.6	T-105	T-111	L-105
3	5.9	C-110	C-126	C-145
3	3.2	T-104	T-110	L-104
4	11.6	C-109	C-125	C-143
4	6.1	T-103	T-109	L-103
5	21.0	C-108	C-124	C-141
5	11.0	T-102	T-108	L-102
6	40.5	C-107	C-123	C-138
6	22.4	T-101	T-107	L-101

## SECTION VI SUPPLEMENTARY DATA

6-1. Radio Receivers R-45/ARR-7 and R-595/ARR-7AX tune over the frequency range of 0.55 to 42.0 mc in six bands as follows:

Band 1	0.55 to 1.6 megacycles
Band 2	1.6 to 3.0 megacycles
Band 3	3.0 to 5.8 megacycles
Band 4	5.8 to 11.0 megacycles
Band 5	11.0 to 21.0 megacycles
Band 6	21.0 to 42.0 megacycles

6-2. The overall audio frequency response of the receivers with the "SELECTIVITY" control in the "I-F BROAD" position is within  $\pm 1$  — 5 decibels of the 400-cycle reference level from 100 to 3000 cycles with a 50-milliwatt output to the phone jack.

6-3. The audio output furnishes at least 50 milliwatts of audio power on any band, with a 30-percent, 400-cycle modulated r-f input signal of not less than 10 microvolts, with less than 10 percent total harmonic distortion.

6-4. The output of Radio Receiver R-595/ARR-7AX is fed to a headset having an impedance of 600 ohms. Optimum results are obtained with Radio Receiver R-45/ARR-7 by use of an 800 ohm headset.

6-5. Sensitivity of Radio Receivers R-45/ARR-7 and R-595/ARR-7AX is better than 10 microvolts at a 10 decibel signal-to-noise ratio on all bands with a 50 milliwatt output.

6-6. The ratio of standard signals input at the intermediate frequency of the receiver, to that at the resonant frequency of the receiver, each signal producing a 50-milliwatt output, is at least 500 on the low frequency band (band 1) and 1000 on the remaining bands.

6-7. Radio Receiver R-595/ARR-7AX — AVC Action. The ratio between the output voltage at 40 microvolts r-f input, over that at 120,000 microvolts r-f input, is not greater than 3:1.

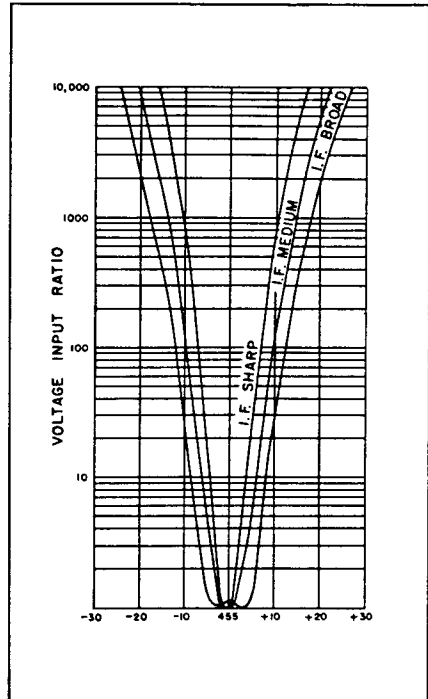

Figure 6-1. Radio Receivers R-45/ARR-7 and R-595/ARR-7AX — I-F Selectivity Curves

**TABLE XVI**  
**I-F SELECTIVITY CHARACTERISTICS**

Ratio: Input Off Resonance Input at Resonance for same output:	Band Width (Kilocycles)	
	I.F. Broad	I.F. Sharp
2	12.0	4.75
1000	40.0	27.0

TABLE XVII  
 RADIO RECEIVER R-45/ARR-7 — AVC ACTION

<i>R-F Input Micro-volts</i>	<i>Variation of voltage output to audio load from that at 200-microvolt input</i>
40 — 200	-10 to 0 db
200 — 1000	-1 to +5 db
1000 — 100000	-1 to +9 db

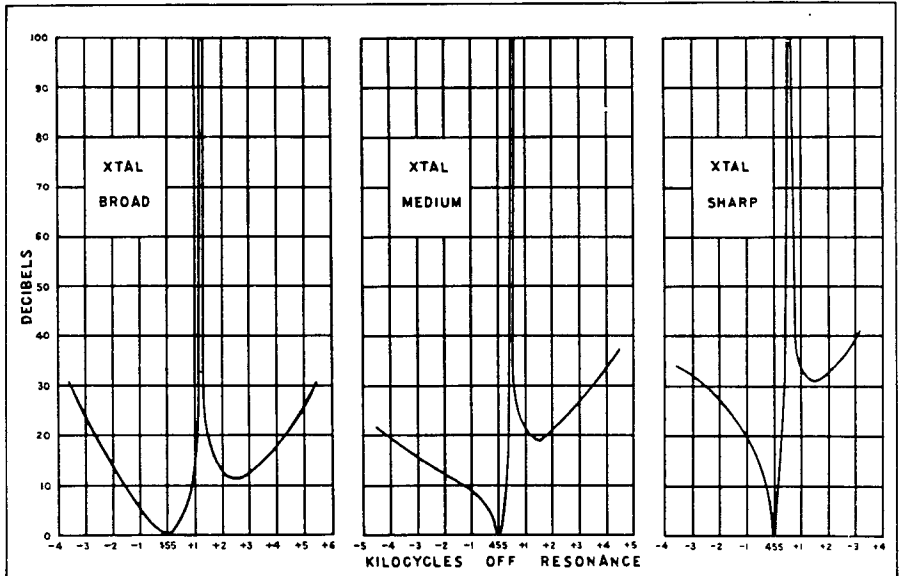

Figure 6-2. Radio Receivers R-45/ARR-7 and R-595/ARR-7AX — Crystal Selectivity Curves

**TABLE XVIII**  
**TUBE COMPLEMENT**

Reference Symbol	Stock No.	Type Designation	Function
Radio Receiver R-45/ARR-7			
V-1	3370-286000-6545	JAN-6SK7	1st r-f amp.
V-2	3370-286000-6545	JAN-6SK7	2nd r-f amp.
V-3	3370-283000-6525	JAN-6SA7	Mixer
V-4	3370-283000-6525	JAN-6SA7	H-F osc.
V-5	3370-286000-6545	JAN-6SK7	1st i-f amp.
V-6	3370-286000-6545	JAN-6SK7	2nd i-f amp.
V-7	3370-304000-6128	JAN-6H6	Detector, AVC, ANL
V-8	3370-265000-6245	JAN-6SQ7	1st a-f amp.
V-9	3370-298000-6575	JAN-6V6GT/G	2nd a-f amp.
V-10	3370-316000-6295	JAN-6J5	B. F. O.
V-11	3370-331000-1795	JAN-OD3/WR150	Voltage regulator
V-12	3370-286000-6115	JAN-6AB7	Re-radiation suppressor
Radio Receiver R-595/ARR-7AX			
V-1	3370-331000-1615	JAN-0A2	Voltage regulator
V-101	3370-316000-5675	JAN-5670	1st r-f amp.
V-102	3370-286000-5755	JAN-5749	2nd r-f amp.
V-103	3370-283000-5755	JAN-5750	Mixer
V-104	3370-283000-5755	JAN-6100/CT	Local osc.
V-105	3370-451000-6145	JAN-5750	2nd converter
V-201	3370-283000-5755	JAN-5749	1st i-f amp.
V-202	3370-286000-6755	JAN-5749	2nd i-f amp.
V-203	3370-262000-6275	JAN-6097	Detector, AVC
V-300	3370-316000-1365	JAN-12AT7	1st a-f amp.
V-301	3370-298000-6475	JAN-6095/CT	Audio output
V-302	3370-316000-5715	JAN-5687	Rec. output
V-401	3370-451000-6145	JAN-6100/CT	B. F. O.
Rectifier Power Unit PP-32/AR			
V-200	3370-304000-5125	*JAN-5R4GY	Rectifier
V-201	3370-304000-5125	*JAN-5R4GY	Rectifier
V-202	3370-304000-5125	*JAN-5R4GY	Rectifier

\*If tube 5R4GY is not available, 5U4G may be substituted.

**TABLE XIX**  
**PILOT LIGHT COMPLEMENT**

Reference Symbol	Stock No.	Type Designation	Location
Radio Receiver R-45/ARR-7			
LM-1	3300-29244800	Madza 47	Behind tuning dial scale
Radio Receiver R-595/ARR-7AX			
I-1 through I-9	*	MIL-S25010-1	On front panel behind screw caps
I-10	8870-938000-855	AN3121-R313	Behind tuning dial scale
Rectifier Power Unit PP-32/AR			
LM-200	3300-292434500	Madza 313	On front panel adjacent to "A.C." switch
LM-201	3300-292448000	Madza 47	On front panel adjacent to "D.C." switch

\* Not Stock Listed

**SECTION VII  
DRAWINGS**

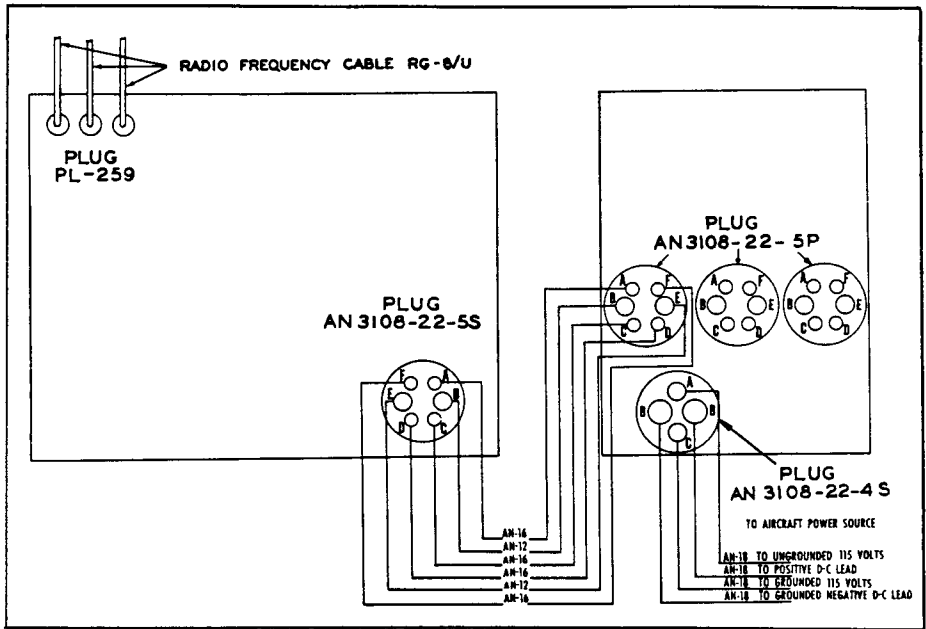

Figure 7-1. Radio Receiving Sets AN/ARR-7 and AN/ARR-7AX — Cording Diagram

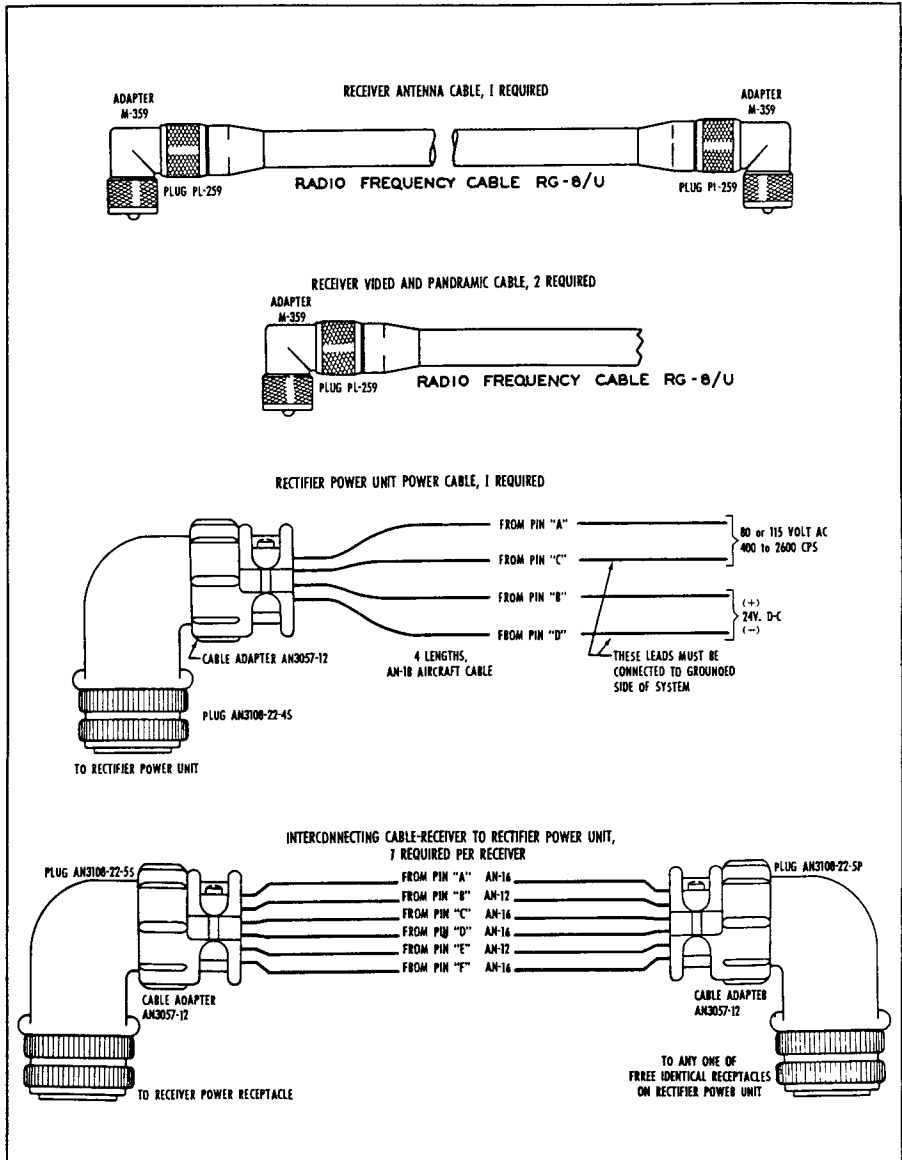

Figure 7-2. Radio Receiving Sets AN/ARR-7 and AN/ARR-TAX—Cable Assembly Diagram

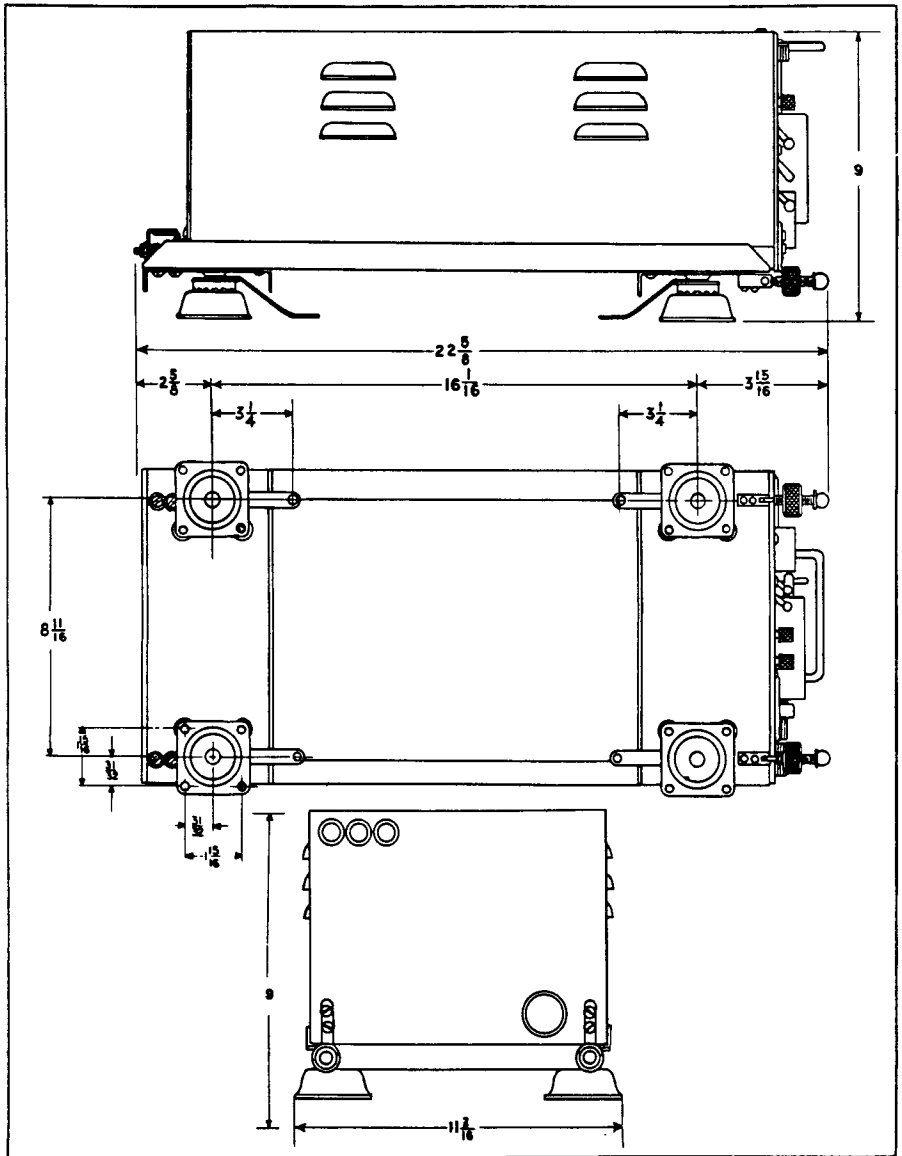

Figure 7-3. Radio Receivers R-45/ARR-7 and R-595/ARR-7AX — Outline Dimensions

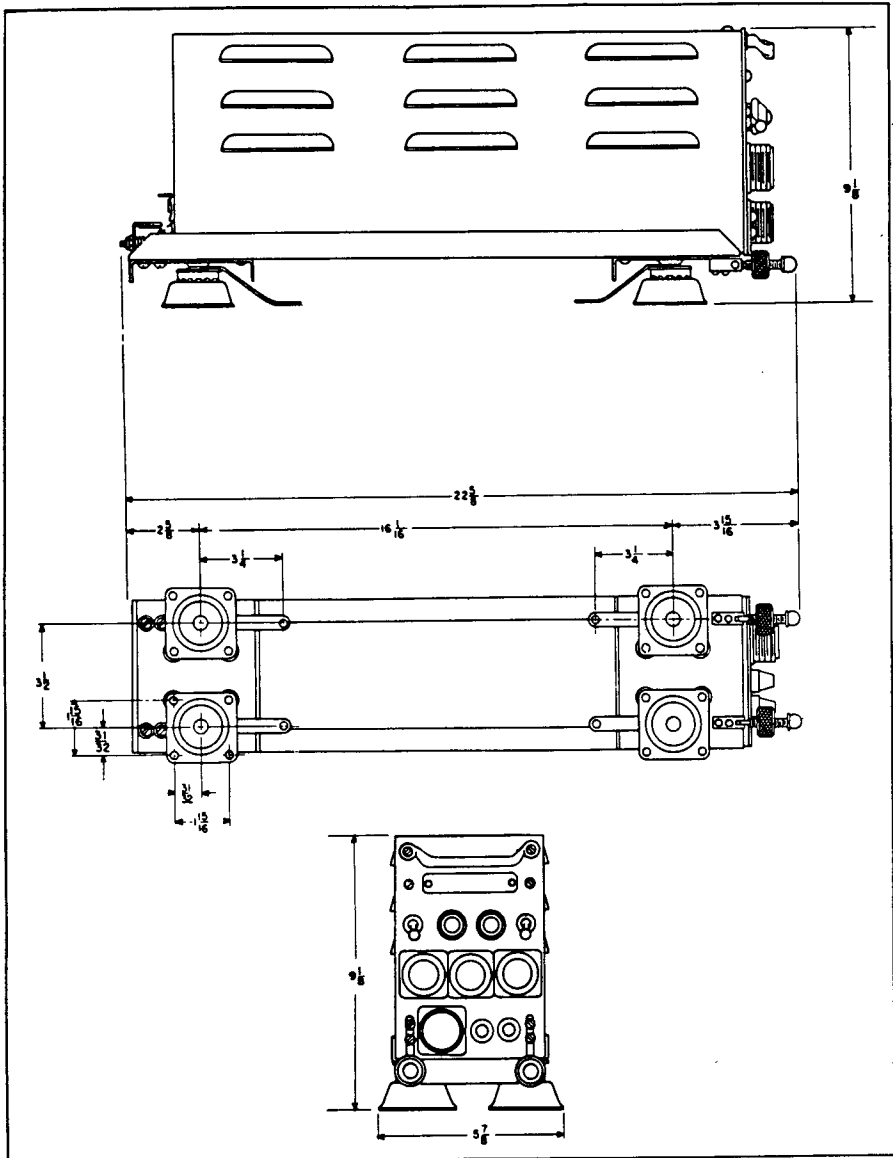
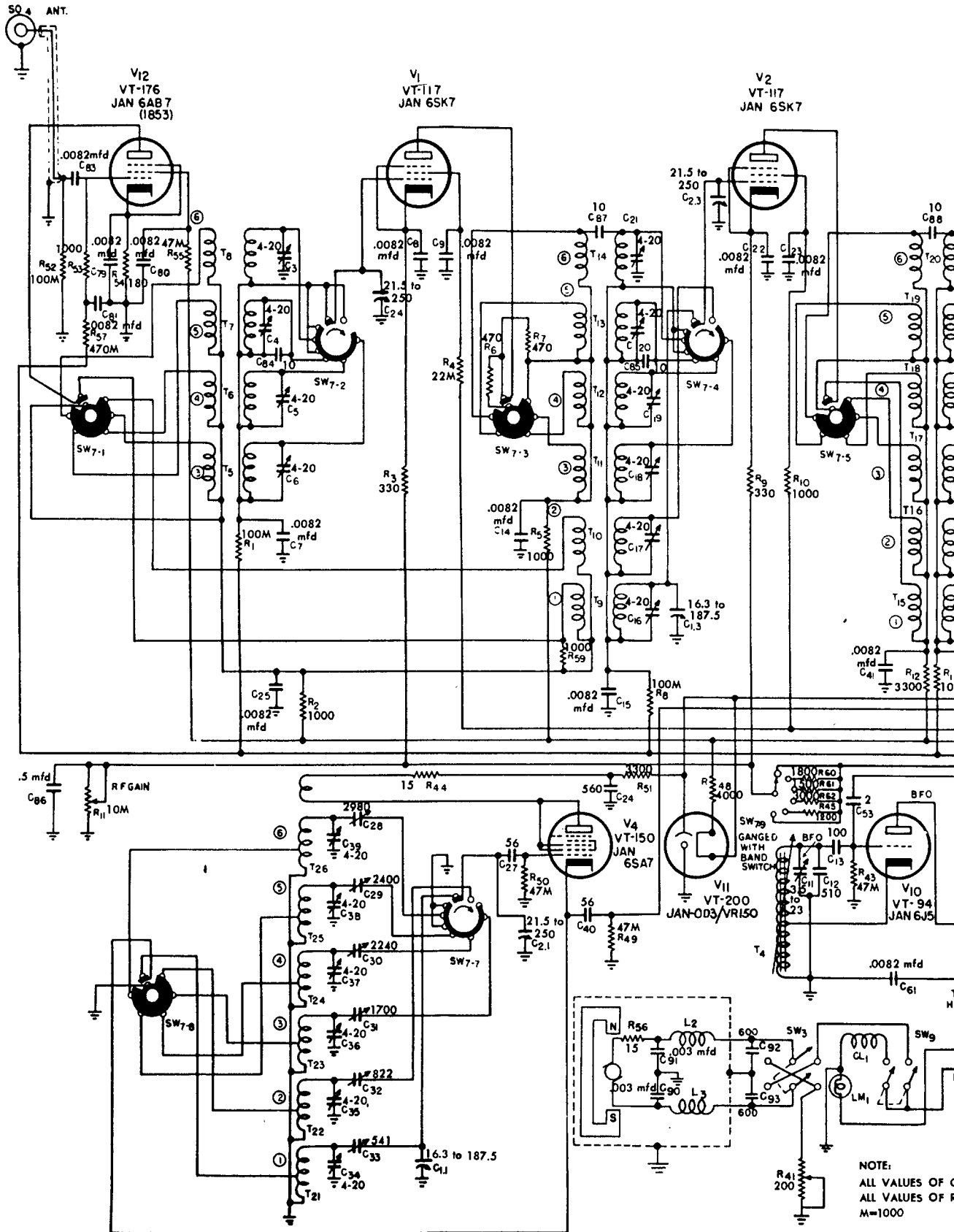

Figure 7-4. Rectifier Power Unit PP-32/AR — Outline Dimensions

AN 16-30ARR7-2



NOTE:  
ALL VALUES OF C  
ALL VALUES OF R  
M=1000

AN 16-30ARR7-2

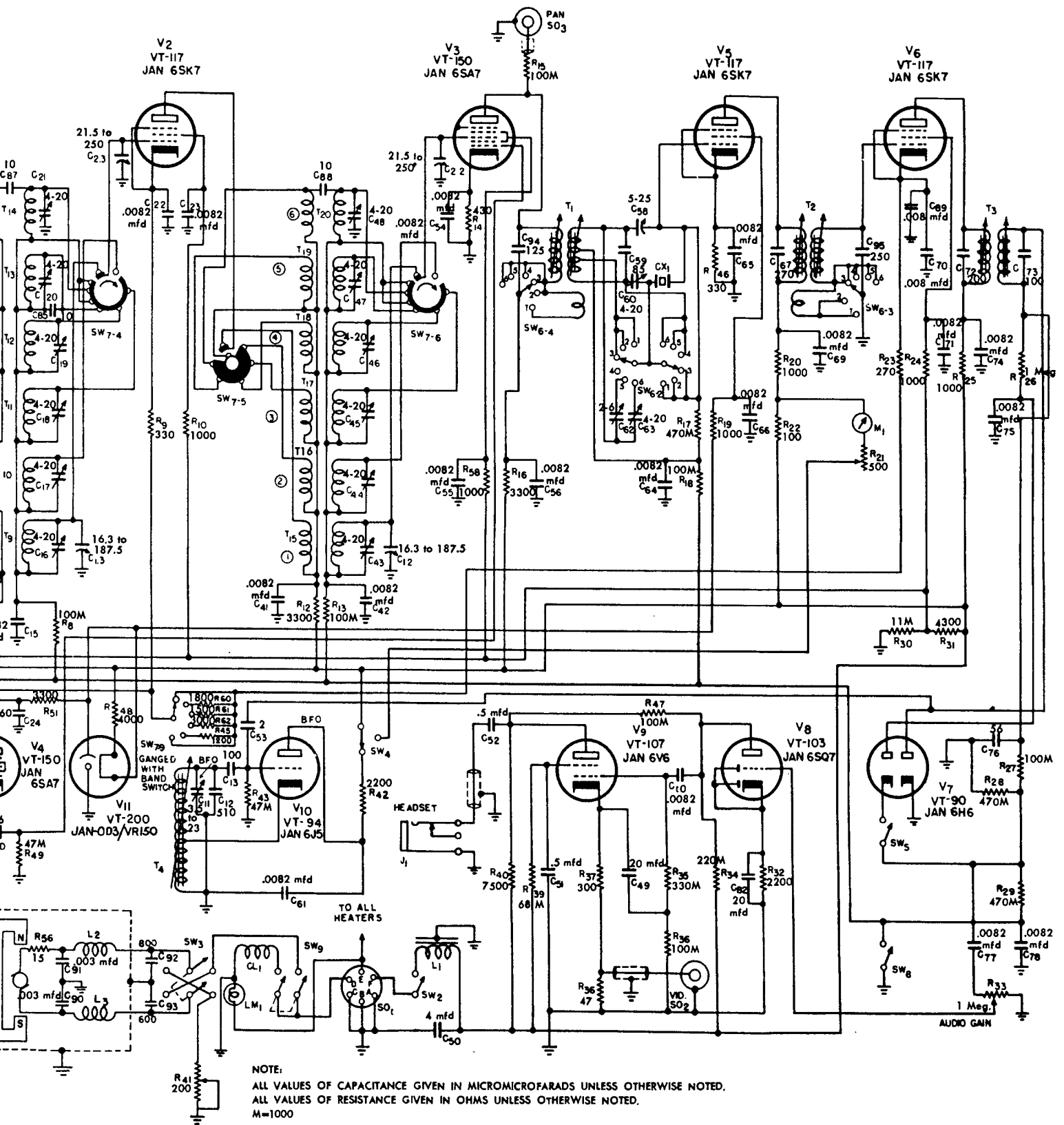

Figure 7-5. Radio Receiver R-45/ARR-7 — Schematic Circuit Diagram

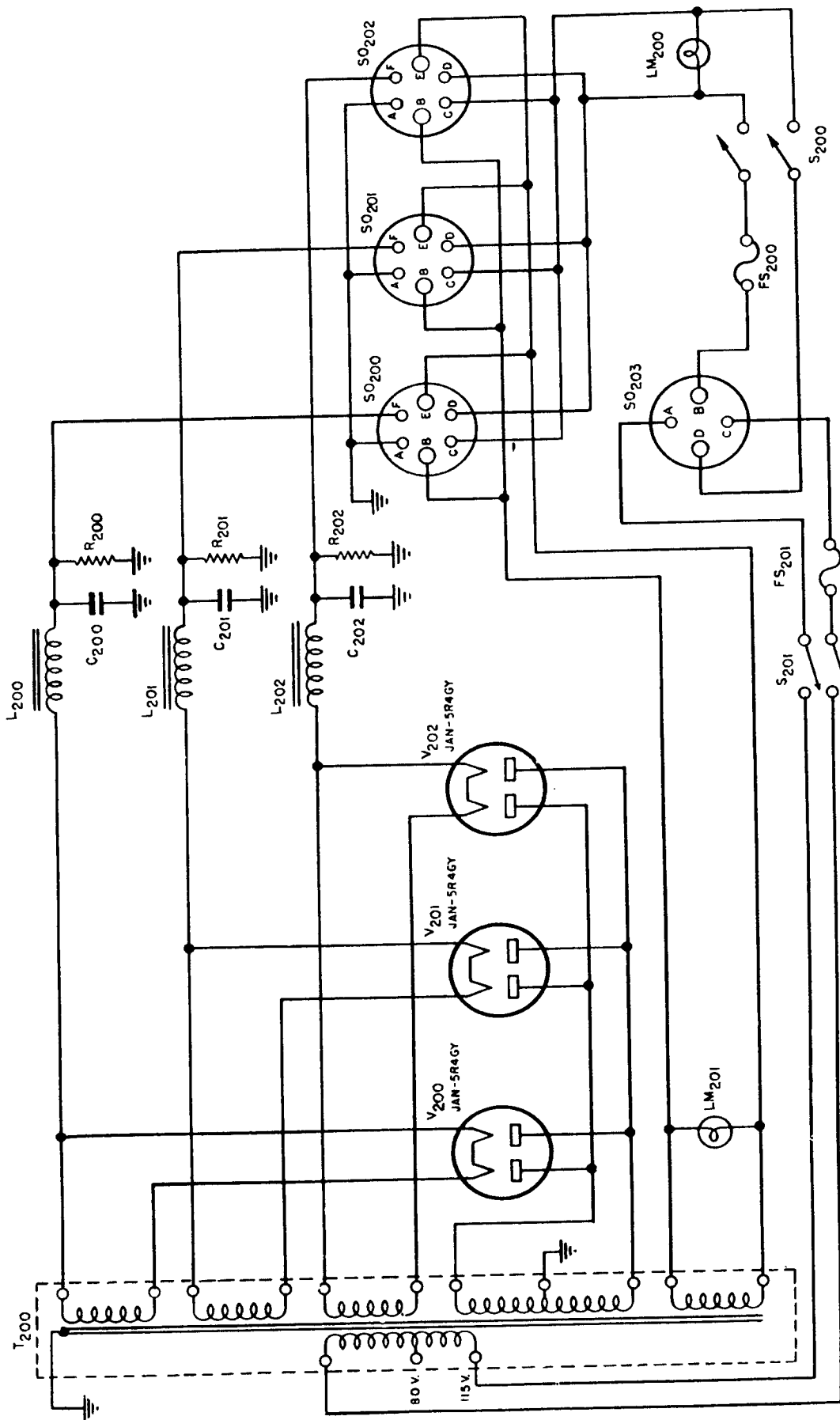

Figure 7-6. Rectifier Power Unit PP-32/AR — Schematic Circuit Diagram

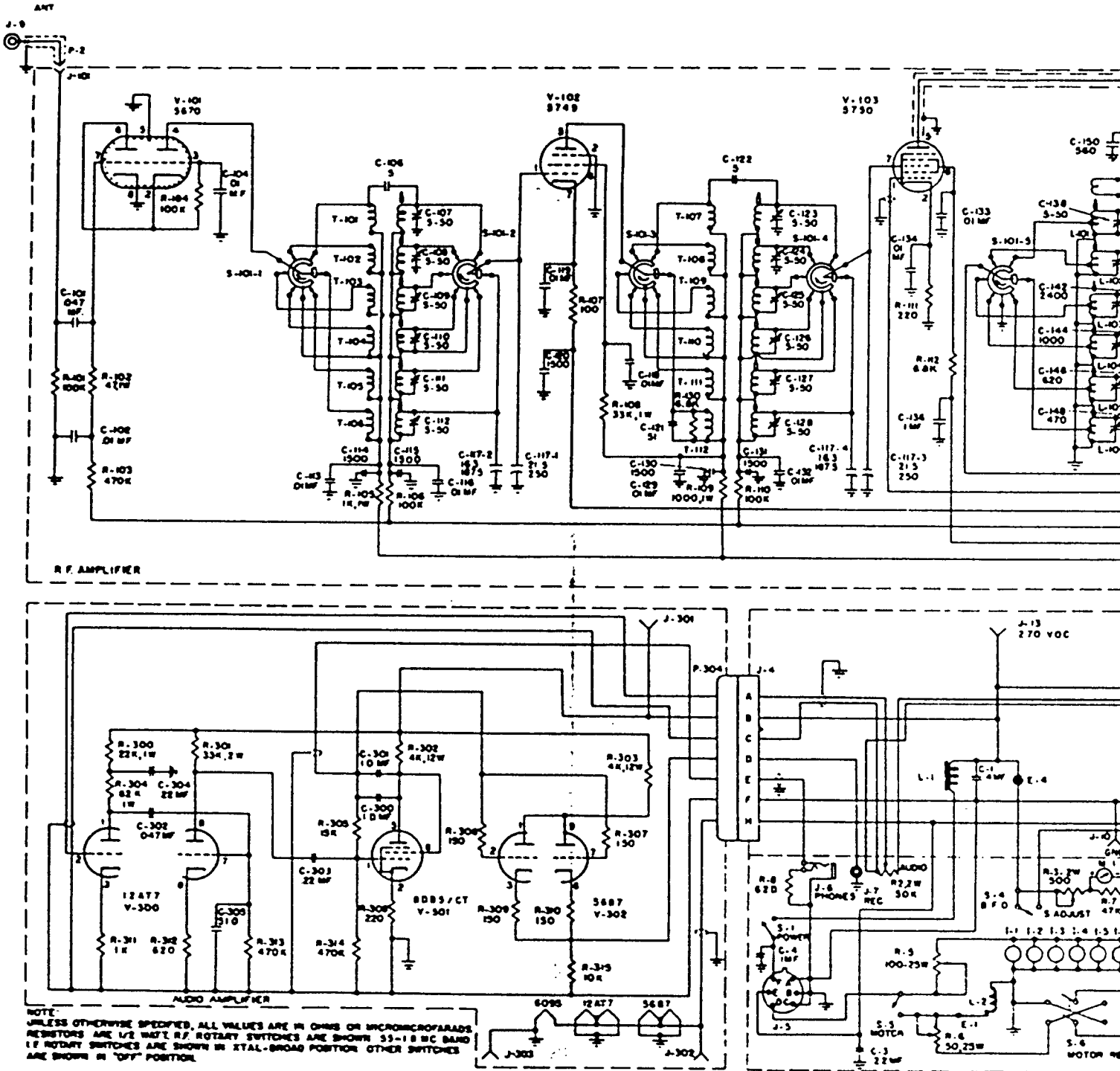

Figure 7-7.

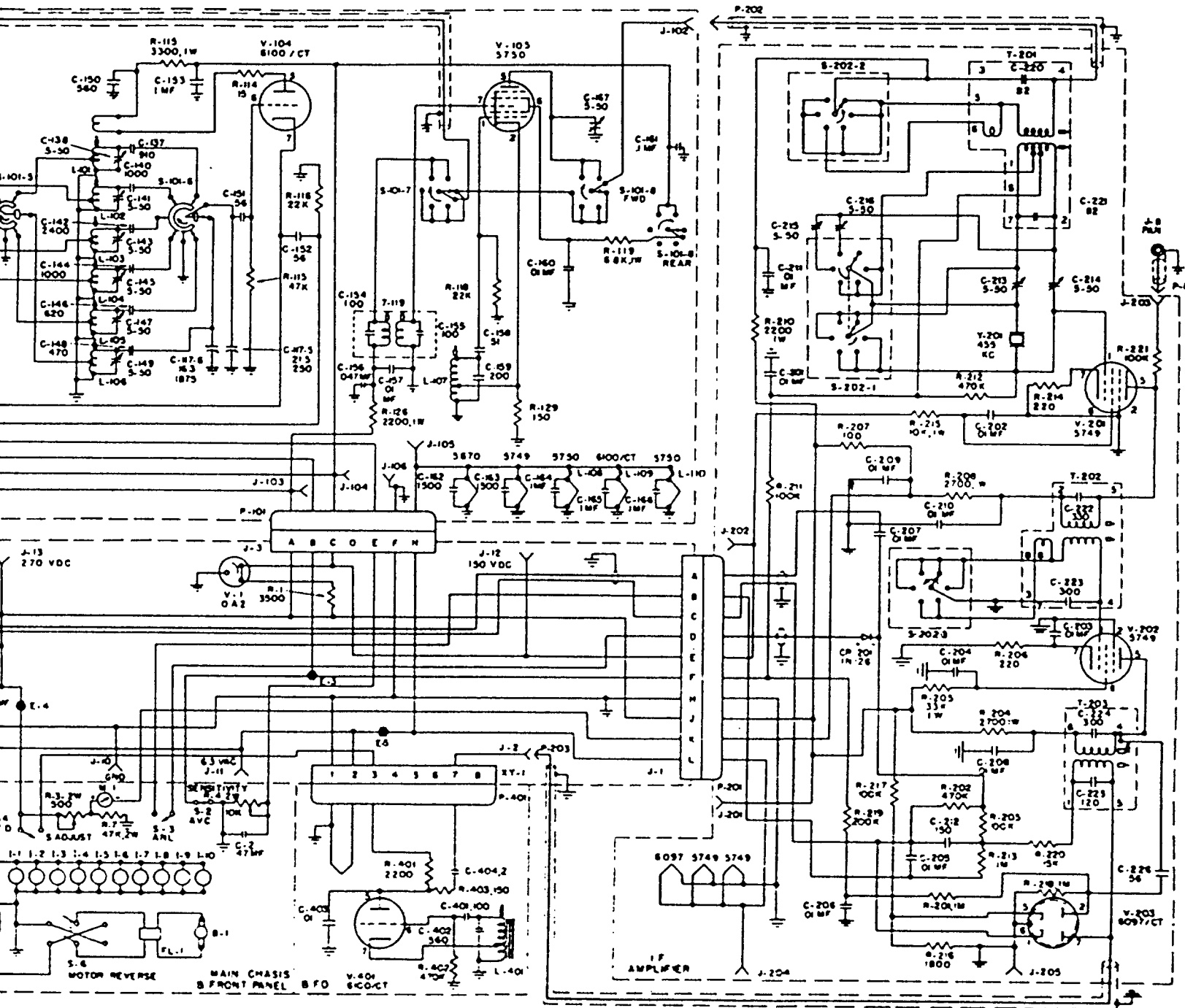

Figure 7-7. Radio Receiver R-595 ARR-7AX — Schematic Circuit Diagram