

# ERRATA

TM 11-638

## WAR DEPARTMENT TECHNICAL MANUAL

### RADIO SET AN/PRC-1 ( )

#### CAUTION:

**BEFORE REMOVING OR INSERTING RECEIVER TRANSMITTER RT/PRC-1 INTO SUITCASE BE CERTAIN THAT THE RECEIVER DIAL READS BELOW 2.**

*Page 1, Par. 2.*

"Headset" should read "Headset HS-30".

"Key" should read "Key J-37".

"Technical Manual" should read "Technical Manual TM 11-638".

The following components should be listed:

- 1 Cord CD-201-A 18 in. (For Key J-37).
- 1 Mounting (for key J-37).
- 1 Cord CD-605 (For Headset HS-30).
- 1 Crystal Case CY-86/TRC-10, including 47 crystal holders FT-243 and crystals.
- 1 Wrench for 8-32 Allen Head Set Screw.
- 1 Wrench for 10-32 Allen Head Set Screw.

*Page 5, Par. 8 a.*

"76" should be "104".

*Page 6, Par. 11 a.* Add:

"(5) Allen Wrenches, (2)."

*Page 6, Par. 11 b.* Add:

"(6) Spare fuses."

*Page 6, Par. 13 a.; Par. 13 b.*

"Cord CD-201-A" should read "Cord CD-201-A 18 in."

*Page 10, Par. 23 a.; Par. 23 c.*

"PLT. VOL." should read "PLT. VOLTS".

*Page 12, Par. 32 b.*

This entire paragraph should read "CASE CY-86/TRC-10 contains 47 Crystal Holders FT-243."

*Page 12, Par. 33 b.* Omit:

"ground wire and selected crystal".

*Page 15-36.c. (8).*

During this operation, at certain frequencies, between 4 and 5 megacycles in the low band, 2 dips may be noticed. Select the dip at the highest frequency indication. If the incorrect dip is used, no minimum plate current drain will be noticed as called for in paragraph 36 C (11).

*Page 16-40.g.*

During this operation, at certain frequencies, between 4 and 5 megacycles, 2 dips may be noticed. Select the dip at the highest frequency indication. If the incorrect dip is used, the high pitched whistle will not be heard at the frequency of the inserted crystal as called for in paragraph 40 i.

*Page 17-41.f.*

During this operation, at certain frequencies, between 4 and 5 megacycles in the low band, 2 peaks may be noticed. Select the peaks at the highest frequency indication. If the incorrect peak is used, no minimum plate current drain will be noticed as called for in paragraph 41 h.

*Page 17, Par. 41 i.* Add:

"To insure the operator that the transmitter is delivering power to the antenna, hold the base of the neon bulb against the metal portion of the antenna binding post. The neon bulb will glow. The intensity of glow will increase with increased power output."

*Page 20, Par. 46.*

"powered iron" should be "powdered iron".

*Page 20, Par. 48.* Add:

"Immediately adjoining Condenser C 41, is a black terminal block. There is a wire, white with blue tracers, attached to this block. When this wire is in the position nearest the front panel, the receiver is connected for use with a low impedance headset. When this wire is in the position nearest the condenser C 41, the receiver is

UNCLASSIFIED  
**SECRET**  
(1)

connected for use with a high impedance headset. The metal tag attached to the phone jack on the front panel should indicate the headset used. The word "HIGH" appears on one side of the tag and the word "LOW" on the reverse side.

*Page 25, Par. 57 a.* Add:

"The term 'output impedance switch' refers to the terminal block described in this 'Errata' under Page 20, Par. 48, immediately above.

*Page 25, Par. 57 b.*

"400-ohm series resistor" should be "0.05 mfd. series capacitor".

*Page 25, Par. 57 c.* Add:

"For this adjustment set the CAL. CW. PHONE SWITCH in the CW position."

*Page 26, Par. 57 d.*

"0.05 series capacitor" should be "400 ohm series resistor."

*Page 30, Par. 61 d.*

The sequence of operations should be: d (5), d (4), d (3), d (2) and d (1). Under d (5) "10 ma." should be "21 ma.", "7 ma" should be "15 ma".

*Page 31, Par. 61 d (6).*

"Load resistor" should be "Shunt resistor."

*Page 31, Par. 62 c. (2) (c).*

"Four screws" should be "six screws".

*Page 34.*

See attached sheets.

*Page 35.*

C 18, C 13, C 31—Quantity per unit should be 3.

*Page 37.*

Signal Corps Stock No. 2Z5842-23 KNOB—dwg. No. should be "L-20460-B."

Signal Corps Stock No. 2Z5842-18 KNOB—dwg. No. should be "L-20460-B."

*Page 38.* Add the following items:

R4 3Z5994A1 Resistor: fixed; wire wound; 4.17 ohms  $\pm 3\%$  special; North American Philips dwg. No. S1.264.04 1

R6 3Z5999A1 Resistor: fixed; wire wound; 9.10 ohms  $\pm 3\%$  special; North American Philips dwg. No. S1.264.05 1

R8 3Z5988D4 Resistor: fixed; wire wound; .840 ohms  $\pm 2\%$  special; North American Philips dwg. No. S1.264.03 1

*Page 39.* Add to R29:

"R34; R35".

Quantity per unit should be "3".

Add the following items:

SW4 3Z9826-24.6 Switch: rotary; single section, 5 position; calibrate, c.w. phone switch; North American Philips Dwg. No. S1.701.02 1

SW1 3Z9826-24.7 Switch: rotary; 2-section; 2 position band-transmitter switch; North American Philips Dwg. No. S1.701.04 1

SW5—Add: "Meter Switch"; "dwg. No. S1.701.02" should be Dwg. No. G8.710.14.

*Page 41, T5—Add:*

"North American Philips Dwg. No. S1.231.06".

"Cord CD-201-A: (for Key U-37)" should be "Cord CD-201-A 18 in. (for Key J-37)".

Stock No. "3E1201A" should be "3E7207-2".

Stock No. "2B8300" should be "2B830U".

**SECRET**

( 2 )

3-H-S-559  
Item 4

# TM 11-638

WAR DEPARTMENT TECHNICAL MANUAL

UNCLASSIFIED

Regraded ..... Date 27 Aug 55  
By Auth of ..... Pam 310-4 ..... 13 May 55  
By ..... Dean .....  
Orgn ..... COLES AREA .....  
SCEL Technical Documents Center

Item 2  
inside

## RADIO SET AN/PRC-1()

COLES AREA  
SCEL Technical Documents Center

**SECRET**



UNCLASSIFIED  
SECRET

---

# RADIO SET AN/PRC-1( )

UNCLASSIFIED

Regraded ..... Date 22 Aug 55  
By Auth of Paw 310-4 13 May 55  
By Dean  
Orgn COLES AREA  
SCEI: Technical Documents Center

---



WAR DEPARTMENT,  
WASHINGTON 25, D. C., 13 October 1944.

TM 11-638, Radio Set AN/PRC-1 ( ), is published for the information and guidance of all concerned.

[A. G. 300.7 (21 June 44).]

BY ORDER OF THE SECRETARY OF WAR:

G. C. MARSHALL,  
*Chief of Staff.*

OFFICIAL:

J. A. ULIO,  
*Major General,  
The Adjutant General.*

DISTRIBUTION:

X.

(For explanation of symbols see FM 21-6.)

# TABLE OF CONTENTS

	<i>Paragraph</i>	<i>Page</i>
SECTION I. Description.		
General .....	1	1
Radio Set AN/PRC-1 ( ), list of components.....	2	1
Range .....	3	1
Frequency coverage .....	4	1
Power source .....	5	2
Power input .....	6	2
Power output .....	7	4
Weight .....	8	4
Adapters .....	9	5
Antenna .....	10	5
Carrying case .....	11	5
Headset HS-30 .....	12	6
Key J-37 .....	13	6
Receiver-Transmitter RT-30( )/PRC-1 with case.....	14	6
Rectifier Power Unit PP-36( )/PRC-1.....	15	8
Controls .....	16	8
LINE SWITCH A .....	17	9
ON OFF B .....	18	9
REC. TUNING 1 .....	19	9
BAND SWITCH 2 .....	20	9
VOLUME 3 .....	21	9
CAL. CW. PHONE 4.....	22	9
METER SWITCH 5 .....	23	10
OSC. TUNING 6.....	24	10
LIGHTS 7 .....	25	10
AMP. TUNING 8 .....	26	10
BAND SWITCH 9 .....	27	10
ANT. SWITCH 10 .....	28	10
ANT. TUNING 11 .....	29	11
SEND REC 12 .....	30	11
Miscellaneous markings .....	31	11
II. Installation and Operation.		
Initial procedure .....	32	12
Installation of receiver-transmitter and rectifier power unit.....	33	12
Installation of antenna .....	34	12
Additional information .....	35	14
Preparation of set for use .....	36	14
Operation .....	37	15

## TABLE OF CONTENTS

	<i>Paragraph</i>	<i>Page</i>
Use of the receiver .....	38	15
Precautions in operation of receiver .....	39	15
Receiver calibration .....	40	16
Use of the transmitter .....	41	16
Summary of instructions .....	42	17
 III. Functioning of parts.		
Receiver .....	43	19
R-f amplifier stage .....	44	19
Converter stage .....	45	20
I-f amplifier stage .....	46	20
Second detector stage .....	47	20
A-f amplifier stage .....	48	20
Beat-frequency oscillator .....	49	21
Transmitter .....	50	21
Power amplifier stage .....	51	21
Power supply .....	52	21
Switches .....	53	22
 IV. Maintenance.		
General .....	54	23
Operational inspection .....	55	23
Replacement of tubes, fuses, and indicator lamps .....	56	23
Receiver alignment .....	57	25
Procedure in locating trouble .....	58	27
Voltage measurements .....	59	30
Point-to-point resistance measurements .....	60	30
Servicing the transmitter .....	61	30
Moistureproofing and fungiproofing .....	62	31
 V. Supplementary data.		
Maintenance parts list for Receiver-Transmitter RT-30( )/PRC-1.....	63	33
Maintenance parts list for Rectifier Power Unit PP-36( )/PRC-1.....	64	38
Maintenance parts list for Radio Set AN/PRC-1 ( ) miscellaneous.....	65	39

# LIST OF ILLUSTRATIONS

<i>Fig. No.</i>	<i>Title</i>	<i>Page</i>
1	Radio Set AN/PRC-1 ( ), components .....	viii
2	Line cord adapters .....	5
3	Adapters in left-hand compartment .....	5
4	Antenna on reel .....	6
5	Right-hand accessory compartment .....	6
6	Headset HS-30 .....	7
7	Key J-37 .....	7
8	Rectifier Power Unit PP-36( )/PRC-1 and Receiver-Transmitter RT-30( )/PRC-1 .....	8
9	Front panels in open carrying case .....	9
10	Radio Set AN/PRC-1 ( ), installed for operation .....	13
11	Receiving section of front panel of Receiver-Transmitter RT-30( )/PRC-1 .....	16
12	Transmitter section of front panel of Receiver-Transmitter RT-30( )/PRC-1 .....	16
13	Block diagram of Radio Set AN/PRC-1 ( ) .....	19
14	Block diagram of Radio Set AN/PRC-1 ( ) set-up for alignment of receiver .....	24
15	Bottom view of receiver-transmitter chassis, showing location of parts .....	24
16	Rear view of receiver-transmitter chassis, showing location of parts .....	25
17	End view of receiver-transmitter chassis, showing location of parts .....	26
18	Rear view of rectifier power unit showing location of parts .....	28
19	Bottom view of rectifier power unit showing location of parts .....	29
20	Schematic diagram of Radio Set AN/PRC-1 ( ) .....	33



## DESTRUCTION NOTICE

**WHY** — To prevent the enemy from using or salvaging this equipment for his benefit.

**WHEN** — When ordered by your commander.

- HOW** —
1. Smash — Use sledges, axes, handaxes, pickaxes, hammers, crowbars, heavy tools.
  2. Cut — Use axes, handaxes, machetes.
  3. Burn — Use gasoline, kerosene, oil, flame throwers, incendiary grenades.
  4. Explosives — Use firearms, grenades, TNT.
  5. Disposal — Bury in slit trenches, fox holes, other holes. Throw in streams. Scatter.

### USE ANYTHING IMMEDIATELY AVAILABLE FOR DESTRUCTION OF THIS EQUIPMENT.

- WHAT** —
1. Smash — Receiver, transmitter, antenna, power transformers, crystals, tubes, head-set, meters, telegraph key, resistors, capacitors, coils, switches, etc.
  2. Cut — Wiring and line cords.
  3. Burn — Capacitors, carrying case, canvas bags and equipment receptacles in carrying cases.
  4. Bend — Panels, chassis, containers, etc.
  5. Bury and scatter — Any or all of the above pieces.

## DESTROY EVERYTHING

---

## SAFETY NOTICE

THIS EQUIPMENT USES DANGEROUSLY HIGH VOLTAGES, AND CONTACT MAY CAUSE DEATH OR PAINFUL INJURY. DO NOT CHANGE TUBES OR MAKE ADJUSTMENTS ON THE TRANSMITTER UNIT WHEN THE POWER PLUG IS CONNECTED TO THE POWER SOURCE.

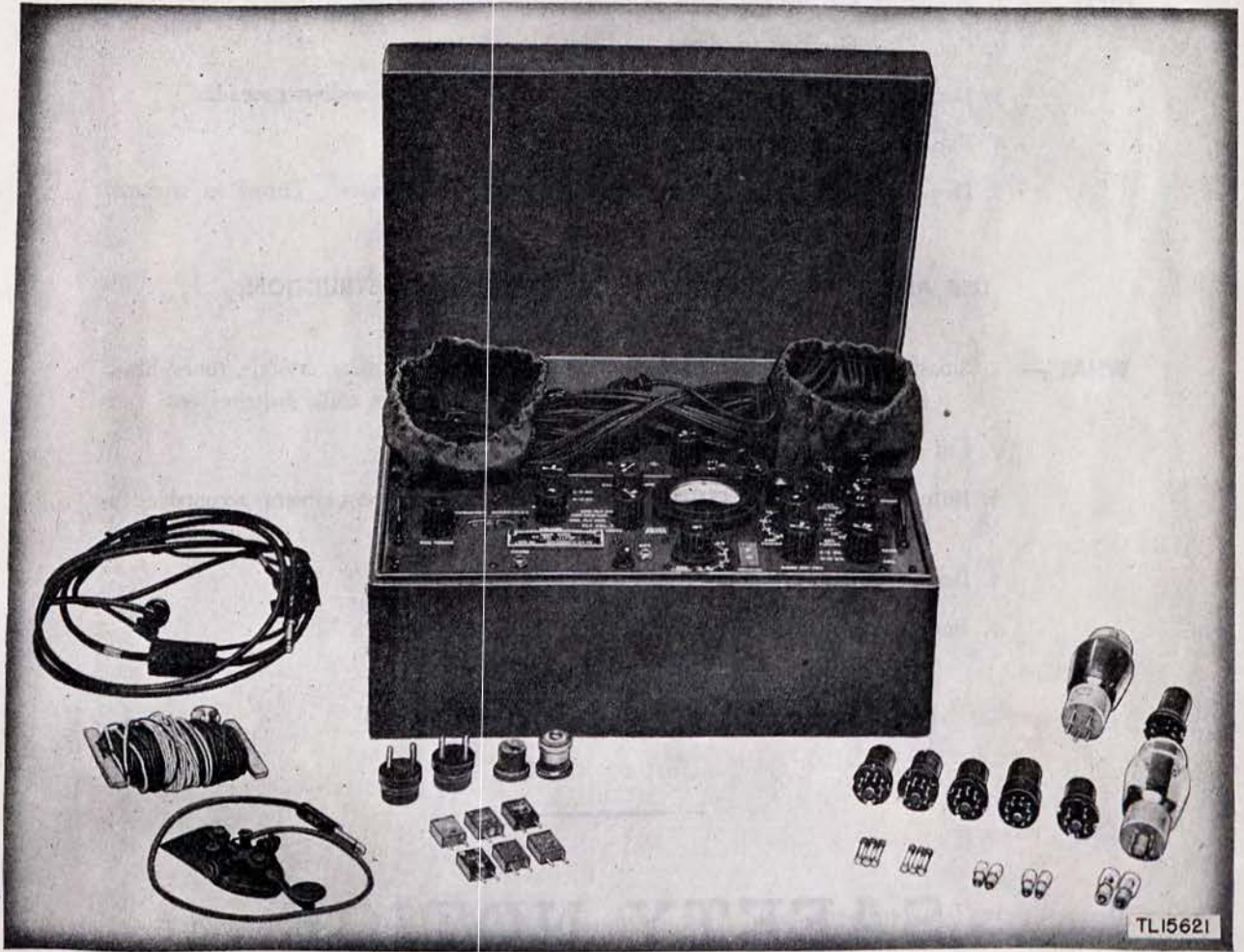

Figure 1. Radio Set AN/PRC-1 ( ), components.

SECRET

# SECTION I DESCRIPTION

**1. GENERAL.**

Radio Set AN/PRC-1 ( ) is a complete portable radio receiver and transmitter system with all auxiliary equipment in one housing. The superheterodyne receiver is designed for the reception of voice and tone modulated signals, as well as continuous wave (c-w) code signals. The crystal-controlled oscillator power amplifier transmitter is designed only for c-w transmission.

**2. RADIO SET AN/PRC-1 ( ), LIST OF COMPONENTS.**

See figure 1 for illustrations.

Quan.	Component
1	Adapters, set consisting of the following: 1 adapter with continental type prongs. 1 adapter with English type prongs. 1 adapter, Edison base to American prong. 1 attachment plug body.
1	Antenna.
1	Case.
1	Headset.
1	Key.
1	Receiver-Transmitter RT-30( )/PRC-1, including the following:
4	Fuses FU-26, 1-amp, 250-v, type 3AG, (one in use, three running spares contained in accessory compartment).
2	Lamps, neon, 1/4-watt, (contained in accessory compartment).
4	Lamps, pilot, 0.25-amp, 6-8-v, (two in use, two running spares).
2	Tubes JAN-6J5 (VT-94) V7 (one in use, one running spare).
2	Tubes JAN-807 (VT-100-A) V2 (one in use, one running spare).
2	Tubes JAN-6SL7GT (VT-229) V6 (one in use, one running spare).

Quan.	Component
2	Tubes JAN-6V6 (VT-107) V1 (one in use, one running spare).
2	Tubes JAN-6SK7 (VT-117) V5 (one in use, one running spare).
2	Tubes JAN-6SA7 (VT-150) V4 (one in use, one running spare).
2	Tubes JAN-6SG7 (VT-211) V3 (one in use, one running spare).
1	Rectifier Power Unit PP-36 ( )/PRC-1, including the following:
4	Fuses, 5-amp, 250-v, type 3AG, (one in use, three running spares).
2	Tubes JAN-5R4GY (V8) (one running spare, one in use).
2	Technical Manual for Radio Set AN/PRC-1 ( ).

**3. RANGE.**

**a. Receiver.** Because of its extreme sensitivity, the operating range of the receiver portion of Radio Set AN/PRC-1 ( ) is limited only by prevailing reception conditions.

**b. Transmitter.** The operating range of the transmitter portion of Radio Set AN/PRC-1 ( ) is dependent upon various factors, the most important of which are: frequency, time of day, antenna installation, and season of the year. In general, the minimum reliable operating range of the transmitter operating on any frequency between 2 to 4 mc is approximately 50 miles. When operating on higher frequencies, the transmitter is capable of covering distances up to several thousand miles.

**4. FREQUENCY COVERAGE.**

**a. Receiver.** The frequency range is continuously variable from 2 to 12 mc, covered in two overlapping bands:

- (1) Low-frequency band—2 to 5.25 mc.
- (2) High-frequency band—5 to 12.0 mc.

**b. Transmitter.** The crystal-controlled transmitter can be operated on any frequency between 2 to 12.0 mc, inclusive. Operation is effected on either the fundamental crystal frequency or its second harmonic (twice the crystal frequency). The range is covered in two bands:

- (1) Low-frequency band—2 to 5 mc.
- (2) High-frequency band—5 to 12.0 mc.

## 5. POWER SOURCE.

Radio Set AN/PRC-1 ( ) operates through its self-contained power supply, Rectifier Power Unit PP-36( ) /PRC-1, connected to an alternating current (a-c) power source of from 115 to 250 volts.

## 6. POWER INPUT.

**a.** Rectifier Power Unit PP-36( )/PRC-1 can be adjusted by means of a rotary selector switch for operation on any of the following voltages: 115, 150, 200, 220, and 250. The receiver requires approximately 125 watts, at 110 volts, 60 cycle. Under key-down conditions the power requirement for the transmitter is approximately 210 watts at 110 volts, 60 cycles. For continuous operation, it is important that the power-line frequency be between 50 and 60 cycles per second (cps). Intermittent operation, however, can be effected on a 40-cycle current provided the working periods do not exceed the following time limits:

- (1) Transmitter ..... 10 minutes.
- (2) Receiver ..... 30 minutes.

**b.** In order to prevent overheating and possible damage to the power transformer, at least 4 hours must elapse between successive operations on 40-cycle alternating current.

**NOTE:** The radio set cannot be operated on direct current. Any attempt to do so will burn out the fuse in the power supply and might cause irreparable damage to the power transformer. Check carefully to be sure the available power is ac. See the note in paragraph 33 on how to make this check.

**c. Principal Power Supply Lines in Foreign Countries.** The power supplies normally available from light sockets and base plugs in various foreign countries are shown in Table I. These values may vary or be changed at any time due to wartime conditions, but in general they should hold true since proper supply must be maintained for the electrical devices, transformers, and equipments used by a given city, town, or area. There may, of course, be emergency circuits in use for feeding a given area which do *not* use the existing standard lines. The location chosen for the radio set may possibly be supplied by these emergency circuits, therefore the line voltage checking procedure outlined in paragraph 33 should always be followed.

**d.** Table I is divided into four columns: territory, d-c volts, a-c volts, and frequency. Where an asterisk (\*) precedes a number it indicates the type of supply and voltage predominating.

**TABLE I**  
**PRINCIPAL POWER SUPPLY LINES IN FOREIGN COUNTRIES**

TERRITORY	D. C. VOLTS	A. C. VOLTS	FREQUENCY
NORTH AMERICA		110, 220	60
Alaska			
British Honduras	110	*110, 150, 115, 230	60, 25
Canada	110	*110	60
Costa Rica	110	*110, 220	60
Cuba	110, 220	*110, 220	60
Dominican Republic	110	*110, 220	60, 50
Guatemala	220, 125	110, 220	60, 50
Haiti		*110, 220	60
Honduras	110, 220	*110, 125, 115, 220, 230	60, 50
Mexico	110, 220	110, 115	50, 60
Newfoundland		*110	60
Nicaragua	110	110, 220	60, 50
Panama (Republic)		110	25
Panama (Canal Zone)		*110	60
Puerto Rico	110, 220	*110	60
Salvador	110, 220		
Virgin Islands	110, 220		

TERRITORY	D. C. VOLTS	A. C. VOLTS	FREQUENCY
<b>WEST INDIES</b>			
Bahamas Is.		115	60
Barbados		110	50
Bermuda		110	60
Curacao		127	50
Jamaica		110	50
Martinique	110	*110	40, 60
Trinidad		110, 220	60
<b>SOUTH AMERICA</b>			
Argentina	*220	*220, 225	50, 60, 43
Bolivia	110	*110, 220	50, 60
Brazil		127, 120, 220	
Chile	220, 110	*220	50, 60
Colombia		*110, 220, 150	60, 50
Ecuador		110	60, 50
Paraguay	*220	220	50
Peru	220, 110	*220, 110	60, 50
Uruguay	220	*220	50
Venezuela	110, 220	*110	60
<b>EUROPE</b>			
Albania	220	*220, 125, 150	50
Austria	220, 110, 150	*220, 120, 127, 110	50
Azores	220	220	50
Belgium	220, 110, 120	*220, 127, 110, 115, 135	50, 40
Bulgaria	220, 120	*220, 120, 150	50
Cyprus (Br.)	*220	110	50
Czechoslovakia	220, 120, 150, 110	*220, 110, 115, 127	50, 42
Denmark	220, 110	*220, 120, 127	50
Estonia	*220, 110	220, 127	50
Finland	*120, 220, 110	220, 120, 115, 110	50
France	110, 220, 120, 125	*110, 115, 120, 125, 220, 230	50, 25
Germany	220, 110, 120, 250	*220, 127, 120, 110	50, 25
Gibraltar	440	*110	76
Greece	*220, 110, 150	*127, 110, 220	50
Hungary	220, 110, 120	*100, 105, 110, 220, 120	42, 50
Iceland		220	50
Irish Free State	*220	*220, 200	50
Italy	110, 125, 150, 220, 250, 160	*150, 125, 120, 110, 115, 120, 260, 220, 135	42, 50, 45
Latvia	220, 110	*220, 120	50
Lithuania	220, 110	*220	50
Malta		105	100
Monaco		110	42
Netherlands	220	220, 120, 127	50
Norway	220	*220, 230, 130, 127, 110, 120, 150	50
Poland	220, 110	*220, 120, 110	50
Portugal	220, 150, 125	*220, 110, 125	50, 42
Rumania	*220, 110, 105, 120	120, 220, 110, 115, 105	50, 42
Russia	220, 110, 120, 115, 250	*120, 110, 220	50
Spain	*110, 120, 115, 105	*120, 125, 150, 110, 115, 220, 130	50
Sweden	220, 110, 120, 115, 250	*220, 127, 110, 125	50, 20, 25
Switzerland	220, 120, 110, 150	*120, 220, 145, 150, 110, 120	50, 40
Turkey	110, 220	*220, 110	50
United Kingdom	230, 220, 240	*230, 240, others	50, 25, 40
Yugoslavia	110, 120	*120, 220, 150	50, 42
<b>ASIA</b>			
Arabia		230	50
British Malaya			
Fed. Malay States		230	50, 60, 40
Non-Fed. Malay States	230		

TERRITORY	D. C. VOLTS	A. C. VOLTS	FREQUENCY
ASIA—cont'd.			
Straits Settlements	*230	230	50
North Borneo		110	60
Ceylon	220	230	50, 60
China	220, 110	*110, 200, 220	50, 60, 25
Hawaii		110, 220	60, 25
India	220, 110, 225, 230, 250	230, 220, 110, others	50, 25
Fr. Indo China	110, 120, 220, 240	*120, 220, 110, 115, 240	50
Iran (Persia)	220, 110	220	50
Iraq	*220, 200	220, 230	50
Japan	100	*100, 110	50, 60
Manchuria		110	60, 50, 25
Palestine		220	50
Philippine Islands		220	60
Syria		110, 115, 220	50
Siam		100	50
Turkey	220, 110	*220, 110	50
AFRICA			
Angola (Port.)		110	50
Algeria	220	*115, 110, 127	50
Belgian Congo		220	60
British West Africa	*220	230	50
British East Africa	*220	240	50
Canary Islands	110	*127, 110	50
Egypt	220	200, 110, 220, 110	50, 40
Ethiopia (Abyssinia)		220, 250	50
Italian Africa			
Cyrenaica	150	*110, 150	50
Eritrea		127	50
Libya (Tripoli)		125, 110, 270	50, 42, 45
Somaliland	120	*230	50
Morocco (Fr.)	110	115, 110	50
Morocco (Spanish)	200	*127, 110, 115	50
Madagascar (Fr.)		120	50
Senegal (Fr.)	230	120	50
Tunisia		110	50
Union of South Africa	220, 230, 240, 110	*220, 230, 240	50
OCEANIA			
Australia			
New South Wales	*240	*240	50
Victoria	230	*230	50
Queensland	220, 240	*240	50
South Australia	200, 230, 220	*200, 230, 240	50
West Australia	*220, 110, 230	250	40
Tasmania	230	*240	50
New Zealand	230	*230	50
Fiji Islands	240, 110, 250		
Society Islands		120	60
Samoa		110	50

## 7. POWER OUTPUT.

**a. Receiver.** The power output of the receiver is 25 milliwatts.

**b. Transmitter.** The power output of the transmitter is not less than 30 watts at any frequency from 2 to 12 mc.

## 8. WEIGHT.

Radio Set AN/PRC-1 ( ) set up for operation, weighs approximately 35 pounds. The set is packed for export as follows:

**a.** The carrying case with about six pounds of Silica Gel is packed in a snug fitting corrugated case, then in a

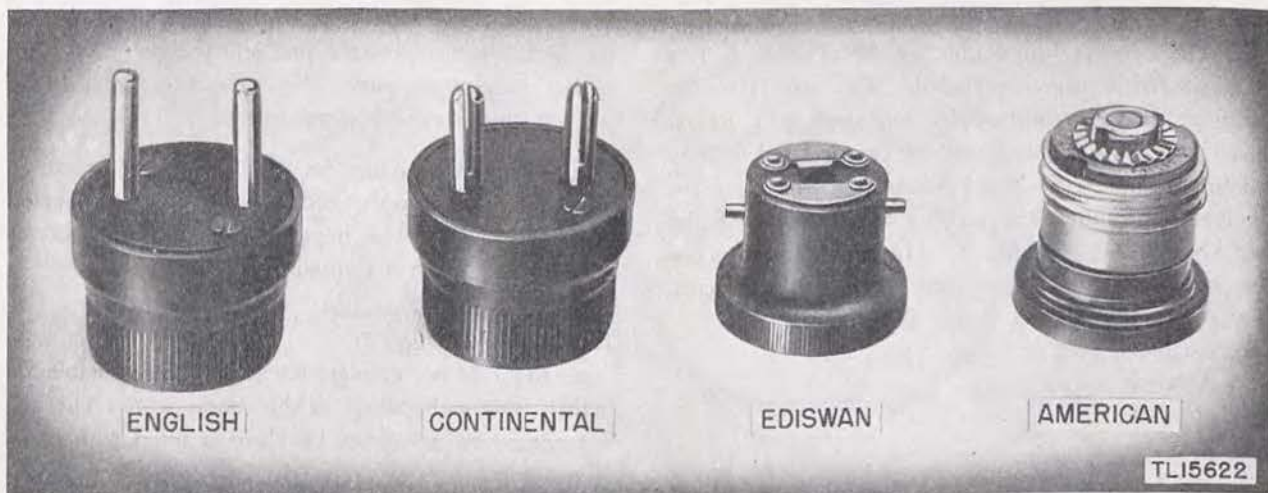

Figure 2. Line cord adapters.

vapor-proof foil barrier, then in a second corrugated case. This unit is packed in an overseas wooden case having inside dimensions approximately  $27\frac{1}{2}$ " x 19" x  $8\frac{3}{4}$ ". This overseas wooden box also has a water-resistant liner. One Crystal Case CY-86/TRC-10 containing a set of 47 crystals individually vapor-proof packed in a similar manner is also packed inside the same wooden overseas case. This complete overseas unit weighs about 76 pounds.

b. Every sixth radio set is packed in a spare parts kit, a large wooden case, with compartments into which are packed spare parts for five radio sets. This spare parts kit case measures  $21\frac{7}{8}$ " x  $27\frac{1}{8}$ " x  $28\frac{1}{4}$ " and when packed for export weighs about 270 pounds.

#### 9. ADAPTERS (fig. 2).

A set of molded line-cord plug adapters is supplied in the left-hand accessory compartment (figs. 2 and 3). The line cord associated with the Rectifier Power Unit PP-36( )/PRC-1 is terminated with a plug fitted with standard American type prongs. In order to use the radio set in countries where other electrical standards are in use, it is necessary to interpose a suitable adapter between the line-cord plug and the available electrical outlet.

a. The adapter with continental type prongs is similar to the American plug except that the prongs are round and slotted.

b. The adapter with English type prongs is similar to the continental plug except that the prongs are smaller in diameter and somewhat longer.

c. The Ediswan base adapter is of the double-contact type having radial lock-in pins.

d. The attachment plug body permits connection of the radio set to standard Edison base socket outlets.

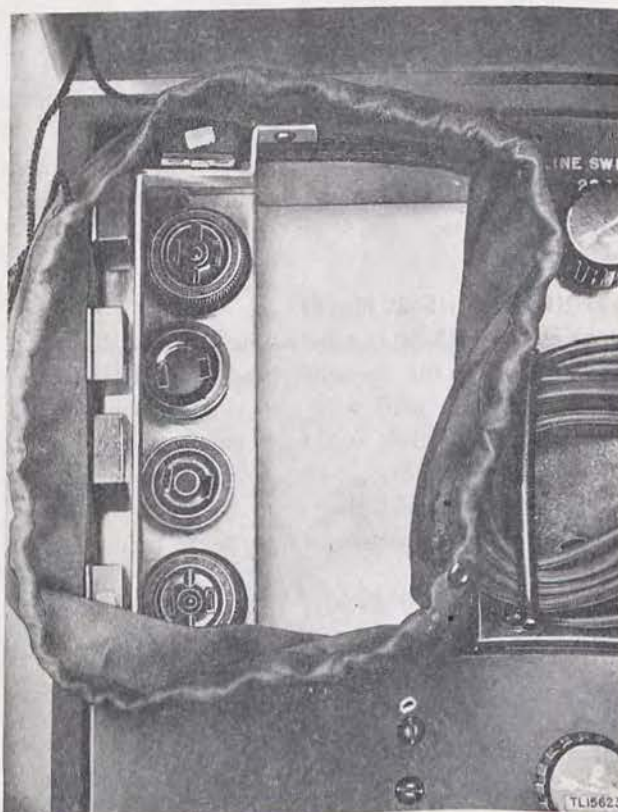

Figure 3. Adapters in left-hand compartment.

#### 10. ANTENNA.

The antenna supplied with Radio Set AN/PRC-1 ( ) in the left-hand accessory compartment (figs. 4 and 9) consists of 150 feet of cotton-covered tinned copper wire, wound on a wooden handreel. One end of the wire is terminated with a phone tip; the other end is attached to a porcelain antenna insulator. A cotton line 20 feet long is tied to the antenna insulator in order to provide a convenient means for securing the far end of the antenna to the support selected.

## 11. CARRYING CASE.

a. The case housing Radio Set AN/PRC-1 ( ) is made of fabric-covered plywood. The case is of the strongest possible construction consistent with its reduced weight. The interior of the case is fitted with an aluminum framework and brackets for supporting the receiver, transmitter, and rectifier power unit of Radio Set AN/PRC-1 ( ) (fig. 8). In addition, two accessory compartments are provided. The left-hand accessory compartment (figs. 3 and 9) contains:

- (1) Adapters, set.
- (2) Antenna.
- (3) Headset.
- (4) Key.

b. The right-hand accessory compartment (fig. 5) contains:

- (1) Set spare tubes for receiver.
- (2) Set spare tubes for transmitter.
- (3) Spare rectifier tube for rectifier power unit.
- (4) Spare neon bulbs.
- (5) Spare dial and panel lamps.

c. A complete schematic diagram of Radio Set AN/PRC-1 ( ) is affixed to the interior of the hinged cover of the case.

## 12. HEADSET HS-30 (fig. 6).

a. Headset HS-30 is a light-weight headset designed to fit closely to the operator's head. The receivers of the headset are fitted with special soft rubber plugs designed to fit lightly in the operator's ear cavities to exclude outside noises. The headset is provided with a headband made of a thin strip of steel so that it can be shaped to fit the contour of the wearer's head. A clip,



Figure 4. Antenna on reel.

affixed to the headset cord can be attached to the operator's clothing to relieve the pull and weight of the cord from the operator's ears. The headset is contained in the left-hand accessory compartment.

b. For use with Radio Set AN/PRC-1 ( ), Headset HS-30 is supplied with Cord CD-605 which terminates in Plug PL-55. The impedance of Headset HS-30 with Cord CD-605 is approximately 4000 ohms.

## 13. KEY J-37 (fig. 7).

a. Key J-37 is a standard telegraph key, adjustable for both tension and spacing of the contact arm. The key is mounted on a bakelite base and is fitted with Cord CD-201-A.

b. Cord CD-201-A is 18 inches long and terminates in Plug PL-55. The key, with its mount and cord, is carried in the left-hand accessory compartment.

## 14. RECEIVER-TRANSMITTER RT-30( )/PRC-1 WITH CASE (fig. 8).

a. Receiver-Transmitter RT-30( )/PRC-1 consists of the radio chassis and front panel of the set mounted in the luggage fabric-covered carrying case. All controls, jacks, terminals, and meter are mounted on the front panel.

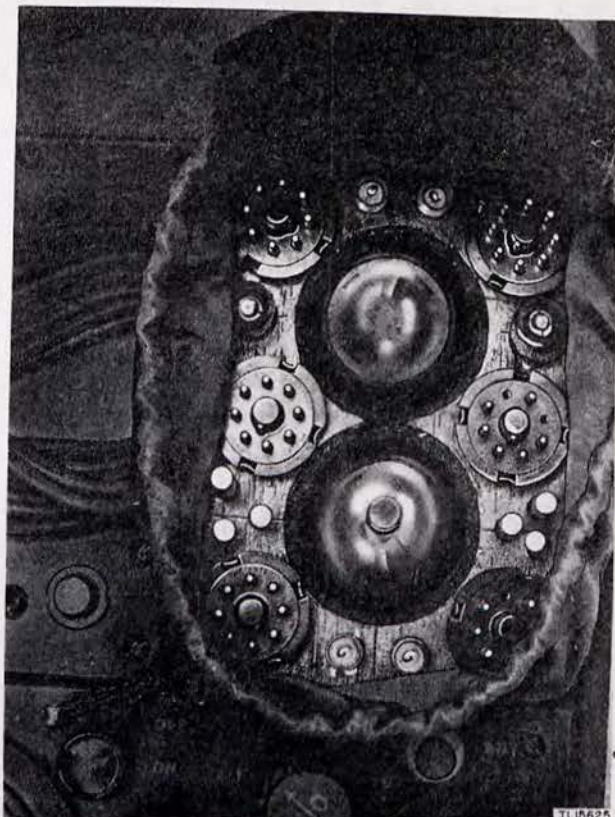

Figure 5. Right-hand accessory compartment.

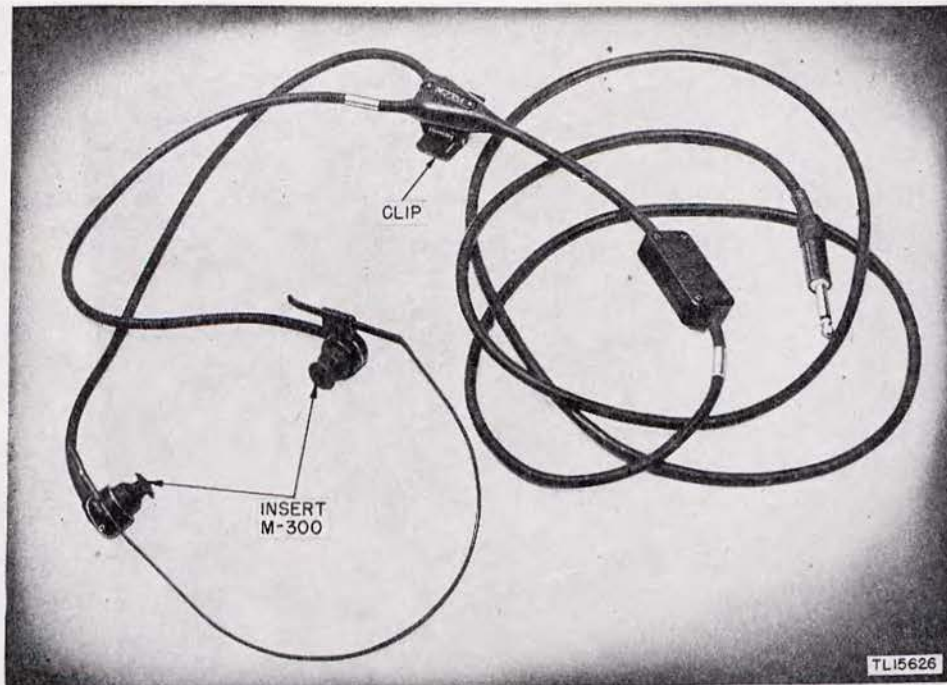

Figure 6. Headset HS-30.

(1) The receiver portion of the radio set consists of a five-tube superheterodyne receiver designed for high-performance reception of amplitude-modulated and c-w signals within the frequency range of 2 to 12 mc.

(2) The transmitter portion of the radio set consists of a two-tube crystal-controlled oscillator power-amplifier combination designed for c-w transmission of intelligence within the frequency range of 2 to 12 mc.

b. Receiver-Transmitter RT-30( )/PRC-1 is mounted on a single panel by means of separate chassis. The receiver and all of its components and controls are mounted on the left-hand side of the panel; the transmitter and its components and controls are mounted on the right-hand side. The separate chassis are attached to the panel with machine screws.

c. The panel supporting the receiver and transmitter chassis is held in place in the case by means of six screws.

d. Receiver-Transmitter RT-30( )PRC-1 is shipped with all tubes and dial lights installed. The tubes are held in place by clips or clamps.

e. A complete set of spare tubes, neon lamps, and dial lamps for the receiver, transmitter, and rectifier power unit is contained in the right-hand accessory compartment.

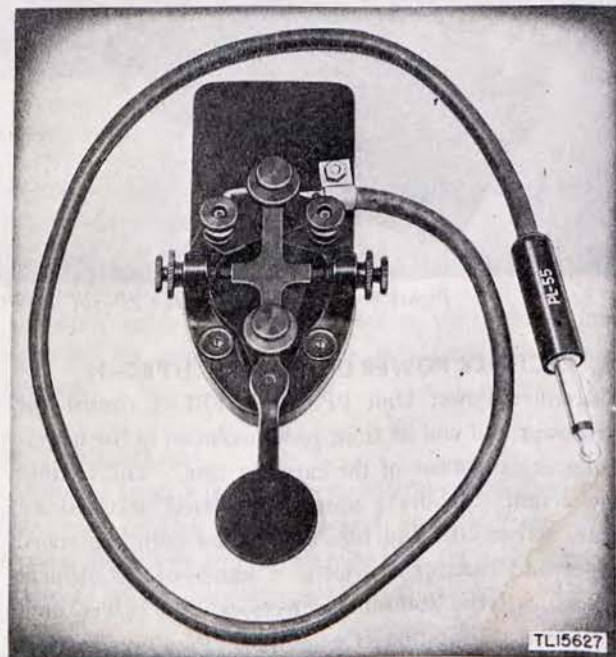

Figure 7. Key J-37



Figure 8. Rectifier Power Unit PP-36( )/PRC-1 and Receiver-Transmitter RT-30( )/PRC-1.

#### 15. RECTIFIER POWER UNIT PP-36( )/PRC-1.

Rectifier Power Unit PP-36( )/PRC-1 consists of the power unit and its front panel mounted in the upper-center compartment of the carrying case. The rectifier power unit provides a source of filtered, rectified a-c plate, screen-grid and bias voltage for both the transmitter and receiver as well as a source of a-c filament voltage for the transmitter, receiver, and power unit. Full-wave rectification is employed. Provision is made for operation of the power unit on various a-c input voltages through the adjustment of a selector switch. All controls, switches, and fuse posts are mounted on the front panel of the power unit (fig. 9). Interconnection between the power unit and the receiver

and transmitter is made by means of a cable ending in a polarized plug which fits into a corresponding receptacle on the chassis of the receiver-transmitter.

#### 16. CONTROLS (fig. 9).

All operating controls, jacks, indicating meter, and fuse posts are mounted on the front panels of Receiver-Transmitter RT-30( )/PRC-1, and the Rectifier Power Unit PP-36( )/PRC-1. These items are visible only when the hinged cover of the housing is opened. The operating control knobs associated with the rectifier power unit bear *letter* designations. (The operating control knobs associated with Receiver-Transmitter RT-30( )/PRC-1 bear *number* designations.)

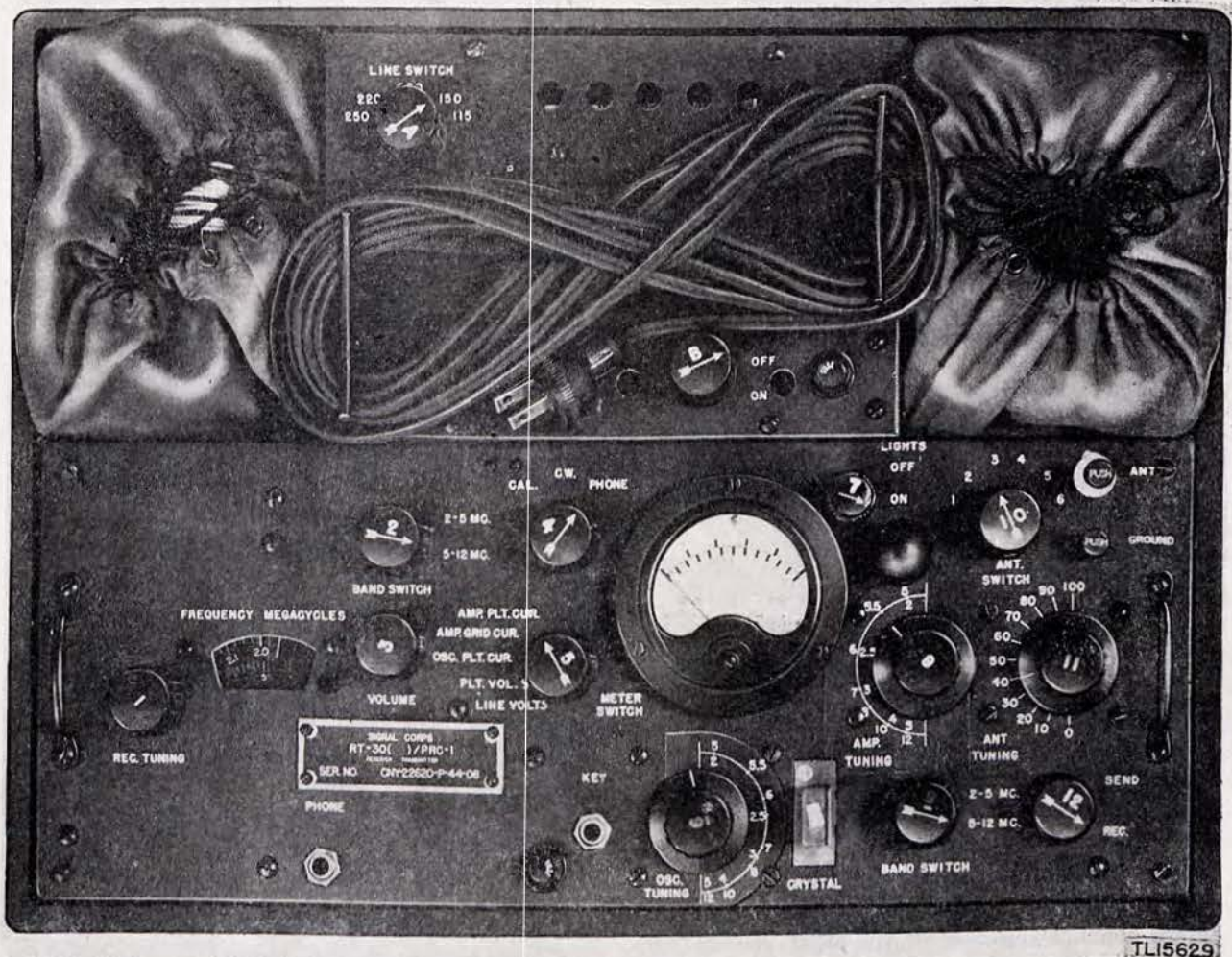

Figure 9. Front panels in open carrying case.

#### 17. LINE SWITCH A.

Control knob A, the line switch, is used to adjust the primary of the power transformer for operation on a-c power sources delivering 115, 150, 200, 220, and 250 volts. Counterclockwise rotation of the knob adjusts the rotary switch to progressively higher voltage connections at the calibration points indicated on the panel. The legend LINE SWITCH is painted on the panel immediately above the control knob.

#### 18. ON OFF B.

Control knob B, the ON OFF switch, is used to connect the rectifier power unit and hence the radio transmitter and receiver to its source of primary power.

#### 19. REC. TUNING 1.

Control knob 1 actuates the tuning dial mechanism of the receiver. The legend REC. TUNING is painted on the panel immediately below the control knob. The dial is calibrated directly in terms of frequency. A

separate calibrated scale is provided for each of the two bands covered by the receiver.

#### 20. BAND SWITCH 2.

Control knob 2 is used to adjust the receiver for operation on either one of the two frequency bands covered.

#### 21. VOLUME 3.

Control knob 3 is the volume control of the receiver. Clockwise rotation of the control knob increases the receiver sensitivity and the amplitude of the audio signal delivered to the headphones.

#### 22. CAL. CW. PHONE 4.

a. Control knob 4 actuates a rotary selector switch used to adjust the receiver.

(1) With the switch in the PHONE position, the receiver is capable of receiving amplitude-modulated signals only.

(2) When the switch is in the CW. position, the incoming signal produces an audible note in the headphones corresponding to the keyed signal impulses.

(3) When the switch is in the CAL. position, the plate-voltage delivered to the receiver is reduced, causing a corresponding decrease in the sensitivity of the receiver. Calibration of the receiver is made through reception of a signal of known frequency generated by the transmitter crystal-controlled oscillator, comparing it with the dial calibration, and adjusting the dial hair-line, if necessary (par. 40).

### 23. METER SWITCH 5.

a. Control knob 5 operates a rotary selector switch which connects an indicating meter in various circuits of the transmitter. Insertion of the meter in the various circuits is shown by the position of the arrow on the control knob.

AMP. PLT. CUR.  
AMP. GRID CUR.  
OSC. PLT. CUR.  
PLT. VOL.  
LINE VOLTS

b. With the arrow of the control knob pointing to the LINE VOLTS position, the meter indicates the magnitude of the voltage delivered to the rectifier power unit by the a-c power source, so the LINE SWITCH A may be set on the correct tap. If the power source delivers direct current, this condition is made known by the abnormal behavior of the meter pointer (par. 33).

c. With the arrow of the control knob pointing to the PLT. VOL. position, the meter indicates the filtered rectified a-c voltage delivered by Rectifier Power Unit PP-36( )/PRC-1 to Receiver-Transmitter RT-30( )/PRC-1.

d. With the arrow of the control knob pointing to the OSC. PLT. CUR. position, the meter reads the current drawn by the plate of the crystal-controlled oscillator tube in the transmitter portion of Receiver-Transmitter RT-30( )/PRC-1. A simultaneous and equally important function is to indicate the oscillatory condition of the crystal and the correct adjustment of the plate tank circuit of the transmitter oscillator.

e. With the arrow of the control knob pointing to the AMP. GRID CUR. position, the meter reads the grid current drawn by the transmitter power amplifier. The meter reading therefore shows the magnitude of r-f excitation voltage delivered to the transmitter Class C power amplifier by the crystal-controlled oscillator. Simultaneously, the meter reading performs the important function of indicating the correct adjustment of

the plate-tank circuit of the crystal-controlled oscillator stage.

f. With the arrow of the control knob pointing to the AMP. PLT. CUR. position, the meter reads the plate current drawn by the transmitter Class C power amplifier. Simultaneously, the meter reading indicates the correct adjustment of the power-amplifier plate-tank circuit and the optimum degree of its loading by the antenna coupling system.

### 24. OSC. TUNING 6.

Control knob 6 drives the transmitter oscillator plate-tank capacitor. The relative position of the indicator line on the knob with the dual-calibrated scale painted on the panel provides an approximate indication of the resonant frequency to which the oscillator tank circuit is adjusted. The dual-calibrated scale is divided into two frequency ranges corresponding to the two frequency bands covered by the transmitter. One scale corresponds to the low-frequency band (2 to 5.0 mc); the other scale corresponds to the high-frequency band (5 to 12 mc). Although not indicated by the dial calibrations, a certain amount of frequency overlap is provided.

### 25. LIGHTS 7.

Control knob 7 is the panel light switch for the transmitter and receiver panel lights.

### 26. AMP. TUNING 8.

Control knob 8 drives the transmitter power-amplifier plate-tank capacitor. The position of the indicator line provides an approximate indication of the resonant frequency to which the power-amplifier plate circuit is adjusted. The dual-calibrated scale is divided into two frequency ranges corresponding to the two frequency bands covered by the transmitter. One scale corresponds to the low-frequency band (2 to 5 mc); the other scale corresponds to the high-frequency band (5 to 12 mc). Although not indicated by the dial calibration, a certain amount of frequency overlap is provided.

### 27. BAND SWITCH 9.

Control knob 9 adjusts the transmitter for operation on either one of the two frequency bands covered. The legend BAND SWITCH is painted on the panel immediately below the control knob.

### 28. ANT. SWITCH 10.

Control knob 10 actuates a rotary selector switch associated with the antenna-loading system in the transmitter part of Receiver-Transmitter RT-30( )/PRC-1. Clockwise rotation of the control knob from its initial point

with the arrow pointing to 1 decreases the inductance in series with the antenna, causing a corresponding decrease in the effective electrical length of the antenna. Six switch points are provided. The legend ANT. SWITCH is painted on the panel immediately below the control knob.

### 29. ANT. TUNING 11.

Control knob 11 drives the variable capacitor associated with the antenna-tuning system in the transmitter part of the Receiver-Transmitter RT-30( )/PRC-1. Clockwise rotation of the control knob from its initial point with the indicator line engraved on the skirt of the control knob pointing to 0, results in an increase in capacitance in the antenna-tuning circuit.

### 30. SEND REC. 12.

Control knob 12 actuates a switch which turns the transmitter off when in the REC. position and the receiver off when in the SEND position.

### 31. MISCELLANEOUS MARKINGS.

In addition to the controls mentioned, the following elements directly associated with the operation of Radio Set AN/PRC-1 ( ) are located on the front panel of the Rectifier Power Unit PP-36( )/PRC-1 and on the panel of Receiver-Transmitter RT-30( )/PRC-1.

a. An extractor fuse post is provided on the front panel of the Rectifier Power Unit PP-36( )/PRC-1. The fuse associated with the extractor post is connected in the primary circuit of the power transformer. Re-

placement of a blown fuse is accomplished through counterclockwise rotation of the small knob engraved FUSE, removal of the defective fuse, and insertion of a new element.

b. The audio output of the receiver part of Receiver-Transmitter RT-30( )/PRC-1 is made available at the jack marked PHONE located on the front panel. Low- or high-impedance output connections are underneath the receiver chassis.

c. The key used in conjunction with the transmitter part of Receiver-Transmitter RT-30( )/PRC-1 is inserted in the keying relay circuit at the jack marked KEY located on the front panel.

d. An extractor fuse post is provided on the front panel of Receiver-Transmitter RT-30( )/PRC-1. The fuse associated with the extractor post is connected in the plate circuit of the transmitter class C power amplifier. Replacement of a blown fuse is accomplished through counterclockwise rotation of the small knob marked FUSE, removal of the defective fuse, and insertion of a new element.

e. A crystal socket is located on the front panel of Receiver-Transmitter RT-30( )/PRC-1 immediately above the legend CRYSTAL painted on the panel. The crystal socket provides a connector receptacle for the crystal in use, in connection with the crystal-controlled oscillator in the transmitter part of Receiver-Transmitter RT-30( )/PRC-1.

f. An antenna binding post and a ground binding post are provided on the front panel of Receiver-Transmitter RT-30( )/PRC-1 immediately to the left of the corresponding legends ANT. and GROUND.

# SECTION II

## INSTALLATION AND OPERATION

### 32. INITIAL PROCEDURE.

Unpack the equipment carefully to prevent loss or damage of the components. Check against the list of components in paragraph 2. See figure 1.

a. Radio Set AN/PRC-1 ( ) is shipped with all tubes installed. The tubes in the receiver and the transmitter, with the exception of the power-amplifier tube, are held in place by clips. The transmitter power-amplifier tube is held in place by a clamp.

b. Five Crystal Holders FT-243 are contained in the upper left-hand compartment, along with the plug adapters, headset, key, and antenna reel. A sixth crystal is shipped inserted in the crystal-holder socket on the panel of Receiver-Transmitter RT-30( )/PRC-1.

c. The spare tubes, fuses, pilot lights, and neon bulbs are contained in the upper right-hand compartment.

### 33. INSTALLATION OF RECEIVER-TRANSMITTER AND RECTIFIER POWER UNIT.

The case housing the transmitter, receiver, and rectifier power unit may be installed in any convenient position. The most suitable position for operation is obtained when the case is mounted on a horizontal plane, preferably on a desk or table of a height suitable for writing. Having selected a suitable location for the case, open the two clasps with the luggage key and lift the cover of the case. Proceed with the installation exactly in accordance with the following steps:

a. Make certain that the power supply ON OFF switch knob B is in the OFF position.

b. Set LINE SWITCH control knob A to 250.

c. Rotate the METER SWITCH control knob 5 to the LINE VOLTS position.

d. Unwind the line cord from the two brackets provided on the front panel of Rectifier Power Unit PP-36( )/PRC-1. The line cord provided is 25 feet long.

e. Inspect the power source and select a suitable adapter for the line cord plug if the electrical system used is other than the U. S. standards.

f. Insert the line-cord plug (through the adapter, if needed) in the power outlet and observe the voltage reading indicated by the meter.

**NOTE:** If the meter pointer swings to either extreme end of the meter scale the power source delivers direct current. As a further check, reverse the polarity of the line cord plug in the receptacle. Assuming that the meter pointer traveled to the extreme right end of the meter scale before the polarity of the line-cord plug was reversed, the meter pointer will now travel to the extreme left end of the meter scale. Radio Set AN/PRC-1 ( ) is designed for operation on alternating current only. *DO NOT ATTEMPT TO OPERATE IT ON A D-C POWER LINE.*

g. Having determined the line voltage through the procedure given in subparagraph f above, rotate the LINE SWITCH control knob A to the position marked with the input voltage indicated by the meter reading. It is not probable that the meter reading will correspond exactly to any of the input voltages painted on the panel in connection with the LINE SWITCH control knob A. In this case, set the switch on the tap nearest the indicated voltage.

h. Remove the headset, key, antenna reel, ground wire, and selected crystal from the upper left-hand accessory compartment. Insert the phone cord plug in the jack marked PHONE; the key cord plug in the jack marked KEY.

### 34. INSTALLATION OF ANTENNA.

a. Optimum performance of the transmitter and, to a lesser extent, of the receiver is dependent upon proper antenna and ground installations. Ideally, the antenna should be located in a horizontal plane, at a height of 20 to 40 feet above the surface of the earth and clear of any nearby objects. Further, the plane of the antenna should be broadside to the direction in which the transmitter intelligence is to be sent. The antenna should be cut to the following lengths for best transmission and reception in relation to frequency:

Operating frequencies	Antenna length
2 to 3 mc .....	150 feet
3 to 7 mc .....	100 feet
7 to 12 mc .....	50 feet



Figure 10. Radio Set AN/PRC-1 ( ) installed for operation.

**b.** The length of antenna best suited for optimum transmitter performance at any frequency within the range covered is that which will result in proper loading of the plate tank circuit of the transmitter power amplifier, with the arrow of the control knob 10 pointing to the 6 tap, and with the indicator line of control knob 11 pointing to the 0 mark of the linearly calibrated scale. It is realized that this condition is difficult and ordinarily impossible to achieve in practice, and for this reason the antenna-tuning circuit has been incorporated in the transmitter part of Receiver-Transmitter RT-30 ( ) /PRC-1 in order to electrically lengthen the antenna.

**c.** For best results try to locate the horizontal antenna in such a position that it will be broadside to the direction in which communication is to take place. Avoid installing the antenna so that it points toward the de-

sired direction of communication. A convenient means to determine the correct orientation of the horizontal antenna is to locate it for optimum reception from a transmitter located in the same part of the world to which you wish to transmit.

**d.** It is realized that it will often be impossible to install an antenna meeting any of the requirements outlined. In such cases, it is suggested that one of the following expedients be used, bearing in mind the advantages and disadvantages of each.

(1) The antenna wire may be laid upon the ground, provided the ground is not wet. In this case, concealment of the wire is relatively easy. The potential range of the transmitter is reduced, and it may be difficult to load the plate tank circuit of the transmitter power amplifier properly.

(2) If the building is of wooden construction, the antenna may be installed inside. Ordinarily, the possibility of concealing the wire is not very good. However, the wire may be laid upon the course of the molding or other decorative trim.

(3) It may sometimes be possible to utilize an existing antenna or abandoned wire once used for other purposes. This opportunity is good from the standpoint of concealment or disguise of the antenna wire, since people in the neighborhood will have long since been accustomed to seeing the antenna. In this case, however, it will be necessary to determine whether the antenna is connected to a radio receiver in use. Follow the lead-in wire from its point of connection at the antenna to its point of entrance to the building. If the antenna is not in use, simply disconnect the lead-in wire at the antenna and substitute the antenna wire supplied with Radio Set AN/PRC-1 ( ), using it as a lead-in wire.

(4) The antenna wire may be laid on the surface of the roof of the building provided the roof is not wet, and is of wood or other nonmetallic construction. Here, too, the potential range of the transmitter will be reduced, and it may be difficult to obtain proper loading conditions in the plate tank circuit of the transmitter power amplifier.

(5) The use of a vertical antenna is permissible provided that it is kept clear of nearby objects. In the event that the equipment is to be located in a building, try to support the antenna away from the side of the building by means of a short pole (broom handle, cane, etc.) which should be nonmetallic. The directive properties of a vertical antenna are considerably less than those of a horizontal antenna. Optimum directivity will be obtained, however, when the antenna is located on the side of the building *facing* the direction in which the transmitted intelligence is to be sent.

**e.** A great deal of reliance must be placed on the ingenuity and training of the operator. The possibilities must be examined very carefully. Select the best antenna installation that circumstances permit.

**f.** If possible, a ground connection should be made to a water pipe, steam pipe, radiator, or any other metallic system connected to the earth. This is important since a good ground will often result in increased range.

**g.** The same antenna is used for both transmission and reception, and is connected to the binding post on the front panel of Receiver-Transmitter RT-30( )/PRC-1 immediately to the left of the legend ANT. The same ground is used for both transmission and reception, and is connected to the binding post on the front panel of Receiver-Transmitter RT-30( )/PRC-1 immediately to the left of the legend GROUND.

### 35. ADDITIONAL INFORMATION.

**a.** In the event that operation is concerned only with reception, fair performance can be obtained from the receiver with an antenna about 10 feet long, strung along the floor or dropped out of a window.

**b.** In many cases a 40 or 50 foot antenna is adequate for long distance transmission.

**c.** No matter what type of antenna installation is selected, arrange it so that it can be dismantled quickly, if necessary.

### 36. PREPARATION OF SET FOR USE.

**a. Preliminary Preparations.** Having completed the installation of the set as described in paragraph 33 above, prepare the set for use as follows:

(1) Set the LINE SWITCH control knob A (rectifier power unit) to the correct input voltage tap as indicated by the meter reading.

(2) Set the METER SWITCH control knob 5 so that the arrow points to the PLT. VOL. position.

(3) Set the rectifier power unit ON OFF switch control knob B so that the arrow points to the ON position.

(4) Assuming that the LINE SWITCH control knob A was set to the proper input voltage tap, the meter reading should be approximately 1,000 volts.

(5) Allow the equipment to run through a warm-up period of approximately 4 minutes.

#### **b. Checking Receiver.**

(1) Set control knob 12 to the REC. position.

(2) Set control knob 4 to the CW. position.

(3) Set control knob 2 to the 2-5 MC. mark.

(4) Rotate control knob 3 in the clockwise direction until the background noise (atmospheric and man-made static) is heard in the headset.

(5) Rotate control knob 1 until signals are heard. In the event that the receiver is tuned to a continuous-wave (c-w) transmitter, the characteristic dot and dash combinations will be observed. In the event the receiver is tuned to speech-modulated transmitter, a continuous heterodyne whistle will be heard. In the latter case, adjust control knob 4 so that its arrow points to the PHONE position. The heterodyne whistle should disappear, thus permitting reception of the amplitude-modulated signals.

(6) Repeat steps (2), (4), and (5) with control knob 2 adjusted so that its arrow points to the 5-12 MC. mark.

#### **c. Checking Transmitter.**

(1) Disconnect the antenna.

(2) Set control knob 12 to the SEND position.

(3) Set control knob 4 to either the CW or PHONE position.

(4) Insert a crystal holder in the crystal holder socket

provided on the front panel of Receiver-Transmitter RT-30( )/PRC-1.

**NOTE:** The transmitter is operated at either the fundamental crystal frequency or its second harmonic. Thus, if a 2.3-mc crystal were used, the transmitter could be operated at either 2.3 mc or 4.6 mc.

- (5) Set control knob 5 to the OSC. PLT. CUR. position.
- (6) Set control knob 9 to either the 2-5 Mc. or 5-12 MC. point in accordance with frequency of the crystal selected.
- (7) Adjust control knob 6 so that its indicator line points to a calibration point close to the frequency of the selected crystal or its second harmonic.
- (8) With the key depressed, rotate control knob 6 quickly in both the clockwise and counterclockwise direction over a few degrees of the arc until a pronounced dip of the meter pointer is observed. This indicates that the crystal-controlled oscillator is operating.
- (9) Set control knob 5 to the AMP. PLT. CUR. position.
- (10) Adjust control knob 8 to a calibration point close to the frequency of the selected crystal or its second harmonic.
- (11) With the key depressed, quickly rotate control knob 8 in both the clockwise and counterclockwise direction over a few degrees of the arc to the point where the meter pointer indicates minimum plate-current drain.
- (12) Hold a neon lamp by its glass bulb so that its bottom contact touches the metal part of the binding post marked ANT. If the transmitter is operating correctly, the neon bulb will glow showing an orange color.

**CAUTION:** Do not attempt any check on the transmitter while located in a hostile area unless you have tried without success to make it work during actual operations. Remember you are *on the air* whenever the transmitter key is closed. Accomplish any *necessary* checking of the transmitter in the shortest possible time.

### 37. OPERATION.

Having prepared the equipment for use as outlined in paragraph 36, it can now be put into operation. Actual operation of the receiver is simple; operation of the transmitter is a trifle more complicated, but it can be reduced to a series of integrated steps provided the instructions given in this manual are carefully followed. Memorize each part of the operation. Use the equipment a number of times under simulated service conditions. Learn *how* and *why* the equipment works; the maximum performance of which the set is capable will be obtained and the chances of being detected will be reduced.

### 38. USE OF THE RECEIVER.

Under normal conditions, the receiver will render its best performance with the set adjusted for c-w reception (control knob 4 in the c-w position).

a. Adjust the VOLUME CONTROL knob 3 in a clockwise direction until a rushing noise is heard in the headset.

b. Tune the receiver SLOWLY. If the REC. TUNING control knob 1 is turned rapidly, the desired station may easily be passed over.

c. Tune the receiver over the band with the left hand. Keep the right hand on the volume control knob, adjusting the volume and hence the sensitivity of the receiver to an optimum level.

d. **Keep the headset on the head with the rubber receiver ear pieces fitted into the ears.**

e. Having located the desired station, reduce or increase the volume to a level that provides the best intelligibility.

f. If the desired station is transmitting speech-modulated or tone-modulated signals, adjust the set for telephone reception (control knob 4 on PHONE position). If the desired station is transmitting c-w signals, leave control knob 4 on the CW. position.

g. Always search for the desired station with the set adjusted for c-w reception.

h. In the event that the station received is being jammed either through accident or intentional enemy design, it is sometimes possible, through careful manipulation of the receiver tuning, to attenuate the jamming signals sufficiently to permit the intelligence transmitted by the desired station to be copied.

i. Copying signals through bad atmospheric conditions is a trick that can be accomplished by concentrating attention entirely on the signals. Since the signals have a definite pitch, try to *tune* the hearing to hear only sounds of the signal pitch. In this connection, observe that the pitch of c-w signals can be varied over a narrow range through detuning the receiver very slightly from resonance.

### 39. PRECAUTIONS IN OPERATION OF RECEIVER.

a. Tune slowly.

b. Keep the volume adjusted to the highest possible level without having the signals audible except in the headset.

c. Always search for the desired station with the set adjusted for c-w reception.

d. Do not try to receive c-w signals with the set adjusted for phone reception.

e. Do not try to receive with control knob 12 in the send position.

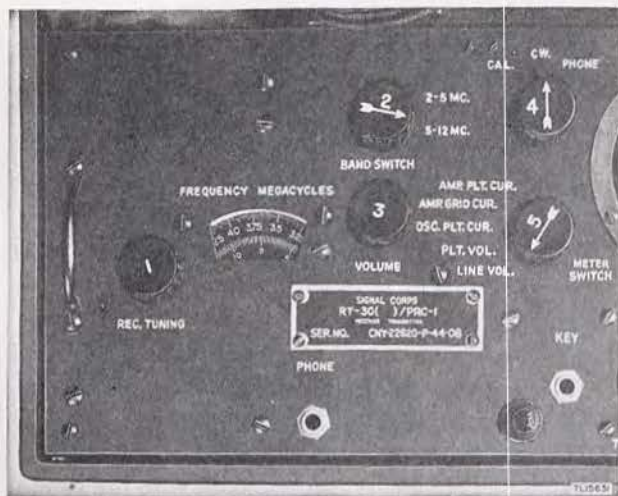

Figure 11. Receiving section of front panel of Receiver-Transmitter RT-30()/PRC-1.

#### 40. RECEIVER CALIBRATION.

If the frequency indicated on the receiver dial does not correspond to the known frequency of the station being received, the receiver dial can be corrected in the manner described below so that the dial will indicate the correct frequency. The following calibration method may also be used if the receiver is to be tuned to one station and left in that position, provided a crystal of the transmitted frequency is available. A check or correction of this type is known as *receiver calibration*. The receiver part of Receiver-Transmitter RT-30( )/PRC-1 is calibrated against a radio-frequency (r-f) voltage of known frequency generated by the crystal-controlled oscillator in the transmitter. When the receiver is set for the reception of c-w signals, the frequency of the receiver is adjusted to a zero-beat condition with the frequency of the transmitter oscillator. Having prepared the set for use in accordance with paragraph 36, proceed with the calibration of the receiver in the following manner:

- Insert a crystal in the crystal holder socket of the frequency at which the calibration check is to be made.
- Set control knob 4 to the CAL. position.
- Set control knob 12 to the REC. position.
- Set METER SWITCH control knob 5 to the OSC. PLT. CUR. position.
- Adjust control knob 2 so that its arrow points to the band covering the frequency at which the calibration check is to be made.
- Adjust control knob 9 so that its arrow points to the band covering the frequency at which the calibration check is to be made.
- Depress the transmitter key and adjust control knob 6 for minimum plate-current drain as indicated by the meter. This condition will be manifested by a slight

dip in the meter pointer and will indicate that the crystal is oscillating.

h. Rotate control knob 3 until the background noise in the receiver is just audible. Do not attempt to calibrate the receiver with the volume control turned full on.

i. Rotate the REC. TUNING knob 1 until the dial indicates the frequency of the inserted crystal. By rotating the knob slowly so that the dial calibration is in the vicinity of the frequency of the inserted crystal, a high-pitched whistle will be observed, the frequency of which will rise and fall and then rise again as the knob is slowly turned. The point midway between the two peaks is zero beat. At this position the REC. TUNING dial should indicate the frequency as stamped on the inserted crystal. If the dial calibration is found to be incorrect, the hairline must be adjusted by means of the adjusting screw just to the right of the lower edge of the dial opening so that it is in line with the dial calibration frequency.

**CAUTION:** Do not attempt to calibrate the receiver in a hostile area unless it is absolutely necessary. Calibration of the receiver involves the use of the transmitter with the consequent risk of detection by enemy direction finding units.

#### 41. USE OF THE TRANSMITTER.

Remember that the transmitter is *on the air* whenever the key is closed. Direction finding is a highly developed art. Detection can be avoided successfully if the key-down tune-up process is limited, and messages are transmitted quickly. Meaningless keying of the transmitter during adjustment attracts more attention than a regular transmission. A great deal of time can be saved through preadjustment of the controls to an approximate position as determined by past experience and observa-

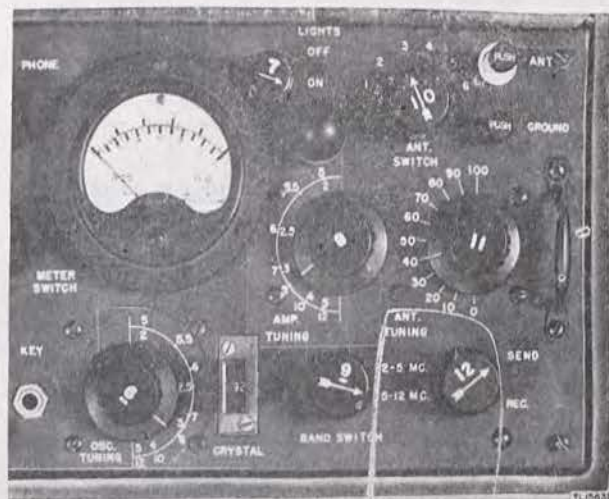

Figure 12. Transmitter section of front panel of Receiver-Transmitter RT-30() / PRC-1.

tion. Before taking this set out on its mission, use it a number of times on practice tests. Too much emphasis cannot be placed upon the need for familiarization with its operation before tactical use. Practice actual antenna installations in several locations; operate the equipment under the conditions to be expected in service use. Prepare a transmitter log so that the following tune-up data is immediately available. If possible, memorize it.

### TRANSMITTER LOG

Crystal frequency	Approximate dial settings	
	OSC. TUNING	AMP. TUNING
a. fundamental	.....	.....
b. harmonic	.....	.....
a. fundamental	.....	.....
b. harmonic	.....	.....
a. fundamental	.....	.....
b. harmonic	.....	.....
a. fundamental	.....	.....
b. harmonic	.....	.....
a. fundamental	.....	.....
b. harmonic	.....	.....

Put the transmitter on the air following the procedure given below:

- a. Select a crystal of the desired operating frequency or  $\frac{1}{2}$  the desired operating frequency (fundamental or harmonic operation). Insert the crystal in the crystal holder socket provided on the front panel of Receiver-Transmitter RT-30( )/PRC-1.
- b. Turn the SEND REC. control knob 12 to the SEND position.
- c. Set control knob 4 to the CW. or PHONE position.
- d. Turn control knob 9 to the band covering the desired operating frequency.
- e. Set the METER SWITCH control knob 5 to the AMP. GRID CUR. position.
- f. Depress the transmitter key and rotate control knob 6 for maximum grid current as indicated by the meter. At this point it should correspond rather closely with the dial calibration.

g. Set the METER SWITCH control knob 5 to the AMP. PLT. CUR. position.

h. Depress the transmitter key and rotate control knob 8 for minimum plate current drain as indicated by the meter.

i. With the transmitter key depressed and with control knob 10 adjusted so that its arrow points to No. 1 of the calibrated scale, rotate control knob 11 clockwise from zero position. At some point during the rotation of control knob 11 the plate current drawn by the transmitter power-amplifier tube should increase to approximately 75 ma. If the meter reading does not indicate such a plate-current increase, return knob 11 to 0 and adjust control knob 10 so that its arrow points to No. 2 of the calibrated scale, then rotate control knob 11 clockwise again. If the meter does not indicate an increase in the plate-current drain, it will be necessary to continue the tuning process, progressively utilizing taps 3, 4, 5, and 6 of knob 10 in connection with the control knob 11. When plate current has increased to approximately 75 ma, retune knob 8 for minimum plate current. Repeat these adjustments until the minimum plate current is at least 75 to 100 ma. If knob 10 has been rotated too far clockwise, the minimum plate current will begin to decrease as knob 8 is retuned. Notice that two factors are involved in respect to the antenna tuning process: operating frequency and physical length of the antenna. In general, the lower the operating frequency, the greater will be the amount of inductance needed to load the antenna (control knob 10 adjusted to either the 1, 2, or 3 position). With the antenna properly loaded, the plate-current reading should be approximately 75 to 100 ma. The meter must not read more than 100 ma. If it does, the antenna is not properly matched to the output circuit of the transmitter. A mismatch will cause a pronounced decrease in efficiency and may damage the transmitter power output tube. Since it is probable that the length of the antenna will vary with each installation, adjustment of control knobs 10 and 11 can be approximated only to the extent that past experience and ability in judging the probable characteristics of the antenna will allow. A keying monitor system is provided so that an audio tone will be heard in the headset when the transmitter key is depressed provided control knob 4 is adjusted to either the CW. or PHONE position. **DO NOT ATTEMPT TO TRANSMIT WITH CONTROL KNOB 4 IN THE CAL. POSITION.**

### 42. SUMMARY OF INSTRUCTIONS.

a. Be careful, when sending after dark, that keying the transmitter does not blink the lights in adjoining rooms and throughout the house or building. This may

lead to detection of the equipment. If serious light-blinking is noticed after a few tentative dashes or dots, suspend operation until everyone has gone to bed and the building is dark. This blinking cannot be cured and is the result of a poorly-wired building or inadequate power service. Remember, lights blinking in a building will suggest to enemy agents or enemy personnel that radio transmission is taking place.

**b.** Do not attempt to transmit with control switch 4 in the CAL. position.

**c.** Do not attempt to transmit with control switch 12

in the REC. position.

**d.** Handle the crystals carefully.

**e.** Make certain that ANT. SWITCH knob 10 and ANT. TUNING knob 11 have been adjusted for optimum matching of the transmitter to the antenna.

**f.** Adjust the contact arm of the key for minimum clearance between it and the other key contact. If the contacts of the key are too far apart the clicking noise attendant to keying the transmitter will be much louder and might result in calling the attention of enemy personnel to your activities.

# SECTION III

## FUNCTIONING OF PARTS

### 43. RECEIVER.

The receiver uses five tubes, two of which are of the double-purpose type, in a superheterodyne circuit (fig. 20), designed for the reception of amplitude-modulated signals (speech or tone-modulation) and c-w signals within the frequency range of 2 to 12 megacycles. The frequency range is covered in two overlapping bands (low-frequency band 2 to 5.25 mc, high-frequency band 5 to 12 mc) either of which is brought into use through suitable positioning of a rotary selector switch actuated by a control knob located on the front panel of the receiver. Tuning of the receiver to any desired frequency is accomplished through capacitance variation by means of a three-section ganged capacitor driven through a gear system by a control knob located on the front panel of the receiver. Reception of c-w signals is accomplished through the incorporation of a beat-frequency oscillator circuit which is switched into or out of operation by means of a control knob located on the front panel of the receiver. The intermediate-frequency (i-f) amplifier uses two permeability-tuned i-f transformers

resonated to the 455-kc, i-f channel frequency. The design of the receiver has been planned to assure the attainment of high performance reception (sensitivity, selectivity, simplicity of control) and the absence of undesirable characteristics (image response, drift, radiation).

### 44. R-F AMPLIFIER STAGE.

With switch SW3 in the RECEIVE position through suitable adjustment of control knob 12, the signal picked up by the antenna is transferred inductively from the antenna coil L7 to coils L6 (low-frequency band) and L8 (high-frequency band) which together with capacitor C17A constitute the input grid circuit of the r-f amplifier Tube JAN-6SG7(V3). Coils L6 and L8 are selectively connected in the circuit through the action of the receiver band switch SW7. C15 and C16 are adjustable trimmer capacitors used to align the input circuit at the high-frequency end of each of the two bands so that the r-f amplifier stage will track with the other r-f circuits of the receiver. C17A, which is one section of the

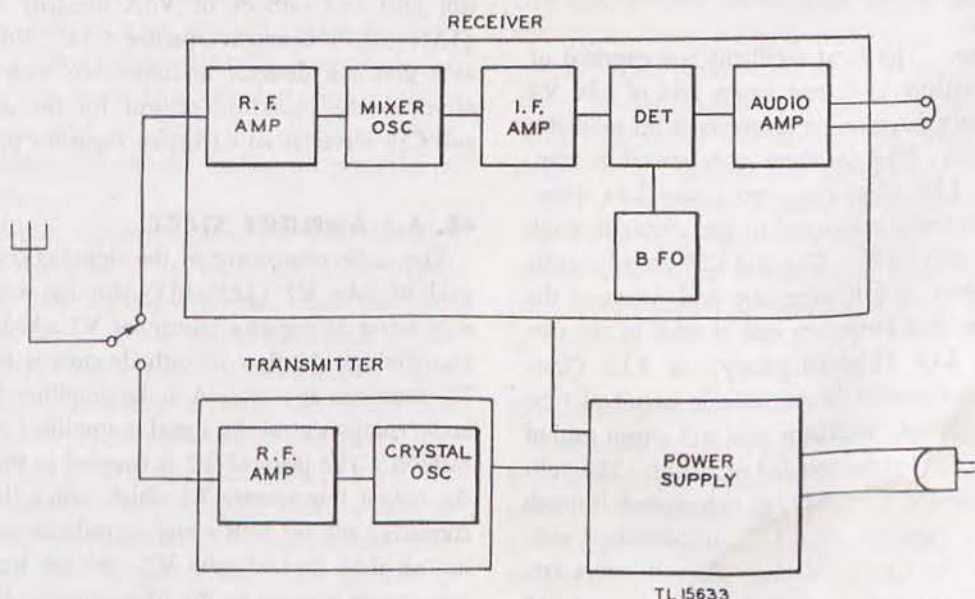

Figure 13. Block diagram of Radio Set AN/PRC-1 ( ).

three-gang tuning capacitors, is adjusted by means of the REC. TUNING control knob so that the input grid circuit is resonated to the frequency of the desired signal, which is impressed upon the grid of tube V3. The signal is amplified in the tube in the normal fashion and its corresponding plate-current change is coupled into either L9 (high-frequency band) or L10 (low-frequency band), depending upon the position of switch SW7. Bias for tube V3 is obtained through the flow of cathode current through resistor R16 and the variable potentiometer R17. R17 is adjusted by means of VOLUME control knob 3. The function of R17 is to provide a means of controlling the magnitude of the grid bias applied to tubes V3 and V5, and therefore to adjust the sensitivity of the receiver to correspond to prevailing needs. R13 serves to provide the minimum bias requirement for V3 when the cathode current is minimum. R14 and R15 serve as a voltage divider network in connection with the screen-grid circuit of V3 and V5. C19A functions as a bypass capacitor to ground for the plate of V3. C19B bypasses the screen-grid circuits of V3 and V5.

#### 45. CONVERTER STAGE.

**a. Mixer.** Since tuned impedance coupling is used between the r-f amplifier stage and the mixer stage, coils L9 (high-frequency) and L10 (low-frequency), selectively connected in the circuit through switch SW7, together with capacitor C17B serve as the input circuit of the mixer stage. The signal is impressed upon the grid of tube V4 (JAN 6SA7) through capacitor C22. R18 serves as a grid bias resistor for the tube. The plate current flowing in tube V4 is a complex function of the signal voltage and the voltage derived from the local oscillator.

**b. Oscillator.** The local oscillator is comprised of the cathode, oscillator grid, and screen grid of tube V4 plus the frequency-determining constants of the oscillator grid tank circuit. The oscillator tank circuit is comprised of coil L13 (high-frequency) and L14 (low-frequency) selectively connected in the circuit through SW7 together with C17C. C24 and C25 are adjustable trimmer capacitors used to align the grid circuit of the oscillator at the high-frequency end of each of the two bands. Coils L11 (high-frequency) or L12 (low-frequency) are connected in the cathode circuit of tube V4 so that the cathode, oscillator grid and screen grid of V4 function as an electron-coupled oscillator. The voltage of the oscillator frequency, as determined through the capacitance variation of C17C, is combined electronically with the signal voltage. The difference frequency, or i-f (455 kc) is coupled to the primary L15 of the first i-f transformer T1. C26 and C27 are the

padding capacitors used in the grid tank circuit of the oscillator to maintain a constant frequency differential between the oscillator voltage and the signal voltage, irrespective of the amount of capacity inserted in the circuit by C17C.

#### 46. I-F AMPLIFIER STAGE.

The signal, after having been converted to a new frequency (455 kc), is coupled to L15, the primary of the first i-f transformer T1. Coil L15 is shunted by a fixed ceramic capacitor. However, resonance, of L15 is determined and adjusted over a narrow range by means of a core of powdered iron, the coaxial position of which is adjusted, with respect to L15 by means of a threaded rod. The signal is transferred inductively from L15 to L16, the secondary of transformer T1, which is similarly shunted by a fixed ceramic capacitor. The resonant condition of L16 is determined and adjusted over a narrow range by means of a core of powdered iron, the coaxial position of which, is adjusted with respect to L16, by a threaded rod. The signal is impressed between the grid and cathode of tube V5 (JAN-6SK7) where it is amplified in the normal fashion. The resultant plate current is coupled to primary L17 of the second i-f transformer T2. The bias for V5 is obtained through the flow of cathode current through R23 in connection with the resistor network utilized in the r-f amplifier stage.

#### 47. SECOND DETECTOR STAGE.

The signal is coupled inductively from L17 to L18 which is the secondary of the permeability-tuned transformer T2. The signal is impressed between the control grid and cathode of V6A one-half of tube V6 (JAN-6SL7) through capacitor C34. V6A functions as a grid-leak detector in connection with R24. R27 serves as the plate-load resistor for the detector tube and C38 serves as an r-f bypass capacitor to ground.

#### 48. A-F AMPLIFIER STAGE.

The audio component of the signal is coupled to the grid of tube V7 (JAN-6J5) through C39 and R29. R28 serves as the grid return for V7 which receives its bias through the flow of cathode current through R30. V7 functions as a class A audio amplifier in which the audio component of the signal is amplified in the normal fashion. The plate of V7 is coupled to the primary of the output transformer T4 which, when the receiver is connected for use with a high-impedance headset, serves as the plate load of tube V7, and the headphones are capacitively coupled to the plate circuit. When the receiver is connected for use with a low-impedance head-

set, the audio output is taken from the secondary of output transformer T4. These connections are underneath the receiver chassis.

#### 49. BEAT-FREQUENCY OSCILLATOR.

Tube V6B, one-half of tube V6 (JAN-6SL7), with transformer T3, functions as a beat-frequency oscillator. The frequency determining constants of the oscillator are permeability tuned L19, shunted by fixed capacitor C35. R25, in connection with C36, functions as a grid leak bias source for tube V6B. C37 functions as a low-impedance r-f bypass to ground. R26 serves as a bleeder resistor to limit the amplitude of the r-f voltage generated by the beat-frequency oscillator. The r-f voltage generated by the beat-frequency oscillator is coupled to the i-f system through the interelectrode capacities of tube V6A and B.

#### 50. TRANSMITTER.

The transmitter consists of a crystal-controlled oscillator of the regenerative type, the output of which is coupled capacitively to a class C power amplifier.

a. The crystal-controlled oscillator stage is of the grid-plate type, with the crystal connected between the grid of tube V1 (JAN-6V6) and ground. The inductance-capacitance (L-C) combination comprised of RFC1 and capacitors C2 and C3, selectively connected in the circuit through the action of SW1, is tuned to a frequency much lower than that of the crystal in order to introduce a slight amount of positive feedback and thus improve the harmonic operation of the oscillator. R1 serves as a grid leak bias resistor. C1 provides a low r-f impedance path to ground for the heater circuit of V1. The frequency-determining constants of the oscillator are: the crystal, and variable capacitor C6 selectively connected in parallel with coil L1 (high-frequency band) and L2 (low-frequency band) through the action of SW1. R3 serves as a voltage-dropping resistor for the screen grid of V1. C5 provides a low-impedance path to the cathode for any r-f potential on the screen grid.

b. The oscillator supplies high output when the plate tank circuit is resonated to the frequency of the crystal. The output is only slightly decreased when the plate tank circuit is tuned to the second harmonic of the crystal frequency. Because of the buffer action which the circuit affords (isolation between the crystal and output circuit), the oscillator is stable and is not susceptible to changes in tuning. Provision is made for selective insertion of a meter in shunt with R4 so as to determine visually the magnitude of plate current drawn by V1. C4B is used to protect the meter against r-f voltage since the capacitor provides a low-impedance r-f

path to ground. R2 serves to provide minimum bias for tube V1 in its non-oscillating state.

#### 51. POWER AMPLIFIER STAGE.

a. The r-f voltage generated by the crystal-controlled oscillator is impressed between the grid and cathode of tube V2 (JAN 807) through capacitor C7. V2 operates as a class C amplifier, biased through the grid leak action of R5 together with the bias voltage developed by the passage of cathode current through R7. The frequency-determining constants of the power amplifier are coils L3 and L4 selectively connected in parallel with variable capacitor C10 through the action of SW1. Provision is made for metering the magnitude of excitation delivered to the grid of V2 through the incorporation of a shunt resistor R6 to which the meter is selectively connected through the action of SW5. C8 offers a low-impedance r-f path to ground and thus provides protection to the meter. C9A, B, and C are respectively heater, cathode, and screen grid bypass capacitors to ground.

b. RFC2, wound on a shunt resistor, is a parasitic suppressor included in the plate circuit of V2 to prevent high-frequency parasitic oscillation of the power amplifier. Provision is made for determining visually the magnitude of the plate current drawn by V2 and the magnitude of plate voltage delivered to V2 through the incorporation of a meter shunt resistor R8 and a meter multiplier resistor R9, to which the meter is selectively connected through the action of SW5. The r-f voltage generated by the crystal oscillator is amplified in the normal fashion by V2, and is coupled through C11 to the antenna-loading system comprised of tapped inductor L5 and variable capacitor C12. Together, L5 and C12 provide an electrical means for lengthening the antenna used with the transmitter. R11 is incorporated in the antenna circuit so as to provide a measure of protection against charges of static electricity accumulating on the antenna with the consequent possible damage to the receiver antenna coil L7.

c. The transmitter is keyed in the cathode circuit of both the oscillator and power amplifier by means of the keying relay which connects the negative side of the high-voltage supply to both stages when the key in J1 is depressed.

#### 52. POWER SUPPLY.

The power supply is used to provide a source of rectified, filtered, a-c voltage for the plate, screen, and bias needs of the receiver and transmitter. It also supplies a-c voltage of the proper magnitude and current rating to heat the filaments of the tubes used in the receiver and transmitter and energize the keying relay.

a. The power supply is comprised of a power transformer T5, rectifier tube V8 (JAN-5R4GY) and associated circuit elements connected as a full-wave rectifier.

b. The primary of T5 is tapped for operation on various line input voltages through suitable positioning of SW9.

c. The filter circuit is comprised of C42, CH, C43, and C44 connected as a capacitor input, two-section, brute force filter. R31 and R32 function as a voltage-divider network in connection with the B voltage requirements of the receiver. R33 functions as a bleeder resistor. R36 functions as a voltage-divider resistor in connection with the B voltage requirements of the transmitter crystal oscillator. R37 functions as a voltage-divider resistor in connection with the screen-grid voltage requirements of the transmitter oscillator.

d. R34 and R35 together with the two-section selenium oxide rectifier function as a half-wave rectifier connected directly to the a-c line for measuring the line voltage. The magnitude of the rectified voltage is determined visually by means of the meter which is selectively connected to the meter rectifier circuit through the action of SW5.

### 53. SWITCHES.

The following are the functions of the various switches in the receiver, transmitter, and power supply.

a. **SW1, Transmitter BAND SWITCH.** SW1 serves to adjust the transmitter for operation on either one of the two frequency bands covered. With the switch in the high-frequency position, coils L1 and L3 are connected to their associated circuits. With the switch in the low-frequency position, capacitor C3, coils L2 and L4 are connected to their associated circuits.

b. **SW2, ANT. SWITCH.** SW2 is a rotary tap switch used in connection with coil L5. With the switch selec-

tively connected to one of the taps, a corresponding amount of inductance is placed in series with the antenna.

c. **SW3, SEND REC. Switch.** Through the action of the SEND REC. switch, the antenna, power-amplifier screen-grid circuit, and keying monitor circuits are connected when the switch is in the SEND position. When in the REC. position, these circuits are broken and the receiver is connected to the antenna and to its plate-voltage supply.

d. **SW4, CAL. CW PHONE Switch.** When SW4 is in the CAL. position, the keying monitor circuit and the screen-grid circuit of the transmitter power amplifier are broken and the receiver beat-frequency oscillator (BFO) is put in its operative condition. When SW4 is in the CW. position the receiver BFO is put in its operative condition and the screen-grid circuit of the transmitter power amplifier is completed. When the switch is in the PHONE position, the BFO circuit is rendered inoperative and the screen-grid circuit of the transmitter power amplifier is completed.

e. **SW6, LIGHTS.** SW6 serves as an ON OFF switch in connection with both the receiver dial light and the transmitter panel light.

f. **SW7, Receiver BAND SWITCH.** SW7 serves to adjust the receiver for operation on either one of the two frequency bands covered. With the switch in the high-frequency band position, coils L8, L9, L11, and L13 are connected to their associated circuits. With the switch in the low-frequency position, coils L6, L10, L12, and L14 are connected to their associated circuits.

g. **SW8, Power Supply OFF ON Switch.** SW8 serves to connect the primary of transformer T5 to its source of power.

h. **SW9, LINE SWITCH.** SW9 is a rotary tap switch connected to the various taps provided on the primary of transformer T5 to adapt it for operation on various input line voltages.

# SECTION IV

## MAINTENANCE

NOTE: Unsatisfactory performance of this equipment will be reported immediately on W. D., A. G. O. Form No. 468. If Form No. 468 is not available, see TM 38-250.

### 54. GENERAL.

Adjustment, repairs, or disassembly of the equipment should not be attempted by personnel not trained to service this type of equipment. Trained personnel and suitable test equipment must be available before the equipment can be tested for major faults. Adequate test equipment for the maintenance and repair of Radio Set AN/PRC-1 ( ) should include the following items:

- a. An r-f standard signal generator.
- b. An a-f output meter.
- c. A universal analyzer capable of indicating all a-c and d-c voltages, necessary direct-current values, and the resistance values of all resistors.
- d. A 300-ohm dummy antenna, transmitting type.

### 55. OPERATIONAL INSPECTION.

a. Check the mounting of all components. Inspect all nuts, bolts, and screws for tightness. Inspect all soldered joint and wiring. Remove all traces of corrosion. Clean the equipment thoroughly and touch up scratched paint.

b. Inspect all plugs and knobs. Make sure that all plug contacts are clean and that knob setscrews are tight. Check headset and key cords. Check the power cord, the power-cord plug, and the adapter plugs furnished with the equipment.

c. Check the antenna wire for breaks and frayed points, and check the connection of the antenna wire at the antenna post.

d. Make sure that all tubes and the crystal are properly seated in their respective sockets.

e. Operate the receiver equipment. Tune in different stations in each band. Select stations providing weak signals and check the receiver sensitivity. Check the noise-level in the receiver and turn on the beat-frequency oscillator and check for the beat note against the incoming signal.

f. Operate the transmitter equipment. Make the proper tuning adjustments while using various crystals

and both bands. Hold the neon bulb against the antenna post to check the antenna current when the key is pressed.

- g. Check the dial and panel light bulbs and spares.

### 56. REPLACEMENT OF TUBES, FUSES, AND INDICATOR LAMPS.

a. Failure of a vacuum tube in the receiver may reduce the sensitivity of the receiver to received signals, may produce intermittent operation, may cause noise or hum, or may cause the receiver to be completely inoperative. In such cases, make substitutions for the tubes in use from the tubes supplied with the equipment as operating spares, until the defective tube is located.

b. Failure of a vacuum tube in the transmitter may cause reduced power output, improper reading on the d-c milliammeter, or complete inoperation of the transmitter. In such cases, make substitutions for the tubes in use from the tubes supplied with the equipment as operating spares, until the defective tube is located.

c. Failure of the rectifier tube in the power supply will cause poor operation or complete inoperation of both the transmitter and the receiver. Substitute a good tube from the operating spares supplied with the equipment.

d. The primary fuse FS2 will burn out when the primary circuit of transformer T5 is overloaded, either because of some defective tube or part in the equipment, momentary overload, or because of the use of an improper line voltage or frequency. Determine and correct the cause of the burned-out fuse. Replace the defective fuse by unscrewing the fuse-extractor post located near the OFF ON switch, and place a new fuse from the operating spares in the holder. Screw the fuse holder back in place firmly.

e. To replace the panel light, remove the black metal cover from the lamp base and unscrew the defective bulb. Replace it with a bulb of the same voltage and

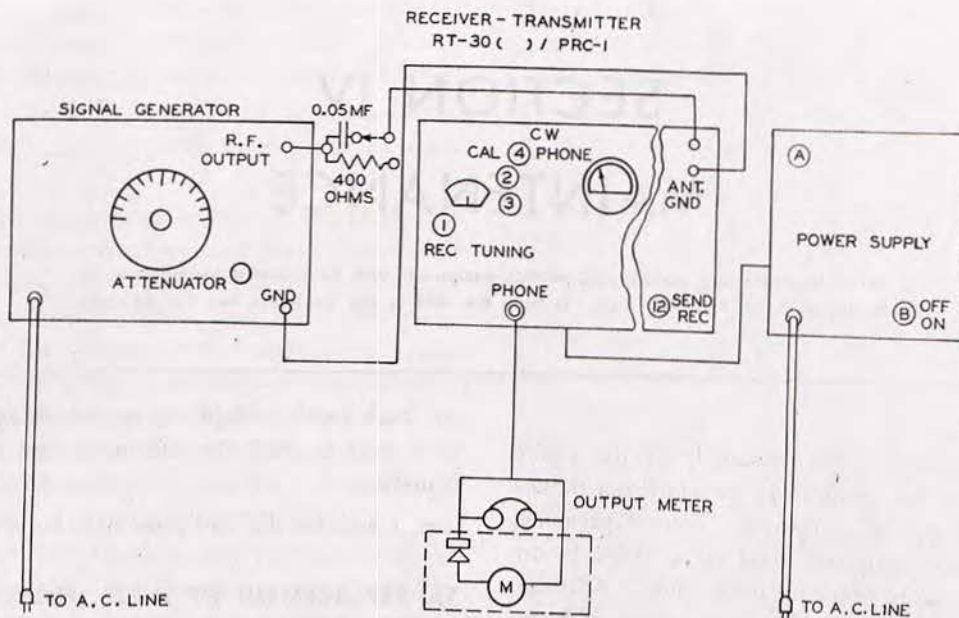

Figure 14. Block diagram of Radio Set AN/PRC-1 ( ) set-up for alignment of receiver.

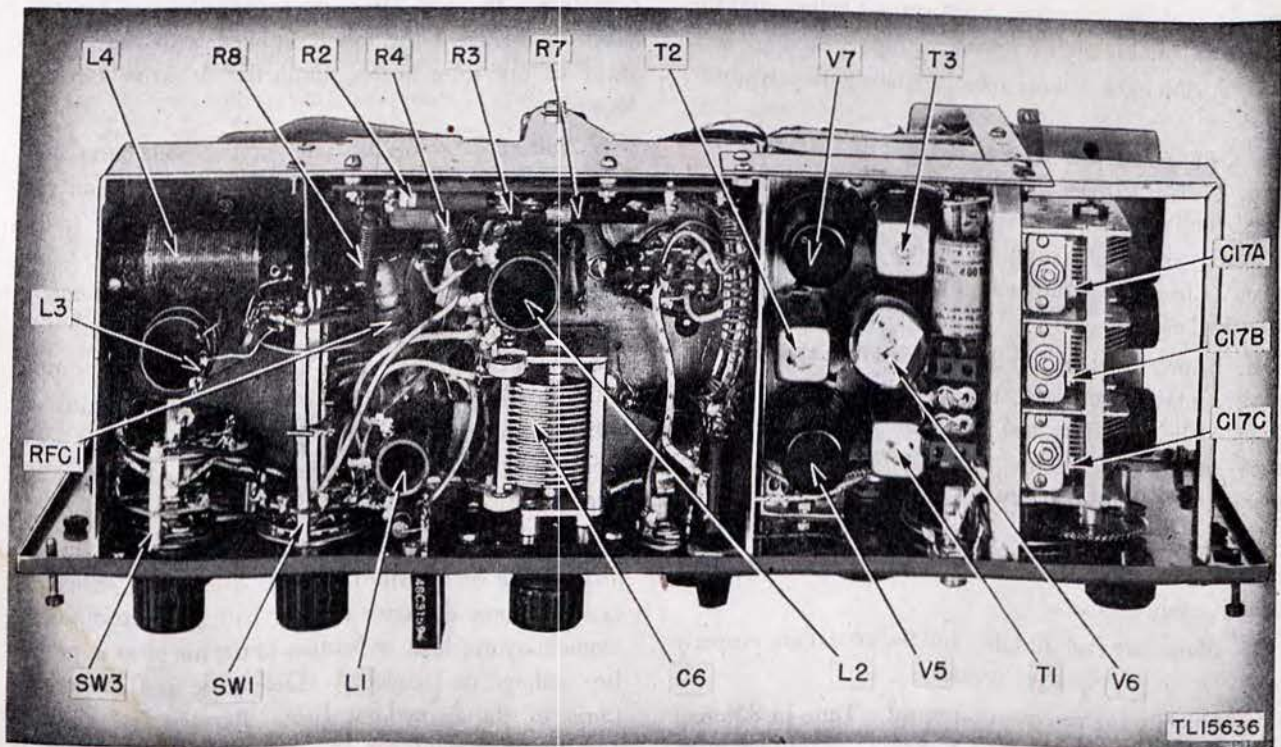

Figure 15. Bottom view of receiver-transmitter chassis, showing location of parts.

current rating from the operating spares. Replace the metal cover.

f. To replace the dial light the chassis must be removed from the case. Loosen the six captive screws in

the corners of the front panel. Slide the chassis out of the case a few inches and, if necessary, disengage the power plug. The dial light is now accessible from the left end of the chassis. Unscrew the defective bulb and

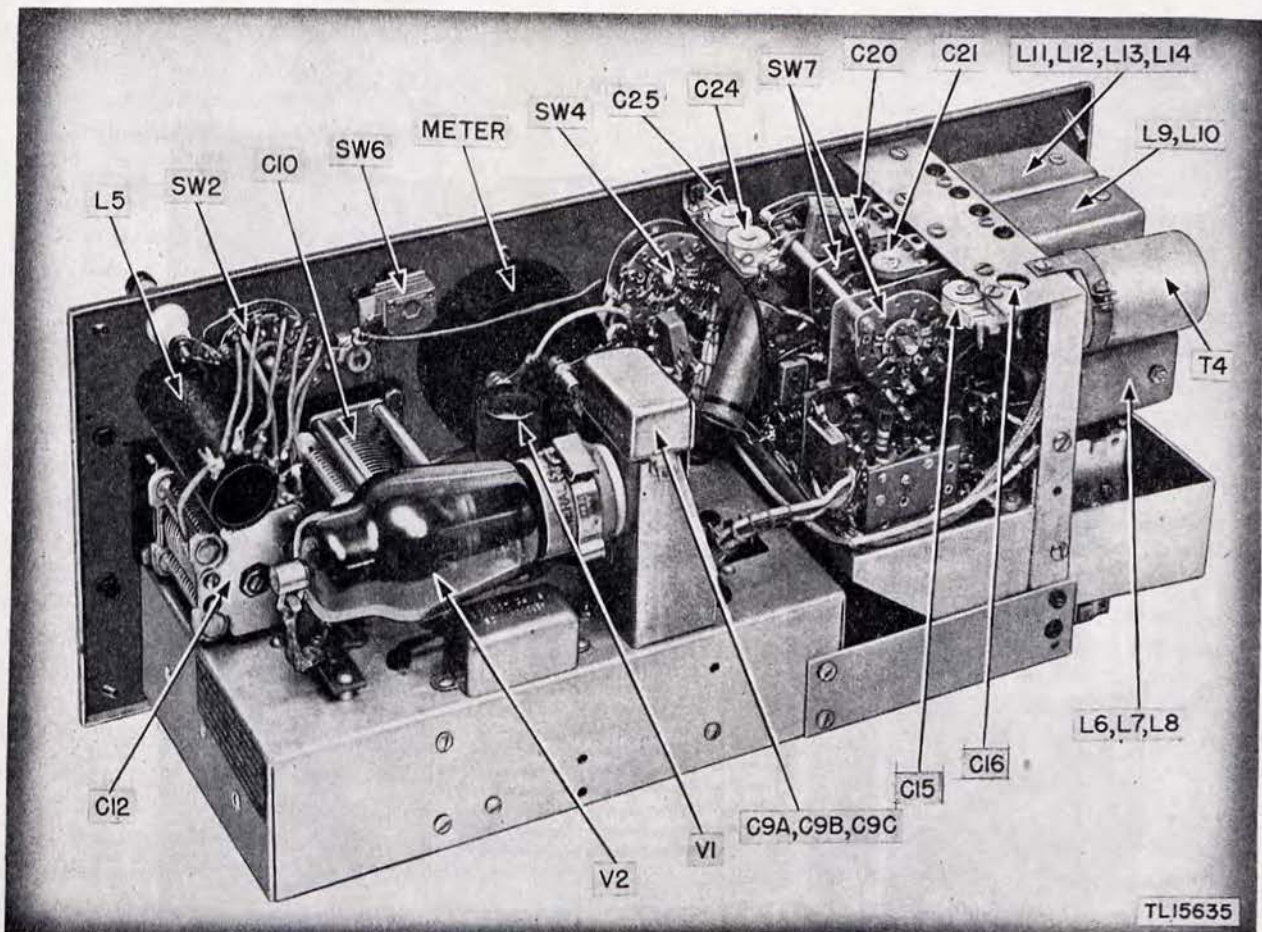

Figure 16. Rear view of receiver-transmitter chassis, showing location of parts.

replace with a new bulb of the same voltage and current rating from the operating spares. Reconnect power cord, replace chassis, and tighten panel screws.

### 57. RECEIVER ALIGNMENT.

If realignment of the receiver section of Radio Set AN/PRC-1 ( ) becomes necessary, the following alignment procedure should be followed. Refer to fig. 14.

**a. General.** All adjustments should be made with an output meter connected to the PHONE jack J2. Place the output impedance switch in the low-impedance position. Make certain the CAL. CW. PHONE switch (knob 4) is in the PHONE position, so the beat-frequency oscillator will not be in operation. Place the VOLUME control (knob 3) in the maximum clockwise position.

**b. I-f Alignment.** The intermediate frequency of the receiver is 455 kilocycles. Tuning adjustments are provided for both the primary and secondary windings of the i-f transformers T1 and T2. The adjusting screws slide iron cores in and out of the coil windings. Set the standard signal generator for an output of 455

kilocycles and connect its high-potential output lead to the signal grid of the mixer tube (terminal 5 of V4) through a 400-ohm series resistor. Connect the low-potential output lead from the signal generator to any metal part making direct connection to the chassis. Adjust the output voltage of the signal generator for an indication of approximately 10 volts on the output meter. Refer to figure 15 for location of i-f adjusting screws. Adjust the i-f adjusting screws on the i-f coils L15, L16, L17, and L18 of transformers T1 and T2, for a maximum indication on the output meter. Repeat the adjustments in consecutive order several times to make certain each coil is peaked properly. Readjust the output of the signal generator from time to time while making the adjustments, in order to keep the output meter indication at or near 10 volts.

**c. Beat-frequency Oscillator Adjustment.** The beat-frequency oscillator should not require adjustment except when the set has been subjected to extremely rough treatment or possible after tube V6 has been changed. The following procedure must be followed in case it is necessary to align the beat-frequency oscil-

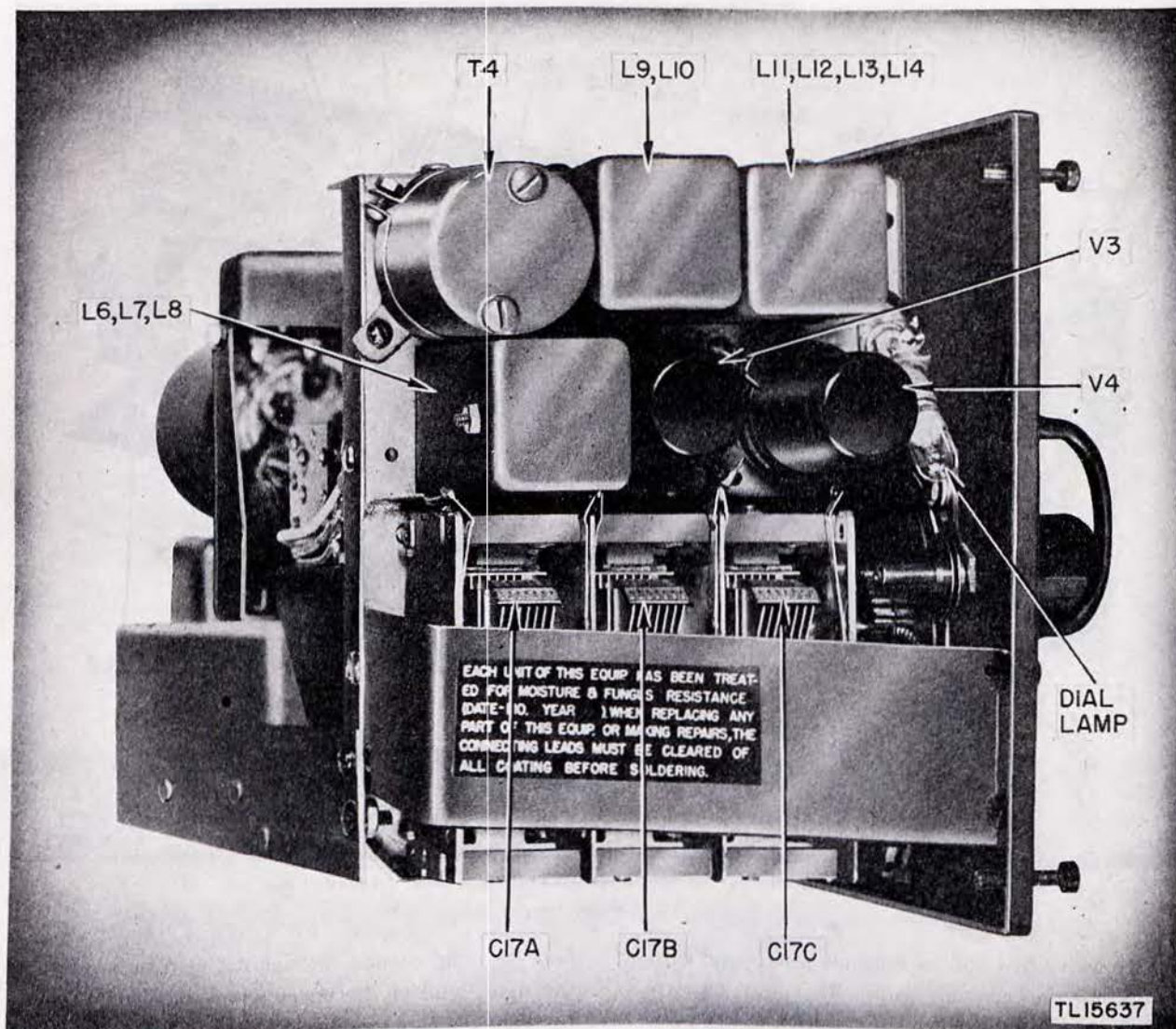

Figure 17. End view of receiver-transmitter chassis, showing location of parts.

lator. With the standard signal generator set for an output of 455 kilocycles, connect it to the radio set as described in subparagraph *b* above. Remove the output meter from the PHONE jack and plug in the headphones. Refer to figure 15 for location of the beat-frequency oscillator adjusting screw. Adjust the iron core adjusting screw on the oscillator transformer T3 until the most pleasing note is obtained. (This adjustment is not critical. A beat-note frequency of about 1,000 cycles is found to be satisfactory in most cases.)

**d. High-frequency Oscillator Alignment.** Realignment of the high-frequency oscillator circuits is seldom necessary unless the resonant frequency of the receiver, as indicated by the reading of the tuning dial, is greatly in error with respect to the actual frequency being received. The following procedure must be followed in adjusting the high-frequency oscillator trim-

mers. All adjustments are made with the output of the signal generator connected to the ANT (through a 0.05 series capacitor) and GND posts in the upper right-hand corner of the front panel, and with the output meter connected as described in subparagraph *a* above. For location of oscillator trimmer adjusting screws refer to figure 16.

(1) H-F OSCILLATOR ALIGNMENT PROCEDURE FOR LOW BAND.

(a) Place BAND-SWITCH (knob 2) in the 2-5MC. position, and set the receiver tuning dial at 5.0 mc.

(b) Set the signal generator output at 5.0 mc.

(c) Adjust trimmer capacitor C25 for maximum output.

(2) H-F OSCILLATOR ALIGNMENT PROCEDURE FOR HIGH BAND.

(a) Place BAND-SWITCH (knob 2) in the 5-12

MC. position, and set the receiver tuning dial at 12.0 mc.

(b) Set the signal generator output at 12.0 mc.

(c) Adjust trimmer capacitor C24 for maximum output.

**e. R-f Amplifier Alignment.** With the output of the signal generator connected to the ANT and GND posts of the receiver, and with the output meter connected as above, align the r-f stage in accordance with the following procedure. For location of r-f trimmer adjusting screws refer to figure 16.

(1) R-F ALIGNMENT FOR LOW BAND.

(a) Place the receiver BAND-SWITCH (knob 2) in the 2-5 MC. position, and set the receiver tuning dial at 5.0 mc.

(b) Set the signal generator output at 5.0 mc.

(c) Adjust trimmer capacitors C16 and C21 for maximum output. Repeat each adjustment several times to make certain each coil is properly peaked.

(2) R-F ALIGNMENT FOR HIGH BAND.

(a) Place the receiver BAND-SWITCH (knob 2) in the 5-12 MC. position, and set the receiver tuning dial at 12.0 mc.

(b) Set the signal generator output at 12.0 mc.

(c) Adjust trimmer capacitors C15 and C20 for maximum output. Repeat each adjustment several times to make certain each coil is properly peaked.

**f. Precautions During Alignment.** It is essential that the input signal from signal generator be kept below the point that will cause the receiving tubes to block. Maintain an output indication of 10 volts or less. Ex-

cessive signal inputs will cause overload of the detector or amplifier circuits and must be avoided because of incorrect alignment indications.

**58. PROCEDURE IN LOCATING TROUBLE.**

**a. Systematic Checks.** Speed in locating trouble in equipment is essential. Frequently, after much time has been wasted searching for the cause of equipment failure, the trouble is found to be so minor that only a few minutes are required to correct it. Follow a systematic procedure in eliminating possible causes of trouble when failure does occur. It is useless to remove the transmitter chassis from the case and institute a thorough-going continuity check of the circuits when the symptom of trouble is a lack of voltage or current indication. Check the power cord, jacks, switches, and fuses in the unit, since they are the common sources of trouble. Make certain that the power cord is connected to the source of power, and that all plugs are making good contact in their sockets or jacks. After such preliminary inspection, closely examine the transmitter and receiver units. Daily inspection of the equipment will serve to minimize failures due to minor faults, such as breaks in connecting cords and poor contacts.

**b. Trouble Chart for Operator.** The trouble chart below lists a number of typical troubles which may occur in this equipment. In case of equipment failure, check the items in the trouble chart before initiating a detailed examination. Note that some of these troubles are caused by failure to adjust the equipment properly when setting it up for use. Always recheck the installation and tune-up procedure before operating the equipment.

**TROUBLE CHART**

Trouble	Probable causes	Remedy
Receiver dead.	Line cord not correctly inserted in the power source. Control knob B in OFF position. Fuse FS2 blown. Equipment connected to d-c power lines.  Control knob 12 adjusted to SEND position. Phone plug not correctly inserted in PHONE jack. Defective or burned-out tube. Defective headset.	Insert correctly, making certain that proper electrical contact is made. Adjust control knob B to ON position. Replace (par. 31a). <b>DISCONNECT EQUIPMENT FROM THE POWER LINES.</b> Adjust control knob 12 to the REC. position. Make certain that the PHONE plug is fully inserted in the PHONE jack. Replace. Replace.

Trouble	Probable causes	Remedy
Weak receiver.	Receiver not tuned properly. Antenna not connected to antenna binding post. Poor antenna installation. Defective headset. Defective or burned-out tube. Misalignment of receiver.	Reset dial. See paragraph 36b. Recalibration may also be necessary. See paragraph 40. Make certain that the antenna wire is making contact with the antenna binding post. Improve antenna. See paragraph 34. Replace. Replace tube. Align receiver.
Transmitter dead.	Line cord not correctly inserted in the power source. Control knob B in OFF position. Fuse FS2 blown. Equipment connected to d-c power lines.  Control knob 12 adjusted to REC. position. Key plug not correctly inserted in the key jack  Defective or burned-out tube. Control knob 4 in the CAL. position.  Defective crystal. Fuse FS1 blown.	Insert correctly, making certain that proper electrical contact is made. Adjust control knob B to ON position. Replace (par. 31a). <b>DISCONNECT EQUIPMENT FROM THE POWER LINES.</b> Adjust control knob 12 to SEND position. Make certain that the key plug is fully inserted in the key jack. Replace. Always transmit with control knob 4 in either the CW or PHONE position. Replace. Replace (par. 31a).
Transmitter weak.	Poor antenna installation. Defective crystal. Mistuned. Defective tube.	Improve antenna. See paragraph 34. Replace. Retune. See paragraph 41. Replace.

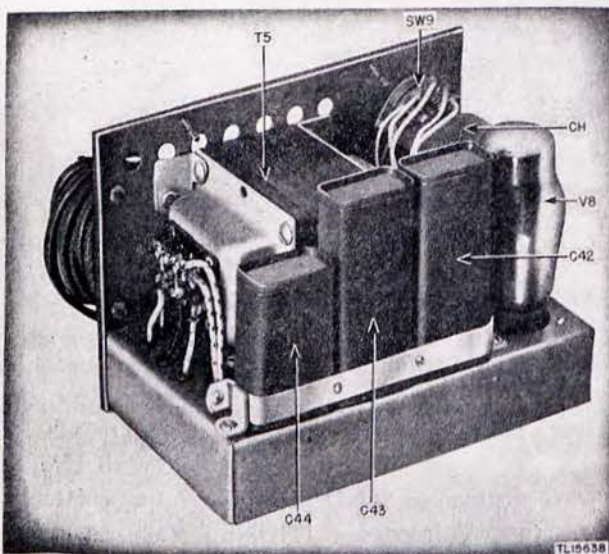

Figure 18. Rear view of rectifier power unit showing location of parts.

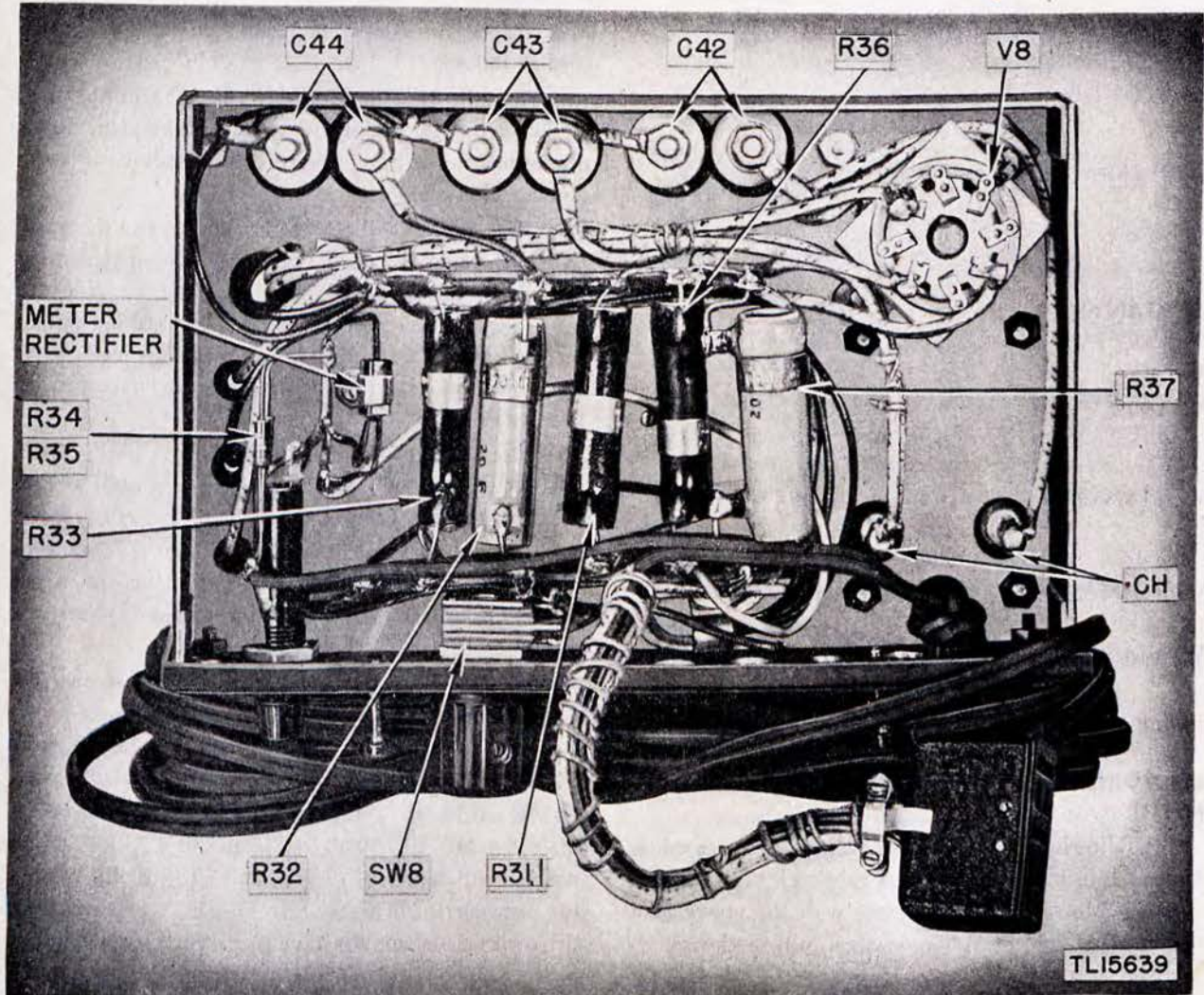

Figure 19. Bottom view of rectifier power unit showing location of parts.

### 59. VOLTAGE MEASUREMENTS.

The following chart shows the voltages obtained from each indicated tube-socket pin to the chassis. Measurements on transmitting tubes V1 and V2 are made with the crystal removed (no excitation) and the key closed.

Tube	Pin No.	Voltage	
V1, (JAN 6V6)	3	200	
	4	180	
	8	10	
V2, (JAN 807)	2	550	
	4	40	
	cap	800	
		Volume control fully clockwise	Volume control fully counter-clockwise
V3, (JAN 6SG7)	3	2.5	40
	6	85	150
	8	250	300
V4, (JAN 6SA7)	3	250	290
	4	60	75
	5	150	150
V5, (JAN 6SK7)	5	5	35
	6	70	100
	8	220	300
V6, (JAN 6SL7)	2	45	45
	5	45	45
V7, (JAN 6J5)	3	250	250
	8	8	8

### 60. POINT-TO-POINT RESISTANCE MEASUREMENTS.

The following chart shows the average resistance values measured from each indicated tube-socket pin to the chassis. Measurements are made with the power cord disconnected and the volume control fully clockwise.

Tube	Tube-socket pin number and resistance in ohms							
	1	2	3	4	5	6	7	8
V1, (JAN 6V6)	0	0.5	50M	60M	90M	60M	0	inf
V2, (JAN 807)	0.5	100M	30M	inf†	0			
V3, (JAN 6SG7)	0	0	300	0.5	300	3,500	0.5	2,500
V4, (JAN 6SA7)	0	0	2,500	3,000	2,000	0	0.5	1 meg
V5, (JAN 6SK7)	0	0	0	22	330	3,500	0.5	2,500
V6, (JAN 6SL7)	300M*	56M	0	1 meg	330M	0	0.5	0
V7, (JAN 6J5)	0	0	47M	inf	550M	inf	0.5	1,000

\*M = thousand.  
†inf = infinity.

### 61. SERVICING THE TRANSMITTER.

#### WARNING: HIGH VOLTAGE—USE EXTREME CAUTION

- Place the SEND REC. switch in the SEND position.
- See that the dummy antenna or the regular antenna is correctly connected.
- Turn on the power and check both bands for proper operation.

d. If the transmitter is inoperative on both bands proceed as follows:

(1) Place the METER SWITCH (knob 5) in the PLT. VOL. position to check the B voltage in the plate circuit of the final amplifier. Compare this reading with the normal reading in paragraph 59.

(2) Place the METER SWITCH (knob 5) in the PLT. CUR. position and depress the key, noting the final amplifier plate current. Tune the final amplifier to resonance for the current dip with knob 8, making certain the minimum plate current is not over 100 ma. If no dip is obtained, excitation is lacking or the final amplifier is defective.

(3) Place the METER SWITCH (knob 5) in the AMP. GRID CUR. position and depress the key while noting the final amplifier grid current. If grid current is lower than normal, excitation from the oscillator is lacking, or the tube is not properly biased. Use a high-resistance d-c voltmeter across the grid resistor and across the cathode resistor to check the bias voltage.

**NOTE:** Make certain the grid current never exceeds 30 ma, the maximum grid current for this tube.

(4) If the final amplifier grid current is normal but the plate current dip is not obtained, check the final amplifier.

(5) If grid current for the final amplifier is lacking, place the METER SWITCH in the OSC. PLT. CUR. position and depress the key to check for oscillation. If the plate current is higher than normal, 10 ma or more, the oscillator is not functioning properly, and requires

further investigation. If the oscillator is functioning properly the plate current will be approximately 7 ma.

(6) When the defective stage has been localized, measure the plate voltage from the B-side of the load resistor to ground. Compare this reading with the normal B reading shown in paragraph 59.

(7) Measure the cathode voltage and the screen-grid voltage and compare these readings to the normal voltages in paragraph 59.

(8) If a circuit is found not having normal voltage within 10 percent, check the components of that circuit.

(9) Replace defective components with exact duplicate replacement parts when possible. Original placement of wiring and parts should be duplicated to maintain original stability and power output.

(10) Repeat tuning process and check the transmitter for normal operation on both bands, checking against the specified standards for power output, frequency range, and accuracy of calibration.

e. If only one frequency band was defective, check only the components of that band.

f. If operation of the transmitter is intermittent on both bands, make a complete and thorough check of all parts and wiring. Many intermittent troubles can be made to recur by gently shaking or jarring the transmitter.

g. Dirt, moisture, and insects often cause trouble in a transmitter. Make certain the transmitter is clean by using a soft cloth or compressed air to remove the dirt. Moisture may be removed by first drying with a soft cloth and then placing the chassis in the sun or under an electric heater until it is thoroughly dried out. Do not overheat.

## 62. MOISTUREPROOFING AND FUNGIPROOFING.

a. **General.** The operation of Signal Corps equipment in tropical areas where temperature and relative humidity are extremely high requires special attention. The following items represent problems which may be encountered in operation:

(1) Resistors, capacitors, coils, chokes, transformer windings, etc., fail.

(2) Electrolytic action takes place in resistors, coils, chokes, transformer windings, etc., causing eventual break-down.

(3) Hook-up wire and cable insulation break down. Fungus growth accelerates deterioration.

(4) Moisture forms electrical leakage paths on terminal boards and insulating strips, causing flash-overs and crosstalk.

b. **Treatment.** A moistureproofing and fungiproofing treatment has been devised which, if properly applied, provides a reasonable degree of protection against fungus growth, insects, corrosion, salt spray, and moisture. The treatment involves the use of a moisture- and fungi-resistant varnish applied with a spray gun or brush. Refer to TB SIG 13, Moistureproofing and Fungiproofing Signal Corps Equipment, for a detailed description of the varnish-spray method of moistureproofing and fungiproofing.

**CAUTION:** Varnish spray may have toxic effects if inhaled. To avoid inhaling the spray, use a respirator if available, otherwise, fasten cheesecloth or some other cloth over the nose and mouth.

### c. Step-by-step Instructions for Treating Radio Set AN/PRC-1( ).

(1) **PREPARATION.** Make all repairs and adjustments necessary for proper operation of the equipment.

(2) **DISASSEMBLY.**

(a) Open the case and remove the contents of the spare parts compartments.

(b) Remove the four screws holding the power unit chassis in the case and remove the unit from the case.

(c) Remove the four screws holding the receiver-transmitter chassis in the case and remove the unit from the case.

(d) Clean all dirt, dust, rust, fungus, oil, grease, etc., from the equipment to be processed.

(3) **MASKING.** Mask the following:

(a) Wafer switches on top of the receiver-transmitter chassis.

(b) Transmitter variable capacitor on top of the chassis.

(c) Relay contacts on top of the chassis.

(d) Contacts of the power plug on top of the chassis.

(e) Ceramic wafer capacitors on top of the chassis.

(f) Wafer switches on the bottom of the chassis.

(g) Variable capacitors on the bottom of the chassis.

(b) Contacts of the microphone and phone jacks on the bottom of the chassis.

(i) Power unit wafer switch.

(j) Power plug contacts on the power unit.

(4) **DRYING.** Place the equipment in an oven or under heat lamps and dry for 2 to 3 hours at 160° F. DO NOT EXCEED 160°.

(5) **VARNISHING.**

(a) Apply three coats of Lacquer, Fungus-resistant, Spec. No. 71-2202 (stock No. 6G1005.3), or equal, with a spray gun or a brush. Allow 15 to 20 minutes for drying between each coat of lacquer.

(b) When the lacquer has dried, remove the masking tape and brush on lacquer to those portions not touched by the spray.

(c) Varnish the inside of the case, using either brush or spray for this operation.

**(6) REASSEMBLY.**

(a) Remove all masking tape.

(b) Clean all contacts with varnish remover and bur-nish the contacts.

(c) Reassemble the set and test its operation.

**(7) MARKING.** Mark the set with "MFP" and the date of treatment.

Example: MFP—8 June 1944.

LEGEND

C1	5,000 mmf	250 v dc (working)	C33	PART OF T2	L17	PART OF T2	R37	40,000 OHMS	20 WATT	
C2	50 mmf	250 v dc (working)	C34	100 mmf 250 v dc (working)	L18	PART OF T2	RFC 1	R-F CHOKE	2.5 MH	
C3	50 mmf	250 v dc (working)	C35	PART OF T3	L19	PART OF T3	RFC 2	PARASITIC SUPPRESSOR		
C4,A,B,C	0.1 mf	600 v dc (working)	C36	50 mmf 250 v dc (working)	L20	PART OF T3				
C5	5,000 mmf	250 v dc (working)	C37	5,000 mmf 250 v dc (working)			SW 1	BAND SWITCH, XMTR	CONTROL KNOB 9	
C6	10-232 mmf	250 v dc (working)	C38	250 mmf 250 v dc (working)			SW 2	ANTENNA SWITCH,	CONTROL KNOB 10	
C7	25 mmf	250 v dc (working)	C39	1,000 mmf 250 v dc (working)			SW 3	SEND/RECEIVE SW.,	CONTROL KNOB 12	
C8	1,000 mmf	250 v dc (working)	C40	5,000 mmf 250 v dc (working)			SW 4	CAL. CW. PHONE,	CONTROL KNOB 4	
C9,A,B,C	0.1 mf	600 v dc (working)	C41	0.05 mf 1,000 v dc (working)			SW 5	METER SWITCH,	CONTROL KNOB 5	
C10	10-232 mmf	250 v dc (working)	C42	2 mf 1,000 v dc (working)			SW 6	LIGHTS OFF/ON,	CONTROL KNOB 7	
C11	500 mmf	250 v dc (working)	C43	2 mf 1,000 v dc (working)			SW 7	BAND SWITCH, REC.,	CONTROL KNOB 2	
C12	10-232 mmf	250 v dc (working)	C44	2 mf 600 v dc (working)			SW 8	OFF/ON	CONTROL KNOB B	
C13	0.01 mf	250 v dc (working)			R1	100,000 OHMS	1 WATT	SW 9	LINE SWITCH,	CONTROL KNOB A
C14	0.5 mf	400 v dc (working)			R2	470 OHMS	1 WATT			
C15	5-40 mmf	250 v dc (working)			R3	8,000 OHMS	1 WATT			
C16	5-40 mmf	250 v dc (working)			R4	4.17 OHMS	1 WATT			
C17,A,B,C	10-261.3 mmf	250 v dc (working)			R5	30,000 OHMS	1 WATT			
C18	0.01 mf	250 v dc (working)			R6	9.10 OHMS	1 WATT			
C19,A,B,C	0.1 mf	600 v dc (working)			R7	400 OHMS	10 WATT			
C20	5-20 mmf	250 v dc (working)			R8	0.840 OHMS	1 WATT			
C21	5-20 mmf	250 v dc (working)			R9	1.2 MEGOHMS	1 WATT			
C22	25 mmf	250 v dc (working)			R10	100,000 OHMS	1/2 WATT			
C23	50 mmf	250 v dc (working)			R11	100,000 OHMS	1 WATT			
C24	4-30 mmf	250 v dc (working)			R12	150,000 OHMS	1/2 WATT			
C25	4-30 mmf	250 v dc (working)			R13	100,000 OHMS	1 WATT			
C26	3,000 mmf	250 v dc (working)			R14	22,000 OHMS	1 WATT			
C27	1,370 mmf	250 v dc (working)			R15	22,000 OHMS	1 WATT			
C28	PART OF T1				R16	330 OHMS	1/2 WATT			
C29	PART OF T1				R17	POTENTIOMETER	25,000 OHMS			
C30,A,B,C	0.1 mf	600 v dc (working)			R18	100,000 OHMS	1/2 WATT			
C31	0.1 mf	250 v dc (working)			R19	68,000 OHMS	1/2 WATT			
C32	PART OF T2				R20	22,000 OHMS	1/2 WATT			
					R21	22,000 OHMS	1/2 WATT			
					R22	1,500 OHMS	1/2 WATT			
					R23	330 OHMS	1/2 WATT			
					R24	1 MEGOHM	1/2 WATT			
					R25	330,000 OHMS	1/2 WATT			
					R26	68,000 OHMS	1/2 WATT			
					R27	330,000 OHMS	1/2 WATT			
					R28	470,000 OHMS	1/2 WATT			
					R29	220,000 OHMS	1/2 WATT			
					R30	1,000 OHMS	1/2 WATT			
					R31	7,500 OHMS	20 WATT			
					R32	7,500 OHMS	20 WATT			
					R33	40,000 OHMS	20 WATT			
					R34	220,000 OHMS	1/2 WATT			
					R35	220,000 OHMS	1/2 WATT			
					R36	30,000 OHMS	20 WATT			

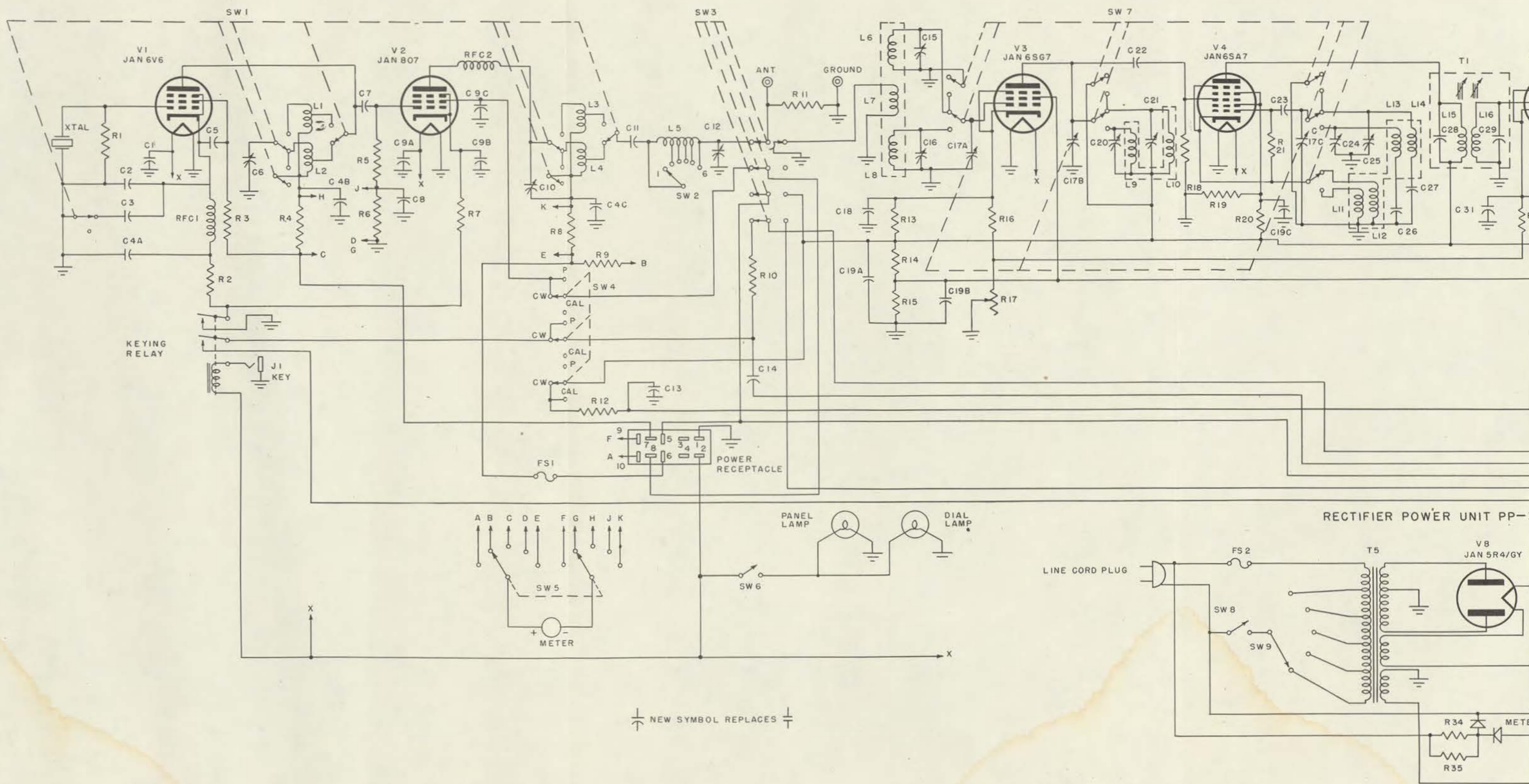

Figure 20. Schematic diagram of Radio Set AN/PRC-1 ( ).

TRANSMITTER

RECEIVER - TRANSMITTER RT-30( )/PRC-1

RECEIVER

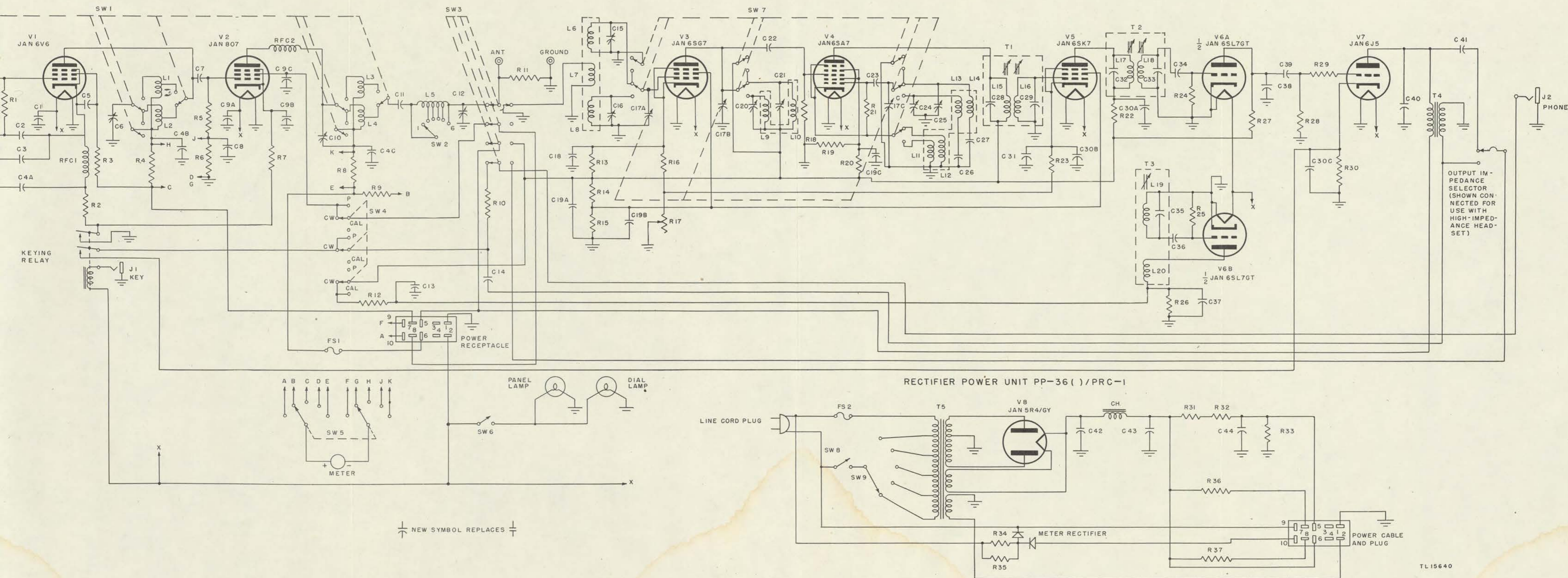

Figure 20. Schematic diagram of Radio Set AN/PRC-1( ).

TL 15640

# LEGEND

Item No.	Description	Quantity	Unit	Material
1	...	...	...	...
2	...	...	...	...
3	...	...	...	...
4	...	...	...	...
5	...	...	...	...
6	...	...	...	...
7	...	...	...	...
8	...	...	...	...
9	...	...	...	...
10	...	...	...	...
11	...	...	...	...
12	...	...	...	...
13	...	...	...	...
14	...	...	...	...
15	...	...	...	...
16	...	...	...	...
17	...	...	...	...
18	...	...	...	...
19	...	...	...	...
20	...	...	...	...
21	...	...	...	...
22	...	...	...	...
23	...	...	...	...
24	...	...	...	...
25	...	...	...	...
26	...	...	...	...
27	...	...	...	...
28	...	...	...	...
29	...	...	...	...
30	...	...	...	...
31	...	...	...	...
32	...	...	...	...
33	...	...	...	...
34	...	...	...	...
35	...	...	...	...
36	...	...	...	...
37	...	...	...	...
38	...	...	...	...
39	...	...	...	...
40	...	...	...	...
41	...	...	...	...
42	...	...	...	...
43	...	...	...	...
44	...	...	...	...
45	...	...	...	...
46	...	...	...	...
47	...	...	...	...
48	...	...	...	...
49	...	...	...	...
50	...	...	...	...
51	...	...	...	...
52	...	...	...	...
53	...	...	...	...
54	...	...	...	...
55	...	...	...	...
56	...	...	...	...
57	...	...	...	...
58	...	...	...	...
59	...	...	...	...
60	...	...	...	...
61	...	...	...	...
62	...	...	...	...
63	...	...	...	...
64	...	...	...	...
65	...	...	...	...
66	...	...	...	...
67	...	...	...	...
68	...	...	...	...
69	...	...	...	...
70	...	...	...	...
71	...	...	...	...
72	...	...	...	...
73	...	...	...	...
74	...	...	...	...
75	...	...	...	...
76	...	...	...	...
77	...	...	...	...
78	...	...	...	...
79	...	...	...	...
80	...	...	...	...
81	...	...	...	...
82	...	...	...	...
83	...	...	...	...
84	...	...	...	...
85	...	...	...	...
86	...	...	...	...
87	...	...	...	...
88	...	...	...	...
89	...	...	...	...
90	...	...	...	...
91	...	...	...	...
92	...	...	...	...
93	...	...	...	...
94	...	...	...	...
95	...	...	...	...
96	...	...	...	...
97	...	...	...	...
98	...	...	...	...
99	...	...	...	...
100	...	...	...	...

# SECTION V

## SUPPLEMENTARY DATA

**MAINTENANCE PARTS LIST FOR RECEIVER-TRANSMITTER RT-30( )/PRC-1.**

Ref symbol	Signal Corps stock No.	Name of part and description	Quan per unit	Run-ning spares	Orgn stock	3d ech	4th ech	5th ech	Depot stock
	2C5130-30	RECEIVER-TRANSMITTER RT-30( )/PRC-1.	1		*	*			*
	3Z741-11	BINDING POST: push type; insulated; ground post; North American Phillips dwg. No. S1.011.01.	1			*	*	*	*
	3Z774-7	BINDING POST: push type; ceramic feed-thru; antenna post and insulator assembly; North American Phillips S1.501.00.	1			*	*	*	*
C22	3D9025-29	CAPACITOR: fixed; mica; 25-mmf $\pm 10\%$ ; 250 v dc (working); Aero-vox 1468.	2			*	*	*	*
C3, 3, C36	3D9050-50	CAPACITOR: fixed; mica; 50-mmf $\pm 10\%$ ; 250 v dc (working); Aero-vox 1468.	4			*	*	*	*
8	3D9250-20	CAPACITOR: fixed; mica; 250-mmf $\pm 10\%$ ; 250 v dc (working); Aero-vox 1468.	1			*	*	*	*
1	3D9500-61	CAPACITOR: fixed; mica; 500-mmf $\pm 10\%$ ; 250 v dc (working); Aero-vox 1467.	1			*	*	*	*
3, C39	3DA1-50	CAPACITOR: fixed; mica; 1,000-mmf $\pm 10\%$ ; 250 v dc (working); Aero-vox 1467.	2			*	*	*	*
7	3DA1370-1	CAPACITOR: fixed; mica; 1,370-mmf $\pm 3\%$ ; 250 v dc (working); Aero-vox 1467.	1			*	*	*	*
26	3DA3-75	CAPACITOR: fixed; mica; 3,000-mmf $\pm 3\%$ ; 250 v dc (working); Aero-vox 1467.	1			*	*	*	*
1, C5, 37, C40	3DA5-14	CAPACITOR: fixed; mica; 5,000-mmf $\pm 10\%$ ; 250 v dc (working); Aero-vox 1467.	4			*	*	*	*
18, C13, 31	3DA10-53	CAPACITOR: fixed; mica; 10,000-mmf $\pm 10\%$ ; 250 v dc (working); Aero-vox 1467.	2			*	*	*	*

\* Indicates stock available.





63. MAINTENANCE PARTS LIST FOR RECEIVER-TRANSMITTER RT-30(1)/PRC-1 (contd.).

Ref symbol	Signal Corps stock No.	Name of part and description	Quan per unit	Run-ning spares	Orgn stock	3d ech	4th ech	5th ech	Depot stock
	2Z5850-16	KNOB: black wood; Syroco No. 2K733BA North American Phillips dwg No. A11696; (for 1/4" shaft; marked "6").	1		*	*	*	*	*
	2Z5850-17	KNOB: (as above marked "8").	1		*	*	*	*	*
	2Z5850-15	KNOB: (as above marked "11").	1		*	*	*	*	*
	2Z5897	LAMP: pilot; 6-8-v, 0.25-amp; Mazda 46; miniature screw base.	2	2		*	*	*	*
	3F6327-2	METER: d-c; multi-scale per North American Phillips dwg No. S1.230-01; De Jur Amsco No. 5-310-0-1; internal resistance, 100 ohm $\pm 2\%$ ; North American Phillips dwg No. S1.221.02.	1			*	*	*	*
	2Z7228.40	RECEPTACLE: female; 10-contact; H. B. Jones Co. No. 310AB.	1				*	*	*
	2Z7598-29	RELAY: keying; DPST; normally open; contacts rated 1,000 v dc at 50 ma; a-c coil 5-7.5; C. P. Clare Co. #A-16134.	1			*	*	*	*
R17	2Z7270.144	POTENTIOMETER: Single section; 25,000-ohm; linear taper; volume control; Globe-Union type NF-113.	1			*	*	*	*
R16, R23	3RC20AE331K	RESISTOR: fixed; carbon; 330-ohm $\pm 10\%$ ; 1/2-w; Erie 504.	2			*	*	*	*
R2	3RC31AE471K	RESISTOR: fixed; carbon; 470-ohm $\pm 10\%$ ; 1-w; Erie 518.	1			*	*	*	*
R30	3RC20AE102K	RESISTOR: fixed; carbon; 1,000-ohm $\pm 10\%$ ; 1/2-w; Erie 504.	1			*	*	*	*
R22	3RC20AE152K	RESISTOR: fixed; carbon; 1,500-ohm $\pm 10\%$ ; 1/2-w; Erie 504.	1			*	*	*	*
R3	3Z6580-17	RESISTOR: fixed; carbon; 8,000-ohm $\pm 10\%$ ; 1-w; Erie 518.	1			*	*	*	*
R20, R21	3RC20AE223K	RESISTOR: fixed; carbon; 22,000-ohm $\pm 10\%$ ; 1/2-w; Erie 504.	2			*	*	*	*
R14, R15	3RC31AE223K	RESISTOR: fixed; carbon; 22,000-ohm $\pm 10\%$ ; 1-w; Erie 518.	2			*	*	*	*
R5	3Z6630-38	RESISTOR: fixed; carbon; 30,000-ohm $\pm 10\%$ ; 1-w; Erie 518.	1			*	*	*	*
R19, R26	3RC20AE683K	RESISTOR: fixed; carbon; 68,000-ohm $\pm 10\%$ ; 1/2-w; Erie 504.	2			*	*	*	*
R10, R18	3RC20AE104K	RESISTOR: fixed; carbon; 100,000-ohm $\pm 10\%$ ; 1/2-w; Erie 504.	2			*	*	*	*
R1, R11, R13	3RC31AE104K	RESISTOR: fixed; carbon; 100,000-ohm $\pm 10\%$ ; 1-w; Erie 518.	3			*	*	*	*

\* Indicates stock available.

63. MAINTENANCE PARTS LIST FOR RECEIVER-TRANSMITTER RT-30( )/PRC-1 (contd.).

Ref symbol	Signal Corps stock No.	Name of part and description	Quan per unit	Run-ning spares	Orgn stock	3d ech	4th ech	5th ech	Depot stock
R12	3RC20AE154K	RESISTOR: fixed; carbon; 150,000-ohm $\pm 10\%$ ; $\frac{1}{2}$ -w; Erie 504.	1			*	*	*	*
R29	3RC20AE224K	RESISTOR: fixed; carbon; 220,000-ohm $\pm 10\%$ ; $\frac{1}{2}$ -w; Erie 504.	1			*	*	*	*
R25, R27	3RC20A334K	RESISTOR: fixed; carbon; 330,000-ohm $\pm 10\%$ ; $\frac{1}{2}$ -w; Erie 504.	2			*	*	*	*
R28	3RC20AE474K	RESISTOR: fixed; carbon; 470,000-ohm $\pm 10\%$ ; $\frac{1}{2}$ -w; Erie 504.	1			*	*	*	*
R24	3RC20AE105K	RESISTOR: fixed; carbon; 1-megohm $\pm 10\%$ ; $\frac{1}{2}$ -w; Erie 504.	1			*	*	*	*
R9	3RC31AE125K	RESISTOR: fixed; carbon; 1.2-megohm $\pm 10\%$ ; 1-w; Erie 512.	1			*	*	*	*
R7	3Z6040-67	RESISTOR: fixed; wire-wound; 400-ohm $\pm 10\%$ ; 10-w; Sprague "Kool-ohm"; (cathode bias for power amplifier).	1			*	*	*	*
SW2	3Z9826-24.4	SWITCH: rotary; 2-section, 6-position; antenna loading; North American Phillips dwg. No. G8.710.09.	1			*	*	*	*
SW3	3Z9826-24.3	SWITCH: rotary; 2-section, 2-position; send-receive switch; North American Phillips dwg. No. S1.701.07.	1			*	*	*	*
SW5	3Z9826-24.2	SWITCH: rotary; single-section, 5-position; North American Phillips dwg. No. S1.701.02.	1			*	*	*	*
SW6	3Z9826-24.1	SWITCH: rotary; SPST; (panel light, ON-OFF); North American Phillips dwg. No. S1.701.08.	1			*	*	*	*
SW7	3Z9826-24.5	SWITCH: rotary; 3-section, 2-position, (receiver BAND SWITCH); North American Phillips dwg. No. S1.701.03.	1			*	*	*	*
T1	3Z9641.137	TRANSFORMER: i-f; input; (permeability tuned); North American Phillips dwg. No. G8.230.19.	1			*	*	*	*
T2	2Z9641.135	TRANSFORMER: i-f; output; (permeability tuned); North American Phillips dwg. No. G8.230.20.	1			*	*	*	*
T3	2Z9641.136	TRANSFORMER: BFO; North American Phillips dwg. No. G8.230.18.	1			*	*	*	*
T4	2Z9632.343	TRANSFORMER: a-f; output; 2-windings; 20,000-ohm primary; 250-ohm secondary; North American Phillips dwg. No. S1.231.00.	1			*	*	*	*
V1	2J6V6	TUBE JAN-6V6: VT-107.	1	1					
V2	2J807	TUBE JAN-807: VT-100-A.	1	1					
V3	2J6SG7	TUBE JAN-6SG7: VT-211.	1	1					
V4	2J6SA7	TUBE JAN-6SA7: VT-150.	1	1					

\* Indicates stock available.

64. MAINTENANCE PARTS LIST FOR RECTIFIER POWER UNIT PP-36( )/PRC-1.

Ref symbol	Signal Corps stock No.	Name of part and description	Quan per unit	Run-ning spares	Orgn stock	3d ech	4th ech	5th ech	Depot stock
V5	2J6SK7	TUBE JAN-6SK7: VT-117.	1	1					
V6A, V6B	2J6SL7GT	TUBE JAN-6SL7GT: VT-229.	1	1					
V7	2J6J5	TUBE JAN-6J5: VT-94.	1	1					
	3H4698-36	RECTIFIER POWER UNIT PP-36( )/ PRC-1.	1		*	*			*
C44	3DB2-27	CAPACITOR: fixed; paper; 2-mf; 600 v dc (working); metal case; Aerovox 609.	1			*	*	*	*
C43, C42	3DB2.1009-2	CAPACITOR: fixed; paper; 2-mf; 1,000 v dc (working); metal case; Aerovox 1009.	2			*	*	*	*
CH	3H4698-36/1	COIL: a-f choke; filter; 4.5 h, 150-ma; d-c resistance, 210-ohm $\pm 15\%$ ; Langevin #L-674. North American Phillips dwg No. S1.211.07.	1						*
	3E7207	CORD: 18" long; 8-conductor; North American Phillips dwg No. A12336 (power cable from rectifier unit to receiver-transmitter).	1			*	*	*	*
	3E7142-4	CORD: 25' long; 2-conductor No. 18AWG; Underwriter's Labs. Inc., parallel rubber covered; terminates in plug, Hubbell No. 7002; (line cord).	1		*	*	*	*	*
FS2	3Z2605.2	FUSE: 5-amp, 250-v; Littelfuse No. 1358, type 3AG.	1	3		*	*	*	*
	3Z3275-1	FUSE EXTRACTOR POST: Littelfuse No. 1075A; (holds fuse FS-2).	1			*	*	*	*
	3H4860-2	RECTIFIER: selenium; full-wave; Selenium Corp. of America type EMBY BS; (meter rectifier for reading line voltage).	1			*	*	*	*
R34, R35	3RC21AE224K	RESISTOR: fixed; carbon; 220,000-ohm $\pm 10\%$ ; $\frac{1}{2}$ -w; Erie 504.	2			*	*	*	*
R31, R32	3Z5475-9	RESISTOR: fixed; wire-wound; 7,500-ohm $\pm 10\%$ ; 20-w; Ward Leonard 2" T.	2			*	*	*	*
R36	3Z5610-1	RESISTOR: fixed; wire-wound; 30,000-ohm $\pm 10\%$ ; 20-w; Ward Leonard 2" T.	1			*	*	*	*
R33, R37	3Z5620.1	RESISTOR: fixed; wire-wound; 40,000-ohm $\pm 10\%$ ; 20-w; Ward Leonard 2" T.	2			*	*	*	*
SW8	3Z9692-1561	SWITCH: rotary; SPST on-off power; North American Phillips dwg No. S1.701.08.	1			*	*	*	*

\* Indicates stock available.

64. MAINTENANCE PARTS LIST FOR RECTIFIER POWER UNIT PP-36(1)/PRC-1 (contd.).

Ref symbol	Signal Corps stock No.	Name of part and description	Quan per unit	Run-ning spares	Orgn stock	3d ech	4th ech	5th ech	Depot stock
SW9	3Z9826-24	SWITCH: rotary; single 1-pole, 5-position; line voltage selector; North American Phillips dwg No. G8.710.01.	1			*	*	*	*
T5	2Z9613.378	TRANSFORMER: filament and plate; (primary tapped for 115 v, 150 v, 200 v, 220 v, and 250 v ac, 50 cps; secondary No. 1, 1460 v, 120 ma, center-tap; secondary No. 2, 5 v, 3 amp; secondary No. 3, 6.3 v, 3.2 amp); Audio Development Co. No. A4359-D.	1			*	*	*	*
V8	2J5R4/GY	TUBE JAN-5R4/GY.	1	1					

65. MAINTENANCE PARTS LIST FOR RADIO SET AN/PRC-1 ( ) MISCELLANEOUS.

Ref symbol	Signal Corps stock No.	Name of part and description	Quan per unit	Run-ning spares	Orgn stock	3d ech	4th ech	5th ech	Depot stock
	6Z111	ADAPTER: Ediswan base to American prong adapter; C. D. Wood Elec. No. 2089.	1			*	*	*	*
	2Z303-1	ADAPTER: English type prongs; C. D. Wood Elec. No. 73.	1			*	*	*	*
	2Z303-2	ADAPTER: European type prongs; C. D. Wood Elec. No. 2064.	1			*	*	*	*
	2A276-23	ANTENNA: reel assembly, complete; North American Phillips dwg No. L20618.	1			*	*	*	*
	6Z7560-9	ATTACHMENT: plug body; C. D. Wood Elec. No. 2053.	1			*	*	*	*
	2Z1859-11	CASE: carrying; per spec. 271-3053, amended.	1			*	*	*	*
	3E1201A	CORD CD-201-A: (for key U-37).	1			*	*	*	*
	3E1605-6.5	CORD CD-605: (for Headset HS-30-U).	1			*	*	*	*
	2B8300	HEADSET HS-30-U.	1			*	*	*	*
	2B1300	INSERT M-300.	2	2		*	*	*	*
	3Z3437	KEY J-37.	1			*	*	*	*
	2Z5884	LAMP: neon; 1/4 w; GE T-4-1/2; (for testing transmitter).	2		*	*	*	*	*

\* Indicates stock available.

22620-P-44-08; 400, 10-14-44

UNCLASSIFIED

Regraded Date 22 Aug 55

By Auth of Pam 310-4 13 May 55

By Delean

COLES AREA

From SGR Technical Documents Center

UNCLASSIFIED

Reproduced by AEDS Date 22 Aug 55  
Pam 310-4  
By Dean 13 May 55

COLES AREA  
SCEL Technical Documents Center

COLES AREA  
SCEL Technical Documents Center

1953 SEP 11 PM 3:49

SEP 22 2 22 PM '53

# ERRATA

TM 11-638

## WAR DEPARTMENT TECHNICAL MANUAL

### RADIO SET AN/PRC-1 ( )

#### CAUTION:

**BEFORE REMOVING OR INSERTING RECEIVER TRANSMITTER RT/PRC-1 INTO SUITCASE BE CERTAIN THAT THE RECEIVER DIAL READS BELOW 2.**

*Page 1, Par. 2.*

"Headset" should read "Headset HS-30".

"Key" should read "Key J-37".

"Technical Manual" should read "Technical Manual TM 11-638".

The following components should be listed:

1 Cord CD-201-A 18 in. (For Key J-37).

1 Mounting (for key J-37).

1 Cord CD-605 (For Headset HS-30).

1 Crystal Case CY-86/TRC-10, including 47 crystal holders FT-243 and crystals.

1 Wrench for 8-32 Allen Head Set Screw.

1 Wrench for 10-32 Allen Head Set Screw.

*Page 5, Par. 8 a.*

"76" should be "104".

*Page 6, Par. 11 a.* Add:

"(5) Allen Wrenches, (2)."

*Page 6, Par. 11 b.* Add:

"(6) Spare fuses."

*Page 6, Par. 13 a.; Par. 13 b.*

"Cord CD-201-A" should read "Cord CD-201-A 18 in."

*Page 10, Par. 23 a.; Par. 23 c.*

"PLT. VOL." should read "PLT. VOLTS".

*Page 12, Par. 32 b.*

This entire paragraph should read "CASE CY-86/TRC-10 contains 47 Crystal Holders FT-243."

*Page 12, Par. 33 b.* Omit:

"ground wire and selected crystal".

*Page 15-36.c. (8).*

During this operation, at certain frequencies, between 4 and 5 megacycles in the low band, 2 dips may be noticed. Select the dip at the highest frequency indication. If the incorrect dip is used, no minimum plate current drain will be noticed as called for in paragraph 36 C (11).

*Page 16-40.g.*

During this operation, at certain frequencies, between 4 and 5 megacycles, 2 dips may be noticed. Select the dip at the highest frequency indication. If the incorrect dip is used, the high pitched whistle will not be heard at the frequency of the inserted crystal as called for in paragraph 40 i.

*Page 17-41.f.*

During this operation, at certain frequencies, between 4 and 5 megacycles in the low band, 2 peaks may be noticed. Select the peaks at the highest frequency indication. If the incorrect peak is used, no minimum plate current drain will be noticed as called for in paragraph 41 h.

*Page 17, Par. 41 i.* Add:

"To insure the operator that the transmitter is delivering power to the antenna, hold the base of the neon bulb against the metal portion of the antenna binding post. The neon bulb will glow. The intensity of glow will increase with increased power output."

*Page 20, Par. 46.*

"powered iron" should be "powdered iron".

*Page 20, Par. 48.* Add:

"Immediately adjoining Condenser C 41, is a black terminal block. There is a wire, white with blue tracers, attached to this block. When this wire is in the position nearest the front panel, the receiver is connected for use with a low impedance headset. When this wire is in the position nearest the condenser C 41, the receiver is

UNCLASSIFIED  
**SECRET**  
UNCLASSIFIED

(1)

## MICA CAPACITOR COLOR CODES

**CAPACITY MARKING:** For coding purposes, capacity is expressed in terms of micromicrofarads. For example .00025 mfd. = 250 mmf.

The colors employed to designate these significant digits in mmf are listed below. Codes are read from left to right in the position required for reading of words molded in case, or by arrow.

Color	Numeral	Volts	Multiplier	Tolerance
Black	0		1	
Brown	1	100	10	1%
Red	2	200	100	2%
Orange	3	300	1,000	3%
Yellow	4	400	10,000	4%
Green	5	500	100,000	5%
Blue	6	600	1,000,000	6%
Violet	7	700	10,000,000	7%
Gray	8	800	100,000,000	8%
White	9	900	1,000,000,000	9%
Gold		1000	.1	
Silver			.01	10%
No Color		500		20%

**3-Dot Color Code:** This is used to indicate capacity (in mmf.) where the working voltage is 500 v.d.o. and the tolerance is  $\pm 20\%$ .

1. The first dot indicates the first significant digit of capacity.
2. The second dot indicates the second digit to capacity.
3. The third dot indicates the number of zeros which follow after the first two digits.

### EXAMPLE:

Red      Green      Black      =      25 mmf.      =      .00025 mfd.

**6-Dot R.M.A. Color Code:** When it is necessary to indicate three significant figures of capacity (such as 2750 mmf.), together with voltage and tolerance information, it is desirable to employ the 6-Dot Code.

On units marked with six dots, the upper three dots are significant figures of capacity in mmf. multiplied by the multiplier indicated by the lower right hand dot. The remaining dots are tolerance and D.C. working voltage rating, as shown in sketch.

## RMA COLOR CODE FOR RESISTORS

<i>Color</i>	<i>Significant Figure</i>	<i>Decimal Multiplier</i>	<i>Tolerance</i>
Black	0	1	
Brown	1	10	1%
Red	2	100	2%
Orange	3	1,000	
Yellow	4	10,000	
Green	5	100,000	5%
Blue	6	1,000,000	
Violet	7	10,000,000	
Gray	8	100,000,000	
White	9	1,000,000,000	
Gold	—	0.1	5%
Silver	—	0.1	10%
No Color	—	—	20%

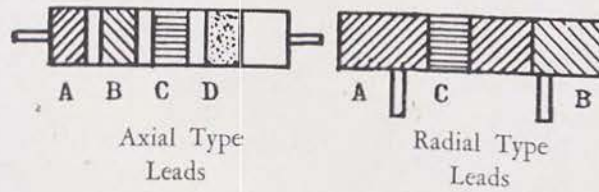

Band A indicates the first significant figure of the resistance of the resistor.

Band B indicates the second significant figure.

Band C indicates the decimal multiplier.

Band D indicates the tolerance limits about the nominal resistance value.

UNCLASSIFIED

Regraded Date 22 Aug 57

Auth of Para 310-4 13 May 53

by W Dean

COLES AREA

Origin SCET Technical Documents Center

UNCLASSIFIED  
SECRET3-14-5559  
Item 2TM 11-638  
C 1TECHNICAL MANUAL  
RADIO SET AN/PRC-1( )CHANGES  
No. 1

TM 11-638, 13 October 1944, is changed as follows:

## 2. RADIO SET AN/PRC-1( ), LIST OF COMPONENTS

See figure 1 for illustrations.

Quantity	Components
*	*
1	Case F/AN/PRC-1.
1	Headset HS-30-U.
1	Key J-37.
*	*
2	TM 11-638.
1	Cord CD-201-A 18 in. (for Key J-37).
1	Cord CD-605 (for Headset HS-30-U).
1	Plate Key Mounting (for Key J-37).
1	Crystal Case CY-86/TRC-10, including 47 Crystal Holders FT-243 and crystals.
1	Wrench for 8-32 Allen head setscrew.
1	Wrench for 10-32 Allen head setscrew.

## 3. RANGE

b. Transmitter. The operating range \* \* \* approximately 50 miles.

## 8. WEIGHT

a. The carrying case \* \* \* wooden overseas case. This complete overseas unit weighs about 104 pounds.

## 11. CARRYING CASE

a. The case housing \* \* \* (figs. 3 and 9) contains:

(5) (Added.) Two Allen wrenches.

b. The right-hand accessory compartment (fig. 5) contains:

(6) (Added.) Spare fuses.

## 13. KEY J-37 (fig. 7)

a. Key J-37 is a \* \* \* the contact arm. The key is mounted on a bakelite base and is fitted with Cord CD-201-A (18-inch).

b. Cord CD-201-A (18-inch) terminates in Plug PL-55. The key, with \* \* \* left-hand accessory compartment.

## 23. METER SWITCH 5

a. Control knob 5 \* \* \* the control knob.  
\* \* \* \* \*

OSC. PLT. CUR.  
PLT. VOLTS  
LINE VOLTS

## 32. INITIAL PROCEDURE

b. (Superseded.) Case CY-86/TRC-10 contains 47 Crystal Holders FT-243.  
\* \* \* \* \*

## 33. INSTALLATION OF RECEIVER-TRANSMITTER AND RECTIFIER POWER UNIT

h. Remove the headset, key, and antenna reel from the upper left-hand accessory compartment. Insert the phone \* \* \* jack marked KEY.

## 36. PREPARATION OF SET FOR USE

## c. Checking Transmitter

(8) With the key \* \* \* oscillator is operating. During this operation, at certain frequencies between 4 and 5 mc in the low band, 2 dips may be noticed. Select the dip at the highest frequency indication. If the incorrect dip is used, no minimum plate current drain will be noticed as called for in subparagraph c (11) below.  
\* \* \* \* \*

37.1. EQUIPMENT PERFORMANCE CHECK LIST  
(Added)

a. General. The equipment performance check list (par. 37.2) will help the operator to determine whether Radio Set AN/PRC-1( ) is functioning properly. The check list gives the items to be checked, the normal indications and tolerances of correct operation, and the corrective measures that the operator can take. Items 1 through 6 are checked before starting, item 7 while starting, items 8 through 16 are checked during operation, and item 17 when stopping. Items 8 through 16

should be checked at least once during a normal operating period or at least four times a day during continuous operation.

**b. Action or Condition.** For some items the information given in the action or condition column consists of the settings of various switches and controls under which the item is to be checked. For other items it represents an action that must be taken in order to check the normal indication given in the normal indication column.

**c. Normal Indication.** The normal indications listed include the visible and audible signs that the operator will perceive when he checks the items. In the case of meter readings, the allowable tolerances of the readings are given. The actual meter readings will depend on the operating frequency; however, if the meter reads between the limits specified, operation can be considered satisfactory. A meter reading outside the limits given is a sign of impending trouble. If the indications are not normal, the operator should apply the recommended corrective measures.

**d. Corrective Measures.** The corrective measures listed are those that the operator can make without turning the set in for repairs. If the set is completely inoperative or if the recommended corrective measures do not yield results, trouble shooting is necessary. However, if the tactical situation requires that communication be maintained and if the set is not completely inoperative,

the operator must maintain the set in operation as long as it is possible to do so.

**e. Items 1 through 7.** Items 1 through 7 should be checked each time the set is put in operation.

**f. Items 8 through 12.** Items 8 through 12 show correct meter readings for the transmitter section of Receiver-Transmitter RT-30( )/PRC-1 when the transmitter is properly tuned and in operation. The meter readings are read with the SEND REC. switch in the SEND position, with the telegraph key plugged in the KEY jack on the front panel, and with the key closed for all items except item 8.

**g. Items 13 through 15.** These items represent general operating characteristics of the radio set. The operator must become familiar with the characteristics of the set during normal operation; he must use that knowledge as a basis for recognizing changes in audible and visible indications, such as relay clicks, keying tone in the headset, etc., when the set is not operating properly.

**h. Item 16.** This item need be performed only when the calibration of the receiver is checked, or when it is necessary to set the receiver to an exact predetermined frequency.

**i. Item 17.** This item is performed whenever the set is taken out of operation. Any abnormal indications at this time are probably caused by trouble in the set and should be corrected before the next expected period of operation.

### 37.2. EQUIPMENT PERFORMANCE CHECK LIST (Added)

	Item No.	Item	Action or condition	Normal indication	Corrective measures
PREPARATORY	1	Key J-37.	Plug in KEY jack.		
	2	Headset HS-30-( ).	Plug in PHONE jack.		
	3	Antenna.	Connect lead-in wire to ANT. binding post.		
	4	Ground.	Connect ground wire to Ground binding post.		
	5	METER SWITCH (5).	Set to LINE VOLTS position.	Meter reads line voltage.	
	6	LINE SWITCH (A).	Set to proper voltage as indicated by meter reading.		
START	7	ON OFF switch (B).	Set to ON position.		

Item No.	Item	Action or condition	Normal indication	Corrective measures		
EQUIPMENT PERFORMANCE	8	Plate voltage (SEND REC. switch (12) in SEND position).	Set METER SWITCH (5) to PLT. VOLTS position.	Meter reads approximately 1,000 volts.	Check line voltage.	
	9	Oscillator plate current. (Key depressed.)	Set METER SWITCH (5) to OSC. PLT. CUR. position.	Meter reads 10 to 20 ma.	See paragraph 61.	
	10	Amplifier grid current. (Key depressed.)	Set METER SWITCH (5) to AMP. GRID CUR. position.	Meter reads 1 to 4 ma.	Retune oscillator. (See par. 61.)	
	11	Final amplifier plate current. (Key depressed.)	Set METER SWITCH (5) to AMP. PLT. CUR. position.	Meter reads 75 to 100 ma.	See paragraph 41.	
	12	Antenna current. (Key depressed.)	Hold neon lamp against ANT. binding post.	Lamp glows brightly.	Check ANT. TUNING control.	
	13	Key (c-w operation).	Key transmitter.	Keying tone is heard in headset.	See paragraph 61.	
	14	SEND REC. (12 switch).	Throw to REC. position.	Rushing noise or signal heard in headset.	Check headset cable, tune receiver.	
	15	VOLUME control (3).	Rotate VOLUME control in clockwise direction.	Volume of signal in headset increases.	See paragraph 58.	
	16	Calibration.	Check receiver calibration as outlined in paragraph 40.	Dial calibration correct.		
	STOP	17	ON OFF switch (B).	Throw to OFF position.	Set inoperative.	

#### 40. RECEIVER CALIBRATION

\* \* \* \* \*

g. Depress the transmitter \* \* \* crystal is oscillating. During this operation, at certain frequencies between 4 and 5 mc in the low band, 2 dips may be noticed. Select the dip at the highest frequency indication. If the incorrect dip is used, the high-pitched whistle will not be heard at the frequency of the inserted crystal as called for in subparagraph i below.

#### 41. USE OF THE TRANSMITTER

\* \* \* \* \*

f. Depress the transmitter \* \* \* the dial calibration. During this operation, at certain frequencies between 4 and 5 mc in the low band, 2 peaks may be noticed. Select the peak at the highest frequency indication. If the incorrect peak is used, no minimum plate current drain will be noticed as called for in subparagraph h below.

\* \* \* \* \*

i. With the transmitter \* \* \* antenna will allow. Hold the base of the neon bulb against the metal portion of the antenna binding post. If the transmitter is delivering power to the antenna, the neon bulb will glow. The intensity of glow will increase with increased power output. A keying monitor \* \* \* THE CAL. POSITION.

#### 46. I-F AMPLIFIER STAGE

The signal, after \* \* \* fixed ceramic capacitor. However, resonance of L15 is determined and adjusted over a narrow range of means

of a core of powdered iron, the coaxial position of which is adjusted, with respect to L15 by means of a threaded rod. The signal is \* \* \* r-f amplifier stage.

#### 48. A-F AMPLIFIER STAGE

\* \* \* the receiver chassis. Immediately adjoining capacitor C41 is a black terminal block. When the wire (white with blue tracers) running to this block is connected to the terminal nearest the front panel, the receiver is connected for use with a low-impedance headset. When this wire is connected to the terminal nearest capacitor C41, the receiver is connected for use with a high-impedance headset. The metal tag attached to the PHONE jack on the front panel should be turned to indicate the headset used. The word HIGH appears on one side of the tag and LOW on the other. Delete the note under the heading SECTION IV, MAINTENANCE, and substitute the following:

NOTE: Failure or unsatisfactory performance of equipment used by Army Ground Forces and Army Service Forces will be reported on WD AGO Form 468 (Unsatisfactory Equipment Report); by Army Air Forces, on Army Air Forces Form 54 (Unsatisfactory Report). If either form is not available, prepare letter containing the data elicited by the sample form shown in figure 20 without reproducing copies of the form.

#### 57. RECEIVER ALIGNMENT

\* \* \* \* \*

a. General. All adjustments should \* \* \* PHONE jack J2. Connect the lead on the terminal block underneath the chassis to the low-impedance output terminal. (See par. 48.) Make certain the \* \* \* maximum clockwise position.

**b. I-f Alignment.** The intermediate frequency \* \* \* the coil windings. Set the standard signal generator for an output of 455 kilocycles and connect its high-potential output lead to the signal grid of the mixer tube (terminal 5 of V4) through a 0.05-mf series capacitor. Connect the low-potential \* \* \* near 10 volts.

**c. Beat-frequency Oscillator Adjustment.** The beat-frequency oscillator \* \* \* subparagraph b above. Set the CAL CW. PHONE switch to the CW. position. Remove the output \* \* \* in most cases.)

**d. High-frequency Oscillator Alignment.** Re-alignment of the \* \* \* high-frequency oscillator trimmers. All adjustments are made with the output of the signal generator connected to the ANT (through a 400-ohm series resistor) and GND posts in the upper right-hand corner of the front panel, and with the output meter connected as described in subparagraph a above. For location of \* \* \* to figure 16.

\* \* \* \* \*

### 58.1. UNSATISFACTORY EQUIPMENT REPORT (Added)

**a.** When trouble in equipment used by Army Ground Forces or Army Service Forces occurs more often than repair personnel feel is normal, War Department Unsatisfactory Equipment Report, WD AGO Form 468, should be filled out and forwarded through channels to the office of the Chief Signal Officer, Washington 25, D. C.

**b.** When trouble in equipment used by Army Air Forces occurs more often than repair personnel feel is normal, Army Air Forces Form 54 should be filled out and forwarded through channels.

**c.** If either form is not available, prepare letter containing the data elicited by the sample form shown in figure 19.1 without reproducing copies of the form.

### 61. SERVICING THE TRANSMITTER

\* \* \* \* \*

**d. (Superseded.)** If the transmitter is inoperative on both bands proceed as follows:

(1) If grid current for the final amplifier is lacking, place the METER SWITCH in the OSC. PLT. CUR. position and depress the key to check for oscillation. If the plate current is higher than normal (21 ma or more), the oscillator is not functioning properly and requires further investigation. If the oscillator is functioning properly, the plate current will be approximately 15 ma and a dip in plate current will be noted when the oscillator tuning control is tuned to the operating frequency.

(2) If the final amplifier grid current is normal but the plate current dip is not obtained, check the final amplifier.

(3) Place the METER SWITCH (knob 5) in the AMP. GRID CUR. position and depress the key while noting the final amplifier grid current. If grid current is lower than normal, excitation from the oscillator is lacking or the tube is not properly biased. Use a high-resistance d-c voltmeter across the grid resistor and across the cathode resistor to check the bias voltage.

(4) Place the METER SWITCH (knob 5) in the PLT. CUR. position and depress the key, noting the final amplifier plate current. Tune the final amplifier to resonance for the plate current dip with knob 8, making certain that the minimum plate current is not more than 100 ma. If no dip is obtained, excitation is lacking or the final amplifier is defective.

(5) Place the METER SWITCH (knob 5) in the PLT. VOLTS position to check the B voltage in the plate circuit of the final amplifier. Compare this reading with the normal reading in paragraph 59.

(6) When the defective stage has been localized, measure the plate voltage from the B-side of the meter shunt resistor to ground. Compare this reading with the normal B reading shown in paragraph 59.

(7) Measure the cathode voltage and screen-grid voltage and compare these readings to the normal voltages in paragraph 59.

(8) If voltages in a circuit are not within 10 percent of normal, check the components of that circuit.

(9) Replace the defective components with exact duplicate replacement parts when possible. Original placement of wiring and parts should be duplicated to maintain original stability and power output.

(10) Repeat the tuning process and check the transmitter for normal operation on both bands, checking against the specified standards for power output, frequency range, and accuracy of calibration.

\* \* \* \* \*

### 62. MOISTUREPROOFING AND FUNGIPROOFING

\* \* \* \* \*

#### c. Step-by-step Instructions for Treating Radio Set AN/PRC-1( )

\* \* \* \* \*

#### (2) DISASSEMBLY.

\* \* \* \* \*

(c) Remove the six screws holding the receiver-transmitter chassis in the case and remove the unit from the case.

\* \* \* \* \*

WAR DEPARTMENT  
UNSATISFACTORY EQUIPMENT REPORT

<b>FOR</b>	TECHNICAL SERVICE Signal Corps	<b>MATÉRIEL</b>	DATE 1 Feb 45
<b>FROM</b>	ORGANIZATION 175 Signal Repair Co		STATION APO 102
<b>TO</b>	NEXT SUPERIOR HEADQUARTERS Supply Sec, Hq Fourth Army Sig Sv	STATION APO 110	TECHNICAL SERVICE Signal Corps

COMPLETE MAJOR ITEM

NOMENCLATURE Radio Transmitter BC-123-A	TYPE Ground, vehicular	MODEL A	
MANUFACTURER American Radio Corp	U. S. A. REG. No. Order No. 1234-Phila-45	SERIAL No. 12345	DATE RECEIVED 5 Jan 45
EQUIPMENT WITH WHICH USED (if applicable) Radio Set SCR-456-A in Tank, Medium, M4			

DEFECTIVE COMPONENT—DESCRIPTION AND CAUSE OF TROUBLE

PART No. Sig C Stk No. 3E47-2	TYPE Capacitor C20; fixed; 1-mf; 500 vdcw	MANUFACTURER American Radio Corp	DATE INSTALLED When manufactured
----------------------------------	--	-------------------------------------	-------------------------------------

DESCRIPTION OF FAILURE AND PROBABLE CAUSE (If additional space is required, use back of form)  
Capacitor C20 shorts out due to humid operating conditions

DATE OF INITIAL TROUBLE 15 Jan 45	TOTAL TIME INSTALLED			TOTAL PERIOD OF OPERATION BEFORE FAILURE					
	YEARS	MONTHS	DAYS	YEARS	MONTHS	DAYS	HOURS	MILES	ROUNDS
	-	-	-	0	0	5		-	-

BRIEF DESCRIPTION OF UNUSUAL SERVICE CONDITIONS AND ANY REMEDIAL ACTION TAKEN  
Operation in tropics; heavy rainfall. Was replaced and set given moistureproofing and fungiproofing treatment, 20 Jan 45.

TRAINING OR SKILL OF USING PERSONNEL			RECOMMENDATIONS (If additional space is required, use back of form)
POOR	FAIR	GOOD X	Substitute capacitor designed for tropical operation

ORIGINATING OFFICER

TYPED NAME, GRADE, AND ORGANIZATION E.A. Wilson, 1st Lt, Sig C 175 Signal Repair Co	SIGNATURE <i>E. A. Wilson</i>
---	----------------------------------

FIRST ENDORSEMENT

<b>TO CHIEF</b>	TECHNICAL SERVICE	OFFICE
NAME, GRADE, AND STATION		STATION      DATE

Instructions

1. It is imperative that the chief of technical service concerned be advised at the earliest practical moment of any constructional, design, or operational defect in matériel. This form is designed to facilitate such reports and to provide a uniform method of submitting the required data.
2. This form will be used for reporting manufacturing, design, or operational defects in matériel, petroleum fuels, lubricants, and preserving materials with a view to improving and correcting such defects, and for use in recommending modifications of matériel.
3. This form will not be used for reporting failures, isolated material defects or malfunctions of matériel resulting from fair-wear-and-tear or accidental damage nor for the replacement, repair or the issue of parts and equipment. It does not replace currently authorized operational or performance records.
4. Reports of malfunctions and accidents involving ammunition will continue to be submitted as directed in the manner described in AR 750-10 (change No. 3).
5. It will not be practicable or desirable in all cases to fill all blank spaces of the report. However, the report should be as complete as possible in order to expedite necessary corrective action. Additional pertinent information not provided for in the blank spaces should be submitted as inclosures to the form. Photographs, sketches, or other illustrative material are highly desirable.
6. When cases arise where it is necessary to communicate with a chief of service in order to assure safety to personnel, more expeditious means of communication are authorized. This form should be used to confirm reports made by more expeditious means.
7. This form will be made out in triplicate by using or service organization. Two copies will be forwarded direct to the technical service; one copy will be forwarded through command channels.
8. Necessity for using this form will be determined by the using or service troops.

W. D., A. G. O. Form No. 468  
30 August 1944

This form supersedes W. D., A. G. O. Form No. 468, 1 December 1943, which may be used until existing stocks are exhausted.

U. S. GOVERNMENT PRINTING OFFICE 16-41568-1

TL 19589A

Figure 20. WD AGO Form 468 with sample entries.

# SECTION V

## SUPPLEMENTARY DATA

---

### 62.1. MAINTENANCE PARTS FOR RADIO SET AN/PRC-1( ) (Added)

The following information was compiled on 10 May 1945. The appropriate pamphlets of the ASF Signal Supply Catalog for Radio Set AN/PRC-1 are:

#### *Organizational Spare Parts*

SIG 7-AN/PRC-1  
SIG 7-HS-30

#### *Higher Echelon Spare Parts*

SIG 8-AN/PRC-1  
SIG 8-HS-30  
SIG 8-PP-36/PRC-1  
SIG 8-RT-30/PRC-1

For an index of available catalog pamphlets, see the latest index of ASF Signal Supply Catalog SIG 2.

# APPENDIX I (Added)

## PREVENTIVE MAINTENANCE TECHNIQUES

### 66. MEANING OF PREVENTIVE MAINTENANCE

Preventive maintenance is a systematic series of operations performed at regular intervals on equipment, when turned off, to eliminate major break-downs, unwanted interruptions in service, and to keep equipment operating at top efficiency. To understand what is meant by preventive maintenance, it is necessary to distinguish between preventive maintenance, trouble shooting, and repair. The prime function of preventive maintenance is to *prevent break-downs* and, therefore, the need for repair. On the other hand, the prime function of trouble shooting and repair is to locate and correct *existing* defects. The importance of preventive maintenance cannot be overemphasized. A system of radio communication depends on the performance of every set. It must be *ready* to go on the air when it is needed, and it *must* operate efficiently. Therefore, it is vitally important that radio operators and repairmen maintain their radio sets properly. (See TB SIG 123.)

**NOTE:** The operations in section II are first and second echelon (organization operators and repairmen) maintenance. Some operations in section IV are higher echelon maintenance.

### 67. DESCRIPTION OF PREVENTIVE MAINTENANCE TECHNIQUES

**a. General.** Most of the electrical parts used in Radio Set AN/PRC-1( ) require routine preventive maintenance. This preventive maintenance varies. Some parts require a different kind of maintenance than others. Some require more, some less. Definite and specific instructions must be followed. Hit-or-miss techniques cannot be applied. This section of the manual contains these specific instructions to guide personnel assigned to perform the six basic maintenance operations: Feel, Inspect, Tighten, Clean, Adjust, and Lubricate. Throughout this manual the lettering system for the six operations will be as follows:

- F—Feel
- I—Inspect
- T—Tighten
- C—Clean
- A—Adjust
- L—Lubricate\*

\*The Lubricate operation is not applicable to Radio Set AN/PRC-1( ).

The first two operations show if the other four are needed. Selection of operations is based on a knowledge of field needs. For example, dust encountered on dirt roads during cross-country travel filters into equipment no matter how much care is taken to prevent it. Rapid changes in weather (such as heavy rain followed by blistering heat), excessive dampness, snow, and ice tend to cause corrosion of exposed surfaces and parts. Without frequent inspections and the necessary tightening, cleaning, and lubricating operations, equipment becomes undependable and subject to break-down when it is needed most.

**b. Feel.** The feel operation is used most often to check rotating machinery, such as dynamotors, blower motors, and drive motors, also to determine whether electrical connections and bushing are overheated. Feeling will show the need for lubrication or the existence of other defects requiring correction. The maintenance man *must* become familiar with the normal operating temperatures of motors, transformers, and other parts, to recognize signs of overheating.

**NOTE:** It is important to perform the feel operation as soon as possible after shut-down and always before any other maintenance is done.

**c. Inspect.** Inspection is the most important operation in preventive maintenance. A careless observer will overlook evidences of minor trouble. Although these defects may not at the moment interfere with performance of the equipment, invaluable time and effort can be saved if they are corrected *before* they lead to major and costly break-downs. To be able to recognize the signs of a defective set, make every effort to become thoroughly familiar with indications of *normal* functioning. Inspection consists of carefully observing all parts of the equipment, noticing their color, placement, state of cleanliness, etc. Inspect for the following conditions:

- (1) Overheating, as indicated by discoloration, blistering, or bulging of the parts or surface of the container; leakage of insulating compounds; and oxidation of metal contact surfaces.
- (2) Placement, by observing that all leads and cabling are in their original positions.
- (3) Cleanliness, by carefully examining all recesses in the units for accumulation of dust, especially between connecting terminals and

binding posts. Parts, connections, and joints should be free of dust, corrosion, and other foreign matter. In tropical and high-humidity areas, look for fungus growth and mildew.

(4) Tightness, by testing any connection or mounting which appears to be loose.

**d. Tighten, Clean, and Adjust.** These operations explain themselves. Specific procedures to be followed in performing them are given wherever necessary throughout this section.

**CAUTION:** Screws, bolts, and nuts should not be tightened carelessly. Fittings tightened beyond the pressure for which they are designed will be damaged or broken.

Whenever a loose connection is tightened, it should be moistureproofed and fungiproofed again by applying the varnish with a small brush. See paragraph 62 for details of moistureproofing and fungiproofing.

**e. Lubricate.\*** Lubrication refers to the application of grease or oil to the bearings of motors or rotating shafts. It may also mean the application of a light oil to door hinges or other sliding surfaces on the equipment.

## 68. VACUUM TUBES

**NOTE:** Do not work on the tubes immediately after shut-down. Severe burns may result from contact with the envelopes of hot tubes.

### a. Inspect (I).

(1) Inspect glass and metal tube envelopes, tube caps, and tube connector clips for accumulation of dirt and for corrosion. Tubes with loose plate caps, grid caps, or envelopes should be replaced if possible.

(2) Examine the spring clips that make contact with the grid caps for corrosion and for loss of tension with resulting looseness. Check the condition of wires soldered to the spring clips. The wires should be free of frayed insulation or broken strands.

(3) Inspect the firmness of tubes in their sockets. Make the inspection by pressing the tubes down in the sockets and testing them in that position, *not* by partially withdrawing the tubes and jiggling them from side to side. Movement of a tube tends to weaken the pins in the base and unnecessarily spread the contacts in the socket. Inspect the tube sockets at the time the tubes are removed.

(4) Be careful when removing a tube from its socket, especially if it is a high-power tube. Never jar a warm tube. Always remove connections to the grid caps and plate caps.

**b. Tighten (T).** Tighten all loose connections to the tube sockets or to the tubes. If the connections are dirty or corroded, clean them before tightening. When tightening locknuts that hold the sockets to the insulated bushings, do not apply excessive pressure. Too much pressure will crack the bushings.

\*The Lubricate operation is not applicable to Radio Set AN/PRC-1( ).

### c. Clean (C).

(1) Clean the tubes, if necessary. Tubes operated at high voltages and with exposed plate and grid connections must be kept free of dirt and dust because of possible leakage between grid and plate terminals. In contrast, tubes operating at low voltages and not having exposed grid and plate caps do not require frequent cleaning. However, do not permit dirt to accumulate on low-voltage tubes.

(2) Remove dust and dirt from the glass or metal envelopes with a clean, lint-free, dry cloth. If proper care is used, the grid and plate caps may be cleaned with a piece of #0000 sandpaper by wrapping the paper around the cap and *gently* rubbing the surface. Excessive pressure is not needed; nor is it necessary to grip the cap tightly. Wipe the cap with a clean dry cloth.

(3) When tube sockets are cleaned and the contacts are accessible, fine sandpaper may be used to remove corrosion, oxidation, and dirt.

## 69. CAPACITORS

### a. Inspect (I).

(1) Inspect the terminals of large fixed capacitors for corrosion and loose connections. Carefully inspect the mountings to discover loose mounting screws, studs, or brackets. Examine the leads for poor insulation, cracks, and evidences of dry rot. Cut away frayed strands on the insulation. If the wire is exposed, wrap it with friction tape. See that the terminals of the capacitors are not cracked or broken.

(2) Thoroughly inspect the case of each large fixed capacitor for leaks, bulges, and discoloration.

(3) Inspect the plates of variable capacitors for dirt, dust, or lint. Examine the movable set of plates for signs of damage or misalignment that would cause them to touch the fixed plates during tuning. Rotate the movable plates using the panel tuning control, and thus check for proper operation of the capacitor.

**b. Tighten (T).** Tighten loose terminals, mountings, and connections on the capacitors, when necessary. Do not break the bushing or damage gasket.

### c. Clean (C).

(1) Clean the cases of fixed capacitors, the insulated bushings, and all connections that are dirty or corroded. The capacitor cases and bushings can usually be cleaned with a dry cloth. However, if the deposit of dirt is hard to remove, moisten the cloth in dry-cleaning solvent (SD).

(2) Clean the plates of variable capacitors with a small brush or pipe cleaner, removing all dust and lint. Dust, if present, may cause arcing.

## 70. RESISTORS

**a. General.** Various types of resistors are used in Radio Set AN/PRC-1( ). The connections to the various resistors are either of the pigtail or solder-lug type.

**b. Inspect (I).** Inspect the coating of the vitreous-enameled resistors for signs of cracks and chipping, especially at the ends. Examine the bodies of all types of resistors for blistering, discoloration, and other indications of overheating. Inspect leads and all other connections for corrosion, dirt, dust, looseness, and broken strands in the connecting wires. Check the security of all mountings. Do not attempt to move resistors with pigtail connections, because there is danger of breaking the connections at the point where they enter the body of the resistor. Such defects cannot be repaired.

**c. Tighten (T).** Tighten resistor connections and mountings whenever they are found loose. If a resistor is allowed to remain loose, vibration may break the connection or damage the body.

**d. Clean (C).**

(1) Clean all carbon resistors with a small brush.

(2) The vitreous-enameled resistors must be kept clean to avoid leakage between the terminals. Wipe them with a dry cloth. However, if the dirt deposit is unusually hard to remove, use dry-cleaning solvent (SD).

(3) Resistors with discolored bodies cannot be cleaned. Discoloration indicates that there has been overloading and overheating at some time prior to the inspection. The discoloration is probably due to circuit trouble which requires analysis and correction. Trouble-shooting procedures are described in section IV.

## 71. FUSES

**a. General.** Fuses used in Radio Set AN/PRC-1( ) are glass case type and are held in place by fuse caps. Glass case fuses are easily removed for inspection. Fuses should be thrown away when they blow.

**b. Inspect (I).** Inspect the fuse caps for evidence of burning, charring, and corrosion.

**c. Clean (C).** Clean fuse ends and the fuse holder with #0000 sandpaper; then wipe them with a clean cloth.

## 72. RELAYS

The keying relay is considered normal if the exterior is free from dirt or dust; the contacts are not burned, pitted, or corroded; the contacts are lined up and correctly spaced; the moving parts travel freely and function in a satisfactory manner; the connections to the relay are tight; the wire insulation is not frayed or torn; the relay assembly is securely mounted; and the field coil shows no signs of overheating.

**a. Inspect (I).**

(1) Inspect the relay for defects. The contacts may be examined with the aid of a flashlight and mirror.

(2) Check the mechanical action of the relays to make certain that when the moving and stationary

contacts come together they make positive contact and are directly in line with each other.

**b. Tighten (T).** Tighten all loose connections and mounting screws, but do not apply enough force to damage the screws or to break the parts they hold.

**c. Clean (C).**

(1) RELAY EXTERIOR. Brush the exterior of the relay with a soft brush. If it is very dirty, clean the exterior with a brush dipped in dry-cleaning solvent (SD). If connections are dirty or corroded, remove the leads and clean them. Replace carefully.

(2) RELAY CONTACTS. When necessary to clean relay contacts, burnish with a clean blade of a burnishing tool (Tool, switchboard, contact burnisher, WECO No. 265C, Sig C stock No. 6R41065C), if available. Place the blade between the contacts of the relay and press the contacts together with slight pressure and move the blade back and forth as necessary to obtain desired results. When contacts are sufficiently dirty to require further cleaning, remove remaining dirt with carbon tetrachloride applied with a toothpick, and clean with the flat side of a clean dry toothpick or similar material. Again burnish using a clean blade of the burnishing tool.

## 73. SWITCHES

**a. Inspect (I).**

(1) Inspect the mechanical action of each switch and, while so doing, look for signs of dirt or corrosion on all exposed elements. In some cases, it will be necessary to examine the elements of the switch visually; in others, the action of the switch is checked by flipping the control knob and noting the freedom of movement and amount of spring tension.

(2) Examine the ganged switches to see that the contacts are clean. Inspection is visual. Do not pry the leaves of the switch apart. The rotary members should make good contact with the stationary members; and as the former slides into the latter, a spreading of the stationary contact leaves should be visible. Switch action should be free. Wiping action of contacts usually removes any dirt at the point of contact.

**b. Clean (C).** Clean the exterior surfaces of switches with a stiff brush, moistened with dry-cleaning solvent (SD).

## 74. COILS

**a. Inspect (I).** Inspect all coils for cleanliness of the ceramic coil form and secureness of mounting supports.

**b. Tighten (T).** Tighten any loose coil mounting or connections by resoldering wires or tightening screws.

**c. Clean (C).** Clean the coil form and coil with a soft brush.

## 75. POTENTIOMETERS

### a. Inspect (I).

- (1) Inspect the mechanical condition of potentiometer R17. The arm should be keyed tightly to the shaft, and the shaft should turn easily in the bushing which supports it.
- (2) Inspect the assembly and mounting screws, setscrews, and nuts.
- (3) Examine the insulating body of the potentiometer for duts, dirt, cracks, and chipped places.
- (4) Examine all metallic parts for dust, dirt, and corrosion.

**b. Tighten (T).** Tighten loose assembly or mounting screws.

### c. Clean (C).

- (1) Clean the exposed contact surfaces of the potentiometer and the connections whenever they are dirty or corroded.
- (2) Remove grease and dirt from the parts with carbon tetrachloride.
- (3) If the contact surfaces are corroded, clean them with crocus cloth.
- (4) Clean the contact surface of the arm by inserting a strip of crocus cloth between the arm and the winding and drawing the cloth back and forth.
- (5) Clean the body of the potentiometer with a brush or cloth.

## 76. TERMINAL BLOCKS

### a. Inspect (I).

- (1) Inspect terminal block for cracks, breakage, dirt, loose connections, and loose mounting screws.
- (2) Carefully examine connections for mechanical defects, dirt, and corrosion.

**b. Tighten (T).** Tighten loose screws, lugs, and mounting bolts. When tightening screws, be sure to select a screw driver of correct size. Do not exert too much pressure. Tighten loose connections.

**c. Clean (C).** Clean terminal block, when required, with a dry brush. When necessary, use a cloth moistened with dry-cleaning solvent (SD). Thoroughly wipe the block with a cloth and then brush it to remove any lint.

## 77. CORDS AND CABLES

The cables in Radio Set AN/PRC-1( ) are the life lines of the equipment. Condition of the cabling must be closely observed. Operating equipment in all kinds of weather subjects cabling to a great deal of punishment.

**a. Inspect (I).** Inspect the cables for cracked or deteriorated insulation, frayed or cut insulation at the connecting and supporting points, and improper placement which places the cables or connections under strain. Also watch for kinks and improper supports.

**b. Tighten (T).** Tighten loose cable clamps, coupling rings, and cable connections.

**c. Clean (C).** Clean connections on cables when they are dirty or corroded. Clean corroded con-

nectors with #0000 sandpaper. Clean the entire surface of the connector. Make no attempt to remove individual prongs from cable plugs.

## 78. METERS

Meters are extremely delicate instruments and must be handled carefully. They require very little maintenance. They are precision instruments and ordinarily cannot be repaired in the field.

**a. Inspect (I).** Inspect the leads and connections of the meter. Look for loose, dirty, and corroded connections. Look for cracked or broken cover glass. Since the movement of a meter is extremely delicate, its accuracy will be seriously affected if the glass is broken and dirt and water filter through.

**b. Tighten (T).** Tighten all connections found loose. Any loose meter wires should be inspected for dirt or corrosion before they are tightened. The tightening of meter connections requires a special technique because careless handling can easily crack the meter case.

**c. Clean (C).** Meter cases can usually be cleaned with a dry cloth. If cleaning is difficult, dampen the cloth with dry-cleaning solvent (SD). Clean dirty connections with a small brush dipped in dry-cleaning solvent (SD), or with a small piece of cloth dipped in the solvent.

**d. Adjust (A).** Normally, the meter in Radio Set AN/PRC-1( ) should indicate zero when the equipment is turned off. Before deciding that the meter needs readjusting, tap the meter case *lightly* with the tip of one finger. This will help the needle to overcome the slight friction which sometimes exists at the bearings and prevents an otherwise normal unit from coming to rest at zero. If adjustment is needed, insert the tip of the thinnest screw driver available into the slotted screw head located below the meter glass and *slowly* turn the adjusting screw until the pointer is at zero. Lightly tap the meter case again and view the meter face and pointer *full on* and not from either side. Avoid turning the screw too far, because the needle may be bent or the hairspring damaged.

## 79. DIAL LAMPS

**a. Inspect (I).** Inspect the dial lamp assemblies for loose lamps, loose mounting screws, and loose, dirty, or corroded connections.

### b. Tighten (T).

- (1) Tighten loose mounting screws and resolder any loose connections. If the connections are dirty or corroded, clean them before soldering.
- (2) Screw loose lamps tightly into their sockets.

## 80. JACKS AND PLUGS

Jacks require very little attention, and then only at infrequent intervals. Occasionally it will be necessary to tighten the mounting nut, clean the contacts, or increase the spring tension.

Remove dirt with a brush and carbon tetrachloride; remove corrosion with a piece of crocus cloth followed by a clean cloth. Increase spring tension, when necessary. Try the action of the jack after each adjustment. Be sure to keep all soldered connections intact. To clean dirty or corroded telephone type plugs, use paste metal polish (Signal Corps stock No. 6G1516). After cleaning, remove all traces of polish remaining with carbon tetrachloride. Finish off with a clean dry cloth.

#### 81. CASE AND CHASSIS

The case which houses the various components of Radio Set AN/PRC-1( ) is constructed of fabric-covered plywood.

**a. Inspect (I).** Inspect the outside and inside of the case thoroughly, paying strict attention to every detail. Check the panels, the panel screws, and the zero setting of the meter. Inspect the panels for loose knobs, switches, and jacks.

**b. Clean (C).** Clean each chassis, outside and in, with a clean dry cloth. Use dry compressed air to blow out all accumulated dirt and dust.

**c. Tighten (T).** Tighten all loose mounting bolts, panel screws, plugs, and control knobs.

#### 82. HEADSET AND KEY

These auxiliary items of equipment are essential to the operation of the radio set. The operator must therefore give them the same care as the radio itself.

**a. Inspect (I).** Inspect all external surfaces for dirt and corrosion. See that all cable connections are tight and that plugs and jacks fit together properly. Inspect the key for proper operation.

**b. Clean (C).** Clean all items of the equipment in accordance with the instructions outlined previously for relays, cords, jacks, etc.

#### 83. COUPLING SHAFTS AND CONTROL KNOBS

The control of various capacitors, switches, and resistors, found throughout the set is effected

through coupling shafts that connect these items to control knobs located on the front panels. It is important that these shafts and control knobs be kept tight at all times. Use the Allen wrenches to tighten these items whenever they are found loose.

#### 84. POWER TRANSFORMERS, FILTER CHOKES, AND AUDIO TRANSFORMERS

Since power transformers, filter chokes, and audio transformers used in Radio Set AN/PRC-1 ( ) are of similar construction, preventive maintenance for them is similar.

**a. Feel (F).** As soon as possible after shutdown, feel filter choke CH for abnormal heating which may indicate an overloaded condition, or imminent failure due to moisture absorption or other causes. Likewise feel audio transformer T4 for abnormal heating. Power transformer T5 normally operates at a warm temperature. Feel for abnormal heating, but use care to avoid burns.

**b. Inspect (I).** Inspect power transformer T5, filter choke CH and audio transformer T4 for signs of blistering, bulging, or leakage of tar or insulating compounds. Inspect for external signs of electrolytic action or corrosion.

**c. Tighten (T).** Tighten all mounting bolts or screws, but not to the point that threads are destroyed. The securing of such heavy parts as transformers and chokes to the chassis is very important in preventive maintenance. Should a heavy filter choke or transformer break loose from its mounting in transit, it may smash tubes, variable capacitors, coils, and resistors, and at the time sever a large number of connections.

**d. Clean (C).** Clean power transformer, filter choke, and audio transformer with a dry cloth. Be sure that no dirt, lint, threads, or foreign material is present between terminals. Dirt, lint, and thread absorb moisture which may provide a leakage path for high-voltages between these terminals. Be sure that none are present.

# APPENDIX II (Added)

## ITEMIZED PREVENTIVE MAINTENANCE

### 85. INTRODUCTION

For ease and efficiency of performance, preventive maintenance on Radio Set AN/PRC-1( ) will be broken down into operations that can be performed at different time intervals. In this appendix the preventive maintenance work to be performed on the radio set at specified time intervals is broken down into units of work called items. The general techniques involved and the application of the FITCAL operations in performing preventive maintenance on individual parts are discussed in appendix I. These general instructions are not repeated in this appendix. When performing preventive maintenance, see appendix I if more information is required for the following items. All work is to be performed with the power removed from the equipment. After preventive maintenance has been performed on a given day, the equipment should be put into operation and checked for satisfactory performance. (See par. 37.2.)

### 86. PREVENTIVE MAINTENANCE TOOLS AND MATERIALS

The following materials will be needed in performing preventive maintenance:

- Common hand tools.
- Clean cloth.
- #0000 sandpaper.
- Crocus cloth.
- Contact burnishing tool.
- Dry-cleaning solvent (SD).
- Paste metal polish (Signal Corps stock No. 6G1516).
- Camel's-hair brush.
- Allen wrench.

**NOTE:** Gasoline will not be used as a cleaning fluid for any purpose. Dry-cleaning solvent (SD) is available as a cleaning fluid, through established supply channels. Oil, Fuel, Diesel, may be used for cleaning purposes when dry-cleaning solvent (SD) is not at hand. Carbon tetrachloride will be used as a cleaning fluid only in the following cases: where inflammable solvents cannot be used because of the fire hazard, and for cleaning electrical contacts including relay contacts, plugs, commutators, etc.

### 87. ITEM 1, EXTERIOR OF RADIO SET AN/PRC-1( )

#### OPERATIONS:

- ITC Case and chassis.
- ITC Jacks.
- IT Dial lights.
- IT Control knobs.
- IC Meter.

**REMARKS:** With an Allen wrench, tighten all loose control knobs.

### 88. ITEM 2, CABLES

#### OPERATIONS:

- IC Cables and connections.

### 89. ITEM 3, HEADSET AND KEY

#### OPERATIONS:

- ITC Cords and plugs.

**REMARKS:** Clean the key contacts according to the method prescribed for cleaning relays.

### 90. ITEM 4, RECEIVER-TRANSMITTER RT-30( ) / PRC-1

**PRELIMINARY STEPS:** Remove the receiver-transmitter unit from the case.

#### OPERATIONS:

- ITC Tubes and sockets.
- IC Power receptacle.
- ITC Capacitors.
- ITC Resistors.
- IC Fuse.
- ITC Relay.
- IC Switches.
- ITC Coils.
- ITC Potentiometer.
- ITCA Meter.
- IT Dial lamps.
- IC Jacks.
- ITC Terminal block.

91. ITEM 5, RECTIFIER POWER UNIT PP-36-  
( )/PRC-1

PRELIMINARY STEPS: Remove the rectifier power unit from the case.

OPERATIONS:

- ITC Tube and socket.
- IC Power plug.
- ITC Capacitors.
- ITC Resistors.
- IC Fuse.
- IC Switches.
- ITC Cords and cables.
- FITC Transformer and choke.

92. PREVENTIVE MAINTENANCE CHECK LIST

Item No.	Operations	Items	When performed					Echelon
			Before operation	After operation	Daily	Weekly	Monthly	
1	ITC---	Exterior of Radio Set AN/PRC-1 ( ).	---	---	X	---	---	1st.
2	IC-----	Cables-----	---	---	X	---	---	1st.
3	ITC---	Headset and key---	---	---	X	---	---	1st.
4	ITCA--	Receiver-Transmitter RT-30( )/PRC-1.	---	---	---	X	---	2d.
5	FITC--	Rectifier Power Unit PP-36( )/PRC-1.	---	X	---	X	---	2d.

NOTE: "X" indicates when operations are to be performed.

F I T C A L\*  
Feel Inspect Tighten Clean Adjust Lubricate

\*The Lubricate operation is not applicable to Radio Set AN/PRC-1 ( ).

APPENDIX III (Added)  
COLOR CODES

---

# RESISTOR COLOR CODES

## RMA COLOR CODE FOR FIXED COMPOSITION RESISTORS

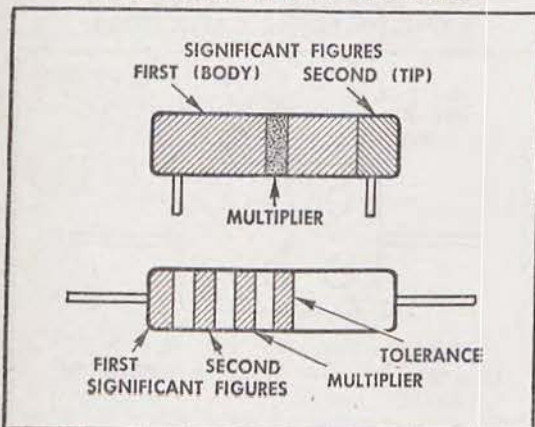

Insulated fixed composition resistors with axial leads are designated by a natural tan background color. Non-insulated fixed composition resistors with axial leads are designated by a black background color.

## AWS COLOR CODE FOR FIXED COMPOSITION RESISTORS

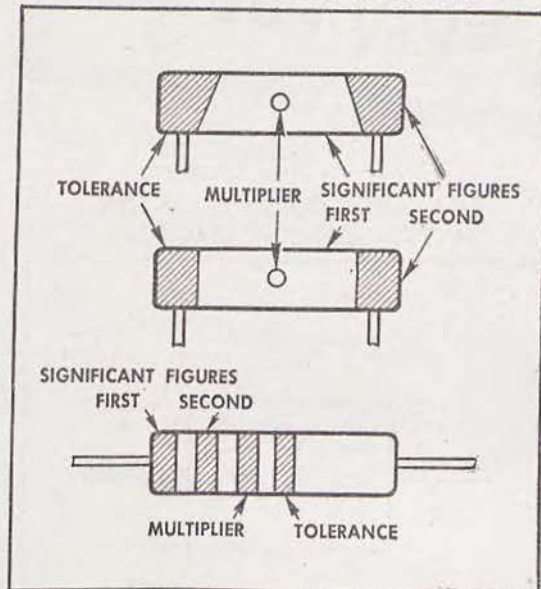

The exterior body color of insulated resistors may be any color except black. The usual color is natural tan. The exterior body color of uninsulated resistors with axial leads may be either black or white. The exterior body color of uninsulated resistors with radial leads may be black or it may be the color of the first significant figure of the resistance value.

COLOR	SIGNIFICANT FIGURE	MULTIPLIER	TOLERANCE (PERCENT)
BLACK	0	1	
BROWN	1	10	
RED	2	100	
ORANGE	3	1000	
YELLOW	4	10,000	
GREEN	5	100,000	
BLUE	6	1,000,000	
VIOLET	7	10,000,000	
GRAY	8	100,000,000	
WHITE	9	1,000,000,000	
GOLD		0.1	5
SILVER		0.01	10
NO COLOR			20

RMA: Radio Manufacturers Association  
AWS: American War Standard  
(American Standards Association)

Figure 21.

TL13418

# CAPACITOR COLOR CODES

## RMA 6-DOT COLOR CODE FOR MICA-DIELECTRIC CAPACITORS

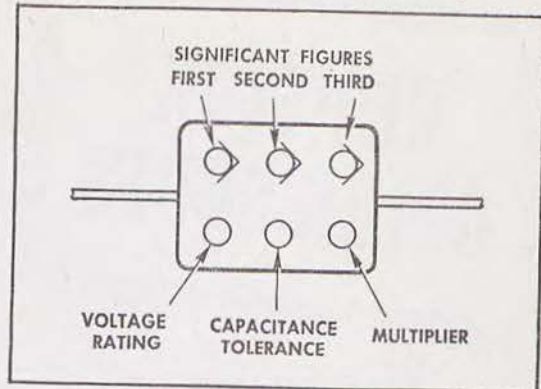

## RMA 3-DOT COLOR CODE FOR MICA-DIELECTRIC CAPACITORS

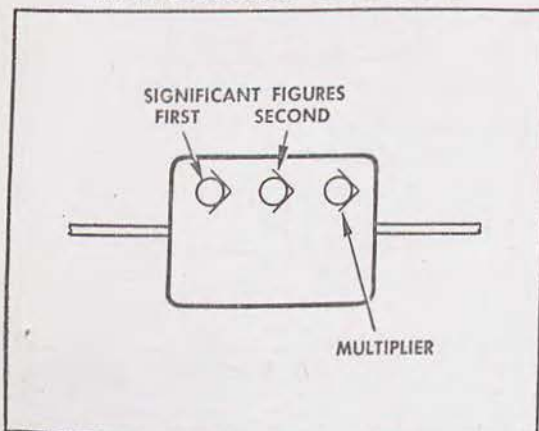

Capacitors marked with this code have a voltage rating of 500 volts.

## AWS 6-DOT COLOR CODE FOR PAPER-DIELECTRIC CAPACITORS

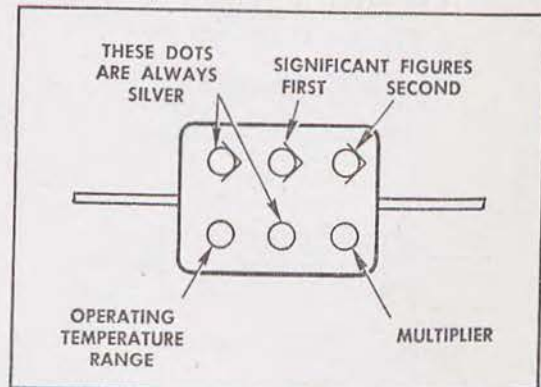

The silver dots serve to identify this marking. The sixth dot shows whether the capacitor has a maximum operating temperature of 167°F (black) or 185°F (brown).

COLOR	SIGNIFICANT FIGURE	MULTIPLIER		VOLTAGE RATING (VOLTS)	CHARACTERISTIC (AWS MICA-DIELECTRIC)
		RMA MICA- AND CERAMIC-DIELECTRIC AWS MICA- AND PAPER-DIELECTRIC	AWS CERAMIC-DIELECTRIC		
BLACK	0	1	1		A
BROWN	1	10	10	100	B
RED	2	100	100	200	C
ORANGE	3	1000	1000	300	D
YELLOW	4	10,000		400	E
GREEN	5	100,000		500	F
BLUE	6	1,000,000		600	G
VIOLET	7	10,000,000		700	
GRAY	8	100,000,000	0.01	800	
WHITE	9	1,000,000,000	0.1	900	
GOLD		0.1		1000	
SILVER		0.01		2000	
NO COLOR				500	

Figure 22.

TL13417-1

### AWS 6-DOT COLOR CODE FOR MICA-DIELECTRIC CAPACITORS

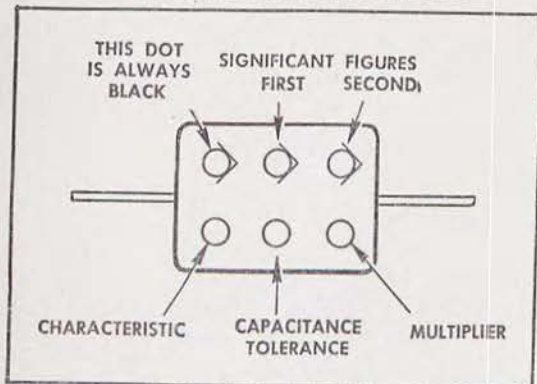

The black dot serves to identify the AWS marking. Capacitors marked with this code are rated at 500 volts, except the following. AWS type CM35 capacitors with capacitances of 6,800, 7,500, and 8,200 micromicrofarads, and AWS type CM40 capacitors with capacitances of 9,100 and 10,000 micromicrofarads are rated at 300 volts.

RMA: Radio Manufacturers Association  
 AWS: American War Standard  
 (American Standards Association)

NOTE: These color codes give all capacitances in micromicrofarads.

### AWS COLOR CODE FOR TUBULAR CERAMIC-DIELECTRIC CAPACITORS

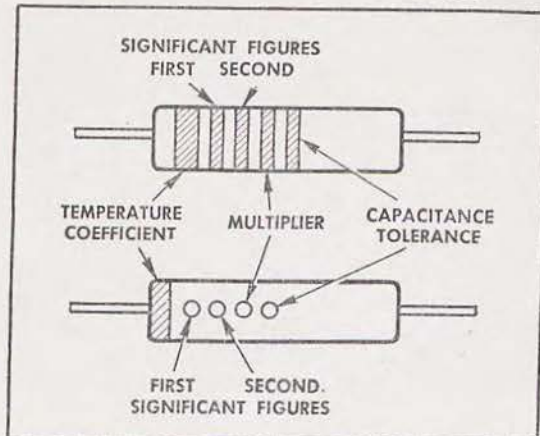

Capacitors marked with this code have a voltage rating of 500 volts.

### RMA COLOR CODE FOR TUBULAR CERAMIC-DIELECTRIC CAPACITORS

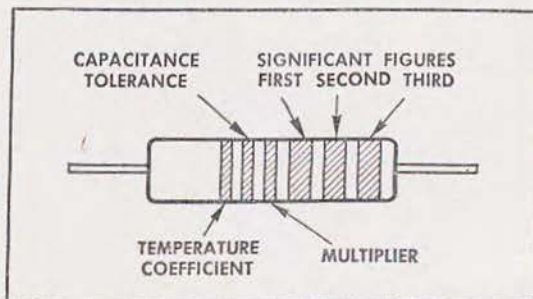

Capacitors marked with this code have a voltage rating of 500 volts.

CAPACITANCE TOLERANCE				TEMPERATURE COEFFICIENT OF CAPACITANCE $\times 10^{-6}$ MMF/MMF/°C
RMA & AWS MICA- AND PAPER-DIELECTRIC (PERCENT)	RMA CERAMIC-DIELECTRIC (PERCENT)	AWS CERAMIC-DIELECTRIC GREATER THAN 10 MMF (PERCENT)	AWS CERAMIC-DIELECTRIC LESS THAN 10 MMF (MMF)	
20	20	20	2.0	0
1	1	1		- 30
2	2	2		- 80
3	3	2.5	0.25	-150
4	4			-220
5	5	5	0.5	-330
6	6			-470
7	7			-750
8	2.5			+ 30
9	10	10	1.0	Not specified
5				
10				
20				

Figure 23.

TL13417-2

[AG 300.7(5 Jun 45)]

BY ORDER OF THE SECRETARY OF WAR:

OFFICIAL:

EDWARD F. WITSELL  
*Major General*  
*Acting The Adjutant General*

G. C. MARSHALL  
*Chief of Staff*

DISTRIBUTION:

AAF (5); AGF (5); ASF (2); T of Opn (5); Dept (5); Base Comd (5); Island Comd (5); Def Comd (2); Arm & Sv Bd (1); S Div ASF (1); Tech Sv (2); PC&S (1); PE (2); Dep 11 (2); Gen Oversea SOS Dep (2); Pro Dist 11 (2); Gen & Sp Sv Sch (5); Lab 11 (2); Rep Shop 11 (2); A (5); CHQ (2); T/O & E 11-107 (3); 11-127 (3); 11-587 (3); 11-592 (3); 11-597 (3).  
Refer to FM 21-6 for explanation of distribution formula.

