



PHILIPS

CALLPAC PRC/VRC 2000 TACTICAL HF RADIO



Operator's Handbook
Manpack Role

WARNING

DANGEROUSLY HIGH R.F. VOLTAGES
occur at the antenna. Avoid
contact with the antenna system.

Publication No 1239

All rights strictly reserved.
Reproduction or issue to third
parties in any form whatever is
not permitted without written
authority from the proprietor.

© MEL 1981

AMDT 1 MAR 82
AMDT 2 JAN 85

MEL

A division of Philips Electronic and Associated Industries Ltd.
Manor Royal, Crawley
West Sussex RH10 2PZ, England
Telephone: Crawley (0293) 28787 Telex: 87267

OPERATOR'S HANDBOOK
for
CALLPAC PACKSET

<u>Contents</u>		<u>Page</u>
SECTION 1 -	INTRODUCTION AND DATA SUMMARY	
1.1	INTRODUCTION	1.1
1.2	DATA SUMMARY	1.2
SECTION 2 -	PREPARATION FOR USE	
2.1	FIT BATTERY	2.1
2.2	INSERT PACKSET INTO CARRYING BAG	2.2
2.3	ASSEMBLE CARRYING FRAME AND HARNESS	2.3
2.4	ATTACH PACKSET TO CARRYING FRAME	2.4
2.5	FIT ANCILLIARY ITEMS	2.5
2.6	INITIAL SETTING-UP	2.6
2.7	HARNESS FITTING AND ADJUSTMENTS FOR CARRYING BAG	2.9
2.8	HARNESS FITTING AND ADJUSTMENTS FOR CARRYING FRAME	2.10
SECTION 3 -	OPERATION WITH PRESET CHANNELS	
3.1	TO COMMUNICATE	3.1
3.2	INTERCOM	3.1
3.3	ADJUSTMENTS DURING USE	3.1
SECTION 4 -	USE OF KEYBOARD	
4.1	SYSTEM SETTING	4.1
4.2	SET AUDIO LEVEL	4.2
4.3	MANUAL ANTENNA TUNE	4.2
4.4	AUTOMATIC ANTENNA RE-TUNE	4.3
4.5	TRANSMITTER POWER LEVEL SELECTION	4.3
4.6	SELECT STORED CHANNEL	4.4
4.7	SET TO NON-STORED MODE	4.5
4.8	SET TO NON-STORED FREQUENCY	4.6
4.9	SET TO NON-STORED FREQUENCY AND MODE	4.7

	<u>Contents(Cont.)</u>	<u>Page</u>
	4.10 CHANNEL STORAGE	4.8
	4.11 CHANNEL EXAMINATION	4.9
	4.12 FREQUENCY INCREMENTING	4.10
	4.13 MEMORY ERASE	4.11
	4.14 CALL	4.11
	4.15 INTERCOM	4.12
SECTION 5 -	ANTENNAE	
5.1	INTRODUCTION	5.1
5.2	DIPOLE ANTENNA	5.2
5.3	END-FED ANTENNA	5.5
SECTION 6 -	BATTERY CHARGING	
6.1	HAND-CRANK GENERATOR	6.1
6.2	SOLAR CHARGING	6.1
SECTION 7 -	ALARMS AND FAULT SYMPTOMS	
7.1	ALARMS	7.1
7.2	FAULT SYMPTOMS	7.1

SECTION 1

INTRODUCTION AND DATA SUMMARY

1.1 INTRODUCTION

- 1 The Callpac packset is a self-contained, man-portable, high-frequency (HF), radio transmitter/receiver, capable of providing single sideband (SSB) or continuous wave (CW) voice or data communication at ranges up to 30km on groundwave.
- 2 Facilities incorporated in the packset allow for single, dual or remote operator working, with intercommunication between two operators whilst maintaining radio silence.
- 3 Microprocessor controlled channelling enables frequency and mode data for up to ten channels to be preset, any one of which can be selected for operational use. When carried on the back, using the carrying bag or frame, the operator operates the channelling system through controls mounted on the special handset or headset control box. In the static role the operator can also operate through a 20-key keyboard and an 8-digit liquid crystal display (LCD).
- 4 A 2.4m whip antenna is attached to the packset front panel, either directly or through a flexible mount. This antenna is automatically coarse tuned as the channel is selected. Provided a transmit/receive channel is selected, the antenna is fine tuned when the transmit key is pressed. When a receive only channel is selected, or to maintain radio silence when a transmit/receive channel is selected, the antenna can be manually tuned from the keyboard. Antenna tuning efficiency is monitored on the LCD. For keyboard operations see Section 4.

5. When used in a static role the packset can be operated into end-fed or dipole wire antennae. For antennae information see Section 5.

6 The packset can be powered from either an internal, rechargeable nickel cadmium battery, or from an external dc supply. For details of battery charging see Section 6.

1.2 DATA SUMMARY

Storage Temp.	:	-40°C to +70°C
Operating Temp	:	-20°C to +60°C
Humidity	:	95% max at +40°C
Immersion	:	Withstand up to 1 hour immersion in water to a depth of 1 metre.
Shock	:	Withstand drop of up to 0.75 metre onto concrete.

1.3 OTHER OPTIONS

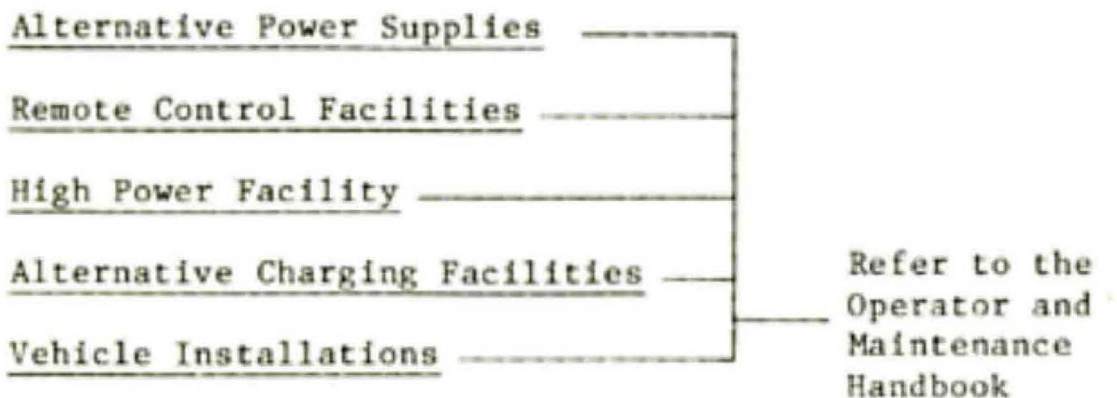

SECTION 2

PREPARATION FOR USE

2.1 FIT BATTERY

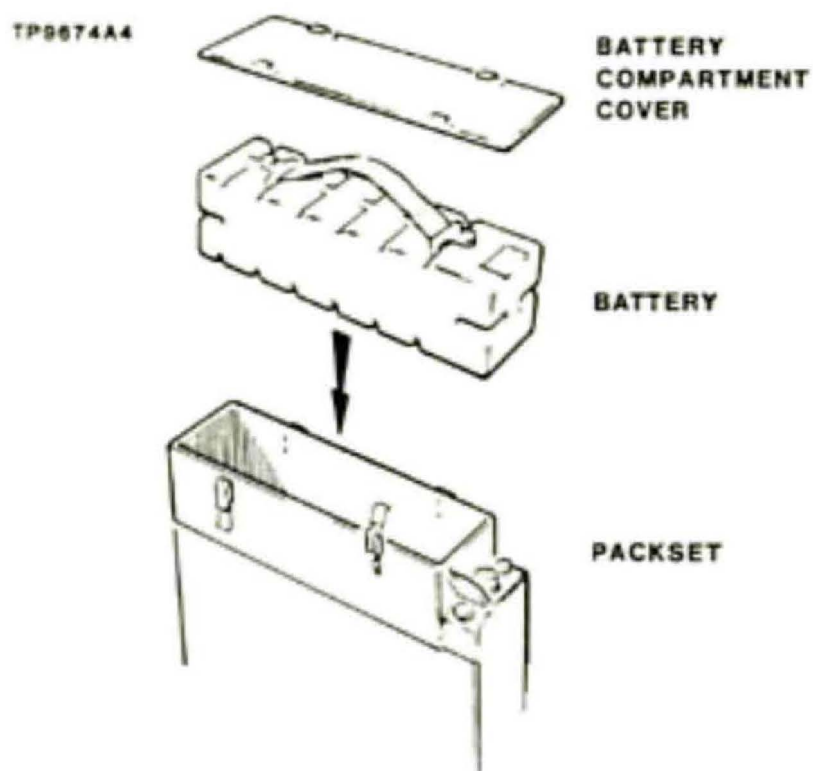

- (1) Stand the packset on its front panel.
- (2) Release the four spring clips holding the battery compartment cover, remove the cover.
- (3) Note the position of the battery connecting pins; insert battery into the battery compartment and press home.
- (4) Locate cover in position and engage the four spring clips to secure cover.

2.2 INSERT PACKSET IN CARRYING BAG

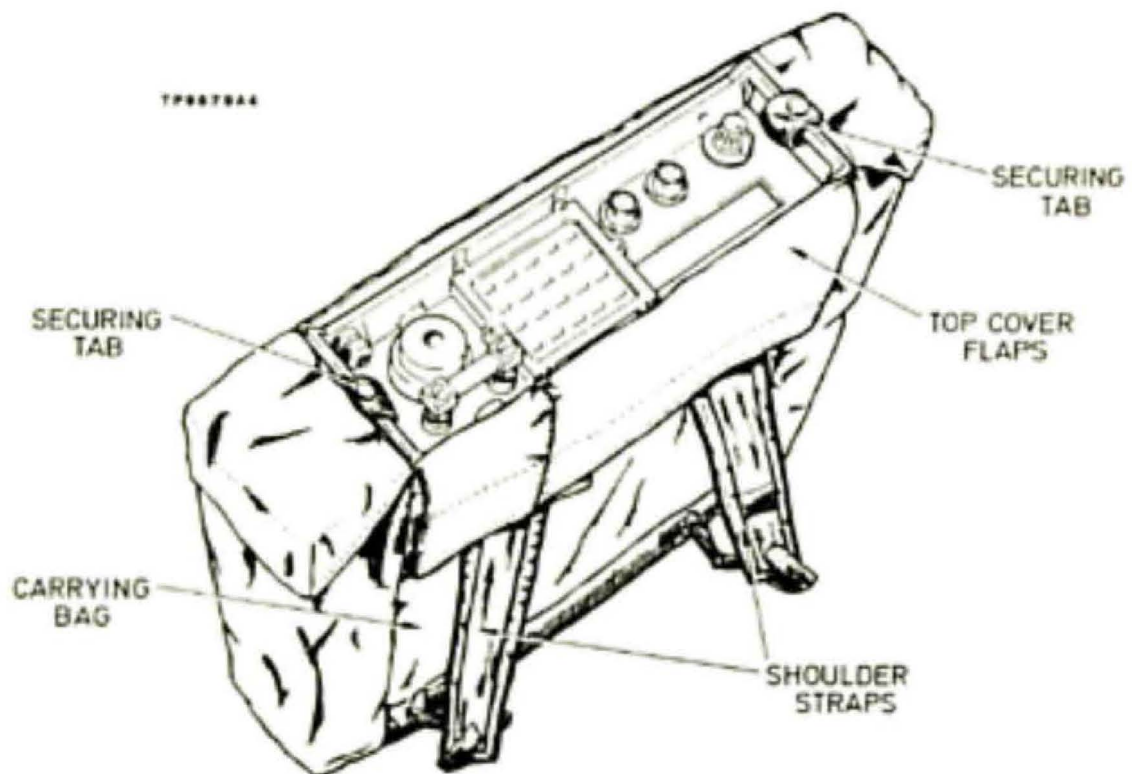

- (1) Insert packset in bag with display adjacent to the larger of the two top cover flaps.
- (2) Pass the securing tabs through the handles and secure using the press fasteners.

2.3 ASSEMBLE CARRYING FRAME AND HARNESS

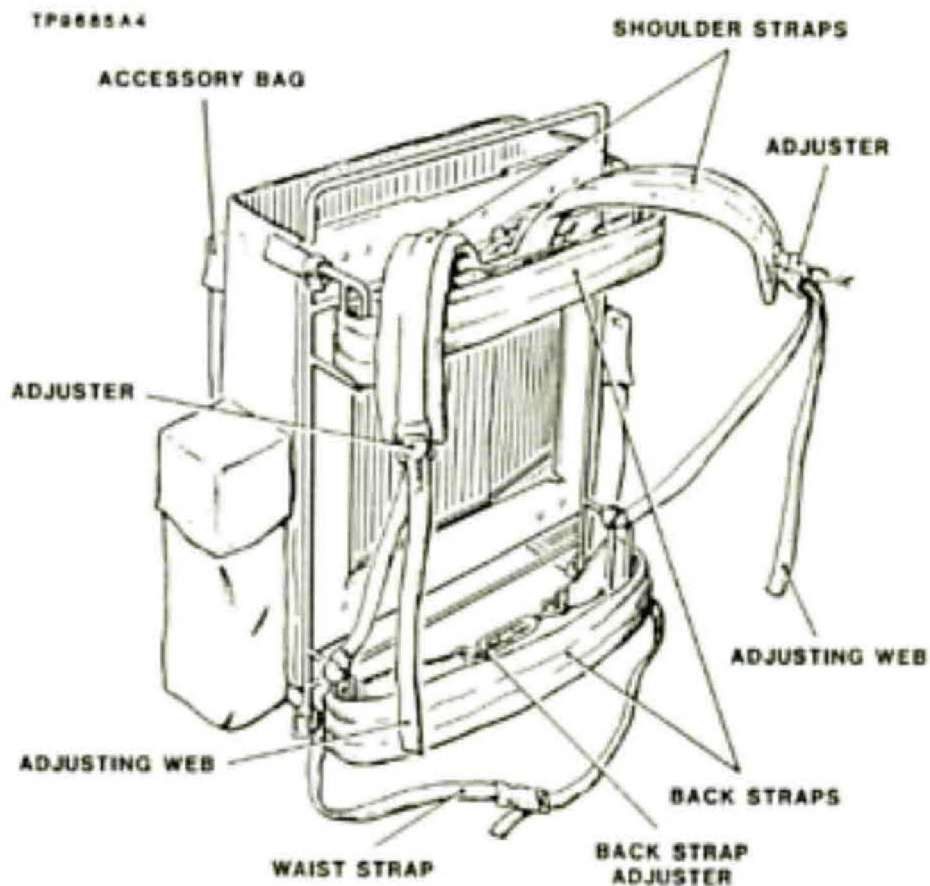

- (1) Stand frame on flat surface.
- (2) Tie back straps to frame ensuring the webs are pulled as tightly as possible.
- (3) Tie looped ends of waist straps to frame.
- (4) Buckle accessory bag to frame (if required).
- (5) Clip shoulder straps to eyes in top of frame.
- (6) Raise adjuster flaps against their springs and remove adjusting webs.

- (7) Tie looped ends of adjusting webs to lower part of frame and pass the remaining ends through their respective adjusters.

2.4 ATTACH PACKSET TO CARRYING FRAME

TP6533A4

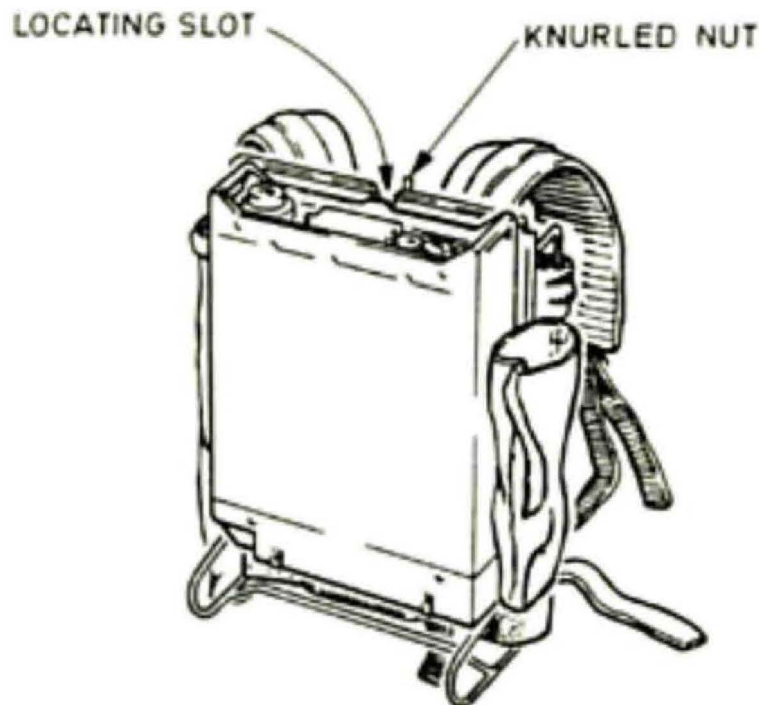

- (1) Release latching bar at top of carrying frame by unscrewing knurled nut.
- (2) Offer up packset to frame so that the four retaining pins on the bottom surface enter their respective fixing blocks and the locating block enters the slot.
- (3) Secure packset to frame by tightening down latching bar over locating block using knurled nut.

2.5 FIT ANCILLIARY ITEMS

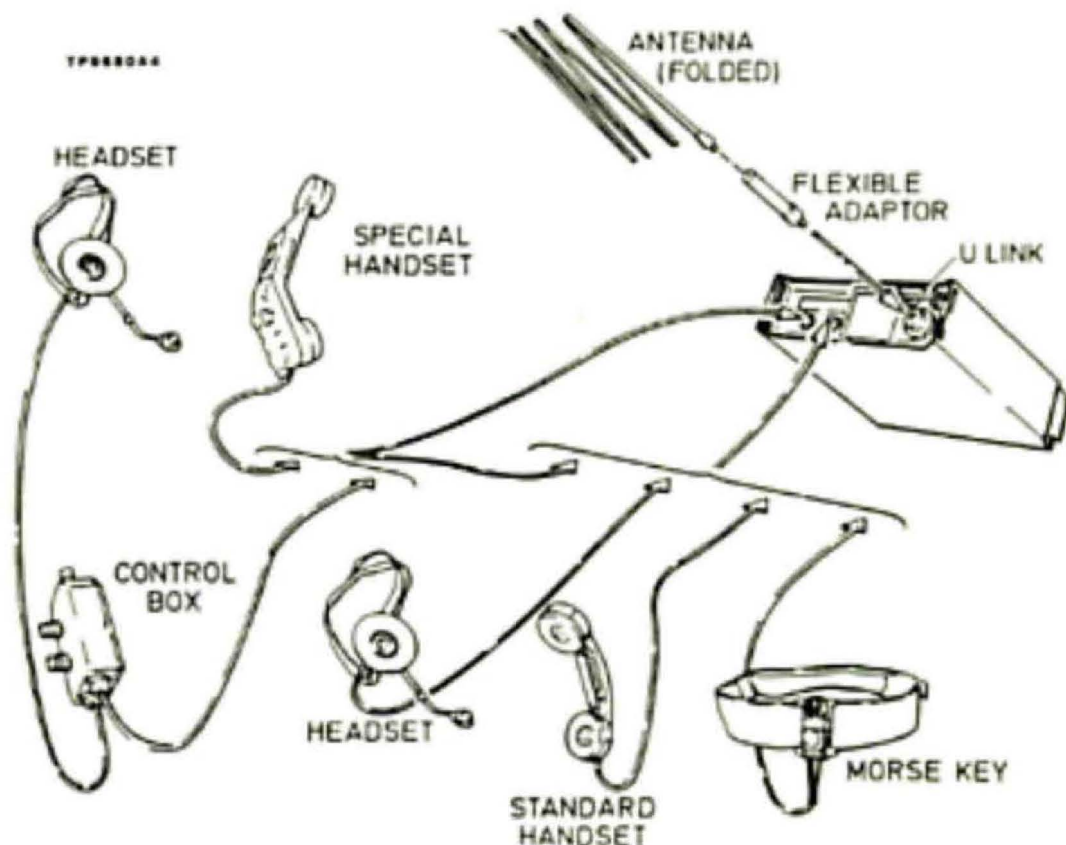

- (1) Erect and fit whip antenna using flexible adaptor if required.
- (2) Fit co-ax 'U' link on front panel.
- (3) Fit audio items as required:

AUDIO 1	AUDIO 2
Special Handset, or Headset and Control box	Special Handset, or Standard Handset, or Headset with/without Control Box, or Morse Key.

2.6 INITIAL SETTING-UP

TP0001A4

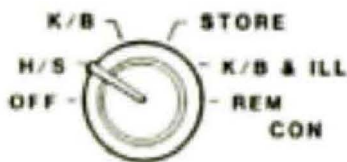
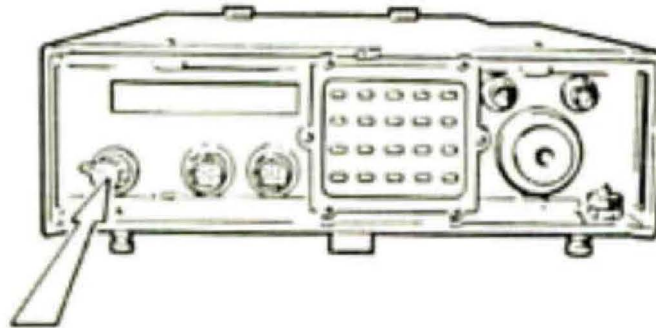

ROTARY SWITCH

- (1) Set Rotary Switch, on front panel, to H/S.

TP0001A4

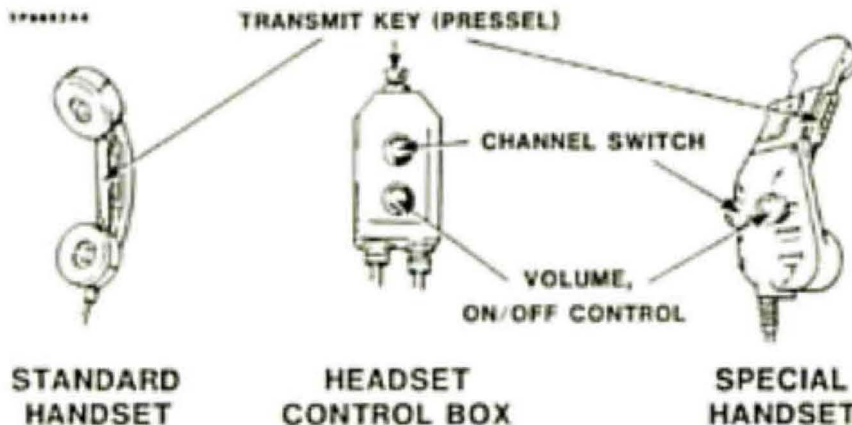

- (2) Switch radio on by rotating clockwise the Volume/On/Off control on the special handset or headset control box (Off position fully counter-clock-wise).

NOTE When the radio is switched on the display shows an option format for approximately 2 seconds. For explanation of the option codes refer to the Operating and Maintenance Handbook.

- (3) Set Channel Switch to each channel in turn and check on the display that working frequency and mode data are stored in appropriate channels. Allow approximately 2-seconds after each channel selection before observing display.

NOTE If 4MHz, Mode 1 is displayed, this indicates that no information is stored in the selected channel.

- (4) Rotate Channel Switch to desired channel number.
- (5) Tune antenna by momentarily operating the pressel; wait for tone to cease.

NOTE Auto tune is inhibited if receive only channel is selected (modes 6,7,8,9 & 0). Refer to Section 4, Para. 4.3 for manual tuning procedure.

- (6) Set audio level:

NOTE Audio level is preset to intermediate level when radio is switched on.

- (i) Set the volume control on the special handset or headset control box for desired audio level.

NOTE If the second operator is using a standard handset or headset without control box, the '+'(increase) and '-'(decrease) keys must be used to preset maximum comfortable sound level.

- (7) Set required transmitter power level:

- (i) Set rotary switch to K/B or K/B & ILL.
- (ii) Press 'CANCEL' key.
- (iii) Press 'PWR' key and observe display.

[Typical Display]

-	-	P	4	-	-	-	1
---	---	---	---	---	---	---	---

 (low)

or

-	-	P	2	0	-	-	1
---	---	---	---	---	---	---	---

 (high)

Received Signal Strength

NOTE The received signal strength digit on the display can be ignored.

High Power - Press '+' key.

Low Power - Press '-' key.

(iv) When satisfied with selection press 'CANCEL' key.

(v) Set rotary switch to H/S.

2.7 HARNESS FITTING AND ADJUSTMENTS FOR CARRYING BAG

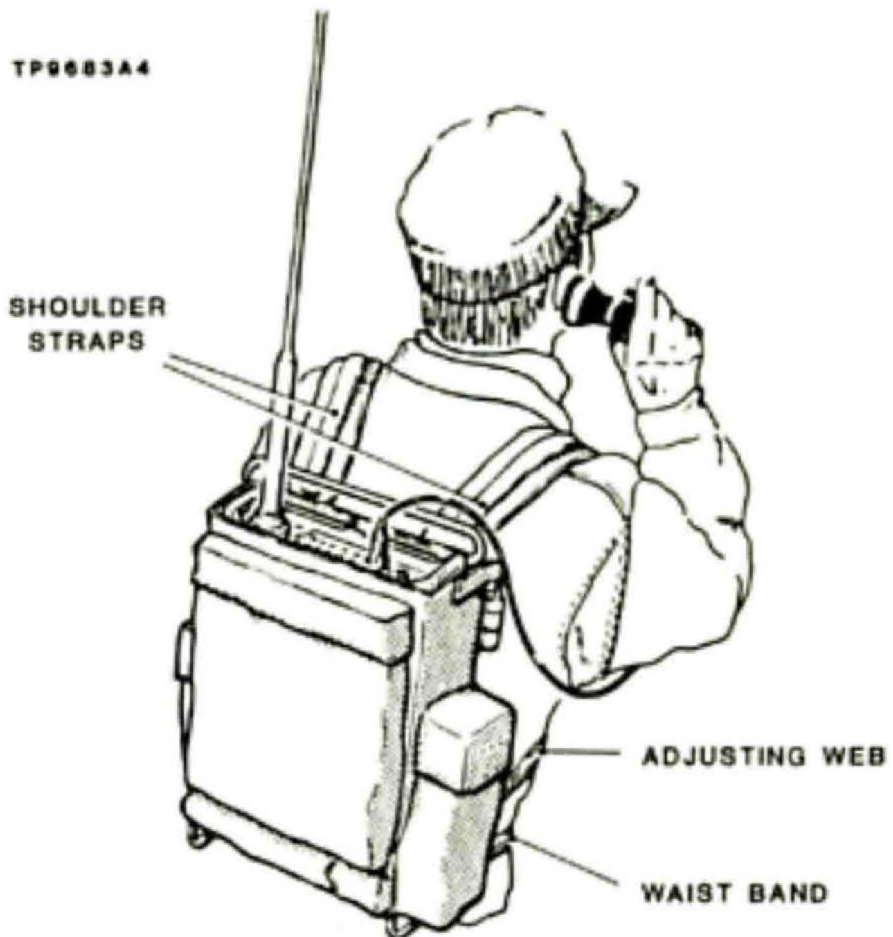

- (1) Place packset and bag on back with arms through shoulder straps.
- (2) Adjust shoulder straps for optimum comfort.

2.8 HARNESS FITTING AND ADJUSTMENTS FOR CARRYING FRAME

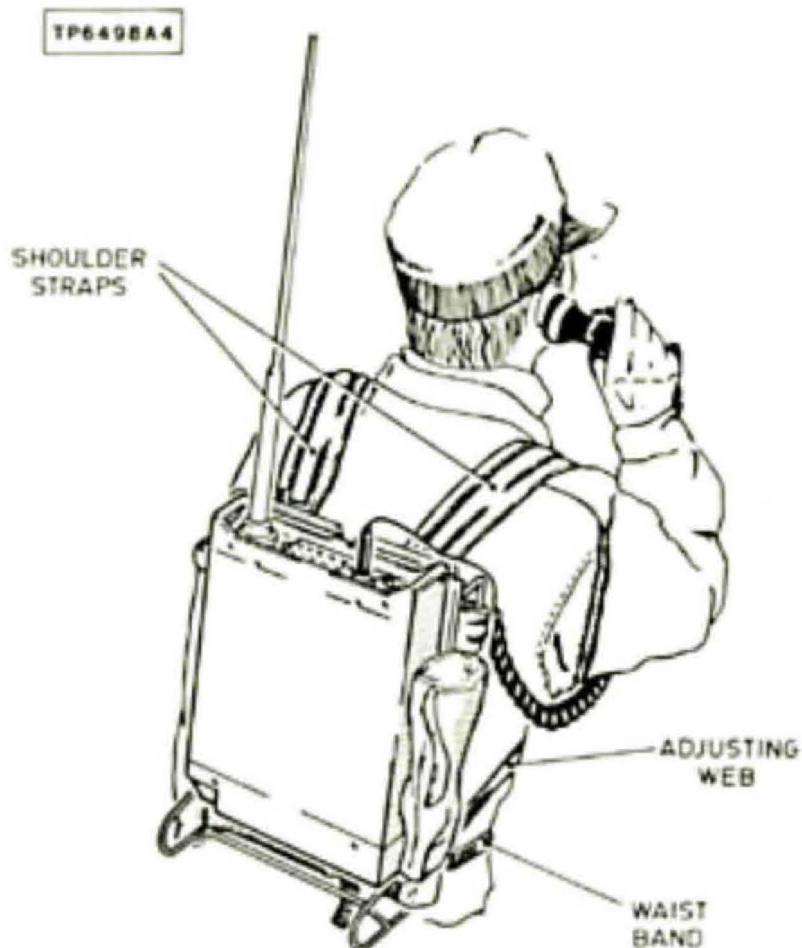

- (1) Place packset on back with arms through shoulder straps.
- (2) Adjust shoulder straps for optimum comfort by pulling down both adjusting webs simultaneously. The packset should be as tight and high on the back as possible.
- (3) Tie waist straps securely around waist.

NOTE Channel selection from the handset or headset control box can only select nine of the ten available channels (Channels 1 to 9 inclusive).

Change Channel - Rotate Channel Control to desired channel number (2 sec. delay). Momentarily operate the transmit pressel to tune the antenna (transmit/receive channels only).

Antenna Retune - Select an alternative channel for a period longer than 2 seconds. Re-select original channel. Momentarily operate transmit pressel to tune antenna (transmit/receive channels only).

Dual Operator Priority - Channel control is allocated to only the special handset or headset control box plugged into Audio 1 socket. Either pressel operates the transmitter.

SECTION 4

USE OF KEYBOARD

4.1 SYSTEM SETTING

TP9676A4

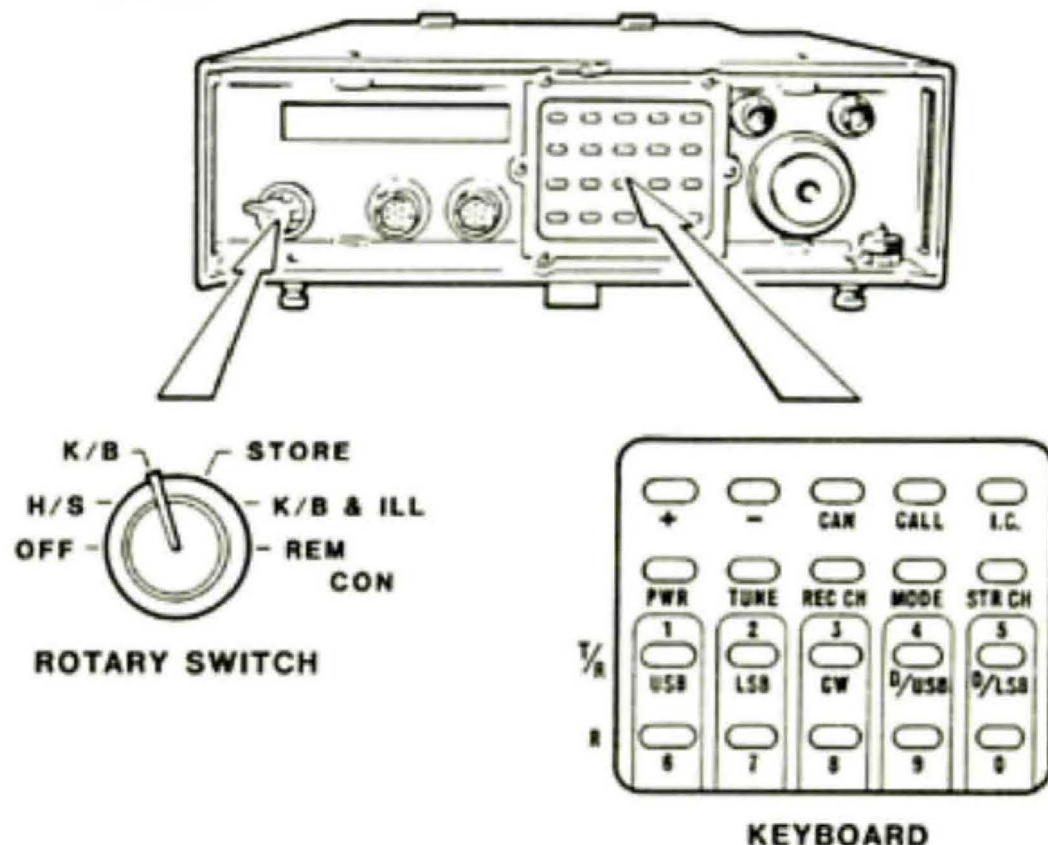

- (1) Set Rotary Switch on front panel to K/B.

NOTE If display illumination is required, set Rotary Switch to K/B&ILL. The display is then illuminated for approx. 10 seconds after selection. As keys are pressed, the display illuminates again and remains illuminated for approx. 10 seconds after each keypress.

4.2 SET AUDIO LEVEL

NOTE The following operation can be performed with the Rotary Switch set to H/S, K/B or K/B&ILL.

(1) Press 'CANCEL' key.

Increase — Press '+' key and hold (audio level gradually increases whilst key is pressed).

Decrease — Press '-' key and hold (audio level gradually decreases whilst key is pressed).

4.3 MANUAL ANTENNA TUNE

(1) Press 'CANCEL' key.

(2) Press 'TUNE' key and observe display.

[Typical Display]



Signal Strength (0 to 9)

(3) Operate the '+' key (increase tune frequency) or '-' key (decrease tune frequency) for maximum received signal strength number on the display, or for best signal volume in the earpiece.

NOTE At low signal levels the noise of the internal tuning motor may mask the audio signal; in this instance operate the '+' or '-' keys momentarily and listen for improved receiver performance between key operations.

(4) When satisfied that tuning is optimum, press 'CANCEL' key to return to normal operation.

NOTE Pressing the 'TUNE' key whilst operating into an antenna connected directly to the RT coaxial socket, displays:

[Typical Display]

-	-	.	-	I	L	.	L	.	-	.	-
---	---	---	---	---	---	---	---	---	---	---	---

4.4 AUTOMATIC ANTENNA RE-TUNE

When transmit/receive channels (modes 1 to 5) are selected, the antenna can be re-tuned at any time as follows:

- (1) Press 'CANCEL' key.
- (2) Press 'STORE CH' key
- (3) Momentarily operate pressel on handset or headset control box to initiate antenna re-tune.

4.5 TRANSMITTER POWER LEVEL SELECTION

- (1) Press 'CANCEL' key.
- (2) Press 'PWR' key and observe display:

[Typical Display]

-	-	.	P	4	-	.	-	.	-	.	1
---	---	---	---	---	---	---	---	---	---	---	---

 (low)

or

-	-	.	P	2	0	.	-	.	-	.	1
---	---	---	---	---	---	---	---	---	---	---	---

 (high)

Received Signal Strength

NOTE The received signal strength digit on the display can be ignored.

High Power – press '+' key.

Low Power – press '-' key.

(3) When satisfied with selection press 'CANCEL' key.

4.6 SELECT STORED CHANNEL

(1) Press 'CANCEL' key.

(2) Press 'REC CH' key.

(3) Press numeral key corresponding to channel number required; observe display:

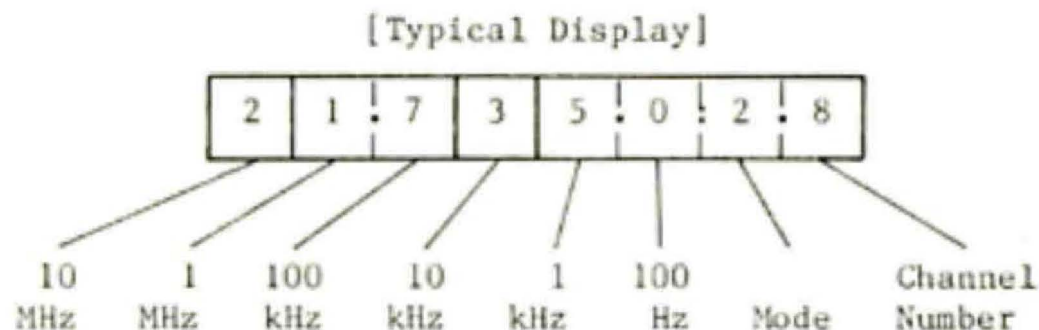

(4) Momentarily operate pressel to tune antenna; wait for tone to cease.

NOTES 1 Auto antenna tune is inhibited if receive only channel (modes 6,7,8,9 or 0) is selected; use manual antenna tune procedure, Para 4.3.

2 During receive, the display is as shown above. During transmit, the display changes to one of the two power formats as follows:

[Typical Display]

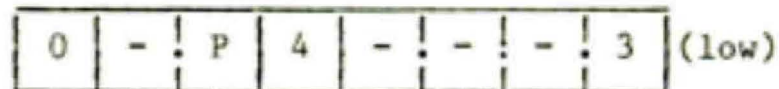

or



Reverse Power
Power Setting
Forward Power

NOTE Selection of a channel which does not contain previously stored frequency and mode data, or has been erased, automatically presents a frequency of 4MHz, mode 1.

4.7 SET TO NON-STORED MODE

NOTE Non-stored information is lost when new data is entered or another channel is selected. Provided channels are not changed, the information is retained if the radio is switched off.

- (1) Check Rotary Switch is set to K/B or K/B&ILL.
- (2) Press 'CANCEL' key.

MODE	Mode Digit	
	TX/RX	RX
USB - Voice or Key	1	6
LSB - Voice or Key	2	7
CW - Key	3	8
USB - Data	4	9
LSB - Data	5	0

- (3) Press 'MODE' key.
- (4) Press numeral key representing the required mode digit (see table); check display:

[Typical Display]

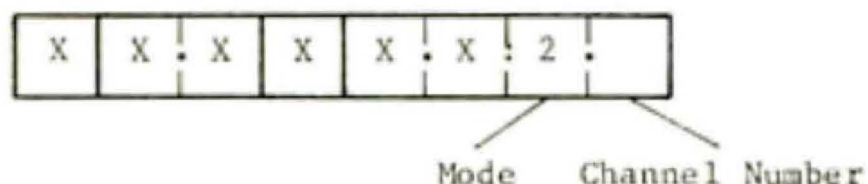

NOTE In case of error press the 'CANCEL' key and re-enter mode from operation (3).

- (5) Press 'STORE CH' key to set radio to new mode but operating with stored or previously entered non-stored frequency; check channel number on display changes to -, indicating non-stored information.

4.8 SET TO NON-STORED FREQUENCY

NOTE Non-stored information is lost when new data is entered or another channel is selected. Provided channels are not changed, the information is retained if the radio is switched off.

- (1) Check Rotary Switch is set to K/B or K/B&ILL.
- (2) Press 'CANCEL' key.
- (3) Enter frequency by pressing numeral keys in descending order of frequency; observe display.

e.g. to enter a frequency of 21.7350 MHz press
'2', '1', '7', '3', '5', '0'.

NOTE It is essential to include the final '0' as the frequency digits enter from the 100Hz digit position and jump across one place as each new digit is entered.

[Typical Display]

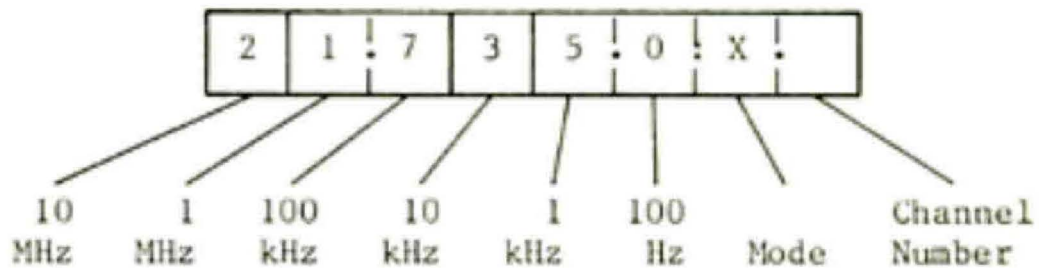

NOTE In case of error press 'CANCEL' key and enter frequency again.

- (4) Press 'STORE CH' key to set radio to new frequency but operating with stored or previously entered non-stored mode; check channel number on display changes to -, indicating non-stored information.

NOTE If the frequency entered is outside the permitted range, the display shows 'ILL'; press 'CANCEL' key and enter correct frequency from operation (3).

- (5) Momentarily operate the transmit pressel to tune the antenna (transmit/receive only).

4.9 SET TO NON-STORED FREQUENCY AND MODE

NOTE Non-stored information is lost when new data is entered or another channel is selected. Provided channels are not changed, the information is retained if the radio is switched off.

- (1) Check Rotary Switch is set to K/B or K/B&ILL.

- (2) Press 'CANCEL' key.
- (3) Enter frequency (eg. 21.7350MHz) by pressing keys in descending order of frequency; observe display.

[Typical Display]

2	1	.	7	3	5	.	0	.	X	.
---	---	---	---	---	---	---	---	---	---	---

- (4) Press 'MODE' key.
- (5) Press numeral key representing the required mode (eg. 4); observe display.

[Typical Display]

2	1	.	7	3	5	.	0	.	4	.
---	---	---	---	---	---	---	---	---	---	---

NOTE In case of error, press 'CANCEL' key and re-enter information from operation (3).

- (6) Press 'STORE CH' key to set radio to new frequency and mode; check channel number on display changes to -, indicating non-stored information.

4.10 CHANNEL STORAGE

- (1) If storage protection option is incorporated, plug the special key into the Audio 2 connector.
- (2) Enter frequency and or mode data as detailed in paragraphs 4.7 to 4.9, but do not press the 'STORE CH' key.
- (3) Set Rotary Switch to STORE.

NOTE A pulsating audio tone will be heard in the hand or headset earpiece.

- (4) Press 'STORE CH' key.
- (5) Press numeral key representing the number of the channel in which the information is to be stored.
- (6) Set Rotary Switch to K/B or K/B&ILL as required.
- (7) Programme as many channels as required; refer to Para 4.11 to check validity of channels.
- (8) If applicable, remove the special key plug from the Audio 2 connector.

4.11 CHANNEL EXAMINATION

NOTE The following operations permit examination of all channel stored information, whilst maintaining a listening watch on a selected channel; transmission is inhibited whilst examination is in progress.

- (1) Set the Rotary Switch to STORE.

NOTE In addition to the normal received audio, a pulsating tone signal will be heard in the hand or headset earpiece.

- (2) Press the 'REC CH' key.
- (3) Press numeral key corresponding to the channel to be examined.
- (4) Examine the display; a blank display indicates that nothing is stored in that channel.
- (5) If further channels are to be examined, repeat from operation (3).

- (6) When examination is complete, reset Rotary Switch to K/B or K/B&ILL.

4.12 FREQUENCY INCREMENTING

- (1) Press 'CANCEL' key.
- (2) Enter frequency increment by pressing numeral keys in descending order of frequency; observe display:

eg. to enter a frequency increment of 10kHz, press '1', '0', '0'.

NOTE It is essential to include the final '0' as the digits enter from the 100Hz digit position and jump across one place as each new digit is entered.

[Typical Display]

	:	1	0	:	0	:	X	:
--	---	---	---	---	---	---	---	---

NOTE In case of error, press the 'CANCEL' key and re-enter frequency increment.

Increase Frequency — press '+' key.

Decrease frequency — press '-' key.

NOTE Momentary operation of the '+' or '-' keys, steps the frequency of the selected channel by one incremental step at a time. If the chosen key is pressed and held, frequency automatically steps at an increasing speed, the starting interval being approximately 2 seconds. Maximum speed is reached after 10 steps.

- (3) When the desired frequency is reached, press the 'CANCEL' key to revert to normal operation.

NOTE Provided a transmit/receive channel (modes 1 to 5) is selected, the antenna will be tuned the first time the transmit pressel is pressed.

4.13 MEMORY ERASE

NOTE The following procedure is not considered a standard operator function but it provides an emergency security feature in the event of imminent equipment capture.

- (1) Set the Rotary Switch to the STORE position.
- (2) Press any three keys simultaneously.

NOTES 1 Stored and non-stored information for all ten operational channels is erased. The display shows the option format for a few seconds and then changes to the following display:

[Typical Display]



Channel Number

- 2 When the Rotary Switch is set to an operational position (K/B or K/B&ILL) each channel, when selected, displays 4MHz, Mode 1.

4.14 CALL

NOTES 1 The call facility initiates transmission of an alternating two-tone audio signal for approximately two seconds, reverting to normal reception when the transmission ends.

2 If the call transmission is the first following a change of channel or a tune enable action, the antenna will retune before the call signal transmission.

- (1) Check that Rotary Switch is set to H/S, K/B or K/B&ILL.
- (2) Press the 'CALL' key; check display changes to a power format and the call signal is audible in the hand or headset earpiece.

NOTE Operation of the call facility whilst intercom is selected, generates the tone signal but does not transmit.

4.15 INTERCOM

NOTE The intercom facility permits conversation between two operators without transmission. Received audio remains audible at reduced volume whilst intercom is selected.

- (1) Check that Rotary Switch is set to K/B or K/B&ILL.
- (2) Press 'IC' key; check display shows:

[Typical Display]



Channel Number

- (3) Communicate by operating the hand or headset pressel, transmission is inhibited.
- (4) To revert to normal operation press 'CANCEL' key.

SECTION 5

ANTENNAE

5.1 INTRODUCTION

1 When operating in the manpack role, the standard tuneable whip antenna provides the best compromise between mobility and performance, over a wide range of terrain. If however increased performance is required and the semi-fixed station role is acceptable, the whip antenna can be replaced by a wire dipole or end-fed antenna. In this instance the antenna cannot be tuned by the packset antenna tuning unit (ATU), and must be tuned by antenna wire length.

2 To facilitate tuning each antenna wire is marked at intervals with sleeves bearing the frequency tuned by that length of antenna. Alternatively the required length may be interpreted from the following table:

DIPOLE (LENGTH IN METRES OF EACH ARM)

MHz	1.5	2	2.5	3	4	5	6	7.5	10	12.5	15	18	22.5	26	30
LENGTH	45	34	27	22	16.5	13	10.5	8	6	4.75	4	3	2.25	2	1.5

3 The wire and throwing cord for each antenna leg is wound on a bobbin. Insulated wire is used so that the antenna wires can be draped over wet foliage.

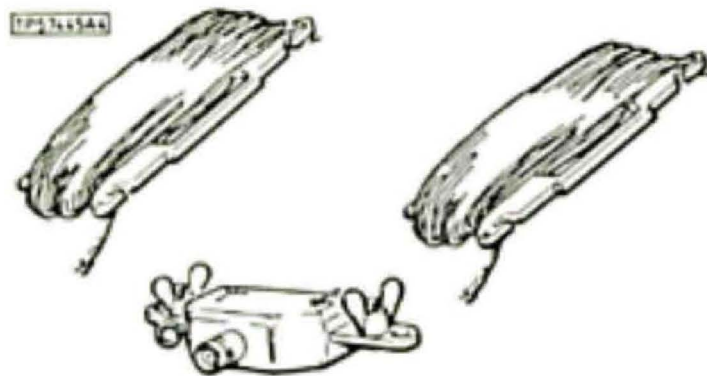

5.2 DIPOLE ANTENNA

NOTE For communication over relatively short distances, antenna direction is not critical, however for communication over distances greater than approx. 100km (60 miles) the antenna should be erected broadside to the direction of communication.

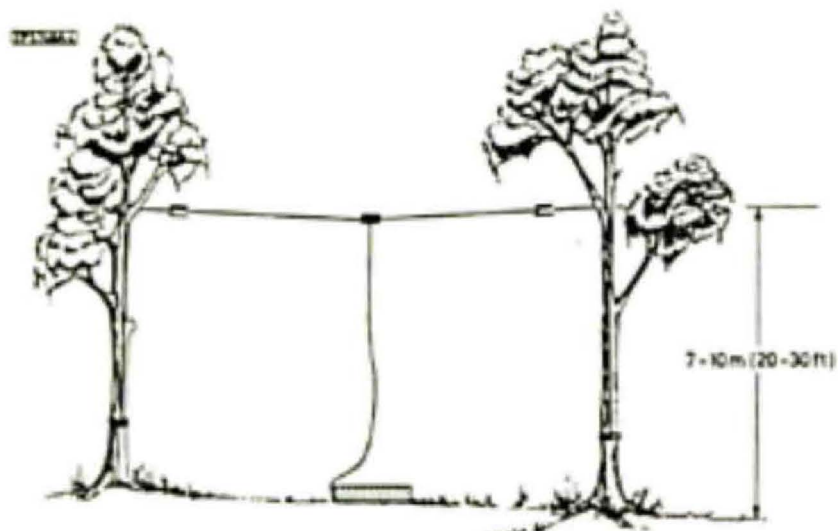

Typical installation for best results at maximum range.

- (1) Unwind the throwing cord from the bobbin.
- (2) Unwind the appropriate length of antenna wire and tie-off on the bobbin so that the relevant marker is just clear of the tie-off point. Refer to table in Para 5.1 if necessary.
- (3) Connect the spade terminal of the antenna wire to wing-nut on the adaptor, and secure the dog-clip through hole adjacent to the wing-nut.
- (4) Repeat operations (1) to (3) for the second antenna leg.
- (5) Connect the co-ax plug at the thimble end of the feeder cable to the co-ax socket on the adaptor; twist the hook on the thimble through the eye-screw at the bottom of the adaptor.

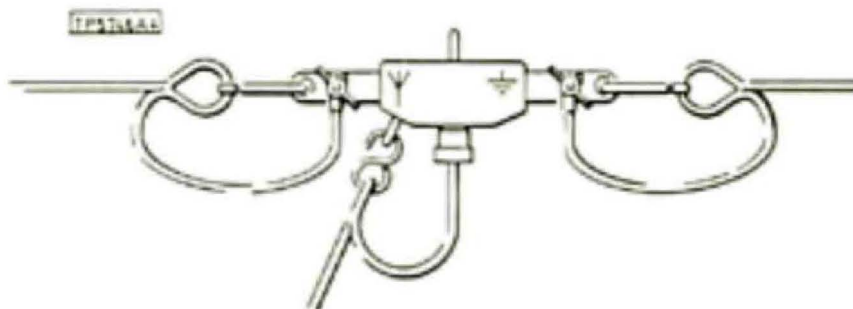

- (6) Using the weight at the end of the throwing cord, throw the cord over a suitable tree branch. Repeat for other antenna leg.

- (7) Hoist the antenna into position and secure.
- (8) At the packset, remove the RT/ATU co-ax 'U' link and connect the free end of the feeder cable to the now exposed RT connector.

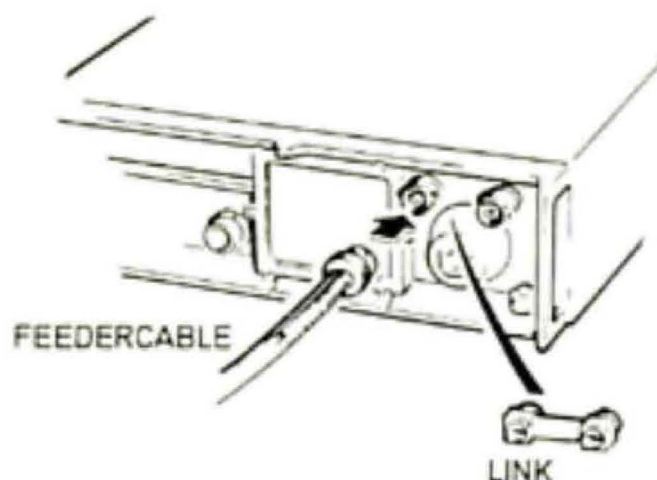

- (9) Select appropriate frequency/mode at keyboard (Section 4) or hand/headset (Section 3).
- (10) Enter mode 3 on the frequency required. Operate pressel switch and note the reverse power indication on the display. If the indication is 2 or more, the antenna length requires adjustment.
- (11) Increment the frequency in 100kHz steps and at each step transmit, noting the reverse power indication; if the number increases, decrement the frequency until a power indication of 0 or 1 appears.
- (12) If the frequency is now less than that required, the antenna is too long and should be shortened a bobbin length. Repeat until the optimum match, giving lowest reverse power indication, is obtained at the desired frequency.

- (13) If the frequency is now more than that required, the antenna is too short and should be lengthened a bobbin length. Repeat until the optimum match, giving lowest reverse power indication, is obtained at the desired frequency.
- (14) Revert to the required working mode if other than mode 3.

5.3 END-FED ANTENNA

NOTE As the end-fed antenna is not as effective as the dipole antenna, it is necessary to arrange that the antenna points in the direction of required transmission. The end-fed antenna uses one of the two antenna bobbins, the adaptor and the earth spike.

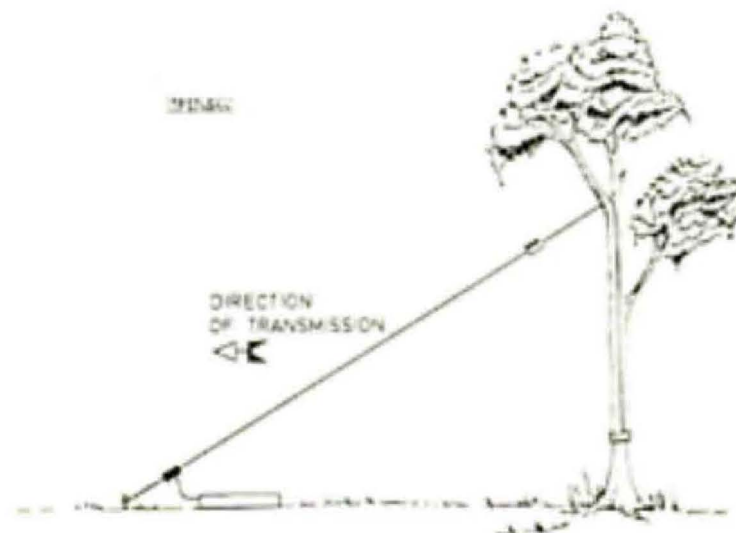

- (1) Unwind the throwing cord from the bobbin.
- (2) Unwind the appropriate length of antenna wire and tie-off on the bobbin so that the relevant marker is just free of the tie-off point. Refer to table in Para 5.1 if necessary.

- (3) Connect the spade terminal of the antenna wire to the wing-nut on the adaptor; secure the dog-clip through hole adjacent to the wing-nut.
- (4) Repeat operation (3) for the earth spike.
- (5) Connect the co-ax plug at the thimble end of the feeder cable to the co-ax socket on the adaptor; twist the hook on the thimble through the eye-screw on the adaptor.
- (6) Drive the earth spike into the ground.
- (7) Using the weight at the end of the throwing cord, throw the cord over a convenient tree branch.
- (8) Hoist the antenna into working position and secure.

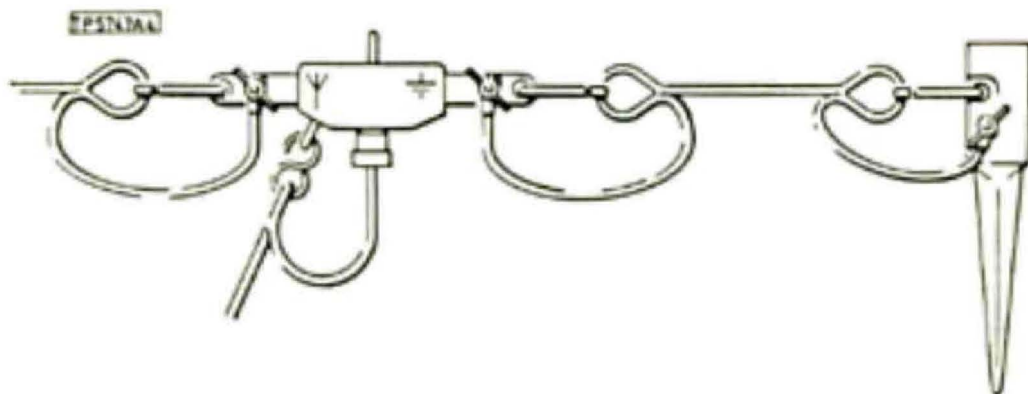

- (9) At the packset, remove the RT/ATU co-ax 'U' link and connect the free end of the feeder cable to the now exposed RT connector.

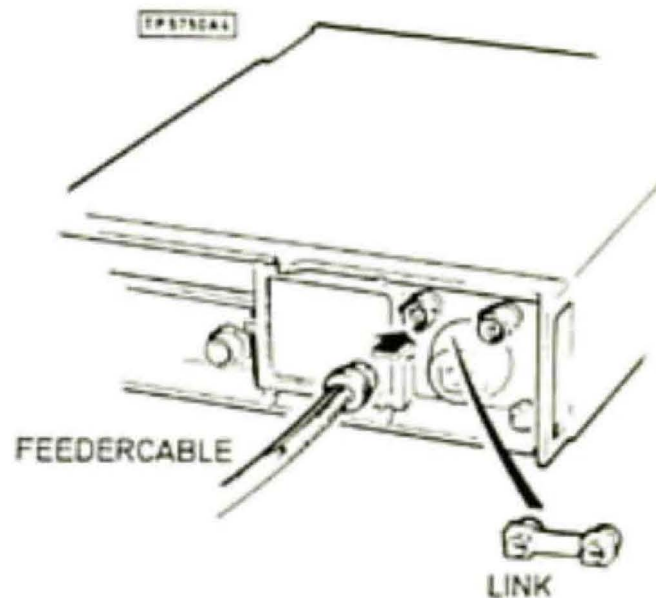

- (10) Select appropriate frequency/mode at keyboard (Section 4) or hand/headset (Section 3).
- (11) Enter mode 3 on the frequency required. Operate pressel switch and note the reverse power indication on the display. If the indication is 2 or more, the antenna length requires adjustment.
- (12) Increment the frequency in 100kHz steps and at each step transmit, noting the reverse power indication; if the number increases, decrement the frequency until a power indication of 0 or 1 appears.
- (13) If the frequency is now less than that required, the antenna is too long and should be shortened a bobbin length. Repeat until the optimum match, giving lowest reverse power indication, is obtained at the desired frequency.
- (14) If the frequency is now more than that required, the antenna is too short and should be lengthened a bobbin length. Repeat until the optimum match,

giving lowest reverse power indication, is obtained at the desired frequency.

- (15) Revert to the required working mode if other than mode 3.

SECTION 6

BATTERY CHARGING

6.1 HAND-CRANK GENERATOR

NOTE The packset can be used whilst hand-crank charging is taking place.

- (1) Mount the hand-crank generator by one of the methods specified in the generator handbook.
- (2) Connect the generator to the socket located at the bottom of the packset, using the lead provided.
- (3) Turn the crank handles (minimum speed - 30 rpm) to charge the battery in accordance with the following:

e.g. A transmit time of 10 minutes requires 20 minutes cranking.

A receive time of 10 minutes requires 1 minute cranking.

NOTE Provided minimum cranking speed is exceeded, the generator output is regulated to provide a constant charging rate, irrespective of cranking speed.

6.2 SOLAR CHARGING

NOTE The packset can be used whilst solar charging is taking place.

- (1) Open out the solar charger panel and position to absorb maximum light.

- (2) Connect the solar charger panel to the socket at the bottom of the packset, using the lead provided.

NOTE Charging time cannot be accurately stipulated as it is dependent upon the strength of light falling on the solar charging panels. As a guide, in strong sunlight, the panel can charge at a rate equivalent to:

$$\frac{\text{Battery Capacity}}{10}$$

In reasonable sunlight conditions, the panel can supply sufficient charge to permit normal continuous operation of the packset.

SECTION 7

ALARMS AND FAULT SYMPTOMS

7.1 ALARMS

Alarm	Cause and Action
1kHz tone burst repeated at 6 sec. intervals. Display showing BA at 6 sec. intervals.	Indicates low battery volts Packset may still be used but battery must be charged as soon as possible.
Continuous pulsating tone Display showing PH at 6 sec. intervals.	Synthesiser not locked. Re-select channel or enter frequency again.
Continuous pulsating tone No display message.	1 Manpack protection against high incoming signal level. Check proximity of transmitter. 2 Rotary Switch set to STORE position.

7.2 FAULT SYMPTOMS

Symptom	Action
1 No noise in earpiece.	1 Check Rotary Switch is set to H/S, K/B or K/B&ILL. 2 Check that hand/headset volume is turned up (clockwise). 3 Check display; If blank, check fuse at the base of the packset. 4 Press and hold '+' key for 10 seconds.

7.2 FAULT SYMPTOMS (Cont.)

Symptom	Action
1 cont.	5 Check battery is charged (replace if necessary). 6 Check connections. 7 Check that the transmit pressel is not operating on either hand/headset.
2 ATU does not tune.	1 Check selected mode, if modes 6,7 8,9 or 0 are selected, auto tuning is inhibited. 2 Check transmit pressel operates. 3 Check connections. 4 RT/ATU link not fitted.
3 No or poor communications	1 Check display shows correct frequency, mode and channel number. 2 Operate transmit pressel and speak into microphone; check that the display shows high forward and low reverse power indications. If not, check antenna and connections and re-tune antenna. 3 Check audio ancillaries and connections.
4 Connections and indications appear correct but fault remains.	1 Check packset using field test set. If a fault is diagnosed, return packset to field repair workshop.

CHECK LIST

PREPARATION FOR USE (Section 2)

- 1 FIT BATTERY
- 2 INSERT PACKSET INTO CARRYING BAG
- 3 FIT ANCILLARY ITEMS
- 4 INITIAL SET-UP
 - Set H/S
 - PRESET VOLUME (Para 4.2)
 - SET CHANNEL (Para 3.3)
 - ANTENNA TUNE
 - AUTO (Pressel)
 - MAN (Para 4.3)
 - POWER LEVEL (Para 4.5)
- 5 FIT AND ADJUST HARNESS

OPERATION WITH PRESET CHANNELS (Section 3)

H/S

- 1 COMMUNICATE
 - SPEECH — operate pressel
 - CW — operate key
- 2 INTERCOM — Select INT on hand/headset
- 3 ADJUSTMENTS
 - Switch ON — set volume
 - Switch OFF — set volume to OFF
 - Change channel — set channel control
 - Antenna retune — select alt channel, reselect, pressel

